



PARTS CATALOGUE

YFM7RZ (1AS2) CANADA

YFM7RZ (1AS3) EUROPE

YFM7RZ (1AS1) OCEANIA



2009/8/24

1J1AS-100E1

()

NEWS NO.	DATE	COMMENT
PE0-MC-090052	Jul.,30,2009	FIG.16: TRANSMISSION LIST CORRECTION
PE0-MC-090060	Aug.,3,2009	FIG.33 FRONT MASTER CYLINDER LIST CORRECTION

YFM7RZ
PARTS CATALOGUE
©2009 by Yamaha Motor Co., Ltd.
1st edition, March 2009
All rights reserved.
Any reprinting or unauthorized use
without the written permission of
Yamaha Motor Co., Ltd.
is expressly prohibited.
Printed in Japan.

FOREWORD

This Parts Catalogue is related to the parts for the model(s) on the cover page. When you are ordering replacement parts, please refer to this Parts Catalogue and quote both part numbers and part names correctly.

1. Modifications or additions which have been made after the issue of the Parts Catalogue will be announced in the Parts News.

It is advisable that you make the necessary corrections to the Parts Catalogue according to the Parts News.

2. Abbreviations

The following abbreviations are used in this Parts Catalogue.

“UR” Use specified parts number.

“UN” Use as many as needed.

“AP” Alternate Parts

“LM” Locally Made (Parts need to be ordered locally)

“F#” Frame No. (Applicable machine No.)

“O/S” Over Size

3. The number of components for assembly

- Parts, which are to be supplied in an assembly, are listed with a dot (.) in front of the part name as shown below.
- The numeral appearing to the right of each component part indicates the quantity of parts for each assembly unit.

PART NO.	DESCRIPTION	Q'TY	REMARKS
2F5-83310-60	FRONT FLASHER LIGHT ASSY	2	
115-83311-60	.BULB (6V-18W)	1	

4. Applicable colours of graphics are represented in the “REMARKS” as shown below.

PART NO.	DESCRIPTION	Q'TY	REMARKS
2N4-24110-00-X5	FUEL TANK COMP.	2	MXR
3J1-24240-10	.GRAPHIC, FUEL TANK	1	FOR MXR

5. Note that the illustrations for reference in finding parts numbers are not to be used for assembling. When assembling, please use the applicable service manual.

6. The asterisk (*) before a reference number indicates modified items after the first edition.

FOREWORD

7. Applicable Serial No.

Engine Serial No.

Frame Serial No.

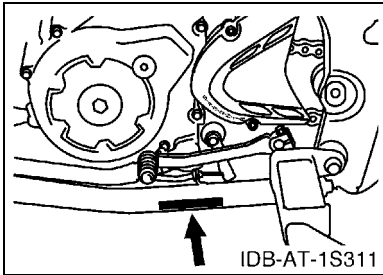
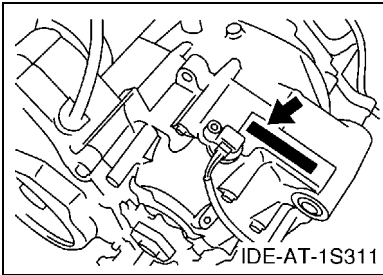

8. Applicable Colour Code (The (*) mark shows Model colour.)

Abbreviation	Colour Name	Colour Code
BWS1(*)	BLUISH WHITE SOLID 1	0892
DPBSE(*)	DEEP PURPLISH BLUE SOLID E	0583

9. Quantity Column Information

Column No.	Name Of Q'ty Column	Destination
1	CAN	CANADA
2	EUR	EUROPE
3	OCE	OCEANIA

CONTENTS

ENGINE

CYLINDER HEAD	1
CYLINDER	2
CRANKSHAFT & PISTON	3
VALVE	4
CAMSHAFT & CHAIN	5
WATER PUMP	6
RADIATOR & HOSE	7
OIL PUMP	8
INTAKE	10
THROTTLE BODY ASSY 1	12
EXHAUST	13
CRANKCASE	14
CRANKCASE COVER 1	15
STARTER	16
CLUTCH	17
TRANSMISSION	19
SHIFT CAM & FORK	21

CHASSIS

FRAME	23
FRONT FENDER	25
REAR FENDER	27
OIL TANK	29
REAR ARM	30
REAR SUSPENSION	33
STEERING	34
FRONT SUSPENSION & WHEEL	35
FUEL TANK	37
SEAT	39
FRONT WHEEL	40
FRONT BRAKE CALIPER	41
REAR WHEEL	43
REAR BRAKE CALIPER	44
STEERING HANDLE & CABLE	46
FRONT MASTER CYLINDER	48
STAND & FOOTREST	49
REAR MASTER CYLINDER	50
GUARD	52
GENERATOR	53
STARTING MOTOR	54
METER	55

HEADLIGHT	56
TAILLIGHT	57
TAILLIGHT 2	58
HANDLE SWITCH & LEVER	59
ELECTRICAL 1	60
ELECTRICAL 2	63
EMBLEM & LABEL 1	64
EMBLEM & LABEL 2	66
EMBLEM & LABEL 3	67

INDEX

NUMERICAL INDEX	68
-----------------------	----

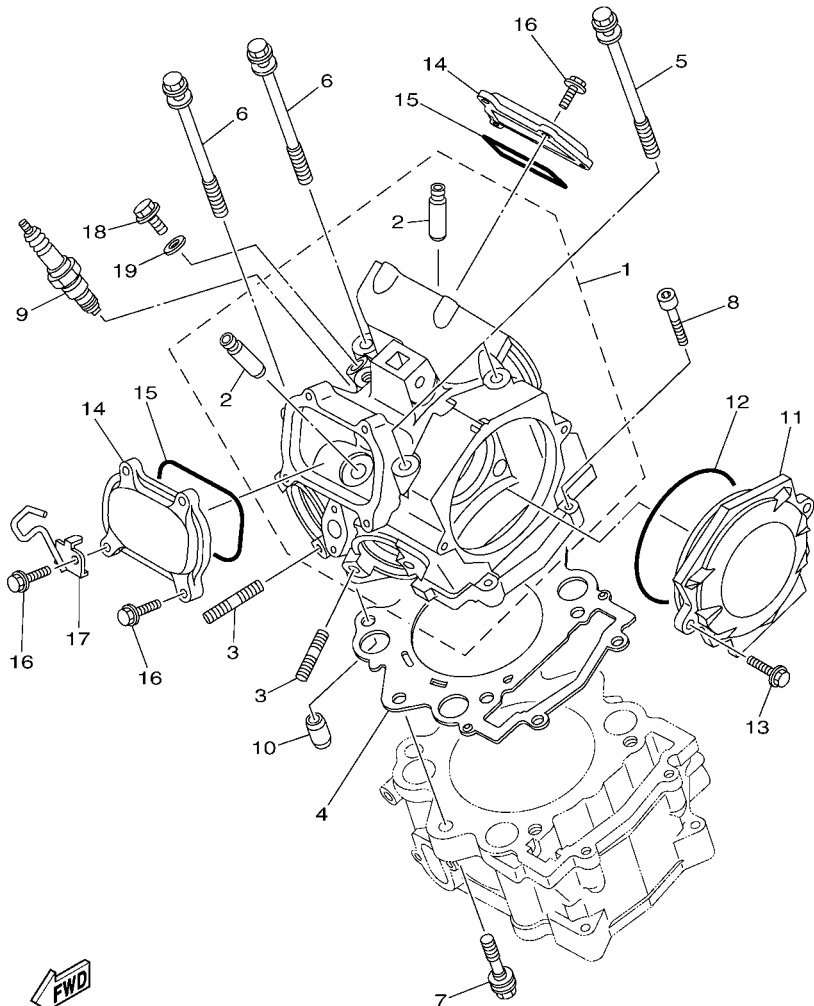

FWD
1S3L100-H010

FIG. 1 CYLINDER HEAD

REF. NO.	PART NO.	DESCRIPTION	CAN	EUR	OCE	REMARKS
1	1S3-11101-10	CYLINDER HEAD ASSY	1	1	1	
2	4G0-11133-11	.GUIDE, VALVE 1	4	4	4	
3	95612-08625	BOLT, STUD	4	4	4	
4	3B4-11181-00	GASKET, CYLINDER HEAD 1	1	1	1	
5	90109-09003	BOLT	2	2	2	
6	90109-09002	BOLT	2	2	2	
7	90109-09005	BOLT	2	2	2	
8	91312-06030	BOLT	2	2	2	
9	94701-00330	PLUG, SPARK (NGK CR8E)	1	1	1	
10	93612-16254	PIN, DOWEL	2	2	2	
11	1S3-11185-00	COVER, CYLINDER HEAD SIDE 3	1	1	1	
12	93210-96601	O-RING	1	1	1	
13	95022-06020	BOLT, FLANGE	2	2	2	
14	1S3-11186-00	COVER, CYLINDER HEAD SIDE 2	2	2	2	
15	93210-78544	O-RING	2	2	2	
16	95022-06020	BOLT, FLANGE	8	8	8	
17	1S3-1131E-00	HOLDER 1	1	1	1	
18	90401-08004	BOLT, UNION	1	1	1	
19	90430-08119	GASKET	1	1	1	

FIG. 2 CYLINDER

REF. NO.	PART NO.	DESCRIPTION	CAN	EUR	OCE	REMARKS
1	1S3-11310-00	CYLINDER	1	1	1	
2	1S3-11351-00	GASKET, CYLINDER	1	1	1	
3	90119-10023	BOLT, WITH WASHER	4	4	4	
4	91312-06040	BOLT	2	2	2	
5	1S3-11395-00	HOLDER	1	1	1	
6	95822-06012	BOLT, FLANGE	1	1	1	

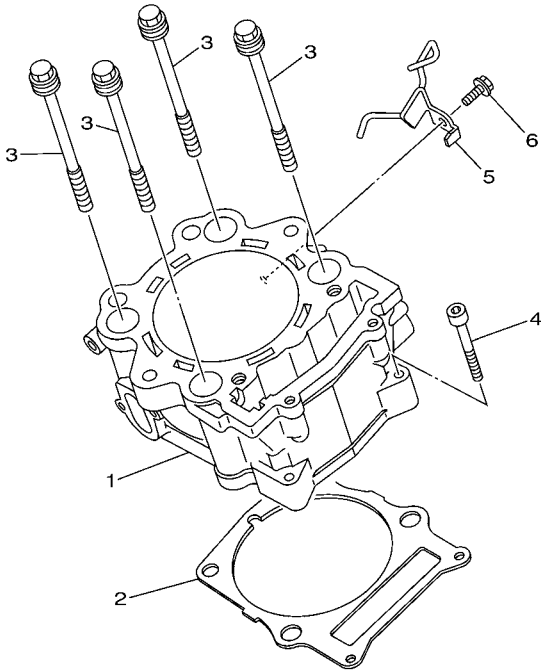

1S31100-E020

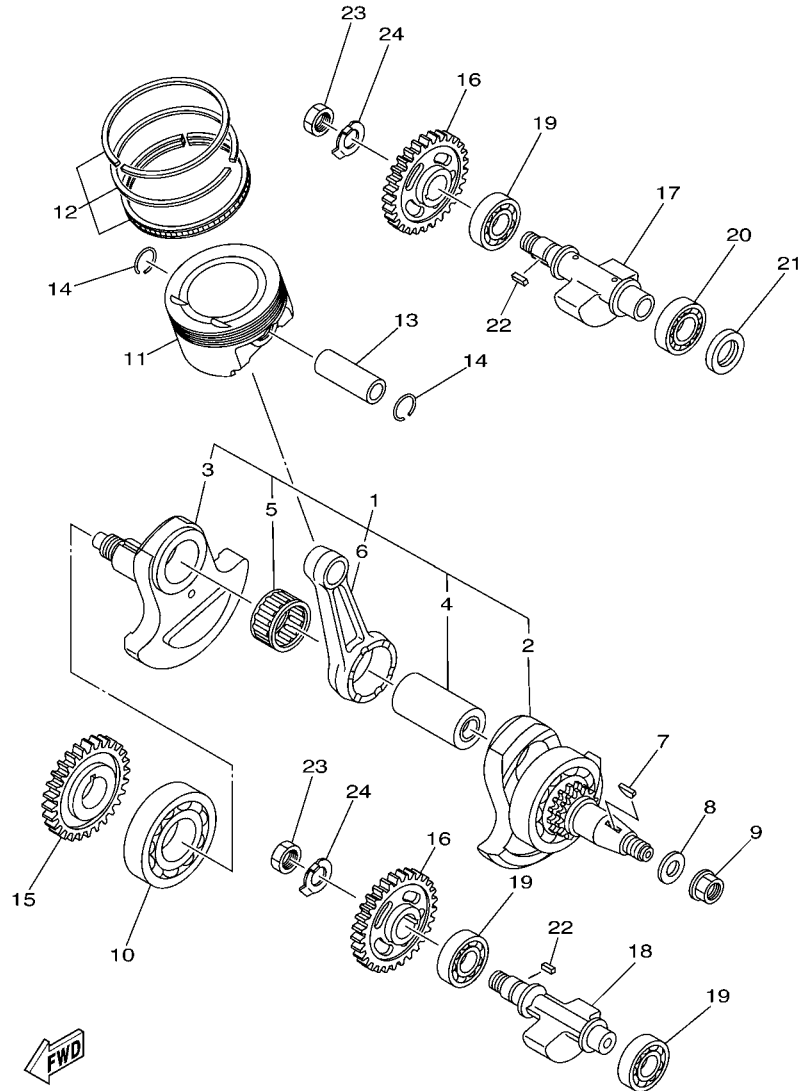

1S31100-E030

FIG. 3 CRANKSHAFT & PISTON

REF. NO.	PART NO.	DESCRIPTION	CAN	EUR	OCE	REMARKS
1	1S3-11400-00	CRANKSHAFT ASSY	1	1	1	
2	1S3-11401-09	.CRANK SUB ASSY 1	1	1	1	
3	1S3-11422-00	.CRANK 2	1	1	1	
4	1S3-11681-00	.PIN, CRANK 1	1	1	1	
5	93310-84017	.BEARING	1	1	1	
6	1S3-11651-00	.ROD, CONNECTING	1	1	1	
7	90280-05001	KEY, WOODRUFF	1	1	1	
8	90201-16013	WASHER, PLATE	1	1	1	
9	90179-16004	NUT	1	1	1	
10	93306-30810	BEARING	1	1	1	
11	1S3-11631-10	PISTON (STD)	1	1	1	
12	1S3-11603-10	PISTON RING SET (STD)	1	1	1	
13	5VK-11633-00	PIN, PISTON	1	1	1	
14	93450-24154	CIRCLIP	2	2	2	
15	1S3-11536-00	GEAR, DRIVE	1	1	1	
16	1S3-11531-00	GEAR, BALANCE WEIGHT	2	2	2	
17	1S3-11454-00	WEIGHT 1	1	1	1	
18	1S3-11464-00	WEIGHT 2	1	1	1	
19	93306-20481	BEARING	3	3	3	
20	93306-00502	BEARING	1	1	1	
21	93101-25106	OIL SEAL	1	1	1	
22	90282-05005	KEY, STRAIGHT	2	2	2	
23	90170-16326	NUT	2	2	2	
24	90215-16221	WASHER, LOCK	2	2	2	

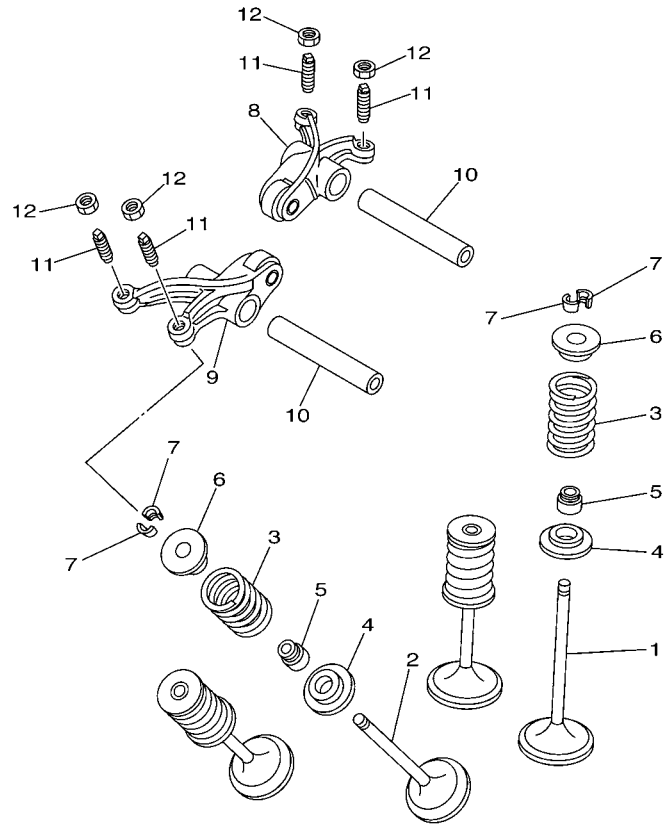
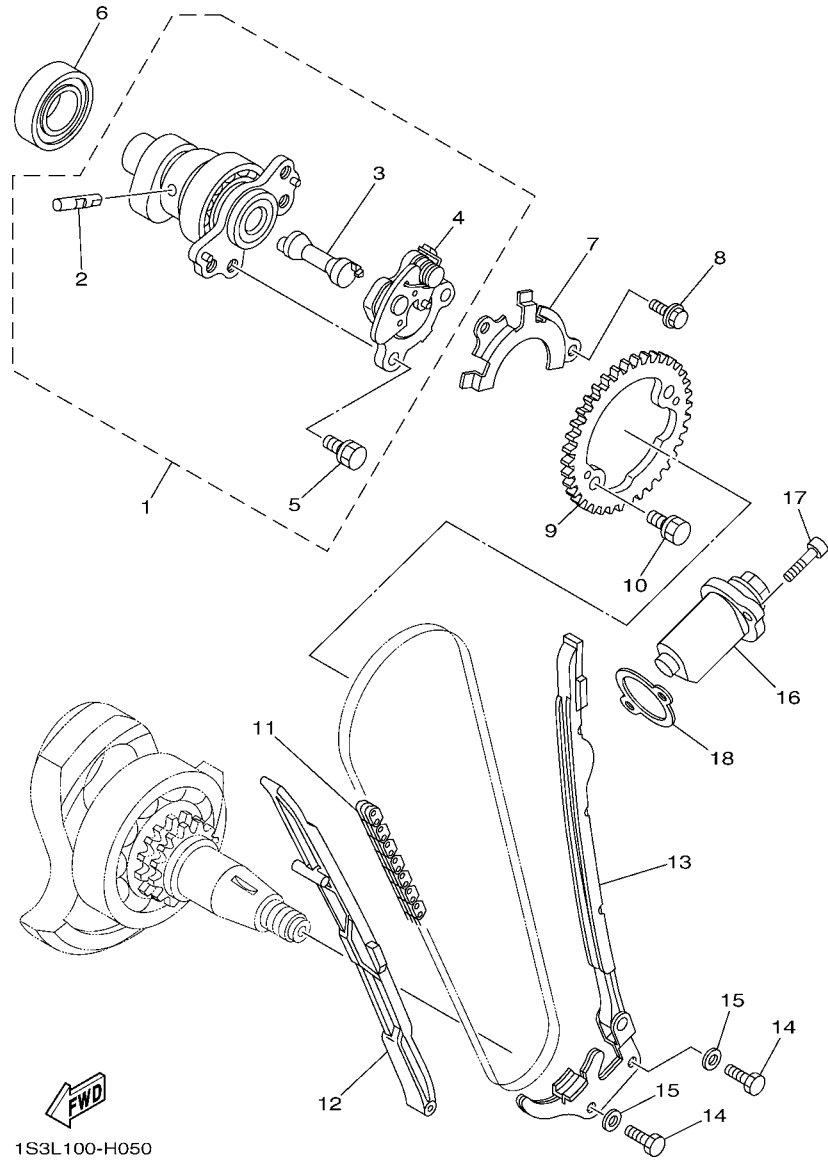

FIG. 4 VALVE

REF. NO.	PART NO.	DESCRIPTION	CAN	EUR	OCE	REMARKS
1	5VK-12111-00	VALVE, INTAKE	2	2	2	
2	5VK-12121-00	VALVE, EXHAUST	2	2	2	
3	1S3-12113-00	SPRING, VALVE INNER	4	4	4	
4	3YF-12116-00	SEAT, VALVE SPRING	4	4	4	
5	5H0-12119-00	SEAL, VALVE STEM	4	4	4	
6	3YF-12117-01	RETAINER, VALVE SPRING	4	4	4	
7	4G0-12118-00	COTTER, VALVE	8	8	8	
8	5VK-12151-00	ARM, VALVE ROCKER	1	1	1	
9	5VK-12161-00	ARM, VALVE ROCKER 2	1	1	1	
10	5VK-12146-00	SHAFT, ROCKER	2	2	2	
11	5XT-12159-00	SCREW, VALVE ADJUSTING	4	4	4	
12	90170-06128	NUT	4	4	4	

1S31100-E040



1S3L100-H050

FIG. 5 CAMSHAFT & CHAIN

REF. NO.	PART NO.	DESCRIPTION	CAN	EUR	OCE	REMARKS
1	1S3-12170-10	CAMSHAFT ASSY 1	1	1	1	
2	5VK-12284-00	.PIN, DECOMPRESSION LEVER	1	1	1	
3	1S3-12290-00	.LEVER, DECOMPRESSION SPRING	1	1	1	
4	1S3-12280-01	.DECOMPRESSION ASSY	1	1	1	
5	90105-07004	.BOLT, FLANGE	2	2	2	
6	93306-07209	BEARING	1	1	1	
7	5VK-1111F-00	PLATE	1	1	1	
8	90105-06078	BOLT, FLANGE	2	2	2	
9	1S3-12176-00	SPROCKET, CAM CHAIN	1	1	1	
10	90105-07004	BOLT, FLANGE	2	2	2	
11	94591-57126	CHAIN (98XRH2010-126M)	1	1	1	
12	5VK-12231-00	GUIDE, STOPPER 1	1	1	1	
13	1S3-12241-00	GUIDE, STOPPER 2	1	1	1	
14	97022-06016	BOLT	2	2	2	
15	92902-06600	WASHER, PLATE	2	2	2	
16	3TB-12210-00	TENSIONER ASSY, CAM CHAIN	1	1	1	
17	91312-06025	BOLT	2	2	2	
18	4DW-12213-00	GASKET, TENSIONER CASE	1	1	1	

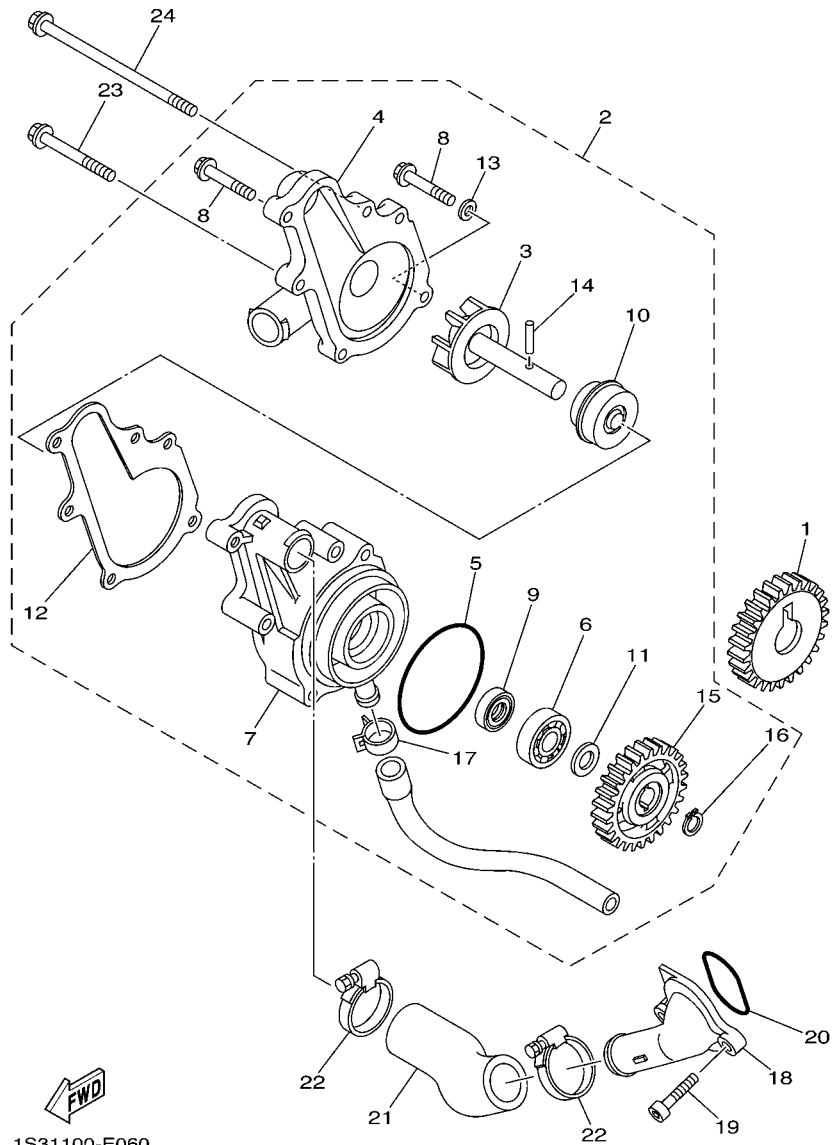

FIG. 6 WATER PUMP

REF. NO.	PART NO.	DESCRIPTION	CAN	EUR	OCE	REMARKS
1	1S3-12436-00	GEAR, DRIVE	1	1	1	
2	1S3-12420-00	WATER PUMP ASSY	1	1	1	
3	1S3-12450-00	.IMPELLER SHAFT ASSY	1	1	1	
4	1S3-12422-00	.COVER, HOUSING	1	1	1	
5	93210-61750	.O-RING	1	1	1	
6	93306-00106	.BEARING	1	1	1	
7	1S3-12421-00	.HOUSING, WATER PUMP	1	1	1	
8	95022-06025	.BOLT, FLANGE	3	3	3	
9	93101-12173	.OIL SEAL	1	1	1	
10	4C8-12438-00	.SEAL, MECHANICAL	1	1	1	
11	90201-12541	.WASHER, PLATE	1	1	1	
12	1S3-12428-00	.GASKET, HOUSING COVER 2	1	1	1	
13	90430-06014	.GASKET	1	1	1	
14	93603-16219	.PIN, DOWEL	1	1	1	
15	5VK-12459-00	.GEAR, IMPELLER SHAFT	1	1	1	
16	99009-12400	.CIRCLIP	1	1	1	
17	90467-13062	.CLIP	1	1	1	
18	1S3-12469-00	JOINT 1	1	1	1	
19	91312-06020	BOLT	2	2	2	
20	93210-33786	O-RING	1	1	1	
21	1S3-12577-00	HOSE 2	1	1	1	
22	90450-32015	HOSE CLAMP ASSY	2	2	2	
23	95022-06050	BOLT, FLANGE	2	2	2	
24	95022-06110	BOLT, FLANGE	1	1	1	

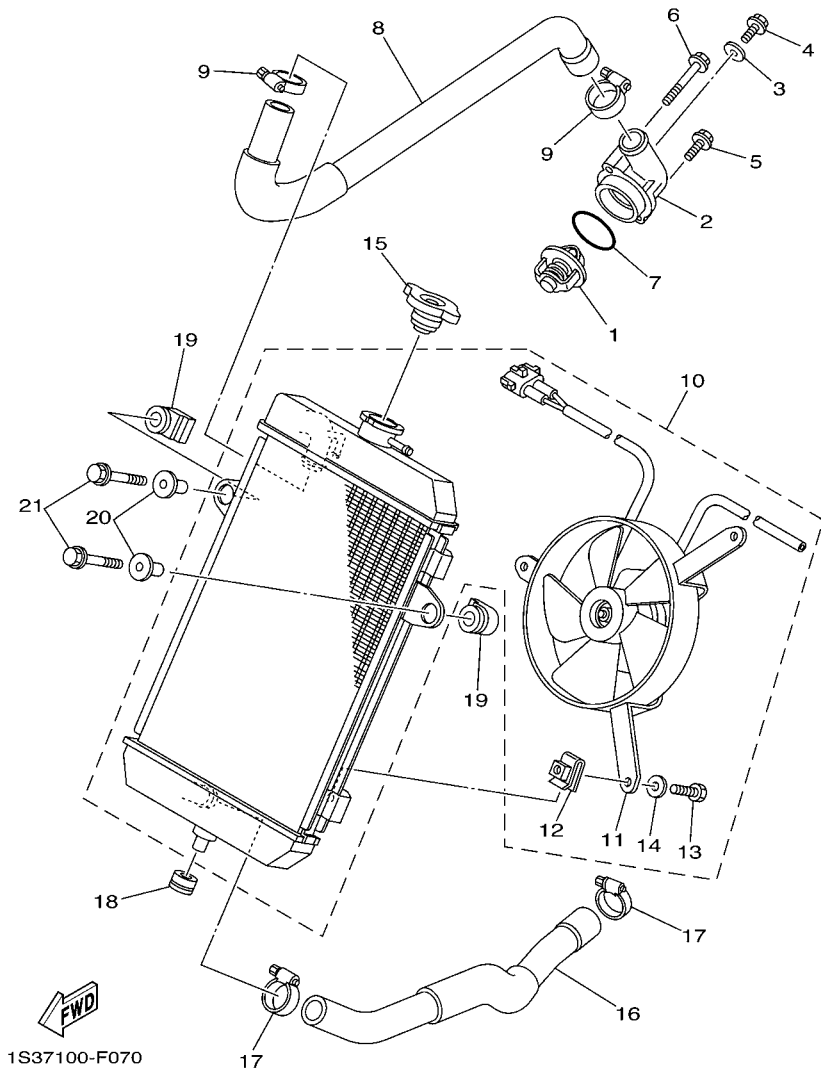

FIG. 7 RADIATOR & HOSE

REF. NO.	PART NO.	DESCRIPTION	CAN	EUR	OCE	REMARKS
1	5VK-12410-00	THERMOSTAT ASSY	1	1	1	
2	1S3-12413-00	COVER, THERMOSTAT	1	1	1	
3	90430-06014	GASKET	1	1	1	
4	95022-06010	BOLT, FLANGE	1	1	1	
5	95022-06020	BOLT, FLANGE	1	1	1	
6	95022-06045	BOLT, FLANGE	1	1	1	
7	93210-41042	O-RING	1	1	1	
8	1S3-12578-00	HOSE 3	1	1	1	
9	90450-32015	HOSE CLAMP ASSY	2	2	2	
10	1S3-1240A-00	RADIATOR ASSY	1	1	1	
11	1S3-12405-00	.BLOWER ASSY	1	1	1	
12	1AA-12535-00	.PLATE	3	3	3	
13	97017-06010	.BOLT	3	3	3	
14	92907-06600	.WASHER, PLATE	3	3	3	
15	22W-12462-00	CAP, RADIATOR	1	1	1	
16	1S3-12579-00	HOSE 4	1	1	1	
17	90450-32015	HOSE CLAMP ASSY	2	2	2	
18	90480-18330	GROMMET	1	1	1	
19	1S3-12465-00	DAMPER, RADIATOR	2	2	2	
20	90387-06166	COLLAR	2	2	2	
21	95802-06030	BOLT, FLANGE	2	2	2	

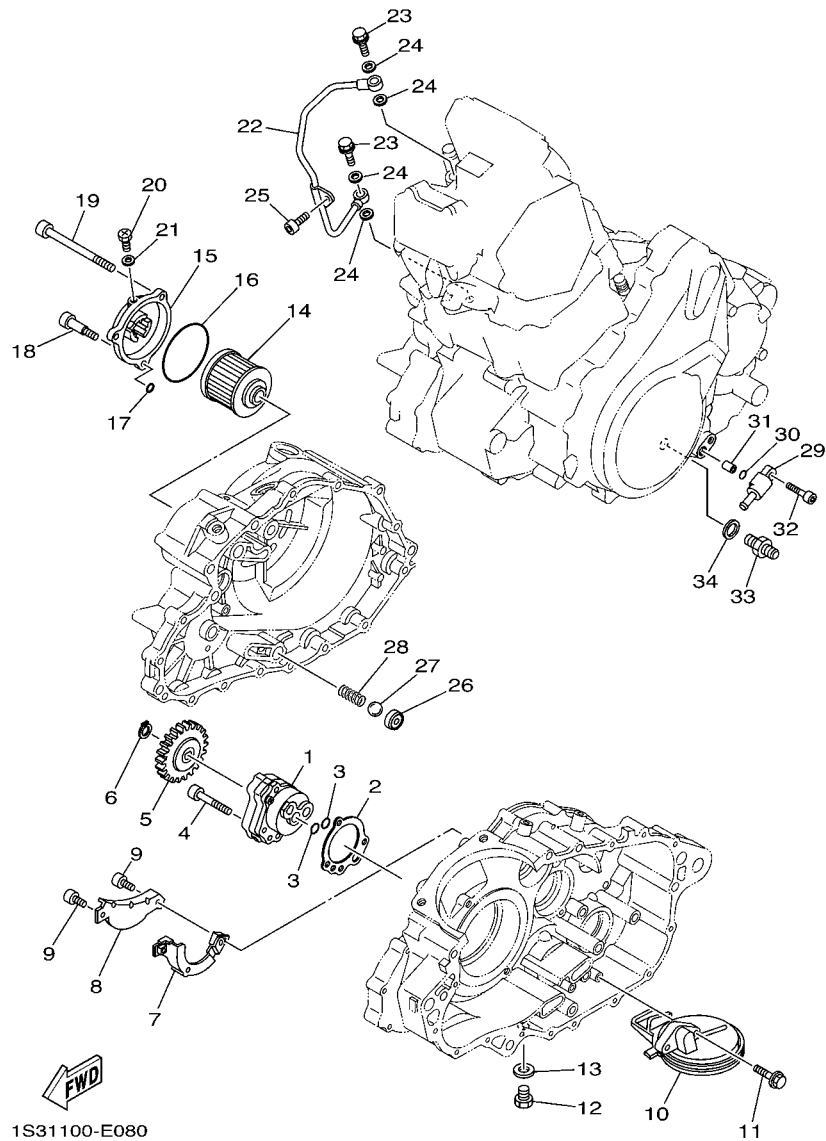

FIG. 8 OIL PUMP

REF. NO.	PART NO.	DESCRIPTION	CAN	EUR	OCE	REMARKS
1	5LP-13300-00	OIL PUMP ASSY	1	1	1	
2	5LP-13329-00	GASKET, PUMP COVER	1	1	1	
3	93210-13361	O-RING	2	2	2	
4	91312-06035	BOLT	3	3	3	
5	3AJ-13325-00	GEAR, PUMP DRIVEN	1	1	1	
6	99009-11400	CIRCLIP	1	1	1	
7	1S3-13356-00	COVER, PUMP 2	1	1	1	
8	1S3-13327-00	COVER, PUMP GEAR	1	1	1	
9	90110-05030	BOLT, HEXAGON SOCKET HEAD	2	2	2	
10	1S3-13410-00	STRAINER HOUSING ASSY	1	1	1	
11	90105-06082	BOLT, FLANGE	2	2	2	
12	90340-14029	PLUG, STRAIGHT SCREW	1	1	1	
13	214-11198-01	GASKET	1	1	1	
14	4X7-13440-01	ELEMENT ASSY, OIL CLEANER	1	1	1	
15	1S3-13447-00	COVER, OIL ELEMENT	1	1	1	
16	93210-64297	O-RING	1	1	1	
17	93210-07135	O-RING	1	1	1	
18	90109-06169	BOLT	1	1	1	
19	91312-06095	BOLT	2	2	2	
20	90149-05018	SCREW	1	1	1	
21	90430-05126	GASKET	1	1	1	
22	1S3-13171-00	PIPE, DELIVERY 2	1	1	1	
23	90401-10024	BOLT, UNION	2	2	2	
24	90430-10188	GASKET	4	4	4	
25	91312-06012	BOLT	1	1	1	
26	583-13113-00	SEAT, CHECK BALL	1	1	1	
27	93503-08007	BALL	1	1	1	

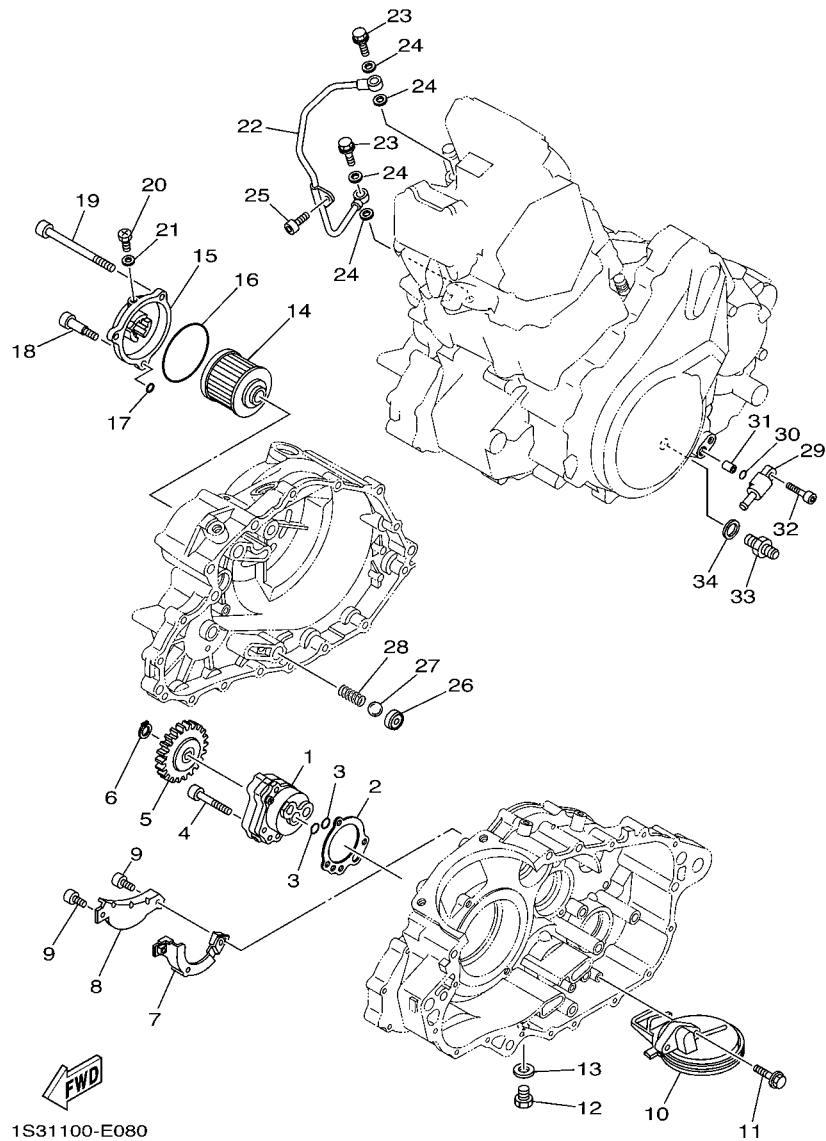
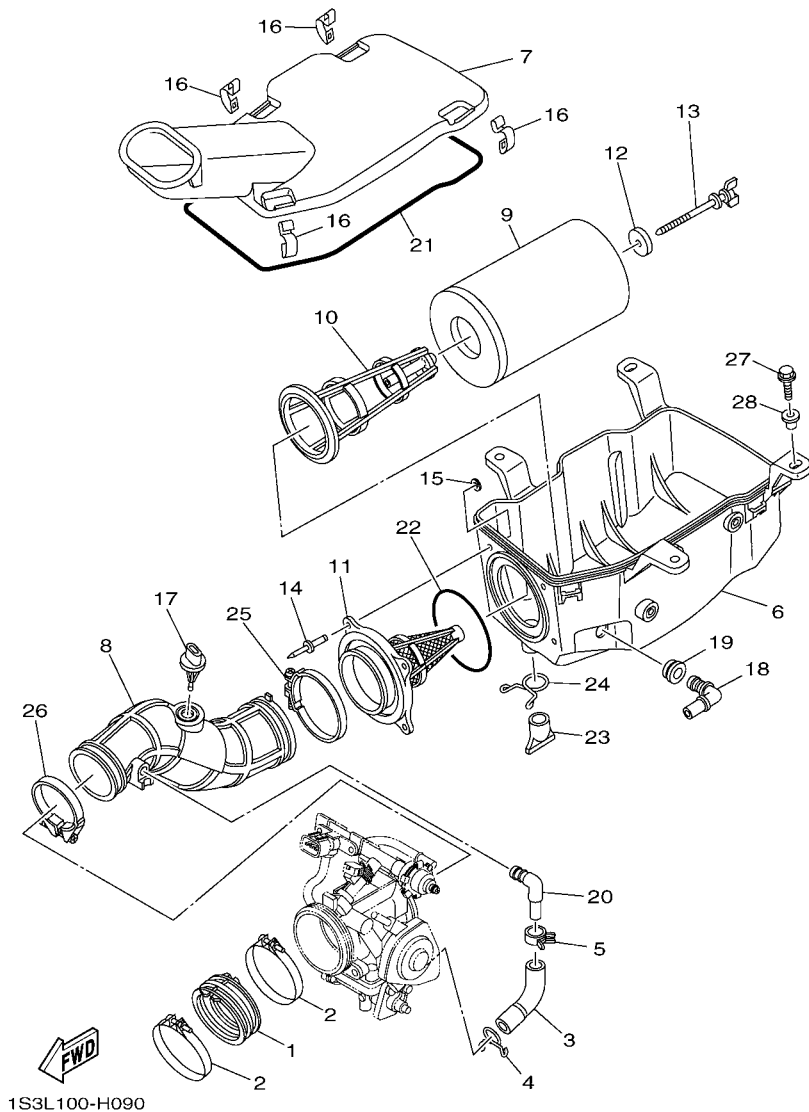

FIG. 8 OIL PUMP

REF. NO.	PART NO.	DESCRIPTION	CAN	EUR	OCE	REMARKS
28	90501-043E0	SPRING, COMPRESSION	1	1	1	
29	1S3-13416-00	PIPE, OIL 1	1	1	1	
30	93210-10197	O-RING	1	1	1	
31	99530-10114	PIN, DOWEL	1	1	1	
32	95022-06025	BOLT, FLANGE	1	1	1	
33	1S3-13132-00	JOINT	1	1	1	
34	90430-14043	GASKET	1	1	1	



1S3L100-H090

FIG. 9 INTAKE

REF. NO.	PART NO.	DESCRIPTION	CAN	EUR	OCE	REMARKS
1	5VK-13586-00	JOINT, CARBURETOR 1	1	1	1	
2	90450-72003	HOSE CLAMP ASSY	2	2	2	
3	1S3-13545-00	HOSE 1	1	1	1	
4	90467-160A4	CLIP	1	1	1	
5	90467-15012	CLIP	1	1	1	
6	1S3-14411-00	CASE, AIR CLEANER 1	1	1	1	
7	1S3-14412-01	CAP, CLEANER CASE 1	1	1	1	
8	1S3-14453-00	JOINT, AIR CLEANER 1	1	1	1	
9	1S3-14451-00	ELEMENT, AIR CLEANER	1	1	1	
10	1S3-14458-00	GUIDE	1	1	1	
11	1S3-14459-01	HOLDER, GUIDE	1	1	1	
12	90209-06096	WASHER	1	1	1	
13	90122-06010	BOLT, WING	1	1	1	
14	90267-48138	RIVET, BLIND	4	4	4	
15	90201-04028	WASHER, PLATE	4	4	4	
16	5GH-14436-00	HOOK	4	4	4	
17	5VU-85886-00	SENSOR, AIR TEMPRATURE	1	1	1	
18	5KM-14419-00	PIPE	1	1	1	
19	31A-14435-00	GROMMET	1	1	1	
20	31A-14419-00	PIPE	1	1	1	
21	10M-14457-00	SEAL	1	1	1	
22	1S3-14457-00	SEAL	1	1	1	
23	59V-14457-00	SEAL	1	1	1	
24	90467-220A1	CLIP	1	1	1	
25	90460-75020	CLAMP, HOSE	1	1	1	
26	90450-59006	HOSE CLAMP ASSY	1	1	1	
27	90105-06084	BOLT, FLANGE	4	4	4	

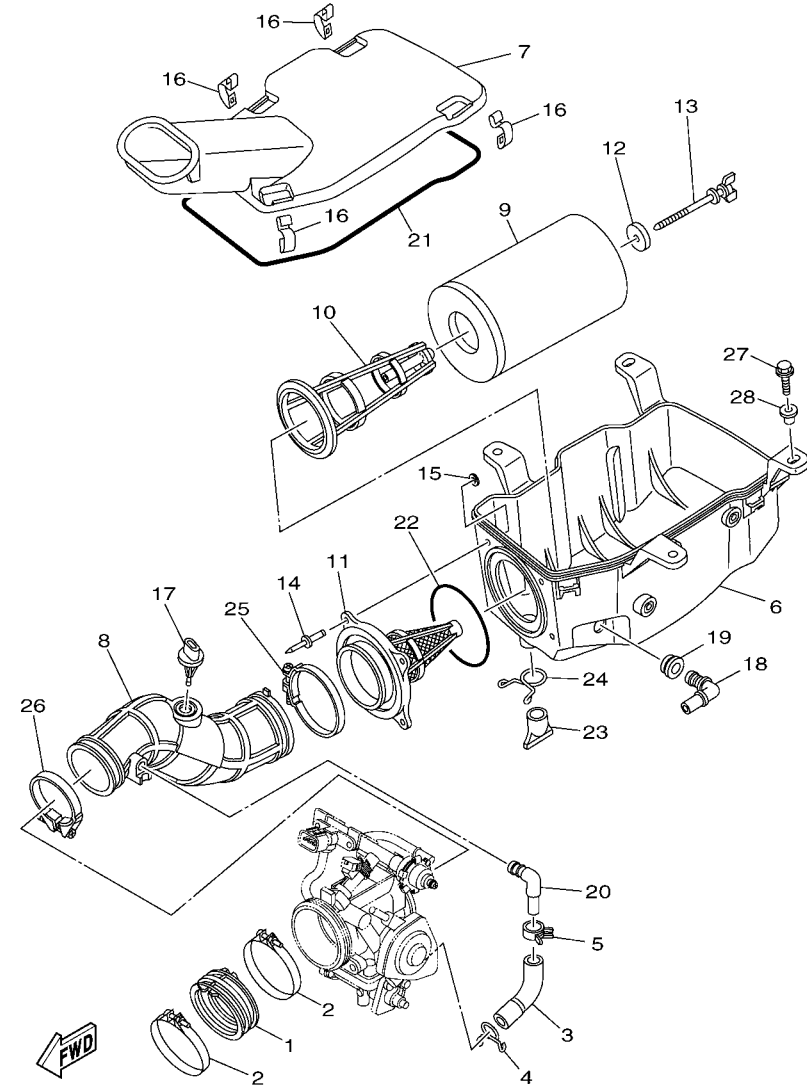

1S3L100-H090

FIG. 9 INTAKE

REF. NO.	PART NO.	DESCRIPTION	CAN	EUR	OCE	REMARKS
28	90387-08073	COLLAR	4	4	4	

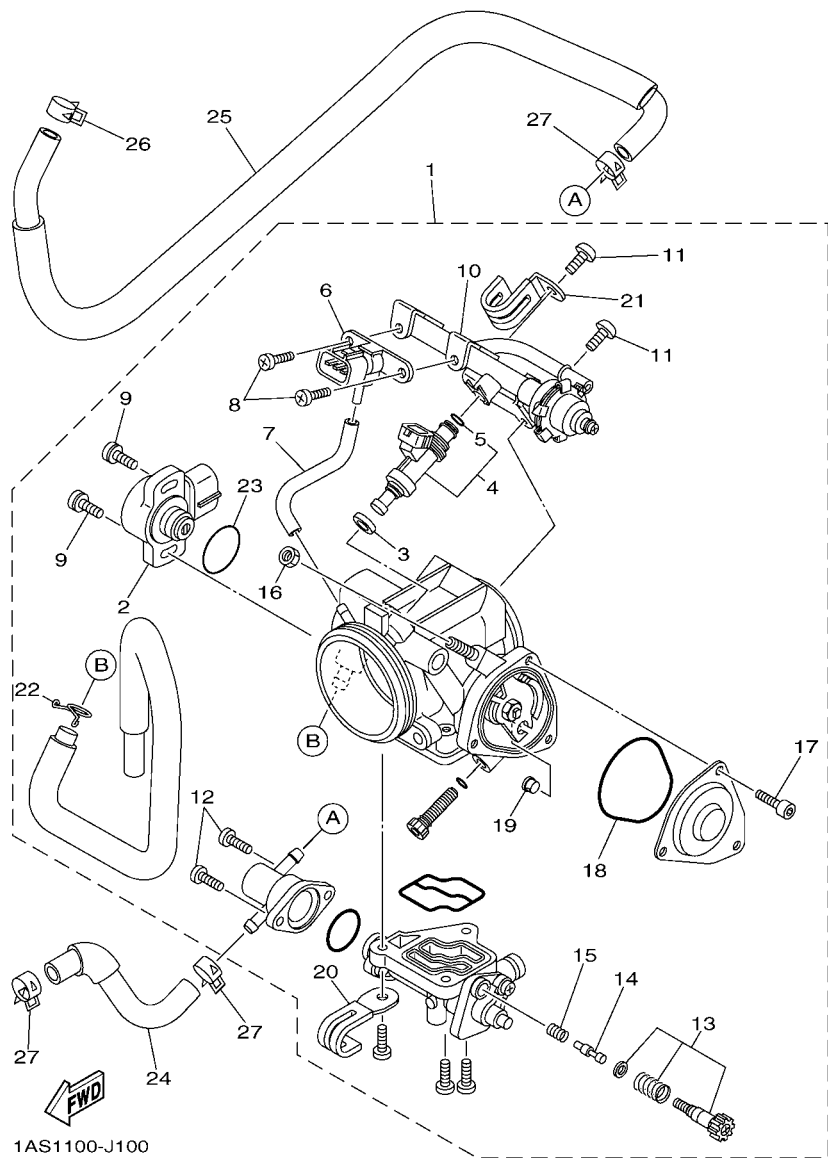

1AS1100-J100

FIG. 10 THROTTLE BODY ASSY 1

REF. NO.	PART NO.	DESCRIPTION	CAN	EUR	OCE	REMARKS
1	1S3-13750-10	THROTTLE BODY ASSY	1	1	1	
2	8GL-85885-00	.THROTTLE SENSOR ASSY	1	1	1	
3	8FP-13556-00	.GASKET, MANIFOLD	1	1	1	
4	5VK-13761-00	.INJECTOR	1	1	1	
5	5PS-14147-00	..O-RING	1	1	1	
6	1C7-82380-00	.SENSOR, PRESSURE	1	1	1	
7	5JW-14348-00	.PIPE 1	1	1	1	
8	98507-06010	.SCREW, PAN HEAD	2	2	2	
9	8CC-14216-10	.SCREW	2	2	2	
10	1S3-13160-00	.DELIVERY PIPE ASSY 1	1	1	1	
11	98507-06012	.SCREW, PAN HEAD	2	2	2	
12	98507-05012	.SCREW, PAN HEAD	2	2	2	
13	5VX-14503-00	.ADJUST SCREW SET	1	1	1	
14	1S3-13493-00	.PLUNGER	1	1	1	
15	4BH-14134-00	.SPRING, AIR ADJUSTING	1	1	1	
16	1S3-14161-00	.NUT, CABLE ADJUSTING	1	1	1	
17	91312-04006	.BOLT	3	3	3	
18	4WV-14147-10	.O-RING	1	1	1	
19	1UY-14155-00	.GUIDE, CABLE	1	1	1	
20	3JC-14146-00	.PLATE	1	1	1	
21	5JW-14945-00	.PLATE	1	1	1	
22	90467-09006	.CLIP	1	1	1	
23	5YP-14562-00	.O-RING	1	1	1	
24	1S3-1243A-00	HOSE 1	1	1	1	
25	1S3-1243E-00	HOSE 2	1	1	1	
26	90467-11090	CLIP	1	1	1	
27	90467-11090	CLIP	3	3	3	

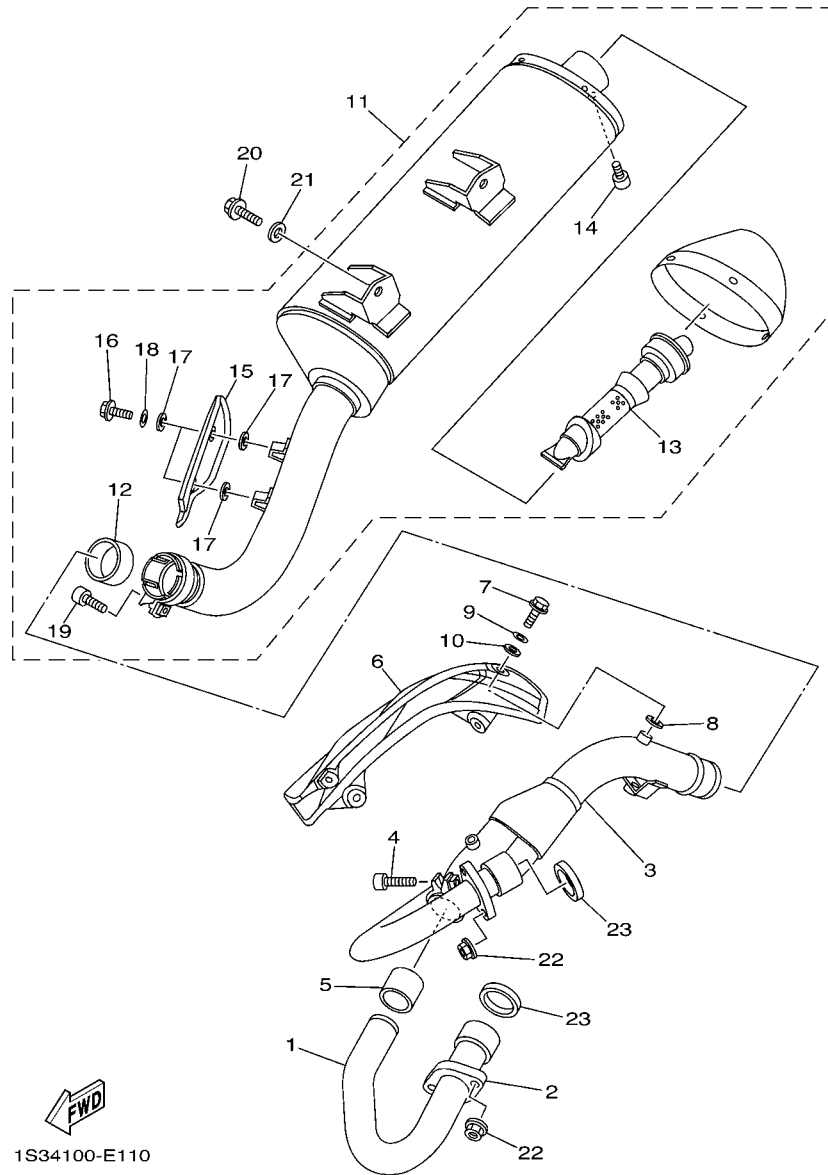

FIG. 11 EXHAUST

REF. NO.	PART NO.	DESCRIPTION	CAN	EUR	OCE	REMARKS
1	1S3-14611-00	PIPE, EXHAUST 1	1	1	1	
2	1S3-14612-00	NUT, RING	1	1	1	
3	1S3-14621-01	PIPE, EXHAUST 2	1	1	1	
4	91314-08035	BOLT, HEXAGON SOCKET HEAD	1	1	1	
5	3YF-14714-00	GASKET, MUFFLER	1	1	1	
6	1S3-14628-00	PROTECTOR, EXHAUST PIPE	1	1	1	
7	95022-06012	BOLT, FLANGE	4	4	4	
8	90201-05015	WASHER, PLATE	4	4	4	
9	90201-06035	WASHER, PLATE	4	4	4	
10	90201-05019	WASHER, PLATE	4	4	4	
11	1S3-14710-11	MUFFLER ASSY 1	1	1	1	
12	5LP-14714-00	.GASKET, MUFFLER	1	1	1	
13	1S3-14752-00	.PIPE, OUTLET	1	1	1	
14	91312-06010	.BOLT	1	1	1	
15	1S3-14728-00	.PROTECTOR, MUFFLER 2	1	1	1	
16	98902-06010	.SCREW, BIND	2	2	2	
17	90201-05015	.WASHER, PLATE	4	4	4	
18	92902-06200	.WASHER	2	2	2	
19	91314-08035	.BOLT, HEXAGON SOCKET HEAD	1	1	1	
20	90105-08142	BOLT, FLANGE	2	2	2	
21	90201-08048	WASHER, PLATE	2	2	2	
22	95702-08500	NUT, FLANGE	4	4	4	
23	3YF-14613-01	GASKET, EXHAUST PIPE	2	2	2	

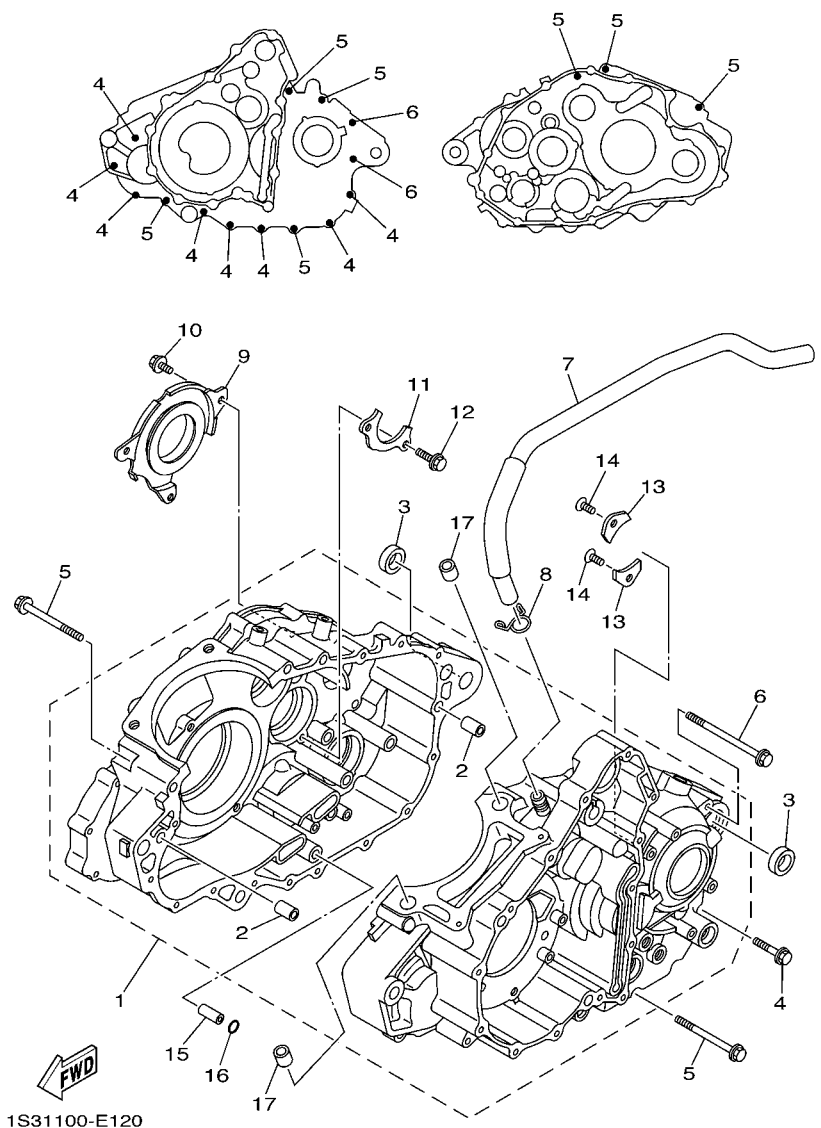

FIG. 12 CRANKCASE

REF. NO.	PART NO.	DESCRIPTION	CAN	EUR	OC	REMARKS
1	1S3-15100-01	CRANKCASE ASSY	1	1	1	
2	99530-10114	.PIN, DOWEL	2	2	2	
3	90387-17009	COLLAR	2	2	2	
4	95022-06030	BOLT, FLANGE	8	8	8	
5	95022-06070	BOLT, FLANGE	7	7	7	
6	95022-06090	BOLT, FLANGE	2	2	2	
7	1S3-11166-00	PIPE, BREATHER 1	1	1	1	
8	90467-140A4	CLIP	1	1	1	
9	1S3-11165-00	PLATE, BREATHER	1	1	1	
10	90105-06081	BOLT, FLANGE	3	3	3	
11	1S3-15383-00	PLATE, BEARING COVER	1	1	1	
12	90105-06082	BOLT, FLANGE	2	2	2	
13	4JT-15381-01	PLATE, BEARING COVER	2	2	2	
14	90149-06074	SCREW	2	2	2	
15	99530-08016	PIN, DOWEL	1	1	1	
16	93210-07135	O-RING	1	1	1	
17	99530-14016	PIN, DOWEL	2	2	2	

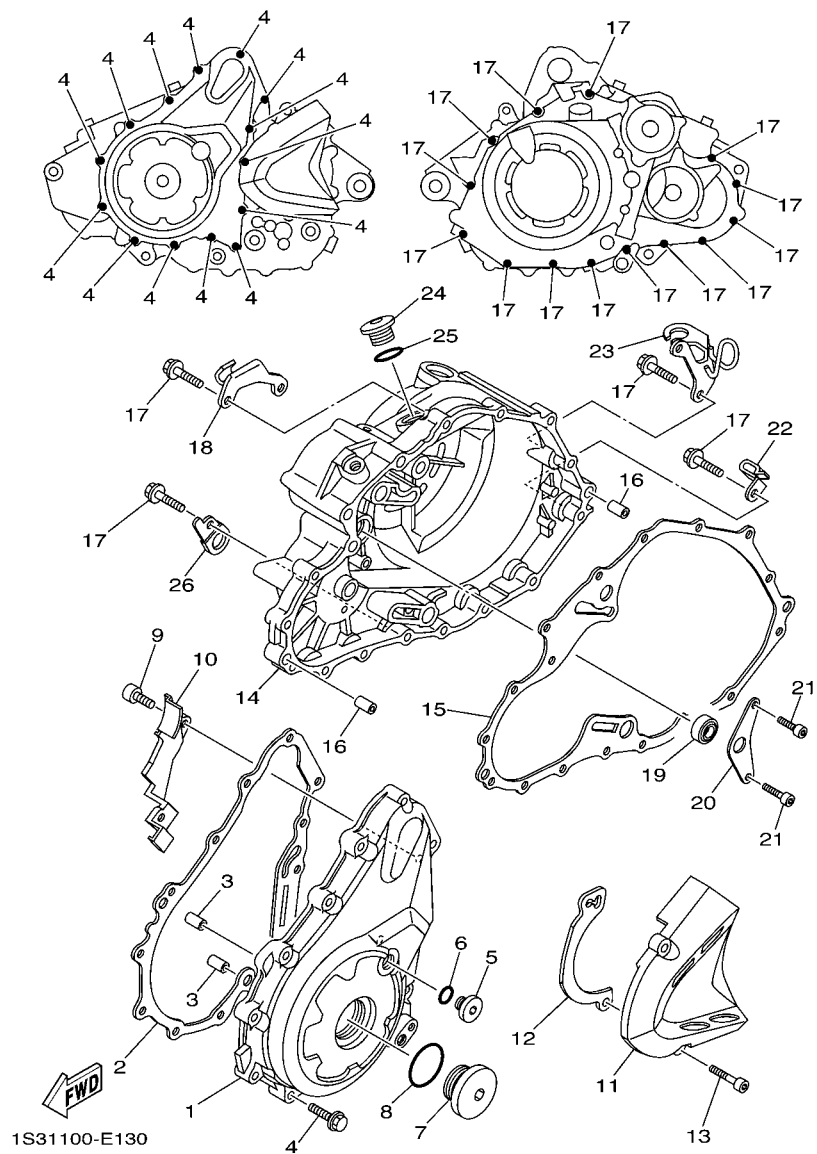
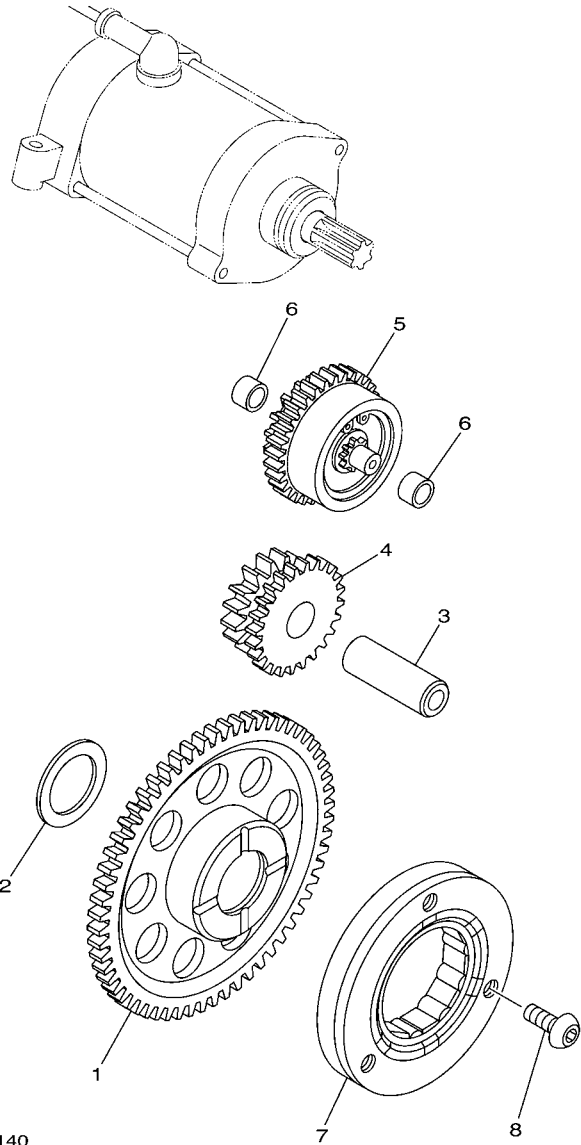

FIG. 13 CRANKCASE COVER 1

REF. NO.	PART NO.	DESCRIPTION	CAN	EUR	OCE	REMARKS
1	1S3-15411-00	COVER, CRANKCASE 1	1	1	1	
2	1S3-15451-00	GASKET, CRANKCASE COVER 1	1	1	1	
3	99530-10114	PIN, DOWEL	2	2	2	
4	95022-06030	BOLT, FLANGE	14	14	14	
5	90340-14003	PLUG, STRAIGHT SCREW	1	1	1	
6	93210-14369	O-RING	1	1	1	
7	90340-36001	PLUG, STRAIGHT SCREW	1	1	1	
8	93210-357A3	O-RING	1	1	1	
9	90110-05031	BOLT, HEXAGON SOCKET HEAD	1	1	1	
10	1S3-15113-00	PLATE	1	1	1	
11	1S3-15421-00	COVER, CRANKCASE 2	1	1	1	
12	1S3-17466-00	GUIDE, CHAIN	1	1	1	
13	91312-06025	BOLT	2	2	2	
14	1S3-15431-00	COVER, CRANKCASE 3	1	1	1	
15	1S3-15462-00	GASKET, CRANKCASE COVER 3	1	1	1	
16	99530-10120	PIN, DOWEL	2	2	2	
17	95022-06030	BOLT, FLANGE	14	14	14	
18	1S3-15441-00	HOLDER, CLUTCH CABLE	1	1	1	
19	93101-14164	OIL SEAL	1	1	1	
20	1S3-15118-00	HOLDER	1	1	1	
21	90110-06182	BOLT, HEXAGON SOCKET HEAD	2	2	2	
22	90461-10011	CLAMP	1	1	1	
23	1S3-1546C-00	HOLDER	1	1	1	
24	1S3-15189-00	PLUG	1	1	1	
25	93210-207A0	O-RING	1	1	1	
26	90462-08046	CLAMP	1	1	1	



1S31100-E140

FIG. 14 STARTER

REF. NO.	PART NO.	DESCRIPTION	CAN	EUR	OCE	REMARKS
1	1S3-15515-00	GEAR 3	1	1	1	
2	90201-286K9	WASHER, PLATE (T1.0)	1	1	1	
3	1VJ-15522-00	SHAFT 2	1	1	1	
4	1S3-15517-00	GEAR, IDLER 2	1	1	1	
5	1S3-15560-00	DAMPER ASSY	1	1	1	
6	90380-10002	BUSH, SOLID	2	2	2	
7	5VK-15590-00	STARTER ONE-WAY ASSY	1	1	1	
8	90149-08049	SCREW	3	3	3	

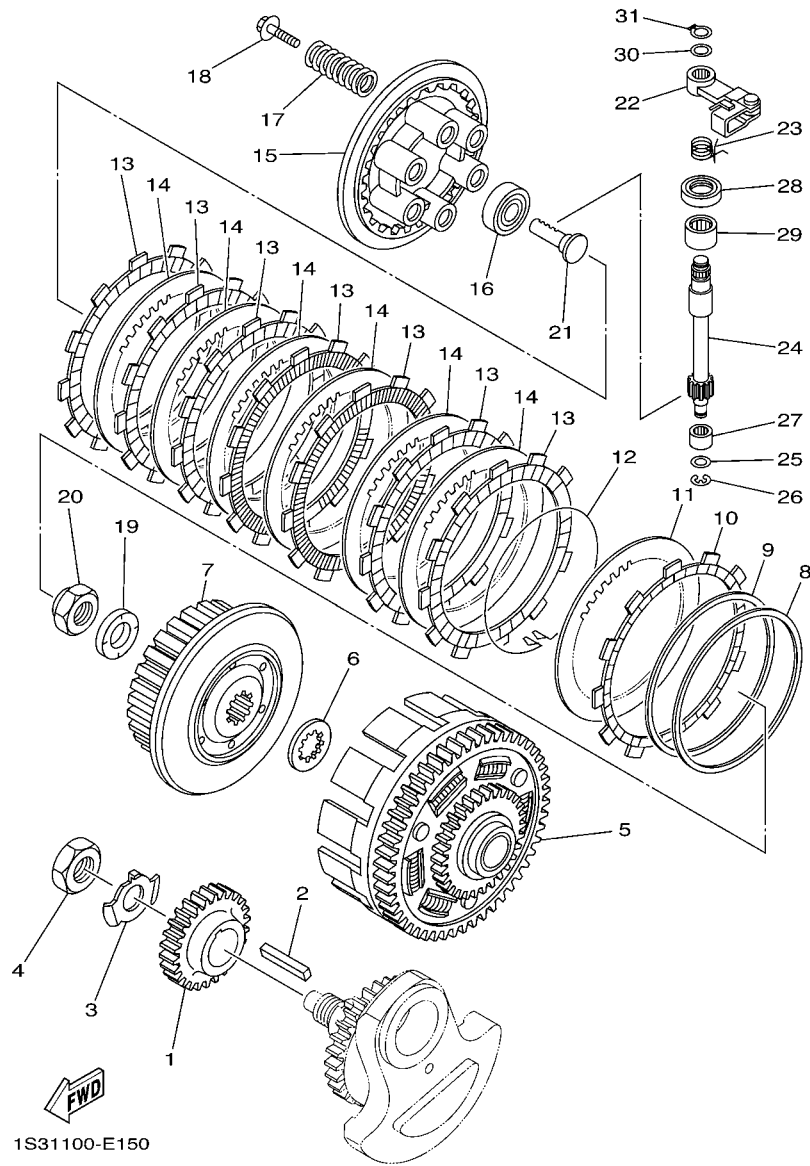

FIG. 15 CLUTCH

REF. NO.	PART NO.	DESCRIPTION	CAN	EUR	OCE	REMARKS
1	1S3-16111-00	GEAR, PRIMARY DRIVE	1	1	1	
2	90282-07003	KEY, STRAIGHT	1	1	1	
3	90215-20006	WASHER, LOCK	1	1	1	
4	90170-20274	NUT	1	1	1	
5	1S3-16150-00	PRIMARY DRIVEN GEAR COMP.	1	1	1	
6	2JN-16154-00	PLATE, THRUST 1	1	1	1	
7	1S3-16371-00	BOSS, CLUTCH	1	1	1	
8	5JG-16384-00	PLATE, SEAT	1	1	1	
9	5JG-16383-00	SPRING, CLUTCH BOSS	1	1	1	
10	5TG-16331-00	PLATE, FRICTION 2	1	1	1	
11	4X7-16325-00	PLATE, CLUTCH 2	1	1	1	
12	4X7-16385-00	RING, CLUTCH BOSS	1	1	1	
13	5TA-16321-00	PLATE, FRICTION	7	7	7	
14	4X7-16325-00	PLATE, CLUTCH 2	6	6	6	
15	1S3-16351-00	PLATE, PRESSURE 1	1	1	1	
16	93306-00304	BEARING	1	1	1	
17	90501-230E4	SPRING, COMPRESSION	6	6	6	
18	90159-06029	SCREW, WITH WASHER	6	6	6	
19	90208-20001	WASHER, CONICAL SPRING	1	1	1	
20	90179-20007	NUT	1	1	1	
21	4XV-16356-01	ROD, PUSH 1	1	1	1	
22	3LD-16340-01	PUSH LEVER ASSY	1	1	1	
23	90508-18018	SPRING, TORSION	1	1	1	
24	5EB-16382-00	AXLE, PUSH LEVER	1	1	1	
25	92902-08600	WASHER, PLATE	1	1	1	
26	99001-07600	CIRCLIP	1	1	1	
27	93317-11020	BEARING	1	1	1	

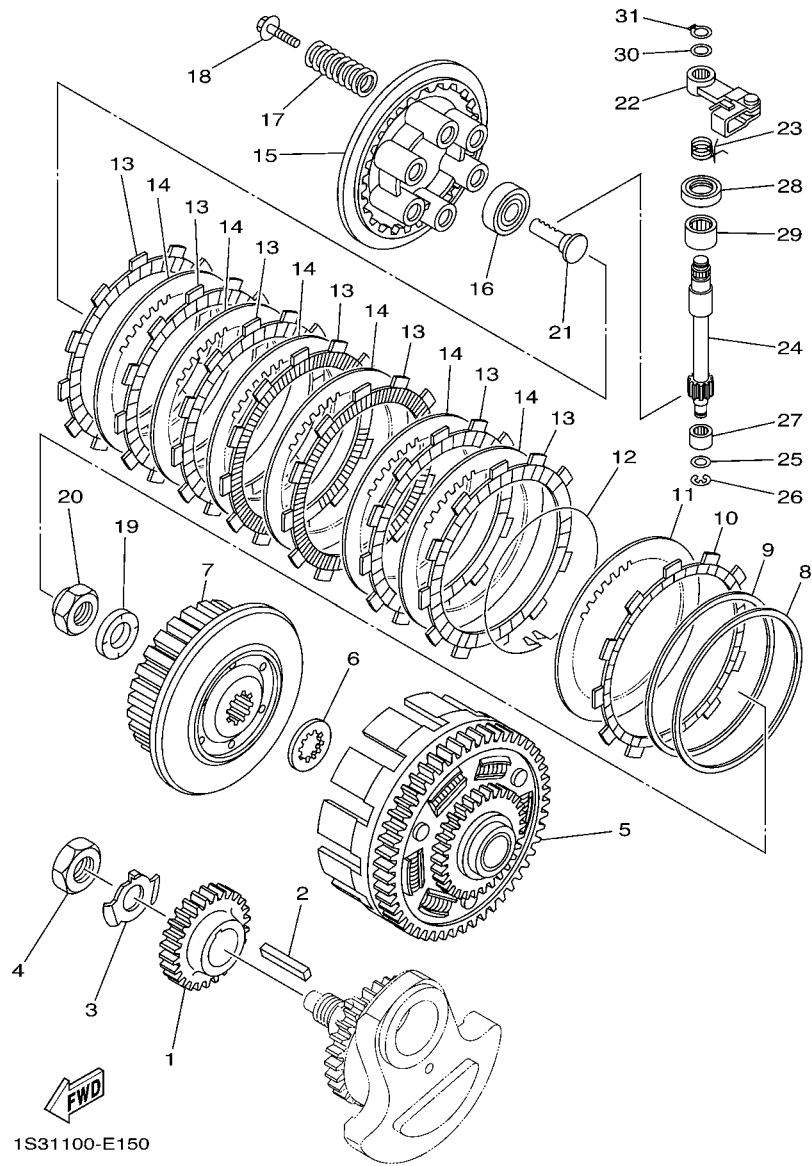

FIG. 15 CLUTCH

REF. NO.	PART NO.	DESCRIPTION	CAN	EUR	OCE	REMARKS
28	93102-15212	OIL SEAL	1	1	1	
29	93315-31502	BEARING	1	1	1	
30	90201-10614	WASHER, PLATE	1	1	1	
31	99009-10400	CIRCLIP	1	1	1	

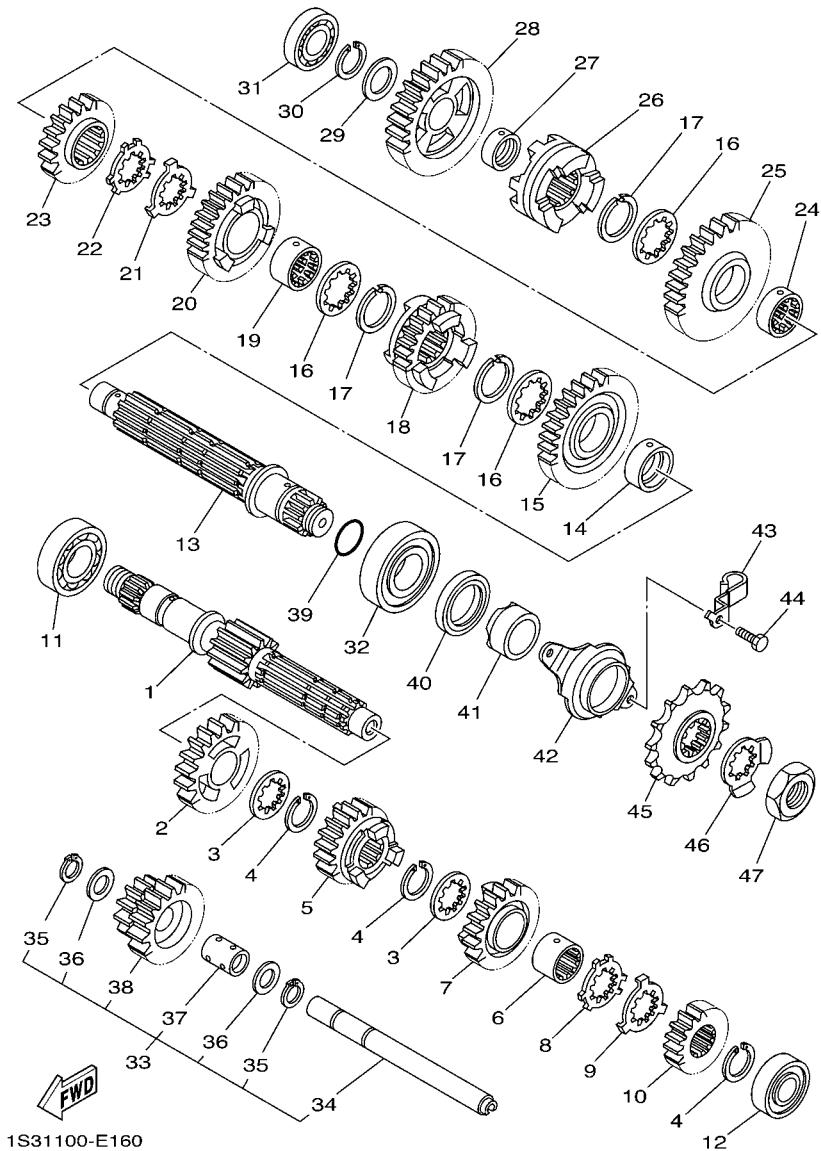
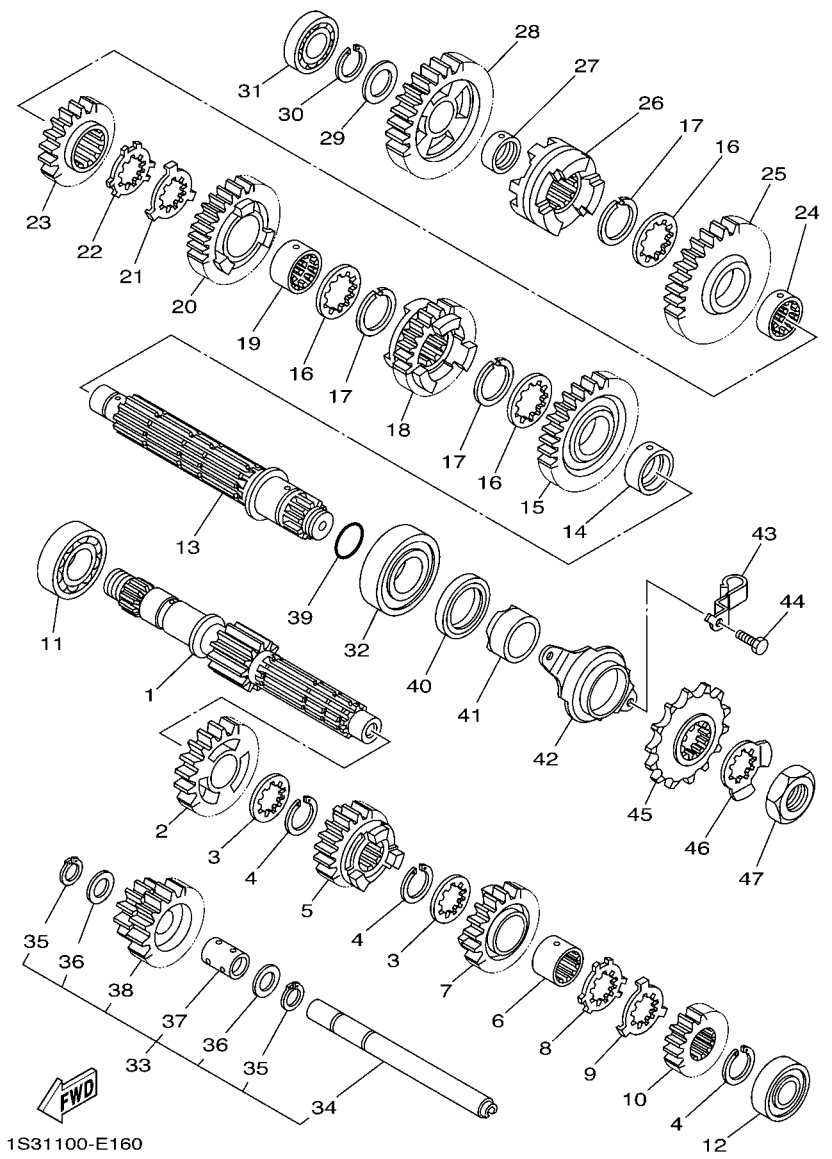

FIG. 16 TRANSMISSION

REF. NO.	PART NO.	DESCRIPTION	CAN	EUR	OCE	REMARKS
1	1S3-17401-00	MAIN AXLE ASSY	1	1	1	
2	1S3-17151-00	GEAR, 5TH PINION (24T)	1	1	1	
3	90209-22008	WASHER	2	2	2	
4	93440-25084	CIRCLIP	3	3	3	
5	1S3-17131-00	GEAR, 3RD PINION (17T)	1	1	1	
6	90387-22006	COLLAR	1	1	1	
7	1S3-17141-00	GEAR, 4TH PINION (22T)	1	1	1	
8	90214-22003	WASHER, CLAW	1	1	1	
9	90214-22002	WASHER, CLAW	1	1	1	
10	1S3-17121-00	GEAR, 2ND PINION (14T)	1	1	1	
11	93306-20501	BEARING	1	1	1	
12	93306-00431	BEARING	1	1	1	
13	1S3-17402-00	DRIVE AXLE ASSY	1	1	1	
14	90387-28008	COLLAR	1	1	1	
15	1S3-17221-00	GEAR, 2ND WHEEL (28T)	1	1	1	
16	90209-26008	WASHER	3	3	3	
17	93440-28062	CIRCLIP	3	3	3	
18	1S3-17241-00	GEAR, 4TH WHEEL (25T)	1	1	1	
19	90387-26005	COLLAR	1	1	1	
20	1S3-17231-00	GEAR, 3RD WHEEL (25T)	1	1	1	
21	90214-26002	WASHER, CLAW	1	1	1	
22	90214-26003	WASHER, CLAW	1	1	1	
23	1S3-17251-00	GEAR, 5TH WHEEL (22T)	1	1	1	
24	90387-26004	COLLAR	1	1	1	
25	1S3-17211-00	GEAR, 1ST WHEEL (38T)	1	1	1	
26	1S3-17285-00	CLUTCH, DOG	1	1	1	
27	90387-20021	COLLAR	1	1	1	



1S31100-E160

FIG. 16 TRANSMISSION

REF. NO.	PART NO.	DESCRIPTION	CAN	EUR	OCE	REMARKS
28	1S3-17253-00	GEAR, REVERSE WHEEL 2 (29T)	1	1	1	
29	90201-20276	WASHER, PLATE (T=1.0)	1	1	1	
30	99009-20400	CIRCLIP	1	1	1	
31	93306-00415	BEARING	1	1	1	
32	93306-27803	BEARING	1	1	1	
33	1S3-17430-00	COUNTER AXLE ASSY	1	1	1	
34	1S3-17432-00	.AXLE, IDLE	1	1	1	
35	93440-15012	.CIRCLIP	2	2	2	
36	90201-152P4	.WASHER, PLATE	2	2	2	
37	90387-1504G	.COLLAR	1	1	1	
38	1S3-17243-00	.GEAR, REVERSE WHEEL1(12T/24T)	1	1	1	
39	93210-25001	O-RING	1	1	1	
40	93102-35393	OIL SEAL	1	1	1	
41	90387-28009	COLLAR	1	1	1	
42	1S3-17471-00	PLATE, COVER	1	1	1	
43	90461-10011	CLAMP	1	1	1	
44	97022-06014	BOLT	2	2	2	
45	9383G-14231	SPROCKET, DRIVE (14T)	1	1	1	
46	90215-25003	WASHER, LOCK	1	1	1	
47	90179-22011	NUT	1	1	1	

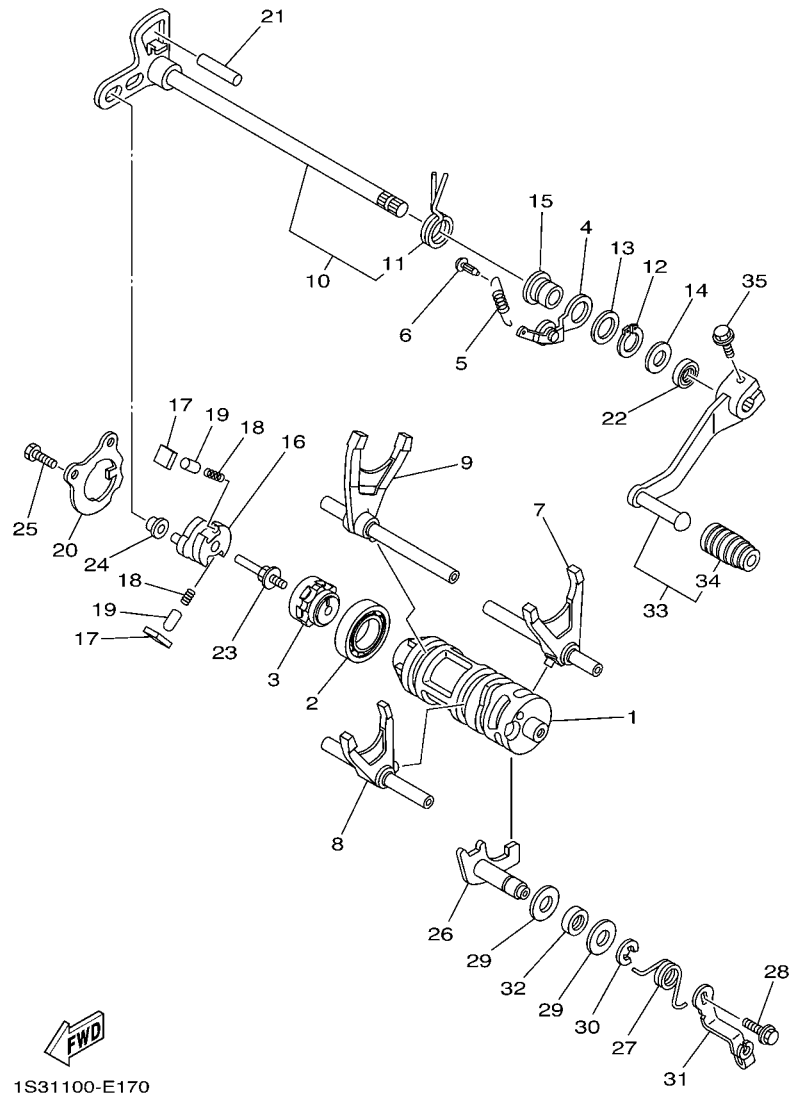

1S31100-E170

FIG. 17 SHIFT CAM & FORK

REF. NO.	PART NO.	DESCRIPTION	CAN	EUR	OCE	REMARKS
1	1S3-18541-00	CAM, SHIFT	1	1	1	
2	93306-90509	BEARING	1	1	1	
3	4EW-18185-00	SEGMENT	1	1	1	
4	1S3-18140-00	STOPPER LEVER ASSY	1	1	1	
5	5JW-18144-00	HANGER, SPRING	1	1	1	
6	132-16346-00	HOOK, SPRING	1	1	1	
7	1S3-18501-00	FORK, SHIFT 1	1	1	1	
8	1S3-18502-00	FORK, SHIFT 2	1	1	1	
9	1S3-18503-00	FORK, SHIFT 3	1	1	1	
10	1S3-18101-00	SHIFT SHAFT ASSY	1	1	1	
11	90508-35007	.SPRING, TORSION	1	1	1	
12	99009-17400	CIRCLIP	1	1	1	
13	90201-177G4	WASHER, PLATE	1	1	1	
14	90201-12040	WASHER, PLATE	1	1	1	
15	5VK-18699-00	BOSS 1	1	1	1	
16	1S3-18122-00	LEVER, SHIFT 2	1	1	1	
17	3XJ-18182-00	PAWL, SHIFTER	2	2	2	
18	90501-052G5	SPRING, COMPRESSION	2	2	2	
19	3XJ-18184-00	PIN, PAWL	2	2	2	
20	1S3-18172-00	GUIDE, SHIFT	1	1	1	
21	93608-30002	PIN, DOWEL	1	1	1	
22	93102-12224	OIL SEAL	1	1	1	
23	3XJ-18173-10	PIN, SHIFT	1	1	1	
24	3XJ-18178-00	ROLLER, SHIFT LEVER	1	1	1	
25	90101-06664	BOLT	2	2	2	
26	1S3-18380-00	SHIFTER BRKT. ASSY	1	1	1	
27	5LP-18337-01	SPRING	1	1	1	

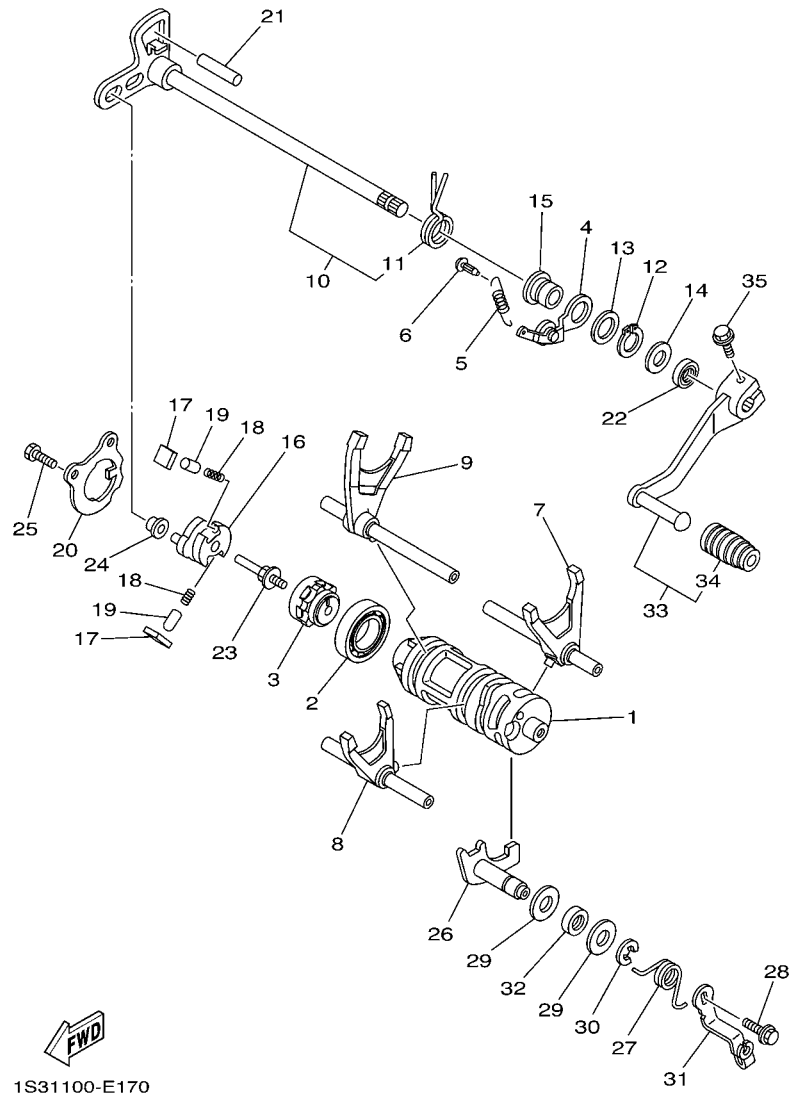

FIG. 17 SHIFT CAM & FORK

REF. NO.	PART NO.	DESCRIPTION	CAN	EUR	OCE	REMARKS
28	95812-06012	BOLT, FLANGE	1	1	1	
29	90201-12575	WASHER, PLATE	2	2	2	
30	99001-10600	CIRCLIP	1	1	1	
31	5LP-18431-00	BRACKET, SHIFTER	1	1	1	
32	93102-12106	OIL SEAL (SD 12-22-5 HS)	1	1	1	
33	1S3-18110-10	SHIFT PEDAL ASSY	1	1	1	
34	5YT-18113-00	.COVER, SHIFT PEDAL	1	1	1	
35	90105-06142	BOLT, FLANGE	1	1	1	

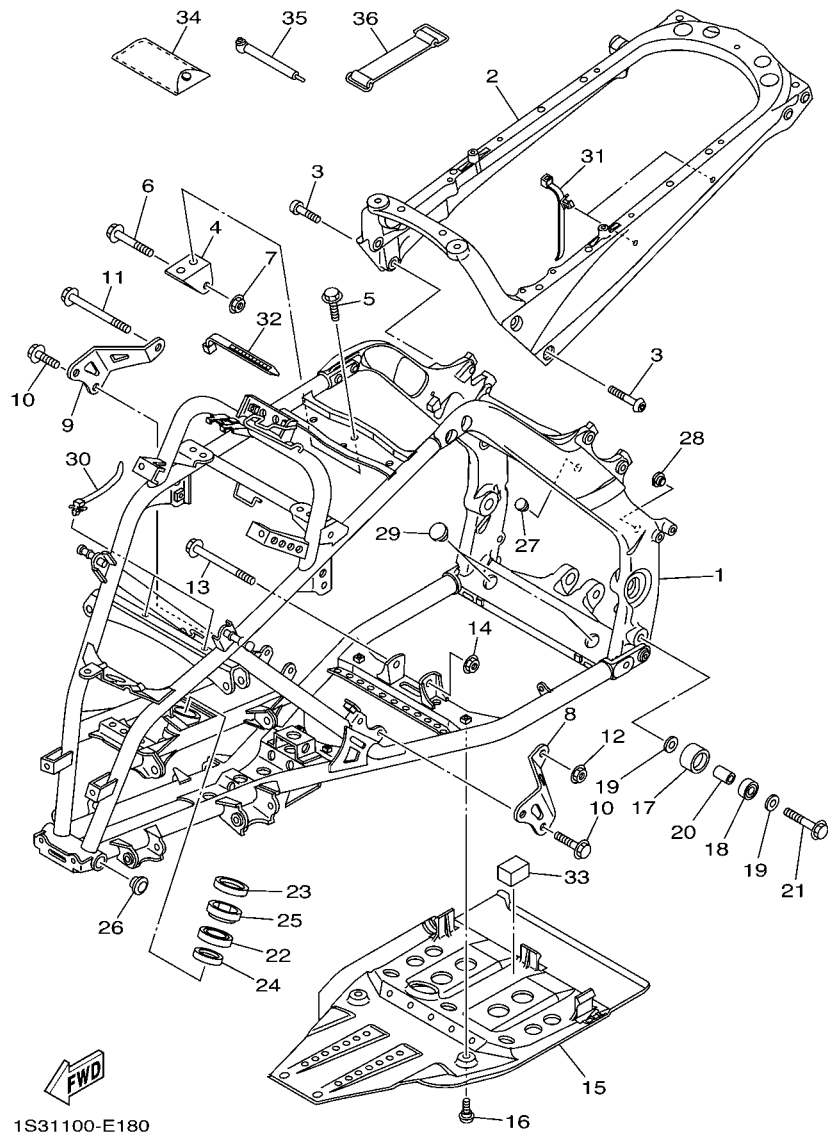

FIG. 18 FRAME

REF. NO.	PART NO.	DESCRIPTION	CAN	EUR	OCE	REMARKS
1	1S3-21101-08	FRONT FRAME COMP.	1	1	1	
2	1S3-21190-08	REAR FRAME COMP.	1	1	1	
3	90149-10034	SCREW	4	4	4	
4	1S3-21315-10	STAY, ENGINE 2	1	1	1	
5	95812-08014	BOLT, FLANGE	2	2	2	
6	95812-10055	BOLT, FLANGE	1	1	1	
7	95602-10200	NUT, U FLANGE	1	1	1	
8	1S3-21316-10	STAY, ENGINE 3	1	1	1	
9	1S3-21317-10	STAY, ENGINE 3	1	1	1	
10	90105-08142	BOLT, FLANGE	4	4	4	
11	95812-10110	BOLT, FLANGE	1	1	1	
12	90185-10011	NUT, SELF-LOCKING	1	1	1	
13	95812-10090	BOLT, FLANGE	1	1	1	
14	90185-10011	NUT, SELF-LOCKING	1	1	1	
15	1S3-21471-00	PROTECTOR, ENGINE	1	1	1	
16	90109-06198	BOLT	4	4	4	
17	5TG-22178-00	TENSIONER	1	1	1	
18	93300-60804	BEARING	1	1	1	
19	90201-08043	WASHER, PLATE	2	2	2	
20	90387-08064	COLLAR	1	1	1	
21	95812-08045	BOLT, FLANGE	1	1	1	
22	93306-20352	BEARING	1	1	1	
23	93102-25081	OIL SEAL	1	1	1	
24	93102-25099	OIL SEAL	1	1	1	
25	5GT-23872-00	HOLDER, BEARING	1	1	1	
26	90338-26004	PLUG	2	2	2	
27	90338-24260	PLUG	2	2	2	

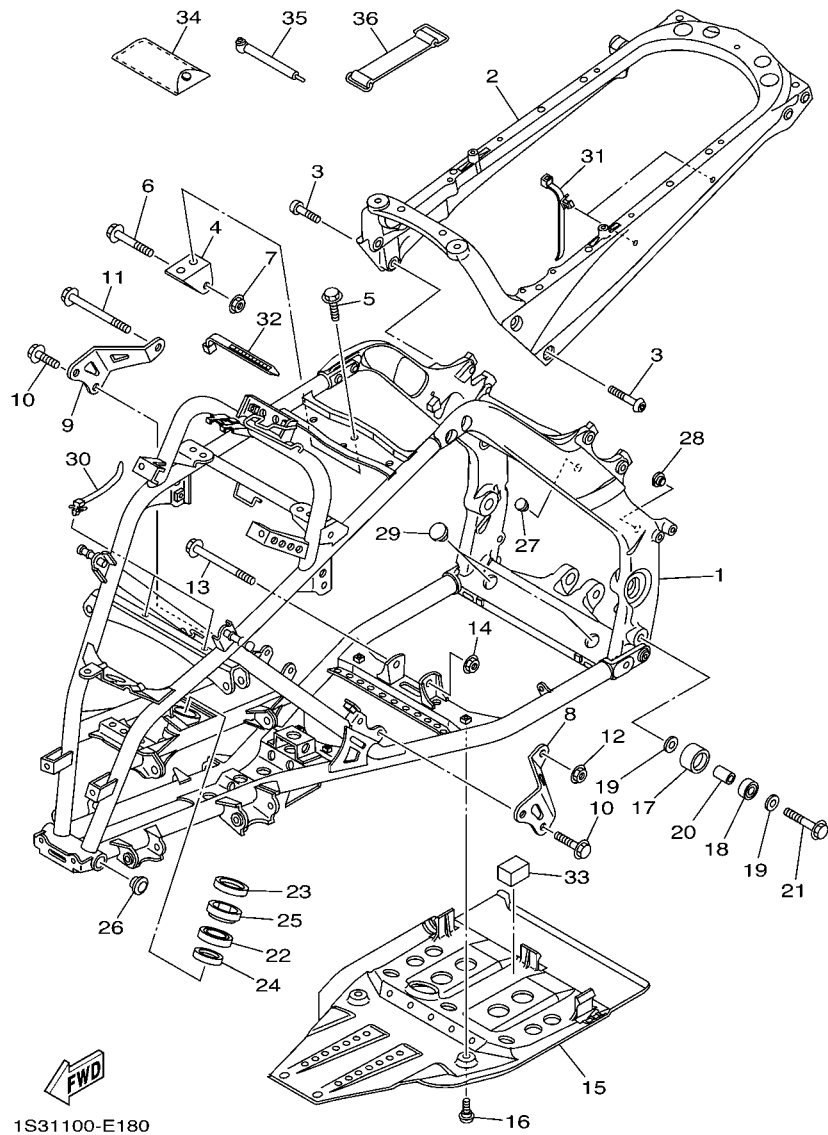

FIG. 18 FRAME

REF. NO.	PART NO.	DESCRIPTION	CAN	EUR	OCE	REMARKS
28	90338-20183	PLUG	2	2	2	
29	90338-23004	PLUG	2	2	2	
30	90464-12036	CLAMP	2	2	2	
31	90464-20213	CLAMP	3	3	3	
32	90464-12045	CLAMP	1	1	1	
33	1S3-2140A-00	DAMPER, STOPPER	1	1	1	
34	5TG-28100-10	TOOL KIT	1	1	1	
35	1NV-2811A-01	GAUGE, AIR	1	1	1	
36	116-82131-00	BAND, BATTERY	1	1	1	

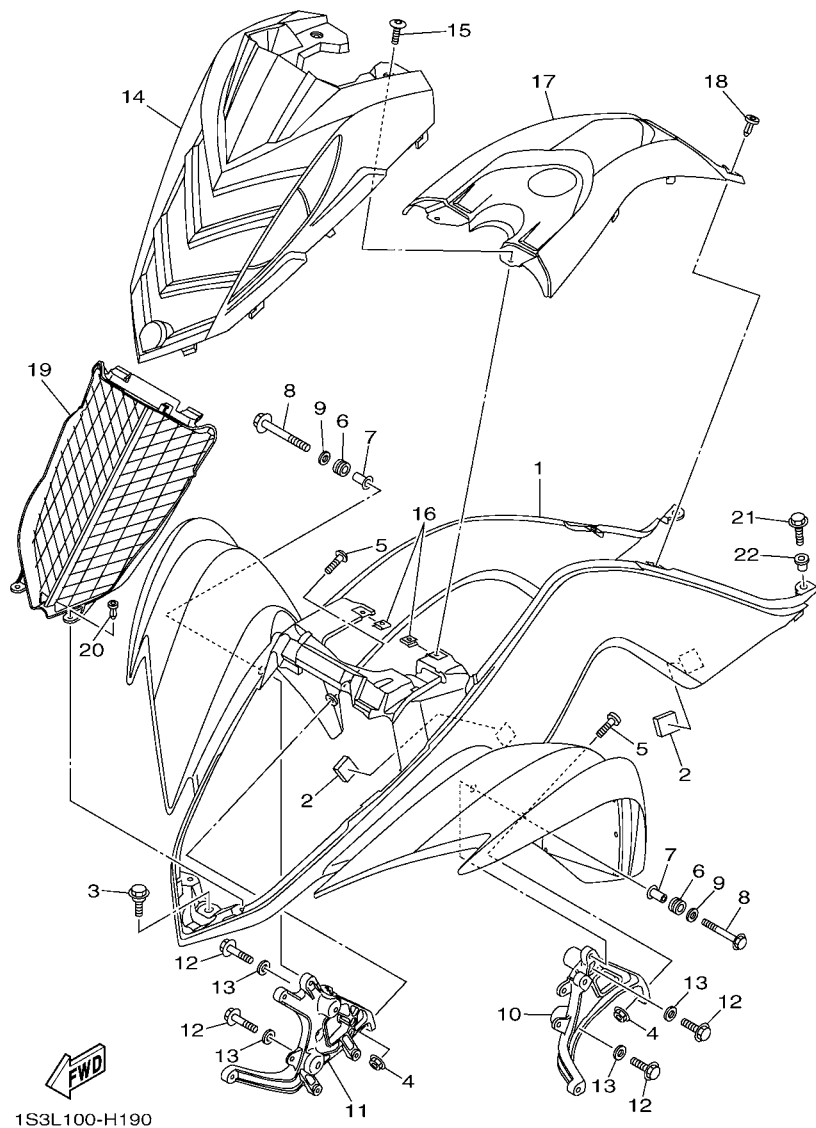
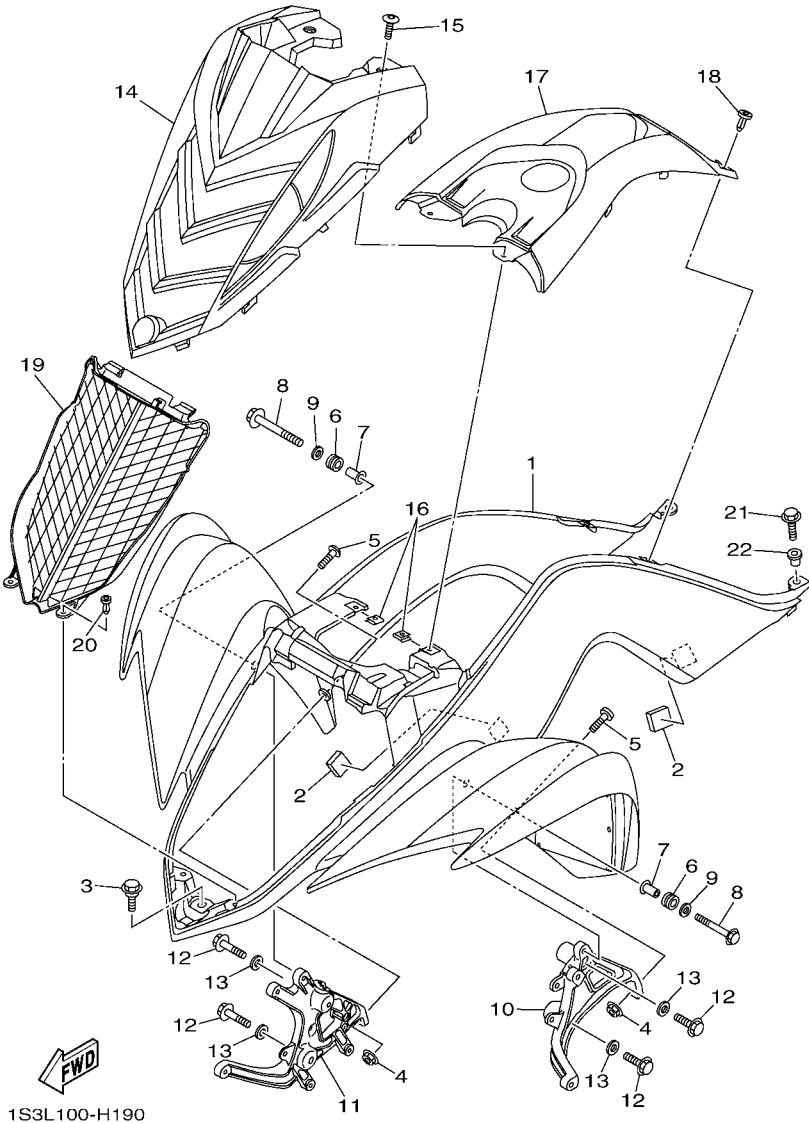

FIG. 19 FRONT FENDER

REF. NO.	PART NO.	DESCRIPTION	CAN	EUR	OCE	REMARKS
1	1S3-W215C-01	FRONT FENDER COMP.2	1			UR FOR DPBSE
	1S3-W215C-11	FRONT FENDER COMP.2	1			UR FOR BWS1
	1S3-W215B-01	FRONT FENDER COMP. 2		1		UR FOR DPBSE
	1S3-W215B-11	FRONT FENDER COMP. 2		1		UR FOR BWS1
	1S3-W215E-01	FRONT FENDER COMP.			1	UR FOR DPBSE
	1S3-W215E-11	FRONT FENDER COMP.			1	UR FOR BWS1
2	1S3-21541-00	DAMPER 1	4	4	4	
3	90109-06172	BOLT	1	1	1	
4	95602-06200	NUT, SELF-LOCKING	2	2	2	
5	90110-06202	BOLT, HEXAGON SOCKET HEAD	2	2	2	
6	90480-14102	GROMMET	2	2	2	
7	90387-06136	COLLAR	2	2	2	
8	95812-06030	BOLT, FLANGE	2	2	2	
9	90201-06078	WASHER, PLATE	2	2	2	
10	1S3-21513-00	STAY, FENDER 1	1	1	1	
11	1S3-21514-00	STAY, FENDER 2	1	1	1	
12	95812-06014	BOLT, FLANGE	4	4	4	
13	90201-06089	WASHER, PLATE	4	4	4	
14	1S3-23391-10	PANEL, FRONT	1	1	1	UR FOR DPBSE
	1S3-23391-20	PANEL, FRONT	1	1	1	UR FOR BWS1
15	90149-05299	SCREW	2	2	2	
16	90183-05008	NUT, SPRING	2	2	2	
17	1S3-2171A-00	COVER, TOP	1	1	1	UR FOR DPBSE
	1S3-2171A-30	COVER, TOP	1	1	1	UR FOR BWS1
18	90269-06002	RIVET	2	2	2	
19	1S3-12467-00	COVER, RADIATOR	1	1	1	
20	90269-06002	RIVET	2	2	2	

FIG. 19 FRONT FENDER



REF. NO.	PART NO.	DESCRIPTION	CAN	EUR	OCE	REMARKS
21	90105-06084	BOLT, FLANGE	2	2	2	
22	90387-06146	COLLAR	2	2	2	

FIG. 20 REAR FENDER

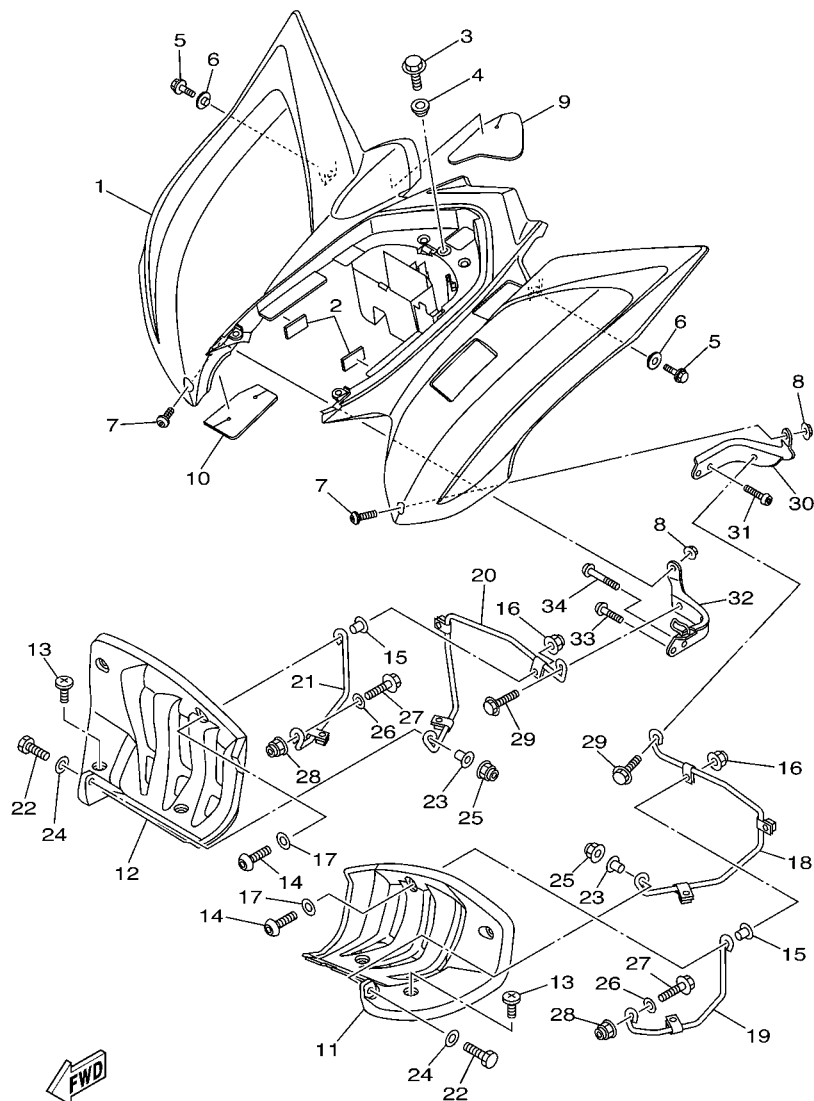

1S31100-E200

REF. NO.	PART NO.	DESCRIPTION	CAN	EUR	OCF	REMARKS
1	1S3-W216C-01	REAR FENDER COMP.2	1			UR FOR DPBSE
	1S3-W216C-11	REAR FENDER COMP.2	1			UR FOR BWS1
	1S3-W216B-01	REAR FENDER COMP.2		1		UR FOR DPBSE
	1S3-W216B-11	REAR FENDER COMP.2		1		UR FOR BWS1
	1S3-W216E-00	REAR FENDER COMP.			1	UR FOR DPBSE
	1S3-W216E-10	REAR FENDER COMP.			1	UR FOR BWS1
2	1S3-2140A-00	DAMPER, STOPPER	2	2	2	
3	90105-06084	BOLT, FLANGE	1	1	1	
4	90387-06153	COLLAR	1	1	1	
5	95812-06014	BOLT, FLANGE	2	2	2	
6	90387-06153	COLLAR	2	2	2	
7	90111-06038	BOLT,HEX. SOCKET BUTTON	2	2	2	
8	95602-06200	NUT, SELF-LOCKING	2	2	2	
9	1S3-2163A-00	COVER, REAR FENDER 1	1	1	1	
10	1S3-2163E-00	COVER, REAR FENDER 2	1	1	1	
11	5TG-21621-00	FLAP	1	1	1	
12	5TG-21691-00	FLAP	1	1	1	
13	90154-05013	SCREW, BINDING	6	6	6	
14	92012-06025	BOLT, BUTTON HEAD	2	2	2	
15	90560-06201	SPACER	2	2	2	
16	95602-06200	NUT, SELF-LOCKING	2	2	2	
17	90201-06076	WASHER, PLATE	2	2	2	
18	1S3-2164F-10	STAY 1	1	1	1	
19	1S3-2164H-10	STAY 3	1	1	1	
20	5TG-2164G-20	STAY 2	1	1	1	
21	1S3-2164J-10	STAY 4	1	1	1	
22	97022-06025	BOLT	2	2	2	

FIG. 20 REAR FENDER

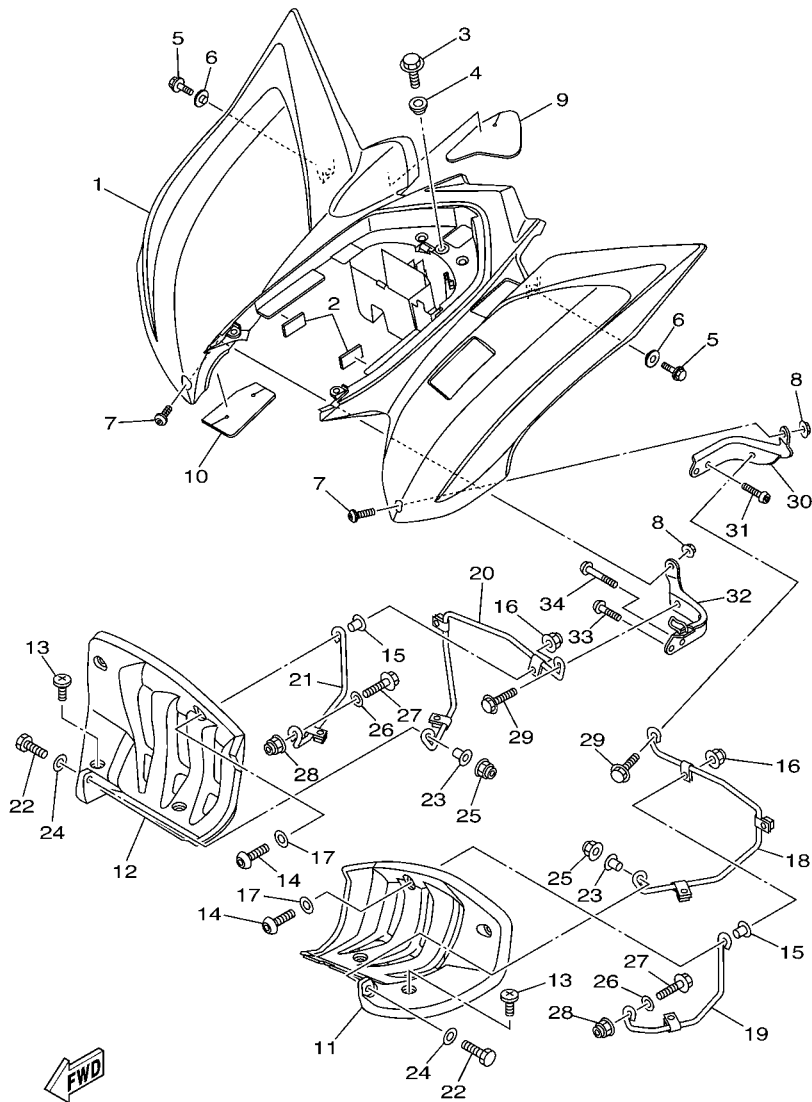

1S31100-E200

REF. NO.	PART NO.	DESCRIPTION	CAN	EUR	OCE	REMARKS
23	90387-06204	COLLAR	2	2	2	
24	90201-06093	WASHER, PLATE	2	2	2	
25	95602-06200	NUT, SELF-LOCKING	2	2	2	
26	90201-08053	WASHER, PLATE	2	2	2	
27	95822-08020	BOLT, FLANGE	2	2	2	
28	95602-08200	NUT, SELF-LOCKING	2	2	2	
29	95822-08016	BOLT, FLANGE	2	2	2	
30	1S3-21643-10	STAY, REAR	1	1	1	
31	92012-08020	BOLT, BUTTON HEAD	2	2	2	
32	1S3-21644-10	STAY, REAR	1	1	1	
33	92012-08016	BOLT, BUTTON HEAD	1	1	1	
34	92012-08035	BOLT, BUTTON HEAD	1	1	1	

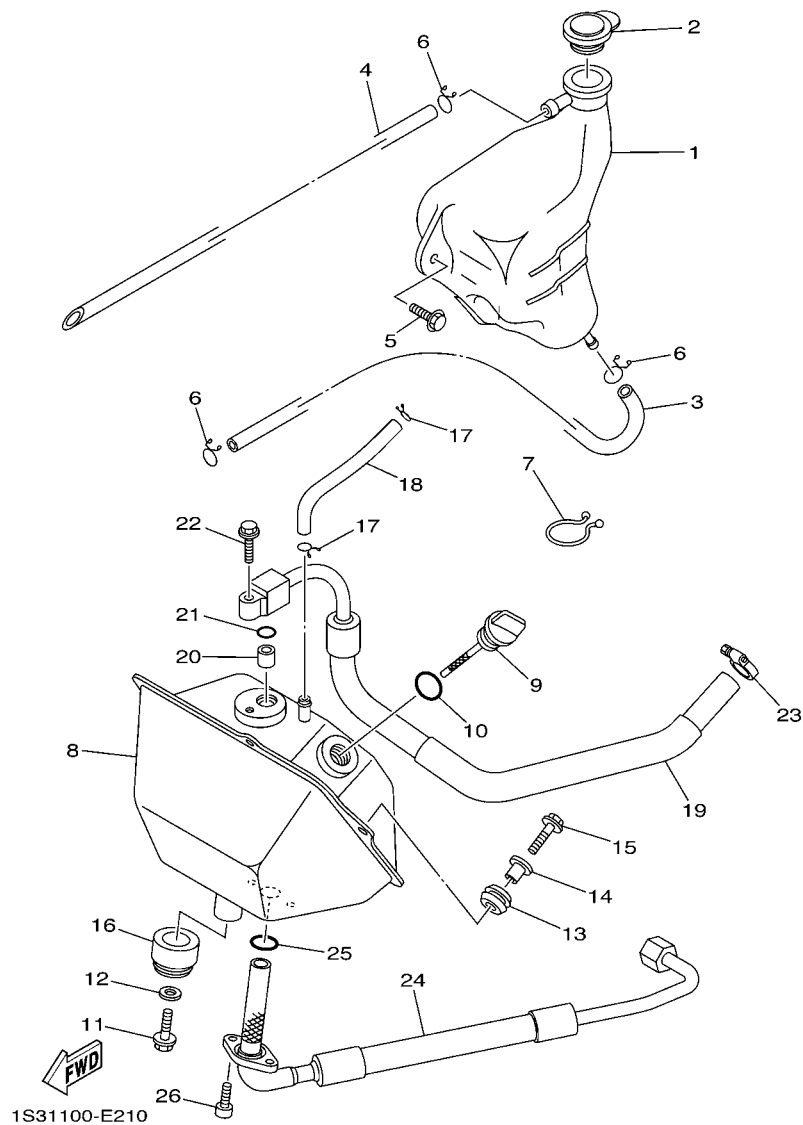

FIG. 21 OIL TANK

REF. NO.	PART NO.	DESCRIPTION	CAN	EUR	OC	REMARKS
1	5KM-21871-00	TANK, RECOVERY	1	1	1	
2	1S3-21875-00	CAP	1	1	1	
3	90445-09M30	HOSE (L630)	1	1	1	
4	90445-09777	HOSE (L300)	1	1	1	
5	90119-06152	BOLT, WITH WASHER	2	2	2	
6	90467-08003	CLIP	3	3	3	
7	90464-23041	CLAMP	2	2	2	
8	1S3-21750-00	OIL TANK ASSY	1	1	1	
9	5LP-21761-01	GAUGE, LEVEL	1	1	1	
10	93210-21190	O-RING	1	1	1	
11	95802-08016	BOLT, FLANGE	1	1	1	
12	90201-082A6	WASHER, PLATE	1	1	1	
13	90480-13459	GROMMET	2	2	2	
14	90387-06205	COLLAR	2	2	2	
15	95822-06020	BOLT, FLANGE	2	2	2	
16	90480-24004	GROMMET	1	1	1	
17	90467-10008	CLIP	2	2	2	
18	90445-11034	HOSE (L147)	1	1	1	
19	1S3-13465-00	HOSE, OIL 2	1	1	1	
20	99530-10114	PIN, DOWEL	1	1	1	
21	93210-10197	O-RING	1	1	1	
22	95022-06025	BOLT, FLANGE	1	1	1	
23	90450-22017	HOSE CLAMP ASSY	1	1	1	
24	1S3-13464-10	HOSE, OIL 1	1	1	1	
25	93210-16629	O-RING	1	1	1	
26	91312-06016	BOLT	2	2	2	

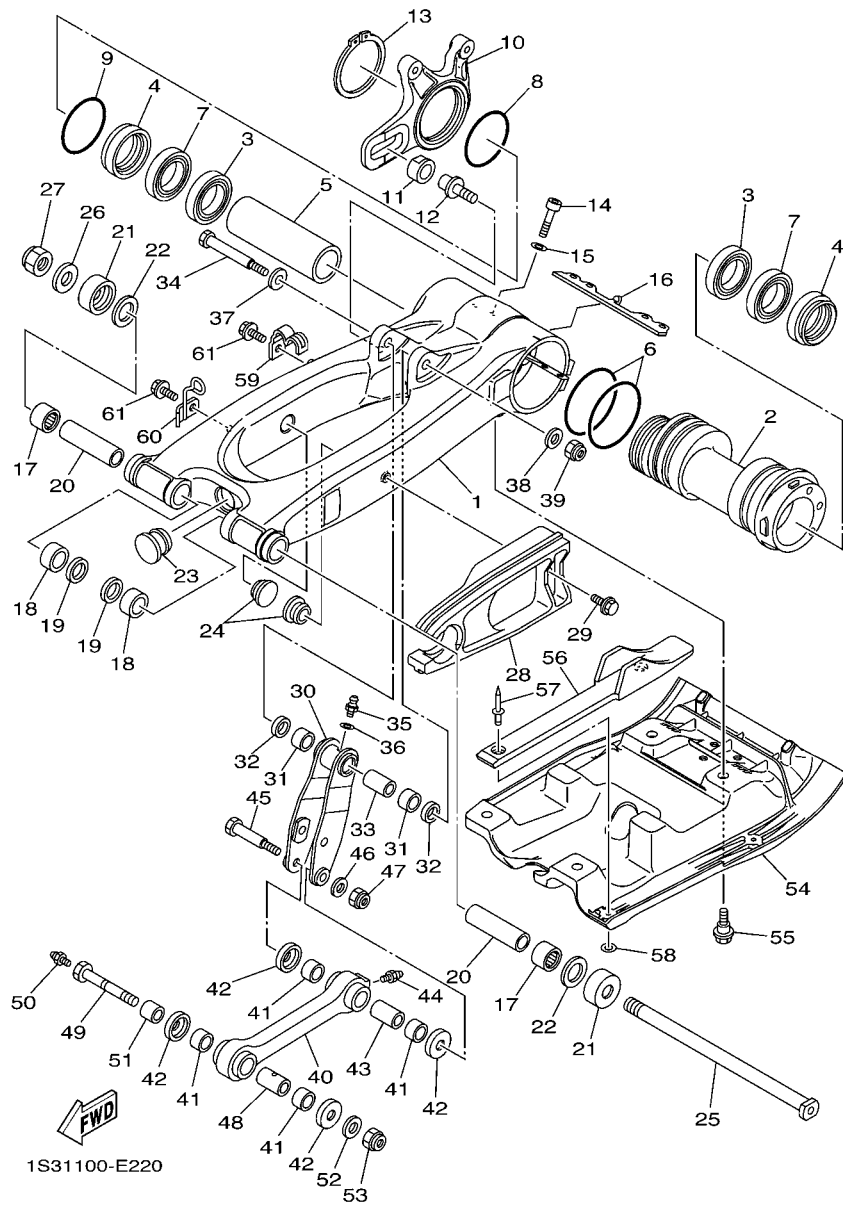

FIG. 22 REAR ARM

REF. NO.	PART NO.	DESCRIPTION	CAN	EUR	OCE	REMARKS
1	1S3-22110-00	REAR ARM COMP.	1	1	1	
2	1S3-25311-00	HUB, REAR	1	1	1	
3	93306-90804	BEARING	2	2	2	
4	93106-46003	OIL SEAL	2	2	2	
5	1S3-25317-00	SPACER, BEARING	1	1	1	
6	1S3-23147-01	O-RING	2	2	2	
7	93306-90805	BEARING	2	2	2	
8	93210-66001	O-RING	1	1	1	
9	93210-71001	O-RING	1	1	1	
10	1S3-25721-00	BRACKET, CALIPER	1	1	1	
11	90387-16014	COLLAR	1	1	1	
12	90110-12001	BOLT, HEXAGON SOCKET HEAD	1	1	1	
13	93410-67085	CIRCLIP	1	1	1	
14	91314-08040	BOLT, HEXAGON SOCKET HEAD	4	4	4	
15	92903-08600	WASHER, PLATE	4	4	4	
16	1S3-22475-00	SEAL, DUST	1	1	1	
17	93317-22237	BEARING	2	2	2	
18	90380-22111	BUSH, SOLID	2	2	2	
19	93106-22019	OIL SEAL (DC 22-28-8)	2	2	2	
20	1S3-22184-00	BUSH	2	2	2	
21	4X7-22129-00	COVER, THRUST 2	2	2	2	
22	3YF-22149-00	WASHER	2	2	2	
23	1S3-22417-00	PLUG	1	1	1	
24	90338-23004	PLUG	2	2	2	
25	1S3-22141-00	SHAFT, PIVOT	1	1	1	
26	90201-16018	WASHER, PLATE	1	1	1	
27	90185-16002	NUT, SELF-LOCKING	1	1	1	

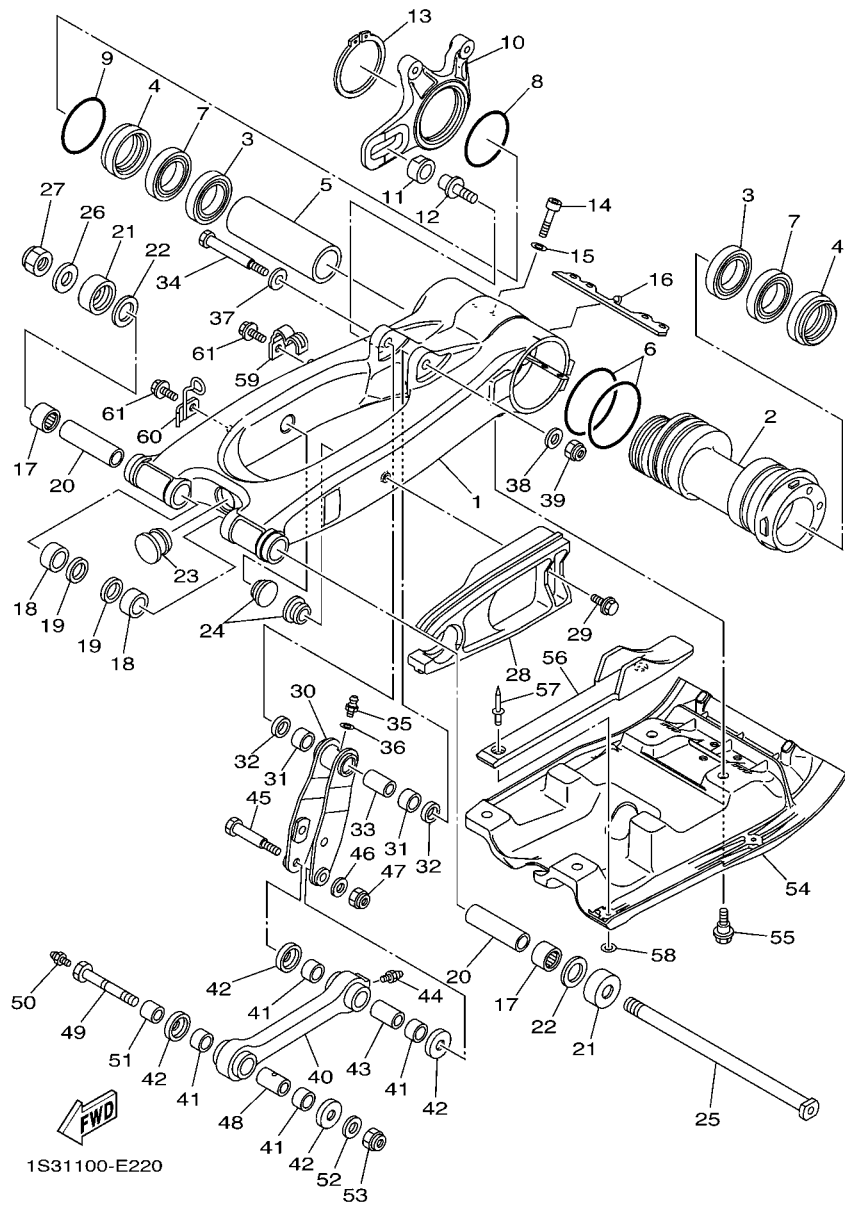

FIG. 22 REAR ARM

REF. NO.	PART NO.	DESCRIPTION	CAN	EUR	OC	REMARKS
28	1S3-22151-00	SEAL, GUARD	1	1	1	
29	90109-06172	BOLT	1	1	1	
30	1S3-2217A-00	ARM, RELAY	1	1	1	
31	90383-20033	BUSH, FORMED	2	2	2	
32	93109-20076	OIL SEAL	2	2	2	
33	90387-12021	COLLAR	1	1	1	
34	90109-10018	BOLT	1	1	1	
35	93700-06004	NIPPLE, GREASE	1	1	1	
36	90201-063F3	WASHER, PLATE	1	1	1	
37	90201-12030	WASHER, PLATE	1	1	1	
38	90201-10034	WASHER, PLATE	1	1	1	
39	90185-10012	NUT, SELF-LOCKING	1	1	1	
40	1S3-2217F-00	ROD, CONNECTING 1	1	1	1	
41	90383-20032	BUSH, FORMED	4	4	4	
42	5YT-22129-00	COVER, THRUST 2	4	4	4	
43	90387-125K2	COLLAR	1	1	1	
44	93700-06004	NIPPLE, GREASE	1	1	1	
45	90109-10020	BOLT	1	1	1	
46	90201-10035	WASHER, PLATE	1	1	1	
47	90185-10012	NUT, SELF-LOCKING	1	1	1	
48	90387-12010	COLLAR	1	1	1	
49	90109-12009	BOLT	1	1	1	
50	93700-06004	NIPPLE, GREASE	1	1	1	
51	90387-12028	COLLAR	1	1	1	
52	90201-12032	WASHER, PLATE	1	1	1	
53	90185-12007	NUT, SELF-LOCKING	1	1	1	
54	1S3-2219X-00	COVER	1	1	1	

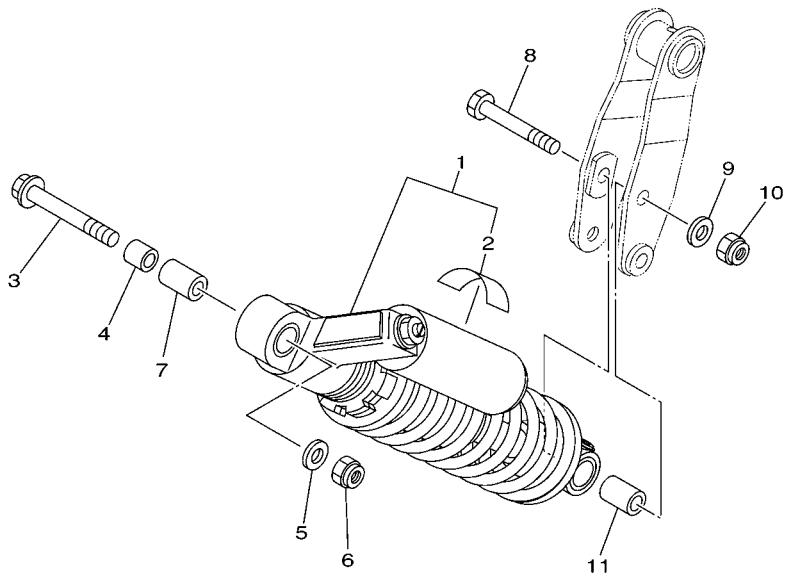
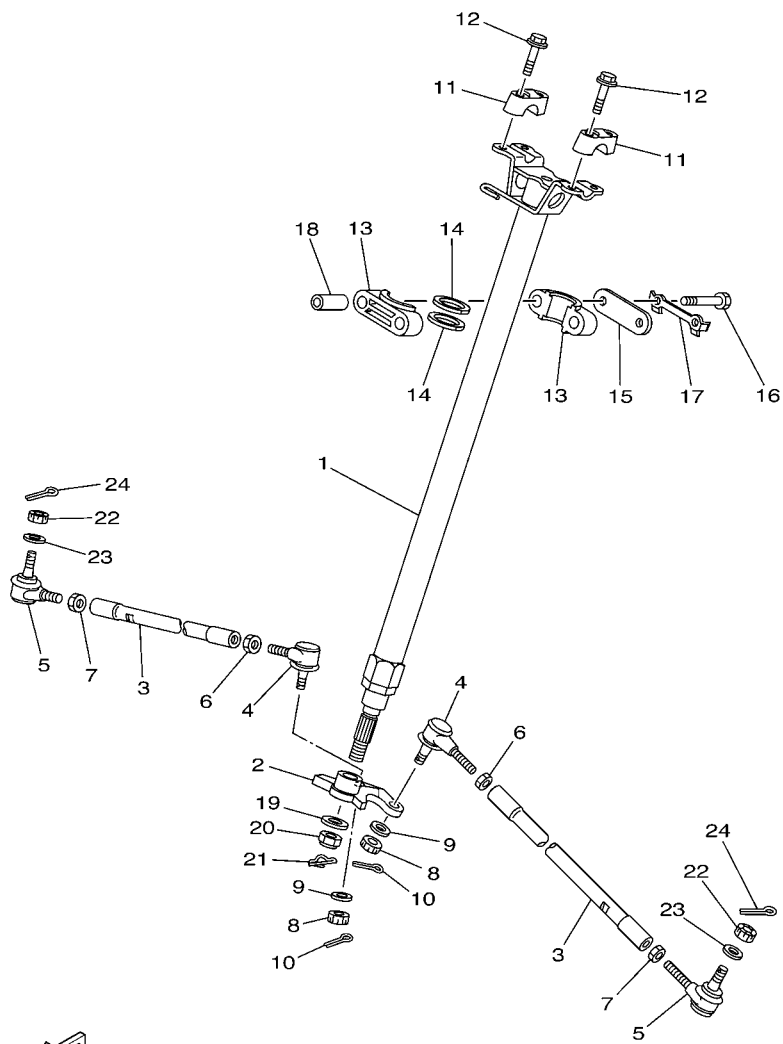

FIG. 23 REAR SUSPENSION

REF. NO.	PART NO.	DESCRIPTION	CAN	EUR	OCE	REMARKS
1	1S3-22210-G1	SHOCK ABSORBER ASSY, REAR	1			UR FOR DPBSE
	1AS-22210-10	SHOCK ABSORBER ASSY, REAR	1			UR FOR BWS1
	1S3-22210-H1	SHOCK ABSORBER ASSY, REAR		1	1	UR FOR DPBSE
	1AS-22210-20	SHOCK ABSORBER ASSY, REAR		1	1	UR FOR BWS1
2	4AA-22259-70	.LABEL, WARNING	1			
	4AA-22259-40	.LABEL, WARNING		1	1	
3	90105-12038	BOLT, FLANGE	1	1	1	
4	90387-12028	COLLAR	1	1	1	
5	90201-12032	WASHER, PLATE	1	1	1	
6	90185-12007	NUT, SELF-LOCKING	1	1	1	
7	90387-12020	COLLAR	1	1	1	
8	90109-10019	BOLT	1	1	1	
9	90201-10036	WASHER, PLATE	1	1	1	
10	90185-10012	NUT, SELF-LOCKING	1	1	1	
11	90387-127W0	COLLAR	1	1	1	



1S31100-E240

FIG. 24 STEERING

REF. NO.	PART NO.	DESCRIPTION	CAN	EUR	OCF	REMARKS
1	1S3-23813-10	COLUMN, STEERING 2	1	1	1	
2	5TG-23816-10	ARM, PITMAN	1	1	1	
3	1S3-23831-20	ROD, TIE	2	2	2	
4	1S3-23841-20	JOINT, UNIVERSAL 1	2	2	2	
5	1S3-23845-20	JOINT, UNIVERSAL 2	2	2	2	
6	90170-12055	NUT	2	2	2	
7	90170-12054	NUT	2	2	2	(RH. THREAD)
8	90171-10001	NUT, CASTLE	2	2	2	
9	90209-10229	WASHER	2	2	2	
10	91402-20020	PIN, COTTER	2	2	2	
11	8K1-23814-00	HOLDER, HANDLE	2	2	2	
12	95822-08030	BOLT, FLANGE	4	4	4	
13	1UY-23812-00	PLANE BEARING, STEERING	2	2	2	
14	93112-31011	OIL SEAL	2	2	2	
15	1UY-23868-01	BRACKET, STEERING LOWER	1	1	1	
16	97022-08060	BOLT	2	2	2	
17	1UY-23894-01	WASHER, LOCK 1	1	1	1	
18	90387-090R0	COLLAR	2	2	2	
19	90201-14021	WASHER, PLATE	1	1	1	
20	90185-14009	NUT, SELF-LOCKING	1	1	1	
21	91402-20025	PIN, COTTER	1	1	1	
22	90171-10001	NUT, CASTLE	2	2	2	
23	90209-10229	WASHER	2	2	2	
24	91402-20020	PIN, COTTER	2	2	2	

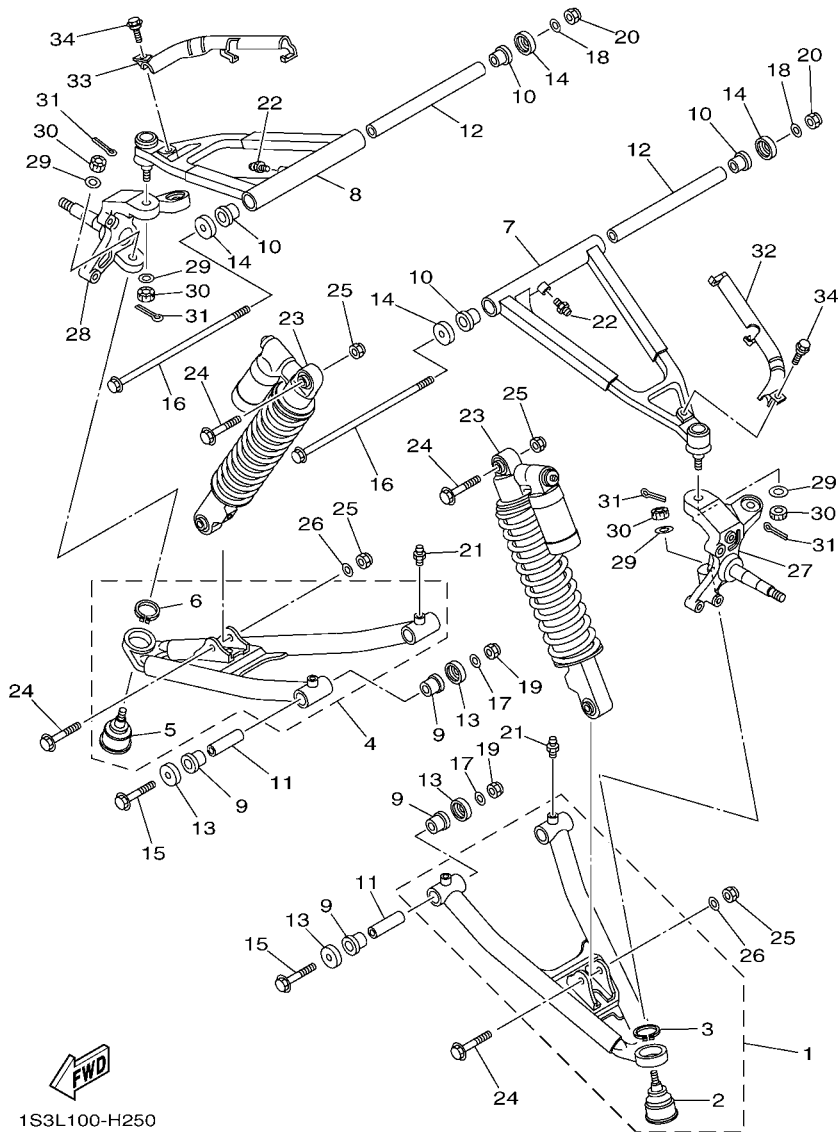

1S3L100-H250

FIG. 25 FRONT SUSPENSION & WHEEL

REF. NO.	PART NO.	DESCRIPTION	CAN	EUR	OCE	REMARKS
1	5TG-23570-00	FRONT LOWER ARM COMP. (LEFT)	1	1	1	
2	5LP-23579-00	.BALL JOINT 2	1	1	1	
3	99009-30400	.CIRCLIP	1	1	1	
4	5TG-23580-00	FRONT LOWER ARM COMP. (RIGHT)	1	1	1	
5	5LP-23579-00	.BALL JOINT 2	1	1	1	
6	99009-30400	.CIRCLIP	1	1	1	
7	5TG-23540-00	FRONT UPPER ARM COMP. (LEFT)	1	1	1	
8	5TG-23550-00	FRONT UPPER ARM COMP. (RIGHT)	1	1	1	
9	90381-15088	BUSH, SOLID	8	8	8	
10	90381-15088	BUSH, SOLID	4	4	4	
11	90387-101R3	COLLAR	4	4	4	
12	90387-100Y6	COLLAR	2	2	2	
13	5YT-23517-00	COVER, THRUST 1	8	8	8	
14	5YT-23517-00	COVER, THRUST 1	4	4	4	
15	90105-10135	BOLT, FLANGE	4	4	4	
16	90105-10132	BOLT, FLANGE	2	2	2	
17	90201-10037	WASHER, PLATE	4	4	4	
18	90201-10037	WASHER, PLATE	2	2	2	
19	90185-10012	NUT, SELF-LOCKING	4	4	4	
20	90185-10012	NUT, SELF-LOCKING	2	2	2	
21	93700-06004	NIPPLE, GREASE	4	4	4	
22	93700-06004	NIPPLE, GREASE	2	2	2	
23	1S3-23350-E1	SHOCK ABSORBER ASSY	2			UR FOR DPBSE
	1AS-23350-10	SHOCK ABSORBER ASSY	2			UR FOR BWS1
	1S3-23350-F1	SHOCK ABSORBER ASSY	2	2		UR FOR DPBSE
	1AS-23350-20	SHOCK ABSORBER ASSY	2	2		UR FOR BWS1
24	90105-10131	BOLT, FLANGE	4	4	4	

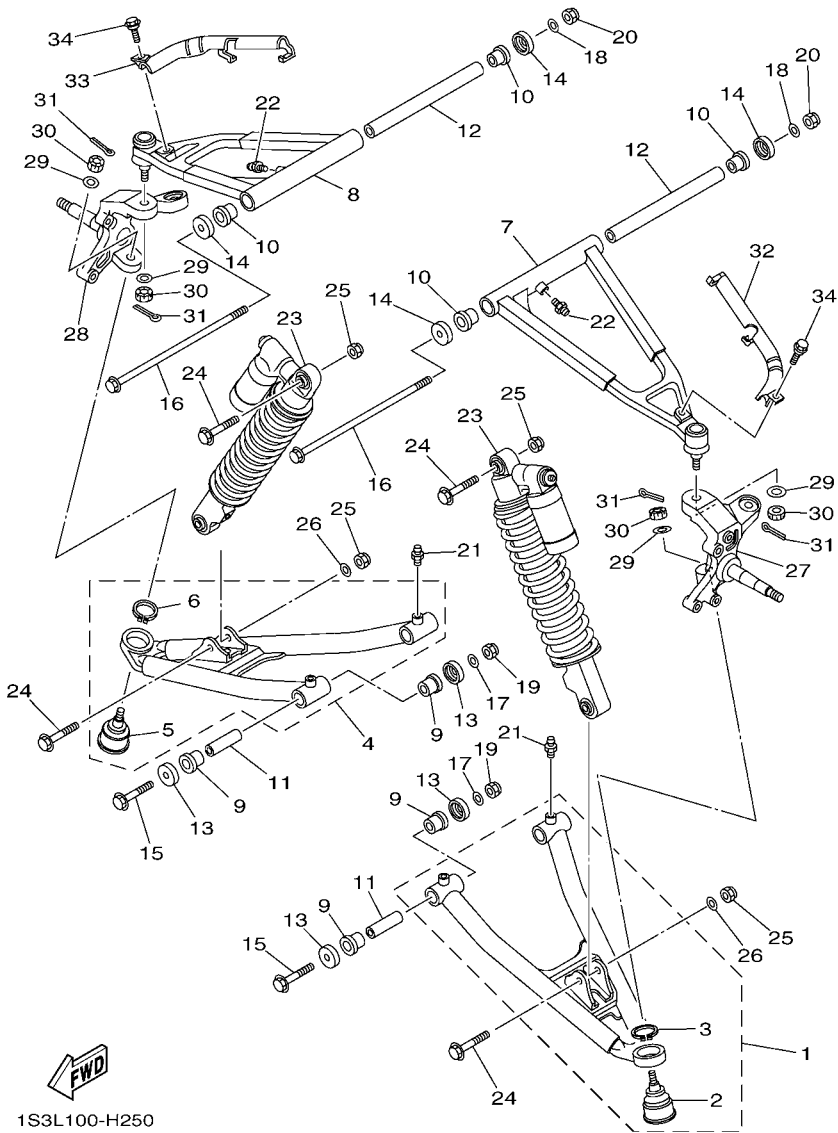

1S3L100-H250

FIG. 25 FRONT SUSPENSION & WHEEL

REF. NO.	PART NO.	DESCRIPTION	CAN	EUR	OCE	REMARKS
25	90185-10012	NUT, SELF-LOCKING	4	4	4	
26	90201-10035	WASHER, PLATE	2	2	2	
27	1S3-23501-00	STEERING KNUCKLE ASSY (LEFT)	1	1	1	
28	1S3-23502-00	STEERING KNUCKLE ASSY (RIGHT)	1	1	1	
29	90209-10229	WASHER	4	4	4	
30	90171-10001	NUT, CASTLE	4	4	4	
31	91402-20020	PIN, COTTER	4	4	4	
32	5TG-25875-00	HOLDER, BRAKE HOSE 1	1	1	1	
33	5TG-25876-00	HOLDER, BRAKE HOSE 2	1	1	1	
34	90109-067F4	BOLT	2	2	2	

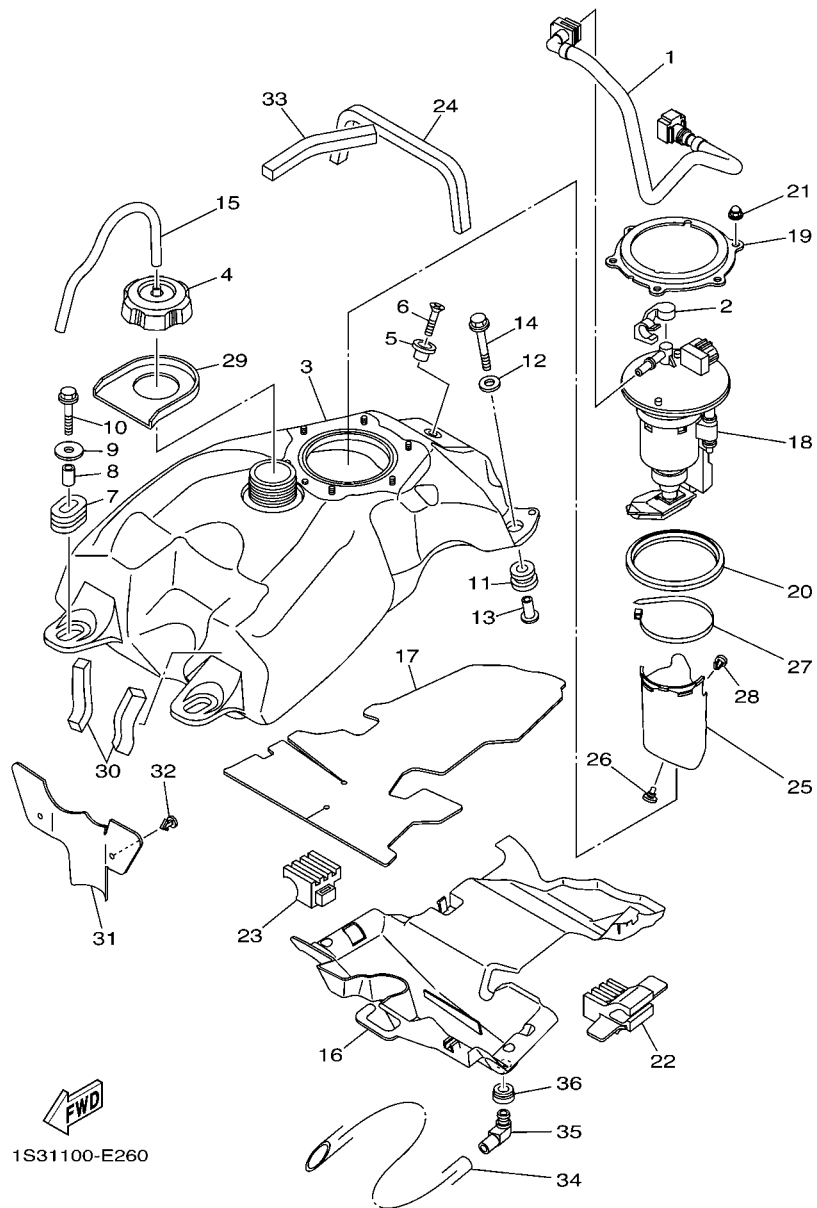

1S31100-E260

FIG. 26 FUEL TANK

REF. NO.	PART NO.	DESCRIPTION	CAN	EUR	OCE	REMARKS
1	1S3-13971-10	PIPE, FUEL 1	1			
	1S3-13971-00	PIPE, FUEL 1		1	1	
2	90464-14004	CLAMP	1	1	1	
3	1S3-24110-20	FUEL TANK COMP.	1			
	1S3-24110-00	FUEL TANK COMP.		1	1	
4	2FJ-24610-00	CAP ASSY	1	1	1	
5	4EW-2412F-00	BRACKET, SEAT	1	1	1	
6	98702-06025	SCREW, FLAT HEAD	1	1	1	
7	90480-01017	GROMMET	2	2	2	
8	90387-06M17	COLLAR	2	2	2	
9	90201-06090	WASHER, PLATE	2	2	2	
10	95802-06035	BOLT, FLANGE	2	2	2	
11	90480-18005	GROMMET	2	2	2	
12	90201-06033	WASHER, PLATE	2	2	2	
13	90387-06098	COLLAR	2	2	2	
14	95802-06035	BOLT, FLANGE	2	2	2	
15	90445-083J4	HOSE (L340)	1	1	1	
16	1S3-2414H-00	DAMPER, PLATE 1	1	1	1	
17	1S3-2416F-00	INSULATOR, FUEL TANK 1	1	1	1	
18	1S3-13907-10	FUEL PUMP COMP.	1	1	1	
19	1S3-24491-10	BRACKET, FUEL PUMP	1	1	1	
20	1S3-24486-00	O-RING	1	1	1	
21	95302-06800	NUT, CROWN	6	6	6	
22	1S3-24278-00	STOPPER 1	1	1	1	
23	1S3-24279-00	STOPPER 2	1	1	1	
24	1S3-24181-00	DAMPER, LOCATING 1	1	1	1	
25	1S3-24452-00	COVER	1	1	1	

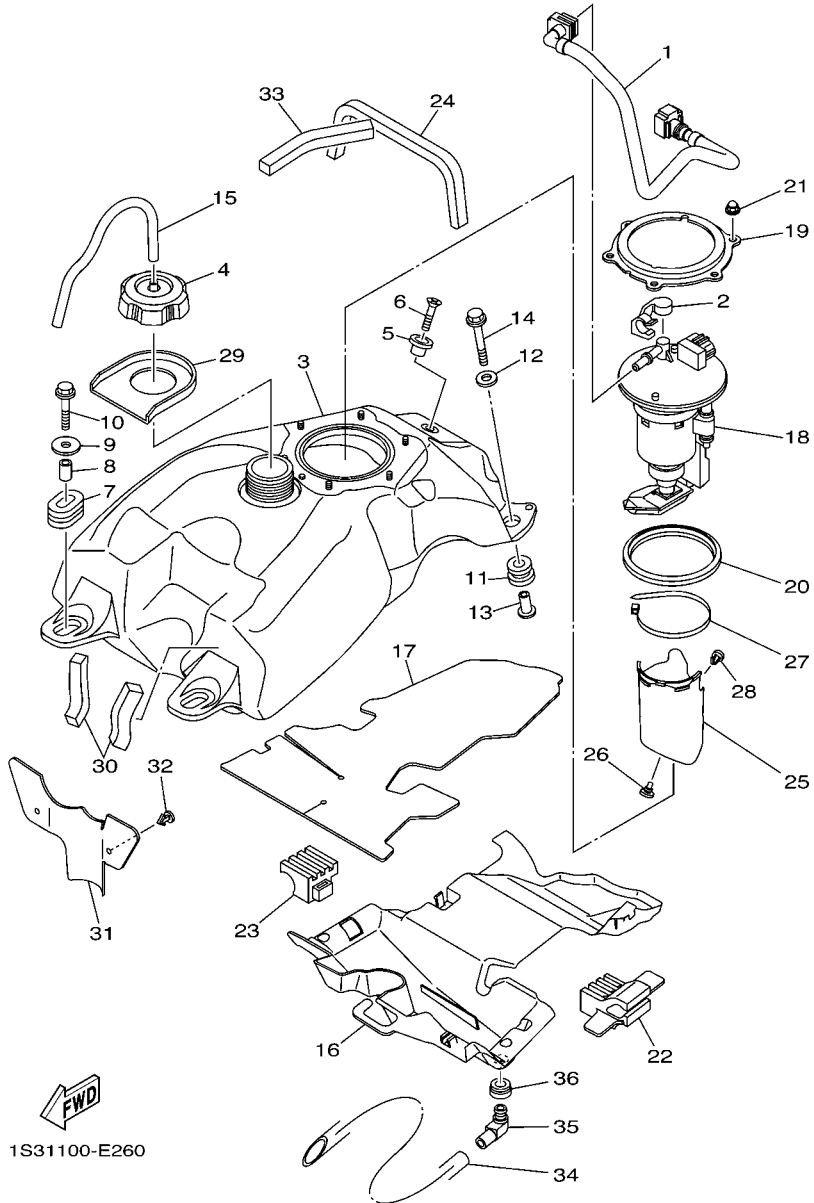

1S31100-E260

FIG. 26 FUEL TANK

REF. NO.	PART NO.	DESCRIPTION	CAN	EUR	OCÉ	REMARKS
26	90338-05008	PLUG	2	2	2	
27	90464-66001	CLAMP	1	1	1	
28	90269-07011	RIVET	1	1	1	
29	1S3-2414J-00	DAMPER, PLATE 2	1	1	1	
30	1S3-24182-00	DAMPER, LOCATING 2	2	2	2	
31	1S3-2413X-00	PLATE	1	1	1	
32	90269-05055	RIVET	2	2	2	
33	1S3-24183-00	DAMPER, LOCATING 3	1	1	1	
34	90445-16007	HOSE (L400)	1	1	1	
35	31A-14419-00	PIPE	1	1	1	
36	31A-14435-00	GROMMET	1	1	1	

FIG. 27 SEAT

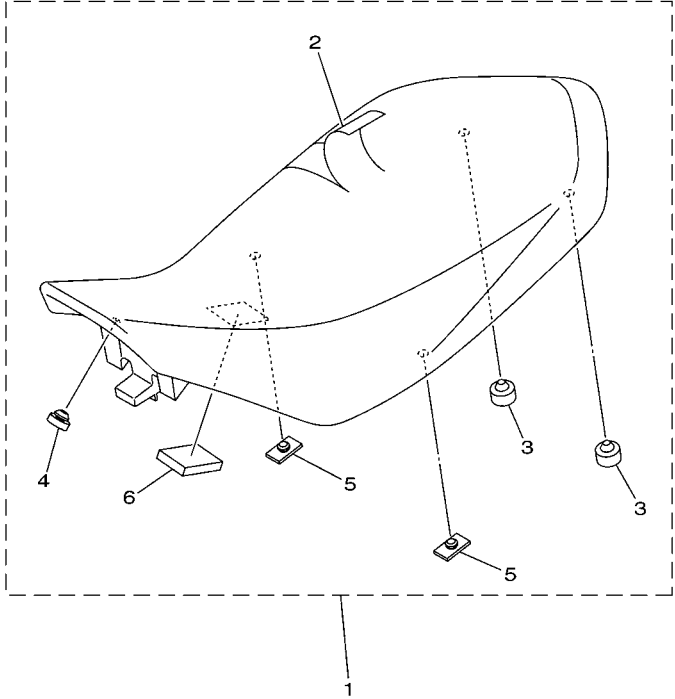

REF. NO.	PART NO.	DESCRIPTION	CAN	EUR	OCE	REMARKS
1	1S3-24710-21	SINGLE SEAT ASSY	1	1	1	
2	1S3-24731-20	.COVER, SEAT	1	1	1	
3	371-27114-00	.STOPPER, MAIN STAND	2	2	2	
4	22W-24741-00	.PAD, SEAT	1	1	1	
5	509-24724-00	.DAMPER, SEAT	2	2	2	
6	1S3-24723-00	.DAMPER, SEAT	1	1	1	

1S31100-E270

FIG. 28 FRONT WHEEL

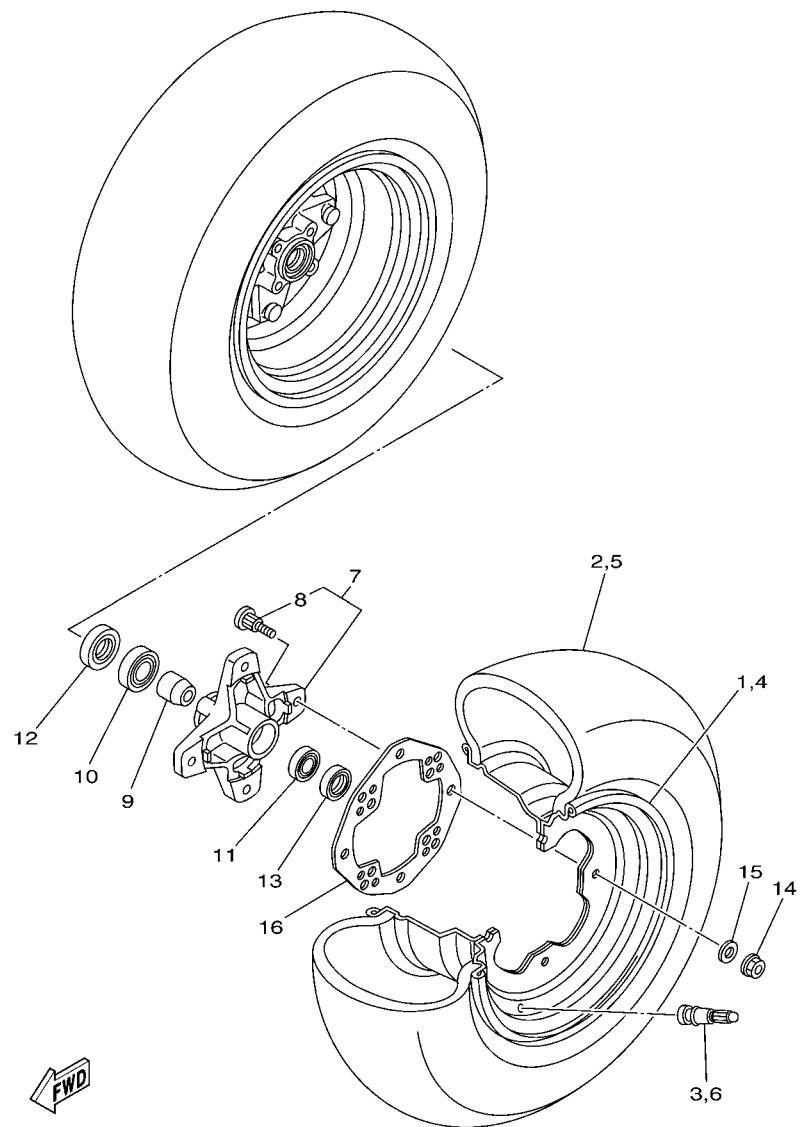

REF. NO.	PART NO.	DESCRIPTION	CAN	EUR	OCÉ	REMARKS
1	5LP-25180-21	WHEEL COMP.	1	1	1	
2	94107-10015	TIRE (AT21X7R10 KT341 T/L N)	1	1	1	DUNLOP
3	93900-00030	VALVE, RIM (TR412)	1	1	1	TAIHEIYO
4	5LP-25180-21	WHEEL COMP.	1	1	1	
5	94107-10015	TIRE (AT21X7R10 KT341 T/L N)	1	1	1	DUNLOP
6	93900-00030	VALVE, RIM (TR412)	1	1	1	TAIHEIYO
7	1S3-25111-00	HUB, FRONT	2	2	2	
8	90114-10006	.BOLT, SERRATION	4	4	4	
9	5LP-25117-00	SPACER, BEARING	2	2	2	
10	93306-00446	BEARING	2	2	2	
11	93306-20231	BEARING	2	2	2	
12	93105-26026	OIL SEAL	2	2	2	
13	93102-22216	OIL SEAL	2	2	2	
14	95702-10500	NUT, FLANGE	8	8	8	
15	92902-10200	WASHER	8	8	8	
16	1S3-25127-00	COVER, PLATE	2	2	2	

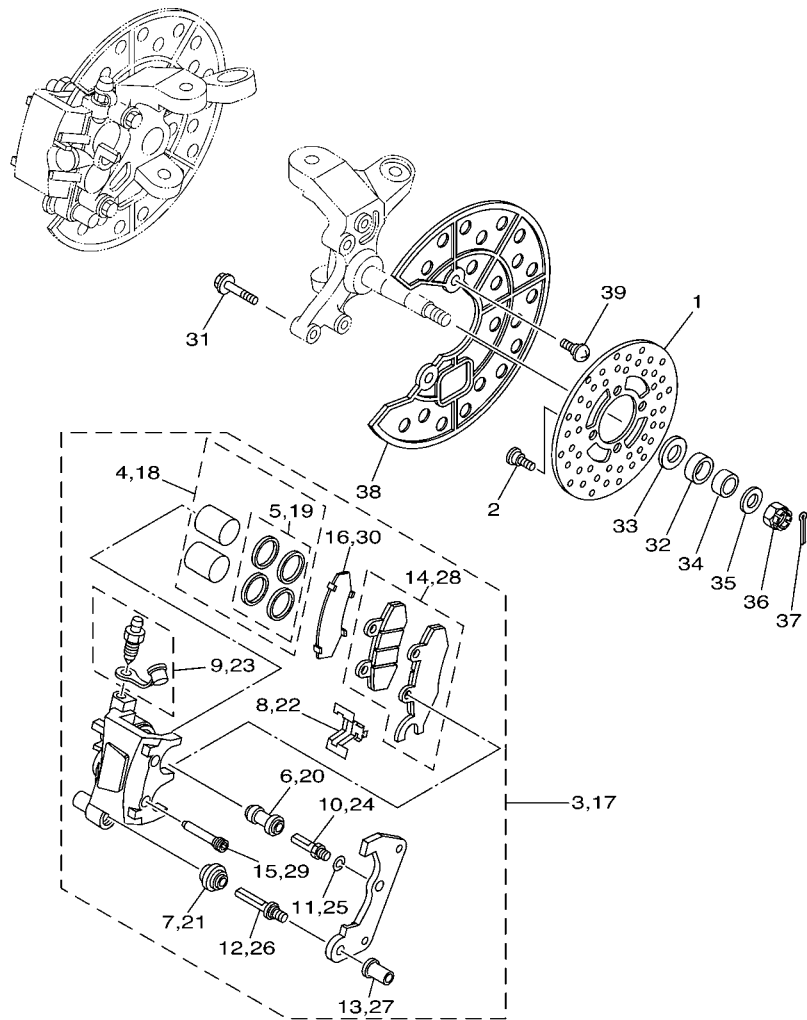

1S31100-E290

FIG. 29 FRONT BRAKE CALIPER

REF. NO.	PART NO.	DESCRIPTION	CAN	EUR	OC	REMARKS
1	3GD-2582T-10	DISC, BRAKE (LEFT)	2	2	2	
2	90109-08082	BOLT	8	8	8	
3	1S3-2580T-01	CALIPER ASSY (LEFT)	1	1	1	
4	5TG-W0057-00	.PISTON ASSY, CALIPER	1	1	1	
5	3LC-W0047-50	..CALIPER SEAL KIT	1	1	1	
6	1UY-25937-51	.BOOT 2	1	1	1	
7	3JD-25917-00	.BOOT, CALIPER	1	1	1	
8	3JD-25919-00	.SUPPORT, PAD	1	1	1	
9	1UY-W0048-50	.BLEED SCREW KIT	1	1	1	
10	1UY-25926-51	.BOLT	1	1	1	
11	1UY-25938-51	.WASHER, SPRING	1	1	1	
12	3JD-25926-00	.BOLT	1	1	1	
13	3JD-25961-00	.NUT	1	1	1	
14	1S3-W0045-00	.BRAKE PAD KIT	1	1	1	LH
15	5TG-25924-00	.PIN, PAD	2	2	2	
16	1S3-25828-00	.SHIM, CALIPER	1	1	1	
17	1S3-2580U-01	CALIPER ASSY (RIGHT)	1	1	1	
18	5TG-W0057-00	.PISTON ASSY, CALIPER	1	1	1	
19	3LC-W0047-50	..CALIPER SEAL KIT	1	1	1	
20	1UY-25937-51	.BOOT 2	1	1	1	
21	3JD-25917-00	.BOOT, CALIPER	1	1	1	
22	3JD-25919-00	.SUPPORT, PAD	1	1	1	
23	1UY-W0048-50	.BLEED SCREW KIT	1	1	1	
24	1UY-25926-51	.BOLT	1	1	1	
25	1UY-25938-51	.WASHER, SPRING	1	1	1	
26	3JD-25926-00	.BOLT	1	1	1	
27	3JD-25961-00	.NUT	1	1	1	

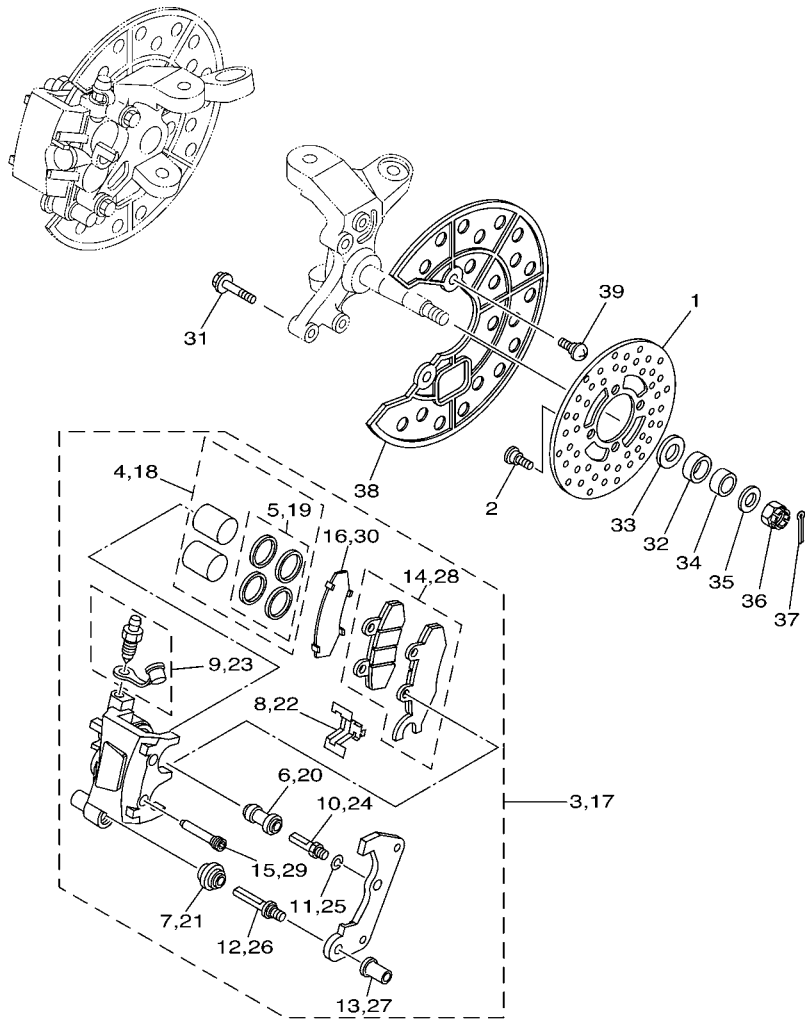

1S31100-E290

FIG. 29 FRONT BRAKE CALIPER

REF. NO.	PART NO.	DESCRIPTION	CAN	EUR	OCÉ	REMARKS
28	1S3-W0045-10	.BRAKE PAD KIT	1	1	1	RH
29	5TG-25924-00	.PIN, PAD	2	2	2	
30	1S3-25828-00	.SHIM, CALIPER	1	1	1	
31	90105-08184	BOLT, FLANGE	4	4	4	
32	90387-20005	COLLAR	2	2	2	
33	90201-20022	WASHER, PLATE	2	2	2	
34	90387-150R1	COLLAR	2	2	2	
35	90201-14586	WASHER, PLATE	2	2	2	
36	90171-14002	NUT, CASTLE	2	2	2	
37	91402-30025	PIN, COTTER	2	2	2	
38	5TG-2514A-00	RING, WHEEL 1	2	2	2	
39	90154-06014	SCREW, BINDING	4	4	4	

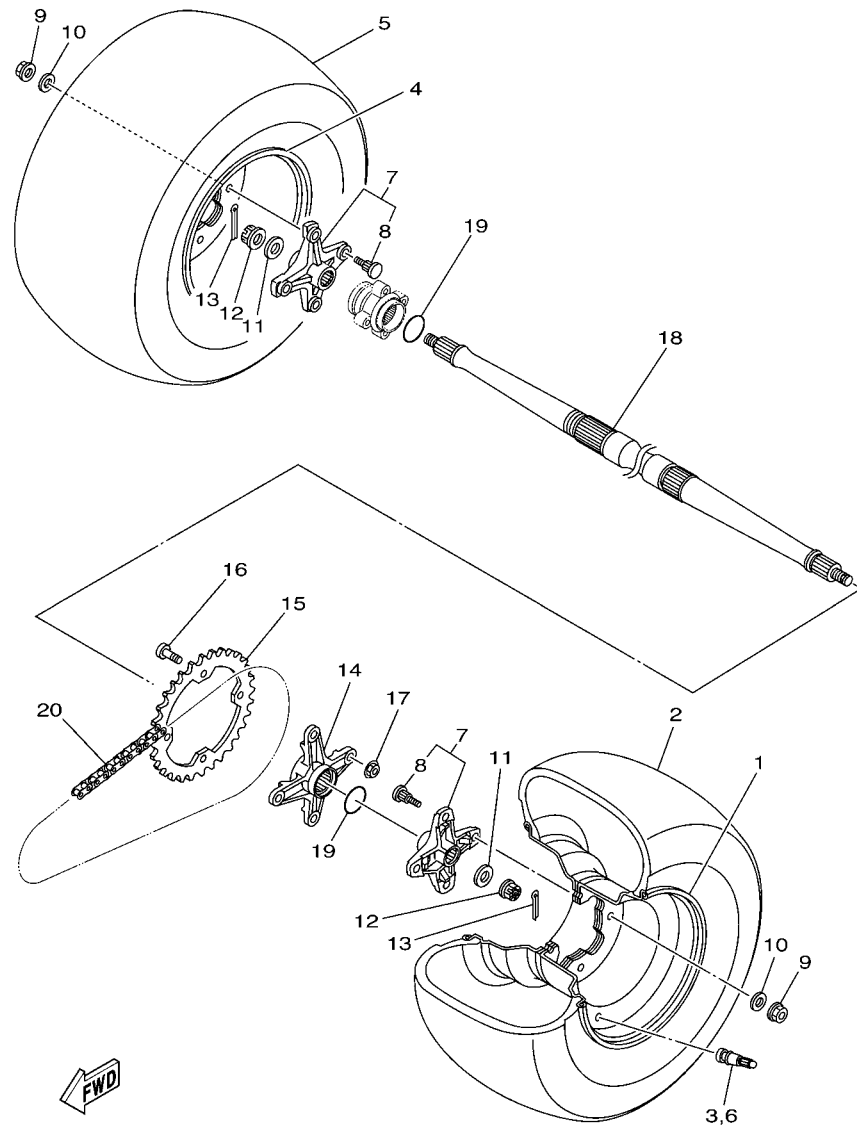

1S31100-E300

FIG. 30 REAR WHEEL

REF. NO.	PART NO.	DESCRIPTION	CAN	EUR	OCÉ	REMARKS
1	5LP-25390-21	REAR WHEEL COMP.	1	1	1	
2	94110-09012	TIRE(AT20X10-R9 KT345 T/L N)	1	1	1	DUNLOP
3	93900-00022	VALVE, RIM (TR413)	1	1	1	TAIHEIYO
4	5LP-25390-21	REAR WHEEL COMP.	1	1	1	
5	94110-09012	TIRE(AT20X10-R9 KT345 T/L N)	1	1	1	DUNLOP
6	93900-00022	VALVE, RIM (TR413)	1	1	1	TAIHEIYO
7	1S3-25383-20	COLLAR, WHEEL	2	2	2	
8	90114-10013	.BOLT, SERRATION	4	4	4	
9	95702-10500	NUT, FLANGE	8	8	8	
10	92902-10200	WASHER	8	8	8	
11	90201-16023	WASHER, PLATE	2	2	2	
12	90171-16002	NUT, CASTLE	2	2	2	
13	90252-03001	PIN, COTTER	2	2	2	
14	1S3-25386-00	COLLAR, SPROCKET AXLE	1	1	1	
15	5TG-25438-10	SPROCKET, DRIVEN (38T)	1	1	1	
16	90109-10013	BOLT	4	4	4	
17	90185-10011	NUT, SELF-LOCKING	4	4	4	
18	1S3-25381-10	AXLE, WHEEL	1	1	1	
19	93210-36769	O-RING	2	2	2	
20	94582-13098	CHAIN (DID520MXV 98LE)	1	1	1	

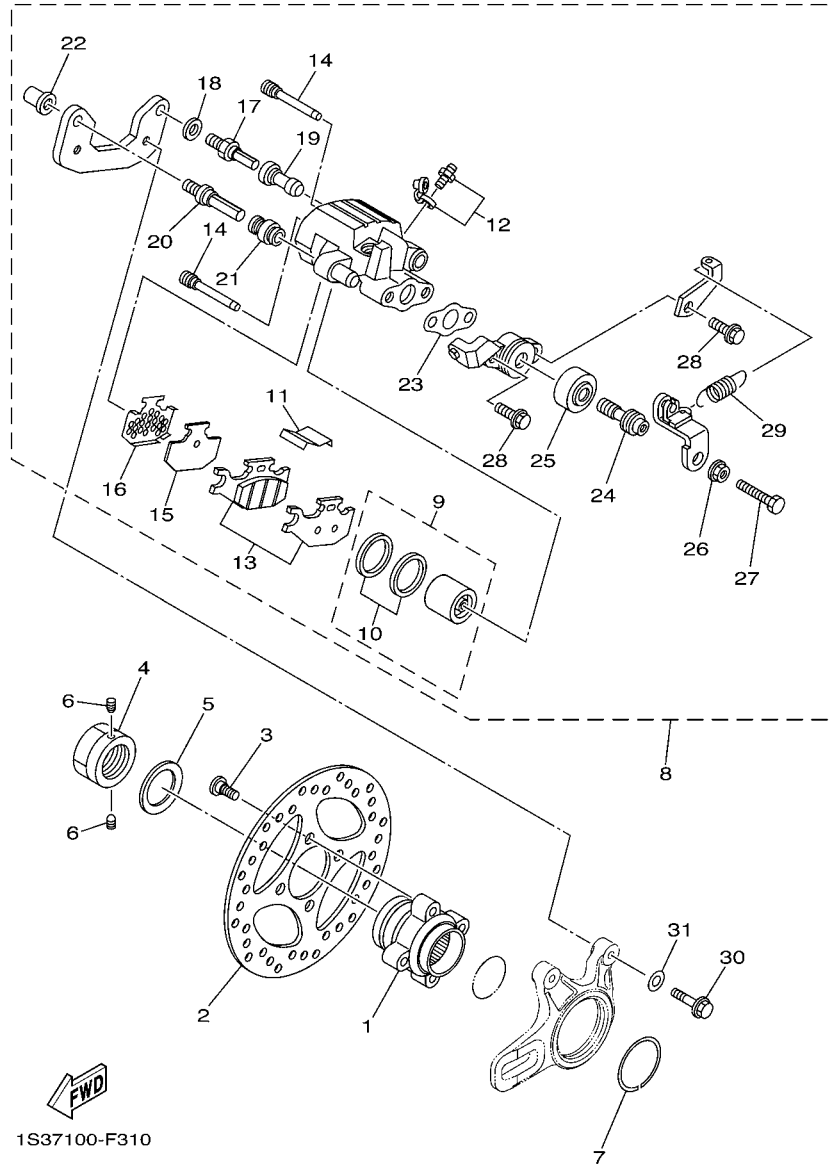

FIG. 31 REAR BRAKE CALIPER

REF. NO.	PART NO.	DESCRIPTION	CAN	EUR	OCÉ	REMARKS
1	1S3-25712-00	BRACKET, DISC	1	1	1	
2	1S3-2582W-10	DISK, REAR BRAKE 2	1	1	1	
3	90109-08076	BOLT	4	4	4	
4	90179-36003	NUT	1	1	1	
5	90208-37001	WASHER, CONICAL SPRING	1	1	1	
6	90113-06055	BOLT, SET	2	2	2	
7	1S3-25415-00	CIRCLIP	1	1	1	
8	1S3-2580V-11	CALIPER ASSY, REAR 1	1	1	1	
9	5UG-W0057-00	.PISTON ASSY, CALIPER	1	1	1	
10	3GD-W0047-00	..CALIPER SEAL KIT	1	1	1	
11	4GY-25919-50	.SUPPORT, PAD	1	1	1	
12	1UY-W0048-50	.BLEED SCREW KIT	1	1	1	
13	1S3-W0046-01	.BRAKE PAD KIT 2	1	1	1	
14	5GH-25924-00	.PIN, PAD	2	2	2	
15	5UG-25827-00	.SHIM, CALIPER	1	1	1	
16	5GH-25828-00	.SHIM, CALIPER	1	1	1	
17	1UY-25926-51	.BOLT	1	1	1	
18	1UY-25938-51	.WASHER, SPRING	1	1	1	
19	1UY-25937-51	.BOOT 2	1	1	1	
20	3JD-25926-00	.BOLT	1	1	1	
21	3JD-25917-00	.BOOT, CALIPER	1	1	1	
22	3JD-25961-00	.NUT	1	1	1	
23	5UG-25898-00	.GASKET	1	1	1	
24	1S3-25978-00	.SHAFT L	1	1	1	
25	1UY-25974-51	.BOOT	1	1	1	
26	1S3-25973-00	.NUT	1	1	1	
27	1S3-25972-00	.ADJUSTBOLT	1	1	1	

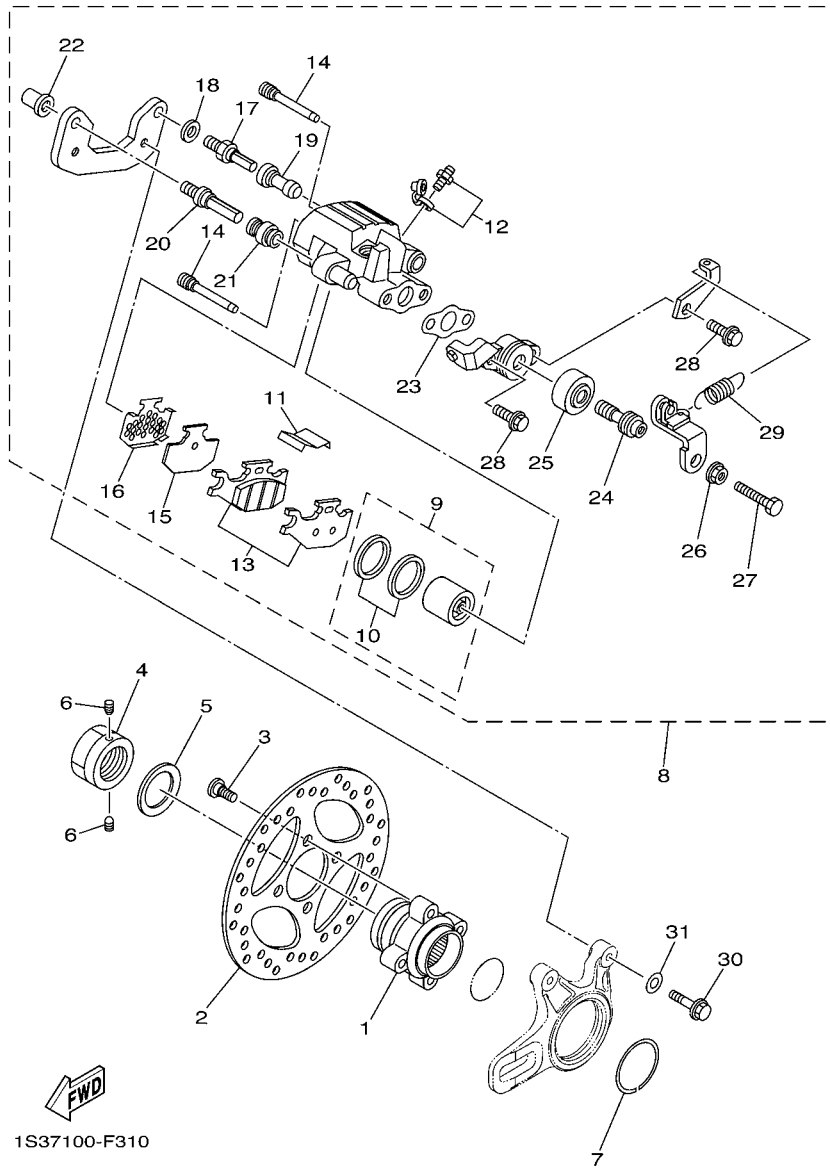
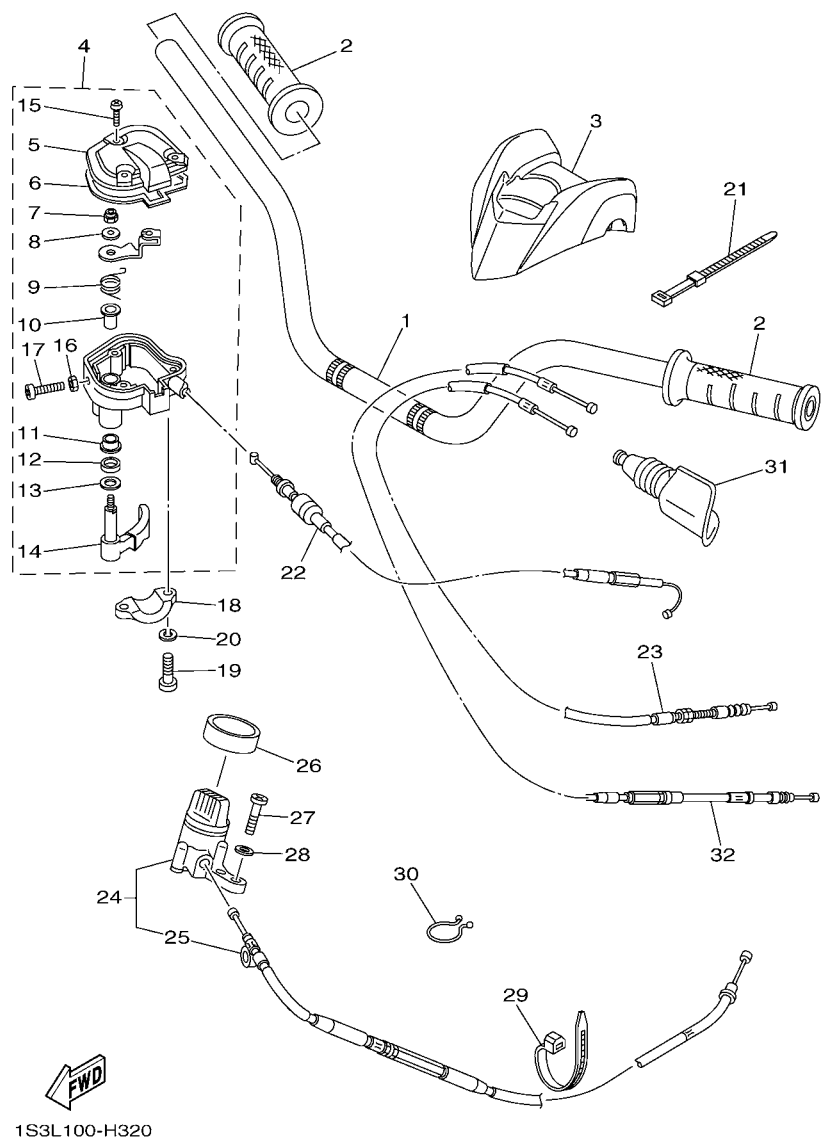

FIG. 31 REAR BRAKE CALIPER

REF. NO.	PART NO.	DESCRIPTION	CAN	EUR	OCE	REMARKS
28	5UG-25833-00	.BOLT, FITTING	2	2	2	
29	5TG-25977-50	.SPRING, RETURN	1	1	1	
30	90105-08104	BOLT, FLANGE	2	2	2	
31	90201-08060	WASHER, PLATE	2	2	2	



1S3L100-H320

FIG. 32 STEERING HANDLE & CABLE

REF. NO.	PART NO.	DESCRIPTION	CAN	EUR	OCE	REMARKS
1	1S3-26111-10	HANDLEBAR	1	1	1	
2	5LP-26241-00	GRIP	2	2	2	
3	1S3-26124-00	PROTECTOR, HANDLEBAR	1	1	1	
4	1S3-26250-00	THROTTLE LEVER ASSY	1	1	1	
5	1S3-2628F-00	.CAP, GEAR	1	1	1	
6	1S3-2628G-00	.GASKET	1	1	1	
7	95602-05100	.NUT, U	1	1	1	
8	1NV-26398-00	.WASHER	1	1	1	
9	1NV-26304-00	.SPRING	1	1	1	
10	1NV-26259-01	.COLLAR	1	1	1	
11	1NV-2625K-00	.COLLAR	1	1	1	
12	93104-09025	.OIL SEAL	1	1	1	
13	1NV-26129-00	.WASHER	1	1	1	
14	1S3-2625G-00	.LEVER, THROTTLE	1	1	1	
15	90149-04278	.SCREW	3	3	3	
16	95302-05700	.NUT	1	1	1	
17	98502-05020	.SCREW, PAN HEAD	1	1	1	
18	1S3-82913-00	HOLDER, LEVER LOWER 1	1	1	1	
19	98502-05020	SCREW, PAN HEAD	2	2	2	
20	92902-05100	WASHER, SPRING	2	2	2	
21	437-83936-01	BAND, SWITCH CORD	4	4	4	
22	1S3-26311-10	CABLE, THROTTLE 1	1	1	1	
23	1S3-26335-00	CABLE, CLUTCH	1	1	1	
24	1S3-26150-10	REV. LEVER ASSY.	1	1	1	
25	1S3-2637E-10	.CABLE, CONTROL 1	1	1	1	
26	1S3-26113-00	DAMPER	1	1	1	
27	98502-05018	SCREW, PAN HEAD	2	2	2	

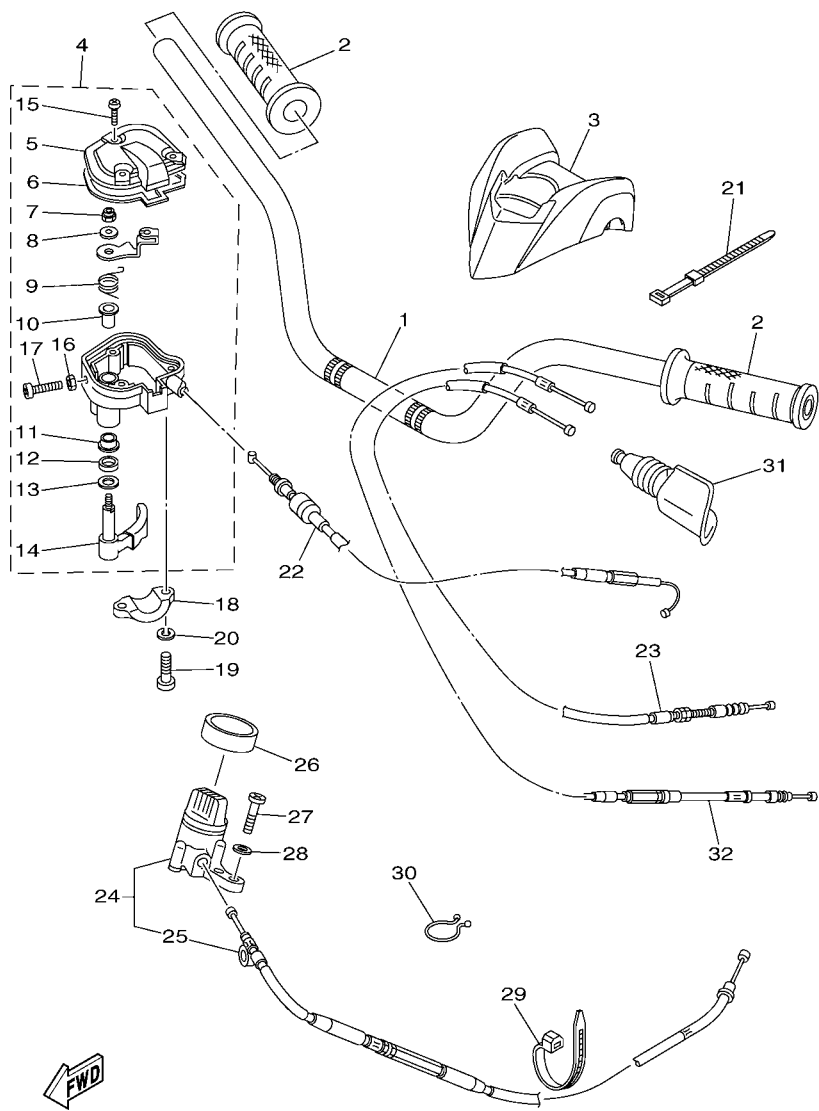

1S3L100-H320

FIG. 32 STEERING HANDLE & CABLE

REF. NO.	PART NO.	DESCRIPTION	CAN	EUR	OCE	REMARKS
28	92902-05600	WASHER, PLATE	2	2	2	
29	90464-13073	CLAMP	1	1	1	
30	90464-23041	CLAMP	1	1	1	
31	31A-26372-00	COVER, HANDLE LEVER 1	1	1	1	
32	1S3-26341-00	WIRE, BRAKE 1	1	1	1	
<hr/>						
<hr/>						
<hr/>						
<hr/>						
<hr/>						
<hr/>						
<hr/>						
<hr/>						
<hr/>						
<hr/>						
<hr/>						

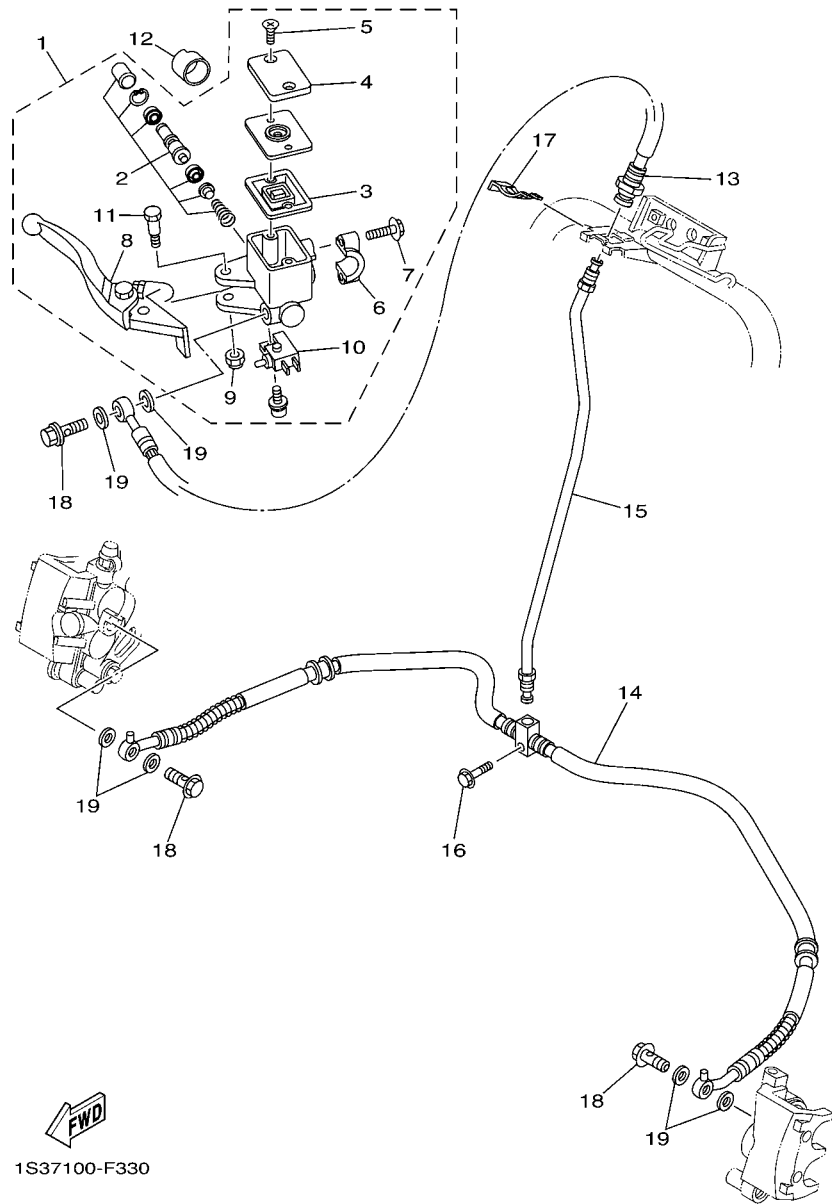

1S37100-F330

FIG. 33 FRONT MASTER CYLINDER

REF. NO.	PART NO.	DESCRIPTION	CAN	EUR	OCE	REMARKS
1	5D3-2583T-00	MASTER CYLINDER ASSY	1	1	1	
2	5D3-W0041-00	.CYLINDER KIT, MASTER	1	1	1	
3	4TT-25854-00	.GASKET, DIAPHRAGM	1	1	1	
4	5D3-25852-00	.CAP, RESERVOIR	1	1	1	
5	4NK-2589H-00	.SCREW	2	2	2	
6	5LP-25867-00	.BRACKET, MASTER CYLINDER	1	1	1	
7	5MV-25833-00	.BOLT, FITTING	2	2	2	
8	5D3-83922-00	.LEVER 2	1	1	1	
9	95604-06100	.NUT, U	1	1	1	
10	5D3-83980-00	.FRONT STOP SWITCH ASSY	1	1	1	
11	3B4-2589F-00	.BOLT, LEVER	1	1	1	
12	1UY-26259-00	COLLAR	1	1	1	
13	1S3-25872-10	HOSE, BRAKE 1	1	1	1	
14	5TG-25873-10	HOSE, BRAKE 2	1	1	1	
15	1S3-25871-10	PIPE, BRAKE	1	1	1	
16	95822-06025	BOLT, FLANGE	1	1	1	
17	2GU-25866-00	CIRCLIP	1	1	1	
18	90401-10015	BOLT, UNION	3	3	3	
19	90201-10118	WASHER, PLATE	6	6	6	

FIG. 34 STAND & FOOTREST

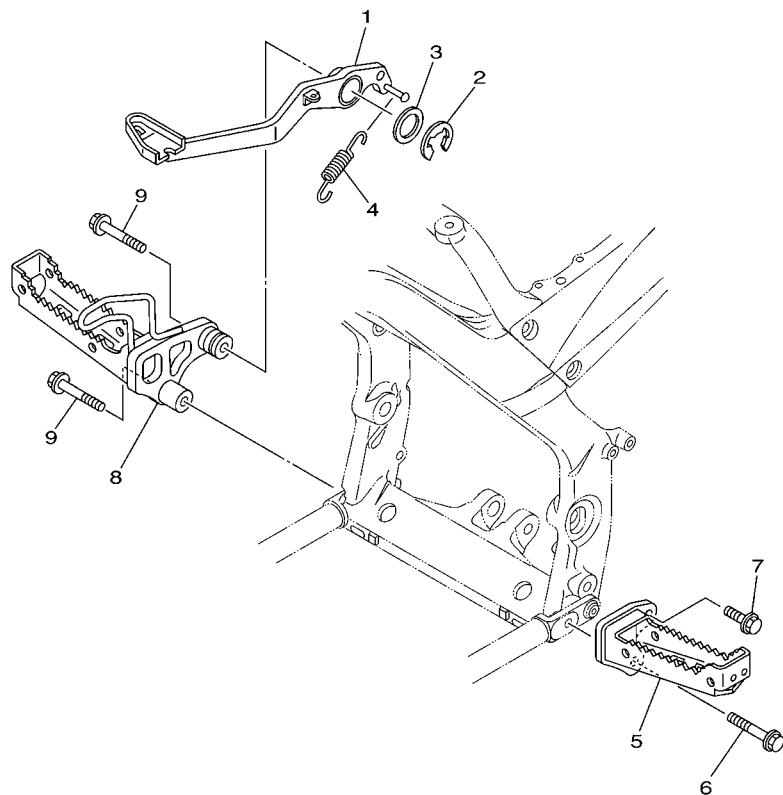

FWD
1S31100-E340

REF. NO.	PART NO.	DESCRIPTION	CAN	EUR	OCE	REMARKS
1	1S3-27211-10	PEDAL, BRAKE	1	1	1	
2	93430-23054	CIRCLIP	1	1	1	
3	90201-266F6	WASHER, PLATE	1	1	1	
4	90506-20380	SPRING, TENSION	1	1	1	
5	1S3-27411-10	FOOTREST 1	1	1	1	
6	90105-10294	BOLT, FLANGE	1	1	1	
7	95812-10030	BOLT, FLANGE	1	1	1	
8	1S3-27421-10	FOOTREST 2	1	1	1	
9	90105-10294	BOLT, FLANGE	2	2	2	

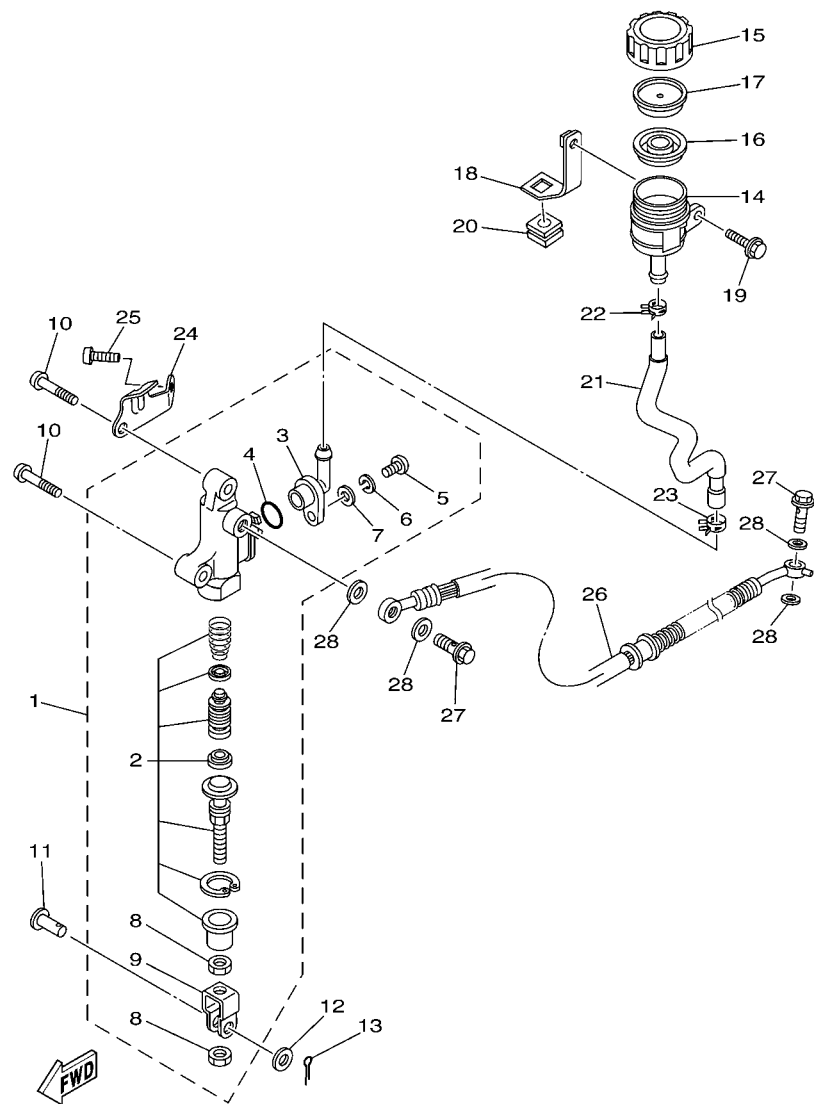

1S31100-E350

FIG. 35 REAR MASTER CYLINDER

REF. NO.	PART NO.	DESCRIPTION	CAN	EUR	OCF	REMARKS
1	1S3-2580E-00	REAR MASTER CYLINDER ASSY	1	1	1	
2	1S3-W0042-50	.CYLINDER KIT, MASTER	1	1	1	
3	1AE-2582A-00	.JOINT	1	1	1	
4	93210-15620	.O-RING	1	1	1	
5	98506-04012	.SCREW, PAN HEAD	1	1	1	
6	92906-04100	.WASHER, SPRING	1	1	1	
7	92906-04600	.WASHER, PLATE	1	1	1	
8	4SS-27218-00	.NUT	2	2	2	
9	2YK-27222-00	.JOINT	1	1	1	
10	92012-08035	BOLT, BUTTON HEAD	2	2	2	
11	90240-08124	PIN, CLEVIS	1	1	1	
12	90201-08083	WASHER, PLATE	1	1	1	
13	91401-16012	PIN, COTTER	1	1	1	
14	5JJ-25894-01	TANK, RESERVOIR	1	1	1	
15	3XP-25852-50	CAP, RESERVOIR	1	1	1	
16	2VN-25854-00	GASKET, DIAPHRAGM	1	1	1	
17	2VN-25855-00	BUSH, DIAPHRAGM	1	1	1	
18	1S3-26292-00	STAY	1	1	1	
19	90119-06137	BOLT, WITH WASHER	1	1	1	
20	90480-15009	GROMMET	1	1	1	
21	1S3-25895-00	HOSE, RESERVOIR	1	1	1	
22	90467-11044	CLIP	1	1	1	
23	90467-14057	CLIP	1	1	1	
24	1S3-27453-00	COVER 1	1	1	1	
25	92012-08016	BOLT, BUTTON HEAD	1	1	1	
26	1S3-25874-10	HOSE, BRAKE	1	1	1	
27	90401-10015	BOLT, UNION	2	2	2	

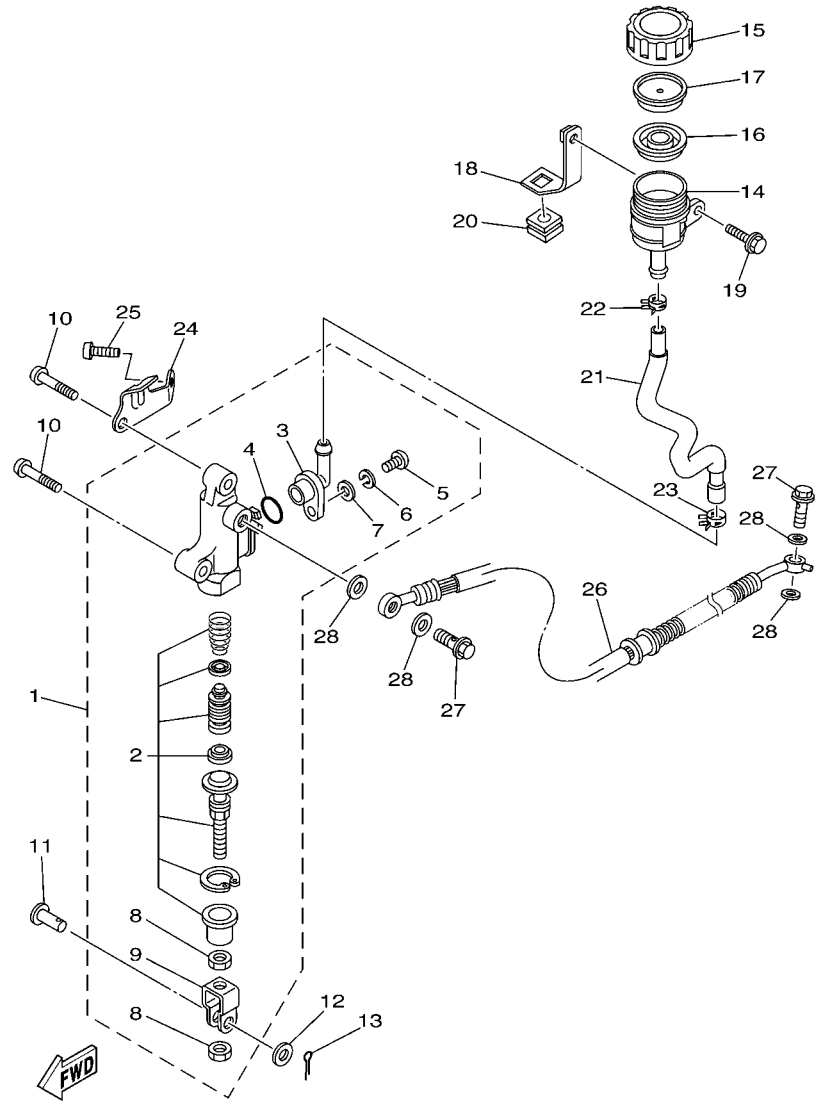

1S31100-E350

FIG. 35 REAR MASTER CYLINDER

REF. NO.	PART NO.	DESCRIPTION	CAN	EUR	OCE	REMARKS
28	90201-10118	WASHER, PLATE	4	4	4	

FIG. 36 GUARD

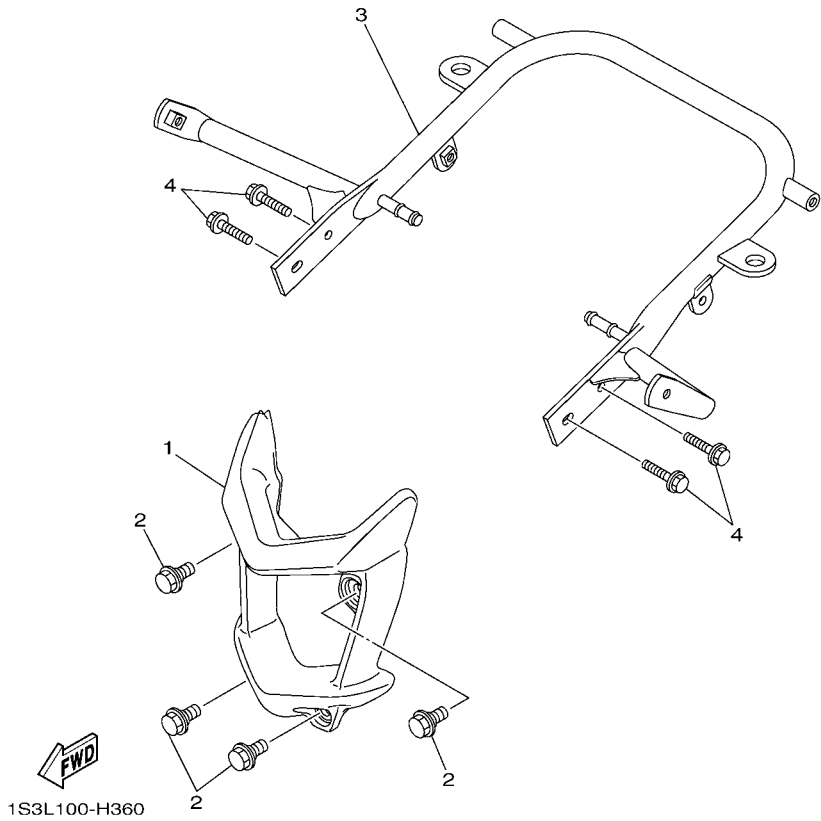
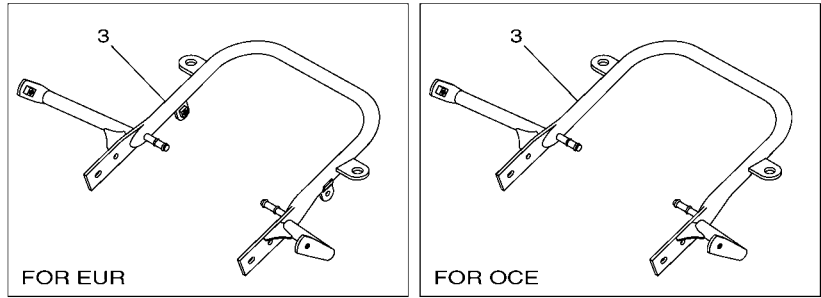

REF. NO.	PART NO.	DESCRIPTION	CAN	EUR	OCE	REMARKS
1	1S3-2845N-00	BAR, CARRY FRONT	1	1	1	
2	90109-08100	BOLT	4	4	4	
3	1S3-2845R-41	BAR, CARRY REAR	1			
	1S3-2845R-51	BAR, CARRY REAR		1		
	1S3-2845R-31	BAR, CARRY REAR			1	
4	90105-08142	BOLT, FLANGE	4	4	4	

FIG. 37 GENERATOR

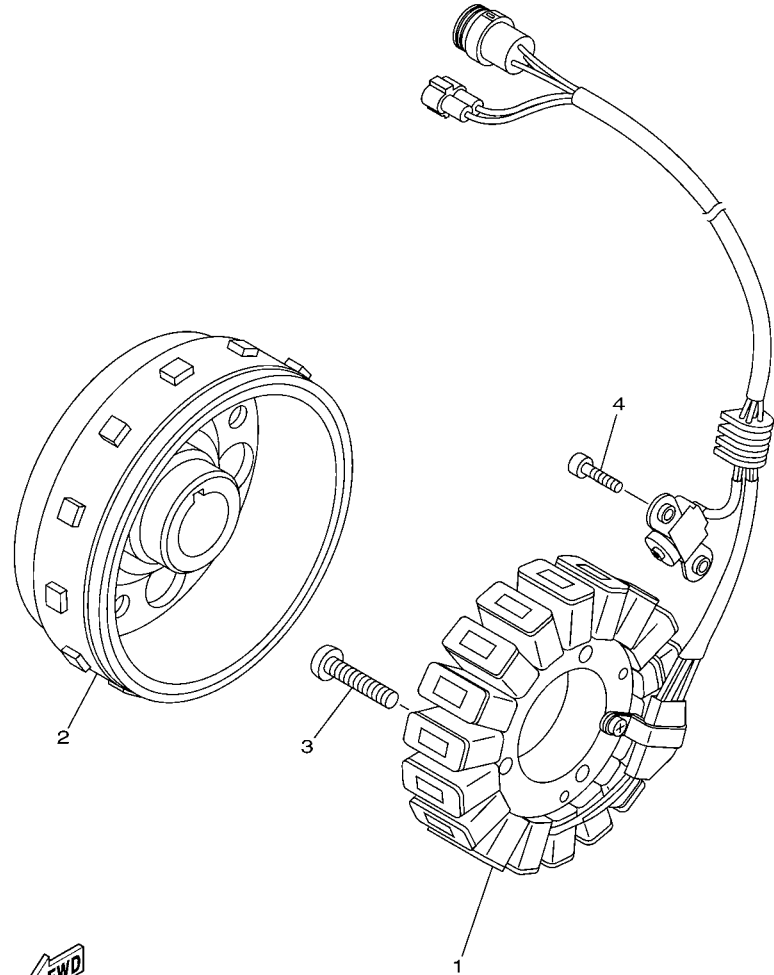

1S31100-E370

REF. NO.	PART NO.	DESCRIPTION	CAN	EUR	OCE	REMARKS
1	1S3-81410-00	STATOR ASSY	1	1	1	
2	1S3-81450-00	ROTOR ASSY	1	1	1	
3	92012-06030	BOLT, BUTTON HEAD	3	3	3	
4	90110-05031	BOLT, HEXAGON SOCKET HEAD	2	2	2	

FIG. 38 STARTING MOTOR

REF. NO.	PART NO.	DESCRIPTION	CAN	EUR	OC	REMARKS
1	1S3-81890-00	MOTOR ASSY	1	1	1	
2	3AJ-81801-00	.BRUSH SET	1	1	1	
3	1FK-81847-00	.O-RING	1	1	1	
4	4NK-81850-00	.ARMATURE ASSY	1	1	1	
5	3KS-81809-00	.WASHER KIT	1	1	1	
6	11H-81844-00	.GASKET	2	2	2	
7	3AJ-81826-00	.BOLT	2	2	2	
8	1S3-81815-00	CORD, STARTER MOTOR	1	1	1	
9	4G0-81871-00	.CAP	1	1	1	
10	4XV-8182A-00	NUT	2	2	2	
11	95812-06030	BOLT, FLANGE	2	2	2	
12	1S3-15484-00	CLAMP 2	1	1	1	

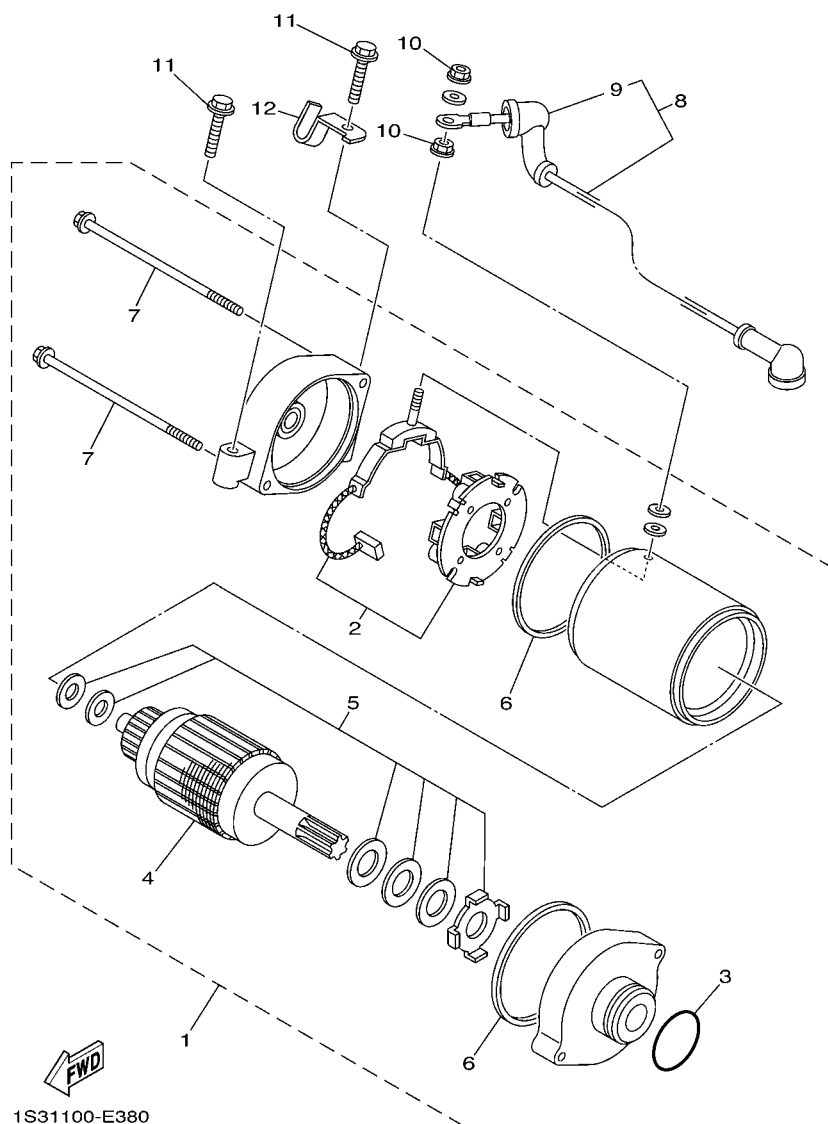
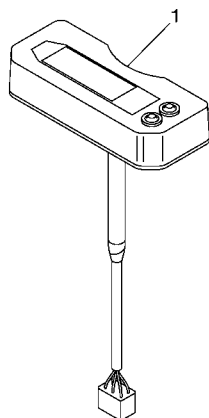

FIG. 39 METER



REF. NO.	PART NO.	DESCRIPTION	CAN	EUR	OCE		REMARKS
1	1S3-83500-20	METER ASSY	1	1	1		KM/H

1S3L100-H390

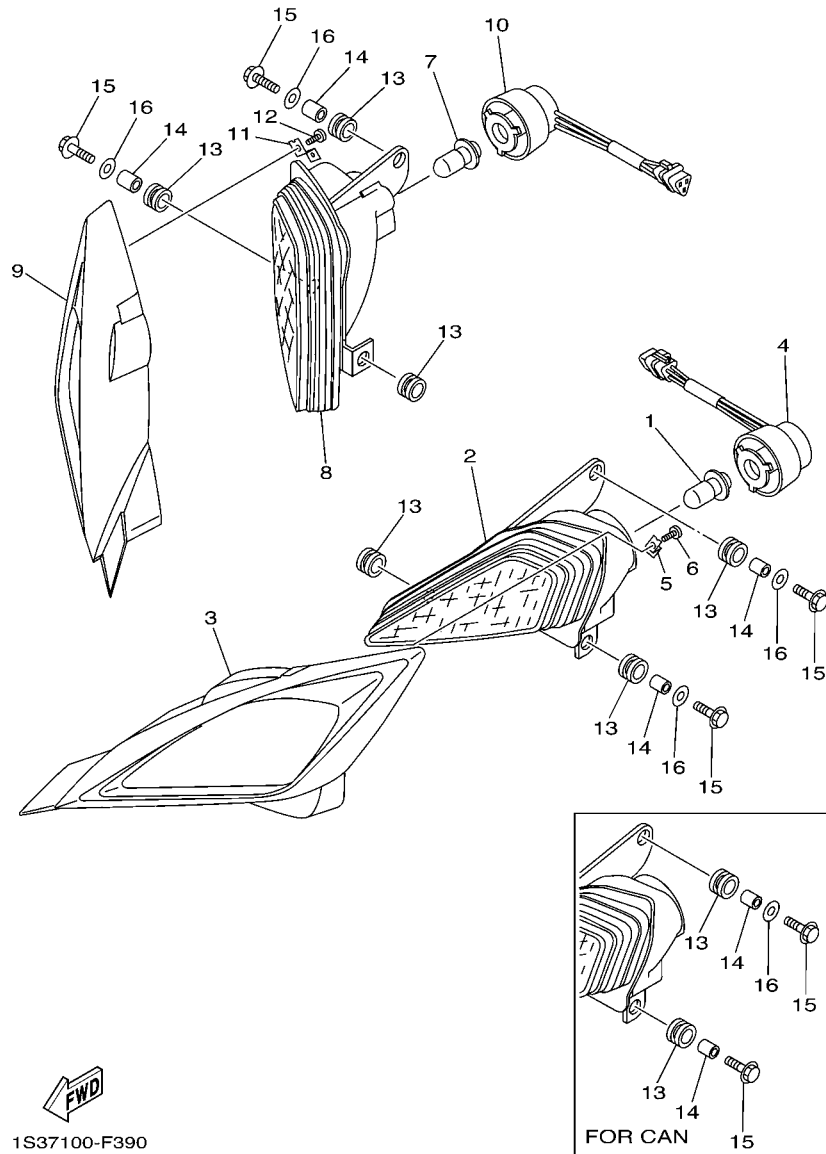

FIG. 40 HEADLIGHT

REF. NO.	PART NO.	DESCRIPTION	CAN	EUR	OCE	REMARKS
1	4KB-84314-01	BULB (12V-30/30W)	1	1	1	
2	5TG-84110-03	HEADLIGHT UNIT ASSY	1	1	1	
3	1S3-84165-00	RIM, HEADLIGHT COVER 1	1	1	1	
4	5TG-84140-01	SOCKET CORD ASSY	1	1	1	
5	1S3-8413J-00	PLATE, FITTING	1	1	1	
6	97707-30510	SCREW, TAPPING	1	1	1	
7	4KB-84314-01	BULB (12V-30/30W)	1	1	1	
8	5TG-84310-03	HEADLIGHT UNIT ASSY	1	1	1	
9	1S3-84166-00	RIM, HEADLIGHT COVER 2	1	1	1	
10	5TG-84340-01	SOCKET CORD ASSY 1	1	1	1	
11	1S3-8413J-00	PLATE, FITTING	1	1	1	
12	97707-30510	SCREW, TAPPING	1	1	1	
13	90480-14102	GROMMET	6	6	6	
14	90387-07598	COLLAR	4	4	4	
15	95812-06030	BOLT, FLANGE	4	4	4	
16	90201-06078	WASHER, PLATE	2	4	4	

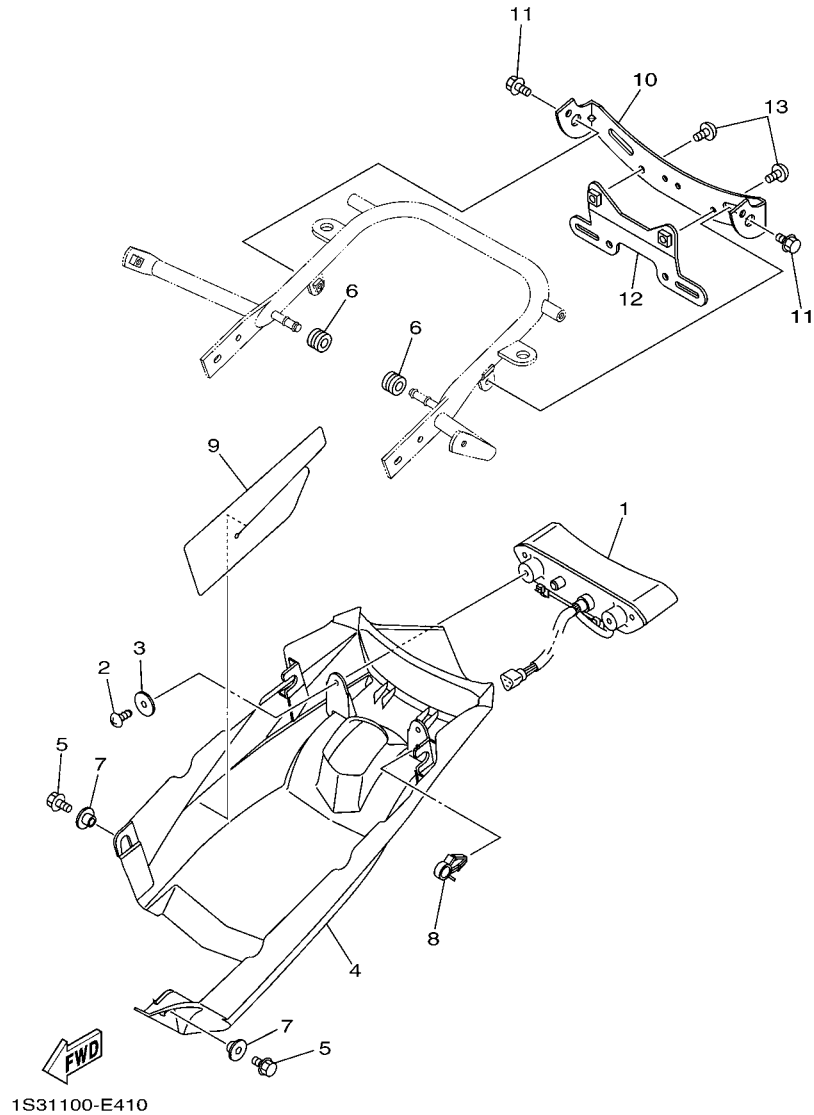
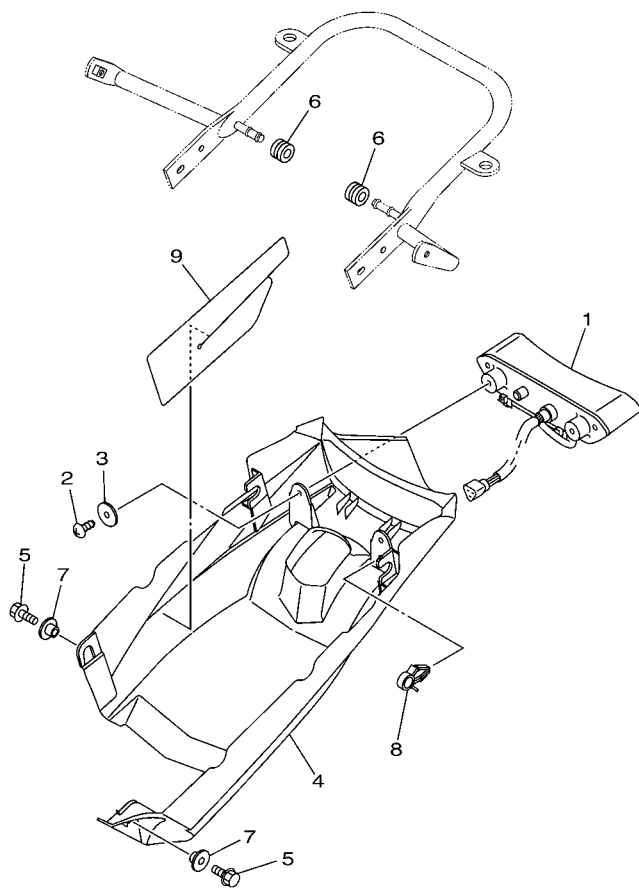

FIG. 41 TAILLIGHT

REF. NO.	PART NO.	DESCRIPTION	CAN	EUR	OCE	REMARKS
1	1S3-84710-01	TAILLIGHT UNIT ASSY	1	1		
2	97702-50016	SCREW, TAPPING	2	2		
3	90201-05025	WASHER, PLATE	2	2		
4	1S3-84716-00	COVER, TAILLIGHT	1	1		UR FOR DPBSE
	1S3-84716-10	COVER, TAILLIGHT	1	1		UR FOR BWS1
5	95802-06010	BOLT, FLANGE	2	2		
6	90480-14101	GROMMET	2	2		
7	90387-06153	COLLAR	2	2		
8	90464-15157	CLAMP	1	1		
9	1S3-84736-00	DAMPER, TAIL 1	1	1		
10	1S3-84703-10	BRACKET	1	1		
11	95802-06010	BOLT, FLANGE	2	2		
12	1S3-84751-10	BRACKET, LICENSE	1			
13	92012-06010	BOLT, BUTTON HEAD	2			

FIG. 42 TAILLIGHT 2



REF. NO.	PART NO.	DESCRIPTION	CAN	EUR	OCE	REMARKS
1	1S3-84710-01	TAILLIGHT UNIT ASSY			1	
2	97702-50016	SCREW, TAPPING			2	
3	90201-05025	WASHER, PLATE			2	
4	1S3-84716-00	COVER, TAILLIGHT			1	UR FOR DPBSE
	1S3-84716-10	COVER, TAILLIGHT			1	UR FOR BWS1
5	95802-06010	BOLT, FLANGE			2	
6	90480-14101	GROMMET			2	
7	90387-06153	COLLAR			2	
8	90464-15157	CLAMP			1	
9	1S3-84736-00	DAMPER, TAIL 1			1	

FWD
1S31100-E400

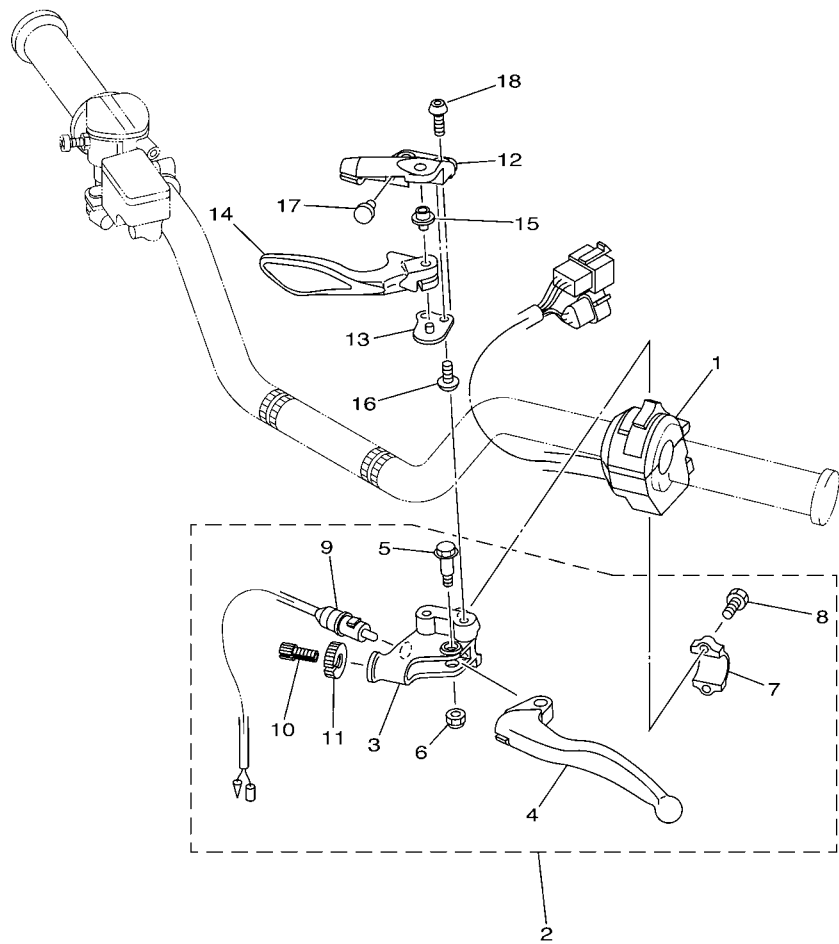

1S31100-E420

FIG. 43 HANDLE SWITCH & LEVER

REF. NO.	PART NO.	DESCRIPTION	CAN	EUR	OCÉ	REMARKS
1	1S3-83973-11	SWITCH, HANDLE 3	1	1	1	
2	5YT-82910-10	LEVER HOLDER ASSY (LEFT)	1	1	1	
3	5YT-82911-10	.HOLDER, LEVER 1	1	1	1	
4	2HT-83912-00	.LEVER 1	1	1	1	
5	90109-06798	.BOLT	1	1	1	
6	95602-06100	.NUT, U	1	1	1	
7	5TG-82913-00	.HOLDER, LEVER LOWER 1	1	1	1	
8	97002-05016	.BOLT	2	2	2	
9	5KM-82917-00	.SWITCH	1	1	1	
10	90123-08046	.BOLT	1	1	1	
11	90179-08148	.NUT	1	1	1	
12	1S3-25727-00	BRACKET, LEVER	1	1	1	
13	5D3-25689-00	PLATE, GUIDE	1	1	1	
14	1S3-25726-00	LEVER, BRAKE	1	1	1	
15	5TG-83923-00	COLLAR, LEVER 2	1	1	1	
16	92012-06012	BOLT, BUTTON HEAD	2	2	2	
17	90338-07007	PLUG	1	1	1	
18	92014-06016	BOLT, BUTTON HEAD	2	2	2	

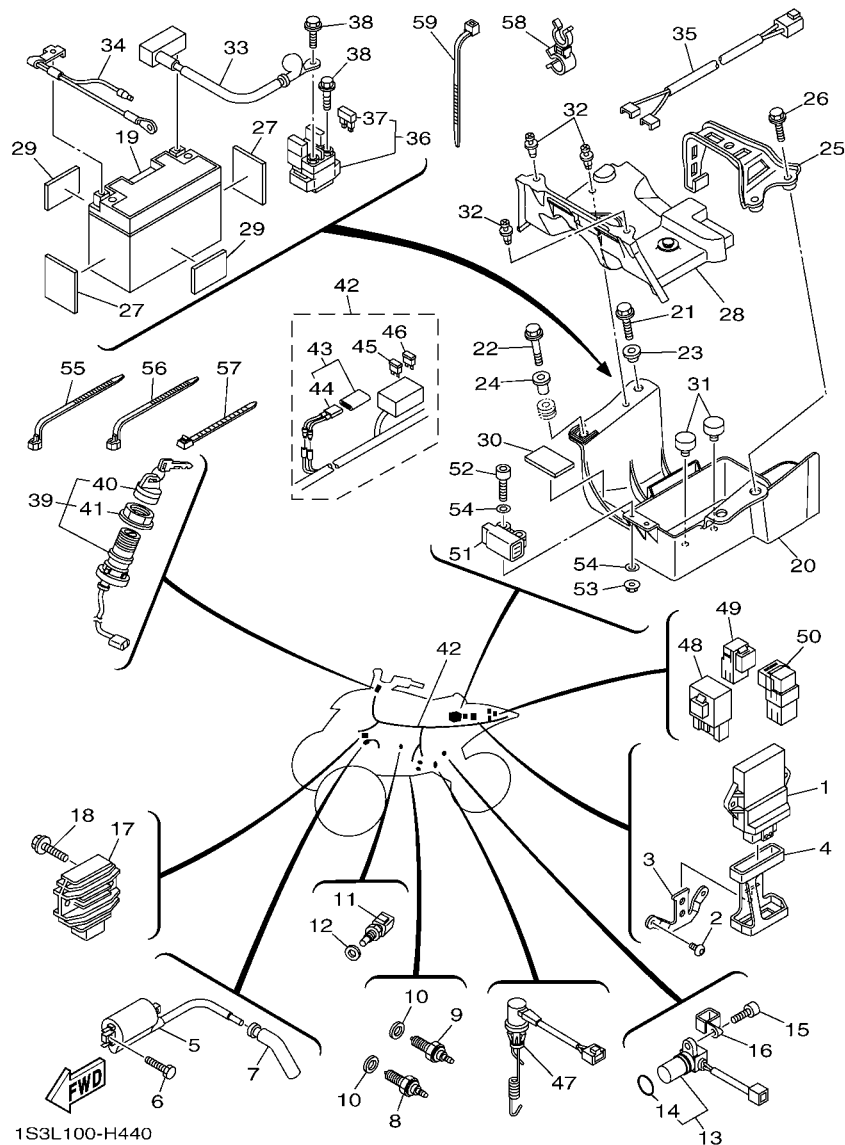

1S3L100-H440

FIG. 44 ELECTRICAL 1

REF. NO.	PART NO.	DESCRIPTION	CAN	EUR	OCE	REMARKS
1	1S3-8591A-10	ENGINE CONTROL UNIT ASSY	1	1	1	
2	92012-06010	BOLT, BUTTON HEAD	2	2	2	
3	1S3-21274-00	BRACKET, C.D.I. UNIT	1	1	1	
4	1S3-85546-00	BAND	1	1	1	
5	3TB-82310-00	IGNITION COIL ASSY	1	1	1	
6	97002-05020	BOLT	2	2	2	
7	5VK-82370-00	PLUG CAP ASSY	1	1	1	
8	5LP-82540-01	NEUTRAL SWITCH ASSY	1	1	1	
9	3GB-82540-01	NEUTRAL SWITCH ASSY	1	1	1	
10	90430-10148	GASKET	2	2	2	
11	5PS-85790-00	THERMOSENSOR ASSY	1	1	1	
12	90430-12202	GASKET	1	1	1	
13	1S3-83755-01	SENSOR, SPEED	1	1	1	
14	4D9-81168-00	.O-RING	1	1	1	
15	91312-06016	BOLT	1	1	1	
16	90461-10004	CLAMP	1	1	1	
17	5BN-81960-00	RECTIFIER & REGULATOR ASSY	1	1	1	
18	95802-06025	BOLT, FLANGE	2	2	2	
19	5GJ-82100-01	BATTERY ASSY (GS GT9B-4)	1	1	1	
20	1S3-8212B-00	BOX, BATTERY 1	1	1	1	
21	90105-06084	BOLT, FLANGE	1	1	1	
22	95802-06030	BOLT, FLANGE	1	1	1	
23	90387-06153	COLLAR	1	1	1	
24	90387-06168	COLLAR	1	1	1	
25	1S3-82128-00	BRACKET, BATTERY	1	1	1	
26	95802-06020	BOLT, FLANGE	2	2	2	
27	1S3-82123-00	SEAT, BATTERY	2	2	2	

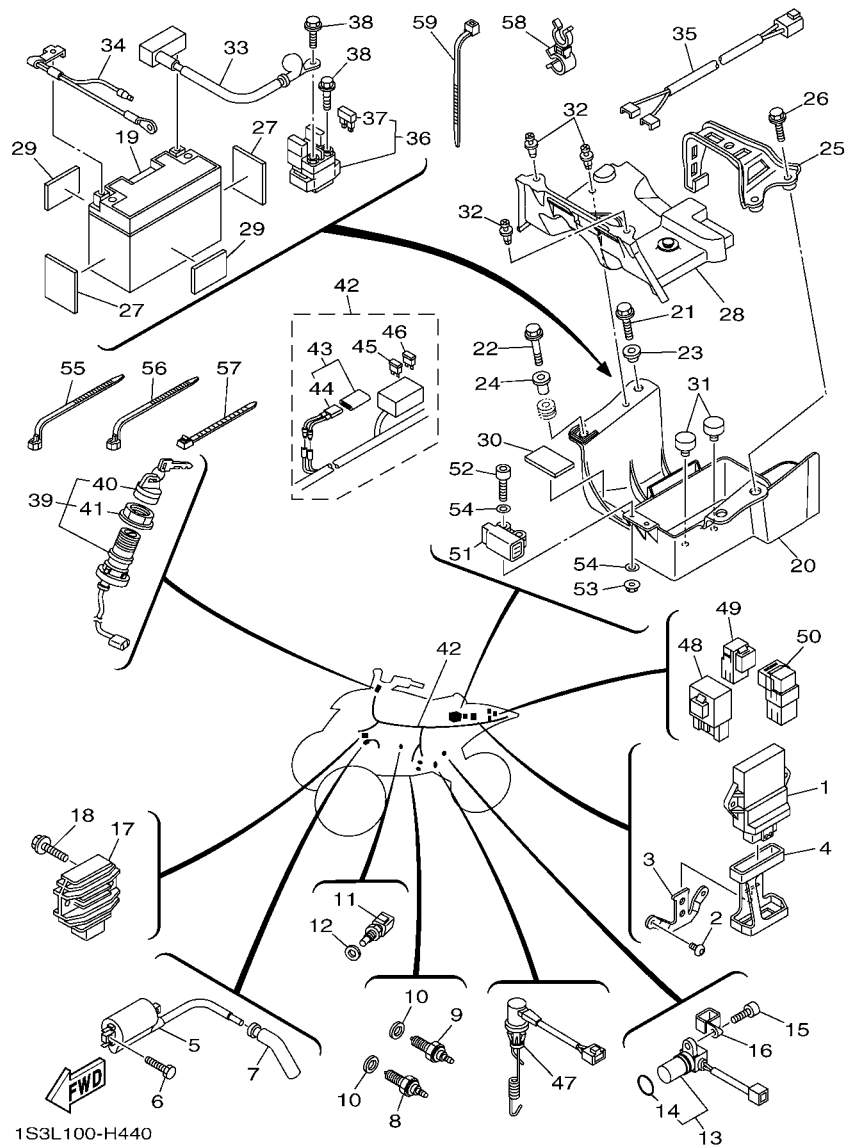
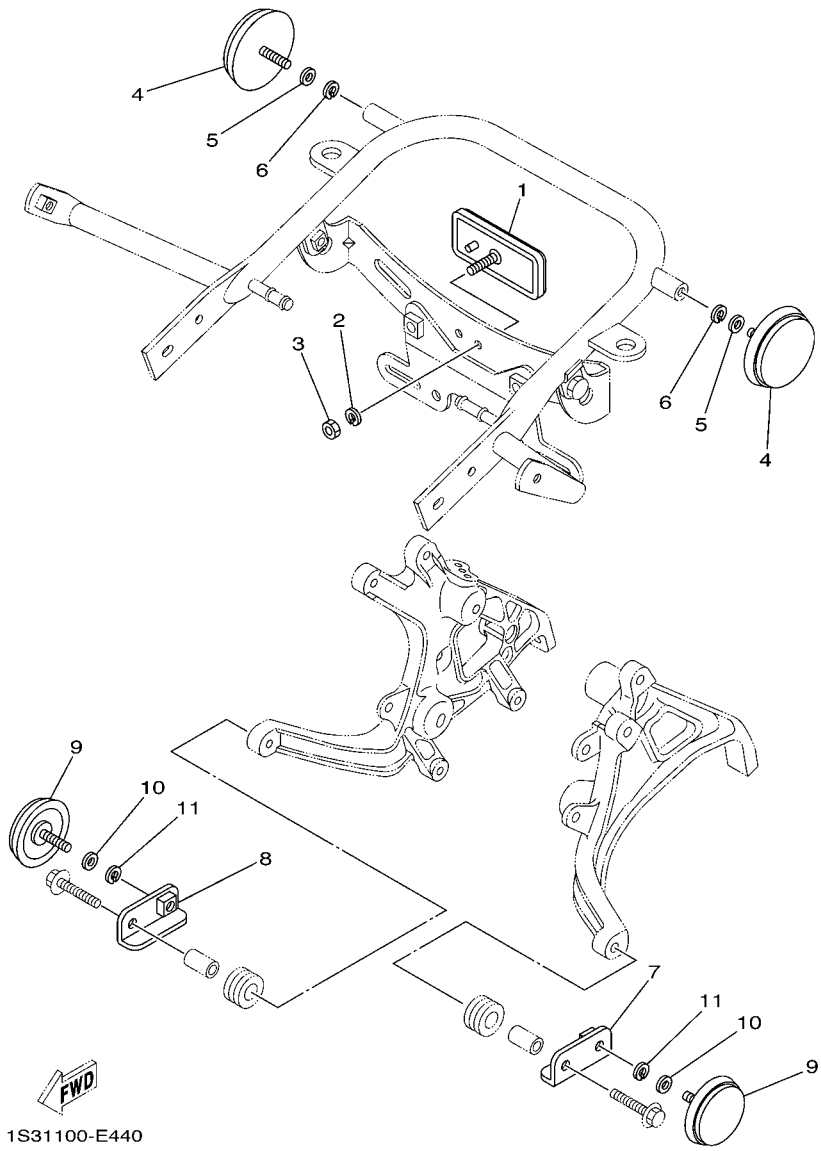

FIG. 44 ELECTRICAL 1

REF. NO.	PART NO.	DESCRIPTION	CAN	EUR	OCE	REMARKS
28	1S3-82129-00	COVER, BATTERY	1	1	1	
29	1S3-82122-00	SEAT, BATTERY	2	2	2	
30	22F-2139X-00	DAMPER	1	1	1	
31	5TG-82121-10	PAD, BATTERY	2	2	2	
32	90269-06002	RIVET	3	3	3	
33	1S3-82115-00	WIRE, PLUS LEAD	1	1	1	
34	1S3-82116-10	WIRE, MINUS LEAD	1	1	1	
35	1S3-82541-00	WIRE, LEAD	1	1	1	
36	1S3-81940-00	STARTER RELAY ASSY	1	1	1	
37	2GH-82151-00	.FUSE (20A-BL)	2	2	2	
38	95022-06008	BOLT, FLANGE	2	2	2	
39	4SH-82510-00	MAIN SWITCH ASSY	1	1	1	
40	3HN-82579-00	.CAP, KEY	1	1	1	
41	3HN-82569-00	.NUT, MAIN SWITCH	1	1	1	
42	1S3-82590-21	WIRE HARNESS ASSY	1			
	1S3-82590-31	WIRE HARNESS ASSY		1	1	
43	5GT-82180-00	.CIRCUIT BREAKER ASSY	1	1	1	
44	5GT-82560-00	..THERMO SWITCH ASSY	1	1	1	
45	5JJ-82151-10	.FUSE (15A-BL)	2	2	2	
46	5JJ-82151-30	.FUSE (10A-BL)	4	4	4	
47	1S3-82530-10	STOP SWITCH ASSY	1	1	1	
48	5VK-81950-30	RELAY ASSY	1	1	1	
49	5EA-81950-20	RELAY ASSY	1	1	1	
50	5DM-81950-00	RELAY ASSY (G8HN-1C4T-DJ-Y52)	1	1	1	
51	5PS-82576-01	SENSOR, LEAN ANGLE	1	1	1	
52	91312-04025	BOLT	2	2	2	
53	95702-04500	NUT, FLANGE	2	2	2	



1S31100-E440

FIG. 45 ELECTRICAL 2

REF. NO.	PART NO.	DESCRIPTION	CAN	EUR	OCE	REMARKS
1	3Y6-85130-02	REAR REFLECTOR ASSY	1	1		
2	92902-05100	WASHER, SPRING	1	1		
3	95302-05600	NUT	1	1		
4	449-85131-02	REFLECTOR, REAR 1	2			
5	92902-05200	WASHER	2			
6	92902-05100	WASHER, SPRING	2			
7	1S3-85112-10	BRACKET, REFLECTOR 1	1			
8	1S3-85122-10	BRACKET, REFLECTOR 2	1			
9	2EK-85111-00	REFLECTOR, FRONT 1	2			
10	92902-05200	WASHER	2			
11	92902-05100	WASHER, SPRING	2			

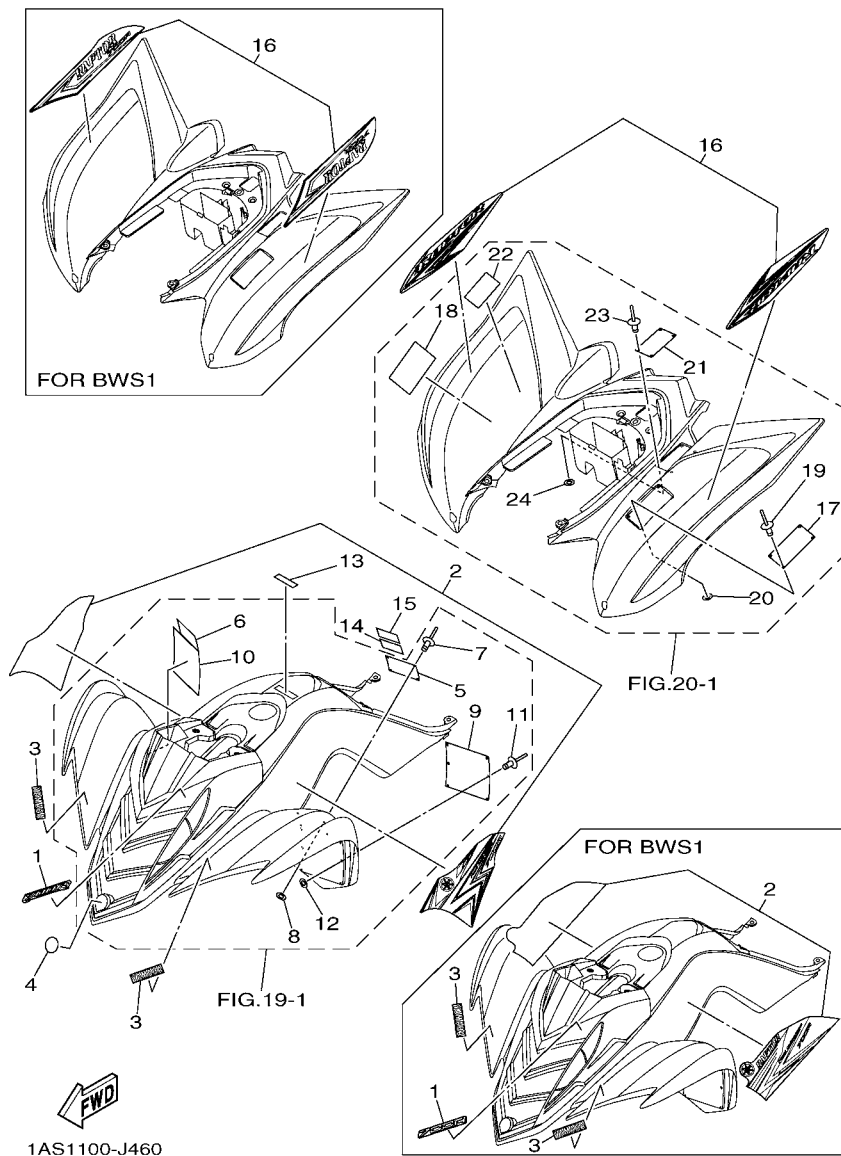

FIG. 46 EMBLEM & LABEL 1

REF. NO.	PART NO.	DESCRIPTION	CAN	EUR	OCE	REMARKS
1	1S3-21565-50	EMBLEM, 2	1			UR FOR DPBSE
	1AS-21565-00	EMBLEM, 2	1			UR FOR BWS1
2	1AS-21570-00	GRAPHIC SET, FRONT FENDER	1			UR FOR DPBSE
	1AS-21570-10	GRAPHIC SET, FRONT FENDER	1			UR FOR BWS1
3	3GD-2153E-00	EMBLEM, YAMAHA	2			UR FOR DPBSE
	3GD-2153E-30	EMBLEM, YAMAHA	2			UR FOR BWS1
4	5KM-2175B-00	TUNING FORK MARK	1			
5	4D3-2816L-00	LABEL, WARNING AGE	1			ENGLISH
6	4D3-2816L-10	LABEL, WARNING AGE	1			FRENCH
7	90267-32004	RIVET, BLIND	4			
8	90201-03008	WASHER, PLATE	4			
9	5FE-21568-01	LABEL, WARNING	1			ENGLISH
10	4WU-21568-10	LABEL, WARNING	1			FRENCH
11	90267-32004	RIVET, BLIND	6			
12	90201-03008	WASHER, PLATE	6			
13	4SH-2416E-00	LABEL, CAUTION CANADA	1			ENGLISH
14	4D3-2817J-00	PLATE, ANSI SVIA	1			ENGLISH
15	4D3-2817J-10	PLATE, ANSI SVIA	1			FRENCH
16	1AS-2165A-00	GRAPHIC SET, REAR FENDER	1			UR FOR DPBSE
	1AS-2165A-20	GRAPHIC SET, REAR FENDER	1			UR FOR BWS1
17	4D3-2816M-00	LABEL, WARNING TIRE & LOAD	1			ENGLISH
18	4D3-2816M-10	LABEL, WARNING TIRE & LOAD	1			FRENCH
19	90267-32004	RIVET, BLIND	4			
20	90201-03008	WASHER, PLATE	4			
21	5FE-2151H-01	LABEL 5	1			ENGLISH
	4WU-2151H-10	LABEL 5	1			FRENCH
23	90267-32004	RIVET, BLIND	4			

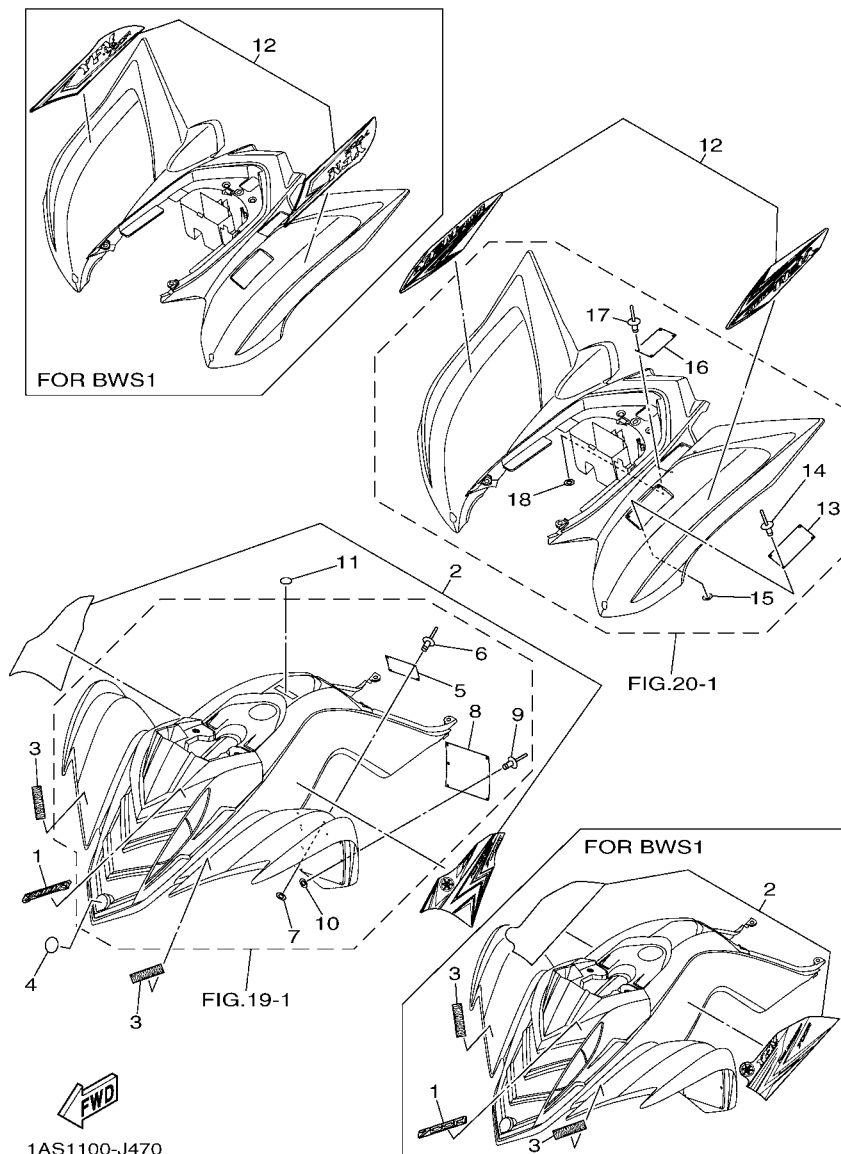

FIG. 47 EMBLEM & LABEL 2

REF. NO.	PART NO.	DESCRIPTION	CAN	EUR	OC	REMARKS
1	1S3-21565-50	EMBLEM, 2		1		UR FOR DPBSE
	1AS-21565-00	EMBLEM, 2		1		UR FOR BWS1
2	1AS-21570-00	GRAPHIC SET, FRONT FENDER		1		UR FOR DPBSE
	1AS-21570-20	GRAPHIC SET, FRONT FENDER		1		UR FOR BWS1
3	3GD-2153E-00	EMBLEM, YAMAHA		2		UR FOR DPBSE
	3GD-2153E-30	EMBLEM, YAMAHA		2		UR FOR BWS1
4	5KM-2175B-00	TUNING FORK MARK		1		
5	4D3-2816L-20	LABEL, WARNING AGE		1		
6	90267-32004	RIVET, BLIND		4		
7	90201-03008	WASHER, PLATE		4		
8	43P-2816R-00	LABEL, WARNING GENERAL INFO.		1		
9	90267-32004	RIVET, BLIND		6		
10	90201-03008	WASHER, PLATE		6		
11	3ME-2415E-01	LABEL, CAUTION		1		
12	1AS-2165A-10	GRAPHIC SET, REAR FENDER		1		UR FOR DPBSE
	1AS-2165A-30	GRAPHIC SET, REAR FENDER		1		UR FOR BWS1
13	4D3-2816M-M0	LABEL, WARNING TIRE & LOAD		1		
14	90267-32004	RIVET, BLIND		4		
15	90201-03008	WASHER, PLATE		4		
16	1AS-2816P-00	LABEL, WARNING PASSENGER		1		
17	90267-32004	RIVET, BLIND		4		
18	90201-03008	WASHER, PLATE		4		

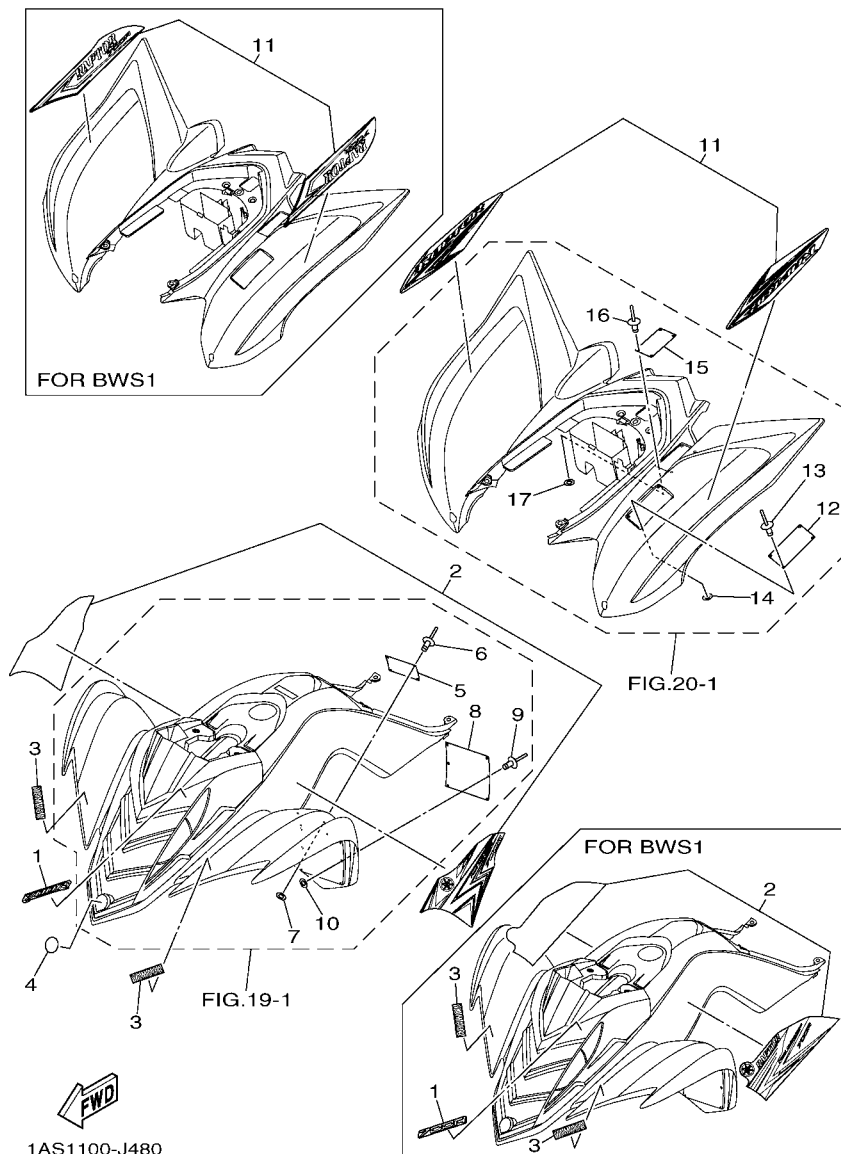

FIG. 48 EMBLEM & LABEL 3

REF. NO.	PART NO.	DESCRIPTION	CAN	EUR	OCG	REMARKS
1	1S3-21565-50	EMBLEM, 2			1	UR FOR DPBSE
	1AS-21565-00	EMBLEM, 2			1	UR FOR BWS1
2	1AS-21570-00	GRAPHIC SET, FRONT FENDER			1	UR FOR DPBSE
	1AS-21570-10	GRAPHIC SET, FRONT FENDER			1	UR FOR BWS1
3	3GD-2153E-00	EMBLEM, YAMAHA			2	UR FOR DPBSE
	3GD-2153E-30	EMBLEM, YAMAHA			2	UR FOR BWS1
4	5KM-2175B-00	TUNING FORK MARK			1	
5	4D3-2816L-00	LABEL, WARNING AGE			1	ENGLISH
6	90267-32004	RIVET, BLIND			4	
7	90201-03008	WASHER, PLATE			4	
8	5FE-21568-11	LABEL, WARNING			1	ENGLISH
9	90267-32004	RIVET, BLIND			6	
10	90201-03008	WASHER, PLATE			6	
11	1AS-2165A-00	GRAPHIC SET, REAR FENDER			1	UR FOR DPBSE
	1AS-2165A-20	GRAPHIC SET, REAR FENDER			1	UR FOR BWS1
12	4D3-2816M-00	LABEL, WARNING TIRE & LOAD			1	ENGLISH
13	90267-32004	RIVET, BLIND			4	
14	90201-03008	WASHER, PLATE			4	
15	5FE-2151H-01	LABEL 5			1	ENGLISH
16	90267-32004	RIVET, BLIND			4	
17	90201-03008	WASHER, PLATE			4	

NUMERICAL INDEX

PART NO.	REF. NO.	PART NO.	REF. NO.	PART NO.	REF. NO.	PART NO.	REF. NO.	PART NO.	REF. NO.	PART NO.	REF. NO.
1S3-11101-10	1 - 1	1S3-12413-00	7 - 2	1S3-14161-00	10 - 16	1S3-15560-00	14 - 5	5LP-18337-01	17 - 27	1S3-21643-10	20 - 30
5VK-1111F-00	5 - 7	1S3-12420-00	6 - 2	8CC-14216-10	10 - 9	5VK-15590-00	14 - 7	1S3-18380-00	17 - 26	1S3-21644-10	20 - 32
4G0-11133-11	1 - 2	1S3-12421-00	6 - 7	5JW-14348-00	10 - 7	1S3-16111-00	15 - 1	5LP-18431-00	17 - 31	1S3-2164F-10	20 - 18
1S3-11165-00	12 - 9	1S3-12422-00	6 - 4	1S3-14411-00	9 - 6	1S3-16150-00	15 - 5	1S3-18501-00	17 - 7	5TG-2164G-20	20 - 20
1S3-11166-00	12 - 7	1S3-12428-00	6 - 12	1S3-14412-01	9 - 7	2JN-16154-00	15 - 6	1S3-18502-00	17 - 8	1S3-2164H-10	20 - 19
3B4-11181-00	1 - 4	1S3-12436-00	6 - 1	31A-14419-00	9 - 20	5TA-16321-00	15 - 13	1S3-18503-00	17 - 9	1S3-2164J-10	20 - 21
1S3-11185-00	1 - 11	4C8-12438-00	6 - 10		26 - 35	4X7-16325-00	15 - 11	1S3-18541-00	17 - 1	1AS-2165A-00	46 - 16
1S3-11186-00	1 - 14	1S3-1243A-00	10 - 24	5KM-14419-00	9 - 18		15 - 14	5VK-18699-00	17 - 15		48 - 11
214-11198-01	8 - 13	1S3-1243E-00	10 - 25	31A-14435-00	9 - 19	5TG-16331-00	15 - 10	1S3-21101-08	18 - 1	1AS-2165A-10	47 - 12
1S3-11310-00	2 - 1	1S3-12450-00	6 - 3		26 - 36	3LD-16340-01	15 - 22	1S3-21190-08	18 - 2	1AS-2165A-20	46 - 16
1S3-1131E-00	1 - 17	5VK-12459-00	6 - 15	5GH-14436-00	9 - 16	132-16346-00	17 - 6	1S3-21274-00	44 - 3		48 - 11
1S3-11351-00	2 - 2	22W-12462-00	7 - 15	1S3-14451-00	9 - 9	1S3-16351-00	15 - 15	1S3-21315-10	18 - 4	1AS-2165A-30	47 - 12
1S3-11395-00	2 - 5	1S3-12465-00	7 - 19	1S3-14453-00	9 - 8	4XV-16356-01	15 - 21	1S3-21316-10	18 - 8	5TG-21691-00	20 - 12
1S3-11400-00	3 - 1	1S3-12467-00	19 - 19	10M-14457-00	9 - 21	1S3-16371-00	15 - 7	1S3-21317-10	18 - 9	1S3-2171A-00	19 - 17
1S3-11401-09	3 - 2	1S3-12469-00	6 - 18	1S3-14457-00	9 - 22	5EB-16382-00	15 - 24	22F-2139X-00	44 - 30	1S3-2171A-30	19 - 17
1S3-11422-00	3 - 3	1AA-12535-00	7 - 12	59V-14457-00	9 - 23	5JG-16383-00	15 - 9	1S3-2140A-00	18 - 33	1S3-21750-00	21 - 8
1S3-11454-00	3 - 17	1S3-12577-00	6 - 21	1S3-14458-00	9 - 10	5JG-16384-00	15 - 8		20 - 2	5KM-2175B-00	46 - 4
1S3-11464-00	3 - 18	1S3-12578-00	7 - 8	1S3-14459-01	9 - 11	4X7-16385-00	15 - 12	1S3-21471-00	18 - 15		47 - 4
1S3-11531-00	3 - 16	1S3-12579-00	7 - 16	5VX-14503-00	10 - 13	1S3-17121-00	16 - 10	1S3-21513-00	19 - 10		48 - 4
1S3-11536-00	3 - 15	583-13113-00	8 - 26	5YP-14562-00	10 - 23	1S3-17131-00	16 - 5	1S3-21514-00	19 - 11	5LP-21761-01	21 - 9
1S3-11603-10	3 - 12	1S3-13132-00	8 - 33	1S3-14611-00	11 - 1	1S3-17141-00	16 - 7	5FE-2151H-01	46 - 21	5KM-21871-00	21 - 1
1S3-11631-10	3 - 11	1S3-13160-00	10 - 10	1S3-14612-00	11 - 2	1S3-17151-00	16 - 2		48 - 15	1S3-21875-00	21 - 2
5VK-11633-00	3 - 13	1S3-13171-00	8 - 22	3YF-14613-01	11 - 23	1S3-17211-00	16 - 25	4WU-2151H-10	46 - 22	1S3-22110-00	22 - 1
1S3-11651-00	3 - 6	5LP-13300-00	8 - 1	1S3-14621-01	11 - 3	1S3-17221-00	16 - 15	3GD-2153E-00	46 - 3	4X7-22129-00	22 - 21
1S3-11681-00	3 - 4	3AJ-13325-00	8 - 5	1S3-14628-00	11 - 6	1S3-17231-00	16 - 20		47 - 3	5YT-22129-00	22 - 42
5VK-12111-00	4 - 1	1S3-13327-00	8 - 8	1S3-14710-11	11 - 11	1S3-17241-00	16 - 18		48 - 3	1S3-22141-00	22 - 25
1S3-12113-00	4 - 3	5LP-13329-00	8 - 2	3YF-14714-00	11 - 5	1S3-17243-00	16 - 38	3GD-2153E-30	46 - 3	3YF-22149-00	22 - 22
3YF-12116-00	4 - 4	1S3-13356-00	8 - 7	5LP-14714-00	11 - 12	1S3-17251-00	16 - 23		47 - 3	1S3-22151-00	22 - 28
3YF-12117-01	4 - 6	1S3-13410-00	8 - 10	1S3-14728-00	11 - 15	1S3-17253-00	16 - 28		48 - 3	1S3-22153-00	22 - 56
4G0-12118-00	4 - 7	1S3-13416-00	8 - 29	1S3-14752-00	11 - 13	1S3-17285-00	16 - 26	1S3-21541-00	19 - 2	5TG-22178-00	18 - 17
5H0-12119-00	4 - 5	4X7-13440-01	8 - 14	5JW-14945-00	10 - 21	1S3-17401-00	16 - 1	1AS-21565-00	46 - 1	1S3-2217A-00	22 - 30
5VK-12121-00	4 - 2	1S3-13447-00	8 - 15	1S3-15100-01	12 - 1	1S3-17402-00	16 - 13		47 - 1	1S3-2217F-00	22 - 40
5VK-12146-00	4 - 10	1S3-13464-10	21 - 24	1S3-15113-00	13 - 10	1S3-17430-00	16 - 33		48 - 1	1S3-22184-00	22 - 20
5VK-12151-00	4 - 8	1S3-13465-00	21 - 19	1S3-15118-00	13 - 20	1S3-17432-00	16 - 34	1S3-21565-50	46 - 1	1S3-2219X-00	22 - 54
5XT-12159-00	4 - 11	1S3-13493-00	10 - 14	1S3-15189-00	13 - 24	1S3-17466-00	13 - 12		47 - 1	1AS-22210-10	23 - 1
5VK-12161-00	4 - 9	1S3-13545-00	9 - 3	4JT-15381-01	12 - 13	1S3-17471-00	16 - 42		48 - 1	1AS-22210-20	23 - 1
1S3-12170-10	5 - 1	8FP-13556-00	10 - 3	1S3-15383-00	12 - 11	1S3-18101-00	17 - 10	5FE-21568-01	46 - 9	1S3-22210-G1	23 - 1
1S3-12176-00	5 - 9	5VK-13586-00	9 - 1	1S3-15411-00	13 - 1	1S3-18110-10	17 - 33	4WU-21568-10	46 - 10	1S3-22210-H1	23 - 1
3TB-12210-00	5 - 16	1S3-13750-10	10 - 1	1S3-15421-00	13 - 11	5YT-18113-00	17 - 34	5FE-21568-11	48 - 8	4AA-22259-40	23 - 2
4DW-12213-00	5 - 18	5VK-13761-00	10 - 4	1S3-15431-00	13 - 14	1S3-18122-00	17 - 16	1AS-21570-00	46 - 2	4AA-22259-70	23 - 2
5VK-12231-00	5 - 12	1S3-13907-10	26 - 18	1S3-15441-00	13 - 18	1S3-18140-00	17 - 4		47 - 2	1S3-22417-00	22 - 23
1S3-12241-00	5 - 13	1S3-13971-00	26 - 1	1S3-15451-00	13 - 2	5JW-18144-00	17 - 5		48 - 2	1S3-22475-00	22 - 16
1S3-12280-01	5 - 4	1S3-13971-10	26 - 1	1S3-15462-00	13 - 15	1S3-18172-00	17 - 20	1AS-21570-10	46 - 2	1S3-23147-01	22 - 6
5VK-12284-00	5 - 2	4BH-14134-00	10 - 15	1S3-1546C-00	13 - 23	3XJ-18173-10	17 - 23		48 - 2	1S3-23317-00	22 - 60
1S3-12290-00	5 - 3	3JC-14146-00	10 - 20	1S3-15484-00	38 - 12	3XJ-18178-00	17 - 24	1AS-21570-20	47 - 2	1AS-23350-10	25 - 23
1S3-12405-00	7 - 11	5PS-14147-00	10 - 5	1S3-15515-00	14 - 1	3XJ-18182-00	17 - 17	5TG-21621-00	20 - 11	1AS-23350-20	25 - 23
1S3-1240A-00	7 - 10	4WV-14147-10	10 - 18	1S3-15517-00	14 - 4	3XJ-18184-00	17 - 19	1S3-2163A-00	20 - 9	1S3-23350-E1	25 - 23
5VK-12410-00	7 - 1	1UY-14155-00	10 - 19	1VJ-15522-00	14 - 3	4EW-18185-00	17 - 3	1S3-2163E-00	20 - 10	1S3-23350-F1	25 - 23

NUMERICAL INDEX

PART NO.	REF. NO.	PART NO.	REF. NO.	PART NO.	REF. NO.	PART NO.	REF. NO.	PART NO.	REF. NO.	PART NO.	REF. NO.
1S3-23391-10	19 - 14	5TG-2514A-00	29 - 38	5MV-2589F-00	33 - 11	1S3-26341-00	32 - 32	1S3-82115-00	44 - 33	4KB-84314-01	40 - 7
1S3-23391-20	19 - 14	5LP-25180-21	28 - 1	4NK-2589H-00	33 - 5	31A-26372-00	32 - 31	1S3-82116-10	44 - 34	5TG-84340-01	40 - 10
1S3-23501-00	25 - 27		28 - 4	3JD-25917-00	29 - 7	1S3-2637E-10	32 - 25	5TG-82121-10	44 - 31	1S3-84703-10	41 - 10
1S3-23502-00	25 - 28	1S3-25311-00	22 - 2		29 - 21	1NV-26398-00	32 - 8	1S3-82122-00	44 - 29	1S3-84710-01	41 - 1
5YT-23517-00	25 - 13	1S3-25317-00	22 - 5		31 - 21	371-27114-00	27 - 3	1S3-82123-00	44 - 27		42 - 1
	25 - 14	1S3-25381-10	30 - 18	3JD-25919-00	29 - 8	1S3-27211-10	34 - 1	1S3-82128-00	44 - 25	1S3-84716-00	41 - 4
5TG-23540-00	25 - 7	1S3-25383-20	30 - 7		29 - 22	4SS-27218-00	35 - 8	1S3-82129-00	44 - 28		42 - 4
5TG-23550-00	25 - 8	1S3-25386-00	30 - 14	4GY-25919-50	31 - 11	2YK-27222-00	35 - 9	1S3-8212B-00	44 - 20	1S3-84716-10	41 - 4
5TG-23570-00	25 - 1	5LP-25390-21	30 - 1	5GH-25924-00	31 - 14	1S3-27411-10	34 - 5	116-82131-00	18 - 36		42 - 4
5LP-23579-00	25 - 2		30 - 4	5TG-25924-00	29 - 15	1S3-27421-10	34 - 8	2GH-82151-00	44 - 37	1S3-84736-00	41 - 9
	25 - 5	1S3-25415-00	31 - 7		29 - 29	1S3-27453-00	35 - 24	5JJ-82151-10	44 - 45		42 - 9
5TG-23580-00	25 - 4	5TG-25438-10	30 - 15	3JD-25926-00	29 - 12	5TG-28100-10	18 - 34	5JJ-82151-30	44 - 46	1S3-84751-10	41 - 12
1UY-23812-00	24 - 13	5D3-25689-00	43 - 13		29 - 26	1NV-2811A-01	18 - 35	5GT-82180-00	44 - 43	2EK-85111-00	45 - 9
1S3-23813-10	24 - 1	1S3-25712-00	31 - 1		31 - 20	4D3-2816L-00	46 - 5	3TB-82310-00	44 - 5	1S3-85112-10	45 - 7
8K1-23814-00	24 - 11	1S3-25721-00	22 - 10	1UY-25926-51	29 - 10		48 - 5	5VK-82370-00	44 - 7	1S3-85122-10	45 - 8
5TG-23816-10	24 - 2	1S3-25726-00	43 - 14		29 - 24	4D3-2816L-10	46 - 6	1C7-82380-00	10 - 6	3Y6-85130-02	45 - 1
1S3-23831-20	24 - 3	1S3-25727-00	43 - 12		31 - 17	4D3-2816L-20	47 - 5	44S-82510-00	44 - 39	44S-85131-02	45 - 4
1S3-23841-20	24 - 4	1S3-2580E-00	35 - 1	1UY-25937-51	29 - 6	4D3-2816M-00	46 - 17	1S3-82530-10	44 - 47	1S3-85546-00	44 - 4
1S3-23845-20	24 - 5	1S3-2580T-01	29 - 3		29 - 20		48 - 12	3GB-82540-01	44 - 9	5PS-85790-00	44 - 11
1UY-23868-01	24 - 15	1S3-2580U-01	29 - 17		31 - 19	4D3-2816M-10	46 - 18	5LP-82540-01	44 - 8	8GL-85885-00	10 - 2
5GT-23872-00	18 - 25	1S3-2580V-11	31 - 8	1UY-25938-51	29 - 11	4D3-2816M-00	47 - 13	5VU-82541-00	44 - 35	5VU-85886-00	9 - 17
1UY-23894-01	24 - 17	5UG-25827-00	31 - 15		29 - 25	1AS-2816P-00	47 - 16	5GT-82560-00	44 - 44	1S3-8591A-10	44 - 1
1S3-24110-00	26 - 3	1S3-25828-00	29 - 16		31 - 18	43P-2816R-00	47 - 8	3HN-82569-00	44 - 41	5D3-W0041-00	33 - 2
1S3-24110-20	26 - 3		29 - 30	3JD-25961-00	29 - 13	4D3-2817J-00	46 - 14	5PS-W0042-01	44 - 51	1S3-W0042-50	35 - 2
4EW-2412F-00	26 - 5	5GH-25828-00	31 - 16		29 - 27	4D3-2817J-10	46 - 15	3HN-82579-00	44 - 40	1S3-W0045-00	29 - 14
1S3-2413X-00	26 - 31	1AE-2582A-00	35 - 3		31 - 22	1S3-2845N-00	36 - 1	1S3-82590-21	44 - 42	1S3-W0045-10	29 - 28
1S3-2414H-00	26 - 16	3GD-2582T-10	29 - 1	1S3-25972-00	31 - 27	1S3-2845R-31	36 - 3	1S3-82590-31	44 - 42	1S3-W0046-01	31 - 13
1S3-2414J-00	26 - 29	1S3-2582W-10	31 - 2	1S3-25973-00	31 - 26	1S3-2845R-41	36 - 3	5YT-82910-10	43 - 2	3GD-W0047-00	31 - 10
3ME-2415E-01	47 - 11	5MV-25833-00	33 - 7	1UY-25974-51	31 - 25	1S3-2845R-51	36 - 3	5YT-82911-10	43 - 3	3LC-W0047-50	29 - 5
4SH-2416E-00	46 - 13	5UG-25833-00	31 - 28	5TG-25977-50	31 - 29	4D9-81168-00	44 - 14	1S3-82913-00	32 - 18		29 - 19
1S3-2416F-00	26 - 17	5D3-2583T-00	33 - 1	1S3-25978-00	31 - 24	1S3-81410-00	37 - 1	5TG-82913-00	43 - 7	1UY-W0048-50	29 - 9
1S3-24181-00	26 - 24	5D3-25852-00	33 - 4	1S3-26111-10	32 - 1	1S3-81450-00	37 - 2	5KM-82917-00	43 - 9		29 - 23
1S3-24182-00	26 - 30	3XP-25852-50	35 - 15	1S3-26113-00	32 - 26	3AJ-81801-00	38 - 2	1S3-83500-20	39 - 1		31 - 12
1S3-24183-00	26 - 33	2VN-25854-00	35 - 16	1S3-26124-00	32 - 3	3KS-81809-00	38 - 5	1S3-83755-01	44 - 13	5TG-W0057-00	29 - 4
1S3-24278-00	26 - 22	4TT-25854-00	33 - 3	1NV-26129-00	32 - 13	1S3-81815-00	38 - 8	2HT-83912-00	43 - 4		29 - 18
1S3-24279-00	26 - 23	2VN-25855-00	35 - 17	1S3-26150-10	32 - 24	3AJ-81826-00	38 - 7	5D3-83922-00	33 - 8	5UG-W0057-00	31 - 9
1S3-24452-00	26 - 25	2GU-25866-00	33 - 17	5LP-26241-00	32 - 2	4XV-8182A-00	38 - 10	5TG-83923-00	43 - 15	1S3-W215B-01	19 - 1
1S3-24486-00	26 - 20	5LP-25867-00	33 - 6	1S3-26250-00	32 - 4	11H-81844-00	38 - 6	437-83936-01	32 - 21	1S3-W215B-11	19 - 1
1S3-24491-10	26 - 19	1S3-25871-10	33 - 15	1UY-26259-00	33 - 12	1FK-81847-00	38 - 3	1S3-83973-11	43 - 1	1S3-W215C-01	19 - 1
2FJ-24610-00	26 - 4	1S3-25872-10	33 - 13	1NV-26259-01	32 - 10	4NK-81850-00	38 - 4	5D3-83980-00	33 - 10	1S3-W215C-11	19 - 1
1S3-24710-21	27 - 1	5TG-25873-10	33 - 14	1S3-2625G-00	32 - 14	4G0-81871-00	38 - 9	5TG-84110-03	40 - 2	1S3-W215E-01	19 - 1
1S3-24723-00	27 - 6	1S3-25874-10	35 - 26	1NV-2625K-00	32 - 11	1S3-81890-00	38 - 1	1S3-8413J-00	40 - 5	1S3-W215E-11	19 - 1
509-24724-00	27 - 5	5TG-25875-00	25 - 32	1S3-2628F-00	32 - 5	1S3-81940-00	44 - 36		40 - 11	1S3-W216B-01	20 - 1
1S3-24731-20	27 - 2	5TG-25876-00	25 - 33	1S3-2628G-00	32 - 6	5DM-81950-00	44 - 50	5TG-84140-01	40 - 4	1S3-W216B-11	20 - 1
22W-24741-00	27 - 4	1S3-25886-00	22 - 59	1S3-26292-00	35 - 18	5EA-81950-20	44 - 49	1S3-84165-00	40 - 3	1S3-W216C-01	20 - 1
1S3-25111-00	28 - 7	5JJ-25894-01	35 - 14	1NV-26304-00	32 - 9	5VK-81950-30	44 - 48	1S3-84166-00	40 - 9	1S3-W216C-11	20 - 1
5LP-25117-00	28 - 9	1S3-25895-00	35 - 21	1S3-26311-10	32 - 22	5BN-81960-00	44 - 17	5TG-84310-03	40 - 8	1S3-W216E-00	20 - 1
1S3-25127-00	28 - 16	5UG-25898-00	31 - 23	1S3-26335-00	32 - 23	5GJ-82100-01	44 - 19	4KB-84314-01	40 - 1	1S3-W216E-10	20 - 1

NUMERICAL INDEX

PART NO.	REF. NO.	PART NO.	REF. NO.	PART NO.	REF. NO.	PART NO.	REF. NO.	PART NO.	REF. NO.	PART NO.	REF. NO.
90101-06664	17 - 25	90113-06055	31 - 6	90201-03008	46 - 20	90201-14021	24 - 19	90282-05005	3 - 22	90387-20005	29 - 32
90105-06078	5 - 8	90114-10006	28 - 8		46 - 24	90201-14586	29 - 35	90282-07003	15 - 2	90387-20021	16 - 27
90105-06081	12 - 10	90114-10013	30 - 8		47 - 7	90201-152P4	16 - 36	90338-05008	26 - 26	90387-22006	16 - 6
90105-06082	8 - 11	90119-06137	35 - 19		47 - 10	90201-16013	3 - 8	90338-07007	43 - 17	90387-26004	16 - 24
	12 - 12	90119-06152	21 - 5		47 - 15	90201-16018	22 - 26	90338-20183	18 - 28	90387-26005	16 - 19
90105-06084	9 - 27	90119-10023	2 - 3		47 - 18	90201-16023	30 - 11	90338-23004	18 - 29	90387-28008	16 - 14
	19 - 21	90122-06010	9 - 13		48 - 7	90201-177G4	17 - 13		22 - 24	90387-28009	16 - 41
	20 - 3	90123-08046	43 - 10		48 - 10	90201-20022	29 - 33	90338-24260	18 - 27	90401-08004	1 - 18
	44 - 21	90149-04278	32 - 15		48 - 14	90201-20276	16 - 29	90338-26004	18 - 26	90401-10015	33 - 18
90105-06142	17 - 35	90149-05018	8 - 20		48 - 17	90201-266F6	34 - 3	90340-14003	13 - 5		35 - 27
90105-07004	5 - 5	90149-05299	19 - 15	90201-04027	22 - 58	90201-286K9	14 - 2	90340-14029	8 - 12	90401-10024	8 - 23
	5 - 10	90149-06074	12 - 14	90201-04028	9 - 15	90208-20001	15 - 19	90340-36001	13 - 7	90430-05126	8 - 21
90105-08104	31 - 30	90149-08049	14 - 8	90201-04030	44 - 54	90208-37001	31 - 5	90380-10002	14 - 6	90430-06014	6 - 13
90105-08142	11 - 20	90149-10034	18 - 3	90201-05015	11 - 8	90209-06096	9 - 12	90380-22111	22 - 18		7 - 3
	18 - 10	90154-05013	20 - 13		11 - 17	90209-10229	24 - 9	90381-15088	25 - 9	90430-08119	1 - 19
	36 - 4	90154-06014	29 - 39	90201-05019	11 - 10		24 - 23		25 - 10	90430-10148	44 - 10
90105-08184	29 - 31	90159-06029	15 - 18	90201-05025	41 - 3		25 - 29	90383-20032	22 - 41	90430-10188	8 - 24
90105-10131	25 - 24	90170-06128	4 - 12		42 - 3	90209-22008	16 - 3	90383-20033	22 - 31	90430-12202	44 - 12
90105-10132	25 - 16	90170-12054	24 - 7	90201-06033	26 - 12	90209-26008	16 - 16	90387-06098	26 - 13	90430-14043	8 - 34
90105-10135	25 - 15	90170-12055	24 - 6	90201-06035	11 - 9	90214-22002	16 - 9	90387-06136	19 - 7	90445-083J4	26 - 15
90105-10294	34 - 6	90170-16326	3 - 23	90201-06076	20 - 17	90214-22003	16 - 8	90445-09777	19 - 22	90445-09777	21 - 4
	34 - 9	90170-20274	15 - 4	90201-06078	19 - 9	90214-26002	16 - 21	90387-06146	20 - 4	90445-09M30	21 - 3
90105-12038	23 - 3	90171-10001	24 - 8		40 - 16	90214-26003	16 - 22	90387-06153	20 - 6	90445-11034	21 - 18
90109-06169	8 - 18		24 - 22	90201-06089	19 - 13	90215-16221	3 - 24		41 - 7	90445-16007	26 - 34
90109-06172	19 - 3		25 - 30	90201-06090	26 - 9	90215-20006	15 - 3		42 - 7	90450-22017	21 - 23
	22 - 29	90171-14002	29 - 36	90201-06093	20 - 24	90215-25003	16 - 46		44 - 23	90450-32015	6 - 22
90109-06198	18 - 16	90171-16002	30 - 12	90201-063F3	22 - 36	90240-08124	35 - 11	90387-06166	7 - 20		7 - 9
90109-06199	22 - 55	90179-08148	43 - 11	90201-08043	18 - 19	90252-03001	30 - 13	90387-06168	44 - 24		7 - 17
90109-06798	43 - 5	90179-16004	3 - 9	90201-08048	11 - 21	90267-32004	46 - 7	90387-06204	20 - 23	90450-59006	9 - 26
90109-067F4	25 - 34	90179-20007	15 - 20	90201-08053	20 - 26		46 - 11	90387-06205	21 - 14	90450-72003	9 - 2
90109-08076	31 - 3	90179-22011	16 - 47	90201-08060	31 - 31		46 - 19	90387-06M17	26 - 8	90460-75020	9 - 25
90109-08082	29 - 2	90179-36003	31 - 4	90201-08083	35 - 12		46 - 23	90387-07598	40 - 14	90461-10004	44 - 16
90109-08100	36 - 2	90183-05008	19 - 16	90201-082A6	21 - 12		47 - 6	90387-08064	18 - 20	90461-10011	13 - 22
90109-09002	1 - 6	90185-10011	18 - 12	90201-10034	22 - 38		47 - 9	90387-08073	9 - 28		16 - 43
90109-09003	1 - 5		18 - 14	90201-10035	22 - 46		47 - 14	90387-090R0	24 - 18	90462-08046	13 - 26
90109-09005	1 - 7		30 - 17		25 - 26		47 - 17	90387-100Y6	25 - 12	90464-12036	18 - 30
90109-10013	30 - 16	90185-10012	22 - 39	90201-10036	23 - 9		48 - 6	90387-101R3	25 - 11	90464-12045	18 - 32
90109-10018	22 - 34		22 - 47	90201-10037	25 - 17		48 - 9	90387-12010	22 - 48	90464-13073	32 - 29
90109-10019	23 - 8		23 - 10		25 - 18		48 - 13	90387-12020	23 - 7		44 - 55
90109-10020	22 - 45		25 - 19	90201-10118	33 - 19		48 - 16	90387-12021	22 - 33	90464-14004	26 - 2
90109-12009	22 - 49		25 - 20		35 - 28	90267-47187	22 - 57	90387-12028	22 - 51	90464-15157	41 - 8
90110-05030	8 - 9		25 - 25	90201-10614	15 - 30	90267-48138	9 - 14		23 - 4		42 - 8
90110-05031	13 - 9	90185-12007	22 - 53	90201-12030	22 - 37	90269-05055	26 - 32	90387-125K2	22 - 43	90464-15195	44 - 56
	37 - 4		23 - 6	90201-12032	22 - 52	90269-06002	19 - 18	90387-127W0	23 - 11	90464-16013	44 - 58
90110-06182	13 - 21	90185-14009	24 - 20		23 - 5		19 - 20	90387-1504G	16 - 37	90464-20213	18 - 31
90110-06202	19 - 5	90185-16002	22 - 27	90201-12040	17 - 14		44 - 32	90387-150R1	29 - 34	90464-23041	21 - 7
90110-12001	22 - 12	90201-03008	46 - 8	90201-12541	6 - 11	90269-07011	26 - 28	90387-16014	22 - 11		32 - 30
90111-06038	20 - 7		46 - 12	90201-12575	17 - 29	90280-05001	3 - 7	90387-17009	12 - 3	90464-66001	26 - 27

NUMERICAL INDEX

PART NO.	REF. NO.	PART NO.	REF. NO.	PART NO.	REF. NO.	PART NO.	REF. NO.	PART NO.	REF. NO.	PART NO.	REF. NO.
90465-10098	44 - 59	91402-20020	24 - 10	93210-07135	8 - 17	93503-08007	8 - 27	95602-08200	20 - 28	98502-05020	32 - 17
90465-13M11	44 - 57		24 - 24		12 - 16	93603-16219	6 - 14	95602-10200	18 - 7		32 - 19
90467-08003	21 - 6		25 - 31	93210-10197	8 - 30	93608-30002	17 - 21	95604-06100	33 - 9	98506-04012	35 - 5
90467-09006	10 - 22	91402-20025	24 - 21		21 - 21	93612-16254	1 - 10	95612-08625	1 - 3	98507-05012	10 - 12
90467-10008	21 - 17	91402-30025	29 - 37	93210-13361	8 - 3	93700-06004	22 - 35	95702-04500	44 - 53	98507-06010	10 - 8
90467-11044	35 - 22	92012-06010	41 - 13	93210-14369	13 - 6		22 - 44	95702-08500	11 - 22	98507-06012	10 - 11
90467-11090	10 - 26		44 - 2	93210-15620	35 - 4		22 - 50	95702-10500	28 - 14	98702-06025	26 - 6
	10 - 27	92012-06012	43 - 16	93210-16629	21 - 25		25 - 21		30 - 9	98902-06010	11 - 16
90467-13062	6 - 17	92012-06025	20 - 14	93210-207A0	13 - 25		25 - 22	95802-06010	41 - 5	99001-07600	15 - 26
90467-14057	35 - 23	92012-06030	37 - 3	93210-21190	21 - 10	9383G-14231	16 - 45		41 - 11	99001-10600	17 - 30
90467-140A4	12 - 8	92012-08016	20 - 33	93210-25001	16 - 39	93900-00022	30 - 3		42 - 5	99009-10400	15 - 31
90467-15012	9 - 5		35 - 25	93210-33786	6 - 20		30 - 6	95802-06020	44 - 26	99009-11400	8 - 6
90467-160A4	9 - 4	92012-08020	20 - 31	93210-357A3	13 - 8	93900-00030	28 - 3	95802-06025	44 - 18	99009-12400	6 - 16
90467-220A1	9 - 24	92012-08035	20 - 34	93210-36769	30 - 19		28 - 6	95802-06030	7 - 21	99009-17400	17 - 12
90480-01017	26 - 7		35 - 10	93210-41042	7 - 7	94107-10015	28 - 2		44 - 22	99009-20400	16 - 30
90480-13459	21 - 13	92014-06016	43 - 18	93210-61750	6 - 5		28 - 5	95802-06035	26 - 10	99009-30400	25 - 3
90480-14101	41 - 6	92902-05100	32 - 20	93210-64297	8 - 16	94110-09012	30 - 2		26 - 14		25 - 6
	42 - 6		45 - 2	93210-66001	22 - 8		30 - 5	95802-08016	21 - 11	99530-08016	12 - 15
90480-14102	19 - 6		45 - 6	93210-71001	22 - 9	94582-13098	30 - 20	95812-06012	17 - 28	99530-10114	8 - 31
	40 - 13		45 - 11	93210-78544	1 - 15	94591-57126	5 - 11	95812-06014	19 - 12		12 - 2
90480-15009	35 - 20	92902-05200	45 - 5	93210-96601	1 - 12	94701-00330	1 - 9		20 - 5		13 - 3
90480-18005	26 - 11		45 - 10	93300-60804	18 - 18	95022-06008	44 - 38	95812-06030	19 - 8		21 - 20
90480-18330	7 - 18	92902-05600	32 - 28	93306-00106	6 - 6	95022-06010	7 - 4		38 - 11	99530-10120	13 - 16
90480-24004	21 - 16	92902-06200	11 - 18	93306-00304	15 - 16	95022-06012	11 - 7		40 - 15	99530-14016	12 - 17
90501-043E0	8 - 28	92902-06600	5 - 15	93306-00415	16 - 31		22 - 61	95812-08014	18 - 5		
90501-052G5	17 - 18	92902-08600	15 - 25	93306-00431	16 - 12	95022-06020	1 - 13	95812-08045	18 - 21		
90501-230E4	15 - 17	92902-10200	28 - 15	93306-00446	28 - 10		1 - 16	95812-10030	34 - 7		
90506-20380	34 - 4		30 - 10	93306-00502	3 - 20		7 - 5	95812-10055	18 - 6		
90508-18018	15 - 23	92903-08600	22 - 15	93306-07209	5 - 6	95022-06025	6 - 8	95812-10090	18 - 13		
90508-35007	17 - 11	92906-04100	35 - 6	93306-20231	28 - 11		8 - 32	95812-10110	18 - 11		
90560-06201	20 - 15	92906-04600	35 - 7	93306-20352	18 - 22		21 - 22	95822-06012	2 - 6		
91312-04006	10 - 17	92907-06600	7 - 14	93306-20481	3 - 19	95022-06030	12 - 4	95822-06020	21 - 15		
91312-04025	44 - 52	93101-12173	6 - 9	93306-20501	16 - 11		13 - 4	95822-06025	33 - 16		
91312-06010	11 - 14	93101-14164	13 - 19	93306-27803	16 - 32		13 - 17	95822-08016	20 - 29		
91312-06012	8 - 25	93101-25106	3 - 21	93306-30810	3 - 10	95022-06045	7 - 6	95822-08020	20 - 27		
91312-06016	21 - 26	93102-12106	17 - 32	93306-90509	17 - 2	95022-06050	6 - 23	95822-08030	24 - 12		
	44 - 15	93102-12224	17 - 22	93306-90804	22 - 3	95022-06070	12 - 5	97002-05016	43 - 8		
91312-06020	6 - 19	93102-15212	15 - 28	93306-90805	22 - 7	95022-06090	12 - 6	97002-05020	44 - 6		
91312-06025	5 - 17	93102-22216	28 - 13	93310-84017	3 - 5	95022-06110	6 - 24	97017-06010	7 - 13		
	13 - 13	93102-25081	18 - 23	93315-31502	15 - 29	95302-05600	45 - 3	97022-06014	16 - 44		
91312-06030	1 - 8	93102-25099	18 - 24	93317-11020	15 - 27	95302-05700	32 - 16	97022-06016	5 - 14		
91312-06035	8 - 4	93102-35393	16 - 40	93317-22237	22 - 17	95302-06800	26 - 21	97022-06025	20 - 22		
91312-06040	2 - 4	93104-09025	32 - 12	93410-67085	22 - 13	95602-05100	32 - 7	97022-08060	24 - 16		
91312-06095	8 - 19	93105-26026	28 - 12	93430-23054	34 - 2	95602-06100	43 - 6	97702-50016	41 - 2		
91314-08035	11 - 4	93106-22019	22 - 19	93440-15012	16 - 35	95602-06200	19 - 4		42 - 2		
	11 - 19	93106-46003	22 - 4	93440-25084	16 - 4		20 - 8	97707-30510	40 - 6		
91314-08040	22 - 14	93109-20076	22 - 32	93440-28062	16 - 17		20 - 16		40 - 12		
91401-16012	35 - 13	93112-31011	24 - 14	93450-24154	3 - 14		20 - 25	98502-05018	32 - 27		