



PARTS CATALOGUE

YFM80RW (5THH) U.S.A.

YFM80RW (5THJ) CANADA

YFM80RW (5THK) EUROPE

YFM80RW (5THH) OCEANIA

YFM80 (5THH) JAPAN

YFM80RW/YFM80
PARTS CATALOGUE
©2006 by Yamaha Motor Co., Ltd.
1st edition, May 2006
All rights reserved.
Any reprinting or unauthorized use
without the written permission of
Yamaha Motor Co., Ltd.
is expressly prohibited.

A3

FOREWORD

This Parts Catalogue is related to the parts for the model(s) on the cover page. When you are ordering replacement parts, please refer to this Parts Catalogue and quote both part numbers and part names correctly.

1. Modifications or additions which have been made after the issue of the Parts Catalogue will be announced in the Parts News.

It is advisable that you make the necessary corrections to the Parts Catalogue according to the Parts News.

2. Abbreviations

The following abbreviations are used in this Parts Catalogue.

“UR” Use specified parts number.

“UN” Use as many as needed.

“AP” Alternate Parts

“LM” Locally Made (Parts need to be ordered locally)

“F#” Frame No. (Applicable machine No.)

“O/S” Over Size

3. The number of components for assembly

- Parts, which are to be supplied in an assembly, are listed with a dot (.) in front of the part name as shown below.
- The numeral appearing to the right of each component part indicates the quantity of parts for each assembly unit.

PART NO.	DESCRIPTION	Q'TY	REMARKS
2F5-83310-60	FRONT FLASHER LIGHT ASSY	2	
115-83311-60	.BULB (6V-18W)	1	

4. Applicable colours of graphics are represented in the “REMARKS” as shown below.

PART NO.	DESCRIPTION	Q'TY	REMARKS
2N4-24110-00-X5	FUEL TANK COMP.	2	MXR
3J1-24240-10	.GRAPHIC, FUEL TANK	1	FOR MXR

5. Note that the illustrations for reference in finding parts numbers are not to be used for assembling. When assembling, please use the applicable service manual.

6. The asterisk (*) before a reference number indicates modified items after the first edition.

FOREWORD

7. Applicable Serial No.

Engine Serial No.

Frame Serial No.

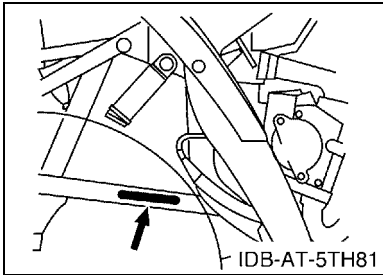
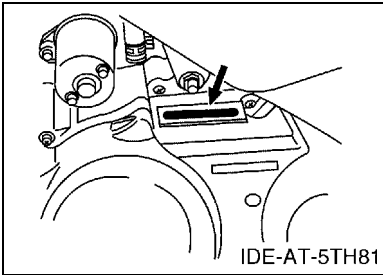

8. Applicable Colour Code (The (*) mark shows Model colour.)

Abbreviation	Colour Name	Colour Code
DPBSE(*)	DEEP PURPLISH BLUE SOLID E	0583
PGD(*)	PASTEL DARK GRAY	003E
SL	SILVER	0035
WW	WHITE	0036
YB	YAMAHA BLACK	0033

9. Quantity Column Information

Column No.	Name Of Q'ty Column	Destination
1	USA	U.S.A.
2	CAN	CANADA
3	EUR	EUROPE
4	OCE	AUSTRALIA, NEW ZEALAND
5	JPN	JAPAN

CONTENTS

ENGINE

CYLINDER	B2
CRANKSHAFT & PISTON	B3
VALVE	B4
CAMSHAFT & CHAIN	B5
OIL PUMP	B6
INTAKE	B7
EXHAUST	B9
CRANKCASE	B10
CRANKCASE COVER 1	B11
STARTER CLUTCH	B12
CLUTCH	B13
TRANSMISSION	B15
MIDDLE DRIVE GEAR	C2
SHIFT CAM & FORK	C3
SHIFT SHAFT	C4

CHASSIS

FRAME	C5
FRONT FENDER	C6
REAR FENDER	C8
REAR ARM	C9
DRIVE SHAFT	C10
REAR SUSPENSION	C12
STEERING	C13
FRONT SUSPENSION & WHEEL	C15
FUEL TANK	D2
SEAT	D3
FRONT WHEEL	D4
REAR WHEEL	D6
STEERING HANDLE & CABLE	D8
STAND & FOOTREST	D10
GUARD	D11
GENERATOR	D12
STARTING MOTOR	D13
HEADLIGHT	D14
HANDLE SWITCH & LEVER	D15
ELECTRICAL 1	E2
ELECTRICAL 2	E4
EMBLEM & LABEL 1	E5
EMBLEM & LABEL 2	E6
EMBLEM & LABEL 3	E7

EMBLEM & LABEL 4	E8
EMBLEM & LABEL 5	E9

INDEX

NUMERICAL INDEX	M1
-----------------------	----

FIG. 1 CYLINDER

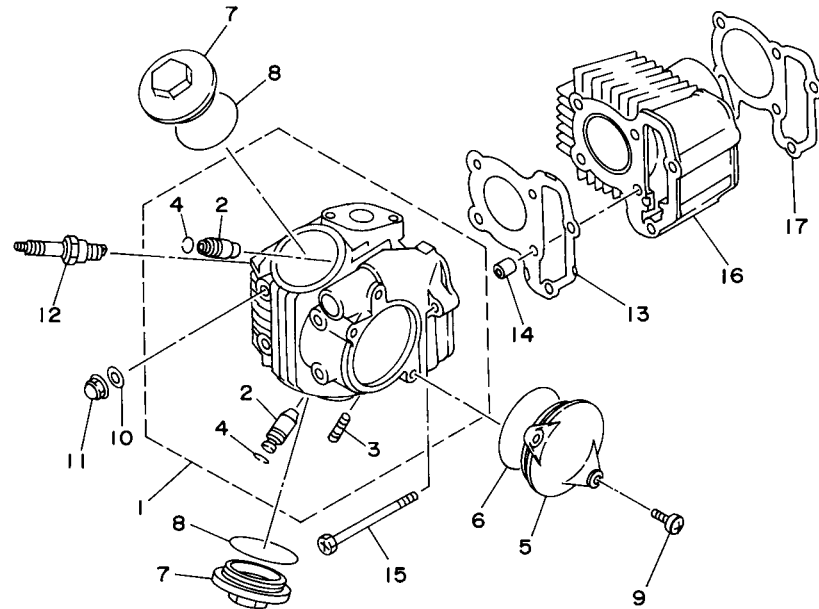

REF. NO.	PART NO.	DESCRIPTION	USA	CAN	EUR	OCE	JPN	REMARKS
1	35T-11110-01	CYLINDER HEAD ASSY	1	1	1	1	1	
2	22F-11134-10	.GUIDE, VALVE 2	2	2	2	2	2	
3	22F-14651-00	.BOLT, STUD	2	2	2	2	2	
4	93440-10109	.CIRCLIP	2	2	2	2	2	
5	22F-11185-10	COVER, CYLINDER HEAD SIDE 1	1	1	1	1	1	
6	93210-63556	O-RING	1	1	1	1	1	
7	22F-11186-10	COVER, CYLINDER HEAD SIDE 2	2	2	2	2	2	
8	93210-44704	O-RING	2	2	2	2	2	
9	98507-06016	SCREW, PAN HEAD	2	2	2	2	2	
10	90201-066F0	WASHER, PLATE	4	4	4	4	4	
11	90176-06065	NUT, CROWN	4	4	4	4	4	
12	94701-00366	PLUG, SPARK (NGK CR7HSA)	1	1	1	1	1	
	94703-00366	PLUG, SPARK (NGK CR7HSA)					1	
13	55X-11181-00	GASKET, CYLINDER HEAD 1	1	1	1	1	1	
14	99530-08012	PIN, DOWEL	2	2	2	2	2	
15	95027-06085	BOLT, FLANGE	2	2	2	2	2	
16	22K-11311-02	CYLINDER 1	1	1	1	1	1	
17	22F-11351-01	GASKET, CYLINDER	1	1	1	1	1	

4EM1100-2010

FIG. 2 CRANKSHAFT & PISTON

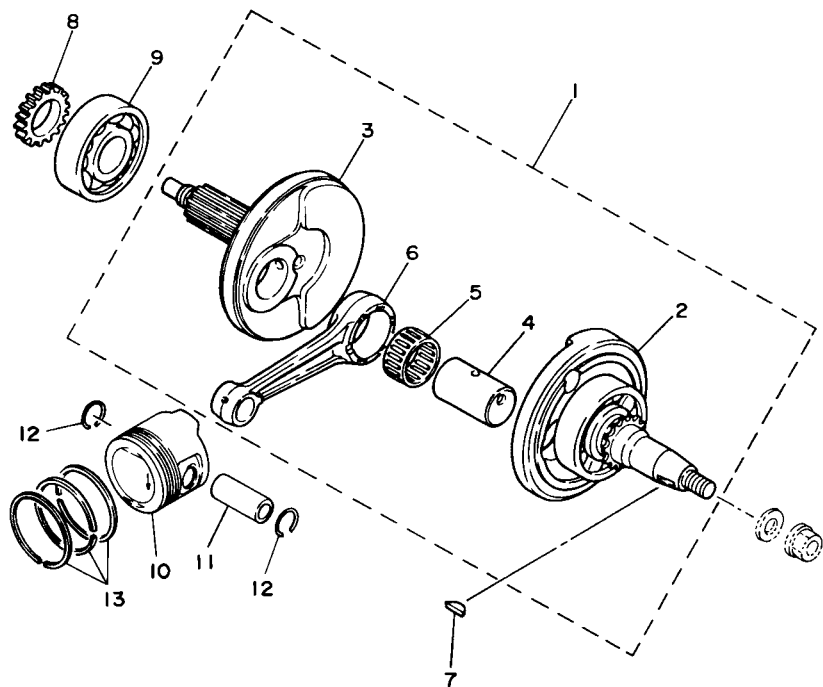

55X110-5020

REF. NO.	PART NO.	DESCRIPTION	USA	CAN	EUR	OCE	JPN	REMARKS
1	22K-11400-01	CRANKSHAFT ASSY	1	1	1	1	1	
2	22K-W1141-00	.CRANK 1	1	1	1	1	1	
3	22K-11422-00	.CRANK 2	1	1	1	1	1	
4	22F-11681-00	.PIN, CRANK 1	1	1	1	1	1	
5	93311-32353	.BEARING	1	1	1	1	1	
6	22K-11651-02	.ROD, CONNECTING	1	1	1	1	1	
7	90280-03017	KEY, WOODRUFF	1	1	1	1	1	
8	46J-13324-00	GEAR, PUMP DRIVE	1	1	1	1	1	
9	93306-30433	BEARING	1	1	1	1	1	
10	55X-11631-00-96	PISTON (STD)	1	1	1	1	1	
	55X-11636-00	PISTON (0.50MM O/S)	1	1	1	1	1	AP
	55X-11638-00	PISTON (1.00MM O/S)	1	1	1	1	1	AP
11	22K-11633-01	PIN, PISTON	1	1	1	1	1	
12	93450-14088	CIRCLIP	2	2	2	2	2	
13	55X-11610-00	PISTON RING SET (STD)	1	1	1	1	1	
	55X-11610-20	PISTON RING SET (0.50MM O/S)	1	1	1	1	1	AP
	55X-11610-40	PISTON RING SET (1.00MM O/S)	1	1	1	1	1	AP

FIG. 3 VALVE

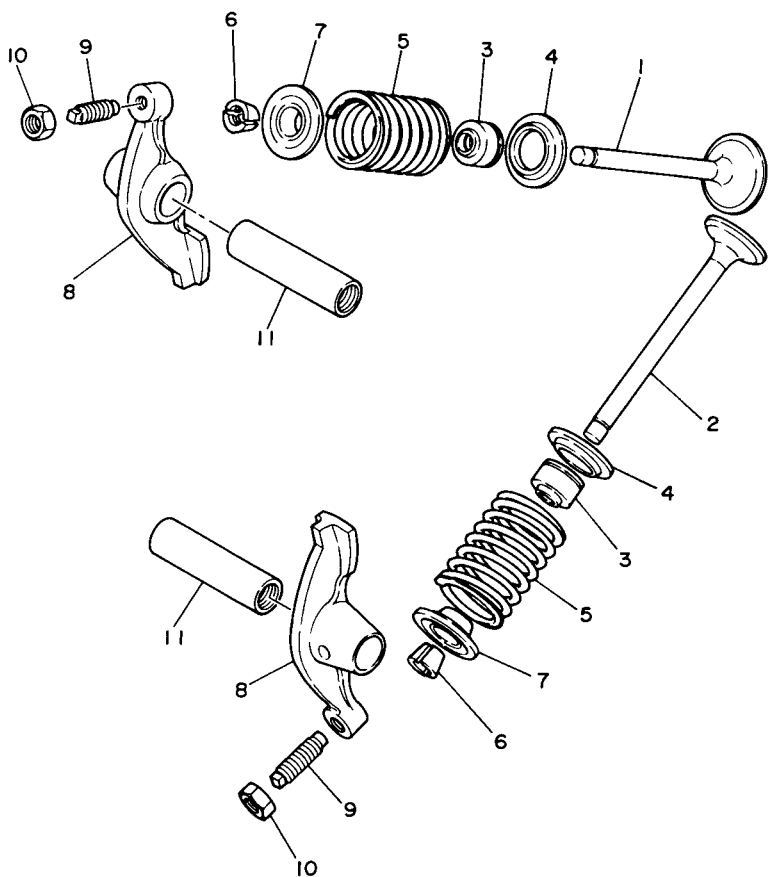

REF. NO.	PART NO.	DESCRIPTION	USA	CAN	EUR	OCE	JPN	REMARKS
1	2D3-12111-00	VALVE, INTAKE	1	1	1	1	1	
2	2D3-12121-00	VALVE, EXHAUST	1	1	1	1	1	
3	2HX-12119-00	SEAL, VALVE STEM	2	2	2	2	2	
4	22F-12116-00	SEAT, VALVE SPRING	2	2	2	2	2	
5	22F-12114-00	SPRING, VALVE OUTER	2	2	2	2	2	
6	22F-12118-01	COTTER, VALVE	4	4	4	4	4	
7	22F-12117-02	RETAINER, VALVE SPRING	2	2	2	2	2	
8	22F-12151-10	ARM, VALVE ROCKER	2	2	2	2	2	
9	22F-12159-00	SCREW, VALVE ADJUSTING	2	2	2	2	2	
10	90170-05302	NUT	2	2	2	2	2	
11	22F-12156-00	SHAFT, ROCKER 2	2	2	2	2	2	

55X110-5030

FIG. 4 CAMSHAFT & CHAIN

REF. NO.	PART NO.	DESCRIPTION	USA	CAN	EUR	OCE	JPN	REMARKS
1	55X-12170-00	CAMSHAFT ASSY 1	1	1	1	1	1	
2	50M-12176-00	SPROCKET, CAM CHAIN (28T)	1	1	1	1	1	
3	90201-08326	WASHER, PLATE	1	1	1	1	1	
4	90101-08590	BOLT	1	1	1	1	1	
5	94580-25082	CHAIN (D.I.D 25)	1	1	1	1	1	
6	22F-12231-01	GUIDE, STOPPER 1	1	1	1	1	1	
7	22F-12241-00	GUIDE, STOPPER 2	1	1	1	1	1	
8	22F-12217-01	ROD, CHAIN TENSIONER	1	1	1	1	1	
9	90334-14037	PLUG, STRAIGHT	1	1	1	1	1	
10	90501-10710	SPRING, COMPRESSION	1	1	1	1	1	
11	90340-18092	PLUG, STRAIGHT SCREW	1	1	1	1	1	
12	90201-186F1	WASHER, PLATE	1	1	1	1	1	
13	90113-06009	BOLT, SET	1	1	1	1	1	
14	93210-06564	O-RING	1	1	1	1	1	
15	90179-06387	NUT	1	1	1	1	1	
16	95307-06800	NUT	1	1	1	1	1	

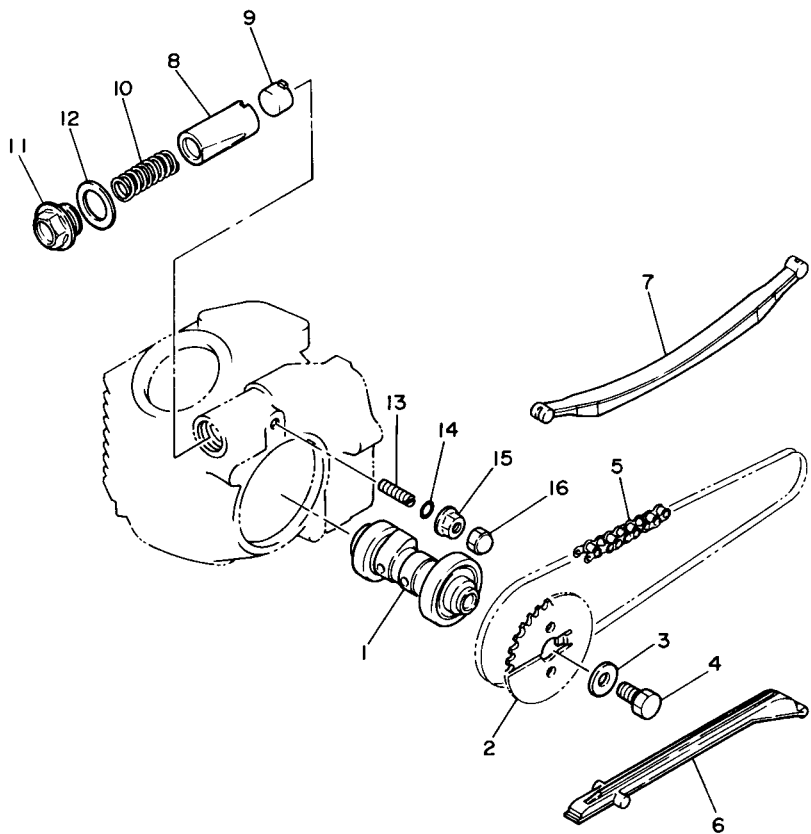

55X110-5040

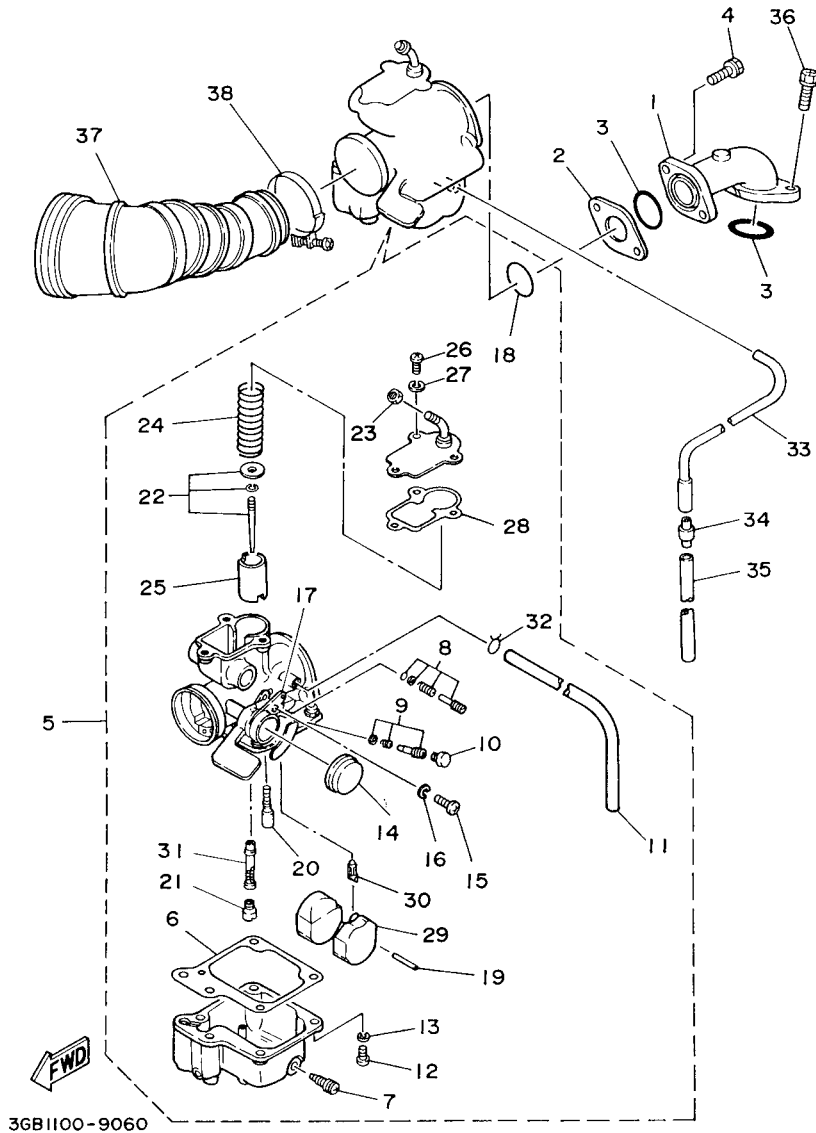
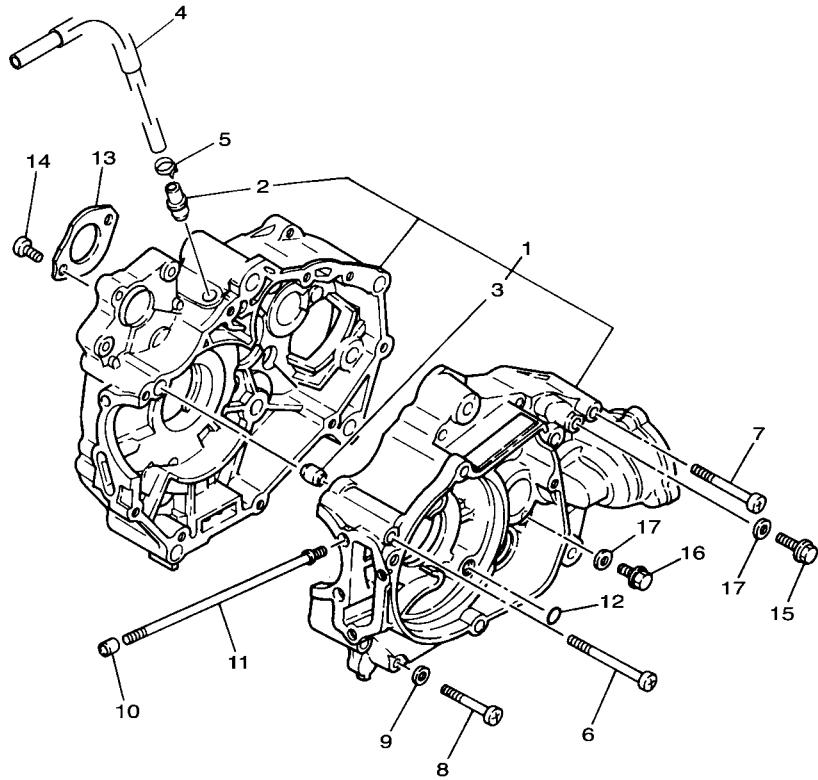

FIG. 6 INTAKE

REF. NO.	PART NO.	DESCRIPTION	USA	CAN	EUR	OCE	JPN	REMARKS
1	55X-13586-00	JOINT, CARBURETOR 1	1	1	1	1	1	
2	22K-13595-00	JOINT	1	1	1	1	1	
3	93210-25552	O-RING	2	2	2	2	2	
4	90159-06076	SCREW, WITH WASHER	2	2	2	2	2	
5	5TH-14101-10	CARBURETOR ASSY 1	1	1				
5TH-14101-00	CARBURETOR ASSY 1				1	1	1	
6	22F-14184-00	.GASKET, FLOAT CHAMBER	1	1	1	1	1	
7	12R-14191-00	.PLUG, DRAIN	1	1	1	1	1	
8	22F-14103-00	.THROTTLE SCREW SET	1	1	1	1	1	
9	22K-14104-00	.AIR SCREW SET	1	1	1	1	1	
10	22F-14991-00	.CAP	1	1	1	1	1	
11	26H-14197-00	.PIPE	1	1	1	1	1	
12	98502-04014	.SCREW, PAN HEAD	4	4	4	4	4	
13	92902-04100	.WASHER, SPRING	4	4	4	4	4	
14	22F-14169-00	.CAP	1	1	1	1	1	
15	98502-04008	.SCREW, PAN HEAD	1	1	1	1	1	
16	92902-04100	.WASHER, SPRING	1	1	1	1	1	
17	55X-14146-00	.PLATE	1	1	1	1	1	
18	22K-14147-00	.O-RING	1	1	1	1	1	
19	127-14186-00	.PIN, FLOAT	1	1	1	1	1	
20	22F-14142-12	.JET, PILOT (#12.5)	1	1	1	1	1	
21	18A-1414E-30	.JET, MAIN(#76.3)	1	1	1	1	1	
22	2HX-1490J-10	.NEEDLE SET	1	1				
22	2HX-1490J-20	.NEEDLE SET			1	1	1	
23	802-14161-00	.NUT, CABLE ADJUSTING	1	1	1	1	1	
24	260-14131-00	.SPRING, THROTTLE VALVE	1	1	1	1	1	
25	2HX-14112-35	.VALVE, THROTTLE 1	1	1	1	1	1	

FIG. 8 CRANKCASE



REF. NO.	PART NO.	DESCRIPTION	USA	CAN	EUR	OCE	JPN	REMARKS
1	2FJ-15100-01	CRANKCASE ASSY	1	1	1	1	1	
2	59V-11167-00	.PIPE, BREATHER 2	1	1	1	1	1	
3	99530-12016	.PIN, DOWEL	2	2	2	2	2	
4	2D3-11166-00	PIPE, BREATHER 1	1	1	1	1	1	
5	90467-13064	CLIP	1	1	1	1	1	
6	98507-06075	SCREW, PAN HEAD	1	1	1	1	1	
7	98507-06060	SCREW, PAN HEAD	2	2	2	2	2	
8	98507-06045	SCREW, PAN HEAD	6	6	6	6	6	
9	90430-06014	GASKET	2	2	2	2	2	
10	99530-08012	PIN, DOWEL	2	2	2	2	2	
11	90116-06399	BOLT, STUD	4	4	4	4	4	
12	93210-06564	O-RING	2	2	2	2	2	
13	22F-15383-01	PLATE, BEARING COVER	1	1	1	1	1	
14	98507-06012	SCREW, PAN HEAD	2	2	2	2	2	
15	95817-06025	BOLT, FLANGE	2	2	2	2	2	
16	95817-06016	BOLT, FLANGE	1	1	1	1	1	
17	90430-06166	GASKET	3	3	3	3	3	

2D31100-D080

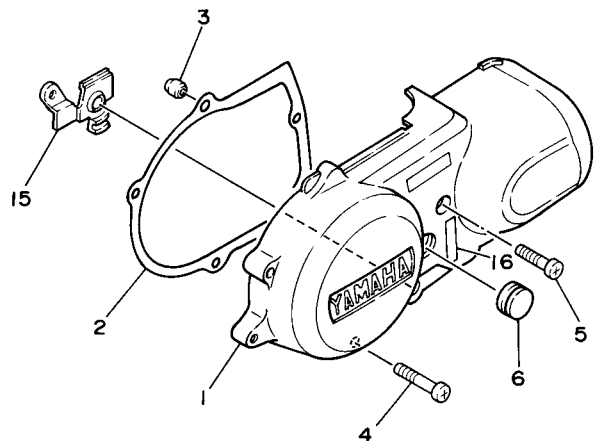
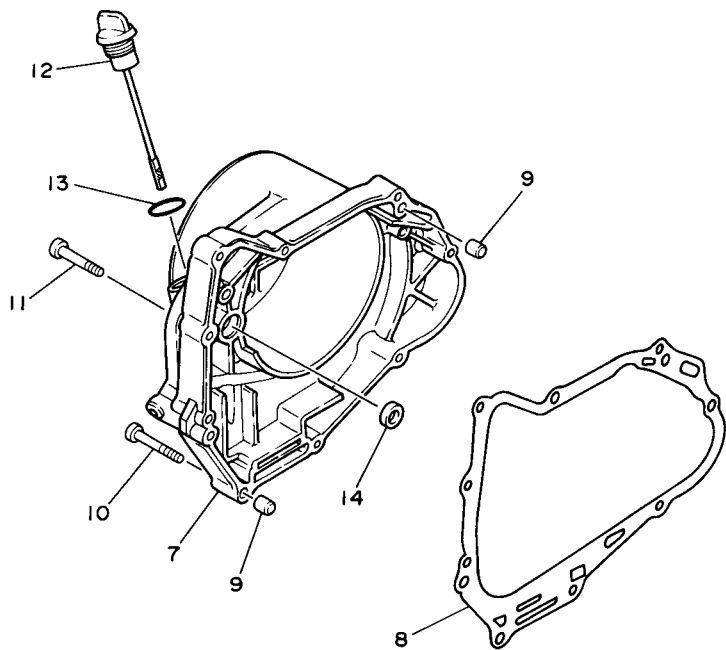

2FJ110-7090

FIG. 9 CRANKCASE COVER 1

REF. NO.	PART NO.	DESCRIPTION	USA	CAN	EUR	OCE	JPN	REMARKS
1	22F-15411-01	COVER, CRANKCASE 1	1	1	1	1	1	
2	3GB-15451-00	GASKET, CRANKCASE COVER 1	1	1	1	1	1	
3	99530-10114	PIN, DOWEL	2	2	2	2	2	
4	98507-06040	SCREW, PAN HEAD	1	1	1	1	1	
5	98507-06030	SCREW, PAN HEAD	2	2	2	2	2	
6	22F-15417-00	COVER, CAP	1	1	1	1	1	
7	2FJ-15421-00	COVER, CRANKCASE 2	1	1	1	1	1	
8	3GB-15461-00	GASKET, CRANKCASE COVER 2	1	1	1	1	1	
9	99530-10120	PIN, DOWEL	2	2	2	2	2	
10	98507-06045	SCREW, PAN HEAD	1	1	1	1	1	
11	98507-06035	SCREW, PAN HEAD	8	8	8	8	8	
12	55X-15362-04	PLUG, OIL LEVEL	1	1	1	1	1	
13	93210-19123	O-RING	1	1	1	1	1	
14	93101-10142	OIL SEAL	1	1	1	1	1	
15	90209-11269	WASHER	1	1	1	1	1	
16	4EM-15443-01	EMBLEM	1	1	1	1	1	

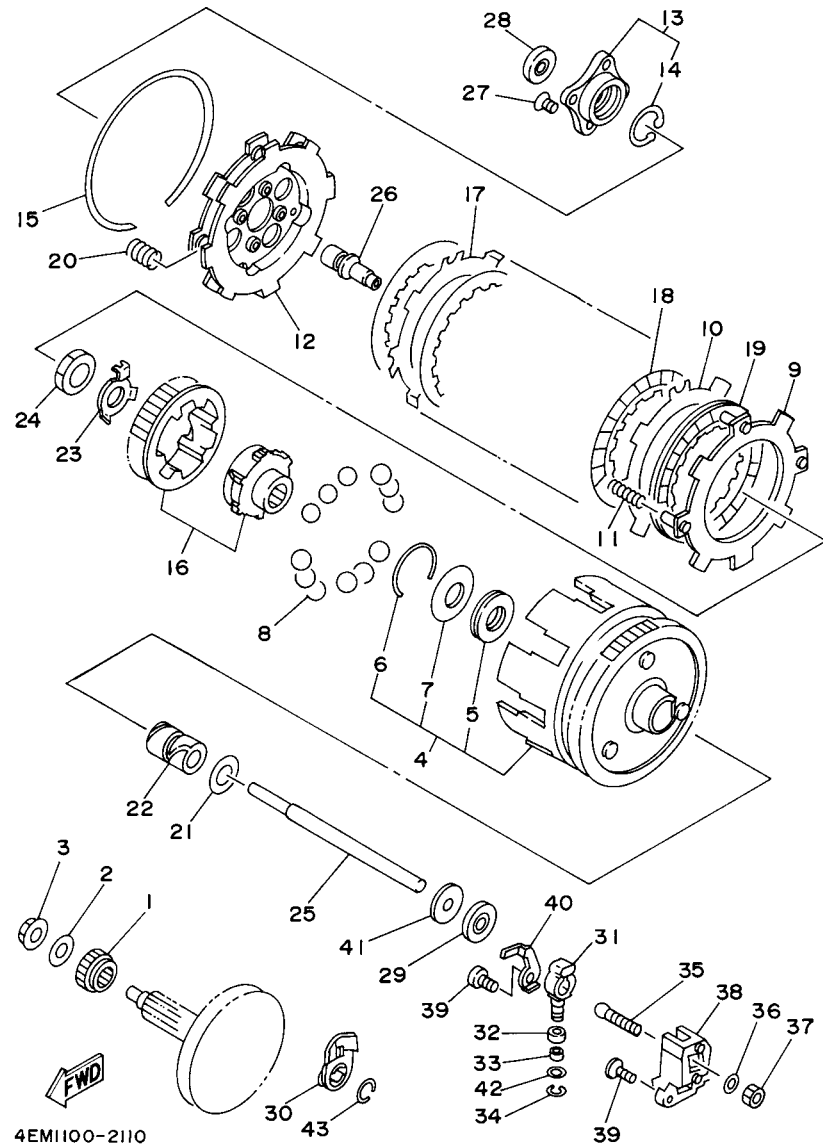

FIG. 11 CLUTCH

REF. NO.	PART NO.	DESCRIPTION	USA	CAN	EUR	OCE	JPN	REMARKS
1	22K-16111-00	GEAR, PRIMARY DRIVE	1	1	1	1	1	
2	90208-12015	WASHER, CONICAL SPRING	1	1	1	1	1	
3	90179-12659	NUT	1	1	1	1	1	
4	3GB-16150-00	PRIMARY DRIVEN GEAR COMP.	1	1	1	1	1	
5	93341-22302	.BEARING	1	1	1	1	1	
6	93450-42112	.CIRCLIP	1	1	1	1	1	
7	22F-16153-40	.WASHER, THRUST (1.7T)	1	1	1	1	1	
8	93505-08030	BALL	12	12	12	12	12	
9	22K-16520-00	PLATE, THRUST WEIGHT	1	1	1	1	1	
10	517-16524-10	PLATE, CLUTCH 1 (1.2T)	4	4	4	4	4	UR
	517-16524-20	PLATE, CLUTCH 1 (1.4T)	4	4	4	4	4	UR
	517-16524-30	PLATE, CLUTCH 1 (1.6T)	4	4	4	4	4	UR
11	90501-105A5	SPRING, COMPRESSION	4	4	4	4	4	
12	22F-16550-00	PRESSURE PLATE ASSY	1	1	1	1	1	
13	22K-16590-00	PUSH PLATE ASSY	1	1	1	1	1	
14	93420-26077	.CIRCLIP	1	1	1	1	1	
15	93451-08094	CIRCLIP	1	1	1	1	1	
16	22K-W1657-00	CLUTCH BOSS SET	1	1	1	1	1	
17	22F-16524-01	PLATE, CLUTCH 1	1	1	1	1	1	
18	3E5-16521-00	PLATE, FRICTION	5	5	5	5	5	
19	22F-16521-00	PLATE, FRICTION	1	1	1	1	1	
20	90501-135A4	SPRING, COMPRESSION	8	8	8	8	8	
21	122-16164-00	PLATE, THRUST 2	1	1	1	1	1	
22	90560-17146	SPACER	1	1	1	1	1	
23	90215-14249	WASHER, LOCK	1	1	1	1	1	
24	90170-14284	NUT	1	1	1	1	1	
25	22F-16357-01	ROD, PUSH 2	1	1	1	1	1	

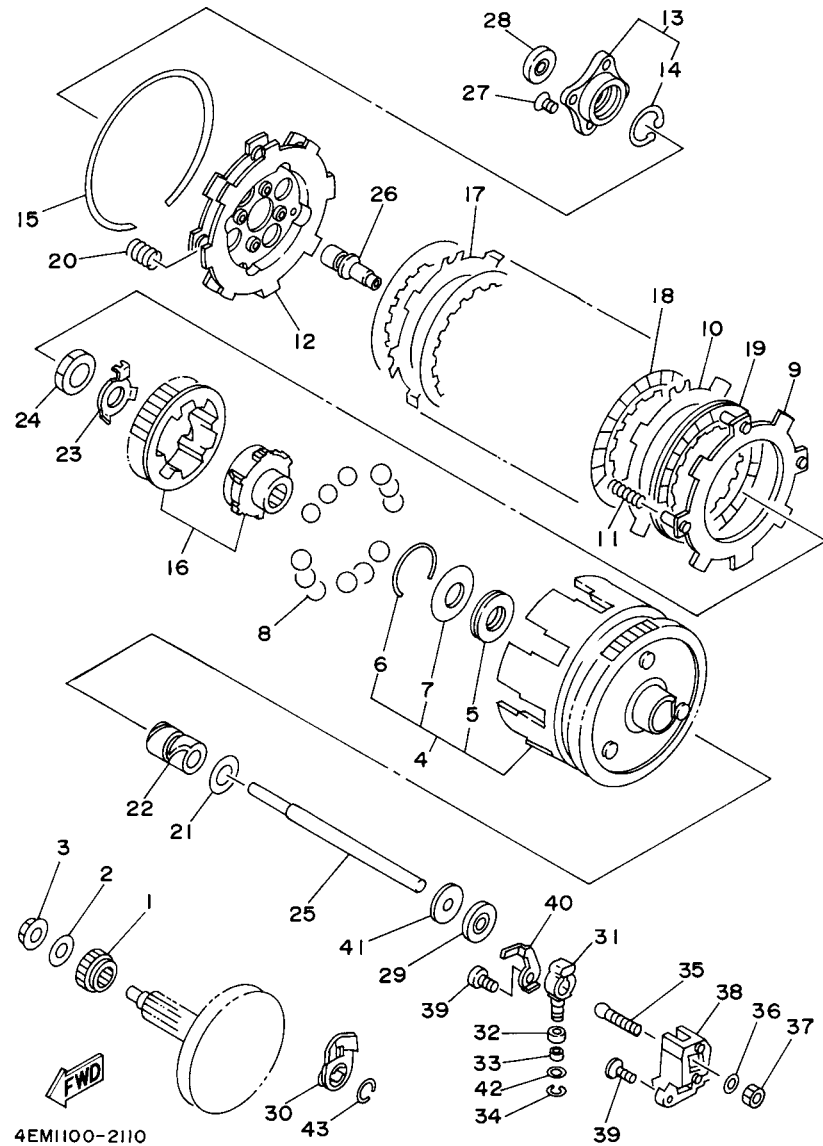
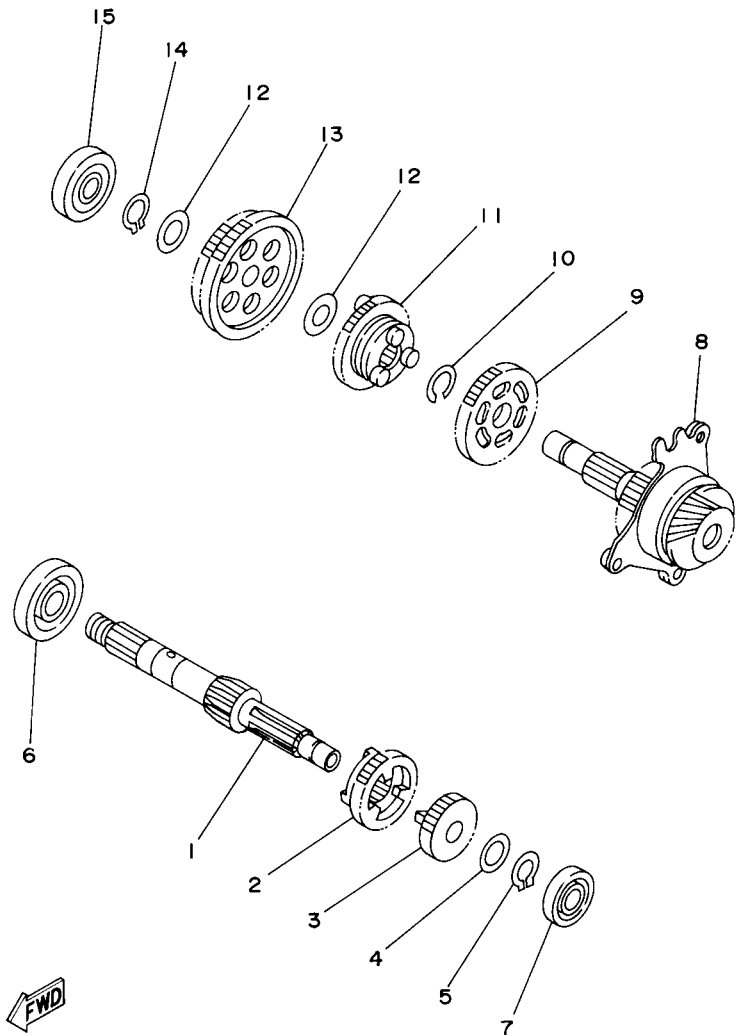

FIG. 11 CLUTCH

REF. NO.	PART NO.	DESCRIPTION	USA	CAN	EUR	OCE	JPN	REMARKS
26	22K-16356-00	ROD, PUSH 1	1	1	1	1	1	
27	90151-06028	SCREW, COUNTERSUNK	4	4	4	4	4	
28	93104-10076	OIL SEAL	1	1	1	1	1	
29	93102-07292	OIL SEAL	1	1	1	1	1	
30	22F-16362-01	LEVER, PUSH 2	1	1	1	1	1	
31	22F-16342-01	LEVER, PUSH	1	1	1	1	1	
32	90387-062G9	COLLAR	1	1	1	1	1	
33	90387-062G8	COLLAR	1	1	1	1	1	
34	99001-04600	CIRCLIP	1	1	1	1	1	
35	22F-16382-00	AXLE, PUSH LEVER	1	1	1	1	1	
36	92907-06600	WASHER, PLATE	1	1	1	1	1	
37	95307-06600	NUT	1	1	1	1	1	
38	22F-16399-00	GUIDE, PUSH ROD	1	1	1	1	1	
39	98507-06016	SCREW, PAN HEAD	2	2	2	2	2	
40	22F-16383-00	SPRING, CLUTCH BOSS	1	1	1	1	1	
41	90380-07118	BUSH, SOLID	1	1	1	1	1	
42	22F-16163-00	WASHER, THRUST 2	1	1	1	1	1	
43	93440-11128	CIRCLIP	1	1	1	1	1	

FIG. 12 TRANSMISSION



4EM1100-2120

REF. NO.	PART NO.	DESCRIPTION	USA	CAN	EUR	OCE	JPN	REMARKS
1	2HX-17411-01	AXLE, MAIN	1	1	1	1	1	
2	55X-17131-00	GEAR, 3RD PINION (22T)	1	1	1	1	1	
3	2HX-17121-00	GEAR, 2ND PINION (17T)	1	1	1	1	1	
4	90201-124F8	WASHER, PLATE	1	1	1	1	1	
5	99009-12400	CIRCLIP	1	1	1	1	1	
6	93306-20301	BEARING	1	1	1	1	1	
7	93306-00105	BEARING	1	1	1	1	1	
8	3GB-17402-00	DRIVE AXLE ASSY	1	1	1	1	1	
9	55X-17231-00	GEAR, 3RD WHEEL (31T)	1	1	1	1	1	
10	93440-16089	CIRCLIP	1	1	1	1	1	
11	55X-17241-00	GEAR, 4TH WHEEL (27T)	1	1	1	1	1	
12	90201-132G5	WASHER, PLATE	2	2	2	2	2	
13	3GB-17211-00	GEAR, 1ST WHEEL (39T)	1	1	1	1	1	
14	99009-12400	CIRCLIP	1	1	1	1	1	
15	93306-30101	BEARING	1	1	1	1	1	

FIG. 13 MIDDLE DRIVE GEAR

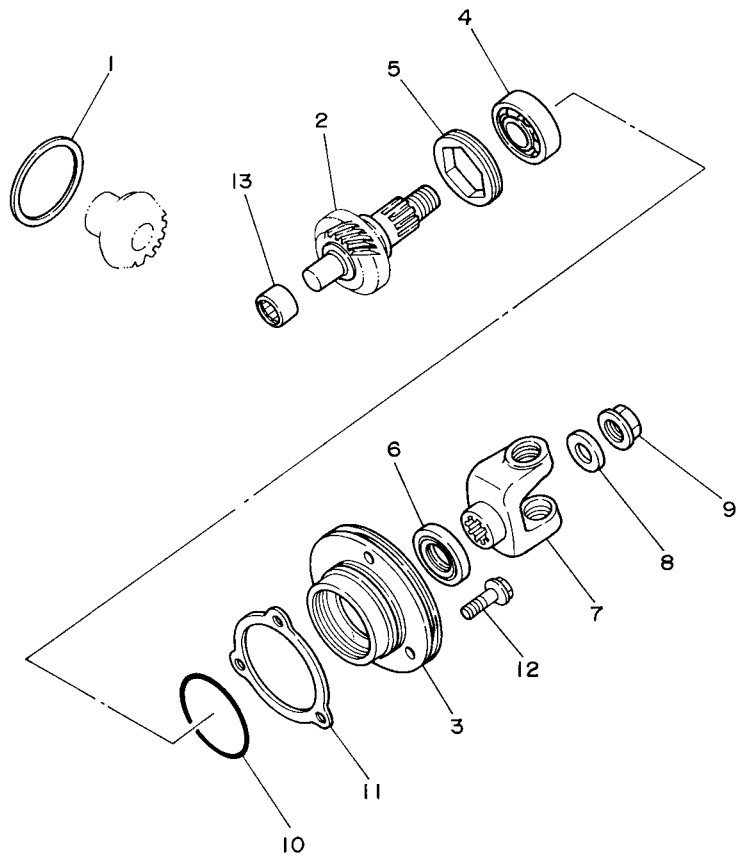

REF. NO.	PART NO.	DESCRIPTION	USA	CAN	EUR	OCE	JPN	REMARKS
1	22F-17537-00	SHIM, THRUST	1	1	1	1	1	
2	3GB-17508-00	MIDDLE DRIVEN GEAR COMP.	1	1	1	1	1	
3	22F-17551-00	HOUSING, BEARING	1	1	1	1	1	
4	93306-20309	BEARING	1	1	1	1	1	
5	90179-42480	NUT	1	1	1	1	1	
6	93101-24110	OIL SEAL	1	1	1	1	1	
7	22F-17556-01	YOKE, JOINT	1	1	1	1	1	
8	90201-125F7	WASHER, PLATE	1	1	1	1	1	
9	90179-12248	NUT	1	1	1	1	1	
10	93210-50553	O-RING	1	1	1	1	1	
11	22F-17531-00-15	SHIM, PINION (0.15T)	1	1	1	1	1	UR
	22F-17531-00-30	SHIM, PINION (0.30T)	1	1	1	1	1	UR
	22F-17531-00-50	SHIM, PINION (0.50T)	1	1	1	1	1	UR
12	95827-06020	BOLT, FLANGE	3	3	3	3	3	
13	93317-21236	BEARING	1	1	1	1	1	



3GB1100-9130

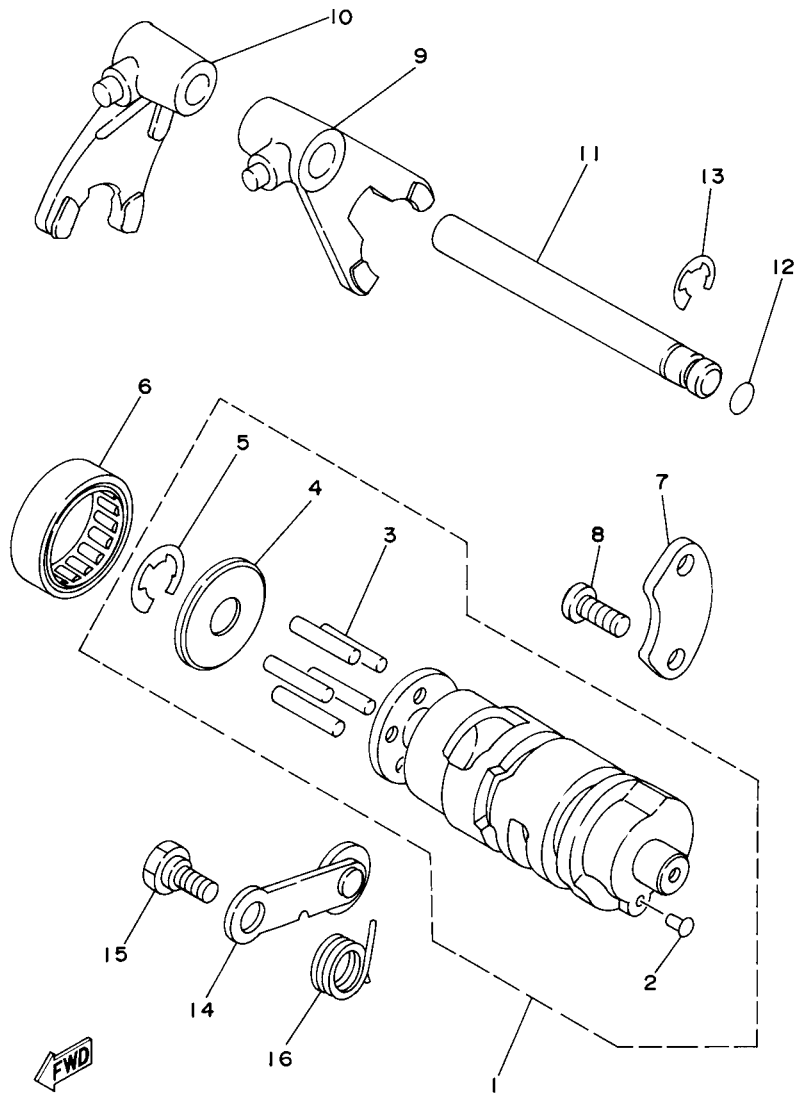

4EMK100-8140

FIG. 14 SHIFT CAM & FORK

REF. NO.	PART NO.	DESCRIPTION	USA	CAN	EUR	OCE	JPN	REMARKS
1	4EM-18540-00	SHIFT CAM ASSY	1	1	1	1	1	
2	136-18542-00	.POINT, NEUTRAL	1	1	1	1	1	
3	93604-22050	.PIN, DOWEL	5	5	5	5	5	
4	296-18561-00	.PLATE, SIDE 1	1	1	1	1	1	
5	99001-09600	.CIRCLIP	1	1	1	1	1	
6	93315-23208	BEARING	1	1	1	1	1	
7	22F-18562-01	PLATE, STOPPER 2	1	1	1	1	1	
8	98507-06014	SCREW, PAN HEAD	2	2	2	2	2	
9	2MK-18511-00	FORK, SHIFT 1	1	1	1	1	1	
10	29F-18512-00	FORK, SHIFT 2	1	1	1	1	1	
11	22F-18531-00	BAR, SHIFT FORK GUIDE 1	1	1	1	1	1	
12	93210-07003	O-RING	1	1	1	1	1	
13	93430-08007	CIRCLIP	1	1	1	1	1	
14	29F-18140-00	STOPPER LEVER ASSY	1	1	1	1	1	
15	90109-063F6	BOLT	1	1	1	1	1	
16	90508-20576	SPRING, TORSION	1	1	1	1	1	

FIG. 16 FRAME

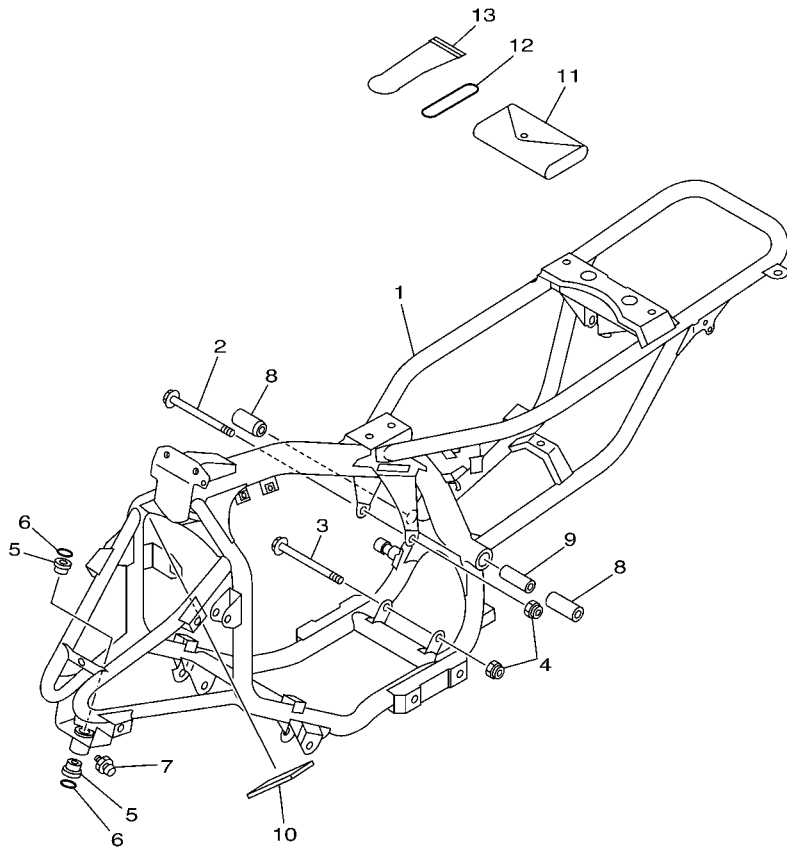

REF. NO.	PART NO.	DESCRIPTION	USA	CAN	EUR	OCE	JPN	REMARKS
1	5TH-21110-20	FRAME COMP.	1		1	1	1	
	5TH-21110-30	FRAME COMP.		1				
2	95817-08115	BOLT, FLANGE	1	1	1	1	1	
3	95817-08120	BOLT, FLANGE	1	1	1	1	1	
4	95607-08200	NUT, SELF-LOCKING	2	2	2	2	2	
5	90381-15040	BUSH, SOLID	2	2	2	2	2	
6	93210-15414	O-RING	2	2	2	2	2	
7	93700-06004	NIPPLE, GREASE	1	1	1	1	1	
8	3GB-22123-00	BUSH 1	2	2	2	2	2	
9	3GB-22155-00	PIPE	1	1	1	1	1	
10	5TH-21268-01	SEAL	1	1	1	1	1	
11	3GB-28100-00	TOOL KIT	1	1	1	1	1	
12	93210-40407	O-RING	1	1	1	1	1	
13	1NV-2811A-01	GAUGE, AIR	1	1	1	1	1	

 5THE100-E160

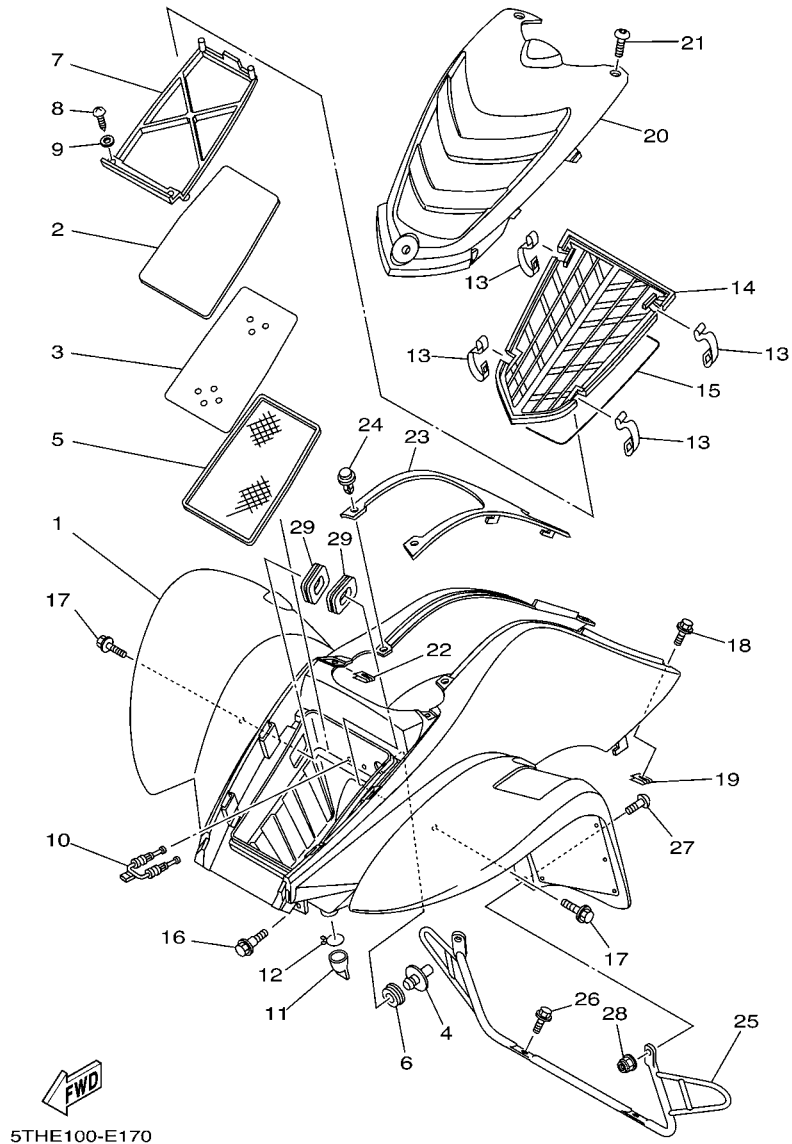
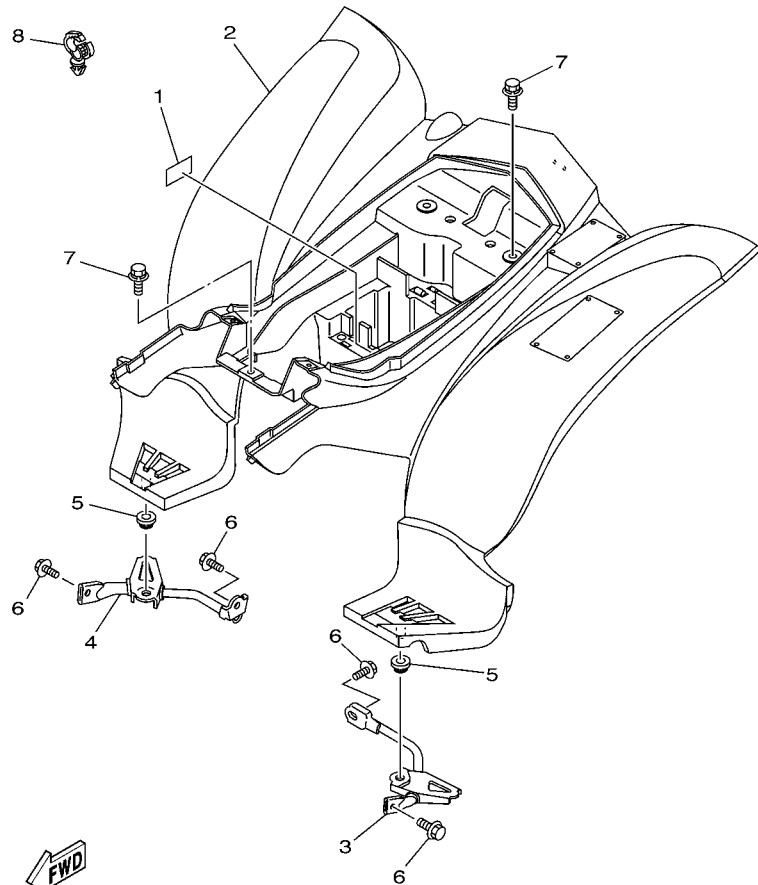

FIG. 17 FRONT FENDER

REF. NO.	PART NO.	DESCRIPTION	USA	CAN	EUR	OC	JPN	REMARKS
1	5TH-W2151-01	FRONT FENDER COMP.	1					UR FOR DPBSE
	5TH-W2151-31	FRONT FENDER COMP.	1					UR FOR PGD
	5TH-W215C-01	FRONT FENDER COMP.2		1				UR FOR DPBSE
	5TH-W215C-31	FRONT FENDER COMP.2		1				UR FOR PGD
	5TH-W215B-01	FRONT FENDER COMP. 2			1			FOR DPBSE
	5TH-W215D-01	FRONT FENDER COMP. 2				1	1	UR FOR DPBSE
	5TH-W215D-31	FRONT FENDER COMP. 2				1		UR FOR PGD
2	55X-14451-00	ELEMENT, AIR CLEANER	1	1	1	1	1	
3	5TH-14477-00	PLATE	1	1	1	1	1	
4	2D3-14419-00	PIPE	1	1	1	1	1	
5	55X-14472-01	PLATE, ELEMENT	1	1	1	1	1	
6	31A-14435-00	GROMMET	1	1	1	1	1	
7	55X-14458-00	GUIDE	1	1	1	1	1	
8	97707-40116	SCREW, TAPPING	2	2	2	2	2	
9	92907-04200	WASHER	2	2	2	2	2	
10	55X-14436-00	HOOK	1	1	1	1	1	
11	59V-14457-00	SEAL	1	1	1	1	1	
12	90467-22080	CLIP	1	1	1	1	1	
13	5TH-14436-00	HOOK	4	4	4	4	4	
14	5TH-14412-00	CAP, CLEANER CASE 1	1	1	1	1	1	
15	5TH-14452-00	SEAL	1	1	1	1	1	
16	90109-063F1	BOLT	1	1	1	1	1	
17	90119-06044	BOLT, WITH WASHER	2	2	2	2	2	
18	90119-05193	BOLT, WITH WASHER	2	2	2	2	2	
19	90183-05008	NUT, SPRING	2	2	2	2	2	
20	5TH-21556-00	FENDER, FRONT 2	1	1	1	1	1	UR FOR DPBSE
	5TH-21556-30	FENDER, FRONT 2	1	1		1		UR FOR PGD

FIG. 18 REAR FENDER



5TH1100-2180

REF. NO.	PART NO.	DESCRIPTION	USA	CAN	EUR	OCE	JPN	REMARKS
1	5TH-2177C-10	PLATE, EPA OFFROAD ATV 1	1	1				
2	5TH-W2161-00	REAR FENDER COMP.	1			1	1	UR FOR DPBSE
	5TH-W2161-30	REAR FENDER COMP.	1			1		UR FOR PGD
	5TH-W216C-00	REAR FENDER COMP.2			1			UR FOR DPBSE
	5TH-W216C-30	REAR FENDER COMP.2			1			UR FOR PGD
	5TH-W216B-00	REAR FENDER COMP.2				1		FOR DPBSE
3	3GB-21613-00	STAY, FENDER 1	1	1	1	1	1	
4	3GB-21614-00	STAY, FENDER 2	1	1	1	1	1	
5	90480-18171	GROMMET	2	2	2	2	2	
6	95807-08012	BOLT, FLANGE	4	4	4	4	4	
7	90119-06056	BOLT, WITH WASHER	4	4	4	4	4	
8	90464-13249	CLAMP	1	1	1	1	1	

FIG. 20 DRIVE SHAFT

REF. NO.	PART NO.	DESCRIPTION	USA	CAN	EUR	OCE	JPN	REMARKS
1	3GB-46151-00	HOUSING, DRIVE SHAFT	1	1	1	1	1	
2	2N4-15371-00	BREATHER	1	1	1	1	1	
3	90445-073F9	HOSE (L1200)	1	1	1	1	1	
4	90467-07029	CLIP	1	1	1	1	1	
5	90340-14132	PLUG, STRAIGHT SCREW	1	1	1	1	1	
6	214-11198-01	GASKET	1	1	1	1	1	
7	3GB-15362-00	PLUG, OIL LEVEL	1	1	1	1	1	
8	93210-14104	O-RING	1	1	1	1	1	
9	3GB-46120-00	DRIVE PINION COMP.	1	1	1	1	1	
10	90560-23355	SPACER	1	1	1	1	1	
11	93210-43713	O-RING	1	1	1	1	1	
12	93102-17271	OIL SEAL	1	1	1	1	1	
13	93306-30306	BEARING	1	1	1	1	1	
14	90179-55464	NUT	1	1	1	1	1	
15	3GB-46110-20	RING GEAR COMP.	1	1	1	1	1	
16	93306-07801	BEARING	1	1	1	1	1	
17	93102-28022	OIL SEAL	1	1	1	1	1	
18	93211-066A9	O-RING	1	1	1	1	1	
19	95817-06016	BOLT, FLANGE	6	6	6	6	6	
20	3GB-46172-01	SHAFT, DRIVE	1	1	1	1	1	
21	99009-17400	CIRCLIP	1	1	1	1	1	
22	2HX-46180-00	CROSS JOINT COMP.	1	1	1	1	1	
23	22F-46187-00	.SPIDER	1	1	1	1	1	
24	93311-20952	.BEARING	2	2	2	2	2	
25	99009-17500	.CIRCLIP	2	2	2	2	2	
26	93311-20952	BEARING	2	2	2	2	2	
27	99009-17500	CIRCLIP	2	2	2	2	2	

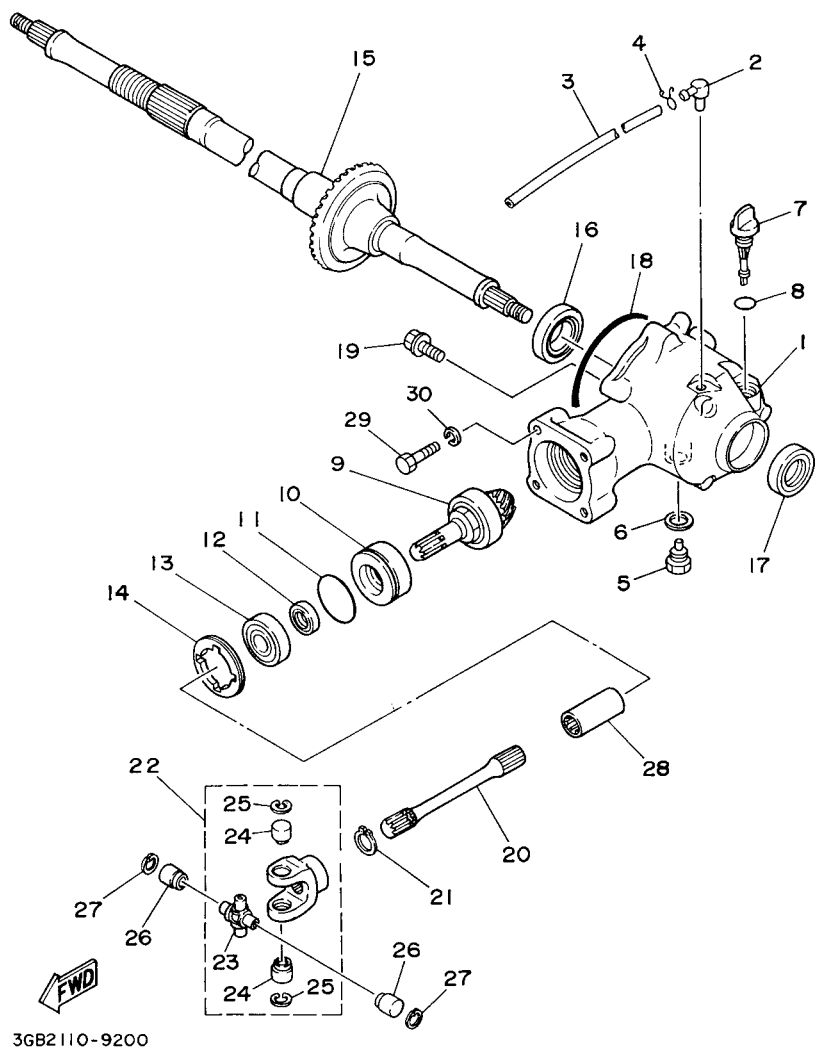

3GB2110-9200

FIG. 22 STEERING

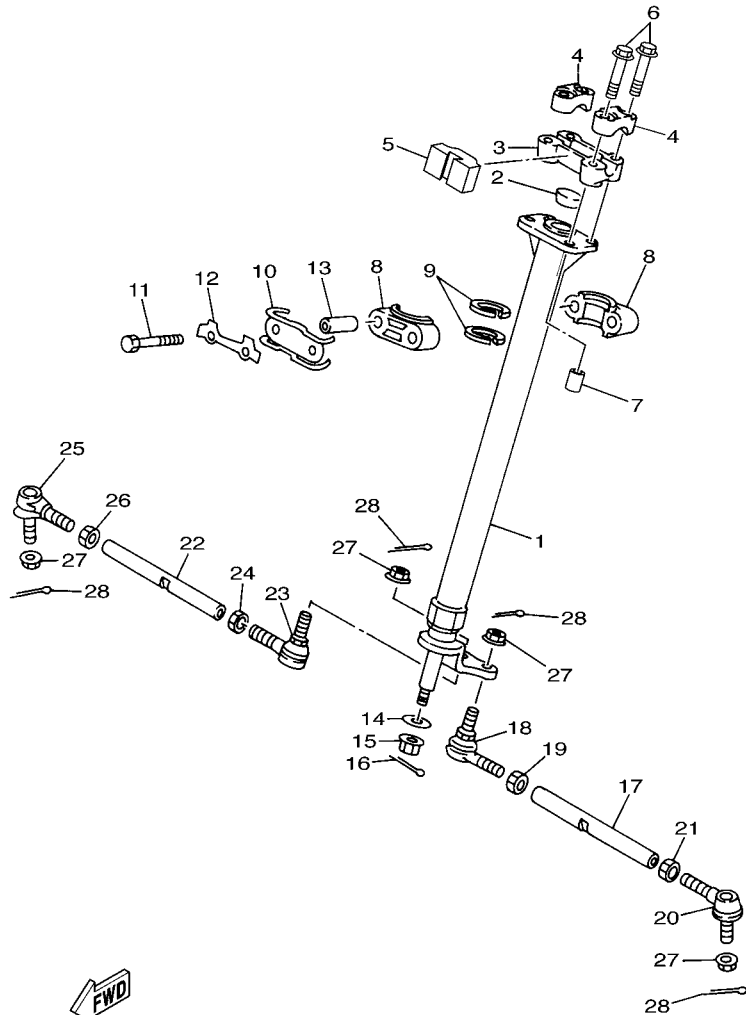

2D31100-D220

REF. NO.	PART NO.	DESCRIPTION	USA	CAN	EUR	OCE	JPN	REMARKS
1	4EM-23813-10	COLUMN, STEERING 2	1	1	1	1	1	
2	90336-28053	PLUG, TAPER	1	1	1	1	1	
3	8G5-23814-00	HOLDER, HANDLE UNDER	1	1	1	1	1	
4	8K1-23814-00	HOLDER, HANDLE	2	2	2	2	2	
5	2D3-23858-00	SPACER	1	1	1	1	1	
6	95827-08055	BOLT, FLANGE	4	4	4	4	4	
7	90445-11418	HOSE (L18)	1	1	1	1	1	
8	1UY-23812-00	PLANE BEARING, STEERING	2	2	2	2	2	
9	93112-31011	OIL SEAL	2	2	2	2	2	
10	3GB-23868-00	BRACKET, STEERING LOWER	1	1	1	1	1	
11	97027-08060	BOLT	2	2	2	2	2	
12	1UY-23894-01	WASHER, LOCK 1	1	1	1	1	1	
13	90387-090R0	COLLAR	2	2	2	2	2	
14	90201-10774	WASHER, PLATE	1	1	1	1	1	
15	90185-10115	NUT, SELF-LOCKING	1	1	1	1	1	
16	91401-20020	PIN, COTTER	1	1	1	1	1	
17	3GB-23831-00	ROD, TIE	1	1	1	1	1	
18	55X-23841-01	JOINT, UNIVERSAL 1	1	1	1	1	1	
19	95307-10700	NUT	1	1	1	1	1	
20	52H-23845-01	JOINT, UNIVERSAL 2	1	1	1	1	1	
21	90170-10186	NUT	1	1	1	1	1	(L.H. THREAD)
22	3GB-23831-00	ROD, TIE	1	1	1	1	1	
23	55X-23841-01	JOINT, UNIVERSAL 1	1	1	1	1	1	
24	95307-10700	NUT	1	1	1	1	1	
25	52H-23845-01	JOINT, UNIVERSAL 2	1	1	1	1	1	
26	90170-10186	NUT	1	1	1	1	1	(L.H. THREAD)
27	90185-10115	NUT, SELF-LOCKING	4	4	4	4	4	

FIG. 22 STEERING

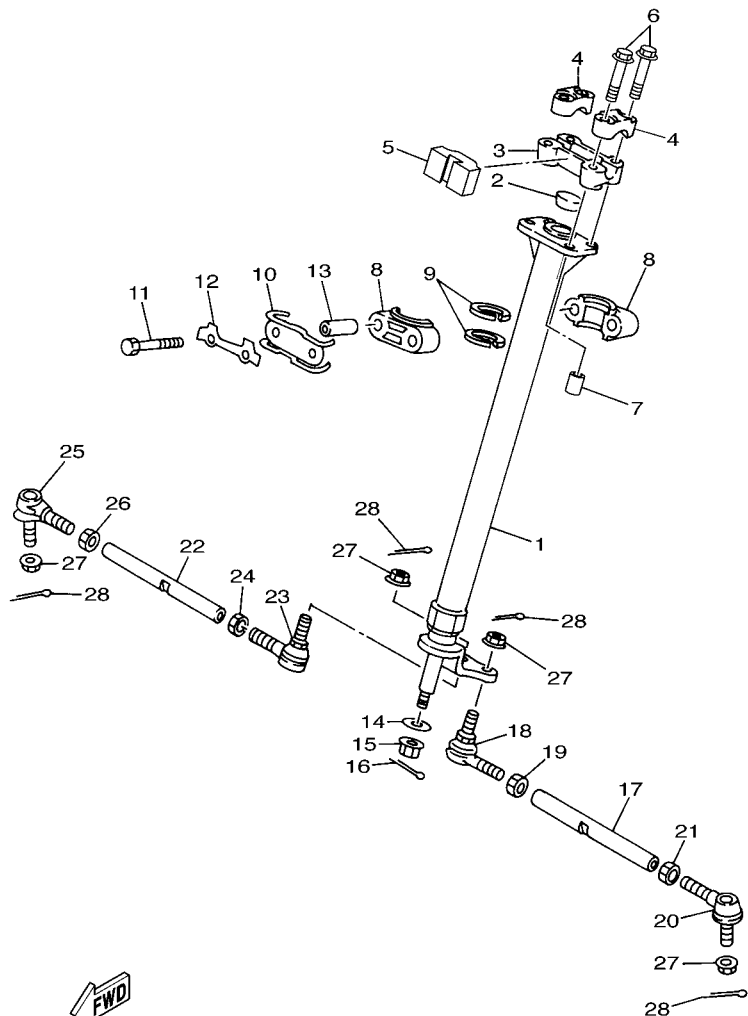

2D31100-D220

REF. NO.	PART NO.	DESCRIPTION	USA	CAN	EUR	OCE	JPN	REMARKS
28	91401-20020	PIN, COTTER	4	4	4	4	4	

FIG. 23 FRONT SUSPENSION & WHEEL

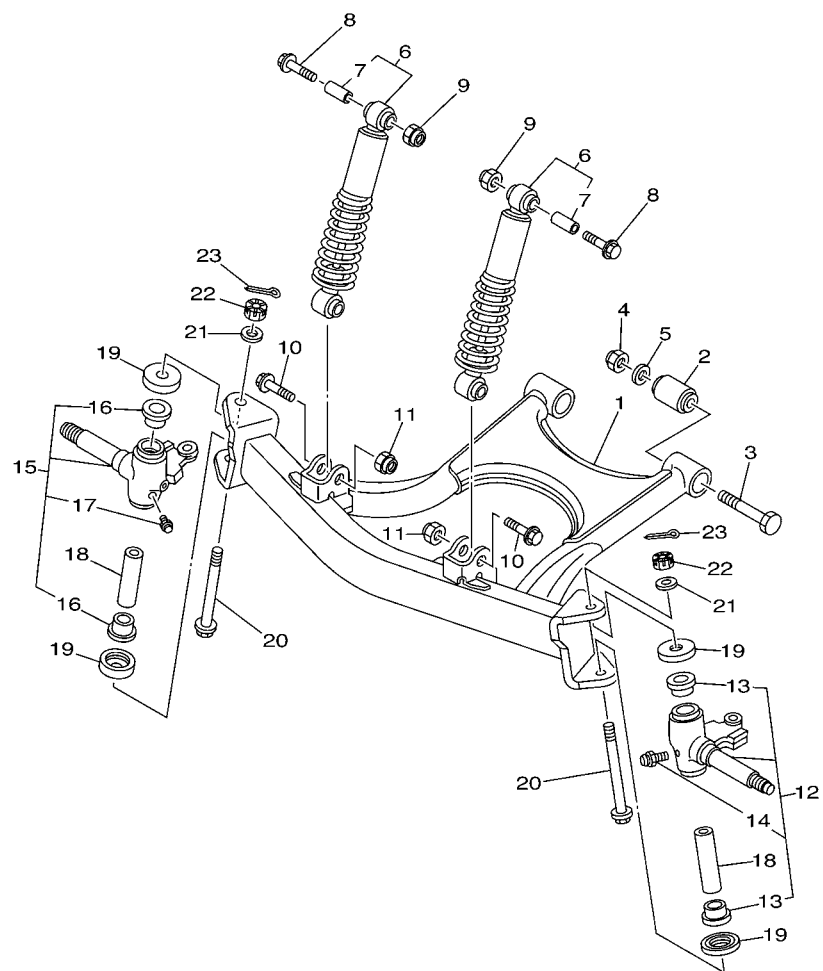

4EMT100-0230

REF. NO.	PART NO.	DESCRIPTION	USA	CAN	EUR	OCE	JPN	REMARKS
1	3GB-23570-00-33	FRONT LOWER ARM COMP.	1	1	1	1	1	YB FOR DPBSE,PGD
2	307-22123-00	BUSH 1	2	2	2	2	2	
3	90101-12498	BOLT	2	2	2	2	2	
4	90185-12046	NUT, SELF-LOCKING	2	2	2	2	2	
5	90201-12688	WASHER, PLATE	2	2	2	2	2	
6	2HX-23350-00-36	SHOCK ABSORBER ASSY	2	2	2	2	2	WW FOR DPBSE,PGD
7	2HX-2331U-00	.COLLAR, DISTANCE	1	1	1	1	1	
8	90105-10561	BOLT, FLANGE	2	2	2	2	2	
9	90185-10091	NUT, SELF-LOCKING	2	2	2	2	2	
10	90105-12460	BOLT, FLANGE	2	2	2	2	2	
11	90185-12046	NUT, SELF-LOCKING	2	2	2	2	2	
12	3GB-23501-10	STEERING KNUCKLE ASSY (LEFT)	1	1	1	1	1	
13	90381-17067	.BUSH, SOLID	2	2	2	2	2	
14	93700-06004	.NIPPLE, GREASE	1	1	1	1	1	
15	3GB-23502-10	STEERING KNUCKLE ASSY (RIGHT)	1	1	1	1	1	
16	90381-17067	.BUSH, SOLID	2	2	2	2	2	
17	93700-06004	.NIPPLE, GREASE	1	1	1	1	1	
18	3GB-23448-00	SPACER	2	2	2	2	2	
19	2NL-23517-00	COVER, THRUST 1	4	4	4	4	4	
20	90109-104A8	BOLT	2	2	2	2	2	
21	90201-08759	WASHER, PLATE	2	2	2	2	2	
22	90171-10004	NUT, CASTLE	2	2	2	2	2	
23	91401-20020	PIN, COTTER	2	2	2	2	2	

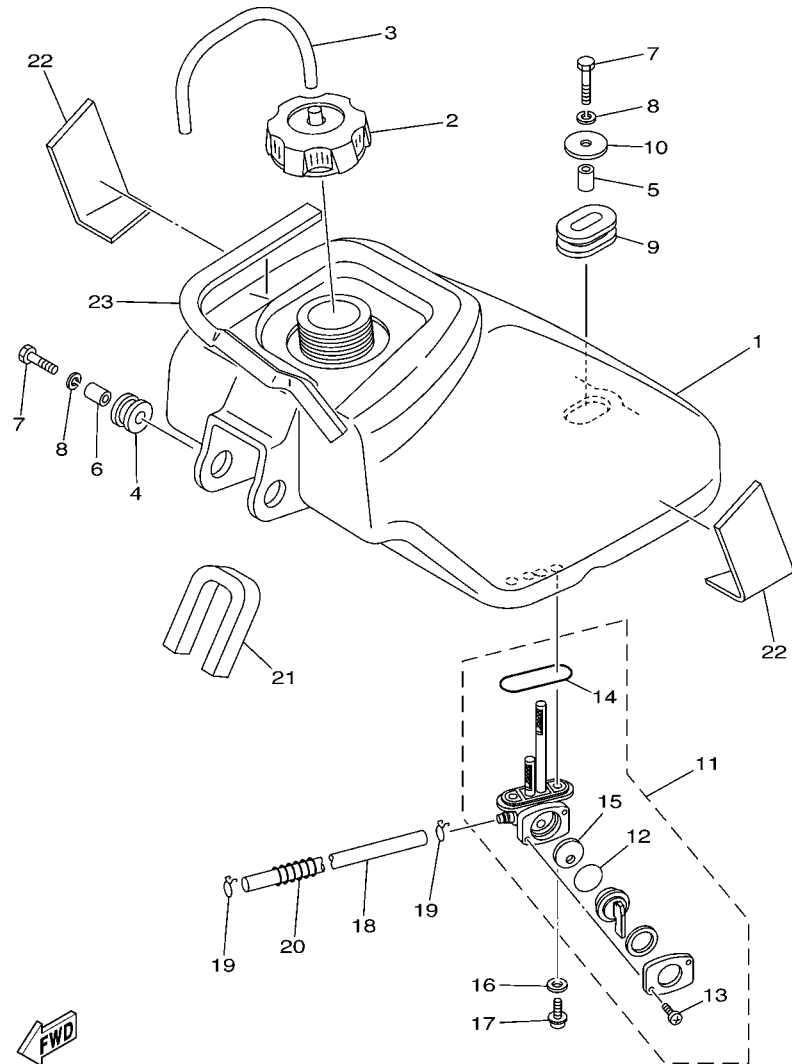

5TH1100-2240

FIG. 24 FUEL TANK

REF. NO.	PART NO.	DESCRIPTION	USA	CAN	EUR	OCE	JPN	REMARKS
1	2HX-24110-00	FUEL TANK COMP.	1	1	1	1	1	
2	2FJ-24610-00	CAP ASSY	1	1	1	1	1	
3	90445-083J4	HOSE (L340)	1	1	1	1	1	
4	90480-18290	GROMMET	2	2	2	2	2	
5	90387-07598	COLLAR	1	1	1	1	1	
6	90387-066J1	COLLAR	2	2	2	2	2	
7	97027-06030	BOLT	3	3	3	3	3	
8	92907-06100	WASHER, SPRING	3	3	3	3	3	
9	90480-01400	GROMMET	1	1	1	1	1	
10	90201-060L5	WASHER, PLATE	1	1	1	1	1	
11	55X-24500-02	FUEL COCK ASSY 1	1	1	1	1	1	
12	3AJ-24534-01	.SEAL, COCK	1	1	1	1	1	
13	98507-03008	.SCREW, PAN HEAD	2	2	2	2	2	
14	4X8-24512-00	.O-RING	1	1	1	1	1	
15	3AC-24523-00	.VALVE PACKING	1	1	1	1	1	
16	90202-05193	WASHER, PLATE	2	2	2	2	2	
17	90149-06011	SCREW	2	2	2	2	2	
18	90445-10638	HOSE (L145)	1	1	1	1	1	
19	90467-09006	CLIP	2	2	2	2	2	
20	90504-06030	SPRING, COMPRESSION	1	1	1	1	1	
21	2HX-24181-00	DAMPER, LOCATING 1	1	1	1	1	1	
22	12R-21747-00	DAMPER	2	2	2	2	2	
23	5TH-2414H-00	DAMPER, PLATE 1	1	1	1	1	1	

FIG. 25 SEAT

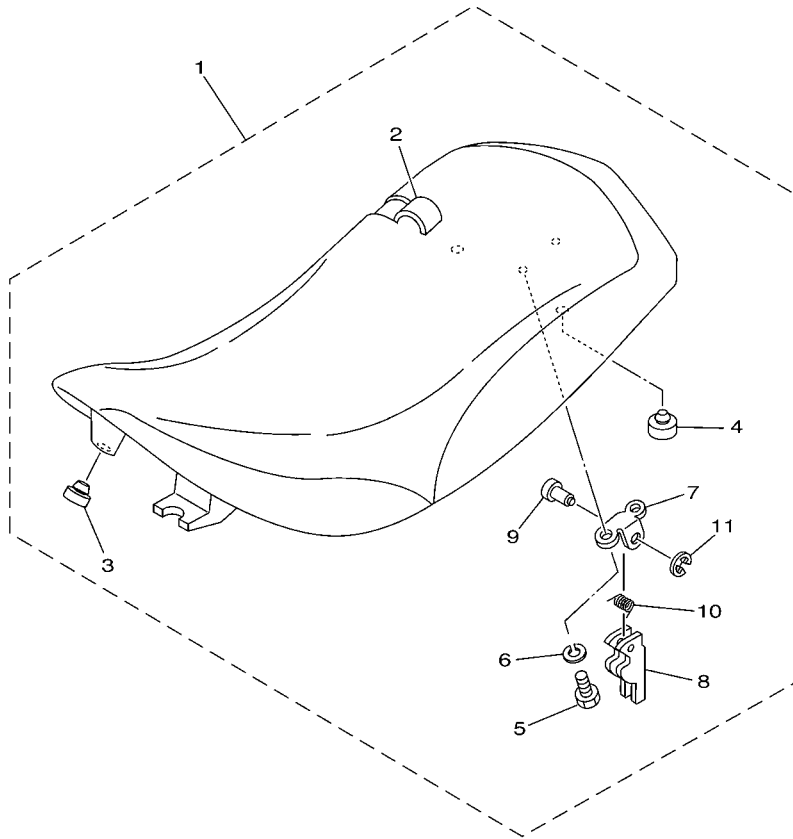

5TH1100-2250

REF. NO.	PART NO.	DESCRIPTION	USA	CAN	EUR	OCE	JPN	REMARKS
1	5TH-24710-00	SINGLE SEAT ASSY	1	1	1	1	1	
2	5TH-2470F-00	.SEAT COVER COMP.	1	1	1	1	1	
3	22W-24741-00	.PAD, SEAT	1	1	1	1	1	
4	371-27114-00	.STOPPER, MAIN STAND	2	2	2	2	2	
5	97007-06012	.BOLT	2	2	2	2	2	
6	92907-06100	.WASHER, SPRING	2	2	2	2	2	
7	4K0-24775-00	.BRACKET, SEAT LEVER	1	1	1	1	1	
8	29U-24776-00	.LEVER, SEAT	1	1	1	1	1	
9	4K0-24774-A0	.PIN	1	1	1	1	1	
10	90508-20454	.SPRING, TORSION	1	1	1	1	1	
11	93430-04002	.CIRCLIP	1	1	1	1	1	

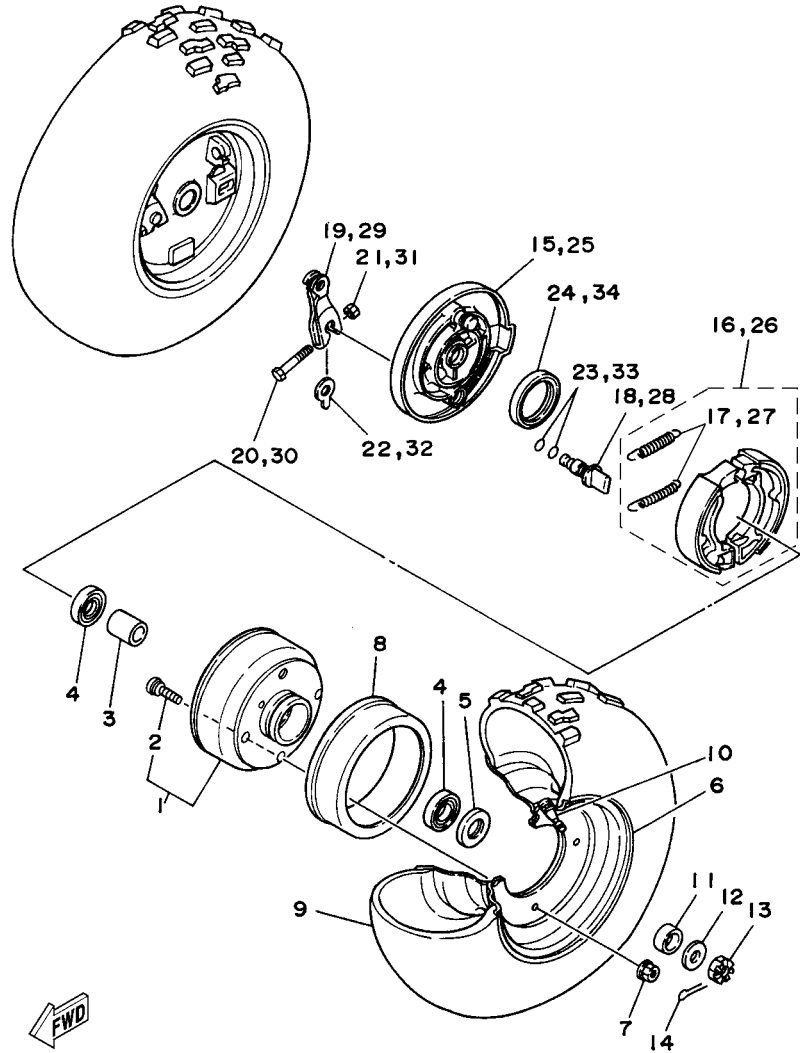

5TH5100-B260

FIG. 26 FRONT WHEEL

REF. NO.	PART NO.	DESCRIPTION	USA	CAN	EUR	OCE	JPN	REMARKS
1	2FJ-25111-00	HUB, FRONT	2	2	2	2	2	
2	90109-08745	.BOLT	4	4	4	4	4	
3	3FA-25117-00	SPACER, BEARING	2	2	2	2	2	
4	93306-00308	BEARING	4	4	4	4	4	
5	93102-23275	OIL SEAL	2	2	2	2	2	
6	2FJ-25180-00-35	WHEEL COMP.	2	2	2	2	2	SL FOR DPBSE,PGD
7	95707-08500	NUT, FLANGE	8	8	8	8	8	
8	3GB-25185-00	RING 1	2	2	2	2	2	
9	94107-07009	TIRE (AT18X7-7 *KT586T/L N)	2	2	2	2	2	DUNLOP
10	93900-00022	VALVE, RIM (TR413)	2	2	2	2	2	TAIHEIYO
11	90387-175R2	COLLAR	2	2	2	2	2	
12	90201-14586	WASHER, PLATE	2	2	2	2	2	
13	90171-14020	NUT, CASTLE	2	2	2	2	2	
14	91401-30025	PIN, SPLIT	2	2	2	2	2	
15	2FJ-25121-00	PLATE, BRAKE SHOE	1	1	1	1	1	
16	4KN-W253E-11	BRAKE SHOE KIT	1	1	1	1	1	
17	90506-15260	.SPRING, TENSION	2	2	2	2	2	
18	3GB-25151-00	CAMSHAFT	1	1	1	1	1	
19	2FJ-25155-00	LEVER, CAMSHAFT 1	1	1	1	1	1	
20	90101-06278	BOLT	1	1	1	1	1	
21	95307-06600	NUT	1	1	1	1	1	
22	52H-2513A-00	PLATE, INDICATOR	1	1	1	1	1	
23	93210-12327	O-RING	2	2	2	2	2	
24	93102-40367	OIL SEAL	1	1	1	1	1	
25	2FJ-25169-00	PLATE, BRAKE SHOE 2	1	1	1	1	1	
26	4KN-W253E-11	BRAKE SHOE KIT	1	1	1	1	1	
27	90506-15260	.SPRING, TENSION	2	2	2	2	2	

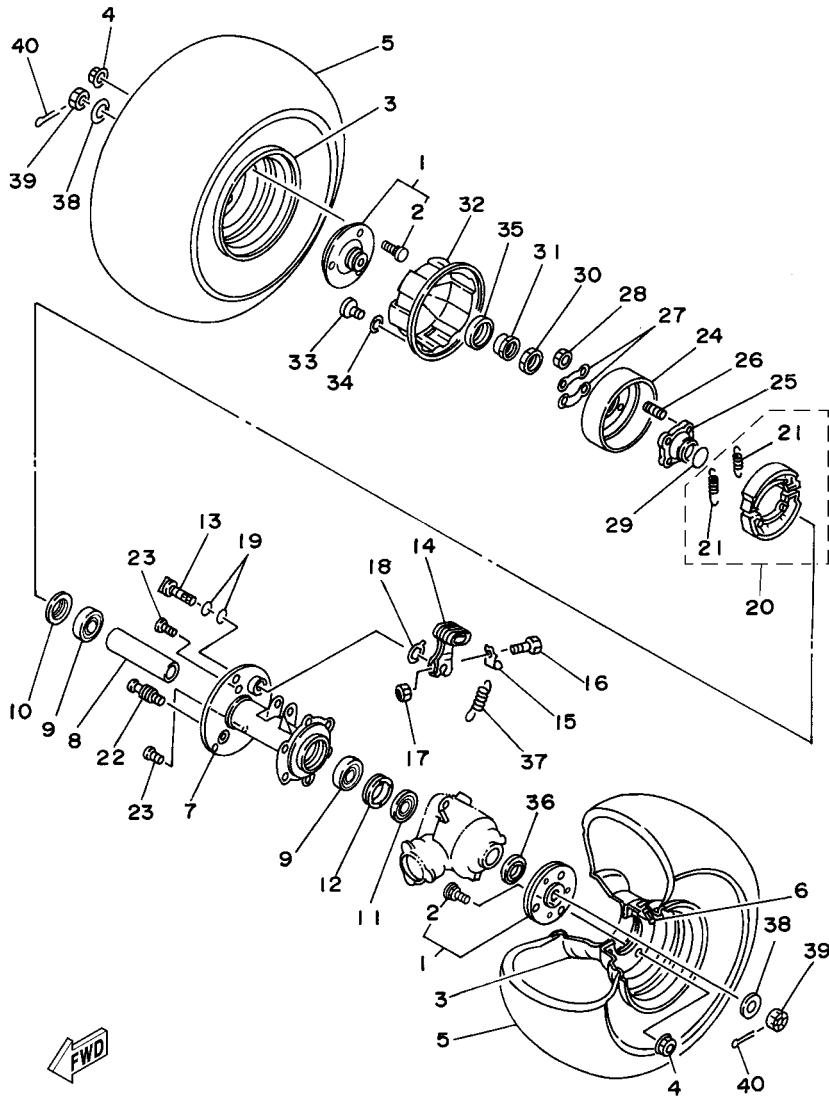

FWD
5TH5100-B270

FIG. 27 REAR WHEEL

REF. NO.	PART NO.	DESCRIPTION	USA	CAN	EUR	OCE	JPN	REMARKS
1	55X-25383-10	COLLAR, WHEEL	2	2	2	2	2	
2	90114-08001	.BOLT, SERRATION	3	3	3	3	3	
3	2FJ-25390-00-35	REAR WHEEL COMP.	2	2	2	2	2	SL FOR DPBSE,PGD
4	95707-08500	NUT, FLANGE	6	6	6	6	6	
5	94108-07009	TIRE (AT18X8-7**KT587T/L N)	2	2	2	2	2	DUNLOP
6	93900-00022	VALVE, RIM (TR413)	2	2	2	2	2	TAIHEIYO
7	3GB-25311-00-33	HUB, REAR	1	1	1	1	1	YB FOR DPBSE,PGD
8	3GB-25317-00	SPACER, BEARING	1	1	1	1	1	
9	93306-00612	BEARING	2	2	2	2	2	
10	93102-38383	OIL SEAL	1	1	1	1	1	
11	93102-36409	OIL SEAL	1	1	1	1	1	
12	3GB-25382-00	NUT, AXLE	1	1	1	1	1	
13	3Y6-25351-00	CAMSHAFT	1	1	1	1	1	
14	55X-25355-00	LEVER, CAMSHAFT	1	1	1	1	1	
15	55X-2533H-00	HOOK, SPRING	1	1	1	1	1	
16	90101-06562	BOLT	1	1	1	1	1	
17	95307-06600	NUT	1	1	1	1	1	
18	23F-2533A-00	PLATE, INDICATOR	1	1	1	1	1	
19	93210-14104	O-RING	2	2	2	2	2	
20	3FA-W253E-00	BRAKE SHOE KIT	1	1	1	1	1	
21	90506-15260	.SPRING, TENSION	2	2	2	2	2	
22	3GB-25326-00	PIN, PIVOT	1	1	1	1	1	
23	90114-10005	BOLT, SERRATION	2	2	2	2	2	
24	3GB-2531E-00	DRUM, BRAKE	1	1	1	1	1	
25	3GB-25343-10	BOSS	1	1	1	1	1	
26	90116-08507	BOLT, STUD	4	4	4	4	4	
27	390-25412-01	WASHER	2	2	2	2	2	

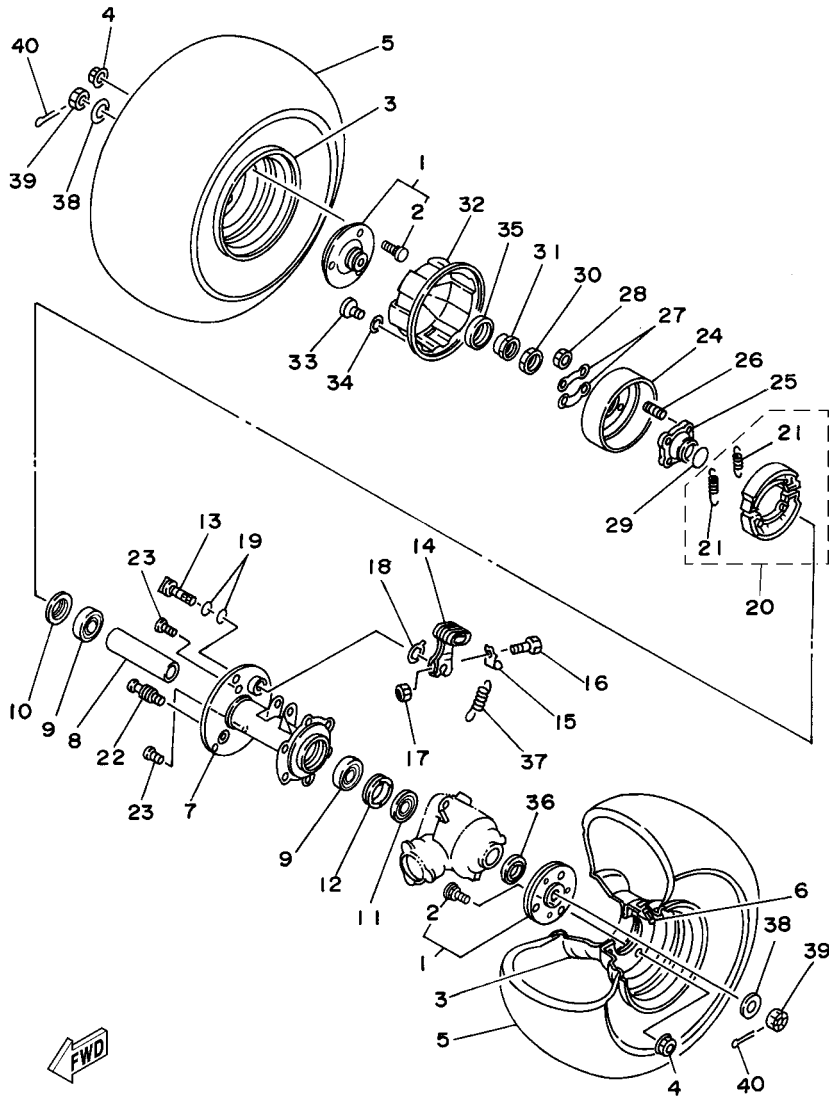

5TH5100-B270

FIG. 27 REAR WHEEL

REF. NO.	PART NO.	DESCRIPTION	USA	CAN	EUR	OCE	JPN	REMARKS
28	95307-08600	NUT	4	4	4	4	4	
29	93210-26606	O-RING	1	1	1	1	1	
30	90170-28011	NUT	1	1	1	1	1	
31	90179-28009	NUT	1	1	1	1	1	
32	3GB-25715-00	COVER 1	1	1	1	1	1	
33	98507-06012	SCREW, PAN HEAD	3	3	3	3	3	
34	92907-06100	WASHER, SPRING	3	3	3	3	3	
35	93102-35349	OIL SEAL	1	1	1	1	1	
36	3GB-25367-00	COVER, HUB DUST	1	1	1	1	1	
37	90507-15038	SPRING, TENSION	1	1	1	1	1	
38	90201-12045	WASHER, PLATE	2	2	2	2	2	
39	90171-12001	NUT, CASTLE	2	2	2	2	2	
40	91401-25025	PIN, COTTER	2	2	2	2	2	

FIG. 28 STEERING HANDLE & CABLE

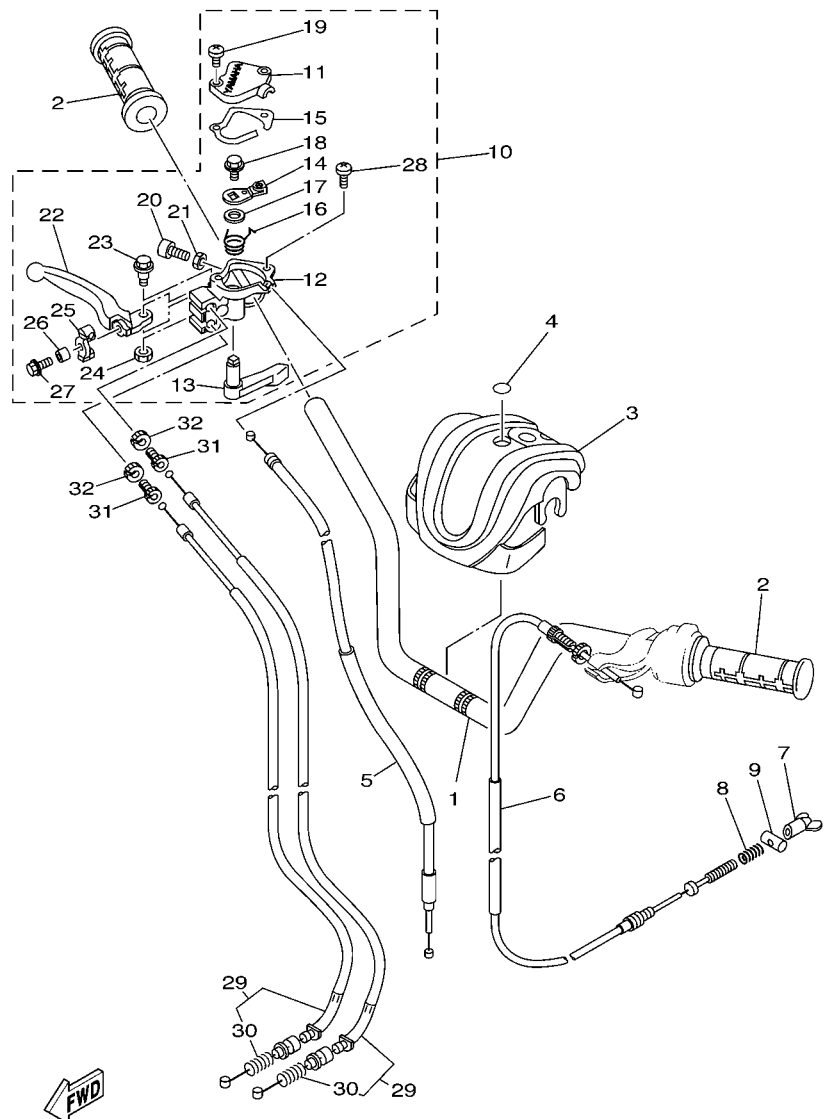

5TH1100-2280

REF. NO.	PART NO.	DESCRIPTION	USA	CAN	EUR	OCE	JPN	REMARKS
1	5TH-26111-10	HANDLEBAR	1	1	1	1	1	
2	5LP-26241-00	GRIP	2	2	2	2	2	
3	5TH-26124-00	PROTECTOR, HANDLEBAR	1	1	1	1	1	UR FOR DPBSE
	5TH-26124-10	PROTECTOR, HANDLEBAR	1	1		1		UR FOR PGD
4	5GT-2836B-10	TUNING FORK MARK	1	1	1	1	1	
5	3GB-26311-02	CABLE, THROTTLE 1	1	1	1	1	1	
6	3GB-26341-01	CABLE, BRAKE	1	1	1	1	1	
7	20E-26343-00	NUT, ADJUSTING	1	1	1	1	1	
8	90501-10782	SPRING, COMPRESSION	1	1	1	1	1	
9	90249-12008	PIN	1	1	1	1	1	
10	5TH-26250-01	THROTTLE LEVER ASSY	1	1	1	1	1	
11	3GB-2628F-00	.CAP, GEAR	1	1	1	1	1	
12	3GB-2625E-01	.BODY, THROTTLE	1	1	1	1	1	
13	3GB-2625G-00	.LEVER, THROTTLE	1	1	1	1	1	
14	3GB-2625H-00	.ARM, THROTTLE	1	1	1	1	1	
15	3GB-2628G-02	.GASKET	1	1	1	1	1	
16	90508-10775	.SPRING, TORSION	1	1	1	1	1	
17	90201-145M4	.WASHER, PLATE	1	1	1	1	1	
18	95807-08012	.BOLT, FLANGE	1	1	1	1	1	
19	98507-04016	.SCREW, PAN HEAD	2	2	2	2	2	
20	91317-05025	.BOLT	1	1	1	1	1	
21	95307-05700	.NUT	1	1	1	1	1	
22	5TH-83922-00	.LEVER 2	1	1	1	1	1	
23	90109-061F3	.BOLT	1	1	1	1	1	
24	95607-06100	.NUT, U	1	1	1	1	1	
25	3GB-26347-00	.JOINT, CABLE	1	1	1	1	1	
26	90387-066V8	.COLLAR	1	1	1	1	1	

FIG. 31 GENERATOR

REF. NO.	PART NO.	DESCRIPTION	USA	CAN	EUR	OCE	JPN	REMARKS
1	2FM-85550-M1	ROTOR ASSY	1	1	1	1	1	
2	4EM-85560-10	BASE ASSY	1	1	1	1	1	
3	5G3-85520-M1	.COIL, CHARGE	1	1	1	1	1	
4	55X-81313-M0	.COIL, LIGHTING 1	1	1	1	1	1	
5	22K-85595-M0	.COIL, PULSER	1	1	1	1	1	
6	98511-04012	.SCREW, PAN HEAD	2	2	2	2	2	
7	98511-04020	.SCREW, PAN HEAD	2	2	2	2	2	
8	98501-04006	.SCREW, PAN HEAD	2	2	2	2	2	
9	92901-04100	.WASHER, SPRING	2	2	2	2	2	
10	98501-05010	.SCREW, PAN HEAD	1	1	1	1	1	
11	92901-05100	.WASHER, SPRING	1	1	1	1	1	
12	93102-19276	.OIL SEAL	1	1	1	1	1	
13	98707-06016	SCREW, FLAT HEAD	2	2	2	2	2	
14	93211-02703	O-RING	1	1	1	1	1	
15	90179-10394	NUT	1	1	1	1	1	
16	90201-101A4	WASHER, PLATE	1	1	1	1	1	

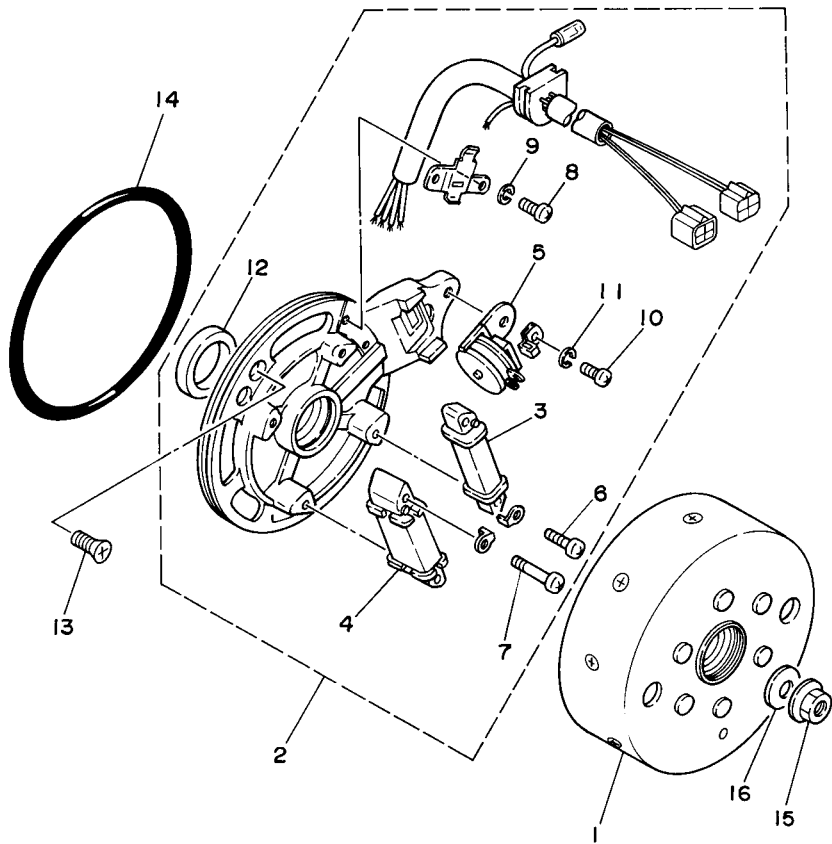

4EM9100-5320

D12

FIG. 34 HANDLE SWITCH & LEVER

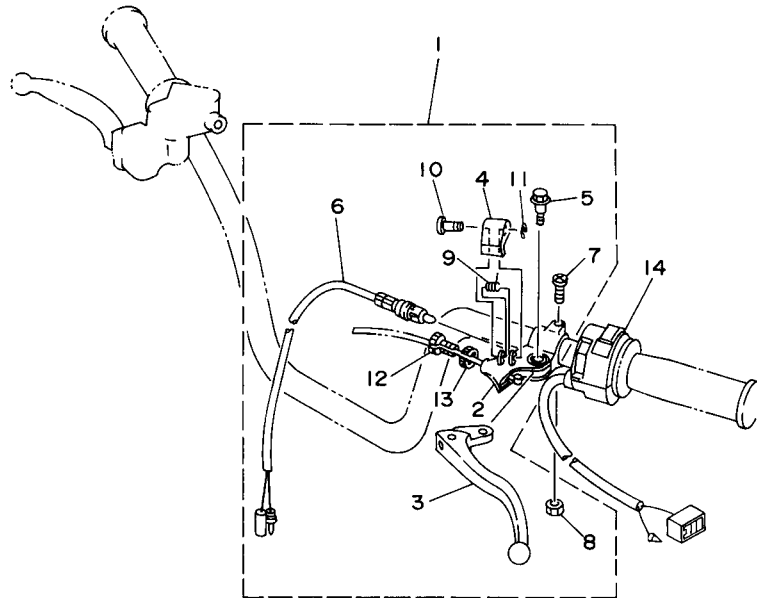

REF. NO.	PART NO.	DESCRIPTION	USA	CAN	EUR	OCE	JPN	REMARKS
1	5TH-82910-01	LEVER HOLDER ASSY (LEFT)	1	1	1	1	1	
2	3FA-82911-01	.HOLDER, LEVER 1	1	1	1	1	1	
3	23X-83912-00	.LEVER 1	1	1	1	1	1	
4	3FA-83965-00	.LEVER, LOCK	1	1	1	1	1	
5	90109-06799	.BOLT	1	1	1	1	1	
6	1YW-83980-00	.FRONT STOP SWITCH ASSY	1	1	1	1	1	
7	98507-06020	.SCREW, PAN HEAD	1	1	1	1	1	
8	95607-06100	.NUT, U	1	1	1	1	1	
9	3FA-83966-00	.SPRING, RETURN	1	1	1	1	1	
10	3FA-83967-00	.PIN, LOCK 1	1	1	1	1	1	
11	3FA-26466-00	.RING, SNAP	1	1	1	1	1	
12	90123-08046	.BOLT	1	1	1	1	1	
13	90179-08148	.NUT	1	1	1	1	1	
14	4EM-83975-00	SWITCH, HANDLE 2	1	1	1	1	1	



4EM9100-5340

FIG. 35 ELECTRICAL 1

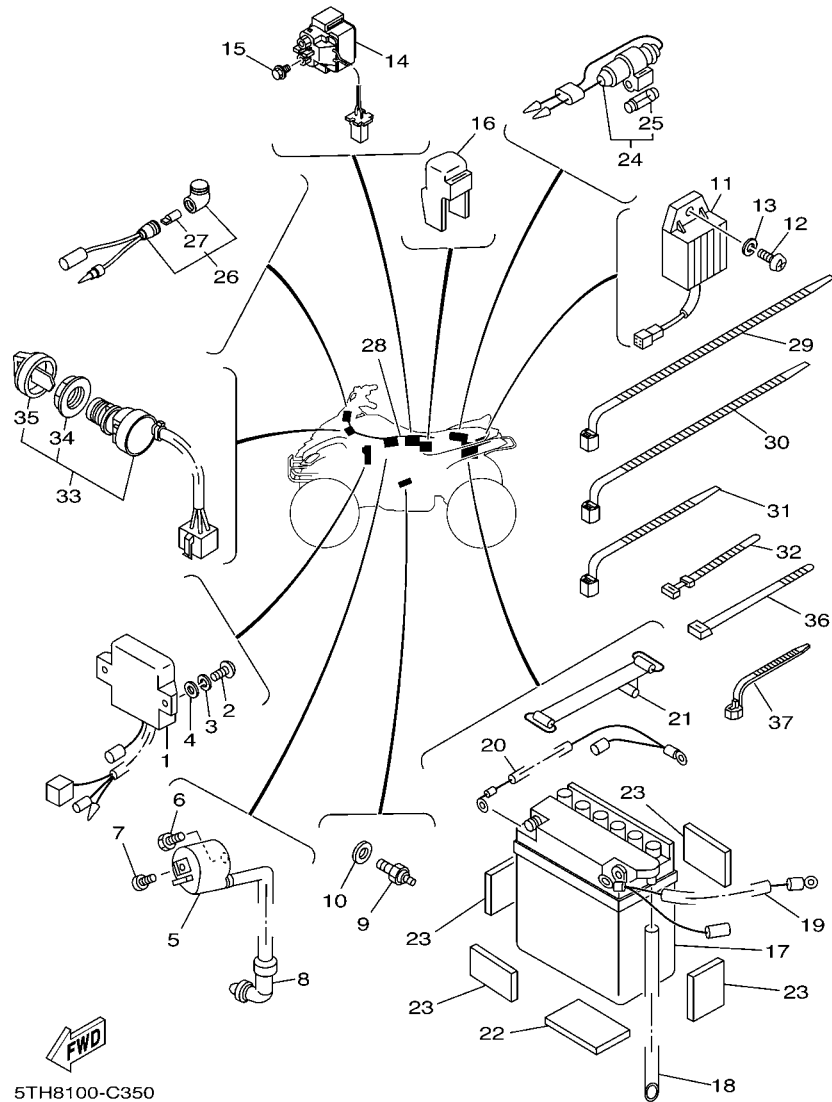

5TH8100-C350

REF. NO.	PART NO.	DESCRIPTION	USA	CAN	EUR	OCE	JPN	REMARKS
1	4EM-85540-10	C.D.I. UNIT ASSY	1	1	1	1	1	
2	98507-06020	SCREW, PAN HEAD	2	2	2	2	2	
3	92907-06100	WASHER, SPRING	2	2	2	2	2	
4	92907-06600	WASHER, PLATE	2	2	2	2	2	
5	4KJ-82310-10	IGNITION COIL ASSY	1	1	1	1	1	
6	97007-06016	BOLT	1	1	1	1	1	
7	90153-06034	SCREW, HEXAGON	1	1	1	1	1	
8	55X-82370-00	PLUG CAP ASSY	1	1	1	1	1	
9	3GB-82540-01	NEUTRAL SWITCH ASSY	1	1	1	1	1	
10	90430-10148	GASKET	1	1	1	1	1	
11	5TH-81960-01	RECTIFIER & REGULATOR ASSY	1	1	1	1	1	
12	98507-06016	SCREW, PAN HEAD	1	1	1	1	1	
13	92907-06100	WASHER, SPRING	1	1	1	1	1	
14	3MW-81940-01	STARTER RELAY ASSY	1	1	1	1	1	
15	95027-06008	BOLT, FLANGE	2	2	2	2	2	
16	1RL-81950-92	RELAY ASSY	1	1	1	1	1	
17	55X-82110-61	BATTERY ASSY (GS 12N7D-3B)	1	1	1	1	1	
	90793-25013	BATTERY ASSY (GS 12N7D-3B)					1	
18	90445-085E0	HOSE (L450)	1	1	1	1	1	
19	55X-82115-01	WIRE, PLUS LEAD	1	1	1	1	1	
20	3GB-82116-00	WIRE, MINUS LEAD	1	1	1	1	1	
21	4J2-82131-01	BAND, BATTERY	1	1	1	1	1	
22	55X-82122-00	SEAT, BATTERY	1	1	1	1	1	
23	29W-82123-00	SEAT, BATTERY	4	4	4	4	4	
24	3GB-82150-00	FUSE HOLDER ASSY	1	1	1	1	1	
25	3GB-82151-00	.FUSE (5A)	2	2	2	2	2	
26	4KB-83530-00	PILOT LIGHT ASSY	1	1	1	1	1	GREEN (NEUTRAL)

FIG. 35 ELECTRICAL 1

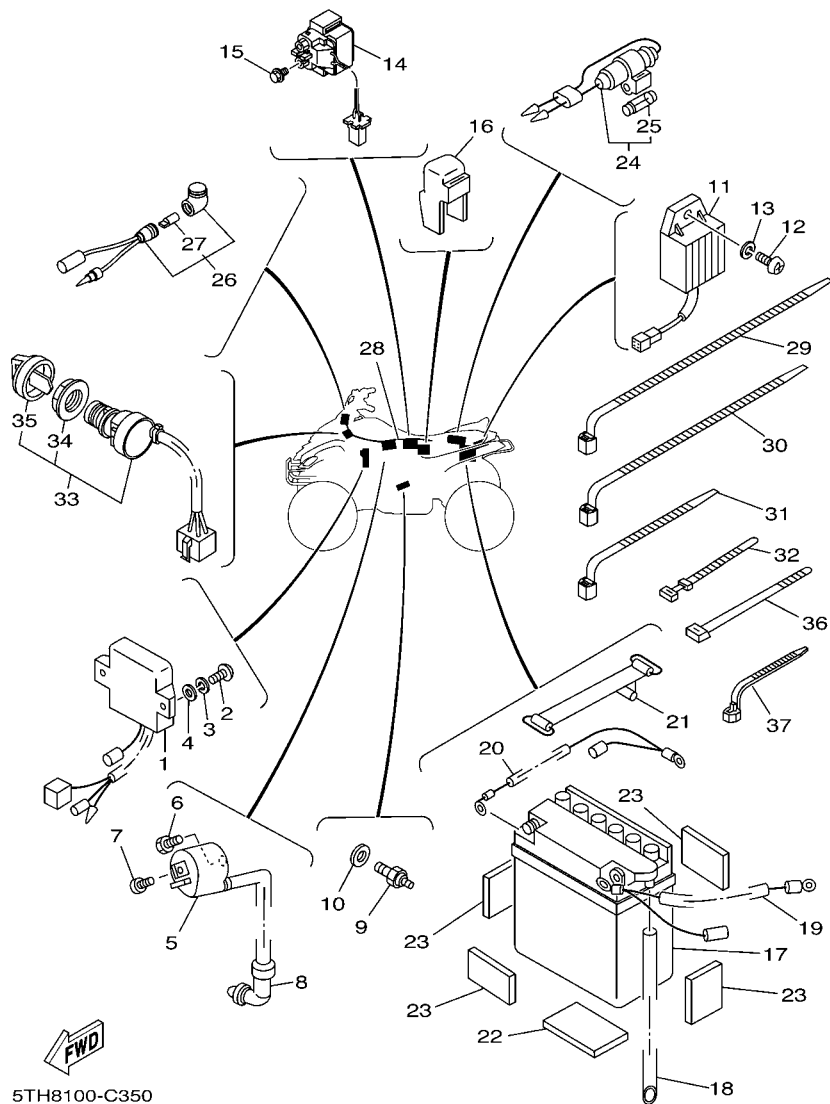

5TH8100-C350

REF. NO.	PART NO.	DESCRIPTION	USA	CAN	EUR	OCE	JPN	REMARKS
27	5GH-83516-00	.BULB (14V-1.7W)	1	1	1	1	1	
28	5TH-82590-00	WIRE HARNESS ASSY	1	1	1	1	1	
29	90460-15126	CLAMP, HOSE	1	1	1	1	1	
30	90464-12045	CLAMP	1	1	1	1	1	
31	90464-13073	CLAMP	3	3	3	3	3	
32	437-83936-01	BAND, SWITCH CORD	1	1	1	1	1	
33	4GB-82510-11	MAIN SWITCH ASSY	1	1	1	1	1	
34	3HN-82569-00	.NUT, MAIN SWITCH	1	1	1	1	1	
35	3HN-82579-00	.CAP, KEY	1	1	1	1	1	
36	90465-10098	CLAMP	1	1	1	1	1	
37	90464-15195	CLAMP	1	1	1	1	1	

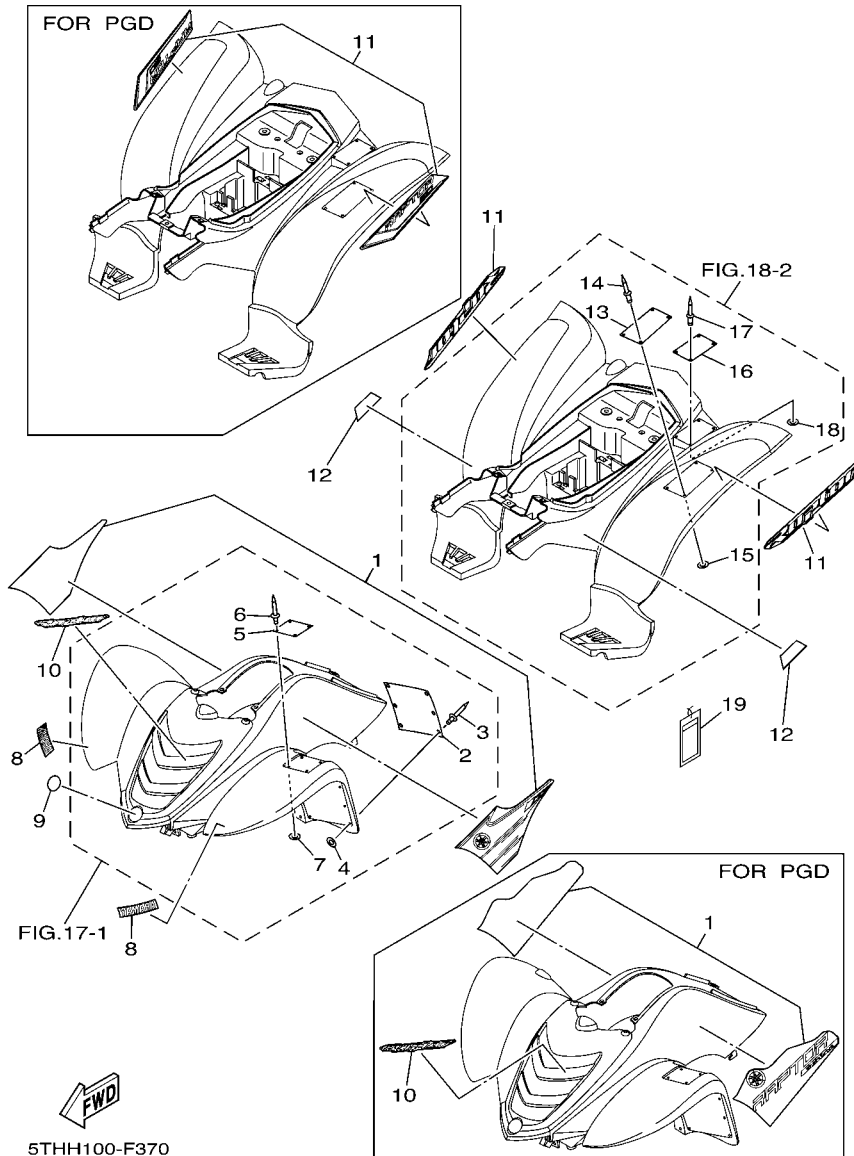

FIG. 37 EMBLEM & LABEL 1

REF. NO.	PART NO.	DESCRIPTION	USA	CAN	EUR	OCE	JPN	REMARKS
1	5YF-21570-60	GRAPHIC SET, FRONT FENDER	1					UR FOR DPBSE
	5YF-21570-70	GRAPHIC SET, FRONT FENDER	1					UR FOR PGD
2	5FE-21568-01	LABEL, WARNING	1					ENGLISH
3	90267-32004	RIVET, BLIND	6					
4	90201-03313	WASHER, PLATE	6					
5	4EM-21697-31	LABEL, CAUTION 2	1					ENGLISH
6	90267-32004	RIVET, BLIND	4					
7	90201-03313	WASHER, PLATE	4					
8	4ES-2153E-40	EMBLEM, YAMAHA	2					
9	5KM-2175B-00	TUNING FORK MARK	1					
10	5YF-21565-20	EMBLEM, 2	1					UR FOR DPBSE
	5YF-21565-40	EMBLEM, 2	1					UR FOR PGD
11	5YF-21609-20	EMBLEM	2					UR FOR DPBSE
	5TH-2165A-20	GRAPHIC SET, REAR FENDER	1					UR FOR PGD
12	5TH-2163G-40	EMBLEM 1	2					FOR DPBSE
13	4EM-21696-11	LABEL, CAUTION	1					ENGLISH
14	90267-32004	RIVET, BLIND	4					
15	90201-03313	WASHER, PLATE	4					
16	5FE-2151H-01	LABEL 5	1					ENGLISH
17	90267-32004	RIVET, BLIND	4					
18	90201-03313	WASHER, PLATE	4					
19	4EM-2819R-00	TAG, WARNING	1					

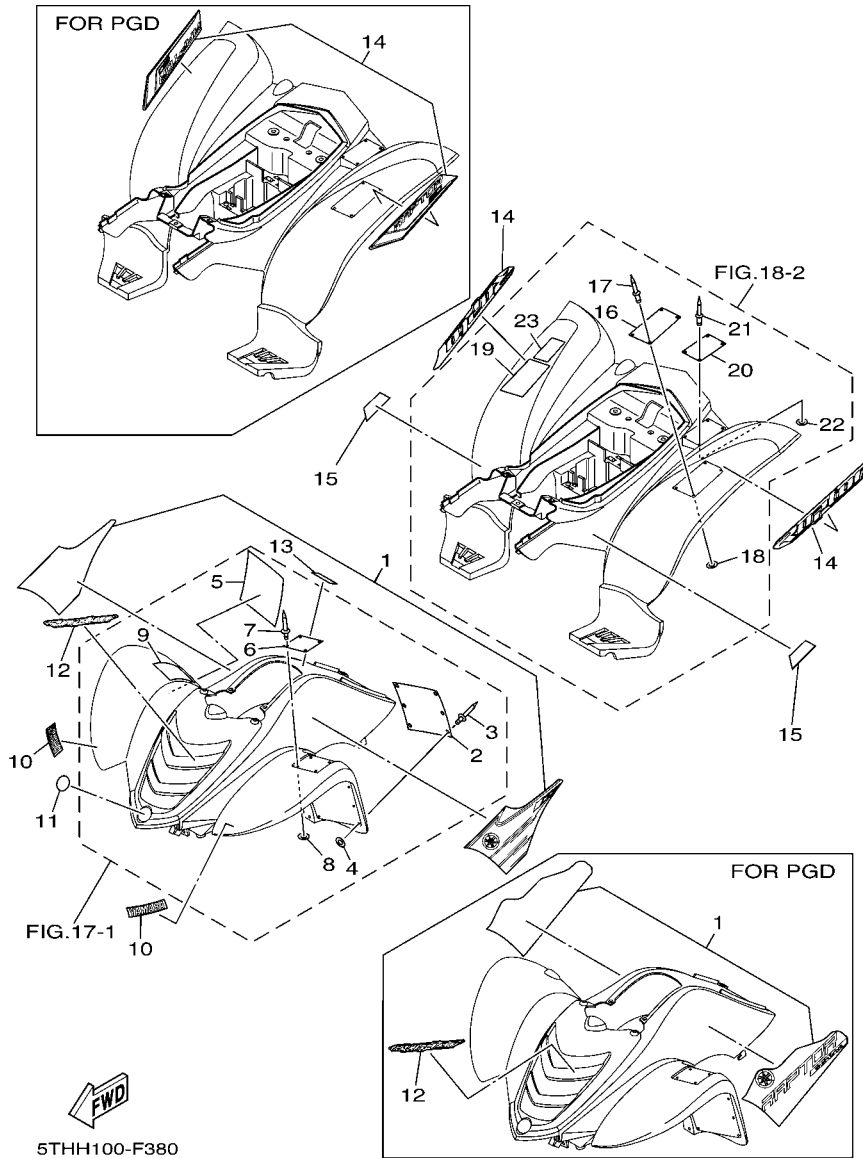
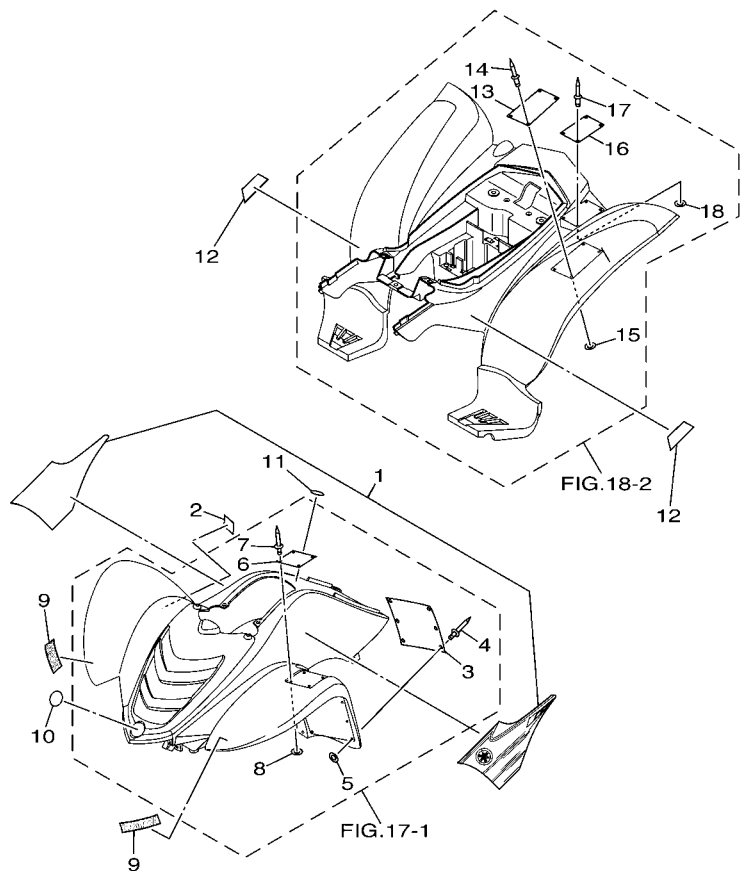

FIG. 38 EMBLEM & LABEL 2

REF. NO.	PART NO.	DESCRIPTION	USA	CAN	EUR	OCE	JPN	REMARKS
1	5YF-21570-60	GRAPHIC SET, FRONT FENDER		1				UR FOR DPBSE
	5YF-21570-70	GRAPHIC SET, FRONT FENDER		1				UR FOR PGD
2	5FE-21568-01	LABEL, WARNING		1				ENGLISH
3	90267-32004	RIVET, BLIND		6				
4	90201-03313	WASHER, PLATE		6				
5	4WU-21568-10	LABEL, WARNING		1				FRENCH
6	4EM-21697-31	LABEL, CAUTION 2		1				ENGLISH
7	90267-32004	RIVET, BLIND		4				
8	90201-03313	WASHER, PLATE		4				
9	4EM-21697-20	LABEL, CAUTION 2		1				FRENCH
10	4ES-2153E-40	EMBLEM, YAMAHA		2				
11	5KM-2175B-00	TUNING FORK MARK		1				
12	5YF-21565-20	EMBLEM, 2		1				UR FOR DPBSE
	5YF-21565-40	EMBLEM, 2		1				UR FOR PGD
13	4SH-2416E-00	LABEL, CAUTION CANADA		1				ENGLISH
14	5YF-21609-20	EMBLEM		2				UR FOR DPBSE
	5TH-2165A-20	GRAPHIC SET, REAR FENDER		1				UR FOR PGD
15	5TH-2163G-40	EMBLEM 1		2				FOR DPBSE
16	4EM-21696-11	LABEL, CAUTION		1				ENGLISH
17	90267-32004	RIVET, BLIND		4				
18	90201-03313	WASHER, PLATE		4				
19	4EM-21696-B0	LABEL, CAUTION		1				FRENCH
20	5FE-2151H-01	LABEL 5		1				ENGLISH
21	90267-32004	RIVET, BLIND		4				
22	90201-03313	WASHER, PLATE		4				
23	4WU-2151H-10	LABEL 5		1				FRENCH

FIG. 39 EMBLEM & LABEL 3



5THH100-F390

REF. NO.	PART NO.	DESCRIPTION	USA	CAN	EUR	OCE	JPN	REMARKS
1	5YF-21570-60	GRAPHIC SET, FRONT FENDER			1			
2	4GB-2155A-00	MARK, EC			1			
3	5FK-21568-00	LABEL, WARNING			1			
4	90267-32004	RIVET, BLIND			6			
5	90201-03313	WASHER, PLATE			6			
6	5NE-21697-00	LABEL, CAUTION 2			1			
7	90267-32004	RIVET, BLIND			4			
8	90201-03313	WASHER, PLATE			4			
9	4ES-2153E-40	EMBLEM, YAMAHA			2			
10	5KM-2175B-00	TUNING FORK MARK			1			
11	3ME-2415E-01	LABEL, CAUTION			1			
12	5TH-2163G-40	EMBLEM 1			2			
13	5YF-21696-M0	LABEL, CAUTION			1			
14	90267-32004	RIVET, BLIND			4			
15	90201-03313	WASHER, PLATE			4			
16	5FK-2151H-00	LABEL 5			1			
17	90267-32004	RIVET, BLIND			4			
18	90201-03313	WASHER, PLATE			4			

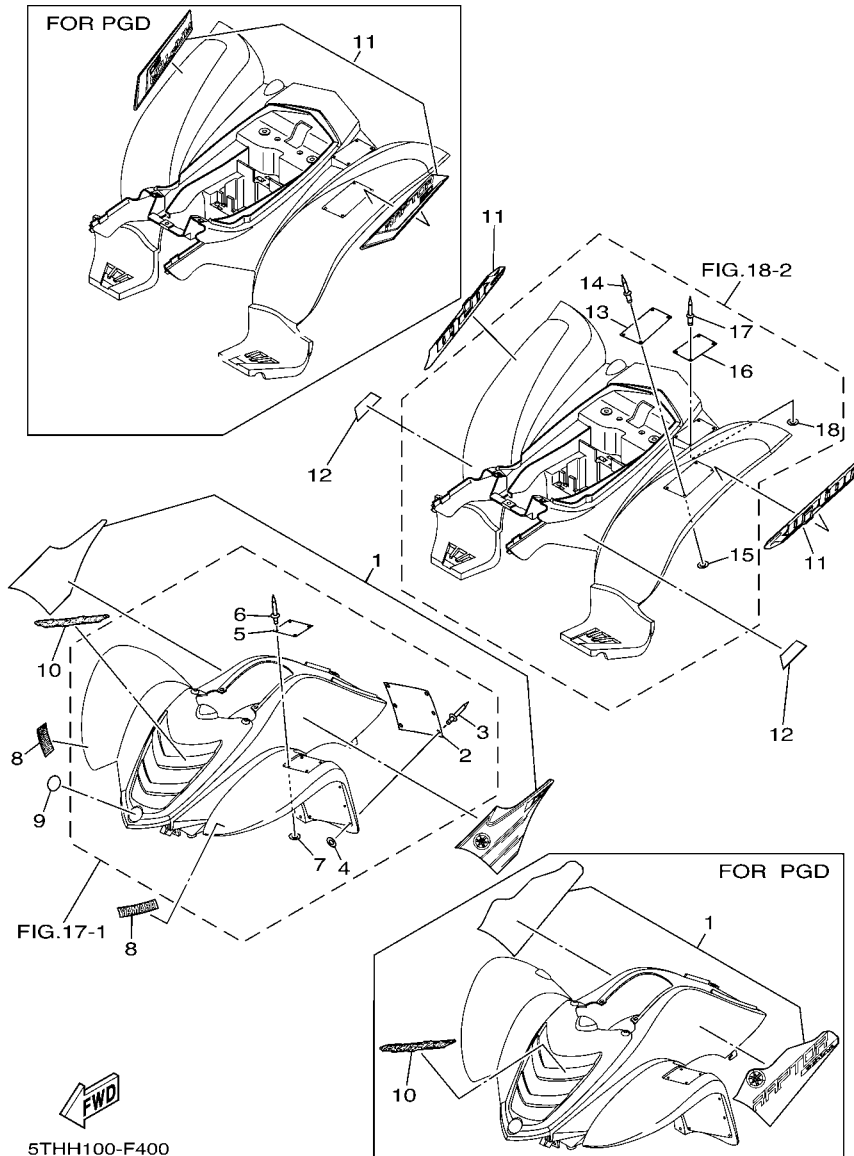

FIG. 40 EMBLEM & LABEL 4

REF. NO.	PART NO.	DESCRIPTION	USA	CAN	EUR	OCE	JPN	REMARKS
1	5YF-21570-60	GRAPHIC SET, FRONT FENDER					1	UR FOR DPBSE
	5YF-21570-70	GRAPHIC SET, FRONT FENDER					1	UR FOR PGD
2	5FE-21568-11	LABEL, WARNING					1	ENGLISH
3	90267-32004	RIVET, BLIND					6	
4	90201-03313	WASHER, PLATE					6	
5	4EM-21697-31	LABEL, CAUTION 2					1	ENGLISH
6	90267-32004	RIVET, BLIND					4	
7	90201-03313	WASHER, PLATE					4	
8	4ES-2153E-40	EMBLEM, YAMAHA					2	
9	5KM-2175B-00	TUNING FORK MARK					1	
10	5YF-21565-20	EMBLEM, 2					1	UR FOR DPBSE
	5YF-21565-40	EMBLEM, 2					1	UR FOR PGD
11	5YF-21609-20	EMBLEM					2	UR FOR DPBSE
	5TH-2165A-20	GRAPHIC SET, REAR FENDER					1	UR FOR PGD
12	5TH-2163G-40	EMBLEM 1					2	FOR DPBSE
13	4EM-21696-11	LABEL, CAUTION					1	ENGLISH
14	90267-32004	RIVET, BLIND					4	
15	90201-03313	WASHER, PLATE					4	
16	5FE-2151H-01	LABEL 5					1	ENGLISH
17	90267-32004	RIVET, BLIND					4	
18	90201-03313	WASHER, PLATE					4	

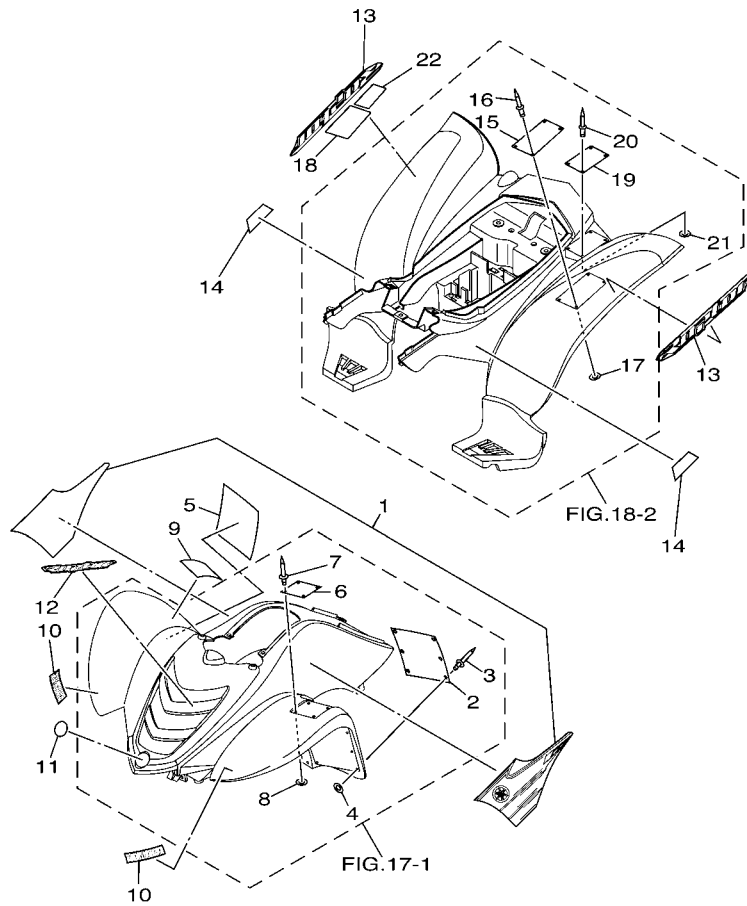

FIG. 41 EMBLEM & LABEL 5

REF. NO.	PART NO.	DESCRIPTION	USA	CAN	EUR	OCE	JPN	REMARKS
1	5YF-21570-60	GRAPHIC SET, FRONT FENDER					1	FOR DPBSE
2	5FE-21568-11	LABEL, WARNING					1	ENGLISH
3	90267-32004	RIVET, BLIND					6	
4	90201-03313	WASHER, PLATE					6	
5	4SH-21568-00	LABEL, WARNING					1	JAPANESE
6	4EM-21697-31	LABEL, CAUTION 2					1	ENGLISH
7	90267-32004	RIVET, BLIND					4	
8	90201-03313	WASHER, PLATE					4	
9	4EM-21697-00	LABEL, CAUTION 2					1	
10	4ES-2153E-40	EMBLEM, YAMAHA					2	
11	5KM-2175B-00	TUNING FORK MARK					1	
12	5YF-21565-20	EMBLEM, 2					1	FOR DPBSE
13	5YF-21609-20	EMBLEM					2	FOR DPBSE
14	5TH-2163G-40	EMBLEM 1					2	FOR DPBSE
15	4EM-21696-11	LABEL, CAUTION					1	ENGLISH
16	90267-32004	RIVET, BLIND					4	
17	90201-03313	WASHER, PLATE					4	
18	4EM-21696-00	LABEL, CAUTION					1	
19	5FE-2151H-01	LABEL 5					1	ENGLISH
20	90267-32004	RIVET, BLIND					4	
21	90201-03313	WASHER, PLATE					4	
22	4LB-2151H-02	LABEL 5					1	

NUMERICAL INDEX

PART NO.	GRID NO.	PART NO.	GRID NO.	PART NO.	GRID NO.	PART NO.	GRID NO.	PART NO.	GRID NO.	PART NO.	GRID NO.
35T-11110-01	B - 2	22K-14104-00	B - 7	4EM-15443-01	B - 11	2MK-18511-00	C - 3	5YF-21609-20	E - 5	3GB-23448-00	C - 15
22F-11134-10	B - 2	2HX-14112-35	B - 7	3GB-15451-00	B - 11	29F-18512-00	C - 3		E - 6	3GB-23501-10	C - 15
2D3-11166-00	B - 10	260-14131-00	B - 7	3GB-15461-00	B - 11	22F-18531-00	C - 3		E - 8	3GB-23502-10	C - 15
59V-11167-00	B - 10	4EM-14141-78	B - 8	2HX-15517-10	B - 12	4EM-18540-00	C - 3		E - 9	2NL-23517-00	C - 15
55X-11181-00	B - 2	22F-14142-12	B - 7	2HX-15520-00	B - 12	136-18542-00	C - 3	3GB-21613-00	C - 8	3GB-23570-00-33	C - 15
22F-11185-10	B - 2	55X-14146-00	B - 7	22M-15570-10	B - 12	296-18561-00	C - 3	3GB-21614-00	C - 8	1UY-23812-00	C - 13
22F-11186-10	B - 2	22K-14147-00	B - 7	22M-15580-10	B - 12	22F-18562-01	C - 3	5TH-2163G-40	E - 5	4EM-23813-10	C - 13
812-11198-00	B - 6	18A-1414E-30	B - 7	3AY-15583-00	B - 12	5TH-21110-20	C - 5		E - 6	8G5-23814-00	C - 13
214-11198-01	C - 10	22F-14150-00	B - 8	22K-16111-00	B - 13	5TH-21110-30	C - 5		E - 7	8K1-23814-00	C - 13
22K-11311-02	B - 2	802-14161-00	B - 7	3GB-16150-00	B - 13	5TH-21268-01	C - 5		E - 8	3GB-23831-00	C - 13
22F-11351-01	B - 2	22F-14169-00	B - 7	22F-16153-40	B - 13	5TH-21513-00	C - 7		E - 9	55X-23841-01	C - 13
22K-11400-01	B - 3	22F-14184-00	B - 7	22F-16163-00	B - 14	5FK-2151H-00	E - 7	5TH-2165A-20	E - 5	52H-23845-01	C - 13
22K-11422-00	B - 3	22F-14185-00	B - 8	122-16164-00	B - 13	5FE-2151H-01	E - 5		E - 6	2D3-23858-00	C - 13
55X-11610-00	B - 3	127-14186-00	B - 7	22F-16342-01	B - 14		E - 5		E - 6	3GB-23868-00	C - 13
55X-11610-20	B - 3	12R-14191-00	B - 7	22K-16356-00	B - 14		E - 8	4EM-21696-00	E - 9	1UY-23894-01	C - 13
55X-11610-40	B - 3	24W-14193-00	B - 8	22F-16357-01	B - 13		E - 9	4EM-21696-11	E - 5	2HX-24110-00	D - 2
55X-11631-00-96	B - 3	55X-14196-00	B - 8	22F-16362-01	B - 14	4LB-2151H-02	E - 9		E - 6	5TH-2414H-00	D - 2
22K-11633-01	B - 3	26H-14197-00	B - 7	22F-16382-00	B - 14	4WU-2151H-10	E - 6		E - 8	3ME-2415E-01	E - 7
55X-11636-00	B - 3	55X-14198-00	B - 8	22F-16383-00	B - 14	4ES-2153E-40	E - 5		E - 9	4SH-2416E-00	E - 6
55X-11638-00	B - 3	5TH-14412-00	C - 6	22F-16399-00	B - 14		E - 6	4EM-21696-B0	E - 6	2HX-24181-00	D - 2
22K-11651-02	B - 3	2D3-14419-00	C - 6	22K-16520-00	B - 13		E - 7	5YF-21696-M0	E - 7	55X-24500-02	D - 2
22F-11681-00	B - 3	31A-14435-00	C - 6	22F-16521-00	B - 13		E - 8	4EM-21697-00	E - 9	4X8-24512-00	D - 2
2D3-12111-00	B - 4	55X-14436-00	C - 6	3E5-16521-00	B - 13		E - 9	5NE-21697-00	E - 7	3AC-24523-00	D - 2
22F-12114-00	B - 4	5TH-14436-00	C - 6	22F-16524-01	B - 13	5TH-21556-00	C - 6	4EM-21697-20	E - 6	3AJ-24534-01	D - 2
22F-12116-00	B - 4	2HX-14437-01	C - 7	517-16524-10	B - 13	5TH-21556-30	C - 6	4EM-21697-31	E - 5	2FJ-24610-00	D - 2
22F-12117-02	B - 4	55X-14451-00	C - 6	517-16524-20	B - 13	4GB-2155A-00	E - 7		E - 6	5TH-2470F-00	D - 3
22F-12118-01	B - 4	5TH-14452-00	C - 6	517-16524-30	B - 13	5YF-21565-20	E - 5		E - 8	5TH-24710-00	D - 3
2HX-12119-00	B - 4	3GB-14453-00	B - 8	22F-16550-00	B - 13		E - 6		E - 9	22W-24741-00	D - 3
2D3-12121-00	B - 4	59V-14457-00	C - 6	22K-16590-00	B - 13		E - 8	5TH-2171A-00	C - 7	4K0-24774-A0	D - 3
22F-12151-10	B - 4	55X-14458-00	C - 6	2HX-17121-00	B - 15		E - 9	5TH-2171A-30	C - 7	4K0-24775-00	D - 3
22F-12156-00	B - 4	55X-14472-01	C - 6	55X-17131-00	B - 15	5YF-21565-40	E - 5	12R-21747-00	D - 2	29U-24776-00	D - 3
22F-12159-00	B - 4	5TH-14477-00	C - 6	3GB-17211-00	B - 15		E - 6	5KM-2175B-00	E - 5	2FJ-25111-00	D - 4
55X-12170-00	B - 5	3DM-14613-00	B - 9	55X-17231-00	B - 15		E - 8		E - 6	3FA-25117-00	D - 4
50M-12176-00	B - 5	22F-14651-00	B - 2	55X-17241-00	B - 15	4SH-21568-00	E - 9		E - 7	2FJ-25121-00	D - 4
22F-12217-01	B - 5	5TH-14711-00	B - 9	3GB-17402-00	B - 15	5FK-21568-00	E - 7		E - 8	52H-2513A-00	D - 4
22F-12231-01	B - 5	55X-14752-00	B - 9	2HX-17411-01	B - 15	5FE-21568-01	E - 5		E - 9	3GB-25151-00	D - 4
22F-12241-00	B - 5	2HX-1490J-10	B - 7	3GB-17508-00	C - 2		E - 6	5TH-2177C-10	C - 8	2FJ-25155-00	D - 4
2FJ-13300-00	B - 6	2HX-1490J-20	B - 7	22F-17531-00-15	C - 2	4WU-21568-10	E - 6	3GB-22110-00-33	C - 9	2FJ-25156-00	D - 5
46J-13324-00	B - 3	55X-14937-00	B - 8	22F-17531-00-30	C - 2	5FE-21568-11	E - 8	307-22123-00	C - 15	2FJ-25169-00	D - 4
46J-13325-00	B - 6	22F-14991-00	B - 7	22F-17531-00-50	C - 2		E - 9	3GB-22123-00	C - 5	2FJ-25180-00-35	D - 4
22F-13329-01	B - 6	2FJ-15100-01	B - 10	22F-17537-00	C - 2	5YF-21570-60	E - 5	3GB-22155-00	C - 5	22W-25181-01	C - 9
22F-13411-01	B - 6	3GB-15362-00	C - 10	22F-17551-00	C - 2		E - 6	3GB-22156-00	C - 9	3GB-25185-00	D - 4
22M-13450-10	B - 12	55X-15362-04	B - 11	22F-17556-01	C - 2		E - 7	55X-22189-00	C - 9	3GB-25311-00-33	D - 6
55X-13586-00	B - 7	2N4-15371-00	C - 10	22F-18101-03	C - 4		E - 8	3GB-2219X-00	C - 9	3GB-25317-00	D - 6
22K-13595-00	B - 7	22F-15383-01	B - 10	2HX-18110-10	C - 4		E - 9	3GB-22210-00-36	C - 12	3GB-2531E-00	D - 6
5TH-14101-00	B - 7	22F-15411-01	B - 11	132-18113-01	C - 4	5YF-21570-70	E - 5	59V-22216-00	C - 12	3GB-25326-00	D - 6
5TH-14101-10	B - 7	22F-15417-00	B - 11	278-18127-01	C - 4		E - 6	2HX-2331U-00	C - 15	23F-2533A-00	D - 6
22F-14103-00	B - 7	2FJ-15421-00	B - 11	29F-18140-00	C - 3		E - 8	2HX-23350-00-36	C - 15	55X-2533H-00	D - 6

NUMERICAL INDEX

PART NO.	GRID NO.	PART NO.	GRID NO.	PART NO.	GRID NO.	PART NO.	GRID NO.	PART NO.	GRID NO.	PART NO.	GRID NO.
3GB-25343-10	D - 6	55X-81826-50	D - 13	5TH-W2151-01	C - 6	90170-10186	C - 13	90215-14249	B - 13	90480-18171	C - 8
3Y6-25351-00	D - 6	5J3-81846-50	D - 13	5TH-W2151-31	C - 6	90170-14284	B - 13	90240-06076	D - 10	90480-18290	D - 2
55X-25355-00	D - 6	22J-81847-50	D - 13	5TH-W215B-01	C - 6	90170-28011	D - 7	90249-12008	D - 8	90501-03799	B - 12
3GB-25367-00	D - 7	5J3-81847-50	D - 13	5TH-W215C-01	C - 6	90171-10004	C - 15		D - 10	90501-08511	D - 9
3GB-25382-00	D - 6	55X-81855-50	D - 13	5TH-W215C-31	C - 6	90171-12001	D - 7	90267-32004	E - 5	90501-10245	D - 10
55X-25383-10	D - 6	3MW-81940-01	E - 2	5TH-W215D-01	C - 6	90171-14020	D - 4		E - 6	90501-105A5	B - 13
2FJ-25390-00-35	D - 6	1RL-81950-92	E - 2	5TH-W215D-31	C - 6	90176-06065	B - 2		E - 7	90501-10710	B - 5
390-25412-01	D - 6	5TH-81960-01	E - 2	5TH-W2161-00	C - 8	90179-06387	B - 5		E - 8	90501-10782	D - 8
3GB-25715-00	D - 7	55X-82110-61	E - 2	5TH-W2161-30	C - 8	90179-08148	D - 9		E - 9	90501-135A4	B - 13
5TH-26111-10	D - 8	55X-82115-01	E - 2	5TH-W216B-00	C - 8		D - 15	90269-06002	C - 7	90504-06030	D - 2
5TH-26124-00	D - 8	3GB-82116-00	E - 2	5TH-W216C-00	C - 8	90179-10394	D - 12	90280-03017	B - 3	90506-08122	C - 4
5TH-26124-10	D - 8	55X-82122-00	E - 2	5TH-W216C-30	C - 8	90179-12248	C - 2	90334-14037	B - 5	90506-15260	D - 4
5LP-26241-00	D - 8	29W-82123-00	E - 2	3FA-W253E-00	D - 6	90179-12659	B - 13	90336-28053	C - 13		D - 6
5TH-26250-01	D - 8	4J2-82131-01	E - 2	4KN-W253E-11	D - 4	90179-28009	D - 7	90340-12097	B - 6	90506-16318	D - 10
3GB-2625E-01	D - 8	3GB-82150-00	E - 2	90101-06278	D - 4	90179-42480	C - 2	90340-14132	C - 10	90507-15038	D - 7
3GB-2625G-00	D - 8	3GB-82151-00	E - 2	90101-06562	D - 9	90179-55464	C - 10	90340-18092	B - 5	90508-10775	D - 8
3GB-2625H-00	D - 8	4KJ-82310-10	E - 2	90101-06576	B - 9	90183-05008	C - 6	90380-07118	B - 14	90508-20454	D - 3
3GB-2628F-00	D - 8	55X-82370-00	E - 2	90101-08461	C - 11	90185-05007	C - 7	90381-15040	C - 5	90508-20576	C - 3
3GB-2628G-02	D - 8	4GB-82510-11	E - 3	90101-08590	B - 5	90185-10091	C - 12	90381-17067	C - 15	90508-32563	C - 4
3GB-26311-02	D - 8	3GB-82540-01	E - 2	90101-12498	C - 15		C - 15	90387-062G8	B - 14	90560-17146	B - 13
3GB-26341-01	D - 8	3HN-82569-00	E - 3	90105-10388	C - 12	90185-10115	C - 9	90387-062G9	B - 14	90560-20196	B - 12
20E-26343-00	D - 8	3HN-82579-00	E - 3	90105-10561	C - 15		C - 13	90387-066J1	D - 2	90560-23355	C - 10
	D - 10	5TH-82590-00	E - 3	90105-12460	C - 15	90185-12046	C - 15	90387-066V8	D - 8	90793-25013	E - 2
3GB-26347-00	D - 8	5TH-82910-01	D - 15	90109-061F3	D - 8	90201-03313	E - 5	90387-07598	D - 2	91317-05025	D - 8
3GB-26361-03	D - 9	3FA-82911-01	D - 15	90109-063F1	C - 6		E - 6	90387-090R0	C - 13	91317-06035	D - 13
3FA-26466-00	D - 15	5GH-83516-00	E - 3	90109-063F6	C - 3		E - 7	90387-175R2	D - 4	91401-20012	D - 10
371-27114-00	D - 3	4KB-83530-00	E - 2	90109-06799	D - 15		E - 8	90430-06014	B - 10	91401-20020	C - 13
3GB-27211-10	D - 10	23X-83912-00	D - 15	90109-08745	D - 4		E - 9	90430-06166	B - 10		C - 15
3GB-27231-00	D - 10	5TH-83922-00	D - 8	90109-104A8	C - 15	90201-060L5	D - 2	90430-10148	E - 2	91401-25025	D - 7
3GB-27411-10	D - 10	437-83936-01	E - 3	90110-05201	C - 7	90201-066F0	B - 2	90445-073F9	C - 10	91401-30025	D - 4
55X-27413-00	D - 10	3FA-83965-00	D - 15	90113-06009	B - 5	90201-08326	B - 5	90445-083J4	D - 2	91A20-07010	B - 8
3GB-27421-10	D - 10	3FA-83966-00	D - 15	90114-08001	D - 6		B - 9	90445-085E0	E - 2	92901-04100	D - 12
3GB-28100-00	C - 5	3FA-83967-00	D - 15	90114-10005	D - 6	90201-08759	C - 15	90445-10638	D - 2	92901-05100	D - 12
1NV-2811A-01	C - 5	4EM-83975-00	D - 15	90116-06399	B - 10	90201-101A4	D - 12	90445-11418	C - 13	92902-04100	B - 7
4EM-2819R-00	E - 5	1YW-83980-00	D - 15	90116-08507	D - 6	90201-10774	C - 13	90460-15126	E - 3	92907-04200	C - 6
5GT-2836B-10	D - 8	5TH-84111-00	D - 14	90119-05193	C - 6	90201-12045	D - 7	90460-43053	B - 8	92907-05100	E - 4
5TH-2845N-20	D - 11	5TH-8411B-00	D - 14	90119-06044	C - 6	90201-124F8	B - 15	90460-75020	C - 9	92907-05200	E - 4
5TH-2845N-30	D - 11	5TH-84121-00	D - 14		D - 14	90201-125F7	C - 2	90460-85135	C - 9	92907-06100	D - 2
3GB-46110-20	C - 10	2EK-85111-00	E - 4	90119-06056	C - 8	90201-12688	C - 15	90464-12045	E - 3		D - 3
3GB-46120-00	C - 10	3Y6-85130-02	E - 4	90123-08046	D - 15	90201-127F4	C - 4	90464-13073	E - 3		D - 7
22F-46123-01	C - 11	449-85131-02	E - 4	90123-08106	D - 9	90201-132G5	B - 15	90464-13249	C - 8		E - 2
3GB-46151-00	C - 10	5G3-85520-M1	D - 12	90149-06011	D - 2	90201-14586	D - 4	90464-15195	E - 3	92907-06200	D - 10
3GB-46172-01	C - 10	4EM-85540-10	E - 2	90151-06028	B - 14	90201-145M4	D - 8	90465-10098	E - 3		D - 13
2HX-46180-00	C - 10	2FM-85550-M1	D - 12	90153-06034	E - 2	90201-15018	D - 10	90467-07029	C - 10	92907-06600	B - 9
22F-46187-00	C - 10	4EM-85560-10	D - 12	90154-05052	C - 7	90201-186F1	B - 5	90467-09006	D - 2		B - 14
55X-81313-M0	D - 12	22K-85595-M0	D - 12	90155-06007	B - 6	90202-05193	D - 2	90467-13064	B - 10		E - 2
55X-81800-51	D - 13	22K-W1141-00	B - 3	90159-06076	B - 7	90208-12015	B - 13	90467-22080	C - 6	92907-08100	C - 11
22J-81801-50	D - 13	22K-W1657-00	B - 13	90170-05302	B - 4	90209-11269	B - 11	90480-01400	D - 2	93101-10142	B - 11

NUMERICAL INDEX

PART NO.	GRID NO.	PART NO.	GRID NO.	PART NO.	GRID NO.	PART NO.	GRID NO.	PART NO.	GRID NO.	PART NO.	GRID NO.
93101-24110	C - 2	93440-10109	B - 2	95827-06020	C - 2						
93102-07292	B - 14	93440-11128	B - 14	95827-08055	C - 13						
93102-12106	C - 4	93440-16089	B - 15	97007-06012	D - 3						
93102-17271	C - 10	93450-14088	B - 3	97007-06016	E - 2						
93102-19276	D - 12	93450-42112	B - 13	97022-06020	C - 4						
93102-23275	D - 4	93451-08094	B - 13	97027-06030	D - 2						
93102-28022	C - 10	93505-08030	B - 13	97027-08060	C - 13						
93102-35349	D - 7	93604-20156	C - 4	97707-40116	C - 6						
93102-36409	D - 6	93604-22050	C - 3	98501-04006	D - 12						
93102-38383	D - 6	93610-10174	B - 12	98501-05010	D - 12						
93102-40367	D - 4	93700-06004	C - 5	98502-04008	B - 7						
93104-10076	B - 14		C - 15	98502-04010	B - 8						
93112-31011	C - 13	93900-00022	D - 4	98502-04014	B - 7						
93210-06564	B - 5		D - 6	98507-03008	D - 2						
	B - 10	94107-07009	D - 4	98507-04016	D - 8						
93210-07003	C - 3	94108-07009	D - 6	98507-06010	B - 9						
93210-12327	D - 4	94580-25082	B - 5	98507-06012	B - 10						
93210-14104	C - 10	94701-00366	B - 2		D - 7						
	D - 6	94703-00366	B - 2	98507-06014	C - 3						
93210-15414	C - 5	95027-06008	E - 2	98507-06016	B - 2						
93210-19123	B - 11	95027-06085	B - 2		B - 14						
93210-25552	B - 7	95307-05600	E - 4		E - 2						
93210-26606	D - 7	95307-05700	D - 8	98507-06020	D - 9						
93210-40407	C - 5	95307-06600	B - 14		D - 15						
93210-43713	C - 10		D - 4		E - 2						
93210-44704	B - 2		D - 6	98507-06030	B - 11						
93210-50553	C - 2	95307-06800	B - 5	98507-06035	B - 11						
93210-63556	B - 2	95307-08600	D - 7	98507-06040	B - 11						
93211-02703	D - 12	95307-10700	C - 13	98507-06045	B - 10						
93211-066A9	C - 10	95607-06100	D - 8		B - 11						
93306-00105	B - 15		D - 15	98507-06060	B - 10						
93306-00308	D - 4	95607-08200	C - 5	98507-06075	B - 10						
93306-00612	D - 6	95707-06500	B - 9	98511-04012	D - 12						
93306-07801	C - 10	95707-08500	D - 4	98511-04020	D - 12						
93306-20301	B - 15		D - 6	98701-06018	B - 12						
93306-20309	C - 2	95807-06010	C - 7	98707-06016	D - 12						
93306-30101	B - 15	95807-06016	D - 9	99001-04600	B - 14						
93306-30306	C - 10	95807-08012	C - 8	99001-05600	B - 6						
93306-30433	B - 3		D - 8	99001-09600	C - 3						
93311-20952	C - 10	95817-06016	B - 10	99009-12400	B - 15						
93311-32353	B - 3		C - 10	99009-17400	C - 10						
93315-23208	C - 3	95817-06025	B - 10	99009-17500	C - 10						
93317-21236	C - 2	95817-08014	C - 9	99530-08012	B - 2						
93340-21209	C - 4		D - 11		B - 10						
93341-22302	B - 13	95817-08016	B - 9	99530-10114	B - 11						
93420-26077	B - 13	95817-08115	C - 5	99530-10120	B - 11						
93430-04002	D - 3	95817-08120	C - 5	99530-12016	B - 10						
93430-08007	C - 3	95817-12020	D - 10								