



PARTS CATALOGUE

YFM80RX (5THL) U.S.A.

YFM80RX (5THM) CANADA

YFM80RX (5THN) EUROPE

YFM80RX (5THL) OCEANIA

YFM80R (5THL) JAPAN

YFM80RX/YFM80R
PARTS CATALOGUE
©2007 by Yamaha Motor Co., Ltd.
1st edition, June 2007
All rights reserved.
Any reprinting or unauthorized use
without the written permission of
Yamaha Motor Co., Ltd.
is expressly prohibited.

A3

FOREWORD

This Parts Catalogue is related to the parts for the model(s) on the cover page. When you are ordering replacement parts, please refer to this Parts Catalogue and quote both part numbers and part names correctly.

1. Modifications or additions which have been made after the issue of the Parts Catalogue will be announced in the Parts News.

It is advisable that you make the necessary corrections to the Parts Catalogue according to the Parts News.

2. Abbreviations

The following abbreviations are used in this Parts Catalogue.

“UR” Use specified parts number.

“UN” Use as many as needed.

“AP” Alternate Parts

“LM” Locally Made (Parts need to be ordered locally)

“F#” Frame No. (Applicable machine No.)

“O/S” Over Size

3. The number of components for assembly

- Parts, which are to be supplied in an assembly, are listed with a dot (.) in front of the part name as shown below.
- The numeral appearing to the right of each component part indicates the quantity of parts for each assembly unit.

PART NO.	DESCRIPTION	Q'TY	REMARKS
2F5-83310-60	FRONT FLASHER LIGHT ASSY	2	
115-83311-60	.BULB (6V-18W)	1	

4. Applicable colours of graphics are represented in the “REMARKS” as shown below.

PART NO.	DESCRIPTION	Q'TY	REMARKS
2N4-24110-00-X5	FUEL TANK COMP.	2	MXR
3J1-24240-10	.GRAPHIC, FUEL TANK	1	FOR MXR

5. Note that the illustrations for reference in finding parts numbers are not to be used for assembling. When assembling, please use the applicable service manual.

6. The asterisk (*) before a reference number indicates modified items after the first edition.

FOREWORD

7. Applicable Serial No.

Engine Serial No.

Frame Serial No.

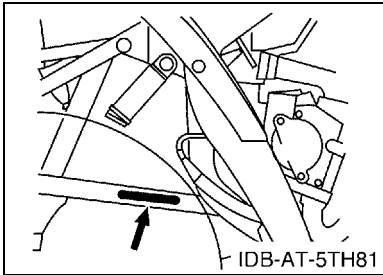
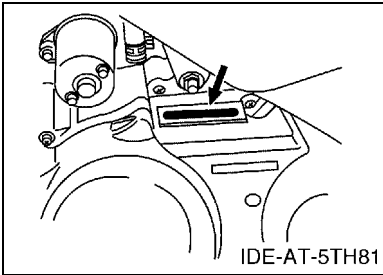

8. Applicable Colour Code (The (*) mark shows Model colour.)

Abbreviation	Colour Name	Colour Code
DPBSE(*)	DEEP PURPLISH BLUE SOLID E	0583
LGB	LOW GLOSS BLACK	0098
PGD(*)	PASTEL DARK GRAY	003E
SL	SILVER	0035
WW	WHITE	0036
YB	YAMAHA BLACK	0033

9. Quantity Column Information

Column No.	Name Of Q'ty Column	Destination
1	USA	U.S.A.
2	CAN	CANADA
3	EUR	EUROPE
4	OCE	AUSTRALIA, NEW ZEALAND
5	JPN	JAPAN

MODEL LABEL

(1) A label called "Model Label" is affixed in the location as indicated in (3) below. When using this parts catalogue, please be sure to cross-reference the "model code – production code No." in the catalogue with the "model code – production code No." indicated on the Model Label affixed onto the product concerned.

(2) "Model Label" Indication

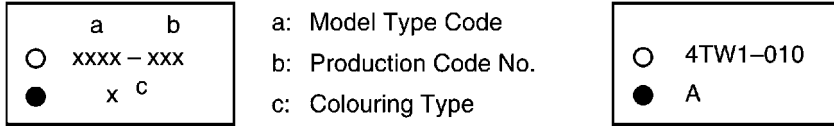

(3) Model Label Affixing Location

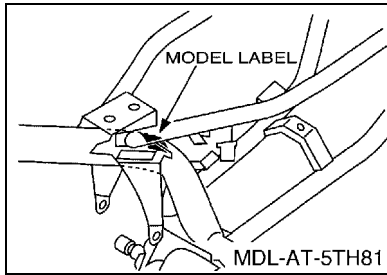

(4) Colouring Information

Model Code	Colouring Type Code	Colour Code	Colour Name	Abbreviation
5THL	A	0583	DEEP PURPLISH BLUE SOLID E	DPBSE
	B	003E	PASTEL DARK GRAY	PGD
5THM	A	0583	DEEP PURPLISH BLUE SOLID E	DPBSE
	B	003E	PASTEL DARK GRAY	PGD
5THN	A	0583	DEEP PURPLISH BLUE SOLID E	DPBSE

(5) Model Code – Production Code Number of Model Listed in This Parts Catalogue

Model Code	Production Code No.	Country (destination)	Model Code	Production Code No.	Country (destination)
5THL	010	U.S.A.			
	020	AUSTRALIA			
		NEW ZEALAND			
	030	JAPAN			
5THM	010	CANADA			
5THN	010	EUROPE			

CONTENTS

ENGINE

CYLINDER	B2
CRANKSHAFT & PISTON	B3
VALVE	B4
CAMSHAFT & CHAIN	B5
OIL PUMP	B6
INTAKE	B7
EXHAUST	B9
CRANKCASE	B10
CRANKCASE COVER 1	B11
STARTER CLUTCH	B12
CLUTCH	B13
TRANSMISSION	B15
MIDDLE DRIVE GEAR	C2
SHIFT CAM & FORK	C3
SHIFT SHAFT	C4

CHASSIS

FRAME	C5
FRONT FENDER	C6
REAR FENDER	C8
REAR ARM	C9
DRIVE SHAFT	C10
REAR SUSPENSION	C12
STEERING	C13
FRONT SUSPENSION & WHEEL	C15
FUEL TANK	D2
SEAT	D3
FRONT WHEEL	D4
REAR WHEEL	D6
STEERING HANDLE & CABLE	D8
STAND & FOOTREST	D10
GUARD	D11
GENERATOR	D12
STARTING MOTOR	D13
HEADLIGHT	D14
HANDLE SWITCH & LEVER	D15
ELECTRICAL 1	E2
ELECTRICAL 2	E4
EMBLEM & LABEL 1	E5
EMBLEM & LABEL 2	E6
EMBLEM & LABEL 3	E7

EMBLEM & LABEL 4	E8
EMBLEM & LABEL 5	E9

INDEX

NUMERICAL INDEX	M1
-----------------------	----

FIG. 1 CYLINDER

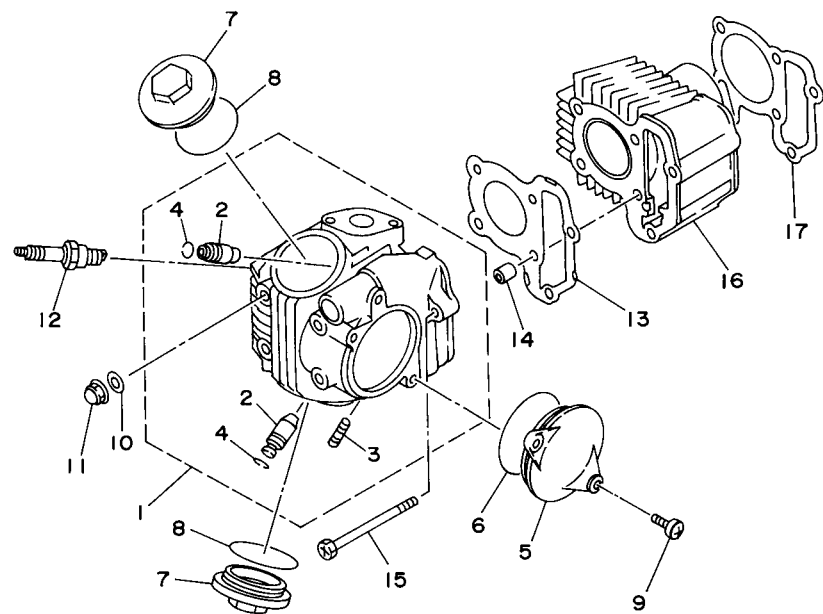

REF. NO.	PART NO.	DESCRIPTION	USA	CAN	EUR	OCE	JPN	REMARKS
1	35T-11110-01	CYLINDER HEAD ASSY	1	1	1	1	1	
2	22F-11134-10	.GUIDE, VALVE 2	2	2	2	2	2	
3	22F-14651-00	.BOLT, STUD	2	2	2	2	2	
4	93440-10109	.CIRCLIP	2	2	2	2	2	
5	22F-11185-10	COVER, CYLINDER HEAD SIDE 1	1	1	1	1	1	
6	93210-63556	O-RING	1	1	1	1	1	
7	22F-11186-10	COVER, CYLINDER HEAD SIDE 2	2	2	2	2	2	
8	93210-44704	O-RING	2	2	2	2	2	
9	98502-06016	SCREW, PAN HEAD	2	2	2	2	2	
10	90201-066F0	WASHER, PLATE	4	4	4	4	4	
11	90176-06014	NUT, CROWN	4	4	4	4	4	
12	94701-00366	PLUG, SPARK (NGK CR7HSA)	1	1	1	1	1	
	94703-00366	PLUG, SPARK (NGK CR7HSA)					1	
13	55X-11181-00	GASKET, CYLINDER HEAD 1	1	1	1	1	1	
14	99530-08012	PIN, DOWEL	2	2	2	2	2	
15	95022-06085	BOLT, FLANGE	2	2	2	2	2	
16	22K-11311-02	CYLINDER 1	1	1	1	1	1	
17	22F-11351-01	GASKET, CYLINDER	1	1	1	1	1	

FWD
4EM1100-2010

FIG. 2 CRANKSHAFT & PISTON

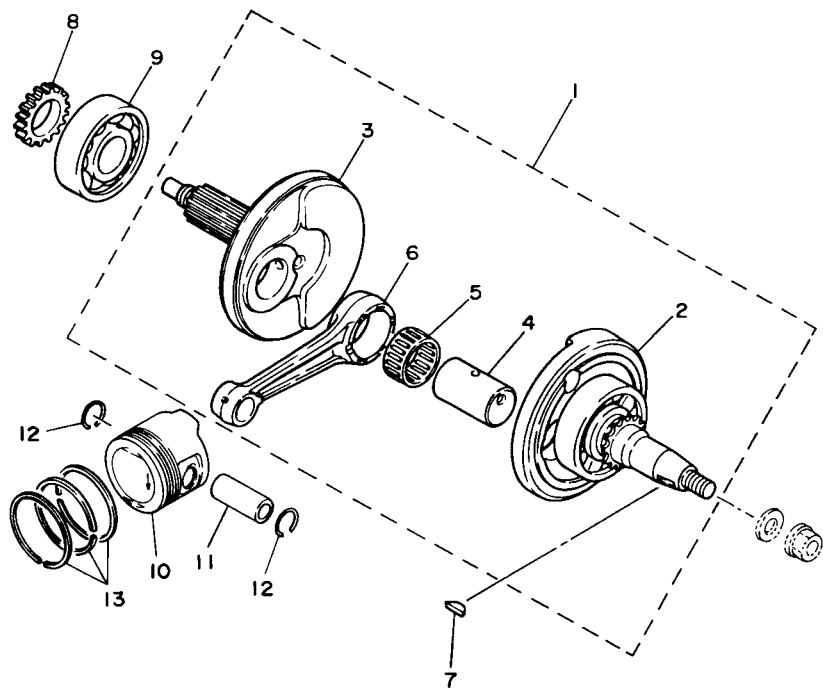

55X110-5020

REF. NO.	PART NO.	DESCRIPTION	USA	CAN	EUR	OCE	JPN	REMARKS
1	22K-11400-01	CRANKSHAFT ASSY	1	1	1	1	1	
2	22K-W1141-00	.CRANK SUB ASSY 1	1	1	1	1	1	
3	22K-11422-00	.CRANK 2	1	1	1	1	1	
4	22F-11681-00	.PIN, CRANK 1	1	1	1	1	1	
5	93311-32353	.BEARING	1	1	1	1	1	
6	22K-11651-02	.ROD, CONNECTING	1	1	1	1	1	
7	90280-03017	KEY, WOODRUFF	1	1	1	1	1	
8	46J-13324-00	GEAR, PUMP DRIVE	1	1	1	1	1	
9	93306-30433	BEARING	1	1	1	1	1	
10	55X-11631-00-96	PISTON (STD)	1	1	1	1	1	
	55X-11636-00	PISTON (0.50MM O/S)	1	1	1	1	1	AP
	55X-11638-00	PISTON (1.00MM O/S)	1	1	1	1	1	AP
11	22K-11633-01	PIN, PISTON	1	1	1	1	1	
12	93450-14088	CIRCLIP	2	2	2	2	2	
13	55X-11610-00	PISTON RING SET (STD)	1	1	1	1	1	
	55X-11610-20	PISTON RING SET (0.50MM O/S)	1	1	1	1	1	AP
	55X-11610-40	PISTON RING SET (1.00MM O/S)	1	1	1	1	1	AP

FIG. 3 VALVE

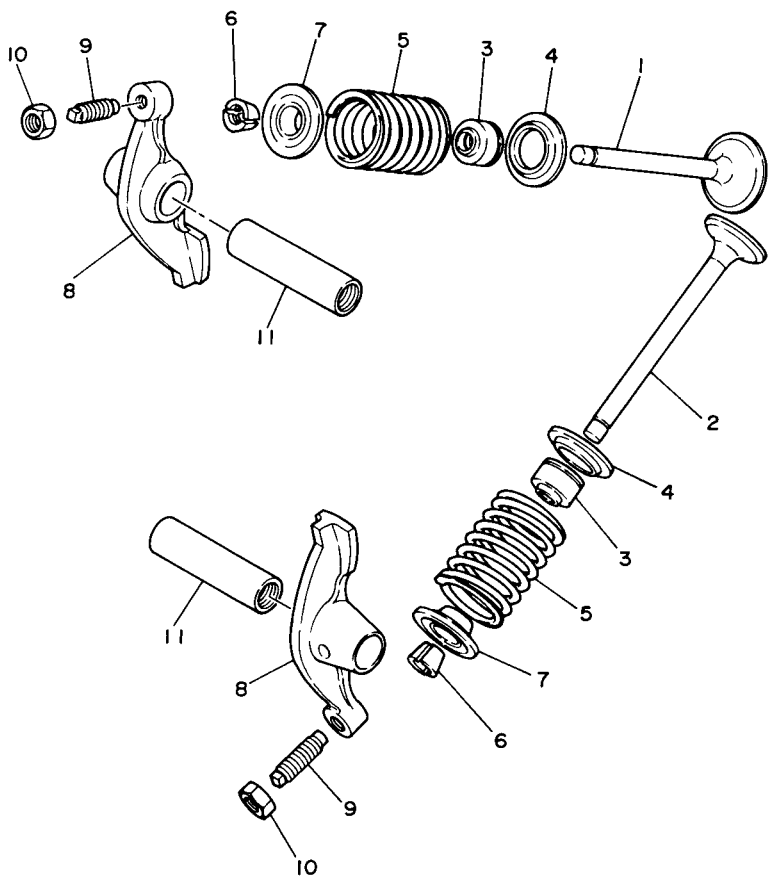

REF. NO.	PART NO.	DESCRIPTION	USA	CAN	EUR	OCE	JPN	REMARKS
1	2D3-12111-00	VALVE, INTAKE	1	1	1	1	1	
2	2D3-12121-00	VALVE, EXHAUST	1	1	1	1	1	
3	2HX-12119-00	SEAL, VALVE STEM	2	2	2	2	2	
4	22F-12116-00	SEAT, VALVE SPRING	2	2	2	2	2	
5	22F-12114-00	SPRING, VALVE OUTER	2	2	2	2	2	
6	22F-12118-01	COTTER, VALVE	4	4	4	4	4	
7	22F-12117-02	RETAINER, VALVE SPRING	2	2	2	2	2	
8	22F-12151-10	ARM, VALVE ROCKER	2	2	2	2	2	
9	22F-12159-00	SCREW, VALVE ADJUSTING	2	2	2	2	2	
10	90170-05302	NUT	2	2	2	2	2	
11	22F-12156-00	SHAFT, ROCKER 2	2	2	2	2	2	

55X110-5030

FIG. 4 CAMSHAFT & CHAIN

REF. NO.	PART NO.	DESCRIPTION	USA	CAN	EUR	OCE	JPN	REMARKS
1	55X-12170-00	CAMSHAFT ASSY 1	1	1	1	1	1	
2	50M-12176-00	SPROCKET, CAM CHAIN (28T)	1	1	1	1	1	
3	90201-08048	WASHER, PLATE	1	1	1	1	1	
4	90101-08055	BOLT	1	1	1	1	1	
5	94580-25082	CHAIN (D.I.D 25)	1	1	1	1	1	
6	22F-12231-01	GUIDE, STOPPER 1	1	1	1	1	1	
7	22F-12241-00	GUIDE, STOPPER 2	1	1	1	1	1	
8	22F-12217-01	ROD, CHAIN TENSIONER	1	1	1	1	1	
9	90334-14037	PLUG, STRAIGHT	1	1	1	1	1	
10	90501-10710	SPRING, COMPRESSION	1	1	1	1	1	
11	90340-18092	PLUG, STRAIGHT SCREW	1	1	1	1	1	
12	90201-186F1	WASHER, PLATE	1	1	1	1	1	
13	90113-06009	BOLT, SET	1	1	1	1	1	
14	93210-06564	O-RING	1	1	1	1	1	
15	90179-06054	NUT	1	1	1	1	1	
16	95302-06800	NUT, CROWN	1	1	1	1	1	

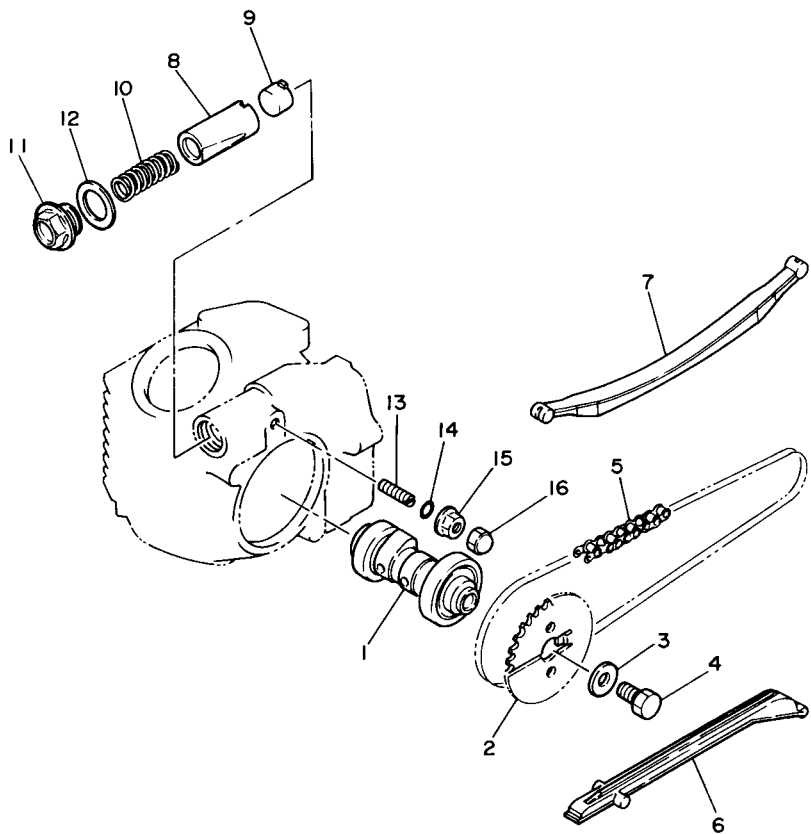

55X110-5040

FIG. 5 OIL PUMP

REF. NO.	PART NO.	DESCRIPTION	USA	CAN	EUR	OCE	JPN	REMARKS
1	2FJ-13300-00	OIL PUMP ASSY	1	1	1	1	1	
2	46J-13325-00	.GEAR, PUMP DRIVEN	1	1	1	1	1	
3	99001-05600	.CIRCLIP	1	1	1	1	1	
4	22F-13329-01	GASKET, PUMP COVER	1	1	1	1	1	
5	90155-06001	SCREW, FLAT FILLISTER	2	2	2	2	2	
6	90340-12097	PLUG, STRAIGHT SCREW	1	1	1	1	1	
7	812-11198-00	GASKET	1	1	1	1	1	
8	22F-13411-01	STRAINER, OIL	1	1	1	1	1	

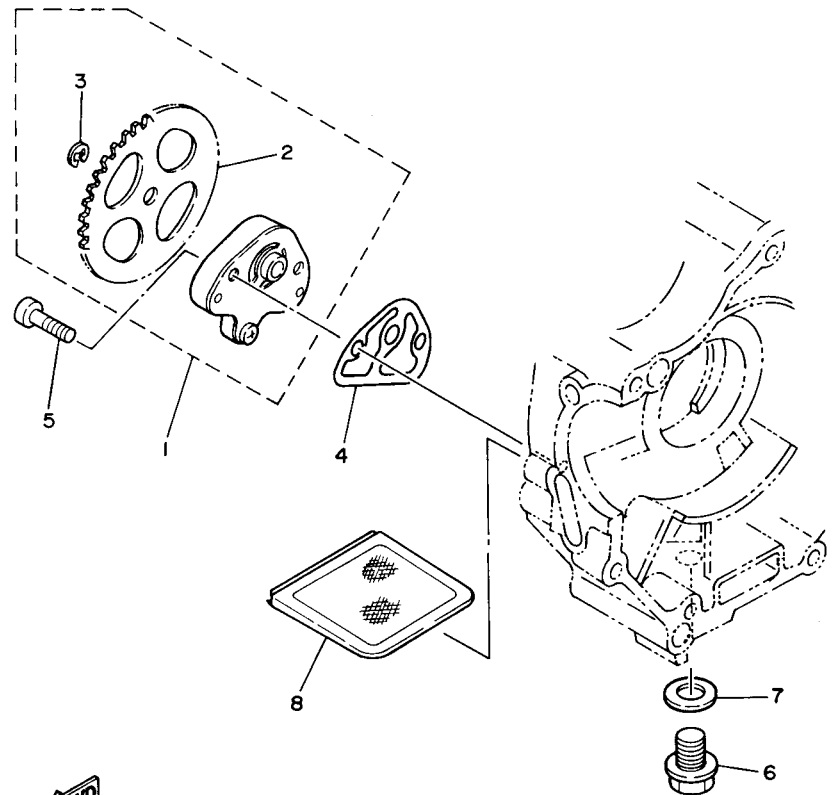

55X110-5050

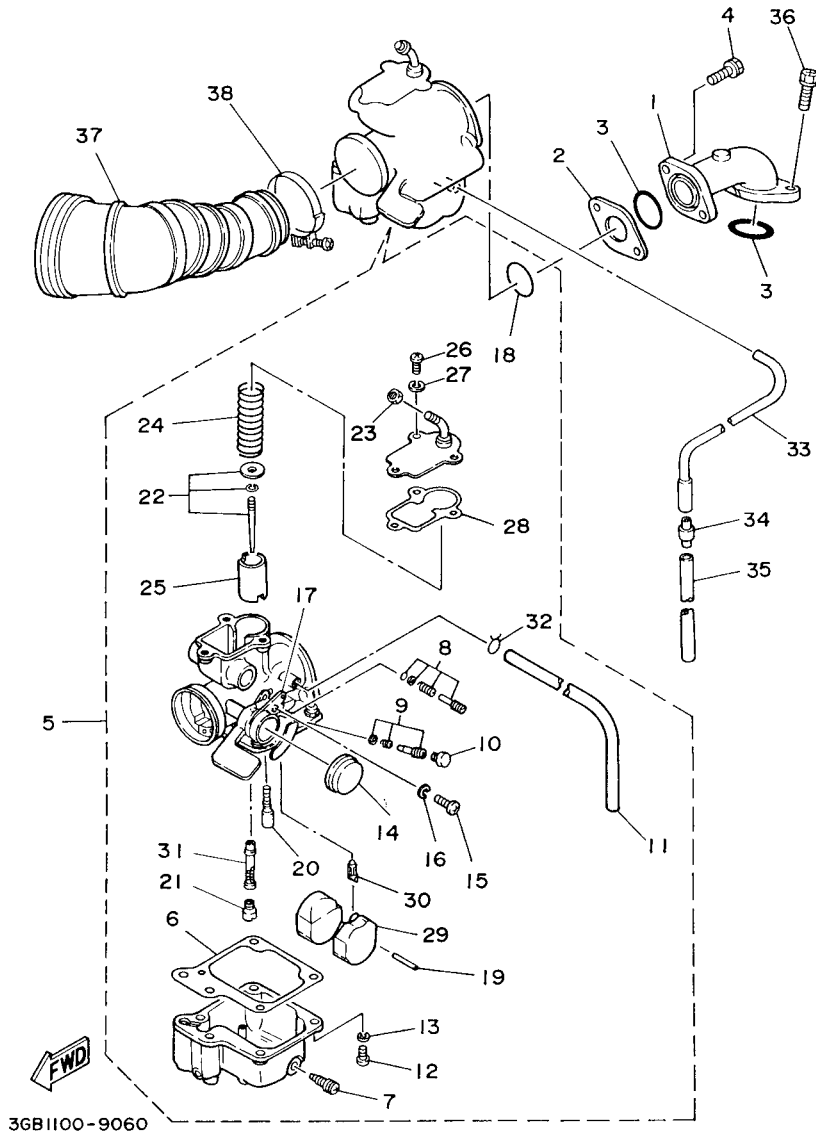

FIG. 6 INTAKE

REF. NO.	PART NO.	DESCRIPTION	USA	CAN	EUR	OCE	JPN	REMARKS
1	55X-13586-00	JOINT, CARBURETOR 1	1	1	1	1	1	
2	22K-13595-00	JOINT	1	1	1	1	1	
3	93210-25552	O-RING	2	2	2	2	2	
4	90159-06041	SCREW, WITH WASHER	2	2	2	2	2	
5	5TH-14101-11	CARBURETOR ASSY 1	1	1				
5TH-14101-01	CARBURETOR ASSY 1				1	1	1	
6	22F-14184-00	.GASKET, FLOAT CHAMBER	1	1	1	1	1	
7	12R-14191-00	.PLUG, DRAIN	1	1	1	1	1	
8	22F-14103-00	.THROTTLE SCREW SET	1	1	1	1	1	
9	22K-14104-00	.AIR SCREW SET	1	1	1	1	1	
10	22F-14991-00	.CAP	1	1	1	1	1	
11	26H-14197-00	.PIPE	1	1	1	1	1	
12	98502-04014	.SCREW, PAN HEAD	4	4	4	4	4	
13	92902-04100	.WASHER, SPRING	4	4	4	4	4	
14	22F-14169-00	.CAP	1	1	1	1	1	
15	98502-04008	.SCREW, PAN HEAD	1	1	1	1	1	
16	92902-04100	.WASHER, SPRING	1	1	1	1	1	
17	55X-14146-00	.PLATE	1	1	1	1	1	
18	22K-14147-00	.O-RING	1	1	1	1	1	
19	127-14186-00	.PIN, FLOAT	1	1	1	1	1	
20	22F-14142-12	.JET, PILOT (#12.5)	1	1	1	1	1	
21	18A-1414E-30	.JET, MAIN(#76.3)	1	1	1	1	1	
22	2HX-1490J-10	.NEEDLE SET	1	1				
22	2HX-1490J-20	.NEEDLE SET			1	1	1	
23	802-14161-00	.NUT, CABLE ADJUSTING	1	1	1	1	1	
24	260-14131-00	.SPRING, THROTTLE VALVE	1	1	1	1	1	
25	2HX-14112-35	.VALVE, THROTTLE 1	1	1	1	1	1	

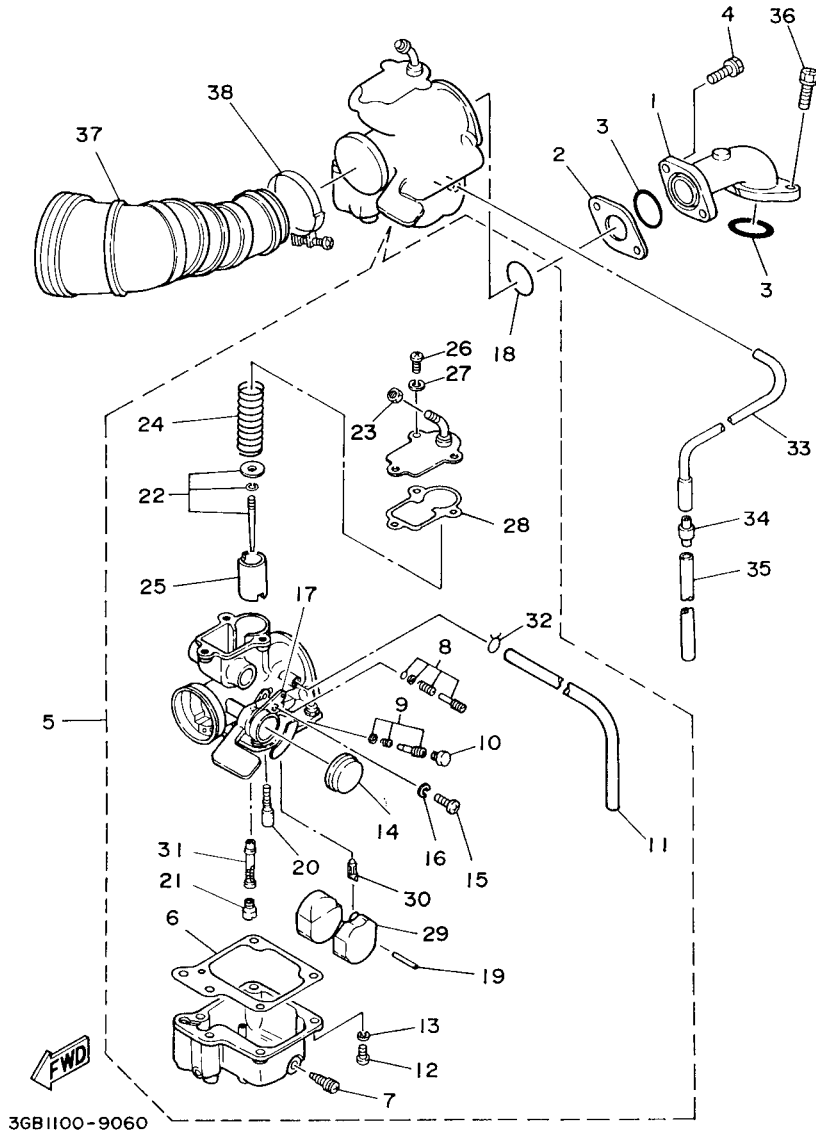
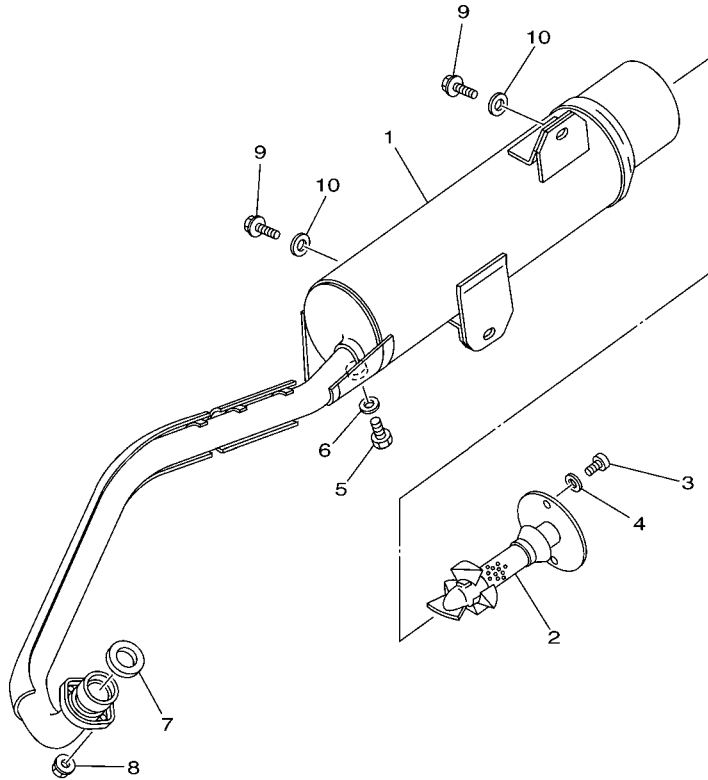

FIG. 6 INTAKE

REF. NO.	PART NO.	DESCRIPTION	USA	CAN	EUR	OCE	JPN	REMARKS
26	98502-04010	.SCREW, PAN HEAD	3	3	3	3	3	
27	92902-04100	.WASHER, SPRING	3	3	3	3	3	
28	55X-14198-00	.GASKET	1	1	1	1	1	
29	22F-14185-00	.FLOAT	1	1	1	1	1	
30	22F-14150-00	.NEEDLE ASSY	1	1	1	1	1	
31	4EM-14141-78	.NOZZLE, MAIN	1	1	1	1	1	
32	55X-14937-00	.CLIP	1	1	1	1	1	
33	55X-14196-00	PIPE	1	1	1	1	1	
34	24W-14193-00	PIPE	1	1	1	1	1	
35	91A20-07010	TUBE, FLEXIBLE VINYL	1	1	1	1	1	
36	90159-06041	SCREW, WITH WASHER	2	2	2	2	2	
37	3GB-14453-00	JOINT, AIR CLEANER 1	1	1	1	1	1	
38	90460-43053	CLAMP, HOSE	1	1	1	1	1	

FIG. 7 EXHAUST



5TH1100-2070

REF. NO.	PART NO.	DESCRIPTION	USA	CAN	EUR	OCE	JPN	REMARKS
1	5TH-14711-00	MUFFLER 1	1	1	1	1	1	
2	55X-14752-00	PIPE, OUTLET	1	1	1	1	1	
3	98502-06010	SCREW, PAN HEAD	2	2	2	2	2	
4	92902-06600	WASHER, PLATE	2	2	2	2	2	
5	90101-06576	BOLT	1	1	1	1	1	
6	92902-06600	WASHER, PLATE	1	1	1	1	1	
7	3DM-14613-00	GASKET, EXHAUST PIPE	1	1	1	1	1	
8	95702-06500	NUT, WITH WASHER	2	2	2	2	2	
9	95812-08016	BOLT, FLANGE	2	2	2	2	2	
10	90201-08048	WASHER, PLATE	2	2	2	2	2	

FIG. 8 CRANKCASE

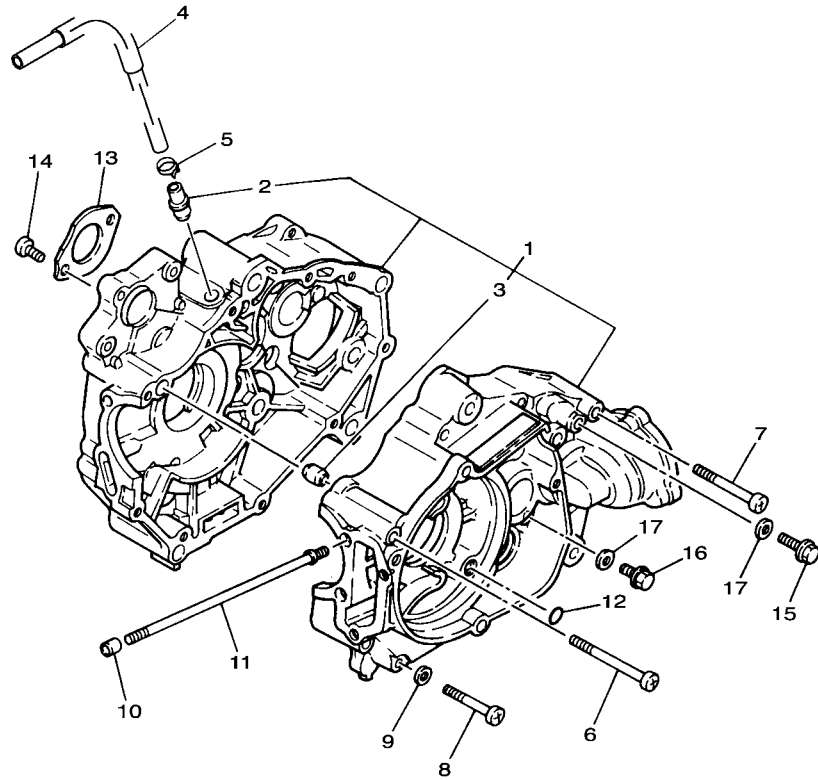

REF. NO.	PART NO.	DESCRIPTION	USA	CAN	EUR	OCE	JPN	REMARKS
1	2FJ-15100-01	CRANKCASE ASSY	1	1	1	1	1	
2	59V-11167-00	.PIPE, BREATHER 2	1	1	1	1	1	
3	99530-12016	.PIN, DOWEL	2	2	2	2	2	
4	2D3-11166-00	PIPE, BREATHER 1	1	1	1	1	1	
5	90467-13064	CLIP	1	1	1	1	1	
6	98502-06075	SCREW, PAN HEAD	1	1	1	1	1	
7	98502-06060	SCREW, PAN HEAD	2	2	2	2	2	
8	98502-06045	SCREW, PAN HEAD	6	6	6	6	6	
9	90430-06014	GASKET	2	2	2	2	2	
10	99530-08012	PIN, DOWEL	2	2	2	2	2	
11	90116-06042	BOLT, STUD	4	4	4	4	4	
12	93210-06564	O-RING	2	2	2	2	2	
13	22F-15383-01	PLATE, BEARING COVER	1	1	1	1	1	
14	98502-06012	SCREW, PAN HEAD	2	2	2	2	2	
15	95812-06025	BOLT, FLANGE	2	2	2	2	2	
16	95812-06016	BOLT, FLANGE	1	1	1	1	1	
17	90430-06166	GASKET	3	3	3	3	3	

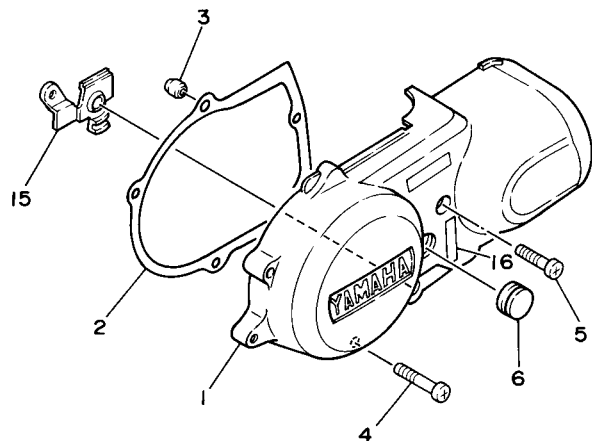
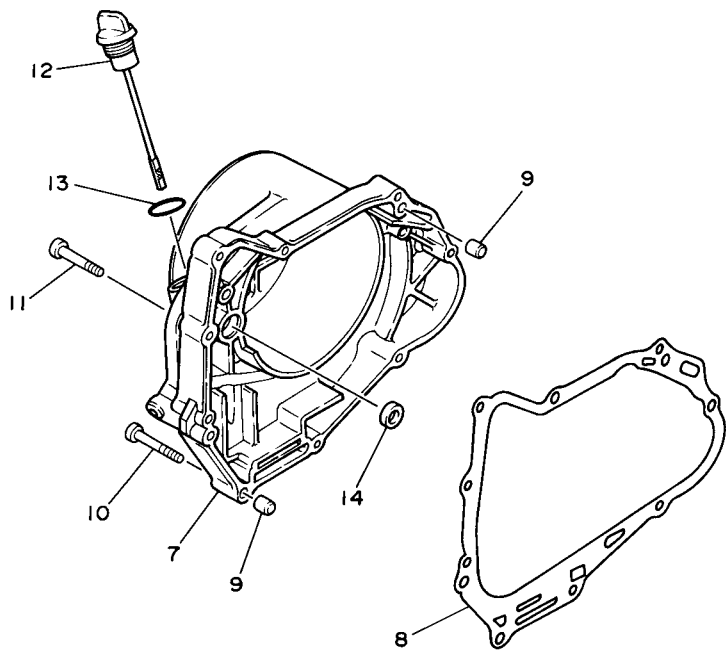

2D31100-D080



2FJ110-7090

FIG. 9 CRANKCASE COVER 1

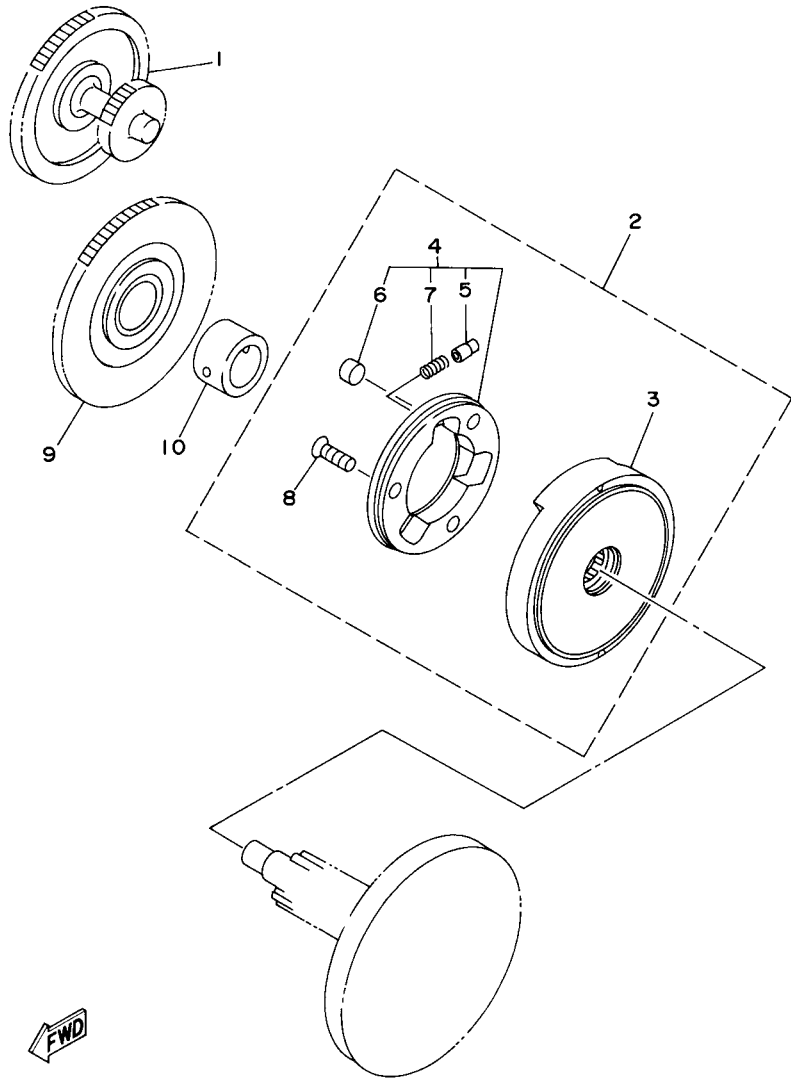
REF. NO.	PART NO.	DESCRIPTION	USA	CAN	EUR	OCE	JPN	REMARKS
1	22F-15411-01	COVER, CRANKCASE 1	1	1	1	1	1	
2	3GB-15451-00	GASKET, CRANKCASE COVER 1	1	1	1	1	1	
3	99530-10114	PIN, DOWEL	2	2	2	2	2	
4	98507-06040	SCREW, PAN HEAD	1	1	1	1	1	
5	98507-06030	SCREW, PAN HEAD	2	2	2	2	2	
6	22F-15417-00	COVER, CAP	1	1	1	1	1	
7	2FJ-15421-00	COVER, CRANKCASE 2	1	1	1	1	1	
8	3GB-15461-00	GASKET, CRANKCASE COVER 2	1	1	1	1	1	
9	99530-10120	PIN, DOWEL	2	2	2	2	2	
10	98507-06045	SCREW, PAN HEAD	1	1	1	1	1	
11	98507-06035	SCREW, PAN HEAD	8	8	8	8	8	
12	55X-15362-04	PLUG, OIL LEVEL	1	1	1	1	1	
13	93210-19123	O-RING	1	1	1	1	1	
14	93101-10142	OIL SEAL	1	1	1	1	1	
15	90209-11269	WASHER	1	1	1	1	1	
16	4EM-15443-01	EMBLEM	1	1	1	1	1	



 4EM1100-2100

FIG. 10 STARTER CLUTCH

REF. NO.	PART NO.	DESCRIPTION	USA	CAN	EUR	OCE	JPN	REMARKS
1	2HX-15520-00	STARTER WHEEL ASSY	1	1	1	1	1	
2	22M-15570-10	STARTER CLUTCH ASSY	1	1	1	1	1	
3	22M-13450-10	.ROTARY FILTER ASSY	1	1	1	1	1	
4	22M-15580-10	.STARTER CLUTCH OUTER ASSY	1	1	1	1	1	
5	3AY-15583-00	..CAP, STARTER CLUTCH SPRING	3	3	3	3	3	
6	93610-10174	..PIN, DOWEL	3	3	3	3	3	
7	90501-03799	..SPRING, COMPRESSION	3	3	3	3	3	
8	98701-06018	.SCREW, FLAT HEAD	3	3	3	3	3	
9	2HX-15517-10	GEAR, IDLER 2	1	1	1	1	1	
10	90560-20196	SPACER	1	1	1	1	1	

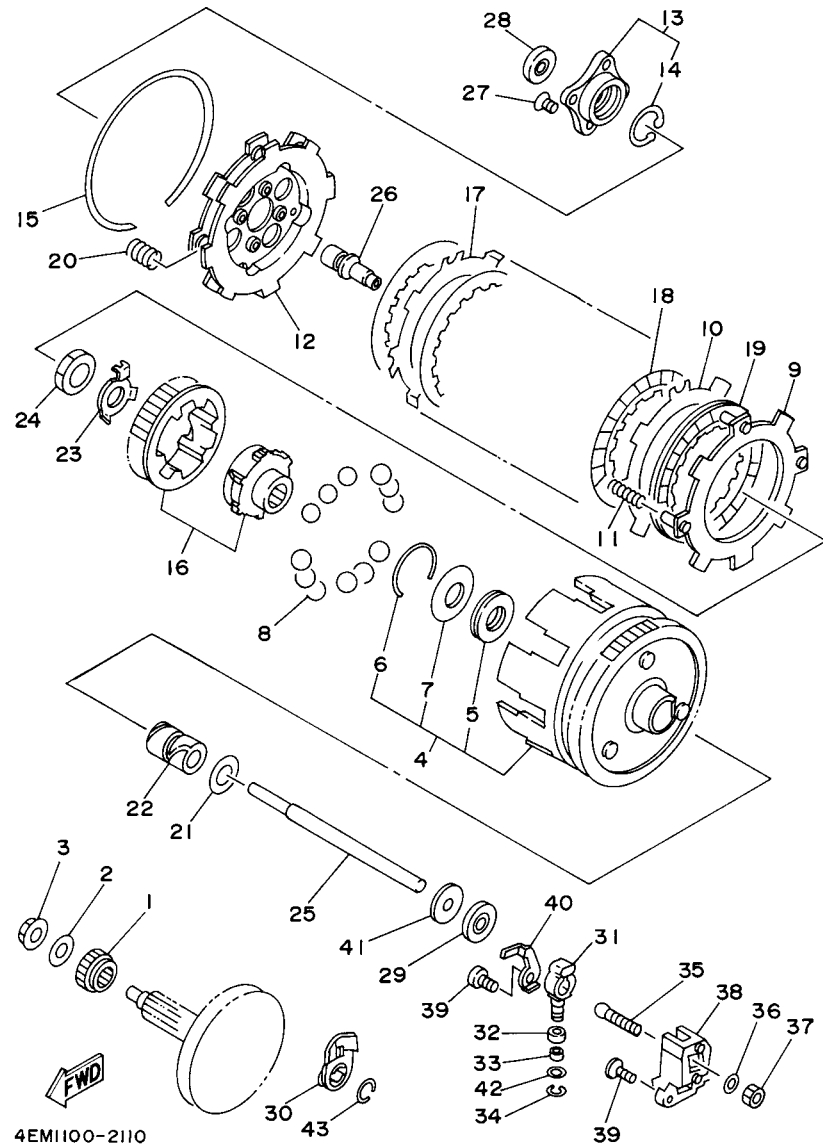

FIG. 11 CLUTCH

REF. NO.	PART NO.	DESCRIPTION	USA	CAN	EUR	OCE	JPN	REMARKS
1	22K-16111-00	GEAR, PRIMARY DRIVE	1	1	1	1	1	
2	90208-12015	WASHER, CONICAL SPRING	1	1	1	1	1	
3	90179-12007	NUT	1	1	1	1	1	
4	3GB-16150-00	PRIMARY DRIVEN GEAR COMP.	1	1	1	1	1	
5	93341-22302	.BEARING	1	1	1	1	1	
6	93450-42112	.CIRCLIP	1	1	1	1	1	
7	22F-16153-40	.WASHER, THRUST (1.7T)	1	1	1	1	1	
8	93505-08030	BALL	12	12	12	12	12	
9	22K-16520-00	PLATE, THRUST WEIGHT	1	1	1	1	1	
10	517-16524-10	PLATE, CLUTCH 1 (1.2T)	4	4	4	4	4	UR
	517-16524-20	PLATE, CLUTCH 1 (1.4T)	4	4	4	4	4	UR
	517-16524-30	PLATE, CLUTCH 1 (1.6T)	4	4	4	4	4	UR
11	90501-105A5	SPRING, COMPRESSION	4	4	4	4	4	
12	22F-16550-00	PRESSURE PLATE ASSY	1	1	1	1	1	
13	22K-16590-00	PUSH PLATE ASSY	1	1	1	1	1	
14	93420-26077	.CIRCLIP	1	1	1	1	1	
15	93451-08094	CIRCLIP	1	1	1	1	1	
16	22K-W1657-00	CLUTCH BOSS SET	1	1	1	1	1	
17	22F-16524-01	PLATE, CLUTCH 1	1	1	1	1	1	
18	3E5-16521-00	PLATE, FRICTION	5	5	5	5	5	
19	22F-16521-00	PLATE, FRICTION	1	1	1	1	1	
20	90501-135A4	SPRING, COMPRESSION	8	8	8	8	8	
21	122-16164-00	PLATE, THRUST 2	1	1	1	1	1	
22	90560-17146	SPACER	1	1	1	1	1	
23	90215-14249	WASHER, LOCK	1	1	1	1	1	
24	90170-14284	NUT	1	1	1	1	1	
25	22F-16357-01	ROD, PUSH 2	1	1	1	1	1	

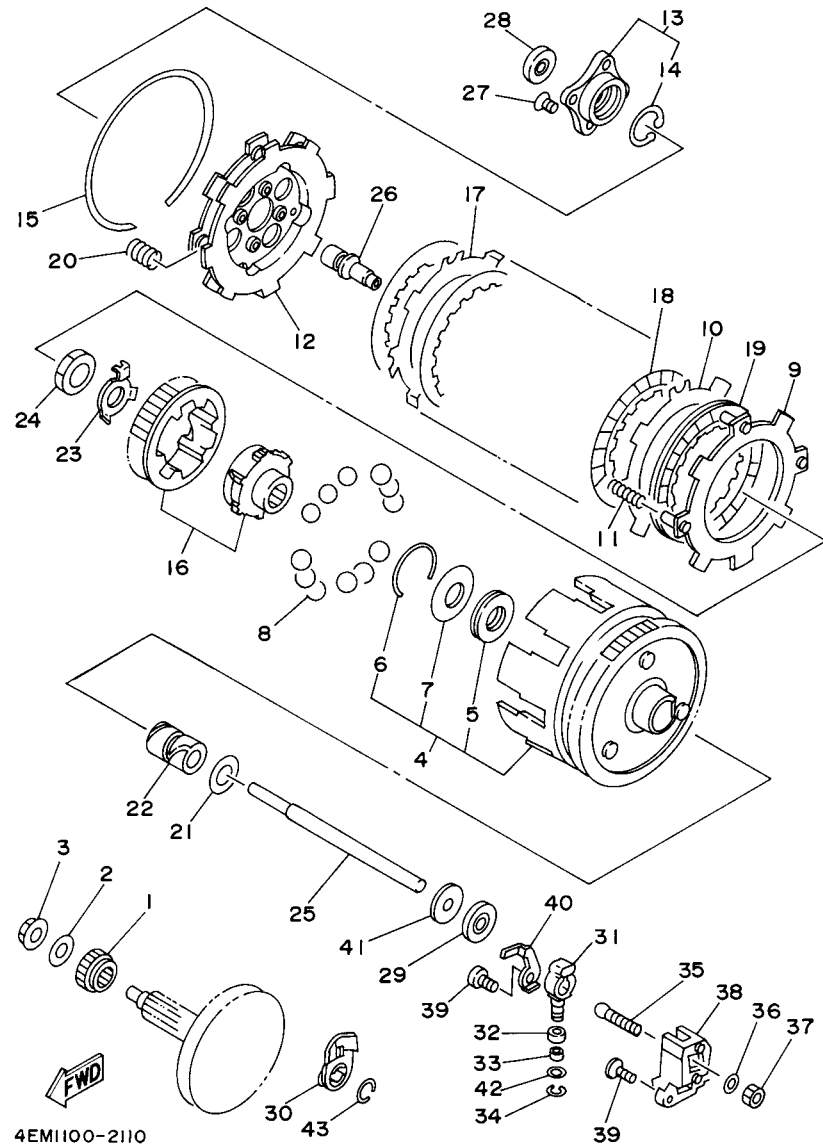
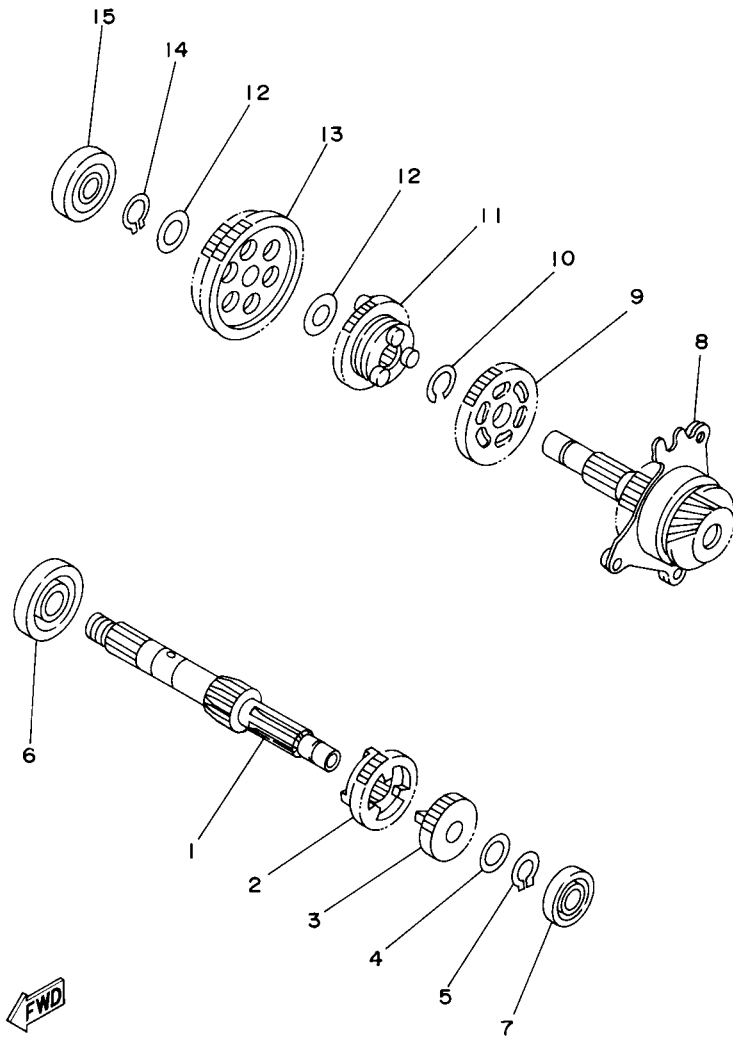

FIG. 11 CLUTCH

REF. NO.	PART NO.	DESCRIPTION	USA	CAN	EUR	OCE	JPN	REMARKS
26	22K-16356-00	ROD, PUSH 1	1	1	1	1	1	
27	90151-06070	SCREW, COUNTERSUNK	4	4	4	4	4	
28	93104-10076	OIL SEAL	1	1	1	1	1	
29	93102-07292	OIL SEAL	1	1	1	1	1	
30	22F-16362-01	LEVER, PUSH 2	1	1	1	1	1	
31	22F-16342-01	LEVER, PUSH	1	1	1	1	1	
32	90387-062G9	COLLAR	1	1	1	1	1	
33	90387-062G8	COLLAR	1	1	1	1	1	
34	99001-04600	CIRCLIP	1	1	1	1	1	
35	22F-16382-00	AXLE, PUSH LEVER	1	1	1	1	1	
36	92902-06600	WASHER, PLATE	1	1	1	1	1	
37	95302-06600	NUT	1	1	1	1	1	
38	22F-16399-00	GUIDE, PUSH ROD	1	1	1	1	1	
39	98502-06016	SCREW, PAN HEAD	2	2	2	2	2	
40	22F-16383-00	SPRING, CLUTCH BOSS	1	1	1	1	1	
41	90380-07118	BUSH, SOLID	1	1	1	1	1	
42	22F-16163-00	WASHER, THRUST 2	1	1	1	1	1	
43	93440-11128	CIRCLIP	1	1	1	1	1	

FIG. 12 TRANSMISSION



4EM1100-2120

REF. NO.	PART NO.	DESCRIPTION	USA	CAN	EUR	OCE	JPN	REMARKS
1	2HX-17411-01	AXLE, MAIN	1	1	1	1	1	
2	55X-17131-00	GEAR, 3RD PINION (22T)	1	1	1	1	1	
3	2HX-17121-00	GEAR, 2ND PINION (17T)	1	1	1	1	1	
4	90201-124F8	WASHER, PLATE	1	1	1	1	1	
5	99009-12400	CIRCLIP	1	1	1	1	1	
6	93306-20301	BEARING	1	1	1	1	1	
7	93306-00105	BEARING	1	1	1	1	1	
8	3GB-17402-00	DRIVE AXLE ASSY	1	1	1	1	1	
9	55X-17231-00	GEAR, 3RD WHEEL (31T)	1	1	1	1	1	
10	93440-16089	CIRCLIP	1	1	1	1	1	
11	55X-17241-00	GEAR, 4TH WHEEL (27T)	1	1	1	1	1	
12	90201-132G5	WASHER, PLATE	2	2	2	2	2	
13	3GB-17211-00	GEAR, 1ST WHEEL (39T)	1	1	1	1	1	
14	99009-12400	CIRCLIP	1	1	1	1	1	
15	93306-30101	BEARING	1	1	1	1	1	

FIG. 13 MIDDLE DRIVE GEAR

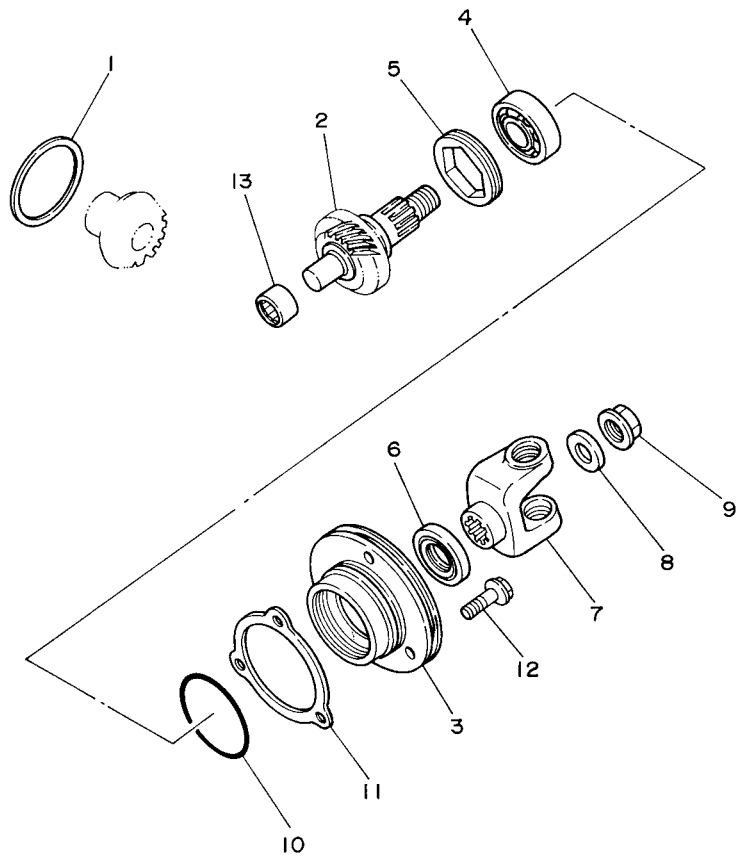

REF. NO.	PART NO.	DESCRIPTION	USA	CAN	EUR	OCE	JPN	REMARKS
1	22F-17537-00	SHIM, THRUST	1	1	1	1	1	
2	3GB-17508-00	MIDDLE DRIVEN GEAR COMP.	1	1	1	1	1	
3	22F-17551-00	HOUSING, BEARING	1	1	1	1	1	
4	93306-20309	BEARING	1	1	1	1	1	
5	90179-42480	NUT	1	1	1	1	1	
6	93101-24110	OIL SEAL	1	1	1	1	1	
7	22F-17556-01	YOKE, JOINT	1	1	1	1	1	
8	90201-125F7	WASHER, PLATE	1	1	1	1	1	
9	90179-12004	NUT	1	1	1	1	1	
10	93210-50553	O-RING	1	1	1	1	1	
11	22F-17531-00-15	SHIM, PINION (0.15T)	1	1	1	1	1	UR
	22F-17531-00-30	SHIM, PINION (0.30T)	1	1	1	1	1	UR
	22F-17531-00-50	SHIM, PINION (0.50T)	1	1	1	1	1	UR
12	95822-06020	BOLT, FLANGE	3	3	3	3	3	
13	93317-21236	BEARING	1	1	1	1	1	



3GB1100-9130

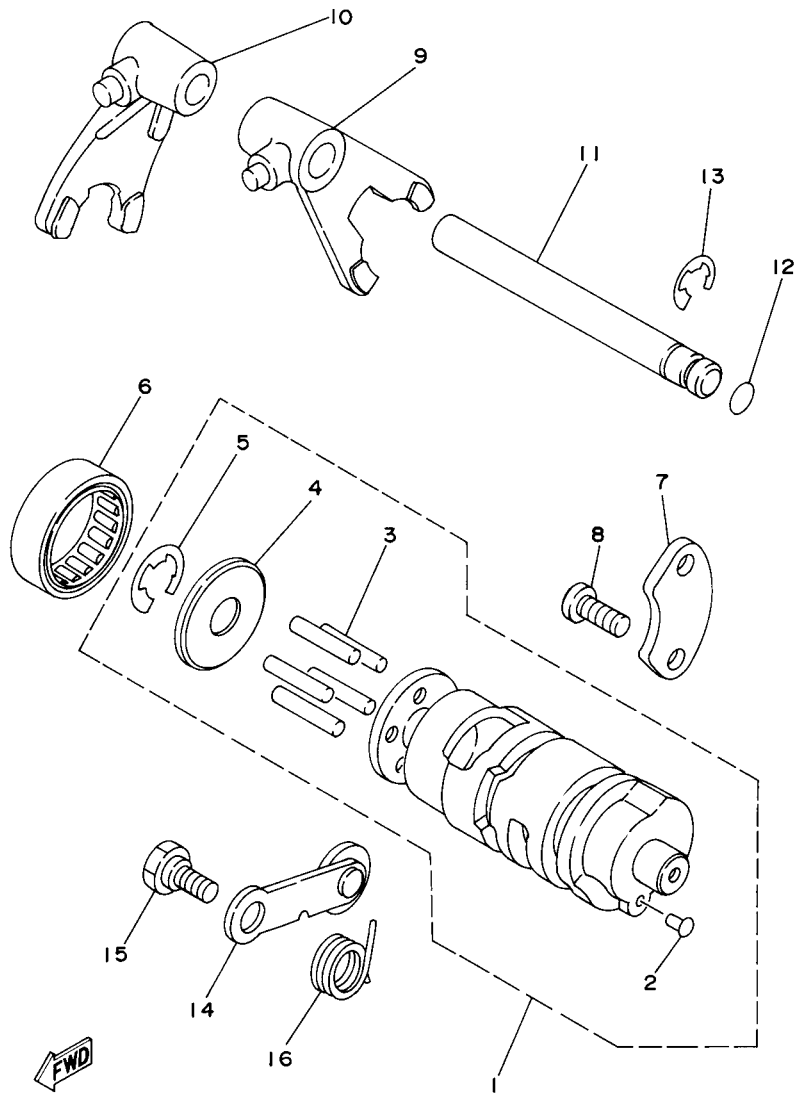

4EMK100-8140

FIG. 14 SHIFT CAM & FORK

REF. NO.	PART NO.	DESCRIPTION	USA	CAN	EUR	OCE	JPN	REMARKS
1	4EM-18540-00	SHIFT CAM ASSY	1	1	1	1	1	
2	136-18542-00	.POINT, NEUTRAL	1	1	1	1	1	
3	93604-22050	.PIN, DOWEL	5	5	5	5	5	
4	296-18561-00	.PLATE, SIDE 1	1	1	1	1	1	
5	99001-09600	.CIRCLIP	1	1	1	1	1	
6	93315-23208	BEARING	1	1	1	1	1	
7	22F-18562-01	PLATE, STOPPER 2	1	1	1	1	1	
8	98502-06014	SCREW, PAN HEAD	2	2	2	2	2	
9	2MK-18511-00	FORK, SHIFT 1	1	1	1	1	1	
10	29F-18512-00	FORK, SHIFT 2	1	1	1	1	1	
11	22F-18531-00	BAR, SHIFT FORK GUIDE 1	1	1	1	1	1	
12	93210-07003	O-RING	1	1	1	1	1	
13	93430-08007	CIRCLIP	1	1	1	1	1	
14	29F-18140-00	STOPPER LEVER ASSY	1	1	1	1	1	
15	90109-06238	BOLT	1	1	1	1	1	
16	90508-20576	SPRING, TORSION	1	1	1	1	1	

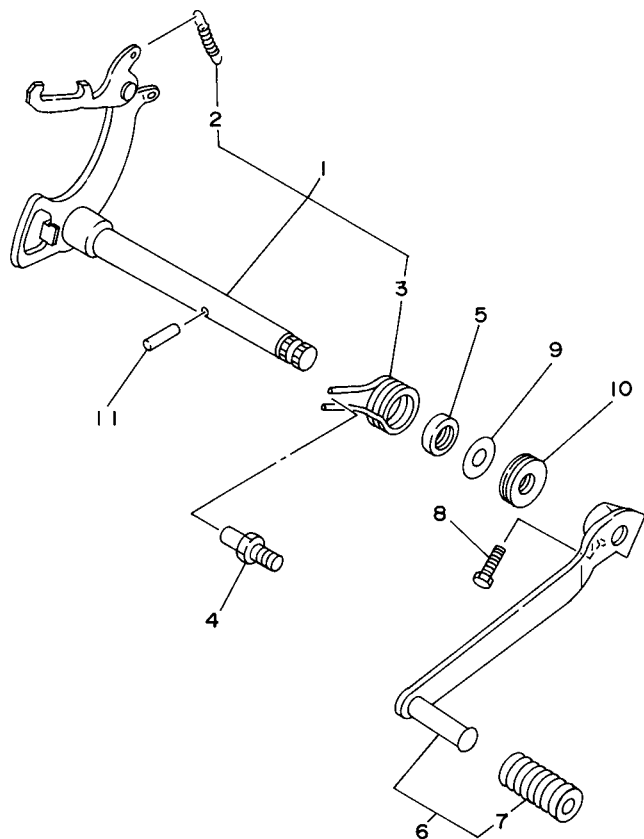
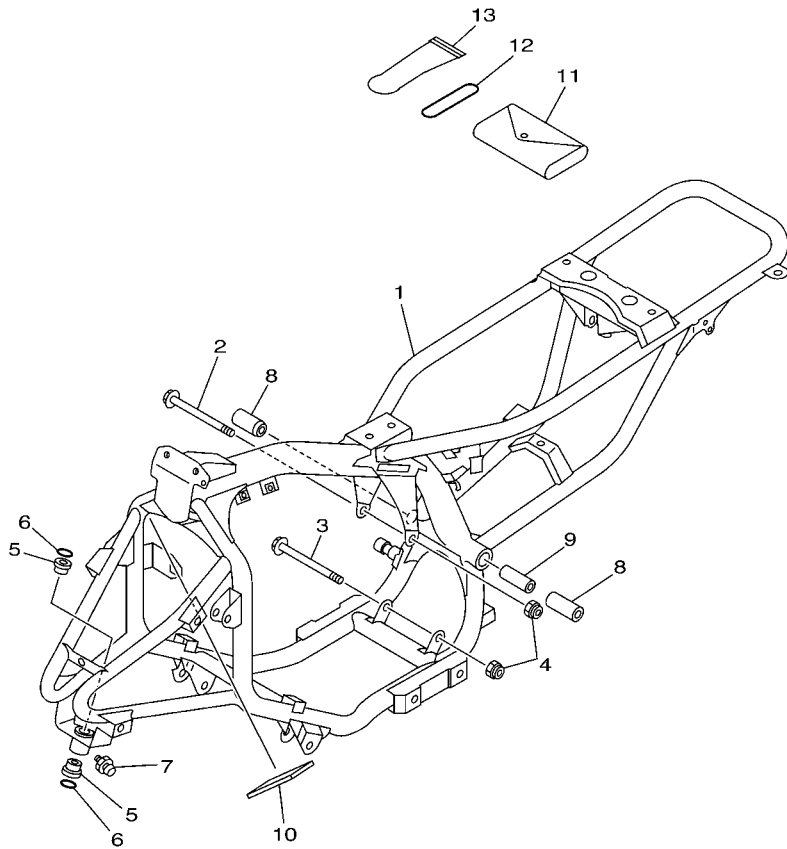

FIG. 15 SHIFT SHAFT

REF. NO.	PART NO.	DESCRIPTION	USA	CAN	EUR	OCE	JPN	REMARKS
1	22F-18101-03	SHIFT SHAFT ASSY	1	1	1	1	1	
2	90506-08122	.SPRING, TENSION	1	1	1	1	1	
3	90508-32563	.SPRING, TORSION	1	1	1	1	1	
4	278-18127-01	STOPPER, SCREW	1	1	1	1	1	
5	93102-12106	OIL SEAL (SD 12-22-5 HS)	1	1	1	1	1	
6	2HX-18110-10	SHIFT PEDAL ASSY	1	1	1	1	1	
7	132-18113-01	.COVER, SHIFT PEDAL	1	1	1	1	1	
8	97022-06020	BOLT	1	1	1	1	1	
9	90201-127F4	WASHER, PLATE	1	1	1	1	1	
10	93340-21209	BEARING	1	1	1	1	1	
11	93604-20156	PIN, DOWEL	1	1	1	1	1	

4EM1100-2150

FIG. 16 FRAME



REF. NO.	PART NO.	DESCRIPTION	USA	CAN	EUR	OCE	JPN	REMARKS
1	5TH-21110-20	FRAME COMP.	1		1	1	1	
	5TH-21110-30	FRAME COMP.		1				
2	95812-08120	BOLT, FLANGE	1	1	1	1	1	
3	95812-08120	BOLT, FLANGE	1	1	1	1	1	
4	95602-08200	NUT, SELF-LOCKING	2	2	2	2	2	
5	90381-15040	BUSH, SOLID	2	2	2	2	2	
6	93210-15414	O-RING	2	2	2	2	2	
7	93700-06004	NIPPLE, GREASE	1	1	1	1	1	
8	3GB-22123-00	BUSH 1	2	2	2	2	2	
9	3GB-22155-00	PIPE	1	1	1	1	1	
10	5TH-21268-01	SEAL	1	1	1	1	1	
11	3GB-28100-00	TOOL KIT	1	1	1	1	1	
12	93210-40407	O-RING	1	1	1	1	1	
13	1NV-2811A-01	GAUGE, AIR	1	1	1	1	1	

 5THE100-E160

FIG. 17 FRONT FENDER

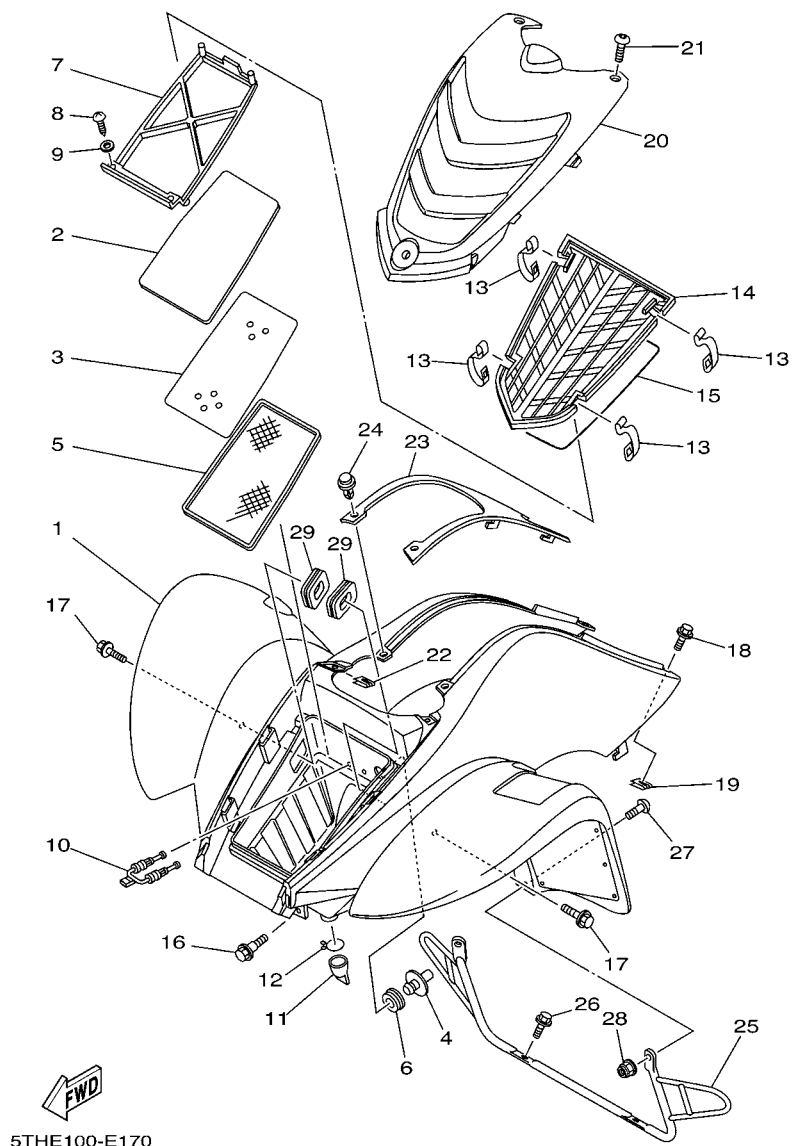

5THE100-E170

REF. NO.	PART NO.	DESCRIPTION	USA	CAN	EUR	OC	JPN	REMARKS
1	5TH-W2151-01	FRONT FENDER COMP.	1					UR FOR DPBSE
	5TH-W2151-31	FRONT FENDER COMP.	1					UR FOR PGD
	5TH-W215C-01	FRONT FENDER COMP.2		1				UR FOR DPBSE
	5TH-W215C-31	FRONT FENDER COMP.2		1				UR FOR PGD
	5TH-W215B-01	FRONT FENDER COMP. 2			1			FOR DPBSE
	5TH-W215D-01	FRONT FENDER COMP. 2				1	1	UR FOR DPBSE
	5TH-W215D-31	FRONT FENDER COMP. 2				1		UR FOR PGD
2	55X-14451-00	ELEMENT, AIR CLEANER	1	1	1	1	1	
3	5TH-14477-00	PLATE	1	1	1	1	1	
4	2D3-14419-00	PIPE	1	1	1	1	1	
5	55X-14472-01	PLATE, ELEMENT	1	1	1	1	1	
6	31A-14435-00	GROMMET	1	1	1	1	1	
7	55X-14458-00	GUIDE	1	1	1	1	1	
8	97702-40116	SCREW, TAPPING	2	2	2	2	2	
9	92902-04200	WASHER, PLAIN	2	2	2	2	2	
10	55X-14436-00	HOOK	1	1	1	1	1	
11	59V-14457-00	SEAL	1	1	1	1	1	
12	90467-220A1	CLIP	1	1	1	1	1	
13	5TH-14436-00	HOOK	4	4	4	4	4	
14	5TH-14412-00	CAP, CLEANER CASE 1	1	1	1	1	1	
15	5TH-14452-00	SEAL	1	1	1	1	1	
16	90109-06172	BOLT	1	1	1	1	1	
17	90119-06137	BOLT, WITH WASHER	2	2	2	2	2	
18	90119-05024	BOLT, WITH WASHER	2	2	2	2	2	
19	90183-050A8	NUT, SPRING	2	2	2	2	2	
20	5TH-21556-40	FENDER, FRONT 2	1	1	1	1	1	UR FOR DPBSE
	5TH-21556-30	FENDER, FRONT 2	1	1		1		UR FOR PGD

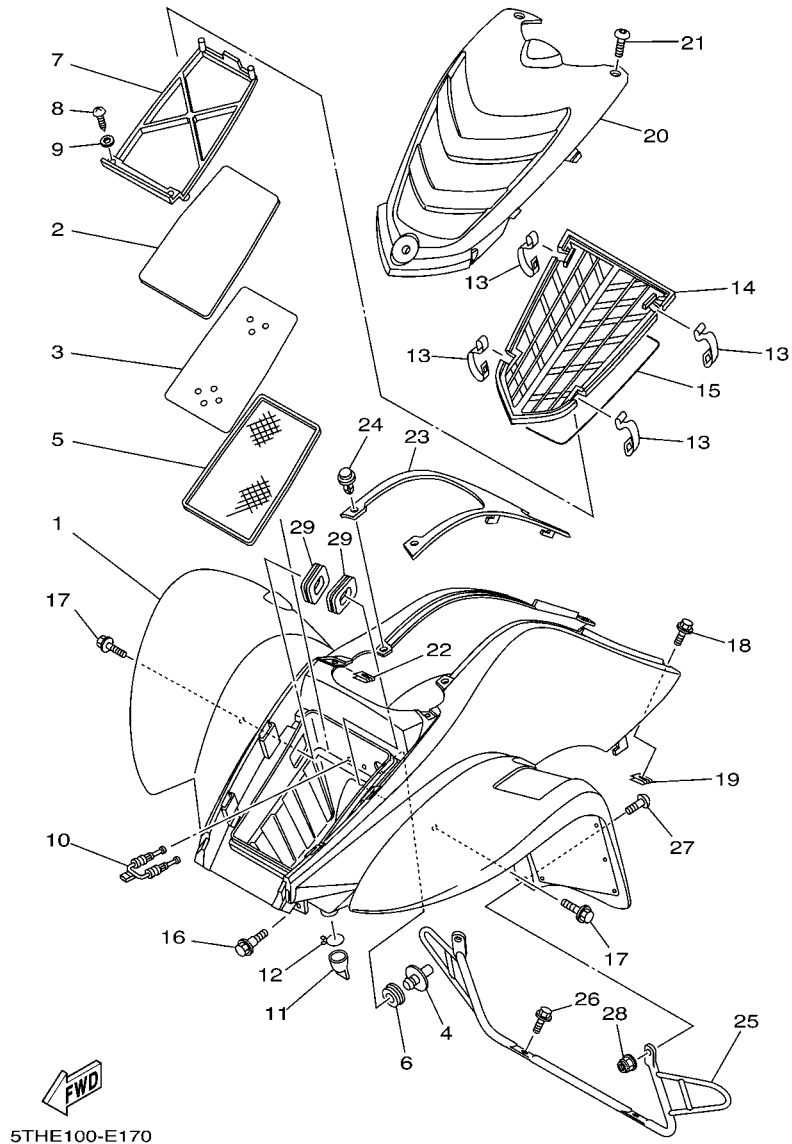
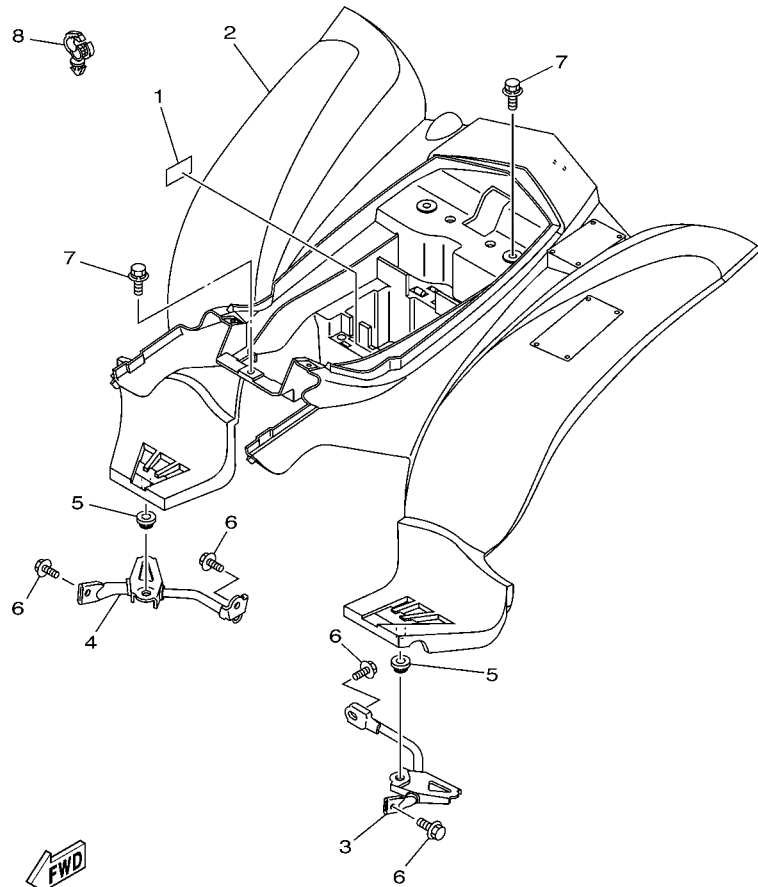

FIG. 17 FRONT FENDER

REF. NO.	PART NO.	DESCRIPTION	USA	CAN	EUR	OCE	JPN	REMARKS
21	90110-05201	BOLT, HEXAGON SOCKET HEAD	2	2	2	2	2	
22	90183-050A8	NUT, SPRING	2	2	2	2	2	
23	5TH-2171A-10	COVER, TOP	1	1	1	1	1	
24	90269-06002	RIVET	2	2	2	2	2	
25	5TH-21513-00	STAY, FENDER 1	1	1	1	1	1	
26	95802-06010	BOLT, FLANGE	2	2	2	2	2	
27	90154-05002	SCREW, BINDING	2	2	2	2	2	
28	90185-05009	NUT, SELF-LOCKING	2	2	2	2	2	
29	2HX-14437-01	DUCT	2	2	2	2	2	

FIG. 18 REAR FENDER



5TH1100-2180

REF. NO.	PART NO.	DESCRIPTION	USA	CAN	EUR	OCE	JPN	REMARKS
1	5TH-2177C-20	PLATE, EPA OFFROAD ATV 1	1					
2	5TH-W2161-00	REAR FENDER COMP.	1			1	1	UR FOR DPBSE
	5TH-W2161-30	REAR FENDER COMP.	1			1		UR FOR PGD
	5TH-W216C-00	REAR FENDER COMP.2			1			UR FOR DPBSE
	5TH-W216C-30	REAR FENDER COMP.2			1			UR FOR PGD
	5TH-W216B-00	REAR FENDER COMP.2				1		FOR DPBSE
3	3GB-21613-00	STAY, FENDER 1	1	1	1	1	1	
4	3GB-21614-00	STAY, FENDER 2	1	1	1	1	1	
5	90480-18171	GROMMET	2	2	2	2	2	
6	95802-08012	BOLT, FLANGE	4	4	4	4	4	
7	90119-06152	BOLT, WITH WASHER	4	4	4	4	4	
8	90464-13249	CLAMP	1	1	1	1	1	

FIG. 19 REAR ARM

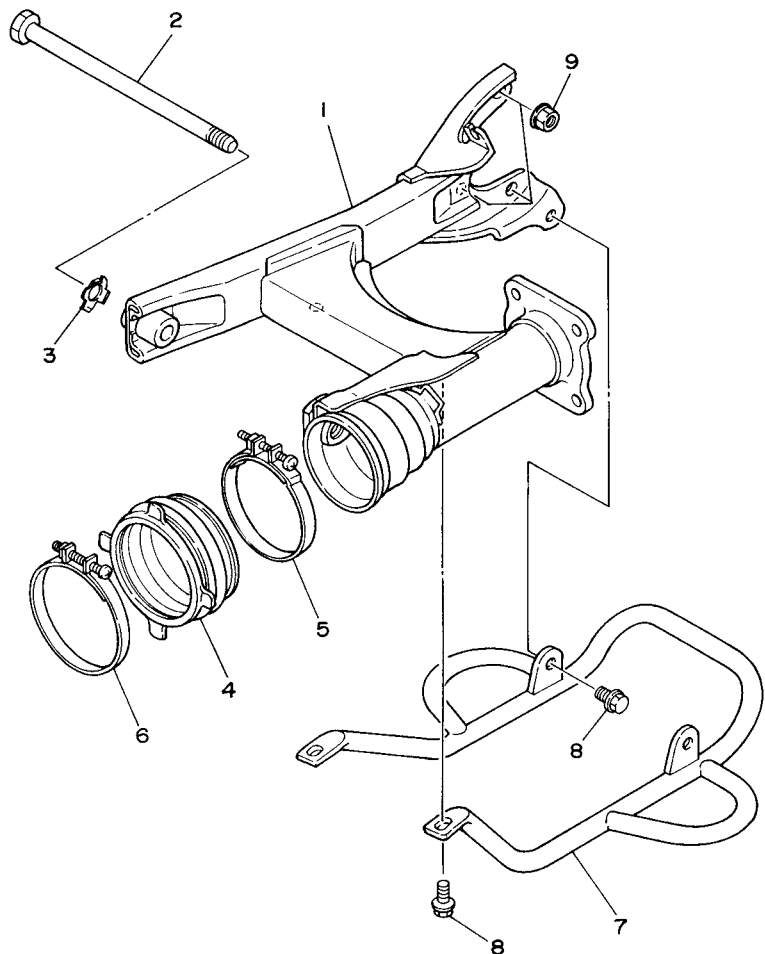

REF. NO.	PART NO.	DESCRIPTION	USA	CAN	EUR	OCE	JPN	REMARKS
1	3GB-22110-00-33	REAR ARM COMP.	1	1	1	1	1	YB
2	22W-25181-01	AXLE, WHEEL	1	1	1	1	1	
3	3GB-22156-00	WASHER, PLATE	1	1	1	1	1	
4	55X-22189-00	BOOT, RUBBER	1	1	1	1	1	
5	90460-75020	CLAMP, HOSE	1	1	1	1	1	
6	90460-85135	CLAMP, HOSE	1	1	1	1	1	
7	3GB-2219X-00	COVER	1	1	1	1	1	
8	95812-08014	BOLT, FLANGE	4	4	4	4	4	
9	90185-10019	NUT, SELF-LOCKING	3	3	3	3	3	



3GB1100-9190

FIG. 20 DRIVE SHAFT

REF. NO.	PART NO.	DESCRIPTION	USA	CAN	EUR	OCE	JPN	REMARKS
1	3GB-46151-00	HOUSING, DRIVE SHAFT	1	1	1	1	1	
2	2N4-15371-00	BREATHER	1	1	1	1	1	
3	90445-073F9	HOSE (L1200)	1	1	1	1	1	
4	90467-07029	CLIP	1	1	1	1	1	
5	90340-14132	PLUG, STRAIGHT SCREW	1	1	1	1	1	
6	214-11198-01	GASKET	1	1	1	1	1	
7	3GB-15362-00	PLUG, OIL LEVEL	1	1	1	1	1	
8	93210-14104	O-RING	1	1	1	1	1	
9	3GB-46120-00	DRIVE PINION COMP.	1	1	1	1	1	
10	90560-23355	SPACER	1	1	1	1	1	
11	93210-43713	O-RING	1	1	1	1	1	
12	93102-17271	OIL SEAL	1	1	1	1	1	
13	93306-30306	BEARING	1	1	1	1	1	
14	90179-55464	NUT	1	1	1	1	1	
15	3GB-46110-20	RING GEAR COMP.	1	1	1	1	1	
16	93306-07801	BEARING	1	1	1	1	1	
17	93102-28022	OIL SEAL	1	1	1	1	1	
18	93211-066A9	O-RING	1	1	1	1	1	
19	95812-06016	BOLT, FLANGE	6	6	6	6	6	
20	3GB-46172-01	SHAFT, DRIVE	1	1	1	1	1	
21	99009-17400	CIRCLIP	1	1	1	1	1	
22	2HX-46180-00	CROSS JOINT COMP.	1	1	1	1	1	
23	22F-46187-00	.SPIDER	1	1	1	1	1	
24	93311-20952	.BEARING	2	2	2	2	2	
25	99009-17500	.CIRCLIP	2	2	2	2	2	
26	93311-20952	BEARING	2	2	2	2	2	
27	99009-17500	CIRCLIP	2	2	2	2	2	

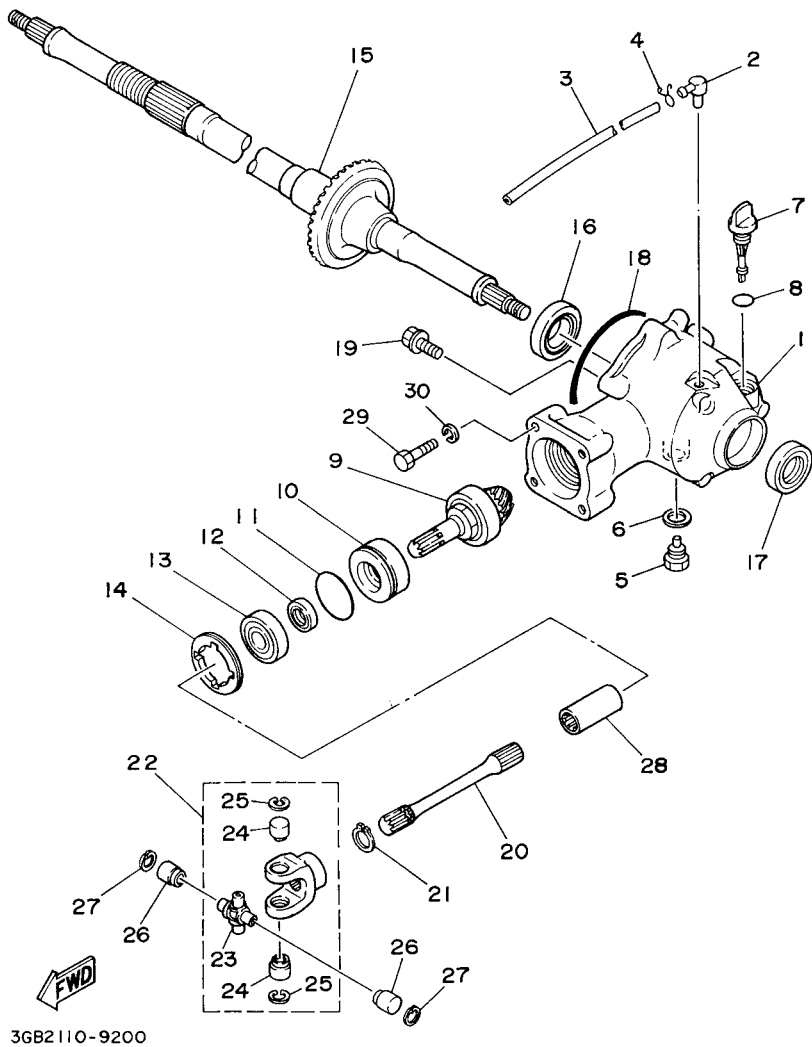

FIG. 20 DRIVE SHAFT

REF. NO.	PART NO.	DESCRIPTION	USA	CAN	EUR	OCE	JPN	REMARKS
28	22F-46123-01	COUPLING, GEAR	1	1	1	1	1	
29	90101-08058	BOLT	4	4	4	4	4	
30	92902-08100	WASHER, SPRING	4	4	4	4	4	
<hr style="border-top: 1px dashed black;"/>								
<hr style="border-top: 1px dashed black;"/>								
<hr style="border-top: 1px dashed black;"/>								
<hr style="border-top: 1px dashed black;"/>								
<hr style="border-top: 1px dashed black;"/>								
<hr style="border-top: 1px dashed black;"/>								
<hr style="border-top: 1px dashed black;"/>								
<hr style="border-top: 1px dashed black;"/>								
<hr style="border-top: 1px dashed black;"/>								

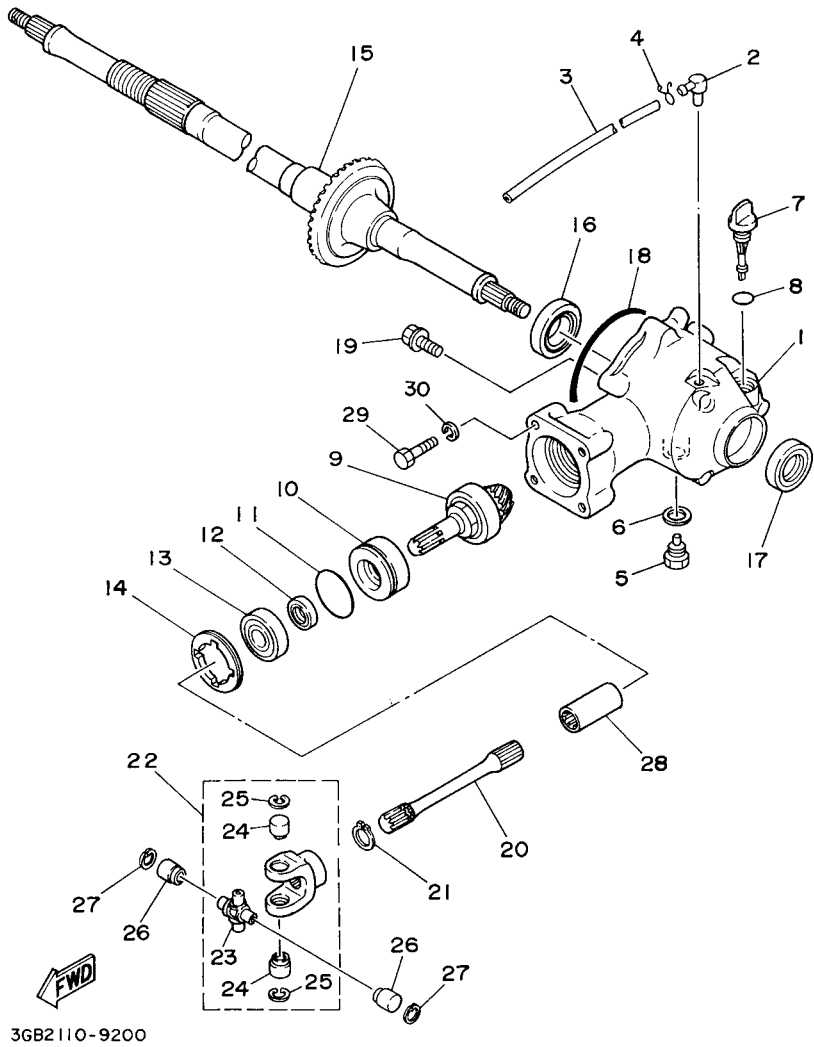
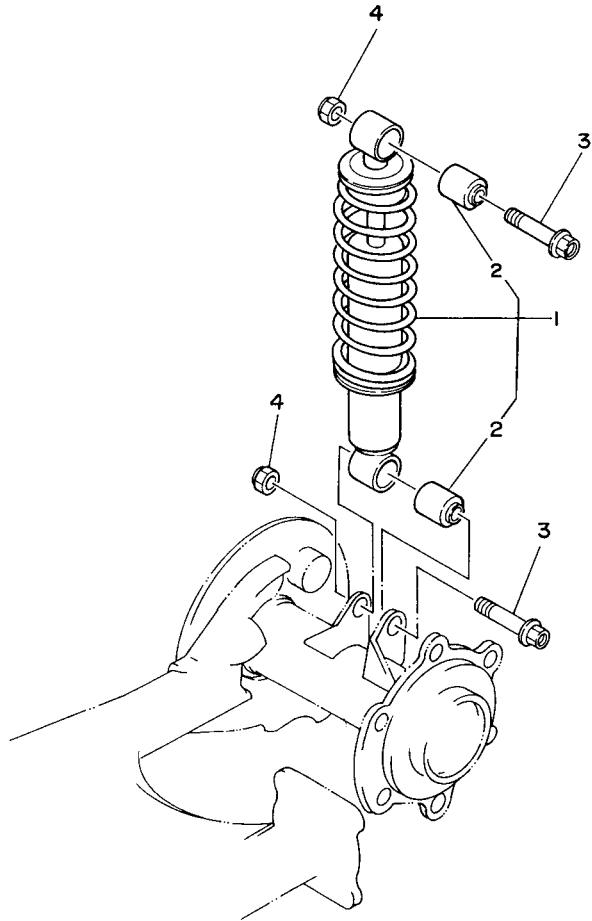

FIG. 21 REAR SUSPENSION



REF. NO.	PART NO.	DESCRIPTION	USA	CAN	EUR	OCE	JPN	REMARKS
1	3GB-22210-00-36	SHOCK ABSORBER ASSY, REAR	1	1	1	1	1	UR WW FOR DPBSE
	3GB-22210-00-35	SHOCK ABSORBER ASSY, REAR	1	1		1		UR SL FOR PGD
2	59V-22216-00	.BUSH, REAR SHOCK ABSORBER	2	2	2	2	2	
3	90105-10131	BOLT, FLANGE	2	2	2	2	2	
4	90185-10022	NUT, SELF-LOCKING	2	2	2	2	2	

 3GB1100-9210

FIG. 22 STEERING

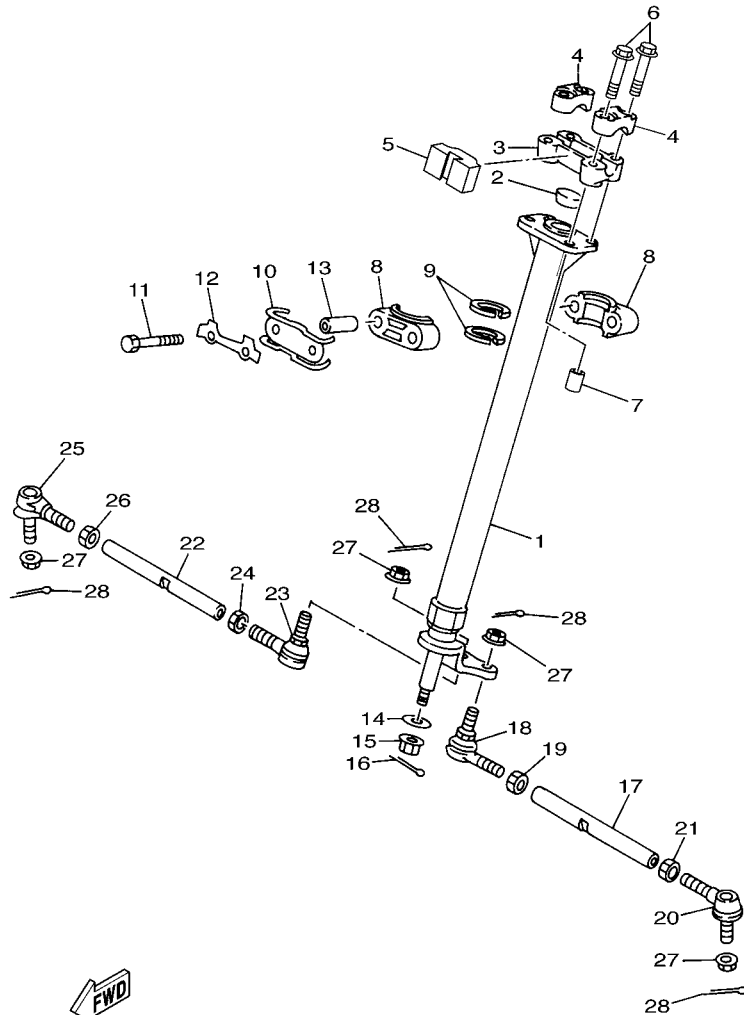

2D31100-D220

REF. NO.	PART NO.	DESCRIPTION	USA	CAN	EUR	OCE	JPN	REMARKS
1	4EM-23813-20	COLUMN, STEERING 2	1	1	1	1	1	
2	90336-28053	PLUG, TAPER	1	1	1	1	1	
3	8G5-23814-00	HOLDER, HANDLE UNDER	1	1	1	1	1	
4	8K1-23814-00	HOLDER, HANDLE	2	2	2	2	2	
5	2D3-23858-00	SPACER	1	1	1	1	1	
6	95822-08055	BOLT, FLANGE	4	4	4	4	4	
7	90445-11418	HOSE (L18)	1	1	1	1	1	
8	1UY-23812-00	PLANE BEARING, STEERING	2	2	2	2	2	
9	93112-31011	OIL SEAL	2	2	2	2	2	
10	3GB-23868-00	BRACKET, STEERING LOWER	1	1	1	1	1	
11	97022-08060	BOLT	2	2	2	2	2	
12	1UY-23894-01	WASHER, LOCK 1	1	1	1	1	1	
13	90387-090R0	COLLAR	2	2	2	2	2	
14	90201-10036	WASHER, PLATE	1	1	1	1	1	
15	90185-10019	NUT, SELF-LOCKING	1	1	1	1	1	
16	91401-20020	PIN, COTTER	1	1	1	1	1	
17	3GB-23831-00	ROD, TIE	1	1	1	1	1	
18	55X-23841-01	JOINT, UNIVERSAL 1	1	1	1	1	1	
19	95302-10700	NUT	1	1	1	1	1	
20	52H-23845-01	JOINT, UNIVERSAL 2	1	1	1	1	1	
21	90170-10010	NUT	1	1	1	1	1	(L.H. THREAD)
22	3GB-23831-00	ROD, TIE	1	1	1	1	1	
23	55X-23841-01	JOINT, UNIVERSAL 1	1	1	1	1	1	
24	95302-10700	NUT	1	1	1	1	1	
25	52H-23845-01	JOINT, UNIVERSAL 2	1	1	1	1	1	
26	90170-10010	NUT	1	1	1	1	1	(L.H. THREAD)
27	90185-10019	NUT, SELF-LOCKING	4	4	4	4	4	

FIG. 22 STEERING

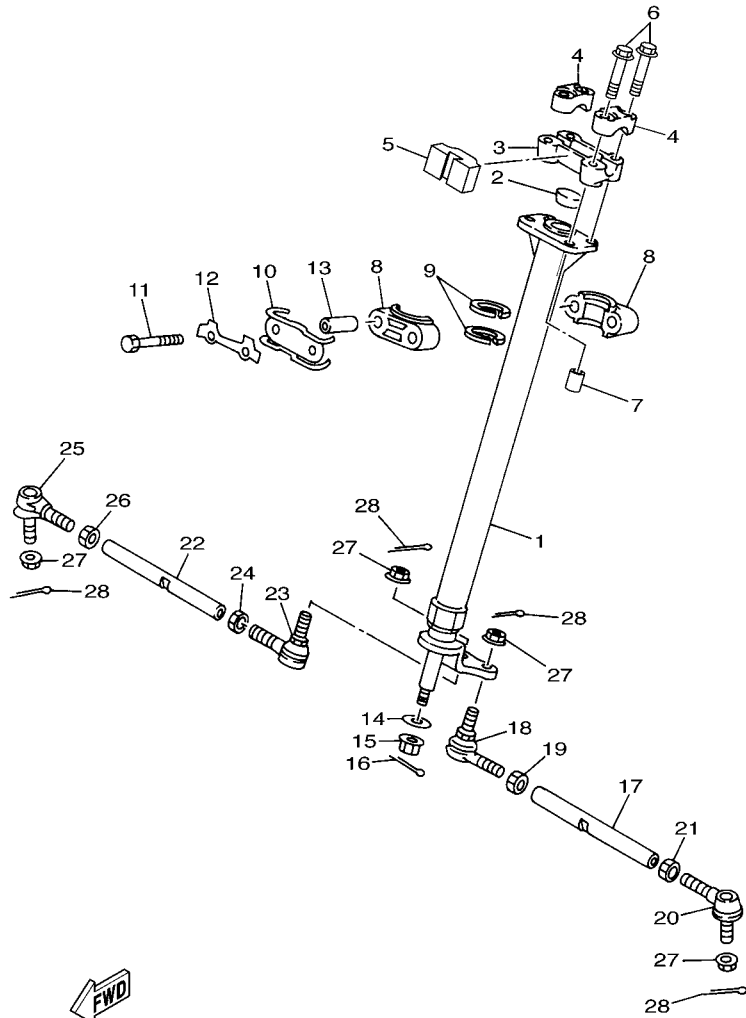

2D31100-D220

REF. NO.	PART NO.	DESCRIPTION	USA	CAN	EUR	OCE	JPN	REMARKS
28	91401-20020	PIN, COTTER	4	4	4	4	4	

FIG. 23 FRONT SUSPENSION & WHEEL

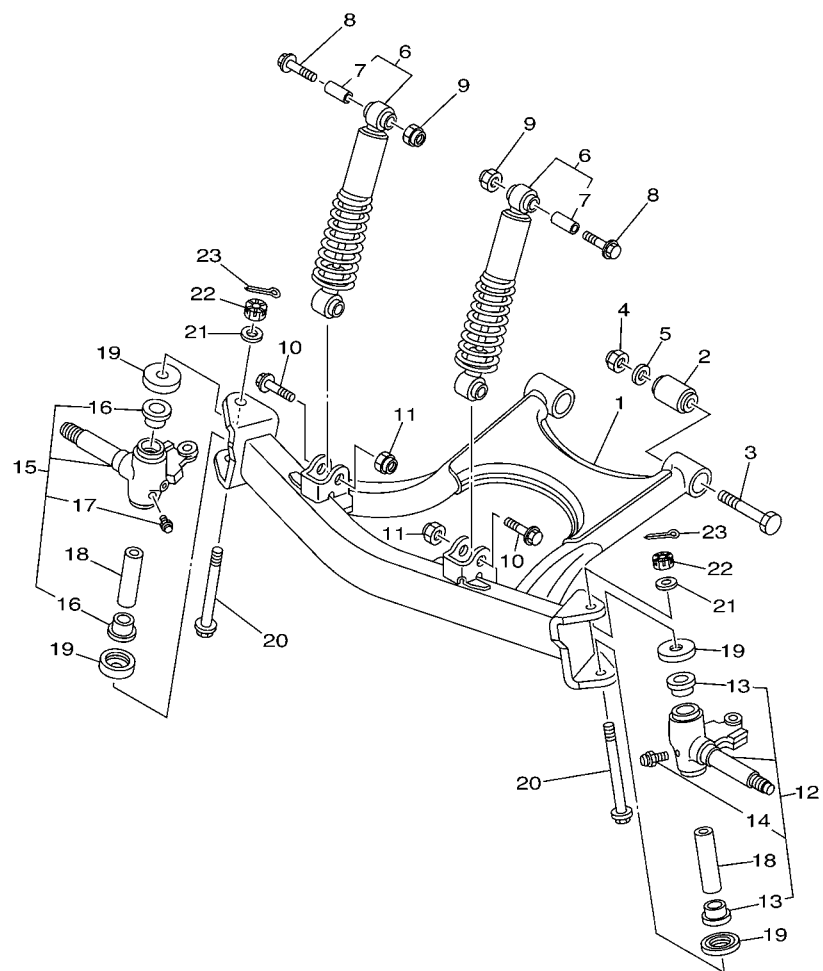

4EMT100-0230

REF. NO.	PART NO.	DESCRIPTION	USA	CAN	EUR	OCE	JPN	REMARKS
1	3GB-23570-00-33	FRONT LOWER ARM COMP.	1	1	1	1	1	YB
2	307-22123-00	BUSH 1	2	2	2	2	2	
3	90101-12033	BOLT	2	2	2	2	2	
4	90185-12010	NUT, SELF-LOCKING	2	2	2	2	2	
5	90201-12050	WASHER, PLATE	2	2	2	2	2	
6	2HX-23350-00-36	SHOCK ABSORBER ASSY	2	2	2	2	2	UR WW FOR DPBSE
	2HX-23350-00-35	SHOCK ABSORBER ASSY	2	2		2		UR SL FOR PGD
7	2HX-2331U-00	.COLLAR, DISTANCE	1	1	1	1	1	
8	90105-10262	BOLT, FLANGE	2	2	2	2	2	
9	90185-10022	NUT, SELF-LOCKING	2	2	2	2	2	
10	90105-12062	BOLT, FLANGE	2	2	2	2	2	
11	90185-12010	NUT, SELF-LOCKING	2	2	2	2	2	
12	3GB-23501-10	STEERING KNUCKLE ASSY (LEFT)	1	1	1	1	1	
13	90381-17067	.BUSH, SOLID	2	2	2	2	2	
14	93700-06004	.NIPPLE, GREASE	1	1	1	1	1	
15	3GB-23502-10	STEERING KNUCKLE ASSY (RIGHT)	1	1	1	1	1	
16	90381-17067	.BUSH, SOLID	2	2	2	2	2	
17	93700-06004	.NIPPLE, GREASE	1	1	1	1	1	
18	3GB-23448-00	SPACER	2	2	2	2	2	
19	2NL-23517-00	COVER, THRUST 1	4	4	4	4	4	
20	90105-10274	BOLT, FLANGE	2	2	2	2	2	
21	90201-10057	WASHER, PLATE	2	2	2	2	2	
22	90171-10003	NUT, CASTLE	2	2	2	2	2	
23	91401-20020	PIN, COTTER	2	2	2	2	2	

FIG. 24 FUEL TANK

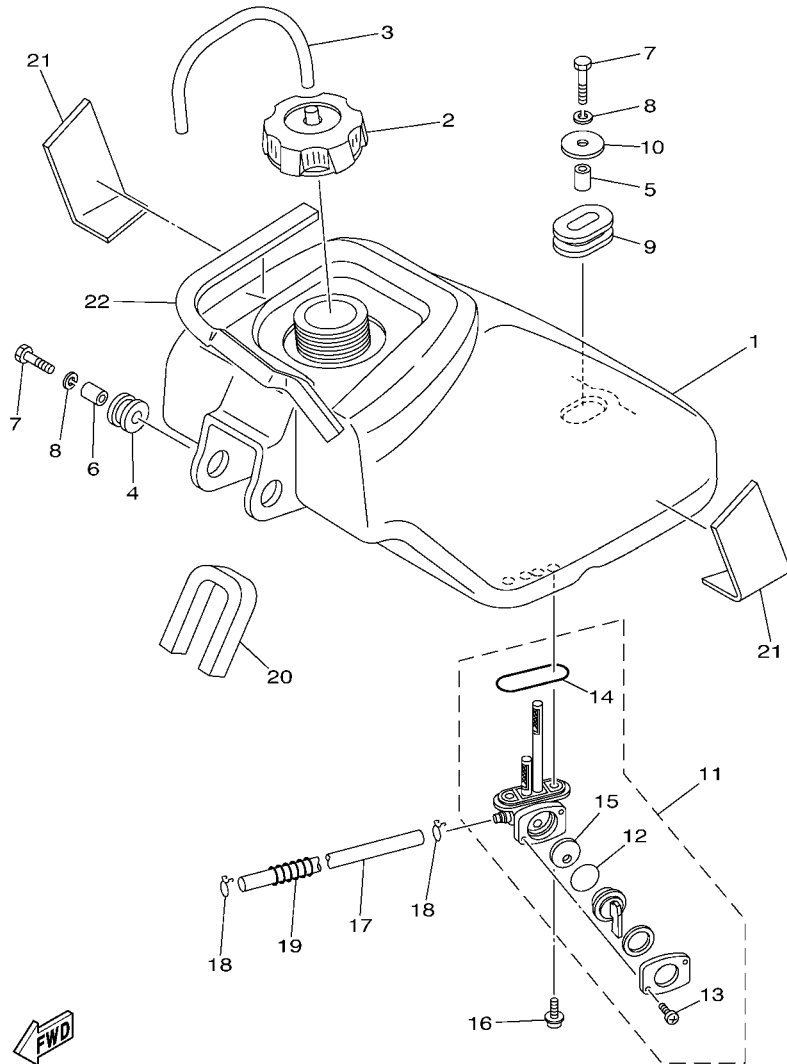

5THL100-G240

REF. NO.	PART NO.	DESCRIPTION	USA	CAN	EUR	OCE	JPN	REMARKS
1	2HX-24110-10	FUEL TANK COMP.	1	1				
	2HX-24110-00	FUEL TANK COMP.			1	1	1	
2	2FJ-24610-00	CAP ASSY	1	1	1	1	1	
3	90445-083J4	HOSE (L340)	1	1	1	1	1	
4	90480-18290	GROMMET	2	2	2	2	2	
5	90387-07598	COLLAR	1	1	1	1	1	
6	90387-066J1	COLLAR	2	2	2	2	2	
7	97022-06030	BOLT	3	3	3	3	3	
8	92902-06600	WASHER, PLATE	3	3	3	3	3	
9	90480-01400	GROMMET	1	1	1	1	1	
10	90201-06090	WASHER, PLATE	1	1	1	1	1	
11	55X-24500-02	FUEL COCK ASSY 1	1	1	1	1	1	
12	3AJ-24534-01	.SEAL, COCK	1	1	1	1	1	
13	98507-03008	.SCREW, PAN HEAD	2	2	2	2	2	
14	4X8-24512-00	.O-RING	1	1	1	1	1	
15	3AC-24523-00	.VALVE PACKING	1	1	1	1	1	
16	90149-06108	SCREW	2	2	2	2	2	
17	90445-10044	HOSE (L145)	1	1				
	90445-10638	HOSE (L145)			1	1	1	
18	90467-090A2	CLIP	2	2	2	2	2	
19	90504-06030	SPRING, COMPRESSION	1	1	1	1	1	
20	2HX-24181-00	DAMPER, LOCATING 1	1	1	1	1	1	
21	12R-21747-00	DAMPER	2	2	2	2	2	
22	5TH-2414H-00	DAMPER, PLATE 1	1	1	1	1	1	

FIG. 25 SEAT

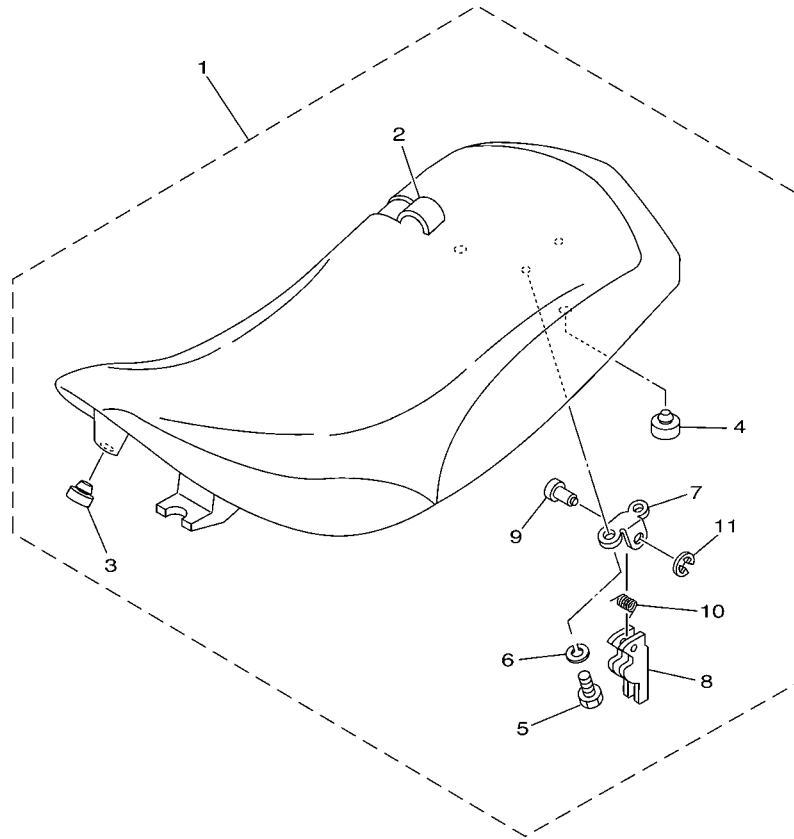

5TH1100-2250

REF. NO.	PART NO.	DESCRIPTION	USA	CAN	EUR	OCE	JPN	REMARKS
1	5TH-24710-01	SINGLE SEAT ASSY	1	1	1	1	1	
2	5TH-2470F-00	.SEAT COVER COMP.	1	1	1	1	1	
3	22W-24741-00	.PAD, SEAT	1	1	1	1	1	
4	371-27114-00	.STOPPER, MAIN STAND	2	2	2	2	2	
5	97002-06012	.BOLT	2	2	2	2	2	
6	92902-06100	.WASHER, SPRING	2	2	2	2	2	
7	4K0-24775-00	.BRACKET, SEAT LEVER	1	1	1	1	1	
8	29U-24776-00	.LEVER, SEAT	1	1	1	1	1	
9	4K0-24774-A0	.PIN	1	1	1	1	1	
10	90508-20454	.SPRING, TORSION	1	1	1	1	1	
11	93430-04002	.CIRCLIP	1	1	1	1	1	

FIG. 26 FRONT WHEEL

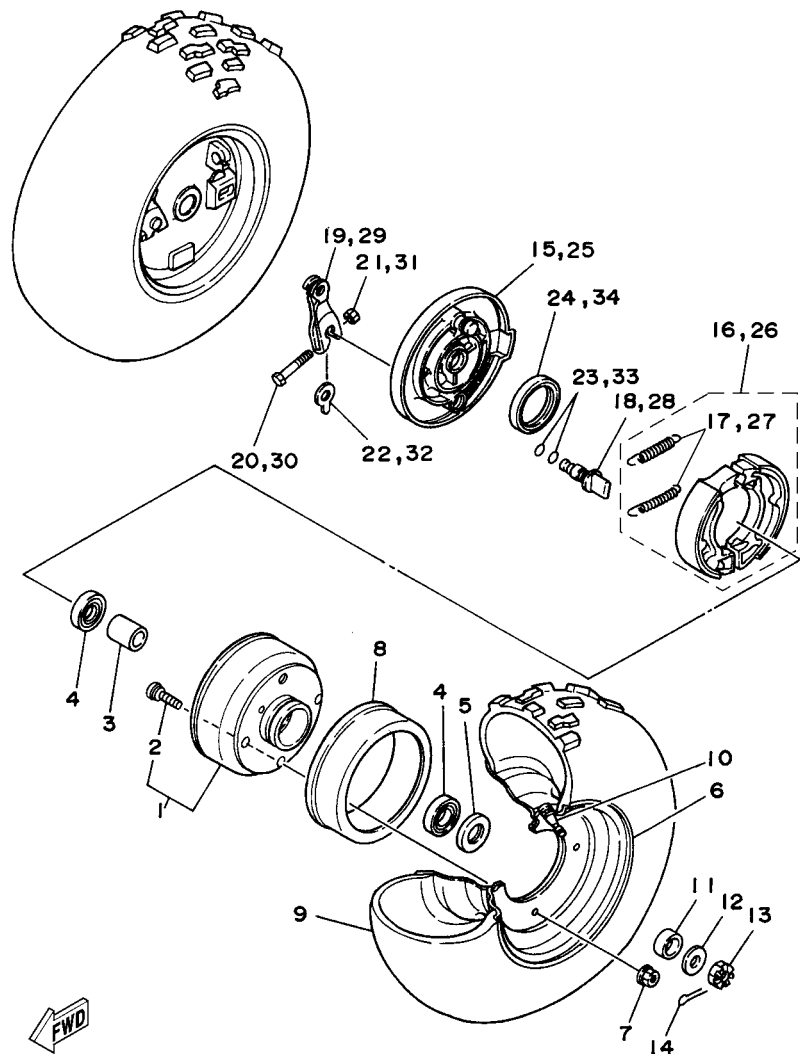

5TH5100-B260

REF. NO.	PART NO.	DESCRIPTION	USA	CAN	EUR	OCE	JPN	REMARKS
1	2FJ-25111-10	HUB, FRONT	2	2	2	2	2	
2	90114-08001	.BOLT, SERRATION	4	4	4	4	4	
3	3FA-25117-00	SPACER, BEARING	2	2	2	2	2	
4	93306-00308	BEARING	4	4	4	4	4	
5	93102-23275	OIL SEAL	2	2	2	2	2	
6	2FJ-25180-00-98	WHEEL COMP.	2	2	2	2	2	LGB
7	95702-08500	NUT, WITH WASHER	8	8	8	8	8	
8	3GB-25185-00	RING 1	2	2	2	2	2	
9	94107-07009	TIRE (AT18X7-7 *KT586T/L N)	2	2	2	2	2	DUNLOP
10	93900-00022	VALVE, RIM (TR413)	2	2	2	2	2	TAIHEIYO
11	90387-175R2	COLLAR	2	2	2	2	2	
12	90201-14586	WASHER, PLATE	2	2	2	2	2	
13	90171-14002	NUT, CASTLE	2	2	2	2	2	
14	91401-30025	PIN, SPLIT	2	2	2	2	2	
15	2FJ-25121-00	PLATE, BRAKE SHOE	1	1	1	1	1	
16	4KN-W253E-11	BRAKE SHOE KIT	1	1	1	1	1	
17	90506-15260	.SPRING, TENSION	2	2	2	2	2	
18	3GB-25151-00	CAMSHAFT	1	1	1	1	1	
19	2FJ-25155-00	LEVER, CAMSHAFT 1	1	1	1	1	1	
20	90101-06046	BOLT	1	1	1	1	1	
21	95302-06600	NUT	1	1	1	1	1	
22	52H-2513A-00	PLATE, INDICATOR	1	1	1	1	1	
23	93210-12327	O-RING	2	2	2	2	2	
24	93102-40367	OIL SEAL	1	1	1	1	1	
25	2FJ-25169-00	PLATE, BRAKE SHOE 2	1	1	1	1	1	
26	4KN-W253E-11	BRAKE SHOE KIT	1	1	1	1	1	
27	90506-15260	.SPRING, TENSION	2	2	2	2	2	

FIG. 26 FRONT WHEEL

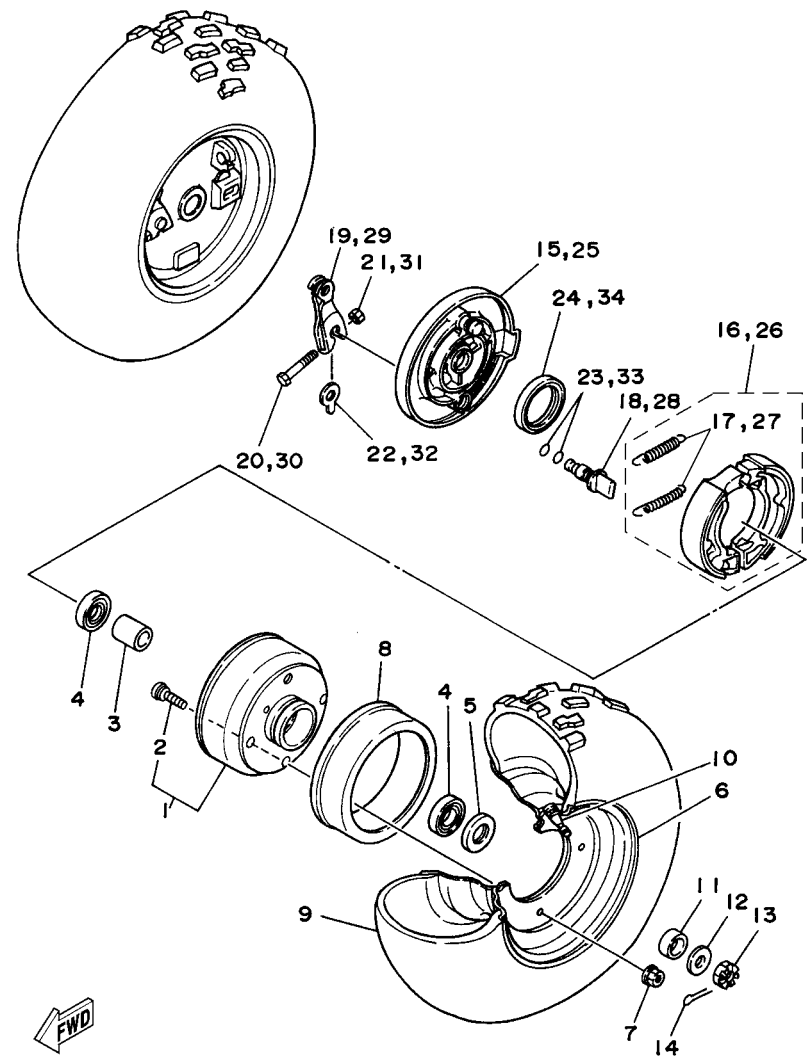

5TH5100-B260



REF. NO.	PART NO.	DESCRIPTION	USA	CAN	EUR	OCE	JPN	REMARKS
28	3GB-25151-00	CAMSHAFT	1	1	1	1	1	
29	2FJ-25156-00	LEVER, CAMSHAFT 2	1	1	1	1	1	
30	90101-06046	BOLT	1	1	1	1	1	
31	95302-06600	NUT	1	1	1	1	1	
32	52H-2513A-00	PLATE, INDICATOR	1	1	1	1	1	
33	93210-12327	O-RING	2	2	2	2	2	
34	93102-40367	OIL SEAL	1	1	1	1	1	

D5

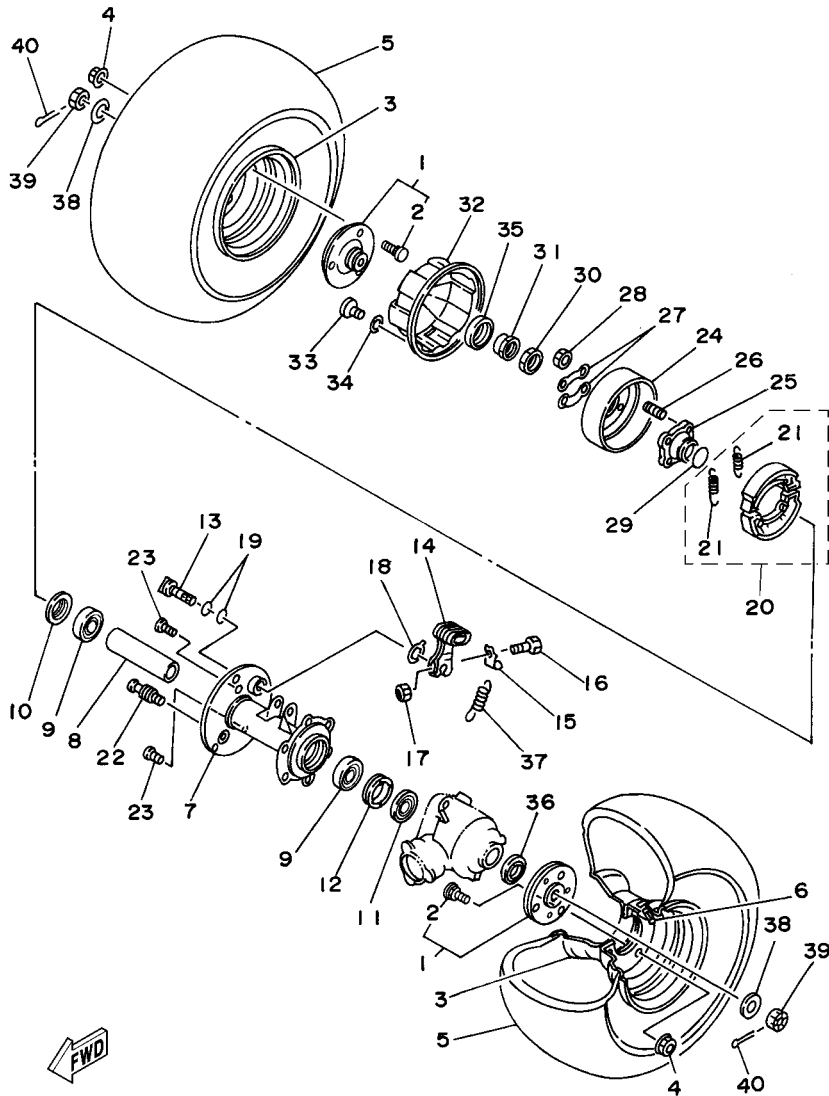

FWD
5TH5100-B270

FIG. 27 REAR WHEEL

REF. NO.	PART NO.	DESCRIPTION	USA	CAN	EUR	OOE	JPN	REMARKS
1	55X-25383-10	COLLAR, WHEEL	2	2	2	2	2	
2	90114-08001	.BOLT, SERRATION	3	3	3	3	3	
3	2FJ-25390-00-98	REAR WHEEL COMP.	2	2	2	2	2	LGB
4	95702-08500	NUT, WITH WASHER	6	6	6	6	6	
5	94108-07009	TIRE (AT18X8-7**KT587T/L N)	2	2	2	2	2	DUNLOP
6	93900-00022	VALVE, RIM (TR413)	2	2	2	2	2	TAIHEIYO
7	3GB-25311-00-33	HUB, REAR	1	1	1	1	1	YB
8	3GB-25317-00	SPACER, BEARING	1	1	1	1	1	
9	93306-00612	BEARING	2	2	2	2	2	
10	93102-38383	OIL SEAL	1	1	1	1	1	
11	93102-36409	OIL SEAL	1	1	1	1	1	
12	3GB-25382-00	NUT, AXLE	1	1	1	1	1	
13	3Y6-25351-00	CAMSHAFT	1	1	1	1	1	
14	55X-25355-00	LEVER, CAMSHAFT	1	1	1	1	1	
15	55X-2533H-00	HOOK, SPRING	1	1	1	1	1	
16	90101-06562	BOLT	1	1	1	1	1	
17	95302-06600	NUT	1	1	1	1	1	
18	23F-2533A-00	PLATE, INDICATOR	1	1	1	1	1	
19	93210-14104	O-RING	2	2	2	2	2	
20	3FA-W253E-00	BRAKE SHOE KIT	1	1	1	1	1	
21	90506-15260	.SPRING, TENSION	2	2	2	2	2	
22	3GB-25326-00	PIN, PIVOT	1	1	1	1	1	
23	90114-10017	BOLT, SERRATION	2	2	2	2	2	
24	3GB-2531E-00	DRUM, BRAKE	1	1	1	1	1	
25	3GB-25343-10	BOSS	1	1	1	1	1	
26	90116-08084	BOLT, STUD	4	4	4	4	4	
27	390-25412-01	WASHER	2	2	2	2	2	

D6

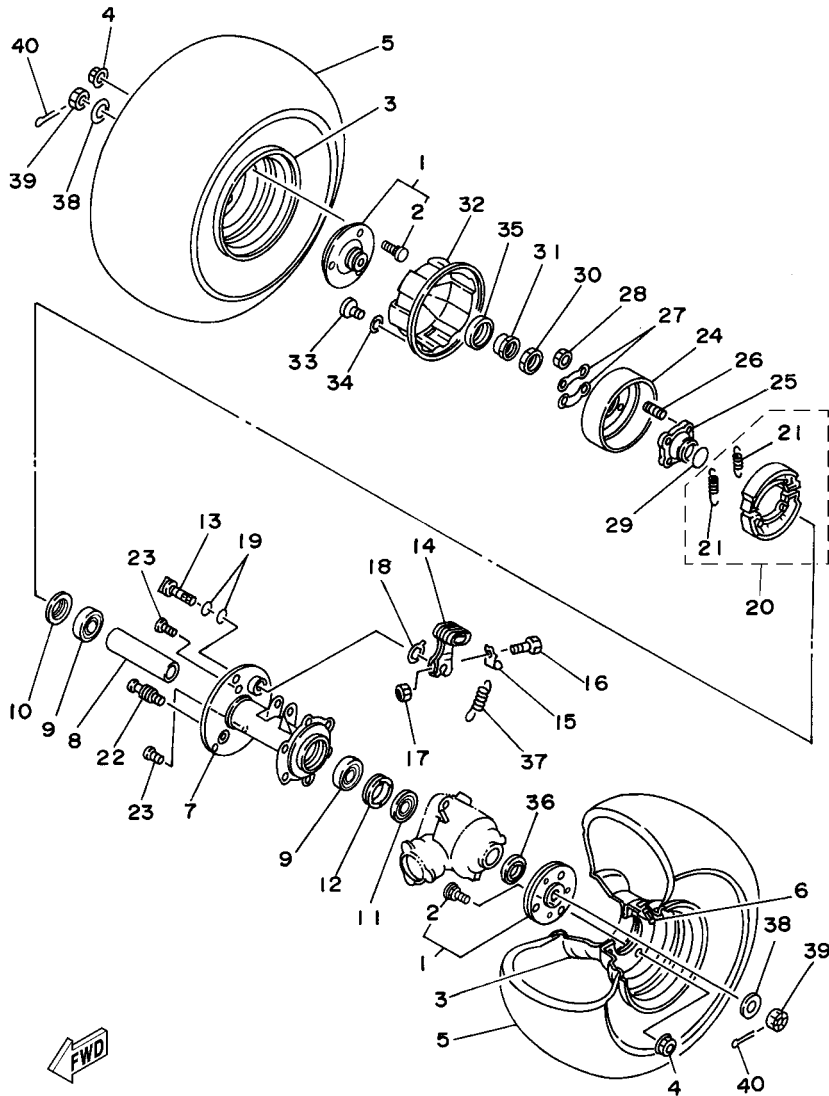

5TH5100-B270

FIG. 27 REAR WHEEL

REF. NO.	PART NO.	DESCRIPTION	USA	CAN	EUR	OCE	JPN	REMARKS
28	95302-08600	NUT	4	4	4	4	4	
29	93210-26606	O-RING	1	1	1	1	1	
30	90170-28011	NUT	1	1	1	1	1	
31	90179-28009	NUT	1	1	1	1	1	
32	3GB-25715-00	COVER 1	1	1	1	1	1	
33	92502-06012	SCREW, PAN HEAD	3	3	3	3	3	
34	92902-06100	WASHER, SPRING	3	3	3	3	3	
35	93102-35349	OIL SEAL	1	1	1	1	1	
36	3GB-25367-00	COVER, HUB DUST	1	1	1	1	1	
37	90507-15038	SPRING, TENSION	1	1	1	1	1	
38	90201-12045	WASHER, PLATE	2	2	2	2	2	
39	90171-12001	NUT, CASTLE	2	2	2	2	2	
40	91401-25025	PIN, COTTER	2	2	2	2	2	

FIG. 28 STEERING HANDLE & CABLE

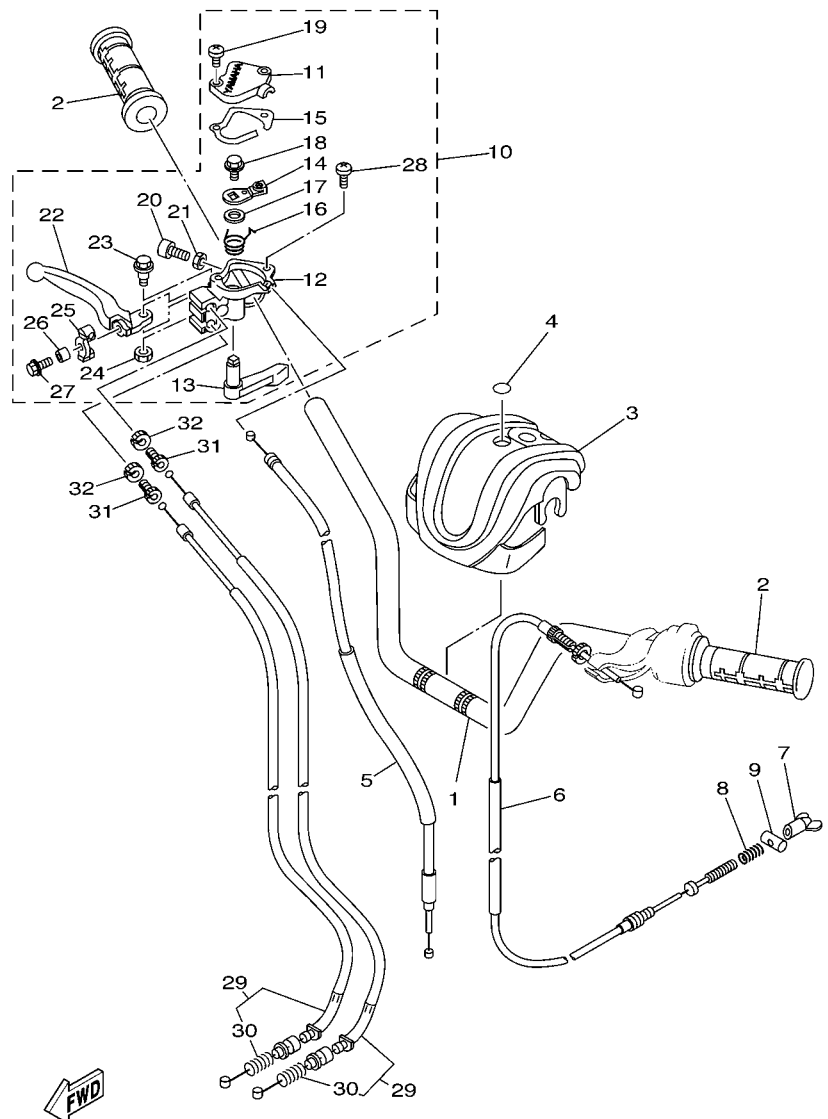

5TH1100-2280

REF. NO.	PART NO.	DESCRIPTION	USA	CAN	EUR	OCE	JPN	REMARKS
1	5TH-26111-20	HANDLEBAR	1	1	1	1	1	
2	5LP-26241-00	GRIP	2	2	2	2	2	
3	5TH-26124-00	PROTECTOR, HANDLEBAR	1	1	1	1	1	UR FOR DPBSE
	5TH-26124-10	PROTECTOR, HANDLEBAR	1	1		1		UR FOR PGD
4	5GT-2836B-10	TUNING FORK MARK	1	1	1	1	1	
5	3GB-26311-02	CABLE, THROTTLE 1	1	1	1	1	1	
6	3GB-26341-01	WIRE, BRAKE 1	1	1	1	1	1	
7	20E-26343-00	NUT, ADJUSTING	1	1	1	1	1	
8	90501-10782	SPRING, COMPRESSION	1	1	1	1	1	
9	90249-12008	PIN	1	1	1	1	1	
10	5TH-26250-10	THROTTLE LEVER ASSY	1	1	1	1	1	
11	3GB-2628F-00	.CAP, GEAR	1	1	1	1	1	
12	3GB-2625E-01	.BODY, THROTTLE	1	1	1	1	1	
13	3GB-2625G-00	.LEVER, THROTTLE	1	1	1	1	1	
14	3GB-2625H-00	.ARM, THROTTLE	1	1	1	1	1	
15	3GB-2628G-02	.GASKET	1	1	1	1	1	
16	90508-10775	.SPRING, TORSION	1	1	1	1	1	
17	90201-145M4	.WASHER, PLATE	1	1	1	1	1	
18	95802-08012	.BOLT, FLANGE	1	1	1	1	1	
19	98502-04016	.SCREW, PAN HEAD	2	2	2	2	2	
20	91312-05025	.BOLT	1	1	1	1	1	
21	95302-05700	.NUT	1	1	1	1	1	
22	5TH-83922-00	.LEVER 2	1	1	1	1	1	
23	90109-06243	.BOLT	1	1	1	1	1	
24	95602-06100	.NUT, U	1	1	1	1	1	
25	3GB-26347-00	.JOINT, CABLE	1	1	1	1	1	
26	90387-066V8	.COLLAR	1	1	1	1	1	

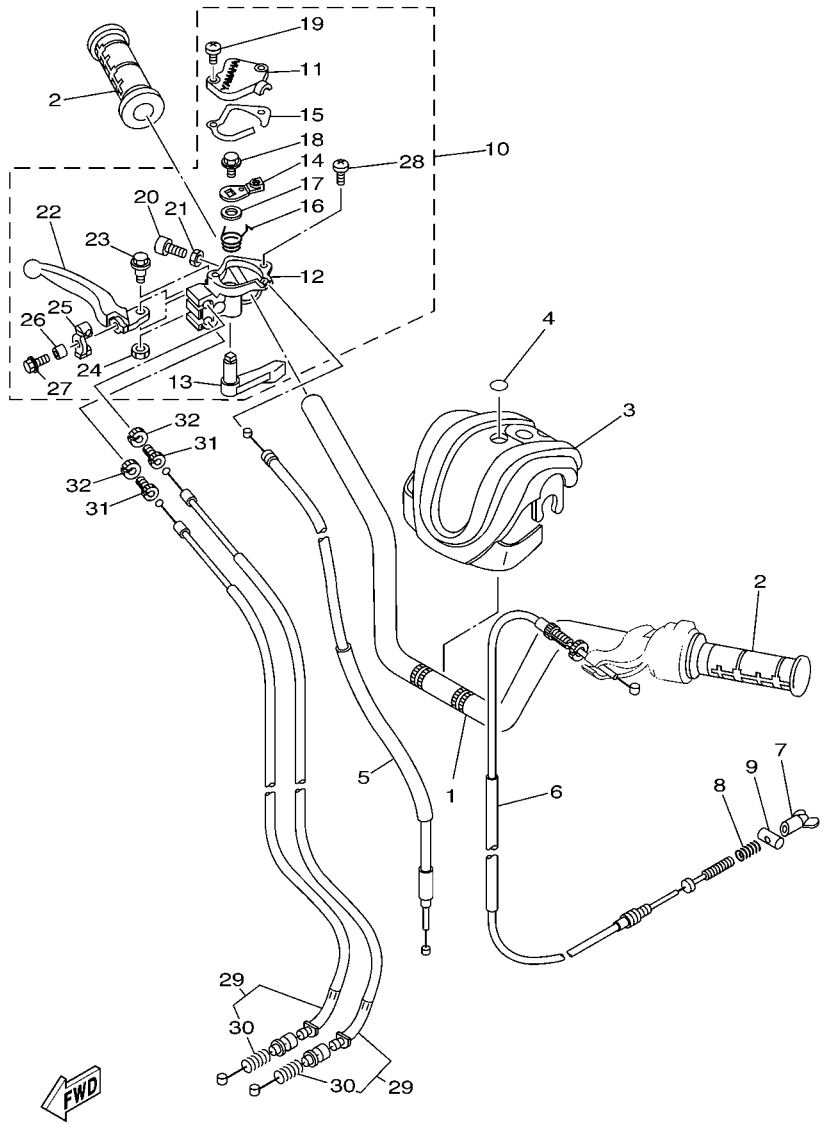

5TH1100-2280

FIG. 28 STEERING HANDLE & CABLE

REF. NO.	PART NO.	DESCRIPTION	USA	CAN	EUR	OCE	JPN	REMARKS
27	95802-06016	.BOLT, FLANGE	1	1	1	1	1	
28	98502-06020	.SCREW, PAN HEAD	1	1	1	1	1	
29	3GB-26361-03	CABLE, BRAKE	2	2	2	2	2	
30	90501-08511	.SPRING, COMPRESSION	1	1	1	1	1	
31	90123-08106	BOLT	2	2	2	2	2	
32	90179-08030	NUT	2	2	2	2	2	
<hr/>								
<hr/>								
<hr/>								
<hr/>								
<hr/>								
<hr/>								
<hr/>								

FIG. 29 STAND & FOOTREST

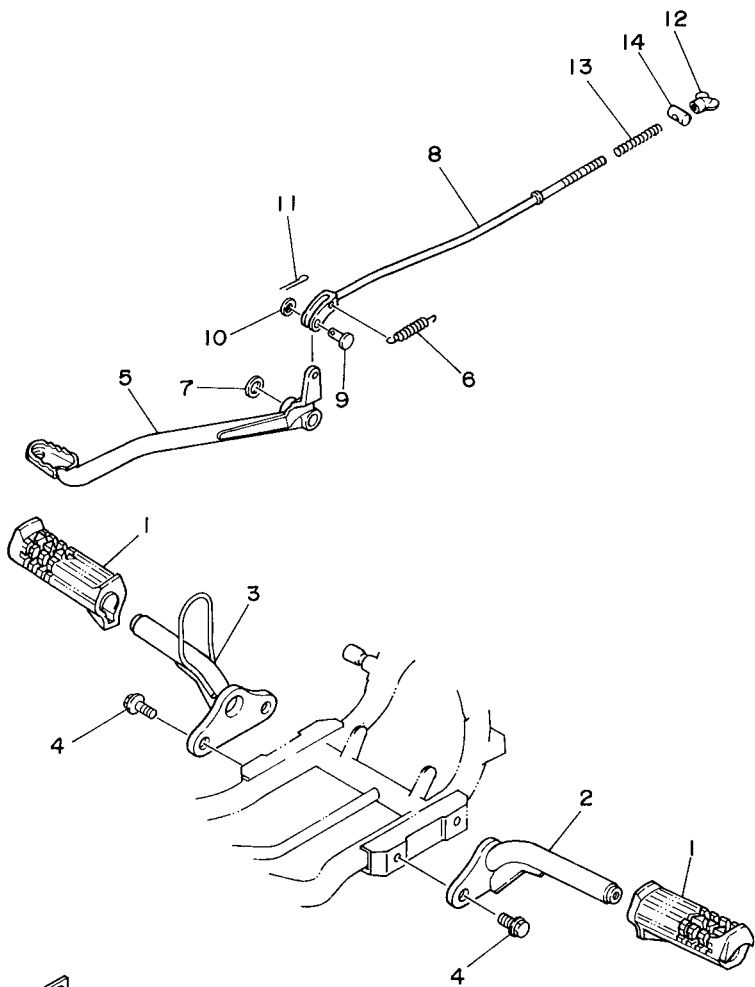

3GB1100-9290

REF. NO.	PART NO.	DESCRIPTION	USA	CAN	EUR	OCE	JPN	REMARKS
1	55X-27413-00	COVER, FOOTREST	2	2	2	2	2	
2	3GB-27411-10	FOOTREST 1	1	1	1	1	1	
3	3GB-27421-10	FOOTREST 2	1	1	1	1	1	
4	95812-12020	BOLT, FLANGE	4	4	4	4	4	
5	3GB-27211-10	PEDAL, BRAKE	1	1	1	1	1	
6	90506-16318	SPRING, TENSION	1	1	1	1	1	
7	90201-15018	WASHER, PLATE	1	1	1	1	1	
8	3GB-27231-00	ROD, BRAKE	1	1	1	1	1	
9	90240-06076	PIN, CLEVIS	1	1	1	1	1	
10	92902-06200	WASHER	1	1	1	1	1	
11	91401-20012	PIN, COTTER	1	1	1	1	1	
12	20E-26343-00	NUT, ADJUSTING	1	1	1	1	1	
13	90501-10245	SPRING, COMPRESSION	1	1	1	1	1	
14	90249-12008	PIN	1	1	1	1	1	

FIG. 31 GENERATOR

REF. NO.	PART NO.	DESCRIPTION	USA	CAN	EUR	OCE	JPN	REMARKS
1	2FM-85550-M1	ROTOR ASSY	1	1	1	1	1	
2	4EM-85560-10	BASE ASSY	1	1	1	1	1	
3	5G3-85520-M1	.COIL, CHARGE	1	1	1	1	1	
4	55X-81313-M0	.COIL, LIGHTING 1	1	1	1	1	1	
5	22K-85595-M0	.COIL, PULSER	1	1	1	1	1	
6	98511-04012	.SCREW, PAN HEAD	2	2	2	2	2	
7	98511-04020	.SCREW, PAN HEAD	2	2	2	2	2	
8	98501-04006	.SCREW, PAN HEAD	2	2	2	2	2	
9	92901-04100	.WASHER, SPRING	2	2	2	2	2	
10	98501-05010	.SCREW, PAN HEAD	1	1	1	1	1	
11	92901-05100	.WASHER, SPRING	1	1	1	1	1	
12	93102-19276	.OIL SEAL	1	1	1	1	1	
13	98702-06016	SCREW, FLAT HEAD	2	2	2	2	2	
14	93211-02703	O-RING	1	1	1	1	1	
15	90179-10023	NUT	1	1	1	1	1	
16	90201-101A4	WASHER, PLATE	1	1	1	1	1	

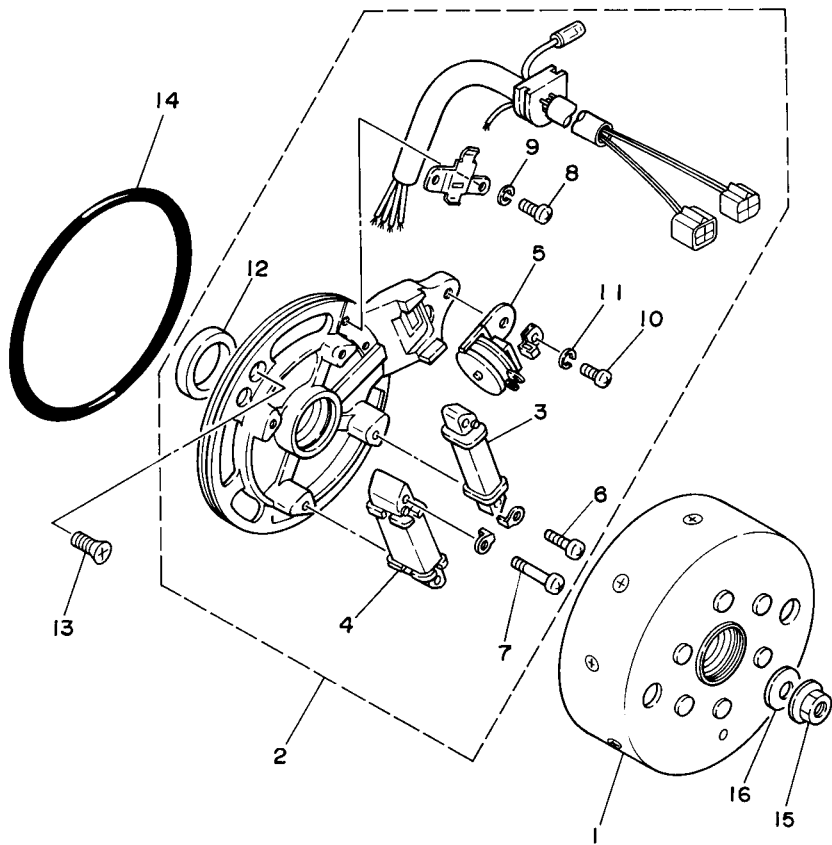

4EM9100-5320

D12

FIG. 32 STARTING MOTOR

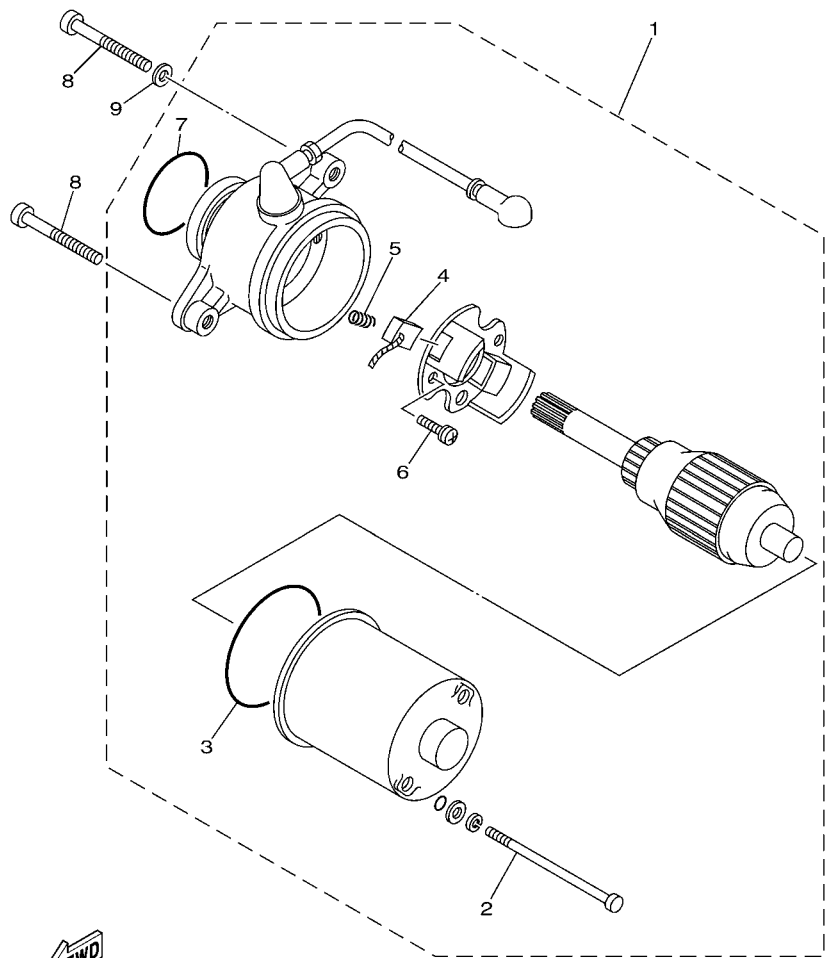

2HX110-7291

REF. NO.	PART NO.	DESCRIPTION	USA	CAN	EUR	OCE	JPN	REMARKS
1	55X-81800-51	STARTING MOTOR ASSY	1	1	1	1	1	
2	55X-81826-50	.BOLT	2	2	2	2	2	
3	5J3-81847-50	.O-RING	1	1	1	1	1	
4	22J-81801-50	.BRUSH SET	1	1	1	1	1	
5	55X-81855-50	.SPRING, BRUSH	2	2	2	2	2	
6	5J3-81846-50	.SCREW	2	2	2	2	2	
7	22J-81847-50	.O-RING	1	1	1	1	1	
8	91312-06035	BOLT	2	2	2	2	2	
9	92902-06200	WASHER	1	1	1	1	1	

FIG. 33 HEADLIGHT

REF. NO.	PART NO.	DESCRIPTION	USA	CAN	EUR	OCE	JPN	REMARKS
1	5TH-84121-00	LENS, HEADLIGHT	2	2	2	2	2	
2	5TH-84111-00	BODY, HEADLIGHT	2	2	2	2	2	
3	5TH-8411B-00	GRAPHIC	2	2	2	2	2	
4	90119-06137	BOLT, WITH WASHER	4	4	4	4	4	

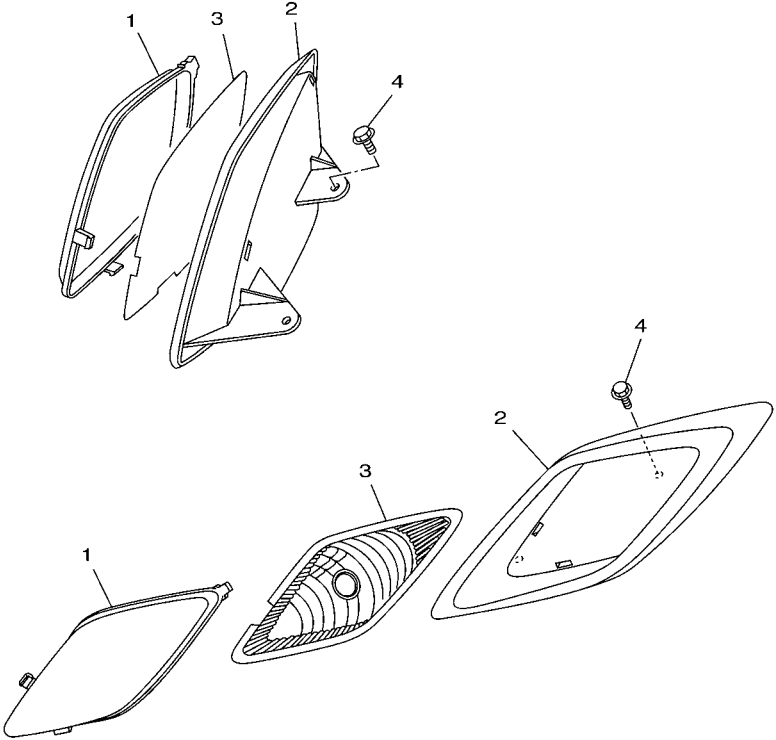

5TH1 100-2330

FIG. 34 HANDLE SWITCH & LEVER

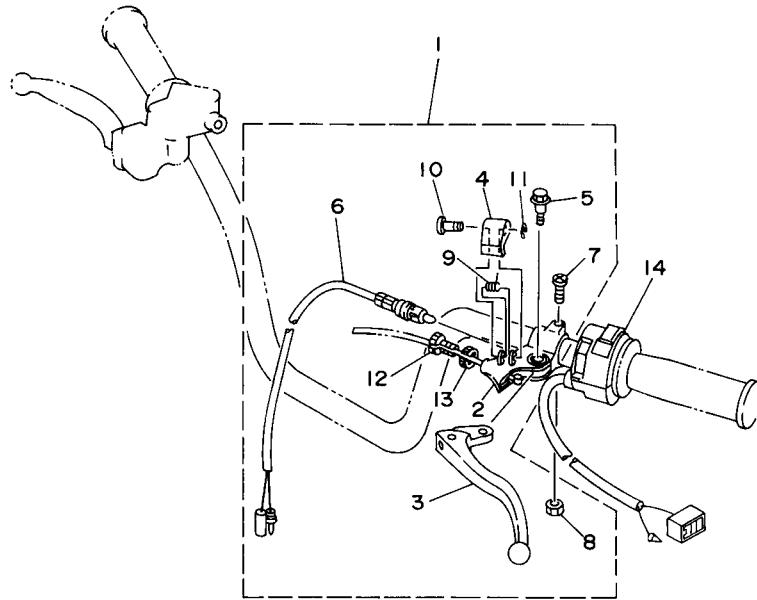

REF. NO.	PART NO.	DESCRIPTION	USA	CAN	EUR	OCE	JPN	REMARKS
1	5TH-82910-01	LEVER HOLDER ASSY (LEFT)	1	1	1	1	1	
2	3FA-82911-01	.HOLDER, LEVER 1	1	1	1	1	1	
3	23X-83912-00	.LEVER 1	1	1	1	1	1	
4	3FA-83965-00	.LEVER, LOCK	1	1	1	1	1	
5	90109-06799	.BOLT	1	1	1	1	1	
6	1YW-83980-00	.FRONT STOP SWITCH ASSY	1	1	1	1	1	
7	98507-06020	.SCREW, PAN HEAD	1	1	1	1	1	
8	95607-06100	.NUT, U	1	1	1	1	1	
9	3FA-83966-00	.SPRING, RETURN	1	1	1	1	1	
10	3FA-83967-00	.PIN, LOCK 1	1	1	1	1	1	
11	3FA-26466-00	.RING, SNAP	1	1	1	1	1	
12	90123-08046	.BOLT	1	1	1	1	1	
13	90179-08148	.NUT	1	1	1	1	1	
14	4EM-83975-00	SWITCH, HANDLE 2	1	1	1	1	1	



4EM9100-5340

FIG. 35 ELECTRICAL 1

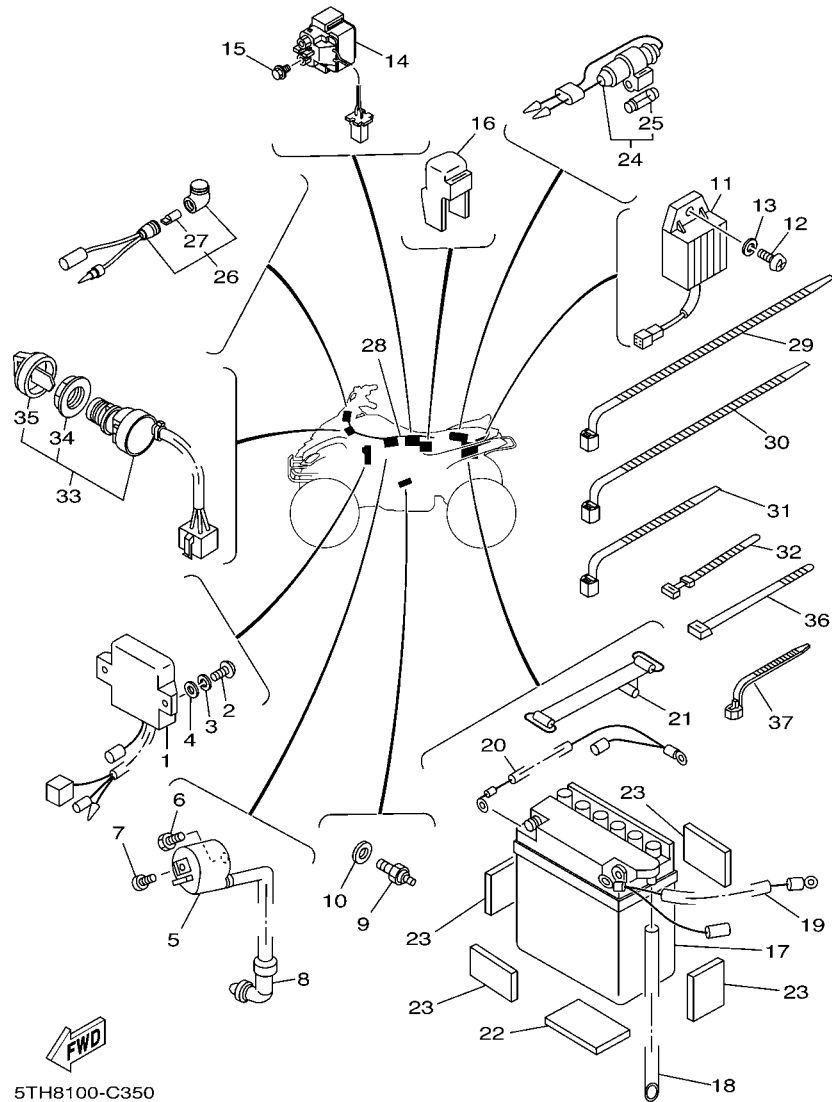

5TH8100-C350

REF. NO.	PART NO.	DESCRIPTION	USA	CAN	EUR	OCE	JPN	REMARKS
1	4EM-85540-10	C.D.I. UNIT ASSY	1	1	1	1	1	
2	92502-06020	SCREW, PAN HEAD	2	2	2	2	2	
3	92902-06100	WASHER, SPRING	2	2	2	2	2	
4	92902-06600	WASHER, PLATE	2	2	2	2	2	
5	4KJ-82310-10	IGNITION COIL ASSY	1	1	1	1	1	
6	97002-06016	BOLT	1	1	1	1	1	
7	90153-06034	SCREW, HEXAGON	1	1	1	1	1	
8	55X-82370-00	PLUG CAP ASSY	1	1	1	1	1	
9	3GB-82540-01	NEUTRAL SWITCH ASSY	1	1	1	1	1	
10	90430-10148	GASKET	1	1	1	1	1	
11	5TH-81960-01	RECTIFIER & REGULATOR ASSY	1	1	1	1	1	
12	92502-06016	SCREW, PAN HEAD	1	1	1	1	1	
13	92902-06600	WASHER, PLATE	1	1	1	1	1	
14	3MW-81940-01	STARTER RELAY ASSY	1	1	1	1	1	
15	95022-06008	BOLT, FLANGE	2	2	2	2	2	
16	1RL-81950-92	RELAY ASSY	1	1	1	1	1	
17	55X-82110-61	BATTERY ASSY (GS 12N7D-3B)	1	1	1	1	1	
	90793-25013	BATTERY ASSY (GS 12N7D-3B)					1	
18	90445-085E0	HOSE (L450)	1	1	1	1	1	
19	55X-82115-01	WIRE, PLUS LEAD	1	1	1	1	1	
20	3GB-82116-00	WIRE, MINUS LEAD	1	1	1	1	1	
21	4J2-82131-01	BAND, BATTERY	1	1	1	1	1	
22	55X-82122-00	SEAT, BATTERY	1	1	1	1	1	
23	29W-82123-00	SEAT, BATTERY	4	4	4	4	4	
24	3GB-82150-00	FUSE HOLDER ASSY	1	1	1	1	1	
25	3GB-82151-00	.FUSE (5A)	2	2	2	2	2	
26	4KB-83530-00	PILOT LIGHT ASSY	1	1	1	1	1	GREEN (NEUTRAL)

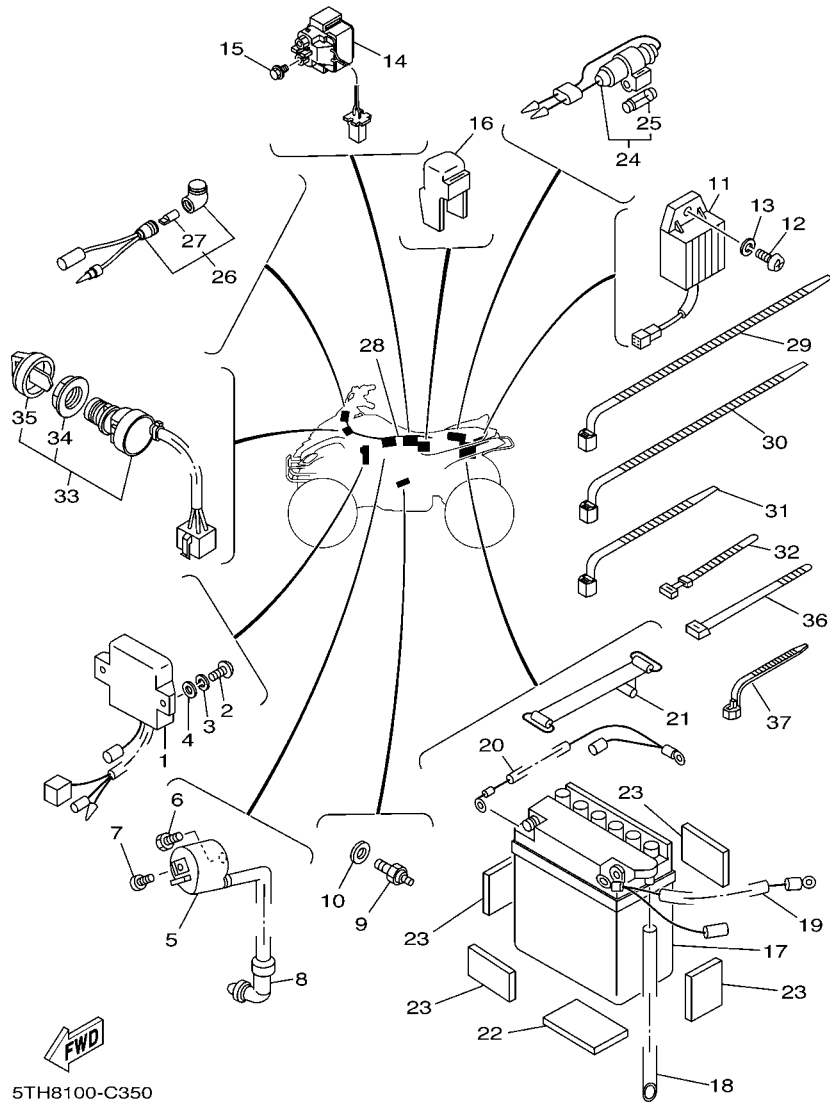
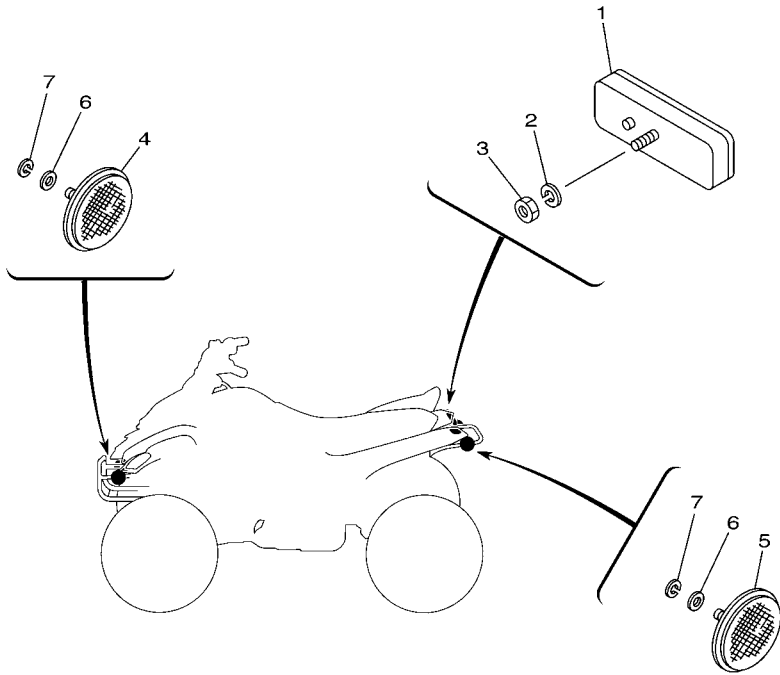

FIG. 35 ELECTRICAL 1

REF. NO.	PART NO.	DESCRIPTION	USA	CAN	EUR	OCE	JPN	REMARKS
27	5GH-83516-00	.BULB (14V-1.7W)	1	1	1	1	1	
28	5TH-82590-00	WIRE HARNESS ASSY	1	1	1	1	1	
29	90460-15126	CLAMP, HOSE	1	1	1	1	1	
30	90464-12045	CLAMP	1	1	1	1	1	
31	90464-13073	CLAMP	3	3	3	3	3	
32	437-83936-01	BAND, SWITCH CORD	1	1	1	1	1	
33	4GB-82510-11	MAIN SWITCH ASSY	1	1	1	1	1	
34	3HN-82569-00	.NUT, MAIN SWITCH	1	1	1	1	1	
35	3HN-82579-00	.CAP, KEY	1	1	1	1	1	
36	90465-10098	CLAMP	1	1	1	1	1	
37	90464-15195	CLAMP	1	1	1	1	1	

FIG. 36 ELECTRICAL 2

REF. NO.	PART NO.	DESCRIPTION	USA	CAN	EUR	OCE	JPN	REMARKS
1	3Y6-85130-02	REAR REFLECTOR ASSY	1	1	1	1	1	
2	92902-05100	WASHER, SPRING	1	1	1	1	1	
3	95302-05600	NUT	1	1	1	1	1	
4	2EK-85111-00	REFLECTOR, FRONT 1			2			
5	449-85131-02	REFLECTOR, REAR 1			2			
6	92902-05200	WASHER		4				
7	92902-05100	WASHER, SPRING		4				



5TH1100-2361

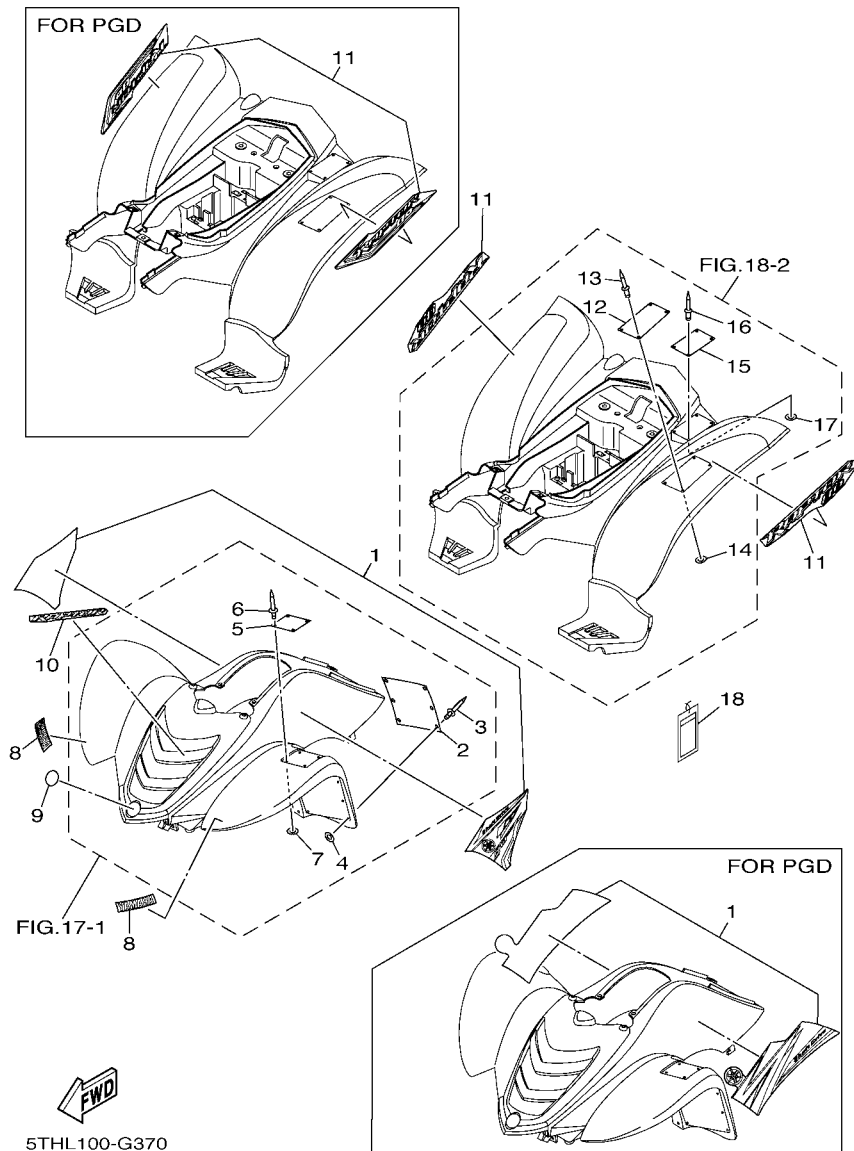

5THL100-G370

FIG. 37 EMBLEM & LABEL 1

REF. NO.	PART NO.	DESCRIPTION	USA	CAN	EUR	OCE	JPN	REMARKS
1	5TH-21570-50	GRAPHIC SET, FRONT FENDER	1					UR FOR DPBSE
	5YF-21570-90	GRAPHIC SET, FRONT FENDER	1					UR FOR PGD
2	5FE-21568-01	LABEL, WARNING	1					ENGLISH
3	90267-32004	RIVET, BLIND	6					
4	90201-03008	WASHER, PLATE	6					
5	4EM-21697-31	LABEL, CAUTION 2	1					ENGLISH
6	90267-32004	RIVET, BLIND	4					
7	90201-03008	WASHER, PLATE	4					
8	4ES-2153E-01	EMBLEM, YAMAHA	2					UR FOR DPBSE
	4ES-2153E-30	EMBLEM, YAMAHA	2					UR FOR PGD
9	5KM-2175B-00	TUNING FORK MARK	1					
10	5YF-21565-50	EMBLEM, 2	1					UR FOR DPBSE
	5YF-21565-60	EMBLEM, 2	1					UR FOR PGD
11	5TH-21609-70	EMBLEM	2					UR FOR DPBSE
	5TH-2165A-30	GRAPHIC SET, REAR FENDER	1					UR FOR PGD
12	4EM-21696-11	LABEL, CAUTION	1					ENGLISH
13	90267-32004	RIVET, BLIND	4					
14	90201-03008	WASHER, PLATE	4					
15	5FE-2151H-01	LABEL 5	1					ENGLISH
16	90267-32004	RIVET, BLIND	4					
17	90201-03008	WASHER, PLATE	4					
18	4EM-2819R-00	TAG, WARNING	1					

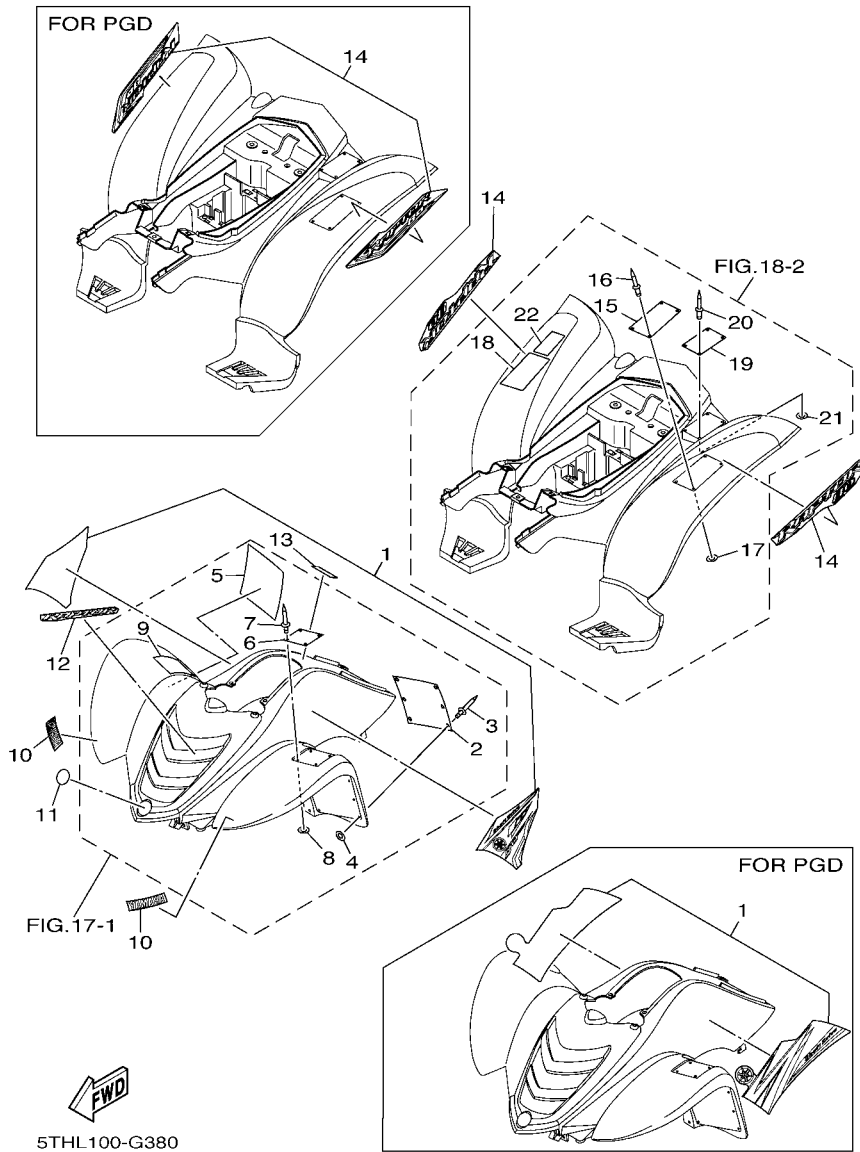
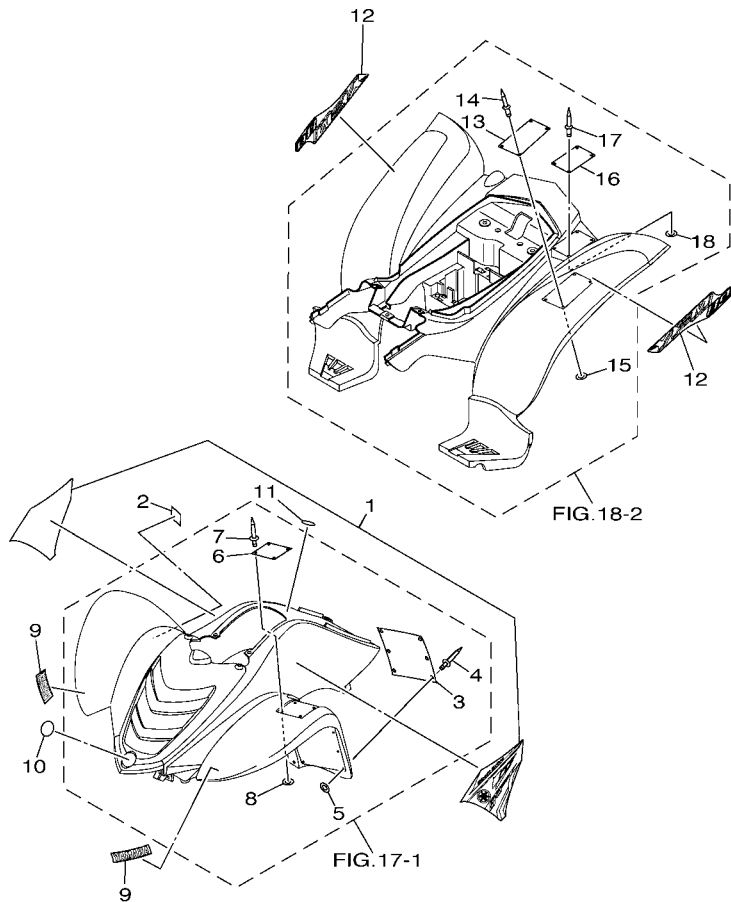

FIG. 38 EMBLEM & LABEL 2

REF. NO.	PART NO.	DESCRIPTION	USA	CAN	EUR	OCE	JPN	REMARKS
1	5TH-21570-50	GRAPHIC SET, FRONT FENDER		1				UR FOR DPBSE
	5YF-21570-90	GRAPHIC SET, FRONT FENDER		1				UR FOR PGD
2	5FE-21568-01	LABEL, WARNING		1				ENGLISH
3	90267-32004	RIVET, BLIND		6				
4	90201-03008	WASHER, PLATE		6				
5	4WU-21568-10	LABEL, WARNING		1				FRENCH
6	4EM-21697-31	LABEL, CAUTION 2		1				ENGLISH
7	90267-32004	RIVET, BLIND		4				
8	90201-03008	WASHER, PLATE		4				
9	4EM-21697-20	LABEL, CAUTION 2		1				FRENCH
10	4ES-2153E-01	EMBLEM, YAMAHA		2				UR FOR DPBSE
	4ES-2153E-30	EMBLEM, YAMAHA		2				UR FOR PGD
11	5KM-2175B-00	TUNING FORK MARK		1				
12	5YF-21565-50	EMBLEM, 2		1				UR FOR DPBSE
	5YF-21565-60	EMBLEM, 2		1				UR FOR PGD
13	4SH-2416E-00	LABEL, CAUTION CANADA		1				ENGLISH
14	5TH-21609-70	EMBLEM		2				UR FOR DPBSE
	5TH-2165A-30	GRAPHIC SET, REAR FENDER		1				UR FOR PGD
15	4EM-21696-11	LABEL, CAUTION		1				ENGLISH
16	90267-32004	RIVET, BLIND		4				
17	90201-03008	WASHER, PLATE		4				
18	4EM-21696-B0	LABEL, CAUTION		1				FRENCH
19	5FE-2151H-01	LABEL 5		1				ENGLISH
20	90267-32004	RIVET, BLIND		4				
21	90201-03008	WASHER, PLATE		4				
22	4WU-2151H-10	LABEL 5		1				FRENCH

FIG. 39 EMBLEM & LABEL 3



REF. NO.	PART NO.	DESCRIPTION	USA	CAN	EUR	OCE	JPN	REMARKS
1	5TH-21570-50	GRAPHIC SET, FRONT FENDER			1			
2	4GB-2155A-00	MARK, EC			1			
3	5FK-21568-00	LABEL, WARNING			1			
4	90267-32004	RIVET, BLIND			6			
5	90201-03008	WASHER, PLATE			6			
6	5NE-21697-00	LABEL, CAUTION 2			1			
7	90267-32004	RIVET, BLIND			4			
8	90201-03008	WASHER, PLATE			4			
9	4ES-2153E-01	EMBLEM, YAMAHA			2			
10	5KM-2175B-00	TUNING FORK MARK			1			
11	3ME-2415E-01	LABEL, CAUTION			1			
12	5TH-21609-80	EMBLEM			2			
13	5YF-21696-M0	LABEL, CAUTION			1			
14	90267-32004	RIVET, BLIND			4			
15	90201-03008	WASHER, PLATE			4			
16	5FK-2151H-00	LABEL 5			1			
17	90267-32004	RIVET, BLIND			4			
18	90201-03008	WASHER, PLATE			4			

 5THL100-G390

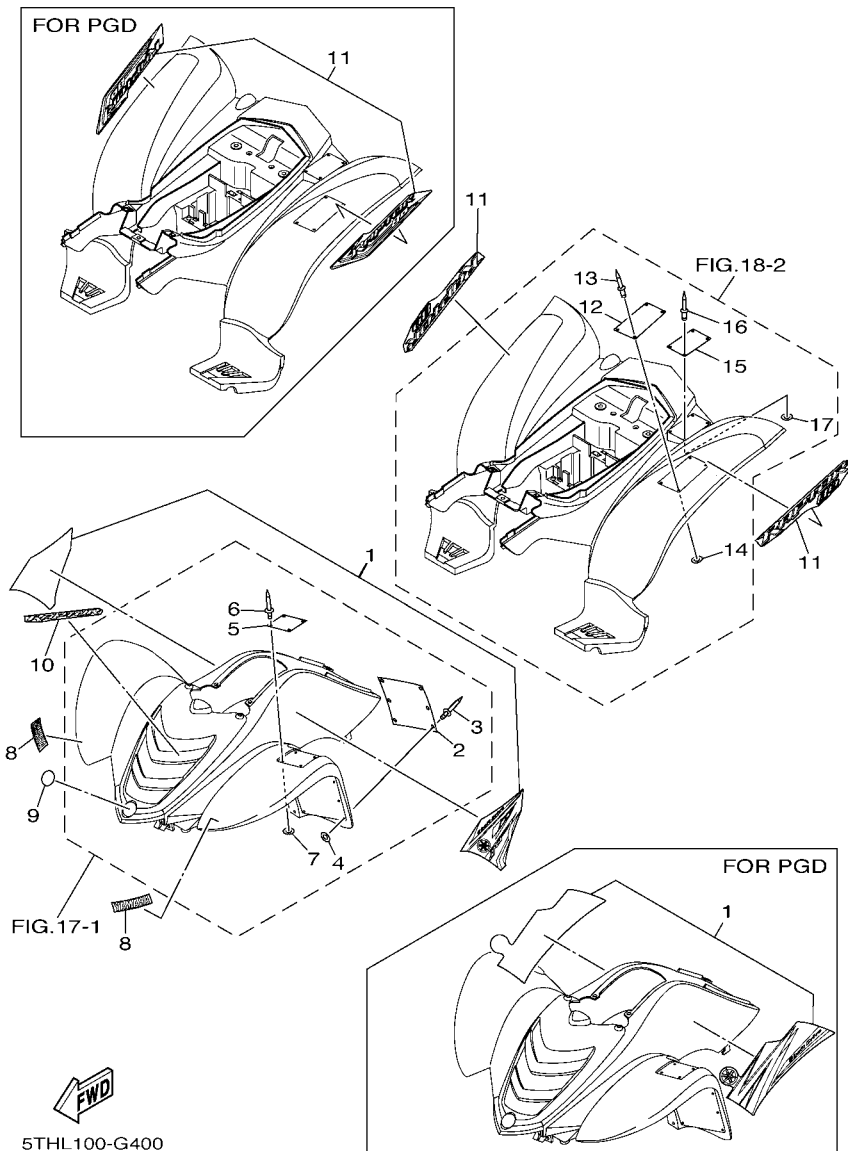

5THL100-G400

FIG. 40 EMBLEM & LABEL 4

REF. NO.	PART NO.	DESCRIPTION	USA	CAN	EUR	OCE	JPN	REMARKS
1	5TH-21570-50	GRAPHIC SET, FRONT FENDER					1	UR FOR DPBSE
	5YF-21570-90	GRAPHIC SET, FRONT FENDER					1	UR FOR PGD
2	5FE-21568-11	LABEL, WARNING					1	ENGLISH
3	90267-32004	RIVET, BLIND					6	
4	90201-03008	WASHER, PLATE					6	
5	4EM-21697-31	LABEL, CAUTION 2					1	ENGLISH
6	90267-32004	RIVET, BLIND					4	
7	90201-03008	WASHER, PLATE					4	
8	4ES-2153E-01	EMBLEM, YAMAHA					2	UR FOR DPBSE
	4ES-2153E-30	EMBLEM, YAMAHA					2	UR FOR PGD
9	5KM-2175B-00	TUNING FORK MARK					1	
10	5YF-21565-50	EMBLEM, 2					1	UR FOR DPBSE
	5YF-21565-60	EMBLEM, 2					1	UR FOR PGD
11	5TH-21609-70	EMBLEM					2	UR FOR DPBSE
	5TH-2165A-30	GRAPHIC SET, REAR FENDER					1	UR FOR PGD
12	4EM-21696-11	LABEL, CAUTION					1	ENGLISH
13	90267-32004	RIVET, BLIND					4	
14	90201-03008	WASHER, PLATE					4	
15	5FE-2151H-01	LABEL 5					1	ENGLISH
16	90267-32004	RIVET, BLIND					4	
17	90201-03008	WASHER, PLATE					4	

FIG. 41 EMBLEM & LABEL 5

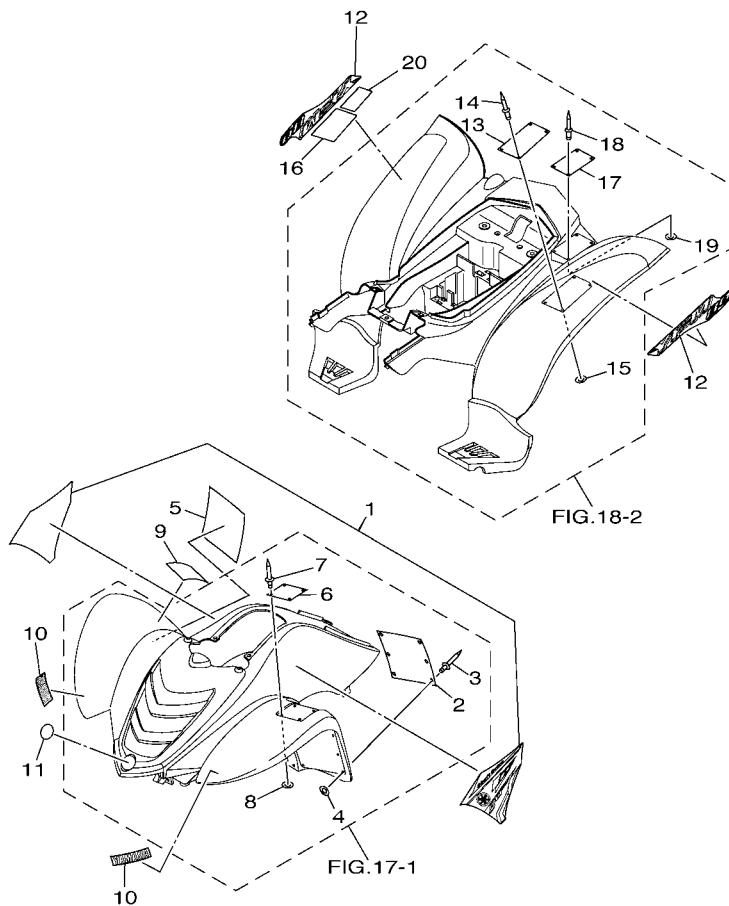

REF. NO.	PART NO.	DESCRIPTION	USA	CAN	EUR	OCE	JPN	REMARKS
1	5TH-21570-50	GRAPHIC SET, FRONT FENDER					1	
2	5FE-21568-11	LABEL, WARNING					1	ENGLISH
3	90267-32004	RIVET, BLIND					6	
4	90201-03008	WASHER, PLATE					6	
5	4SH-21568-00	LABEL, WARNING					1	JAPANESE
6	4EM-21697-31	LABEL, CAUTION 2					1	ENGLISH
7	90267-32004	RIVET, BLIND					4	
8	90201-03008	WASHER, PLATE					4	
9	4EM-21697-00	LABEL, CAUTION 2					1	
10	4ES-2153E-01	EMBLEM, YAMAHA					2	
11	5KM-2175B-00	TUNING FORK MARK					1	
12	5TH-21609-80	EMBLEM					2	
13	4EM-21696-11	LABEL, CAUTION					1	ENGLISH
14	90267-32004	RIVET, BLIND					4	
15	90201-03008	WASHER, PLATE					4	
16	4EM-21696-00	LABEL, CAUTION					1	
17	5FE-2151H-01	LABEL 5					1	ENGLISH
18	90267-32004	RIVET, BLIND					4	
19	90201-03008	WASHER, PLATE					4	
20	4LB-2151H-02	LABEL 5					1	

5THL100-G410

NUMERICAL INDEX

PART NO.	GRID NO.	PART NO.	GRID NO.	PART NO.	GRID NO.	PART NO.	GRID NO.	PART NO.	GRID NO.	PART NO.	GRID NO.
35T-11110-01	B - 2	22K-14104-00	B - 7	4EM-15443-01	B - 11	2MK-18511-00	C - 3	5YF-21570-90	E - 6	3GB-23501-10	C - 15
22F-11134-10	B - 2	2HX-14112-35	B - 7	3GB-15451-00	B - 11	29F-18512-00	C - 3		E - 8	3GB-23502-10	C - 15
2D3-11166-00	B - 10	260-14131-00	B - 7	3GB-15461-00	B - 11	22F-18531-00	C - 3	5TH-21609-70	E - 5	2NL-23517-00	C - 15
59V-11167-00	B - 10	4EM-14141-78	B - 8	2HX-15517-10	B - 12	4EM-18540-00	C - 3		E - 6	3GB-23570-00-33	C - 15
55X-11181-00	B - 2	22F-14142-12	B - 7	2HX-15520-00	B - 12	136-18542-00	C - 3		E - 8	1UY-23812-00	C - 13
22F-11185-10	B - 2	55X-14146-00	B - 7	22M-15570-10	B - 12	296-18561-00	C - 3	5TH-21609-80	E - 7	4EM-23813-20	C - 13
22F-11186-10	B - 2	22K-14147-00	B - 7	22M-15580-10	B - 12	22F-18562-01	C - 3		E - 9	8G5-23814-00	C - 13
812-11198-00	B - 6	18A-1414E-30	B - 7	3AY-15583-00	B - 12	5TH-21110-20	C - 5	3GB-21613-00	C - 8	8K1-23814-00	C - 13
214-11198-01	C - 10	22F-14150-00	B - 8	22K-16111-00	B - 13	5TH-21110-30	C - 5	3GB-21614-00	C - 8	3GB-23831-00	C - 13
22K-11311-02	B - 2	802-14161-00	B - 7	3GB-16150-00	B - 13	5TH-21268-01	C - 5	5TH-2165A-30	E - 5	55X-23841-01	C - 13
22F-11351-01	B - 2	22F-14169-00	B - 7	22F-16153-40	B - 13	5TH-21513-00	C - 7		E - 6	52H-23845-01	C - 13
22K-11400-01	B - 3	22F-14184-00	B - 7	22F-16163-00	B - 14	5FK-2151H-00	E - 7		E - 8	2D3-23858-00	C - 13
22K-11422-00	B - 3	22F-14185-00	B - 8	122-16164-00	B - 13	5FE-2151H-01	E - 5	4EM-21696-00	E - 9	3GB-23868-00	C - 13
55X-11610-00	B - 3	127-14186-00	B - 7	22F-16342-01	B - 14		E - 6	4EM-21696-11	E - 5	1UY-23894-01	C - 13
55X-11610-20	B - 3	12R-14191-00	B - 7	22K-16356-00	B - 14		E - 8		E - 6	2HX-24110-00	D - 2
55X-11610-40	B - 3	24W-14193-00	B - 8	22F-16357-01	B - 13		E - 9		E - 8	2HX-24110-10	D - 2
55X-11631-00-96	B - 3	55X-14196-00	B - 8	22F-16362-01	B - 14	4LB-2151H-02	E - 9		E - 9	5TH-2414H-00	D - 2
22K-11633-01	B - 3	26H-14197-00	B - 7	22F-16382-00	B - 14	4WU-2151H-10	E - 6	4EM-21696-B0	E - 6	3ME-2415E-01	E - 7
55X-11636-00	B - 3	55X-14198-00	B - 8	22F-16383-00	B - 14	4ES-2153E-01	E - 5	5YF-21696-M0	E - 7	4SH-2416E-00	E - 6
55X-11638-00	B - 3	5TH-14412-00	C - 6	22F-16399-00	B - 14		E - 6	4EM-21697-00	E - 9	2HX-24181-00	D - 2
22K-11651-02	B - 3	2D3-14419-00	C - 6	22K-16520-00	B - 13		E - 7	5NE-21697-00	E - 7	55X-24500-02	D - 2
22F-11681-00	B - 3	31A-14435-00	C - 6	22F-16521-00	B - 13		E - 8	4EM-21697-20	E - 6	4X8-24512-00	D - 2
2D3-12111-00	B - 4	55X-14436-00	C - 6	3E5-16521-00	B - 13		E - 9	4EM-21697-31	E - 5	3AC-24523-00	D - 2
22F-12114-00	B - 4	5TH-14436-00	C - 6	22F-16524-01	B - 13	4ES-2153E-30	E - 5		E - 6	3AJ-24534-01	D - 2
22F-12116-00	B - 4	2HX-14437-01	C - 7	517-16524-10	B - 13		E - 6		E - 8	2FJ-24610-00	D - 2
22F-12117-02	B - 4	55X-14451-00	C - 6	517-16524-20	B - 13		E - 8		E - 9	5TH-2470F-00	D - 3
22F-12118-01	B - 4	5TH-14452-00	C - 6	517-16524-30	B - 13	5TH-21556-30	C - 6	5TH-2171A-10	C - 7	5TH-24710-01	D - 3
2HX-12119-00	B - 4	3GB-14453-00	B - 8	22F-16550-00	B - 13	5TH-21556-40	C - 6	12R-21747-00	D - 2	22W-24741-00	D - 3
2D3-12121-00	B - 4	59V-14457-00	C - 6	22K-16590-00	B - 13	4GB-2155A-00	E - 7	5KM-2175B-00	E - 5	4K0-24774-A0	D - 3
22F-12151-10	B - 4	55X-14458-00	C - 6	2HX-17121-00	B - 15	5YF-21565-50	E - 5		E - 6	4K0-24775-00	D - 3
22F-12156-00	B - 4	55X-14472-01	C - 6	55X-17131-00	B - 15		E - 6		E - 7	29U-24776-00	D - 3
22F-12159-00	B - 4	5TH-14477-00	C - 6	3GB-17211-00	B - 15		E - 8		E - 8	2FJ-25111-10	D - 4
55X-12170-00	B - 5	3DM-14613-00	B - 9	55X-17231-00	B - 15	5YF-21565-60	E - 5		E - 9	3FA-25117-00	D - 4
50M-12176-00	B - 5	22F-14651-00	B - 2	55X-17241-00	B - 15		E - 6	5TH-2177C-20	C - 8	2FJ-25121-00	D - 4
22F-12217-01	B - 5	5TH-14711-00	B - 9	3GB-17402-00	B - 15		E - 8	3GB-22110-00-33	C - 9	52H-2513A-00	D - 4
22F-12231-01	B - 5	55X-14752-00	B - 9	2HX-17411-01	B - 15	4SH-21568-00	E - 9	307-22123-00	C - 15	3GB-25151-00	D - 4
22F-12241-00	B - 5	2HX-1490J-10	B - 7	3GB-17508-00	C - 2	5FK-21568-00	E - 7	3GB-22123-00	C - 5	2FJ-25155-00	D - 4
2FJ-13300-00	B - 6	2HX-1490J-20	B - 7	22F-17531-00-15	C - 2	5FE-21568-01	E - 5	3GB-22155-00	C - 5	2FJ-25156-00	D - 5
46J-13324-00	B - 3	55X-14937-00	B - 8	22F-17531-00-30	C - 2		E - 6	3GB-22156-00	C - 9	2FJ-25169-00	D - 4
46J-13325-00	B - 6	22F-14991-00	B - 7	22F-17531-00-50	C - 2	4WU-21568-10	E - 6	55X-22189-00	C - 9	2FJ-25180-00-98	D - 4
22F-13329-01	B - 6	2FJ-15100-01	B - 10	22F-17537-00	C - 2	5FE-21568-11	E - 8	3GB-2219X-00	C - 9	22W-25181-01	C - 9
22F-13411-01	B - 6	3GB-15362-00	C - 10	22F-17551-00	C - 2		E - 9	3GB-22210-00-35	C - 12	3GB-25185-00	D - 4
22M-13450-10	B - 12	55X-15362-04	B - 11	22F-17556-01	C - 2	5TH-21570-50	E - 5	3GB-22210-00-36	C - 12	3GB-25311-00-33	D - 6
55X-13586-00	B - 7	2N4-15371-00	C - 10	22F-18101-03	C - 4		E - 6	59V-22216-00	C - 12	3GB-25317-00	D - 6
22K-13595-00	B - 7	22F-15383-01	B - 10	2HX-18110-10	C - 4		E - 7	2HX-2331U-00	C - 15	3GB-2531E-00	D - 6
5TH-14101-01	B - 7	22F-15411-01	B - 11	132-18113-01	C - 4		E - 8	2HX-23350-00-35	C - 15	3GB-25326-00	D - 6
5TH-14101-11	B - 7	22F-15417-00	B - 11	278-18127-01	C - 4		E - 9	2HX-23350-00-36	C - 15	23F-2533A-00	D - 6
22F-14103-00	B - 7	2FJ-15421-00	B - 11	29F-18140-00	C - 3	5YF-21570-90	E - 5	3GB-23448-00	C - 15	55X-2533H-00	D - 6

NUMERICAL INDEX

PART NO.	GRID NO.	PART NO.	GRID NO.	PART NO.	GRID NO.	PART NO.	GRID NO.	PART NO.	GRID NO.	PART NO.	GRID NO.
3GB-25343-10	D - 6	55X-81826-50	D - 13	5TH-W2151-01	C - 6	90170-10010	C - 13	90240-06076	D - 10	90480-18171	C - 8
3Y6-25351-00	D - 6	5J3-81846-50	D - 13	5TH-W2151-31	C - 6	90170-14284	B - 13	90249-12008	D - 8	90480-18290	D - 2
55X-25355-00	D - 6	22J-81847-50	D - 13	5TH-W215B-01	C - 6	90170-28011	D - 7		D - 10	90501-03799	B - 12
3GB-25367-00	D - 7	5J3-81847-50	D - 13	5TH-W215C-01	C - 6	90171-10003	C - 15	90267-32004	E - 5	90501-08511	D - 9
3GB-25382-00	D - 6	55X-81855-50	D - 13	5TH-W215C-31	C - 6	90171-12001	D - 7		E - 6	90501-10245	D - 10
55X-25383-10	D - 6	3MW-81940-01	E - 2	5TH-W215D-01	C - 6	90171-14002	D - 4		E - 7	90501-105A5	B - 13
2FJ-25390-00-98	D - 6	1RL-81950-92	E - 2	5TH-W215D-31	C - 6	90176-06014	B - 2		E - 8	90501-10710	B - 5
390-25412-01	D - 6	5TH-81960-01	E - 2	5TH-W2161-00	C - 8	90179-06054	B - 5		E - 9	90501-10782	D - 8
3GB-25715-00	D - 7	55X-82110-61	E - 2	5TH-W2161-30	C - 8	90179-08030	D - 9	90269-06002	C - 7	90501-135A4	B - 13
5TH-26111-20	D - 8	55X-82115-01	E - 2	5TH-W216B-00	C - 8	90179-08148	D - 15	90280-03017	B - 3	90504-06030	D - 2
5TH-26124-00	D - 8	3GB-82116-00	E - 2	5TH-W216C-00	C - 8	90179-10023	D - 12	90334-14037	B - 5	90506-08122	C - 4
5TH-26124-10	D - 8	55X-82122-00	E - 2	5TH-W216C-30	C - 8	90179-12004	C - 2	90336-28053	C - 13	90506-15260	D - 4
5LP-26241-00	D - 8	29W-82123-00	E - 2	3FA-W253E-00	D - 6	90179-12007	B - 13	90340-12097	B - 6		D - 6
5TH-26250-10	D - 8	4J2-82131-01	E - 2	4KN-W253E-11	D - 4	90179-28009	D - 7	90340-14132	C - 10	90506-16318	D - 10
3GB-2625E-01	D - 8	3GB-82150-00	E - 2	90101-06046	D - 4	90179-42480	C - 2	90340-18092	B - 5	90507-15038	D - 7
3GB-2625G-00	D - 8	3GB-82151-00	E - 2	90101-06562	D - 6	90179-55464	C - 10	90380-07118	B - 14	90508-10775	D - 8
3GB-2625H-00	D - 8	4KJ-82310-10	E - 2	90101-06576	B - 9	90183-050A8	C - 6	90381-15040	C - 5	90508-20454	D - 3
3GB-2628F-00	D - 8	55X-82370-00	E - 2	90101-08055	B - 5	90185-05009	C - 7	90381-17067	C - 15	90508-20576	C - 3
3GB-2628G-02	D - 8	4GB-82510-11	E - 3	90101-08058	C - 11	90185-10019	C - 9	90387-062G8	B - 14	90508-32563	C - 4
3GB-26311-02	D - 8	3GB-82540-01	E - 2	90101-12033	C - 15		C - 13	90387-062G9	B - 14	90560-17146	B - 13
3GB-26341-01	D - 8	3HN-82569-00	E - 3	90105-10131	C - 12	90185-10022	C - 12	90387-066J1	D - 2	90560-20196	B - 12
20E-26343-00	D - 8	3HN-82579-00	E - 3	90105-10262	C - 15		C - 15	90387-066V8	D - 8	90560-23355	C - 10
	D - 10	5TH-82590-00	E - 3	90105-10274	C - 15	90185-12010	C - 15	90387-07598	D - 2	90793-25013	E - 2
3GB-26347-00	D - 8	5TH-82910-01	D - 15	90105-12062	C - 15	90201-03008	E - 5	90387-090R0	C - 13	91312-05025	D - 8
3GB-26361-03	D - 9	3FA-82911-01	D - 15	90109-06172	C - 6		E - 6	90387-175R2	D - 4	91312-06035	D - 13
3FA-26466-00	D - 15	5GH-83516-00	E - 3	90109-06238	C - 3		E - 7	90430-06014	B - 10	91401-20012	D - 10
371-27114-00	D - 3	4KB-83530-00	E - 2	90109-06243	D - 8		E - 8	90430-06166	B - 10	91401-20020	C - 13
3GB-27211-10	D - 10	23X-83912-00	D - 15	90109-06799	D - 15		E - 9	90430-10148	E - 2		C - 15
3GB-27231-00	D - 10	5TH-83922-00	D - 8	90110-05201	C - 7	90201-06090	D - 2	90445-073F9	C - 10	91401-25025	D - 7
3GB-27411-10	D - 10	437-83936-01	E - 3	90113-06009	B - 5	90201-066F0	B - 2	90445-083J4	D - 2	91401-30025	D - 4
55X-27413-00	D - 10	3FA-83965-00	D - 15	90114-08001	D - 4	90201-08048	B - 5	90445-085E0	E - 2	91A20-07010	B - 8
3GB-27421-10	D - 10	3FA-83966-00	D - 15		D - 6		B - 9	90445-10044	D - 2	92502-06012	D - 7
3GB-28100-00	C - 5	3FA-83967-00	D - 15	90114-10017	D - 6	90201-10036	C - 13	90445-10638	D - 2	92502-06016	E - 2
1NV-2811A-01	C - 5	4EM-83975-00	D - 15	90116-06042	B - 10	90201-10057	C - 15	90445-11418	C - 13	92502-06020	E - 2
4EM-2819R-00	E - 5	1YW-83980-00	D - 15	90116-08084	D - 6	90201-101A4	D - 12	90460-15126	E - 3	92901-04100	D - 12
5GT-2836B-10	D - 8	5TH-84111-00	D - 14	90119-05024	C - 6	90201-12045	D - 7	90460-43053	B - 8	92901-05100	D - 12
5TH-2845N-40	D - 11	5TH-8411B-00	D - 14	90119-06137	C - 6	90201-12050	C - 15	90460-75020	C - 9	92902-04100	B - 7
5TH-2845N-50	D - 11	5TH-84121-00	D - 14		D - 14	90201-124F8	B - 15	90460-85135	C - 9	92902-04200	C - 6
3GB-46110-20	C - 10	2EK-85111-00	E - 4	90119-06152	C - 8	90201-125F7	C - 2	90464-12045	E - 3	92902-05100	E - 4
3GB-46120-00	C - 10	3Y6-85130-02	E - 4	90123-08046	D - 15	90201-127F4	C - 4	90464-13073	E - 3	92902-05200	E - 4
22F-46123-01	C - 11	449-85131-02	E - 4	90123-08106	D - 9	90201-132G5	B - 15	90464-13249	C - 8	92902-06100	D - 3
3GB-46151-00	C - 10	5G3-85520-M1	D - 12	90149-06108	D - 2	90201-14586	D - 4	90464-15195	E - 3		D - 7
3GB-46172-01	C - 10	4EM-85540-10	E - 2	90151-06070	B - 14	90201-145M4	D - 8	90465-10098	E - 3		E - 2
2HX-46180-00	C - 10	2FM-85550-M1	D - 12	90153-06034	E - 2	90201-15018	D - 10	90467-07029	C - 10	92902-06200	D - 10
22F-46187-00	C - 10	4EM-85560-10	D - 12	90154-05002	C - 7	90201-186F1	B - 5	90467-090A2	D - 2		D - 13
55X-81313-M0	D - 12	22K-85595-M0	D - 12	90155-06001	B - 6	90208-12015	B - 13	90467-13064	B - 10	92902-06600	B - 9
55X-81800-51	D - 13	22K-W1141-00	B - 3	90159-06041	B - 7	90209-11269	B - 11	90467-220A1	C - 6		B - 14
22J-81801-50	D - 13	22K-W1657-00	B - 13	90170-05302	B - 4	90215-14249	B - 13	90480-01400	D - 2		D - 2

NUMERICAL INDEX

PART NO.	GRID NO.	PART NO.	GRID NO.	PART NO.	GRID NO.	PART NO.	GRID NO.	PART NO.	GRID NO.	PART NO.	GRID NO.
92902-06600	E - 2	93420-26077	B - 13	95812-08120	C - 5						
92902-08100	C - 11	93430-04002	D - 3	95812-12020	D - 10						
93101-10142	B - 11	93430-08007	C - 3	95822-06020	C - 2						
93101-24110	C - 2	93440-10109	B - 2	95822-08055	C - 13						
93102-07292	B - 14	93440-11128	B - 14	97002-06012	D - 3						
93102-12106	C - 4	93440-16089	B - 15	97002-06016	E - 2						
93102-17271	C - 10	93450-14088	B - 3	97022-06020	C - 4						
93102-19276	D - 12	93450-42112	B - 13	97022-06030	D - 2						
93102-23275	D - 4	93451-08094	B - 13	97022-08060	C - 13						
93102-28022	C - 10	93505-08030	B - 13	97702-40116	C - 6						
93102-35349	D - 7	93604-20156	C - 4	98501-04006	D - 12						
93102-36409	D - 6	93604-22050	C - 3	98501-05010	D - 12						
93102-38383	D - 6	93610-10174	B - 12	98502-04008	B - 7						
93102-40367	D - 4	93700-06004	C - 5	98502-04010	B - 8						
93104-10076	B - 14		C - 15	98502-04014	B - 7						
93112-31011	C - 13	93900-00022	D - 4	98502-04016	D - 8						
93210-06564	B - 5		D - 6	98502-06010	B - 9						
	B - 10	94107-07009	D - 4	98502-06012	B - 10						
93210-07003	C - 3	94108-07009	D - 6	98502-06014	C - 3						
93210-12327	D - 4	94580-25082	B - 5	98502-06016	B - 2						
93210-14104	C - 10	94701-00366	B - 2		B - 14						
	D - 6	94703-00366	B - 2	98502-06020	D - 9						
93210-15414	C - 5	95022-06008	E - 2	98502-06045	B - 10						
93210-19123	B - 11	95022-06085	B - 2	98502-06060	B - 10						
93210-25552	B - 7	95302-05600	E - 4	98502-06075	B - 10						
93210-26606	D - 7	95302-05700	D - 8	98507-03008	D - 2						
93210-40407	C - 5	95302-06600	B - 14	98507-06020	D - 15						
93210-43713	C - 10		D - 4	98507-06030	B - 11						
93210-44704	B - 2		D - 6	98507-06035	B - 11						
93210-50553	C - 2	95302-06800	B - 5	98507-06040	B - 11						
93210-63556	B - 2	95302-08600	D - 7	98507-06045	B - 11						
93211-02703	D - 12	95302-10700	C - 13	98511-04012	D - 12						
93211-066A9	C - 10	95602-06100	D - 8	98511-04020	D - 12						
93306-00105	B - 15	95602-08200	C - 5	98701-06018	B - 12						
93306-00308	D - 4	95607-06100	D - 15	98702-06016	D - 12						
93306-00612	D - 6	95702-06500	B - 9	99001-04600	B - 14						
93306-07801	C - 10	95702-08500	D - 4	99001-05600	B - 6						
93306-20301	B - 15		D - 6	99001-09600	C - 3						
93306-20309	C - 2	95802-06010	C - 7	99009-12400	B - 15						
93306-30101	B - 15	95802-06016	D - 9	99009-17400	C - 10						
93306-30306	C - 10	95802-08012	C - 8	99009-17500	C - 10						
93306-30433	B - 3		D - 8	99530-08012	B - 2						
93311-20952	C - 10	95812-06016	B - 10		B - 10						
93311-32353	B - 3		C - 10	99530-10114	B - 11						
93315-23208	C - 3	95812-06025	B - 10	99530-10120	B - 11						
93317-21236	C - 2	95812-08014	C - 9	99530-12016	B - 10						
93340-21209	C - 4		D - 11								
93341-22302	B - 13	95812-08016	B - 9								