



PARTS CATALOGUE

YFZ450RA (18PE) CANADA

YFZ450RA (18PF) EUROPE

YFZ450RA (18PD) OCEANIA

YFZ450R (18PD) JAPAN

1K18P-100E1

()



2011/2/4

NEWS NO.	DATE	COMMENT
PE0-MC-100052	Dec.,22,2010	FIG.9 THROTTLE BODY ASSY 1 LIST/ILLUST. CORRECTION

YFZ450RA/YFZ450R
PARTS CATALOGUE
©2010 by Yamaha Motor Co., Ltd.
1st edition, June 2010
All rights reserved.
Any reprinting or unauthorized use
without the written permission of
Yamaha Motor Co., Ltd.
is expressly prohibited.
Printed in Japan.

FOREWORD

This Parts Catalogue is related to the parts for the model(s) on the cover page. When you are ordering replacement parts, please refer to this Parts Catalogue and quote both part numbers and part names correctly.

1. Modifications or additions which have been made after the issue of the Parts Catalogue will be announced in the Parts News.

It is advisable that you make the necessary corrections to the Parts Catalogue according to the Parts News.

2. Abbreviations

The following abbreviations are used in this Parts Catalogue.

“UR” Use specified parts number.

“UN” Use as many as needed.

“AP” Alternate Parts

“LM” Locally Made (Parts need to be ordered locally)

“F#” Frame No. (Applicable machine No.)

“O/S” Over Size

3. The number of components for assembly

- Parts, which are to be supplied in an assembly, are listed with a dot (.) in front of the part name as shown below.
- The numeral appearing to the right of each component part indicates the quantity of parts for each assembly unit.

PART NO.	DESCRIPTION	Q'TY	REMARKS
2F5-83310-60	FRONT FLASHER LIGHT ASSY	2	
115-83311-60	.BULB (6V-18W)	1	

4. Applicable colours of graphics are represented in the “REMARKS” as shown below.

PART NO.	DESCRIPTION	Q'TY	REMARKS
2N4-24110-00-X5	FUEL TANK COMP.	2	MXR
3J1-24240-10	.GRAPHIC, FUEL TANK	1	FOR MXR

5. Note that the illustrations for reference in finding parts numbers are not to be used for assembling. When assembling, please use the applicable service manual.

6. The asterisk (*) before a reference number indicates modified items after the first edition.

FOREWORD

7. Applicable Serial No.

Engine Serial No.

Frame Serial No.

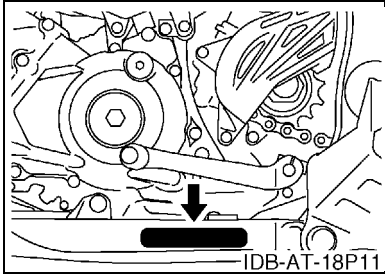
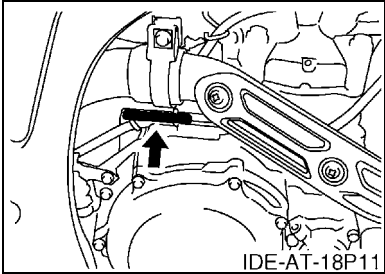

8. Applicable Colour Code (The (*) mark shows Model colour.)

Abbreviation	Colour Name	Colour Code
DPBSE(*)	DEEP PURPLISH BLUE SOLID E	0583
YB	YAMAHA BLACK	0033

9. Quantity Column Information

Column No.	Name Of Q'ty Column	Destination
1	CAN	CANADA
2	EUR	EUROPE
3	OCE	OCEANIA
4	JPN	JAPAN

CONTENTS

ENGINE

CYLINDER	1
CRANKSHAFT & PISTON	3
VALVE	4
CAMSHAFT & CHAIN	6
WATER PUMP	7
RADIATOR & HOSE	8
OIL PUMP	9
INTAKE	10
THROTTLE BODY ASSY 1	12
EXHAUST	13
CRANKCASE	14
CRANKCASE COVER 1	15
STARTER	18
CLUTCH	19
TRANSMISSION	21
SHIFT CAM & FORK	23

CHASSIS

FRAME	25
FRONT FENDER	27
REAR FENDER	28
SIDE COVER	30
REAR ARM	31
REAR SUSPENSION	34
STEERING	35
FRONT SUSPENSION & WHEEL	36
FUEL TANK	38
SEAT	39
FRONT WHEEL	40
FRONT BRAKE CALIPER	41
REAR WHEEL	43
REAR BRAKE CALIPER	44
STEERING HANDLE & CABLE	45
FRONT MASTER CYLINDER	47
STAND & FOOTREST	48
REAR MASTER CYLINDER	49
GUARD	51
GENERATOR	52
STARTING MOTOR	53
HEADLIGHT	54
TAILLIGHT	55

TAILLIGHT 2	56
HANDLE SWITCH & LEVER	57
ELECTRICAL 1	58
ELECTRICAL 2	61
GRAPHICS	62
EMBLEM & LABEL 1	63
EMBLEM & LABEL 2	64
EMBLEM & LABEL 3	65
EMBLEM & LABEL 4	66

INDEX

NUMERICAL INDEX	67
-----------------------	----

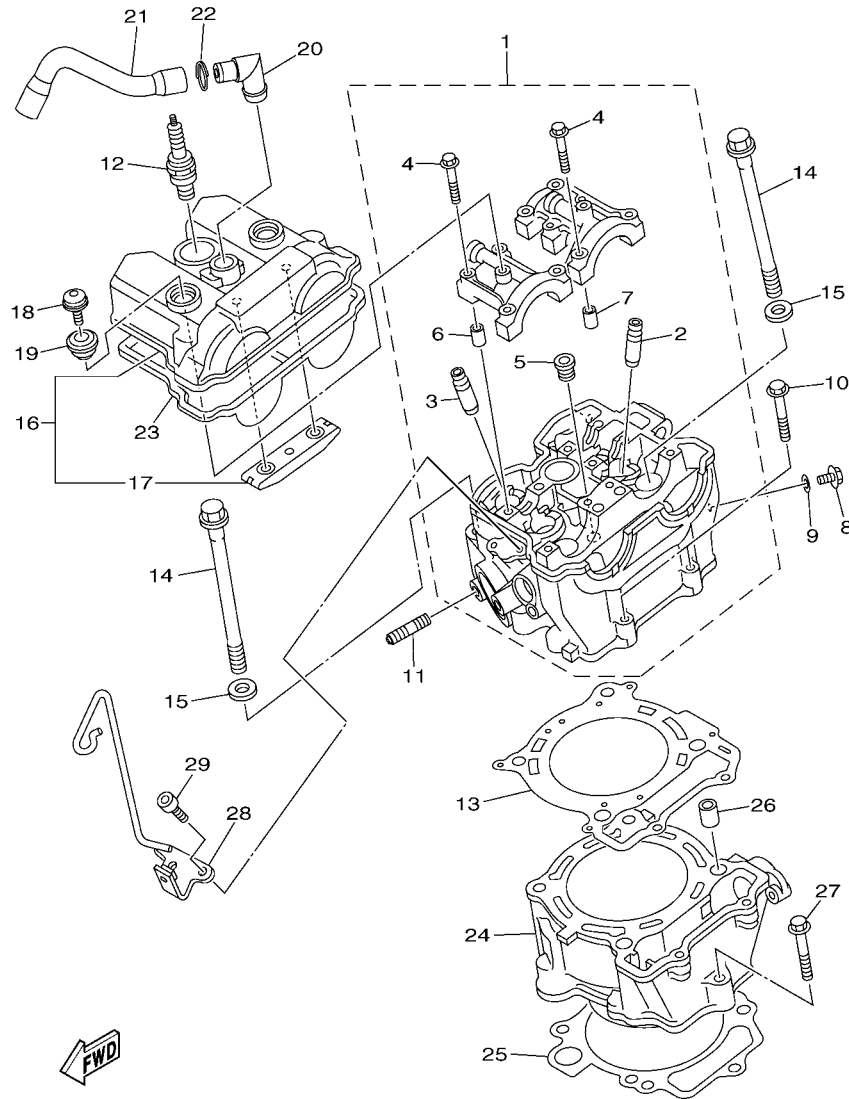

FWD
18P1100-H010

FIG. 1 CYLINDER

REF. NO.	PART NO.	DESCRIPTION	CAN	EUR	OC	JPN	REMARKS
1	18P-11102-10	CYLINDER HEAD ASSY	1	1	1	1	
2	5TA-11133-10	.GUIDE, VALVE 1	3	3	3	3	
3	5TA-11134-10	.GUIDE, VALVE 2	2	2	2	2	
4	90105-06027	.BOLT, FLANGE	10	10	10	10	
5	90340-12007	.PLUG, STRAIGHT SCREW	1	1	1	1	
6	91808-16023	.PIN, DOWEL	2	2	2	2	
7	91808-16023	.PIN, DOWEL	2	2	2	2	
8	95022-06010	BOLT, FLANGE	1	1	1	1	
9	90430-06014	GASKET	1	1	1	1	
10	95022-06035	BOLT, FLANGE	2	2	2	2	
11	90116-08022	BOLT, STUD	2	2	2	2	
12	94701-00330	PLUG, SPARK (NGK CR8E)	1	1	1		
	94703-00330	PLUG, SPARK (NGK CR8E)				1	
13	2S2-11181-00	GASKET, CYLINDER HEAD 1	1	1	1	1	
14	90105-10163	BOLT, FLANGE	4	4	4	4	
15	90201-10025	WASHER, PLATE	4	4	4	4	
16	2S2-11190-20	COVER, CYLINDER HEAD 1	1	1	1	1	
17	5BE-12241-00	.GUIDE, STOPPER 2	1	1	1	1	
18	90109-06203	BOLT	2	2	2	2	
19	5VY-1111G-00	RUBBER, MOUNT 1	2	2	2	2	
20	18P-11167-00	PIPE, BREATHER 2	1	1	1	1	
21	18P-11166-00	PIPE, BREATHER 1	1	1	1	1	
22	90468-100A1	CLIP	1	1	1	1	
23	2S2-11193-00	GASKET, HEAD COVER 1	1	1	1	1	
24	2S2-11311-10	CYLINDER 1	1	1	1	1	
25	2S2-11351-00	GASKET, CYLINDER	1	1	1	1	
26	93612-16254	PIN, DOWEL	2	2	2	2	

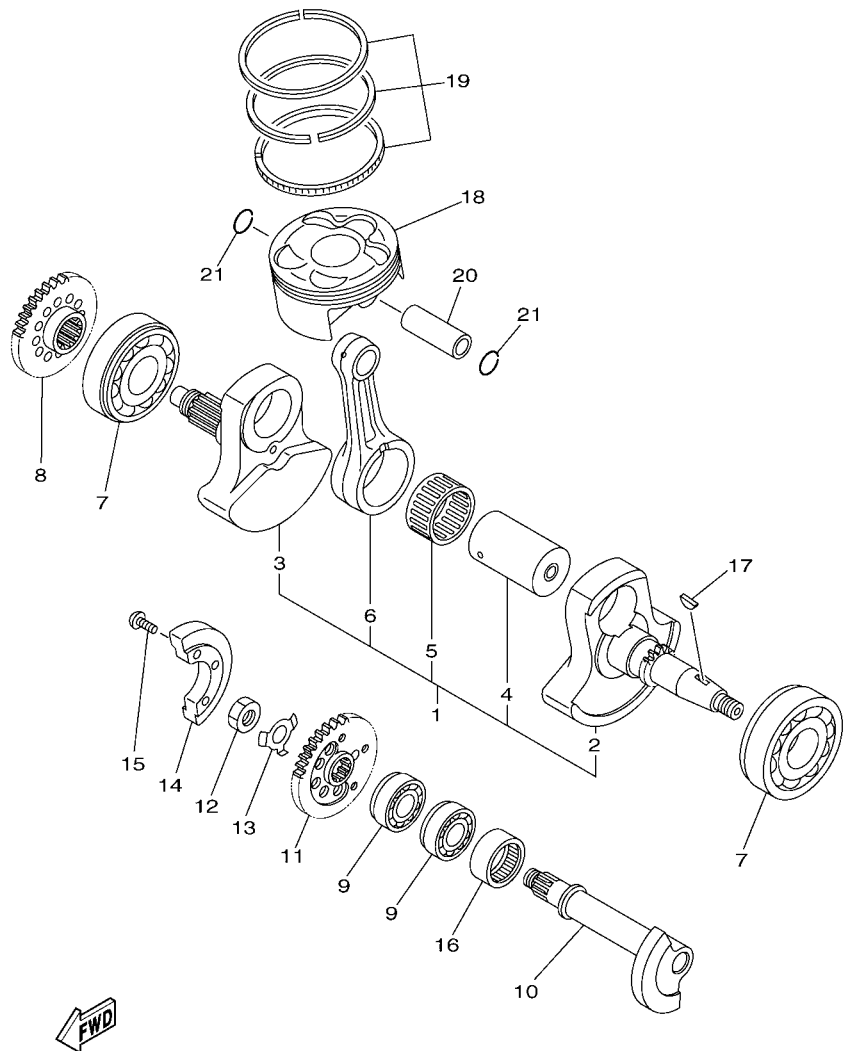

FWD
18P1100-H020

FIG. 2 CRANKSHAFT & PISTON

REF. NO.	PART NO.	DESCRIPTION	CAN	EUR	OC	JPN	REMARKS
1	18P-11400-01	CRANKSHAFT ASSY	1	1	1	1	
2	18P-11412-00	.CRANK 1	1	1	1	1	
3	18P-11422-00	.CRANK 2	1	1	1	1	
4	18P-11681-01	.PIN, CRANK 1	1	1	1	1	
5	93310-73606	.BEARING	1	1	1	1	
6	18P-11651-00	.ROD, CONNECTING	1	1	1	1	
7	93306-30644	BEARING	2	2	2	2	
8	18P-11536-00	GEAR, DRIVE	1	1	1	1	
9	93306-20353	BEARING	2	2	2	2	
10	18P-11455-00	SHAFT 1	1	1	1	1	
11	18P-11531-00	GEAR, BALANCE WEIGHT	1	1	1	1	
12	90170-14171	NUT	1	1	1	1	
13	90215-14287	WASHER, LOCK	1	1	1	1	
14	18P-11454-00	WEIGHT 1	1	1	1	1	
15	90149-06069	SCREW	3	3	3	3	
16	93311-62574	BEARING	1	1	1	1	
17	90280-03006	KEY, WOODRUFF	1	1	1	1	
18	5TG-11631-11	PISTON (STD)	1	1	1	1	
19	5TG-11603-00	PISTON RING SET (STD)	1	1	1	1	
20	5TG-11633-10	PIN, PISTON	1	1	1	1	
21	93450-22027	CIRCLIP	2	2	2	2	

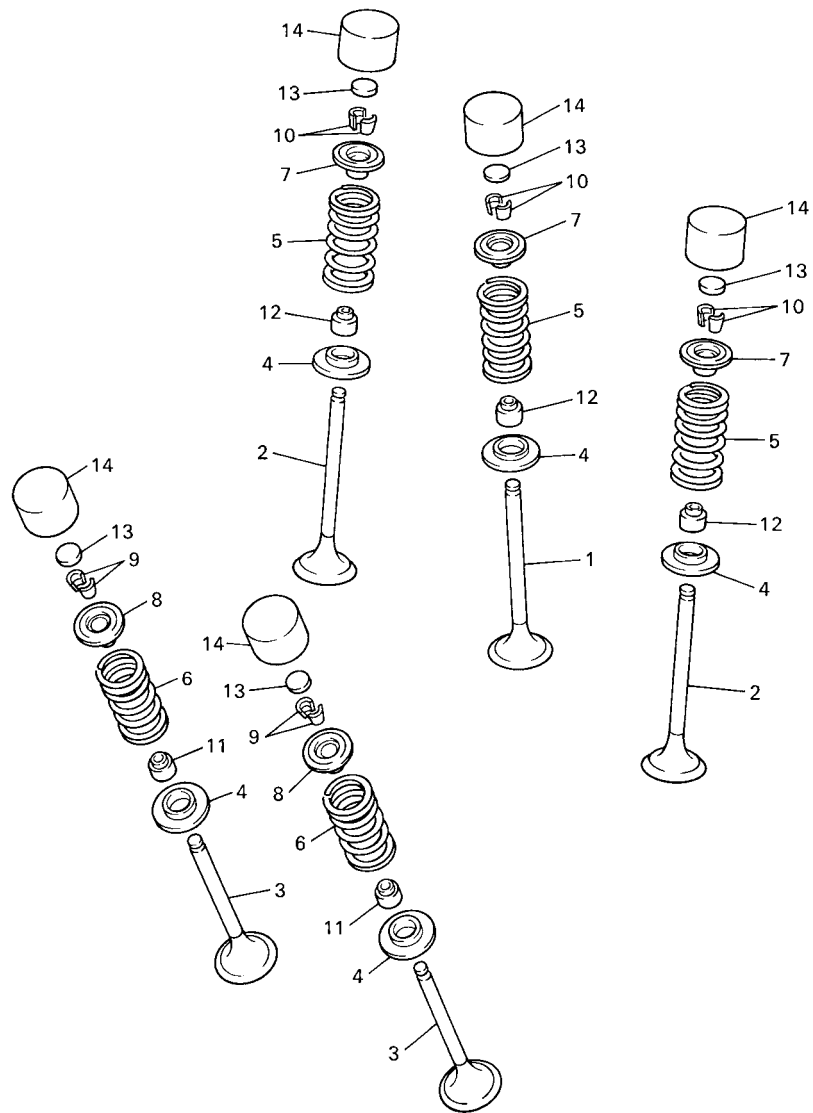

5BE100-8030

FIG. 3 VALVE

REF. NO.	PART NO.	DESCRIPTION	CAN	EUR	OC	JPN	REMARKS
1	5TA-12111-00	VALVE, INTAKE	1	1	1	1	
2	5TA-12112-00	VALVE, INTAKE 2	2	2	2	2	
3	5TA-12121-00	VALVE, EXHAUST	2	2	2	2	
4	3GM-12126-00	SEAT, VALVE SPRING 2	5	5	5	5	
5	5TJ-12113-00	SPRING, VALVE INNER	3	3	3	3	
6	5TA-12114-00	SPRING, VALVE OUTER	2	2	2	2	
7	5BE-12117-00	RETAINER, VALVE SPRING	3	3	3	3	
8	4GY-12117-00	RETAINER, VALVE SPRING	2	2	2	2	
9	1AA-12118-00	COTTER, VALVE	4	4	4	4	
10	1WG-12118-00	COTTER, VALVE	6	6	6	6	
11	33M-12119-00	SEAL, VALVE STEM	2	2	2	2	
12	4SV-12119-00	SEAL, VALVE STEM	3	3	3	3	
13	3LD-12168-00	PAD, ADJUSTING (1.20)	5	5	5	5	UR
	3LD-12168-20	PAD, ADJUSTING (1.25)	5	5	5	5	UR
	3LD-12168-40	PAD, ADJUSTING (1.30)	5	5	5	5	UR
	3LD-12168-60	PAD, ADJUSTING (1.35)	5	5	5	5	UR
	3LD-12168-80	PAD, ADJUSTING (1.40)	5	5	5	5	UR
	3LD-12168-A0	PAD, ADJUSTING (1.45)	5	5	5	5	UR
	3LD-12168-F0	PAD, ADJUSTING (1.50)	5	5	5	5	UR
	3LD-12168-H1	PAD, ADJUSTING (1.55)	5	5	5	5	UR
	3LD-12168-K1	PAD, ADJUSTING (1.60)	5	5	5	5	UR
	3LD-12168-M1	PAD, ADJUSTING (1.65)	5	5	5	5	UR
	3LD-12168-R1	PAD, ADJUSTING (1.70)	5	5	5	5	UR
	3LD-12168-U1	PAD, ADJUSTING (1.75)	5	5	5	5	UR
	3LD-12168-W1	PAD, ADJUSTING (1.80)	5	5	5	5	UR
	3LD-12168-Y1	PAD, ADJUSTING (1.85)	5	5	5	5	UR
	3LD-12169-11	PAD, ADJUSTING (1.90)	5	5	5	5	UR

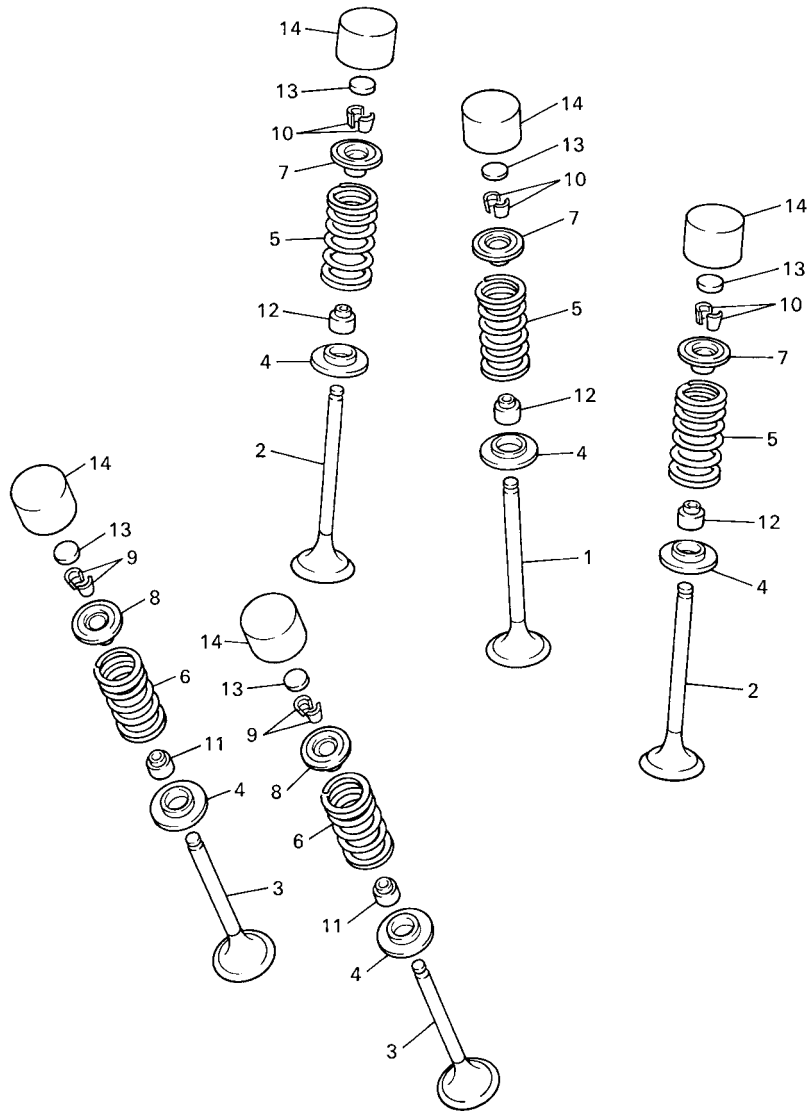

5BE100-8030

FIG. 3 VALVE

REF. NO.	PART NO.	DESCRIPTION	CAN	EUR	OCE	JPN	REMARKS
13	3LD-12169-31	PAD, ADJUSTING (1.95)	5	5	5	5	UR
	3LD-12169-50	PAD, ADJUSTING (2.00)	5	5	5	5	UR
	3LD-12169-70	PAD, ADJUSTING (2.05)	5	5	5	5	UR
	3LD-12169-90	PAD, ADJUSTING (2.10)	5	5	5	5	UR
	3LD-12169-E0	PAD, ADJUSTING (2.15)	5	5	5	5	UR
	3LD-12169-G0	PAD, ADJUSTING (2.20)	5	5	5	5	UR
	3LD-12169-J0	PAD, ADJUSTING (2.25)	5	5	5	5	UR
	3LD-12169-L0	PAD, ADJUSTING (2.30)	5	5	5	5	UR
	3LD-12169-N0	PAD, ADJUSTING (2.35)	5	5	5	5	UR
	3LD-12169-T0	PAD, ADJUSTING (2.40)	5	5	5	5	UR
14	3FV-12153-10	LIFTER, VALVE	5	5	5	5	YELLOW

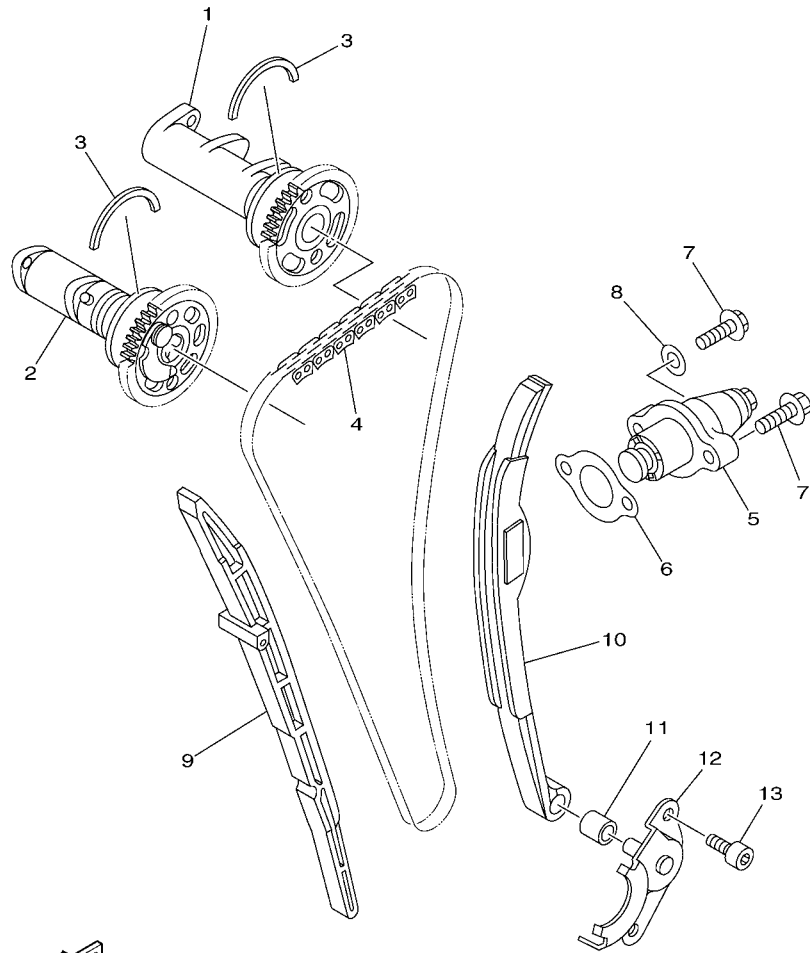



 18P1100-H040

FIG. 4 CAMSHAFT & CHAIN

REF. NO.	PART NO.	DESCRIPTION	CAN	EUR	OCE	JPN	REMARKS
1	18P-12170-00	CAMSHAFT ASSY 1	1	1	1	1	
2	18P-12180-00	CAMSHAFT ASSY 2	1	1	1	1	
3	93440-41178	CIRCLIP	2	2	2	2	
4	94591-57120	CHAIN (98XRH2010-120M)	1	1	1	1	
5	5TA-12210-10	TENSIONER ASSY, CAM CHAIN	1	1	1	1	
6	4FM-12213-00	GASKET, TENSIONER CASE	1	1	1	1	
7	95022-06025	BOLT, FLANGE	2	2	2	2	
8	90430-06014	GASKET	1	1	1	1	
9	2S2-12251-00	DAMPER, CHAIN 1	1	1	1	1	
10	18P-12252-00	DAMPER, CHAIN 2	1	1	1	1	
11	90387-07030	COLLAR	1	1	1	1	
12	18P-12233-00	PLATE, GUIDE STOPPER 1	1	1	1	1	
13	90110-06168	BOLT, HEXAGON SOCKET HEAD	2	2	2	2	

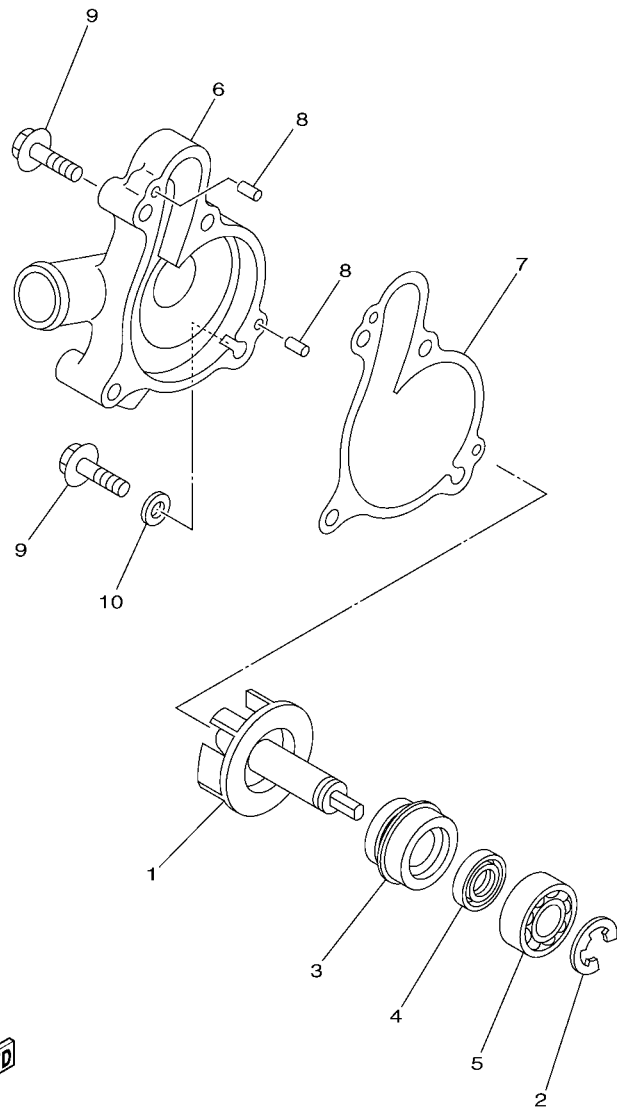
FIG. 5 WATER PUMP



18P1100-H050

REF. NO.	PART NO.	DESCRIPTION	CAN	EUR	OC	JPN	REMARKS
1	18P-12450-00	IMPELLER SHAFT ASSY	1	1	1	1	
2	99009-12400	CIRCLIP	1	1	1	1	
3	4C8-12438-00	SEAL, MECHANICAL	1	1	1	1	
4	93101-12173	OIL SEAL	1	1	1	1	
5	93306-00106	BEARING	1	1	1	1	
6	18P-12422-00	COVER, HOUSING	1	1	1	1	
7	18P-12428-00	GASKET, HOUSING COVER 2	1	1	1	1	
8	93604-10011	PIN, DOWEL	2	2	2	2	
9	95022-06030	BOLT, FLANGE	3	3	3	3	
10	90430-06014	GASKET	1	1	1	1	

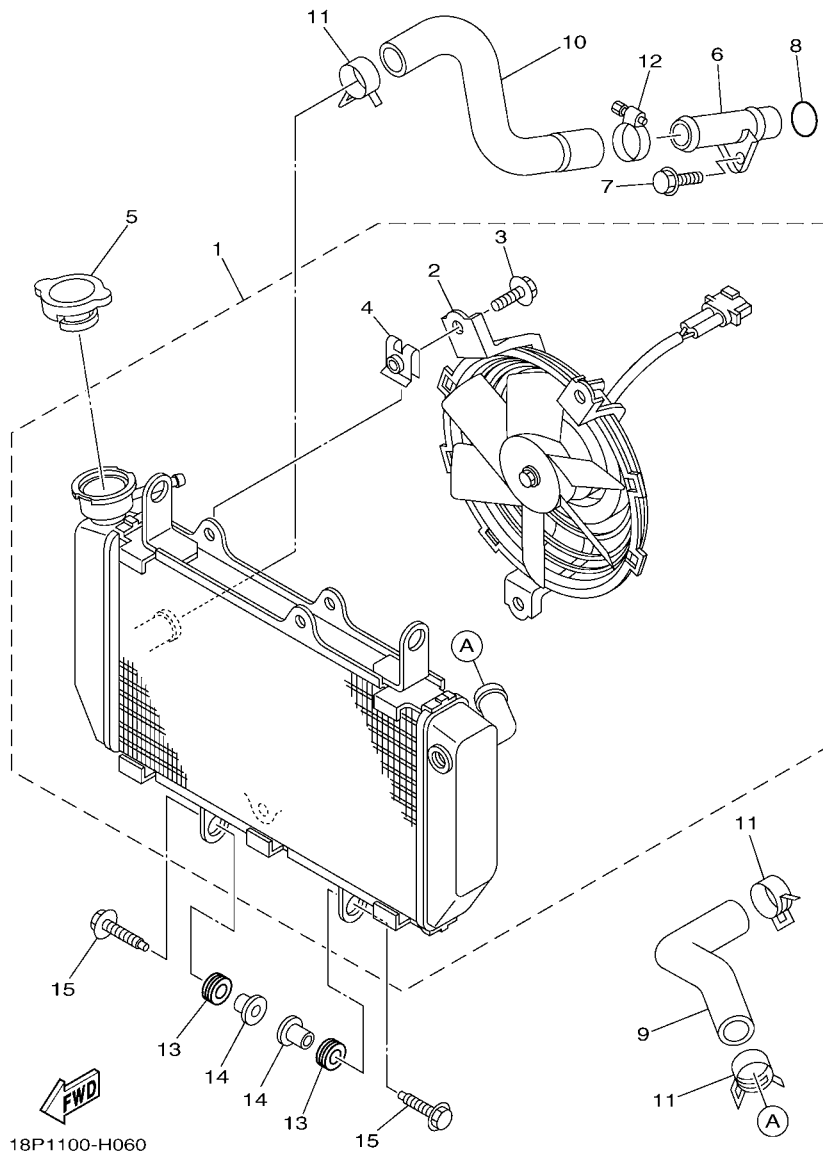
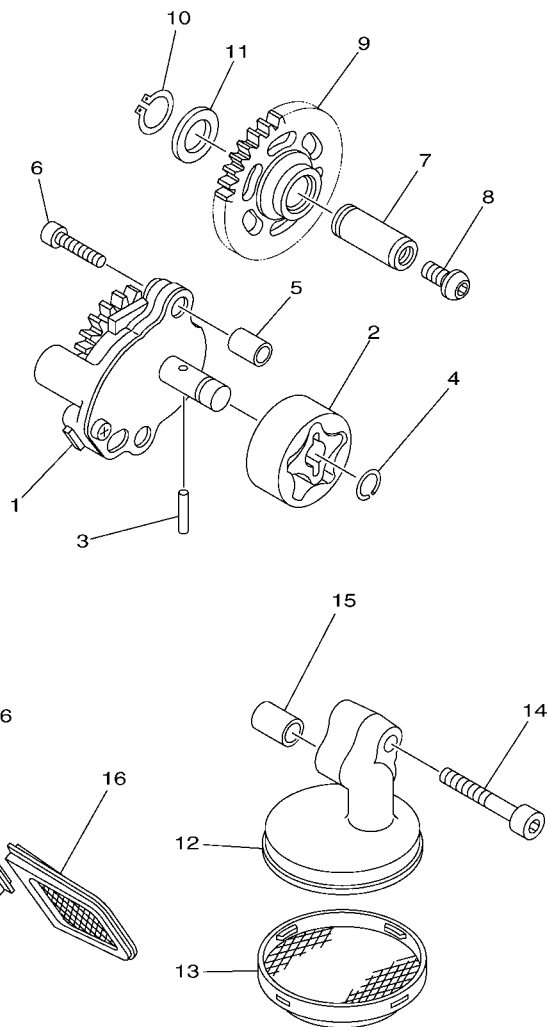

FIG. 6 RADIATOR & HOSE

REF. NO.	PART NO.	DESCRIPTION	CAN	EUR	OCE	JPN	REMARKS
1	18P-1240A-00	RADIATOR ASSY	1	1	1	1	
2	18P-12405-00	.BLOWER ASSY	1	1	1	1	
3	2S3-12675-00	.BOLT, BLOWER HOLDING	3	3	3	3	
4	18P-12671-00	.NUT 1	3	3	3	3	
5	5SL-12462-00	CAP, RADIATOR	1	1	1	1	
6	5TG-12481-00	PIPE 1	1	1	1	1	
7	95022-06012	BOLT, FLANGE	1	1	1	1	
8	93210-16500	O-RING	1	1	1	1	
9	18P-12576-00	HOSE 1	1	1	1	1	
10	18P-12577-00	HOSE 2	1	1	1	1	
11	90467-23109	CLIP	3	3	3	3	
12	90450-32015	HOSE CLAMP ASSY	1	1	1	1	
13	90480-15058	GROMMET	4	4	4	4	
14	90387-07391	COLLAR	4	4	4	4	
15	90119-06181	BOLT, WITH WASHER	4	4	4	4	



18P1100-H070

FIG. 7 OIL PUMP

REF. NO.	PART NO.	DESCRIPTION	CAN	EUR	OCE	JPN	REMARKS
1	18P-13300-00	OIL PUMP ASSY	1	1	1	1	
2	5TA-13320-00	ROTOR ASSY 2	1	1	1	1	
3	93603-16219	PIN, DOWEL	1	1	1	1	
4	93440-10153	CIRCLIP	1	1	1	1	
5	99530-08012	PIN, DOWEL	2	2	2	2	
6	91312-06030	BOLT	2	2	2	2	
7	2S2-13342-00	SHAFT, IDLE GEAR	1	1	1	1	
8	90149-06069	SCREW	1	1	1	1	
9	18P-13341-00	GEAR, OIL PUMP IDLE	1	1	1	1	
10	99009-12400	CIRCLIP	1	1	1	1	
11	90201-12166	WASHER, PLATE	1	1	1	1	
12	18P-13412-01	HOUSING, STRAINER	1	1	1	1	
13	18P-13411-00	STRAINER, OIL	1	1	1	1	
14	90110-06208	BOLT, HEXAGON SOCKET HEAD	1	1	1	1	
15	99530-10114	PIN, DOWEL	1	1	1	1	
16	18P-13421-00	STRAINER 2	2	2	2	2	

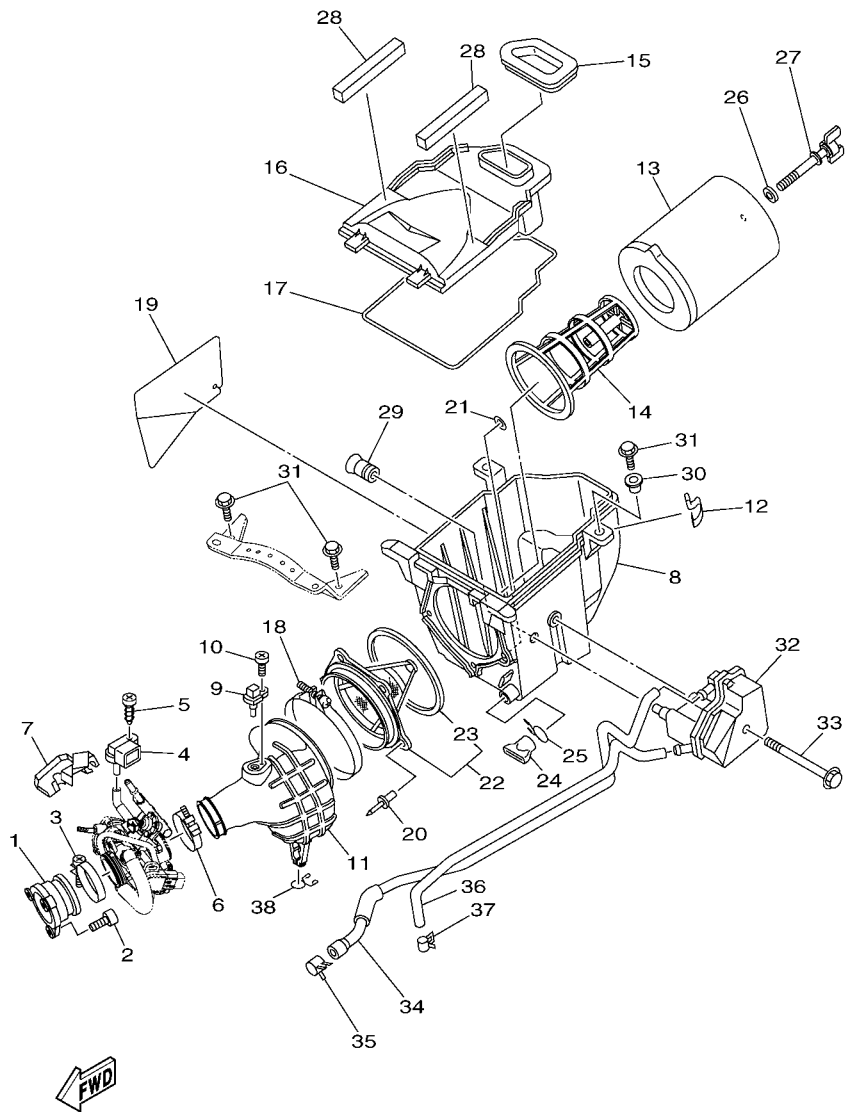

18P1100-H080

FIG. 8 INTAKE

REF. NO.	PART NO.	DESCRIPTION	CAN	EUR	OCE	JPN	REMARKS
1	18P-13597-00	JOINT, CARBURETOR 3	1	1	1	1	
2	91312-06020	BOLT	3	3	3	3	
3	90450-58005	HOSE CLAMP ASSY	1	1	1	1	
4	5S7-82380-00	SENSOR, PRESSURE	1	1	1	1	
5	97702-60125	SCREW, TAPPING	1	1	1	1	
6	90450-54009	HOSE CLAMP ASSY	1	1	1	1	
7	18P-13843-00	PLATE 1	1	1	1	1	
8	18P-14411-00	CASE, AIR CLEANER 1	1	1	1	1	
9	8FP-85886-00	SENSOR, AIR TEMPERATURE	1	1	1	1	
10	98502-05010	SCREW, PAN HEAD	1	1	1	1	
11	18P-14453-00	JOINT, AIR CLEANER 1	1	1	1	1	
12	5GH-14436-00	HOOK	2	2	2	2	
13	5TG-14451-00	ELEMENT, AIR CLEANER	1	1	1	1	
14	5TG-14458-00	GUIDE	1	1	1	1	
15	18P-14479-00	FUNNEL	1	1	1	1	
16	18P-14412-00	CAP, CLEANER CASE 1	1	1	1	1	
17	5KM-14452-00	SEAL	1	1	1	1	
18	90450-99014	HOSE CLAMP ASSY	1	1	1	1	
19	18P-1442F-00	PROTECTOR	1	1	1	1	
20	90267-48025	RIVET, BLIND	5	5	5	5	
21	90201-04028	WASHER, PLATE	5	5	5	5	
22	5D3-14459-00	HOLDER, GUIDE	1	1	1	1	
23	4ES-14462-00	.SEAL	1	1	1	1	
24	59V-14457-00	SEAL	1	1	1	1	
25	90467-220A1	CLIP	1	1	1	1	
26	90209-06096	WASHER	1	1	1	1	
27	90122-06010	BOLT, WING	1	1	1	1	

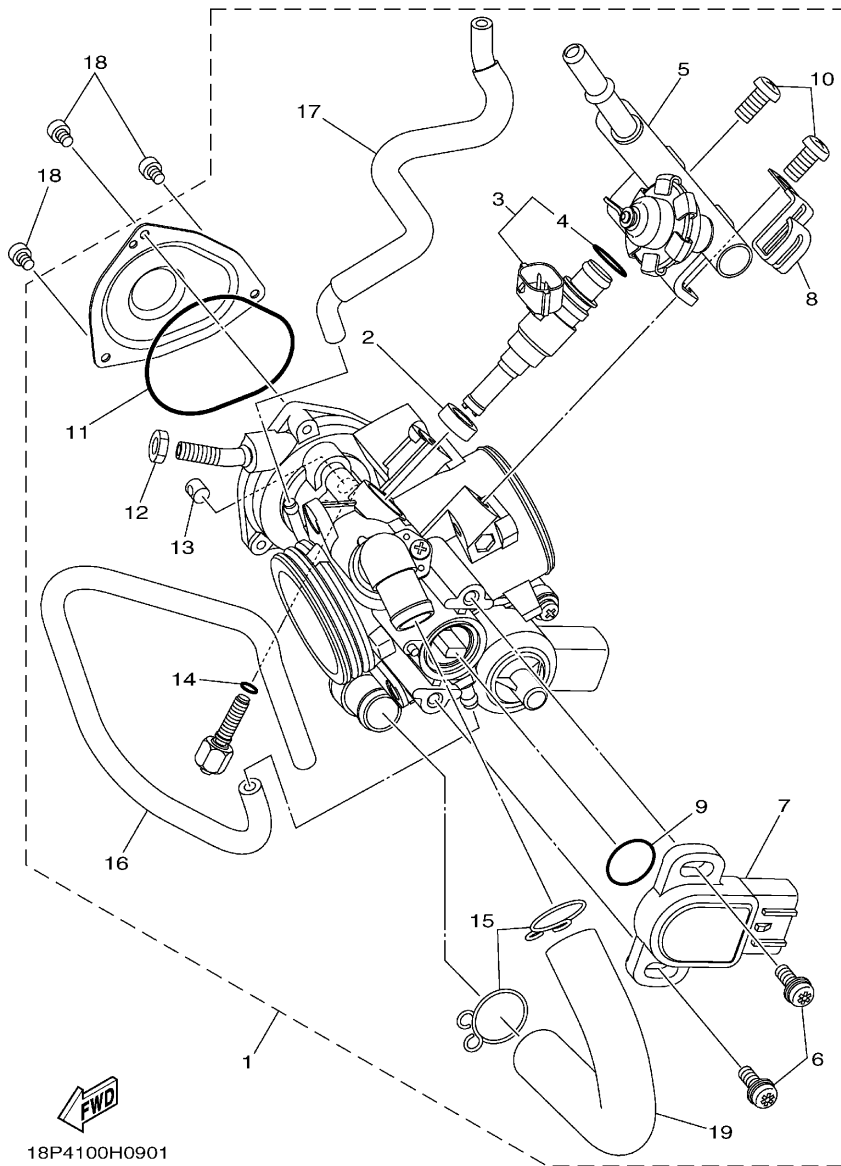

FIG. 9 THROTTLE BODY ASSY 1

REF. NO.	PART NO.	DESCRIPTION	CAN	EUR	OCE	JPN	REMARKS
1	18P-13750-00	THROTTLE BODY ASSY	1	1	1	1	
2	8FP-13556-00	.RUBBER, INJECTOR	1	1	1	1	
3	3B4-13761-00	.INJECTOR	1	1	1	1	
4	5PS-14147-00	.O-RING	1	1	1	1	
5	18P-13160-00	.DELIVERY PIPE ASSY 1	1	1	1	1	
6	8CC-14216-10	.SCREW	2	2	2	2	
7	3B4-85885-00	.THROTTLE SENSOR ASSY	1	1	1	1	
8	5JW-14945-00	.PLATE	1	1	1	1	
9	5YP-14562-00	.O-RING	1	1	1	1	
10	98507-06012	.SCREW, PAN HEAD	2	2	2	2	
11	5LP-14147-00	.O-RING	1	1	1	1	
12	1S3-14161-00	.NUT, CABLE ADJUSTING	1	1	1	1	
13	1UY-14155-00	.GUIDE, CABLE	1	1	1	1	
14	2H0-14147-00	.O-RING	1	1	1	1	
15	8FP-14137-00	.CLIP	2	2	2	2	
16	18P-13543-00	.HOSE, AIR	1	1	1	1	
17	18P-14348-00	.PIPE 1	1	1	1	1	
18	91312-04006	BOLT	3	3	3	3	
19	18P-13545-00	.HOSE	1	1	1	1	

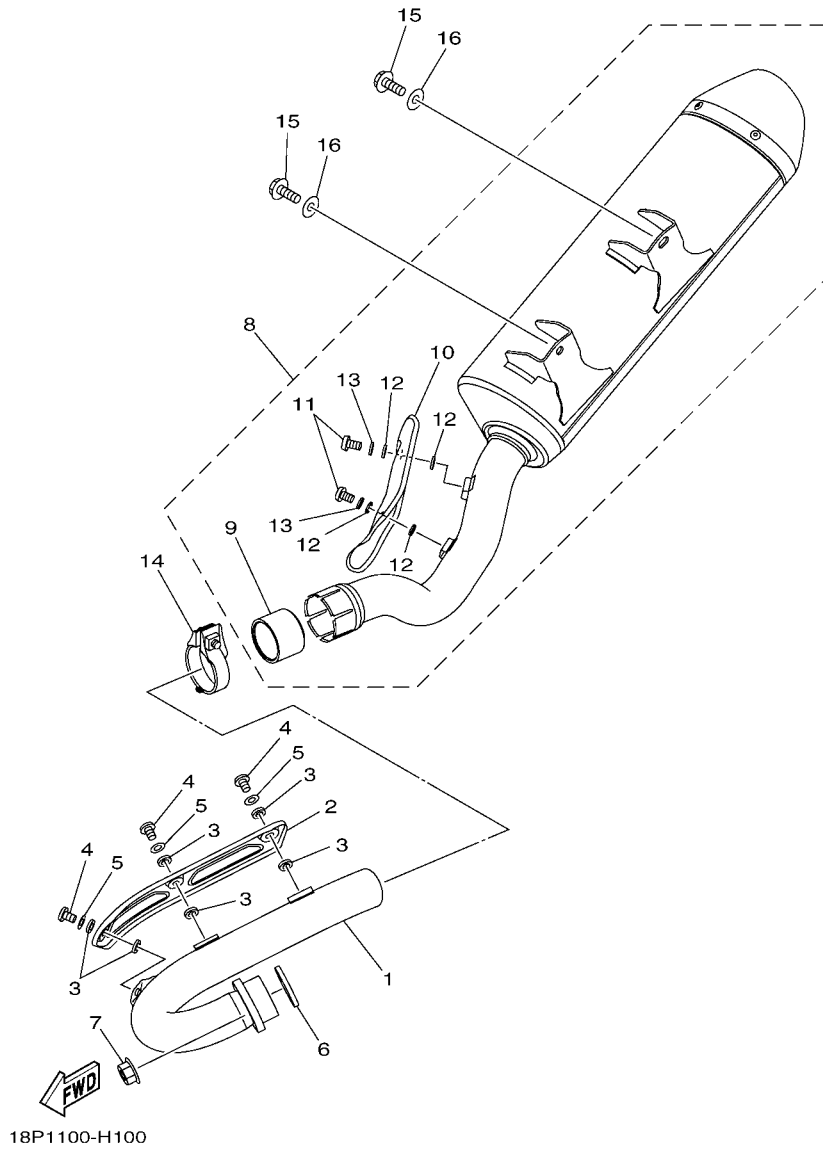
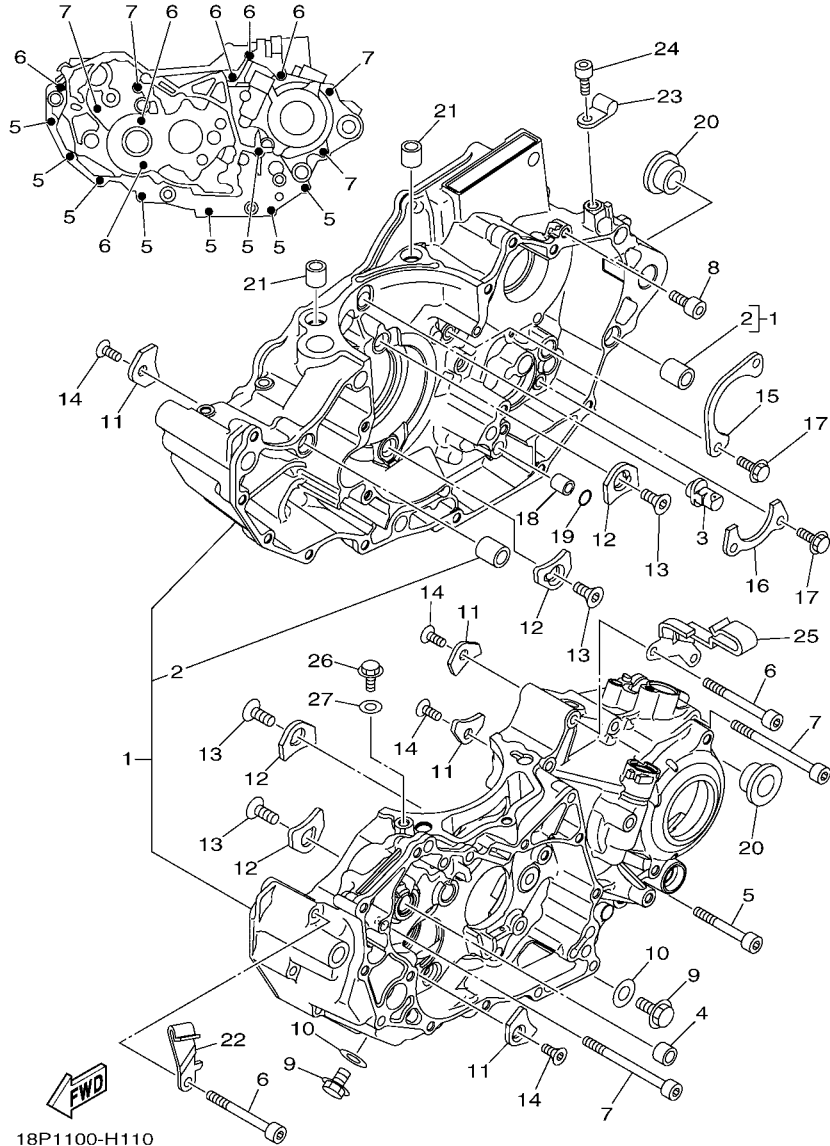

FIG. 10 EXHAUST

REF. NO.	PART NO.	DESCRIPTION	CAN	EUR	OC	JPN	REMARKS
1	18P-14611-00	PIPE, EXHAUST 1	1	1	1	1	
2	18P-14628-00	PROTECTOR, EXHAUST PIPE	1	1	1	1	
3	90201-05015	WASHER, PLATE	6	6	6	6	
4	98980-06010	SCREW, BIND	3	3	3	3	
5	92990-06200	WASHER, PLAIN	3	3	3	3	
6	3VD-14613-01	GASKET, EXHAUST PIPE	1	1	1	1	
7	95702-08500	NUT, FLANGE	2	2	2	2	
8	18P-14710-01	MUFFLER ASSY 1	1	1	1	1	
9	8FA-14714-10	.GASKET, MUFFLER	1	1	1	1	
10	18P-14718-00	.PROTECTOR, MUFFLER 1	1	1	1	1	
11	98902-06010	.SCREW, BIND	2	2	2	2	
12	90201-05015	.WASHER, PLATE	4	4	4	4	
13	92902-06200	.WASHER	2	2	2	2	
14	5BE-14788-00	BAND, SILENCER	1	1	1	1	
15	90105-08129	BOLT, FLANGE	2	2	2	2	
16	90201-08048	WASHER, PLATE	2	2	2	2	

LEFT SIDE



18P1100-H110

FIG. 11 CRANKCASE

REF. NO.	PART NO.	DESCRIPTION	CAN	EUR	OCE	JPN	REMARKS
1	18P-15100-00	CRANKCASE ASSY	1	1	1	1	
2	99530-14016	.PIN, DOWEL	2	2	2	2	
3	2S2-15155-10	NOZZLE 3	1	1	1	1	
4	90380-10002	BUSH, SOLID	1	1	1	1	
5	91312-06050	BOLT	8	8	8	8	
6	91312-06060	BOLT	6	6	6	6	
7	91312-06080	BOLT	4	4	4	4	
8	91312-06016	BOLT	1	1	1	1	
9	95022-10016	BOLT, FLANGE	2	2	2	2	
10	90430-10148	GASKET	2	2	2	2	
11	4JT-15381-01	PLATE, BEARING COVER	4	4	4	4	
12	18P-15383-00	PLATE, BEARING COVER	4	4	4	4	
13	90151-08003	SCREW, COUNTERSUNK	4	4	4	4	
14	90149-06074	SCREW	4	4	4	4	
15	2S2-15388-00	PLATE, BEARING COVER	1	1	1	1	
16	2S2-18562-00	PLATE, STOPPER 2	1	1	1	1	
17	90105-06081	BOLT, FLANGE	4	4	4	4	
18	99530-10114	PIN, DOWEL	1	1	1	1	
19	93210-10197	O-RING	1	1	1	1	
20	90387-164N2	COLLAR	2	2	2	2	
21	99530-14016	PIN, DOWEL	2	2	2	2	
22	90462-10056	CLAMP	1	1	1	1	
23	90461-10135	CLAMP	1	1	1	1	
24	91312-06016	BOLT	1	1	1	1	
25	18P-15378-00	HOLDER	1	1	1	1	
26	95022-06012	BOLT, FLANGE	1	1	1	1	
27	90430-06014	GASKET	1	1	1	1	

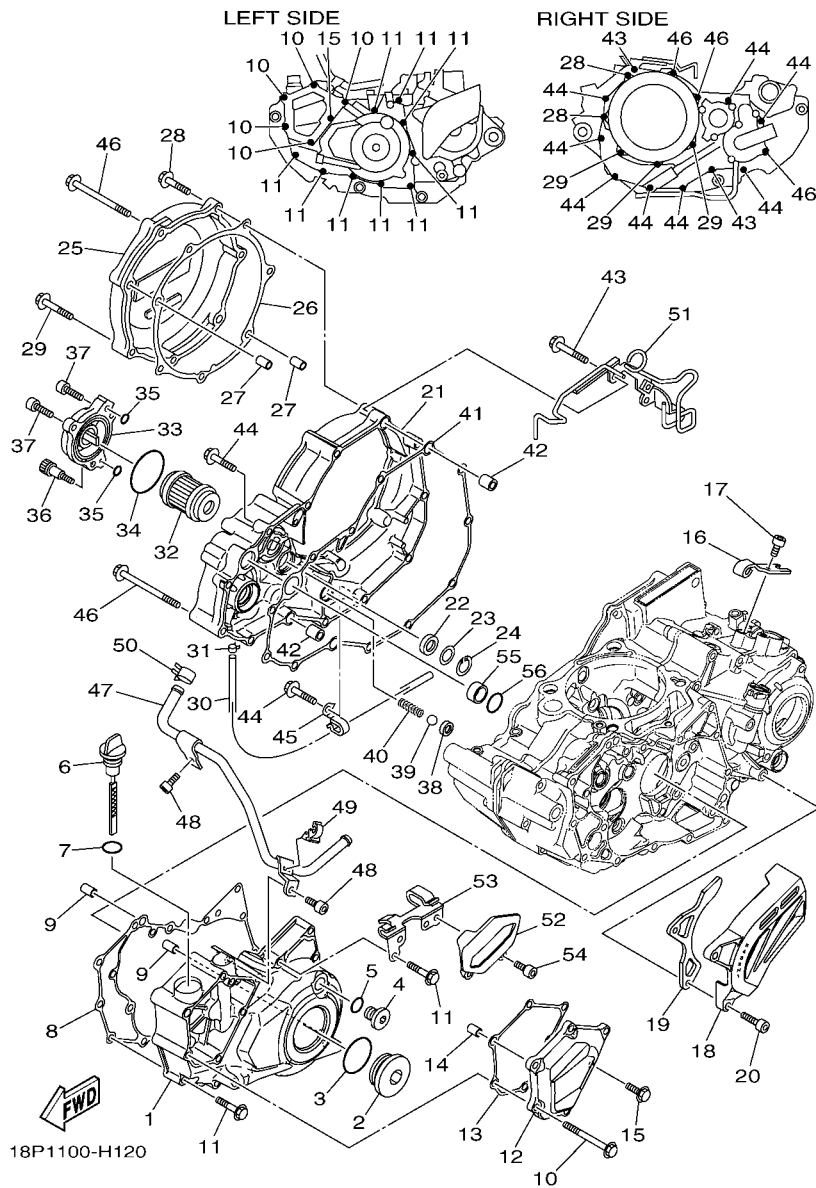

FIG. 12 CRANKCASE COVER 1

REF. NO.	PART NO.	DESCRIPTION	CAN	EUR	OCE	JPN	REMARKS
1	18P-15411-00	COVER, CRANKCASE 1	1	1	1	1	
2	90340-36002	PLUG, STRAIGHT SCREW	1	1	1	1	
3	93210-357A3	O-RING	1	1	1	1	
4	90340-14011	PLUG, STRAIGHT SCREW	1	1	1	1	
5	93210-14369	O-RING	1	1	1	1	
6	18P-15362-01	PLUG, OIL LEVEL	1	1	1	1	
7	93210-19026	O-RING	1	1	1	1	
8	18P-15451-00	GASKET, CRANKCASE COVER 1	1	1	1	1	
9	99530-08016	PIN, DOWEL	2	2	2	2	
10	95022-06065	BOLT, FLANGE	5	5	5	5	
11	95022-06035	BOLT, FLANGE	9	9	9	9	
12	18P-15423-00	COVER 2	1	1	1	1	
13	18P-15463-00	GASKET, COVER PINION 2	1	1	1	1	
14	99530-08012	PIN, DOWEL	1	1	1	1	
15	95022-06020	BOLT, FLANGE	1	1	1	1	
16	5TA-15441-01	HOLDER, CLUTCH CABLE	1	1	1	1	
17	91312-06016	BOLT	1	1	1	1	
18	18P-15421-00	COVER, CRANKCASE 2	1	1	1	1	
19	18P-17466-00	GUIDE, CHAIN	1	1	1	1	
20	91312-06025	BOLT	2	2	2	2	
21	18P-15431-00	COVER, CRANKCASE 3	1	1	1	1	
22	93101-14164	OIL SEAL	1	1	1	1	
23	90201-15701	WASHER, PLATE (T=1.0)	1	1	1	1	
24	99009-22500	CIRCLIP	1	1	1	1	
25	5TG-15415-00	COVER, GENERATOR	1	1	1	1	
26	18P-15453-00	GASKET	1	1	1	1	
27	99530-08016	PIN, DOWEL	2	2	2	2	

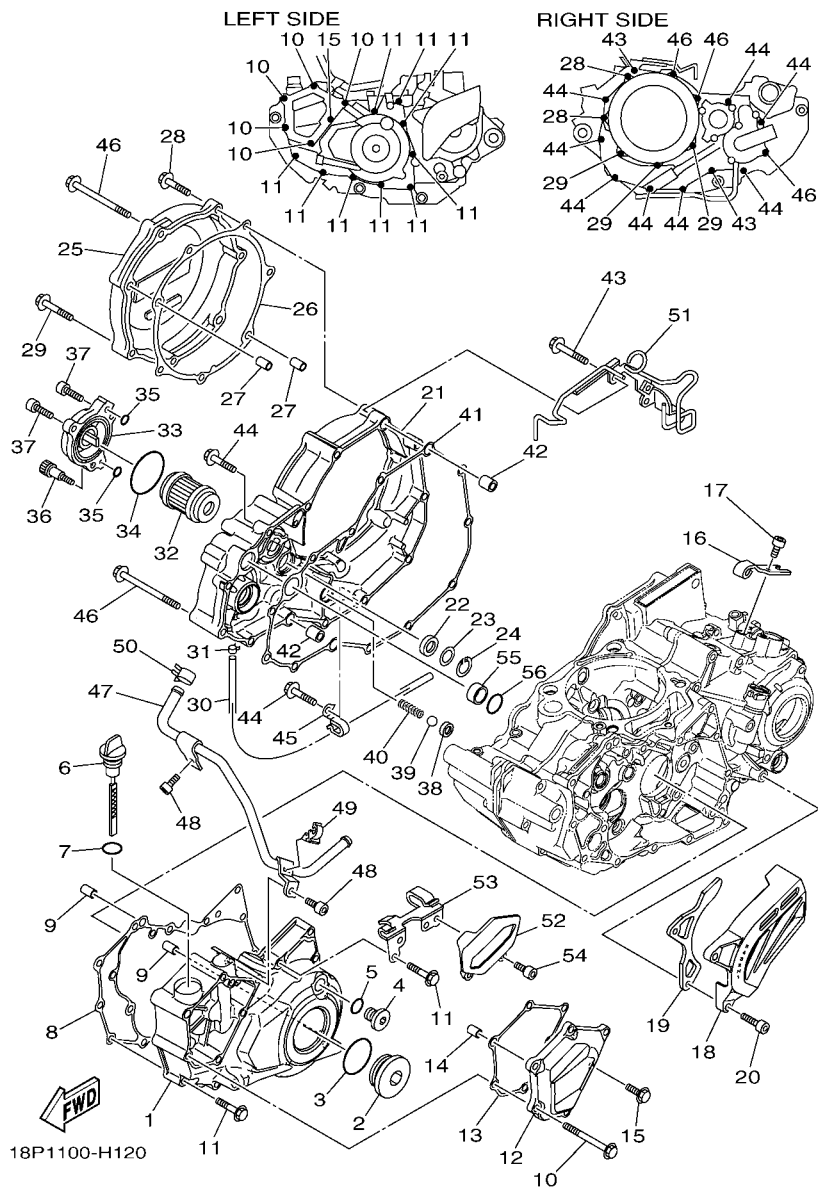
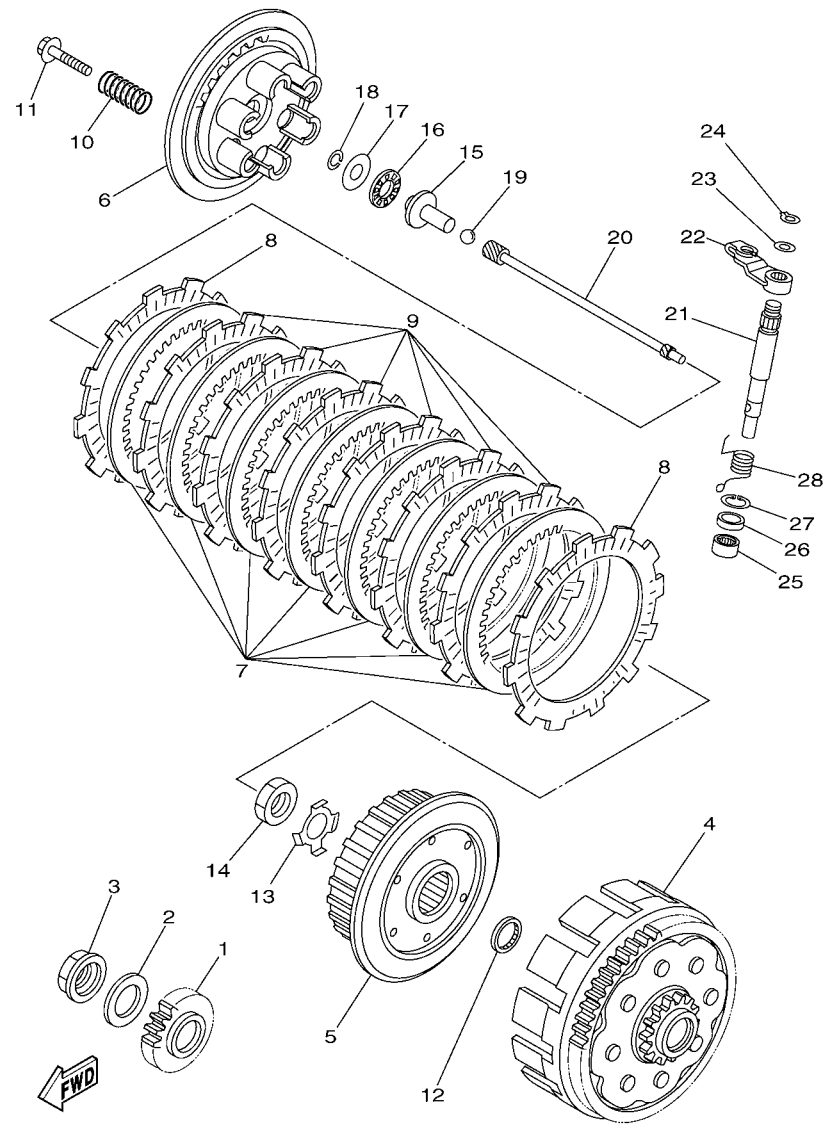

FIG. 12 CRANKCASE COVER 1

REF. NO.	PART NO.	DESCRIPTION	CAN	EUR	OCE	JPN	REMARKS
28	95022-06030	BOLT, FLANGE	2	2	2	2	
29	95022-06040	BOLT, FLANGE	3	3	3	3	
30	18P-1243A-00	HOSE 1	1	1	1	1	
31	90467-070A0	CLIP	1	1	1	1	
32	5D3-13440-00	ELEMENT ASSY, OIL CLEANER	1	1	1	1	
33	5BE-13447-10	COVER, OIL ELEMENT	1	1	1	1	
34	93210-47675	O-RING	1	1	1	1	
35	93210-07135	O-RING	3	3	3	3	
36	90110-06228	BOLT, HEXAGON SOCKET HEAD	1	1	1	1	
37	91312-06020	BOLT	2	2	2	2	
38	583-13113-00	SEAT, CHECK BALL	1	1	1	1	
39	93503-08007	BALL	1	1	1	1	
40	90501-043E0	SPRING, COMPRESSION	1	1	1	1	
41	18P-15462-00	GASKET, CRANKCASE COVER 3	1	1	1	1	
42	99530-10120	PIN, DOWEL	2	2	2	2	
43	95022-06040	BOLT, FLANGE	2	2	2	2	
44	95022-06030	BOLT, FLANGE	8	8	8	8	
45	90465-08127	CLAMP	1	1	1	1	
46	95022-06080	BOLT, FLANGE	3	3	3	3	
47	18P-15393-01	PIPE, BREATHER 2	1	1	1	1	
48	91312-06016	BOLT	2	2	2	2	
49	90464-08051	CLAMP	1	1	1	1	
50	90467-140A6	CLIP	1	1	1	1	
51	18P-15484-00	CLAMP 2	1	1	1	1	
52	18P-15413-00	COVER	1	1	1	1	
53	18P-1541A-00	STAY, CRANKCASE COVER 1	1	1	1	1	
54	91312-06016	BOLT	2	2	2	2	



18PD100-K140

FIG. 14 CLUTCH

REF. NO.	PART NO.	DESCRIPTION	CAN	EUR	OCE	JPN	REMARKS
1	2S2-16111-60	GEAR, PRIMARY DRIVE	1	1	1	1	
2	90208-25045	WASHER, CONICAL SPRING	1	1	1	1	
3	90179-20009	NUT	1	1	1	1	
4	18P-16150-10	PRIMARY DRIVEN GEAR COMP.	1	1	1	1	
5	5TA-16371-10	BOSS, CLUTCH	1	1	1	1	
6	2S2-16351-00	PLATE, P <small>RE</small> SSURE 1	1	1	1	1	
7	4X7-16325-00	PLATE, CLUTCH 2	7	7	7	7	
8	5TA-16321-00	PLATE, FRICTION	2	2	2	2	
9	5VY-16321-00	PLATE, FRICTION	6	6	6	6	
10	90501-231E9	SPRING, COMPRESSION	6	6	6	6	
11	90159-06010	SCREW, WITH WASHER	6	6	6	6	
12	5TA-16154-00	PLATE, THRUST 1	1	1	1	1	
13	90215-20005	WASHER, LOCK	1	1	1	1	
14	90170-20327	NUT	1	1	1	1	
15	5TG-16356-00	ROD, PUSH 1	1	1	1	1	
16	93340-21505	B <small>EA</small> R <small>IN</small> G	1	1	1	1	
17	90201-125L6	WASHER, PLATE	1	1	1	1	
18	93440-10085	C <small>IR</small> C <small>L</small> I <small>P</small>	1	1	1	1	
19	93515-32029	B <small>A</small> L <small>L</small>	1	1	1	1	
20	18P-16357-00	ROD, PUSH 2	1	1	1	1	
21	18P-16382-00	A <small>X</small> L <small>E</small> , P <small>U</small> S <small>H</small> L <small>E</small> V <small>E</small> R	1	1	1	1	
22	18P-16342-00	L <small>E</small> V <small>E</small> R, P <small>U</small> S <small>H</small>	1	1	1	1	
23	90201-10032	WASHER, PLATE	1	1	1	1	
24	99009-10400	C <small>IR</small> C <small>L</small> I <small>P</small>	1	1	1	1	
25	93317-11287	B <small>E</small> A <small>R</small> I <small>N</small> G	1	1	1	1	
26	93102-12224	O <small>I</small> L S <small>E</small> A <small>L</small>	1	1	1	1	
27	99009-20500	C <small>IR</small> C <small>L</small> I <small>P</small>	1	1	1	1	

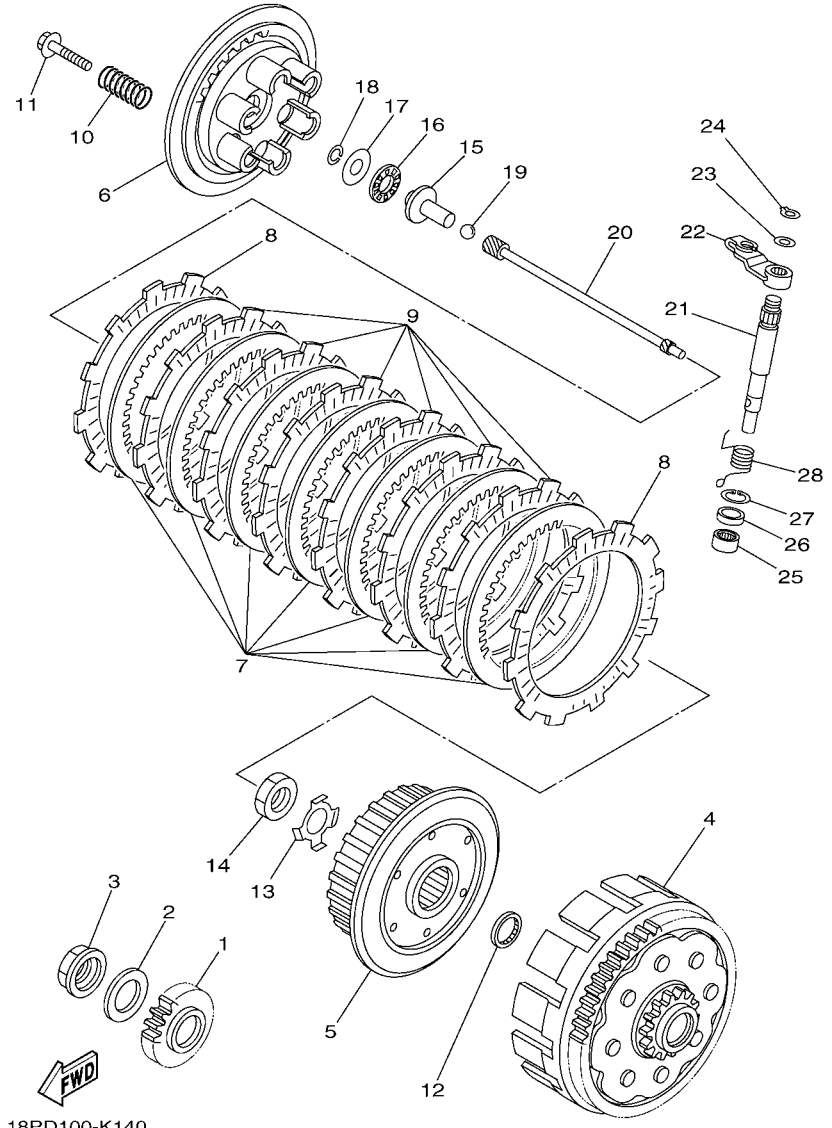

18PD100-K140

FIG. 14 CLUTCH

REF. NO.	PART NO.	DESCRIPTION	CAN	EUR	OCE	JPN	REMARKS
28	90508-16061	SPRING, TORSION	1	1	1	1	

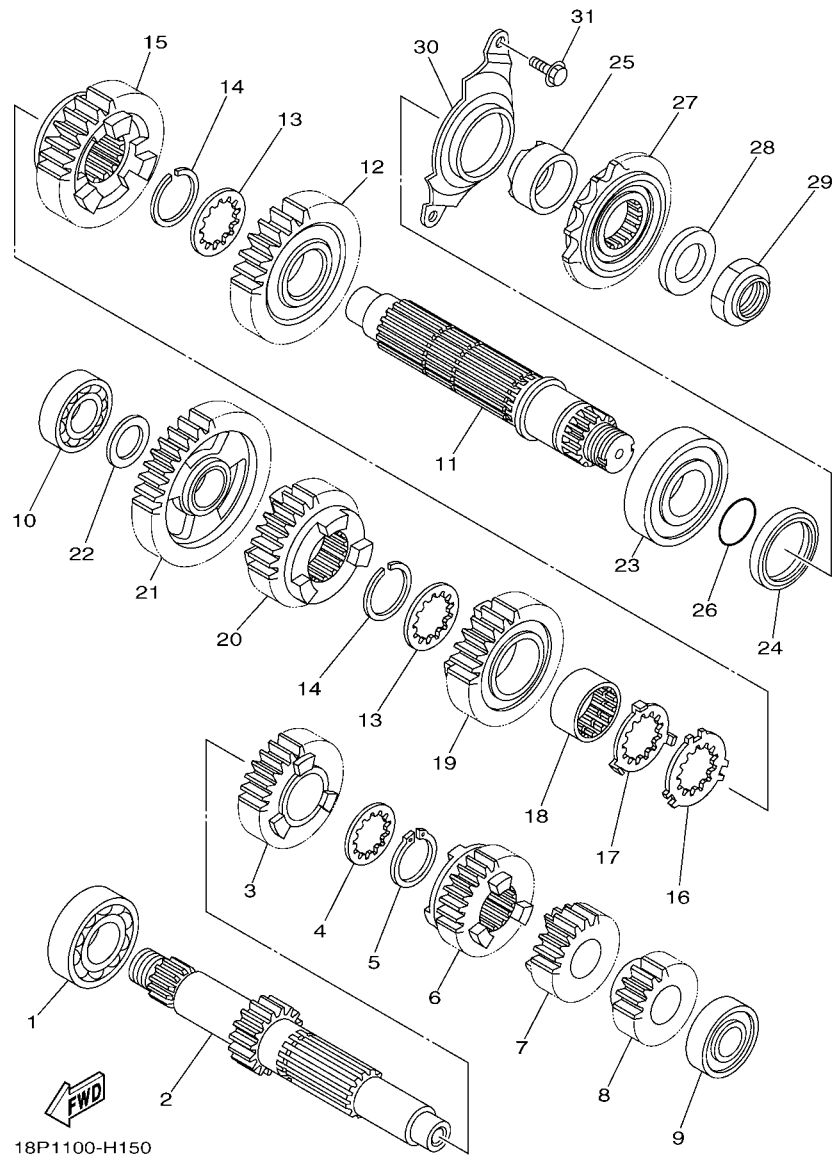

FIG. 15 TRANSMISSION

REF. NO.	PART NO.	DESCRIPTION	CAN	EUR	OC	JPN	REMARKS
1	93306-20532	BEARING	1	1	1	1	
2	18P-17411-00	AXLE, MAIN	1	1	1	1	
3	18P-17151-00	GEAR, 5TH PINION (21T)	1	1	1	1	
4	90209-23012	WASHER	1	1	1	1	
5	93410-26067	CIRCLIP	1	1	1	1	
6	18P-17141-00	GEAR, 4TH PINION (21T)	1	1	1	1	
7	18P-17131-00	GEAR, 3RD PINION (19T)	1	1	1	1	
8	18P-17121-00	GEAR, 2ND PINION (15T)	1	1	1	1	
9	93306-20332	BEARING	1	1	1	1	
10	93306-00426	BEARING	1	1	1	1	
11	18P-17402-00	DRIVE AXLE ASSY	1	1	1	1	
12	18P-17221-00	GEAR, 2ND WHEEL (30T)	1	1	1	1	
13	90209-26008	WASHER	2	2	2	2	
14	93440-28062	CIRCLIP	2	2	2	2	
15	18P-17231-00	GEAR, 3RD WHEEL (31T)	1	1	1	1	
16	90214-26002	WASHER, CLAW	1	1	1	1	
17	90214-26003	WASHER, CLAW	1	1	1	1	
18	90387-26005	COLLAR	1	1	1	1	
19	18P-17241-00	GEAR, 4TH WHEEL (28T)	1	1	1	1	
20	18P-17251-00	GEAR, 5TH WHEEL (23T)	1	1	1	1	
21	18P-17211-00	GEAR, 1ST WHEEL (35T)	1	1	1	1	
22	90201-20276	WASHER, PLATE (T=1.0)	1	1	1	1	
23	93306-27803	BEARING	1	1	1	1	
24	93102-35393	OIL SEAL	1	1	1	1	
25	90387-28009	COLLAR	1	1	1	1	
26	93210-25001	O-RING	1	1	1	1	
27	18P-17460-00	SPROCKET, DRIVE (14T)	1	1	1	1	

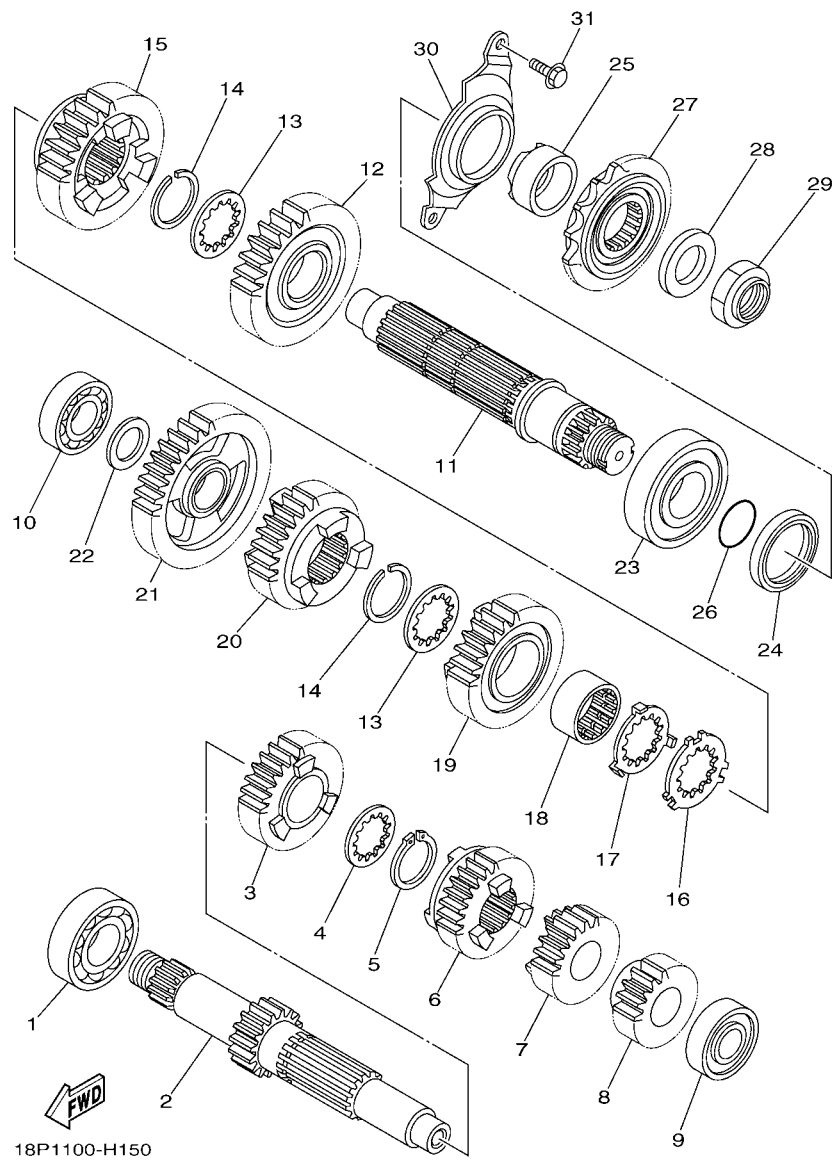
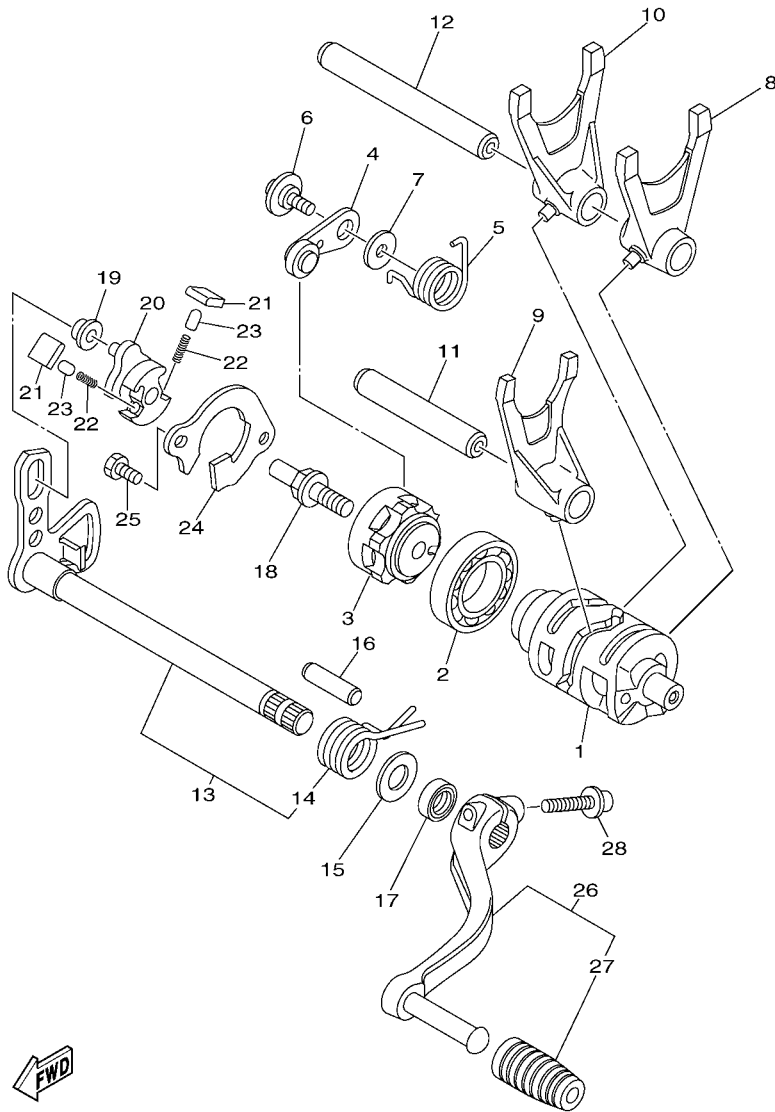

FIG. 15 TRANSMISSION

REF. NO.	PART NO.	DESCRIPTION	CAN	EUR	OCE	JPN	REMARKS
28	90201-22015	WASHER, PLATE	1	1	1	1	
29	90179-22018	NUT	1	1	1	1	
30	1S3-17471-00	PLATE, COVER	1	1	1	1	
31	95022-06014	BOLT, FLANGE	2	2	2	2	



18P1100-H160

FIG. 16 SHIFT CAM & FORK

REF. NO.	PART NO.	DESCRIPTION	CAN	EUR	OC	JPN	REMARKS
1	18P-18541-00	CAM, SHIFT	1	1	1	1	
2	93306-90509	BEARING	1	1	1	1	
3	2S2-18185-00	SEGMENT	1	1	1	1	
4	2S2-18140-10	STOPPER LEVER ASSY	1	1	1	1	
5	90508-26021	SPRING, TORSION	1	1	1	1	
6	90109-06198	BOLT	1	1	1	1	
7	90201-06013	WASHER, PLATE	1	1	1	1	
8	18P-18511-00	FORK, SHIFT 1	1	1	1	1	
9	18P-18512-00	FORK, SHIFT 2	1	1	1	1	
10	18P-18513-00	FORK, SHIFT 3	1	1	1	1	
11	18P-18531-00	BAR, SHIFT FORK GUIDE 1	1	1	1	1	
12	1WG-18531-01	BAR, SHIFT FORK GUIDE 1	1	1	1	1	
13	18P-18101-00	SHIFT SHAFT ASSY	1	1	1	1	
14	90508-32136	.SPRING, TORSION	1	1	1	1	
15	90201-127E1	WASHER, PLATE	1	1	1	1	
16	93608-30002	PIN, DOWEL	1	1	1	1	
17	93102-12224	OIL SEAL	1	1	1	1	
18	3XJ-18173-10	PIN, SHIFT	1	1	1	1	
19	3XJ-18178-00	ROLLER, SHIFT LEVER	1	1	1	1	
20	18P-18122-00	LEVER, SHIFT 2	1	1	1	1	
21	3XJ-18182-00	PAWL, SHIFTER	2	2	2	2	
22	90501-052G5	SPRING, COMPRESSION	2	2	2	2	
23	3XJ-18184-00	PIN, PAWL	2	2	2	2	
24	5BE-18172-00	GUIDE, SHIFT	1	1	1	1	
25	90101-06041	BOLT	2	2	2	2	
26	18P-18110-00	SHIFT PEDAL ASSY	1	1	1	1	
27	5YT-18113-00	.COVER, SHIFT PEDAL	1	1	1	1	

FIG. 16 SHIFT CAM & FORK

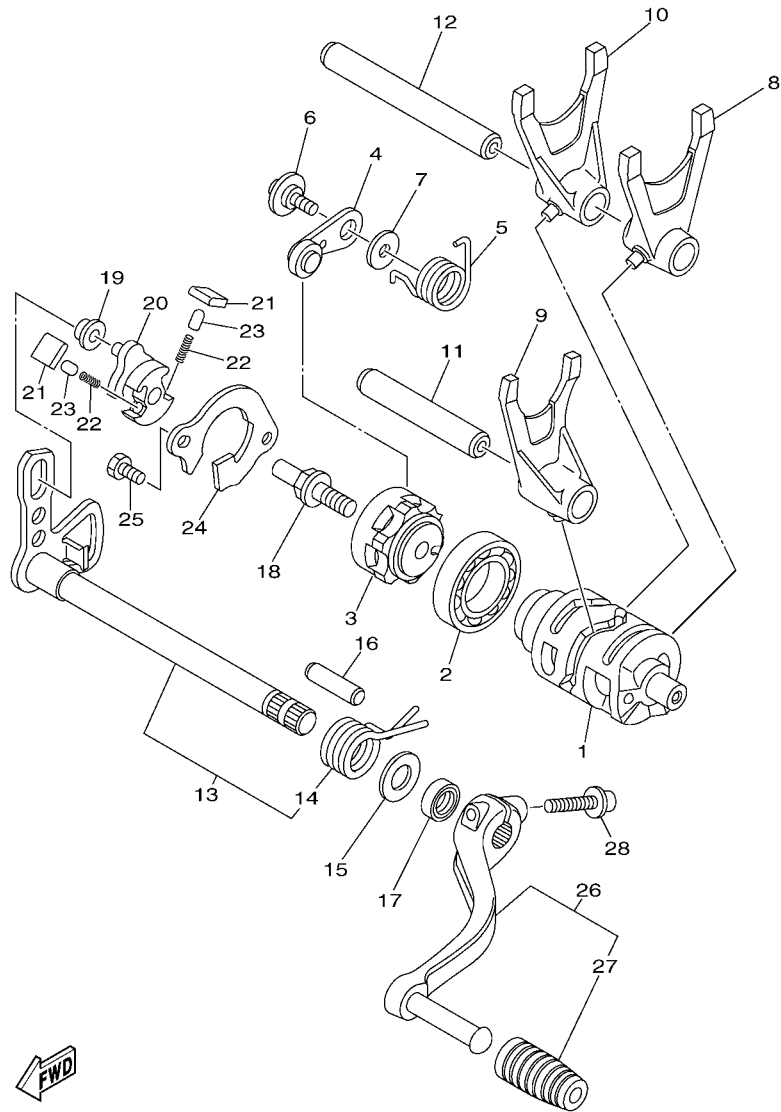

18P1100-H160

REF. NO.	PART NO.	DESCRIPTION	CAN	EUR	OCE	JPN	REMARKS
28	90109-06031	BOLT	1	1	1	1	
<hr/>							
<hr/>							
<hr/>							
<hr/>							
<hr/>							
<hr/>							
<hr/>							
<hr/>							
<hr/>							
<hr/>							
<hr/>							
<hr/>							
<hr/>							
<hr/>							
<hr/>							
<hr/>							
<hr/>							
<hr/>							
<hr/>							
<hr/>							
<hr/>							
<hr/>							
<hr/>							
<hr/>							
<hr/>							

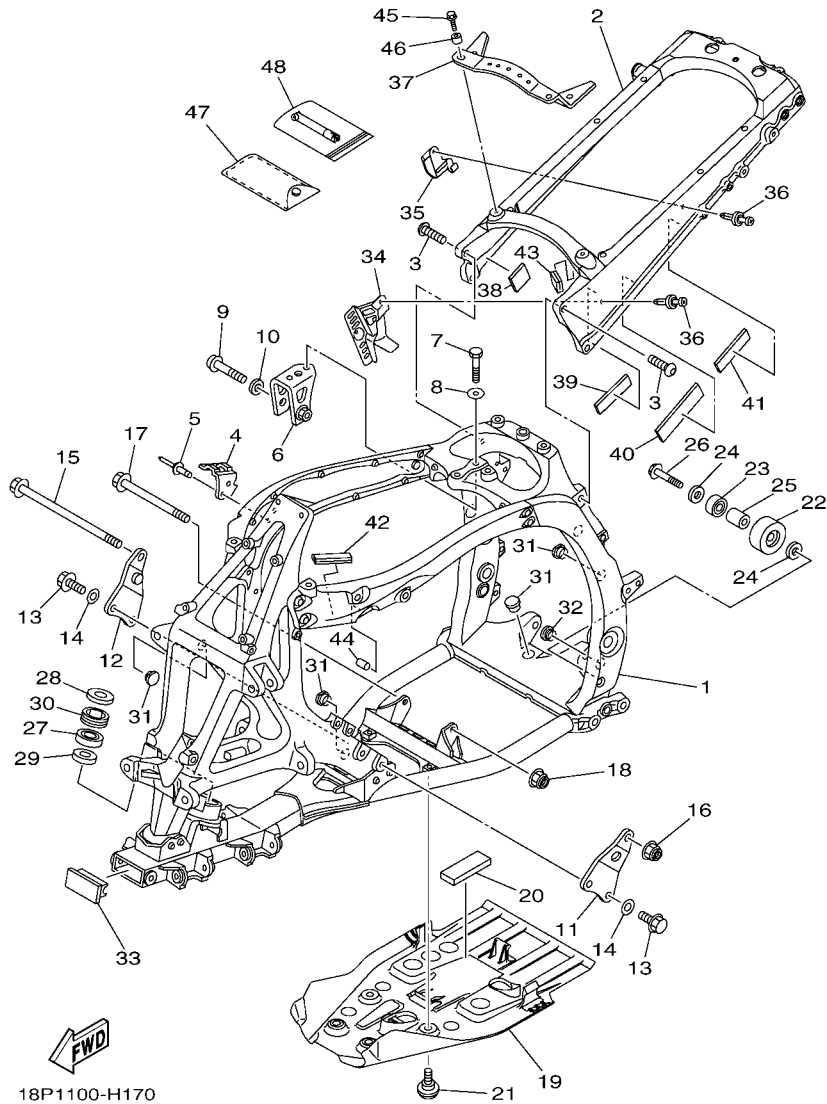

18P1100-H170

FIG. 17 FRAME

REF. NO.	PART NO.	DESCRIPTION	CAN	EUR	OC	JPN	REMARKS
1	18P-21101-09	FRONT FRAME COMP.	1	1	1	1	
2	18P-21190-09	REAR FRAME COMP.	1	1	1	1	
3	90149-10034	SCREW	4	4	4	4	
4	18P-2133H-00	BRKT., BRAKE PIPE 1	1	1	1	1	
5	90267-48176	RIVET, BLIND (4.8X17 YELLOW)	2	2	2	2	
6	18P-21315-00	STAY, ENGINE 1	1	1	1	1	
7	97012-08035	BOLT	2	2	2	2	
8	90201-08053	WASHER, PLATE	2	2	2	2	
9	90110-10029	BOLT, HEXAGON SOCKET HEAD	1	1	1	1	
10	90201-10036	WASHER, PLATE	1	1	1	1	
11	18P-21316-00	STAY, ENGINE 2	1	1	1	1	
12	18P-21317-00	STAY, ENGINE 3	1	1	1	1	
13	95812-10030	BOLT, FLANGE	4	4	4	4	
14	90201-10043	WASHER, PLATE	4	4	4	4	
15	90105-10350	BOLT, FLANGE	1	1	1	1	
16	90185-10011	NUT, SELF-LOCKING	1	1	1	1	
17	90105-10148	BOLT, FLANGE	1	1	1	1	
18	90185-10011	NUT, SELF-LOCKING	1	1	1	1	
19	18P-21471-00	PROTECTOR, ENGINE	1	1	1	1	
20	41R-21717-00	DAMPER	1	1	1	1	
21	90109-06198	BOLT	4	4	4	4	
22	5TG-22178-00	TENSIONER	1	1	1	1	
23	93300-60804	BEARING	1	1	1	1	
24	90201-08043	WASHER, PLATE	2	2	2	2	
25	90387-086N4	COLLAR	1	1	1	1	
26	90105-08112	BOLT, FLANGE	1	1	1	1	
27	93306-20352	BEARING	1	1	1	1	

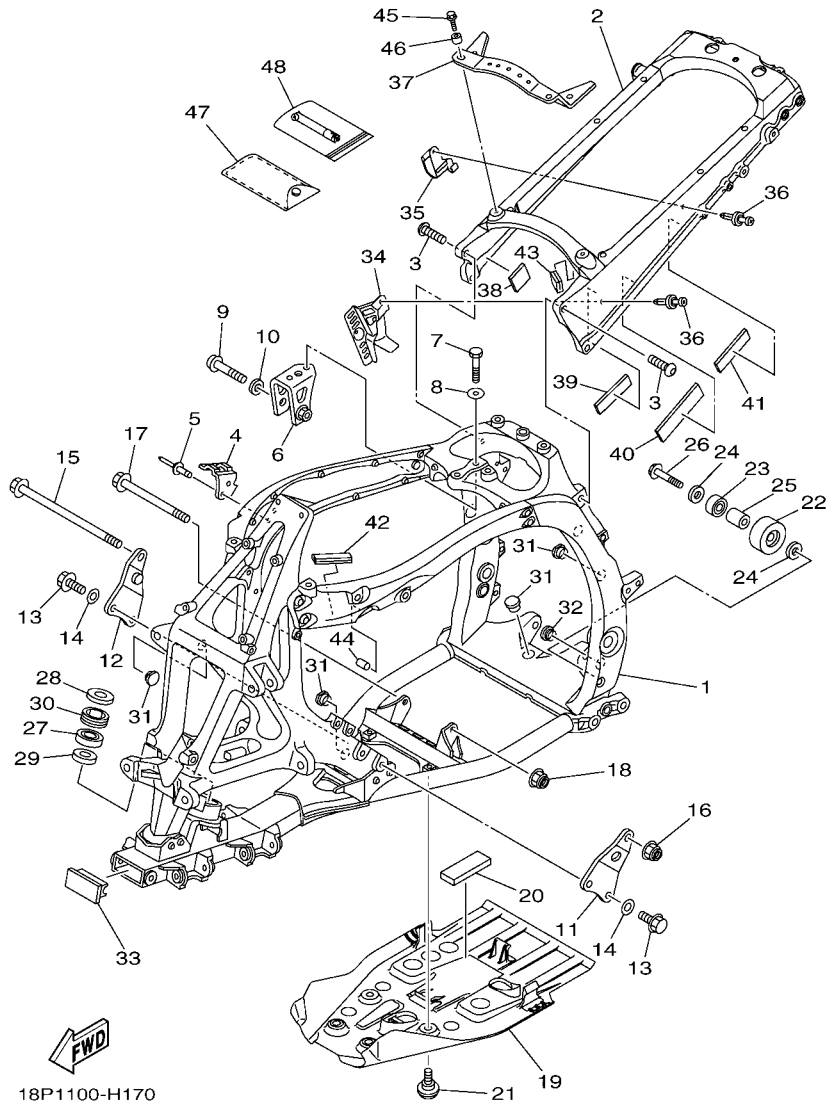
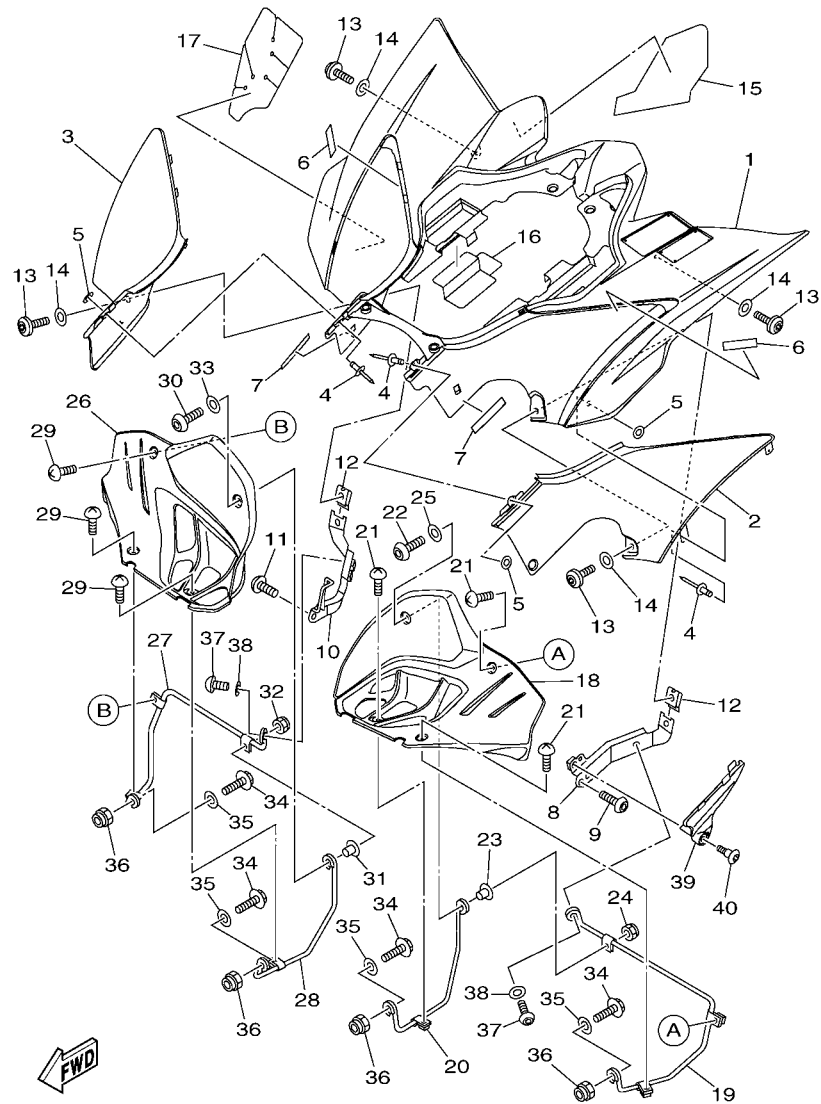

FIG. 17 FRAME

REF. NO.	PART NO.	DESCRIPTION	CAN	EUR	OCE	JPN	REMARKS
28	93102-25081	OIL SEAL	1	1	1	1	
29	93102-25099	OIL SEAL	1	1	1	1	
30	5GT-23872-00	HOLDER, BEARING	1	1	1	1	
31	90338-20183	PLUG	10	10	10	10	
32	90338-16007	PLUG	1	1	1	1	
33	18P-2111A-00	CAP, MAIN PIPE	1	1	1	1	
34	18P-21335-00	CLAMP, WIRE HARNESS 1	1	1	1	1	
35	18P-21336-00	CLAMP, WIRE HARNESS 2	1	1	1	1	
36	90269-05001	RIVET	2	2	2	2	
37	18P-21131-00	REINF., SEAT RAIL	1	1	1	1	
38	3KJ-24723-00	DAMPER, SEAT	1	1	1	1	
39	4XY-21638-00	DAMPER 1	1	1	1	1	
40	2S2-2177M-00	DAMPER, LOCATING 3	1	1	1	1	
41	1C3-2214F-00	DAMPER 1	1	1	1	1	
42	4XY-28347-00	MOLE 3	1	1	1	1	
43	3YX-2171L-00	MOLE, SIDE COVER 1	1	1	1	1	
44	90445-11418	HOSE (L18)	1	1	1	1	
45	90105-06084	BOLT, FLANGE	2	2	2	2	
46	90387-06197	COLLAR	2	2	2	2	
47	18P-28100-01	TOOL KIT	1	1	1	1	
48	1NV-2811A-01	GAUGE, AIR	1	1	1	1	



18P1100-H190

FIG. 19 REAR FENDER

REF. NO.	PART NO.	DESCRIPTION	CAN	EUR	OC	JPN	REMARKS
1	18P-W216C-00	REAR FENDER COMP.2	1				
	18P-W216B-01	REAR FENDER COMP.2		1			
	18P-W216D-00	REAR FENDER COMP			1	1	
2	18P-2476U-10	PROTECTOR,1	1	1	1	1	
3	18P-2476V-10	PROTECTOR,2	1	1	1	1	
4	90267-32004	RIVET, BLIND	6	6	6	6	
5	90201-03008	WASHER, PLATE	6	6	6	6	
6	18P-2173U-00	TAPE 2	2	2	2	2	
7	18P-2173T-00	TAPE 1	2	2	2	2	
8	18P-21643-00	STAY, FENDER 3	1	1	1	1	
9	92012-08016	BOLT, BUTTON HEAD	2	2	2	2	
10	18P-21644-00	STAY, FENDER 4	1	1	1	1	
11	92012-08016	BOLT, BUTTON HEAD	1	1	1	1	
12	90183-061A5	NUT, SPRING	2	2	2	2	
13	90111-06116	BOLT,HEX. SOCKET BUTTON	4	4	4	4	
14	90201-06085	WASHER, PLATE	4	4	4	4	
15	18P-21652-00	PROTECTOR	1	1	1	1	
16	18P-2163E-00	COVER, 2	1	1	1	1	
17	18P-2163F-00	COVER, 3	1	1	1	1	
18	18P-21621-00	FLAP	1	1	1	1	
19	18P-2164F-00	STAY 1	1	1	1	1	
20	18P-2164H-00	STAY 3	1	1	1	1	
21	90154-05043	SCREW, BINDING	3	3	3	3	
22	92012-06030	BOLT, BUTTON HEAD	1	1	1	1	
23	90387-06205	COLLAR	1	1	1	1	
24	95602-06200	NUT, SELF-LOCKING	1	1	1	1	
25	90201-06076	WASHER, PLATE	1	1	1	1	

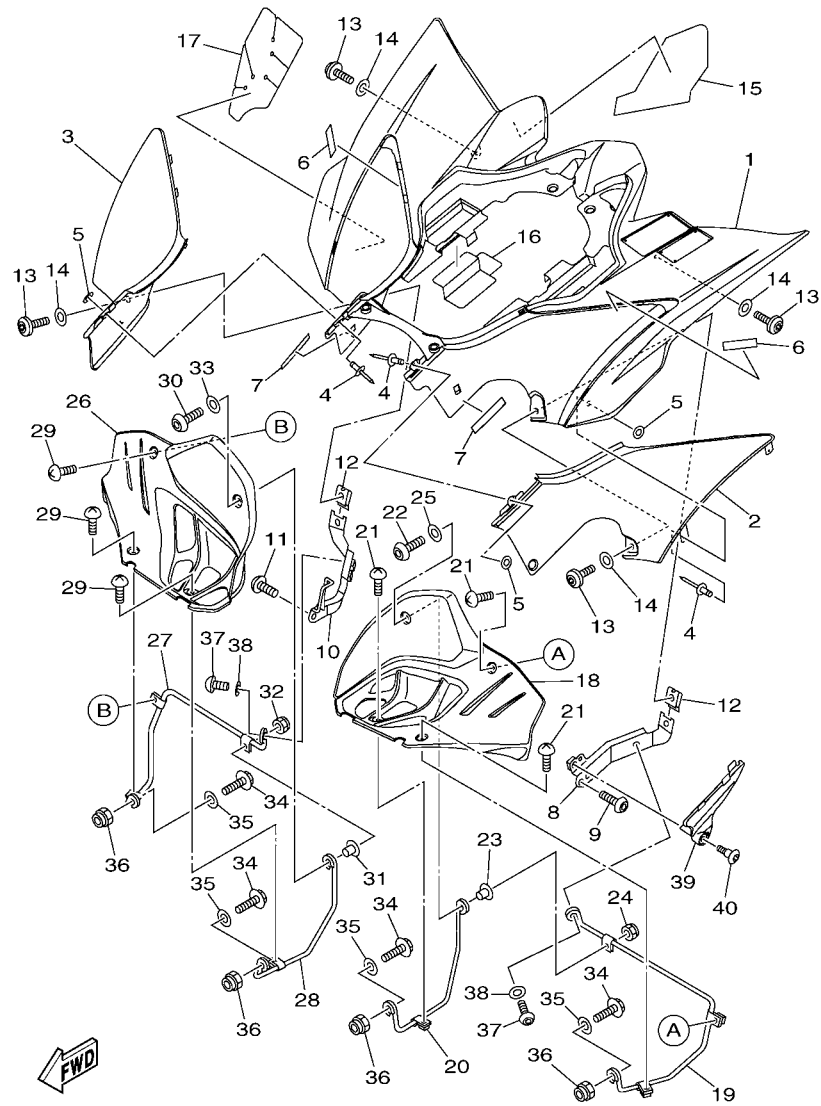
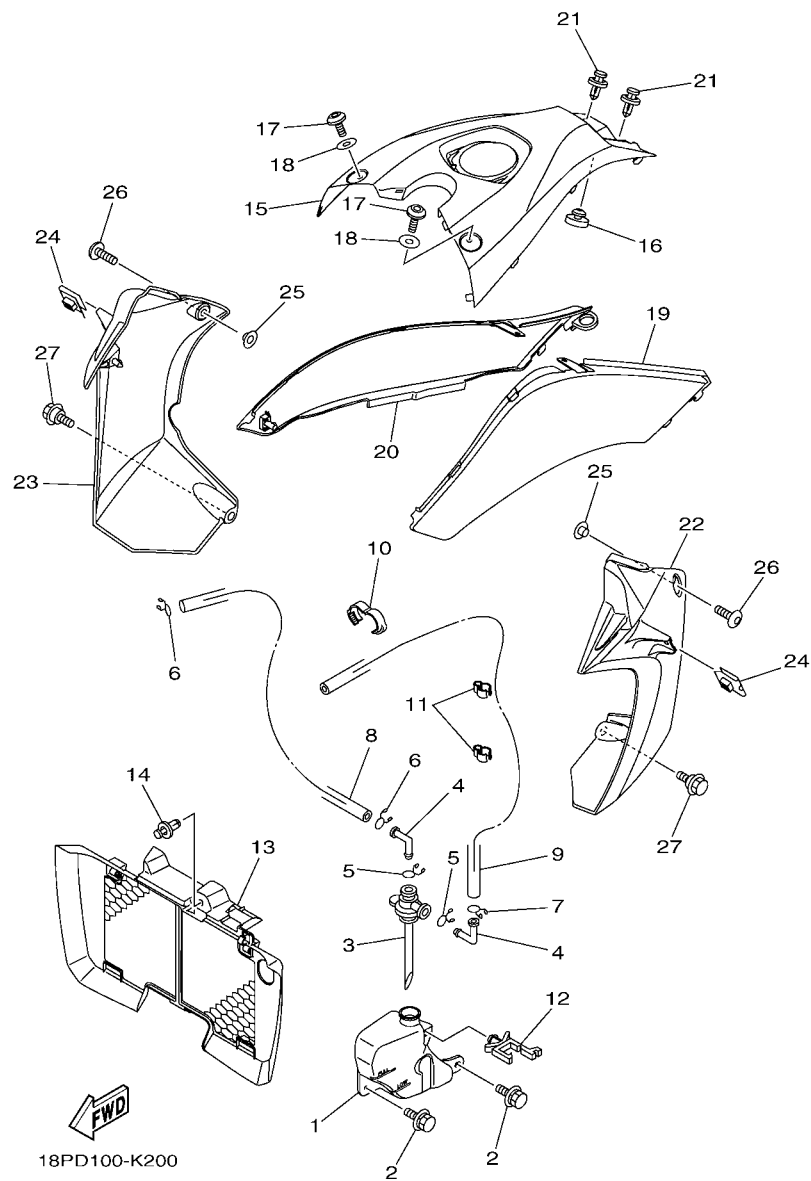

FIG. 19 REAR FENDER

REF. NO.	PART NO.	DESCRIPTION	CAN	EUR	OC	JPN	REMARKS
26	18P-21691-00	FLAP	1	1	1	1	
27	18P-2164G-00	STAY 2	1	1	1	1	
28	18P-2164J-00	STAY 4	1	1	1	1	
29	90154-05043	SCREW, BINDING	3	3	3	3	
30	92012-06030	BOLT, BUTTON HEAD	1	1	1	1	
31	90387-06205	COLLAR	1	1	1	1	
32	95602-06200	NUT, SELF-LOCKING	1	1	1	1	
33	90201-06076	WASHER, PLATE	1	1	1	1	
34	95822-08025	BOLT, FLANGE	4	4	4	4	
35	90201-08048	WASHER, PLATE	4	4	4	4	
36	95602-08200	NUT, SELF-LOCKING	4	4	4	4	
37	92012-08020	BOLT, BUTTON HEAD	2	2	2	2	
38	90201-08043	WASHER, PLATE	2	2	2	2	
39	18P-2163A-00	COVER, REAR FENDER 1	1	1	1	1	
40	90109-06249	BOLT	1	1	1	1	



18PD100-K200

FIG. 20 SIDE COVER

REF. NO.	PART NO.	DESCRIPTION	CAN	EUR	OCE	JPN	REMARKS
1	18P-21871-00	TANK, RECOVERY	1	1	1	1	
2	90119-06152	BOLT, WITH WASHER	2	2	2	2	
3	20S-21875-10	CAP	1	1	1	1	
4	26H-21828-00	ELBOW	2	2	2	2	
5	90467-11019	CLIP	2	2	2	2	
6	90467-08003	CLIP	2	2	2	2	
7	90467-08003	CLIP	1	1	1	1	
8	90445-09251	HOSE (L350)	1	1	1	1	
9	90445-09123	HOSE (L730)	1	1	1	1	
10	90464-16001	CLAMP	1	1	1	1	
11	90464-15065	CLAMP	2	2	2	2	
12	90464-15M08	CLAMP	1	1	1	1	
13	18P-12467-00	COVER, RADIATOR	1	1	1	1	
14	90269-07076	RIVET	1	1	1	1	
15	18P-2171A-00	COVER, TOP	1	1	1	1	
16	22W-24741-00	PAD, SEAT	1	1	1	1	
17	90111-06116	BOLT,HEX. SOCKET BUTTON	2	2	2	2	
18	90201-06085	WASHER, PLATE	2	2	2	2	
19	18P-21711-20	COVER, SIDE 1	1	1	1	1	
20	18P-21721-20	COVER, SIDE 2	1	1	1	1	
21	90269-07010	RIVET	2	2	2	2	
22	18P-21731-10	COVER, SIDE 3	1	1	1	1	
23	18P-21741-10	COVER, SIDE 4	1	1	1	1	
24	90183-061A5	NUT, SPRING	2	2	2	2	
25	90387-06170	COLLAR	2	2	2	2	
26	90111-06084	BOLT,HEX. SOCKET BUTTON	2	2	2	2	
27	90109-06172	BOLT	2	2	2	2	

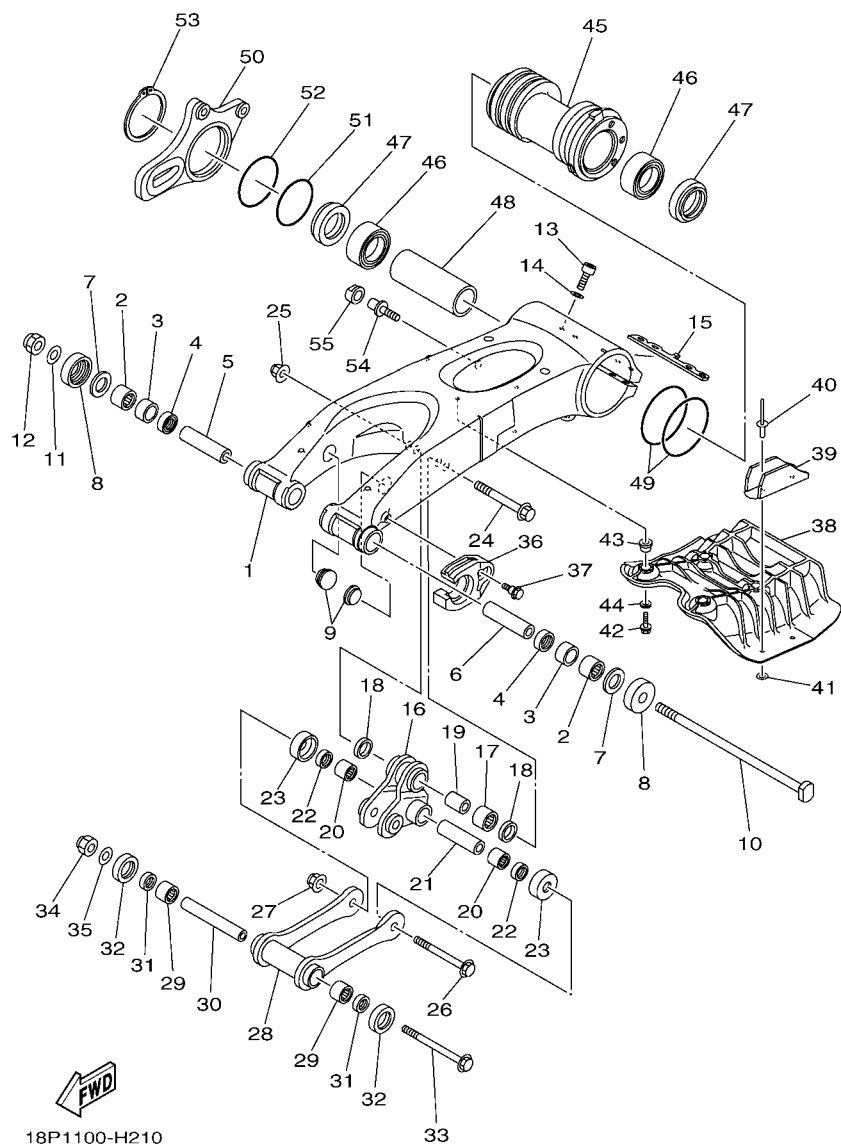

FIG. 21 REAR ARM

REF. NO.	PART NO.	DESCRIPTION	CAN	EUR	OCE	JPN	REMARKS
1	18P-22110-00	REAR ARM COMP.	1	1	1	1	
2	93317-22237	BEARING	2	2	2	2	
3	90380-22111	BUSH, SOLID	2	2	2	2	
4	93106-22019	OIL SEAL (DC 22-28-8)	2	2	2	2	
5	90387-16027	COLLAR	1	1	1	1	
6	90387-160W1	COLLAR	1	1	1	1	
7	3YF-22149-00	WASHER	2	2	2	2	
8	4X7-22129-00	COVER, THRUST 2	2	2	2	2	
9	90338-23004	PLUG	2	2	2	2	
10	18P-22141-00	SHAFT, PIVOT	1	1	1	1	
11	90201-16018	WASHER, PLATE	1	1	1	1	
12	90185-16002	NUT, SELF-LOCKING	1	1	1	1	
13	91314-08040	BOLT, HEXAGON SOCKET HEAD	4	4	4	4	
14	92903-08600	WASHER, PLATE	4	4	4	4	
15	5TG-22475-00	SEAL, DUST	1	1	1	1	
16	18P-2217A-00	ARM, RELAY 1	1	1	1	1	
17	93315-32056	BEARING	1	1	1	1	
18	93109-20001	OIL SEAL	2	2	2	2	
19	90387-12043	COLLAR	1	1	1	1	
20	93315-31758	BEARING	2	2	2	2	
21	90387-12041	COLLAR	1	1	1	1	
22	93109-17071	OIL SEAL	2	2	2	2	
23	55K-22129-00	COVER, THRUST 2	2	2	2	2	
24	90105-12064	BOLT, FLANGE	1	1	1	1	
25	90185-12002	NUT, SELF-LOCKING	1	1	1	1	
26	90105-12065	BOLT, FLANGE	1	1	1	1	
27	90185-12002	NUT, SELF-LOCKING	1	1	1	1	

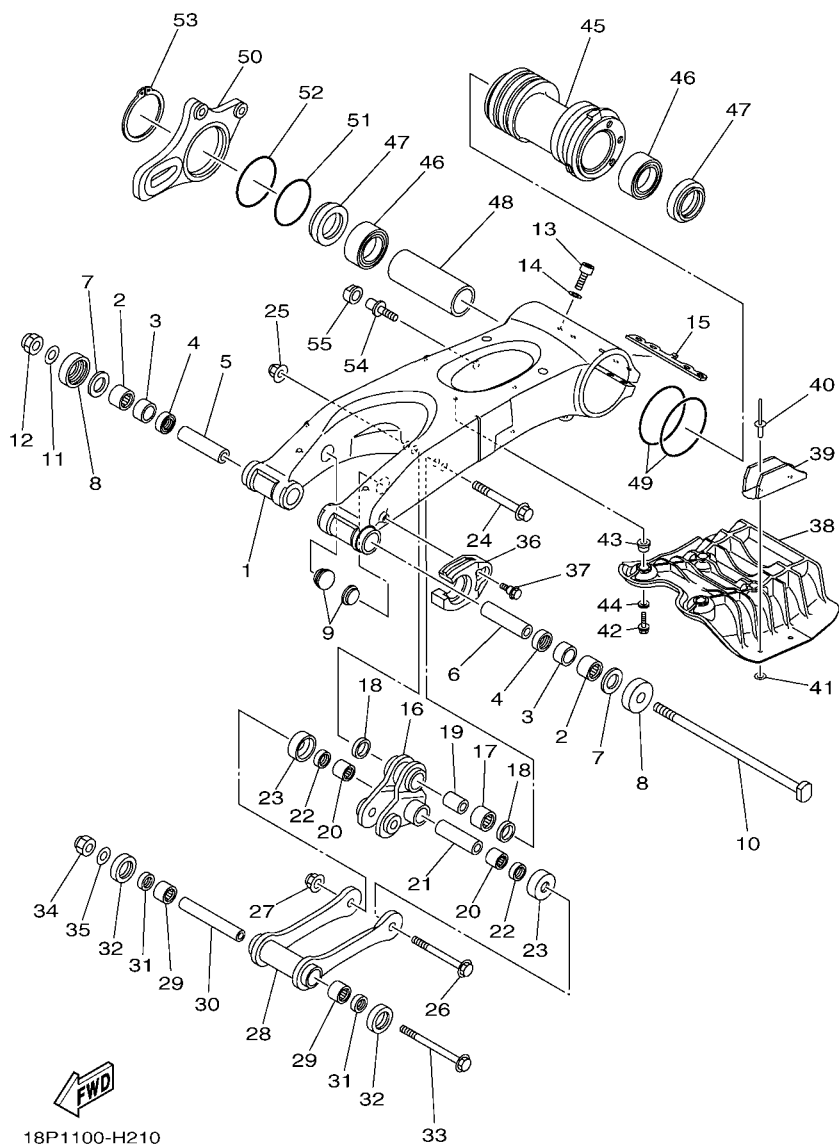

FIG. 21 REAR ARM

REF. NO.	PART NO.	DESCRIPTION	CAN	EUR	OCE	JPN	REMARKS
28	18P-2217F-00	ROD, CONNECTING 1	1	1	1	1	
29	93315-31758	BEARING	2	2	2	2	
30	90387-12042	COLLAR	1	1	1	1	
31	93109-17071	OIL SEAL	2	2	2	2	
32	55K-22129-00	COVER, THRUST 2	2	2	2	2	
33	90105-12066	BOLT, FLANGE	1	1	1	1	
34	90185-12007	NUT, SELF-LOCKING	1	1	1	1	
35	90201-12032	WASHER, PLATE	1	1	1	1	
36	18P-22151-10	SEAL, GUARD	1	1	1	1	
37	90109-06172	BOLT	1	1	1	1	
38	18P-22361-00	GUARD 1	1	1	1	1	
39	5TG-22153-10	GUARD, CHAIN	1	1	1	1	
40	90267-47187	RIVET, BLIND (4.7X16.4 BLACK)	2	2	2	2	
41	90201-04027	WASHER, PLATE	2	2	2	2	
42	95812-06025	BOLT, FLANGE	4	4	4	4	
43	90387-06151	COLLAR	4	4	4	4	
44	90201-06033	WASHER, PLATE	4	4	4	4	
45	5TG-25311-20	HUB, REAR	1	1	1	1	
46	93304-20812	BEARING	2	2	2	2	
47	93106-48001	OIL SEAL	2	2	2	2	
48	5TG-25317-00	SPACER, BEARING	1	1	1	1	
49	1S3-23147-01	O-RING	2	2	2	2	
50	5TG-25721-20	BRACKET, CALIPER	1	1	1	1	
51	93210-71001	O-RING	1	1	1	1	
52	93210-66001	O-RING	1	1	1	1	
53	93410-67085	CIRCLIP	1	1	1	1	
54	90110-12001	BOLT, HEXAGON SOCKET HEAD	1	1	1	1	

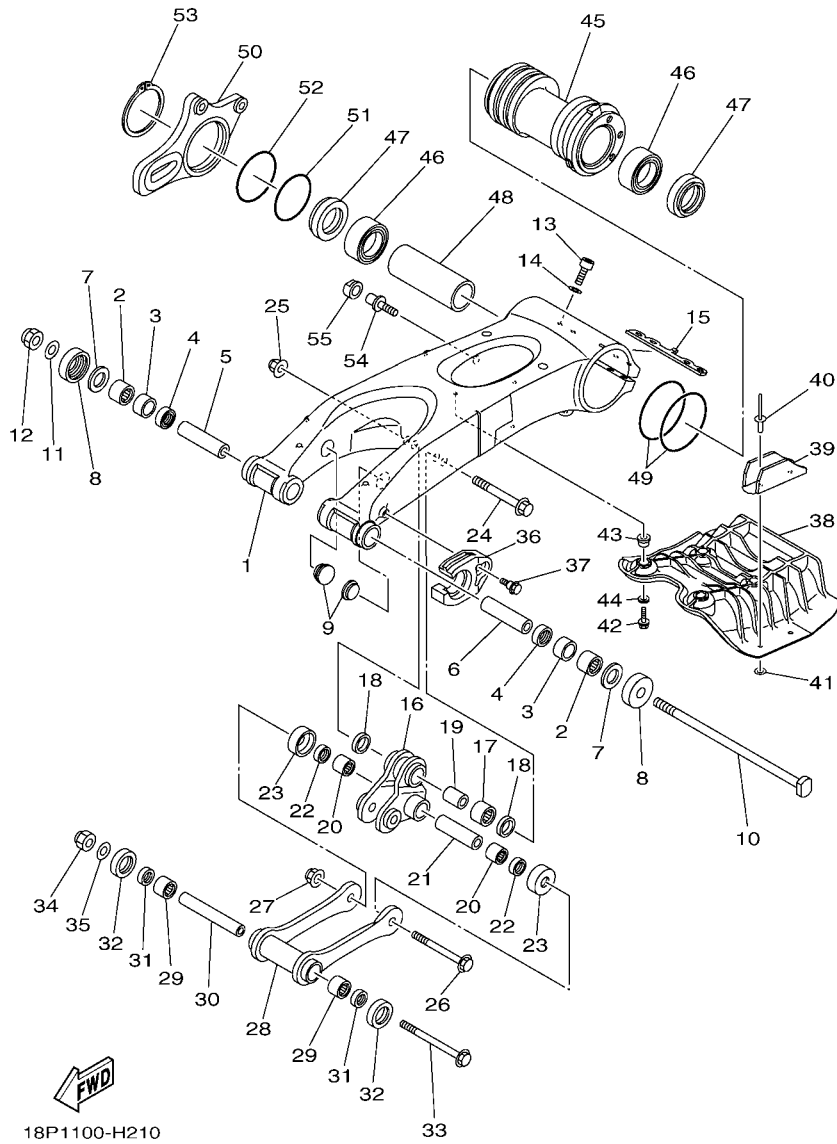
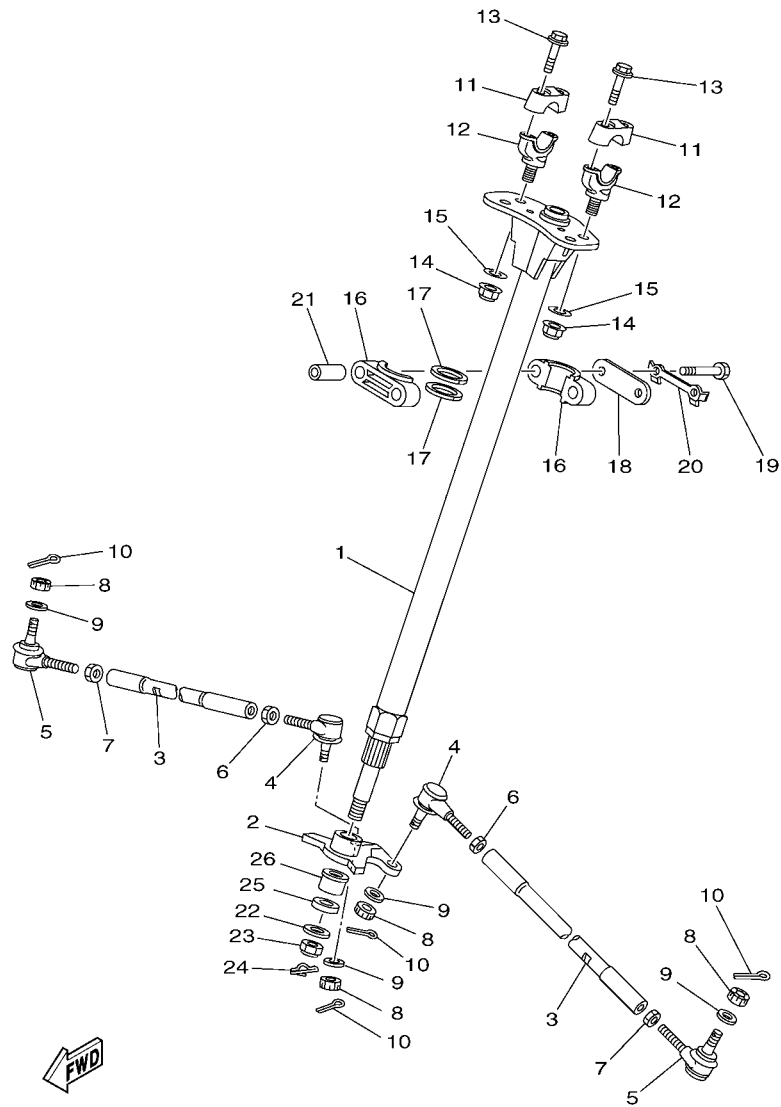

FIG. 21 REAR ARM

REF. NO.	PART NO.	DESCRIPTION	CAN	EUR	OCE	JPN	REMARKS
55	90387-16014	COLLAR	1	1	1	1	



18P1100-H230

FIG. 23 STEERING

REF. NO.	PART NO.	DESCRIPTION	CAN	EUR	OCF	JPN	REMARKS
1	18P-23813-00	COLUMN, STEERING 2	1	1	1	1	
2	18P-23816-00	ARM, PITMAN	1	1	1	1	
3	18P-23831-00	ROD, TIE	2	2	2	2	
4	1S3-23841-20	JOINT, UNIVERSAL 1	2	2	2	2	
5	1S3-23845-20	JOINT, UNIVERSAL 2	2	2	2	2	
6	90170-12055	NUT	2	2	2	2	
7	90170-12054	NUT	2	2	2	2	(RH. THREAD)
8	90171-10001	NUT, CASTLE	4	4	4	4	
9	90209-10229	WASHER	4	4	4	4	
10	91402-20020	PIN, COTTER	4	4	4	4	
11	18P-23441-00	HOLDER, HANDLE UPPER	2	2	2	2	
12	18P-23442-10	HOLDER, HANDLE UNDER	2	2	2	2	
13	90105-08154	BOLT, FLANGE	4	4	4	4	
14	90185-12002	NUT, SELF-LOCKING	2	2	2	2	
15	90201-12034	WASHER, PLATE	2	2	2	2	
16	1UY-23812-00	PLANE BEARING, STEERING	2	2	2	2	
17	93112-31011	OIL SEAL	2	2	2	2	
18	1UY-23868-01	BRACKET, STEERING LOWER	1	1	1	1	
19	97022-08065	BOLT	2	2	2	2	
20	1UY-23894-01	WASHER, LOCK 1	1	1	1	1	
21	90387-090R0	COLLAR	2	2	2	2	
22	90201-14021	WASHER, PLATE	1	1	1	1	
23	90185-14009	NUT, SELF-LOCKING	1	1	1	1	
24	91402-20025	PIN, COTTER	1	1	1	1	
25	90387-176R6	COLLAR	1	1	1	1	
26	90387-17013	COLLAR	1	1	1	1	

FIG. 24 FRONT SUSPENSION & WHEEL

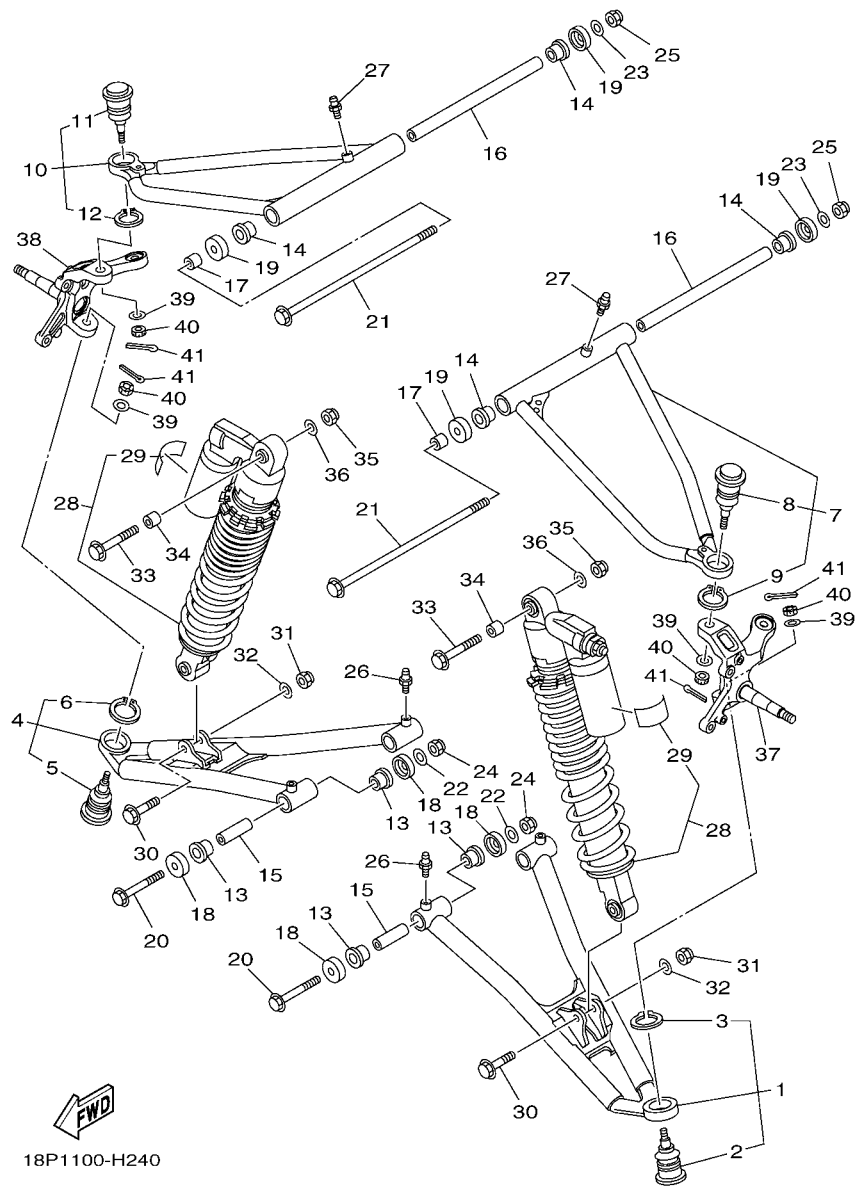

18P1100-H240

REF. NO.	PART NO.	DESCRIPTION	CAN	EUR	OCE	JPN	REMARKS
1	18P-23570-00-33	FRONT LOWER ARM COMP. (LEFT)	1	1	1	1	YB
2	5LP-23579-00	.BALL JOINT 2	1	1	1	1	
3	99009-30400	.CIRCLIP	1	1	1	1	
4	18P-23580-00-33	FRONT LOWER ARM COMP. (RIGHT)	1	1	1	1	YB
5	5LP-23579-00	.BALL JOINT 2	1	1	1	1	
6	99009-30400	.CIRCLIP	1	1	1	1	
7	18P-23540-00-33	FRONT UPPER ARM COMP. (LEFT)	1	1	1	1	YB
8	5LP-23579-00	.BALL JOINT 2	1	1	1	1	
9	99009-30400	.CIRCLIP	1	1	1	1	
10	18P-23550-00-33	FRONT UPPER ARM COMP. (RIGHT)	1	1	1	1	YB
11	5LP-23579-00	.BALL JOINT 2	1	1	1	1	
12	99009-30400	.CIRCLIP	1	1	1	1	
13	90381-15088	BUSH, SOLID	8	8	8	8	
14	90381-15088	BUSH, SOLID	4	4	4	4	
15	90387-101R3	COLLAR	4	4	4	4	
16	90387-10069	COLLAR	2	2	2	2	
17	90387-10043	COLLAR	2	2	2	2	
18	5YT-23517-00	COVER, THRUST 1	8	8	8	8	
19	5YT-23517-00	COVER, THRUST 1	4	4	4	4	
20	90105-10135	BOLT, FLANGE	4	4	4	4	
21	90105-10301	BOLT, FLANGE	2	2	2	2	
22	90201-10037	WASHER, PLATE	4	4	4	4	
23	90201-10037	WASHER, PLATE	2	2	2	2	
24	90185-10012	NUT, SELF-LOCKING	4	4	4	4	
25	90185-10012	NUT, SELF-LOCKING	2	2	2	2	
26	93700-06004	NIPPLE, GREASE	4	4	4	4	
27	93700-06004	NIPPLE, GREASE	2	2	2	2	

FIG. 24 FRONT SUSPENSION & WHEEL

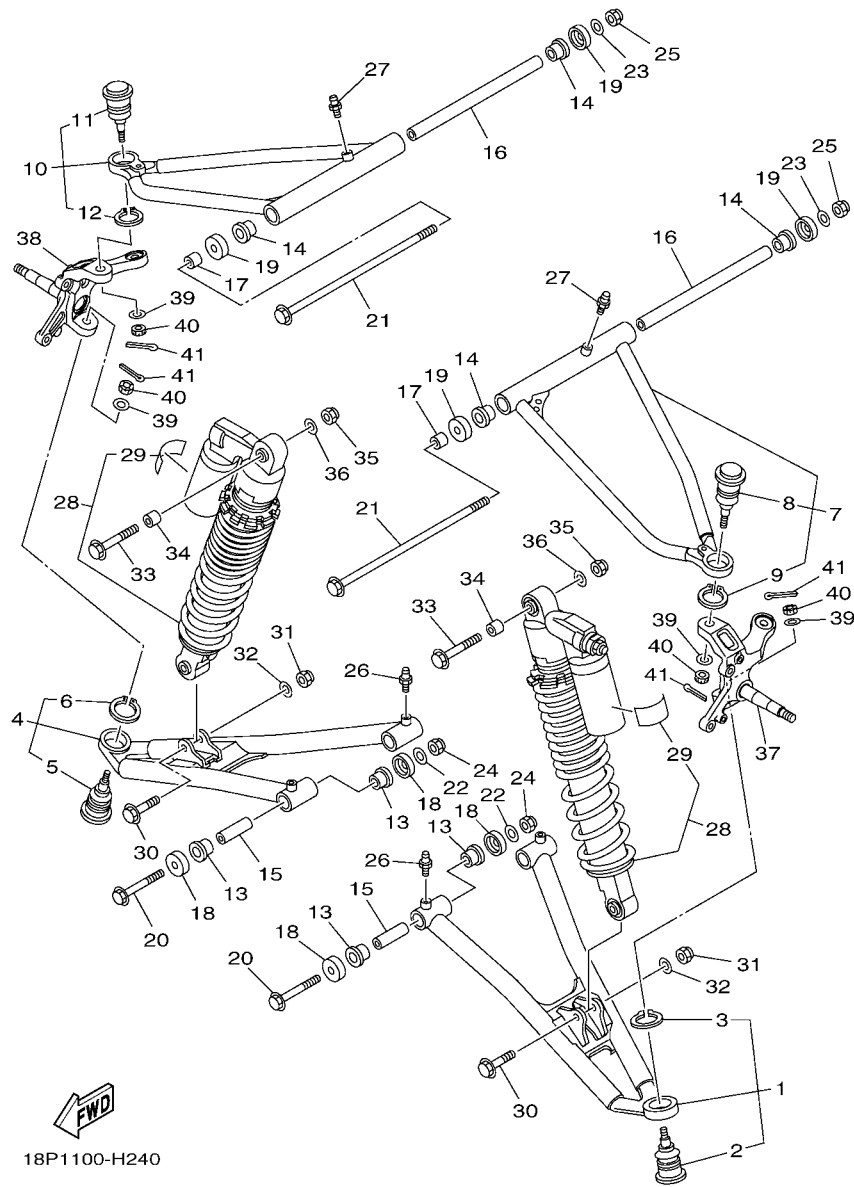

18P1100-H240

REF. NO.	PART NO.	DESCRIPTION	CAN	EUR	OC	JPN	REMARKS
28	18P-23350-F0	SHOCK ABSORBER ASSY	2				
	18P-23350-G0	SHOCK ABSORBER ASSY		2	2		
	18P-23350-H0	SHOCK ABSORBER ASSY				2	
29	4AA-22259-70	.LABEL, WARNING	1				
	4AA-22259-40	.LABEL, WARNING		1	1		
	4AA-22259-50	.LABEL, WARNING				1	
30	90105-10339	BOLT, FLANGE	2	2	2	2	
31	90185-10012	NUT, SELF-LOCKING	2	2	2	2	
32	90201-10035	WASHER, PLATE	2	2	2	2	
33	90105-10351	BOLT, FLANGE	2	2	2	2	
34	90387-10043	COLLAR	2	2	2	2	
35	90185-10012	NUT, SELF-LOCKING	2	2	2	2	
36	90201-10037	WASHER, PLATE	2	2	2	2	
37	18P-23501-00	STEERING KNUCKLE ASSY (LEFT)	1	1	1	1	
38	18P-23502-00	STEERING KNUCKLE ASSY (RIGHT)	1	1	1	1	
39	90209-10229	WASHER	4	4	4	4	
40	90171-10001	NUT, CASTLE	4	4	4	4	
41	91402-20020	PIN, COTTER	4	4	4	4	

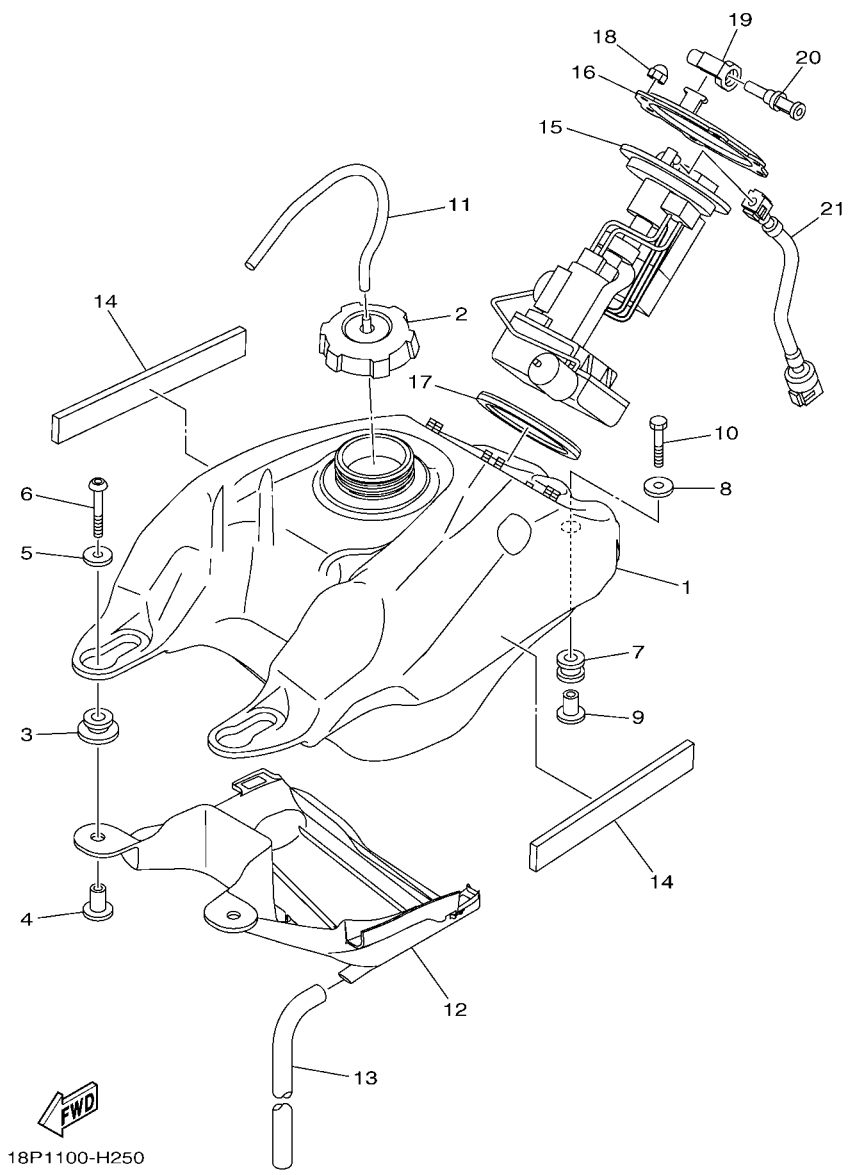

18P1100-H250

FIG. 25 FUEL TANK

REF. NO.	PART NO.	DESCRIPTION	CAN	EUR	OC	JPN	REMARKS
1	18P-24110-00	FUEL TANK COMP.	1				
	18P-24110-10	FUEL TANK COMP.		1	1	1	
2	5KM-24610-00	CAP ASSY	1	1	1	1	
3	90480-18004	GROMMET	2	2	2	2	
4	90387-06258	COLLAR	2	2	2	2	
5	90201-06033	WASHER, PLATE	2	2	2	2	
6	92012-06040	BOLT, BUTTON HEAD	2	2	2	2	
7	90480-18290	GROMMET	1	1	1	1	
8	90201-06033	WASHER, PLATE	1	1	1	1	
9	90387-06257	COLLAR	1	1	1	1	
10	95812-06030	BOLT, FLANGE	1	1	1	1	
11	90445-08008	HOSE	1	1	1	1	
12	18P-2414H-00	DAMPER, PLATE 1	1	1	1	1	
13	18P-2247A-00	HOSE 1	1	1	1	1	
14	90520-08001	DAMPER, PLATE	2	2	2	2	
15	18P-13907-00	FUEL PUMP COMP.	1	1	1	1	
16	18P-24491-00	BRACKET, FUEL PUMP	1	1	1	1	
17	1S3-24486-00	O-RING	1	1	1	1	
18	95302-06800	NUT, CROWN	6	6	6	6	
19	18P-2464V-00	CASE, CAP	1	1	1	1	
20	18P-2467E-00	CAP	1	1	1	1	
21	18P-13971-00	PIPE, FUEL 1	1	1	1	1	

FIG. 26 SEAT

REF. NO.	PART NO.	DESCRIPTION	CAN	EUR	OCE	JPN	REMARKS
1	18P-24710-00	SINGLE SEAT ASSY	1	1	1	1	
2	18P-2470F-00	.SEAT COVER COMP.	1	1	1	1	
3	371-27114-00	.STOPPER, MAIN STAND	2	2	2	2	
4	214-24724-00	.DAMPER, SEAT	2	2	2	2	
5	22W-24741-00	.PAD, SEAT	5	5	5	5	
6	18P-24725-00	.SPACER 1	1	1	1	1	
7	18P-24723-00	.DAMPER, SEAT	2	2	2	2	

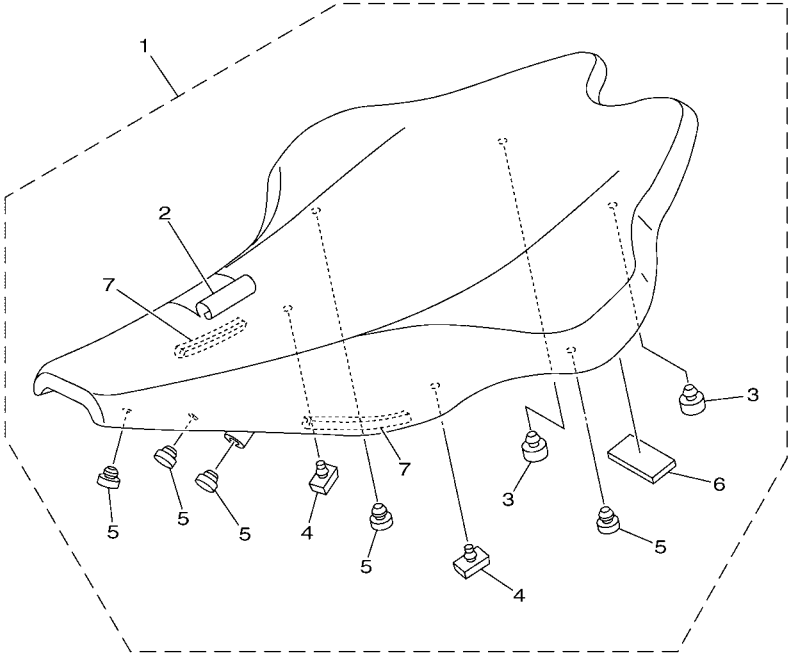

18P1100-H260

FIG. 27 FRONT WHEEL

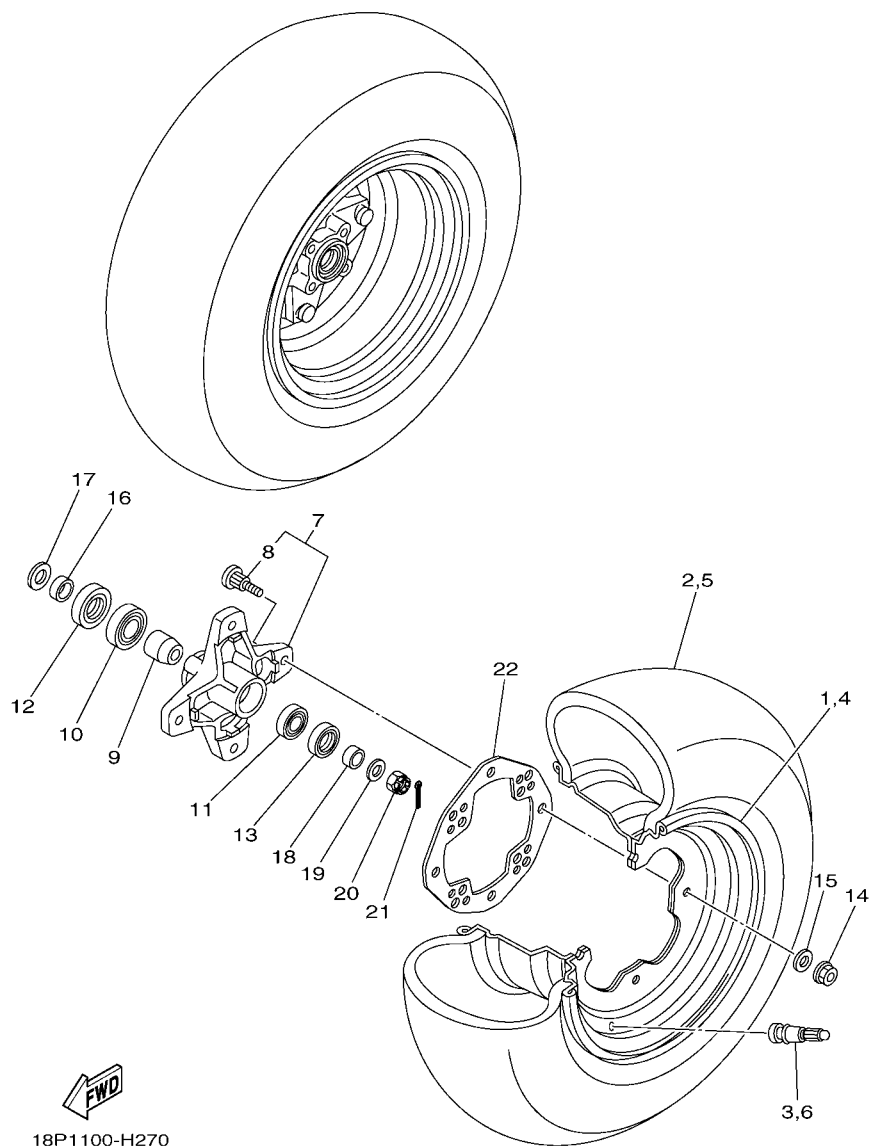

18P1100-H270

REF. NO.	PART NO.	DESCRIPTION	CAN	EUR	OCE	JPN	REMARKS
1	1S3-25180-00	WHEEL COMP.	1	1	1	1	
2	94107-10025	TIRE (AT21X7R10 KT351 T/L(N))	1	1	1	1	DUNLOP
3	93900-00030	VALVE, RIM (TR412)	1	1	1	1	TAIHEIYO
4	1S3-25180-00	WHEEL COMP.	1	1	1	1	
5	94107-10025	TIRE (AT21X7R10 KT351 T/L(N))	1	1	1	1	DUNLOP
6	93900-00030	VALVE, RIM (TR412)	1	1	1	1	TAIHEIYO
7	1S3-25111-00	HUB, FRONT	2	2	2	2	
8	90114-10006	.BOLT, SERRATION	4	4	4	4	
9	5LP-25117-00	SPACER, BEARING	2	2	2	2	
10	93306-00446	BEARING	2	2	2	2	
11	93306-20231	BEARING	2	2	2	2	
12	93105-26026	OIL SEAL	2	2	2	2	
13	93102-22216	OIL SEAL	2	2	2	2	
14	95702-10500	NUT, FLANGE	8	8	8	8	
15	92902-10200	WASHER	8	8	8	8	
16	90387-20005	COLLAR	2	2	2	2	
17	90201-20022	WASHER, PLATE	2	2	2	2	
18	90387-150R1	COLLAR	2	2	2	2	
19	90201-14586	WASHER, PLATE	2	2	2	2	
20	90171-14002	NUT, CASTLE	2	2	2	2	
21	91402-30025	PIN, COTTER	2	2	2	2	
22	1S3-25127-01	COVER, PLATE	2	2	2	2	

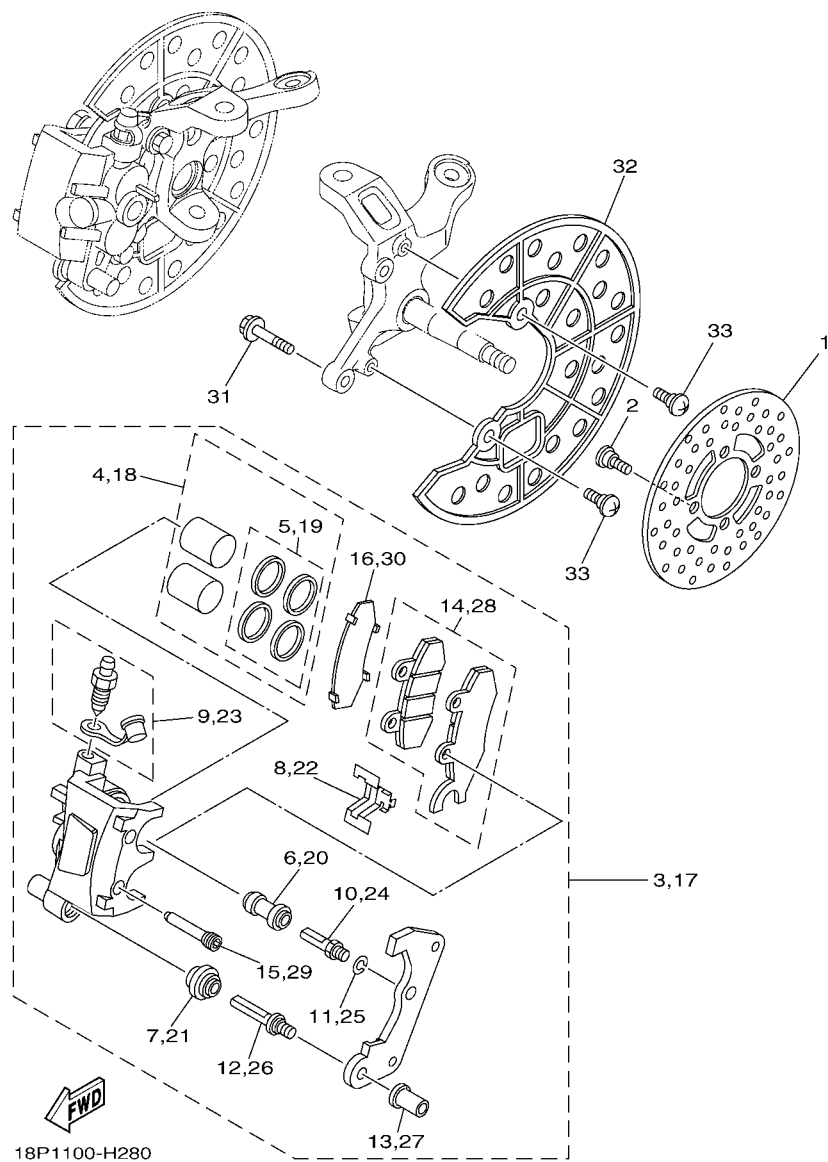

FIG. 28 FRONT BRAKE CALIPER

REF. NO.	PART NO.	DESCRIPTION	CAN	EUR	OC	JPN	REMARKS
1	3GD-2582T-10	DISC, BRAKE (LEFT)	2	2	2	2	
2	90109-08082	BOLT	8	8	8	8	
3	5TG-2580T-11	CALIPER ASSY (LEFT)	1	1	1	1	
4	5TG-W0057-00	.PISTON ASSY, CALIPER	1	1	1	1	
5	3LC-W0047-50	..CALIPER SEAL KIT	1	1	1	1	
6	1UY-25937-51	.BOOT 2	1	1	1	1	
7	3JD-25917-00	.BOOT, CALIPER	1	1	1	1	
8	3JD-25919-00	.SUPPORT, PAD	1	1	1	1	
9	1UY-W0048-50	.BLEED SCREW KIT	1	1	1	1	
10	1UY-25926-51	.BOLT	1	1	1	1	
11	1UY-25938-51	.WASHER, SPRING	1	1	1	1	
12	3JD-25926-00	.BOLT	1	1	1	1	
13	3JD-25961-00	.NUT	1	1	1	1	
14	5TG-W0045-20	.BRAKE PAD KIT	1	1	1	1	
15	5TG-25924-00	.PIN, PAD	2	2	2	2	
16	1S3-25828-00	.SHIM, CALIPER	1	1	1	1	
17	5TG-2580U-11	CALIPER ASSY (RIGHT)	1	1	1	1	
18	5TG-W0057-00	.PISTON ASSY, CALIPER	1	1	1	1	
19	3LC-W0047-50	..CALIPER SEAL KIT	1	1	1	1	
20	1UY-25937-51	.BOOT 2	1	1	1	1	
21	3JD-25917-00	.BOOT, CALIPER	1	1	1	1	
22	3JD-25919-00	.SUPPORT, PAD	1	1	1	1	
23	1UY-W0048-50	.BLEED SCREW KIT	1	1	1	1	
24	1UY-25926-51	.BOLT	1	1	1	1	
25	1UY-25938-51	.WASHER, SPRING	1	1	1	1	
26	3JD-25926-00	.BOLT	1	1	1	1	
27	3JD-25961-00	.NUT	1	1	1	1	

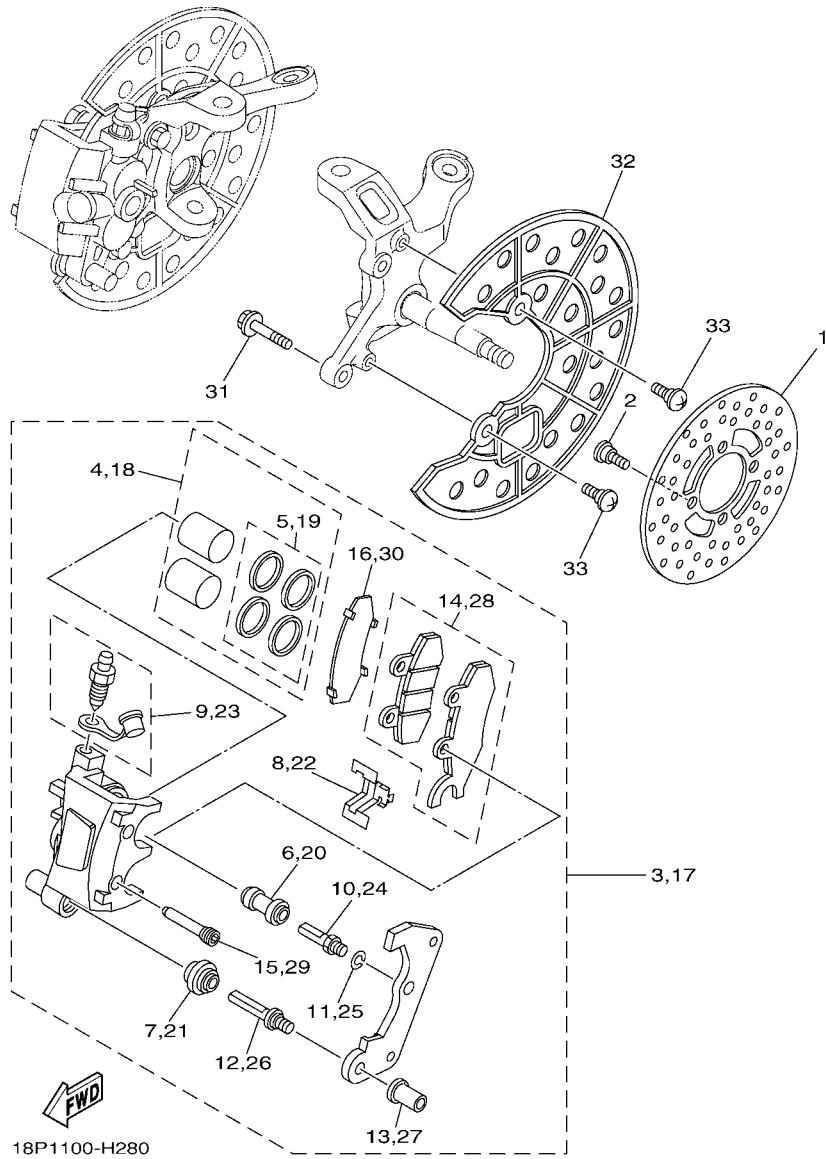
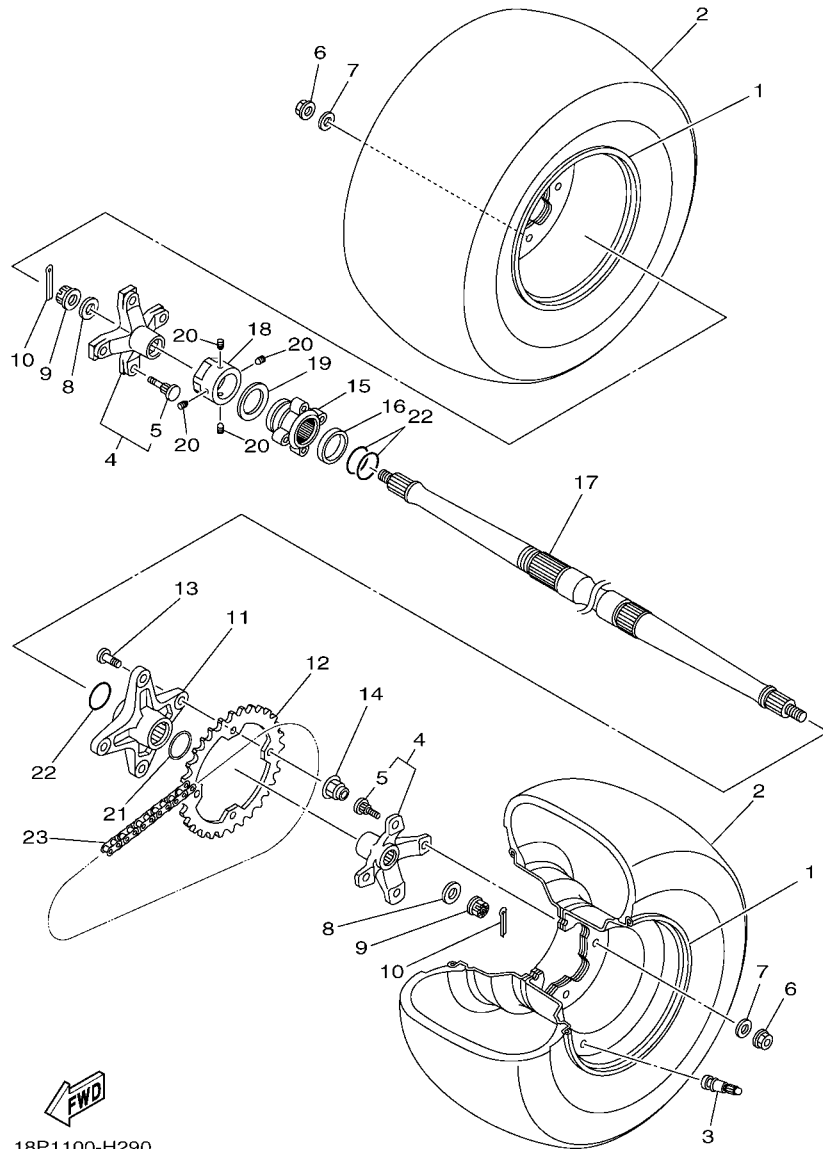

FIG. 28 FRONT BRAKE CALIPER

REF. NO.	PART NO.	DESCRIPTION	CAN	EUR	OCE	JPN	REMARKS
28	5TG-W0045-30	.BRAKE PAD KIT	1	1	1	1	
29	5TG-25924-00	.PIN, PAD	2	2	2	2	
30	1S3-25828-00	.SHIM, CALIPER	1	1	1	1	
31	90105-08184	BOLT, FLANGE	4	4	4	4	
32	5TG-2514A-00	RING, WHEEL 1	2	2	2	2	
33	90149-06117	SCREW	4	4	4	4	



18P1100-H290

FIG. 29 REAR WHEEL

REF. NO.	PART NO.	DESCRIPTION	CAN	EUR	OCE	JPN	REMARKS
1	1S3-25390-00	REAR WHEEL COMP.	2	2	2	2	
2	94110-09025	TIRE (AT20X10R9 KT356 TL(N))	2	2	2	2	DUNLOP
3	93900-00022	VALVE, RIM (TR413)	2	2	2	2	TAIHEIYO
4	18P-25383-00	COLLAR, WHEEL	2	2	2	2	
5	90114-10013	.BOLT, SERRATION	4	4	4	4	
6	95702-10500	NUT, FLANGE	8	8	8	8	
7	92902-10200	WASHER	8	8	8	8	
8	90201-16023	WASHER, PLATE	2	2	2	2	
9	90171-16002	NUT, CASTLE	2	2	2	2	
10	90252-03001	PIN, COTTER	2	2	2	2	
11	18P-25386-00	COLLAR, SPROCKET AXLE	1	1	1	1	
12	5TG-25438-10	SPROCKET, DRIVEN (38T)	1	1	1	1	
13	90109-10013	BOLT	4	4	4	4	
14	90185-10011	NUT, SELF-LOCKING	4	4	4	4	
15	18P-25712-00	BRACKET, DISC	1	1	1	1	
16	90387-40001	COLLAR	1	1	1	1	
17	18P-25381-00	AXLE, WHEEL	1	1	1	1	
18	90179-38001	NUT	1	1	1	1	
19	90208-39001	WASHER, CONICAL SPRING	1	1	1	1	
20	90113-06055	BOLT, SET	4	4	4	4	
21	18P-25415-00	CIRCLIP	1	1	1	1	
22	93210-37003	O-RING	3	3	3	3	
23	94582-13098	CHAIN (DID520MXV 98LE)	1	1	1	1	

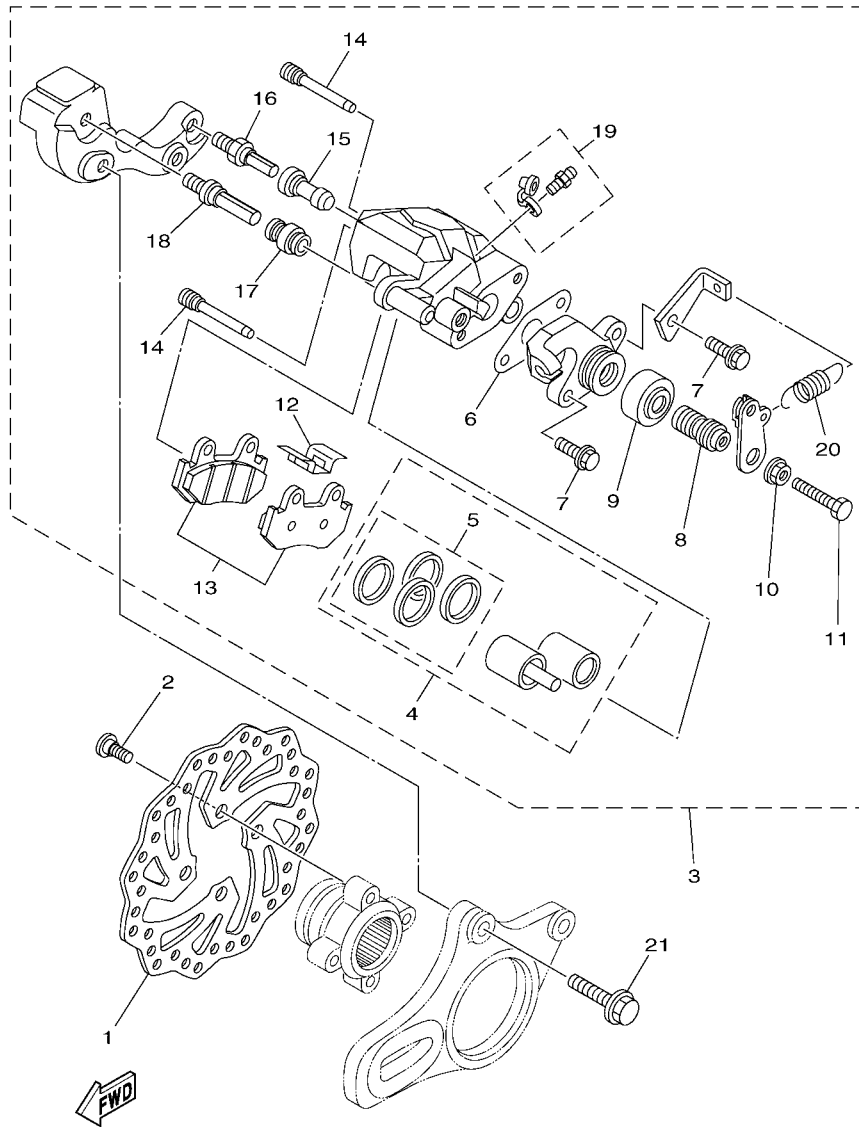

18P1100-H300

FIG. 30 REAR BRAKE CALIPER

REF. NO.	PART NO.	DESCRIPTION	CAN	EUR	OC	JPN	REMARKS
1	1S3-2582W-20	DISK, REAR BRAKE 2	1	1	1	1	
2	90149-08044	SCREW	4	4	4	4	
3	5TG-2580W-20	CALIPER ASSY, REAR 2	1	1	1	1	
4	5TG-W0057-10	.PISTON ASSY, CALIPER	1	1	1	1	
5	5TG-W0047-00	..CALIPER SEAL KIT	1	1	1	1	
6	5TG-25975-00	.RUBBER, BUSHING	1	1	1	1	
7	5UG-25833-00	.BOLT, FITTING	2	2	2	2	
8	5TG-25978-00	.SHAFT L	1	1	1	1	
9	1UY-25974-51	.BOOT	1	1	1	1	
10	1UY-25973-51	.NUT	1	1	1	1	
11	5TG-25972-00	.ADJUST BOLT	1	1	1	1	
12	3LD-25934-01	.SPRING, PAD	1	1	1	1	
13	5TG-W0046-10	.BRAKE PAD KIT 2	1	1	1	1	
14	5DH-25933-00	.PIN, PAD	2	2	2	2	
15	1UY-25937-51	.BOOT 2	1	1	1	1	
16	3SP-25914-51	.PIN, SLIDE	1	1	1	1	
17	3JD-25917-00	.BOOT, CALIPER	1	1	1	1	
18	3SP-25926-51	.BOLT	1	1	1	1	
19	1UY-W0048-50	.BLEED SCREW KIT	1	1	1	1	
20	5TG-25977-50	.SPRING, RETURN	1	1	1	1	
21	90105-101A9	BOLT, FLANGE	2	2	2	2	

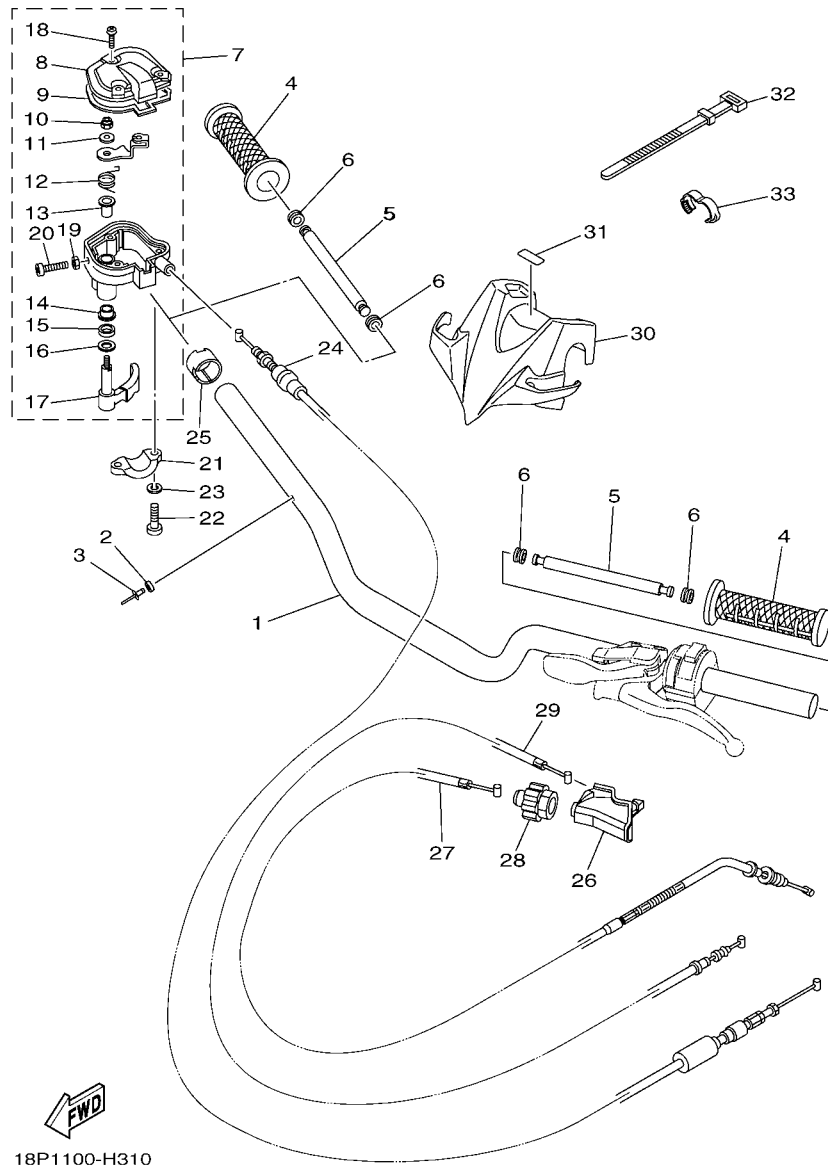

18P1100-H310

FIG. 31 STEERING HANDLE & CABLE

REF. NO.	PART NO.	DESCRIPTION	CAN	EUR	OCE	JPN	REMARKS
1	5D3-26111-11	HANDLEBAR	1	1	1	1	
2	90387-02001	COLLAR	1	1	1	1	
3	90267-24143	RIVET, BLIND	1	1	1	1	
4	5LP-26241-00	GRIP	2	2	2	2	
5	18P-2622H-00	WEIGHT	2	2	2	2	
6	90480-11006	GROMMET	4	4	4	4	
7	1S3-26250-00	THROTTLE LEVER ASSY	1	1	1	1	
8	1S3-2628F-00	.CAP, GEAR	1	1	1	1	
9	1S3-2628G-00	.GASKET	1	1	1	1	
10	95602-05100	.NUT, U	1	1	1	1	
11	1NV-26398-00	.WASHER	1	1	1	1	
12	1NV-26304-00	.SPRING	1	1	1	1	
13	1NV-26259-01	.COLLAR	1	1	1	1	
14	1NV-2625K-00	.COLLAR	1	1	1	1	
15	93104-09025	.OIL SEAL	1	1	1	1	
16	1NV-26129-00	.WASHER	1	1	1	1	
17	1S3-2625G-00	.LEVER, THROTTLE	1	1	1	1	
18	90149-04278	.SCREW	3	3	3	3	
19	95302-05700	.NUT	1	1	1	1	
20	98502-05020	.SCREW, PAN HEAD	1	1	1	1	
21	1S3-82913-00	HOLDER, LEVER LOWER 1	1	1	1	1	
22	98502-05020	SCREW, PAN HEAD	2	2	2	2	
23	92902-05100	WASHER, SPRING	2	2	2	2	
24	18P-26311-00	CABLE, THROTTLE 1	1	1	1	1	
25	1UY-26259-00	COLLAR	1	1	1	1	
26	5TG-26372-00	COVER, HANDLE LEVER 1	1	1	1	1	
27	18P-26335-00	CABLE, CLUTCH	1	1	1	1	

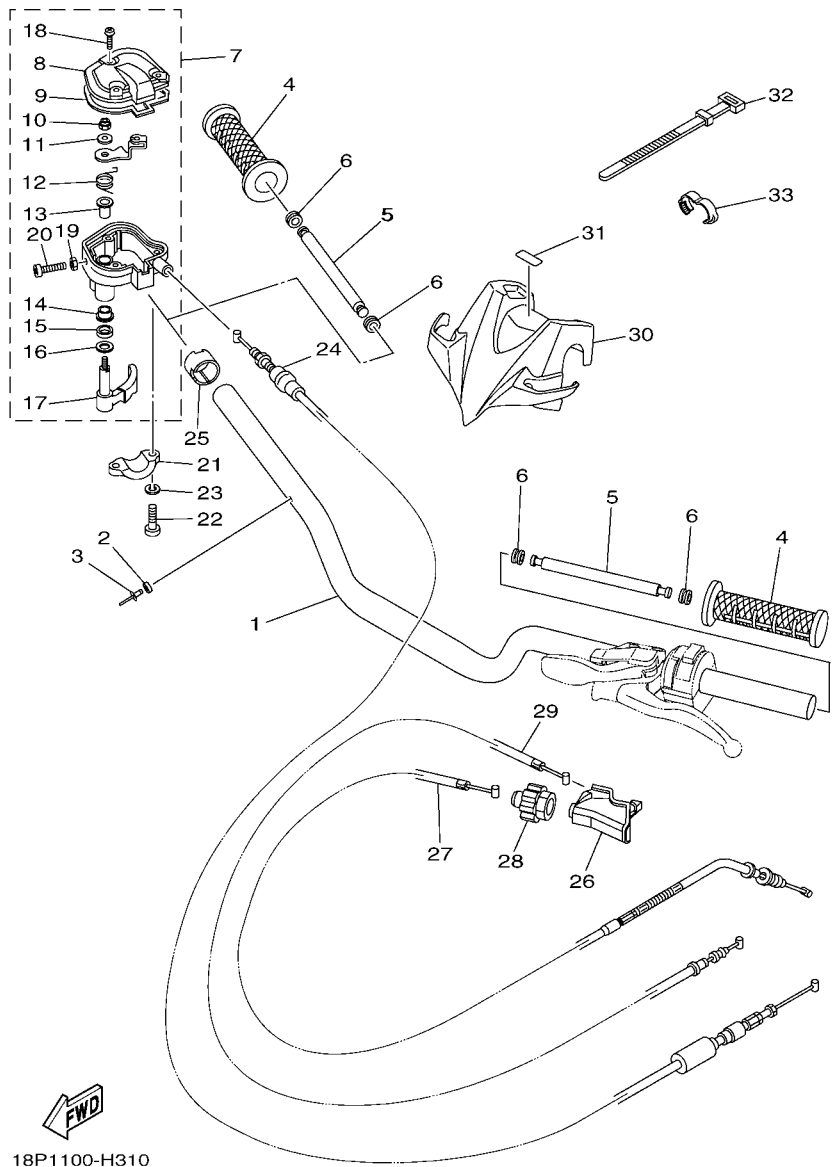
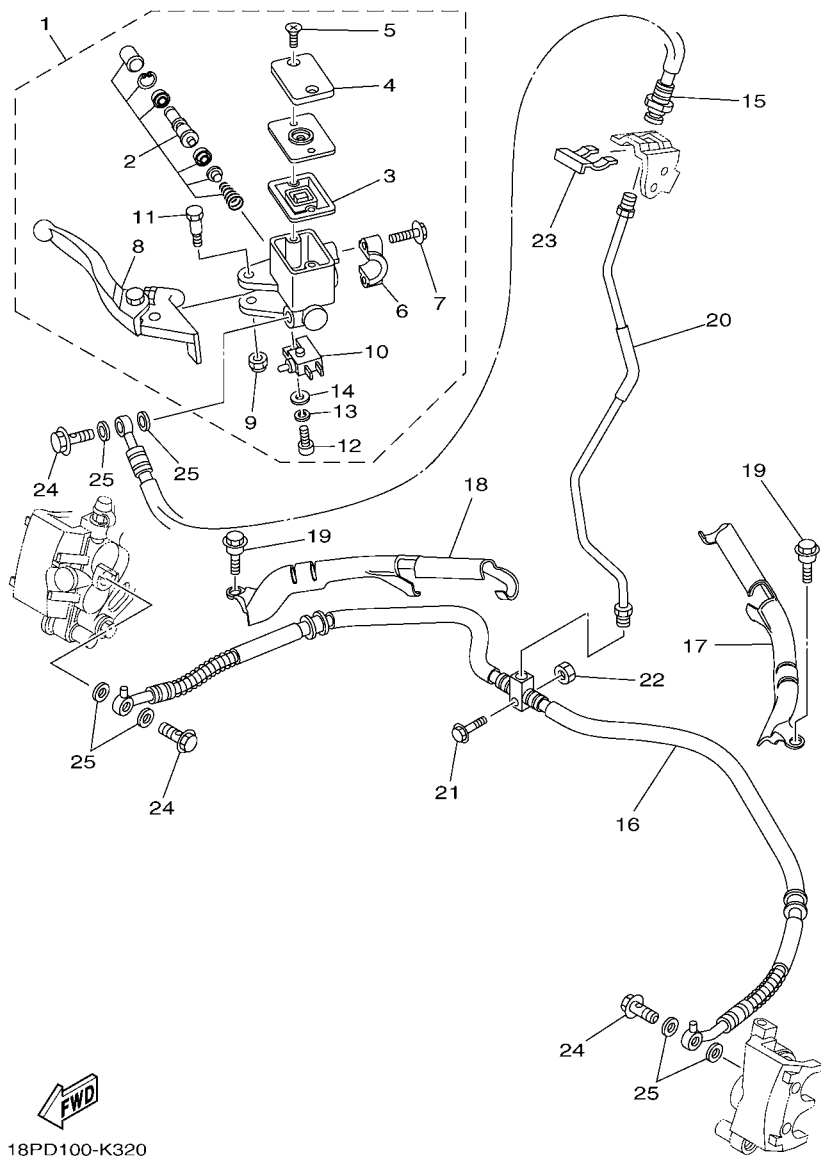

FIG. 31 STEERING HANDLE & CABLE

REF. NO.	PART NO.	DESCRIPTION	CAN	EUR	OCE	JPN	REMARKS
28	1C3-26342-50	BOOT, CABLE	1	1	1	1	
29	18P-26341-00	WIRE, BRAKE 1	1	1	1	1	
30	18P-26124-00	PROTECTOR, HANDLEBAR	1	1	1	1	
31	5D3-26219-10	EMBLEM	1	1	1	1	
32	437-83936-01	BAND, SWITCH CORD	2	2	2	2	
33	90464-16001	CLAMP	1	1	1	1	



18PD100-K320

FIG. 32 FRONT MASTER CYLINDER

REF. NO.	PART NO.	DESCRIPTION	CAN	EUR	OC	JPN	REMARKS
1	5D3-2583T-01	MASTER CYLINDER ASSY	1	1	1	1	
2	5D3-W0041-00	.CYLINDER KIT, MASTER	1	1	1	1	
3	4TT-25854-00	.DIAPHRAGM, RESERVOIR	1	1	1	1	
4	5D3-25852-00	.CAP, RESERVOIR	1	1	1	1	
5	4NK-2589H-00	.SCREW	2	2	2	2	
6	5LP-25867-00	.BRACKET, MASTER CYLINDER	1	1	1	1	
7	5MV-25833-00	.BOLT, FITTING	2	2	2	2	
8	5D3-83922-00	.LEVER 2	1	1	1	1	
9	95604-06100	.NUT, U	1	1	1	1	
10	5D3-83980-00	.FRONT STOP SWITCH ASSY	1	1	1	1	
11	3B4-2589F-00	.BOLT, LEVER	1	1	1	1	
12	98502-04014	.SCREW, PAN HEAD	1	1	1	1	
13	92902-04100	.WASHER, SPRING	1	1	1	1	
14	92902-04600	.WASHER, PLATE	1	1	1	1	
15	18P-25872-10	HOSE, BRAKE 1	1	1	1	1	
16	18P-25873-10	HOSE, BRAKE 2	1	1	1	1	
17	18P-25875-00	HOLDER, BRAKE HOSE 1	1	1	1	1	
18	18P-25876-00	HOLDER, BRAKE HOSE 2	1	1	1	1	
19	90109-06264	BOLT	2	2	2	2	
20	18P-25871-10	PIPE, BRAKE	1	1	1	1	
21	95822-06035	BOLT, FLANGE	1	1	1	1	
22	95312-06600	NUT	1	1	1	1	
23	2GU-25866-00	CIRCLIP	1	1	1	1	
24	90401-10015	BOLT, UNION	3	3	3	3	
25	90201-10118	WASHER, PLATE	6	6	6	6	

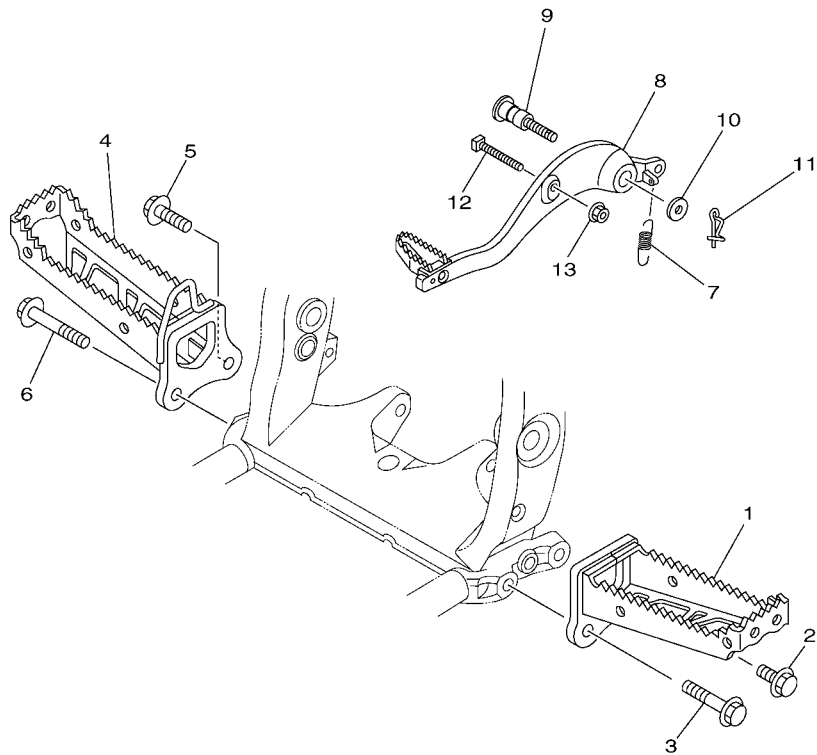

 18P1100-H330

FIG. 33 STAND & FOOTREST

REF. NO.	PART NO.	DESCRIPTION	CAN	EUR	OC	JPN	REMARKS
1	18P-27411-00	FOOTREST 1	1	1	1	1	
2	95812-12025	BOLT, FLANGE	1	1	1	1	
3	95812-12055	BOLT, FLANGE	1	1	1	1	
4	18P-27421-00	FOOTREST 2	1	1	1	1	
5	95812-12035	BOLT, FLANGE	1	1	1	1	
6	95812-12065	BOLT, FLANGE	1	1	1	1	
7	90506-25001	SPRING, TENSION	1	1	1	1	
8	18P-27211-01	PEDAL, BRAKE	1	1	1	1	
9	18P-27217-00	BOLT	1	1	1	1	
10	90201-08077	WASHER, PLATE	1	1	1	1	
11	90468-16191	CLIP	1	1	1	1	
12	90108-05001	BOLT, SQUARE	1	1	1	1	
13	95602-05200	NUT, SELF-LOCKING	1	1	1	1	

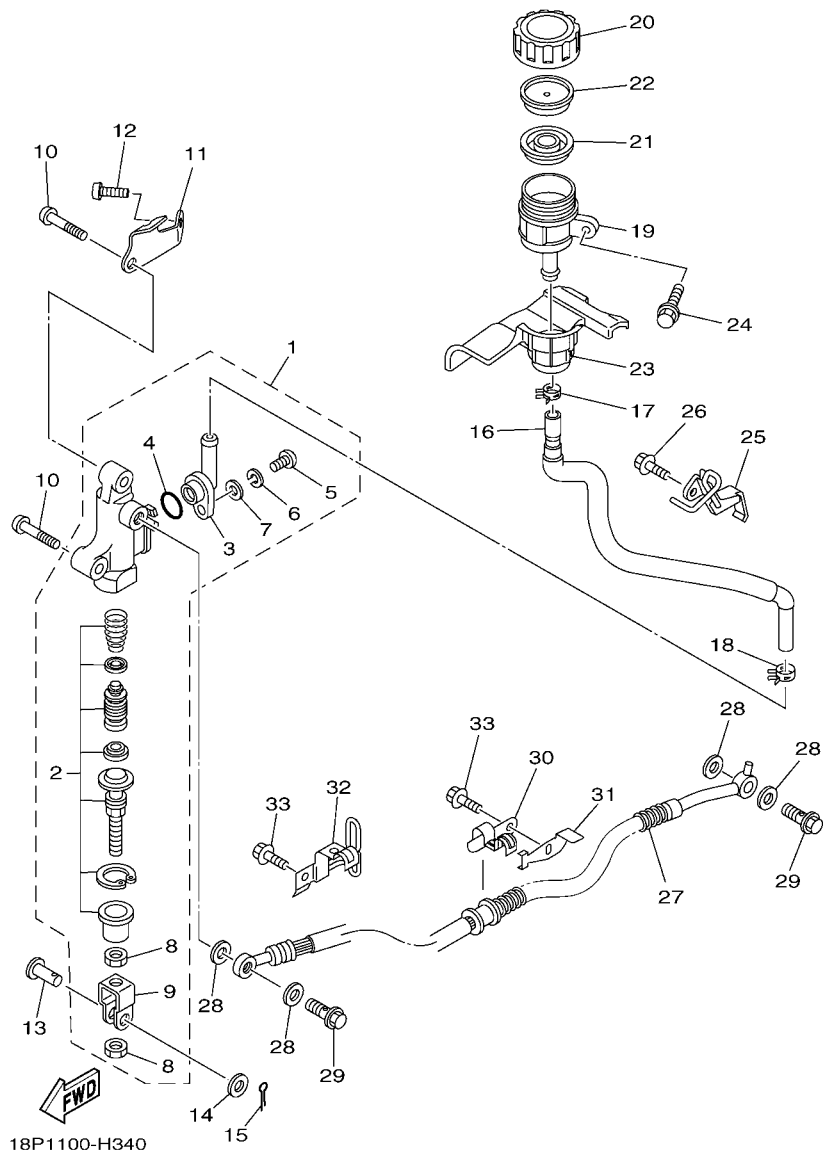

18P1100-H340

FIG. 34 REAR MASTER CYLINDER

REF. NO.	PART NO.	DESCRIPTION	CAN	EUR	OC	JPN	REMARKS
1	1S3-2580E-00	REAR MASTER CYLINDER ASSY	1	1	1	1	
2	1S3-W0042-50	.CYLINDER KIT, MASTER	1	1	1	1	
3	1AE-2582A-00	.JOINT	1	1	1	1	
4	93210-15620	.O-RING	1	1	1	1	
5	98506-04012	.SCREW, PAN HEAD	1	1	1	1	
6	92906-04100	.WASHER, SPRING	1	1	1	1	
7	92906-04600	.WASHER, PLATE	1	1	1	1	
8	4SS-27218-00	.NUT	2	2	2	2	
9	2YK-27222-00	.JOINT	1	1	1	1	
10	92012-08035	BOLT, BUTTON HEAD	2	2	2	2	
11	18P-27453-00	COVER 1	1	1	1	1	
12	92012-08012	BOLT, BUTTON HEAD	1	1	1	1	
13	90240-08124	PIN, CLEVIS	1	1	1	1	
14	90201-08083	WASHER, PLATE	1	1	1	1	
15	91401-16012	PIN, COTTER	1	1	1	1	
16	18P-25895-00	HOSE, RESERVOIR	1	1	1	1	
17	90467-11044	CLIP	1	1	1	1	
18	90467-14057	CLIP	1	1	1	1	
19	5JJ-25894-01	TANK, RESERVOIR	1	1	1	1	
20	3XP-25852-50	CAP, RESERVOIR	1	1	1	1	
21	2VN-25854-00	DIAPHRAGM, RESERVOIR	1	1	1	1	
22	2VN-25855-00	BUSH,DIAPHRAGM	1	1	1	1	
23	18P-25897-00	DAMPER	1	1	1	1	
24	90119-06177	BOLT, WITH WASHER	1	1	1	1	
25	18P-27263-00	BRACKET 1	1	1	1	1	
26	95022-06012	BOLT, FLANGE	1	1	1	1	
27	18P-25874-00	HOSE, BRAKE	1	1	1	1	

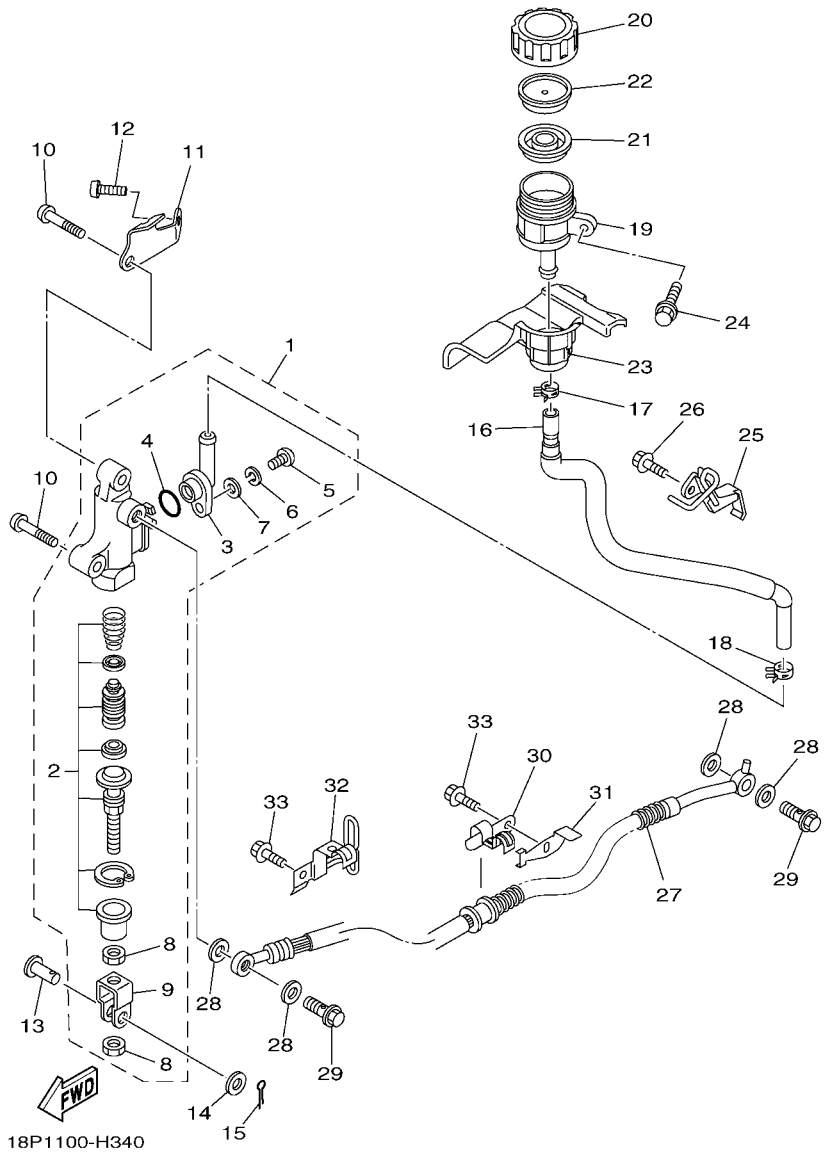
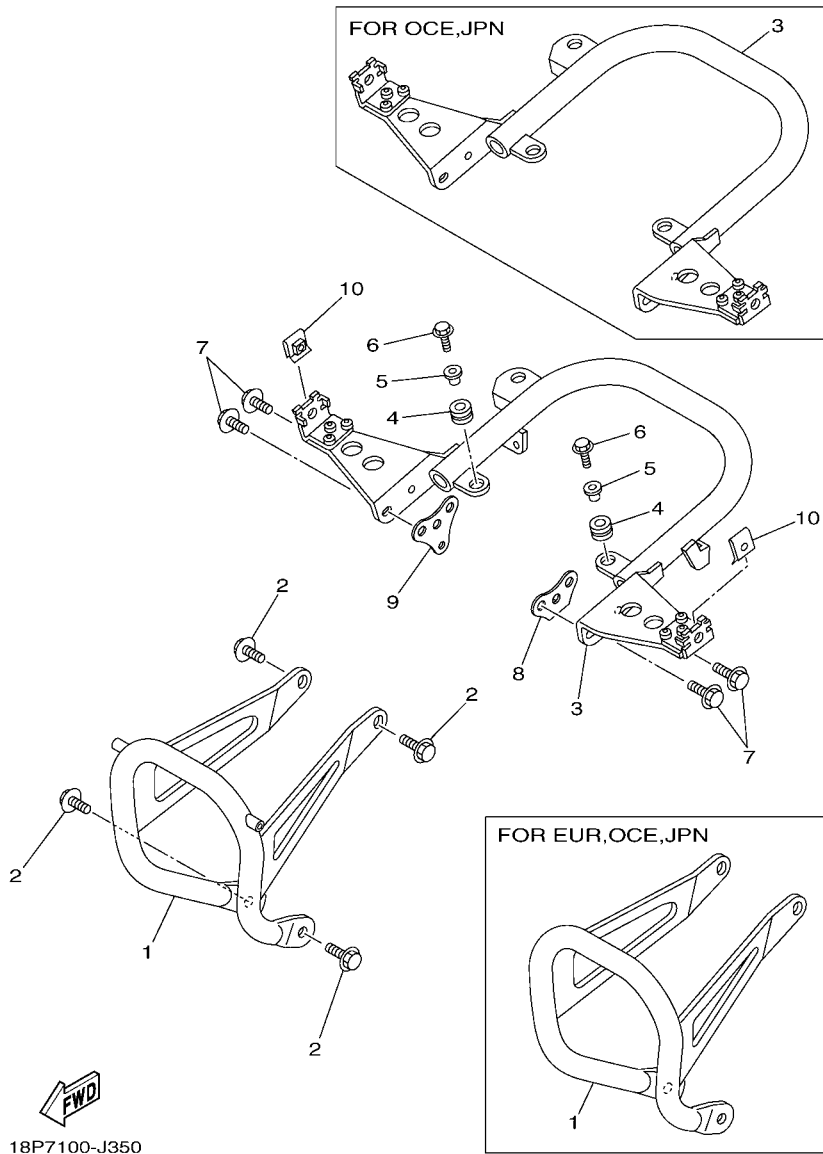

FIG. 34 REAR MASTER CYLINDER

REF. NO.	PART NO.	DESCRIPTION	CAN	EUR	OCE	JPN	REMARKS
28	90201-10118	WASHER, PLATE	4	4	4	4	
29	90401-10015	BOLT, UNION	2	2	2	2	
30	18P-25886-00	HOLDER, BRAKE HOSE	1	1	1	1	
31	18P-2743E-00	STOPPER	1	1	1	1	
32	18P-23317-00	HOLDER, CABLE	1	1	1	1	
33	90105-06063	BOLT, FLANGE	2	2	2	2	



18P7100-J350

FIG. 35 GUARD

REF. NO.	PART NO.	DESCRIPTION	CAN	EUR	OCE	JPN	REMARKS
1	18P-2845N-10	BAR, CARRY FRONT	1				
	18P-2845N-00	BAR, CARRY FRONT		1	1	1	
2	95812-08020	BOLT, FLANGE	4	4	4	4	
3	18P-2845R-10	BAR, CARRY REAR	1	1			
	18P-2845R-00	BAR, CARRY REAR			1	1	
4	90480-10289	GROMMET	2	2	2	2	
5	90387-06063	COLLAR	2	2	2	2	
6	95812-06020	BOLT, FLANGE	2	2	2	2	
7	95812-08020	BOLT, FLANGE	4	4	4	4	
8	5TG-28215-00	WASHER, SPECIAL	1	1	1	1	
9	18P-28215-00	WASHER, SPECIAL	1	1	1	1	
10	90183-061A5	NUT, SPRING	2	2	2	2	

FIG. 36 GENERATOR

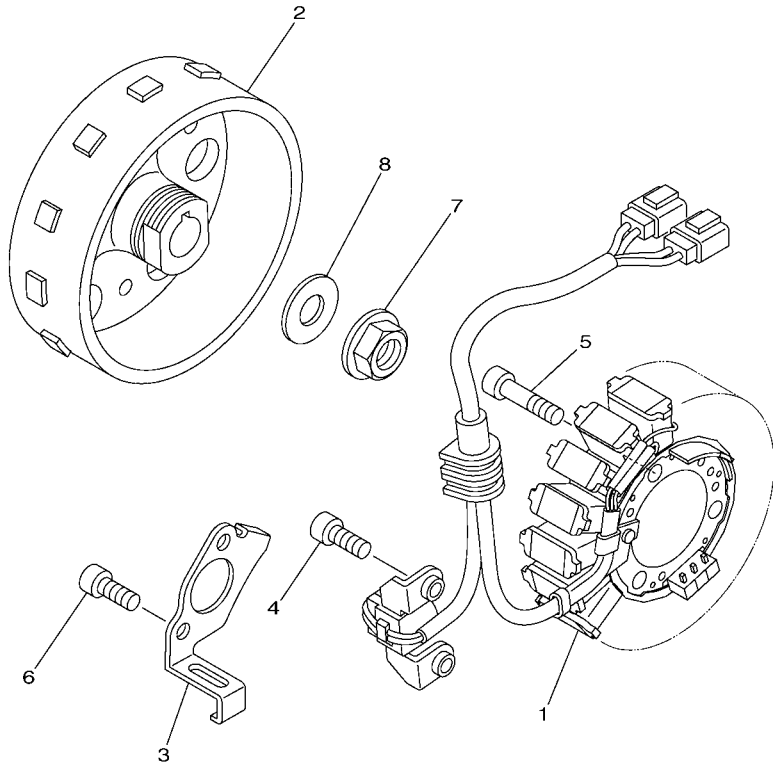

18P1100-H360

REF. NO.	PART NO.	DESCRIPTION	CAN	EUR	OCE	JPN	REMARKS
1	18P-81410-00	STATOR ASSY	1	1	1	1	
2	18P-81450-00	ROTOR ASSY	1	1	1	1	
3	18P-81528-00	CLAMP 1	1	1	1	1	
4	90110-06168	BOLT, HEXAGON SOCKET HEAD	2	2	2	2	
5	90110-06169	BOLT, HEXAGON SOCKET HEAD	3	3	3	3	
6	90110-06168	BOLT, HEXAGON SOCKET HEAD	2	2	2	2	
7	90179-12657	NUT	1	1	1	1	
8	90201-12020	WASHER, PLATE	1	1	1	1	

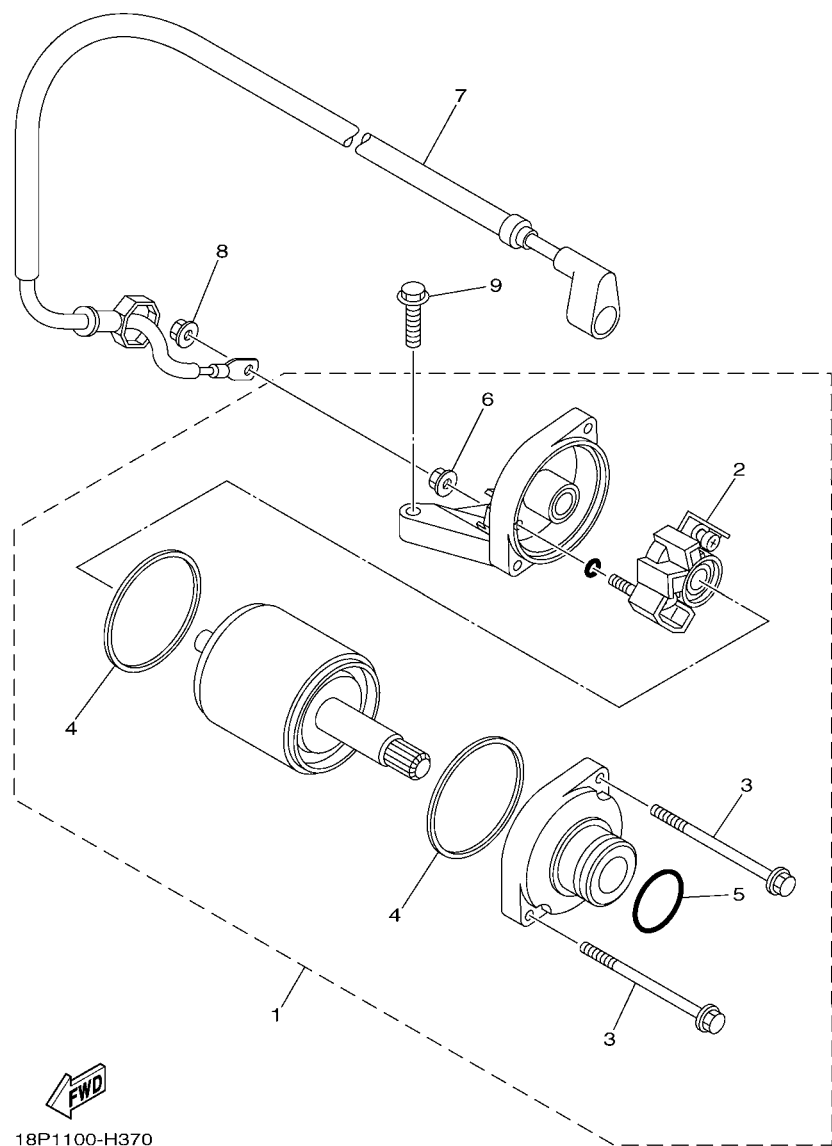

 18P1100-H370

FIG. 37 STARTING MOTOR

REF. NO.	PART NO.	DESCRIPTION	CAN	EUR	OCE	JPN	REMARKS
1	18P-81890-00	MOTOR ASSY	1	1	1	1	
2	18P-81801-00	.BRUSH SET	1	1	1	1	
3	18P-81826-00	.BOLT	2	2	2	2	
4	4B5-81844-00	.GASKET	2	2	2	2	
5	1FK-81847-00	.O-RING	1	1	1	1	
6	4XV-8182A-00	.NUT	1	1	1	1	
7	18P-81815-00	CORD, STARTER MOTOR	1	1	1	1	
8	4XV-8182A-00	NUT	1	1	1	1	
9	95022-06025	BOLT, FLANGE	2	2	2	2	

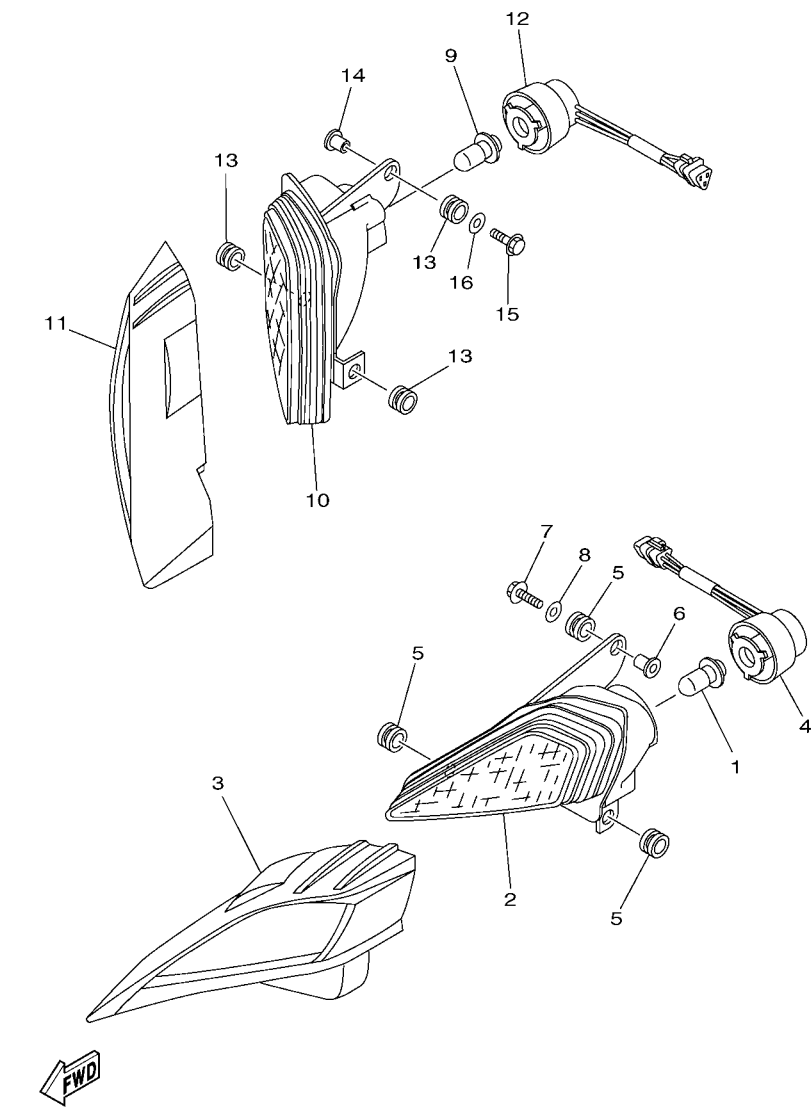

18P1100-H380

FIG. 38 HEADLIGHT

REF. NO.	PART NO.	DESCRIPTION	CAN	EUR	OCE	JPN	REMARKS
1	4KB-84314-01	BULB (12V-30/30W)	1	1	1	1	
2	5TG-84110-03	HEADLIGHT UNIT ASSY	1	1	1	1	
3	18P-84165-00	RIM, HEADLIGHT COVER 1	1	1	1	1	
4	5TG-84140-01	SOCKET CORD ASSY	1	1	1	1	
5	90480-14102	GROMMET	3	3	3	3	
6	90387-06136	COLLAR	1	1	1	1	
7	95802-06025	BOLT, FLANGE	1	1	1	1	
8	90201-06078	WASHER, PLATE	1	1	1	1	
9	4KB-84314-01	BULB (12V-30/30W)	1	1	1	1	
10	5TG-84310-03	HEADLIGHT UNIT ASSY	1	1	1	1	
11	18P-84166-00	RIM, HEADLIGHT COVER 2	1	1	1	1	
12	5TG-84340-01	SOCKET CORD ASSY 1	1	1	1	1	
13	90480-14102	GROMMET	3	3	3	3	
14	90387-06136	COLLAR	1	1	1	1	
15	95802-06025	BOLT, FLANGE	1	1	1	1	
16	90201-06078	WASHER, PLATE	1	1	1	1	

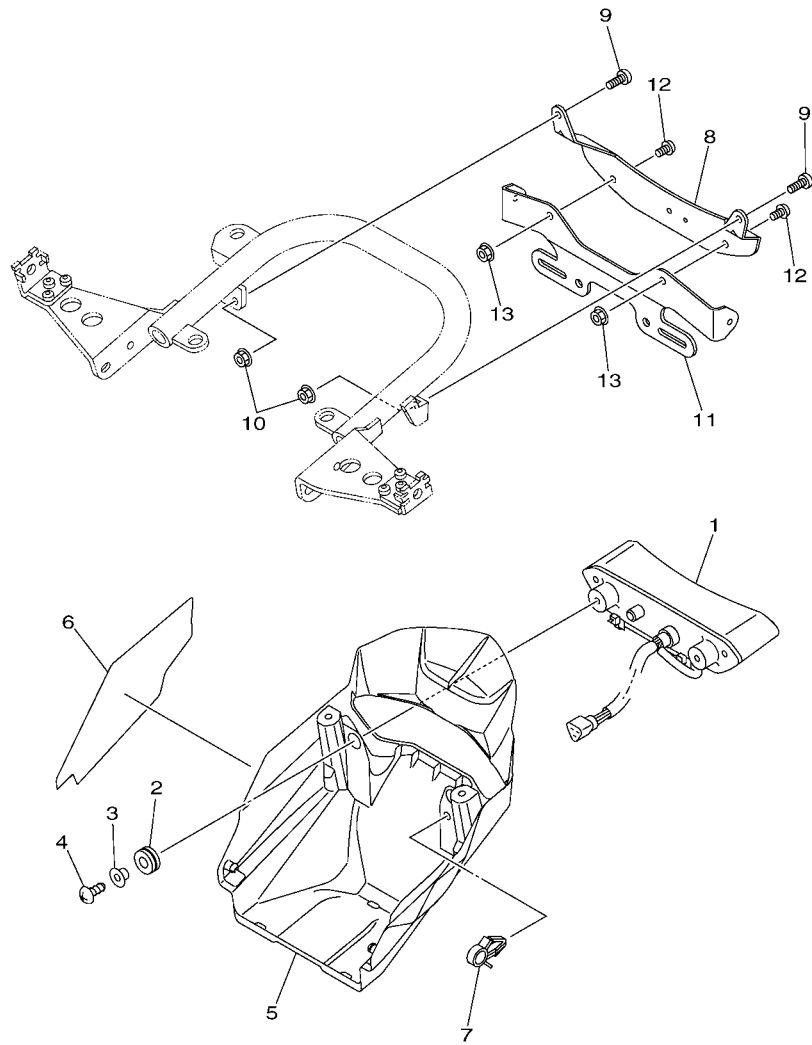

FWD
18P1100-H390

FIG. 39 TAILLIGHT

REF. NO.	PART NO.	DESCRIPTION	CAN	EUR	OCE	JPN	REMARKS
1	1S3-84710-01	TAILLIGHT UNIT ASSY	1	1			
2	90480-14323	GROMMET	2	2			
3	90387-06204	COLLAR	2	2			
4	97702-50025	SCREW, TAPPING	2	2			
5	18P-84716-00	COVER, TAILLIGHT	1	1			
6	18P-8411K-00	PLATE, INSULATOR	1	1			
7	90464-15157	CLAMP	1	1			
8	18P-84703-00	BRACKET	1	1			
9	90111-06059	BOLT,HEX. SOCKET BUTTON	2	2			
10	95602-06200	NUT, SELF-LOCKING	2	2			
11	18P-84751-00	BRACKET, LICENSE	1				
12	92012-06012	BOLT, BUTTON HEAD	2				
13	95602-06200	NUT, SELF-LOCKING	2				

FIG. 40 TAILLIGHT 2

REF. NO.	PART NO.	DESCRIPTION	CAN	EUR	OCE	JPN	REMARKS
1	1S3-84710-01	TAILLIGHT UNIT ASSY			1	1	
2	90480-14323	GROMMET			2	2	
3	90387-06204	COLLAR			2	2	
4	97702-50025	SCREW, TAPPING			2	2	
5	18P-84716-00	COVER, TAILLIGHT			1	1	
6	18P-8411K-00	PLATE, INSULATOR			1	1	
7	90464-15157	CLAMP			1	1	

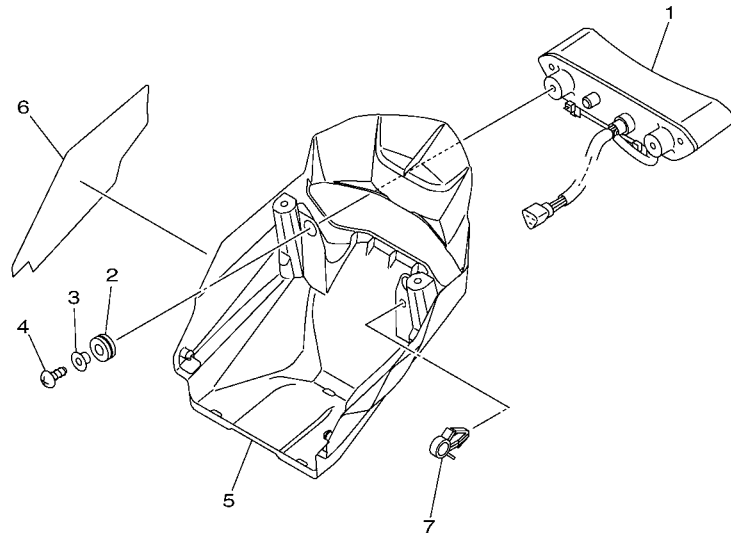

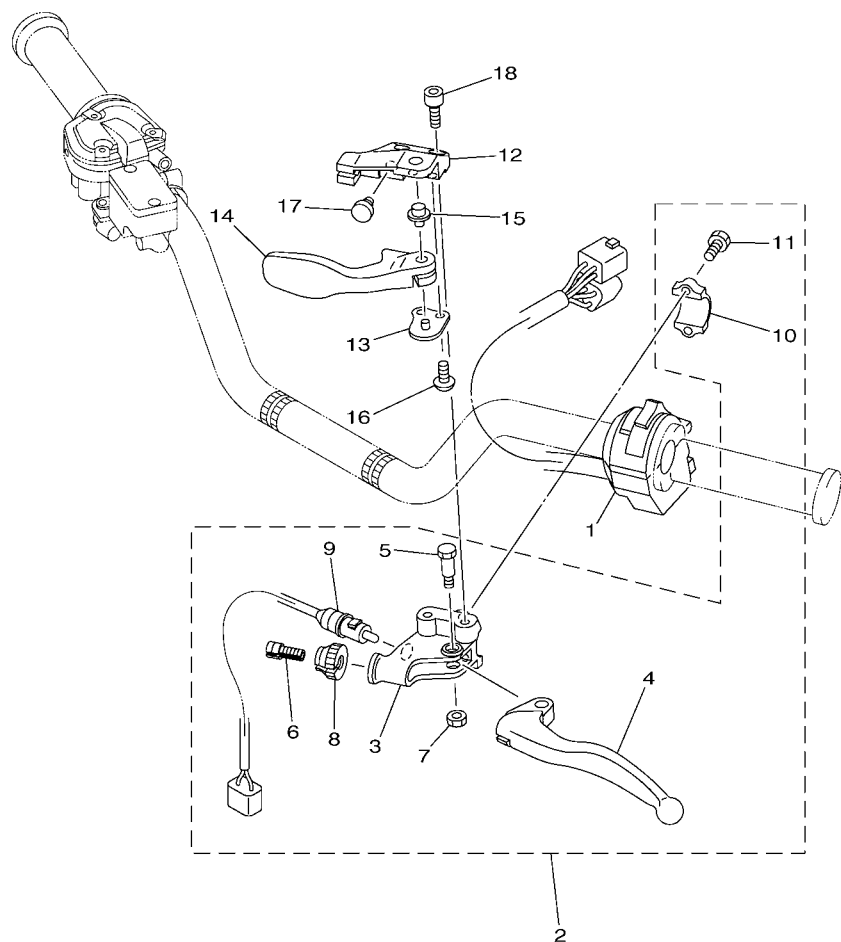

18P1100-H400

FIG. 41 HANDLE SWITCH & LEVER

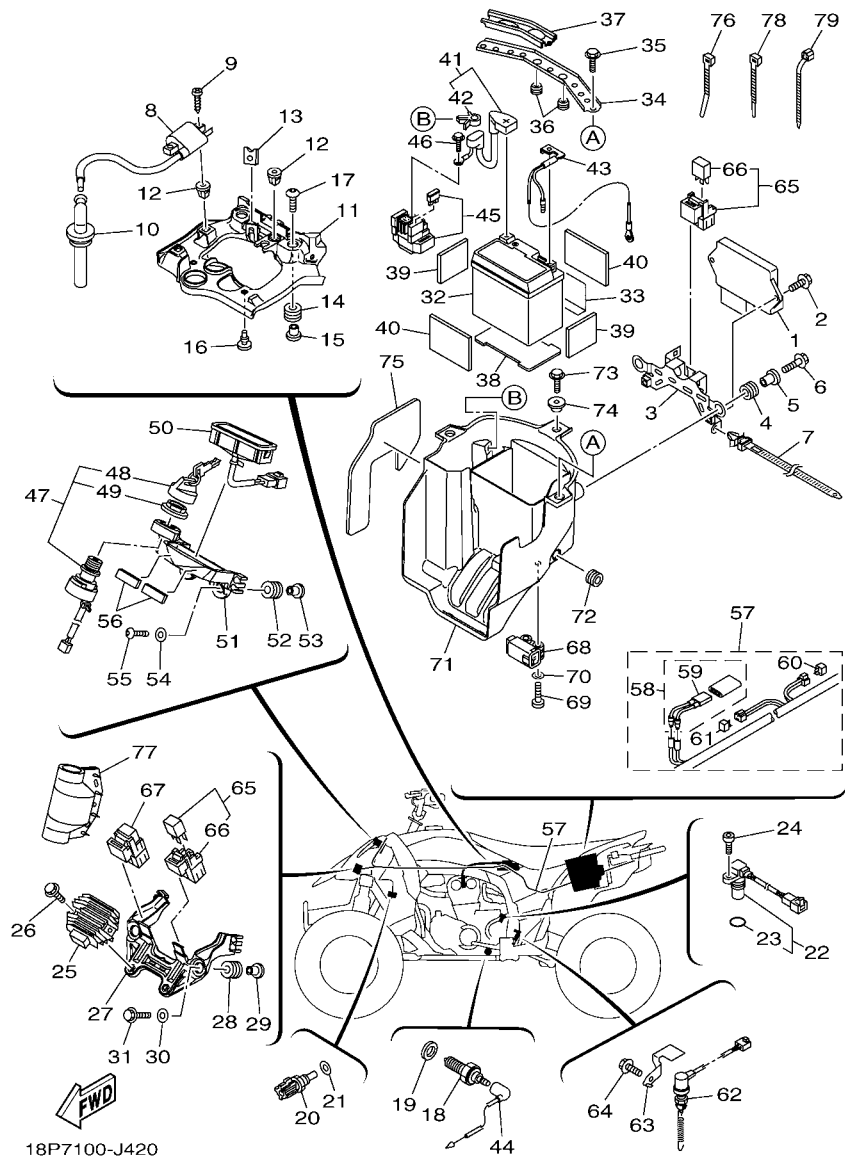

REF. NO.	PART NO.	DESCRIPTION	CAN	EUR	OCE	JPN	REMARKS
1	1S3-83973-11	SWITCH, HANDLE 3	1	1	1	1	
2	18P-82910-00	LEVER HOLDER ASSY (LEFT)	1	1	1	1	
3	5TG-82911-00	.HOLDER, LEVER 1	1	1	1	1	
4	5TJ-83912-00	.LEVER 1	1	1	1	1	
5	90109-06034	.BOLT	1	1	1	1	
6	5TA-26337-00	.BOLT, ADJUSTING	1	1	1	1	
7	95602-06100	.NUT, U	1	1	1	1	
8	5HD-83951-00	.BOLT, CABLE ADJUSTING	1	1	1	1	
9	5KM-82917-00	.SWITCH	1	1	1	1	
10	5TG-82913-00	.HOLDER, LEVER LOWER 1	1	1	1	1	
11	90101-05033	.BOLT	2	2	2	2	
12	5TG-25727-01	BRACKET, LEVER	1	1	1	1	
13	5D3-25689-00	PLATE, GUIDE	1	1	1	1	
14	5TG-25726-01	LEVER, BRAKE	1	1	1	1	
15	5TG-83923-00	COLLAR, LEVER 2	1	1	1	1	
16	92012-06014	BOLT, BUTTON HEAD	2	2	2	2	
17	90338-07007	PLUG	1	1	1	1	
18	92012-06016	BOLT, BUTTON HEAD	2	2	2	2	

FWD
18P1100-H410



18P7100-J420

FIG. 42 ELECTRICAL 1

REF. NO.	PART NO.	DESCRIPTION	CAN	EUR	OCE	JPN	REMARKS
1	18P-8591A-11	ENGINE CONTROL UNIT ASSY	1	1	1	1	
2	95812-06016	BOLT, FLANGE	2	2	2	2	
3	18P-85991-00	BRACKET, UNIT	1	1	1	1	
4	90480-14011	GROMMET	2	2	2	2	
5	90387-06388	COLLAR	2	2	2	2	
6	95812-06020	BOLT, FLANGE	2	2	2	2	
7	90464-12036	CLAMP	1	1	1	1	
8	18P-82310-00	IGNITION COIL ASSY	1	1	1	1	
9	97702-60125	SCREW, TAPPING	2	2	2	2	
10	18P-82370-00	PLUG CAP ASSY	1	1	1	1	
11	18P-81948-00	BRACKET	1	1	1	1	
12	90338-08226	PLUG	3	3	3	3	
13	90183-060A6	NUT, SPRING	1	1	1	1	
14	90480-14323	GROMMET	2	2	2	2	
15	90387-06161	COLLAR	2	2	2	2	
16	90338-05008	PLUG	2	2	2	2	
17	90111-06084	BOLT, HEX. SOCKET BUTTON	2	2	2	2	
18	3GB-82540-01	NEUTRAL SWITCH ASSY	1	1	1	1	
19	90430-10148	GASKET	1	1	1	1	
20	8CC-85790-01	THERMOSENSOR ASSY	1	1	1	1	
21	90430-12202	GASKET	1	1	1	1	
22	18P-83755-00	SENSOR, SPEED	1	1	1	1	
23	4D9-81168-00	.O-RING	1	1	1	1	
24	91312-06016	BOLT	1	1	1	1	
25	5BN-81960-00	RECTIFIER & REGULATOR ASSY	1	1	1	1	
26	95802-06020	BOLT, FLANGE	2	2	2	2	
27	18P-87208-00	STAY, REGULATOR	1	1	1	1	

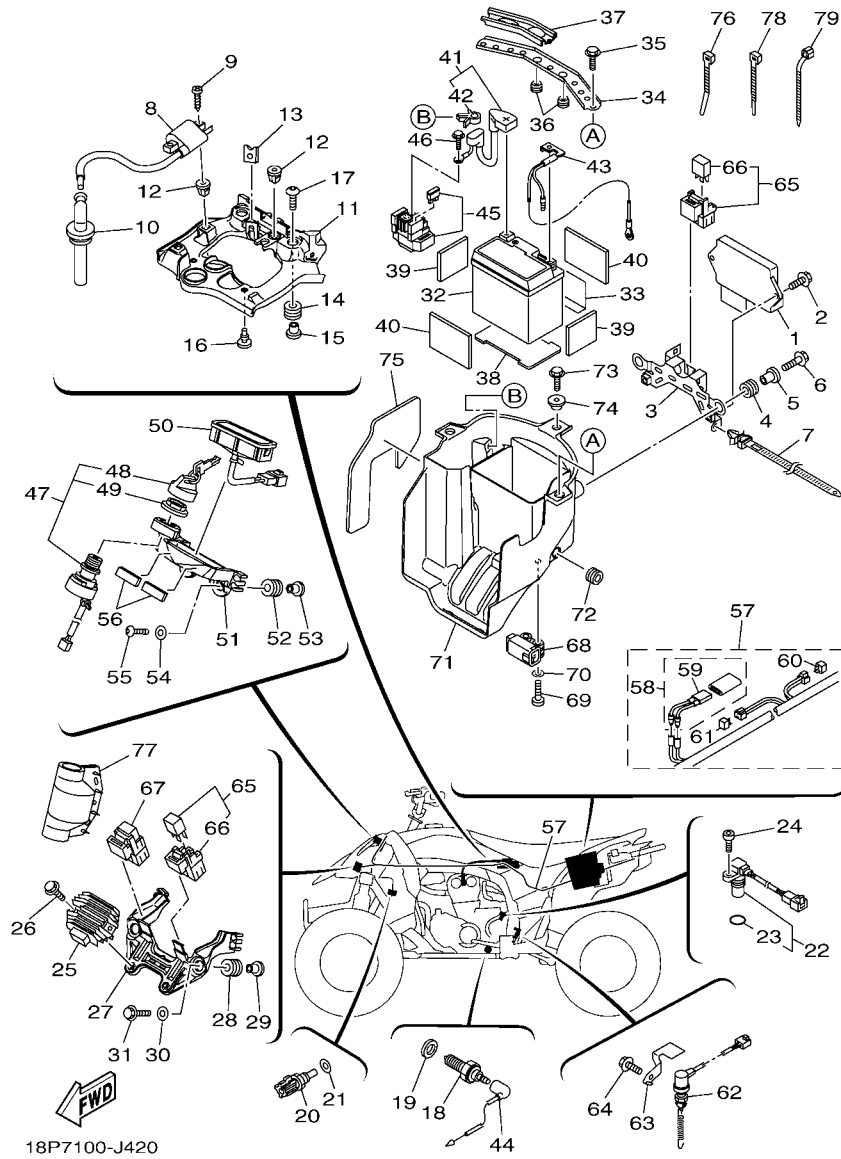

18P7100-J420

FIG. 42 ELECTRICAL 1

REF. NO.	PART NO.	DESCRIPTION	CAN	EUR	OCE	JPN	REMARKS
28	90480-10289	GROMMET	2	2	2	2	
29	90387-06204	COLLAR	2	2	2	2	
30	90201-06078	WASHER, PLATE	2	2	2	2	
31	95802-06025	BOLT, FLANGE	2	2	2	2	
32	1S4-82100-10	BATTERY ASSY (YTZ7S)	1	1	1		
	5XT-82100-00	BATTERY ASSY (YTZ7S)				1	
33	18P-82122-00	SEAT, BATTERY	1	1	1	1	
34	18P-82128-00	BRACKET, BATTERY	1	1	1	1	
35	90105-06084	BOLT, FLANGE	2	2	2	2	
36	90338-12192	PLUG	2	2	2	2	
37	18P-82129-00	COVER, BATTERY	1	1	1	1	
38	4D3-82122-00	SEAT, BATTERY	1	1	1	1	
39	5MP-21747-00	DAMPER	2	2	2	2	
40	4HC-27415-00	PLATE, FOOTREST	2	2	2	2	
41	18P-W8211-10	WIRE, PLUS LEAD	1	1	1	1	
42	90464-12001	.CLAMP	1	1	1	1	
43	18P-82116-00	WIRE, MINUS LEAD	1	1	1	1	
44	18P-82541-00	WIRE, LEAD	1	1	1	1	
45	18P-81940-00	STARTER RELAY ASSY	1	1	1	1	
46	95022-06008	BOLT, FLANGE	2	2	2	2	
47	4SH-82510-00	MAIN SWITCH ASSY	1	1	1	1	
48	3HN-82579-00	.CAP, KEY	1	1	1	1	
49	3HN-82569-00	.NUT, MAIN SWITCH	1	1	1	1	
50	18P-83530-00	PILOT LIGHT ASSY	1	1	1	1	
51	18P-8361L-00	BRACKET, INDICATOR	1	1	1	1	
52	90480-10289	GROMMET	2	2	2	2	
53	90387-06204	COLLAR	2	2	2	2	

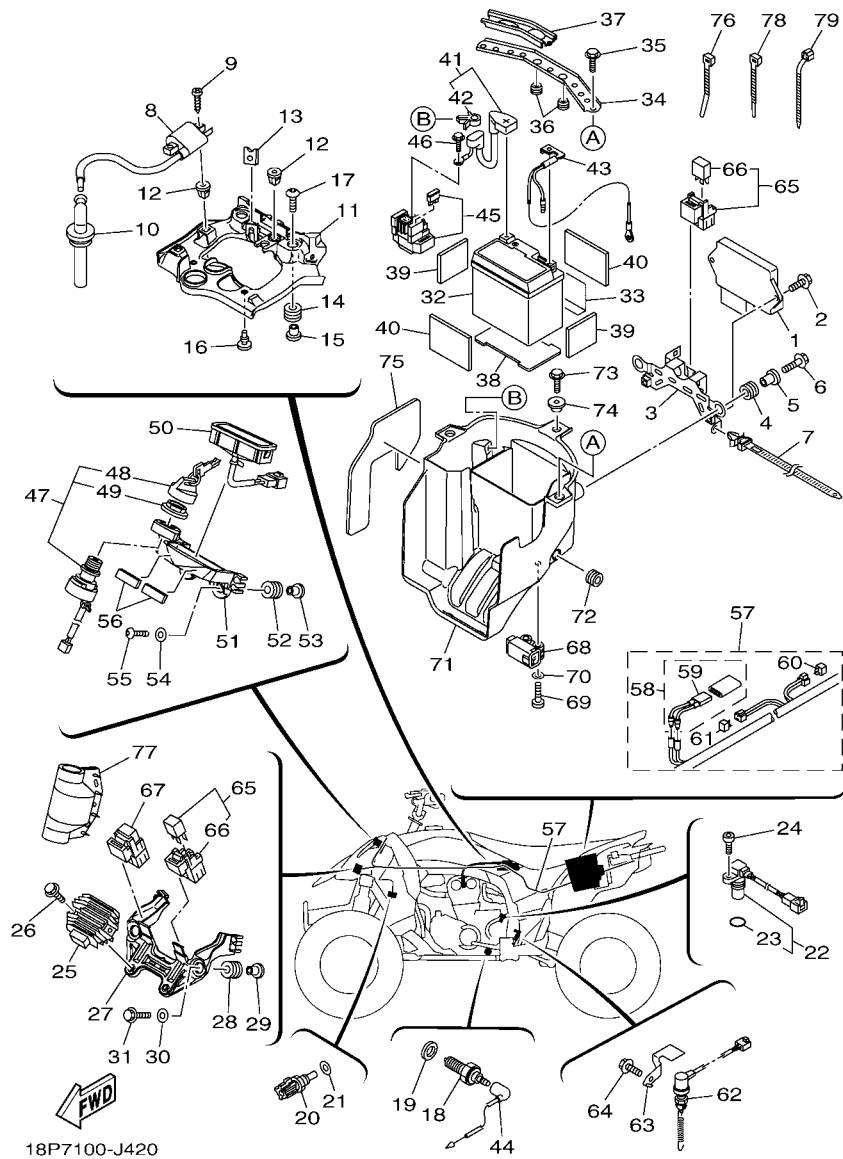

18P7100-J420

FIG. 42 ELECTRICAL 1

REF. NO.	PART NO.	DESCRIPTION	CAN	EUR	OC	JPN	REMARKS
54	90201-06078	WASHER, PLATE	2	2	2	2	
55	92012-06025	BOLT, BUTTON HEAD	2	2	2	2	
56	2C0-28372-00	DAMPER	2	2	2	2	
57	18P-82590-00	WIRE HARNESS ASSY	1				
	18P-82590-10	WIRE HARNESS ASSY		1	1	1	
58	5ND-82180-00	.CIRCUIT BREAKER ASSY	1	1	1	1	
59	5ND-82560-00	..THERMO SWITCH ASSY	1	1	1	1	
60	4WA-81980-00	.DIODE ASSY	1	1	1	1	
61	3WP-81980-00	.DIODE ASSY	1	1	1	1	
62	18P-82530-00	STOP SWITCH ASSY	1	1	1	1	
63	18P-8246B-00	COVER 1	1	1	1	1	
64	95022-06010	BOLT, FLANGE	1	1	1	1	
65	5EA-81950-20	RELAY ASSY	2	2	2	2	
66	5EA-81952-00	.HOLDER, RELAY	1	1	1	1	
67	5DM-81950-00	RELAY ASSY (G8HN-1C4T-DJ-Y52)	1	1	1	1	
68	5PS-82576-01	SENSOR, LEAN ANGLE	1	1	1	1	
69	91312-04025	BOLT	2	2	2	2	
70	90201-04030	WASHER, PLATE	2	2	2	2	
71	18P-8212B-00	BOX, BATTERY 1	1	1	1	1	
72	90480-12007	GROMMET	2	2	2	2	
73	90105-06084	BOLT, FLANGE	1	1	1	1	
74	90387-06153	COLLAR	1	1	1	1	
75	18P-8254E-00	INSULATOR	1	1	1	1	
76	90465-10098	CLAMP	1	1	1	1	
77	5RU-8252U-00	COVER	1	1	1	1	
78	90465-13M11	CLAMP	1	1	1	1	
79	90464-13073	CLAMP	2	2	2	2	

FIG. 43 ELECTRICAL 2

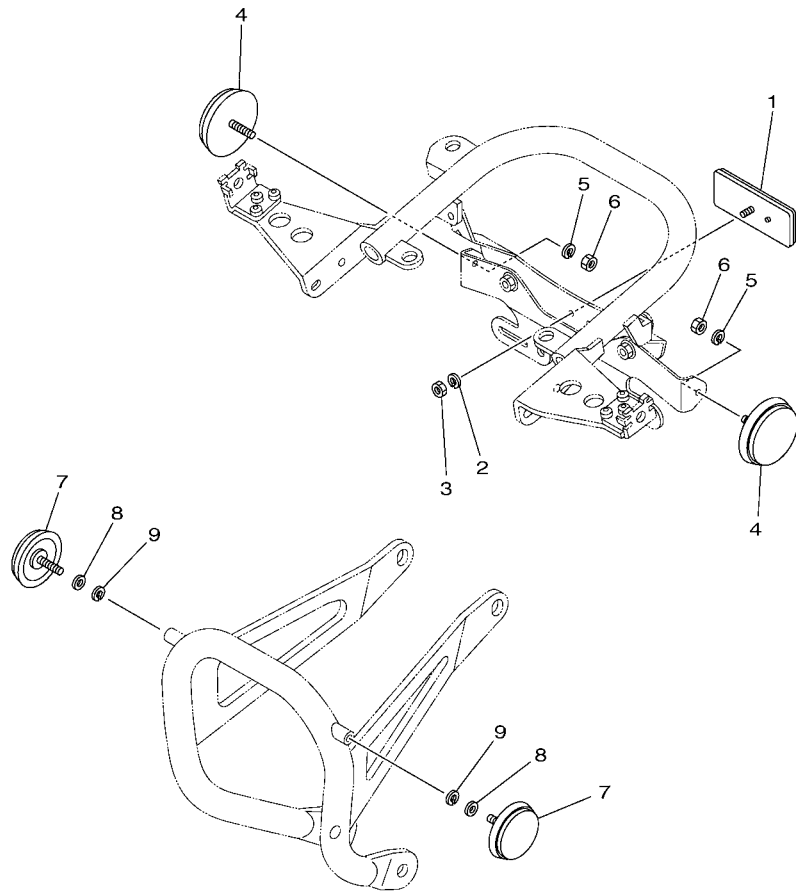

 18P1100-H430

REF. NO.	PART NO.	DESCRIPTION	CAN	EUR	OCE	JPN	REMARKS
1	3Y6-85130-02	REAR REFLECTOR ASSY	1	1			
2	92902-05100	WASHER, SPRING	1	1			
3	95302-05600	NUT	1	1			
4	449-85131-02	REFLECTOR, REAR 1	2				
5	92902-05100	WASHER, SPRING	2				
6	95302-05600	NUT	2				
7	2EK-85111-00	REFLECTOR, FRONT 1	2				
8	92902-05200	WASHER	2				
9	92902-05100	WASHER, SPRING	2				

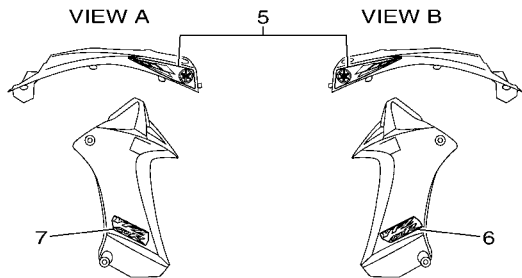
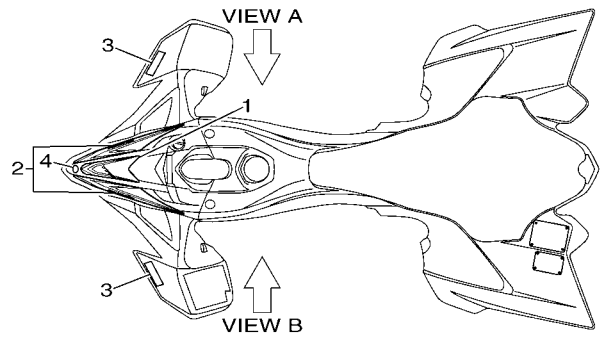

FIG. 44 GRAPHICS

REF. NO.	PART NO.	DESCRIPTION	CAN	EUR	OCE	JPN	REMARKS
1	18P-21569-60	GRAPHIC, 1	1	1	1	1	
2	18P-2159A-60	GRAPHIC SET 1	1	1	1	1	
3	4ES-2153E-01	EMBLEM, YAMAHA	2	2	2	2	
4	4KN-2836B-10	TUNING FORK MARK	1	1	1	1	
5	18P-2173L-00	GRAPHIC SET 1	1	1	1	1	
6	18P-21781-20	EMBLEM, 1	1	1	1	1	
7	18P-21781-20	EMBLEM, 1	1	1	1	1	

18PD100-K440

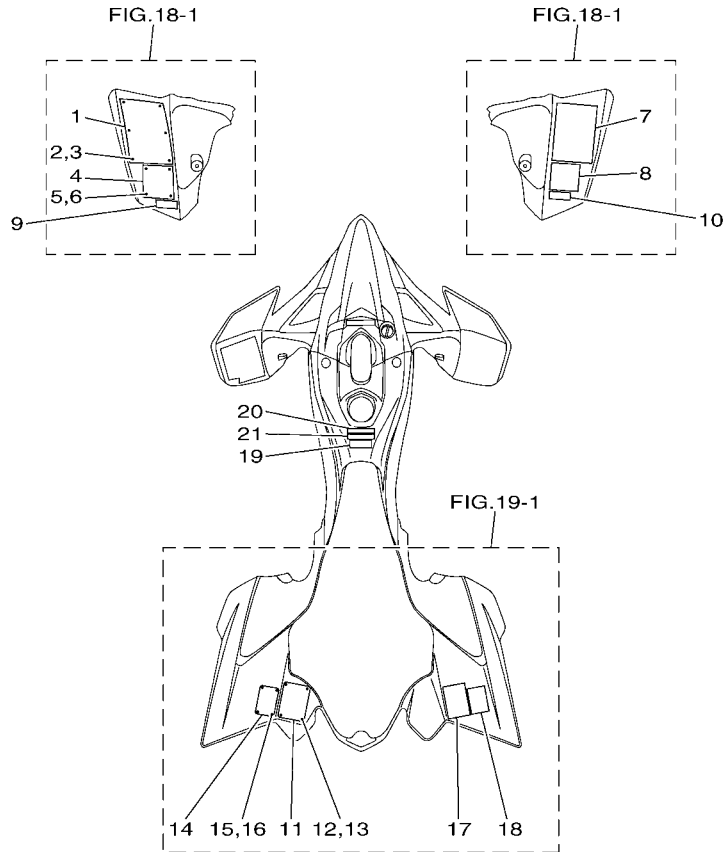
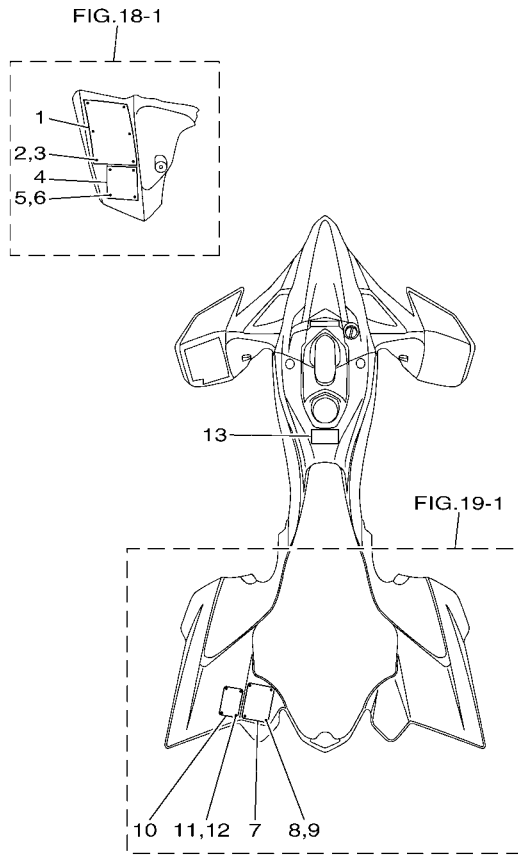

FIG. 45 EMBLEM & LABEL 1

REF. NO.	PART NO.	DESCRIPTION	CAN	EUR	OCE	JPN	REMARKS
1	5FE-21568-01	LABEL, WARNING	1				ENGLISH
2	90267-32004	RIVET, BLIND	6				
3	90201-03008	WASHER, PLATE	6				
4	4D3-2816L-00	LABEL, WARNING AGE	1				ENGLISH
5	90267-32004	RIVET, BLIND	4				
6	90201-03008	WASHER, PLATE	4				
7	4WU-21568-10	LABEL, WARNING	1				FRENCH
8	4D3-2816L-10	LABEL, WARNING AGE	1				FRENCH
9	4D3-2817J-00	PLATE, ANSI SVIA	1				ENGLISH
10	4D3-2817J-10	PLATE, ANSI SVIA	1				FRENCH
11	5D3-2816M-00	LABEL, WARNING TIRE & LOAD	1				ENGLISH
12	90267-32004	RIVET, BLIND	4				
13	90201-03008	WASHER, PLATE	4				
14	5FE-2151H-01	LABEL 5	1				ENGLISH
15	90267-32004	RIVET, BLIND	4				
16	90201-03008	WASHER, PLATE	4				
17	5D3-2816M-10	LABEL, WARNING TIRE & LOAD	1				FRENCH
18	4WU-2151H-10	LABEL 5	1				FRENCH
19	4SH-2416E-00	LABEL, CAUTION CANADA	1				ENGLISH
20	5PW-2415E-11	LABEL, CAUTION	1				ENGLISH
21	5PW-2415E-31	LABEL, CAUTION	1				FRENCH



18P1100-H460

FIG. 46 EMBLEM & LABEL 2

REF. NO.	PART NO.	DESCRIPTION	CAN	EUR	OCE	JPN	REMARKS
1	43P-2816R-01	LABEL, WARNING GENERAL INFO.		1			
2	90267-32004	RIVET, BLIND		6			
3	90201-03008	WASHER, PLATE		6			
4	4D3-2816L-20	LABEL, WARNING AGE		1			
5	90267-32004	RIVET, BLIND		4			
6	90201-03008	WASHER, PLATE		4			
7	5D3-2816M-M0	LABEL, WARNING TIRE & LOAD		1			
8	90267-32004	RIVET, BLIND		4			
9	90201-03008	WASHER, PLATE		4			
10	1AS-2816P-00	LABEL, WARNING PASSENGER		1			
11	90267-32004	RIVET, BLIND		4			
12	90201-03008	WASHER, PLATE		4			
13	5TG-2415E-00	LABEL, CAUTION		1			

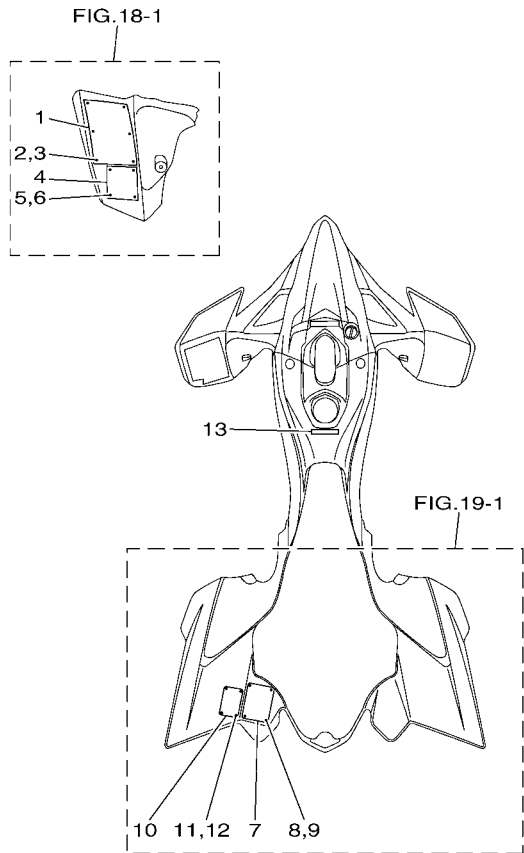

FIG. 47 EMBLEM & LABEL 3

REF. NO.	PART NO.	DESCRIPTION	CAN	EUR	OCE	JPN	REMARKS
1	5FE-21568-11	LABEL, WARNING			1		ENGLISH
2	90267-32004	RIVET, BLIND			6		
3	90201-03008	WASHER, PLATE			6		
4	4D3-2816L-00	LABEL, WARNING AGE			1		ENGLISH
5	90267-32004	RIVET, BLIND			4		
6	90201-03008	WASHER, PLATE			4		
7	5D3-2816M-00	LABEL, WARNING TIRE & LOAD			1		ENGLISH
8	90267-32004	RIVET, BLIND			4		
9	90201-03008	WASHER, PLATE			4		
10	5FE-2151H-01	LABEL 5			1		ENGLISH
11	90267-32004	RIVET, BLIND			4		
12	90201-03008	WASHER, PLATE			4		
13	5TG-2415E-10	LABEL, CAUTION			1		ENGLISH

18P1100-H470

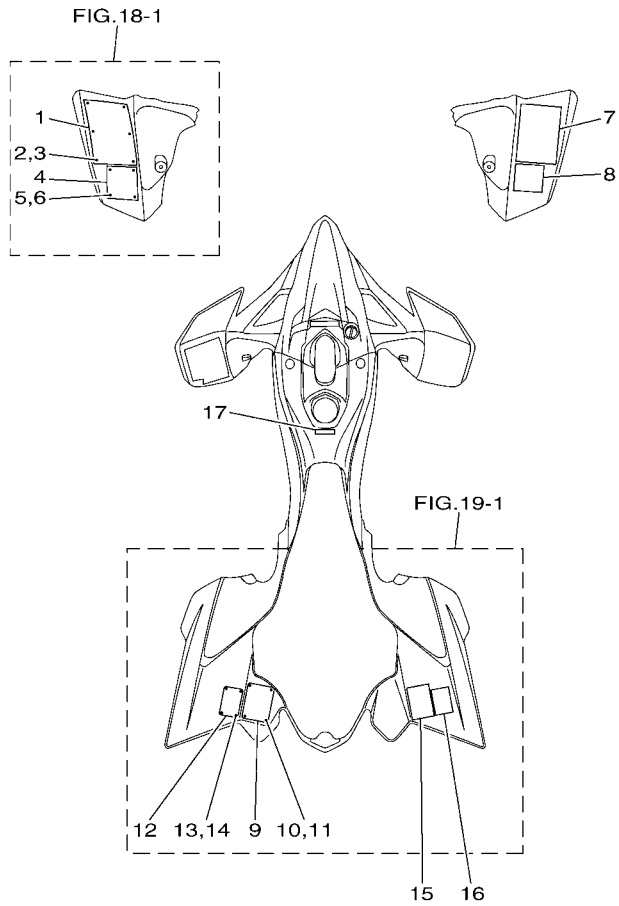

FIG. 48 EMBLEM & LABEL 4

REF. NO.	PART NO.	DESCRIPTION	CAN	EUR	OCE	JPN	REMARKS
1	5FE-21568-11	LABEL, WARNING				1	ENGLISH
2	90267-32004	RIVET, BLIND				6	
3	90201-03008	WASHER, PLATE				6	
4	4D3-2816L-00	LABEL, WARNING AGE				1	ENGLISH
5	90267-32004	RIVET, BLIND				4	
6	90201-03008	WASHER, PLATE				4	
7	4SH-21568-00	LABEL, WARNING				1	JAPANESE
8	4SH-21697-00	LABEL, CAUTION 2				1	JAPANESE
9	5D3-2816M-00	LABEL, WARNING TIRE & LOAD				1	ENGLISH
10	90267-32004	RIVET, BLIND				4	
11	90201-03008	WASHER, PLATE				4	
12	5FE-2151H-01	LABEL 5				1	ENGLISH
13	90267-32004	RIVET, BLIND				4	
14	90201-03008	WASHER, PLATE				4	
15	5D3-2816M-20	LABEL, WARNING TIRE & LOAD				1	JAPANESE
16	4LB-2151H-02	LABEL 5				1	JAPANESE
17	3FB-2415E-C1	LABEL, CAUTION				1	JAPANESE

NUMERICAL INDEX

PART NO.	REF. NO.	PART NO.	REF. NO.	PART NO.	REF. NO.	PART NO.	REF. NO.	PART NO.	REF. NO.	PART NO.	REF. NO.
18P-11102-10	1 - 1	3LD-12168-U1	3 - 13	18P-13543-00	9 - 16	2S2-15388-00	11 - 15	5YT-18113-00	16 - 27	18P-21644-00	19 - 10
5VY-1111G-00	1 - 19	3LD-12168-W1	3 - 13	8FP-13556-00	9 - 2	18P-15393-01	12 - 47	18P-18122-00	16 - 20	18P-2164F-00	19 - 19
5TA-11133-10	1 - 2	3LD-12168-Y1	3 - 13	18P-13597-00	8 - 1	18P-15411-00	12 - 1	2S2-18140-10	16 - 4	18P-2164G-00	19 - 27
5TA-11134-10	1 - 3	3LD-12169-11	3 - 13	18P-13750-00	9 - 1	18P-15413-00	12 - 52	5BE-18172-00	16 - 24	18P-2164H-00	19 - 20
18P-11166-00	1 - 21	3LD-12169-31	3 - 13	3B4-13761-00	9 - 3	5TG-15415-00	12 - 25	3XJ-18173-10	16 - 18	18P-2164J-00	19 - 28
18P-11167-00	1 - 20	3LD-12169-50	3 - 13	18P-13843-00	8 - 7	18P-1541A-00	12 - 53	3XJ-18178-00	16 - 19	18P-21652-00	19 - 15
2S2-11181-00	1 - 13	3LD-12169-70	3 - 13	18P-13907-00	25 - 15	18P-15421-00	12 - 18	3XJ-18182-00	16 - 21	18P-21691-00	19 - 26
2S2-11190-20	1 - 16	3LD-12169-90	3 - 13	18P-13971-00	25 - 21	18P-15423-00	12 - 12	3XJ-18184-00	16 - 23	4SH-21697-00	48 - 8
2S2-11193-00	1 - 23	3LD-12169-E0	3 - 13	8FP-14137-00	9 - 15	18P-15431-00	12 - 21	2S2-18185-00	16 - 3	18P-21711-20	20 - 19
2S2-11311-10	1 - 24	3LD-12169-G0	3 - 13	2H0-14147-00	9 - 14	5TA-15441-01	12 - 16	18P-18511-00	16 - 8	41R-21717-00	17 - 20
2S2-11351-00	1 - 25	3LD-12169-J0	3 - 13	5LP-14147-00	9 - 11	18P-15451-00	12 - 8	18P-18512-00	16 - 9	18P-2171A-00	20 - 15
18P-11395-00	1 - 28	3LD-12169-L0	3 - 13	5PS-14147-00	9 - 4	18P-15453-00	12 - 26	18P-18513-00	16 - 10	3YX-2171L-00	17 - 43
18P-11400-01	2 - 1	3LD-12169-N0	3 - 13	1UY-14155-00	9 - 13	18P-15462-00	12 - 41	18P-18531-00	16 - 11	18P-21721-20	20 - 20
18P-11412-00	2 - 2	3LD-12169-T0	3 - 13	1S3-14161-00	9 - 12	18P-15463-00	12 - 13	1WG-18531-01	16 - 12	18P-21731-10	20 - 22
18P-11422-00	2 - 3	18P-12170-00	4 - 1	8CC-14216-10	9 - 6	18P-15484-00	12 - 51	18P-18541-00	16 - 1	18P-2173L-00	44 - 5
18P-11454-00	2 - 14	18P-12180-00	4 - 2	18P-14348-00	9 - 17	18P-15515-00	13 - 5	2S2-18562-00	11 - 16	18P-2173T-00	19 - 7
18P-11455-00	2 - 10	5TA-12210-10	4 - 5	18P-14409-00	8 - 28	18P-15517-00	13 - 4	18P-21101-09	17 - 1	18P-2173U-00	19 - 6
18P-11531-00	2 - 11	4FM-12213-00	4 - 6	18P-14411-00	8 - 8	18P-15521-00	13 - 3	18P-2111A-00	17 - 33	18P-21741-10	20 - 23
18P-11536-00	2 - 8	18P-12233-00	4 - 12	18P-14412-00	8 - 16	18P-15560-00	13 - 1	18P-21131-00	17 - 37	5MP-21747-00	42 - 39
5TG-11603-00	2 - 19	5BE-12241-00	1 - 17	18P-1442F-00	8 - 19	5TJ-15590-00	13 - 6	18P-21190-09	17 - 2	2S2-2177M-00	17 - 40
5TG-11631-11	2 - 18	2S2-12251-00	4 - 9	18P-14435-00	8 - 29	2S2-16111-60	14 - 1	18P-21315-00	17 - 6	18P-21781-20	44 - 6
5TG-11633-10	2 - 20	18P-12252-00	4 - 10	5GH-14436-00	8 - 12	18P-16150-10	14 - 4	18P-21316-00	17 - 11		44 - 7
18P-11651-00	2 - 6	18P-12405-00	6 - 2	5TG-14451-00	8 - 13	5TA-16154-00	14 - 12	18P-21317-00	17 - 12	26H-21828-00	20 - 4
18P-11681-01	2 - 4	18P-1240A-00	6 - 1	5KM-14452-00	8 - 17	5TA-16321-00	14 - 8	18P-21335-00	17 - 34	18P-21871-00	20 - 1
5TA-12111-00	3 - 1	18P-12422-00	5 - 6	18P-14453-00	8 - 11	5VY-16321-00	14 - 9	18P-21336-00	17 - 35	20S-21875-10	20 - 3
5TA-12112-00	3 - 2	18P-12428-00	5 - 7	59V-14457-00	8 - 24	4X7-16325-00	14 - 7	18P-2133H-00	17 - 4	18P-22110-00	21 - 1
5TJ-12113-00	3 - 5	4CB-12438-00	5 - 3	5TG-14458-00	8 - 14	18P-16342-00	14 - 22	18P-21471-00	17 - 19	4X7-22129-00	21 - 8
5TA-12114-00	3 - 6	18P-1243A-00	12 - 30	5D3-14459-00	8 - 22	2S2-16351-00	14 - 6	18P-21513-00	18 - 6	55K-22129-00	21 - 23
4GY-12117-00	3 - 8	18P-12450-00	5 - 1	4ES-14462-00	8 - 23	5TG-16356-00	14 - 15	18P-21514-00	18 - 7		21 - 32
5BE-12117-00	3 - 7	5SL-12462-00	6 - 5	18P-14479-00	8 - 15	18P-16357-00	14 - 20	5FE-2151H-01	45 - 14	18P-22141-00	21 - 10
1AA-12118-00	3 - 9	18P-12467-00	20 - 13	5YP-14562-00	9 - 9	5TA-16371-10	14 - 5		47 - 10	3YF-22149-00	21 - 7
1WG-12118-00	3 - 10	5TG-12481-00	6 - 6	18P-14611-00	10 - 1	18P-16382-00	14 - 21		48 - 12	1C3-2214F-00	17 - 41
33M-12119-00	3 - 11	5BE-12564-00	12 - 55	3VD-14613-01	10 - 6	18P-17121-00	15 - 8	4LB-2151H-02	48 - 16	18P-22151-10	21 - 36
4SV-12119-00	3 - 12	18P-12576-00	6 - 9	18P-14628-00	10 - 2	18P-17131-00	15 - 7	4WU-2151H-10	45 - 18	5TG-22153-10	21 - 39
5TA-12121-00	3 - 3	18P-12577-00	6 - 10	18P-14710-01	10 - 8	18P-17141-00	15 - 6	4ES-2153E-01	44 - 3	5TG-22178-00	17 - 22
3GM-12126-00	3 - 4	18P-12671-00	6 - 4	8FA-14714-10	10 - 9	18P-17151-00	15 - 3	4SH-21568-00	48 - 7	18P-2217A-00	21 - 16
3FV-12153-10	3 - 14	2S3-12675-00	6 - 3	18P-14718-00	10 - 10	18P-17211-00	15 - 21	5FE-21568-01	45 - 1	18P-2217F-00	21 - 28
3LD-12168-00	3 - 13	583-13113-00	12 - 38	5BE-14788-00	10 - 14	18P-17221-00	15 - 12	4WU-21568-10	45 - 7	18P-22210-C0	22 - 1
3LD-12168-20	3 - 13	18P-13160-00	9 - 5	5JW-14945-00	9 - 8	18P-17231-00	15 - 15	5FE-21568-11	47 - 1	18P-22210-D0	22 - 1
3LD-12168-40	3 - 13	18P-13300-00	7 - 1	18P-15100-00	11 - 1	18P-17241-00	15 - 19		48 - 1	18P-22210-E0	22 - 1
3LD-12168-60	3 - 13	5TA-13320-00	7 - 2	2S2-15155-10	11 - 3	18P-17251-00	15 - 20	18P-21569-60	44 - 1	4AA-22259-40	22 - 2
3LD-12168-80	3 - 13	18P-13341-00	7 - 9	18P-1531A-00	8 - 34	18P-17402-00	15 - 11	18P-2159A-60	44 - 2		24 - 29
3LD-12168-A0	3 - 13	2S2-13342-00	7 - 7	18P-1532A-00	8 - 36	18P-17411-00	15 - 2	18P-21621-00	19 - 18	4AA-22259-50	22 - 2
3LD-12168-F0	3 - 13	18P-13411-00	7 - 13	18P-15362-01	12 - 6	18P-17460-00	15 - 27	4XY-21638-00	17 - 39		24 - 29
3LD-12168-H1	3 - 13	18P-13412-01	7 - 12	18P-15370-00	8 - 32	18P-17466-00	12 - 19	18P-2163A-00	19 - 39	4AA-22259-70	22 - 2
3LD-12168-K1	3 - 13	18P-13421-00	7 - 16	18P-15378-00	11 - 25	1S3-17471-00	15 - 30	18P-2163E-00	19 - 16		24 - 29
3LD-12168-M1	3 - 13	5D3-13440-00	12 - 32	4JT-15381-01	11 - 11	18P-18101-00	16 - 13	18P-2163F-00	19 - 17	18P-22361-00	21 - 38
3LD-12168-R1	3 - 13	5BE-13447-10	12 - 33	18P-15383-00	11 - 12	18P-18110-00	16 - 26	18P-21643-00	19 - 8	5TG-22475-00	21 - 15

NUMERICAL INDEX

PART NO.	REF. NO.	PART NO.	REF. NO.	PART NO.	REF. NO.	PART NO.	REF. NO.	PART NO.	REF. NO.	PART NO.	REF. NO.
18P-2247A-00	25 - 13	18P-24725-00	26 - 6	18P-25876-00	32 - 18	1NV-26304-00	31 - 12	18P-81528-00	36 - 3	18P-8361L-00	42 - 51
1S3-23147-01	21 - 49	22W-24741-00	20 - 16	18P-25886-00	34 - 30	18P-26311-00	31 - 24	18P-81801-00	37 - 2	18P-83755-00	42 - 22
18P-23317-00	34 - 32		26 - 5	5JJ-25894-01	34 - 19	18P-26335-00	31 - 27	18P-81815-00	37 - 7	5TJ-83912-00	41 - 4
18P-23350-F0	24 - 28	18P-2476U-10	19 - 2	18P-25895-00	34 - 16	5TA-26337-00	41 - 6	18P-81826-00	37 - 3	5D3-83922-00	32 - 8
18P-23350-G0	24 - 28	18P-2476V-10	19 - 3	18P-25897-00	34 - 23	18P-26341-00	31 - 29	4XV-8182A-00	37 - 6	5TG-83923-00	41 - 15
18P-23350-H0	24 - 28	1S3-25111-00	27 - 7	3B4-2589F-00	32 - 11	1C3-26342-50	31 - 28		37 - 8	437-83936-01	31 - 32
18P-23441-00	23 - 11	5LP-25117-00	27 - 9	4NK-2589H-00	32 - 5	5TG-26372-00	31 - 26	4B5-81844-00	37 - 4	5HD-83951-00	41 - 8
18P-23442-10	23 - 12	1S3-25127-01	27 - 22	1NV-26398-00	30 - 16	1NV-26398-00	31 - 11	1FK-81847-00	37 - 5	1S3-83973-11	41 - 1
18P-23501-00	24 - 37	5TG-2514A-00	28 - 32	3JD-25917-00	28 - 7	371-27114-00	26 - 3	18P-81890-00	37 - 1	5D3-83980-00	32 - 10
18P-23502-00	24 - 38	1S3-25180-00	27 - 1		28 - 21	18P-27211-01	33 - 8	18P-81940-00	42 - 45	5TG-84110-03	38 - 2
5YT-23517-00	24 - 18		27 - 4		30 - 17	18P-27217-00	33 - 9	18P-81948-00	42 - 11	18P-8411K-00	39 - 6
	24 - 19	5TG-25311-20	21 - 45	3JD-25919-00	28 - 8	4SS-27218-00	34 - 8	5DM-81950-00	42 - 67		40 - 6
18P-23540-00-33	24 - 7	5TG-25317-00	21 - 48		28 - 22	2YK-27222-00	34 - 9	5EA-81950-20	42 - 65	5TG-84140-01	38 - 4
18P-23550-00-33	24 - 10	18P-25381-00	29 - 17	5TG-25924-00	28 - 15	18P-27263-00	34 - 25	5EA-81952-00	42 - 66	18P-84165-00	38 - 3
18P-23570-00-33	24 - 1	18P-25383-00	29 - 4		28 - 29	18P-27411-00	33 - 1	5BN-81960-00	42 - 25	18P-84166-00	38 - 11
5LP-23579-00	24 - 2	18P-25386-00	29 - 11	3JD-25926-00	28 - 12	4HC-27415-00	42 - 40	3WP-81980-00	42 - 61	5TG-84310-03	38 - 10
	24 - 5	1S3-25390-00	29 - 1		28 - 26	18P-27421-00	33 - 4	4WA-81980-00	42 - 60	4KB-84314-01	38 - 1
	24 - 8	18P-25415-00	29 - 21	1UY-25926-51	28 - 10	18P-2743E-00	34 - 31	5XT-82100-00	42 - 32		38 - 9
	24 - 11	5TG-25438-10	29 - 12		28 - 24	18P-27453-00	34 - 11	1S4-82100-10	42 - 32	5TG-84340-01	38 - 12
18P-23580-00-33	24 - 4	5D3-25689-00	41 - 13	3SP-25926-51	30 - 18	18P-28100-01	17 - 47	18P-82116-00	42 - 43	18P-84703-00	39 - 8
1UY-23812-00	23 - 16	18P-25712-00	29 - 15	5DH-25933-00	30 - 14	1NV-2811A-01	17 - 48	18P-82122-00	42 - 33	1S3-84710-01	39 - 1
18P-23813-00	23 - 1	5TG-25721-20	21 - 50	3LD-25934-01	30 - 12	4D3-2816L-00	45 - 4	4D3-82122-00	42 - 38		40 - 1
18P-23816-00	23 - 2	5TG-25726-01	41 - 14	1UY-25937-51	28 - 6		47 - 4	18P-82128-00	42 - 34	18P-84716-00	39 - 5
18P-23831-00	23 - 3	5TG-25727-01	41 - 12		28 - 20		48 - 4	18P-82129-00	42 - 37		40 - 5
1S3-23841-20	23 - 4	1S3-2580E-00	34 - 1		30 - 15	4D3-2816L-10	45 - 8	18P-8212B-00	42 - 71	18P-84751-00	39 - 11
1S3-23845-20	23 - 5	5TG-2580T-11	28 - 3	1UY-25938-51	28 - 11	4D3-2816L-20	46 - 4	5ND-82180-00	42 - 58	2EK-85111-00	43 - 7
1UY-23868-01	23 - 18	5TG-2580U-11	28 - 17		28 - 25	5D3-2816M-00	45 - 11	18P-82310-00	42 - 8	3Y6-85130-02	43 - 1
5GT-23872-00	17 - 30	5TG-2580W-20	30 - 3	3JD-25961-00	28 - 13		47 - 7	18P-82370-00	42 - 10	449-85131-02	43 - 4
1UY-23894-01	23 - 20	1S3-25828-00	28 - 16		28 - 27		48 - 9	5S7-82380-00	8 - 4	8CC-85790-01	42 - 20
18P-24110-00	25 - 1		28 - 30	5TG-25972-00	30 - 11	5D3-2816M-10	45 - 17	18P-8246B-00	42 - 63	3B4-85885-00	9 - 7
18P-24110-10	25 - 1	1AE-2582A-00	34 - 3	1UY-25973-51	30 - 10	5D3-2816M-20	48 - 15	4SH-82510-00	42 - 47	8FP-85886-00	8 - 9
18P-2414H-00	25 - 12	3GD-2582T-10	28 - 1	1UY-25974-51	30 - 9	5D3-2816M-M0	46 - 7	5RU-8252U-00	42 - 77	18P-8591A-11	42 - 1
5TG-2415E-00	46 - 13	1S3-2582W-20	30 - 1	5TG-25975-00	30 - 6	1AS-2816P-00	46 - 10	18P-82530-00	42 - 62	18P-85991-00	42 - 3
5TG-2415E-10	47 - 13	5MV-25833-00	32 - 7	5TG-25977-50	30 - 20	43P-2816R-01	46 - 1	3GB-82540-01	42 - 18	18P-87208-00	42 - 27
5PW-2415E-11	45 - 20	5UG-25833-00	30 - 7	5TG-25978-00	30 - 8	4D3-2817J-00	45 - 9	18P-82541-00	42 - 44	5D3-W0041-00	32 - 2
5PW-2415E-31	45 - 21	5D3-2583T-01	32 - 1	5D3-26111-11	31 - 1	4D3-2817J-10	45 - 10	18P-8254E-00	42 - 75	1S3-W0042-50	34 - 2
3FB-2415E-C1	48 - 17	5D3-25852-00	32 - 4	18P-26124-00	31 - 30	18P-28215-00	35 - 9	5ND-82560-00	42 - 59	5TG-W0045-20	28 - 14
4SH-2416E-00	45 - 19	3XP-25852-50	34 - 20	1NV-26129-00	31 - 16	5TG-28215-00	35 - 8	3HN-82569-00	42 - 49	5TG-W0045-30	28 - 28
1S3-24486-00	25 - 17	2VN-25854-00	34 - 21	5D3-26219-10	31 - 31	4XY-28347-00	17 - 42	5PS-82576-01	42 - 68	5TG-W0046-10	30 - 13
18P-24491-00	25 - 16	4TT-25854-00	32 - 3	18P-2622H-00	31 - 5	4KN-2836B-10	44 - 4	3HN-82579-00	42 - 48	5TG-W0047-00	30 - 5
5KM-24610-00	25 - 2	2VN-25855-00	34 - 22	5LP-26241-00	31 - 4	2C0-28372-00	42 - 56	18P-82590-00	42 - 57	3LC-W0047-50	28 - 5
18P-2464V-00	25 - 19	2GU-25866-00	32 - 23	1S3-26250-00	31 - 7	18P-2845N-00	35 - 1	18P-82590-10	42 - 57		28 - 19
18P-2467E-00	25 - 20	5LP-25867-00	32 - 6	1UY-26259-00	31 - 25	18P-2845N-10	35 - 1	18P-82910-00	41 - 2	1UY-W0048-50	28 - 9
18P-2470F-00	26 - 2	18P-25871-10	32 - 20	1NV-26259-01	31 - 13	18P-2845R-00	35 - 3	5TG-82911-00	41 - 3		28 - 23
18P-24710-00	26 - 1	18P-25872-10	32 - 15	1S3-2625G-00	31 - 17	18P-2845R-10	35 - 3	1S3-82913-00	31 - 21		30 - 19
18P-24723-00	26 - 7	18P-25873-10	32 - 16	1NV-2625K-00	31 - 14	4D9-81168-00	42 - 23	5TG-82913-00	41 - 10	5TG-W0057-00	28 - 4
3KJ-24723-00	17 - 38	18P-25874-00	34 - 27	1S3-2628F-00	31 - 8	18P-81410-00	36 - 1	5KM-82917-00	41 - 9		28 - 18
214-24724-00	26 - 4	18P-25875-00	32 - 17	1S3-2628G-00	31 - 9	18P-81450-00	36 - 2	18P-83530-00	42 - 50	5TG-W0057-10	30 - 4

NUMERICAL INDEX

PART NO.	REF. NO.	PART NO.	REF. NO.	PART NO.	REF. NO.	PART NO.	REF. NO.	PART NO.	REF. NO.	PART NO.	REF. NO.
18P-W215B-02	18 - 1	90110-06168	36 - 4	90183-061A5	20 - 24	90201-06078	42 - 54	90240-08124	34 - 13	90387-06170	20 - 25
18P-W215C-00	18 - 1		36 - 6		35 - 10	90201-06085	18 - 5	90252-03001	29 - 10	90387-06197	17 - 46
18P-W215D-00	18 - 1	90110-06169	36 - 5	90185-10011	17 - 16		19 - 14	90267-24143	31 - 3	90387-06204	39 - 3
18P-W216B-01	19 - 1	90110-06208	7 - 14		17 - 18		20 - 18	90267-32004	19 - 4		40 - 3
18P-W216C-00	19 - 1	90110-06228	12 - 36		29 - 14	90201-08043	17 - 24		45 - 2		42 - 29
18P-W216D-00	19 - 1	90110-10029	17 - 9	90185-10012	24 - 24		19 - 38		45 - 5		42 - 53
18P-W8211-10	42 - 41	90110-12001	21 - 54		24 - 25	90201-08048	10 - 16		45 - 12	90387-06205	19 - 23
90101-05033	41 - 11	90111-06059	39 - 9		24 - 31		19 - 35		45 - 15		19 - 31
90101-06041	16 - 25	90111-06084	20 - 26		24 - 35	90201-08053	17 - 8		46 - 2	90387-06257	25 - 9
90102-12005	22 - 7		42 - 17	90185-12002	21 - 25	90201-08077	33 - 10		46 - 5	90387-06258	25 - 4
90105-06027	1 - 4	90111-06116	18 - 3		21 - 27	90201-08083	34 - 14		46 - 8	90387-06388	42 - 5
90105-06063	34 - 33		19 - 13		22 - 5	90201-10025	1 - 15		46 - 11	90387-07030	4 - 11
90105-06081	11 - 17		20 - 17		23 - 14	90201-10032	14 - 23		47 - 2	90387-07391	6 - 14
90105-06084	8 - 31	90113-06055	29 - 20	90185-12007	21 - 34	90201-10035	24 - 32		47 - 5	90387-08073	8 - 30
	17 - 45	90114-10006	27 - 8	90185-14009	23 - 23	90201-10036	17 - 10		47 - 8	90387-086N4	17 - 25
	42 - 35	90114-10013	29 - 5	90185-16002	21 - 12	90201-10037	24 - 22		47 - 11	90387-090R0	23 - 21
	42 - 73	90116-08022	1 - 11	90201-03008	19 - 5		24 - 23		48 - 2	90387-10043	24 - 17
90105-08112	17 - 26	90119-06152	20 - 2		45 - 3		24 - 36		48 - 5		24 - 34
90105-08129	10 - 15	90119-06177	34 - 24		45 - 6	90201-10043	17 - 14		48 - 10	90387-10069	24 - 16
90105-08154	23 - 13	90119-06181	6 - 15		45 - 13	90201-10118	32 - 25		48 - 13	90387-101R3	24 - 15
90105-08184	28 - 31	90122-06010	8 - 27		45 - 16		34 - 28	90267-47187	21 - 40	90387-12041	21 - 21
90105-10135	24 - 20	90149-04278	31 - 18		46 - 3	90201-12020	36 - 8	90267-48025	8 - 20	90387-12042	21 - 30
90105-10148	17 - 17	90149-06069	2 - 15		46 - 6	90201-12032	21 - 35	90267-48176	17 - 5	90387-12043	21 - 19
90105-10163	1 - 14		7 - 8		46 - 9		22 - 4	90269-05001	17 - 36	90387-12046	22 - 6
90105-101A9	30 - 21	90149-06074	11 - 14		46 - 12	90201-12034	22 - 8	90269-07010	20 - 21	90387-150R1	27 - 18
90105-10301	24 - 21	90149-06117	28 - 33		47 - 3		23 - 15	90269-07076	20 - 14	90387-16014	21 - 55
90105-10339	24 - 30	90149-08044	30 - 2		47 - 6	90201-12166	7 - 11	90280-03006	2 - 17	90387-16027	21 - 5
90105-10350	17 - 15	90149-10034	17 - 3		47 - 9	90201-125L6	14 - 17	90338-05008	42 - 16	90387-160W1	21 - 6
90105-10351	24 - 33	90151-08003	11 - 13		47 - 12	90201-127E1	16 - 15	90338-07007	41 - 17	90387-164N2	11 - 20
90105-12038	22 - 3	90154-05043	19 - 21		48 - 3	90201-14021	23 - 22	90338-08226	42 - 12	90387-17013	23 - 26
90105-12064	21 - 24		19 - 29		48 - 6	90201-14586	27 - 19	90338-12192	42 - 36	90387-176R6	23 - 25
90105-12065	21 - 26	90159-06010	14 - 11		48 - 11	90201-15701	12 - 23	90338-16007	17 - 32	90387-20005	27 - 16
90105-12066	21 - 33	90170-12054	23 - 7		48 - 14	90201-16018	21 - 11	90338-20183	17 - 31	90387-26005	15 - 18
90108-05001	33 - 12	90170-12055	23 - 6	90201-04027	21 - 41	90201-16023	29 - 8	90338-23004	21 - 9	90387-28009	15 - 25
90109-06031	16 - 28	90170-14171	2 - 12	90201-04028	8 - 21	90201-20022	27 - 17	90340-12007	1 - 5	90387-40001	29 - 16
90109-06034	41 - 5	90170-20327	14 - 14	90201-04030	42 - 70	90201-20276	15 - 22	90340-14011	12 - 4	90401-10015	32 - 24
90109-06172	20 - 27	90171-10001	23 - 8	90201-05015	10 - 3	90201-22015	15 - 28	90340-36002	12 - 2		34 - 29
	21 - 37		24 - 40		10 - 12	90208-25045	14 - 2	90380-10002	11 - 4	90430-06014	1 - 9
90109-06198	16 - 6	90171-14002	27 - 20	90201-06013	16 - 7	90208-39001	29 - 19	90380-22111	21 - 3		4 - 8
	17 - 21	90171-16002	29 - 9	90201-06033	18 - 4	90209-06096	8 - 26	90381-15088	24 - 13		5 - 10
	18 - 10	90179-12657	36 - 7		21 - 44	90209-10229	23 - 9		24 - 14		11 - 27
90109-06199	1 - 18	90179-20009	14 - 3		25 - 5		24 - 39	90387-02001	31 - 2	90430-10148	11 - 10
90109-06203	19 - 40	90179-22018	15 - 29		25 - 8	90209-23012	15 - 4	90387-06063	35 - 5		42 - 19
90109-06249	32 - 19	90179-38001	29 - 18	90201-06076	19 - 25	90209-26008	15 - 13	90387-06136	38 - 6	90430-12202	42 - 21
90109-06264	28 - 2	90183-060A6	42 - 13		19 - 33	90214-26002	15 - 16		38 - 14	90445-08008	25 - 11
90109-08082	29 - 13	90183-061A5	18 - 2	90201-06078	38 - 8	90214-26003	15 - 17	90387-06151	21 - 43	90445-09123	20 - 9
90109-10013	4 - 13		18 - 8		38 - 16	90215-14287	2 - 13	90387-06153	42 - 74	90445-09251	20 - 8
90110-06168	13 - 7		19 - 12		42 - 30	90215-20005	14 - 13	90387-06161	42 - 15	90445-11418	17 - 44

NUMERICAL INDEX

PART NO.	REF. NO.	PART NO.	REF. NO.	PART NO.	REF. NO.	PART NO.	REF. NO.	PART NO.	REF. NO.	PART NO.	REF. NO.
90450-32015	6 - 12	90501-043E0	12 - 40	92902-05100	43 - 2	93306-20353	2 - 9	95022-06025	37 - 9	97012-08035	17 - 7
90450-54009	8 - 6	90501-052G5	16 - 22		43 - 5	93306-20532	15 - 1	95022-06030	5 - 9	97022-08065	23 - 19
90450-58005	8 - 3	90501-231E9	14 - 10		43 - 9	93306-27803	15 - 23		12 - 28	97702-50025	39 - 4
90450-99014	8 - 18	90506-25001	33 - 7	92902-05200	43 - 8	93306-30644	2 - 7		12 - 44		40 - 4
90461-10135	11 - 23	90508-16061	14 - 28	92902-06200	10 - 13	93306-90509	16 - 2	95022-06035	1 - 10	97702-60125	8 - 5
90462-10056	11 - 22	90508-26021	16 - 5	92902-10200	27 - 15	93310-11268	13 - 2		1 - 27		42 - 9
90464-08051	12 - 49	90508-32136	16 - 14		29 - 7	93310-73606	2 - 5		12 - 11	98502-04014	32 - 12
90464-12001	42 - 42	90520-08001	25 - 14	92903-08600	21 - 14	93311-62574	2 - 16	95022-06040	12 - 29	98502-05010	8 - 10
90464-12036	42 - 7	91312-04006	9 - 18	92906-04100	34 - 6	93315-31758	21 - 20		12 - 43	98502-05020	31 - 20
90464-13073	42 - 79	91312-04025	42 - 69	92906-04600	34 - 7		21 - 29	95022-06065	12 - 10		31 - 22
90464-15065	20 - 11	91312-06014	1 - 29	92990-06200	10 - 5	93315-32056	21 - 17	95022-06080	12 - 46	98506-04012	34 - 5
90464-15157	39 - 7	91312-06016	11 - 8	93101-12173	5 - 4	93317-11287	14 - 25	95022-10016	11 - 9	98507-06012	9 - 10
	40 - 7		11 - 24	93101-14164	12 - 22	93317-22237	21 - 2	95302-05600	43 - 3	98902-06010	10 - 11
90464-15M08	20 - 12		12 - 17	93102-12224	14 - 26	93340-21505	14 - 16		43 - 6	98980-06010	10 - 4
90464-16001	20 - 10		12 - 48		16 - 17	93410-26067	15 - 5	95302-05700	31 - 19	99009-10400	14 - 24
	31 - 33		12 - 54	93102-22216	27 - 13	93410-67085	21 - 53	95302-06800	25 - 18	99009-12400	5 - 2
90465-08127	12 - 45		42 - 24	93102-25081	17 - 28	93440-10085	14 - 18	95312-06600	32 - 22		7 - 10
90465-10098	42 - 76	91312-06020	8 - 2	93102-25099	17 - 29	93440-10153	7 - 4	95602-05100	31 - 10	99009-20500	14 - 27
90465-13M11	42 - 78		12 - 37	93102-35393	15 - 24	93440-28062	15 - 14	95602-05200	33 - 13	99009-22500	12 - 24
90467-070A0	12 - 31	91312-06025	12 - 20	93104-09025	31 - 15	93440-41178	4 - 3	95602-06100	41 - 7	99009-30400	24 - 3
90467-08003	20 - 6	91312-06030	7 - 6	93105-26026	27 - 12	93450-22027	2 - 21	95602-06200	19 - 24		24 - 6
	20 - 7	91312-06050	11 - 5	93106-22019	21 - 4	93503-08007	12 - 39		19 - 32		24 - 9
90467-11019	20 - 5	91312-06060	11 - 6	93106-48001	21 - 47	93515-32029	14 - 19		39 - 10		24 - 12
90467-11044	34 - 17	91312-06080	11 - 7	93109-17071	21 - 22	93603-16219	7 - 3		39 - 13	99530-08012	7 - 5
90467-12052	8 - 38	91314-08040	21 - 13		21 - 31	93604-10011	5 - 8	95602-08200	19 - 36		12 - 14
90467-14057	34 - 18	91401-16012	34 - 15	93109-20001	21 - 18	93608-30002	16 - 16	95604-06100	32 - 9	99530-08016	12 - 9
90467-140A6	8 - 35	91402-20020	23 - 10	93112-31011	23 - 17	93612-16254	1 - 26	95702-08500	10 - 7		12 - 27
	8 - 37		24 - 41	93210-07135	12 - 35	93700-06004	24 - 26	95702-10500	27 - 14	99530-10114	7 - 15
	12 - 50	91402-20025	23 - 24	93210-10197	11 - 19		24 - 27		29 - 6		11 - 18
90467-220A1	8 - 25	91402-30025	22 - 9	93210-14369	12 - 5	93900-00022	29 - 3	95802-06020	42 - 26	99530-10120	12 - 42
90467-23109	6 - 11		27 - 21	93210-15620	34 - 4	93900-00030	27 - 3	95802-06025	38 - 7	99530-14016	11 - 2
90468-100A1	1 - 22	91808-16023	1 - 6	93210-16500	6 - 8		27 - 6		38 - 15		11 - 21
90468-16191	33 - 11		1 - 7	93210-19026	12 - 7	94107-10025	27 - 2		42 - 31		
90480-01559	18 - 9	92012-06012	39 - 12	93210-19758	12 - 56		27 - 5	95812-06016	42 - 2		
90480-10289	35 - 4	92012-06014	41 - 16	93210-25001	15 - 26	94110-09025	29 - 2	95812-06020	35 - 6		
	42 - 28	92012-06016	41 - 18	93210-357A3	12 - 3	94582-13098	29 - 23		42 - 6		
	42 - 52	92012-06025	42 - 55	93210-37003	29 - 22	94591-57120	4 - 4	95812-06025	21 - 42		
90480-11006	31 - 6	92012-06030	19 - 22	93210-47675	12 - 34	94701-00330	1 - 12	95812-06030	25 - 10		
90480-12007	42 - 72		19 - 30	93210-66001	21 - 52	94703-00330	1 - 12	95812-06110	8 - 33		
90480-14011	42 - 4	92012-06040	25 - 6	93210-71001	21 - 51	95022-06008	42 - 46	95812-08020	35 - 2		
90480-14102	38 - 5	92012-08012	34 - 12	93300-60804	17 - 23	95022-06010	1 - 8		35 - 7		
	38 - 13	92012-08016	19 - 9	93304-20812	21 - 46		42 - 64	95812-10030	17 - 13		
90480-14323	39 - 2		19 - 11	93306-00106	5 - 5	95022-06012	6 - 7	95812-12025	33 - 2		
	40 - 2	92012-08020	19 - 37	93306-00426	15 - 10		11 - 26	95812-12035	33 - 5		
	42 - 14	92012-08035	34 - 10	93306-00446	27 - 10		34 - 26	95812-12055	33 - 3		
90480-15058	6 - 13	92902-04100	32 - 13	93306-20231	27 - 11	95022-06014	15 - 31	95812-12065	33 - 6		
90480-18004	25 - 3	92902-04600	32 - 14	93306-20332	15 - 9	95022-06020	12 - 15	95822-06035	32 - 21		
90480-18290	25 - 7	92902-05100	31 - 23	93306-20352	17 - 27	95022-06025	4 - 7	95822-08025	19 - 34		