

**PARTS
CATALOGUE
CATALOGO
DE REPUESTOS**

9.9FMH'01 (63V0)

15FMH '01 (63W0)

E9.9CMH'01 (65E0)

E15CMH '01 (65F0)

2Z63V-200S1

YAMAHA
GENUINE
Parts & Accessories

FOREWORD

This Parts Catalogue is related to the parts for the model(s) in the below frame. When you are ordering replacement parts, please refer to this Parts Catalogue and quote both part numbers and part names correctly.

9.9FMH'01(63V0), 15FMH'01(63W0),
E9.9CMH'01(65E0), E15CMH'01(65F0)

1. Modifications or additions which have been made after issue of the Parts Catalogue will be announced in the Yamaha Parts News.
It is advisable that you make necessary corrections to the Parts Catalogue according to the Yamaha Parts News.

2. Abbreviations
The Following abbreviations are used in this Parts Catalogue.

- "UR" Use specified parts number.
- "UN" Use as many as needed.
- "AP" Alternate Parts
- "LM" Local Made
(Parts need to be ordered locally)
- "O/S" Over Size

3. Parts, which are to be supplied in an assembly, are listed with a dot(.) in front of the part name as shown below.

EXAMPLE
CARBURETOR ASSY
.JET, PILOT
.NOZZLE, MAIN

4. Number of component for assembly
The numeral appearing to the right of each component part indicates the quantity of parts for each assembly unit.

EXAMPLE

PART NO.	DESCRIPTION	U	H	L	REMARKS
6E0-85500-70	C.D.I. MAGNETO ASSY	1			
6E0-85550-70	.ROTOR ASSY	1			
6E0-15723-00-94.	.PULLY, STARTER	1			

5. Quantity Column Information

NAME for Q'TY COLUMN	APPLICABLE MODEL
9.9F	9.9FMH
15F	15FMH
E99C	E9.9CMH
E15C	E15CMH

6. Applicable Starting Serial No. and Color Code

1) Engine Starting Sserial No.

<p>9.9FMH S : 171593 L : 468360</p> <p>15FMH S : 427129 L : 163609</p>	<p>E9.9CMH S : 101485 L : 412732 U : 950116</p> <p>E15CMH S : 151711 L : 526204 U : 700136</p>
--	--

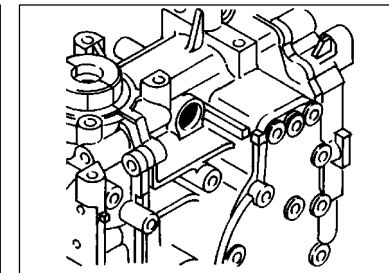
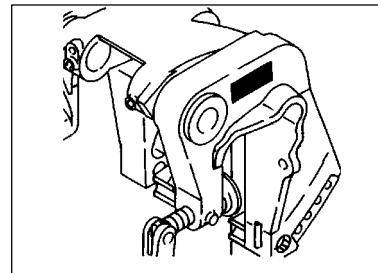

2) Color Code

Color Code	Color Name	Abbreviation
004D	DARK BLuish GRAY METALLIC 2	DBNM2

7. Note that the illustrations for reference in finding parts numbers, not to be used for assembling. When assembling, please use the applicable service manual.

8. The asterisk (*) before a reference number indicates modification items after the first edition.

CONTENTS

TOP COWLING	A4
CYLINDER, CRANKCASE	A5
CRANKSHAFT, PISTON	A7
INTAKE	B2
CARBURETOR	B3
FUEL	B5
STARTER	B6
GENERATOR	C1
ELECTRICAL	C2
BOTTOM COWLING	C3
STEERING	C4
CONTROL	C6
REMOTE CONTROL ATTACHMENT	D1
BRACKET 1	D2
BRACKET 2	D4
UPPER CASING	D6
LOWER CASING, DRIVE 1	D7
LOWER CASING, DRIVE 2	E3
FUEL TANK	E5
STEERING GUIDE	E6
REMOTE CONTROL BOX	E7
REMOTE CONTROL ASSY	F1
REPAIR KIT 1	F3
REPAIR KIT 2	F4
INDEX	
NUMERICAL INDEX	F6

FIG. 1 TOP COWLING

SOPORTE SUPERIOR

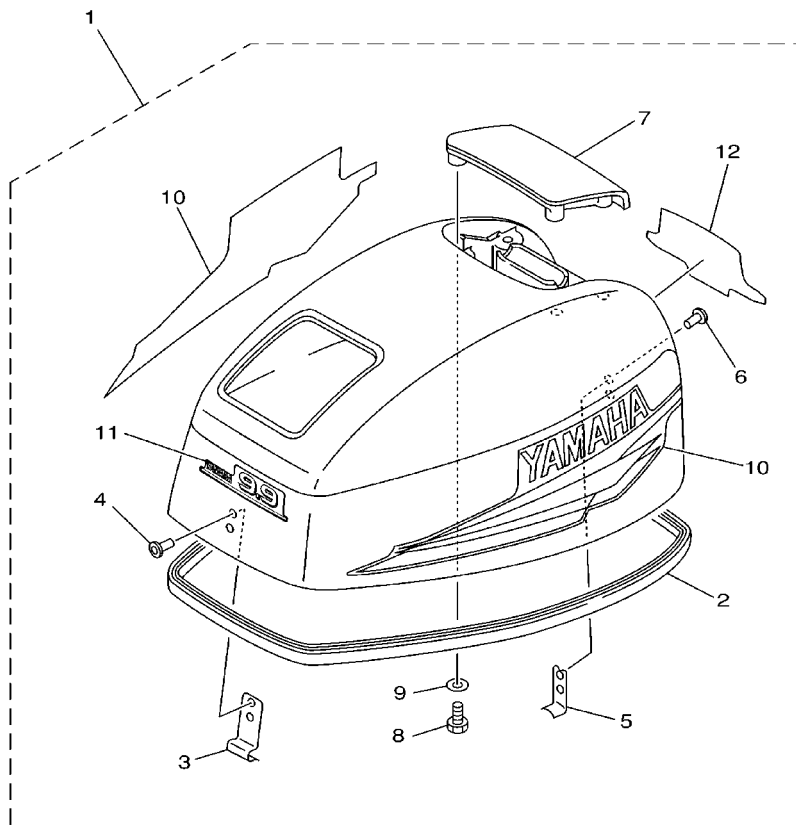

REF. NO.	PART NO. CODIGO NO.	DESCRIPTION DESCRIPTION	9.9F	15F	E99C	E15C	REMARKS OBSERVACION
1	63V-42610-12-4D	TOP COWLING ASSY SOPORTE SUPERIOR COMPL.	1				
	63W-42610-12-4D	TOP COWLING ASSY SOPORTE SUPERIOR COMPL.		1			
	65E-42610-H2-4D	TOP COWLING ASSY SOPORTE SUPERIOR COMPL.			1		
	65F-42610-H2-4D	TOP COWLING ASSY SOPORTE SUPERIOR COMPL.				1	
	65F-42610-J1-4D	TOP COWLING ASSY SOPORTE SUPERIOR COMPL.				1	FOR SIDE SHIFT
2	63V-42615-00	.SEAL .SELLO	1	1	1	1	
3	6G1-42651-02	.HOOK .GANCHO	1	1	1	1	
4	90266-04M04	.RIVET .REMACHE	2	2	2	2	
5	6L2-42647-00	.HOLDER, CLAMP BAND .MORDAZA DE ABRAZADERA	1	1	1	1	
6	90266-04M04	.RIVET .REMACHE	2	2	2	2	
7	63V-42613-00-4D	MOLDING, AIR DUCT .MOLDURA CONDUCTO AIRE	1	1	1	1	
8	97095-06016	.BOLT .PERNO	4	4	4	4	
9	92995-06600	.WASHER .ARANDELA	4	4	4	4	
10	63V-W0070-11	.GRAPHIC SET .JUEGO DE EMBLEMA	1	1			
	65E-W0070-H0	.GRAPHIC SET .JUEGO DE EMBLEMA			1		
	65F-W0070-H0	.GRAPHIC SET .JUEGO DE EMBLEMA				1	
11	63V-42677-11	.GRAPHIC, FRONT .CALCAMONIA FRONTAL	1				
	63W-42677-11	.GRAPHIC, FRONT .CALCAMONIA FRONTAL		1			
	682-42677-H0	.GRAPHIC, FRONT .CALCAMONIA FRONTAL			1	1	
12	63V-42678-10	.GRAPHIC, REAR .CALCAMONIA TRASERA	1				
	63W-42678-10	.GRAPHIC, REAR .CALCAMONIA TRASERA		1			
	65E-42678-H0	.GRAPHIC, REAR .CALCAMONIA TRASERA			1		
	65F-42678-H0	.GRAPHIC, REAR .CALCAMONIA TRASERA				1	



63V0100-0010

1
**CRANK CYLINDER
 ASSY**
 (Fig. 2, Ref. No. 2 to 27
 Fig. 3, Ref. No. 1 to 29)

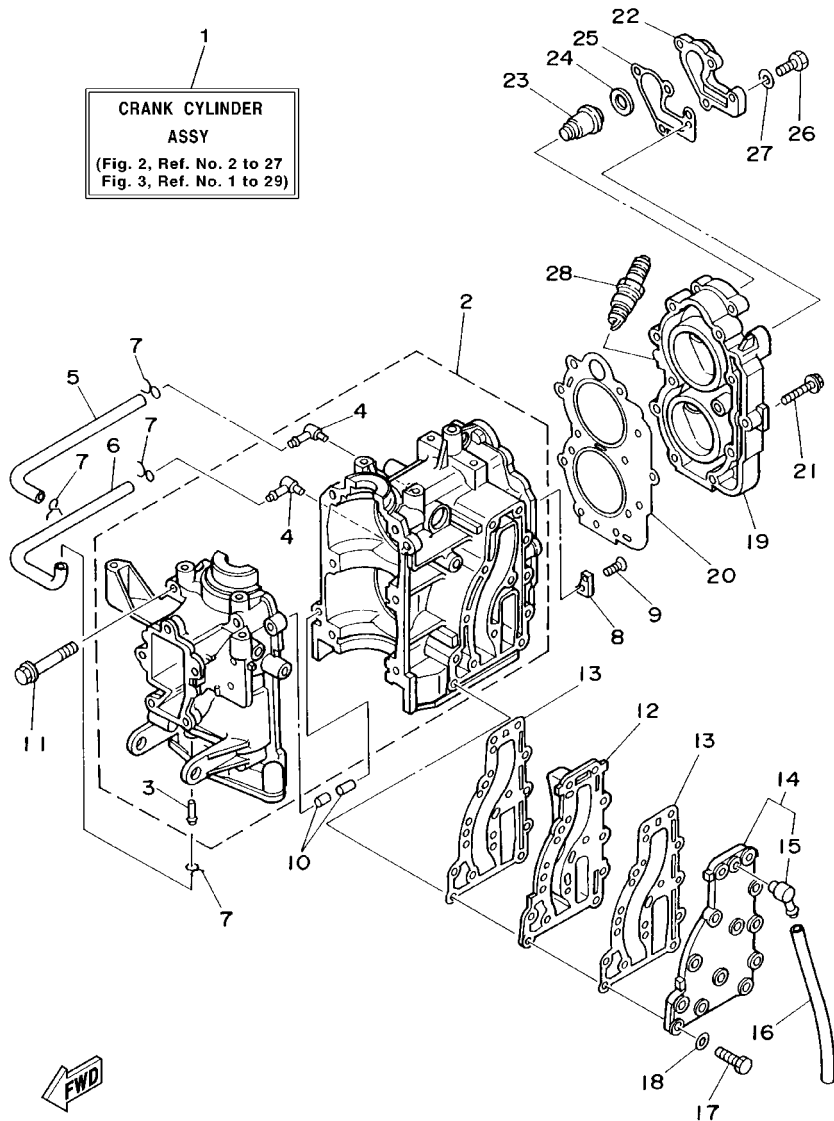

63V0010-5020

FIG. 2 CYLINDER, CRANKCASE CYLINDRO, CARTER

REF. NO.	PART NO. CODIGO NO.	DESCRIPTION DESCRIPTION	9,9F	15F	E99C	E15C	REMARKS OBSERVACION
1	63V-W0090-03-1S	CRANK CYLINDER ASSY BLOQUE MOTOR COMPLETO	1	1	1	1	
2	63V-15100-02-1S	CRANKCASE ASSY CARTER COMPLETO	1	1	1	1	
3	624-14485-00	.PIPE, JOINT .TUBO DE UNION	1	1	1	1	
4	650-14485-02	.PIPE, JOINT .TUBO DE UNION	2	2	2	2	
5	90445-07M08	HOSE (L220) TUBO (L220)	1	1	1	1	
6	90445-07M08	HOSE (L220) TUBO (L220)	1	1	1	1	
7	90467-06016	CLIP PRESILLA	4	4	4	4	
8	682-11325-00	ANODE ANODO	1	1	1	1	
9	98780-05015	SCREW, FLAT HEAD TORNILLO DE CABEZA PLANA	1	1	1	1	
10	93606-12019	PIN, DOWEL PASADOR DE CLAVIJA	2	2	2	2	
11	90119-08M07	BOLT, WITH WASHER TORNILLO CON ARANDELA	6	6	6	6	
12	63V-41111-00-1S	INNER COVER, EXHAUST CUBIERTA INTERIOR DE ESCAPE	1	1	1	1	
13	63V-41112-A0	GASKET, EXHAUST INNER COVER EMPAQUE	2	2	2	2	
14	63V-41113-00-1S	OUTER COVER, EXHAUST CUBOERTA EXTERIOR DE ESCAPE	1	1	1	1	
15	676-11372-00	.NIPPLE, HOSE .NIPLE DE MANGUERA	1	1	1	1	
16	90445-09105	HOSE (L300) TUBO (L300)	1	1	1	1	
17	97013-06030	BOLT PERNO	13	13	13	13	
18	92903-06600	WASHER, PLATE ARANDELA	13	13	13	13	
19	6E7-11111-01-1S	HEAD, CYLINDER 1 CULATA CILINDRO 1	1	1	1	1	
20	63V-11181-A1	GASKET, CYLINDER HEAD 1 JUNTA, DE CULATA 1	1	1	1	1	
21	90105-07M05	BOLT, WASHER BASED TORNILLO CON ARANDELA	11	11	11	11	
22	682-12413-00-1S	COVER, THERMOSTAT CUBIERTA TERMOSTATO	1	1	1	1	
23	6E5-12411-20	THERMOSTAT TERMOSTAT	1	1	1	1	
24	90201-16M03	WASHER, PLATE ARANDELA PLANA	1	1	1	1	
25	682-12414-A1	GASKET, COVER EMPAQUE	1	1	1	1	
26	97013-06020	BOLT PERNO	4	4	4	4	
27	92903-06600	WASHER, PLATE ARANDELA	4	4	4	4	

**CRANK CYLINDER
ASSY**
(Fig. 2, Ref. No. 2 to 27
Fig. 3, Ref. No. 1 to 29)

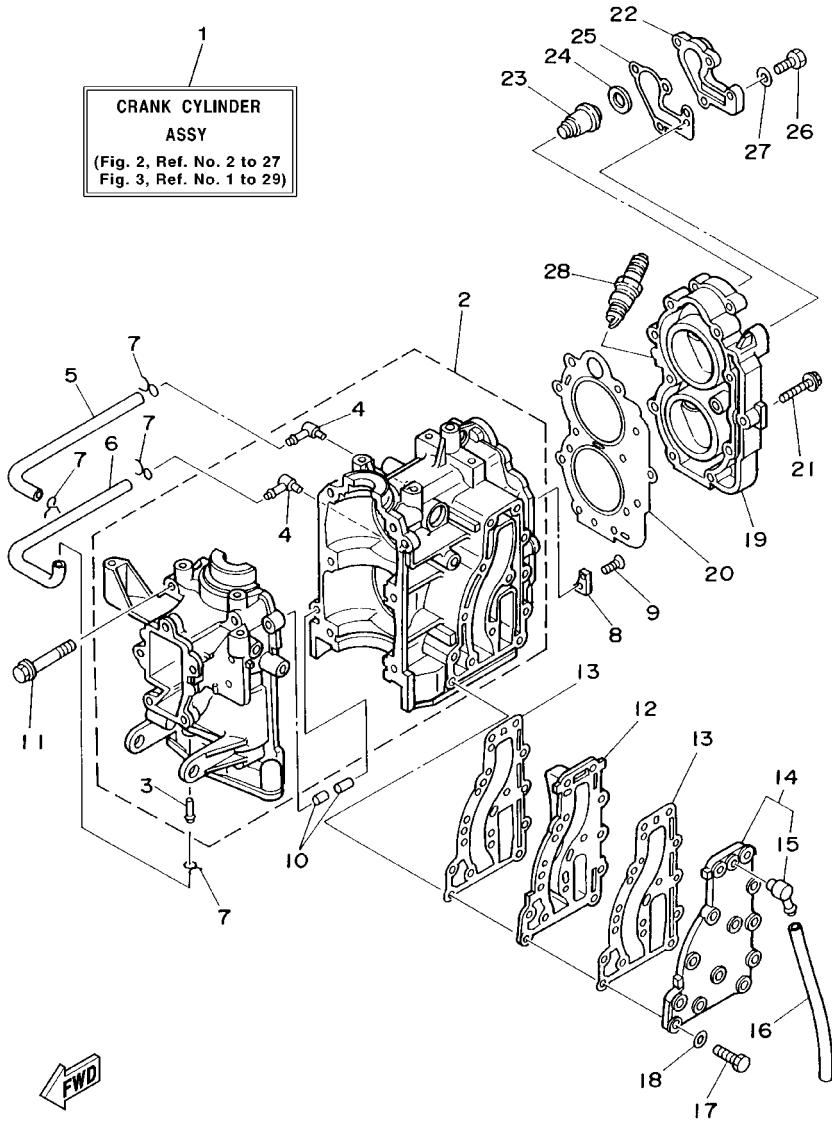

63V0010-5020

FIG. 2 CYLINDER. CRANKCASE CYLINDRO. CARTER

REF. NO.	PART NO. CODIGO NO.	DESCRIPTION DESCRIPTION	9.9F	15F	E99C	E15C	REMARKS OBSERVACION
28	94702-00217	PLUG, SPARK (NGK B7HS-10) BUJIA (NGK B7HS-10)	2	2	2	2	
	94702-00271	PLUG, SPARK (NGK BR7HS-10) BUJIA (NGK BR7HS-10)	2	2	2	2	FOR CHINA,CARIB

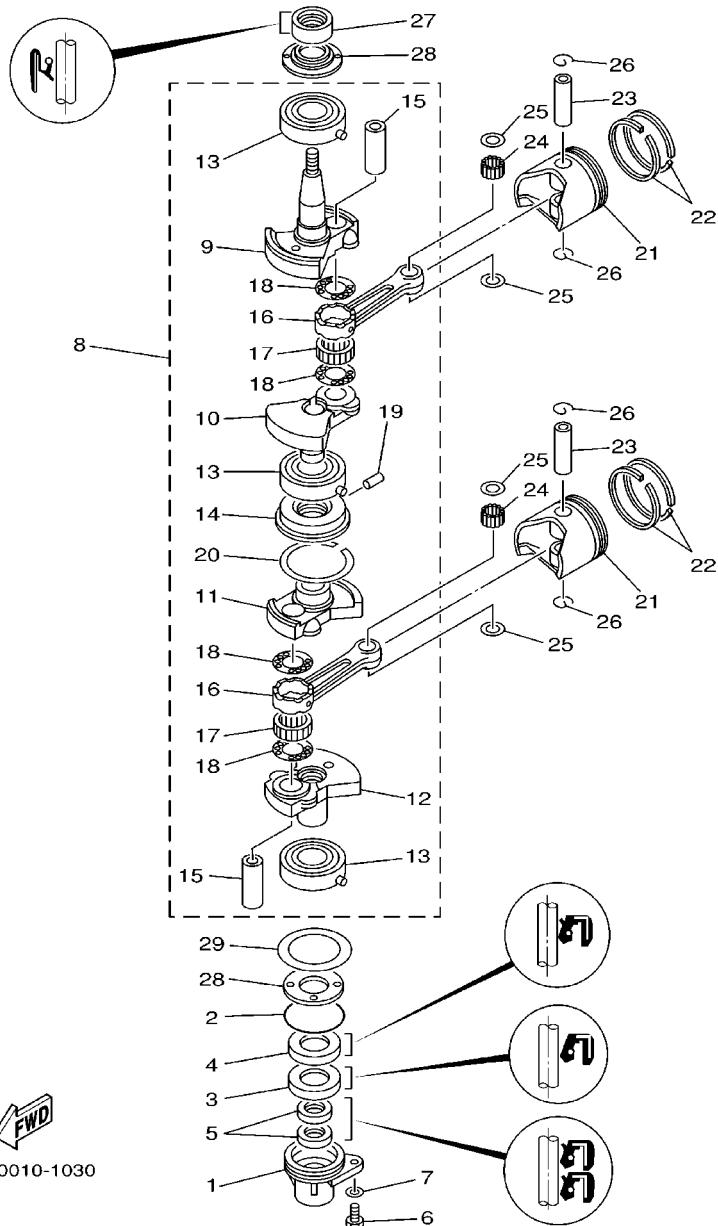

63V0010-1030

FIG. 3 CRANKSHAFT. PISTON CIGUENAL. PISTON

REF. NO.	PART NO. CODIGO NO.	DESCRIPTION DESCRIPTION	9.9F	15F	E99C	E15C	REMARKS OBSERVACION
1	63V-15396-01-94	HOUSING, OIL SEAL CAJA DE SELLO DE ACEITE	1	1	1	1	
2	93210-46M16	O-RING ANILLO O	1	1	1	1	
3	93101-25018	OIL SEAL SELLO ACEITE	1	1	1	1	
4	93102-25M48	OIL SEAL SELLO ACEITE	1	1	1	1	
5	93101-13018	OIL SEAL SELLO ACEITE	2	2	2	2	
6	97095-06016	BOLT PERNO	1	1	1	1	
7	92995-06600	WASHER ARANDELA	1	1	1	1	
8	63V-11400-01	CRANKSHAFT ASSY CIGUENAL COMPLETO	1	1	1	1	
9	63V-11412-00	.CRANK 1 .MANIVELA 1	1	1	1	1	
10	63V-11422-00	.CRANK 2 .MANIVELA 2	1	1	1	1	
11	63V-11432-00	.CRANK 3 .MANIVELA 3	1	1	1	1	
12	63V-11442-00	.CRANK 4 .MANIVELA 4	1	1	1	1	
13	93306-205U7	.BEARING .COJINETE	3	3	3	3	
14	63V-11515-02	SEAL, LABYRINTH 1 SELLO LABERINTO 1	1	1	1	1	
15	682-11681-00	.PIN, CRANK 1 .PASADOR MANIVELA 1	2	2	2	2	
16	650-11651-04	.ROD, CONNECTING .BIELA	2	2	2	2	
17	93310-620V5	.BEARING .COJINETE	2	2	2	2	
18	90209-20M23	.WASHER ARANDELA DE SEPARACION	4	4	4	4	
19	91609-20008	.PIN, SPRING .PASADOR DE RESORTE	1	1	1	1	
20	93440-52009	.CIRCLIP BOLA	1	1	1	1	
21	6E7-11631-00-97	PISTÓN (STD) PISTON (STD)	2	2	2	2	
	6E7-11635-00	PISTON (0.25MM O/S)	2	2	2	2	AP
	6E7-11636-00	PISTON (0.50MM O/S)	2	2	2	2	AP
22	682-11610-01	PISTON RING SET (STD) JUEGO DE AROS (STD)	2	2	2	2	
	682-11610-11	PISTON RING SET (0.25MM O/S) JUEGO DE AROS (0.25MM O/S)	2	2	2	2	AP
	682-11610-21	PISTON RING SET (0.50MM O/S) JUEGO DE AROS (0.50MM O/S)	2	2	2	2	AP
23	634-11633-00	PIN, PISTON PASADOR, PISTON	2	2	2	2	

A7

FIG. 3 CRANKSHAFT. PISTON

CIGUENAL. PISTON

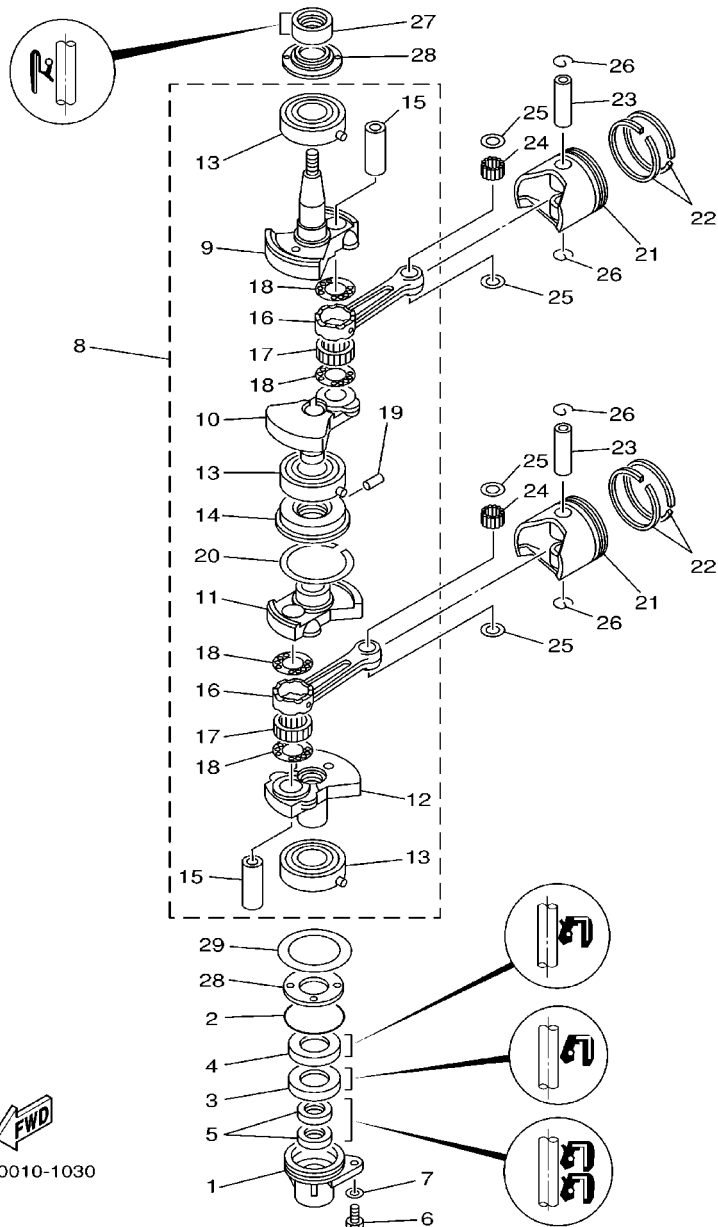

63V0010-1030

REF. NO.	PART NO. CODIGO NO.	DESCRIPTION DESCRIPTION	9.9F	15F	E99C	E15C	REMARKS OBSERVACION
24	93602-14104	PIN, DOWEL PASADOR DE CLAVIJA	50	50	50	50	
25	90201-14377	WASHER, PLATE ARANDELA PLANA	4	4	4	4	
26	93450-15023	CIRCLIP BOLA	4	4	4	4	
27	93110-23M00	OIL SEAL SELLO ACEITE	1	1	1	1	
28	63V-11445-00	SPACER ESPACIADOR	2	2	2	2	
29	90201-46M29	WASHER, PLATE ARANDELA PLANA	1	1	1	1	

FIG. 4 INTAKE

ADMISION

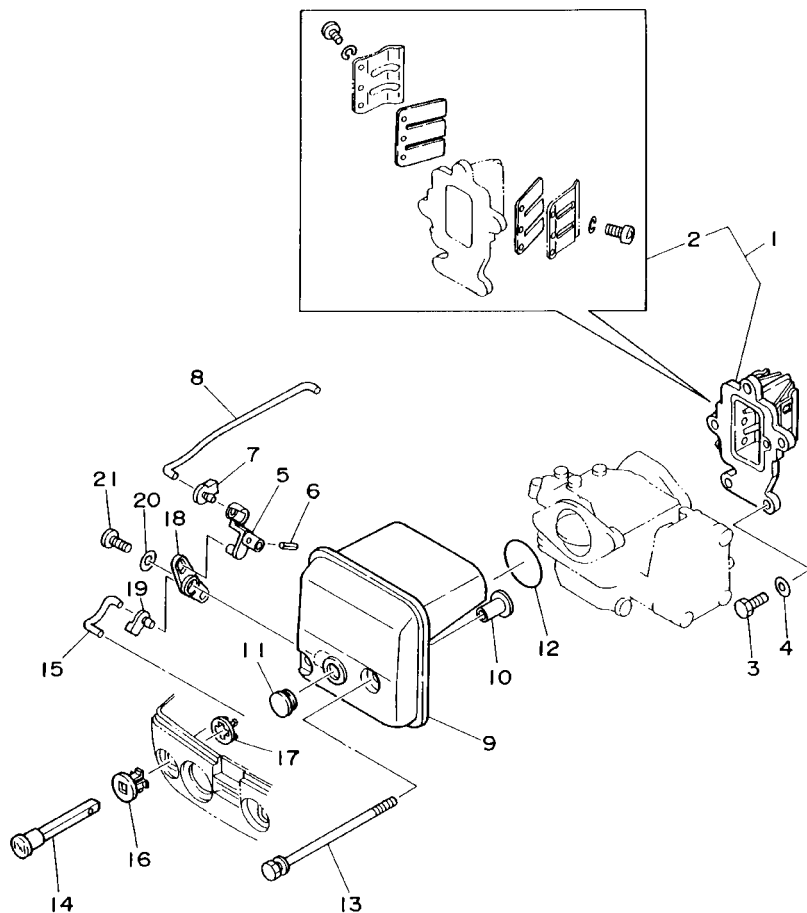

REF. NO.	PART NO. CODIGO NO.	DESCRIPTION DESCRIPTION	9.9F	15F	E99C	E15C	REMARKS OBSERVACION
1	63V-13610-10	REED VALVE ASSY	1		1		
	63W-13610-00	VALVULA DE LAMINAS COMPLETA					
	63W-13610-00	REED VALVE ASSY		1		1	
	63W-13610-00	VALVULA DE LAMINAS COMPLETA					
2	682-W0004-00	.REED SET	1	1	1	1	
	682-W0004-00	JUEGO DE VALVULAS DE LENGUETA					
3	97095-06020	BOLT	3	3	3	3	
	97095-06020	PERNO					
4	92995-06600	WASHER	3	3	3	3	
	92995-06600	ARANDELA					
5	63V-41253-00	LEVER, CHOKE	1	1	1	1	
	63V-41253-00	PALANCA AHOGADOR					
6	91690-20010	PIN, SPRING	1	1	1	1	
	91690-20010	PASADOR DE RESORTE					
7	63V-41262-00	JOINT, CHOKE LEVER	1	1			
	63V-41262-00	CONECTOR DE AHOGADOR					
8	63V-41257-00	ROD, CHOKE 2	1	1			
	63V-41257-00	VARILLA DE AHOGADOR					
9	63V-14440-00	SILENCER ASSY, INTAKE	1	1	1	1	
	63V-14440-00	SILENCIADOR COMPL DE ADMISION					
10	90387-06M15	COLLAR	2	2	2	2	
	90387-06M15	CASQUILLO CON VALONA					
11	90480-12M25	GROMMET	1	1	1	1	
	90480-12M25	TAPON					
12	93210-35M86	O-RING	1	1	1	1	
	93210-35M86	ANILLO O					
13	90119-06M94	BOLT, WITH WASHER	2	2	2	2	
	90119-06M94	TORNILLO CON ARANDELA					
14	6H4-41271-01	KNOB, CHOKE	1	1	1	1	
	6H4-41271-01	PERILLA AHOGADOR					
15	63V-41256-00	ROD, CHOKE 1	1	1	1	1	
	63V-41256-00	VARILLA DE AHOGADOR					
16	689-41273-00	GROMMET	1	1	1	1	
	689-41273-00	TAPON PROTECTOR					
17	6J8-41274-00	GROMMET 2	1	1	1	1	
	6J8-41274-00	TAPON 2					
18	63V-41252-00	LEVER, CHOKE 1	1	1	1	1	
	63V-41252-00	PALANCA AHOGADOR 1					
19	661-41262-02	JOINT, CHOKE LEVER	1	1	1	1	
	661-41262-02	CONECTOR DE AHOGADOR					
20	90201-05M09	WASHER, PLATE	1	1	1	1	
	90201-05M09	ARANDELA PLANA					
21	90164-05M03	SCREW, TAPPING	1	1	1	1	
	90164-05M03	TORNILLO ROSCA HEMBRA					



63V0010-5040

FIG. 5 CARBURETOR

CARBURADOR

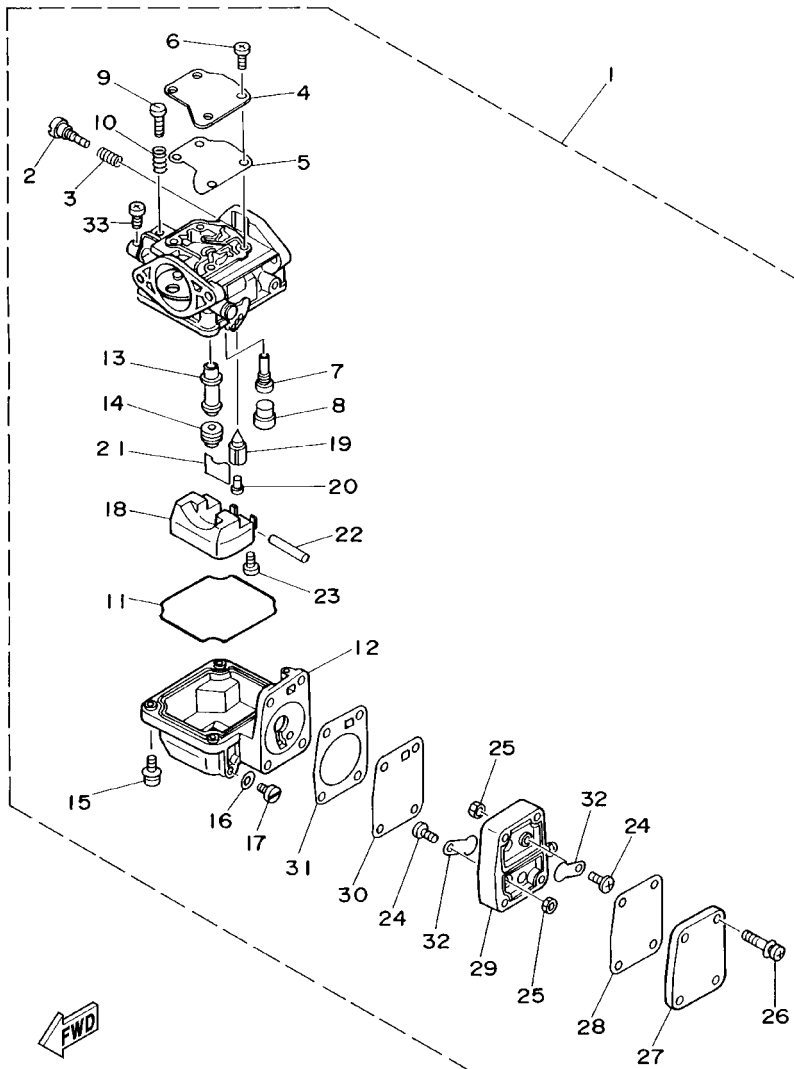

REF. NO.	PART NO. CODIGO NO.	DESCRIPTION DESCRIPTION	9.9F	15F	E99C	E15C	REMARKS OBSERVACION
1	63V-14301-00	CARBURETOR ASSY 1 CARBURADOR COMPLETO 1	1	1	1	1	
	65D-14301-01	CARBURETOR ASSY 1 CARBURADOR COMPLETO 1				1	FOR BRAZIL
2	679-14923-00	.SCREW, PILOT .TORNILLO DE AJUSTE	1	1	1	1	
3	679-14555-00	.SPRING .RESORTE	1	1	1	1	
4	63V-14527-00	.PLATE .PLACA	1	1	1	1	
5	63V-14126-00	.GASKET EMPAQUE	1	1	1	1	
6	97803-04010	.SCREW, PAN HEAD .TORNILLO DE CABEZA CON PLANA	4	4	4	4	
7	63V-14948-06	.JET (#48) .INYECTOR (#48)	1	1	1	1	
	63V-14948-08	.JET (#52) .INYECTOR (#52)				1	FOR BRAZIL
8	679-14966-00	.RUBBER CAP .CAUCHOCHAPEAU	1	1	1	1	
9	63V-14523-00	.SCREW, STOP .TORNILLO DE TOPE	1	1	1	1	
10	90501-10326	.SPRING, COMPRESSION .RESORTE DE COMPRESION	1	1	1	1	
11	63V-14984-00	.GASKET, FLOAT CHAMBER EMPAQUE CAMARA DE BOIA	1	1	1	1	
12	63V-14980-00	BODY, FLOAT CHAMBER .CUERPO CAMARA DE BOIA	1	1	1	1	
13	63V-14947-00	.JET, NEEDLE .INYECTOR DE AGUJA	1	1	1	1	
14	676-14943-29	.JET, MAIN (#110) .INYECTOR PRINCIPAL (#110)	1	1	1	1	
	676-14943-81	.JET, MAIN (#118) .INYECTOR PRINCIPAL (#118)				1	FOR BRAZIL
15	97980-04114	.SCREW, WITH WASHER .TORNILLO, CON ARANDELA	4	4	4	4	
16	6G1-14398-00	.WASHER EMPAQUE	1	1	1	1	
17	6G1-14992-00	.SCREW, DRAIN .TORNILLO, SEGURO	1	1	1	1	
18	63V-14985-00	.FLOAT BOIA	1	1	1	1	
19	6G1-14546-00	.VALVE, NEEDLE .VALVULA DE AGUJA	1	1	1	1	
	62D-14546-00	.VALVE, NEEDLE .VALVULA DE AGUJA				1	FOR BRAZIL
20	676-14186-00	.PIN, FLOAT .PASADOR DE LA BOYA	1	1	1	1	
21	663-14159-00	.CLIP .PRESILLA	1	1	1	1	
22	6H4-14548-00	.PIN, FLOAT ARM .PASADOR DE BRAZO DE BOIA	1	1	1	1	
23	98580-04008	.SCREW, PAN HEAD .TORNILLO DE CABEZA CON PLANA	1	1	1	1	

FIG. 5 CARBURETOR

CARBURADOR

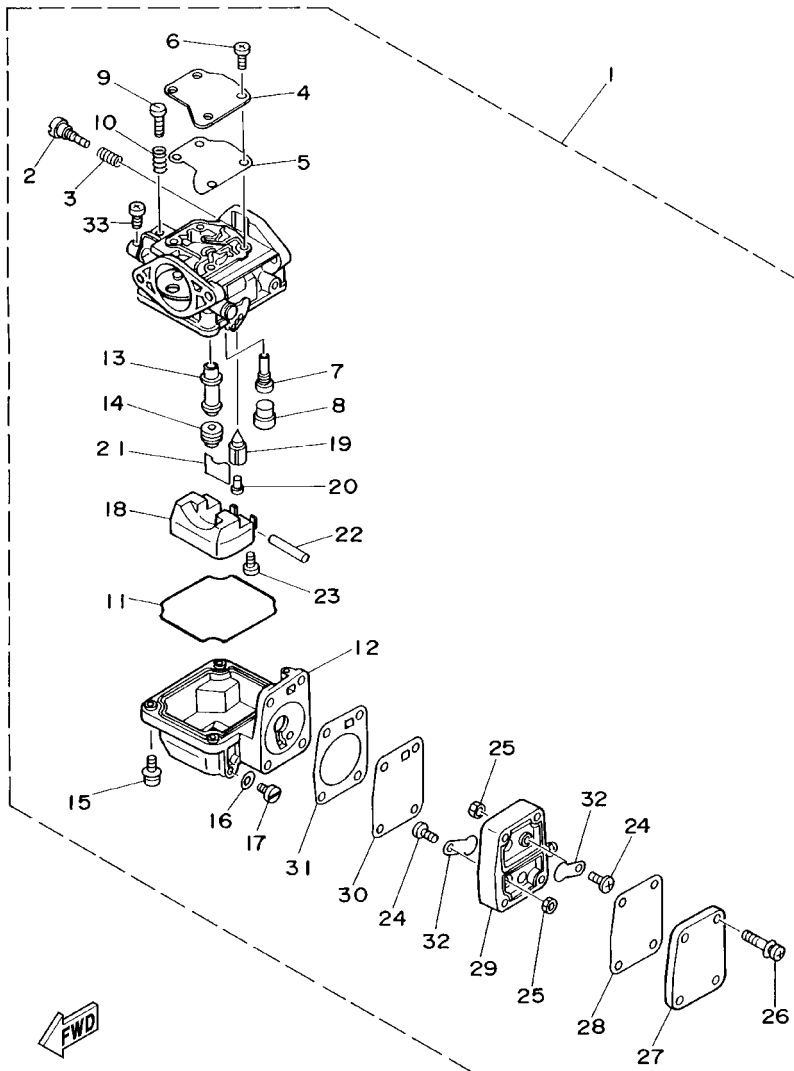

63V0010-5050

REF. NO.	PART NO. CODIGO NO.	DESCRIPTION DESCRIPTION	9.9F	15F	E99C	E15C	REMARKS OBSERVACION
24	98980-03006	.SCREW, BIND .TORNILLO DE LIGAR	2	2	2	2	
25	95380-03600	.NUT .TUERCA	2	2	2	2	
26	97980-04125	.SCREW, WITH WASHER .TORNILLO, CON ARANDELA	4	4	4	4	
27	6G1-24452-00	.COVER .CUBIERTA	1	1	1	1	
28	63V-24411-00	.DIAPHRAGM .DIAFRAGMA	1	1	1	1	
29	6G1-24412-01	.BODY 1 .CUERPO 1	1	1	1	1	
30	6G1-24411-00	.DIAPHRAGM .DIAFRAGMA	1	1	1	1	
31	6G1-24431-01	.GASKET, FUEL PUMP 1 .EMPAQUE BOMBA COMBUST 1	1	1	1	1	
32	6L5-24421-00	.VALVE, CHECK .VALVULA DE RETENCION	2	2	2	2	
33	98580-04006	.SCREW, PAN HEAD .TORNILLO DE CABEZA CON PLANA	1	1	1	1	

FIG. 6 FUEL

COMBUSTIBLE

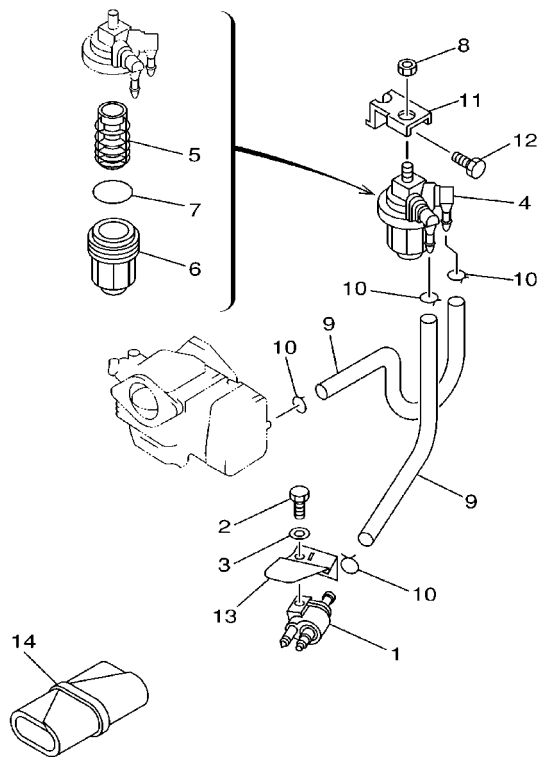

REF. NO.	PART NO. CODIGO NO.	DESCRIPTION DESCRIPTION	9.9F	15F	E99C	E15C	REMARKS OBSERVACION
1	6G1-24304-02	FUEL PIPE JOINT COMP. 1 CONECTOR MANGUERA COMBUST.1	1	1	1	1	
2	97095-06020	BOLT PERNO	1	1	1	1	
3	92995-06600	WASHER ARANDELA	1	1	1	1	
4	61N-24560-00	FILTER ASSY FILTRO COMPLETO	1	1	1	1	
5	61N-24563-00	.ELEMENT, FILTER .ELEMENTO DEL FILTRO	1	1	1	1	
6	61N-24521-00	.CUP, FILTER .COPA DE FILTRO	1	1	1	1	
7	93210-32738	.O-RING .ANILLO O	1	1	1	1	
8	95380-08600	NUT TUERCA	1	1	1	1	
9	90445-09M00	HOSE (L180) TUBO (L180)	2	2	2	2	
10	90467-08004	CLIP PRESILLA	4	4	4	4	
11	682-24566-01	BRACKET, FILTER SOPORTE DEL FILTRO	1	1	1	1	
12	97013-06010	BOLT PERNO	1	1	1	1	
13	63V-24396-01	PLATE PLACA	1	1	1	1	
14	656-W2810-02	TOOL KIT JUEGO DE HERRAMIENTAS	1	1	1	1	



63V0010-1060

FIG. 7 STARTER

ARRANQUE

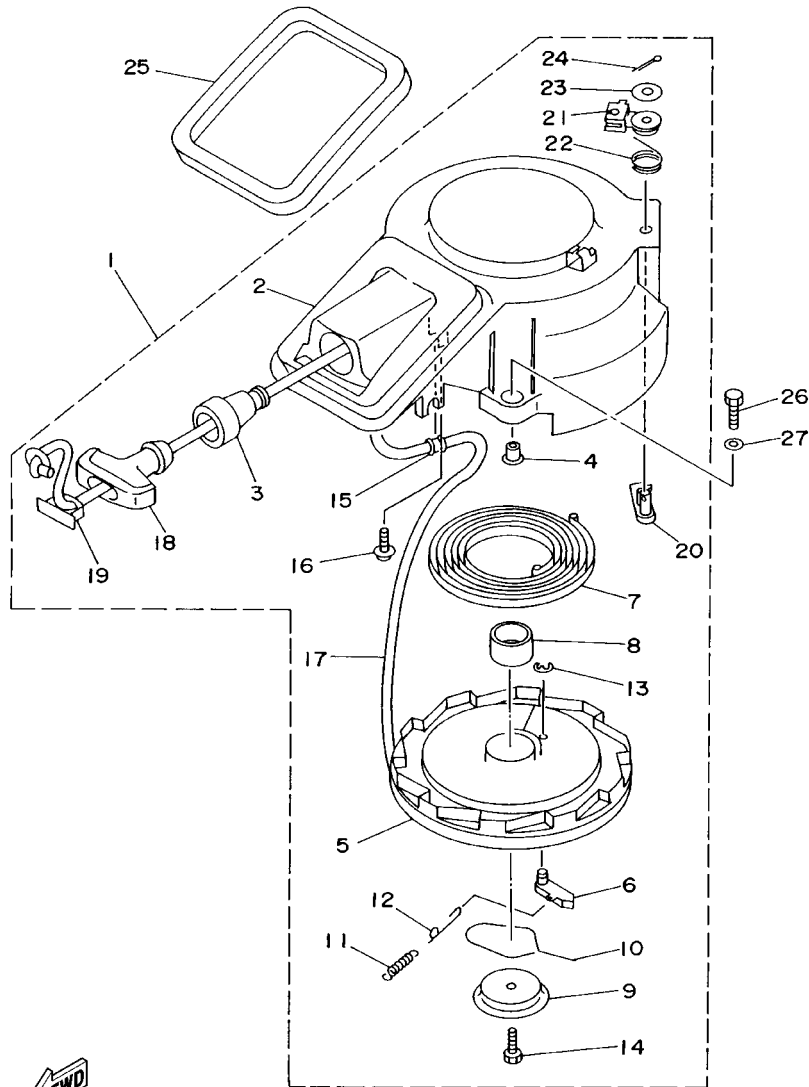

REF. NO.	PART NO. CODIGO NO.	DESCRIPTION DESCRIPTION	9.9F	15F	E99C	E15C	REMARKS OBSERVACION
1	63V-15710-12	STARTER ASSY ARRANQUE COMPLETO		1	1	1	WITH SAFETY DEVICE
	63V-15710-02	STARTER ASSY ARRANQUE COMPLETO	1	1	1	1	
2	63V-15711-01	.CASE, STARTER .CAJA DE ARRANQUE	1	1	1	1	
3	63V-15795-01	.GUIDE, ROPE .GUIA DE CUEEDA	1	1	1	1	
4	90387-06M05	.COLLAR .CASQUILLO CON VALONA	3	3	3	3	
5	63V-15714-00	.DRUM, SHEAVE .TAMBOR ROLDANA	1	1	1	1	
6	63V-15741-00	.PAWL, DRIVE .TRINQUETE DE TRACCION	1	1	1	1	
7	63V-15713-00	.SPRING, STARTER .RESORTE DE ARRANQUE	1	1	1	1	
8	63V-15753-00	.BUSH .BUJE	1	1	1	1	
9	63V-15716-00	.PLATE, DRIVE .PLACA DE TRACCION	1	1	1	1	
10	63V-15705-01	.SPRING, DRIVE PAWL .RESORTE	1	1	1	1	
11	63V-15767-01	.SPRING .RESORTE	1	1	1	1	
12	63V-15784-01	.SPRING, RETURN .RESORTE DE RETORNO	1	1	1	1	
13	63V-15744-00	.CIRCLIP .SEGURO	1	1	1	1	
14	63V-15768-00	BOLT TORNILLO	1	1	1	1	
15	63V-15764-00	.COLLAR 1 .COLLAR 1	1	1	1	1	
16	63V-15793-00	.SCREW TORNILLO	1	1	1	1	
17	*	.WIRE, STARTER (L:1800MM) .CUERDA DE ARRANQUE (L:1800MM)	1	1	1	1	
18	6G1-15755-00	.HANDLE, STARTER .MANIJA DE ARRANQUE	1	1	1	1	
19	6G1-15779-00	.COVER .CUBIERTA	1	1	1	1	
20	63V-15794-00	.STOPPER .TOPE	1	1	1	1	WITH SAFETY DEVICE
21	63V-15748-00	.PLUNGER, STARTER STOP EMBOLO SEGURO DE ARRANQUE	1	1	1	1	WITH SAFETY DEVICE
22	63V-15734-00	.SPRING, RETURN .RESORTE DE RETORNO	1	1	1	1	WITH SAFETY DEVICE
23	63V-15726-00	.WASHER, FLAT .ARANDELA PLANA	1	1	1	1	WITH SAFETY DEVICE
24	91490-16018	.PIN, COTTER .PASADOR DE CHAVETA	1	1	1	1	WITH SAFETY DEVICE
* CUT FROM 50M ROLLS, PART NO. 90890-44373, CUTTING LENGTH 1.8M							
* CORTE DE UN RODILLO DE 50M , PARTS NUMERO 90890-44373, LARGO DEL CORTE 1.8M							

FIG. 7 STARTER

ARRANQUE

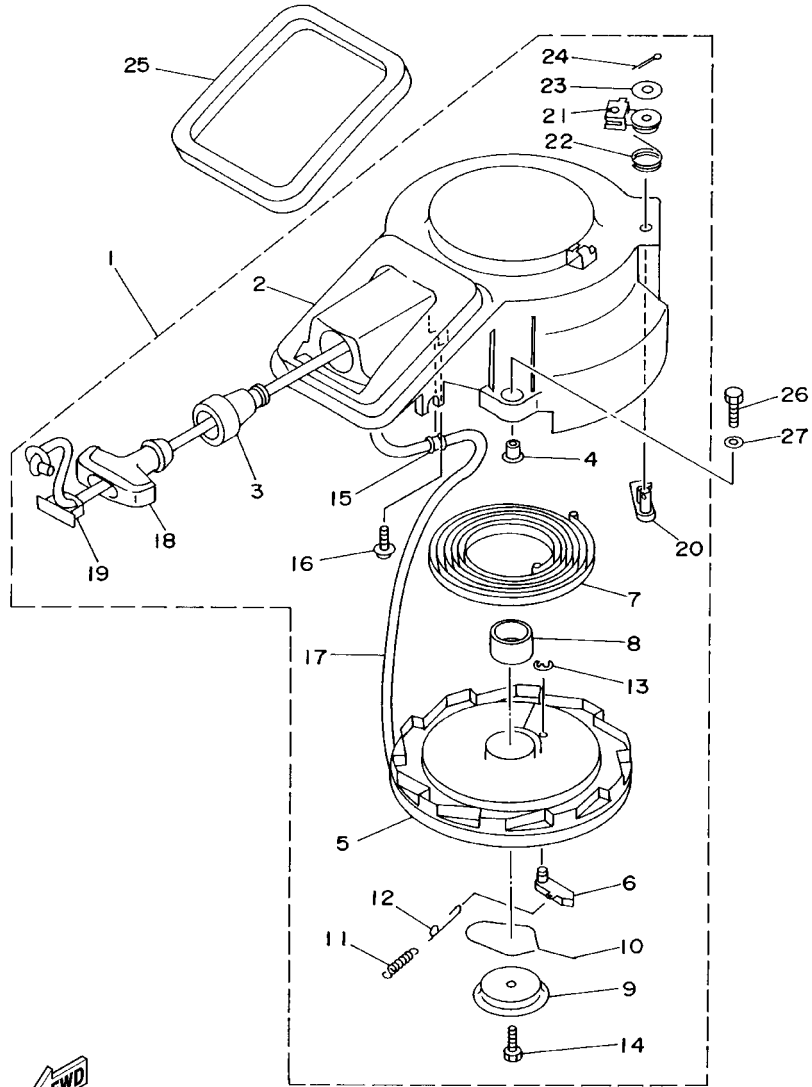

REF. NO.	PART NO. CODIGO NO.	DESCRIPTION DESCRIPTION	9.9F	15F	E99C	E15C	REMARKS OBSERVACION
25	63V-15762-00	SEAL, RUBBER 2 SELLO DE GOMA 2	1	1	1	1	
26	97095-06020	BOLT PERNO	3	3	3	3	
27	92995-06600	WASHER ARANDELA	3	3	3	3	

63V0010-5070

FIG. 8 GENERATOR

GENERADOR

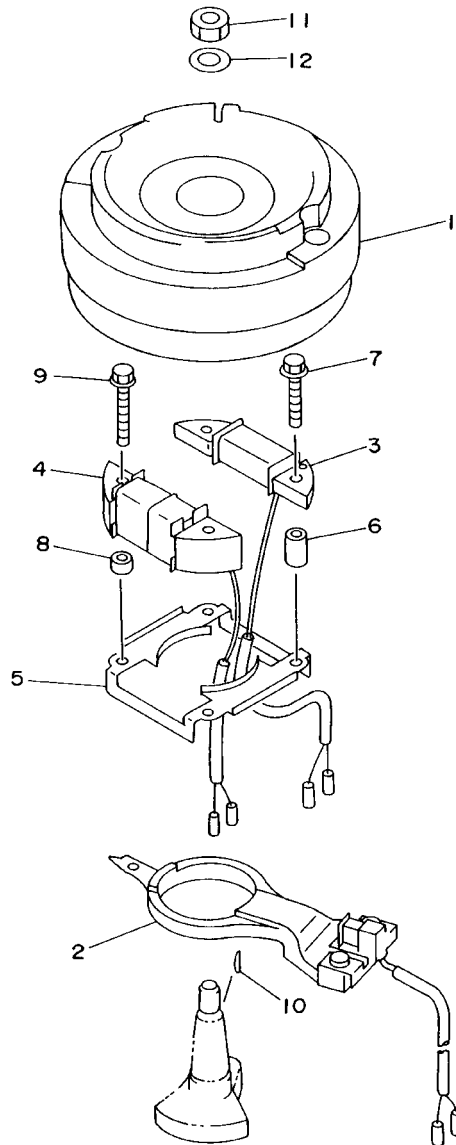

REF. NO.	PART NO. CODIGO NO.	DESCRIPTION DESCRIPTION	9.9F	15F	E99C	E15C	REMARKS OBSERVACION
1	63V-85550-10	ROTOR ASSY ROTOR COMPLETO	1	1	1	1	
2	63V-85580-00	COIL, PULSER BOBINA DE PULSACION	1	1	1	1	
3	63V-85520-00	COIL, CHARGE BOBINA DE CARGA	1	1	1	1	
4	63V-85533-00	COIL, LIGHTING BOBINA DE LUZ	1	1	1	1	
5	63V-41611-00	RETAINER, MAGNETO BASE RETENEDOR, BASE MAGNETO.	1	1	1	1	
6	90387-06M53	COLLAR CASQUILLO CON VALONA	2	2	2	2	
7	90105-06M68	BOLT, WASHER BASED TORNILLO CON ARANDELA	2	2	2	2	
8	90387-06M24	COLLAR CASQUILLO CON VALONA	2	2	2	2	
9	90105-06M69	BOLT, WASHER BASED TORNILLO CON ARANDELA	2	2	2	2	
	97095-06012	BOLT PERNO			2	2	WITHOUT #4
10	90280-05013	KEY, WOODRUFF CUNA WOODRUFF	1	1	1	1	
11	90170-12066	NUT TUERCA	1	1	1	1	
12	90201-12472	WASHER, PLATE ARANDELA PLANA	1	1	1	1	

 63V0010-5080

FIG. 9 ELECTRICAL

EQUIPO ELECTRICO

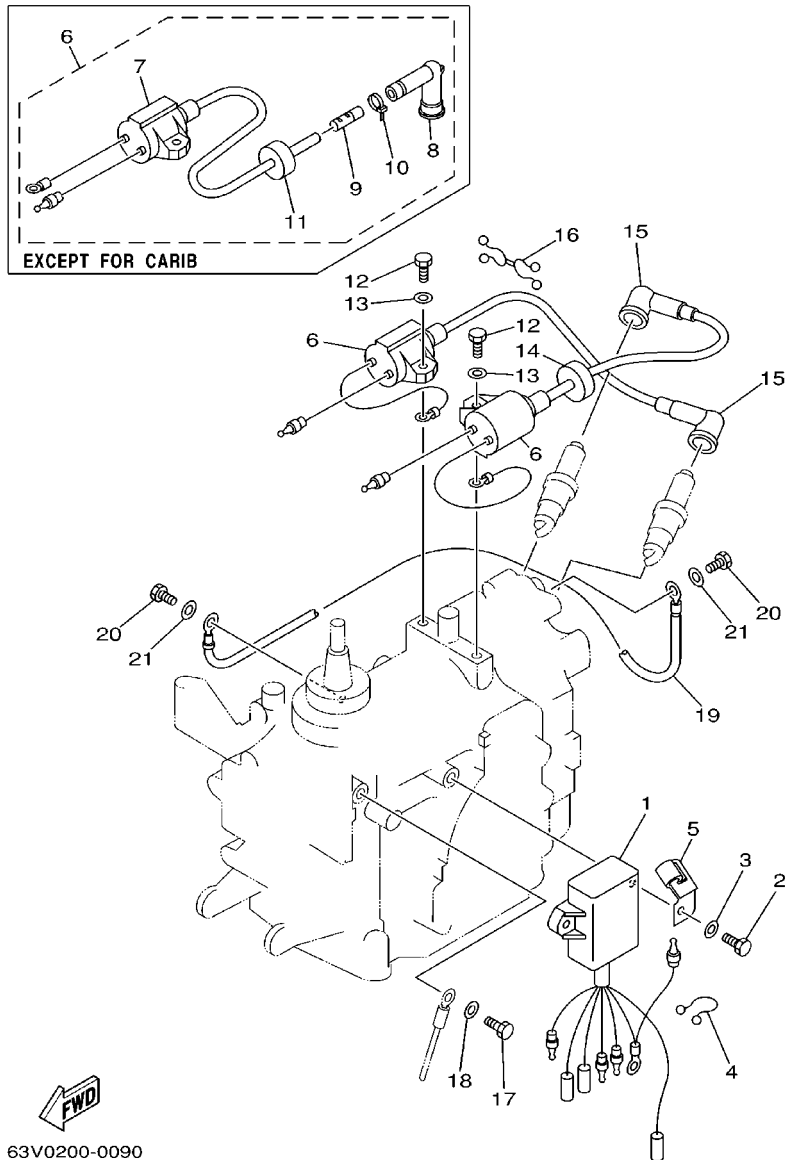

63V0200-0090

REF. NO.	PART NO. CODIGO NO.	DESCRIPTION DESCRIPTION	9.9F	15F	E99C	E15C	REMARKS OBSERVACION
1	63V-85540-01	C.D.I. UNIT ASSY UNIDAD C.D.I. COMPLETA	1	1	1	1	
2	97095-06020	BOLT PERNO	2	2	2	2	
3	92995-06600	WASHER ARANDELA	2	2	2	2	
4	90464-15M11	CLAMP BRIDA	1	1	1	1	
5	90465-08M61	CLAMP BRIDA	1	1	1	1	
6	63V-85570-00	IGNITION COIL ASSY BOBINA DE IGNICION COMPLETO	2	2	2	2	E9.9C/E15C FOR CARIB
	65E-85530-00	IGNITION COIL ASSY BOBINA DE IGNICION COMPLETO			2	2	EXCEPT FOR CARIB
7	65E-85570-00	IGNITION COIL ASSY .BOBINA DE IGNICION COMPLETO			1	1	
8	62E-82371-11	.CAP, PLUG .TAPON DE BUJIA COMPLT			1	1	
9	62E-8231X-00	.TERMINAL 1 .TERMINAL 1			1	1	
10	90465-11M10	.CLAMP .BRIDA			1	1	
11	90480-25161	.GROMMET .TAPON			1	1	
12	97095-06018	BOLT PERNO	2	2	2	2	
13	92995-06600	WASHER ARANDELA	2	2	2	2	
14	90480-25161	GROMMET TAPON	1	1	1	1	E9.9C/E15C FOR CARIB
15	663-82370-01	PLUG CAP ASSY TAPON DE BUJIA COMPLT	2	2			
	6E3-82370-21	PLUG CAP ASSY TAPON DE BUJIA COMPLT			2	2	E9.9C/E15C FOR CARIB
16	90464-08M02	CLAMP BRIDA	1	1	1	1	
17	97095-06012	BOLT PERNO	1	1	1	1	
18	92995-06600	WASHER ARANDELA	1	1	1	1	
19	662-82519-00	WIRE, EARTH LEAD CABLE CONDUCTOR A TIERRA	1	1	1	1	
20	97095-06012	BOLT PERNO	2	2	2	2	
21	92995-06600	WASHER ARANDELA	2	2	2	2	

FIG. 10 BOTTOM COWLING

CUBIERTA INFERIOR

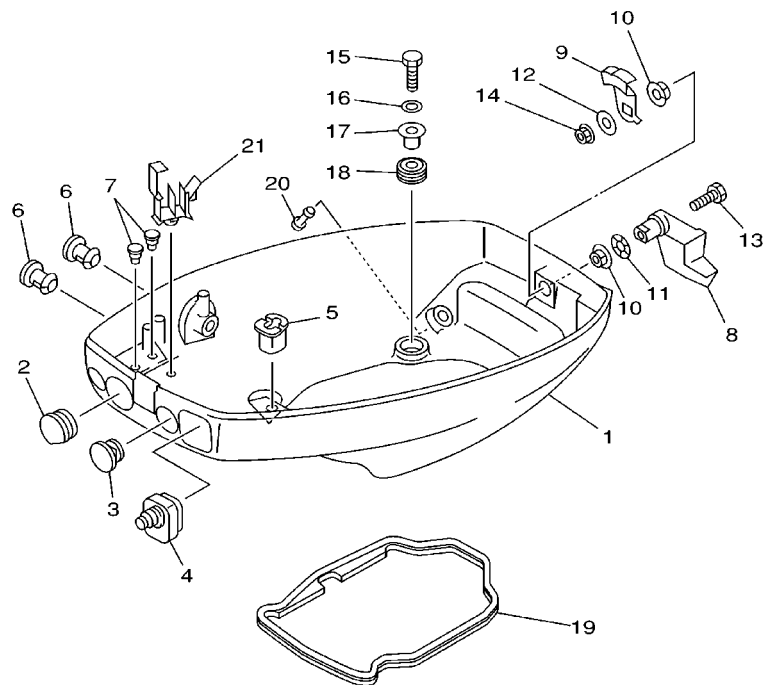

63V0100-1110

REF. NO.	PART NO. CODIGO NO.	DESCRIPTION DESCRIPTION	9.9F	15F	E99C	E15C	REMARKS OBSERVACION
1	63V-42711-03-4D	COWLING, BOTTOM CUBIERTA INFERIOR	1	1	1	1	
2	682-42724-00	GROMMET TAPON	1	1	1	1	
3	682-42725-02	GROMMET TAPON	1	1	1	1	
4	63V-42726-00	GROMMET TAPON	1	1	1	1	
	65F-42726-00	GROMMET TAPON				1	FOR SIDE SHIFT
5	682-42727-00	GROMMET TAPON	1	1	1	1	
6	6G1-42748-00	GROMMET TAPON	2	2	2	2	
	6G1-42748-00	GROMMET TAPON				1	FOR SIDE SHIFT
7	90480-06M19	GROMMET TAPON	2	2	2	2	
8	63V-42815-01-4D	LEVER, CLAMP PALANCA ABRAZADERA	1	1	1	1	
9	6E7-42816-00	LEVER, CLAMP PALANCA ABRAZADERA	1	1	1	1	
10	90386-12M45	BUSH BUJE	2	2	2	2	
11	90206-12052	WASHER, WAVE ARANDELA ONDULADA	1	1	1	1	
12	90201-06068	WASHER, PLATE ARANDELA PLANA	1	1	1	1	
13	97095-06025	BOLT PERNO	1	1	1	1	
14	95380-06700	NUT TUERCA	1	1	1	1	
15	97095-06025	BOLT PERNO	4	4	4	4	
16	92995-06600	WASHER ARANDELA	4	4	4	4	
17	90387-06034	COLLAR CASQUILLO CON VALONA	4	4	4	4	
18	90480-15M31	GROMMET TAPON	4	4	4	4	
19	63V-42716-02	RUBBER, SEAL 1 SELLO DE GOMA 1	1	1	1	1	
20	6H3-44391-01	NIPPLE, HOSE NIPLE MANGUERA	1	1	1	1	
21	90465-25M57	CLAMP BRIDA	1	1	1	1	

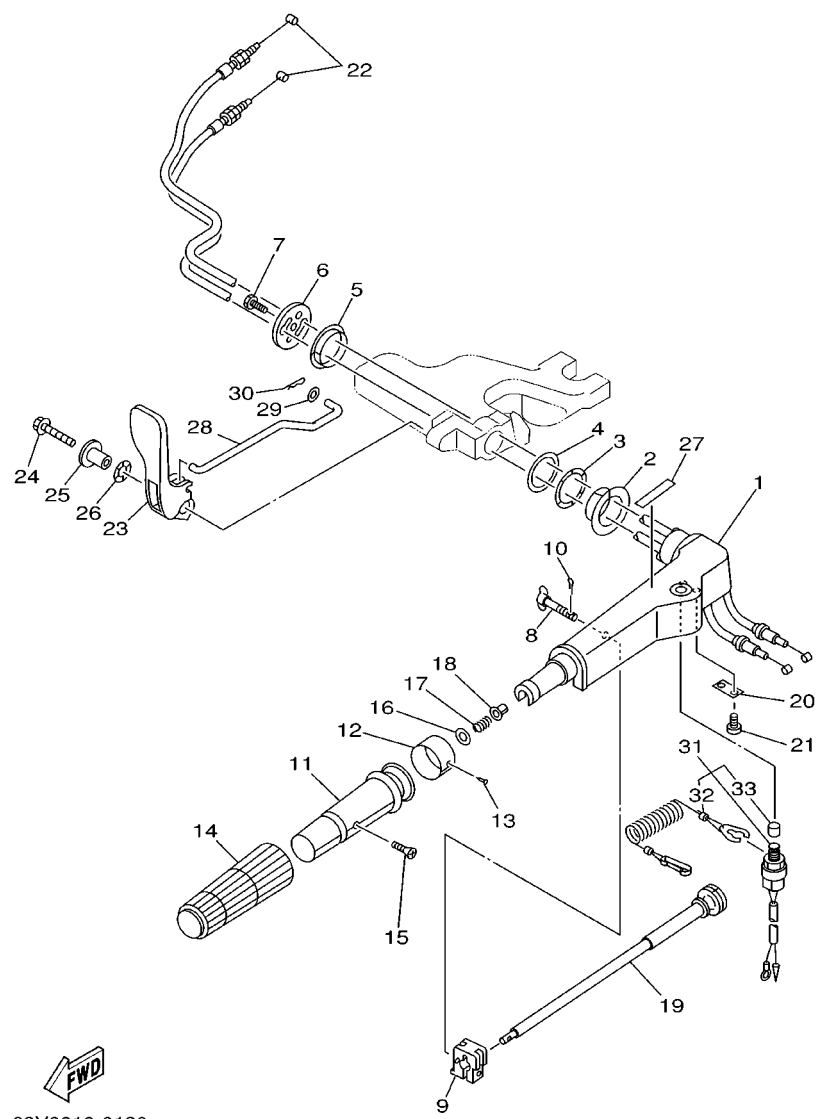
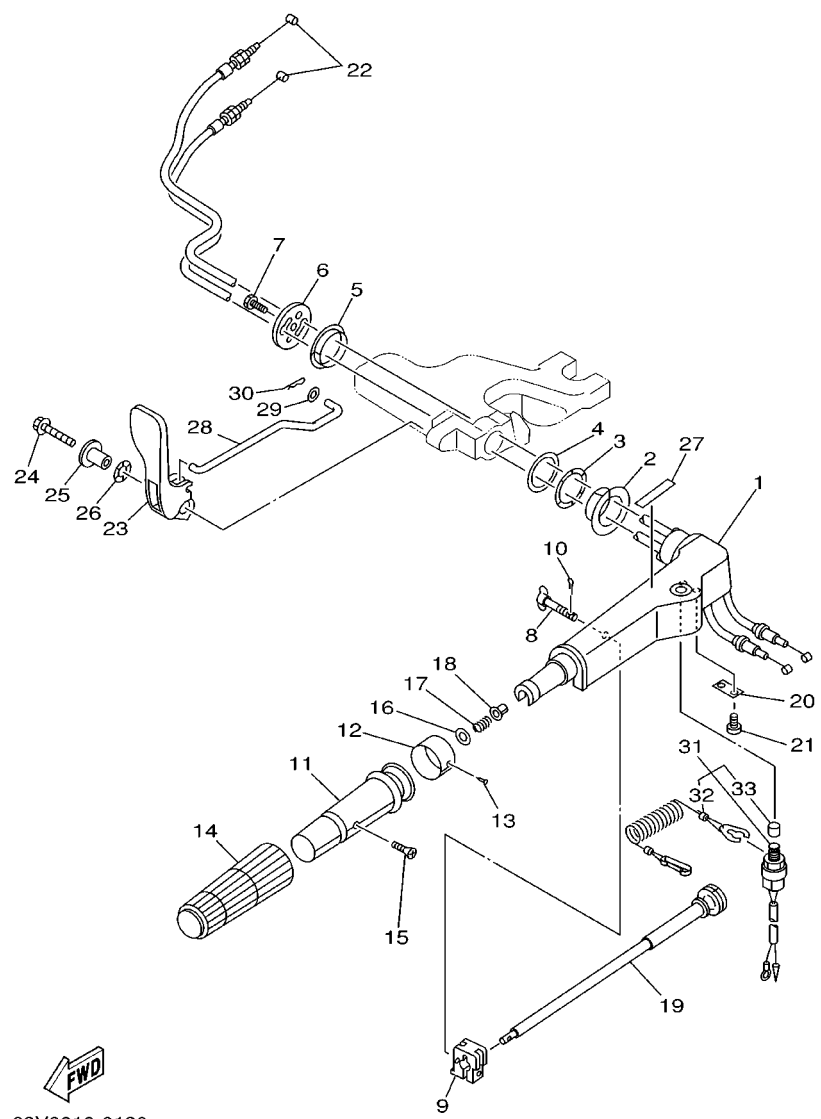

FIG. 11 STEERING

DIRECCION

REF. NO.	PART NO. CODIGO NO.	DESCRIPTION DESCRIPTION	9.9F	15F	E99C	E15C	REMARKS OBSERVACION
1	63V-42111-00-4D	HANDLE, STEERING MANIJA DE DIRECCION	1	1	1	1	
2	90386-34M97	BUSH BUJE	1	1	1	1	
3	90206-36M21	WASHER, WAVE ARANDELA ONDULADA	1	1	1	1	
4	90202-36M55	WASHER, PLATE ARANDELA DE PLANA	1	1	1	1	
5	90386-33M96	BUSH BUJE	1	1	1	1	
6	6G1-42131-01	COVER, HANDLE STEERING CUBIERTA MANIJA DIRRECCION	1	1	1	1	
7	97095-06020	BOLT PERNO	1	1	1	1	
8	6G1-42125-01	BOLT, FRICTION ADJUSTING TORNILLO FRICCION ADJUSTA	1	1	1	1	
9	6G1-42126-00	FRICTION, STEERING HANDLE GRIP FRICCION DE MANGO DIRECCION	1	1	1	1	
10	91490-16010	PIN, COTTER PASADOR DE CHAVETA	1	1	1	1	
11	664-42119-00	GRIP, STEERING HANDLE MANGO, MANIJA DE DIRRECCION	1	1	1	1	
12	6H2-42137-00 697-42137-10	INDICATOR, THROTTLE INDICADOR ACELERADOR INDICADOR, THROTTLE INDICADOR ACELERADOR	1	1		1	
13	90269-02M09	RIVET REMACHE	1	1	1	1	
14	6G1-42177-00	RUBBER, HANDLE HULE DE MANIJA	1	1	1	1	
15	90149-05M13	SCREW TORNILLO DE REGLAJE	1	1	1	1	
16	92903-10600	WASHER, PLATE ARANDELA	1	1	1	1	
17	90501-23215	SPRING, COMPRESSION RESORTE DE COMPRESION	1	1	1	1	
18	90386-08032	BUSH BUJE	1	1	1	1	
19	6G1-42138-01	LEVER, THROTTLE PLANCA DE ACELERACION	1	1	1	1	
20	6E0-42159-02	STAY SOPORTE	1	1	1	1	
21	97885-05012	SCREW, PAN HEAD TORNILLO DE CABEZA CON PLANA	2	2	2	2	
22	6L2-26301-00	THROTTLE CABLE ASSY CABLE DE ACELERADOR COMPLETO	2	2	2	2	
23	63V-44111-02	HANDLE, GEAR SHIFT MANIJA DE CAMBIO DE MARCHAS	1	1	1	1	FOR FRONT SHIFT
24	90119-06M05	BOLT, WITH WASHER TORNILLO CON ARANDELA	1	1	1	1	FOR FRONT SHIFT
25	90387-06M86	COLLAR CASQUILLO CON VALONA	1	1	1	1	FOR FRONT SHIFT
26	90206-15M18	WASHER, WAVE ARANDELA ONDULADA	1	1	1	1	FOR FRONT SHIFT



63V0010-0130

FIG. 11 STEERING DIRECCION

REF. NO.	PART NO. CODIGO NO.	DESCRIPTION DESCRIPTION	9.9F	15F	E99C	E15C	REMARKS OBSERVACION
27	6E0-44191-11	INDICATOR, SHIFT INDICADOR DE CAMBIOS	1	1	1	1	FOR FRONT SHIFT
28	63V-44124-02	LINK, SHIFT ROD ESLABON	1	1	1	1	FOR FRONT SHIFT
29	90202-06009	WASHER, PLATE ARANDELA DE PLANA	1	1	1	1	FOR FRONT SHIFT
30	90468-18008	CLIP PRESILLA	1	1	1	1	FOR FRONT SHIFT
31	65W-82575-00	ENGINE STOP SWITCH ASSY INTERRUPTOR DE PARADA COMPL	1	1	1	1	
32	682-82556-00	.STOPPER .RETEN	1	1	1	1	
33	689-8257Y-00	.CAP .CASQUILLO	1	1	1	1	

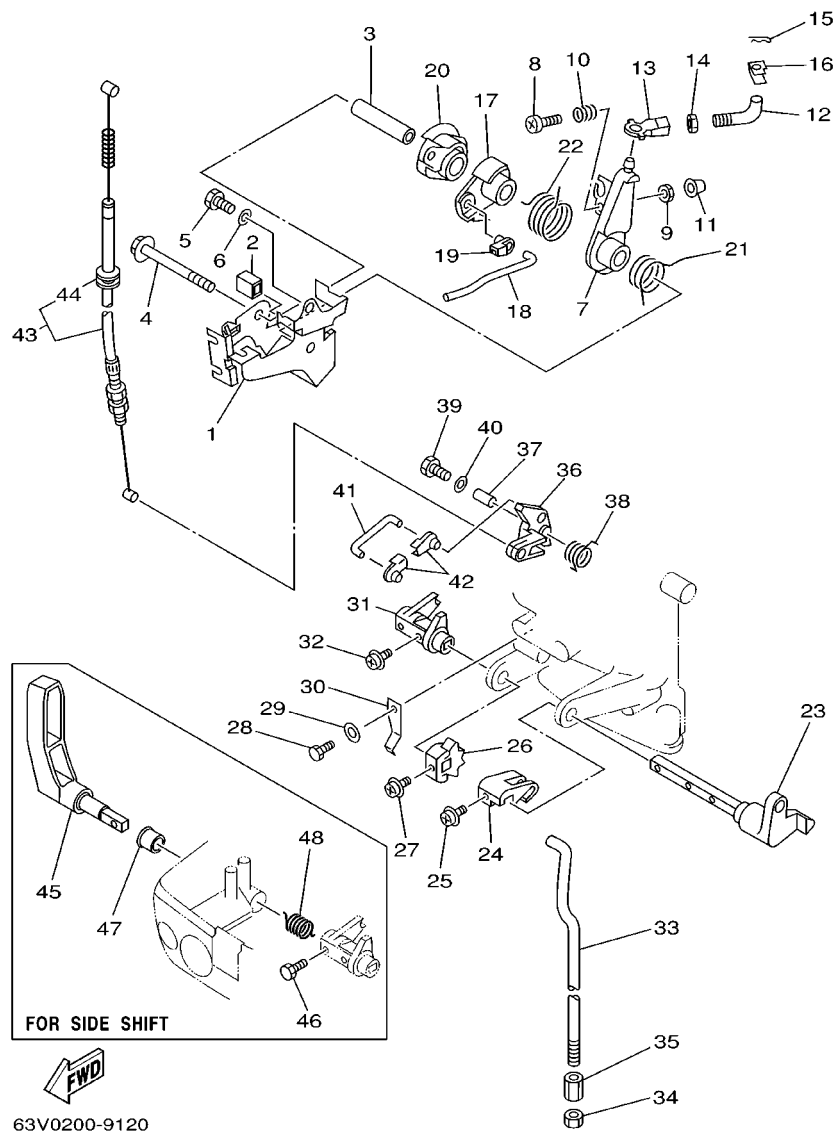

FIG. 12 CONTROL

CONTROL

REF. NO.	PART NO. CODIGO NO.	DESCRIPTION DESCRIPTION	9.9F	15F	E99C	E15C	REMARKS OBSERVACION
1	63V-14497-01	STAY, THROTTLE WIRE SOPORTE VALVULA DE OBTURACION	1	1	1	1	
2	689-44194-00	CAP TAPA	1	1	1	1	
3	90387-06M50	COLLAR CASQUILLO CON VALONA	1	1	1	1	
4	95895-06065	BOLT, FLANGE TUERCA DE REBORDE	1	1	1	1	
5	97095-06012	BOLT PERNO	1	1	1	1	
6	92995-06600	WASHER ARANDELA	1	1	1	1	
7	63V-41631-00	LEVER, MAGNETO CONTROL PALANCA DE CONTROL DE MAGNETO	1	1	1	1	
8	97885-06030	SCREW, PAN HEAD TORNILLO DE CABEZA CON PLANA	1	1	1	1	
9	95380-06600	NUT, HEXAGON TUERCA	1	1	1	1	
10	90501-12M16	SPRING, COMPRESSION RESORTE DE COMPRESION	1	1	1	1	
11	688-44194-00	CAP TAPA	1	1	1	1	
12	63V-41238-00	JOINT, LINK CONECTOR	1	1	1	1	
13	6H4-41237-00	JOINT, LINK CONECTOR	1	1	1	1	
14	95380-05700	NUT TUERCA	1	1	1	1	
15	90468-10005	CLIP PRESILLA	1	1	1	1	
16	63V-41223-00	WASHER, LOCK 1 ARANDELA DE SEGURO1	1	1	1	1	
17	63V-41283-01	LEVER, FREE ACCEL. PALANCA	1	1	1	1	
18	63V-41211-00	LINK, ACCEL. ESLABON, ACELERADOR	1	1	1	1	
19	661-41262-02	JOINT, CHOKE LEVER CONECTOR DE AHOGADOR	1	1	1	1	
20	63V-41638-00	PULLEY POLEA	1	1	1	1	
21	90508-16M37	SPRING, TORSION RESORTE DE TORSION	1	1	1	1	
22	90508-20M38	SPRING, TORSION RESORTE DE TORSION	1	1	1	1	
23	63V-44123-01	ARM, SHIFT ROD BRAZO VARILLA DE CAMBIOS	1	1	1	1	
24	63V-44121-01	LEVER, SHIFT ROD PALANCA VARILLA CAMBIOS	1	1	1	1	
25	90159-05M25	SCREW, WITH WASHER TORNILLO CON VALONA	1	1	1	1	
26	63V-44125-00	LEVER, SHIFT ROD PALANCA VARILLA CAMBIOS	1	1	1	1	
27	90159-05M25	SCREW, WITH WASHER TORNILLO CON VALONA	1	1	1	1	

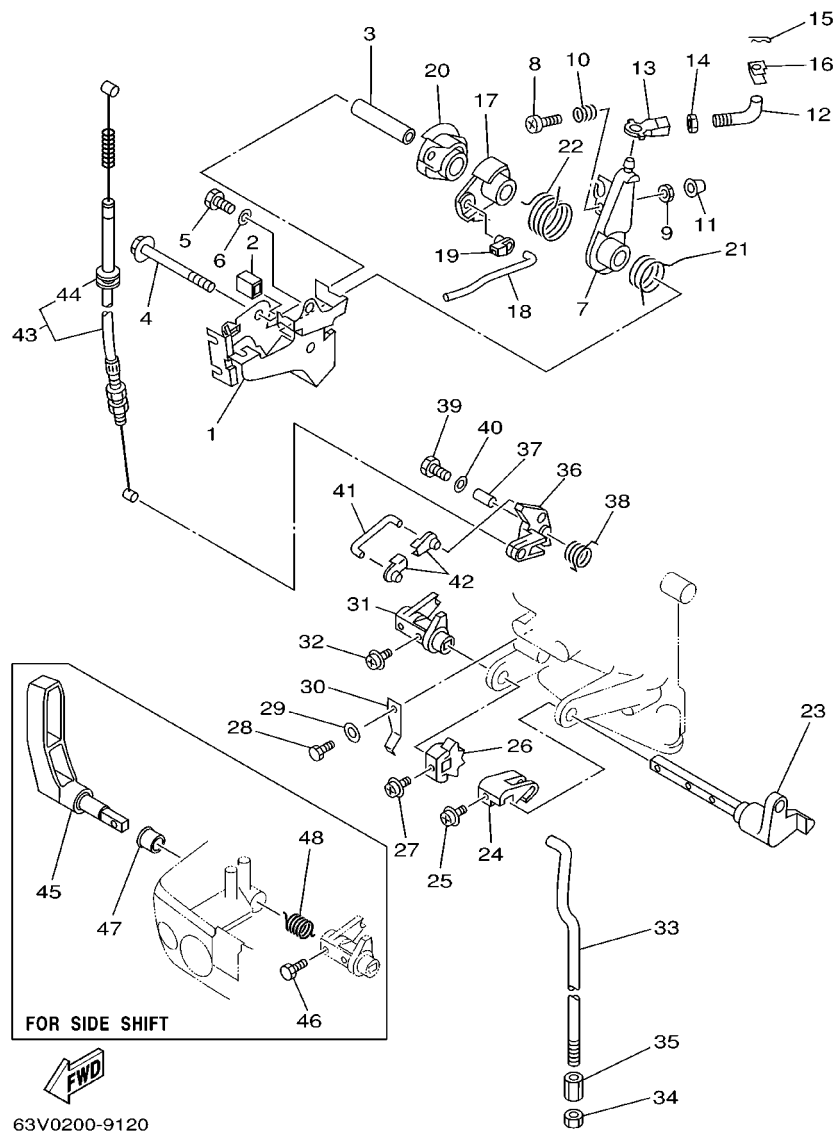

FIG. 12 CONTROL

CONTROL

REF. NO.	PART NO. CODIGO NO.	DESCRIPTION DESCRIPTION	9.9F	15F	E99C	E15C	REMARKS OBSERVACION
28	97095-06012	BOLT PERNO	1	1	1	1	
29	92995-06600	WASHER ARANDELA	1	1	1	1	
30	63V-44116-00	SPRING RESORTE	1	1	1	1	
31	63V-44122-01	BUSHING, SHIFT ROD LEVER BUJE PALANCA VARILLA DE CAMBIO	1	1	1	1	
32	90159-05M25	SCREW, WITH WASHER TORNILLO CON VALONA	1	1	1	1	
33	63V-44143-01	ROD, SHIFT VARILLA DE CAMBIO	1	1	1	1	
34	95380-06700	NUT TUERCA	1	1	1	1	
35	90170-06015	NUT TUERCA	1	1	1	1	
36	63V-15746-00	ARM BRAZO	1				FOR SAFETY DEVICE
	63V-15746-10	ARM BRAZO		1		1	FOR SAFETY DEVICE
37	90387-06M06	COLLAR CASQUILLO CON VALONA	1	1	1	1	FOR SAFETY DEVICE
38	90508-08M39	SPRING, TORSION RESORTE DE TORSION	1	1	1	1	FOR SAFETY DEVICE
39	97095-06020	BOLT PERNO	1	1	1	1	FOR SAFETY DEVICE
40	92995-06600	WASHER ARANDELA	1	1	1	1	FOR SAFETY DEVICE
41	6L2-15747-00	LINK ESLABON	1	1	1	1	FOR SAFETY DEVICE
42	661-41262-02	JOINT, CHOKE LEVER CONECTOR DE AHOGADOR	2	2	2	2	FOR SAFETY DEVICE
43	63V-15770-00	CABLE COMP., STARTER STOP CABLECOMPL DE SEGURO ARRANQUE	1	1	1	1	FOR SAFETY DEVICE
44	90480-10M16	.GROMMET .TAPON	1	1	1	1	
45	65F-44111-00	HANDLE, GEAR SHIFT MANIJA DE CAMBIO DE MARCHAS				1	FOR SIDE SHIFT
46	90105-05M79	BOLT, WASHER BASED TORNILLO CON ARANDELA				1	FOR SIDE SHIFT
47	90386-10009	BUSH BUJE				1	FOR SIDE SHIFT
48	90501-12M85	SPRING, COMPRESSION RESORTE DE COMPRESION				1	FOR SIDE SHIFT

FIG. 13 REMOTE CONTROL ATTACHMENT

CONJUNTO ADITAMENTO

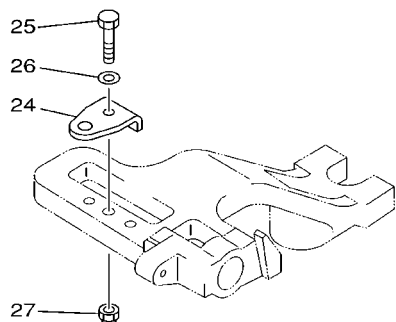
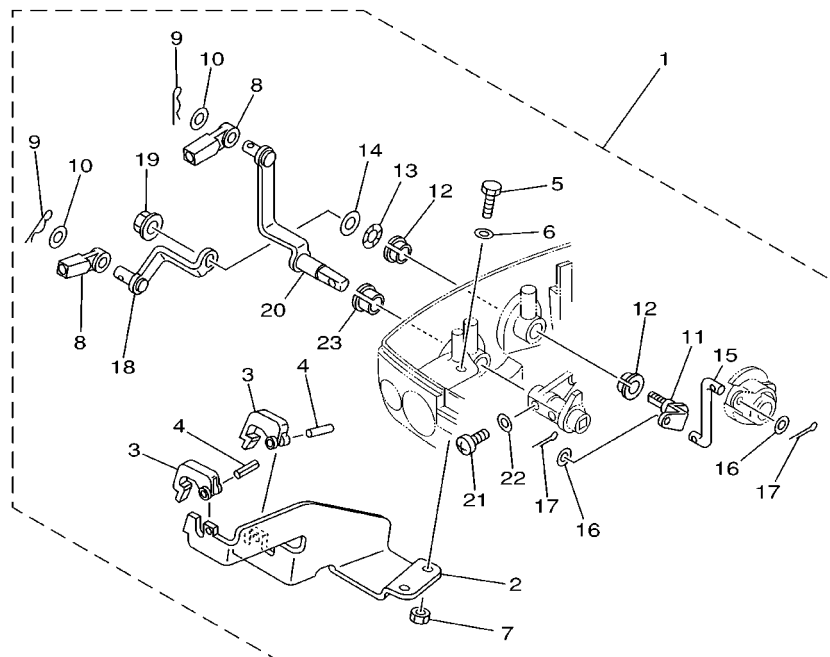

63V0100-0140

REF. NO.	PART NO. CODIGO NO.	DESCRIPTION DESCRIPTION	9.9F	15F	E99C	E15C	REMARKS OBSERVACION
1	63V-48501-00	REMOTE CONT. ATTACHMENT ASSY. CONJUNTO ADITAMENTO	1	1	1	1	AP
2	63V-48531-00	.BRACKET, REMOTE CONTROL 1 .SOPORTE DE CONTROL REMOTO	1	1	1	1	
3	682-48538-50	.CLAMP, CABLE 1 .GRAMPA DE CABLE	2	2	2	2	
4	91590-30012	.PIN, CLEVIS .PASADOR DE ABRAZADERA	2	2	2	2	
5	97095-06016	.BOLT .PERNO	2	2	2	2	
6	92990-06600	.WASHER, PLATE .ARANDELA	2	2	2	2	
7	95380-06600	.NUT, HEXAGON .TUERCA	2	2	2	2	
8	663-48344-00	.CABLE END, REMOTE CONTROL .BASE CONTROL	2	2	2	2	
9	90468-18008	.CLIP .PRESILLA	2	2	2	2	
10	90201-08M12	.WASHER, PLATE .ARANDELA PLANA	2	2	2	2	
11	63V-42154-00	.LEVER, THROTTLE CONTROL .PALANCA CONTROL ACELERADOR	1	1	1	1	
12	90386-10025	.BUSH .BUJE	2	2	2	2	
13	90206-10M04	.WASHER, WAVE .ARANDELA ONDULADA	1	1	1	1	
14	90201-10M02	.WASHER, PLATE .ARANDELA PLANA	1	1	1	1	
15	63V-42192-00	.ROD 2 .VARILLA 2	1	1	1	1	
16	90201-04M06	.WASHER, PLATE .ARANDELA PLANA	2	2	2	2	
17	91490-20010	.PIN, COTTER .PASADOR DE CHAVETA	2	2	2	2	
18	63V-48534-00	.THROTTLE LEVER, CONTROL .PALANCA DE CONTROL DE ACELERA	1	1	1	1	
19	95780-08300	.NUT, FLANGE .TUERCA DE BRIDA	1	1	1	1	
20	63V-48544-00	.LEVER, SHIFTCONTROL .PALANCA, CONTROL CAMBIOS	1	1	1	1	
21	97885-05012	.SCREW, PAN HEAD .TORNILLO DE CABEZA CON PLANA	1	1	1	1	
22	92990-05600	.WASHER, PLATE .ARANDELA	1	1	1	1	
23	90386-10009	.BUSH .BUJE	1	1	1	1	
24	63V-48511-01	.HOOK, STEERING .GANCHO DIRECCION	1	1	1	1	AP
25	97075-08035	.BOLT .PERNO	1	1	1	1	AP
26	92995-08600	.WASHER .ARANDELA	1	1	1	1	AP
27	90185-08057	.NUT, SELF-LOCKING .TUERCA AUTOBLOCANTE	1	1	1	1	AP

D1

FIG. 14 BRACKET 1

SOPORTE 1

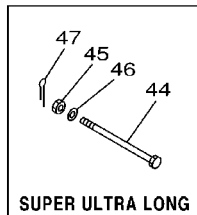
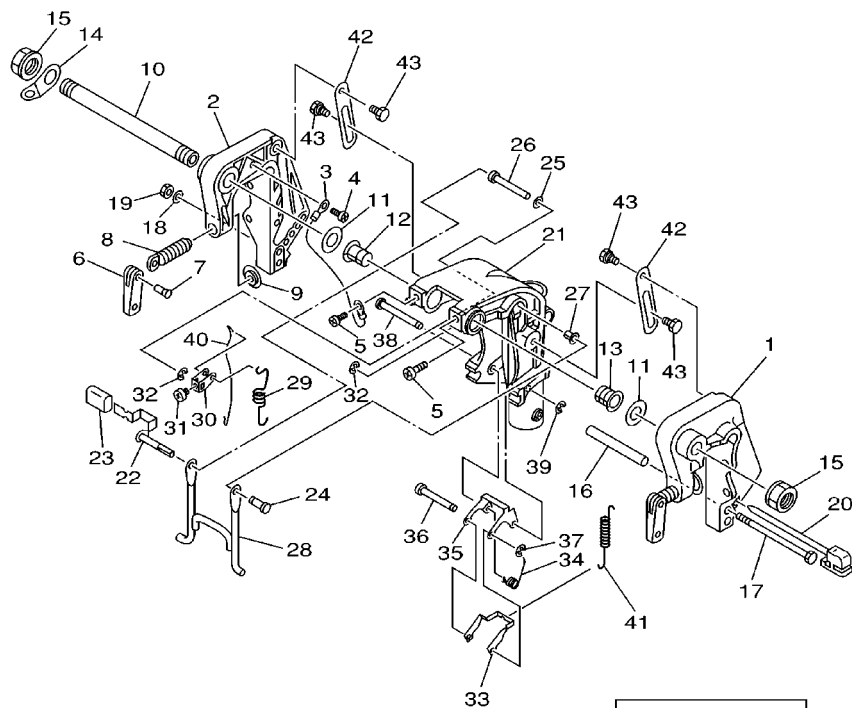

REF. NO.	PART NO. CODIGO NO.	DESCRIPTION DESCRIPTION	9.9F	15F	E99C	E15C	REMARKS OBSERVACION
1	63V-43111-05-4D	BRACKET, CLAMP SOPORTE DE LA ABRAZADERA	1	1	1	1	
2	63V-43112-06-4D	BRACKET, CLAMP SOPORTE DE LA ABRAZADERA	1	1	1	1	
3	66M-82148-00	WIRE, LEAD 4 CABLE CONDUCTOR 4	1	1	1	1	
4	97885-06008	SCREW, PAN HEAD TORNILLO DE CABEZA CON PLANA	1	1	1	1	
5	97885-08010	SCREW, PAN HEAD TORNILLO DE CABEZA CON PLANA	2	2	2	2	
6	6E0-43118-01	HANDLE, TRANSOM CLAMP MANIJA DE LA ABRAZADERA DEL ES	2	2	2	2	
7	90243-04M01	PIN PASADOR	2	2	2	2	
8	6E7-43116-00	SCREW, TRANSOM CLAMP TORNILLO DE ABRAZADERA	2	2	2	2	
9	648-43114-01	PAD, TRANSOM CLAMP ARANDELA DE ABRAZADERA	2	2	2	2	
10	63W-43131-00	BOLT, CLAMP BRACKET TORNILLO DE ABRAZADERA DEL SOP	1	1	1	1	
11	90202-22M54	WASHER, PLATE ARANDELA DE PLANA	2	2	2	2	
12	90386-22M94	BUSH BUJE	1	1	1	1	
13	90386-22M94	BUSH BUJE	1	1	1	1	
14	6J8-43113-01	PLATE, CLAMP BRACKET PLACA ABRAZADERA SOPORTE	1	1	1	1	
15	63V-43145-00	CAP, CLAMP BRACKET TAPA	2	2	2	2	
16	90387-06M13	COLLAR CASQUILLO CON VALONA	1	1	1	1	
17	90101-06M29	BOLT TORNILLO	1	1	1	1	
18	92995-06600	WASHER ARANDELA	1	1	1	1	
19	95380-06700	NUT TUERCA	1	1	1	1	
20	6L2-43160-00	TILT ROD ASSY VARILLA DE BASCULACION COMPL.	1	1	1	1	
21	63V-43311-03-4D	BRACKET, SWIVEL 1 SOPORTE GIRATORIO 1	1	1	1	1	
22	66M-43630-01	TILT LEVER ASSY PLANCA DE INCLINACION COMPL	1	1	1	1	
23	682-43318-01	COVER CUBIERTA	1	1	1	1	
24	63V-43191-00	SHAFT, STOPPER EJE DE TOPE	1	1	1	1	
25	90202-07M60	WASHER, PLATE ARANDELA DE PLANA	1	1	1	1	
26	90387-07M07	COLLAR CASQUILLO CON VALONA	1	1	1	1	
27	90386-07M95	BUSH BUJE	1	1	1	1	

63V0200-1140

FIG. 14 BRACKET 1

SOPORTE 1

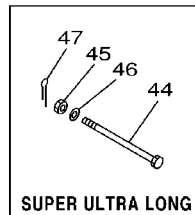
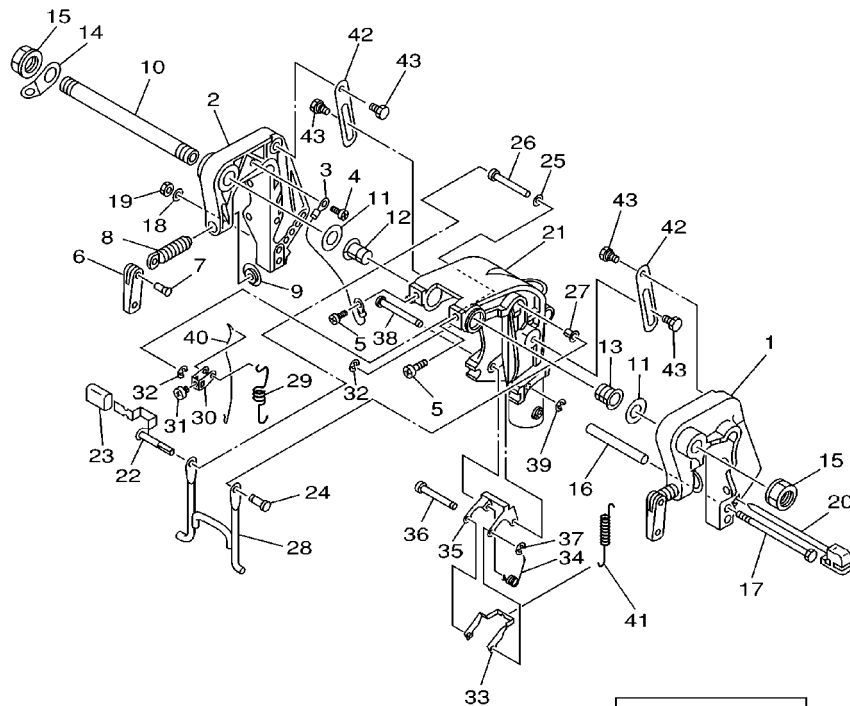

63V0200-1140

REF. NO.	PART NO. CODIGO NO.	DESCRIPTION DESCRIPTION	9.9F	15F	E99C	E15C	REMARKS OBSERVACION
28	66M-43350-01	RECEIVER ASSY RECIBIDOR COMPL	1	1	1	1	
29	90507-20M00	SPRING, TENSION RESORTE DE TENSION	1	1	1	1	
30	63V-43641-01	LEVER, TILT PALANCA DE INCLINACION	1	1	1	1	
31	90149-05M17	SCREW TORNILLO DE REGLAJE	1	1	1	1	
32	93430-05027	CIRCLIP BOLA	2	2	2	2	
33	66R-43614-00	PLATE, TILT LOCK PLACA DE SEGURO DE INCLINACION	1	1	1	1	
34	90508-18M41	SPRING, TORSION RESORTE DE TORSION	1	1	1	1	
35	66R-43615-00	PLATE, TILT LOCK PLACA DE SEGURO DE INCLINACION	1	1	1	1	
36	66R-43611-00	SHAFT, TILT LOCK EJE SEGURO INCLINACION	1	1	1	1	
37	93430-04M03	CIRCLIP BOLA	1	1	1	1	
38	63V-43659-00	SHAFT, REVERSE LOCK EJE SEGURO DE REVERSA	1	1	1	1	
39	93430-05027	CIRCLIP BOLA	1	1	1	1	
40	66R-43617-00	ROD, TILT LOCK VARILLA SEGURO DE INCLINACION	1	1	1	1	
41	90506-26M38	SPRING, TENSION RESORTE DE TENSION	1	1	1	1	
42	63V-43181-00	LEVER, TILT STOP PALANCA TOPE INCLINACION	2	2	2	2	
43	90109-06M84	BOLT PERNO	4	4	4	4	
44	90102-08M03	BOLT, WITH HOLE PERNO CON ORIFICIO			1	1	U
45	90171-08M00	NUT, CASTLE TUERCA ENTALLADA			1	1	U
46	92995-08600	WASHER ARANDELA			1	1	U
47	91490-20015	PIN, COTTER PASADOR DE CHAVETA			1	1	U

FIG. 15 BRACKET 2

SOPORTE 2

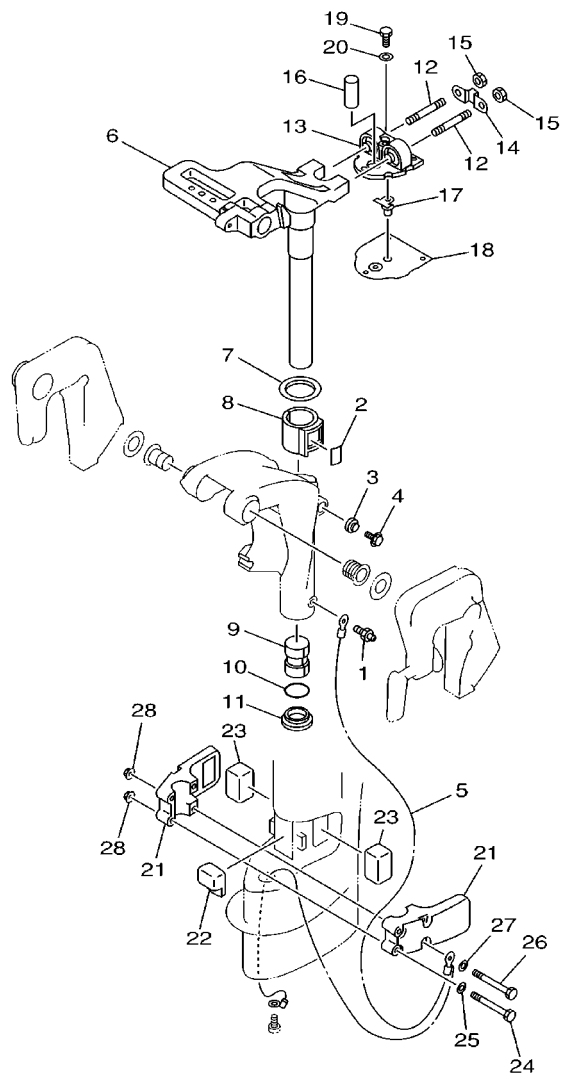



63V0010-1160

REF. NO.	PART NO. CODIGO NO.	DESCRIPTION DESCRIPTION	9.9F	15F	E99C	E15C	REMARKS OBSERVACION
1	93700-06M03	NIPPLE, GREASE NIPLE DE ENGRASAR	1	1	1	1	
2	63V-42528-00	PLATE, FRICTION PIEZA DE FRICCION	1	1	1	1	
3	689-43373-01	SEAL, DAMPER SELLO DE GOMA	1	1	1	1	
4	90105-06M07	BOLT, WASHER BASED TORNILLO CON ARANDELA	1	1	1	1	
5	63V-82127-00	WIRE, LEAD 2 CABLE CONDUCTOR 2	1	1	1	1	
6	63V-42511-04-4D	BRACKET, STEERING SOPORTE DE DIRECCION	1	1	1	1	
7	90209-40008	WASHER ARANDELA DE SEPARACION	1	1	1	1	
8	65F-42537-00	BUSHING, PIVOT SHAFT BUJE DEL PIVOTE DE LA FLECHA	1	1	1	1	
9	90386-30048	BUSH BUJE	1	1	1	1	
10	93210-29M94	O-RING ANILLO O	1	1	1	1	
11	90386-30M60	BUSH BUJE	1	1	1	1	
12	90116-08M54	BOLT, STUD ESPARRAGO	2	2	2	2	
13	63V-44514-01-5B 63V-44514-31-5B	MOUNT DAMPER, UPPER SIDE AMORTIGUADOR LADO SUPERIOR	1	1	1	1	S,L
14	63V-44526-00	PLATE PLACA_1	1	1	1	1	U
15	95380-08600	NUT TUERCA	2	2	2	2	
16	90387-16002	COLLAR CASQUILLO CON VALONA	1	1	1	1	
17	63V-44366-01	DAMPER, WATER SEAL GOMA DEL SELLO DE AGUA	1	1	1	1	
18	63V-45114-A0	GASKET, UPPER CASING EMPAQUE	1	1	1	1	
19	97095-06018	BOLT PERNO	3	3	3	3	
20	92995-06600	WASHER ARANDELA	3	3	3	3	
21	63V-44551-01-4D	HOUSING, LOWER MOUNT RUBBER CAJA AMORTIGUADOR INFERIOR HU	2	2	2	2	
22	63V-44557-00	MOUNT DAMPER, LOWER FRONT AMORTIGUADOR DE HULE FRENTE IN	1	1	1	1	
23	682-44555-00 682-44555-30	MOUNT DAMPER, LOWER SIDE AMORTIGUADOR DE HULE LADO INFE	2	2	2	2	S,L U
24	97075-06055	BOLT PERNO	2	2	2	2	
25	92995-06600	WASHER ARANDELA	2	2	2	2	

D4

FIG. 15 BRACKET 2

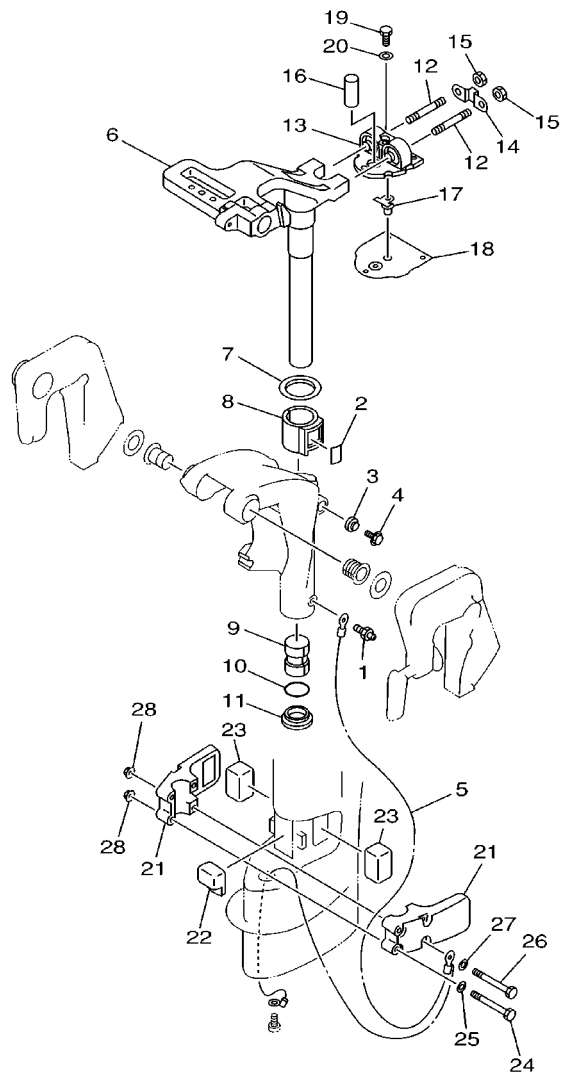
SOPORTE 2



63V0010-1160

REF. NO.	PART NO. CODIGO NO.	DESCRIPTION DESCRIPTION	9.9F	15F	E99C	E15C	REMARKS OBSERVACION
26	97075-06075	BOLT PERNO	2	2	2	2	
27	92995-06600	WASHER ARANDELA	2	2	2	2	
28	90179-06M28	NUT TUERCA	4	4	4	4	

FIG. 16 UPPER CASING

FUNDA SUPERIOR

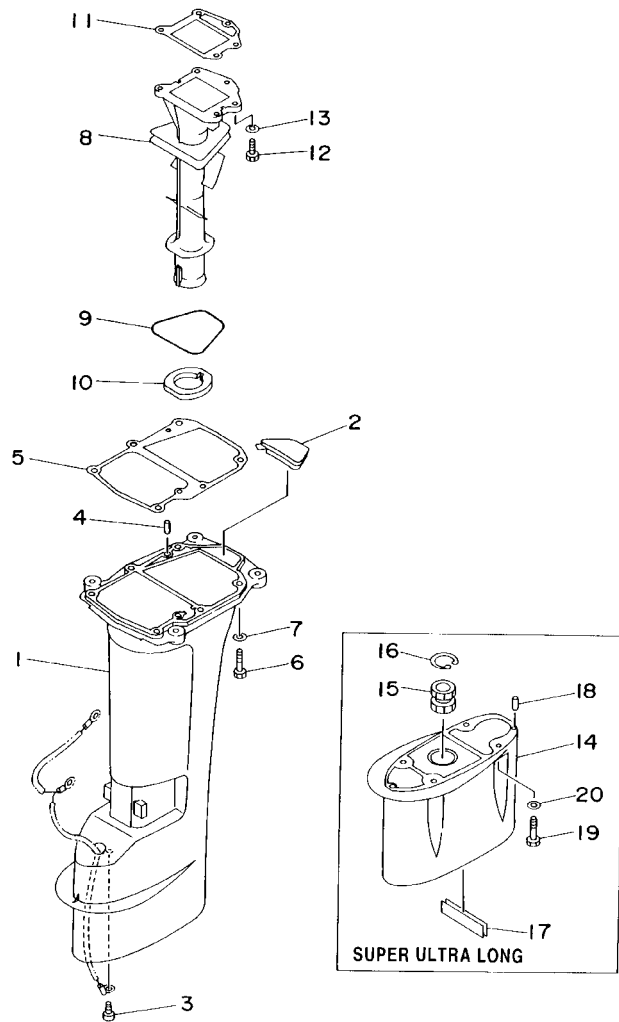

REF. NO.	PART NO. CODIGO NO.	DESCRIPTION DESCRIPTION	9.9F	15F	E99C	E15C	REMARKS OBSERVACION	
1	63V-45111-04-4D	CASING, UPPER CAJA SUPERIOR	1	1	1	1	S	
	63V-45111-14-4D	CASING, UPPER CAJA SUPERIOR	1	1	1	1	L,U	
2	63V-45126-00	PLATE, SEAL DAMPER PLACA DE SELLO DE HULE	1	1	1	1		
3	90157-06M06	SCREW, PAN HEAD TORNILLO CABEZA CONICA PLANA	1	1	1	1		
4	93606-12019	PIN, DOWEL PASADOR DE CLAVIJA	2	2	2	2		
5	63V-45113-A1	GASKET, UPPER CASING EMPAQUE	1	1	1	1		
6	97095-08030	BOLT PERNO	6	6	6	6		
7	92995-08600	WASHER ARANDELA	6	6	6	6		
8	63V-41131-02-5B	MANIFOLD, EXT. 1 TUBO MULTIPLE DE ESCAPE	1	1	1	1		
9	93210-71MH6	O-RING ANILLO O	1	1	1	1		
10	63V-41135-00	GASKET, EXHAUST MANIFOLD EMPAQUE	1	1	1	1		
11	63V-41133-A1	GASKET, EXHAUST MANIFOLD 1 EMPAQUE ESCAPE MULTIPLE	1	1	1	1		
12	97095-06020	BOLT PERNO	5	5	5	5		
13	92995-06600	WASHER ARANDELA	5	5	5	5		
14	63V-45211-30-4D	EXTENSION EXTENSION				1	1	U
15	682-45318-00	BUSHING, DRIVE SHAFT BUJE, EJE DE MANDO				1	1	U
16	93420-30042	CIRCLIP BOLA				1	1	U
17	63V-45127-00	SEAL SELLO DE GOMA				1	1	U
18	93604-12M07	PIN, DOWEL PASADOR DE CLAVIJA				2	2	U
19	97075-08030	BOLT PERNO				4	4	U
20	92995-08600	WASHER ARANDELA				4	4	U



63V0200-5160

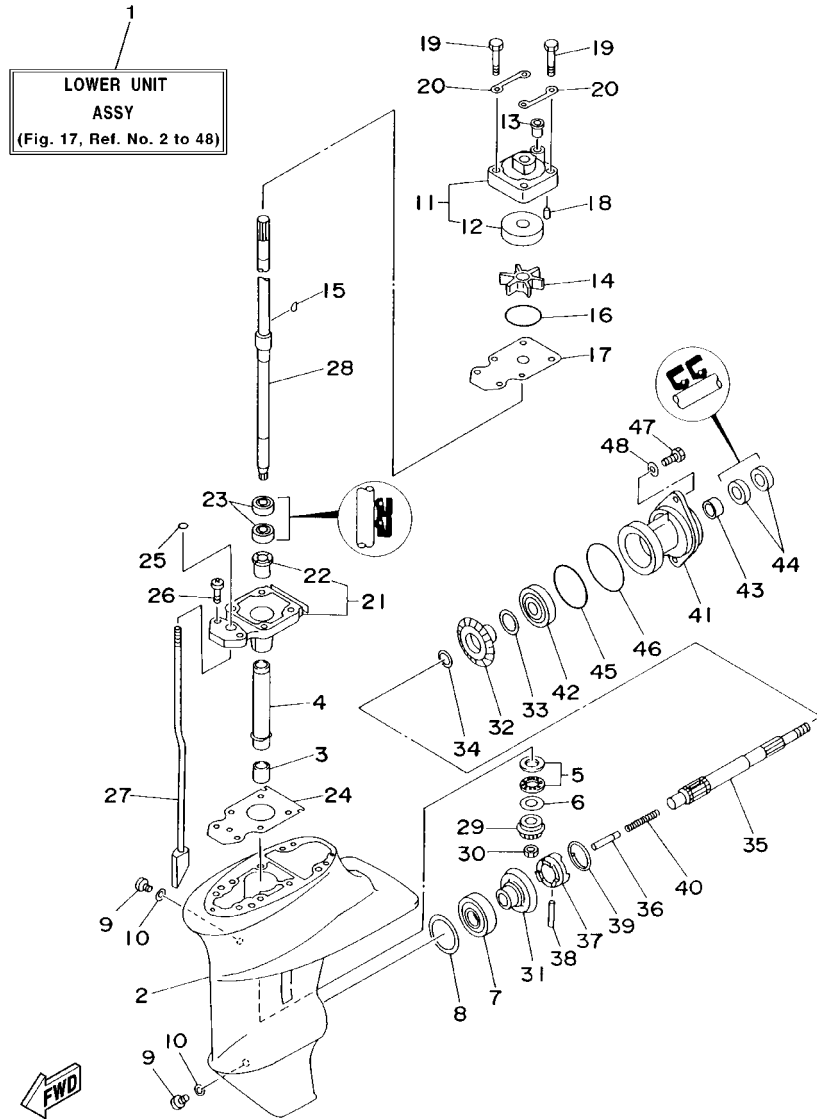

63W0664-5170

FIG. 17 LOWER CASING, DRIVE 1 IMPULSOR E INFERIOR 1

REF. NO.	PART NO. CODIGO NO.	DESCRIPTION DESCRIPTION	9.9F	15F	E99C	E15C	REMARKS OBSERVACION
1	63V-45300-03-4D	LOWER UNIT ASSY CONJUNTO UNIDAD INFERIOR	1	1			S
	63V-45300-13-4D	LOWER UNIT ASSY CONJUNTO UNIDAD INFERIOR	1	1			L
	65E-45300-02-4D	LOWER UNIT ASSY CONJUNTO UNIDAD INFERIOR			1	1	S
	65E-45300-12-4D	LOWER UNIT ASSY CONJUNTO UNIDAD INFERIOR			1	1	L
	65E-45300-32-4D	LOWER UNIT ASSY CONJUNTO UNIDAD INFERIOR			1	1	U
2	63V-45311-01-4D	CASING, LOWER FUNDA INFERIOR	1	1	1	1	
3	93315-314V8	BEARING COJINETE	1	1	1	1	
4	63V-45536-00	SLEEVE, DRIVE SHAFT CAMISA EJE DE MANDO	1	1	1	1	
5	93341-41414	BEARING COJINETE	1	1	1	1	
6	6E8-45587-10-13	SHIM (T:1.13MM) LAINA (T:1.13MM)	1	1	1	1	UR
	6E8-45587-10-20	SHIM (T:1.20MM) LAINA (T:1.20MM)	1	1	1	1	UR
7	93332-00005	BEARING COJINETE	1	1	1	1	
8	664-45567-01-10	SHIM (T:0.10MM) LAINA (T:0.10MM)	1	1	1	1	UR
	664-45567-01-12	SHIM (T:0.12MM) LAINA (T:0.12MM)	1	1	1	1	UR
	664-45567-01-15	SHIM (T:0.15MM) LAINA (T:0.15MM)	1	1	1	1	UR
	664-45567-01-18	SHIM (T:0.18MM) LAINA (T:0.18MM)	1	1	1	1	UR
	664-45567-01-30	SHIM (T:0.30MM) LAINA (T:0.30MM)	1	1	1	1	UR
	664-45567-01-40	SHIM (T:0.40MM) LAINA (T:0.40MM)	1	1	1	1	UR
	664-45567-01-50	SHIM (T:0.50MM) LAINA (T:0.50MM)	1	1	1	1	UR
9	90340-08M04	PLUG, STRAIGHT SCREW TORNILLO, DE DRENAJE	2	2	2	2	
10	90430-08020	GASKET JUNTA	2	2	2	2	
11	63V-44301-00	WATER PUMP HOUSING COMP. CAJA DE BOMBE DE AGUA COMPL	1	1	1	1	
	63V-44301-40	WATER PUMP HOUSING COMP. CAJA DE BOMBE DE AGUA COMPL	1	1	1	1	FOR CHROMATE
12	63V-44322-00	.INSERT, CARTRIDGE .CARTUCHO	1	1	1	1	
	63V-44322-40	.INSERT, CARTRIDGE .CARTUCHO	1	1	1	1	FOR CHROMATE
13	647-44366-00	DAMPÉR, WATER SEAL GOMA DEL SELLO DE AGUA	1	1	1	1	
14	63V-44352-01	IMPELLER IMPULSOR	1	1	1	1	

D7

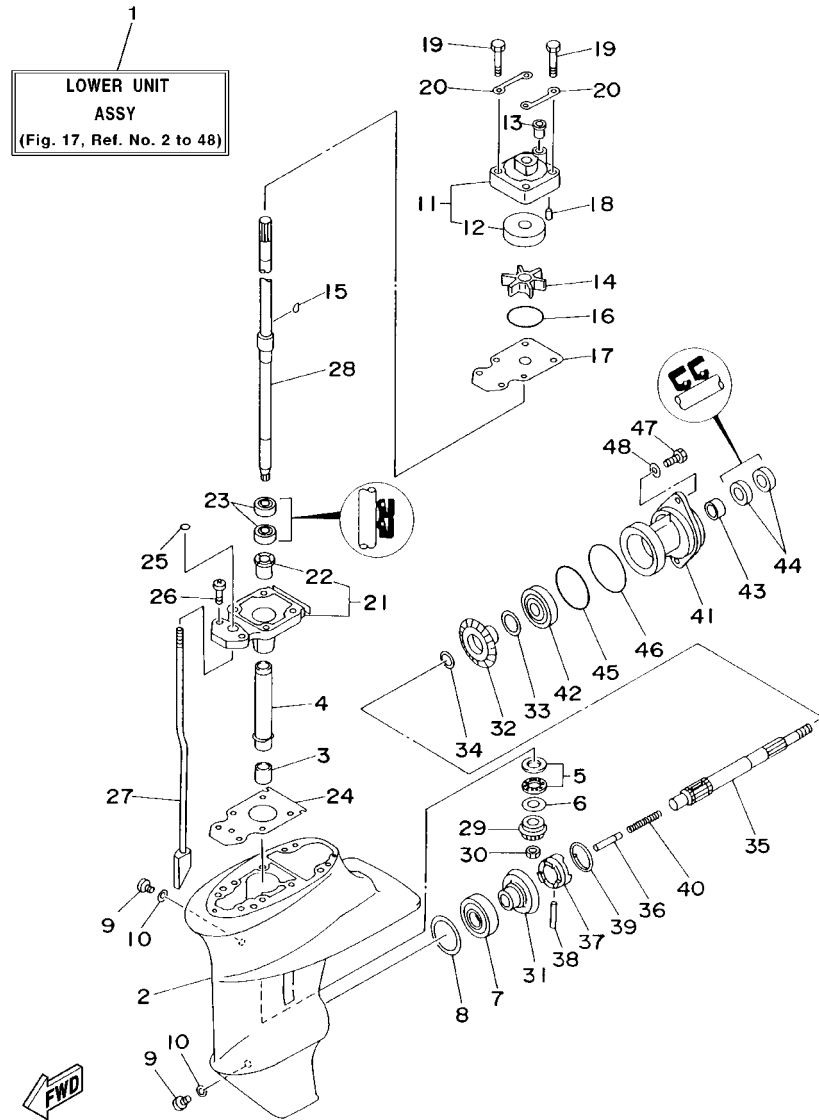

63W0664-5170

FIG. 17 LOWER CASING, DRIVE 1 IMPULSOR E INFERIOR 1

REF. NO.	PART NO. CODIGO NO.	DESCRIPTION DESCRIPTION	9.9F	15F	E99C	E15C	REMARKS OBSERVACION
15	63V-44338-00	KEY, WOODRUFF CUNA WOODRUFF	1	1	1	1	
16	93210-44398	O-RING ANILLO O	1	1	1	1	
17	63V-44323-00	OUTER PLATE, CARTRIDGE PLACA EXTERIOR DEL CARTUCHO	1	1	1	1	
	63V-44323-40	OUTER PLATE, CARTRIDGE PLACA EXTERIOR DEL CARTUCHO	1	1	1	1	FOR CHROMATE
18	93604-12M07	PIN, DOWEL PASADOR DE CLAVIJA	2	2	2	2	
19	97080-08045	BOLT PERNO	4	4	4	4	
20	63V-44328-00	PLATE PLACA	2	2	2	2	
21	63V-45331-00-5B	HOUSING, BEARING CAJA DE COJINETE	1	1	1	1	
22	90381-14020	BUSH, SOLID BUJE SOLIDO	1	1	1	1	
23	93101-20048	OIL SEAL SELLO ACEITE	2	2	2	2	
24	63V-45315-A0	PACKING, LOWER CASING EMPAQUE	1	1	1	1	
25	93210-06ME6	O-RING ANILLO O	1	1	1	1	
26	97080-08025	BOLT PERNO	2	2	2	2	
27	63V-44150-00	SHIFT CAM ASSY CONJUNTO EJE LEVA COMPL.	1	1	1	1	S
	63V-44150-10	SHIFT CAM ASSY CONJUNTO EJE LEVA COMPL.	1	1	1	1	L
	63V-44150-30	SHIFT CAM ASSY CONJUNTO EJE LEVA COMPL.			1	1	U
28	63V-45510-01	DRIVE SHAFT ASSY EJE DE MANDO COMPL.	1	1	1	1	S
	63V-45510-11	DRIVE SHAFT ASSY EJE DE MANDO COMPL.	1	1	1	1	L
	63V-45510-31	DRIVE SHAFT ASSY EJE DE MANDO COMPL.			1	1	U
29	63V-45551-00	PINION PINON	1	1	1	1	
30	90179-08M06	NUT TUERCA	1	1	1	1	
31	6E7-45560-01	GEAR ENGRANE COMPLE 1	1	1	1	1	
32	6E7-45571-00	GEAR ENGRANAJE	1	1	1	1	
33	626-45577-00-01	SHIM (T:0.10MM) LAINA (T:0.10MM)	1	1	1	1	UR
	626-45577-00-03	SHIM (T:0.30MM) LAINA (T:0.30MM)	1	1	1	1	UR
	626-45577-00-05	SHIM (T:0.50MM) LAINA (T:0.50MM)	1	1	1	1	UR
34	90201-17682	WASHER, PLATE ARANDELA PLANA	1	1	1	1	

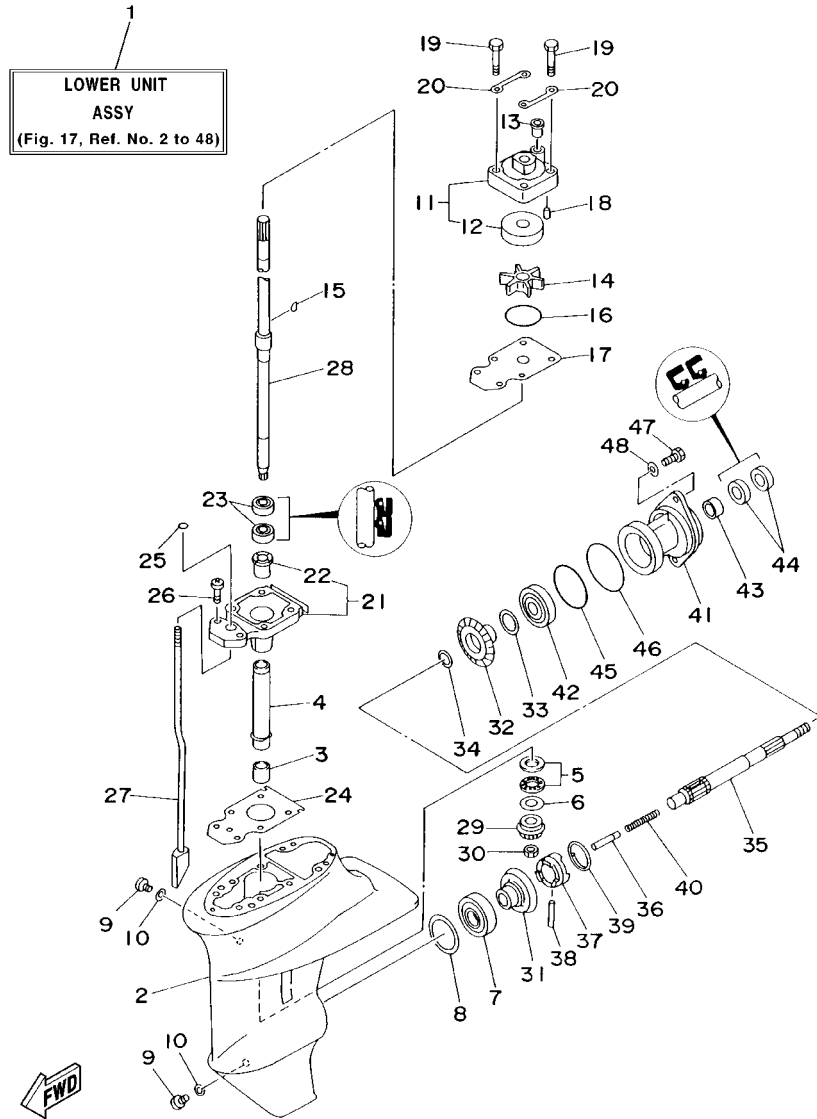

63W0664-5170

FIG. 17 LOWER CASING, DRIVE 1 IMPULSOR E INFERIOR 1

REF. NO.	PART NO. CODIGO NO.	DESCRIPTION DESCRIPTION	9.9F	15F	E99C	E15C	REMARKS OBSERVACION
35	683-45611-00	SHAFT, PROPELLER EJE PROPUSOR	1	1	1	1	
36	650-45635-00	PLUNGER, SHIFT EMBOLO DE CAMBIO	1	1	1	1	
37	682-45631-00	CLUTCH, DOG EMBRAGUE DE GARRA	1	1	1	1	
38	90250-05010	PIN, STRAIGHT PASADOR CILINDRICO	1	1	1	1	
39	648-45633-00	RING, CROSS PIN ANILLO DE PASADOR	1	1	1	1	
40	90501-14M06	SPRING, COMPRESSION RESORTE DE COMPRESION	1	1	1	1	
41	683-45361-02-4D	CAP, LOWER CASING FUNDA INFERIOR	1	1	1	1	
42	93306-00501	BEARING (B6005) COJINETE	1	1	1	1	
43	93315-317U2	BEARING COJINETE	1	1	1	1	
44	93101-17054	OIL SEAL SELLO ACEITE	2	2	2	2	
45	93210-57M09	O-RING ANILLO O	1	1	1	1	
46	93210-56M80	O-RING ANILLO O	1	1	1	1	
47	97095-06020	BOLT PERNO	2	2	2	2	
48	92995-06600	WASHER ARANDELA	2	2	2	2	

FIG. 18 LOWER CASING, DRIVE 2 IMPULSOR E INFERIOR 2

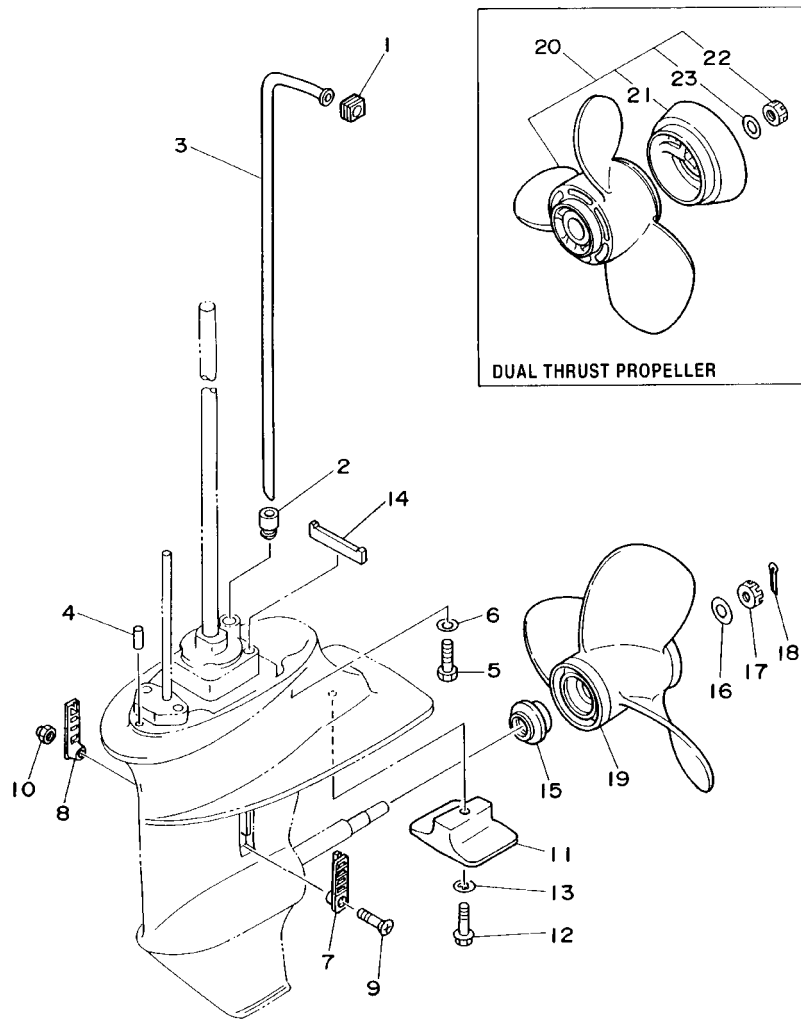

63V0010-5190

REF. NO.	PART NO. CODIGO NO.	DESCRIPTION DESCRIPTION	9.9F	15F	E99C	E15C	REMARKS OBSERVACION
1	63V-44365-10	DAMPER, WATER SEAL HULE DE SELLO DE AGUA	1	1	1	1	
2	63V-44368-00	RUBBER, WATER SEAL 4 CAUCHO AGUA SERTISSURE 4	1	1	1	1	
3	63V-44361-01	TUBE, WATER TUBO DE AGUA	1	1	1	1	S
	63V-44361-11	TUBE, WATER TUBO DE AGUA	1	1	1	1	L
	63V-44361-31	TUBE, WATER TUBO DE AGUA			1	1	U
4	93604-12M07	PIN, DOWEL PASADOR DE CLAVIJA	2	2	2	2	
5	97075-08030	BOLT PERNO	4	4	4	4	
6	92995-08600	WASHER ARANDELA	4	4	4	4	
7	6G1-45214-00	COVER, WATER INLET CUBIERTA ENTRADA AGUA	1	1	1	1	
8	63V-45215-00	COVER, WATER INLET CUBIERTA ENTRADA AGUA	1	1	1	1	
9	90152-05M04	SCREW, COUNTERSUNK TORNILLO EMBUTIDO	1	1	1	1	
10	90185-05002	NUT, SELF-LOCKING TUERCA AUTOBLOCANTE	1	1	1	1	
11	61N-45251-00	ANODE CATODE	1	1	1	1	
12	95895-06030	BOLT, FLANGE TUERCA DE REBORDE	1	1	1	1	
13	92990-06300	WASHER, INTERNAL TOOTH ARANDELA	1	1	1	1	
14	63V-45375-00	DAMPER, SEAL GOMA DE SELLO	1	1	1	1	
15	6E7-45987-01	SPACER ESPACIADOR	1	1	1	1	
16	90201-10M01	WASHER, PLATE ARANDELA PLANA	1	1	1	1	
17	90171-10M01	NUT, CASTLE TUERCA ENTALLADA	1	1	1	1	
18	91490-30020	PIN, COTTER PASADOR DE CHAVETA	1	1	1	1	
19	683-45941-00-EL	PROPELLER (3X9-1/4"X12"-J) PROPERA (3X9-1/4"X12"-J)	1	1	1	1	UR
	683-45943-00-EL	PROPELLER (3X9-1/4"X10-1/2"-J) PROPERA (3X9-1/4"X10-1/2"-J)	1	1	1	1	UR
	683-45945-00-EL	PROPELLER (3X9-1/4"X9"-J) PROPELA (3X9-1/4X9"-J)	1	1	1	1	UR
	683-45947-00-EL	PROPELLER (3X9-1/4"X8"-J) PROPERA (3X9-1/4"X8"-J)	1	1	1	1	UR
	683-45949-00-EL	PROPELLER (3X9-1/2"X6-1/2"-J) PROPERA (3X9-1/2"X6-1/2"-J)	1	1	1	1	UR
	683-45952-00-EL	PROPELLER (3X9-1/4"X9-3/4"-J) PROPERA (3X9-1/4"X9-3/4"-J)	1	1	1	1	UR
	63V-45945-00-EL	PROPELLER (3X9-1/4"X9"-J) PROPERA (3X9-1/4"X9"-J)	1	1	1	1	UR

FIG. 18 LOWER CASING, DRIVE 2 IMPULSOR E INFERIOR 2

REF. NO.	PART NO. CODIGO NO.	DESCRIPTION DESCRIPTION	9.9F	15F	E99C	E15C	REMARKS OBSERVACION
19	63V-45947-00-EL	PROPELLER (3X9-1/4"X8"-J) PROPELA (3X9-1/4"X8"-J)	1	1	1	1	UR
20	683-W4591-02-EL	PROPELLER (3X9-3/4"X8"-J) PROPELA (3X9-3/4"X8"-J)	1	1	1	1	UR DUAL THRUST PROP.
	683-W4592-02-EL	PROPELLER (3X9-3/4"X6-1/2"-J) PROPELA (3X9-3/4"X6-1/2"-J)	1	1	1	1	UR DUAL THRUST PROP.
21	6E7-45986-00	.RING, DEFLECTOR .ANILLO REFLECTOR	1	1	1	1	
22	90171-10M07	.NUT, CASTLE .TUERCA ENTALLADA	1	1	1	1	
23	90201-10M02	.WASHER, PLATE .ARANDELA PLANA	1	1	1	1	

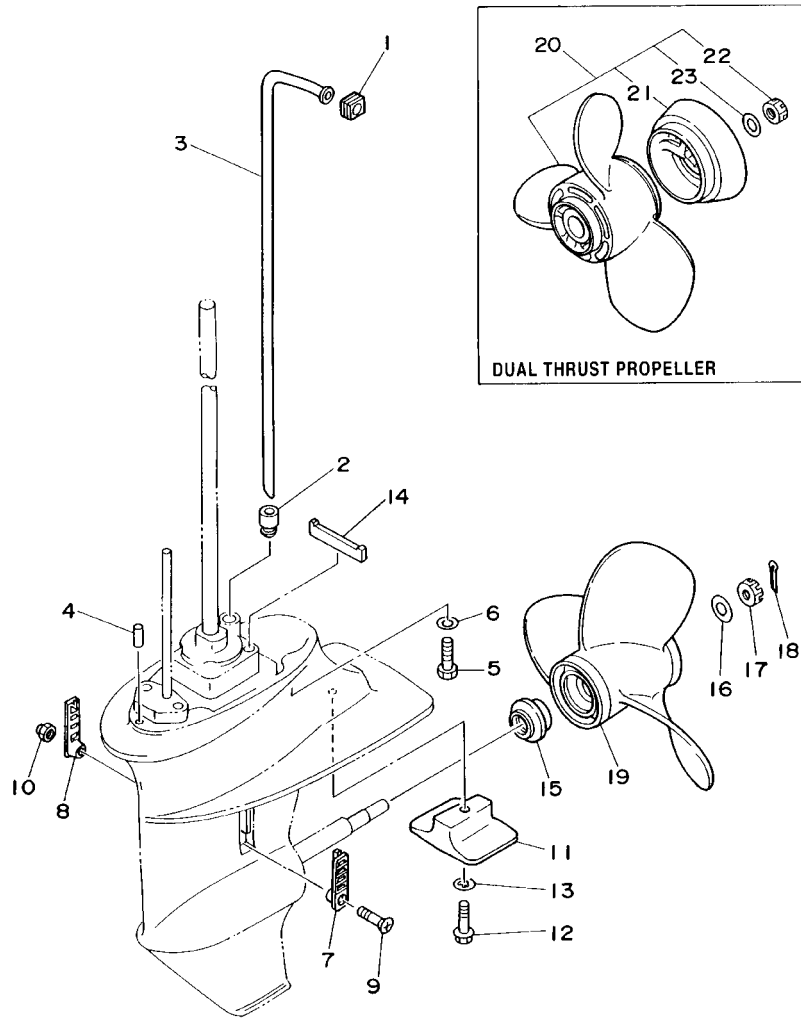

63V0010-5190

FIG. 19 FUEL TANK

DEPOSITO DE COMBUSTIBLE

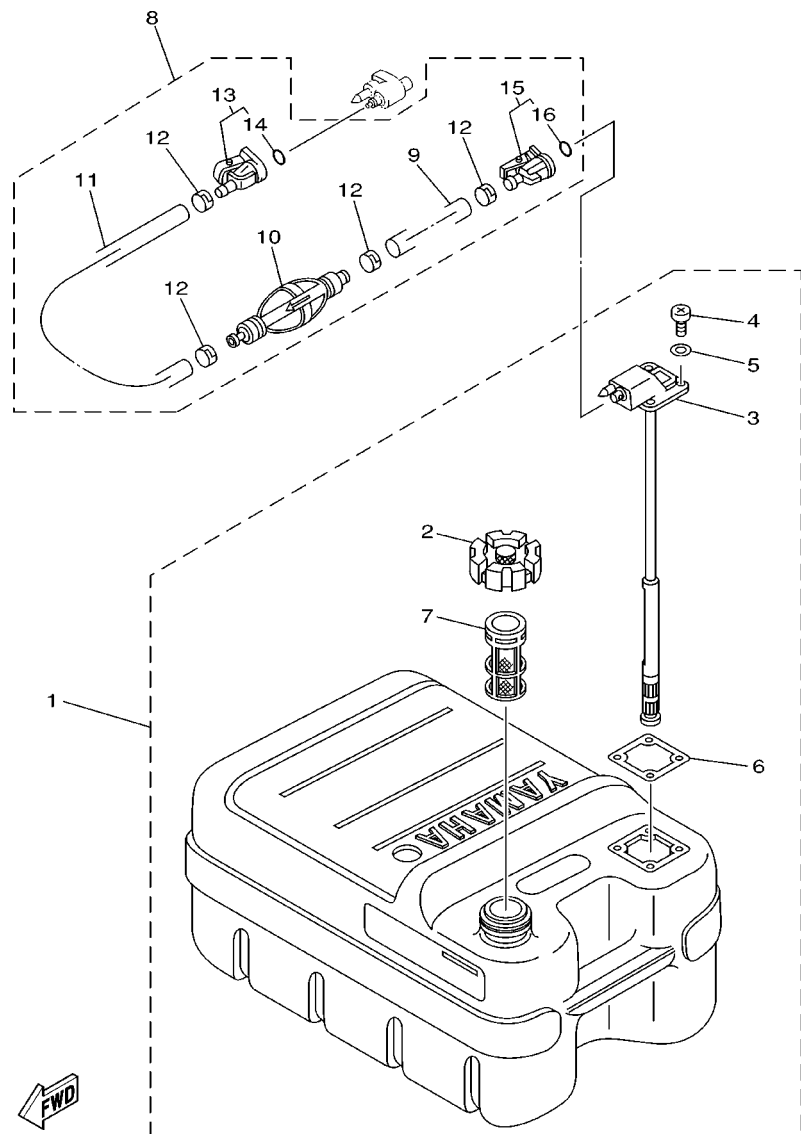

67C0100-9300

REF. NO.	PART NO. CODIGO NO.	DESCRIPTION DESCRIPTION	9.9F	15F	E99C	E15C	REMARKS OBSERVACION
1	6YJ-24201-00	FUEL TANK ASSY (24L) TANQUE DEL COMBUSTIBLE (24L)	1	1	1	1	AP
	6YJ-24201-10	FUEL TANK ASSY (24L) TANQUE DEL COMBUSTIBLE (24L)	1	1			AP WITH INDICATOR
2	6YJ-24610-01	.CAP ASSY .TAPA COMPLETA	1	1	1	1	
3	6YJ-24260-00	.FUEL METER ASSY .MEDIDOR DE COMBUSTIBLE COMPL.	1	1	1	1	
	6Y1-24260-12	.FUEL METER ASSY .MEDIDOR DE COMBUSTIBLE COMPL.	1	1			WITH INDICATOR
4	98586-05016	.SCREW, PAN HEAD .TORNILLO DE CABEZA CON PLANA	4	4	4	4	
5	6Y1-24329-00	.SEAL .SELLO	4	4	4	4	
6	6Y1-24268-00	.GASKET, FUEL METER .EMPAQ MEDIDOR DE COMBUSTIBLE	1	1	1	1	
7	6YJ-24167-00	.STRAINER .COLADOR	1	1	1	1	
8	61J-24306-02	FUEL PIPE COMP. 1 TUBO COMBUST. COMPL 1	1	1	1	1	AP
9	90445-11M06	.HOSE (L2050) .MANGUERA (L2050)	1	1	1	1	
10	61J-24360-00	.PRIMER PUMP ASSY .SOPORTE BOMBA	1	1	1	1	
11	90445-11M05	.HOSE (L:850MM) .MANGUERA (L:850MM)	1	1	1	1	
12	650-24351-51	BAND 1 .ABRAZADERA 1	4	4	4	4	
13	6G1-24305-03	FUEL PIPE JOINT COMP. 2 CONECTOR MANGUERA COMBUST.2	1	1	1	1	
14	93210-08287	.O-RING .ANILLO O	1	1	1	1	
15	6Y1-24305-04	FUEL PIPE JOINT COMP. 2 CONECTOR MANGUERA COMBUST.2	1	1	1	1	
16	93210-08287	.O-RING .ANILLO O	1	1	1	1	

FIG. 20 STEERING GUIDE

DIRECCIONGUIAR

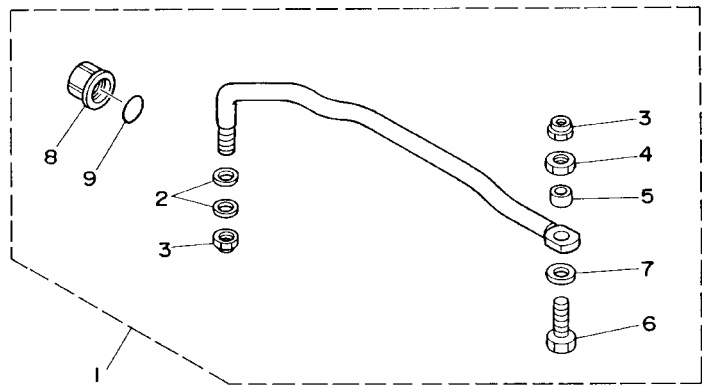

REF. NO.	PART NO. CODIGO NO.	DESCRIPTION DESCRIPTION	9.9F	15F	E99C	E15C	REMARKS OBSERVACION
1	63V-61350-00	STEERING GUIDE ATTACHMENT KIT ESTUCHE ADITAMENTO GUIA DE TIM	1	1	1	1	AP
2	90201-10M20	.WASHER, PLATE .ARANDELA PLANA	2	2	2	2	
3	90185-09M01	.NUT, SELF-LOCKING .TUERCA AUTOBLOCANTE	2	2	2	2	
4	90170-09M03	.NUT .TUERCA	1	1	1	1	
5	90387-10M42	.COLLAR .CASQUILLO CON VALONA	1	1	1	1	
6	6E5-61355-00	.BOLT .TORNILLO	1	1	1	1	
7	90201-10M63	.WASHER, PLATE .ARANDELA PLANA	1	1	1	1	
8	6E5-43145-01	.CAP, CLAMP BRACKET .TAPA	1	1	1	1	
9	93210-16275	.O-RING .ANILLO O	1	1	1	1	

63V0100-5210

FIG. 21 REMOTE CONTROL BOX CONTROL REMOTO COMPL.

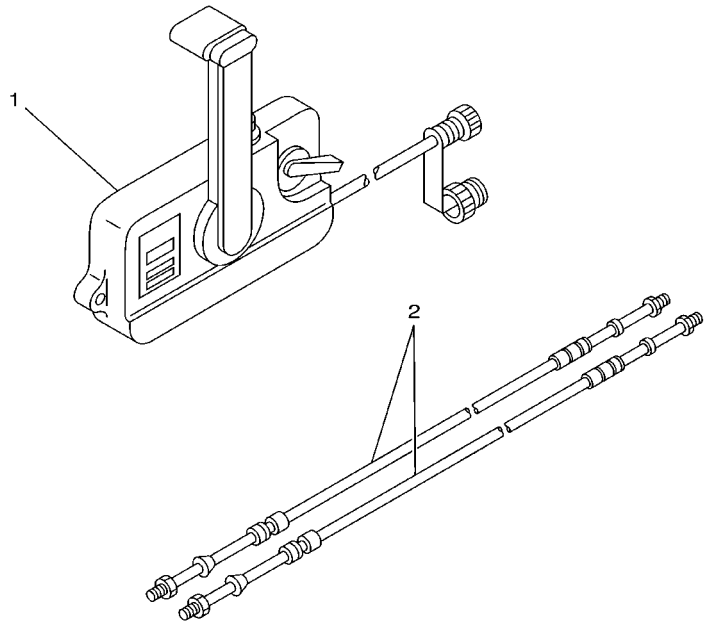

REF. NO.	PART NO. CODIGO NO.	DESCRIPTION DESCRIPTION	9,9F	15F	E99C	E15C	REMARKS OBSERVACION
1	701-48130-02	REMOTE CONTROL ASSY 3 REMOTO CONTROL COMPL 3	1	1	1	1	AP
2	701-48310-80	CABLE, REMOTE CONTROL L=10F CABLE CONTROL REMOTO L=10F	2	2	2	2	UR
	701-48310-90	CABLE, REMOTE CONTROL L=11F CABLE CONTROL REMOTO L=11F	2	2	2	2	UR
	701-48320-00	CABLE, REMOTE CONTROL L=12F CABLE CONTROL REMOTO L=12F	2	2	2	2	UR
	701-48320-20	CABLE, REMOTE CONTROL L=13F CABLE CONTROL REMOTO L=13F	2	2	2	2	UR
	701-48320-30	CABLE, REMOTE CONTROL L=14F CABLE CONTROL REMOTO L=14F	2	2	2	2	UR
	701-48320-50	CABLE, REMOTE CONTROL L=15F CABLE CONTROL REMOTO L=15F	2	2	2	2	UR

63V0100-9220

FIG. 22 REMOTE CONTROL ASSY CONTROL REMOTO COMPL.

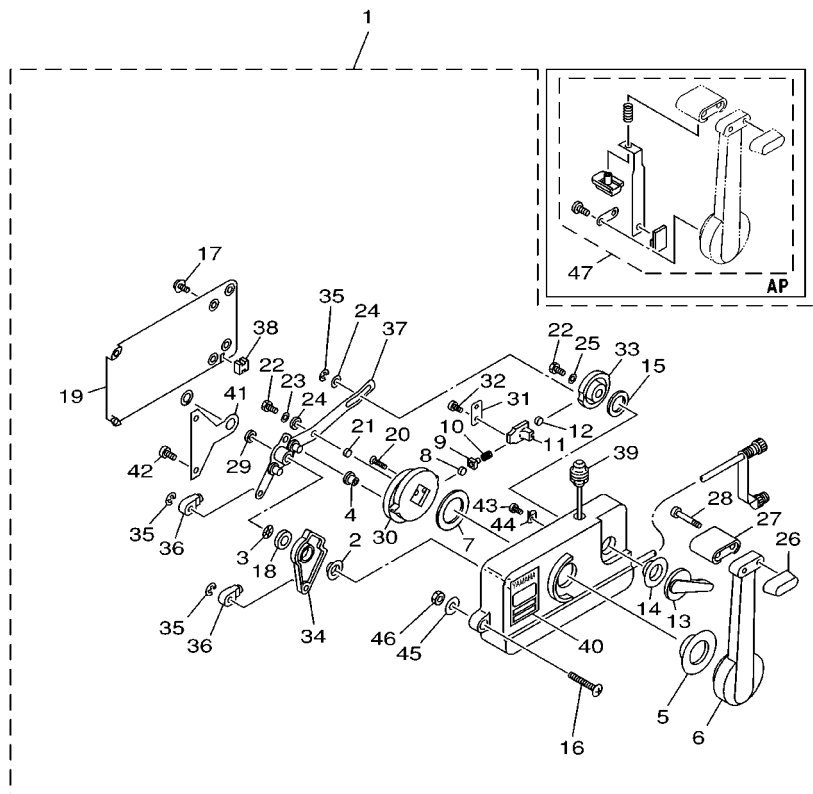

REF. NO.	PART NO. CODIGO NO.	DESCRIPTION DESCRIPTION	9.9F	15F	E99C	E15C	REMARKS OBSERVACION
1	701-48130-02	REMOTE CONTROL ASSY 3 REMOTO CONTROL COMPL 3	1	1	1	1	AP
2	701-48235-00	.BUSHING .BUJE	1	1	1	1	
3	701-48197-10	.WASHER, WAVE .RONDANA ONDULADA 2	1	1	1	1	
4	701-48252-00	.ROLLER, CAM .RODILLO LEVA	1	1	1	1	
5	701-48234-00	.BUSHING 1 .BUJE	1	1	1	1	
6	701-48221-00	.LEVER, CONTROL .PALANCA CONTROL	1	1	1	1	
7	701-48196-11	.WASHER, WAVE .ARANDELA ONDULADA	1	1	1	1	
8	701-48236-00	.ROLLER, DETENT .RODILLO	1	1	1	1	
9	702-48237-00	.ADAPTOR .ADAPTADOR	1	1	1	1	
10	702-48238-00	.SPRING, DETENT .RESORTE	1	1	1	1	
11	701-48249-00	.ADAPTOR, SPRING .RESORTE ADAPTADOR	1	1	1	1	
12	701-48248-00	.ROLLER, FREE ACCEL. .RODILLO ACELERADOR LIBRE	1	1	1	1	
13	701-48152-11	.KNOB, FREE ACCEL. .PERILLA	1	1	1	1	RIGHT
14	701-48243-00	.BUSHING .BUJE 3	1	1	1	1	
15	701-48198-10	.WASHER, WAVE .RONDANA ONDULADA 3	1	1	1	1	
16	701-48281-10	.SCREW .TORNILLO 1	3	3	3	3	
17	98580-05010	.SCREW, PAN HEAD .TORNILLO DE CABEZA CON PLANA	4	4	4	4	
18	701-48268-00	.SPACER .ESPACIADOR 3	1	1	1	1	
19	701-48213-00	.BACK PLATE 2 .PLACA TRASERA 2	1	1	1	1	
20	98780-06025	.SCREW, FLAT HEAD .TORNILLO DE CABEZA PLANA	2	2	2	2	
21	701-48255-00	.COLLAR .COLLAR 1	1	1	1	1	
22	97080-06018	.BOLT .PERNO	2	2	2	2	
23	702-48288-00	.WASHER, PLAIN .ARANDELA	1	1	1	1	
24	701-48246-00	.SPACER .ESPACIADOR	2	2	2	2	
25	92990-06300	.WASHER, INTERNAL TOOTH .ARANDELA	1	1	1	1	
26	701-48229-00	.GRIP, CONTROL LEVER .MANGO DE PALANCA CONTROL 2	1	1	1	1	
27	701-48222-00	.GRIP, CONTROL LEVER .MANGO DE PALANCA CONTROL	1	1	1	1	

FIG. 22 REMOTE CONTROL ASSY CONTROL REMOTO COMPL.

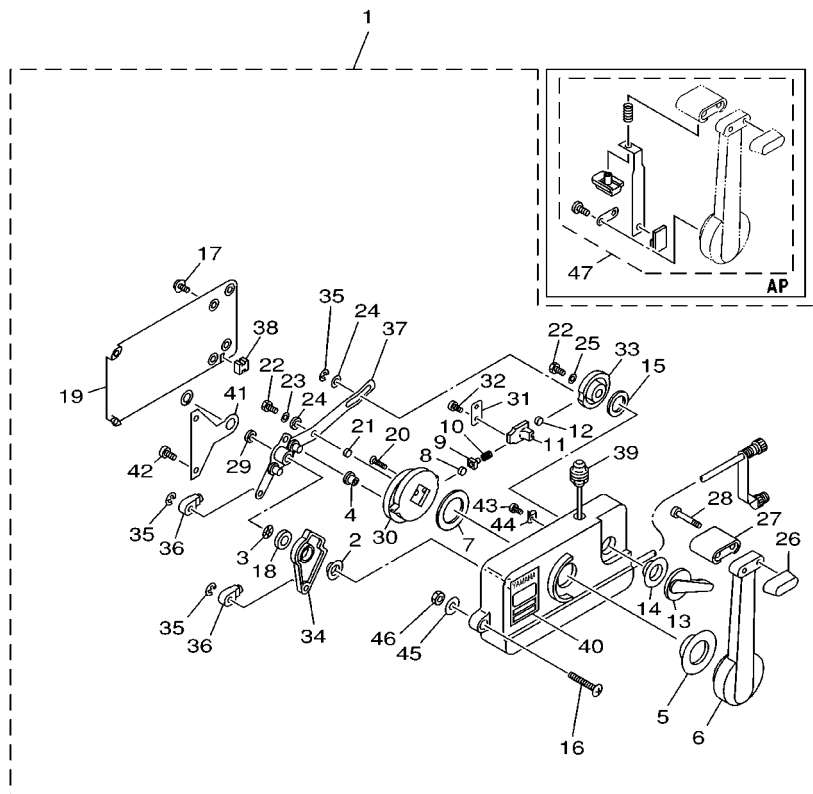

REF. NO.	PART NO. CODIGO NO.	DESCRIPTION DESCRIPTION	9.9F	15F	E99C	E15C	REMARKS OBSERVACION
28	98580-05555	SCREW, PAN HEAD .TORNILLO DE CABEZA CON PLANA	2	2	2	2	
29	701-48266-00	SPACER .ESPACIADOR 2	1	1	1	1	
30	701-48232-00	GEAR .ENGRANAJE 1	1	1	1	1	
31	701-48189-11	RETAINER .RETENEDOR	1	1	1	1	
32	98580-05010	SCREW, PAN HEAD .TORNILLO DE CABEZA CON PLANA	2	2	2	2	
33	701-48153-12	SHAFT, FREE ACCEL. .EJE	1	1	1	1	
34	701-48271-00	ARM, SHIFT .BRAZO CAMBIADOR	1	1	1	1	RIGHT
35	93430-06024	CIRCLIP .BOLA	3	3	3	3	
36	703-48345-01	CABLE END, REMOTE CONTROL 2 .TERMINAL CABLE DE CONTROL REM	2	2	2	2	
37	701-48261-20	ARM, THROTTLE .BRAZO ACELERADOR	1	1	1	1	
38	701-48358-00	ANCHOR, CABLE .ABRAZADERA CABLE	1	1	1	1	
39	701-82550-51	ENGINE STOP SWITCH ASSY .INTERRUP. DE PARADA COMPLETO	1	1	1	1	
40	701-48126-00	GRAPHIC .MARCADOR	1	1	1	1	
41	701-48133-00	PLATE, LINK .PLACA DE ESLABON	1	1	1	1	
42	98580-05020	SCREW, PAN HEAD .TORNILLO DE CABEZA CON PLANA	2	2	2	2	
43	701-48283-00	SCREW .TORNILLO 3	1	1	1	1	
44	701-82594-00	CLAMP .GRAMPA	1	1	1	1	
45	701-48287-00	WASHER .ARANDELA	3	3	3	3	
46	95380-06600	NUT, HEXAGON .TUERCA	3	3	3	3	
47	701-48280-00	NEUTRAL LOCK KIT .TORNILLO	1	1	1	1	AP



63V0100-9230

FIG. 23 REPAIR KIT 1

ESTUCHE REPARATION 1

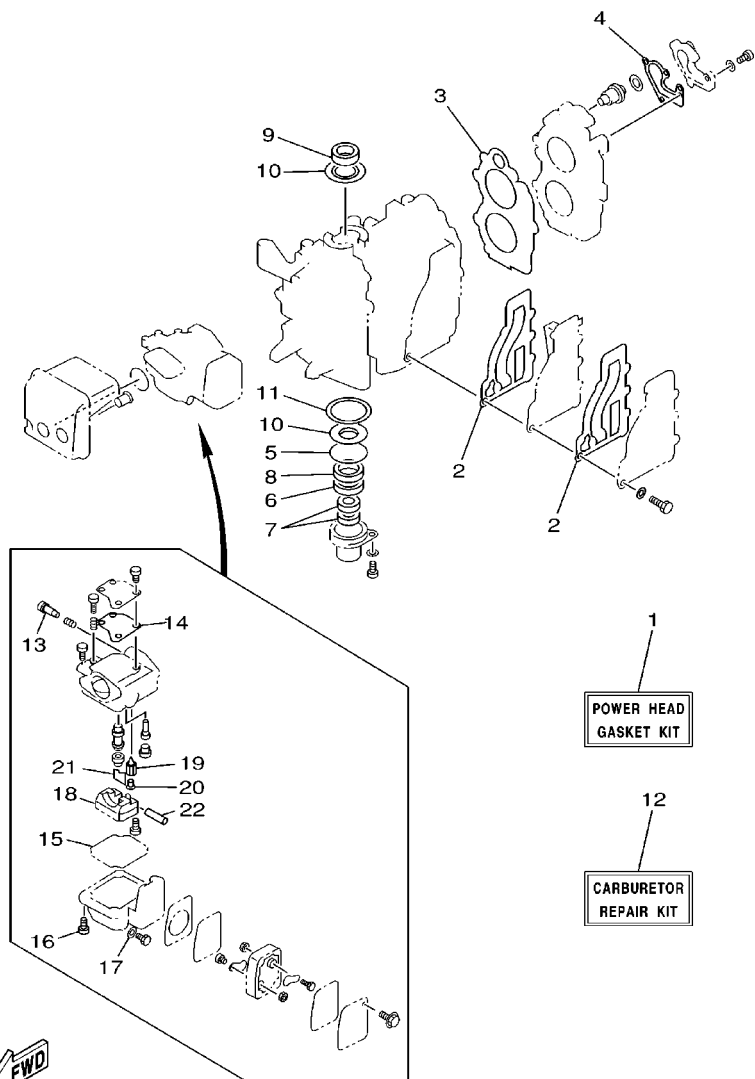

63V0100-1240

REF. NO.	PART NO. CODIGO NO.	DESCRIPTION DESCRIPTION	9.9F	15F	E99C	E15C	REMARKS OBSERVACION
1	63V-W0001-02	POWER HEAD GASKET KIT JUEGO DE EMPAQUE DE MOTOR	1	1	1	1	
2	63V-41112-A0	.GASKET, EXHAUST INNER COVER .EMPAQUE	2	2	2	2	
3	63V-11181-A1	.GASKET, CYLINDER HEAD 1 .JUNTA, DE CULATA 1	1	1	1	1	
4	682-12414-A1	.GASKET, COVER .EMPAQUE	1	1	1	1	
5	93210-46M16	.O-RING .ANILLO O	1	1	1	1	
6	93102-25018	.OIL SEAL .SELLO ACEITE	1	1	1	1	
7	93101-13018	.OIL SEAL .SELLO ACEITE	2	2	2	2	
8	93102-25M48	.OIL SEAL .SELLO ACEITE	1	1	1	1	
9	93110-23M00	.OIL SEAL .SELLO ACEITE	1	1	1	1	
10	63V-11445-00	.SPACER .ESPACIADOR	2	2	2	2	
11	90201-46M29	.WASHER, PLATE .ARANDELA PLANA	1	1	1	1	
12	63V-W0093-00	CARBURETOR REPAIR KIT KIT REPARACION CARBURADOR	1	1	1	1	
13	679-14923-00	.SCREW, PILOT .TORNILLO DE AJUSTE	1	1	1	1	
14	63V-14126-00	.GASKET .EMPAQUE	1	1	1	1	
15	63V-14984-00	.GASKET, FLOAT CHAMBER .EMPAQUE CAMARA DE BOIA	1	1	1	1	
16	97980-04114	.SCREW, WITH WASHER .TORNILLO, CON ARANDELA	4	4	4	4	
17	6G1-14398-00	.WASHER .EMPAQUE	1	1	1	1	
18	63V-14985-00	.FLOAT .BOIA	1	1	1	1	
19	6G1-14546-00	.VALVE, NEEDLE .VALVULA DE AGUJA	1	1	1	1	
20	676-14186-00	.PIN, FLOAT .PASADOR DE LA BOYA	1	1	1	1	
21	663-14159-00	.CLIP .PRESILLA	1	1	1	1	
22	6H4-14548-00	.PIN, FLOAT ARM .PASADOR DE BRAZO DE BOIA	1	1	1	1	

FIG. 24 REPAIR KIT 2

ESTUCHE REPARATION 2

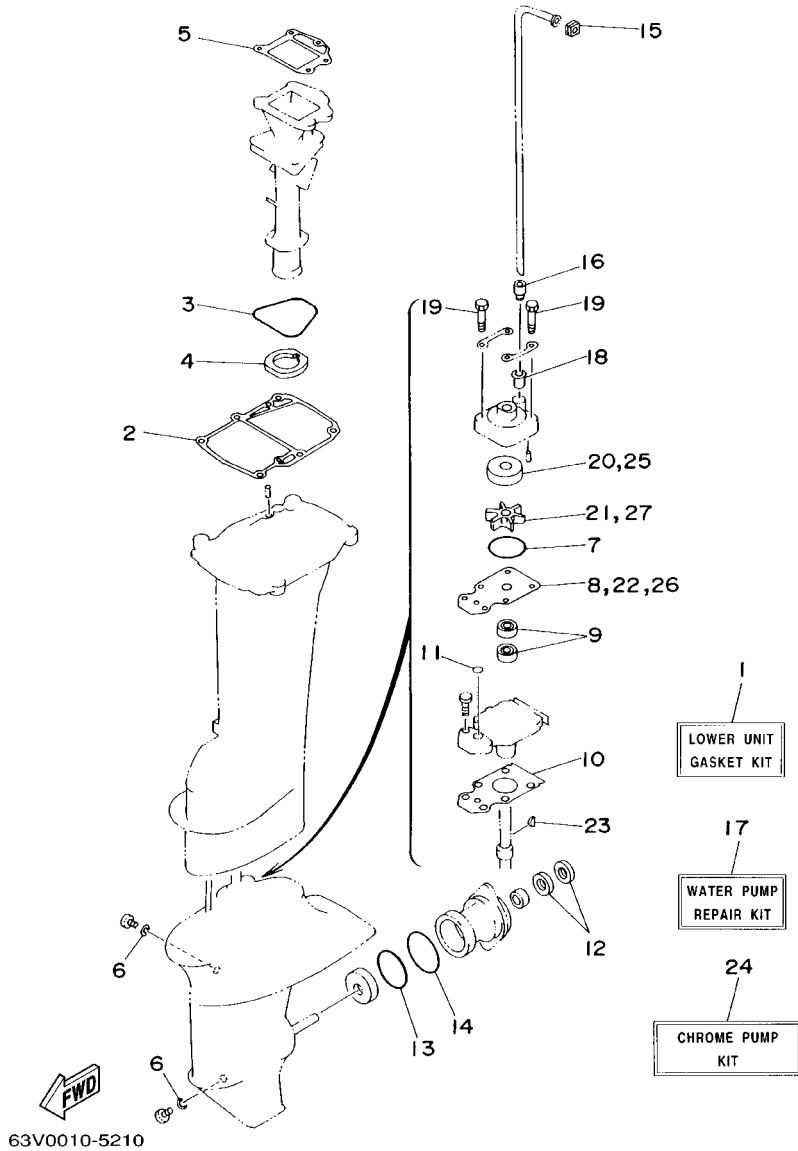

REF. NO.	PART NO. CODIGO NO.	DESCRIPTION DESCRIPTION	9.9F	15F	E99C	E15C	REMARKS OBSERVACION
1	63V-W0001-21	LOWER UNIT GASKET KIT	1	1	1	1	
	65G-W0001-C0	LOWER UNIT GASKET KIT	1	1	1	1	FOR CHROMATE
2	63V-45113-A1	.GASKET, UPPER CASING	1	1	1	1	
3	93210-71MH6	.O-RING	1	1	1	1	
		.ANILLO O					
4	63V-41135-00	.GASKET, EXHAUST MANIFOLD	1	1	1	1	
		.EMPAQUE					
5	63V-41133-A1	.GASKET, EXHAUST MANIFOLD 1	1	1	1	1	
		.EMPAQUE ESCAPE MULTIPLE					
6	90430-08020	.GASKET	2	2	2	2	
		.JUNTA					
7	93210-44398	.O-RING	1	1	1	1	
		.ANILLO O					
8	63V-44323-00	.OUTER PLATE, CARTRIDGE	1	1	1	1	
		.PLACA EXTERIOR DEL CARTUCHO					
	63V-44323-40	.OUTER PLATE, CARTRIDGE	1	1	1	1	FOR CHROMATE
		.PLACA EXTERIOR DEL CARTUCHO					
9	93101-20048	.OIL SEAL	2	2	2	2	
		.SELLO ACEITE					
10	63V-45315-A0	.PACKING, LOWER CASING	1	1	1	1	
		.EMPAQUE					
11	93210-06ME6	.O-RING	1	1	1	1	
		.ANILLO O					
12	93101-17054	.OIL SEAL	2	2	2	2	
		.SELLO ACEITE					
13	93210-57M09	.O-RING	1	1	1	1	
		.ANILLO O					
14	93210-56M80	.O-RING	1	1	1	1	
		.ANILLO O					
15	63V-44365-10	.DAMPER, WATER SEAL	1	1	1	1	
		.HULE DE SELLO DE AGUA					
16	63V-44368-00	.RUBBER, WATER SEAL 4	1	1	1	1	
		.CAUCHO AGUA SERTISSURE 4					
17	63V-W0078-01	WATER PUMP REPAIR KIT	1	1	1	1	
		ESTUCHE REPARACION BOMBA AGUA					
	65G-W0078-01	WATER PUMP REPAIR KIT	1	1	1	1	FOR CHROMATE
		ESTUCHE REPARACION BOMBA AGUA					
18	647-44366-00	.DAMPER, WATER SEAL	1	1	1	1	
		.GOMA DEL SELLO DE AGUA					
19	97080-08045	.BOLT	4	4	4	4	
		.PERNO					
20	63V-44322-00	.INSERT, CARTRIDGE	1	1	1	1	
		.CARTUCHO					
	63V-44322-40	.INSERT, CARTRIDGE	1	1	1	1	FOR CHROMATE
		.CARTUCHO					
21	63V-44352-01	.IMPELLER	1	1	1	1	
		.IMPULSOR					
22	63V-44323-00	.OUTER PLATE, CARTRIDGE	1	1	1	1	
		.PLACA EXTERIOR DEL CARTUCHO					
	63V-44323-40	.OUTER PLATE, CARTRIDGE	1	1	1	1	FOR CHROMATE
		.PLACA EXTERIOR DEL CARTUCHO					

FIG. 24 REPAIR KIT 2

ESTUCHE REPARATION 2

REF. NO.	PART NO. CODIGO NO.	DESCRIPTION DESCRIPTION	9,9F	15F	E99C	E15C	REMARKS OBSERVACION
23	63V-44338-00	.KEY, WOODRUFF .CUNA WOODRUFF	1	1	1	1	
24	63V-W0078-0A	CHROME PUMP KIT ESTUCHE REPARACION BOMBA AGUA	1	1	1	1	AP
25	63V-44322-40	.INSERT, CARTRIDGE .CARTUCHO	1	1	1	1	
26	63V-44323-40	.OUTER PLATE, CARTRIDGE .PLACA EXTERIOR DEL CARTUCHO	1	1	1	1	
27	63V-44352-01	.IMPELLER .IMPULSOR	1	1	1	1	

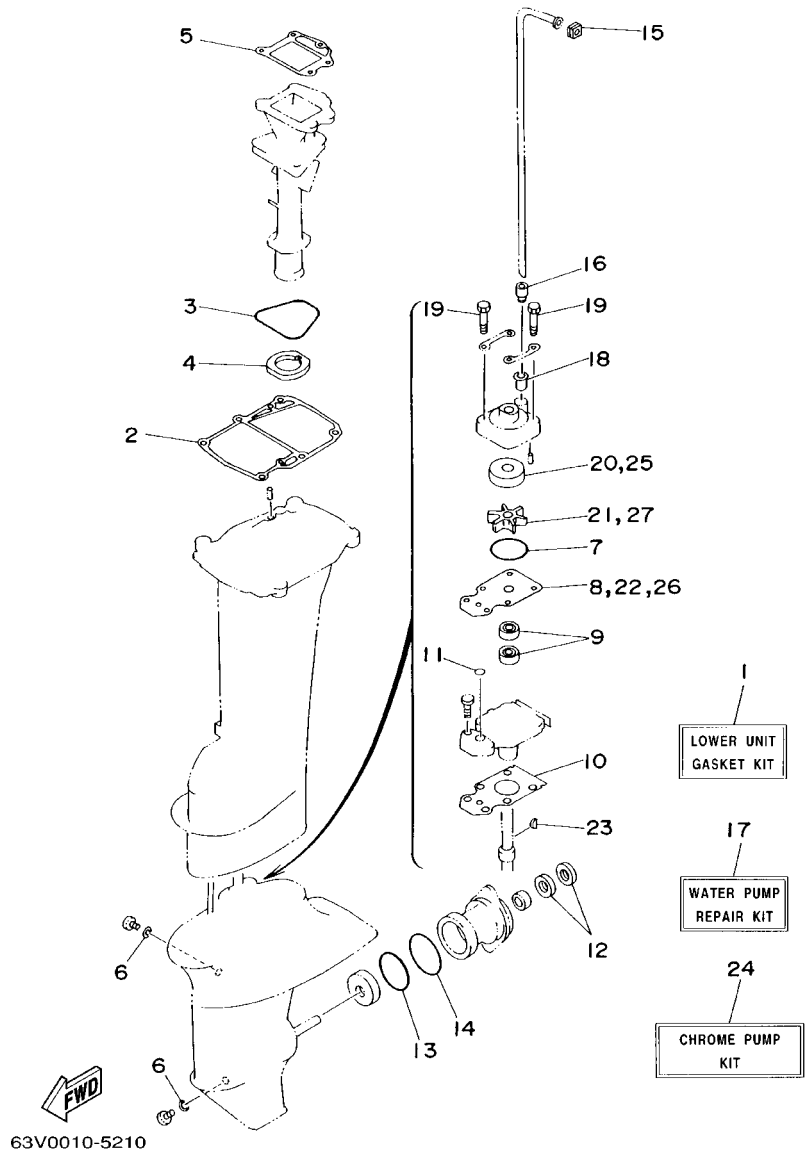

NUMERICAL INDEX
INDICE NUMERICO

PART NO. CODIGO NO.	REF. NO.	PART NO. CODIGO NO.	REF. NO.	PART NO. CODIGO NO.	REF. NO.	PART NO. CODIGO NO.	REF. NO.	PART NO. CODIGO NO.	REF. NO.	PART NO. CODIGO NO.	REF. NO.
63V-W0001-02	23 - 1	676-14186-00	23 - 20	63V-15753-00	7 - 8	63V-41223-00	12 - 16	65F-42678-H0	1 - 12	689-44194-00	12 - 2
63V-W0001-21	24 - 1	63V-14301-00	5 - 1	6G1-15755-00	7 - 18	6H4-41237-00	12 - 13	63V-42711-03-4D	10 - 1	63V-44301-00	17 - 11
65G-W0001-C0	24 - 1	65D-14301-01	5 - 1	63V-15762-00	7 - 25	63V-41238-00	12 - 12	63V-42716-02	10 - 19	63V-44301-40	17 - 11
682-W0004-00	4 - 2	6G1-14398-00	5 - 16	63V-15764-00	7 - 15	63V-41252-00	4 - 18	682-42724-00	10 - 2	63V-44322-00	17 - 12
63V-W0070-11	1 - 10		23 - 17	63V-15767-01	7 - 11	63V-41253-00	4 - 5	682-42725-02	10 - 3		24 - 20
65E-W0070-H0	1 - 10	63V-14440-00	4 - 9	63V-15768-00	7 - 14	63V-41256-00	4 - 15	63V-42726-00	10 - 4	63V-44322-40	17 - 12
65F-W0070-H0	1 - 10	624-14485-00	2 - 3	63V-15770-00	12 - 43	63V-41257-00	4 - 8	65F-42726-00	10 - 4		24 - 20
63V-W0078-0A	24 - 24	650-14485-02	2 - 4	6G1-15779-00	7 - 19	63V-41262-00	4 - 7	682-42727-00	10 - 5		24 - 25
63V-W0078-01	24 - 17	63V-14497-01	12 - 1	63V-15784-01	7 - 12	661-41262-02	4 - 19	6G1-42748-00	10 - 6	63V-44323-00	17 - 17
65G-W0078-01	24 - 17	63V-14523-00	5 - 9	63V-15793-00	7 - 16		12 - 19	63V-42815-01-4D	10 - 8		24 - 8
63V-W0090-03-1S	2 - 1	63V-14527-00	5 - 4	63V-15794-00	7 - 20		12 - 42	6E7-42816-00	10 - 9		24 - 22
63V-W0093-00	23 - 12	6G1-14546-00	5 - 19	63V-15795-01	7 - 3	6H4-41271-01	4 - 14	63V-43111-05-4D	14 - 1	63V-44323-40	17 - 17
656-W2810-02	6 - 14		23 - 19	6YJ-24167-00	19 - 7	689-41273-00	4 - 16	63V-43112-06-4D	14 - 2		24 - 8
683-W4591-02-EL	18 - 20	62D-14546-00	5 - 19	6YJ-24201-00	19 - 1	6J8-41274-00	4 - 17	6J8-43113-01	14 - 14		24 - 22
683-W4592-02-EL	18 - 20	6H4-14548-00	5 - 22	6YJ-24201-10	19 - 1	63V-41283-00	12 - 17	648-43114-01	14 - 9		24 - 26
6E7-11111-01-1S	2 - 19		23 - 22	6YJ-24260-00	19 - 3	63V-41611-00	8 - 5	6E7-43116-00	14 - 8	63V-44328-00	17 - 20
63V-11181-A1	2 - 20	679-14555-00	5 - 3	6Y1-24260-12	19 - 3	63V-41631-00	12 - 7	6E0-43118-01	14 - 6	63V-44338-00	17 - 15
	23 - 3	679-14923-00	5 - 2	6Y1-24268-00	19 - 6	63V-41638-00	12 - 20	63V-43131-00	14 - 10		24 - 23
682-11325-00	2 - 8		23 - 13	6G1-24304-02	6 - 1	63V-42111-00-4D	11 - 1	6E5-43145-01	20 - 8	63V-44352-01	17 - 14
676-11372-00	2 - 15	676-14943-29	5 - 14	6G1-24305-03	19 - 13	664-42119-00	11 - 11	63V-43145-00	14 - 15		24 - 21
63V-11400-01	3 - 8	676-14943-81	5 - 14	6Y1-24305-04	19 - 15	6G1-42125-01	11 - 8	6L2-43160-00	14 - 20		24 - 27
63V-11412-00	3 - 9	63V-14947-00	5 - 13	61J-24306-02	19 - 8	6G1-42126-00	11 - 9	63V-43181-00	14 - 42	63V-44361-01	18 - 3
63V-11422-00	3 - 10	63V-14948-06	5 - 7	6Y1-24329-00	19 - 5	6G1-42131-01	11 - 6	63V-43191-00	14 - 24	63V-44361-11	18 - 3
63V-11432-00	3 - 11	63V-14948-08	5 - 7	650-24351-51	19 - 12	6H2-42137-00	11 - 12	63V-43311-03-4D	14 - 21	63V-44361-31	18 - 3
63V-11442-00	3 - 12	679-14966-00	5 - 8	61J-24360-00	19 - 10	697-42137-10	11 - 12	682-43318-01	14 - 23	63V-44365-10	18 - 1
63V-11445-00	3 - 28	63V-14980-00	5 - 12	63V-24396-01	6 - 13	6G1-42138-01	11 - 19	66M-43350-01	14 - 28		24 - 15
	23 - 10	63V-14984-00	5 - 11	6G1-24411-00	5 - 30	63V-42154-00	13 - 11	689-43373-01	15 - 3	63V-44366-01	15 - 17
63V-11515-02	3 - 14		23 - 15	63V-24411-00	5 - 28	6E0-42159-02	11 - 20	66R-43611-00	14 - 36	647-44366-00	17 - 13
682-11610-01	3 - 22	63V-14985-00	5 - 18	6G1-24412-01	5 - 29	6G1-42177-00	11 - 14	66R-43614-00	14 - 33		24 - 18
682-11610-11	3 - 22		23 - 18	6L5-24421-00	5 - 32	63V-42192-00	13 - 15	66R-43615-00	14 - 35	63V-44368-00	18 - 2
682-11610-21	3 - 22	6G1-14992-00	5 - 17	6G1-24431-01	5 - 31	63V-42511-04-4D	15 - 6	66R-43617-00	14 - 40		24 - 16
6E7-11631-00-97	3 - 21	63V-15100-02-1S	2 - 2	6G1-24452-00	5 - 27	63V-42528-00	15 - 2	66M-43630-01	14 - 22	6H3-44391-01	10 - 20
634-11633-00	3 - 23	63V-15396-01-94	3 - 1	61N-24521-00	6 - 6	65F-42537-00	15 - 8	63V-43641-01	14 - 30	63V-44514-01-5B	15 - 13
6E7-11635-00	3 - 21	63V-15705-01	7 - 10	61N-24560-00	6 - 4	63V-42610-12-4D	1 - 1	63V-43659-00	14 - 38	63V-44514-31-5B	15 - 13
6E7-11636-00	3 - 21	63V-15710-02	7 - 1	61N-24563-00	6 - 5	63W-42610-12-4D	1 - 1	63V-44111-02	11 - 23	63V-44526-00	15 - 14
650-11651-04	3 - 16	63V-15710-12	7 - 1	682-24566-01	6 - 11	65E-42610-H2-4D	1 - 1	65F-44111-00	12 - 45	63V-44551-01-4D	15 - 21
682-11681-00	3 - 15	63V-15711-01	7 - 2	6YJ-24610-01	19 - 2	65F-42610-H2-4D	1 - 1	63V-44116-00	12 - 30	682-44555-00	15 - 23
6E5-12411-20	2 - 23	63V-15713-00	7 - 7	6L2-26301-00	11 - 22	65F-42610-J1-4D	1 - 1	63V-44121-01	12 - 24	682-44555-30	15 - 23
682-12413-00-1S	2 - 22	63V-15714-00	7 - 5	63V-41111-00-1S	2 - 12	63V-42613-00-4D	1 - 7	63V-44122-01	12 - 31	63V-44557-00	15 - 22
682-12414-A1	2 - 25	63V-15716-00	7 - 9	63V-41112-A0	2 - 13	63V-42615-00	1 - 2	63V-44123-01	12 - 23	63V-45111-04-4D	16 - 1
	23 - 4	63V-15726-00	7 - 23		23 - 2	6L2-42647-00	1 - 5	63V-44124-02	11 - 28	63V-45111-14-4D	16 - 1
63V-13610-10	4 - 1	63V-15734-00	7 - 22	63V-41113-00-1S	2 - 14	6G1-42651-02	1 - 3	63V-44125-00	12 - 26	63V-45113-A1	16 - 5
63W-13610-00	4 - 1	63V-15741-00	7 - 6	63V-41131-02-5B	16 - 8	63V-42677-11	1 - 11	63V-44143-01	12 - 33		24 - 2
63V-14126-00	5 - 5	63V-15744-00	7 - 13	63V-41133-A1	16 - 11	63W-42677-11	1 - 11	63V-44150-00	17 - 27	63V-45114-A0	15 - 18
	23 - 14	63V-15746-00	12 - 36		24 - 5	682-42677-H0	1 - 11	63V-44150-10	17 - 27	63V-45126-00	16 - 2
663-14159-00	5 - 21	63V-15746-10	12 - 36	63V-41135-00	16 - 10	63V-42678-10	1 - 12	63V-44150-30	17 - 27	63V-45127-00	16 - 17
	23 - 21	6L2-15747-00	12 - 41		24 - 4	63W-42678-10	1 - 12	6E0-44191-11	11 - 27	63V-45211-30-4D	16 - 14
676-14186-00	5 - 20	63V-15748-00	7 - 21	63V-41211-00	12 - 18	65E-42678-H0	1 - 12	688-44194-00	12 - 11	6G1-45214-00	18 - 7

NUMERICAL INDEX
INDICE NUMERICO

PART NO. CODIGO NO.	REF. NO.	PART NO. CODIGO NO.	REF. NO.	PART NO. CODIGO NO.	REF. NO.	PART NO. CODIGO NO.	REF. NO.	PART NO. CODIGO NO.	REF. NO.	PART NO. CODIGO NO.	REF. NO.
63V-45215-00	18 - 8	701-48130-02	21 - 1	63V-48544-00	13 - 20	90171-10M07	18 - 22	90386-30048	15 - 9	90508-18M41	14 - 34
61N-45251-00	18 - 11		22 - 1	63V-61350-00	20 - 1	90179-06M28	15 - 28	90386-33M96	11 - 5	90508-20M38	12 - 22
63V-45300-03-4D	17 - 1	701-48133-00	22 - 41	6E5-61355-00	20 - 6	90179-08M06	17 - 30	90386-34M97	11 - 2	91490-16010	11 - 10
63V-45300-13-4D	17 - 1	701-48152-11	22 - 13	63V-82127-00	15 - 5	90185-05002	18 - 10	90387-06M05	7 - 4	91490-16018	7 - 24
65E-45300-02-4D	17 - 1	701-48153-12	22 - 33	66M-82148-00	14 - 3	90185-08057	13 - 27	90387-06M06	12 - 37	91490-20010	13 - 17
65E-45300-12-4D	17 - 1	701-48189-11	22 - 31	62E-8231X-00	9 - 9	90185-09M01	20 - 3	90387-06M13	14 - 16	91490-20015	14 - 47
65E-45300-32-4D	17 - 1	701-48196-11	22 - 7	6E3-82370-21	9 - 15	90201-04M06	13 - 16	90387-06M15	4 - 10	91490-30020	18 - 18
63V-45311-01-4D	17 - 2	701-48197-10	22 - 3	663-82370-01	9 - 15	90201-05M09	4 - 20	90387-06M24	8 - 8	91590-30012	13 - 4
63V-45315-A0	17 - 24	701-48198-10	22 - 15	62E-82371-11	9 - 8	90201-06068	10 - 12	90387-06M50	12 - 3	91609-20008	3 - 19
	24 - 10	701-48213-00	22 - 19	662-82519-00	9 - 19	90201-08M12	13 - 10	90387-06M53	8 - 6	91690-20010	4 - 6
682-45318-00	16 - 15	701-48221-00	22 - 6	701-82550-51	22 - 39	90201-10M01	18 - 16	90387-06M86	11 - 25	92903-06600	2 - 18
63V-45331-00-5B	17 - 21	701-48222-00	22 - 27	682-82556-00	11 - 32	90201-10M02	13 - 14	90387-06034	10 - 17		2 - 27
683-45361-02-4D	17 - 41	701-48229-00	22 - 26	689-8257Y-00	11 - 33		18 - 23	90387-07M07	14 - 26	92903-10600	11 - 16
63V-45375-00	18 - 14	701-48232-00	22 - 30	65W-82575-00	11 - 31	90201-10M20	20 - 2	90387-10M42	20 - 5	92990-05600	13 - 22
63V-45510-01	17 - 28	701-48234-00	22 - 5	701-82594-00	22 - 44	90201-10M63	20 - 7	90387-16002	15 - 16	92990-06300	18 - 13
63V-45510-11	17 - 28	701-48235-00	22 - 2	63V-85520-00	8 - 3	90201-12472	8 - 12	90430-08020	17 - 10		22 - 25
63V-45510-31	17 - 28	701-48236-00	22 - 8	65E-85530-00	9 - 6	90201-14377	3 - 25		24 - 6	92990-06600	13 - 6
63V-45536-00	17 - 4	702-48237-00	22 - 9	63V-85533-00	8 - 4	90201-16M03	2 - 24	90445-07M08	2 - 5	92995-06600	1 - 9
63V-45551-00	17 - 29	702-48238-00	22 - 10	63V-85540-01	9 - 1	90201-17682	17 - 34		2 - 6		3 - 7
6E7-45560-01	17 - 31	701-48243-00	22 - 14	63V-85550-10	8 - 1	90201-46M29	3 - 29	90445-09M00	6 - 9		4 - 4
664-45567-01-10	17 - 8	701-48246-00	22 - 24	63V-85570-00	9 - 6		23 - 11	90445-09105	2 - 16		6 - 3
664-45567-01-12	17 - 8	701-48248-00	22 - 12	65E-85570-00	9 - 7	90202-06009	11 - 29	90445-11M05	19 - 11		7 - 27
664-45567-01-15	17 - 8	701-48249-00	22 - 11	63V-85580-00	8 - 2	90202-07M60	14 - 25	90445-11M06	19 - 9		9 - 3
664-45567-01-18	17 - 8	701-48252-00	22 - 4	90101-06M29	14 - 17	90202-22M54	14 - 11	90464-08M02	9 - 16		9 - 13
664-45567-01-30	17 - 8	701-48255-00	22 - 21	90102-08M03	14 - 44	90202-36M55	11 - 4	90464-15M11	9 - 4		9 - 18
664-45567-01-40	17 - 8	701-48261-20	22 - 37	90105-05M79	12 - 46	90206-10M04	13 - 13	90465-08M61	9 - 5		9 - 21
664-45567-01-50	17 - 8	701-48266-00	22 - 29	90105-06M07	15 - 4	90206-12052	10 - 11	90465-11M10	9 - 10		10 - 16
6E7-45571-00	17 - 32	701-48268-00	22 - 18	90105-06M68	8 - 7	90206-15M18	11 - 26	90465-25M57	10 - 21		12 - 6
626-45577-00-01	17 - 33	701-48271-00	22 - 34	90105-06M69	8 - 9	90206-36M21	11 - 3	90467-06016	2 - 7		12 - 29
626-45577-00-03	17 - 33	701-48280-00	22 - 47	90105-07M05	2 - 21	90209-20M23	3 - 18	90467-08004	6 - 10		12 - 40
626-45577-00-05	17 - 33	701-48281-10	22 - 16	90109-06M84	14 - 43	90209-40008	15 - 7	90468-10005	12 - 15		14 - 18
6E8-45587-10-13	17 - 6	701-48283-00	22 - 43	90116-08M54	15 - 12	90243-04M01	14 - 7	90468-18008	11 - 30		15 - 20
6E8-45587-10-20	17 - 6	701-48287-00	22 - 45	90119-06M05	11 - 24	90250-05010	17 - 38		13 - 9		15 - 25
683-45611-00	17 - 35	702-48288-00	22 - 23	90119-06M94	4 - 13	90266-04M04	1 - 4	90480-06M19	10 - 7		15 - 27
682-45631-00	17 - 37	701-48310-80	21 - 2	90119-08M07	2 - 11		1 - 6	90480-10M16	12 - 44		16 - 13
648-45633-00	17 - 39	701-48310-90	21 - 2	90149-05M13	11 - 15	90269-02M09	11 - 13	90480-12M25	4 - 11		17 - 48
650-45635-00	17 - 36	701-48320-00	21 - 2	90149-05M17	14 - 31	90280-05013	8 - 10	90480-15M31	10 - 18	92995-08600	13 - 26
683-45941-00-EL	18 - 19	701-48320-20	21 - 2	90152-05M04	18 - 9	90340-08M04	17 - 9	90480-25161	9 - 11		14 - 46
683-45943-00-EL	18 - 19	701-48320-30	21 - 2	90157-06M06	16 - 3	90381-14020	17 - 22		9 - 14		16 - 7
63V-45945-00-EL	18 - 19	701-48320-50	21 - 2	90159-05M25	12 - 25	90386-07M95	14 - 27	90501-10326	5 - 10		16 - 20
683-45945-00-EL	18 - 19	663-48344-00	13 - 8		12 - 27	90386-08032	11 - 18	90501-12M16	12 - 10		18 - 6
63V-45947-00-EL	18 - 19	703-48345-01	22 - 36		12 - 32	90386-10009	12 - 47	90501-12M85	12 - 48	93101-13018	3 - 5
683-45947-00-EL	18 - 19	701-48358-00	22 - 38	90164-05M03	4 - 21		13 - 23	90501-14M06	17 - 40		23 - 7
683-45949-00-EL	18 - 19	63V-48501-00	13 - 1	90170-06015	12 - 35	90386-10025	13 - 12	90501-23215	11 - 17	93101-17054	17 - 44
683-45952-00-EL	18 - 19	63V-48511-01	13 - 24	90170-09M03	20 - 4	90386-12M45	10 - 10	90506-26M38	14 - 41		24 - 12
6E7-45986-00	18 - 21	63V-48531-00	13 - 2	90170-12066	8 - 11	90386-22M94	14 - 12	90507-20M00	14 - 29	93101-20048	17 - 23
6E7-45987-01	18 - 15	63V-48534-00	13 - 18	90171-08M00	14 - 45		14 - 13	90508-08M39	12 - 38		24 - 9
701-48126-00	22 - 40	682-48538-50	13 - 3	90171-10M01	18 - 17	90386-30M60	15 - 11	90508-16M37	12 - 21	93101-25018	3 - 3

NUMERICAL INDEX
INDICE NUMERICO

PART NO. CODIGO NO.	REF. NO.	PART NO. CODIGO NO.	REF. NO.	PART NO. CODIGO NO.	REF. NO.	PART NO. CODIGO NO.	REF. NO.	PART NO. CODIGO NO.	REF. NO.	PART NO. CODIGO NO.	REF. NO.
93102-25M48	3 - 4	95380-06600	12 - 9	97885-06030	12 - 8						
	23 - 8		13 - 7	97885-08010	14 - 5						
93102-25018	23 - 6		22 - 46	97980-04114	5 - 15						
93110-23M00	3 - 27	95380-06700	10 - 14		23 - 16						
	23 - 9		12 - 34	97980-04125	5 - 26						
93210-06ME6	17 - 25		14 - 19	98580-04006	5 - 33						
	24 - 11	95380-08600	6 - 8	98580-04008	5 - 23						
93210-08287	19 - 14		15 - 15	98580-05010	22 - 17						
	19 - 16	95780-08300	13 - 19		22 - 32						
93210-16275	20 - 9	95895-06030	18 - 12	98580-05020	22 - 42						
93210-29M94	15 - 10	95895-06065	12 - 4	98580-05555	22 - 28						
93210-32738	6 - 7	97013-06010	6 - 12	98586-05016	19 - 4						
93210-35M86	4 - 12	97013-06020	2 - 26	98780-05015	2 - 9						
93210-44398	17 - 16	97013-06030	2 - 17	98780-06025	22 - 20						
	24 - 7	97075-06055	15 - 24	98980-03006	5 - 24						
93210-46M16	3 - 2	97075-06075	15 - 26								
	23 - 5	97075-08030	16 - 19								
93210-56M80	17 - 46		18 - 5								
	24 - 14	97075-08035	13 - 25								
93210-57M09	17 - 45	97080-06018	22 - 22								
	24 - 13	97080-08025	17 - 26								
93210-71MH6	16 - 9	97080-08045	17 - 19								
	24 - 3		24 - 19								
93306-00501	17 - 42	97095-06012	8 - 9								
93306-205U7	3 - 13		9 - 17								
93310-620V5	3 - 17		9 - 20								
93315-314V8	17 - 3		12 - 5								
93315-317U2	17 - 43		12 - 28								
93332-00005	17 - 7	97095-06016	1 - 8								
93341-41414	17 - 5		3 - 6								
93420-30042	16 - 16		13 - 5								
93430-04M03	14 - 37	97095-06018	9 - 12								
93430-05027	14 - 32		15 - 19								
	14 - 39	97095-06020	4 - 3								
93430-06024	22 - 35		6 - 2								
93440-52009	3 - 20		7 - 26								
93450-15023	3 - 26		9 - 2								
93602-14104	3 - 24		11 - 7								
93604-12M07	16 - 18		12 - 39								
	17 - 18		16 - 12								
	18 - 4		17 - 47								
93606-12019	2 - 10	97095-06025	10 - 13								
	16 - 4		10 - 15								
93700-06M03	15 - 1	97095-08030	16 - 6								
94702-00217	2 - 28	97803-04010	5 - 6								
94702-00271	2 - 28	97885-05012	11 - 21								
95380-03600	5 - 25		13 - 21								
95380-05700	12 - 14	97885-06008	14 - 4								