

PARTS CATALOGUE

9.9MHA(63V1)

15MHA (63W1)

9.9FMH'02(63V1)

15FMH '02(63W1)

FOREWORD

This Parts Catalogue is related to the parts for the model(s) in the below frame. When you are ordering replacement parts, please refer to this Parts Catalogue and quote both part numbers and part names correctly.

9.9MHA(63V1), 15MHA(63W1),
9.9FMH'02(63V1), 15FMH'02(63W1)

1. Modifications or additions which have been made after issue of the Parts Catalogue will be announced in the Yamaha Parts News.
It is advisable that you make necessary corrections to the Parts Catalogue according to the Yamaha Parts News.

2. Abbreviations
The Following abbreviations are used in this Parts Catalogue.

- “UR” Use specified parts number.
- “UN” Use as many as needed.
- “AP” Alternate Parts
- “LM” Local Made
(Parts need to be ordered locally)
- “O/S” Over Size

3. Parts, which are to be supplied in an assembly, are listed with a dot(.) in front of the part name as shown below.

EXAMPLE
CARBURETOR ASSY
.JET, PILOT
.NOZZLE, MAIN

4. Number of component for assembly
The numeral appearing to the right of each component part indicates the quantity of parts for each assembly unit.

EXAMPLE

PART NO.	DESCRIPTION	□	▣	▤	▥	REMARKS
6E0-85500-70	C.D.I. MAGNETO ASSY	1				
6E0-85550-70	.ROTOR ASSY	1				
6E0-15723-00-94.	.PULLY, STARTER	1				

5. Quantity Column Information

NAME for Q'TY COLUMN	APPLICABLE MODEL
99F	9.9MHA, 9.9FMH
15F	15MHA, 15FMH

6. Applicable Starting Serial No. and Color Code

1) Engine Starting Sserial No.

9.9MHA 682K S : 121964	9.9FMH 682K S : 121964
15MHA 684K S : 311771	15FMH 684K S : 311771
	684K L : 450613

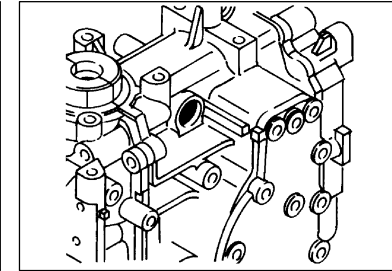
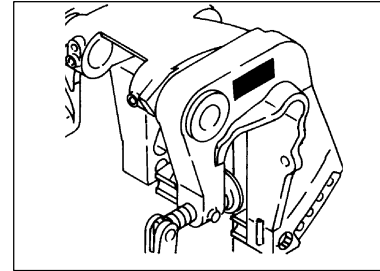

2) Color Code

Color Code	Color Name	Abbreviation
004D	DARK BLUISH GRAY METALLIC 2	DBNM2

7. Note that the illustrations for reference in finding parts numbers, not to be used for assembling. When assembling, please use the applicable service manual.

8. The asterisk (*) before a reference number indicates modification items after the first edition.

CONTENTS

TOP COWLING	A4
CYLINDER. CRANKCASE	A5
CRANKSHAFT. PISTON	A7
INTAKE	B2
CARBURETOR	B3
FUEL 1	B5
FUEL 2	B6
STARTER	B7
GENERATOR	C2
ELECTRICAL	C3
BOTTOM COWLING	C4
STEERING	C5
CONTROL	C7
REMOTE CONTROL ATTACHMENT	D2
BRACKET 1	D3
BRACKET 2	D5
UPPER CASING	D7
LOWER CASING. DRIVE 1	E1
LOWER CASING. DRIVE 2	E4
FUEL TANK	E6
REPAIR KIT 1	E7
REPAIR KIT 2	F1
INDEX	
NUMERICAL INDEX	F2

FIG. 1 TOP COWLING

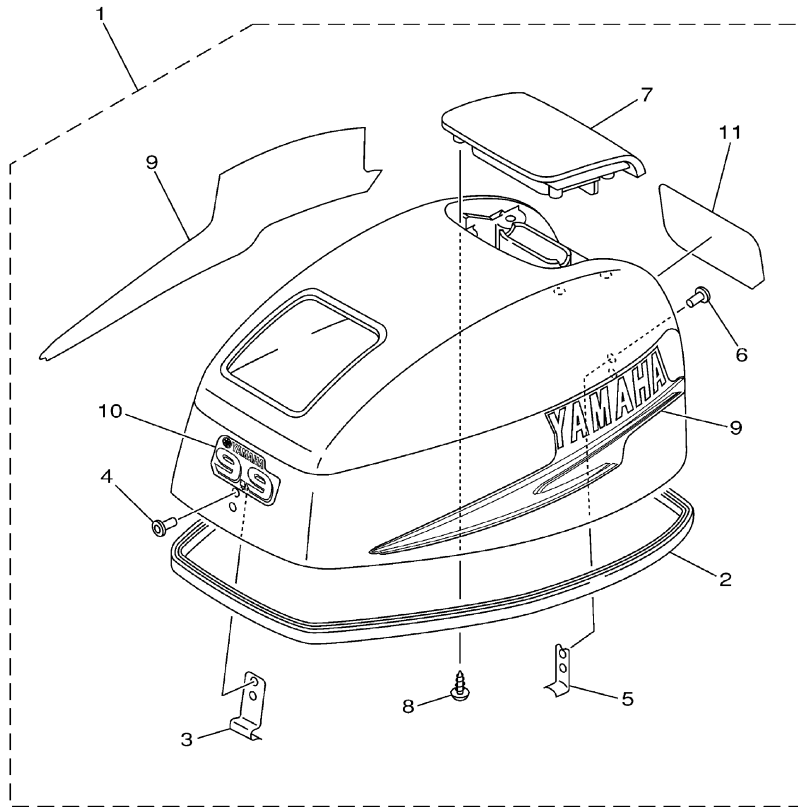

REF. NO.	PART NO.	DESCRIPTION	99F	15F				REMARKS
1	63V-42610-30-4D	TOP COWLING ASSY	1					
	63W-42610-30-4D	TOP COWLING ASSY		1				
2	63V-42615-00	.SEAL	1	1				
3	6G1-42651-02	.HOOK	1	1				
4	90266-04M04	.RIVET	2	2				
5	6L2-42647-00	.HOLDER, CLAMP BAND	1	1				
6	90266-04M04	.RIVET	2	2				
7	63V-42613-01-4D	.MOLDING, AIR DUCT	1	1				
8	90163-06002	.SCREW, TAPPING	4	4				
9	63V-W0070-20	.GRAPHIC SET	1	1				
10	63V-42677-30	.GRAPHIC, FRONT	1					
	63W-42677-30	.GRAPHIC, FRONT		1				
11	63V-42678-20	.GRAPHIC, REAR	1					
	63W-42678-20	.GRAPHIC, REAR		1				



63V1100-2010

1
**CRANK CYLINDER
 ASSY**
 (Fig. 2, Ref. No. 2 to 27
 Fig. 3, Ref. No. 1 to 29)

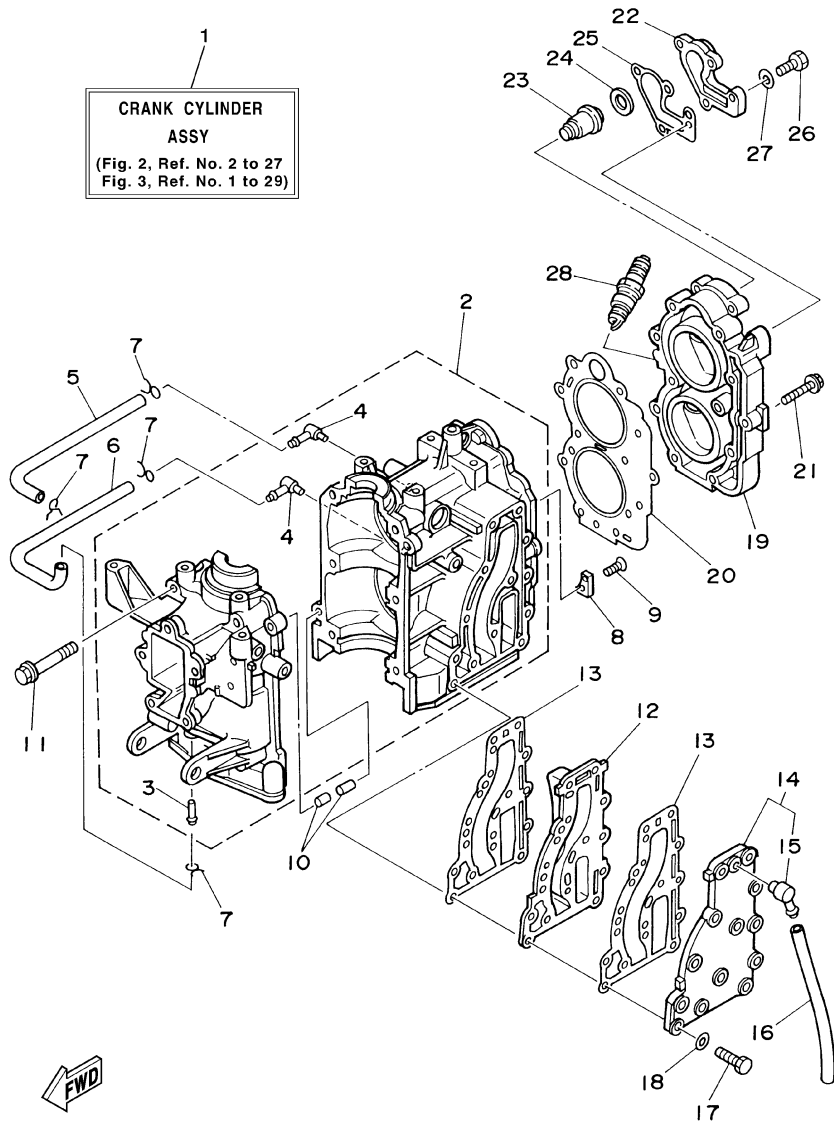

63V0010-5020

FIG. 2 CYLINDER. CRANKCASE

REF. NO.	PART NO.	DESCRIPTION	99F	15F	REMARKS
1	63V-W0090-03-1S	CRANK CYLINDER ASSY	1	1	
2	63V-15100-02-1S	CRANKCASE ASSY	1	1	
3	624-14485-00	.PIPE, JOINT	1	1	
4	650-14485-02	.PIPE, JOINT	2	2	
5	90445-07M08	HOSE (L220)	1	1	
6	90445-07M08	HOSE (L220)	1	1	
7	90467-06016	CLIP	4	4	
8	682-11325-00	ANODE	1	1	
9	98780-05015	SCREW, FLAT HEAD	1	1	
10	93606-12019	PIN, DOWEL	2	2	
11	90119-08M07	BOLT, WITH WASHER	6	6	
12	63V-41111-00-1S	INNER COVER, EXHAUST	1	1	
13	63V-41112-A0	GASKET, EXHAUST INNER COVER	2	2	
14	63V-41113-00-1S	OUTER COVER, EXHAUST	1	1	
15	676-11372-00	.NIPPLE, HOSE	1	1	
16	90445-09105	HOSE (L300)	1	1	
17	97013-06030	BOLT	13	13	
18	92903-06600	WASHER, PLATE	13	13	
19	6E7-11111-01-1S	HEAD, CYLINDER 1	1	1	
20	63V-11181-A1	GASKET, CYLINDER HEAD 1	1	1	
21	90105-07M05	BOLT, FLANGE	11	11	
22	682-12413-00-1S	COVER, THERMOSTAT	1	1	
23	6E5-12411-20	THERMOSTAT	1	1	
24	90201-16M03	WASHER, PLATE	1	1	
25	682-12414-A1	GASKET, COVER	1	1	
26	97013-06020	BOLT	4	4	
27	92903-06600	WASHER, PLATE	4	4	

1
**CRANK CYLINDER
 ASSY**
 (Fig. 2, Ref. No. 2 to 27
 Fig. 3, Ref. No. 1 to 29)

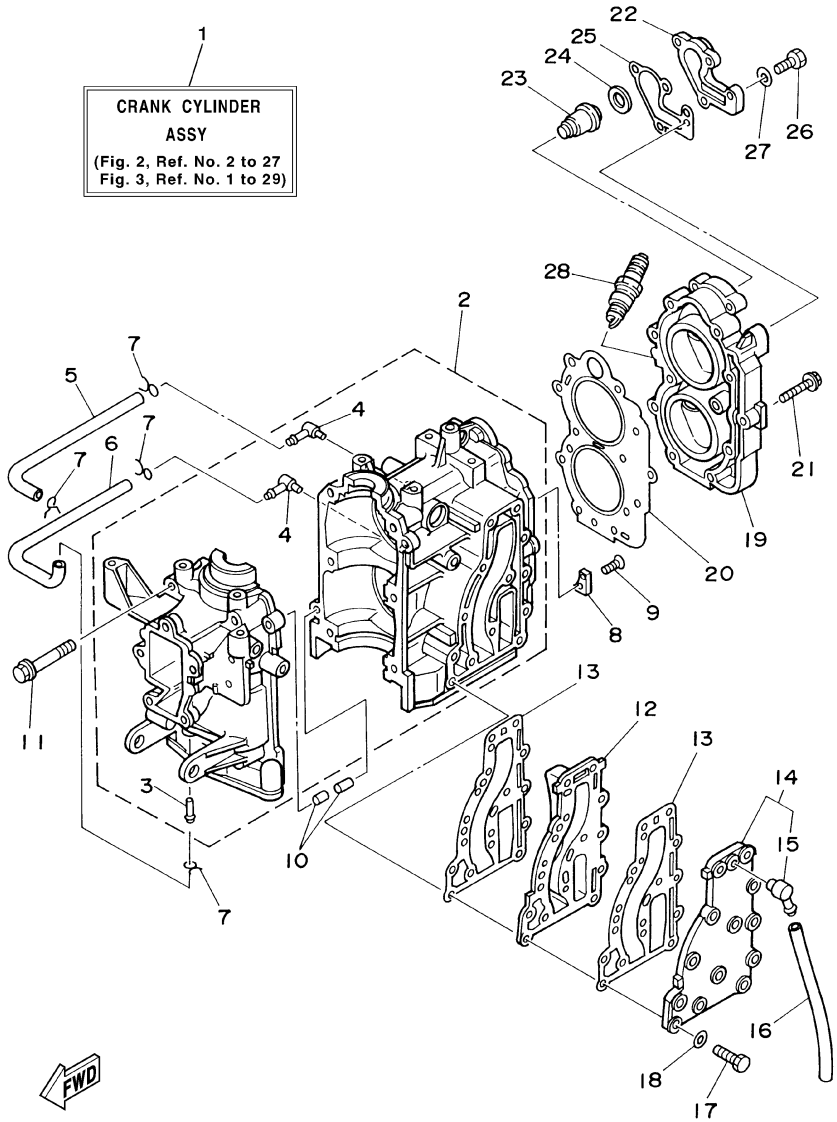

63V0010-5020

FIG. 2 CYLINDER. CRANKCASE

REF. NO.	PART NO.	DESCRIPTION	99F	15F		REMARKS
28	94702-00271	PLUG, SPARK (NGK BR7HS-10)	2	2		FOR CANADA, OCEANIA
	94702-00217	PLUG, SPARK (NGK B7HS-10)	2	2		FOR USA

FIG. 3 CRANKSHAFT. PISTON

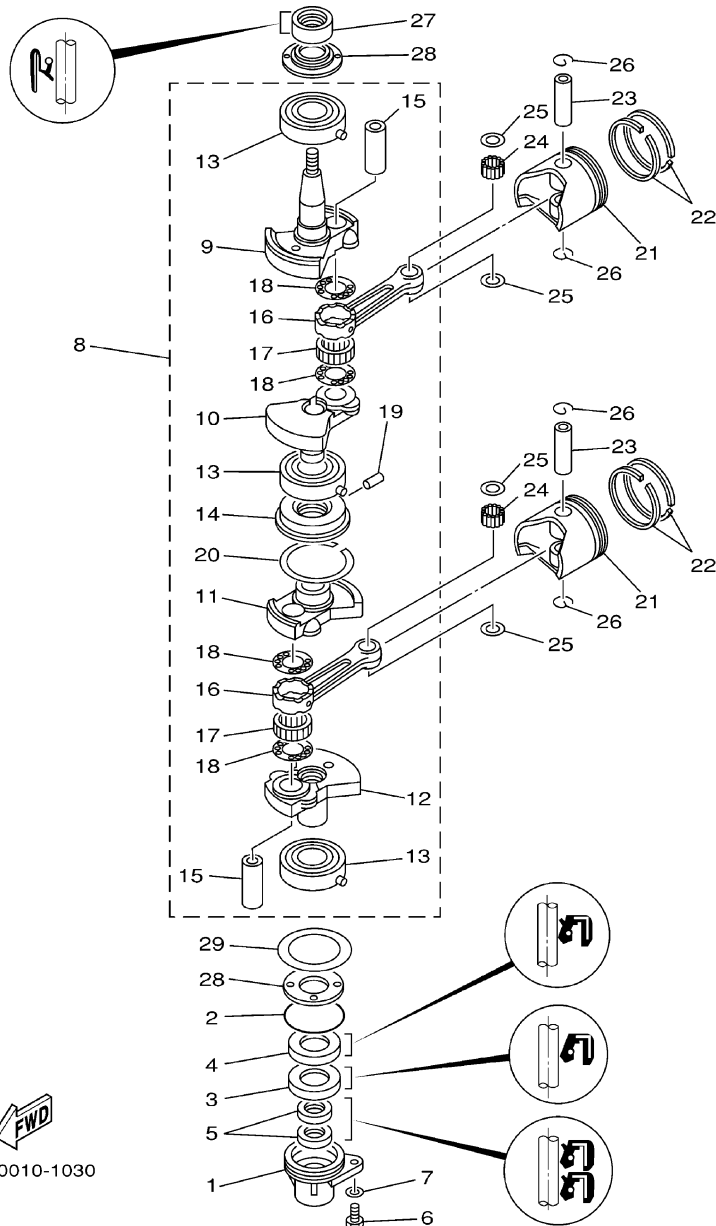

REF. NO.	PART NO.	DESCRIPTION	99F	15F	REMARKS
1	63V-15396-01-94	HOUSING, OIL SEAL	1	1	
2	93210-46M16	O-RING	1	1	
3	93101-25018	OIL SEAL	1	1	
4	93102-25M48	OIL SEAL	1	1	
5	93101-13018	OIL SEAL	2	2	
6	97095-06016	BOLT	1	1	
7	92995-06600	WASHER	1	1	
8	63V-11400-01	CRANKSHAFT ASSY	1	1	
9	63V-11412-00	.CRANK 1	1	1	FOR OCEANIA
10	63V-11422-00	.CRANK 2	1	1	FOR OCEANIA
11	63V-11432-00	.CRANK 3	1	1	FOR OCEANIA
12	63V-11442-00	.CRANK 4	1	1	FOR OCEANIA
13	93306-205U7	.BEARING	3	3	
14	63V-11515-02	.SEAL, LABYRINTH 1	1	1	FOR OCEANIA
15	682-11681-00	.PIN, CRANK 1	2	2	FOR OCEANIA
16	650-11651-04	.ROD, CONNECTING	2	2	FOR OCEANIA
17	93310-620V5	.BEARING	2	2	FOR OCEANIA
18	90209-20M23	.WASHER	4	4	FOR OCEANIA
19	91609-20008	.PIN, SPRING	1	1	FOR OCEANIA
20	93440-52009	.CIRCLIP	1	1	FOR OCEANIA
21	6E7-11631-00-97	PISTON (STD)	2	2	
	6E7-11635-00	PISTON (0.25MM O/S)	2	2	AP
	6E7-11636-00	PISTON (0.50MM O/S)	2	2	AP
22	682-11610-01	PISTON RING SET (STD)	2	2	
	682-11610-11	PISTON RING SET (0.25MM O/S)	2	2	AP
	682-11610-21	PISTON RING SET (0.50MM O/S)	2	2	AP
23	634-11633-00	PIN, PISTON	2	2	

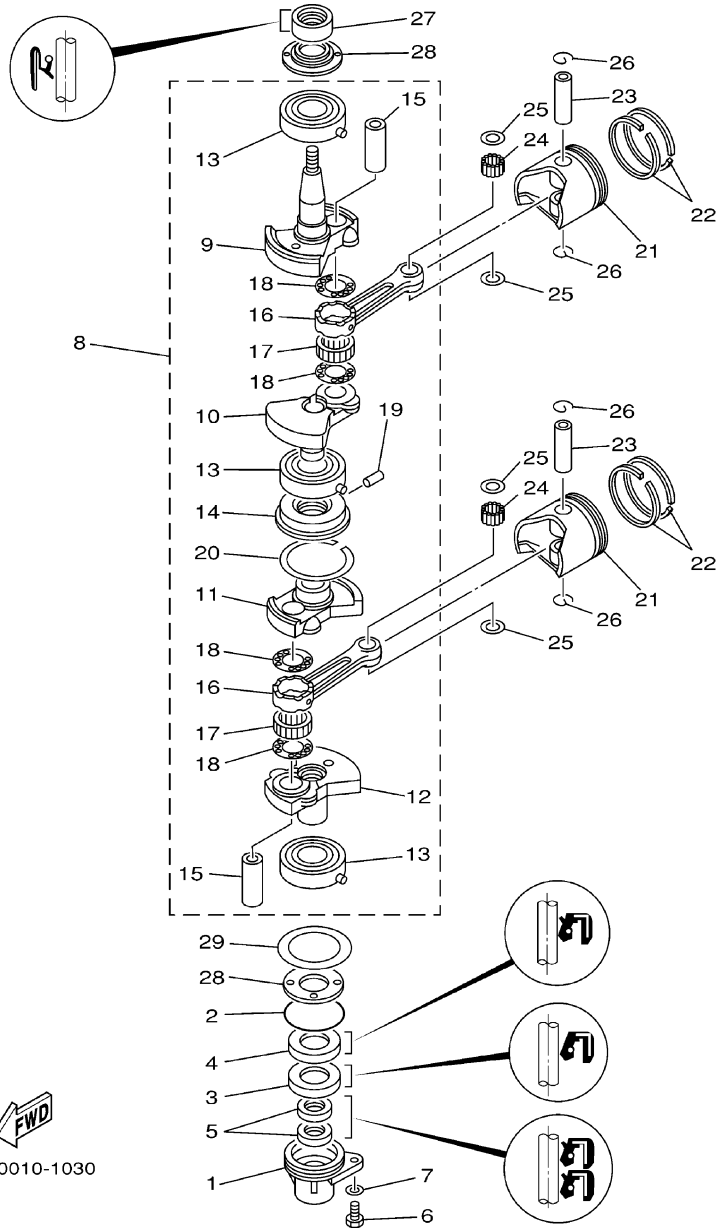

63V0010-1030

FIG. 3 CRANKSHAFT. PISTON

REF. NO.	PART NO.	DESCRIPTION	99F	15F	REMARKS
24	93602-14104	PIN, DOWEL	50	50	
25	90201-14377	WASHER, PLATE	4	4	
26	93450-15023	CIRCLIP	4	4	
27	93110-23M00	OIL SEAL	1	1	
28	63V-11445-00	SPACER	2	2	
29	90201-46M29	WASHER, PLATE	1	1	

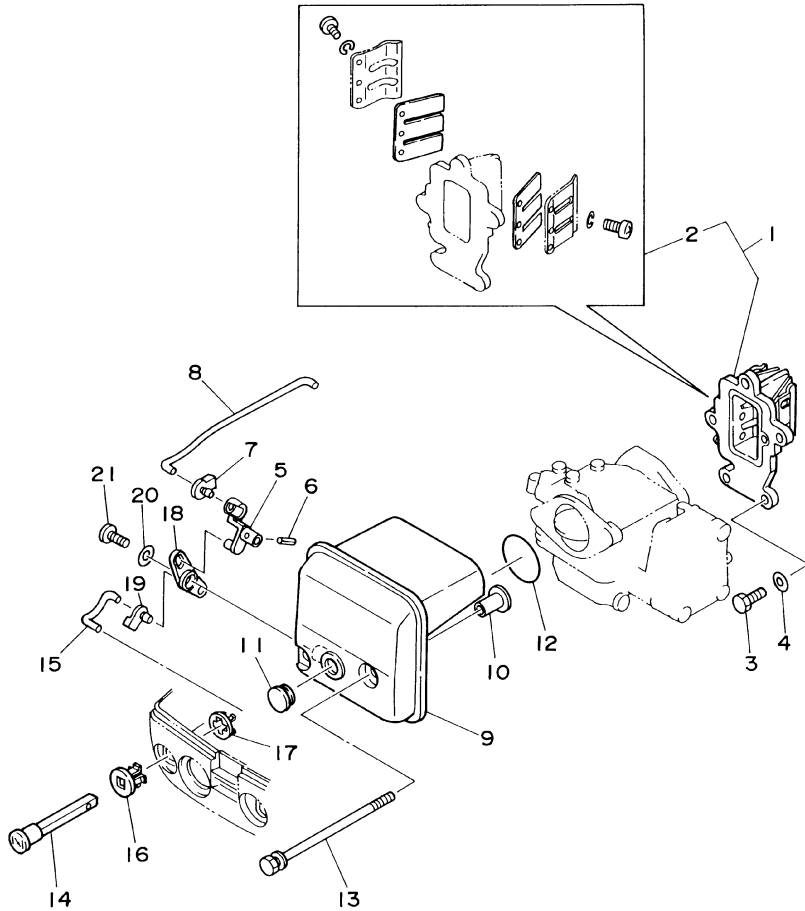



 63V0010-5040

FIG. 4 INTAKE

REF. NO.	PART NO.	DESCRIPTION	99F	15F	REMARKS
1	63V-13610-00	REED VALVE ASSY	1		FOR USA,OCEANIA
	63V-13610-10	REED VALVE ASSY	1		FOR CANADA
	63W-13610-00	REED VALVE ASSY		1	
2	682-W0004-00	.REED SET	1	1	
3	97095-06020	BOLT	3	3	
4	92995-06600	WASHER	3	3	
5	63V-41253-00	LEVER, CHOKE	1	1	
6	91690-20010	PIN, SPRING	1	1	
7	63V-41262-00	JOINT, CHOKE LEVER	1	1	
8	63V-41257-00	ROD, CHOKE 2	1	1	
9	63V-14440-00	SILENCER ASSY, INTAKE	1	1	
10	90387-06M15	COLLAR	2	2	
11	90480-12M25	GROMMET	1	1	
12	93210-35M86	O-RING	1	1	
13	90119-06M94	BOLT, WITH WASHER	2	2	
14	6H4-41271-01	KNOB, CHOKE	1	1	
15	63V-41256-00	ROD, CHOKE 1	1	1	
16	689-41273-00	GROMMET	1	1	
17	6J8-41274-00	GROMMET 2	1	1	
18	63V-41252-00	LEVER, CHOKE 1	1	1	
19	661-41262-02	JOINT, CHOKE LEVER	1	1	
20	90201-05M09	WASHER, PLATE	1	1	
21	90164-05M03	SCREW, TAPPING	1	1	

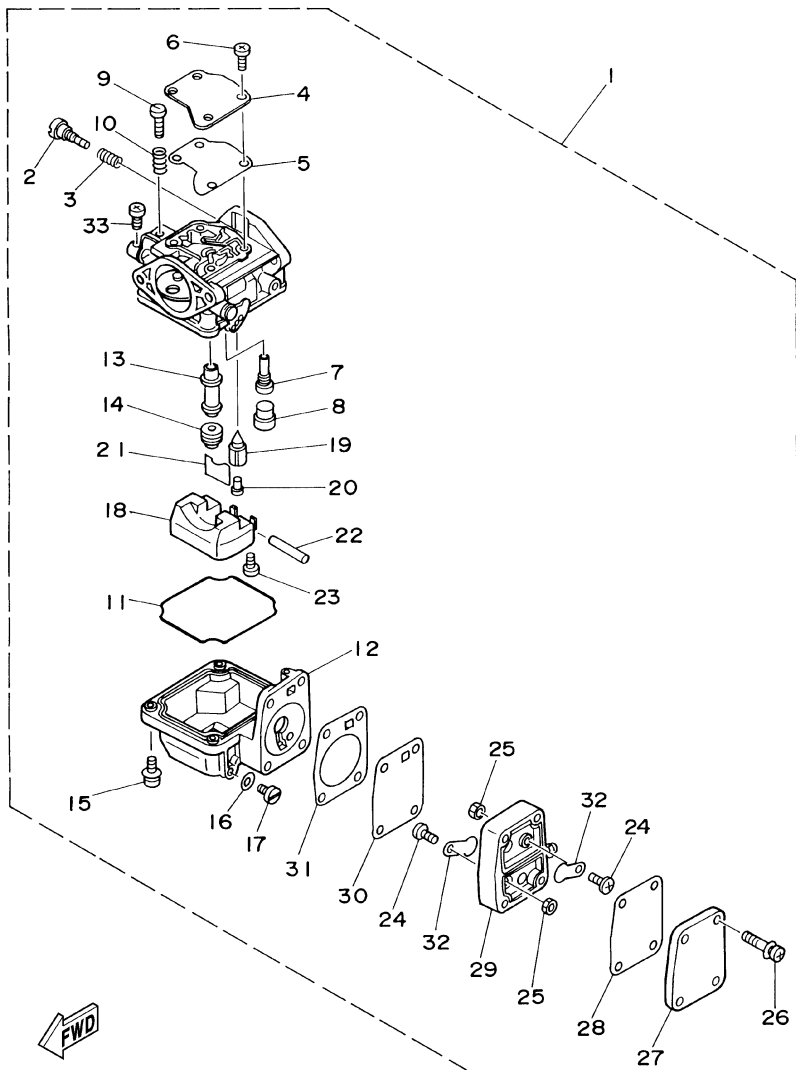
FIG. 5 CARBURETOR



63V0010-5050

REF. NO.	PART NO.	DESCRIPTION	99F	15F				REMARKS
1	63V-14301-00	CARBURETOR ASSY 1	1	1				
2	679-14923-00	.SCREW, PILOT	1	1				
3	679-14555-00	.SPRING	1	1				
4	63V-14527-00	.PLATE	1	1				
5	63V-14126-00	.GASKET	1	1				
6	97803-04010	.SCREW, PAN HEAD	4	4				
7	63V-14948-06	.JET (#48)	1	1				
8	679-14966-00	.RUBBER CAP	1	1				
9	63V-14523-00	.SCREW, STOP	1	1				
10	90501-10326	.SPRING, COMPRESSION	1	1				
11	63V-14984-00	.GASKET, FLOAT CHAMBER	1	1				
12	63V-14980-00	.BODY, FLOAT CHAMBER	1	1				
13	63V-14947-00	.JET, NEEDLE	1	1				
14	676-14943-29	.JET, MAIN (#110)	1	1				
15	97980-04114	.SCREW, WITH WASHER	4	4				
16	6G1-14398-00	.WASHER	1	1				
17	6G1-14992-00	.SCREW, DRAIN	1	1				
18	63V-14985-00	.FLOAT	1	1				
19	6G1-14546-00	.VALVE, NEEDLE	1	1				
20	676-14186-00	.PIN, FLOAT	1	1				
21	663-14159-00	.CLIP	1	1				
22	6H4-14548-00	.PIN, FLOAT ARM	1	1				
23	98580-04008	.SCREW, PAN HEAD	1	1				
24	98980-03006	.SCREW, BIND	2	2				
25	95380-03600	.NUT	2	2				
26	97980-04125	.SCREW, WITH WASHER	4	4				
27	6G1-24452-00	.COVER	1	1				

FIG. 5 CARBURETOR

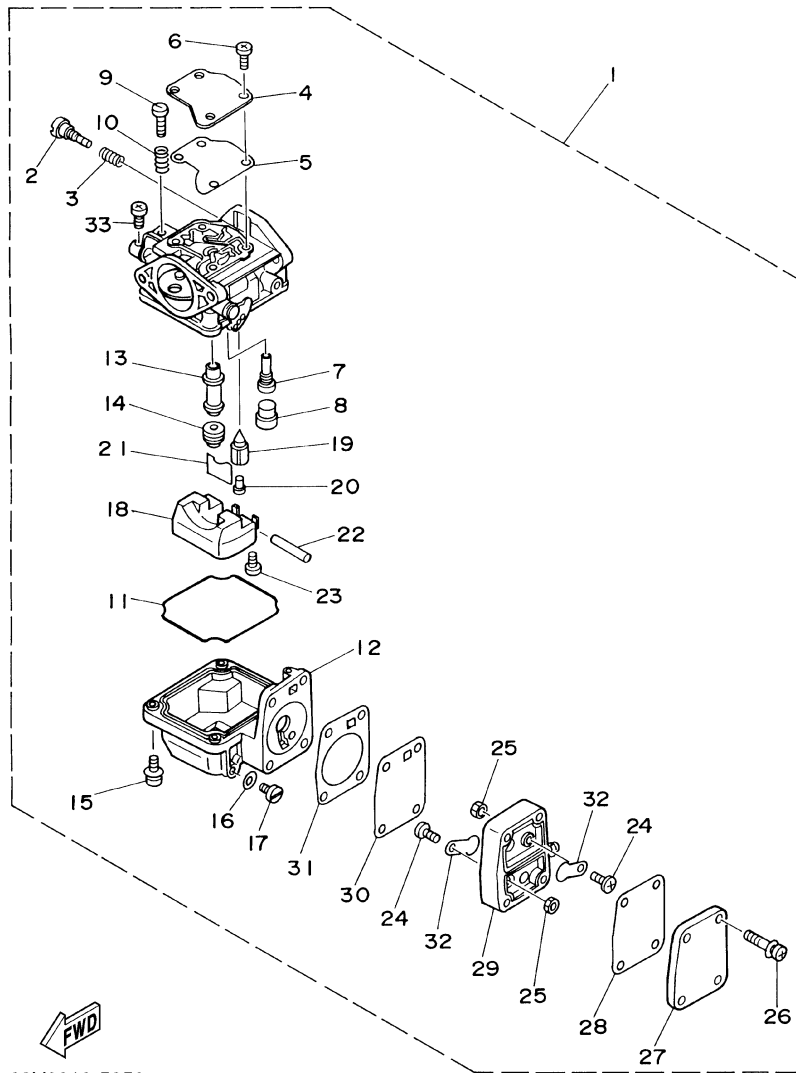

63V0010-5050

REF. NO.	PART NO.	DESCRIPTION	99F	15F				REMARKS
28	63V-24411-00	.DIAPHRAGM	1	1				
29	6G1-24412-01	.BODY 1	1	1				
30	6G1-24411-00	.DIAPHRAGM	1	1				
31	6G1-24431-01	.GASKET, FUEL PUMP 1	1	1				
32	6L5-24421-00	.VALVE, CHECK	2	2				
33	98580-04006	.SCREW, PAN HEAD	1	1				

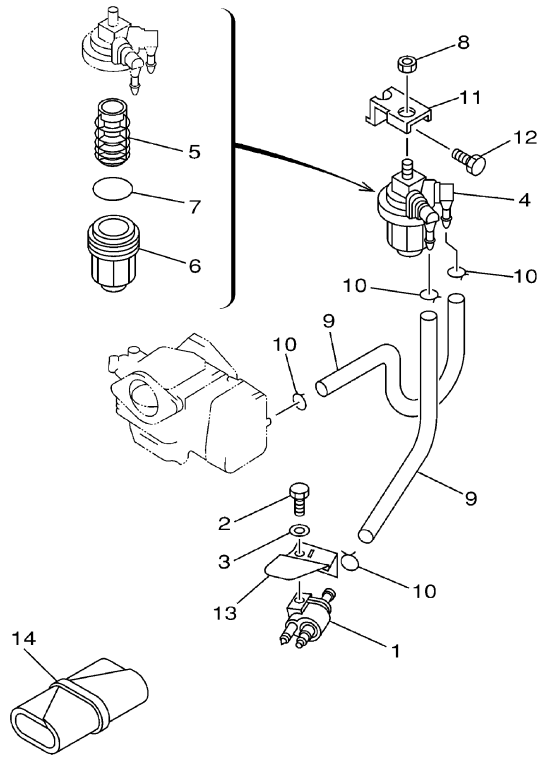

FIG. 6 FUEL 1

REF. NO.	PART NO.	DESCRIPTION	99F	15F				REMARKS
1	6G1-24304-02	FUEL PIPE JOINT COMP. 1	1	1				
2	97095-06020	BOLT	1	1				
3	92995-06600	WASHER	1	1				
4	61N-24560-00	FILTER ASSY	1	1				
5	61N-24563-00	.ELEMENT, FILTER	1	1				
6	61N-24521-00	.CUP, FILTER	1	1				
7	93210-32738	.O-RING	1	1				
8	95380-08600	NUT	1	1				
9	90445-09M00	HOSE (L180)	2	2				
10	90467-08004	CLIP	4	4				
11	682-24566-01	BRACKET, FILTER	1	1				
12	97013-06010	BOLT	1	1				
13	63V-24396-01	PLATE	1	1				
14	656-W2810-02	TOOL KIT	1	1				FOR CANADA, OCEANIA-9.9FMHX



63V0010-1060

FIG. 7 FUEL 2

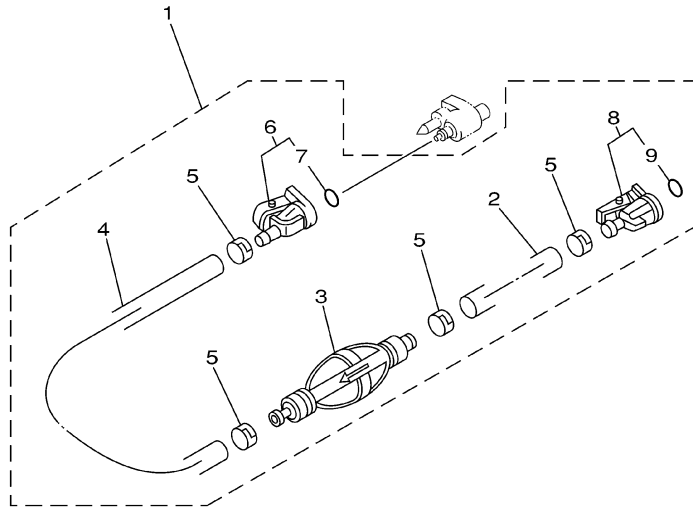

REF. NO.	PART NO.	DESCRIPTION	99F	15F				REMARKS
1	6Y1-24306-53	FUEL PIPE COMP. 1	1	1				AP FOR USA
2	90445-11M06	.HOSE (L2050)	1	1				
3	6Y1-24360-52	.PRIMER PUMP ASSY	1	1				
4	90445-11M05	.HOSE (L:850MM)	1	1				
5	650-24351-51	.BAND 1	4	4				
6	6G1-24305-03	.FUEL PIPE JOINT COMP. 2	1	1				
7	93210-08287	..O-RING	1	1				
8	6Y1-24305-04	.FUEL PIPE JOINT COMP. 2	1	1				
9	93210-08287	..O-RING	1	1				

67C0100-0100

FIG. 8 STARTER

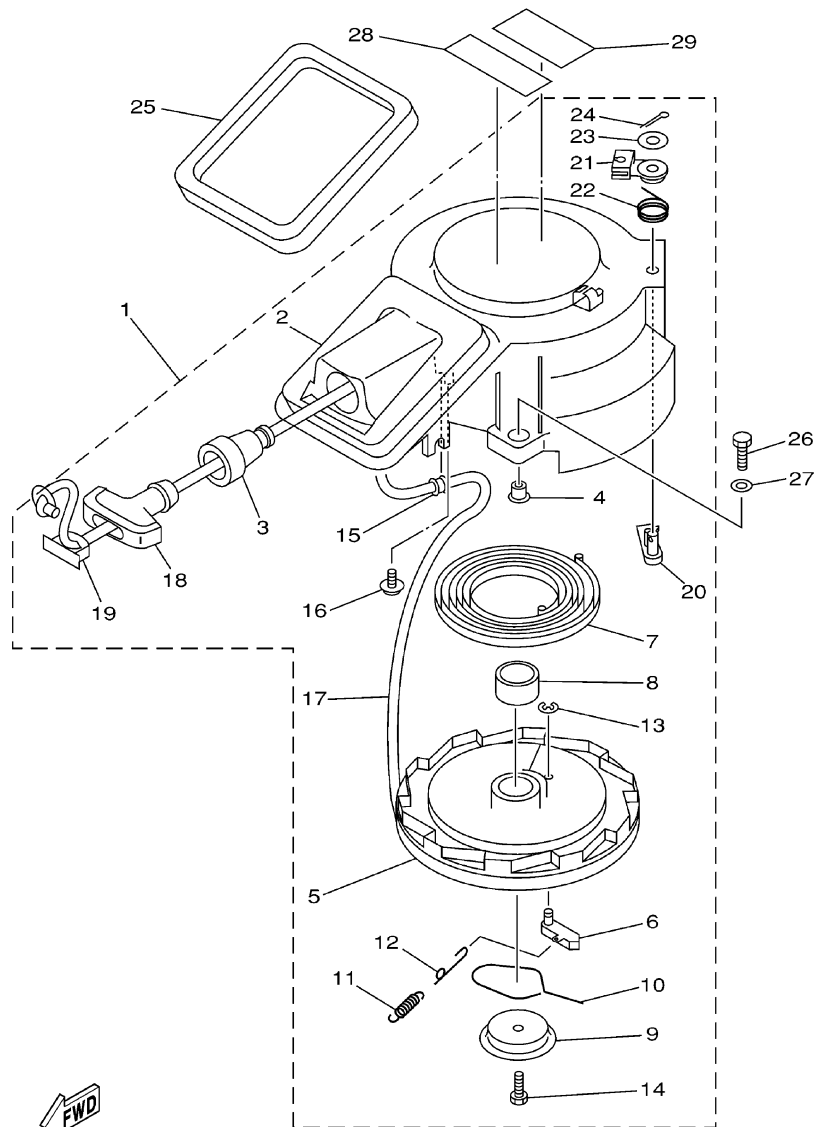



63V1100-2080

REF. NO.	PART NO.	DESCRIPTION	99F	15F	REMARKS
1	63V-15710-12	STARTER ASSY	1	1	WITH SAFETY DEVICE
2	63V-15711-01	.CASE, STARTER	1	1	
3	63V-15795-01	.GUIDE, ROPE	1	1	
4	90387-06M05	.COLLAR	3	3	
5	63V-15714-00	.DRUM, SHEAVE	1	1	
6	63V-15741-00	.PAWL, DRIVE	1	1	
7	63V-15713-00	.SPRING, STARTER	1	1	
8	63V-15753-00	.BUSH	1	1	
9	63V-15716-00	.PLATE, DRIVE	1	1	
10	63V-15705-01	.SPRING, DRIVE PAWL	1	1	
11	63V-15767-01	.SPRING	1	1	
12	63V-15784-01	.SPRING, RETURN	1	1	
13	63V-15744-00	.CIRCLIP	1	1	
14	63V-15768-00	.BOLT	1	1	
15	63V-15764-00	.COLLAR 1	1	1	
16	63V-15793-00	.SCREW	1	1	
17	*	.WIRE, STARTER (L:1800MM)	1	1	
18	6G1-15755-00	.HANDLE, STARTER	1	1	
19	6G1-15779-00	.COVER	1	1	
20	63V-15794-00	.STOPPER	1	1	
21	63V-15748-00	.PLUNGER, STARTER STOP	1	1	
22	63V-15734-00	.SPRING, RETURN	1	1	
23	63V-15726-00	.WASHER, FLAT	1	1	
24	91490-16018	.PIN, COTTER	1	1	
25	63V-15762-00	SEAL, RUBBER 2	1	1	

* CUT FROM 50M ROLLS, PART NO. 90890-44373,
CUTTING LENGTH 1.8M

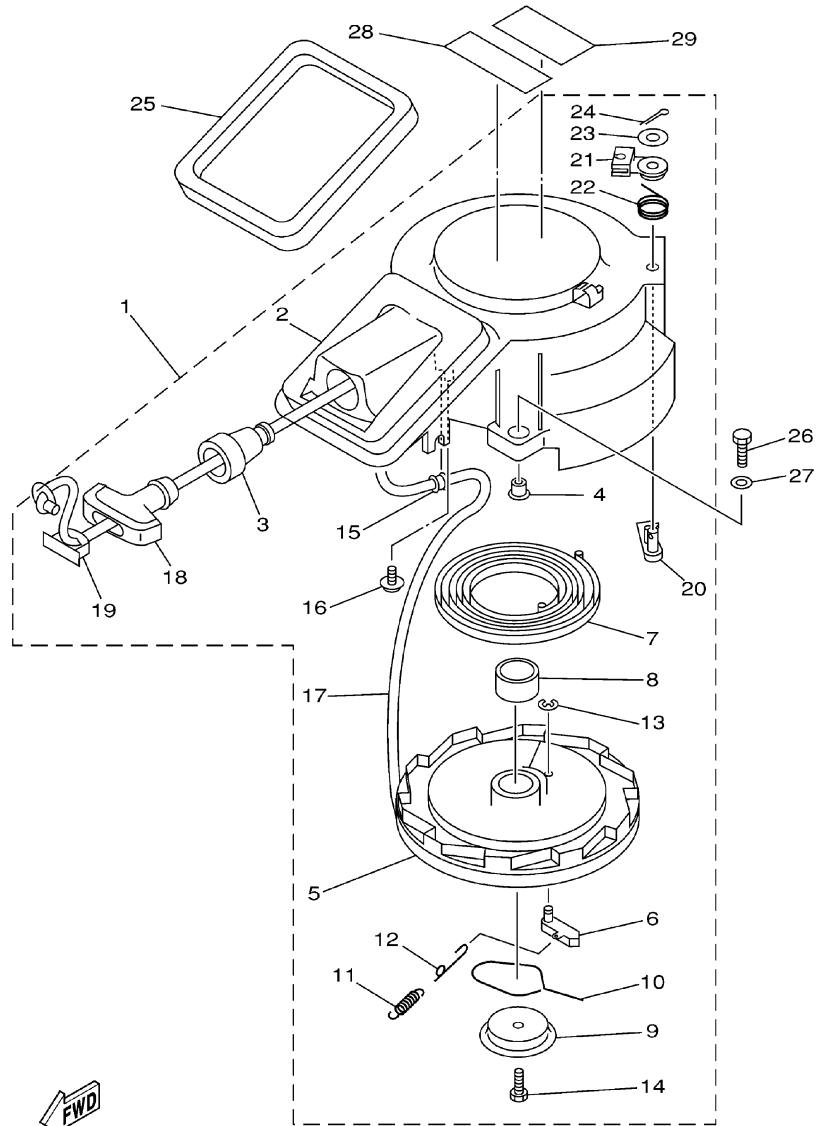
FIG. 8 STARTER



REF. NO.	PART NO.	DESCRIPTION	99F	15F	REMARKS
26	97095-06020	BOLT	3	3	
27	92995-06600	WASHER	3	3	
28	6A1-83625-41	MARK 5	1	1	
29	6A1-83625-51	MARK 5	1	1	FOR CANADA

63V1100-2080

FIG. 9 GENERATOR

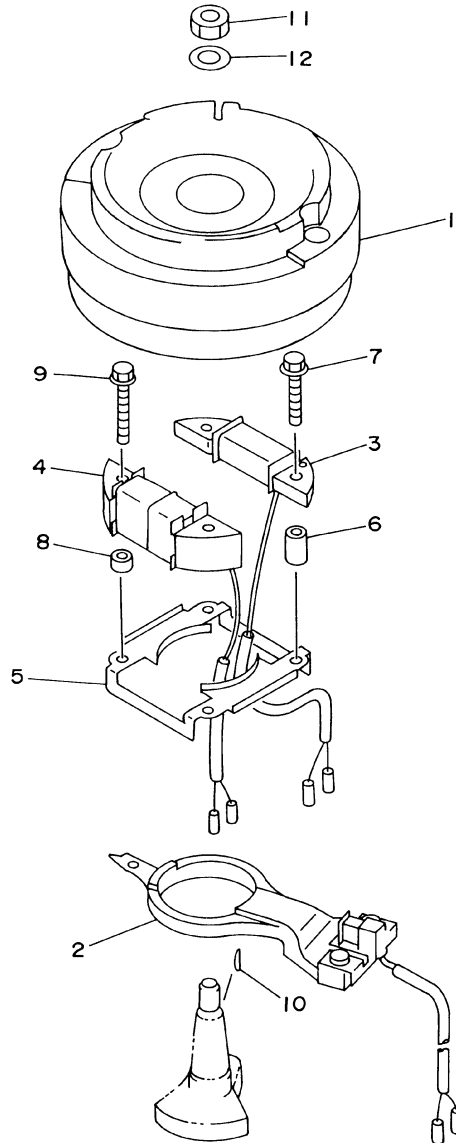

REF. NO.	PART NO.	DESCRIPTION	99F	15F			REMARKS
1	63V-85550-10	ROTOR ASSY	1	1			FOR USA,OCEANIA
	63V-85550-00	ROTOR ASSY (WITH RING GEAR)	1	1			FOR CANADA
2	63V-85580-00	COIL, PULSER	1	1			
3	63V-85520-00	COIL, CHARGE	1	1			
4	63V-85533-00	COIL, LIGHTING	1	1			
5	63V-41611-00	RETAINER, MAGNETO BASE	1	1			
6	90387-06M53	COLLAR	2	2			
7	90105-06M68	BOLT, FLANGE	2	2			
8	90387-06M24	COLLAR	2	2			
9	90105-06M69	BOLT, FLANGE	2	2			
10	90280-05013	KEY, WOODRUFF	1	1			
11	90170-12066	NUT	1	1			
12	90201-12472	WASHER, PLATE	1	1			

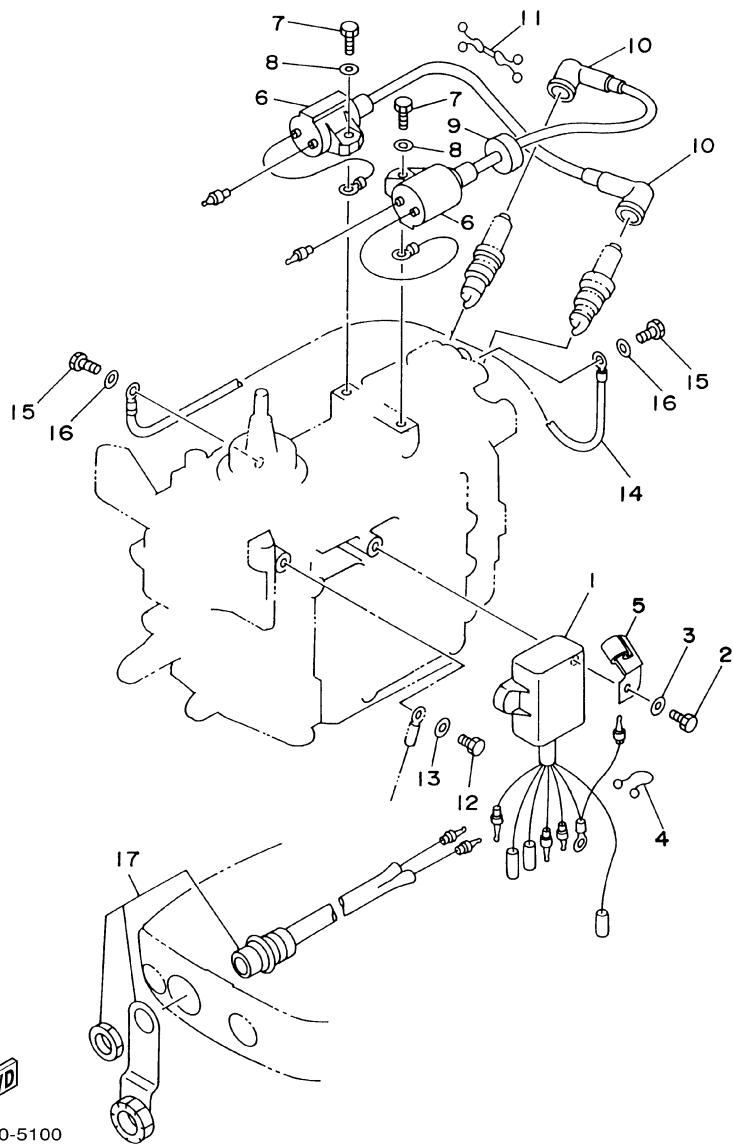

63V0010-5080

FIG. 10 ELECTRICAL

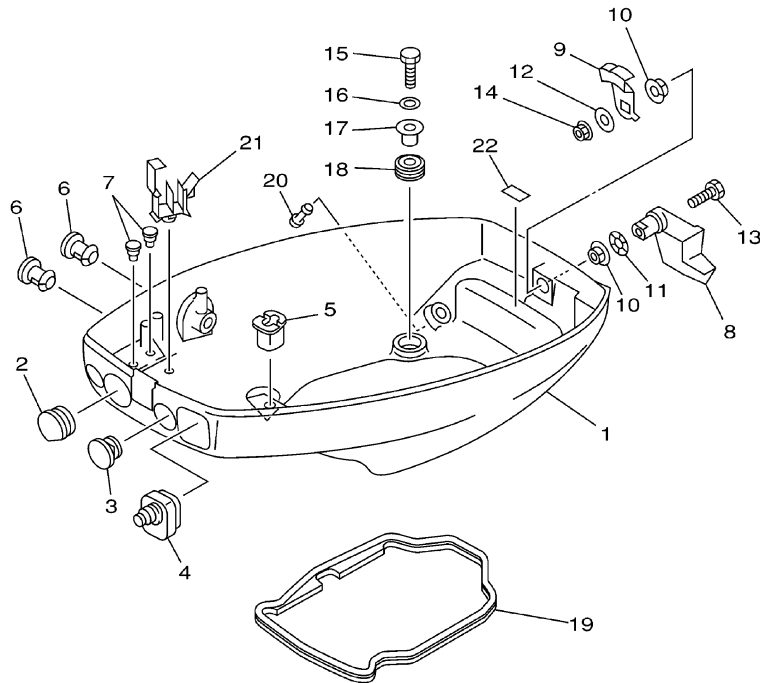

REF. NO.	PART NO.	DESCRIPTION	99F	15F	REMARKS
1	63V-85540-01	C.D.I. UNIT ASSY	1	1	
2	97095-06020	BOLT	2	2	
3	92995-06600	WASHER	2	2	
4	90464-15M11	CLAMP	1	1	
5	90465-08M61	CLAMP	1	1	
6	63V-85570-00	IGNITION COIL ASSY	2	2	
7	97095-06018	BOLT	2	2	
8	92995-06600	WASHER	2	2	
9	90480-25161	GROMMET	1	1	
10	6E3-82370-21	PLUG CAP ASSY	2	2	FOR CANADA, OCEANIA
	663-82370-01	PLUG CAP ASSY	2	2	FOR USA
11	90464-08M02	CLAMP	1	1	
12	97095-06012	BOLT	1	1	
13	92995-06600	WASHER	1	1	
14	662-82519-00	WIRE, EARTH LEAD	1	1	
15	97095-06012	BOLT	2	2	
16	92995-06600	WASHER	2	2	
17	682-84381-00	2P CONCENT	1	1	FOR OCEANIA

FIG. 11 BOTTOM COWLING



63V1100-2110

REF. NO.	PART NO.	DESCRIPTION	99F	15F	REMARKS
1	63V-42711-03-4D	COWLING, BOTTOM	1	1	
2	682-42724-00	GROMMET	1	1	FOR USA,CANADA
3	682-42725-02	GROMMET	1	1	
4	63V-42726-00	GROMMET	1	1	
5	682-42727-00	GROMMET	1	1	
6	6G1-42748-00	GROMMET	2	2	
7	90480-06M19	GROMMET	2	2	
8	63V-42815-01-4D	LEVER, CLAMP	1	1	
9	6E7-42816-00	LEVER, CLAMP	1	1	
10	90386-12M45	BUSH	2	2	
11	90206-12052	WASHER, WAVE	1	1	
12	90201-06068	WASHER, PLATE	1	1	
13	97095-06025	BOLT	1	1	
14	95380-06700	NUT	1	1	
15	97095-06025	BOLT	4	4	
16	92995-06600	WASHER	4	4	
17	90387-06034	COLLAR	4	4	
18	90480-15M31	GROMMET	4	4	
19	63V-42716-02	RUBBER, SEAL 1	1	1	
20	6H3-44391-01	NIPPLE, HOSE	1	1	
21	90465-25M57	CLAMP	1	1	
22	6E7-42791-10	MARK 1	1	1	FOR CANADA, OCEANIA
	6E7-42791-00	MARK 1	1	1	FOR USA

FIG. 12 STEERING

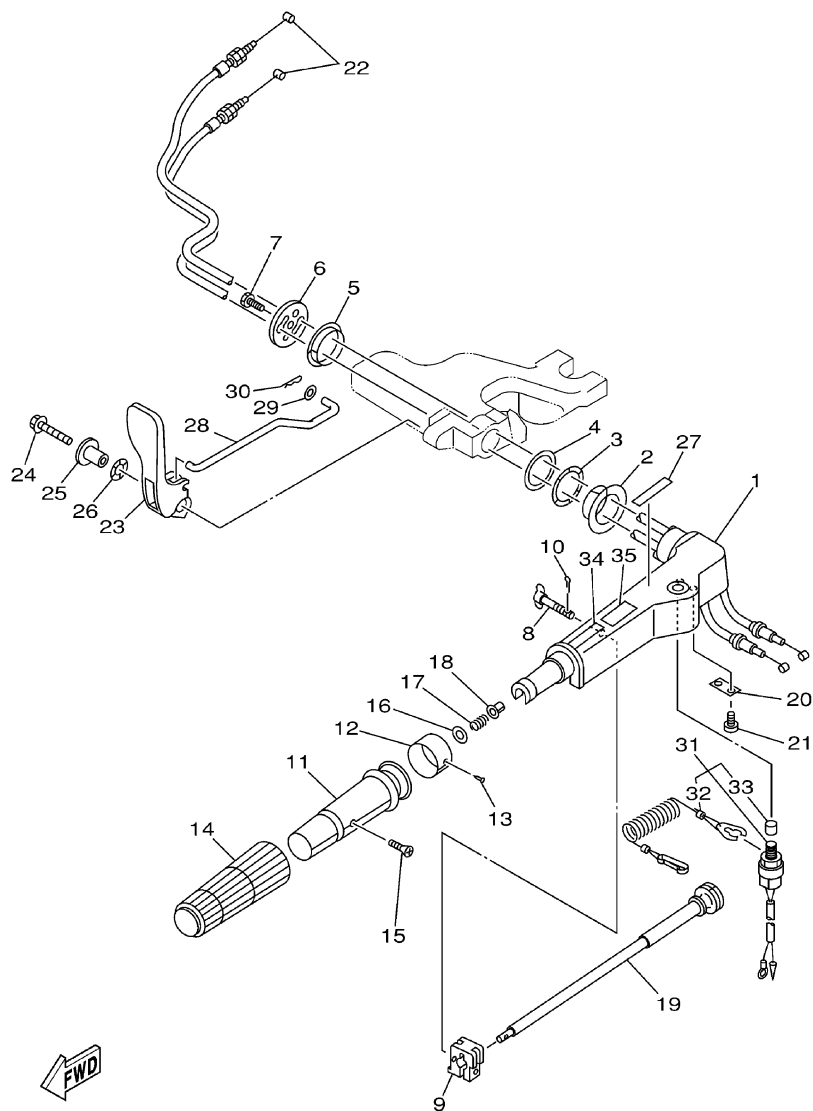

63V1100-2120

REF. NO.	PART NO.	DESCRIPTION	99F	15F				REMARKS
1	63V-42111-00-4D	HANDLE, STEERING	1	1				
2	90386-34M97	BUSH	1	1				
3	90206-36M21	WASHER, WAVE	1	1				
4	90202-36M55	WASHER, PLATE	1	1				
5	90386-33M96	BUSH	1	1				
6	6G1-42131-01	COVER, HANDLE STEERING	1	1				
7	97095-06020	BOLT	1	1				
8	6G1-42125-01	BOLT, FRICTION ADJUSTING	1	1				
9	6G1-42126-00	FRICTION, STEERING HANDLE GRIP	1	1				
10	91490-16010	PIN, COTTER	1	1				
11	664-42119-00	GRIP, STEERING HANDLE	1	1				
12	6H2-42137-00	INDICATOR, THROTTLE	1	1				
13	90269-02M09	RIVET	1	1				
14	6G1-42177-00	RUBBER, HANDLE	1	1				
15	90149-05M13	SCREW	1	1				
16	92903-10600	WASHER, PLATE	1	1				
17	90501-23215	SPRING, COMPRESSION	1	1				
18	90386-08032	BUSH	1	1				
19	6G1-42138-01	LEVER, THROTTLE	1	1				
20	6E0-42159-02	STAY	1	1				
21	97885-05012	SCREW, PAN HEAD	2	2				
22	6L2-26301-00	THROTTLE CABLE ASSY	2	2				
23	63V-44111-02	HANDLE, GEAR SHIFT	1	1				
24	90119-06M05	BOLT, WITH WASHER	1	1				
25	90387-06M86	COLLAR	1	1				
26	90206-15M18	WASHER, WAVE	1	1				
27	6E0-44191-11	INDICATOR, SHIFT	1	1				

FIG. 12 STEERING

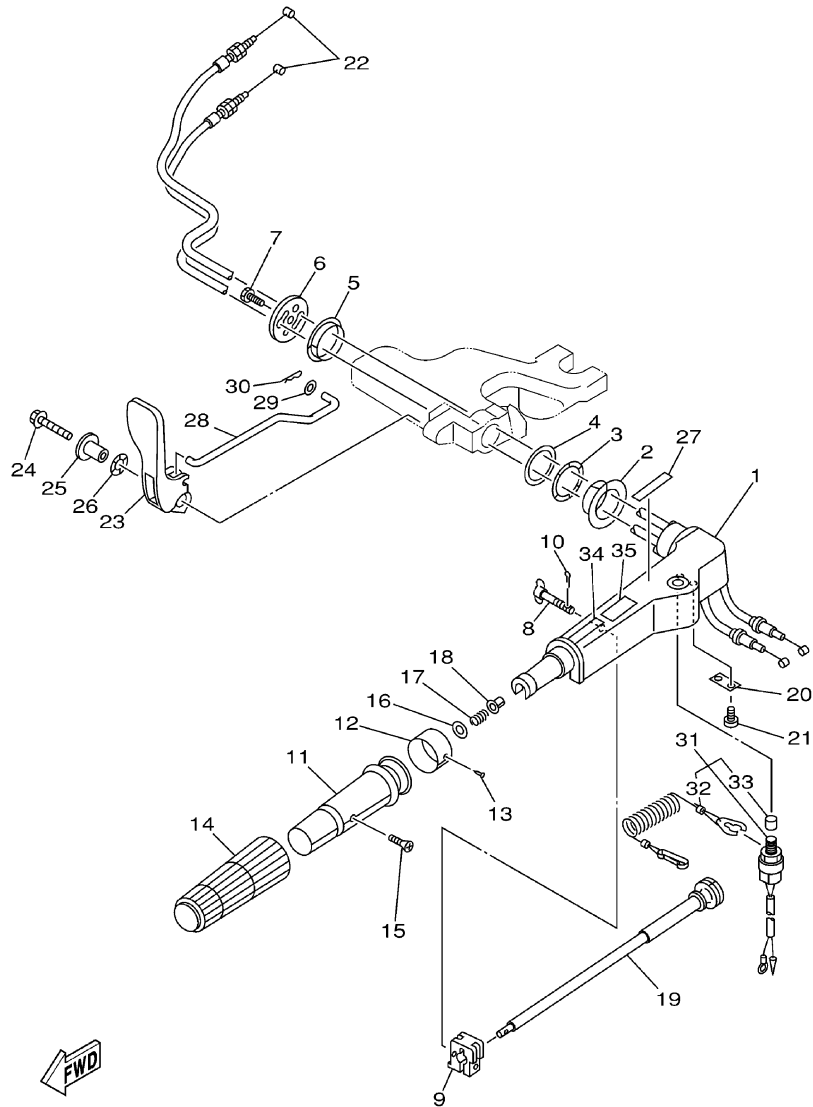

63V1100-2120

REF. NO.	PART NO.	DESCRIPTION	99F	15F				REMARKS
28	63V-44124-02	LINK, SHIFT ROD	1	1				
29	90202-06009	WASHER, PLATE	1	1				
30	90468-18008	CLIP	1	1				
31	65W-82575-01	ENGINE STOP SWITCH ASSY	1	1				
32	682-82556-00	.STOPPER	1	1				
33	689-8257Y-00	.CAP	1	1				
34	6E0-83627-41	LABEL, CAUTION 7	1	1				
35	6E0-83627-51	LABEL, CAUTION 7	1	1				FOR CANADA

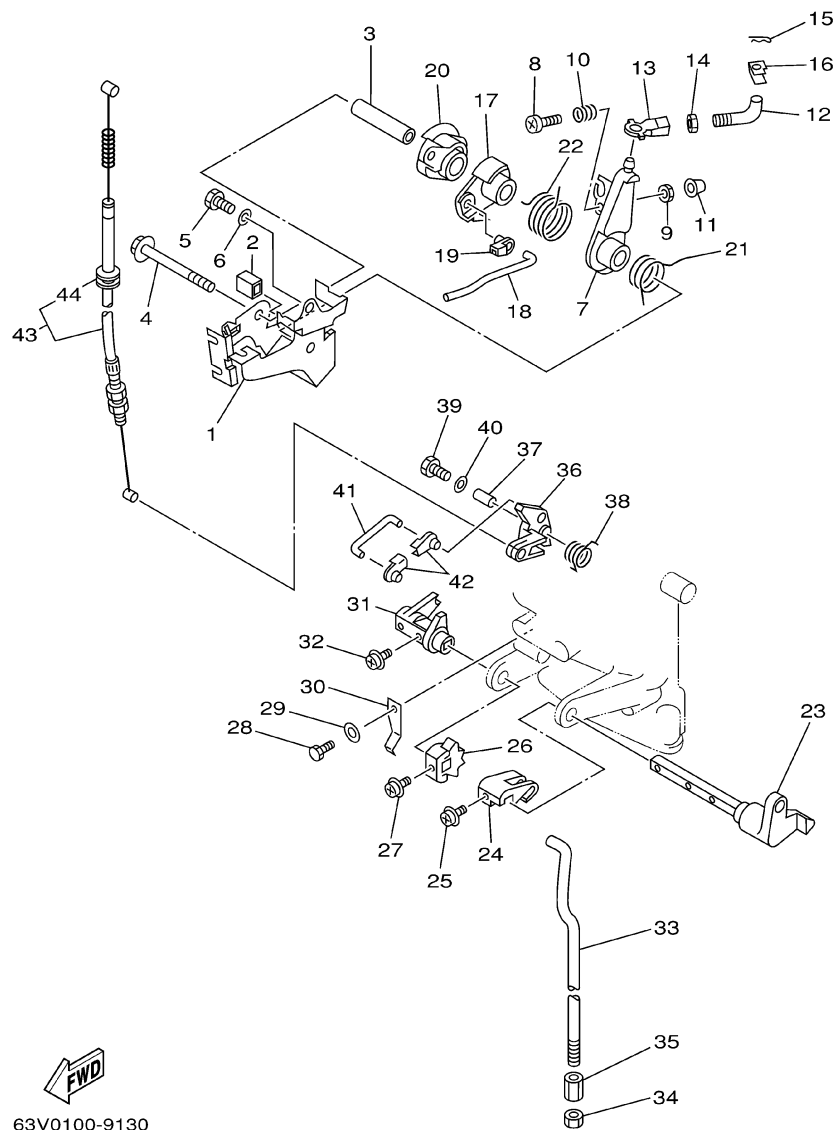

63V0100-9130

FIG. 13 CONTROL

REF. NO.	PART NO.	DESCRIPTION	99F	15F	REMARKS
1	63V-14497-01	STAY, THROTTLE WIRE	1	1	
2	689-44194-00	CAP	1	1	
3	90387-06M50	COLLAR	1	1	
4	95895-06065	BOLT, FLANGE	1	1	
5	97095-06012	BOLT	1	1	
6	92995-06600	WASHER	1	1	
7	63V-41631-00	LEVER, MAGNETO CONTROL	1	1	
8	97885-06030	SCREW, PAN HEAD	1	1	
9	95380-06600	NUT, HEXAGON	1	1	
10	90501-12M16	SPRING, COMPRESSION	1	1	
11	688-44194-00	CAP	1	1	
12	63V-41238-00	JOINT, LINK	1	1	
13	6H4-41237-00	JOINT, LINK	1	1	
14	95380-05700	NUT	1	1	
15	90468-10005	CLIP	1	1	
16	63V-41223-00	WASHER, LOCK 1	1	1	
17	63V-41283-01	LEVER, FREE ACCEL.	1	1	
18	63V-41211-00	LINK, ACCEL.	1	1	
19	661-41262-02	JOINT, CHOKE LEVER	1	1	
20	63V-41638-00	PULLEY	1	1	
21	90508-16M37	SPRING, TORSION	1	1	
22	90508-20M38	SPRING, TORSION	1	1	
23	63V-44123-01	ARM, SHIFT ROD	1	1	
24	63V-44121-01	LEVER, SHIFT ROD	1	1	
25	90159-05M25	SCREW, WITH WASHER	1	1	
26	63V-44125-00	LEVER, SHIFT ROD	1	1	
27	90159-05M25	SCREW, WITH WASHER	1	1	

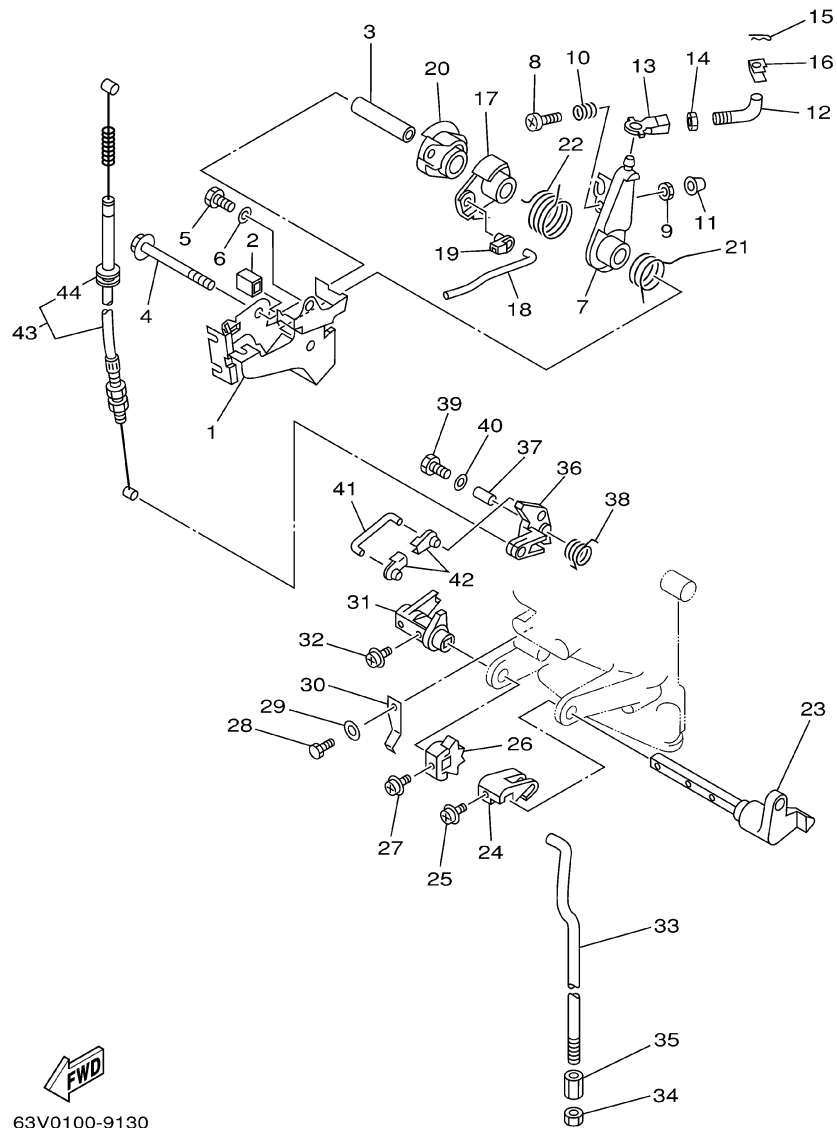
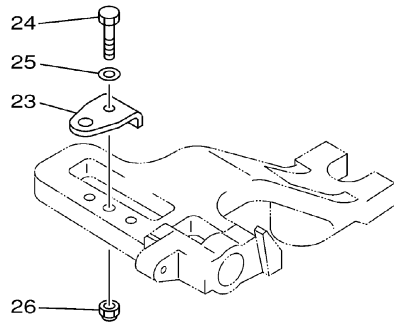
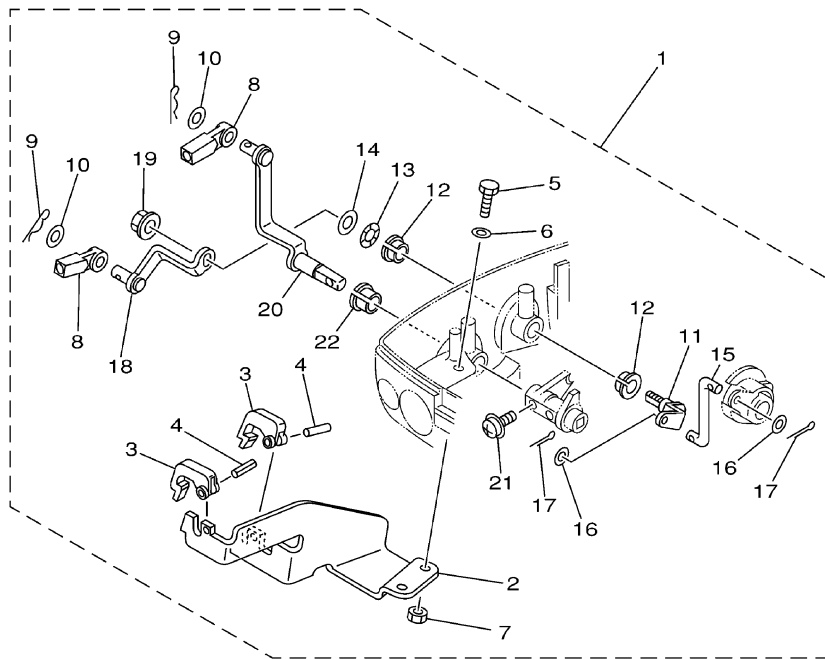

FIG. 13 CONTROL

REF. NO.	PART NO.	DESCRIPTION	99F	15F	REMARKS
28	97095-06012	BOLT	1	1	
29	92995-06600	WASHER	1	1	
30	63V-44116-00	SPRING	1	1	
31	63V-44122-01	BUSHING, SHIFT ROD LEVER	1	1	
32	90159-05M25	SCREW, WITH WASHER	1	1	
33	63V-44143-01	ROD, SHIFT	1	1	
34	95380-06700	NUT	1	1	
35	90170-06015	NUT	1	1	
36	63V-15746-00	ARM	1	1	
37	90387-06M06	COLLAR	1	1	
38	90508-08M39	SPRING, TORSION	1	1	
39	97095-06020	BOLT	1	1	
40	92995-06600	WASHER	1	1	
41	6L2-15747-00	LINK	1	1	
42	661-41262-02	JOINT, CHOKE LEVER	2	2	
43	63V-15770-00	CABLE COMP., STARTER STOP	1	1	
44	90480-10M16	.GROMMET	1	1	

FWD
63V0100-9130

FIG. 14 REMOTE CONTROL ATTACHMENT



63V1100-2140

REF. NO.	PART NO.	DESCRIPTION	99F	15F				REMARKS
1	63V-48501-00	REMOTE CONT. ATTACHMENT ASSY.	1	1				AP
2	63V-48531-00	.BRACKET, REMOTE CONTROL 1	1	1				
3	682-48538-50	.CLAMP, CABLE 1	2	2				
4	91690-30012	.PIN, SPRING	2	2				
5	97095-06016	.BOLT	2	2				
6	92995-06600	.WASHER	2	2				
7	95380-06600	.NUT, HEXAGON	2	2				
8	663-48344-00	.CABLE END, REMOTE CONTROL	2	2				
9	90468-18008	.CLIP	2	2				
10	90201-08M12	.WASHER, PLATE	2	2				
11	63V-42154-00	.LEVER, THROTTLE CONTROL	1	1				
12	90386-10025	.BUSH	2	2				
13	90206-10M04	.WASHER, WAVE	1	1				
14	90201-10M02	.WASHER, PLATE	1	1				
15	63V-42192-00	.ROD 2	1	1				
16	90201-04M06	.WASHER, PLATE	2	2				
17	91490-20010	.PIN, COTTER	2	2				
18	63V-48534-00	.THROTTLE LEVER, CONTROL	1	1				
19	95780-08300	.NUT, FLANGE	1	1				
20	63V-48544-00	.LEVER, SHIFTCONTROL	1	1				
21	90159-05M25	.SCREW, WITH WASHER	1	1				
22	90386-10009	.BUSH	1	1				
23	63V-48511-01	HOOK, STEERING	1	1				AP
24	97075-08035	BOLT	1	1				AP
25	92995-08600	WASHER	1	1				AP
26	90185-08057	NUT, SELF-LOCKING	1	1				AP

FIG. 15 BRACKET 1

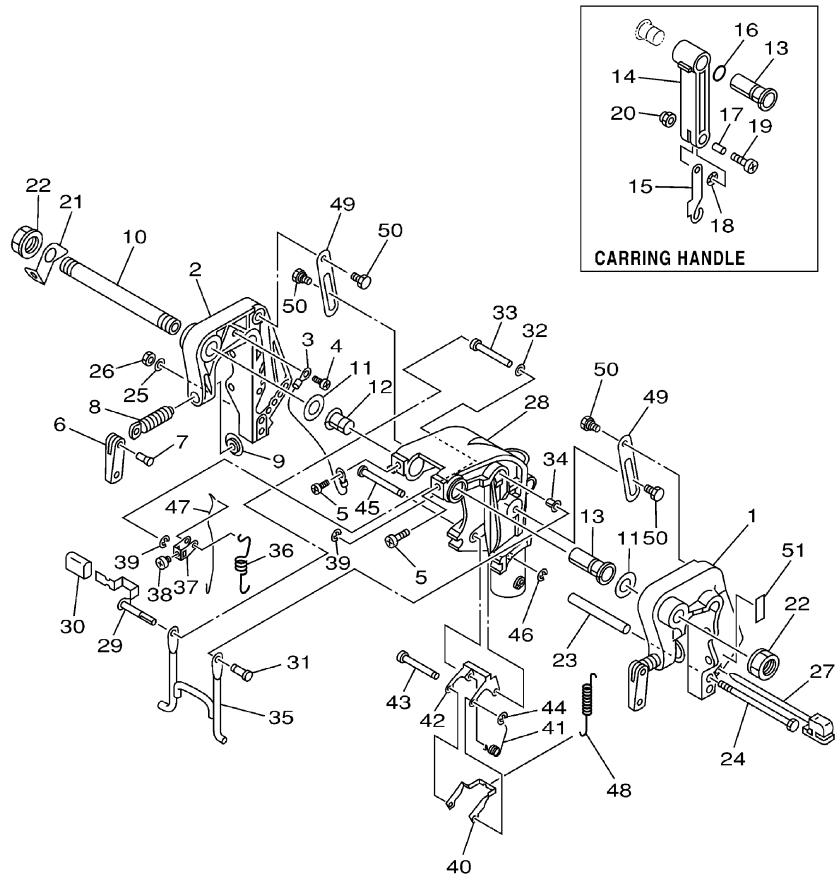

FWD
63V1100-2150

REF. NO.	PART NO.	DESCRIPTION	99F	15F	REMARKS
1	63V-43111-05-4D	BRACKET, CLAMP	1	1	
2	63V-43112-06-4D	BRACKET, CLAMP	1	1	
3	66M-82148-00	WIRE, LEAD 4	1	1	
4	97885-06008	SCREW, PAN HEAD	1	1	
5	97885-08010	SCREW, PAN HEAD	2	2	
6	6E0-43118-01	HANDLE, TRANSOM CLAMP	2	2	
7	90243-04M01	PIN	2	2	
8	6E7-43116-00	SCREW, TRANSOM CLAMP	2	2	
9	648-43114-01	PAD, TRANSOM CLAMP	2	2	
10	63W-43131-01	BOLT, CLAMP BRACKET	1	1	
11	90202-22M54	WASHER, PLATE	2	2	
12	90386-22M94	BUSH	1	1	
13	90386-22M69	BUSH	1	1	
14	63V-42731-00-4D	CARRYING HANDLE	1	1	
15	63V-43676-01	HOOK	1	1	
16	93210-20M65	O-RING	1	1	
17	90387-06M75	COLLAR	1	1	
18	90206-08010	WASHER, WAVE	1	1	
19	97885-06025	SCREW, PAN HEAD	1	1	
20	95780-06300	NUT, FLANGE	1	1	
21	6J8-43113-01	PLATE, CLAMP BRACKET	1	1	
22	90185-22043	NUT, SELF-LOCKING	2	2	
23	90387-06M13	COLLAR	1	1	
24	90101-06M29	BOLT	1	1	
25	92995-06600	WASHER	1	1	
26	95380-06700	NUT	1	1	
27	6L2-43160-00	TILT ROD ASSY	1	1	

FIG. 15 BRACKET 1

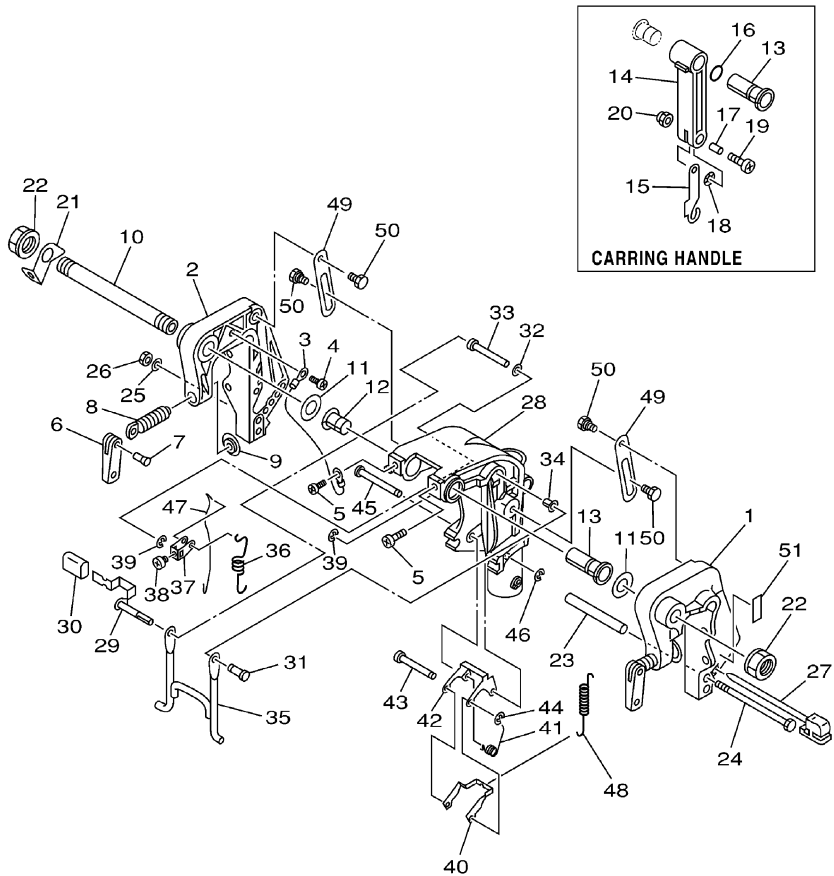

FWD
63V1100-2150

REF. NO.	PART NO.	DESCRIPTION	99F	15F				REMARKS
28	63V-43311-03-4D	BRACKET, SWIVEL 1	1	1				
29	66M-43630-01	TILT LEVER ASSY	1	1				
30	682-43318-01	COVER	1	1				
31	63V-43191-00	SHAFT, STOPPER	1	1				
32	90202-07M60	WASHER, PLATE	1	1				
33	90387-07M07	COLLAR	1	1				
34	90386-07M95	BUSH	1	1				
35	66M-43350-01	RECEIVER ASSY	1	1				
36	90507-20M00	SPRING, TENSION	1	1				
37	63V-43641-01	LEVER, TILT	1	1				
38	90157-05014	SCREW, PAN HEAD	1	1				
39	99080-05600	CIRCLIP	2	2				
40	63V-43614-10	PLATE, TILT LOCK	1	1				
41	90508-18M41	SPRING, TORSION	1	1				
42	66R-43615-00	PLATE, TILT LOCK	1	1				
43	66R-43611-00	SHAFT, TILT LOCK	1	1				
44	93430-04M03	CIRCLIP	1	1				
45	63V-43659-00	SHAFT, REVERSE LOCK	1	1				
46	99080-05600	CIRCLIP	1	1				
47	66R-43617-00	ROD, TILT LOCK	1	1				
48	63V-43656-00	SPRING, REVERSE LOCK 1	1	1				
49	63V-43181-00	LEVER, TILT STOP	2	2				
50	90109-06M84	BOLT	4	4				
51	63V-82377-50	LABEL (SPARK,IGNITION)	1	1				FOR CANADA

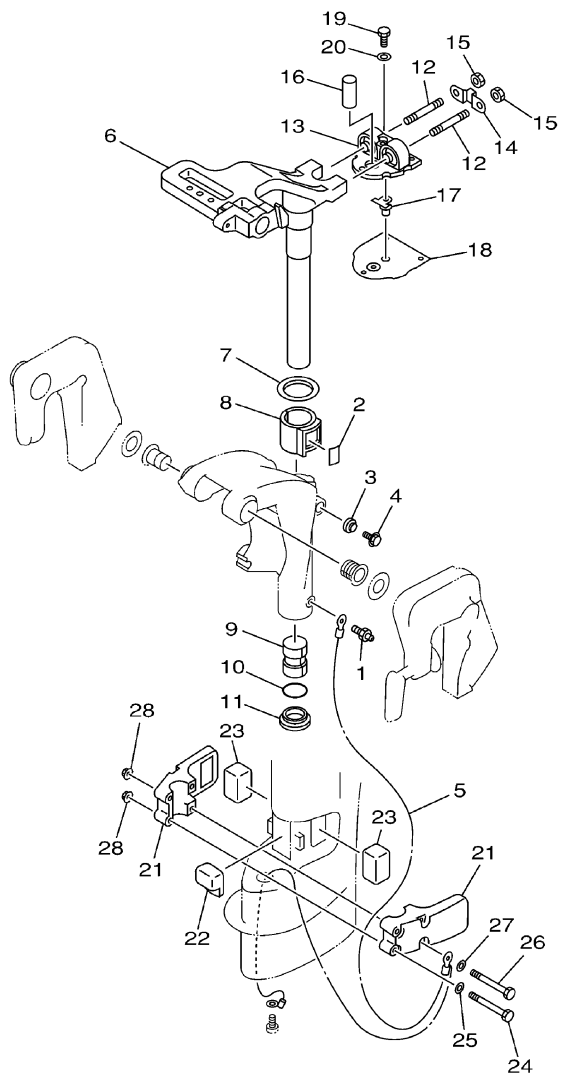

63V0010-1160

FIG. 16 BRACKET 2

REF. NO.	PART NO.	DESCRIPTION	99F	15F	REMARKS
1	93700-06M03	NIPPLE, GREASE	1	1	
2	63V-42528-00	PLATE, FRICTION	1	1	
3	689-43373-01	SEAL, DAMPER	1	1	
4	90105-06M07	BOLT, FLANGE	1	1	
5	63V-82127-00	WIRE, LEAD 2	1	1	
6	63V-42511-04-4D	BRACKET, STEERING	1	1	
7	90209-40008	WASHER	1	1	
8	65F-42537-00	BUSHING, PIVOT SHAFT	1	1	
9	90386-30048	BUSH	1	1	
10	93210-29M94	O-RING	1	1	
11	90386-30M60	BUSH	1	1	
12	90116-08M54	BOLT, STUD	2	2	
13	63V-44514-01-5B	MOUNT DAMPER, UPPER SIDE	1	1	
14	63V-44526-00	PLATE	1	1	
15	95380-08600	NUT	2	2	
16	90387-16002	COLLAR	1	1	
17	63V-44366-01	DAMPER, WATER SEAL	1	1	
18	63V-45114-A0	GASKET, UPPER CASING	1	1	
19	97095-06018	BOLT	3	3	
20	92995-06600	WASHER	3	3	
21	63V-44551-01-4D	HOUSING, LOWER MOUNT RUBBER	2	2	
22	63V-44557-00	MOUNT DAMPER, LOWER FRONT	1	1	
23	682-44555-00	MOUNT DAMPER, LOWER SIDE	2	2	
24	97075-06055	BOLT	2	2	
25	92995-06600	WASHER	2	2	
26	97075-06075	BOLT	2	2	
27	92995-06600	WASHER	2	2	

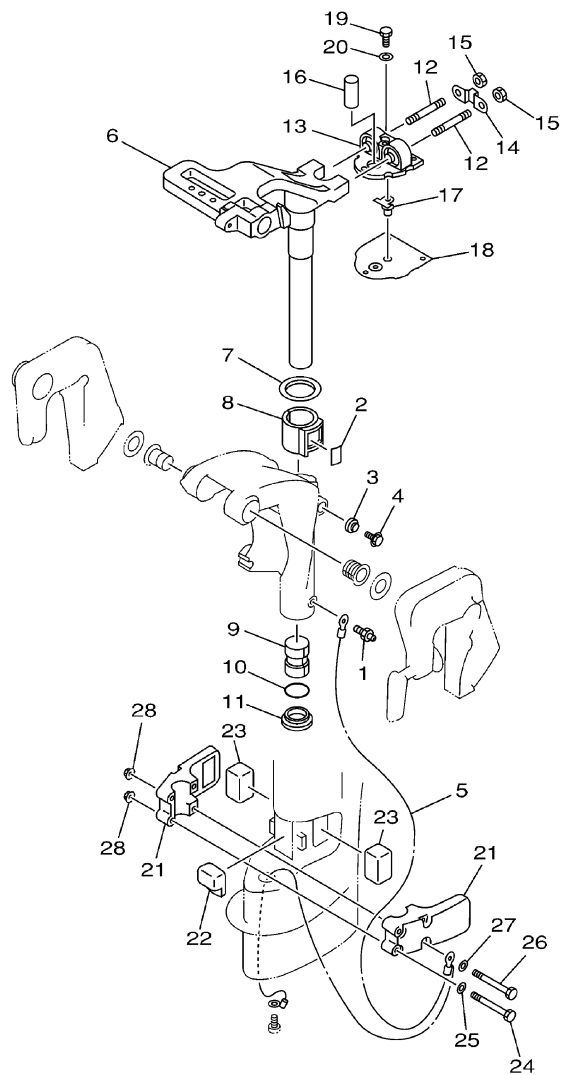

63V0010-1160

FIG. 16 BRACKET 2

REF. NO.	PART NO.	DESCRIPTION	99F	15F		REMARKS
28	90179-06M28	NUT	4	4		

FIG. 17 UPPER CASING

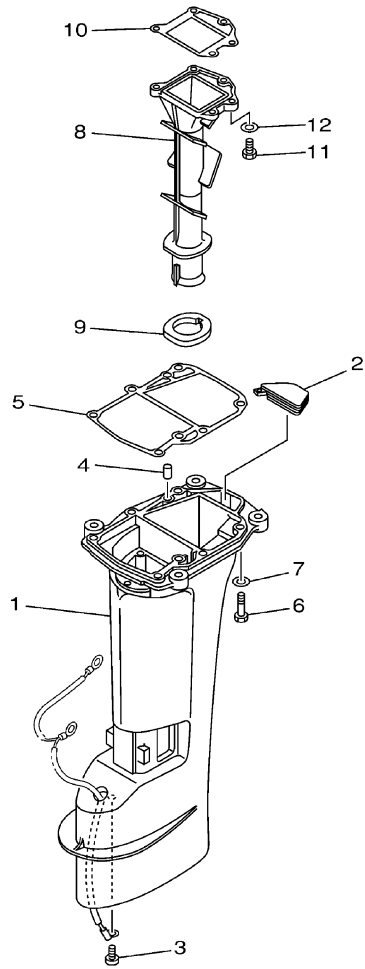

REF. NO.	PART NO.	DESCRIPTION	99F	15F				REMARKS
1	63V-45111-04-4D	CASING, UPPER	1	1				S
	63V-45111-14-4D	CASING, UPPER		1				L
2	63V-45126-00	PLATE, SEAL DAMPER	1	1				
3	90157-06M06	SCREW, PAN HEAD	1	1				
4	93606-12019	PIN, DOWEL	2	2				
5	63V-45113-A1	GASKET, UPPER CASING	1	1				
6	97095-08030	BOLT	6	6				
7	92995-08600	WASHER	6	6				
8	65F-41131-00-5B	MANIFOLD, EXT. 1	1	1				
9	63V-41135-00	GASKET, EXHAUST MANIFOLD	1	1				
10	63V-41133-A1	GASKET, EXHAUST MANIFOLD 1	1	1				
11	97095-06020	BOLT	5	5				
12	92995-06600	WASHER	5	5				



63V0100-1170

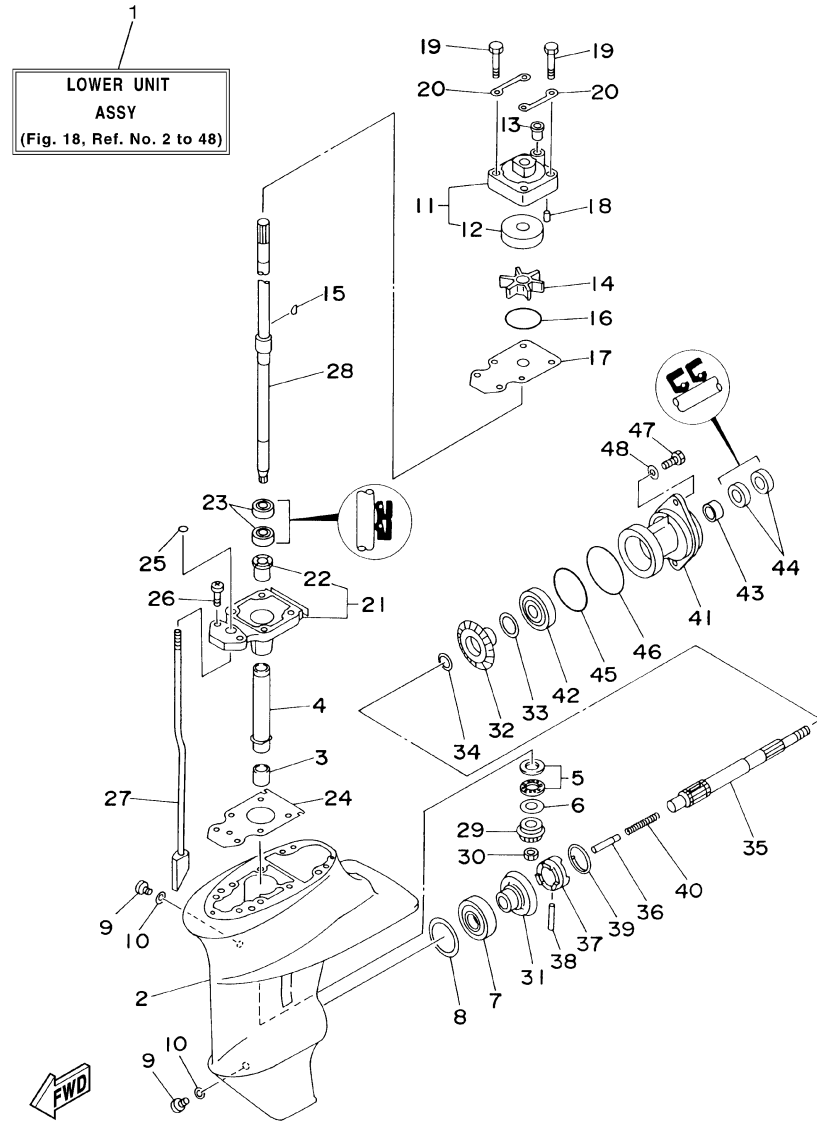

63V0010-5180

FIG. 18 LOWER CASING, DRIVE 1

REF. NO.	PART NO.	DESCRIPTION	99F	15F		REMARKS
1	63V-45300-03-4D	LOWER UNIT ASSY	1	1		S
	63V-45300-13-4D	LOWER UNIT ASSY		1		L
2	63V-45311-01-4D	CASING, LOWER	1	1		
3	93315-314V8	BEARING	1	1		
4	63V-45536-00	SLEEVE, DRIVE SHAFT	1	1		
5	93341-41414	BEARING	1	1		
6	6E8-45587-10-13	SHIM (T:1.13MM)	1	1		UR
	6E8-45587-10-20	SHIM (T:1.20MM)	1	1		UR
7	93332-00005	BEARING	1	1		
8	664-45567-01-10	SHIM (T:0.10MM)	1	1		UR
	664-45567-01-12	SHIM (T:0.12MM)	1	1		UR
	664-45567-01-15	SHIM (T:0.15MM)	1	1		UR
	664-45567-01-18	SHIM (T:0.18MM)	1	1		UR
	664-45567-01-30	SHIM (T:0.30MM)	1	1		UR
	664-45567-01-40	SHIM (T:0.40MM)	1	1		UR
	664-45567-01-50	SHIM (T:0.50MM)	1	1		UR
9	90340-08M04	PLUG, STRAIGHT SCREW	2	2		
10	90430-08020	GASKET	2	2		
11	63V-44301-00	WATER PUMP HOUSING COMP.	1	1		
12	63V-44322-00	.INSERT, CARTRIDGE	1	1		
13	647-44366-00	DAMPER, WATER SEAL	1	1		
14	63V-44352-01	IMPELLER	1	1		
15	63V-44338-00	KEY, WOODRUFF	1	1		
16	93210-44398	O-RING	1	1		
17	63V-44323-00	OUTER PLATE, CARTRIDGE	1	1		
18	93604-12M07	PIN, DOWEL	2	2		
19	97080-08045	BOLT	4	4		

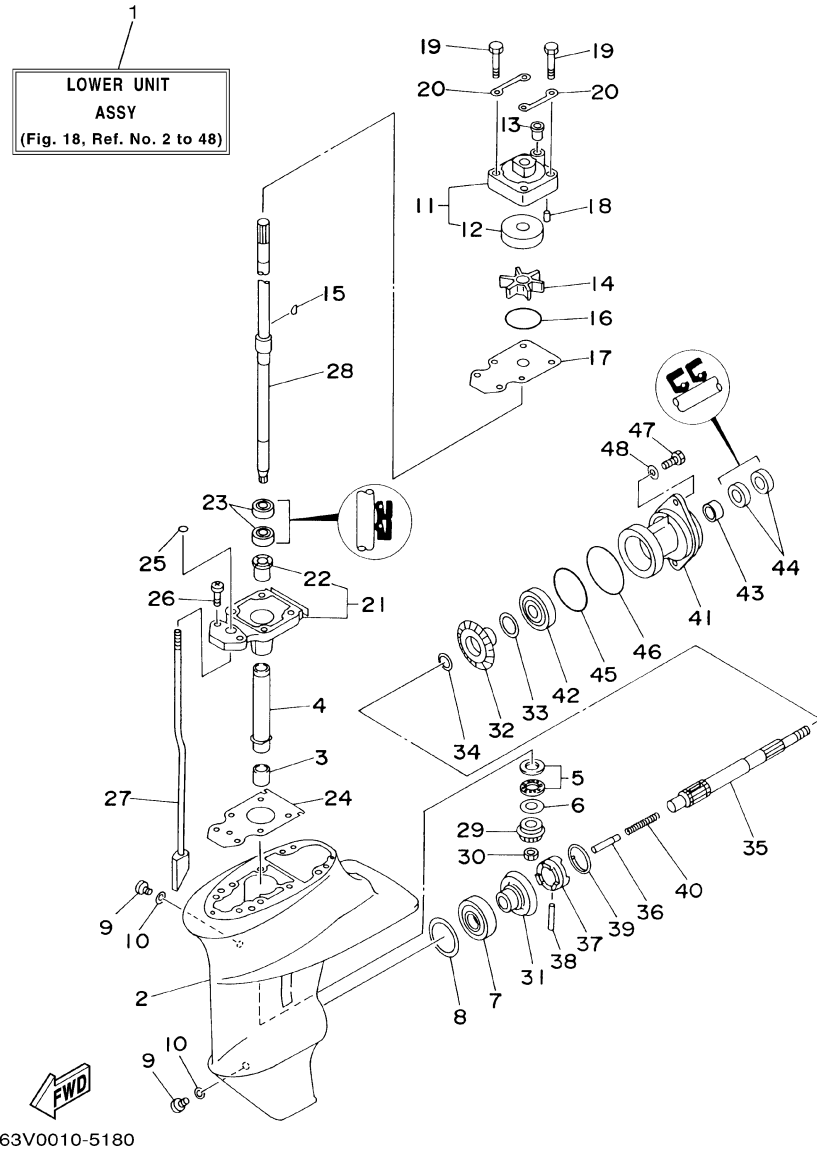

63V0010-5180

FIG. 18 LOWER CASING, DRIVE 1

REF. NO.	PART NO.	DESCRIPTION	99F	15F		REMARKS
20	63V-44328-00	PLATE	2	2		
21	63V-45331-00-5B	HOUSING, BEARING	1	1		
22	90381-14020	.BUSH, SOLID	1	1		
23	93101-20048	OIL SEAL	2	2		
24	63V-45315-A0	PACKING, LOWER CASING	1	1		
25	93210-06ME6	O-RING	1	1		
26	97080-08025	BOLT	2	2		
27	63V-44150-00	SHIFT CAM ASSY	1	1		S
	63V-44150-10	SHIFT CAM ASSY		1		L
28	63V-45510-01	DRIVE SHAFT ASSY	1	1		S
	63V-45510-11	DRIVE SHAFT ASSY		1		L
29	63V-45551-00	PINION	1	1		
30	90179-08M06	NUT	1	1		
31	6E7-45560-01	GEAR	1	1		
32	6E7-45571-00	GEAR	1	1		
33	626-45577-00-01	SHIM (T:0.10MM)	1	1		UR
	626-45577-00-03	SHIM (T:0.30MM)	1	1		UR
	626-45577-00-05	SHIM (T:0.50MM)	1	1		UR
34	90201-17682	WASHER, PLATE	1	1		
35	683-45611-00	SHAFT, PROPELLER	1	1		
36	650-45635-00	PLUNGER, SHIFT	1	1		
37	682-45631-00	CLUTCH, DOG	1	1		
38	90250-05010	PIN, STRAIGHT	1	1		
39	648-45633-00	RING, CROSS PIN	1	1		
40	90501-14M06	SPRING, COMPRESSION	1	1		
41	683-45361-02-4D	CAP, LOWER CASING	1	1		
42	93306-00501	BEARING (B6005)	1	1		

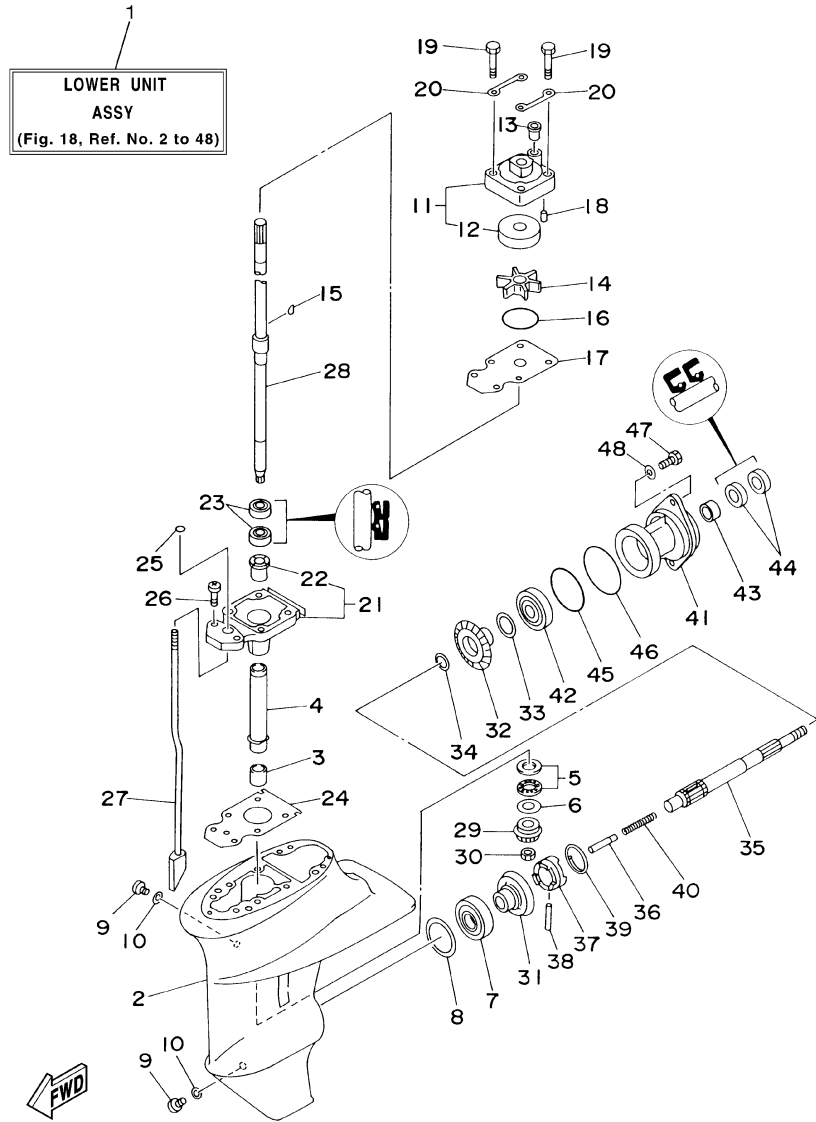

63V0010-5180

FIG. 18 LOWER CASING. DRIVE 1

REF. NO.	PART NO.	DESCRIPTION	99F	15F				REMARKS
43	93315-317U2	BEARING	1	1				
44	93101-17054	OIL SEAL	2	2				
45	93210-57M09	O-RING	1	1				
46	93210-56M80	O-RING	1	1				
47	97095-06020	BOLT	2	2				
48	92995-06600	WASHER	2	2				

FIG. 19 LOWER CASING. DRIVE 2

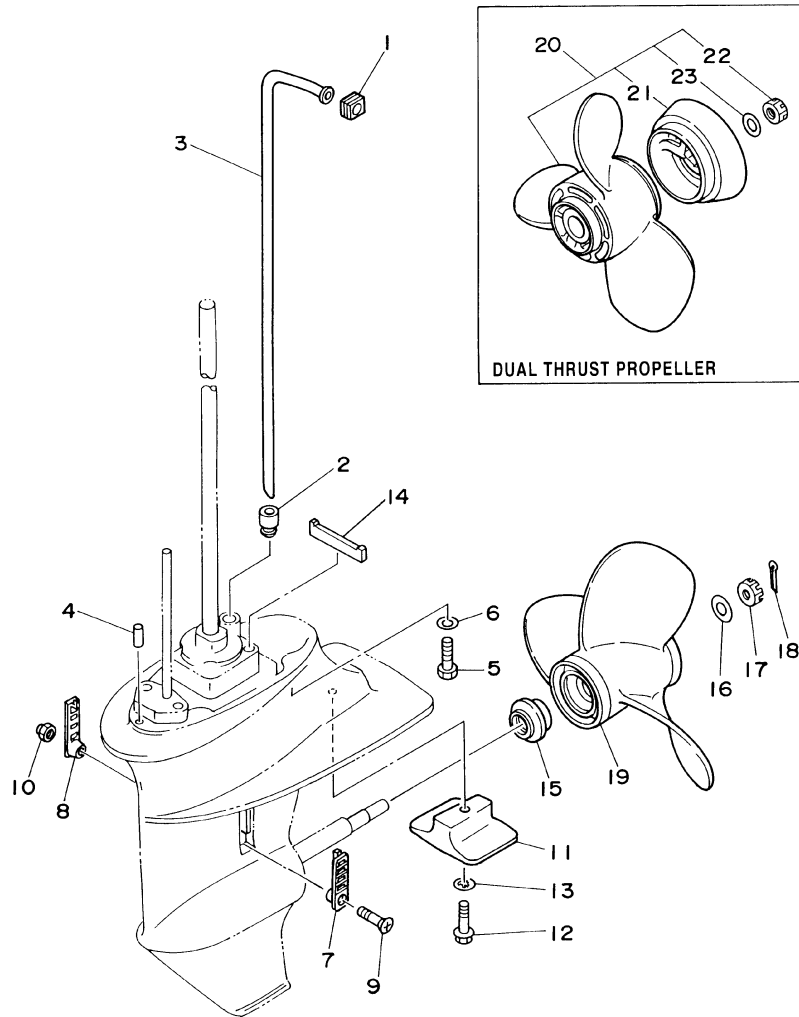

63V0010-5190

REF. NO.	PART NO.	DESCRIPTION	99F	15F				REMARKS
1	63V-44365-10	DAMPER, WATER SEAL	1	1				
2	63V-44368-00	RUBBER, WATER SEAL 4	1	1				
3	63V-44361-01	TUBE, WATER	1	1				S
	63V-44361-11	TUBE, WATER		1				L
4	93604-12M07	PIN, DOWEL	2	2				
5	97075-08030	BOLT	4	4				
6	92995-08600	WASHER	4	4				
7	6G1-45214-00	COVER, WATER INLET	1	1				
8	63V-45215-00	COVER, WATER INLET	1	1				
9	90152-05M04	SCREW, COUNTERSUNK	1	1				
10	90185-05002	NUT, SELF-LOCKING	1	1				
11	61N-45251-00	ANODE	1	1				
12	95895-06030	BOLT, FLANGE	1	1				
13	92990-06300	WASHER, INTERNAL TOOTH	1	1				
14	63V-45375-00	DAMPER, SEAL	1	1				
15	6E7-45987-01	SPACER	1	1				
16	90201-10M01	WASHER, PLATE	1	1				
17	90171-10M01	NUT, CASTLE	1	1				
18	91490-30020	PIN, COTTER	1	1				
19	683-45941-00-EL	PROPELLER (3X9-1/4"X12"-J)	1	1				UR
	683-45943-00-EL	PROPELLER (3X9-1/4"X10-1/2"-J)	1	1				UR
	683-45945-00-EL	PROPELLER (3X9-1/4"X9"-J)	1	1				UR
	683-45947-00-EL	PROPELLER (3X9-1/4"X8"-J)	1	1				UR
	683-45949-00-EL	PROPELLER (3X9-1/2"X6-1/2"-J)	1	1				UR
	683-45952-00-EL	PROPELLER (3X9-1/4"X9-3/4"-J)	1	1				UR
	63V-45945-00-EL	PROPELLER (3X9-1/4"X9"-J)	1	1				UR
20	683-W4591-02-EL	PROPELLER (3X9-3/4"X8"-J)	1	1				UR DUAL THRUST PROP.

FIG. 19 LOWER CASING. DRIVE 2

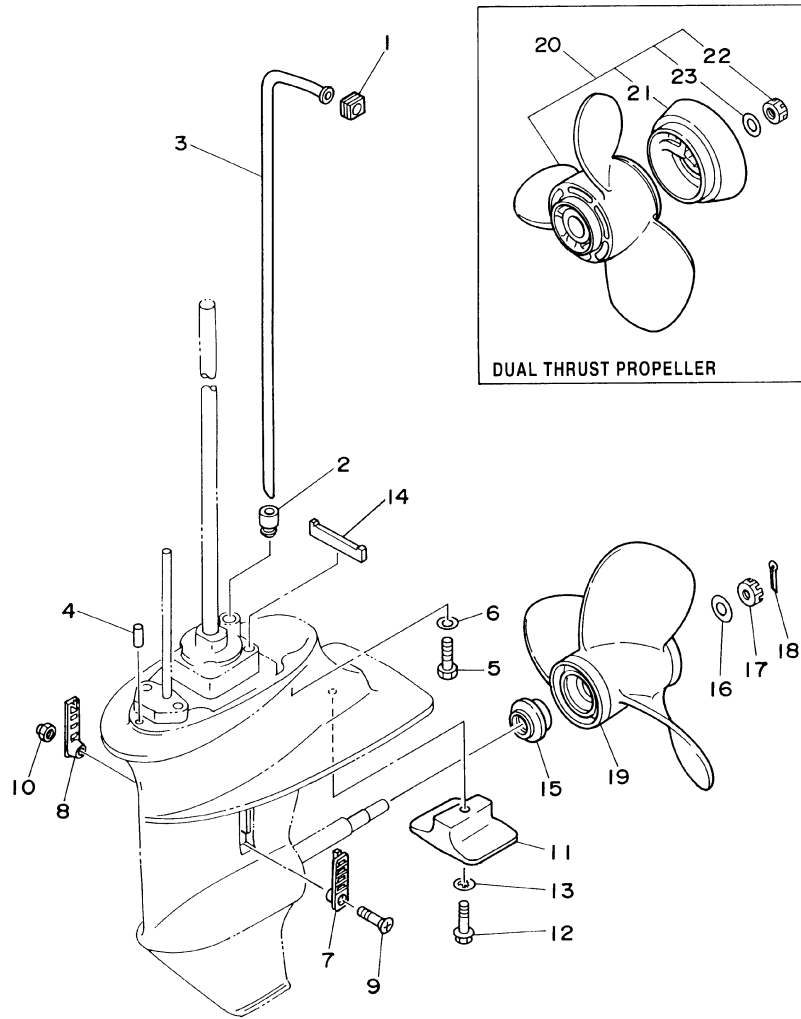

FWD
63V0010-5190

REF. NO.	PART NO.	DESCRIPTION	99F	15F			REMARKS
20	683-W4592-02-EL	PROPELLER (3X9-3/4"X6-1/2"-J)	1	1			UR DUAL THRUST PROP.
21	6E7-45986-00	.RING, DEFLECTOR	1	1			
22	90171-10M07	.NUT, CASTLE	1	1			
23	90201-10M02	.WASHER, PLATE	1	1			

FIG. 20 FUEL TANK

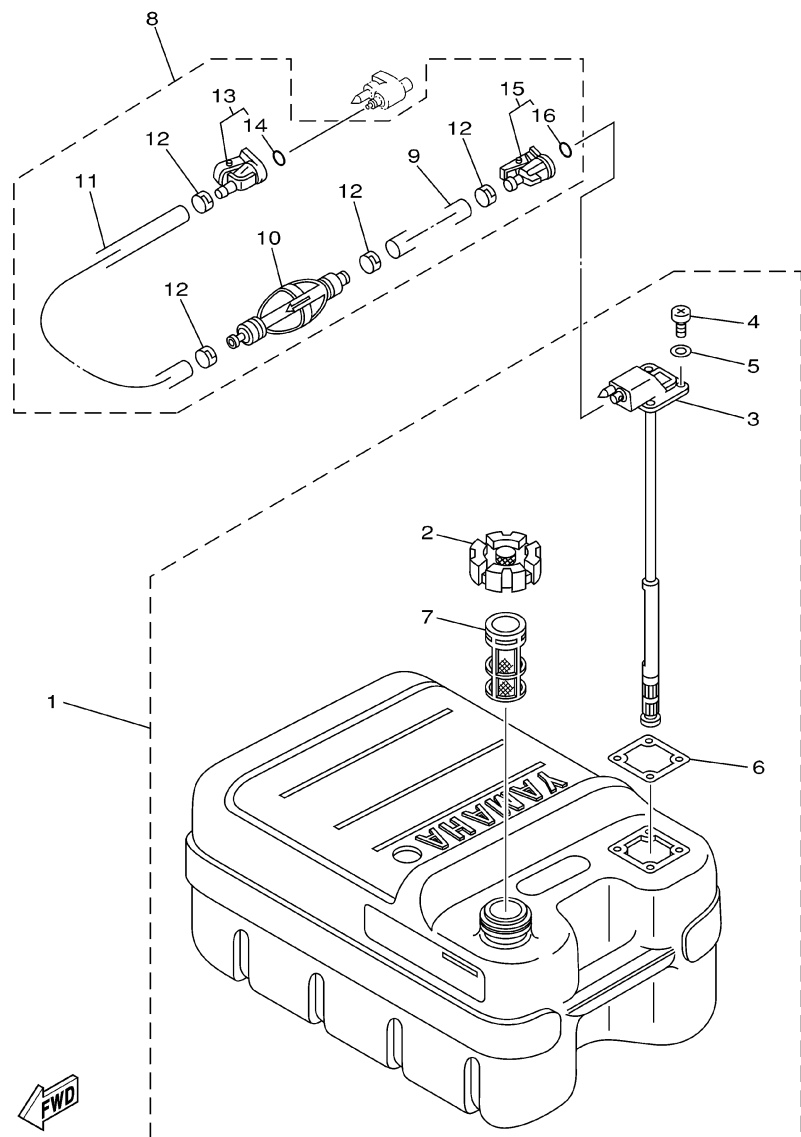

67C0100-9300

REF. NO.	PART NO.	DESCRIPTION	99F	15F	REMARKS
1	6YJ-24201-50	FUEL TANK ASSY	1	1	AP FOR CANADA
	6YJ-24201-10	FUEL TANK ASSY (24L)	1	1	AP FOR OCEANIA WITH INDICATOR
2	6YJ-24610-01	.CAP ASSY	1	1	WITH INDICATOR
3	6Y1-24260-12	.FUEL METER ASSY	1	1	
4	98586-05016	.SCREW, PAN HEAD	4	4	
5	6Y1-24329-00	.SEAL	4	4	
6	6Y1-24268-00	.GASKET, FUEL METER	1	1	
7	6YJ-24167-00	.STRAINER	1	1	
8	6Y1-24306-53	FUEL PIPE COMP. 1	1	1	AP FOR CANADA
	61J-24306-02	FUEL PIPE COMP. 1	1	1	AP FOR OCEANIA
9	90445-11M06	.HOSE (L2050)	1	1	
10	6Y1-24360-52	.PRIMER PUMP ASSY	1	1	FOR 6Y1-24306-53
	61J-24360-00	.PRIMER PUMP ASSY	1	1	FOR 61J-24306-02
11	90445-11M05	.HOSE (L:850MM)	1	1	
12	650-24351-51	.BAND 1	4	4	
13	6G1-24305-03	.FUEL PIPE JOINT COMP. 2	1	1	
14	93210-08287	..O-RING	1	1	
15	6Y1-24305-04	.FUEL PIPE JOINT COMP. 2	1	1	
16	93210-08287	..O-RING	1	1	

FIG. 21 REPAIR KIT 1

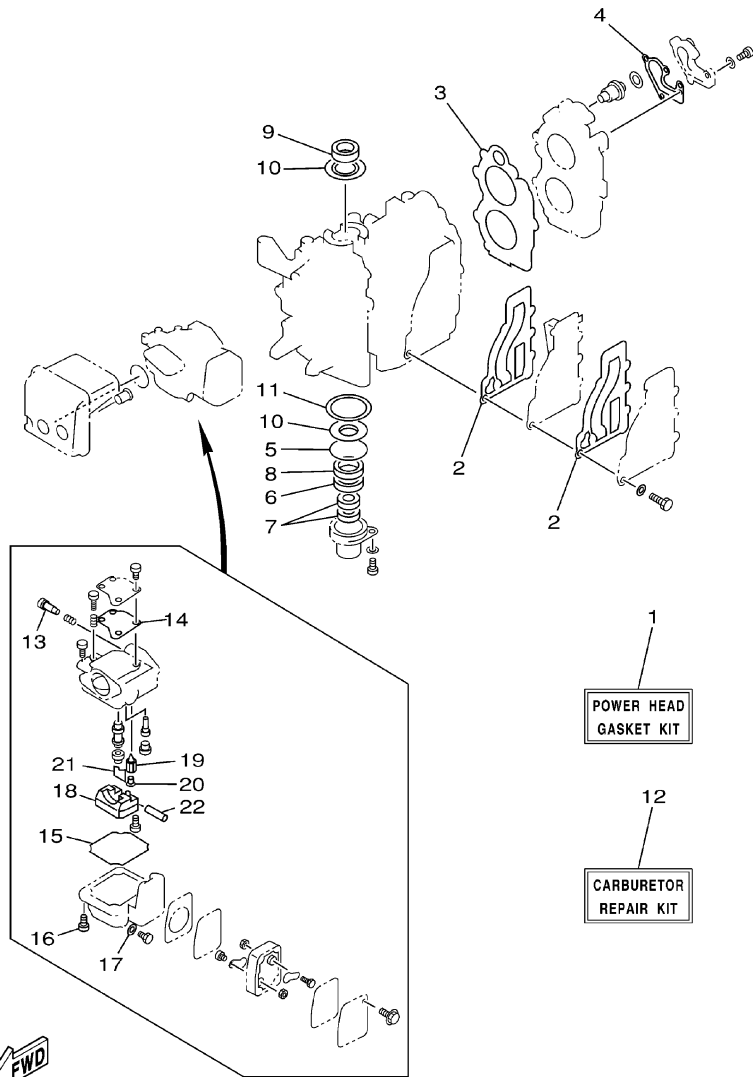

63V0100-1240

REF. NO.	PART NO.	DESCRIPTION	99F	15F				REMARKS
1	63V-W0001-02	POWER HEAD GASKET KIT	1	1				
2	63V-41112-A0	.GASKET, EXHAUST INNER COVER	2	2				
3	63V-11181-A1	.GASKET, CYLINDER HEAD 1	1	1				
4	682-12414-A1	.GASKET, COVER	1	1				
5	93210-46M16	.O-RING	1	1				
6	93101-25018	.OIL SEAL	1	1				
7	93101-13018	.OIL SEAL	2	2				
8	93102-25M48	.OIL SEAL	1	1				
9	93110-23M00	.OIL SEAL	1	1				
10	63V-11445-00	.SPACER	2	2				
11	90201-46M29	.WASHER, PLATE	1	1				
12	63V-W0093-00	CARBURETOR REPAIR KIT	1	1				
13	679-14923-00	.SCREW, PILOT	1	1				
14	63V-14126-00	.GASKET	1	1				
15	63V-14984-00	.GASKET, FLOAT CHAMBER	1	1				
16	97980-04114	.SCREW, WITH WASHER	4	4				
17	6G1-14398-00	.WASHER	1	1				
18	63V-14985-00	.FLOAT	1	1				
19	6G1-14546-00	.VALVE, NEEDLE	1	1				
20	676-14186-00	.PIN, FLOAT	1	1				
21	663-14159-00	.CLIP	1	1				
22	6H4-14548-00	.PIN, FLOAT ARM	1	1				

FIG. 22 REPAIR KIT 2

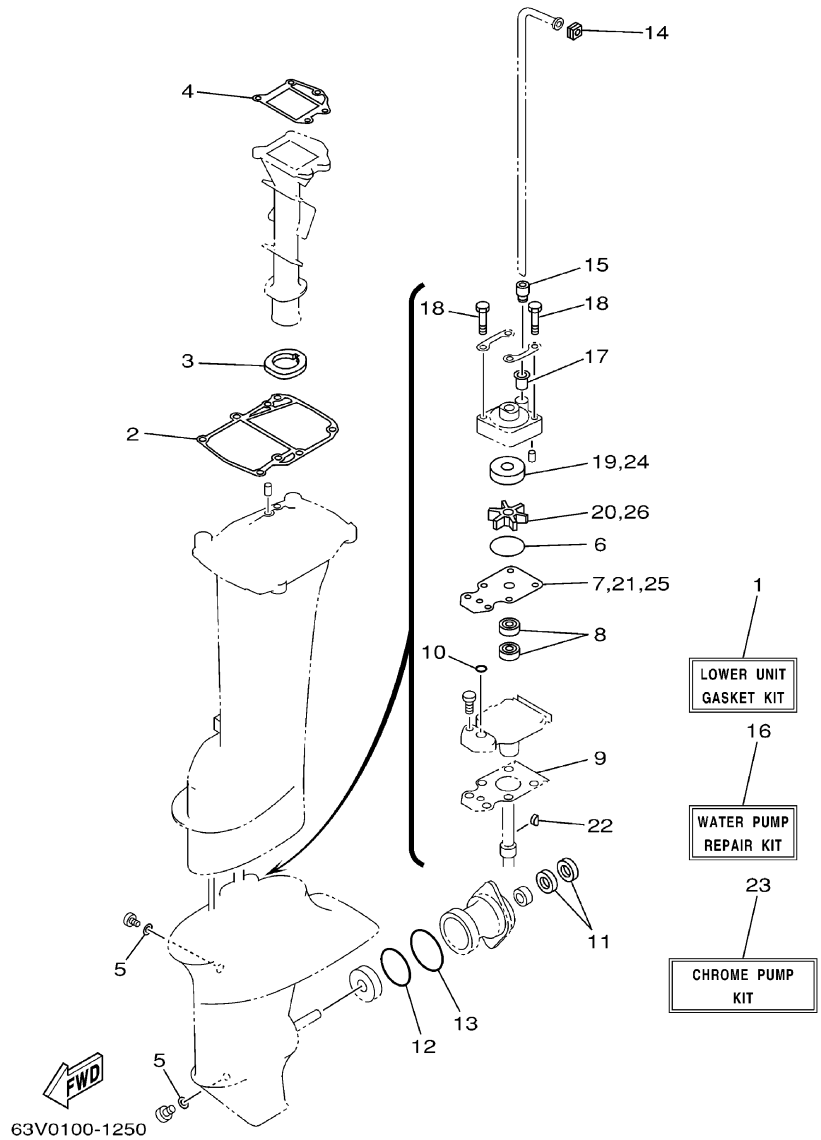

REF. NO.	PART NO.	DESCRIPTION	99F	15F				REMARKS
1	63V-W0001-22	LOWER UNIT GASKET KIT	1	1				
2	63V-45113-A1	.GASKET, UPPER CASING	1	1				
3	63V-41135-00	.GASKET, EXHAUST MANIFOLD	1	1				
4	63V-41133-A1	.GASKET, EXHAUST MANIFOLD 1	1	1				
5	90430-08020	.GASKET	2	2				
6	93210-44398	.O-RING	1	1				
7	63V-44323-00	.OUTER PLATE, CARTRIDGE	1	1				
8	93101-20048	.OIL SEAL	2	2				
9	63V-45315-A0	.PACKING, LOWER CASING	1	1				
10	93210-06ME6	.O-RING	1	1				
11	93101-17054	.OIL SEAL	2	2				
12	93210-57M09	.O-RING	1	1				
13	93210-56M80	.O-RING	1	1				
14	63V-44365-10	.DAMPER, WATER SEAL	1	1				
15	63V-44368-00	.RUBBER, WATER SEAL 4	1	1				
16	63V-W0078-01	WATER PUMP REPAIR KIT	1	1				
17	647-44366-00	.DAMPER, WATER SEAL	1	1				
18	97080-08045	.BOLT	4	4				
19	63V-44322-00	.INSERT, CARTRIDGE	1	1				
20	63V-44352-01	.IMPELLER	1	1				
21	63V-44323-00	.OUTER PLATE, CARTRIDGE	1	1				
22	63V-44338-00	.KEY, WOODRUFF	1	1				
23	63V-W0078-0A	CHROME PUMP KIT	1	1				
24	63V-44322-40	.INSERT, CARTRIDGE	1	1				
25	63V-44323-40	.OUTER PLATE, CARTRIDGE	1	1				
26	63V-44352-01	.IMPELLER	1	1				

NUMERICAL INDEX

PARTNO.	REF. NO.	PARTNO.	REF. NO.	PARTNO.	REF. NO.	PARTNO.	REF. NO.	PARTNO.	REF. NO.	PARTNO.	REF. NO.
63V-W0001-02	21 - 1	6G1-14398-00	21 - 17	63V-15793-00	8 - 16	63V-41252-00	4 - 18	6E7-42791-10	11 - 22	63V-44338-00	18 - 15
63V-W0001-22	22 - 1	63V-14440-00	4 - 9	63V-15794-00	8 - 20	63V-41253-00	4 - 5	63V-42815-01-4D	11 - 8		22 - 22
682-W0004-00	4 - 2	624-14485-00	2 - 3	63V-15795-01	8 - 3	63V-41256-00	4 - 15	6E7-42816-00	11 - 9	63V-44352-01	18 - 14
63V-W0070-20	1 - 9	650-14485-02	2 - 4	6YJ-24167-00	20 - 7	63V-41257-00	4 - 8	63V-43111-05-4D	15 - 1		22 - 20
63V-W0078-0A	22 - 23	63V-14497-01	13 - 1	6YJ-24201-10	20 - 1	63V-41262-00	4 - 7	63V-43112-06-4D	15 - 2		22 - 26
63V-W0078-01	22 - 16	63V-14523-00	5 - 9	6YJ-24201-50	20 - 1	661-41262-02	4 - 19	6J8-43113-01	15 - 21	63V-44361-01	19 - 3
63V-W0090-03-1S	2 - 1	63V-14527-00	5 - 4	6Y1-24260-12	20 - 3			648-43114-01	15 - 9	63V-44361-11	19 - 3
63V-W0093-00	21 - 12	6G1-14546-00	5 - 19	6Y1-24268-00	20 - 6			6E7-43116-00	15 - 8	63V-44365-10	19 - 1
656-W2810-02	6 - 14			6G1-24304-02	6 - 1	6H4-41271-01	4 - 14	6E0-43118-01	15 - 6		22 - 14
683-W4591-02-EL	19 - 20	6H4-14548-00	5 - 22	6G1-24305-03	7 - 6	689-41273-00	4 - 16	63W-43131-01	15 - 10	63V-44366-01	16 - 17
683-W4592-02-EL	19 - 20					6J8-41274-00	4 - 17	6L2-43160-00	15 - 27	647-44366-00	18 - 13
6E7-11111-01-1S	2 - 19	679-14555-00	5 - 3	6Y1-24305-04	7 - 8	63V-41283-01	13 - 17	63V-43181-00	15 - 49		22 - 17
63V-11181-A1	2 - 20	679-14923-00	5 - 2			63V-41611-00	9 - 5	63V-43191-00	15 - 31	63V-44368-00	19 - 2
	21 - 3			6Y1-24306-53	7 - 1	63V-41631-00	13 - 7	63V-43311-03-4D	15 - 28		22 - 15
682-11325-00	2 - 8	676-14943-29	5 - 14			682-41638-00	13 - 20	682-43318-01	15 - 30	6H3-44391-01	11 - 20
676-11372-00	2 - 15	63V-14947-00	5 - 13	61J-24306-02	20 - 8	63V-42111-00-4D	12 - 1	66M-43350-01	15 - 35	63V-44514-01-5B	16 - 13
63V-11400-01	3 - 8	63V-14948-06	5 - 7	6Y1-24329-00	20 - 5	664-42119-00	12 - 11	689-43373-01	16 - 3	63V-44526-00	16 - 14
63V-11412-00	3 - 9	679-14966-00	5 - 8	650-24351-51	7 - 5	6G1-42125-01	12 - 8	66R-43611-00	15 - 43	63V-44551-01-4D	16 - 21
63V-11422-00	3 - 10	63V-14980-00	5 - 12			6G1-42126-00	12 - 9	63V-43614-10	15 - 40	682-44555-00	16 - 23
63V-11432-00	3 - 11	63V-14984-00	5 - 11	6Y1-24360-52	7 - 3	6G1-42131-01	12 - 6	66R-43615-00	15 - 42	63V-44557-00	16 - 22
63V-11442-00	3 - 12					6H2-42137-00	12 - 12	66R-43617-00	15 - 47	63V-45111-04-4D	17 - 1
63V-11445-00	3 - 28	63V-14985-00	5 - 18	61J-24360-00	20 - 10	6G1-42138-01	12 - 19	66M-43630-01	15 - 29	63V-45111-14-4D	17 - 1
	21 - 10			63V-24396-01	6 - 13	63V-42154-00	14 - 11	63V-43641-01	15 - 37	63V-45113-A1	17 - 5
63V-11515-02	3 - 14	6G1-14992-00	5 - 17	6G1-24411-00	5 - 30	6E0-42159-02	12 - 20	63V-43656-00	15 - 48		22 - 2
682-11610-01	3 - 22	63V-15100-02-1S	2 - 2	63V-24411-00	5 - 28	6G1-42177-00	12 - 14	63V-43659-00	15 - 45	63V-45114-A0	16 - 18
682-11610-11	3 - 22	63V-15396-01-94	3 - 1	6G1-24412-01	5 - 29	63V-42192-00	14 - 15	63V-43676-01	15 - 15	63V-45126-00	17 - 2
682-11610-21	3 - 22	63V-15705-01	8 - 10	6L5-24421-00	5 - 32	63V-42511-04-4D	16 - 6	63V-44111-02	12 - 23	6G1-45214-00	19 - 7
6E7-11631-00-97	3 - 21	63V-15710-12	8 - 1	6G1-24431-01	5 - 31	63V-42528-00	16 - 2	63V-44116-00	13 - 30	63V-45215-00	19 - 8
634-11633-00	3 - 23	63V-15711-01	8 - 2	6G1-24452-00	5 - 27	65F-42537-00	16 - 8	63V-44121-01	13 - 24	61N-45251-00	19 - 11
6E7-11635-00	3 - 21	63V-15713-00	8 - 7	61N-24521-00	6 - 6	63V-42610-30-4D	1 - 1	63V-44122-01	13 - 31	63V-45300-03-4D	18 - 1
6E7-11636-00	3 - 21	63V-15714-00	8 - 5	61N-24560-00	6 - 4	63W-42610-30-4D	1 - 1	63V-44123-01	13 - 23	63V-45300-13-4D	18 - 1
650-11651-04	3 - 16	63V-15716-00	8 - 9	61N-24563-00	6 - 5	63V-42613-01-4D	1 - 7	63V-44124-02	12 - 28	63V-45311-01-4D	18 - 2
682-11681-00	3 - 15	63V-15726-00	8 - 23	682-24566-01	6 - 11	63V-42615-00	1 - 2	63V-44125-00	13 - 26	63V-45315-A0	18 - 24
6E5-12411-20	2 - 23	63V-15734-00	8 - 22	6YJ-24610-01	20 - 2	6L2-42647-00	1 - 5	63V-44143-01	13 - 33		22 - 9
682-12413-00-1S	2 - 22	63V-15741-00	8 - 6	6L2-26301-00	12 - 22	6G1-42651-02	1 - 3	63V-44150-00	18 - 27	63V-45331-00-5B	18 - 21
682-12414-A1	2 - 25	63V-15744-00	8 - 13	63V-41111-00-1S	2 - 12	63V-42677-30	1 - 10	63V-44150-10	18 - 27	683-45361-02-4D	18 - 41
	21 - 4	63V-15746-00	13 - 36	63V-41112-A0	2 - 13	63V-42678-20	1 - 11	6E0-44191-11	12 - 27	63V-45375-00	19 - 14
63V-13610-00	4 - 1	6L2-15747-00	13 - 41			63V-42678-20	1 - 11	688-44194-00	13 - 11	63V-45510-01	18 - 28
63V-13610-10	4 - 1	63V-15748-00	8 - 21	63V-41113-00-1S	2 - 14	63W-42678-20	1 - 11	689-44194-00	13 - 2	63V-45510-11	18 - 28
63V-13610-00	4 - 1	63V-15753-00	8 - 8	65F-41131-00-5B	17 - 8	63V-42711-03-4D	11 - 1	63V-44301-00	18 - 11	63V-45536-00	18 - 4
63V-14126-00	5 - 5	6G1-15755-00	8 - 18	63V-41133-A1	17 - 10	63V-42716-02	11 - 19	63V-44322-00	18 - 12	63V-45551-00	18 - 29
	21 - 14	63V-15762-00	8 - 25			682-42724-00	11 - 2			6E7-45560-01	18 - 31
663-14159-00	5 - 21	63V-15764-00	8 - 15	63V-41135-00	17 - 9	682-42725-02	11 - 3	63V-44322-40	22 - 24	664-45567-01-10	18 - 8
	21 - 21	63V-15767-01	8 - 11			63V-42726-00	11 - 4	63V-44323-00	18 - 17	664-45567-01-12	18 - 8
676-14186-00	5 - 20	63V-15768-00	8 - 14	63V-41211-00	13 - 18	682-42727-00	11 - 5			664-45567-01-15	18 - 8
	21 - 20	63V-15770-00	13 - 43	63V-41223-00	13 - 16	63V-42731-00-4D	15 - 14			664-45567-01-18	18 - 8
63V-14301-00	5 - 1	6G1-15779-00	8 - 19	6H4-41237-00	13 - 13	6G1-42748-00	11 - 6	63V-44323-40	22 - 25	664-45567-01-30	18 - 8
6G1-14398-00	5 - 16	63V-15784-01	8 - 12	63V-41238-00	13 - 12	6E7-42791-00	11 - 22	63V-44328-00	18 - 20	664-45567-01-40	18 - 8

NUMERICAL INDEX

PARTNO.	REF. NO.	PARTNO.	REF. NO.	PARTNO.	REF. NO.	PARTNO.	REF. NO.	PARTNO.	REF. NO.	PARTNO.	REF. NO.
664-45567-01-50	18 - 8	90101-06M29	15 - 24	90206-12052	11 - 11	90465-08M61	10 - 5	92995-06600	16 - 27	93604-12M07	19 - 4
6E7-45571-00	18 - 32	90105-06M07	16 - 4	90206-15M18	12 - 26	90465-25M57	11 - 21		17 - 12	93606-12019	2 - 10
626-45577-00-01	18 - 33	90105-06M68	9 - 7	90206-36M21	12 - 3	90467-06016	2 - 7		18 - 48		17 - 4
626-45577-00-03	18 - 33	90105-06M69	9 - 9	90209-20M23	3 - 18	90467-08004	6 - 10	92995-08600	14 - 25	93700-06M03	16 - 1
626-45577-00-05	18 - 33	90105-07M05	2 - 21	90209-40008	16 - 7	90468-10005	13 - 15		17 - 7	94702-00217	2 - 28
6E8-45587-10-13	18 - 6	90109-06M84	15 - 50	90243-04M01	15 - 7	90468-18008	12 - 30		19 - 6	94702-00271	2 - 28
6E8-45587-10-20	18 - 6	90116-08M54	16 - 12	90250-05010	18 - 38		14 - 9	93101-13018	3 - 5	95380-03600	5 - 25
683-45611-00	18 - 35	90119-06M05	12 - 24	90266-04M04	1 - 4	90480-06M19	11 - 7		21 - 7	95380-05700	13 - 14
682-45631-00	18 - 37	90119-06M94	4 - 13		1 - 6	90480-10M16	13 - 44	93101-17054	18 - 44	95380-06600	13 - 9
648-45633-00	18 - 39	90119-08M07	2 - 11	90269-02M09	12 - 13	90480-12M25	4 - 11		22 - 11		14 - 7
650-45635-00	18 - 36	90149-05M13	12 - 15	90280-05013	9 - 10	90480-15M31	11 - 18	93101-20048	18 - 23	95380-06700	11 - 14
683-45941-00-EL	19 - 19	90152-05M04	19 - 9	90340-08M04	18 - 9	90480-25161	10 - 9		22 - 8		13 - 34
683-45943-00-EL	19 - 19	90157-05014	15 - 38	90381-14020	18 - 22	90501-10326	5 - 10	93101-25018	3 - 3		15 - 26
63V-45945-00-EL	19 - 19	90157-06M06	17 - 3	90386-07M95	15 - 34	90501-12M16	13 - 10		21 - 6	95380-08600	6 - 8
683-45945-00-EL	19 - 19	90159-05M25	13 - 25	90386-08032	12 - 18	90501-14M06	18 - 40	93102-25M48	3 - 4		16 - 15
683-45947-00-EL	19 - 19		13 - 27	90386-10009	14 - 22	90501-23215	12 - 17		21 - 8	95780-06300	15 - 20
683-45949-00-EL	19 - 19		13 - 32	90386-10025	14 - 12	90507-20M00	15 - 36	93110-23M00	3 - 27	95780-08300	14 - 19
683-45952-00-EL	19 - 19		14 - 21	90386-12M45	11 - 10	90508-08M39	13 - 38		21 - 9	95895-06030	19 - 12
6E7-45986-00	19 - 21	90163-06002	1 - 8	90386-22M69	15 - 13	90508-16M37	13 - 21	93210-06ME6	18 - 25	95895-06065	13 - 4
6E7-45987-01	19 - 15	90164-05M03	4 - 21	90386-22M94	15 - 12	90508-18M41	15 - 41		22 - 10	97013-06010	6 - 12
663-48344-00	14 - 8	90170-06015	13 - 35	90386-30M60	16 - 11	90508-20M38	13 - 22	93210-08287	7 - 7	97013-06020	2 - 26
63V-48501-00	14 - 1	90170-12066	9 - 11	90386-30048	16 - 9	91490-16010	12 - 10		7 - 9	97013-06030	2 - 17
63V-48511-01	14 - 23	90171-10M01	19 - 17	90386-33M96	12 - 5	91490-16018	8 - 24		20 - 14	97075-06055	16 - 24
63V-48531-00	14 - 2	90171-10M07	19 - 22	90386-34M97	12 - 2	91490-20010	14 - 17		20 - 16	97075-06075	16 - 26
63V-48534-00	14 - 18	90179-06M28	16 - 28	90387-06M05	8 - 4	91490-30020	19 - 18	93210-20M65	15 - 16	97075-08030	19 - 5
682-48538-50	14 - 3	90179-08M06	18 - 30	90387-06M06	13 - 37	91609-20008	3 - 19	93210-29M94	16 - 10	97075-08035	14 - 24
63V-48544-00	14 - 20	90185-05002	19 - 10	90387-06M13	15 - 23	91690-20010	4 - 6	93210-32738	6 - 7	97080-08025	18 - 26
63V-82127-00	16 - 5	90185-08057	14 - 26	90387-06M15	4 - 10	91690-30012	14 - 4	93210-35M86	4 - 12	97080-08045	18 - 19
66M-82148-00	15 - 3	90185-22043	15 - 22	90387-06M24	9 - 8	92903-06600	2 - 18	93210-44398	18 - 16		22 - 18
6E3-82370-21	10 - 10	90201-04M06	14 - 16	90387-06M50	13 - 3		2 - 27		22 - 6	97095-06012	10 - 12
663-82370-01	10 - 10	90201-05M09	4 - 20	90387-06M53	9 - 6	92903-10600	12 - 16	93210-46M16	3 - 2		10 - 15
63V-82377-50	15 - 51	90201-06068	11 - 12	90387-06M75	15 - 17	92990-06300	19 - 13		21 - 5		13 - 5
662-82519-00	10 - 14	90201-08M12	14 - 10	90387-06M86	12 - 25	92995-06600	3 - 7	93210-56M80	18 - 46		13 - 28
682-82556-00	12 - 32	90201-10M01	19 - 16	90387-06034	11 - 17		4 - 4		22 - 13	97095-06016	3 - 6
689-8257Y-00	12 - 33	90201-10M02	14 - 14	90387-07M07	15 - 33		6 - 3	93210-57M09	18 - 45		14 - 5
65W-82575-01	12 - 31		19 - 23	90387-16002	16 - 16		8 - 27		22 - 12	97095-06018	10 - 7
6A1-83625-41	8 - 28	90201-12472	9 - 12	90430-08020	18 - 10		10 - 3	93306-00501	18 - 42		16 - 19
6A1-83625-51	8 - 29	90201-14377	3 - 25		22 - 5		10 - 8	93306-205U7	3 - 13	97095-06020	4 - 3
6E0-83627-41	12 - 34	90201-16M03	2 - 24	90445-07M08	2 - 5		10 - 13	93310-620V5	3 - 17		6 - 2
6E0-83627-51	12 - 35	90201-17682	18 - 34		2 - 6		10 - 16	93315-314V8	18 - 3		8 - 26
682-84381-00	10 - 17	90201-46M29	3 - 29	90445-09M00	6 - 9		11 - 16	93315-317U2	18 - 43		10 - 2
63V-85520-00	9 - 3		21 - 11	90445-09105	2 - 16		13 - 6	93332-00005	18 - 7		12 - 7
63V-85533-00	9 - 4	90202-06009	12 - 29	90445-11M05	7 - 4		13 - 29	93341-41414	18 - 5		13 - 39
63V-85540-01	10 - 1	90202-07M60	15 - 32		20 - 11		13 - 40	93430-04M03	15 - 44		17 - 11
63V-85550-00	9 - 1	90202-22M54	15 - 11	90445-11M06	7 - 2		14 - 6	93440-52009	3 - 20		18 - 47
63V-85550-10	9 - 1	90202-36M55	12 - 4		20 - 9		15 - 25	93450-15023	3 - 26	97095-06025	11 - 13
63V-85570-00	10 - 6	90206-08010	15 - 18	90464-08M02	10 - 11		16 - 20	93602-14104	3 - 24		11 - 15
63V-85580-00	9 - 2	90206-10M04	14 - 13	90464-15M11	10 - 4		16 - 25	93604-12M07	18 - 18	97095-08030	17 - 6

NUMERICAL INDEX

PART NO.	REF. NO.	PART NO.	REF. NO.	PART NO.	REF. NO.	PART NO.	REF. NO.	PART NO.	REF. NO.	PART NO.	REF. NO.
97803-04010	5 - 6										
97885-05012	12 - 21										
97885-06008	15 - 4										
97885-06025	15 - 19										
97885-06030	13 - 8										
97885-08010	15 - 5										
97980-04114	5 - 15										
	21 - 16										
97980-04125	5 - 26										
98580-04006	5 - 33										
98580-04008	5 - 23										
98586-05016	20 - 4										
98780-05015	2 - 9										
98980-03006	5 - 24										
99080-05600	15 - 39										
	15 - 46										

9.9MHA/15MHA/9.9FMH/15FMH
PARTS CATALOGUE

©2001 by Yamaha Motor Co., Ltd.
1st Edition, May 2001

All rights reserved.

Any reprinting or unauthorized use
without the written permission of
Yamaha Motor Co., Ltd.
is expressly prohibited.

G7