



**PARTS
CATALOGUE
CATÁLOGO
DE PEÇAS**

15FMH '07 (65D6)

15FMH '08 (65D7)

15FMH '07/15FMH '08
PARTS CATALOGUE
©2007 by Yamaha Motor Co., Ltd.
1st edition, September 2007
All rights reserved.
Any reprinting or unauthorized use
without the written permission of
Yamaha Motor Co., Ltd.
is expressly prohibited.

15FMH '07/15FMH '08
CATÁLOGO DE PEÇAS
©2007, Yamaha Motor Co., Ltd.
1ª edição, Setembro 2007
Todos os direitos reservados.
É proibida expressamente toda e qualquer
reimpressão ou utilização sem a autorização
por escrita da
Yamaha Motor Co., Ltd.

FOREWORD

This Parts Catalogue is related to the parts for the model(s) on the cover page. When you are ordering replacement parts, please refer to this Parts Catalogue and quote both part numbers and part names correctly.

1. Modifications or additions which have been made after the issue of the Parts Catalogue will be announced in the Parts News.
It is advisable that you make the necessary corrections to the Parts Catalogue according to the Parts News.

2. Abbreviations
The following abbreviations are used in this Parts Catalogue.

“UR” Use specified parts number.
 “UN” Use as many as needed.
 “AP” Alternate Parts
 “LM” Locally Made (Parts need to be ordered locally)
 “F#” Frame No. (Applicable machine No.)
 “O/S” Over Size

3. The number of components for assembly
 - Parts, which are to be supplied in an assembly, are listed with a dot (.) in front of the part name as shown below.
 - The numeral appearing to the right of each component part indicates the quantity of parts for each assembly unit.

PART NO.	DESCRIPTION	Q'TY	REMARKS
2F5-83310-60	FRONT FLASHER LIGHT ASSY	2	
115-83311-60	.BULB (6V-18W)	1	

4. Applicable colours of graphics are represented in the “REMARKS” as shown below.

PART NO.	DESCRIPTION	Q'TY	REMARKS
2N4-24110-00-X5	FUEL TANK COMP.	2	MXR
3J1-24240-10	.GRAPHIC, FUEL TANK	1	FOR MXR

5. Note that the illustrations for reference in finding parts numbers are not to be used for assembling. When assembling, please use the applicable service manual.

6. The asterisk (*) before a reference number indicates modified items after the first edition.
7. Applicable Serial No.

Engine Serial No.

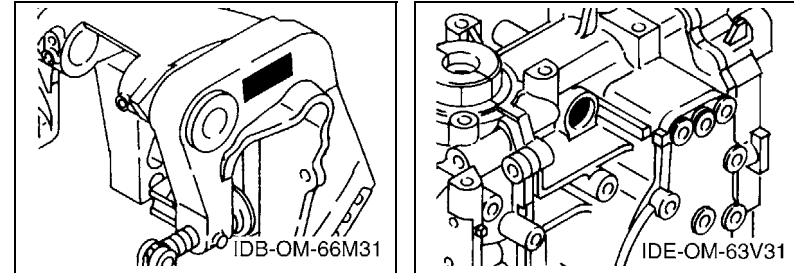

8. Applicable Engine Starting Serial No.

Model	Serial No.	Model	Serial No.
15F '07	65D-1030551	15F '08	65D-1036051

9. Applicable Colour Code

Abbreviation	Colour Name	Colour Code
DBNM2	DARK BLUISH GRAY METALLIC 2	004D

10. Quantity Column Information

Column No.	Name Of Q'ty Column	Applicable Model
1	65D6	15FMH '07
2	65D7	15FMH '08

PREFÁCIO

Este Catálogo de Peças se refere as Peças dos modelos relacionados na capa. Quando for solicitar peças de reposição para estes Modelos, recorra a este Catálogo de Peças e especifique corretamente os códigos e Nomes das Peças.

1. As Modificações ou adições que tenham sido efetuadas após a publicação deste Catálogo de Peças, serão comunicadas a Rede de Concessionárias através das informações de Modificação de Peças (Parts News).

2. Abreviaturas
Seguem abaixo as abreviaturas utilizadas neste Catálogo de Peças:

“UR” Uso Restrito para o Código da Peça

“UN” Uso Necessário

“AP” Peça Alternativa

“LM” Fabricação Local (A peça pode ser pedida localmente)

“F#” No. de Série do Chassi (Aplicação do Número de Série)

“O/S” Tamanho Maior

3. Peças componentes de conjuntos

- As peças que são fornecidas dentro de conjuntos estão listadas com um ponto de identificação (.) como segue abaixo.
- O número que aparece a direita da descrição da Peça indica o número de Peças usado em cada Conjunto Individual.

No. PEÇA	DESCRIÇÃO	QTDE	OBSERVAÇÕES
2F5-83310-60	PISCA DIANTEIRO CONJ.	2	
115-83311-60	.LÂMPADA (6V-18W)	1	

4. Os gráficos que são Aplicados em Peças Coloridas estão representados na coluna “OBSERVAÇÕES”, como segue abaixo.

No. PEÇA	DESCRIÇÃO	QTDE	OBSERVAÇÕES
2N4-24110-00-X5	TANQUE DE COMBUSTÍVEL COMPL.	2	MXR
3J1-24240-10	.GRÁFICO, TANQUE DE COMB.	1	PARA MXR

5. Observe que as ilustrações são referentes apenas a indicação dos códigos das peças, e não para montagem. Para montagem, por favor utilize o Manual de Montagem apropriado.

6. O asterisco (*) antes do Número de referência da peça indica a modificação ocorrida após a primeira edição.

7. Aplicação do Número de Série

No. de Série do Motor

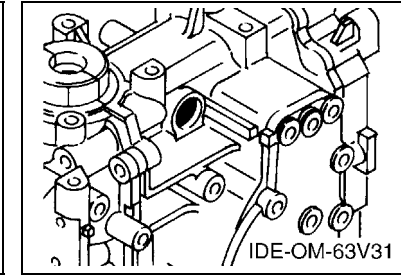
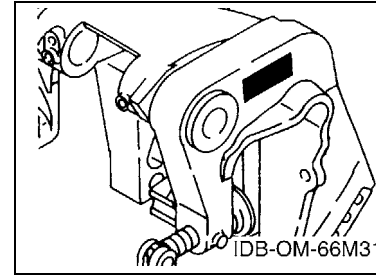

8. Aplicação do No. de Série Inicial

Modelo	No. Série	Modelo	No. Série
15F '07	65D-1030551	15F '08	65D-1036051

9. Aplicação do Código de Cor

Abreviação	Nome da Cor	Código da Cor
DBNM2	DARK BLUISH GRAY METALLIC 2	004D

10. Informação na Coluna de Quantidade

No. da Coluna	Nome na Coluna de Qtde	Modelo Aplicável
1	65D6	15FMH '07
2	65D7	15FMH '08

CONTENTS

TOP COWLING	1
CYLINDER & CRANKCASE	2
CRANKSHAFT & PISTON	3
INTAKE	5
CARBURETOR	6
FUEL	8
STARTER	9
GENERATOR	11
ELECTRICAL	12
BOTTOM COWLING	13
STEERING	14
CONTROL	16
BRACKET 1	18
BRACKET 2	20
UPPER CASING	22
LOWER CASING & DRIVE 1	23
LOWER CASING & DRIVE 2	26
FUEL TANK	28
REPAIR KIT 1	29
REPAIR KIT 2	30

INDEX

NUMERICAL INDEX	31
-----------------------	----

ÍNDICE GERAL

CAPO SUPERIOR	1
CILINDRO E CARCACA DO MOTOR	2
VIRABREQUIM E PISTAO	3
ADMISSAO	5
CARBURADOR	6
COMBUSTIVEL	8
PARTIDA	9
GERADOR	11
ELETRICO	12
BANDEJA DO CAPO	13
DIRECAO	14
CONTROLE	16
SUPORTE 1	18
SUPORTE 2	20
CAPA INFERIOR	22
CARCACA INF. E TRANSMISSAO 1	23
CARCACA INF. E TRANSMISSAO 2	26
TANQUE DE COMBUSTIVEL	28
KIT DE REPARO 1	29
KIT DE REPARO 2	30

ÍNDICE GERAL

ÍNDICE NUMÉRICO	31
-----------------------	----

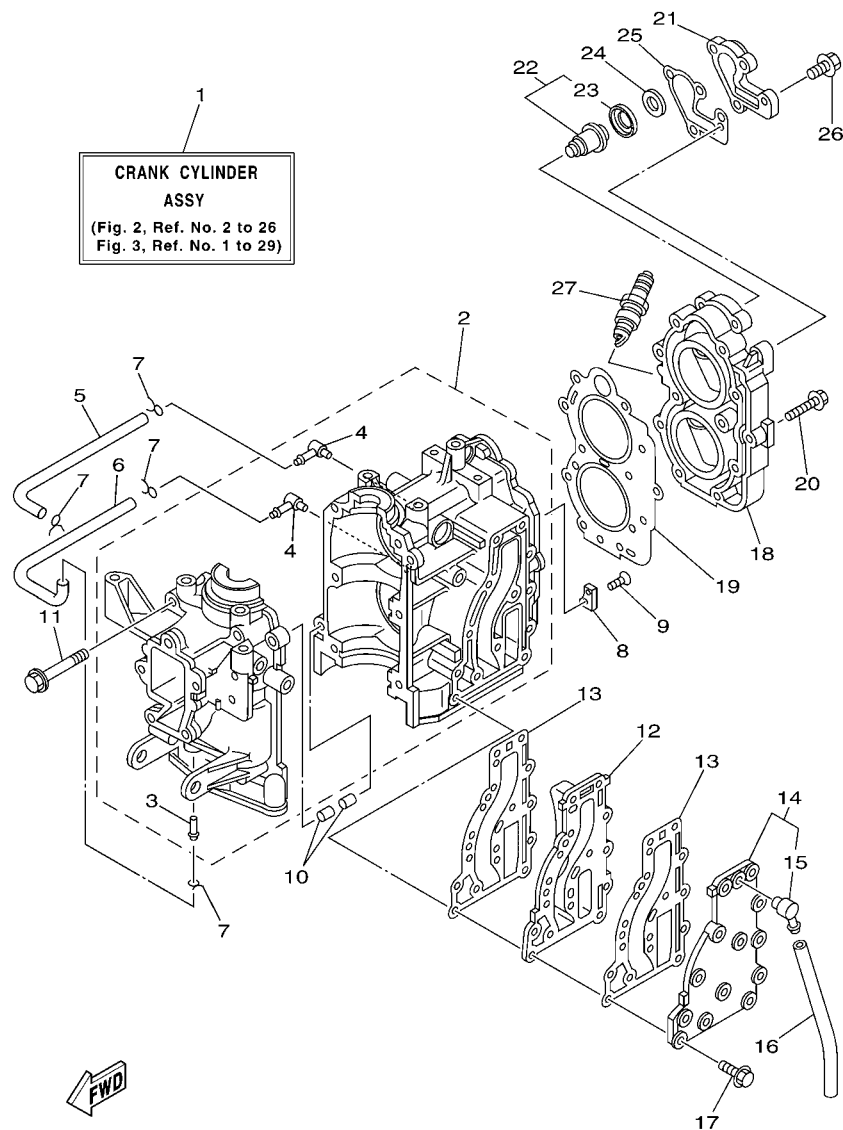

63V5200-E020

FIG. 2 CYLINDER & CRANKCASE CILINDRO E CARCACA DO MOTOR

REF. NO.	PART NO. No. PEÇA	DESCRIPTION DESCRIÇÃO	65D6	65D7	REMARKS OBSERVAÇÕES
1	63V-W0090-03-1S	CRANK CYLINDER ASSY CARCACA DO CILINDRO CONJ.	1	1	
2	63V-15100-02-1S	CRANKCASE ASSY CARCACA DO MOTOR COMPLETA	1	1	
3	624-14485-00	.PIPE, JOINT .TUBO DE JUNCAO	1	1	
4	650-14485-03	.PIPE, JOINT .TUBO DE JUNCAO	2	2	
5	90445-07M08	HOSE (L220) TUBO (L220)	1	1	
6	90445-07M08	HOSE (L220) TUBO (L220)	1	1	
7	90467-06016	CLIP PRESILHA	4	4	
8	682-11325-00	ANODE ANODO	1	1	
9	98780-05015	SCREW, FLAT HEAD PARAFUSO CABECA PLANA	1	1	
10	93606-12019	PIN, DOWEL PINO GUIA	2	2	
11	90119-08M07	BOLT, WITH WASHER PARAFUSO COM ARRUELA	6	6	
12	63V-41111-00-1S	INNER COVER, EXHAUST TAMPA INTERNA DO ESCAPE	1	1	
13	63V-41112-A0	GASKET, EXHAUST INNER COVER GAXETA TAMPA INTERNA DO ESCAPE	2	2	
14	63V-41113-00-1S	OUTER COVER, EXHAUST TAMPA EXTERNA DO ESCAPE	1	1	
15	676-11372-00	.NIPPLE, HOSE .JUNCAO DA MANGUEIRA	1	1	
16	90445-09104	HOSE (L300) TUBO (L300)	1	1	
17	90119-06MA4	BOLT, WITH WASHER PARAFUSO COM ARRUELA	13	13	
18	6E7-11111-01-1S	HEAD, CYLINDER 1 CABECOTE DO CILINDRO 1	1	1	
19	63V-11181-A1	GASKET, CYLINDER HEAD 1 GAXETA CABECOTE DO CILINDRO 1	1	1	
20	90105-07M05	BOLT, FLANGE PARAFUSO FLANGE	11	11	
21	682-12413-00-1S	COVER, THERMOSTAT TAMPA DO TERMOSTATO	1	1	
22	6E5-12411-30	THERMOSTAT TERMOSTATO	1	1	
23	688-12412-00	.SEAL, THERMOSTAT .VEDACAO DO TERMOSTATO	1	1	
24	90201-16M03	WASHER, PLATE ARRUELA PLANA	1	1	
25	682-12414-A1	GASKET, COVER GAXETA DA TAMPA	1	1	
26	90119-06MA2	BOLT, WITH WASHER PARAFUSO COM ARRUELA	4	4	
27	94702-00217	PLUG, SPARK (NGK B7HS-10) VELA DE IGNICAO (NGK B7HS-10)	2	2	

FIG. 3 CRANKSHAFT & PISTON

VIRABREQUIM E PISTAO

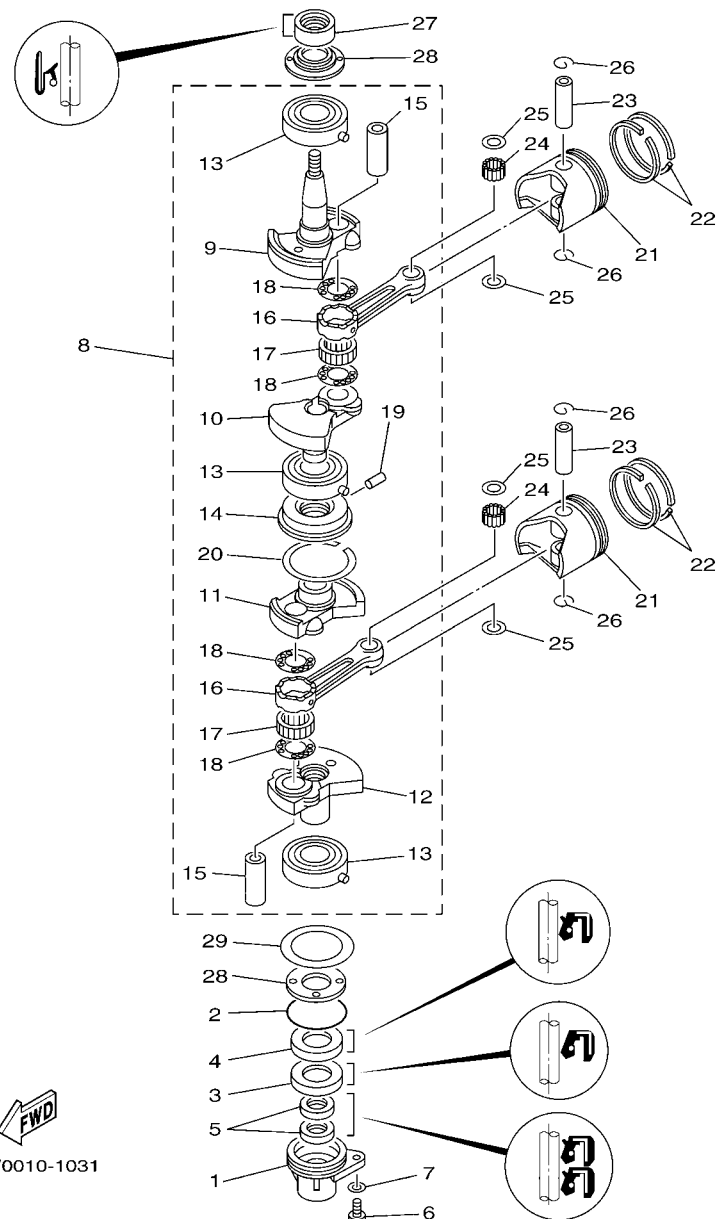

63V0010-1031

REF. NO.	PART NO. No. PEÇA	DESCRIPTION DESCRIÇÃO	65D6	65D7	REMARKS OBSERVAÇÕES
1	63V-15396-01-94	HOUSING, OIL SEAL CAIXA DO RETENTOR DE OLEO	1	1	
2	93210-46M16	O-RING ANEL DE BORRACHA	1	1	
3	93101-25018	OIL SEAL RETENTOR DE OLEO	1	1	
4	93102-25M48	OIL SEAL RETENTOR DE OLEO	1	1	
5	93101-13018	OIL SEAL RETENTOR DE OLEO	2	2	
6	97095-06016	BOLT PARAFUSO	1	1	
7	92995-06600	WASHER ARRUELA	1	1	
8	63V-11400-01	CRANKSHAFT ASSY VIRABREQUIM CONJ.	1	1	
9	63V-11412-00	.CRANK 1 .VIRABREQUIM 1	1	1	
10	63V-11422-00	.CRANK 2 .VIRABREQUIM 2	1	1	
11	63V-11432-00	.CRANK 3 .VIRABREQUIM 3	1	1	
12	63V-11442-00	.CRANK 4 .VIRABREQUIM 4	1	1	
13	93306-205U7	.BEARING .ROLAMENTO	3	3	
14	63V-11515-02	.SEAL, LABYRINTH 1 .VEDACAO DO LABIRINTO 1	1	1	
15	682-11681-00	.PIN, CRANK 1 .PINO DO VIRABREQUIM 1	2	2	
16	650-11651-04	.ROD, CONNECTING .BIELA	2	2	
17	93310-620V5	.BEARING .ROLAMENTO	2	2	
18	90209-20M23	.WASHER .ARRUELA	4	4	
19	91609-20008	.PIN, SPRING .PINO MOLA	1	1	
20	93440-52009	.CIRCLIP .ANEL TRAVA	1	1	
21	6E7-11631-00-97	PISTON (STD) PISTAO (STD)	2	2	
	6E7-11635-00	PISTON (0.25MM O/S) PISTAO (0.25MM O/S)	2	2	AP AP
	6E7-11636-00	PISTON (0.50MM O/S) PISTAO (0.50MM O/S)	2	2	AP AP
22	682-11610-01	PISTON RING SET (STD) JG ANEIS DO PISTAO (STD)	2	2	
	682-11610-11	PISTON RING SET (0.25MM O/S) JG ANEIS DO PISTAO (0.25MM O/S)	2	2	AP AP
	682-11610-21	PISTON RING SET (0.50MM O/S) JG ANEIS DO PISTAO (0.50MM O/S)	2	2	AP AP
23	634-11633-00	PIN, PISTON PINO DO PISTAO	2	2	

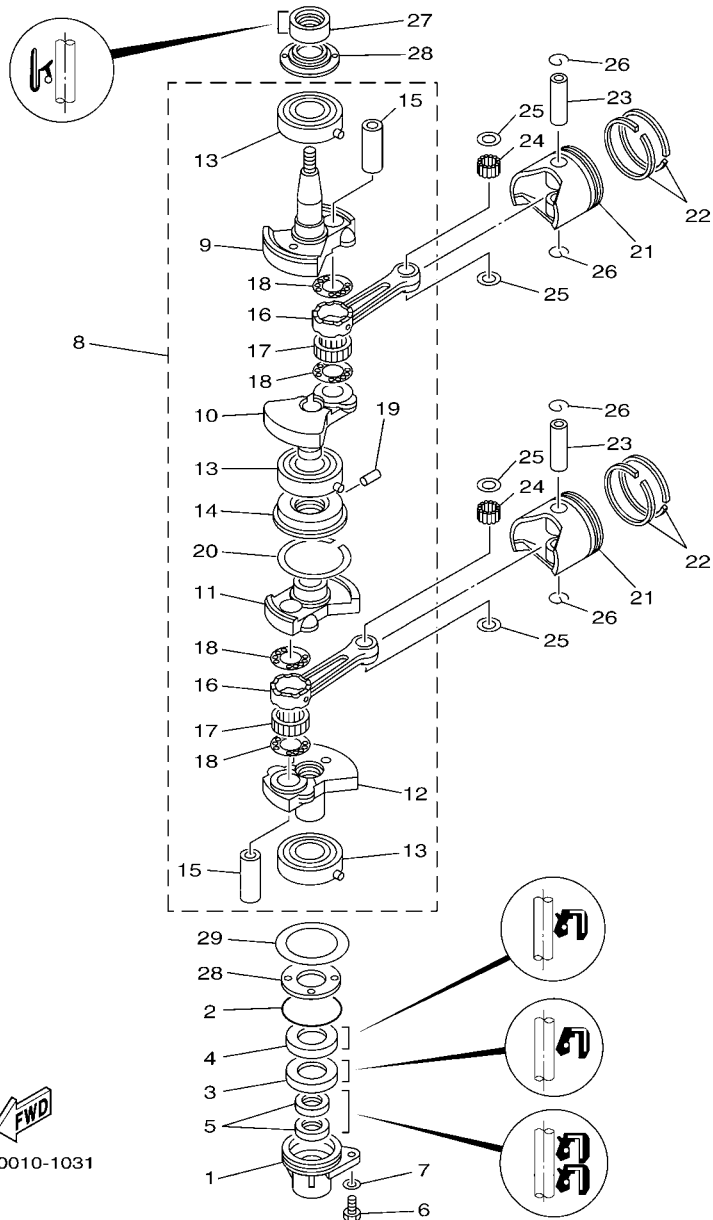
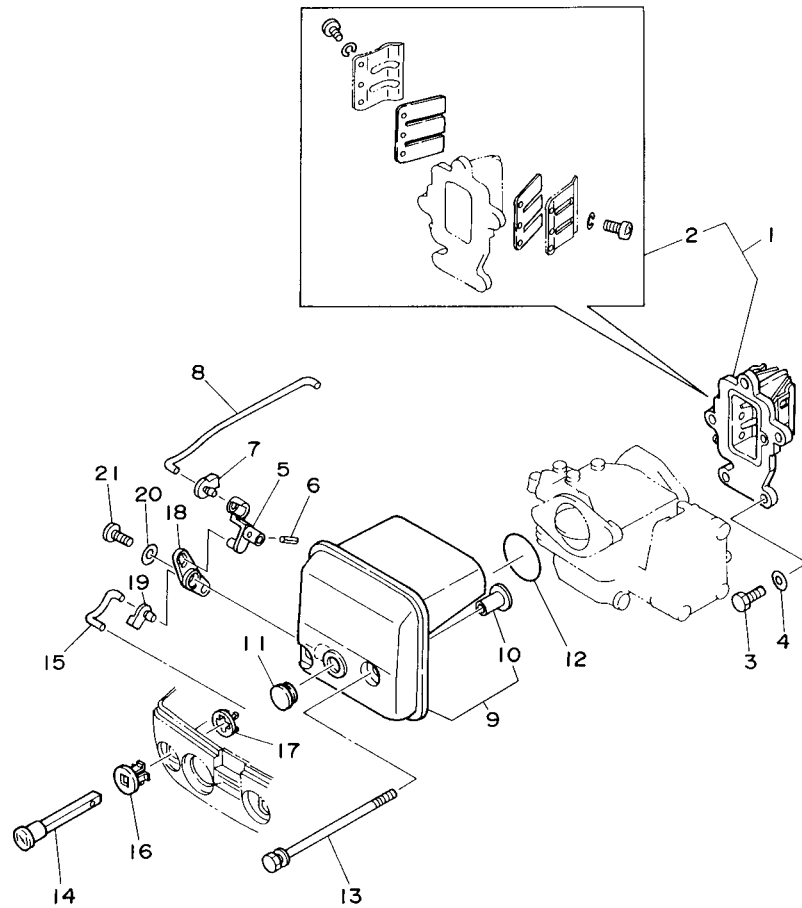

FIG. 3 CRANKSHAFT & PISTAO

VIRABREQUIM E PISTAO

REF. NO.	PART NO. No. PEÇA	DESCRIPTION DESCRIÇÃO	65D6	65D7	REMARKS OBSERVAÇÕES
24	93602-14104	PIN, DOWEL PINO GUIA	50	50	
25	90201-14377	WASHER, PLATE ARRUELA PLANA	4	4	
26	93450-15023	CIRCLIP ANEL TRAVA	4	4	
27	93110-23M00	OIL SEAL RETENTOR DE OLEO	1	1	
28	63V-11445-00	SPACER ESPACADOR	2	2	
29	90201-46M29	WASHER, PLATE ARRUELA PLANA	1	1	





 63V0010-5041

FIG. 4 INTAKE

ADMISSAO

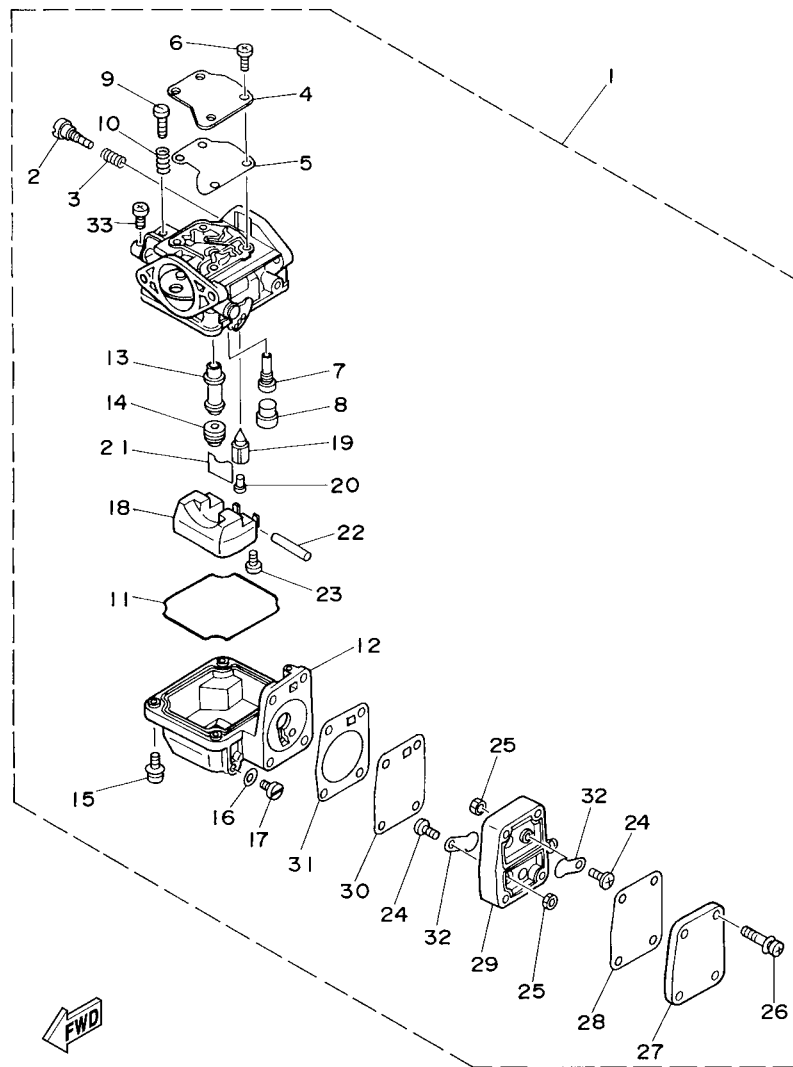
REF. NO.	PART NO. No. PEÇA	DESCRIPTION DESCRIÇÃO	65D6	65D7	REMARKS OBSERVAÇÕES
1	63W-13610-00	REED VALVE ASSY VALVULA DA PALHETA COMP.	1	1	
2	682-W0004-00	.REED SET .JOGO DE VALVULAS DA PALHETA	1	1	
3	97095-06020	BOLT PARAFUSO	3	3	
4	92995-06600	WASHER ARRUELA	3	3	
5	63V-41253-00	LEVER, CHOKE ALAVANCA DO AFOGADOR	1	1	
6	91690-20010	PIN, SPRING PINO MOLA	1	1	
7	63V-41262-00	JOINT, CHOKE LEVER JUNCAO DA ALAVANCA DO AFOGADOR	1	1	
8	63V-41257-00	ROD, CHOKE 2 HASTE DO AFOGADOR 2	1	1	
9	63V-14440-00	SILENCER ASSY, INTAKE SILENCIADOR DA ADMISSAO CONJ.	1	1	
10	90387-06M15	.COLLAR .ESPACADOR	2	2	
11	90480-12M25	GROMMET ILHO DE BORRACHA	1	1	
12	93210-35M86	O-RING ANEL DE BORRACHA	1	1	
13	90119-06M94	BOLT, WITH WASHER PARAFUSO COM ARRUELA	2	2	
14	6H4-41271-01	KNOB, CHOKE BOTAO DO AFOGADOR	1	1	
15	63V-41256-00	ROD, CHOKE 1 HASTE DO AFOGADOR 1	1	1	
16	689-41273-00	GROMMET ILHO	1	1	
17	6J8-41274-00	GROMMET 2 ILHO 2	1	1	
18	63V-41252-00	LEVER, CHOKE 1 ALAVANCA DO AFOGADOR 1	1	1	
19	661-41262-02	JOINT, CHOKE LEVER JUNCAO DA ALAVANCA DO AFOGADOR	1	1	
20	90201-05M09	WASHER, PLATE ARRUELA PLANA	1	1	
21	90164-05M03	SCREW, TAPPING PARAFUSO	1	1	



63V0010-5050

FIG. 5 CARBURETOR

CARBURADOR

REF. NO.	PART NO. No. PEÇA	DESCRIPTION DESCRIÇÃO	65D6	65D7	REMARKS OBSERVAÇÕES
1	65D-14301-01	CARBURETOR ASSY 1 CARBURADOR COMPLETO 1	1	1	
2	679-14923-00	.SCREW, PILOT .PARAFUSO PILOTO	1	1	
3	679-14555-00	.SPRING .MOLA	1	1	
4	63V-14527-00	.PLATE .PLACA	1	1	
5	63V-14126-00	.GASKET .GAXETA	1	1	
6	97803-04010	.SCREW, PAN HEAD .PARAFUSO	4	4	
7	63V-14948-08	.JET (#52) .GICLEUR (#52)	1	1	
8	679-14966-00	.RUBBER CAP .ALAVANCA DE PARTIDA	1	1	
9	63V-14523-00	.SCREW, STOP .PARAFUSO DE PARADA	1	1	
10	90501-10326	.SPRING, COMPRESSION .MOLA DE COMPRESSAO	1	1	
11	63V-14984-00	.GASKET, FLOAT CHAMBER .GAXETA DA CAMARA DA BOIA.	1	1	
12	63V-14980-00	.BODY, FLOAT CHAMBER .CORPO DA CAMARA DA BOIA	1	1	
13	63V-14947-00	.JET, NEEDLE .GICLEUR DA AGULHA	1	1	
14	676-14943-81	.JET, MAIN (#118) .GICLEUR PRINCIPAL (#118)	1	1	
15	97980-04114	.SCREW, WITH WASHER .PARAFUSO	4	4	
16	65W-14398-00	.GASKET .GAXETA	1	1	
17	6G1-14992-00	.SCREW, DRAIN .HASTE	1	1	
18	63V-14985-00	.FLOAT .BOIA	1	1	
19	62D-14546-01	.VALVE, NEEDLE .VALVULA DA AGULHA	1	1	
20	676-14186-00	.PIN, FLOAT .PINO DA BOIA	1	1	
21	663-14159-00	.CLIP .PRESILHA	1	1	
22	6H4-14548-00	.PIN, FLOAT ARM .PINO DA BOIA	1	1	
23	98580-04008	.SCREW, PAN HEAD .PARAFUSO	1	1	
24	98980-03006	.SCREW, BIND .PARAFUSO	2	2	
25	95380-03600	.NUT .PORCA	2	2	
26	97980-04125	.SCREW, WITH WASHER .PARAFUSO	4	4	
27	6G1-24452-00	.COVER .TAMPA	1	1	

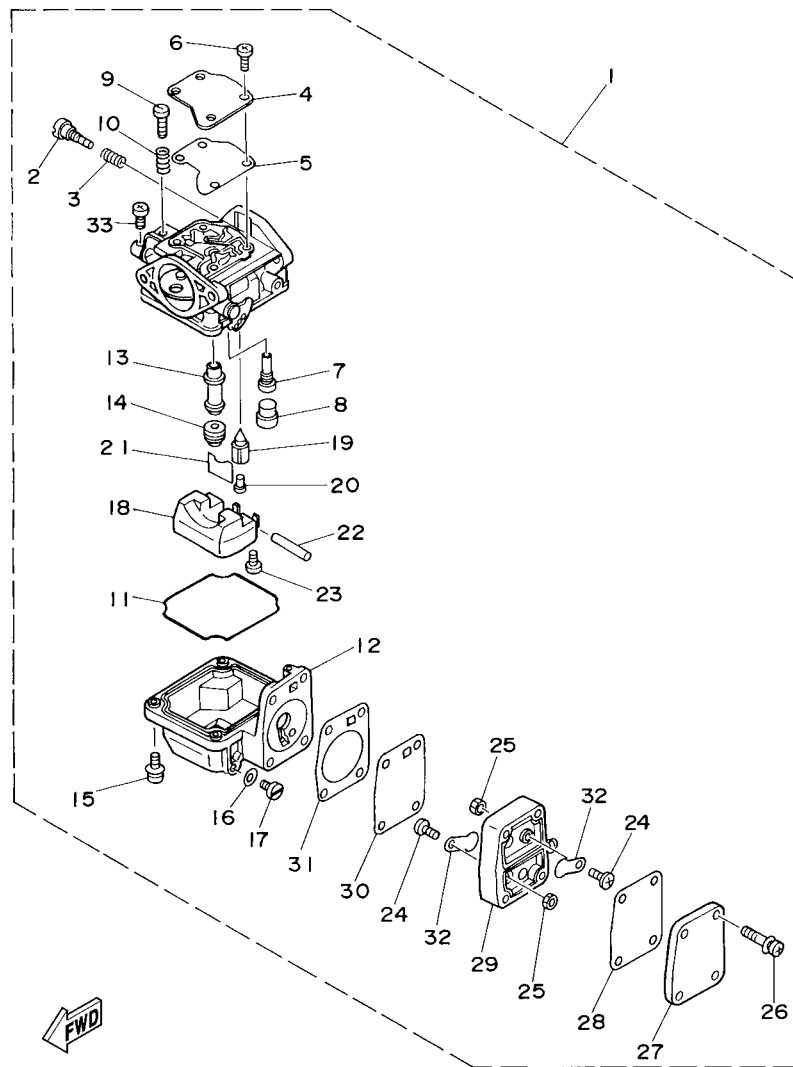

63V0010-5050



FIG. 5 CARBURETOR

CARBURADOR

REF. NO.	PART NO. No. PEÇA	DESCRIPTION DESCRIÇÃO	65D6	65D7	REMARKS OBSERVAÇÕES
28	63V-24411-00	.DIAPHRAGM .DIAFRAGMA	1	1	
29	6G1-24412-01	.BODY 1 .CARCACA 1	1	1	
30	6G1-24411-00	.DIAPHRAGM .DIAFRAGMA	1	1	
31	6G1-24431-01	.GASKET, FUEL PUMP 1 .GAXETA BOMBA DE COMBUSTIVEL 1	1	1	
32	6L5-24421-00	.VALVE, CHECK .VALVULA DA BOMBA	2	2	
33	98580-04006	.SCREW, PAN HEAD .PARAFUSO	1	1	

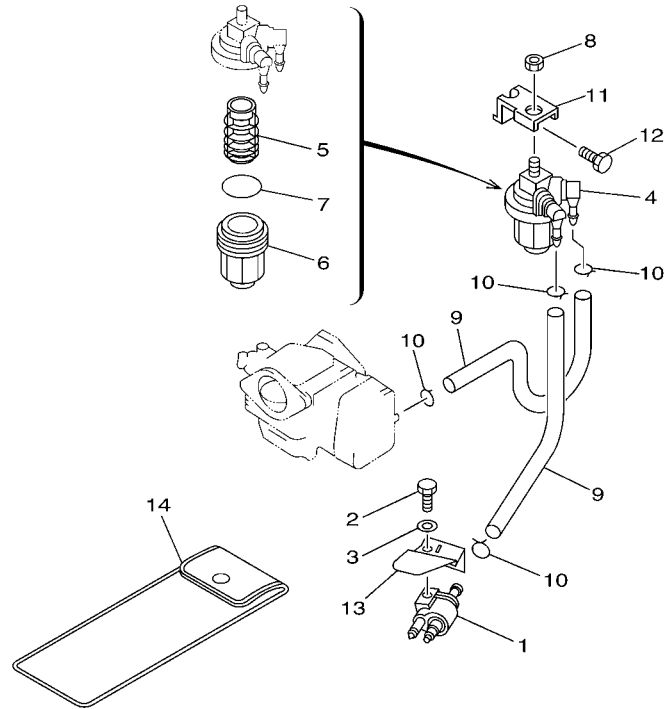
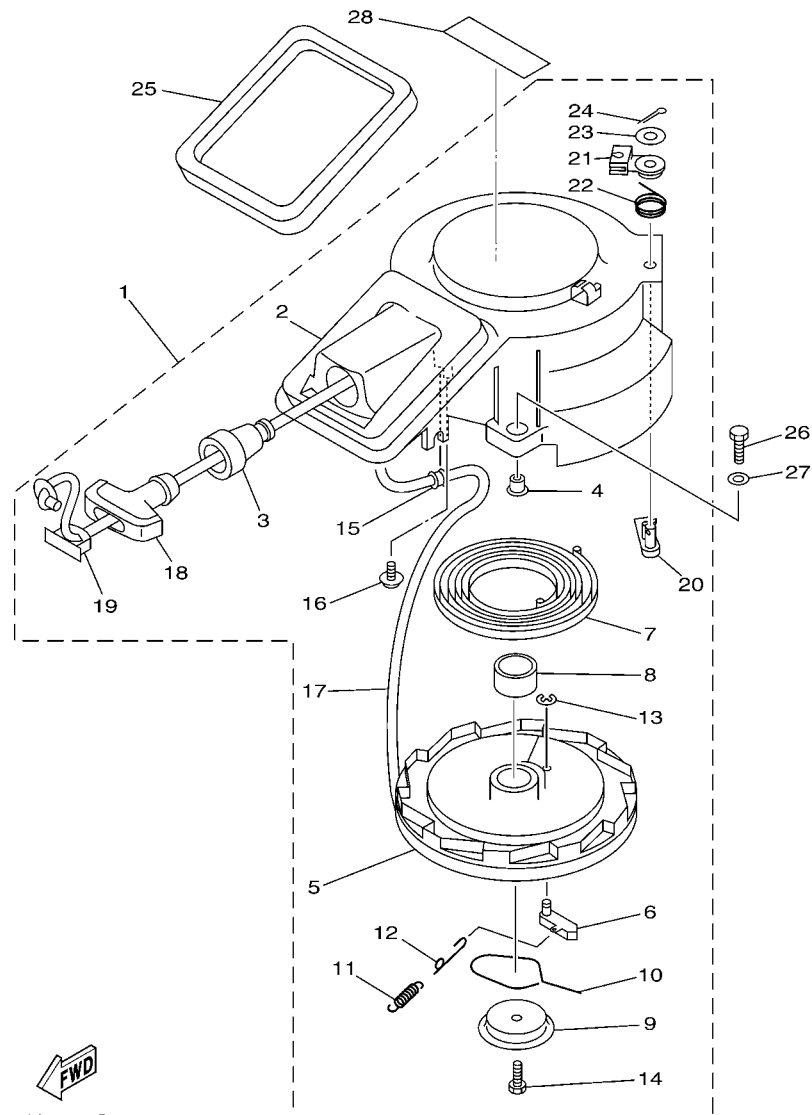

FIG. 6 FUEL

COMBUSTIVEL

REF. NO.	PART NO. No. PEÇA	DESCRIPTION DESCRIÇÃO	65D6	65D7	REMARKS OBSERVAÇÕES
1	6G1-24304-02	FUEL PIPE JOINT COMP. 1 JUNCAO TUBO DE COMBUSTIVEL 1	1	1	
2	97095-06020	BOLT PARAFUSO	1	1	
3	92995-06600	WASHER ARRUELA	1	1	
4	61N-24560-00	FILTER ASSY FILTRO DE COMBUSTIVEL CONJ.	1	1	
5	61N-24563-00	.ELEMENT, FILTER .ELEMENTO DO FILTRO	1	1	
6	61N-24521-00	.CUP, FILTER .COPO DO FILTRO	1	1	
7	93210-32738	.O-RING .ANEL DE BORRACHA	1	1	
8	95380-08600	NUT PORCA	1	1	
9	90445-09M00	HOSE (L180) TUBO (L180)	2	2	
10	90467-08004	CLIP PRESILHA	4	4	
11	682-24566-01	BRACKET, FILTER SUPORTE DO FILTRO	1	1	
12	97013-06010	BOLT PARAFUSO	1	1	
13	63V-24396-01	PLATE PLACA	1	1	
14	61J-F8100-01	TOOL KIT JOGO DE FERRAMENTAS	1	1	

65D7280-G060



63V3110-C080

*1: CUT FROM 50M ROLLS, PART NO.90890-44373, CUTTING LENGTH 1.8M

FIG. 7 STARTER

PARTIDA

REF. NO.	PART NO. No. PEÇA	DESCRIPTION DESCRIÇÃO	65D6	65D7	REMARKS OBSERVAÇÕES
1	63V-15710-12	STARTER ASSY PARTIDA COMPLETA	1	1	WITH SAFETY DEVICE WITH SAFETY DEVICE
2	63V-15711-01	.CASE, STARTER .CAIXA DA PARTIDA	1	1	
3	63V-15795-01	.GUIDE, ROPE .GUIA DO CABO	1	1	
4	90387-06M05	.COLLAR .ESPACADOR	3	3	
5	63V-15714-00	.DRUM, SHEAVE .TAMBOR DA ROLDANA	1	1	
6	63V-15741-00	.PAWL, DRIVE .LING?ETA MOTORA	1	1	
7	63V-15713-00	.SPRING, STARTER .MOLA DA PARTIDA	1	1	
8	63V-15753-00	.BUSH .BUCHA	1	1	
9	63V-15716-00	.PLATE, DRIVE .PLACA MOTORA	1	1	
10	63V-15705-01	.SPRING, DRIVE PAWL .MOLA ESPECIAL DA PARTIDA	1	1	
11	63V-15767-01	.SPRING .MOLA	1	1	
12	63V-15784-01	.SPRING, RETURN .MOLA DE RETORNO	1	1	
13	63V-15744-00	.CIRCLIP .ANEL TRAVA	1	1	
14	63V-15768-00	.BOLT .PARAFUSO	1	1	
15	63V-15764-00	.COLLAR 1 .ESPACADOR 1	1	1	
16	63V-15793-00	.SCREW .PARAFUSO	1	1	
17	*	.WIRE, STARTER (L:1800MM) .CABO DE PARTIDA (L:1800MM)	1	1	*1 *1
18	6G1-15755-00	.HANDLE, STARTER .MANOPLA DE PARTIDA	1	1	
19	6G1-15779-00	.COVER .TAMPA	1	1	
20	63V-15794-00	.STOPPER .BUJAO	1	1	
21	63V-15748-00	.PLUNGER, STARTER STOP .ACIONADOR DA PARTIDA	1	1	
22	63V-15734-00	.SPRING, RETURN .MOLA DE RETORNO	1	1	
23	63V-15726-00	.WASHER, FLAT .ARRUELA PLANA	1	1	
24	91490-16018	.PIN, COTTER .CUPILHA	1	1	
25	63V-15762-00	SEAL, RUBBER 2 VEDACAO DE BORRACHA 2	1	1	
26	97095-06020	BOLT PARAFUSO	3	3	
27	92995-06600	WASHER ARRUELA	3	3	

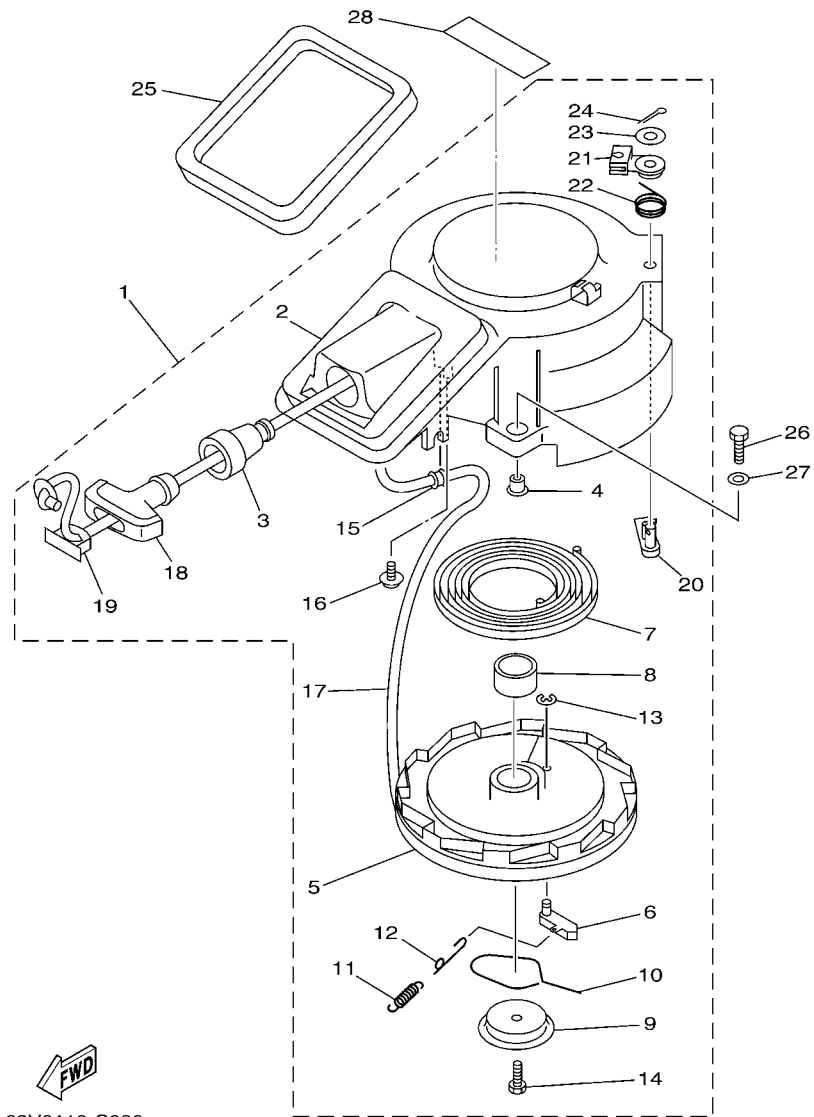

FWD
63V3110-C080

*1: CUT FROM 50M ROLLS, PART NO.90890-44373, CUTTING LENGTH 1.8M

FIG. 7 STARTER

PARTIDA

REF. NO.	PART NO. No. PEÇA	DESCRIPTION DESCRIÇÃO	65D6	65D7				REMARKS OBSERVAÇÕES
28	6A1-83625-41	MARK 5 EMBLEMA 5	1	1				

FIG. 9 ELECTRICAL

ELETRICO

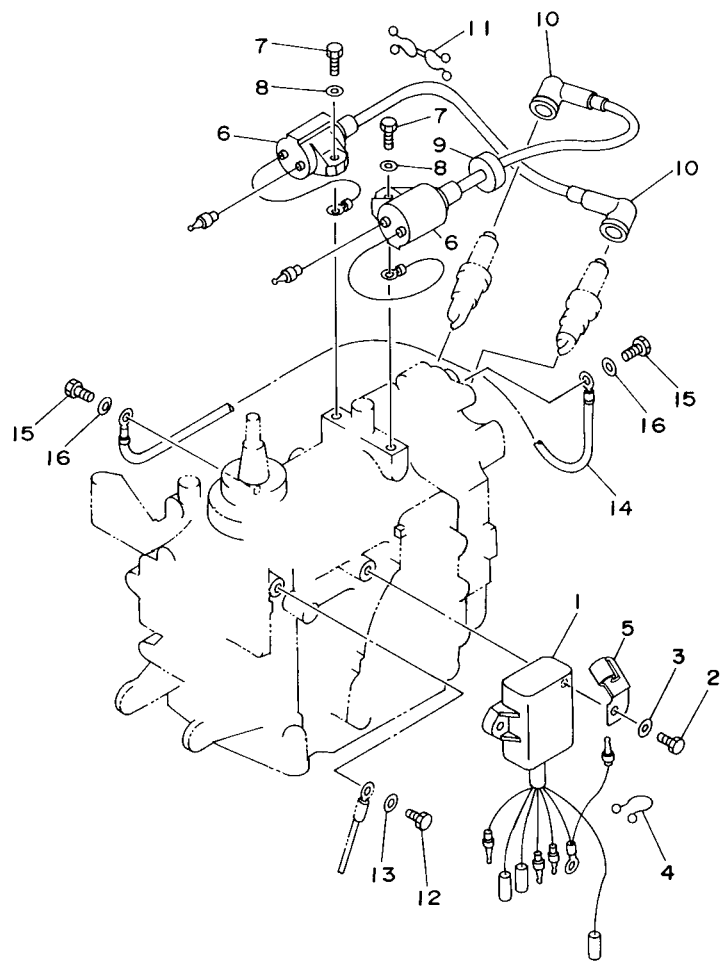

REF. NO.	PART NO. No. PEÇA	DESCRIPTION DESCRIÇÃO	65D6	65D7	REMARKS OBSERVAÇÕES
1	63V-85540-01	C.D.I. UNIT ASSY UNIDADE DE IGNICAO CONJ. (CDI)	1	1	
2	97095-06020	BOLT PARAFUSO	2	2	
3	92995-06600	WASHER ARRUELA	2	2	
4	90464-15M11	CLAMP BRACADEIRA	1	1	
5	90465-08M61	CLAMP BRACADEIRA	1	1	
6	63V-85570-00	IGNITION COIL ASSY BOBINA DE IGNICAO CONJ.	2	2	
7	97095-06018	BOLT PARAFUSO	2	2	
8	92995-06600	WASHER ARRUELA	2	2	
9	90480-25161	GROMMET ILHO DE BORRACHA	1	1	
10	663-82370-01	PLUG CAP ASSY CACHIMBO DA VELA CONJ.	2	2	
11	90464-08M02	CLAMP BRACADEIRA	1	1	
12	97095-06012	BOLT PARAFUSO	1	1	
13	92995-06600	WASHER ARRUELA	1	1	
14	662-82519-00	WIRE, EARTH LEAD FIO TERRA	1	1	
15	97095-06012	BOLT PARAFUSO	2	2	
16	92995-06600	WASHER ARRUELA	2	2	



63V0010-5090

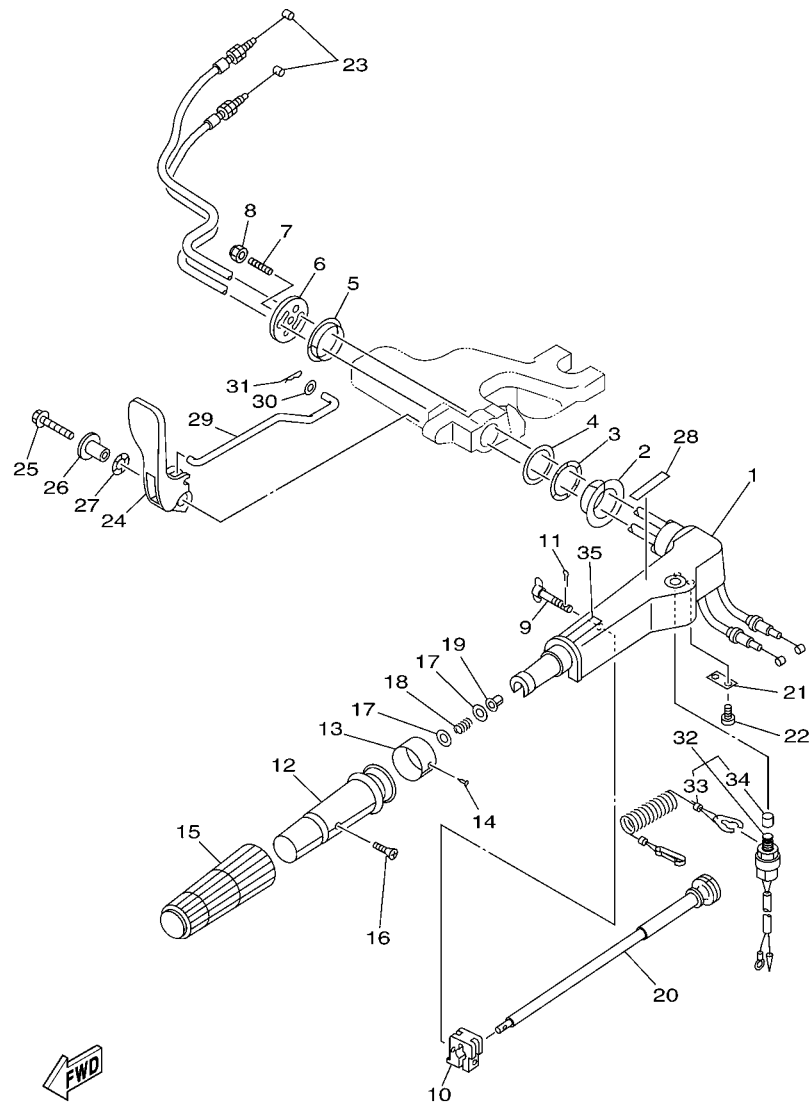

63V6110-F120

FIG. 11 STEERING

DIRECAO

REF. NO.	PART NO. No. PEÇA	DESCRIPTION DESCRIÇÃO	65D6	65D7	REMARKS OBSERVAÇÕES
1	63V-42111-01-4D	HANDLE, STEERING ALAVANCA DE DIRECIONAL	1	1	
2	90386-34M97	BUSH BUCHA	1	1	
3	90206-36M21	WASHER, WAVE ARRUELA ONDULADA	1	1	
4	90202-36M55	WASHER, PLATE ARRUELA PLANA	1	1	
5	90386-33M96	BUSH BUCHA	1	1	
6	6G1-42131-02	COVER, HANDLE STEERING TAMPA DA ALAVANCA DIRECIONAL	1	1	
7	90116-08016	BOLT, STUD PRISIONEIRO	1	1	
8	90185-08057	NUT, SELF-LOCKING PORCA AUTO-TRAVANTE	1	1	
9	6G1-42125-01	BOLT, FRICTION ADJUSTING PARAFUSO DE AJUSTE DA FRICCAO	1	1	
10	6G1-42126-00	FRICTION, STEERING HANDLE GRIP FRICCAO DIRECIONAL	1	1	
11	91490-16010	PIN, COTTER CUPILHA	1	1	
12	664-42119-00	GRIP, STEERING HANDLE MANOPLA DA ALAVANCA DIRECIONAL	1	1	
13	6H2-42137-00	INDICATOR, THROTTLE INDICADOR DE ACELERACAO	1	1	
14	90269-02M09	RIVET REBITE	1	1	
15	6G1-42177-00	RUBBER, HANDLE BORRACHA DO GUIDAO	1	1	
16	90149-05M13	SCREW PARAFUSO	1	1	
17	90201-10M02	WASHER, PLATE ARRUELA PLANA	2	2	
18	90501-23215	SPRING, COMPRESSION MOLA DE COMPRESSAO	1	1	
19	90386-08032	BUSH BUCHA	1	1	
20	6G1-42138-01	LEVER, THROTTLE ALAVANCA DE ACELERACAO	1	1	
21	6E0-42159-02	STAY FIXADOR	1	1	
22	97885-05012	SCREW, PAN HEAD PARAFUSO	2	2	
23	6L2-26301-01	THROTTLE CABLE ASSY CABO ACELERADOR CONJ.	2	2	
24	63V-44111-02	HANDLE, GEAR SHIFT ALAVANCA DE MUDANCA	1	1	
25	90119-06M05	BOLT, WITH WASHER PARAFUSO COM ARRUELA	1	1	
26	90387-06M86	COLLAR ESPACADOR	1	1	
27	90206-15M18	WASHER, WAVE ARRUELA ONDULADA	1	1	

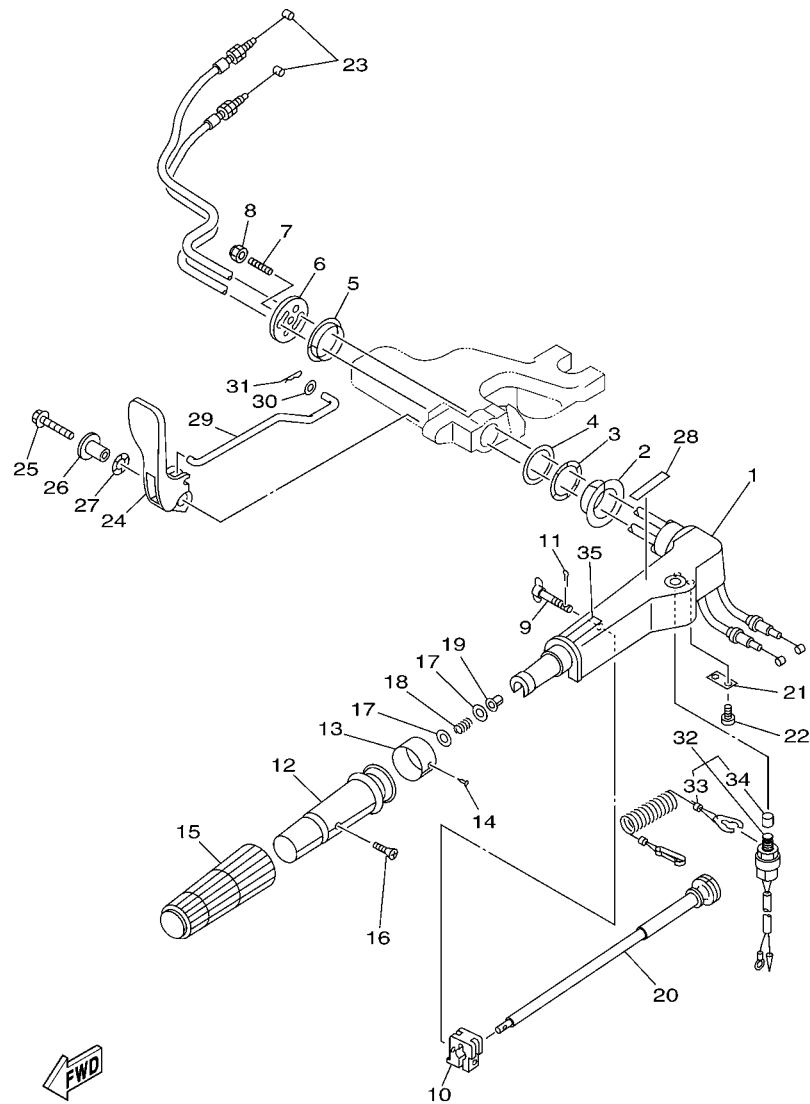

63V6110-F120

FIG. 11 STEERING

DIRECAO

REF. NO.	PART NO. No. PEÇA	DESCRIPTION DESCRIÇÃO	65D6	65D7	REMARKS OBSERVAÇÕES
28	6E0-44191-11	INDICATOR, SHIFT INDICADOR DE MUDANCA	1	1	
29	63V-44124-02	LINK, SHIFT ROD ARGOLA DA HASTE DE MUDANCA	1	1	
30	90202-06009	WASHER, PLATE ARRUELA PLANA	1	1	
31	90468-18008	CLIP PRESILHA	1	1	
32	65W-82575-01	ENGINE STOP SWITCH ASSY INTERRUPTOR DE PARADA C.J.	1	1	
33	682-82556-00	.LANYARD, STOP SWITCH .AMORTIZADOR DO LIMITADOR	1	1	
34	689-8257Y-00	.CAP .CAPA DO INTERRUPTOR DE PARADA	1	1	
35	6E0-83627-41	LABEL, CAUTION 7 ETIQUETA DE ADVERTENCIA	1	1	

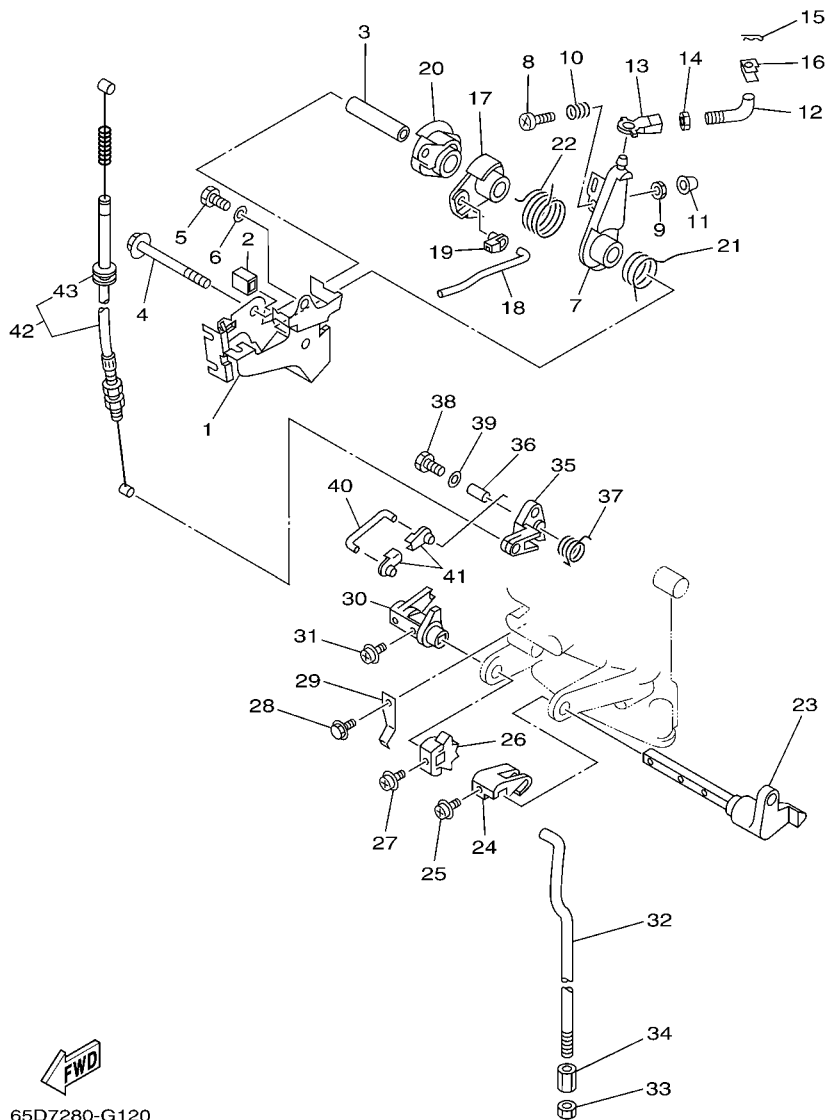

65D7280-G120

FIG. 12 CONTROL

CONTROLE

REF. NO.	PART NO. No. PEÇA	DESCRIPTION DESCRIÇÃO	65D6	65D7	REMARKS OBSERVAÇÕES
1	63V-14497-02	STAY, THROTTLE WIRE SUPORTE DO CABO DE ACELERAÇÃO	1	1	
2	689-44194-00	CAP CHAVETA	1	1	
3	90387-06M50	COLLAR ESPACADOR	1	1	
4	95895-06065	BOLT, FLANGE PARAFUSO FLANGE	1	1	
5	97095-06012	BOLT PARAFUSO	1	1	
6	92995-06600	WASHER ARRUELA	1	1	
7	63V-41631-01	LEVER, MAGNETO CONTROL ALAVANCA CONTROLE DO MAGNETO	1	1	
8	97885-06030	SCREW, PAN HEAD PARAFUSO	1	1	
9	95380-06600	NUT, HEXAGON PORCA SEXTAVADA	1	1	
10	90501-12M16	SPRING, COMPRESSION MOLA DE COMPRESSÃO	1	1	
11	688-44194-00	CAP CHAVETA	1	1	
12	63V-41238-00	JOINT, LINK JUNÇÃO DO ARTICULADOR	1	1	
13	6H4-41237-00	JOINT, LINK JUNÇÃO DO ARTICULADOR	1	1	
14	95380-05700	NUT PORCA	1	1	
15	90468-10005	CLIP PRESILHA	1	1	
16	63V-41223-00	WASHER, LOCK 1 ARRUELA TRAVA 1	1	1	
17	63V-41283-01	LEVER, FREE ACCEL. ALAVANCA DE ACELERAÇÃO	1	1	
18	63V-41211-00	LINK, ACCEL. ARTICULADOR DO ACELERAÇÃO	1	1	
19	661-41262-02	JOINT, CHOKE LEVER JUNÇÃO DA ALAVANCA DO AFOGADOR	1	1	
20	63V-41638-00	PULLEY POLIA	1	1	
21	90508-16M37	SPRING, TORSION MOLA DE TORÇÃO	1	1	
22	90508-20M38	SPRING, TORSION MOLA DE TORÇÃO	1	1	
23	63V-44123-01	ARM, SHIFT ROD BRANCO DA HASTE DE MUDANÇA	1	1	
24	63V-44121-01	LEVER, SHIFT ROD ALAVANCA DA HASTE DE MUDANÇA	1	1	
25	90159-05M25	SCREW, WITH WASHER PARAFUSO COM ARRUELA	1	1	
26	63V-44125-00	LEVER, SHIFT ROD ALAVANCA DA HASTE DE MUDANÇA	1	1	
27	90159-05M25	SCREW, WITH WASHER PARAFUSO COM ARRUELA	1	1	

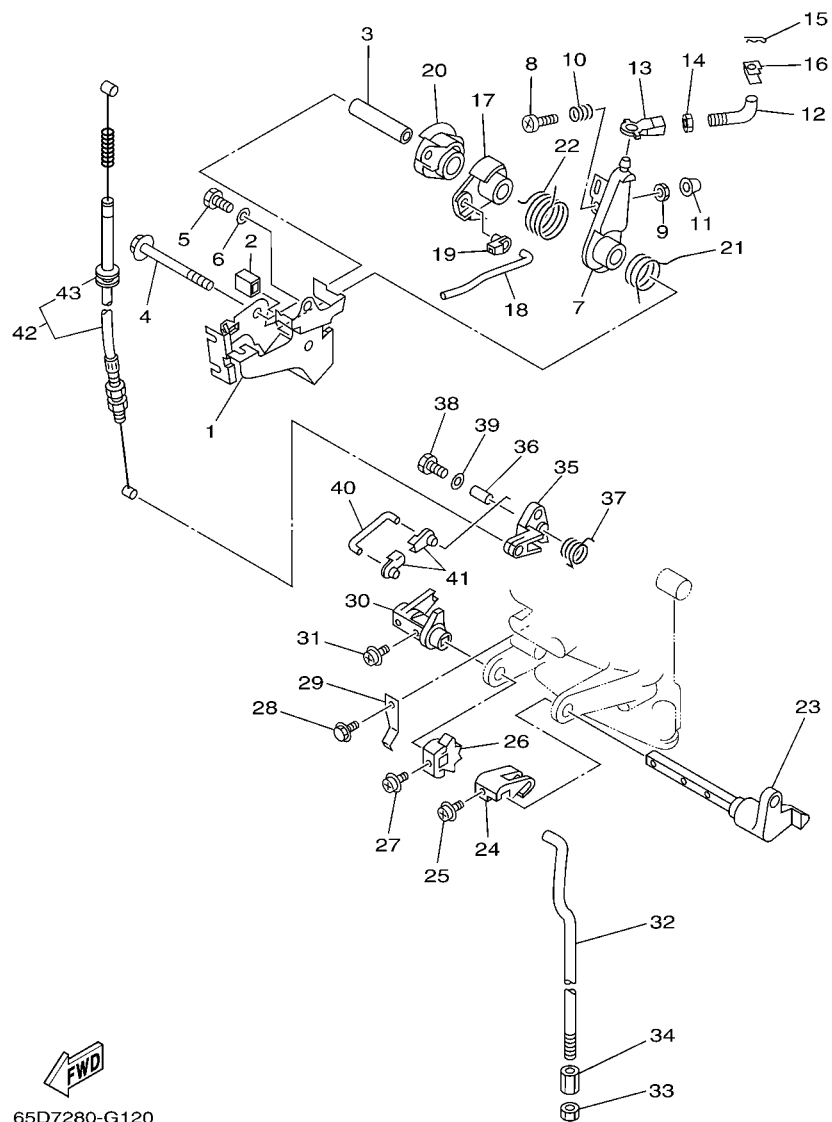

65D7280-G120

FIG. 12 CONTROL

CONTROLE

REF. NO.	PART NO. No. PEÇA	DESCRIPTION DESCRIÇÃO	65D6	65D7	REMARKS OBSERVAÇÕES
28	95895-06012	BOLT, FLANGE PARAFUSO FLANGE	1	1	
29	63V-44116-00	SPRING MOLA	1	1	
30	63V-44122-01	BUSHING, SHIFT ROD LEVER BUCHA DA ALAVANCA DE MUDANCA	1	1	
31	90159-05M25	SCREW, WITH WASHER PARAFUSO COM ARRUELA	1	1	
32	63V-44143-01	ROD, SHIFT HASTE DE MUDANCA	1	1	
33	95380-06700	NUT PORCA	1	1	
34	90170-06015	NUT PORCA	1	1	
35	63V-15746-10	ARM BRACO	1	1	
36	90387-06M06	COLLAR ESPACADOR	1	1	
37	90508-08M39	SPRING, TORSION MOLA DE TORCAO	1	1	
38	97095-06020	BOLT PARAFUSO	1	1	
39	92995-06600	WASHER ARRUELA	1	1	
40	6L2-15747-00	LINK ARTICULADOR	1	1	
41	661-41262-02	JOINT, CHOKE LEVER JUNCAO DA ALAVANCA DO AFOGADOR	2	2	
42	63V-15770-01	CABLE COMP., STARTER STOP CABO COMP. DE PARADA (PARTIDA)	1	1	
43	90480-10M16	.GRÖMMET .ILHO DE BORRACHA	1	1	

FIG. 13 BRACKET 1

SUPORTE 1

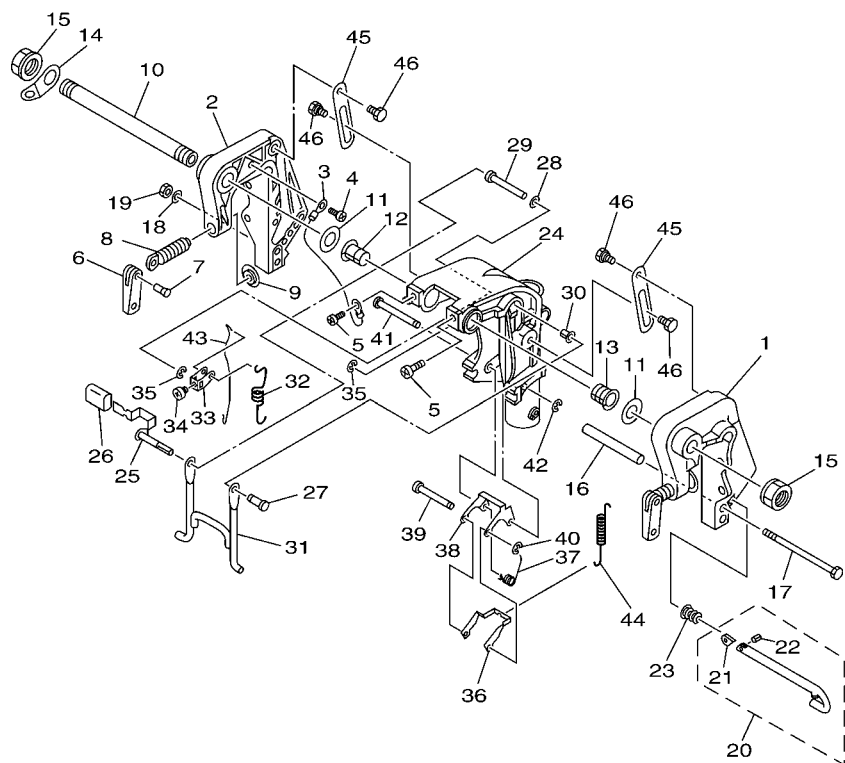

63V3300-C140

REF. NO.	PART NO. No. PEÇA	DESCRIPTION DESCRIÇÃO	65D6	65D7	REMARKS OBSERVAÇÕES
1	63V-43111-07-4D	BRACKET, CLAMP 1 SUPORTE DA BRACADEIRA 1	1	1	
2	63V-43112-08-4D	BRACKET, CLAMP 2 SUPORTE DA BRACADEIRA 2	1	1	
3	66M-82148-00	WIRE, LEAD 4 FIO CONDUTOR 4	1	1	
4	97885-06008	SCREW, PAN HEAD PARAFUSO	1	1	
5	97885-08010	SCREW, PAN HEAD PARAFUSO	2	2	
6	6E0-43118-01	HANDLE, TRANSOM CLAMP ALAVANCA DE FIXACAO	2	2	
7	90243-04M01	PIN PINO	2	2	
8	6E7-43116-00	SCREW, TRANSOM CLAMP PARAFUSO DE ACO DA ALAVANCA	2	2	
9	648-43114-01	PAD, TRANSOM CLAMP PASTILHA DE TRANSMISSAO	2	2	
10	63W-43131-01	BOLT, CLAMP BRACKET PARAFUSO DE ACO	1	1	
11	90202-22M54	WASHER, PLATE ARRUELA PLANA	2	2	
12	90386-22M94	BUSH BUCHA	1	1	
13	90386-22M94	BUSH BUCHA	1	1	
14	6J8-43113-01	PLATE, CLAMP BRACKET PLACA DE SUPORTE DA BRACADEIRA	1	1	
15	90185-22043	NUT, SELF-LOCKING PORCA AUTO-TRAVANTE	2	2	
16	90387-06M13	COLLAR ESPACADOR	1	1	
17	90101-06M29	BOLT PARAFUSO	1	1	
18	92995-06600	WASHER ARRUELA	1	1	
19	95380-06700	NUT PORCA	1	1	
20	689-43160-00	TILT ROD ASSY BARRA INCLINADA CONJ	1	1	
21	689-43165-00	.PLATE, TILT LOCK .PLACA DA BARRA INCLINADA	1	1	
22	91690-30008	.PIN, SPRING .PINO MOLA	1	1	
23	90502-10M07	SPRING, CONICAL MOLA CONICA	1	1	
24	63V-43311-03-4D	BRACKET, SWIVEL 1 SUPORTE DO EIXO GIRATORIO	1	1	
25	66M-43630-01	TILT LEVER ASSY ALAVANCA DE INCLINACAO COMPL.	1	1	
26	682-43318-01	COVER TAMPA	1	1	
27	63V-43191-00	SHAFT, STOPPER EIXO LIMITADOR	1	1	

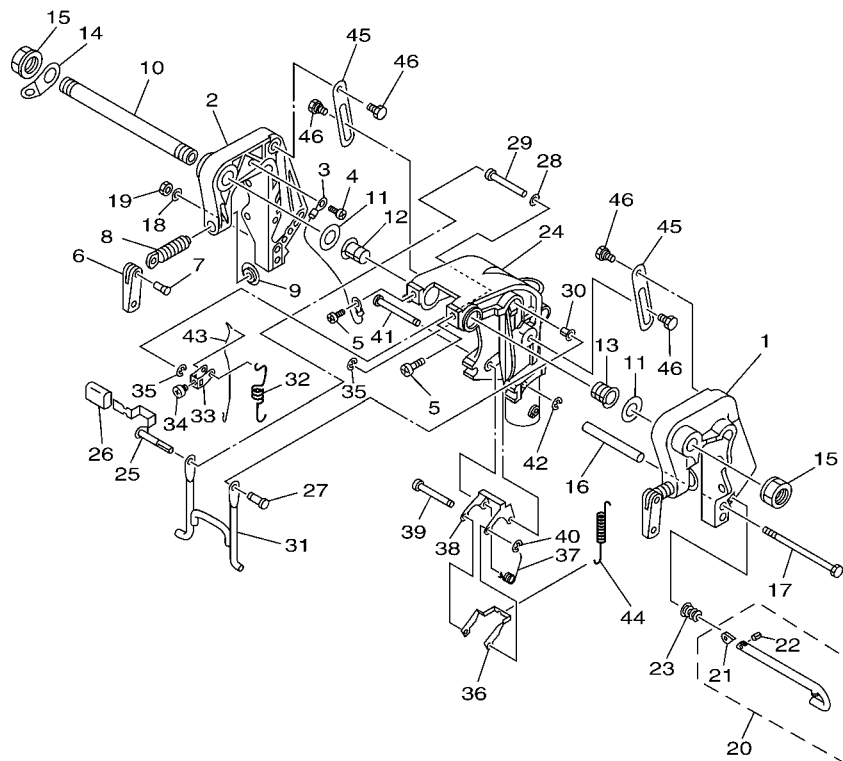

63V3300-C140

FIG. 13 BRACKET 1

SUPORTE 1

REF. NO.	PART NO. No. PEÇA	DESCRIPTION DESCRIÇÃO	65D6	65D7	REMARKS OBSERVAÇÕES
28	90202-07M60	WASHER, PLATE ARRUELA PLANA	1	1	
29	90387-07M07	COLLAR ESPACADOR	1	1	
30	90386-07M95	BUSH BUCHA	1	1	
31	66M-43350-01	RECEIVER ASSY ADAPTADOR DE RECEBIMENTO CJ.	1	1	
32	90507-20M00	SPRING, TENSION MOLA DE TENSAO	1	1	
33	63V-43641-01	LEVER, TILT ALAVANCA DE INCLINACAO	1	1	
34	90157-05014	SCREW, PAN HEAD PARAFUSO	1	1	
35	99080-05600	CIRCLIP ANEL TRAVA	2	2	
36	63V-43614-10	PLATE, TILT LOCK PLACA DE FIXADOR DE INCLINACAO	1	1	
37	90508-18M41	SPRING, TORSION MOLA DE TORCAO	1	1	
38	66R-43615-00	PLATE, TILT LOCK PLACA DE FIXADOR DE INCLINACAO	1	1	
39	66R-43611-00	SHAFT, TILT LOCK EIXO DE FIXADOR DE INCLINACAO	1	1	
40	93430-04M03	CIRCLIP ANEL TRAVA	1	1	
41	63V-43659-00	SHAFT, REVERSE LOCK EIXO DA TRAVA REVERSAO	1	1	
42	99080-05600	CIRCLIP ANEL TRAVA	1	1	
43	66R-43617-00	ROD, TILT LOCK HASTE DE FIXADOR DE INCLINACAO	1	1	
44	63V-43656-00	SPRING, REVERSE LOCK 1 MOLA DE RETORNO	1	1	
45	63V-43181-00	LEVER, TILT STOP ALAVANCA LIMITADORA INCLINAC.	2	2	
46	90109-06M84	BOLT PARAFUSO	4	4	

FIG. 14 BRACKET 2

SUPORTE 2

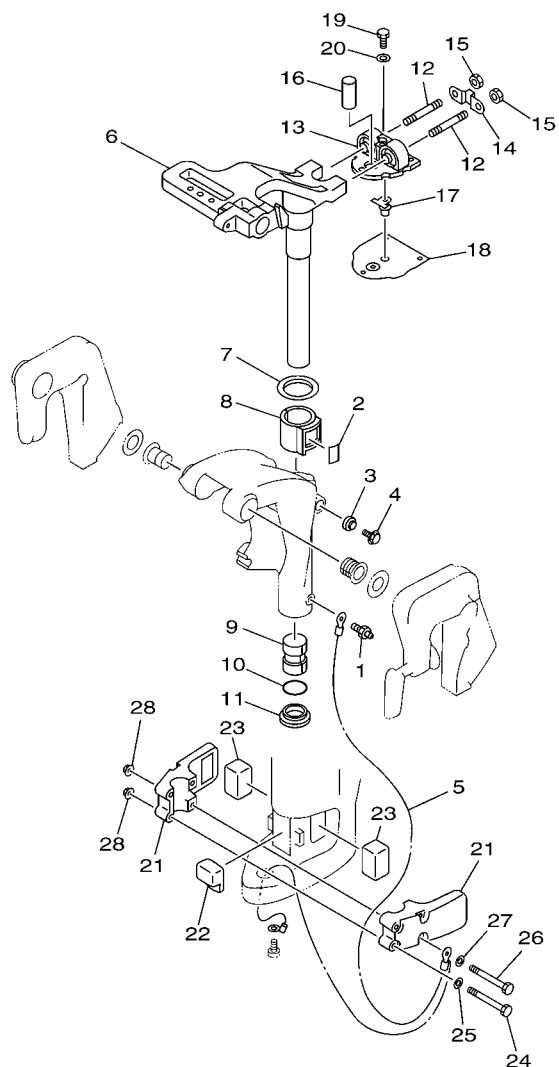

65D7280-G140

REF. NO.	PART NO. No. PEÇA	DESCRIPTION DESCRIÇÃO			REMARKS OBSERVAÇÕES
			65D6	65D7	
1	93700-06M03	NIPPLE, GREASE GRAXEIRA	1	1	
2	63V-42528-00	PLATE, FRICTION PLACA DE FRICCAO	1	1	
3	689-43373-01	SEAL, DAMPER RETENTOR DE BORRACHA	1	1	
4	90105-06M07	BOLT, FLANGE PARAFUSO FLANGE	1	1	
5	63V-82127-00	WIRE, LEAD 2 FIO CONDUTOR 2	1	1	
6	63V-42511-04-4D	BRACKET, STEERING SUPORTE DIRECIONAL	1	1	
7	90209-40008	WASHER ARRUELA	1	1	
8	65F-42537-00	BUSHING, PIVOT SHAFT BUCHA DO EIXO PIVO	1	1	
9	90386-30048	BUSH BUCHA	1	1	
10	93210-29M94	O-RING ANEL DE BORRACHA	1	1	
11	90386-30M60	BUSH BUCHA	1	1	
12	90116-08M54	BOLT, STUD PRISIONEIRO	2	2	
13	63V-44514-01-5B	MOUNT DAMPER, UPPER SIDE AMORTIZADOR SUPERIOR	1	1	
14	63V-44526-00	PLATE PLACA	1	1	
15	95380-08600	NUT PORCA	2	2	
16	90387-16002	COLLAR ESPACADOR	1	1	
17	63V-44366-01	DAMPER, WATER SEAL AMORTIZADOR DE BORRACHA	1	1	
18	63V-45114-A1	GASKET, UPPER CASING GAXETA DA CAIXA SUPERIOR	1	1	
19	97095-06018	BOLT PARAFUSO	3	3	
20	92995-06600	WASHER ARRUELA	3	3	
21	63V-44551-01-4D	HOUSING, LOWER MOUNT RUBBER ALOJAMENTO DO SUPORTE INFERIOR	2	2	
22	63V-44557-00	MOUNT DAMPER, LOWER FRONT AMORTIZADOR INFERIOR	1	1	
23	682-44555-00	MOUNT DAMPER, LOWER SIDE AMORTIZADOR INFERIOR	2	2	
24	97075-06055	BOLT PARAFUSO	2	2	
25	92995-06600	WASHER ARRUELA	2	2	
26	97075-06075	BOLT PARAFUSO	2	2	
27	92995-06600	WASHER ARRUELA	2	2	

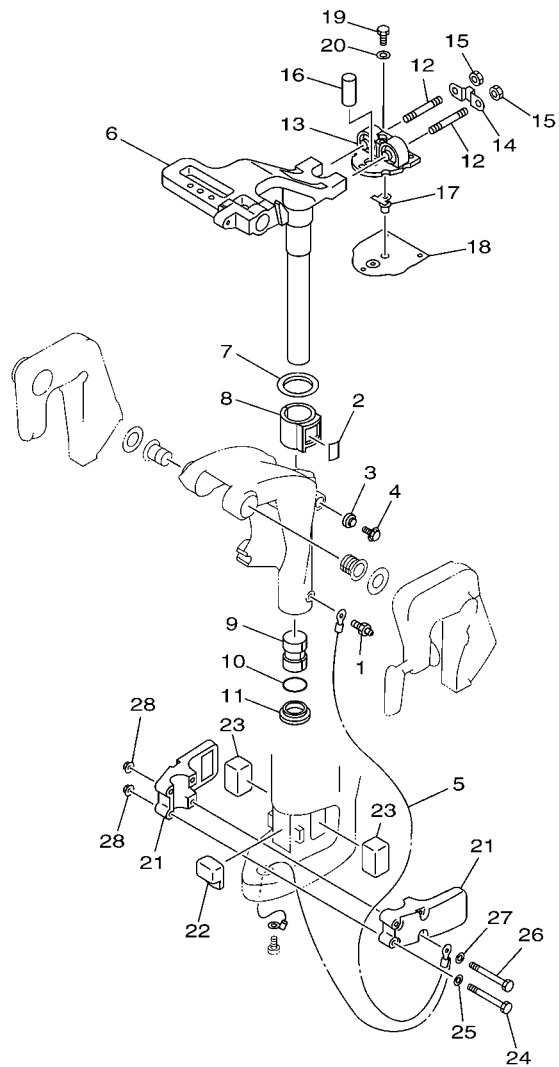

65D7280-G140

FIG. 14 BRACKET 2

SUPORTE 2

REF. NO.	PART NO. No. PEÇA	DESCRIPTION DESCRIÇÃO	65D6	65D7		REMARKS OBSERVAÇÕES
28	90179-06M28	NUT PORCA DE REGULAGEM	4	4		

FIG. 15 UPPER CASING

CAPA INFERIOR

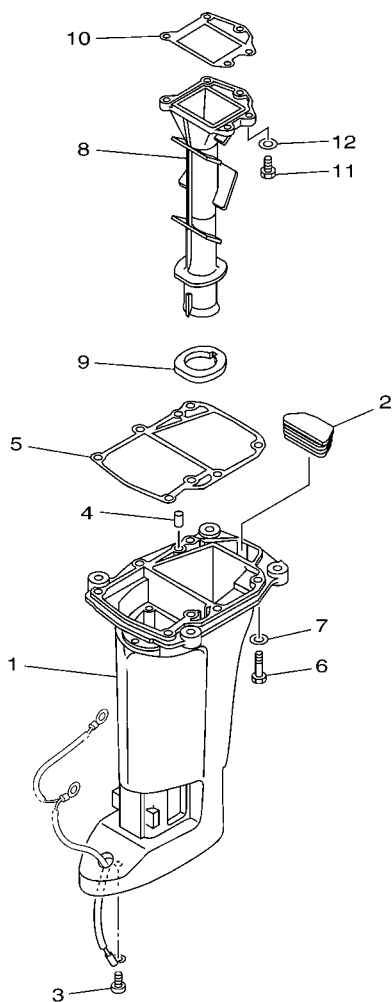

REF. NO.	PART NO. No. PEÇA	DESCRIPTION DESCRIÇÃO	CAPA INFERIOR		REMARKS OBSERVAÇÕES
			65D6	65D7	
1	63V-45111-05-4D	CASING, UPPER CAIXA SUPERIOR	1	1	S(17.3") S(17.3")
2	63V-45126-01	PLATE, SEAL DAMPER PLACA DO AMORTIZADOR	1	1	
3	90157-06M06	SCREW, PAN HEAD PARAFUSO	1	1	
4	93606-12019	PIN, DOWEL PINO GUIA	2	2	
5	63V-45113-A1	GASKET, UPPER CASING GAXETA DA CAIXA SUPERIOR	1	1	
6	97095-08030	BOLT PARAFUSO	6	6	
7	92995-08600	WASHER ARRUELA	6	6	
8	65F-41131-00-5B	MANIFOLD, EXT. 1 TUBO MULTIPLO DE ESCAPE 1	1	1	
9	63V-41135-00	GASKET, EXHAUST MANIFOLD GAXETA DO MULTIPLO DE ESCAPE	1	1	
10	63V-41133-A1	GASKET, EXHAUST MANIFOLD 1 GAXETA DO MULTIPLO DE ESCAPE 1	1	1	
11	97095-06020	BOLT PARAFUSO	5	5	
12	92995-06600	WASHER ARRUELA	5	5	

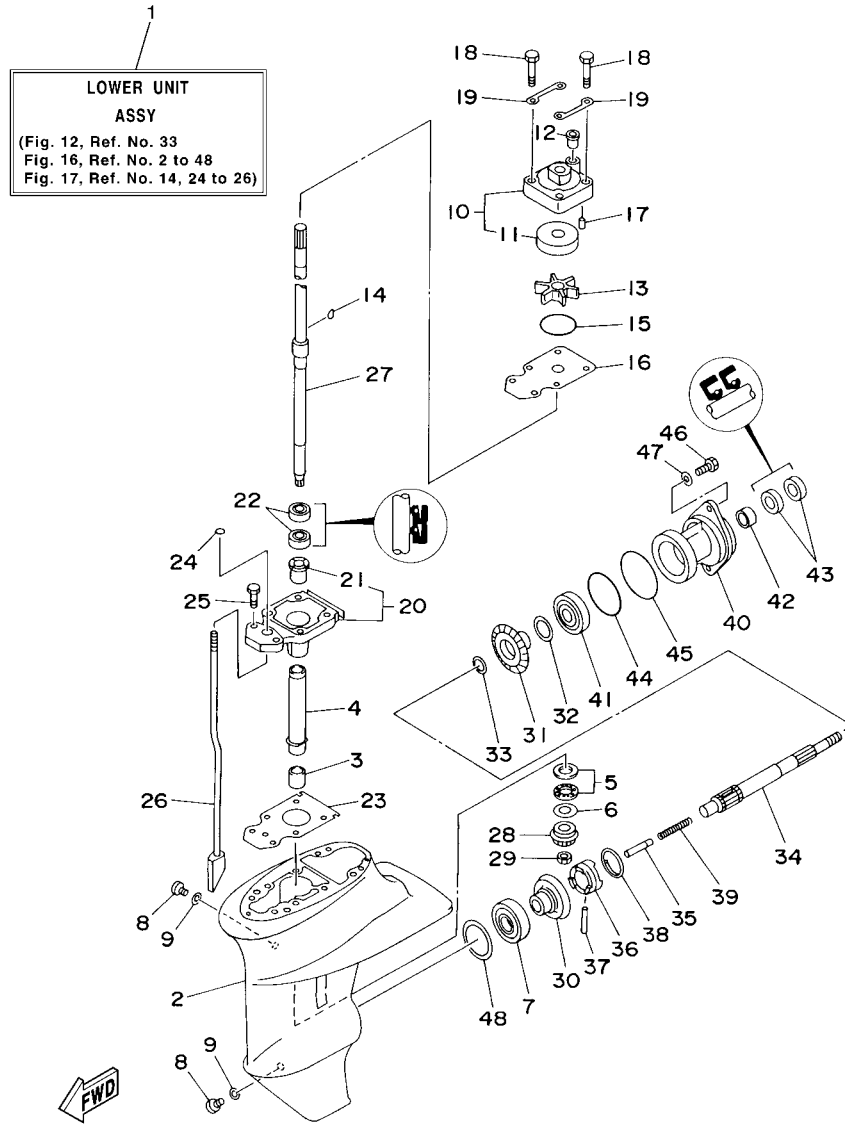

65D7280-G150



65D7280-G160

FIG. 16 LOWER CASING & DRIVE 1 CARCACA INF. E TRANSMISSAO 1

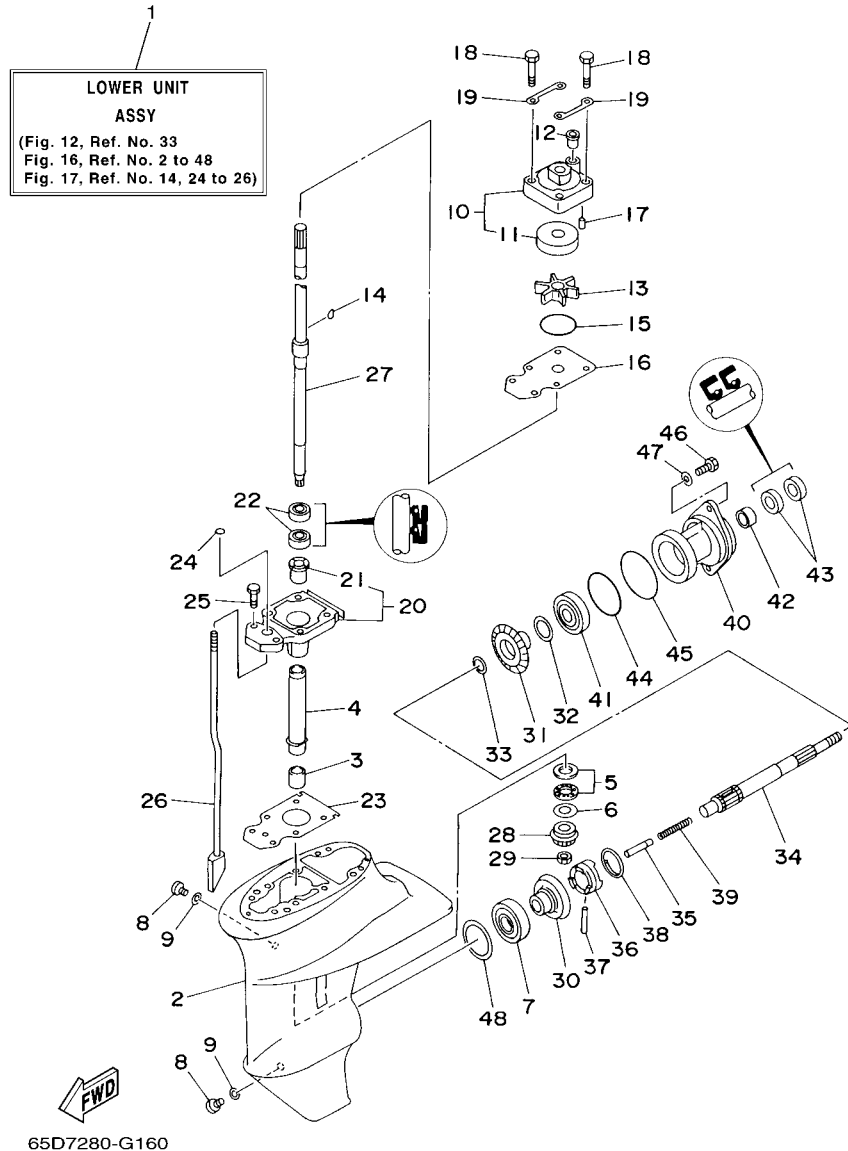
REF. NO.	PART NO. No. PEÇA	DESCRIPTION DESCRIÇÃO			REMARKS OBSERVAÇÕES
			65D6	65D7	
1	66M-45300-02-4D	LOWER UNIT ASSY UNIDADE DA RABETA INFERIOR CJ.	1	1	S(17.3") S(17.3")
2	66M-45311-01-4D	CASING, LOWER RABETA INFERIOR	1	1	S(17.3") S(17.3")
3	93315-314V8	BEARING ROLAMENTO CILINDRICO	1	1	
4	63V-45536-00	SLEEVE, DRIVE SHAFT PROTECTOR DO EIXO DE DIRECIONAL	1	1	
5	93341-41414	BEARING ROLAMENTO	1	1	
6	6E8-45587-10	SHIM (T:1.13MM) CALCO (T:1.13MM)	1	1	UR UR
	6E8-45587-30	SHIM (T:1.20MM) CALCO (T:1.20MM)	1	1	UR UR
7	93332-00005	BEARING ROLAMENTO	1	1	
8	90340-08002	PLUG, STRAIGHT SCREW TAMPAO DO DRENO	2	2	
9	90430-08020	GASKET GAXETA	2	2	
10	63V-44301-40	WATER PUMP HOUSING COMP. ALOJAMENTO DA BOMBA D'AGUA	1	1	FOR CHROMATE FOR CHROMATE
11	63V-44322-40	.INSERT, CARTRIDGE .INSERTO DA BOMBA D'AGUA	1	1	
12	647-44366-00	DAMPER, WATER SEAL AMORTIZADOR DE BORRACHA	1	1	
13	63V-44352-01	IMPELLER IMPULSOR	1	1	
14	63V-44338-00	KEY, WOODRUFF CHAVETA DE ACO	1	1	
15	93210-44398	O-RING ANEL DE BORRACHA	1	1	
16	63V-44323-40	OUTER PLATE, CARTRIDGE PLACA DA EXTERNA DA BOMBA	1	1	FOR CHROMATE FOR CHROMATE
17	93604-12M07	PIN, DOWEL PINO GUIA	2	2	
18	97080-08045	BOLT PARAFUSO	4	4	
19	63V-44328-00	PLATE PLACA	2	2	
20	63V-45331-00-5B	HOUSING, BEARING ALOJAMENTO DO ROLAMENTO	1	1	
21	626-45316-09	.BUSHING, DRIVE SHAFT .BUCHA DO EIXO DE DIRECAO	1	1	
22	93101-20048	OIL SEAL RETENTOR DE OLEO	2	2	
23	63V-45315-A0	PACKING, LOWER CASING GAXETA DA RABETA INFERIOR	1	1	
24	93210-06ME6	O-RING ANEL DE BORRACHA	1	1	
25	97080-08025	BOLT PARAFUSO	2	2	
26	63V-44150-00	SHIFT CAM ASSY CAME DE MUDANCA CONJ.	1	1	S(17.3") S(17.3")



65D7280-G160

FIG. 16 LOWER CASING & DRIVE 1 CARCACA INF. E TRANSMISSAO 1

REF. NO.	PART NO. No. PEÇA	DESCRIPTION DESCRIÇÃO	65D6	65D7	REMARKS OBSERVAÇÕES
27	63V-45510-01	DRIVE SHAFT ASSY EIXO DE DIRECIONAL COMPL.	1	1	S(17.3") S(17.3")
28	63V-45551-00	PINION (13T) PINHAO (13D)	1	1	
29	90179-08M06	NUT PORCA DE REGULAGEM	1	1	
30	6E7-45560-01	GEAR 1 (27T) ENGRENAGEM 1 (27D)	1	1	
31	6E7-45571-00	GEAR 2 (27T) ENGRENAGEM 2 (27D)	1	1	
32	626-45577-00	SHIM (T:0.10MM) CALCO (T:0.10MM)	1	1	UR
	626-45577-10	SHIM (T:0.20MM) CALCO (T:0.20MM)	1	1	UR
	626-45577-20	SHIM (T:0.30MM) CALCO (T:0.30MM)	1	1	UR
	626-45577-30	SHIM (T:0.40MM) CALCO (T:0.40MM)	1	1	UR
	626-45577-40	SHIM (T:0.50MM) CALCO (T:0.50MM)	1	1	UR
33	90201-17682	WASHER, PLATE ARRUELA PLANA	1	1	
34	683-45611-00	SHAFT, PROPELLER EIXO DA HELICE	1	1	
35	650-45635-00	PLUNGER, SHIFT ACIONADOR DE MUDANCA	1	1	
36	682-45631-00	CLUTCH, DOG ENGATE DA ENGRENAGEM	1	1	
37	90250-05010	PIN, STRAIGHT PINO DIRECTO	1	1	
38	648-45633-00	RING, CROSS PIN ANEL DE FIXACAO DO PINHAO	1	1	
39	90501-14M06	SPRING, COMPRESSION MOLA DE COMPRESSAO	1	1	
40	683-45361-02-4D	CAP, LOWER CASING CAPA DA RABETA INFERIOR	1	1	
41	93306-00501	BEARING ROLAMENTO	1	1	
42	93315-317U2	BEARING ROLAMENTO CILINDRICO	1	1	
43	93101-17054	OIL SEAL RETENTOR DE OLEO	2	2	
44	93210-57M09	O-RING ANEL DE BORRACHA	1	1	
45	93210-56M80	O-RING ANEL DE BORRACHA	1	1	
46	97095-06020	BOLT PARAFUSO	2	2	
47	92995-06600	WASHER ARRUELA	2	2	
48	664-45567-01	SHIM (T:0.10MM) CALCO (T:0.10MM)	1	1	UR
	664-45567-10	SHIM (T:0.12MM) CALCO (T:0.12MM)	1	1	UR

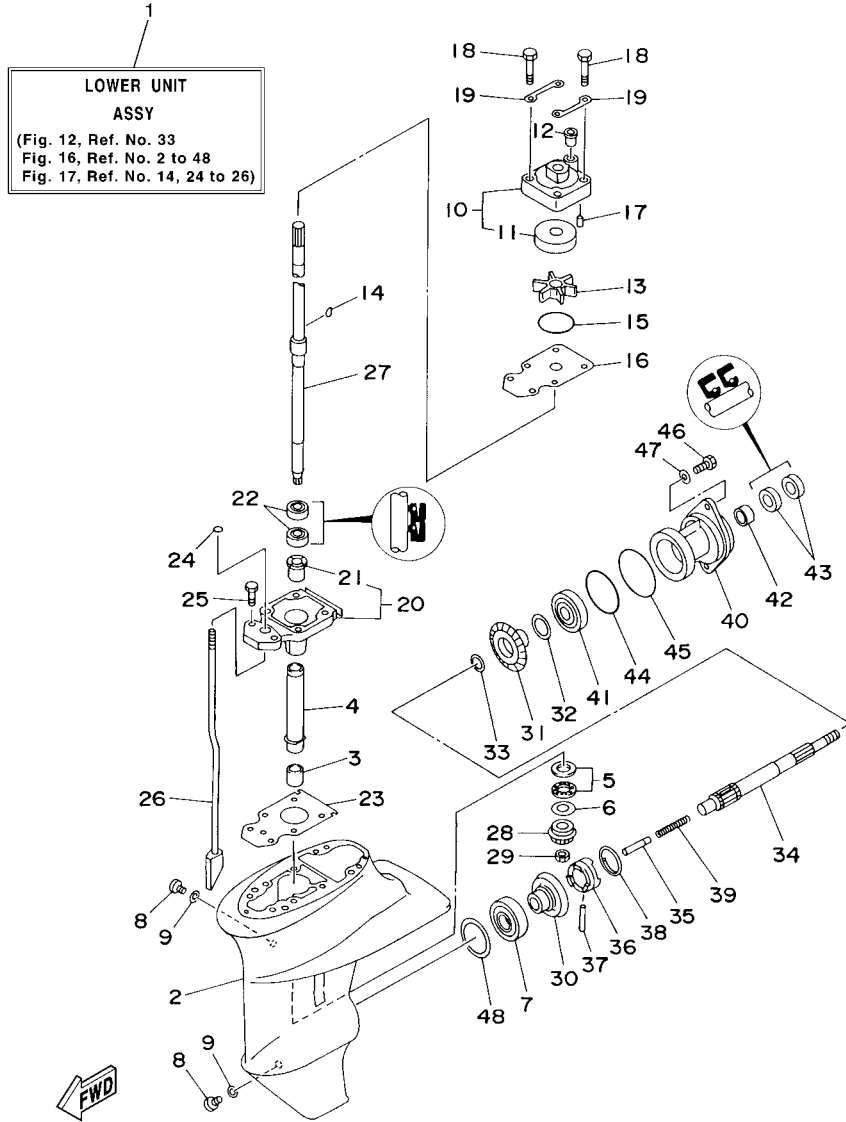

65D7280-G160

FIG. 16 LOWER CASING & DRIVE 1

CARCACA INF. E TRANSMISSAO 1

REF. NO.	PART NO. No. PEÇA	DESCRIPTION DESCRIÇÃO	65D6	65D7	REMARKS OBSERVAÇÕES
48	664-45567-20	SHIM (T:0.15MM) CALCO (T:0.15MM)	1	1	UR UR
	664-45567-30	SHIM (T:0.18MM) CALCO (T:0.18MM)	1	1	UR UR
	664-45567-40	SHIM (T:0.30MM) CALCO (T:0.30MM)	1	1	UR UR
	664-45567-50	SHIM (T:0.40MM) CALCO (T:0.40MM)	1	1	UR UR
	664-45567-60	SHIM (T:0.50MM) CALCO (T:0.50MM)	1	1	UR UR

FIG. 17 LOWER CASING & DRIVE 2 CARCACA INF. E TRANSMISSAO 2

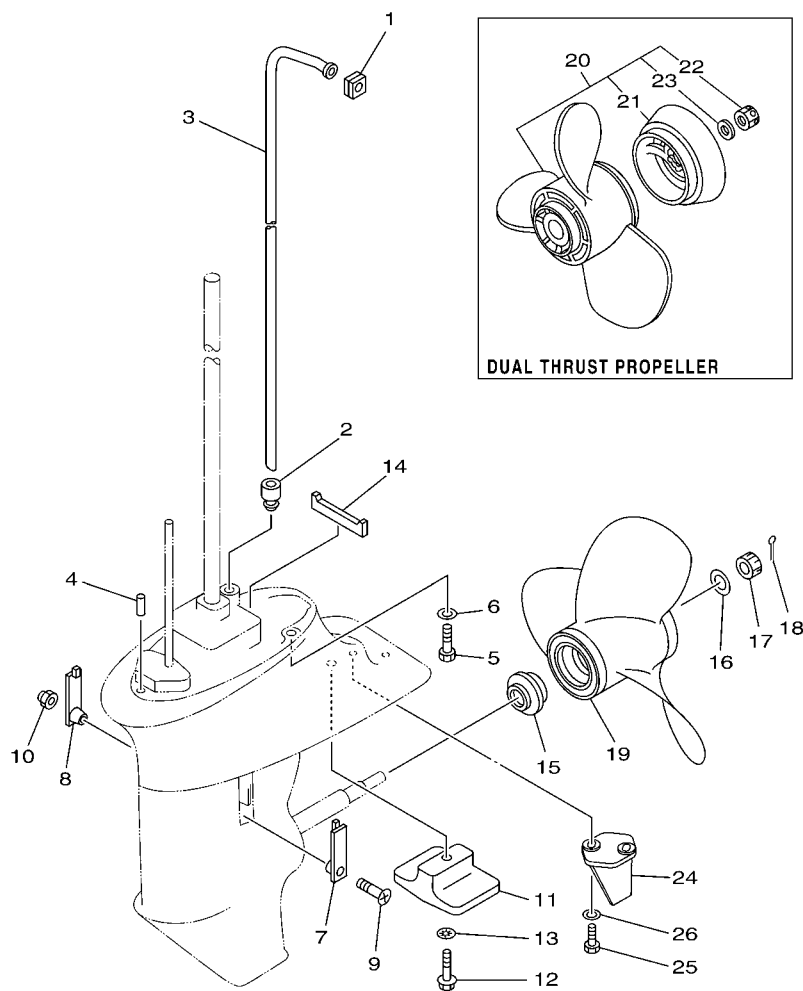



65D7280-G170

REF. NO.	PART NO. No. PEÇA	DESCRIPTION DESCRIÇÃO	65D6	65D7	REMARKS OBSERVAÇÕES
1	63V-44365-10	DAMPER, WATER SEAL AMORTIZADOR DE BORRACHA	1	1	
2	63V-44368-00	RUBBER, WATER SEAL 4 BORRACHA DO TUBO DE AGUA 4.	1	1	
3	63V-44361-01	TUBE, WATER TUBO DE AGUA	1	1	S(17.3") S(17.3")
4	93604-12M07	PIN, DOWEL PINO GUIA	2	2	
5	97075-08030	BOLT PARAFUSO	4	4	
6	92995-08600	WASHER ARRUELA	4	4	
7	6G1-45214-00	COVER, WATER INLET 1 TAMPA DA ENTRADA DE AGUA 1	1	1	
8	63V-45215-00	COVER, WATER INLET 2 TAMPA DA ENTRADA DE AGUA 2	1	1	
9	90152-05M04	SCREW, COUNTERSUNK PARAFUSO TRAMBULADOR	1	1	
10	90185-05002	NUT, SELF-LOCKING PORCA AUTO-TRAVANTE	1	1	
11	61N-45251-01	ANODE ANODO	1	1	
12	95895-06030	BOLT, FLANGE PARAFUSO FLANGE	1	1	
13	92990-06300	WASHER, INTERNAL TOOTH ARRUELA	1	1	
14	63V-45375-00	DAMPER, SEAL AMORTIZADOR DE VEDACAO	1	1	
15	6E7-45987-01	SPACER ESPACADOR	1	1	
16	90201-10M01	WASHER, PLATE ARRUELA PLANA	1	1	
17	90171-10M01	NUT, CASTLE PORCA CASTELO	1	1	
18	91490-30020	PIN, COTTER CUPILHA	1	1	
19	683-45941-00-EL	PROPELLER (3X9-1/4"X12"-J) HELICE (3X9-1/4"X12"-J)	1	1	UR UR
	683-45943-00-EL	PROPELLER (3X9-1/4"X10-1/2"-J) HELICE (3X9-1/4"X10-1/2"-J)	1	1	UR UR
	683-45945-00-EL	PROPELLER (3X9-1/4"X9"-J) HELICE (3X9-1/4"X9"-J)	1	1	UR UR
	683-45947-00-EL	PROPELLER (3X9-1/4"X8"-J) HELICE (3X9-1/4"X8"-J)	1	1	UR UR
	683-45949-00-EL	PROPELLER (3X9-1/2"X6-1/2"-J) HELICE (3X9-1/2"X6-1/2"-J)	1	1	UR UR
	683-45952-00-EL	PROPELLER (3X9-1/4"X9-3/4"-J) HELICE (3X9-1/4"X9-3/4"-J)	1	1	UR UR
	63V-45943-10-EL	PROPELLER (3X9-1/4"X11"-J1) HELICE (3X9-1/4"X11"-J1)	1	1	UR UR
	63V-45945-10-EL	PROPELLER (3X9-1/4"X9"-J1) HELICE (3X9-1/4"X9"-J1)	1	1	UR UR
	63V-45947-00-EL	PROPELLER (3X9-1/4"X8"-J) HELICE (3X9-1/4"X8"-J)	1	1	UR UR

FIG. 17 LOWER CASING & DRIVE 2

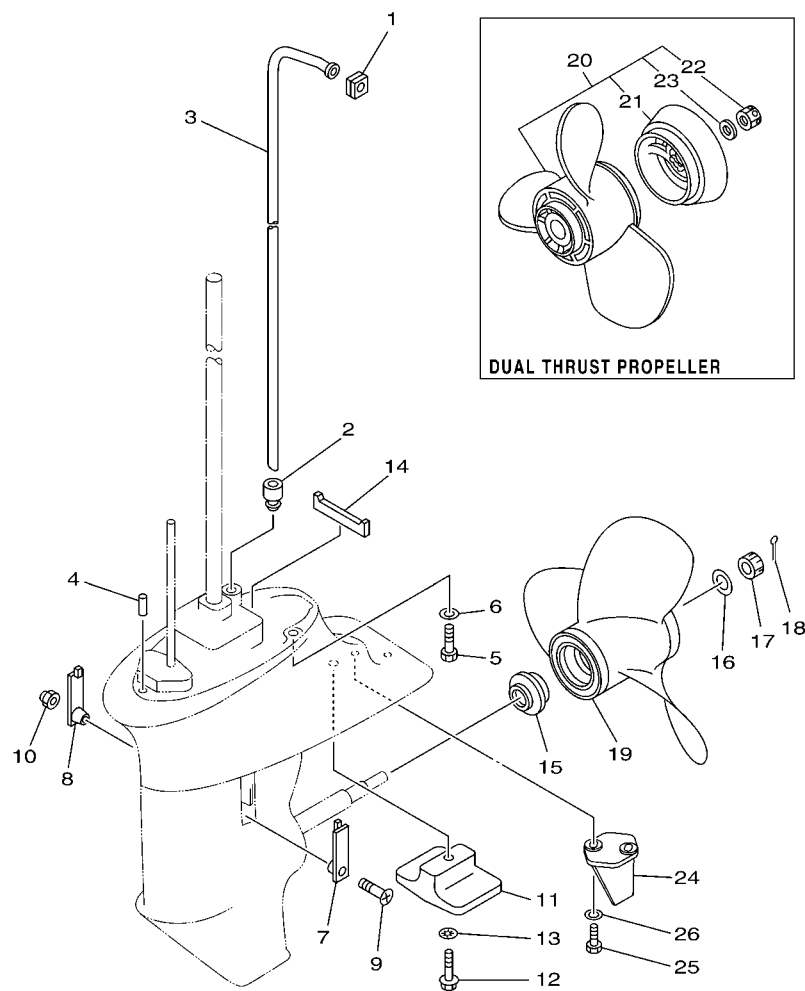
CARACA INF. E TRANSMISSAO 2



65D7280-G170

REF. NO.	PART NO. No. PEÇA	DESCRIPTION DESCRIÇÃO	65D6	65D7	REMARKS OBSERVAÇÕES
19	63V-45952-10-EL	PROPELLER (3X9-1/4"X10"-J1) HELICE (3X9-1/4"X10"-J1)	1	1	UR UR
20	683-W4591-02-EL	PROPELLER (3X9-3/4"X8"-J) HELICE (3X9-3/4"X8"-J)	1	1	UR UR
	683-W4592-02-EL	PROPELLER (3X9-3/4"X6-1/2"-J) HELICE (3X9-3/4"X6-1/2"-J)	1	1	UR UR
21	6E7-45986-00	.RING, DEFLECTOR .ANEL DEFLETOR	1	1	
22	90171-10M07	.NUT, CASTLE .PORCA CASTELO	1	1	
23	90201-10M02	.WASHER, PLATE .ARRUELA PLANA	1	1	
24	65D-45371-00-4D	TAB-TRIM ESTABILIZADOR DE DIRECAO	1	1	
25	97095-06016	BOLT PARAFUSO	2	2	
26	92995-06600	WASHER ARRUELA	2	2	

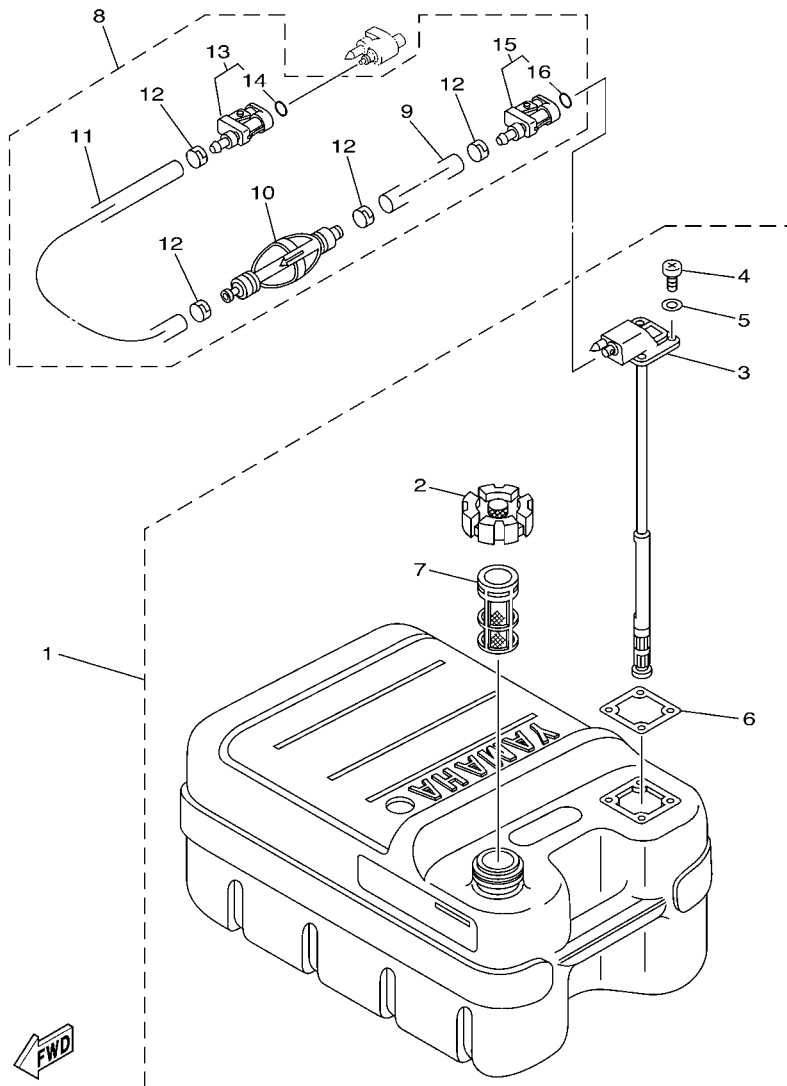

68U3100-C240

FIG. 18 FUEL TANK

TANQUE DE COMBUSTIVEL

REF. NO.	PART NO. No. PEÇA	DESCRIPTION DESCRIÇÃO	65D6	65D7	REMARKS OBSERVAÇÕES
1	61J-F4201-00	FUEL TANK ASSY TANQUE DE COMBUSTIVEL CONJ.	1	1	AP AP
2	6YJ-24610-01	.CAP ASSY .TAMPA DO TANQUE CJ.	1	1	
3	6YJ-24260-00	.FUEL METER ASSY .MEDIDOR NIVEL DO COMBUSTIVEL	1	1	
4	90157-05M19	.SCREW, PAN HEAD .PARAFUSO	4	4	
5	6Y1-24329-00	.SEAL .GUARNICAO	4	4	
6	6Y1-24268-00	.GASKET, FUEL METER .GAXETA DO MEDIDOR DO NIVEL	1	1	
7	6YJ-24167-00	.STRAINER .FILTRO	1	1	
8	61J-24306-04	FUEL PIPE COMP. 1 TUBO DE COMBUSTIVEL COMP. 1	1	1	AP AP
9	90445-11M06	.HOSE (L2050) .TUBO (L2050)	1	1	
10	61J-24360-00	.PRIMER PUMP ASSY .BOMBA PRIMARIA CONJ.	1	1	
11	90445-11M05	.HOSE (L850) .TUBO (L850)	1	1	
12	650-24351-01	.BAND 1 .BRACADEIRA 1	4	4	
13	6G1-24305-05	.FUEL PIPE JOINT COMP. 2 .JUNCAO TUBO DE COMBUSTIVEL 2	1	1	
14	93210-08287	..O-RING ..ANEL DE BORRACHA	1	1	
15	6Y1-24305-06	.FUEL PIPE JOINT COMP. 2 .JUNCAO TUBO DE COMBUSTIVEL 2	1	1	
16	93210-08287	..O-RING ..ANEL DE BORRACHA	1	1	

FIG. 19 REPAIR KIT 1

KIT DE REPARO 1

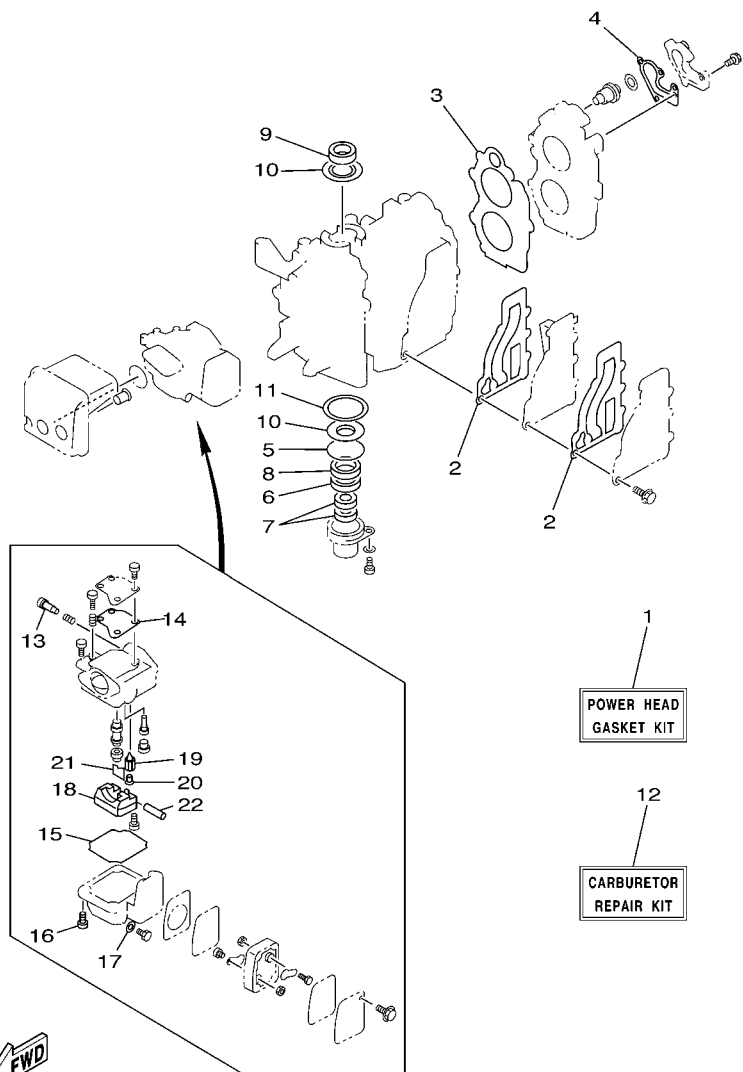

FWD
63V2100-3210

REF. NO.	PART NO. No. PEÇA	DESCRIPTION DESCRIÇÃO	KIT DE REPARO 1		REMARKS OBSERVAÇÕES
			65D6	65D7	
1	63V-W0001-02	POWER HEAD GASKET KIT JOGO DE GAXETAS	1	1	
2	63V-41112-A0	.GASKET, EXHAUST INNER COVER .GAXETA TAMPA INTERNA DO ESCAPE	2	2	
3	63V-11181-A1	.GASKET, CYLINDER HEAD 1 .GAXETA CABECOTE DO CILINDRO 1	1	1	
4	682-12414-A1	.GASKET, COVER .GAXETA DA TAMPA	1	1	
5	93210-46M16	.O-RING .ANEL DE BORRACHA	1	1	
6	93101-25018	.OIL SEAL .RETENTOR DE OLEO	1	1	
7	93101-13018	.OIL SEAL .RETENTOR DE OLEO	2	2	
8	93102-25M48	.OIL SEAL .RETENTOR DE OLEO	1	1	
9	93110-23M00	.OIL SEAL .RETENTOR DE OLEO	1	1	
10	63V-11445-00	.SPACER .ESPACADOR	2	2	
11	90201-46M29	.WASHER, PLATE .ARRUELA PLANA	1	1	
12	63V-W0093-00	CARBURETOR REPAIR KIT JOGO DE REPARO DO CARBURADOR	1	1	
13	679-14923-00	.SCREW, PILOT .PARAFUSO PILOTO	1	1	
14	63V-14126-00	.GASKET .GAXETA	1	1	
15	63V-14984-00	.GASKET, FLOAT CHAMBER .GAXETA DA CAMARA DA BOIA.	1	1	
16	97980-04114	.SCREW, WITH WASHER .PARAFUSO	4	4	
17	65W-14398-00	.GASKET .GAXETA	1	1	
18	63V-14985-00	.FLOAT .BOIA	1	1	
19	6G1-14546-01	.VALVE, NEEDLE .VALVULA DA AGULHA	1	1	
20	676-14186-00	.PIN, FLOAT .PINO DA BOIA	1	1	
21	663-14159-00	.CLIP .PRESILHA	1	1	
22	6H4-14548-00	.PIN, FLOAT ARM .PINO DA BOIA	1	1	

FIG. 20 REPAIR KIT 2

KIT DE REPARO 2

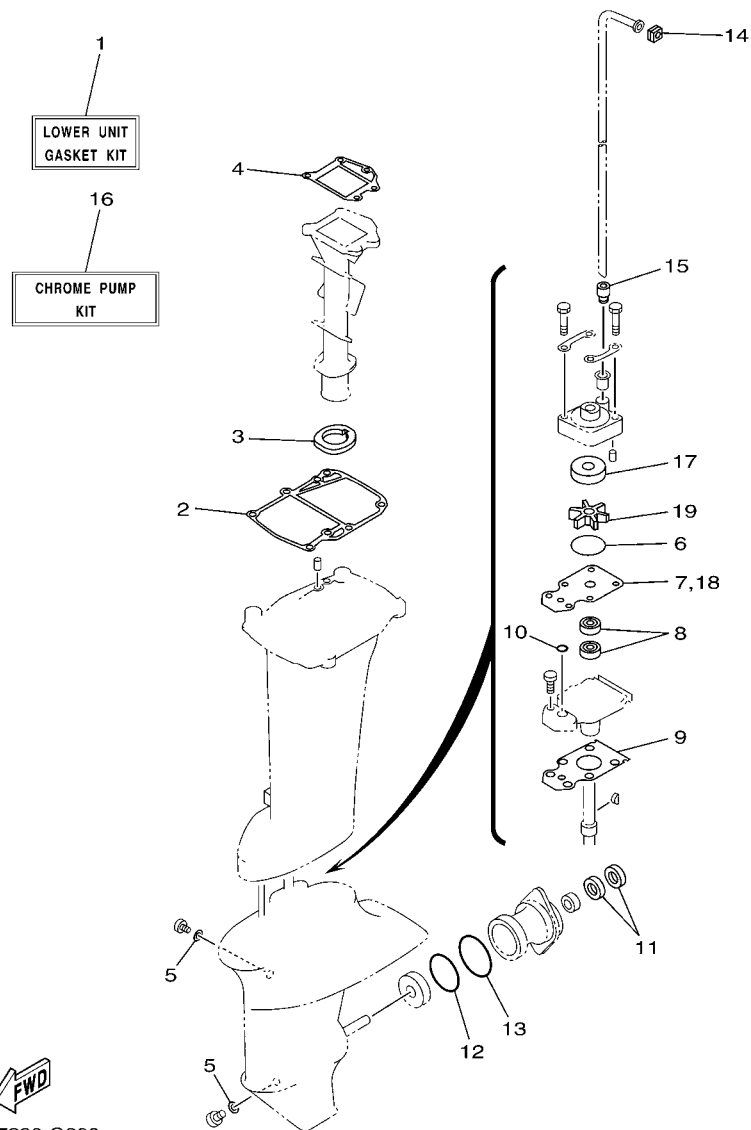

65D7280-G200

REF. NO.	PART NO. No. PEÇA	DESCRIPTION DESCRIÇÃO			REMARKS OBSERVAÇÕES
			65D6	65D7	
1	63V-W0001-22	LOWER UNIT GASKET KIT JOGO DE GAXETAS	1	1	
2	63V-45113-A1	.GASKET, UPPER CASING .GAXETA DA CAIXA SUPERIOR	1	1	
3	63V-41135-00	.GASKET, EXHAUST MANIFOLD .GAXETA DO MULTIPLO DE ESCAPE	1	1	
4	63V-41133-A1	.GASKET, EXHAUST MANIFOLD 1 .GAXETA DO MULTIPLO DE ESCAPE 1	1	1	
5	90430-08020	.GASKET .GAXETA	2	2	
6	93210-44398	.O-RING .ANEL DE BORRACHA	1	1	
7	63V-44323-00	.OUTER PLATE, CARTRIDGE .PLACA DA EXTERNA DA BOMBA	1	1	
8	93101-20048	.OIL SEAL .RETENTOR DE OLEO	2	2	
9	63V-45315-A0	.PACKING, LOWER CASING .GAXETA DA RABETA INFERIOR	1	1	
10	93210-06ME6	.O-RING .ANEL DE BORRACHA	1	1	
11	93101-17054	.OIL SEAL .RETENTOR DE OLEO	2	2	
12	93210-57M09	.O-RING .ANEL DE BORRACHA	1	1	
13	93210-56M80	.O-RING .ANEL DE BORRACHA	1	1	
14	63V-44365-10	.DAMPER, WATER SEAL .AMORTIZADOR DE BORRACHA	1	1	
15	63V-44368-00	.RUBBER, WATER SEAL 4 .BORRACHA DO TUBO DE AGUA 4.	1	1	
16	63V-W0078-0A	CHROME PUMP KIT JOGO DE REPARO DA BOMBA D'AGUA	1	1	
17	63V-44322-40	.INSERT, CARTRIDGE .INSERTO DA BOMBA D'AGUA	1	1	
18	63V-44323-40	.OUTER PLATE, CARTRIDGE .PLACA DA EXTERNA DA BOMBA	1	1	
19	63V-44352-01	.IMPELLER .IMPULSOR	1	1	

NUMERICAL INDEX
ÍNDICE NUMÉRICO

PART NO. No. PEÇA	REF. NO.	PART NO. No. PEÇA	REF. NO.	PART NO. No. PEÇA	REF. NO.	PART NO. No. PEÇA	REF. NO.	PART NO. No. PEÇA	REF. NO.	PART NO. No. PEÇA	REF. NO.
6E7-11111-01-1S	2 - 18	679-14923-00	5 - 2	61J-24360-00	18 - 10	6G1-42138-01	11 - 20	63V-44121-01	12 - 24	65D-45371-00-4D	17 - 24
63V-11181-A1	2 - 19		19 - 13	63V-24396-01	6 - 13	6E0-42159-02	11 - 21	63V-44122-01	12 - 30	63V-45375-00	17 - 14
	19 - 3	676-14943-81	5 - 14	63V-24411-00	5 - 28	6G1-42177-00	11 - 15	63V-44123-01	12 - 23	63V-45510-01	16 - 27
682-11325-00	2 - 8	63V-14947-00	5 - 13	6G1-24411-00	5 - 30	63V-42511-04-4D	14 - 6	63V-44124-02	11 - 29	63V-45536-00	16 - 4
676-11372-00	2 - 15	63V-14948-08	5 - 7	6G1-24412-01	5 - 29	63V-42528-00	14 - 2	63V-44125-00	12 - 26	63V-45551-00	16 - 28
63V-11400-01	3 - 8	679-14966-00	5 - 8	6L5-24421-01	5 - 32	65F-42537-00	14 - 8	63V-44143-01	12 - 32	6E7-45560-01	16 - 30
63V-11412-00	3 - 9	63V-14980-00	5 - 12	6G1-24431-01	5 - 31	63W-42610-20-4D	1 - 1	63V-44150-00	16 - 26	664-45567-01	16 - 48
63V-11422-00	3 - 10	63V-14984-00	5 - 11	6G1-24452-00	5 - 27	63V-42613-01-4D	1 - 7	6E0-44191-11	11 - 28	664-45567-10	16 - 48
63V-11432-00	3 - 11		19 - 15	61N-24521-00	6 - 6	63V-42615-00	1 - 2	688-44194-00	12 - 11	664-45567-20	16 - 48
63V-11442-00	3 - 12	63V-14985-00	5 - 18	61N-24560-00	6 - 4	6L2-42647-00	1 - 5	689-44194-00	12 - 2	664-45567-30	16 - 48
63V-11445-00	3 - 28		19 - 18	61N-24563-00	6 - 5	6G1-42651-02	1 - 3	63V-44301-40	16 - 10	664-45567-40	16 - 48
	19 - 10	6G1-14992-00	5 - 17	682-24566-01	6 - 11	63W-42677-20	1 - 11	63V-44322-40	16 - 11	664-45567-50	16 - 48
63V-11515-02	3 - 14	63V-15100-02-1S	2 - 2	6YJ-24610-01	18 - 2	63W-42678-10	1 - 12		20 - 17	664-45567-60	16 - 48
682-11610-01	3 - 22	63V-15396-01-94	3 - 1	6L2-26301-01	11 - 23	63V-42711-03-4D	10 - 1	63V-44323-00	20 - 7	6E7-45571-00	16 - 31
682-11610-11	3 - 22	63V-15705-01	7 - 10	63V-41111-00-1S	2 - 12	63V-42716-02	10 - 19	63V-44323-40	16 - 16	626-45577-00	16 - 32
682-11610-21	3 - 22	63V-15710-12	7 - 1	63V-41112-A0	2 - 13	682-42724-00	10 - 2		20 - 18	626-45577-10	16 - 32
6E7-11631-00-97	3 - 21	63V-15711-01	7 - 2		19 - 2	682-42725-02	10 - 3	63V-44328-00	16 - 19	626-45577-20	16 - 32
634-11633-00	3 - 23	63V-15713-00	7 - 7	63V-41113-00-1S	2 - 14	63V-42726-00	10 - 4	63V-44338-00	16 - 14	626-45577-30	16 - 32
6E7-11635-00	3 - 21	63V-15714-00	7 - 5	65F-41131-00-5B	15 - 8	682-42727-00	10 - 5	63V-44352-01	16 - 13	626-45577-40	16 - 32
6E7-11636-00	3 - 21	63V-15716-00	7 - 9	63V-41133-A1	15 - 10	6G1-42748-00	10 - 6		20 - 19	6E8-45587-10	16 - 6
650-11651-04	3 - 16	63V-15726-00	7 - 23		20 - 4	6E7-42791-00	10 - 22	63V-44361-01	17 - 3	6E8-45587-30	16 - 6
682-11681-00	3 - 15	63V-15734-00	7 - 22	63V-41135-00	15 - 9	63V-42815-01-4D	10 - 8	63V-44365-10	17 - 1	683-45611-00	16 - 34
6E5-12411-30	2 - 22	63V-15741-00	7 - 6		20 - 3	6E7-42816-00	10 - 9		20 - 14	682-45631-00	16 - 36
688-12412-00	2 - 23	63V-15744-00	7 - 13	63V-41211-00	12 - 18	63V-43111-07-4D	13 - 1	647-44366-00	16 - 12	648-45633-00	16 - 38
682-12413-00-1S	2 - 21	63V-15746-10	12 - 35	63V-41223-00	12 - 16	63V-43112-08-4D	13 - 2	63V-44366-01	14 - 17	650-45635-00	16 - 35
682-12414-A1	2 - 25	6L2-15747-00	12 - 40	6H4-41237-00	12 - 13	6J8-43113-01	13 - 9	63V-44368-00	17 - 2	683-45941-00-EL	17 - 19
	19 - 4	63V-15748-00	7 - 21	63V-41238-00	12 - 12	648-43114-01	13 - 14		20 - 15	683-45943-00-EL	17 - 19
63W-13610-00	4 - 1	63V-15753-00	7 - 8	63V-41252-00	4 - 18	6E7-43116-00	13 - 8	6H3-44391-01	10 - 20	63V-45943-10-EL	17 - 19
63V-14126-00	5 - 5	6G1-15755-00	7 - 18	63V-41253-00	4 - 5	6E0-43118-01	13 - 6	63V-44514-01-5B	14 - 13	683-45945-00-EL	17 - 19
	19 - 14	63V-15762-00	7 - 25	63V-41256-00	4 - 15	63W-43131-01	13 - 10	63V-44526-00	14 - 14	63V-45945-10-EL	17 - 19
663-14159-00	5 - 21	63V-15764-00	7 - 15	63V-41257-00	4 - 8	689-43160-00	13 - 20	63V-44551-01-4D	14 - 21	63V-45947-00-EL	17 - 19
	19 - 21	63V-15767-01	7 - 11	63V-41262-00	4 - 7	689-43165-00	13 - 21	682-44555-00	14 - 23	683-45947-00-EL	17 - 19
676-14186-00	5 - 20	63V-15768-00	7 - 14	661-41262-02	4 - 19	63V-43181-00	13 - 45	63V-44557-00	14 - 22	683-45949-00-EL	17 - 19
	19 - 20	63V-15770-01	12 - 42		12 - 19	63V-43191-00	13 - 27	63V-45111-05-4D	15 - 1	683-45952-00-EL	17 - 19
65D-14301-01	5 - 1	6G1-15779-00	7 - 19		12 - 41	63V-43311-03-4D	13 - 24	63V-45113-A1	15 - 5	63V-45952-10-EL	17 - 19
65W-14398-00	5 - 16	63V-15784-01	7 - 12	6H4-41271-01	4 - 14	682-43318-01	13 - 26		20 - 2	6E7-45986-00	17 - 21
	19 - 17	63V-15793-00	7 - 16	689-41273-00	4 - 16	66M-43350-01	13 - 31	63V-45114-A1	14 - 18	6E7-45987-01	17 - 15
63V-14440-00	4 - 9	63V-15794-00	7 - 20	6J8-41274-00	4 - 17	689-43373-01	14 - 3	63V-45126-01	15 - 2	63V-82127-00	14 - 5
624-14485-00	2 - 3	63V-15795-01	7 - 3	63V-41283-01	12 - 17	66R-43611-00	13 - 39	6G1-45214-00	17 - 7	66M-82148-00	13 - 3
650-14485-03	2 - 4	6YJ-24167-00	18 - 7	63V-41611-00	8 - 5	63V-43614-10	13 - 36	63V-45215-00	17 - 8	663-82370-01	9 - 10
63V-14497-02	12 - 1	6YJ-24260-00	18 - 3	63V-41631-01	12 - 7	66R-43615-10	13 - 38	61N-45251-01	17 - 11	662-82519-00	9 - 14
63V-14523-00	5 - 9	6Y1-24268-00	18 - 6	63V-41638-00	12 - 20	66R-43617-00	13 - 43	66M-45300-02-4D	16 - 1	682-82556-00	11 - 33
63V-14527-00	5 - 4	6G1-24304-02	6 - 1	63V-42111-01-4D	11 - 1	66M-43630-01	13 - 25	66M-45311-01-4D	16 - 2	65W-82575-01	11 - 32
62D-14546-01	5 - 19	6G1-24305-05	18 - 13	664-42119-00	11 - 12	63V-43641-01	13 - 33	63V-45315-A0	16 - 23	689-8257Y-00	11 - 34
6G1-14546-01	19 - 19	6Y1-24305-06	18 - 15	6G1-42125-01	11 - 9	63V-43656-00	13 - 44		20 - 9	6A1-83625-41	7 - 28
6H4-14548-00	5 - 22	61J-24306-04	18 - 8	6G1-42126-00	11 - 10	63V-43659-00	13 - 41	626-45316-09	16 - 21	6E0-83627-41	11 - 35
	19 - 22	6Y1-24329-00	18 - 5	6G1-42131-Q2	11 - 6	63V-44111-02	11 - 24	63V-45331-00-5B	16 - 20	63V-85520-01	8 - 3
679-14555-00	5 - 3	650-24351-01	18 - 12	6H2-42137-00	11 - 13	63V-44116-00	12 - 29	683-45361-02-4D	16 - 40	63V-85533-00	8 - 4

NUMERICAL INDEX
ÍNDICE NUMÉRICO

PART NO. No. PEÇA	REF. NO.	PART NO. No. PEÇA	REF. NO.	PART NO. No. PEÇA	REF. NO.	PART NO. No. PEÇA	REF. NO.	PART NO. No. PEÇA	REF. NO.	PART NO. No. PEÇA	REF. NO.	PART NO. No. PEÇA	REF. NO.
63V-85540-01	9 - 1	90201-10M01	17 - 16	90445-07M08	2 - 6	92995-06600	14 - 20	93606-12019	2 - 10	98580-04008	5 - 23		
63V-85550-11	8 - 1	90201-10M02	11 - 17	90445-09104	2 - 16		14 - 25		15 - 4	98780-05015	2 - 9		
63V-85570-00	9 - 6		17 - 23	90445-09M00	6 - 9		14 - 27	93700-06M03	14 - 1	98980-03006	5 - 24		
63V-85580-01	8 - 2	90201-12472	8 - 12	90445-11M05	18 - 11		15 - 12	94702-00217	2 - 27	99080-05600	13 - 35		
61J-F4201-00	18 - 1	90201-14377	3 - 25	90445-11M06	18 - 9		16 - 47	95380-03600	5 - 25				
61J-F8100-01	6 - 14	90201-16M03	2 - 24	90464-08M02	9 - 11		17 - 26	95380-05700	12 - 14				
63V-W0001-02	19 - 1	90201-17682	16 - 33	90464-15M11	9 - 4	92995-08600	15 - 7	95380-06600	12 - 9				
63V-W0001-22	20 - 1	90201-46M29	3 - 29	90465-08M61	9 - 5		17 - 6	95380-06700	10 - 14				
682-W0004-00	4 - 2		19 - 11	90465-25M57	10 - 21	93101-13018	3 - 5		12 - 33				
63V-W0070-11	1 - 10	90202-06009	11 - 30	90467-06016	2 - 7		19 - 7		13 - 19				
63V-W0078-0A	20 - 16	90202-07M60	13 - 28	90467-08004	6 - 10	93101-17054	16 - 43	95380-08600	6 - 8				
63V-W0090-03-1S	2 - 1	90202-22M54	13 - 11	90468-10005	12 - 15		20 - 11		14 - 15				
63V-W0093-00	19 - 12	90202-36M55	11 - 4	90468-18008	11 - 31	93101-20048	16 - 22	95895-06012	12 - 28				
683-W4591-02-EL	17 - 20	90206-12052	10 - 11	90480-06M19	10 - 7		20 - 8	95895-06030	17 - 12				
683-W4592-02-EL	17 - 20	90206-15M18	11 - 27	90480-10M16	12 - 43	93101-25018	3 - 3	95895-06065	12 - 4				
90101-06M29	13 - 17	90206-36M21	11 - 3	90480-12M25	4 - 11		19 - 6	97013-06010	6 - 12				
90105-06M07	14 - 4	90209-20M23	3 - 18	90480-15M31	10 - 18	93102-25M48	3 - 4	97075-06055	14 - 24				
90105-06M68	8 - 7	90209-40008	14 - 7	90480-25161	9 - 9		19 - 8	97075-06075	14 - 26				
90105-06M69	8 - 9	90243-04M01	13 - 7	90501-10326	5 - 10	93110-23M00	3 - 27	97075-08030	17 - 5				
90105-07M05	2 - 20	90250-05010	16 - 37	90501-12M16	12 - 10		19 - 9	97080-08025	16 - 25				
90109-06M84	13 - 46	90266-04M04	1 - 4	90501-14M06	16 - 39	93210-06ME6	16 - 24	97080-08045	16 - 18				
90116-08016	11 - 7		1 - 6	90501-23215	11 - 18		20 - 10	97095-06012	9 - 12				
90116-08M54	14 - 12	90269-02M09	11 - 14	90502-10M07	13 - 23	93210-08287	18 - 14		9 - 15				
90119-06M05	11 - 25	90280-05013	8 - 10	90507-20M00	13 - 32		18 - 16		12 - 5				
90119-06M94	4 - 13	90340-08002	16 - 8	90508-08M39	12 - 37	93210-29M94	14 - 10	97095-06016	1 - 8				
90119-06MA2	2 - 26	90386-07M95	13 - 30	90508-16M37	12 - 21	93210-32738	6 - 7		3 - 6				
90119-06MA4	2 - 17	90386-08032	11 - 19	90508-18M41	13 - 37	93210-35M86	4 - 12		17 - 25				
90119-08M07	2 - 11	90386-12M45	10 - 10	90508-20M38	12 - 22	93210-44398	16 - 15	97095-06018	9 - 7				
90149-05M13	11 - 16	90386-22M94	13 - 12	91490-16010	11 - 11		20 - 6		14 - 19				
90152-05M04	17 - 9		13 - 13	91490-16018	7 - 24	93210-46M16	3 - 2	97095-06020	4 - 3				
90157-05014	13 - 34	90386-30048	14 - 9	91490-30020	17 - 18		19 - 5		6 - 2				
90157-05M19	18 - 4	90386-30M60	14 - 11	91609-20008	3 - 19	93210-56M80	16 - 45		7 - 26				
90157-06M06	15 - 3	90386-33M96	11 - 5	91690-20010	4 - 6		20 - 13		9 - 2				
90159-05M25	12 - 25	90386-34M97	11 - 2	91690-30008	13 - 22	93210-57M09	16 - 44		12 - 38				
	12 - 27	90387-06034	10 - 17	92990-06300	17 - 13		20 - 12		15 - 11				
	12 - 31	90387-06M05	7 - 4	92995-06600	1 - 9	93306-00501	16 - 41		16 - 46				
90164-05M03	4 - 21	90387-06M06	12 - 36		3 - 7	93306-205U7	3 - 13	97095-06025	10 - 13				
90170-06015	12 - 34	90387-06M13	13 - 16		4 - 4	93310-620V5	3 - 17		10 - 15				
90170-12066	8 - 11	90387-06M15	4 - 10		6 - 3	93315-314V8	16 - 3	97095-08030	15 - 6				
90171-10M01	17 - 17	90387-06M24	8 - 8		7 - 27	93315-317U2	16 - 42	97803-04010	5 - 6				
90171-10M07	17 - 22	90387-06M50	12 - 3		9 - 3	93332-00005	16 - 7	97885-05012	11 - 22				
90179-06M28	14 - 28	90387-06M53	8 - 6		9 - 8	93341-41414	16 - 5	97885-06008	13 - 4				
90179-08M06	16 - 29	90387-06M86	11 - 26		9 - 13	93430-04M03	13 - 40	97885-06030	12 - 8				
90185-05002	17 - 10	90387-07M07	13 - 29		9 - 16	93440-52009	3 - 20	97885-08010	13 - 5				
90185-08057	11 - 8	90387-16002	14 - 16		10 - 16	93450-15023	3 - 26	97980-04114	5 - 15				
90185-22043	13 - 15	90430-08020	16 - 9		12 - 6	93602-14104	3 - 24		19 - 16				
90201-05M09	4 - 20		20 - 5		12 - 39	93604-12M07	16 - 17	97980-04125	5 - 26				
90201-06068	10 - 12	90445-07M08	2 - 5		13 - 18		17 - 4	98580-04006	5 - 33				