

PARTS CATALOGUE

150TR'08 (64C8)

150FETO'08 (64C8)

175DETO'08 (64D8)



2008/6/27

1G64C-100E1

()

NEWS NO.	DATE	COMMENT
PE0-OM-080015	Mar.,17,2008	MOD:FIG.18 CAM, TRIM SENDER P/No. REVISION
PE0-OM-080047	MAY,22,2008	MOD:FIG.19 PTT P/No. REVISION

150TR
150FETO/175DETO
PARTS CATALOGUE
©2007 by Yamaha Motor Co., Ltd.
1st edition, April 2007
All rights reserved.
Any reprinting or unauthorized use
without the written permission of
Yamaha Motor Co., Ltd.
is expressly prohibited.
Printed in Japan.

FOREWORD

This Parts Catalogue is related to the parts for the model(s) on the cover page. When you are ordering replacement parts, please refer to this Parts Catalogue and quote both part numbers and part names correctly.

1. Modifications or additions which have been made after the issue of the Parts Catalogue will be announced in the Parts News.

It is advisable that you make the necessary corrections to the Parts Catalogue according to the Parts News.

2. Abbreviations

The following abbreviations are used in this Parts Catalogue.

“UR” Use specified parts number.

“UN” Use as many as needed.

“AP” Alternate Parts

“LM” Locally Made (Parts need to be ordered locally)

“F#” Frame No. (Applicable machine No.)

“O/S” Over Size

3. The number of components for assembly

- Parts, which are to be supplied in an assembly, are listed with a dot (.) in front of the part name as shown below.
- The numeral appearing to the right of each component part indicates the quantity of parts for each assembly unit.

PART NO.	DESCRIPTION	Q'TY	REMARKS
2F5-83310-60	FRONT FLASHER LIGHT ASSY	2	
115-83311-60	.BULB (6V-18W)	1	

4. Applicable colours of graphics are represented in the “REMARKS” as shown below.

PART NO.	DESCRIPTION	Q'TY	REMARKS
2N4-24110-00-X5	FUEL TANK COMP.	2	MXR
3J1-24240-10	.GRAPHIC, FUEL TANK	1	FOR MXR

5. Note that the illustrations for reference in finding parts numbers are not to be used for assembling. When assembling, please use the applicable service manual.

6. The asterisk (*) before a reference number indicates modified items after the first edition.

7. Applicable Serial No.

Engine Serial No.

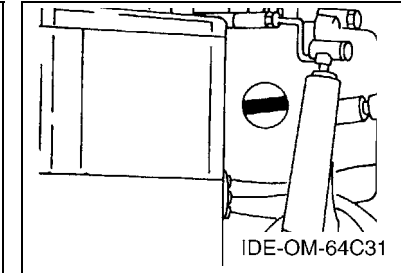
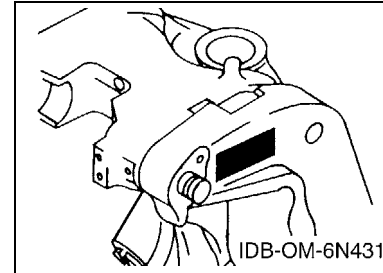

8. Applicable Engine Starting Serial No.

Model	Serial No.	Model	Serial No.
150	6G4-1019349	150F	6G4-1019349
175D	6G5-1001102		

9. Applicable Colour Code

Abbreviation	Colour Name	Colour Code
DBNM2	DARK BLUISH GRAY METALLIC 2	004D

10. Quantity Column Information

Column No.	Name Of Q'ty Column	Applicable Model
1	64C8	150TR, 150FETO
2	64D8	175DETO

CONTENTS

TOP COWLING	1
CYLINDER & CRANKCASE 1	3
CRANKSHAFT & PISTON	4
CYLINDER & CRANKCASE 2	6
INTAKE	8
CARBURETOR	10
OIL PUMP	12
OIL TANK	14
FUEL 1	16
FUEL 2	18
GENERATOR	19
ELECTRICAL 1	20
ELECTRICAL 2	22
STARTING MOTOR	25
BOTTOM COWLING	26
CONTROL	28
BRACKET 1	31
BRACKET 2	33
POWER TRIM & TILT ASSY 1	35
POWER TRIM & TILT ASSY 2	37
UPPER CASING	39
LOWER CASING & DRIVE 1	41
LOWER CASING & DRIVE 2	45
FUEL TANK	47
STEERING GUIDE	48
REMOTE CONTROL BOX	49
REMOTE CONTROL ASSY	50
METER	53
REPAIR KIT 1	54
REPAIR KIT 2	56
INDEX	
NUMERICAL INDEX	58

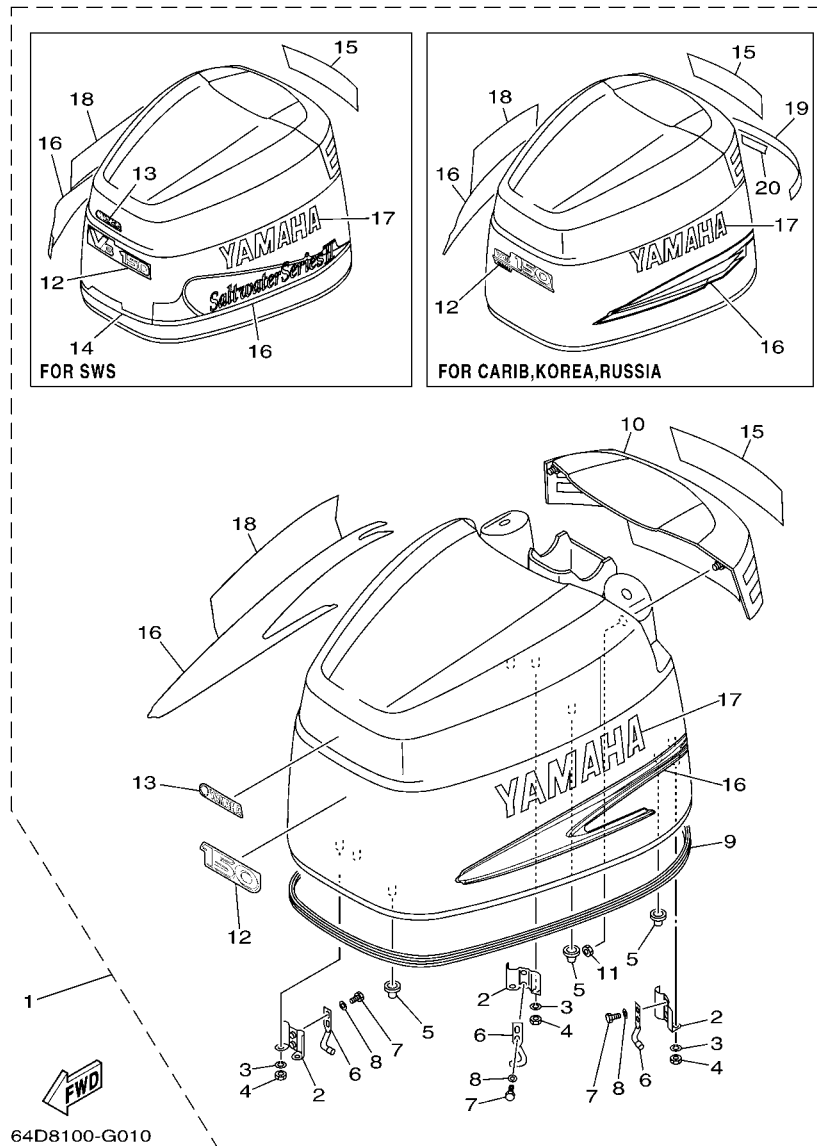

FIG. 1 TOP COWLING

REF. NO.	PART NO.	DESCRIPTION	64C8	64D8			REMARKS
1	64C-42610-50-4D	TOP COWLING ASSY	1				FOR USA
	64C-42610-60-4D	TOP COWLING ASSY	1				FOR CAR,KOR,RUS
	64C-42610-T0-4D	TOP COWLING ASSY	1				FOR OCE-SWS
	64D-42610-T0-4D	TOP COWLING ASSY		1			FOR OCE-SWS
2	6R3-42647-00	.HOLDER, CLAMP BAND	3	3			
3	92990-06100	.WASHER, SPRING	6	6			
4	95380-06600	.NUT, HEXAGON	6	6			
5	64D-42662-00	.DAMPER	3	3			
6	64D-42814-00	.HOOK, CLAMP	3	3			
7	97095-06012	.BOLT	6	6			
8	92995-06600	.WASHER	6	6			
9	64D-42615-00	.SEAL	1	1			
10	64D-42613-00-4D	.MOLDING, AIR DUCT	1	1			
11	90179-06M24	.NUT	4	4			
12	64C-42677-60	.GRAPHIC, FRONT	1				FOR USA
	64C-42677-50	.GRAPHIC, FRONT	1				FOR CAR,KOR,RUS
	64C-42677-40	.GRAPHIC, FRONT	1				FOR OCE-SWS
	64D-42677-40	.GRAPHIC, FRONT		1			FOR OCE-SWS
13	64C-42677-80	.GRAPHIC, FRONT	1				FOR USA
	64D-42677-B0	.GRAPHIC, FRONT	1	1			FOR OCE-SWS
14	64D-42677-S0	.GRAPHIC, FRONT	1	1			FOR OCE-SWS
15	64C-42687-40	.EMBLEM, REAR	1				FOR USA
	64C-42687-30	.EMBLEM, REAR	1				FOR CAR,KOR,RUS
	64C-42687-00	.EMBLEM, REAR	1				FOR OCE-SWS
	64D-42687-00	.EMBLEM, REAR		1			FOR OCE-SWS
16	64C-W0070-50	.GRAPHIC SET	1				FOR USA
	64D-W0070-30	.GRAPHIC SET		1			FOR CAR,KOR,RUS

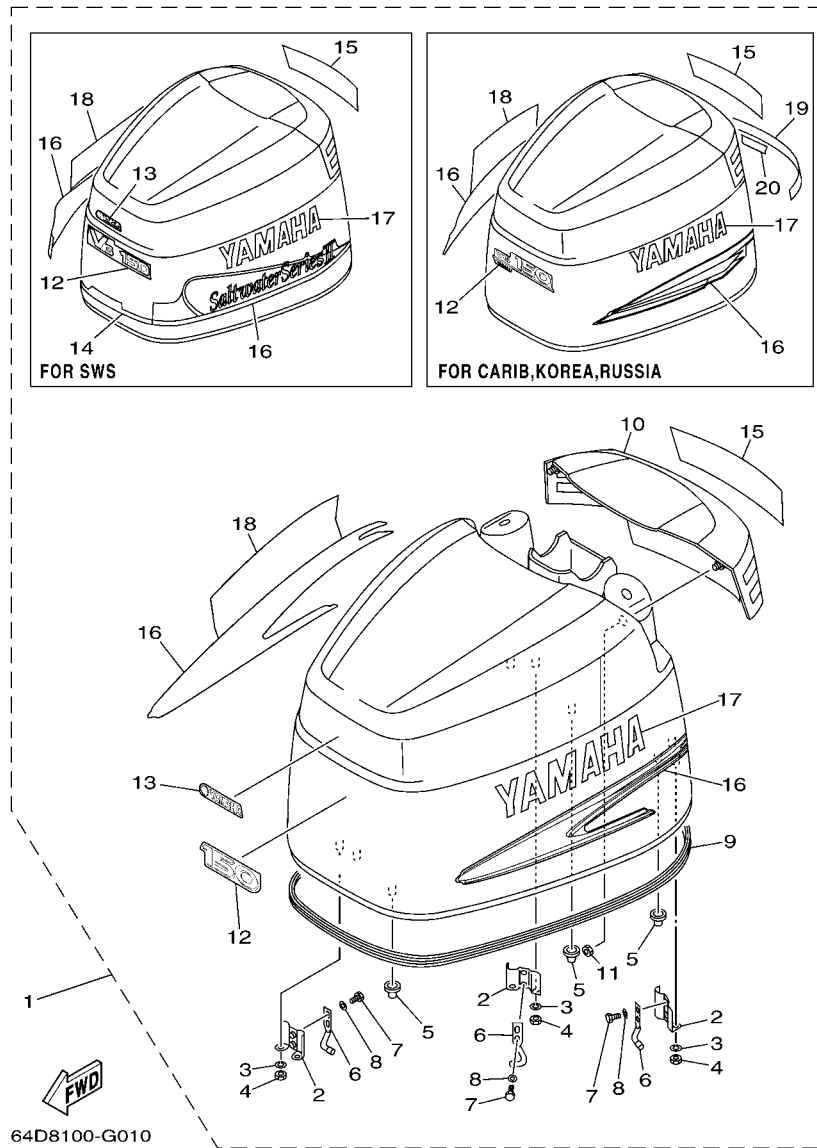
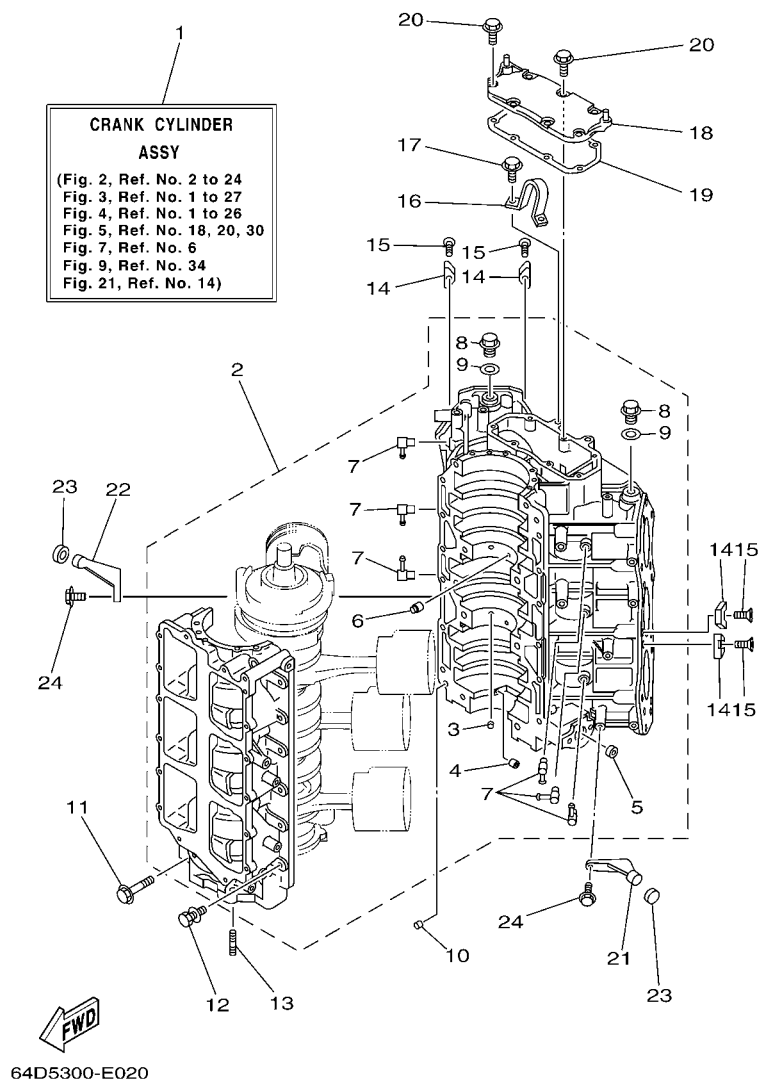

FIG. 1 TOP COWLING

REF. NO.	PART NO.	DESCRIPTION	64C8	64D8		REMARKS
			1	1		
16	64D-W0070-S0	.GRAPHIC SET	1	1		FOR OCE-SWS
17	64C-42681-50	.MARK, COWLING	1			FOR USA
	64C-42681-30	.MARK, COWLING	1			FOR CAR,KOR,RUS
	64D-42681-40	.MARK, COWLING	1	1		FOR OCE-SWS
18	64C-42682-50	.MARK, COWLING	1			FOR USA
	64C-42682-30	.MARK, COWLING	1			FOR CAR,KOR,RUS
	64D-42682-40	.MARK, COWLING	1	1		FOR OCE-SWS
19	64D-4267A-30	.GRAPHIC, REAR 2	1			FOR CAR,KOR,RUS
	64D-4267A-S0	.GRAPHIC, REAR 2	1	1		FOR OCE-SWS
20	64D-42678-30	.GRAPHIC, REAR	1			FOR CAR,KOR,RUS

FIG. 2 CYLINDER & CRANKCASE 1



REF. NO.	PART NO.	DESCRIPTION	64C8	64D8			REMARKS
1	64C-W0090-15-1S	CRANK CYLINDER ASSY	1				
	64D-W0090-15-1S	CRANK CYLINDER ASSY		1			
2	64C-15100-01-1S	CRANKCASE ASSY	1				
	64D-15100-01-1S	CRANKCASE ASSY		1			
3	624-11379-00	.VALVE, CHECK	2	2			
4	90384-06M07	.BUSH, BIMETAL FORMED	1	1			
5	90384-14M09	.BUSH, BIMETAL FORMED	1	1			
6	663-11518-01	.LOCK, BEARING	2	2			
7	646-11370-01	.CHECK VALVE ASSY	6	6			
8	90340-14M00	.PLUG, STRAIGHT SCREW	2	2			
9	90430-14115	.GASKET	2	2			
10	93608-12063	PIN, DOWEL	2	2			
11	90105-10M20	BOLT, FLANGE	8	8			
12	90119-08M94	BOLT, WITH WASHER	12	12			
13	90116-08026	BOLT, STUD	2	2			
14	6E5-11325-00	ANODE	8	8			
15	98780-04015	SCREW, FLAT HEAD	8	8			
16	67H-11119-01	HANGER, ENGINE	1	1			
17	90119-08MA3	BOLT, WITH WASHER	2	2			
18	6K7-11371-01-1S	COVER	1	1			
19	6E5-11381-A2	GASKET 1	1	1			
20	90119-06MA2	BOLT, WITH WASHER	7	7			
21	6E5-42761-00-1S	STOPPER	1	1			
22	6E5-42762-00-1S	STOPPER	1	1			
23	68F-44533-00	DAMPER, UPPER MOUNT RUBBER	2	2			
24	90119-06MA2	BOLT, WITH WASHER	4	4			

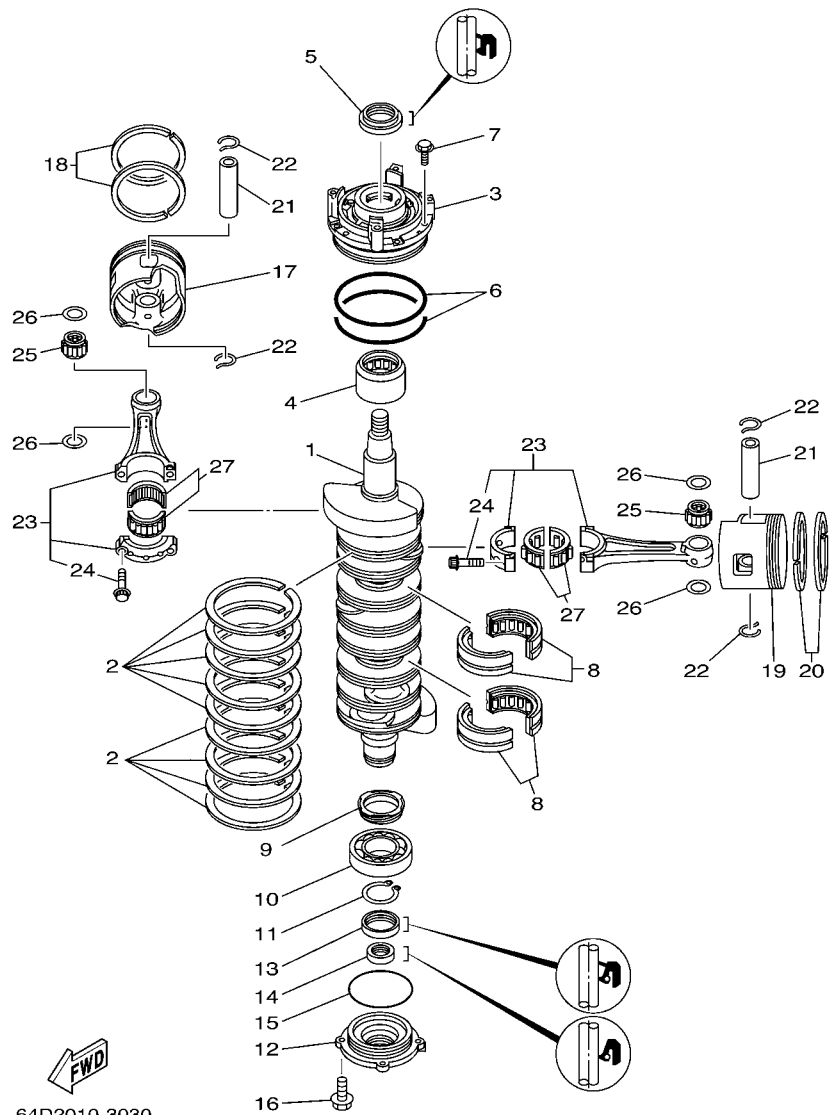

64D2010-3030

FIG. 3 CRANKSHAFT & PISTON

REF. NO.	PART NO.	DESCRIPTION	64C8	64D8			REMARKS
1	6G5-11411-02	CRANKSHAFT	1	1			
2	6E5-11447-00	SEAL, CRANK	9	9			
3	6R3-15163-00-1S	HOUSING, BEARING 1	1	1			
4	93311-940U3	BEARING	1	1			
5	93102-40M14	OIL SEAL	1	1			
6	93211-04001	O-RING	2	2			
7	90119-06MA2	BOLT, WITH WASHER	3	3			
8	93310-954U1	BEARING	2	2			
9	6R3-11536-00	GEAR, DRIVE	1	1			
10	93306-208U0	BEARING	1	1			
11	93410-40M03	CIRCLIP	1	1			
12	6G5-15359-00-94	HOUSING, OIL SEAL	1	1			
13	93102-35M13	OIL SEAL	1	1			
14	93101-22M15	OIL SEAL	1	1			
15	93210-74M35	O-RING	1	1			
16	90119-06MA2	BOLT, WITH WASHER	4	4			
17	64D-11631-02-90	PISTON (STD)	3	3			
	64D-11635-02	PISTON (0.25MM O/S)	3	3			AP
	64D-11636-02	PISTON (0.50MM O/S)	3	3			AP
18	64D-11603-02	PISTON RING SET (STD)	3	3			
	64D-11604-02	PISTON RING SET (0.25MM O/S)	3	3			AP
	64D-11605-02	PISTON RING SET (0.50MM O/S)	3	3			AP
19	64D-11642-02-90	PISTON 2 (STD)	3	3			
	64D-11645-02	PISTON 2 (0.25MM O/S)	3	3			AP
	64D-11646-02	PISTON 2 (0.50MM O/S)	3	3			AP
20	64D-11603-02	PISTON RING SET (STD)	3	3			
	64D-11604-02	PISTON RING SET (0.25MM O/S)	3	3			AP

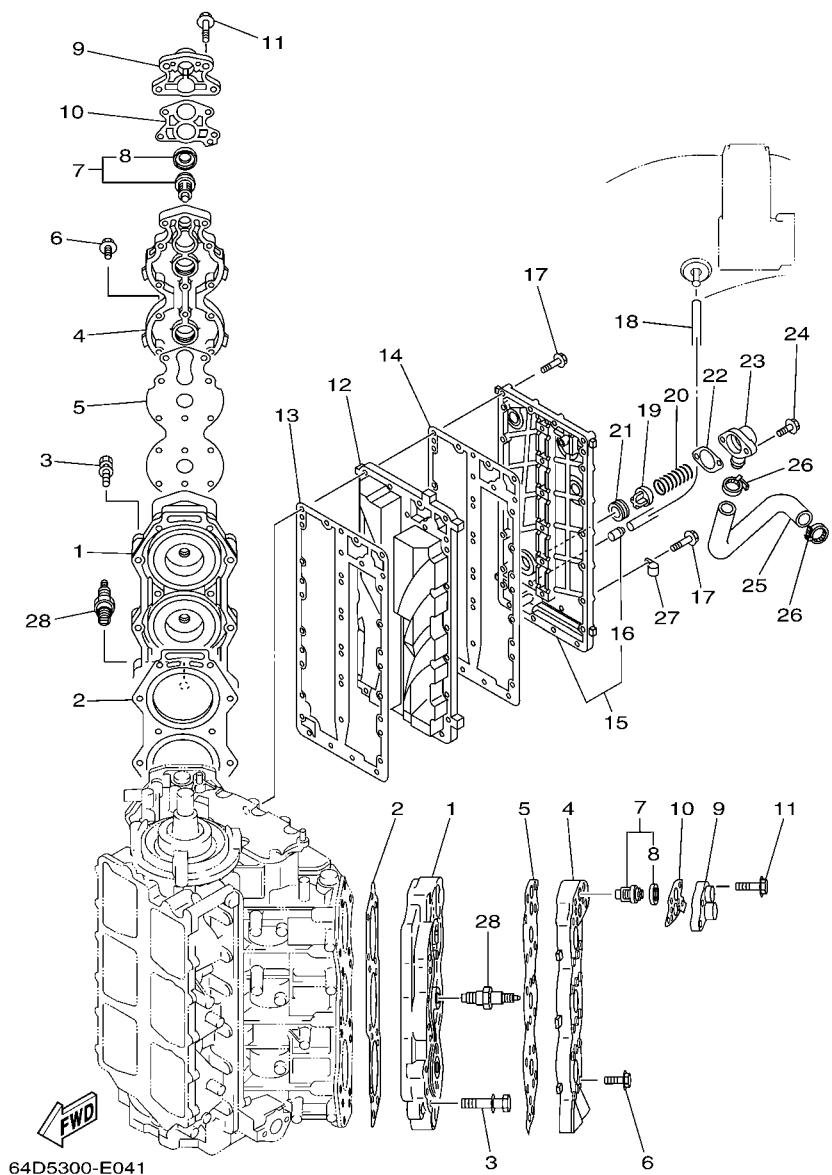

64D5300-E041

FIG. 4 CYLINDER & CRANKCASE 2

REF. NO.	PART NO.	DESCRIPTION	64C8	64D8			REMARKS
1	6G5-11111-04-1S	HEAD, CYLINDER 1	2	2			
2	6G5-11181-A2	GASKET, CYLINDER HEAD 1	2	2			
3	90119-08MA8	BOLT, WITH WASHER	28	28			
4	6G5-11191-00-1S	COVER, CYLINDER HEAD 1	2	2			
5	6G5-11193-A1	GASKET, HEAD COVER 1	2	2			
6	90119-06MA4	BOLT, WITH WASHER	36	36			
7	6E5-12411-30	THERMOSTAT	2	2			
8	688-12412-00	.SEAL, THERMOSTAT	1	1			
9	688-12413-00-1S	COVER, THERMOSTAT	2	2			
10	688-12414-A1	GASKET, COVER	2	2			
11	90119-06MA6	BOLT, WITH WASHER	8	8			
12	64D-41111-00-1S	INNER COVER, EXHAUST	1	1			
13	6G5-41112-A1	GASKET, EXHAUST INNER COVER	1	1			
14	6G5-41114-A0	GASKET, EXHAUST OUTER COVER	1	1			
15	6R3-41113-00-1S	OUTER COVER, EXHAUST	1	1			
16	650-24378-00	.PIPE, JOINT 4	1	1			
17	90119-06MA5	BOLT, WITH WASHER	29	29			
18	90445-09097	HOSE (L250)	1	1			
19	60H-12416-00	VALVE, PRESSURE CONTROL	1	1			
20	90501-16M11	SPRING, COMPRESSION	1	1			
21	90480-20M05	GROMMET	1	1			
22	6G5-11382-A1	GASKET 2	1	1			
23	6G5-11372-00-1S	COVER, BYPASS 2	1	1			
24	97595-06420	BOLT, WITH WASHER	2	2			
25	6G5-12576-00	HOSE 1	1	1			
26	90465-13M18	CLAMP	2	2			
27	90465-06M86	CLAMP	2	2			

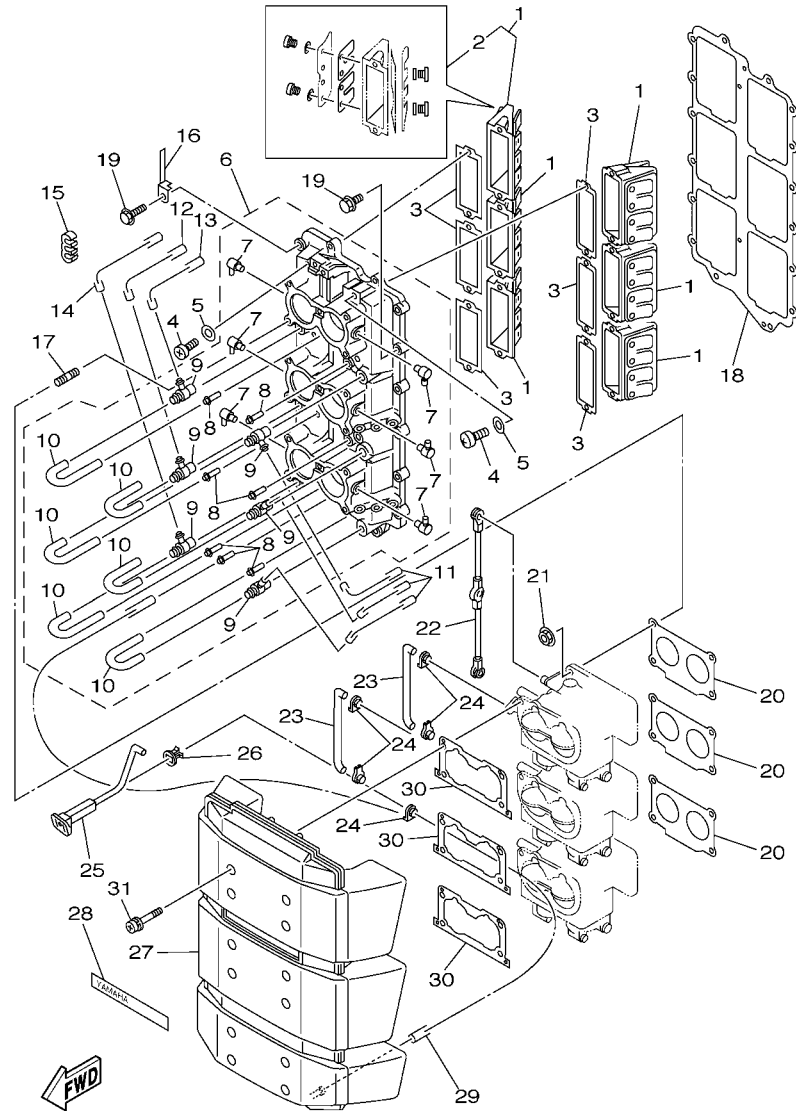

64D2100-3050

FIG. 5 INTAKE

REF. NO.	PART NO.	DESCRIPTION	64C8	64D8			REMARKS
1	6E5-13610-00	REED VALVE ASSY	6	6			
2	6E5-W0004-00	.REED SET	1	1			
3	6E5-13621-A1	GASKET, VALVE SEAT	6	6			
4	97880-05016	SCREW, PAN HEAD	12	12			
5	92990-05600	WASHER, PLATE	12	12			
6	6G5-13641-11-1S	MANIFOLD 1	1	1			
7	6E5-13552-01	.NOZZLE	6	6			
8	624-14485-00	.PIPE, JOINT	7	7			
9	6E5-11370-01	.CHECK VALVE ASSY	6	6			
10	90445-07M28	.HOSE (L70)	6	6			
11	90445-07M45	HOSE (L340)	3	3			
12	90445-07M46	HOSE (L360)	1	1			
13	90445-07M09	HOSE (L380)	1	1			
14	90445-07M59	HOSE (L410)	1	1			
15	90464-07M05	CLAMP	2	2			
16	90465-10M91	CLAMP	2	2			
17	90116-06M30	BOLT, STUD	12	12			
18	6G5-13645-A2	GASKET, MANIFOLD 1	1	1			
19	90119-06MA3	BOLT, WITH WASHER	16	16			
20	6E5-14198-A2	GASKET	3	3			
21	90179-06M28	NUT	12	12			
22	6G5-41217-01	ROD, ACCEL. LEVER	1	1			
23	6E5-41256-01	ROD, CHOKE 1	2	2			
24	661-41262-02	JOINT, CHOKE LEVER	5	5			
25	6R3-41271-00	KNOB, CHOKE	1	1			
26	689-41273-00	GROMMET	1	1			
27	6R3-14440-02	SILENCER ASSY, INTAKE	1				FOR STD

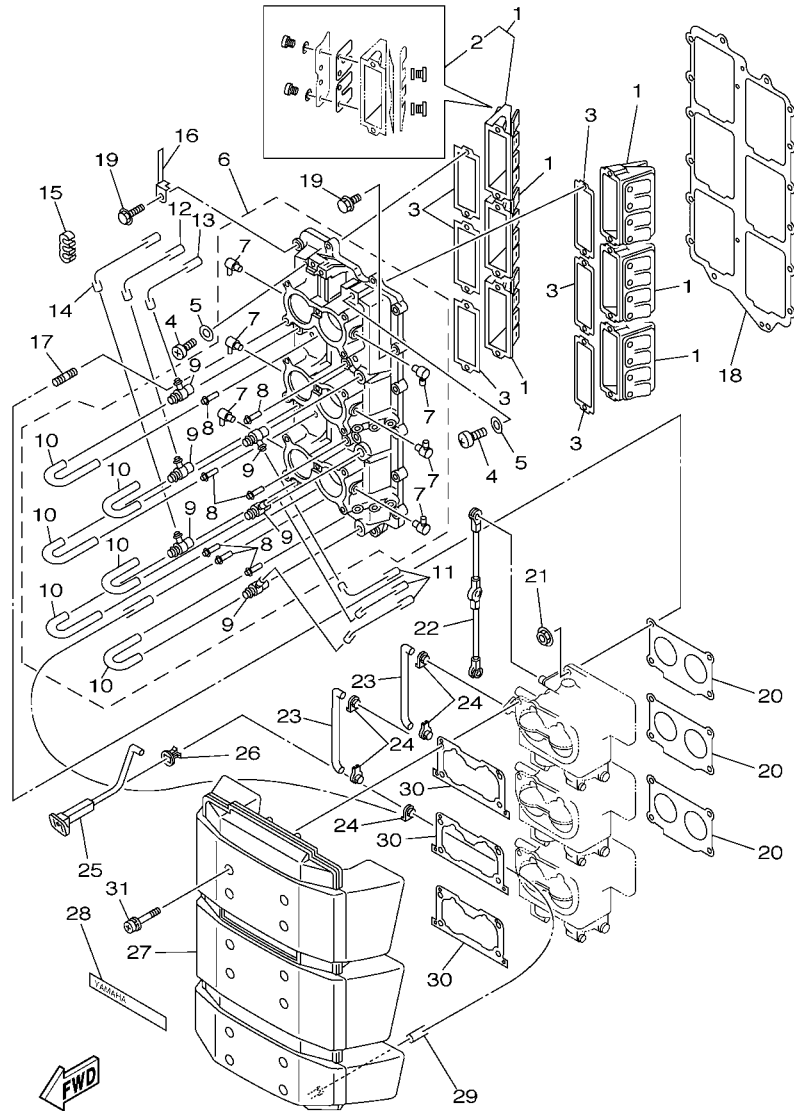

64D2100-3050

FIG. 5 INTAKE

REF. NO.	PART NO.	DESCRIPTION	64C8	64D8			REMARKS
27	64D-14440-00	SILENCER ASSY, INTAKE	1	1			FOR SWS
28	6G5-1441K-00	EMBLEM	1				FOR STD
29	90445-07MA3	HOSE (L200)	1	1			
30	6K7-14483-00	GASKET	3	3			
31	90159-06M14	SCREW, WITH WASHER	12				FOR STD
	90159-06M08	SCREW, WITH WASHER	12	12			FOR SWS

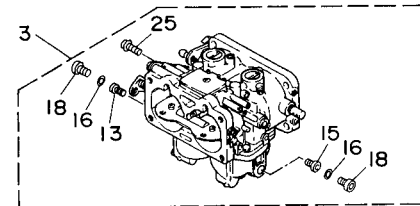
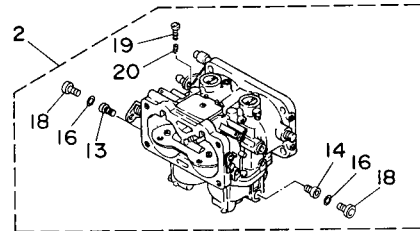
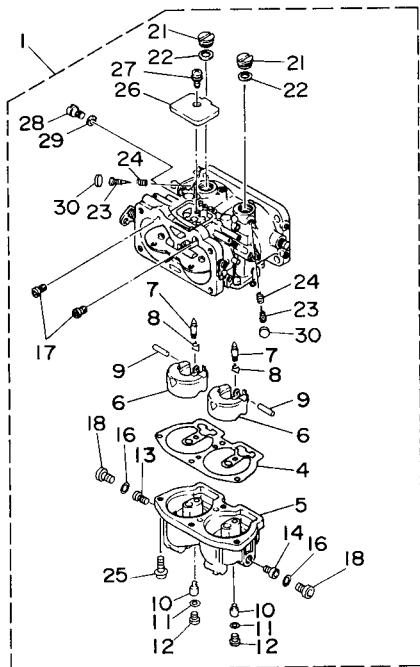

64D4100-D060

FIG. 6 CARBURETOR

REF. NO.	PART NO.	DESCRIPTION	64C8	64D8			REMARKS
1	64C-14301-10	CARBURETOR ASSY 1	1				FOR USA
	64C-14301-S2	CARBURETOR ASSY 1	1				FOR OCE-SWS
	64D-14301-S2	CARBURETOR ASSY 1		1			FOR OCE-SWS
	64C-14301-02	CARBURETOR ASSY 1	1				FOR CAR,KOR,RUS
2	64C-14302-10	CARBURETOR ASSY 2	1				FOR USA
	64C-14302-S2	CARBURETOR ASSY 2	1				FOR OCE-SWS
	64D-14302-S2	CARBURETOR ASSY 2		1			FOR OCE-SWS
	64C-14302-02	CARBURETOR ASSY 2	1				FOR CAR,KOR,RUS
3	64C-14303-10	CARBURETOR ASSY 3	1				FOR USA
	64C-14303-S2	CARBURETOR ASSY 3	1				FOR OCE-SWS
	64D-14303-S2	CARBURETOR ASSY 3		1			FOR OCE-SWS
	64C-14303-02	CARBURETOR ASSY 3	1				FOR CAR,KOR,RUS
4	64D-14384-01	.GASKET, FLOAT CHAMBER	3	3			
5	64D-14381-10	.BODY, FLOAT CHAMBER	3	3			FOR USA,OCE-SWS
	64D-14381-00	.BODY, FLOAT CHAMBER	3				FOR CAR,KOR,RUS
6	6E5-14385-02	.FLOAT	6	6			
7	6E5-14546-00	.VALVE, NEEDLE	6	6			
8	6E5-14159-00	.CLIP	6	6			
9	6E5-14386-02	.PIN, FLOAT	6	6			
10	64D-1492F-42	.JET, AIR SLOW (#84)	6	6			
11	61U-14959-00	.GASKET	6	6			
12	64D-14394-00	.VALVE, DRAIN	6	6			
13	64D-1492E-71	.JET, MAIN (#142)	3	3			FOR USA,OCE-SWS
	64D-1492E-75	.JET, MAIN (#150)	3				FOR CAR,KOR,RUS
14	64D-1492E-71	.JET, MAIN (#142)	2	2			FOR USA,OCE-SWS
	64D-1492E-77	.JET, MAIN (#154)	2				FOR CAR,KOR,RUS
15	64D-1492E-71	JET, MAIN (#142)	1	1			FOR USA,OCE-SWS

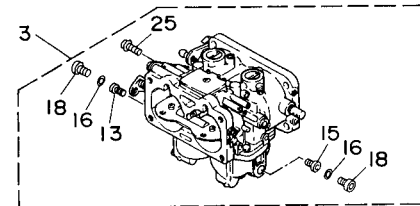
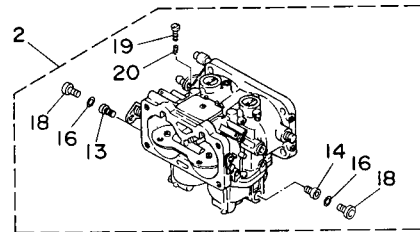
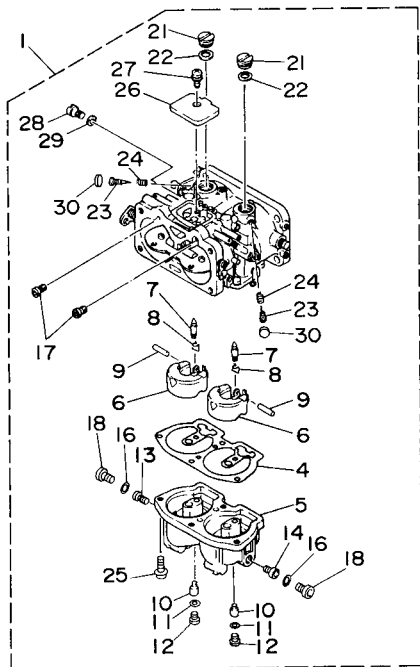

64D4100-D060

FIG. 6 CARBURETOR

REF. NO.	PART NO.	DESCRIPTION	64C8	64D8			REMARKS
15	64D-1492E-79	.JET, MAIN (#158)	1				FOR CAR,KOR,RUS
16	6E5-14398-01	.GASKET	6	6			
17	61A-1492H-12	.JET, SLOW AIR BLEED (#60)	6	6			
18	61A-14383-01	.SCREW, DRAIN	6	6			
19	6E5-14321-00	.SCREW, THROTTLE	1	1			#2
20	6J8-14334-00	.SPRING, THROTTLE	1	1			#2
21	6E5-14328-01	.PLUG	6	6			
22	6E5-14979-00	.GASKET	6	6			
23	6E5-14323-03	.SCREW, AIR ADJUSTING	6	6			
24	6E5-14223-00	.SPRING, AIR ADJUSTING	6	6			
25	97980-05116	.SCREW, WITH WASHER	12	12			FOR USA,OCE-SWS
	97980-05116	.SCREW, WITH WASHER	13				FOR CAR,KOR,RUS
26	6E5-14527-01	.PLATE	3	3			
27	97980-05108	.SCREW, WITH WASHER	3	3			
28	6E5-14324-00	.SCREW, FLAT HEAD	3	3			
29	6J8-14959-00	.GASKET	3	3			
30	64E-1432A-00	.PLUG	6				FOR USA

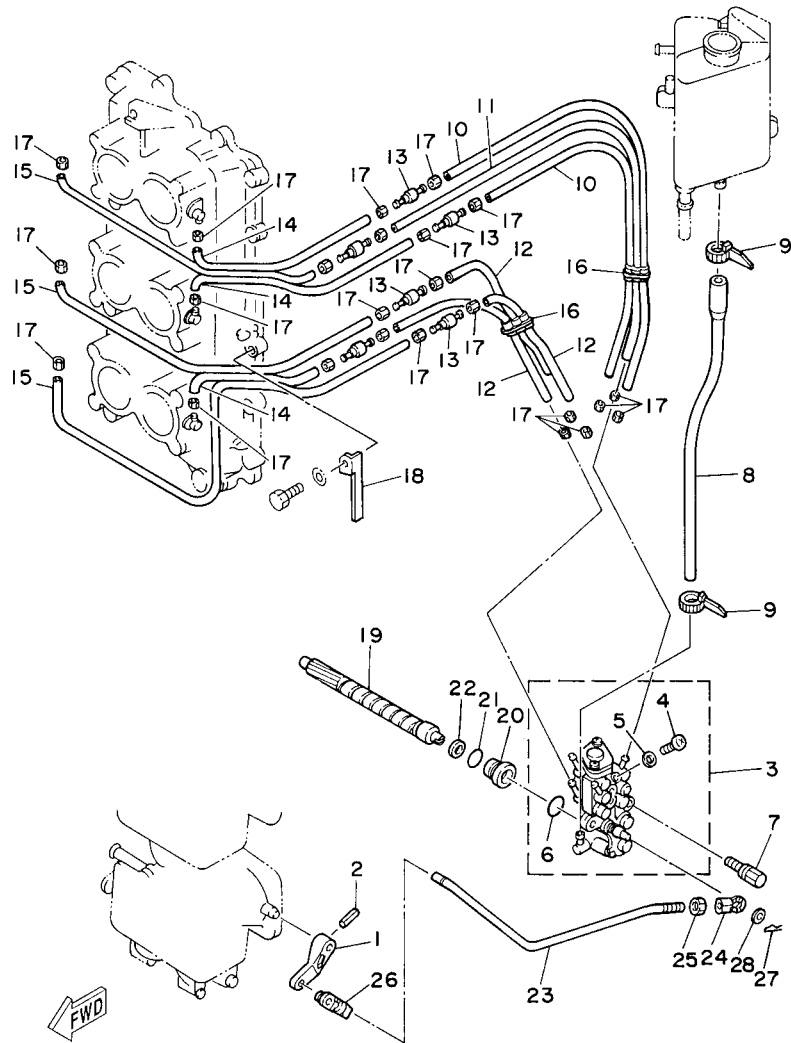

64D0010-6070

FIG. 7 OIL PUMP

REF. NO.	PART NO.	DESCRIPTION	64C8	64D8			REMARKS
1	6E5-14276-01	LEVER	1	1			
2	91690-30016	PIN, SPRING	1	1			
3	6R4-13200-02	OIL INJECTION PUMP ASSY	1	1			
4	6R3-13471-00	.PLUG, DRAIN	1	1			
5	6L2-13475-00	.GASKET	1	1			
6	93210-19M82	.O-RING	1	1			
7	90109-06M40	BOLT	2	2			
8	6R3-13416-00	PIPE, OIL 1	1	1			
9	90465-11M10	CLAMP	2	2			
10	90445-07M72	HOSE (L250)	2	2			
11	90445-07M89	HOSE (L310)	1	1			
12	90445-07M83	HOSE (L150)	3	3			
13	6R3-13183-10	VALVE, CHECK	6	6			
14	90445-07M87	HOSE (L110)	3	3			
15	90445-07M96	HOSE (L310)	3	3			
16	90464-07M05	CLAMP	2	2			
17	90468-07M02	CLIP	24	24			
18	90465-10M91	CLAMP	2	2			
19	6R3-11537-00	GEAR, DRIVEN	1	1			
20	6R3-13117-00	COLLAR, DISTANCE	1	1			
21	93210-13M04	O-RING	1	1			
22	90202-08M44	WASHER, PLATE	1	1			
23	6R3-41241-00	ROD, LINK	1	1			
24	6H1-41237-00	JOINT, LINK	1	1			
25	95380-05600	NUT	1	1			
26	6R5-41237-00	JOINT, LINK	1	1			
27	90468-05M03	CLIP	1	1			

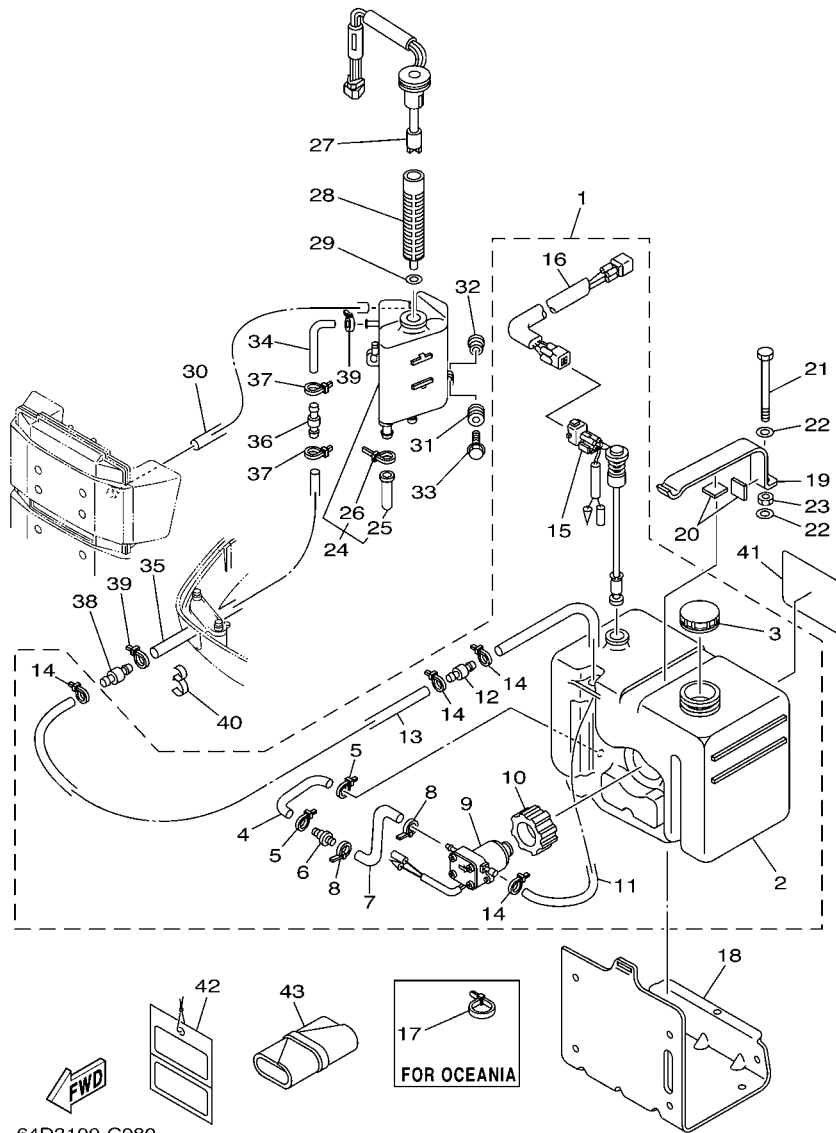

FIG. 8 OIL TANK

REF. NO.	PART NO.	DESCRIPTION	64C8	64D8			REMARKS
1	61A-21708-20	SUB OIL TANK ASSY	1	1			FOR OCE
	6E5-21708-10	SUB OIL TANK ASSY	1				FOR CAR,KOR,RUS
2	6E5-21733-20	.SUB TANK, OIL (10.5L)	1	1			
3	6E5-21770-03	.OIL TANK CAP ASSY	1	1			
4	6E5-24322-00	.PIPE 11	1	1			
5	90465-11M10	.CLAMP	2	2			
6	646-24251-02	.STRAINER 1	1	1			
7	6E5-24319-01	.PIPE, OIL	1	1			
8	90465-11M10	.CLAMP	2	2			
9	6E5-81900-01	.OIL FEED PUMP ASSY	1	1			
10	6E5-81922-00	.GROMMET	1	1			
11	6E5-24321-01	.PIPE 10	1	1			
12	6E5-24379-00	.PIPE, JOINT 4	1	1			
13	90445-11M26	.HOSE (L6500)	1	1			FOR 61A-21708-20
	90445-11M81	.HOSE (L3000)	1				FOR 6E5-21708-10
14	90465-11M10	.CLAMP	4	4			
15	6E5-85720-05	.OIL LEVEL GAUGE ASSY	1	1			
16	6R3-85721-80	.WIRE, LEAD (L=8.0M)	1	1			FOR 61A-21708-20
	6R3-85721-30	.WIRE, LEAD (L=3.0M)	1				FOR 6E5-21708-10
17	90465-13M11	CLAMP	1	1			FOR OCE
18	6E5-21734-01-33	HOLDER, OIL SUB TANK	1	1			
19	6E5-21798-01-33	BRACKET, DAMPER	1	1			
20	6E5-21746-00	DAMPER	2	2			
21	97080-06100	BOLT	1	1			
22	92990-06600	WASHER, PLATE	2	2			
23	95380-06600	NUT, HEXAGON	1	1			
24	6E5-21750-05	OIL TANK ASSY	1	1			

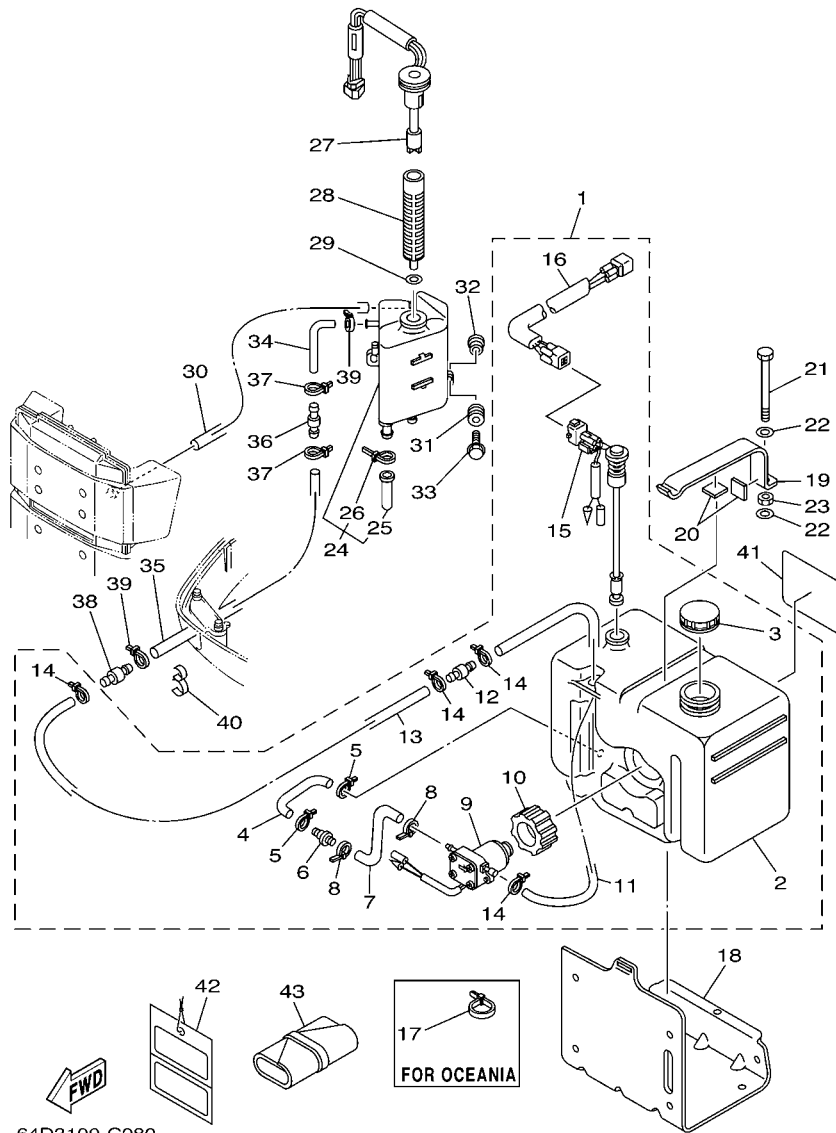
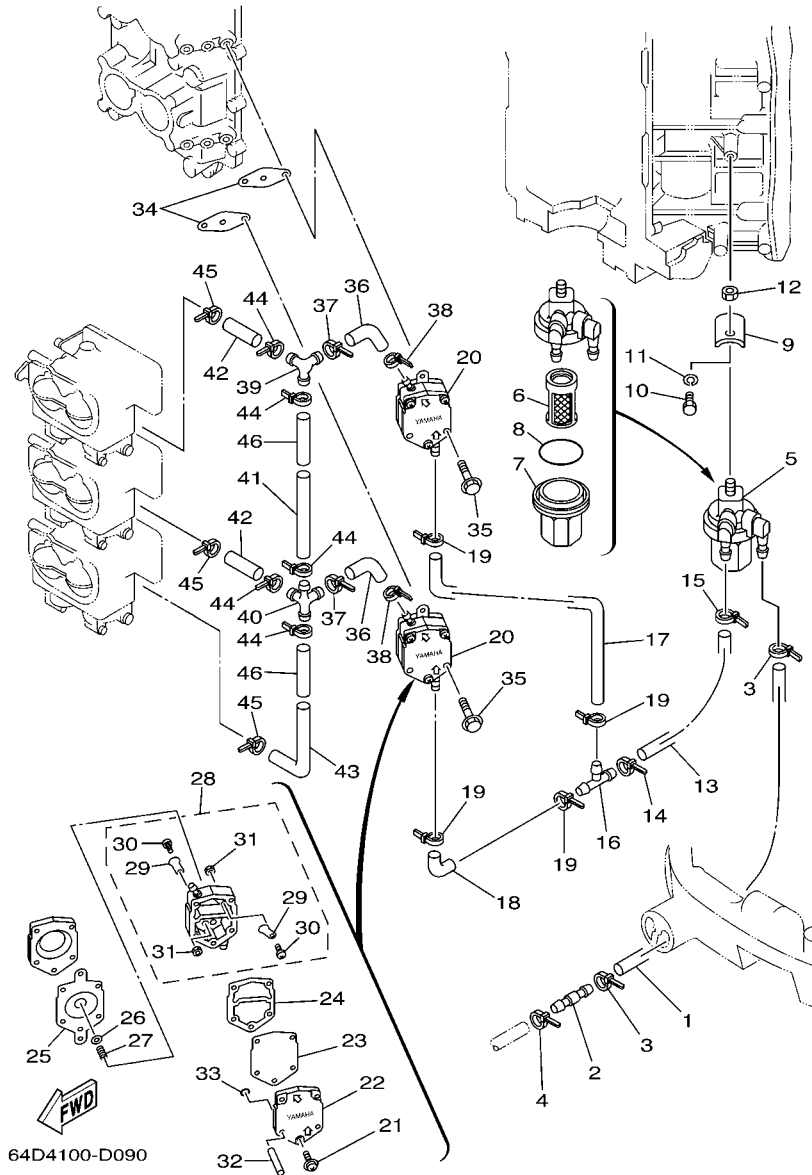

FIG. 8 OIL TANK

REF. NO.	PART NO.	DESCRIPTION	64C8	64D8			REMARKS
			1	1			
25	6E5-13448-00	.CAP	1	1			
26	90465-13M11	.CLAMP	1	1			
27	6R3-85730-03	OIL LEVEL GAUGE ASSY	1	1			
28	6E5-13411-00	STRAINER, OIL	1	1			
29	6E5-13414-00	GASKET, STRAINER COVER	1	1			
30	90445-05M02	HOSE (L380)	1	1			
31	6A0-82317-00	DAMPER, IGNITION COIL	3	3			
32	90387-06119	COLLAR	3	3			
33	90119-06M65	BOLT, WITH WASHER	3	3			
34	64E-24323-00	PIPE 12	1	1			
35	90445-12207	HOSE (L2400)	1	1			FOR USA,OCE
	90445-12M13	HOSE (L880)	1				FOR CAR,KOR,RUS
36	6E5-24379-00	PIPE, JOINT 4	1	1			
37	90465-11M10	CLAMP	2	2			
38	6E5-24379-00	PIPE, JOINT 4	1	1			
39	90465-11M10	CLAMP	2	2			
40	90464-13M34	CLAMP	1	1			
41	6E5-13437-43	MARK, CAUTION	1	1			FOR OCE,KOR
	6E5-13437-62	MARK, CAUTION	1				FOR CAR,RUS
42	61H-2819R-31	TAG, WARNING	1	1			EXCEPT FOR KOR
43	656-W2810-02	TOOL KIT	1	1			AP



64D4100-D090

FIG. 9 FUEL 1

REF. NO.	PART NO.	DESCRIPTION	64C8	64D8	REMARKS
1	6R3-24313-20	PIPE 3 (L2820)	1	1	FOR USA,OCE
	6R3-24313-01	PIPE 3 (L880)	1		FOR CAR,KOR,RUS
2	6R3-24377-10	PIPE, JOINT 2	1		FOR USA
	6R3-24377-00	PIPE, JOINT 2	1	1	EXCEPT FOR USA
3	90465-11M10	CLAMP	2	2	
4	90465-11M10	CLAMP	1	1	
5	6R3-24560-00	FILTER ASSY	1	1	
6	6R3-24563-00	.ELEMENT, FILTER	1	1	
7	61N-24521-00	.CUP, FILTER	1	1	
8	93210-32738	.O-RING	1	1	
9	648-24566-02	BRACKET, FILTER	1	1	
10	97013-06014	BOLT	1	1	
11	92903-06100	WASHER, SPRING	1	1	
12	95380-08600	NUT	1	1	
13	6G5-24314-00	PIPE 4	1	1	
14	90465-11M10	CLAMP	1	1	
15	90465-11M10	CLAMP	1	1	
16	6E5-24378-00	PIPE, JOINT 3	1	1	
17	6G5-24315-00	PIPE 5	1	1	
18	6E5-24315-00	PIPE 5	1	1	
19	90465-11M10	CLAMP	4	4	
20	6E5-24410-04	FUEL PUMP ASSY	2	2	
21	6E5-24444-01	.SCREW	3	3	
22	6E5-24413-01	.BODY 2	1	1	
23	6E5-24471-01	.DIAPHRAGM	1	1	
24	6E5-24435-01	.GASKET, BODY 2	1	1	
25	6E5-24411-01	.DIAPHRAGM	1	1	

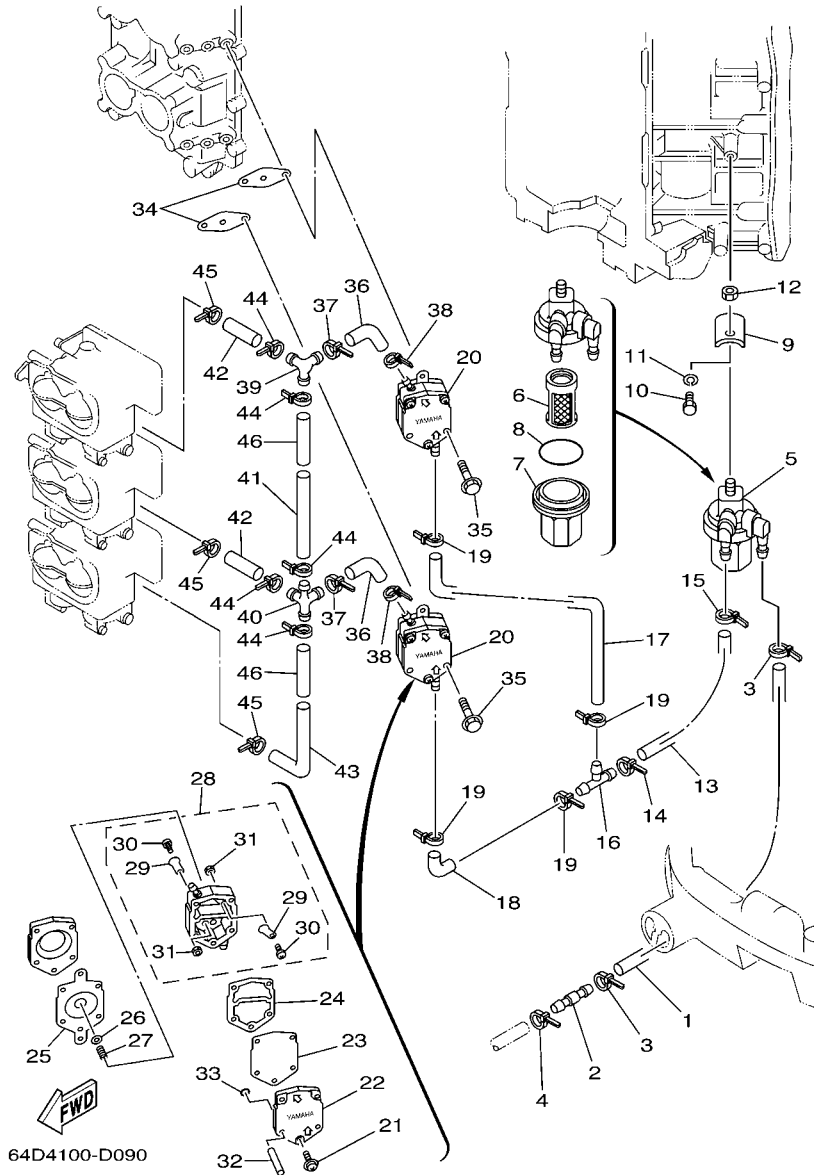
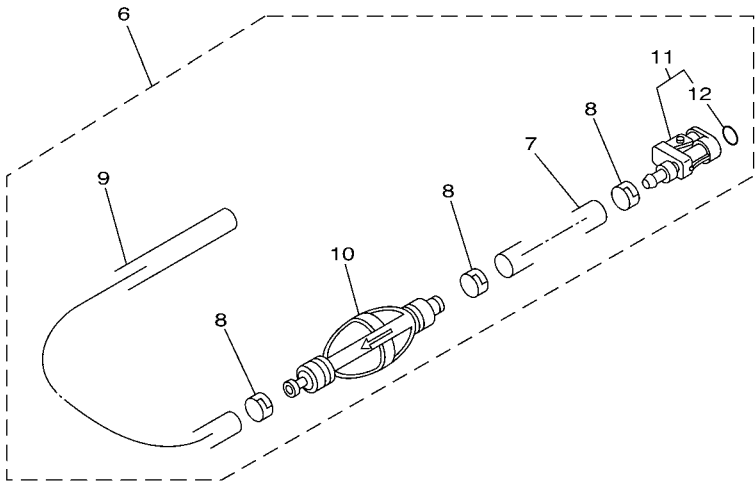
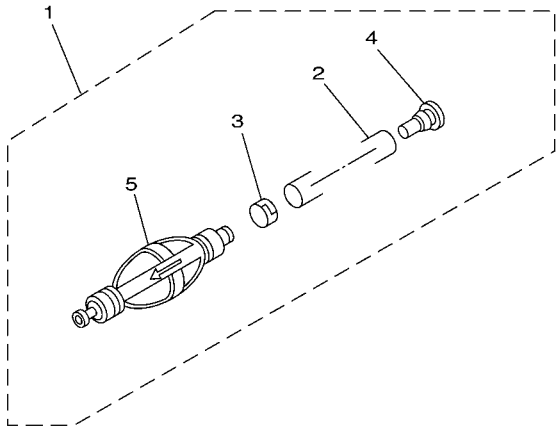

FIG. 9 FUEL 1

REF. NO.	PART NO.	DESCRIPTION	64C8	64D8			REMARKS
26	648-24424-00	.SEAT, SPRING	1	1			
27	6E5-24423-00	.SPRING, DIAPHRAGM	1	1			
28	6E5-24412-11	.BODY 1	1	1			
29	6A0-24421-01	..VALVE, CHECK	4	4			
30	6A0-14325-00	..SCREW, PAN HEAD	4	4			
31	95380-03600	..NUT	4	4			
32	6E5-24492-00	.BUSH, FUEL PUMP	2	2			
33	6E5-24486-00	.O-RING	2	2			
34	650-24431-A0	GASKET, FUEL PUMP 1	2	2			
35	97595-06550	BOLT, WITH WASHER	4	4			
36	6G5-24316-10	PIPE 6	2	2			
37	90465-11M10	CLAMP	2	2			
38	90465-11M10	CLAMP	2	2			
39	6G5-24376-00	PIPE, JOINT 1	1	1			
40	6G5-24377-00	PIPE, JOINT 2	1	1			
41	6G5-24317-01	PIPE 7	1	1			
42	6G5-24318-10	PIPE, OVERFLOW	2	2			
43	6G5-24319-10	PIPE, OIL	1	1			
44	90465-11M10	CLAMP	5	5			
45	90465-11M10	CLAMP	3	3			
46	90446-15M07	HOSE (L60)	2	2			



64D3100-C100

FIG. 10 FUEL 2

REF. NO.	PART NO.	DESCRIPTION	64C8	64D8			REMARKS
1	6Y2-24307-50	FUEL PIPE COMP. 2	1	1			AP FOR OCE
2	90445-13M01	.HOSE (L2050)	1	1			
3	6E5-24351-51	.BAND 1	1	1			
4	90480-06M19	.GROMMET	1	1			
5	6Y2-24360-60	.PRIMER PUMP ASSY	1	1			
6	6Y2-24306-45	FUEL PIPE COMP. 1	1				AP FOR KOR
	6YK-24306-44	FUEL PIPE COMP. 1	1				AP FOR RUS
7	90445-13M01	.HOSE (L2050)	1				FOR 6Y2-24306-45
8	6E5-24351-51	.BAND 1		3			FOR 6Y2-24306-45
9	90445-13M35	.HOSE (L250)	1				FOR 6Y2-24306-45
10	6Y2-24360-60	.PRIMER PUMP ASSY	1				FOR 6Y2-24306-45
11	6Y2-24305-06	.FUEL PIPE JOINT COMP. 2	1				FOR 6Y2-24306-45
12	93210-08287	..O-RING	1				FOR 6Y2-24306-45

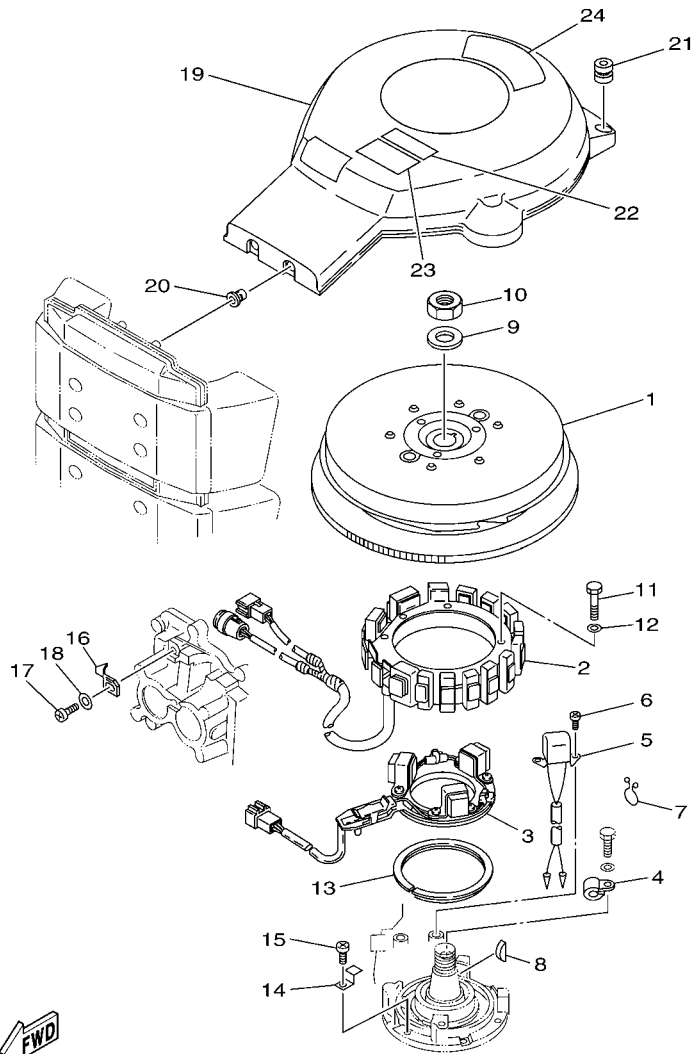

64D8100-G110

FIG. 11 GENERATOR

REF. NO.	PART NO.	DESCRIPTION	64C8	64D8			REMARKS
			1	1			
1	64D-85550-02	ROTOR ASSY	1	1			
2	6R3-85510-00	STATOR ASSY	1	1			
3	64D-85580-00	COIL, PULSER	1	1			
4	90465-06M86	CLAMP	1	1			
5	6R5-85895-01	CRANK POSITION SENDER	1	1			
6	97885-05012	SCREW, PAN HEAD	2	2			
7	90464-15M11	CLAMP	1	1			
8	90280-05015	KEY, WOODRUFF	1	1			
9	90201-21M18	WASHER, PLATE	1	1			
10	90170-20137	NUT	1	1			
11	97013-06070	BOLT	4	4			
12	92903-06600	WASHER, PLATE	4	4			
13	688-41611-00	RETAINER, MAGNETO BASE	1	1			
14	688-41612-00	RETAINER, MAGNETO BASE	4	4			
15	97880-06018	SCREW, PAN HEAD	4	4			
16	6E5-81332-00	PLATE, TIMING	1	1			
17	97885-06010	SCREW, PAN HEAD	1	1			
18	92995-06600	WASHER	1	1			
19	64D-81337-10	COVER, FLYWHEEL	1				FOR STD
	64D-81337-01	COVER, FLYWHEEL	1	1			FOR SWS
20	6G5-82317-00	DAMPER, IGNITION COIL	2				FOR STD
	90480-13M24	GROMMET	1	1			FOR SWS
21	663-82317-01	DAMPER, IGNITION COIL	2	2			
22	6A1-83625-41	MARK 5	1	1			
23	6A1-83625-51	MARK 5	1				FOR RUS
24	6G5-14488-02	LABEL, CAUTION	1	1			

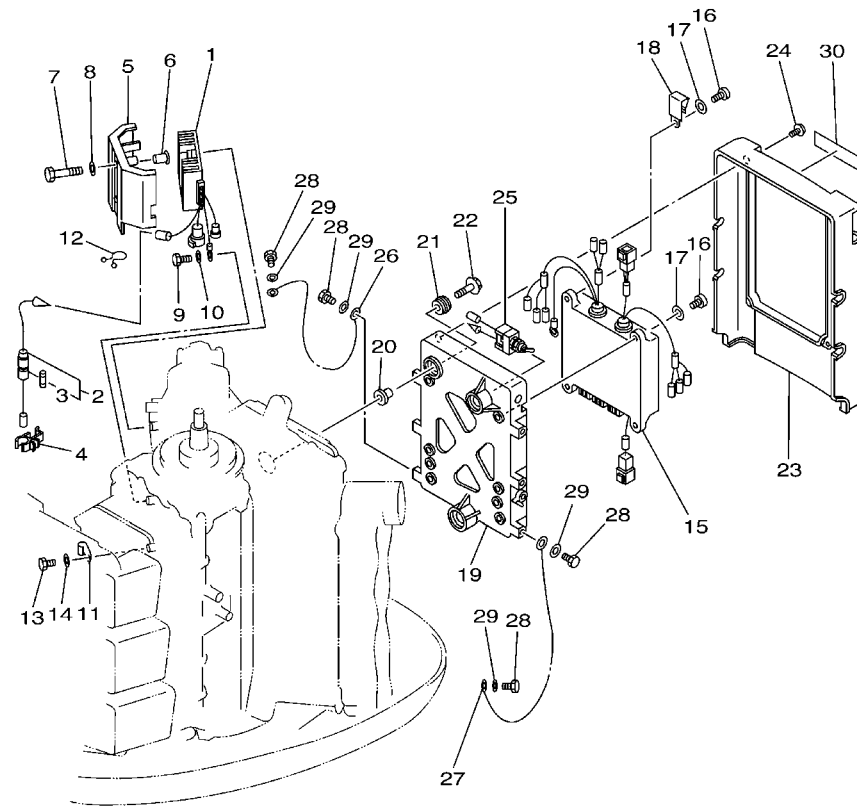

64L1100-2120

FIG. 12 ELECTRICAL 1

REF. NO.	PART NO.	DESCRIPTION	64C8	64D8			REMARKS
1	6R3-81960-10	RECTIFIER & REGULATOR ASSY	1	1			
2	6R3-82150-00	FUSE HOLDER ASSY	1	1			
3	705-82151-00	.FUSE (30A)	1	1			
4	6G5-82152-00	HOLDER, FUSE	1	1			
5	64D-81942-00	COVER	1	1			
6	90387-06M66	COLLAR	2	2			
7	97013-06055	BOLT	2	2			
8	92903-06600	WASHER, PLATE	2	2			
9	97095-06012	BOLT	1	1			
10	92995-06600	WASHER	1	1			
11	90465-06M88	CLAMP	1	1			
12	90464-15M11	CLAMP	1	1			
13	97095-06012	BOLT	1	1			
14	92995-06600	WASHER	1	1			
15	64D-85540-01	C.D.I. UNIT ASSY	1	1			
16	97880-06020	SCREW, PAN HEAD	4	4			
17	92990-06600	WASHER, PLATE	4	4			
18	90465-05M87	CLAMP	1	1			
19	6R3-85542-03-1S	BRACKET	1	1			
20	90387-06M03	COLLAR	3	3			
21	90480-09M12	GROMMET	3	3			
22	90119-06M61	BOLT, WITH WASHER	3	3			
23	64D-85537-00	COVER	1	1			
24	90159-06M11	SCREW, WITH WASHER	4	4			
25	6R3-8259E-00	SWITCH ASSY	1	1			
26	662-82519-00	WIRE, EARTH LEAD	1	1			
27	6R3-82519-00	WIRE, EARTH LEAD	1	1			

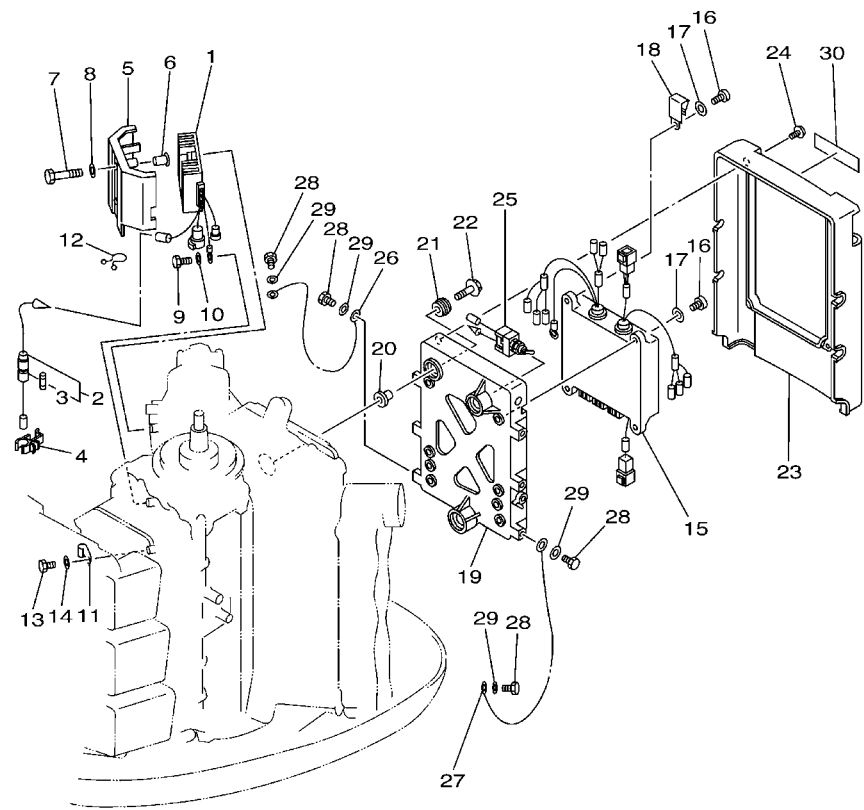

64L1100-2120

FIG. 12 ELECTRICAL 1

REF. NO.	PART NO.	DESCRIPTION	64C8	64D8	REMARKS
28	97095-06012	BOLT	5	5	
29	92995-06600	WASHER	5	5	
30	6E5-85711-40	MARK, CAUTION	1	1	EXCEPT FOR RUS
	6E5-85711-60	MARK, CAUTION	1		FOR RUS

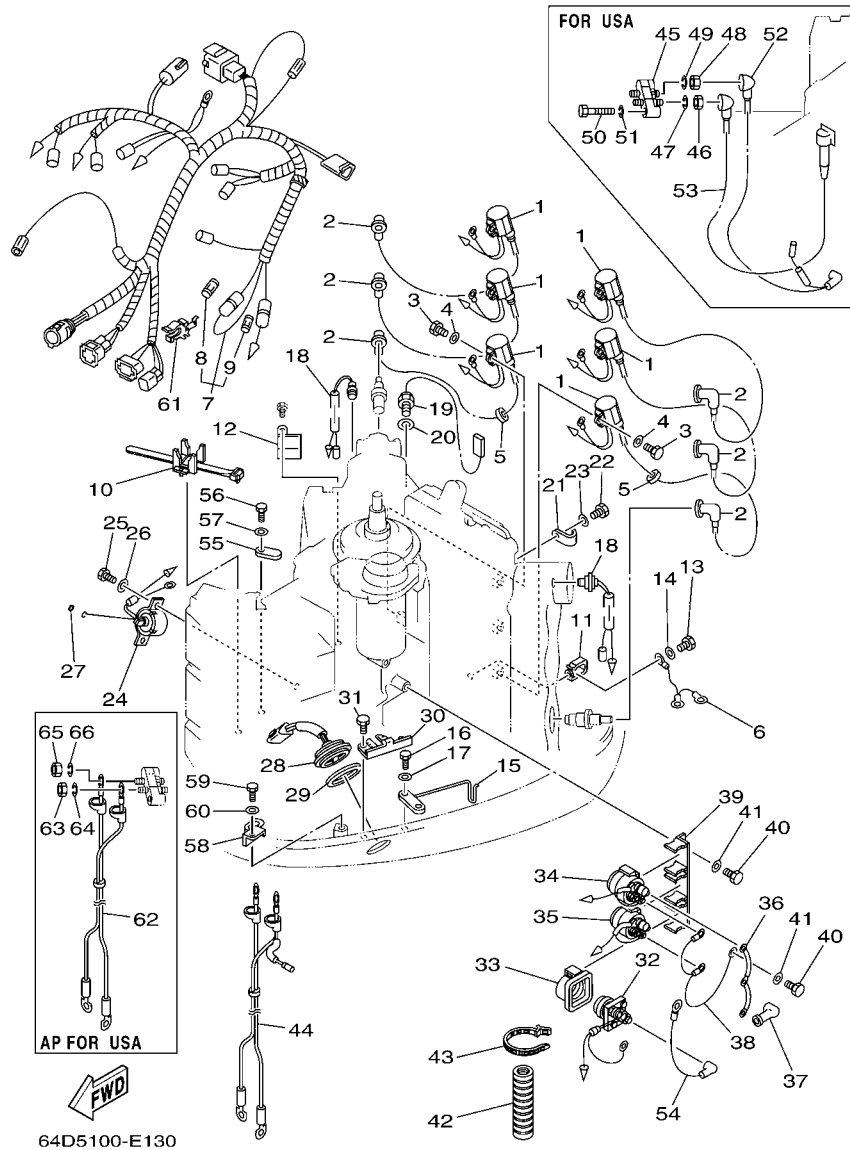

FIG. 13 ELECTRICAL 2

REF. NO.	PART NO.	DESCRIPTION	64C8	64D8	REMARKS
1	6R3-85570-01	IGNITION COIL ASSY	6	6	
2	6E3-82370-21	PLUG CAP ASSY	6	6	
3	97095-06020	BOLT	6	6	
4	92995-06600	WASHER	6	6	
5	90480-25161	GROMMET	2	2	
6	6E5-82531-10	WIRE, LEAD	1	1	
7	64D-82590-20	WIRE HARNESS ASSY	1	1	
8	663-82151-00	.FUSE (12V-20A)	1	1	
9	705-82151-00	.FUSE (30A)	1	1	
10	688-82594-00	CLAMP	1	1	
11	90465-05M87	CLAMP	1	1	
12	90465-08M89	CLAMP	1	1	
13	97095-06012	BOLT	1	1	
14	92995-06600	WASHER	1	1	
15	6K7-82588-00	PLATE	1	1	
16	97095-06020	BOLT	1	1	
17	92995-06600	WASHER	1	1	
18	688-82560-10	THERMO SWITCH ASSY	2	2	
19	61A-85790-00	THERMOSENSOR ASSY	1	1	
20	92990-10600	WASHER, PLATE	1	1	
21	90465-06M86	CLAMP	1	1	
22	97095-06012	BOLT	1	1	
23	92995-06600	WASHER	1	1	
24	64D-86110-01	SOLENOID	1	1	
25	97095-06016	BOLT	2	2	
26	92995-06600	WASHER	2	2	
27	93210-03261	O-RING	1	1	

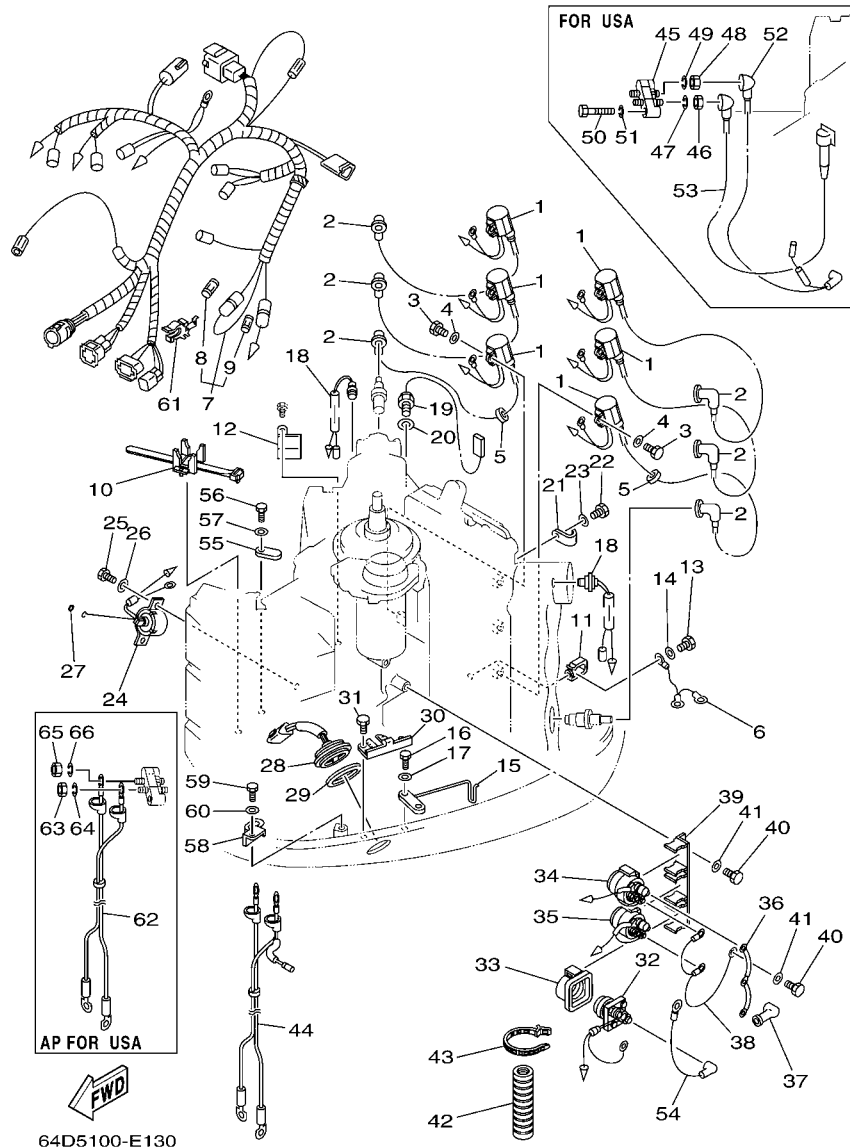

FIG. 13 ELECTRICAL 2

REF. NO.	PART NO.	DESCRIPTION	64C8	64D8	REMARKS
28	6R3-82563-00	TRIM & TILT SWITCH ASSY	1	1	
29	6E5-82587-00	GASKET	1	1	
30	6R3-83614-00	BRACKET	1	1	
31	97095-06012	BOLT	2	2	
32	61A-81941-00	STARTER RELAY ASSY	1	1	
33	689-81952-10	HOLDER, RELAY	1	1	
34	6E5-81950-00	RELAY ASSY	1	1	
35	6E5-8195A-00	RELAY ASSY	1	1	
36	6G5-87149-10	CONNECTOR	1	1	
37	6G5-82119-00	COVER, LEAD WIRE	2	2	
38	6E5-82116-00	WIRE, MINUS LEAD	1	1	
39	6G5-81948-11	BRACKET	1	1	
40	97095-06016	BOLT	2	2	
41	92995-06600	WASHER	2	2	
42	6E9-83557-70	TUBE	1	1	
43	90465-13M18	CLAMP	1	1	
44	6R3-82105-02	WIRE HARNESS	1	1	EXCEPT FOR USA
45	64D-81920-01	TERMINAL ASSY	1		FOR USA
46	95380-08700	NUT	1		FOR USA
47	92990-08100	WASHER, SPRING	1		FOR USA
48	95380-06700	NUT	1		FOR USA
49	92990-06100	WASHER, SPRING	1		FOR USA
50	97095-06035	BOLT	2		FOR USA
51	92995-06100	WASHER, SPRING	2		FOR USA
52	64D-82117-00	WIRE, LEAD	1		FOR USA
53	64D-82116-00	WIRE, MINUS LEAD	1		FOR USA
54	6E5-82117-01	WIRE, LEAD	1	1	

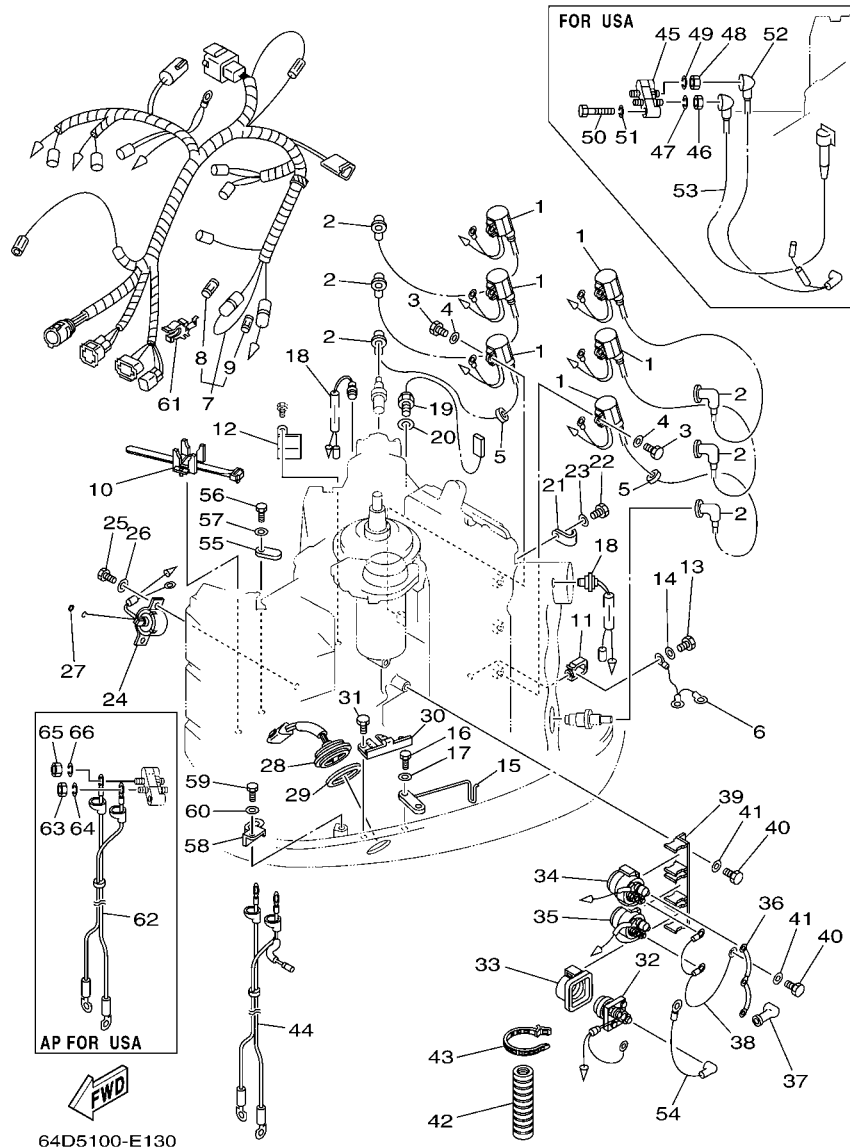

FIG. 13 ELECTRICAL 2

REF. NO.	PART NO.	DESCRIPTION	64C8	64D8			REMARKS
			1	1			
55	6E5-82588-00	PLATE	1	1			
56	97095-06020	BOLT	1	1			
57	92995-06600	WASHER	1	1			
58	90465-12M25	CLAMP	1	1			
59	97095-06012	BOLT	1	1			
60	92995-06600	WASHER	1	1			
61	6G5-82152-00	HOLDER, FUSE	2	2			
62	64D-82105-00	WIRE HARNESS	1				AP FOR USA
63	95380-08700	NUT	1				AP FOR USA
64	92990-08100	WASHER, SPRING	1				AP FOR USA
65	95380-06700	NUT	1				AP FOR USA
66	92990-06100	WASHER, SPRING	1				AP FOR USA

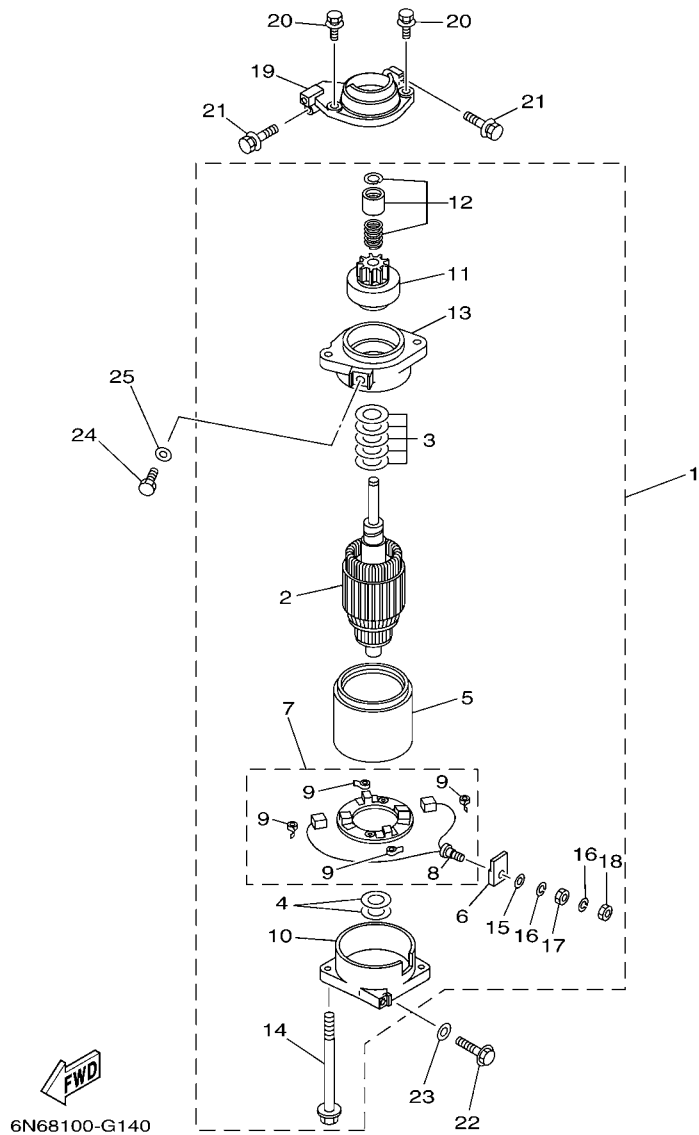

FIG. 14 STARTING MOTOR

REF. NO.	PART NO.	DESCRIPTION	64C8	64D8			REMARKS
1	6N7-81800-10	STARTING MOTOR ASSY	1	1			
2	6N7-81850-10	.ARMATURE ASSY	1	1			
3	61A-81809-00	.WASHER KIT	1	1			
4	61A-81824-00	.WASHER 2	2	2			
5	6N7-81810-00	.STATOR ASSY	1	1			
6	6K7-8182G-10	.BUSH, TERMINAL	1	1			
7	6N7-81840-00	.BRUSH HOLDER ASSY	1	1			
8	6N7-81801-00	..BRUSH SET	1	1			
9	6N7-81813-00	..SPRING, BRUSH	4	4			
10	6N7-81820-10	.REAR BRACKET ASSY	1	1			
11	6N7-81807-00	.GEAR ASSY, STARTING MOTOR	1	1			
12	6N7-81857-00	.RETAINER	1	1			
13	6N7-81830-00	.FRONT BRACKET ASSY	1	1			
14	6K7-81826-11	.BOLT	2	2			
15	6E5-8182E-10	.WASHER	1	1			
16	6E5-8182F-10	.WASHER	2	2			
17	6E5-8182A-10	.NUT	1	1			
18	6E5-8182K-10	.NUT	1	1			
19	6R3-81822-00-94	BRACKET, STARTING MOTOR	1	1			
20	90119-08M76	BOLT, WITH WASHER	2	2			
21	90119-08M77	BOLT, WITH WASHER	2	2			
22	90119-08M57	BOLT, WITH WASHER	1	1			
23	92990-08600	WASHER, PLATE	1	1			
24	97095-08016	BOLT	1	1			
25	92995-08600	WASHER	1	1			

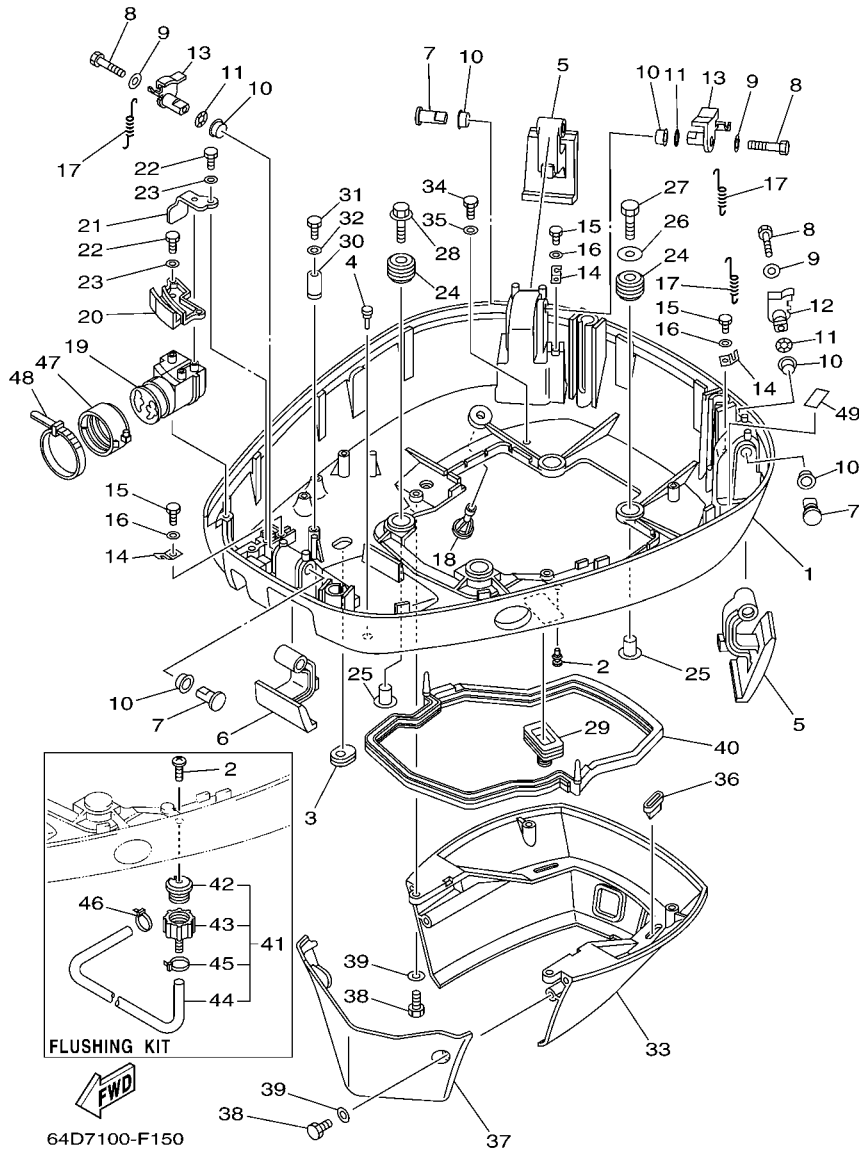

FIG. 15 BOTTOM COWLING

REF. NO.	PART NO.	DESCRIPTION	64C8	64D8	REMARKS
1	64D-42711-01-8D	COWLING, BOTTOM 1	1	1	
2	90169-05M00	SCREW, TRUSS HEAD TAPPING	1	1	FOR STD
	90480-06M19	GROMMET	1		
3	61A-42727-00	GROMMET	1	1	
4	6H4-42748-00	GROMMET	1	1	
5	64D-42815-00-4D	LEVER, CLAMP	2	2	
6	64D-42816-00-4D	LEVER, CLAMP	1	1	
7	64D-42835-00	PIN, SET 1	3	3	
8	97095-06040	BOLT	3	3	
9	90201-06068	WASHER, PLATE	3	3	
10	90386-15M73	BUSH	6	6	
11	90206-15M18	WASHER, WAVE	3	3	
12	64D-42818-20	LEVER, CLAMP	1	1	
13	64D-42818-30	LEVER, CLAMP	2	2	
14	64D-43144-00	HOOK, SPRING	3	3	
15	97090-06012	BOLT	3	3	
16	92990-06600	WASHER, PLATE	3	3	
17	90506-16M34	SPRING, TENSION	3	3	
18	6E5-44391-00	NIPPLE, HOSE	1	1	
19	64D-42725-30	GROMMET	1	1	FOR USA,OCE
	64D-42725-20	GROMMET	1		FOR CAR,KOR,RUS
20	64D-42738-00-5B	PLATE, FITTING	1	1	
21	64D-42738-10-5B	PLATE, FITTING	1	1	
22	97095-06016	BOLT	3	3	
23	92995-06600	WASHER	3	3	
24	90480-22M15	GROMMET	4	4	
25	90387-08M37	COLLAR	4	4	

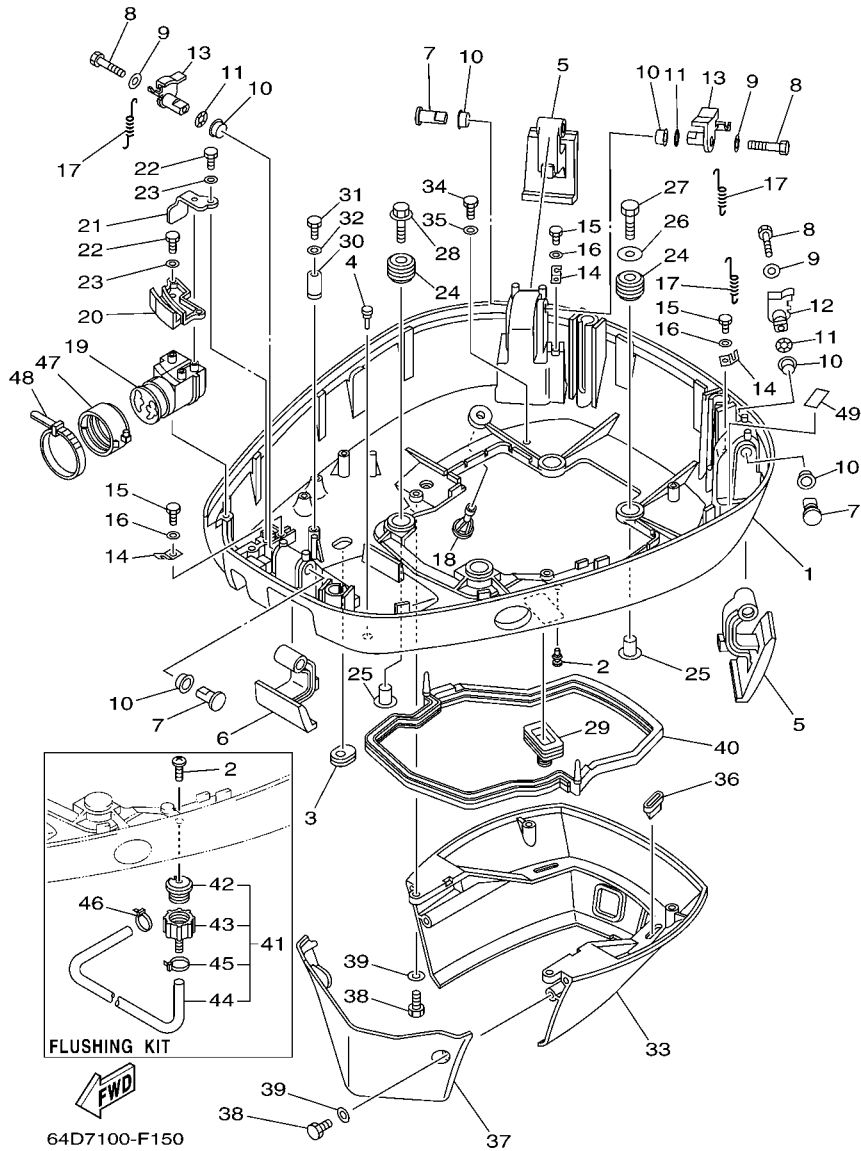
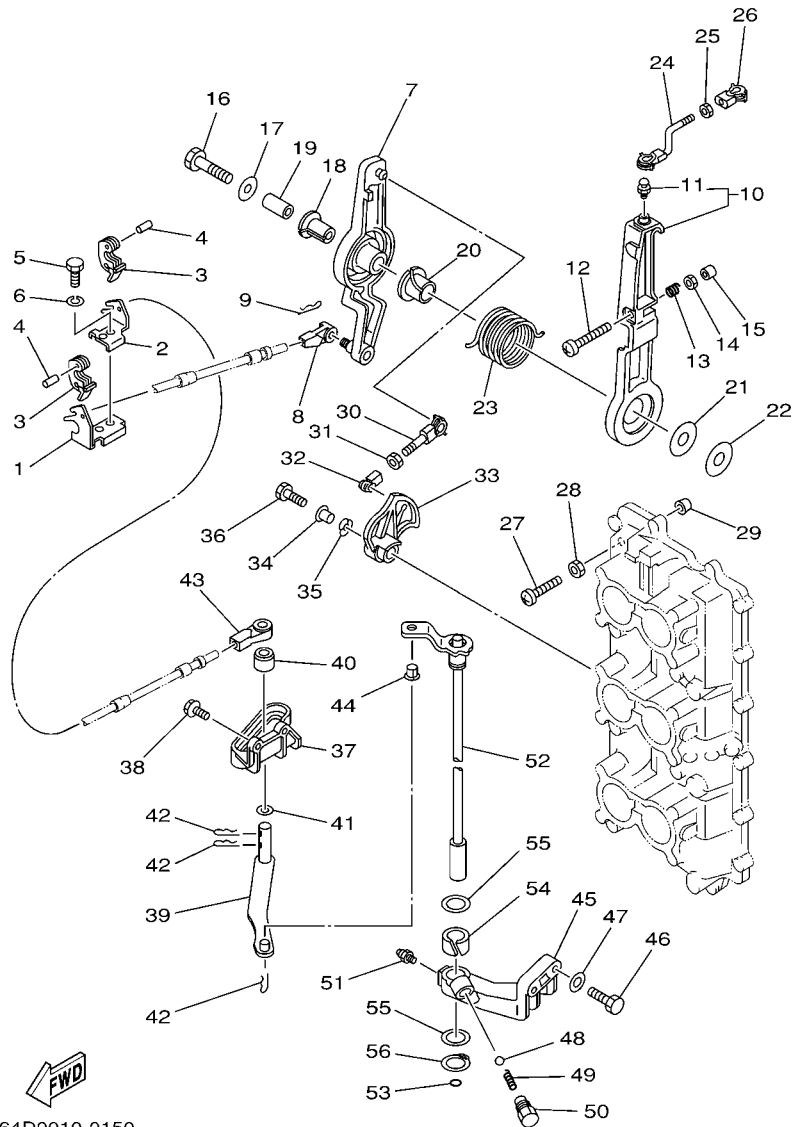

FIG. 15 BOTTOM COWLING

REF. NO.	PART NO.	DESCRIPTION	64C8	64D8			REMARKS
26	90201-08M54	WASHER, PLATE	1	1			
27	97075-08035	BOLT	1	1			
28	90119-08M22	BOLT, WITH WASHER	3	3			
29	688-42726-10	GROMMET	1	1			
30	6E5-82588-00	PLATE	1	1			
31	97095-06020	BOLT	1	1			
32	92995-06600	WASHER	1	1			
33	6R3-42741-02-8D	APRON	1	1			
34	97095-06020	BOLT	2	2			
35	92995-06600	WASHER	2	2			
36	64D-42717-00	RUBBER, SEAL 2	2	2			
37	6R3-42771-01-8D	APRON	1	1			
38	97095-06020	BOLT	4	4			
39	92995-06600	WASHER	4	4			
40	6E5-42716-10	RUBBER, SEAL 1	1	1			
41	6R3-Y125J-70	FLUSHING KIT	1	1			
42	6R3-12572-00	.ADAPTER	1	1			
43	6R3-12580-00	.JOINT ASSY	1	1			
44	90445-11M35	.HOSE (L540)	1	1			
45	90465-11M10	.CLAMP	1	1			
46	90465-11M10	CLAMP	1	1			
47	68F-42753-00	FASTNER	1	1			AP FOR OCE
48	90464-20258	CLAMP	1	1			AP FOR OCE
49	6E7-42791-10	MARK 1	1				
	6G5-42791-10	MARK 1		1			



64D0010-0150

FIG. 16 CONTROL

REF. NO.	PART NO.	DESCRIPTION	64C8	64D8			REMARKS
1	64D-48531-00	BRACKET, REMOTE CONTROL 1	1	1			
2	64D-48532-00	BRACKET, REMOTE CONTROL 2	1	1			
3	6E5-48538-00	CLAMP, CABLE	2	2			
4	91690-30012	PIN, SPRING	2	2			
5	97095-08020	BOLT	1	1			
6	92995-08100	WASHER	1	1			
7	61H-41632-02-1S	LEVER, MAGNETO CONTROL	1	1			
8	6E5-48344-00	CABLE END, REMOTE CONTROL	1	1			
9	90468-18008	CLIP	1	1			
10	6G5-41631-01-1S	LEVER, MAGNETO CONTROL	1	1			
11	663-85518-00	JOINT, BALL	1	1			
12	90157-06013	SCREW, PAN HEAD	1	1			
13	90501-16M12	SPRING, COMPRESSION	1	1			
14	95303-06600	NUT	1	1			
15	688-44194-00	CAP	1	1			
16	97013-08045	BOLT	1	1			
17	90201-08M23	WASHER, PLATE	1	1			
18	90386-12089	BUSH	1	1			
19	90387-08M16	COLLAR	1	1			
20	90386-22M13	BUSH	1	1			
21	90202-12092	WASHER, PLATE	1	1			
22	90201-08M13	WASHER, PLATE	1	1			
23	90508-29M12	SPRING, TORSION	1	1			
24	6G5-41636-01	ROD, MAGNETO CONTROL	1	1			
25	95380-05600	NUT	1	1			
26	662-41237-01	JOINT, LINK	1	1			
27	90157-06M00	SCREW, PAN HEAD	1	1			

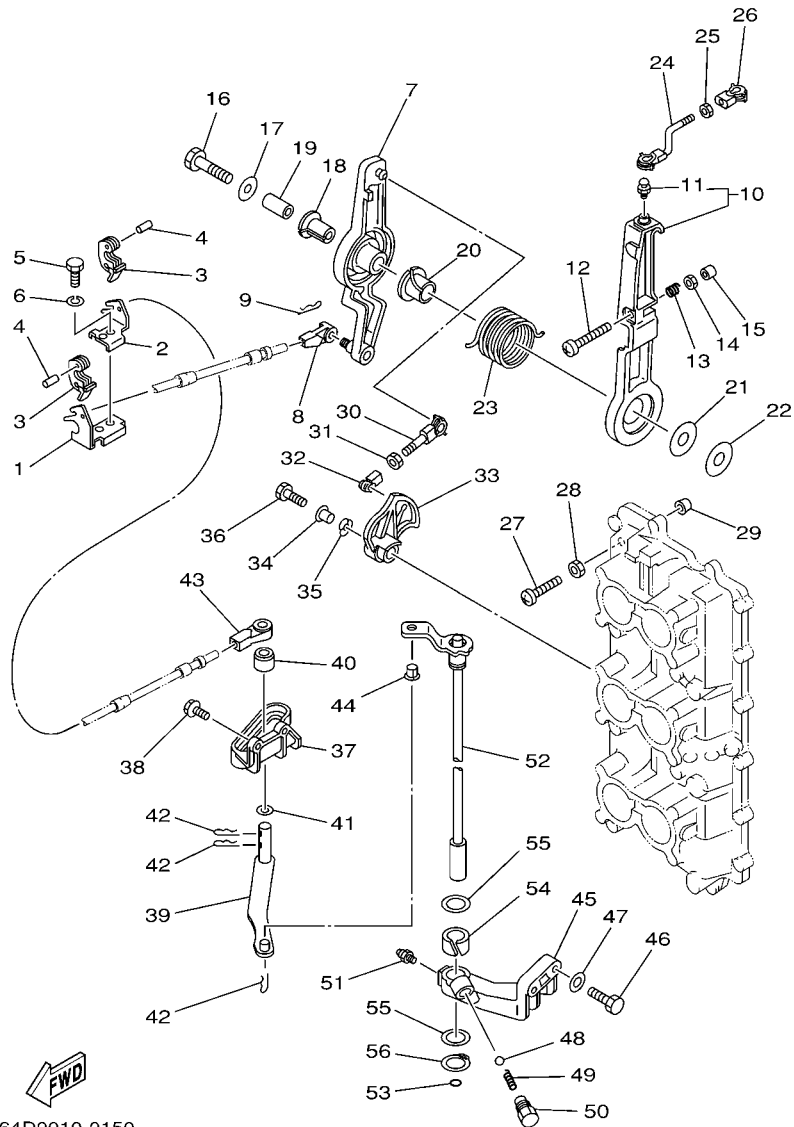

64D0010-0150

FIG. 16 CONTROL

REF. NO.	PART NO.	DESCRIPTION	64C8	64D8			REMARKS
			1	1			
28	95303-06600	NUT	1	1			
29	688-44194-00	CAP	1	1			
30	6G5-41211-01	LINK, ACCEL.	1	1			
31	95380-05600	NUT	1	1			
32	662-41237-01	JOINT, LINK	1	1			
33	6G5-41213-00	CAM, ACCEL.	1	1			
34	90387-06M29	COLLAR	1	1			
35	90206-10M04	WASHER, WAVE	1	1			
36	97095-06025	BOLT	1	1			
37	6E5-44117-00-1S	BRACKET	1	1			
38	90119-06MA2	BOLT, WITH WASHER	2	2			
39	68F-44121-00	LEVER, SHIFT ROD	1	1			
40	6E5-44122-00	BUSHING, SHIFT ROD LEVER	1	1			
41	90202-08M20	WASHER, PLATE	1	1			
42	90468-18008	CLIP	3	3			
43	6E5-48344-00	CABLE END, REMOTE CONTROL	1	1			
44	90386-06M12	BUSH	1	1			
45	6E5-44118-01-94	BRACKET	1	1			
46	97013-08030	BOLT	2	2			
47	92903-08600	WASHER, PLATE	2	2			
48	93501-04M02	BALL	1	1			
49	90501-12082	SPRING, COMPRESSION	1	1			
50	648-42715-00	BUSHING	1	1			
51	93700-06M03	NIPPLE, GREASE	1	1			
52	6E5-44120-03	HANDLE GEAR SHIFT ASSY	1				L(20.3")
	6E5-44120-23	HANDLE GEAR SHIFT ASSY	1	1			X(25.3")
53	93210-09165	O-RING	1	1			

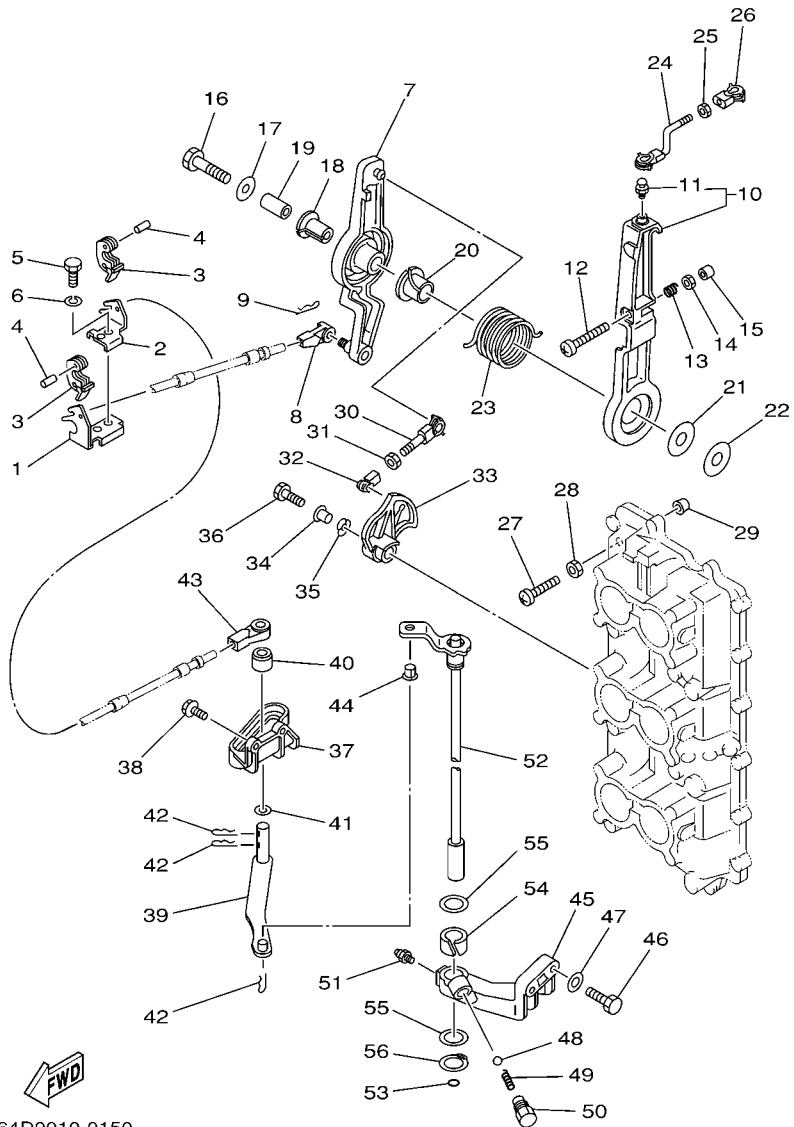

64D0010-0150

FIG. 16 CONTROL

REF. NO.	PART NO.	DESCRIPTION	64C8	64D8			REMARKS
			1	1			
54	90386-16M66	BUSH	1	1			
55	90202-16061	WASHER, PLATE	2	2			
56	93410-16006	CIRCLIP	1	1			

FIG. 17 BRACKET 1

REF. NO.	PART NO.	DESCRIPTION	64C8	64D8	REMARKS
1	64E-43111-02-8D	BRACKET, CLAMP 1	1	1	
2	6G5-45251-02	ANODE	1	1	
3	6G5-44526-00	PLATE	2	2	
4	97095-06030	BOLT	4	4	
5	92995-06100	WASHER, SPRING	4	4	
6	6E5-82148-00	WIRE, LEAD 4	1	1	
7	97095-06010	BOLT	1	1	
8	92995-06600	WASHER	1	1	
9	64E-43112-02-8D	BRACKET, CLAMP 2	1	1	
10	6E5-82148-00	WIRE, LEAD 4	1	1	
11	97880-06012	SCREW, PAN HEAD	1	1	
12	92990-06600	WASHER, PLATE	1	1	
13	93700-06M03	NIPPLE, GREASE	1	1	
14	663-45119-00	CAP, GREASE NIPPLE	1	1	AP
15	64E-43131-01	BOLT, CLAMP BRACKET	1	1	
16	97095-08020	BOLT	1	1	
17	92995-08100	WASHER	1	1	
18	90386-25M31	BUSH	2	2	
19	90201-26M59	WASHER, PLATE	2	2	
20	90185-22M11	NUT, SELF-LOCKING	1	1	
21	90465-11M10	CLAMP	1	1	
22	64E-43311-10-8D	BRACKET, SWIVEL 1	1		L(20.3")
	64E-43311-20-8D	BRACKET, SWIVEL 1	1	1	X(25.3")
23	90465-08M63	CLAMP	1	1	
24	93700-06M03	NIPPLE, GREASE	5	5	
25	663-45119-00	CAP, GREASE NIPPLE	5	5	AP
26	6E5-82147-00	WIRE, LEAD 4	1		L(20.3")

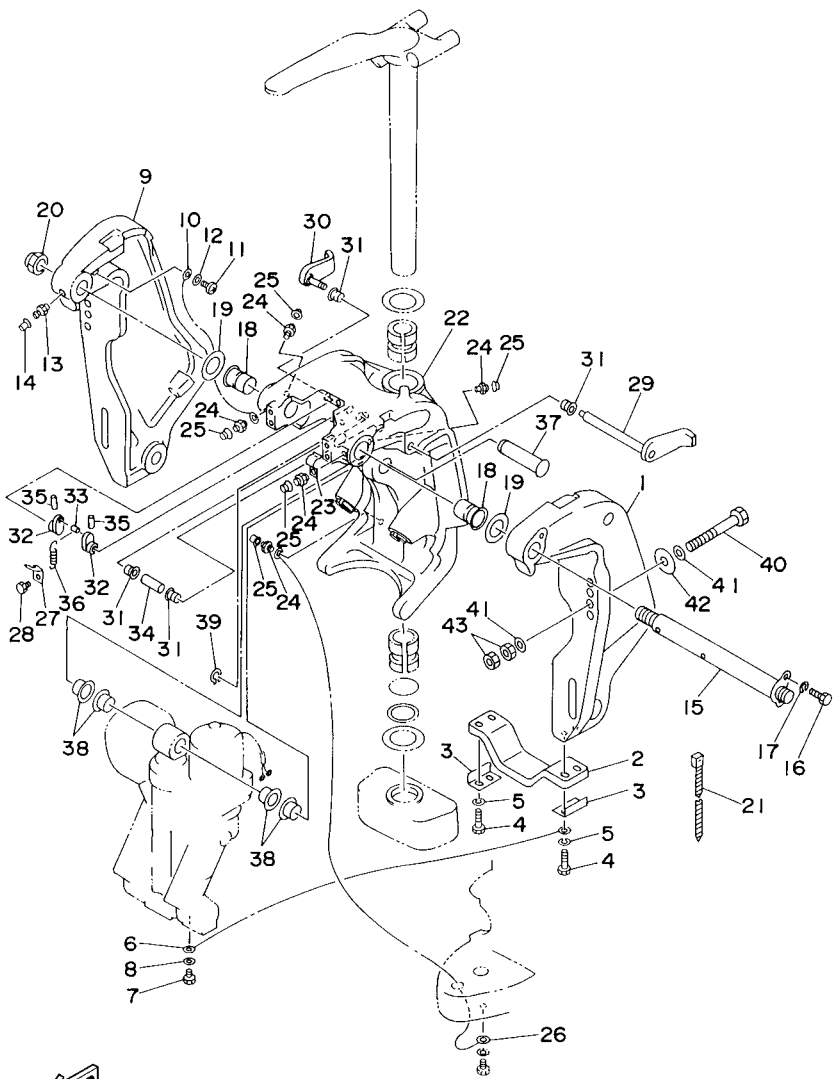

6N60010-7160

FIG. 17 BRACKET 1

REF. NO.	PART NO.	DESCRIPTION	64C8	64D8	REMARKS
26	6E5-82147-20	WIRE, LEAD 4	1	1	X(25.3")
27	6G5-43144-00	HOOK, SPRING	1	1	
28	97095-06010	BOLT	1	1	
29	6G5-43181-02	LEVER, TILT STOP	1	1	
30	6G5-43185-02	LEVER, TILT STOP	1	1	
31	90386-10M16	BUSH	4	4	
32	6G5-43148-00	COLLAR, DISTANCE	2	2	
33	90249-06M19	PIN	1	1	
34	90387-10M05	COLLAR	1	1	
35	91690-30020	PIN, SPRING	2	2	
36	90506-14M24	SPRING, TENSION	1	1	
37	64E-43126-00	PIN, UPPER SHOCK MOUNT	1	1	
38	90386-22M98	BUSH	4	4	
39	93410-22M11	CIRCLIP	1	1	
40	90101-12M05	BOLT (L:130MM)	4	4	FOR USA,OCE
	90101-12M77	BOLT (L:150MM)	2	2	FOR USA,OCE
	90101-12M03	BOLT (L:115MM)	4		FOR CAR,KOR,RUS
41	90201-13M01	WASHER, PLATE	8	8	
42	90201-12M05	WASHER, PLATE	4	4	
43	95380-12600	NUT	8	8	

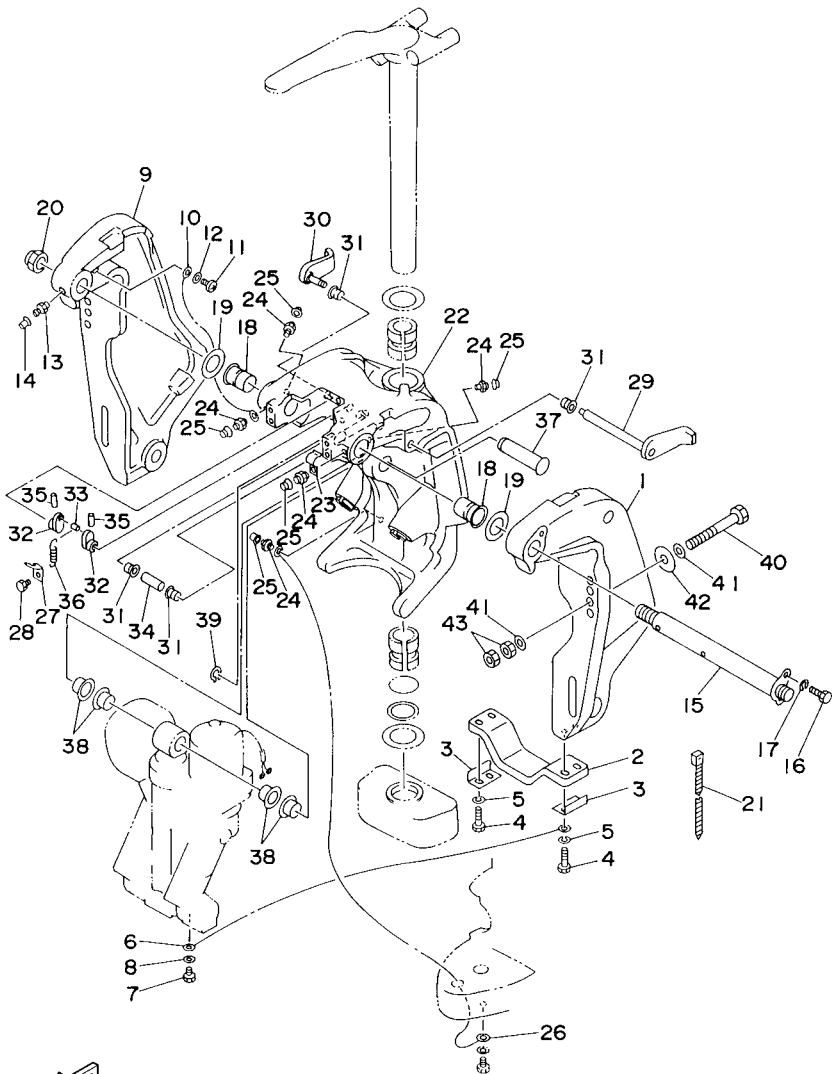

6N60010-7160

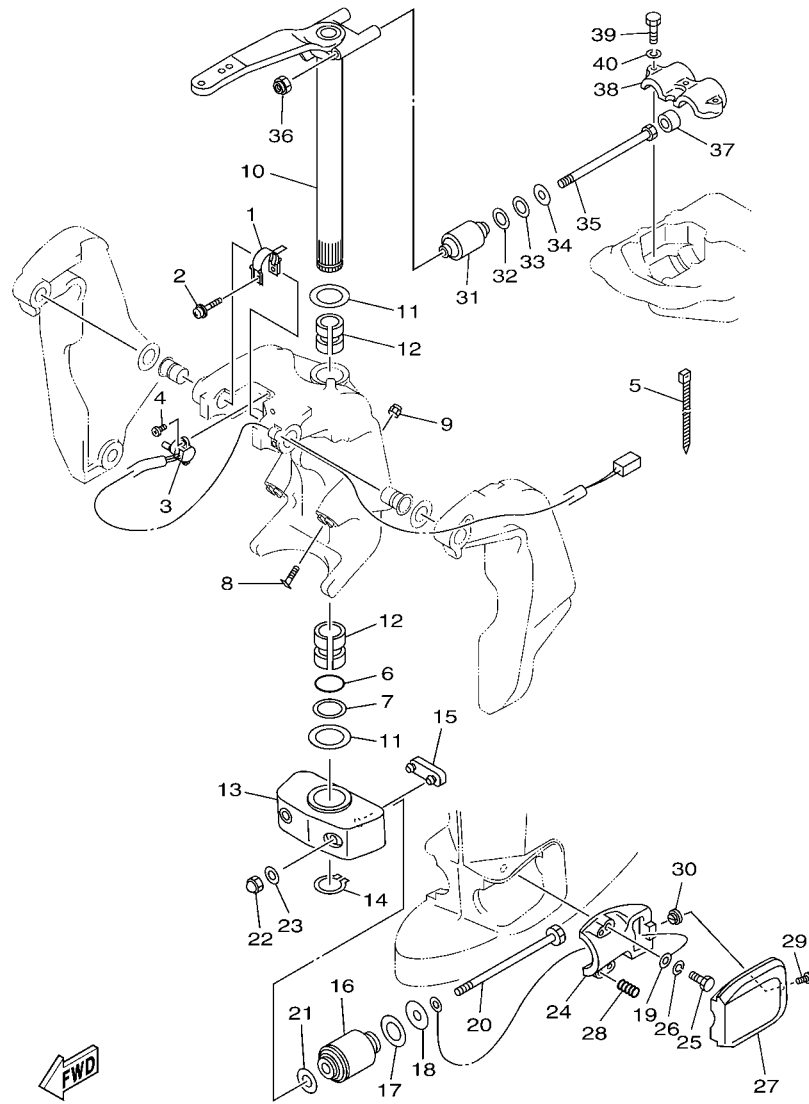

6N68100-G180

FIG. 18 BRACKET 2

REF. NO.	PART NO.	DESCRIPTION	64C8	64D8	REMARKS
1	64E-43139-10	CAM, TRIM SENDER	1	1	
2	90159-05059	SCREW, WITH WASHER	1	1	
3	67H-83672-00	TRIM SENDER	1	1	
4	97885-06016	SCREW, PAN HEAD	2	2	
5	90465-11M10	CLAMP	3	3	
6	93210-37MH7	O-RING	1	1	
7	90202-40M47	WASHER, PLATE	1	1	
8	61A-43376-00	BOLT, THRUST RECEIVER	2	2	
9	95780-10300	NUT, FLANGE	2	2	
10	6E5-42510-A1-8D	STEERING BRACKET ASSY	1		L(20.3")
	6E5-42510-B1-8D	STEERING BRACKET ASSY	1	1	X(25.3")
11	90201-38M60	WASHER, PLATE	2	2	
12	90386-38M32	BUSH	2	2	
13	6G5-44551-01-8D	HOUSING, LOWER MOUNT RUBBER	1	1	
14	93410-37M04	CIRCLIP	1	1	
15	6E5-44575-00	DAMPER, LOWER MOUNT RUBBER	1	1	
16	6G5-44555-00-94	MOUNT DAMPER, LOWER SIDE	2	2	
17	90202-32M19	WASHER, PLATE	2	2	
18	90201-16M55	WASHER, PLATE	2	2	
19	6E5-82149-00	WIRE, LEAD 3	1	1	
20	90109-14M34	BOLT	2	2	
21	90201-15M58	WASHER, PLATE	2	2	
22	95380-14800	NUT	2	2	
23	92995-14600	WASHER	2	2	
24	6E5-44552-01-94	HOUSING, LOWER MOUNT RUBBER	2	2	
25	97095-10045	BOLT	4	4	
26	92995-10100	WASHER	4	4	

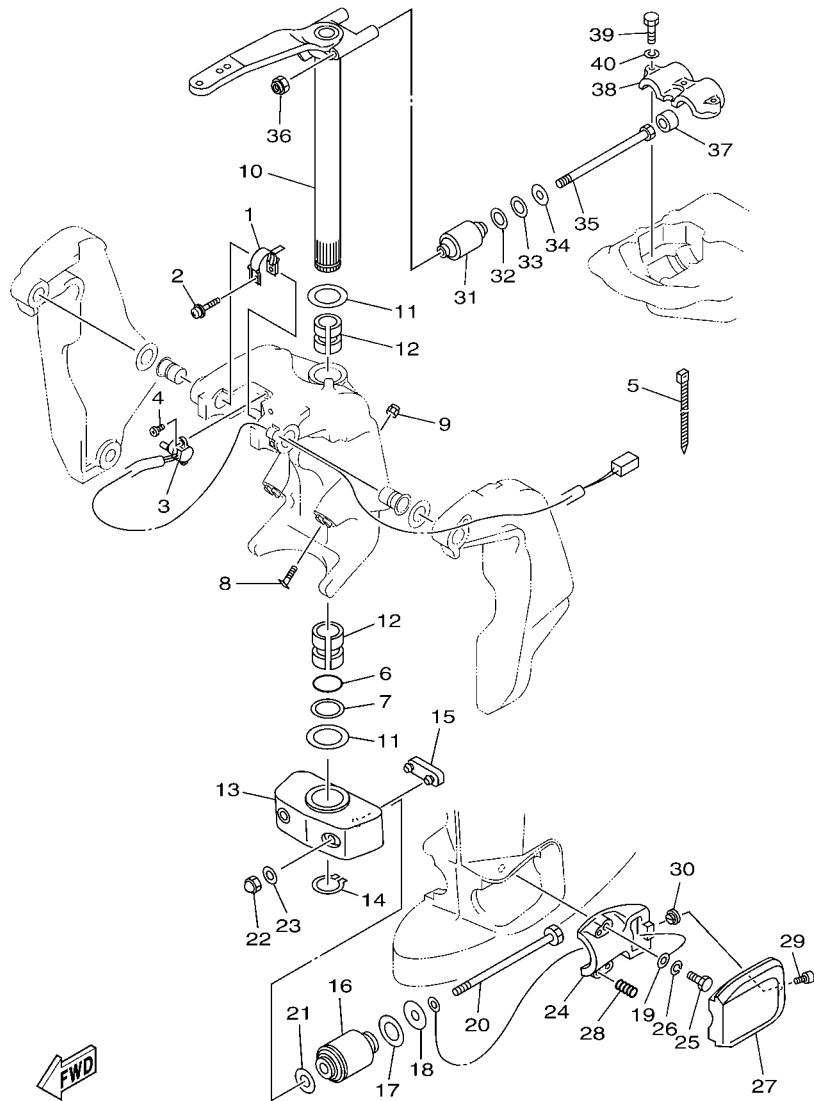

6N68100-G180

FIG. 18 BRACKET 2

REF. NO.	PART NO.	DESCRIPTION	64C8	64D8			REMARKS
27	6E5-44553-01-8D	COVER, LOWER MOUNT	2	2			
28	90501-16M28	SPRING, COMPRESSION	4	4			
29	97885-06016	SCREW, PAN HEAD	2	2			
30	90179-06066	NUT	2	2			
31	6G5-44514-00-94	MOUNT DAMPER, UPPER SIDE	2	2			
32	90201-26M57	WASHER, PLATE	2	2			
33	90202-26M18	WASHER, PLATE	2	2			
34	90201-14M56	WASHER, PLATE	2	2			
35	90109-12007	BOLT	2	2			
36	90185-12M12	NUT, SELF-LOCKING	2	2			
37	663-44575-00	DAMPER, LOWER MOUNT RUBBER	2	2			
38	6E5-44511-00-5B	COVER, UPPER MOUNT	1	1			
39	97095-10045	BOLT	3	3			
40	92995-10100	WASHER	3	3			

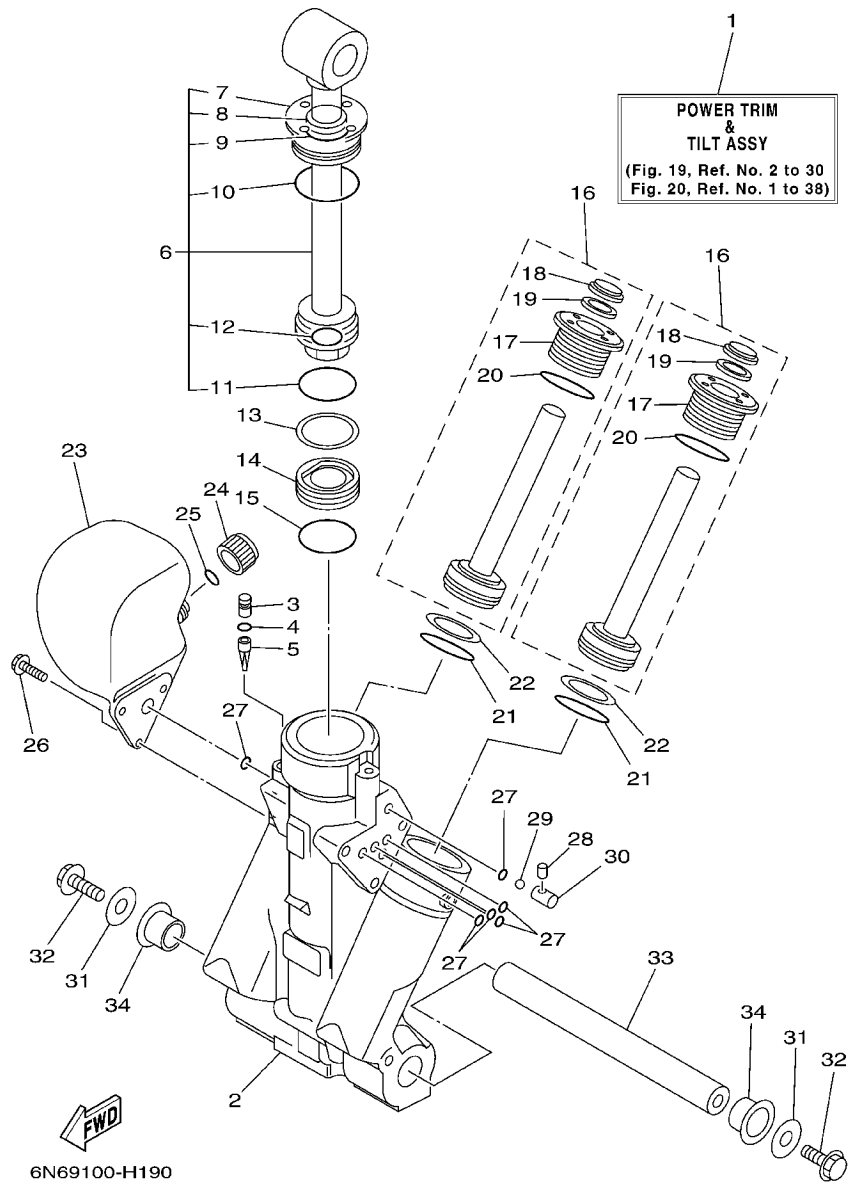

FIG. 19 POWER TRIM & TILT ASSY 1

REF. NO.	PART NO.	DESCRIPTION	64C8	64D8			REMARKS
1	64E-43800-04-4D	POWER TRIM & TILT ASSY	1	1			
2	64E-43825-02	HOUSING, TRIM & TILT	1	1			
3	64E-4388J-00	PLUG 2	1	1			
4	93210-10M74	O-RING	1	1			
5	64E-43817-00	FILTER 2	1	1			
6	64E-43810-01	TILT PISTON SUB ASSY	1	1			
7	64E-43811-01	.SCREW, CYLINDER END	1	1			
8	64E-43898-00	.SEAL ,DUST 2	1	1			
9	64E-43867-00	.O-RING	1	1			
10	64E-43866-00	.O-RING	1	1			
11	6E5-43862-00	.O-RING	1	1			
12	64E-43883-00	.O-RING	1	1			
13	6E5-43872-00	RING, BACK UP	1	1			
14	6E5-43814-02	PISTON, FREE	1	1			
15	6E5-43862-00	O-RING	1	1			
16	64E-43820-01	TRIM PISTON SUB ASSY	2	2			
17	64E-43821-01	.SCREW, TRIM CYLINDER END	1	1			
18	64E-43822-00	.SEAL, TRIM DUST	1	1			
19	64E-4384J-00	.SEAL, TRIM DOWN	1	1			
20	6G5-43864-00	.O-RING	1	1			
21	6E5-43864-00	O-RING	2	2			
22	6E5-43874-01	RING, BACK UP	2	2			
23	64E-43828-00	BODY, RESERVOIR	1	1			
24	64E-43829-00	PLUG, RESERVOIR	1	1			
25	64E-43897-00	O-RING	1	1			
26	64E-4388E-00	BOLT ,SCREW (L:14MM)	3	3			
27	64E-43869-00	O-RING	6	6			

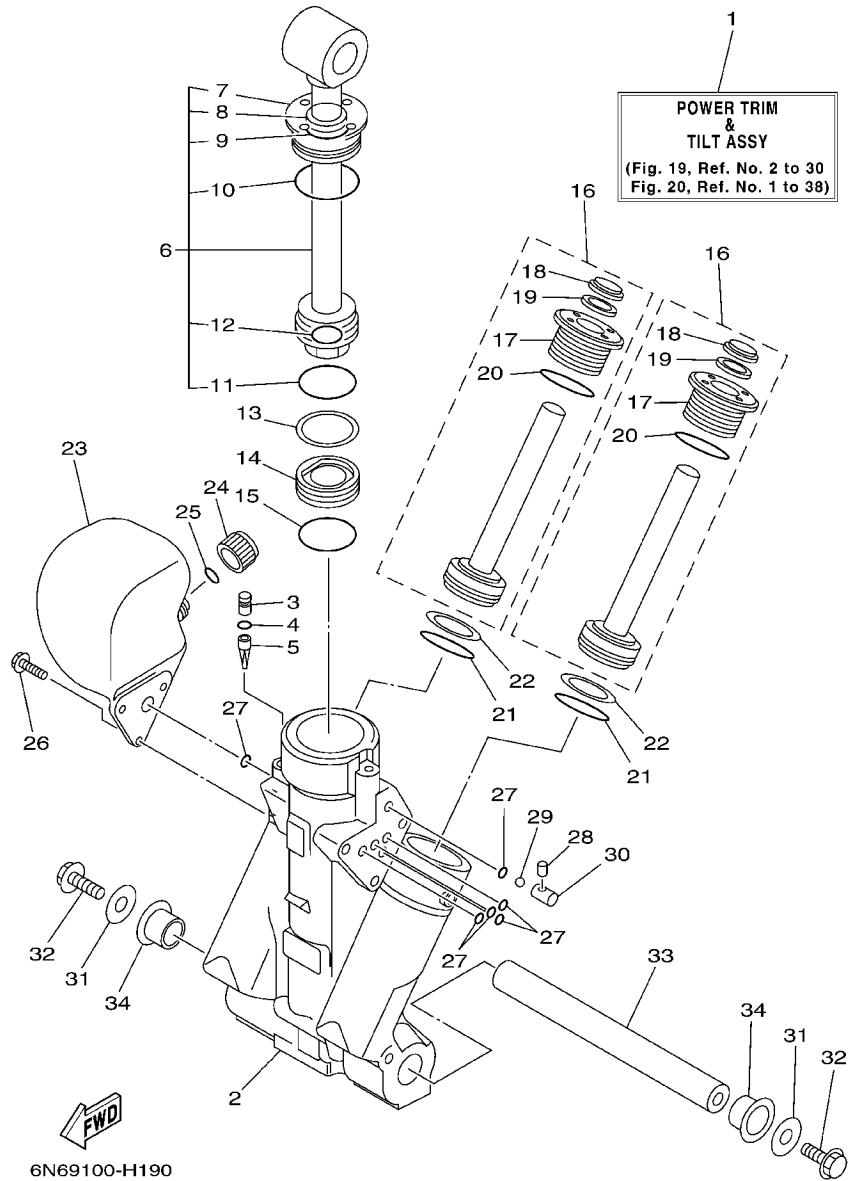

FIG. 19 POWER TRIM & TILT ASSY 1

REF. NO.	PART NO.	DESCRIPTION	64C8	64D8			REMARKS
28	64E-4381G-00	PIN	1	1			
29	6E5-43858-00	BALL	1	1			
30	64E-4382G-00	VALVE, SEAT	1	1			
31	90201-10060	WASHER, PLATE	2	2			Go to P/N : PE0-OM-080047
32	97575-10530	BOLT, WITH WASHER	2	2			Go to P/N : PE0-OM-080047
33	6BC-43818-00	PIN, LOWER SHOCK MOUNT	1	1			Go to P/N : PE0-OM-080047
34	90386-22M98	BUSH	2	2			

PARTS NEWS

News No. PE0-OM-080047

Date:2008/5/22

Signature:K . Otsuka

Cause Revision Notice Correction Sales Unit Change Others

Model	150TR, 150FETO '08 (64C8) / 175DETO '08 (64D8)
Subject	PARTS CATALOGUE CORRECTIONS
CATALOGUE NO.	1G64C-100E1
Time of YPEC Revision	Text, Illustration --> Jun./20/2008 PDF Replace --> Jun./20/2008 (YPEC = Yamaha Parts Electrical Catalogue = Website parts catalogue)

FIG.19 POWER TRIM & TILT ASSY 1

1. LIST CORRECTION

Fig.No-Ref.No.	PART NO.	PART NAME	Q'TY	*1	REMARKS
19-31	OLD 90201-08M14	WASHER, PLATE	2	○	*Part number revision
	NEW 90201-10060				
19-32	OLD 97080-08016	BOLT	2	○	*Part number revision
	NEW 97575-10530	BOLT, WITH WASHER			
19-33	OLD 64E-43818-01	PIN, LOWER SHOCK MOUNT	1	○	*Part number revision
	NEW 6BC-43818-00				

*Applicable Engine Serial No.

MODEL NAME	MODEL CODE	Applicable Engine Serial No.
150TR, 150FETO	64C8	6G4:1019937-
175DETO	64D8	6G5:1001147-

*1: Interchangeability

A	Old Parts	→	Old Parts
	New Parts	→	New Parts
B	Old Parts	→	Old Parts
	New Parts	→	New Parts
C	Old Parts	→	Old Parts
	New Parts	→	New Parts
○	These parts are interchangeable with a set		

2. ILLUSTRATION CORRECTION

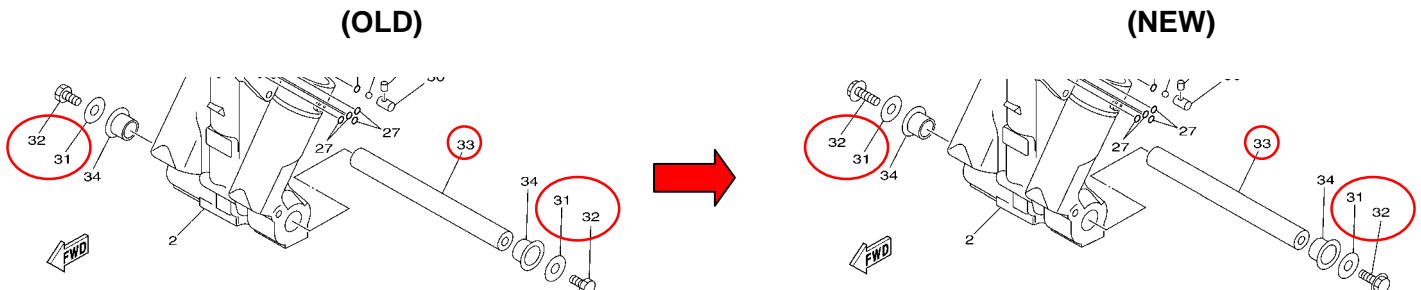

Thank you very much for your cooperation.

Parts
Manager
Check

Service
Manager
Check

Parts
Manager
File

YAMAHA MOTOR CO.,LTD
2500 Shingai Iwata Shizuoka 438-8501.Japan
Technical Publication Dept.

FIG. 20 POWER TRIM & TILT ASSY 2

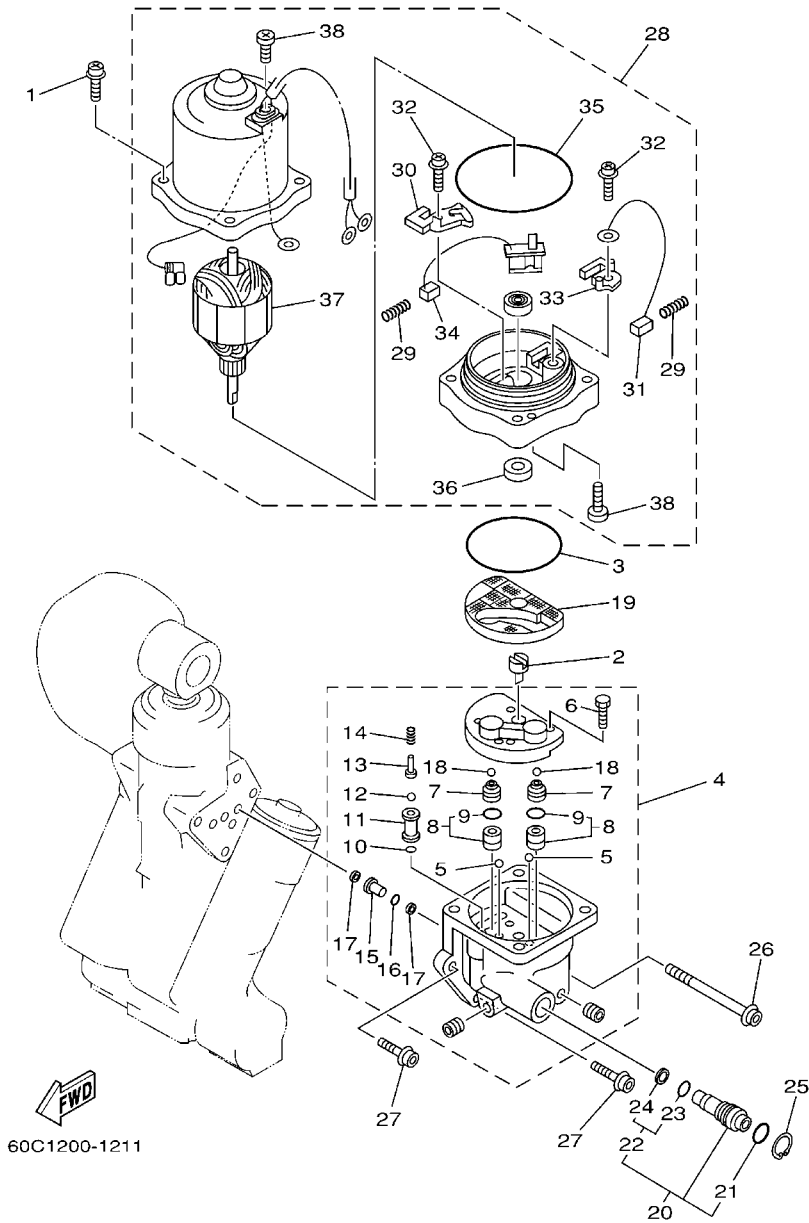

60C1200-1211

REF. NO.	PART NO.	DESCRIPTION	64C8	64D8			REMARKS
1	64E-4388E-10	BOLT ,SCREW (L:34.7MM)	4	4			
2	64E-43831-00	CONNECTOR, SHAFT	1	1			
3	64E-43868-00	O-RING	1	1			
4	64E-43830-00	GEAR PUMP ASSY	1	1			
5	72X-43858-00	.BALL	2	2			
6	64E-43843-00	.SCREW, VALVE LOCK	4	4			
7	64E-43841-00	.PISTON, SHUTTLE	2	2			
8	64E-43802-00	.VALVE SUB ASSY	2	2			
9	6E5-43896-00	..O-RING	1	1			
10	6G5-43863-00	.O-RING	1	1			
11	64E-43851-00	.SEAT, RELIEF VALVE	1	1			
12	64E-43858-00	.BALL	1	1			
13	64E-43859-00	.PIN, VALVE SUPPORT	1	1			
14	64E-43855-00	.SPRING, UP RELIEF	1	1			
15	64E-43850-00	.VALVE SUB ASSY	1	1			
16	64E-43865-00	.O-RING	1	1			
17	64E-43816-00	.FILTER 1	2	2			
18	64E-43858-00	.BALL	2	2			
19	64E-43817-10	FILTER 2	1	1			
20	64E-43860-00	MANUAL VALVE SUB-ASSY	1	1			
21	72X-85075-L0	.O-RING	1	1			
22	64E-43827-00	.RING SET	1	1			
23	64E-4387A-00	..O-RING	1	1			
24	64E-43873-00	..RING, BACK UP	1	1			
25	64E-43875-00	RING, SNAP	1	1			
26	64E-43879-10	SCREW, WITH WASHER	1	1			
27	64E-43879-00	SCREW, WITH WASHER	2	2			

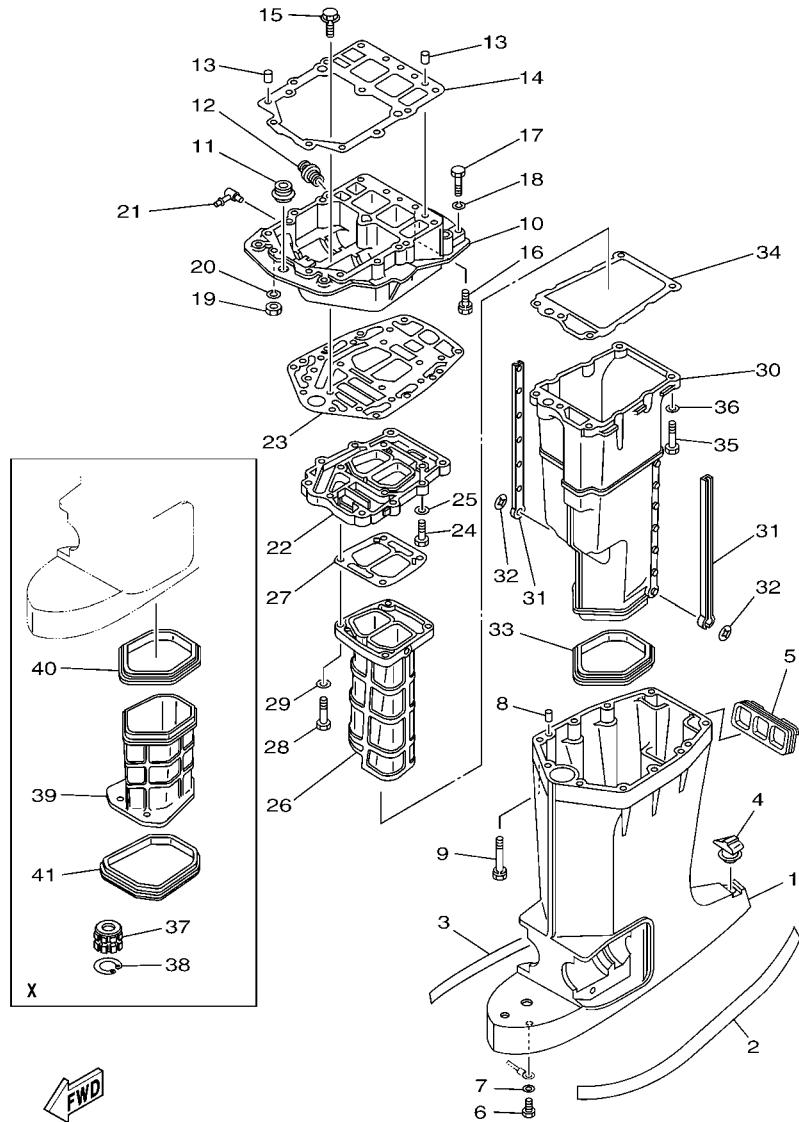

64D4100-D210

FIG. 21 UPPER CASING

REF. NO.	PART NO.	DESCRIPTION	64C8	64D8	REMARKS
1	6E5-45111-02-8D	CASING, UPPER	1		L(20.3")
	6E5-45111-23-8D	CASING, UPPER	1	1	X(25.3")
2	6R3-42791-41	MARK 1	1	1	
3	6R3-42792-41	MARK	1	1	
4	6E5-45155-00	CAP	1	1	
5	6E5-42769-00	SEAL, RUBBER	1	1	
6	97095-06010	BOLT	1	1	
7	92995-06600	WASHER	1	1	
8	93608-12M05	PIN, DOWEL	2	2	
9	90119-08078	BOLT, WITH WASHER	6	6	
10	6G5-41137-11-94	GUIDE, EXHAUST	1	1	FLUSHING KIT
	6G5-41137-02-94	GUIDE, EXHAUST	1		FOR STD
11	6E5-42724-00	GROMMET	1	1	
12	6G5-12581-00	JOINT, HOSE 1	1	1	
13	93608-12M05	PIN, DOWEL	2	2	
14	68F-45113-00	GASKET, UPPER CASING	1	1	
15	90119-08M79	BOLT, WITH WASHER	2	2	
16	90119-08077	BOLT, WITH WASHER	4	4	
17	97095-08045	BOLT	2	2	
18	92995-08100	WASHER	2	2	
19	95380-08700	NUT	2	2	
20	92995-08100	WASHER	2	2	
21	6H1-11372-00	NIPPLE, HOSE	1	1	FLUSHING KIT
22	6G5-41131-01-5B	MANIFOLD, EXT. 1	1	1	
23	6G5-45114-A1	GASKET, UPPER CASING	1	1	
24	97095-08030	BOLT	4	4	
25	92995-08600	WASHER	4	4	

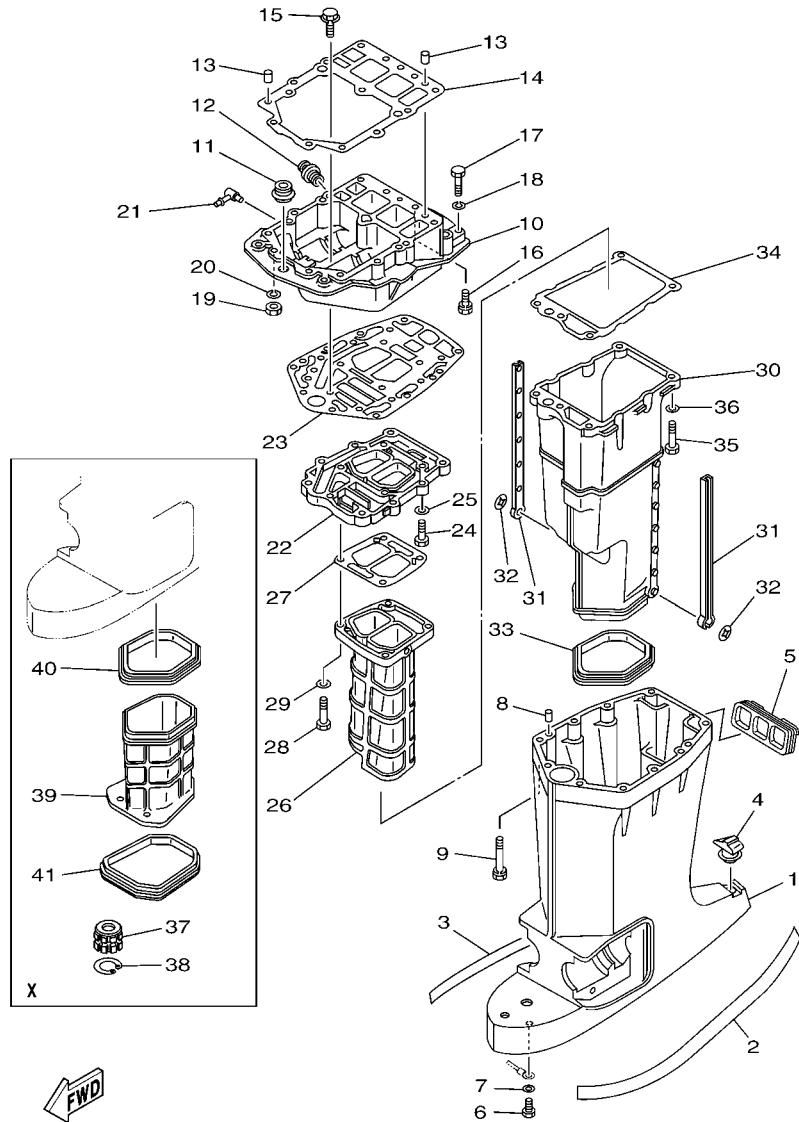

64D4100-D210

FIG. 21 UPPER CASING

REF. NO.	PART NO.	DESCRIPTION	64C8	64D8			REMARKS
			1	1			
26	64D-41132-00-5B	MANIFOLD, EXHAUST	1	1			
27	6G5-41134-A1	GASKET, EXHAUST MANIFOLD	1	1			
28	97095-08045	BOLT	4	4			
29	92995-08600	WASHER	4	4			
30	6E5-14711-01-5B	MUFFLER 1	1	1			
31	6E5-14737-00	DAMPER, MUFFLER	2	2			
32	90183-05M02	NUT, SPRING	2	2			
33	6E5-45123-00	GASKET, MUFFLER	1	1			
34	6E5-41135-A0	GASKET, EXHAUST MANIFOLD	1	1			
35	97095-08045	BOLT	5	5			
36	92995-08600	WASHER	5	5			
37	6E5-45318-00	BUSHING, DRIVE SHAFT	1	1			X(25.3")
38	93420-36M01	CIRCLIP	1	1			X(25.3")
39	64D-14721-20-5B	MUFFLER 2	1	1			X(25.3")
40	64D-45123-00	GASKET, MUFFLER	1	1			X(25.3")
41	64D-45375-00	DAMPER, SEAL	1	1			X(25.3")

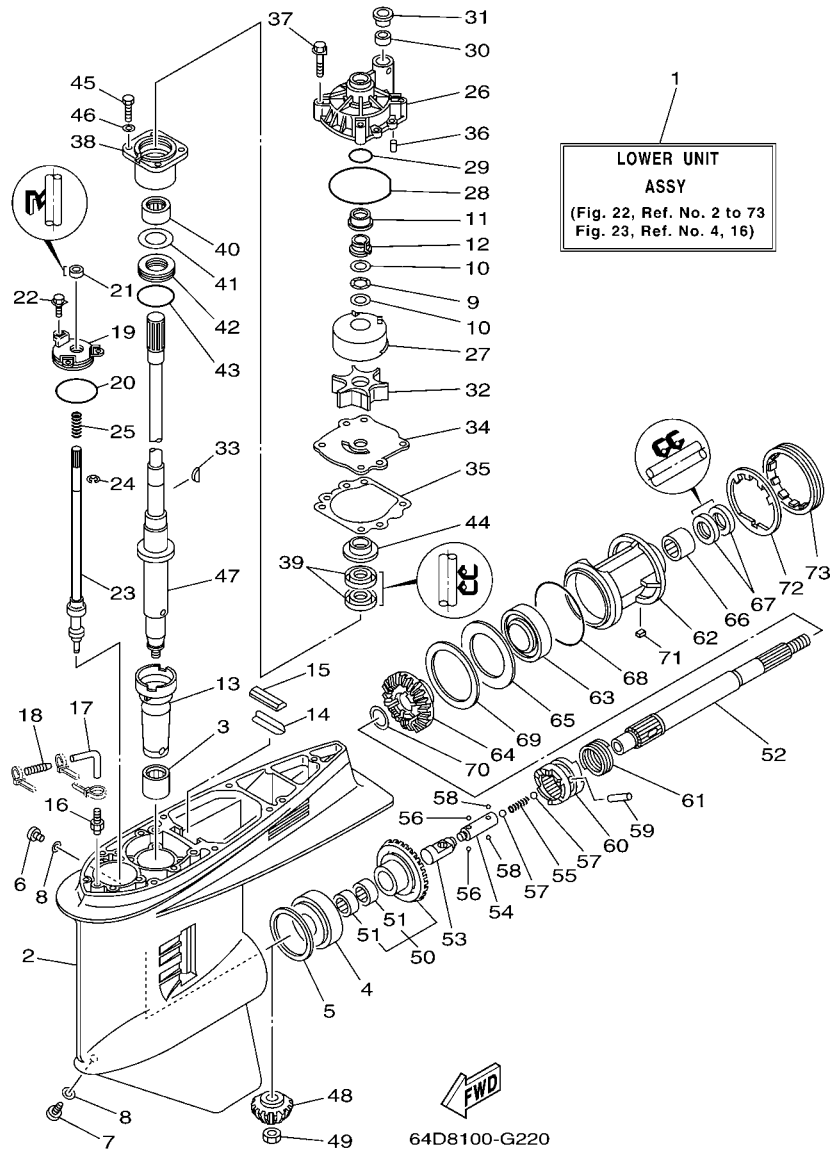

FIG. 22 LOWER CASING & DRIVE 1

REF. NO.	PART NO.	DESCRIPTION	64C8	64D8			REMARKS
1	64D-45300-02-8D	LOWER UNIT ASSY	1				L(20.3"),RH
	64D-45300-22-8D	LOWER UNIT ASSY	1	1			X(25.3"),RH
2	6J9-45301-05-8D	CASING, LOWER	1	1			
3	93311-928U5	BEARING	1	1			
4	93332-000V3	BEARING	1	1			
5	6G5-45567-01	SHIM (T:0.10MM)	1	1			UR
	6G5-45567-10	SHIM (T:0.12MM)	1	1			UR
	6G5-45567-20	SHIM (T:0.15MM)	1	1			UR
	6G5-45567-30	SHIM (T:0.18MM)	1	1			UR
	6G5-45567-40	SHIM (T:0.30MM)	1	1			UR
	6G5-45567-50	SHIM (T:0.40MM)	1	1			UR
	6G5-45567-60	SHIM (T:0.50MM)	1	1			UR
6	90340-08002	PLUG, STRAIGHT SCREW	1	1			
7	688-45341-10	PLUG, DRAIN	1	1			
8	90430-08020	GASKET	2	2			
9	90206-22M19	WASHER, WAVE	1	1			
10	90201-22M01	WASHER, PLATE	2	2			
11	61A-45527-00	COLLAR, DRIVE SHAFT	1	1			
12	61A-45538-00	SPACER 1	1	1			
13	6G5-45536-01	SLEEVE, DRIVE SHAFT	1	1			
14	663-45376-00-94	GUIDE, SEAL DAMPER	1				L(20.3")
	64D-45376-00-94	GUIDE, SEAL DAMPER	1	1			X(25.3")
15	688-45375-00	DAMPER, SEAL	1	1			
16	6E5-45378-00	NIPPLE, HOSE	1	1			
17	90445-07ME8	HOSE (L80)	1				L(20.3")
	90445-07ME9	HOSE (L120)	1	1			X(25.3")
18	6E5-83558-10	END, NIPPLE	1	1			

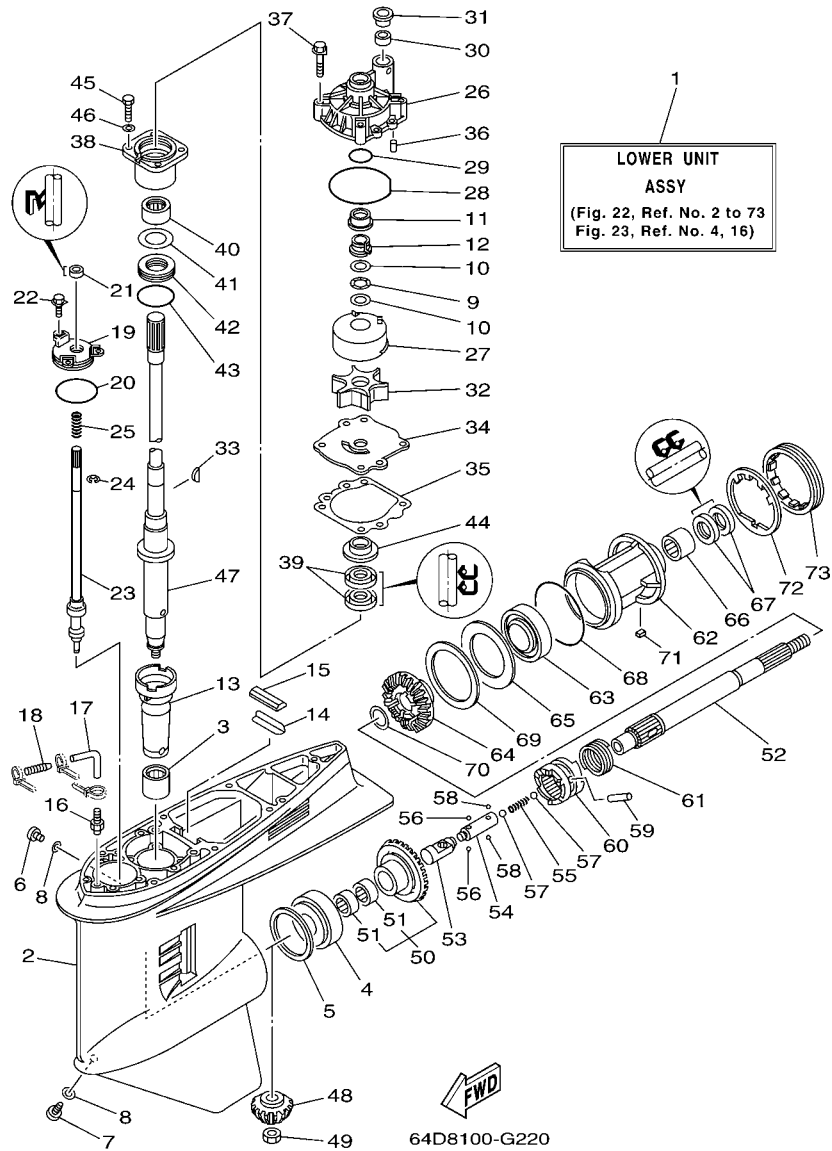

FIG. 22 LOWER CASING & DRIVE 1

REF. NO.	PART NO.	DESCRIPTION	64C8	64D8			REMARKS
			1	1			
19	6E5-45321-00	PLATE	1	1			
20	93210-58144	O-RING	1	1			
21	93106-09014	OIL SEAL	1	1			
22	90119-06M10	BOLT, WITH WASHER	3	3			
23	6G5-44150-02	SHIFT CAM ASSY	1	1			
24	99001-08600	CIRCLIP	1	1			
25	90501-11M10	SPRING, COMPRESSION	1	1			
26	61A-44311-01	HOUSING, WATER PUMP	1	1			
27	61A-44322-02	INSERT, CARTRIDGE	1	1			
28	93210-86M38	O-RING	1	1			
29	93210-37160	O-RING	1	1			
30	6E5-44365-00	DAMPER, WATER SEAL	1	1			
31	6E5-44312-00	COVER, WATER PUMP HOUSING	1	1			
32	6E5-44352-01	IMPELLER	1	1			
33	90280-04M05	KEY, WOODRUFF	1	1			
34	6G5-44323-00	OUTER PLATE, CARTRIDGE	1	1			
35	6E5-44315-A0	GASKET, WATER PUMP	1	1			
36	93606-12019	PIN, DOWEL	2	2			
37	90119-08M14	BOLT, WITH WASHER	4	4			
38	6E5-45331-00-94	HOUSING, BEARING	1	1			
39	93101-28M16	OIL SEAL	2	2			
40	93317-330U2	BEARING	1	1			
41	6E5-45587-01	SHIM (T:0.10MM)	1	1			UR
	6E5-45587-10	SHIM (T:0.12MM)	1	1			UR
	6E5-45587-20	SHIM (T:0.15MM)	1	1			UR
	6E5-45587-30	SHIM (T:0.18MM)	1	1			UR
	6E5-45587-40	SHIM (T:0.30MM)	1	1			UR

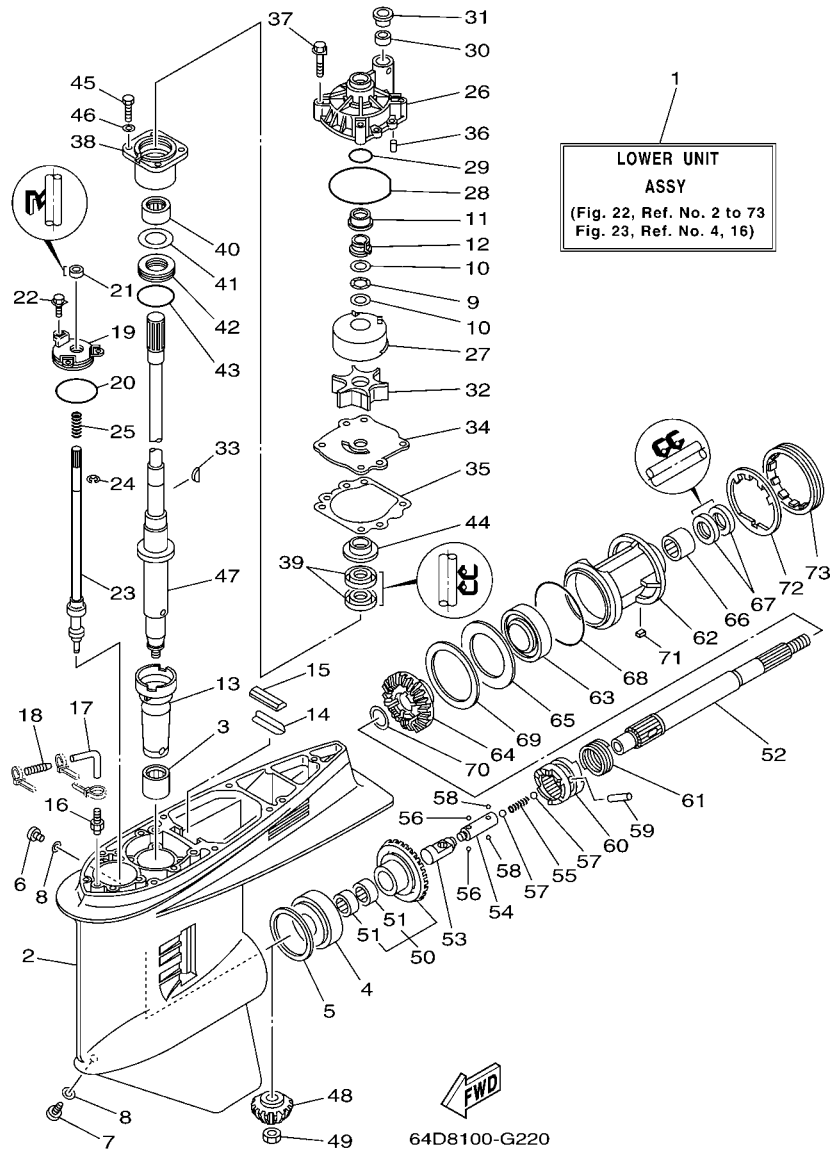

FIG. 22 LOWER CASING & DRIVE 1

REF. NO.	PART NO.	DESCRIPTION	64C8	64D8			REMARKS
41	6E5-45587-50	SHIM (T:0.40MM)	1	1			UR
	6E5-45587-60	SHIM (T:0.50MM)	1	1			UR
42	93341-930V2	BEARING	1	1			
43	93210-55M14	O-RING	1	1			
44	6E5-45344-00	COVER, OIL SEAL	1	1			
45	97095-08025	BOLT	4	4			
46	92995-08600	WASHER	4	4			
47	6G5-45501-01	DRIVE SHAFT COMP.	1				L(20.3")
	6G5-45501-21	DRIVE SHAFT COMP.	1	1			X(25.3")
48	6G5-45551-10	PINION (14T)	1	1			
49	90170-16M01	NUT	1	1			
50	6G5-45560-10	GEAR 1 (26T)	1	1			
51	93315-425V3	.BEARING	2	2			
52	6J9-45611-01	SHAFT, PROPELLER	1	1			
53	6E5-45641-03	SHIFTER	1	1			
54	6E5-45634-01	SLIDE, SHIFT	1	1			
55	90501-16M37	SPRING, COMPRESSION	1	1			
56	93507-32009	BALL	2	2			
57	93511-32017	BALL	2	2			
58	93503-16003	BALL	2	2			
59	90250-08M07	PIN, STRAIGHT	1	1			
60	6G5-45631-00	CLUTCH, DOG	1	1			
61	6E5-45633-01	RING, CROSS PIN	1	1			
62	6J9-45332-00-94	HOUSING, BEARING	1	1			
63	93306-209U0	BEARING	1	1			
64	6G5-45571-02	GEAR 2 (26T)	1	1			
65	6G5-45576-10	WASHER, THRUST	1	1			

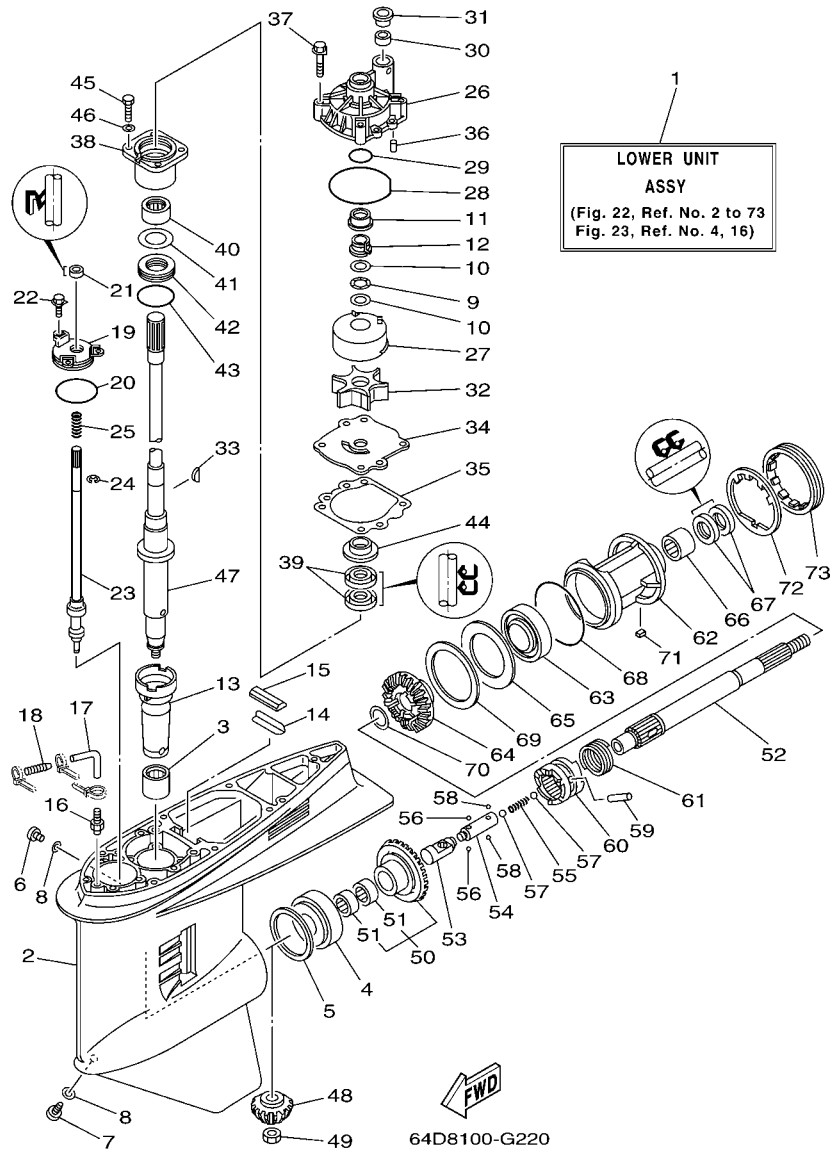
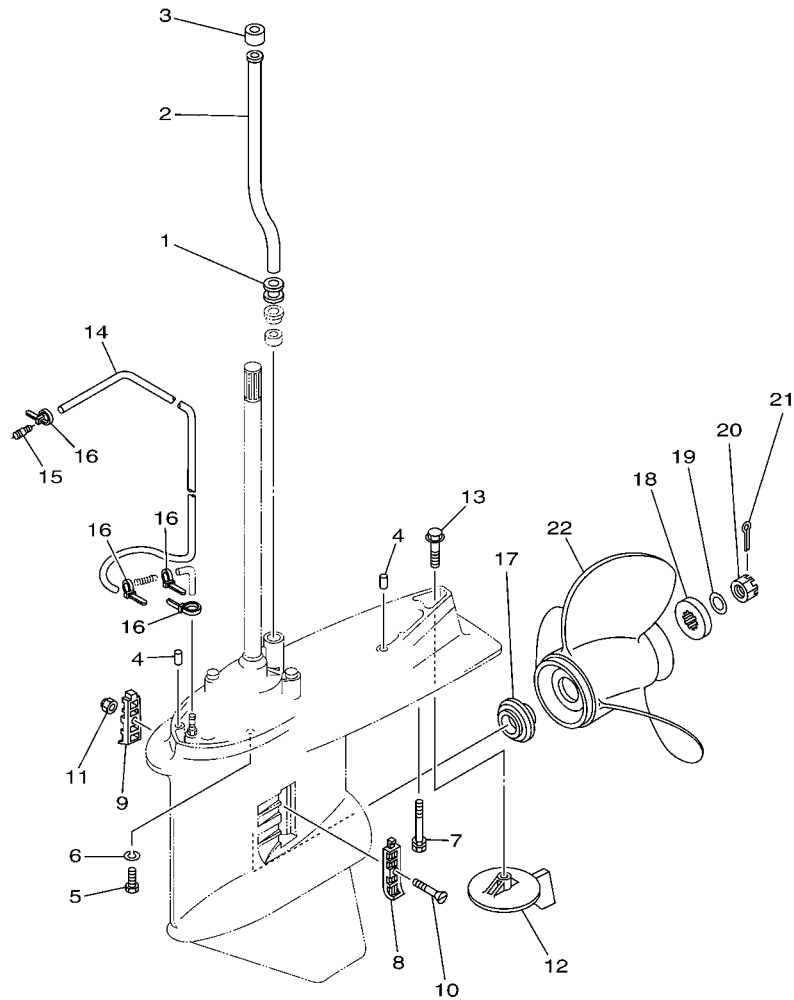

FIG. 22 LOWER CASING & DRIVE 1

REF. NO.	PART NO.	DESCRIPTION	64C8	64D8			REMARKS
			1	1			
66	93315-43061	BEARING	1	1			
67	93101-30M17	OIL SEAL	2	2			
68	93210-97M55	O-RING	1	1			
69	6G5-45577-02	SHIM (T:0.10MM)	1	1			UR
	6G5-45577-10	SHIM (T:0.12MM)	1	1			UR
	6G5-45577-20	SHIM (T:0.15MM)	1	1			UR
	6G5-45577-30	SHIM (T:0.18MM)	1	1			UR
	6G5-45577-40	SHIM (T:0.30MM)	1	1			UR
	6G5-45577-50	SHIM (T:0.40MM)	1	1			UR
	6G5-45577-60	SHIM (T:0.50MM)	1	1			UR
70	90201-30M92	WASHER, PLATE	1	1			
71	90282-04M00	KEY, STRAIGHT	1	1			
72	6G5-45383-01	WASHER, CLAW	1	1			
73	6G5-45384-00	NUT	1	1			



67H0010-9250

FIG. 23 LOWER CASING & DRIVE 2

REF. NO.	PART NO.	DESCRIPTION	64C8	64D8			REMARKS
1	6E5-44366-00	DAMPER, WATER SEAL	1	1			
2	6E5-44361-00	TUBE, WATER	1				L(20.3")
	6E5-44361-20	TUBE, WATER	1	1			X(25.3")
3	6E5-44365-00	DAMPER, WATER SEAL	1	1			
4	93608-12M05	PIN, DOWEL	2	2			
5	97075-10045	BOLT	6	6			
6	92995-10100	WASHER	6	6			
7	90119-10M89	BOLT, WITH WASHER	1	1			
8	6J9-45214-00	COVER, WATER INLET 1	1	1			
9	6J9-45215-00	COVER, WATER INLET 2	1	1			
10	90152-05M08	SCREW, COUNTERSUNK	1	1			
11	90185-05002	NUT, SELF-LOCKING	1	1			
12	6J9-45371-01	TAB-TRIM	1	1			
13	90105-10M00	BOLT, FLANGE	1	1			
14	90445-07M33	HOSE (L1080)	1	1			
15	6E5-83558-00	END, NIPPLE	1	1			
16	90465-11M10	CLAMP	4	4			
17	6E5-45987-01	SPACER	1	1			
18	688-45997-01	SPACER	1	1			
19	92990-18200	WASHER	1	1			
20	90171-18M04	NUT, CASTLE	1	1			
21	91490-40030	PIN, COTTER	1	1			
22	6G5-45941-00-98	PROPELLER (3X15-1/4"X15"-M)	1	1			UR
	6G5-45943-01-98	PROPELLER (3X13-3/4"X21"-M)	1	1			UR
	6G5-45945-01-98	PROPELLER (3X14"X19"-M)	1	1			UR
	6G5-45947-01-98	PROPELLER (3X14-1/2"X17"-M)	1	1			UR
	6G5-45949-00-98	PROPELLER (3X13-1/2"X23"-M)	1	1			UR

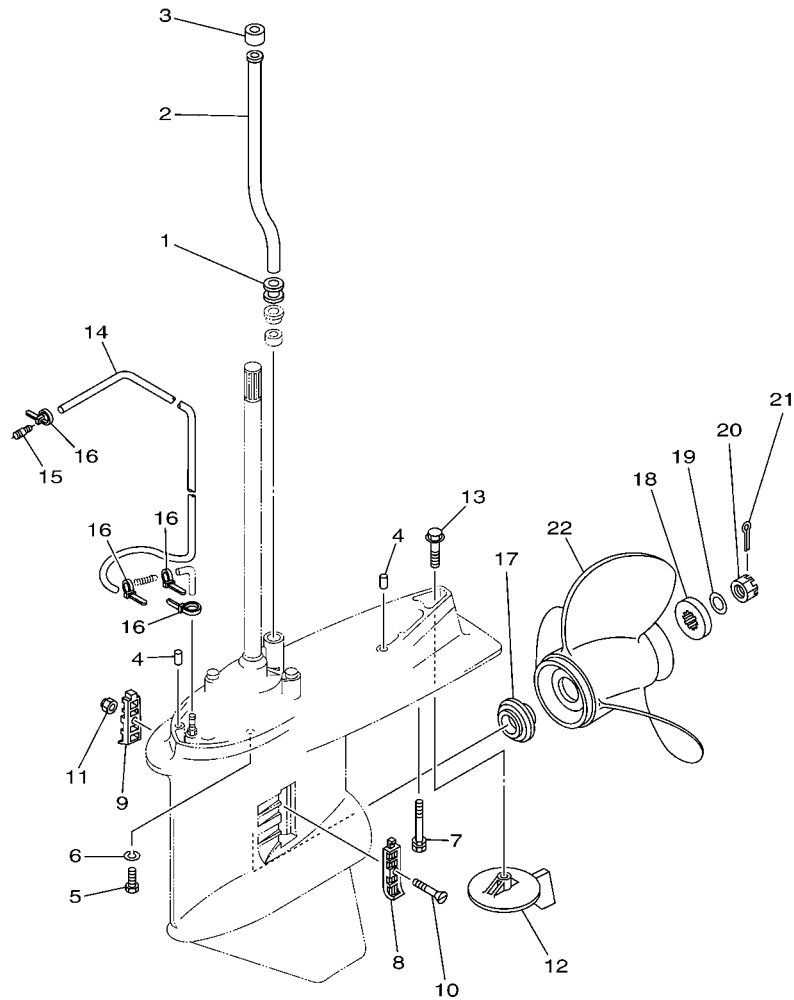

67H0010-9250

FIG. 23 LOWER CASING & DRIVE 2

REF. NO.	PART NO.	DESCRIPTION	64C8	64D8			REMARKS
22	6G5-45952-00-98	PROPELLER (3X14-5/8"X16"-M)	1	1			UR
	6G5-45930-00-98	PROPELLER (3X13-3/8"X25"-M)	1	1			UR
	6G5-45932-00-98	PROPELLER (3X15-3/4"X13"-M)	1	1			UR
	6G5-45970-02-98	PROPELLER (3X15-1/4"X15"-M)	1	1			UR
	6G5-45972-02-98	PROPELLER (3X13-3/4"X21"-M)	1	1			UR
	6G5-45974-03-98	PROPELLER (3X13-3/4"X19"-M2)	1	1			UR
	6G5-45976-01-98	PROPELLER (3X13-3/8"X23"-M)	1	1			UR
	6G5-45978-03-98	PROPELLER (3X13-3/4"X17"-M2)	1	1			UR
	6R4-45970-A1	PROPELLER (3X15-1/4"X19"-M)	1	1			UR
	6R4-45972-A0	PROPELLER (3X14-7/8"X21"-M)	1	1			UR
	6R4-45974-A0	PROPELLER (3X14-1/2"X23"-M)	1	1			UR
	6R4-45976-A0	PROPELLER (3X14-1/2"X15"-M)	1	1			UR
	6R4-45978-A0	PROPELLER (3X15-1/4"X17"-M)	1	1			UR

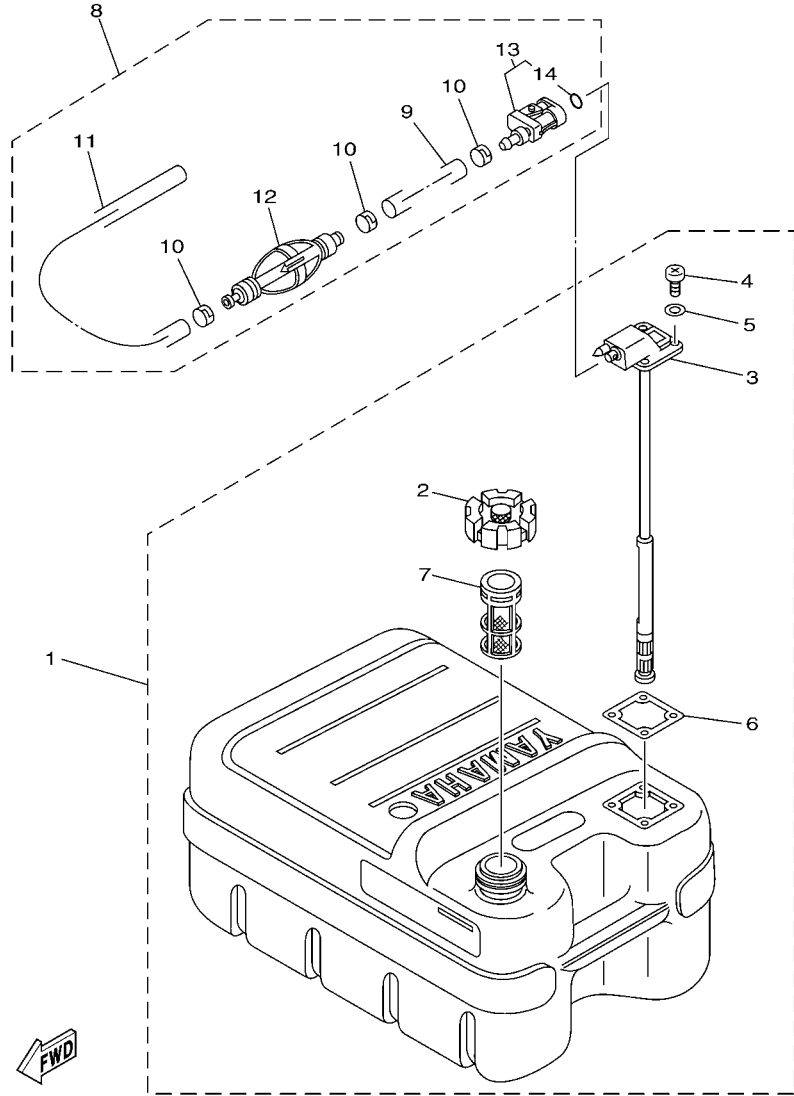

6N43100-C270

FIG. 24 FUEL TANK

REF. NO.	PART NO.	DESCRIPTION	64C8	64D8	REMARKS
1	6YJ-24201-10	FUEL TANK ASSY (24L)	1		AP FOR CAR
2	6YJ-24610-01	.CAP ASSY	1		
3	6Y1-24260-12	.FUEL METER ASSY	1		WITH INDICATOR
4	90157-05M19	.SCREW, PAN HEAD	4		
5	6Y1-24329-00	.SEAL	4		
6	6Y1-24268-00	.GASKET, FUEL METER	1		
7	6YJ-24167-00	.STRAINER	1		
8	6Y2-24306-45	FUEL PIPE COMP. 1	1		AP FOR CAR
9	90445-13M01	.HOSE (L2050)	1		
10	6E5-24351-51	.BAND 1	3		
11	90445-13M35	.HOSE (L250)	1		
12	6Y2-24360-60	.PRIMER PUMP ASSY	1		
13	6Y2-24305-06	.FUEL PIPE JOINT COMP. 2	1		
14	93210-08287	..O-RING	1		

FIG. 25 STEERING GUIDE

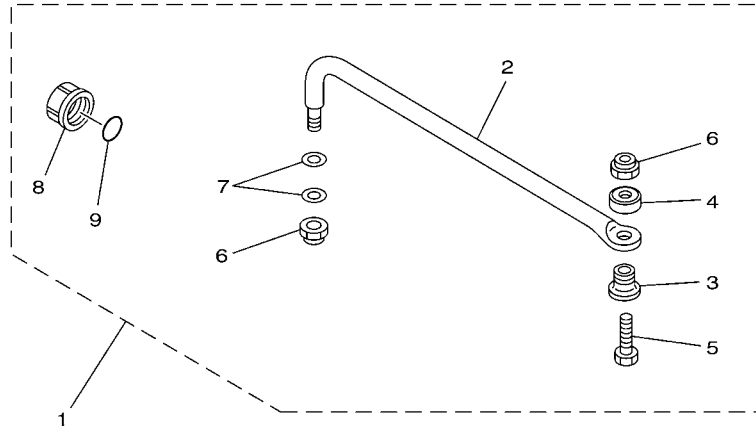

67H0100-9290

REF. NO.	PART NO.	DESCRIPTION	64C8	64D8		REMARKS
1	6E5-61350-02	STEERING GUIDE ATTACHMENT KIT	1	1		AP
2	6E5-61351-01	.ROD, STEERING LINK	1	1		
3	90387-10M61	.COLLAR	1	1		
4	90560-12M01	.SPACER	1	1		
5	6E5-61355-00	.BOLT	1	1		
6	90185-09M01	.NUT, SELF-LOCKING	2	2		
7	90201-10M20	.WASHER, PLATE	2	2		
8	6E5-43145-01	.CAP, CLAMP BRACKET	1	1		
9	93210-16275	.O-RING	1	1		

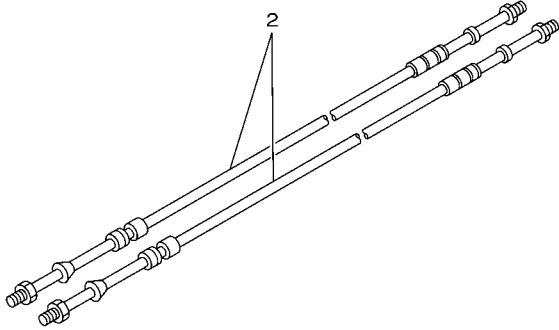
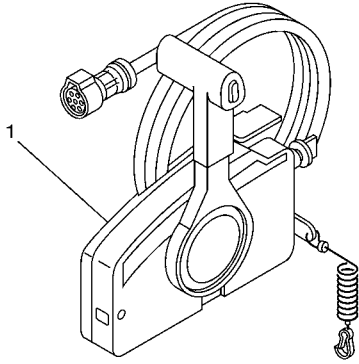

67M0100-8280

FIG. 26 REMOTE CONTROL BOX

REF. NO.	PART NO.	DESCRIPTION	64C8	64D8			REMARKS
1	703-48205-17	REMOTE CONTROL ASSY (10P)	1				AP WITH PT/T SW.
2	701-48320-50	CABLE, REMOTE CONTROL L=15F	2				UR
	701-48320-60	CABLE, REMOTE CONTROL L=16F	2				UR
	701-48320-80	CABLE, REMOTE CONTROL L=17F	2				UR
	701-48350-00	CABLE, REMOTE CONTROL L=21F	2				UR
	701-48350-20	CABLE, REMOTE CONTROL L=23F	2				UR

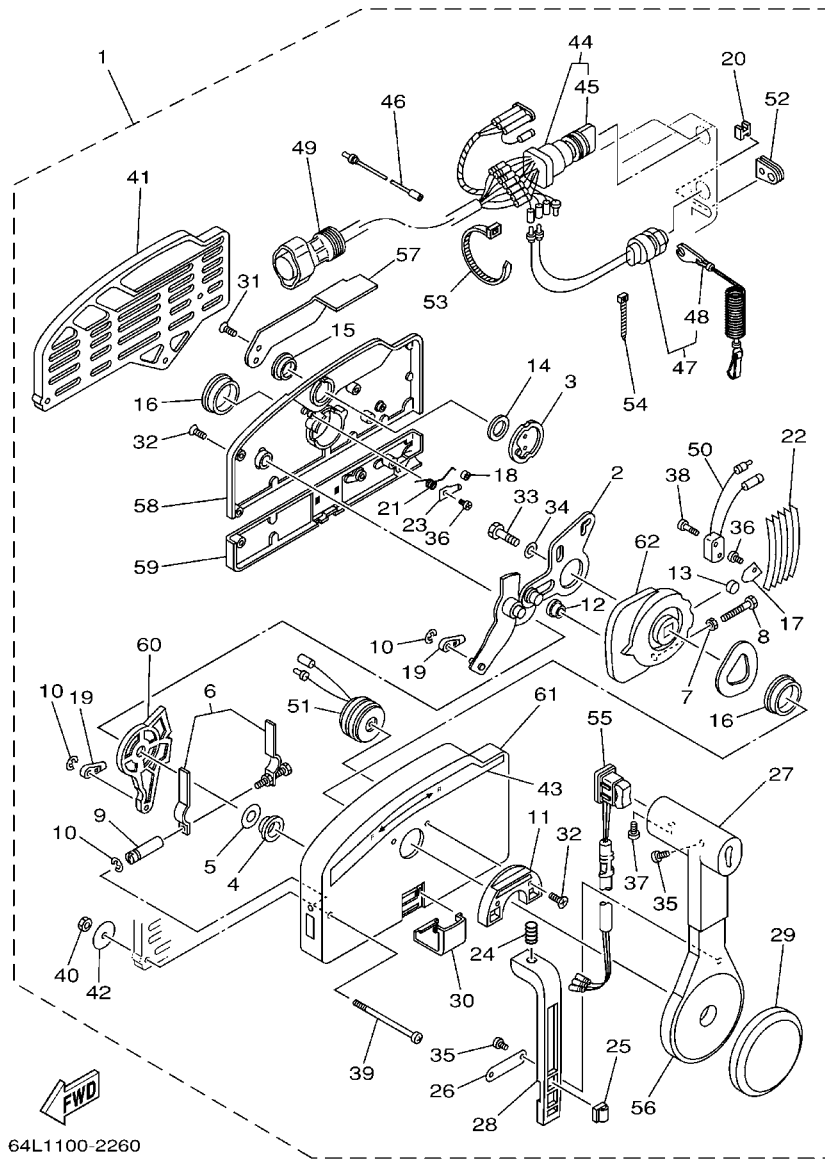

64L1100-2260

FIG. 27 REMOTE CONTROL ASSY

REF. NO.	PART NO.	DESCRIPTION	64C8	64D8	REMARKS
1	703-48205-17	REMOTE CONTROL ASSY (10P)	1		AP WITH PT/T SW.
2	703-48261-01	.ARM, THROTTLE	1		
3	703-48153-00	.SHAFT, FREE ACCEL.	1		
4	703-48235-00	.BUSHING	1		
5	703-48268-00	.SPACER	1		
6	703-48264-00	.FRICTION, THROTTLE	1		
7	95380-05600	.NUT	1		
8	97380-05025	.BOLT	1		
9	703-48265-00	.SHAFT, FRICTION	1		
10	93430-06024	.CIRCLIP	3		
11	703-48245-00	.PLATE, LOCK	1		
12	703-48252-00	.ROLLER, CAM	1		
13	701-48248-00	.ROLLER, FREE ACCEL.	1		
14	703-48198-00	.WASHER, WAVE	1		
15	703-48243-00	.BUSHING	1		
16	703-48236-00	.BUSHING 1	2		
17	703-48189-00	.RETAINER	1		
18	703-48234-00	.ROLLER, DETENT	1		
19	703-48345-01	.CABLE END, REMOTE CONTROL 2	2		
20	703-48358-00	.ANCHOR, CABLE	1		
21	703-48244-00	.SPRING, FREE ACCEL.	1		
22	703-48238-00	.SPRING, DETENT	5		
23	703-48246-00	.SPACER	1		
24	703-48227-00	.SPRING, NEUTRAL LOCK	1		
25	703-82594-00	.CLAMP	1		WITH PT/T SW.
26	703-48226-00	.PLATE, STOPPER	1		
27	703-48222-00	.GRIP, CONTROL LEVER	1		SINGLE

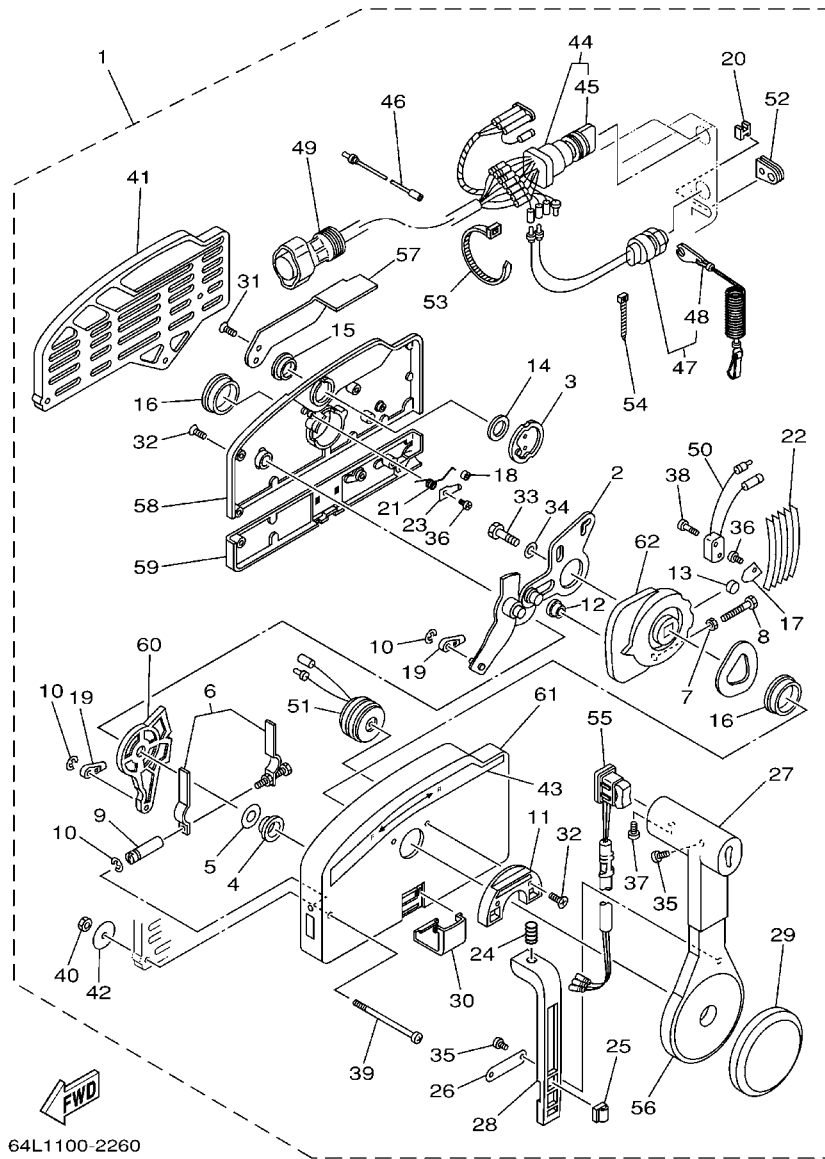

64L1100-2260

FIG. 27 REMOTE CONTROL ASSY

REF. NO.	PART NO.	DESCRIPTION	64C8	64D8		REMARKS
28	703-48223-00	.LOCK, NEUTRAL	1			
29	703-48225-00	.COVER	1			
30	703-48219-00	.COVER, LEAD	1			
31	703-48281-00	.SCREW	2			
32	703-48282-00	.SCREW	7			
33	97380-08030	.BOLT	1			
34	92990-08600	.WASHER, PLATE	1			
35	98580-04010	.SCREW, PAN HEAD	3			
36	98580-04006	.SCREW, PAN HEAD	2			
37	98580-05010	.SCREW, PAN HEAD	1			
38	98580-03015	.SCREW, PAN HEAD	2			
39	703-48291-10	.SCREW (M6)	3			
40	95380-06600	.NUT, HEXAGON	3			
41	703-48293-10	.SPACER, REMOTE CONTROL	1			SINGLE
42	701-48287-00	.WASHER	3			
43	703-48215-00	.GRAPHIC	1			
44	703-82510-43	.MAIN SWITCH ASSY	1			
45	703-82577-00	..CAP, KEY	1			
46	703-82531-00	.WIRE, LEAD (L70)	1			
47	688-82575-01	.ENGINE STOP SWITCH ASSY	1			
48	682-82556-00	..LANYARD, STOP SWITCH	1			
49	688-8258A-20	.EXTENSION, WIRE HARNESS (4.9M)	1			(10P)
50	703-82540-00	.NEUTRAL SWITCH ASSY	1			
51	703-83383-02	.BUZZER	1			
52	703-48284-00	.GROMMET	1			
53	703-82591-00	.BAND	1			
54	703-82592-00	.BAND	1			

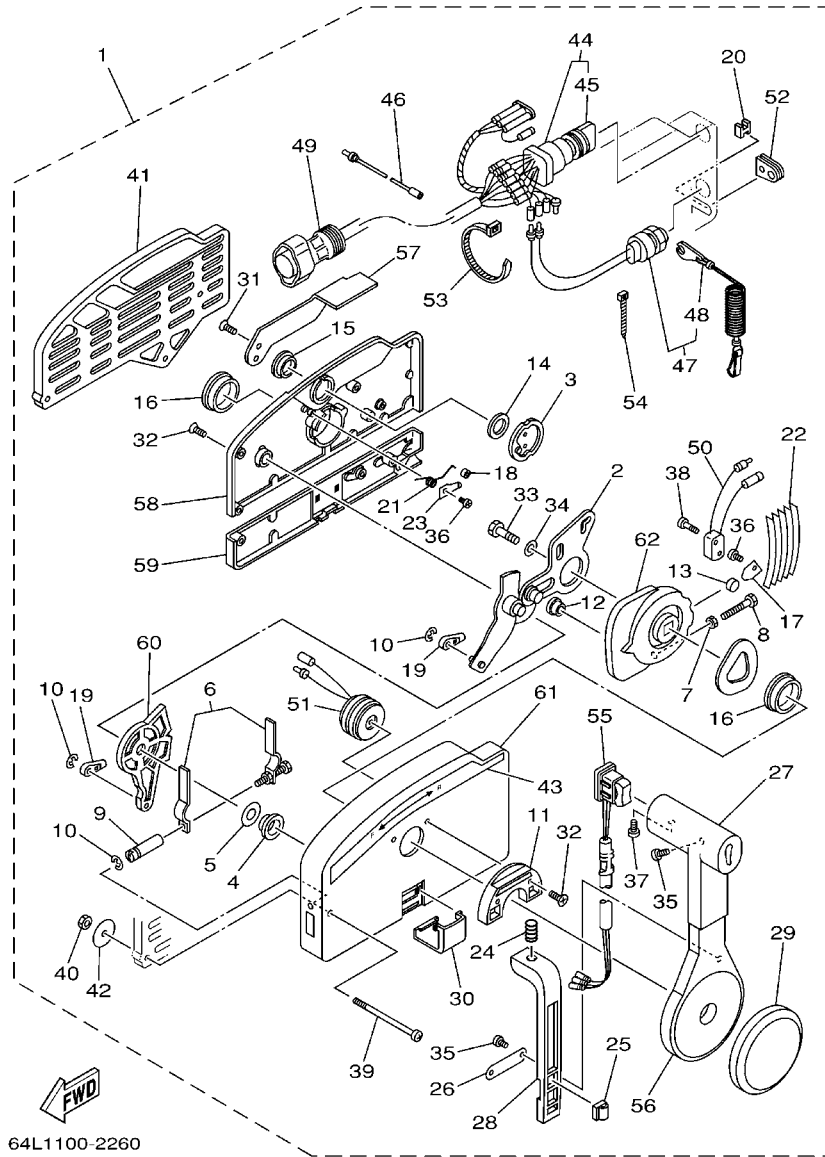

64L1100-2260

FIG. 27 REMOTE CONTROL ASSY

REF. NO.	PART NO.	DESCRIPTION	64C8	64D8	REMARKS
55	703-82563-02	.TRIM & TILT SWITCH ASSY	1		WITH PT/T SW.
56	703-48221-00	.LEVER, CONTROL	1		
57	703-48152-00	.KNOB, FREE ACCEL.	1		
58	703-48212-00	.BACK PLATE 1	1		
59	703-48213-00	.BACK PLATE 2	1		
60	703-48271-00	.ARM, SHIFT	1		
61	703-48211-01	.HOUSING,1	1		
62	703-48232-00	.GEAR	1		

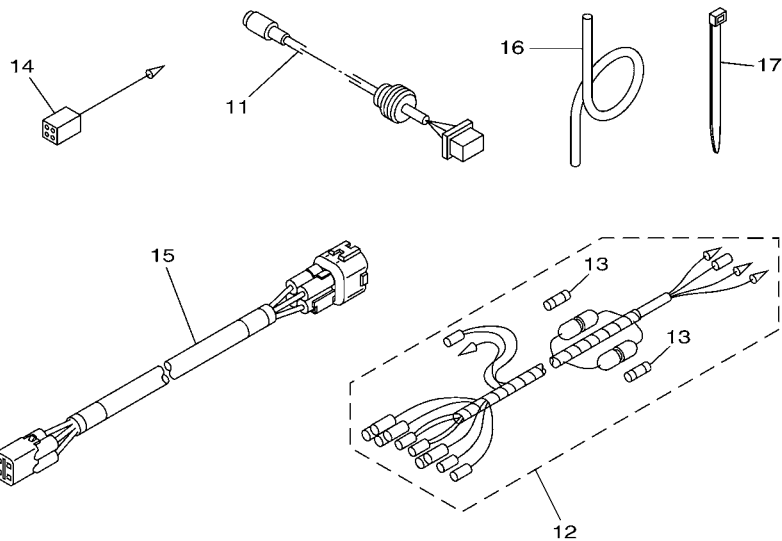
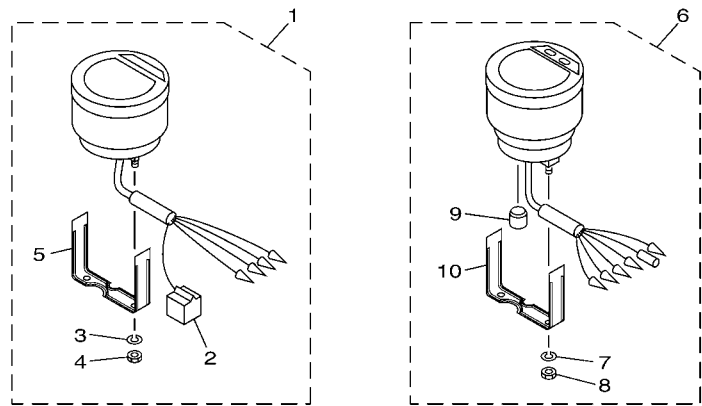

6C14100-G370

FIG. 28 METER

REF. NO.	PART NO.	DESCRIPTION	64C8	64D8			REMARKS
1	6Y5-8350T-90	DIGITAL TACHOMETER ASSY	1	1			AP EXCEPT USA
2	9E450-04533	.CONNECTOR	1	1			F-4-W
3	92990-04100	.WASHER, SPRING	2	2			
4	95380-04600	.NUT	2	2			
5	6Y5-8355X-T1	.BRACKET, METER 1	1	1			
6	6Y5-83570-S5	SPEEDOMETER ASSY	1	1			AP EXCEPT USA
7	92990-04100	.WASHER, SPRING	2	2			
8	95380-04600	.NUT	2	2			
9	6Y5-83533-T2	.GROMMET	1	1			
10	6Y5-8355X-T1	.BRACKET, METER 1	1	1			
11	6Y5-87122-S0	CORD ASSY 1	1	1			AP EXCEPT USA
12	6Y5-83553-M0	WIRE, LEAD (L=2.5M)	1	1			AP EXCEPT USA
13	1E6-82151-00	.FUSE (10A)	2	2			
14	6Y5-82117-00	WIRE, LEAD (BLACK) (L300)	1	1			AP EXCEPT USA
15	6Y5-83653-30	WIRE, LEAD	1	1			AP OCE 4P,8M
	6Y5-83653-20	WIRE, LEAD	1				AP CAR,KOR,RUS 4P,7M
16	6Y5-83557-10	TUBE (8M)	1	1			AP OCE
	6Y5-83557-00	TUBE (6M)	1				AP CAR,KOR,RUS
17	90465-11M10	CLAMP	2	2			AP EXCEPT USA

FIG. 29 REPAIR KIT 1

REF. NO.	PART NO.	DESCRIPTION	64C8	64D8	REMARKS
1	64D-W0001-01	POWER HEAD GASKET KIT	1	1	
2	6E5-11381-A2	.GASKET 1	1	1	
3	6G5-11181-A2	.GASKET, CYLINDER HEAD 1	2	2	
4	6G5-11193-A1	.GASKET, HEAD COVER 1	2	2	
5	688-12414-A1	.GASKET, COVER	2	2	
6	6G5-41112-A1	.GASKET, EXHAUST INNER COVER	1	1	
7	6G5-41114-A0	.GASKET, EXHAUST OUTER COVER	1	1	
8	6G5-11382-A1	.GASKET 2	1	1	
9	93102-40M14	.OIL SEAL	1	1	
10	93211-04001	.O-RING	2	2	
11	93102-35M13	.OIL SEAL	1	1	
12	93101-22M15	.OIL SEAL	1	1	
13	93210-74M35	.O-RING	1	1	
14	6E5-13621-A1	.GASKET, VALVE SEAT	6	6	
15	6G5-13645-A2	.GASKET, MANIFOLD 1	1	1	
16	6E5-14198-A2	.GASKET	3	3	
17	6K7-14483-00	.GASKET	3	3	
18	650-24431-A0	.GASKET, FUEL PUMP 1	2	2	
19	68F-45113-00	.GASKET, UPPER CASING	1	1	
20	64D-W0093-01	CARBURETOR REPAIR KIT	1	1	
21	64D-14384-01	.GASKET, FLOAT CHAMBER	1	1	
22	6E5-14546-00	.VALVE, NEEDLE	2	2	
23	6E5-14159-00	.CLIP	2	2	
24	6E5-14386-02	.PIN, FLOAT	2	2	
25	61U-14959-00	.GASKET	2	2	
26	64D-14394-00	.VALVE, DRAIN	2	2	
27	6E5-14398-01	.GASKET	2	2	

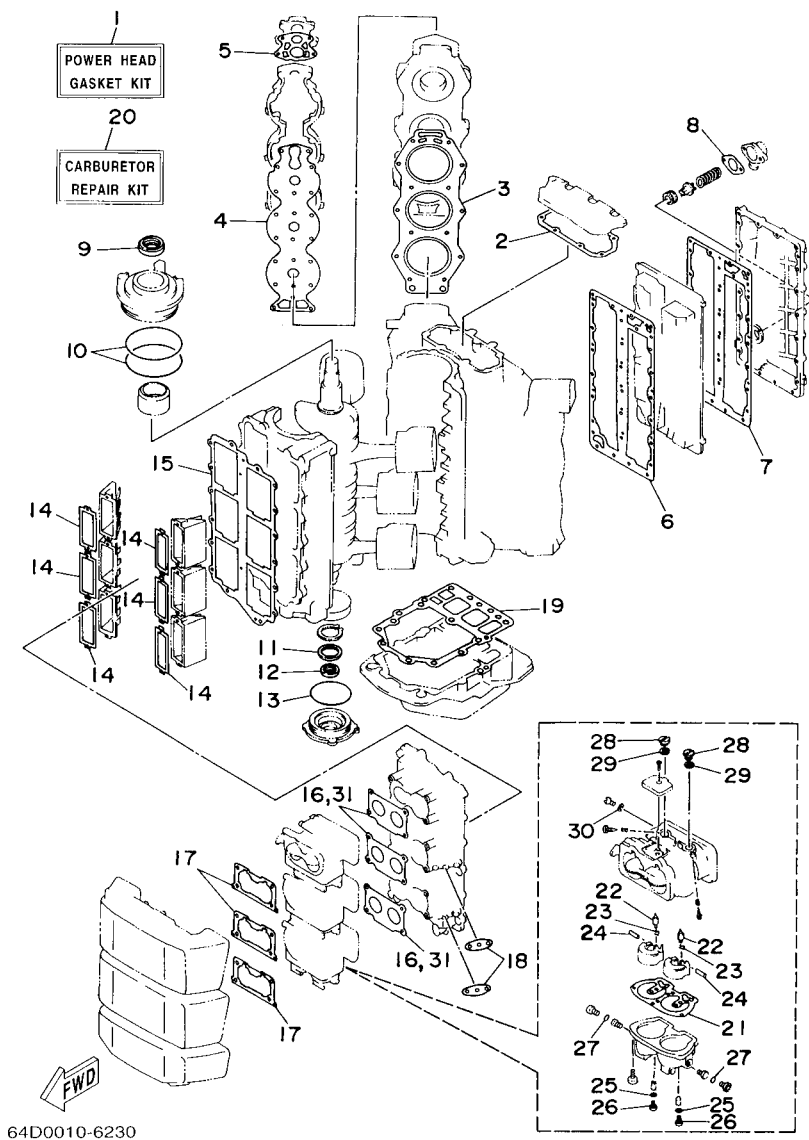

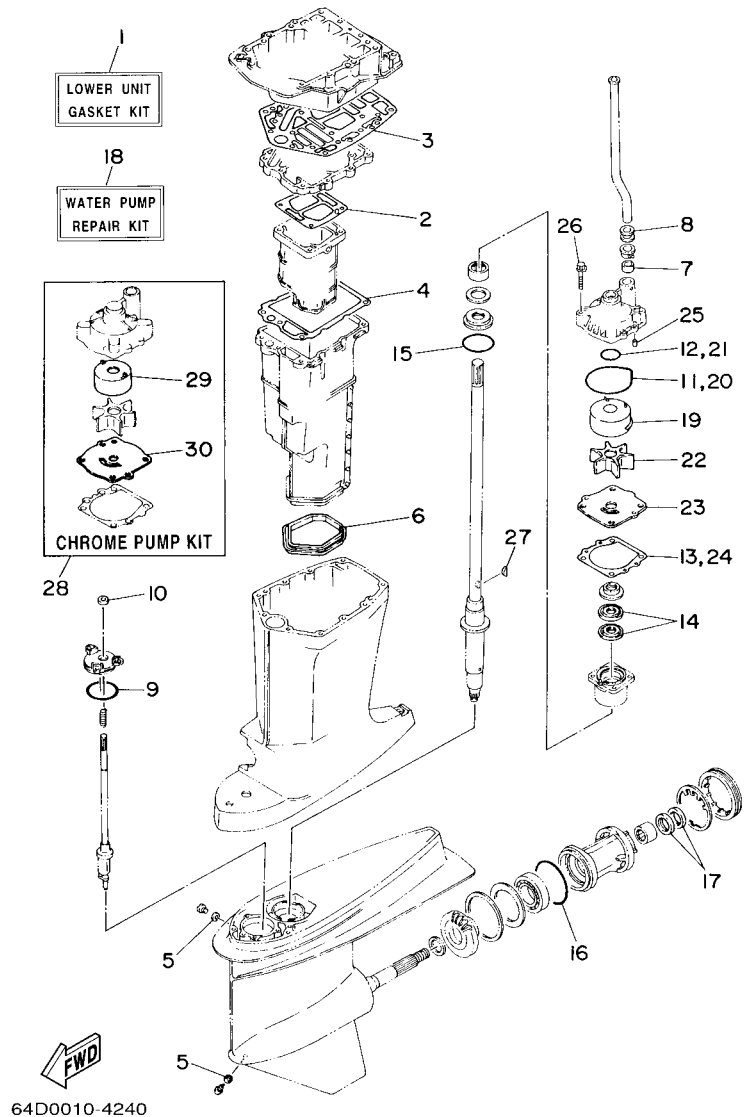

FIG. 30 REPAIR KIT 2

REF. NO.	PART NO.	DESCRIPTION	64C8	64D8	REMARKS
1	6G5-W0001-C1	LOWER UNIT GASKET KIT	1	1	
2	6G5-41134-A1	.GASKET, EXHAUST MANIFOLD	1	1	
3	6G5-45114-A1	.GASKET, UPPER CASING	1	1	
4	6E5-41135-A0	.GASKET, EXHAUST MANIFOLD	1	1	
5	90430-08020	.GASKET	2	2	
6	6E5-45123-00	.GASKET, MUFFLER	1	1	
7	6E5-44365-00	.DAMPER, WATER SEAL	1	1	
8	6E5-44366-00	.DAMPER, WATER SEAL	1	1	
9	93210-58144	.O-RING	1	1	
10	93106-09014	.OIL SEAL	1	1	
11	93210-86M38	.O-RING	1	1	
12	93210-37160	.O-RING	1	1	
13	6E5-44315-A0	.GASKET, WATER PUMP	1	1	
14	93101-28M16	.OIL SEAL	2	2	
15	93210-55M14	.O-RING	1	1	
16	93210-97M55	.O-RING	1	1	
17	93101-30M17	.OIL SEAL	2	2	
18	61A-W0078-A3	WATER PUMP REPAIR KIT	1	1	
19	61A-44322-02	.INSERT, CARTRIDGE	1	1	
20	93210-86M38	.O-RING	1	1	
21	93210-37160	.O-RING	1	1	
22	6E5-44352-01	.IMPELLER	1	1	
23	6G5-44323-00	.OUTER PLATE, CARTRIDGE	1	1	
24	6E5-44315-A0	.GASKET, WATER PUMP	1	1	
25	93606-12019	.PIN, DOWEL	2	2	
26	90119-08M14	.BOLT, WITH WASHER	4	4	
27	90280-04M05	.KEY, WOODRUFF	1	1	

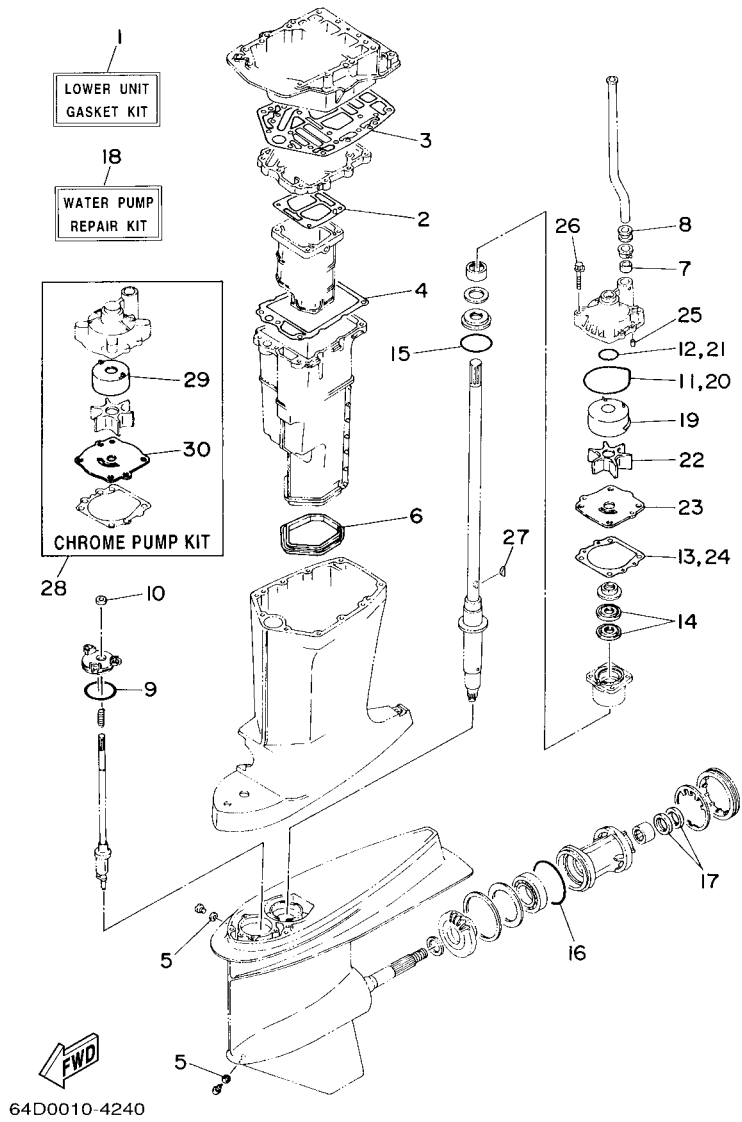

FIG. 30 REPAIR KIT 2

REF. NO.	PART NO.	DESCRIPTION	64C8	64D8			REMARKS
			1	1			
28	61A-W0078-2A	CHROME PUMP KIT	1	1			
29	6R3-44322-42	.INSERT, CARTRIDGE	1	1			
30	6G5-44323-40	.OUTER PLATE, CARTRIDGE	1	1			

NUMERICAL INDEX

PART NO.	REF. NO.	PART NO.	REF. NO.	PART NO.	REF. NO.	PART NO.	REF. NO.	PART NO.	REF. NO.	PART NO.	REF. NO.
6G5-11111-04-1S	4 - 1	6R3-13117-00	7 - 20	64D-14384-01	6 - 4	6YJ-24167-00	24 - 7	650-24431-A0	29 - 18	64D-42610-T0-4D	1 - 1
67H-11119-01	2 - 16	6R3-13183-10	7 - 13		29 - 21	6YJ-24201-10	24 - 1	6E5-24435-01	9 - 24	64D-42613-00-4D	1 - 10
6G5-11181-A2	4 - 2	6R4-13200-02	7 - 3	6E5-14385-02	6 - 6	646-24251-02	8 - 6	6E5-24444-01	9 - 21	64D-42615-00	1 - 9
	29 - 3	6E5-13411-00	8 - 28	6E5-14386-02	6 - 9	6Y1-24260-12	24 - 3	6E5-24471-01	9 - 23	6R3-42647-00	1 - 2
6G5-11191-00-1S	4 - 4	6E5-13414-00	8 - 29		29 - 24	6Y1-24268-00	24 - 6	6E5-24486-00	9 - 33	64D-42662-00	1 - 5
6G5-11193-A1	4 - 5	6R3-13416-00	7 - 8	64D-14394-00	6 - 12	6Y2-24305-06	10 - 11	6E5-24492-00	9 - 32	64C-42677-40	1 - 12
	29 - 4	6E5-13437-43	8 - 41		29 - 26		24 - 13	61N-24521-00	9 - 7	64D-42677-40	1 - 12
6E5-11325-00	2 - 14	6E5-13437-62	8 - 41	6E5-14398-01	6 - 16	6YK-24306-44	10 - 6	6R3-24560-00	9 - 5	64C-42677-50	1 - 12
646-11370-01	2 - 7	6E5-13448-00	8 - 25		29 - 27	6Y2-24306-45	10 - 6	6R3-24563-00	9 - 6	64C-42677-60	1 - 12
6E5-11370-01	5 - 9	6R3-13471-00	7 - 4	6G5-1441K-00	5 - 28		24 - 8	648-24566-02	9 - 9	64C-42677-80	1 - 13
6K7-11371-01-1S	2 - 18	6L2-13475-00	7 - 5	64D-14440-00	5 - 27	6Y2-24307-50	10 - 1	6YJ-24610-01	24 - 2	64D-42677-B0	1 - 13
6H1-11372-00	21 - 21	6E5-13552-01	5 - 7	6R3-14440-02	5 - 27	6R3-24313-01	9 - 1	61H-2819R-31	8 - 42	64D-42677-S0	1 - 14
6G5-11372-00-1S	4 - 23	6E5-13610-00	5 - 1	6K7-14483-00	5 - 30	6R3-24313-20	9 - 1	64D-41111-00-1S	4 - 12	64D-42678-30	1 - 20
624-11379-00	2 - 3	6E5-13621-A1	5 - 3		29 - 17	6G5-24314-00	9 - 13	6G5-41112-A1	4 - 13	64D-4267A-30	1 - 19
6E5-11381-A2	2 - 19		29 - 14	624-14485-00	5 - 8	6E5-24315-00	9 - 18		29 - 6	64D-4267A-S0	1 - 19
	29 - 2	6G5-13641-11-1S	5 - 6	6G5-14488-02	11 - 24	6G5-24315-00	9 - 17	6R3-41113-00-1S	4 - 15	64C-42681-30	1 - 17
6G5-11382-A1	4 - 22	6G5-13645-A2	5 - 18	6E5-14527-01	6 - 26	6G5-24316-10	9 - 36	6G5-41114-A0	4 - 14	64D-42681-40	1 - 17
	29 - 8		29 - 15	6E5-14546-00	6 - 7	6G5-24317-01	9 - 41		29 - 7	64C-42681-50	1 - 17
6G5-11411-02	3 - 1	6E5-14159-00	6 - 8		29 - 22	6G5-24318-10	9 - 42	6G5-41131-01-5B	21 - 22	64C-42682-30	1 - 18
6E5-11447-00	3 - 2		29 - 23	6E5-14711-01-5B	21 - 30	6E5-24319-01	8 - 7	64D-41132-00-5B	21 - 26	64D-42682-40	1 - 18
663-11518-01	2 - 6	6E5-14198-A2	5 - 20	64D-14721-20-5B	21 - 39	6G5-24319-10	9 - 43	6G5-41134-A1	21 - 27	64C-42682-50	1 - 18
6R3-11536-00	3 - 9		29 - 16	6E5-14737-00	21 - 31	6E5-24321-01	8 - 11		30 - 2	64C-42687-00	1 - 15
6R3-11537-00	7 - 19		29 - 31	64D-1492E-71	6 - 13	6E5-24322-00	8 - 4	6E5-41135-A0	21 - 34	64D-42687-00	1 - 15
64D-11603-02	3 - 18	6E5-14223-00	6 - 24		6 - 14	64E-24323-00	8 - 34		30 - 4	64C-42687-30	1 - 15
	3 - 20	6E5-14276-01	7 - 1		6 - 15	6Y1-24329-00	24 - 5	6G5-41137-02-94	21 - 10	64C-42687-40	1 - 15
64D-11604-02	3 - 18	64C-14301-02	6 - 1	64D-1492E-75	6 - 13	6E5-24351-51	10 - 3	6G5-41137-11-94	21 - 10	64D-42711-01-8D	15 - 1
	3 - 20	64C-14301-10	6 - 1	64D-1492E-77	6 - 14		10 - 8	6G5-41211-01	16 - 30	648-42715-00	16 - 50
64D-11605-02	3 - 18	64C-14301-S2	6 - 1	64D-1492E-79	6 - 15		24 - 10	6G5-41213-00	16 - 33	6E5-42716-10	15 - 40
	3 - 20	64D-14301-S2	6 - 1	64D-1492F-42	6 - 10	6Y2-24360-60	10 - 5	6G5-41217-01	5 - 22	64D-42717-00	15 - 36
64D-11631-02-90	3 - 17	64C-14302-02	6 - 2	61A-1492H-12	6 - 17		10 - 10	6H1-41237-00	7 - 24	6E5-42724-00	21 - 11
6R5-11633-10	3 - 21	64C-14302-10	6 - 2	61U-14959-00	6 - 11		24 - 12	6R5-41237-00	7 - 26	64D-42725-20	15 - 19
6R5-11634-10	3 - 22	64C-14302-S2	6 - 2		29 - 25	6G5-24376-00	9 - 39	662-41237-01	16 - 26	64D-42725-30	15 - 19
64D-11635-02	3 - 17	64D-14302-S2	6 - 2	6J8-14959-00	6 - 29	6G5-24377-00	9 - 40		16 - 32	688-42726-10	15 - 29
64D-11636-02	3 - 17	64C-14303-02	6 - 3		29 - 30	6R3-24377-00	9 - 2	6R3-41241-00	7 - 23	61A-42727-00	15 - 3
64D-11642-02-90	3 - 19	64C-14303-10	6 - 3	6E5-14979-00	6 - 22	6R3-24377-10	9 - 2	6E5-41256-01	5 - 23	64D-42738-00-5B	15 - 20
64D-11645-02	3 - 19	64C-14303-S2	6 - 3		29 - 29	650-24378-00	4 - 16	661-41262-02	5 - 24	64D-42738-10-5B	15 - 21
64D-11646-02	3 - 19	64D-14303-S2	6 - 3	64C-15100-01-1S	2 - 2	6E5-24378-00	9 - 16	6R3-41271-00	5 - 25	6R3-42741-02-8D	15 - 33
6R5-11650-10	3 - 23	6E5-14321-00	6 - 19	64D-15100-01-1S	2 - 2	6E5-24379-00	8 - 12	689-41273-00	5 - 26	6H4-42748-00	15 - 4
6E5-12411-30	4 - 7	6E5-14323-03	6 - 23	6R3-15163-00-1S	3 - 3		8 - 36	688-41611-00	11 - 13	68F-42753-00	15 - 47
688-12412-00	4 - 8	6E5-14324-00	6 - 28	6G5-15359-00-94	3 - 12		8 - 38	688-41612-00	11 - 14	6E5-42761-00-1S	2 - 21
688-12413-00-1S	4 - 9	6A0-14325-00	9 - 30	6E5-21708-10	8 - 1	6E5-24410-04	9 - 20	6G5-41631-01-1S	16 - 10	6E5-42762-00-1S	2 - 22
688-12414-A1	4 - 10	6E5-14328-01	6 - 21	61A-21708-20	8 - 1	6E5-24411-01	9 - 25	61H-41632-02-1S	16 - 7	6E5-42769-00	21 - 5
	29 - 5		29 - 28	6E5-21733-20	8 - 2	6E5-24412-11	9 - 28	6G5-41636-01	16 - 24	6R3-42771-01-8D	15 - 37
60H-12416-00	4 - 19	64E-1432A-00	6 - 30	6E5-21734-01-33	8 - 18	6E5-24413-01	9 - 22	6E5-42510-A1-8D	18 - 10	6E7-42791-10	15 - 49
6R3-12572-00	15 - 42	6J8-14334-00	6 - 20	6E5-21746-00	8 - 20	6A0-24421-01	9 - 29	6E5-42510-B1-8D	18 - 10	6G5-42791-10	15 - 49
6G5-12576-00	4 - 25	64D-14381-00	6 - 5	6E5-21750-05	8 - 24	6E5-24423-00	9 - 27	64C-42610-50-4D	1 - 1	6R3-42791-41	21 - 2
6R3-12580-00	15 - 43	64D-14381-10	6 - 5	6E5-21770-03	8 - 3	648-24424-00	9 - 26	64C-42610-60-4D	1 - 1	6R3-42792-41	21 - 3
6G5-12581-00	21 - 12	61A-14383-01	6 - 18	6E5-21798-01-33	8 - 19	650-24431-A0	9 - 34	64C-42610-T0-4D	1 - 1	64D-42814-00	1 - 6

NUMERICAL INDEX

PART NO.	REF. NO.	PART NO.	REF. NO.	PART NO.	REF. NO.	PART NO.	REF. NO.	PART NO.	REF. NO.	PART NO.	REF. NO.
64D-42815-00-4D	15 - 5	64E-43855-00	20 - 14	6E5-44315-A0	30 - 13	6E5-45331-00-94	22 - 38	6G5-45932-00-98	23 - 22	703-48264-00	27 - 6
64D-42816-00-4D	15 - 6	64E-43858-00	20 - 12		30 - 24	6J9-45332-00-94	22 - 62	6G5-45941-00-98	23 - 22	703-48265-00	27 - 9
64D-42818-20	15 - 12		20 - 18	61A-44322-02	22 - 27	688-45341-10	22 - 7	6G5-45943-01-98	23 - 22	703-48268-00	27 - 5
64D-42818-30	15 - 13	6E5-43858-00	19 - 29		30 - 19	6E5-45344-00	22 - 44	6G5-45945-01-98	23 - 22	703-48271-00	27 - 60
64D-42835-00	15 - 7	72X-43858-00	20 - 5	6R3-44322-42	30 - 29	6J9-45371-01	23 - 12	6G5-45947-01-98	23 - 22	703-48281-00	27 - 31
64E-43111-02-8D	17 - 1	64E-43859-00	20 - 13	6G5-44323-00	22 - 34	64D-45375-00	21 - 41	6G5-45949-00-98	23 - 22	703-48282-00	27 - 32
64E-43112-02-8D	17 - 9	64E-43860-00	20 - 20		30 - 23	688-45375-00	22 - 15	6G5-45952-00-98	23 - 22	703-48284-00	27 - 52
64E-43126-00	17 - 37	6E5-43862-00	19 - 11	6G5-44323-40	30 - 30	64D-45376-00-94	22 - 14	6G5-45970-02-98	23 - 22	701-48287-00	27 - 42
64E-43131-01	17 - 15		19 - 15	6E5-44352-01	22 - 32	663-45376-00-94	22 - 14	6R4-45970-A1	23 - 22	703-48291-10	27 - 39
64E-43139-10	18 - 1	6G5-43863-00	20 - 10		30 - 22	6E5-45378-00	22 - 16	6G5-45972-02-98	23 - 22	703-48293-10	27 - 41
64D-43144-00	15 - 14	6E5-43864-00	19 - 21	6E5-44361-00	23 - 2	6G5-45383-01	22 - 72	6R4-45972-A0	23 - 22	701-48320-50	26 - 2
6G5-43144-00	17 - 27	6G5-43864-00	19 - 20	6E5-44361-20	23 - 2	6G5-45384-00	22 - 73	6G5-45974-03-98	23 - 22	701-48320-60	26 - 2
6E5-43145-01	25 - 8	64E-43865-00	20 - 16	6E5-44365-00	22 - 30	6G5-45501-01	22 - 47	6R4-45974-A0	23 - 22	701-48320-80	26 - 2
6G5-43148-00	17 - 32	6G5-43865-00	20 - 35		23 - 3	6G5-45501-21	22 - 47	6G5-45976-01-98	23 - 22	6E5-48344-00	16 - 8
6G5-43181-02	17 - 29	64E-43866-00	19 - 10		30 - 7	61A-45527-00	22 - 11	6R4-45976-A0	23 - 22		16 - 43
6G5-43185-02	17 - 30	64E-43867-00	19 - 9	6E5-44366-00	23 - 1	6G5-45536-01	22 - 13	6G5-45978-03-98	23 - 22	703-48345-01	27 - 19
64E-43311-10-8D	17 - 22	64E-43868-00	20 - 3		30 - 8	61A-45538-00	22 - 12	6R4-45978-A0	23 - 22	701-48350-00	26 - 2
64E-43311-20-8D	17 - 22	64E-43869-00	19 - 27	6E5-44391-00	15 - 18	6G5-45551-10	22 - 48	6E5-45987-01	23 - 17	701-48350-20	26 - 2
61A-43376-00	18 - 8	6H1-4386K-10	20 - 29	6E5-44511-00-5B	18 - 38	6G5-45560-10	22 - 50	688-45997-01	23 - 18	703-48358-00	27 - 20
64E-43800-04-4D	19 - 1	6E5-43872-00	19 - 13	6G5-44514-00-94	18 - 31	6G5-45567-01	22 - 5	703-48152-00	27 - 57	64D-48531-00	16 - 1
64E-43802-00	20 - 8	64E-43873-00	20 - 24	6G5-44526-00	17 - 3	6G5-45567-10	22 - 5	703-48153-00	27 - 3	64D-48532-00	16 - 2
64E-43805-00	20 - 37	6E5-43874-01	19 - 22	68F-44533-00	2 - 23	6G5-45567-20	22 - 5	703-48189-00	27 - 17	6E5-48538-00	16 - 3
64E-4380F-00	20 - 33	64E-43875-00	20 - 25	6G5-44551-01-8D	18 - 13	6G5-45567-30	22 - 5	703-48198-00	27 - 14	6E5-61350-02	25 - 1
64E-4380J-00	20 - 30	64E-43879-00	20 - 27	6E5-44552-01-94	18 - 24	6G5-45567-40	22 - 5	703-48205-17	26 - 1	6E5-61351-01	25 - 2
64E-43810-01	19 - 6	64E-43879-10	20 - 26	6E5-44553-01-8D	18 - 27	6G5-45567-50	22 - 5		27 - 1	6E5-61355-00	25 - 5
64E-43811-01	19 - 7	64E-4387A-00	20 - 23	6G5-44555-00-94	18 - 16	6G5-45567-60	22 - 5	703-48211-01	27 - 61	6E5-81332-00	11 - 16
6E5-43814-02	19 - 14	64E-43880-02	20 - 28	663-44575-00	18 - 37	6G5-45571-02	22 - 64	703-48212-00	27 - 58	64D-81337-01	11 - 19
64E-43816-00	20 - 17	64E-43883-00	19 - 12	6E5-44575-00	18 - 15	6G5-45576-10	22 - 65	703-48213-00	27 - 59	64D-81337-10	11 - 19
64E-43817-00	19 - 5	64E-4388E-00	19 - 26	6E5-45111-02-8D	21 - 1	6G5-45577-02	22 - 69	703-48215-00	27 - 43	6N7-81800-10	14 - 1
64E-43817-10	20 - 19	64E-4388E-10	20 - 1	6E5-45111-23-8D	21 - 1	6G5-45577-10	22 - 69	703-48219-00	27 - 30	6N7-81801-00	14 - 8
64E-43818-01	19 - 33	64E-4388J-00	19 - 3	68F-45113-00	21 - 14	6G5-45577-20	22 - 69	703-48221-00	27 - 56	6N7-81807-00	14 - 11
64E-4381G-00	19 - 28	64E-43891-00	20 - 31		29 - 19	6G5-45577-30	22 - 69	703-48222-00	27 - 27	61A-81809-00	14 - 3
64E-43820-01	19 - 16	64E-43892-00	20 - 34	6G5-45114-A1	21 - 23	6G5-45577-40	22 - 69	703-48223-00	27 - 28	6N7-81810-00	14 - 5
64E-43821-01	19 - 17	6E5-43896-00	20 - 9		30 - 3	6G5-45577-50	22 - 69	703-48225-00	27 - 29	6N7-81813-00	14 - 9
64E-43822-00	19 - 18	64E-43897-00	19 - 25	663-45119-00	17 - 14	6G5-45577-60	22 - 69	703-48226-00	27 - 26	6N7-81820-10	14 - 10
64E-43825-02	19 - 2	64E-43898-00	19 - 8		17 - 25	6E5-45587-01	22 - 41	703-48227-00	27 - 24	6R3-81822-00-94	14 - 19
64E-43827-00	20 - 22	6E5-44117-00-1S	16 - 37	64D-45123-00	21 - 40	6E5-45587-10	22 - 41	703-48232-00	27 - 62	61A-81824-00	14 - 4
64E-43828-00	19 - 23	6E5-44118-01-94	16 - 45	6E5-45123-00	21 - 33	6E5-45587-20	22 - 41	703-48234-00	27 - 18	6K7-81826-11	14 - 14
64E-43829-00	19 - 24	6E5-44120-03	16 - 52		30 - 6	6E5-45587-30	22 - 41	703-48235-00	27 - 4	6E5-8182A-10	14 - 17
64E-4382G-00	19 - 30	6E5-44120-23	16 - 52	6E5-45155-00	21 - 4	6E5-45587-40	22 - 41	703-48236-00	27 - 16	6E5-8182E-10	14 - 15
64E-43830-00	20 - 4	68F-44121-00	16 - 39	6J9-45214-00	23 - 8	6E5-45587-50	22 - 41	703-48238-00	27 - 22	6E5-8182F-10	14 - 16
64E-43831-00	20 - 2	6E5-44122-00	16 - 40	6J9-45215-00	23 - 9	6E5-45587-60	22 - 41	703-48243-00	27 - 15	6K7-8182G-10	14 - 6
64E-43841-00	20 - 7	6G5-44150-02	22 - 23	6G5-45251-02	17 - 2	6J9-45611-01	22 - 52	703-48244-00	27 - 21	6E5-8182K-10	14 - 18
64E-43843-00	20 - 6	688-44194-00	16 - 15	64D-45300-02-8D	22 - 1	6G5-45631-00	22 - 60	703-48245-00	27 - 11	6N7-81830-00	14 - 13
64E-43843-10	20 - 38		16 - 29	64D-45300-22-8D	22 - 1	6E5-45633-01	22 - 61	703-48246-00	27 - 23	6N7-81840-00	14 - 7
64E-4384J-00	19 - 19	61A-44311-01	22 - 26	6J9-45301-05-8D	22 - 2	6E5-45634-01	22 - 54	701-48248-00	27 - 13	6N7-81850-10	14 - 2
64E-43850-00	20 - 15	6E5-44312-00	22 - 31	6E5-45318-00	21 - 37	6E5-45641-03	22 - 53	703-48252-00	27 - 12	6N7-81857-00	14 - 12
64E-43851-00	20 - 11	6E5-44315-A0	22 - 35	6E5-45321-00	22 - 19	6G5-45930-00-98	23 - 22	703-48261-01	27 - 2	6E5-81900-01	8 - 9

NUMERICAL INDEX

PART NO.	REF. NO.	PART NO.	REF. NO.	PART NO.	REF. NO.	PART NO.	REF. NO.	PART NO.	REF. NO.	PART NO.	REF. NO.
64D-81920-01	13 - 45	6K7-82588-00	13 - 15	6E5-W0004-00	5 - 2	90157-05M19	24 - 4	90250-08M07	22 - 59	90445-11M81	8 - 13
6E5-81922-00	8 - 10	688-8258A-20	27 - 49	64D-W0070-30	1 - 16	90157-06013	16 - 12	90280-04M05	22 - 33	90445-12207	8 - 35
61A-81941-00	13 - 32	64D-82590-20	13 - 7	64C-W0070-50	1 - 16	90157-06M00	16 - 27		30 - 27	90445-12M13	8 - 35
64D-81942-00	12 - 5	703-82591-00	27 - 53	64D-W0070-S0	1 - 16	90159-06M08	5 - 31	90280-05015	11 - 8	90445-13M01	10 - 2
6G5-81948-11	13 - 39	703-82592-00	27 - 54	61A-W0078-2A	30 - 28	90159-06M11	12 - 24	90282-04M00	22 - 71		10 - 7
6E5-81950-00	13 - 34	688-82594-00	13 - 10	61A-W0078-A3	30 - 18	90159-06M14	5 - 31	90340-08002	22 - 6		24 - 9
689-81952-10	13 - 33	703-82594-00	27 - 25	64C-W0090-15-1S	2 - 1	90169-05M00	15 - 2	90340-14M00	2 - 8	90445-13M35	10 - 9
6E5-8195A-00	13 - 35	6R3-8259E-00	12 - 25	64D-W0090-15-1S	2 - 1	90170-16M01	22 - 49	90384-06M07	2 - 4		24 - 11
6R3-81960-10	12 - 1	703-83383-02	27 - 51	64D-W0093-01	29 - 20	90170-20137	11 - 10	90384-14M09	2 - 5	90446-15M07	9 - 46
64D-82105-00	13 - 62	6Y5-8350T-90	28 - 1	656-W2810-02	8 - 43	90171-18M04	23 - 20	90386-06M12	16 - 44	90464-07M05	5 - 15
6R3-82105-02	13 - 44	6Y5-83533-T2	28 - 9	6R3-Y125J-70	15 - 41	90179-06066	18 - 30	90386-10M16	17 - 31		7 - 16
64D-82116-00	13 - 53	6Y5-83553-M0	28 - 12	90101-12M03	17 - 40	90179-06M24	1 - 11	90386-12089	16 - 18	90464-13M34	8 - 40
6E5-82116-00	13 - 38	6Y5-83557-00	28 - 16	90101-12M05	17 - 40	90179-06M28	5 - 21	90386-15M73	15 - 10	90464-15M11	11 - 7
64D-82117-00	13 - 52	6Y5-83557-10	28 - 16	90101-12M77	17 - 40	90183-05M02	21 - 32	90386-16M66	16 - 54		12 - 12
6Y5-82117-00	28 - 14	6E9-83557-70	13 - 42	90105-10M00	23 - 13	90185-05002	23 - 11	90386-22M13	16 - 20	90464-20258	15 - 48
6E5-82117-01	13 - 54	6E5-83558-00	23 - 15	90105-10M20	2 - 11	90185-09M01	25 - 6	90386-22M98	17 - 38	90465-05M87	12 - 18
6G5-82119-00	13 - 37	6E5-83558-10	22 - 18	90109-06M40	7 - 7	90185-12M12	18 - 36		19 - 34		13 - 11
6E5-82147-00	17 - 26	6Y5-8355X-T1	28 - 5	90109-08022	3 - 24	90185-22M11	17 - 20	90386-25M31	17 - 18	90465-06M86	4 - 27
6E5-82147-20	17 - 26		28 - 10	90109-12007	18 - 35	90201-06068	15 - 9	90386-38M32	18 - 12		11 - 4
6E5-82148-00	17 - 6	6Y5-83570-S5	28 - 6	90109-14M34	18 - 20	90201-08M13	16 - 22	90387-06119	8 - 32		13 - 21
	17 - 10	6R3-83614-00	13 - 30	90116-06M30	5 - 17	90201-08M14	19 - 31	90387-06M03	12 - 20	90465-06M88	12 - 11
6E5-82149-00	18 - 19	6A1-83625-41	11 - 22	90116-08026	2 - 13	90201-08M23	16 - 17	90387-06M29	16 - 34	90465-08M63	17 - 23
6R3-82150-00	12 - 2	6A1-83625-51	11 - 23	90119-06M10	22 - 22	90201-08M54	15 - 26	90387-06M66	12 - 6	90465-08M89	13 - 12
1E6-82151-00	28 - 13	6Y5-83653-20	28 - 15	90119-06M61	12 - 22	90201-10M20	25 - 7	90387-08M16	16 - 19	90465-10M91	5 - 16
663-82151-00	13 - 8	6Y5-83653-30	28 - 15	90119-06M65	8 - 33	90201-12M05	17 - 42	90387-08M37	15 - 25		7 - 18
705-82151-00	12 - 3	67H-83672-00	18 - 3	90119-06MA2	2 - 20	90201-13M01	17 - 41	90387-10M05	17 - 34	90465-11M10	7 - 9
	13 - 9	72X-85075-L0	20 - 21		2 - 24	90201-14M56	18 - 34	90387-10M61	25 - 3		8 - 5
6G5-82152-00	12 - 4	6R3-85510-00	11 - 2		3 - 7	90201-15M58	18 - 21	90430-08020	22 - 8		8 - 8
	13 - 61	663-85518-00	16 - 11		3 - 16	90201-16M55	18 - 18		30 - 5		8 - 14
6A0-82317-00	8 - 31	64D-85537-00	12 - 23		16 - 38	90201-21M18	11 - 9	90430-14115	2 - 9		8 - 37
6G5-82317-00	11 - 20	64D-85540-01	12 - 15	90119-06MA3	5 - 19	90201-22M01	22 - 10	90445-05M02	8 - 30		8 - 39
663-82317-01	11 - 21	6R3-85542-03-1S	12 - 19	90119-06MA4	4 - 6	90201-23M01	3 - 26	90445-07M09	5 - 13		9 - 3
6E3-82370-21	13 - 2	64D-85550-02	11 - 1	90119-06MA5	4 - 17	90201-26M57	18 - 32	90445-07M28	5 - 10		9 - 4
703-82510-43	27 - 44	6R3-85570-01	13 - 1	90119-06MA6	4 - 11	90201-26M59	17 - 19	90445-07M33	23 - 14		9 - 14
662-82519-00	12 - 26	64D-85580-00	11 - 3	90119-08077	21 - 16	90201-30M92	22 - 70	90445-07M45	5 - 11		9 - 15
6R3-82519-00	12 - 27	6E5-85711-40	12 - 30	90119-08078	21 - 9	90201-38M60	18 - 11	90445-07M46	5 - 12		9 - 19
703-82531-00	27 - 46	6E5-85711-60	12 - 30	90119-08M14	22 - 37	90202-05088	7 - 28	90445-07M59	5 - 14		9 - 37
6E5-82531-10	13 - 6	6E5-85720-05	8 - 15		30 - 26	90202-08M20	16 - 41	90445-07M72	7 - 10		9 - 38
703-82540-00	27 - 50	6R3-85721-30	8 - 16	90119-08M22	15 - 28	90202-08M44	7 - 22	90445-07M83	7 - 12		9 - 44
682-82556-00	27 - 48	6R3-85721-80	8 - 16	90119-08M57	14 - 22	90202-12092	16 - 21	90445-07M87	7 - 14		9 - 45
688-82560-10	13 - 18	6R3-85730-03	8 - 27	90119-08M76	14 - 20	90202-16061	16 - 55	90445-07M89	7 - 11		15 - 45
6R3-82563-00	13 - 28	61A-85790-00	13 - 19	90119-08M77	14 - 21	90202-26M18	18 - 33	90445-07M96	7 - 15		15 - 46
703-82563-02	27 - 55	6R5-85895-01	11 - 5	90119-08M79	21 - 15	90202-32M19	18 - 17	90445-07MA3	5 - 29		17 - 21
688-82575-01	27 - 47	64D-86110-01	13 - 24	90119-08M94	2 - 12	90202-40M47	18 - 7	90445-07ME8	22 - 17		18 - 5
703-82577-00	27 - 45	6Y5-87122-S0	28 - 11	90119-08MA3	2 - 17	90206-10M04	16 - 35	90445-07ME9	22 - 17		23 - 16
6E5-82587-00	13 - 29	6G5-87149-10	13 - 36	90119-08MA8	4 - 3	90206-15M18	15 - 11	90445-09097	4 - 18		28 - 17
6E5-82588-00	13 - 55	64D-W0001-01	29 - 1	90119-10M89	23 - 7	90206-22M19	22 - 9	90445-11M26	8 - 13	90465-12M25	13 - 58
	15 - 30	6G5-W0001-C1	30 - 1	90152-05M08	23 - 10	90249-06M19	17 - 33	90445-11M35	15 - 44	90465-13M11	8 - 17

NUMERICAL INDEX

PART NO.	REF. NO.	PART NO.	REF. NO.	PART NO.	REF. NO.	PART NO.	REF. NO.	PART NO.	REF. NO.	PART NO.	REF. NO.
90465-13M11	8 - 26	92995-06100	13 - 51	93210-08287	10 - 12	93606-12019	30 - 25	97095-06012	13 - 13	98780-04015	2 - 15
90465-13M18	4 - 26		17 - 5		24 - 14	93608-12063	2 - 10		13 - 22	99001-08600	22 - 24
	13 - 43	92995-06600	1 - 8	93210-09165	16 - 53	93608-12M05	21 - 8		13 - 31	9E450-04533	28 - 2
90468-05M03	7 - 27		11 - 18	93210-10M74	19 - 4		21 - 13		13 - 59		
90468-07M02	7 - 17		12 - 10	93210-13M04	7 - 21		23 - 4	97095-06016	13 - 25		
90468-18008	16 - 9		12 - 14	93210-16275	25 - 9	93700-06M03	16 - 51		13 - 40		
	16 - 42		12 - 29	93210-19M82	7 - 6		17 - 13		15 - 22		
90480-06M19	10 - 4		13 - 4	93210-32738	9 - 8		17 - 24	97095-06020	13 - 3		
	15 - 2		13 - 14	93210-37160	22 - 29	94702-00247	4 - 28		13 - 16		
90480-09M12	12 - 21		13 - 17		30 - 12	94702-00271	4 - 28		13 - 56		
90480-13M24	11 - 20		13 - 23		30 - 21	95303-06600	16 - 14		15 - 31		
90480-20M05	4 - 21		13 - 26	93210-37MH7	18 - 6		16 - 28		15 - 34		
90480-22M15	15 - 24		13 - 41	93210-55M14	22 - 43	95380-03600	9 - 31		15 - 38		
90480-25161	13 - 5		13 - 57		30 - 15	95380-04600	28 - 4	97095-06025	16 - 36		
90501-11M10	22 - 25		13 - 60	93210-58144	22 - 20		28 - 8	97095-06030	17 - 4		
90501-12082	16 - 49		15 - 23		30 - 9	95380-05600	7 - 25	97095-06035	13 - 50		
90501-16M11	4 - 20		15 - 32	93210-74M35	3 - 15		16 - 25	97095-06040	15 - 8		
90501-16M12	16 - 13		15 - 35		29 - 13		16 - 31	97095-08016	14 - 24		
90501-16M28	18 - 28		15 - 39	93210-86M38	22 - 28		27 - 7	97095-08020	16 - 5		
90501-16M37	22 - 55		17 - 8		30 - 11	95380-06600	1 - 4		17 - 16		
90506-14M24	17 - 36		21 - 7		30 - 20		8 - 23	97095-08025	22 - 45		
90506-16M34	15 - 17	92995-08100	16 - 6	93210-97M55	22 - 68		27 - 40	97095-08030	21 - 24		
90508-29M12	16 - 23		17 - 17		30 - 16	95380-06700	13 - 48	97095-08045	21 - 17		
90560-12M01	25 - 4		21 - 18	93211-04001	3 - 6		13 - 65		21 - 28		
91490-40030	23 - 21		21 - 20		29 - 10	95380-08600	9 - 12		21 - 35		
91690-30012	16 - 4	92995-08600	14 - 25	93306-208U0	3 - 10	95380-08700	13 - 46	97095-10045	18 - 25		
91690-30016	7 - 2		21 - 25	93306-209U0	22 - 63		13 - 63		18 - 39		
91690-30020	17 - 35		21 - 29	93310-32337	3 - 25		21 - 19	97380-05025	27 - 8		
92903-06100	9 - 11		21 - 36	93310-836V2	3 - 27	95380-12600	17 - 43	97380-08030	27 - 33		
92903-06600	11 - 12		22 - 46	93310-954U1	3 - 8	95380-14800	18 - 22	97595-06420	4 - 24		
	12 - 8	92995-10100	18 - 26	93311-928U5	22 - 3	95780-10300	18 - 9	97595-06550	9 - 35		
92903-08600	16 - 47		18 - 40	93311-940U3	3 - 4	97013-06014	9 - 10	97607-04310	20 - 32		
92990-04100	28 - 3		23 - 6	93315-425V3	22 - 51	97013-06055	12 - 7	97880-05016	5 - 4		
	28 - 7	92995-14600	18 - 23	93315-43061	22 - 66	97013-06070	11 - 11	97880-06012	17 - 11		
92990-05600	5 - 5	93101-22M15	3 - 14	93317-330U2	22 - 40	97013-08030	16 - 46	97880-06018	11 - 15		
92990-06100	1 - 3		29 - 12	93332-000V3	22 - 4	97013-08045	16 - 16	97880-06020	12 - 16		
	13 - 49	93101-28M16	22 - 39	93341-930V2	22 - 42	97075-08035	15 - 27	97885-05012	11 - 6		
	13 - 66		30 - 14	93410-16006	16 - 56	97075-10045	23 - 5	97885-06010	11 - 17		
92990-06600	8 - 22	93101-30M17	22 - 67	93410-22M11	17 - 39	97080-06100	8 - 21	97885-06016	18 - 4		
	12 - 17		30 - 17	93410-37M04	18 - 14	97080-08016	19 - 32		18 - 29		
	15 - 16	93102-08M43	20 - 36	93410-40M03	3 - 11	97090-06012	15 - 15	97980-05108	6 - 27		
	17 - 12	93102-35M13	3 - 13	93420-36M01	21 - 38	97095-06010	17 - 7	97980-05116	6 - 25		
92990-08100	13 - 47		29 - 11	93430-06024	27 - 10		17 - 28		6 - 25		
	13 - 64	93102-40M14	3 - 5	93501-04M02	16 - 48		21 - 6	97980-05230	18 - 2		
92990-08600	14 - 23		29 - 9	93503-16003	22 - 58	97095-06012	1 - 7	98580-03015	27 - 38		
	27 - 34	93106-09014	22 - 21	93507-32009	22 - 56		12 - 9	98580-04006	27 - 36		
92990-10600	13 - 20		30 - 10	93511-32017	22 - 57		12 - 13	98580-04010	27 - 35		
92990-18200	23 - 19	93210-03261	13 - 27	93606-12019	22 - 36		12 - 28	98580-05010	27 - 37		