

PARTS CATALOGUE

(S)200FETO'08 (64E8)
L200FETO'08 (64H8)



2008/6/27

1G64E-700E1

()

NEWS NO.	DATE	COMMENT
PE0-OM-080015	Mar.,17,2008	MOD:FIG.23 CAM, TRIM SENDER P/No. REVISION
PE0-OM-080048	MAY,22,2008	MOD:FIG.24 PTT P/No. REVISION

(S)200FETO/L200FETO
PARTS CATALOGUE
©2007 by Yamaha Motor Co., Ltd.
1st edition, May 2007
All rights reserved.
Any reprinting or unauthorized use
without the written permission of
Yamaha Motor Co., Ltd.
is expressly prohibited.
Printed in Japan.

FOREWORD

This Parts Catalogue is related to the parts for the model(s) on the cover page. When you are ordering replacement parts, please refer to this Parts Catalogue and quote both part numbers and part names correctly.

1. Modifications or additions which have been made after the issue of the Parts Catalogue will be announced in the Parts News.

It is advisable that you make the necessary corrections to the Parts Catalogue according to the Parts News.

2. Abbreviations

The following abbreviations are used in this Parts Catalogue.

“UR” Use specified parts number.

“UN” Use as many as needed.

“AP” Alternate Parts

“LM” Locally Made (Parts need to be ordered locally)

“F#” Frame No. (Applicable machine No.)

“O/S” Over Size

3. The number of components for assembly

- Parts, which are to be supplied in an assembly, are listed with a dot (.) in front of the part name as shown below.
- The numeral appearing to the right of each component part indicates the quantity of parts for each assembly unit.

PART NO.	DESCRIPTION	Q'TY	REMARKS
2F5-83310-60	FRONT FLASHER LIGHT ASSY	2	
115-83311-60	.BULB (6V-18W)	1	

4. Applicable colours of graphics are represented in the “REMARKS” as shown below.

PART NO.	DESCRIPTION	Q'TY	REMARKS
2N4-24110-00-X5	FUEL TANK COMP.	2	MXR
3J1-24240-10	.GRAPHIC, FUEL TANK	1	FOR MXR

5. Note that the illustrations for reference in finding parts numbers are not to be used for assembling. When assembling, please use the applicable service manual.

6. The asterisk (*) before a reference number indicates modified items after the first edition.

7. Applicable Serial No.

Engine Serial No.

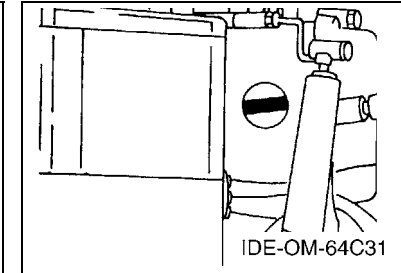
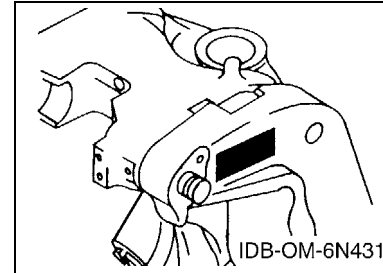

8. Applicable Engine Starting Serial No.

Model	Serial No.	Model	Serial No.
200F	6G6-1032843	S200F	6G6-1032843
L200F	6K1-1006029		

9. Applicable Colour Code

Abbreviation	Colour Name	Colour Code
DBNM2	DARK BLUISH GRAY METALLIC 2	004D

10. Quantity Column Information

Column No.	Name Of Q'ty Column	Applicable Model
1	200	200FETO
2	S200	S200FETO
3	L200	L200FETO

CONTENTS

TOP COWLING	1
CYLINDER & CRANKCASE 1	2
CYLINDER & CRANKCASE 2	3
CRANKSHAFT & PISTON	5
CYLINDER & CRANKCASE 3	7
INTAKE 1	9
INTAKE 2	11
CARBURETOR	13
OIL PUMP 1	15
OIL PUMP 2	17
OIL TANK	19
FUEL 1	21
FUEL 2	23
FUEL 3	25
FUEL 4	26
GENERATOR	27
ELECTRICAL 1	28
ELECTRICAL 2	30
STARTING MOTOR	32
BOTTOM COWLING	33
CONTROL	35
BRACKET 1	38
BRACKET 2	40
POWER TRIM & TILT ASSY 1	42
POWER TRIM & TILT ASSY 2	44
UPPER CASING	46
LOWER CASING & DRIVE 1	48
LOWER CASING & DRIVE 2	52
LOWER CASING & DRIVE 3	54
LOWER CASING & DRIVE 4	58
FUEL TANK	59
STEERING GUIDE ATTACHMENT 1	60
STEERING GUIDE ATTACHMENT 2	61
REMOTE CONTROL BOX	62
REMOTE CONTROL ASSY 1	63
REMOTE CONTROL ASSY 2	66
METER	69
SWITCH & PANEL	71
REPAIR KIT 1	72
REPAIR KIT 2	74
REPAIR KIT 3	76

INDEX

NUMERICAL INDEX	78
-----------------------	----

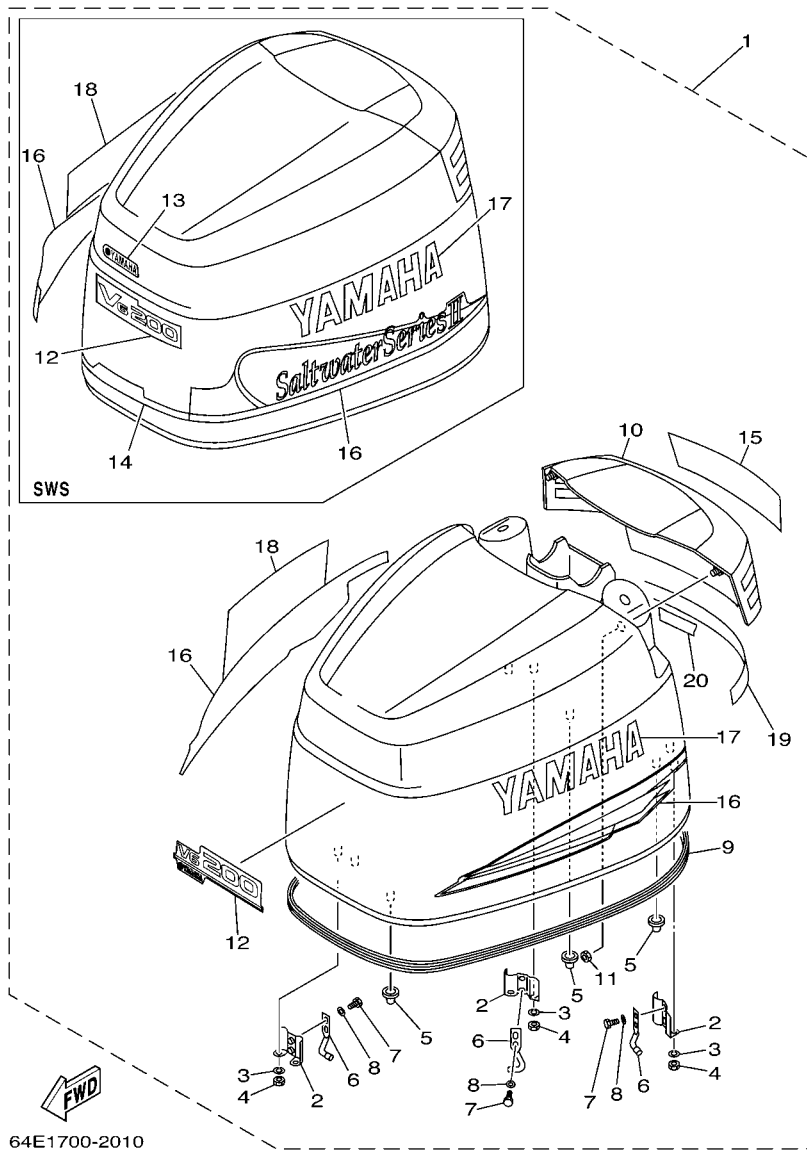
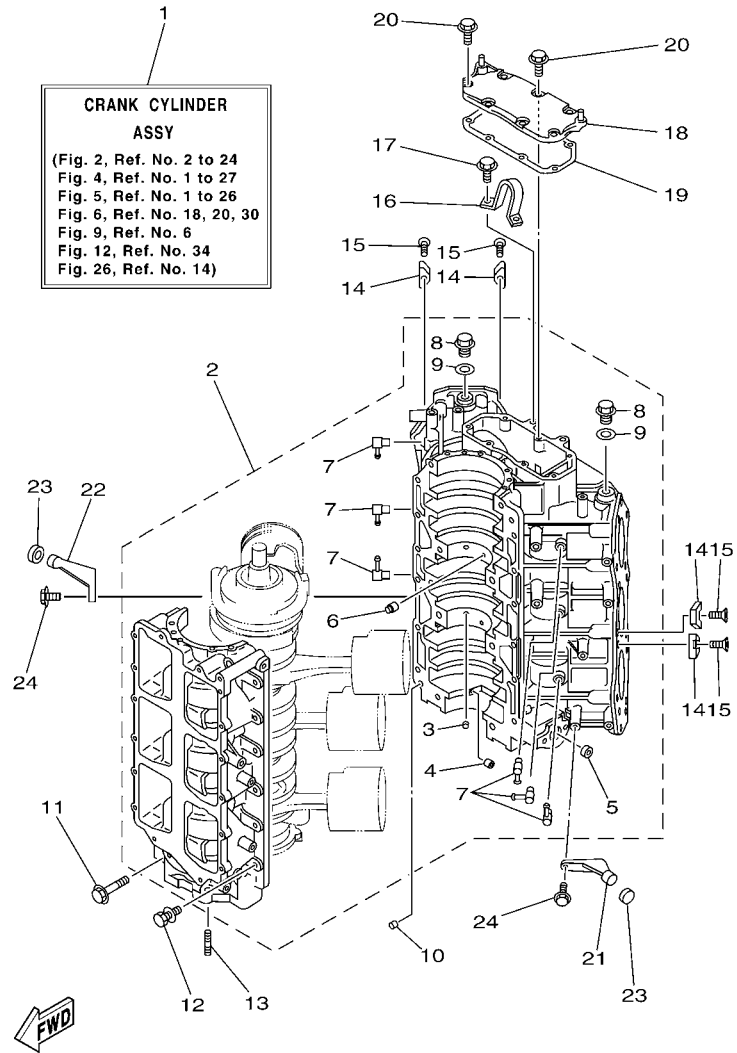

FIG. 1 TOP COWLING

REF. NO.	PART NO.	DESCRIPTION	200	S200	L200	REMARKS
1	64E-42610-50-4D	TOP COWLING ASSY	1			FOR STD
	64E-42610-T0-4D	TOP COWLING ASSY		1	1	FOR SWS
2	6R3-42647-00	.HOLDER, CLAMP BAND	3	3	3	
3	92990-06100	.WASHER, SPRING	6	6	6	
4	95380-06600	.NUT, HEXAGON	6	6	6	
5	64D-42662-00	.DAMPER	3	3	3	
6	64D-42814-00	.HOOK, CLAMP	3	3	3	
7	97095-06012	.BOLT	6	6	6	
8	92995-06600	.WASHER	6	6	6	
9	64D-42615-00	.SEAL	1	1	1	
10	64D-42613-00-4D	.MOLDING, AIR DUCT	1	1	1	
11	90179-06M24	.NUT	4	4	4	
12	64E-42677-50	.GRAPHIC, FRONT	1			FOR STD
	64E-42677-40	.GRAPHIC, FRONT		1	1	FOR SWS
13	64D-42677-B0	.GRAPHIC, FRONT		1	1	FOR SWS
14	64D-42677-S0	.GRAPHIC, FRONT		1	1	FOR SWS
15	64E-42687-30	.EMBLEM, REAR	1			FOR STD
	64E-42687-00	.EMBLEM, REAR		1	1	FOR SWS
16	64D-W0070-30	.GRAPHIC SET	1			FOR STD
	64D-W0070-S0	.GRAPHIC SET		1	1	FOR SWS
17	64C-42681-30	.MARK, COWLING	1			FOR STD
	64D-42681-40	.MARK, COWLING		1	1	FOR SWS
18	64C-42682-30	.MARK, COWLING	1			FOR STD
	64D-42682-40	.MARK, COWLING		1	1	FOR SWS
19	64D-4267A-30	.GRAPHIC, REAR 2	1			FOR STD
	64D-4267A-S0	.GRAPHIC, REAR 2		1	1	FOR SWS
20	64D-42678-30	.GRAPHIC, REAR	1			FOR STD

FOR STD



64E7700-F020

FIG. 2 CYLINDER & CRANKCASE 1

REF. NO.	PART NO.	DESCRIPTION	200	S200	L200	REMARKS
1	64E-W0090-15-1S	CRANK CYLINDER ASSY	1			
2	64E-15100-01-1S	CRANKCASE ASSY	1			
3	624-11379-00	.VALVE, CHECK	2			
4	90384-06M07	.BUSH, BIMETAL FORMED	1			
5	90384-14M09	.BUSH, BIMETAL FORMED	1			
6	663-11518-01	.LOCK, BEARING	2			
7	646-11370-01	.CHECK VALVE ASSY	6			
8	90340-14M00	.PLUG, STRAIGHT SCREW	2			
9	90430-14115	.GASKET	2			
10	93608-12063	PIN, DOWEL	2			
11	90105-10M20	BOLT, FLANGE	8			
12	90119-08M94	BOLT, WITH WASHER	12			
13	90116-08026	BOLT, STUD	2			
14	6E5-11325-00	ANODE	8			
15	98780-04015	SCREW, FLAT HEAD	8			
16	67H-11119-01	HANGER, ENGINE	1			
17	90119-08MA3	BOLT, WITH WASHER	2			
18	6K7-11371-01-1S	COVER	1			
19	6E5-11381-A2	GASKET 1	1			
20	90119-06MA2	BOLT, WITH WASHER	7			
21	6E5-42761-00-1S	STOPPER	1			
22	6E5-42762-00-1S	STOPPER	1			
23	68F-44533-00	DAMPER, UPPER MOUNT RUBBER	2			
24	90119-06MA2	BOLT, WITH WASHER	4			

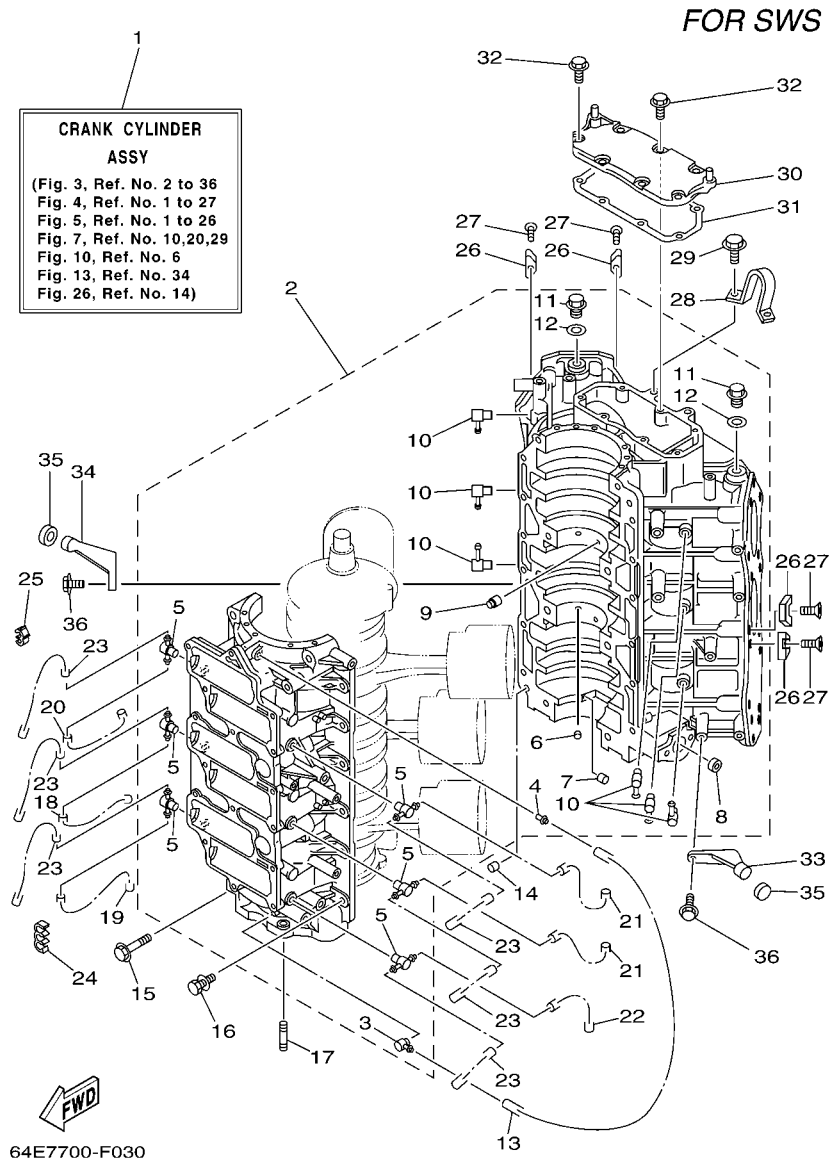
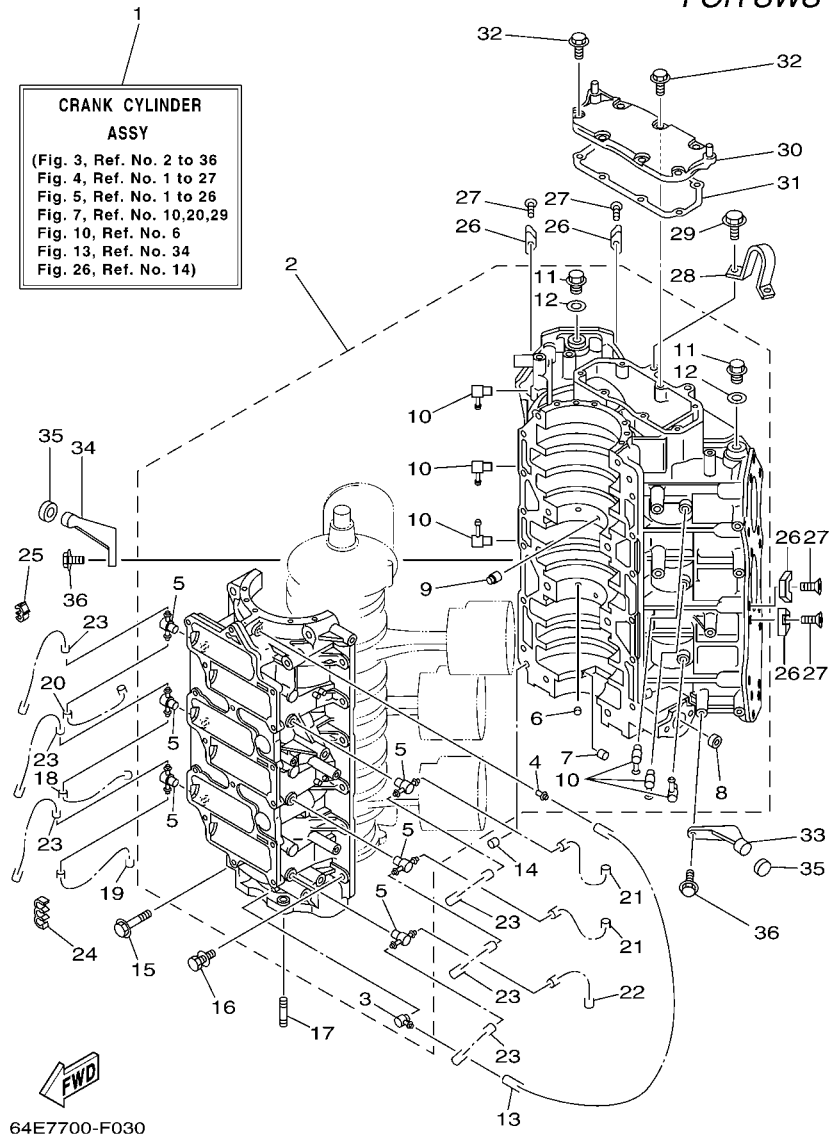

FIG. 3 CYLINDER & CRANKCASE 2

REF. NO.	PART NO.	DESCRIPTION	200	S200	L200	REMARKS
1	64E-W0090-S5-1S	CRANK CYLINDER ASSY		1	1	
2	64E-15100-S1-1S	CRANKCASE ASSY		1	1	
3	6E5-11372-01	.NIPPLE, HOSE		1	1	
4	624-14485-00	.PIPE, JOINT		1	1	
5	6F6-11372-01	.NIPPLE, HOSE		6	6	
6	624-11379-00	.VALVE, CHECK		2	2	
7	90384-06M07	.BUSH, BIMETAL FORMED		1	1	
8	90384-14M09	.BUSH, BIMETAL FORMED		1	1	
9	663-11518-01	.LOCK, BEARING		2	2	
10	646-11370-01	.CHECK VALVE ASSY		6	6	
11	90340-14M00	.PLUG, STRAIGHT SCREW		2	2	
12	90430-14115	.GASKET		2	2	
13	90445-07M10	HOSE (L510)		1	1	
14	93608-12063	PIN, DOWEL		2	2	
15	90105-10M20	BOLT, FLANGE		8	8	
16	90119-08M94	BOLT, WITH WASHER		12	12	
17	90116-08026	BOLT, STUD		2	2	
18	90445-07M11	HOSE (L610)		1	1	
19	90445-07M09	HOSE (L380)		1	1	
20	90445-07M12	HOSE (L300)		1	1	
21	90445-07M08	HOSE (L220)		2	2	
22	90445-07M90	HOSE (L390)		1	1	
23	90445-07M34	HOSE (L260)		6	6	
24	90464-07M05	CLAMP		1	1	
25	90464-07M20	CLAMP		1	1	
26	6E5-11325-00	ANODE		8	8	
27	98780-04015	SCREW, FLAT HEAD		8	8	



64E7700-F030

FIG. 3 CYLINDER & CRANKCASE 2

REF. NO.	PART NO.	DESCRIPTION	200	S200	L200	REMARKS
28	67H-11119-01	HANGER, ENGINE		1	1	
29	90119-08MA3	BOLT, WITH WASHER		2	2	
30	6K7-11371-01-1S	COVER		1	1	
31	6E5-11381-A2	GASKET 1		1	1	
32	90119-06MA2	BOLT, WITH WASHER		7	7	
33	6E5-42761-00-1S	STOPPER		1	1	
34	6E5-42762-00-1S	STOPPER		1	1	
35	68F-44533-00	DAMPER, UPPER MOUNT RUBBER		2	2	
36	90119-06MA2	BOLT, WITH WASHER		4	4	

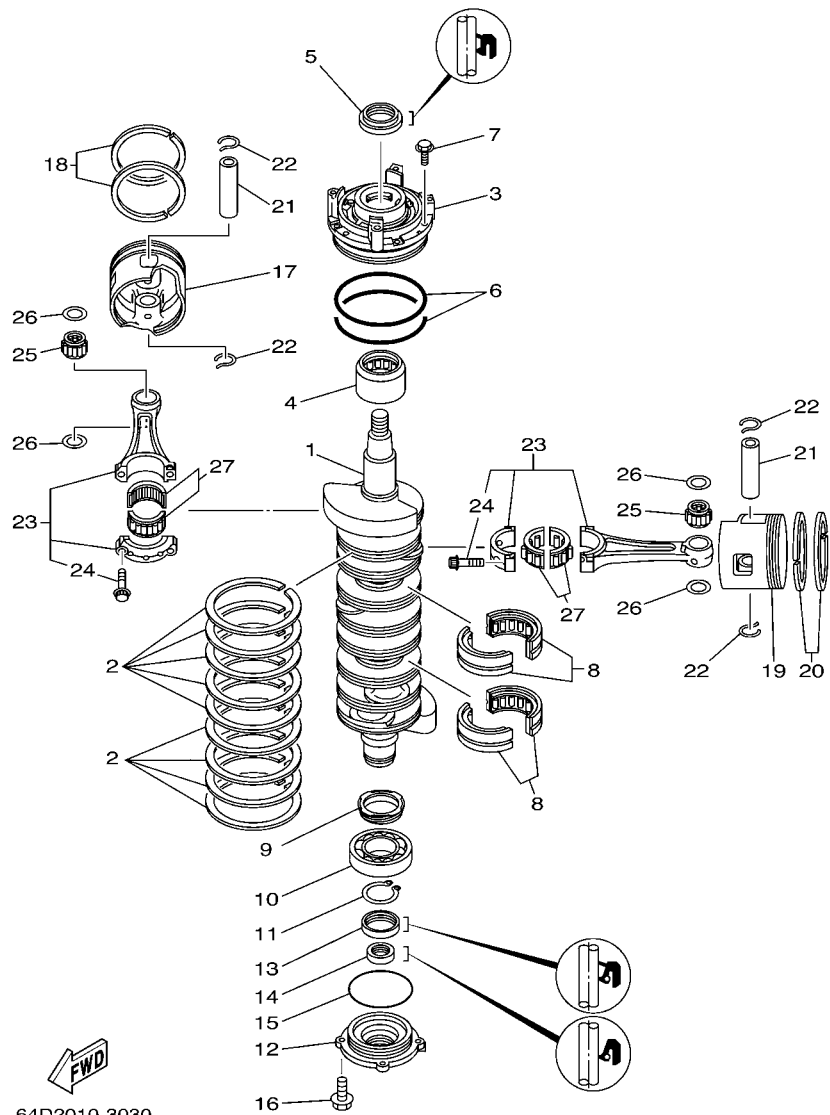

64D2010-3030

FIG. 4 CRANKSHAFT & PISTON

REF. NO.	PART NO.	DESCRIPTION	200	S200	L200	REMARKS
1	6G5-11411-02	CRANKSHAFT	1	1	1	
2	6E5-11447-00	SEAL, CRANK	9	9	9	
3	6R3-15163-00-1S	HOUSING, BEARING 1	1	1	1	
4	93311-940U3	BEARING	1	1	1	
5	93102-40M14	OIL SEAL	1	1	1	
6	93211-04001	O-RING	2	2	2	
7	90119-06MA2	BOLT, WITH WASHER	3	3	3	
8	93310-954U1	BEARING	2	2	2	
9	6R3-11536-00	GEAR, DRIVE	1	1	1	
10	93306-208U0	BEARING	1	1	1	
11	93410-40M03	CIRCLIP	1	1	1	
12	6G5-15359-00-94	HOUSING, OIL SEAL	1	1	1	
13	93102-35M13	OIL SEAL	1	1	1	
14	93101-22M15	OIL SEAL	1	1	1	
15	93210-74M35	O-RING	1	1	1	
16	90119-06MA2	BOLT, WITH WASHER	4	4	4	
17	64D-11631-02-90	PISTON (STD)	3	3	3	
	64D-11635-02	PISTON (0.25MM O/S)	3	3	3	AP
	64D-11636-02	PISTON (0.50MM O/S)	3	3	3	AP
18	64D-11603-02	PISTON RING SET (STD)	3	3	3	
	64D-11604-02	PISTON RING SET (0.25MM O/S)	3	3	3	AP
	64D-11605-02	PISTON RING SET (0.50MM O/S)	3	3	3	AP
19	64D-11642-02-90	PISTON 2 (STD)	3	3	3	
	64D-11645-02	PISTON 2 (0.25MM O/S)	3	3	3	AP
	64D-11646-02	PISTON 2 (0.50MM O/S)	3	3	3	AP
20	64D-11603-02	PISTON RING SET (STD)	3	3	3	
	64D-11604-02	PISTON RING SET (0.25MM O/S)	3	3	3	AP

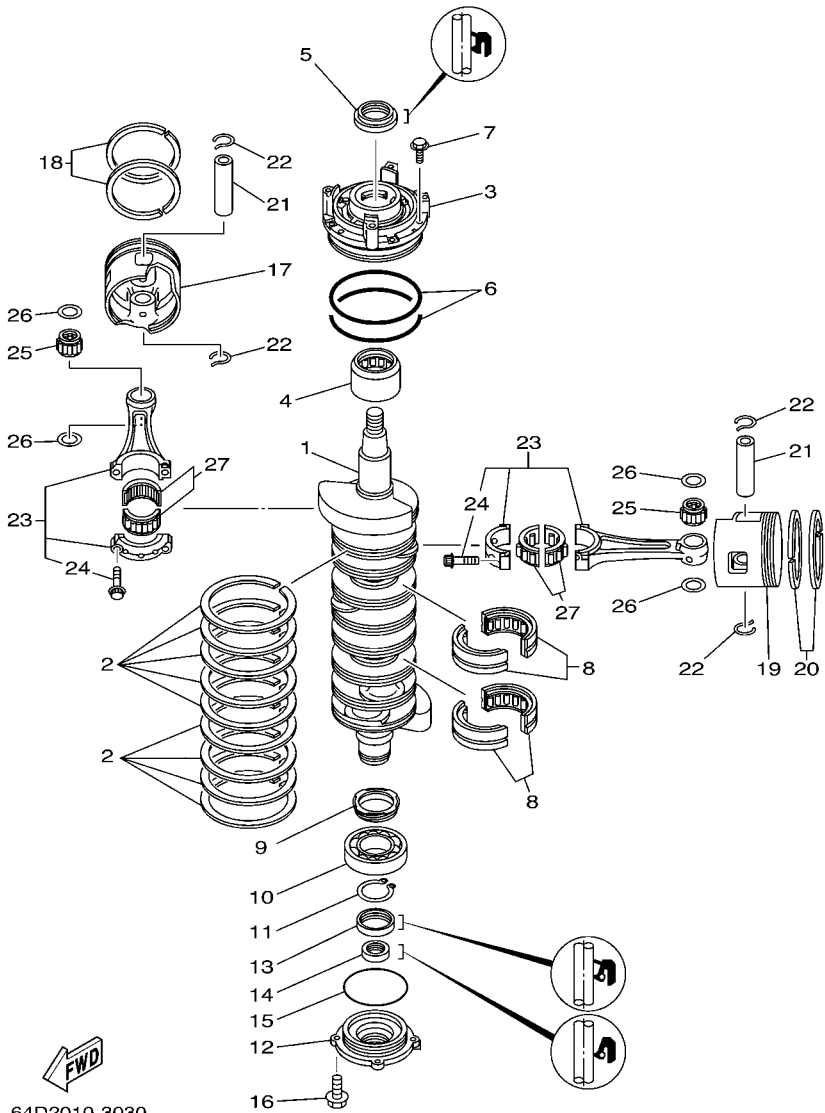

64D2010-3030

FIG. 4 CRANKSHAFT & PISTON

REF. NO.	PART NO.	DESCRIPTION	200	S200	L200	REMARKS
20	64D-11605-02	PISTON RING SET (0.50MM O/S)	3	3	3	AP
21	6R5-11633-10	PIN, PISTON	6	6	6	
22	6R5-11634-10	CLIP, PISTON PIN	12	12	12	
23	6R5-11650-10	CONNECTING ROD ASSY	6	6	6	
24	90109-08022	.BOLT	2	2	2	
25	93310-32337	BEARING	6	6	6	
26	90201-23M01	WASHER, PLATE	12	12	12	
27	93310-836V2	BEARING	6	6	6	

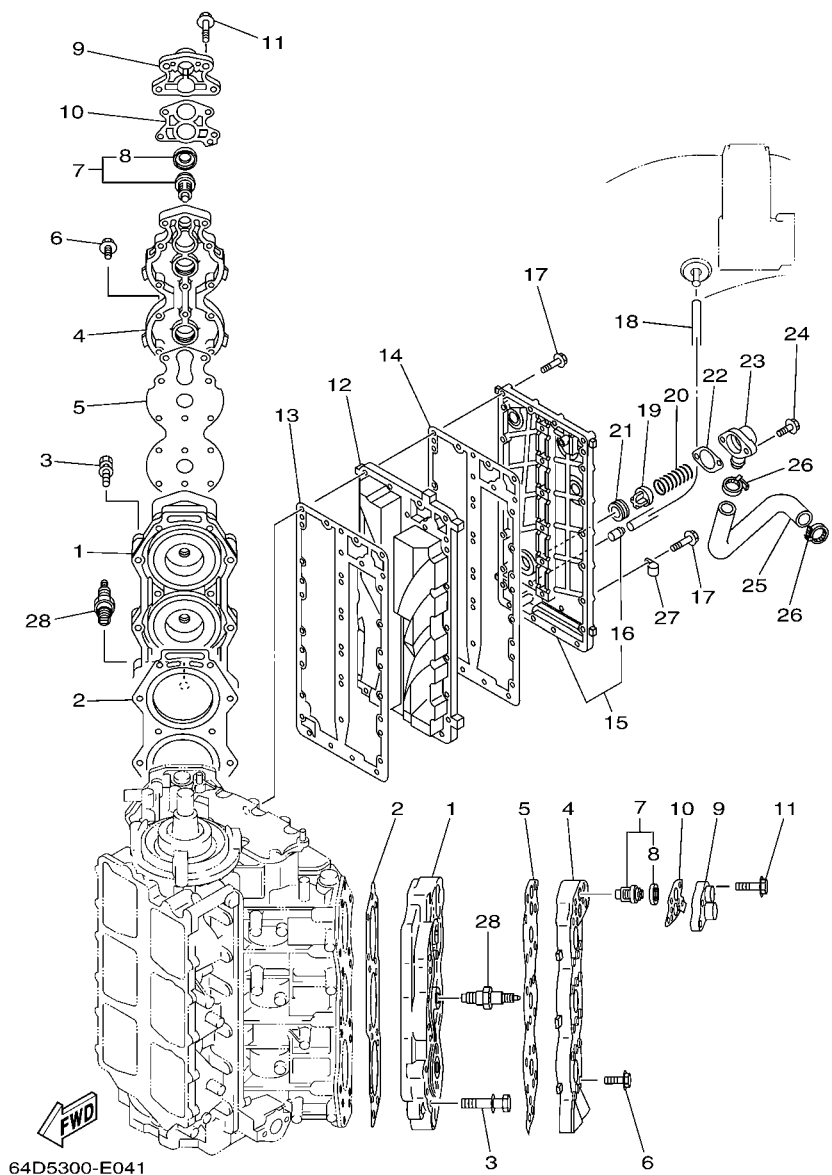

64D5300-E041

FIG. 5 CYLINDER & CRANKCASE 3

REF. NO.	PART NO.	DESCRIPTION	200	S200	L200	REMARKS
1	64E-11111-00-1S	HEAD, CYLINDER 1	2	2	2	
2	6G5-11181-A2	GASKET, CYLINDER HEAD 1	2	2	2	
3	90119-08MA8	BOLT, WITH WASHER	28	28	28	
4	6G5-11191-00-1S	COVER, CYLINDER HEAD 1	2	2	2	
5	6G5-11193-A1	GASKET, HEAD COVER 1	2	2	2	
6	90119-06MA4	BOLT, WITH WASHER	36	36	36	
7	6E5-12411-30	THERMOSTAT	2	2	2	
8	688-12412-00	.SEAL, THERMOSTAT	1	1	1	
9	688-12413-00-1S	COVER, THERMOSTAT	2	2	2	
10	688-12414-A1	GASKET, COVER	2	2	2	
11	90119-06MA6	BOLT, WITH WASHER	8	8	8	
12	64D-41111-00-1S	INNER COVER, EXHAUST	1	1	1	
13	6G5-41112-A1	GASKET, EXHAUST INNER COVER	1	1	1	
14	6G5-41114-A0	GASKET, EXHAUST OUTER COVER	1	1	1	
15	6R3-41113-00-1S	OUTER COVER, EXHAUST	1	1	1	
16	650-24378-00	.PIPE, JOINT 4	1	1	1	
17	90119-06MA5	BOLT, WITH WASHER	29	29	29	
18	90445-09097	HOSE (L250)	1	1	1	
19	60H-12416-00	VALVE, PRESSURE CONTROL	1	1	1	
20	90501-16M11	SPRING, COMPRESSION	1	1	1	
21	90480-20M05	GROMMET	1	1	1	
22	6G5-11382-A1	GASKET 2	1	1	1	
23	6G5-11372-00-1S	COVER, BYPASS 2	1	1	1	
24	97595-06420	BOLT, WITH WASHER	2	2	2	
25	6G5-12576-00	HOSE 1	1	1	1	
26	90465-13M18	CLAMP	2	2	2	
27	90465-06M86	CLAMP	2	2	2	

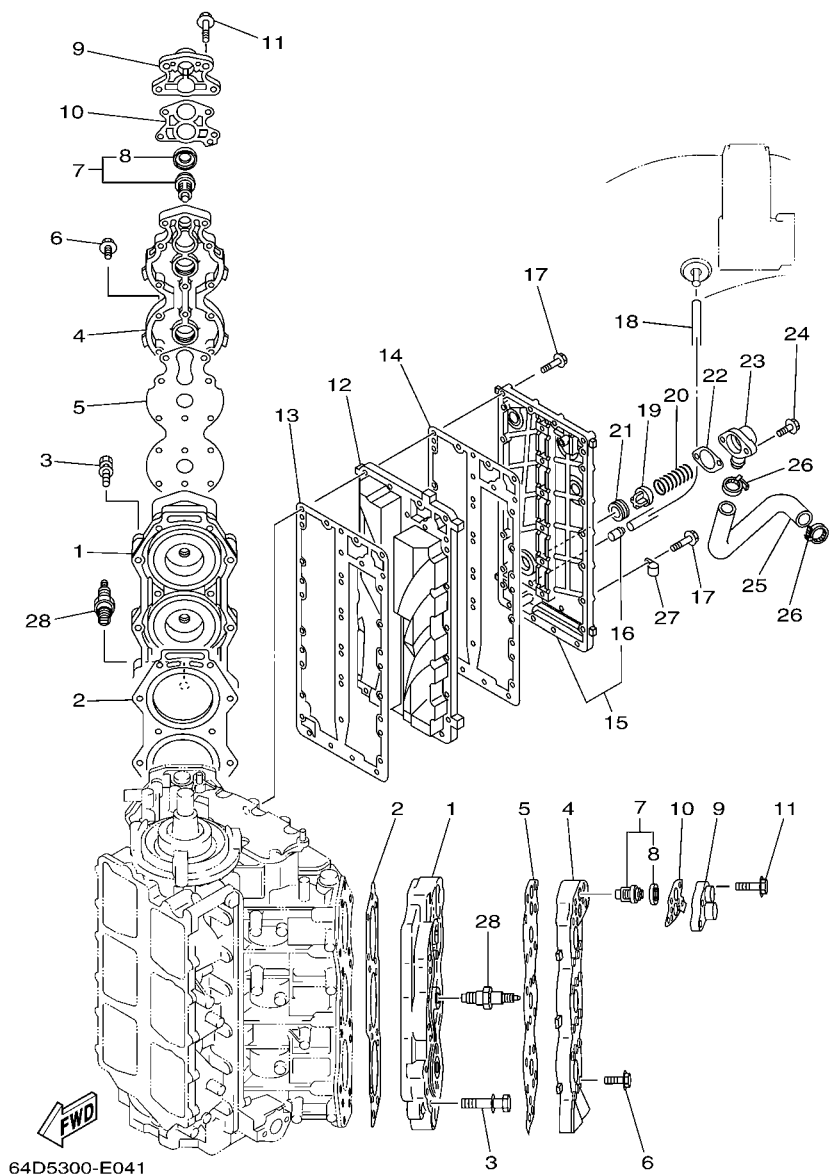

64D5300-E041

FIG. 5 CYLINDER & CRANKCASE 3

REF. NO.	PART NO.	DESCRIPTION	200	S200	L200	REMARKS
28	94702-00247	PLUG, SPARK (NGK BR8HS-10)	6	6	6	

FOR STD

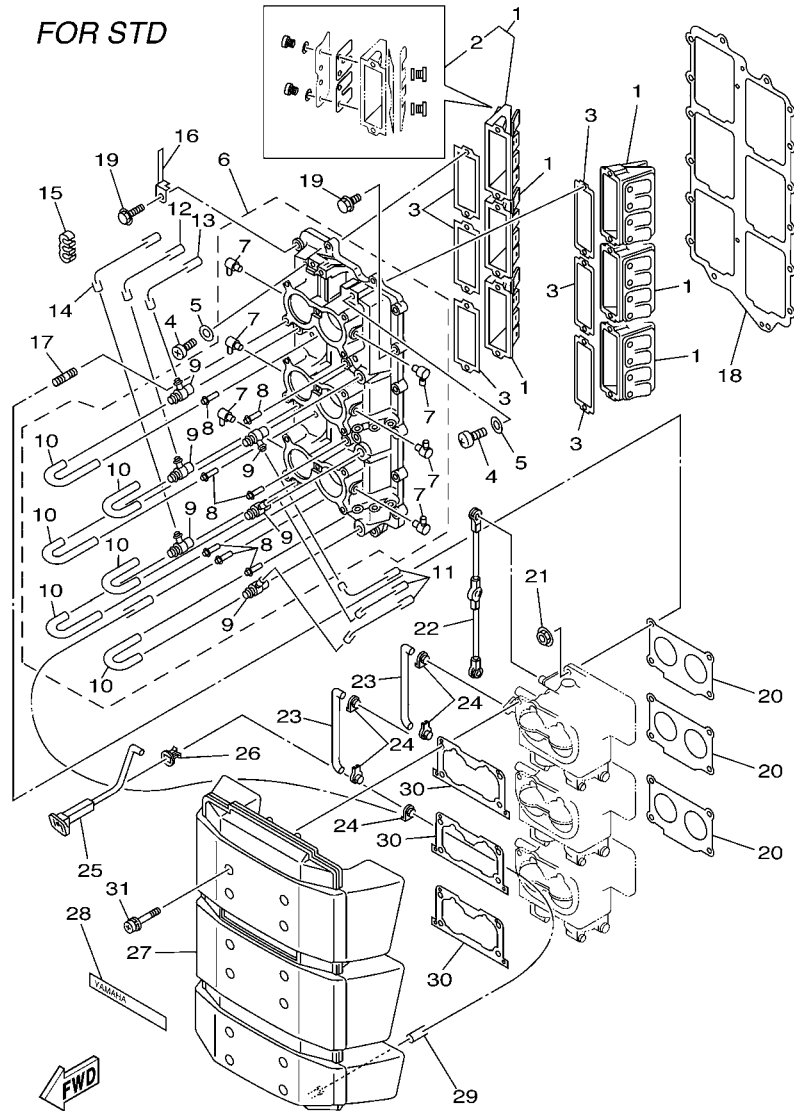

64E2700-3060

FIG. 6 INTAKE 1

REF. NO.	PART NO.	DESCRIPTION	200	S200	L200	REMARKS
1	6E5-13610-00	REED VALVE ASSY	6			
2	6E5-W0004-00	.REED SET	1			
3	6E5-13621-A1	GASKET, VALVE SEAT	6			
4	97880-05016	SCREW, PAN HEAD	12			
5	92990-05600	WASHER, PLATE	12			
6	6G5-13641-11-1S	MANIFOLD 1	1			
7	6E5-13552-01	.NOZZLE	6			
8	624-14485-00	.PIPE, JOINT	7			
9	6E5-11370-01	.CHECK VALVE ASSY	6			
10	90445-07M28	.HOSE (L70)	6			
11	90445-07M45	HOSE (L340)	3			
12	90445-07M46	HOSE (L360)	1			
13	90445-07M09	HOSE (L380)	1			
14	90445-07M59	HOSE (L410)	1			
15	90464-07M05	CLAMP	2			
16	90465-10M91	CLAMP	2			
17	90116-06M30	BOLT, STUD	12			
18	6G5-13645-A2	GASKET, MANIFOLD 1	1			
19	90119-06MA3	BOLT, WITH WASHER	16			
20	6E5-14198-A2	GASKET	3			
21	90179-06M28	NUT	12			
22	6G5-41217-01	ROD, ACCEL. LEVER	1			
23	6E5-41256-01	ROD, CHOKE 1	2			
24	661-41262-02	JOINT, CHOKE LEVER	5			
25	6R3-41271-00	KNOB, CHOKE	1			
26	689-41273-00	GROMMET	1			
27	6R3-14440-02	SILENCER ASSY, INTAKE	1			

FOR STD

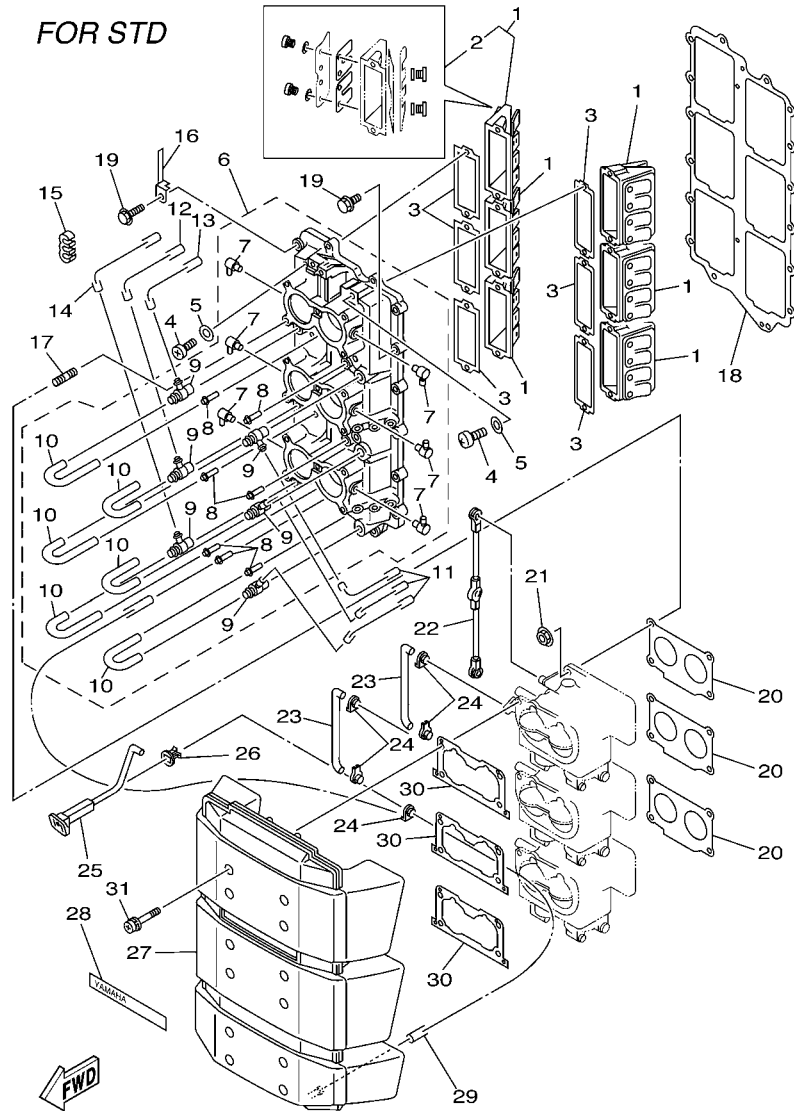

64E2700-3060

FIG. 6 INTAKE 1

REF. NO.	PART NO.	DESCRIPTION	200	S200	L200	REMARKS
28	6G5-1441K-00	EMBLEM	1			
29	90445-07MA3	HOSE (L200)	1			
30	6K7-14483-00	GASKET	3			
31	90159-06M14	SCREW, WITH WASHER	12			

FOR SWS

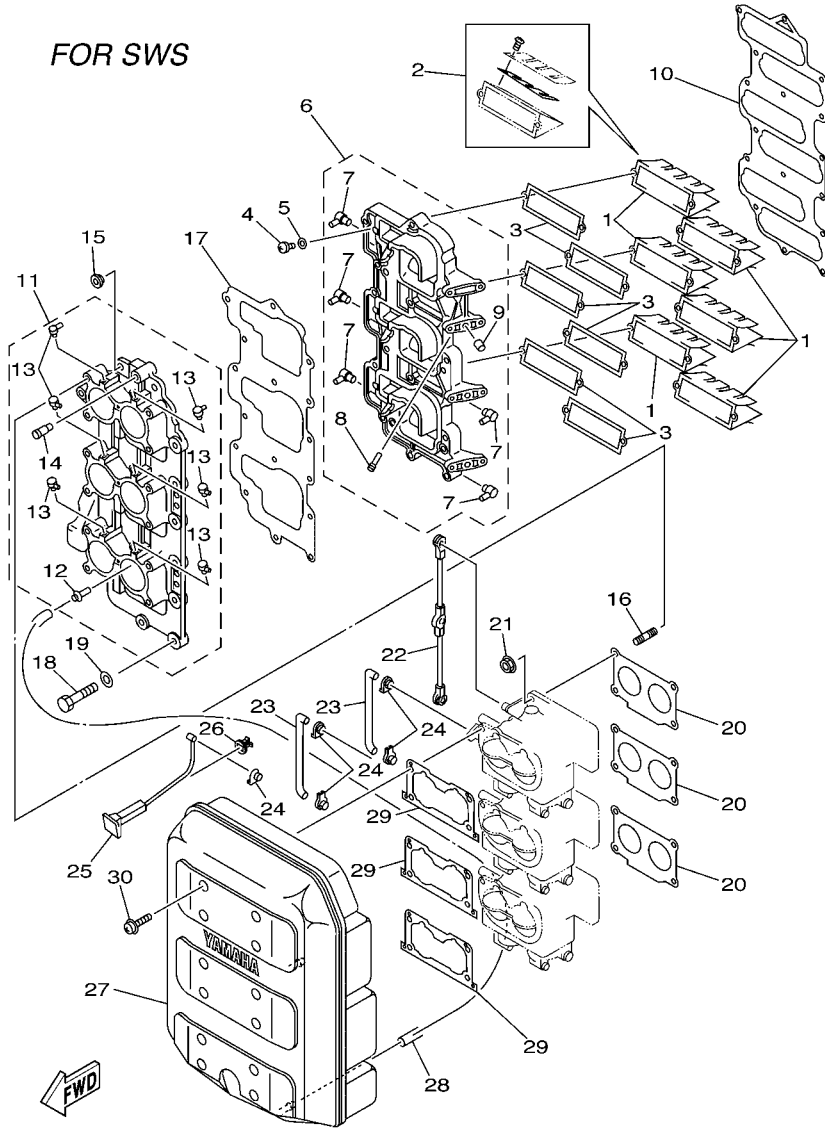

64E2700-3070

FIG. 7 INTAKE 2

REF. NO.	PART NO.	DESCRIPTION	200	S200	L200	REMARKS
1	6K7-13610-00	REED VALVE ASSY		6	6	
2	6E5-W0004-00	.REED SET		1	1	
3	6K7-13621-A1	GASKET, VALVE SEAT		6	6	
4	97880-05016	SCREW, PAN HEAD		12	12	
5	92990-05600	WASHER, PLATE		12	12	
6	64E-13624-00-1S	PLATE, REED VALVE		1	1	
7	688-11372-01	.NIPPLE, HOSE		5	5	
8	6R5-14485-00	.PIPE, JOINT		1	1	
9	90336-08M06	.PLUG, TAPER		1	1	
10	6K7-13646-A2	GASKET, MANIFOLD 2		1	1	
11	64E-13641-00-1S	MANIFOLD 1		1	1	
12	624-14485-00	.PIPE, JOINT		1	1	
13	6E5-13552-01	.NOZZLE		6	6	
14	6K7-81338-01	.CLAMP, LEAD		1	1	
15	90480-10M28	GROMMET		6	6	
16	90116-06M30	BOLT, STUD		12	12	
17	64E-13645-A0	GASKET, MANIFOLD 1		1	1	
18	97013-06050	BOLT		16	16	
19	92903-06600	WASHER, PLATE		16	16	
20	6E5-14198-A2	GASKET		3	3	
21	90179-06M28	NUT		12	12	
22	6G5-41217-01	ROD, ACCEL. LEVER		1	1	
23	6E5-41256-01	ROD, CHOKE 1		2	2	
24	661-41262-02	JOINT, CHOKE LEVER		5	5	
25	61H-41271-10	KNOB, CHOKE		1	1	
26	689-41273-00	GROMMET		1	1	
27	64D-14440-00	SILENCER ASSY, INTAKE		1	1	

FOR SWS

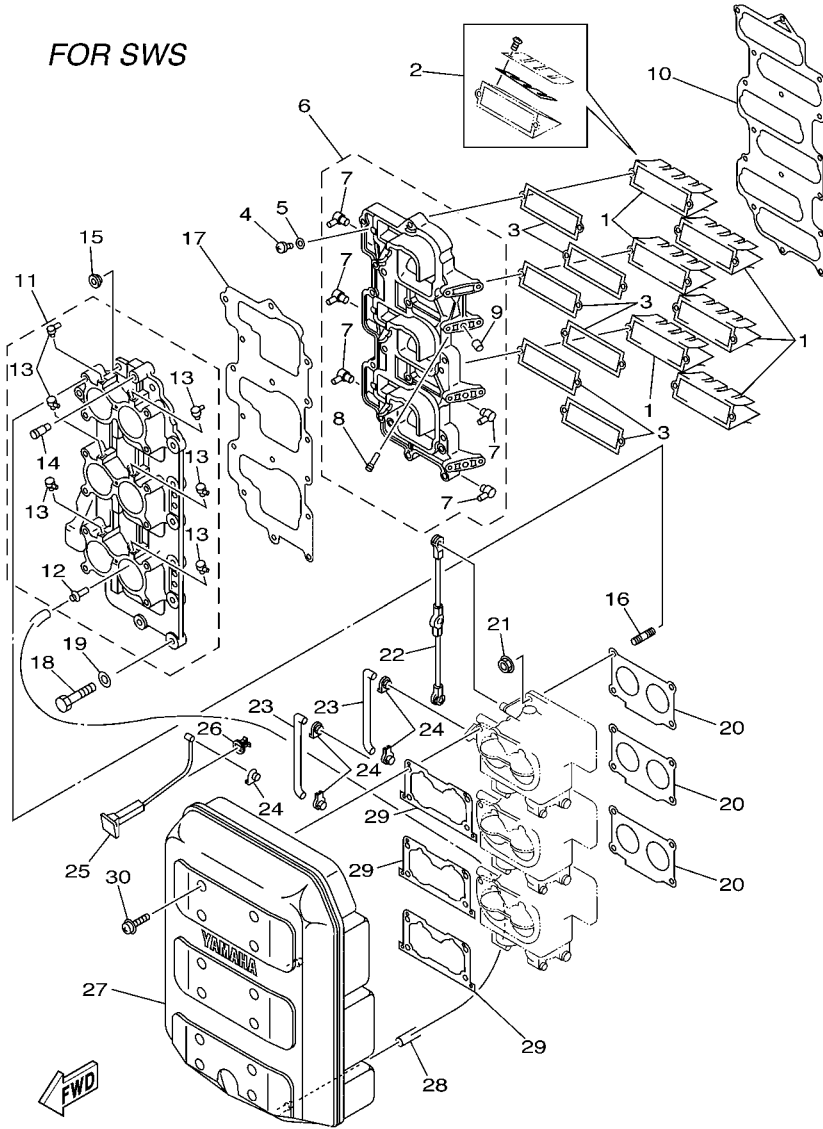

64E2700-3070

FIG. 7 INTAKE 2

REF. NO.	PART NO.	DESCRIPTION	200	S200	L200	REMARKS
28	90445-07MA3	HOSE (L200)		1	1	
29	6K7-14483-00	GASKET		3	3	
30	90159-06M08	SCREW, WITH WASHER		12	12	

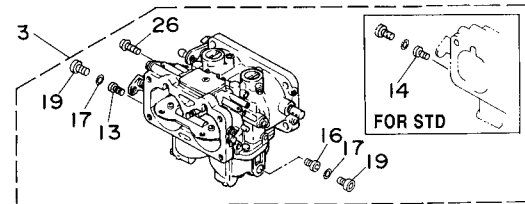
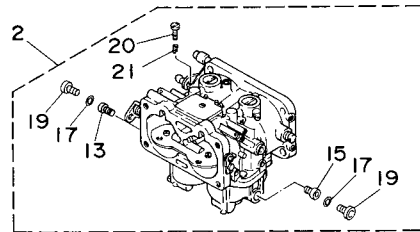
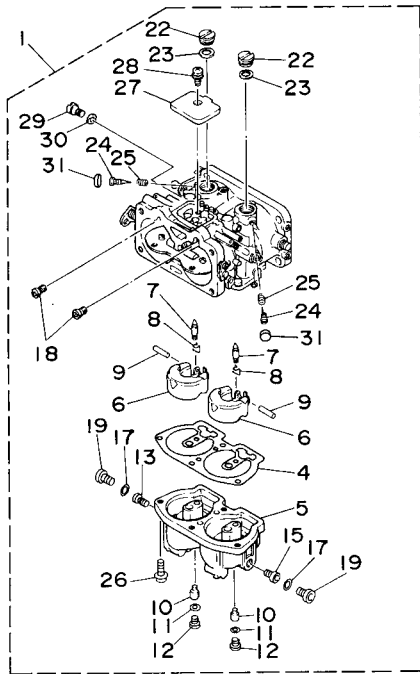

64E4700-D080

FIG. 8 CARBURETOR

REF. NO.	PART NO.	DESCRIPTION	200	S200	L200	REMARKS
1	64E-14301-02	CARBURETOR ASSY 1	1			FOR STD
	64E-14301-20	CARBURETOR ASSY 1		1	1	FOR CAR(EPA)
	64E-14301-S2	CARBURETOR ASSY 1		1	1	FOR SWS-OCE,CAR
2	64E-14302-02	CARBURETOR ASSY 2	1			FOR STD
	64E-14302-20	CARBURETOR ASSY 2		1	1	FOR CAR(EPA)
	64E-14302-S2	CARBURETOR ASSY 2		1	1	FOR SWS-OCE,CAR
3	64E-14303-02	CARBURETOR ASSY 3	1			FOR STD
	64E-14303-20	CARBURETOR ASSY 3		1	1	FOR CAR(EPA)
	64E-14303-S2	CARBURETOR ASSY 3		1	1	FOR SWS-OCE,CAR
4	64D-14384-01	.GASKET, FLOAT CHAMBER	3	3	3	
5	64D-14381-00	.BODY, FLOAT CHAMBER	3			
	64D-14381-10	.BODY, FLOAT CHAMBER		3	3	
6	6E5-14385-02	.FLOAT	6	6	6	
7	6E5-14546-00	.VALVE, NEEDLE	6	6	6	
8	6E5-14159-00	.CLIP	6	6	6	
9	6E5-14386-02	.PIN, FLOAT	6	6	6	
10	64D-1492F-42	.JET, AIR SLOW (#84)	6	6	6	
11	61U-14959-00	.GASKET	6	6	6	
12	64D-14394-00	.VALVE, DRAIN	6	6	6	
13	64D-1492E-75	.JET, MAIN (#150)	2			FOR STD
	64D-1492E-73	.JET, MAIN (#146)		6	6	FOR SWS,CAR(EPA)
14	64D-1492E-76	.JET, MAIN (#152)	1			FOR STD
15	64D-1492E-77	.JET, MAIN (#154)	2			FOR STD
16	64D-1492E-79	.JET, MAIN (#158)	1			FOR STD
17	6E5-14398-01	.GASKET	6	6	6	
18	61A-1492H-12	.JET, SLOW AIR BLEED (#60)	6	6	6	
19	61A-14383-01	.SCREW, DRAIN	6	6	6	

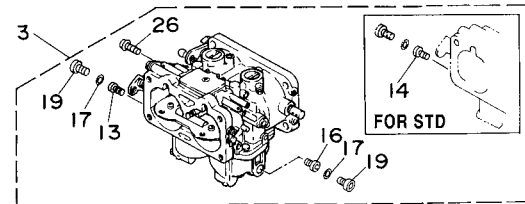
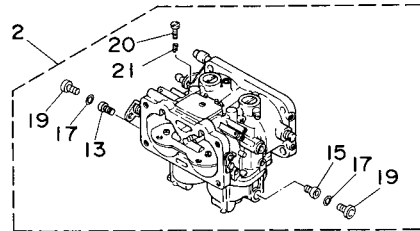
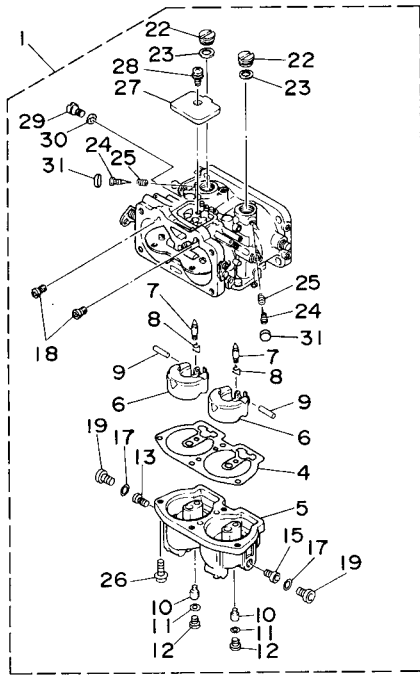

64E4700-D080

FIG. 8 CARBURETOR

REF. NO.	PART NO.	DESCRIPTION	200	S200	L200	REMARKS
20	6E5-14321-00	.SCREW, THROTTLE	1	1	1	#2
21	6J8-14334-00	.SPRING, THROTTLE	1	1	1	#2
22	6E5-14328-01	.PLUG	6	6	6	
23	6E5-14979-00	.GASKET	6	6	6	
24	6E5-14323-03	.SCREW, AIR ADJUSTING	6	6	6	
25	6E5-14223-00	.SPRING, AIR ADJUSTING	6	6	6	
26	97980-05116	.SCREW, WITH WASHER	13	13	13	FOR STD,SWS
	97980-05116	.SCREW, WITH WASHER		12	12	FOR CAR(EPA)
27	6E5-14527-01	.PLATE	3	3	3	
28	97980-05108	.SCREW, WITH WASHER	3	3	3	
29	6E5-14324-00	.SCREW, FLAT HEAD	3	3	3	
30	6J8-14959-00	.GASKET	3	3	3	
31	64E-1432A-00	.PLUG		6	6	FOR CAR(EPA)

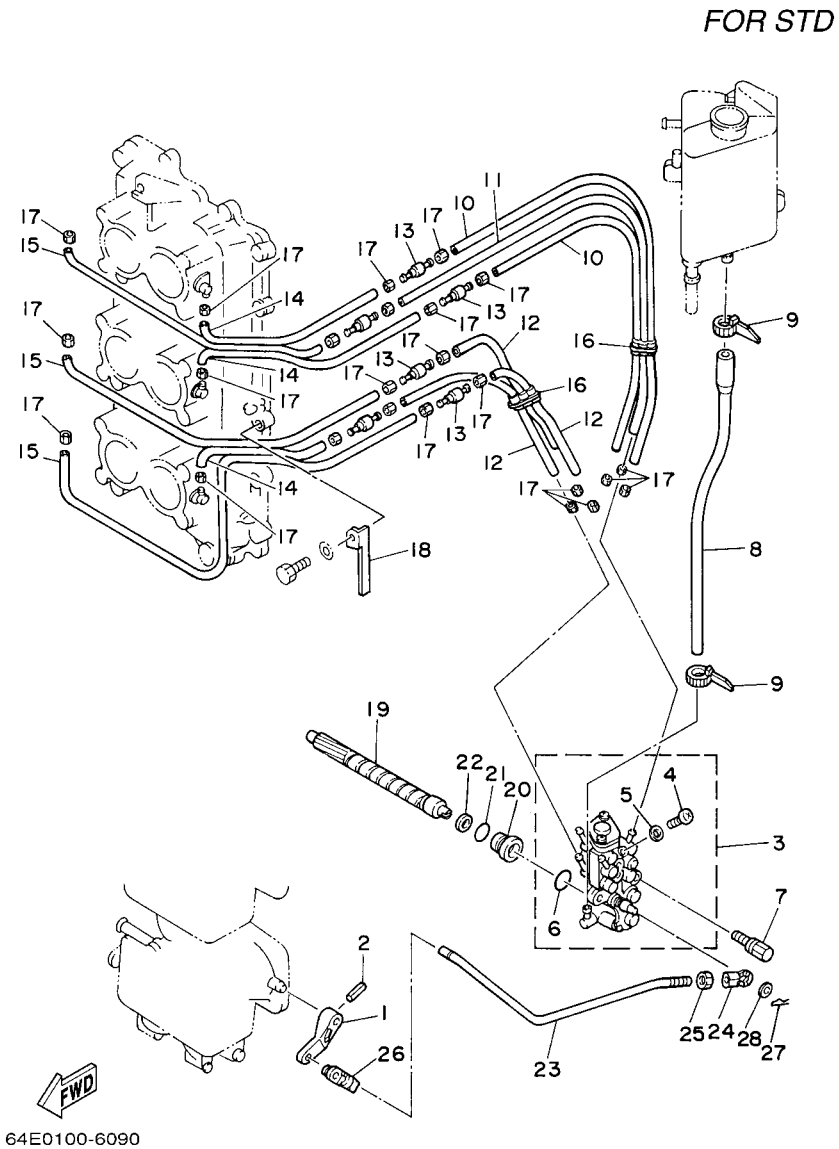
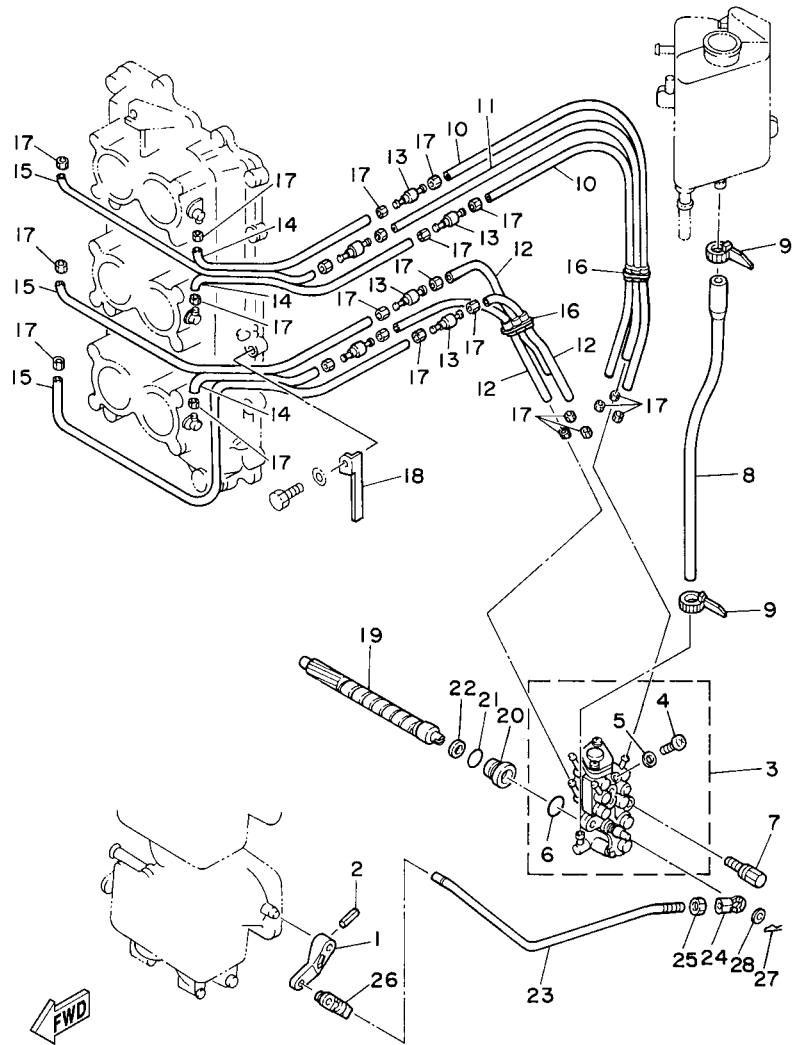

FIG. 9 OIL PUMP 1

REF. NO.	PART NO.	DESCRIPTION	200	S200	L200	REMARKS
1	6E5-14276-01	LEVER	1			
2	91690-30016	PIN, SPRING	1			
3	6R5-13200-12	OIL INJECTION PUMP ASSY	1			
4	6R3-13471-00	.PLUG, DRAIN	1			
5	6L2-13475-00	.GASKET	1			
6	93210-19M82	.O-RING	1			
7	90109-06M40	BOLT	2			
8	6R3-13416-00	PIPE, OIL 1	1			
9	90465-11M10	CLAMP	2			
10	90445-07M72	HOSE (L250)	2			
11	90445-07M89	HOSE (L310)	1			
12	90445-07M83	HOSE (L150)	3			
13	6R3-13183-10	VALVE, CHECK	6			
14	90445-07M87	HOSE (L110)	3			
15	90445-07M96	HOSE (L310)	3			
16	90464-07M05	CLAMP	2			
17	90468-07M02	CLIP	24			
18	90465-10M91	CLAMP	2			
19	6R3-11537-00	GEAR, DRIVEN	1			
20	6R3-13117-00	COLLAR, DISTANCE	1			
21	93210-13M04	O-RING	1			
22	90202-08M44	WASHER, PLATE	1			
23	6R3-41241-00	ROD, LINK	1			
24	6H1-41237-00	JOINT, LINK	1			
25	95380-05600	NUT	1			
26	6R5-41237-00	JOINT, LINK	1			
27	90468-05M03	CLIP	1			

FOR STD



64E0100-6090

FIG. 9 OIL PUMP 1

REF. NO.	PART NO.	DESCRIPTION	200	S200	L200	REMARKS
28	90202-05088	WASHER, PLATE	1			

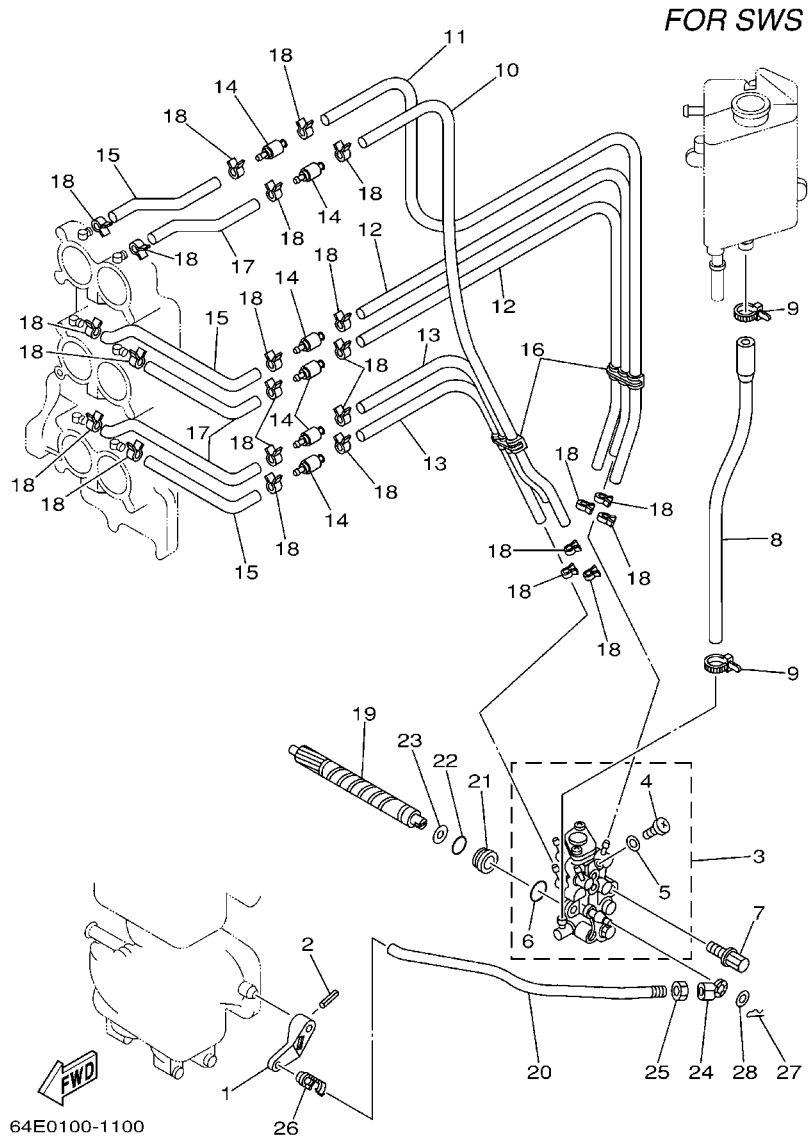

FIG. 10 OIL PUMP 2

REF. NO.	PART NO.	DESCRIPTION	200	S200	L200	REMARKS
1	6E5-14276-01	LEVER		1	1	
2	91690-30016	PIN, SPRING		1	1	
3	6R5-13200-12	OIL INJECTION PUMP ASSY		1	1	
4	6R3-13471-00	.PLUG, DRAIN		1	1	
5	6L2-13475-00	.GASKET		1	1	
6	93210-19M82	.O-RING		1	1	
7	90109-06M40	BOLT		2	2	
8	6R3-13416-00	PIPE, OIL 1		1	1	
9	90465-11M10	CLAMP		2	2	
10	90445-07M77	HOSE (L350)		1	1	
11	90445-07M85	HOSE (L330)		1	1	
12	90445-07M72	HOSE (L250)		2	2	
13	90445-07196	HOSE (L160)		2	2	
14	6R3-13183-10	VALVE, CHECK		6	6	
15	90445-07M87	HOSE (L110)		3	3	
16	90464-07M05	CLAMP		2	2	
17	90445-07M07	HOSE (L180)		3	3	
18	90468-07M02	CLIP		24	24	
19	6R3-11537-00	GEAR, DRIVEN		1	1	
20	6R5-41241-00	ROD, LINK		1	1	
21	6R3-13117-00	COLLAR, DISTANCE		1	1	
22	93210-13M04	O-RING		1	1	
23	90202-08M44	WASHER, PLATE		1	1	
24	6H1-41237-00	JOINT, LINK		1	1	
25	95380-05600	NUT		1	1	
26	6R5-41237-00	JOINT, LINK		1	1	
27	90468-05M03	CLIP		1	1	

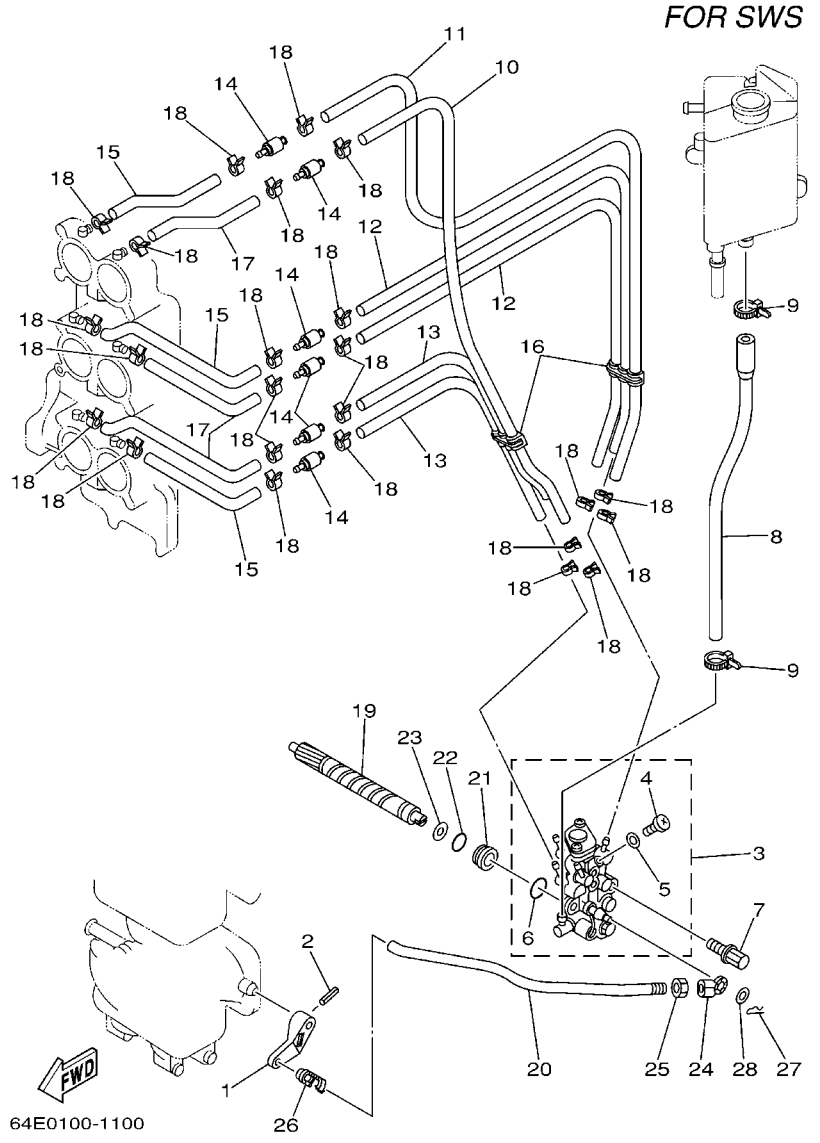

FIG. 10 OIL PUMP 2

REF. NO.	PART NO.	DESCRIPTION	200	S200	L200	REMARKS
28	90202-05088	WASHER, PLATE		1	1	
<hr style="border-top: 1px dashed black;"/>						
<hr style="border-top: 1px dashed black;"/>						
<hr style="border-top: 1px dashed black;"/>						
<hr style="border-top: 1px dashed black;"/>						
<hr style="border-top: 1px dashed black;"/>						
<hr style="border-top: 1px dashed black;"/>						
<hr style="border-top: 1px dashed black;"/>						
<hr style="border-top: 1px dashed black;"/>						
<hr style="border-top: 1px dashed black;"/>						

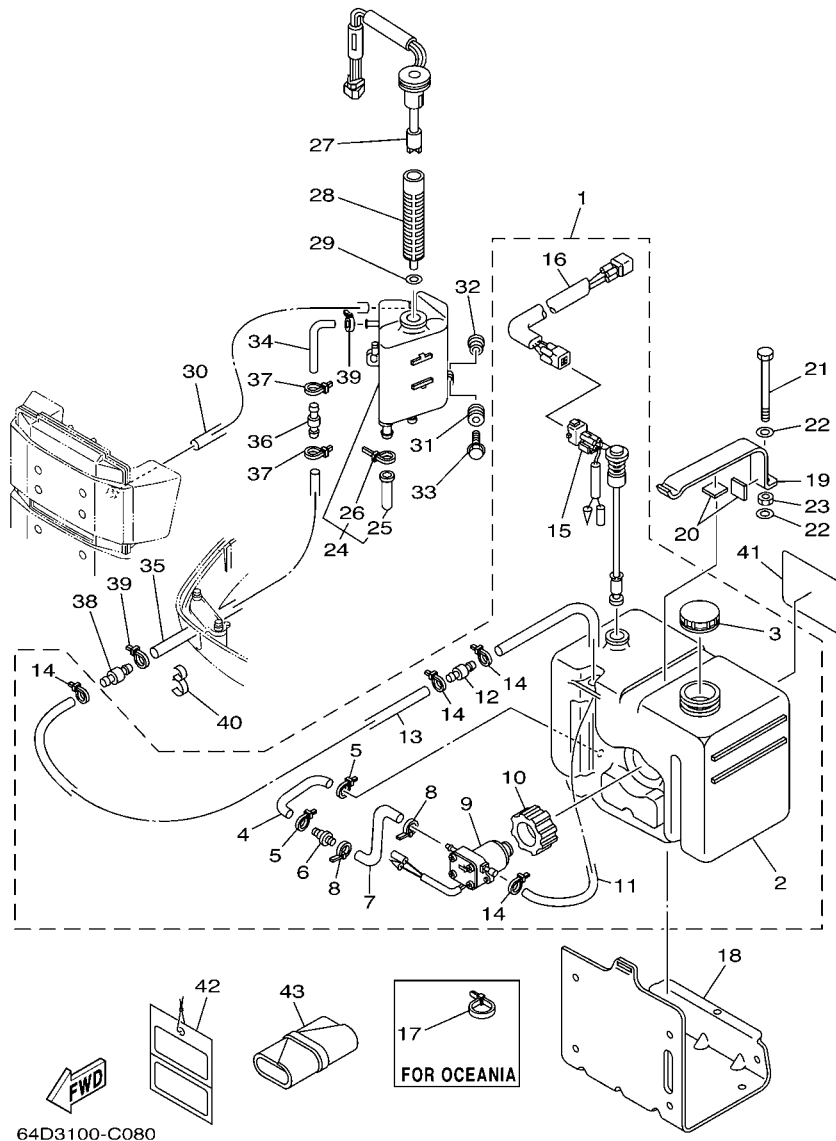

FIG. 11 OIL TANK

REF. NO.	PART NO.	DESCRIPTION	200	S200	L200	REMARKS
1	61A-21708-20	SUB OIL TANK ASSY		1	1	FOR OCE
	6E5-21708-10	SUB OIL TANK ASSY	1	1		FOR CAR,KOR
	6K1-21708-10	SUB OIL TANK ASSY			1	FOR CAR
2	6E5-21733-20	.SUB TANK, OIL (10.5L)	1	1	1	
3	6E5-21770-03	.OIL TANK CAP ASSY	1	1	1	
4	6E5-24322-00	.PIPE 11	1	1	1	
5	90465-11M10	.CLAMP	2	2	2	
6	646-24251-02	.STRAINER 1	1	1	1	
7	6E5-24319-01	.PIPE, OIL	1	1	1	
8	90465-11M10	.CLAMP	2	2	2	
9	6E5-81900-01	.OIL FEED PUMP ASSY	1	1	1	
10	6E5-81922-00	.GROMMET	1	1	1	
11	6E5-24321-01	.PIPE 10	1	1	1	
12	6E5-24379-00	.PIPE, JOINT 4	1	1	1	
13	90445-11M26	.HOSE (L6500)		1	1	FOR 61A-21708-20
	90445-11M81	.HOSE (L3000)	1	1		FOR 6E5-21708-10
	90445-11M00	.HOSE (L8000)			1	FOR 6K1-21708-10
14	90465-11M10	.CLAMP	4	4	4	
15	6E5-85720-05	.OIL LEVEL GAUGE ASSY	1	1	1	
16	6R3-85721-80	.WIRE, LEAD (L=8.0M)		1	1	(4P)
	6R3-85721-30	.WIRE, LEAD (L=3.0M)	1	1		FOR 6E5-21708-10
17	90465-13M11	CLAMP		1	1	FOR OCE
18	6E5-21734-01-33	HOLDER, OIL SUB TANK	1	1	1	
19	6E5-21798-01-33	BRACKET, DAMPER	1	1	1	
20	6E5-21746-00	DAMPER	2	2	2	
21	97080-06100	BOLT	1	1	1	
22	92990-06600	WASHER, PLATE	2	2	2	

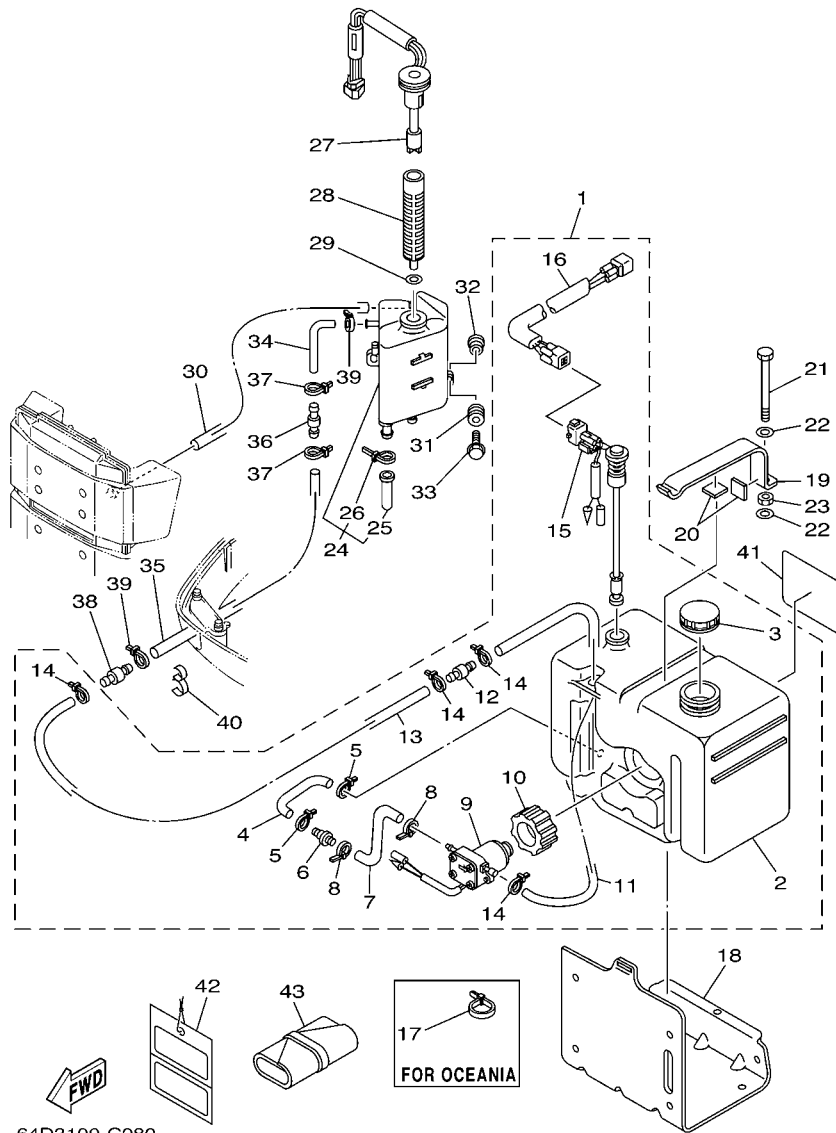
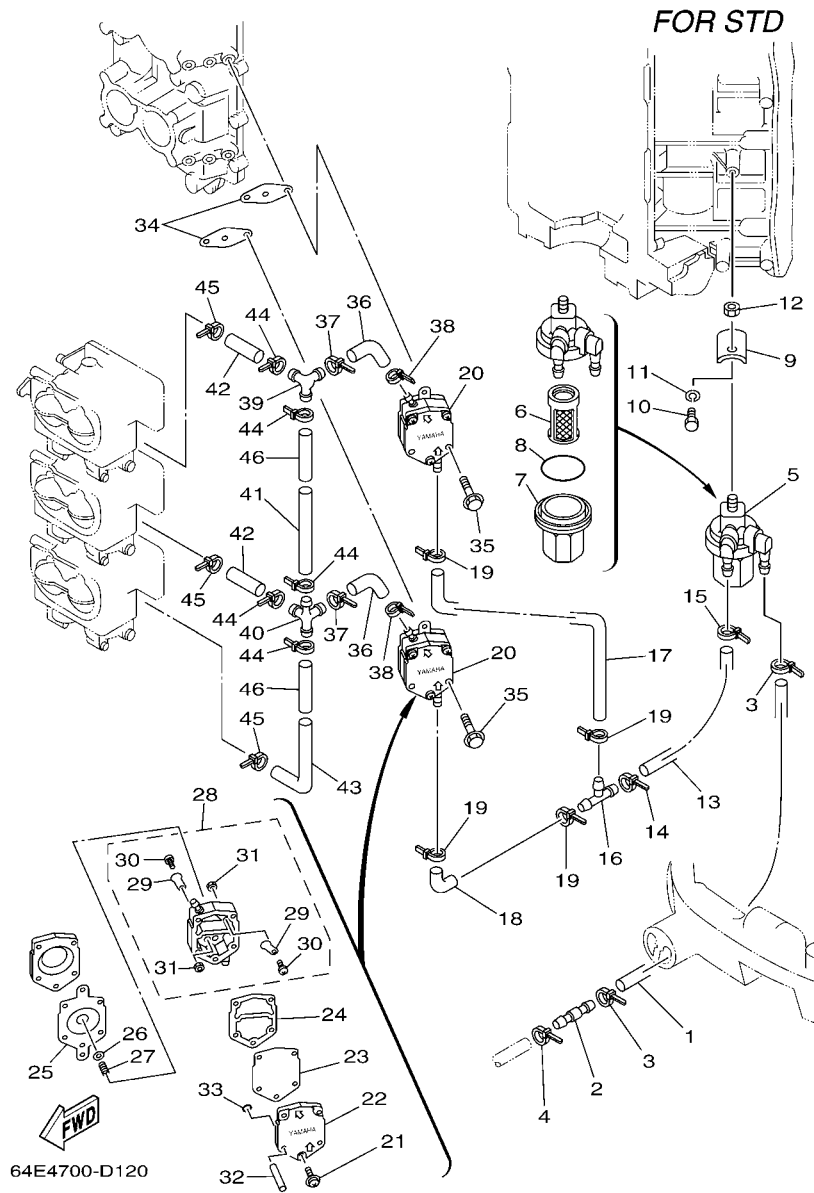

FIG. 11 OIL TANK

REF. NO.	PART NO.	DESCRIPTION	200	S200	L200	REMARKS
23	95380-06600	NUT, HEXAGON	1	1	1	
24	6E5-21750-05	OIL TANK ASSY	1	1	1	
25	6E5-13448-00	.CAP	1	1	1	
26	90465-13M11	.CLAMP	1	1	1	
27	6R3-85730-03	OIL LEVEL GAUGE ASSY	1	1	1	
28	6E5-13411-00	STRAINER, OIL	1	1	1	
29	6E5-13414-00	GASKET, STRAINER COVER	1	1	1	
30	90445-05M02	HOSE (L380)	1	1	1	
31	6A0-82317-00	DAMPER, IGNITION COIL	3	3	3	
32	90387-06119	COLLAR	3	3	3	
33	90119-06M65	BOLT, WITH WASHER	3	3	3	
34	64E-24323-00	PIPE 12	1	1	1	
35	90445-12207	HOSE (L2400)		1	1	FOR OCE
	90445-12M13	HOSE (L880)	1	1	1	FOR CAR,KOR
36	6E5-24379-00	PIPE, JOINT 4	1	1	1	
37	90465-11M10	CLAMP	2	2	2	
38	6E5-24379-00	PIPE, JOINT 4	1	1	1	
39	90465-11M10	CLAMP	2	2	2	
40	90464-13M34	CLAMP	1	1	1	
41	6E5-13437-43	MARK, CAUTION	1	1	1	FOR OCE,KOR
	6E5-13437-62	MARK, CAUTION	1	1	1	FOR CAR
42	61H-2819R-31	TAG, WARNING	1	1	1	FOR OCE,CAR
43	656-W2810-02	TOOL KIT	1	1	1	AP



64E4700-D120

FIG. 12 FUEL 1

REF. NO.	PART NO.	DESCRIPTION	200	S200	L200	REMARKS
1	6R3-24313-01	PIPE 3 (L880)	1			
2	6R3-24377-00	PIPE, JOINT 2	1			
3	90465-11M10	CLAMP	2			
4	90465-11M10	CLAMP	1			
5	6R3-24560-00	FILTER ASSY	1			
6	6R3-24563-00	.ELEMENT, FILTER	1			
7	61N-24521-00	.CUP, FILTER	1			
8	93210-32738	.O-RING	1			
9	648-24566-02	BRACKET, FILTER	1			
10	97013-06014	BOLT	1			
11	92903-06100	WASHER, SPRING	1			
12	95380-08600	NUT	1			
13	6G5-24314-00	PIPE 4	1			
14	90465-11M10	CLAMP	1			
15	90465-11M10	CLAMP	1			
16	6E5-24378-00	PIPE, JOINT 3	1			
17	6G5-24315-00	PIPE 5	1			
18	6E5-24315-00	PIPE 5	1			
19	90465-11M10	CLAMP	4			
20	6E5-24410-04	FUEL PUMP ASSY	2			
21	6E5-24444-01	.SCREW	3			
22	6E5-24413-01	.BODY 2	1			
23	6E5-24471-01	.DIAPHRAGM	1			
24	6E5-24435-01	.GASKET, BODY 2	1			
25	6E5-24411-01	.DIAPHRAGM	1			
26	648-24424-00	.SEAT, SPRING	1			
27	6E5-24423-00	.SPRING, DIAPHRAGM	1			

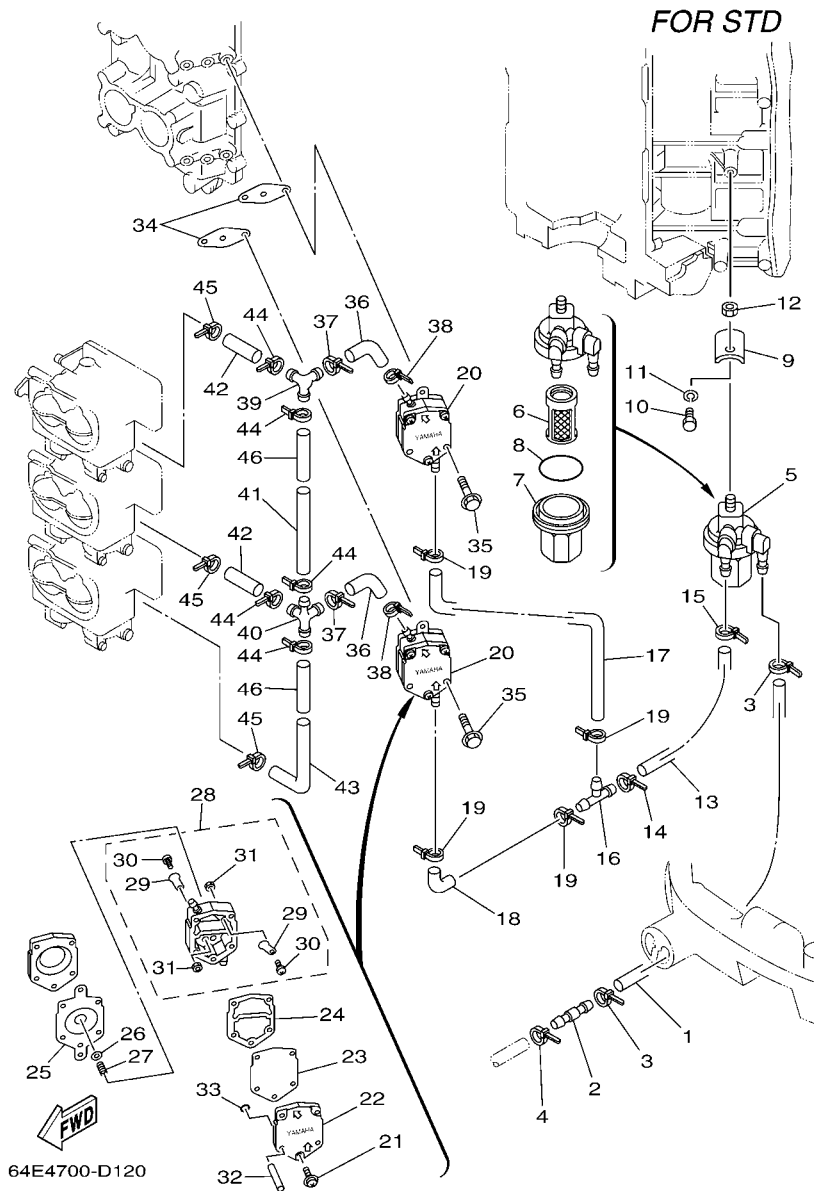

FIG. 12 FUEL 1

REF. NO.	PART NO.	DESCRIPTION	200	S200	L200	REMARKS
28	6E5-24412-11	.BODY 1	1			
29	6A0-24421-01	..VALVE, CHECK	4			
30	6A0-14325-00	..SCREW, PAN HEAD	4			
31	95380-03600	..NUT	4			
32	6E5-24492-00	.BUSH, FUEL PUMP	2			
33	6E5-24486-00	.O-RING	2			
34	650-24431-A0	GASKET, FUEL PUMP 1	2			
35	97595-06550	BOLT, WITH WASHER	4			
36	6G5-24316-10	PIPE 6	2			
37	90465-11M10	CLAMP	2			
38	90465-11M10	CLAMP	2			
39	6G5-24376-00	PIPE, JOINT 1	1			
40	6G5-24377-00	PIPE, JOINT 2	1			
41	6G5-24317-01	PIPE 7	1			
42	6G5-24318-10	PIPE, OVERFLOW	2			
43	6G5-24319-10	PIPE, OIL	1			
44	90465-11M10	CLAMP	5			
45	90465-11M10	CLAMP	3			
46	90446-15M07	HOSE (L60)	2			

FOR SWS

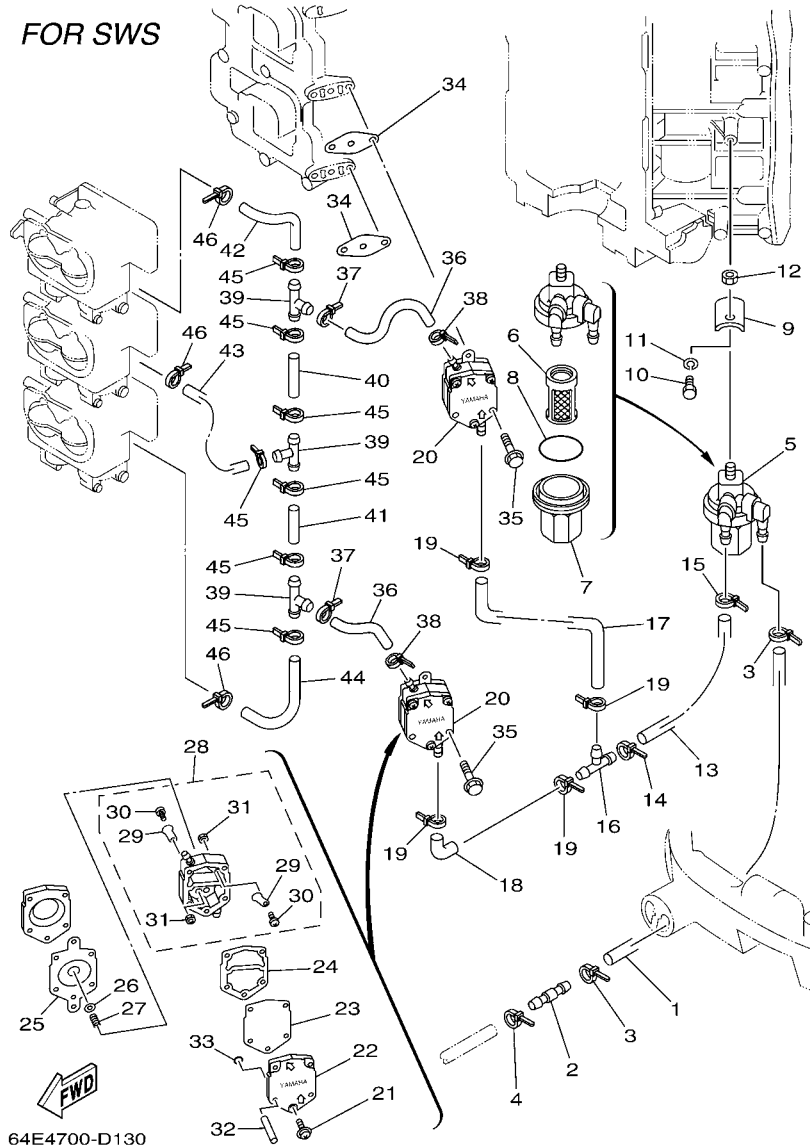

FIG. 13 FUEL 2

REF. NO.	PART NO.	DESCRIPTION	200	S200	L200	REMARKS
1	6R3-24313-20	PIPE 3 (L2820)		1	1	FOR OCE
	6R3-24313-01	PIPE 3 (L880)		1	1	FOR CAR
2	6R3-24377-00	PIPE, JOINT 2		1	1	
3	90465-11M10	CLAMP		2	2	
4	90465-11M10	CLAMP		1	1	
5	6R3-24560-00	FILTER ASSY		1	1	
6	6R3-24563-00	.ELEMENT, FILTER		1	1	
7	61N-24521-00	.CUP, FILTER		1	1	
8	93210-32738	.O-RING		1	1	
9	648-24566-02	BRACKET, FILTER		1	1	
10	97013-06014	BOLT		1	1	
11	92903-06100	WASHER, SPRING		1	1	
12	95380-08600	NUT		1	1	
13	6G5-24314-00	PIPE 4		1	1	
14	90465-11M10	CLAMP		1	1	
15	90465-11M10	CLAMP		1	1	
16	6E5-24378-00	PIPE, JOINT 3		1	1	
17	6K7-24315-00	PIPE 5		1	1	
18	6E5-24315-00	PIPE 5		1	1	
19	90465-11M10	CLAMP		4	4	
20	6E5-24410-04	FUEL PUMP ASSY		2	2	
21	6E5-24444-01	.SCREW		3	3	
22	6E5-24413-01	.BODY 2		1	1	
23	6E5-24471-01	.DIAPHRAGM		1	1	
24	6E5-24435-01	.GASKET, BODY 2		1	1	
25	6E5-24411-01	.DIAPHRAGM		1	1	
26	648-24424-00	.SEAT, SPRING		1	1	

FOR SWS

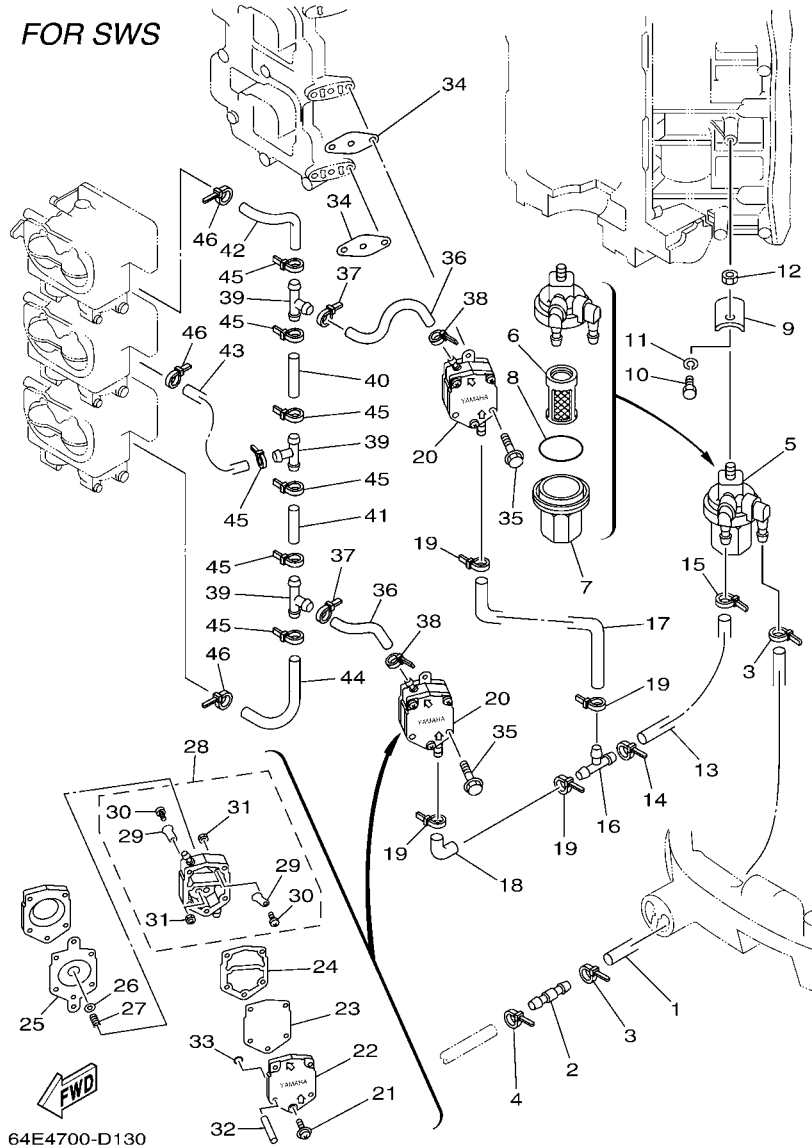
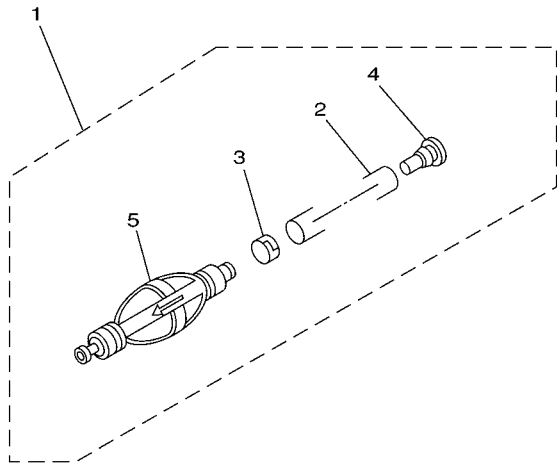

FIG. 13 FUEL 2

REF. NO.	PART NO.	DESCRIPTION	200	S200	L200	REMARKS
27	6E5-24423-00	..SPRING, DIAPHRAGM		1	1	
28	6E5-24412-11	..BODY 1		1	1	
29	6A0-24421-01	..VALVE, CHECK		4	4	
30	6A0-14325-00	..SCREW, PAN HEAD		4	4	
31	95380-03600	..NUT		4	4	
32	6E5-24492-00	..BUSH, FUEL PUMP		2	2	
33	6E5-24486-00	..O-RING		2	2	
34	650-24431-A0	GASKET, FUEL PUMP 1		2	2	
35	97595-06550	BOLT, WITH WASHER		4	4	
36	6G5-24316-10	PIPE 6		2	2	
37	90465-11M10	CLAMP		2	2	
38	90465-11M10	CLAMP		2	2	
39	6E5-24378-00	PIPE, JOINT 3		3	3	
40	90445-13M03	HOSE (L50)		1	1	
41	90445-13M02	HOSE (L40)		1	1	
42	6K7-24317-00	PIPE 7		1	1	
43	6K7-24318-00	PIPE, OVERFLOW		1	1	
44	6K7-24319-00	PIPE, OIL		1	1	
45	90465-11M10	CLAMP		7	7	
46	90465-11M10	CLAMP		3	3	



68V0100-0110

FIG. 14 FUEL 3

REF. NO.	PART NO.	DESCRIPTION	200	S200	L200	REMARKS
1	6Y2-24307-50	FUEL PIPE COMP. 2		1	1	AP FOR OCE
2	90445-13M01	.HOSE (L2050)		1	1	
3	6E5-24351-51	.BAND 1		1	1	
4	90480-06M19	.GROMMET		1	1	
5	6Y2-24360-60	.PRIMER PUMP ASSY		1	1	

FIG. 15 FUEL 4

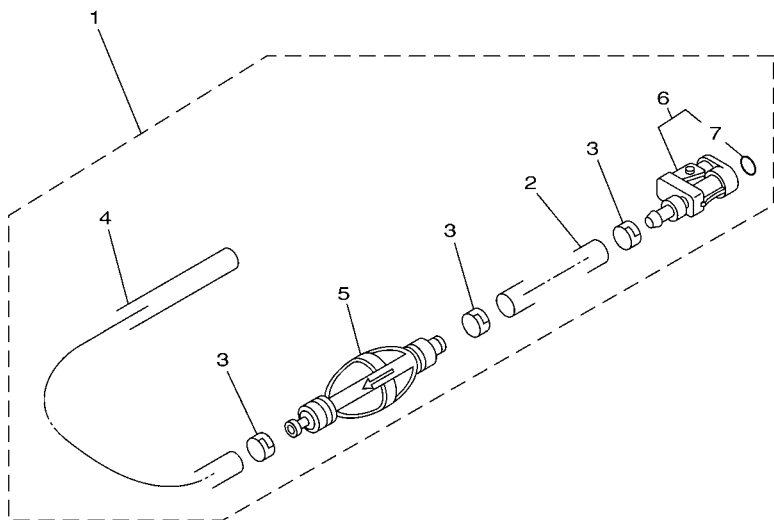

REF. NO.	PART NO.	DESCRIPTION	200	S200	L200	REMARKS
1	6Y2-24306-45	FUEL PIPE COMP. 1	1		1	AP 200-FOR KOR
2	90445-13M01	.HOSE (L2050)	1		1	
3	6E5-24351-51	.BAND 1	3		3	
4	90445-13M35	.HOSE (L250)	1		1	
5	6Y2-24360-60	.PRIMER PUMP ASSY	1		1	
6	6Y2-24305-06	.FUEL PIPE JOINT COMP. 2	1		1	
7	93210-08287	.O-RING	1		1	



6N43100-C100

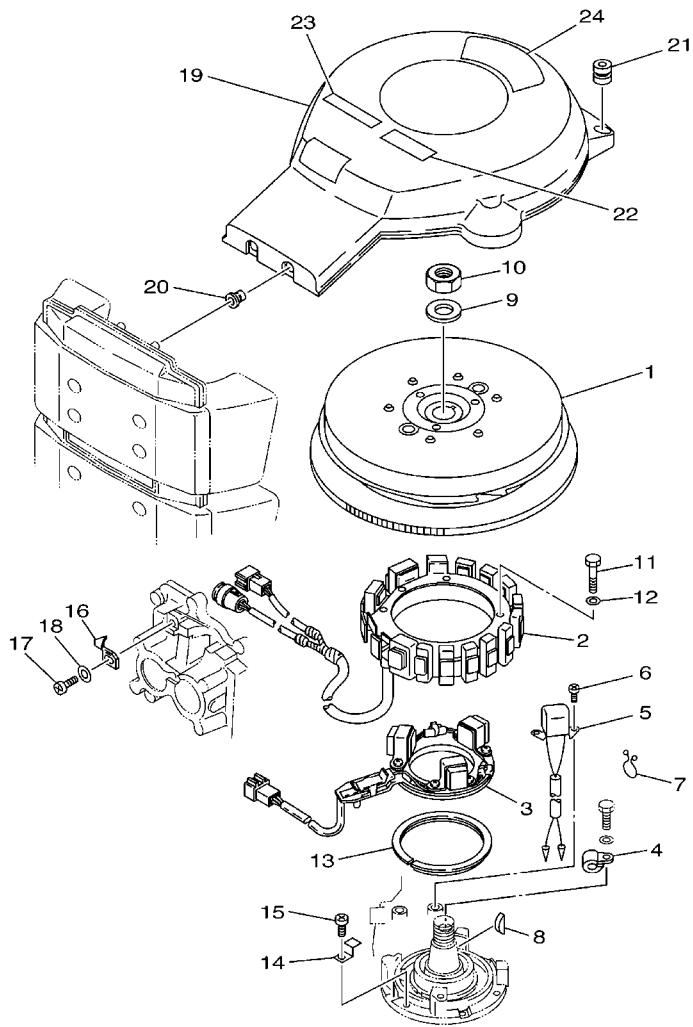

FWD
64E1700-2160

FIG. 16 GENERATOR

REF. NO.	PART NO.	DESCRIPTION	200	S200	L200	REMARKS
1	64D-85550-02	ROTOR ASSY	1	1	1	
2	6R3-85510-00	STATOR ASSY	1	1	1	
3	64D-85580-00	COIL, PULSER	1	1	1	
4	90465-06M86	CLAMP	1	1	1	
5	6R5-85895-01	CRANK POSITION SENDER	1	1	1	
6	97885-05012	SCREW, PAN HEAD	2	2	2	
7	90464-15M11	CLAMP	1	1	1	
8	90280-05015	KEY, WOODRUFF	1	1	1	
9	90201-21M18	WASHER, PLATE	1	1	1	
10	90170-20137	NUT	1	1	1	
11	97013-06070	BOLT	4	4	4	
12	92903-06600	WASHER, PLATE	4	4	4	
13	688-41611-00	RETAINER, MAGNETO BASE	1	1	1	
14	688-41612-00	RETAINER, MAGNETO BASE	4	4	4	
15	97880-06018	SCREW, PAN HEAD	4	4	4	
16	6E5-81332-00	PLATE, TIMING	1	1	1	
17	97885-06010	SCREW, PAN HEAD	1	1	1	
18	92995-06600	WASHER	1	1	1	
19	64D-81337-10	COVER, FLYWHEEL	1			FOR STD
	64D-81337-01	COVER, FLYWHEEL		1	1	FOR SWS
20	6G5-82317-00	DAMPER, IGNITION COIL	2			FOR STD
	90480-13M24	GROMMET		1	1	FOR SWS
21	663-82317-01	DAMPER, IGNITION COIL	2	2	2	
22	6A1-83625-41	MARK 5	1	1	1	
23	6K1-83623-41	MARK 3			1	
24	6G5-14488-02	LABEL, CAUTION	1			FOR STD
	64E-14488-00	LABEL, CAUTION		1	1	FOR SWS

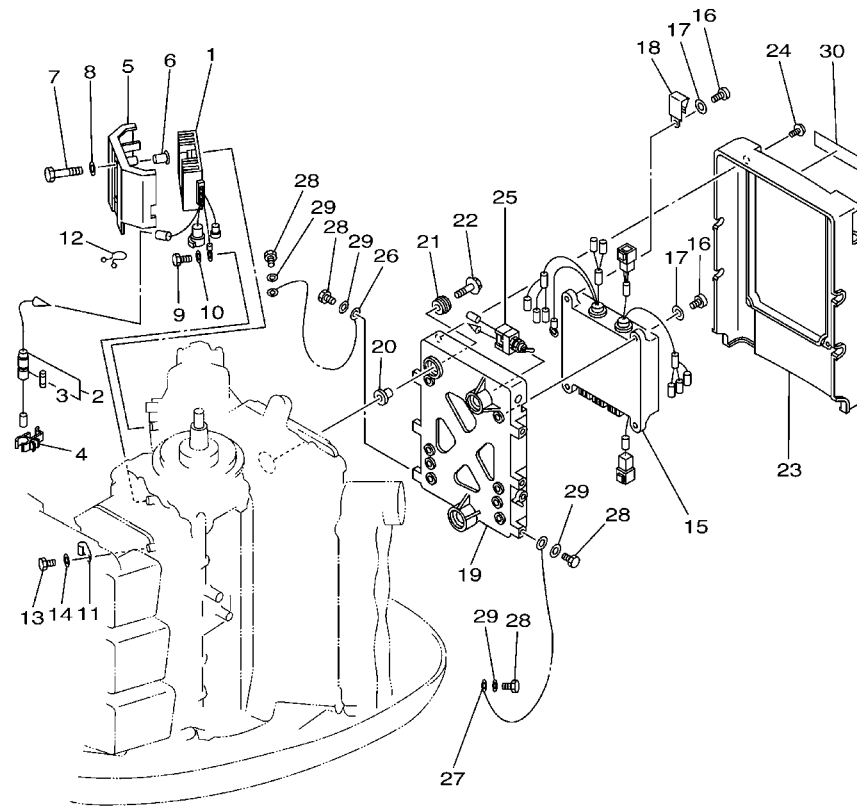

64L1100-2120

FIG. 17 ELECTRICAL 1

REF. NO.	PART NO.	DESCRIPTION	200	S200	L200	REMARKS
1	6R3-81960-10	RECTIFIER & REGULATOR ASSY	1	1	1	
2	6R3-82150-00	FUSE HOLDER ASSY	1	1	1	
3	705-82151-00	.FUSE (30A)	1	1	1	
4	6G5-82152-00	HOLDER, FUSE	1	1	1	
5	64D-81942-00	COVER	1	1	1	
6	90387-06M66	COLLAR	2	2	2	
7	97013-06055	BOLT	2	2	2	
8	92903-06600	WASHER, PLATE	2	2	2	
9	97095-06012	BOLT	1	1	1	
10	92995-06600	WASHER	1	1	1	
11	90465-06M88	CLAMP	1	1	1	
12	90464-15M11	CLAMP	1	1	1	
13	97095-06012	BOLT	1	1	1	
14	92995-06600	WASHER	1	1	1	
15	64D-85540-01	C.D.I. UNIT ASSY	1			FOR STD
	64E-85540-01	C.D.I. UNIT ASSY		1	1	FOR SWS
16	97880-06020	SCREW, PAN HEAD	4	4	4	
17	92990-06600	WASHER, PLATE	4	4	4	
18	90465-05M87	CLAMP	1	1	1	
19	6R3-85542-03-1S	BRACKET	1	1	1	
20	90387-06M03	COLLAR	3	3	3	
21	90480-09M12	GROMMET	3	3	3	
22	90119-06M61	BOLT, WITH WASHER	3	3	3	
23	64D-85537-00	COVER	1	1	1	
24	90159-06M11	SCREW, WITH WASHER	4	4	4	
25	6R3-8259E-00	SWITCH ASSY	1	1	1	
26	662-82519-00	WIRE, EARTH LEAD	1	1	1	

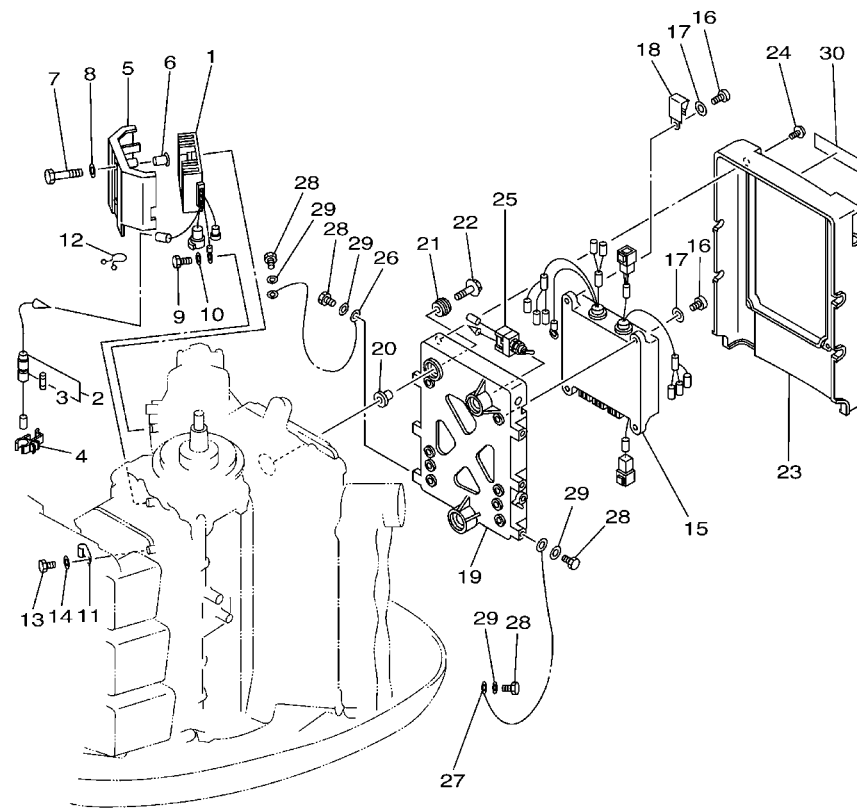

64L1100-2120

FIG. 17 ELECTRICAL 1

REF. NO.	PART NO.	DESCRIPTION	200	S200	L200	REMARKS
27	6R3-82519-00	WIRE, EARTH LEAD	1	1	1	
28	97095-06012	BOLT	5	5	5	
29	92995-06600	WASHER	5	5	5	
30	6E5-85711-40	MARK, CAUTION	1	1	1	

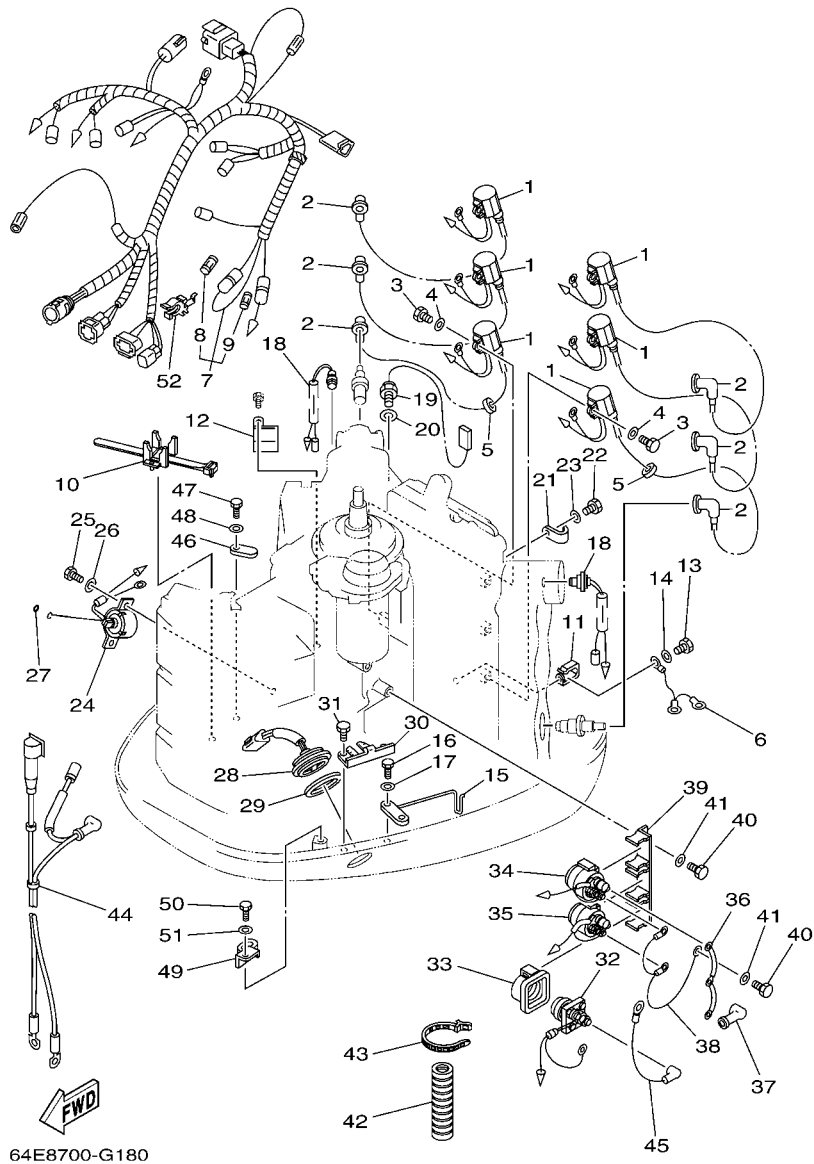

64E8700-G180

FIG. 18 ELECTRICAL 2

REF. NO.	PART NO.	DESCRIPTION	200	S200	L200	REMARKS
1	6R3-85570-01	IGNITION COIL ASSY	6	6	6	
2	6E3-82370-21	PLUG CAP ASSY	6	6	6	
3	97095-06020	BOLT	6	6	6	
4	92995-06600	WASHER	6	6	6	
5	90480-25161	GROMMET	2	2	2	
6	6E5-82531-10	WIRE, LEAD	1	1	1	
7	64D-82590-20	WIRE HARNESS ASSY	1	1	1	
8	663-82151-00	.FUSE (12V-20A)	1	1	1	
9	705-82151-00	.FUSE (30A)	1	1	1	
10	688-82594-00	CLAMP	1	1	1	
11	90465-05M87	CLAMP	1	1	1	
12	90465-08M89	CLAMP	1	1	1	
13	97095-06012	BOLT	1	1	1	
14	92995-06600	WASHER	1	1	1	
15	6K7-82588-00	PLATE	1	1	1	
16	97095-06020	BOLT	1	1	1	
17	92995-06600	WASHER	1	1	1	
18	688-82560-10	THERMO SWITCH ASSY	2	2	2	
19	61A-85790-00	THERMOSENSOR ASSY	1	1	1	
20	92990-10600	WASHER, PLATE	1	1	1	
21	90465-06M86	CLAMP	1	1	1	
22	97095-06012	BOLT	1	1	1	
23	92995-06600	WASHER	1	1	1	
24	64D-86110-01	SOLENOID	1			FOR STD
	64E-86110-01	SOLENOID		1	1	FOR SWS
25	97095-06016	BOLT	2	2	2	
26	92995-06600	WASHER	2	2	2	

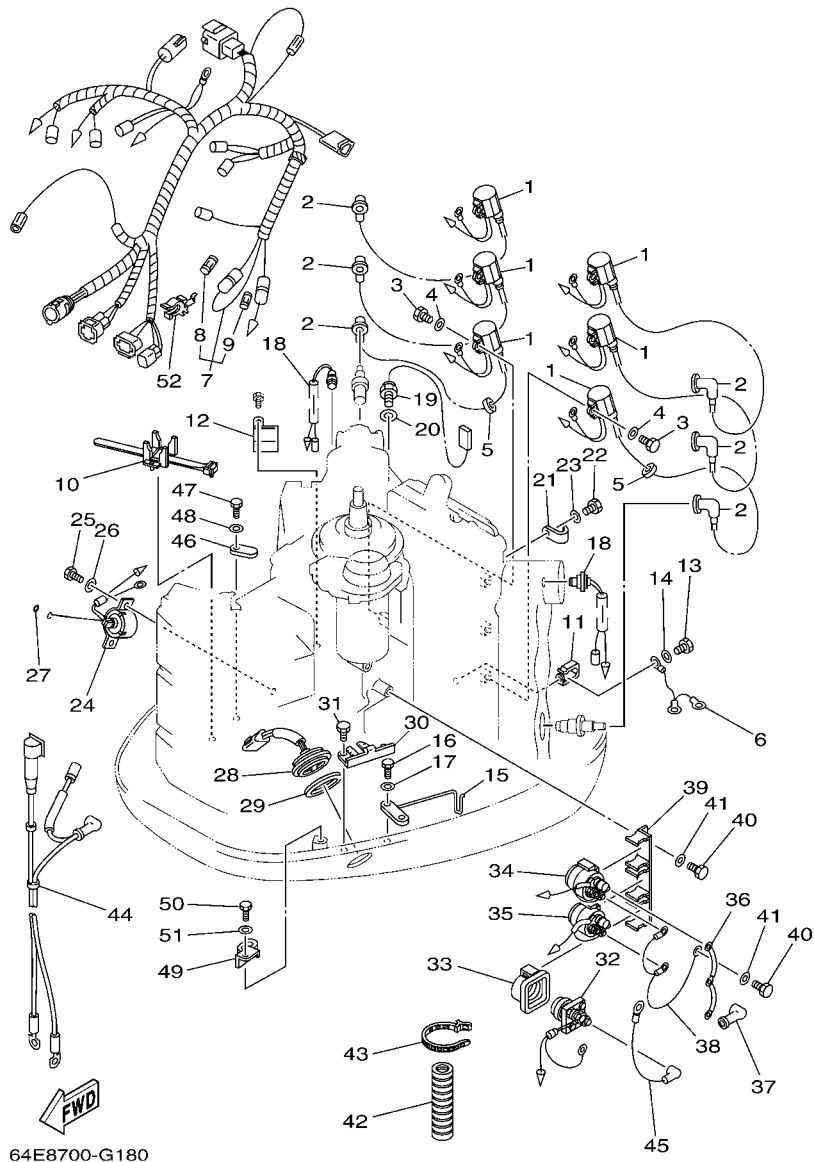

64E8700-G180

FIG. 18 ELECTRICAL 2

REF. NO.	PART NO.	DESCRIPTION	200	S200	L200	REMARKS
27	93210-03261	O-RING	1	1	1	
28	6R3-82563-00	TRIM & TILT SWITCH ASSY	1	1	1	
29	6E5-82587-00	GASKET	1	1	1	
30	6R3-83614-00	BRACKET	1	1	1	
31	97095-06012	BOLT	2	2	2	
32	61A-81941-00	STARTER RELAY ASSY	1	1	1	
33	689-81952-10	HOLDER, RELAY	1	1	1	
34	6E5-81950-00	RELAY ASSY	1	1	1	
35	6E5-8195A-00	RELAY ASSY	1	1	1	
36	6G5-87149-10	CONNECTOR	1	1	1	
37	6G5-82119-00	COVER, LEAD WIRE	2	2	2	
38	6E5-82116-00	WIRE, MINUS LEAD	1	1	1	
39	6G5-81948-11	BRACKET	1	1	1	
40	97095-06016	BOLT	2	2	2	
41	92995-06600	WASHER	2	2	2	
42	6E9-83557-70	TUBE	1	1	1	
43	90465-13M18	CLAMP	1	1	1	
44	6R3-82105-02	WIRE HARNESS	1	1	1	
45	6E5-82117-01	WIRE, LEAD	1	1	1	
46	6E5-82588-00	PLATE	1	1	1	
47	97095-06020	BOLT	1	1	1	
48	92995-06600	WASHER	1	1	1	
49	90465-12M25	CLAMP	1	1	1	
50	97095-06012	BOLT	1	1	1	
51	92995-06600	WASHER	1	1	1	
52	6G5-82152-00	HOLDER, FUSE	2	2	2	

FIG. 19 STARTING MOTOR

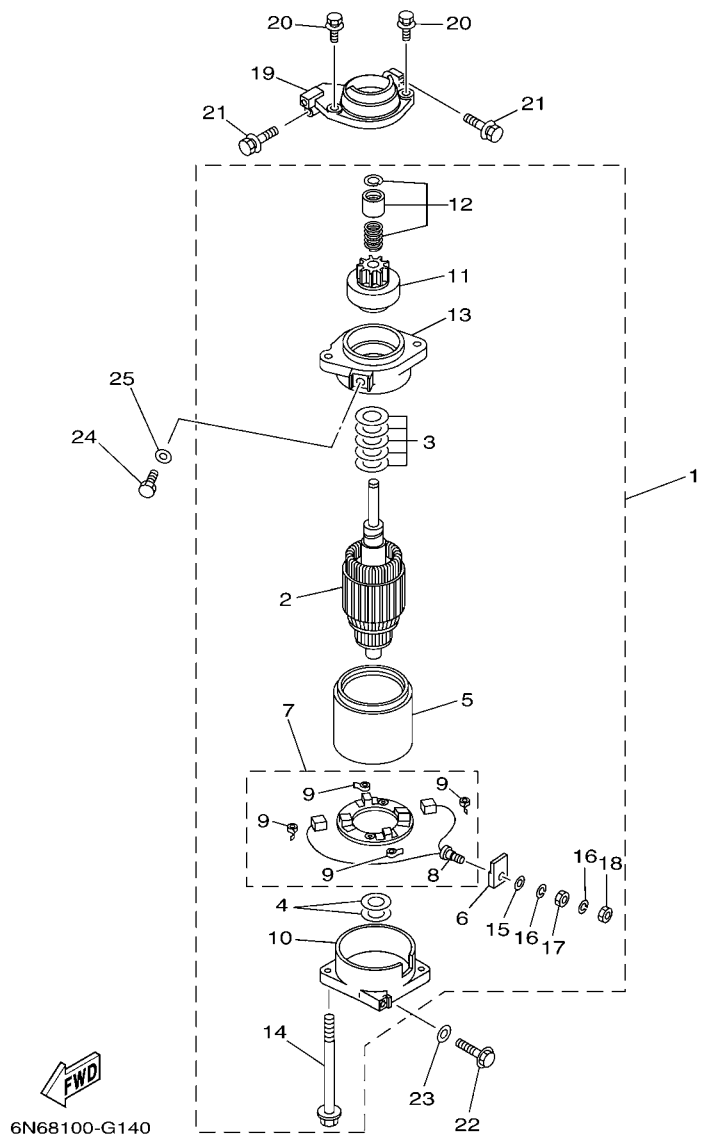

REF. NO.	PART NO.	DESCRIPTION	200	S200	L200	REMARKS
1	6N7-81800-10	STARTING MOTOR ASSY	1	1	1	
2	6N7-81850-10	.ARMATURE ASSY	1	1	1	
3	61A-81809-00	.WASHER KIT	1	1	1	
4	61A-81824-00	.WASHER 2	2	2	2	
5	6N7-81810-00	.STATOR ASSY	1	1	1	
6	6K7-8182G-10	.BUSH, TERMINAL	1	1	1	
7	6N7-81840-00	.BRUSH HOLDER ASSY	1	1	1	
8	6N7-81801-00	..BRUSH SET	1	1	1	
9	6N7-81813-00	..SPRING, BRUSH	4	4	4	
10	6N7-81820-10	.REAR BRACKET ASSY	1	1	1	
11	6N7-81807-00	.GEAR ASSY, STARTING MOTOR	1	1	1	
12	6N7-81857-00	.RETAINER	1	1	1	
13	6N7-81830-00	.FRONT BRACKET ASSY	1	1	1	
14	6K7-81826-11	.BOLT	2	2	2	
15	6E5-8182E-10	.WASHER	1	1	1	
16	6E5-8182F-10	.WASHER	2	2	2	
17	6E5-8182A-10	.NUT	1	1	1	
18	6E5-8182K-10	.NUT	1	1	1	
19	6R3-81822-00-94	BRACKET, STARTING MOTOR	1			FOR STD
	6K7-81822-00-94	BRACKET, STARTING MOTOR		1	1	FOR SWS
20	90119-08M76	BOLT, WITH WASHER	2	2	2	
21	90119-08M77	BOLT, WITH WASHER	2	2	2	
22	90119-08M57	BOLT, WITH WASHER	1	1	1	
23	92990-08600	WASHER, PLATE	1	1	1	
24	97095-08016	BOLT	1	1	1	
25	92995-08600	WASHER	1	1	1	

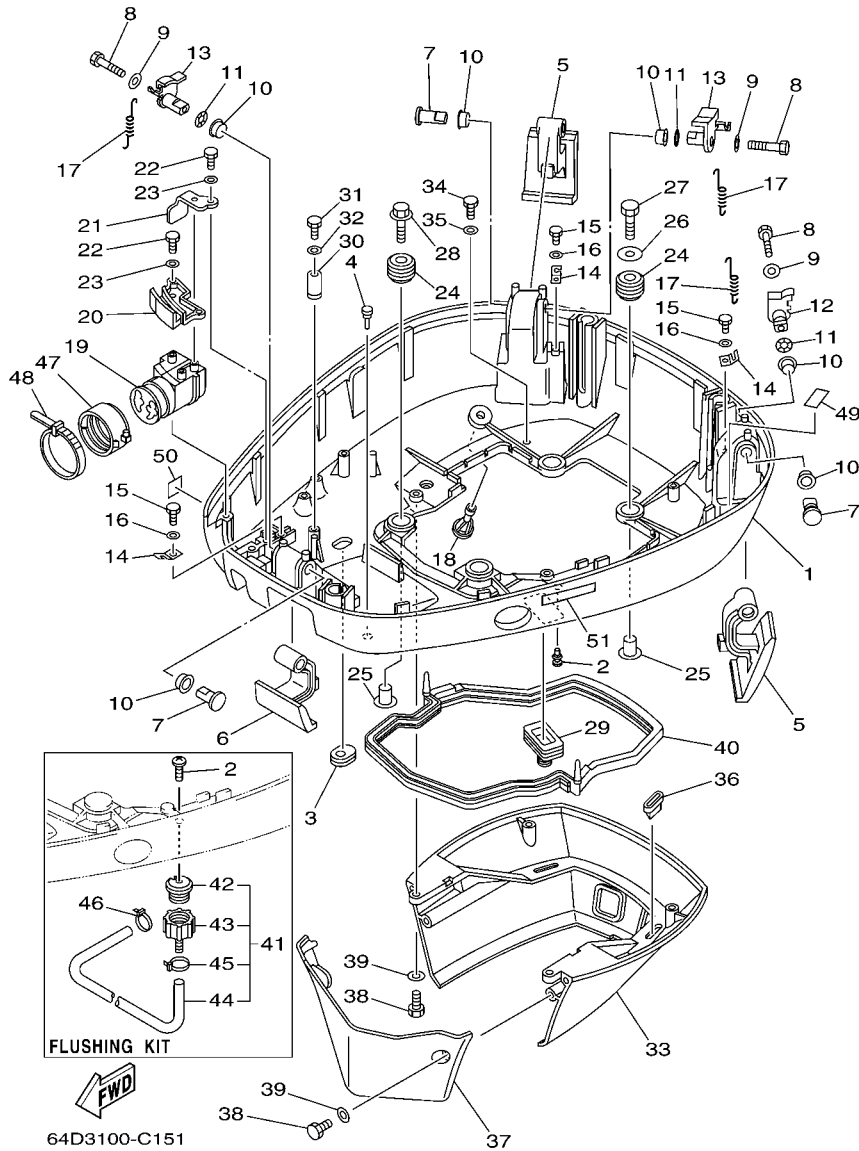

FIG. 20 BOTTOM COWLING

REF. NO.	PART NO.	DESCRIPTION	200	S200	L200	REMARKS
1	64D-42711-01-8D	COWLING, BOTTOM 1	1	1	1	
2	90480-06M19	GROMMET	1			
	90169-05M00	SCREW, TRUSS HEAD TAPPING		1	1	
3	61A-42727-00	GROMMET	1	1		
	64G-42727-00	GROMMET			1	
4	6H4-42748-00	GROMMET	1	1	1	
5	64D-42815-00-4D	LEVER, CLAMP	2	2	2	
6	64D-42816-00-4D	LEVER, CLAMP	1	1	1	
7	64D-42835-00	PIN, SET 1	3	3	3	
8	97095-06040	BOLT	3	3	3	
9	90201-06068	WASHER, PLATE	3	3	3	
10	90386-15M73	BUSH	6	6	6	
11	90206-15M18	WASHER, WAVE	3	3	3	
12	64D-42818-20	LEVER, CLAMP	1	1	1	
13	64D-42818-30	LEVER, CLAMP	2	2	2	
14	64D-43144-00	HOOK, SPRING	3	3	3	
15	97090-06012	BOLT	3	3	3	
16	92990-06600	WASHER, PLATE	3	3	3	
17	90506-16M34	SPRING, TENSION	3	3	3	
18	6E5-44391-00	NIPPLE, HOSE	1	1	1	
19	64D-42725-30	GROMMET	1	1		FOR OCE
	64D-42725-20	GROMMET	1	1	1	FOR CAR,KOR
20	64D-42738-00-5B	PLATE, FITTING	1	1	1	
21	64D-42738-10-5B	PLATE, FITTING	1	1	1	
22	97095-06016	BOLT	3	3	3	
23	92995-06600	WASHER	3	3	3	
24	90480-22M15	GROMMET	4	4	4	

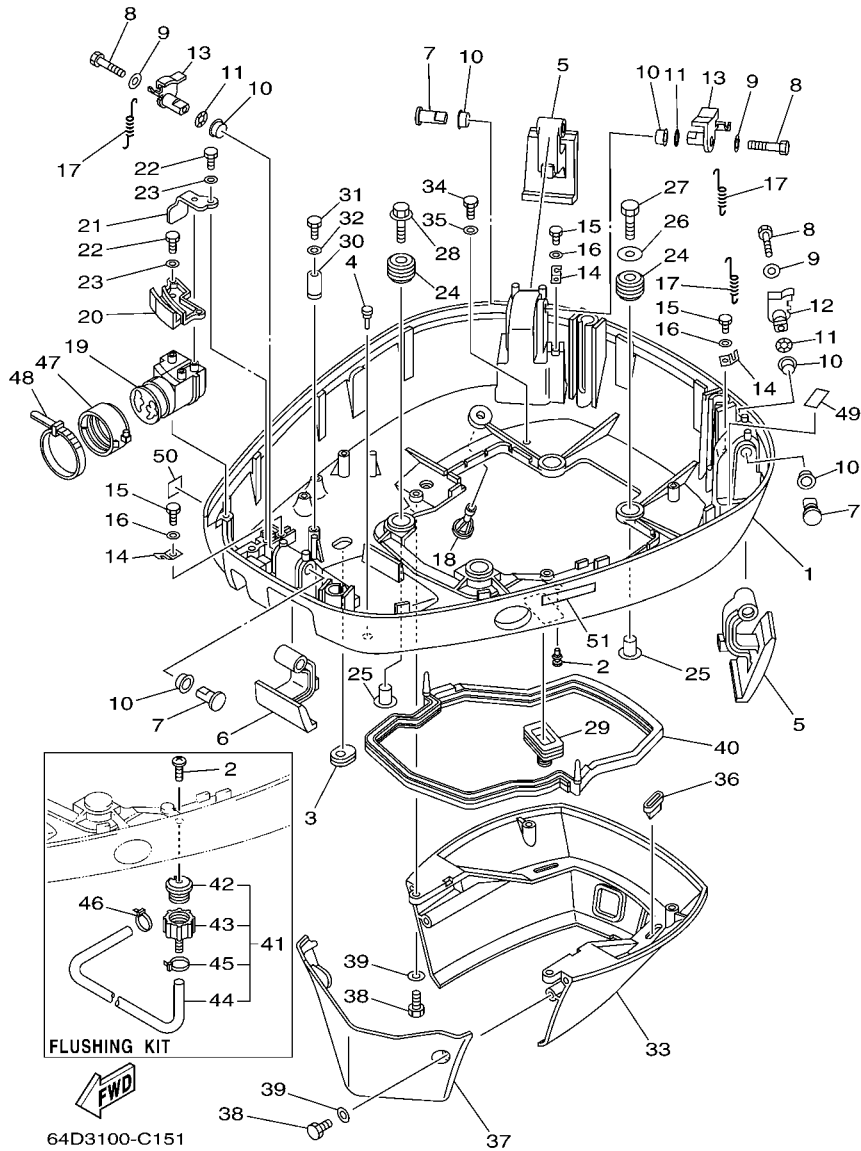
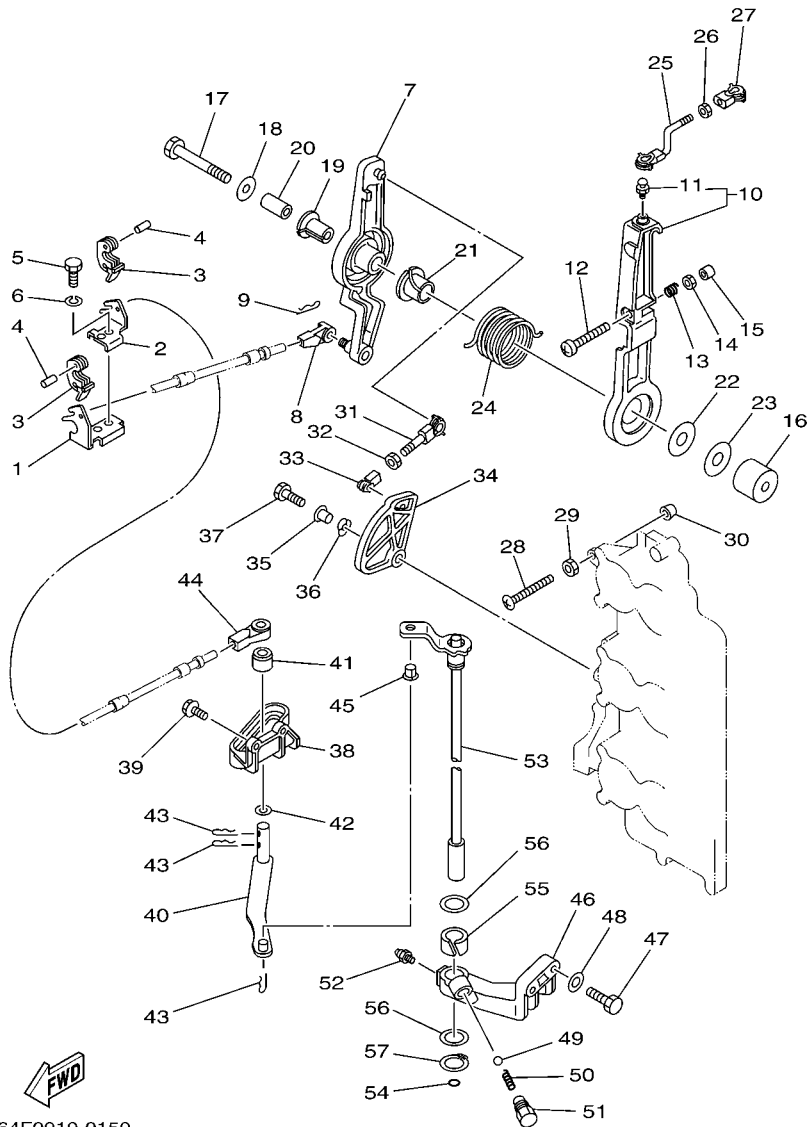

FIG. 20 BOTTOM COWLING

REF. NO.	PART NO.	DESCRIPTION	200	S200	L200	REMARKS
25	90387-08M37	COLLAR	4	4	4	
26	90201-08M54	WASHER, PLATE	1	1	1	
27	97075-08035	BOLT	1	1	1	
28	90119-08M22	BOLT, WITH WASHER	3	3	3	
29	688-42726-10	GROMMET	1	1	1	
30	6E5-82588-00	PLATE	1	1	1	
31	97095-06020	BOLT	1	1	1	
32	92995-06600	WASHER	1	1	1	
33	6R3-42741-02-8D	APRON	1	1	1	
34	97095-06020	BOLT	2	2	2	
35	92995-06600	WASHER	2	2	2	
36	64D-42717-00	RUBBER, SEAL 2	2	2	2	
37	6R3-42771-01-8D	APRON	1	1	1	
38	97095-06020	BOLT	4	4	4	
39	92995-06600	WASHER	4	4	4	
40	6E5-42716-10	RUBBER, SEAL 1	1	1	1	
41	6R3-Y125J-70	FLUSHING KIT		1	1	
42	6R3-12572-00	.ADAPTER		1	1	
43	6R3-12580-00	.JOINT ASSY		1	1	
44	90445-11M35	.HOSE (L540)		1	1	
45	90465-11M10	.CLAMP		1	1	
46	90465-11M10	CLAMP		1	1	
47	68F-42753-00	FASTNER		1	1	AP FOR OCE
48	90464-20258	CLAMP		1	1	AP FOR OCE
49	6G5-42791-10	MARK 1		1	1	
50	6A1-28176-00	LABEL, CAUTION		1	1	FOR CAR(CE)
51	6E3-8257H-00	PLATE, MARK		1	1	FOR CAR(CE)



64F0010-0150

FIG. 21 CONTROL

REF. NO.	PART NO.	DESCRIPTION	200	S200	L200	REMARKS
1	64D-48531-00	BRACKET, REMOTE CONTROL 1	1	1	1	
2	64D-48532-00	BRACKET, REMOTE CONTROL 2	1	1	1	
3	6E5-48538-00	CLAMP, CABLE	2	2	2	
4	91690-30012	PIN, SPRING	2	2	2	
5	97095-08020	BOLT	1	1	1	
6	92995-08100	WASHER	1	1	1	
7	61H-41632-02-1S	LEVER, MAGNETO CONTROL	1	1	1	
8	6E5-48344-00	CABLE END, REMOTE CONTROL	1	1	1	
9	90468-18008	CLIP	1	1	1	
10	6G5-41631-01-1S	LEVER, MAGNETO CONTROL	1	1	1	
11	663-85518-00	JOINT, BALL	1	1	1	
12	90157-06013	SCREW, PAN HEAD	1	1	1	
13	90501-16M12	SPRING, COMPRESSION	1	1	1	
14	95303-06600	NUT	1	1	1	
15	688-44194-00	CAP	1	1	1	
16	90387-08M17	COLLAR	1	1	1	FOR SWS
17	97013-08045	BOLT	1			FOR STD
	90101-08M14	BOLT		1	1	FOR SWS
18	90201-08M23	WASHER, PLATE	1	1	1	
19	90386-12089	BUSH	1	1	1	
20	90387-08M16	COLLAR	1	1	1	
21	90386-22M13	BUSH	1	1	1	
22	90202-12092	WASHER, PLATE	1	1	1	
23	90201-08M13	WASHER, PLATE	1	1	1	
24	90508-29M12	SPRING, TORSION	1	1	1	
25	6G5-41636-01	ROD, MAGNETO CONTROL	1	1	1	
26	95380-05600	NUT	1	1	1	

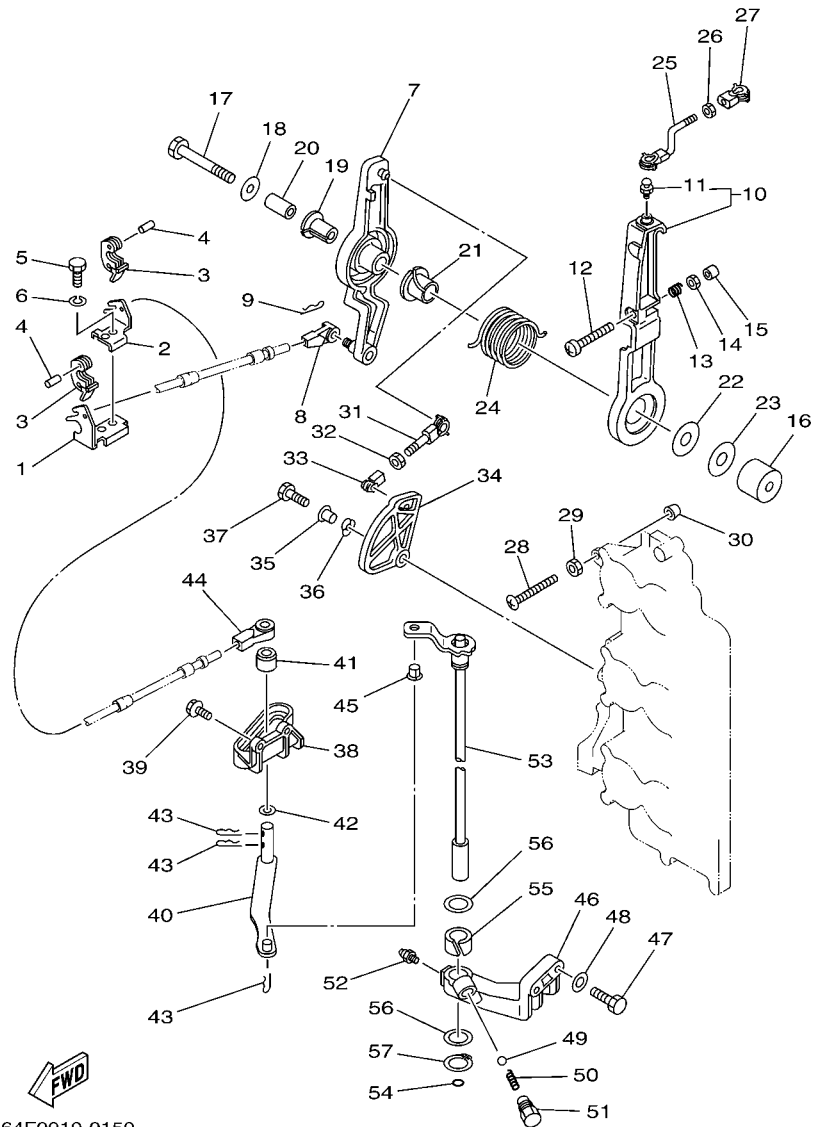

64F0010-0150

FIG. 21 CONTROL

REF. NO.	PART NO.	DESCRIPTION	200	S200	L200	REMARKS
27	662-41237-01	JOINT, LINK	1	1	1	
28	90157-06M00	SCREW, PAN HEAD	1			FOR STD
	90157-06M07	SCREW, PAN HEAD		1	1	FOR SWS
29	95303-06600	NUT	1	1	1	
30	688-44194-00	CAP	1	1	1	
31	6G5-41211-01	LINK, ACCEL.	1			FOR STD
	682-41237-50	JOINT, LINK		1	1	FOR SWS
32	95380-05600	NUT	1	1	1	
33	662-41237-01	JOINT, LINK	1	1	1	
34	6G5-41213-00	CAM, ACCEL.	1			FOR STD
	61H-41213-00	CAM, ACCEL.		1	1	FOR SWS
35	90387-06M29	COLLAR	1	1	1	
36	90206-10M04	WASHER, WAVE	1	1	1	
37	97095-06025	BOLT	1	1	1	
38	6E5-44117-00-1S	BRACKET	1	1	1	
39	90119-06MA2	BOLT, WITH WASHER	2	2	2	
40	68F-44121-00	LEVER, SHIFT ROD	1	1	1	
41	6E5-44122-00	BUSHING, SHIFT ROD LEVER	1	1	1	
42	90202-08M20	WASHER, PLATE	1	1	1	
43	90468-18008	CLIP	3	3	3	
44	6E5-48344-00	CABLE END, REMOTE CONTROL	1	1	1	
45	90386-06M12	BUSH	1	1	1	
46	6E5-44118-01-94	BRACKET	1	1	1	
47	97013-08030	BOLT	2	2	2	
48	92903-08600	WASHER, PLATE	2	2	2	
49	93501-04M02	BALL	1	1	1	
50	90501-12082	SPRING, COMPRESSION	1	1	1	

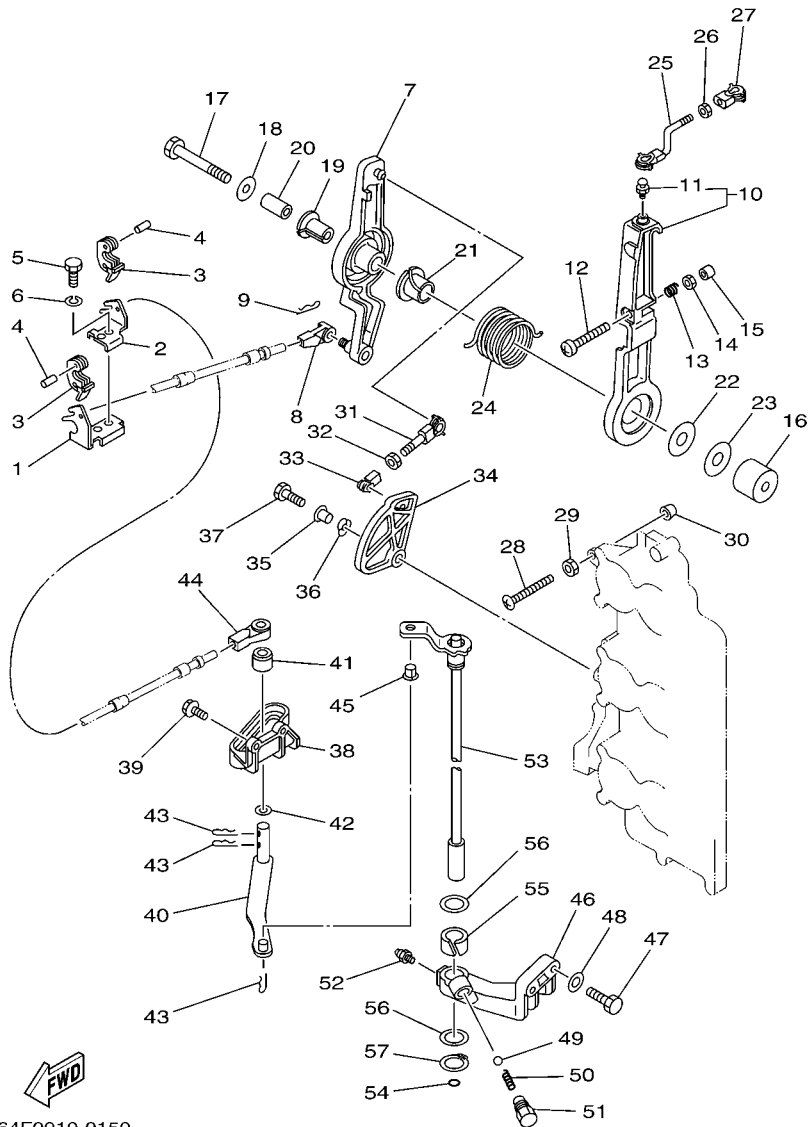

64F0010-0150

FIG. 21 CONTROL

REF. NO.	PART NO.	DESCRIPTION	200	S200	L200	REMARKS
51	648-42715-00	BUSHING	1	1	1	
52	93700-06M03	NIPPLE, GREASE	1	1	1	
53	6E5-44120-03	HANDLE GEAR SHIFT ASSY	1			L(20.3")
	6E5-44120-23	HANDLE GEAR SHIFT ASSY	1	1	1	X(25.3")
54	93210-09165	O-RING	1	1	1	
55	90386-16M66	BUSH	1	1	1	
56	90202-16061	WASHER, PLATE	2	2	2	
57	93410-16006	CIRCLIP	1	1	1	

FIG. 22 BRACKET 1

REF. NO.	PART NO.	DESCRIPTION	200	S200	L200	REMARKS
1	64E-43111-02-8D	BRACKET, CLAMP 1	1	1	1	
2	6G5-45251-02	ANODE	1	1	1	
3	6G5-44526-00	PLATE	2	2	2	
4	97095-06030	BOLT	4	4	4	
5	92995-06100	WASHER, SPRING	4	4	4	
6	6E5-82148-00	WIRE, LEAD 4	1	1	1	
7	97095-06010	BOLT	1	1	1	
8	92995-06600	WASHER	1	1	1	
9	64E-43112-02-8D	BRACKET, CLAMP 2	1	1	1	
10	6E5-82148-00	WIRE, LEAD 4	1	1	1	
11	97885-06012	SCREW, PAN HEAD	1	1	1	
12	92995-06600	WASHER	1	1	1	
13	93700-06M03	NIPPLE, GREASE	1	1	1	
14	663-45119-00	CAP, GREASE NIPPLE	1	1	1	AP
15	64E-43131-01	BOLT, CLAMP BRACKET	1	1	1	
16	97095-08020	BOLT	1	1	1	
17	92995-08100	WASHER	1	1	1	
18	90386-25M31	BUSH	2	2	2	
19	90201-26M59	WASHER, PLATE	2	2	2	
20	90185-22M11	NUT, SELF-LOCKING	1	1	1	
21	90465-11M10	CLAMP	1	1	1	
22	64E-43311-10-8D	BRACKET, SWIVEL 1	1			L(20.3")
	64E-43311-20-8D	BRACKET, SWIVEL 1	1	1	1	X(25.3")
23	90465-08M63	CLAMP	1	1	1	
24	93700-06M03	NIPPLE, GREASE	5	5	5	
25	663-45119-00	CAP, GREASE NIPPLE	5	5	5	AP
26	6E5-82147-00	WIRE, LEAD 4	1			L(20.3")

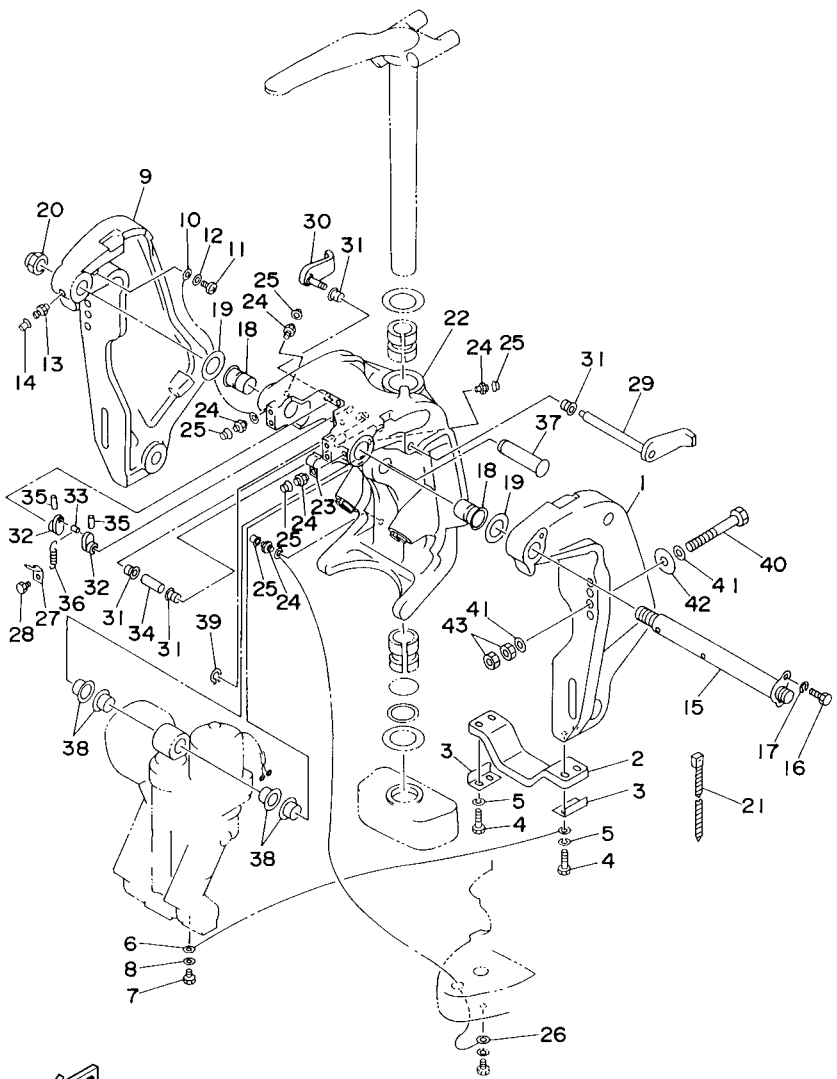

6N60010-7160

FIG. 22 BRACKET 1

REF. NO.	PART NO.	DESCRIPTION	200	S200	L200	REMARKS
26	6E5-82147-20	WIRE, LEAD 4	1	1	1	X(25.3")
27	6G5-43144-00	HOOK, SPRING	1	1	1	
28	97095-06010	BOLT	1	1	1	
29	6G5-43181-02	LEVER, TILT STOP	1	1	1	
30	6G5-43185-02	LEVER, TILT STOP	1	1	1	
31	90386-10M16	BUSH	4	4	4	
32	6G5-43148-00	COLLAR, DISTANCE	2	2	2	
33	90249-06M19	PIN	1	1	1	
34	90387-10M05	COLLAR	1	1	1	
35	91690-30020	PIN, SPRING	2	2	2	
36	90506-14M24	SPRING, TENSION	1	1	1	
37	64E-43126-00	PIN, UPPER SHOCK MOUNT	1	1	1	
38	90386-22M98	BUSH	4	4	4	
39	93410-22M11	CIRCLIP	1	1	1	
40	90101-12M05	BOLT (L:130MM)	4	4	4	FOR OCE
	90101-12M77	BOLT (L:150MM)	2	2	2	FOR OCE
	90101-12M03	BOLT (L:115MM)	4	4	4	FOR CAR,KOR
41	90201-13M01	WASHER, PLATE	8	8	8	
42	90201-12M05	WASHER, PLATE	4	4	4	
43	95380-12600	NUT	8	8	8	

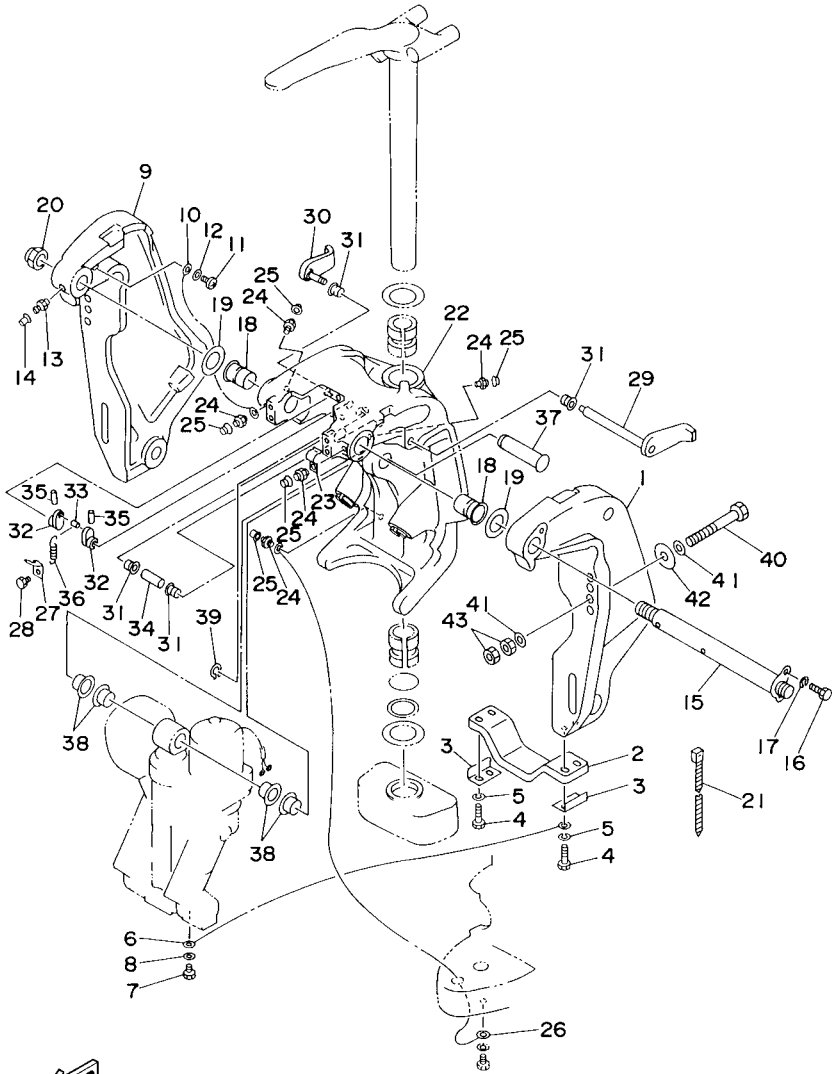

6N60010-7160

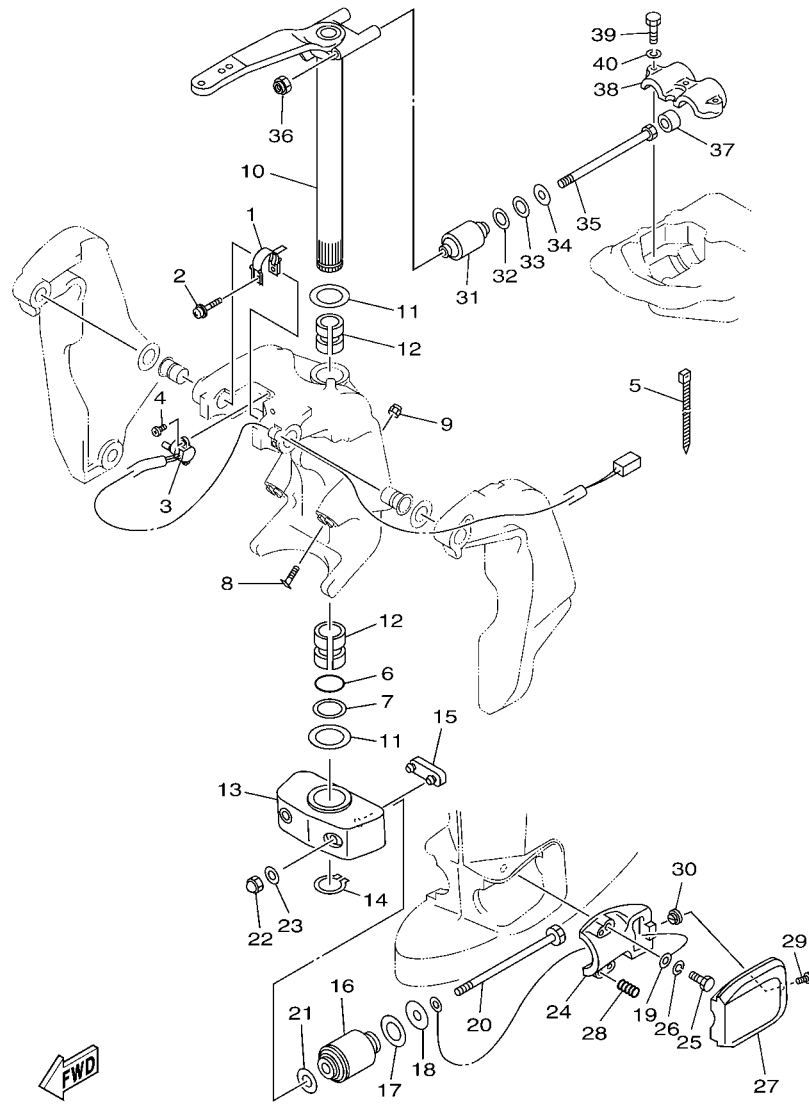

6N68100-G180

FIG. 23 BRACKET 2

REF. NO.	PART NO.	DESCRIPTION	200	S200	L200	REMARKS
1	64E-43139-10	CAM, TRIM SENDER	1	1	1	
2	90159-05059	SCREW, WITH WASHER	1	1	1	
3	67H-83672-00	TRIM SENDER	1	1	1	
4	97885-06016	SCREW, PAN HEAD	2	2	2	
5	90465-11M10	CLAMP	3	3	3	
6	93210-37MH7	O-RING	1	1	1	
7	90202-40M47	WASHER, PLATE	1	1	1	
8	61A-43376-00	BOLT, THRUST RECEIVER	2	2	2	
9	95780-10300	NUT, FLANGE	2	2	2	
10	6E5-42510-A1-8D	STEERING BRACKET ASSY	1			L(20.3")
	6E5-42510-B1-8D	STEERING BRACKET ASSY	1	1	1	X(25.3")
11	90201-38M60	WASHER, PLATE	2	2	2	
12	90386-38M32	BUSH	2	2	2	
13	6G5-44551-01-8D	HOUSING, LOWER MOUNT RUBBER	1	1	1	
14	93410-37M04	CIRCLIP	1	1	1	
15	6E5-44575-00	DAMPER, LOWER MOUNT RUBBER	1	1	1	
16	6G5-44555-00-94	MOUNT DAMPER, LOWER SIDE	2	2	2	
17	90202-32M19	WASHER, PLATE	2	2	2	
18	90201-16M55	WASHER, PLATE	2	2	2	
19	6E5-82149-00	WIRE, LEAD 3	1	1	1	
20	90109-14M34	BOLT	2	2	2	
21	90201-15M58	WASHER, PLATE	2	2	2	
22	95380-14800	NUT	2	2	2	
23	92995-14600	WASHER	2	2	2	
24	6E5-44552-01-94	HOUSING, LOWER MOUNT RUBBER	2	2	2	
25	97095-10045	BOLT	4	4	4	
26	92995-10100	WASHER	4	4	4	

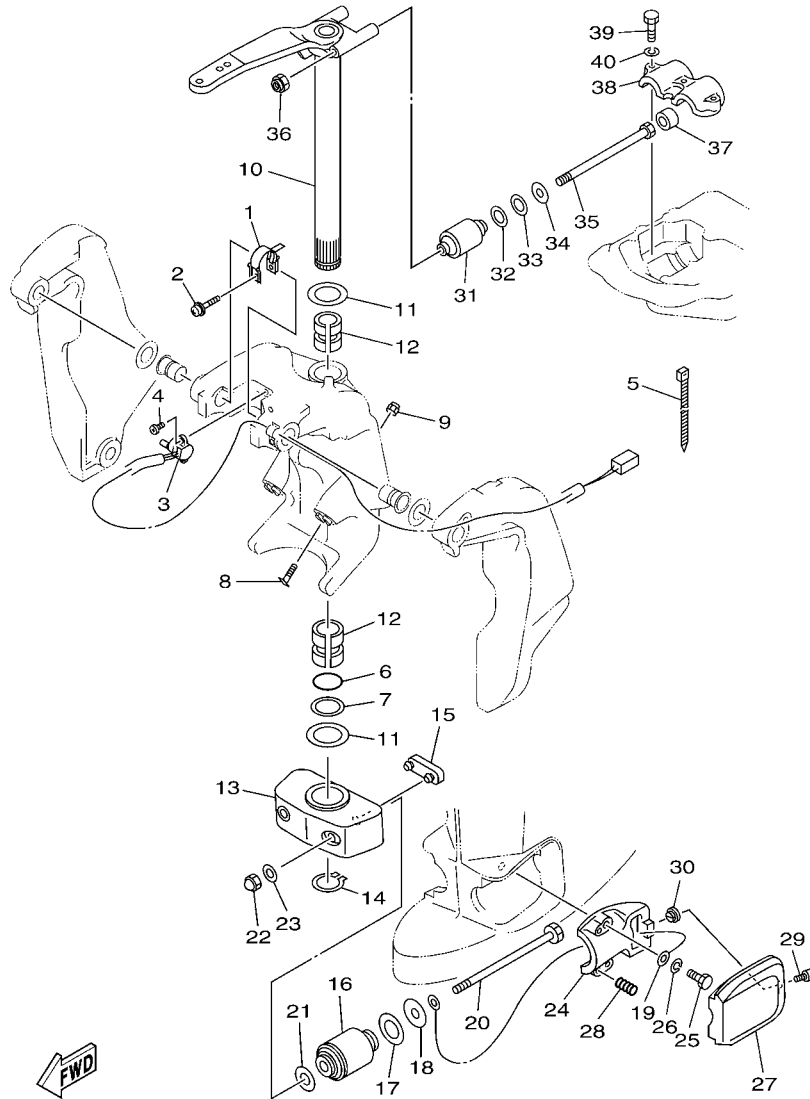

6N68100-G180

FIG. 23 BRACKET 2

REF. NO.	PART NO.	DESCRIPTION	200	S200	L200	REMARKS
27	6E5-44553-01-8D	COVER, LOWER MOUNT	2	2	2	
28	90501-16M28	SPRING, COMPRESSION	4	4	4	
29	97885-06016	SCREW, PAN HEAD	2	2	2	
30	90179-06066	NUT	2	2	2	
31	6G5-44514-00-94	MOUNT DAMPER, UPPER SIDE	2	2	2	
32	90201-26M57	WASHER, PLATE	2	2	2	
33	90202-26M18	WASHER, PLATE	2	2	2	
34	90201-14M56	WASHER, PLATE	2	2	2	
35	90109-12007	BOLT	2	2	2	
36	90185-12M12	NUT, SELF-LOCKING	2	2	2	
37	663-44575-00	DAMPER, LOWER MOUNT RUBBER	2	2	2	
38	6E5-44511-00-5B	COVER, UPPER MOUNT	1	1	1	
39	97095-10045	BOLT	3	3	3	
40	92995-10100	WASHER	3	3	3	

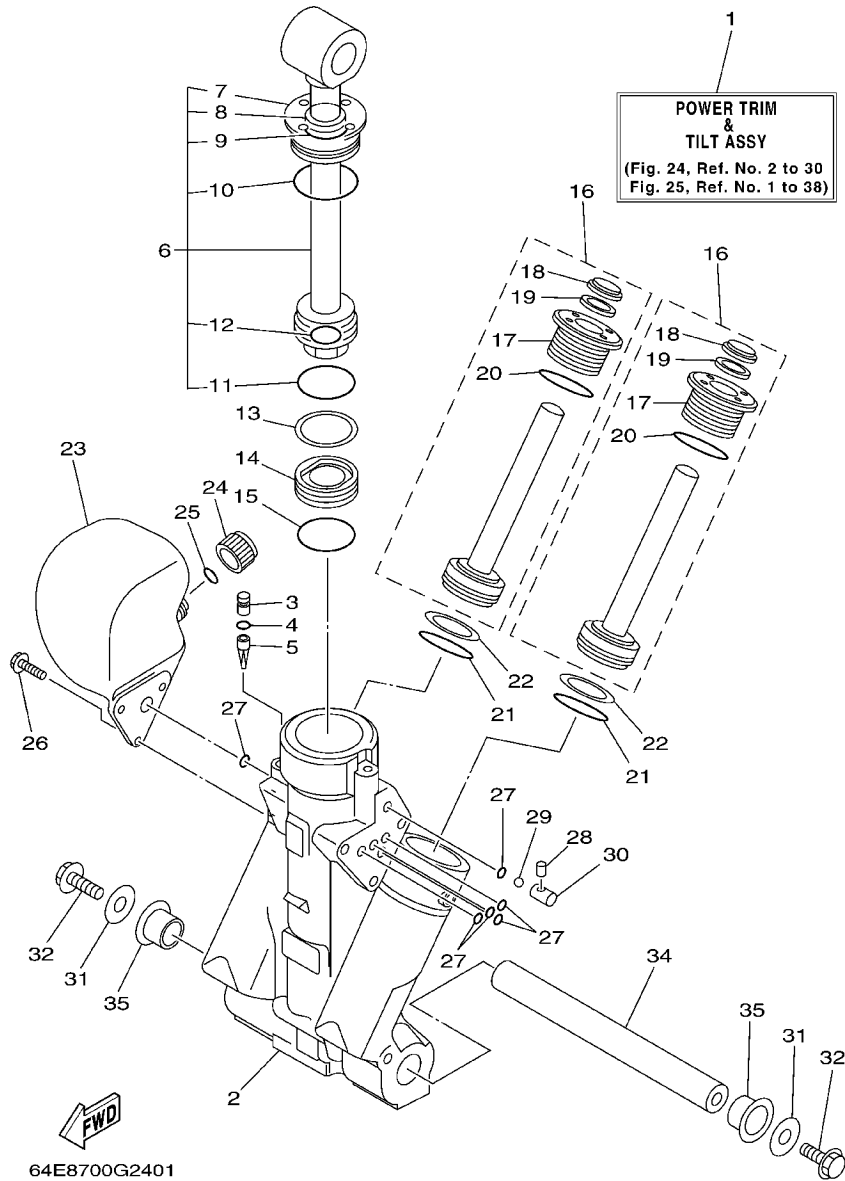

FIG. 24 POWER TRIM & TILT ASSY 1

REF. NO.	PART NO.	DESCRIPTION	200	S200	L200	REMARKS
1	64E-43800-04-4D	POWER TRIM & TILT ASSY	1	1	1	
2	64E-43825-02	HOUSING, TRIM & TILT	1	1	1	
3	64E-4388J-00	PLUG 2	1	1	1	
4	93210-10M74	O-RING	1	1	1	
5	64E-43817-00	FILTER 2	1	1	1	
6	64E-43810-01	TILT PISTON SUB ASSY	1	1	1	
7	64E-43811-01	.SCREW, CYLINDER END	1	1	1	
8	64E-43898-00	.SEAL ,DUST 2	1	1	1	
9	64E-43867-00	.O-RING	1	1	1	
10	64E-43866-00	.O-RING	1	1	1	
11	6E5-43862-00	.O-RING	1	1	1	
12	64E-43883-00	.O-RING	1	1	1	
13	6E5-43872-00	RING, BACK UP	1	1	1	
14	6E5-43814-02	PISTON, FREE	1	1	1	
15	6E5-43862-00	O-RING	1	1	1	
16	64E-43820-01	TRIM PISTON SUB ASSY	2	2	2	
17	64E-43821-01	.SCREW, TRIM CYLINDER END	1	1	1	
18	64E-43822-00	.SEAL, TRIM DUST	1	1	1	
19	64E-4384J-00	.SEAL, TRIM DOWN	1	1	1	
20	6G5-43864-00	.O-RING	1	1	1	
21	6E5-43864-00	O-RING	2	2	2	
22	6E5-43874-01	RING, BACK UP	2	2	2	
23	64E-43828-00	BODY, RESERVOIR	1	1	1	
24	64E-43829-00	PLUG, RESERVOIR	1	1	1	
25	64E-43897-00	O-RING	1	1	1	
26	64E-4388E-00	BOLT ,SCREW (L:14MM)	3	3	3	
27	64E-43869-00	O-RING	6	6	6	

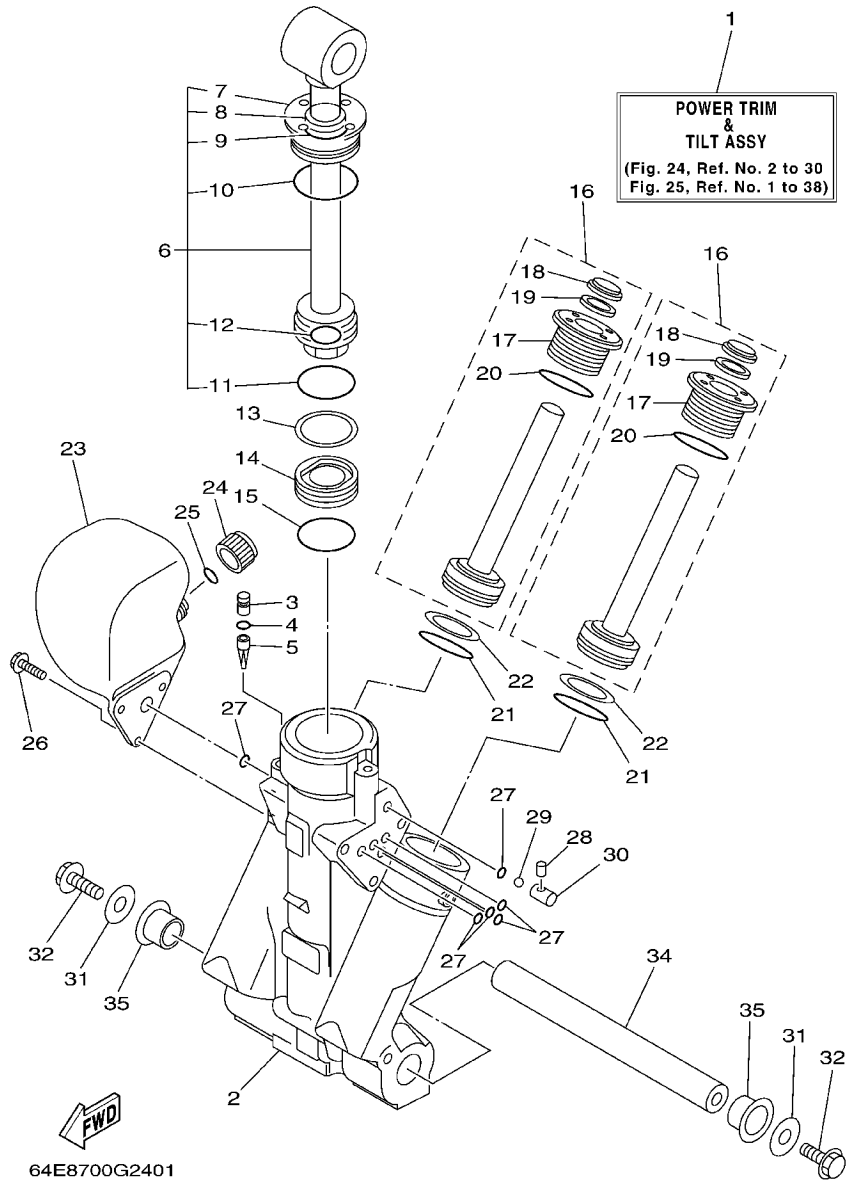

FIG. 24 POWER TRIM & TILT ASSY 1

REF. NO.	PART NO.	DESCRIPTION	200	S200	L200	REMARKS
28	64E-4381G-00	PIN	1	1	1	
29	6E5-43858-00	BALL	1	1	1	
30	64E-4382G-00	VALVE, SEAT	1	1	1	
31	90201-10060	WASHER, PLATE	2	2	2	Go to P/N : PE0-OM-080048
32	97575-10530	BOLT, WITH WASHER	2	2	2	Go to P/N : PE0-OM-080048

34	6BC-43818-00	PIN, LOWER SHOCK MOUNT	1	1	1	Go to P/N : PE0-OM-080048
35	90386-22M98	BUSH	2	2	2	

PARTS NEWS

News No. PE0-OM-080048(1/2)

Date:2008/5/22

Signature: K . Otsuka

 Cause Revision Notice Correction Sales Unit Change Others

Model	(L)150FETO '08 (64C8, 64G8) / (L)200FETO '08 (64E8, 64H8)
Subject	PARTS CATALOGUE CORRECTIONS
CATALOGUE NO.	See the "List of Models and CATALOGUE No's below."
Time of YPEC Revision	Text, Illustration --> Jun./20/2008
	PDF Replace --> Jun./20/2008
(YPEC = Yamaha Parts Electrical Catalogue = Website parts catalogue)	

POWER TRIM & TILT ASSY 1

1. LIST CORRECTION

Fig. No.	Ref. No.	PART NO.	PART NAME	Q'TY	*1	REMARKS
*1	31	OLD 90201-10060 90201-08M14	WASHER, PLATE	2	○	Please use New part from now on. *Part number revision
		NEW 90201-10060				
	32	OLD 97075-10030 97080-08016	BOLT	2	○	Please use New part from now on. *Part number revision
		NEW 97575-10530	BOLT, WITH WASHER			
	33	- 92995-10600	WASHER	2		*Deleted Parts
	34	OLD 6BC-43818-00 64E-43818-01	PIN, LOWER SHOCK MOUNT	1	○	Please use New part from now on. *Part number revision
		NEW 6BC-43818-00				

*Applicable Engine Serial No.

MODEL NAME	MODEL CODE	Applicable Engine Serial No.
150FETO	64C8	6G4:1019937-
L150FETO	64G8	6K0:1001193-
200FETO	64E8	6G6:1035110-
L200FETO	64H8	6K1:1006423-

*1: Interchangeability

A	Old Parts	→	Old Parts
	New Parts	→	New Parts
B	Old Parts	→	Old Parts
	New Parts	→	New Parts
C	Old Parts	→	Old Parts
	New Parts	→	New Parts
○	These parts are interchangeable with a set		

2. ILLUSTRATION CORRECTION

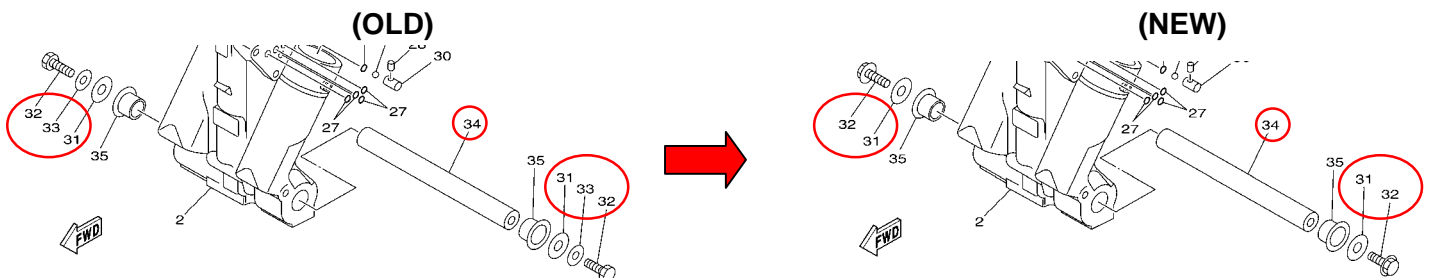

Parts Manager Check	Service Manager Check	Parts Manager File
---------------------	-----------------------	--------------------

 YAMAHA MOTOR CO.,LTD
 2500 Shingai Iwata Shizuoka 438-8501 Japan
 Technical Publication Dept.

PARTS NEWS

News No. PE0-OM-080048(2/2)

Date: _____

Signature: _____

Cause Revision Notice Correction Sales Unit Change Others

Model	(L)150FETO '08 (64C8, 64G8) / (L)200FETO '08 (64E8, 64H8)
Subject	PARTS CATALOGUE CORRECTIONS
CATALOGUE NO.	See the "List of Models and CATALOGUE No's below."

Time of YPEC Revision Text, Illustration --> Jun./20/2008 PDF Replace --> Jun./20/2008
(YPEC = Yamaha Parts Electrical Catalogue = Website parts catalogue)

3.LIST of Models and CATALOGUE No's.

The applicable MODELS, MODEL CODES, and CATALOGUE No's are as follows.

MODEL NAME	MODEL CODE	MODEL YEAR	CATALOGUE NO.	Fig.No. *1
150FETO L150FETO 200FETO L200FETO	64C8 64G8 64E8 64H8	2008	1G64C-664E1	20
(S)200FETO L200FETO	64E8 64H8	2008	1G64E-700E1	24
200FETO L200FETO	64E8 64H8	2008	1G64E-300F1	19
200FETO	64E8	2008	1G64E-415M1	18

Thank you very much for your cooperation.

Parts
Manager
CheckService
Manager
CheckParts
Manager
FileYAMAHA MOTOR CO.,LTD
2500 Shingai Iwata Shizuoka 438-8501.Japan
Technical Publication Dept.

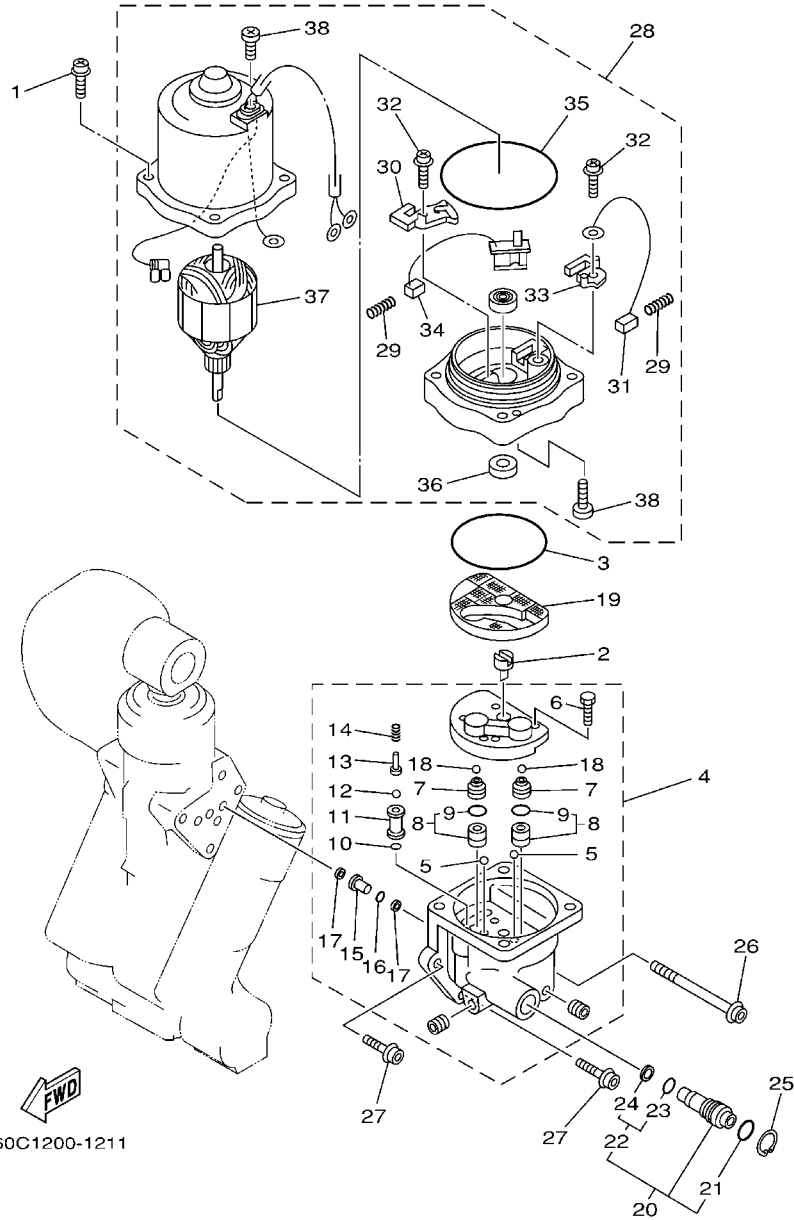
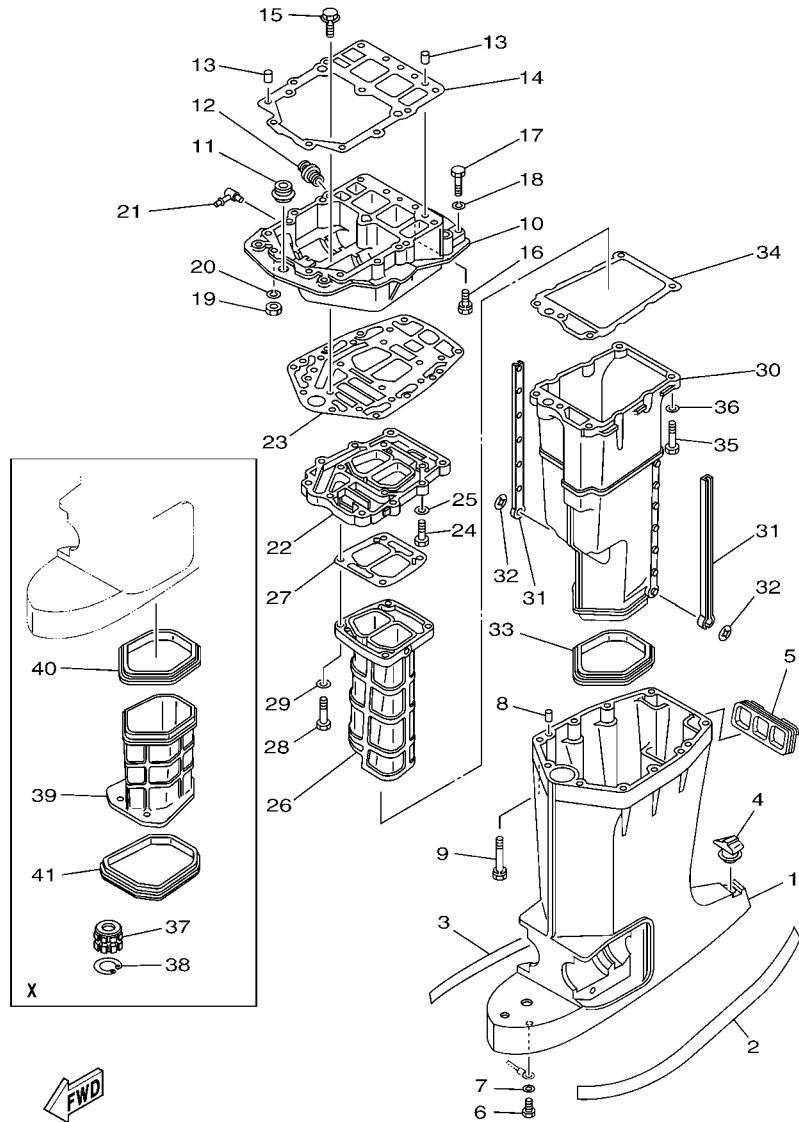

FIG. 25 POWER TRIM & TILT ASSY 2

REF. NO.	PART NO.	DESCRIPTION	200	S200	L200	REMARKS
1	64E-4388E-10	BOLT ,SCREW (L:34.7MM)	4	4	4	
2	64E-43831-00	CONNECTOR, SHAFT	1	1	1	
3	64E-43868-00	O-RING	1	1	1	
4	64E-43830-00	GEAR PUMP ASSY	1	1	1	
5	72X-43858-00	.BALL	2	2	2	
6	64E-43843-00	.SCREW, VALVE LOCK	4	4	4	
7	64E-43841-00	.PISTON, SHUTTLE	2	2	2	
8	64E-43802-00	.VALVE SUB ASSY	2	2	2	
9	6E5-43896-00	..O-RING	1	1	1	
10	6G5-43863-00	.O-RING	1	1	1	
11	64E-43851-00	.SEAT, RELIEF VALVE	1	1	1	
12	64E-43858-00	.BALL	1	1	1	
13	64E-43859-00	.PIN, VALVE SUPPORT	1	1	1	
14	64E-43855-00	.SPRING, UP RELIEF	1	1	1	
15	64E-43850-00	.VALVE SUB ASSY	1	1	1	
16	64E-43865-00	.O-RING	1	1	1	
17	64E-43816-00	.FILTER 1	2	2	2	
18	64E-43858-00	.BALL	2	2	2	
19	64E-43817-10	FILTER 2	1	1	1	
20	64E-43860-00	MANUAL VALVE SUB-ASSY	1	1	1	
21	72X-85075-L0	.O-RING	1	1	1	
22	64E-43827-00	.RING SET	1	1	1	
23	64E-4387A-00	..O-RING	1	1	1	
24	64E-43873-00	..RING, BACK UP	1	1	1	
25	64E-43875-00	RING, SNAP	1	1	1	
26	64E-43879-10	SCREW, WITH WASHER	1	1	1	
27	64E-43879-00	SCREW, WITH WASHER	2	2	2	



64D4100-D210

FIG. 26 UPPER CASING

REF. NO.	PART NO.	DESCRIPTION	200	S200	L200	REMARKS
1	6E5-45111-02-8D	CASING, UPPER	1			L(20.3")
	6E5-45111-23-8D	CASING, UPPER	1	1	1	X(25.3")
2	6R3-42791-41	MARK 1	1	1	1	
3	6R3-42792-41	MARK	1	1	1	
4	6E5-45155-00	CAP	1	1	1	
5	6E5-42769-00	SEAL, RUBBER	1	1	1	
6	97095-06010	BOLT	1	1	1	
7	92995-06600	WASHER	1	1	1	
8	93608-12M05	PIN, DOWEL	2	2	2	
9	90119-08078	BOLT, WITH WASHER	6	6	6	
10	6G5-41137-02-94	GUIDE, EXHAUST	1			FOR STD
	6G5-41137-11-94	GUIDE, EXHAUST		1	1	FLUSHING KIT
11	6E5-42724-00	GROMMET	1	1	1	
12	6G5-12581-00	JOINT, HOSE 1	1	1	1	
13	93608-12M05	PIN, DOWEL	2	2	2	
14	68F-45113-00	GASKET, UPPER CASING	1	1	1	
15	90119-08M79	BOLT, WITH WASHER	2	2	2	
16	90119-08077	BOLT, WITH WASHER	4	4	4	
17	97095-08045	BOLT	2	2	2	
18	92995-08100	WASHER	2	2	2	
19	95380-08700	NUT	2	2	2	
20	92995-08100	WASHER	2	2	2	
21	6H1-11372-00	NIPPLE, HOSE		1	1	FLUSHING KIT
22	6G5-41131-01-5B	MANIFOLD, EXT. 1	1	1	1	
23	6G5-45114-A1	GASKET, UPPER CASING	1	1	1	
24	97095-08030	BOLT	4	4	4	
25	92995-08600	WASHER	4	4	4	

FIG. 26 UPPER CASING

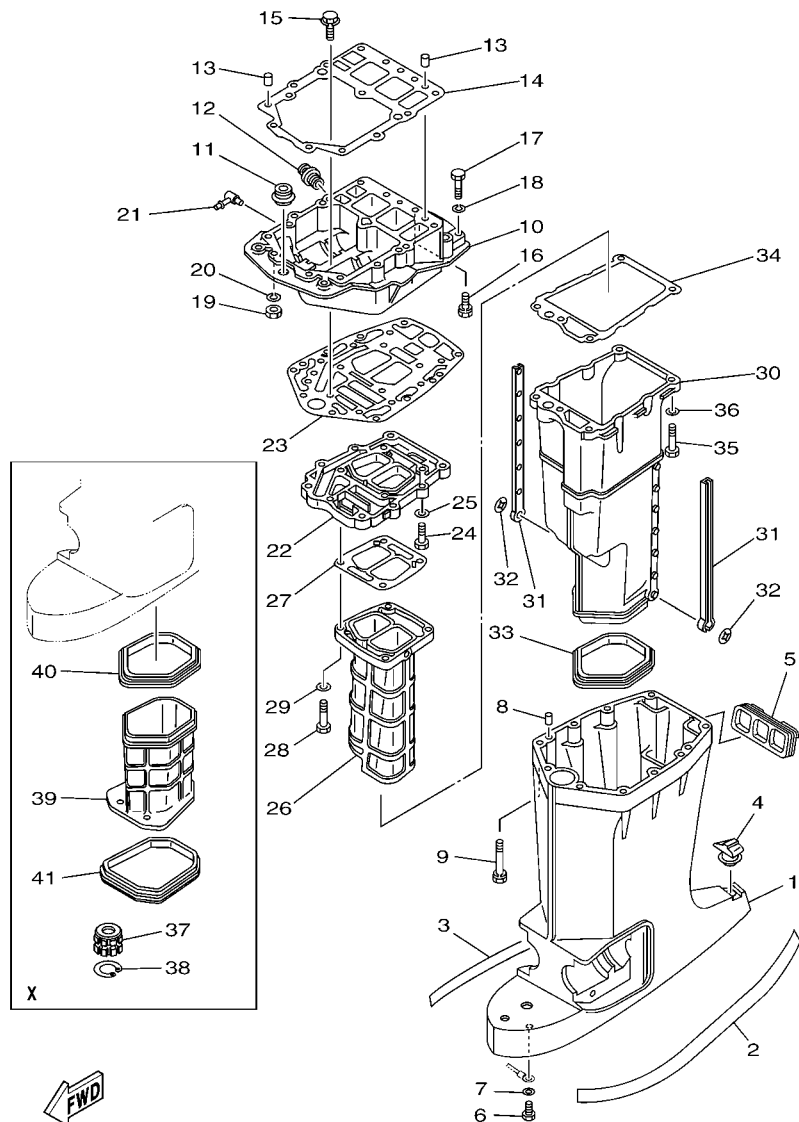

64D4100-D210

REF. NO.	PART NO.	DESCRIPTION	200	S200	L200	REMARKS
26	64D-41132-00-5B	MANIFOLD, EXHAUST	1	1	1	
27	6G5-41134-A1	GASKET, EXHAUST MANIFOLD	1	1	1	
28	97095-08045	BOLT	4	4	4	
29	92995-08600	WASHER	4	4	4	
30	6E5-14711-01-5B	MUFFLER 1	1	1	1	
31	6E5-14737-00	DAMPER, MUFFLER	2	2	2	
32	90183-05M02	NUT, SPRING	2	2	2	
33	6E5-45123-00	GASKET, MUFFLER	1	1	1	
34	6E5-41135-A0	GASKET, EXHAUST MANIFOLD	1	1	1	
35	97095-08045	BOLT	5	5	5	
36	92995-08600	WASHER	5	5	5	
37	6E5-45318-00	BUSHING, DRIVE SHAFT	1	1	1	X(25.3")
38	93420-36M01	CIRCLIP	1	1	1	X(25.3")
39	64D-14721-20-5B	MUFFLER 2	1	1	1	X(25.3")
40	64D-45123-00	GASKET, MUFFLER	1	1	1	X(25.3")
41	64D-45375-00	DAMPER, SEAL	1	1	1	X(25.3")

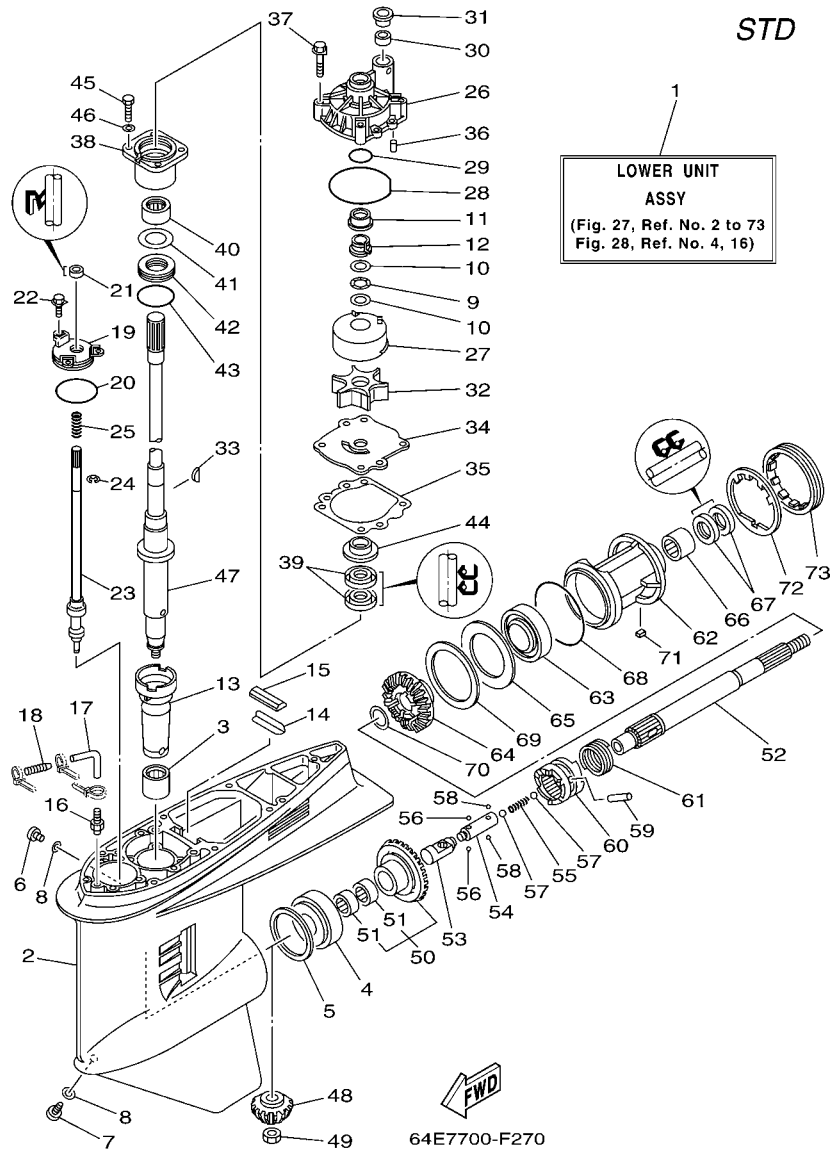

FIG. 27 LOWER CASING & DRIVE 1

REF. NO.	PART NO.	DESCRIPTION	200	S200	L200	REMARKS
1	64E-45300-02-8D	LOWER UNIT ASSY	1			L(20.3"),RH
	64E-45300-22-8D	LOWER UNIT ASSY	1	1		X(25.3"),RH
2	6J9-45301-05-8D	CASING, LOWER	1	1		
3	93311-928U5	BEARING	1	1		
4	93332-000V3	BEARING	1	1		
5	6G5-45567-01	SHIM (T:0.10MM)	1	1		UR
	6G5-45567-10	SHIM (T:0.12MM)	1	1		UR
	6G5-45567-20	SHIM (T:0.15MM)	1	1		UR
	6G5-45567-30	SHIM (T:0.18MM)	1	1		UR
	6G5-45567-40	SHIM (T:0.30MM)	1	1		UR
	6G5-45567-50	SHIM (T:0.40MM)	1	1		UR
	6G5-45567-60	SHIM (T:0.50MM)	1	1		UR
6	90340-08002	PLUG, STRAIGHT SCREW	1	1		
7	688-45341-10	PLUG, DRAIN	1	1		
8	90430-08020	GASKET	2	2		
9	90206-22M19	WASHER, WAVE	1	1		
10	90201-22M01	WASHER, PLATE	2	2		
11	61A-45527-00	COLLAR, DRIVE SHAFT	1	1		
12	61A-45538-00	SPACER 1	1	1		
13	6G5-45536-01	SLEEVE, DRIVE SHAFT	1	1		
14	663-45376-00-94	GUIDE, SEAL DAMPER	1			L(20.3")
	64D-45376-00-94	GUIDE, SEAL DAMPER	1	1		X(25.3")
15	688-45375-00	DAMPER, SEAL	1	1		
16	6E5-45378-00	NIPPLE, HOSE	1	1		
17	90445-07ME8	HOSE (L80)	1			L(20.3")
	90445-07ME9	HOSE (L120)	1	1		X(25.3")
18	6E5-83558-10	END, NIPPLE	1	1		

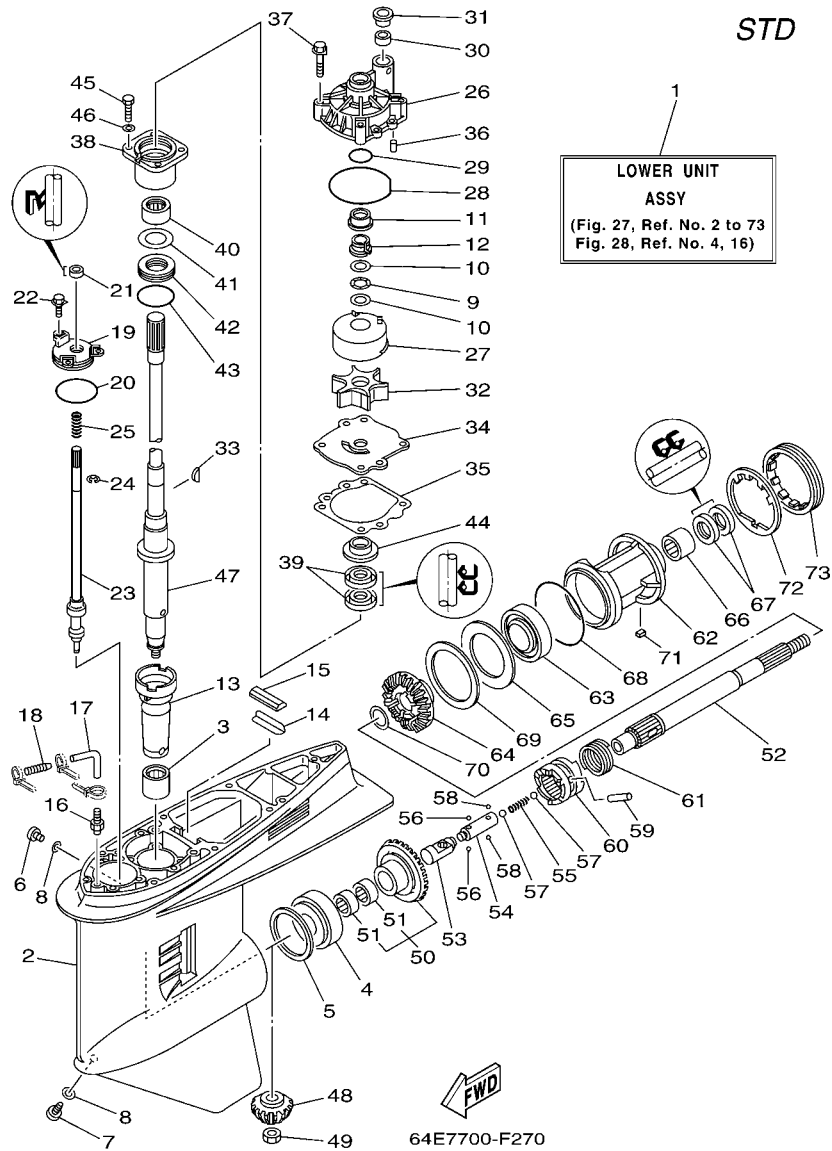

FIG. 27 LOWER CASING & DRIVE 1

REF. NO.	PART NO.	DESCRIPTION	200	S200	L200	REMARKS
19	6E5-45321-00	PLATE	1	1		
20	93210-58144	O-RING	1	1		
21	93106-09014	OIL SEAL	1	1		
22	90119-06M10	BOLT, WITH WASHER	3	3		
23	6G5-44150-02	SHIFT CAM ASSY	1	1		
24	99001-08600	CIRCLIP	1	1		
25	90501-11M10	SPRING, COMPRESSION	1	1		
26	61A-44311-01	HOUSING, WATER PUMP	1	1		
27	61A-44322-02	INSERT, CARTRIDGE	1	1		
28	93210-86M38	O-RING	1	1		
29	93210-37160	O-RING	1	1		
30	6E5-44365-00	DAMPER, WATER SEAL	1	1		
31	6E5-44312-00	COVER, WATER PUMP HOUSING	1	1		
32	6E5-44352-01	IMPELLER	1	1		
33	90280-04M05	KEY, WOODRUFF	1	1		
34	6G5-44323-00	OUTER PLATE, CARTRIDGE	1	1		
35	6E5-44315-A0	GASKET, WATER PUMP	1	1		
36	93606-12019	PIN, DOWEL	2	2		
37	90119-08M14	BOLT, WITH WASHER	4	4		
38	6E5-45331-00-94	HOUSING, BEARING	1	1		
39	93101-28M16	OIL SEAL	2	2		
40	93317-330U2	BEARING	1	1		
41	6E5-45587-01	SHIM (T:0.10MM)	1	1		UR
	6E5-45587-10	SHIM (T:0.12MM)	1	1		UR
	6E5-45587-20	SHIM (T:0.15MM)	1	1		UR
	6E5-45587-30	SHIM (T:0.18MM)	1	1		UR
	6E5-45587-40	SHIM (T:0.30MM)	1	1		UR

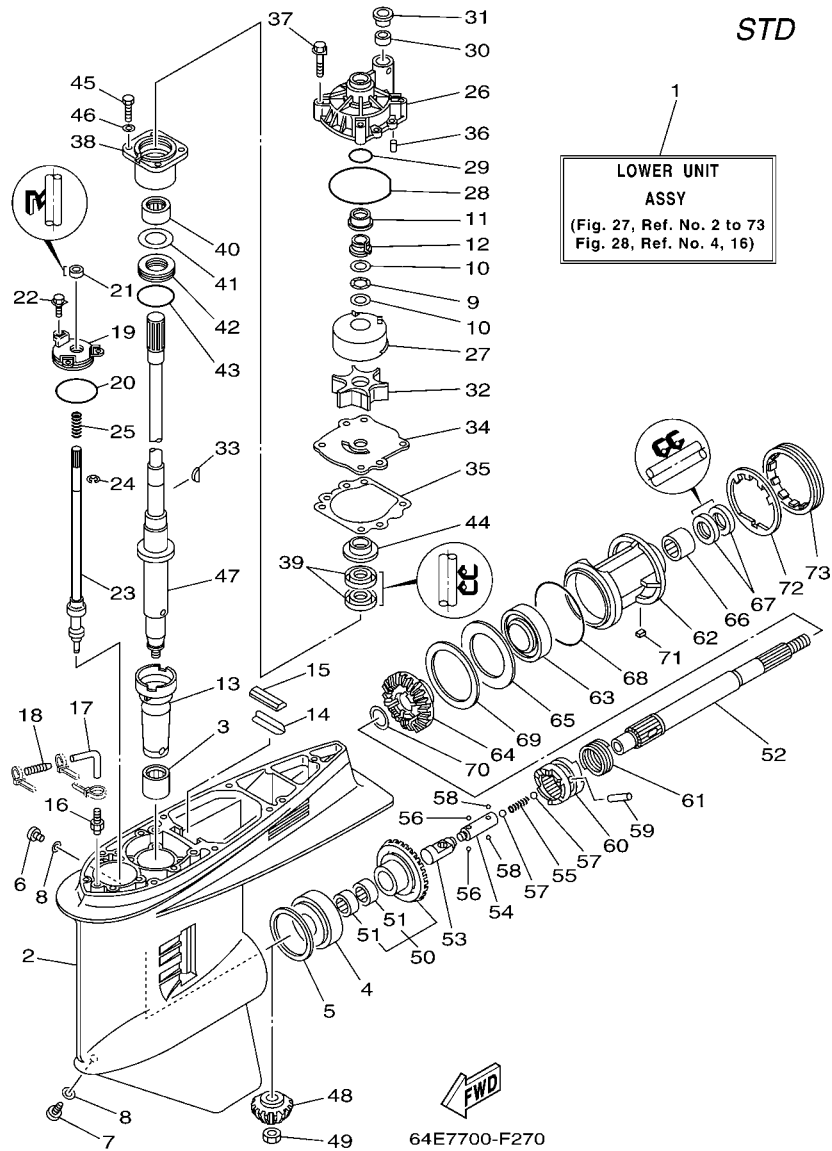

FIG. 27 LOWER CASING & DRIVE 1

REF. NO.	PART NO.	DESCRIPTION	200	S200	L200	REMARKS
41	6E5-45587-50	SHIM (T:0.40MM)	1	1		UR
	6E5-45587-60	SHIM (T:0.50MM)	1	1		UR
42	93341-930V2	BEARING	1	1		
43	93210-55M14	O-RING	1	1		
44	6E5-45344-00	COVER, OIL SEAL	1	1		
45	97095-08025	BOLT	4	4		
46	92995-08600	WASHER	4	4		
47	6G5-45501-01	DRIVE SHAFT COMP.	1			L(20.3")
	6G5-45501-21	DRIVE SHAFT COMP.	1	1		X(25.3")
48	6G5-45551-10	PINION (14T)	1	1		
49	90170-16M01	NUT	1	1		
50	6G5-45560-10	GEAR 1 (26T)	1	1		
51	93315-425V3	.BEARING	2	2		
52	6J9-45611-01	SHAFT, PROPELLER	1	1		
53	6E5-45641-03	SHIFTER	1	1		
54	6E5-45634-01	SLIDE, SHIFT	1	1		
55	90501-16M37	SPRING, COMPRESSION	1	1		
56	93507-32009	BALL	2	2		
57	93511-32017	BALL	2	2		
58	93503-16003	BALL	2	2		
59	90250-08M07	PIN, STRAIGHT	1	1		
60	6G5-45631-10	CLUTCH, DOG	1	1		
61	6E5-45633-01	RING, CROSS PIN	1	1		
62	6J9-45332-00-94	HOUSING, BEARING	1	1		
63	93306-209U0	BEARING	1	1		
64	6G5-45571-02	GEAR 2 (26T)	1	1		
65	6G5-45576-10	WASHER, THRUST	1	1		

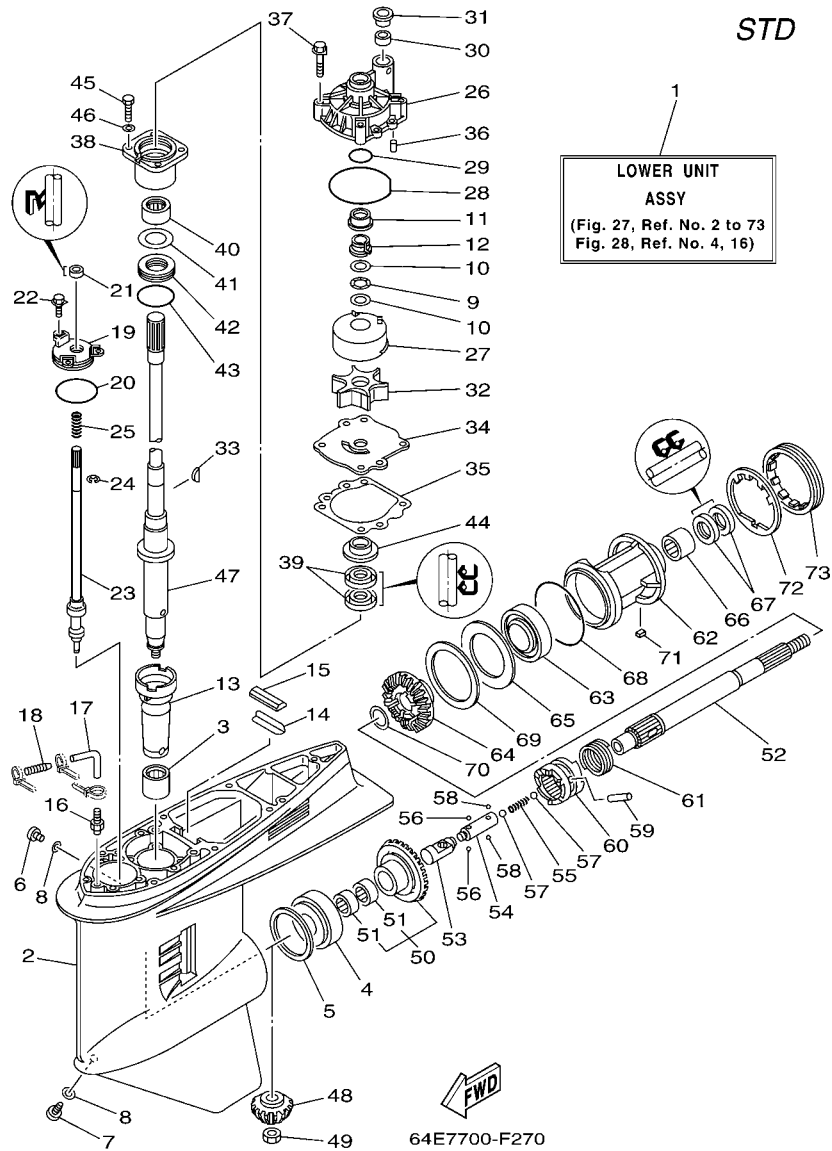
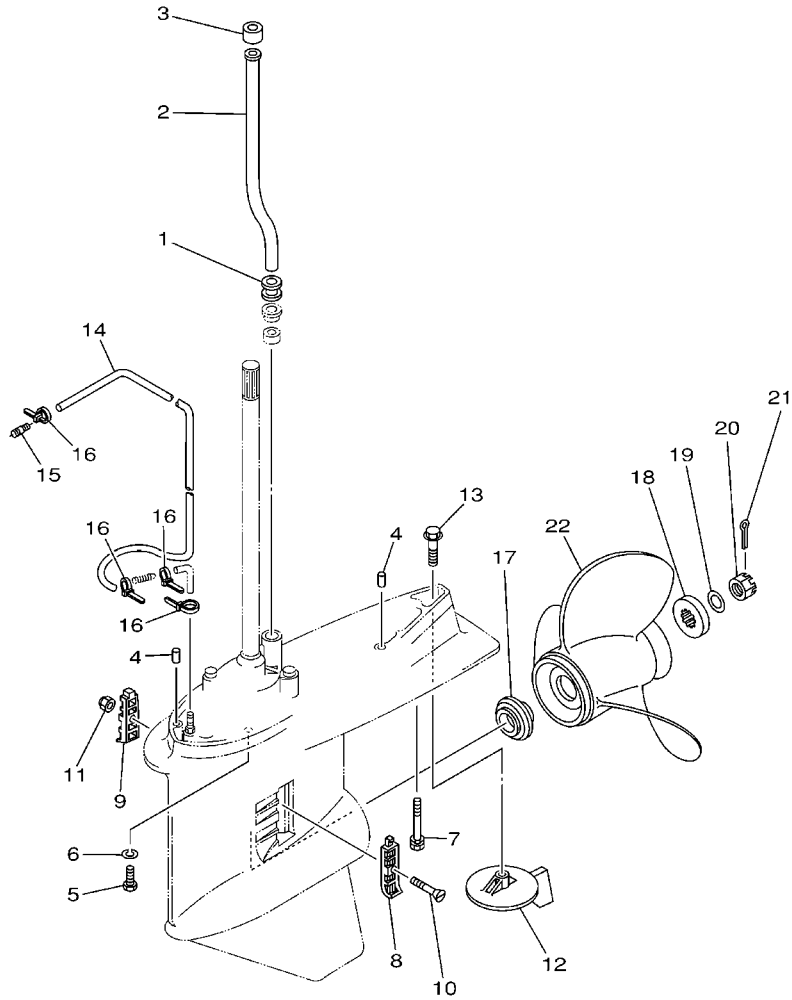

FIG. 27 LOWER CASING & DRIVE 1

REF. NO.	PART NO.	DESCRIPTION	200	S200	L200	REMARKS
66	93315-43061	BEARING	1	1		
67	93101-30M17	OIL SEAL	2	2		
68	93210-97M55	O-RING	1	1		
69	6G5-45577-02	SHIM (T:0.10MM)	1	1		UR
	6G5-45577-10	SHIM (T:0.12MM)	1	1		UR
	6G5-45577-20	SHIM (T:0.15MM)	1	1		UR
	6G5-45577-30	SHIM (T:0.18MM)	1	1		UR
	6G5-45577-40	SHIM (T:0.30MM)	1	1		UR
	6G5-45577-50	SHIM (T:0.40MM)	1	1		UR
	6G5-45577-60	SHIM (T:0.50MM)	1	1		UR
70	90201-30M92	WASHER, PLATE	1	1		
71	90282-04M00	KEY, STRAIGHT	1	1		
72	6G5-45383-01	WASHER, CLAW	1	1		
73	6G5-45384-00	NUT	1	1		

STD



67H0100-1260

FIG. 28 LOWER CASING & DRIVE 2

REF. NO.	PART NO.	DESCRIPTION	200	S200	L200	REMARKS
1	6E5-44366-00	DAMPER, WATER SEAL	1	1		
2	6E5-44361-00	TUBE, WATER	1			L(20.3")
	6E5-44361-20	TUBE, WATER	1	1		X(25.3")
3	6E5-44365-00	DAMPER, WATER SEAL	1	1		
4	93608-12M05	PIN, DOWEL	2	2		
5	97075-10045	BOLT	6	6		
6	92995-10100	WASHER	6	6		
7	90119-10M89	BOLT, WITH WASHER	1	1		
8	6J9-45214-00	COVER, WATER INLET 1	1	1		
9	6J9-45215-00	COVER, WATER INLET 2	1	1		
10	90152-05M08	SCREW, COUNTERSUNK	1	1		
11	90185-05002	NUT, SELF-LOCKING	1	1		
12	6J9-45371-01	TAB-TRIM	1	1		
13	90105-10M00	BOLT, FLANGE	1	1		
14	90445-07M33	HOSE (L1080)	1	1		
15	6E5-83558-00	END, NIPPLE	1	1		
16	90465-11M10	CLAMP	4	4		
17	6E5-45987-01	SPACER	1	1		
18	688-45997-01	SPACER	1	1		
19	92990-18200	WASHER	1	1		
20	90171-18M04	NUT, CASTLE	1	1		
21	91490-40030	PIN, COTTER	1	1		
22	6G5-45941-00-98	PROPELLER (3X15-1/4"X15"-M)	1	1		UR
	6G5-45943-01-98	PROPELLER (3X13-3/4"X21"-M)	1	1		UR
	6G5-45945-01-98	PROPELLER (3X14"X19"-M)	1	1		UR
	6G5-45947-01-98	PROPELLER (3X14-1/2"X17"-M)	1	1		UR
	6G5-45949-00-98	PROPELLER (3X13-1/2"X23"-M)	1	1		UR

STD

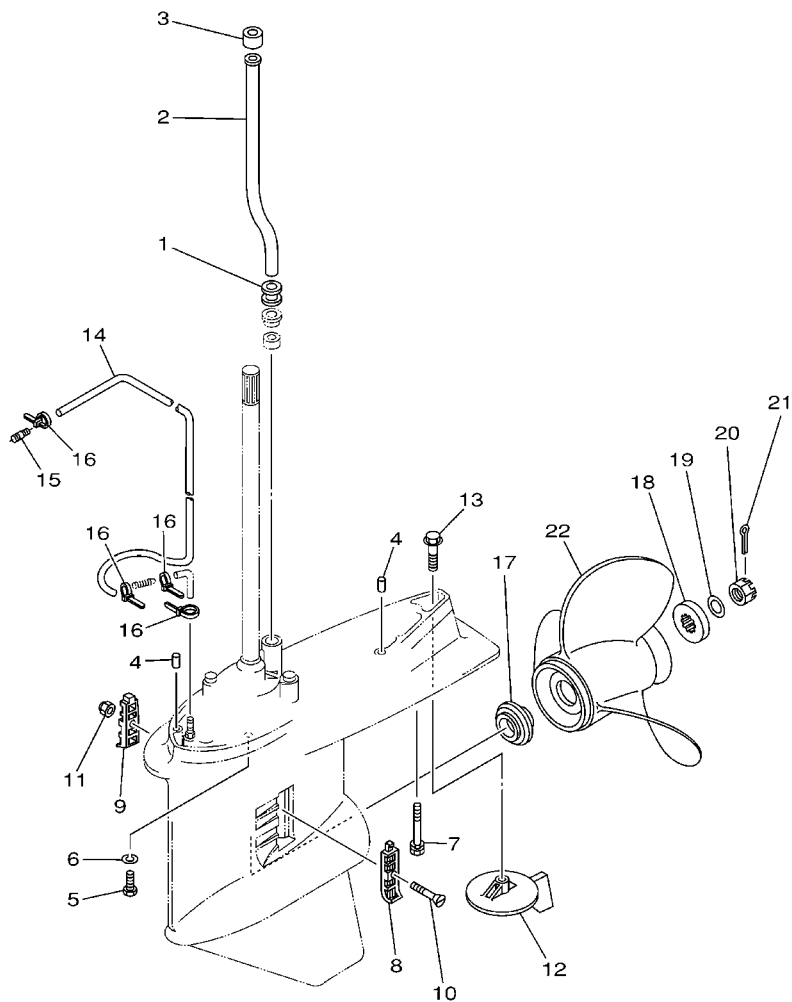

67H0100-1260

FIG. 28 LOWER CASING & DRIVE 2

REF. NO.	PART NO.	DESCRIPTION	200	S200	L200	REMARKS
22	6G5-45952-00-98	PROPELLER (3X14-5/8"X16"-M)	1	1		UR
	6G5-45930-00-98	PROPELLER (3X13-3/8"X25"-M)	1	1		UR
	6G5-45932-00-98	PROPELLER (3X15-3/4"X13"-M)	1	1		UR
	6G5-45970-02-98	PROPELLER (3X15-1/4"X15"-M)	1	1		UR
	6G5-45972-02-98	PROPELLER (3X13-3/4"X21"-M)	1	1		UR
	6G5-45974-03-98	PROPELLER (3X13-3/4"X19"-M2)	1	1		UR
	6G5-45976-01-98	PROPELLER (3X13-3/8"X23"-M)	1	1		UR
	6G5-45978-03-98	PROPELLER (3X13-3/4"X17"-M2)	1	1		UR
	6R4-45970-A1	PROPELLER (3X15-1/4"X19"-M)	1	1		UR
	6R4-45972-A0	PROPELLER (3X14-7/8"X21"-M)	1	1		UR
	6R4-45974-A0	PROPELLER (3X14-1/2"X23"-M)	1	1		UR
	6R4-45976-A0	PROPELLER (3X14-1/2"X15"-M)	1	1		UR
	6R4-45978-A0	PROPELLER (3X15-1/4"X17"-M)	1	1		UR

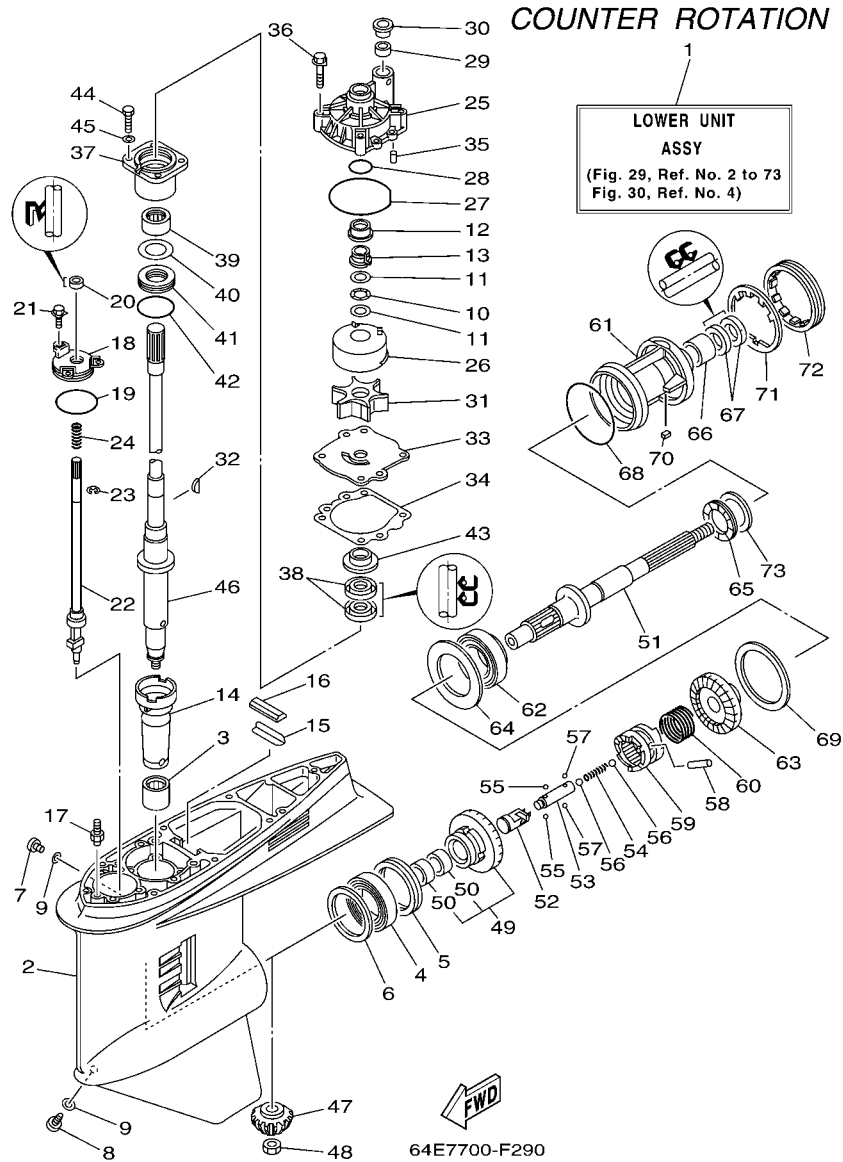

FIG. 29 LOWER CASING & DRIVE 3

REF. NO.	PART NO.	DESCRIPTION	200	S200	L200	REMARKS
1	64H-45300-22-8D	LOWER UNIT ASSY			1	X(25.3"),LH
2	6J9-45301-05-8D	CASING, LOWER			1	
3	93311-928U5	BEARING			1	
4	93390-000U2	BEARING			1	
5	93341-465U4	BEARING			1	
6	6G5-45567-01	SHIM (T:0.10MM)			1	UR
	6G5-45567-10	SHIM (T:0.12MM)			1	UR
	6G5-45567-20	SHIM (T:0.15MM)			1	UR
	6G5-45567-30	SHIM (T:0.18MM)			1	UR
	6G5-45567-40	SHIM (T:0.30MM)			1	UR
	6G5-45567-50	SHIM (T:0.40MM)			1	UR
	6G5-45567-60	SHIM (T:0.50MM)			1	UR
7	90340-08002	PLUG, STRAIGHT SCREW			1	
8	688-45341-10	PLUG, DRAIN			1	
9	90430-08020	GASKET			2	
10	90206-22M19	WASHER, WAVE			1	
11	90201-22M01	WASHER, PLATE			2	
12	61A-45527-00	COLLAR, DRIVE SHAFT			1	
13	61A-45538-00	SPACER 1			1	
14	6G5-45536-01	SLEEVE, DRIVE SHAFT			1	
15	64D-45376-00-94	GUIDE, SEAL DAMPER			1	X(25.3")
16	688-45375-00	DAMPER, SEAL			1	
17	6J8-45378-00	NIPPLE, HOSE			1	
18	6E5-45321-00	PLATE			1	
19	93210-58144	O-RING			1	
20	93106-09014	OIL SEAL			1	
21	90119-06M10	BOLT, WITH WASHER			3	

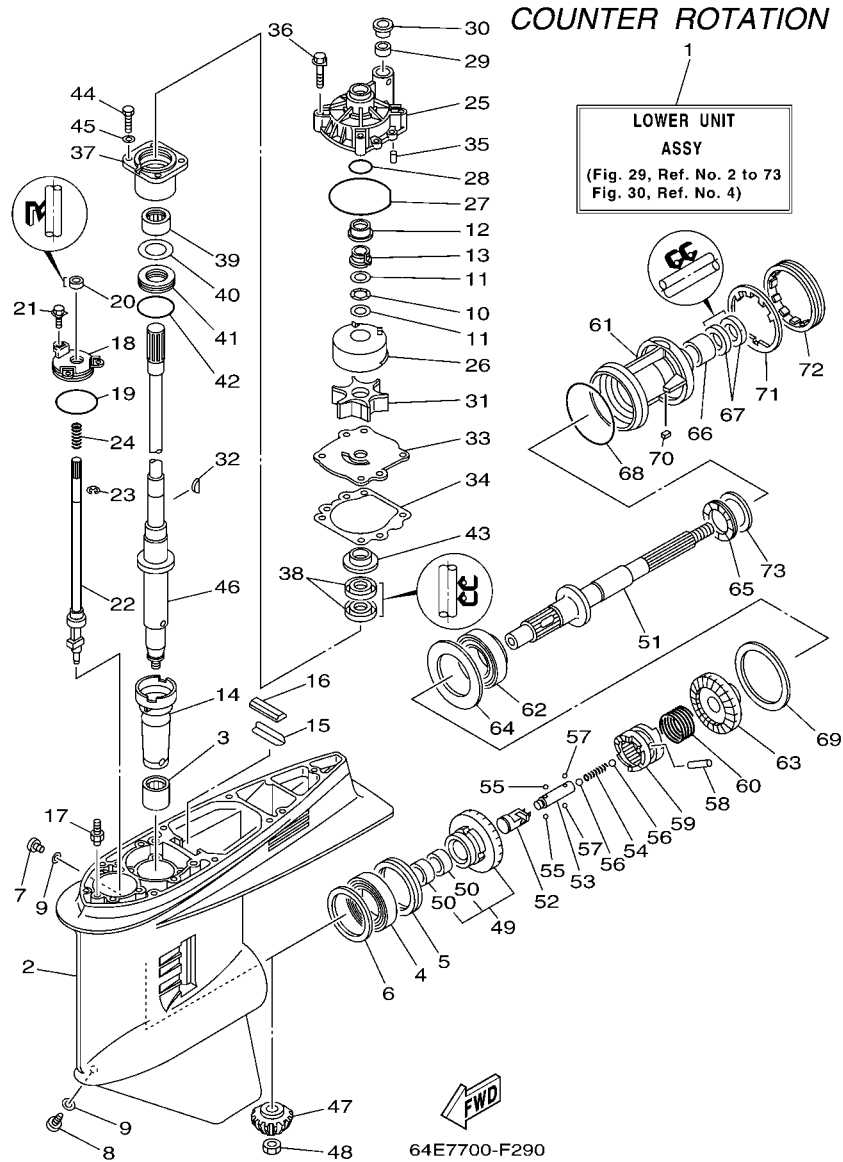

FIG. 29 LOWER CASING & DRIVE 3

REF. NO.	PART NO.	DESCRIPTION	200	S200	L200	REMARKS
22	6K1-44150-01	SHIFT CAM ASSY			1	
23	99001-08600	CIRCLIP			1	
24	90501-11M10	SPRING, COMPRESSION			1	
25	61A-44311-01	HOUSING, WATER PUMP			1	
26	61A-44322-02	INSERT, CARTRIDGE			1	
27	93210-86M38	O-RING			1	
28	93210-37160	O-RING			1	
29	6E5-44365-00	DAMPER, WATER SEAL			1	
30	6E5-44312-00	COVER, WATER PUMP HOUSING			1	
31	6E5-44352-01	IMPELLER			1	
32	90280-04M05	KEY, WOODRUFF			1	
33	6G5-44323-00	OUTER PLATE, CARTRIDGE			1	
34	6E5-44315-A0	GASKET, WATER PUMP			1	
35	93606-12019	PIN, DOWEL			2	
36	90119-08M14	BOLT, WITH WASHER			4	
37	6E5-45331-00-94	HOUSING, BEARING			1	
38	93101-28M16	OIL SEAL			2	
39	93317-330U2	BEARING			1	
40	6E5-45587-01	SHIM (T:0.10MM)			1	UR
	6E5-45587-10	SHIM (T:0.12MM)			1	UR
	6E5-45587-20	SHIM (T:0.15MM)			1	UR
	6E5-45587-30	SHIM (T:0.18MM)			1	UR
	6E5-45587-40	SHIM (T:0.30MM)			1	UR
	6E5-45587-50	SHIM (T:0.40MM)			1	UR
	6E5-45587-60	SHIM (T:0.50MM)			1	UR
41	93341-930V2	BEARING			1	
42	93210-55M14	O-RING			1	

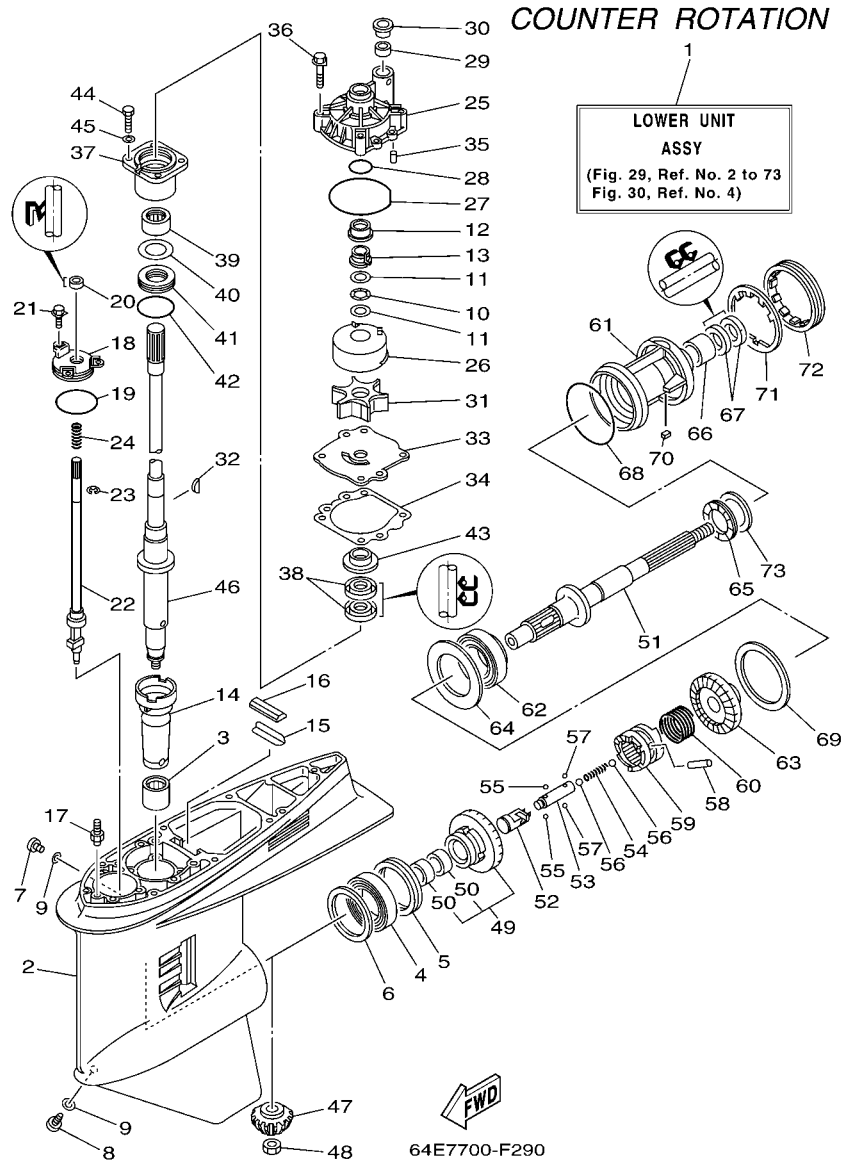

FIG. 29 LOWER CASING & DRIVE 3

REF. NO.	PART NO.	DESCRIPTION	200	S200	L200	REMARKS
43	6E5-45344-00	COVER, OIL SEAL			1	
44	97095-08025	BOLT			4	
45	92995-08600	WASHER			4	
46	6G5-45501-21	DRIVE SHAFT COMP.			1	X(25.3")
47	6G5-45551-10	PINION (14T)			1	
48	90170-16M01	NUT			1	
49	6K1-45560-01	GEAR 1 (26T)			1	
50	93315-425V3	.BEARING			2	
51	6K1-45611-10	SHAFT, PROPELLER			1	
52	6K1-45641-01	SHIFTER			1	
53	6E5-45634-01	SLIDE, SHIFT			1	
54	90501-16M37	SPRING, COMPRESSION			1	
55	93507-32009	BALL			2	
56	93511-32017	BALL			2	
57	93503-16003	BALL			2	
58	90250-08M07	PIN, STRAIGHT			1	
59	6G5-45631-10	CLUTCH, DOG			1	
60	6E5-45633-01	RING, CROSS PIN			1	
61	6K1-45332-01-94	HOUSING, BEARING			1	
62	93332-00048	BEARING			1	
63	6K1-45570-20	GEAR 2 (26T)			1	
64	6K1-45576-00	WASHER, THRUST			1	
65	93341-440U5	BEARING			1	
66	93315-43061	BEARING			1	
67	93101-30M17	OIL SEAL			2	
68	93210-97M55	O-RING			1	
69	6G5-45577-02	SHIM (T:0.10MM)			1	UR

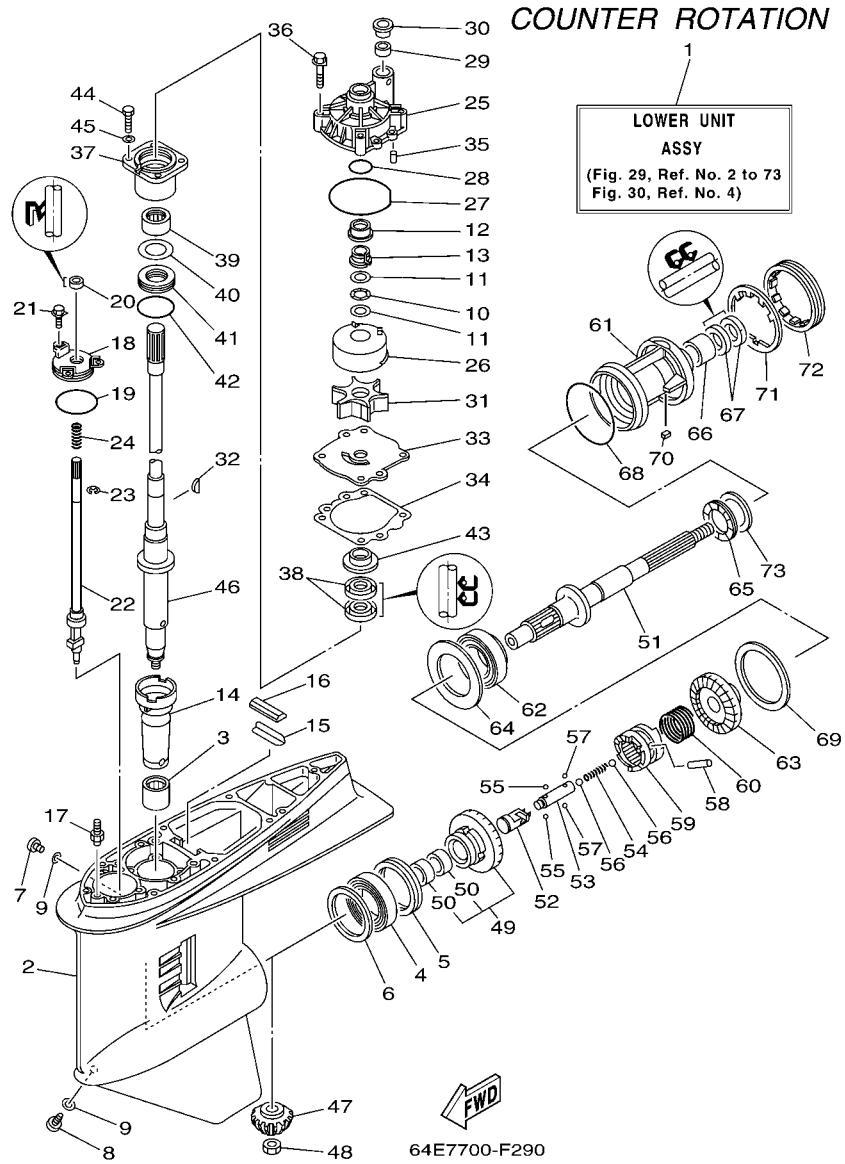
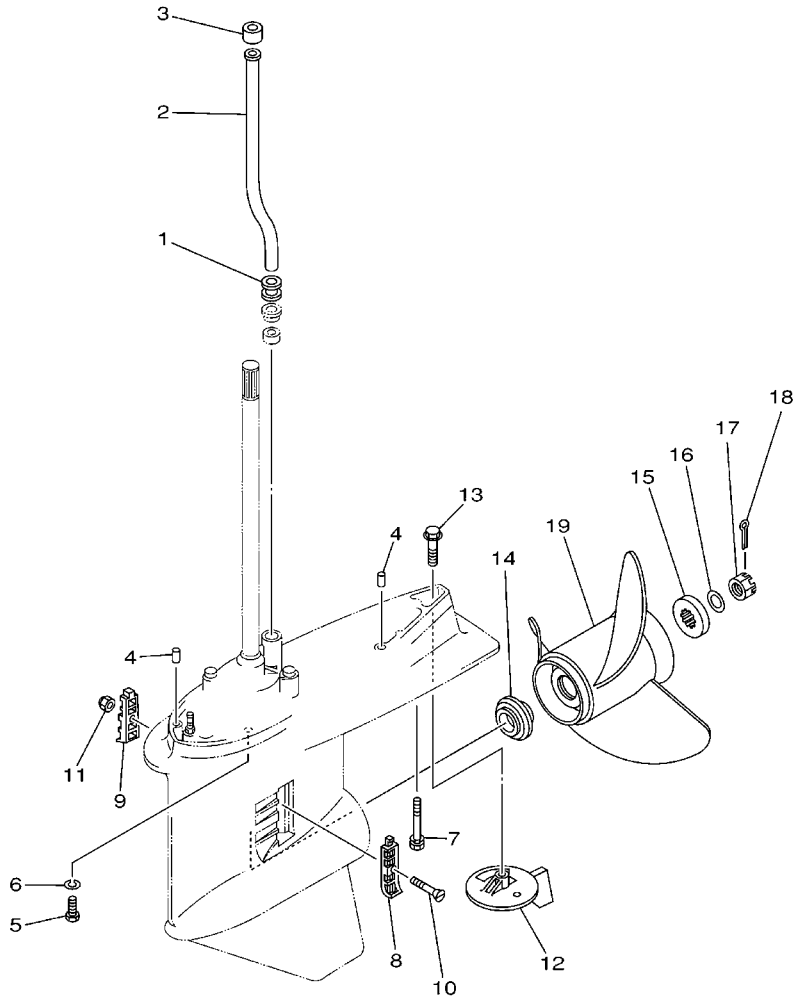

FIG. 29 LOWER CASING & DRIVE 3

REF. NO.	PART NO.	DESCRIPTION	200	S200	L200	REMARKS
69	6G5-45577-10	SHIM (T:0.12MM)			1	UR
	6G5-45577-20	SHIM (T:0.15MM)			1	UR
	6G5-45577-30	SHIM (T:0.18MM)			1	UR
	6G5-45577-40	SHIM (T:0.30MM)			1	UR
	6G5-45577-50	SHIM (T:0.40MM)			1	UR
	6G5-45577-60	SHIM (T:0.50MM)			1	UR
70	90282-04M00	KEY, STRAIGHT			1	
71	6G5-45383-01	WASHER, CLAW			1	
72	6G5-45384-00	NUT			1	
73	6K1-45578-01	SHIM (T:0.10MM)			1	UR
	6K1-45578-10	SHIM (T:0.12MM)			1	UR
	6K1-45578-20	SHIM (T:0.15MM)			1	UR
	6K1-45578-30	SHIM (T:0.18MM)			1	UR
	6K1-45578-40	SHIM (T:0.30MM)			1	UR
	6K1-45578-50	SHIM (T:0.40MM)			1	UR
	6K1-45578-60	SHIM (T:0.50MM)			1	UR

COUNTER ROTATION



64G0100-1250

FIG. 30 LOWER CASING & DRIVE 4

REF. NO.	PART NO.	DESCRIPTION	200	S200	L200	REMARKS
1	6E5-44366-00	DAMPER, WATER SEAL			1	
2	6E5-44361-20	TUBE, WATER			1	X(25.3")
3	6E5-44365-00	DAMPER, WATER SEAL			1	
4	93608-12M05	PIN, DOWEL			2	
5	97075-10045	BOLT			6	
6	92995-10100	WASHER			6	
7	90119-10M89	BOLT, WITH WASHER			1	
8	6J9-45214-00	COVER, WATER INLET 1			1	
9	6J9-45215-00	COVER, WATER INLET 2			1	
10	90152-05M08	SCREW, COUNTERSUNK			1	
11	90185-05002	NUT, SELF-LOCKING			1	
12	6K1-45371-02	TAB-TRIM			1	
13	90105-10M00	BOLT, FLANGE			1	
14	6E5-45987-01	SPACER			1	
15	688-45997-01	SPACER			1	
16	92990-18200	WASHER			1	
17	90171-18M04	NUT, CASTLE			1	
18	91490-40030	PIN, COTTER			1	
19	6K1-45970-01-98	PROPELLER (3X15-1/4"X15"-ML)			1	UR
	6K1-45972-01-98	PROPELLER (3X13-3/4"X21"-ML)			1	UR
	6K1-45974-02-98	PROPELLER (3X13-3/4"X19"-ML1)			1	UR
	6K1-45978-02-98	PROPELLER (3X13-3/4"X17"-ML1)			1	UR
	6R1-45970-A1	PROPELLER (3X15-1/4"X19"-ML)			1	UR
	6R1-45972-A0	PROPELLER (3X14-7/8"X21"-ML)			1	UR
	6R1-45974-A0	PROPELLER (3X14-1/2"X23"-ML)			1	UR
	6R1-45976-A0	PROPELLER (3X15-1/4"X15"-ML)			1	UR
	6R1-45978-A0	PROPELLER (3X15-1/4"X17"-ML)			1	UR

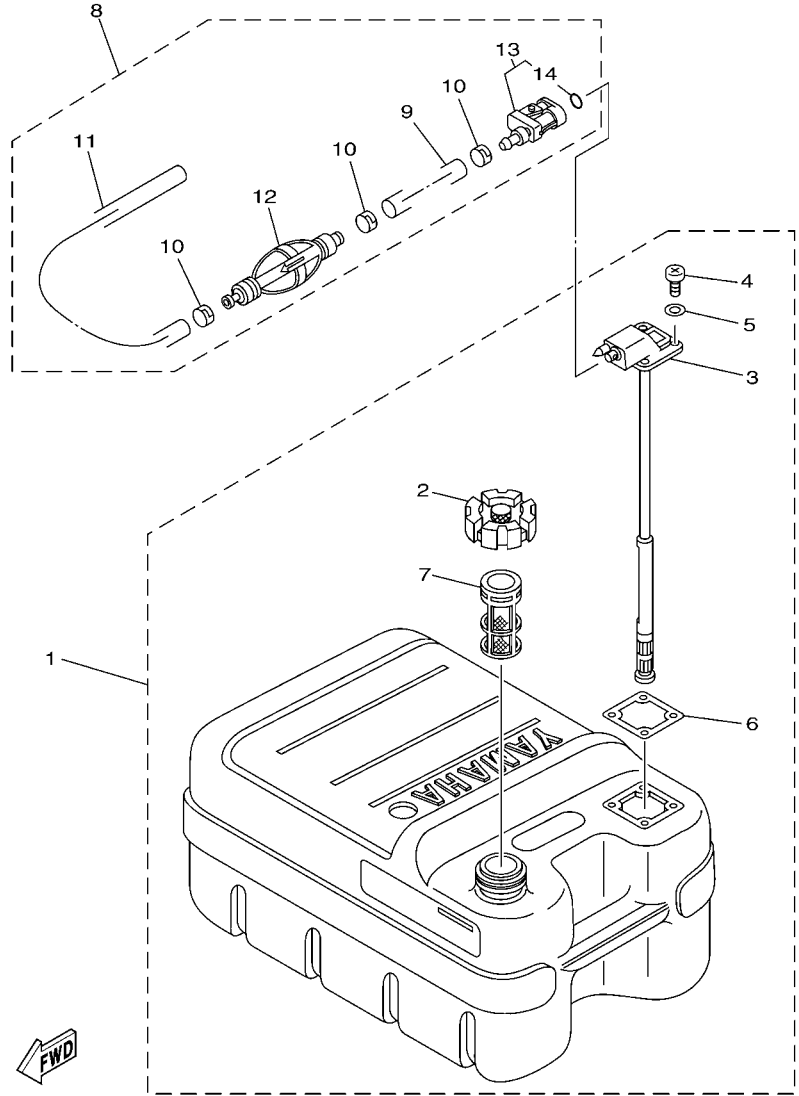

6N43100-C270

FIG. 31 FUEL TANK

REF. NO.	PART NO.	DESCRIPTION	200	S200	L200	REMARKS
1	6YJ-24201-10	FUEL TANK ASSY (24L)	1	1		AP FOR CAR
2	6YJ-24610-01	.CAP ASSY	1	1		
3	6Y1-24260-12	.FUEL METER ASSY	1	1		WITH INDICATOR
4	90157-05M19	.SCREW, PAN HEAD	4	4		
5	6Y1-24329-00	.SEAL	4	4		
6	6Y1-24268-00	.GASKET, FUEL METER	1	1		
7	6YJ-24167-00	.STRAINER	1	1		
8	6Y2-24306-45	FUEL PIPE COMP. 1	1	1		AP FOR CAR
9	90445-13M01	.HOSE (L2050)	1	1		
10	6E5-24351-51	.BAND 1	3	3		
11	90445-13M35	.HOSE (L250)	1	1		
12	6Y2-24360-60	.PRIMER PUMP ASSY	1	1		
13	6Y2-24305-06	.FUEL PIPE JOINT COMP. 2	1	1		
14	93210-08287	..O-RING	1	1		

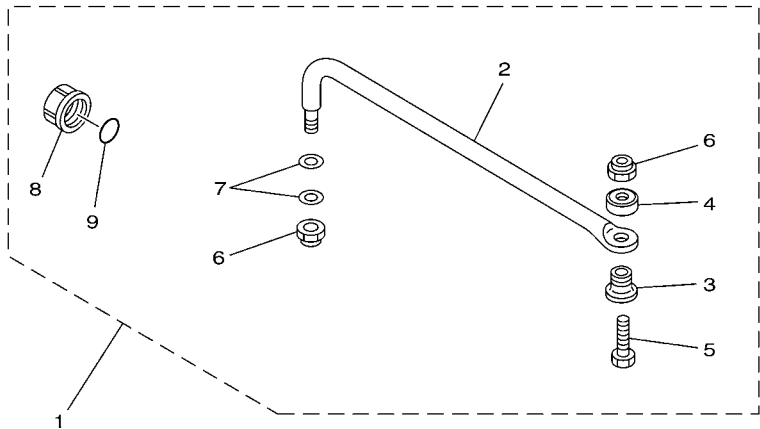

67H0100-9290

FIG. 32 STEERING GUIDE ATTACHMENT 1

REF. NO.	PART NO.	DESCRIPTION	200	S200	L200	REMARKS
1	6E5-61350-02	STEERING GUIDE ATTACHMENT KIT	1	1	1	AP L200-FOR OCE
2	6E5-61351-01	.ROD, STEERING LINK	1	1	1	
3	90387-10M61	.COLLAR	1	1	1	
4	90560-12M01	.SPACER	1	1	1	
5	6E5-61355-00	.BOLT	1	1	1	
6	90185-09M01	.NUT, SELF-LOCKING	2	2	2	
7	90201-10M20	.WASHER, PLATE	2	2	2	
8	6E5-43145-01	.CAP, CLAMP BRACKET	1	1	1	
9	93210-16275	.O-RING	1	1	1	

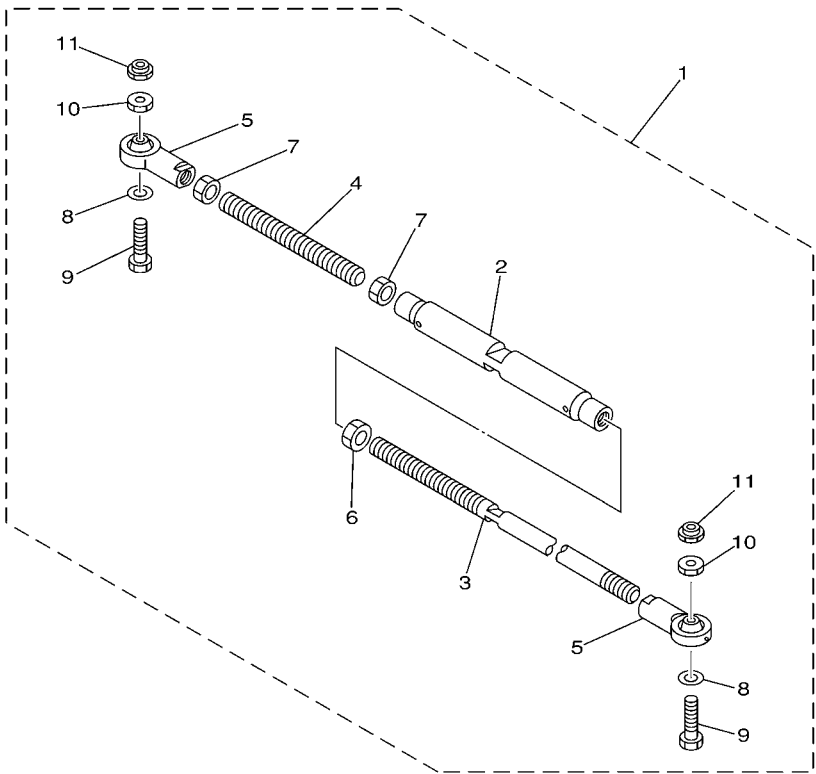

67H0100-0300

FIG. 33 STEERING GUIDE ATTACHMENT 2

REF. NO.	PART NO.	DESCRIPTION	200	S200	L200	REMARKS
1	6E5-61301-01	TWIN KIT (L:600-800MM)			1	AP
2	6E5-61313-00	.ADJUSTER			1	
3	6E5-61311-11	.TIE BAR			1	
4	6E5-61315-00	.TIE BAR			1	
5	6E5-61303-00	.STEERING AXLE COMP.			2	
6	90170-14M06	.NUT			1	
7	95380-14700	.NUT			2	
8	90201-10M76	.WASHER, PLATE			2	
9	90101-09M70	.BOLT			2	
10	90170-09M05	.NUT			2	
11	90185-09M01	.NUT, SELF-LOCKING			2	

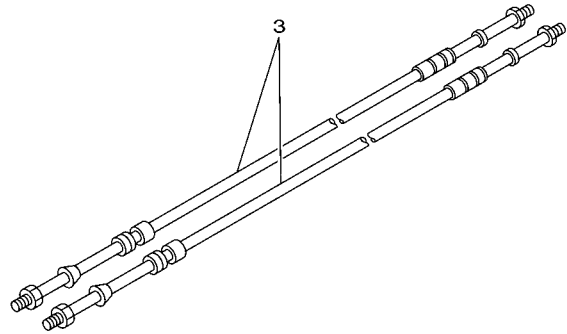
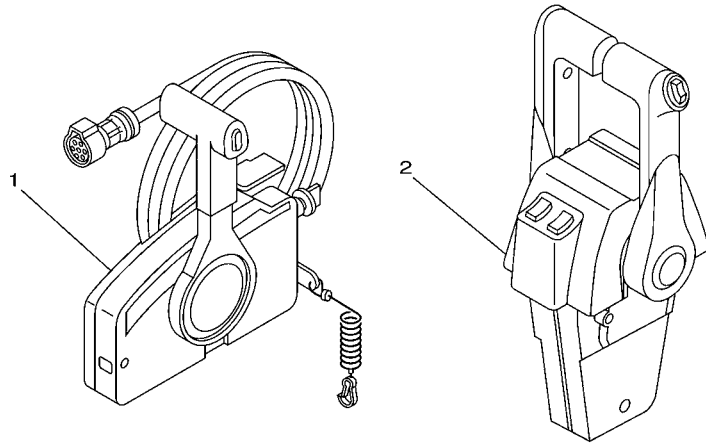

68V4100-D350

FIG. 34 REMOTE CONTROL BOX

REF. NO.	PART NO.	DESCRIPTION	200	S200	L200	REMARKS
1	703-48205-17	REMOTE CONTROL ASSY (10P)	1	1		AP WITH PT/T SW.
2	704-48207-P1	REMOTE CONTROL ASSY			1	AP WITH PT/T SW.
3	701-48320-50	CABLE, REMOTE CONTROL L=15F	2	2	2	UR
	701-48320-60	CABLE, REMOTE CONTROL L=16F	2	2	2	UR
	701-48320-80	CABLE, REMOTE CONTROL L=17F	2	2	2	UR
	701-48320-40	CABLE, REMOTE CONTROL L=19F	2	2	2	UR
	701-48350-00	CABLE, REMOTE CONTROL L=21F	2	2	2	UR
	701-48350-20	CABLE, REMOTE CONTROL L=23F	2	2	2	UR

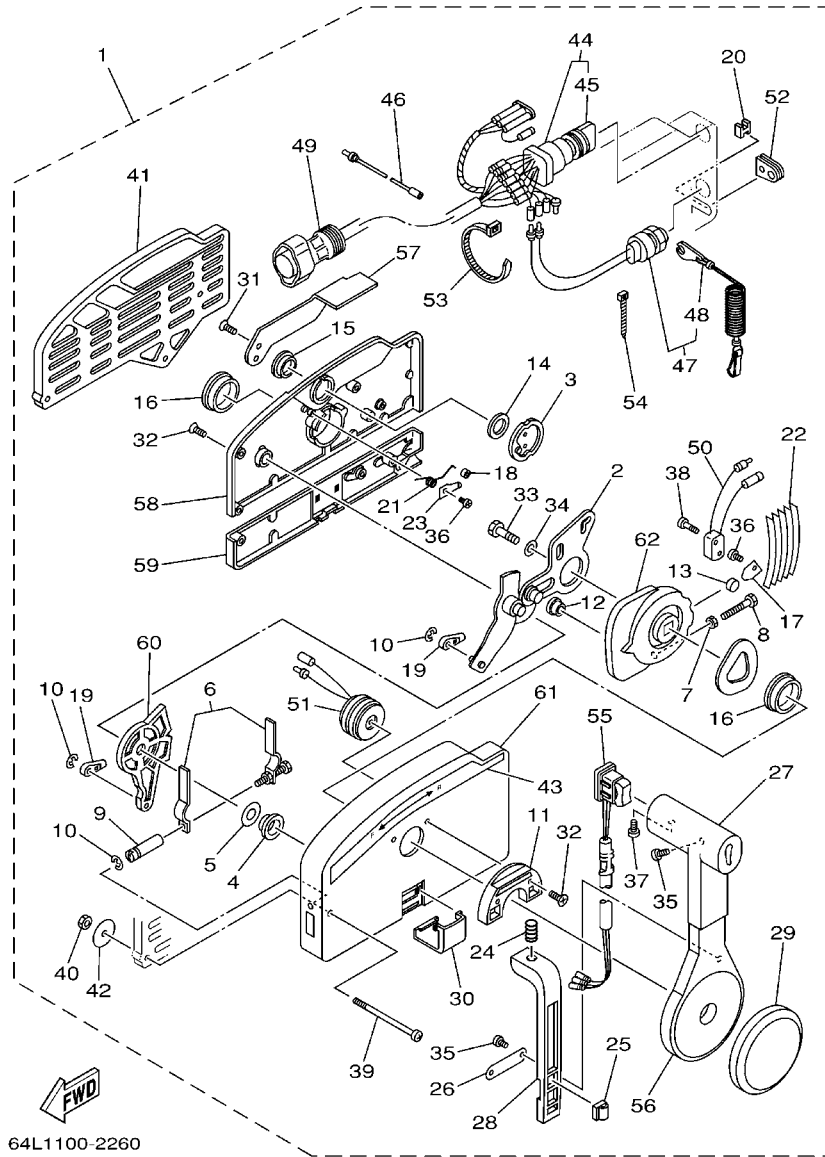

64L1100-2260

FIG. 35 REMOTE CONTROL ASSY 1

REF. NO.	PART NO.	DESCRIPTION	200	S200	L200	REMARKS
1	703-48205-17	REMOTE CONTROL ASSY (10P)	1	1		AP WITH PT/T SW.
2	703-48261-01	.ARM, THROTTLE	1	1		
3	703-48153-00	.SHAFT, FREE ACCEL.	1	1		
4	703-48235-00	.BUSHING	1	1		
5	703-48268-00	.SPACER	1	1		
6	703-48264-00	.FRICTION, THROTTLE	1	1		
7	95380-05600	.NUT	1	1		
8	97380-05025	.BOLT	1	1		
9	703-48265-00	.SHAFT, FRICTION	1	1		
10	93430-06024	.CIRCLIP	3	3		
11	703-48245-00	.PLATE, LOCK	1	1		
12	703-48252-00	.ROLLER, CAM	1	1		
13	701-48248-00	.ROLLER, FREE ACCEL.	1	1		
14	703-48198-00	.WASHER, WAVE	1	1		
15	703-48243-00	.BUSHING	1	1		
16	703-48236-00	.BUSHING 1	2	2		
17	703-48189-00	.RETAINER	1	1		
18	703-48234-00	.ROLLER, DETENT	1	1		
19	703-48345-01	.CABLE END, REMOTE CONTROL 2	2	2		
20	703-48358-00	.ANCHOR, CABLE	1	1		
21	703-48244-00	.SPRING, FREE ACCEL.	1	1		
22	703-48238-00	.SPRING, DETENT	5	5		
23	703-48246-00	.SPACER	1	1		
24	703-48227-00	.SPRING, NEUTRAL LOCK	1	1		
25	703-82594-00	.CLAMP	1	1		WITH PT/T SW.
26	703-48226-00	.PLATE, STOPPER	1	1		
27	703-48222-00	.GRIP, CONTROL LEVER	1	1		SINGLE

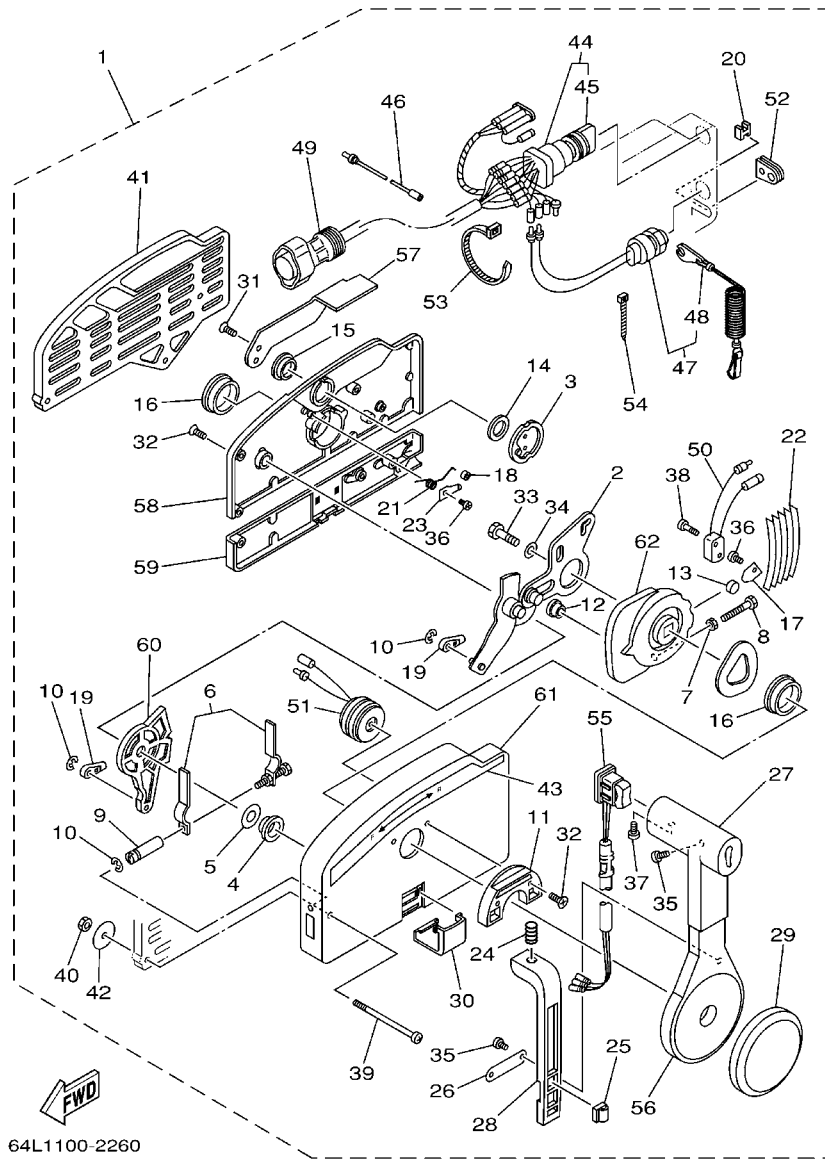
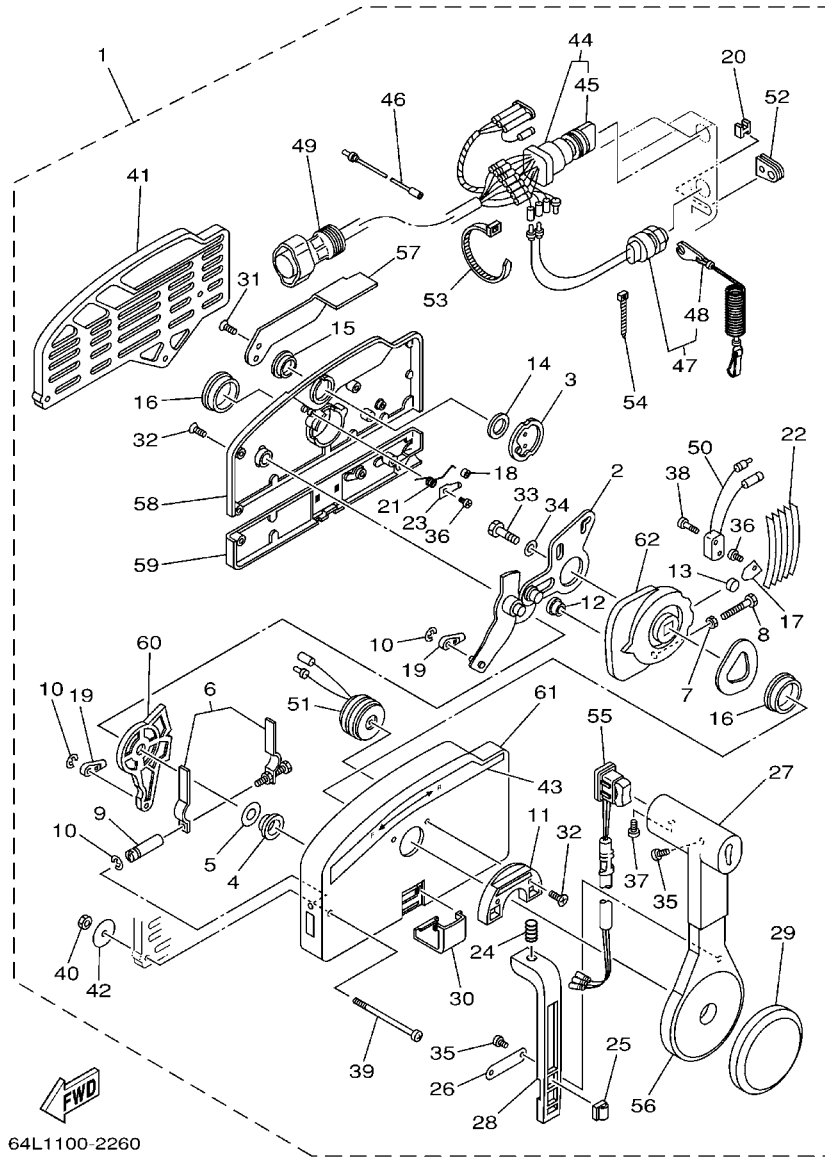

FIG. 35 REMOTE CONTROL ASSY 1

REF. NO.	PART NO.	DESCRIPTION	200	S200	L200	REMARKS
28	703-48223-00	.LOCK, NEUTRAL	1	1		
29	703-48225-00	.COVER	1	1		
30	703-48219-00	.COVER, LEAD	1	1		
31	703-48281-00	.SCREW	2	2		
32	703-48282-00	.SCREW	7	7		
33	97380-08030	.BOLT	1	1		
34	92990-08600	.WASHER, PLATE	1	1		
35	98580-04010	.SCREW, PAN HEAD	3	3		
36	98580-04006	.SCREW, PAN HEAD	2	2		
37	98580-05010	.SCREW, PAN HEAD	1	1		
38	98580-03015	.SCREW, PAN HEAD	2	2		
39	703-48291-10	.SCREW (M6)	3	3		
40	95380-06600	.NUT, HEXAGON	3	3		
41	703-48293-10	.SPACER, REMOTE CONTROL	1	1		SINGLE
42	701-48287-00	.WASHER	3	3		
43	703-48215-00	.GRAPHIC	1	1		
44	703-82510-43	.MAIN SWITCH ASSY	1	1		
45	703-82577-00	..CAP, KEY	1	1		
46	703-82531-00	.WIRE, LEAD (L70)	1	1		
47	688-82575-01	.ENGINE STOP SWITCH ASSY	1	1		
48	682-82556-00	..LANYARD, STOP SWITCH	1	1		
49	688-8258A-20	.EXTENSION, WIRE HARNESS (4.9M)	1	1		(10P)
50	703-82540-00	.NEUTRAL SWITCH ASSY	1	1		
51	703-83383-02	.BUZZER	1	1		
52	703-48284-00	.GROMMET	1	1		
53	703-82591-00	.BAND	1	1		
54	703-82592-00	.BAND	1	1		



64L1100-2260

FIG. 35 REMOTE CONTROL ASSY 1

REF. NO.	PART NO.	DESCRIPTION	200	S200	L200	REMARKS
55	703-82563-02	.TRIM & TILT SWITCH ASSY	1	1		WITH PT/T SW.
56	703-48221-00	.LEVER, CONTROL	1	1		
57	703-48152-00	.KNOB, FREE ACCEL.	1	1		
58	703-48212-00	.BACK PLATE 1	1	1		
59	703-48213-00	.BACK PLATE 2	1	1		
60	703-48271-00	.ARM, SHIFT	1	1		
61	703-48211-01	.HOUSING,1	1	1		
62	703-48232-00	.GEAR	1	1		

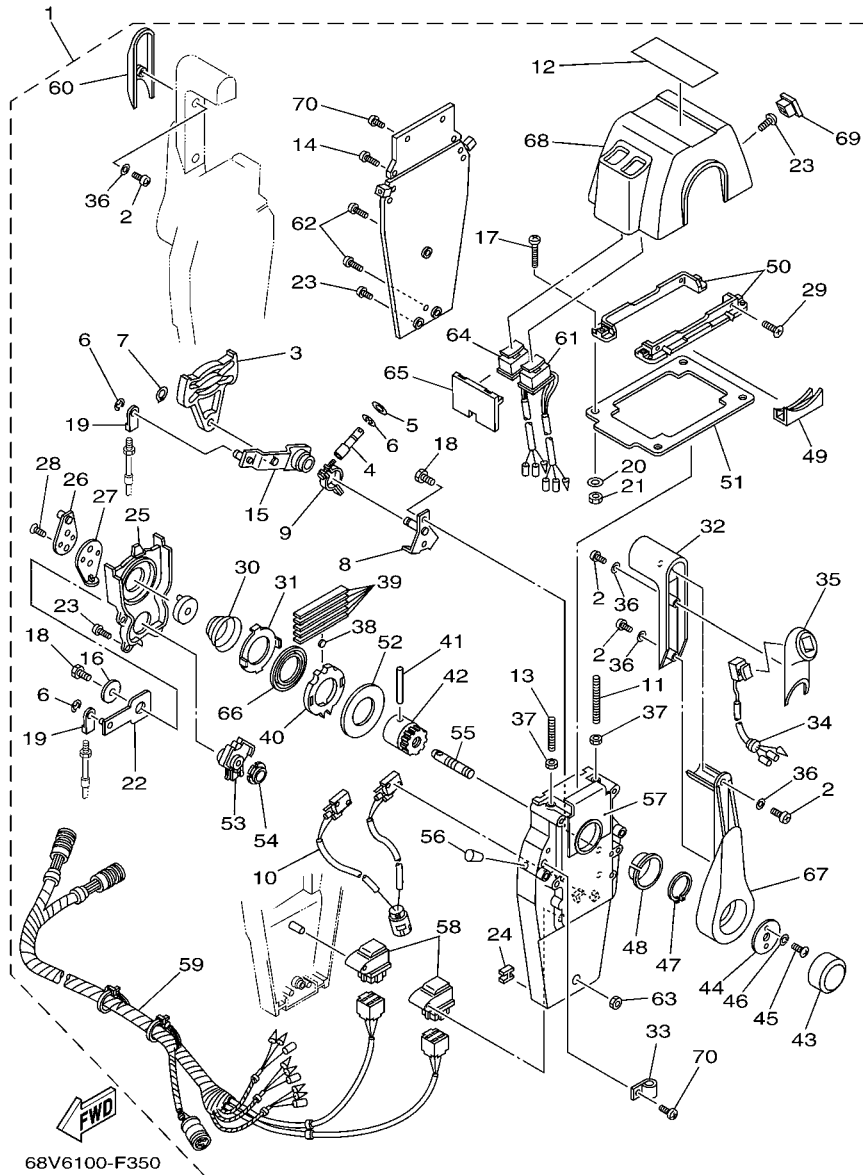

FIG. 36 REMOTE CONTROL ASSY 2

REF. NO.	PART NO.	DESCRIPTION	200	S200	L200	REMARKS
1	704-48207-P1	REMOTE CONTROL ASSY			1	AP WITH PT/T SW.
2	704-48128-00	.SCREW 2			6	
3	EL8-48251-00	.PLATE, CAM			2	
4	704-48265-00	.SHAFT, FRICTION			2	
5	701-48246-00	.SPACER			2	
6	93430-06024	.CIRCLIP			8	
7	EL8-48259-00	.CIRCLIP 1			2	
8	704-48262-00	.SHAFT, THROTTLE			2	
9	704-48264-00	.THROTTLE, FRICTION			2	
10	704-82540-30	.NEUTRAL SWITCH ASSY			1	
11	EL8-48281-00	.SCREW			2	
12	704-48215-30	.GRAPHIC			1	
13	704-48281-00	.SCREW			2	
14	97890-05025	.SCREW, PAN HEAD			4	
15	704-48261-00	.ARM, THROTTLE			2	
16	EL8-48191-00	.WASHER 1			2	
17	704-48283-00	.SCREW			4	
18	97380-06018	.BOLT			6	
19	703-48345-01	.CABLE END, REMOTE CONTROL 2			4	
20	704-48287-00	.WASHER			4	
21	95380-05600	.NUT			4	
22	704-48271-00	.ARM, SHIFT			2	
23	EL8-48127-00	.SCREW 1			18	
24	703-48358-00	.ANCHOR, CABLE			2	
25	704-48231-00	.HOUSING, GEAR			2	
26	EL8-48241-00	.ARM, DRIVE			2	
27	EL8-48254-00	.STOPPER, THROTTLE ADJUSTING			2	

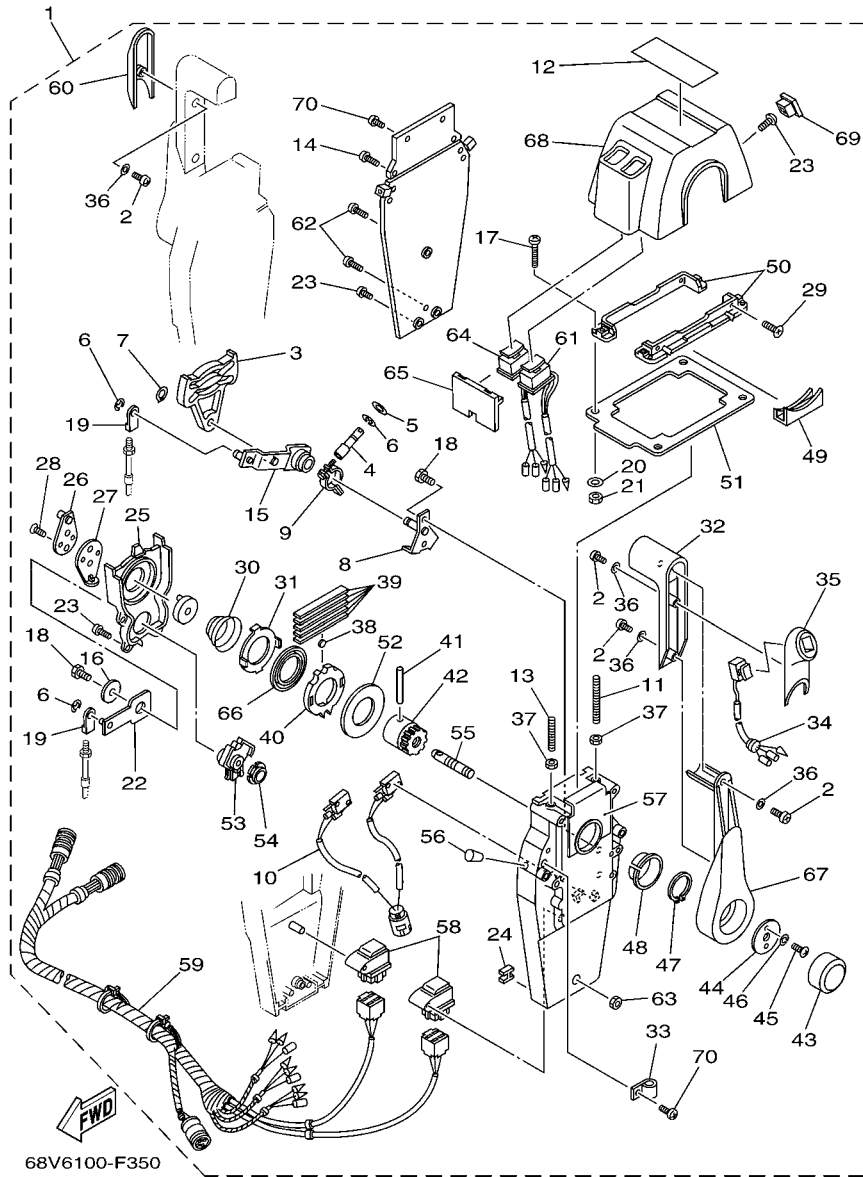

FIG. 36 REMOTE CONTROL ASSY 2

REF. NO.	PART NO.	DESCRIPTION	200	S200	L200	REMARKS
28	92780-06020	.SCREW, FLAT HEAD			4	
29	98780-05018	.SCREW, FLAT HEAD			4	
30	EL8-48244-00	.SPRING, FREE ACCEL.			2	
31	EL8-48245-00	.PLATE, LOCK			2	
32	704-48222-P0	.GRIP, CONTROL LEVER			2	
33	704-82594-00	.CLAMP			1	
34	704-82563-51	.TRIM & TILT SWITCH ASSY			1	
35	704-48229-P1	.GRIP, CONTROL LEVER			1	
36	92990-05300	.WASHER, INTERNAL TOOTH			6	
37	95380-06600	.NUT, HEXAGON			4	
38	701-48248-00	.ROLLER, FREE ACCEL.			2	
39	704-48238-00	.SPRING, DETENT			10	
40	704-48232-P1	.GEAR			2	
41	EL8-48164-00	.PIN 2			2	
42	704-48242-10	.SHAFT, DRIVE			2	
43	6X3-48225-20	.COVER			2	
44	704-48192-00	.WASHER 2			2	
45	97890-06018	.SCREW, PAN HEAD			4	
46	92990-06300	.WASHER, INTERNAL TOOTH			4	
47	EL8-48279-00	.CIRCLIP 2			2	
48	704-48234-00	.BUSHING 1			2	
49	704-48219-P0	.COVER, LEAD			2	
50	704-48144-20	.PLATE, STOPPER 2			2	
51	704-48176-10	.GROMMET			1	
52	704-48192-P0	.WASHER 2			2	
53	704-48233-00	.GEAR 2			2	
54	704-48235-00	.BUSHING			2	

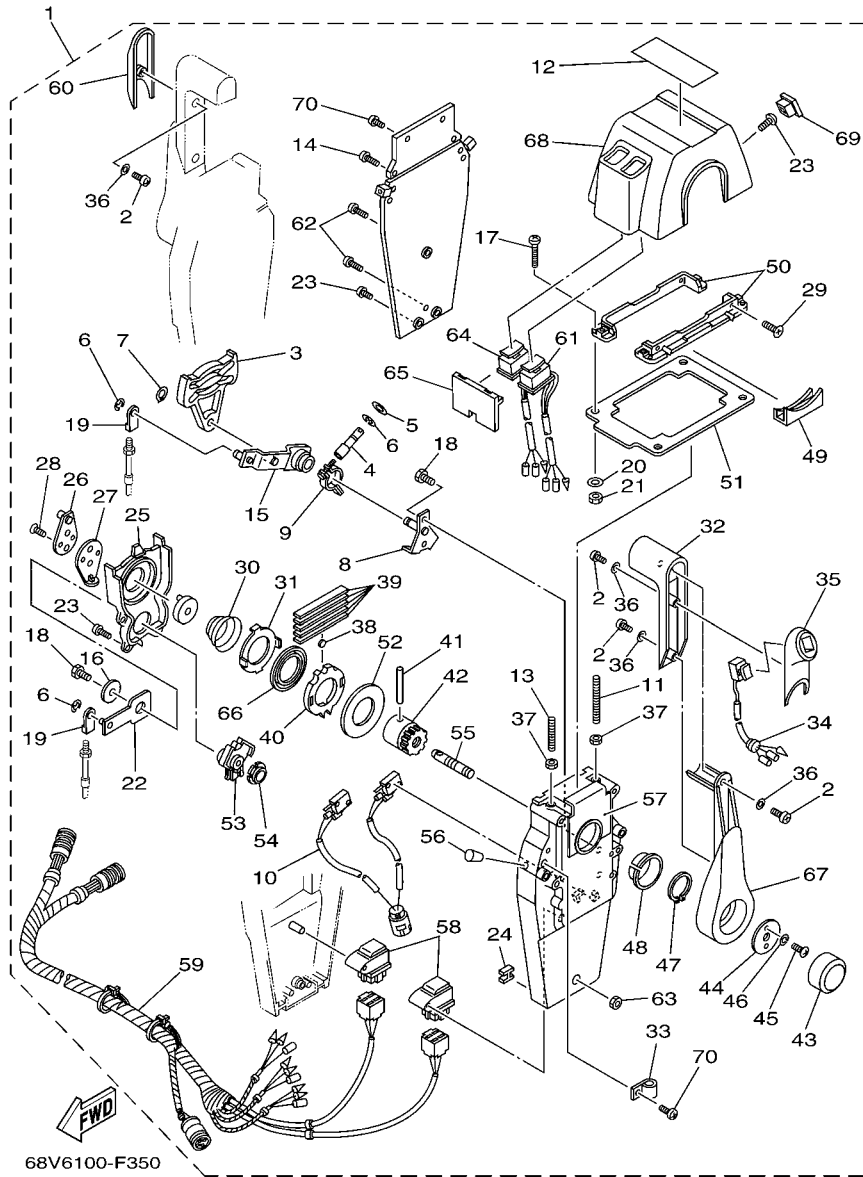

FIG. 36 REMOTE CONTROL ASSY 2

REF. NO.	PART NO.	DESCRIPTION	200	S200	L200	REMARKS
55	704-48153-00	.SHAFT, FREE ACCEL.			2	
56	704-48166-00	.PLUG			2	
57	704-48284-P0	.GROMMET			2	
58	704-81950-10	.RELAY ASSY			2	
59	704-82590-10	.WIRE HARNESS ASSY			1	
60	704-48229-R0	.GRIP, CONTROL LEVER			1	
61	704-82563-H1	.TRIM & TILT SWITCH ASSY			1	
62	704-48128-00	.SCREW 2			3	
63	704-48156-00	.NUT 1			1	
64	704-82563-J1	.TRIM & TILT SWITCH ASSY			1	
65	704-48285-10	.GROMMET 2			1	
66	704-48178-00	.PLATE, SHIFT			2	
67	704-48221-P0	.LEVER, CONTROL			2	
68	704-48119-41	.COVER			1	
69	704-48167-11	.PLUG			1	
70	97890-05016	.SCREW, PAN HEAD			5	

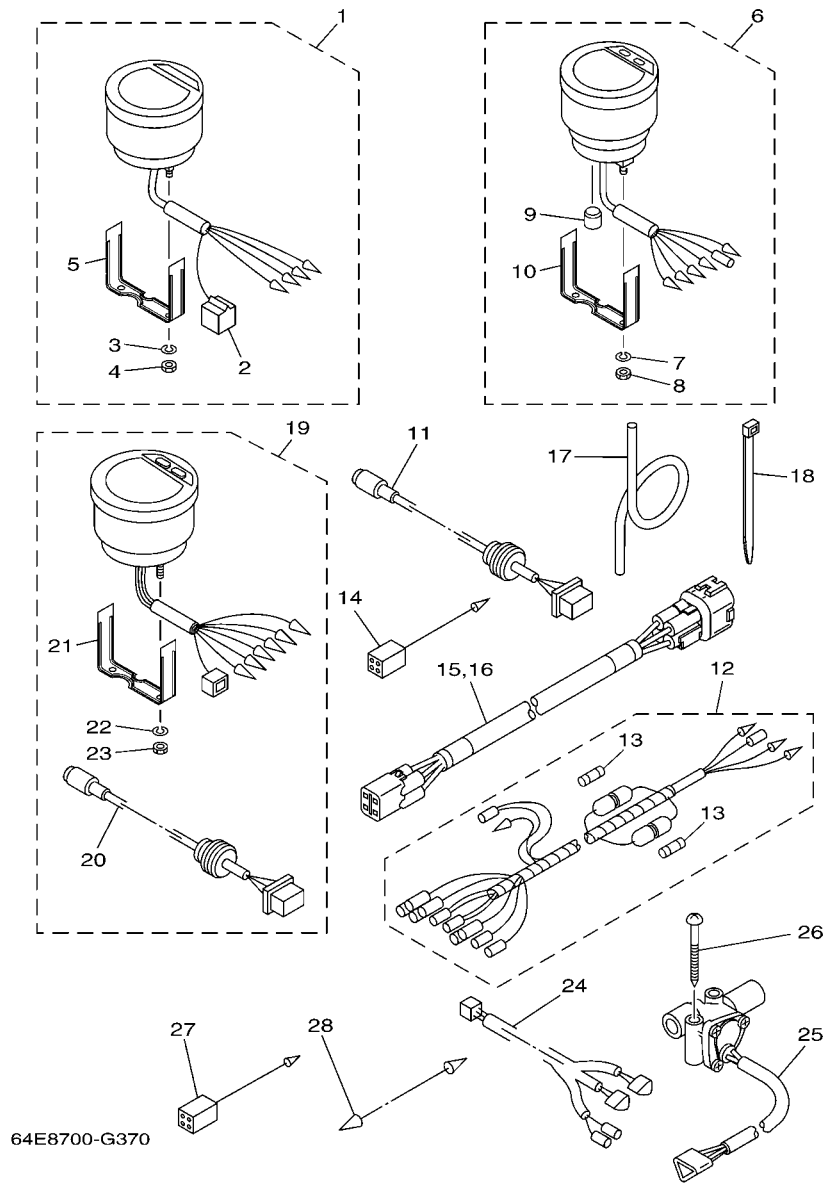

FIG. 37 METER

REF. NO.	PART NO.	DESCRIPTION	200	S200	L200	REMARKS
1	6Y5-8350T-90	DIGITAL TACHOMETER ASSY	1	1	1	AP
2	9E450-04533	.CONNECTOR	1	1	1	F-4-W
3	92990-04100	.WASHER, SPRING	2	2	2	
4	95380-04600	.NUT	2	2	2	
5	6Y5-8355X-T1	.BRACKET, METER 1	1	1	1	
6	6Y5-83570-S5	SPEEDOMETER ASSY	1	1		AP
7	92990-04100	.WASHER, SPRING	2	2		
8	95380-04600	.NUT	2	2		
9	6Y5-83533-T2	.GROMMET	1	1		
10	6Y5-8355X-T1	.BRACKET, METER 1	1	1		
11	6Y5-87122-S0	CORD ASSY 1	1	1		AP
12	6Y5-83553-M0	WIRE, LEAD (L=2.5M)	1	1		AP
	6Y5-83553-00	WIRE, LEAD (L=2.5M)			1	AP
13	1E6-82151-00	.FUSE (10A)	2	2		FOR 6Y5-83553-M0
	1E6-82151-00	.FUSE (10A)			1	FOR 6Y5-83553-00
14	6Y5-82117-00	WIRE, LEAD (BLACK) (L300)	1	1		AP
15	6Y5-83653-20	WIRE, LEAD	1	1		AP CAR,KOR 4P,7M
	6Y5-83653-30	WIRE, LEAD			1	AP OCE 4P,8M
	6Y5-83653-30	WIRE, LEAD			1	AP CAR 4P,8M
	6Y5-83653-40	WIRE, LEAD			1	AP OCE 4P,9M
16	6Y5-83653-00	WIRE, LEAD			1	AP CAR 4P,5M
17	6Y5-83557-00	TUBE (6M)	1	1		AP CAR,KOR
	6Y5-83557-10	TUBE (8M)			1	AP OCE
18	90465-11M10	CLAMP	2	2		AP
19	6Y5-8350F-00	FUEL MANAGEMENT METER			1	AP OCE
20	6Y5-87122-S0	.CORD ASSY 1			1	
21	6Y5-8355X-T1	.BRACKET, METER 1			1	

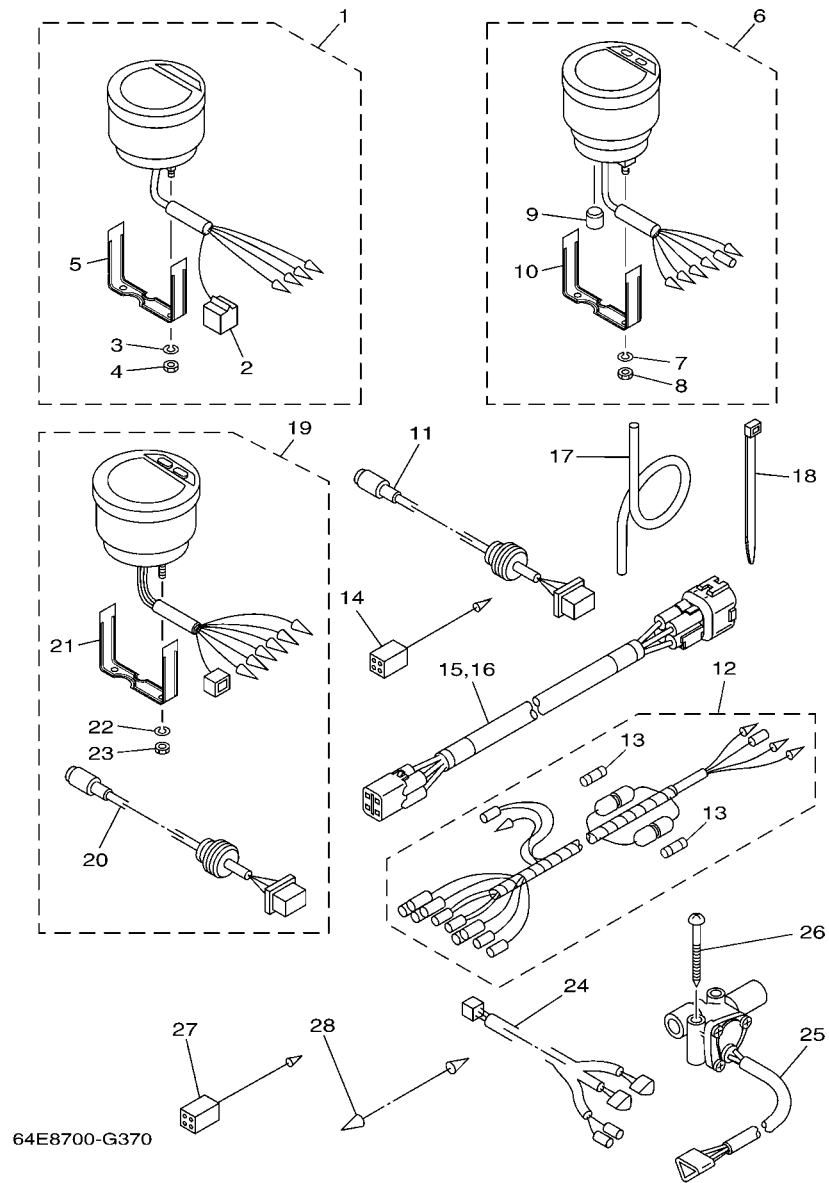

FIG. 37 METER

REF. NO.	PART NO.	DESCRIPTION	200	S200	L200	REMARKS
22	92990-04100	.WASHER, SPRING			2	
23	95380-04600	.NUT			2	
24	6Y5-83553-F1	WIRE, LEAD (L=8.0M)			1	AP OCE
25	6Y5-85752-02	SENDER UNIT ASSY, FUEL METER			2	AP OCE
26	90158-06003	SCREW, WOOD			4	AP OCE
27	6Y5-82117-00	WIRE, LEAD (BLACK) (L300)			1	AP OCE
28	703-82531-00	WIRE, LEAD (L70)			1	AP OCE

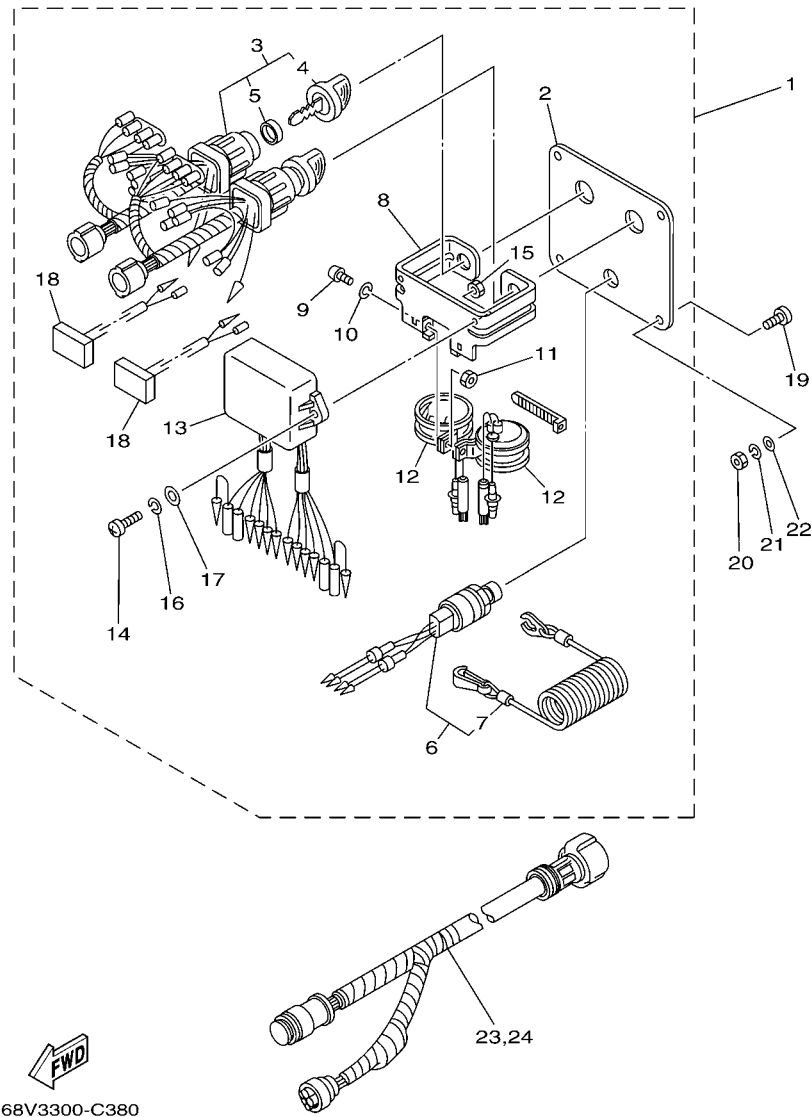
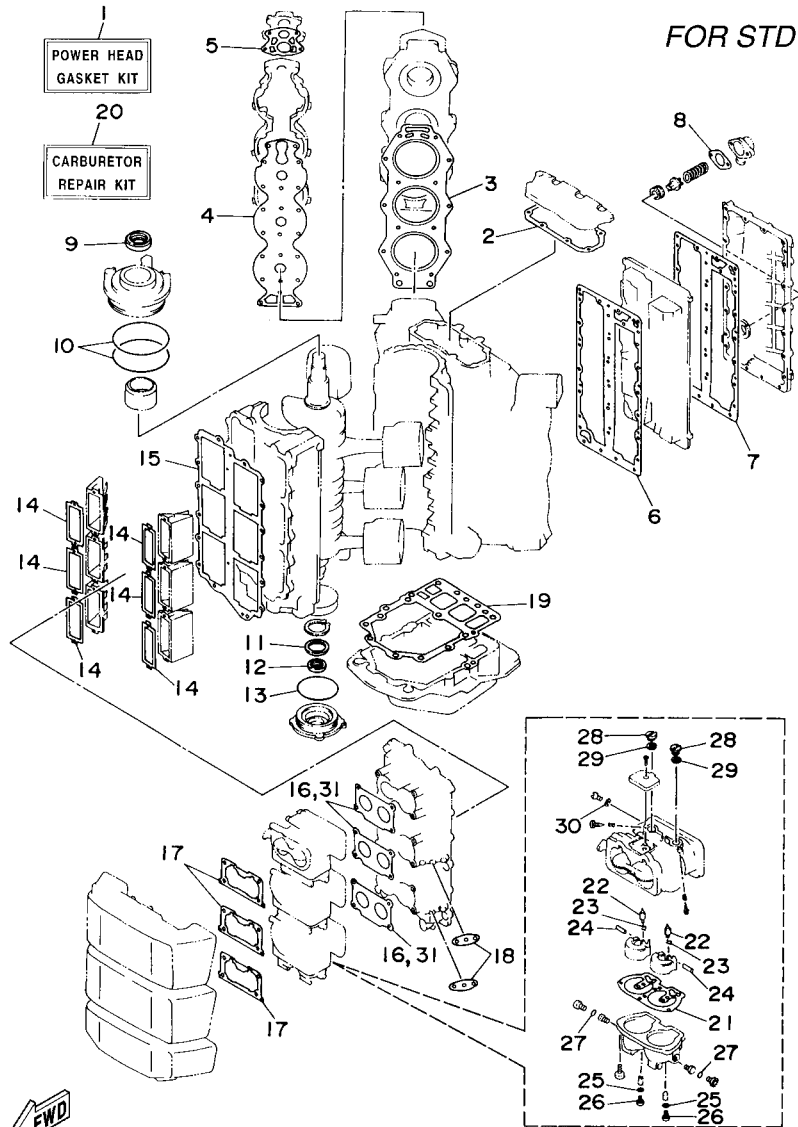

FIG. 38 SWITCH & PANEL

REF. NO.	PART NO.	DESCRIPTION	200	S200	L200	REMARKS
1	6K1-82570-08	PANEL SWITCH ASSY			1	AP
2	6K1-82571-02	.PLATE, PANEL SWITCH			1	
3	6K1-82510-06	.MAIN SWITCH ASSY			2	
4	703-82577-00	..CAP, KEY			1	
5	6K1-82532-00	..CAP			1	
6	6K1-82575-00	.ENGINE STOP SWITCH ASSY			1	
7	682-82556-00	..LANYARD, STOP SWITCH			1	
8	6K1-83614-01	.BRACKET			1	
9	98980-05010	.SCREW, BIND			2	
10	92990-05100	.WASHER, SPRING			2	
11	95380-05600	.NUT			2	
12	688-83383-11	.BUZZER			2	
13	6K1-85830-01	.CONTROL UNIT ASSY			1	
14	98980-06020	.SCREW, BIND			2	
15	95380-06600	.NUT, HEXAGON			2	
16	92990-06100	.WASHER, SPRING			2	
17	92990-06600	.WASHER, PLATE			2	
18	6K1-81980-00	.DIODE ASSY			2	
19	90149-05M05	SCREW			4	AP
20	95380-05600	NUT			4	AP
21	92990-05100	WASHER, SPRING			4	AP
22	92990-05600	WASHER, PLATE			4	AP
23	6K1-8258A-40	EXTENSION, WIRE HARNESS (8M)			1	AP OCE (10P)
	6K1-8258A-40	EXTENSION, WIRE HARNESS (8M)			2	AP CAR (10P)
24	61B-8258A-01	EXTENSION, WIRE HARNESS (9.5M)			1	AP OCE (10P)



64E0100-6380

FIG. 39 REPAIR KIT 1

REF. NO.	PART NO.	DESCRIPTION	200	S200	L200	REMARKS
1	64D-W0001-01	POWER HEAD GASKET KIT	1			
2	6E5-11381-A2	.GASKET 1	1			
3	6G5-11181-A2	.GASKET, CYLINDER HEAD 1	2			
4	6G5-11193-A1	.GASKET, HEAD COVER 1	2			
5	688-12414-A1	.GASKET, COVER	2			
6	6G5-41112-A1	.GASKET, EXHAUST INNER COVER	1			
7	6G5-41114-A0	.GASKET, EXHAUST OUTER COVER	1			
8	6G5-11382-A1	.GASKET 2	1			
9	93102-40M14	.OIL SEAL	1			
10	93211-04001	.O-RING	2			
11	93102-35M13	.OIL SEAL	1			
12	93101-22M15	.OIL SEAL	1			
13	93210-74M35	.O-RING	1			
14	6E5-13621-A1	.GASKET, VALVE SEAT	6			
15	6G5-13645-A2	.GASKET, MANIFOLD 1	1			
16	6E5-14198-A2	.GASKET	3			
17	6K7-14483-00	.GASKET	3			
18	650-24431-A0	.GASKET, FUEL PUMP 1	2			
19	68F-45113-00	.GASKET, UPPER CASING	1			
20	64D-W0093-01	CARBURETOR REPAIR KIT	1			
21	64D-14384-01	.GASKET, FLOAT CHAMBER	1			
22	6E5-14546-00	.VALVE, NEEDLE	2			
23	6E5-14159-00	.CLIP	2			
24	6E5-14386-02	.PIN, FLOAT	2			
25	61U-14959-00	.GASKET	2			
26	64D-14394-00	.VALVE, DRAIN	2			
27	6E5-14398-01	.GASKET	2			

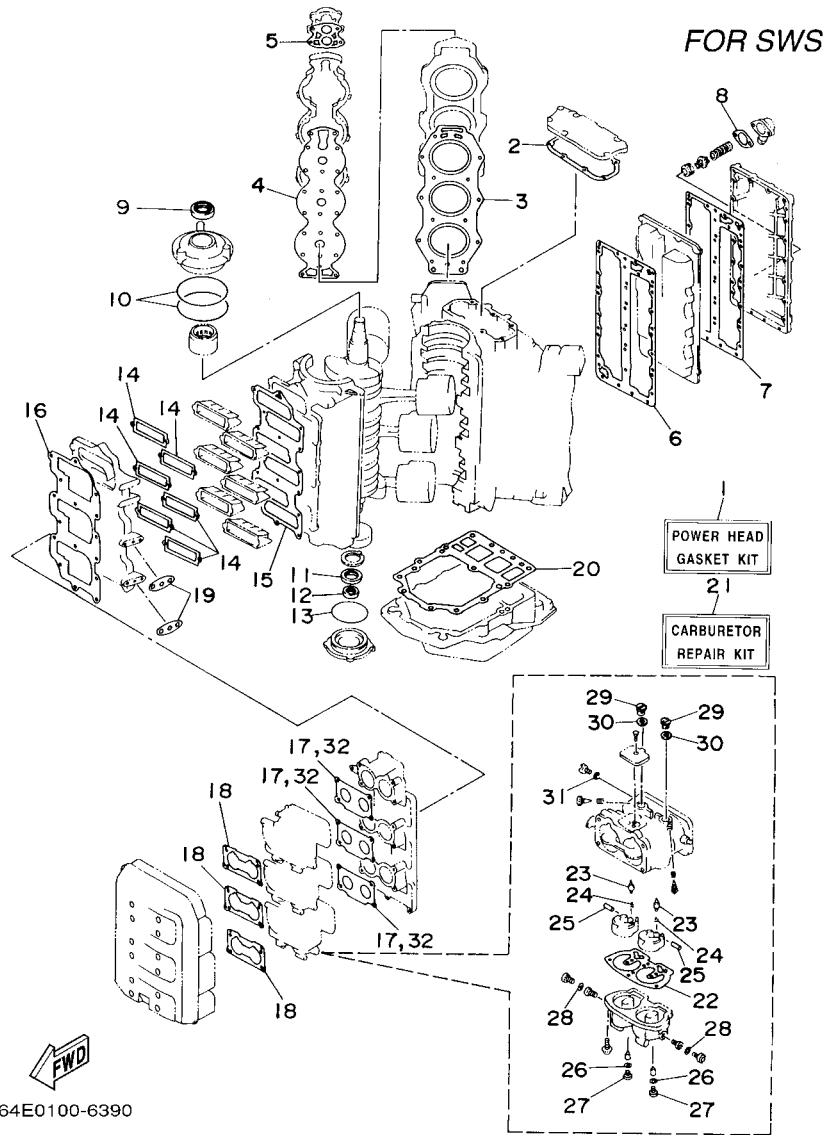

64E0100-6390

FIG. 40 REPAIR KIT 2

REF. NO.	PART NO.	DESCRIPTION	200	S200	L200	REMARKS
1	64H-W0001-01	POWER HEAD GASKET KIT		1	1	
2	6E5-11381-A2	.GASKET 1		1	1	
3	6G5-11181-A2	.GASKET, CYLINDER HEAD 1		2	2	
4	6G5-11193-A1	.GASKET, HEAD COVER 1		2	2	
5	688-12414-A1	.GASKET, COVER		2	2	
6	6G5-41112-A1	.GASKET, EXHAUST INNER COVER		1	1	
7	6G5-41114-A0	.GASKET, EXHAUST OUTER COVER		1	1	
8	6G5-11382-A1	.GASKET 2		1	1	
9	93102-40M14	.OIL SEAL		1	1	
10	93211-04001	.O-RING		2	2	
11	93102-35M13	.OIL SEAL		1	1	
12	93101-22M15	.OIL SEAL		1	1	
13	93210-74M35	.O-RING		1	1	
14	6K7-13621-A1	.GASKET, VALVE SEAT		6	6	
15	6K7-13646-A2	.GASKET, MANIFOLD 2		1	1	
16	64E-13645-A0	.GASKET, MANIFOLD 1		1	1	
17	6E5-14198-A2	.GASKET		3	3	
18	6K7-14483-00	.GASKET		3	3	
19	650-24431-A0	.GASKET, FUEL PUMP 1		2	2	
20	68F-45113-00	.GASKET, UPPER CASING		1	1	
21	64D-W0093-01	CARBURETOR REPAIR KIT		1	1	
22	64D-14384-01	.GASKET, FLOAT CHAMBER		1	1	
23	6E5-14546-00	.VALVE, NEEDLE		2	2	
24	6E5-14159-00	.CLIP		2	2	
25	6E5-14386-02	.PIN, FLOAT		2	2	
26	61U-14959-00	.GASKET		2	2	
27	64D-14394-00	.VALVE, DRAIN		2	2	

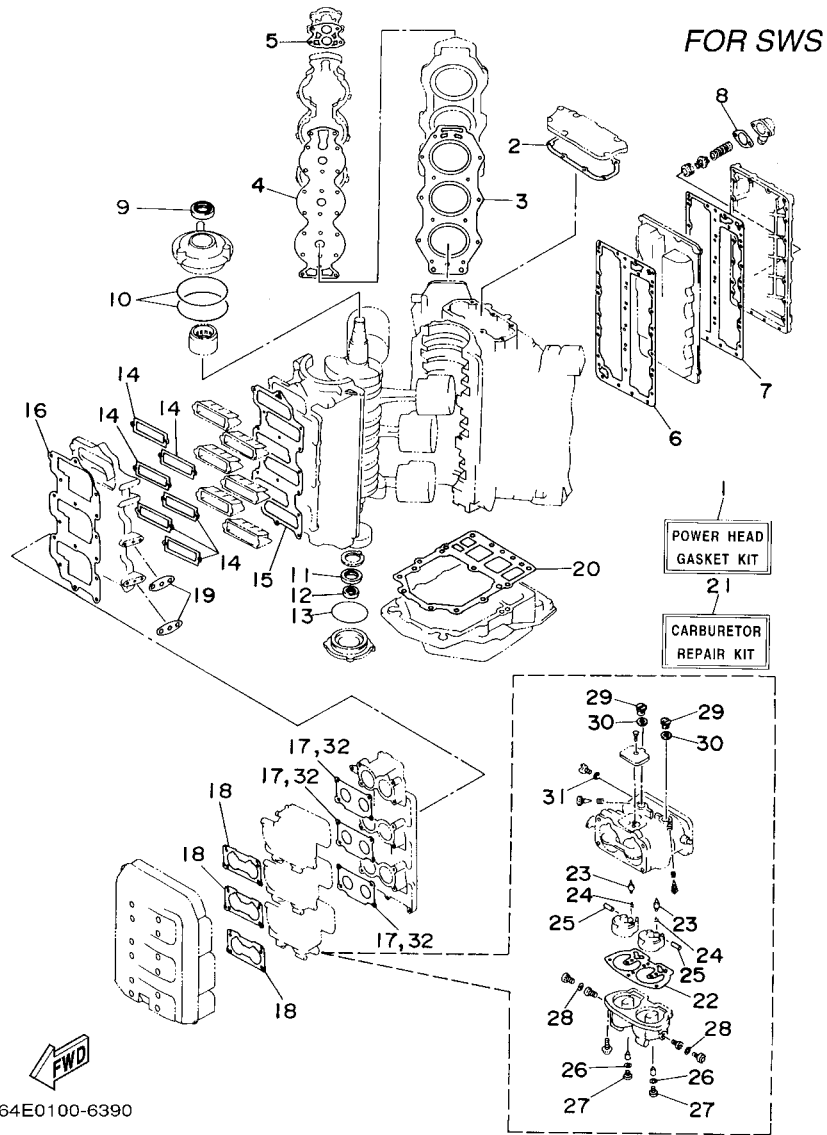

64E0100-6390

FIG. 40 REPAIR KIT 2

REF. NO.	PART NO.	DESCRIPTION	200	S200	L200	REMARKS
28	6E5-14398-01	.GASKET		2	2	
29	6E5-14328-01	.PLUG		2	2	
30	6E5-14979-00	.GASKET		2	2	
31	6J8-14959-00	.GASKET		1	1	
32	6E5-14198-A2	.GASKET		1	1	
<hr/>						
<hr/>						
<hr/>						
<hr/>						
<hr/>						
<hr/>						
<hr/>						
<hr/>						
<hr/>						
<hr/>						

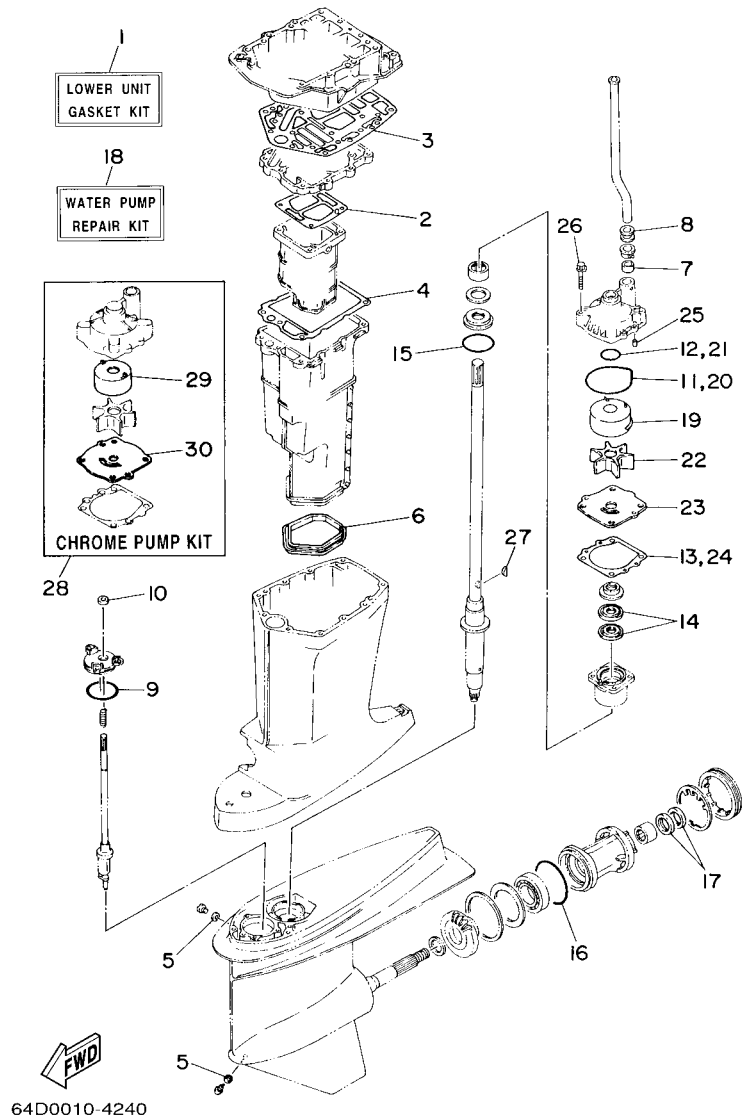

FIG. 41 REPAIR KIT 3

REF. NO.	PART NO.	DESCRIPTION	200	S200	L200	REMARKS
1	6G5-W0001-C1	LOWER UNIT GASKET KIT	1	1	1	
2	6G5-41134-A1	.GASKET, EXHAUST MANIFOLD	1	1	1	
3	6G5-45114-A1	.GASKET, UPPER CASING	1	1	1	
4	6E5-41135-A0	.GASKET, EXHAUST MANIFOLD	1	1	1	
5	90430-08020	.GASKET	2	2	2	
6	6E5-45123-00	.GASKET, MUFFLER	1	1	1	
7	6E5-44365-00	.DAMPER, WATER SEAL	1	1	1	
8	6E5-44366-00	.DAMPER, WATER SEAL	1	1	1	
9	93210-58144	.O-RING	1	1	1	
10	93106-09014	.OIL SEAL	1	1	1	
11	93210-86M38	.O-RING	1	1	1	
12	93210-37160	.O-RING	1	1	1	
13	6E5-44315-A0	.GASKET, WATER PUMP	1	1	1	
14	93101-28M16	.OIL SEAL	2	2	2	
15	93210-55M14	.O-RING	1	1	1	
16	93210-97M55	.O-RING	1	1	1	
17	93101-30M17	.OIL SEAL	2	2	2	
18	61A-W0078-A3	WATER PUMP REPAIR KIT	1	1	1	
19	61A-44322-02	.INSERT, CARTRIDGE	1	1	1	
20	93210-86M38	.O-RING	1	1	1	
21	93210-37160	.O-RING	1	1	1	
22	6E5-44352-01	.IMPELLER	1	1	1	
23	6G5-44323-00	.OUTER PLATE, CARTRIDGE	1	1	1	
24	6E5-44315-A0	.GASKET, WATER PUMP	1	1	1	
25	93606-12019	.PIN, DOWEL	2	2	2	
26	90119-08M14	.BOLT, WITH WASHER	4	4	4	
27	90280-04M05	.KEY, WOODRUFF	1	1	1	

NUMERICAL INDEX

PART NO.	REF. NO.	PART NO.	REF. NO.	PART NO.	REF. NO.	PART NO.	REF. NO.	PART NO.	REF. NO.	PART NO.	REF. NO.
64E-11111-00-1S	5 - 1	64D-11636-02	4 - 17	6K7-13646-A2	7 - 10	6E5-14398-01	40 - 28	6E5-21770-03	11 - 3	6E5-24379-00	11 - 12
67H-11119-01	2 - 16	64D-11642-02-90	4 - 19		40 - 15	6G5-1441K-00	6 - 28	6E5-21798-01-33	11 - 19		11 - 36
	3 - 28	64D-11645-02	4 - 19	6E5-14159-00	8 - 8	64D-14440-00	7 - 27	6YJ-24167-00	31 - 7		11 - 38
6G5-11181-A2	5 - 2	64D-11646-02	4 - 19		39 - 23	6R3-14440-02	6 - 27	6YJ-24201-10	31 - 1	6E5-24410-04	12 - 20
	39 - 3	6R5-11650-10	4 - 23		40 - 24	6K7-14483-00	6 - 30	646-24251-02	11 - 6		13 - 20
	40 - 3	6E5-12411-30	5 - 7	6E5-14198-A2	6 - 20		7 - 29	6Y1-24260-12	31 - 3	6E5-24411-01	12 - 25
6G5-11191-00-1S	5 - 4	688-12412-00	5 - 8		7 - 20		39 - 17	6Y1-24268-00	31 - 6		13 - 25
6G5-11193-A1	5 - 5	688-12413-00-1S	5 - 9		39 - 16		40 - 18	6Y2-24305-06	15 - 6	6E5-24412-11	12 - 28
	39 - 4	688-12414-A1	5 - 10		39 - 31	624-14485-00	3 - 4		31 - 13		13 - 28
	40 - 4		39 - 5		40 - 17		6 - 8	6Y2-24306-45	15 - 1	6E5-24413-01	12 - 22
6E5-11325-00	2 - 14		40 - 5		40 - 32		7 - 12		31 - 8		13 - 22
	3 - 26	60H-12416-00	5 - 19	6E5-14223-00	8 - 25	6R5-14485-00	7 - 8	6Y2-24307-50	14 - 1	6A0-24421-01	12 - 29
646-11370-01	2 - 7	6R3-12572-00	20 - 42	6E5-14276-01	9 - 1	64E-14488-00	16 - 24	6R3-24313-01	12 - 1		13 - 29
	3 - 10	6G5-12576-00	5 - 25		10 - 1	6G5-14488-02	16 - 24		13 - 1	6E5-24423-00	12 - 27
6E5-11370-01	6 - 9	6R3-12580-00	20 - 43	64E-14301-02	8 - 1	6E5-14527-01	8 - 27	6R3-24313-20	13 - 1		13 - 27
6K7-11371-01-1S	2 - 18	6G5-12581-00	26 - 12	64E-14301-20	8 - 1	6E5-14546-00	8 - 7	6G5-24314-00	12 - 13	648-24424-00	12 - 26
	3 - 30	6R3-13117-00	9 - 20	64E-14301-S2	8 - 1		39 - 22		13 - 13		13 - 26
6H1-11372-00	26 - 21		10 - 21	64E-14302-02	8 - 2		40 - 23	6E5-24315-00	12 - 18	650-24431-A0	12 - 34
6G5-11372-00-1S	5 - 23	6R3-13183-10	9 - 13	64E-14302-20	8 - 2	6E5-14711-01-5B	26 - 30		13 - 18		13 - 34
688-11372-01	7 - 7		10 - 14	64E-14302-S2	8 - 2	64D-14721-20-5B	26 - 39	6G5-24315-00	12 - 17		39 - 18
6E5-11372-01	3 - 3	6R5-13200-12	9 - 3	64E-14303-02	8 - 3	6E5-14737-00	26 - 31	6K7-24315-00	13 - 17		40 - 19
6F6-11372-01	3 - 5		10 - 3	64E-14303-20	8 - 3	64D-1492E-73	8 - 13	6G5-24316-10	12 - 36	6E5-24435-01	12 - 24
624-11379-00	2 - 3	6E5-13411-00	11 - 28	64E-14303-S2	8 - 3	64D-1492E-75	8 - 13		13 - 36		13 - 24
	3 - 6	6E5-13414-00	11 - 29	64E-14321-00	8 - 20	64D-1492E-76	8 - 14	6K7-24317-00	13 - 42	6E5-24444-01	12 - 21
6E5-11381-A2	2 - 19	6R3-13416-00	9 - 8	6E5-14323-03	8 - 24	64D-1492E-77	8 - 15	6G5-24317-01	12 - 41		13 - 21
	3 - 31		10 - 8	6E5-14324-00	8 - 29	64D-1492E-79	8 - 16	6K7-24318-00	13 - 43	6E5-24471-01	12 - 23
	39 - 2	6E5-13437-43	11 - 41	6A0-14325-00	12 - 30	64D-1492F-42	8 - 10	6G5-24318-10	12 - 42		13 - 23
	40 - 2	6E5-13437-62	11 - 41		13 - 30	61A-1492H-12	8 - 18	6K7-24319-00	13 - 44	6E5-24486-00	12 - 33
6G5-11382-A1	5 - 22	6E5-13448-00	11 - 25	6E5-14328-01	8 - 22	61U-14959-00	8 - 11	6E5-24319-01	11 - 7		13 - 33
	39 - 8	6R3-13471-00	9 - 4		39 - 28		39 - 25	6G5-24319-10	12 - 43	6E5-24492-00	12 - 32
	40 - 8		10 - 4		40 - 29		40 - 26	6E5-24321-01	11 - 11		13 - 32
6G5-11411-02	4 - 1	6L2-13475-00	9 - 5	64E-1432A-00	8 - 31	6J8-14959-00	8 - 30	6E5-24322-00	11 - 4	61N-24521-00	12 - 7
6E5-11447-00	4 - 2		10 - 5	6J8-14334-00	8 - 21		39 - 30	64E-24323-00	11 - 34		13 - 7
663-11518-01	2 - 6	6E5-13552-01	6 - 7	64D-14381-00	8 - 5		40 - 31	6Y1-24329-00	31 - 5	6R3-24560-00	12 - 5
	3 - 9		7 - 13	64D-14381-10	8 - 5	6E5-14979-00	8 - 23	6E5-24351-51	14 - 3		13 - 5
6R3-11536-00	4 - 9	6E5-13610-00	6 - 1	61A-14383-01	8 - 19		39 - 29		15 - 3	6R3-24563-00	12 - 6
6R3-11537-00	9 - 19	6K7-13610-00	7 - 1	64D-14384-01	8 - 4		40 - 30		31 - 10		13 - 6
	10 - 19	6E5-13621-A1	6 - 3		39 - 21	64E-15100-01-1S	2 - 2	6Y2-24360-60	14 - 5	648-24566-02	12 - 9
64D-11603-02	4 - 18		39 - 14		40 - 22	64E-15100-S1-1S	3 - 2		15 - 5		13 - 9
	4 - 20	6K7-13621-A1	7 - 3	6E5-14385-02	8 - 6	6R3-15163-00-1S	4 - 3		31 - 12	6YJ-24610-01	31 - 2
64D-11604-02	4 - 18		40 - 14	6E5-14386-02	8 - 9	6G5-15359-00-94	4 - 12	6G5-24376-00	12 - 39	6A1-28176-00	20 - 50
	4 - 20	64E-13624-00-1S	7 - 6		39 - 24	6E5-21708-10	11 - 1	6G5-24377-00	12 - 40	61H-2819R-31	11 - 42
64D-11605-02	4 - 18	64E-13641-00-1S	7 - 11		40 - 25	6K1-21708-10	11 - 1	6R3-24377-00	12 - 2	64D-41111-00-1S	5 - 12
	4 - 20	6G5-13641-11-1S	6 - 6	64D-14394-00	8 - 12	61A-21708-20	11 - 1		13 - 2	6G5-41112-A1	5 - 13
64D-11631-02-90	4 - 17	64E-13645-A0	7 - 17		39 - 26	6E5-21733-20	11 - 2	650-24378-00	5 - 16		39 - 6
6R5-11633-10	4 - 21		40 - 16		40 - 27	6E5-21734-01-33	11 - 18	6E5-24378-00	12 - 16		40 - 6
6R5-11634-10	4 - 22	6G5-13645-A2	6 - 18	6E5-14398-01	8 - 17	6E5-21746-00	11 - 20		13 - 16	6R3-41113-00-1S	5 - 15
64D-11635-02	4 - 17		39 - 15		39 - 27	6E5-21750-05	11 - 24		13 - 39	6G5-41114-A0	5 - 14

NUMERICAL INDEX

PART NO.	REF. NO.	PART NO.	REF. NO.	PART NO.	REF. NO.	PART NO.	REF. NO.	PART NO.	REF. NO.	PART NO.	REF. NO.
6G5-41114-A0	39 - 7	64D-42677-S0	1 - 14	6G5-43148-00	22 - 32	6G5-43865-00	25 - 35	6G5-44323-40	41 - 30	6J9-45301-05-8D	27 - 2
	40 - 7	64D-42678-30	1 - 20	6G5-43181-02	22 - 29	64E-43866-00	24 - 10	6E5-44352-01	27 - 32		29 - 2
6G5-41131-01-5B	26 - 22	64D-4267A-30	1 - 19	6G5-43185-02	22 - 30	64E-43867-00	24 - 9		29 - 31	6E5-45318-00	26 - 37
64D-41132-00-5B	26 - 26	64D-4267A-S0	1 - 19	64E-43311-10-8D	22 - 22	64E-43868-00	25 - 3		41 - 22	6E5-45321-00	27 - 19
6G5-41134-A1	26 - 27	64C-42681-30	1 - 17	64E-43311-20-8D	22 - 22	64E-43869-00	24 - 27	6E5-44361-00	28 - 2		29 - 18
	41 - 2	64D-42681-40	1 - 17	61A-43376-00	23 - 8	6H1-4386K-10	25 - 29	6E5-44361-20	28 - 2	6E5-45331-00-94	27 - 38
6E5-41135-A0	26 - 34	64C-42682-30	1 - 18	64E-43800-04-4D	24 - 1	6E5-43872-00	24 - 13		30 - 2		29 - 37
	41 - 4	64D-42682-40	1 - 18	64E-43802-00	25 - 8	64E-43873-00	25 - 24	6E5-44365-00	27 - 30	6J9-45332-00-94	27 - 62
6G5-41137-02-94	26 - 10	64E-42687-00	1 - 15	64E-43805-00	25 - 37	6E5-43874-01	24 - 22		28 - 3	6K1-45332-01-94	29 - 61
6G5-41137-11-94	26 - 10	64E-42687-30	1 - 15	64E-4380F-00	25 - 33	64E-43875-00	25 - 25		29 - 29	688-45341-10	27 - 7
6G5-41211-01	21 - 31	64D-42711-01-8D	20 - 1	64E-4380J-00	25 - 30	64E-43879-00	25 - 27		30 - 3		29 - 8
61H-41213-00	21 - 34	648-42715-00	21 - 51	64E-43810-01	24 - 6	64E-43879-10	25 - 26		41 - 7	6E5-45344-00	27 - 44
6G5-41213-00	21 - 34	6E5-42716-10	20 - 40	64E-43811-01	24 - 7	64E-4387A-00	25 - 23	6E5-44366-00	28 - 1		29 - 43
6G5-41217-01	6 - 22	64D-42717-00	20 - 36	6E5-43814-02	24 - 14	64E-43880-02	25 - 28		30 - 1	6J9-45371-01	28 - 12
	7 - 22	6E5-42724-00	26 - 11	64E-43816-00	25 - 17	64E-43883-00	24 - 12		41 - 8	6K1-45371-02	30 - 12
6H1-41237-00	9 - 24	64D-42725-20	20 - 19	64E-43817-00	24 - 5	64E-4388E-00	24 - 26	6E5-44391-00	20 - 18	64D-45375-00	26 - 41
	10 - 24	64D-42725-30	20 - 19	64E-43817-10	25 - 19	64E-4388E-10	25 - 1	6E5-44511-00-5B	23 - 38	688-45375-00	27 - 15
6R5-41237-00	9 - 26	688-42726-10	20 - 29	6BC-43818-00	24 - 34	64E-4388J-00	24 - 3	6G5-44514-00-94	23 - 31		29 - 16
	10 - 26	61A-42727-00	20 - 3	64E-4381G-00	24 - 28	64E-43891-00	25 - 31	6G5-44526-00	22 - 3	64D-45376-00-94	27 - 14
662-41237-01	21 - 27	64G-42727-00	20 - 3	64E-43820-01	24 - 16	64E-43892-00	25 - 34	68F-44533-00	2 - 23		29 - 15
	21 - 33	64D-42738-00-5B	20 - 20	64E-43821-01	24 - 17	6E5-43896-00	25 - 9		3 - 35	663-45376-00-94	27 - 14
682-41237-50	21 - 31	64D-42738-10-5B	20 - 21	64E-43822-00	24 - 18	64E-43897-00	24 - 25	6G5-44551-01-8D	23 - 13	6E5-45378-00	27 - 16
6R3-41241-00	9 - 23	6R3-42741-02-8D	20 - 33	64E-43825-02	24 - 2	64E-43898-00	24 - 8	6E5-44552-01-94	23 - 24	6J8-45378-00	29 - 17
6R5-41241-00	10 - 20	6H4-42748-00	20 - 4	64E-43827-00	25 - 22	6E5-44117-00-1S	21 - 38	6E5-44553-01-8D	23 - 27	6G5-45383-01	27 - 72
6E5-41256-01	6 - 23	68F-42753-00	20 - 47	64E-43828-00	24 - 23	6E5-44118-01-94	21 - 46	6G5-44555-00-94	23 - 16		29 - 71
	7 - 23	6E5-42761-00-1S	2 - 21	64E-43829-00	24 - 24	6E5-44120-03	21 - 53	663-44575-00	23 - 37	6G5-45384-00	27 - 73
661-41262-02	6 - 24		3 - 33	64E-4382G-00	24 - 30	6E5-44120-23	21 - 53	6E5-44575-00	23 - 15		29 - 72
	7 - 24	6E5-42762-00-1S	2 - 22	64E-43830-00	25 - 4	68F-44121-00	21 - 40	6E5-45111-02-8D	26 - 1	6G5-45501-01	27 - 47
6R3-41271-00	6 - 25		3 - 34	64E-43831-00	25 - 2	6E5-44122-00	21 - 41	6E5-45111-23-8D	26 - 1	6G5-45501-21	27 - 47
61H-41271-10	7 - 25	6E5-42769-00	26 - 5	64E-43841-00	25 - 7	6K1-44150-01	29 - 22	68F-45113-00	26 - 14		29 - 46
689-41273-00	6 - 26	6R3-42771-01-8D	20 - 37	64E-43843-00	25 - 6	6G5-44150-02	27 - 23		39 - 19	61A-45527-00	27 - 11
	7 - 26	6G5-42791-10	20 - 49	64E-43843-10	25 - 38	688-44194-00	21 - 15		40 - 20		29 - 12
688-41611-00	16 - 13	6R3-42791-41	26 - 2	64E-4384J-00	24 - 19		21 - 30	6G5-45114-A1	26 - 23	6G5-45536-01	27 - 13
688-41612-00	16 - 14	6R3-42792-41	26 - 3	64E-43850-00	25 - 15	61A-44311-01	27 - 26		41 - 3		29 - 14
6G5-41631-01-1S	21 - 10	64D-42814-00	1 - 6	64E-43851-00	25 - 11		29 - 25	663-45119-00	22 - 14	61A-45538-00	27 - 12
61H-41632-02-1S	21 - 7	64D-42815-00-4D	20 - 5	64E-43855-00	25 - 14	6E5-44312-00	27 - 31		22 - 25		29 - 13
6G5-41636-01	21 - 25	64D-42816-00-4D	20 - 6	64E-43858-00	25 - 12		29 - 30	64D-45123-00	26 - 40	6G5-45551-10	27 - 48
6E5-42510-A1-8D	23 - 10	64D-42818-20	20 - 12		25 - 18	6E5-44315-A0	27 - 35	6E5-45123-00	26 - 33		29 - 47
6E5-42510-B1-8D	23 - 10	64D-42818-30	20 - 13	6E5-43858-00	24 - 29		29 - 34		41 - 6	6K1-45560-01	29 - 49
64E-42610-50-4D	1 - 1	64D-42835-00	20 - 7	72X-43858-00	25 - 5		41 - 13	6E5-45155-00	26 - 4	6G5-45560-10	27 - 50
64E-42610-T0-4D	1 - 1	64E-43111-02-8D	22 - 1	64E-43859-00	25 - 13		41 - 24	6J9-45214-00	28 - 8	6G5-45567-01	27 - 5
64D-42613-00-4D	1 - 10	64E-43112-02-8D	22 - 9	64E-43860-00	25 - 20	61A-44322-02	27 - 27		30 - 8		29 - 6
64D-42615-00	1 - 9	64E-43126-00	22 - 37	6E5-43862-00	24 - 11		29 - 26	6J9-45215-00	28 - 9	6G5-45567-10	27 - 5
6R3-42647-00	1 - 2	64E-43131-01	22 - 15		24 - 15		41 - 19		30 - 9		29 - 6
64D-42662-00	1 - 5	64E-43139-10	23 - 1	6G5-43863-00	25 - 10	6R3-44322-42	41 - 29	6G5-45251-02	22 - 2	6G5-45567-20	27 - 5
64E-42677-40	1 - 12	64D-43144-00	20 - 14	6E5-43864-00	24 - 21	6G5-44323-00	27 - 34	64E-45300-02-8D	27 - 1		29 - 6
64E-42677-50	1 - 12	6G5-43144-00	22 - 27	6G5-43864-00	24 - 20		29 - 33	64E-45300-22-8D	27 - 1	6G5-45567-30	27 - 5
64D-42677-B0	1 - 13	6E5-43145-01	32 - 8	64E-43865-00	25 - 16		41 - 23	64H-45300-22-8D	29 - 1		29 - 6

NUMERICAL INDEX

PART NO.	REF. NO.	PART NO.	REF. NO.	PART NO.	REF. NO.	PART NO.	REF. NO.	PART NO.	REF. NO.	PART NO.	REF. NO.
6G5-45567-40	27 - 5	6G5-45631-10	29 - 59	704-48166-00	36 - 56	EL8-48245-00	36 - 31	6E5-61303-00	33 - 5	6E5-82147-00	22 - 26
	29 - 6	6E5-45633-01	27 - 61	704-48167-11	36 - 69	701-48246-00	36 - 5	6E5-61311-11	33 - 3	6E5-82147-20	22 - 26
6G5-45567-50	27 - 5		29 - 60	704-48176-10	36 - 51	703-48246-00	35 - 23	6E5-61313-00	33 - 2	6E5-82148-00	22 - 6
	29 - 6	6E5-45634-01	27 - 54	704-48178-00	36 - 66	701-48248-00	35 - 13	6E5-61315-00	33 - 4		22 - 10
6G5-45567-60	27 - 5		29 - 53	703-48189-00	35 - 17		36 - 38	6E5-61350-02	32 - 1	6E5-82149-00	23 - 19
	29 - 6	6K1-45641-01	29 - 52	EL8-48191-00	36 - 16	EL8-48251-00	36 - 3	6E5-61351-01	32 - 2	6R3-82150-00	17 - 2
6K1-45570-20	29 - 63	6E5-45641-03	27 - 53	704-48192-00	36 - 44	703-48252-00	35 - 12	6E5-61355-00	32 - 5	1E6-82151-00	37 - 13
6G5-45571-02	27 - 64	6G5-45930-00-98	28 - 22	704-48192-P0	36 - 52	EL8-48254-00	36 - 27	6E5-81332-00	16 - 16		37 - 13
6K1-45576-00	29 - 64	6G5-45932-00-98	28 - 22	703-48198-00	35 - 14	EL8-48259-00	36 - 7	64D-81337-01	16 - 19	663-82151-00	18 - 8
6G5-45576-10	27 - 65	6G5-45941-00-98	28 - 22	703-48205-17	34 - 1	704-48261-00	36 - 15	64D-81337-10	16 - 19	705-82151-00	17 - 3
6G5-45577-02	27 - 69	6G5-45943-01-98	28 - 22		35 - 1	703-48261-01	35 - 2	6K7-81338-01	7 - 14		18 - 9
	29 - 69	6G5-45945-01-98	28 - 22	704-48207-P1	34 - 2	704-48262-00	36 - 8	6N7-81800-10	19 - 1	6G5-82152-00	17 - 4
6G5-45577-10	27 - 69	6G5-45947-01-98	28 - 22		36 - 1	703-48264-00	35 - 6	6N7-81801-00	19 - 8		18 - 52
	29 - 69	6G5-45949-00-98	28 - 22	703-48211-01	35 - 61	704-48264-00	36 - 9	6N7-81807-00	19 - 11	6A0-82317-00	11 - 31
6G5-45577-20	27 - 69	6G5-45952-00-98	28 - 22	703-48212-00	35 - 58	703-48265-00	35 - 9	61A-81809-00	19 - 3	6G5-82317-00	16 - 20
	29 - 69	6K1-45970-01-98	30 - 19	703-48213-00	35 - 59	704-48265-00	36 - 4	6N7-81810-00	19 - 5	663-82317-01	16 - 21
6G5-45577-30	27 - 69	6G5-45970-02-98	28 - 22	703-48215-00	35 - 43	703-48268-00	35 - 5	6N7-81813-00	19 - 9	6E3-82370-21	18 - 2
	29 - 69	6R1-45970-A1	30 - 19	704-48215-30	36 - 12	703-48271-00	35 - 60	6N7-81820-10	19 - 10	6K1-82510-06	38 - 3
6G5-45577-40	27 - 69	6R4-45970-A1	28 - 22	703-48219-00	35 - 30	704-48271-00	36 - 22	6K7-81822-00-94	19 - 19	703-82510-43	35 - 44
	29 - 69	6K1-45972-01-98	30 - 19	704-48219-P0	36 - 49	EL8-48279-00	36 - 47	6R3-81822-00-94	19 - 19	662-82519-00	17 - 26
6G5-45577-50	27 - 69	6G5-45972-02-98	28 - 22	703-48221-00	35 - 56	703-48281-00	35 - 31	61A-81824-00	19 - 4	6R3-82519-00	17 - 27
	29 - 69	6R1-45972-A0	30 - 19	704-48221-P0	36 - 67	704-48281-00	36 - 13	6K7-81826-11	19 - 14	703-82531-00	35 - 46
6G5-45577-60	27 - 69	6R4-45972-A0	28 - 22	703-48222-00	35 - 27	EL8-48281-00	36 - 11	6E5-8182A-10	19 - 17		37 - 28
	29 - 69	6K1-45974-02-98	30 - 19	704-48222-P0	36 - 32	703-48282-00	35 - 32	6E5-8182E-10	19 - 15	6E5-82531-10	18 - 6
6K1-45578-01	29 - 73	6G5-45974-03-98	28 - 22	703-48223-00	35 - 28	704-48283-00	36 - 17	6E5-8182F-10	19 - 16	6K1-82532-00	38 - 5
6K1-45578-10	29 - 73	6R1-45974-A0	30 - 19	703-48225-00	35 - 29	703-48284-00	35 - 52	6K7-8182G-10	19 - 6	703-82540-00	35 - 50
6K1-45578-20	29 - 73	6R4-45974-A0	28 - 22	6X3-48225-20	36 - 43	704-48284-P0	36 - 57	6E5-8182K-10	19 - 18	704-82540-30	36 - 10
6K1-45578-30	29 - 73	6G5-45976-01-98	28 - 22	703-48226-00	35 - 26	704-48285-10	36 - 65	6N7-81830-00	19 - 13	682-82556-00	35 - 48
6K1-45578-40	29 - 73	6R1-45976-A0	30 - 19	703-48227-00	35 - 24	701-48287-00	35 - 42	6N7-81840-00	19 - 7		38 - 7
6K1-45578-50	29 - 73	6R4-45976-A0	28 - 22	704-48229-P1	36 - 35	704-48287-00	36 - 20	6N7-81850-10	19 - 2	688-82560-10	18 - 18
6K1-45578-60	29 - 73	6K1-45978-02-98	30 - 19	704-48229-R0	36 - 60	703-48291-10	35 - 39	6N7-81857-00	19 - 12	6R3-82563-00	18 - 28
6E5-45587-01	27 - 41	6G5-45978-03-98	28 - 22	704-48231-00	36 - 25	703-48293-10	35 - 41	6E5-81900-01	11 - 9	703-82563-02	35 - 55
	29 - 40	6R1-45978-A0	30 - 19	703-48232-00	35 - 62	701-48320-40	34 - 3	6E5-81922-00	11 - 10	704-82563-51	36 - 34
6E5-45587-10	27 - 41	6R4-45978-A0	28 - 22	704-48232-P1	36 - 40	701-48320-50	34 - 3	61A-81941-00	18 - 32	704-82563-H1	36 - 61
	29 - 40	6E5-45987-01	28 - 17	704-48233-00	36 - 53	701-48320-60	34 - 3	64D-81942-00	17 - 5	704-82563-J1	36 - 64
6E5-45587-20	27 - 41		30 - 14	703-48234-00	35 - 18	701-48320-80	34 - 3	6G5-81948-11	18 - 39	6K1-82570-08	38 - 1
	29 - 40	688-45997-01	28 - 18	704-48234-00	36 - 48	6E5-48344-00	21 - 8	6E5-81950-00	18 - 34	6K1-82571-02	38 - 2
6E5-45587-30	27 - 41		30 - 15	703-48235-00	35 - 4		21 - 44	704-81950-10	36 - 58	6K1-82575-00	38 - 6
	29 - 40	704-48119-41	36 - 68	704-48235-00	36 - 54	703-48345-01	35 - 19	689-81952-10	18 - 33	688-82575-01	35 - 47
6E5-45587-40	27 - 41	EL8-48127-00	36 - 23	703-48236-00	35 - 16		36 - 19	6E5-8195A-00	18 - 35	703-82577-00	35 - 45
	29 - 40	704-48128-00	36 - 2	703-48238-00	35 - 22	701-48350-00	34 - 3	6R3-81960-10	17 - 1		38 - 4
6E5-45587-50	27 - 41		36 - 62	704-48238-00	36 - 39	701-48350-20	34 - 3	6K1-81980-00	38 - 18	6E3-8257H-00	20 - 51
	29 - 40	704-48144-20	36 - 50	EL8-48241-00	36 - 26	703-48358-00	35 - 20	6R3-82195-02	18 - 44	6E5-82587-00	18 - 29
6E5-45587-60	27 - 41	703-48152-00	35 - 57	704-48242-10	36 - 42		36 - 24	6E5-82116-00	18 - 38	6E5-82588-00	18 - 46
	29 - 40	703-48153-00	35 - 3	703-48243-00	35 - 15	64D-48531-00	21 - 1	6Y5-82117-00	37 - 14		20 - 30
6J9-45611-01	27 - 52	704-48153-00	36 - 55	703-48244-00	35 - 21	64D-48532-00	21 - 2		37 - 27	6K7-82588-00	18 - 15
6K1-45611-10	29 - 51	704-48156-00	36 - 63	EL8-48244-00	36 - 30	6E5-48538-00	21 - 3	6E5-82117-01	18 - 45	61B-8258A-01	38 - 24
6G5-45631-10	27 - 60	EL8-48164-00	36 - 41	703-48245-00	35 - 11	6E5-61301-01	33 - 1	6G5-82119-00	18 - 37	688-8258A-20	35 - 49

NUMERICAL INDEX

PART NO.	REF. NO.	PART NO.	REF. NO.	PART NO.	REF. NO.	PART NO.	REF. NO.	PART NO.	REF. NO.	PART NO.	REF. NO.
6K1-8258A-40	38 - 23	6E5-85720-05	11 - 15	90119-06M61	17 - 22	90171-18M04	30 - 17	90250-08M07	29 - 58	90445-07M12	3 - 20
	38 - 23	6R3-85721-30	11 - 16	90119-06M65	11 - 33	90179-06066	23 - 30	90280-04M05	27 - 33	90445-07M28	6 - 10
704-82590-10	36 - 59	6R3-85721-80	11 - 16	90119-06MA2	2 - 20	90179-06M24	1 - 11		29 - 32	90445-07M33	28 - 14
64D-82590-20	18 - 7	6R3-85730-03	11 - 27		2 - 24	90179-06M28	6 - 21		41 - 27	90445-07M34	3 - 23
703-82591-00	35 - 53	6Y5-85752-02	37 - 25		3 - 32		7 - 21	90280-05015	16 - 8	90445-07M45	6 - 11
703-82592-00	35 - 54	61A-85790-00	18 - 19		3 - 36	90183-05M02	26 - 32	90282-04M00	27 - 71	90445-07M46	6 - 12
688-82594-00	18 - 10	6K1-85830-01	38 - 13		4 - 7	90185-05002	28 - 11		29 - 70	90445-07M59	6 - 14
703-82594-00	35 - 25	6R5-85895-01	16 - 5		4 - 16		30 - 11	90336-08M06	7 - 9	90445-07M72	9 - 10
704-82594-00	36 - 33	64D-86110-01	18 - 24		21 - 39	90185-09M01	32 - 6	90340-08002	27 - 6		10 - 12
6R3-8259E-00	17 - 25	64E-86110-01	18 - 24	90119-06MA3	6 - 19		33 - 11		29 - 7	90445-07M77	10 - 10
703-83383-02	35 - 51	6Y5-87122-S0	37 - 11	90119-06MA4	5 - 6	90185-12M12	23 - 36	90340-14M00	2 - 8	90445-07M83	9 - 12
688-83383-11	38 - 12		37 - 20	90119-06MA5	5 - 17	90185-22M11	22 - 20		3 - 11	90445-07M85	10 - 11
6Y5-8350F-00	37 - 19	6G5-87149-10	18 - 36	90119-06MA6	5 - 11	90201-06068	20 - 9	90384-06M07	2 - 4	90445-07M87	9 - 14
6Y5-8350T-90	37 - 1	64D-W0001-01	39 - 1	90119-08077	26 - 16	90201-08M13	21 - 23		3 - 7		10 - 15
6Y5-83533-T2	37 - 9	64H-W0001-01	40 - 1	90119-08078	26 - 9	90201-08M23	21 - 18	90384-14M09	2 - 5	90445-07M89	9 - 11
6Y5-83553-00	37 - 12	6G5-W0001-C1	41 - 1	90119-08M14	27 - 37	90201-08M54	20 - 26		3 - 8	90445-07M90	3 - 22
6Y5-83553-F1	37 - 24	6E5-W0004-00	6 - 2		29 - 36	90201-10060	24 - 31	90386-06M12	21 - 45	90445-07M96	9 - 15
6Y5-83553-M0	37 - 12		7 - 2		41 - 26	90201-10M20	32 - 7	90386-10M16	22 - 31	90445-07MA3	6 - 29
6Y5-83557-00	37 - 17	64D-W0070-30	1 - 16	90119-08M22	20 - 28	90201-10M76	33 - 8	90386-12089	21 - 19		7 - 28
6Y5-83557-10	37 - 17	64D-W0070-S0	1 - 16	90119-08M57	19 - 22	90201-12M05	22 - 42	90386-15M73	20 - 10	90445-07ME8	27 - 17
6E9-83557-70	18 - 42	61A-W0078-2A	41 - 28	90119-08M76	19 - 20	90201-13M01	22 - 41	90386-16M66	21 - 55	90445-07ME9	27 - 17
6E5-83558-00	28 - 15	61A-W0078-A3	41 - 18	90119-08M77	19 - 21	90201-14M56	23 - 34	90386-22M13	21 - 21	90445-09097	5 - 18
6E5-83558-10	27 - 18	64E-W0090-15-1S	2 - 1	90119-08M79	26 - 15	90201-15M58	23 - 21	90386-22M98	22 - 38	90445-11M00	11 - 13
6Y5-8355X-T1	37 - 5	64E-W0090-S5-1S	3 - 1	90119-08M94	2 - 12	90201-16M55	23 - 18		24 - 35	90445-11M26	11 - 13
	37 - 10	64D-W0093-01	39 - 20		3 - 16	90201-21M18	16 - 9	90386-25M31	22 - 18	90445-11M35	20 - 44
	37 - 21		40 - 21	90119-08MA3	2 - 17	90201-22M01	27 - 10	90386-38M32	23 - 12	90445-11M81	11 - 13
6Y5-83570-S5	37 - 6	656-W2810-02	11 - 43		3 - 29		29 - 11	90387-06119	11 - 32	90445-12207	11 - 35
6R3-83614-00	18 - 30	6R3-Y125J-70	20 - 41	90119-08MA8	5 - 3	90201-23M01	4 - 26	90387-06M03	17 - 20	90445-12M13	11 - 35
6K1-83614-01	38 - 8	90101-08M14	21 - 17	90119-10M89	28 - 7	90201-26M57	23 - 32	90387-06M29	21 - 35	90445-13M01	14 - 2
6K1-83623-41	16 - 23	90101-09M70	33 - 9		30 - 7	90201-26M59	22 - 19	90387-06M66	17 - 6		15 - 2
6A1-83625-41	16 - 22	90101-12M03	22 - 40	90149-05M05	38 - 19	90201-30M92	27 - 70	90387-08M16	21 - 20		31 - 9
6Y5-83653-00	37 - 16	90101-12M05	22 - 40	90152-05M08	28 - 10	90201-38M60	23 - 11	90387-08M17	21 - 16	90445-13M02	13 - 41
6Y5-83653-20	37 - 15	90101-12M77	22 - 40		30 - 10	90202-05088	9 - 28	90387-08M37	20 - 25	90445-13M03	13 - 40
6Y5-83653-30	37 - 15	90105-10M00	28 - 13	90157-05M19	31 - 4		10 - 28	90387-10M05	22 - 34	90445-13M35	15 - 4
	37 - 15		30 - 13	90157-06013	21 - 12	90202-08M20	21 - 42	90387-10M61	32 - 3		31 - 11
6Y5-83653-40	37 - 15	90105-10M20	2 - 11	90157-06M00	21 - 28	90202-08M44	9 - 22	90430-08020	27 - 8	90446-15M07	12 - 46
67H-83672-00	23 - 3		3 - 15	90157-06M07	21 - 28		10 - 23		29 - 9	90464-07M05	3 - 24
72X-85075-L0	25 - 21	90109-06M40	9 - 7	90158-06003	37 - 26	90202-12092	21 - 22		41 - 5		6 - 15
6R3-85510-00	16 - 2		10 - 7	90159-06M08	7 - 30	90202-16061	21 - 56	90430-14115	2 - 9		9 - 16
663-85518-00	21 - 11	90109-08022	4 - 24	90159-06M11	17 - 24	90202-26M18	23 - 33		3 - 12		10 - 16
64D-85537-00	17 - 23	90109-12007	23 - 35	90159-06M14	6 - 31	90202-32M19	23 - 17	90445-05M02	11 - 30	90464-07M20	3 - 25
64D-85540-01	17 - 15	90109-14M34	23 - 20	90169-05M00	20 - 2	90202-40M47	23 - 7	90445-07196	10 - 13	90464-13M34	11 - 40
64E-85540-01	17 - 15	90116-06M30	6 - 17	90170-09M05	33 - 10	90206-10M04	21 - 36	90445-07M07	10 - 17	90464-15M11	16 - 7
6R3-85542-03-1S	17 - 19		7 - 16	90170-14M06	33 - 6	90206-15M18	20 - 11	90445-07M08	3 - 21		17 - 12
64D-85550-02	16 - 1	90116-08026	2 - 13	90170-16M01	27 - 49	90206-22M19	27 - 9	90445-07M09	3 - 19	90464-20258	20 - 48
6R3-85570-01	18 - 1		3 - 17		29 - 48		29 - 10		6 - 13	90465-05M87	17 - 18
64D-85580-00	16 - 3	90119-06M10	27 - 22	90170-20137	16 - 10	90249-06M19	22 - 33	90445-07M10	3 - 13		18 - 11
6E5-85711-40	17 - 30		29 - 21	90171-18M04	28 - 20	90250-08M07	27 - 59	90445-07M11	3 - 18	90465-06M86	5 - 27

NUMERICAL INDEX

PART NO.	REF. NO.	PART NO.	REF. NO.	PART NO.	REF. NO.	PART NO.	REF. NO.	PART NO.	REF. NO.	PART NO.	REF. NO.
90465-06M86	16 - 4	90468-18008	21 - 43	92990-06600	20 - 16	93101-28M16	29 - 38	93211-04001	4 - 6	93700-06M03	22 - 13
	18 - 21	90480-06M19	14 - 4		38 - 17		41 - 14		39 - 10		22 - 24
90465-06M88	17 - 11		20 - 2	92990-08600	19 - 23	93101-30M17	27 - 67		40 - 10	94702-00247	5 - 28
90465-08M63	22 - 23	90480-09M12	17 - 21		35 - 34		29 - 67	93306-208U0	4 - 10	95303-06600	21 - 14
90465-08M89	18 - 12	90480-10M28	7 - 15	92990-10600	18 - 20		41 - 17	93306-209U0	27 - 63		21 - 29
90465-10M91	6 - 16	90480-13M24	16 - 20	92990-18200	28 - 19	93102-08M43	25 - 36	93310-32337	4 - 25	95380-03600	12 - 31
	9 - 18	90480-20M05	5 - 21		30 - 16	93102-35M13	4 - 13	93310-836V2	4 - 27		13 - 31
90465-11M10	9 - 9	90480-22M15	20 - 24	92995-06100	22 - 5		39 - 11	93310-954U1	4 - 8	95380-04600	37 - 4
	10 - 9	90480-25161	18 - 5	92995-06600	1 - 8		40 - 11	93311-928U5	27 - 3		37 - 8
	11 - 5	90501-11M10	27 - 25		16 - 18	93102-40M14	4 - 5		29 - 3		37 - 23
	11 - 8		29 - 24		17 - 10		39 - 9	93311-940U3	4 - 4	95380-05600	9 - 25
	11 - 14	90501-12082	21 - 50		17 - 14		40 - 9	93315-425V3	27 - 51		10 - 25
	11 - 37	90501-16M11	5 - 20		17 - 29	93106-09014	27 - 21		29 - 50		21 - 26
	11 - 39	90501-16M12	21 - 13		18 - 4		29 - 20	93315-43061	27 - 66		21 - 32
	12 - 3	90501-16M28	23 - 28		18 - 14		41 - 10		29 - 66		35 - 7
	12 - 4	90501-16M37	27 - 55		18 - 17	93210-03261	18 - 27	93317-330U2	27 - 40		36 - 21
	12 - 14		29 - 54		18 - 23	93210-08287	15 - 7		29 - 39		38 - 11
	12 - 15	90506-14M24	22 - 36		18 - 26		31 - 14	93332-00048	29 - 62		38 - 20
	12 - 19	90506-16M34	20 - 17		18 - 41	93210-09165	21 - 54	93332-000V3	27 - 4	95380-06600	1 - 4
	12 - 37	90508-29M12	21 - 24		18 - 48	93210-10M74	24 - 4	93341-440U5	29 - 65		11 - 23
	12 - 38	90560-12M01	32 - 4		18 - 51	93210-13M04	9 - 21	93341-465U4	29 - 5		35 - 40
	12 - 44	91490-40030	28 - 21		20 - 23		10 - 22	93341-930V2	27 - 42		36 - 37
	12 - 45		30 - 18		20 - 32	93210-16275	32 - 9		29 - 41		38 - 15
	13 - 3	91690-30012	21 - 4		20 - 35	93210-19M82	9 - 6	93390-000U2	29 - 4	95380-08600	12 - 12
	13 - 4	91690-30016	9 - 2		20 - 39		10 - 6	93410-16006	21 - 57		13 - 12
	13 - 14		10 - 2		22 - 8	93210-32738	12 - 8	93410-22M11	22 - 39	95380-08700	26 - 19
	13 - 15	91690-30020	22 - 35		22 - 12		13 - 8	93410-37M04	23 - 14	95380-12600	22 - 43
	13 - 19	92780-06020	36 - 28		26 - 7	93210-37160	27 - 29	93410-40M03	4 - 11	95380-14700	33 - 7
	13 - 37	92903-06100	12 - 11	92995-08100	21 - 6		29 - 28	93420-36M01	26 - 38	95380-14800	23 - 22
	13 - 38		13 - 11		22 - 17		41 - 12	93430-06024	35 - 10	95780-10300	23 - 9
	13 - 45	92903-06600	7 - 19		26 - 18		41 - 21		36 - 6	97013-06014	12 - 10
	13 - 46		16 - 12		26 - 20	93210-37MH7	23 - 6	93501-04M02	21 - 49		13 - 10
	20 - 45		17 - 8	92995-08600	19 - 25	93210-55M14	27 - 43	93503-16003	27 - 58	97013-06050	7 - 18
	20 - 46	92903-08600	21 - 48		26 - 25		29 - 42		29 - 57	97013-06055	17 - 7
	22 - 21	92990-04100	37 - 3		26 - 29		41 - 15	93507-32009	27 - 56	97013-06070	16 - 11
	23 - 5		37 - 7		26 - 36	93210-58144	27 - 20		29 - 55	97013-08030	21 - 47
	28 - 16		37 - 22		27 - 46		29 - 19	93511-32017	27 - 57	97013-08045	21 - 17
	37 - 18	92990-05100	38 - 10		29 - 45		41 - 9		29 - 56	97075-08035	20 - 27
90465-12M25	18 - 49		38 - 21	92995-10100	23 - 26	93210-74M35	4 - 15	93606-12019	27 - 36	97075-10030	24 - 32
90465-13M11	11 - 17	92990-05300	36 - 36		23 - 40		39 - 13		29 - 35	97075-10045	28 - 5
	11 - 26	92990-05600	6 - 5		28 - 6		40 - 13		41 - 25		30 - 5
90465-13M18	5 - 26		7 - 5		30 - 6	93210-86M38	27 - 28	93608-12063	2 - 10	97080-06100	11 - 21
	18 - 43		38 - 22	92995-10600	24 - 33		29 - 27		3 - 14	97090-06012	20 - 15
90468-05M03	9 - 27	92990-06100	1 - 3	92995-14600	23 - 23		41 - 11	93608-12M05	26 - 8	97095-06010	22 - 7
	10 - 27		38 - 16	93101-22M15	4 - 14		41 - 20		26 - 13		22 - 28
90468-07M02	9 - 17	92990-06300	36 - 46		39 - 12	93210-97M55	27 - 68		28 - 4		26 - 6
	10 - 18	92990-06600	11 - 22		40 - 12		29 - 68		30 - 4	97095-06012	1 - 7
90468-18008	21 - 9		17 - 17	93101-28M16	27 - 39		41 - 16	93700-06M03	21 - 52		17 - 9

NUMERICAL INDEX

PART NO.	REF. NO.	PART NO.	REF. NO.	PART NO.	REF. NO.	PART NO.	REF. NO.	PART NO.	REF. NO.	PART NO.	REF. NO.
97095-06012	17 - 13	97980-05108	8 - 28								
	17 - 28	97980-05116	8 - 26								
	18 - 13		8 - 26								
	18 - 22	97980-05230	23 - 2								
	18 - 31	98580-03015	35 - 38								
	18 - 50	98580-04006	35 - 36								
97095-06016	18 - 25	98580-04010	35 - 35								
	18 - 40	98580-05010	35 - 37								
	20 - 22	98780-04015	2 - 15								
97095-06020	18 - 3		3 - 27								
	18 - 16	98780-05018	36 - 29								
	18 - 47	98980-05010	38 - 9								
	20 - 31	98980-06020	38 - 14								
	20 - 34	99001-08600	27 - 24								
	20 - 38		29 - 23								
97095-06025	21 - 37	9E450-04533	37 - 2								
97095-06030	22 - 4										
97095-06040	20 - 8										
97095-08016	19 - 24										
97095-08020	21 - 5										
	22 - 16										
97095-08025	27 - 45										
	29 - 44										
97095-08030	26 - 24										
97095-08045	26 - 17										
	26 - 28										
	26 - 35										
97095-10045	23 - 25										
	23 - 39										
97380-05025	35 - 8										
97380-06018	36 - 18										
97380-08030	35 - 33										
97595-06420	5 - 24										
97595-06550	12 - 35										
	13 - 35										
97607-04310	25 - 32										
97880-05016	6 - 4										
	7 - 4										
97880-06018	16 - 15										
97880-06020	17 - 16										
97885-05012	16 - 6										
97885-06010	16 - 17										
97885-06012	22 - 11										
97885-06016	23 - 4										
	23 - 29										
97890-05016	36 - 70										
97890-05025	36 - 14										
97890-06018	36 - 45										