



**PARTS
CATALOGUE
CATÁLOGO
DE PEÇAS**

25BMH '07 (69U7)

25BMH '08 (69U8)

25BMH '07/25BMH '08
PARTS CATALOGUE
©2007 by Yamaha Motor Co., Ltd.
1st edition, September 2007
All rights reserved.
Any reprinting or unauthorized use
without the written permission of
Yamaha Motor Co., Ltd.
is expressly prohibited.

25BMH '07/25BMH '08
CATÁLOGO DE PEÇAS
©2007, Yamaha Motor Co., Ltd.
1ª edição, Setembro 2007
Todos os direitos reservados.
É proibida expressamente toda e qualquer
reimpressão ou utilização sem a autorização
por escrita da
Yamaha Motor Co., Ltd.

FOREWORD

This Parts Catalogue is related to the parts for the model(s) on the cover page. When you are ordering replacement parts, please refer to this Parts Catalogue and quote both part numbers and part names correctly.

1. Modifications or additions which have been made after the issue of the Parts Catalogue will be announced in the Parts News.
It is advisable that you make the necessary corrections to the Parts Catalogue according to the Parts News.

2. Abbreviations

The following abbreviations are used in this Parts Catalogue.

“UR” Use specified parts number.

“UN” Use as many as needed.

“AP” Alternate Parts

“LM” Locally Made (Parts need to be ordered locally)

“F#” Frame No. (Applicable machine No.)

“O/S” Over Size

3. The number of components for assembly

- Parts, which are to be supplied in an assembly, are listed with a dot (.) in front of the part name as shown below.
- The numeral appearing to the right of each component part indicates the quantity of parts for each assembly unit.

PART NO.	DESCRIPTION	Q'TY	REMARKS
2F5-83310-60	FRONT FLASHER LIGHT ASSY	2	
115-83311-60	.BULB (6V-18W)	1	

4. Applicable colours of graphics are represented in the “REMARKS” as shown below.

PART NO.	DESCRIPTION	Q'TY	REMARKS
2N4-24110-00-X5	FUEL TANK COMP.	2	MXR
3J1-24240-10	.GRAPHIC, FUEL TANK	1	FOR MXR

5. Note that the illustrations for reference in finding parts numbers are not to be used for assembling. When assembling, please use the applicable service manual.

6. The asterisk (*) before a reference number indicates modified items after the first edition.

7. Applicable Serial No.

Engine Serial No.

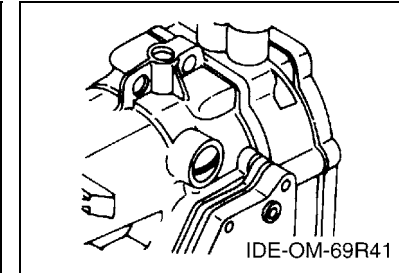
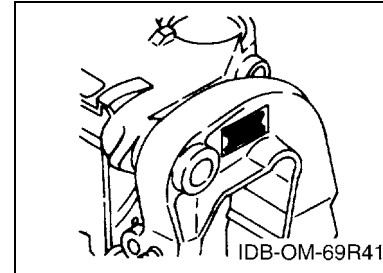

8. Applicable Engine Starting Serial No.

Model	Serial No.	Model	Serial No.
25B '07	69U-1005001	25B '08	69U-1006151

9. Applicable Colour Code

Abbreviation	Colour Name	Colour Code
DBNM2	DARK BLUISH GRAY METALLIC 2	004D

10. Quantity Column Information

Column No.	Name Of Q'ty Column	Applicable Model
1	69U7	25BMH '07
2	69U8	25BMH '08

PREFÁCIO

Este Catálogo de Peças se refere as Peças dos modelos relacionados na capa. Quando for solicitar peças de reposição para estes Modelos, recorra a este Catálogo de Peças e especifique corretamente os códigos e Nomes das Peças.

1. As Modificações ou adições que tenham sido efetuadas após a publicação deste Catálogo de Peças, serão comunicadas a Rede de Concessionárias através das informações de Modificação de Peças (Parts News).

2. Abreviaturas

Seguem abaixo as abreviaturas utilizadas neste Catálogo de Peças:

“UR” Uso Restrito para o Código da Peça

“UN” Uso Necessário

“AP” Peça Alternativa

“LM” Fabricação Local (A peça pode ser pedida localmente)

“F#” No. de Série do Chassi (Aplicação do Número de Série)

“O/S” Tamanho Maior

3. Peças componentes de conjuntos

- As peças que são fornecidas dentro de conjuntos estão listadas com um ponto de identificação (.) como segue abaixo.
- O número que aparece a direita da descrição da Peça indica o número de Peças usado em cada Conjunto Individual.

No. PEÇA	DESCRIÇÃO	QTDE	OBSERVAÇÕES
2F5-83310-60	PISCA DIANTEIRO CONJ.	2	
115-83311-60	.LÂMPADA (6V-18W)	1	

4. Os gráficos que são Aplicados em Peças Coloridas estão representados na coluna “OBSERVAÇÕES”, como segue abaixo.

No. PEÇA	DESCRIÇÃO	QTDE	OBSERVAÇÕES
2N4-24110-00-X5	TANQUE DE COMBUSTÍVEL COMPL.	2	MXR
3J1-24240-10	.GRÁFICO, TANQUE DE COMB.	1	PARA MXR

5. Observe que as ilustrações são referentes apenas a indicação dos códigos das peças, e não para montagem. Para montagem, por favor utilize o Manual de Montagem apropriado.

6. O asterisco (*) antes do Número de referência da peça indica a modificação ocorrida após a primeira edição.

7. Aplicação do Número de Série

No. de Série do Motor

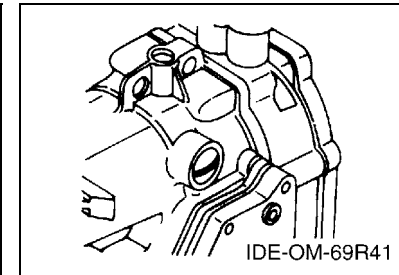
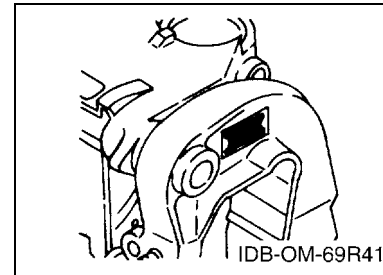

8. Aplicação do No. de Série Inicial

Modelo	No. Série	Modelo	No. Série
25B '07	69U-1005001	25B '08	69U-1006151

9. Aplicação do Código de Cor

Abreviação	Nome da Cor	Código da Cor
DBNM2	DARK BLUISH GRAY METALLIC 2	004D

10. Informação na Coluna de Quantidade

No. da Coluna	Nome na Coluna de Qtde	Modelo Aplicável
1	69U7	25BMH '07
2	69U8	25BMH '08

CONTENTS

TOP COWLING	1
CYLINDER & CRANKCASE	2
CRANKSHAFT & PISTON	4
INTAKE	5
CARBURETOR	6
FUEL	7
STARTER	9
GENERATOR	11
ELECTRICAL	12
BOTTOM COWLING	14
STEERING	15
CONTROL	16
REMO CON ATTACHMENT	18
BRACKET 1	19
BRACKET 2	21
UPPER CASING	23
LOWER CASING & DRIVE 1	24
LOWER CASING & DRIVE 2	27
FUEL TANK	28
REPAIR KIT 1	29
REPAIR KIT 2	30

INDEX

NUMERICAL INDEX	31
-----------------------	----

ÍNDICE GERAL

CAPO SUPERIOR	1
CILINDRO E CARCACA DO MOTOR	2
VIRABREQUIM E PISTAO	4
ADMISSAO	5
CARBURADOR	6
COMBUSTIVEL	7
PARTIDA	9
GERADOR	11
ELETRICO	12
BANDEJA DO CAPO	14
DIRECAO	15
CONTROLE	16
ACESSORIOS DO CONTROLE REMOTO	18
SUPORTE 1	19
SUPORTE 2	21
CAPA INFERIOR	23
CARCACA INF. E TRANSMISSAO 1	24
CARCACA INF. E TRANSMISSAO 2	27
TANQUE DE COMBUSTIVEL	28
KIT DE REPARO 1	29
KIT DE REPARO 2	30
ÍNDICE GERAL	
ÍNDICE NUMÉRICO	31

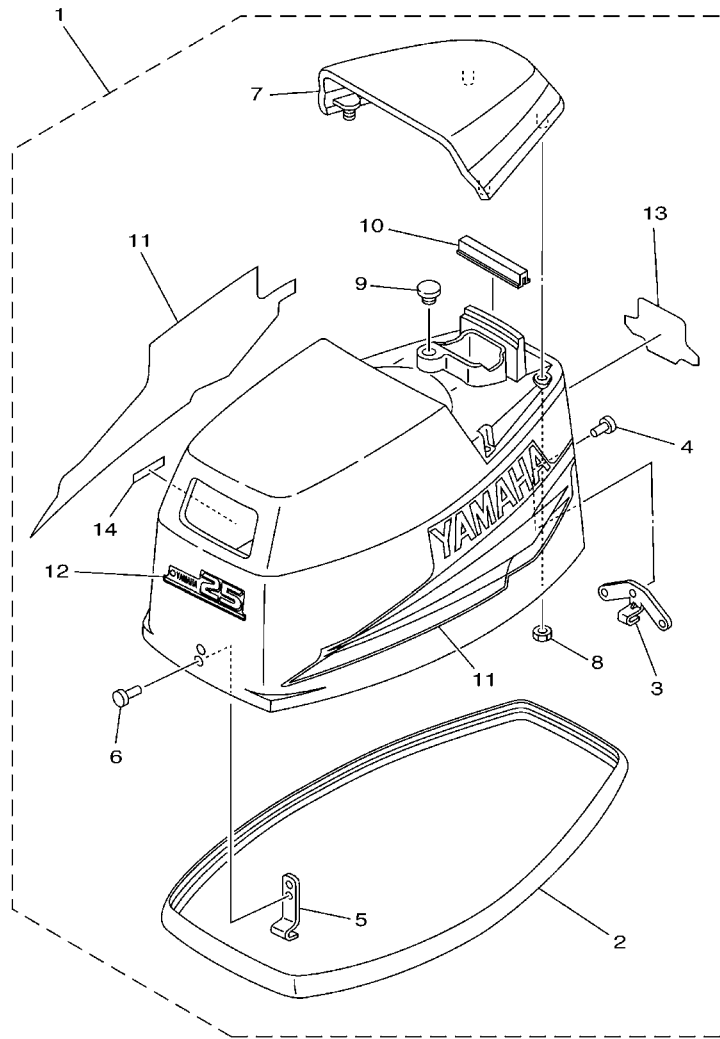

69R2664-2010

FIG. 1 TOP COWLING

CAPO SUPERIOR

REF. NO.	PART NO. No. PEÇA	DESCRIPTION DESCRIÇÃO			REMARKS OBSERVAÇÕES
			69U7	69U8	
1	69R-42610-20-4D	TOP COWLING ASSY CAPO SUPERIOR CONJ.	1	1	
2	6G0-42615-00	.SEAL .VEDACAO	1	1	
3	689-42647-00	.HOLDER, CLAMP BAND .SUPORTE DA BRACADEIRA	1	1	
4	90266-04M01	.RIVET .REBITE	3	3	
5	6G0-42651-02	.HOOK .GANCHO	1	1	
6	90266-04M00	.RIVET .REBITE	2	2	
7	69P-42613-00-4D	.MOLDING, AIR DUCT .MOLDURA DO DUTO DE AR	1	1	
8	90179-06M24	.NUT .PORCA DE REGULAGEM	4	4	
9	90480-14M14	.GROMMET .ILHO DE BORRACHA	1	1	
10	61N-42628-00	.SEAL .VEDACAO	1	1	
11	61R-W0070-10	.GRAPHIC SET .JOGO DE GRAFICOS	1	1	
12	69R-42677-00	.GRAPHIC, FRONT .GRAFICO DIANTEIRO	1	1	
13	61R-42678-10	.GRAPHIC, REAR .GRAFICO TRASEIRO	1	1	
14	6E0-44191-11	.INDICATOR, SHIFT .INDICADOR DE MUDANCA	1	1	

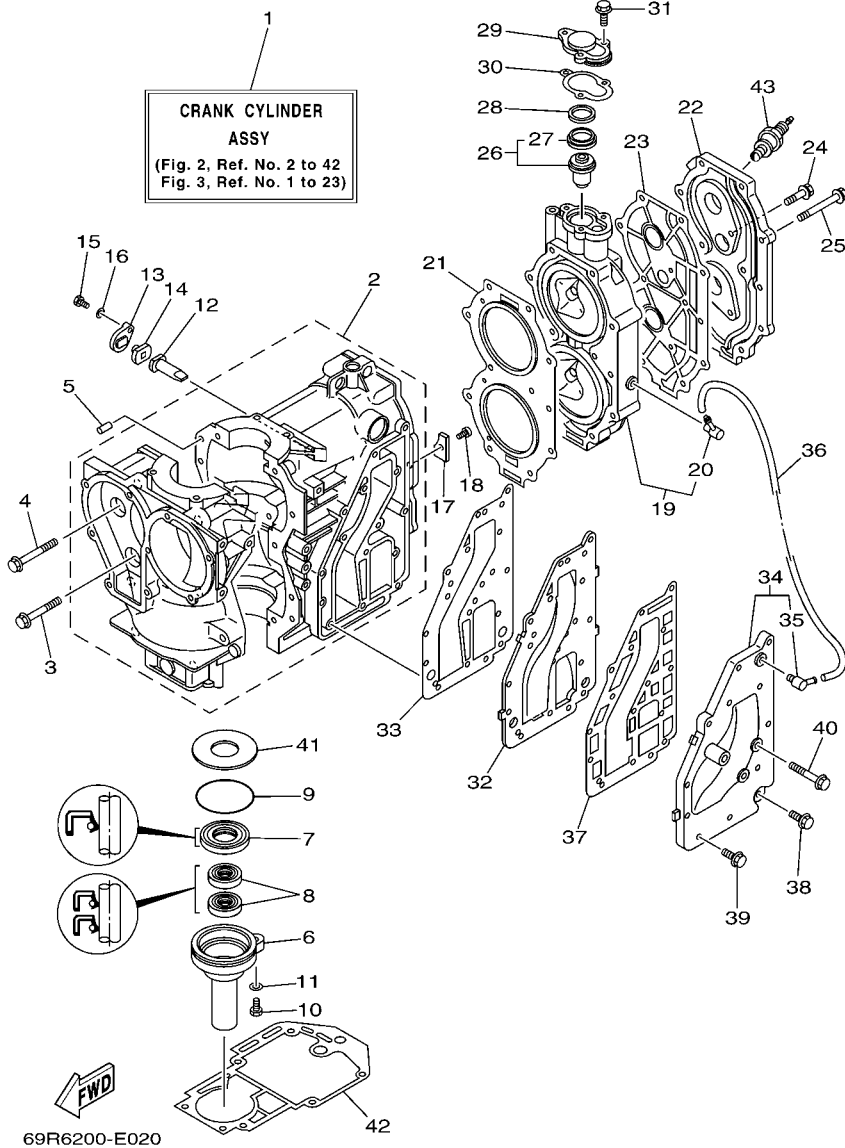
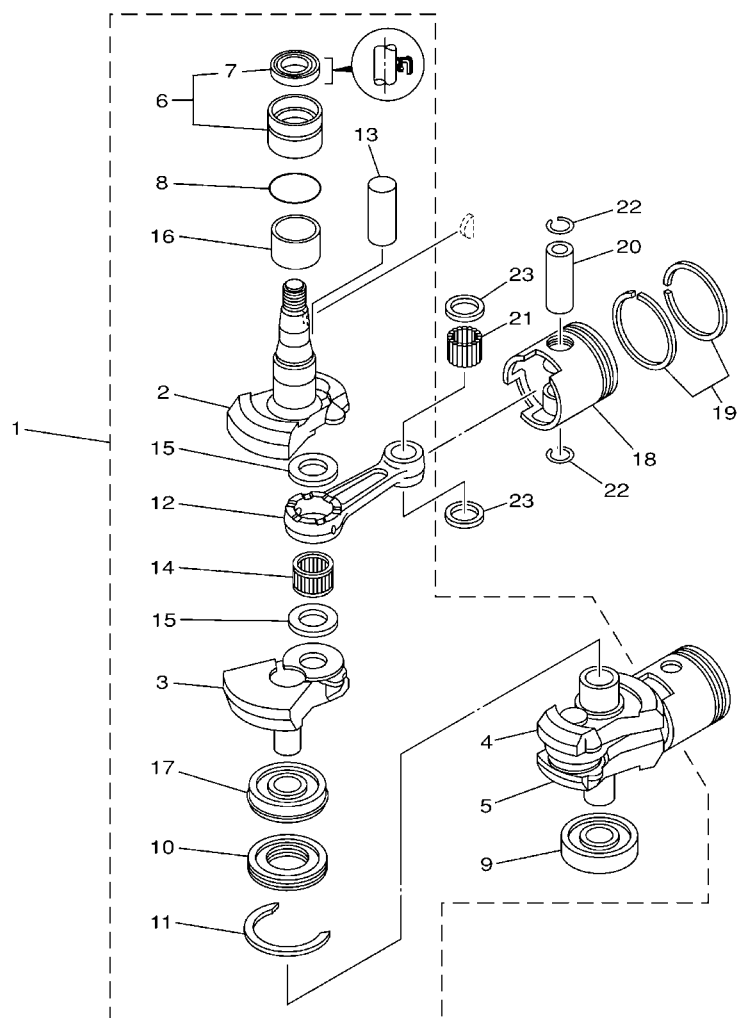

FIG. 2 CYLINDER & CRANKCASE CILINDRO E CARCACA DO MOTOR

REF. NO.	PART NO. No. PEÇA	DESCRIPTION DESCRIÇÃO	69U7	69U8		REMARKS OBSERVAÇÕES
1	69P-W0090-00-1S	CRANK CYLINDER ASSY CARCACA DO CILINDRO CONJ.	1	1		
2	69P-15100-00-1S	CRANKCASE ASSY CARCACA DO MOTOR COMPLETA	1	1		
3	90119-08009	BOLT, WITH WASHER PARAFUSO COM ARRUELA	2	2		
4	90119-08M65	BOLT, WITH WASHER PARAFUSO COM ARRUELA	8	8		
5	93606-12019	PIN, DOWEL PINO GUIA	2	2		
6	689-15396-01-5B	HOUSING, OIL SEAL CAIXA DO RETENTOR DE OLEO	1	1		
7	93102-25008	OIL SEAL RETENTOR DE OLEO	1	1		
8	93101-16001	OIL SEAL RETENTOR DE OLEO	2	2		
9	93210-58M21	O-RING ANEL DE BORRACHA	1	1		
10	97095-06022	BOLT PARAFUSO	1	1		
11	92995-06600	WASHER ARRUELA	1	1		
12	6J8-11325-00	ANODE ANODO	1	1		
13	6H3-11327-00-1S	COVER, ANODE CAPA DO ANODO	1	1		
14	6H3-11328-00	GROMMET, ANODE ILHO DO ANODO	1	1		
15	97013-06016	BOLT PARAFUSO	1	1		
16	92903-06600	WASHER, PLATE ARRUELA PLANA	1	1		
17	689-11325-00	ANODE ANODO	1	1		
18	90151-06M02	SCREW, COUNTERSUNK PARAFUSO TRAMBULADOR	1	1		
19	61N-11111-01-1S	HEAD, CYLINDER 1 CABECOTE DO CILINDRO 1	1	1		
20	676-11372-00	.NIPPLE, HOSE .JUNCAO DA MANGUEIRA	1	1		
21	61N-11181-A1	GASKET, CYLINDER HEAD 1 GAXETA CABECOTE DO CILINDRO 1	1	1		
22	61N-11191-01-1S	COVER, CYLINDER HEAD 1 TAMPA, CABECOTE DO CILINDRO 1	1	1		
23	61T-11193-A1	GASKET, HEAD COVER 1 GAXETA DA TAMPA DO CABECOTE 1	1	1		
24	90119-06MA2	BOLT, WITH WASHER PARAFUSO COM ARRUELA	2	2		
25	90119-08015	BOLT, WITH WASHER PARAFUSO COM ARRUELA	11	11		
26	6E5-12411-02	THERMOSTAT TERMOSTATO	1	1		
27	6E5-12412-00	.SEAL, THERMOSTAT .VEDACAO DO TERMOSTATO	1	1		

FIG. 3 CRANKSHAFT & PISTON

VIRABREQUIM E PISTAO



69R0010-1030

REF. NO.	PART NO. No. PEÇA	DESCRIPTION DESCRIÇÃO	69U7	69U8		REMARKS OBSERVAÇÕES
1	69P-11400-00	CRANKSHAFT ASSY VIRABREQUIM CONJ.	1	1		
2	69P-11412-00	.CRANK 1 .VIRABREQUIM 1	1	1		
3	61N-11422-00	.CRANK 2 .VIRABREQUIM 2	1	1		
4	61N-11432-00	.CRANK 3 .VIRABREQUIM 3	1	1		
5	61N-11442-00	.CRANK 4 .VIRABREQUIM 4	1	1		
6	93399-99951	.BEARING .ROLAMENTO	1	1		
7	93102-32M07	.OIL SEAL .RETENTOR DE OLEO	1	1		
8	93210-46M16	.O-RING .ANEL DE BORRACHA	1	1		
9	93306-305U3	.BEARING .ROLAMENTO	1	1		
10	61N-11515-00	.SEAL, LABYRINTH 1 .VEDACAO DO LABIRINTO 1	1	1		
11	93440-62057	.CIRCLIP .ANEL TRAVA	1	1		
12	689-11651-00	.ROD, CONNECTING .BIELA	2	2		
13	689-11681-01	.PIN, CRANK 1 .PINO DO VIRABREQUIM 1	2	2		
14	93310-62406	.BEARING .ROLAMENTO	2	2		
15	90209-24M03	.WASHER .ARRUELA	4	4		
16	90387-32002	.COLLAR .ESPACADOR	1	1		
17	93390-00009	.BEARING .ROLAMENTO	1	1		
18	61N-11631-00-95	PISTON (STD) PISTAO (STD)	2	2		
	61N-11635-00	PISTON (0.25MM O/S) PISTAO (0.25MM O/S)	2	2		AP
	61N-11636-00	PISTON (0.50MM O/S) PISTAO (0.50MM O/S)	2	2		AP
19	61N-11603-00	PISTON RING SET (STD) JG. DE ANEIS (STD)	2	2		
	61N-11604-00	PISTON RING SET (0.25MM O/S) JG. DE ANEIS (0.25MM O/S)	2	2		AP
	61N-11605-00	PISTON RING SET (0.50MM O/S) JG. DE ANEIS (0.50MM O/S)	2	2		AP
20	689-11633-00	PIN, PISTON PINO DO PISTAO	2	2		
21	93602-20M02	PIN, DOWEL PINO GUIA	68	68		
22	688-11634-00	CLIP, PISTON PIN PRESILHA DO PINO DO PISTAO	4	4		
23	90201-20M27	WASHER, PLATE ARRUELA PLANA	4	4		

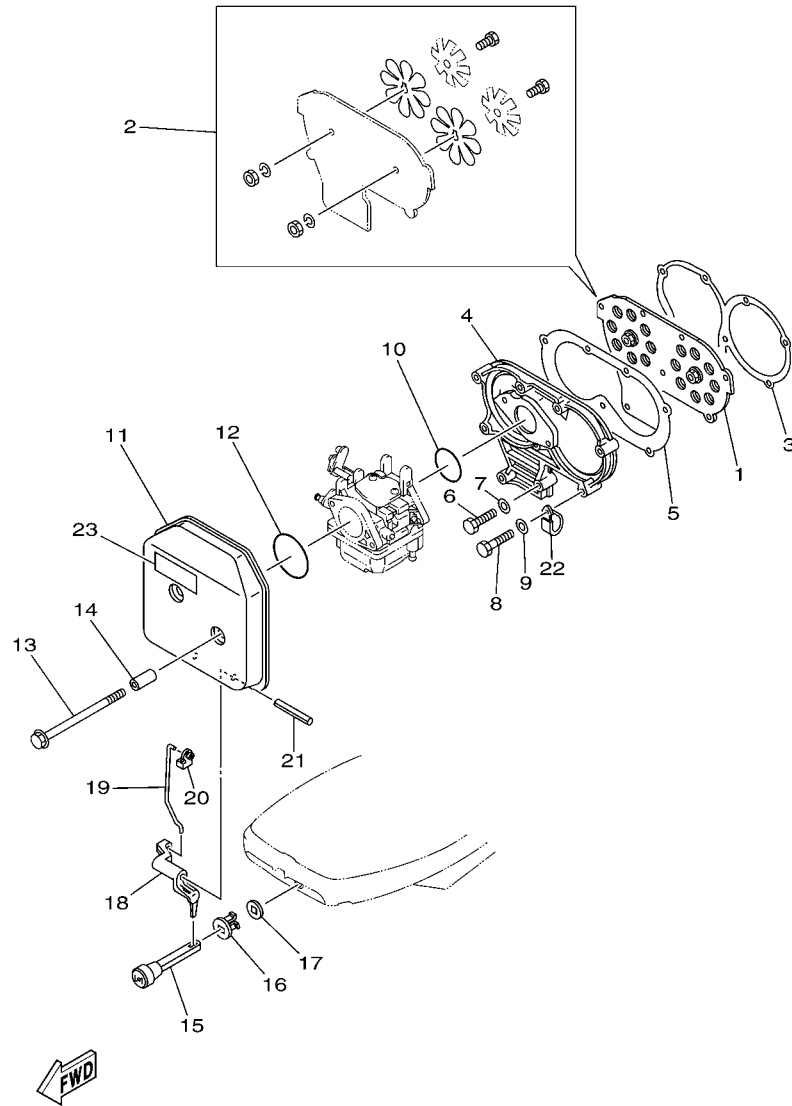

69U8280-G040

FIG. 4 INTAKE

ADMISSAO

REF. NO.	PART NO. No. PEÇA	DESCRIPTION DESCRIÇÃO	69U7	69U8	REMARKS OBSERVAÇÕES
1	61N-13610-00	REED VALVE ASSY VALVULA DA PALHETA COMP.	1	1	
2	689-W0004-00	.REED SET .JOGO DE VALVULAS DA PALHETA	1	1	
3	648-13621-A1	GASKET, VALVE SEAT GAXETA DO ASSENTO DA VALVULA	1	1	
4	61N-13641-01-1S	MANIFOLD 1 TUBO MULTIPLO 1	1	1	
5	648-13645-A0	GASKET, MANIFOLD 1 GAXETA DO TUBO MULTIPLO 1	1	1	
6	97013-06025	BOLT PARAFUSO	2	2	
7	92903-06600	WASHER, PLATE ARRUELA PLANA	2	2	
8	97013-06035	BOLT PARAFUSO	7	7	
9	92903-06600	WASHER, PLATE ARRUELA PLANA	7	7	
10	61N-14198-00	GASKET GAXETA	1	1	
11	61N-14440-00	SILENCER ASSY, INTAKE SILENCIADOR DA ADMISSAO CONJ.	1	1	
12	93210-40659	O-RING ANEL DE BORRACHA	1	1	
13	90119-06M94	BOLT, WITH WASHER PARAFUSO COM ARRUELA	2	2	
14	90387-06M26	COLLAR ESPACADOR	2	2	
15	682-41271-00	KNOB, CHOKE BOTAO DO AFOGADOR	1	1	
16	689-41273-00	GROMMET ILHO	1	1	
17	6J8-41274-00	GROMMET 2 ILHO 2	1	1	
18	689-41252-01	LEVER, CHOKE 1 ALAVANCA DO AFOGADOR 1	1	1	
19	61N-41256-00	ROD, CHOKE 1 HASTE DO AFOGADOR 1	1	1	
20	661-41262-02	JOINT, CHOKE LEVER JUNCAO DA ALAVANCA DO AFOGADOR	1	1	
21	91690-40048	PIN, SPRING PINO MOLA	1	1	
22	90465-06M88	CLAMP BRACADEIRA	1	1	
23	6A1-83625-41	MARK 5 EMBLEMA 5	1	1	

FIG. 5 CARBURETOR

CARBURADOR

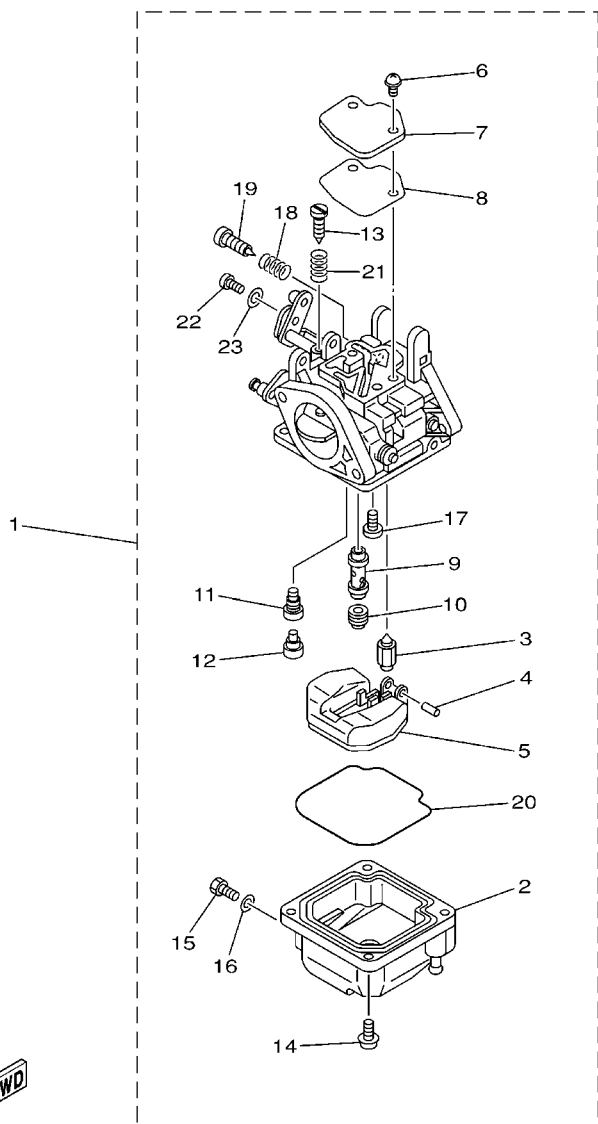

69R0010-1050

REF. NO.	PART NO. No. PEÇA	DESCRIPTION DESCRIÇÃO	69U7	69U8	REMARKS OBSERVAÇÕES
1	69P-14301-10	CARBURETOR ASSY 1 CARBURADOR COMPLETO 1	1	1	
2	61N-14381-00	.BODY, FLOAT CHAMBER .CORPO DA CAMARA DA BOIA	1	1	
3	61N-14392-00	.VALVE, NEEDLE .VALVULA DA AGULHA	1	1	
4	6E5-14386-01	.PIN, FLOAT .PINO DA BOIA	1	1	
5	6L2-14385-00	.FLOAT .BOIA	1	1	
6	97980-04110	.SCREW, WITH WASHER .PARAFUSO	2	2	
7	6L2-14157-00	.COVER, MIXING .TAMPA DO MISTURADOR	1	1	
8	6L2-14399-00	.GASKET .VALVULA BIMETALICA	1	1	
9	61N-14341-00	.NOZZLE, MAIN .PULVERIZADOR PRINCIPAL	1	1	
10	61N-14343-68	.JET, MAIN (#135) .GICLEUR, PRINCIPAL (#135)	1	1	
11	6L2-14342-36	.JET, PILOT (# 72) .GICLEUR PILOTO (# 72)	1	1	
12	50M-14355-00	.PLUG .PULVERIZADOR PRINCIPAL 2	1	1	
13	664-14321-01	.SCREW, THROTTLE .PARAFUSO DE ACELERACAO	1	1	
14	97980-04112	.SCREW, WITH WASHER .PARAFUSO	4	4	
15	677-14383-01	.SCREW, DRAIN .PARAFUSO DE DRENO	1	1	
16	6L2-14398-00	.GASKET .GAXETA	1	1	
17	98980-04006	.SCREW, BIND .PARAFUSO	2	2	
18	646-14212-01	.SPRING, PILOT ADJUSTING .MOLA DE AJUSTE PILOTO	1	1	
19	61N-14323-00	.SCREW, AIR ADJUSTING .PARAFUSO DE AJUSTE DO AR	1	1	
20	6L2-14384-00	.GASKET, FLOAT CHAMBER .GAXETA DA CAMARA DA BOIA	1	1	
21	61N-14212-00	.SPRING, PILOT ADJUSTING .MOLA DE AJUSTE PILOTO	1	1	
22	97890-05006	.SCREW, PAN HEAD .PARAFUSO	1	1	
23	62Y-14597-00	.WASHER .ARRUELA	1	1	

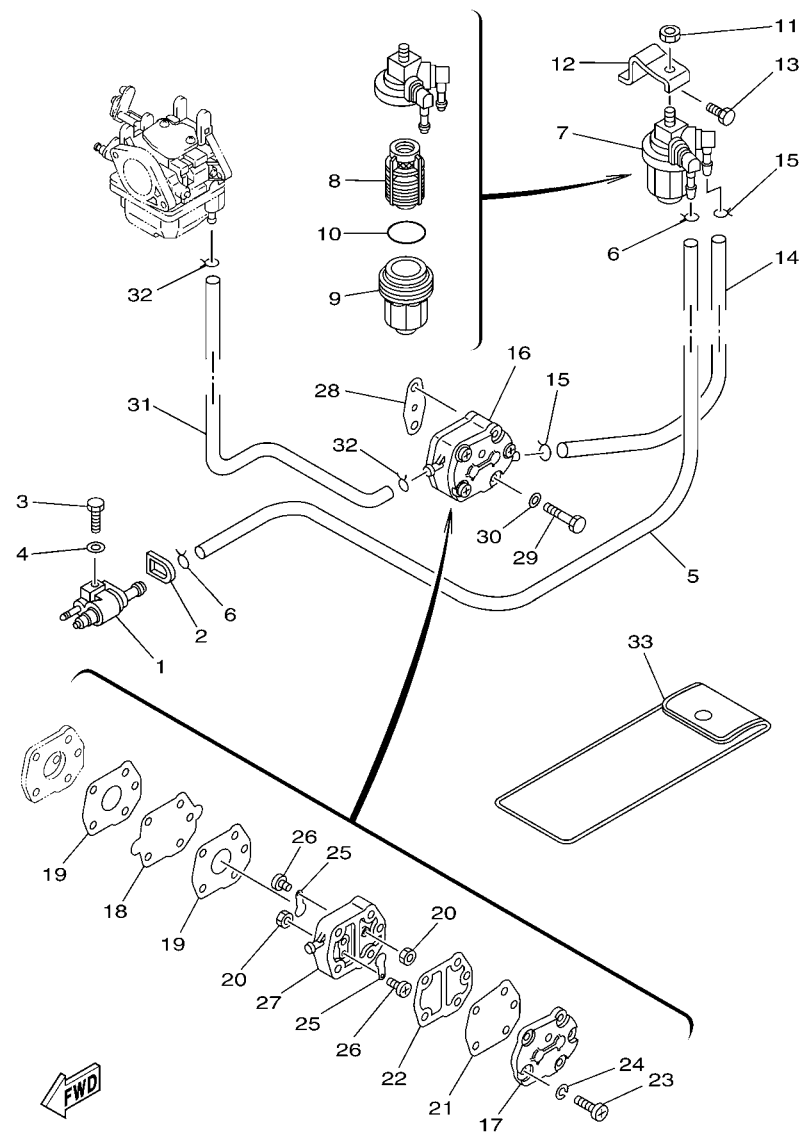

69U8280-G060

FIG. 6 FUEL

COMBUSTIVEL

REF. NO.	PART NO. No. PEÇA	DESCRIPTION DESCRIÇÃO	69U7	69U8	REMARKS OBSERVAÇÕES
1	6G1-24304-02	FUEL PIPE JOINT COMP. 1 JUNCAO TUBO DE COMBUSTIVEL 1	1	1	
2	61N-24329-00	SEAL GUARNICAO	1	1	
3	97095-06020	BOLT PARAFUSO	1	1	
4	92995-06600	WASHER ARRUELA	1	1	
5	90445-09M75	HOSE (L370) TUBO (L370)	1	1	
6	90467-08004	CLIP PRESILHA	2	2	
7	61N-24560-00	FILTER ASSY FILTRO DE COMBUSTIVEL CONJ.	1	1	
8	61N-24563-00	.ELEMENT, FILTER .ELEMENTO DO FILTRO	1	1	
9	61N-24521-00	.CUP, FILTER .COPO DO FILTRO	1	1	
10	93210-32738	.O-RING .ANEL DE BORRACHA	1	1	
11	95380-08600	NUT PORCA	1	1	
12	61N-24566-01	BRACKET, FILTER SUPORTE DO FILTRO	1	1	
13	97013-06014	BOLT PARAFUSO	1	1	
14	689-24311-00	PIPE, FUEL 1 TUBO DE COMBUSTIVEL 1	1	1	
15	90467-08004	CLIP PRESILHA	2	2	
16	692-24410-00	FUEL PUMP ASSY BOMBA DE COMBUSTIVEL CONJ.	1	1	
17	6A0-24413-00	.BODY 2 .CARCACA 2	1	1	
18	692-24411-00	.DIAPHRAGM .DIAFRAGMA	1	1	
19	648-24434-01	.GASKET, BODY .GAXETA DO CORPO DA BOMBA	2	2	
20	95380-03600	.NUT .PORCA	2	2	
21	663-24411-00	.DIAPHRAGM .DIAFRAGMA	1	1	
22	648-24435-02	.GASKET, BODY 2 .GAXETA DO CORPO DA BOMBA 2	1	1	
23	98503-05028	.SCREW, PAN HEAD .PARAFUSO	3	3	
24	92990-05100	.WASHER, SPRING .ARRUELA COM MOLA	3	3	
25	6A0-24421-01	.VALVE, CHECK .VALVULA DA BOMBA	2	2	
26	6A0-14325-00	.SCREW, PAN HEAD .PARAFUSO DE CABECA PANEIA	2	2	
27	6A0-24412-02	.BODY 1 .CARCACA 1	1	1	

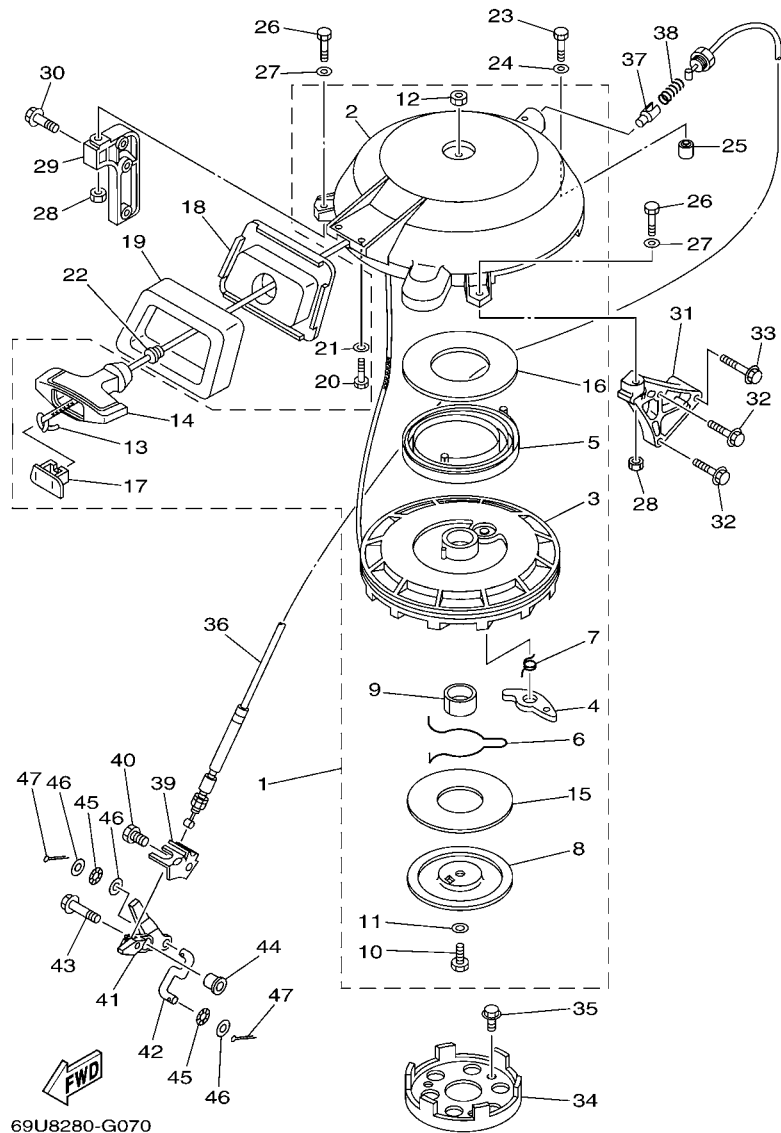

69U8280-G070

*1: CUT FROM 50M ROLLS, PART NO. 90890-44373, CUTTING LENGTH 1.9M

FIG. 7 STARTER

PARTIDA

REF. NO.	PART NO. No. PEÇA	DESCRIPTION DESCRIÇÃO	69U7	69U8	REMARKS OBSERVAÇÕES
1	61N-W1571-11	STARTER ASSY PARTIDA CONJ.	1	1	
2	61N-15711-10	.CASE, STARTER .CAIXA DA PARTIDA	1	1	
3	6G0-15714-01	.DRUM, SHEAVE .TAMBOR DA ROLDANA	1	1	
4	6F5-15741-01	.PAWL, DRIVE .LING?ETA MOTORA	1	1	
5	6F5-15713-01	.SPRING, STARTER .MOLA DA PARTIDA	1	1	
6	61N-15715-00	.SPRING, FRICTION .MOLA DE FRICCAO	1	1	
7	61N-15734-00	.SPRING, RETURN .MOLA DE RETORNO	1	1	
8	6F5-15716-01	.PLATE, DRIVE .PLACA MOTORA	1	1	
9	6G0-15754-00	.BUSH 2 .BUCHA 3	1	1	
10	97013-08030	.BOLT .PARAFUSO	1	1	
11	6F5-15726-01	.WASHER, FLAT .ARRUELA PLANA	1	1	
12	95303-08700	.NUT .PORCA	1	1	
13	*	.WIRE (L:1900MM) .CABO (L:1900MM)	1	1	*1 *1
14	689-15755-01	.HANDLE, STARTER .MANOPLA DE PARTIDA	1	1	
15	6F5-15764-00	.COLLAR 1 .ESPACADOR 1	1	1	
16	6F5-15739-00	.WASHER, THRUST .ARRUELA DE ENCOSTO	1	1	
17	6F5-15779-02	.COVER .TAMPA	1	1	
18	61N-15758-01-4D	GUIDE, ROPE GUIA DO CABO DA PARTIDA	1	1	
19	61N-15762-00	SEAL, RUBBER 2 VEDACAO DE BORRACHA 2	1	1	
20	97095-06016	BOLT PARAFUSO	2	2	
21	92995-06600	WASHER ARRUELA	2	2	
22	6A0-15789-00	DAMPER AMORTIZADOR	1	1	
23	97095-06035	BOLT PARAFUSO	1	1	
24	92995-06600	WASHER ARRUELA	1	1	
25	99530-10014	PIN, DOWEL PINO GUIA	1	1	
26	97095-06035	BOLT PARAFUSO	2	2	
27	92995-06600	WASHER ARRUELA	2	2	

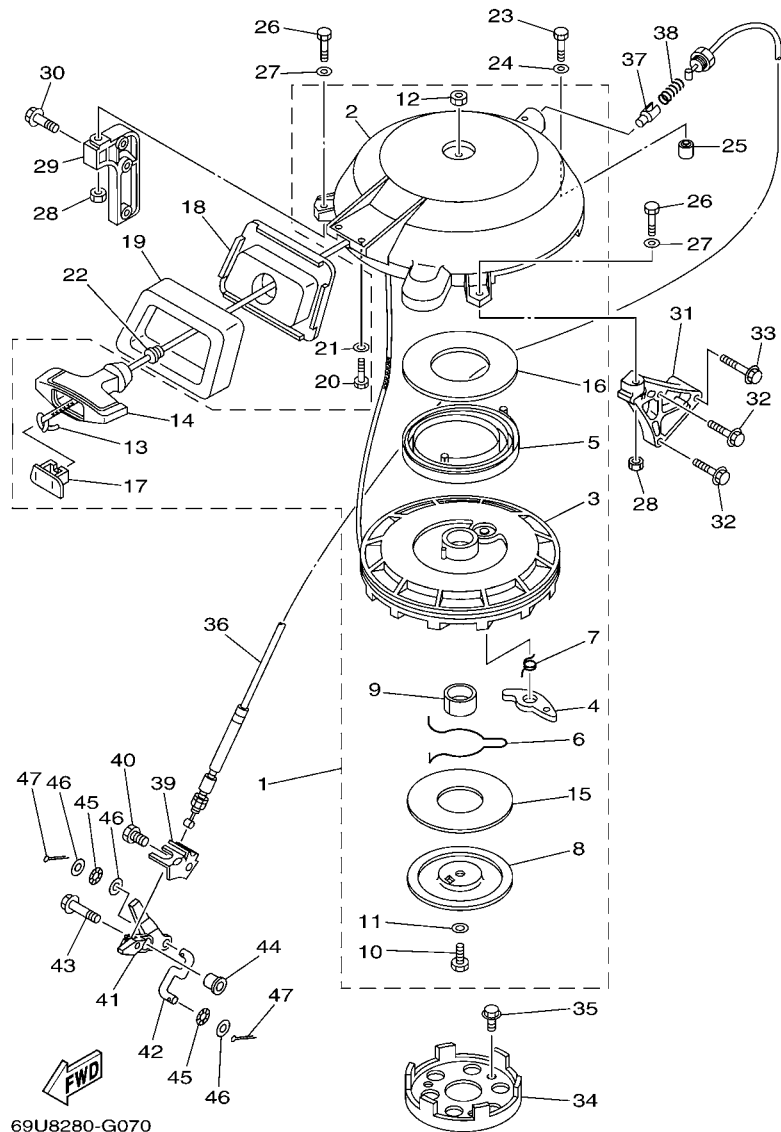

*1: CUT FROM 50M ROLLS, PART NO. 90890-44373, CUTTING LENGTH 1.9M

FIG. 7 STARTER

PARTIDA

REF. NO.	PART NO. No. PEÇA	DESCRIPTION DESCRIÇÃO	69U7	69U8	REMARKS OBSERVAÇÕES
28	95380-06600	NUT, HEXAGON PORCA SEXTAVADA	2	2	
29	6H7-15771-01-94	STAY 1 FIXADOR 1	1	1	
30	90119-06MA3	BOLT, WITH WASHER PARAFUSO COM ARRUELA	2	2	
31	656-15772-00-94	STAY 2 FIXADOR 2	1	1	
32	90119-06MA3	BOLT, WITH WASHER PARAFUSO COM ARRUELA	2	2	
33	90119-06025	BOLT, WITH WASHER PARAFUSO COM ARRUELA	1	1	
34	6F5-15723-01	PULLEY, STARTER ROLDANA DA PARTIDA	1	1	
35	90105-08M10	BOLT, FLANGE PARAFUSO FLANGE	3	3	
36	61T-15770-00	CABLE COMP., STARTER STOP CABO COMP. DE PARADA (PARTIDA)	1	1	
37	656-15748-00	PLUNGER, STARTER STOP ACIONADOR DA PARTIDA	1	1	
38	90501-10227	SPRING, COMPRESSION MOLA DE COMPRESSAO	1	1	
39	69P-15774-00	STAY 4 FIXADOR 4	1	1	
40	97095-06010	BOLT PARAFUSO	1	1	
41	69P-15746-00	ARM BRACO	1	1	
42	689-15747-70	LINK ARTICULADOR	1	1	
43	90119-06M23	BOLT, WITH WASHER PARAFUSO COM ARRUELA	1	1	
44	90387-06013	COLLAR ESPACADOR	1	1	
45	90206-05005	WASHER, WAVE ARRUELA ONDULADA	2	2	
46	92903-05600	WASHER, PLATE ARRUELA PLANA	3	3	
47	91490-16010	PIN, COTTER CUPILHA	2	2	

FIG. 8 GENERATOR

GERADOR

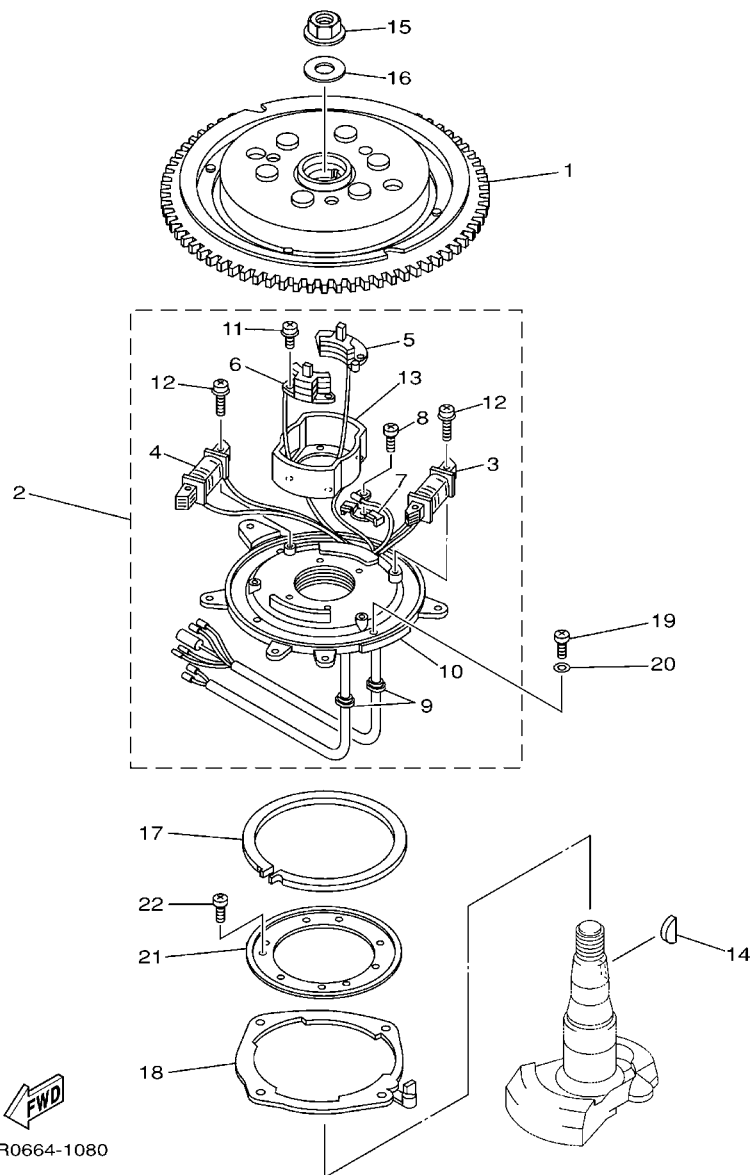

69R0664-1080

REF. NO.	PART NO. No. PEÇA	DESCRIPTION DESCRIÇÃO	69U7	69U8	REMARKS OBSERVAÇÕES
1	61T-85550-10	ROTOR ASSY ROTOR CONJ.	1	1	
2	69P-85560-00	BASE ASSY BASE CONJ.	1	1	
3	69P-85541-09	.COIL, CHARGE .BOBINA DE CARGA	1	1	
4	61N-81313-09	.COIL, LIGHTING 1 .BOBINA DE ILUMINACAO 1	1	1	
5	61N-85543-09	.COIL, PULSER .BOBINA DE PULSO	1	1	
6	61N-85543-19	.COIL, PULSER .BOBINA DE PULSO	1	1	
7	6E9-81328-70	.CLAMP .BRACADEIRA	1	1	
8	97802-04006	.SCREW, PAN HEAD .PARAFUSO	1	1	
9	6E9-85516-70	.GROMMET .ESPACADOR	2	2	
10	69P-85561-00	.BASE, MAGNETO .BASE DO MAGNETO	1	1	
11	97607-04112	.SCREW, WITH WASHER .PARAFUSO	4	4	
12	97607-06125	.SCREW, WITH WASHER .PARAFUSO	4	4	
13	61N-85537-00	.COVER .TAMPA	1	1	
14	90280-05015	KEY, WOODRUFF CHAVETA MEIA LUA	1	1	
15	90179-16M05	NUT PORCA DE REGULAGEM	1	1	
16	90201-16M44	WASHER, PLATE ARRUELA PLANA	1	1	
17	676-41611-00	RETAINER, MAGNETO BASE RETENTOR DA BASE DO MAGNETO	1	1	
18	676-41613-00	PLATE, BASE FRICTION PLACA DA BASE DA FRICCAO	1	1	
19	97880-05012	SCREW, PAN HEAD PARAFUSO	4	4	
20	92990-05600	WASHER, PLATE ARRUELA PLANA	4	4	
21	689-41612-01	RETAINER, MAGNETO BASE RETENTOR DA BASE DO MAGNETO	1	1	
22	97880-06010	SCREW, PAN HEAD PARAFUSO	4	4	

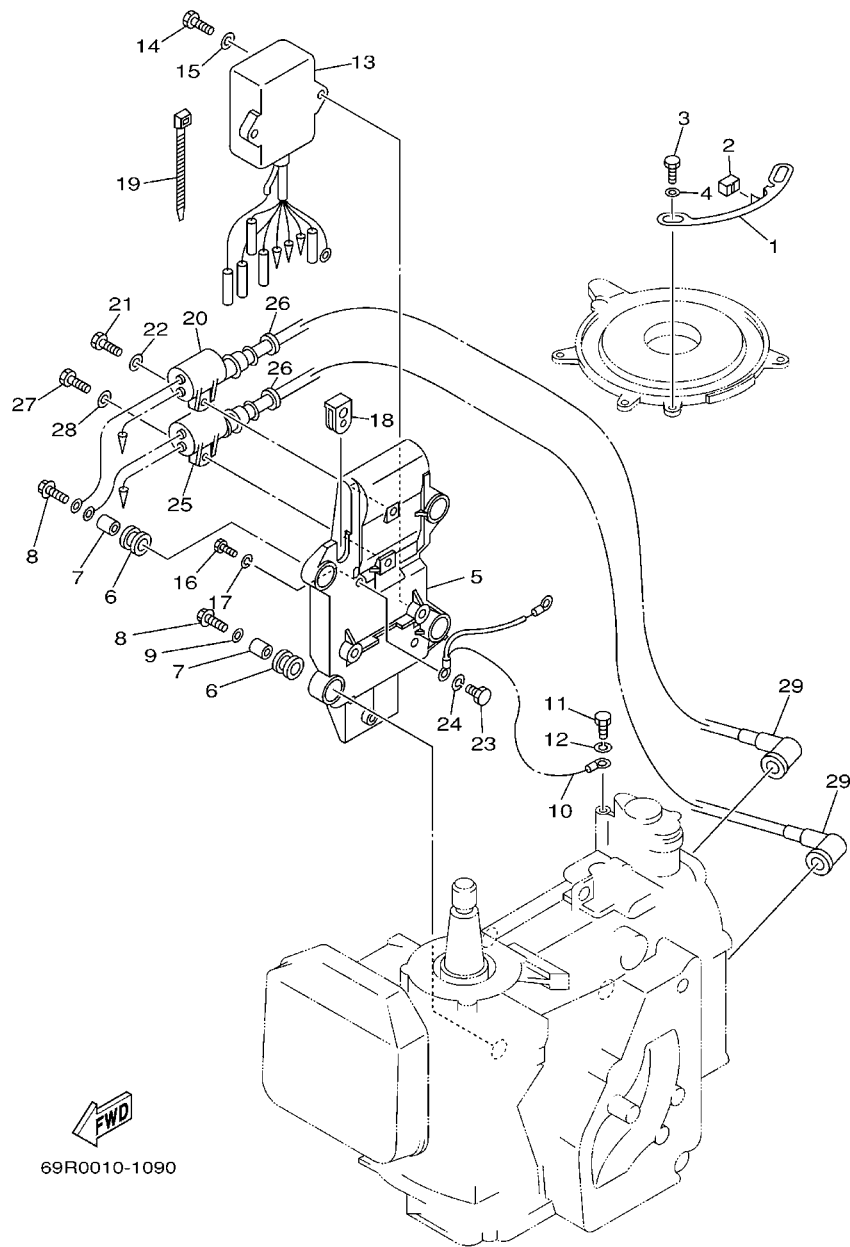

69R0010-1090

FIG. 9 ELECTRICAL

ELETRICO

REF. NO.	PART NO. No. PEÇA	DESCRIPTION DESCRIÇÃO	69U7	69U8	REMARKS OBSERVAÇÕES
1	61N-41615-00	STOPPER, MAGNETO BASE LIMITADOR DA BASE DO MAGNETO	1	1	
2	61N-44194-01	CAP CHAVETA	1	1	
3	97095-06010	BOLT PARAFUSO	2	2	
4	92995-06600	WASHER ARRUELA	2	2	
5	61N-85542-00-94	BRACKET SUPORTE	1	1	
6	61N-82317-00	DAMPER, IGNITION COIL AMORTIZADOR BOBINA DE IGNICAO	4	4	
7	90387-06119	COLLAR ESPACADOR	4	4	
8	90119-06M95	BOLT, WITH WASHER PARAFUSO COM ARRUELA	4	4	
9	90201-06M30	WASHER, PLATE ARRUELA PLANA	2	2	
10	61N-82519-01	WIRE, EARTH LEAD FIO TERRA	1	1	
11	97090-06012	BOLT PARAFUSO	1	1	
12	92990-06100	WASHER, SPRING ARRUELA COM MOLA	1	1	
13	61N-85540-13	C.D.I. UNIT ASSY UNIDADE DE IGNICAO CONJ. (CDI)	1	1	
14	97095-06020	BOLT PARAFUSO	2	2	
15	92995-06600	WASHER ARRUELA	2	2	
16	97090-06012	BOLT PARAFUSO	1	1	
17	92990-06100	WASHER, SPRING ARRUELA COM MOLA	1	1	
18	6H3-81922-00	GROMMET ILHO	1	1	
19	90465-13M11	CLAMP BRACADEIRA	1	1	
20	61N-85570-00	IGNITION COIL ASSY BOBINA DE IGNICAO CONJ.	1	1	
21	97095-06020	BOLT PARAFUSO	1	1	
22	92995-06600	WASHER ARRUELA	1	1	
23	97090-06012	BOLT PARAFUSO	1	1	
24	92990-06100	WASHER, SPRING ARRUELA COM MOLA	1	1	
25	61N-85570-10	IGNITION COIL ASSY BOBINA DE IGNICAO CONJ.	1	1	
26	90480-25161	GROMMET ILHO DE BORRACHA	2	2	
27	97095-06020	BOLT PARAFUSO	1	1	

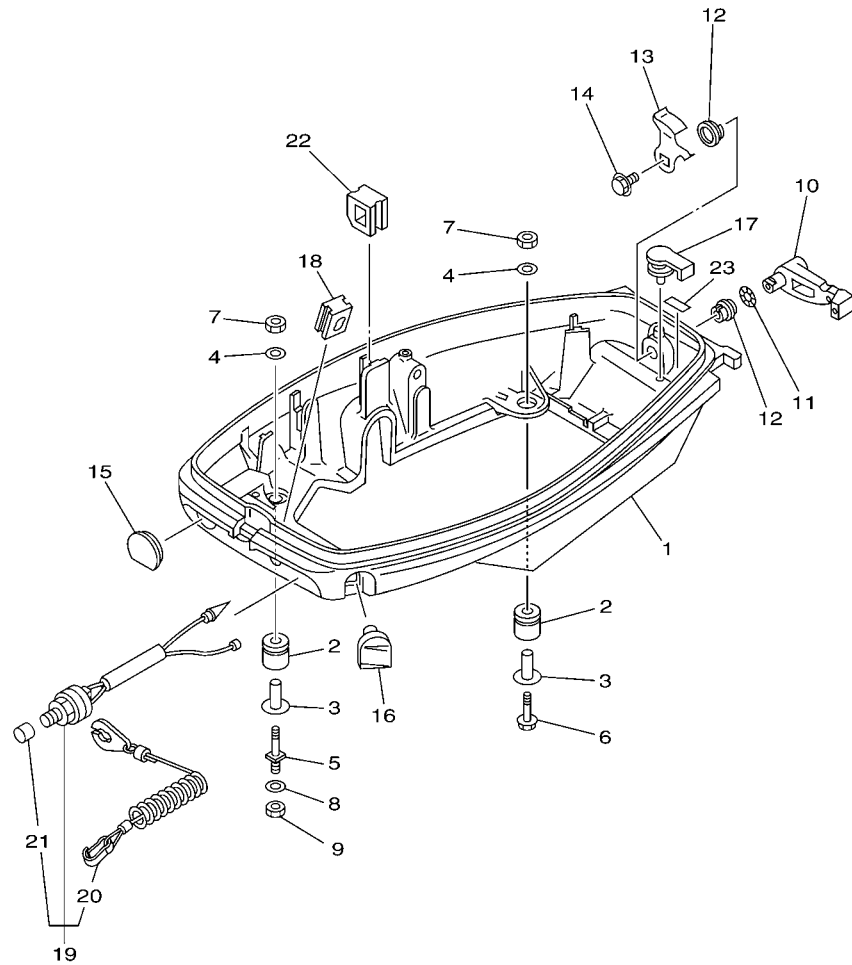

69U8280-G100

FIG. 10 BOTTOM COWLING

BANDEJA DO CAPO

REF. NO.	PART NO. No. PEÇA	DESCRIPTION DESCRIÇÃO	69U7	69U8	REMARKS OBSERVAÇÕES
1	689-42711-04-4D	COWLING, BOTTOM 1 COBERTURA INFERIOR DO CAPO 1	1	1	
2	90480-15M06	GROMMET ILHO DE BORRACHA	4	4	
3	90387-08M25	COLLAR ESPACADOR	4	4	
4	90201-08M87	WASHER, PLATE ARRUELA PLANA	4	4	
5	6G0-42796-00	BOLT 1 COLAR	2	2	
6	97585-08540	BOLT, WITH WASHER PARAFUSO COM ARRUELA	2	2	
7	95380-08700	NUT PORCA	4	4	
8	92990-08600	WASHER, PLATE ARRUELA PLANA	2	2	
9	95380-08700	NUT PORCA	2	2	
10	689-42815-00	LEVER, CLAMP ALAVANCA DA BRACADEIRA	1	1	
11	90206-12052	WASHER, WAVE ARRUELA ONDULADA	1	1	
12	90386-12069	BUSH BUCHA	2	2	
13	689-42816-00	LEVER, CLAMP ALAVANCA DA BRACADEIRA	1	1	
14	90119-06M73	BOLT, WITH WASHER PARAFUSO COM ARRUELA	1	1	
15	682-42724-00	GROMMET ILHO	1	1	
16	689-42725-01	GROMMET ILHO	1	1	
17	647-42523-00	SPACER, FRICTION ESPACADOR DA FRICCAO	1	1	
18	61N-26326-00	GROMMET ILHO	1	1	
19	6E9-82575-02	ENGINE STOP SWITCH ASSY INTERRUPTOR DE PARADA C.J.	1	1	
20	682-82556-00	.LANYARD, STOP SWITCH .AMORTIZADOR DO LIMITADOR	1	1	
21	689-8257Y-00	.CAP .CAPA DO INTERRUPTOR DE PARADA	1	1	
22	90480-17M08	GROMMET ILHO DE BORRACHA	1	1	
23	6E7-42791-00	MARK 1 EMBLEMA 1	1	1	

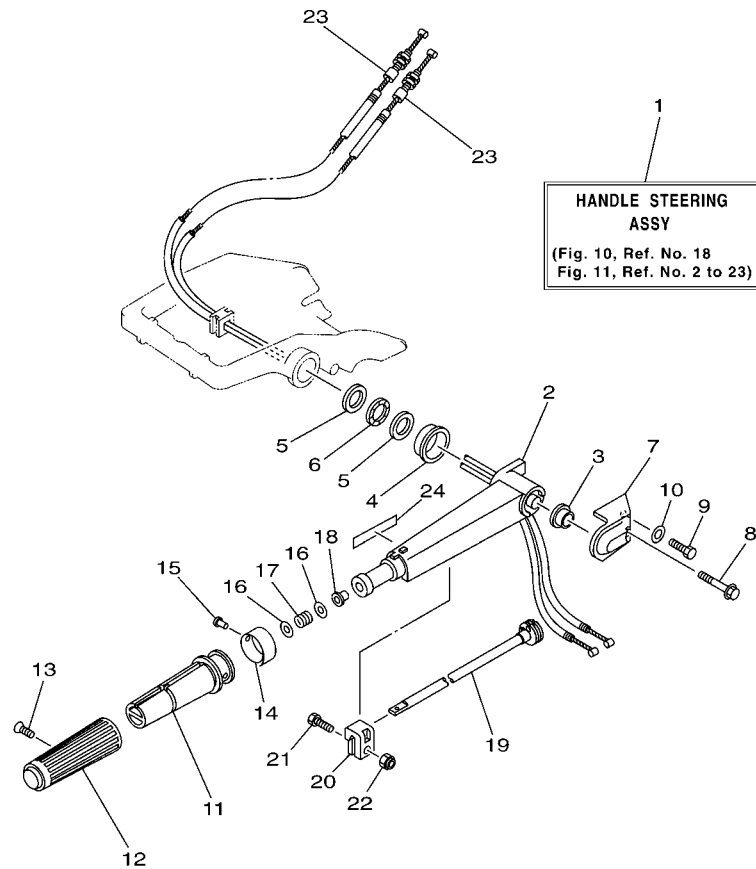

69U8280-G110

FIG. 11 STEERING

DIRECAO

REF. NO.	PART NO. No. PEÇA	DESCRIPTION DESCRIÇÃO	69U7	69U8	REMARKS OBSERVAÇÕES
1	69P-W0084-00-4D	HANDLE STEERING ASSY ALAVANCA DA DIRECAO CONJ.	1	1	
2	689-42111-01-4D	HANDLE, STEERING ALAVANCA DE DIRECIONAL	1	1	
3	90387-13003	COLLAR ESPACADOR	1	1	
4	90387-33001	COLLAR ESPACADOR	1	1	
5	90201-28013	WASHER, PLATE ARRUELA PLANA	2	2	
6	90206-28001	WASHER, WAVE ARRUELA ONDULADA	1	1	
7	69P-42112-00-4D	HANDLE, STEERING ALAVANCA DE DIRECIONAL	1	1	
8	97595-06550	BOLT, WITH WASHER PARAFUSO COM ARRUELA	1	1	
9	97095-06020	BOLT PARAFUSO	1	1	
10	92995-06600	WASHER ARRUELA	1	1	
11	664-42119-00	GRIP, STEERING HANDLE MANOPLA DA ALAVANCA DIRECIONAL	1	1	
12	6F6-42177-A0	RUBBER, HANDLE BORRACHA DO GUIDAO	1	1	
13	90149-05M13	SCREW PARAFUSO	1	1	
14	6G1-42137-10	INDICATOR, THROTTLE INDICADOR DE ACELERACAO	1	1	
15	90269-02M09	RIVET REBITE	1	1	
16	90201-10M02	WASHER, PLATE ARRUELA PLANA	2	2	
17	90501-23215	SPRING, COMPRESSION MOLA DE COMPRESSAO	1	1	
18	90386-08032	BUSH BUCHA	1	1	
19	689-42138-00	LEVER, THROTTLE ALAVANCA DE ACELERACAO	1	1	
20	656-42126-01	FRICITION, STEERING HANDLE GRIP FRICCAO DIRECIONAL	1	1	
21	97095-06020	BOLT PARAFUSO	1	1	
22	90185-06062	NUT, SELF-LOCKING PORCA AUTO-TRAVANTE	1	1	
23	61N-26311-01	CABLE, THROTTLE 1 CABO DO ACELERADOR 1	2	2	
24	6E0-83627-41	LABEL, CAUTION 7 ETIQUETA DE ADVERTENCIA	1	1	

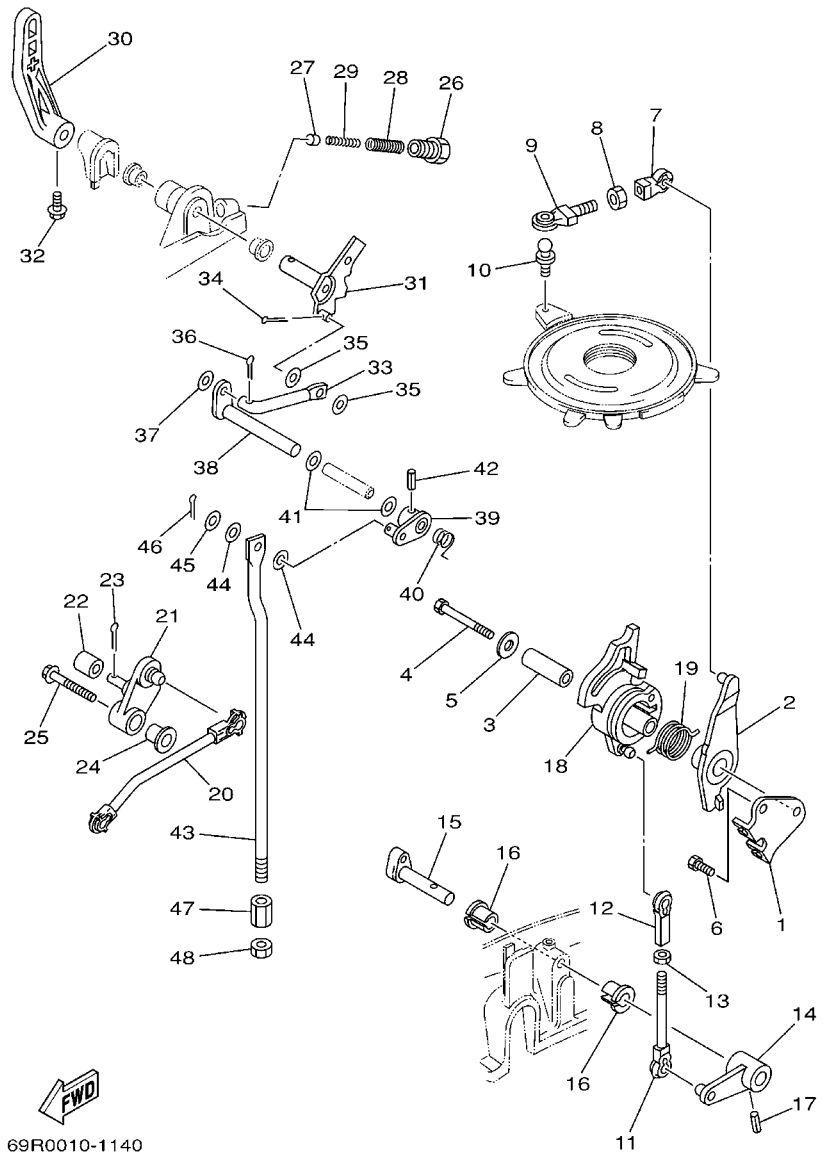

69R0010-1140

FIG. 12 CONTROL

CONTROLE

REF. NO.	PART NO. No. PEÇA	DESCRIPTION DESCRIÇÃO	69J7	69J8	REMARKS OBSERVAÇÕES
1	69P-14497-00	STAY, THROTTLE WIRE SUPORTE DO CABO DE ACELERAÇÃO	1	1	
2	69P-41631-00	LEVER, MAGNETO CONTROL ALAVANCA CONTROLE DO MAGNETO	1	1	
3	90387-06M59	COLLAR ESPACADOR	1	1	
4	97095-06045	BOLT PARAFUSO	1	1	
5	90201-06416	WASHER, PLATE ARRUELA PLANA	1	1	
6	97095-06012	BOLT PARAFUSO	1	1	
7	662-41237-01	JOINT, LINK JUNÇÃO DO ARTICULADOR	1	1	
8	95380-05700	NUT PORCA	1	1	
9	679-41241-01	ROD, LINK HASTE DE ARTICULAÇÃO	1	1	
10	663-85518-00	JOINT, BALL JUNÇÃO DA ESFERA	1	1	
11	682-41238-01	JOINT, LINK JUNÇÃO DO ARTICULADOR	1	1	
12	682-41237-00	JOINT, LINK JUNÇÃO DO ARTICULADOR	1	1	
13	95380-05600	NUT PORCA	1	1	
14	69P-42157-00-94	LEVER, THROTTLE ALAVANCA DE ACELERAÇÃO	1	1	
15	656-42153-00-94	SHAFT, THROTTLE CONTROL EIXO DE CONTROLE DA ACELERAÇÃO	1	1	
16	90386-10009	BUSH BUCHA	2	2	
17	91690-40018	PIN, SPRING PINO MOLA	1	1	
18	69P-41213-00	CAM, ACCEL. CAMES DO ACELERADOR	1	1	
19	69P-42167-00	SPRING 1 MOLA	1	1	
20	69P-41241-00	ROD, LINK HASTE DE ARTICULAÇÃO	1	1	
21	69P-42154-00	LEVER, THROTTLE CONTROL ALAVANCA ACELERAÇÃO	1	1	
22	62Y-42171-00	BUSHING BUCHA	1	1	
23	91490-16010	PIN, COTTER CUPILHA	1	1	
24	90387-06M60	COLLAR ESPACADOR	1	1	
25	90119-06M17	BOLT, WITH WASHER PARAFUSO COM ARRUELA	1	1	
26	664-42715-00	BUSHING BUCHA	1	1	
27	664-44167-01	PLUNGER, SHIFT CAM AFOGADOR DO CAME DE MUDANÇA	1	1	

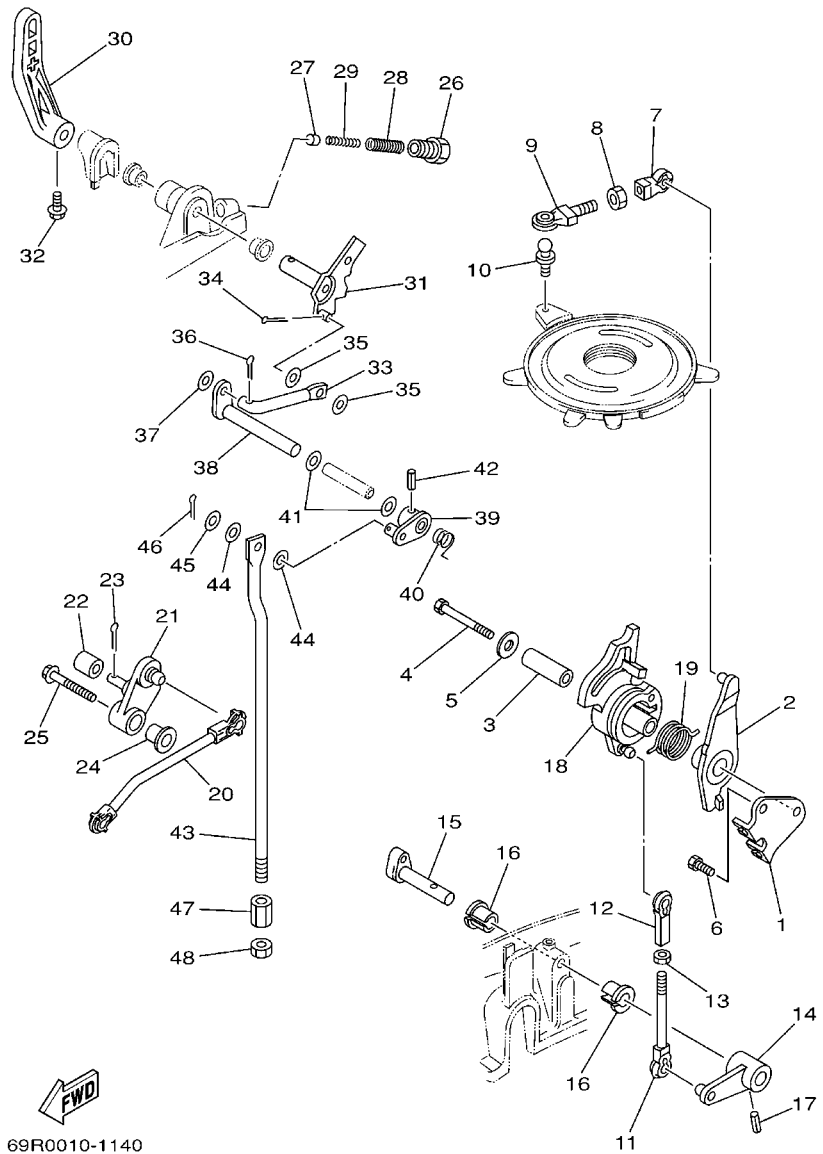

69R0010-1140

FIG. 12 CONTROL

CONTROLE

REF. NO.	PART NO. No. PEÇA	DESCRIPTION DESCRIÇÃO	69U7	69U8	REMARKS OBSERVAÇÕES
28	90501-14M07	SPRING, COMPRESSION MOLA DE COMPRESSAO	1	1	
29	90501-09M08	SPRING, COMPRESSION MOLA DE COMPRESSAO	1	1	
30	689-44111-01-4D	HANDLE, GEAR SHIFT ALAVANCA DE MUDANCA	1	1	
31	664-44113-01	CAM PLATE, HANDLE PLACA DA ALAVANCA	1	1	
32	90105-06M07	BOLT, FLANGE PARAFUSO FLANGE	1	1	
33	664-44142-00	JOINT RETENTOR	1	1	
34	91490-16010	PIN, COTTER CUPILHA	1	1	
35	90202-06007	WASHER, PLATE ARRUELA PLANA	2	2	
36	91490-12010	PIN, COTTER CUPILHA	1	1	
37	92990-05600	WASHER, PLATE ARRUELA PLANA	1	1	
38	689-44121-01	LEVER, SHIFT ROD ALAVANCA DA HASTE DE MUDANCA	1	1	
39	689-44125-00	LEVER, SHIFT ROD ALAVANCA DA HASTE DE MUDANCA	1	1	
40	90508-14M13	SPRING, TORSION MOLA DE TORCAO	1	1	
41	90202-10024	WASHER, PLATE ARRUELA PLANA	2	2	
42	91690-40016	PIN, SPRING PINO MOLA	1	1	
43	61N-44143-00	ROD, SHIFT HASTE DE MUDANCA	1	1	
44	90202-06007	WASHER, PLATE ARRUELA PLANA	2	2	
45	92990-05600	WASHER, PLATE ARRUELA PLANA	1	1	
46	91490-20010	PIN, COTTER CUPILHA	1	1	
47	61N-44146-00	CONNECTOR, SHIFT ROD CONNECTOR DA HASTE DE MUDANCA	1	1	
48	95380-06600	NUT, HEXAGON PORCA SEXTAVADA	1	1	

FIG. 13 REMO CON ATTACHMENT

ACESSORIOS DO CONTROLE REMOTO

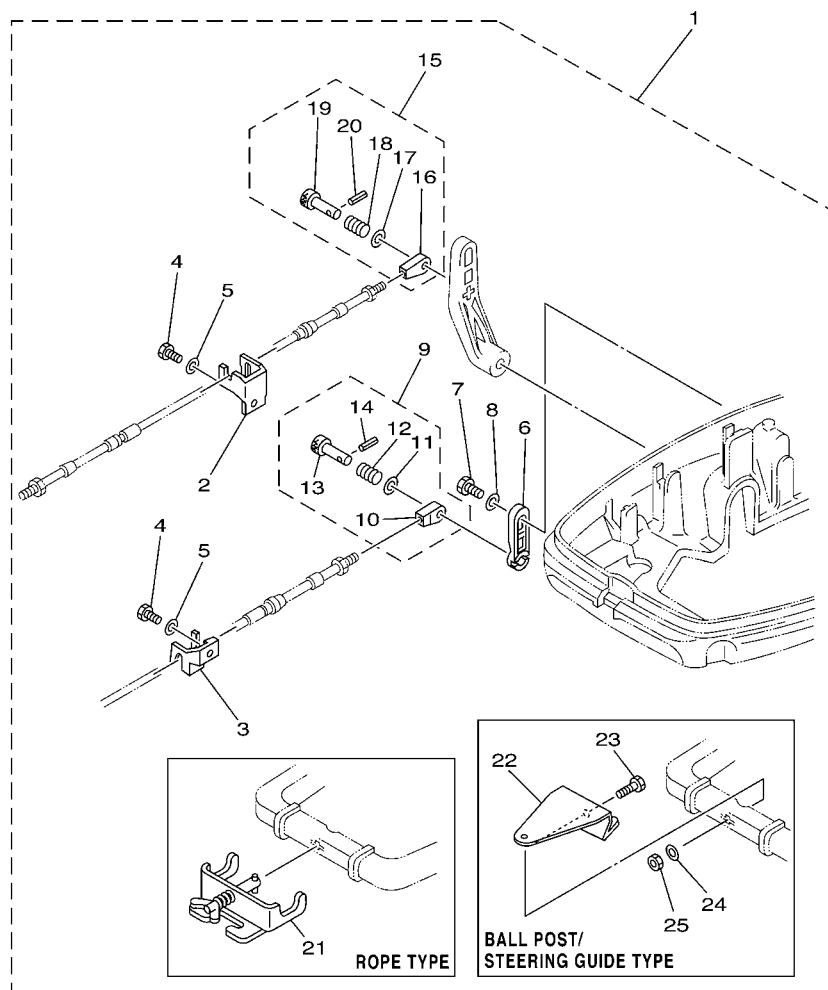

69R3664-3170

REF. NO.	PART NO. No. PEÇA	DESCRIPTION DESCRIÇÃO	69U7	69U8	REMARKS OBSERVAÇÕES
1	689-48501-01-4D	REMOTE CONT. ATTACHMENT ASSY. KIT DE ADAPTACAO	1	1	AP ROPE TYPE AP ROPE TYPE
	689-48501-21-4D	REMOTE CONT. ATTACHMENT ASSY. KIT DE ADAPTACAO	1	1	AP AP
2	689-48531-50	.BRACKET, REMOTE CONTROL 1 .SUPORTE CONTROLE REMOTO	1	1	
3	689-48532-50	.BRACKET, REMOTE CONTROL 2 .SUPORTE CONTROLE REMOTO	1	1	
4	97095-06016	.BOLT .PARAFUSO	2	2	
5	92995-06600	.WASHER .ARRUELA	2	2	
6	648-48534-50-4D	.THROTTLE LEVER, CONTROL .ALAVANCA DO CONTROLE DE ACEL.	1	1	
7	97095-06012	.BOLT .PARAFUSO	1	1	
8	92995-06600	.WASHER .ARRUELA	1	1	
9	648-48340-50	.CABLE END ASSY .TERMINAL DO CONTROLE 2	1	1	
10	617-48346-90	..CABLE END, REMOTE CONTROL ..TERMINAL DO CABO DE CONTROLE	1	1	
11	92990-08600	..WASHER, PLATE ..ARRUELA PLANA	1	1	
12	90501-10264	..SPRING, COMPRESSION ..MOLA DE COMPRESSAO	1	1	
13	617-48361-91	..HOOK, CABLE ..PINO	1	1	
14	91690-30012	..PIN, SPRING ..PINO MOLA	1	1	
15	648-48330-50	..CABLE END ASSY ..TERMINAL DO CABO COMPL.	1	1	
16	648-48346-50	..CABLE END, REMOTE CONTROL ..TERMINAL DO CABO DE CONTROLE	1	1	
17	92990-08600	..WASHER, PLATE ..ARRUELA PLANA	1	1	
18	90501-10071	..SPRING, COMPRESSION ..MOLA DE COMPRESSAO	1	1	
19	617-48331-91	..HOOK, CABLE ..PINO	1	1	
20	91690-30012	..PIN, SPRING ..PINO MOLA	1	1	
21	700-48510-12	.STEERING HOOK ASSY .GANCHO DE DIRECAO CONJUNTO	1	1	ROPE TYPE ROPE TYPE
22	689-48511-01	.HOOK, STEERING .GANCHO DO DIRECIONADOR	1	1	
23	97075-10040	.BOLT .PARAFUSO	1	1	
24	92990-10600	.WASHER, PLATE ..ARRUELA PLANA	1	1	
25	90185-10051	.NUT, SELF-LOCKING ..PORCA AUTO-TRAVANTE	1	1	

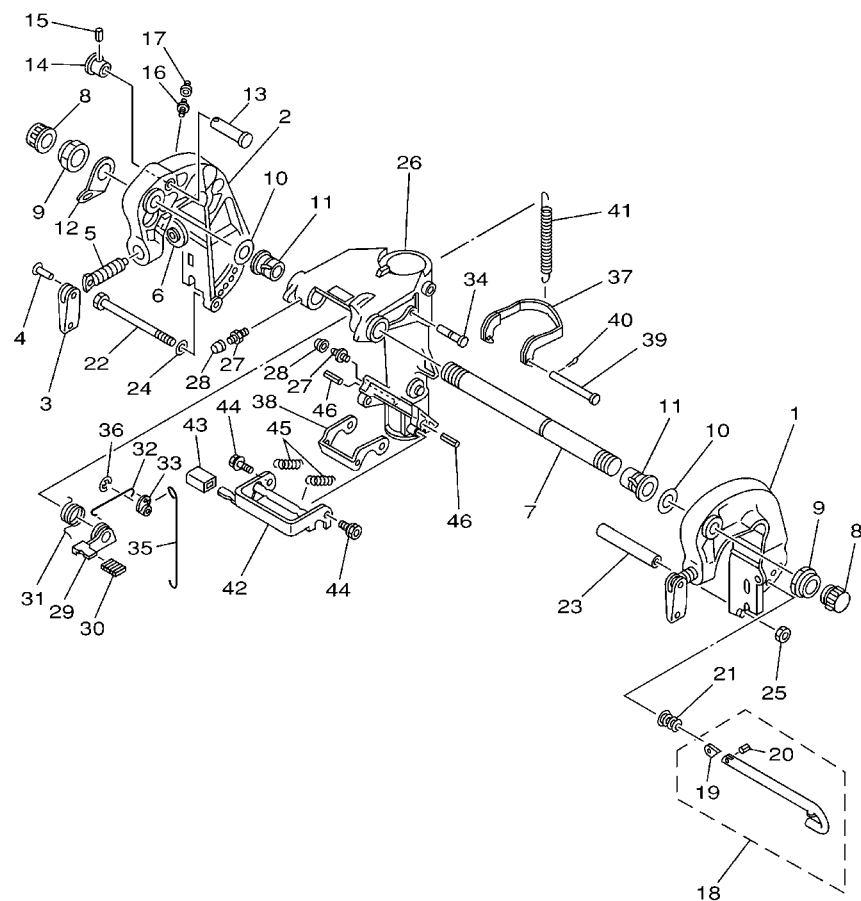

FWD
69R0010-1150

FIG. 14 BRACKET 1

SUPORTE 1

REF. NO.	PART NO. No. PEÇA	DESCRIPTION DESCRIÇÃO	69U7	69U8		REMARKS OBSERVAÇÕES
1	689-43111-03-4D	BRACKET, CLAMP 1 SUPORTE DA BRACADEIRA 1	1	1		
2	689-43112-02-4D	BRACKET, CLAMP 2 SUPORTE DA BRACADEIRA 2	1	1		
3	6E0-43118-01	HANDLE, TRANSOM CLAMP ALAVANCA DE FIXACAO	2	2		
4	90243-04M01	PIN PINO	2	2		
5	90149-14030	SCREW PARAFUSO	2	2		
6	648-43114-01	PAD, TRANSOM CLAMP PASTILHA DE TRANSMISSAO	2	2		
7	6J8-43131-01	BOLT, CLAMP BRACKET PARAFUSO DE ACO	1	1		
8	6G5-43145-01	CAP, CLAMP BRACKET CAPA DA PORCA DA VARETA	2	2		
9	90185-22043	NUT, SELF-LOCKING PORCA AUTO-TRAVANTE	2	2		
10	90201-22M03	WASHER, PLATE ARRUELA PLANA	2	2		
11	90386-22M67	BUSH BUCHA	2	2		
12	6J8-43113-01	PLATE, CLAMP BRACKET PLACA DE SUPORTE DA BRACADEIRA	1	1		
13	689-43191-00	SHAFT, STOPPER EIXO LIMITADOR	1	1		
14	689-43192-01	KNOB, STOPPER BOTAO LIMITADOR	1	1		
15	91690-30016	PIN, SPRING PINO MOLA	1	1		
16	93700-06M03	NIPPLE, GREASE GRAXEIRA	1	1		
17	663-45119-00	CAP, GREASE NIPPLE CAPA DA COPO DE LUBRIFICACAO	1	1		AP AP
18	689-43160-00	TILT ROD ASSY BARRA INCLINADA CONJ	1	1		
19	689-43165-00	.PLATE, TILT LOCK .PLACA DA BARRA INCLINADA	1	1		
20	91690-30008	.PIN, SPRING .PINO MOLA	1	1		
21	90502-10M07	SPRING, CONICAL MOLA CONICA	1	1		
22	90101-08339	BOLT PARAFUSO	1	1		
23	90387-08M03	COLLAR ESPACADOR	1	1		
24	92990-08600	WASHER, PLATE ARRUELA PLANA	1	1		
25	95380-08600	NUT PORCA	1	1		
26	689-43311-03-4D	BRACKET, SWIVEL 1 SUPORTE DO EIXO GIRATORIO	1	1		
27	93700-06M03	NIPPLE, GREASE GRAXEIRA	3	3		

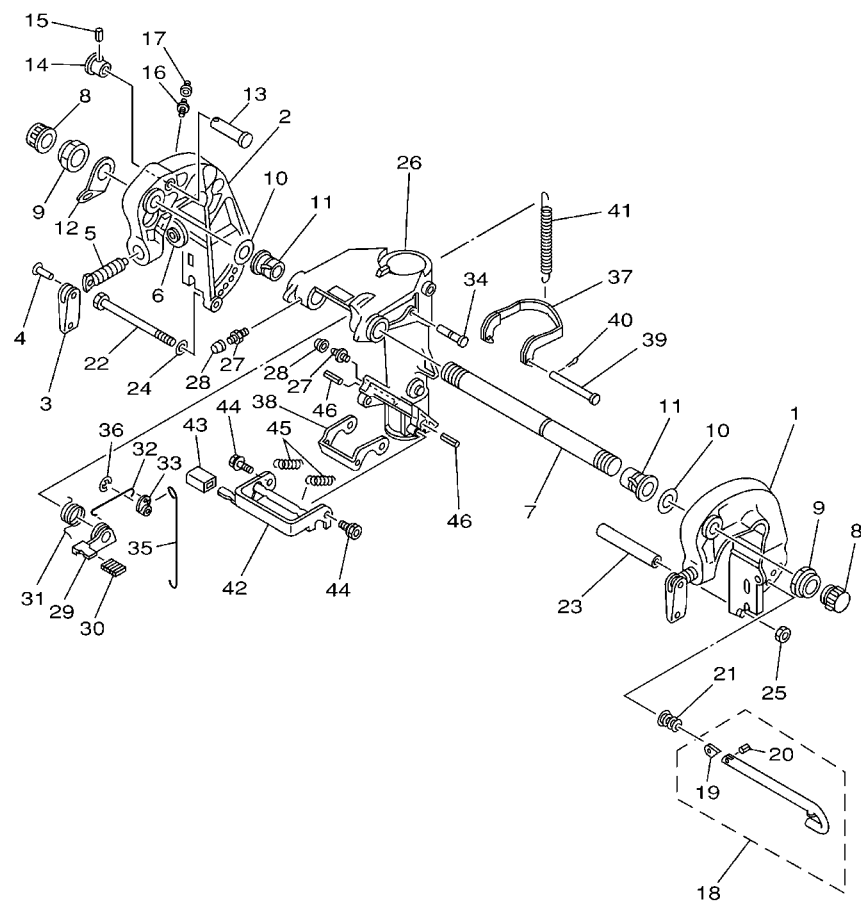

69R0010-1150

FIG. 14 BRACKET 1

SUPORTE 1

REF. NO.	PART NO. No. PEÇA	DESCRIPTION DESCRIÇÃO	69U7	69U8	REMARKS OBSERVAÇÕES
28	663-45119-00	CAP, GREASE NIPPLE CAPA DA COPO DE LUBRIFICACAO	3	3	AP AP
29	689-43631-00	LEVER, TILT ALAVANCA DE INCLINACAO	1	1	
30	689-43633-00	COVER, TILT LEVER CAPA DA ALAVANCA DE INCLINACAO	1	1	
31	689-43643-00	SPRING MOLA	1	1	
32	689-43616-00	ROD, TILT LOCK HASTE DE FIXADOR DE INCLINACAO	1	1	
33	648-43642-00	LEVER, TILT 1 MOLA DE RETORNO	1	1	
34	90249-06M22	PIN PINO	1	1	
35	648-43617-00	ROD, TILT LOCK HASTE DE FIXADOR DE INCLINACAO	1	1	
36	99080-05600	CIRCLIP ANEL TRAVA	1	1	
37	689-43614-01	PLATE, TILT LOCK PLACA DE FIXADOR DE INCLINACAO	1	1	
38	648-43615-00	PLATE, TILT LOCK PLACA DE FIXADOR DE INCLINACAO	1	1	
39	90240-05047	PIN, CLEVIS PINO	1	1	
40	91490-16010	PIN, COTTER CUPILHA	1	1	
41	90506-30M27	SPRING, TENSION MOLA DE TENSAO	1	1	
42	689-43681-01	LEVER, SHALLOW WATER DRIVE 1 ALAVANCA	1	1	
43	682-43318-01	COVER TAMPA	1	1	
44	90109-06M18	BOLT PARAFUSO	2	2	
45	90506-16M17	SPRING, TENSION MOLA DE TENSAO	2	2	
46	91690-40035	PIN, SPRING PINO MOLA	2	2	

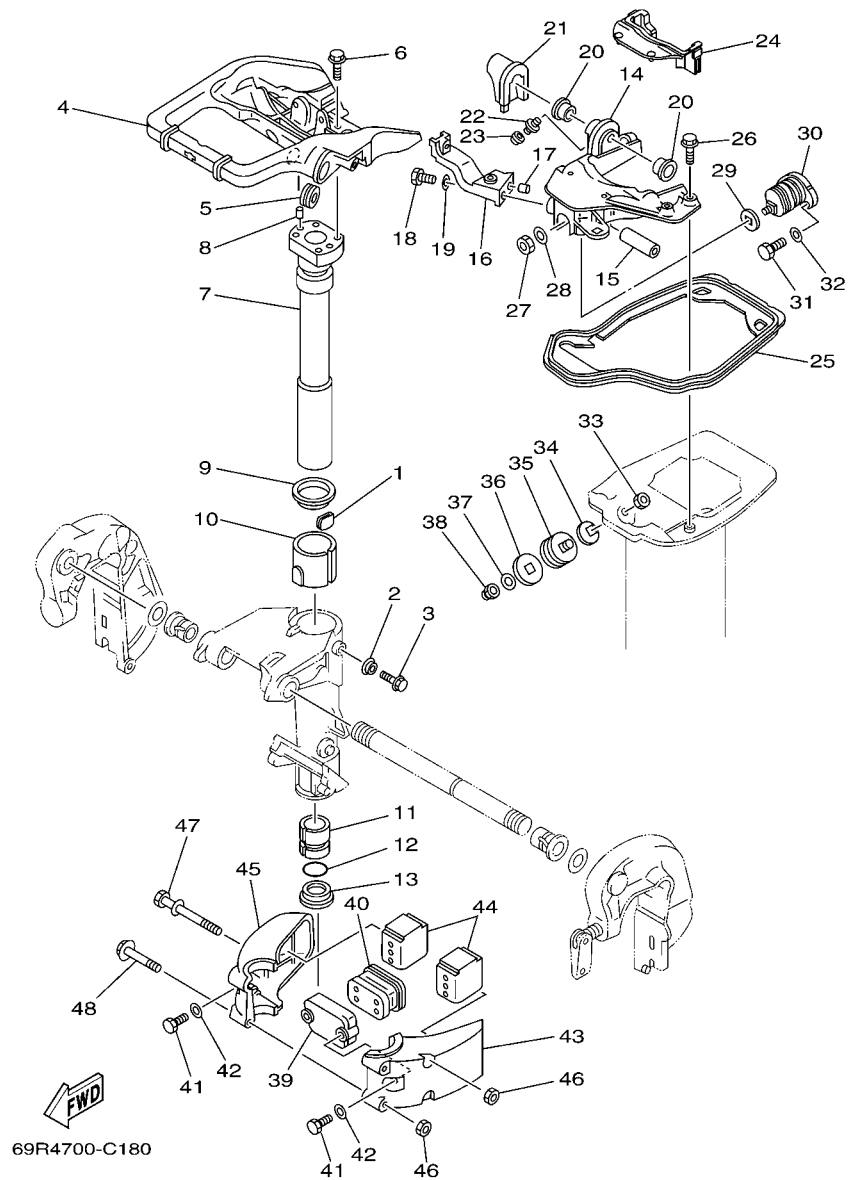

69R4700-C180

FIG. 15 BRACKET 2

SUPORTE 2

REF. NO.	PART NO. No. PEÇA	DESCRIPTION DESCRIÇÃO	69J7	69J8	REMARKS OBSERVAÇÕES
1	648-42528-00	PLATE, FRICTION PLACA DE FRICCAO	1	1	
2	689-43373-01	SEAL, DAMPER RETENTOR DE BORRACHA	1	1	
3	90105-06M18	BOLT, FLANGE PARAFUSO FLANGE	1	1	
4	69P-42511-00-4D	BRACKET, STEERING SUPORTE DIRECIONAL	1	1	
5	90480-29045	GROMMET ILHO DE BORRACHA	1	1	
6	90105-06M07	BOLT, FLANGE PARAFUSO FLANGE	4	4	
7	689-42521-00-94	SHAFT, STEERING PIVOT EIXO PIVO DO DIRECIONADOR	1	1	
8	93608-12063	PIN, DOWEL PINO GUIA	2	2	
9	90209-47016	WASHER ARRUELA	1	1	
10	90386-47M22	BUSH BUCHA	1	1	
11	90386-38090	BUSH BUCHA	1	1	
12	93210-37160	O-RING ANEL DE BORRACHA	1	1	
13	90386-38022	BUSH BUCHA	1	1	
14	69P-44518-00-94	BRACKET COMP. SUPORTE COMPLETO	1	1	
15	90387-10M39	COLLAR ESPACADOR	1	1	
16	648-44519-00-94	BRACKET SUPORTE	1	1	
17	93606-12019	PIN, DOWEL PINO GUIA	1	1	
18	97095-06018	BOLT PARAFUSO	1	1	
19	92995-06600	WASHER ARRUELA	1	1	
20	90381-12M01	BUSH, SOLID BUCHA SOLIDA	2	2	
21	689-42718-00	RUBBER, SEAL 3 BORRACHA DE VEDACAO 3	1	1	
22	93700-06M03	NIPPLE, GREASE GRAXEIRA	1	1	
23	663-45119-00	CAP, GREASE NIPPLE CAPA DA COPO DE LUBRIFICACAO	1	1	AP AP
24	69P-42717-00	RUBBER, SEAL 2 BORRACHA DE VEDACAO 2	1	1	
25	69P-42716-00	RUBBER, SEAL 1 BORRACHA DE VEDACAO 1	1	1	
26	90105-06M08	BOLT, FLANGE PARAFUSO FLANGE	4	4	
27	90170-10M42	NUT PORCA	1	1	

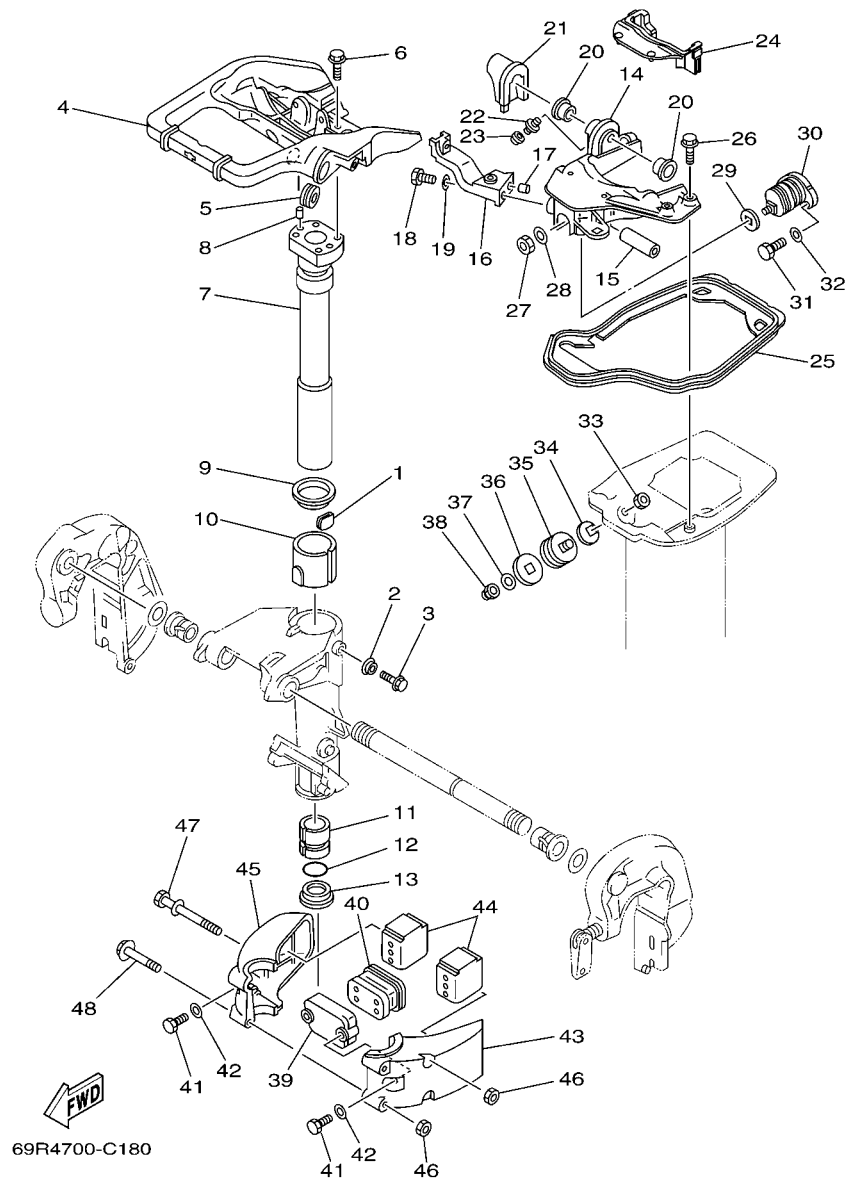

FIG. 15 BRACKET 2

SUPORTE 2

REF. NO.	PART NO. No. PEÇA	DESCRIPTION DESCRIÇÃO	69J7	69J8		REMARKS OBSERVAÇÕES
28	92990-10200	WASHER, PLAIN ARRUELA PLANA	1	1		
29	648-44591-A0	GASKET GASKETA	1	1		
30	689-44516-00	MOUNT DAMPER, UPPER FRONT AMORTIZADOR SUPERIOR	1	1		
31	97095-06020	BOLT PARAFUSO	2	2		
32	92995-06600	WASHER ARRUELA	2	2		
33	90170-10M42	NUT PORCA	2	2		
34	648-44591-A0	GASKET GASKETA	2	2		
35	664-44514-00-94	MOUNT DAMPER, UPPER SIDE AMORTIZADOR SUPERIOR	2	2		
36	664-44591-A0	GASKET GASKETA	2	2		
37	92990-10200	WASHER, PLAIN ARRUELA PLANA	2	2		
38	90176-10M01	NUT, CROWN PORCA COROA	2	2		
39	689-44553-00-94	COVER, LOWER MOUNT COBERTURA AMORTIZADORA INFE.	1	1		
40	689-44557-00	MOUNT DAMPER, LOWER FRONT AMORTIZADOR INFERIOR	1	1		
41	97075-08025	BOLT PARAFUSO	2	2		
42	92995-08600	WASHER ARRUELA	2	2		
43	689-44551-01-4D	HOUSING, LOWER MOUNT RUBBER ALOJAMENTO DO SUPORTE INFERIOR	1	1		
44	689-44555-00	MOUNT DAMPER, LOWER SIDE AMORTIZADOR INFERIOR	2	2		
45	689-44552-01-4D	HOUSING, LOWER MOUNT RUBBER ALOJAMENTO DO SUPORTE INFERIOR	1	1		
46	95380-08600	NUT PORCA	4	4		
47	90119-08M03	BOLT, WITH WASHER PARAFUSO COM ARRUELA	2	2		
48	97595-08565	BOLT, WITH WASHER PARAFUSO COM ARRUELA	2	2		

FIG. 16 UPPER CASING

CAPA INFERIOR

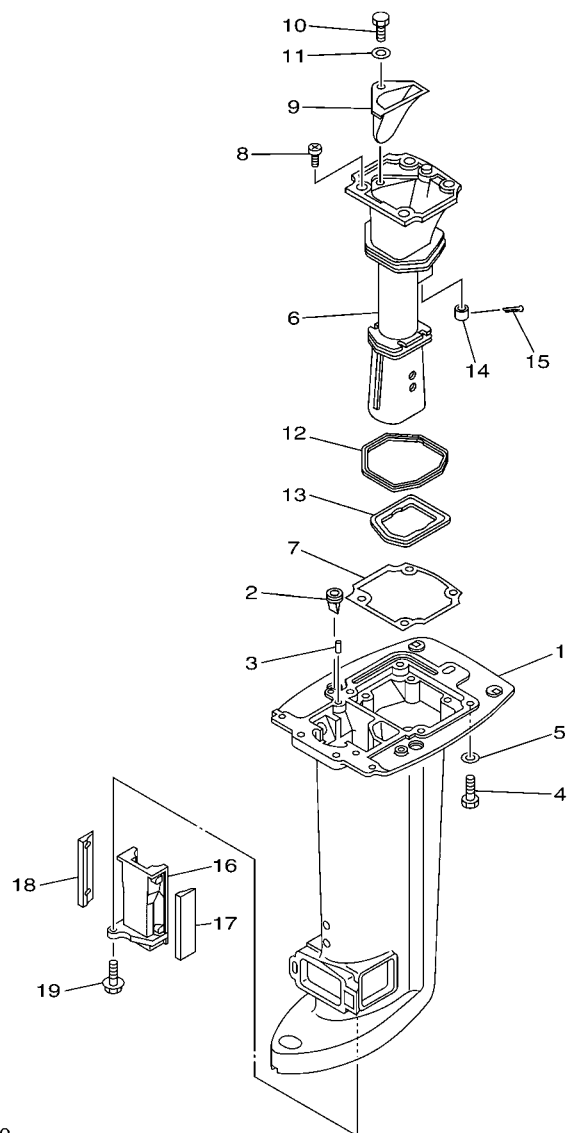

69U8280-G160

REF. NO.	PART NO. No. PEÇA	DESCRIPTION DESCRIÇÃO			REMARKS OBSERVAÇÕES
			69U7	69U8	
1	69P-45111-00-4D	CASING, UPPER CAIXA SUPERIOR	1	1	S(16.7") S(16.7")
2	65W-42717-00	RUBBER, SEAL 2 BORRACHA DE VEDACAO 2	2	2	
3	93606-12019	PIN, DOWEL PINO GUIA	2	2	
4	97075-08030	BOLT PARAFUSO	6	6	
5	92995-08600	WASHER ARRUELA	6	6	
6	69P-41131-01-5B	MANIFOLD, EXT. 1 TUBO MULTIPLO DE ESCAPE 1	1	1	
7	69P-41134-A0	GASKET, EXHAUST MANIFOLD GAXETA DO MULTIPLO DE ESCAPE	1	1	
8	97880-06016	SCREW, PAN HEAD PARAFUSO	4	4	
9	69P-41137-00-5B	GUIDE, EXHAUST GUIA DO ESCAPE	1	1	
10	97095-08020	BOLT PARAFUSO	1	1	
11	92995-08600	WASHER ARRUELA	1	1	
12	69P-41138-00	SEAL, EXT. 1 VEDACAO DO ESCAPE 1	1	1	
13	69P-41139-00	SEAL, EXT. 2 VEDACAO DO ESCAPE 2	1	1	
14	6A8-41135-00	GASKET, EXHAUST MANIFOLD GAXETA DO MULTIPLO DE ESCAPE	1	1	
15	91490-30025	PIN, COTTER CUPILHA	1	1	
16	69P-47467-00-5B	PLATE, GUIDE GUIA DA PLACA DA RABETA	1	1	S(16.7") S(16.7")
17	69P-45127-00	SEAL RETENTOR DE BORRACHA	1	1	
18	69P-45128-00	SEAL 2 RETENTOR	1	1	
19	90119-06024	BOLT, WITH WASHER PARAFUSO COM ARRUELA	1	1	

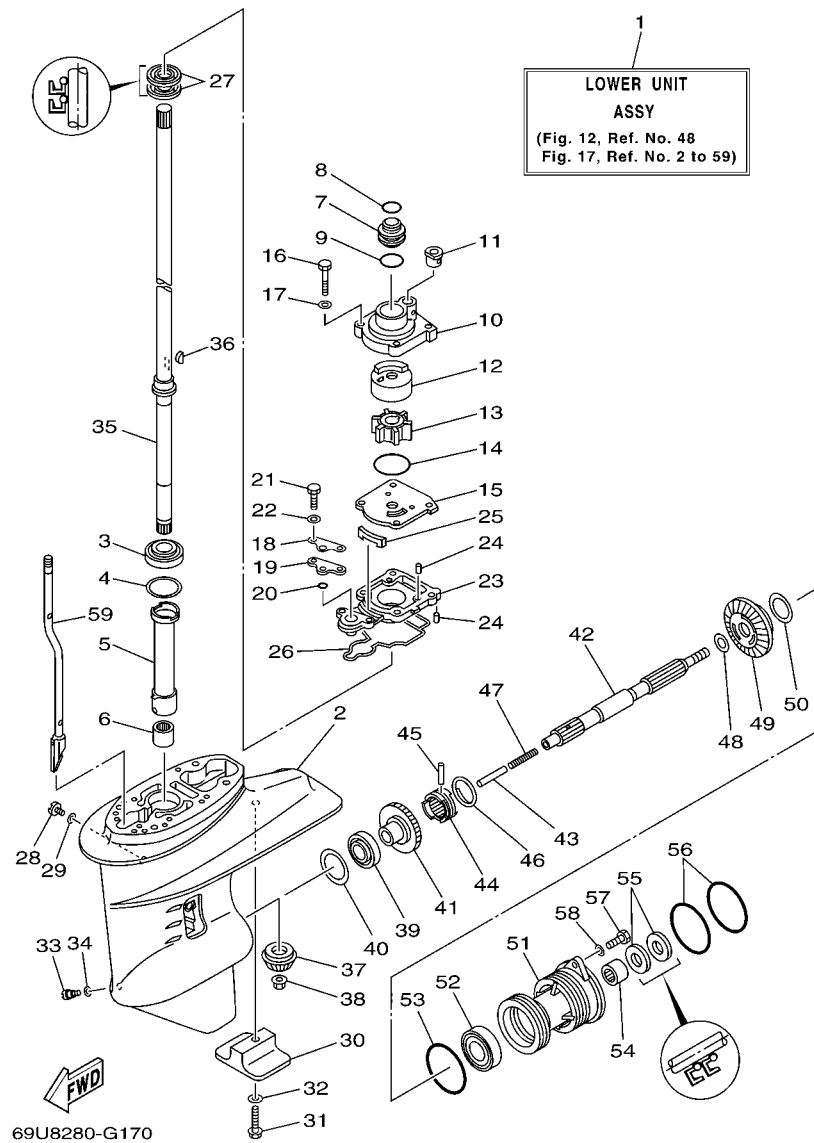

FIG. 17 LOWER CASING & DRIVE 1 CARCACA INF. E TRANSMISSAO 1

REF. NO.	PART NO. No. PEÇA	DESCRIPTION DESCRIÇÃO	69U7	69U8	REMARKS OBSERVAÇÕES
1	69P-45300-01-4D	LOWER UNIT ASSY UNIDADE DA RABETA INFERIOR CJ.	1	1	S(16.7") S(16.7")
2	61N-45311-02-4D	CASING, LOWER RABETA INFERIOR	1	1	
3	93332-000W5	BEARING ROLAMENTO	1	1	
4	61N-45587-00	SHIM (T:0.7MM) CALCO (T:0.7MM)	1	1	UR UR
	61N-45587-10	SHIM (T:1.0MM) CALCO (T:1.0MM)	1	1	UR UR
	61N-45587-20	SHIM (T:1.1MM) CALCO (T:1.1MM)	1	1	UR UR
	61N-45587-30	SHIM (T:1.2MM) CALCO (T:1.2MM)	1	1	UR UR
	61N-45587-40	SHIM (T:1.3MM) CALCO (T:1.3MM)	1	1	UR UR
	61N-45587-50	SHIM (T:1.4MM) CALCO (T:1.4MM)	1	1	UR UR
	61N-45587-60	SHIM (T:1.5MM) CALCO (T:1.5MM)	1	1	UR UR
	61N-45587-70	SHIM (T:1.6MM) CALCO (T:1.6MM)	1	1	UR UR
5	61N-45536-00	SLEEVE, DRIVE SHAFT PROTETOR DO EIXO DE DIRECIONAL	1	1	
6	93315-220V7	BEARING ROLAMENTO CILINDRICO	1	1	
7	61N-44362-00	TUBE, WATER TUBO DE AGUA	1	1	S(16.7") S(16.7")
8	93210-22164	O-RING ANEL DE BORRACHA	1	1	S(16.7") S(16.7")
9	93210-26130	O-RING ANEL DE BORRACHA	1	1	S(16.7") S(16.7")
10	69P-44311-00	HOUSING, WATER PUMP ALOJAMENTO DA BOMBA D'AGUA	1	1	
11	6L2-44367-00	DAMPER, WATER SEAL AMORTIZADOR DE BORRACHA	1	1	
12	69P-44322-40	INSERT, CARTRIDGE INSERTO DA BOMBA D'AGUA	1	1	FOR CHROMATE FOR CHROMATE
13	6H4-44352-02	IMPELLER IMPULSOR	1	1	
14	93210-45161	O-RING ANEL DE BORRACHA	1	1	
15	61N-44323-40	OUTER PLATE, CARTRIDGE PLACA DA EXTERNA DA BOMBA	1	1	FOR CHROMATE FOR CHROMATE
16	97095-06040	BOLT PARAFUSO	4	4	
17	92995-06600	WASHER ARRUELA	4	4	
18	61N-44176-00	BRACKET SUPORTE	1	1	
19	61N-45321-00	PLATE PLACA	1	1	
20	93210-06ME6	O-RING ANEL DE BORRACHA	1	1	

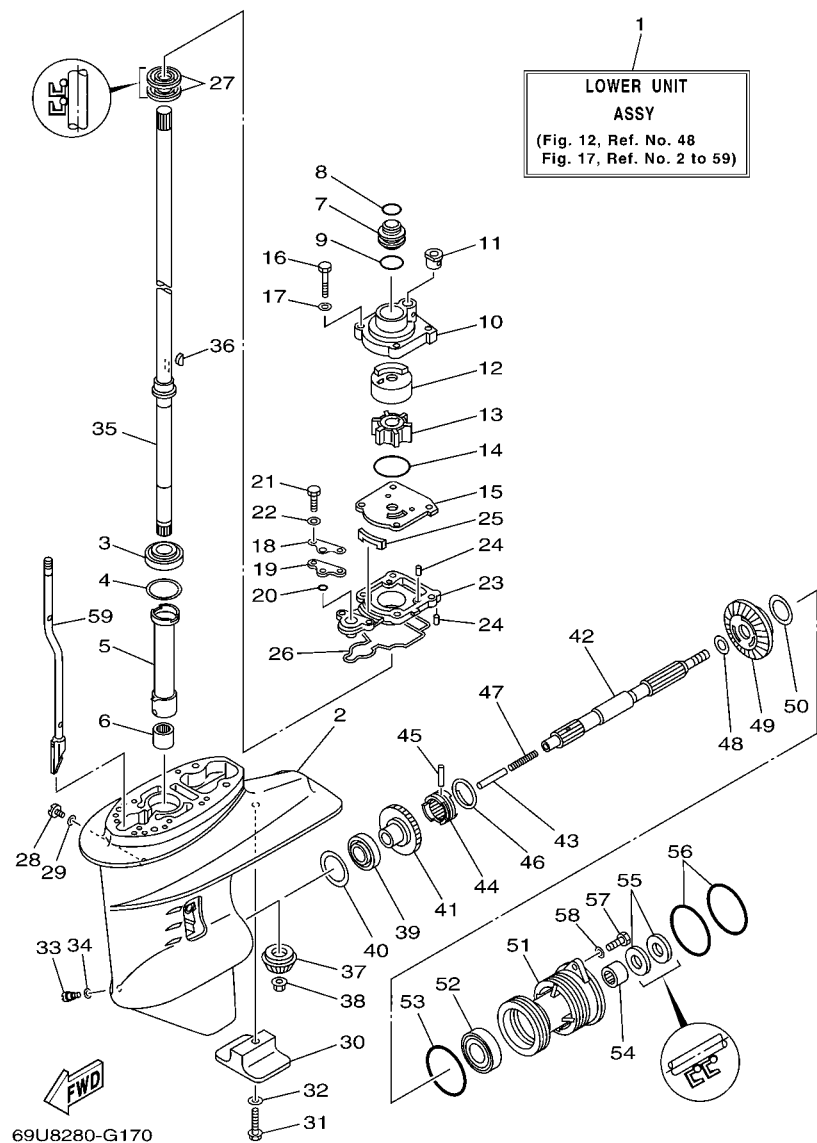

FIG. 17 LOWER CASING & DRIVE 1 CARCACA INF. E TRANSMISSAO 1

REF. NO.	PART NO. No. PEÇA	DESCRIPTION DESCRIÇÃO	69U7	69U8	REMARKS OBSERVAÇÕES
21	97095-06025	BOLT PARAFUSO	2	2	
22	92995-06600	WASHER ARRUELA	2	2	
23	61N-45331-00-5B	HOUSING, BEARING ALOJAMENTO DO ROLAMENTO	1	1	
24	93604-10M03	PIN, DOWEL PINO GUIA	3	3	
25	61N-45127-00	SEAL RETENTOR DE BORRACHA	1	1	
26	61N-45315-00	PACKING, LOWER CASING GAXETA DA RABETA INFERIOR	1	1	
27	93101-22067	OIL SEAL RETENTOR DE OLEO	2	2	
28	90340-08002	PLUG, STRAIGHT SCREW TAMPAO DO DRENO	1	1	
29	90430-08020	GASKET GAXETA	1	1	
30	61N-45251-01	ANODE ANODO	1	1	
31	95895-06035	BOLT, FLANGE PARAFUSO FLANGE	1	1	
32	92990-06300	WASHER, INTERNAL TOOTH ARRUELA	1	1	
33	688-45341-10	PLUG, DRAIN TAMPAO DE ESGOTO	1	1	
34	90430-08020	GASKET GAXETA	1	1	
35	61N-45510-00	DRIVE SHAFT ASSY EIXO DE DIRECIONAL COMPL.	1	1	S(16.7") S(16.7")
36	90280-03M03	KEY, WOODRUFF CHAVETA MEIA LUA	1	1	
37	61N-45551-00	PINION (13T) PINHAO (13D)	1	1	
38	90179-10M14	NUT PORCA DE REGULAGEM	1	1	
39	93332-00005	BEARING ROLAMENTO	1	1	
40	6L2-45567-00	SHIM (T:1.0MM) CALCO (T:1.0MM)	1	1	UR UR
40	6L2-45567-10	SHIM (T:1.1MM) CALCO (T:1.1MM)	1	1	UR UR
40	6L2-45567-20	SHIM (T:1.2MM) CALCO (T:1.2MM)	1	1	UR UR
40	6L2-45567-30	SHIM (T:1.3MM) CALCO (T:1.3MM)	1	1	UR UR
40	6L2-45567-40	SHIM (T:1.4MM) CALCO (T:1.4MM)	1	1	UR UR
41	61N-45560-10	GEAR 1 (27T) ENGRENAGEM (27D)	1	1	
42	65W-45611-00	SHAFT, PROPELLER EIXO DA HELICE	1	1	
43	648-45635-00	PLUNGER, SHIFT ACIONADOR DE MUDANCA	1	1	

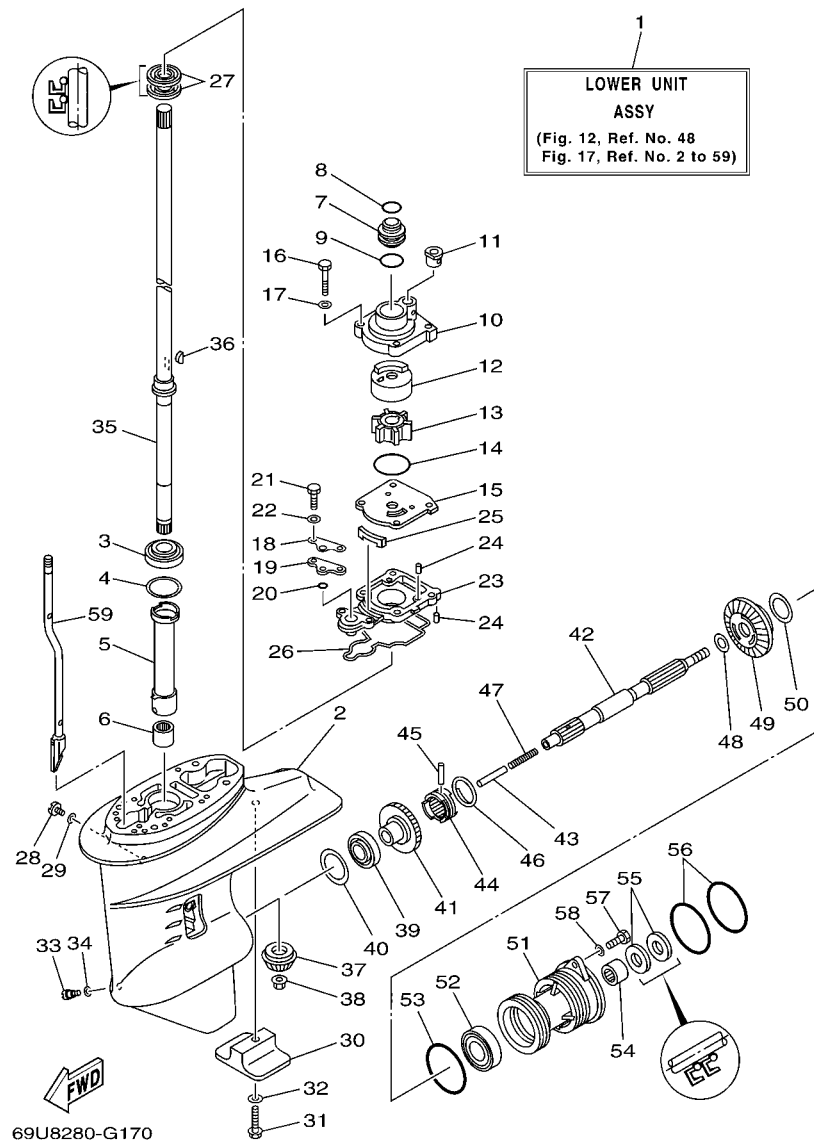
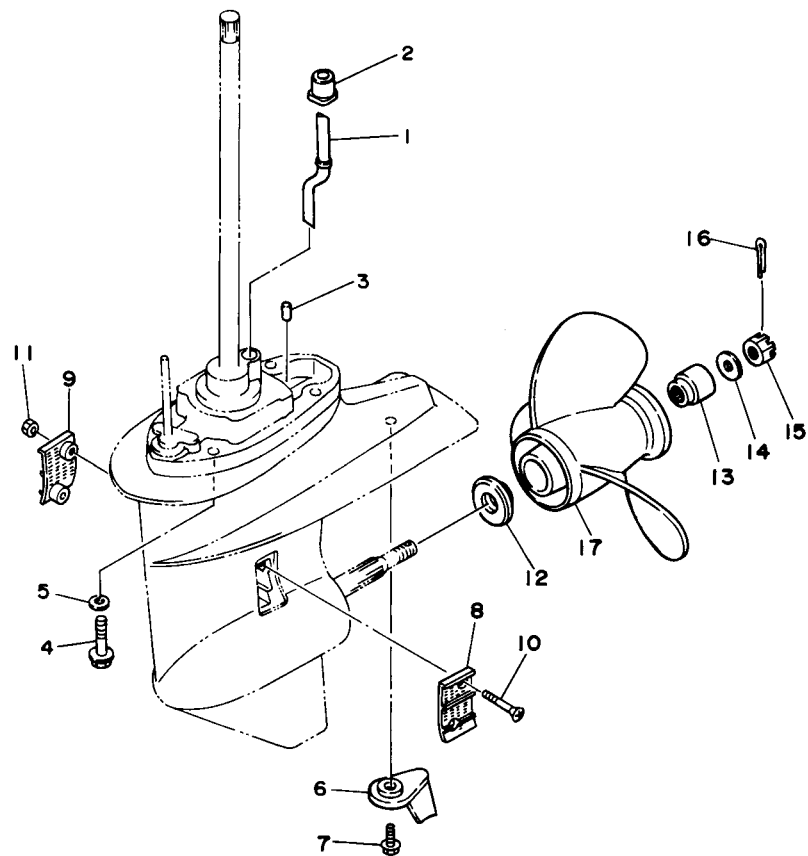

FIG. 17 LOWER CASING & DRIVE 1 CARCACA INF. E TRANSMISSAO 1

REF. NO.	PART NO. No. PEÇA	DESCRIPTION DESCRIÇÃO	69U7	69U8	REMARKS OBSERVAÇÕES
44	664-45631-02	CLUTCH, DOG ENGATE DA ENGRENAGEM	1	1	
45	90250-05010	PIN, STRAIGHT PINO DIRECTO	1	1	
46	648-45633-00	RING, CROSS PIN ANEL DE FIXACAO DO PINHAO	1	1	
47	90501-10065	SPRING, COMPRESSION MOLA DE COMPRESSAO	1	1	
48	90201-20417	WASHER, PLATE ARRUELA PLANA	1	1	
49	61N-45571-00	GEAR 2 (27T) ENGRENAGEM (27D)	1	1	
50	6L2-45577-00	SHIM (T:1.0MM) CALCO (T:1.0MM)	1	1	UR
	6L2-45577-10	SHIM (T:1.1MM) CALCO (T:1.1MM)	1	1	UR
	6L2-45577-20	SHIM (T:1.2MM) CALCO (T:1.2MM)	1	1	UR
	6L2-45577-30	SHIM (T:1.3MM) CALCO (T:1.3MM)	1	1	UR
51	61N-45361-01-4D	CAP, LOWER CASING CAPA DA RABETA INFERIOR	1	1	
52	93306-00612	BEARING ROLAMENTO	1	1	
53	93210-64ME7	O-RING ANEL DE BORRACHA	1	1	
54	93315-22004	BEARING ROLAMENTO CILINDRICO	1	1	
55	93101-20M07	OIL SEAL RETENTOR DE OLEO	2	2	
56	93210-65M50	O-RING ANEL DE BORRACHA	2	2	
57	97075-06020	BOLT PARAFUSO	2	2	
58	92995-06600	WASHER ARRUELA	2	2	
59	61N-44150-00	SHIFT CAM ASSY CAME DE MUDANCA CONJ.	1	1	S(16.7") S(16.7")

FIG. 18 LOWER CASING & DRIVE 2

CARCACA INF. E TRANSMISSAO 2



61R0010-4180

REF. NO.	PART NO. No. PEÇA	DESCRIPTION DESCRIÇÃO	69U7	69U8		REMARKS OBSERVAÇÕES
1	61N-44361-00	TUBE, WATER TUBO DE AGUA	1	1		S(16.7") S(16.7")
2	689-44366-00	DAMPER, WATER SEAL AMORTIZADOR DE BORRACHA	1	1		
3	93606-11M24	PIN, DOWEL PINO GUIA	2	2		
4	90105-10M12	BOLT, FLANGE PARAFUSO FLANGE	4	4		
5	92995-10600	WASHER ARRUELA	4	4		
6	61N-45371-00	TAB-TRIM ESTABILIZADOR DE DIRECAO	1	1		
7	90119-06M48	BOLT, WITH WASHER PARAFUSO COM ARRUELA	1	1		
8	6L2-45214-00	COVER, WATER INLET 1 TAMPA DA ENTRADA DE AGUA 1	1	1		
9	6L2-45215-00	COVER, WATER INLET 2 TAMPA DA ENTRADA DE AGUA 2	1	1		
10	90151-05M05	SCREW, COUNTERSUNK PARAFUSO TRAMBULADOR	2	2		
11	90185-05002	NUT, SELF-LOCKING PORCA AUTO-TRAVANTE	2	2		
12	6L2-45987-01	SPACER ESPADADOR	1	1		
13	689-45997-00	SPACER ESPADADOR	1	1		
14	92990-14200	WASHER, PLAIN ARRUELA PLANA	1	1		
15	90171-14013	NUT, CASTLE PORCA CASTELO	1	1		
16	91490-30022	PIN, COTTER CUPILHA	1	1		
17	664-45941-01-EL	PROPELLER (3X9-7/8"X9"-F) HELICE (3X9-7/8"X9"-F)	1	1		UR UR
	664-45943-01-EL	PROPELLER (3X9-7/8"X8"-F) HELICE (3X9-7/8"X8"-F)	1	1		UR UR
	664-45945-00-EL	PROPELLER (3X9-7/8"X10-1/2"-F) HELICE (3X9-7/8"X10-1/2"-F)	1	1		UR UR
	664-45947-01-EL	PROPELLER (3X9-7/8"X11-1/4"-F) HELICE (3X9-7/8"X11-1/4"-F)	1	1		UR UR
	664-45949-02-EL	PROPELLER (3X9-7/8"X13"-F) HELICE (3X9-7/8"X13"-F)	1	1		UR UR
	664-45952-00-EL	PROPELLER (3X9-7/8"X14"-F) HELICE (3X9-7/8"X14"-F)	1	1		UR UR
	664-45954-01-EL	PROPELLER (3X9-7/8"X12"-F) HELICE (3X9-7/8"X12"-F)	1	1		UR UR
	62C-45941-00-EL	PROPELLER (3X9-7/8"X10"-F) HELICE (3X9-7/8"X10"-F)	1	1		UR UR

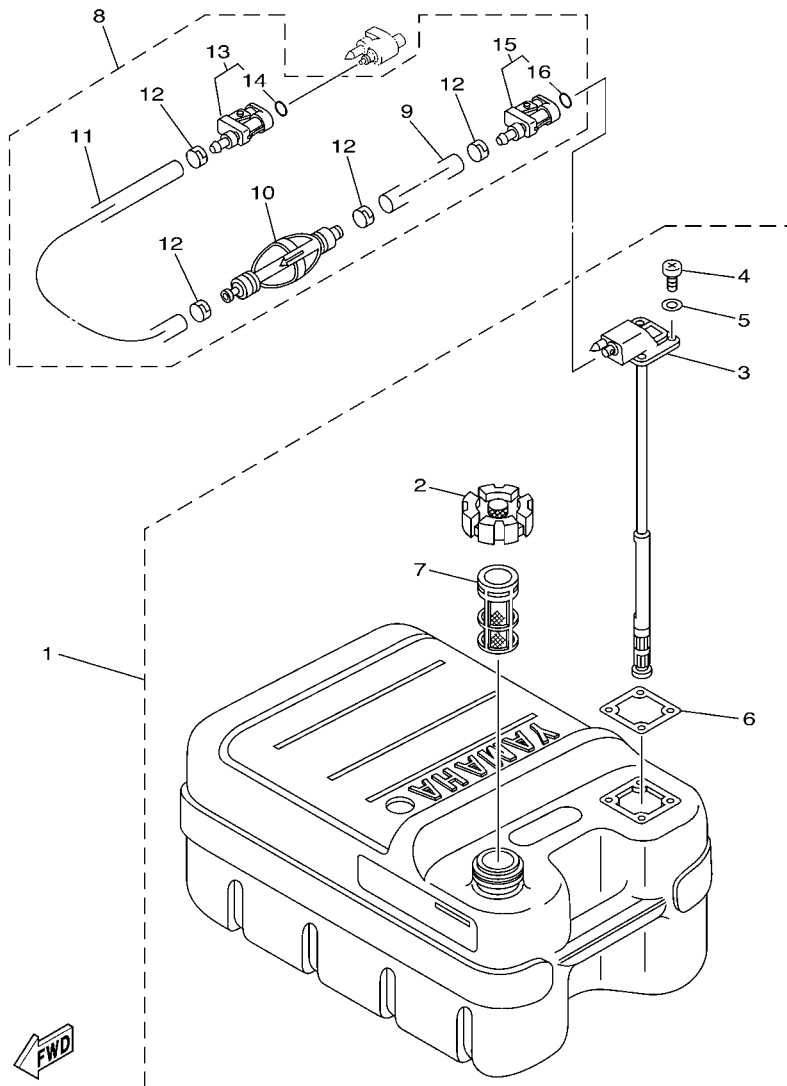

68U3100-C240

FIG. 19 FUEL TANK

TANQUE DE COMBUSTIVEL

REF. NO.	PART NO. No. PEÇA	DESCRIPTION DESCRIÇÃO			REMARKS OBSERVAÇÕES
			68U7	68U8	
1	61J-F4201-00	FUEL TANK ASSY TANQUE DE COMBUSTIVEL CONJ.	1	1	AP AP
2	6YJ-24610-01	.CAP ASSY .TAMPA DO TANQUE CJ.	1	1	
3	6YJ-24260-00	.FUEL METER ASSY .MEDIDOR NIVEL DO COMBUSTIVEL	1	1	
4	90157-05M19	.SCREW, PAN HEAD .PARAFUSO	4	4	
5	6Y1-24329-00	.SEAL .GUARNICAO	4	4	
6	6Y1-24268-00	.GASKET, FUEL METER .GAXETA DO MEDIDOR DO NIVEL	1	1	
7	6YJ-24167-00	.STRAINER .FILTRO	1	1	
8	61J-24306-04	FUEL PIPE COMP. 1 TUBO DE COMBUSTIVEL COMP. 1	1	1	AP AP
9	90445-11M06	.HOSE (L2050) .TUBO (L2050)	1	1	
10	61J-24360-00	.PRIMER PUMP ASSY .BOMBA PRIMARIA CONJ.	1	1	
11	90445-11M05	.HOSE (L850) .TUBO (L850)	1	1	
12	650-24351-01	.BAND 1 .BRACADEIRA 1	4	4	
13	6G1-24305-05	.FUEL PIPE JOINT COMP. 2 .JUNCAO TUBO DE COMBUSTIVEL 2	1	1	
14	93210-08287	..O-RING ..ANEL DE BORRACHA	1	1	
15	6Y1-24305-06	.FUEL PIPE JOINT COMP. 2 .JUNCAO TUBO DE COMBUSTIVEL 2	1	1	
16	93210-08287	..O-RING ..ANEL DE BORRACHA	1	1	

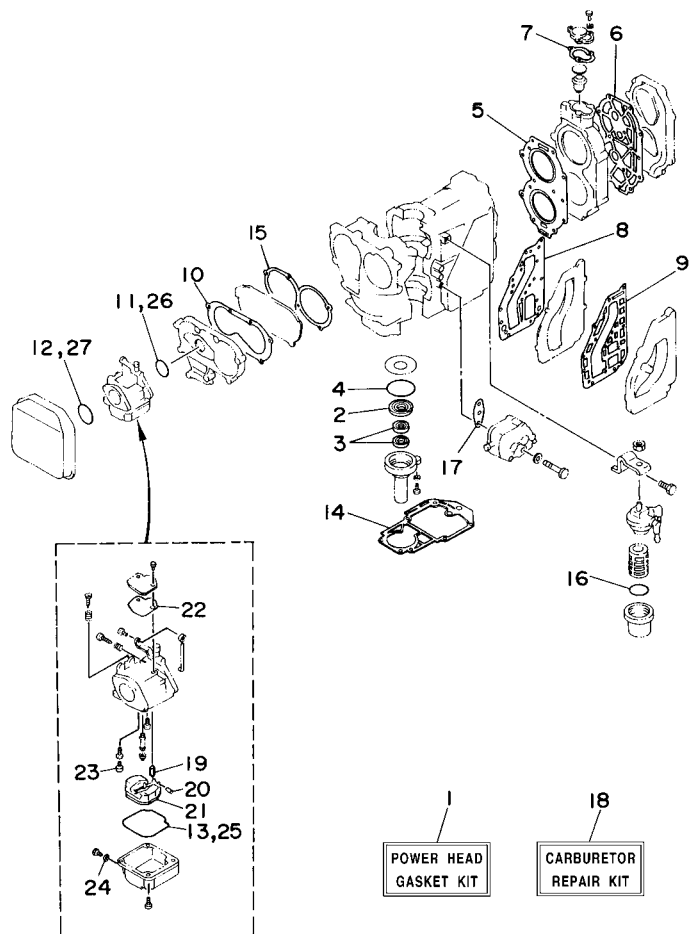

61R0700-4180

FIG. 20 REPAIR KIT 1

KIT DE REPARO 1

REF. NO.	PART NO. No. PEÇA	DESCRIPTION DESCRIÇÃO	69U7	69U8	REMARKS OBSERVAÇÕES
1	69P-W0001-00	POWER HEAD GASKET KIT JOGO DE GAXETAS	1	1	
2	93102-25008	.OIL SEAL .RETENTOR DE OLEO	1	1	
3	93101-16001	.OIL SEAL .RETENTOR DE OLEO	2	2	
4	93210-58M21	.O-RING .ANEL DE BORRACHA	1	1	
5	61N-11181-A1	.GASKET, CYLINDER HEAD 1 .GAXETA CABECOTE DO CILINDRO 1	1	1	
6	61T-11193-A1	.GASKET, HEAD COVER 1 .GAXETA DA TAMPA DO CABECOTE 1	1	1	
7	655-12414-A1	.GASKET, COVER .GAXETA DA TAMPA	1	1	
8	6K8-41122-A1	.GASKET, EXHAUST INNER COVER .GAXETA TAMPA INTERNA DO ESCAPE	1	1	
9	6K8-41124-A1	.GASKET, EXHAUST OUTER COVER .GAXETA TAMPA EXTERNA DO ESCAPE	1	1	
10	648-13645-A0	.GASKET, MANIFOLD 1 .GAXETA DO TUBO MULTIPLO 1	1	1	
11	61N-14198-00	.GASKET .GAXETA	1	1	
12	93210-40659	.O-RING .ANEL DE BORRACHA	1	1	
13	6L2-14384-00	.GASKET, FLOAT CHAMBER .GAXETA DA CAMARA DA BOIA	1	1	
14	689-45113-A1	.GASKET, UPPER CASING .GAXETA DA CAIXA SUPERIOR	1	1	
15	648-13621-A1	.GASKET, VALVE SEAT .GAXETA DO ASSENTO DA VALVULA	1	1	
16	93210-32738	.O-RING .ANEL DE BORRACHA	1	1	
17	650-24431-A0	.GASKET, FUEL PUMP 1 .GAXETA BOMBA DE COMBUSTIVEL 1	1	1	
18	61N-W0093-00	CARBURETOR REPAIR KIT JOGO DE REPARO DO CARBURADOR	1	1	
19	61N-14392-00	.VALVE, NEEDLE .VALVULA DA AGULHA	1	1	
20	6E5-14386-01	.PIN, FLOAT .PINO DA BOIA	1	1	
21	6L2-14385-00	.FLOAT .BOIA	1	1	
22	6L2-14399-00	.GASKET .VALVULA BIMETALICA	1	1	
23	50M-14355-00	.PLUG .PULVERIZADOR PRINCIPAL 2	1	1	
24	6L2-14398-00	.GASKET .GAXETA	1	1	
25	6L2-14384-00	.GASKET, FLOAT CHAMBER .GAXETA DA CAMARA DA BOIA	1	1	
26	61N-14198-00	.GASKET .GAXETA	1	1	
27	93210-40659	.O-RING .ANEL DE BORRACHA	1	1	

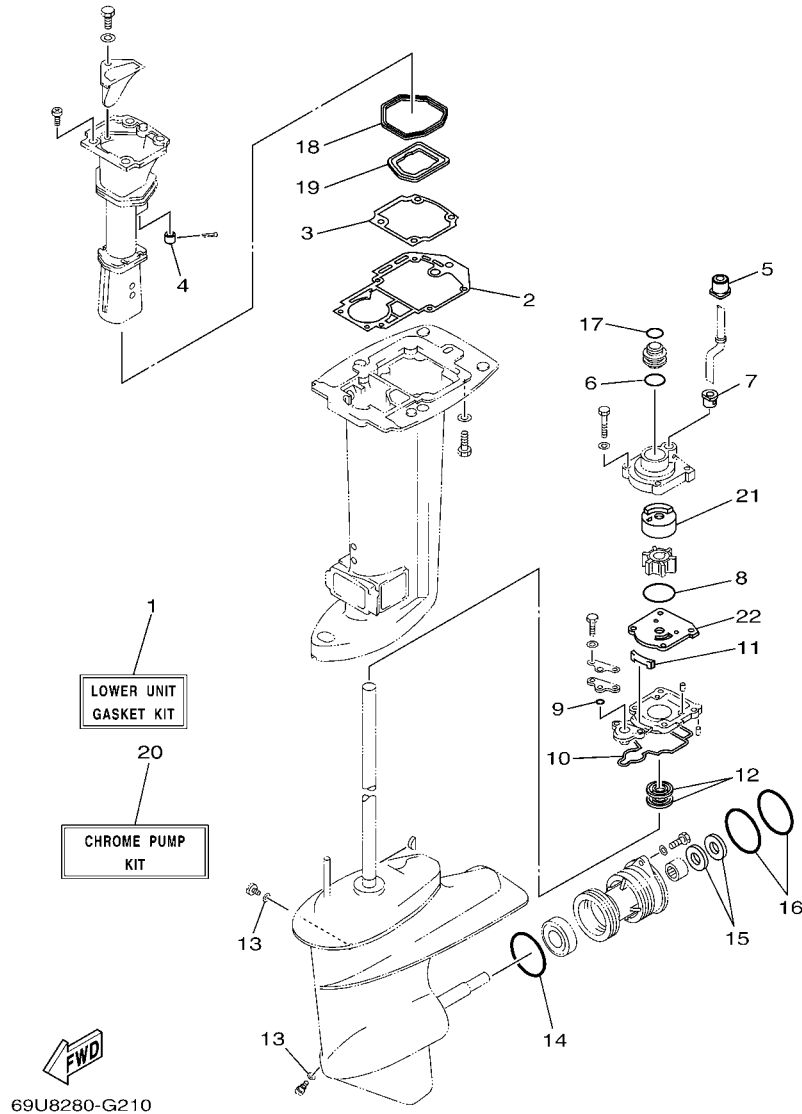

FIG. 21 REPAIR KIT 2

KIT DE REPARO 2

REF. NO.	PART NO. No. PEÇA	DESCRIPTION DESCRIÇÃO	69U7	69U8	REMARKS OBSERVAÇÕES
1	69P-W0001-20	LOWER UNIT GASKET KIT JOGO DE GAXETAS	1	1	
2	689-45113-A1	.GASKET, UPPER CASING .GAXETA DA CAIXA SUPERIOR	1	1	
3	69P-41134-A0	.GASKET, EXHAUST MANIFOLD .GAXETA DO MULTIPLO DE ESCAPE	1	1	
4	6A8-41135-00	.GASKET, EXHAUST MANIFOLD .GAXETA DO MULTIPLO DE ESCAPE	1	1	
5	689-44366-00	.DAMPER, WATER SEAL .AMORTIZADOR DE BORRACHA	1	1	
6	93210-26130	.O-RING .ANEL DE BORRACHA	3	3	UN UN
7	6L2-44367-00	.DAMPER, WATER SEAL .AMORTIZADOR DE BORRACHA	1	1	
8	93210-45161	.O-RING .ANEL DE BORRACHA	1	1	
9	93210-06ME6	.O-RING .ANEL DE BORRACHA	1	1	
10	61N-45315-00	.PACKING, LOWER CASING .GAXETA DA RABETA INFERIOR	1	1	
11	61N-45127-00	.SEAL .RETENTOR DE BORRACHA	1	1	
12	93101-22067	.OIL SEAL .RETENTOR DE OLEO	2	2	
13	90430-08020	.GASKET .GAXETA	2	2	
14	93210-64ME7	.O-RING .ANEL DE BORRACHA	1	1	
15	93101-20M07	.OIL SEAL .RETENTOR DE OLEO	2	2	
16	93210-65M50	.O-RING .ANEL DE BORRACHA	2	2	
17	93210-22164	.O-RING .ANEL DE BORRACHA	1	1	S(16.7") S(16.7")
18	69P-41138-00	.SEAL, EXT. 1 .VEDACAO DO ESCAPE 1	1	1	
19	69P-41139-00	.SEAL, EXT. 2 .VEDACAO DO ESCAPE 2	1	1	
20	69P-W0078-0A	CHROME PUMP KIT JOGO DE REPARO DA BOMBA D'AGUA	1	1	
21	69P-44322-40	.INSERT, CARTRIDGE .INSERTO DA BOMBA D'AGUA	1	1	
22	61N-44323-40	.OUTER PLATE, CARTRIDGE .PLACA DA EXTERNA DA BOMBA	1	1	

NUMERICAL INDEX
ÍNDICE NUMÉRICO

PART NO. No. PEÇA	REF. NO.	PART NO. No. PEÇA	REF. NO.	PART NO. No. PEÇA	REF. NO.	PART NO. No. PEÇA	REF. NO.	PART NO. No. PEÇA	REF. NO.	PART NO. No. PEÇA	REF. NO.
61N-11111-01-1S	2 - 19	6A0-14325-00	6 - 26	6F5-15779-02	7 - 17	69P-41213-00	12 - 18	689-42725-01	10 - 16	689-44366-00	18 - 2
61N-11181-A1	2 - 21	61N-14341-00	5 - 9	6A0-15789-00	7 - 22	682-41237-00	12 - 12	6E7-42791-00	10 - 23		21 - 5
	20 - 5	6L2-14342-36	5 - 11	6YJ-24167-00	19 - 7	662-41237-01	12 - 7	6G0-42796-00	10 - 5	6L2-44367-00	17 - 11
61N-11191-01-1S	2 - 22	61N-14343-68	5 - 10	6YJ-24260-00	19 - 3	682-41238-01	12 - 11	689-42815-00	10 - 10		21 - 7
61T-11193-A1	2 - 23	50M-14355-00	5 - 12	69P-41241-00	19 - 6	69P-41241-00	12 - 20	689-42816-00	10 - 13	664-44514-00-94	15 - 35
	20 - 6		20 - 23	6G1-24304-02	6 - 1	679-41241-01	12 - 9	689-43111-03-4D	14 - 1	689-44516-00	15 - 30
689-11325-00	2 - 17	61N-14381-00	5 - 2	6G1-24305-05	19 - 13	689-41252-01	4 - 18	689-43112-02-4D	14 - 2	69P-44518-00-94	15 - 14
6J8-11325-00	2 - 12	677-14383-01	5 - 15	6Y1-24305-06	19 - 15	61N-41256-00	4 - 19	689-42816-00	14 - 12	648-44519-00-94	15 - 16
6H3-11327-00-1S	2 - 13	6L2-14384-00	5 - 20	61J-24306-04	19 - 8	661-41262-02	4 - 20	648-43114-01	14 - 6	689-44551-01-4D	15 - 43
6H3-11328-00	2 - 14		20 - 13	689-24311-00	6 - 14	682-41271-00	4 - 15	6E0-43118-01	14 - 3	689-44552-01-4D	15 - 45
676-11372-00	2 - 20		20 - 25	6A1-24311-00	6 - 31	689-41273-00	4 - 16	689-43131-01	14 - 7	689-44553-00-94	15 - 39
	2 - 35	6L2-14385-00	5 - 5	61N-24329-00	6 - 2	6J8-41274-00	4 - 17	6G5-43145-01	14 - 8	689-44555-00	15 - 44
69P-11400-00	3 - 1		20 - 21	6Y1-24329-00	19 - 5	676-41611-00	8 - 17	689-43160-00	14 - 18	689-44557-00	15 - 40
69P-11412-00	3 - 2	6E5-14386-01	5 - 4	650-24351-01	19 - 12	689-41612-01	8 - 21	689-43165-00	14 - 19	648-44591-A0	15 - 29
61N-11422-00	3 - 3		20 - 20	61J-24360-00	19 - 10	676-41613-00	8 - 18	689-43191-00	14 - 13		15 - 34
61N-11432-00	3 - 4	61N-14392-00	5 - 3	662-24410-00	6 - 16	61N-41615-00	9 - 1	689-43192-01	14 - 14	664-44591-A0	15 - 36
61N-11442-00	3 - 5		20 - 19	693-24411-00	6 - 21	69P-41631-00	12 - 2	689-43111-03-4D	14 - 26	69P-45111-00-4D	16 - 1
61N-11515-00	3 - 10	6L2-14398-00	5 - 16	692-24411-00	6 - 18	689-42111-01-4D	11 - 2	682-43318-01	14 - 43	689-45113-A1	2 - 42
61N-11603-00	3 - 19		20 - 24	6A0-24412-02	6 - 27	69P-42112-00-4D	11 - 7	689-43373-01	15 - 2		20 - 14
61N-11604-00	3 - 19	6L2-14399-00	5 - 8	6A0-24413-00	6 - 17	664-42119-00	11 - 11	689-43614-01	14 - 37		21 - 2
61N-11605-00	3 - 19		20 - 22	6A0-24421-01	6 - 25	656-42126-01	11 - 20	648-43615-00	14 - 38	663-45119-00	14 - 17
61N-11631-00-95	3 - 18	61N-14440-00	4 - 11	650-24431-A0	6 - 28	6G1-42137-10	11 - 14	689-43616-00	14 - 32		14 - 28
689-11633-00	3 - 20	69P-14497-00	12 - 1		20 - 17	689-42138-00	11 - 19	648-43617-00	14 - 35		15 - 23
688-11634-00	3 - 22	62Y-14597-00	5 - 23	648-24434-01	6 - 19	656-42153-00-94	12 - 15	689-43631-00	14 - 29	61N-45127-00	17 - 25
61N-11635-00	3 - 18	69P-15100-00-1S	2 - 2	648-24435-02	6 - 22	69P-42154-00	12 - 21	689-43633-00	14 - 30		21 - 11
61N-11636-00	3 - 18	689-15396-01-5B	2 - 6	61N-24521-00	6 - 9	69P-42157-00-94	12 - 14	648-43642-00	14 - 33	69P-45127-00	16 - 17
689-11651-00	3 - 12	61N-15711-10	7 - 2	61N-24560-00	6 - 7	69P-42167-00	12 - 19	689-43643-00	14 - 31	69P-45128-00	16 - 18
689-11681-01	3 - 13	6F5-15713-01	7 - 5	61N-24563-00	6 - 8	62Y-42171-00	12 - 22	689-43681-01	14 - 42	6L2-45214-00	18 - 8
6E5-12411-02	2 - 26	6G0-15714-01	7 - 3	61N-24566-01	6 - 12	6F6-42177-A0	11 - 12	689-44111-01-4D	12 - 30	6L2-45215-00	18 - 9
6E5-12412-00	2 - 27	61N-15715-00	7 - 6	6YJ-24610-01	19 - 2	69P-42511-00-4D	15 - 4	664-44113-01	12 - 31	61N-45251-01	17 - 30
655-12413-01-1S	2 - 29	6F5-15716-01	7 - 8	61N-26311-01	11 - 23	689-42521-00-94	15 - 7	689-44121-01	12 - 38	69P-45300-01-4D	17 - 1
655-12414-A1	2 - 30	6F5-15723-01	7 - 34	61N-26326-00	10 - 18	647-42523-00	10 - 17	689-44125-00	12 - 39	61N-45311-02-4D	17 - 2
	20 - 7	6F5-15726-01	7 - 11	6K8-41121-00-1S	2 - 32	648-42528-00	15 - 1	664-44142-00	12 - 33	61N-45315-00	17 - 26
61N-13610-00	4 - 1	61N-15734-00	7 - 7	6K8-41122-A1	2 - 33	69R-42610-20-4D	1 - 1	61N-44143-00	12 - 43		21 - 10
648-13621-A1	4 - 3	6F5-15739-00	7 - 16		20 - 8	69P-42613-00-4D	1 - 7	61N-44146-00	12 - 47	61N-45321-00	17 - 19
	20 - 15	6F5-15741-01	7 - 4	61N-41123-01-1S	2 - 34	6G0-42615-00	1 - 2	61N-44150-00	17 - 59	61N-45331-00-5B	17 - 23
61N-13641-01-1S	4 - 4	69P-15746-00	7 - 41	6K8-41124-A1	2 - 37	61N-42628-00	1 - 10	664-44167-01	12 - 27	688-45341-10	17 - 33
648-13645-A0	4 - 5	689-15747-70	7 - 42		20 - 9	689-42647-00	1 - 3	61N-44176-00	17 - 18	61N-45361-01-4D	17 - 51
	20 - 10	656-15748-00	7 - 37	69P-41131-01-5B	16 - 6	6G0-42651-02	1 - 5	6E0-44191-11	1 - 14	61N-45371-00	18 - 6
6L2-14157-00	5 - 7	6G0-15754-00	7 - 9	69P-41134-A0	16 - 7	69R-42677-00	1 - 12	61N-44194-01	9 - 2	61N-45510-00	17 - 35
61N-14198-00	4 - 10	689-15755-01	7 - 14		21 - 3	61R-42678-10	1 - 13	69P-44311-00	17 - 10	61N-45536-00	17 - 5
	20 - 11	61N-15758-01-4D	7 - 18	6A8-41135-00	16 - 14	689-42711-04-4D	10 - 1	69P-44322-40	17 - 12	61N-45551-00	17 - 37
	20 - 26	61N-15762-00	7 - 19		21 - 4	664-42715-00	12 - 26		21 - 21	61N-45560-10	17 - 41
61N-14212-00	5 - 21	6F5-15764-00	7 - 15	69P-41137-00-5B	16 - 9	69P-42716-00	15 - 25	61N-44323-40	17 - 15	6L2-45567-00	17 - 40
646-14212-01	5 - 18	61T-15770-00	7 - 36	69P-41138-00	16 - 12	65W-42717-00	16 - 2		21 - 22	6L2-45567-10	17 - 40
69P-14301-10	5 - 1	6H7-15771-01-94	7 - 29		21 - 18	69P-42717-00	15 - 24	6H4-44352-02	17 - 13	6L2-45567-20	17 - 40
664-14321-01	5 - 13	656-15772-00-94	7 - 31	69P-41139-00	16 - 13	689-42718-00	15 - 21	61N-44361-00	18 - 1	6L2-45567-30	17 - 40
61N-14323-00	5 - 19	69P-15774-00	7 - 39		21 - 19	682-42724-00	10 - 15	61N-44362-00	17 - 7	6L2-45567-40	17 - 40

NUMERICAL INDEX
ÍNDICE NUMÉRICO

PART NO. No. PEÇA	REF. NO.	PART NO. No. PEÇA	REF. NO.	PART NO. No. PEÇA	REF. NO.	PART NO. No. PEÇA	REF. NO.	PART NO. No. PEÇA	REF. NO.	PART NO. No. PEÇA	REF. NO.
61N-45571-00	17 - 49	6E9-82575-02	10 - 19	90119-06MA3	7 - 30	90269-02M09	11 - 15	90506-16M17	14 - 45	92995-06600	9 - 28
6L2-45577-00	17 - 50	689-8257Y-00	10 - 21		7 - 32	90280-03M03	17 - 36	90506-30M27	14 - 41		11 - 10
6L2-45577-10	17 - 50	6A1-83625-41	4 - 23	90119-06MA4	2 - 39	90280-05015	8 - 14	90508-14M13	12 - 40		13 - 5
6L2-45577-20	17 - 50	6E0-83627-41	11 - 24	90119-08009	2 - 3	90340-08002	17 - 28	91490-12010	12 - 36		13 - 8
6L2-45577-30	17 - 50	6E9-85516-70	8 - 9	90119-08015	2 - 25	90381-12M01	15 - 20	91490-16010	7 - 47		15 - 19
61N-45587-00	17 - 4	663-85518-00	12 - 10	90119-08M03	15 - 47	90386-08032	11 - 18		12 - 23		15 - 32
61N-45587-10	17 - 4	61N-85537-00	8 - 13	90119-08M65	2 - 4	90386-10009	12 - 16		12 - 34		17 - 17
61N-45587-20	17 - 4	61N-85540-13	9 - 13	90149-05M13	11 - 13	90386-12069	10 - 12		14 - 40		17 - 22
61N-45587-30	17 - 4	69P-85541-09	8 - 3	90149-14030	14 - 5	90386-22M67	14 - 11	91490-20010	12 - 46		17 - 58
61N-45587-40	17 - 4	61N-85542-00-94	9 - 5	90151-05M05	18 - 10	90386-38022	15 - 13	91490-30022	18 - 16	92995-08600	15 - 42
61N-45587-50	17 - 4	61N-85543-09	8 - 5	90151-06M02	2 - 18	90386-38090	15 - 11	91490-30025	16 - 15		16 - 5
61N-45587-60	17 - 4	61N-85543-19	8 - 6	90157-05M19	19 - 4	90386-47M22	15 - 10	91690-30008	14 - 20		16 - 11
61N-45587-70	17 - 4	61T-85550-10	8 - 1	90170-10M42	15 - 27	90387-06013	7 - 44	91690-30012	13 - 14	92995-10600	18 - 5
65W-45611-00	17 - 42	69P-85560-00	8 - 2		15 - 33	90387-06119	9 - 7		13 - 20	93101-16001	2 - 8
664-45631-02	17 - 44	69P-85561-00	8 - 10	90171-14013	18 - 15	90387-06M26	4 - 14	91690-30016	14 - 15		20 - 3
648-45633-00	17 - 46	61N-85570-00	9 - 20	90176-10M01	15 - 38	90387-06M59	12 - 3	91690-40016	12 - 42		17 - 55
648-45635-00	17 - 43	61N-85570-10	9 - 25	90179-06M24	1 - 8	90387-06M60	12 - 24	91690-40018	12 - 17	93101-20M07	21 - 15
62C-45941-00-EL	18 - 17	61J-F4201-00	19 - 1	90179-10M14	17 - 38	90387-08M03	14 - 23	91690-40035	14 - 46	93101-22067	17 - 27
664-45941-01-EL	18 - 17	61J-F8100-01	6 - 33	90179-16M05	8 - 15	90387-08M25	10 - 3	91690-40048	4 - 21		21 - 12
664-45943-01-EL	18 - 17	69P-W0001-00	20 - 1	90185-05002	18 - 11	90387-10M39	15 - 15	92903-05600	7 - 46	93102-25008	2 - 7
664-45945-00-EL	18 - 17	69P-W0001-20	21 - 1	90185-06062	11 - 22	90387-13003	11 - 3	92903-06600	2 - 16		20 - 2
664-45947-01-EL	18 - 17	689-W0004-00	4 - 2	90185-10051	13 - 25	90387-32002	3 - 16		4 - 7	93102-32M07	3 - 7
664-45949-02-EL	18 - 17	61R-W0070-10	1 - 11	90185-22043	14 - 9	90387-33001	11 - 4		4 - 9	93210-06ME6	17 - 20
664-45952-00-EL	18 - 17	69P-W0078-0A	21 - 20	90201-06416	12 - 5	90430-08020	17 - 29	92990-05100	6 - 24		21 - 9
664-45954-01-EL	18 - 17	69P-W0084-00-4D	11 - 1	90201-06M30	9 - 9		17 - 34	92990-05600	8 - 20	93210-08287	19 - 14
6L2-45987-01	18 - 12	69P-W0090-00-1S	2 - 1	90201-08M87	10 - 4		21 - 13		12 - 37		19 - 16
689-45997-00	18 - 13	61N-W0093-00	20 - 18	90201-10M02	11 - 16	90445-09M75	6 - 5		12 - 45	93210-22164	17 - 8
69P-47467-00-5B	16 - 16	61N-W1571-11	7 - 1	90201-16M44	8 - 16	90445-10M41	2 - 36	92990-06100	9 - 12		21 - 17
648-48330-50	13 - 15	90101-08339	14 - 22	90201-20417	17 - 48	90445-11M05	19 - 11		9 - 17	93210-26130	17 - 9
617-48331-91	13 - 19	90105-06M07	12 - 32	90201-20M27	3 - 23	90445-11M06	19 - 9		9 - 24		21 - 6
648-48340-50	13 - 9		15 - 6	90201-21567	2 - 28	90465-06M88	4 - 22	92990-06300	17 - 32	93210-32738	6 - 10
648-48346-50	13 - 16	90105-06M08	15 - 26	90201-22M03	14 - 10	90465-13M11	9 - 19	92990-08600	10 - 8		20 - 16
617-48346-90	13 - 10	90105-06M18	15 - 3	90201-28013	11 - 5	90467-08004	6 - 6		13 - 11	93210-37160	15 - 12
617-48361-91	13 - 13	90105-08M10	7 - 35	90201-50306	2 - 41		6 - 15		13 - 17	93210-40659	4 - 12
689-48501-01-4D	13 - 1	90105-10M12	18 - 4	90202-06007	12 - 35		6 - 32		14 - 24		20 - 12
689-48501-21-4D	13 - 1	90109-06M18	14 - 44		12 - 44	90480-14M14	1 - 9	92990-10200	15 - 28		20 - 27
700-48510-12	13 - 21	90119-06024	16 - 19	90202-10024	12 - 41	90480-15M06	10 - 2		15 - 37	93210-45161	17 - 14
689-48511-01	13 - 22	90119-06025	7 - 33	90206-05005	7 - 45	90480-17M08	10 - 22	92990-10600	13 - 24		21 - 8
689-48531-50	13 - 2	90119-06M17	12 - 25	90206-12052	10 - 11	90480-25161	9 - 26	92990-14200	18 - 14	93210-46M16	3 - 8
689-48532-50	13 - 3	90119-06M23	7 - 43	90206-28001	11 - 6	90480-29045	15 - 5	92995-06600	2 - 11	93210-58M21	2 - 9
648-48534-50-4D	13 - 6	90119-06M48	18 - 7	90209-24M03	3 - 15	90501-09M08	12 - 29		6 - 4		20 - 4
61N-81313-09	8 - 4	90119-06M73	10 - 14	90209-47016	15 - 9	90501-10065	17 - 47		6 - 30	93210-64ME7	17 - 53
6E9-81328-70	8 - 7	90119-06M94	4 - 13	90240-05047	14 - 39	90501-10071	13 - 18		7 - 21		21 - 14
6H3-81922-00	9 - 18	90119-06M95	9 - 8	90243-04M01	14 - 4	90501-10227	7 - 38		7 - 24	93210-65M50	17 - 56
61N-82317-00	9 - 6	90119-06MA0	2 - 40	90249-06M22	14 - 34	90501-10264	13 - 12		7 - 27		21 - 16
663-82370-01	9 - 29	90119-06MA2	2 - 24	90250-05010	17 - 45	90501-14M07	12 - 28		9 - 4	93306-00612	17 - 52
61N-82519-01	9 - 10		2 - 31	90266-04M00	1 - 6	90501-23215	11 - 17		9 - 15	93306-305U3	3 - 9
682-82556-00	10 - 20	90119-06MA3	2 - 38	90266-04M01	1 - 4	90502-10M07	14 - 21		9 - 22	93310-62406	3 - 14

NUMERICAL INDEX
ÍNDICE NUMÉRICO

PART NO. No. PEÇA	REF. NO.	PART NO. No. PEÇA	REF. NO.	PART NO. No. PEÇA	REF. NO.	PART NO. No. PEÇA	REF. NO.	PART NO. No. PEÇA	REF. NO.	PART NO. No. PEÇA	REF. NO.
93315-22004	17 - 54	97095-06018	15 - 18								
93315-220V7	17 - 6	97095-06020	6 - 3								
93332-00005	17 - 39		9 - 14								
93332-000W5	17 - 3		9 - 21								
93390-00009	3 - 17		9 - 27								
93399-99951	3 - 6		11 - 9								
93440-62057	3 - 11		11 - 21								
93602-20M02	3 - 21		15 - 31								
93604-10M03	17 - 24	97095-06022	2 - 10								
93606-11M24	18 - 3	97095-06025	17 - 21								
93606-12019	2 - 5	97095-06035	7 - 23								
	15 - 17		7 - 26								
	16 - 3	97095-06040	6 - 29								
93608-12063	15 - 8		17 - 16								
93700-06M03	14 - 16	97095-06045	12 - 4								
	14 - 27	97095-08020	16 - 10								
	15 - 22	97585-08540	10 - 6								
94702-00217	2 - 43	97595-06550	11 - 8								
95303-08700	7 - 12	97595-08565	15 - 48								
95380-03600	6 - 20	97607-04112	8 - 11								
95380-05600	12 - 13	97607-06125	8 - 12								
95380-05700	12 - 8	97802-04006	8 - 8								
95380-06600	7 - 28	97880-05012	8 - 19								
	12 - 48	97880-06010	8 - 22								
95380-08600	6 - 11	97880-06016	16 - 8								
	14 - 25	97890-05006	5 - 22								
	15 - 46	97980-04110	5 - 6								
95380-08700	10 - 7	97980-04112	5 - 14								
	10 - 9	98503-05028	6 - 23								
95895-06035	17 - 31	98980-04006	5 - 17								
97013-06014	6 - 13	99080-05600	14 - 36								
97013-06016	2 - 15	99530-10014	7 - 25								
97013-06025	4 - 6										
97013-06035	4 - 8										
97013-08030	7 - 10										
97075-06020	17 - 57										
97075-08025	15 - 41										
97075-08030	16 - 4										
97075-10040	13 - 23										
97090-06012	9 - 11										
	9 - 16										
	9 - 23										
97095-06010	7 - 40										
	9 - 3										
97095-06012	12 - 6										
	13 - 7										
97095-06016	7 - 20										
	13 - 4										