

**PARTS
CATALOGUE
CATALOGO
DE REPUESTOS**

4AC '01 (6E00)

5C '01 (6E30)

5CS '01 (6E40)

FOREWORD

This Parts Catalogue is related to the parts for the model(s) in the below frame. When you are ordering replacement parts, please refer to this Parts Catalogue and quote both part numbers and part names correctly.

4AC'01(6E00), 5C'01(6E30), 5CS'01(6E40)

1. Modifications or additions which have been made after issue of the Parts Catalogue will be announced in the Yamaha Parts News.
It is advisable that you make necessary corrections to the Parts Catalogue according to the Yamaha Parts News.

2. Abbreviations

The Following abbreviations are used in this Parts Catalogue.

- "UR" Use specified parts number.
- "UN" Use as many as needed.
- "AP" Alternate Parts
- "LM" Local Made
(Parts need to be ordered locally)
- "O/S" Over Size

3. Parts, which are to be supplied in an assembly, are listed with a dot(.) in front of the part name as shown below.

EXAMPLE
 CARBURETOR ASSY
 .JET, PILOT
 .NOZZLE, MAIN

4. Number of component for assembly

The numeral appearing to the right of each component part indicates the quantity of parts for each assembly unit.

EXAMPLE

PART NO.	DESCRIPTION	U	H	L	R	REMARKS
6E0-85500-70	C.D.I. MAGNETO ASSY	1				
6E0-85550-70	.ROTOR ASSY	1				
6E0-15723-00-94.	.PULLY, STARTER	1				

5. Quantity Column Information

NAME for Q'TY COLUMN	APPLICABLE MODEL
4AC	4ACMH
5C	5CMH
5CS	5CSMH

6. Applicable Starting Serial No. and Color Code

1) Engine Starting Serial No.

<p>4ACMH S : 180154 L : 359731</p>	<p>5CMH S : 024748 L : 314822</p> <p>5CSMH S : 182534 L : 448319</p>
--	--

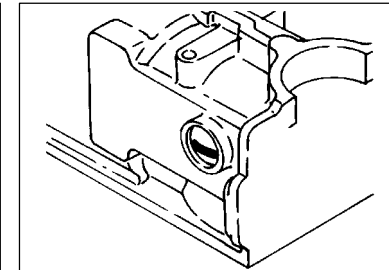
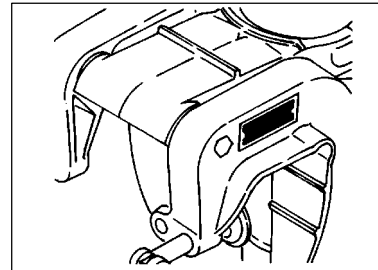

2) Color Code

Color Code	Color Name	Abbreviation
004D	DARK BLUISH GRAY METALLIC 2	DBNM2

7. Note that the illustrations for reference in finding parts numbers, not to be used for assembling. When assembling, please use the applicable service manual.
8. The asterisk (*) before a reference number indicates modification items after the first edition.

CONTENTS

TOP COWLING	A4
CYLINDER, CRANKCASE	A5
INTAKE	B1
STARTER	B3
GENERATOR	B5
ELECTRICAL	B6
BOTTOM COWLING 1	B7
BOTTOM COWLING 2	C2
CONTROL	C3
UPPER CASING, BRACKET	C5
LOWER CASING, DRIVE	D1
FUEL TANK	D4
REPAIR KIT	D5
INDEX	
NUMERICAL INDEX	D7

FIG. 1 TOP COWLING

SOPORTE SUPERIOR

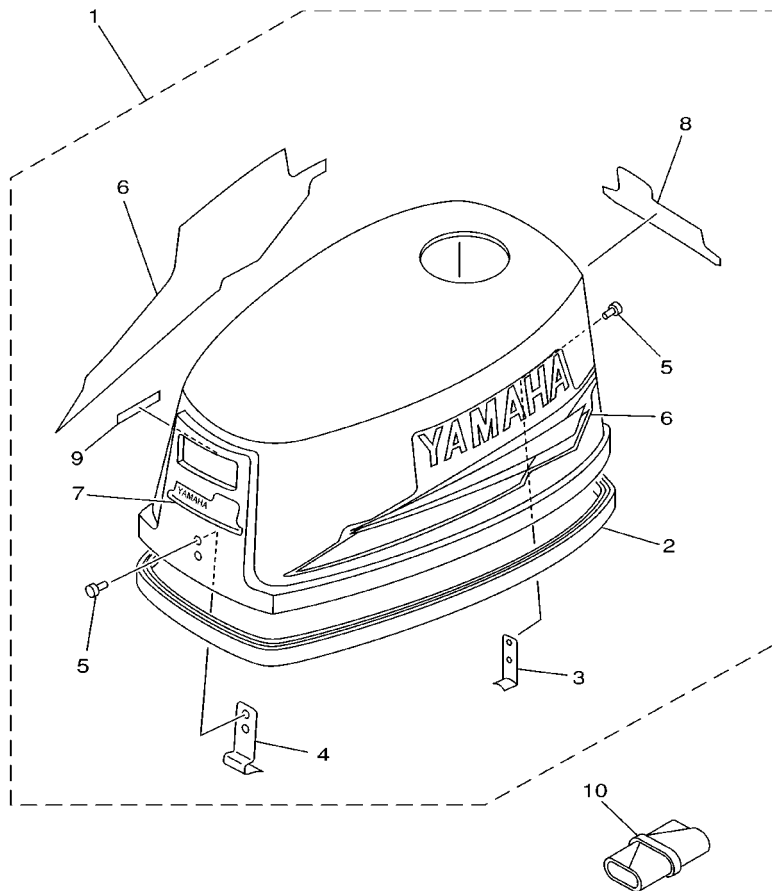

REF. NO.	PART NO. CODIGO NO.	DESCRIPTION DESCRIPTION	4AC	5C	5CS	REMARKS OBSERVACION
1	6E0-42610-15-4D	TOP COWLING ASSY SOPORTE SUPERIOR COMPL.	1			
	6E3-42610-15-4D	TOP COWLING ASSY SOPORTE SUPERIOR COMPL.		1		
	6E4-42610-15-4D	TOP COWLING ASSY SOPORTE SUPERIOR COMPL.			1	
2	6E0-42615-00	.SEAL .SELLO	1	1	1	
3	6E0-42647-01	.HOLDER, CLAMP BAND .MORDAZA DE ABRAZADERA	1	1	1	
4	6E0-42651-02	.HOOK .GANCHO	1	1	1	
5	90266-04M00	.RIVET .REMACHE	4	4	4	
6	6E0-W0070-14	.GRAPHIC SET .JUEGO DE EMBLEMA	1	1	1	
7	6E0-42677-11	.GRAPHIC, FRONT .CALCAMONIA FRONTAL	1			
	6E3-42677-11	.GRAPHIC, FRONT .CALCAMONIA FRONTAL		1	1	
8	6E0-42678-12	.GRAPHIC, REAR .CALCAMONIA TRASERA	1			
	6E3-42678-12	.GRAPHIC, REAR .CALCAMONIA TRASERA		1	1	
9	6E0-44191-11	.INDICATOR, SHIFT .INDICADOR DE CAMBIOS	1	1	1	
10	656-W2810-02	TOOL KIT JUEGO DE HERRAMIENTAS	1	1	1	



6E00010-8010

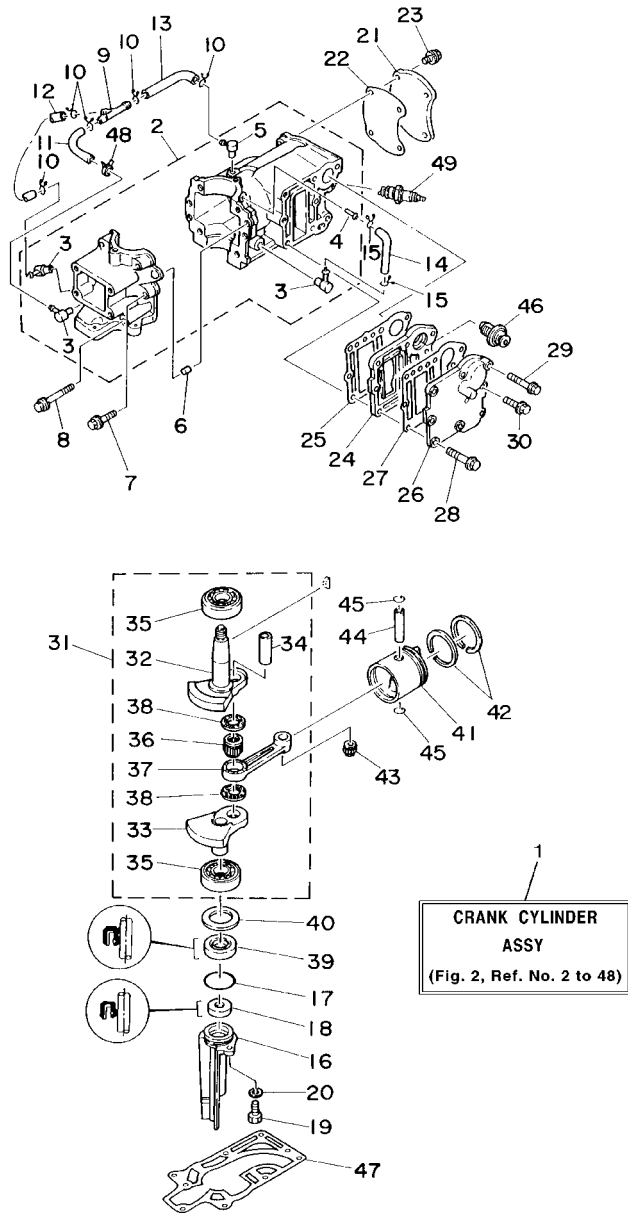

FIG. 2 CYLINDER, CRANKCASE CYLINDRO, CARTER

REF. NO.	PART NO. CODIGO NO.	DESCRIPTION DESCRIPTION	4AC	5C	5CS	REMARKS OBSERVACION
1	6E0-W0090-04-1S	CRANK CYLINDER ASSY BLOQUE MOTOR COMPLETO	1			
	6E3-W0090-04-1S	CRANK CYLINDER ASSY BLOQUE MOTOR COMPLETO		1	1	
2	6E0-15100-01-1S	CRANKCASE ASSY CARTER COMPLETO	1			
	6E3-15100-02-1S	CRANKCASE ASSY CARTER COMPLETO		1	1	
3	650-11370-00	.CHECK VALVE ASSY .VALVULA DE CONTROL COMPL.	3	3	3	
4	624-14485-00	.PIPE, JOINT .TUBO DE UNION	1	1	1	
5	6E5-11372-00	.NIPPLE, HOSE .NIPLE DE MANGUERA	1	1	1	
6	93606-12019	PIN, DOWEL PASADOR DE CLAVIJA	2	2	2	
7	90105-06M16	BOLT, WASHER BASED TORNILLO CON ARANDELA	4	4	4	
8	90105-06M17	BOLT, WASHER BASED TORNILLO CON ARANDELA	2	2	2	
9	6E0-24378-00	PIPE, JOINT 4 TUBO DE UNION 4	1	1	1	
10	90467-06016	CLIP PRESILLA	5	5	5	
11	90445-07M00	HOSE (L100) TUBO (L100)	1	1	1	
12	90445-07M28	HOSE (L70) TUBO (L70)	1	1	1	
13	90445-07M32	HOSE (L120) TUBO (L120)	1	1	1	
14	90445-07M28	HOSE (L70) TUBO (L70)	1	1	1	
15	90467-06016	CLIP PRESILLA	2	2	2	
16	6E0-15396-03-5B	HOUSING, OIL SEAL CAJA DE SELLO DE ACEITE	1	1	1	
17	93210-31MJ5	O-RING ANILLO O	1	1	1	
18	93101-10M25	OIL SEAL SELLO ACEITE	1	1	1	
19	97095-06016	BOLT PERNO	1	1	1	
20	92995-06600	WASHER ARANDELA	1	1	1	
21	6E0-11191-01-1S	COVER, CYLINDER HEAD 1 TAPA CULATA DE CILINDRO 1	1			
	6E3-11191-01-1S	COVER, CYLINDER HEAD 1 TAPA CULATA DE CILINDRO 1		1	1	
22	6E0-11193-A1	GASKET, HEAD COVER 1 EMPAQUE	1			
	6E3-11193-A1	GASKET, HEAD COVER 1 EMPAQUE		1	1	
23	90105-06M14	BOLT FLANGE TORNILLO CON ARANDELA	4	4	4	



6E00100-4020

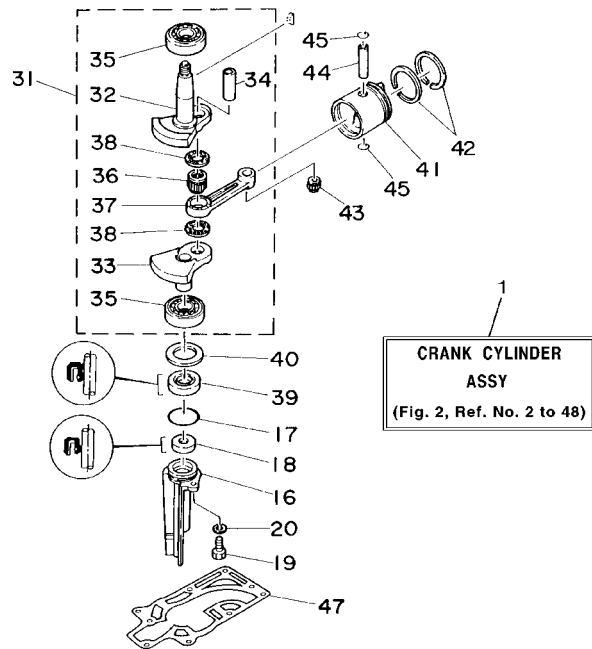
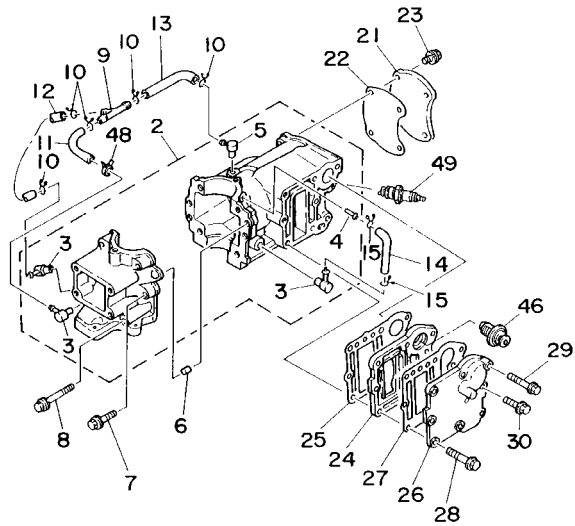

FIG. 2 CYLINDER, CRANKCASE CYLINDRO, CARTER

REF. NO.	PART NO. CODIGO NO.	DESCRIPTION DESCRIPTION	4AC	5C	5CS	REMARKS OBSERVACION
24	6E0-41111-01-1S	INNER COVER, EXHAUST CUBIERTA INTERIOR DE ESCAPE	1			
	6E3-41111-01-1S	INNER COVER, EXHAUST CUBIERTA INTERIOR DE ESCAPE		1	1	
25	6E0-41112-A1	GASKET, EXHAUST INNER COVER EMPAQUE	1			
	6E3-41112-A1	GASKET, EXHAUST INNER COVER EMPAQUE		1	1	
26	6E0-41113-01-1S	OUTER COVER, EXHAUST CUBOERTA EXTERIOR DE ESCAPE	1			
	6E3-41113-01-1S	OUTER COVER, EXHAUST CUBOERTA EXTERIOR DE ESCAPE		1	1	
27	6E0-41114-A1	GASKET, EXHAUST OUTER COVER EMPAQUE	1			
	6E3-41114-A1	GASKET, EXHAUST OUTER COVER EMPAQUE		1	1	
28	90105-06M24	BOLT, WASHER BASED TORNILLO CON ARANDELA	7			
	90105-06M24	BOLT, WASHER BASED TORNILLO CON ARANDELA		8	8	
29	90105-06M16	BOLT, WASHER BASED TORNILLO CON ARANDELA	1			
30	90105-06M14	BOLT FLANGE TORNILLO CON ARANDELA	1	1	1	
31	6E0-11400-00	CRANKSHAFT ASSY CIGUENAL COMPLETO	1			
	6E3-11400-00	CRANKSHAFT ASSY CIGUENAL COMPLETO		1	1	
32	6E0-11412-00	.CRANK 1 .MANIVELA 1	1			
	6E3-11412-00	.CRANK 1 .MANIVELA 1		1	1	
33	6E0-11422-00	.CRANK 2 .MANIVELA 2	1			
	6E3-11422-00	.CRANK 2 .MANIVELA 2		1	1	
34	6G1-11681-00	.PIN, CRANK 1 .PASADOR MANIVELA 1	1	1	1	
35	93306-204U0	.BEARING .COJINETE	2	2	2	
36	93310-418V1	.BEARING .COJINETE	1	1	1	
37	6E0-11651-01	.ROD, CONNECTING .BIELA	1	1	1	
38	90209-18112	.WASHER .ARANDELA DE SEPARACION	2	2	2	
39	93101-20M29	OIL SEAL SELLO ACEITE	1	1	1	
40	90201-32M48	WASHER, PLATE ARANDELA PLANA	1	1	1	
41	6E0-11631-00-98	PISTON (STD) PISTON (STD)	1			
	6E3-11631-00-98	PISTON (STD) PISTON (STD)		1	1	



6E00100-4020

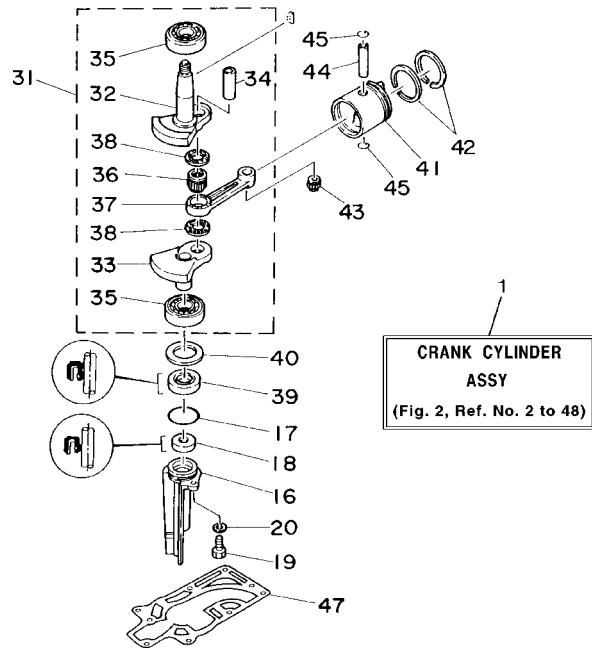
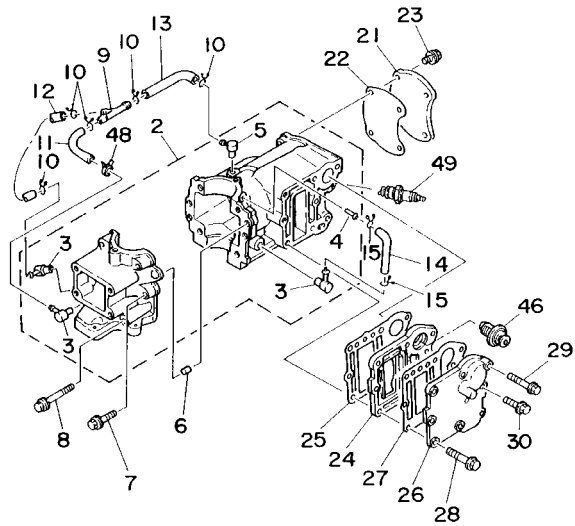

FIG. 2 CYLINDER, CRANKCASE CYLINDRO. CARTER

REF. NO.	PART NO. CODIGO NO.	DESCRIPTION DESCRIPTION	4AC	5C	5CS	REMARKS OBSERVACION
42	6G1-11610-00	PISTON RING SET (STD) JUEGO DE AROS (STD)	1			
	6J1-11610-00	PISTON RING SET (STD) JUEGO DE AROS (STD)		1	1	
43	93310-112V0	BEARING COJINETE	1	1	1	
44	6G1-11633-00	PIN, PISTON PASADOR, PISTON	1	1	1	
45	93450-13022	CIRCLIP BOLA	2	2	2	
46	6E5-12411-01	THERMOSTAT TERMOSTAT	1	1	1	AP
47	6E0-45113-A1	GASKET, UPPER CASING EMPAQUE	1	1	1	
48	90468-07M02	CLIP PRESILLA	1	1	1	
49	94702-00040	PLUG, SPARK (NGK B7HS) BUJIA (NGK B7HS)	1	1	1	
	94702-00272	PLUG, SPARK (NGK BR7HS) BUJIA (NGK BR7HS)	1	1	1	FOR CHINA,CARIB



6E00100-4020

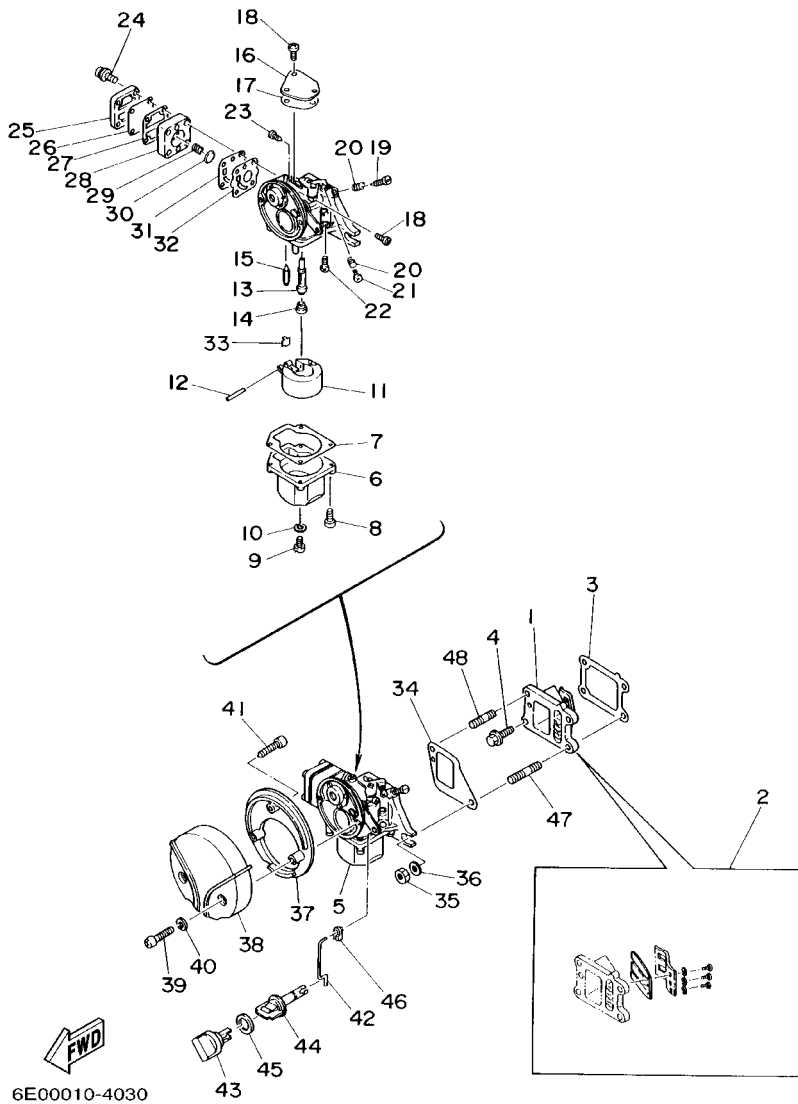
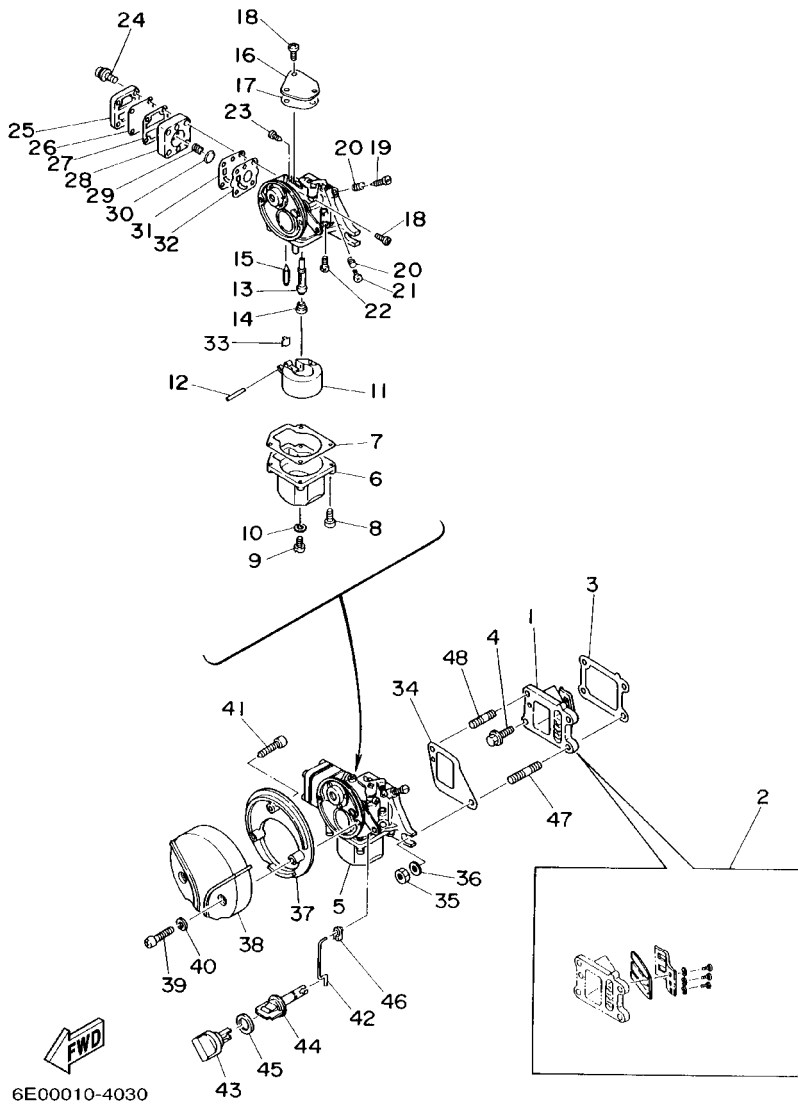

FIG. 3 INTAKE

ADMISION

REF. NO.	PART NO. CODIGO NO.	DESCRIPTION DESCRIPTION	4AC	5C	5CS	REMARKS OBSERVACION
1	6J1-13610-00	REED VALVE ASSY VALVULA DE LAMINAS COMPLETA	1	1	1	
	6E0-13610-00	REED VALVE ASSY VALVULA DE LAMINAS COMPLETA	1			FOR CARIB
2	6J1-W0004-00	.REED SET .JUEGO DE VALVULAS DE LENGUETA	1	1	1	
	6E0-W0004-00	.REED SET .JUEGO DE VALVULAS DE LENGUETA	1			FOR CARIB
3	6E0-13621-A2	GASKET, VALVE SEAT JUNTA DE VALV DE EMPAQUE	1	1	1	
4	95895-06016	BOLT, FLANGE TUERCA DE REBORDE	2	2	2	
5	6E0-14301-05	CARBURETOR ASSY 1 CARBURADOR COMPLETO 1	1			
	6E3-14301-05	CARBURETOR ASSY 1 CARBURADOR COMPLETO 1		1	1	
6	6E0-14381-02	.BODY, FLOAT CHAMBER .CUERPO DE CAMARA DE BOIA	1	1	1	
7	6E0-14384-00	.GASKET, FLOAT CHAMBER .EMPAQUE DE CAMARA DE BOIA	1	1	1	
8	97980-04116	.SCREW, WITH WASHER .TORNILLO, CON ARANDELA	4	4	4	
9	97890-05006	.SCREW, PAN HEAD .TORNILLO DE CABEZA CON PLANA	1	1	1	
10	646-14198-01	.GASKET .EMPAQUE	1	1	1	
11	6E7-14385-01	FLOAT BOIA	1	1	1	
12	647-14386-00	PIN, FLOAT PASADOR DE BOIA	1	1	1	
13	6E0-14341-01	.NOZZLE, MAIN .BOQUILLA PRINCIPAL	1			
	6E3-14341-02	.NOZZLE, MAIN .BOQUILLA PRINCIPAL		1	1	
14	648-14343-40	.JET, MAIN (#80) .INYECTOR PRINCIPAL (#80)	1	1	1	
15	6F5-14392-00	.VALVE, NEEDLE .VALVULA DE AGUJA	1	1	1	
16	6E0-14157-00	.COVER, PLATE .CUBIERTA DE MEZCLA	1	1	1	
17	6E0-14227-00	.GASKET EMPAQUE	1	1	1	
18	97890-04007	.SCREW, PAN HEAD .TORNILLO DE CABEZA CON PLANA	4	4	4	
19	647-14323-00	.SCREW, AIR ADJUSTING .TORNILLO DE AJUSTE DE AIRE	1	1	1	
20	646-14212-01	.SPRING, PILOT ADJUSTING .RESORTE DE AJUSTE DE PILOTO	2	2	2	
21	664-14321-01	.SCREW, THROTTLE .TORNILLO DE OBTURADOR	1	1	1	
22	648-14342-23	.JET, PILOT (#46) ESPREA DE PILOTO (#46)	1			
	648-14342-26	.JET, PILOT (#52) ESPREA DE PILOTO (#52)		1	1	



6E00010-4030

FIG. 3 INTAKE ADMISION

REF. NO.	PART NO. CODIGO NO.	DESCRIPTION DESCRIPTION	4AC	5C	5CS	REMARKS OBSERVACION
23	647-14326-00	.SCREW, GUIDE .TORNILLO DE GUIA	1	1	1	
24	97980-04120	.SCREW, WITH WASHER .TORNILLO, CON ARANDELA	4	4	4	
25	6E0-24413-00	.COVER .CUERPO 2	1	1	1	
26	6E0-24471-00	.DIAPHRAGM .DIAFRAGMA	1	1	1	
27	6E0-24435-00	.GASKET, BODY 2 .EMPAQUE	1	1	1	
28	6E0-24412-00	.BODY 1 .CUERPO 1	1	1	1	
29	6E0-24423-00	.SPRING, DIAPHRAGM .RESORTE DE DIAFRAGMA	1	1	1	
30	6E0-14346-00	.PLATE .PLACA	1	1	1	
31	6E0-24411-00	.DIAPHRAGM .DIAFRAGMA	1	1	1	
32	6E0-24434-00	.GASKET, BODY .EMPAQUE	1	1	1	
33	6E0-14159-00	.CLIP .PRESILLA	1	1	1	
34	6E0-14198-A0	GASKET EMPAQUE	1	1	1	
35	95380-06700	NUT TUERCA	2	2	2	
36	92995-06600	WASHER ARANDELA	2	2	2	
37	6E0-14417-00	COVER 1 CUBIERTA 1	1	1	1	
38	6E0-14418-00	COVER 2 CUBIERTA 2	1	1	1	
39	97880-05025	SCREW, PAN HEAD TORNILLO DE CABEZA CON PLANA	2	2	2	
40	92990-05600	WASHER, PLATE ARANDELA	2	2	2	
41	97780-40720	SCREW, TAPPING TORNILLO ROSCA HEMBRA	1	1	1	
42	6E0-41256-00	ROD, CHOKE 1 VARILLA DE AHOGADOR	1	1	1	
43	6E0-41271-00	KNÖB, CHOKE PERILLA AHOGADOR	1	1	1	
44	6E0-41272-00	KNÖB, CHOKE PERILLA AHOGADOR	1	1	1	
45	90202-12M16	WASHER, PLATE ARANDELA DE PLANA	1	1	1	
46	661-41262-02	JOINT, CHOKE LEVER CONECTOR DE AHOGADOR	1	1	1	
47	95627-06325	BOLT, STUD PERNO DE PUNTAL	1	1	1	
48	90116-06M08	BOLT, STUD ESPARRAGO	1	1	1	

FIG. 4 STARTER

ARRANQUE

REF. NO.	PART NO. CODIGO NO.	DESCRIPTION DESCRIPTION	4AC	5C	5CS	REMARKS OBSERVACION
1	6E0-15710-03-94	STARTER ASSY ARRANQUE COMPLETO	1			EXCEPT FOR CARIB
	6E0-15710-72-94	STARTER ASSY ARRANQUE COMPLETO	1			WITH SAFETY DEVICE
	6E3-15710-03-94	STARTER ASSY ARRANQUE COMPLETO		1	1	"5CS" EXCEPT FOR CARIB
	6E4-15710-73-94	STARTER ASSY ARRANQUE COMPLETO			1	WITH SAFETY DEVICE
2	6E0-15711-01-94	.CASE, STARTER .CAJA DE ARRANQUE	1	1	1	
	6E4-15711-71-94	.CASE, STARTER .CAJA DE ARRANQUE	1		1	WITH SAFETY DEVICE
3	6E0-15714-01	.DRUM, SHEAVE .TAMBOR ROLDANA	1	1	1	
4	90510-08M03	.SPRING, SPIRAL .RESORTE EN ESPIRAL	1	1	1	
5	6E0-15717-00	.SHAFT, STARTER .EJE DE ARRANQUE	1	1	1	
6	97013-06035	.BOLT .PERNO	1	1	1	
7	95601-06200	.NUT, U FLANGE .TUERCA DE AUTO-CIERRE	1	1	1	
8	90201-06M30	.WASHER, PLATE .ARANDELA PLANA	1	1	1	
9	677-15741-01	.PAWL, DRIVE .TRINQUETE DE TRACCION	1	1	1	
10	93430-06M02	.CIRCLIP .BOLA	1	1	1	
11	6E0-15705-00	.SPRING, DRIVE PAWL .RESORTE	1	1	1	
12	6G1-15779-00	.COVER .CUBIERTA	1	1	1	
13	*	.WIRE (L1850) .CABLE	1	1	1	
14	6G1-15755-00	.HANDLE, STARTER .MANIJA DE ARRANQUE	1	1	1	
15	6E0-15758-01	.GUIDE, ROPE .GUIA DE CUERDA	1			
	6E3-15758-01	.GUIDE, ROPE .GUIA DE CUERDA		1	1	
16	6E0-15761-00	.SEAL, RUBBER 1 .SELLO DE GOMA 1	1	1	1	
17	95895-06016	.BOLT, FLANGE .TUERCA DE REBORDE	2	2	2	
18	95895-06020	BOLT, FLANGE TUERCA DE REBORDE	3	3	3	
19	656-15748-00	PLUNGER, STARTER STOP EMBOLO SEGURO DE ARRANQUE	1		1	FOR SAFETY DEVICE
20	90501-10227	SPRING, COMPRESSION RESORTE DE COMPRESION	1		1	FOR SAFETY DEVICE

* CUT FROM 50M ROLLS, PART NO. 90890-44372, CUTTING LENGTH 1.85M

* CORTE DE UN RODILLO DE 50M, PARTS NUMERO 90890-44372, LARGO DEL CORTE 1.85M

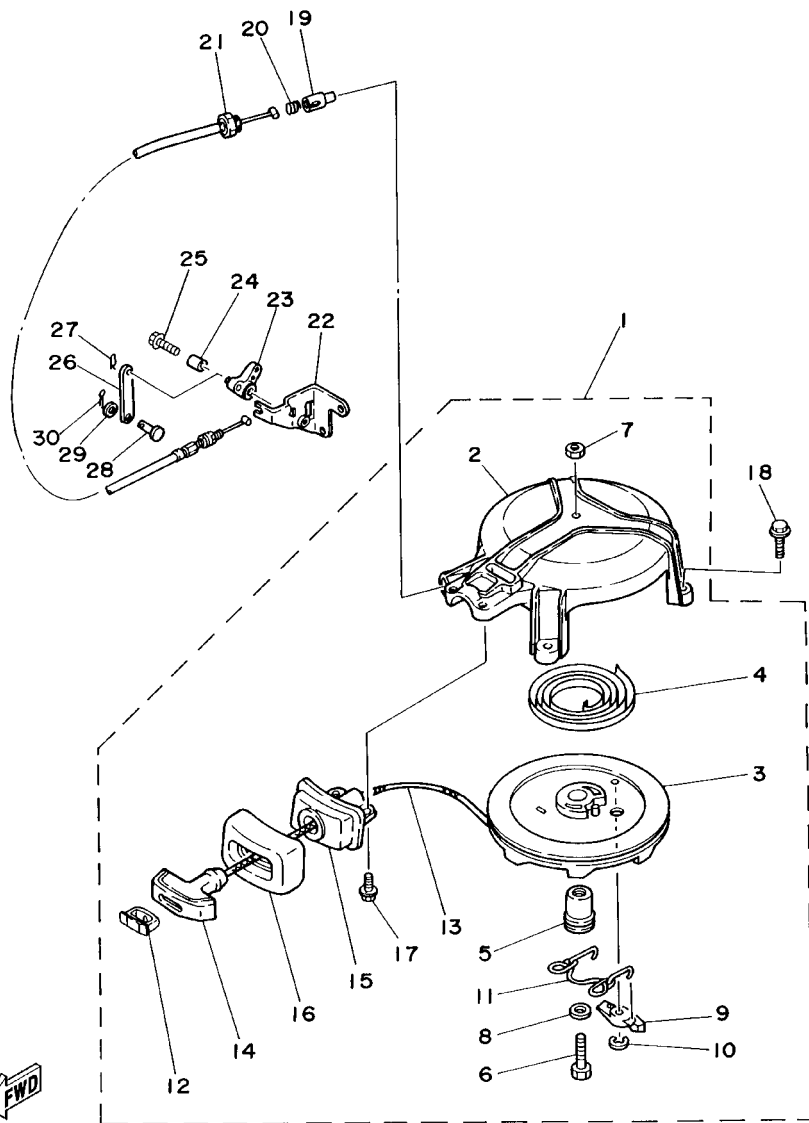

6E00010-4040

FIG. 4 STARTER

ARRANQUE

REF. NO.	PART NO. CODIGO NO.	DESCRIPTION DESCRIPTION	4AC	5C	5CS	REMARKS OBSERVACION
21	6E4-15770-70	CABLE COMP., STARTER STOP CABLECOMPL DE SEGURO ARRANQUE	1		1	FOR SAFETY DEVICE
22	6E0-15772-71	STAY 2 SOPORTE 2	1			FOR SAFETY DEVICE
	6E4-15772-71	STAY 2 SOPORTE 2			1	FOR SAFETY DEVICE
23	6E4-15746-70	ARM BRAZO	1		1	FOR SAFETY DEVICE
24	90387-06504	COLLAR CASQUILLO CON VALONA	1		1	FOR SAFETY DEVICE
25	90119-06M18	BOLT, WITH WASHER TORNILLO CON ARANDELA	1		1	FOR SAFETY DEVICE
26	6E4-15747-70	LINK ESLABON	1		1	FOR SAFETY DEVICE
27	90468-10005	CLIP PRESILLA	1		1	FOR SAFETY DEVICE
28	91790-05010	PIN, CLEVIS PASADOR DE ABRAZADERA	1		1	FOR SAFETY DEVICE
29	90202-05088	WASHER, PLATE ARANDELA DE PLANA	1		1	FOR SAFETY DEVICE
30	91490-16010	PIN, COTTER PASADOR DE CHAVETA	1		1	FOR SAFETY DEVICE

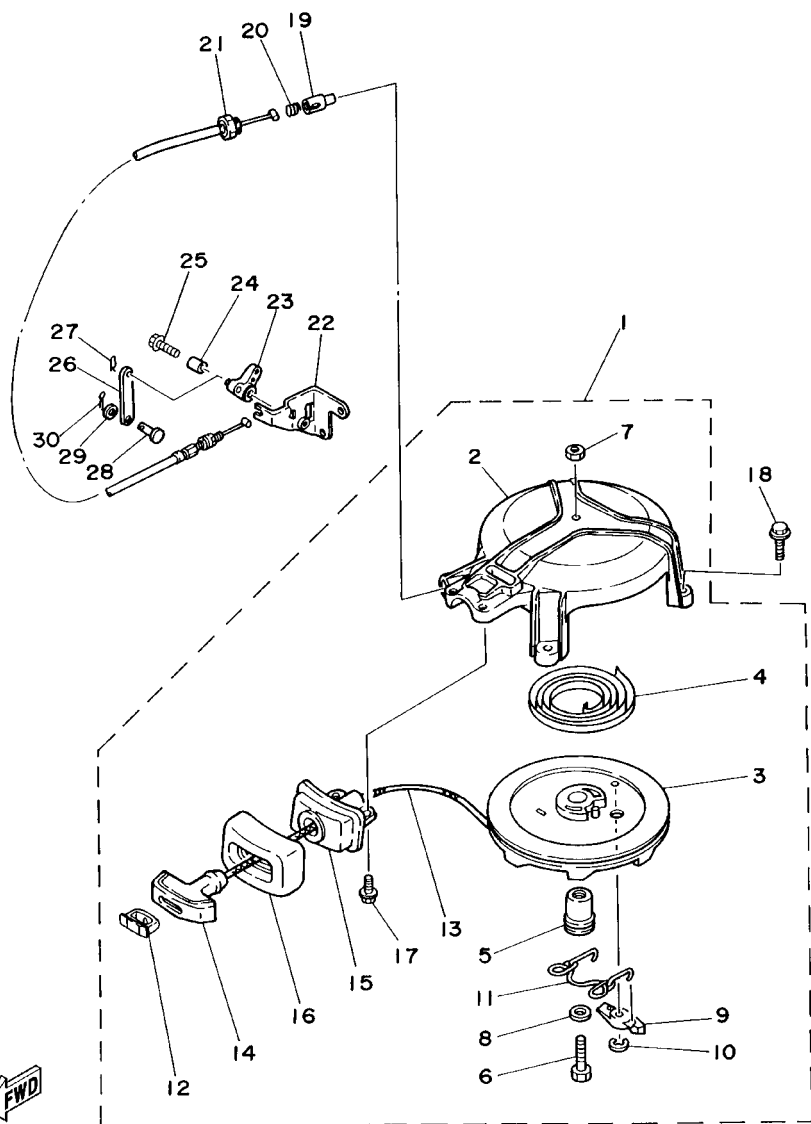

6E00010-4040

FIG. 5 GENERATOR

GENERADOR

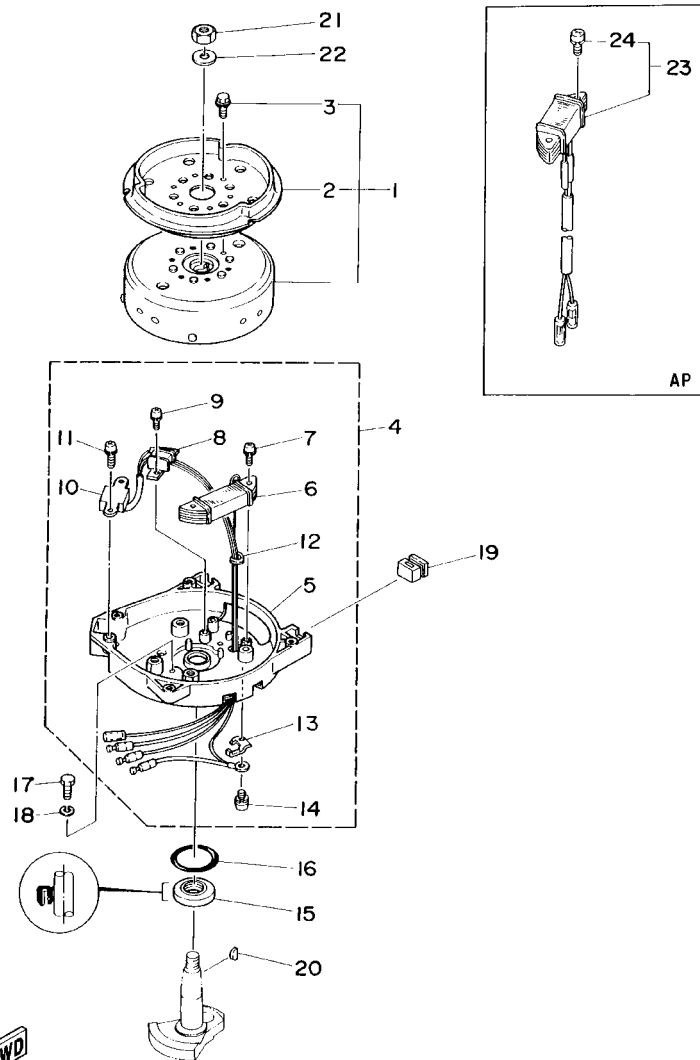

6E00010-4050

REF. NO.	PART NO. CODIGO NO.	DESCRIPTION DESCRIPTION	4AC	5C	5CS	REMARKS OBSERVACION
1	6E0-85550-71	ROTOR ASSY ROTOR COMPLETO	1	1	1	
2	6E0-15723-00-94	.PULLEY, STARTER .POLEA DE ARRANQUE	1	1	1	
3	90105-06M14	.BOLT FLANGE .TORNILLO CON ARANDELA	3	3	3	
4	6E0-85560-70	BASE ASSY CONJUNTO BASE	1	1	1	
5	6E0-15359-00-94	.HOUSING, OIL SEAL .CAJA DE SELLO DE ACEITE	1	1	1	
6	6E0-85520-70	.COIL, CHARGE .BOBINA DE CARGA	1	1	1	
7	90159-05038	.SCREW, WITH WASHER .TORNILLO CON VALONA	2	2	2	
8	6E0-85595-70	.COIL, PULSER .BOBINA DE PULSACION CONJUNTA	1	1	1	
9	90159-04036	.SCREW, WITH WASHER .TORNILLO CON VALONA	2	2	2	
10	6E0-85592-70	.PULSER COIL ASSY .BOBINA DE PULSACION CONJUNTA	1	1	1	
11	90159-05037	.SCREW, WITH WASHER .TORNILLO CON VALONA	2	2	2	
12	6E0-81336-70	.GROMMET .TAPON PROTECTOR	1	1	1	
13	6E0-81328-70	.CLAMP .GRAMPA	1	1	1	
14	90159-04035	.SCREW, WITH WASHER .TORNILLO CON VALONA	1	1	1	
15	93102-20M25	OIL SEAL SELLO ACEITE	1	1	1	
16	93210-42159	O-RING ANILLO O	1	1	1	
17	97095-06016	BOLT PERNO	2	2	2	
18	92995-06100	WASHER, SPRING ARANDELA	2	2	2	
19	6E0-24183-00	DAMPER, LOCATING 3 AMORTIGUADOR DE MONTAJE 3	2	2	2	
20	90280-04M06	KEY, WOODRUFF CUNA WOODRUFF	1	1	1	
21	90170-10113	NUT TUERCA	1	1	1	
22	90201-10126	WASHER, PLATE ARANDELA PLANA	1	1	1	
23	6E0-81303-40	LIGHTING COIL ASSY BOBINA DE ILUMINACION COMPL.	1	1	1	AP 40W
	6E0-81303-80	LIGHTING COIL ASSY BOBINA DE ILUMINACION COMPL.	1	1	1	AP 60W
24	90159-05040	.SCREW, WITH WASHER .TORNILLO CON VALONA	2	2	2	

FIG. 6 ELECTRICAL

EQUIPO ELECTRICO

REF. NO.	PART NO. CODIGO NO.	DESCRIPTION DESCRIPTION	4AC	5C	5CS	REMARKS OBSERVACION
1	95895-06016	BOLT, FLANGE TUERCA DE REBORDE	2	2	2	
2	663-82370-01	PLUG CAP ASSY TAPON DE BUJIA COMPLT	1	1	1	
	6E3-82370-21	PLUG CAP ASSY TAPON DE BUJIA COMPLT			1	FOR CARIB
3	6E0-82316-01-94	BRACKET, IGNITION COIL SOPORTE BOBINA ENCENDIDO	1	1	1	
4	6E0-82317-00	DAMPER, IGNITION COIL AMORTIGUADOR BOBINA ENCENDIDO	2	2	2	
5	6E0-85570-00	IGNITION COIL ASSY BOBINA DE IGNICION COMPLETO	1	1	1	
6	97095-06016	BOLT PERNO	2	2	2	
7	92995-06600	WASHER ARANDELA	2	2	2	
8	90480-25161	GROMMET TAPON	1	1	1	
9	97080-06010	BOLT PERNO	1	1	1	
10	6E0-85548-00	HOLDER SOSTEN	1	1	1	
11	6E0-85540-71	C.D.I. UNIT ASSY UNIDAD C.D.I. COMPLETA	1	1	1	
12	95895-06020	BOLT, FLANGE TUERCA DE REBORDE	2	2	2	

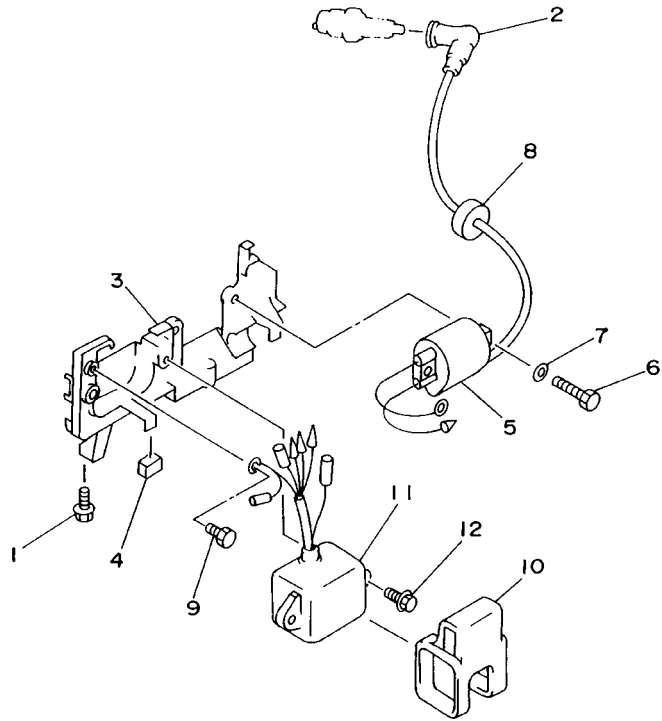

6E00010-6060

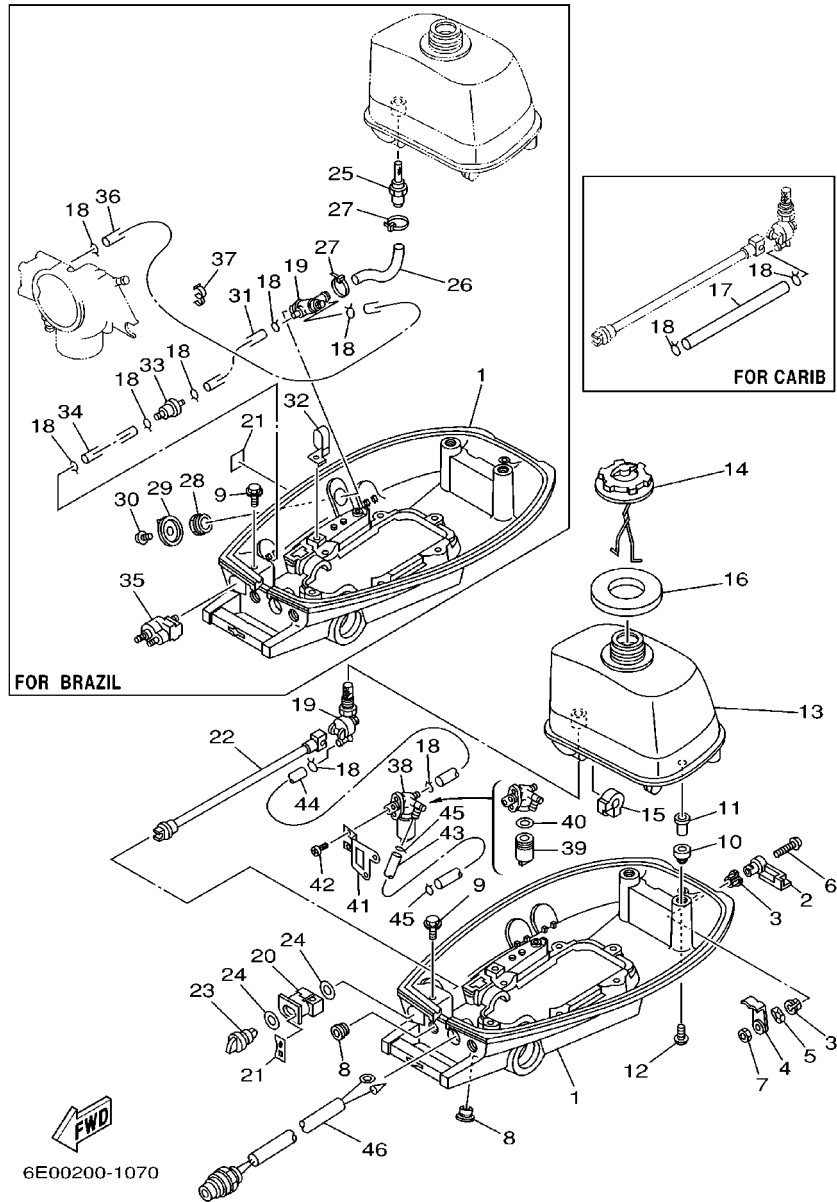
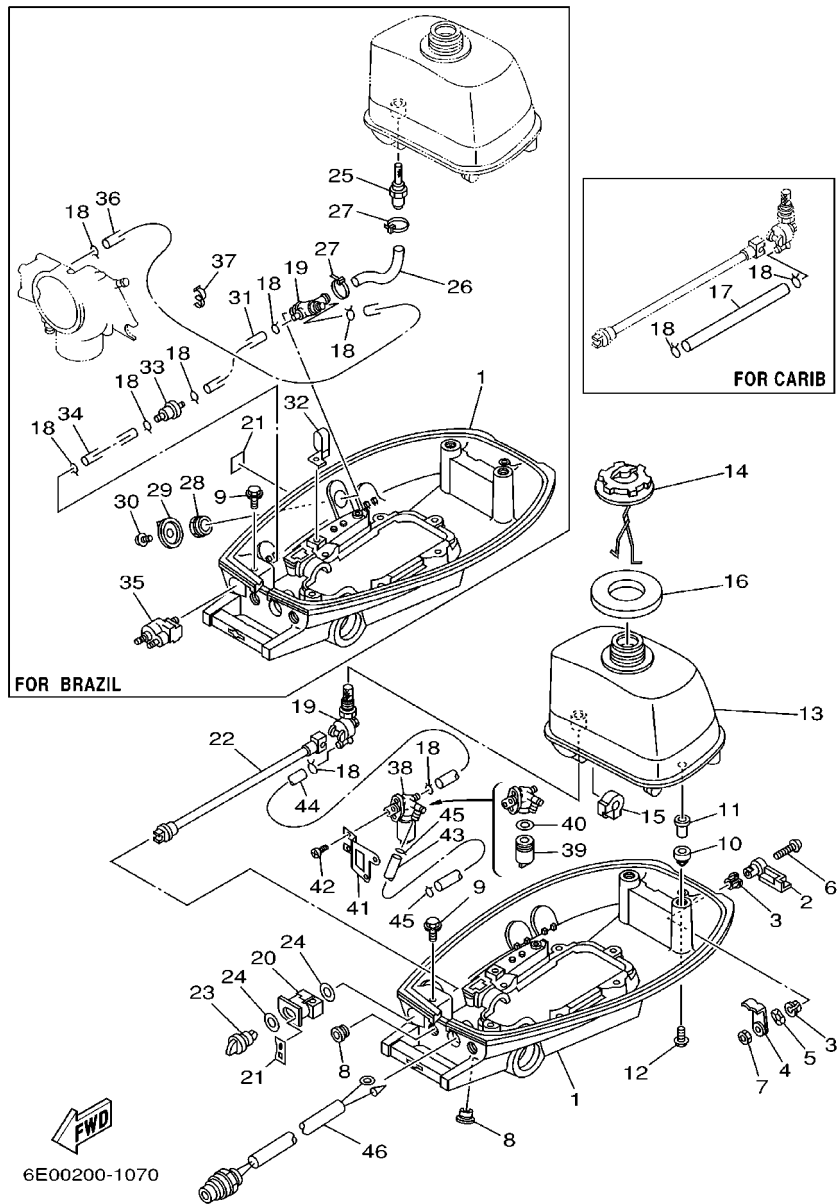

FIG. 7 BOTTOM COWLING 1 CUBIERTA INFERIOR 1

REF. NO.	PART NO. CODIGO NO.	DESCRIPTION DESCRIPTION	4AC	5C	5CS	REMARKS OBSERVACION
1	6E0-42711-05-4D	COWLING, BOTTOM CUBIERTA INFERIOR	1	1		
	6E0-42711-10-4D	COWLING, BOTTOM CUBIERTA INFERIOR	1			FOR BRAZIL
2	6E0-42815-00-4D	LEVER, CLAMP PALANCA ABRAZADERA	1	1		
3	90386-12069	BUSH BUJE	2	2		
4	6E0-42816-00	LEVER, CLAMP PALANCA ABRAZADERA	1	1		
5	90206-12052	WASHER, WAVE ARANDELA ONDULADA	1	1		
6	97885-06030	SCREW, PAN HEAD TORNILLO DE CABEZA CON PLANA	1	1		
7	95380-06700	NUT TUERCA	1	1		
8	90480-14M14	GROMMET TAPON	2	2		
9	95895-06020	BOLT, FLANGE TUERCA DE REBORDE	1	1		
10	6E0-24182-00	DAMPER, LOCATING 2 AMORTIGUADOR DE MONTAJE 2	2			
	6E3-24182-00	DAMPER, LOCATING 2 AMORTIGUADOR DE MONTAJE 2		2		
11	6E0-42542-00	PIPE TUBO	2	2		
12	95895-06025	BOLT, FLANGE TUERCA DE REBORDE	2	2		
13	6E0-24110-01-4D	FUEL TANK COMP. DEPOSITO DE COMBUSTIBLE COMP.	1	1		
14	6E0-24610-02	CAP ASSY TAPA COMPLETA	1	1		
15	6E0-24181-00	DAMPER, LOCATING 1 AMORTIGUADOR DE MONTAJE	2	2		
16	6E0-24641-00	GASKET, CAP 1 EMPAQUE DE TAPA 1	1			
	6E3-24641-00	GASKET, CAP 1 EMPAQUE DE TAPA 1		1		
17	90445-09M37	HOSE (L240) TUBO (L240)	1			FOR CARIB
18	90467-08004	CLIP PRESILLA	2	2		
	90467-08004	CLIP PRESILLA	6			FOR BRAZIL
19	6E0-24500-00	FUEL COCK ASSY 1 GRIFO DE COMBUSTIBLE 1	1	1		
	6E0-24500-10	FUEL COCK ASSY 1 GRIFO DE COMBUSTIBLE 1	1			FOR BRAZIL
20	6E0-24571-00	BUSHING BUJE	1	1		
21	6E0-24591-00	GRAPHIC CALCAMONIA PALANCA DE CAMBIO	1	1		
	6E0-24591-10	EMBLEM, FUEL COCK CALCAMONIA PALANCA DE CAMBIO	1			FOR BRAZIL

FIG. 7 BOTTOM COWLING 1

CUBIERTA INFERIOR 1



REF. NO.	PART NO. CODIGO NO.	DESCRIPTION DESCRIPTION	4AC	5C	5CS	REMARKS OBSERVACION
22	6E0-24572-00	SHAFT, FUEL CHANGE EJE SELECTOR COMBUSTIBLE	1	1		
23	6E0-24575-01	LEVER, FUEL CHANGE PALANCA SELECTOR COMBUSTIBLE	1	1		
24	90202-12M17	WASHER, PLATE ARANDELA DE PLANA	2	2		
25	6E0-24335-00	PIPE, SUCTION 1 TUBO DE SUCCION 1	1			FOR BRAZIL
26	6E0-24311-00	PIPE, FUEL 1 TUBO DE COMBUSTIBLE 1	1			FOR BRAZIL
27	90465-13M11	CLAMP BRIDA	2			FOR BRAZIL
28	90170-16M35	NUT TUERCA	1			FOR BRAZIL
29	6J1-24524-00	LEVER, COCK LLAVE DEL GRIFO	1			FOR BRAZIL
30	90159-04M24	SCREW, WITH WASHER TORNILLO CON VALONA	1			FOR BRAZIL
31	90445-09M27	HOSE (L125) TUBO (L125)	1			FOR BRAZIL
32	90465-08M62	CLAMP BRIDA	1			FOR BRAZIL
33	646-24251-02	STRAINER 1 COLADOR 1	1			FOR BRAZIL
34	90445-09057	HOSE (L45) TUBO (L45)	1			FOR BRAZIL
35	6G1-24304-02	FUEL PIPE JOINT COMP. 1 CONECTOR MANGUERA COMBUST.1	1			FOR BRAZIL
36	6E0-24312-00	PIPE 2 TUBO 2	1			FOR BRAZIL
37	90464-09M21	CLAMP BRIDA	1			FOR BRAZIL
38	6E0-24500-60	FUEL COCK ASSY 1 GRIFO DE COMBUSTIBLE 1	1	1		WATER SEPARATER TYPE
39	624-24521-01	.CUP, FILTER .COPA DE FILTRO	1	1		
40	102-24522-01	.GASKET .EMPAQUE	1	1		
41	6E0-24566-61	BRACKET, FILTER SOPORTE DEL FILTRO	1			
	6E3-24566-61	BRACKET, FILTER SOPORTE DEL FILTRO		1		
42	97885-04010	SCREW, PAN HEAD TORNILLO DE CABEZA CON PLANA	2	2		
43	90445-09072	HOSE (L120) TUBO (L120)	1	1		
44	90445-09082	HOSE TUBO	1	1		
45	90467-08004	CLIP PRESILLA	2	2		
46	6E0-82550-01	ENGINE STOP SWITCH ASSY INTERRUP. DE PARADA COMPLETO	1	1		

FIG. 8 BOTTOM COWLING 2

CUBIERTA INFERIOR 2

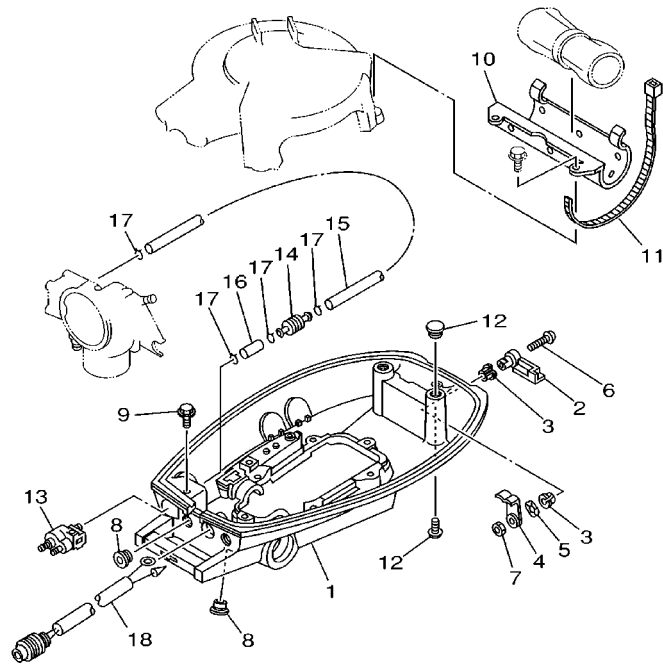

REF. NO.	PART NO. CODIGO NO.	DESCRIPTION DESCRIPTION	4AC	5C	5CS	REMARKS OBSERVACION
1	6E0-42711-05-4D	COWLING, BOTTOM CUBIERTA INFERIOR			1	
2	6E0-42815-00-4D	LEVER, CLAMP PALANCA ABRAZADERA			1	
3	90386-12069	BUSH BUJE			2	
4	6E0-42816-00	LEVER, CLAMP PALANCA ABRAZADERA			1	
5	90206-12052	WASHER, WAVE ARANDELA ONDULADA			1	
6	97885-06030	SCREW, PAN HEAD TORNILLO DE CABEZA CON PLANA			1	
7	95380-06700	NUT TUERCA			1	
8	90480-14M14	GROMMET TAPON			2	
9	95895-06020	BOLT, FLANGE TUERCA DE REBORDE			1	
10	6E1-42643-01	PLATE, CLAMP PLACA GRAMPA			1	
11	6G1-2811G-00	BAND BANDA			1	
12	6E1-24182-00	DAMPER, LOCATING 2 AMORTIGUADOR DE MONTAJE 2			2	
13	6G1-24304-02	FUEL PIPE JOINT COMP. 1 CONECTOR MANGUERA COMBUST.1			1	
14	646-24251-02	STRAINER 1 COLADOR 1			1	
15	688-24313-00	PIPE 3 TUBO 3			1	
16	90445-09057	HOSE (L45) TUBO (L45)			1	
17	90467-08004	CLIP PRESILLA			4	
18	6E0-82550-01	ENGINE STOP SWITCH ASSY INTERRUP. DE PARADA COMPLETO			1	



6E00200-1080

FIG. 9 CONTROL

CONTROL

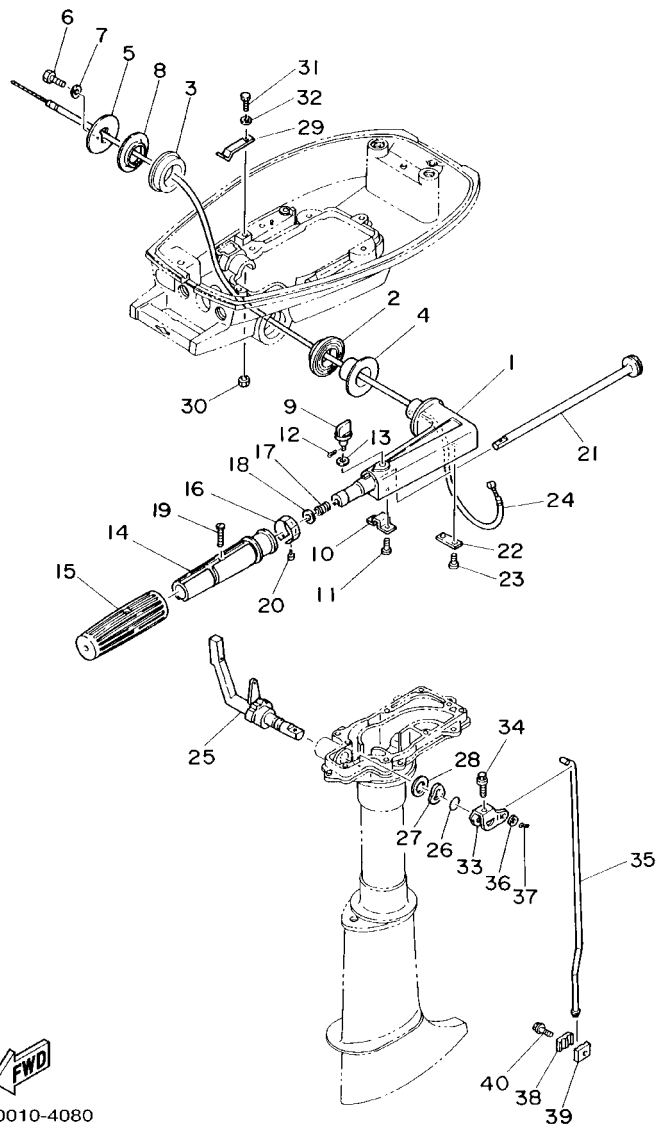



6E00010-4080

REF. NO.	PART NO. CODIGO NO.	DESCRIPTION DESCRIPTION	4AC	5C	5CS	REMARKS OBSERVACION
1	6E0-42111-02-4D	HANDLE, STEERING MANIJA DE DIRECCION	1	1	1	
2	6E0-42129-02	BUSHING, RUBBER BUJE 1	1	1	1	
3	6E4-42129-00	BUSHING, RUBBER BUJE 1	1	1	1	
4	90386-26M30	BUSH BUJE	1	1	1	
5	6E0-42131-02-94	COVER, HANDLE STEERING CUBIERTA MANIJA DIRRECCION	1	1	1	
6	97013-05020	BOLT PERNO	2	2	2	
7	92903-05600	WASHER, PLATE ARANDELA	2	2	2	
8	90386-26M33	BUSH BUJE	1	1	1	
9	6E0-42125-00	BOLT, FRICTION ADJUSTING TORNILLO FRICCION ADJUSTA	1	1	1	
10	6E0-42134-02	COVER, THROTTLE LEVER CUBIERTA PALANCA ACELERADOR	1	1	1	
11	97885-05012	SCREW, PAN HEAD TORNILLO DE CABEZA CON PLANA	2	2	2	
12	91490-12010	PIN, COTTER PASADOR DE CHAVETA	1	1	1	
13	90202-07M22	WASHER, PLATE ARANDELA DE PLANA	1	1	1	
14	6E0-42119-00	GRIP, STEERING HANDLE MANGO, MANIJA DE DIRRECCION	1	1	1	
15	6E0-42177-00	RUBBER, HANDLE HULE DE MANIJA	1	1	1	
16	6E0-42137-10	INDICATOR, THROTTLE INDICADOR ACELERADOR	1	1	1	
17	90501-23215	SPRING, COMPRESSION RESORTE DE COMPRESION	1	1	1	
18	90201-10119	WASHER, PLATE ARANDELA PLANA	1	1	1	
19	90149-05M13	SCREW TORNILLO DE REGLAJE	1	1	1	
20	90269-02M09	RIVET REMACHE	1	1	1	
21	6E0-42138-01	LEVER, THROTTLE PLANCA DE ACELERACION	1	1	1	
22	6E0-42159-02	STAY SOPORTE	1	1	1	
23	97885-05012	SCREW, PAN HEAD TORNILLO DE CABEZA CON PLANA	2	2	2	
24	6E0-26301-01	THROTTLE CABLE ASSY CABLE DE ACELERADOR COMPLETO	1	1	1	
25	6E0-44111-02	HANDLE, GEAR SHIFT MANIJA DE CAMBIO DE MARCHAS	1	1	1	
26	6E4-44111-72-4D	HANDLE, GEAR SHIFT MANIJA DE CAMBIO DE MARCHAS	1	1	1	FOR SAFETY DEVICE
27	93210-12327	O-RING ANILLO O	1	1	1	

FIG. 9 CONTROL

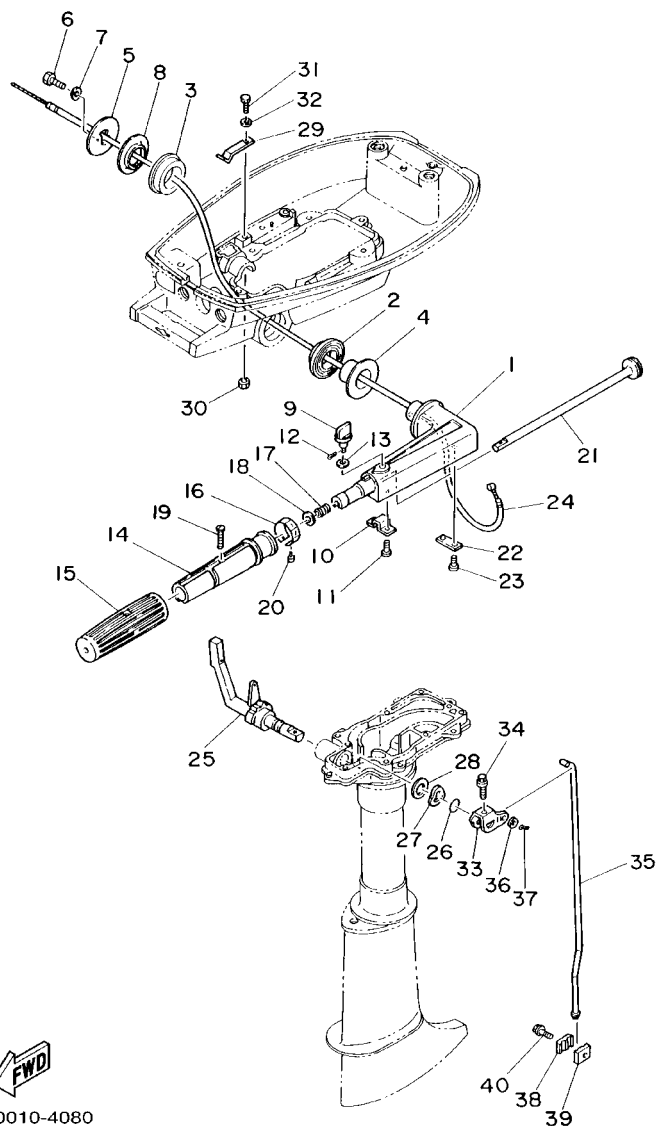
CONTROL



REF. NO.	PART NO. CODIGO NO.	DESCRIPTION DESCRIPTION	4AC	5C	5CS	REMARKS OBSERVACION
27	90206-16M06	WASHER, WAVE ARANDELA ONDULADA	1	1	1	
28	90202-16061	WASHER, PLATE ARANDELA DE PLANA	1	1	1	
29	6E0-44116-00	SPRING RESORTE	1	1	1	
30	95380-06700	NUT TUERCA	1	1	1	
31	97095-06012	BOLT PERNO	1	1	1	
32	92995-06600	WASHER ARANDELA	1	1	1	
33	6E0-44121-00	LEVER, SHIFT ROD PALANCA VARILLA CAMBIOS	1	1	1	
34	95895-06025	BOLT, FLANGE TUERCA DE REBORDE	1	1	1	
35	6E0-44143-00	ROD, SHIFT VARILLA DE CAMBIO	1	1	1	S
	6E0-44143-10	ROD, SHIFT VARILLA DE CAMBIO	1	1	1	L
36	92990-05600	WASHER, PLATE ARANDELA	1	1	1	
37	91490-16010	PIN, COTTER PASADOR DE CHAVETA	1	1	1	
38	6E0-44145-00	CONNECTOR, SHIFT ROD CONECTOR, VARILLA CAMBIO	1	1	1	
39	6E0-44146-00	CONNECTOR, SHIFT ROD CONECTOR VARILLA DE CAMBIO	1	1	1	
40	95895-06020	BOLT, FLANGE TUERCA DE REBORDE	1	1	1	

6E00010-4080

FIG. 10 UPPER CASING . BRACKET CUBIERTA SUPERIOR Y SOPORTE

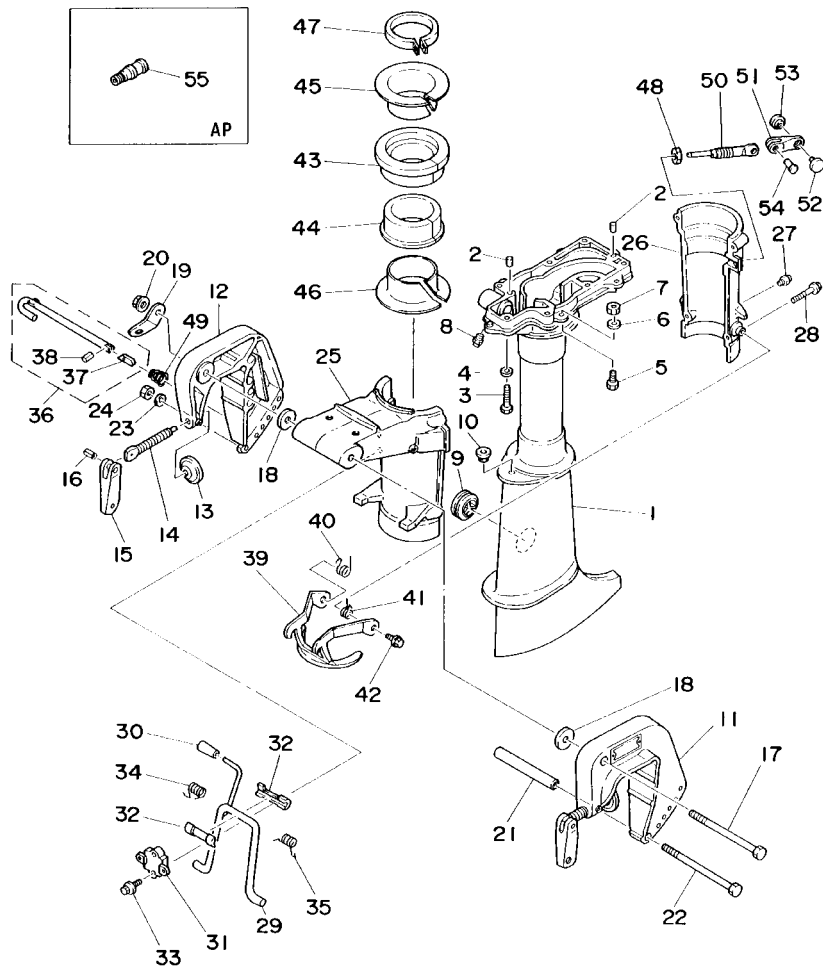

REF. NO.	PART NO. CODIGO NO.	DESCRIPTION DESCRIPTION	4AC	5C	5CS	REMARKS OBSERVACION
1	6E0-45111-02-4D	CASING, UPPER CAJA SUPERIOR	1	1	1	S
	6E0-45111-12-4D	CASING, UPPER CAJA SUPERIOR	1	1	1	L
2	93606-12019	PIN, DOWEL PASADOR DE CLAVIJA	2	2	2	
3	97095-06030	BOLT PERNO	7	7	7	
4	92995-06600	WASHER ARANDELA	7	7	7	
5	97095-06016	BOLT PERNO	4	4	4	
6	92995-06600	WASHER ARANDELA	4	4	4	
7	95380-06700	NUT TUERCA	4	4	4	
8	93700-06M03	NIPPLE, GREASE NIPLE DE ENGRASAR	1	1	1	
9	647-45151-01	COVER, UPPER CASING CUBIERTA FUNDA SUPERIOR	1	1	1	
10	90480-10M13	GROMMET TAPON	1	1	1	
11	6E0-43111-02-4D	BRACKET, CLAMP SOPORTE DE LA ABRAZADERA	1	1	1	
12	6E0-43112-01-4D	BRACKET, CLAMP SOPORTE DE LA ABRAZADERA	1	1	1	
13	620-43114-00	PAD, TRANSOM CLAMP ARANDELA DE ABRAZADERA	2	2	2	
14	6E0-43116-01	SCREW, TRANSOM CLAMP TORNILLO DE ABRAZADERA	2	2	2	
15	6E0-43118-01	HANDLE, TRANSOM CLAMP MANIJA DE LA ABRAZADERA DEL ES	2	2	2	
16	90243-04M01	PIN PASADOR	2	2	2	
17	90101-08M07	BOLT TORNILLO	1	1	1	
18	90201-08M03	WASHER, PLATE ARANDELA PLANA	2	2	2	
19	6A1-43113-01	PLATE, CLAMP BRACKET PLACA ABRAZADERA SOPORTE	1	1	1	
20	90185-08057	NUT, SELF-LOCKING TUERCA AUTOBLOCANTE	1	1	1	
21	90387-06M11	COLLAR CASQUILLO CON VALONA	1	1	1	
22	90101-06335	BOLT TORNILLO	1	1	1	
23	92990-06600	WASHER, PLATE ARANDELA	1	1	1	
24	95380-06600	NUT, HEXAGON TUERCA	1	1	1	
25	6E0-43311-04-4D	BRACKET, SWIVEL 1 SOPORTE GIRATORIO 1	1	1	1	
26	6E0-43312-02-4D	BRACKET, SWIVEL 2 SOPORTE GIRATORIO 2	1	1	1	

6E00010-4090

FIG. 10 UPPER CASING . BRACKET CUBIERTA SUPERIOR Y SOPORTE

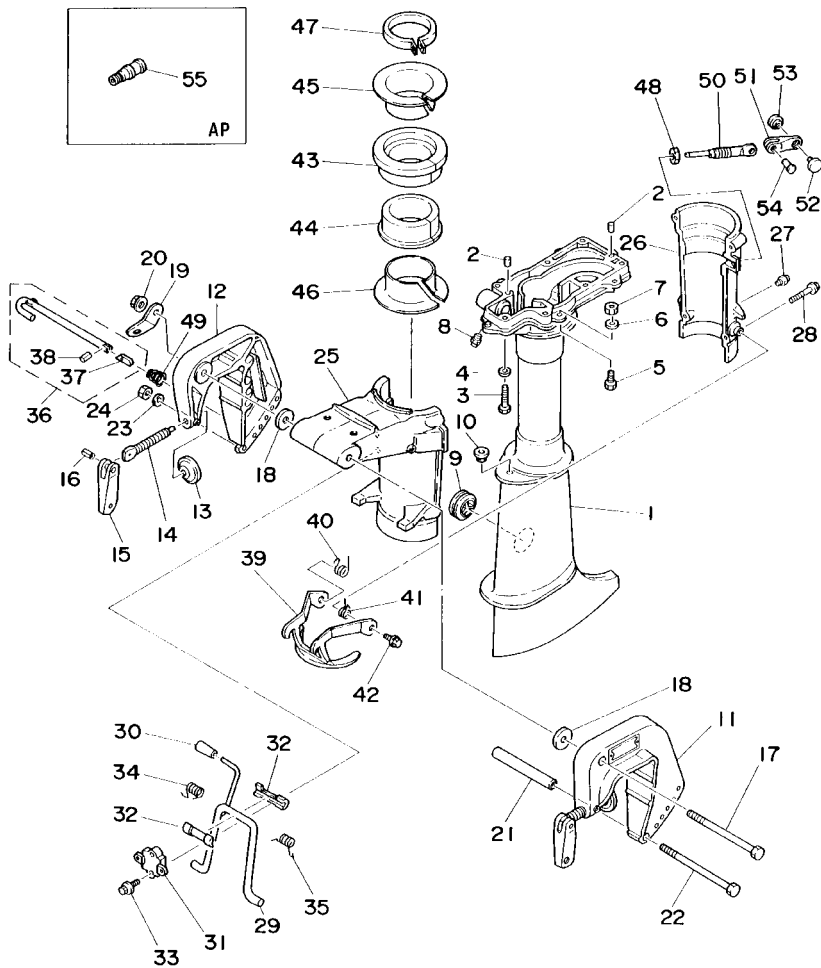

6E00010-4090

REF. NO.	PART NO. CODIGO NO.	DESCRIPTION DESCRIPTION	4AC	5C	5CS	REMARKS OBSERVACION
27	93700-06M03	NIPPLE, GREASE NIPLE DE ENGRASAR	1	1	1	
28	95895-06035	BOLT, FLANGE TUERCA DE REBORDE	4	4	4	
29	6E0-43181-00	LEVER, TILT STOP PALANCA TOPE INCLINACION	1	1	1	
30	6E0-43632-00	KNOB, TILT PERILLA INCLINADOR	1	1	1	
31	6E0-43313-00-94	BRACKET, SWIVEL 3 SOPORTE GIRATORIO 3	1	1	1	
32	620-43189-00	BUSHING BUJE	2	2	2	
33	95895-06020	BOLT, FLANGE TUERCA DE REBORDE	2	2	2	
34	90508-16020	SPRING, TORSION RESORTE DE TORSION	1	1	1	
35	90508-16021	SPRING, TORSION RESORTE DE TORSION	1	1	1	
36	6E0-43160-01	TILT ROD ASSY VARILLA DE BASCULACION COMPL.	1	1	1	
37	689-43165-00	PLATE, TILT LOCK PLACA DE TOPE, VARILLA SEGUR	1	1	1	
38	91690-30008	PIN, SPRING PASADOR DE RESORTE	1	1	1	
39	6E0-43614-00-5B	PLATE, TILT LOCK PLACA DE SEGURO DE INCLINACION	1	1	1	
40	90508-14M10	SPRING, TORSION RESORTE DE TORSION	1	1	1	
41	90508-14M11	SPRING, TORSION RESORTE DE TORSION	1	1	1	
42	95895-06010	BOLT, FLANGE TUERCA DE REBORDE	2	2	2	
43	6E0-42537-02	BUSHING, PIVOT SHAFT BUJE DEL PIVOTE DE LA FLECHA	1	1	1	
44	6E0-42538-02	BUSHING, PIVOT SHAFT BUJE DEL PIVOTE DE LA FLECHA	1	1	1	
45	6E0-42539-00	BUSHING, PIVOT SHAFT BUJE DEL PIVOTE DE LA FLECHA	1	1	1	
46	6E0-42549-00	BUSHING, PIVOT SHAFT BUJEDEL PIVOTE DE LA FLECHA	1	1	1	
47	6E0-42528-03	PLATE, FRICTION PIEZA DE FRICCION	1	1	1	
48	95380-08600	NUT TUERCA	1	1	1	
49	90502-08M05	SPRING, CONICAL RESORTE CONICO	1	1	1	
50	6L5-42529-01	SCREW, FRICTION PIECE TORNILLO PIEZA FRICCION	1	1	1	
51	6L5-42561-00	KNOB, STEERING LOCK PERILLA	1	1	1	
52	6L5-44196-00	INDICATOR 3 INDICADOR 3	1	1	1	
53	6L5-44197-00	INDICATOR 4 INDICADOR 4	1	1	1	

FIG. 10 UPPER CASING . BRACKET CUBIERTA SUPERIOR Y SOPORTE

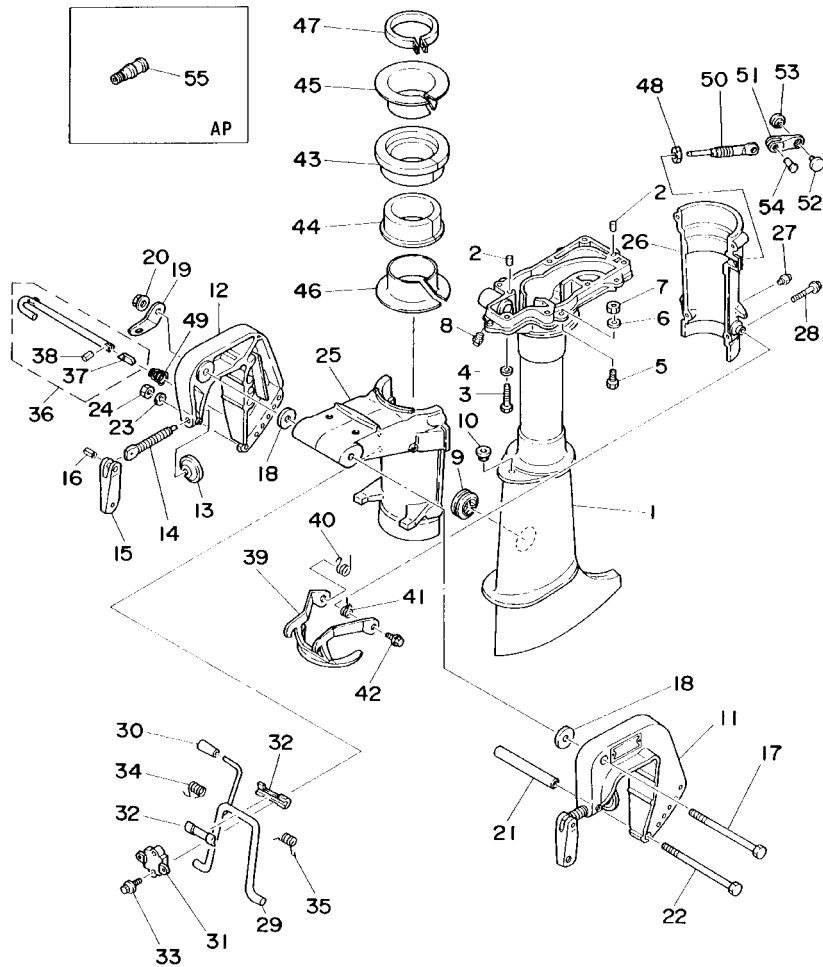

REF. NO.	PART NO. CODIGO NO.	DESCRIPTION DESCRIPTION	4AC	5C	5CS	REMARKS OBSERVACION
54	90266-04M05	RIVET REMACHE	1	1	1	
55	626-28193-01-94	PLUG, WATER CHECK TAPON DE CONTROL DE LA AGUA	1		1	AP D:15MM
	6E0-28193-00-94	PLUG, WATER CHECK TAPON DE CONTROL DE LA AGUA			1	AP D:12.5MM
<hr/>						
<hr/>						
<hr/>						
<hr/>						
<hr/>						
<hr/>						
<hr/>						
<hr/>						
<hr/>						
<hr/>						
<hr/>						
<hr/>						

6E00010-4090

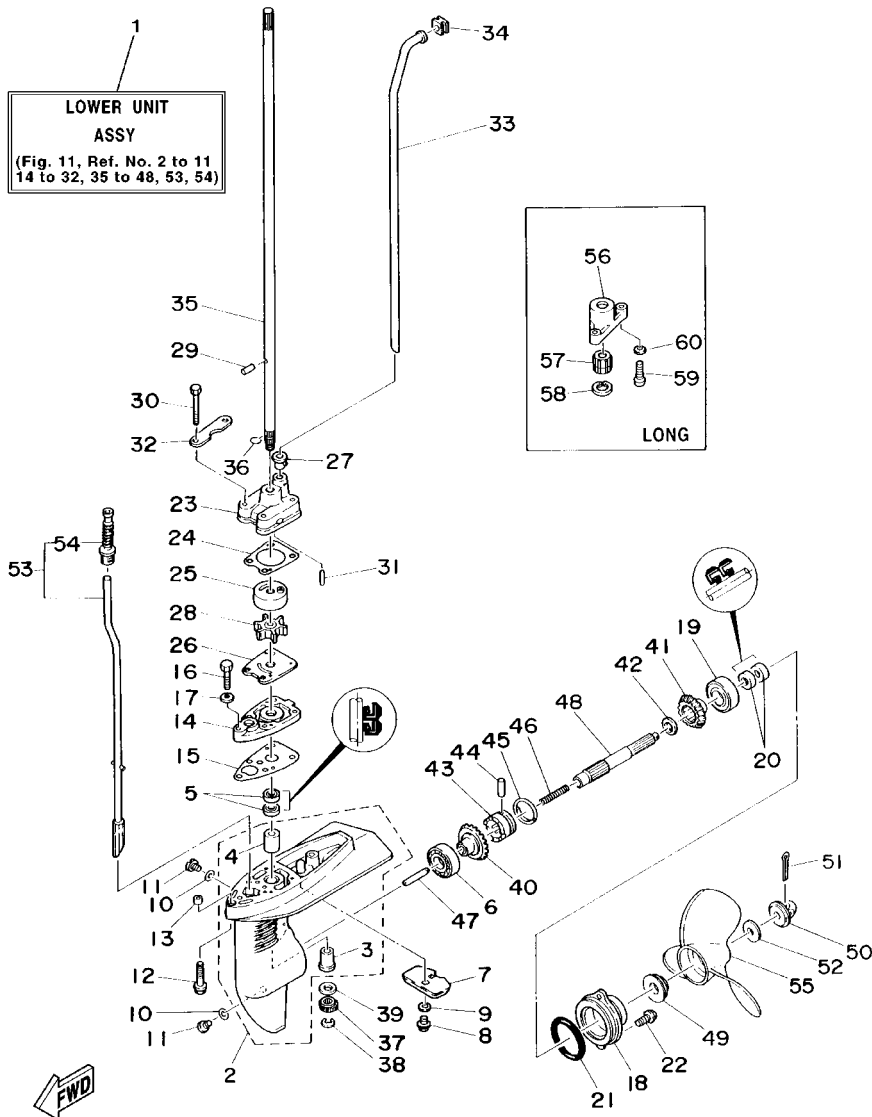

6E00200-4110

FIG. 11 LOWER CASING. DRIVE IMPULSOR E INFERIOR

REF. NO.	PART NO. CODIGO NO.	DESCRIPTION DESCRIPTION	4AC	5C	5CS	REMARKS OBSERVACION
1	6E0-45300-03-4D	LOWER UNIT ASSY CONJUNTO UNIDAD INFERIOR	1	1	1	S
	6E0-45300-13-4D	LOWER UNIT ASSY CONJUNTO UNIDAD INFERIOR	1	1	1	L
2	6E0-45311-02-4D	CASING, LOWER FUNDA INFERIOR	1	1	1	
3	6E0-45317-09	.BUSHING, DRIVE SHAFT .BUJE	1	1	1	
4	6E0-45316-09	.BUSHING, DRIVE SHAFT .BUJE, EJE DE MANDO	1	1	1	
5	93101-10M14	OIL SEAL SELLO ACEITE	2	2	2	
6	93306-004U0	BEARING COJINETE	1	1	1	
7	6L5-45251-02	ANODE CATODE	1	1	1	
8	95895-06012	BOLT, FLANGE TUERCA DE REBORDE	1	1	1	
9	92990-06300	WASHER, INTERNAL TOOTH ARANDELA	1	1	1	
10	90430-08020	GASKET JUNTA	3	3	3	
11	90340-08M04	PLUG, STRAIGHT SCREW TORNILLO, DE DRENAJE	3	3	3	
12	90119-06M40	BOLT, WITH WASHER TORNILLO CON ARANDELA	2	2	2	
13	90387-06M14	COLLAR CASQUILLO CON VALONA	2	2	2	
14	6E0-45321-01-5B	PLATE PLACA	1	1	1	
15	6E0-45315-A0	PACKING, LOWER CASING EMPAQUE	1	1	1	
16	97095-06025	BOLT PERNO	1	1	1	
17	92995-06600	WASHER ARANDELA	1	1	1	
18	6E0-45361-01-4D	CAP, LOWER CASING FUNDA INFERIOR	1	1	1	
19	93306-004U0	BEARING COJINETE	1	1	1	
20	93101-13M12	OIL SEAL SELLO ACEITE	2	2	2	
21	93210-48214	O-RING ANILLO O	1	1	1	
22	95895-06016	BOLT, FLANGE TUERCA DE REBORDE	2	2	2	
23	6E0-44311-00	HOUSING, WATER PUMP CAJA BOMBA DE AGUA	1	1	1	
24	6E0-44315-A0	GASKET, WATER PUMP EMPAQUE	1	1	1	
25	6E0-44322-02	INSERT, CARTRIDGE CARTUCHO	1	1	1	
	6E0-44322-40	INSERT, CARTRIDGE CARTUCHO		1		FOR CHINA CHROMATE

D1

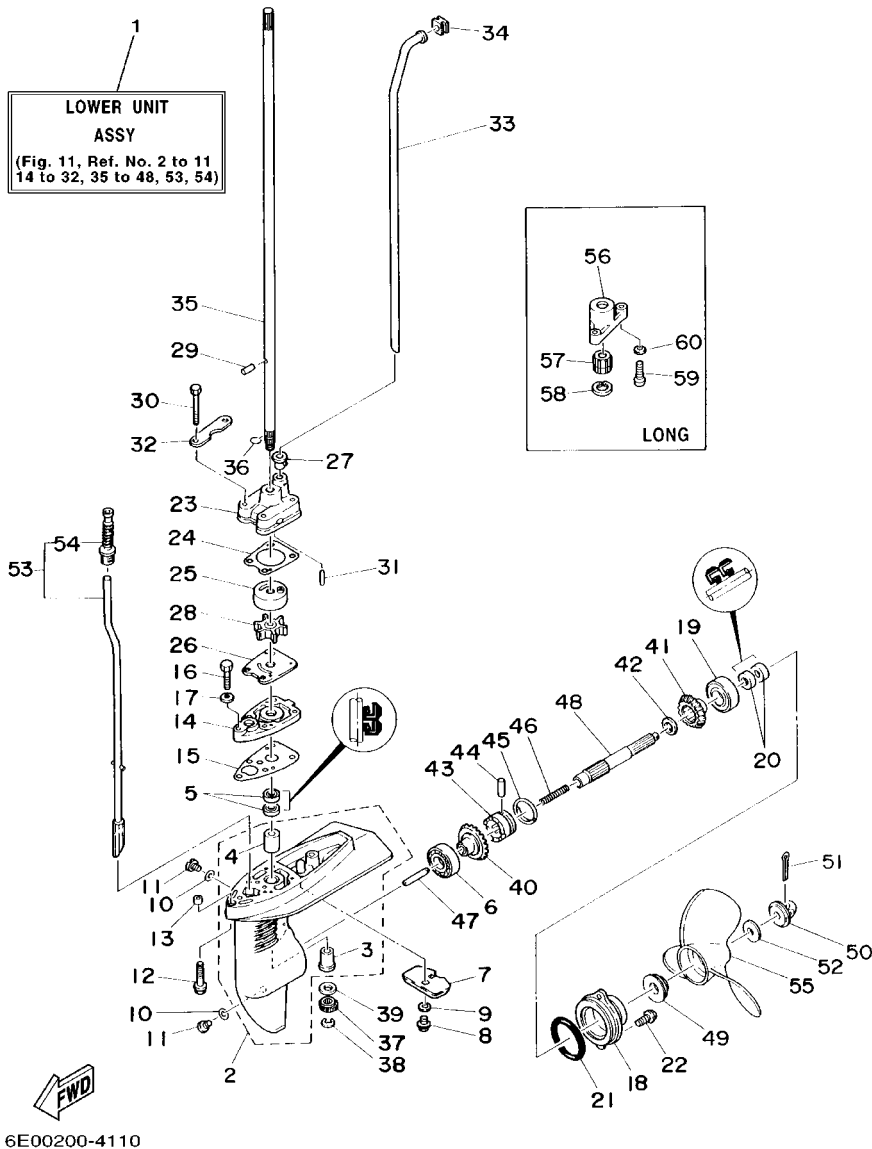
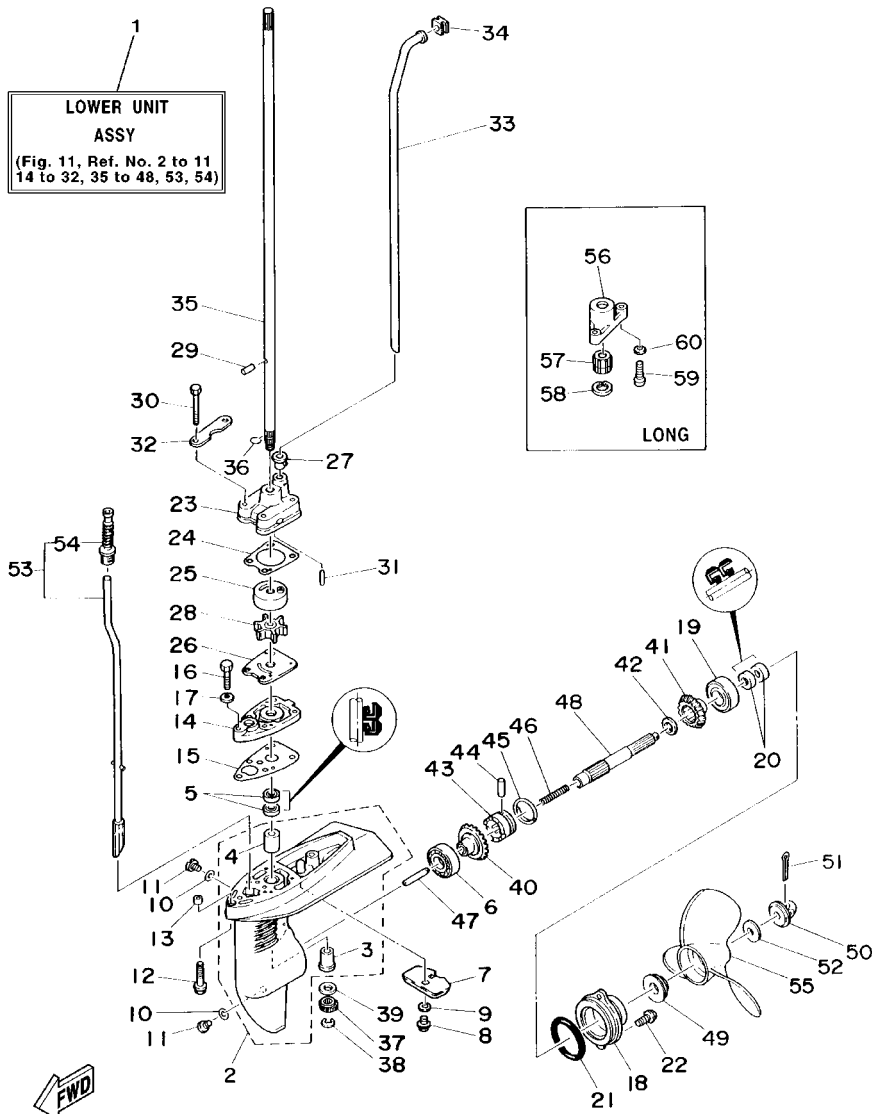

FIG. 11 LOWER CASING. DRIVE IMPULSOR E INFERIOR

REF. NO.	PART NO. CODIGO NO.	DESCRIPTION DESCRIPTION	4AC	5C	5CS	REMARKS OBSERVACION
26	6E0-44323-00	OUTER PLATE, CARTRIDGE PLACA EXTERIOR DEL CARTUCHO	1	1	1	
	6E0-44323-40	OUTER PLATE, CARTRIDGE PLACA EXTERIOR DEL CARTUCHO		1		FOR CHINA CHROMATE
27	6E0-44366-00	DAMPER, WATER SEAL GOMA DEL SELLO DE AGUA	1	1	1	
28	6E0-44352-00	IMPELLER IMPULSOR	1	1	1	
29	93604-09066	PIN, DOWEL PASADOR DE CLAVIJA	1	1	1	
30	97095-06045	BOLT PERNO	4	4	4	
31	93604-18080	PIN, DOWEL PASADOR DE CLAVIJA	2	2	2	
32	6E0-44328-00	PLATE PLACA	2	2	2	
33	6E0-44361-00	TUBE, WATER TUBO DE AGUA	1	1	1	S
	6E0-44361-10	TUBE, WATER TUBO DE AGUA	1	1	1	L
34	646-44365-00	DAMPER, WATER SEAL HULE DE SELLO DE AGUA	1	1	1	
35	6E0-45511-01	SHAFT, DRIVE EJE DE MANDO	1	1	1	S
	6E0-45511-11	SHAFT, DRIVE EJE DE MANDO	1	1	1	L
36	90467-08M01	CLIP PRESILLA	1	1	1	
37	6E0-45551-00	PINION PINON	1	1	1	
38	93430-06005	CIRCLIP BOLA	1	1	1	
39	90201-11M49	WASHER, PLATE ARANDELA PLANA	1	1	1	
40	6E0-45560-00	GEAR ENGRANE COMPLE 1	1	1	1	
41	6E0-45570-00	GEAR ENGRANE COMPL 2	1	1	1	
42	90201-13M50	WASHER, PLATE ARANDELA PLANA	1	1	1	
43	6E0-45631-00	CLUTCH, DOG EMBRAGUE DE GARRA	1	1	1	
44	90250-05046	PIN, STRAIGHT PASADOR CILINDRICO	1	1	1	
45	654-45633-00	RING, CROSS PIN ANILLO DE PASADOR	1	1	1	
46	90501-10064	SPRING, COMPRESSION RESORTE DE COMPRESION	1	1	1	
47	654-45635-00	PLUNGER, SHIFT EMBOLO DE CAMBIO	1	1	1	
48	6E0-45611-01	SHAFT, PROPELLER EJE PROPUSOR	1	1	1	
49	6L5-45987-01	SPACER ESPACIADOR	1	1	1	



6E00200-4110

FIG. 11 LOWER CASING. DRIVE IMPULSOR E INFERIOR

REF. NO.	PART NO. CODIGO NO.	DESCRIPTION DESCRIPTION	4AC	5C	5CS	REMARKS OBSERVACION
50	6L5-45616-00	NUT, PROPELLER TUERCA DE HELICE	1	1	1	
51	91490-25030	PIN, COTTER PASADOR DE CHAVETA	1	1	1	
52	90201-08M54	WASHER, PLATE ARANDELA PLANA	1	1	1	
53	6E0-44150-00	SHIFT CAM ASSY CONJUNTO EJE LEVA COMPL.	1	1	1	S
	6E0-44150-10	SHIFT CAM ASSY CONJUNTO EJE LEVA COMPL.	1	1	1	L
54	6G1-44147-00	BOOT, SHIFT ROD .HULE DE VARILLA	1	1	1	
55	6E0-45941-01-EL	PROPELLER (3X7-1/2"X8"-BA) PROPELA (3X7-1/2"X8"-BA)	1	1	1	UR
	6E0-45943-01-EL	PROPELLER (3X7-1/2"X7"-BA) PROPELA (3X7-1/2"X7"-BA)	1	1	1	UR
	6E0-45949-00-EL	PROPELLER (3X7-1/4"X6-1/2"-BA) PROPELA (3X7-1/4"X6-1/2"-BA)	1	1	1	UR
56	6E0-45331-00-5B	HOUSING, BEARING CAJA DE COJINETE	1	1	1	L
57	6E0-45318-01	BUSHING, DRIVE SHAFT BUJE, EJE DE MANDO	1	1	1	L
58	93420-22M03	CIRCLIP BOLA	1	1	1	L
59	97880-05025	SCREW, PAN HEAD TORNILLO DE CABEZA CON PLANA	2	2	2	L
60	92990-05600	WASHER, PLATE ARANDELA	2	2	2	L

FIG. 12 FUEL TANK

DEPOSITO DE COMBUSTIBLE

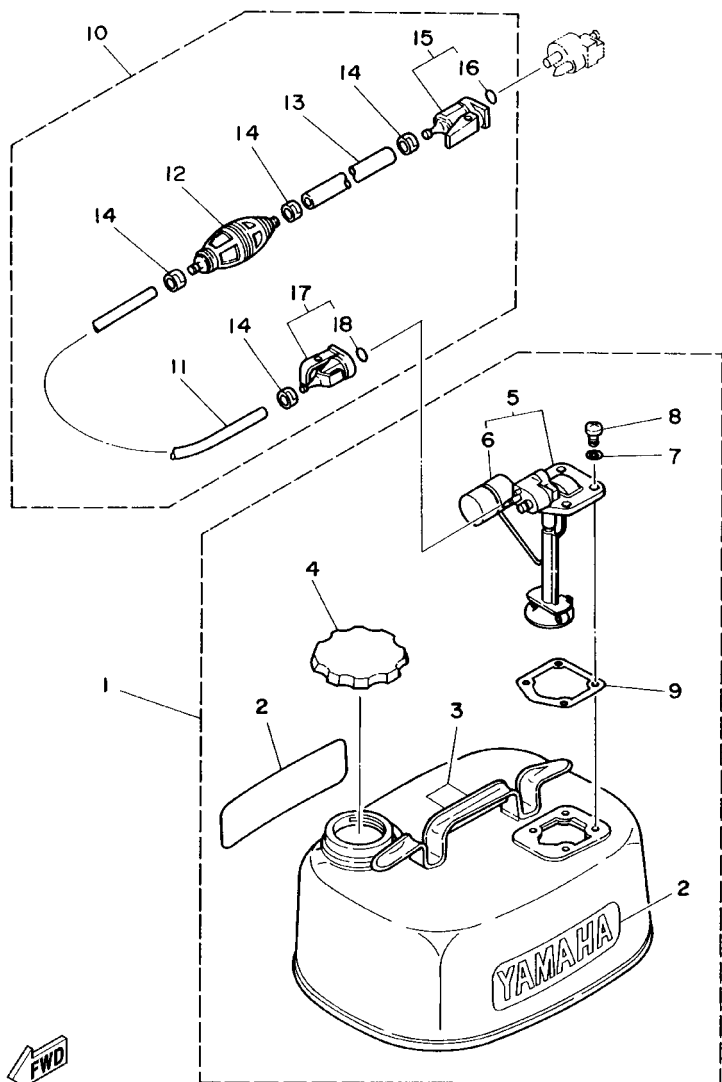

FWD
6E00200-9120

REF. NO.	PART NO. CODIGO NO.	DESCRIPTION DESCRIPTION	4AC	5C	5CS	REMARKS OBSERVACION
1	6Y0-W2420-03-24	FUEL TANK ASSY			1	AP FOR CHINA WITH INDICATOR
	6Y0-W2420-63-24	TANQUE DEL COMBUSTIBLE COMPL.			1	
2	6Y1-24246-00	FUEL TANK ASSY			2	AP
		TANQUE DEL COMBUSTIBLE COMPL.			2	
3	6Y1-24257-00	.GRAPHIC			1	FOR CHINA
		.CALCOMANIA 3			1	
4	802-24610-00	.CAP ASSY			1	FOR CHINA
	647-24610-03	.TAPA COMPLETA			1	
5	6Y0-24260-01	.FUEL METER ASSY			1	FOR CHINA WITH INDICATOR
	6Y0-24275-60	.MEDIDOR DE COMBUSTIBLE COMPL.			1	
6	663-24264-00	.FUEL METER COMP.			1	WITH INDICATOR
		.MEDIDOR DEL COMBUSTIBLE COMPL			1	
7	6Y1-24329-00	..FLOAT			4	WITH INDICATOR
		..BOIA			4	
8	98580-05016	.SEAL			4	FOR CHINA
		.SELLO			4	
9	663-24268-00	.SCREW, PAN HEAD			1	AP FOR CHINA
		.TORNILLO DE CABEZA CON PLANA			1	
10	6Y1-24306-06	.GASKET, FUEL METER			1	AP
	6Y0-24306-06	.EMPAQ MEDIDOR DE COMBUSTIBLE			1	
11	90445-11M06	FUEL PIPE COMP. 1			1	FOR CHINA
	90445-11M79	TUBO COMBUST. COMPL 1			1	
12	6Y1-24360-02	FUEL PIPE COMP. 1			1	FOR CHINA
	61J-24360-00	TUBO COMBUST. COMPL 1			1	
13	90445-11M05	.HOSE (L2050)			1	FOR CHINA
		.MANGUERA (L2050)			1	
14	650-24351-01	.HOSE (L1500)			4	FOR CHINA
	650-24351-01	.TUBO (L1500)			4	
15	6G1-24305-03	.PRIMER PUMP ASSY			3	FOR CHINA
		.SOPORTE BOMBA			3	
16	93210-08287	.PRIMER PUMP ASSY			1	FOR CHINA
		.SOPORTE BOMBA			1	
17	6Y1-24305-03	.HOSE (L:850MM)			1	FOR CHINA
		.MANGUERA (L:850MM)			1	
18	93210-08287	.BAND 1			4	FOR CHINA
		.ABRAZADERA 1			4	
		.BAND 1			3	FOR CHINA
		.ABRAZADERA 1			3	
		.FUEL PIPE JOINT COMP. 2			1	FOR CHINA
		.CONECTOR MANGUERA COMBUST.2			1	
		..O-RING			1	FOR CHINA
		..ANILLO O			1	
		.FUEL PIPE JOINT COMP. 2			1	FOR CHINA
		.CONECTOR MANGUERA COMBUST.2			1	
		..O-RING			1	FOR CHINA
		..ANILLO O			1	

FIG. 13 REPAIR KIT

ESTUCHE REPARATION

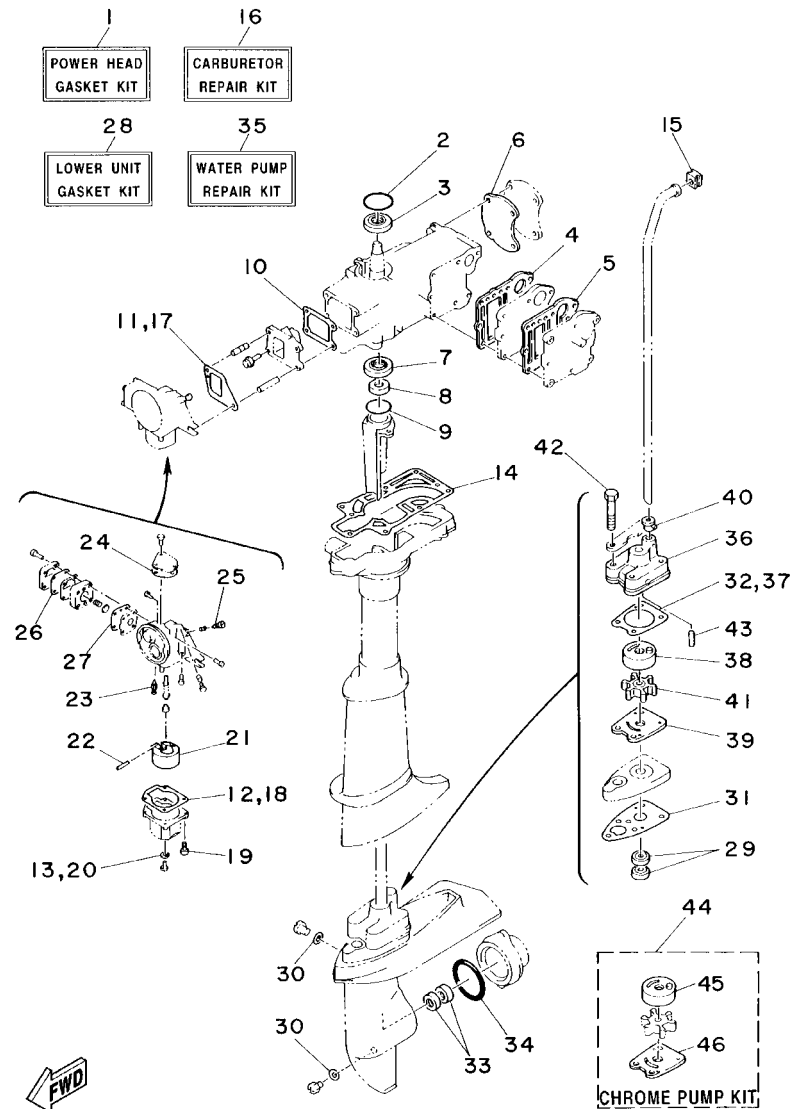

6E00100-4110

REF. NO.	PART NO. CODIGO NO.	DESCRIPTION DESCRIPTION	4AC	5C	5CS	REMARKS OBSERVACION
1	6E0-W0001-A4	POWER HEAD GASKET KIT JUEGO DE EMPAQUE DE MOTOR	1			
	6E3-W0001-A4	POWER HEAD GASKET KIT JUEGO DE EMPAQUE DE MOTOR		1	1	
2	93210-42159	.O-RING .ANILLO O	1	1	1	
3	93102-20M25	.OIL SEAL SELLO ACEITE	1	1	1	
4	6E0-41112-A1	.GASKET, EXHAUST INNER COVER EMPAQUE	1			
	6E3-41112-A1	.GASKET, EXHAUST INNER COVER EMPAQUE		1	1	
5	6E0-41114-A1	.GASKET, EXHAUST OUTER COVER EMPAQUE	1			
	6E3-41114-A1	.GASKET, EXHAUST OUTER COVER EMPAQUE		1	1	
6	6E0-11193-A1	.GASKET, HEAD COVER 1 EMPAQUE	1			
	6E3-11193-A1	.GASKET, HEAD COVER 1 EMPAQUE		1	1	
7	93101-20M29	.OIL SEAL SELLO ACEITE	1	1	1	
8	93101-10M25	.OIL SEAL SELLO ACEITE	1	1	1	
9	93210-31114	.O-RING .ANILLO O	1	1	1	
10	6E0-13621-A2	.GASKET, VALVE SEAT .JUNTA, DE VALV.DE EMPAQUE	1	1	1	
11	6E0-14198-A0	.GASKET EMPAQUE	1	1	1	
12	6E0-14384-00	.GASKET, FLOAT CHAMBER EMPAQUE DE CAMARA DE BOIA	1	1	1	
13	646-14198-01	.GASKET EMPAQUE	1	1	1	
14	6E0-45113-A1	.GASKET, UPPER CASING EMPAQUE	1	1	1	
15	646-44365-00	.DAMPER, WATER SEAL HULE DE SELLO DE AGUA	1	1	1	
16	6E0-W0093-04	CARBURETOR REPAIR KIT KIT REPARACION CARBURADOR	1	1	1	
17	6E0-14198-A0	.GASKET EMPAQUE	1	1	1	
18	6E0-14384-00	.GASKET, FLOAT CHAMBER EMPAQUE DE CAMARA DE BOIA	1	1	1	
19	97980-04116	.SCREW, WITH WASHER .TORNILLO, CON ARANDELA	1	1	1	
20	646-14198-01	.GASKET EMPAQUE	1	1	1	
21	6E7-14385-01	.FLOAT BOIA	1	1	1	
22	647-14386-00	.PIN, FLOAT .PASADOR DE BOIA	1	1	1	
23	6F5-14392-00	.VALVE, NEEDLE .VALVULA DE AGUJA	1	1	1	

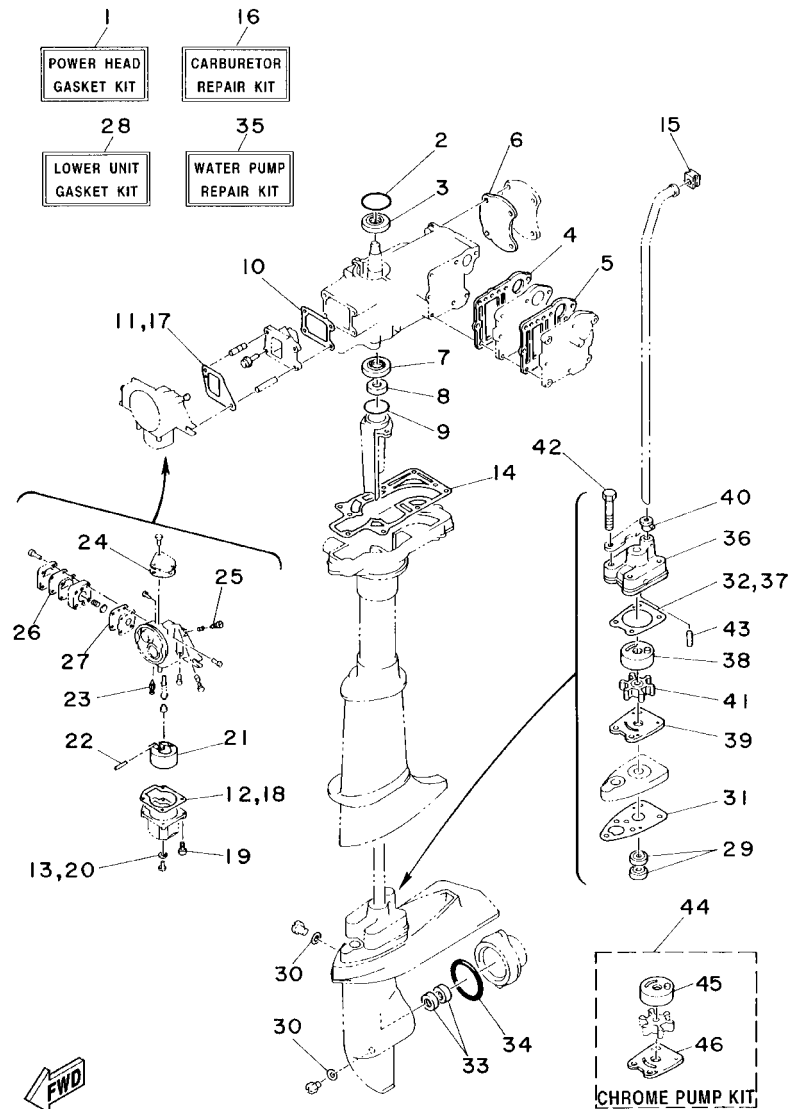

FIG. 13 REPAIR KIT

ESTUCHE REPARATION

REF. NO.	PART NO. CODIGO NO.	DESCRIPTION DESCRIPTION	4AC	5C	5CS	REMARKS OBSERVACION
24	6E0-14227-00	.GASKET .EMPAQUE	1	1	1	
25	647-14323-00	.SCREW, AIR ADJUSTING .TORNILLO DE AJUSTE DE AIRE	1	1	1	
26	6E0-24471-00	.DIAPHRAGM .DIAFRAGMA	1	1	1	
27	6E0-24411-00	.DIAPHRAGM .DIAFRAGMA	1	1	1	
28	6E0-W0001-C1	LOWER UNIT GASKET KIT JUEGO DE JUNTA UNIDAD INFERIOR	1	1	1	
29	93101-10M14	.OIL SEAL .SELLO ACEITE	2	2	2	
30	90430-08020	.GASKET .JUNTA	3	3	3	
31	6E0-45315-A0	.PACKING, LOWER CASING .EMPAQUE	1	1	1	
32	6E0-44315-A0	.GASKET, WATER PUMP .EMPAQUE	1	1	1	
33	93101-13M12	.OIL SEAL .SELLO ACEITE	2	2	2	
34	93210-48214	.O-RING .ANILLO O	1	1	1	
35	6E0-W0078-A3	WATER PUMP REPAIR KIT ESTUCHE REPARACION BOMBA AGUA	1	1	1	
36	6E0-44311-00	.HOUSING, WATER PUMP .CAJA BOMBA DE AGUA	1	1	1	
37	6E0-44315-A0	.GASKET, WATER PUMP .EMPAQUE	1	1	1	
38	6E0-44322-02	.INSERT, CARTRIDGE .CARTUCHO	1	1	1	
39	6E0-44323-00	.OUTER PLATE, CARTRIDGE .PLACA EXTERIOR DEL CARTUCHO	1	1	1	
40	6E0-44366-00	.DAMPER, WATER SEAL .GOMA DEL SELLO DE AGUA	1	1	1	
41	6E0-44352-00	.IMPELLER .IMPULSOR	1	1	1	
42	97095-06045	.BOLT .PERNO	4	4	4	
43	93604-18080	.PIN, DOWEL .PASADOR DE CLAVIJA	1	1	1	
44	6E0-W0078-0A	CHROME PUMP KIT ESTUCHE REPARACION BOMBA AGUA	1	1	1	AP
45	6E0-44322-40	.INSERT, CARTRIDGE .CARTUCHO	1	1	1	CHROMATE
46	6E0-44323-40	.OUTER PLATE, CARTRIDGE .PLACA EXTERIOR DEL CARTUCHO	1	1	1	CHROMATE

6E00100-4110

NUMERICAL INDEX
INDICE NUMERICO

PART NO. CODIGO NO.	REF. NO.	PART NO. CODIGO NO.	REF. NO.	PART NO. CODIGO NO.	REF. NO.	PART NO. CODIGO NO.	REF. NO.	PART NO. CODIGO NO.	REF. NO.	PART NO. CODIGO NO.	REF. NO.
6E0-W0001-A4	13 - 1	646-14212-01	3 - 20	6E3-15758-01	4 - 15	102-24522-01	7 - 40	6E0-42538-02	10 - 44	6E0-44150-10	11 - 53
6E0-W0001-C1	13 - 28	6E0-14227-00	3 - 17	6E0-15761-00	4 - 16	6J1-24524-00	7 - 29	6E0-42539-00	10 - 45	6E0-44191-11	1 - 9
6E3-W0001-A4	13 - 1			6E0-15770-70	4 - 21	6E0-24566-61	7 - 41	6E0-42542-00	7 - 11	6L5-44196-00	10 - 52
6E0-W0004-00	3 - 2	6E0-14301-05	3 - 5	6E0-15772-71	4 - 22	6E3-24566-61	7 - 41	6E0-42549-00	10 - 46	6L5-44197-00	10 - 53
6J1-W0004-00	3 - 2	6E3-14301-05	3 - 5	6E4-15772-71	4 - 22	6E0-24571-00	7 - 20	6L5-42561-00	10 - 51	6E0-44311-00	11 - 23
6E0-W0070-14	1 - 6	664-14321-01	3 - 21	6G1-15779-00	4 - 12	6E0-24572-00	7 - 22	6E0-42610-15-4D	1 - 1		13 - 36
6E0-W0078-A3	13 - 35	647-14323-00	3 - 19	6E0-24110-01-4D	7 - 13	6E0-24575-01	7 - 23	6E3-42610-15-4D	1 - 1	6E0-44315-A0	11 - 24
6E0-W0078-0A	13 - 44			6E0-24181-00	7 - 15	6E0-24591-00	7 - 21	6E4-42610-15-4D	1 - 1		13 - 32
6E0-W0090-04-1S	2 - 1	647-14326-00	3 - 23	6E0-24182-00	7 - 10	6E0-24591-10	7 - 21	6E0-42615-00	1 - 2		13 - 37
6E3-W0090-04-1S	2 - 1	6E0-14341-01	3 - 13	6E1-24182-00	8 - 12	6E0-24610-02	7 - 14	6E1-42643-01	8 - 10	6E0-44322-02	11 - 25
6E0-W0093-04	13 - 16	6E3-14341-02	3 - 13	6E3-24182-00	7 - 10	647-24610-03	12 - 4	6E0-42647-01	1 - 3		13 - 38
6Y0-W2420-03-24	12 - 1	648-14342-23	3 - 22	6E0-24183-00	5 - 19	802-24610-00	12 - 4	6E0-42651-02	1 - 4	6E0-44322-40	11 - 25
6Y0-W2420-63-24	12 - 1	648-14342-26	3 - 22	6Y1-24246-00	12 - 2	6E0-24641-00	7 - 16	6E0-42677-11	1 - 7		13 - 45
656-W2810-02	1 - 10	648-14343-40	3 - 14	646-24251-02	7 - 33	6E3-24641-00	7 - 16	6E3-42677-11	1 - 7	6E0-44323-00	11 - 26
6E0-11191-01-1S	2 - 21	6E0-14346-00	3 - 30			6E0-26301-01	9 - 24	6E0-42678-12	1 - 8		13 - 39
6E3-11191-01-1S	2 - 21	6E0-14381-02	3 - 6	6Y1-24257-00	12 - 3	6G1-2811G-00	8 - 11	6E3-42678-12	1 - 8	6E0-44323-40	11 - 26
6E0-11193-A1	2 - 22	6E0-14384-00	3 - 7	6Y0-24260-01	12 - 5	6E0-28193-00-94	10 - 55	6E0-42711-05-4D	7 - 1		13 - 46
	13 - 6			663-24264-00	12 - 6	626-28193-01-94	10 - 55		8 - 1	6E0-44328-00	11 - 32
6E3-11193-A1	2 - 22			663-24268-00	12 - 9	6E0-41111-01-1S	2 - 24	6E0-42711-10-4D	7 - 1	6E0-44352-00	11 - 28
	13 - 6	6E7-14385-01	3 - 11	6Y0-24275-60	12 - 5	6E3-41111-01-1S	2 - 24	6E0-42815-00-4D	7 - 2		13 - 41
650-11370-00	2 - 3			6G1-24304-02	7 - 35	6E0-41112-A1	2 - 25		8 - 2	6E0-44361-00	11 - 33
6E5-11372-00	2 - 5	647-14386-00	3 - 12					6E0-42816-00	7 - 4	6E0-44361-10	11 - 33
6E0-11400-00	2 - 31			6G1-24305-03	12 - 15	6E3-41112-A1	2 - 25		8 - 4	646-44365-00	11 - 34
6E3-11400-00	2 - 31	6F5-14392-00	3 - 15	6Y1-24305-03	12 - 17			6E0-43111-02-4D	10 - 11		13 - 15
6E0-11412-00	2 - 32			6Y0-24306-06	12 - 10	6E0-41113-01-1S	2 - 26	6E0-43112-01-4D	10 - 12	6E0-44366-00	11 - 27
6E3-11412-00	2 - 32	6E0-14417-00	3 - 37	6Y1-24306-06	12 - 10	6E3-41113-01-1S	2 - 26	6A1-43113-01	10 - 19		13 - 40
6E0-11422-00	2 - 33	6E0-14418-00	3 - 38	6E0-24311-00	7 - 26	6E0-41114-A1	2 - 27	620-43114-00	10 - 13	6E0-45111-02-4D	10 - 1
6E3-11422-00	2 - 33	624-14485-00	2 - 4	6E0-24312-00	7 - 36			6E0-43116-01	10 - 14	6E0-45111-12-4D	10 - 1
6G1-11610-00	2 - 42	6E0-15100-01-1S	2 - 2	688-24313-00	8 - 15	6E3-41114-A1	2 - 27	6E0-43118-01	10 - 15	6E0-45113-A1	2 - 47
6J1-11610-00	2 - 42	6E3-15100-02-1S	2 - 2	6Y1-24329-00	12 - 7			6E0-43160-01	10 - 36		13 - 14
6E0-11631-00-98	2 - 41	6E0-15359-00-94	5 - 5	6E0-24335-00	7 - 25	6E0-41256-00	3 - 42	689-43165-00	10 - 37	647-45151-01	10 - 9
6E3-11631-00-98	2 - 41	6E0-15396-03-5B	2 - 16	650-24351-01	12 - 14	661-41262-02	3 - 46	6E0-43181-00	10 - 29	6L5-45251-02	11 - 7
6G1-11633-00	2 - 44	6E0-15705-00	4 - 11	6Y1-24360-02	12 - 12	6E0-41271-00	3 - 43	620-43189-00	10 - 32	6E0-45300-03-4D	11 - 1
6E0-11651-01	2 - 37	6E0-15710-03-94	4 - 1	61J-24360-00	12 - 12	6E0-41272-00	3 - 44	6E0-43311-04-4D	10 - 25	6E0-45300-13-4D	11 - 1
6G1-11681-00	2 - 34	6E0-15710-72-94	4 - 1	6E0-24378-00	2 - 9	6E0-42111-02-4D	9 - 1	6E0-43312-02-4D	10 - 26	6E0-45311-02-4D	11 - 2
6E5-12411-01	2 - 46	6E3-15710-03-94	4 - 1	6E0-24411-00	3 - 31	6E0-42119-00	9 - 14	6E0-43313-00-94	10 - 31	6E0-45315-A0	11 - 15
6E0-13610-00	3 - 1	6E4-15710-73-94	4 - 1			6E0-42125-00	9 - 9	6E0-43614-00-5B	10 - 39		13 - 31
6J1-13610-00	3 - 1	6E0-15711-01-94	4 - 2	6E0-24412-00	3 - 28	6E0-42129-02	9 - 2	6E0-43632-00	10 - 30	6E0-45316-09	11 - 4
6E0-13621-A2	3 - 3	6E4-15711-71-94	4 - 2	6E0-24413-00	3 - 25	6E4-42129-00	9 - 3	6E0-44111-02	9 - 25	6E0-45317-09	11 - 3
	13 - 10	6E0-15714-01	4 - 3	6E0-24423-00	3 - 29	6E0-42131-02-94	9 - 5	6E4-44111-72-4D	9 - 25	6E0-45318-01	11 - 57
6E0-14157-00	3 - 16	6E0-15717-00	4 - 5	6E0-24434-00	3 - 32	6E0-42134-02	9 - 10	6E0-44116-00	9 - 29	6E0-45321-01-5B	11 - 14
6E0-14159-00	3 - 33	6E0-15723-00-94	5 - 2	6E0-24435-00	3 - 27	6E0-42137-10	9 - 16	6E0-44121-00	9 - 33	6E0-45331-00-5B	11 - 56
6E0-14198-A0	3 - 34	677-15741-01	4 - 9	6E0-24471-00	3 - 26	6E0-42138-01	9 - 21	6E0-44143-00	9 - 35	6E0-45361-01-4D	11 - 18
	13 - 11	6E4-15746-70	4 - 23			6E0-42159-02	9 - 22	6E0-44143-10	9 - 35	6E0-45511-01	11 - 35
	13 - 17	6E4-15747-70	4 - 26	6E0-24500-00	7 - 19	6E0-42177-00	9 - 15	6E0-44145-00	9 - 38	6E0-45511-11	11 - 35
646-14198-01	3 - 10	656-15748-00	4 - 19	6E0-24500-10	7 - 19	6E0-42528-03	10 - 47	6E0-44146-00	9 - 39	6E0-45551-00	11 - 37
	13 - 13	6G1-15755-00	4 - 14	6E0-24500-60	7 - 38	6L5-42529-01	10 - 50	6G1-44147-00	11 - 54	6E0-45560-00	11 - 40
	13 - 20	6E0-15758-01	4 - 15	624-24521-01	7 - 39	6E0-42537-02	10 - 43	6E0-44150-00	11 - 53	6E0-45570-00	11 - 41

NUMERICAL INDEX
INDICE NUMERICO

PART NO. CODIGO NO.	REF. NO.	PART NO. CODIGO NO.	REF. NO.	PART NO. CODIGO NO.	REF. NO.	PART NO. CODIGO NO.	REF. NO.	PART NO. CODIGO NO.	REF. NO.	PART NO. CODIGO NO.	REF. NO.
6E0-45611-01	11 - 48	90185-08057	10 - 20	90465-08M62	7 - 32	93101-13M12	13 - 33	95895-06020	6 - 12		
6L5-45616-00	11 - 50	90201-06M30	4 - 8	90465-13M11	7 - 27	93101-20M29	2 - 39		7 - 9		
6E0-45631-00	11 - 43	90201-08M03	10 - 18	90467-06016	2 - 10		13 - 7		8 - 9		
654-45633-00	11 - 45	90201-08M54	11 - 52		2 - 15	93102-20M25	5 - 15		9 - 40		
654-45635-00	11 - 47	90201-10119	9 - 18	90467-08M01	11 - 36		13 - 3		10 - 33		
6E0-45941-01-EL	11 - 55	90201-10126	5 - 22	90467-08004	7 - 18	93210-08287	12 - 16	95895-06025	7 - 12		
6E0-45943-01-EL	11 - 55	90201-11M49	11 - 39		7 - 45		12 - 18		9 - 34		
6E0-45949-00-EL	11 - 55	90201-13M50	11 - 42		8 - 17	93210-12327	9 - 26	95895-06035	10 - 28		
6L5-45987-01	11 - 49	90201-32M48	2 - 40	90468-07M02	2 - 48	93210-31MJ5	2 - 17	97013-05020	9 - 6		
6E0-81303-40	5 - 23	90202-05088	4 - 29	90468-10005	4 - 27	93210-31114	13 - 9	97013-06035	4 - 6		
6E0-81303-80	5 - 23	90202-07M22	9 - 13	90480-10M13	10 - 10	93210-42159	5 - 16	97080-06010	6 - 9		
6E0-81328-70	5 - 13	90202-12M16	3 - 45	90480-14M14	7 - 8		13 - 2	97095-06012	9 - 31		
6E0-81336-70	5 - 12	90202-12M17	7 - 24		8 - 8	93210-48214	11 - 21	97095-06016	2 - 19		
6E0-82316-01-94	6 - 3	90202-16061	9 - 28	90480-25161	6 - 8		13 - 34		5 - 17		
6E0-82317-00	6 - 4	90206-12052	7 - 5	90501-10064	11 - 46	93306-004U0	11 - 6		6 - 6		
6E3-82370-21	6 - 2		8 - 5	90501-10227	4 - 20		11 - 19		10 - 5		
663-82370-01	6 - 2	90206-16M06	9 - 27	90501-23215	9 - 17	93306-204U0	2 - 35	97095-06025	11 - 16		
6E0-82550-01	7 - 46	90209-18112	2 - 38	90502-08M05	10 - 49	93310-112V0	2 - 43	97095-06030	10 - 3		
	8 - 18	90243-04M01	10 - 16	90508-14M10	10 - 40	93310-418V1	2 - 36	97095-06045	11 - 30		
6E0-85520-70	5 - 6	90250-05046	11 - 44	90508-14M11	10 - 41	93420-22M03	11 - 58		13 - 42		
6E0-85540-71	6 - 11	90266-04M00	1 - 5	90508-16020	10 - 34	93430-06M02	4 - 10	97780-40720	3 - 41		
6E0-85548-00	6 - 10	90266-04M05	10 - 54	90508-16021	10 - 35	93430-06005	11 - 38	97880-05025	3 - 39		
6E0-85550-71	5 - 1	90269-02M09	9 - 20	90510-08M03	4 - 4	93450-13022	2 - 45		11 - 59		
6E0-85560-70	5 - 4	90280-04M06	5 - 20	91490-12010	9 - 12	93604-09066	11 - 29	97885-04010	7 - 42		
6E0-85570-00	6 - 5	90340-08M04	11 - 11	91490-16010	4 - 30	93604-18080	11 - 31	97885-05012	9 - 11		
6E0-85592-70	5 - 10	90386-12069	7 - 3		9 - 37		13 - 43		9 - 23		
6E0-85595-70	5 - 8		8 - 3	91490-25030	11 - 51	93606-12019	2 - 6	97885-06030	7 - 6		
90101-06335	10 - 22	90386-26M30	9 - 4	91690-30008	10 - 38		10 - 2		8 - 6		
90101-08M07	10 - 17	90386-26M33	9 - 8	91790-05010	4 - 28	93700-06M03	10 - 8	97890-04007	3 - 18		
90105-06M14	2 - 23	90387-06M11	10 - 21	92903-05600	9 - 7		10 - 27	97890-05006	3 - 9		
	2 - 30	90387-06M14	11 - 13	92990-05600	3 - 40	94702-00040	2 - 49	97980-04116	3 - 8		
	5 - 3	90387-06504	4 - 24		9 - 36	94702-00272	2 - 49		13 - 19		
90105-06M16	2 - 7	90430-08020	11 - 10		11 - 60	95380-06600	10 - 24	97980-04120	3 - 24		
	2 - 29		13 - 30	92990-06300	11 - 9	95380-06700	3 - 35	98580-05016	12 - 8		
90105-06M17	2 - 8	90445-07M00	2 - 11	92990-06600	10 - 23		7 - 7				
90105-06M24	2 - 28	90445-07M28	2 - 12	92995-06100	5 - 18		8 - 7				
90116-06M08	3 - 48		2 - 14	92995-06600	2 - 20		9 - 30				
90119-06M18	4 - 25	90445-07M32	2 - 13		3 - 36		10 - 7				
90119-06M40	11 - 12	90445-09M27	7 - 31		6 - 7	95380-08600	10 - 48				
90149-05M13	9 - 19	90445-09M37	7 - 17		9 - 32	95601-06200	4 - 7				
90159-04M24	7 - 30	90445-09057	7 - 34		10 - 4	95627-06325	3 - 47				
90159-04035	5 - 14		8 - 16		10 - 6	95895-06010	10 - 42				
90159-04036	5 - 9	90445-09072	7 - 43		11 - 17	95895-06012	11 - 8				
90159-05037	5 - 11	90445-09082	7 - 44	93101-10M14	11 - 5	95895-06016	3 - 4				
90159-05038	5 - 7	90445-11M05	12 - 13		13 - 29		4 - 17				
90159-05040	5 - 24	90445-11M06	12 - 11	93101-10M25	2 - 18		6 - 1				
90170-10113	5 - 21	90445-11M79	12 - 11		13 - 8		11 - 22				
90170-16M35	7 - 28	90464-09M21	7 - 37	93101-13M12	11 - 20	95895-06020	4 - 18				