

**YAMAHA**

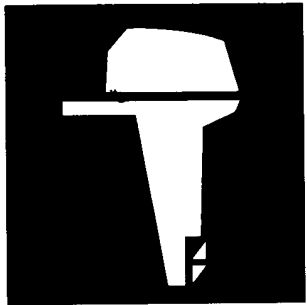

**PARTS  
CATALOGUE  
CATALOGO  
DE REPUESTOS**

**4AC'98(6E0)**

**5C '98(6E3)**

**5CS'98(6E4)**

---

1W6E0-200S1

**YAMAHA**  
**GENUINE**  
Parts & Accessories

## FOREWORD

This Parts Catalogue is related to the parts for the model(s) in the below frame. When you are ordering replacement parts, please refer to this Parts Catalogue and quote both part numbers and part names correctly.

4AC'98(6E0), 5C'98(6E3), 5CS'98(6E4)

1. Modifications or additions which have been made after issue of the Parts Catalogue will be announced in the Yamaha Parts News.  
It is advisable that you make necessary corrections to the Parts Catalogue according to the Yamaha Parts News.

### 2. Abbreviations

The following abbreviations are used in this Parts Catalogue.

"UR" Use specified parts number.	"M" Manual start model
"UN" Use as many as needed.	"E" Electric start model
"AP" Alternate Parts	"PTT" Power Trim & Tilt model
"LM" Local Made (Parts need to be ordered locally)	"H/T" Hydro Tilt model
"O/S" Over Size	"M/T" Manual Tilt model
	"T.H/D" Tiller Handle model

3. Parts, which are to be supplied in an assembly, are listed with a dot (.) in front of the part name as shown below.

#### EXAMPLE

CARBURETOR ASSY  
 . JET, PILOT  
 . NOZZLE, MAIN

4. Number of component for assembly

The numeral appearing to the right of each component part indicates the quantity of parts for each assembly unit.

#### EXAMPLE

PART NO.	DESCRIPTION	Q'TY	REMARKS
6E0-85500-70	C.D.I. MAGNETO ASSY	1	
6E0-85550-70	. ROTOR ASSY	1	
6E0-15723-00-94	. . PULLY, STARTER	1	

5. Applicable Serial No. and Color Code

Engine Serial No.	4ACMH S : 166020 ~ L : 355003 ~
	5CMH S : 019431 ~ L : 312815 ~
	5CSMH S : 177982 ~ L : 446216 ~

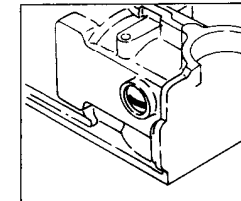
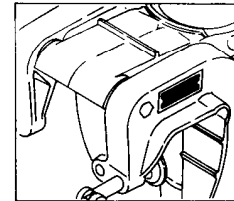

Color Code	Color Name	Abbreviation
4D	DARK BLUISH GRAY METALLIC 2	DBNM2

6. Note that the illustrations are for reference in finding parts numbers, not to be used for assembling. When assembling, please use the applicable service manual.

## PROLOGO

Este Catálogo de Repuestos corresponde a las piezas para el(los) modelo(s) del recuadro siguiente. Al formular el pedido de repuestos, se ruega citar este Catálogo de Repuestos y especificar correctamente los números de parte y los nombres de parte.

4AC'98(6E0), 5C'98(6E3), 5CS'98(6E4)

1. Las modificaciones y agregados que se hayan realizado después de la edición de este Catálogo de Repuestos, serán anunciados en las Informaciones de Recambios Yamaha.

### 2. Abreviaciones

En este Catálogo de Repuestos se emplean las siguientes abreviaciones.

"UR"	Usar el número de partes especificado
"UN"	Usar la cantidad necesaria
"AP"	Piezas sustitutivas
"OS"	Sobre Tamaño
"LM"	Fabricación local (Partes necesarias que se pedirán localmente)
"M"	Modelo de arranque manual
"E"	Modelo de arranque eléctrico
"PTT"	Modelo de asiento e inclinación asistidos
"H/T"	Modelo de inclinación hidráulica
"M/T"	Modelo de inclinación manual
"T.H/D"	Modelo de control de caña de timon

3. Las piezas suministradas como conjunto se describen con un punto (.) que precede al nombre de la pieza como se indica a continuación.

#### EJEMPLO

CONJUNTO CARBURADOR

- . INYECTOR, piloto
- . BOQUILLA, principal

4. Cantidad de componentes de un conjunto

La numeración que aparece a la derecha de cada descripción, indica la cantidad de piezas por cada unidad de conjunto.

#### EJEMPLO

PIEZAS NO.	DESCRIPCION	CANT.	OBSERVACION
6E0-85500-70	MAGNETO C.D.I COMPLETO	1	
6E0-85550-70	. ROTOR COMPLETO	1	
6E0-15723-00-94	. . POLEA DE ARRANQUE	1	

5. Números de Serie y Códigos de Color aplicables

No. de Serie del motor	4ACMH S : 166020 ~
	L : 355003 ~
	5CMH S : 019431 ~
	L : 312815 ~
	5CSMH S : 177982 ~
	L : 446216 ~

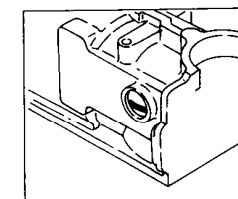
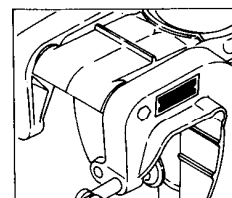

Código de Color	Nombre del Color	Abreviación
4D	DARK BLuish GRAY METALLIC 2	DBNM2

6 Debe tenerse en cuenta que las ilustraciones sirven como guía para la búsqueda de las referencias y no deben usarse para el montaje. Durante el montaje, se recomienda usar el manual de Taller correspondiente.

# CONTENTS

FIG. 1	CYLINDER. CRANKCASE .....	A6~B1
FIG. 2	INTAKE .....	B2, B3
FIG. 3	STARTER .....	B4
FIG. 4	TOP COWLING .....	B5
FIG. 5	BOTTOM COWLING .....	B6, B7
FIG. 6	UPPER CASING. BRACKET .....	C1, C2
FIG. 7	CONTROL .....	C3, C4
FIG. 8	LOWER CASING. DRIVE 1.....	C5~C7
FIG. 9	GENERATOR .....	D1
FIG. 10	ELECTRICAL 1 .....	D2
FIG. 11	REPAIR KIT .....	D3, D4
	NUMERICAL INDEX	

## CONTENIDO

FIG. 1	CYLINDRO. CARTER .....	A6~B1
FIG. 2	ADMISION .....	B2, B3
FIG. 3	ARRANQUE .....	B4
FIG. 4	CUBIERTA SUPERIOR .....	B5
FIG. 5	CUBIERTA INFERIOR .....	B6, B7
FIG. 6	CUBIERTA SUPERIOR Y SOPORTE.....	C1, C2
FIG. 7	CONTROL .....	C3, C4
FIG. 8	IMPULSOR E INFERIOR 1 .....	C5~C7
FIG. 9	GENERADOR .....	D1
FIG. 10	EQUIPO ELECTRICO 1 .....	D2
FIG. 11	ESTUCHE REPARACION .....	D3, D4
	INDICE NUMERICO	

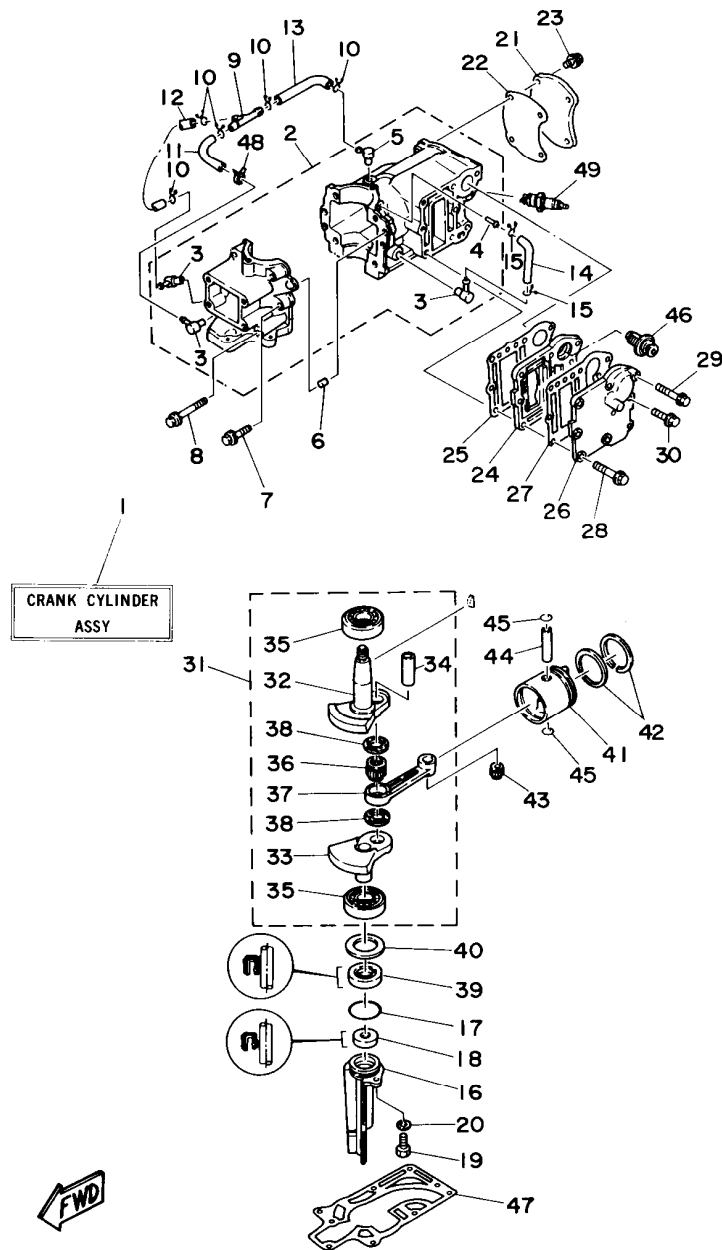

FIG. 1 CYLINDER. CRANKCASE CYLINDRO. CARTER

REF. NO.	PART NO. CODIGO NO.	DESCRIPTION DESCRIPCION	Q'TY CANT.	REMARKS OBSERVACION
1	6E0-W0090-04-4D	CRANK CYLINDER ASSY BLOQUE MOTOR COMPLETO (REF.NO. 2 ~ 48)	1	UR 4AC
	6E3-W0090-04-4D	CRANK CYLINDER ASSY BLOQUE MOTOR COMPLETO (REF.NO. 2 ~ 48)	1	UR 5C/5CS
2	6E0-15100-01-94	CRANKCASE ASSY CARTER COMPLETO	1	UR 4AC
	6E3-15100-02-94	CRANKCASE ASSY CARTER COMPLETO	1	UR 5C/5CS
3	650-11370-00	.CHECK VALVE ASSY .VALVULA DE CONTROL COMPL.	3	
4	624-14485-00	.PIPE, JOINT .TUBO DE UNION	1	
5	6E5-11372-00	.NIPPLE, HOSE .NIPLE DE MANGUERA	1	
6	93604-08062	PIN, DOWEL PASADOR DE CLAVIJA	2	
7	90105-06M16	BOLT, WASHER BASED TORNILLO CON ARANDELA	4	
8	90105-06M17	BOLT, WASHER BASED TORNILLO CON ARANDELA	2	
9	6E0-24378-00	PIPE, JOINT 4 TUBO DE UNION 4	1	
10	90467-06016	CLIP PRESILLA	5	
11	90445-07M00	HOSE TUBO	1	
12	90445-07M28	HOSE TUBO	1	
13	90445-07M32	HOSE TUBO	1	
14	90445-07M28	HOSE TUBO	1	
15	90467-06016	CLIP PRESILLA	2	
16	6E0-15396-03-5B	HOUSING, OIL SEAL CAJA DE SELLO DE ACEITE	1	
17	93210-31114	O-RING JUNTA TORICA	1	
18	93101-10M25	OIL SEAL RETEN DE ACEITE	1	
19	97095-06016	BOLT PERNO	1	
20	92990-06600	WASHER, PLATE ARANDELA PLANA	1	
21	6E0-11191-01-9M	COVER, CYLINDER HEAD 1 TAPA CULATA DE CILINDRO 1	1	UR 4AC
	6E3-11191-01-9M	COVER, CYLINDER HEAD 1 TAPA CULATA DE CILINDRO 1	1	UR 5C/5CS
22	6E0-11193-A1	GASKET, HEAD COVER 1 EMPAQUE	1	UR 4AC
	6E3-11193-A1	GASKET, HEAD COVER 1 EMPAQUE	1	UR 5C/5CS
23	90105-06M14	BOLT, FLANGE TORNILLO CON ARANDELA	4	

A6

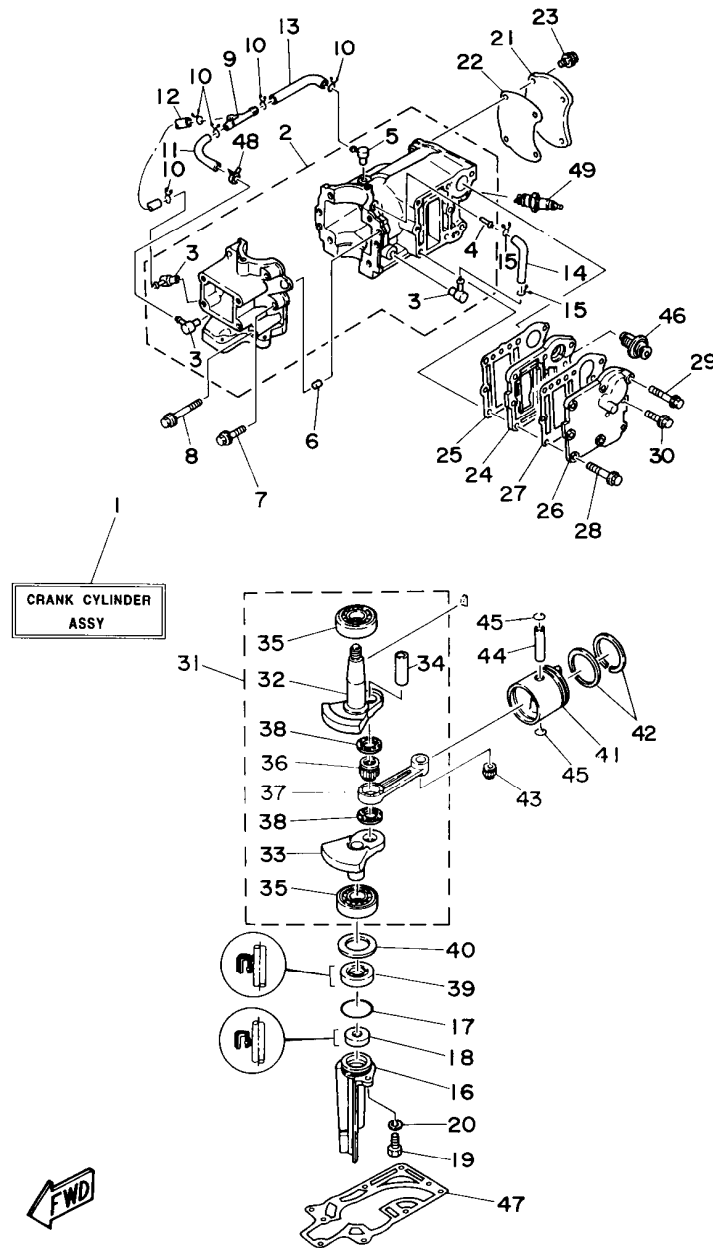

FIG. 1 CYLINDER. CRANKCASE CYLINDRO. CARTER

REF. NO.	PART NO. CODIGO NO.	DESCRIPTION DESCRIPCION	Q'TY CANT.	REMARKS OBSERVACION
24	6E0-41111-01-9M	INNER COVER, EXHAUST	1	UR 4AC
	6E3-41111-01-9M	CUBIERTA INTERIOR DE ESCAPE	1	UR 5C/5CS
25	6E0-41112-A1	INNER COVER, EXHAUST	1	UR 4AC
	6E3-41112-A1	GASKET, EXHAUST INNER COVER	1	UR 5C/5CS
26	6E0-41113-01-9M	OUTER COVER, EXHAUST	1	UR 4AC
	6E3-41113-01-9M	CUBOERTA EXTERIOR DE ESCAPE	1	UR 5C/5CS
27	6E0-41114-A1	OUTER COVER, EXHAUST	1	UR 4AC
	6E3-41114-A1	GASKET, EXHAUST OUTER COVER	1	UR 5C/5CS
28	90105-06M24	BOLT, WASHER BASED	7	
29	90105-06M16	TORNILLO CON ARANDELA	1	UR 4AC
	90105-06M24	TORNILLO CON ARANDELA	1	UR 5C/5CS
30	90105-06M14	BOLT, FLANGE	1	
31	6E0-11400-00	TORNILLO CON ARANDELA	1	UR 4AC
	6E3-11400-00	CRANKSHAFT ASSY	1	UR 5C/5CS
32	6E0-11412-00	CIGUENAL COMPLETO	1	UR 4AC
	6E3-11412-00	.CRANK 1	1	UR 5C/5CS
33	6E0-11422-00	.CRANK 1	1	UR 4AC
	6E3-11422-00	.MANIVELA 1	1	UR 5C/5CS
34	6E0-11422-00	.CRANK 2	1	UR 4AC
	6E3-11422-00	.MANIVELA 2	1	UR 5C/5CS
35	6G1-11681-00	.PIN, CRANK 1	1	
	93306-204U0	.PASADOR MANIVELA 1	2	
36	93310-418V1	.BEARING	1	
	6E0-11651-01	.COJINETE	1	
37	90209-18112	.BEARING, CYLINDRICAL	1	
	93101-20M29	.COJINETE DE RODILLOS	1	
38	676-45567-00-09	.ROD, CONNECTING	1	
	6E0-11631-00-98	.BIELA	1	
39	6E3-11631-00-98	.WASHER	2	
	6G1-11610-00	.ARANDELA DE SEPARACION	1	
40	676-45567-00-09	OIL SEAL	1	
	6E0-11631-00-98	REten DE ACEITE	1	
41	6E0-11631-00-98	SHIM (T:0.9MM)	1	
	6E3-11631-00-98	LAMINA (T:0.9MM)	1	UR 4AC
42	6E0-11631-00-98	PISTON (STD)	1	UR 5C/5CS
	6E3-11631-00-98	PISTON (STD)	1	UR 5C/5CS
	6G1-11610-00	PISTON (STD)	1	UR 4AC
	6G1-11610-00	PISTON RING SET (STD)	1	UR 4AC
	6G1-11610-00	JUEGO DE AROS (NORMA)	1	

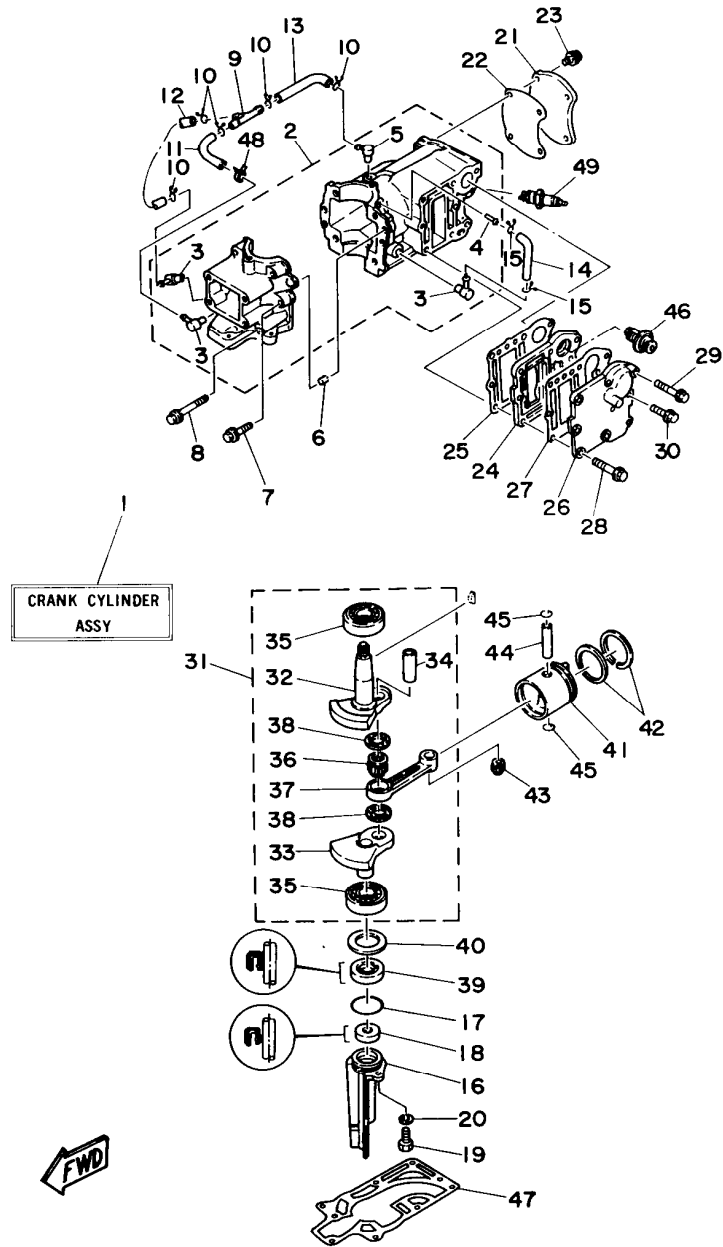

FIG. 1 CYLINDER. CRANKCASE CYLINDRO. CARTER

REF. NO.	PART NO. CODIGO NO.	DESCRIPTION DESCRIPCION	Q'TY CANT.	REMARKS OBSERVACION
42	6J1-11610-00	PISTON RING SET (STD) JUEGO DE AROS (NORMA)	1	UR 5C/5CS
43	93310-112V0	BEARING, CYLINDRICAL COJINETE DE RODILLOS	1	
44	6G1-11633-00	PIN, PISTON PASADOR, PISTON	1	
45	93450-13022	CIRCLIP SEGURO	2	
46	6E5-12411-01	THERMOSTAT TERMOSTAT	1	
47	6E0-45113-A1	GASKET, UPPER CASING EMPAQUE	1	
48	90468-07M02	CLIP PRESILLA	1	
49	94701-00040	PLUG, SPARK (NGK B7HS) BUJIA (NGK B7HS)	1	

**B1**



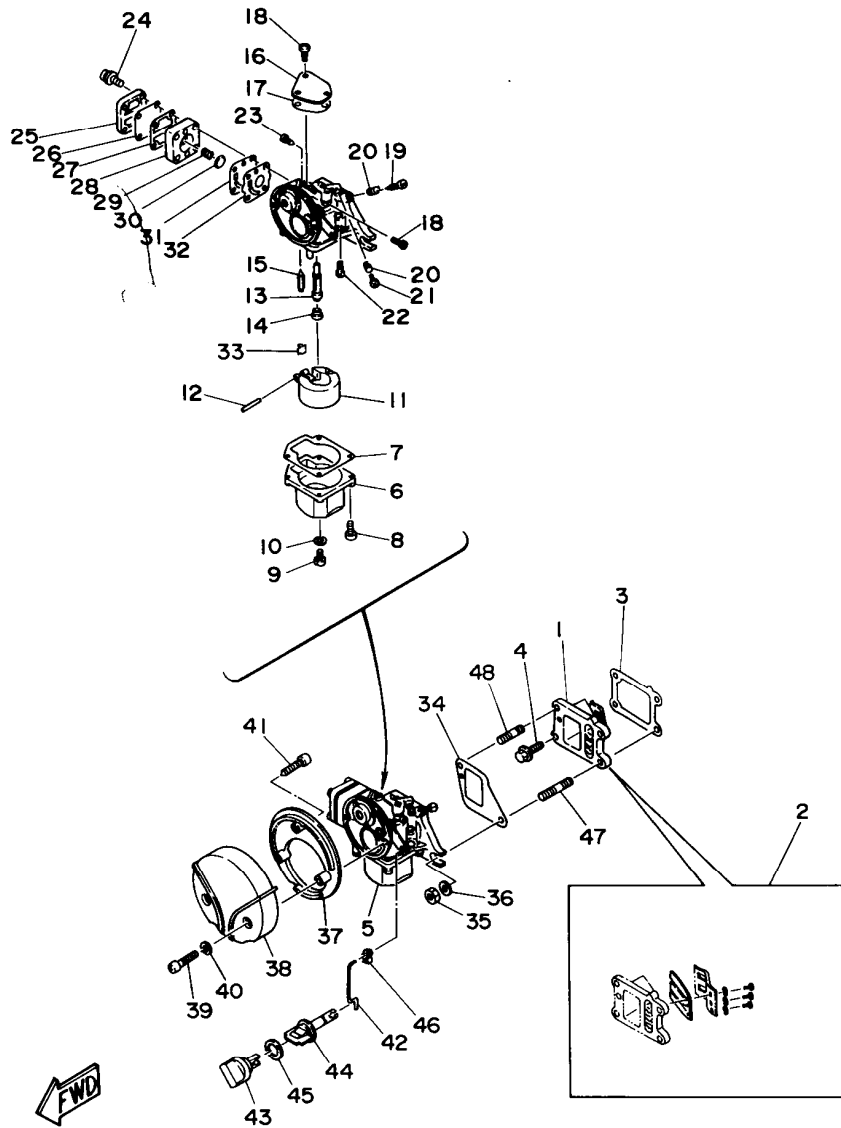

FIG. 2 INTAKE

ADMISION

REF. NO.	PART NO. CODIGO NO.	DESCRIPTION DESCRIPCION	Q' TY CANT.	REMARKS OBSERVACION
1	6J1-13610-00	REED VALVE ASSY VALVULA DE LAMINAS COMPLETA	1	
2	6J1-W0004-00	.REED SET .JUEGO DE VALVULAS DE LENGUETA	1	
3	6E0-13621-A2	GASKET, VALVE SEAT JUNTA, DE VALV. DE EMPAQUE	1	
4	95895-06016	BOLT, FLANGE TORNILLO DE REBORDE	2	
5	6E0-14301-05	CARBURETOR ASSY 1 CARBURADOR COMPLETO 1	1	UR 4AC
	6E3-14301-05	CARBURETOR ASSY 1 CARBURADOR COMPLETO 1	1	UR 5C/5CS
6	6E0-14381-02	.BODY, FLOAT CHAMBER .CUERPO DE CAMARA DE BOIA	1	
7	6E0-14384-00	.GASKET, FLOAT CHAMBER .EMPAQUE DE CAMARA DE BOIA	1	
8	97980-04116	.SCREW, WITH WASHER .TORNILLO, CON ARANDELA	4	
9	97890-05006	.SCREW, PAN HEAD .TORNILLO	1	
10	646-14198-01	.GASKET .EMPAQUE	1	
11	6E7-14385-01	.FLOAT .BOIA	1	
12	647-14386-10	.PIN, FLOAT .PASADOR DE BOIA	1	
13	6E0-14341-01	.NOZZLE, MAIN .BOQUILLA PRINCIPAL	1	UR 4AC
	6E3-14341-02	.NOZZLE, MAIN .BOQUILLA PRINCIPAL	1	UR 5C/5CS
14	648-14343-40	.JET, MAIN (# 80) .INJECTOR PRINCIPAL (# 80)	1	
15	6F5-14392-00	.VALVE, NEEDLE .VALVULA DE AGUJA	1	
16	6E0-14157-00	.COVER, PLATE .CUBIERTA DE MEZCLA	1	
17	6E0-14227-00	.GASKET .EMPAQUE	1	
18	97890-04007	.SCREW, PAN HEAD .TORNILLO	4	
19	647-14323-00	.SCREW, AIR ADJUSTING .TORNILLO DE AJUSTE DE AIRE	1	
20	646-14212-01	.SPRING, PILOT ADJUSTING .RESORTE DE AJUSTE DE PILOTO	2	
21	664-14321-01	.SCREW, THROTTLE .TORNILLO DE OBTURADOR	1	
22	648-14342-23	.JET, PILOT (# 46) .ESPREA DE PILOTO (# 46)	1	UR 4AC
	648-14342-26	.JET, PILOT (# 52) .ESPREA DE PILOTO (# 52)	1	UR 5C/5CS
23	647-14326-00	.SCREW, GUIDE .TORNILLO DE GUIA	1	
24	97980-04120	.SCREW, WITH WASHER .TORNILLO, CON ARANDELA	4	
25	6E0-24413-00	.COVER .CUERPO 2	1	

**B2**

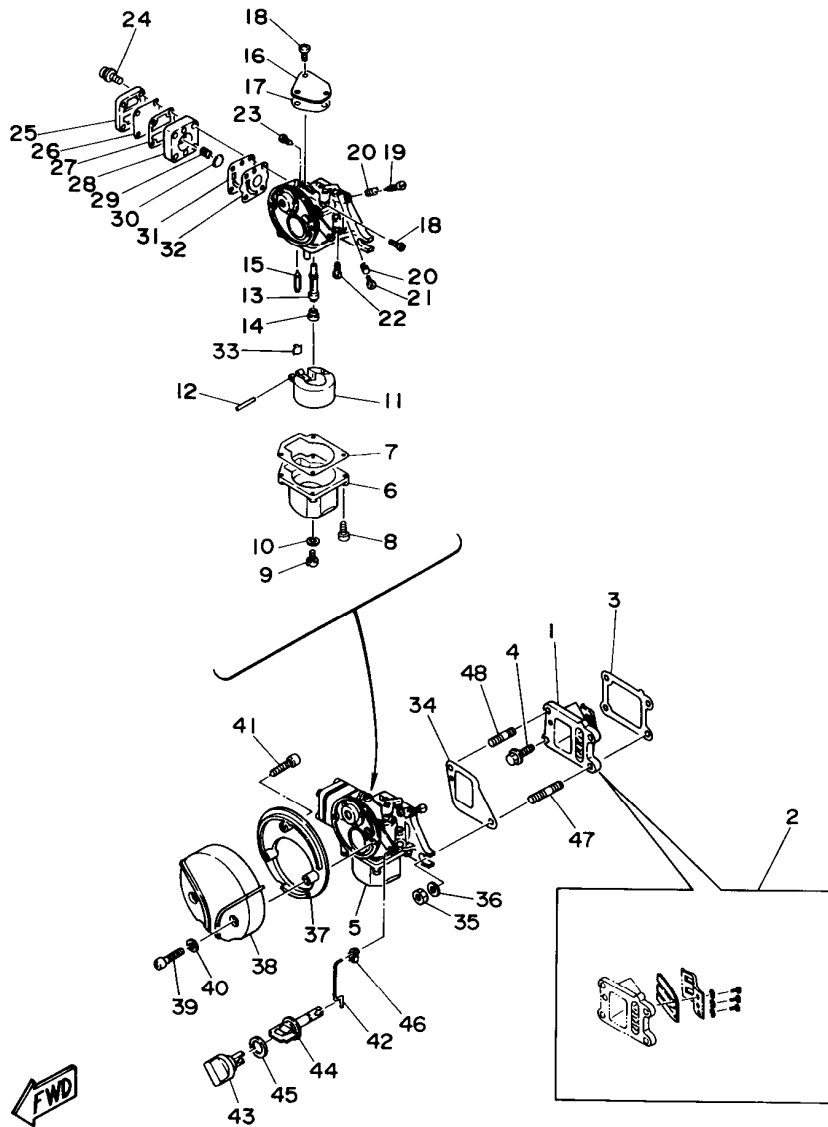

FIG. 2 INTAKE

ADMISION

REF. NO.	PART NO. CODIGO NO.	DESCRIPTION DESCRIPCION	Q'TY CANT.	REMARKS OBSERVACION
26	6E0-24471-00	.DIAPHRAGM .DIAFRAGMA	1	
27	6E0-24435-00	.GASKET, BODY 2 .EMPAQUE	1	
28	6E0-24412-00	.BODY 1 .CUERPO 1	1	
29	6E0-24423-00	.SPRING, DIAPHRAGM .RESORTE DE DIAFRAGMA	1	
30	6E0-14346-00	.PLATE .PLACA	1	
31	6E0-24411-00	.DIAPHRAGM .DIAFRAGMA	1	
32	6E0-24434-00	.GASKET, BODY .EMPAQUE	1	
33	6E0-14159-00	.CLIP .PRESILLA	1	
34	6E0-14198-A0	GASKET EMPAQUE	1	
35	95380-06700	NUT TUERCA	2	
36	92990-06600	WASHER, PLATE ARANDELA PLANA	2	
37	6E0-14417-00	COVER 1 CUBIERTA 1	1	
38	6E0-14418-00	COVER 2 CUBIERTA 2	1	
39	98580-05525	SCREW, PAN HEAD TORNILLO DE CABEZA CRUZADA	2	
40	92990-05600	WASHER, PLATE ARANDELA PLANA	2	
41	97780-40320	SCREW, TAPPING TORNILLO DE CABEZA DE CONO ACH	1	
42	6E0-41256-00	ROD, CHOKE 1 VARILLA DE AHOGADOR	1	
43	6E0-41271-00	KNOB, CHOKE PERILLA AHOGADOR	1	
44	6E0-41272-00	KNOB, CHOKE PERILLA AHOGADOR	1	
45	90202-12M16	WASHER, PLATE ARANDELA DE PLANA	1	
46	661-41262-02	JOINT, CHOKE LEVER CONECTOR DE AHOGADOR	1	
47	95627-06325	BOLT, STUD PERNO DE PUNTAL	1	
48	90116-06M08	BOLT, STUD ESPARRAGO	1	

**B3**

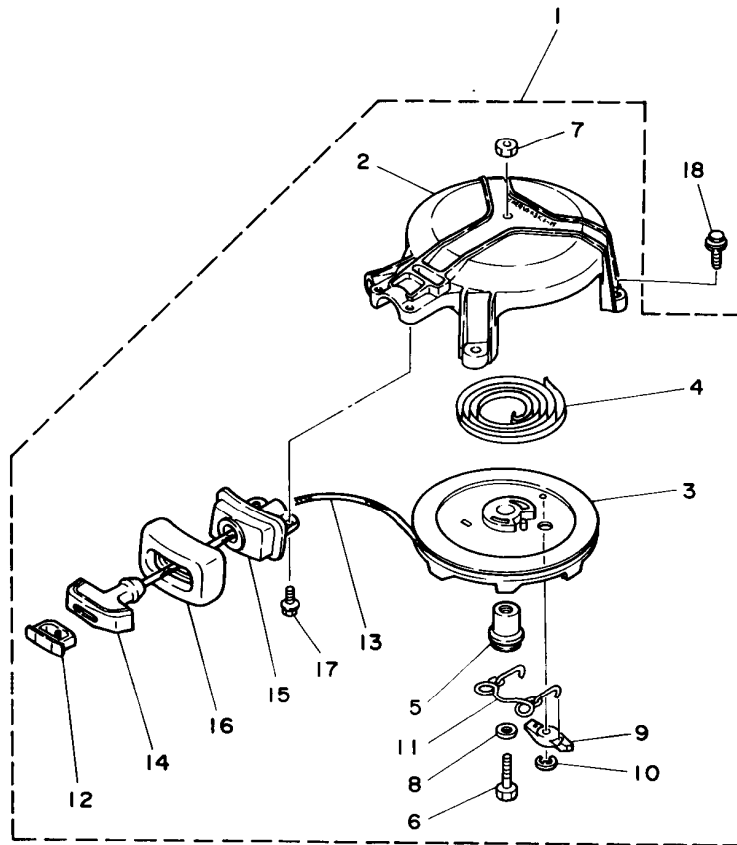

FIG. 3 STARTER

ARRANQUE

REF. NO.	PART NO. CODIGO NO.	DESCRIPTION DESCRIPCION	Q'TY CANT.	REMARKS OBSERVACION
1	6E0-15710-03-94	STARTER ASSY	1	UR 4AC
	6E3-15710-03-94	ARRANQUE COMPLETO		
	6E3-15710-03-94	STARTER ASSY	1	UR 5C/5CS
	6E3-15710-03-94	ARRANQUE COMPLETO		
2	6E4-15711-71-94	.CASE, STARTER	1	
		.CAJA DE ARRANQUE		
3	6E0-15714-01	.DRUM, SHEAVE	1	
		.TAMBOR ROLDANA		
4	90510-08M03	.SPRING, SPIRAL	1	
		.RESORTE EN ESPIRAL		
5	6E0-15717-00	.SHAFT, STARTER	1	
		.EJE DE ARRANQUE		
6	97014-06035	.BOLT	1	
		.PERNO		
7	95380-06600	.NUT	1	
		.TUERCA		
8	90201-06M30	.WASHER, PLATE	1	
		.ARANDELA PLANA		
9	677-15741-01	.PAWL, DRIVE	1	
		.TRINQUETE DE TRACCION		
10	93430-06M02	.CIRCLIP	1	
		.SEGURO		
11	6E0-15705-00	.SPRING, DRIVE PAWL	1	
		.RESORTE		
12	6G1-15779-00	.COVER	1	
		.CUBIERTA		
13	*	.WIRE (L:1850)	1	
		.CABLE (L:1850)		
14	6G1-15755-00	.HANDLE, STARTER	1	
		.MANIJA DE ARRANQUE		
15	6E0-15758-01	.GUIDE, ROPE	1	UR 4AC
		.GUIA DE CUERDA		
	6E3-15758-01	.GUIDE, ROPE	1	UR 5C/5CS
		.GUIA DE CUERDA		
16	6E0-15761-00	.SEAL, RUBBER 1	1	
		.SELLO DE GOMA 1		
17	95895-06016	.BOLT, FLANGE	2	
		.TORNILLO DE REBORDE		
18	95895-06020	BOLT, FLANGE	3	
		TORNILLO DE REBORDE		

\* CUT FROM 50M ROLLS, PARTS NO.90890-44372, CUTTING LENGTH 1.85M.

\* CORTE DE UN RODILLO 50M, PARTES NUMERO 90890-44372, LARGO DEL CORTE 1.85M.



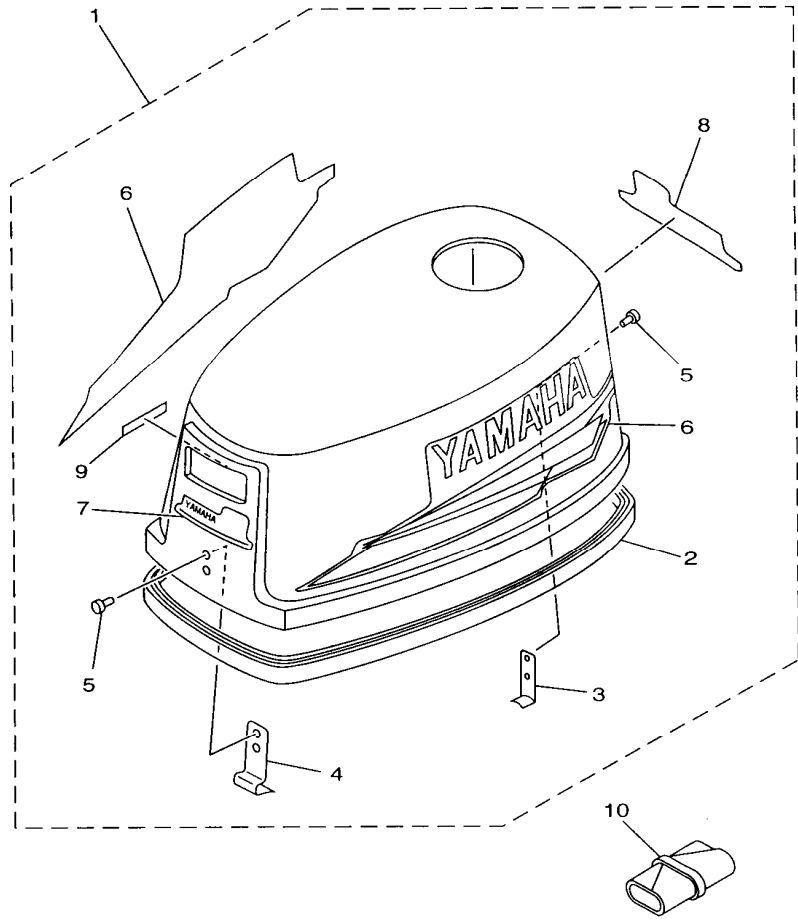

FIG. 4 TOP COWLING

CUBIERTA SUPERIOR

REF. NO.	PART NO. CODIGO NO.	DESCRIPTION DESCRIPCION	Q'TY CANT.	REMARKS OBSERVACION
1	6E0-42610-15-4D	TOP COWLING ASSY	1	UR 4AC
	6E3-42610-15-4D	SOPORTE SUPERIOR COMPL.	1	UR 5C
	6E4-42610-15-4D	TOP COWLING ASSY	1	UR 5CS
		SOPORTE SUPERIOR COMPL.		
2	6E0-42615-00	.SEAL	1	
		.SELLO		
3	6E0-42647-01	.HOLDER, CLAMP BAND	1	
		.MORDAZA DE ABRAZADERA		
4	6E0-42651-02	.HOOK	1	
		.GANCHO		
5	90266-04M00	.RIVET	4	
		.REMACHE		
6	6E0-W0070-14	.GRAPHIC SET	1	
		.JUEGO DE EMBLEMA		
7	6E0-42677-11	.GRAPHIC, FRONT	1	UR 4AC
		.CALCAMONIA FRONTAL		
	6E3-42677-11	.GRAPHIC, FRONT	1	UR 5C/5CS
		.CALCAMONIA FRONTAL		
8	6E0-42678-12	.GRAPHIC, REAR	1	UR 4AC
		.CALCAMONIA TRASERA		
	6E3-42678-12	.GRAPHIC, REAR	1	UR 5C/5CS
		.CALCAMONIA TRASERA		
9	6E0-44191-11	.INDICATOR, SHIFT	1	
		.INDICADOR DE CAMBIOS		
10	656-W2810-02	TOOL KIT	1	
		JUEGO DE HERRAMIENTAS		

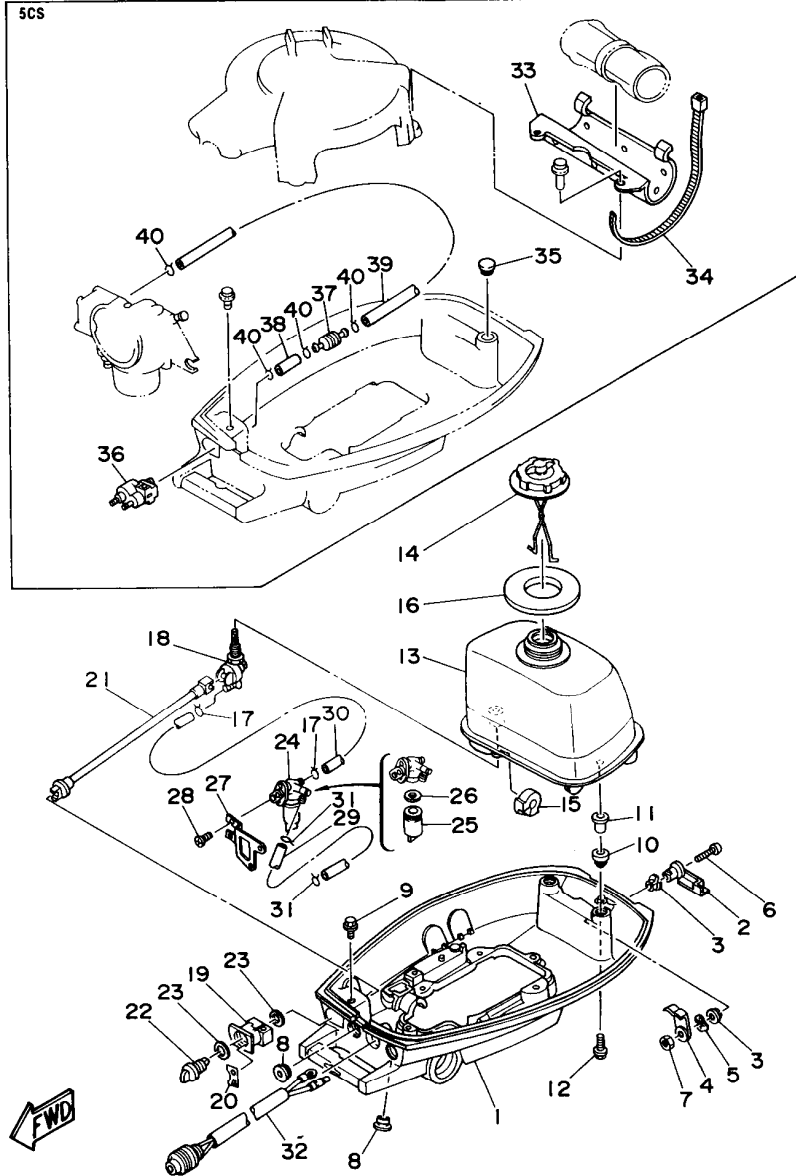

FIG. 5 BOTTOM COWLING

CUBIERTA INFERIOR

REF. NO.	PART NO. CODIGO NO.	DESCRIPTION DESCRIPCION	Q'TY CANT.	REMARKS OBSERVACION
1	6E0-42711-05-4D	COWLING, BOTTOM CUBIERTA INFERIOR	1	
2	6E0-42815-00-4D	LEVER, CLAMP PALANCA ABRAZADERA	1	
3	90386-12069	BUSH BUJE	2	
4	6E0-42816-00	LEVER, CLAMP PALANCA ABRAZADERA	1	
5	90206-12052	WASHER, WAVE ARANDELA ONDULADA	1	
6	97885-06030	SCREW, PAN HEAD TORNILLO DE CABEZA CON PLANA	1	
7	95380-06700	NUT TUERCA	1	
8	90480-14M14	GROMMET TAPON	2	
9	95895-06020	BOLT, FLANGE TORNILLO DE REBORDE	1	
10	6E0-24182-00	DAMPER, LOCATING 2 AMORTIGUADOR DE MONTAJE 2	2	UR 4AC
	6E3-24182-00	DAMPER, LOCATING 2 AMORTIGUADOR DE MONTAJE 2	2	UR 5C
11	6E0-42542-00	PIPE TUBO	2	4AC/5C
12	95895-06025	BOLT, FLANGE TORNILLO DE REBORDE	2	4AC/5C
13	6E0-24110-01-4D	FUEL TANK COMP. DEPOSITO DE COMBUSTIBLE COMP.	1	4AC/5C
14	6E0-24610-02	CAP ASSY TAPA COMPLETA	1	4AC/5C
15	6E0-24181-00	DAMPER, LOCATING 1 AMORTIGUADOR DE MONTAJE	2	4AC/5C
16	6E0-24641-00	GASKET, CAP 1 EMPAQUE DE TAPA 1	1	UR 4AC
	6E3-24641-00	GASKET, CAP 1 EMPAQUE DE TAPA 1	1	UR 5C
17	90467-08004	CLIP PRESILLA	2	4AC/5C
18	6E0-24500-00	FUEL COCK ASSY 1 GRIFO DE COMBUSTIBLE 1	1	4AC/5C
19	6E0-24571-00	BUSHING BUJE	1	4AC/5C
20	6E0-24591-00	GRAPHIC CALCAMONIA PALANCA DE CAMBIO	1	4AC/5C
21	6E0-24572-00	SHAFT, FUEL CHANGE EJE SELECTOR COMBUSTIBLE	1	4AC/5C
22	6E0-24575-01	LEVER, FUEL CHANGE PALANCA SELECTOR COMBUSTIBLE	1	4AC/5C
23	90202-12M17	WASHER, PLATE ARANDELA DE PLANA	2	4AC/5C
24	6E0-24500-60	FUEL COCK ASSY 1 GRIFO DE COMBUSTIBLE 1	1	4AC/5C
25	624-24521-01	.CUP, FILTER .COPA DE FILTRO	1	4AC/5C
26	102-24522-01	.GASKET .EMPAQUE	1	4AC/5C

**B6**

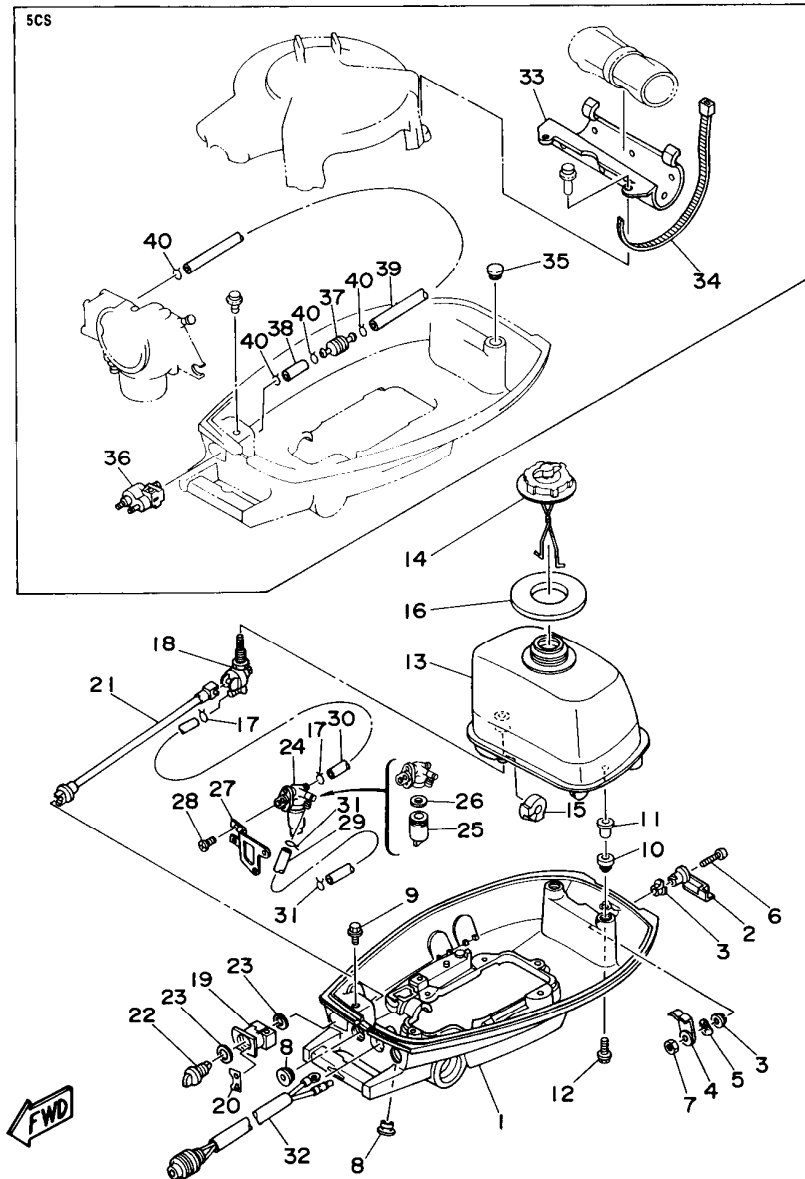

FIG. 5 BOTTOM COWLING

CUBIERTA INFERIOR

REF. NO.	PART NO. CODIGO NO.	DESCRIPTION DESCRIPCION	Q'TY CANT.	REMARKS OBSERVACION
27	6E0-24566-60	BRACKET, FILTER	1	UR 4AC
	6E3-24566-60	BRACKET, FILTER	1	UR 5C
28	98580-04010	SCREW, PAN HEAD	2	4AC/5C
		TORNILLO DE CABEZA CRUZADA		
29	90445-09072	HOSE	1	4AC/5C
		TUBO		
30	90445-09083	HOSE	1	4AC/5C
		TUBO		
31	90467-08004	CLIP	2	4AC/5C
		PRESILLA		
32	6E0-82550-01	ENGINE STOP SWITCH ASSY	1	
		INTERRUP. DE PARADA COMPLETO		
33	6E1-42643-01	PLATE, CLAMP	1	5CS
		PLACA GRAMPA		
34	6E1-42694-00	BAND	1	5CS
		ABRAZADERA		
35	6E1-24182-00	DAMPER, LOCATING 2	2	5CS
		AMORTIGUADOR DE MONTAJE 2		
36	6G1-24304-02	FUEL PIPE JOINT COMP. 1	1	5CS
		CONECTOR MANGUERA COMBUST.1		
37	646-24251-02	STRAINER 1	1	5CS
		COLADOR 1		
38	90445-09057	HOSE	1	5CS
		TUBO		
39	688-24313-00	PIPE 3	1	5CS
		TUBO 3		
40	90467-08004	CLIP	4	5CS
		PRESILLA		

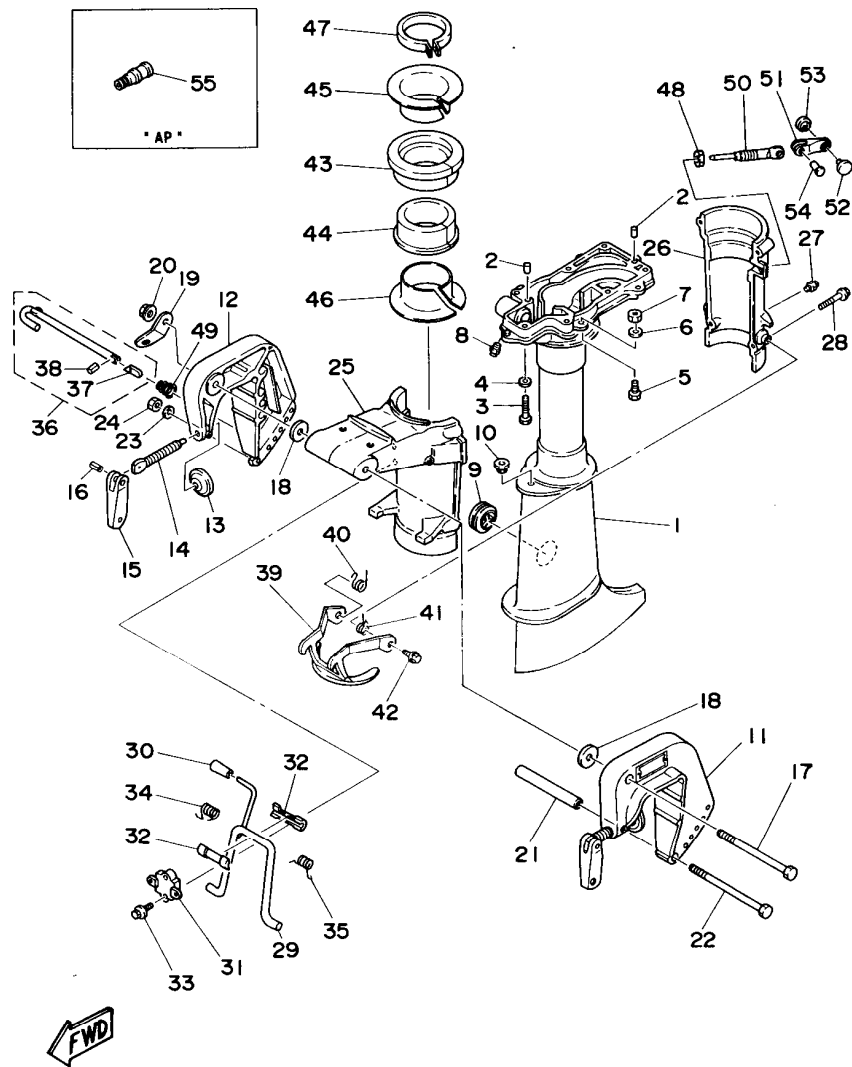

FIG. 6 UPPER CASING. BRACKET CUBIERTA SUPERIOR Y SOPORTE

REF. NO.	PART NO. CODIGO NO.	DESCRIPTION DESCRIPCION	Q'TY CANT.	REMARKS OBSERVACION
1	6E0-45111-02-4D	CASING, UPPER	1	UR SHORT
	6E0-45111-12-4D	CASING, UPPER	1	UR LONG
2	93606-12019	PIN, DOWEL	2	
3	97095-06030	BOLT	7	
4	92990-06600	WASHER, PLATE	7	
5	97095-06016	BOLT	4	
6	92990-06600	WASHER, PLATE	4	
7	95380-06700	NUT	4	
8	93700-06M03	NIPPLE, GREASE	1	
9	647-45151-01	BOOUILLA DE ENGRASAR	1	
10	90480-10M13	GROMMET	1	
11	6E0-43111-02-4D	BRACKET, CLAMP	1	
12	6E0-43112-01-4D	BRACKET, CLAMP	1	
13	648-43114-01	PAD, TRANSOM CLAMP	2	
14	6E0-43116-01	SCREW, TRANSOM CLAMP	2	
15	6E0-43118-01	HANDLE, TRANSOM CLAMP	2	
16	90243-04M01	PIN	2	
17	90101-08M07	BOLT	1	
18	90201-08M03	WASHER, PLATE	2	
19	6A1-43113-01	PLATE, CLAMP BRACKET	1	
20	95780-08300	NUT, FLANGE	1	
21	90387-06M11	COLLAR	1	
22	90101-06335	CASQUILLO CON VALONA	1	
23	92990-06600	WASHER, PLATE	1	
24	95380-06600	NUT	1	
25	6E0-43311-04-4D	BRACKET, SWIVEL	1	
26	6E0-43312-02-4D	BRACKET, SWIVEL	1	
27	93700-06M03	NIPPLE, GREASE	1	

C1

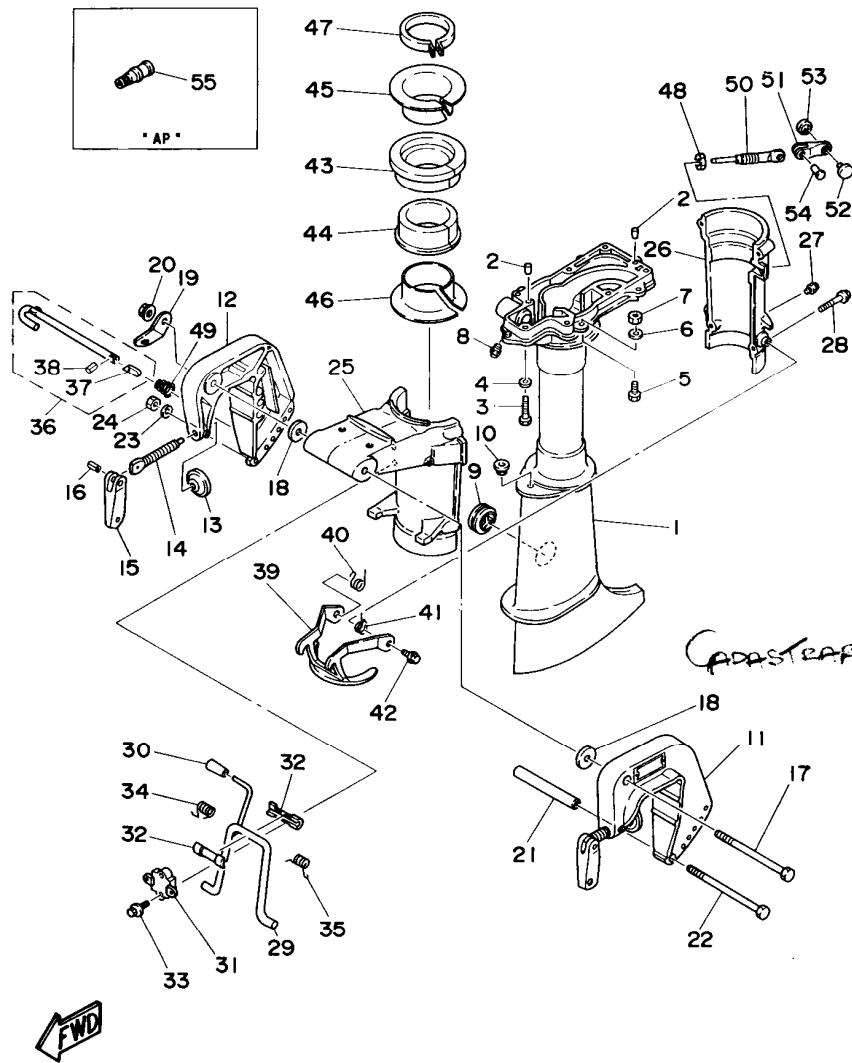

FIG. 6 UPPER CASING. BRACKET CUBIERTA SUPERIOR Y SOPORTE

REF. NO.	PART NO. CODIGO NO.	DESCRIPTION DESCRIPCION	Q'TY CANT.	REMARKS OBSERVACION
28	95895-06035	BOLT, FLANGE TORNILLO DE REBORDE	4	
29	6E0-43181-00	LEVER, TILT STOP PALANCA TOPE INCLINACION	1	
30	6E0-43632-00	KNOB, TILT PERILLA INCLINADOR	1	
31	6E0-43313-00-94	BRACKET, SWIVEL SOPORTE GIRATORIO	1	
32	620-43189-00	BUSHING BUJE	2	
33	95895-06020	BOLT, FLANGE TORNILLO DE REBORDE	2	
34	90508-16020	SPRING, TORSION RESORTE DE TORSION	1	
35	90508-16021	SPRING, TORSION RESORTE DE TORSION	1	
36	6E0-43160-01	TILT ROD ASSY VARILLA DE BASCULACION COMPL.	1	
37	689-43165-00	.PLATE, TILT LOCK .PLACA DE TOPE, VARILLA SEGUR	1	
38	91690-30008	.PIN, SPRING .PASADOR DE RESORTE	1	
39	6E0-43614-00-5B	PLATE, TILT LOCK PLACA DE SEGURO DE INCLINACION	1	
40	90508-14M10	SPRING, TORSION RESORTE DE TORSION	1	
41	90508-14M11	SPRING, TORSION RESORTE DE TORSION	1	
42	95895-06010	BOLI, FLANGE TORNILLO DE REBORDE	2	
43	6E0-42537-02	BUSHING, PIVOT SHAFT BUJE DEL PIVOTE DE LA FLECHA	1	
44	6E0-42538-02	BUSHING, PIVOT SHAFT BUJE DEL PIVOTE DE LA FLECHA	1	
45	6E0-42539-00	BUSHING, PIVOT SHAFT BUJE DEL PIVOTE DE LA FLECHA	1	
46	6E0-42549-00	BUSHING, PIVOT SHAFT BUJE DEL PIVOIE DE LA FLECHA	1	
47	6E0-42528-03	PLATE, FRICTION PIEZA DE FRICCION	1	
48	95380-08600	NUT TUERCA	1	
49	90502-08M05	SPRING, CONICAL RESORTE CONICO	1	
50	6L5-42529-01	SCREW, FRICTION PIECE TORNILLO PIEZA FRICCION	1	
51	6L5-42561-00	KNOB, STEERING LOCK PERILLA	1	
52	6L5-44196-00	INDICATOR 3 INDICADOR 3	1	
53	6L5-44197-00	INDICATOR 4 INDICADOR 4	1	
54	90266-04M05	RIVET REMACHE	1	
55	626-28193-01-94	PLUG, WATER CHECK TAPON DE CONTROL DE LA AGUA	1 AP	

C2



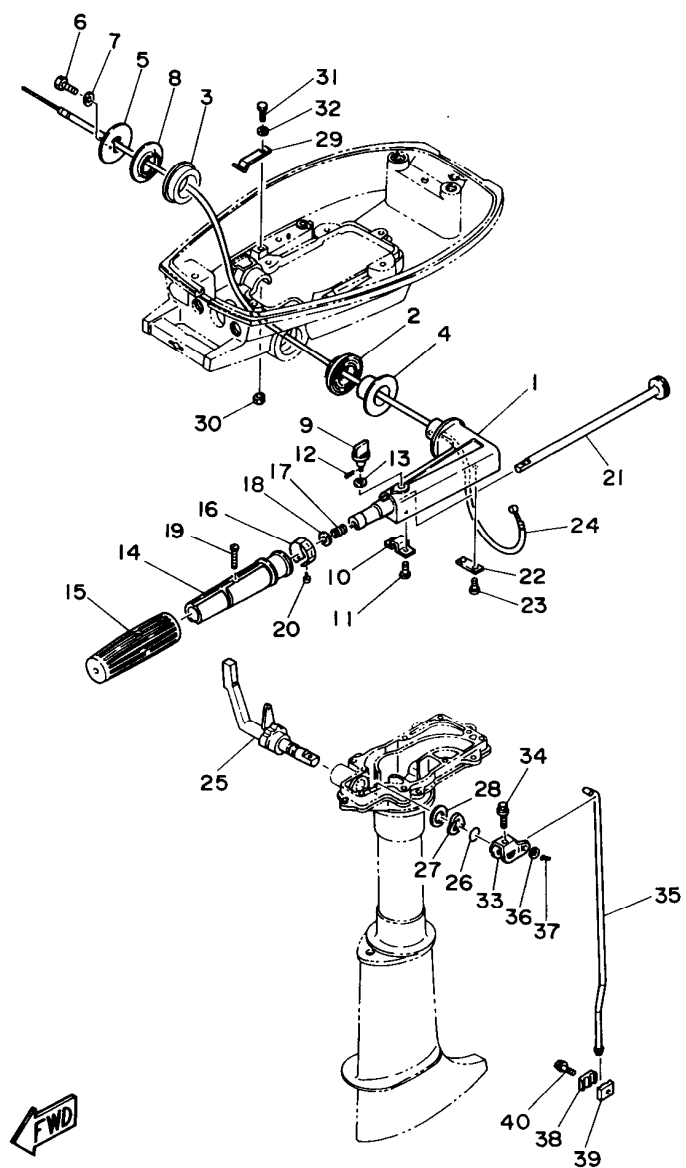

FIG. 7 CONTROL

CONTROL

REF. NO.	PART NO. CODIGO NO.	DESCRIPTION DESCRIPCION	Q'TY CANT.	REMARKS OBSERVACION
1	6E0-42111-02-4D	HANDLE, STEERING MANIJA DE DIRECCION	1	
2	6E0-42129-02	BUSHING, RUBBER BUJE 1	1	
3	6E4-42129-00	BUSHING, RUBBER BUJE 1	1	
4	90386-26M30	BUSH BUJE	1	
5	6E0-42131-02-94	COVER, HANDLE STEERING CUBIERTA MANIJA DIRRECCION	1	
6	97313-05020	BOLT TORNILLO DE HEXAGONAL	2	
7	92990-05600	WASHER, PLATE ARANDELA PLANA	2	
8	90386-26M33	BUSH BUJE	1	
9	6E0-42125-00	BOLT, FRICTION ADJUSTING TORNILLO FRICCION AJUSTA	1	
10	6E0-42134-02	COVER, THROTTLE LEVER CUBIERTA PALANCA ACELERADOR	1	
11	97885-05012	SCREW, PAN HEAD TORNILLO DE CABEZA CON PLANA	2	
12	91490-12012	PIN, COTTER CHAVETA	1	
13	90202-07M22	WASHER, PLATE ARANDELA DE PLANA	1	
14	6E0-42119-00	GRIP, STEERING HANDLE MANGO, MANIJA DE DIRRECCION	1	
15	6E0-42177-00	RUBBER, HANDLE HULE DE MANIJA	1	
16	6E0-42137-10	INDICATOR, THROTTLE INDICADOR ACELERADOR	1	
17	90501-23215	SPRING, COMPRESSION RESORTE DE COMPRESION	1	
18	90201-10119	WASHER, PLATE ARANDELA PLANA	1	
19	90149-05M13	SCREW TORNILLO DE REGLAJE	1	
20	90269-02M09	RIVET REMACHE	1	
21	6E0-42138-01	LEVER, THROTTLE PLANCA DE ACELERACION	1	
22	6E0-42159-02	STAY SOPORTE	1	
23	97885-05012	SCREW, PAN HEAD TORNILLO DE CABEZA CON PLANA	2	
24	6E0-26301-01	THROTTLE CABLE ASSY CABLE DE ACELERADOR COMPLETO	1	
25	6E0-44111-02	HANDLE, GEAR SHIFT MANIJA DE CAMBIO DE MARCHAS	1	
26	93210-12790	O-RING JUNTA TORICA	1	
27	90206-16M06	WASHER, WAVE ARANDELA ONDULADA	1	
28	90202-16061	WASHER, PLATE ARANDELA DE PLANA	1	

C3

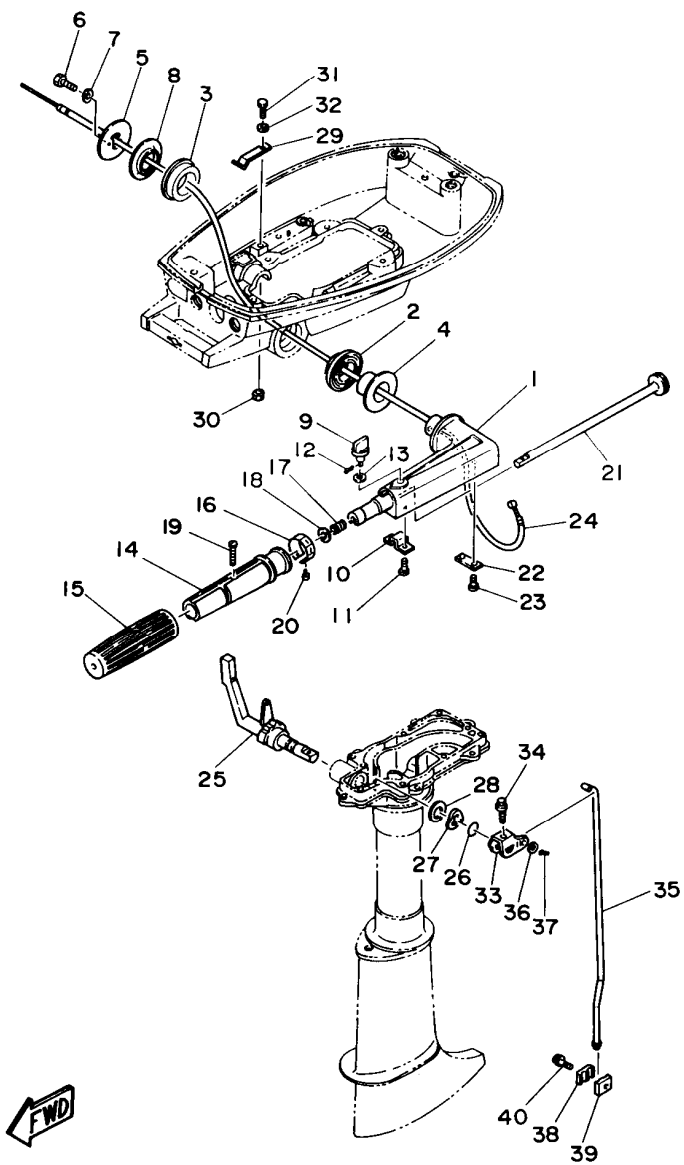

FIG. 7 CONTROL

CONTROL

REF. NO.	PART NO. CODIGO NO.	DESCRIPTION DESCRIPCION	Q'TY CANT.	REMARKS OBSERVACION
29	6E0-44116-00	SPRING RESORTE	1	
30	95380-06700	NUT TUERCA	1	
31	97095-06012	BOLT PERNO	1	
32	92990-06600	WASHER, PLATE ARANDELA PLANA	1	
33	6E0-44121-00	LEVER, SHIFT ROD PALANCA VARILLA CAMBIOS	1	
34	95895-06025	BOLT, FLANGE TORNILLO DE REBORDE	1	
35	6E0-44143-00	ROD, SHIFT VARILLA DE CAMBIO	1	UR SHORT
	6E0-44143-10	ROD, SHIFT VARILLA DE CAMBIO	1	UR LONG
36	92990-05600	WASHER, PLATE ARANDELA PLANA	1	
37	91490-16010	PIN, COTTER CHAVETA	1	
38	6E0-44145-00	CONNECTOR, SHIFT ROD CONECTOR, VARILLA CAMBIO	1	
39	6E0-44146-00	CONNECTOR, SHIFT ROD (M6x1.0) CONECTOR VARILLA DE CAMBIO (M6x1.0)	1	
40	95895-06020	BOLT, FLANGE TORNILLO DE REBORDE	1	

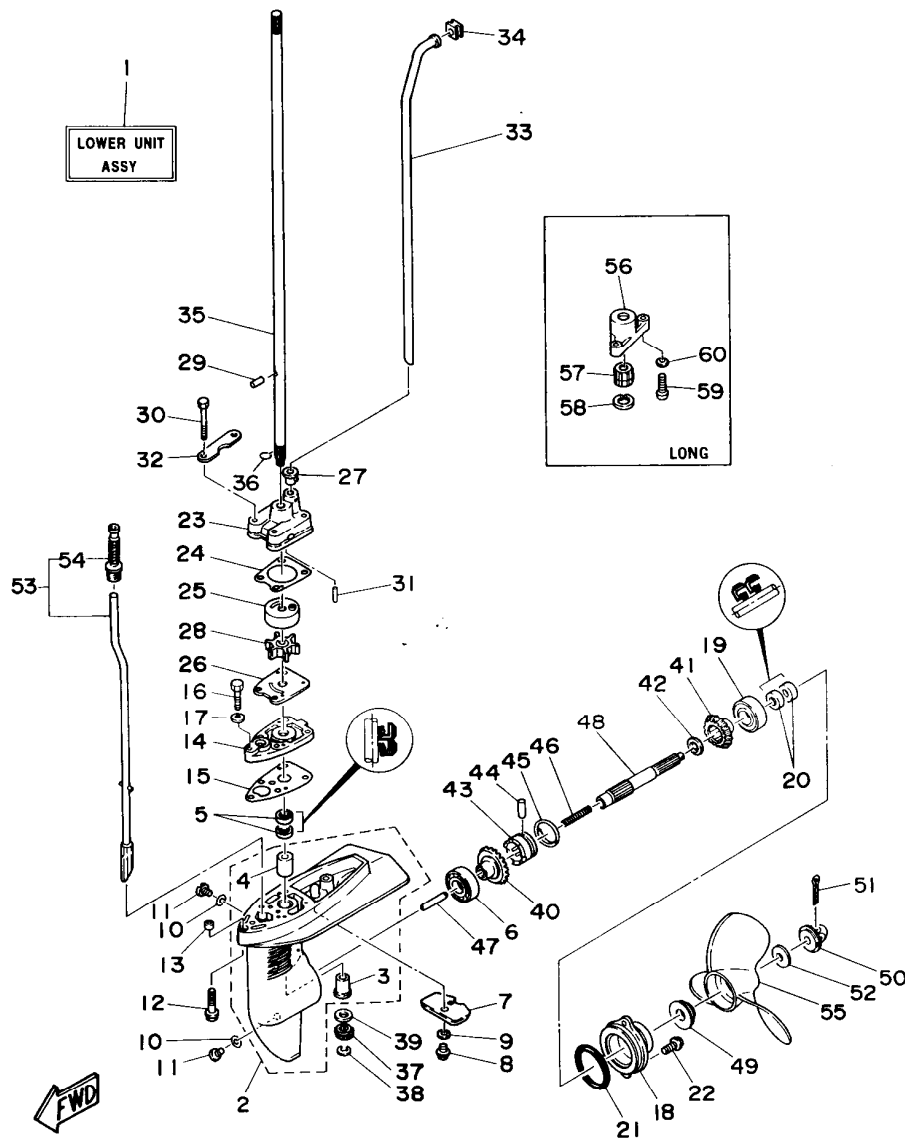

FIG. 8 LOWER CASING. DRIVE 1 IMPULSOR E INFERIOR 1

REF. NO.	PART NO. CODIGO NO.	DESCRIPTION DESCRIPCION	Q'TY CANT.	REMARKS OBSERVACION
1	6E0-45300-03-4D	LOWER UNIT ASSY CONJUNTO UNIDAD INFERIOR (REF.NO. 2 ~ 11, 14 ~ 32, 35 ~ 48, 53 ~ 54)	1	UR SHORT
	6E0-45300-13-4D	LOWER UNIT ASSY CONJUNTO UNIDAD INFERIOR (REF.NO. 2 ~ 11, 14 ~ 32, 35 ~ 48, 53 ~ 54)	1	UR LONG
2	6E0-45311-02-4D	CASING, LOWER FUNDA INFERIOR	1	
3	6E0-45317-09	.BUSHING, DRIVE SHAFT .BUJE	1	
4	6E0-45316-09	.BUSHING, DRIVE SHAFT .BUJE, EJE DE MANDO	1	
5	93101-10M14	OIL SEAL RETEN DE ACEITE	2	
6	93306-00426	BEARING COJINETE	1	
7	6L5-45251-02	ANODE CATODE	1	
8	95895-06012	BOLT, FLANGE TORNILLO DE REBORDE	1	
9	92990-06300	WASHER, INTERNAL TOOTH ARANDELA PLANA	1	
10	90430-08020	GASKET JUNTA	3	
11	90340-08M04	PLUG, STRAIGHT SCREW TORNILLO, DE DRENAJE	3	
12	90119-06M40	BOLT, WITH WASHER TORNILLO CON ARANDELA	2	
13	90387-06M14	COLLAR CASQUILLO CON VALONA	2	
14	6E0-45321-01-5B	PLATE PLACA	1	
15	6E0-45315-A0	PACKING, LOWER CASING EMPAQUE	1	
16	97095-06025	BOLT PERNO	1	
17	92990-06600	WASHER, PLATE ARANDELA PLANA	1	
18	6E0-45361-01-4D	CAP, LOWER CASING FUNDA INFERIOR	1	
19	93306-00426	BEARING COJINETE	1	
20	93101-13M12	OIL SEAL RETEN DE ACEITE	2	
21	93210-48214	O-RING JUNTA TORICA	1	
22	95895-06016	BOLT, FLANGE TORNILLO DE REBORDE	2	
23	6E0-44311-00	HOUSING, WATER PUMP CAJA BOMBA DE AGUA	1	
24	6E0-44315-A0	GASKET, WATER PUMP EMPAQUE	1	
25	6E0-44322-02	INSERT, CARTRIDGE CARTUCHO	1	

C5

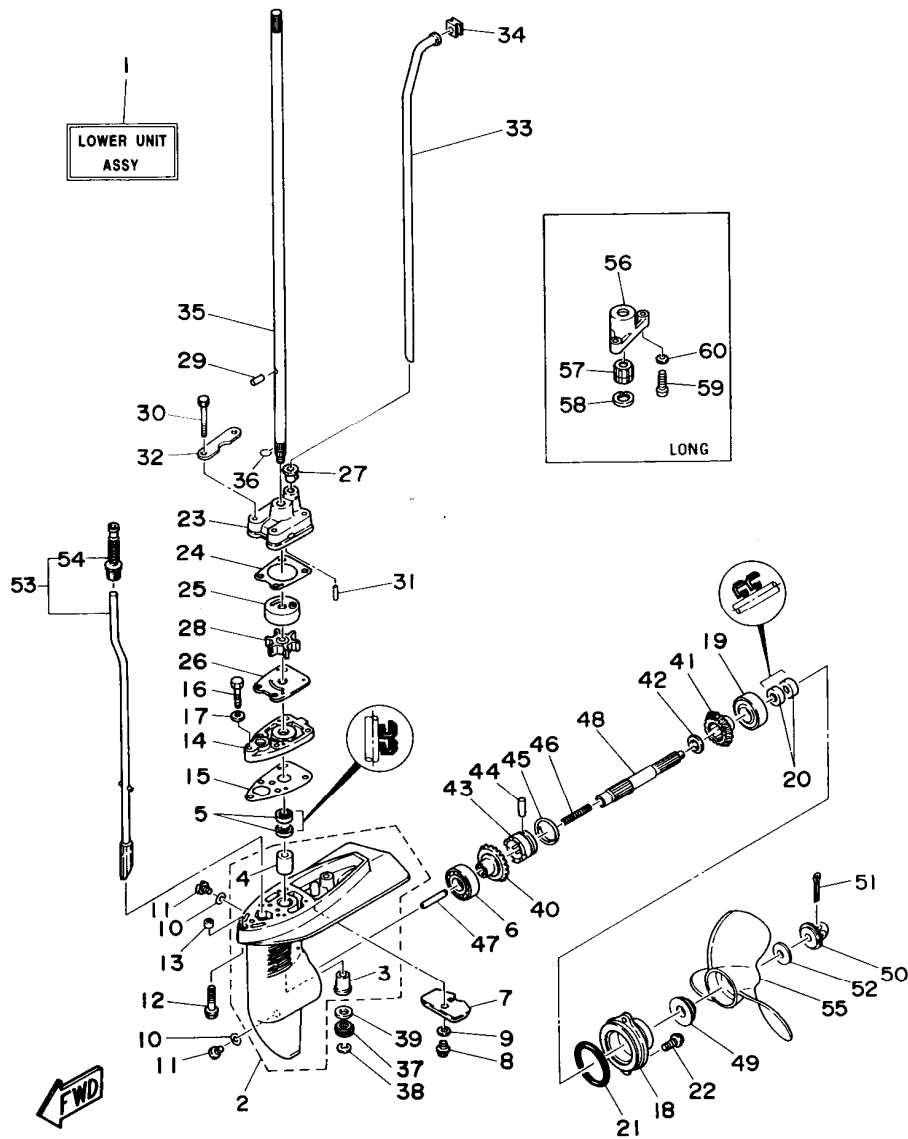

FIG. 8 LOWER CASING. DRIVE 1 IMPULSOR E INFERIOR 1

REF. NO.	PART NO. CODIGO NO.	DESCRIPTION DESCRIPCION	Q'TY CANT.	REMARKS OBSERVACION
26	6E0-44323-00	OUTER PLATE, CARTRIDGE PLACA EXTERIOR DEL CARTUCHO	1	
27	6E0-44366-00	DAMPER, WATER SEAL GOMA DEL SELLO DE AGUA	1	
28	6E0-44352-00	IMPELLER IMPULSOR	1	
29	93604-09066	PIN, DOWEL PASADOR DE CLAVIJA	1	
30	97095-06045	BOLT PERNO	4	
31	93604-18080	PIN, DOWEL PASADOR DE CLAVIJA	2	
32	6E0-44328-00	PLATE PLACA	2	
33	6E0-44361-00	TUBE, WATER TUBO DE AGUA	1	UR SHORT
	6E0-44361-10	TUBE, WATER TUBO DE AGUA	1	UR LONG
34	646-44365-00	DAMPER, WATER SEAL HULE DE SELLO DE AGUA	1	
35	6E0-45511-00	SHAFT, DRIVE EJE DE MANDO	1	UR SHORT
	6E0-45511-10	SHAFT, DRIVE EJE DE MANDO	1	UR LONG
36	90467-08M01	CLIP PRESILLA	1	
37	6E0-45551-00	PINION PINON	1	
38	99009-06600	CIRCLIP PRESILLA REDONDA	1	
39	90201-11M49	WASHER, PLATE ARANDELA PLANA	1	
40	6E0-45560-00	GEAR ENGRANE COMPLE 1	1	
41	6E0-45570-00	GEAR ENGRANE COMPLE 2	1	
42	90201-13M50	WASHER, PLATE ARANDELA PLANA	1	
43	6E0-45631-00	CLUTCH, DOG EMBRAGUE DE GARRA	1	
44	90250-05046	PIN, STRAIGHT PASADOR CILINDRICO	1	
45	654-45633-00	RING, CROSS PIN ANILLO DE PASADOR	1	
46	90501-10064	SPRING, COMPRESSION RESORTE DE COMPRESION	1	
47	654-45635-00	PLUNGER, SHIFT EMBOLO DE CAMBIO	1	
48	6E0-45611-01	SHAFT, PROPELLER EJE PROPUSOR	1	
49	6L5-45987-01	SPACER ESPACIADOR	1	
50	6L5-45616-00	NUT, PROPELLER TUERCA DE HELICE	1	
51	91490-25030	PIN, COTTER CHAVETA	1	

C6

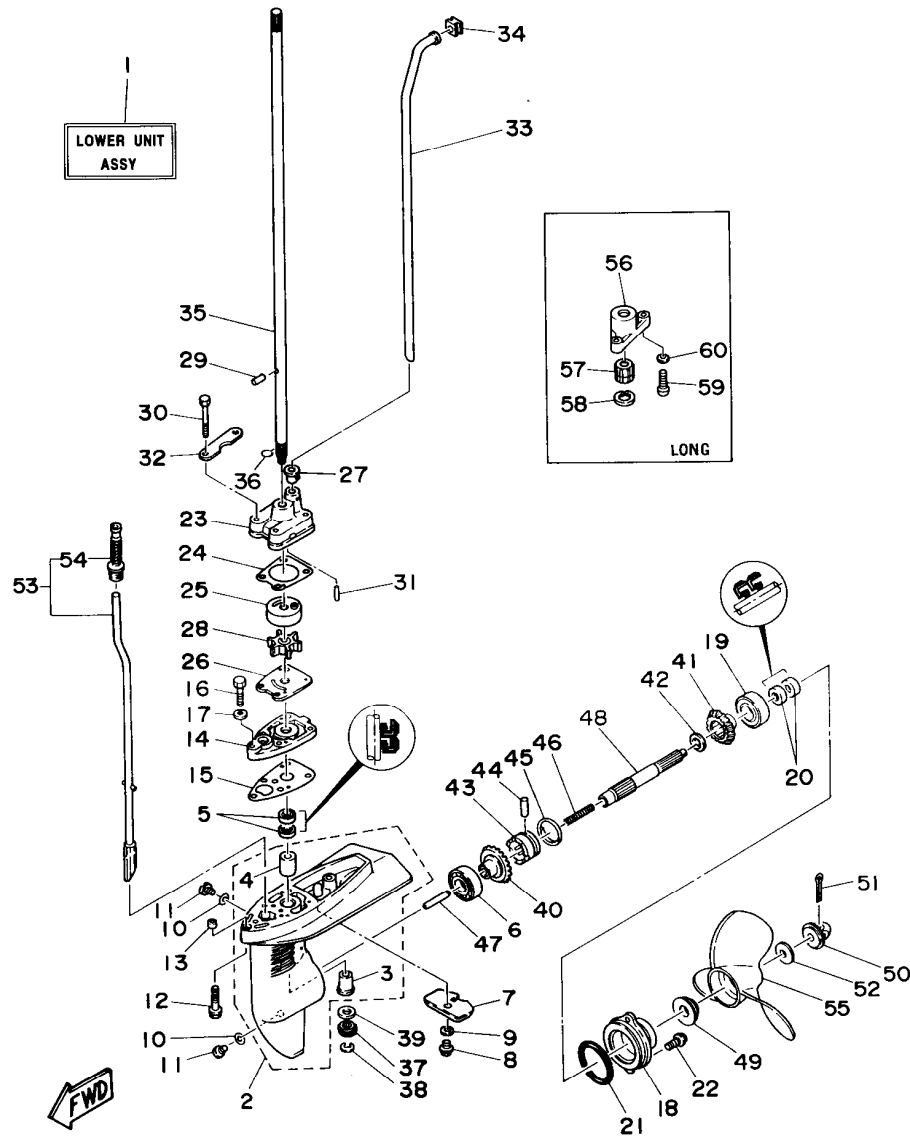

FIG. 8 LOWER CASING. DRIVE 1 IMPULSOR E INFERIOR 1

REF. NO.	PART NO. CODIGO NO.	DESCRIPTION DESCRIPCION	Q'TY CANT.	REMARKS OBSERVACION
52	90201-08M54	WASHER, PLATE ARANDELA PLANA	1	
53	6E0-44150-00	SHIFT CAM ASSY CONJUNTO EJE LEVA COMPL.	1	UR SHORT
	6E0-44150-10	SHIFT CAM ASSY CONJUNTO EJE LEVA COMPL.	1	UR LONG
54	6G1-44147-00	.BOOT, SHIFT ROD .HULE DE VARILLA	1	
55	6E0-45943-01-EL	PROPELLER (3X7-1/2"X7"-BA) PROPELA (3X7-1/2"X7"-BA)	1	UR
	6E0-45941-01-EL	PROPELLER (3X7-1/2"X8"-BA) PROPELA (3X7-1/2"X8"-BA)	1	UR
	6E0-45949-00-EL	PROPELLER (3X7-1/4"X6-1/2"-BA) PROPELA (3X7-1/4"X6-1/2"-BA)	1	UR
56	6E0-45331-00-5B	HOUSING, BEARING CAJA DE COJINETE	1	LONG
57	6E0-45318-01	BUSHING, DRIVE SHAFT BUJE, EJE DE MANDO	1	LONG
58	93420-22M03	CIRCLIP SEGURO	1	LONG
59	98580-05525	SCREW, PAN HEAD TORNILLO DE CABEZA CRUZADA	2	LONG
60	92990-05600	WASHER, PLATE ARANDELA PLANA	2	LONG

C7

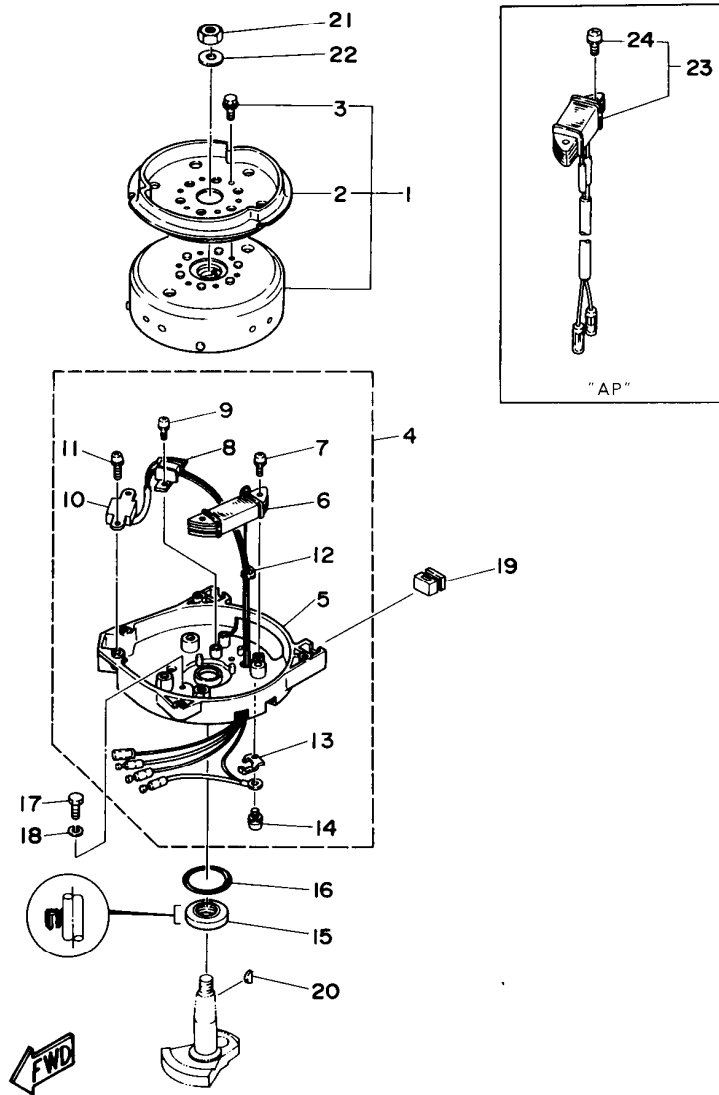

FIG. 9 GENERATOR

GENERADOR

REF. NO.	PART NO. CODIGO NO.	DESCRIPTION DESCRIPCION	Q'TY CANT.	REMARKS OBSERVACION
1	6E0-85550-71	ROTOR ASSY ROTOR COMPLETO	1	
2	6E0-15723-00-94	.PULLEY, STARTER .POLEA DE ARRANQUE	1	
3	90105-06M14	.BOLT, FLANGE .TORNILLO CON ARANDELA	3	
4	6E0-85560-70	BASE ASSY CONJUNTO BASE	1	
5	6E0-15359-00-94	.HOUSING, OIL SEAL .CAJA DE SELLO DE ACEITE	1	
6	6E0-85520-70	.COIL, CHARGE .BOBINA DE CARGA	1	
7	90159-05038	.SCREW, WITH WASHER .TORNILLO CON VALONA	2	
8	6E0-85595-70	.COIL, PULSER .BOBINA DE PULSACION CONJUNTA	1	
9	90159-04036	.SCREW, WITH WASHER .TORNILLO CON VALONA	2	
10	6E0-85592-70	.PULSER COIL ASSY .BOBINA DE PULSACION CONJUNTA	1	
11	90159-05037	.SCREW, WITH WASHER .TORNILLO CON VALONA	2	
12	6E0-81336-70	.GROMMET .TAPON PROTECTOR	1	
13	6E0-81328-70	.CLAMP .GRAMPA	1	
14	90159-04035	.SCREW, WITH WASHER .TORNILLO CON VALONA	1	
15	93102-20M25	OIL SEAL RETEN DE ACEITE	1	
16	93210-42159	O-RING JUNTA TORICA	1	
17	97095-06016	BOLT PERNO	2	
18	92995-06100	WASHER, SPRING ARANDELA	2	
19	6E0-24183-00	DAMPER, LOCATING 3 AMORTIGUADOR DE MONTAJE 3	2	
20	90280-04M06	KEY, WOODRUFF CUNA WOODRUFF	1	
21	90170-10113	NUT TUERCA	1	
22	90201-102G9	WASHER, PLATE ARANDELA PLANA	1	
23	6E0-81303-80	LIGHTING COIL ASSY BOBINA DE ILUMINACION COMPL.	1	AP 60W
	6E0-81303-40	LIGHTING COIL ASSY BOBINA DE ILUMINACION COMPL.	1	AP 40W
24	90159-05040	.SCREW, WITH WASHER .TORNILLO CON VALONA	2	

D1

FIG. 10 ELECTRICAL 1

EQUIPO ELECTRICO 1

REF. NO.	PART NO. CODIGO NO.	DESCRIPTION DESCRIPCION	Q'TY CANT.	REMARKS OBSERVACION
1	95895-06016	BOLT, FLANGE TORNILLO DE REBORDE	2	
2	663-82370-01	PLUG CAP ASSY TAPON DE BUJIA COMPLT	1	
3	6E0-82316-01-94	BRACKET, IGNITION COIL SOPORTE BOBINA ENCENDIDO	1	
4	6E0-82317-00	DAMPER, IGNITION COIL AMORTIGUADOR BOBINA ENCENDIDO	2	
5	6E0-85570-00	IGNITION COIL ASSY BOBINA DE IGNICION COMPLETO	1	
6	97095-06030	BOLT PERNO	2	
7	92990-06600	WASHER, PLATE ARANDELA, PLANA	2	
8	90480-25161	GROMMET TAPON	1	
9	97095-06010	BOLT PERNO	1	
10	6E0-85548-00	HOLDER SOSTEN	1	
11	6E0-85540-71	C.D.I. UNIT ASSY UNIDAD C.D.I. COMPLETA	1	
12	95895-06020	BOLT, FLANGE TORNILLO DE REBORDE	2	

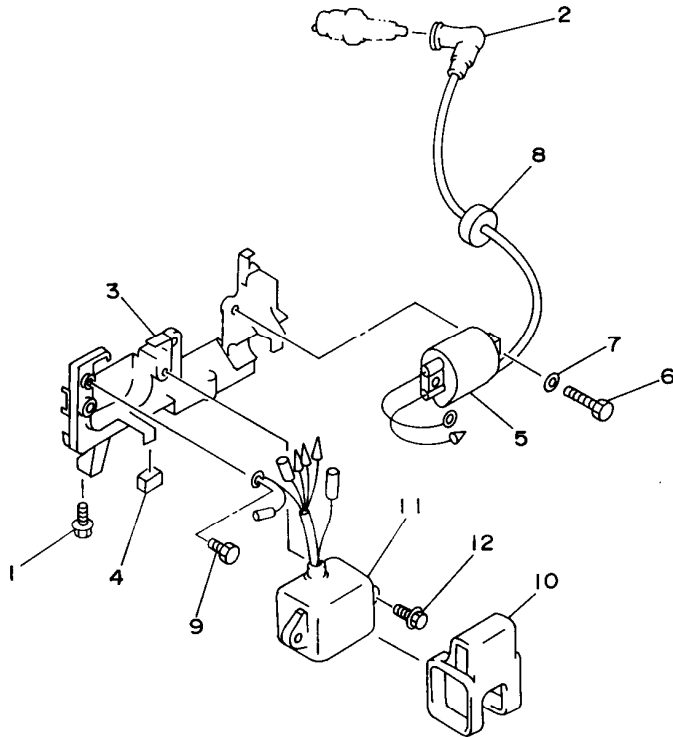

FWD

D2

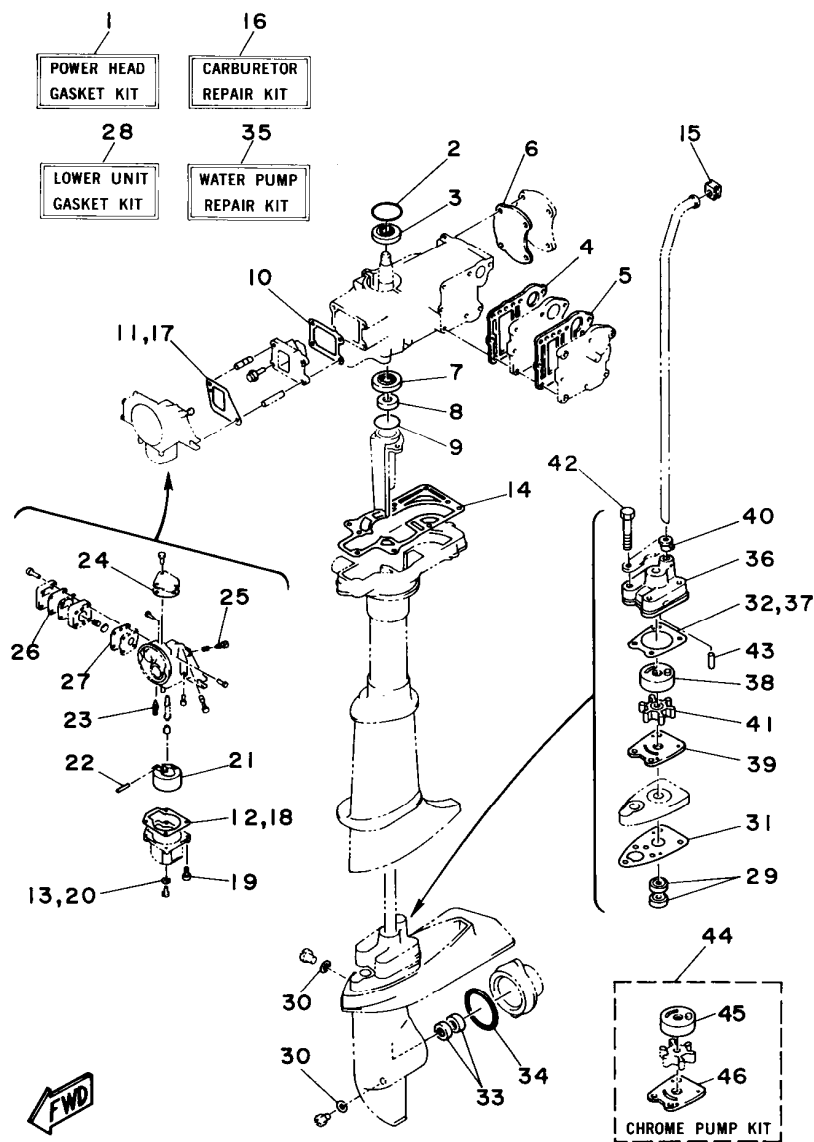

FIG. 11 REPAIR KIT

ESTUCHE REPARATION

REF. NO.	PART NO. CODIGO NO.	DESCRIPTION DESCRIPCION	Q'TY CANT.	REMARKS OBSERVACION
1	6E0-W0001-A4	POWER HEAD GASKET KIT	1	UR 4AC
	6E3-W0001-A4	POWER HEAD GASKET KIT	1	UR 5C/5CS
2	93210-42159	.O-RING	1	
3	93102-20M25	.JUNTA TORICA	1	
4	6E0-41112-A1	.GASKET, EXHAUST INNER COVER	1	UR 4AC
	6E3-41112-A1	.GASKET, EXHAUST INNER COVER	1	UR 5C/5CS
5	6E0-41114-A1	.GASKET, EXHAUST OUTER COVER	1	UR 4AC
	6E3-41114-A1	.GASKET, EXHAUST OUTER COVER	1	UR 5C/5CS
6	6E0-11193-A1	.GASKET, HEAD COVER 1	1	UR 4AC
	6E3-11193-A1	.GASKET, HEAD COVER 1	1	UR 5C/5CS
7	93101-20M29	.OIL SEAL	1	
8	93101-10M25	.OIL SEAL	1	
9	93210-31114	.O-RING	1	
10	6E0-13621-A2	.GASKET, VALVE SEAT	1	
11	6E0-14198-A0	.JUNTA, DE VALV.DE EMPAQUE	1	
12	6E0-14384-00	.GASKET, FLOAT CHAMBER	1	
13	646-14198-01	.GASKET	1	
14	6E0-45113-A1	.GASKET, UPPER CASING	1	
15	646-44365-00	.DAMPER, WATER SEAL	1	
16	6E0-W0093-04	CARBURETOR REPAIR KIT	1	
17	6E0-14198-A0	.GASKET	1	
18	6E0-14384-00	.GASKET, FLOAT CHAMBER	1	
19	97980-04116	.SCREW, WITH WASHER	1	
20	646-14198-01	.GASKET	1	
21	6E7-14385-01	.FLOAT	1	
22	647-14386-10	.PIN, FLOAT	1	
23	6F5-14392-00	.VALVE, NEEDLE	1	
24	6E0-14227-00	.GASKET	1	

D3



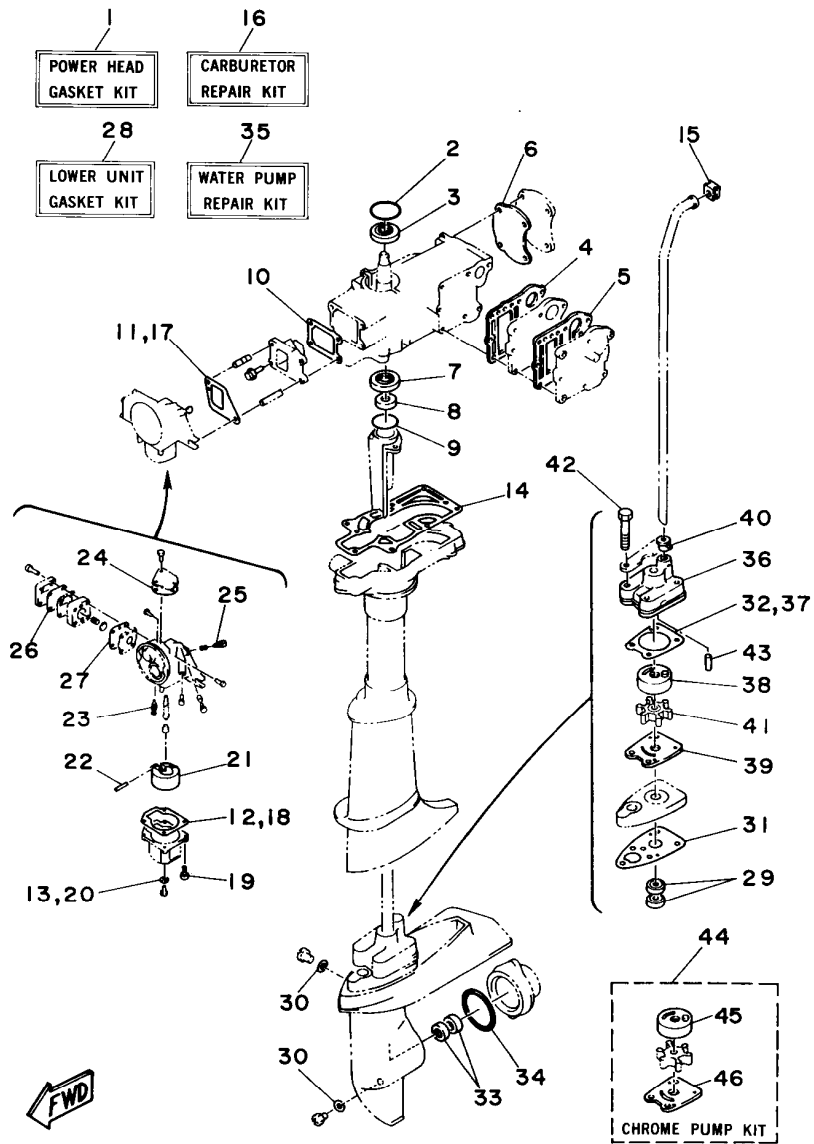

FIG. 11 REPAIR KIT

ESTUCHE REPARATION

REF. NO.	PART NO. CODIGO NO.	DESCRIPTION DESCRIPCION	Q'TY CANT.	REMARKS OBSERVACION
25	647-14323-00	.SCREW, AIR ADJUSTING .TORNILLO DE AJUSTE DE AIRE	1	
26	6E0-24471-00	.DIAPHRAGM .DIAFRAGMA	1	
27	6E0-24411-00	.DIAPHRAGM .DIAFRAGMA	1	
28	6E0-W0001-C1	LOWER UNIT GASKET KIT JUEGO DE JUNTA UNIDAD INFERIOR	1	
29	93101-10M14	.OIL SEAL .RETEN DE ACEITE	2	
30	90430-08020	.GASKET .JUNTA	3	
31	6E0-45315-A0	.PACKING, LOWER CASING .EMPAQUE	1	
32	6E0-44315-A0	.GASKET, WATER PUMP .EMPAQUE	1	
33	93101-13M12	.OIL SEAL .RETEN DE ACEITE	2	
34	93210-48214	.O-RING .JUNTA TORICA	1	
35	6E0-W0078-A3	WATER PUMP REPAIR KIT ESTUCHE REPARACION BOMBA AGUA	1	
36	6E0-44311-00	.HOUSING, WATER PUMP .CAJA BOMBA DE AGUA	1	
37	6E0-44315-A0	.GASKET, WATER PUMP .EMPAQUE	1	
38	6E0-44322-02	.INSERT, CARTRIDGE .CARTUCHO	1	
39	6E0-44323-00	.OUTER PLATE, CARTRIDGE .PLACA EXTERIOR DEL CARTUCHO	1	
40	6E0-44366-00	.DAMPER, WATER SEAL .GOMA DEL SELLO DE AGUA	1	
41	6E0-44352-00	.IMPELLER .IMPULSOR	1	
42	97095-06045	.BOLT .PERNO	4	
43	93604-18080	.PIN, DOWEL .PASADOR DE CLAVIJA	2	
44	6E0-W0078-0A	CHROME PUMP KIT ESTUCHE REPARACION BOMBA AGUA	1	
45	6E0-44322-40	.INSERT, CARTRIDGE .CARTUCHO	1	CHROMATE
46	6E0-44323-40	.OUTER PLATE, CARTRIDGE .PLACA EXTERIOR DEL CARTUCHO	1	CHROMATE

NUMERICAL INDEX  
INDICE NUMERICO

PART NO. CODIGO NO.	REF. NO. REF. NO.	PART NO. CODIGO NO.	REF. NO. REF. NO.	PART NO. CODIGO NO.	REF. NO. REF. NO.	PART NO. CODIGO NO.	REF. NO. REF. NO.	PART NO. CODIGO NO.	REF. NO. REF. NO.	PART NO. CODIGO NO.	REF. NO. REF. NO.
6E0-W0001-A4	11- 1	6E3-14301-05	2- 5	6G1-24304-02	5-36	6E0-42131-02-94	7- 5	6E0-44143-10	7-35	6E0-45551-00	8-37
6E0-W0001-C1	11-28	664-14321-01	2-21	688-24313-00	5-39	6E0-42134-02	7-10	6E0-44145-00	7-38	6E0-45560-00	8-40
6E3-W0001-A4	11- 1	647-14323-00	2-19	6E0-24378-00	1- 9	6E0-42137-10	7-16	6E0-44146-00	7-39	676-45567-00-09	1-40
6J1-W0004-00	2- 2		11-25	6E0-24411-00	2-31	6E0-42138-01	7-21	6G1-44147-00	8-54	6E0-45570-00	8-41
6E0-W0070-14	4- 6	647-14326-00	2-23		11-27	6E0-42159-02	7-22	6E0-44150-00	8-53	6E0-45611-01	8-48
6E0-W0078-A3	11-35	6E0-14341-01	2-13	6E0-24412-00	2-28	6E0-42177-00	7-15	6E0-44150-10	8-53	6L5-45616-00	8-50
6E0-W0078-0A	11-44	6E3-14341-02	2-13	6E0-24413-00	2-25	6E0-42528-03	6-47	6E0-44191-11	4- 9	6E0-45631-00	8-43
6E0-W0090-04-4D	1- 1	648-14342-23	2-22	6E0-24423-00	2-29	6L5-42529-01	6-50	6L5-44196-00	6-52	654-45633-00	8-45
6E3-W0090-04-4D	1- 1	648-14342-26	2-22	6E0-24434-00	2-32	6E0-42537-02	6-43	6L5-44197-00	6-53	654-45635-00	8-47
6E0-W0093-04	11-16	648-14343-40	2-14	6E0-24435-00	2-27	6E0-42538-02	6-44	6E0-44311-00	8-23	6E0-45941-01-EL	8-55
656-W2810-02	4-10	6E0-14346-00	2-30	6E0-24471-00	2-26	6E0-42539-00	6-45		11-36	6E0-45943-01-EL	8-55
6E0-11191-01-9M	1-21	6E0-14381-02	2- 6		11-26	6E0-42542-00	5-11	6E0-44315-A0	8-24	6E0-45949-00-EL	8-55
6E3-11191-01-9M	1-21	6E0-14384-00	2- 7	6E0-24500-00	5-18	6E0-42549-00	6-46		11-32	6L5-45987-01	8-49
6E0-11193-A1	1-22		11-12	6E0-24500-60	5-24	6L5-42561-00	6-51		11-37	6E0-81303-40	9-23
	11- 6		11-18	624-24521-01	5-25	6E0-42610-15-4D	4- 1	6E0-44322-02	8-25	6E0-81303-80	9-23
6E3-11193-A1	1-22	6E7-14385-01	2-11	102-24522-01	5-26	6E3-42610-15-4D	4- 1		11-38	6E0-81328-70	9-13
	11- 6		11-21	6E0-24566-60	5-27	6E4-42610-15-4D	4- 1	6E0-44322-40	11-45	6E0-81336-70	9-12
650-11370-00	1- 3	647-14386-10	2-12	6E3-24566-60	5-27	6E0-42615-00	4- 2	6E0-44323-00	8-26	6E0-82316-01-94	10- 3
6E5-11372-00	1- 5		11-22	6E0-24571-00	5-19	6E1-42643-01	5-33		11-39	6E0-82317-00	10- 4
6E0-11400-00	1-31	6F5-14392-00	2-15	6E0-24572-00	5-21	6E0-42647-01	4- 3	6E0-44323-40	11-46	663-82370-01	10- 2
6E3-11400-00	1-31		11-23	6E0-24575-01	5-22	6E0-42651-02	4- 4	6E0-44328-00	8-32	6E0-82550-01	5-32
6E0-11412-00	1-32	6E0-14417-00	2-37	6E0-24591-00	5-20	6E0-42677-11	4- 7	6E0-44352-00	8-28	6E0-85520-70	9- 6
6E3-11412-00	1-32	6E0-14418-00	2-38	6E0-24610-02	5-14	6E3-42677-11	4- 7		11-41	6E0-85540-71	10-11
6E0-11422-00	1-33	624-14485-00	1- 4	6E0-24641-00	5-16	6E0-42678-12	4- 8	6E0-44361-00	8-33	6E0-85548-00	10-10
6E3-11422-00	1-33	6E0-15100-01-94	1- 2	6E3-24641-00	5-16	6E3-42678-12	4- 8	6E0-44361-10	8-33	6E0-85550-71	9- 1
6G1-11610-00	1-42	6E3-15100-02-94	1- 2	6E0-26301-01	7-24	6E1-42694-00	5-34	646-44365-00	8-34	6E0-85560-70	9- 4
6J1-11610-00	1-42	6E0-15359-00-94	9- 5	626-28193-01-94	6-55	6E0-42711-05-4D	5- 1		11-15	6E0-85570-00	10- 5
6E0-11631-00-98	1-41	6E0-15396-03-5B	1-16	6E0-41111-01-9M	1-24	6E0-42815-00-4D	5- 2	6E0-44366-00	8-27	6E0-85592-70	9-10
6E3-11631-00-98	1-41	6E0-15705-00	3-11	6E3-41111-01-9M	1-24	6E0-42816-00	5- 4		11-40	6E0-85595-70	9- 8
6G1-11633-00	1-44	6E0-15710-03-94	3- 1	6E0-41112-A1	1-25	6E0-43111-02-4D	6-11	6E0-45111-02-4D	6- 1	90101-06335	6-22
6E0-11651-01	1-37	6E3-15710-03-94	3- 1		11- 4	6E0-43112-01-4D	6-12	6E0-45111-12-4D	6- 1	90101-08M07	6-17
6G1-11681-00	1-34	6E4-15711-71-94	3- 2	6E3-41112-A1	1-25	6A1-43113-01	6-19	6E0-45113-A1	1-47	90105-06M14	1-23
6E5-12411-01	1-46	6E0-15714-01	3- 3		11- 4	648-43114-01	6-13		11-14		1-30
6J1-13610-00	2- 1	6E0-15717-00	3- 5	6E0-41113-01-9M	1-26	6E0-43116-01	6-14	647-45151-01	6- 9		9- 3
6E0-13621-A2	2- 3	6E0-15723-00-94	9- 2	6E3-41113-01-9M	1-26	6E0-43118-01	6-15	6L5-45251-02	8- 7	90105-06M16	1- 7
	11-10	677-15741-01	3- 9	6E0-41114-A1	1-27	6E0-43160-01	6-36	6E0-45300-03-4D	8- 1		1-29
6E0-14157-00	2-16	6G1-15755-00	3-14		11- 5	689-43165-00	6-37	6E0-45300-13-4D	8- 1	90105-06M17	1- 8
6E0-14159-00	2-33	6E0-15758-01	3-15	6E3-41114-A1	1-27	6E0-43181-00	6-29	6E0-45311-02-4D	8- 2	90105-06M24	1-28
6E0-14198-A0	2-34	6E3-15758-01	3-15		11- 5	620-43189-00	6-32	6E0-45315-A0	8-15		1-29
	11-11	6E0-15761-00	3-16	6E0-41256-00	2-42	6E0-43311-04-4D	6-25		11-31	90116-06M08	2-48
	11-17	6G1-15779-00	3-12	661-41262-02	2-46	6E0-43312-02-4D	6-26	6E0-45316-09	8- 4	90119-06M40	8-12
646-14198-01	2-10	6E0-24110-01-4D	5-13	6E0-41271-00	2-43	6E0-43313-00-94	6-31	6E0-45317-09	8- 3	90149-05M13	7-19
	11-13	6E0-24181-00	5-15	6E0-41272-00	2-44	6E0-43614-00-5B	6-39	6E0-45318-01	8-57	90159-04035	9-14
	11-20	6E0-24182-00	5-10	6E0-42111-02-4D	7- 1	6E0-43632-00	6-30	6E0-45321-01-5B	8-14	90159-04036	9- 9
646-14212-01	2-20	6E1-24182-00	5-35	6E0-42119-00	7-14	6E0-44111-02	7-25	6E0-45331-00-5B	8-56	90159-05037	9-11
6E0-14227-00	2-17	6E3-24182-00	5-10	6E0-42125-00	7- 9	6E0-44116-00	7-29	6E0-45361-01-4D	8-18	90159-05038	9- 7
	11-24	6E0-24183-00	9-19	6E0-42129-02	7- 2	6E0-44121-00	7-33	6E0-45511-00	8-35	90159-05040	9-24
6E0-14301-05	2- 5	646-24251-02	5-37	6E4-42129-00	7- 3	6E0-44143-00	7-35	6E0-45511-10	8-35	90170-10113	9-21

NUMERICAL INDEX  
INDICE NUMERICO

PART NO. CODIGO NO.	REF. NO. REF. NO.	PART NO. CODIGO NO.	REF. NO. REF. NO.	PART NO. CODIGO NO.	REF. NO. REF. NO.	PART NO. CODIGO NO.	REF. NO. REF. NO.	PART NO. CODIGO NO.	REF. NO. REF. NO.	PART NO. CODIGO NO.	REF. NO. REF. NO.
90201-06M30	3- 8	90508-14M10	6-40	93450-13022	1-45	97890-04007	2-18				
90201-08M03	6-18	90508-14M11	6-41	93604-08062	1- 6	97890-05006	2- 9				
90201-08M54	8-52	90508-16020	6-34	93604-09066	8-29	97980-04116	2- 8				
90201-10119	7-18	90508-16021	6-35	93604-18080	8-31		11-19				
90201-10269	9-22	90510-08M03	3- 4		11-43	97980-04120	2-24				
90201-11M49	8-39	90890-44372	3-13	93606-12019	6- 2	98580-04010	5-28				
90201-13M50	8-42	91490-12012	7-12	93700-06M03	6- 8	98580-05525	2-39				
90202-07M22	7-13	91490-16010	7-37		6-27		8-59				
90202-12M16	2-45	91490-25030	8-51	94701-00040	1-49	99009-06600	8-38				
90202-12M17	5-23	91690-30008	6-38	95380-06600	3- 7						
90202-16061	7-28	92990-05600	2-40		6-24						
90206-12052	5- 5		7- 7	95380-06700	2-35						
90206-16M06	7-27		7-36		5- 7						
90209-18112	1-38		8-60		6- 7						
90243-04M01	6-16	92990-06300	8- 9		7-30						
90250-05046	8-44	92990-06600	1-20	95380-08600	6-48						
90266-04M00	4- 5		2-36	95627-06325	2-47						
90266-04M05	6-54		6- 4	95780-08300	6-20						
90269-02M09	7-20		6- 6	95895-06010	6-42						
90280-04M06	9-20		6-23	95895-06012	8- 8						
90340-08M04	8-11		7-32	95895-06016	2- 4						
90386-12069	5- 3		8-17		3-17						
90386-26M30	7- 4		10- 7		8-22						
90386-26M33	7- 8	92995-06100	9-18		10- 1						
90387-06M11	6-21	93101-10M14	8- 5	95895-06020	3-18						
90387-06M14	8-13		11-29		5- 9						
90430-08020	8-10	93101-10M25	1-18		6-33						
	11-30		11- 8		7-40						
90445-07M00	1-11	93101-13M12	8-20		10-12						
90445-07M28	1-12		11-33	95895-06025	5-12						
	1-14	93101-20M29	1-39		7-34						
90445-07M32	1-13		11- 7	95895-06035	6-28						
90445-09057	5-38	93102-20M25	9-15	97014-06035	3- 6						
90445-09072	5-29		11- 3	97095-06010	10- 9						
90445-09083	5-30	93210-12790	7-26	97095-06012	7-31						
90467-06016	1-10	93210-31114	1-17	97095-06016	1-19						
	1-15		11- 9		6- 5						
90467-08M01	8-36	93210-42159	9-16		9-17						
90467-08004	5-17		11- 2	97095-06025	8-16						
	5-31	93210-48214	8-21	97095-06030	6- 3						
	5-40		11-34		10- 6						
90468-07M02	1-48	93306-00426	8- 6	97095-06045	8-30						
90480-10M13	6-10		8-19		11-42						
90480-14M14	5- 8	93306-204U0	1-35	97313-05020	7- 6						
90480-25161	10- 8	93310-112V0	1-43	97780-40320	2-41						
90501-10064	8-46	93310-418V1	1-36	97885-05012	7-11						
90501-23215	7-17	93420-22M03	8-58		7-23						
90502-08M05	6-49	93430-06M02	3-10	97885-06030	5- 6						

—MEMO—

A series of horizontal dotted lines for writing.

*COPYRIGHT : All rights reserved. No part of this publication  
may be reproduced without permission.*

*RESERVADO : EL DERECHO DE REPRODUCCION  
NO SE PUEDE REPRODUCIR NINGUNA PARTE  
DE ESTA LISTA SIN PERMISO.*

PRINTED ON RECYCLED PAPER  
IMPRESO EN PAPEL RECICLADO

**YAMAHA**  
YAMAHA MOTOR CO., LTD.  
2500 SHINGAI IWATA SHIZUOKA JAPAN  
SERVICE INFORMATION DIV.

Printed in Japan  
First edition AUG., 1997  
**T6**

PUBLICADO EN JAPON  
Primera edición AGO., 1997  
**T6**