

**PARTS
CATALOGUE
CATALOGO
DE REPUESTOS**

40X '00 (66T)

E40X'00 (66T)

FOREWORD

This Parts Catalogue is related to the parts for the model(s) in the below frame. When you are ordering replacement parts, please refer to this Parts Catalogue and quote both part numbers and part names correctly.

40X'00(66T), E40X'00(66T)

1. Modifications or additions which have been made after issue of the Parts Catalogue will be announced in the Yamaha Parts News.
It is advisable that you make necessary corrections to the Parts Catalogue according to the Yamaha Parts News.

2. Abbreviations

The Following abbreviations are used in this Parts Catalogue.

- "UR" Use specified parts number.
- "UN" Use as many as needed.
- "AP" Alternate Parts
- "LM" Local Made
(Parts need to be ordered locally)
- "O/S" Over Size

3. Parts, which are to be supplied in an assembly, are listed with a dot(.) in front of the part name as shown below.

EXAMPLE
 CARBURETOR ASSY
 .JET, PILOT
 .NOZZLE, MAIN

4. Number of component for assembly

The numeral appearing to the right of each component part indicates the quantity of parts for each assembly unit.

EXAMPLE

PART NO.	DESCRIPTION	E	H	L	H	L	REMARKS
6E0-85500-70	C.D.I. MAGNETO ASSY	1					
6E0-85550-70	.ROTOR ASSY	1					
6E0-15723-00-94	.PULLY, STARTER	1					

5. Quantity Column Information

NAME for Q'TY COLUMN	APPLICABLE MODEL
MH	40XMH, E40XMH
WH	40XWH, E40XWH
W	40XW, E40XW
WT	40XWT

6. Applicable Starting Serial No. and Color Code

1) Engine Starting Sserial No.

<table style="width: 100%; border-collapse: collapse;"> <tr> <td style="width: 50%;">40XMH</td> <td style="width: 50%;">S : 004656</td> </tr> <tr> <td></td> <td>L : 210768</td> </tr> <tr> <td>40XW</td> <td>S : 121081</td> </tr> <tr> <td>40XWH</td> <td>L : 351039</td> </tr> <tr> <td>40XWT</td> <td>L : 451457</td> </tr> </table>	40XMH	S : 004656		L : 210768	40XW	S : 121081	40XWH	L : 351039	40XWT	L : 451457	<table style="width: 100%; border-collapse: collapse;"> <tr> <td style="width: 50%;">E40XMH</td> <td style="width: 50%;">S : 004656</td> </tr> <tr> <td></td> <td>L : 210768</td> </tr> <tr> <td></td> <td>X : 700787</td> </tr> <tr> <td>E40XWH</td> <td>L : 351014</td> </tr> <tr> <td>E40XW</td> <td>S : 121095</td> </tr> <tr> <td></td> <td>L : 401264</td> </tr> </table>	E40XMH	S : 004656		L : 210768		X : 700787	E40XWH	L : 351014	E40XW	S : 121095		L : 401264
40XMH	S : 004656																						
	L : 210768																						
40XW	S : 121081																						
40XWH	L : 351039																						
40XWT	L : 451457																						
E40XMH	S : 004656																						
	L : 210768																						
	X : 700787																						
E40XWH	L : 351014																						
E40XW	S : 121095																						
	L : 401264																						

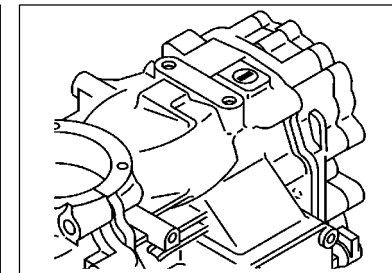
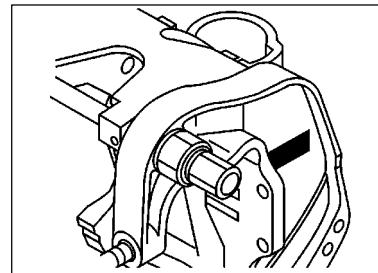

2) Color Code

Color Code	Color Name	Abbreviation
004D	DARK BLUIISH GRAY METALLIC 2	DBNM2

7. Note that the illustrations for reference in funding parts numbers, not to be used for assembling. When assembling, pleas use the applicable service manual.
8. The asterisk (*) before a reference number indicates modification items after the first edition.

CONTENTS

SHEET 1/2

TOP COWLING	A4
CYLINDER. CRANKCASE	A5
CRANKSHAFT. PISTON	A7
INTAKE	B1
CARBURETOR	B2
FUEL	B4
STARTER	B6
GENERATOR	C1
ELECTRICAL 1	C2
ELECTRICAL 2	C3
ELECTRICAL 3	C5
STARTING MOTOR	C6
BOTTOM COWLING	C7
STEERING 1	D2
STEERING 2	D4
CONTROL	D5
REMOTE CONTROL ATTACHMENT	D7
BRACKET 1	E1
BRACKET 2	E5
BRACKET 3	E7
POWER TRIM & TILT ASSY	F2
UPPER CASING	F5
LOWER CASING. DRIVE 1	F6

INDEX

NUMERICAL INDEX	G1
-----------------------	----

SHEET 2/2

LOWER CASING. DRIVE 1	A4*
LOWER CASING. DRIVE 2	A6*
FUEL TANK	B1*
STEERING GUIDE	B2*
REMOTE CONTROL BOX	B3*
REMOTE CONTROL ASSY	B4*
REPAIR KIT 1	B7*
REPAIR KIT 2	C2*
REPAIR KIT 3	C3*

INDEX

NUMERICAL INDEX	G1*
-----------------------	-----

FIG. 1 TOP COWLING

SOPORTE SUPERIOR

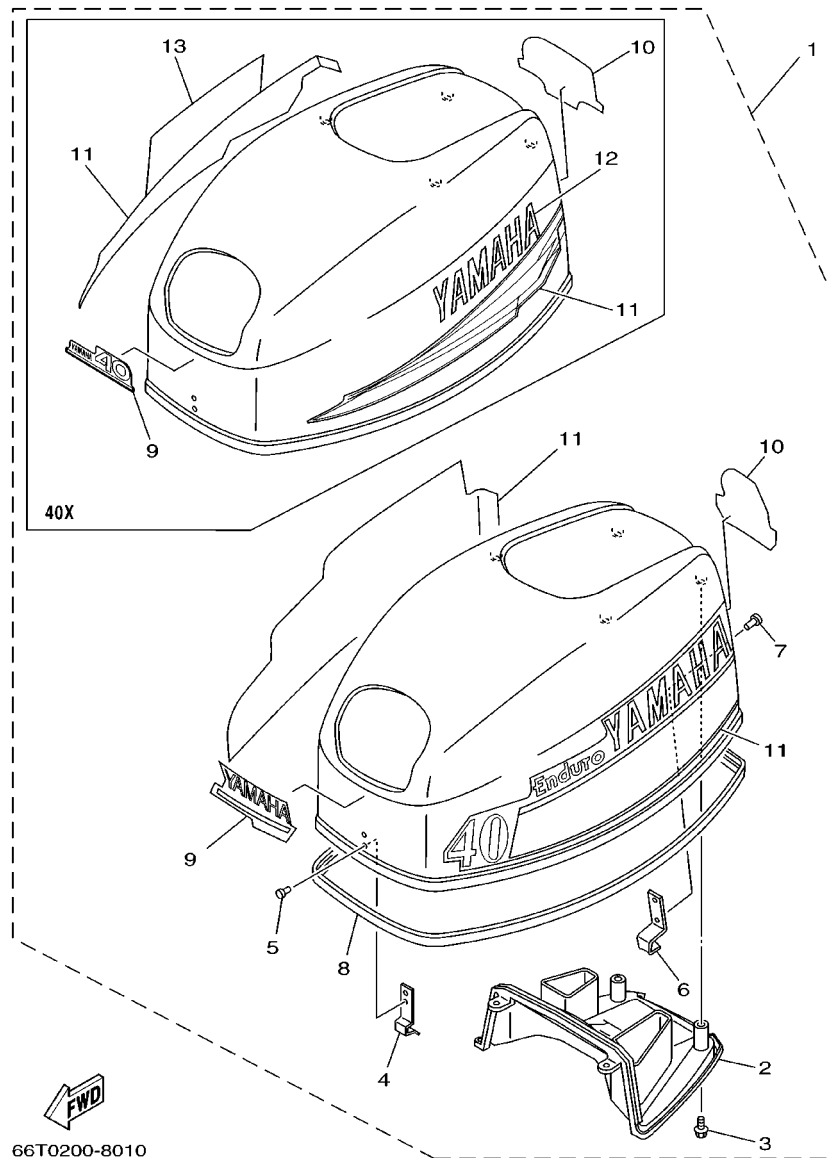

REF. NO.	PART NO. CODIGO NO.	DESCRIPTION DESCRIPTION	MH	WH	W	WT	REMARKS OBSERVACION
1	66T-42610-10-4D	TOP COWLING ASSY SOPORTE SUPERIOR COMPL.	1		1	1	YAMAHA 40
	66T-42610-H0-4D	TOP COWLING ASSY SOPORTE SUPERIOR COMPL.	1	1	1		ENDURO
2	66T-42613-00	.MOLDING, AIR DUCT .MOLDURA CONDUCTO AIRE	1	1	1	1	
3	97780-60520	.SCREW, TAPPING .TORNILLO ROSCA HEMBRA	4	4	4	4	
4	6E0-42651-02	.HOOK .GANCHO	1	1	1	1	
5	90266-04M04	.RIVET .REMACHE	2	2	2	2	
6	6F5-42652-01	.HOOK .GANCHO	1	1	1	1	
7	90266-04M04	.RIVET .REMACHE	2	2	2	2	
8	66T-42615-01	.SEAL .SELLO	1	1	1	1	
9	63D-42677-11	.GRAPHIC, FRONT .CALCAMONIA FRONTAL	1		1	1	YAMAHA 40
	61N-42677-H0	.GRAPHIC, FRONT .CALCAMONIA FRONTAL	1	1	1		ENDURO
10	63D-42678-11	.GRAPHIC, REAR .CALCAMONIA TRASERA	1		1	1	YAMAHA 40
	6J4-42678-H0	.GRAPHIC, REAR .CALCAMONIA TRASERA	1	1	1		ENDURO
11	63D-W0070-10	.GRAPHIC SET .JUEGO DE EMBLEMA	1		1	1	YAMAHA 40
	66T-W0070-H0	.GRAPHIC SET .JUEGO DE EMBLEMA	1	1	1		ENDURO
12	63D-42681-10	.MARK, COWLING .MARCA DE CUBIERTA	1		1	1	
13	63D-42682-10	.MARK, COWLING .MARCA DE CUBIERTA	1		1	1	

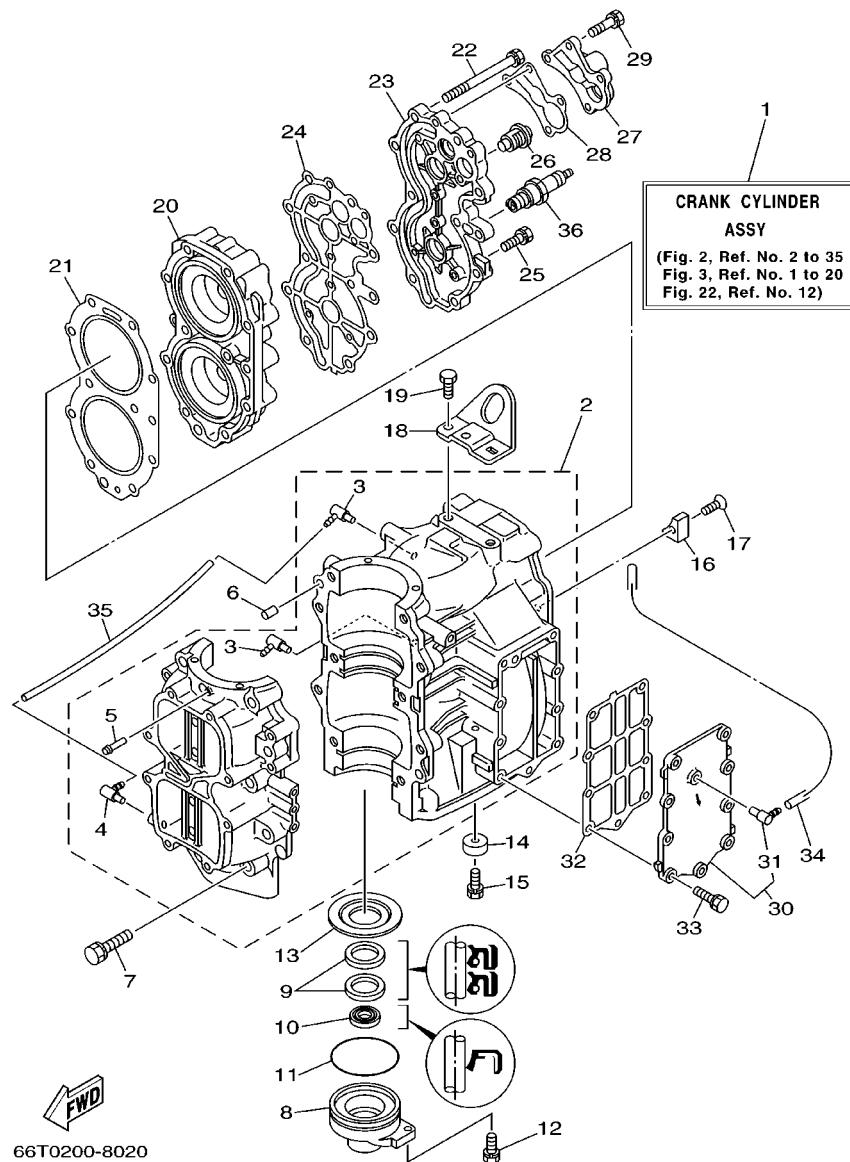

FIG. 2 CYLINDER, CRANKCASE CYLINDRO, CARTER

REF. NO.	PART NO. CODIGO NO.	DESCRIPTION DESCRIPTION	MH	WH	W	WT	REMARKS OBSERVACION
1	66T-W0090-00-4D	CRANK CYLINDER ASSY BLOQUE MOTOR COMPLETO	1	1	1	1	
2	66T-15100-00-94	CRANKCASE ASSY CARTER COMPLETO	1	1	1	1	
3	6E5-13552-00	.NOZZLE .BOQUILLA	2	2	2	2	
4	6E5-13552-00	.NOZZLE .BOQUILLA	1	1	1	1	
5	624-14485-00	.PIPE, JOINT .TUBO DE UNION	1	1	1	1	
6	93608-12063	PIN, DOWEL PASADOR DE CLAVIJA	2	2	2	2	
7	90119-10M07	BOLT, WITH WASHER TORNILLO CON ARANDELA	10	10	10	10	
8	66T-15396-00	HOUSING, OIL SEAL CAJA DE SELLO DE ACEITE	1	1	1	1	
9	93102-30M53	OIL SEAL SELLO ACEITE	2	2	2	2	
10	93104-16M01	OIL SEAL SELLO ACEITE	1	1	1	1	
11	93210-65M50	O-RING ANILLO O	1	1	1	1	
12	97595-06520	BOLT, WITH WASHER PERNO CON ARANDELA RONDELLE	1	1	1	1	
13	90209-34M27	WASHER ARANDELA DE SEPARACION	1	1	1	1	
14	676-45251-00	ANODE CATODE	1	1	1	1	
15	97595-06520	BOLT, WITH WASHER PERNO CON ARANDELA RONDELLE	1	1	1	1	
16	676-11325-00	ANODE ANODO	1	1	1	1	
17	90141-06M00	SCREW, COUNTERSUNK TORNILLO RANURADO	1	1	1	1	
18	66T-11119-00	HANGER, ENGINE SOPORTE DEL MOTOR	1	1	1	1	
19	97013-08020	BOLT PERNO	2	2	2	2	
20	66T-11111-00-94	HEAD, CYLINDER 1 CULATA CILINDRO 1	1	1	1	1	
21	66T-11181-A0	GASKET, CYLINDER HEAD 1 JUNTA, DE CULATA 1	1	1	1	1	
22	90119-08M09	BOLT, WITH WASHER TORNILLO CON ARANDELA	11	11	11	11	
23	66T-11191-00-9M	COVER, CYLINDER HEAD 1 TAPA CULATA DE CILINDRO 1	1	1	1	1	
24	66T-11193-A1	GASKET, HEAD COVER 1 EMPAQUE	1	1	1	1	
25	97513-06525	BOLT, WITH WASHER PERNO CON ARANDELA RONDELLE	4	4	4	4	
26	6E5-12411-01	THERMOSTAT THERMOSTAT	1	1	1	1	
27	676-12413-00-9M	COVER, THERMOSTAT CUBIERTA THERMOSTATO	1	1	1	1	

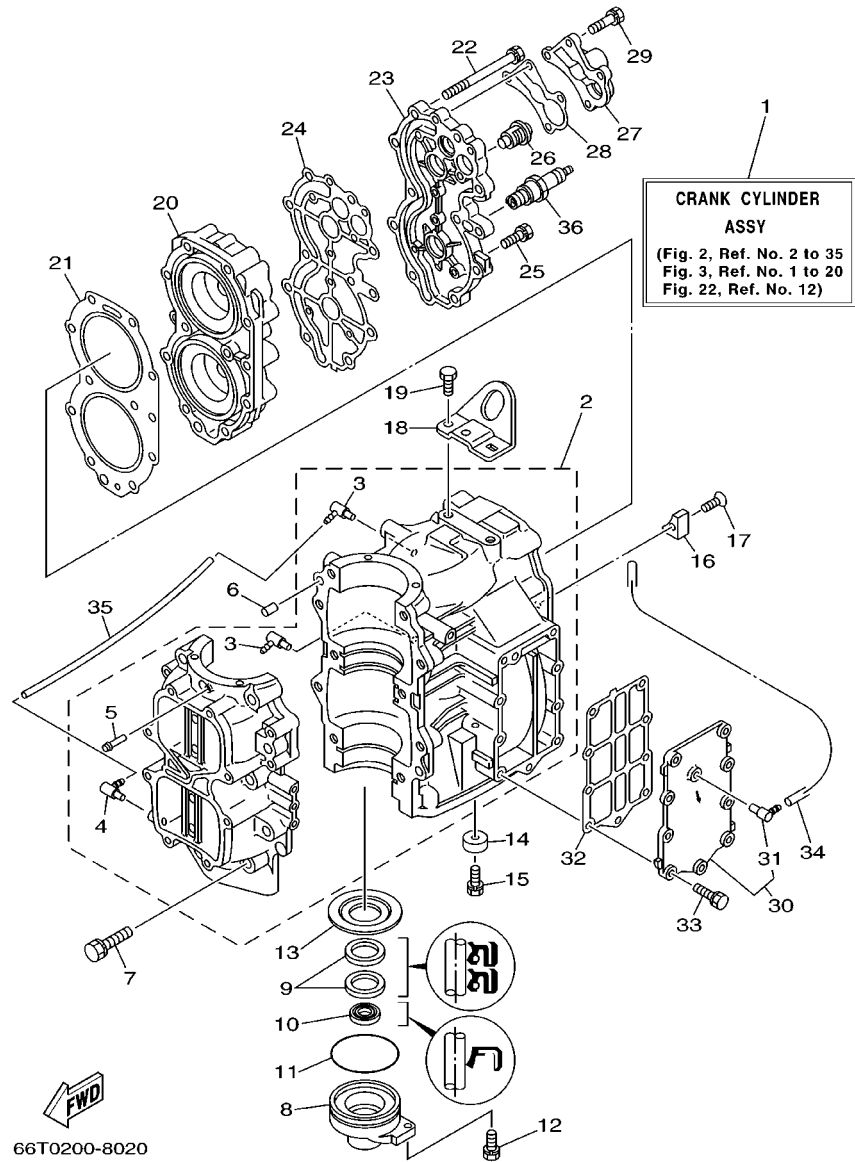

FIG. 2 CYLINDER, CRANKCASE CYLINDRO, CARTER

REF. NO.	PART NO. CODIGO NO.	DESCRIPTION DESCRIPTION	MH	WH	W	WT	REMARKS OBSERVACION
28	676-12414-A0	GASKET, COVER EMPAQUE	1	1	1	1	
29	97513-06535	BOLT, WITH WASHER PERNO CON ARANDELA RONDELLE	4	4	4	4	
30	66T-41113-00-9M	OUTER COVER, EXHAUST CUBOERTA EXTERIOR DE ESCAPE	1	1	1	1	
31	676-11372-00	.NIPPLE, HOSE .NIPLLE DE MANGUERA	1	1	1	1	
32	66T-41114-A0	GASKET, EXHAUST OUTER COVER EMPAQUE	1	1	1	1	
33	97513-06525	BOLT, WITH WASHER PERNO CON ARANDELA RONDELLE	9	9	9	9	
34	90445-09M75	HOSE TUBO	1	1	1	1	
35	90445-07M08	HOSE TUBO	1	1	1	1	
36	94702-00040	PLUG, SPARK (NGK B7HS) BUJIA (NGK B7HS)	2	2	2		
	94702-00272	PLUG, SPARK (NGK BR7HS) BUJIA (NGK BR7HS)	2	2	2	2	FOR CHINA

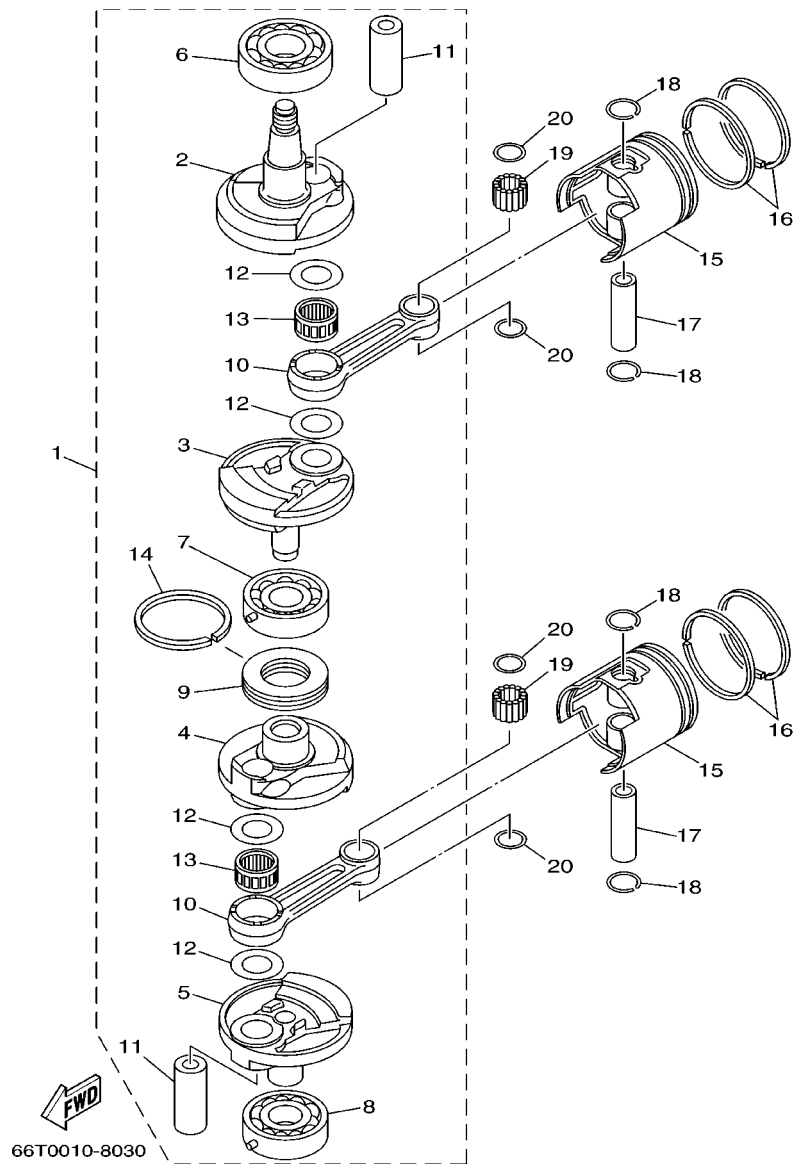

FIG. 3 CRANKSHAFT. PISTON

CIGUENAL. PISTON

REF. NO.	PART NO. CODIGO NO.	DESCRIPTION DESCRIPTION	MH	WH	W	WT	REMARKS OBSERVACION
1	66T-11400-00	CRANKSHAFT ASSY CIGUENAL COMPLETO	1	1	1	1	
2	66T-11412-00	.CRANK 1 .MANIVELA 1	1	1	1	1	
3	66T-11422-00	.CRANK 2 .MANIVELA 2	1	1	1	1	
4	66T-11432-00	.CRANK 3 .MANIVELA 3	1	1	1	1	
5	66T-11442-00	.CRANK 4 .MANIVELA 4	1	1	1	1	
6	93306-307U0	.BEARING .COJINETE	1	1	1	1	
7	93306-306V6	.BEARING .COJINETE	1	1	1	1	
8	93306-306V5	.BEARING .COJINETE	1	1	1	1	
9	6F5-11515-00	.SEAL, LABYRINTH 1 .SELLO LABERINTO 1	1	1	1	1	
10	6F5-11651-00	.ROD, CONNECTING .BIELA	2	2	2	2	
11	66T-11681-00	.PIN, CRANK 1 .PASADOR MANIVELA 1	2	2	2	2	
12	90209-27M07	.WASHER .ARANDELA DE SEPARACION	4	4	4	4	
13	93310-727U0	.BEARING .COJINETE	2	2	2	2	
14	93440-68M03	.CIRCLIP .BOLA	1	1	1	1	
15	66T-11631-00-93	PISTON (STD) PISTON (STD)	2	2	2	2	
	66T-11635-00	PISTON (0.25MM O/S)	2	2	2	2	AP
	66T-11636-00	PISTON (0.25MM O/S)	2	2	2	2	AP
	66T-11637-00	PISTON (0.50MM O/S)	2	2	2	2	AP
	66T-11638-00	PISTON (0.50MM O/S)	2	2	2	2	AP
16	66T-11603-00	PISTON RING SET (STD) JUEGO DE ANILLOS (STD)	2	2	2	2	
	66T-11604-00	PISTON RING SET (0.25MM O/S) JUEGO DE ANILLOS (0.25MM O/S)	2	2	2	2	AP
	66T-11605-00	PISTON RING SET (0.50MM O/S) JUEGO DE ANILLOS (0.50MM O/S)	2	2	2	2	AP
17	6F5-11633-00	PIN, PISTON PASADOR, PISTON	2	2	2	2	
18	663-11634-00	CLIP, PISTON PIN PRESILLA, BULON DE PISTON	4	4	4	4	
19	93603-21111	PIN, DOWEL PASADOR DE CLAVIJA	56	56	56	56	
20	90201-20417	WASHER, PLATE ARANDELA PLANA	4	4	4	4	

FIG. 4 INTAKE

ADMISION

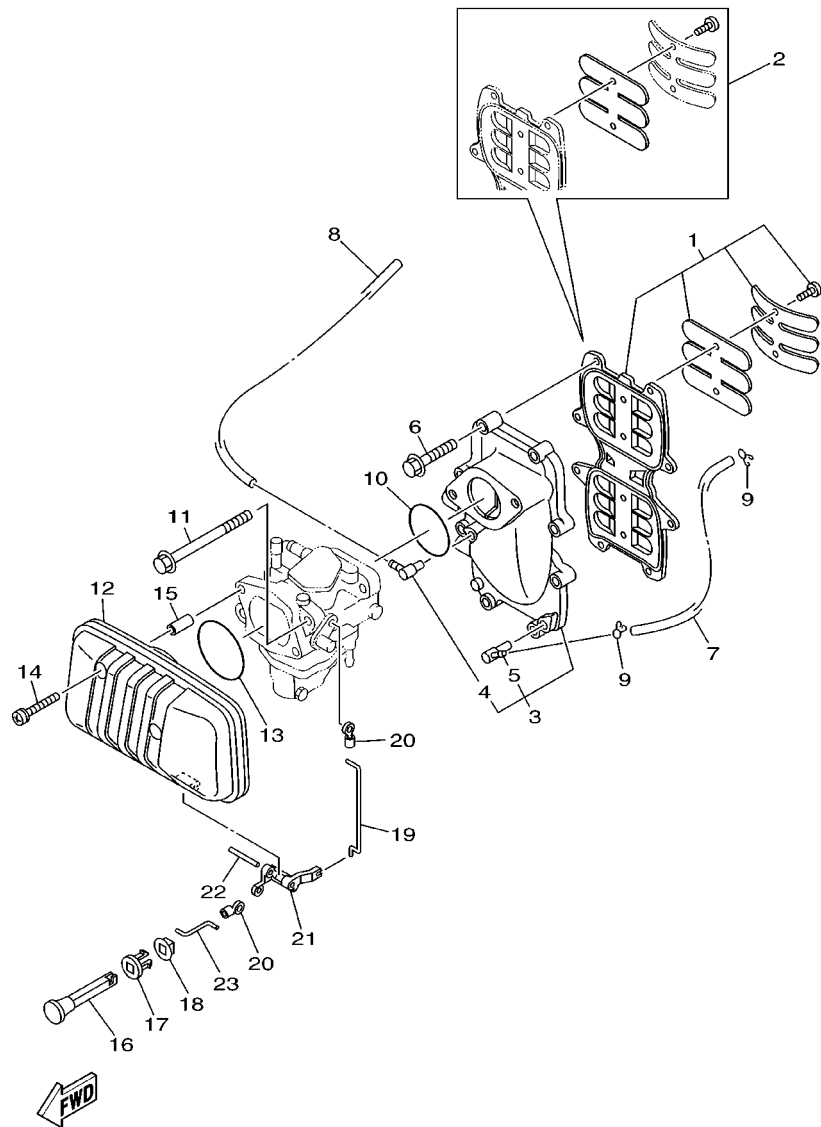

66T0010-8040

REF. NO.	PART NO. CODIGO NO.	DESCRIPTION DESCRIPTION	MH	WH	W	WT	REMARKS OBSERVACION
1	66T-13610-00	REED VALVE ASSY VALVULA DE LAMINAS COMPLETA	1	1	1	1	
2	66T-W0004-00	.REED SET .JUEGO DE VALVULAS DE LENGUETA	1	1	1	1	
3	66T-13641-01-94	MANIFOLD 1 MULTIPLE 1	1	1	1	1	
4	6E5-13552-00	.NOZZLE .BOQUILLA	1	1	1	1	
5	650-11372-00	.NIPPLE, HOSE .NIPLE DE MANGUERA	1	1	1	1	
6	97513-06535	BOLT, WITH WASHER PERNO CON ARANDELA RONDELLE	8	8	8	8	
7	90445-07M24	HOSE TUBO	1	1	1	1	
8	90445-07MA4	HOSE TUBO	1	1	1	1	
9	90467-06016	CLIP PRESILLA	2	2	2	2	
10	93210-46M16	O-RING ANILLO O	1	1	1	1	
11	90119-08M50	BOLT, WITH WASHER TORNILLO CON ARANDELA	2	2	2	2	
12	66T-14440-00	SILENCER ASSY, INTAKE SILENCIADOR COMPL DE ADMISION	1	1	1	1	
13	93210-54M54	O-RING ANILLO O	1	1	1	1	
14	97985-06240	SCREW, WITH WASHER TORNILLO, CON ARANDELA	2	2	2	2	
15	90387-06M80	COLLAR CASQUILLO CON VALONA	2	2	2	2	
16	6H4-41271-01	KNOB, CHOKE PERILLA AHOGADOR	1	1	1	1	
17	689-41273-00	GROMMET TAPON PROTECTOR	1	1	1	1	
18	6J8-41274-00	GROMMET 2 TAPON 2	1	1	1	1	
19	66T-41256-00	ROD, CHOKE 1 VARILLA DE AHOGADOR	1	1	1	1	
20	661-41262-02	JOINT, CHOKE LEVER CONECTOR DE AHOGADOR	2	2	2	2	
21	66T-41252-00	LEVER, CHOKE 1 PALANCA AHOGADOR 1	1	1	1	1	
22	91690-40032	PIN, SPRING PASADOR DE RESORTE	1	1	1	1	
23	66T-41257-00	ROD, CHOKE 2 VARILLA DE AHOGADOR	1	1	1	1	

FIG. 5 CARBURETOR

CARBURADOR

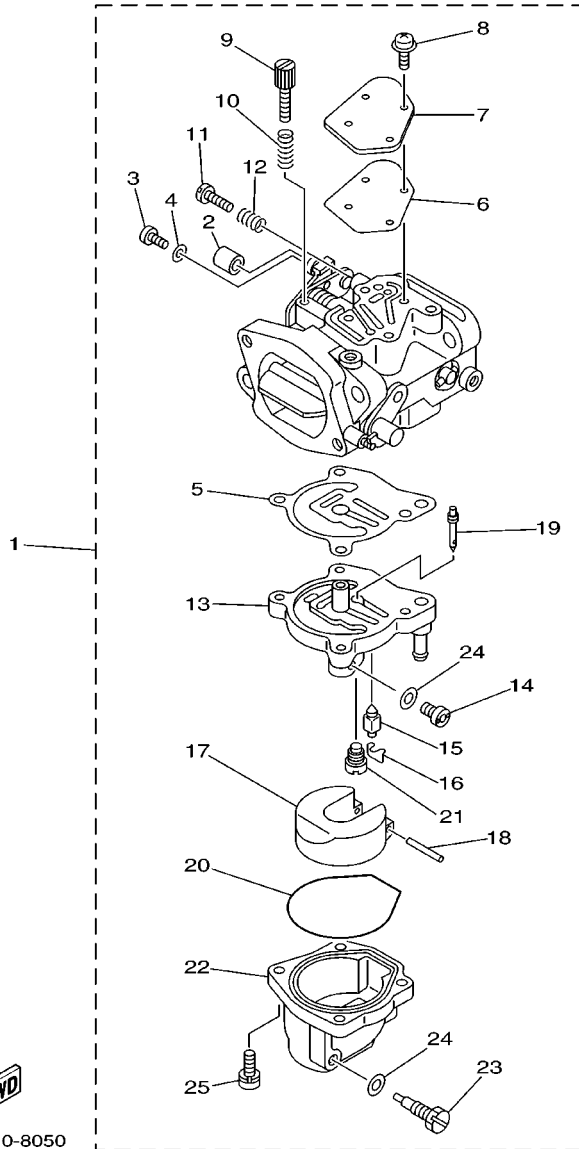

66T0010-8050

REF. NO.	PART NO. CODIGO NO.	DESCRIPTION DESCRIPTION	MH	WH	W	WT	REMARKS OBSERVACION
1	66T-14301-01	CARBURETOR ASSY 1 CARBURADOR COMPLETO 1	1	1			
	66T-14301-11	CARBURETOR ASSY 1 CARBURADOR COMPLETO 1			1	1	
	66T-14301-21	CARBURETOR ASSY 1 CARBURADOR COMPLETO 1	1				FOR BRAZIL
	66T-14301-31	CARBURETOR ASSY 1 CARBURADOR COMPLETO 1			1		FOR BRAZIL
2	6J8-14578-00	.COLLAR .COLLAR	1	1	1	1	
3	6J8-14592-01	.SCREW .TORNILLO	1	1	1	1	
4	92990-05600	.WASHER, PLATE .ARANDELA	1	1	1	1	
5	66T-14384-01	.GASKET, FLOAT CHAMBER .EMPAQUE DE CAMARA DE BOIA	1	1	1	1	
6	66T-14536-00	.GASKET .EMPAQUE	1	1	1	1	
7	66T-14527-00	.PLATE .PLACA	1	1	1	1	
8	97980-04112	.SCREW, WITH WASHER .TORNILLO, CON ARANDELA	4	4	4	4	
9	66T-14523-00	.SCREW, STOP .TORNILLO DE TOPE	1	1	1	1	
10	6J8-14334-00	.SPRING, THROTTLE .RESORTE DE AJUSTADOR DE AIRE	1	1	1	1	
11	6E5-14323-03	.SCREW, AIR ADJUSTING .TORNILLO DE AJUSTE DE AIRE	1	1	1	1	
12	6E5-14223-00	.SPRING, AIR ADJUSTING .RESORTE, AJUSTE DE AIRE	1	1	1	1	
13	66T-14945-01	.SPACER ASSY .BRIDA DE ESPACIADOR 1	1	1	1	1	
14	61A-1492E-85	.JET, MAIN (#170) .INYECTOR, PRINCIPAL (#170)	1	1	1	1	
	61A-1492E-88	.JET, MAIN (#176) .INYECTOR, PRINCIPAL (#176)	1	1			FOR BRAZIL
15	6E5-14546-00	.VALVE, NEEDLE .VALVULA DE AGUJA	1	1	1	1	
16	6E5-14159-00	.CLIP .PRESILLA	1	1	1	1	
17	6E5-14385-02	.FLOAT BOIA	1	1	1	1	
18	6E5-14386-02	.PIN, FLOAT .PASADOR DE BOIA	1	1	1	1	
19	66T-1492F-35	.JET, AIR SLOW (#70) ESPREA (#70)	1	1	1	1	
	66T-1492F-37	.JET, AIR SLOW (#74) ESPREA (#74)	1	1			FOR BRAZIL
20	66T-14984-00	.GASKET, FLOAT CHAMBER .EMPAQUE CAMARA DE BOIA	1	1	1	1	
21	66T-14992-00	.PLUG .TAPON	1	1	1	1	
22	66T-14981-00	.BODY, FLOAT CHAMBER .CUERPO CAMARA DE BOIA	1	1	1	1	

FIG. 5 CARBURETOR

CARBURADOR

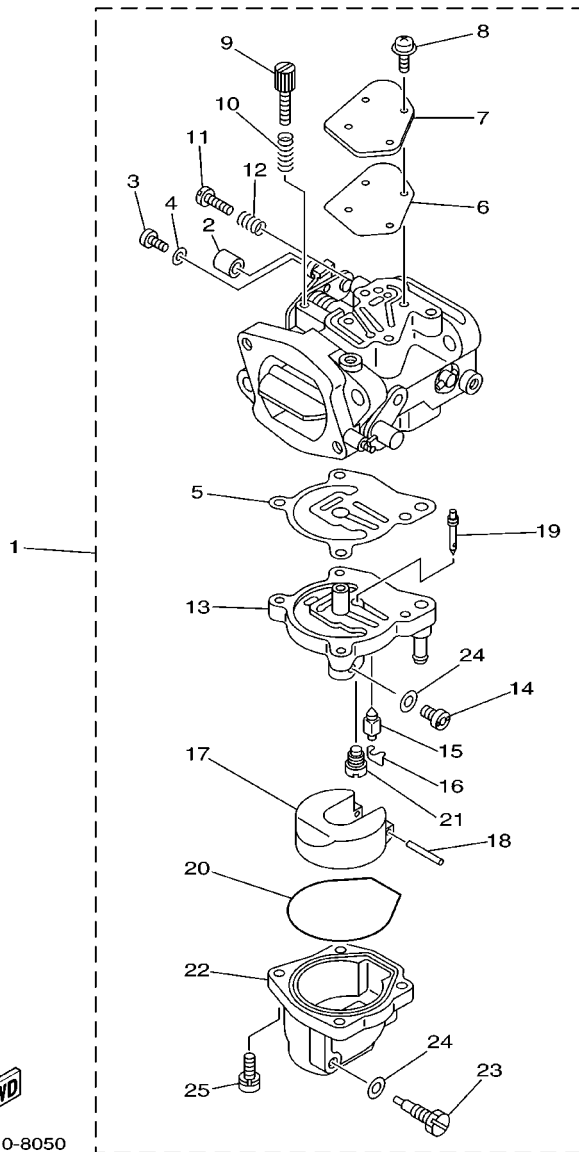

66T0010-8050

REF. NO.	PART NO. CODIGO NO.	DESCRIPTION DESCRIPTION	MH	WH	W	WT	REMARKS OBSERVACION
23	66T-14991-00	.PLUG, DRAIN .TAPON, DREN	1	1	1	1	
24	66T-14959-00	.GASKET .EMPAQUE	2	2	2	2	
25	97980-05125	.SCREW, WITH WASHER .TORNILLO, CON ARANDELA	4	4	4	4	

FIG. 6 FUEL

COMBUSTIBLE

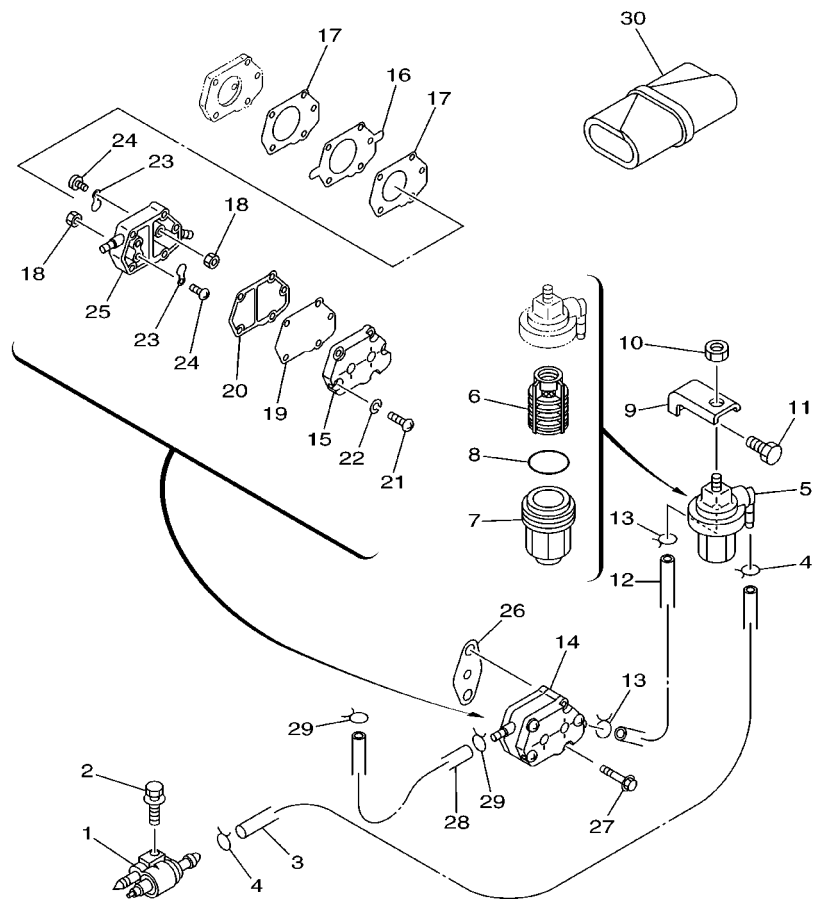

REF. NO.	PART NO. CODIGO NO.	DESCRIPTION DESCRIPTION	MH	WH	W	WT	REMARKS OBSERVACION
1	6G1-24304-02	FUEL PIPE JOINT COMP. 1 CONECTOR MANGUERA COMBUST.1	1	1	1	1	
2	97595-06530	BOLT, WITH WASHER PERNO CON ARANDELA RONDELLE	1	1	1	1	
3	90445-09M08	HOSE TUBO	1	1	1	1	
4	90467-08004	CLIP PRESILLA	2	2	2	2	
5	61N-24560-00	FILTER ASSY FILTRO COMPLETO	1	1	1	1	
6	61N-24563-00	.ELEMENT, FILTER .ELEMENTO DEL FILTRO	1	1	1	1	
7	61N-24521-00	.CUP, FILTER .COPA DE FILTRO	1	1	1	1	
8	93210-32738	.O-RING .ANILLO O	1	1	1	1	
9	648-24566-02	BRACKET, FILTER SOPORTE DEL FILTRO	1	1	1	1	
10	95380-08600	NUT TUERCA	1	1	1	1	
11	97013-06014	BOLT PERNO	1	1	1	1	
12	90445-09086	HOSE TUBO	1	1	1	1	
13	90467-08004	CLIP PRESILLA	2	2	2	2	
14	692-24410-00	FUEL PUMP ASSY BOMBA DE COMBUSTIBLE COMPLETA	1	1	1	1	
15	6A0-24413-00	.BODY 2 .CUERPO 2	1	1	1	1	
16	692-24411-00	.DIAPHRAGM .DIAFRAGMA	1	1	1	1	
17	648-24434-01	.GASKET, BODY .EMPAQUE	2	2	2	2	
18	95380-03600	.NUT .TUERCA	2	2	2	2	
19	663-24411-00	.DIAPHRAGM .DIAFRAGMA	1	1	1	1	
20	648-24435-02	.GASKET, BODY 2 .EMPAQUE	1	1	1	1	
21	98503-05028	.SCREW, PAN HEAD .TORNILLO DE CABEZA CON PLANA	3	3	3	3	
22	92990-05100	.WASHER, SPRING ARANDELA	3	3	3	3	
23	6A0-24421-01	.VALVE, CHECK .VALVULA DE RETENCION	2	2	2	2	
24	6A0-14325-00	.SCREW, PAN HEAD .TORNILLO CABEZA REDONDA	2	2	2	2	
25	6A0-24412-02	.BODY 1 .CUERPO 1	1	1	1	1	
26	650-24431-A0	GASKET, FUEL PUMP 1 EMPAQUE BOMBA COMBUST 1	1	1	1	1	
27	97595-06540	BOLT, WITH WASHER PERNO CON ARANDELA RONDELLE	2	2	2	2	



66T0010-8060

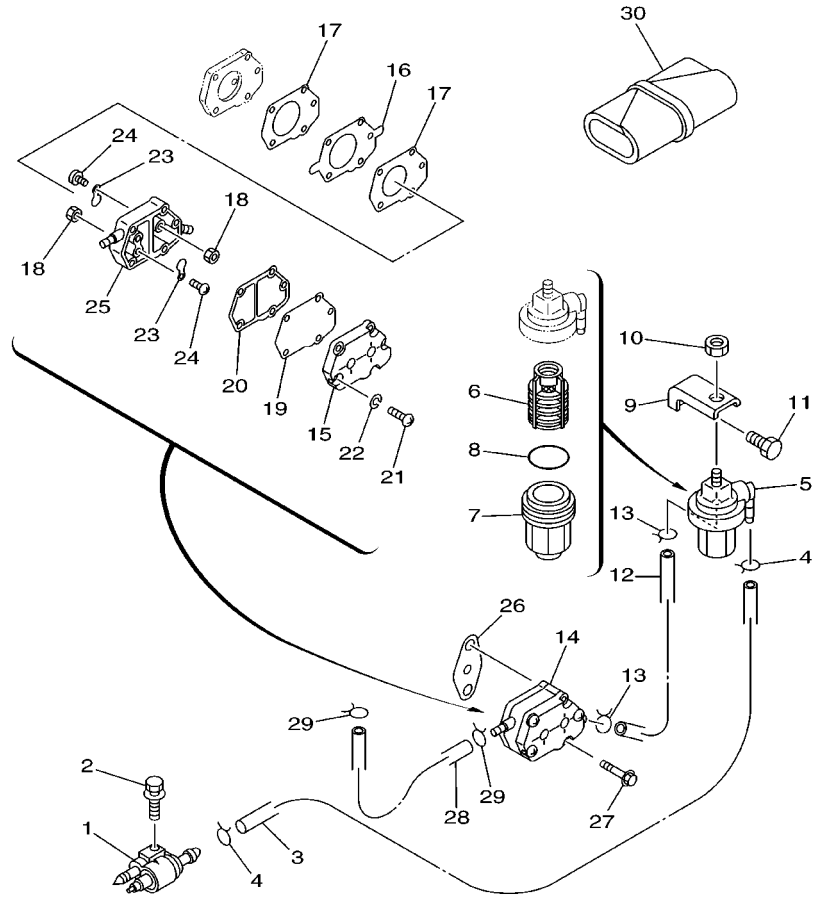

FIG. 6 FUEL

COMBUSTIBLE

REF. NO.	PART NO. CODIGO NO.	DESCRIPTION DESCRIPTION	MH	WH	W	WT	REMARKS OBSERVACION
28	90445-09086	HOSE TUBO	1	1	1	1	
29	90467-08004	CLIP PRESILLA	2	2	2	2	
30	676-W2810-01	TOOL KIT JUEGO DE HERRAMIENTAS	1	1	1	1	



66T0010-8060

FIG. 7 STARTER

ARRANQUE

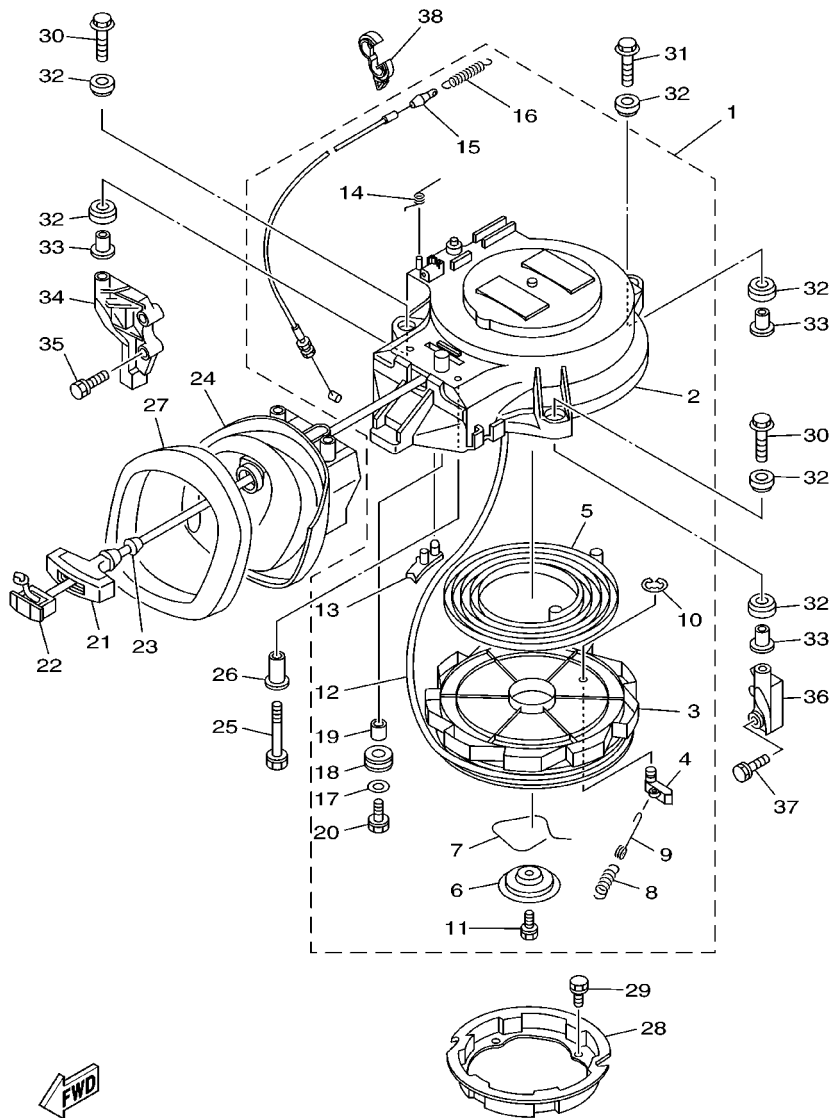

REF. NO.	PART NO. CODIGO NO.	DESCRIPTION DESCRIPTION	MH	WH	W	WT	REMARKS OBSERVACION
1	66T-15710-00	STARTER ASSY ARRANQUE COMPLETO	1	1	1	1	
2	66T-15711-00	.CASE, STARTER .CAJA DE ARRANQUE	1	1	1	1	
3	66T-15714-00	.DRUM, SHEAVE .TAMBOR ROLDANA	1	1	1	1	
4	63V-15741-00	.PAWL, DRIVE .TRINQUETE DE TRACCION	1	1	1	1	
5	66T-15713-00	.SPRING, STARTER .RESORTE DE ARRANQUE	1	1	1	1	
6	66T-15716-00	.PLATE, DRIVE .PLACA DE TRACCION	1	1	1	1	
7	66T-15705-00	.SPRING, DRIVE PAWL .RESORTE	1	1	1	1	
8	66T-15767-00	.SPRING .RESORTE	1	1	1	1	
9	66T-15784-00	.SPRING, RETURN .RESORTE DE RETORNO	1	1	1	1	
10	63V-15744-00	.CIRCLIP .SEGURO	1	1	1	1	
11	63V-15768-00	.BOLT .TORNILLO	1	1	1	1	
12	*	.WIRE, STARTER (1.8M) .CUERDA DE ARRANQUE (1,8M)	1	1	1	1	
13	66T-15794-00	.STOPPER .TOPE	1	1	1	1	
14	66T-15734-00	.SPRING, RETURN .RESORTE DE RETORNO	1	1	1	1	
15	66T-15770-00	.CABLE COMPL, STARTER STOP .CABLECOMPL DE SEGURO ARRANQUE	1	1	1	1	
16	66T-15731-00	.SPRING, RETURN .RESORTE DE RETORNO	1	1	1	1	
17	6F5-15791-00	.WASHER, LOCK .EMBLEMA	1	1	1	1	
18	6F5-15752-00	.ROLLER, WIRE .RODILLO DE CUERDA	1	1	1	1	
19	6F5-15753-00	.BUSH .BUJE	1	1	1	1	
20	6F5-15768-00	.BOLT .TORNILLO	1	1	1	1	
21	689-15755-01	.HANDLE, STARTER MANIJA DE ARRANQUE	1	1	1	1	
22	6F5-15779-02	.COVER CUBIERTA	1	1	1	1	
23	697-15789-00	.DAMPER AMORTIGUADOR	1	1	1	1	
24	66T-15758-00	.GUIDE, ROPE GUIA DE CUERDA	1	1	1	1	
25	97595-06535	.BOLT, WITH WASHER PERNO CON ARANDELA RONDELLE	2	2	2	2	

* CUT FROM 50M ROLLS, PART NO. 90890-44374, CUTTING LENGTH 1.8M

* CORTE DE UN RODILLO DE 50M, PARTS NUMERO 90890-44374, LARGO DEL CORTE 1.8M



66T0010-8070

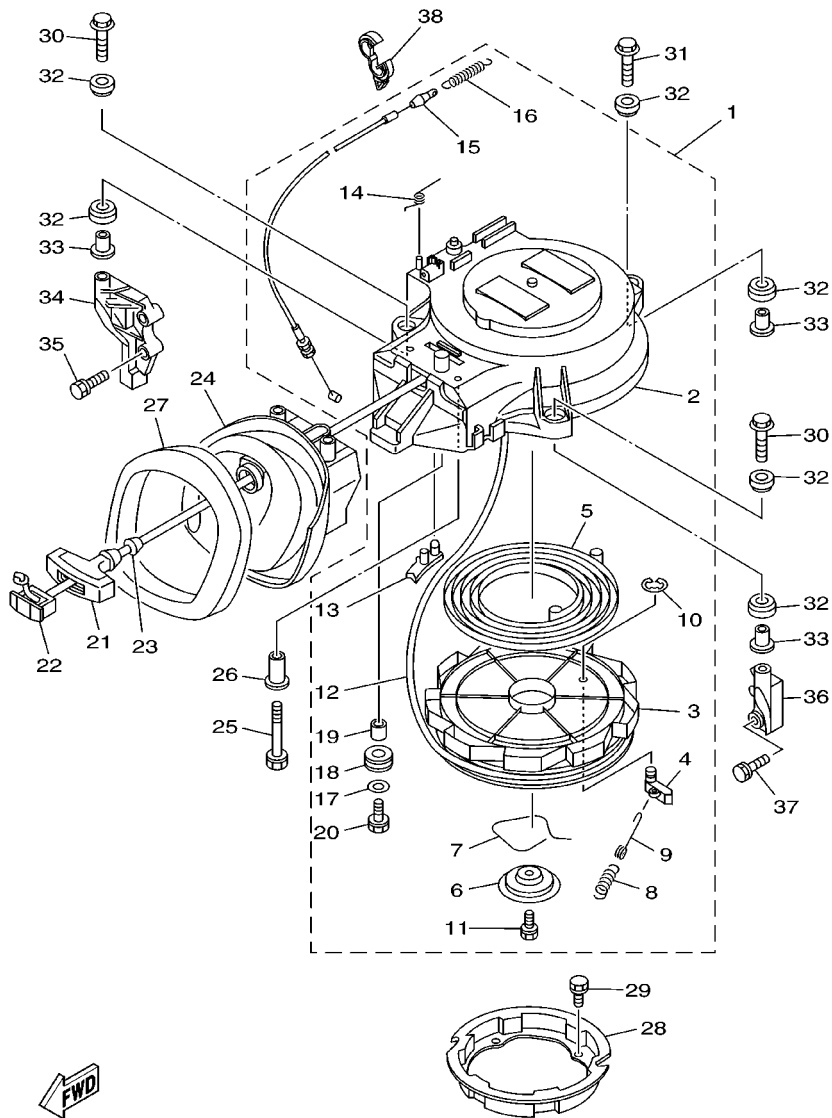

FIG. 7 STARTER

ARRANQUE

REF. NO.	PART NO. CODIGO NO.	DESCRIPTION DESCRIPTION	MH	WH	W	WT	REMARKS OBSERVACION
26	90387-06M66	COLLAR CASQUILLO CON VALONA	2	2	2	2	
27	66T-15762-00	SEAL, RUBBER 2 SELLO DE GOMA 2	1	1	1	1	
28	66T-15723-00	PULLEY, STARTER POLEA DE ARRANQUE	1	1	1	1	
29	97595-06510	BOLT, WITH WASHER PERNO CON ARANDELA RONDELLE	4	4	4	4	
30	90119-08M10	BOLT, WITH WASHER TORNILLO CON ARANDELA	2	2	2	2	
31	90119-08M51	BOLT, WITH WASHER TORNILLO CON ARANDELA	1	1	1	1	
32	90385-12M04	BUSH BUJE	6	6	6	6	
33	90387-08M05	COLLAR CASQUILLO CON VALONA	3	3	3	3	
34	66T-15771-00-94	STAY 1 SOPORTE 1	1	1	1	1	
35	97513-06530	BOLT, WITH WASHER PERNO CON ARANDELA RONDELLE	2	2	2	2	
36	66T-15772-00-94	STAY 2 SOPORTE 2	1	1	1	1	
37	97513-06530	BOLT, WITH WASHER PERNO CON ARANDELA RONDELLE	2	2	2	2	
38	90464-13249	CLAMP BRIDA	1	1	1	1	

FWD
66T0010-8070

FIG. 8 GENERATOR

GENERADOR

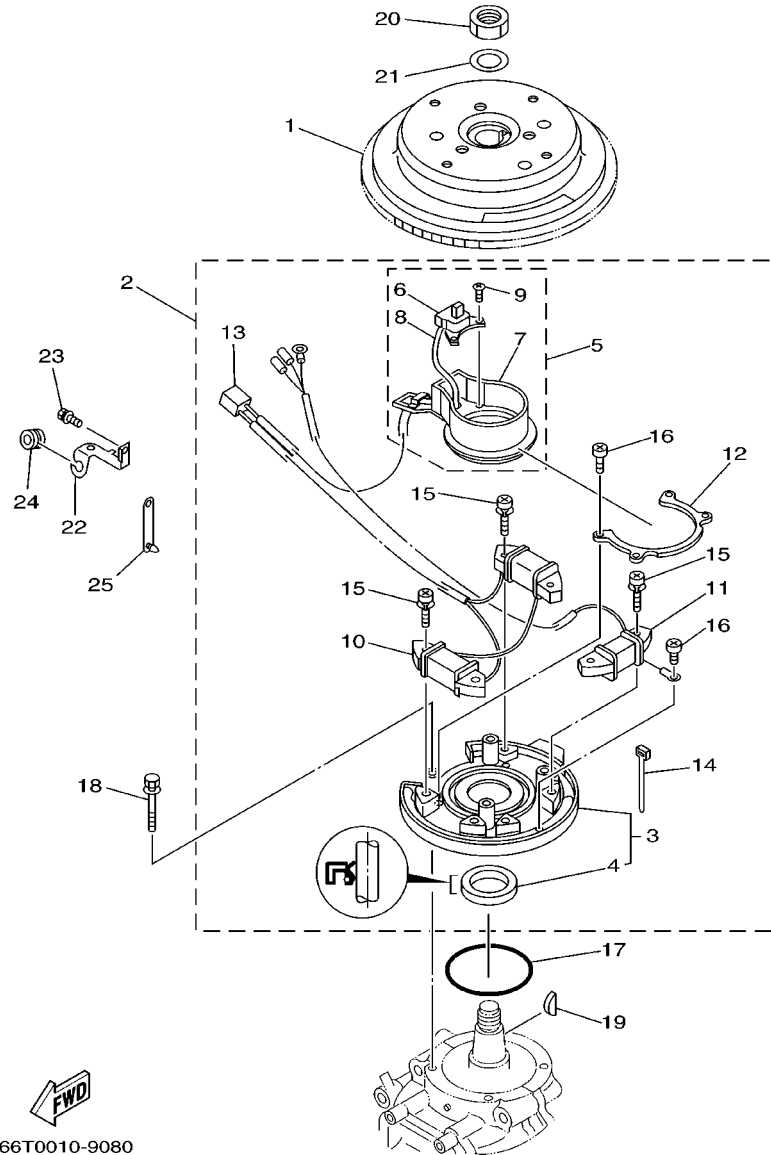

REF. NO.	PART NO. CODIGO NO.	DESCRIPTION DESCRIPTION	MH	WH	W	WT	REMARKS OBSERVACION
1	66T-85550-00	ROTOR ASSY ROTOR COMPLETO		1	1	1	
	66T-85550-10	ROTOR ASSY ROTOR COMPLETO	1				
2	66T-85560-00	BASE ASSY (W/LIGHTING COIL) CONJUNTO BASE(C/BOBINA DE LUZ)	1	1	1	1	
	66T-85560-10	BASE ASSY CONJUNTO BASE	1				
3	66T-85561-00	.BASE, MAGNETO .BASE DE MAGNETO	1	1	1	1	
4	93102-35M58	..OIL SEAL ..SELLO ACEITE	1	1	1	1	
5	66T-85580-00	.PULSER COIL ASSY .BOBINA DE PULSACION COMPLETA	1	1	1	1	
6	66T-85596-00	..COIL, PULSER 1 ..BOBINA DE PULSACION 1	1	1	1	1	
7	66T-85582-00	..ATTACHMENT, PULSER ..IMPLEMENTO DE PULSACION	1	1	1	1	
8	66T-85515-00	..LEAD WIRE ASSY ..CABLE CONDUCTOR COMPLETO	1	1	1	1	
9	97902-04108	..SCREW, WITH WASHER ..TORNILLO, CON ARANDELA	2	2	2	2	
10	66T-85520-00	.COIL, CHARGE .BOBINA DE CARGA	1	1	1	1	
11	66T-85533-00	.COIL, LIGHTING .BOBINA DE LUZ	1	1	1	1	FOR 66T-85560-00
12	66T-41611-00	.RETAINER, MAGNETO BASE .RETENEDOR BASE MAGNETO	1	1	1	1	
13	9E471-04305	.CONNECTOR CONECTOR	1	1	1	1	
14	66T-81328-00	.CLAMP .GRAMPA	1	1	1	1	
15	97902-06125	.SCREW, WITH WASHER .TORNILLO, CON ARANDELA	6	6	6	6	
16	97802-04006	.SCREW, PAN HEAD .TORNILLO DE CABEZA CON PLANA	5	5	5	5	
17	93210-75M51	O-RING ANILLO O	1	1	1	1	
18	97595-06540	BOLT, WITH WASHER PERNO CON ARANDELA RONDELLE	4	4	4	4	
19	90280-05015	KEY, WOODRUFF CUNA WOODRUFF	1	1	1	1	
20	90170-20137	NUT TUERCA	1	1	1	1	
21	90201-21M18	WASHER, PLATE ARANDELA PLANA	1	1	1	1	
22	90465-15M74	CLAMP BRIDA	1	1	1	1	
23	97595-06516	BOLT, WITH WASHER PERNO CON ARANDELA RONDELLE	1	1	1	1	
24	90480-10M71	GRÖMMÉT TAPON	1	1	1	1	
25	90464-12M00	CLAMP BRIDA	1	1	1	1	

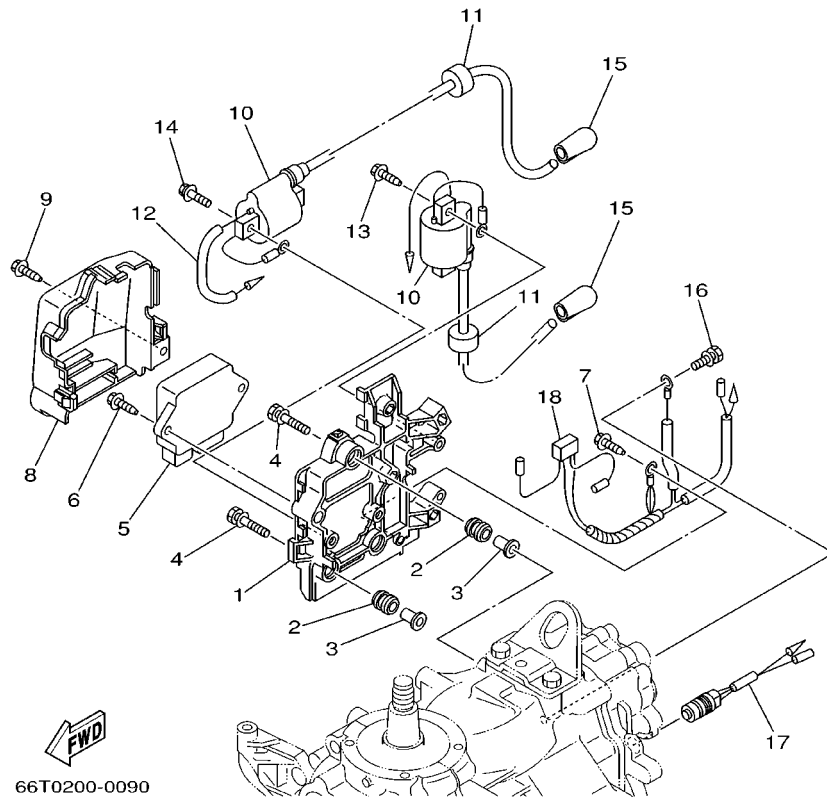
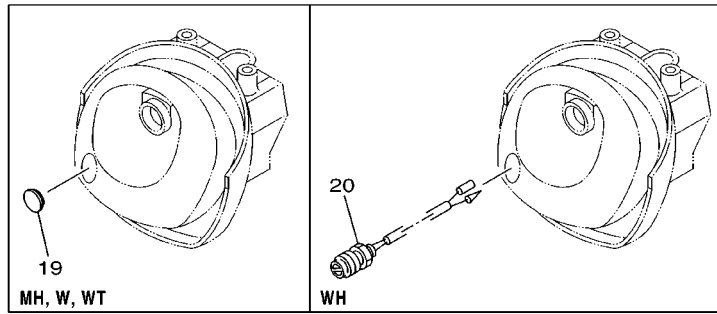

FIG. 9 ELECTRICAL 1

EQUIPO ELECTRICO 1

REF. NO.	PART NO. CODIGO NO.	DESCRIPTION DESCRIPTION	MH	WH	W	WT	REMARKS OBSERVACION
1	66T-8554B-01-94	BRACKET SOPORTE (REF.NO. 6, 7, 9, 13, FIG.10, REF.NO. 12)	1	1	1	1	
2	6A0-82317-00	DAMPER, IGNITION COIL AMORTIGUADOR BOBINA ENCENDIDO	3	3	3	3	
3	624-42542-00	PIPE TUBO	3	3	3	3	
4	90119-06M65	BOLT, WITH WASHER TORNILLO CON ARANDELA	3	3	3	3	
5	66T-85540-00	C.D.I. UNIT ASSY UNIDAD C.D.I. COMPLETA	1	1	1	1	
6	90109-06M81	BOLT PERNO	2	2	2	2	
7	90109-06M80	BOLT PERNO	1	1	1	1	
8	66T-81916-01	COVER, TERMINAL CUBIERTA DE TERMINAL	1	1	1	1	
9	90109-06M81	BOLT PERNO	1	1	1	1	
10	66T-85570-00	IGNITION COIL ASSY BOBINA DE IGNICION COMPLETO	2	2	2	2	
11	90480-25161	GROMMET TAPON	2	2	2	2	
12	90446-03MA3	HOSE TUBO RESEIRADERO	1	1	1	1	
13	90109-06M81	BOLT PERNO	2	2	2	2	
14	97595-06525	BOLT, WITH WASHER PERNO CON ARANDELA RONDELLE	2	2	2	2	
15	66T-82370-00	PLUG CAP ASSY TAPON DE BUJIA COMPLT	2	2	2		
	6E3-82370-21	PLUG CAP ASSY TAPON DE BUJIA COMPLT				2	
16	97595-06512	BOLT, WITH WASHER PERNO CON ARANDELA RONDELLE	1	1	1	1	
17	688-82560-10	THERMO SWITCH ASSY INTER. DE TERMO	1	1	1	1	
18	66T-82519-00	WIRE, EARTH LEAD CABLE CONDUCTOR A TIERRA	1	1			
19	6G1-42725-00	GROMMET TAPON	1		1	1	
20	689-81870-00	STARTING SWITCH ASSY INTERRUPTOR DE ARRANQUE COMPL.		1			

FIG. 10 ELECTRICAL 2

EQUIPO ELECTRICO 2

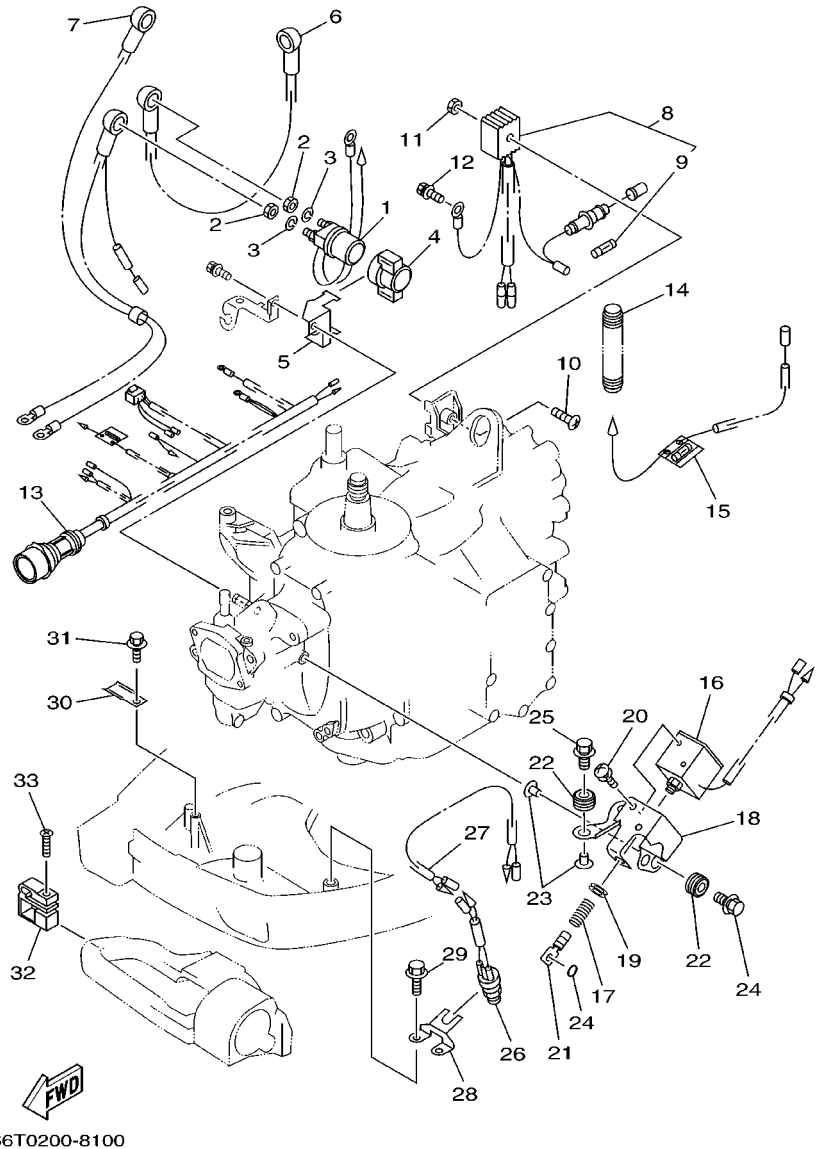

66T0200-8100

REF. NO.	PART NO. CODIGO NO.	DESCRIPTION DESCRIPTION	MH	WH	W	WT	REMARKS OBSERVACION
1	6G1-8194A-10	RELAY RELE		1	1	1	
2	90170-06M30	NUT TUERCA		2	2	2	
3	90204-06M00	WASHER, SPRING ARANDELA DE RESORTE		2	2	2	
4	6G1-81952-00	HOLDER, RELAY SOSTEN DE RELE		1	1	1	
5	6L2-81945-00	PLATE, SWITCH FITTING PLACA ACCESORIA DE INTERRUPT.		1	1		
6	6E5-82117-00	WIRE, LEAD CABLE CONDUCTOR		1	1	1	
7	66T-82105-00	WIRE HARNESS ARNES DE CABLES		1	1	1	
8	6G1-81970-61	RECTIFIER ASSY RECTIFICADOR COMPLETO		1	1	1	
9	6G1-82151-00	.FUSE .FUSIBLE		1	1	1	
10	97980-05230	SCREW, WITH WASHER TORNILLO CON ARANDELA		1	1	1	
11	95380-05600	NUT TUERCA		1	1	1	
12	90109-06M80	BOLT PERNO		1	1	1	
13	66T-82590-00	WIRE HARNESS ASSY CONJUNTO DE CABLES			1		
14	66T-83557-00	TUBE ENCHUFE DE ACEITE		1	1		I.DIA.: 13MM
	6N7-83557-00	TUBE ENCHUFE DE ACEITE				1	I.DIA.: 22MM
15	66T-82115-00	WIRE, PLUS LEAD CABLE CONDUCTOR POSITIVO		1			
16	6J4-86111-00	COIL, SOLENOID CONJUNTO BOBINA SOLENOIDE			1	1	
17	6J4-86116-00	WIRE, PULL ALAMBRE-JALADOR		1	1		
18	66T-86112-00	STAY, SOLENOID SOPORTE SOLENOIDE		1	1		
19	90480-10155	GROMMET TAPON		1	1		
20	97880-05008	SCREW, PAN HEAD TORNILLO DE CABEZA CON PLANA		4	4		
21	682-86117-00	HOOK, WIRE PULL GANCHO JALADOR DE ALAMBRE		1	1		
22	90480-10M23	GROMMET TAPON		3	3		
23	90387-06M60	COLLAR CASQUILLO CON VALONA		3	3		
24	93210-03261	O-RING ANILLO O		1	1		
25	90119-06M88	BOLT, WITH WASHER TORNILLO CON ARANDELA		3	3		
26	6F5-82540-00	NEUTRAL SWITCH ASSY INTERRUPTOR NEUTRAL COMPL		1			

FIG. 10 ELECTRICAL 2

EQUIPO ELECTRICO 2

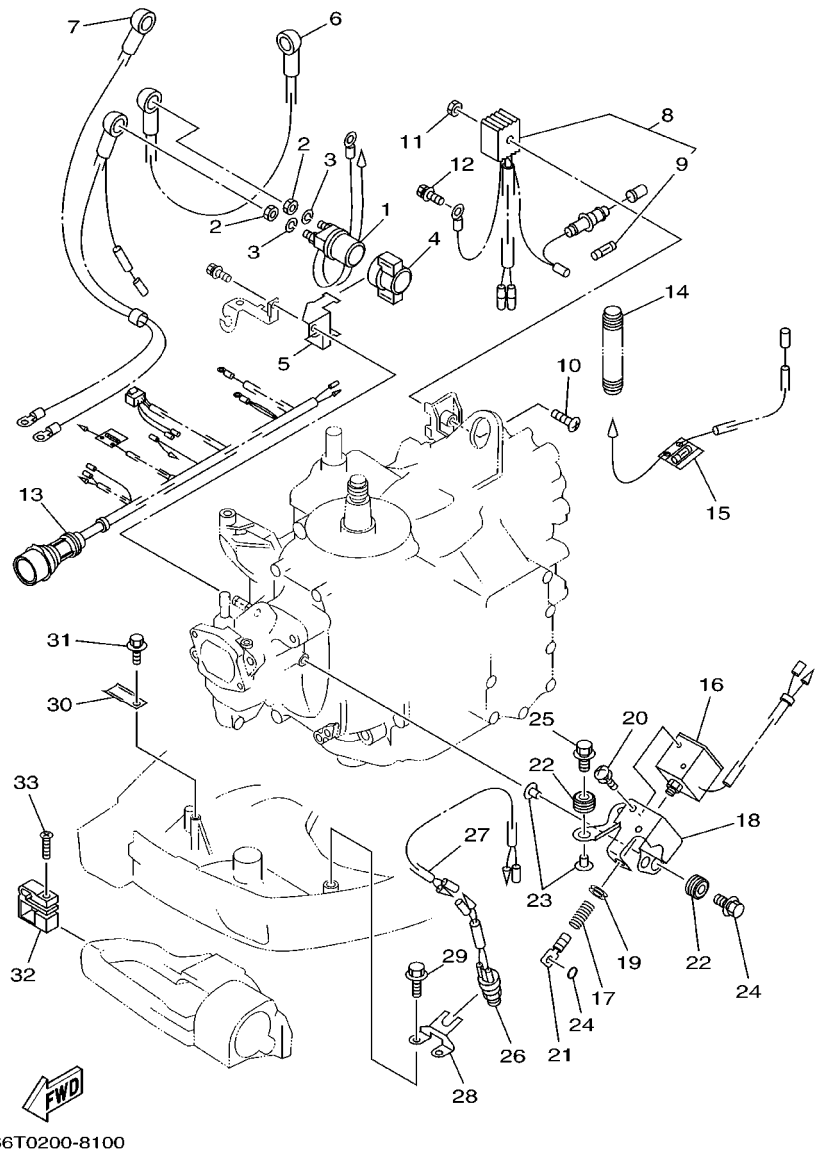

REF. NO.	PART NO. CODIGO NO.	DESCRIPTION DESCRIPTION	MH	WH	W	WT	REMARKS OBSERVACION
27	66T-82553-00	EXTENSION, WIRE LEAD CABLE		1			
28	66T-82554-00	STAY, NEUTRAL SWITCH SOPORTE INTERRUPTOR DE NEUTRAL		1			
29	90109-06M86	BOLT PERNO		2			
30	90465-20M31	CLAMP BRIDA		1	1	1	
31	90109-06M86	BOLT PERNO		1	1	1	
32	65W-82594-00	CLAMP GRAMPA		1			
33	90161-06M00	SCREW, TAPPING TORNILLO DE CABEZA PLANA		1			

FIG. 11 ELECTRICAL 3

EQUIPO ELECTRICO 3

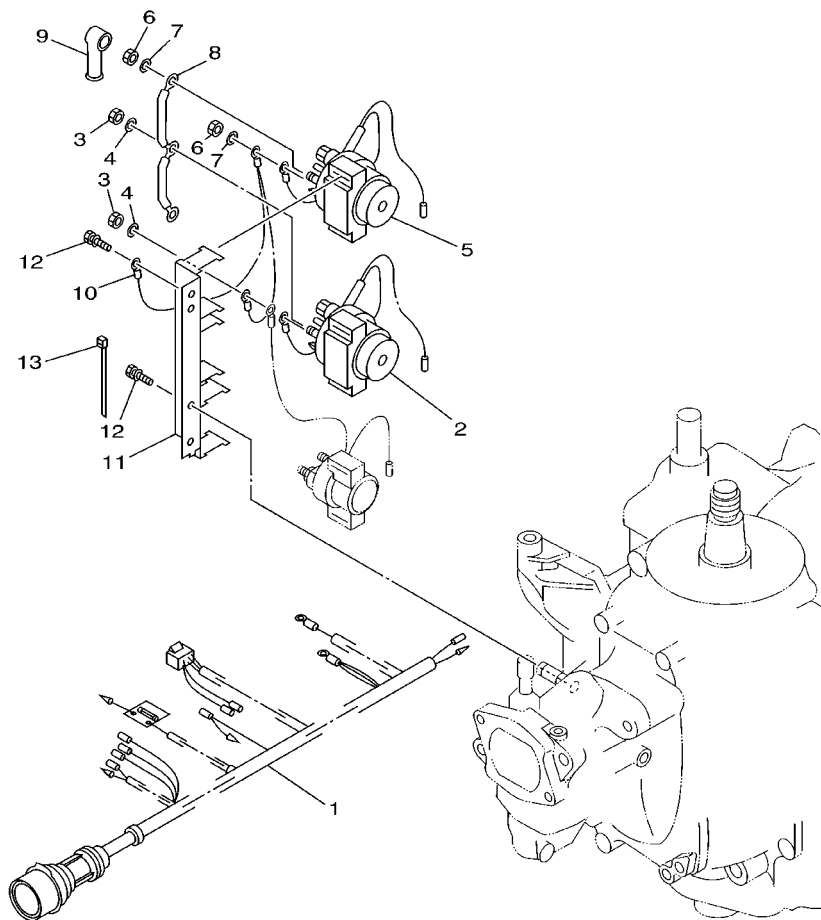



66T0010-8110

REF. NO.	PART NO. CODIGO NO.	DESCRIPTION DESCRIPTION	MH	WH	W	WT	REMARKS OBSERVACION
1	66T-82590-20	WIRE HARNESS ASSY CONJUNTO DE CABLES				1	
2	6E5-8195B-01	RELAY ASSY RELE COMPLETO				1	
3	90170-06M30	NUT TUERCA				3	
4	90204-06M00	WASHER, SPRING ARANDELA DE RESORTE				3	
5	6E5-8195C-01	RELAY ASSY RELE COMPLETO				1	
6	90170-06M30	NUT TUERCA				3	
7	90204-06M00	WASHER, SPRING ARANDELA DE RESORTE				3	
8	66T-87149-00	CONNECTOR CONECTOR				1	
9	6G5-82119-00	COVER, LEAD WIRE CUBIERTA DE CABLE CONDUCTOR				4	
10	6E5-82116-00	WIRE, MINUS LEAD CABLE CONDUCTOR NEGATIVO				1	
11	66T-81948-00	BRACKET SOPORTE				1	
12	97595-06516	BOLT, WITH WASHER PERNO CON ARANDELA RONDELLE				1	
13	90465-11M10	CLAMP BRIDA				1	

FIG. 12 STARTING MOTOR

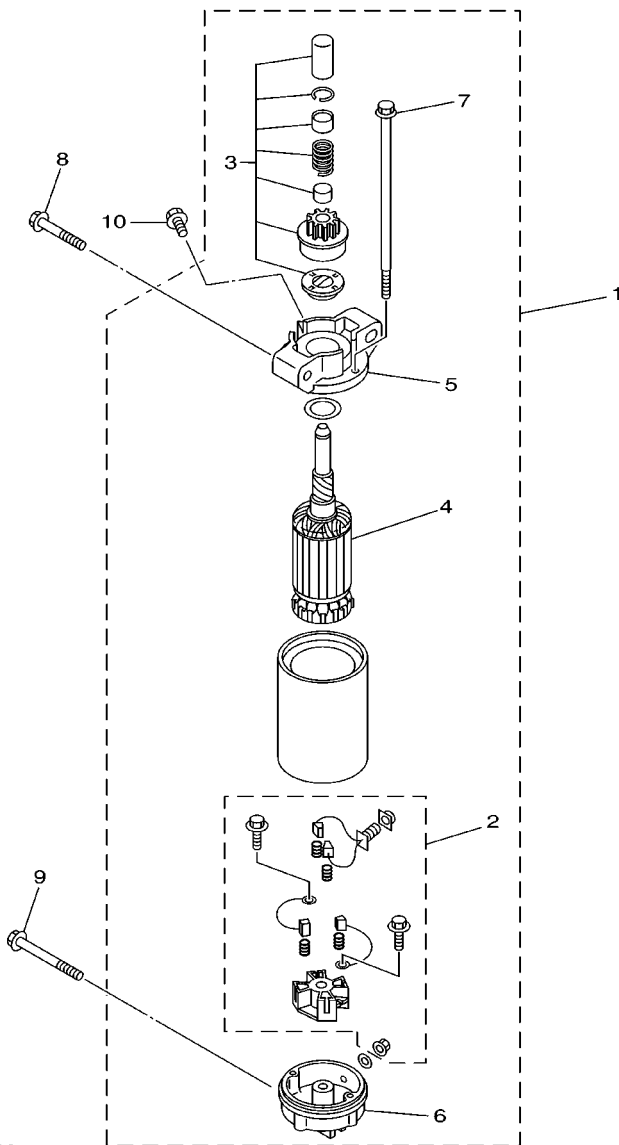
MOTOR DE ARRANQUE



66T0010-8120



REF. NO.	PART NO. CODIGO NO.	DESCRIPTION DESCRIPTION	MH	WH	W	WT	REMARKS OBSERVACION
1	66T-81800-00	STARTING MOTOR ASSY MOTOR DE ARRANQUE COMPLETO		1	1	1	
2	66T-81840-00	.BRUSH HOLDER ASSY .SOSTEN DE ESCOBILLA COMPLETO		1	1	1	
3	66T-81857-00	.PINION STOPPER SET .JUEGO TAPON PINON		1	1	1	
4	66T-81850-00	.ARMATURE ASSY .INDUCIDO COMPLETO		1	1	1	
5	66T-81830-00	.FRONT BRACKET ASSY .SOPORTE DELANTERO COMPLETO		1	1	1	
6	66T-81820-00	.REAR BRACKET ASSY .CUBIERTA TRASERA COMPL		1	1	1	
7	66T-81826-00	.BOLT .PERNO		1	1	1	
8	90119-08M39	BOLT, WITH WASHER TORNILLO CON ARANDELA		2	2	2	
9	90119-08M52	BOLT, WITH WASHER TORNILLO CON ARANDELA		1	1	1	
10	97595-08516	BOLT, WITH WASHER PERNO CON ARANDELA RONDELLE		1	1	1	

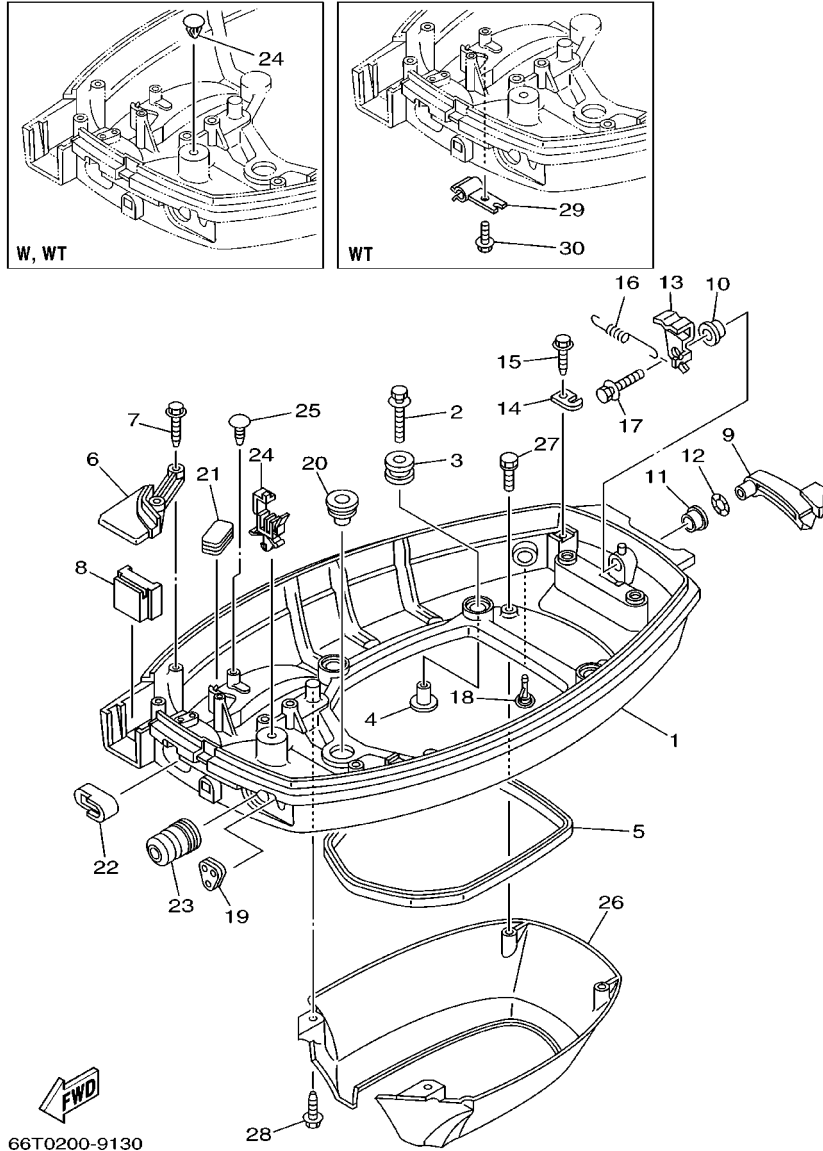

FIG. 13 BOTTOM COWLING

CUBIERTA INFERIOR

REF. NO.	PART NO. CODIGO NO.	DESCRIPTION DESCRIPTION	MH	WH	W	WT	REMARKS OBSERVACION
1	66T-42710-00-4D	BOTTOM COWLING ASSY CUBIERTA INFERIOR COMPL. (REF.NO. 7, 15, 28, 30 FIG.10, REF.NO. 29, 31 FIG.16, REF.NO. 18, 20)	1	1	1	1	
2	90119-06M61	BOLT, WITH WASHER TORNILLO CON ARANDELA	4	4	4	4	
3	90480-09M21	GROMMET TAPON	4	4	4	4	
4	90387-06M41	COLLAR CASQUILLO CON VALONA	4	4	4	4	
5	66T-42716-00	RUBBER, SEAL 1 SELLO DE GOMA 1	1	1	1	1	
6	66T-42738-00-5B	PLATE, FITTING PLACA DE AJUSTE	1	1	1	1	
7	90109-06M81	BOLT PERNO	2	2	2	2	
8	66T-42725-00	GROMMET TAPON	1				
	66T-42725-10	GROMMET TAPON		1			
	66T-42725-20	GROMMET TAPON			1	1	
9	66T-42815-00-4D	LEVER, CLAMP PALANCA ABRAZADERA	1	1	1	1	
10	90386-12M37	BUSH BUJE	1	1	1	1	
11	90386-12MA2	BUSH BUJE	1	1	1	1	
12	90206-12052	WASHER, WAVE ARANDELA ONDULADA	1	1	1	1	
13	66T-42816-00	LEVER, CLAMP PALANCA ABRAZADERA	1	1	1	1	
14	66T-43144-00	HOOK, SPRING GANCHO	1	1	1	1	
15	90109-06M86	BOLT PERNO	1	1	1	1	
16	90506-16M34	SPRING, TENSION RESORTE DE TENSIÓN	1	1	1	1	
17	90119-06M73	BOLT, WITH WASHER TORNILLO CON ARANDELA	1	1	1	1	
18	6E5-44391-00	NIPPLE, HOSE NIPLE MANGUERA	1	1	1	1	
19	65W-26326-00	GROMMET TAPON PROTECTOR	1	1			
	65W-26326-10	GROMMET TAPON PROTECTOR			1	1	
20	676-42727-00	GROMMET TAPON	1	1	1	1	
21	6H4-42726-00	GROMMET TAPON	1	1	1		
	6H1-42726-10	GROMMET TAPON				1	

FIG. 13 BOTTOM COWLING

CUBIERTA INFERIOR

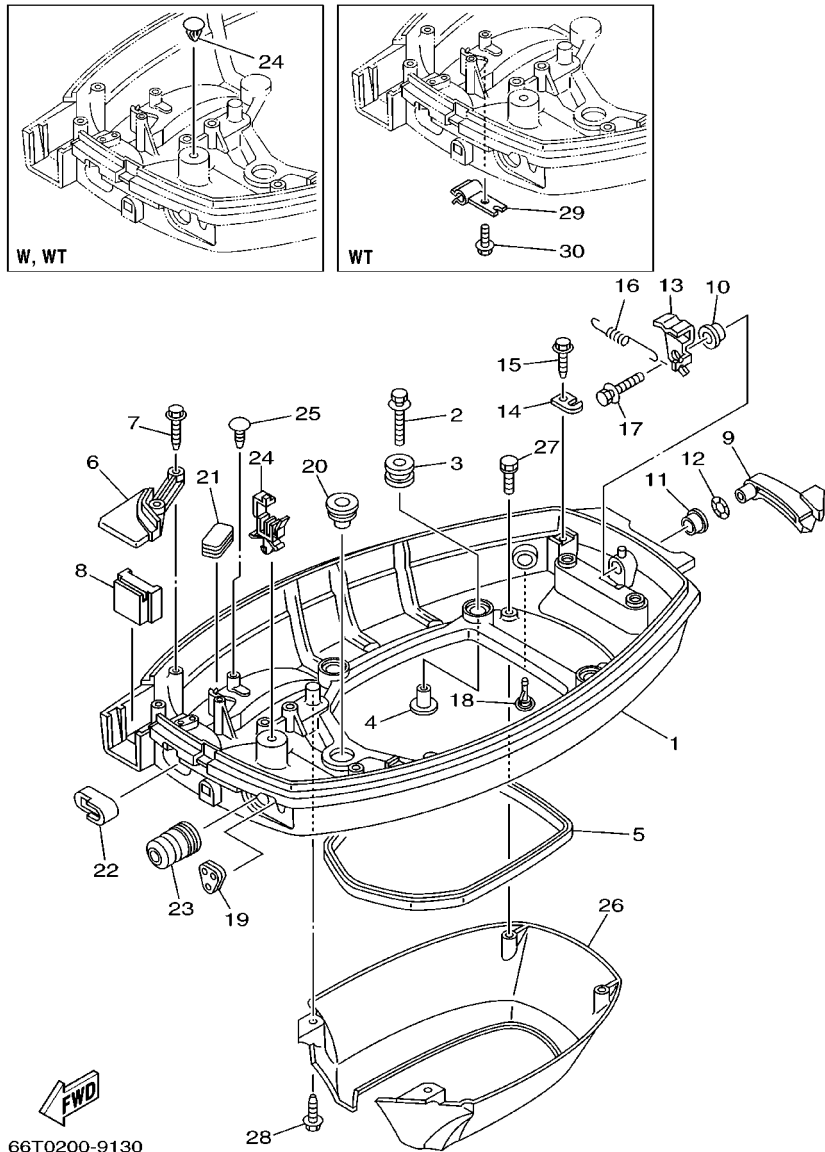

REF. NO.	PART NO. CODIGO NO.	DESCRIPTION DESCRIPTION	MH	WH	W	WT	REMARKS OBSERVACION
22	66T-24329-00	SEAL SELLO	1	1	1	1	
23	65W-42726-00	GROMMET TAPON	1	1			
	65W-42726-10	GROMMET TAPON			1	1	
24	90465-25M57	CLAMP BRIDA	1	1			
	90338-07M00	PLUG TAPON			1	1	
25	90338-05M03	PLUG TAPON	1	1	1		
26	66T-42741-00	APRON MANDIL	1	1	1	1	
27	97595-06516	BOLT, WITH WASHER PERNO CON ARANDELA RONDELLE	2	2	2	2	
28	90109-06M80	BOLT PERNO	2	2	2	2	
29	90464-09M49	CLAMP BRIDA				1	
30	90109-06M80	BOLT PERNO				1	

FIG. 14 STEERING 1

DIRECCION 1

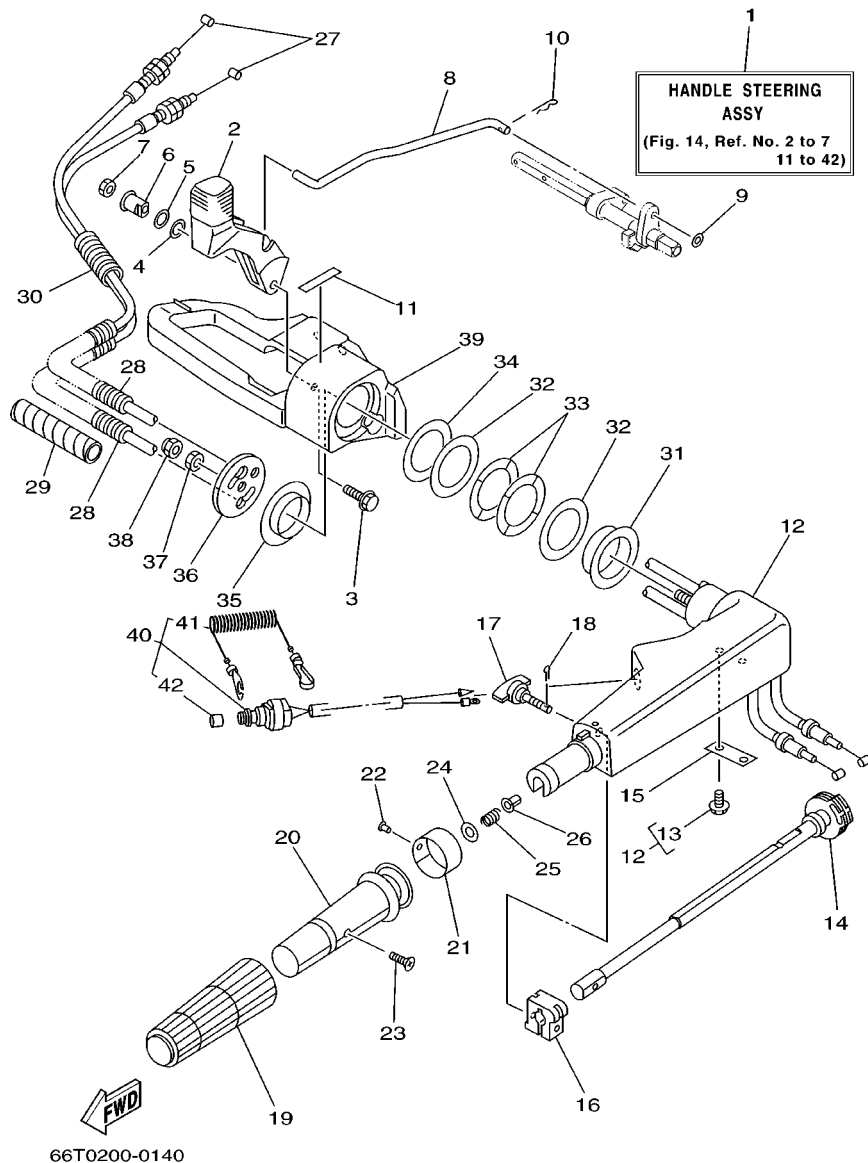

REF. NO.	PART NO. CODIGO NO.	DESCRIPTION DESCRIPTION	MH	WH	W	WT	REMARKS OBSERVACION
1	66T-W0084-01-4D	HANDLE STEERING ASSY CONJUNTO DE MANIJA	1	1			
2	66T-44111-01	HANDLE, GEAR SHIFT MANIJA DE CAMBIO DE MARCHAS	1	1			
3	90119-06M85	BOLT, WITH WASHER TORNILLO CON ARANDELA	1	1			
4	90201-12M07	WASHER, PLATE ARANDELA PLANA	1	1			
5	90206-12M00	WASHER, WAVE ARANDELA ONDULADA	1	1			
6	65W-42123-00	BOLT, HANDLE JOINT TORNILLO CONEXION DE LA MANIJA	1	1			
7	95380-06600	NUT, HEXAGON TUERCA	1	1			
8	66T-44124-00	LINK, SHIFT ROD ESLABON	1	1			
9	92990-06200	WASHER, PLAIN ARANDELA	1	1			
10	90468-18008	CLIP PRESILLA	1	1			
11	6E0-44191-11	INDICATOR, SHIFT INDICADOR DE CAMBIOS	1	1			
12	65W-42101-01-4D	HANDLE, STEERING MANIJA DE DIRECCION	1	1			
13	90109-06M86	BOLT PERNO	2	2			
14	65W-42138-00	LEVER, THROTTLE PLANCA DE ACELERACION	1	1			
15	65W-42159-00	STAY SOPORTE	1	1			
16	6G1-42126-00	FRICTION, STEERING HANDLE GRIP FRICCION DE MANGO DIRECCION	1	1			
17	65W-42125-00	BOLT, FRICTION ADJUSTING TORNILLO FRICCION ADJUSTA	1	1			
18	91490-20010	PIN, COTTER PASADOR DE CHAVETA	1	1			
19	6F6-42177-A0	RUBBER, HANDLE HULE DE MANIJA	1	1			
20	664-42119-00	GRIP, STEERING HANDLE MANGO, MANIJA DE DIRRECCION	1	1			
21	6G1-42137-10	INDICATOR, THROTTLE INDICADOR ACELERADOR	1	1			
22	90269-02M09	RIVET REMACHE	1	1			
23	90149-05M13	SCREW TORNILLO DE REGLAJE	1	1			
24	92903-10600	WASHER, PLATE ARANDELA	1	1			
25	90501-23215	SPRING, COMPRESSION RESORTE DE COMPRESION	1	1			
26	90386-08032	BUSH BUJE	1	1			
27	66T-26301-00	THROTTLE CABLE ASSY CABLE DE ACELERADOR COMPLETO	2	2			

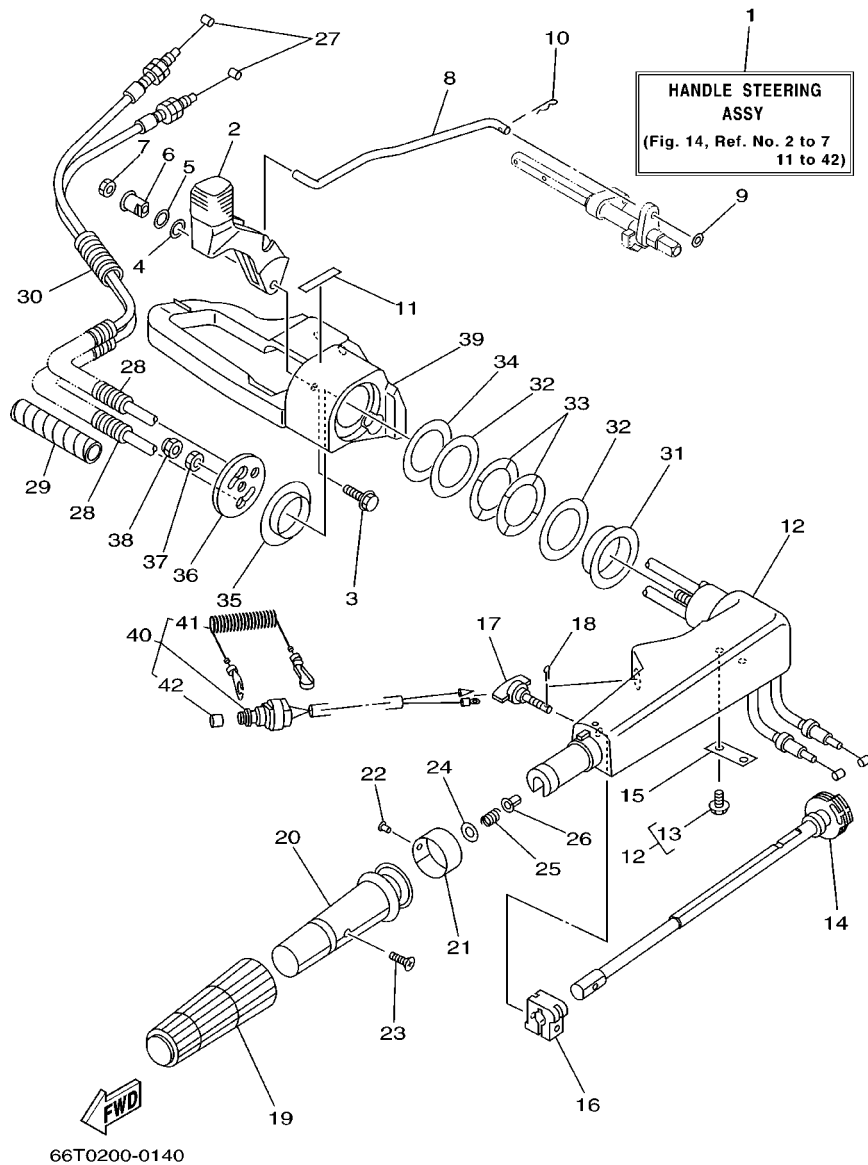

FIG. 14 STEERING 1

DIRECCION 1

REF. NO.	PART NO. CODIGO NO.	DESCRIPTION DESCRIPTION	MH	WH	W	WT	REMARKS OBSERVACION
28	90446-10M82	HOSE TUBO RESEIRADERO	2	2			
29	90446-10MH1	HOSE TUBO RESEIRADERO	2	2			
30	90446-10M86	HOSE TUBO RESEIRADERO	2	2			
31	90386-40MA0	BUSH BUJE	1	1			
32	90201-43M00	WASHER, PLATE ARANDELA PLANA	2	2			
33	90206-43M22	WASHER, WAVE ARANDELA ONDULADA	2	2			
34	90202-43M57	WASHER, PLATE ARANDELA DE PLANA	1	1			
35	90386-40M99	BUSH BUJE	1	1			
36	65W-42131-01	COVER, HANDLE STEERING CUBIERTA MANIJA DIRRECCION	1	1			
37	95380-10700	NUT TUERCA	1	1			
38	95780-10300	NUT, FLANGE TUERCA DE BRIDA	1	1			
39	65W-42121-01-4D	BRACKET SOPORTE	1	1			
40	66T-82575-00	ENGINE STOP SWITCH ASSY INTERRUPTOR DE PARADA COMPL	1	1			
41	682-82556-00	STOPPER .RETEN	1	1			
42	689-8257Y-00	.CAP .CASQUILLO	1	1			

FIG. 15 STEERING 2

DIRECCION 2

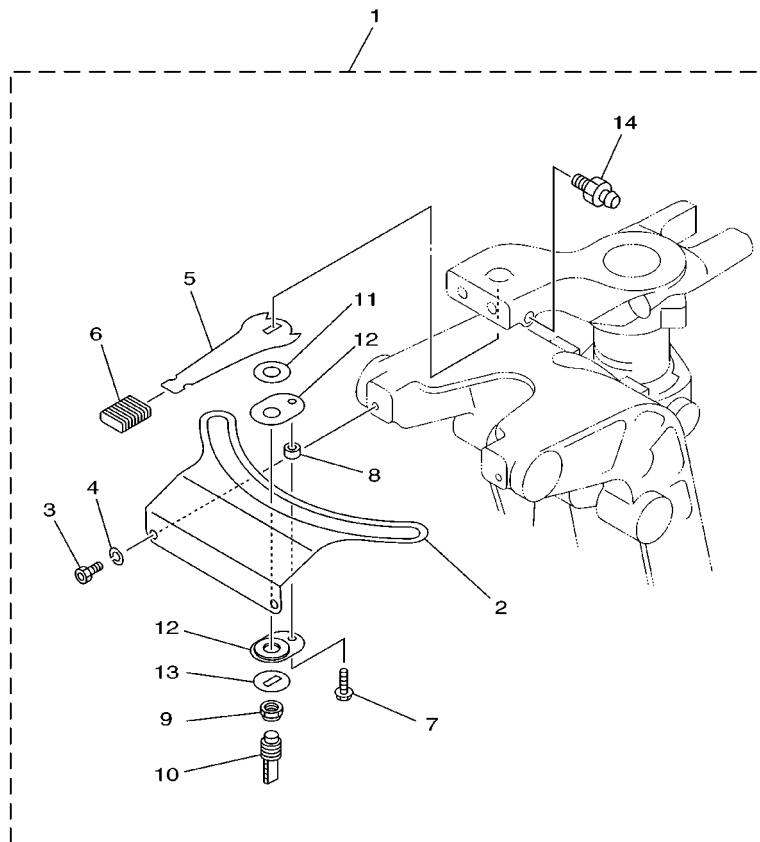

REF. NO.	PART NO. CODIGO NO.	DESCRIPTION DESCRIPTION	MH	WH	W	WT	REMARKS OBSERVACION
1	65W-42508-00	STEERING FRICTION ASSY DIRECCION FRICCION COMP.	1				AP
2	65W-42527-00	.PLATE, FRICTION .PLACA DE FRICCION	1				
3	90109-06M50	.BOLT .PERNO	2				
4	92990-06100	.WASHER, SPRING ARANDELA	2				
5	65W-42561-00	.KNOB, STEERING LOCK .PERILLA	1				
6	689-43633-00	.COVER, TILT LEVER .CUBIERTA PALANCA DE INCLINAC	1				
7	97595-05516	.BOLT, WITH WASHER .PERNO CON ARANDELA RONDELLE	1				
8	90387-05M11	.COLLAR .CASQUILLO CON VALONA	1				
9	90185-10M14	.NUT, SELF-LOCKING .TUERCA AUTOBLOCANTE	1				
10	65W-42562-00	.SHAFT, STEERING LOCK .EJE CERRADURA DE DIRECCION	1				
11	90202-10M56	.WASHER, PLATE .ARANDELA DE PLANA	1				
12	65W-42528-00	.PLATE, FRICTION .PIEZA DE FRICCION	2				
13	90209-10M26	.WASHER .ARANDELA DE SEPARACION	1				
14	93700-06M03	.NIPPLE, GREASE .NIPLE DE ENGRASAR	1				



65W0010-8180

FIG. 16 CONTROL

CONTROL

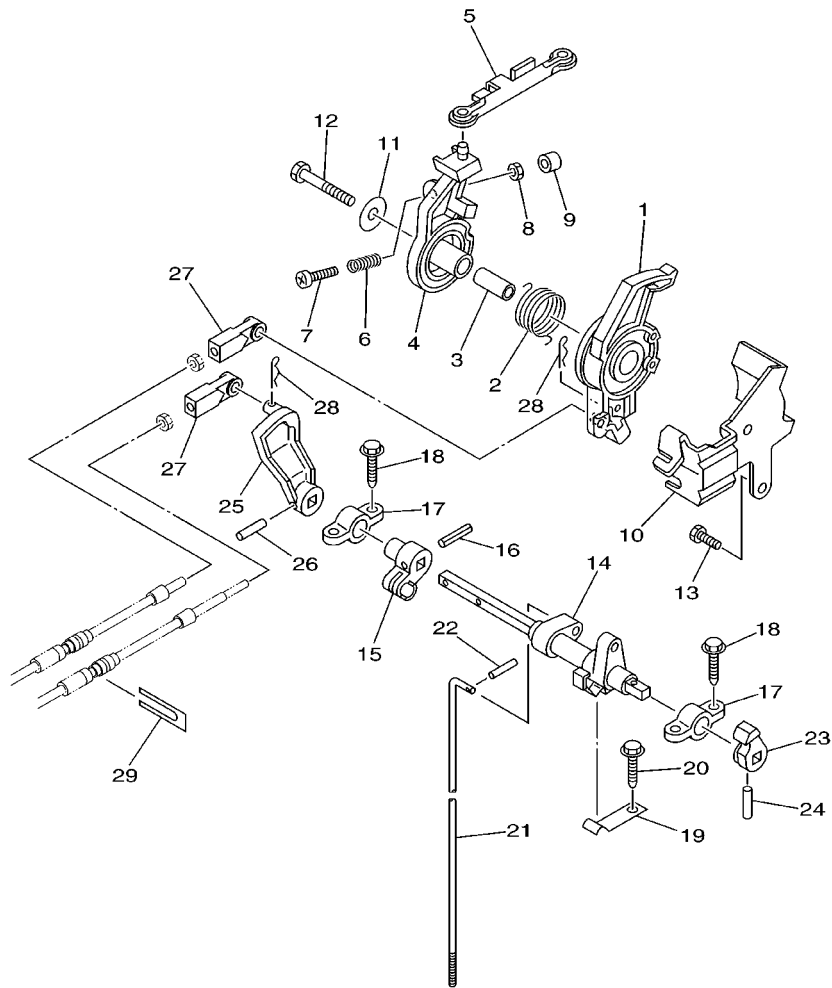

FWD
66T0010-8160

REF. NO.	PART NO. CODIGO NO.	DESCRIPTION DESCRIPTION	MH	WH	W	WT	REMARKS OBSERVACION
1	66T-41638-00	PULLEY POLEA	1	1	1	1	
2	66T-42167-00	SPRING 1 RESORTE 1	1	1	1	1	
3	90387-08M16	COLLAR CASQUILLO CON VALONA	1	1	1	1	
4	66T-41631-00	LEVER, MAGNETO CONTROL PALANCA DE CONTROL DE MAGNETO	1	1	1	1	
5	66T-41237-00	JOINT, LINK CONECTOR	1	1	1	1	
6	90501-10M84	SPRING, COMPRESSION RESORTE DE COMPRESION	1	1	1	1	
7	97880-06035	SCREW, PAN HEAD TORNILLO DE CABEZA CON PLANA	1	1	1	1	
8	95380-06700	NUT TUERCA	1	1	1	1	
9	688-44194-00	CAP TAPA	1	1	1	1	
10	66T-14497-00	STAY, THROTTLE WIRE SOPORTE VALVULA DE OBTURACION	1	1	1	1	
11	90201-08M54	WASHER, PLATE ARANDELA PLANA	1	1	1	1	
12	97095-08045	BOLT PERNO	1	1	1	1	
13	97095-06014	BOLT PERNO	1	1	1	1	
14	66T-44121-00	LEVER, SHIFT ROD PALANCA VARILLA CAMBIOS	1	1	1	1	
15	66M-44122-00	BUSHING, SHIFT ROD LEVER BUJE PALANCA VARILLA DE CAMBIO	1	1	1	1	
16	90254-03M05	PIN, SPRING PASADOR DE TIPO A RESORTE	1	1	1	1	
17	6F5-41662-00	BRACKET SOPORTE	2	2	2	2	
18	90109-06M81	BOLT PERNO	4	4	4	4	
19	682-44116-01	SPRING RESORTE	1	1	1	1	
20	90109-06M86	BOLT PERNO	1	1	1	1	
21	66T-44143-00	ROD, SHIFT VARILLA DE CAMBIO	1	1			S
	66T-44143-10	ROD, SHIFT VARILLA DE CAMBIO	1	1	1	1	L,X
22	91490-16012	PIN, COTTER PASADOR DE CHAVETA	1	1	1	1	
23	65W-44173-00	LEVER, SHIFT CONTROL PALANCA CONTROL CAMBIOS		1			
24	90254-03M04	PIN, SPRING PASADOR DE TIPO A RESORTE		1			
25	66T-44125-00	LEVER, SHIFT ROD PALANCA VARILLA CAMBIOS			1	1	
26	90254-03M04	PIN, SPRING PASADOR DE TIPO A RESORTE			1	1	

D5

FIG. 16 CONTROL

CONTROL

REF. NO.	PART NO. CODIGO NO.	DESCRIPTION DESCRIPTION	MH	WH	W	WT	REMARKS OBSERVACION
27	663-48344-00	CABLE END, REMOTE CONTROL BASE CONTROL			2	2	
28	90468-18008	CLIP PRESILLA			2	2	
29	6H3-48538-00	CLAMP, CABLE 1 GRAMPA DE CABLE			1	1	

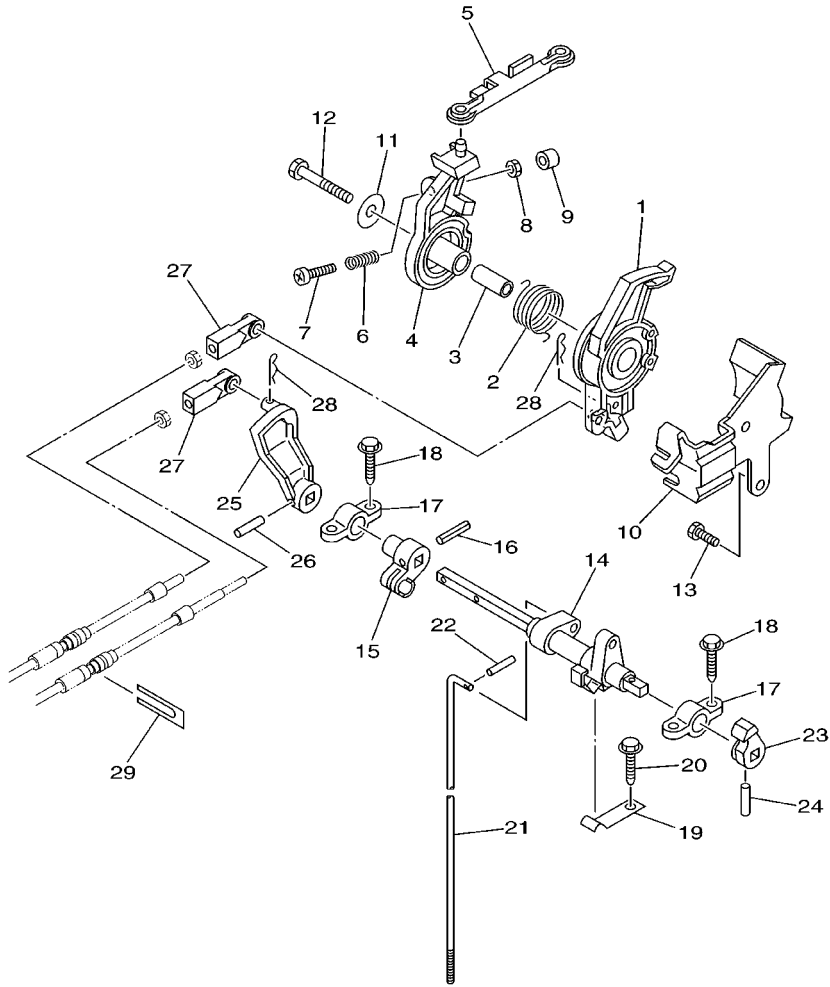

66T0010-8160

FIG. 17 REMOTE CONTROL ATTACHMENT CONJUNTO ADITAMENTO

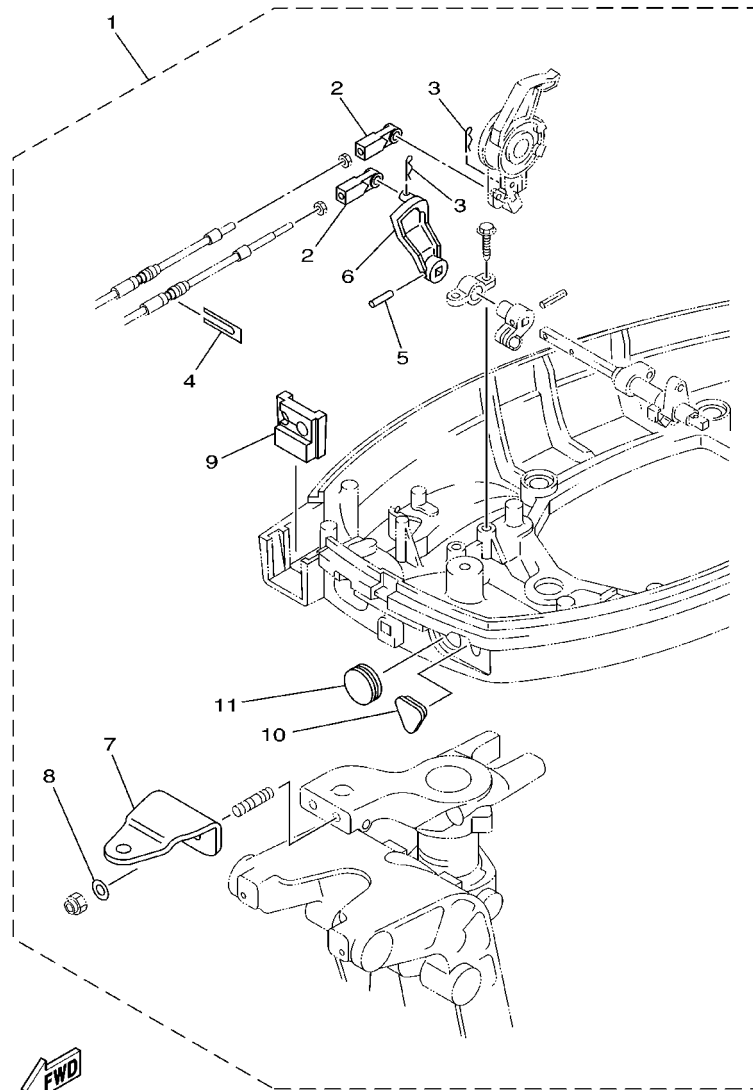

66T0010-9170

REF. NO.	PART NO. CODIGO NO.	DESCRIPTION DESCRIPTION	MH	WH	W	WT	REMARKS OBSERVACION
1	66T-48501-00	REMOTE CONT. ATTACHMENT ASSY. CONJUNTO ADITAMENTO	1	1			AP
2	663-48344-00	.CABLE END, REMOTE CONTROL .BASE CONTROL	2	2			
3	90468-18008	.CLIP .PRESILLA	2	2			
4	6H3-48538-00	.CLAMP, CABLE 1 .GRAMPA DE CABLE	1	1			
5	91690-30318	.PIN, SPRING .PASADOR DE RESORTE	1	1			
6	66T-44125-00	.LEVER, SHIFT ROD .PALANCA VARILLA CAMBIOS	1	1			
7	65W-48511-00	.HOOK, STEERING .GANCHO DIRECCION	1	1			
8	90201-10120	.WASHER, PLATE .ARANDELA PLANA	2	2			
9	66T-42725-30	.GROMMET .TAPON	1	1			
10	65W-26326-10	.GROMMET .TAPON PROTECTOR	1	1			
11	65W-42726-10	.GROMMET .TAPON	1	1			

FIG. 18 BRACKET 1

SOPORTE 1

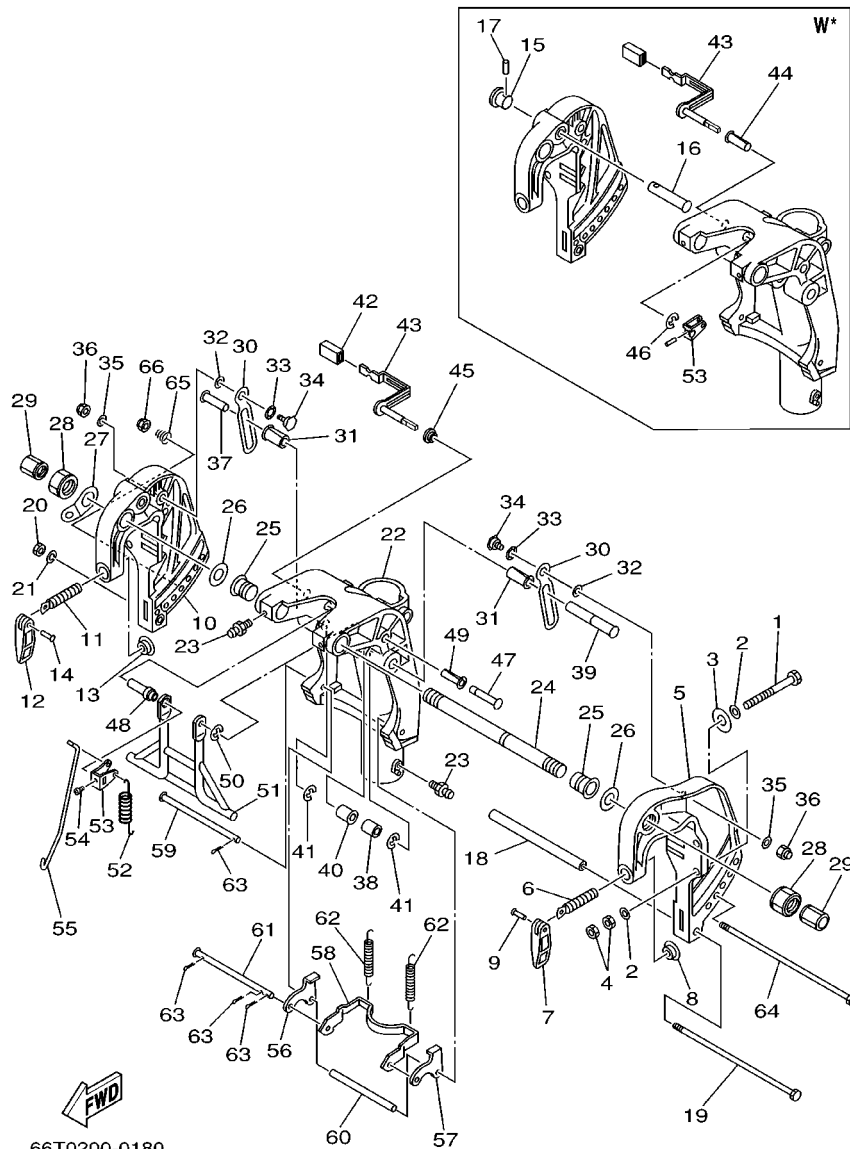

REF. NO.	PART NO. CODIGO NO.	DESCRIPTION DESCRIPTION	MH	WH	W	WT	REMARKS OBSERVACION
1	90101-10M58	BOLT TORNILLO	4	4	4		
2	92995-10600	WASHER ARANDELA	8	8	8		
3	90201-12426	WASHER, PLATE ARANDELA PLANA	4	4	4		
4	95380-10600	NUT TUERCA	8	8	8		
5	66T-43111-00-4D	BRACKET, CLAMP SOPORTE DE LA ABRAZADERA	1	1	1		
6	90149-14M12	SCREW TORNILLO DE REGLAJE	1	1	1		
7	663-43118-01-4D	HANDLE, TRANSOM CLAMP MANIJA DE LA ABRAZADERA DEL ES	1	1	1		
8	648-43114-01	PAD, TRANSOM CLAMP ARANDELA DE ABRAZADERA	1	1	1		
9	90243-04007	PIN PASADOR	1	1	1		
10	66T-43112-00-4D	BRACKET, CLAMP SOPORTE DE LA ABRAZADERA	1	1	1		
11	90149-14M12	SCREW TORNILLO DE REGLAJE	1	1	1		
12	663-43118-01-4D	HANDLE, TRANSOM CLAMP MANIJA DE LA ABRAZADERA DEL ES	1	1	1		
13	648-43114-01	PAD, TRANSOM CLAMP ARANDELA DE ABRAZADERA	1	1	1		
14	90243-04007	PIN PASADOR	1	1	1		
15	65W-43192-00	KNOB, STOPPER PERILLA DE TOPE	1	1	1		W*
16	65W-43191-00	SHAFT, STOPPER EJE DE TOPE	1	1	1		W*
17	91690-30018	PIN, SPRING PASADOR DE RESORTE	1	1	1		W*
18	90387-08M29	COLLAR CASQUILLO CON VALONA	1	1	1		
19	90101-08M76	BOLT TORNILLO	1	1	1		
20	95380-08600	NUT TUERCA	1	1	1		
21	92990-08100	WASHER, SPRING ARANDELA	1	1	1		
22	65W-43311-00-4D	BRACKET, SWIVEL SOPORTE GIRATORIO	1	1			S
	65W-43311-10-4D	BRACKET, SWIVEL SOPORTE GIRATORIO	1	1	1		L,X
W* : WITHOUT SHALLOW WATER DRIVE W* : SIN NAVEGACION EN AGUAS POCO PROFUNDAS							

FIG. 18 BRACKET 1

SOPORTE 1

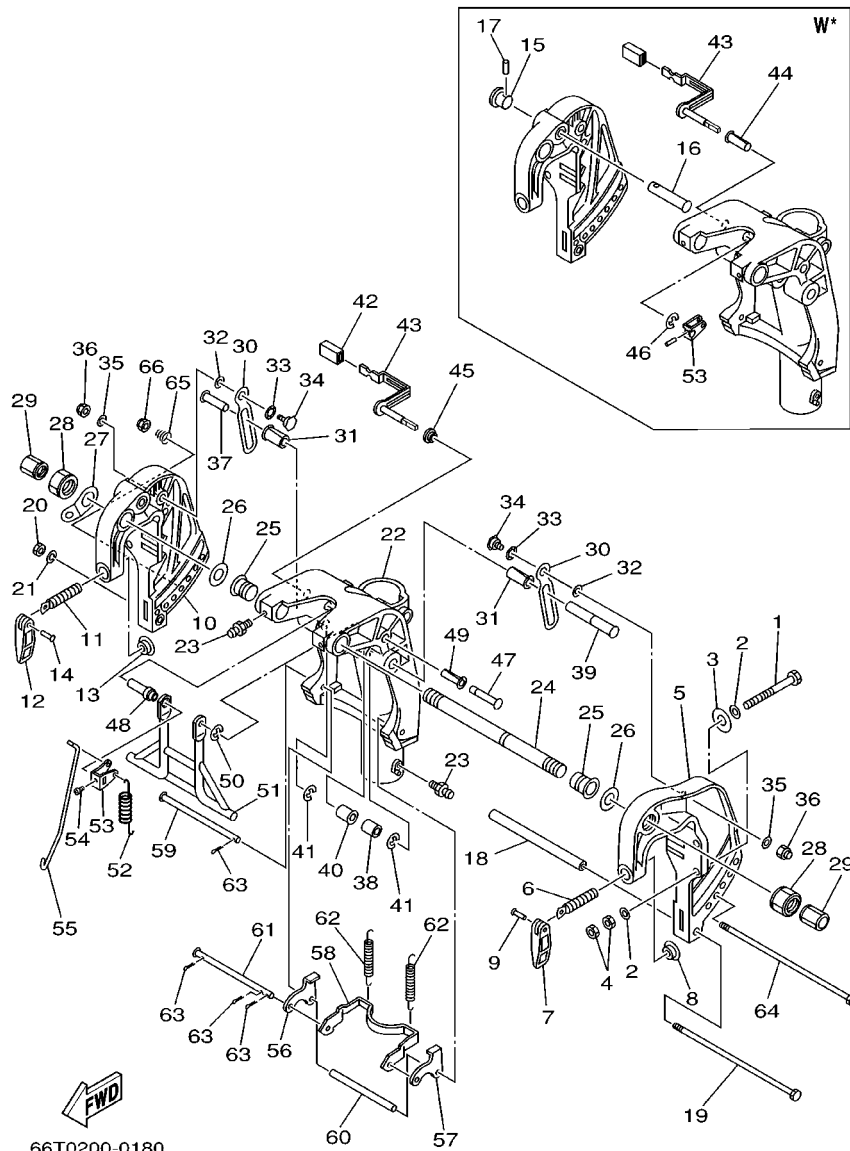

66T0200-0180

REF. NO.	PART NO. CODIGO NO.	DESCRIPTION DESCRIPTION	MH	WH	W	WT	REMARKS OBSERVACION
23	93700-06M03	NIPPLE, GREASE NIPLE DE ENGRASAR	1				
	93700-06M03	NIPPLE, GREASE NIPLE DE ENGRASAR		3	3		
24	63D-43131-00	BOLT, CLAMP BRACKET TORNILLO DE ABRAZADERA DEL SOP	1	1	1		
25	90386-22M15	BUSH BUJE	2	2	2		
26	90201-22M03	WASHER, PLATE ARANDELA PLANA	2	2	2		
27	6J8-43113-01	PLATE, CLAMP BRACKET PLACA ABRAZADERA SOPORTE	1	1	1		
28	63V-43145-00	CAP, CLAMP BRACKET TAPA	2	2	2		
29	6G5-43145-00	CAP, CLAMP BRACKET TAPA	2	2	2		
30	66T-43627-00	STOPPER RETEN	2	2	2		
31	90386-12M98	BUSH BUJE	2	2	2		
32	90202-12031	WASHER, PLATE ARANDELA DE PLANA	2	2	2		
33	90206-12M00	WASHER, WAVE ARANDELA ONDULADA	2	2	2		
34	90109-08M90	BOLT PERNO	2	2	2		
35	90201-08M07	WASHER, PLATE ARANDELA PLANA	2	2	2		
36	90185-08057	NUT, SELF-LOCKING TUERCA AUTOBLOCANTE	2	2	2		
37	90249-12M34	PIN PASADOR	1	1	1		
38	90387-12M04	COLLAR CASQUILLO CON VALONA	1	1	1		D*
39	90249-12M39	PIN PASADOR	1	1	1		D*
	90249-12M34	PIN PASADOR	1	1	1		W*
40	90386-12MA0	BUSH BUJE	1	1	1		D*
41	93430-10M00	CIRCLIP BOLA	2	2	2		
42	682-43318-01	COVER CUBIERTA	1	1	1		
43	65W-43630-11	TILT LEVER ASSY PLANCA DE INCLINACION COMPL	1	1	1		D*

D* : FOR SHALLOW WATER DRIVE
D* : PARA NAVEGACION EN AGUAS POCO PROFUNDAS

W* : WITHOUT SHALLOW WATER DRIVE
W* : SIN NAVEGACION EN AGUAS POCO PROFUNDAS

FIG. 18 BRACKET 1

SOPORTE 1

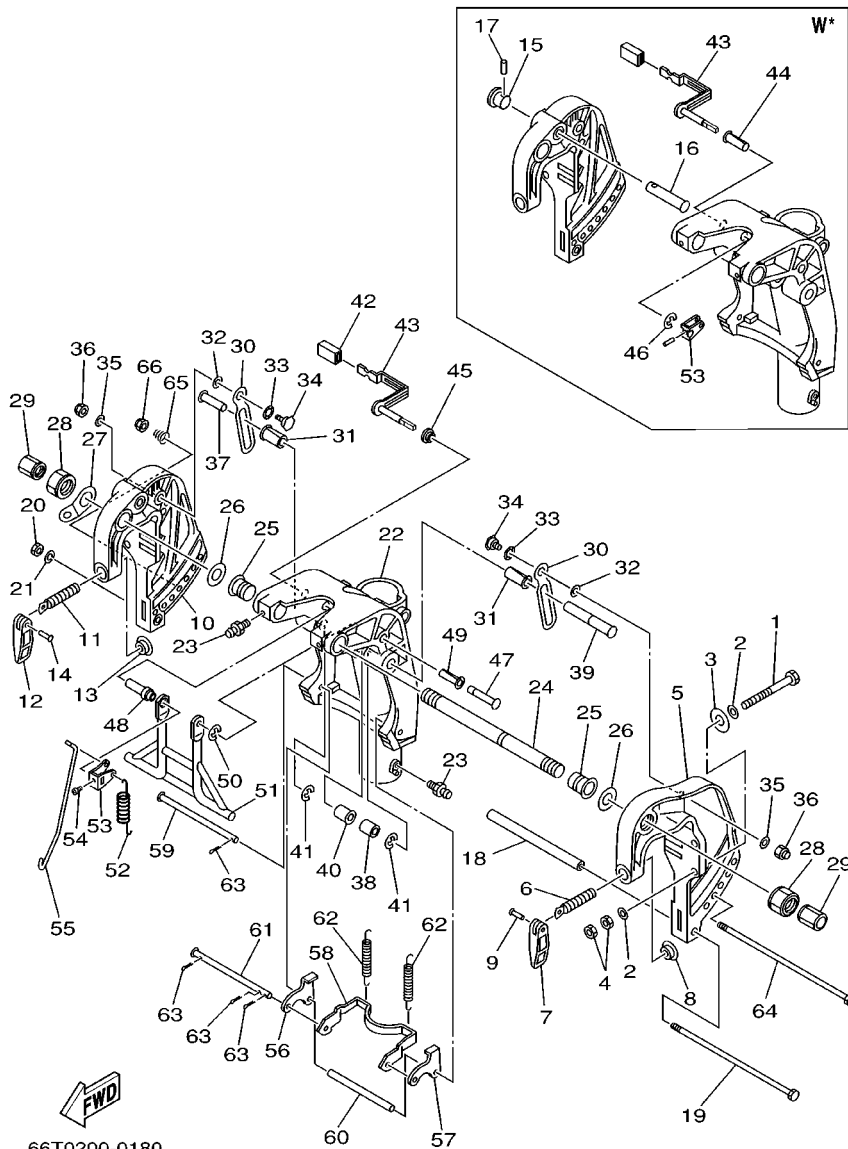

REF. NO.	PART NO. CODIGO NO.	DESCRIPTION DESCRIPTION	MH	WH	W	WT	REMARKS OBSERVACION
43	65W-43630-02	TILT LEVER ASSY PLANCA DE INCLINACION COMPL	1	1	1		W*
44	90386-10M99	BUSH BUJE	1	1	1		W*
45	90386-07MA2	BUSH BUJE	1	1	1		D*
46	99080-08600	CIRCLIP PRESILLA REDONDA	1	1	1		W*
47	90249-10M31	PIN PASADOR	1	1	1		D*
48	90387-07M05	COLLAR CASQUILLO CON VALONA	1	1	1		D*
49	90386-10M99	BUSH BUJE	1	1	1		D*
50	99080-08600	CIRCLIP PRESILLA REDONDA	1	1	1		D*
51	66T-43350-01	RECEIVER ASSY RECIBIDOR COMPL	1	1	1		D*
52	90506-20M37	SPRING, TENSION RESORTE DE TENSION	1	1	1		D*
53	66T-43631-11	LEVER, TILT PALANCA DE INCLINACION	1	1	1		D*
	66T-43631-01	LEVER, TILT PALANCA DE INCLINACION	1	1	1		W*
54	90149-05M17	SCREW TORNILLO DE REGLAJE	1	1	1		D*
	90254-03M03	PIN, SPRING PASADOR DE TIPO A RESORTE	1	1	1		W*
55	65W-43616-00	ROD, TILT LOCK VARILLA SEGURO DE INCLINACION	1	1	1		
56	65W-43614-00	PLATE, TILT LOCK PLACA DE SEGURO DE INCLINACION	1	1	1		
57	65W-43615-00	PLATE, TILT LOCK PLACA DE SEGURO DE INCLINACION	1	1	1		
58	65W-43613-00	ARM, TILT LOCK BRAZO DE SEGURO DE INCLINACION	1	1	1		
59	90249-07M32	PIN PASADOR	1	1	1		
60	90387-07M29	COLLAR CASQUILLO CON VALONA	1	1	1		
61	90249-07M33	PIN PASADOR	1	1	1		
62	90506-30M00	SPRING, TENSION RESORTE DE TENSION	2	2	2		
63	91490-20015	PIN, COTTER PASADOR DE CHAVETA	4	4	4		

D* : FOR SHALLOW WATER DRIVE
D* : PARA NAVEGACION EN AGUAS POCO PROFUNDAS

W* : WITHOUT SHALLOW WATER DRIVE
W* : SIN NAVEGACION EN AGUAS POCO PROFUNDAS

FIG. 18 BRACKET 1

SOPORTE 1

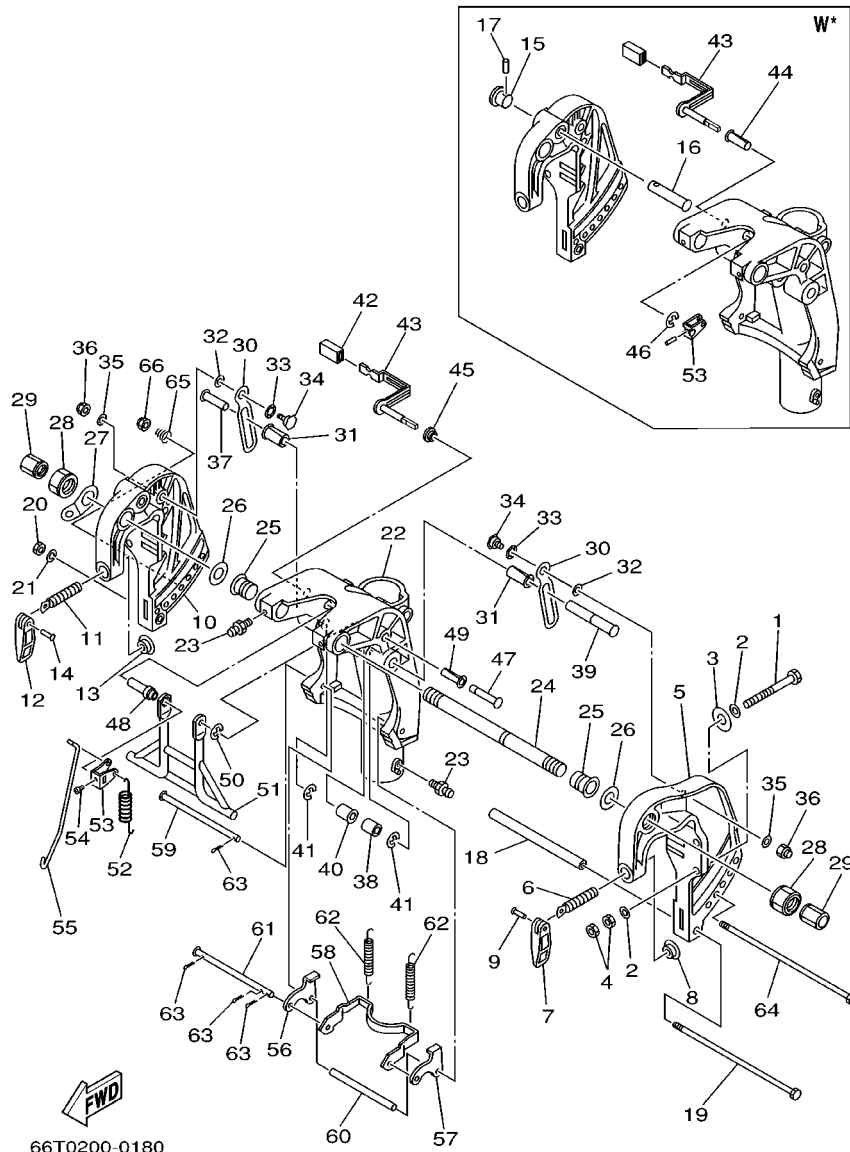

REF. NO.	PART NO. CODIGO NO.	DESCRIPTION DESCRIPTION	MH	WH	W	WT	REMARKS OBSERVACION
64	90101-08M28	BOLT TORNILLO	1	1	1		
65	90502-10M06	SPRING, CONICAL RESORTE CONICO	1	1	1		
66	90185-08057	NUT, SELF-LOCKING TUERCA AUTOBLOCANTE	1	1	1		

FIG. 19 BRACKET 2

SOPORTE 2

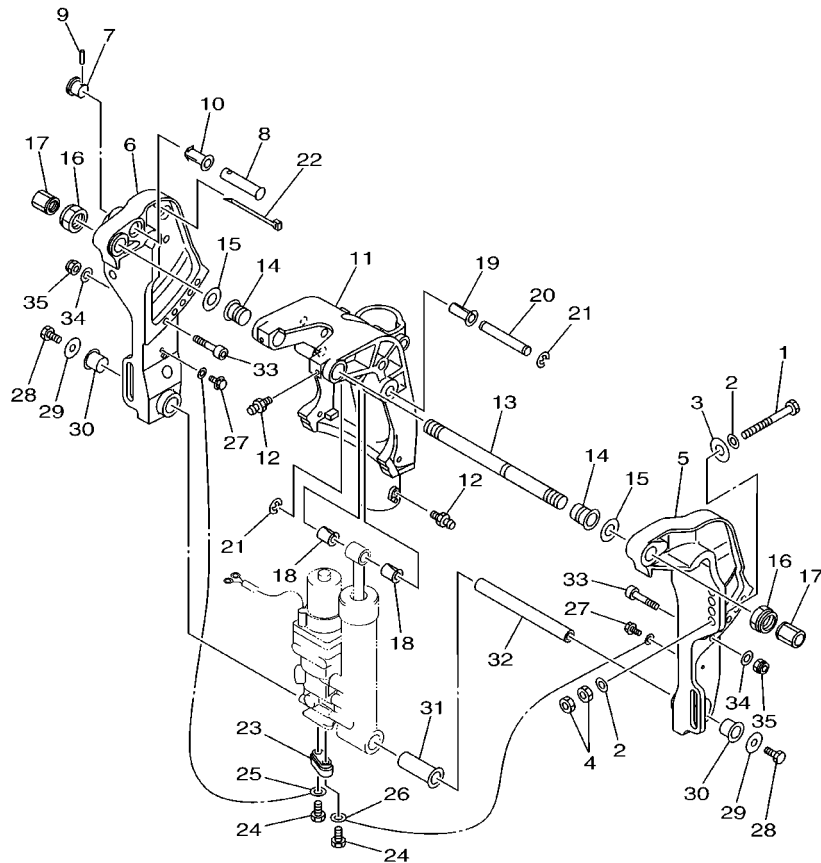

REF. NO.	PART NO. CODIGO NO.	DESCRIPTION DESCRIPTION	MH	WH	W	WT	REMARKS OBSERVACION
1	90101-12M65	BOLT TORNILLO				4	
2	92995-12200	WASHER ARANDELA				8	
3	90201-12426	WASHER, PLATE ARANDELA PLANA				4	
4	95380-12600	NUT TUERCA				8	
5	65W-43111-10-4D	BRACKET, CLAMP SOPORTE DE LA ABRAZADERA				1	
6	65W-43112-10-4D	BRACKET, CLAMP SOPORTE DE LA ABRAZADERA				1	
7	65W-43192-00	KNOB, STOPPER PERILLA DE TOPE				1	
8	65W-43191-00	SHAFT, STOPPER EJE DE TOPE				1	
9	91690-30018	PIN, SPRING PASADOR DE RESORTE				1	
10	90386-14MA1	BUSH BUJE				1	
11	65W-43311-10-4D	BRACKET, SWIVEL SOPORTE GIRATORIO				1	
12	93700-06M03	NIPPLE, GREASE NIPLE DE ENGRASAR				3	
13	63D-43131-00	BOLT, CLAMP BRACKET TORNILLO DE ABRAZADERA DEL SOP				1	
14	90386-22M15	BUSH BUJE				2	
15	90201-22M03	WASHER, PLATE ARANDELA PLANA				2	
16	90185-22M11	NUT, SELF-LOCKING TUERCA AUTOBLOCANTE				2	
17	6G5-43145-00	CAP, CLAMP BRACKET TAPA				2	
18	90386-12MA0	BUSH BUJE				2	
19	90386-12M98	BUSH BUJE				1	
20	90249-12M38	PIN PASADOR				1	
21	93430-10M00	CIRCLIP BOLA				2	
22	90465-13M11	CLAMP BRIDA				2	
23	65W-45251-00	ANODE CATODE				1	
24	97085-06025	BOLT PERNO				2	
25	6H1-82148-00	WIRE, LEAD 4 CABLE CONDUCTOR 4				1	
26	6U0-82127-00	WIRE, LEAD 2 CABLE CONDUCTOR 2				1	
27	97595-06514	BOLT, WITH WASHER PERNO CON ARANDELA RONDELLE				2	



66T0010-8190

FIG. 19 BRACKET 2

SOPORTE 2

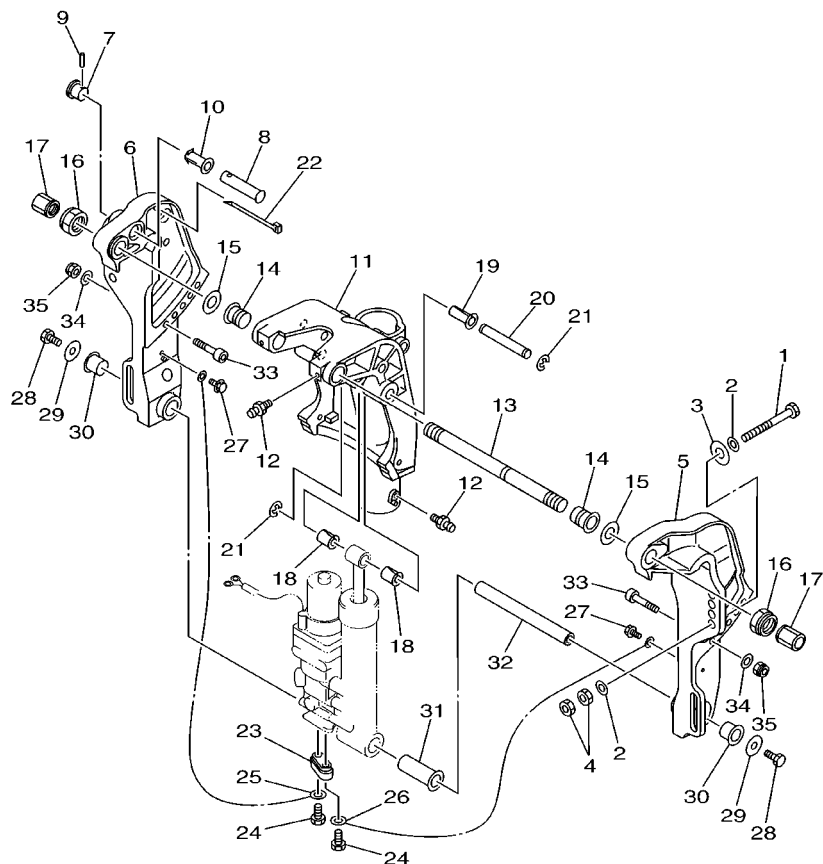

REF. NO.	PART NO. CODIGO NO.	DESCRIPTION DESCRIPTION	MH	WH	W	WT	REMARKS OBSERVACION
28	97080-08016	BOLT PERNO				2	
29	90201-08M00	WASHER, PLATE ARANDELA PLANA				2	
30	90386-18M44	BUSH BUJE				2	
31	90386-18MA0	BUSH BUJE				1	
32	90249-18M35	PIN PASADOR				1	
33	90110-10M02	BOLT, HEXAGON SOCKET HEAD TORNILLO ALLEN				2	
34	92995-10600	WASHER ARANDELA				2	
35	90185-10M13	NUT, SELF-LOCKING TUERCA AUTOBLOCANTE				2	



66T0010-8190

FIG. 20 BRACKET 3

SOPORTE 3

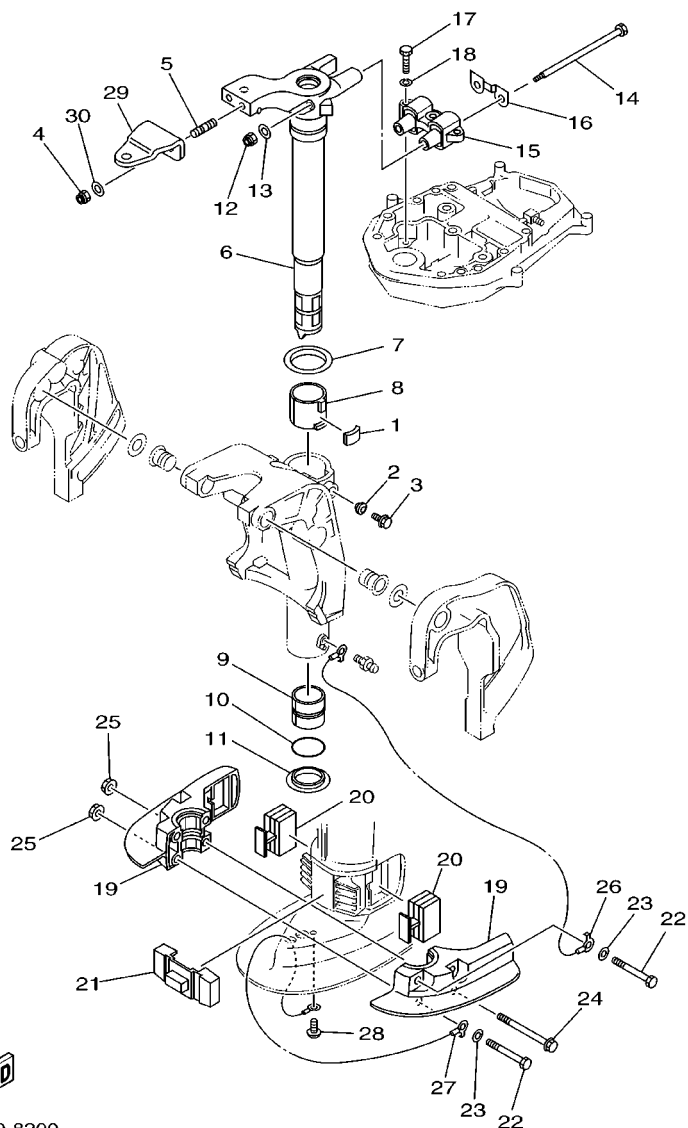

66T0010-8200

REF. NO.	PART NO. CODIGO NO.	DESCRIPTION DESCRIPTION	MH	WH	W	WT	REMARKS OBSERVACION
1	648-42528-00	PLATE, FRICTION PIEZA DE FRICCION	1	1	1	1	
2	65W-43373-00	SEAL, DAMPER SELLO DE GOMA	1	1	1	1	
3	90105-08M76	BOLT, WASHER BASED TORNILLO CON ARANDELA	1	1	1	1	
4	90185-10051	NUT, SELF-LOCKING TUERCA AUTOBLOCANTE	2	2	2	2	
5	90116-10M28	BOLT, STUD ESPARRAGO	2	2	2	2	
6	65W-42511-00-4D	BRACKET, STEERING SOPORTE DE DIRECCION	1	1			S
	65W-42511-10-4D	BRACKET, STEERING SOPORTE DE DIRECCION	1	1	1	1	L,X
7	90209-52M00	WASHER ARANDELA DE SEPARACION	1	1	1	1	
8	90386-52M02	BUSH BUJE	1	1	1	1	
9	90386-44M03	BUSH BUJE	1	1	1	1	
10	93210-43MJ0	O-RING ANILLO O	1	1	1	1	
11	90386-44M99	BUSH BUJE	1	1	1	1	
12	90185-08045	NUT, SELF-LOCKING TUERCA AUTOBLOCANTE	2	2	2	2	
13	92995-08200	WASHER ARANDELA	2	2	2	2	
14	90101-08M86	BOLT TORNILLO	2	2	2	2	
15	66T-44514-00-4D	MOUNT DAMPER, UPPER SIDE AMORTIGUADOR LADO SUPERIOR	1	1	1	1	S,L
	66T-44514-30-4D	MOUNT DAMPER, UPPER SIDE AMORTIGUADOR LADO SUPERIOR	1				X
16	66T-44526-00	PLATE PLACA 1	1	1	1	1	S,L
	66T-44526-30	PLATE PLACA 1	1				X
17	97075-08030	BOLT PERNO	3	3	3	3	
18	92995-08100	WASHER ARANDELA	3	3	3	3	
19	65W-44551-00-4D	HOUSING, LOWER MOUNT RUBBER CAJA AMORTIGUADOR INFERIOR HU	2	2	2	2	
20	65W-44555-10	MOUNT DAMPER, LOWER SIDE AMORTIGUADOR DE HULE LADO INFE	2	2	2	2	
21	66T-44575-00	DAMPER, LOWER MOUNT RUBBER AMORTIGUADOR INFERIOR	1	1	1	1	
22	97075-10070	BOLT PERNO	2	2	2	2	
23	92995-10600	WASHER ARANDELA	2	2	2	2	
24	90119-10M04	BOLT, WITH WASHER TORNILLO CON ARANDELA	2	2	2	2	

FIG. 20 BRACKET 3

SOPORTE 3

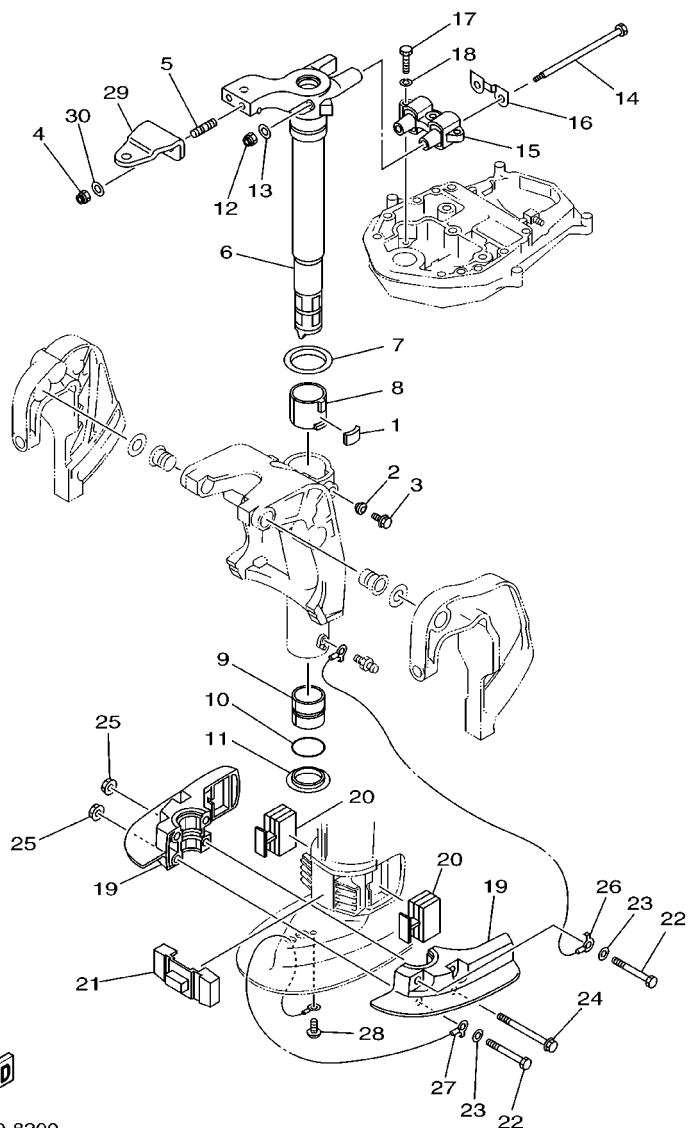

66T0010-8200

REF. NO.	PART NO. CODIGO NO.	DESCRIPTION DESCRIPTION	MH	WH	W	WT	REMARKS OBSERVACION
25	90179-10M33	NUT TUERCA	4	4	4	4	
26	66T-82127-00	WIRE, LEAD 2 CABLE CONDUCTOR 2				1	
27	66T-82127-10	WIRE, LEAD 2 CABLE CONDUCTOR 2				1	
28	97885-06008	SCREW, PAN HEAD TORNILLO DE CABEZA CON PLANA				1	
29	65W-48511-00	HOOK, STEERING GANCHO DIRECCION			1	1	
30	90201-10120	WASHER, PLATE ARANDELA PLANA			2	2	

FIG. 21 POWER TRIM & TILT ASSY COMPONER Y PODER VARILLA

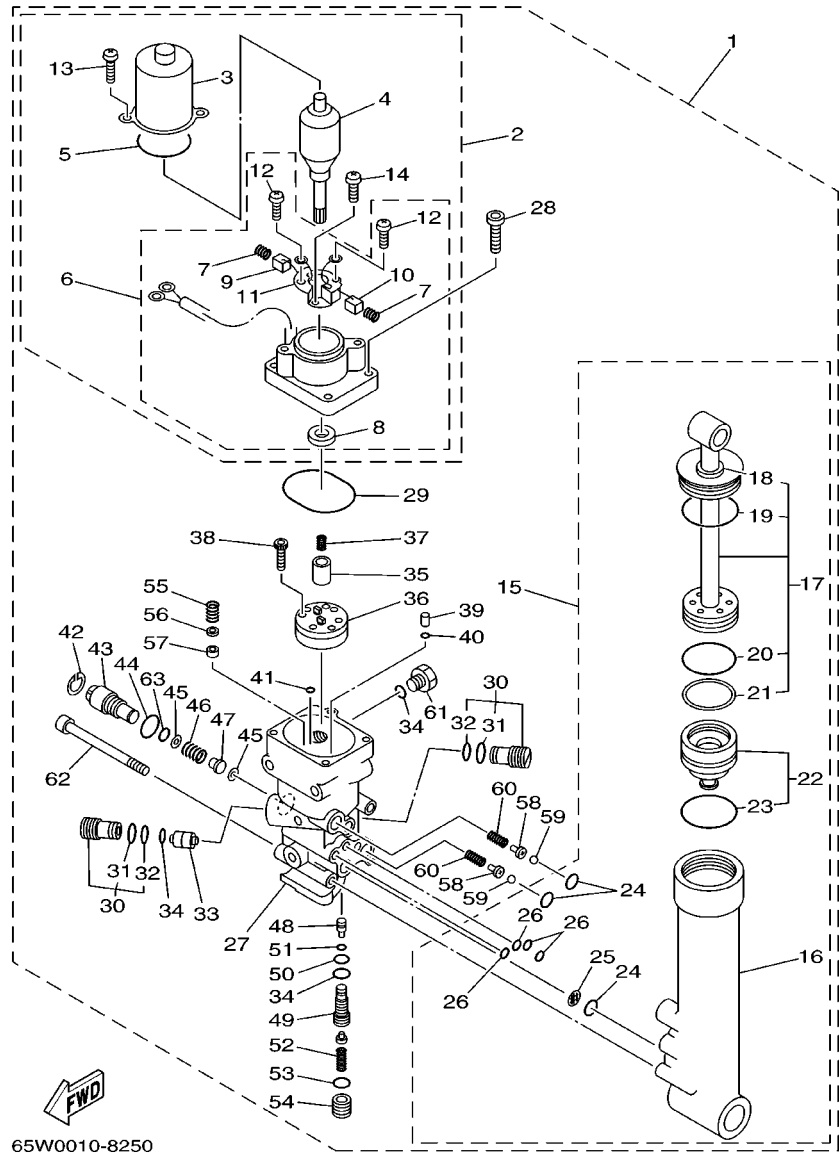

65W0010-8250

REF. NO.	PART NO. CODIGO NO.	DESCRIPTION DESCRIPTION	MH	WH	W	WT	REMARKS OBSERVACION
1	65W-43800-02-4D	POWER TRIM & TILT ASSY ELEVADOR HIDRAULICO COMPL				1	
2	65W-43880-00	.MOTOR ASSY .MOTOR COMPL.				1	
3	65W-43804-00	.STATOR ASSY .ESTATOR COMPL				1	
4	65W-43805-00	.ARMATURE ASSY .INDUCIDO COMPL.				1	
5	65W-43869-00	.O-RING .ANILLO EN O 9				1	
6	65W-43881-00	.FRAME, END .CUADRO EXTERMO				1	
7	65W-4386K-00	.SPRING, BRUSH .RESORTE, ESCOBILLA				2	
8	65W-43882-00	.OIL SEAL .SELLO ACEITE				1	
9	65W-43892-00	.BRUSH 2 .ESCOBILLA 2				1	
10	65W-43891-00	.BRUSH 1 .ESCOBILLA 1				1	
11	65W-4380F-00	.PLATE, BRUSH HOLDER .PLACA				1	
12	65W-43879-00	.SCREW, WITH WASHER .TORNILLO CON RONDANA				2	
13	65W-43887-00	.BOLT, THROUGH .TORNILLO				2	
14	65W-4388E-00	.BOLT .PERNO				1	
15	65W-43840-00	.POWER TILT ASSY .CONJUNTO COMPONER				1	
16	65W-4380K-00	.CYLINDER, TILT SUB ASSY .CILINDRO, INCLINACION				1	
17	65W-43810-00	.PISTON SUB ASSY .SUB-PISTON COMPL				1	
18	65W-43812-00	.SEAL, DUST .SELLO DE POLVO				1	
19	65W-43865-00	.O-RING .ANILLO EN O 5				1	
20	6H1-43861-10	.O-RING .ANILLO EN O 1				1	
21	65W-43871-00	.RING, BACK UP .ANILLO				1	
22	65W-4381B-00	.FREE PISTON SUB ASSY .SUB-PISTON COMPL				1	
23	6H1-43861-10	.O-RING .ANILLO EN O 1				1	
24	93210-11368	.O-RING .ANILLO O				3	
25	6H1-43816-00	.FILTER 1 .FIELTRO 1				1	
26	93210-064A5	.O-RING .ANILLO O				4	
27	65W-4380L-00	.HOUSING, TRIM & TILT SUB ASSY .CAJA, INCLINACION Y ADRNO				1	

FIG. 21 POWER TRIM & TILT ASSY COMONER Y PODER VARILLA

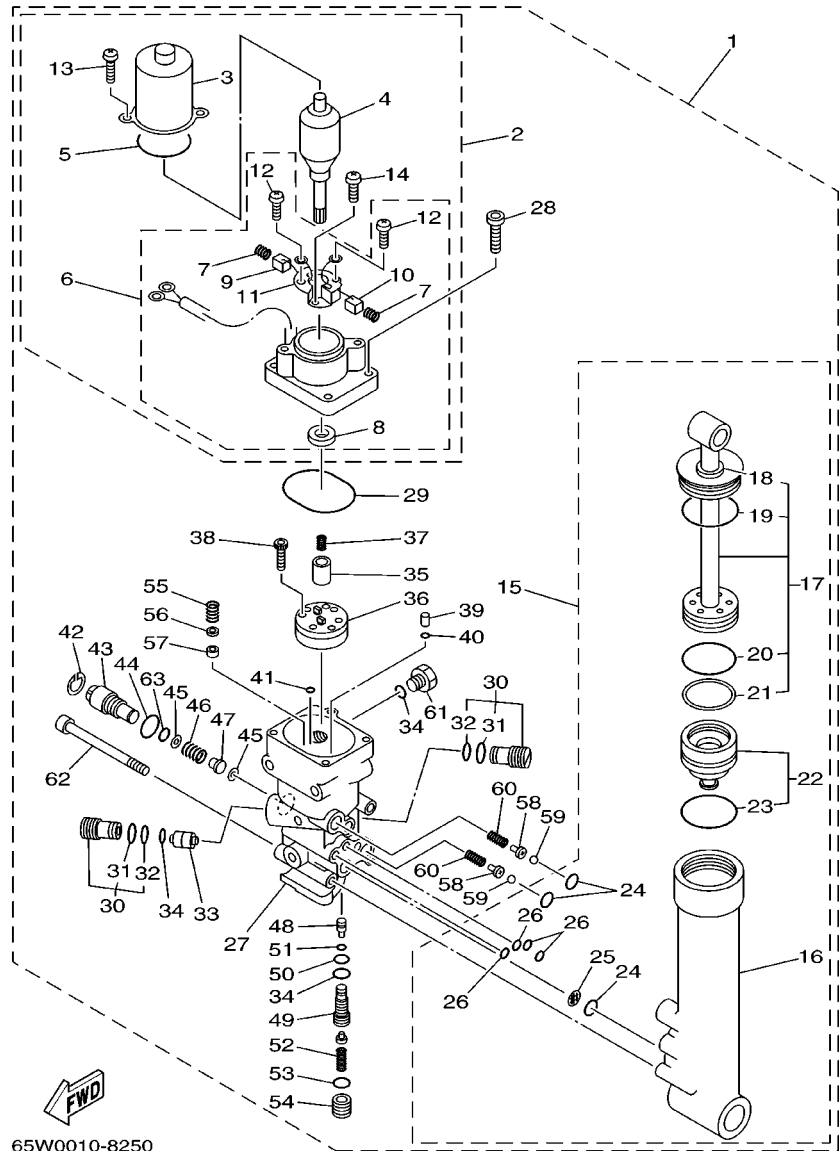

REF. NO.	PART NO. CODIGO NO.	DESCRIPTION DESCRIPTION	MH	WH	W	WT	REMARKS OBSERVACION
28	65W-43888-00	.BOLT, SOCKET .TORNILLO ENCASTRE				4	
29	93210-50768	.O-RING .ANILLO O				1	
30	6T4-43802-03	.VALVE SUB ASSY .VALVULA PRINCIPAL COMPL.				2	
31	6H1-43866-00	.O-RING .ANILLO EN O 6				1	
32	6H1-43867-00	.O-RING .ANILLO EN O 7				1	
33	62X-43841-00	.PISTON, SHUTTLE .PISTON				1	
34	93210-09165	.O-RING .ANILLO O				3	
35	65W-43831-00	.CONNECTOR, SHAFT .CONEXION EJE				1	
36	65W-43830-00	.GEAR PUMP ASSY .ENGRANAJE BOMBA COMPL.				1	
37	6T4-43853-00	.SPRING, MAIN VALVE .RESORTE				1	
38	91318-04025	.BOLT .PERNO				4	
39	65W-43817-00	.FILTER 2 .FILTRO 2				2	
40	65W-43861-00	.O-RING .ANILLO EN O 1				2	
41	65W-43862-00	.O-RING .ANILLO EN O 2				2	
42	6H1-43875-00	.RING, SNAP .ANILLO				1	
43	6H1-43845-00	.SCREW, MANUAL RELEASE .TORNILLO DESCOPLO MANUAL				1	
44	93210-18397	.O-RING .ANILLO O				1	
45	6H1-43847-00	.SEAT, MANUAL VALVE .ASIENTO VALVULA MANUAL				2	
46	65W-43854-00	.SPRING, MANUAL RELEASE .RESORTE DESCOPLO MANUAL				1	
47	65W-4382A-00	.ADAPTOR 1 .ADAPTADOR 1				1	
48	65W-43844-00	.PIN, VALVE SUPPORT .PASADOR VALVULA SOPORTE				1	
49	65W-43851-00	.SEAT, RELIEF VALVE .ASIENTO VALVULA DE DESCARGA				1	
50	93210-08006	.O-RING .ANILLO O				1	
51	93210-03478	.O-RING .ANILLO O				1	
52	65W-43855-00	.SPRING, UP RELIEF .RESORTE SEGURIDAD SUPERIOR				1	
53	93210-11073	.O-RING .ANILLO O				1	
54	65W-43843-00	.SCREW, VALVE LOCK .TORNILLO				1	

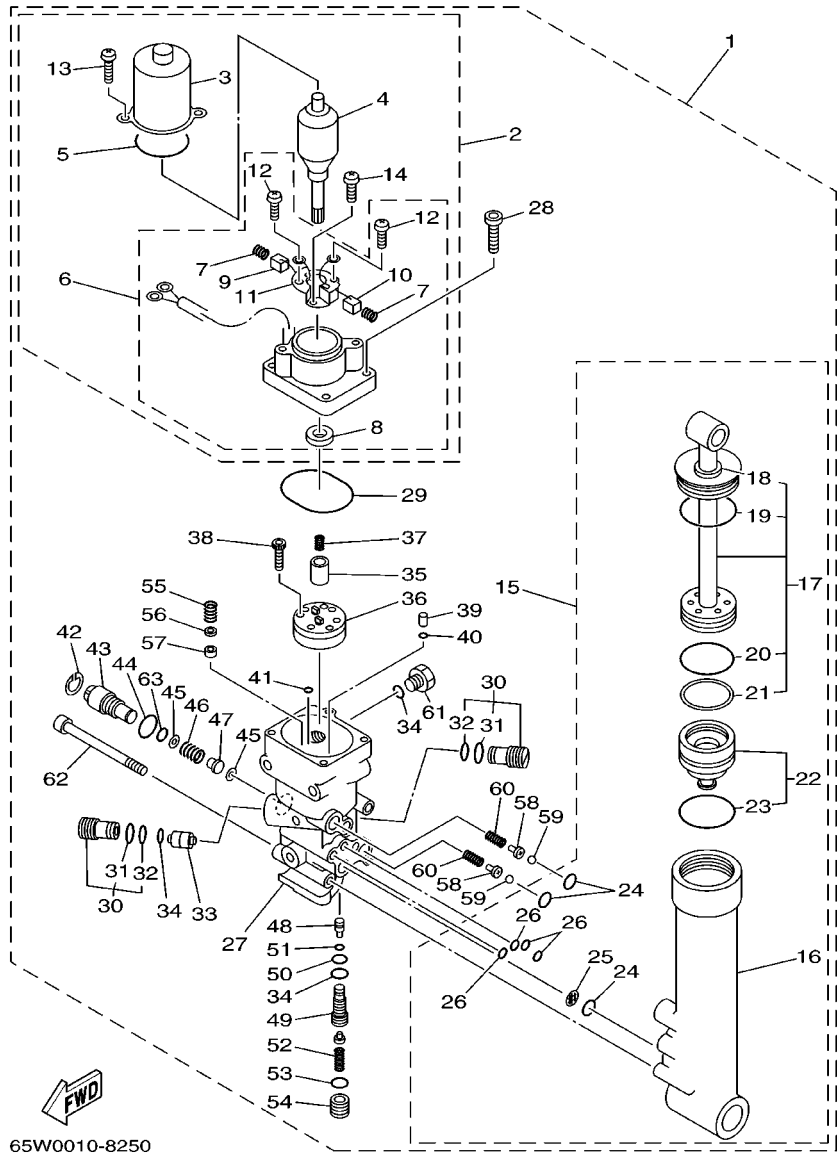

65W0010-8250

FIG. 21 POWER TRIM & TILT ASSY COMPONER Y PODER VARILLA

REF. NO.	PART NO. CODIGO NO.	DESCRIPTION DESCRIPTION	MH	WH	W	WT	REMARKS OBSERVACION
55	6H1-43856-10	.SPRING, DOWN RELIEF .RESORTE SEGURIDAD				1	
56	6H1-43844-10	.PIN, VALVE SUPPORT .PASADOR VALVULA SOPORTE				1	
57	6H1-4384F-10	.SEAL, MAIN VALVE .ASIENTO				1	
58	65W-4386A-00	.PIN, ABSORBER VALVE .PASADOR VALVULA ABSORBER				2	
59	93501-08001	.BALL .BOLA				2	
60	65W-43853-00	.SPRING, MAIN VALVE .RESORTE				2	
61	6H1-43829-00	.PLUG, RESERVOIR .TAPON DEPOSITO				1	
62	62X-43878-00	.BOLT, SOCKET .TORNILLO ENCASTRE				3	
63	93210-10M74	.O-RING .ANILLO O				1	

FIG. 22 UPPER CASING

FUNDA SUPERIOR

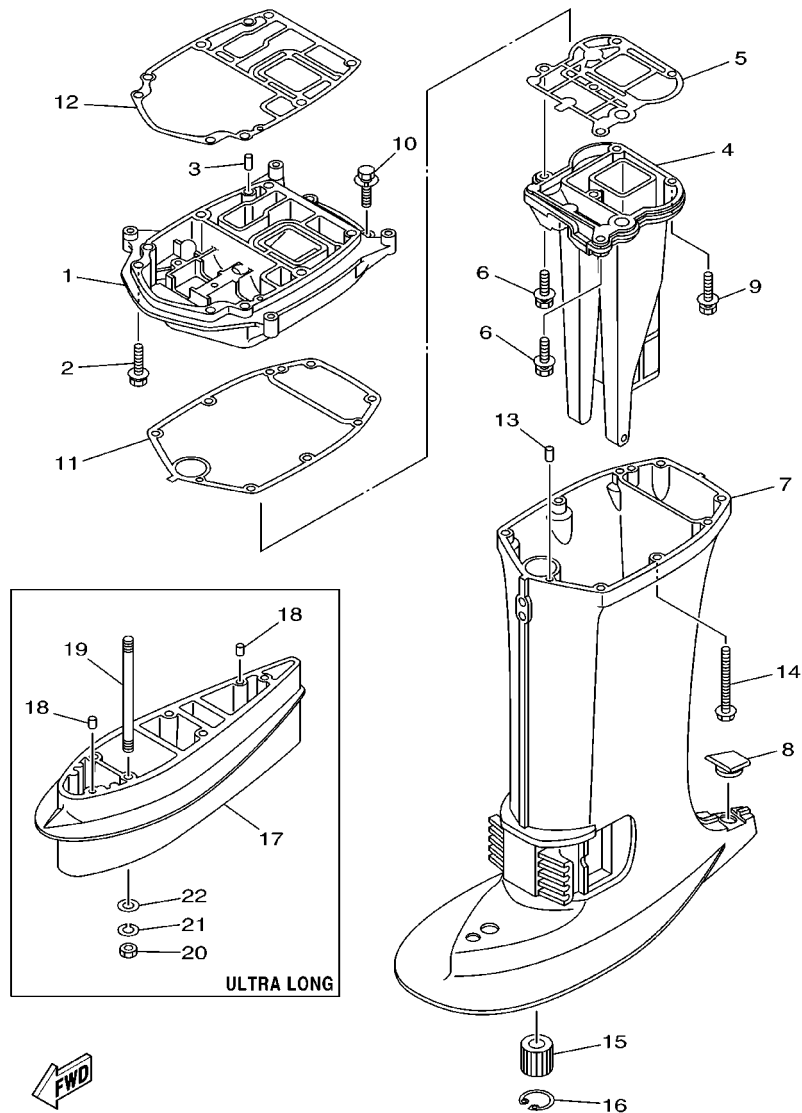

REF. NO.	PART NO. CODIGO NO.	DESCRIPTION DESCRIPTION	MH	WH	W	WT	REMARKS OBSERVACION
1	66T-41137-00-94	GUIDE, EXHAUST GUIA DE ESCAPE	1	1	1	1	
2	90119-08M79	BOLT, WITH WASHER TORNILLO CON ARANDELA	2	2	2	2	
3	93606-12019	PIN, DOWEL PASADOR DE CLAVIJA	2	2	2	2	
4	66T-41131-00-5B	MANIFOLD, EXT. 1 TUBO MULTIPLE DE ESCAPE	1	1	1	1	
5	66T-41133-A0	GASKET, EXHAUST MANIFOLD 1 EMPAQUE ESCAPE MULTIPLE	1	1	1	1	
6	97575-08530	BOLT, WITH WASHER PERNO CON ARANDELA RONDELLE	2	2	2	2	
7	66T-45111-00-4D	CASING, UPPER CAJA SUPERIOR	1	1			S
	66T-45111-10-4D	CASING, UPPER CAJA SUPERIOR	1	1	1	1	L,X
8	63D-45155-00	CAP TAPA	1	1	1	1	
9	97575-08545	BOLT, WITH WASHER PERNO CON ARANDELA RONDELLE	3	3	3	3	
10	90119-08M79	BOLT, WITH WASHER TORNILLO CON ARANDELA	2	2	2	2	
11	66T-45114-A0	GASKET, UPPER CASING EMPAQUE	1	1	1	1	
12	66T-45113-A0	GASKET, UPPER CASING EMPAQUE	1	1	1	1	
13	93606-12019	PIN, DOWEL PASADOR DE CLAVIJA	2	2	2	2	
14	90119-08M42	BOLT, WITH WASHER TORNILLO CON ARANDELA	6	6	6	6	
15	66T-45318-00	BUSHING, DRIVE SHAFT BUJE, EJE DE MANDO	1	1	1	1	L
16	93420-30042	CIRCLIP BOLA	1	1	1	1	L
17	66T-45211-00-4D	EXTENSION EXTENSION	1				X
18	93606-12019	PIN, DOWEL PASADOR DE CLAVIJA	2				X
19	90116-10M23	BOLT, STUD ESPARRAGO	4				X
20	95380-10600	NUT TUERCA	4				X
21	92990-10100	WASHER, SPRING ARANDELA	4				X
22	92990-10600	WASHER, PLATE ARANDELA	4				X

66T0200-8220

FIG. 23 LOWER CASING, DRIVE 1

IMPULSOR E INFERIOR 1

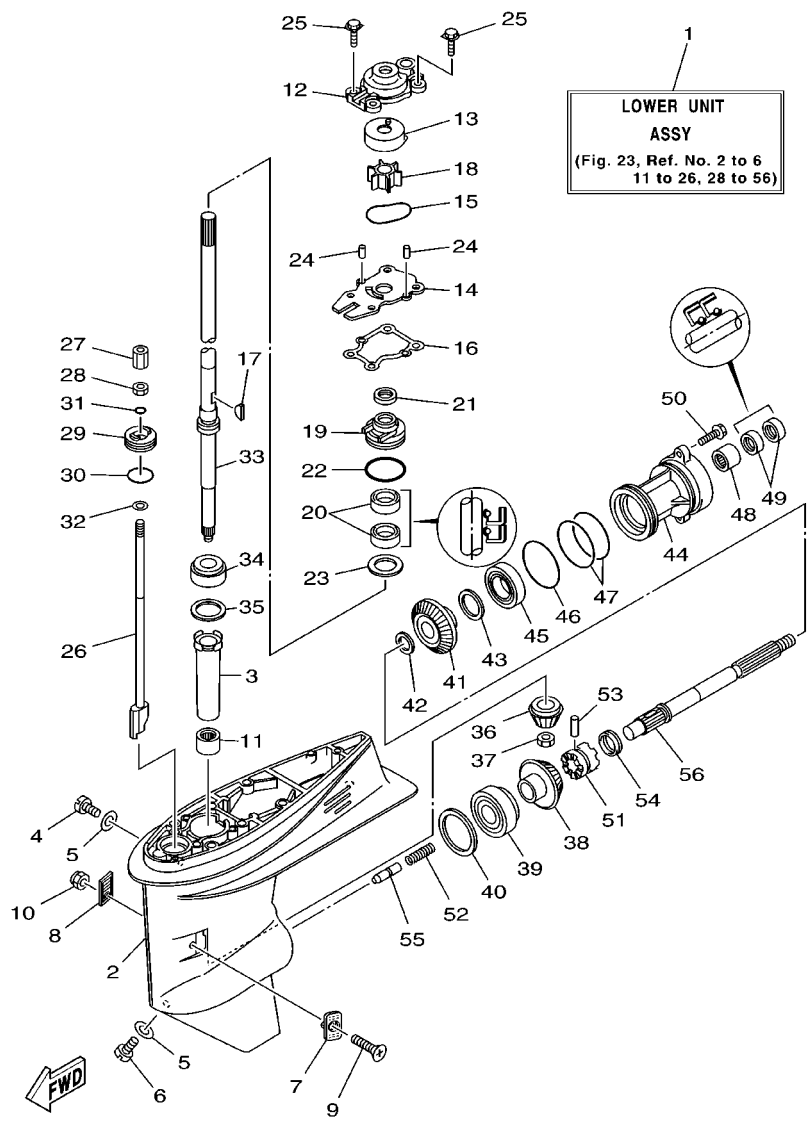

66T0200-8230

REF. NO.	PART NO. CODIGO NO.	DESCRIPTION DESCRIPTION	MH	WH	W	WT	REMARKS OBSERVACION
1	66T-45300-00-4D	LOWER UNIT ASSY CONJUNTO UNIDAD INFERIOR	1		1		S
	66T-45300-10-4D	LOWER UNIT ASSY CONJUNTO UNIDAD INFERIOR	1	1	1	1	L
	66T-45300-30-4D	LOWER UNIT ASSY CONJUNTO UNIDAD INFERIOR	1				X
2	66T-45311-00-4D	CASING, LOWER FUNDA INFERIOR	1	1	1	1	
3	6H4-45536-00	SLEEVE, DRIVE SHAFT CAMISA EJE DE MANDO	1	1	1	1	
4	90340-08M04	PLUG, STRAIGHT SCREW TORNILLO, DE DRENAJE	1	1	1	1	
5	90430-08020	GASKET JUNTA	2	2	2	2	
6	688-45341-00	PLUG, DRAIN TAPON, DREN	1	1	1	1	
7	63D-45214-00	COVER, WATER INLET CUBIERTA ENTRADA AGUA	1	1	1	1	
8	63D-45215-00	COVER, WATER INLET CUBIERTA ENTRADA AGUA	1	1	1	1	
9	90142-05M06	SCREW, COUNTERSUNK TORNILLO EMBUTIDO	1	1	1	1	
10	95380-05600	NUT TUERCA	1	1	1	1	
11	93315-32224	BEARING COJINETE	1	1	1	1	
12	66T-44311-00	HOUSING, WATER PUMP CAJA BOMBA DE AGUA	1	1	1	1	
13	63D-44322-00	INSERT, CARTRIDGE CARTUCHO				1	
	63D-44322-40	INSERT, CARTRIDGE CARTUCHO	1	1	1		FOR CHROMATE
14	66T-44323-00	OUTER PLATE, CARTRIDGE PLACA EXTERIOR DEL CARTUCHO				1	
	66T-44323-40	OUTER PLATE, CARTRIDGE PLACA EXTERIOR DEL CARTUCHO	1	1	1		FOR CHROMATE
15	93210-59MG7	O-RING ANILLO O	1	1	1	1	
16	63D-44316-00	GASKET, WATER PUMP EMPAQUE	1	1	1	1	
17	90280-03M07	KEY, WOODRUFF CUNA WOODRUFF	1	1	1	1	
18	6H4-44352-02	IMPELLER IMPULSOR	1	1	1	1	
19	63D-44341-00	HOUSING, WATER PUMP CAJA BOMBA DE AGUA	1	1	1	1	
20	93101-22M60	OIL SEAL SELLO ACEITE	2	2	2	2	
21	66T-45344-00	COVER, OIL SEAL CUBIERTA SELLO ACEITE	1	1	1	1	
22	93210-48MG8	O-RING ANILLO O	1	1	1	1	
23	90201-27M00	WASHER, PLATE ARANDELA PLANA	1	1	1	1	

FIG. 23 LOWER CASING. DRIVE 1

IMPULSOR E INFERIOR 1

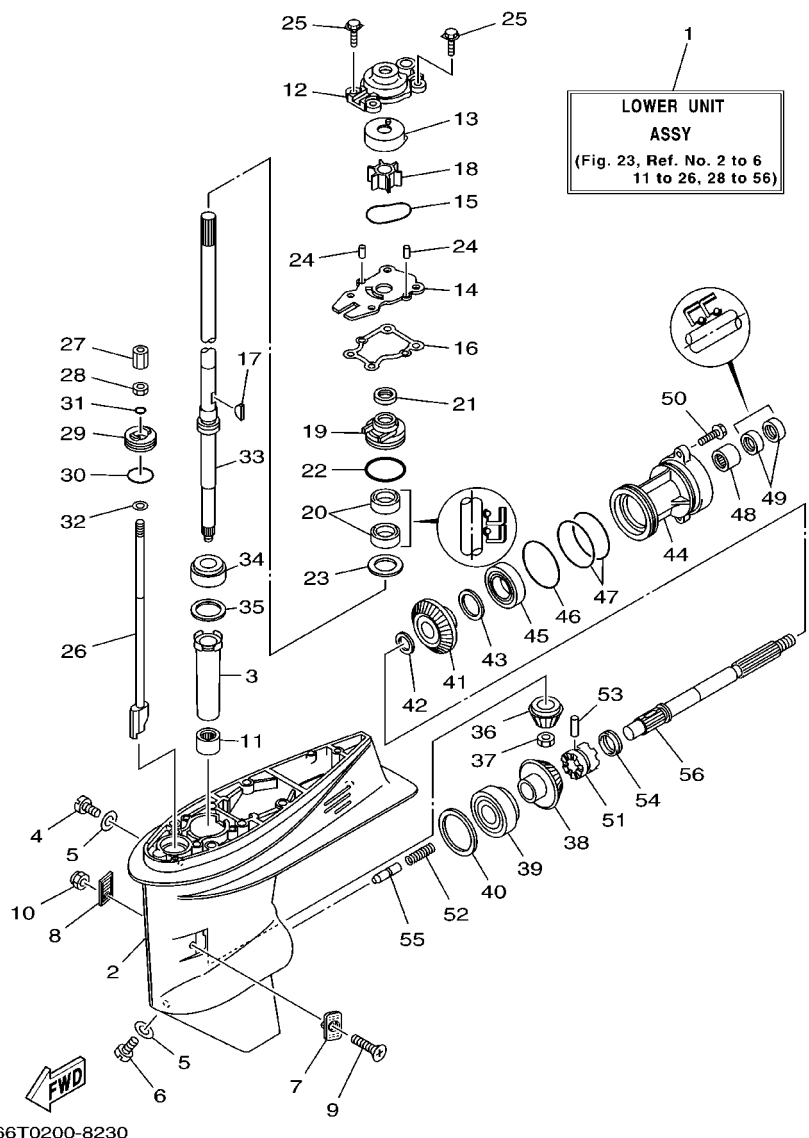

REF. NO.	PART NO. CODIGO NO.	DESCRIPTION DESCRIPTION	MH	WH	W	WT	REMARKS OBSERVACION
24	93604-08062	PIN, DOWEL PASADOR DE CLAVIJA	2	2	2	2	
25	90119-08M15	BOLT, WITH WASHER TORNILLO CON ARANDELA	4	4	4	4	
26	66T-44150-01	SHIFT CAM ASSY CONJUNTO EJE LEVA COMPL.	1		1		S
	66T-44150-11	SHIFT CAM ASSY CONJUNTO EJE LEVA COMPL.	1	1	1	1	L
	66T-44150-21	SHIFT CAM ASSY CONJUNTO EJE LEVA COMPL.	1				X
27	61N-44146-00	CONNECTOR, SHIFT ROD CONECTOR VARILLA DE CAMBIO	1	1	1	1	
28	95380-06700	NUT TUERCA	1	1	1	1	
29	66T-45321-00	PLATE PLACA	1	1	1	1	
30	93210-33MG4	O-RING ANILLO O	1	1	1	1	
31	93210-06ME6	O-RING ANILLO O	1	1	1	1	
32	92990-06600	WASHER, PLATE ARANDELA	1	1	1	1	
33	66T-45501-00	DRIVE SHAFT COMP. EJE DE MANDO COMPL.	1		1		S
	66T-45501-10	DRIVE SHAFT COMP. EJE DE MANDO COMPL.	1	1	1	1	L
	66T-45501-20	DRIVE SHAFT COMP. EJE DE MANDO COMPL.	1				X
34	93332-00001	BEARING COJINETE	1	1	1	1	
35	663-45587-01-10	SHIM (T:0.10MM) LAINA (T:0.10MM)	1	1	1	1	UR
	663-45587-01-12	SHIM (T:0.12MM) LAINA (T:0.12MM)	1	1	1	1	UR
	663-45587-01-15	SHIM (T:0.15MM) LAINA (T:0.15MM)	1	1	1	1	UR
	663-45587-01-18	SHIM (T:0.18MM) LAINA (T:0.18MM)	1	1	1	1	UR
	663-45587-01-30	SHIM (T:0.30MM) LAINA (T:0.30MM)	1	1	1	1	UR
	663-45587-01-40	SHIM (T:0.40MM) LAINA (T:0.40MM)	1	1	1	1	UR
	663-45587-01-50	SHIM (T:0.50MM) LAINA (T:0.50MM)	1	1	1	1	UR
36	66T-45551-00	PINION PINON	1	1	1	1	
37	90170-12138	NUT TUERCA	1	1	1	1	
38	66T-45560-00	GEAR ENGRANE COMPLE 1	1	1	1	1	
39	93332-00003	BEARING COJINETE	1	1	1	1	
40	663-45567-01-10	SHIM (T:0.10MM) LAINA(T:0.10MM)	1	1	1	1	UR

FIG. 23 LOWER CASING, DRIVE 1

IMPULSOR E INFERIOR 1

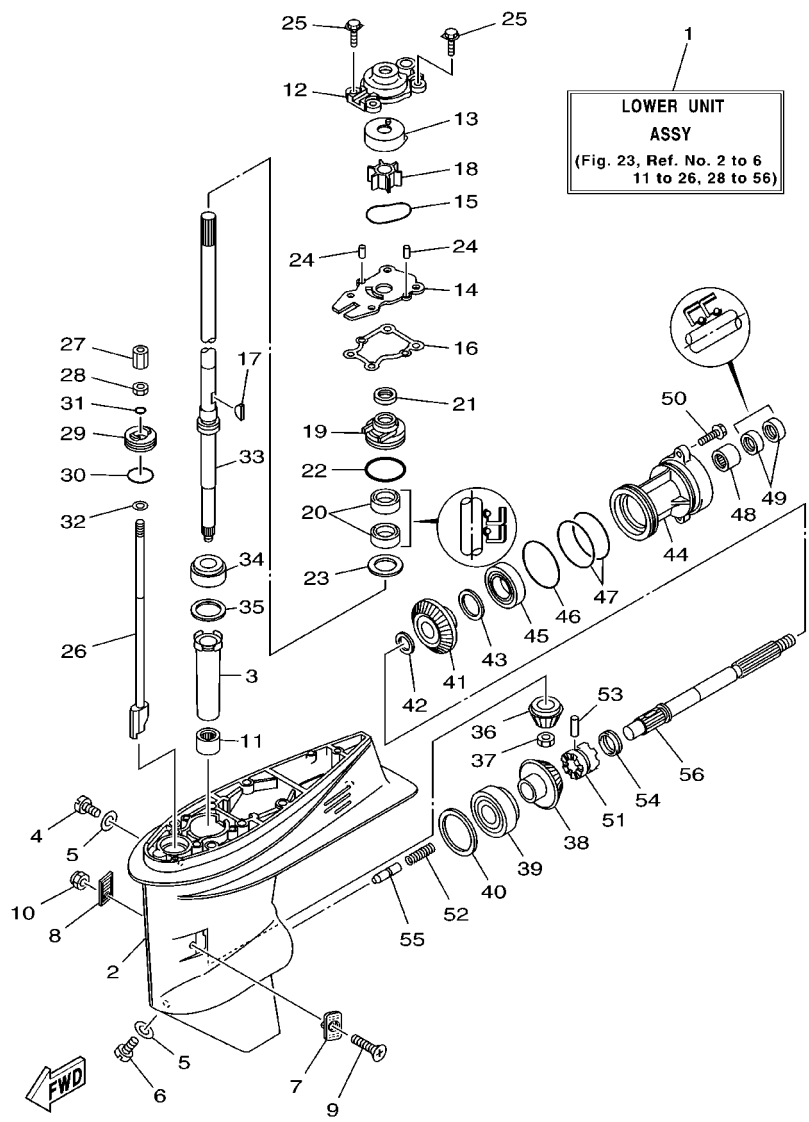

66T0200-8230

REF. NO.	PART NO. CODIGO NO.	DESCRIPTION DESCRIPTION	MH	WH	W	WT	REMARKS OBSERVACION
40	663-45567-01-12	SHIM (T:0.12MM) LAINA (T:0.12MM)	1	1	1	1	UR
	663-45567-01-15	SHIM (T:0.15MM) LAINA (T:0.15MM)	1	1	1	1	UR
	663-45567-01-18	SHIM (T:0.18MM) LAINA (T:0.18MM)	1	1	1	1	UR
	663-45567-01-30	SHIM (T:0.30MM) LAINA (T:0.30MM)	1	1	1	1	UR
	663-45567-01-40	SHIM (T:0.40MM) LAINA (T:0.40MM)	1	1	1	1	UR
	663-45567-01-50	SHIM (T:0.50MM) LAINA (T:0.50MM)	1	1	1	1	UR
41	66T-45571-00	GEAR ENGRANAJE	1	1	1	1	
42	90201-22429	WASHER, PLATE ARANDELA PLANA	1	1	1	1	
43	63D-45577-00-10	SHIM (T:0.10MM) LAINA (T:0.10MM)	1	1	1	1	UR
	63D-45577-00-12	SHIM (T:0.12MM) LAINA (T:0.12MM)	1	1	1	1	UR
	63D-45577-00-15	SHIM (T:0.15MM) LAINA (T:0.15MM)	1	1	1	1	UR
	63D-45577-00-18	SHIM (T:0.18MM) LAINA (T:0.18MM)	1	1	1	1	UR
	63D-45577-00-30	SHIM (T:0.30MM) LAINA (T:0.30MM)	1	1	1	1	UR
	63D-45577-00-40	SHIM (T:0.40MM) LAINA (T:0.40MM)	1	1	1	1	UR
	63D-45577-00-50	SHIM (T:0.50MM) LAINA (T:0.50MM)	1	1	1	1	UR
44	63D-45361-02-4D	CAP, LOWER CASING FUNDA INFERIOR	1	1	1	1	
45	93306-001U1	BEARING COJINETE	1	1	1	1	
46	93210-69MG6	O-RING ANILLO O	1	1	1	1	
47	93210-74MG5	O-RING ANILLO O	2	2	2	2	
48	93317-22204	BEARING COJINETE	1	1	1	1	
49	93101-22M00	OIL SEAL SELLO ACEITE	2	2	2	2	
50	90105-08M61	BOLT, WASHER BASED TORNILLO CON ARANDELA	2	2	2	2	
51	66T-45631-00	CLUTCH, DOG EMBRAGUE DE GARRA	1	1	1	1	
52	90501-15M01	SPRING, COMPRESSION RESORTE DE COMPRESION	1	1	1	1	
53	90250-06023	PIN, STRAIGHT PASADOR CILINDRICO	1	1	1	1	
54	663-45633-00	RING, CROSS PIN ANILLO DE PASADOR	1	1	1	1	
55	66T-45635-00	PLUNGER, SHIFT EMBOLO DE CAMBIO	1	1	1	1	

FIG. 23 LOWER CASING, DRIVE 1 IMPULSOR E INFERIOR 1

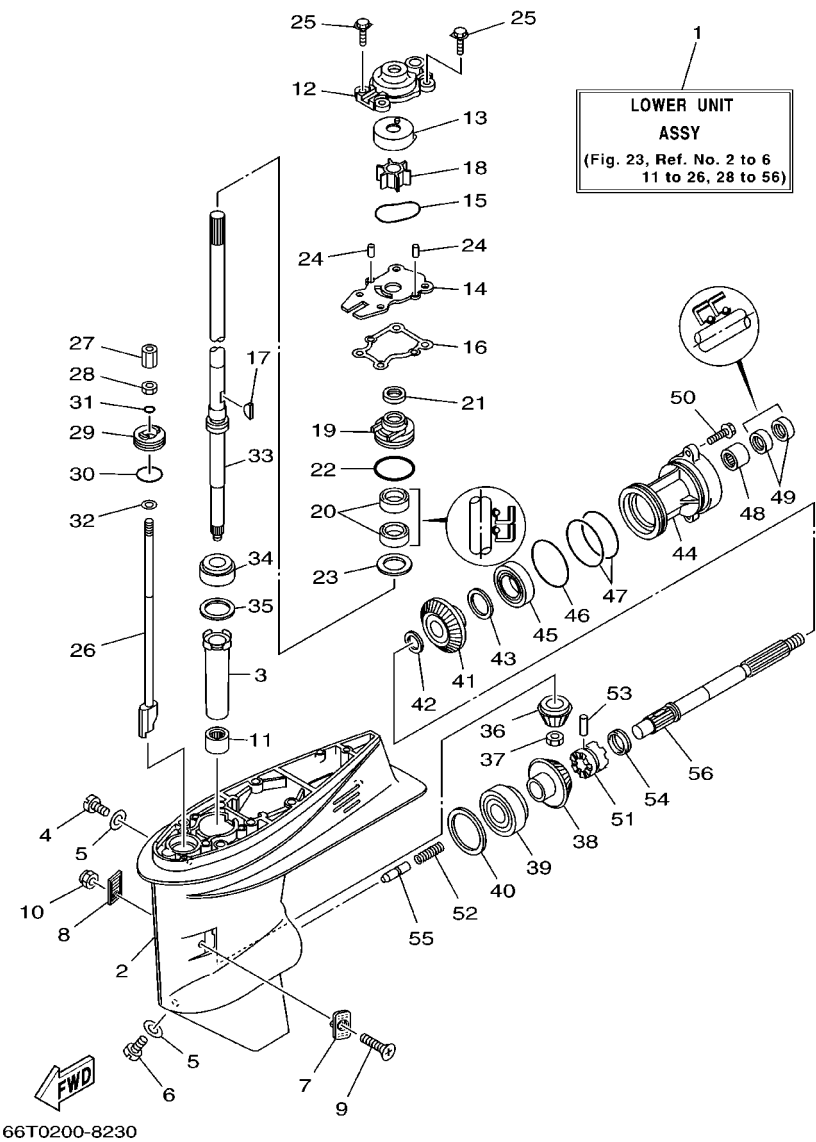

REF. NO.	PART NO. CODIGO NO.	DESCRIPTION DESCRIPTION	MH	WH	W	WT	REMARKS OBSERVACION
56	66T-45611-00	SHAFT, PROPELLER EJE PROPUSOR	1	1	1	1	

FIG. 24 LOWER CASING. DRIVE 2

IMPULSOR E INFERIOR 2

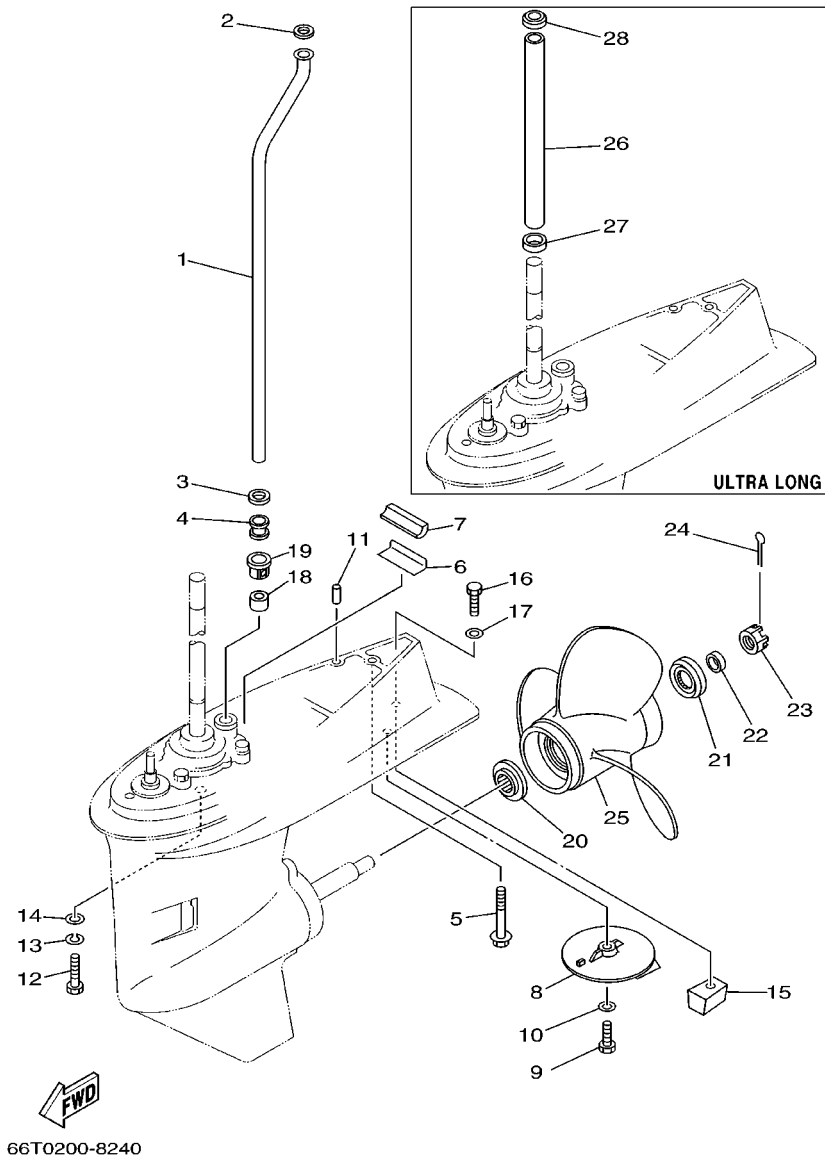

REF. NO.	PART NO. CODIGO NO.	DESCRIPTION DESCRIPTION	MH	WH	W	WT	REMARKS OBSERVACION
1	66T-44361-00	TUBE, WATER TUBO DE AGUA	1		1		S
	66T-44361-10	TUBE, WATER TUBO DE AGUA	1	1	1	1	L
	66T-44361-20	TUBE, WATER TUBO DE AGUA	1				X
2	90202-12060	WASHER, PLATE ARANDELA DE PLANA	1	1	1	1	
3	90430-12072	GASKET JUNTA	1	1	1	1	
4	663-44367-00	DAMPER, WATER SEAL GOMA DEL SELLO DE AGUA	1	1	1	1	
5	90119-08M44	BOLT, WITH WASHER TORNILLO CON ARANDELA	1	1	1	1	S,L
	90119-08M43	BOLT, WITH WASHER TORNILLO CON ARANDELA	1				X
6	663-45376-00	GUIDE, SEAL DAMPER GUIA DE SELLO GOMA	1	1	1	1	
7	63D-45375-00	DAMPER, SEAL GOMA DE SELLO	1	1	1	1	
8	664-45371-01	TAB-TRIM QUILLA ESTABILIZADOR	1	1	1	1	
9	97095-08025	BOLT PERNO	1	1	1	1	
10	92995-08100	WASHER ARANDELA	1	1	1	1	
11	93606-12019	PIN, DOWEL PASADOR DE CLAVIJA	2	2	2	2	
12	97075-10040	BOLT PERNO	4	4	4	4	S,L
13	92995-10100	WASHER ARANDELA	4	4	4	4	S,L
14	92995-10600	WASHER ARANDELA	4	4	4	4	S,L
15	67C-45251-00	ANODE CATODE	1	1	1	1	
16	97095-08035	BOLT PERNO	1	1	1	1	
17	92995-08100	WASHER ARANDELA	1	1	1	1	
18	663-44366-00	DAMPER, WATER SEAL GOMA DEL SELLO DE AGUA	1	1	1	1	
19	63D-44312-00	COVER, WATER PUMP HOUSING CUBIERTA CAJA BOMBA DE AGUA	1	1	1	1	
20	663-45987-02	SPACER ESPACIADOR	1	1	1	1	
21	66T-45997-00	SPACER ESPACIADOR	1	1	1	1	
22	90389-22M01	BUSH BUJE	1	1	1	1	
23	90171-16011	NUT, CASTLE TUERCA ENTALLADA	1	1	1	1	
24	91490-30025	PIN, COTTER PASADOR DE CHAVETA	1	1	1	1	

FIG. 24 LOWER CASING. DRIVE 2

IMPULSOR E INFERIOR 2

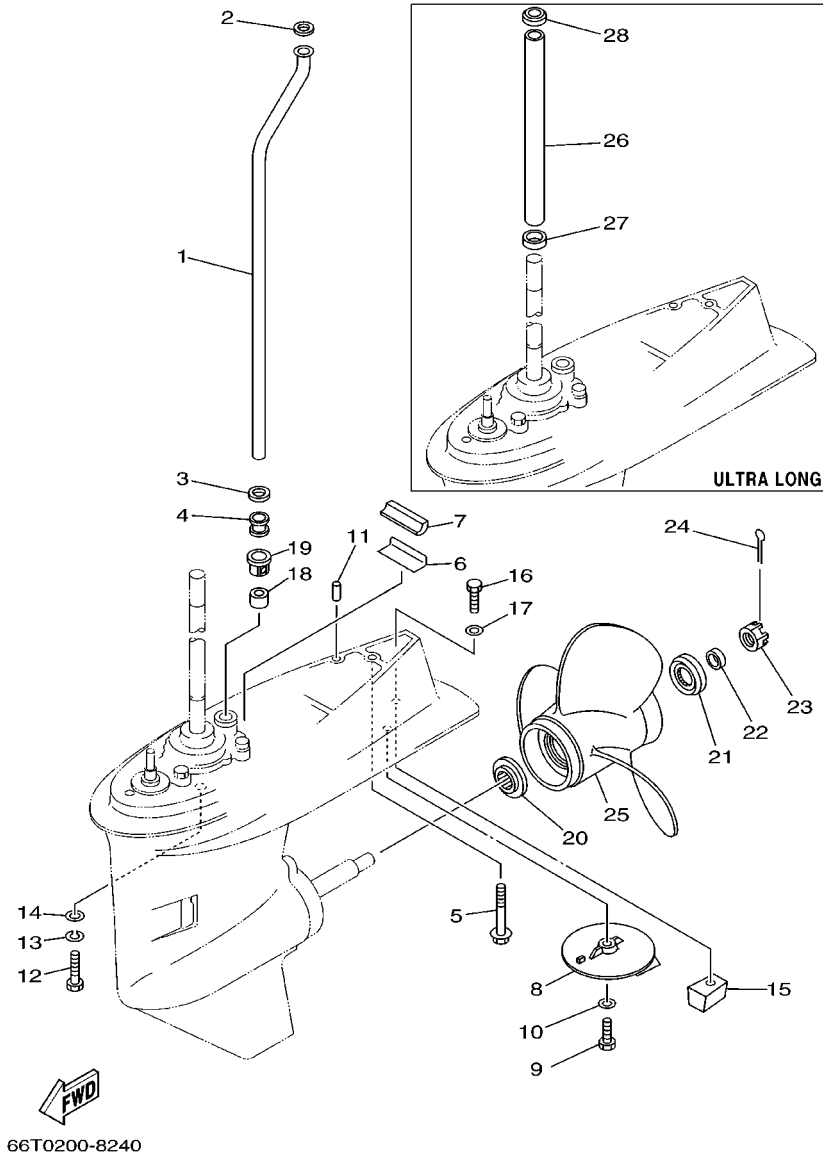

REF. NO.	PART NO. CODIGO NO.	DESCRIPTION DESCRIPTION	MH	WH	W	WT	REMARKS OBSERVACION
25	63D-45941-00-EL	PROPELLER (3X12-1/4"X8"-G) PROPELA (3X12-1/4"X8"-G)	1	1	1	1	UR
	663-45930-00-98	PROPELLER (3X10-1/4"X14"-G) PROPELA (3X10-1/4"X14"-G)	1	1	1	1	UR
	663-45941-01-EL	PROPELLER (3X10-3/4"X17"-G) PROPELA (3X10-3/4"X17"-G)	1	1	1	1	UR
	663-45943-02-EL	PROPELLER (3X11"X15"-G) PROPELA (3X11"X15"-G)	1	1	1	1	UR
	663-45945-02-EL	PROPELLER (3X11-1/8"X13"-G) PROPELA (3X11-1/8"X13"-G)	1	1	1	1	UR
	663-45947-02-EL	PROPELLER (3X11-5/8"X11"-G) PROPELA (3X11-5/8"X11"-G)	1	1	1	1	UR
	663-45949-01-EL	PROPELLER (3X10-3/4"X16"-G) PROPELA (3X10-3/4"X16"-G)	1	1	1	1	UR
	663-45952-02-EL	PROPELLER (3X11-3/8"X12"-G) PROPELA (3X11-3/8"X12"-G)	1	1	1	1	UR
	663-45954-01-EL	PROPELLER (3X11-3/4"X10"-G) PROPELA (3X11-3/4"X10"-G)	1	1	1	1	UR
	663-45956-01-EL	PROPELLER (3X12-1/4"X9"-G) PROPELA (3X12-1/4"X9"-G)	1	1	1	1	UR
	663-45958-01-EL	PROPELLER (3X11-1/4"X14"-G) PROPELA (3X11-1/4"X14"-G)	1	1	1	1	UR
	663-45970-60-98	PROPELLER (3X11-3/4"X12"-G) PROPELA (3X11-3/4"X12"-G)	1	1	1	1	UR
	663-45972-60-98	PROPELLER (3X12"X11"-G) PROPELA (3X12"X11"-G)	1	1	1	1	UR
	663-45974-60-98	PROPELLER (3X11-1/2"X13"-G) PROPELA (3X11-1/2"X13"-G)	1	1	1	1	UR
	663-45976-00-98	PROPELLER (3X10-1/4"X15"-G) PROPELA (3X10-1/4"X15"-G)	1	1	1	1	UR
	663-45978-00-98	PROPELLER (3X10-1/4"X16"-G) PROPELA (3X10-1/4"X16"-G)	1	1	1	1	UR
26	66T-44362-20	TUBE, WATER TUBO DE AGUA	1				X
27	90480-25M70	GROMMET TAPON	1				X
28	90480-30M71	GROMMET TAPON	1				X

FIG. 25 FUEL TANK

DEPOSITO DE COMBUSTIBLE

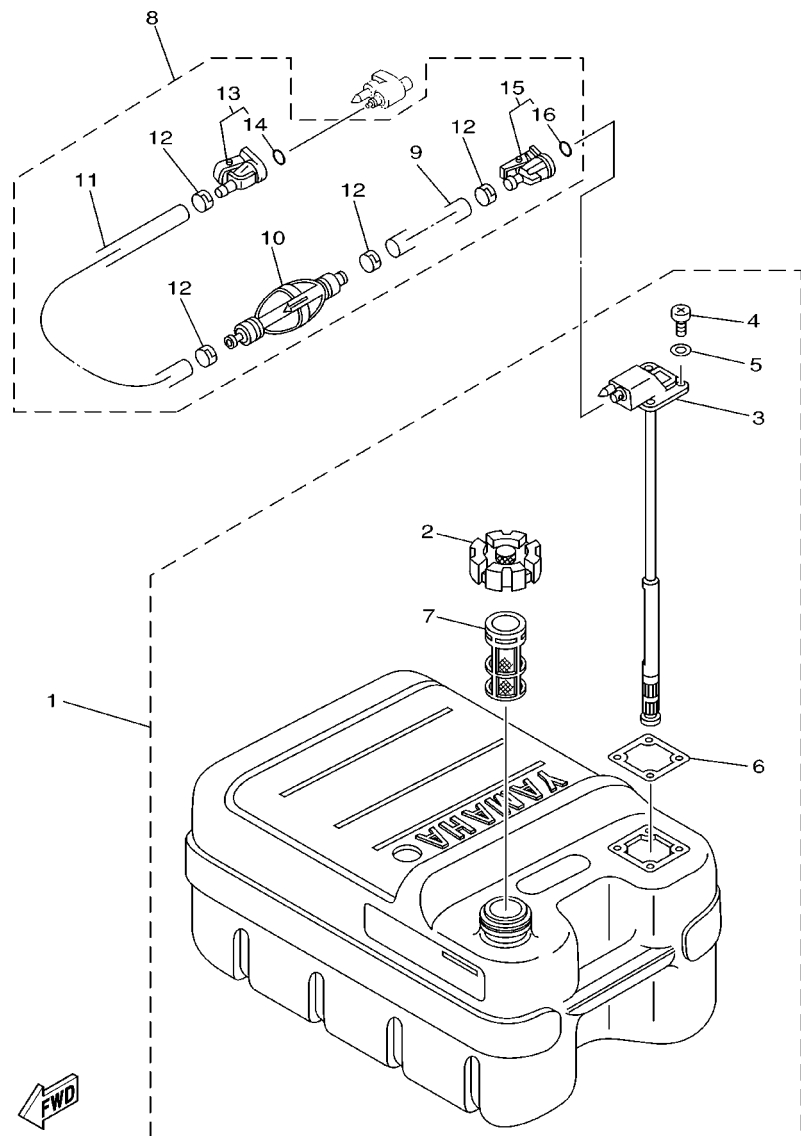

66T0100-9240

REF. NO.	PART NO. CODIGO NO.	DESCRIPTION DESCRIPTION	MH	WH	W	WT	REMARKS OBSERVACION
1	6YJ-24201-00	FUEL TANK ASSY (24L) TANQUE DEL COMBUSTIBLE (24L)	1	1	1	1	AP
	6YJ-24201-10	FUEL TANK ASSY (24L) TANQUE DEL COMBUSTIBLE (24L)	1	1	1		AP WITH INDICATOR
2	6YJ-24610-01	.CAP ASSY .TAPA COMPLETA	1	1	1	1	
3	6YJ-24260-00	.FUEL METER ASSY .MEDIDOR DE COMBUSTIBLE COMPL.	1	1	1	1	
	6Y1-24260-12	.FUEL METER ASSY .MEDIDOR DE COMBUSTIBLE COMPL.	1	1	1		WITH INDICATOR
4	98586-05016	.SCREW, PAN HEAD .TORNILLO DE CABEZA CON PLANA	4	4	4	4	
5	6Y1-24329-00	.SEAL .SELLO	4	4	4	4	
6	6Y1-24268-00	.GASKET, FUEL METER .EMPAQ MEDIDOR DE COMBUSTIBLE	1	1	1	1	
7	6YJ-24167-00	.STRAINER .COLADOR	1	1	1	1	
8	6Y1-24306-06	FUEL PIPE COMP. 1 TUBO COMBUST. COMPL 1	1	1	1	1	AP
9	90445-11M06	.HOSE (L:2050MM) .MANGUERA (L:2050MM)	1	1	1	1	
10	6Y1-24360-51	.PRIMER PUMP ASSY .SOPORTE BOMBA	1	1	1	1	
11	90445-11M05	.HOSE (L:850MM) .MANGUERA (L:850MM)	1	1	1	1	
12	650-24351-51	BAND 1 .ABRAZADERA 1	4	4	4	4	
13	6G1-24305-01	FUEL PIPE JOINT COMP. 2 CONECTOR MANGUERA COMBUST.2	1	1	1	1	
14	93210-08287	.O-RING .ANILLO O	1	1	1	1	
15	6Y1-24305-02	FUEL PIPE JOINT COMP. 2 CONECTOR MANGUERA COMBUST.2	1	1	1	1	
16	93210-08287	.O-RING .ANILLO O	1	1	1	1	

FIG. 26 STEERING GUIDE

DIRECCIONGUIAR

REF. NO.	PART NO. CODIGO NO.	DESCRIPTION DESCRIPTION	MH	WH	W	WT	REMARKS OBSERVACION
1	65W-61350-00	STEERING GUIDE ATTACHMENT KIT ESTUCHE ADITAMENTO GUIA DE TIM			1	1	AP
2	65W-61351-00	.ROD, STEERING LINK .VARILLA ESLABON DIRECCION			1	1	
3	90201-10M20	.WASHER, PLATE .ARANDELA PLANA			2	2	
4	90185-09M01	.NUT, SELF-LOCKING .TUERCA AUTOBLOCANTE			2	2	
5	90170-09M03	.NUT .TUERCA			1	1	
6	90387-10M42	.COLLAR .CASQUILLO CON VALONA			1	1	
7	90101-09M01	.BOLT .TORNILLO			1	1	
8	90201-10M63	.WASHER, PLATE .ARANDELA PLANA			1	1	
9	6E5-43145-01	.CAP, CLAMP BRACKET .TAPA			1	1	
10	93210-16275	.O-RING .ANILLO O			1	1	

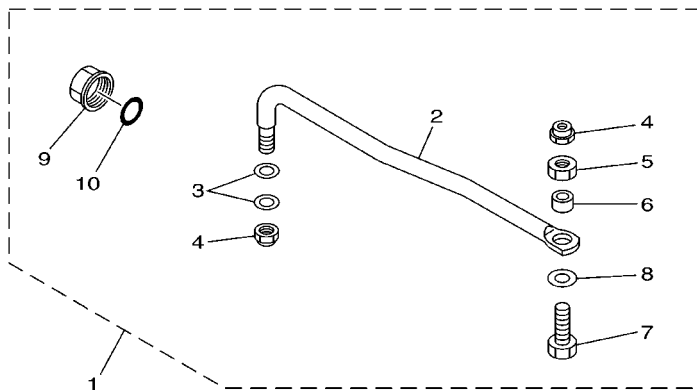

65W0010-8210

FIG. 27 REMOTE CONTROL BOX CONTROL REMOTO COMPL.

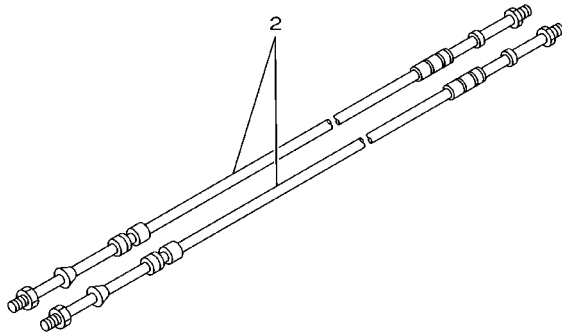
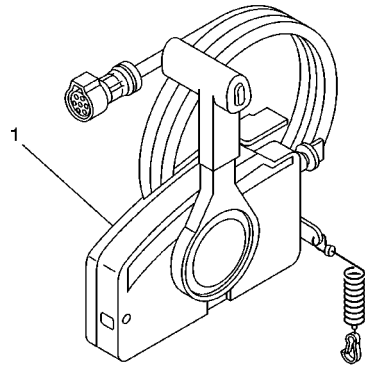

67M0100-8280

REF. NO.	PART NO. CODIGO NO.	DESCRIPTION DESCRIPTION	MH	WH	W	WT	REMARKS OBSERVACION
1	703-48205-15	REMOTE CONTROL ASSY (10P) REMOTO CONTROL COMPL. (10P)				1	AP WITH PT/T SW.
	703-48203-14	REMOTE CONTROL ASSY (7P) REMOTO CONTROL COMPL. (7P)			1		AP
2	701-48320-20	CABLE, REMOTE CONTROL L=13F CABLE CONTROL REMOTO L=13F			2	2	UR
	701-48320-50	CABLE, REMOTE CONTROL L=15F CABLE CONTROL REMOTO L=15F			2		UR

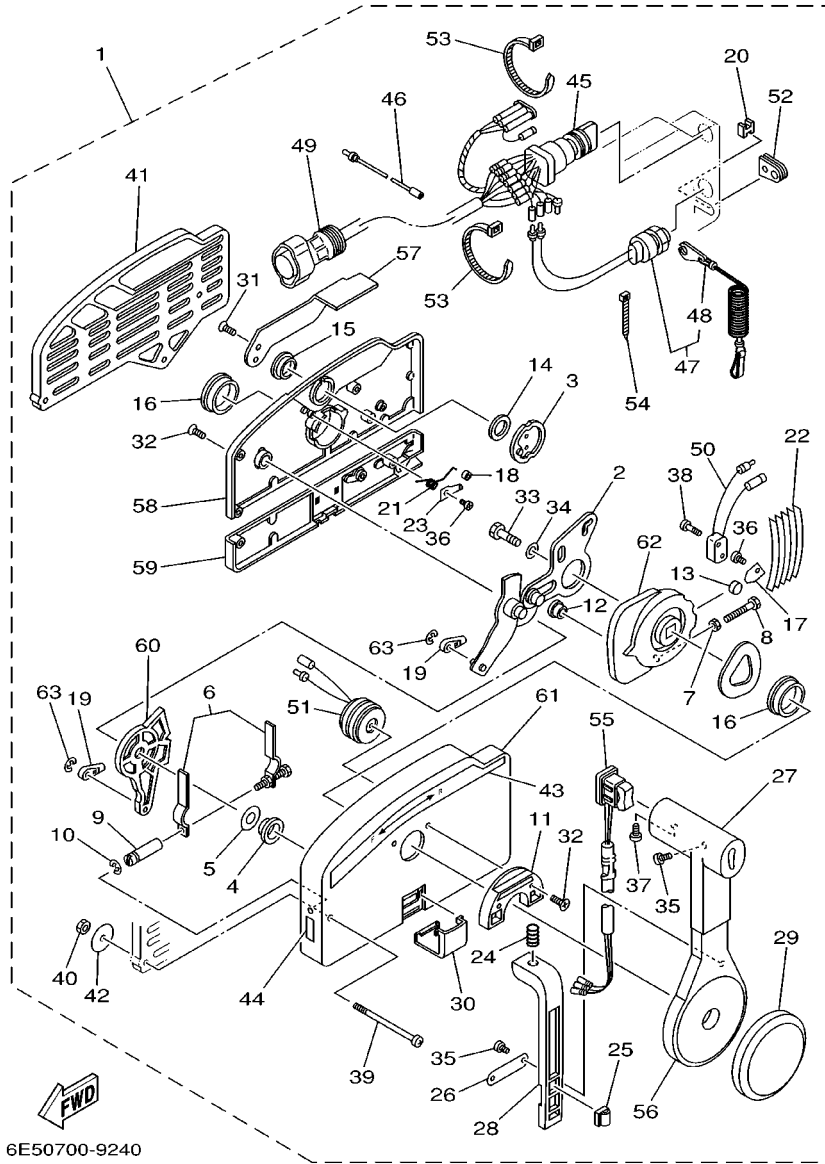
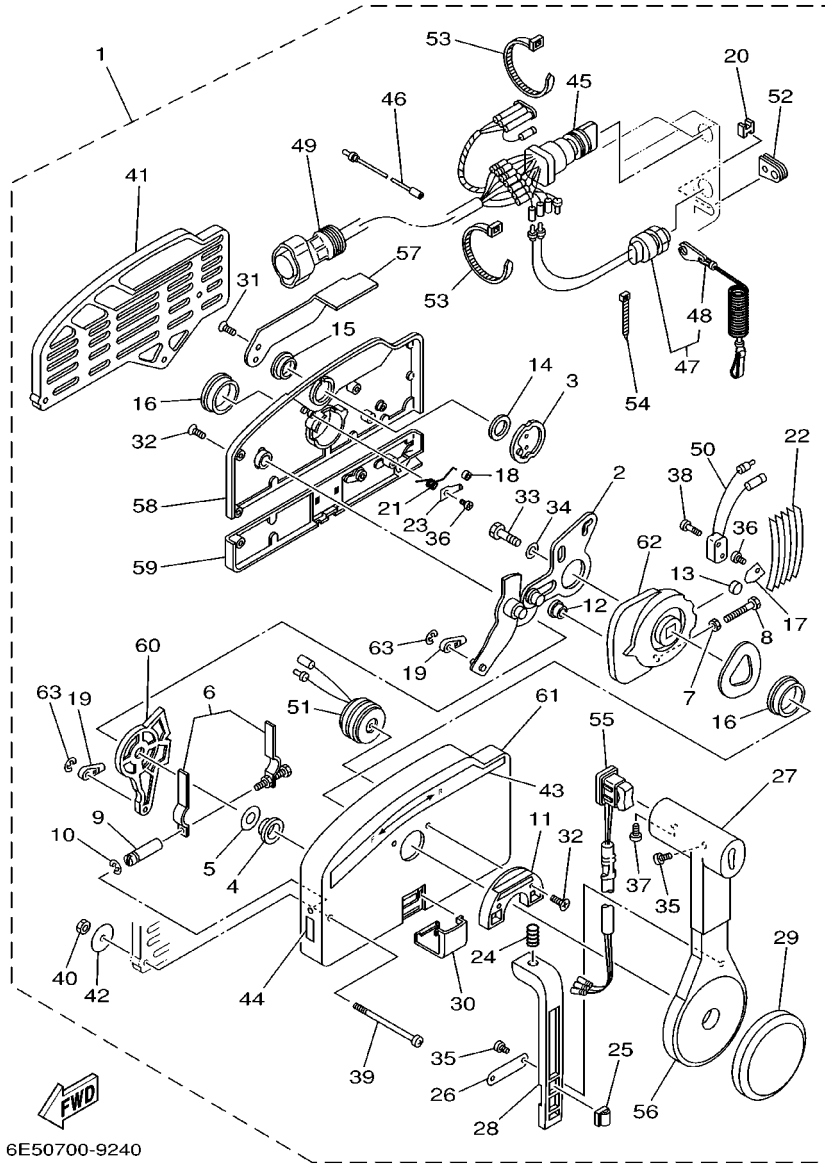

FIG. 28 REMOTE CONTROL ASSY CONTROL REMOTO COMPL.

REF. NO.	PART NO. CODIGO NO.	DESCRIPTION DESCRIPTION	MH	WH	W	WT	REMARKS OBSERVACION
1	703-48205-15	REMOTE CONTROL ASSY (10P)				1	AP WITH PT/T SW.
	703-48203-14	REMOTE CONTROL COMPL. (10P)			1		AP
2	703-48261-01	.ARM, THROTTLE			1	1	
3	703-48153-00	.BRAZO ACELERADOR			1	1	
4	703-48235-00	.SHAFT, FREE ACCEL.			1	1	
		.EJE					
5	703-48235-00	.BUSHING			1	1	
		.BUJE					
6	703-48268-00	.SPACER			1	1	
		.ESPACIADOR 3					
7	703-48264-00	.THROTTLE, FRICTION			1	1	
		.FRICCION ACELERADOR					
8	95380-05600	.NUT			1	1	
		.TUERCA					
9	97380-05025	.BOLT			1	1	
		.PERNO					
10	703-48265-00	.SHAFT, FRICTION			1	1	
		.EJE FRICCION					
11	93430-06024	.CIRCLIP			3	3	
		.BOLA					
12	703-48245-00	.PLATE, LOCK			1	1	
		.PLACA CERRADURA					
13	703-48252-00	.ROLLER, CAM			1	1	
		.RODILLO LEVA					
14	701-48248-00	.ROLLER, FREE ACCEL.			1	1	
		.RODILLO ACELERADOR LIBRE					
15	703-48198-00	.WASHER, WAVE			1	1	
		.RONDANA ONDULADA 3					
16	703-48243-00	.BUSHING			1	1	
		.BUJE 3					
17	703-48236-00	.BUSHING 1			2	2	
		.BUJE					
18	703-48189-00	.RETAINER			1	1	
		.RETENEDOR					
19	703-48236-00	.BUSHING 1			1	1	
		.BUJE					
20	703-48345-01	.CABLE END,REMOTE CONTROL 2			2	2	
		.TERMINAL CABLE DE CONTROL REM					
21	703-48358-00	.ANCHOR, CABLE			1	1	
		.ABRAZADERA CABLE					
22	703-48244-00	.SPRING, FREE ACCEL.			1	1	
		.RESORTE ACELERADOR LIBRE					
23	703-48238-00	.SPRING, DETENT			5	5	
		.RESORTE					
24	703-48246-00	.SPACER			1	1	
		.ESPACIADOR					
25	703-48227-00	.SPRING, NEUTRAL LOCK			1	1	
		.RESORTE DE SEGURO					
26	703-82594-00	.CLAMP			1	1	WITH PT/T SW.
		.GRAMPA					
27	703-48226-00	.PLATE, STOPPER			1	1	
		.PLACA RETEN					



6E50700-9240

FIG. 28 REMOTE CONTROL ASSY CONTROL REMOTO COMPL.

REF. NO.	PART NO. CODIGO NO.	DESCRIPTION DESCRIPTION	MH	WH	W	WT	REMARKS OBSERVACION
27	703-48222-00	.GRIP, CONTROL LEVER .MANGO DE PALANCA CONTROL			1	1	SINGLE
28	703-48223-00	.LOCK, NEUTRAL .CERRADURA NEUTRO			1	1	
29	703-48225-00	.COVER .CUBIERTA			1	1	
30	703-48219-00	.COVER, LEAD .CUBIERTA			1	1	
31	703-48281-00	.SCREW .TORNILLO 1			2	2	
32	703-48282-00	.SCREW .TORNILLO 2			7	7	
33	97095-08030	.BOLT .PERNO			1	1	
34	92990-08600	.WASHER, PLATE .ARANDELA			1	1	
35	98580-04010	.SCREW, PAN HEAD .TORNILLO DE CABEZA CON PLANA			3	3	
36	98580-04006	.SCREW, PAN HEAD .TORNILLO DE CABEZA CON PLANA			2	2	
37	98580-05010	.SCREW, PAN HEAD .TORNILLO DE CABEZA CON PLANA			1	1	
38	98580-03015	.SCREW, PAN HEAD .TORNILLO DE CABEZA CON PLANA			2	2	
39	703-48291-10	.SCREW (M6) .TORNILLO (M6)			3	3	
40	95380-06600	.NUT, HEXAGON .TUERCA			3	3	
41	703-48293-10	.SPACER, REMOTE CONTROL .ESPACIADOR			1	1	SINGLE
42	701-48287-00	.WASHER .ARANDELA			3	3	
43	703-48215-00	.GRAPHIC .CALCOMANIA 1			1	1	
44	702-48217-00	.MARK .MARCA 1			1	1	
45	703-82510-41	.MAIN SWITCH ASSY (10P) .CONJUNTO DE LLAVE IGNICION(10			1		
	703-82510-31	.MAIN SWITCH ASSY (7P) .CONJUNTO DE LLAVE IGNICION(7P			1		
46	703-82531-00	.WIRE, LEAD .CABLE CONDUCTOR			1	1	
47	688-82575-01	.ENGINE STOP SWITCH ASSY .INTERRUPTOR DE PARADA COMPL			1	1	
48	682-82556-00	.STOPPER .RETEN			1	1	
49	688-8258A-20	.EXTENSION, WIRE HARNESS .EXTENSION, ARNES DE CABLES			1		L:5M (10P)
	688-82586-21	.EXTENSION, WIRE HARNESS .EXTENSION, CONJ. DE CABLES			1		L:5M (7P)
50	703-82540-00	.NEUTRAL SWITCH ASSY .INTERRUPTOR NEUTRAL COMPL			1	1	
51	703-83383-02	.BUZZER .ZUMBADOR			1	1	

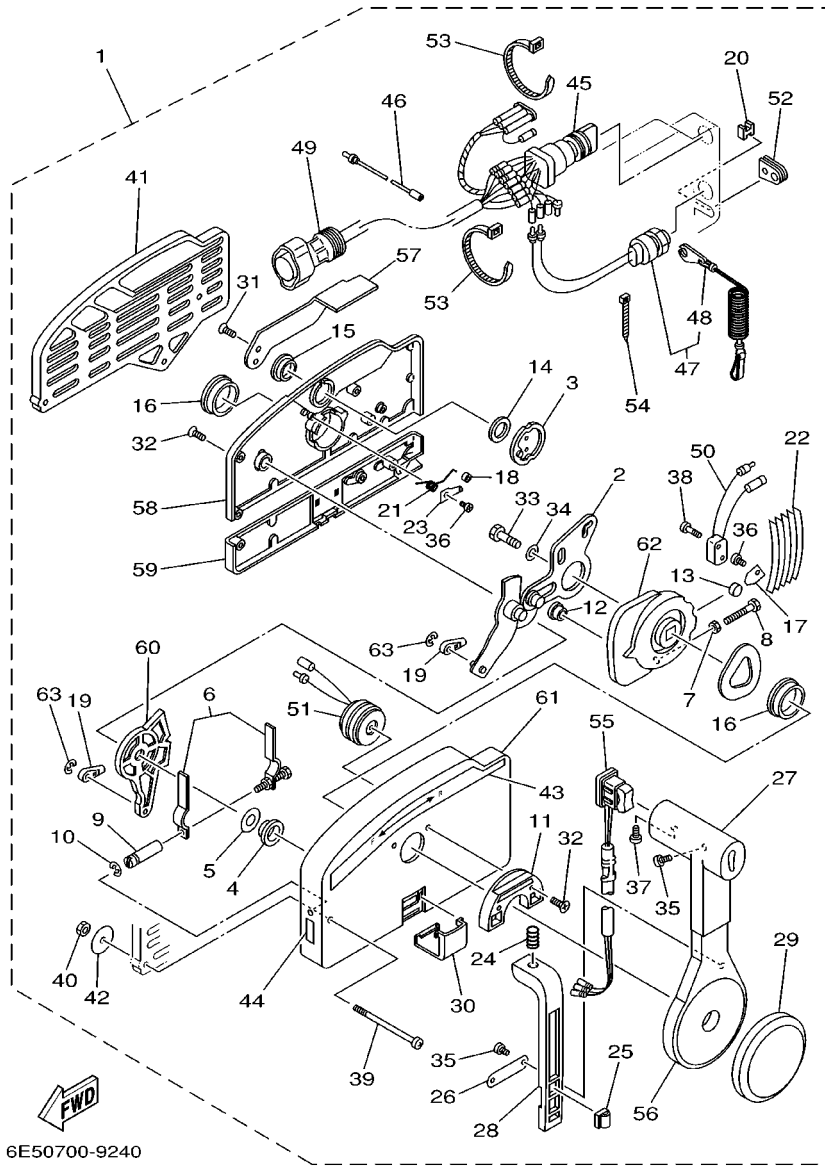

6E50700-9240

FIG. 28 REMOTE CONTROL ASSY CONTROL REMOTO COMPL.

REF. NO.	PART NO. CODIGO NO.	DESCRIPTION DESCRIPTION	MH	WH	W	WT	REMARKS OBSERVACION
52	703-48284-00	.GROMMET .TAPON 1				1 1	
53	703-82591-00	.BAND .BANDA				2 2	
54	703-82592-00	.BAND .BANDA				1 1	
55	703-82563-01	.TRIM & TILT SWITCH ASSY .INTERRUPTOR DE INCLINACION				1	
	703-48224-00	.COVER, CONTROL LEVER .CUBIERTA DE PALANCA CONTROL				1	WITHOUT PT/T SW.
56	703-48221-00	.LEVER, CONTROL .PALANCA CONTROL				1 1	
57	703-48152-00	.KNOB, FREE ACCEL. .PERILLA				1 1	
58	703-48212-00	.BACK PLATE 1 .PLACA TRASERA 1				1 1	
59	703-48213-00	.BACK PLATE 2 .PLACA TRASERA 2				1 1	
60	703-48271-00	.ARM, SHIFT .BRAZO CAMBIADOR				1 1	
61	703-48211-01	.HOUSING, 1 .CAJA				1 1	
62	703-48232-00	.GEAR .ENGRANAJE 1				1 1	
63	93430-06024	.CIRCLIP .BOLA				2 2	

FIG. 29 REPAIR KIT 1

ESTUCHE REPARATION 1

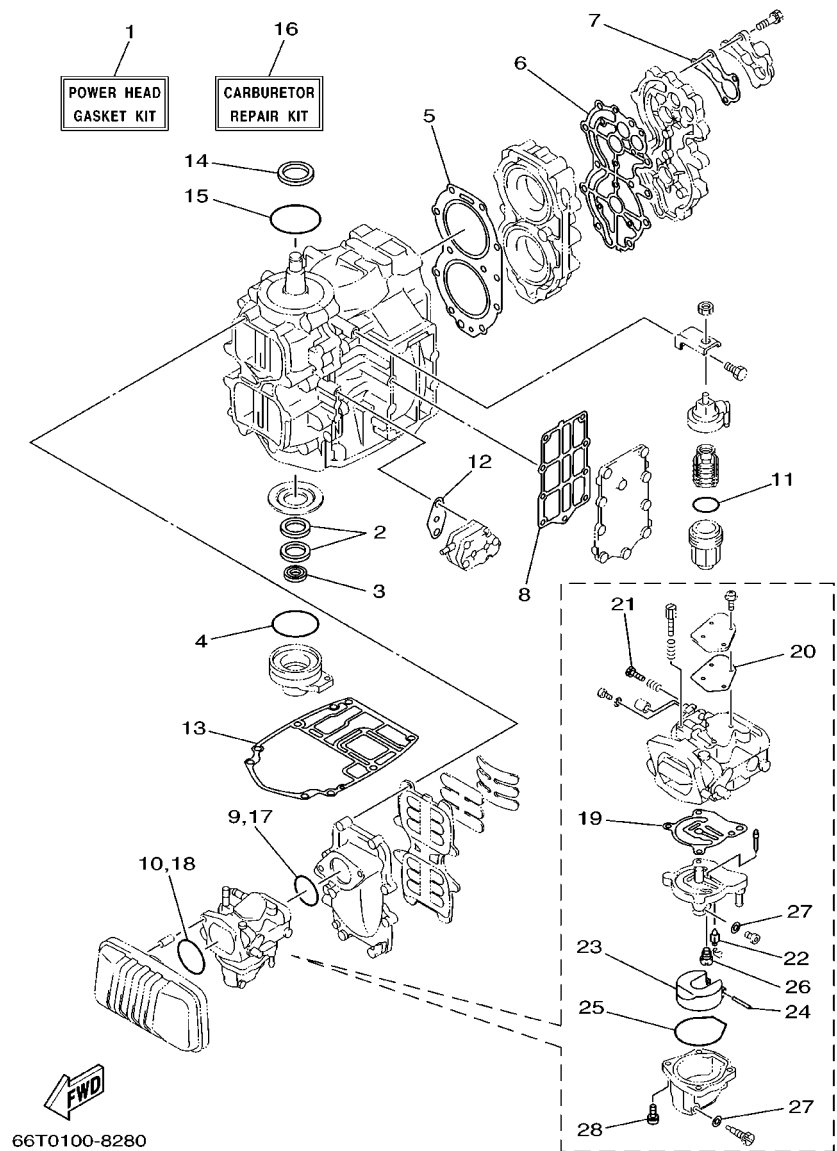

REF. NO.	PART NO. CODIGO NO.	DESCRIPTION DESCRIPTION	MH	WH	W	WT	REMARKS OBSERVACION
1	66T-W0001-00	POWER HEAD GASKET KIT JUEGO DE EMPAQUE MOTOR	1	1	1	1	
2	93102-30M53	.OIL SEAL .SELLO ACEITE	2	2	2	2	
3	93104-16M01	.OIL SEAL .SELLO ACEITE	1	1	1	1	
4	93210-65M50	.O-RING ANILLO O	1	1	1	1	
5	66T-11181-A0	.GASKET, CYLINDER HEAD 1 JUNTA, DE CULATA 1	1	1	1	1	
6	66T-11193-A1	.GASKET, HEAD COVER 1 EMPAQUE	1	1	1	1	
7	676-12414-A0	.GASKET, COVER EMPAQUE	1	1	1	1	
8	66T-41114-A0	.GASKET, EXHAUST OUTER COVER EMPAQUE	1	1	1	1	
9	93210-46M16	.O-RING ANILLO O	1	1	1	1	
10	93210-54M54	.O-RING ANILLO O	1	1	1	1	
11	93210-32738	.O-RING ANILLO O	1	1	1	1	
12	650-24431-A0	.GASKET, FUEL PUMP 1 EMPAQUE BOMBA COMBUST 1	1	1	1	1	
13	66T-45113-A0	.GASKET, UPPER CASING EMPAQUE	1	1	1	1	
14	93102-35M58	.OIL SEAL .SELLO ACEITE	1	1	1	1	
15	93210-75M51	.O-RING ANILLO O	1	1	1	1	
16	66T-W0093-01	CARBURETOR REPAIR KIT KIT REPARACION CARBURADOR	1	1	1	1	
17	93210-46M16	.O-RING ANILLO O	1	1	1	1	
18	93210-54M54	.O-RING ANILLO O	1	1	1	1	
19	66T-14384-01	.GASKET, FLOAT CHAMBER EMPAQUE DE CAMARA DE BOIA	1	1	1	1	
20	66T-14536-00	.GASKET EMPAQUE	1	1	1	1	
21	6E5-14323-03	.SCREW, AIR ADJUSTING .TORNILLO DE AJUSTE DE AIRE	1	1	1	1	
22	6E5-14546-00	.VALVE, NEEDLE .VALVULA DE AGUJA	1	1	1	1	
23	6E5-14385-02	.FLOAT BOIA	1	1	1	1	
24	6E5-14386-02	.PIN, FLOAT .PASADOR DE BOIA	1	1	1	1	
25	66T-14984-00	.GASKET, FLOAT CHAMBER EMPAQUE CAMARA DE BOIA	1	1	1	1	
26	66T-14992-00	.PLUG .TAPON	1	1	1	1	
27	66T-14959-00	.GASKET EMPAQUE	2	2	2	2	

ESTUCHE REPARATION 1

FIG. 29 REPAIR KIT 1

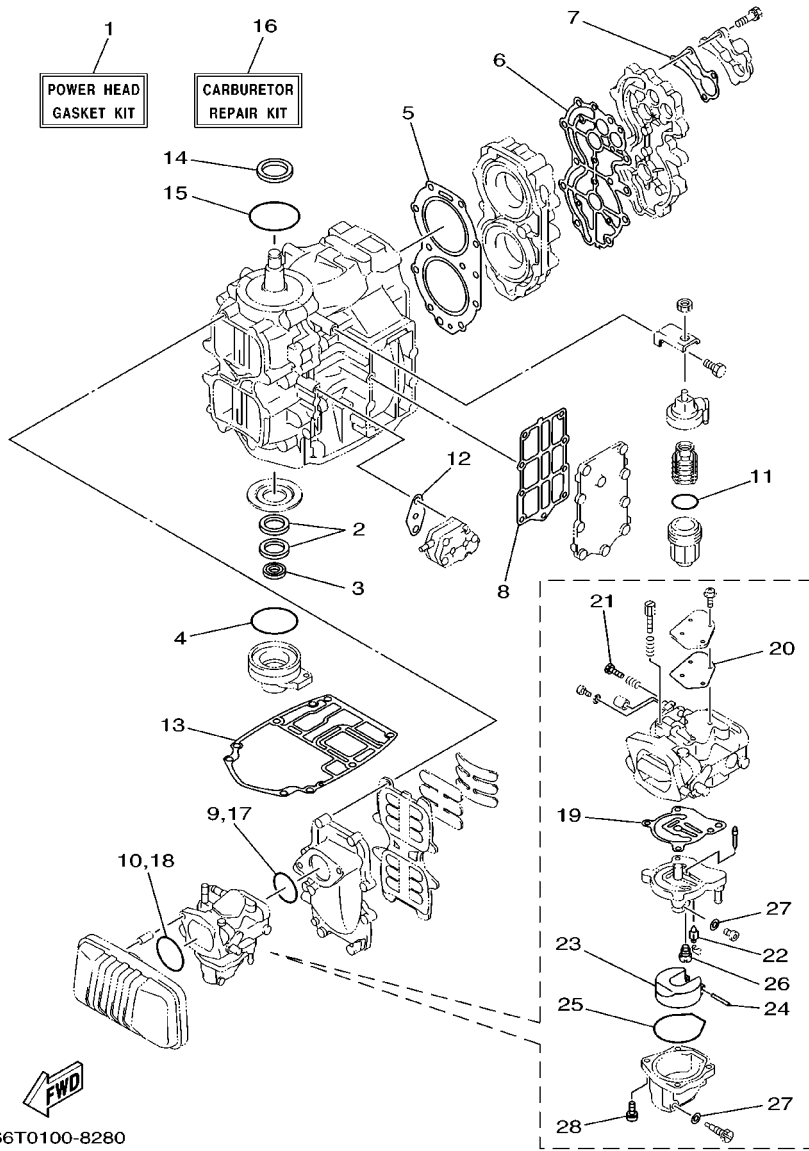

REF. NO.	PART NO. CODIGO NO.	DESCRIPTION DESCRIPTION	MH	WH	W	WT	REMARKS OBSERVACION
28	97980-05125	.SCREW, WITH WASHER .TORNILLO, CON ARANDELA	4	4	4	4	

FIG. 30 REPAIR KIT 2

ESTUCHE REPARATION 2

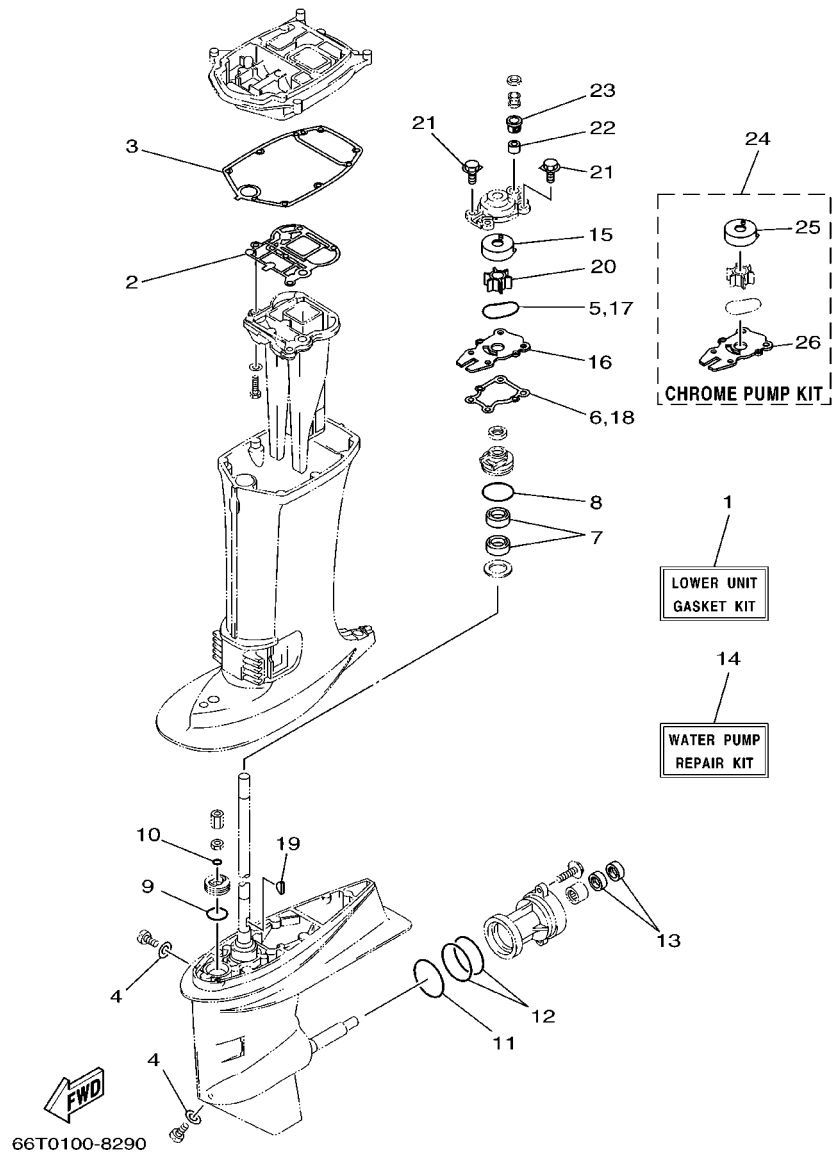

REF. NO.	PART NO. CODIGO NO.	DESCRIPTION DESCRIPTION	MH	WH	W	WT	REMARKS OBSERVACION
1	66T-W0001-20	LOWER UNIT GASKET KIT JUEGO DE EMPAQUE UNIDAD INFER	1	1	1	1	
2	66T-41133-A0	.GASKET, EXHAUST MANIFOLD 1 .EMPAQUE ESCAPE MULTIPLE	1	1	1	1	
3	66T-45114-A0	.GASKET, UPPER CASING .EMPAQUE	1	1	1	1	
4	90430-08020	.GASKET JUNTA	2	2	2	2	
5	93210-59MG7	.O-RING .ANILLO O	1	1	1	1	
6	63D-44316-00	.GASKET, WATER PUMP .EMPAQUE	1	1	1	1	
7	93101-22M60	.OIL SEAL .SELLO ACEITE	2	2	2	2	
8	93210-48MG8	.O-RING .ANILLO O	1	1	1	1	
9	93210-33MG4	.O-RING .ANILLO O	1	1	1	1	
10	93210-06ME6	.O-RING .ANILLO O	1	1	1	1	
11	93210-69MG6	.O-RING .ANILLO O	1	1	1	1	
12	93210-74MG5	.O-RING .ANILLO O	2	2	2	2	
13	93101-22M00	.OIL SEAL .SELLO ACEITE	2	2	2	2	
14	66T-W0078-00	WATER PUMP REPAIR KIT ESTUCHE REPARACION BOMBA AGUA	1	1	1	1	
15	63D-44322-00	.INSERT, CARTRIDGE .CARTUCHO	1	1	1	1	
16	66T-44323-00	.OUTER PLATE, CARTRIDGE .PLACA EXTERIOR DEL CARTUCHO	1	1	1	1	
17	93210-59MG7	.O-RING .ANILLO O	1	1	1	1	
18	63D-44316-00	.GASKET, WATER PUMP .EMPAQUE	1	1	1	1	
19	90280-03M07	.KEY, WOODRUFF .CUNA WOODRUFF	1	1	1	1	
20	6H4-44352-02	.IMPELLER .IMPULSOR	1	1	1	1	
21	90119-08M15	.BOLT, WITH WASHER .TORNILLO CON ARANDELA	1	1	1	1	
22	663-44366-00	.DAMPER, WATER SEAL .GOMA DEL SELLO DE AGUA	1	1	1	1	
23	63D-44312-00	.COVER, WATER PUMP HOUSING .CUBIERTA CAJA BOMBA DE AGUA	1	1	1	1	
24	66T-W0078-0A	CHROME PUMP KIT ESTUCHE REPARACION BOMBA AGUA	1	1	1	1	
25	63D-44322-40	.INSERT, CARTRIDGE .CARTUCHO	1	1	1	1	
26	66T-44323-40	.OUTER PLATE, CARTRIDGE .PLACA EXTERIOR DEL CARTUCHO	1	1	1	1	

FIG. 31 REPAIR KIT 3

ESTUCHE REPARATION 3

REF. NO.	PART NO. CODIGO NO.	DESCRIPTION DESCRIPTION	MH	WH	W	WT	REMARKS OBSERVACION
1	66T-81303-00	LIGHTING COIL ASSY BOBINA DE ILUMINACION COMPL.	1	1	1	1	AP
2	66T-85533-00	.COIL, LIGHTING .BOBINA DE LUZ	1	1	1	1	
3	97902-06125	.SCREW, WITH WASHER .TORNILLO, CON ARANDELA	2	2	2	2	
4	97802-04006	.SCREW, PAN HEAD .TORNILLO DE CABEZA CON PLANA	1	1	1	1	

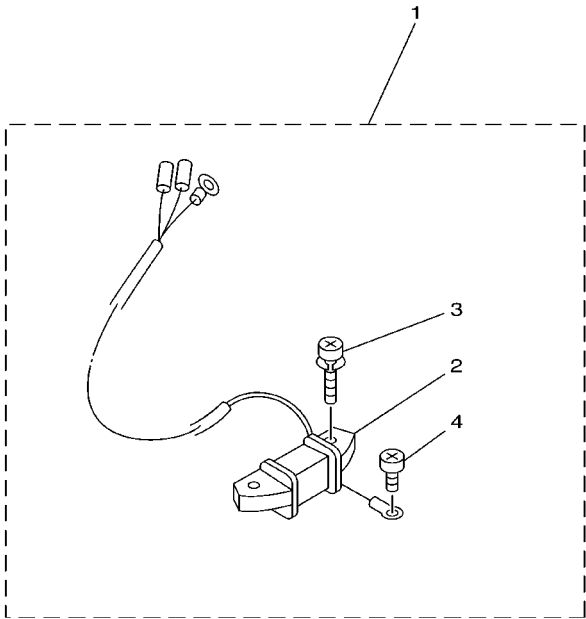

66T0010-9270

NUMERICAL INDEX
INDICE NUMERICO

PART NO. CODIGO NO.	REF. NO.	PART NO. CODIGO NO.	REF. NO.	PART NO. CODIGO NO.	REF. NO.	PART NO. CODIGO NO.	REF. NO.	PART NO. CODIGO NO.	REF. NO.	PART NO. CODIGO NO.	REF. NO.
66T-W0001-20	29 - 1	66T-14301-01	5 - 1	66T-15734-00	7 - 14	66T-26301-00	14 - 27	6E0-42651-02	1 - 4	682-43318-01	18 - 42
66T-W0001-00	30 - 1	66T-14301-11	5 - 1	63V-15741-00	7 - 4	65W-26326-00	13 - 19	6F5-42652-01	1 - 6	66T-43350-01	18 - 51
66T-W0004-00	4 - 2	66T-14301-21	5 - 1	63V-15744-00	7 - 10	65W-26326-10	13 - 19	61N-42677-H0	1 - 9	65W-43373-00	20 - 2
63D-W0070-10	1 - 11	66T-14301-31	5 - 1	6F5-15752-00	7 - 18		17 - 10	63D-42677-11	1 - 9	65W-43613-00	18 - 58
66T-W0070-H0	1 - 11	6E5-14323-03	5 - 11	6F5-15753-00	7 - 19	66T-41113-00-9M	2 - 30	6J4-42678-H0	1 - 10	65W-43614-00	18 - 56
66T-W0078-0A	30 - 24		29 - 21	689-15755-01	7 - 21	66T-41114-A0	2 - 32	63D-42678-11	1 - 10	65W-43615-00	18 - 57
66T-W0078-00	30 - 14	6A0-14325-00	6 - 24	66T-15758-00	7 - 24		29 - 8	63D-42681-10	1 - 12	65W-43616-00	18 - 55
66T-W0084-01-4D	14 - 1	6J8-14334-00	5 - 10	66T-15762-00	7 - 27	66T-41131-00-5B	22 - 4	63D-42682-10	1 - 13	66T-43627-00	18 - 30
66T-W0090-00-4D	2 - 1	66T-14384-01	5 - 5	66T-15767-00	7 - 8	66T-41133-A0	22 - 5	66T-42710-00-4D	13 - 1	65W-43630-02	18 - 43
66T-W0093-01	29 - 16		29 - 19	6F5-15768-00	7 - 20		30 - 2	66T-42716-00	13 - 5	65W-43630-11	18 - 43
676-W2810-01	6 - 30	6E5-14385-02	5 - 17	63V-15768-00	7 - 11	66T-41137-00-94	22 - 1	6G1-42725-00	9 - 19	66T-43631-01	18 - 53
66T-11111-00-94	2 - 20		29 - 23	66T-15770-00	7 - 15	66T-41237-00	16 - 5	66T-42725-00	13 - 8	66T-43631-11	18 - 53
66T-11119-00	2 - 18	6E5-14386-02	5 - 18	66T-15771-00-94	7 - 34	66T-41252-00	4 - 21	66T-42725-10	13 - 8	689-43633-00	15 - 6
66T-11181-A0	2 - 21		29 - 24	66T-15772-00-94	7 - 36	66T-41256-00	4 - 19	66T-42725-20	13 - 8	65W-4380F-00	21 - 11
	29 - 5	66T-14440-00	4 - 12	6F5-15779-02	7 - 22	66T-41257-00	4 - 23	66T-42725-30	17 - 9	65W-4380K-00	21 - 16
66T-11191-00-9M	2 - 23	624-14485-00	2 - 5	66T-15784-00	7 - 9	661-41262-02	4 - 20	6H1-42726-10	13 - 21	65W-4380L-00	21 - 27
66T-11193-A1	2 - 24	66T-14497-00	16 - 10	697-15789-00	7 - 23	6H4-41271-01	4 - 16	6H4-42726-00	13 - 21	65W-43800-02-4D	21 - 1
	29 - 6	66T-14523-00	5 - 9	6F5-15791-00	7 - 17	689-41273-00	4 - 17	65W-42726-00	13 - 23	674-43802-03	21 - 30
676-11325-00	2 - 16	66T-14527-00	5 - 7	66T-15794-00	7 - 13	6J8-41274-00	4 - 18	65W-42726-10	13 - 23	65W-43804-00	21 - 3
650-11372-00	4 - 5	66T-14536-00	5 - 6	6YJ-24167-00	25 - 7	66T-41611-00	8 - 12		17 - 11	65W-43805-00	21 - 4
676-11372-00	2 - 31		29 - 20	6YJ-24101-00	25 - 1	66T-41631-00	16 - 4	676-42727-00	13 - 20	65W-4381B-00	21 - 22
66T-11400-00	3 - 1	6E5-14546-00	5 - 15	6YJ-24201-10	25 - 1	66T-41638-00	16 - 1	66T-42738-00-5B	13 - 6	65W-43810-00	21 - 17
66T-11412-00	3 - 2		29 - 22	6YJ-24260-00	25 - 3	6F5-41662-00	16 - 17	66T-42741-00	13 - 26	65W-43812-00	21 - 18
66T-11422-00	3 - 2	6J8-14578-00	5 - 2	6Y1-24260-12	25 - 3	65W-42101-01-4D	14 - 12	66T-42815-00-4D	13 - 9	6H1-43816-00	21 - 25
66T-11432-00	3 - 4	6J8-14592-01	5 - 3	6Y1-24268-00	25 - 6	664-42119-00	14 - 20	66T-42816-00	13 - 13	65W-43817-00	21 - 39
66T-11442-00	3 - 5	61A-1492E-85	5 - 14	6G1-24304-02	6 - 1	65W-42121-01-4D	14 - 39	65W-43111-10-4D	19 - 5	65W-4382A-00	21 - 47
6F5-11515-00	3 - 9	61A-1492E-88	5 - 14	6G1-24305-01	25 - 13	65W-42123-00	14 - 6	66T-43111-00-4D	18 - 5	6H1-43829-00	21 - 61
66T-11603-00	3 - 16	66T-1492F-35	5 - 19	6Y1-24305-02	25 - 15	65W-42125-00	14 - 17	65W-43112-10-4D	19 - 6	65W-43830-00	21 - 36
66T-11604-00	3 - 16	66T-1492F-37	5 - 19	6Y1-24306-06	25 - 8	6G1-42126-00	14 - 16	66T-43112-00-4D	18 - 10	65W-43831-00	21 - 35
66T-11605-00	3 - 16	66T-14945-01	5 - 13	6Y1-24329-00	25 - 5	65W-42131-01	14 - 36	6J8-43113-01	18 - 27	6H1-4384F-10	21 - 57
66T-11631-00-93	3 - 15	66T-14959-00	5 - 24	66T-24329-00	13 - 22	6G1-42137-10	14 - 21	648-43114-01	18 - 8	65W-43840-00	21 - 15
6F5-11633-00	3 - 17		29 - 27	650-24351-51	25 - 12	65W-42138-00	14 - 14		18 - 13	62X-43841-00	21 - 33
663-11634-00	3 - 18	66T-14981-00	5 - 22	6Y1-24360-51	25 - 10	65W-42159-00	14 - 15	663-43118-01-4D	18 - 7	65W-43843-00	21 - 54
66T-11635-00	3 - 15	66T-14984-00	5 - 20	692-24410-00	6 - 14	66T-42167-00	16 - 2		18 - 12	6H1-43844-10	21 - 56
66T-11636-00	3 - 15		29 - 25	663-24411-00	6 - 19	6F6-42177-A0	14 - 19	63D-43131-00	18 - 24	65W-43844-00	21 - 48
6F5-11651-00	3 - 10	66T-14991-00	5 - 23	692-24411-00	6 - 16	65W-42508-00	15 - 1		19 - 13	6H1-43845-00	21 - 43
66T-11681-00	3 - 11	66T-14992-00	5 - 21	6A0-24412-02	6 - 25	65W-42511-00-4D	20 - 6	66T-43144-00	13 - 14	6H1-43847-00	21 - 45
6E5-12411-01	2 - 26		29 - 26	6A0-24413-00	6 - 15	65W-42511-10-4D	20 - 6	6E5-43145-01	26 - 9	65W-43851-00	21 - 49
676-12413-00-9M	2 - 27	66T-15100-00-94	2 - 2	6A0-24421-01	6 - 23	65W-42527-00	15 - 2	6G5-43145-00	18 - 29	674-43853-00	21 - 37
676-12414-A0	2 - 28	66T-15396-00	2 - 8	650-24431-A0	6 - 26	648-42528-00	20 - 1		19 - 17	65W-43853-00	21 - 60
	29 - 7	66T-15705-00	7 - 7		29 - 12	65W-42528-00	15 - 12	63V-43145-00	18 - 28	65W-43854-00	21 - 46
6E5-13552-00	2 - 3	66T-15710-00	7 - 1	648-24434-01	6 - 17	624-42542-00	9 - 3	65W-43191-00	18 - 16	65W-43855-00	21 - 52
	2 - 4	66T-15711-00	7 - 2	648-24435-02	6 - 20	65W-42561-00	15 - 5		19 - 8	6H1-43856-10	21 - 55
	4 - 4	66T-15713-00	7 - 5	61N-24521-00	6 - 7	65W-42562-00	15 - 10	65W-43192-00	18 - 15	65W-4386A-00	21 - 58
66T-13610-00	4 - 1	66T-15714-00	7 - 3	61N-24560-00	6 - 5	66T-42610-H0-4D	1 - 1		19 - 7	65W-4386K-00	21 - 7
66T-13641-01-94	4 - 3	66T-15716-00	7 - 6	61N-24563-00	6 - 6	66T-42610-10-4D	1 - 1	65W-43311-00-4D	18 - 22	6H1-43861-10	21 - 20
6E5-14159-00	5 - 16	66T-15723-00	7 - 28	648-24566-02	6 - 9	66T-42613-00	1 - 2	65W-43311-10-4D	18 - 22		21 - 23
6E5-14223-00	5 - 12	66T-15731-00	7 - 16	6YJ-24610-01	25 - 2	66T-42615-01	1 - 8		19 - 11	65W-43861-00	21 - 40

NUMERICAL INDEX
INDICE NUMERICO

PART NO. CODIGO NO.	REF. NO.	PART NO. CODIGO NO.	REF. NO.	PART NO. CODIGO NO.	REF. NO.	PART NO. CODIGO NO.	REF. NO.	PART NO. CODIGO NO.	REF. NO.	PART NO. CODIGO NO.	REF. NO.
65W-43862-00	21 - 41	6H4-44352-02	23 - 18	663-45567-01-10	23 - 40	703-48203-14	27 - 1	6H3-48538-00	16 - 29	66T-82575-00	14 - 40
65W-43865-00	21 - 19		30 - 20	663-45567-01-12	23 - 40		28 - 1		17 - 4	688-82575-01	28 - 47
6H1-43866-00	21 - 31	66T-44361-00	24 - 1	663-45567-01-15	23 - 40	703-48205-15	27 - 1	65W-61350-00	26 - 1	688-8258A-20	28 - 49
6H1-43867-00	21 - 32	66T-44361-10	24 - 1	663-45567-01-18	23 - 40		28 - 1	65W-61351-00	26 - 2	688-82586-21	28 - 49
65W-43869-00	21 - 5	66T-44361-20	24 - 1	663-45567-01-30	23 - 40	703-48211-01	28 - 61	66T-81303-00	31 - 1	66T-82590-00	10 - 13
65W-43871-00	21 - 21	66T-44362-20	24 - 26	663-45567-01-40	23 - 40	703-48212-00	28 - 58	66T-81328-00	8 - 14	66T-82590-20	11 - 1
6H1-43875-00	21 - 42	663-44366-00	24 - 18	663-45567-01-50	23 - 40	703-48213-00	28 - 59	66T-81800-00	12 - 1	703-82591-00	28 - 53
62X-43878-00	21 - 62		30 - 22	66T-45571-00	23 - 41	703-48215-00	28 - 43	66T-81820-00	12 - 6	703-82592-00	28 - 54
65W-43879-00	21 - 12	663-44367-00	24 - 4	63D-45577-00-10	23 - 43	702-48217-00	28 - 44	66T-81826-00	12 - 7	65W-82594-00	10 - 32
65W-4388E-00	21 - 14	6E5-44391-00	13 - 18	63D-45577-00-12	23 - 43	703-48219-00	28 - 30	66T-81830-00	12 - 5	703-82594-00	28 - 25
65W-43880-00	21 - 2	66T-44514-00-4D	20 - 15	63D-45577-00-15	23 - 43	703-48221-00	28 - 56	66T-81840-00	12 - 2	703-83383-02	28 - 51
65W-43881-00	21 - 6	66T-44514-30-4D	20 - 15	63D-45577-00-18	23 - 43	703-48222-00	28 - 27	66T-81850-00	12 - 4	6N7-83557-00	10 - 14
65W-43882-00	21 - 8	66T-44526-00	20 - 16	63D-45577-00-30	23 - 43	703-48223-00	28 - 28	66T-81857-00	12 - 3	66T-83557-00	10 - 14
65W-43887-00	21 - 13	66T-44526-30	20 - 16	63D-45577-00-40	23 - 43	703-48224-00	28 - 55	689-81870-00	9 - 20	66T-85515-00	8 - 8
65W-43888-00	21 - 28	65W-44551-00-4D	20 - 19	63D-45577-00-50	23 - 43	703-48225-00	28 - 29	66T-81916-01	9 - 8	66T-85520-00	8 - 10
65W-43891-00	21 - 10	65W-44555-10	20 - 20	663-45587-01-10	23 - 35	703-48226-00	28 - 26	6G1-8194A-10	10 - 1	66T-85533-00	8 - 11
65W-43892-00	21 - 9	66T-44575-00	20 - 21	663-45587-01-12	23 - 35	703-48227-00	28 - 24	6L2-81945-00	10 - 5		31 - 2
66T-44111-01	14 - 2	66T-45111-00-4D	22 - 7	663-45587-01-15	23 - 35	703-48232-00	28 - 62	66T-81948-00	11 - 11	66T-8554B-01-94	9 - 1
682-44116-01	16 - 19	66T-45111-10-4D	22 - 7	663-45587-01-18	23 - 35	703-48235-00	28 - 4	6E5-8195B-01	11 - 2	66T-85540-00	9 - 5
66T-44121-00	16 - 14	66T-45113-A0	22 - 12	663-45587-01-30	23 - 35	703-48236-00	28 - 16	6E5-8195C-01	11 - 5	66T-85550-00	8 - 1
66M-44122-00	16 - 15		29 - 13	663-45587-01-40	23 - 35		28 - 18	6G1-81952-00	10 - 4	66T-85550-10	8 - 1
66T-44124-00	14 - 8	66T-45114-A0	22 - 11	663-45587-01-50	23 - 35	703-48238-00	28 - 22	6G1-81970-61	10 - 8	66T-85560-00	8 - 2
66T-44125-00	16 - 25		30 - 3	66T-45611-00	23 - 56	703-48243-00	28 - 15	66T-82105-00	10 - 7	66T-85560-10	8 - 2
	17 - 6	63D-45155-00	22 - 8	66T-45631-00	23 - 51	703-48244-00	28 - 21	66T-85561-00	10 - 15	66T-85561-00	8 - 3
66T-44143-00	16 - 21	66T-45211-00-4D	22 - 17	663-45633-00	23 - 54	703-48245-00	28 - 11	6E5-82116-00	11 - 10	66T-85570-00	9 - 10
66T-44143-10	16 - 21	63D-45214-00	23 - 7	66T-45635-00	23 - 55	703-48246-00	28 - 23	6E5-82117-00	10 - 6	66T-85580-00	8 - 5
61N-44146-00	23 - 27	63D-45215-00	23 - 8	663-45930-00-98	24 - 25	701-48248-00	28 - 13	6G5-82119-00	11 - 9	66T-85582-00	8 - 7
66T-44150-01	23 - 26	65W-45251-00	19 - 23	63D-45941-00-EL	24 - 25	703-48252-00	28 - 12	6U0-82127-00	19 - 26	66T-85596-00	8 - 6
66T-44150-11	23 - 26	67C-45251-00	24 - 15	663-45941-01-EL	24 - 25	703-48261-01	28 - 2	66T-82127-00	20 - 26	6J4-86111-00	10 - 16
66T-44150-21	23 - 26	676-45251-00	2 - 14	663-45943-02-EL	24 - 25	703-48264-00	28 - 6	66T-82127-10	20 - 27	66T-86112-00	10 - 18
65W-44173-00	16 - 23	66T-45300-00-4D	23 - 1	663-45945-02-EL	24 - 25	703-48265-00	28 - 9	6H1-82148-00	19 - 25	6J4-86116-00	10 - 17
6E0-44191-11	14 - 11	66T-45300-10-4D	23 - 1	663-45947-02-EL	24 - 25	703-48268-00	28 - 5	6G1-82151-00	10 - 9	682-86117-00	10 - 21
688-44194-00	16 - 9	66T-45300-30-4D	23 - 1	663-45949-01-EL	24 - 25	703-48271-00	28 - 60	6A0-82317-00	9 - 2	66T-87149-00	11 - 8
66T-44311-00	23 - 12	66T-45311-00-4D	23 - 2	663-45952-02-EL	24 - 25	703-48281-00	28 - 31	6E3-82370-21	9 - 15	9E471-04305	8 - 13
63D-44312-00	24 - 19	66T-45318-00	22 - 15	663-45954-01-EL	24 - 25	703-48282-00	28 - 32	66T-82370-00	9 - 15	90101-08M28	18 - 64
	30 - 23	66T-45321-00	23 - 29	663-45956-01-EL	24 - 25	703-48284-00	28 - 52	703-82510-31	28 - 45	90101-08M76	18 - 19
63D-44316-00	23 - 16	688-45341-00	23 - 6	663-45958-01-EL	24 - 25	701-48287-00	28 - 42	703-82510-41	28 - 45	90101-08M86	20 - 14
	30 - 6	66T-45344-00	23 - 21	663-45970-60-98	24 - 25	703-48291-10	28 - 39	66T-82519-00	9 - 18	90101-09M01	26 - 7
	30 - 18	63D-45361-02-4D	23 - 44	663-45972-60-98	24 - 25	703-48293-10	28 - 41	703-82531-00	28 - 46	90101-10M58	18 - 1
63D-44322-00	23 - 13	664-45371-01	24 - 8	663-45974-60-98	24 - 25	701-48320-20	27 - 2	6F5-82540-00	10 - 26	90101-12M65	19 - 1
	30 - 15	63D-45375-00	24 - 7	663-45976-00-98	24 - 25	701-48320-50	27 - 2	703-82540-00	28 - 50	90105-08M61	23 - 50
63D-44322-40	23 - 13	663-45376-00	24 - 6	663-45978-00-98	24 - 25	663-48344-00	16 - 27	66T-82553-00	10 - 27	90105-08M76	20 - 3
	30 - 25	66T-45501-00	23 - 33	663-45987-02	24 - 20		17 - 2	66T-82554-00	10 - 28	90109-06M50	15 - 3
66T-44323-00	23 - 14	66T-45501-10	23 - 33	66T-45997-00	24 - 21	703-48345-01	28 - 19	682-82556-00	14 - 41	90109-06M80	9 - 7
	30 - 16	66T-45501-20	23 - 33	703-48152-00	28 - 57		28 - 20		28 - 48		10 - 12
66T-44323-40	23 - 14	6H4-45536-00	23 - 3	703-48153-00	28 - 3	703-48358-00	28 - 1	688-82560-10	9 - 17		13 - 28
	30 - 26	66T-45551-00	23 - 36	703-48189-00	28 - 17	66T-48501-00	17 - 1	703-82563-01	28 - 55		13 - 30
63D-44341-00	23 - 19	66T-45560-00	23 - 38	703-48198-00	28 - 14	65W-48511-00	17 - 7	689-8257Y-00	14 - 42	90109-06M81	9 - 6

NUMERICAL INDEX
INDICE NUMERICO

PART NO. CODIGO NO.	REF. NO.	PART NO. CODIGO NO.	REF. NO.	PART NO. CODIGO NO.	REF. NO.	PART NO. CODIGO NO.	REF. NO.	PART NO. CODIGO NO.	REF. NO.	PART NO. CODIGO NO.	REF. NO.
90109-06M81	9 - 9	90185-08045	20 - 12	90249-12M39	18 - 39	90387-12M04	18 - 38	91490-16012	16 - 22	93210-11073	21 - 53
	9 - 13	90185-08057	18 - 36	90249-18M35	19 - 32	90389-22M01	24 - 22	91490-20010	14 - 18	93210-11368	21 - 24
	13 - 7		18 - 66	90250-06023	23 - 53	90430-08020	23 - 5	91490-20015	18 - 63	93210-16275	26 - 10
	16 - 18	90185-09M01	26 - 4	90254-03M03	18 - 54		30 - 4	91490-30025	24 - 24	93210-18397	21 - 44
90109-06M86	10 - 29	90185-10M13	19 - 35	90254-03M04	16 - 24	90430-12072	24 - 3	91690-30018	18 - 17	93210-32738	6 - 8
	10 - 31	90185-10M14	15 - 9		16 - 26	90445-07MA4	4 - 8		19 - 9		29 - 11
	13 - 15	90185-10051	20 - 4	90254-03M05	16 - 16	90445-07M08	2 - 35	91690-30318	17 - 5	93210-33MG4	23 - 30
	14 - 13	90185-22M11	19 - 16	90266-04M04	1 - 5	90445-07M24	4 - 7	91690-40032	4 - 22		30 - 9
	16 - 20	90201-08M00	19 - 29		1 - 7	90445-09M08	6 - 3	92903-10600	14 - 24	93210-43MJ0	20 - 10
90109-08M90	18 - 34	90201-08M07	18 - 35	90269-02M09	14 - 22	90445-09M75	2 - 34	92990-05100	6 - 22	93210-46M16	4 - 10
90110-10M02	19 - 33	90201-08M54	16 - 11	90280-03M07	23 - 17	90445-09086	6 - 12	92990-05600	5 - 4		29 - 9
90116-10M23	22 - 19	90201-10M20	26 - 3		30 - 19		6 - 28	92990-06100	15 - 4		29 - 17
90116-10M28	20 - 5	90201-10M63	26 - 8	90280-05015	8 - 19	90445-11M05	25 - 11	92990-06200	14 - 9	93210-48MG8	23 - 22
90119-06M61	13 - 2	90201-10120	17 - 8	90338-05M03	13 - 25	90445-11M06	25 - 9	92990-06600	23 - 32		30 - 8
90119-06M65	9 - 4		20 - 30	90338-07M00	13 - 24	90446-03MA3	9 - 12	92990-08100	18 - 21	93210-50768	21 - 29
90119-06M73	13 - 17	90201-12M07	14 - 4	90340-08M04	23 - 4	90446-10MH1	14 - 29	92990-08600	28 - 34	93210-54M54	4 - 13
90119-06M85	14 - 3	90201-12426	18 - 3	90385-12M04	7 - 32	90446-10M82	14 - 28	92990-10100	22 - 21		29 - 10
90119-06M88	10 - 25		19 - 3	90386-07MA2	18 - 45	90446-10M86	14 - 30	92990-10600	22 - 22		29 - 18
90119-08M09	2 - 22	90201-20417	3 - 20	90386-08032	14 - 26	90464-09M49	13 - 29	92995-08100	20 - 18	93210-59MG7	23 - 15
90119-08M10	7 - 30	90201-21M18	8 - 21	90386-10M99	18 - 44	90464-12M00	8 - 25		24 - 10		30 - 5
90119-08M15	23 - 25	90201-22M03	18 - 26		18 - 49	90464-13249	7 - 38		24 - 17		30 - 17
	30 - 21		19 - 15	90386-12MA0	18 - 40	90465-11M10	11 - 13	92995-08200	20 - 13	93210-65M50	2 - 11
90119-08M39	12 - 8	90201-22429	23 - 42		19 - 18	90465-13M11	19 - 22	92995-10100	24 - 13		29 - 4
90119-08M42	22 - 14	90201-27M00	23 - 23	90386-12MA2	13 - 11	90465-15M74	8 - 22	92995-10600	18 - 2	93210-69MG6	23 - 46
90119-08M43	24 - 5	90201-43M00	14 - 32	90386-12M37	13 - 10	90465-20M31	10 - 30		19 - 34		30 - 11
90119-08M44	24 - 5	90202-10M56	15 - 11	90386-12M98	18 - 31	90465-25M57	13 - 24		20 - 23	93210-74MG5	23 - 47
90119-08M50	4 - 11	90202-12031	18 - 32		19 - 19	90467-06016	4 - 9		24 - 14		30 - 12
90119-08M51	7 - 31	90202-12060	24 - 2	90386-14MA1	19 - 10	90467-08004	6 - 4	92995-12200	19 - 2	93210-75M51	8 - 17
90119-08M52	12 - 9	90202-43M57	14 - 34	90386-18MA0	19 - 31		6 - 13	93101-22M00	23 - 49		29 - 15
90119-08M79	22 - 2	90204-06M00	10 - 3	90386-18M44	19 - 30		6 - 29		30 - 13	93306-001U1	23 - 45
	22 - 10		11 - 4	90386-22M15	18 - 25	90468-18008	14 - 10	93101-22M60	23 - 20	93306-306V5	3 - 8
90119-10M04	20 - 24		11 - 7		19 - 14		16 - 28		30 - 7	93306-306V6	3 - 7
90119-10M07	2 - 7	90206-12M00	14 - 5	90386-40MA0	14 - 31		17 - 3	93102-30M53	2 - 9	93306-307U0	3 - 6
90141-06M00	2 - 17		18 - 33	90386-40M99	14 - 35	90480-09M21	13 - 3		29 - 2	93310-727U0	3 - 13
90142-05M06	23 - 9	90206-12052	13 - 12	90386-44M03	20 - 9	90480-10M23	10 - 22	93102-35M58	8 - 4	93315-32224	23 - 11
90149-05M13	14 - 23	90206-43M22	14 - 33	90386-44M99	20 - 11	90480-10M71	8 - 24		29 - 14	93317-22204	23 - 48
90149-05M17	18 - 54	90209-10M26	15 - 13	90386-52M02	20 - 8	90480-10155	10 - 19	93104-16M01	2 - 10	93332-00001	23 - 34
90149-14M12	18 - 6	90209-27M07	3 - 12	90387-05M11	15 - 8	90480-25M70	24 - 27		29 - 3	93332-00003	23 - 39
	18 - 11	90209-34M27	2 - 13	90387-06M41	13 - 4	90480-25161	9 - 11	93210-03261	10 - 24	93420-30042	22 - 16
90161-06M00	10 - 33	90209-52M00	20 - 7	90387-06M60	10 - 23	90480-30M71	24 - 28	93210-03478	21 - 51	93430-06024	28 - 10
90170-06M30	10 - 2	90243-04007	18 - 9	90387-06M66	7 - 26	90501-10M84	16 - 6	93210-06ME6	23 - 31		28 - 63
	11 - 3		18 - 14	90387-06M80	4 - 15	90501-15M01	23 - 52		30 - 10	93430-10M00	18 - 41
	11 - 6	90249-07M32	18 - 59	90387-07M05	18 - 48	90501-23215	14 - 25	93210-064A5	21 - 26		19 - 21
90170-09M03	26 - 5	90249-07M33	18 - 61	90387-07M29	18 - 60	90502-10M06	18 - 65	93210-08006	21 - 50	93440-68M03	3 - 14
90170-12138	23 - 37	90249-10M31	18 - 47	90387-08M05	7 - 33	90506-16M34	13 - 16	93210-08287	25 - 14	93501-08001	21 - 59
90170-20137	8 - 20	90249-12M34	18 - 37	90387-08M16	16 - 3	90506-20M37	18 - 52		25 - 16	93603-21111	3 - 19
90171-16011	24 - 23		18 - 39	90387-08M29	18 - 18	90506-30M00	18 - 62	93210-09165	21 - 34	93604-08062	23 - 24
90179-10M33	20 - 25	90249-12M38	19 - 20	90387-10M42	26 - 6	91318-04025	21 - 38	93210-10M74	21 - 63	93606-12019	22 - 3

NUMERICAL INDEX
INDICE NUMERICO

PART NO. CODIGO NO.	REF. NO.	PART NO. CODIGO NO.	REF. NO.	PART NO. CODIGO NO.	REF. NO.	PART NO. CODIGO NO.	REF. NO.	PART NO. CODIGO NO.	REF. NO.
93606-12019	22 - 13	97595-06514	19 - 27						
	22 - 18	97595-06516	8 - 23						
	24 - 11		11 - 12						
93608-12063	2 - 6		13 - 27						
93700-06M03	15 - 14	97595-06520	2 - 12						
	18 - 23		2 - 15						
	19 - 12	97595-06525	9 - 14						
94702-00040	2 - 36	97595-06530	6 - 2						
94702-00272	2 - 36	97595-06535	7 - 25						
95380-03600	6 - 18	97595-06540	6 - 27						
95380-05600	10 - 11		8 - 18						
	23 - 10	97595-08516	12 - 10						
	28 - 7	97780-60520	1 - 3						
95380-06600	14 - 7	97802-04006	8 - 16						
	28 - 40		31 - 4						
95380-06700	16 - 8	97880-05008	10 - 20						
	23 - 28	97880-06035	16 - 7						
95380-08600	6 - 10	97885-06008	20 - 28						
	18 - 20	97902-04108	8 - 9						
95380-10600	18 - 4	97902-06125	8 - 15						
	22 - 20		31 - 3						
95380-10700	14 - 37	97980-04112	5 - 8						
95380-12600	19 - 4	97980-05125	5 - 25						
95780-10300	14 - 38		29 - 28						
97013-06014	6 - 11	97980-05230	10 - 10						
97013-08020	2 - 19	97985-06240	4 - 14						
97075-08030	20 - 17	98503-05028	6 - 21						
97075-10040	24 - 12	98580-03015	28 - 38						
97075-10070	20 - 22	98580-04006	28 - 36						
97080-08016	19 - 28	98580-04010	28 - 35						
97085-06025	19 - 24	98580-05010	28 - 37						
97095-06014	16 - 13	98586-05016	25 - 4						
97095-08025	24 - 9	99080-08600	18 - 46						
97095-08030	28 - 33		18 - 50						
97095-08035	24 - 16								
97095-08045	16 - 12								
97380-05025	28 - 8								
97513-06525	2 - 25								
	2 - 33								
97513-06530	7 - 35								
	7 - 37								
97513-06535	2 - 29								
	4 - 6								
97575-08530	22 - 6								
97575-08545	22 - 9								
97595-05516	15 - 7								
97595-06510	7 - 29								
97595-06512	9 - 16								