



**PARTS
CATALOGUE
CATÁLOGO
DE PEÇAS**

40XMH '07 (67TA)

40XMH '08 (67TC)

40XW '07 (67T9)

40XW '08 (67TB)

40XMH,40XW '07/40XMH,40XW '08
PARTS CATALOGUE
©2007 by Yamaha Motor Co., Ltd.
1st edition, September 2007
All rights reserved.
Any reprinting or unauthorized use
without the written permission of
Yamaha Motor Co., Ltd.
is expressly prohibited.

40XMH,40XW '07/40XMH,40XW '08
CATÁLOGO DE PEÇAS
©2007, Yamaha Motor Co., Ltd.
1ª edição, Setembro 2007
Todos os direitos reservados.
É proibida expressamente toda e qualquer
reimpressão ou utilização sem a autorização
por escrita da
Yamaha Motor Co., Ltd.

FOREWORD

This Parts Catalogue is related to the parts for the model(s) on the cover page. When you are ordering replacement parts, please refer to this Parts Catalogue and quote both part numbers and part names correctly.

1. Modifications or additions which have been made after the issue of the Parts Catalogue will be announced in the Parts News.
It is advisable that you make the necessary corrections to the Parts Catalogue according to the Parts News.

2. Abbreviations

The following abbreviations are used in this Parts Catalogue.

“UR” Use specified parts number.

“UN” Use as many as needed.

“AP” Alternate Parts

“LM” Locally Made (Parts need to be ordered locally)

“F#” Frame No. (Applicable machine No.)

“O/S” Over Size

3. The number of components for assembly

- Parts, which are to be supplied in an assembly, are listed with a dot (.) in front of the part name as shown below.
- The numeral appearing to the right of each component part indicates the quantity of parts for each assembly unit.

PART NO.	DESCRIPTION	Q'TY	REMARKS
2F5-83310-60	FRONT FLASHER LIGHT ASSY	2	
115-83311-60	.BULB (6V-18W)	1	

4. Applicable colours of graphics are represented in the “REMARKS” as shown below.

PART NO.	DESCRIPTION	Q'TY	REMARKS
2N4-24110-00-X5	FUEL TANK COMP.	2	MXR
3J1-24240-10	.GRAPHIC, FUEL TANK	1	FOR MXR

5. Note that the illustrations for reference in finding parts numbers are not to be used for assembling. When assembling, please use the applicable service manual.

6. The asterisk (*) before a reference number indicates modified items after the first edition.

7. Applicable Serial No.

Engine Serial No.

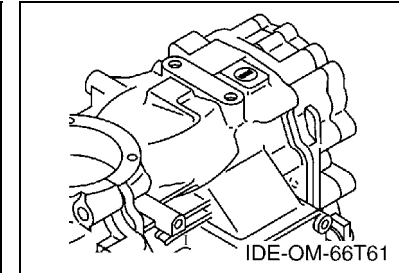
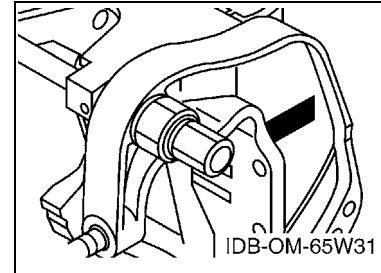

8. Applicable Engine Starting Serial No.

Model	Serial No.	Model	Serial No.
40XMH '07	67T-1100876	40XW '07	67T-1002576
40XMH '08	67T-1101251	40XW '08	67T-1003001

9. Applicable Colour Code

Abbreviation	Colour Name	Colour Code
DBNM2	DARK BLUISH GRAY METALLIC 2	004D

10. Quantity Column Information

Column No.	Name Of Q'ty Column	Applicable Model
1	67TA	40XMH '07
2	67TC	40XMH '08
3	67T9	40XW '07
4	67TB	40XW '08

PREFÁCIO

Este Catálogo de Peças se refere as Peças dos modelos relacionados na capa. Quando for solicitar peças de reposição para estes Modelos, recorra a este Catálogo de Peças e especifique corretamente os códigos e Nomes das Peças.

1. As Modificações ou adições que tenham sido efetuadas após a publicação deste Catálogo de Peças, serão comunicadas a Rede de Concessionárias através das informações de Modificação de Peças (Parts News).

2. Abreviaturas

Seguem abaixo as abreviaturas utilizadas neste Catálogo de Peças:

“UR” Uso Restrito para o Código da Peça

“UN” Uso Necessário

“AP” Peça Alternativa

“LM” Fabricação Local (A peça pode ser pedida localmente)

“F#” No. de Série do Chassi (Aplicação do Número de Série)

“O/S” Tamanho Maior

3. Peças componentes de conjuntos

- As peças que são fornecidas dentro de conjuntos estão listadas com um ponto de identificação (.) como segue abaixo.
- O número que aparece a direita da descrição da Peça indica o número de Peças usado em cada Conjunto Individual.

No. PEÇA	DESCRIÇÃO	QTDE	OBSERVAÇÕES
2F5-83310-60	PISCA DIANTEIRO CONJ.	2	
115-83311-60	.LÂMPADA (6V-18W)	1	

4. Os gráficos que são Aplicados em Peças Coloridas estão representados na coluna “OBSERVAÇÕES”, como segue abaixo.

No. PEÇA	DESCRIÇÃO	QTDE	OBSERVAÇÕES
2N4-24110-00-X5	TANQUE DE COMBUSTÍVEL COMPL.	2	MXR
3J1-24240-10	.GRÁFICO, TANQUE DE COMB.	1	PARA MXR

5. Observe que as ilustrações são referentes apenas a indicação dos códigos das peças, e não para montagem. Para montagem, por favor utilize o Manual de Montagem apropriado.

6. O asterisco (*) antes do Número de referência da peça indica a modificação ocorrida após a primeira edição.

7. Aplicação do Número de Série

No. de Série do Motor

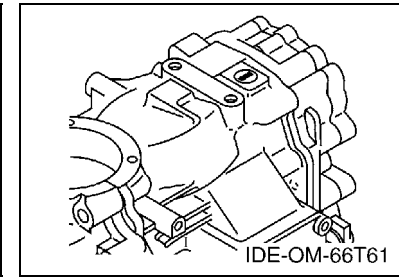
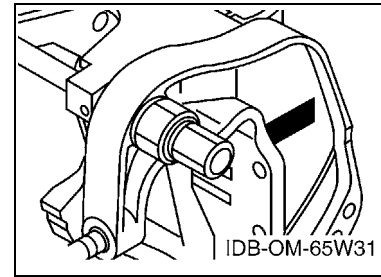

8. Aplicação do No. de Série Inicial

Modelo	No. Série	Modelo	No. Série
40XMH '07	67T-1100876	40XW '07	67T-1002576
40XMH '08	67T-1101251	40XW '08	67T-1003001

9. Aplicação do Código de Cor

Abreviação	Nome da Cor	Código da Cor
DBNM2	DARK BLUISH GRAY METALLIC 2	004D

10. Informação na Coluna de Quantidade

No. da Coluna	Nome na Coluna de Qtde	Modelo Aplicável
1	67TA	40XMH '07
2	67TC	40XMH '08
3	67T9	40XW '07
4	67TB	40XW '08

CONTENTS

TOP COWLING	1
CYLINDER & CRANKCASE	2
CRANKSHAFT & PISTON	4
INTAKE	5
CARBURETOR	6
FUEL	7
STARTER	9
GENERATOR	11
ELECTRICAL 1	12
ELECTRICAL 2	13
STARTING MOTOR	14
BOTTOM COWLING	15
STEERING	17
CONTROL	19
REMO CON ATTACHMENT	20
BRACKET 1	21
BRACKET 2	24
UPPER CASING	26
LOWER CASING & DRIVE 1	27
LOWER CASING & DRIVE 2	30
FUEL TANK	32
STEERING GUIDE	33
REMOTE CONTROL BOX	34
REMOTE CONTROL ASSY	35
REPAIR KIT 1	38
REPAIR KIT 2	40
REPAIR KIT 3	41

INDEX

NUMERICAL INDEX	42
-----------------------	----

ÍNDICE GERAL

CAPO SUPERIOR	1
CILINDRO E CARCACA DO MOTOR	2
VIRABREQUIM E PISTAO	4
ADMISSAO	5
CARBURADOR	6
COMBUSTIVEL	7
PARTIDA	9
GERADOR	11
SISTEMA ELETRICO 1	12
SISTEMA ELETRICO 2	13
MOTOR DE PARTIDA	14
BANDEJA DO CAPO	15
DIRECAO	17
CONTROLE	19
ACESSORIOS DO CONTROLE REMOTO	20
SUPORTE 1	21
SUPORTE 2	24
CAPA INFERIOR	26
CARCACA INF. E TRANSMISSAO 1	27
CARCACA INF. E TRANSMISSAO 2	30
TANQUE DE COMBUSTIVEL	32
HASTE DA DIRECAO	33
CAIXA DO CONTROLE REMOTO	34
CONTROLE REMOTO CONJ.	35
KIT DE REPARO 1	38
KIT DE REPARO 2	40
KIT DE REPARO 3	41

ÍNDICE GERAL

ÍNDICE NUMÉRICO	42
-----------------------	----

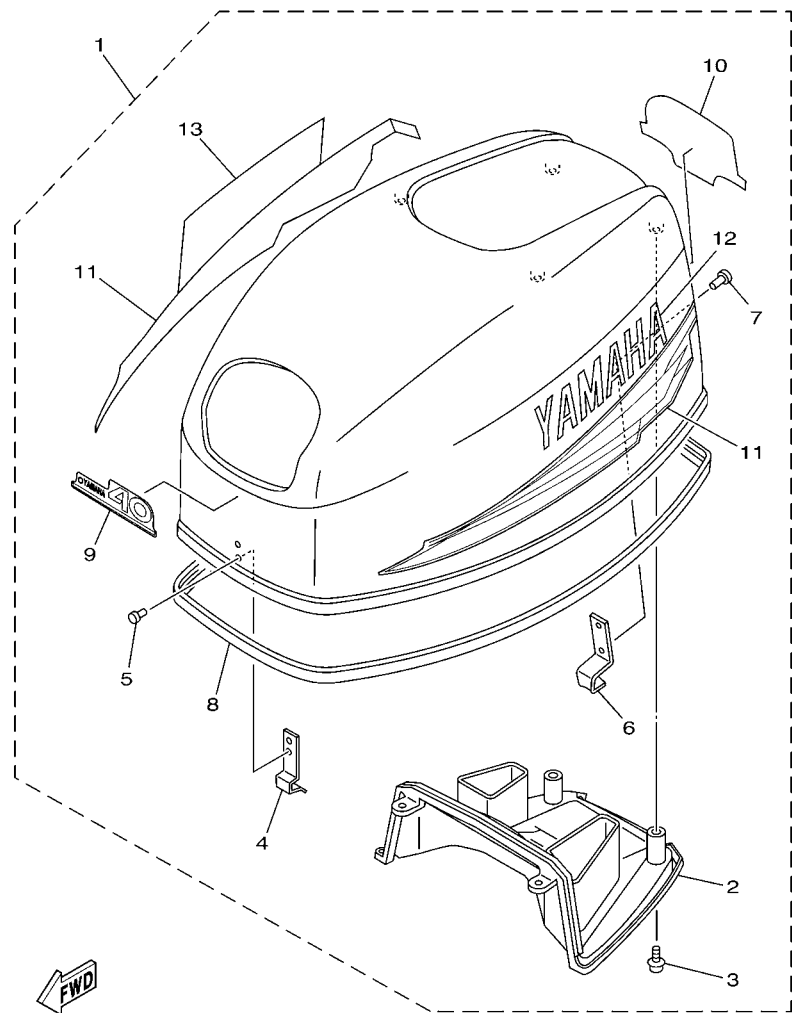

67TC280-G010

FIG. 1 TOP COWLING

CAPO SUPERIOR

REF. NO.	PART NO. No. PEÇA	DESCRIPTION DESCRIÇÃO	67TA	67TC	67T9	67TB	REMARKS OBSERVAÇÕES
1	66T-42610-20-4D	TOP COWLING ASSY CAPO SUPERIOR CONJ.	1	1	1	1	
2	66T-42613-01	.MOLDING, AIR DUCT .MOLDURA DO DUTO DE AR	1	1	1	1	
3	97780-50616	.SCREW, TAPPING .PARAFUSO	4	4	4	4	
4	6E0-42651-02	.HOOK .GANCHO	1	1	1	1	
5	90266-04M04	.RIVET .REBITE	2	2	2	2	
6	6F5-42652-01	.HOOK .GANCHO	1	1	1	1	
7	90266-04M01	.RIVET .REBITE	2	2	2	2	
8	66T-42615-02	.SEAL .VEDACAO	1	1	1	1	
9	63D-42677-20	.GRAPHIC, FRONT .GRAFICO DIANTEIRO	1	1	1	1	
10	63D-42678-11	.GRAPHIC, REAR .GRAFICO TRASEIRO	1	1	1	1	
11	63D-W0070-10	.GRAPHIC SET .JOGO DE GRAFICOS	1	1	1	1	
12	63D-42681-10	.MARK, COWLING .MARCA DO CAPO (ADESIVO)	1	1	1	1	
13	63D-42682-10	.MARK, COWLING .MARCA DO CAPO (ADESIVO)	1	1	1	1	

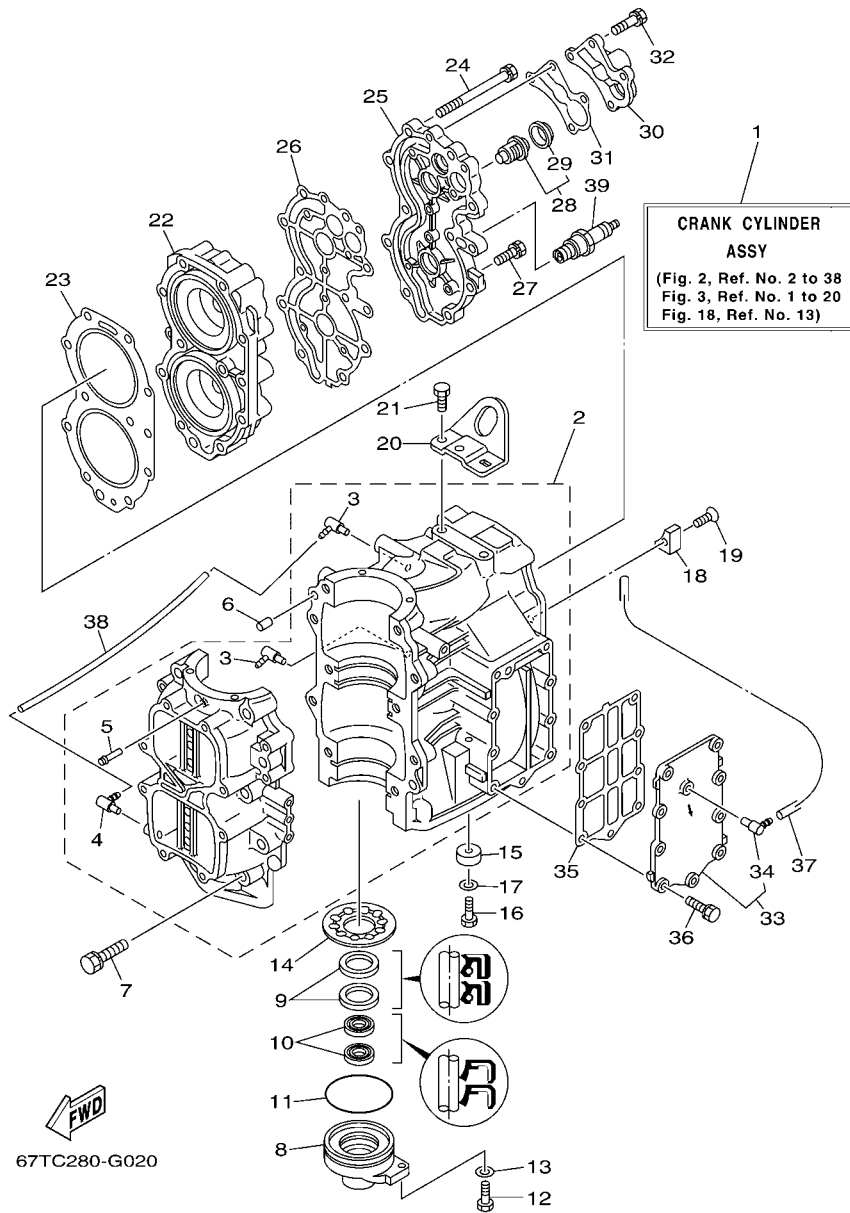
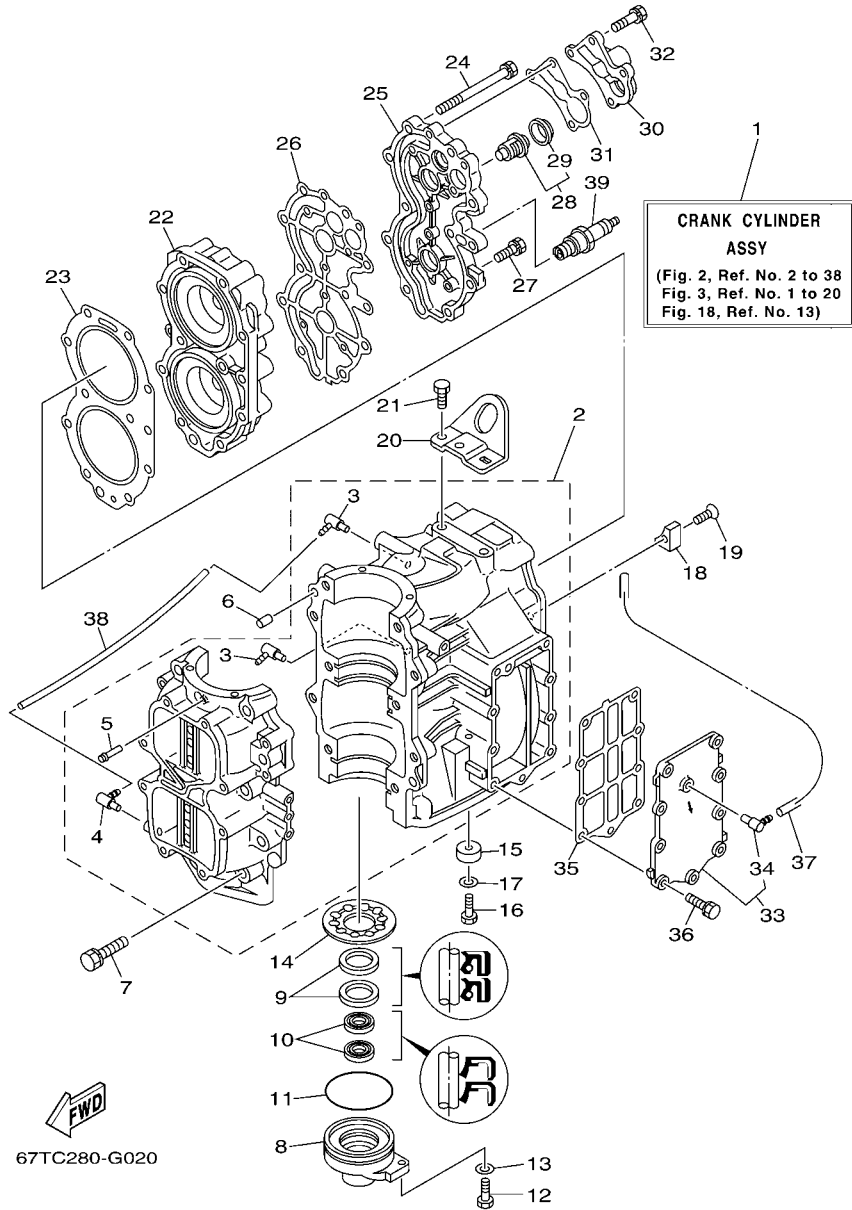

FIG. 2 CYLINDER & CRANKCASE CILINDRO E CARCACA DO MOTOR

REF. NO.	PART NO. No. PEÇA	DESCRIPTION DESCRIÇÃO	67TA	67TC	67T9	67TB	REMARKS OBSERVAÇÕES
1	66T-W0090-02-1S	CRANK CYLINDER ASSY CARCACA DO CILINDRO CONJ.	1	1	1	1	
2	66T-15100-02-1S	CRANKCASE ASSY CARCACA DO MOTOR COMPLETA	1	1	1	1	
3	6E5-13552-01	.NOZZLE .BICO	2	2	2	2	
4	6E5-13552-01	.NOZZLE .BICO	1	1	1	1	
5	624-14485-00	.PIPE, JOINT .TUBO DE JUNCAO	1	1	1	1	
6	93608-12063	PIN, DOWEL PINO GUIA	2	2	2	2	
7	90119-10005	BOLT, WITH WASHER PARAFUSO COM ARRUELA	10	10	10	10	
8	66T-15396-01-94	HOUSING, OIL SEAL CAIXA DO RETENTOR DE OLEO	1	1	1	1	
9	93102-30M56	OIL SEAL RETENTOR DE OLEO	2	2	2	2	
10	93101-16001	OIL SEAL RETENTOR DE OLEO	2	2	2	2	
11	93210-65M50	O-RING ANEL DE BORRACHA	1	1	1	1	
12	97095-06020	BOLT PARAFUSO	1	1	1	1	
13	92995-06600	WASHER ARRUELA	1	1	1	1	
14	66T-11565-00	WASHER, BEARING COVER ARRUELA DA TAMPA DO ROLAMENTO	1	1	1	1	
15	676-45251-00	ANODE ANODO	1	1	1	1	
16	97095-06020	BOLT PARAFUSO	1	1	1	1	
17	92995-06600	WASHER ARRUELA	1	1	1	1	
18	676-11325-00	ANODE ANODO	1	1	1	1	
19	90141-06M00	SCREW, COUNTERSUNK PARAFUSO TRAMBULADOR	1	1	1	1	
20	66T-11119-00	HANGER, ENGINE ALCA DO MOTOR	1	1	1	1	
21	90101-08002	BOLT PARAFUSO	2	2	2	2	
22	66T-11111-01-1S	HEAD, CYLINDER 1 CABECOTE DO CILINDRO 1	1	1	1	1	
23	66T-11181-A2	GASKET, CYLINDER HEAD 1 GAXETA CABECOTE DO CILINDRO 1	1	1	1	1	
24	90119-08MA5	BOLT, WITH WASHER PARAFUSO COM ARRUELA	11	11	11	11	
25	66T-11191-00-1S	COVER, CYLINDER HEAD 1 TAMPA, CABECOTE DO CILINDRO 1	1	1	1	1	
26	66T-11193-A3	GASKET, HEAD COVER 1 GAXETA DA TAMPA DO CABECOTE 1	1	1	1	1	
27	90119-06MA3	BOLT, WITH WASHER PARAFUSO COM ARRUELA	4	4	4	4	



67TC280-G020

FIG. 2 CYLINDER & CRANKCASE CILINDRO E CARCACA DO MOTOR

REF. NO.	PART NO. No. PEÇA	DESCRIPTION DESCRIÇÃO	67TA	67TC	67T9	67TB	REMARKS OBSERVAÇÕES
28	6E5-12411-02	THERMOSTAT TERMOSTATO	1	1	1	1	
29	6E5-12412-00	.SEAL, THERMOSTAT .VEDACAO DO TERMOSTATO	1	1	1	1	
30	676-12413-00-1S	COVER, THERMOSTAT TAMPA DO TERMOSTATO	1	1	1	1	
31	676-12414-A1	GASKET, COVER GAXETA DA TAMPA	1	1	1	1	
32	90119-06MA5	BOLT, WITH WASHER PARAFUSO COM ARRUELA	4	4	4	4	
33	66T-41113-00-1S	OUTER COVER, EXHAUST TAMPA EXTERNA DO ESCAPE	1	1	1	1	
34	676-11372-00	.NIPPLE, HOSE .JUNCAO DA MANGUEIRA	1	1	1	1	
35	66T-41114-A0	GASKET, EXHAUST OUTER COVER GAXETA TAMPA EXTERNA DO ESCAPE	1	1	1	1	
36	90119-06MA3	BOLT, WITH WASHER PARAFUSO COM ARRUELA	9	9	9	9	
37	90445-09M75	HOSE (L370) TUBO (L370)	1	1	1	1	
38	90445-07M08	HOSE (L220) TUBO (L220)	1	1	1	1	
39	94702-00040	PLUG, SPARK (NGK B7HS) VELA DE IGNICAO (NGK B7HS)	2	2	2	2	
<hr/>							
<hr/>							
<hr/>							
<hr/>							
<hr/>							

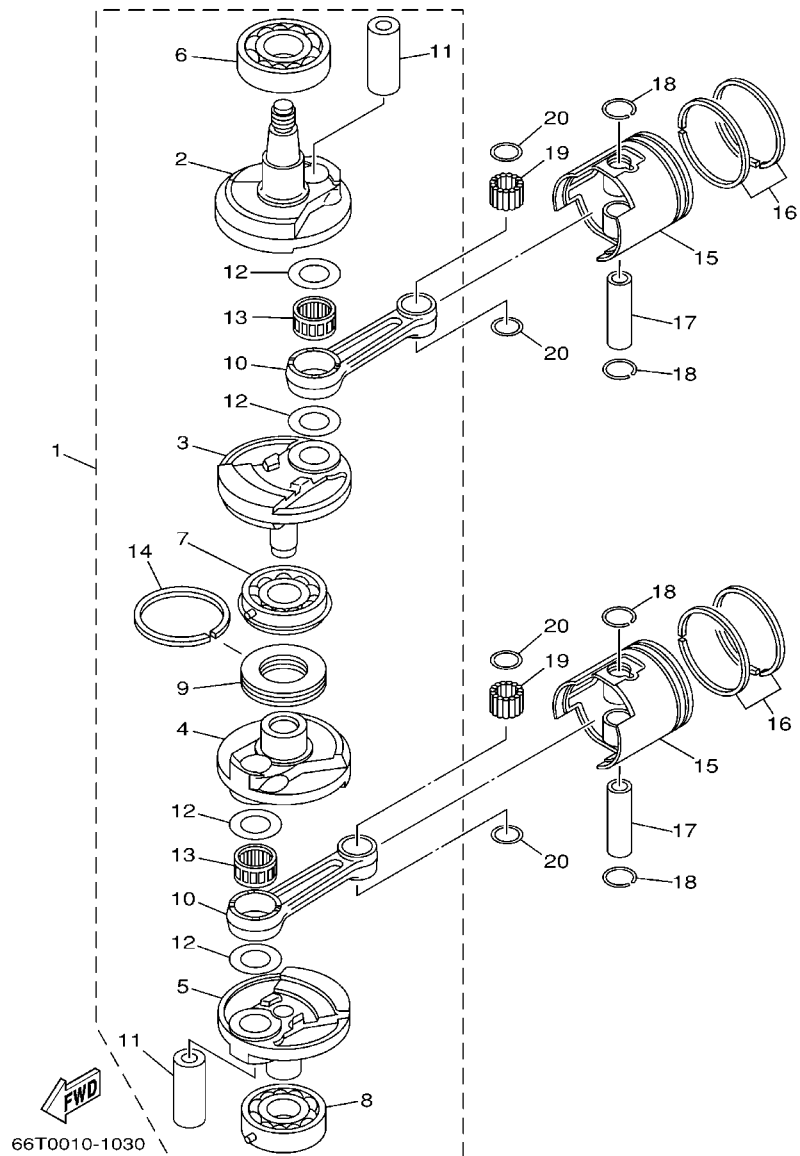

FIG. 3 CRANKSHAFT & PISTON

VIRABREQUIM E PISTAO

REF. NO.	PART NO. No. PEÇA	DESCRIPTION DESCRIÇÃO	67TA	67TC	67T9	67TB	REMARKS OBSERVAÇÕES
1	66T-11400-01	CRANKSHAFT ASSY VIRABREQUIM CONJ.	1	1	1	1	
2	66T-11412-00	.CRANK 1 .VIRABREQUIM 1	1	1	1	1	
3	66T-11422-00	.CRANK 2 .VIRABREQUIM 2	1	1	1	1	
4	66T-11432-00	.CRANK 3 .VIRABREQUIM 3	1	1	1	1	
5	66T-11442-00	.CRANK 4 .VIRABREQUIM 4	1	1	1	1	
6	93306-307U0	.BEARING .ROLAMENTO	1	1	1	1	
7	93332-000UE	.BEARING .ROLAMENTO	1	1	1	1	
8	93306-306V5	.BEARING .ROLAMENTO	1	1	1	1	
9	6F5-11515-00	.SEAL, LABYRINTH 1 .VEDACAO DO LABIRINTO 1	1	1	1	1	
10	6F5-11651-00	.ROD, CONNECTING .BIELA	2	2	2	2	
11	66T-11681-00	.PIN, CRANK 1 .PINO DO VIRABREQUIM 1	2	2	2	2	
12	90209-27012	.WASHER .ARRUELA	4	4	4	4	
13	93310-727U0	.BEARING .ROLAMENTO	2	2	2	2	
14	93440-68M03	.CIRCLIP .ANEL TRAVA	1	1	1	1	
15	66T-11631-01-93	PISTON (STD) PISTAO (STD)	2	2	2	2	
	66T-11635-01	PISTON (0.25MM O/S) PISTAO (0.25MM O/S)	2	2	2	2	AP AP
	66T-11636-01	PISTON (0.50MM O/S) PISTAO (0.50MM O/S)	2	2	2	2	AP AP
16	66T-11603-00	PISTON RING SET (STD) JG. DE ANEIS (STD)	2	2	2	2	
	66T-11604-00	PISTON RING SET (0.25MM O/S) JG. DE ANEIS (0.25MM O/S)	2	2	2	2	AP AP
	66T-11605-00	PISTON RING SET (0.50MM O/S) JG. DE ANEIS (0.50MM O/S)	2	2	2	2	AP AP
17	6F5-11633-00	PIN, PISTON PINO DO PISTAO	2	2	2	2	
18	663-11634-00	CLIP, PISTON PIN PRESILHA DO PINO DO PISTAO	4	4	4	4	
19	93603-21111	PIN, DOWEL PINO GUIA	56	56	56	56	
20	90201-20417	WASHER, PLATE ARRUELA PLANA	4	4	4	4	

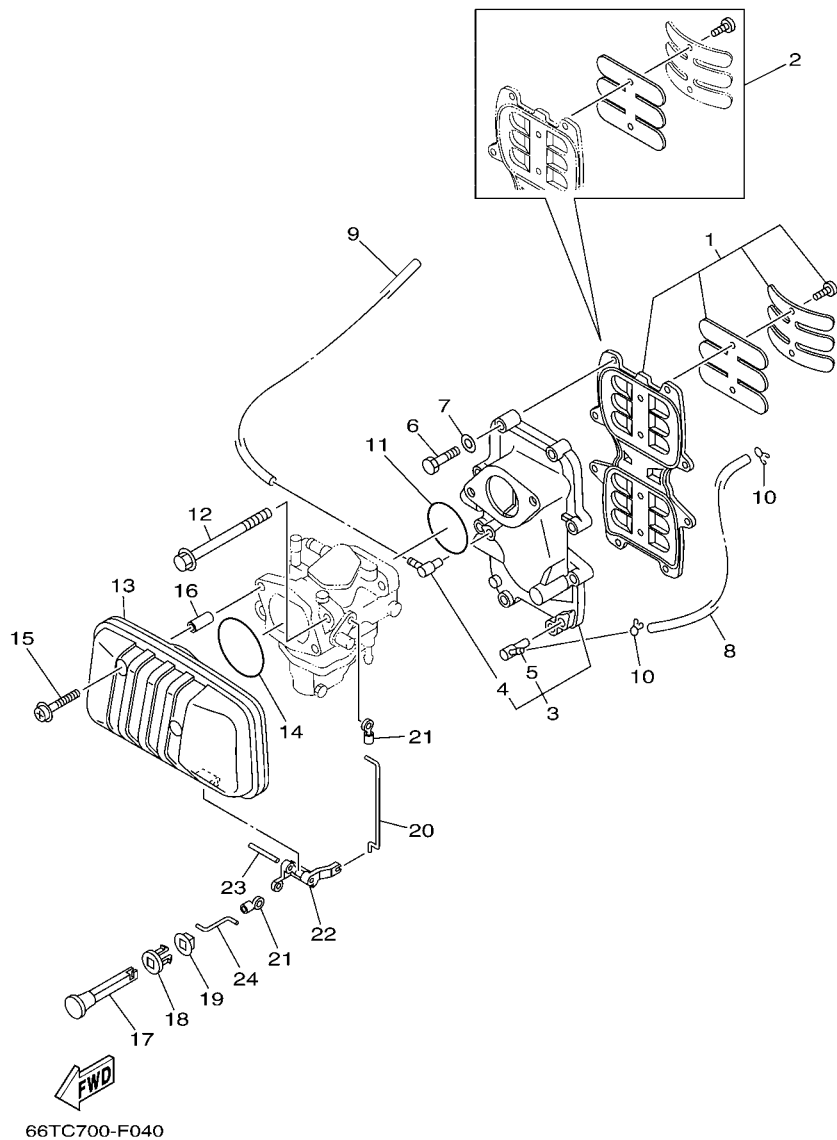
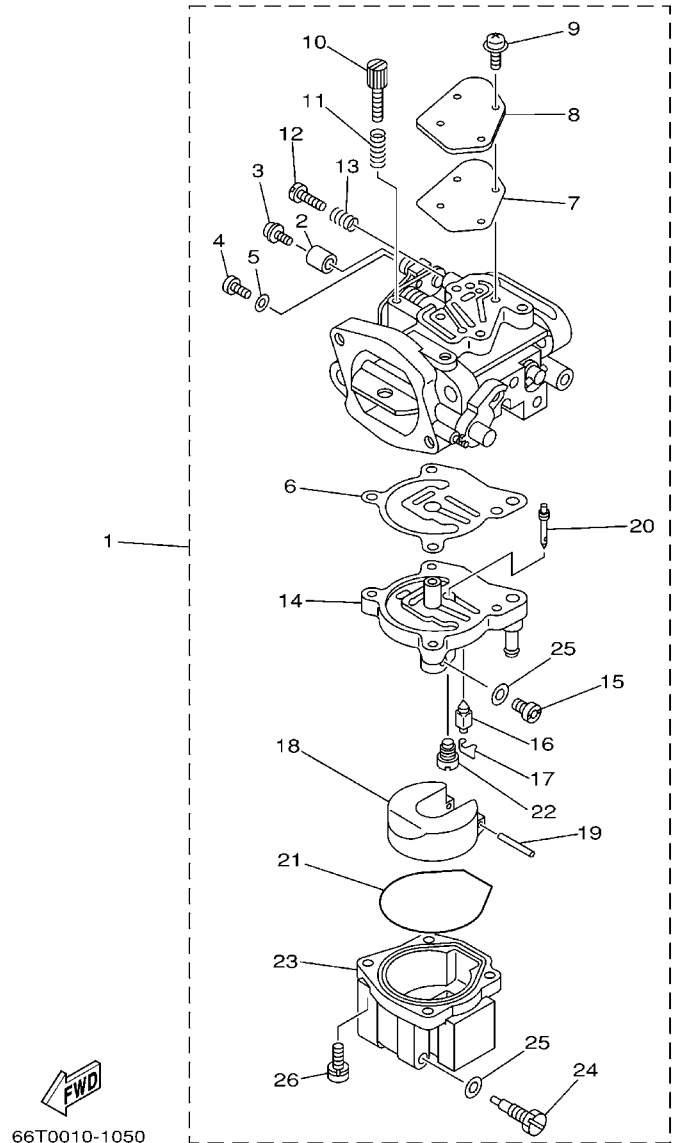

FIG. 4 INTAKE

ADMISSAO

REF. NO.	PART NO. No. PEÇA	DESCRIPTION DESCRIÇÃO	67TA	67TC	67T9	67TB	REMARKS OBSERVAÇÕES
1	66T-13610-00	REED VALVE ASSY VALVULA DA PALHETA COMP.	1	1	1	1	
2	66T-W0004-00	.REED SET .JOGO DE VALVULAS DA PALHETA	1	1	1	1	
3	66T-13641-02-1S	MANIFOLD 1 TUBO MULTIPLO 1	1	1	1	1	
4	6E5-13552-01	.NOZZLE .BICO	1	1	1	1	
5	650-11372-01	.NIPPLE, HOSE .JUNCAO DA MANGUEIRA	1	1	1	1	
6	97013-06035	BOLT PARAFUSO	8	8	8	8	
7	92903-06600	WASHER, PLATE ARRUELA PLANA	8	8	8	8	
8	90445-07M24	HOSE (L240) TUBO (L240)	1	1	1	1	
9	90445-07MA4	HOSE (L280) TUBO (L280)	1	1	1	1	
10	90467-06016	CLIP PRESILHA	2	2	2	2	
11	93210-46M16	O-RING ANEL DE BORRACHA	1	1	1	1	
12	90119-08M03	BOLT, WITH WASHER PARAFUSO COM ARRUELA	2	2	2	2	
13	66T-14440-00	SILENCER ASSY, INTAKE SILENCIADOR DA ADMISSAO CONJ.	1	1	1	1	
14	93210-54M54	O-RING ANEL DE BORRACHA	1	1	1	1	
15	90159-06034	SCREW, WITH WASHER PARAFUSO COM ARRUELA	2	2	2	2	
16	90387-06M80	COLLAR ESPACADOR	2	2	2	2	
17	6H4-41271-01	KNOB, CHOKE BOTAO DO AFOGADOR	1	1	1	1	
18	689-41273-00	GROMMET ILHO	1	1	1	1	
19	6J8-41274-00	GROMMET 2 ILHO 2	1	1	1	1	
20	66T-41256-00	ROD, CHOKE 1 HASTE DO AFOGADOR 1	1	1	1	1	
21	661-41262-02	JOINT, CHOKE LEVER JUNCAO DA ALAVANCA DO AFOGADOR	2	2	2	2	
22	66T-41252-00	LEVER, CHOKE 1 ALAVANCA DO AFOGADOR 1	1	1	1	1	
23	91690-40032	PIN, SPRING PINO MOLA	1	1	1	1	
24	66T-41257-00	ROD, CHOKE 2 HASTE DO AFOGADOR 2	1	1	1	1	



66T0010-1050

FIG. 5 CARBURETOR CARBURADOR

REF. NO.	PART NO. No. PEÇA	DESCRIPTION DESCRIÇÃO	67TA	67TC	67T9	67TB	REMARKS OBSERVAÇÕES
1	66T-14301-22	CARBURETOR ASSY 1 CARBURADOR COMPLETO 1	1	1			
	66T-14301-32	CARBURETOR ASSY 1 CARBURADOR COMPLETO 1			1	1	
2	66T-14578-00	.COLLAR .ESPACADOR	1	1	1	1	
3	66T-14584-00	.STOPPER .PARAFUSO DO CARBURADOR	1	1	1	1	
4	6J8-14592-01	.SCREW .PARAFUSO	1	1	1	1	
5	92990-05600	.WASHER, PLATE .ARRUELA PLANA	1	1	1	1	
6	66T-14384-01	.GASKET, FLOAT CHAMBER .GAXETA DA CAMARA DA BOIA	1	1	1	1	
7	66T-14536-01	.GASKET .GAXETA	1	1	1	1	
8	66T-14527-00	.PLATE .PLACA	1	1	1	1	
9	97980-04112	.SCREW, WITH WASHER .PARAFUSO	4	4	4	4	
10	66T-14523-00	.SCREW, STOP .PARAFUSO DE PARADA	1	1	1	1	
11	6J8-14334-00	.SPRING, THROTTLE .MOLA DE REGULAGEM DO AR	1	1	1	1	
12	6E5-14323-03	.SCREW, AIR ADJUSTING .PARAFUSO DE AJUSTE DO AR	1	1	1	1	
13	6E5-14223-00	.SPRING, AIR ADJUSTING .MOLA DE VALVULA DE DRENO	1	1	1	1	
14	66T-14945-02	.SPACER ASSY (#38) .ESPACADOR (#38)	1	1	1	1	
15	61A-1492E-88	.JET, MAIN (#176) .GICLEUR, PRINCIPAL (#176)	1	1	1	1	
16	6E5-14546-00	.VALVE, NEEDLE .VALVULA DA AGULHA	1	1	1	1	
17	6E5-14159-00	.CLIP .PRESILHA	1	1	1	1	
18	6E5-14385-02	.FLOAT .BOIA	1	1	1	1	
19	6E5-14386-02	.PIN, FLOAT .PINO DA BOIA	1	1	1	1	
20	66T-1492F-37	.JET, AIR SLOW (#74) .GICLEUR BAIXA (#74)	1	1	1	1	
21	66T-14984-00	.GASKET, FLOAT CHAMBER .GAXETA DA CAMARA DA BOIA.	1	1	1	1	
22	66T-14992-00	.PLUG .HASTE	1	1	1	1	
23	66T-14981-00	.BODY, FLOAT CHAMBER .CORPO DA CAMARA DA BOIA	1	1	1	1	
24	66T-14991-00	.PLUG, DRAIN .PARAFUSO	1	1	1	1	
25	66T-14959-00	.GASKET .GAXETA	2	2	2	2	
26	97980-05125	.SCREW, WITH WASHER .PARAFUSO	4	4	4	4	

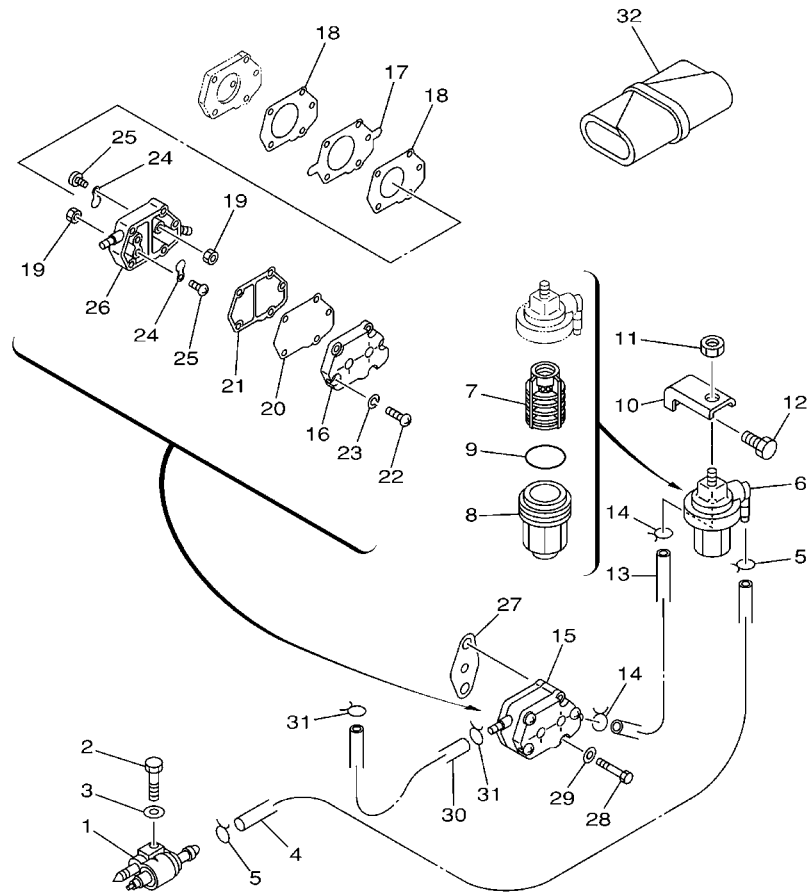

66T0010-1060

FIG. 6 FUEL

COMBUSTIVEL

REF. NO.	PART NO. No. PEÇA	DESCRIPTION DESCRIÇÃO	67TA	67TC	67T9	67TB	REMARKS OBSERVAÇÕES
1	6G1-24304-02	FUEL PIPE JOINT COMP. 1 JUNCAO TUBO DE COMBUSTIVEL 1	1	1	1	1	
2	97095-06030	BOLT PARAFUSO	1	1	1	1	
3	92995-06600	WASHER ARRUELA	1	1	1	1	
4	90445-09M08	HOSE (L550) TUBO (L550)	1	1	1	1	
5	90467-08004	CLIP PRESILHA	2	2	2	2	
6	61N-24560-00	FILTER ASSY FILTRO DE COMBUSTIVEL CONJ.	1	1	1	1	
7	61N-24563-00	.ELEMENT, FILTER .ELEMENTO DO FILTRO	1	1	1	1	
8	61N-24521-00	.CUP, FILTER .COPO DO FILTRO	1	1	1	1	
9	93210-32738	.O-RING .ANEL DE BORRACHA	1	1	1	1	
10	648-24566-02	BRACKET, FILTER SUPORTE DO FILTRO	1	1	1	1	
11	95380-08600	NUT PORCA	1	1	1	1	
12	97013-06014	BOLT PARAFUSO	1	1	1	1	
13	90445-09086	HOSE (L170) TUBO (L170)	1	1	1	1	
14	90467-08004	CLIP PRESILHA	2	2	2	2	
15	692-24410-00	FUEL PUMP ASSY BOMBA DE COMBUSTIVEL CONJ.	1	1	1	1	
16	6A0-24413-00	.BODY 2 .CARCACA 2	1	1	1	1	
17	692-24411-00	.DIAPHRAGM .DIAFRAGMA	1	1	1	1	
18	648-24434-01	.GASKET, BODY .GAXETA DO CORPO DA BOMBA	2	2	2	2	
19	95380-03600	.NUT .PORCA	2	2	2	2	
20	663-24411-00	.DIAPHRAGM .DIAFRAGMA	1	1	1	1	
21	648-24435-02	.GASKET, BODY 2 .GAXETA DO CORPO DA BOMBA 2	1	1	1	1	
22	98503-05028	.SCREW, PAN HEAD .PARAFUSO	3	3	3	3	
23	92990-05100	.WASHER, SPRING .ARRUELA COM MOLA	3	3	3	3	
24	6A0-24421-01	.VALVE, CHECK .VALVULA DA BOMBA	2	2	2	2	
25	6A0-14325-00	.SCREW, PAN HEAD .PARAFUSO DE CABECA PANELA	2	2	2	2	
26	6A0-24412-02	.BODY 1 .CARCACA 1	1	1	1	1	
27	650-24431-A0	GASKET, FUEL PUMP 1 GAXETA BOMBA DE COMBUSTIVEL 1	1	1	1	1	

FIG. 6 FUEL

COMBUSTIVEL

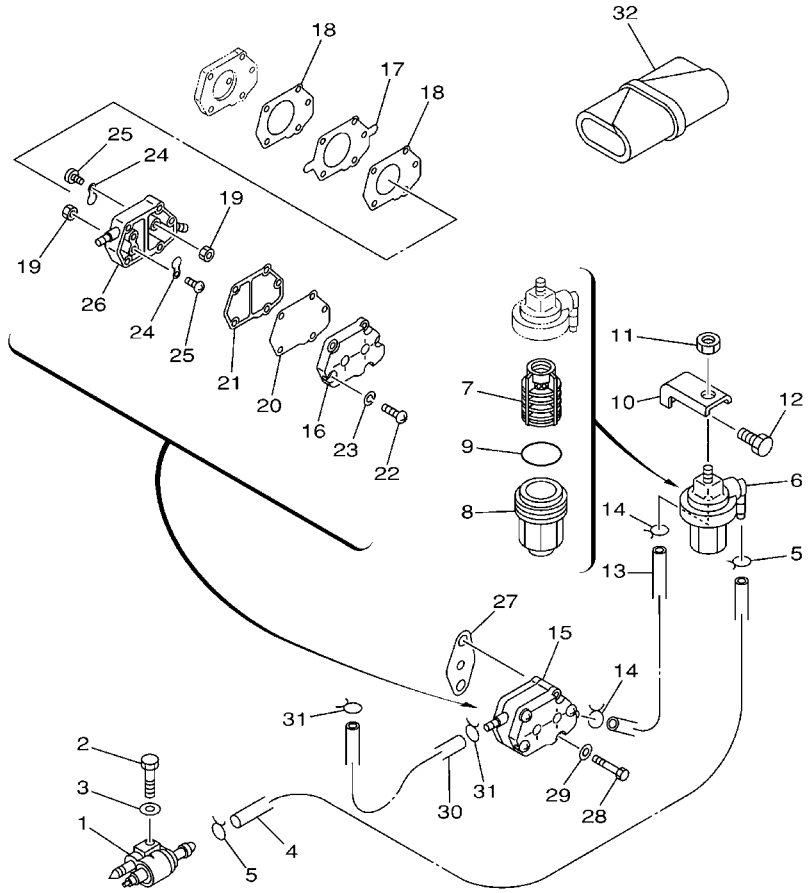

REF. NO.	PART NO. No. PEÇA	DESCRIPTION DESCRIÇÃO	67TA	67TC	67T9	67TB	REMARKS OBSERVAÇÕES
28	97095-06040	BOLT PARAFUSO	2	2	2	2	
29	92995-06600	WASHER ARRUELA	2	2	2	2	
30	90445-09086	HOSE (L170) TUBO (L170)	1	1	1	1	
31	90467-08004	CLIP PRESILHA	2	2	2	2	
32	676-W2810-01	TOOL KIT CONJ DE FERRAMENTAS	1	1	1	1	

FWD
66T0010-1060

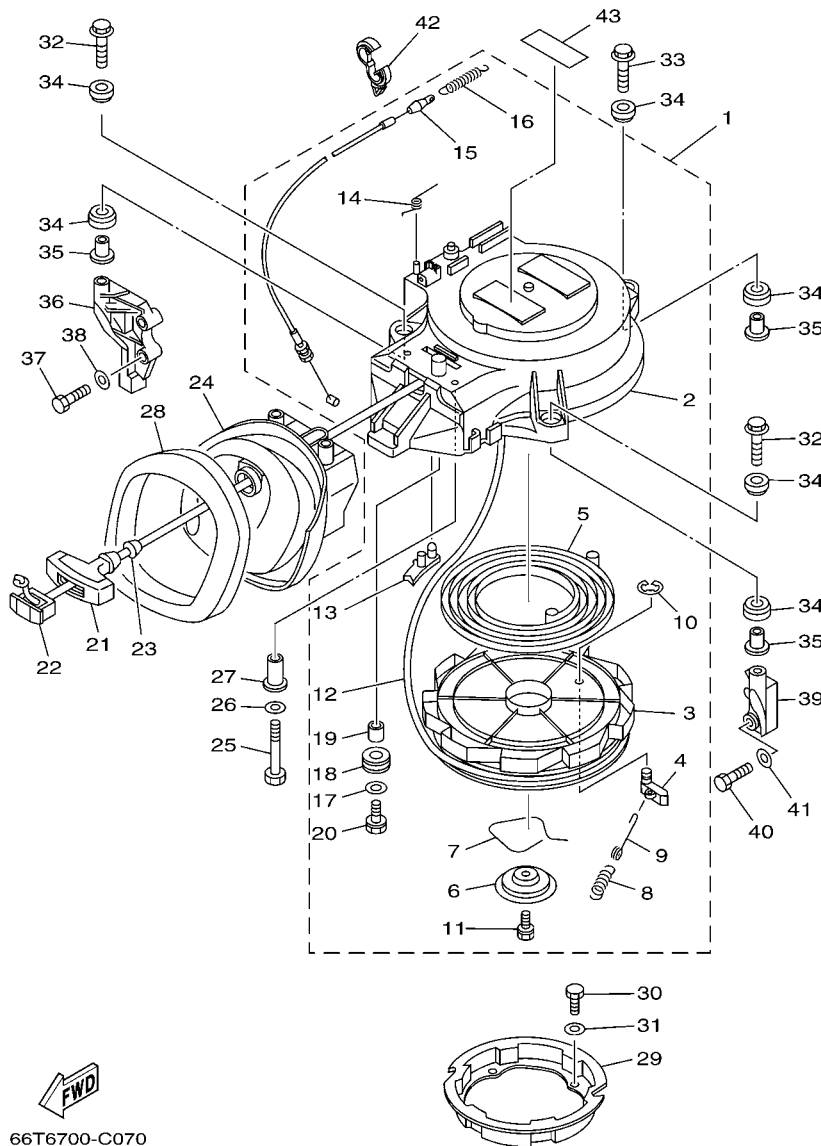

66T6700-C070

*1: CUT FROM 50M ROLLS, PART NO. 90890-44374, CUTTING LENGTH 1.8M

FIG. 7 STARTER

PARTIDA

REF. NO.	PART NO. No. PEÇA	DESCRIPTION DESCRIÇÃO	67TA	67TC	67T9	67TB	REMARKS OBSERVAÇÕES
1	66T-15710-00	STARTER ASSY PARTIDA COMPLETA	1	1	1	1	
2	66T-15711-00	.CASE, STARTER .CAIXA DA PARTIDA	1	1	1	1	
3	66T-15714-00	.DRUM, SHEAVE .TAMBOR DA ROLDANA	1	1	1	1	
4	63V-15741-00	.PAWL, DRIVE .LING?ETA MOTORA	1	1	1	1	
5	66T-15713-00	.SPRING, STARTER .MOLA DA PARTIDA	1	1	1	1	
6	66T-15716-00	.PLATE, DRIVE .PLACA MOTORA	1	1	1	1	
7	66T-15705-00	.SPRING, DRIVE PAWL .MOLA ESPECIAL DA PARTIDA	1	1	1	1	
8	66T-15767-00	.SPRING .MOLA	1	1	1	1	
9	66T-15784-00	.SPRING, RETURN .MOLA DE RETORNO	1	1	1	1	
10	63V-15744-00	.CIRCLIP .ANEL TRAVA	1	1	1	1	
11	63V-15768-00	.BOLT .PARAFUSO	1	1	1	1	
12	*	.WIRE, STARTER (L:1800MM) .CABO DE PARTIDA (L:1800MM)	1	1	1	1	*1 *1
13	66T-15794-00	.STOPPER .BUJAO	1	1	1	1	
14	66T-15734-00	.SPRING, RETURN .MOLA DE RETORNO	1	1	1	1	
15	66T-15770-00	.CABLE COMP., STARTER STOP .CABO COMP. DE PARADA (PARTIDA)	1	1	1	1	
16	66T-15731-00	.SPRING, RETURN .MOLA	1	1	1	1	
17	6F5-15791-00	.WASHER, LOCK .ARRUELA TRAVA	1	1	1	1	
18	6F5-15752-00	.ROLLER, WIRE .ROLAMENTO DE CABO	1	1	1	1	
19	6F5-15753-00	.BUSH .BUCHA	1	1	1	1	
20	6F5-15768-00	.BOLT .PARAFUSO	1	1	1	1	
21	689-15755-01	HANDLE, STARTER MANOPLA DE PARTIDA	1	1	1	1	
22	6F5-15779-02	COVER TAMPA	1	1	1	1	
23	697-15789-00	DAMPER AMORTIZADOR	1	1	1	1	
24	66T-15758-01	GUIDE, ROPE GUIA DO CABO DA PARTIDA	1	1	1	1	
25	97095-06035	BOLT PARAFUSO	2	2	2	2	
26	92995-06600	WASHER ARRUELA	2	2	2	2	
27	90387-06M66	COLLAR ESPACADOR	2	2	2	2	

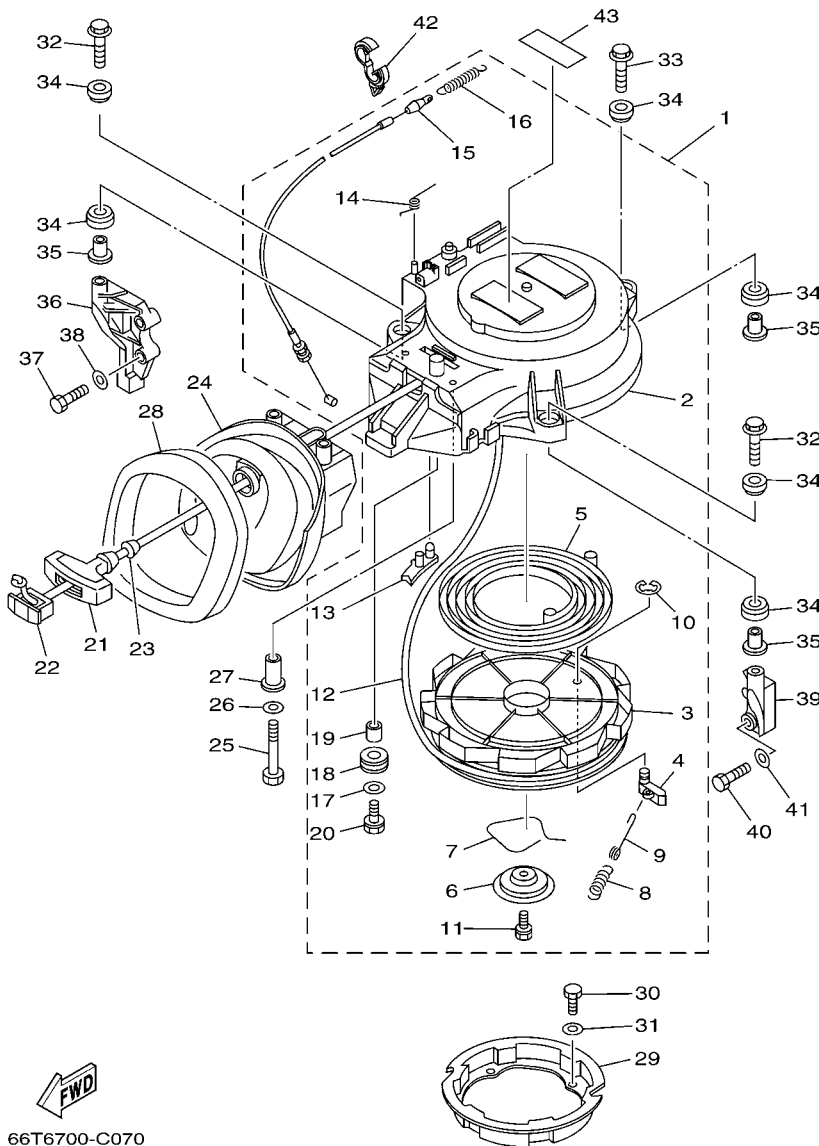

66T6700-C070

*1: CUT FROM 50M ROLLS, PART NO. 90890-44374, CUTTING LENGTH 1.8M

FIG. 7 STARTER

PARTIDA

REF. NO.	PART NO. No. PEÇA	DESCRIPTION DESCRIÇÃO	PARTIDA				REMARKS OBSERVAÇÕES
			67TA	67TC	67T9	67TB	
28	66T-15762-01	SEAL, RUBBER 2 VEDACAO DE BORRACHA 2	1	1	1	1	
29	66T-15723-00	PULLEY, STARTER ROLDANA DA PARTIDA	1	1	1	1	
30	97095-06010	BOLT PARAFUSO	4	4	4	4	
31	92995-06600	WASHER ARRUELA	4	4	4	4	
32	90119-08M10	BOLT, WITH WASHER PARAFUSO COM ARRUELA	2	2	2	2	
33	90119-08M51	BOLT, WITH WASHER PARAFUSO COM ARRUELA	1	1	1	1	
34	90385-12M04	BUSH BUCHA	6	6	6	6	
35	90387-08M05	COLLAR ESPACADOR	3	3	3	3	
36	66T-15771-00-94	STAY 1 FIXADOR 1	1	1	1	1	
37	97013-06030	BOLT PARAFUSO	2	2	2	2	
38	92903-06600	WASHER, PLATE ARRUELA PLANA	2	2	2	2	
39	66T-15772-00-94	STAY 2 FIXADOR 2	1	1	1	1	
40	97013-06030	BOLT PARAFUSO	2	2	2	2	
41	92903-06600	WASHER, PLATE ARRUELA PLANA	2	2	2	2	
42	90464-13249	CLAMP BRACADEIRA			1	1	
43	6A1-83625-41	MARK 5 EMBLEMA 5	1	1	1	1	

FIG. 8 GENERATOR

GERADOR

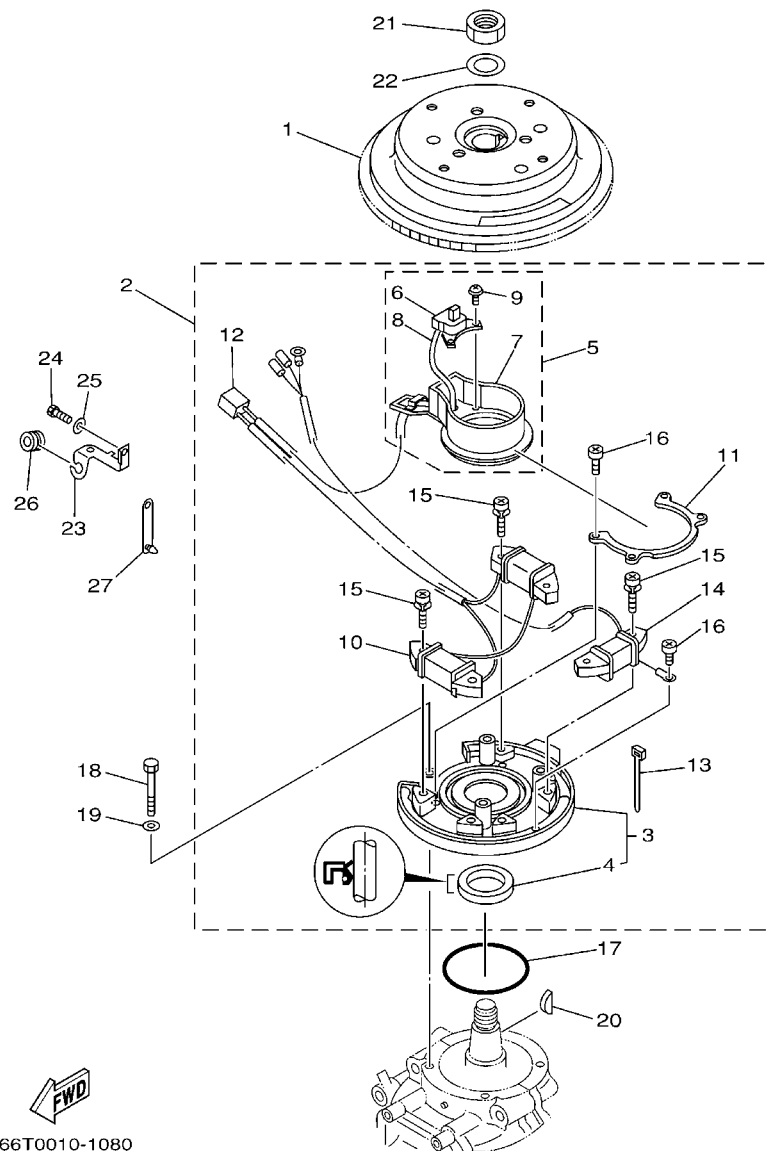

66T0010-1080

REF. NO.	PART NO. No. PEÇA	DESCRIPTION DESCRIÇÃO	67TA	67TC	67T9	67TB	REMARKS OBSERVAÇÕES
1	66T-85550-00	ROTOR ASSY ROTOR CONJ.	1	1	1	1	
2	66T-85560-01	BASE ASSY BASE CONJ.	1	1	1	1	
3	66T-85561-00	.BASE, MAGNETO .BASE DO MAGNETO	1	1	1	1	
4	93102-35008	..OIL SEAL ..RETENTOR DE OLEO	1	1	1	1	
5	66T-85580-00	.PULSER COIL ASSY .BOBINA DE PULSO CONJUNTO	1	1	1	1	
6	66T-85596-00	..COIL, PULSER 1 ..BOBINA DE PULSO 1	1	1	1	1	
7	66T-85582-00	..ATTACHMENT, PULSER ..ADIANTAMENTO DE PULSO	1	1	1	1	
8	66T-85515-00	..LEAD WIRE ASSY ..FIOS CHICOTE CONJ.	1	1	1	1	
9	97902-04108	..SCREW, WITH WASHER ..PARAFUSO	2	2	2	2	
10	66T-85520-00	.COIL, CHARGE .BOBINA DE CARGA	1	1	1	1	
11	66T-41611-00	.RETAINER, MAGNETO BASE .RETENTOR DA BASE DO MAGNETO	1	1	1	1	
12	9E471-04305	.CONNECTOR .CONECTOR	1	1	1	1	
13	66T-81328-00	.CLAMP .BRACADEIRA	1	1	1	1	
14	66T-85533-00	.COIL, LIGHTING .BOBINA DE LUZ	1	1	1	1	
15	97902-06125	.SCREW, WITH WASHER .PARAFUSO	6	6	6	6	
16	97802-04006	.SCREW, PAN HEAD .PARAFUSO	5	5	5	5	
17	93210-75M51	O-RING ANEL DE BORRACHA	1	1	1	1	
18	97095-06040	BOLT PARAFUSO	4	4	4	4	
19	92995-06600	WASHER ARRUELA	4	4	4	4	
20	90280-05015	KEY, WOODRUFF CHAVETA MEIA LUA	1	1	1	1	
21	90170-20137	NUT PORCA	1	1	1	1	
22	90201-21M18	WASHER, PLATE ARRUELA PLANA	1	1	1	1	
23	90465-15M74	CLAMP BRACADEIRA	1	1	1	1	
24	97095-06016	BOLT PARAFUSO	1	1	1	1	
25	92995-06600	WASHER ARRUELA	1	1	1	1	
26	90480-10M71	GROMMET ILHO DE BORRACHA	1	1	1	1	
27	90464-12M00	CLAMP BRACADEIRA	1	1	1	1	

FIG. 9 ELECTRICAL 1

SISTEMA ELETRICO 1

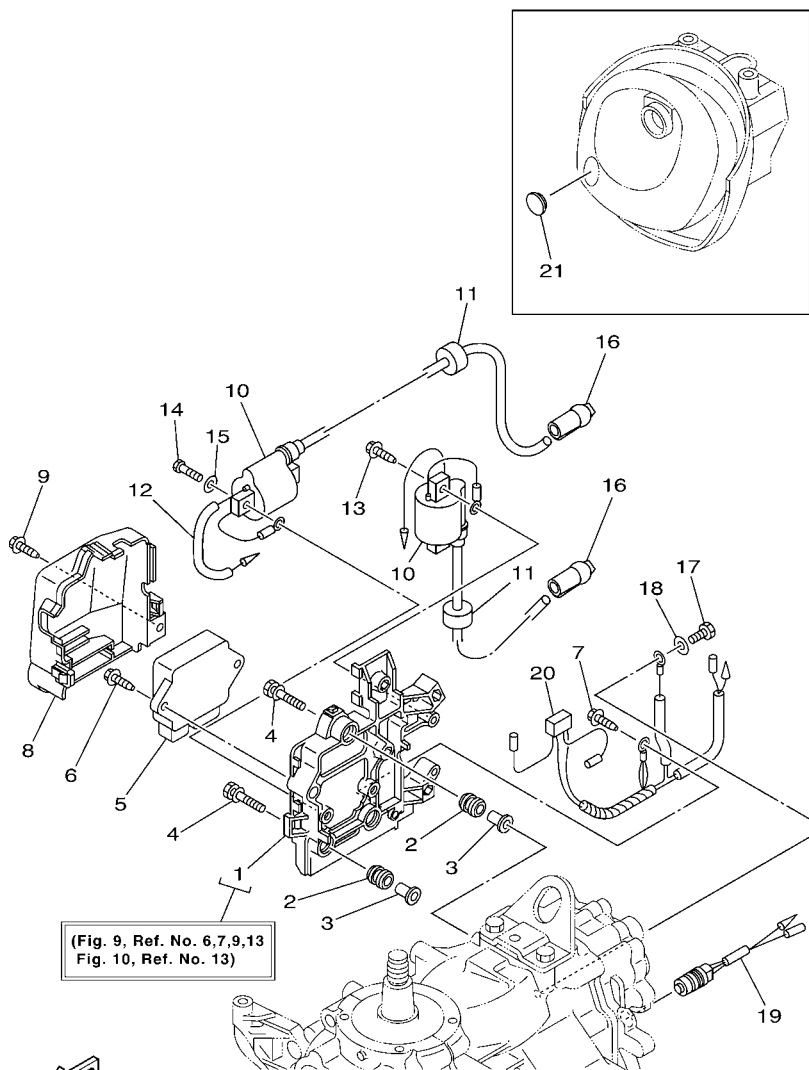

(Fig. 9, Ref. No. 6,7,9,13
Fig. 10, Ref. No. 13)



67TC280-G090

REF. NO.	PART NO. No. PEÇA	DESCRIPTION DESCRIÇÃO	67TA	67TC	67T9	67TB	REMARKS OBSERVAÇÕES
1	66T-8554B-01-94	BRACKET SUPORTE	1	1	1	1	
2	6A0-82317-00	DAMPER, IGNITION COIL AMORTIZADOR BOBINA DE IGNICAO	3	3	3	3	
3	90387-06119	COLLAR ESPACADOR	3	3	3	3	
4	90119-06M65	BOLT, WITH WASHER PARAFUSO COM ARRUELA	3	3	3	3	
5	66T-85540-01	C.D.I. UNIT ASSY UNIDADE DE IGNICAO CONJ. (CDI)	1	1	1	1	
6	90109-06M81	BOLT PARAFUSO	2	2	2	2	
7	90109-06M80	BOLT PARAFUSO	1	1	1	1	
8	66T-81916-01	COVER, TERMINAL TAMPA DO TERMINAL	1	1	1	1	
9	90109-06M81	BOLT PARAFUSO	1	1	1	1	
10	66T-85570-00	IGNITION COIL ASSY BOBINA DE IGNICAO CONJ.	2	2	2	2	
11	90480-25161	GROMMET ILHO DE BORRACHA	2	2	2	2	
12	90446-03MA3	HOSE TUBO	1	1	1	1	
13	90109-06M81	BOLT PARAFUSO	2	2	2	2	
14	97095-06025	BOLT PARAFUSO	2	2	2	2	
15	92995-06600	WASHER ARRUELA	2	2	2	2	
16	66T-82370-00	PLUG CAP ASSY CACHIMBO DA VELA CONJ.	2	2	2	2	
17	97095-06012	BOLT PARAFUSO	1	1	1	1	
18	92995-06600	WASHER ARRUELA	1	1	1	1	
19	688-82560-10	THERMO SWITCH ASSY INTERRUPTOR TERMICO CONJ.	1	1	1	1	
20	66T-82519-00	WIRE, EARTH LEAD FIO TERRA	1	1			
21	6G1-42725-00	GROMMET ILHO	1	1	1	1	

FIG. 10 ELECTRICAL 2

SISTEMA ELETRICO 2

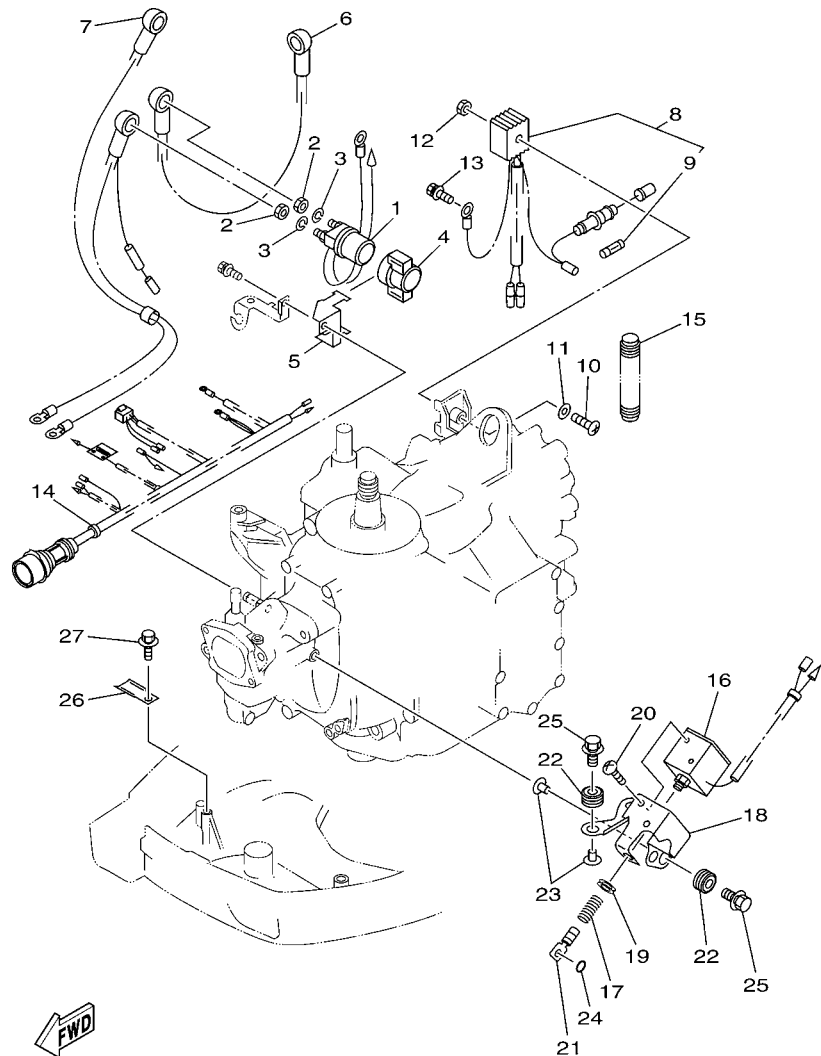

67TC280-G100

REF. NO.	PART NO. No. PEÇA	DESCRIPTION DESCRIÇÃO	67TA	67TC	67T9	67TB	REMARKS OBSERVAÇÕES
1	6G1-8194A-10	RELAY RELE			1	1	
2	90170-06M30	NUT PORCA			2	2	
3	90204-06M00	WASHER, SPRING ARRUELA PRESSAOA			2	2	
4	6G1-81952-00	HOLDER, RELAY SUPPORTO DO RELE			1	1	
5	6L2-81945-00	PLATE, SWITCH FITTING PLACA INTERRUPTOR DA PARTIDA			1	1	
6	6E5-82117-01	WIRE, LEAD FIO CONDUTOR			1	1	
7	66T-82105-00	WIRE HARNESS CHICOTE DE FIOS			1	1	
8	6G1-81970-61	RECTIFIER ASSY RETIFICADOR CONJ.			1	1	
9	6G1-82151-00	.FUSE (10A) .FUSIVEL (10A)			1	1	
10	97880-05030	SCREW, PAN HEAD PARAFUSO			1	1	
11	92990-05600	WASHER, PLATE ARRUELA PLANA			1	1	
12	95380-05600	NUT PORCA			1	1	
13	90109-06M80	BOLT PARAFUSO			1	1	
14	66T-82590-00	WIRE HARNESS ASSY CHICOTE PRINCIPAL COMPLETO			1	1	
15	66T-83557-00	TUBE (I.DIA:13MM) TUBO (I.DIA:13MM)			1	1	
16	6J4-86111-00	COIL, SOLENOID BOBINA DO SOLENOIDE			1	1	
17	6J4-86116-00	WIRE, PULL CABO			1	1	
18	66T-86112-00	STAY, SOLENOID SUPPORTO SOLENOID			1	1	
19	90480-10155	GROMMET ILHO DE BORRACHA			1	1	
20	97880-05008	SCREW, PAN HEAD PARAFUSO			4	4	
21	682-86117-00	HOOK, WIRE PULL GANCHO CABO			1	1	
22	90480-10M23	GROMMET ILHO DE BORRACHA			3	3	
23	90387-06M60	COLLAR ESPACADOR			3	3	
24	93210-03261	O-RING ANEL DE BORRACHA			1	1	
25	90119-06M88	BOLT, WITH WASHER PARAFUSO COM ARRUELA			3	3	
26	90465-20M31	CLAMP BRACADEIRA			1	1	
27	90109-06M86	BOLT PARAFUSO			1	1	

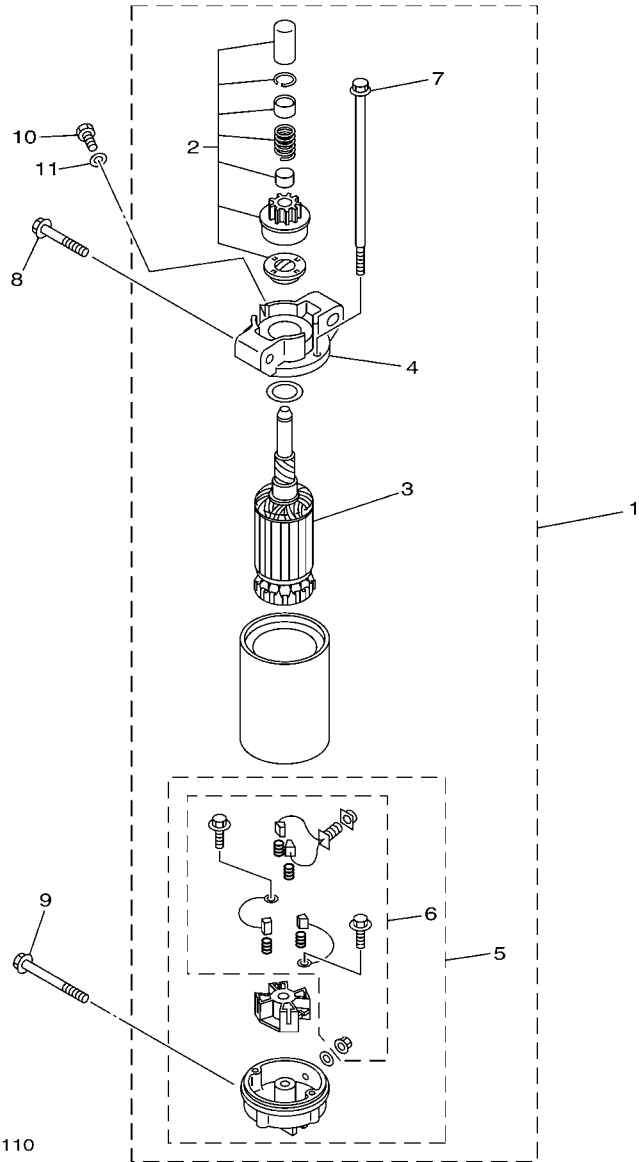

66TA664-E110

FIG. 11 STARTING MOTOR

MOTOR DE PARTIDA

REF. NO.	PART NO. No. PEÇA	DESCRIPTION DESCRIÇÃO	67TA	67TC	67T9	67TB	REMARKS OBSERVAÇÕES
1	66T-81800-02	STARTING MOTOR ASSY MOTOR DE PARTIDA COMPLETO			1	1	
2	66T-81857-00	.PINION STOPPER SET .LIMITADOR DO PINHAO			1	1	
3	66T-81850-01	.ARMATURE ASSY .INDUZIDO CONJ.			1	1	
4	66T-81830-00	.FRONT BRACKET ASSY .SUPORTE DIANTEIRO CONJ.			1	1	
5	66T-81820-00	.REAR BRACKET ASSY .SUPORTE TRASEIRO CONJ.			1	1	
6	66T-81840-00	..BRUSH HOLDER ASSY ..FIXADOR DAS ESCOVAS CONJ.			1	1	
7	66T-81826-00	.BOLT .PARAFUSO			2	2	
8	90119-08M39	BOLT, WITH WASHER PARAFUSO COM ARRUELA			2	2	
9	90119-08M52	BOLT, WITH WASHER PARAFUSO COM ARRUELA			1	1	
10	97095-08016	BOLT PARAFUSO			1	1	
11	92995-08600	WASHER ARRUELA			1	1	

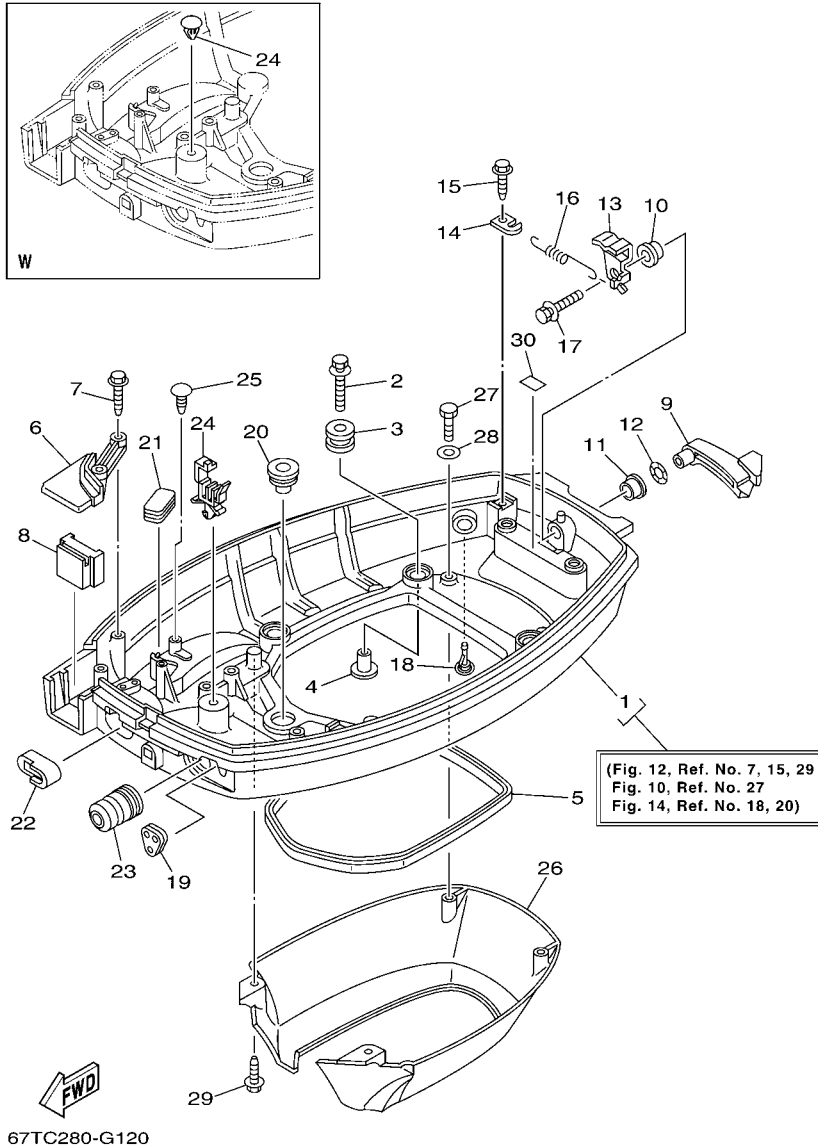
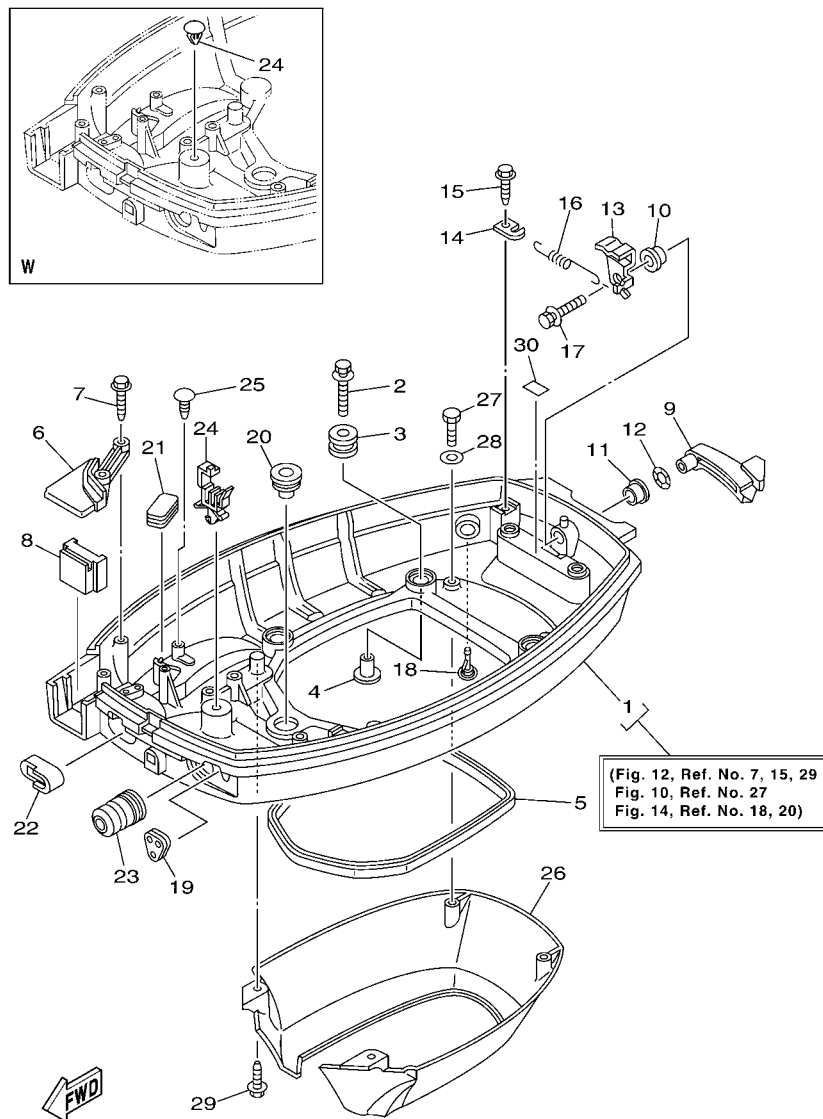

FIG. 12 BOTTOM COWLING

BANDEJA DO CAPO

REF. NO.	PART NO. No. PEÇA	DESCRIPTION DESCRIÇÃO	67TA	67TC	67T9	67TB	REMARKS OBSERVAÇÕES
1	66T-42710-01-4D	BOTTOM COWLING ASSY BASE DO CAPO CONJ.	1	1	1	1	
2	90119-06M61	BOLT, WITH WASHER PARAFUSO COM ARRUELA	4	4	4	4	
3	90480-09M21	GROMMET ILHO DE BORRACHA	4	4	4	4	
4	90387-06035	COLLAR ESPACADOR	4	4	4	4	
5	66T-42716-00	RUBBER, SEAL 1 BORRACHA DE VEDACAO 1	1	1	1	1	
6	66T-42738-00-5B	PLATE, FITTING PLACA DA FIXADORA	1	1	1	1	
7	90109-06M81	BOLT PARAFUSO	2	2	2	2	
8	66T-42725-00	GROMMET ILHO	1	1			
	66T-42725-20	GROMMET ILHO			1	1	
9	66T-42815-01-4D	LEVER, CLAMP ALAVANCA DA BRACADEIRA	1	1	1	1	
10	90386-12M37	BUSH BUCHA	1	1	1	1	
11	90386-12MA2	BUSH BUCHA	1	1	1	1	
12	90206-12052	WASHER, WAVE ARRUELA ONDULADA	1	1	1	1	
13	66T-42816-00	LEVER, CLAMP ALAVANCA DA BRACADEIRA	1	1	1	1	
14	66T-43144-00	HOOK, SPRING GANCHO DA MOLA	1	1	1	1	
15	90109-06M86	BOLT PARAFUSO	1	1	1	1	
16	90506-16M34	SPRING, TENSION MOLA DE TENSAO	1	1	1	1	
17	90119-06M73	BOLT, WITH WASHER PARAFUSO COM ARRUELA	1	1	1	1	
18	6E5-44391-00	NIPPLE, HOSE JUNCAO DO TUBO	1	1	1	1	
19	65W-26326-00	GROMMET ILHO	1	1			
	65W-26326-10	GROMMET ILHO			1	1	
20	676-42727-00	GROMMET ILHO	1	1	1	1	
21	6H4-42726-00	GROMMET ILHO	1	1	1	1	
22	66T-24329-00	SEAL GUARNICAO	1	1	1	1	
23	65W-42726-00	GROMMET ILHO	1	1			
	65W-42726-10	GROMMET ILHO			1	1	
24	90465-25M57	CLAMP BRACADEIRA	1	1			



67TC280-G120

FIG. 12 BOTTOM COWLING

BANDEJA DO CAPO

REF. NO.	PART NO. No. PEÇA	DESCRIPTION DESCRIÇÃO	67TA	67TC	67T9	67TB	REMARKS OBSERVAÇÕES
24	90338-07M00	PLUG TAMPÃO			1	1	
25	90338-05M03	PLUG TAMPÃO	1	1	1	1	
26	66T-42741-00	APRON ABA	1	1	1	1	
27	97095-06016	BOLT PARAFUSO	2	2	2	2	
28	92995-06600	WASHER ARRUELA	2	2	2	2	
29	90109-06M80	BOLT PARAFUSO	2	2	2	2	
30	664-42791-00	MARK 1 EMBLEMA 1	1	1	1	1	

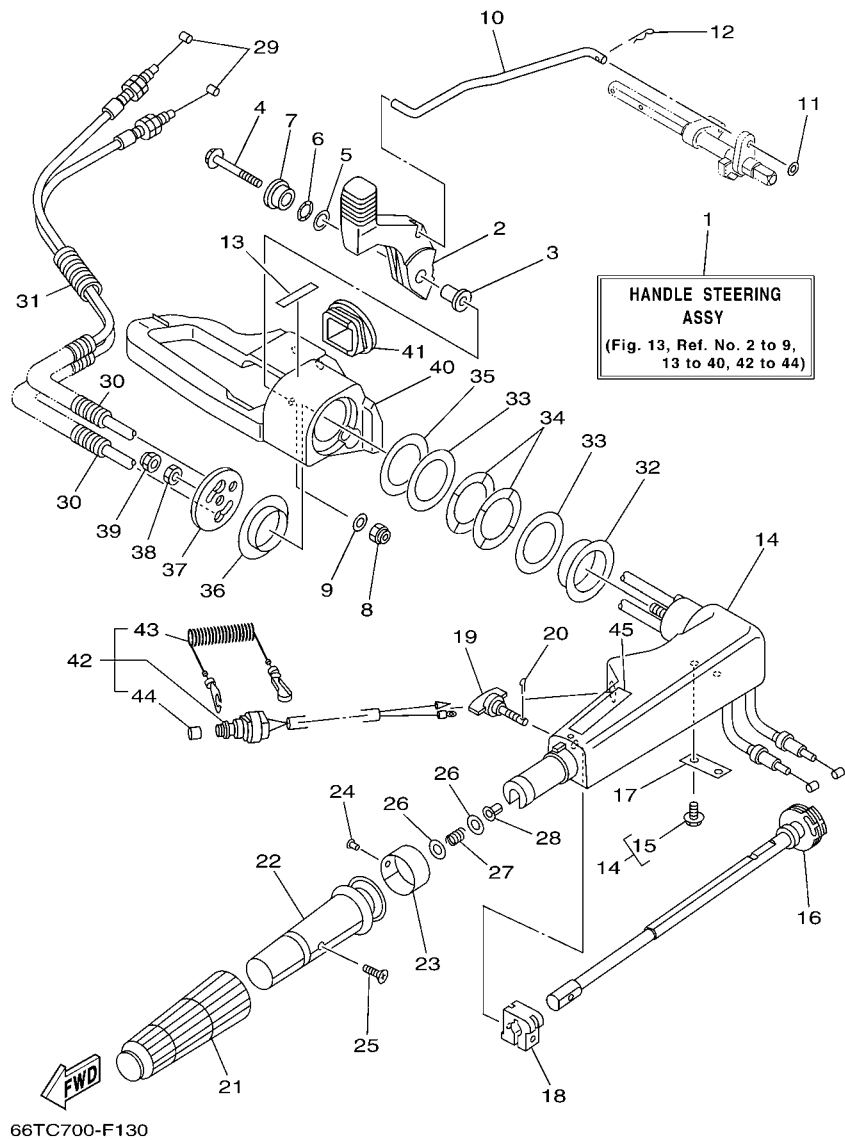

66TC700-F130

FIG. 13 STEERING

DIRECAO

REF. NO.	PART NO. No. PEÇA	DESCRIPTION DESCRIÇÃO	67TA	67TC	67T9	67TB	REMARKS OBSERVAÇÕES
1	66T-W0084-02-4D	HANDLE STEERING ASSY ALAVANCA DA DIRECAO CONJ.	1	1			
2	66T-44111-02	HANDLE, GEAR SHIFT ALAVANCA DE MUDANCA	1	1			
3	90387-06M86	COLLAR ESPACADOR	1	1			
4	97595-06550	BOLT, WITH WASHER PARAFUSO COM ARRUELA	1	1			
5	90201-12M07	WASHER, PLATE ARRUELA PLANA	1	1			
6	90206-12052	WASHER, WAVE ARRUELA ONDULADA	1	1			
7	66T-42123-00	BOLT, HANDLE JOINT PARAFUSO DE JUNCAO DA ALAVANCA	1	1			
8	95780-06300	NUT, FLANGE PORCA FLANGE	1	1			
9	92995-06200	WASHER ARRUELA	1	1			
10	66T-44124-00	LINK, SHIFT ROD ARGOLA DA HASTE DE MUDANCA	1	1			
11	92990-06200	WASHER, PLAIN ARRUELA PLANA	1	1			
12	90468-18008	CLIP PRESILHA	1	1			
13	6E0-44191-11	INDICATOR, SHIFT INDICADOR DE MUDANCA	1	1			
14	65W-42101-01-4D	HANDLE, STEERING ALAVANCA DE DIRECIONAL	1	1			
15	90109-06M86	.BOLT .PARAFUSO	2	2			
16	65W-42138-00	LEVER, THROTTLE ALAVANCA DE ACELERACAO	1	1			
17	65W-42159-00	STAY FIXADOR	1	1			
18	6G1-42126-00	FRICITION, STEERING HANDLE GRIP FRICCAO DIRECIONAL	1	1			
19	65W-42125-00	BOLT, FRICTION ADJUSTING PARAFUSO DE AJUSTE DA FRICCAO	1	1			
20	91490-20010	PIN, COTTER CUPILHA	1	1			
21	6F6-42177-A0	RUBBER, HANDLE BORRACHA DO GUIDAO	1	1			
22	664-42119-00	GRIP, STEERING HANDLE MANOPLA DA ALAVANCA DIRECIONAL	1	1			
23	6G1-42137-10	INDICATOR, THROTTLE INDICADOR DE ACELERACAO	1	1			
24	90269-02M09	RIVET REBITE	1	1			
25	90149-05M13	SCREW PARAFUSO	1	1			
26	90201-10M02	WASHER, PLATE ARRUELA PLANA	2	2			
27	90501-23215	SPRING, COMPRESSION MOLA DE COMPRESSAO	1	1			

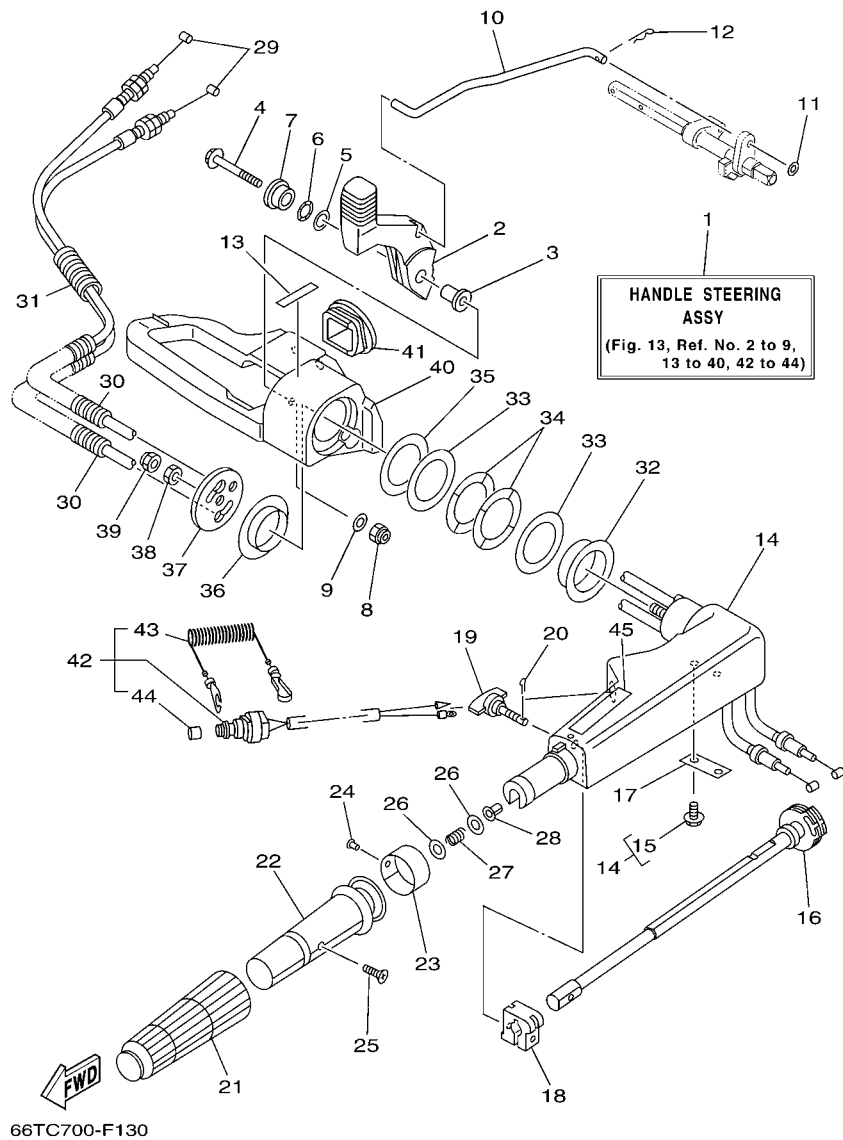

FIG. 13 STEERING

DIRECAO

REF. NO.	PART NO. No. PEÇA	DESCRIPTION DESCRIÇÃO	67TA	67TC	67T9	67TB	REMARKS OBSERVAÇÕES
28	90386-08032	BUSH BUCHA	1	1			
29	66T-26301-00	THROTTLE CABLE ASSY CABO ACELERADOR CONJ.	2	2			
30	90446-10M87	HOSE (L75) TUBO (L75)	2	2			
31	90446-10M86	HOSE (L140) TUBO (L140)	2	2			
32	90386-40MA0	BUSH BUCHA	1	1			
33	90201-43M00	WASHER, PLATE ARRUELA PLANA	2	2			
34	90206-43M22	WASHER, WAVE ARRUELA ONDULADA	2	2			
35	90202-43M57	WASHER, PLATE ARRUELA PLANA	1	1			
36	90386-40M99	BUSH BUCHA	1	1			
37	65W-42131-01	COVER, HANDLE STEERING TAMPA DA ALAVANCA DIRECIONAL	1	1			
38	95380-10700	NUT PORCA	1	1			
39	95780-10300	NUT, FLANGE PORCA FLANGE	1	1			
40	65W-42121-01-4D	BRACKET SUPORTE	1	1			
41	66T-41273-00	GROMMET ILHO	1	1			
42	66T-82575-01	ENGINE STOP SWITCH ASSY INTERRUPTOR DE PARADA C.J.	1	1			
43	682-82556-00	.LANYARD, STOP SWITCH .AMORTIZADOR DO LIMITADOR	1	1			
44	689-8257Y-00	.CAP .CAPA DO INTERRUPTOR DE PARADA	1	1			
45	6E0-83627-41	LABEL, CAUTION 7 ETIQUETA DE ADVERTENCIA	1	1			

FIG. 14 CONTROL

CONTROLE

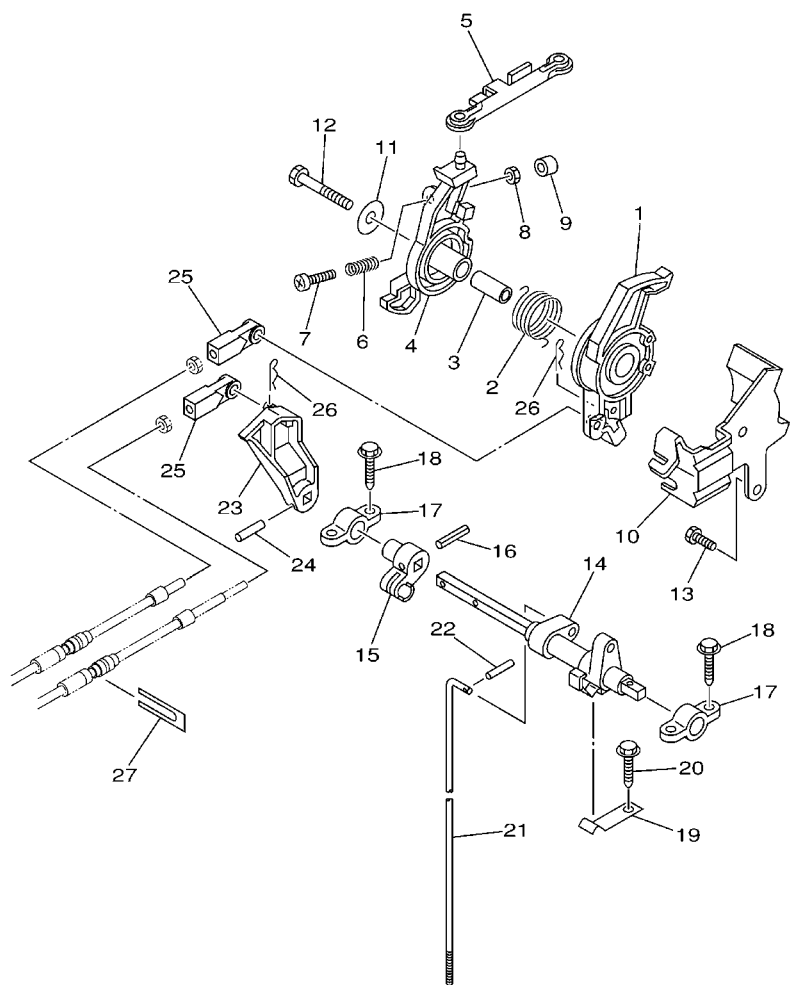

66T0664-1140

REF. NO.	PART NO. No. PEÇA	DESCRIPTION DESCRIÇÃO	67TA	67TC	67T9	67TB	REMARKS OBSERVAÇÕES
1	66T-41638-00	PULLEY POLIA	1	1	1	1	
2	66T-42167-00	SPRING 1 MOLA	1	1	1	1	
3	90387-08M16	COLLAR ESPACADOR	1	1	1	1	
4	66T-41631-01	LEVER, MAGNETO CONTROL ALAVANCA CONTROLE DO MAGNETO	1	1	1	1	
5	66T-41237-00	JOINT, LINK JUNCAO DO ARTICULADOR	1	1	1	1	
6	90501-10M84	SPRING, COMPRESSION MOLA DE COMPRESSAO	1	1	1	1	
7	97880-06035	SCREW, PAN HEAD PARAFUSO	1	1	1	1	
8	95380-06700	NUT PORCA	1	1	1	1	
9	688-44194-00	CAP CHAVETA	1	1	1	1	
10	66T-14497-00	STAY, THROTTLE WIRE SUPORTE DO CABO DE ACELERACAO	1	1	1	1	
11	90201-08M54	WASHER, PLATE ARRUELA PLANA	1	1	1	1	
12	97095-08045	BOLT PARAFUSO	1	1	1	1	
13	97095-06014	BOLT PARAFUSO	1	1	1	1	
14	66T-44121-00	LEVER, SHIFT ROD ALAVANCA DA HASTE DE MUDANCA	1	1	1	1	
15	66M-44122-00	BUSHING, SHIFT ROD LEVER BUCHA DA ALAVANCA DE MUDANCA	1	1	1	1	
16	90254-03M05	PIN, SPRING PINO MOLA	1	1	1	1	
17	6F5-41662-00	BRACKET 2 SUPORTE 2	2	2	2	2	
18	90109-06M81	BOLT PARAFUSO	4	4	4	4	
19	682-44116-01	SPRING MOLA	1	1	1	1	
20	90109-06M80	BOLT PARAFUSO	1	1	1	1	
21	66T-44143-00	ROD, SHIFT HASTE DE MUDANCA	1	1	1	1	S(16.7") S(16.7")
22	91490-16012	PIN, COTTER CUPILHA	1	1	1	1	
23	66T-44125-01	LEVER, SHIFT ROD ALAVANCA DA HASTE DE MUDANCA	1	1	1	1	
24	90254-03M04	PIN, SPRING PINO MOLA	1	1	1	1	
25	663-48344-00	CABLE END, REMOTE CONTROL TERMINAL DO CABO DE CONTROL			2	2	
26	90468-18008	CLIP PRESILHA			2	2	
27	6H3-48538-00	CLAMP, CABLE 1 GRAMPO DO CABO 1			1	1	

FIG. 15 REMO CON ATTACHMENT

ACESSORIOS DO CONTROLE REMOTO

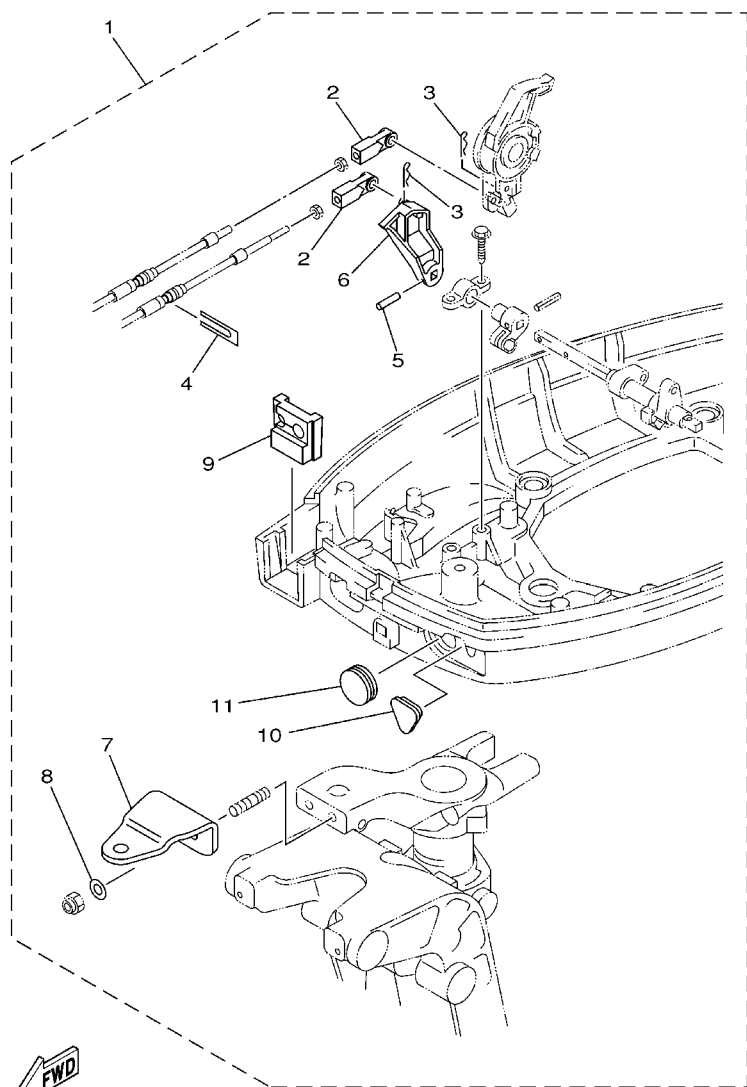

66T0010-1170

REF. NO.	PART NO. No. PEÇA	DESCRIPTION DESCRIÇÃO	67TA	67TC	67T9	67TB	REMARKS OBSERVAÇÕES
1	66T-48501-01	REMOTE CONT. ATTACHMENT ASSY. KIT DE ADAPTACAO	1	1			AP AP
2	663-48344-00	.CABLE END, REMOTE CONTROL .TERMINAL DO CABO DE CONTROL	2	2			
3	90468-18008	.CLIP .PRESILHA	2	2			
4	6H3-48538-00	.CLAMP, CABLE 1 .GRAMPO DO CABO 1	1	1			
5	90254-03M04	.PIN, SPRING .PINO MOLA	1	1			
6	66T-44125-01	.LEVER, SHIFT ROD .ALAVANCA DA HASTE DE MUDANCA	1	1			
7	65W-48511-00	.HOOK, STEERING .GANCHO DO DIRECIONADOR	1	1			
8	90201-10120	.WASHER, PLATE .ARRUELA PLANA	2	2			
9	66T-42725-30	.GROMMET .ILHO	1	1			
10	65W-26326-10	.GROMMET .ILHO	1	1			
11	65W-42726-10	.GROMMET .ILHO	1	1			

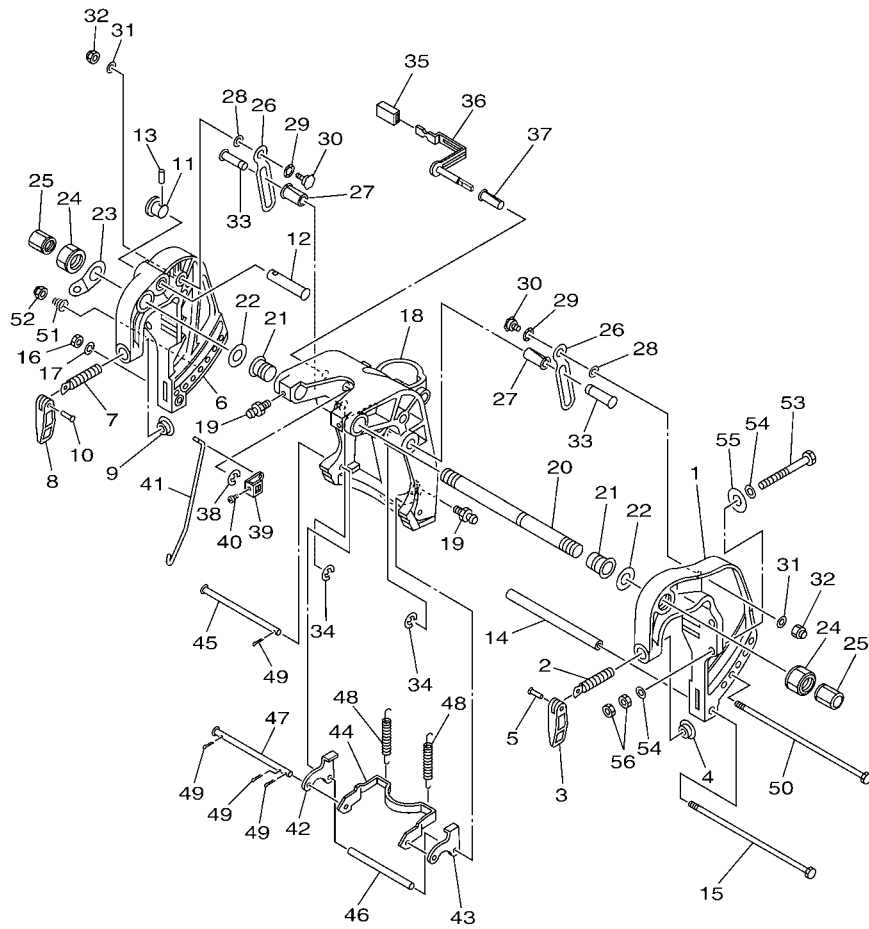

67TC280-G160

FIG. 16 BRACKET 1

SUPORTE 1

REF. NO.	PART NO. No. PEÇA	DESCRIPTION DESCRIÇÃO	67TA	67TC	67T9	67TB	REMARKS OBSERVAÇÕES
1	66T-43111-01-4D	BRACKET, CLAMP 1 SUPORTE DA BRACADEIRA 1	1	1	1	1	
2	90149-14M12	SCREW PARAFUSO	1	1	1	1	
3	663-43118-01-4D	HANDLE, TRANSOM CLAMP ALAVANCA DE FIXACAO	1	1	1	1	
4	648-43114-01	PAD, TRANSOM CLAMP PASTILHA DE TRANSMISSAO	1	1	1	1	
5	90243-04007	PIN PINO	1	1	1	1	
6	66T-43112-01-4D	BRACKET, CLAMP 2 SUPORTE DA BRACADEIRA 2	1	1	1	1	
7	90149-14M12	SCREW PARAFUSO	1	1	1	1	
8	663-43118-01-4D	HANDLE, TRANSOM CLAMP ALAVANCA DE FIXACAO	1	1	1	1	
9	648-43114-01	PAD, TRANSOM CLAMP PASTILHA DE TRANSMISSAO	1	1	1	1	
10	90243-04007	PIN PINO	1	1	1	1	
11	65W-43192-00	KNOB, STOPPER BOTAO LIMITADOR	1	1	1	1	
12	65W-43191-00	SHAFT, STOPPER EIXO LIMITADOR	1	1	1	1	
13	91690-30018	PIN, SPRING PINO MOLA	1	1	1	1	
14	90387-08M29	COLLAR ESPACADOR	1	1	1	1	
15	90101-08M76	BOLT PARAFUSO	1	1	1	1	
16	95380-08600	NUT PORCA	1	1	1	1	
17	92990-08100	WASHER, SPRING ARRUELA COM MOLA	1	1	1	1	
18	65W-43311-00-4D	BRACKET, SWIVEL 1 SUPORTE DO EIXO GIRATORIO	1	1	1	1	S(16.7") S(16.7")
19	93700-06M03	NIPPLE, GREASE GRAXEIRA	3	3	3	3	
20	63D-43131-01	BOLT, CLAMP BRACKET PARAFUSO DE ACO	1	1	1	1	
21	90386-22M15	BUSH BUCHA	2	2	2	2	
22	90201-22M03	WASHER, PLATE ARRUELA PLANA	2	2	2	2	
23	6J8-43113-01	PLATE, CLAMP BRACKET PLACA DE SUPORTE DA BRACADEIRA	1	1	1	1	
24	90185-22043	NUT, SELF-LOCKING PORCA AUTO-TRAVANTE	2	2	2	2	
25	6G5-43145-01	CAP, CLAMP BRACKET CAPA DA PORCA DA VARETA	2	2	2	2	
26	66T-43627-00	STOPPER LIMITADOR	2	2	2	2	
27	90386-12M98	BUSH BUCHA	2	2	2	2	

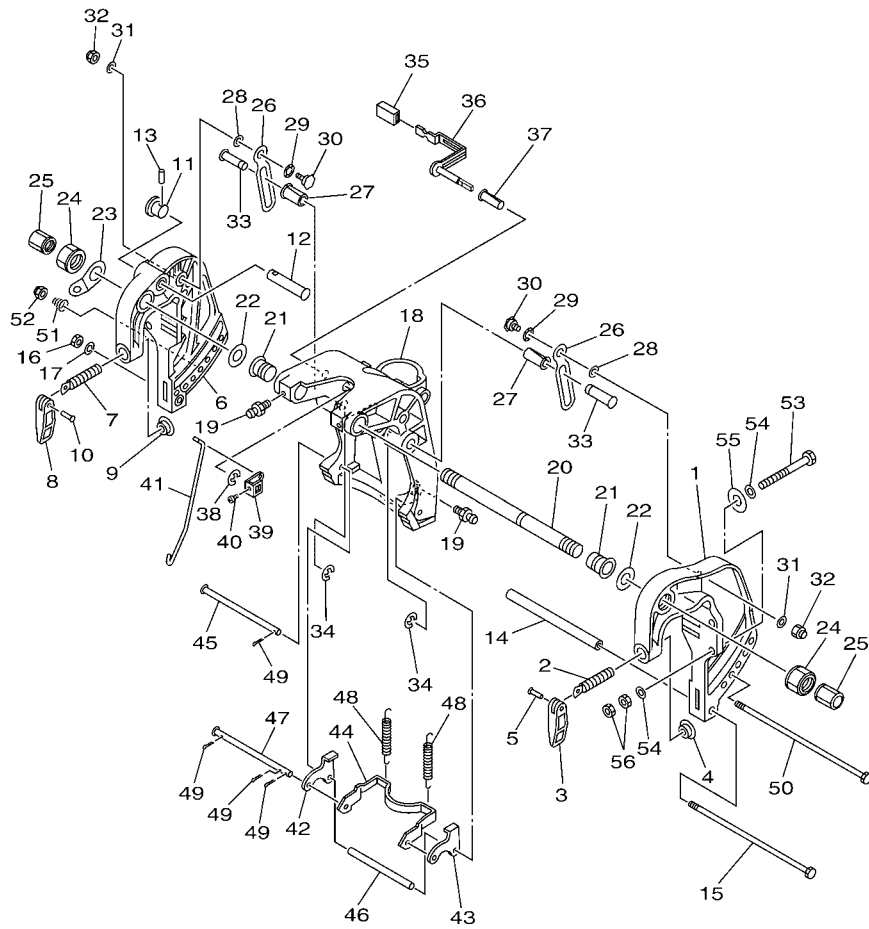

67TC280-G160

FIG. 16 BRACKET 1

SUPORTE 1

REF. NO.	PART NO. No. PEÇA	DESCRIPTION DESCRIÇÃO	67TA	67TC	67T9	67TB	REMARKS OBSERVAÇÕES
28	90202-12031	WASHER, PLATE ARRUELA PLANA	2	2	2	2	
29	90206-12M00	WASHER, WAVE ARRUELA ONDULADA	2	2	2	2	
30	90109-08M90	BOLT PARAFUSO	2	2	2	2	
31	90201-08M07	WASHER, PLATE ARRUELA PLANA	2	2	2	2	
32	90185-08057	NUT, SELF-LOCKING PORCA AUTO-TRAVANTE	2	2	2	2	
33	90249-12M34	PIN PINO	2	2	2	2	
34	93430-10M00	CIRCLIP ANEL TRAVA	2	2	2	2	
35	682-43318-01	COVER TAMPA	1	1	1	1	
36	65W-43630-02	TILT LEVER ASSY ALAVANCA DE INCLINACAO COMPL.	1	1	1	1	
37	90386-10M99	BUSH BUCHA	1	1	1	1	
38	99080-08600	CIRCLIP ANEL TRAVA	1	1	1	1	
39	66T-43631-01	LEVER, TILT ALAVANCA DE INCLINACAO	1	1	1	1	
40	90157-05014	SCREW, PAN HEAD PARAFUSO	1	1	1	1	
41	65W-43616-00	ROD, TILT LOCK HASTE DE FIXADOR DE INCLINACAO	1	1	1	1	
42	65W-43614-01	PLATE, TILT LOCK PLACA DE FIXADOR DE INCLINACAO	1	1	1	1	
43	65W-43615-01	PLATE, TILT LOCK PLACA DE FIXADOR DE INCLINACAO	1	1	1	1	
44	65W-43613-00	ARM, TILT LOCK BRACO DE FIXADOR DE INCLINACAO	1	1	1	1	
45	90249-07M32	PIN PINO	1	1	1	1	
46	90387-07M29	COLLAR ESPACADOR	1	1	1	1	
47	90249-07M33	PIN PINO	1	1	1	1	
48	90506-30M00	SPRING, TENSION MOLA DE TENSÃO	2	2	2	2	
49	91490-20012	PIN, COTTER CUPILHA	4	4	4	4	
50	90101-08M28	BOLT PARAFUSO	1	1	1	1	
51	90502-10M06	SPRING, CONICAL MOLA CÔNICA	1	1	1	1	
52	90185-08057	NUT, SELF-LOCKING PORCA AUTO-TRAVANTE	1	1	1	1	
53	90101-10M58	BOLT PARAFUSO	4	4	4	4	
54	92995-10600	WASHER ARRUELA	8	8	8	8	

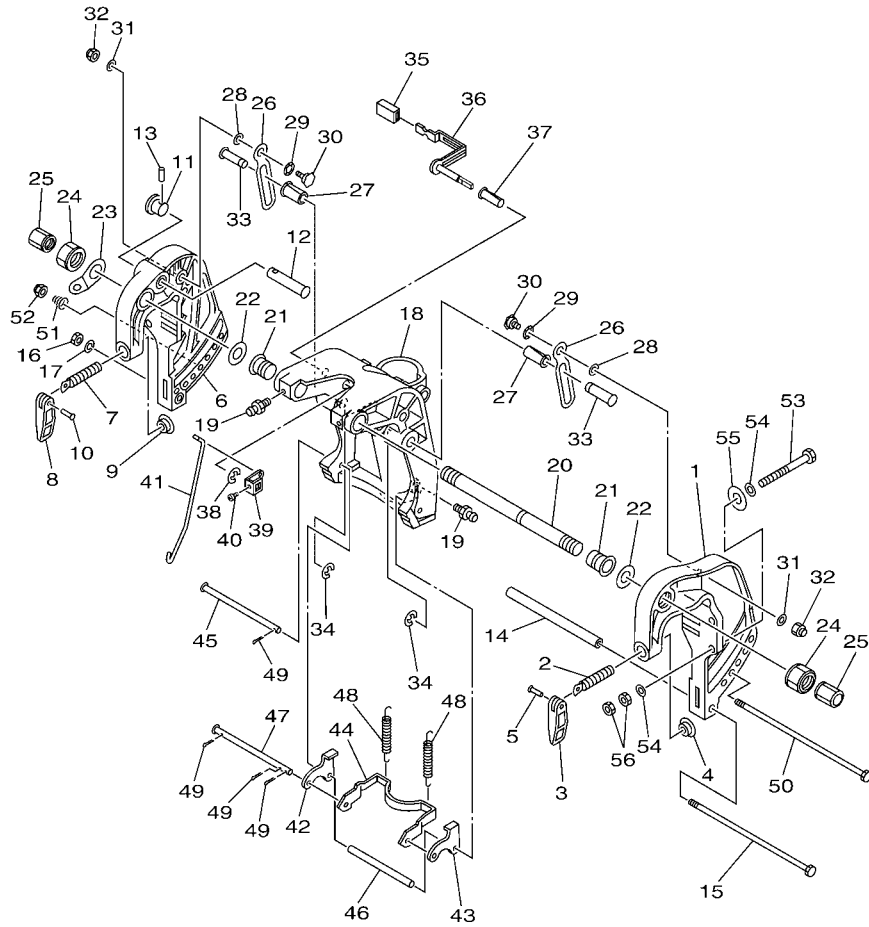

67TC280-G160

FIG. 16 BRACKET 1

SUPORTE 1

REF. NO.	PART NO. No. PEÇA	DESCRIPTION DESCRIÇÃO	67TA	67TC	67T9	67TB	REMARKS OBSERVAÇÕES
55	90201-12426	WASHER, PLATE ARRUELA PLANA	4	4	4	4	
56	95380-10600	NUT PORCA	8	8	8	8	

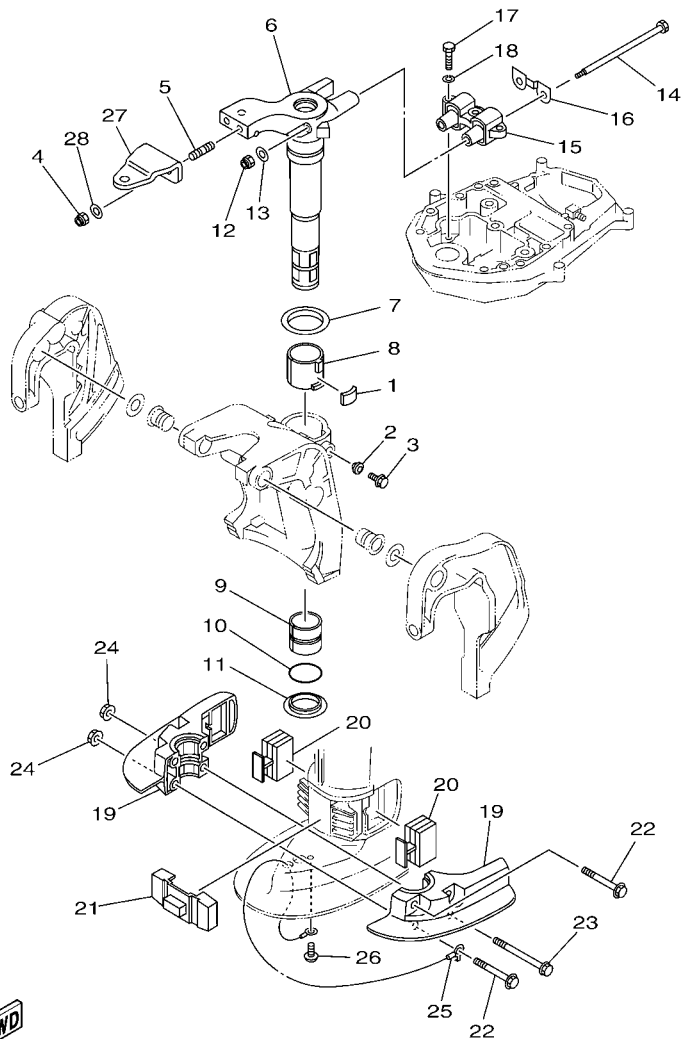

67TC280-G170

FIG. 17 BRACKET 2

SUPORTE 2

REF. NO.	PART NO. No. PEÇA	DESCRIPTION DESCRIÇÃO	67TA	67TC	67T9	67TB	REMARKS OBSERVAÇÕES
1	648-42528-00	PLATE, FRICTION PLACA DE FRICCAO	1	1	1	1	
2	65W-43373-00	SEAL, DAMPER RETENTOR DE BORRACHA	1	1	1	1	
3	90105-08M76	BOLT, FLANGE PARAFUSO FLANGE	1	1	1	1	
4	90185-10051	NUT, SELF-LOCKING PORCA AUTO-TRAVANTE	2	2	2	2	
5	90116-10M28	BOLT, STUD PRISIONEIRO	2	2	2	2	
6	65W-42511-00-4D	BRACKET, STEERING SUPORTE DIRECIONAL	1	1	1	1	S(16.7") S(16.7")
7	90209-52M00	WASHER ARRUELA	1	1	1	1	
8	90386-52M02	BUSH BUCHA	1	1	1	1	
9	90386-44M03	BUSH BUCHA	1	1	1	1	
10	93210-43MJ0	O-RING ANEL DE BORRACHA	1	1	1	1	
11	90386-44M99	BUSH BUCHA	1	1	1	1	
12	90185-08045	NUT, SELF-LOCKING PORCA AUTO-TRAVANTE	2	2	2	2	
13	92995-08200	WASHER ARRUELA	2	2	2	2	
14	90101-08M86	BOLT PARAFUSO	2	2	2	2	
15	66T-44514-00-4D	MOUNT DAMPER, UPPER SIDE AMORTIZADOR SUPERIOR	1	1	1	1	
16	66T-44526-00	PLATE PLACA	1	1	1	1	
17	97075-08030	BOLT PARAFUSO	3	3	3	3	
18	92995-08100	WASHER ARRUELA	3	3	3	3	
19	65W-44551-00-4D	HOUSING, LOWER MOUNT RUBBER ALOJAMENTO DO SUPORTE INFERIOR	2	2	2	2	
20	65W-44555-10	MOUNT DAMPER, LOWER SIDE AMORTIZADOR INFERIOR	2	2	2	2	
21	66T-44575-00	DAMPÉR, LOWER MOUNT RUBBER BORRACHA AMORTIZADOR INFERIOR	1	1	1	1	
22	97575-10570	BOLT, WITH WASHER PARAFUSO COM ARRUELA	2	2	2	2	
23	90119-10M04	BOLT, WITH WASHER PARAFUSO COM ARRUELA	2	2	2	2	
24	90179-10M33	NUT PORCA DE REGULAGEM	4	4	4	4	
25	66T-82127-10	WIRE, LEAD 2 FIO CONDUTOR 2	1	1	1	1	
26	97885-06008	SCREW, PAN HEAD PARAFUSO	1	1	1	1	
27	65W-48511-00	HOOK, STEERING GANCHO DO DIRECIONAL			1	1	

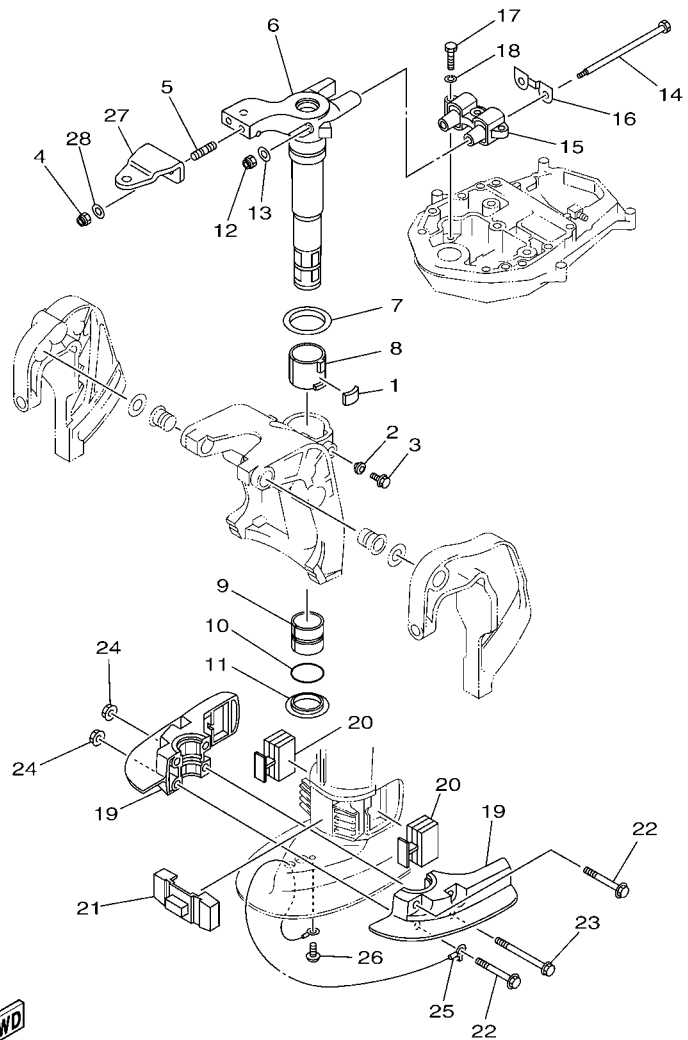

67TC280-G170

FIG. 17 BRACKET 2

SUPORTE 2

REF. NO.	PART NO. No. PEÇA	DESCRIPTION DESCRIÇÃO	67TA	67TC	67T9	67TB	REMARKS OBSERVAÇÕES
28	90201-10120	WASHER, PLATE ARRUELA PLANA			2	2	

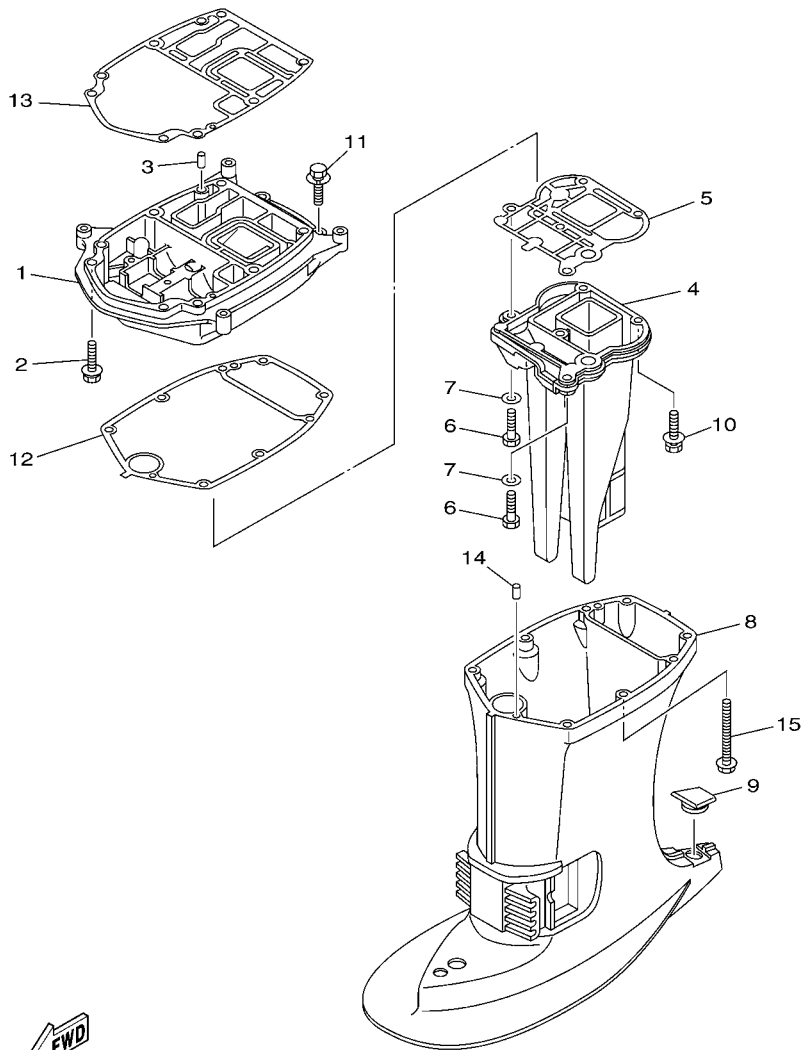

67TC280-G180

FIG. 18 UPPER CASING

CAPA INFERIOR

REF. NO.	PART NO. No. PEÇA	DESCRIPTION DESCRIÇÃO	67TA	67TC	67T9	67TB	REMARKS OBSERVAÇÕES
1	66T-41137-00-5B	GUIDE, EXHAUST GUIA DO ESCAPE	1	1	1	1	
2	90119-08M79	BOLT, WITH WASHER PARAFUSO COM ARRUELA	2	2	2	2	
3	93606-12019	PIN, DOWEL PINO GUIA	2	2	2	2	
4	66T-41131-00-5B	MANIFOLD, EXT. 1 TUBO MULTIPLO DE ESCAPE 1	1	1	1	1	S(16.7") S(16.7")
5	66T-41133-A0	GASKET, EXHAUST MANIFOLD 1 GAXETA DO MULTIPLO DE ESCAPE 1	1	1	1	1	
6	97075-08030	BOLT PARAFUSO	2	2	2	2	
7	92995-08600	WASHER ARRUELA	2	2	2	2	
8	66T-45111-00-4D	CASING, UPPER CAIXA SUPERIOR	1	1	1	1	S(16.7") S(16.7")
9	63D-45155-00	CAP CAPA	1	1	1	1	
10	97575-08545	BOLT, WITH WASHER PARAFUSO COM ARRUELA	3	3	3	3	
11	90119-08M79	BOLT, WITH WASHER PARAFUSO COM ARRUELA	2	2	2	2	
12	66T-45114-A0	GASKET, UPPER CASING GAXETA DA CAIXA SUPERIOR	1	1	1	1	
13	66T-45113-A0	GASKET, UPPER CASING GAXETA DA CAIXA SUPERIOR	1	1	1	1	
14	93606-12019	PIN, DOWEL PINO GUIA	2	2	2	2	
15	90119-08M42	BOLT, WITH WASHER PARAFUSO COM ARRUELA	6	6	6	6	

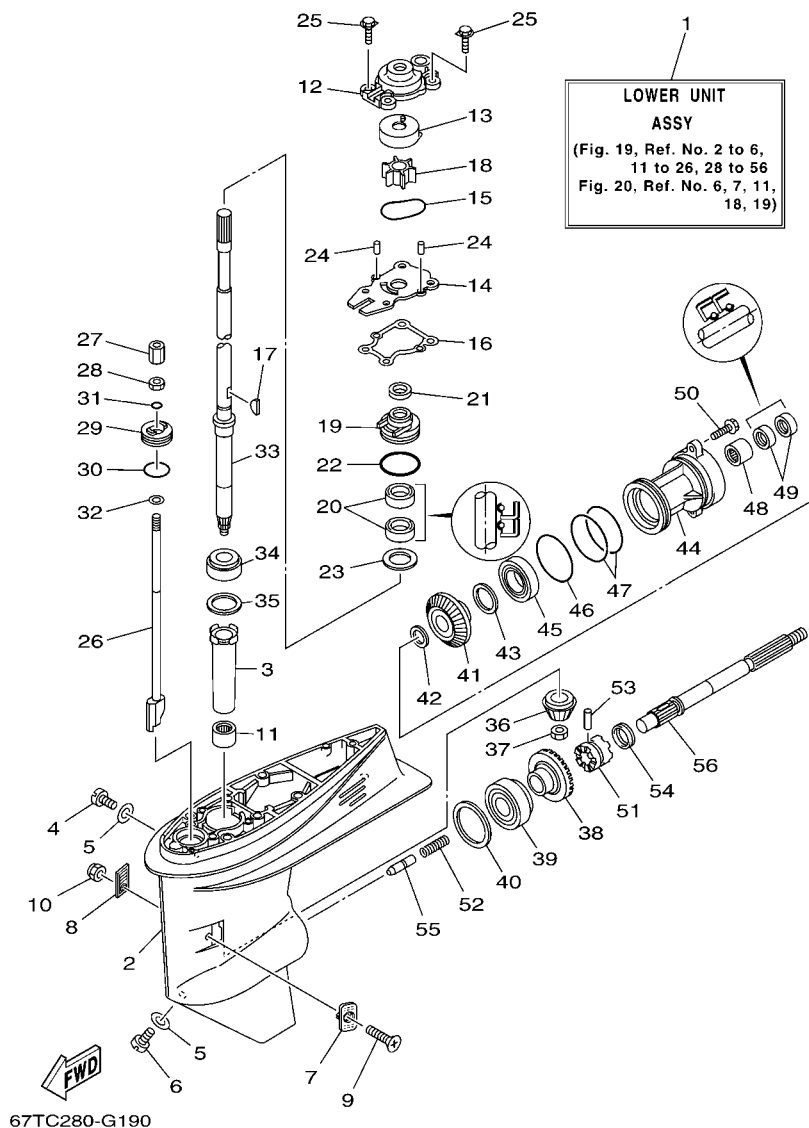

FIG. 19 LOWER CASING & DRIVE 1 CARCACA INF. E TRANSMISSAO 1

REF. NO.	PART NO. No. PEÇA	DESCRIPTION DESCRIÇÃO	67TA	67TC	67T9	67TB	REMARKS OBSERVAÇÕES
1	66T-45300-01-4D	LOWER UNIT ASSY UNIDADE DA RABETA INFERIOR CJ.	1	1	1	1	S(16.7") S(16.7")
2	66T-45311-01-4D	CASING, LOWER RABETA INFERIOR	1	1	1	1	
3	6H4-45536-00	SLEEVE, DRIVE SHAFT PROTECTOR DO EIXO DE DIRECIONAL	1	1	1	1	
4	90340-08002	PLUG, STRAIGHT SCREW TAMPAO DO DRENO	1	1	1	1	
5	90430-08020	GASKET GAXETA	2	2	2	2	
6	688-45341-10	PLUG, DRAIN TAMPAO DE ESGOTO	1	1	1	1	
7	63D-45214-00	COVER, WATER INLET 1 TAMPA DA ENTRADA DE AGUA 1	1	1	1	1	
8	63D-45215-00	COVER, WATER INLET 2 TAMPA DA ENTRADA DE AGUA 2	1	1	1	1	
9	90142-05M06	SCREW, COUNTERSUNK PARAFUSO TRAMBULADOR	1	1	1	1	
10	95380-05600	NUT PORCA	1	1	1	1	
11	93315-32224	BEARING ROLAMENTO CILINDRICO	1	1	1	1	
12	66T-44311-00	HOUSING, WATER PUMP ALOJAMENTO DA BOMBA D'AGUA	1	1	1	1	
13	63D-44322-40	INSERT, CARTRIDGE INSERTO DA BOMBA D'AGUA	1	1	1	1	FOR CHROMATE FOR CHROMATE
14	66T-44323-40	OUTER PLATE, CARTRIDGE PLACA DA EXTERNA DA BOMBA	1	1	1	1	FOR CHROMATE FOR CHROMATE
15	93210-59MG7	O-RING ANEL DE BORRACHA	1	1	1	1	
16	63D-44316-00	GASKET, WATER PUMP GAXETA DA BOMBA D'AGUA	1	1	1	1	
17	90280-03M03	KEY, WOODRUFF CHAVETA MEIA LUA	1	1	1	1	
18	6H4-44352-02	IMPELLER IMPULSOR	1	1	1	1	
19	63D-44341-00	HOUSING, WATER PUMP CAIXA DA BOMBA D'AGUA 2	1	1	1	1	
20	93101-22M60	OIL SEAL RETENTOR DE OLEO	2	2	2	2	
21	66T-45344-01	COVER, OIL SEAL TAMPA DO RETENTOR DE OLEO	1	1	1	1	
22	93210-48MG8	O-RING ANEL DE BORRACHA	1	1	1	1	
23	90201-27M00	WASHER, PLATE ARRUELA PLANA	1	1	1	1	
24	93604-08062	PIN, DOWEL PINO GUIA	2	2	2	2	
25	90119-08M15	BOLT, WITH WASHER PARAFUSO COM ARRUELA	4	4	4	4	
26	66T-44150-01	SHIFT CAM ASSY CAME DE MUDANCA CONJ.	1	1	1	1	S(16.7") S(16.7")
27	61N-44146-00	CONNECTOR, SHIFT ROD CONNECTOR DA HASTE DE MUDANCA	1	1	1	1	

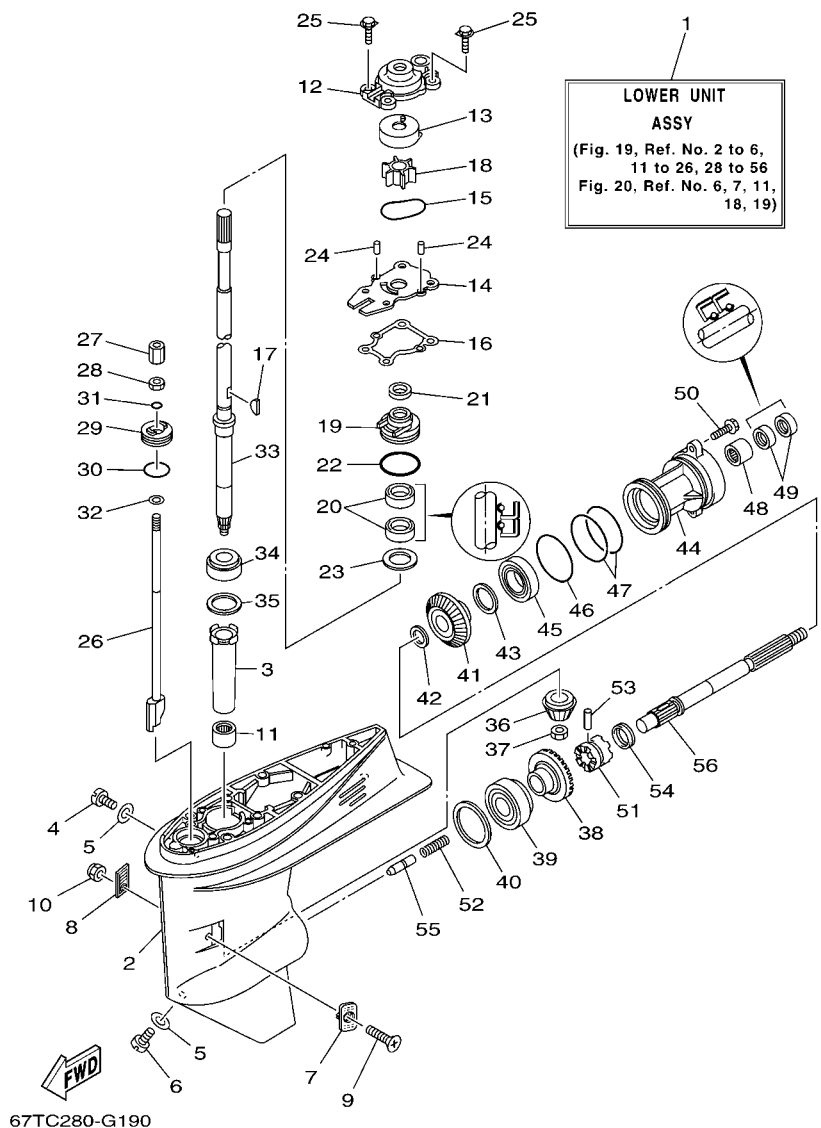
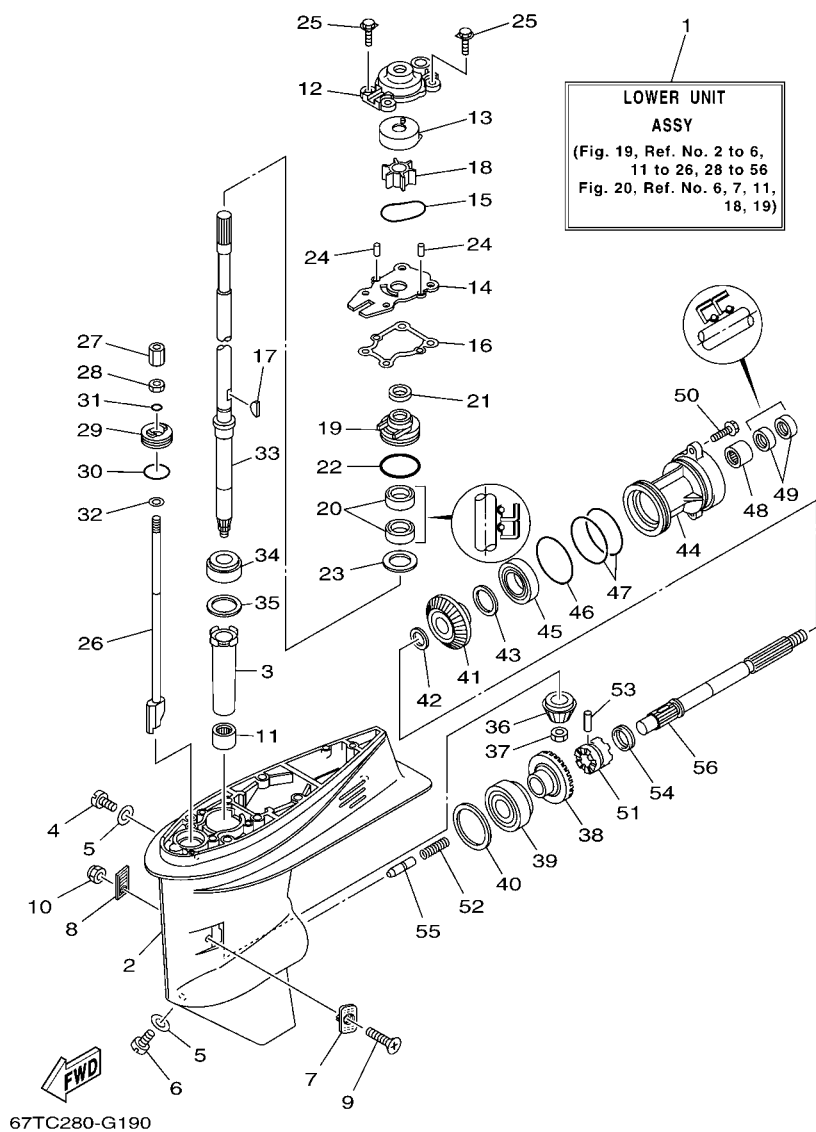

FIG. 19 LOWER CASING & DRIVE 1 CARCACA INF. E TRANSMISSAO 1

REF. NO.	PART NO. No. PEÇA	DESCRIPTION DESCRIÇÃO	67TA	67TC	67T9	67TB	REMARKS OBSERVAÇÕES
28	95380-06700	NUT PORCA	1	1	1	1	
29	66T-45321-00	PLATE PLACA	1	1	1	1	
30	93210-33MG4	O-RING ANEL DE BORRACHA	1	1	1	1	
31	93210-06ME6	O-RING ANEL DE BORRACHA	1	1	1	1	
32	92990-06600	WASHER, PLATE ARRUELA PLANA	1	1	1	1	
33	66T-45501-01	DRIVE SHAFT COMP. EIXO DE DIRECIONAL COMPL.	1	1	1	1	S(16.7") S(16.7")
34	93332-00001	BEARING ROLAMENTO	1	1	1	1	
35	663-45587-01	SHIM (T:0.10MM) CALCO (T:0.10MM)	1	1	1	1	UR UR
	663-45587-10	SHIM (T:0.12MM) CALCO (T:0.12MM)	1	1	1	1	UR UR
	663-45587-20	SHIM (T:0.15MM) CALCO (T:0.15MM)	1	1	1	1	UR UR
	663-45587-30	SHIM (T:0.18MM) CALCO (T:0.18MM)	1	1	1	1	UR UR
	663-45587-40	SHIM (T:0.30MM) CALCO (T:0.30MM)	1	1	1	1	UR UR UR
	663-45587-50	SHIM (T:0.40MM) CALCO (T:0.40MM)	1	1	1	1	UR UR
	663-45587-60	SHIM (T:0.50MM) CALCO (T:0.50MM)	1	1	1	1	UR UR
36	66T-45551-00	PINION (13T) PINHAO (13D)	1	1	1	1	
37	90170-12138	NUT PORCA	1	1	1	1	
38	66T-45560-01	GEAR 1 (26T) ENGRENAGEM (26D)	1	1	1	1	
39	93332-00003	BEARING ROLAMENTO	1	1	1	1	
40	663-45567-01	SHIM (T:0.10MM) CALCO (T:0.10MM)	1	1	1	1	UR UR
	663-45567-10	SHIM (T:0.12MM) CALCO (T:0.12MM)	1	1	1	1	UR UR
	663-45567-20	SHIM (T:0.15MM) CALCO (T:0.15MM)	1	1	1	1	UR UR
	663-45567-30	SHIM (T:0.18MM) CALCO (T:0.18MM)	1	1	1	1	UR UR
	663-45567-40	SHIM (T:0.30MM) CALCO (T:0.30MM)	1	1	1	1	UR UR
	663-45567-50	SHIM (T:0.40MM) CALCO (T:0.40MM)	1	1	1	1	UR UR
	663-45567-60	SHIM (T:0.50MM) CALCO (T:0.50MM)	1	1	1	1	UR UR
41	66T-45571-00	GEAR 2 (26T) ENGRENAGEM (26D)	1	1	1	1	
42	90201-22429	WASHER, PLATE ARRUELA PLANA	1	1	1	1	

FIG. 19 LOWER CASING & DRIVE 1

CARACA INF. E TRANSMISSAO 1



REF. NO.	PART NO. No. PEÇA	DESCRIPTION DESCRIÇÃO	67TA	67TC	67T9	67TB	REMARKS OBSERVAÇÕES
43	63D-45577-00	SHIM (T:0.10MM) CALCO (T:0.10MM)	1	1	1	1	UR UR
	63D-45577-10	SHIM (T:0.12MM) CALCO (T:0.12MM)	1	1	1	1	UR UR
	63D-45577-20	SHIM (T:0.15MM) CALCO (T:0.15MM)	1	1	1	1	UR UR
	63D-45577-30	SHIM (T:0.18MM) CALCO (T:0.18MM)	1	1	1	1	UR UR
	63D-45577-40	SHIM (T:0.30MM) CALCO (T:0.30MM)	1	1	1	1	UR UR
	63D-45577-50	SHIM (T:0.40MM) CALCO (T:0.40MM)	1	1	1	1	UR UR
	63D-45577-60	SHIM (T:0.50MM) CALCO (T:0.50MM)	1	1	1	1	UR UR
44	63D-45361-02-4D	CAP, LOWER CASING CAPA DA RABETA INFERIOR	1	1	1	1	
45	93306-001U1	BEARING ROLAMENTO	1	1	1	1	
46	93210-69MG6	O-RING ANEL DE BORRACHA	1	1	1	1	
47	93210-74MG5	O-RING ANEL DE BORRACHA	2	2	2	2	
48	93317-22204	BEARING ROLAMENTO	1	1	1	1	
49	93101-22M00	OIL SEAL RETENTOR DE OLEO	2	2	2	2	
50	90105-08M61	BOLT, FLANGE PARAFUSO FLANGE	2	2	2	2	
51	66T-45631-00	CLUTCH, DOG ENGATE DA ENGRENAGEM	1	1	1	1	
52	90501-15M01	SPRING, COMPRESSION MOLA DE COMPRESSAO	1	1	1	1	
53	90250-06023	PIN, STRAIGHT PINO DIRECTO	1	1	1	1	
54	663-45633-00	RING, CROSS PIN ANEL DE FIXACAO DO PINHAO	1	1	1	1	
55	66T-45635-00	PLUNGER, SHIFT ACIONADOR DE MUDANCA	1	1	1	1	
56	66T-45611-00	SHAFT, PROPELLER EIXO DA HELICE	1	1	1	1	

FIG. 20 LOWER CASING & DRIVE 2

CARACA INF. E TRANSMISSAO 2

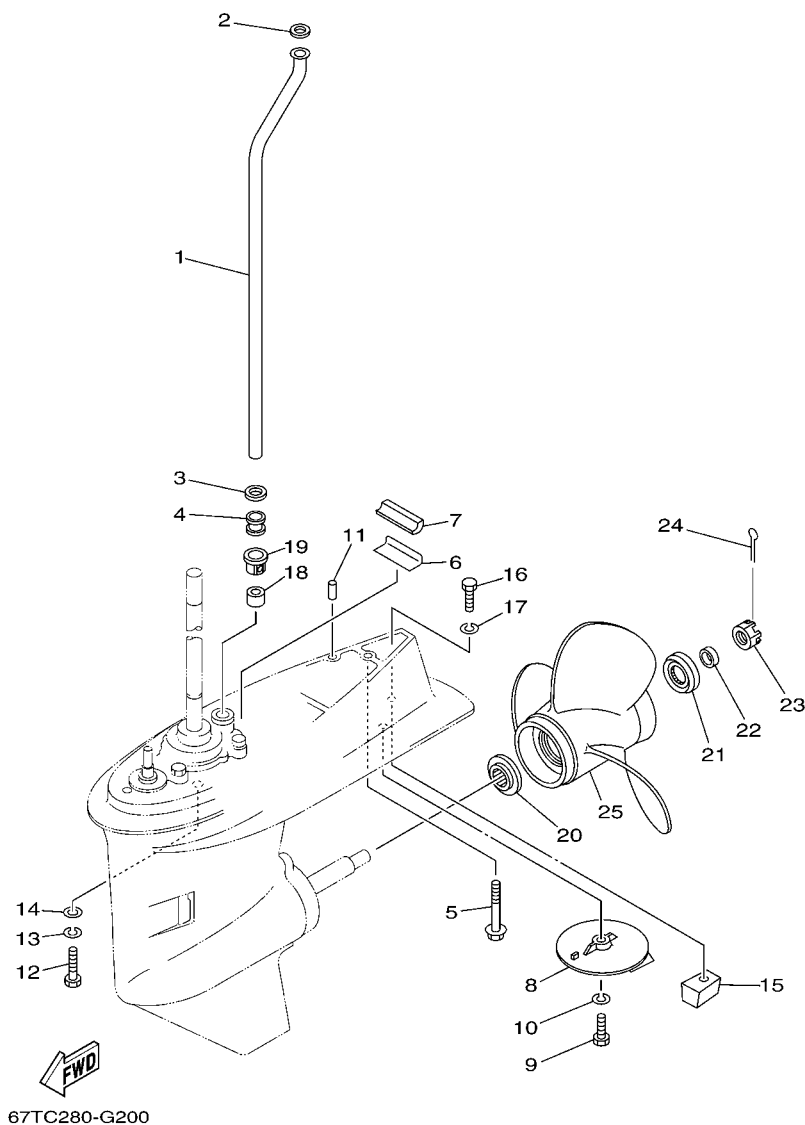

REF. NO.	PART NO. No. PEÇA	DESCRIPTION DESCRIÇÃO	67TA	67TC	67T9	67TB	REMARKS OBSERVAÇÕES
1	66T-44361-00	TUBE, WATER TUBO DE AGUA	1	1	1	1	S(16.7") S(16.7")
2	90202-12060	WASHER, PLATE ARRUELA PLANA	1	1	1	1	
3	90430-12072	GASKET GAXETA	1	1	1	1	
4	663-44367-00	DAMPER, WATER SEAL AMORTIZADOR DE BORRACHA	1	1	1	1	
5	90119-08M44	BOLT, WITH WASHER PARAFUSO COM ARRUELA	1	1	1	1	
6	663-45376-00-94	GUIDE, SEAL DAMPER GUIA DE AMORTIZADOR DE VEDACAO	1	1	1	1	
7	63D-45375-00	DAMPER, SEAL AMORTIZADOR DE VEDACAO	1	1	1	1	
8	664-45371-01	TAB-TRIM ESTABILIZADOR DE DIRECAO	1	1	1	1	
9	97095-08025	BOLT PARAFUSO	1	1	1	1	
10	92995-08100	WASHER ARRUELA	1	1	1	1	
11	93606-12019	PIN, DOWEL PINO GUIA	2	2	2	2	
12	97075-10040	BOLT PARAFUSO	4	4	4	4	
13	92995-10100	WASHER ARRUELA	4	4	4	4	
14	92995-10600	WASHER ARRUELA	4	4	4	4	
15	67C-45251-00	ANODE ANODO	1	1	1	1	
16	97095-08035	BOLT PARAFUSO	1	1	1	1	
17	92995-08100	WASHER ARRUELA	1	1	1	1	
18	663-44366-00	DAMPER, WATER SEAL AMORTIZADOR DE BORRACHA	1	1	1	1	
19	63D-44312-00	COVER, WATER PUMP HOUSING TAMPA DA BOMBA D'AGUA	1	1	1	1	
20	663-45987-02	SPACER ESPACADOR	1	1	1	1	
21	66T-45997-00	SPACER ESPACADOR	1	1	1	1	
22	90389-22M01	BUSH BUCHA	1	1	1	1	
23	90171-16011	NUT, CASTLE PORCA CASTELO	1	1	1	1	
24	91490-30025	PIN, COTTER CUPILHA	1	1	1	1	
25	69W-45943-00-EL	PROPELLER (3X11"X15"-G) HELICE (3X11"X15"-G)	1	1	1	1	UR UR
	69W-45945-00-EL	PROPELLER (3X11-1/8"X13"-G) HELICE (3X11-1/8"X13"-G)	1	1	1	1	UR UR
	69W-45947-00-EL	PROPELLER (3X11-5/8"X11"-G) HELICE (3X11-5/8"X11"-G)	1	1	1	1	UR UR

FIG. 20 LOWER CASING & DRIVE 2 CARCACA INF. E TRANSMISSAO 2

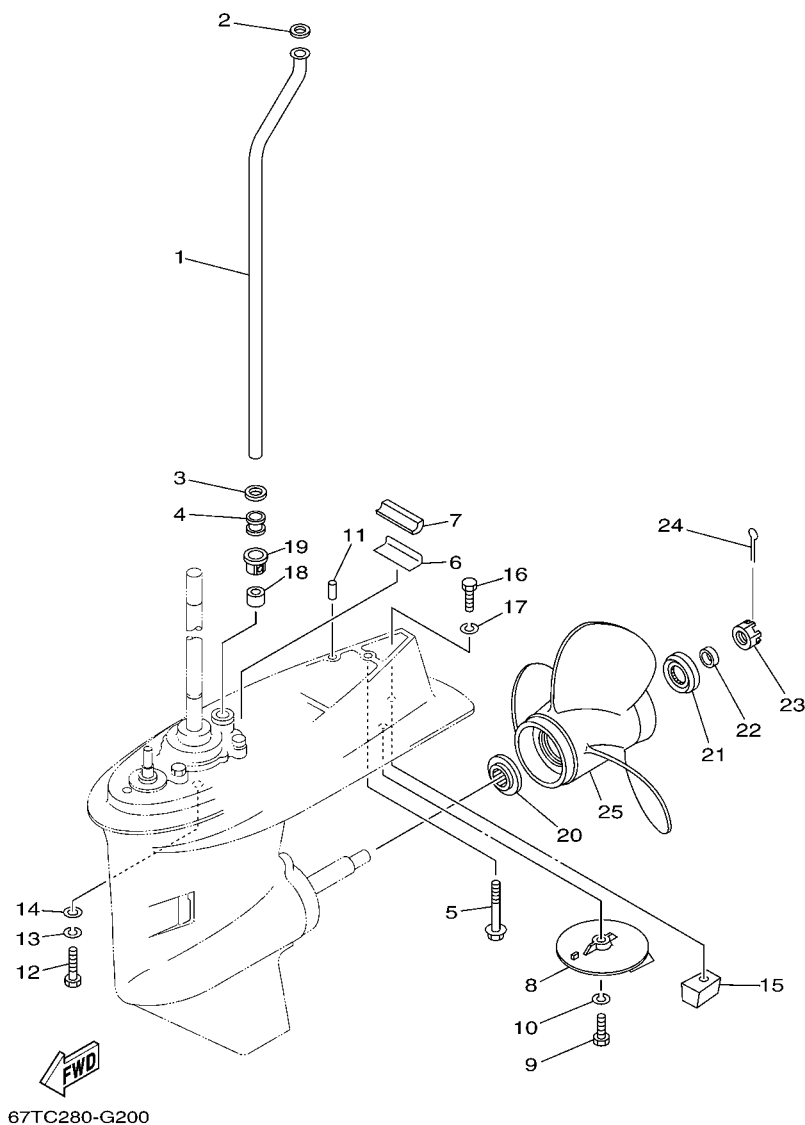

REF. NO.	PART NO. No. PEÇA	DESCRIPTION DESCRIÇÃO	67TA	67TC	67T9	67TB	REMARKS OBSERVAÇÕES
25	69W-45952-00-EL	PROPELLER (3X11-3/8"X12"-G) HELICE (3X11-3/8"X12"-G)	1	1	1	1	UR UR
	69W-45958-00-EL	PROPELLER (3X11-1/4"X14"-G) HELICE (3X11-1/4"X14"-G)	1	1	1	1	UR UR
	63D-45941-00-EL	PROPELLER (3X12-1/4"X8"-G) HELICE (3X12-1/4"X8"-G)	1	1	1	1	UR UR
	663-45941-01-EL	PROPELLER (3X10-3/4"X17"-G) HELICE (3X10-3/4"X17"-G)	1	1	1	1	UR UR
	663-45949-01-EL	PROPELLER (3X10-3/4"X16"-G) HELICE (3X10-3/4"X16"-G)	1	1	1	1	UR UR
	663-45952-02-EL	PROPELLER (3X11-3/8"X12"-G) HELICE (3X11-3/8"X12"-G)	1	1	1	1	UR UR
	663-45954-01-EL	PROPELLER (3X11-3/4"X10"-G) HELICE (3X11-3/4"X10"-G)	1	1	1	1	UR UR
	663-45956-01-EL	PROPELLER (3X12-1/4"X9"-G) HELICE (3X12-1/4"X9"-G)	1	1	1	1	UR UR
	663-45958-01-EL	PROPELLER (3X11-1/4"X14"-G) HELICE (3X11-1/4"X14"-G)	1	1	1	1	UR UR
	663-45930-00-98	PROPELLER (3X10-1/4"X14"-G) HELICE (3X10-1/4"X14"-G)	1	1	1	1	UR UR
	663-45976-00-98	PROPELLER (3X10-1/4"X15"-G) HELICE (3X10-1/4"X15"-G)	1	1	1	1	UR UR
	663-45978-00-98	PROPELLER (3X10-1/4"X16"-G) HELICE (3X10-1/4"X16"-G)	1	1	1	1	UR UR
	663-45970-60-98	PROPELLER (3X11-3/4"X12"-G) HELICE (3X11-3/4"X12"-G)	1	1	1	1	UR UR
	663-45972-60-98	PROPELLER (3X12"X11"-G) HELICE (3X12"X11"-G)	1	1	1	1	UR UR
	663-45974-60-98	PROPELLER (3X11-1/2"X13"-G) HELICE (3X11-1/2"X13"-G)	1	1	1	1	UR UR

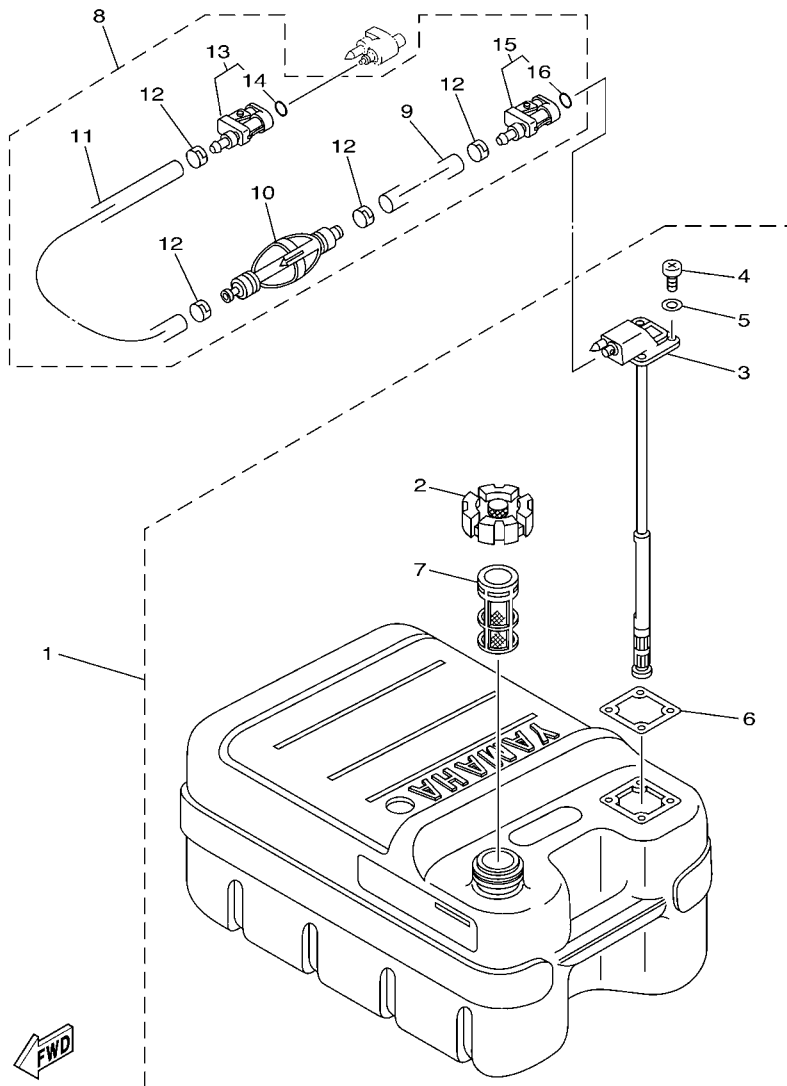

68U3100-C240

FIG. 21 FUEL TANK

TANQUE DE COMBUSTIVEL

REF. NO.	PART NO. No. PEÇA	DESCRIPTION DESCRIÇÃO	67TA	67TC	67T9	67TB	REMARKS OBSERVAÇÕES
1	61J-F4201-00	FUEL TANK ASSY TANQUE DE COMBUSTIVEL CONJ.	1	1	1	1	AP AP
2	6YJ-24610-01	.CAP ASSY .TAMPA DO TANQUE CJ.	1	1	1	1	
3	6YJ-24260-00	.FUEL METER ASSY .MEDIDOR NIVEL DO COMBUSTIVEL	1	1	1	1	
4	90157-05M19	.SCREW, PAN HEAD .PARAFUSO	4	4	4	4	
5	6Y1-24329-00	.SEAL .GUARNICAO	4	4	4	4	
6	6Y1-24268-00	.GASKET, FUEL METER .GAXETA DO MEDIDOR DO NIVEL	1	1	1	1	
7	6YJ-24167-00	.STRAINER .FILTRO	1	1	1	1	
8	61J-24306-04	FUEL PIPE COMP. 1 TUBO DE COMBUSTIVEL COMP. 1	1	1	1	1	AP AP
9	90445-11M06	.HOSE (L2050) .TUBO (L2050)	1	1	1	1	
10	61J-24360-00	.PRIMER PUMP ASSY .BOMBA PRIMARIA CONJ.	1	1	1	1	
11	90445-11M05	.HOSE (L850) .TUBO (L850)	1	1	1	1	
12	650-24351-01	.BAND 1 .BRACADEIRA 1	4	4	4	4	
13	6G1-24305-05	.FUEL PIPE JOINT COMP. 2 .JUNCAO TUBO DE COMBUSTIVEL 2	1	1	1	1	
14	93210-08287	..O-RING ..ANEL DE BORRACHA	1	1	1	1	
15	6Y1-24305-06	.FUEL PIPE JOINT COMP. 2 .JUNCAO TUBO DE COMBUSTIVEL 2	1	1	1	1	
16	93210-08287	..O-RING ..ANEL DE BORRACHA	1	1	1	1	

FIG. 22 STEERING GUIDE

HASTE DA DIRECAO

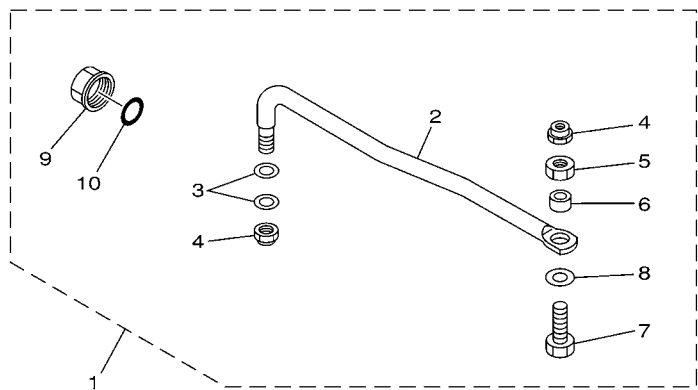

65W0010-8210

REF. NO.	PART NO. No. PEÇA	DESCRIPTION DESCRIÇÃO	67TA	67TC	67T9	67TB	REMARKS OBSERVAÇÕES
1	65W-61350-00	STEERING GUIDE ATTACHMENT KIT KIT DA GUIA DO DIRECIONADOR			1	1	AP AP
2	65W-61351-00	.ROD, STEERING LINK .HASTE DA DIRECAO			1	1	
3	90201-10M20	.WASHER, PLATE .ARRUELA PLANA			2	2	
4	90185-09M01	.NUT, SELF-LOCKING .PORCA AUTO-TRAVANTE			2	2	
5	90170-09M03	.NUT .PORCA			1	1	
6	90387-10M42	.COLLAR .ESPACADOR			1	1	
7	90101-09M01	.BOLT .PARAFUSO			1	1	
8	90201-10M63	.WASHER, PLATE .ARRUELA PLANA			1	1	
9	6E5-43145-01	.CAP, CLAMP BRACKET .CAPA DA PORCA DA VARETA			1	1	
10	93210-16275	.O-RING .ANEL DE BORRACHA			1	1	

FIG. 23 REMOTE CONTROL BOX

CAIXA DO CONTROLE REMOTO

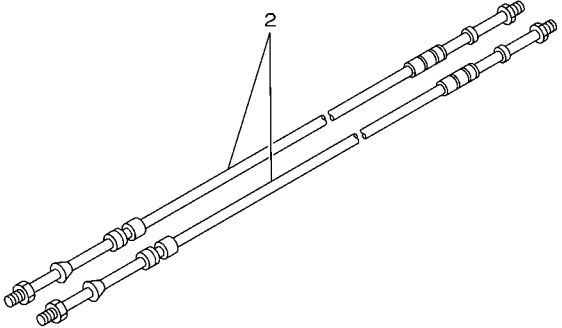
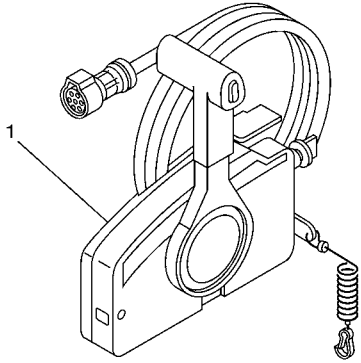

REF. NO.	PART NO. No. PEÇA	DESCRIPTION DESCRIÇÃO	67TA	67TC	67T9	67TB	REMARKS OBSERVAÇÕES
1	703-48203-15	REMOTE CONTROL ASSY (7P) CONJ CONTROLE REMOTO (7P)			1	1	AP AP
2	701-48320-20	CABLE, REMOTE CONTROL L=13F CABO, CONTROLE REMOTO L=13F			2	2	

67M0100-8280

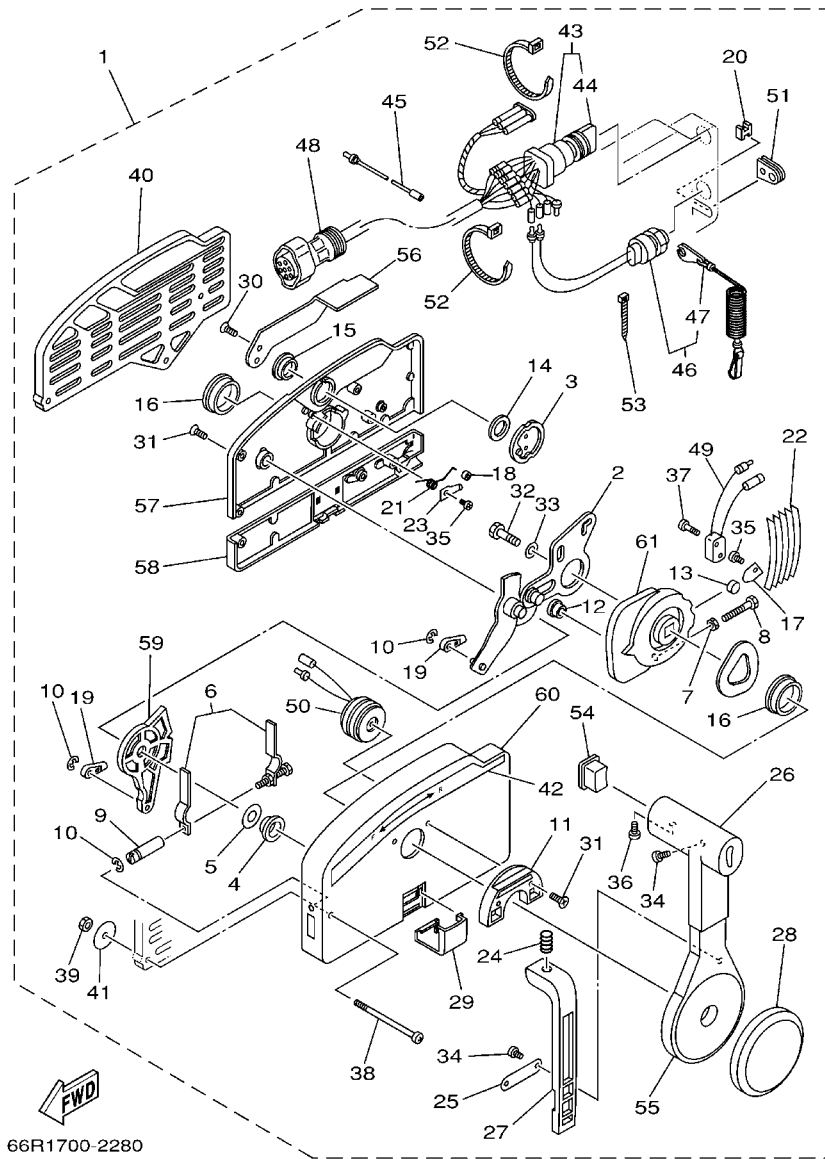

66R1700-2280

FIG. 24 REMOTE CONTROL ASSY CONTROLE REMOTO CONJ.

REF. NO.	PART NO. No. PEÇA	DESCRIPTION DESCRIÇÃO	67TA	67TC	67T9	67TB	REMARKS OBSERVAÇÕES
1	703-48203-15	REMOTE CONTROL ASSY (7P) CONJ CONTROLE REMOTO (7P)			1	1	AP AP
2	703-48261-01	.ARM, THROTTLE .BRACO DE ACELERACAO			1	1	
3	703-48153-00	.SHAFT, FREE ACCEL. .EIXO DE ACELERACAO LIVRE			1	1	
4	703-48235-00	.BUSHING .BUCHA			1	1	
5	703-48268-00	.SPACER .ESPACADOR 3			1	1	
6	703-48264-00	.FRICTION, THROTTLE .ACCELERADOR, FRICCAO			1	1	
7	95380-05600	.NUT .PORCA			1	1	
8	97380-05025	.BOLT .PARAFUSO			1	1	
9	703-48265-00	.SHAFT, FRICTION .EIXO FRICCAO			1	1	
10	93430-06024	.CIRCLIP .ANEL TRAVA			3	3	
11	703-48245-00	.PLATE, LOCK .PLACA TRAVA			1	1	
12	703-48252-00	.ROLLER, CAM .ROLETE			1	1	
13	701-48248-00	.ROLLER, FREE ACCEL. .ROLETE			1	1	
14	703-48198-00	.WASHER, WAVE .ARRUELA ONDULADA 3			1	1	
15	703-48243-00	.BUSHING .BUCHA 3			1	1	
16	703-48236-00	.BUSHING 1 .ROLETE			2	2	
17	703-48189-00	.RETAINER .RETENTOR			1	1	
18	703-48234-00	.ROLLER, DETENT .ROLETE			1	1	
19	703-48345-01	.CABLE END, REMOTE CONTROL 2 .TERNINAL DO CABO			2	2	
20	703-48358-00	.ANCHOR, CABLE .BRACADEIRA DO CABO			1	1	
21	703-48244-00	.SPRING, FREE ACCEL. .MOLA DO COMANDO			1	1	
22	703-48238-00	.SPRING, DETENT .MOLA			5	5	
23	703-48246-00	.SPACER .ESPACADOR			1	1	
24	703-48227-00	.SPRING, NEUTRAL LOCK .MOLA, TRAVA PONTO NEUTRO			1	1	
25	703-48226-00	.PLATE, STOPPER .PLACA LIMITADORA			1	1	
26	703-48222-00	.GRIP, CONTROL LEVER .TRAVA, ALAVANCA DE CONTROLE			1	1	SINGLE SINGLE
27	703-48223-00	.LOCK, NEUTRAL .TRAVA DO NEUTRO			1	1	

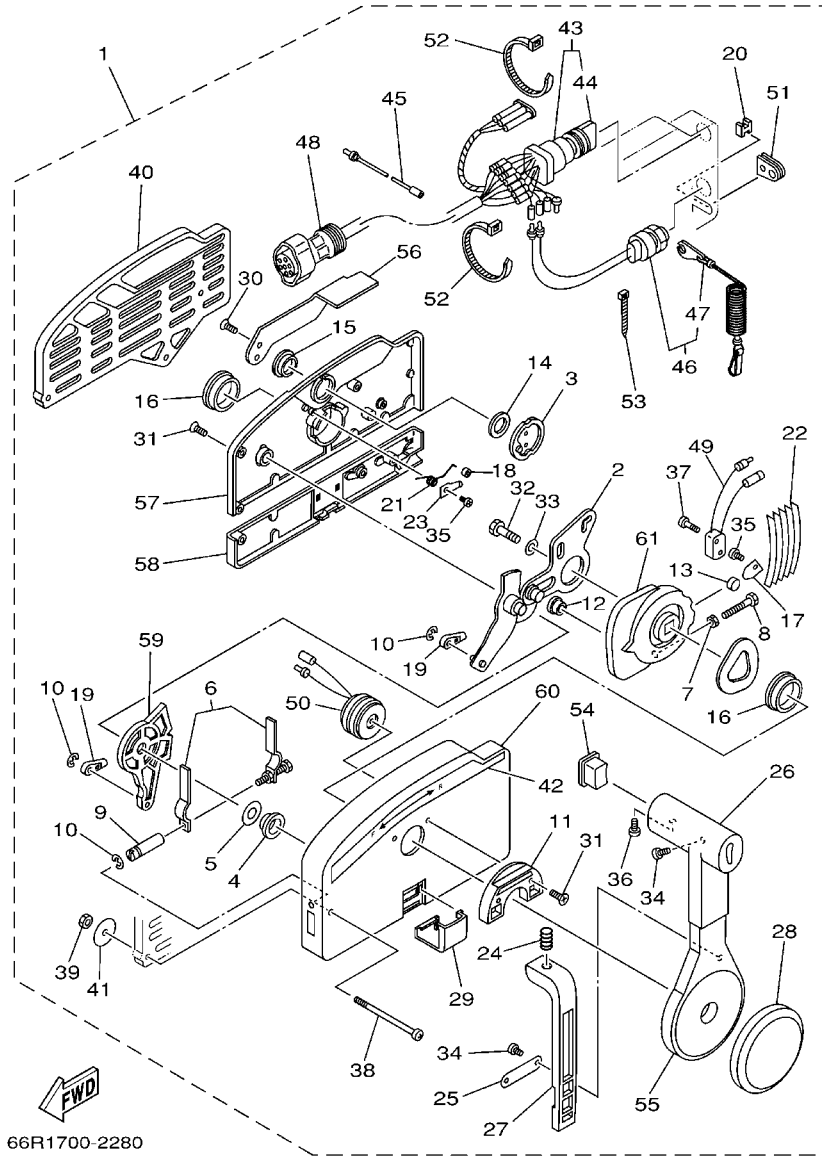

66R1700-2280

FIG. 24 REMOTE CONTROL ASSY CONTROLE REMOTO CONJ.

REF. NO.	PART NO. No. PEÇA	DESCRIPTION DESCRIÇÃO	67TA	67TC	67T9	67TB	REMARKS OBSERVAÇÕES
28	703-48225-00	.COVER .TAMPA			1	1	
29	703-48219-00	.COVER, LEAD .TAMPA DE MOLDURA			1	1	
30	703-48281-00	.SCREW .PARAFUSO 1			2	2	
31	703-48282-00	.SCREW .PARAFUSO 2			7	7	
32	97380-08030	.BOLT .PARAFUSO			1	1	
33	92990-08600	.WASHER, PLATE .ARRUELA PLANA			1	1	
34	98580-04010	.SCREW, PAN HEAD .PARAFUSO			3	3	
35	98580-04006	.SCREW, PAN HEAD .PARAFUSO			2	2	
36	98580-05010	.SCREW, PAN HEAD .PARAFUSO			1	1	
37	98580-03015	.SCREW, PAN HEAD .PARAFUSO			2	2	
38	703-48291-10	.SCREW (M6) .PARAFUSO			3	3	
39	95380-06600	.NUT, HEXAGON .PORCA SEXTAVADA			3	3	
40	703-48293-10	.SPACER, REMOTE CONTROL .ESPACADOR			1	1	SINGLE SINGLE
41	701-48287-00	.WASHER .ARRUELA			3	3	
42	703-48215-00	.GRAPHIC .GRAFICO 1			1	1	
43	703-82510-33	.MAIN SWITCH ASSY .INTERRUPTOR PRINCIPAL. CONJ.			1	1	
44	703-82577-00	..CAP, KEY ..CAPA DA CHAVE			1	1	
45	703-82531-00	.WIRE, LEAD (L70) .CHICOTE DE FIOS			1	1	
46	688-82575-01	.ENGINE STOP SWITCH ASSY .INTERRUPTOR DE PARADA CJ.			1	1	
47	682-82556-00	..LANYARD, STOP SWITCH ..AMORTIZADOR DO LIMITADOR			1	1	
48	688-82586-21	.EXTENSION, WIRE HARNESS (4.9M) .EXTENSAO DO CHICOTE DE FIOS			1	1	(7P) (7P)
49	703-82540-00	.NEUTRAL SWITCH ASSY .INTERRUPTOR NEUTRO CONJ.			1	1	
50	703-83383-02	.BUZZER .ALARME			1	1	
51	703-48284-00	.GROMMET .ILHO			1	1	
52	703-82591-00	.BAND .BRACADEIRA			1	1	
53	703-82592-00	.BAND .BRACADEIRA			1	1	
54	703-48224-00	.COVER, CONTROL LEVER .CAPA, ALAVANCA DE CONTROLE			1	1	WITHOUT PT/T SW. WITHOUT PT/T SW.

FIG. 24 REMOTE CONTROL ASSY

CONTROLE REMOTO CONJ.

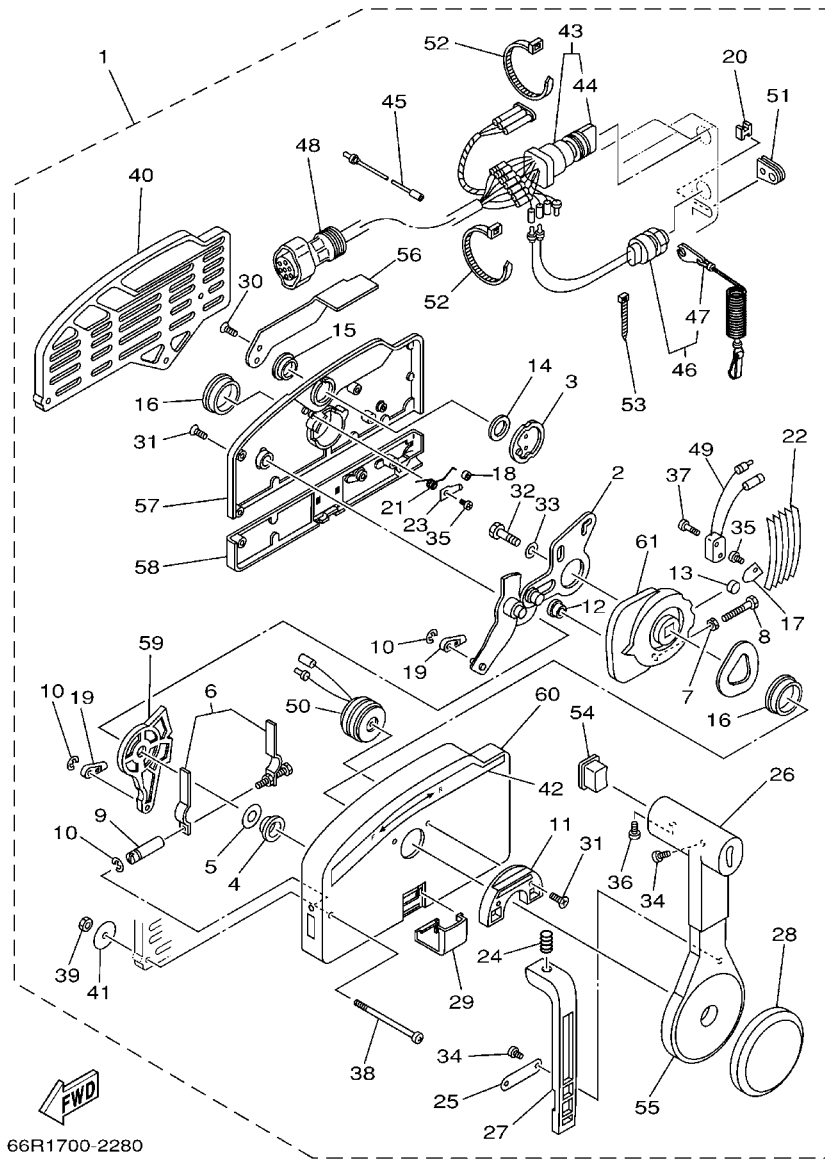

66R1700-2280

REF. NO.	PART NO. No. PEÇA	DESCRIPTION DESCRIÇÃO	67TA	67TC	67T9	67TB	REMARKS OBSERVAÇÕES
55	703-48221-00	.LEVER, CONTROL .ALAVANCA DO CONTROLE REMOTO			1	1	
56	703-48152-00	.KNOB, FREE ACCEL. .ALAVANCA DE ACELERACAO			1	1	
57	703-48212-00	.BACK PLATE 1 .TAMPA DO COMANDO 1			1	1	
58	703-48213-00	.BACK PLATE 2 .TAMPA DO COMANDO 2			1	1	
59	703-48271-00	.ARM, SHIFT .BRACO DO CAMBIO			1	1	
60	703-48211-01	.HOUSING,1 .CORPO DO COMANDO			1	1	
61	703-48232-00	.GEAR .ENGRENAGEM DO COMANDO			1	1	

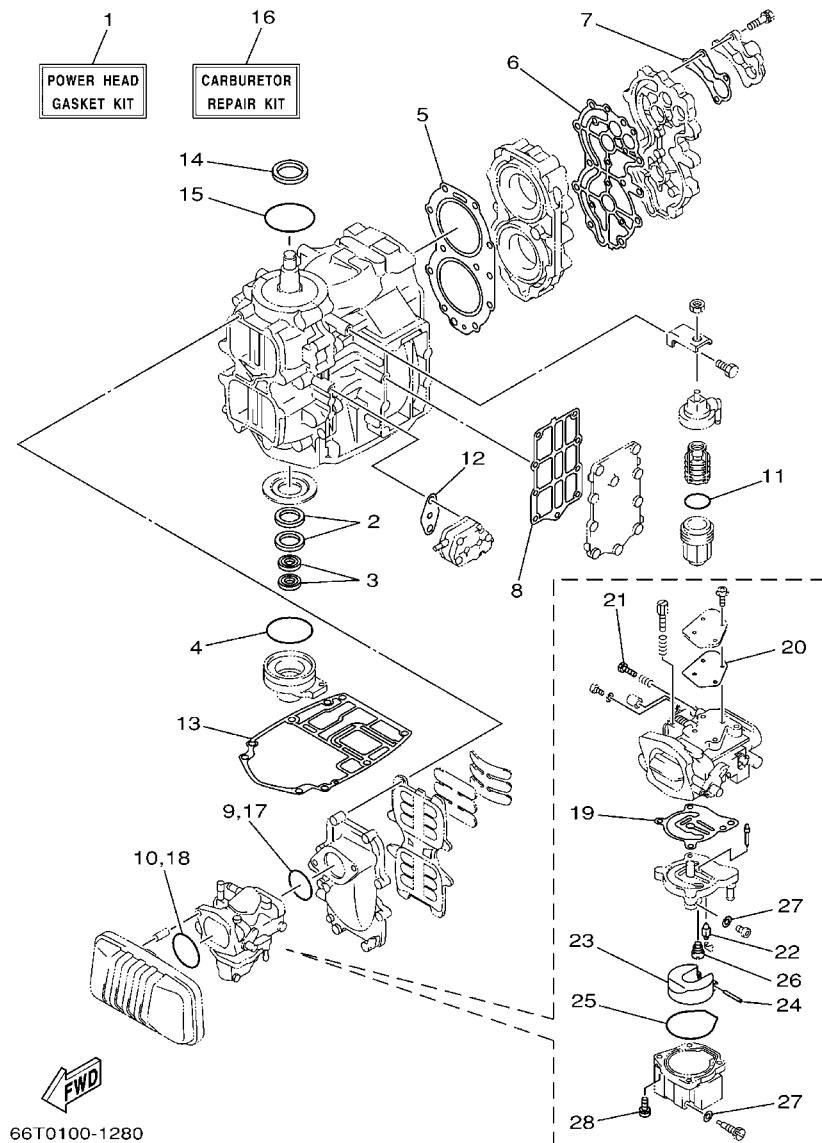

66T0100-1280

FIG. 25 REPAIR KIT 1

KIT DE REPARO 1

REF. NO.	PART NO. No. PEÇA	DESCRIPTION DESCRIÇÃO	67TA	67TC	67T9	67TB	REMARKS OBSERVAÇÕES
1	66T-W0001-01	POWER HEAD GASKET KIT JOGO DE GAXETAS	1	1	1	1	
2	93102-30M56	.OIL SEAL .RETENTOR DE OLEO	2	2	2	2	
3	93101-16001	.OIL SEAL .RETENTOR DE OLEO	2	2	2	2	
4	93210-65M50	.O-RING .ANEL DE BORRACHA	1	1	1	1	
5	66T-11181-A2	.GASKET, CYLINDER HEAD 1 .GAXETA CABECOTE DO CILINDRO 1	1	1	1	1	
6	66T-11193-A3	.GASKET, HEAD COVER 1 .GAXETA DA TAMPA DO CABECOTE 1	1	1	1	1	
7	676-12414-A1	.GASKET, COVER .GAXETA DA TAMPA	1	1	1	1	
8	66T-41114-A0	.GASKET, EXHAUST OUTER COVER .GAXETA TAMPA EXTERNA DO ESCAPE	1	1	1	1	
9	93210-46M16	.O-RING .ANEL DE BORRACHA	1	1	1	1	
10	93210-54M54	.O-RING .ANEL DE BORRACHA	1	1	1	1	
11	93210-32738	.O-RING .ANEL DE BORRACHA	1	1	1	1	
12	650-24431-A0	.GASKET, FUEL PUMP 1 .GAXETA BOMBA DE COMBUSTIVEL 1	1	1	1	1	
13	66T-45113-A0	.GASKET, UPPER CASING .GAXETA DA CAIXA SUPERIOR	1	1	1	1	
14	93102-35008	.OIL SEAL .RETENTOR DE OLEO	1	1	1	1	
15	93210-75M51	.O-RING .ANEL DE BORRACHA	1	1	1	1	
16	66T-W0093-01	CARBURETOR REPAIR KIT JOGO DE REPARO DO CARBURADOR	1	1	1	1	
17	93210-46M16	.O-RING .ANEL DE BORRACHA	1	1	1	1	
18	93210-54M54	.O-RING .ANEL DE BORRACHA	1	1	1	1	
19	66T-14384-01	.GASKET, FLOAT CHAMBER .GAXETA DA CAMARA DA BOIA	1	1	1	1	
20	66T-14536-01	.GASKET .GAXETA	1	1	1	1	
21	6E5-14323-03	.SCREW, AIR ADJUSTING .PARAFUSO DE AJUSTE DO AR	1	1	1	1	
22	6E5-14546-00	.VALVE, NEEDLE .VALVULA DA AGULHA	1	1	1	1	
23	6E5-14385-02	.FLOAT .BOIA	1	1	1	1	
24	6E5-14386-02	.PIN, FLOAT .PINO DA BOIA	1	1	1	1	
25	66T-14984-00	.GASKET, FLOAT CHAMBER .GAXETA DA CAMARA DA BOIA.	1	1	1	1	
26	66T-14992-00	.PLUG .HASTE	1	1	1	1	
27	66T-14959-00	.GASKET .GAXETA	2	2	2	2	

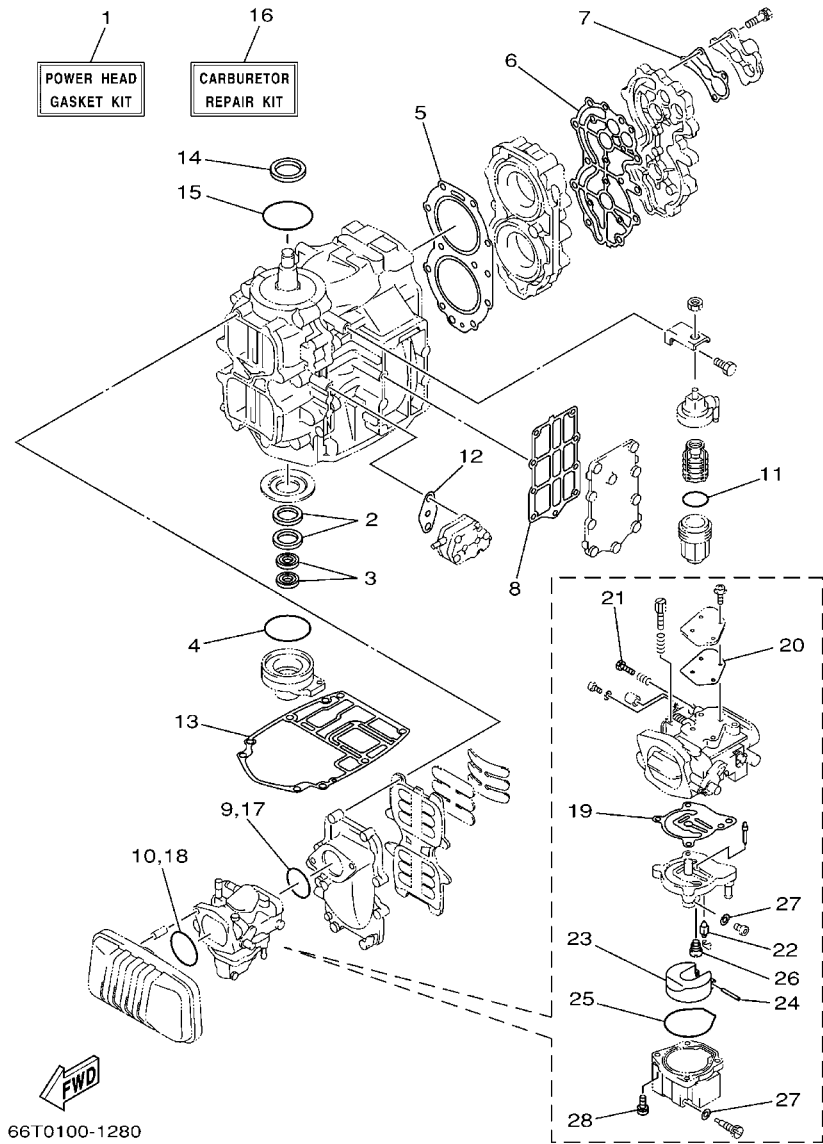

FIG. 25 REPAIR KIT 1

KIT DE REPARO 1

REF. NO.	PART NO. No. PEÇA	DESCRIPTION DESCRIÇÃO	67TA	67TC	67T9	67TB	REMARKS OBSERVAÇÕES
28	97980-05125	.SCREW, WITH WASHER .PARAFUSO	4	4	4	4	

FIG. 26 REPAIR KIT 2

KIT DE REPARO 2

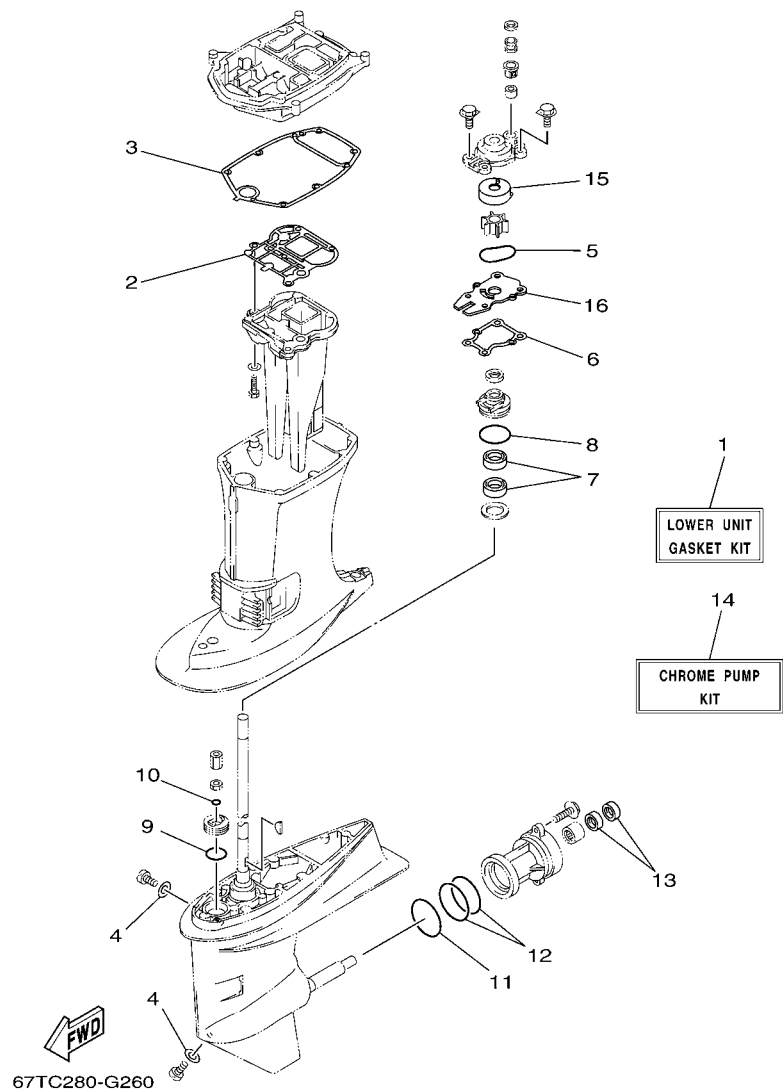

REF. NO.	PART NO. No. PEÇA	DESCRIPTION DESCRIÇÃO	67TA	67TC	67T9	67TB	REMARKS OBSERVAÇÕES
1	66T-W0001-20	LOWER UNIT GASKET KIT JOGO DE GAXETAS	1	1	1	1	
2	66T-41133-A0	.GASKET, EXHAUST MANIFOLD 1 .GAXETA DO MULTIPLO DE ESCAPE 1	1	1	1	1	
3	66T-45114-A0	.GASKET, UPPER CASING .GAXETA DA CAIXA SUPERIOR	1	1	1	1	
4	90430-08020	.GASKET .GAXETA	2	2	2	2	
5	93210-59MG7	.O-RING .ANEL DE BORRACHA	1	1	1	1	
6	63D-44316-00	.GASKET, WATER PUMP .GAXETA DA BOMBA D'AGUA	1	1	1	1	
7	93101-22M60	.OIL SEAL .RETENTOR DE OLEO	2	2	2	2	
8	93210-48MG8	.O-RING .ANEL DE BORRACHA	1	1	1	1	
9	93210-33MG4	.O-RING .ANEL DE BORRACHA	1	1	1	1	
10	93210-06ME6	.O-RING .ANEL DE BORRACHA	1	1	1	1	
11	93210-69MG6	.O-RING .ANEL DE BORRACHA	1	1	1	1	
12	93210-74MG5	.O-RING .ANEL DE BORRACHA	2	2	2	2	
13	93101-22M00	.OIL SEAL .RETENTOR DE OLEO	2	2	2	2	
14	66T-W0078-0A	CHROME PUMP KIT JOGO DE REPARO DA BOMBA D'AGUA	1	1	1	1	
15	63D-44322-40	.INSERT, CARTRIDGE .INSERTO DA BOMBA D'AGUA	1	1	1	1	
16	66T-44323-40	.OUTER PLATE, CARTRIDGE .PLACA DA EXTERNA DA BOMBA	1	1	1	1	

FIG. 27 REPAIR KIT 3

KIT DE REPARO 3

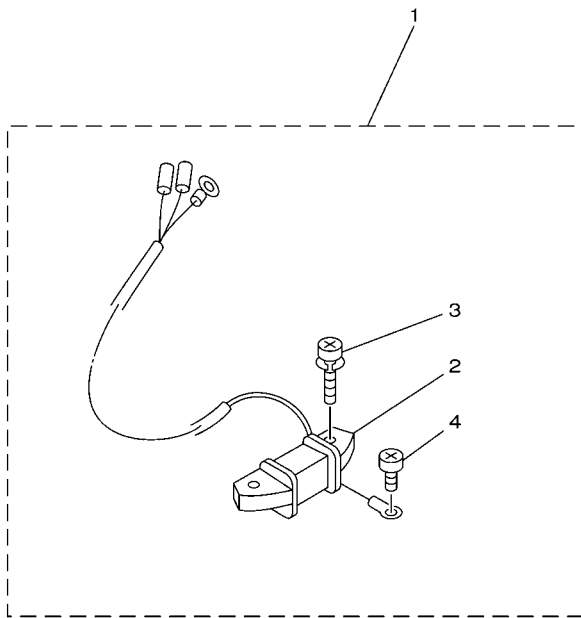

REF. NO.	PART NO. No. PEÇA	DESCRIPTION DESCRIÇÃO	67TA	67TC	67T9	67TB	REMARKS OBSERVAÇÕES
1	66T-81303-00	LIGHTING COIL ASSY BOBINA DE ILUMINACAO	1	1	1	1	AP AP
2	66T-85533-00	.COIL, LIGHTING .BOBINA DE LUZ	1	1	1	1	
3	97902-06125	.SCREW, WITH WASHER .PARAFUSO	2	2	2	2	
4	97802-04006	.SCREW, PAN HEAD .PARAFUSO	1	1	1	1	



66T0010-9270

NUMERICAL INDEX
ÍNDICE NUMÉRICO

PART NO. No. PEÇA	REF. NO.	PART NO. No. PEÇA	REF. NO.	PART NO. No. PEÇA	REF. NO.	PART NO. No. PEÇA	REF. NO.	PART NO. No. PEÇA	REF. NO.	PART NO. No. PEÇA	REF. NO.
66T-11111-01-1S	2 - 22	6E5-14385-02	25 - 23	66T-15771-00-94	7 - 36	661-41262-02	4 - 21	66T-43111-01-4D	16 - 1	6E5-44391-00	12 - 18
66T-11119-00	2 - 20	6E5-14386-02	5 - 19	66T-15772-00-94	7 - 39	6H4-41271-01	4 - 17	66T-43112-01-4D	16 - 6	66T-44514-00-4D	17 - 15
66T-11181-A2	2 - 23		25 - 24	6F5-15779-02	7 - 22	66T-41273-00	13 - 41	6J8-43113-01	16 - 23	66T-44526-00	17 - 16
	25 - 5	66T-14440-00	4 - 13	66T-15784-00	7 - 9	689-41273-00	4 - 18	648-43114-01	16 - 4	65W-44551-00-4D	17 - 19
66T-11191-00-1S	2 - 25	624-14485-00	2 - 5	6J8-41274-00	7 - 23	6J8-41274-00	4 - 19		16 - 9	65W-44555-10	17 - 20
66T-11193-A3	2 - 26	66T-14497-00	14 - 10	6F5-15791-00	7 - 17	66T-41611-00	8 - 11	663-43118-01-4D	16 - 3	66T-44575-00	17 - 21
	25 - 6	66T-14523-00	5 - 10	66T-15794-00	7 - 13	66T-41631-01	14 - 4		16 - 8	66T-45111-00-4D	18 - 8
676-11325-00	2 - 18	66T-14527-00	5 - 8	6YJ-24167-00	21 - 7	66T-41638-00	14 - 1	63D-43131-01	16 - 20	66T-45113-A0	18 - 13
676-11372-00	2 - 34	66T-14536-01	5 - 7	6YJ-24260-00	21 - 3	6F5-41662-00	14 - 17	66T-43144-00	12 - 14		25 - 13
650-11372-01	4 - 5		25 - 20	6Y1-24268-00	21 - 6	65W-42101-01-4D	13 - 14	6E5-43145-01	22 - 9	66T-45114-A0	18 - 12
66T-11400-01	3 - 1	6E5-14546-00	5 - 16	6G1-24304-02	6 - 1	664-42119-00	13 - 22	6G5-43145-01	16 - 25		26 - 3
66T-11412-00	3 - 2		25 - 22	6G1-24305-05	21 - 13	65W-42121-01-4D	13 - 40	65W-43191-00	16 - 12	63D-45155-00	18 - 9
66T-11422-00	3 - 3	66T-14578-00	5 - 2	6Y1-24305-06	21 - 15	66T-42123-00	13 - 7	65W-43192-00	16 - 11	63D-45214-00	19 - 7
66T-11432-00	3 - 4	66T-14584-00	5 - 3	61J-24306-04	21 - 8	65W-42125-00	13 - 19	65W-43311-00-4D	16 - 18	63D-45215-00	19 - 8
66T-11442-00	3 - 5	6J8-14592-01	5 - 4	66T-24329-00	12 - 22	6G1-42126-00	13 - 18	682-43318-01	16 - 35	676-45251-00	2 - 15
6F5-11515-00	3 - 9	61A-1492E-88	5 - 15	6Y1-24329-00	21 - 5	65W-42131-01	13 - 37	65W-43373-00	17 - 2	67C-45251-00	20 - 15
66T-11565-00	2 - 14	66T-1492F-37	5 - 20	650-24351-01	21 - 12	6G1-42137-10	13 - 23	65W-43613-00	16 - 44	66T-45300-01-4D	19 - 1
66T-11603-00	3 - 16	66T-14945-02	5 - 14	61J-24360-00	21 - 10	65W-42138-00	13 - 16	65W-43614-01	16 - 42	66T-45311-01-4D	19 - 2
66T-11604-00	3 - 16	66T-14959-00	5 - 25	692-24410-00	6 - 15	65W-42159-00	13 - 17	65W-43615-01	16 - 43	66T-45321-00	19 - 29
66T-11605-00	3 - 16		25 - 27	663-24411-00	6 - 20	66T-42167-00	14 - 2	65W-43616-00	16 - 41	688-45341-10	19 - 6
66T-11631-01-93	3 - 15	66T-14981-00	5 - 23	692-24411-00	6 - 17	6F6-42177-A0	13 - 21	66T-43627-00	16 - 26	66T-45344-01	19 - 21
6F5-11633-00	3 - 17	66T-14984-00	5 - 21	6A0-24412-02	6 - 26	65W-42511-00-4D	17 - 6	65W-43630-02	16 - 36	63D-45361-02-4D	19 - 44
663-11634-00	3 - 18		25 - 25	6A0-24413-00	6 - 16	648-42528-00	17 - 1	66T-43631-01	16 - 39	664-45371-01	20 - 8
66T-11635-01	3 - 15	66T-14991-00	5 - 24	6A0-24421-01	6 - 24	66T-42610-20-4D	1 - 1	66T-44111-02	13 - 2	63D-45375-00	20 - 7
66T-11636-01	3 - 15	66T-14992-00	5 - 22	650-24431-A0	6 - 27	66T-42613-01	1 - 2	682-44116-01	14 - 19	663-45376-00-94	20 - 6
6F5-11651-00	3 - 10		25 - 26		25 - 12	66T-42615-02	1 - 8	66T-44121-00	14 - 14	66T-45501-01	19 - 33
66T-11681-00	3 - 11	66T-15100-02-1S	2 - 2	648-24434-01	6 - 18	6E0-42651-02	1 - 4	66M-44122-00	14 - 15	6H4-45536-00	19 - 3
6E5-12411-02	2 - 28	66T-15396-01-94	2 - 8	648-24435-02	6 - 21	6F5-42652-01	1 - 6	66T-44124-00	13 - 10	66T-45551-00	19 - 36
6E5-12412-00	2 - 29	66T-15705-00	7 - 7	61N-24521-00	6 - 8	63D-42677-20	1 - 9	66T-44125-01	14 - 23	66T-45560-01	19 - 38
676-12413-00-1S	2 - 30	66T-15710-00	7 - 1	61N-24560-00	6 - 6	63D-42678-11	1 - 10		15 - 6	663-45567-01	19 - 40
676-12414-A1	2 - 31	66T-15711-00	7 - 2	61N-24563-00	6 - 7	63D-42681-10	1 - 12	66T-44143-00	14 - 21	663-45567-10	19 - 40
	25 - 7	66T-15713-00	7 - 5	648-24566-02	6 - 10	63D-42682-10	1 - 13	61N-44146-00	19 - 27	663-45567-20	19 - 40
6E5-13552-01	2 - 3	66T-15714-00	7 - 3	6YJ-24610-01	21 - 2	66T-42710-01-4D	12 - 1	66T-44150-01	19 - 26	663-45567-30	19 - 40
	2 - 4	66T-15716-00	7 - 6	66T-26301-00	13 - 29	66T-42716-00	12 - 5	6E0-44191-11	13 - 13	663-45567-40	19 - 40
	4 - 4	66T-15723-00	7 - 29	65W-26326-00	12 - 19	66T-42725-00	12 - 8	688-44194-00	14 - 9	663-45567-50	19 - 40
66T-13610-00	4 - 1	66T-15731-00	7 - 16	65W-26326-10	12 - 19	6G1-42725-00	9 - 21	66T-44311-00	19 - 12	663-45567-60	19 - 40
66T-13641-02-1S	4 - 3	66T-15734-00	7 - 14		15 - 10	66T-42725-20	12 - 8	63D-44312-00	20 - 19	66T-45571-00	19 - 41
6E5-14159-00	5 - 17	63V-15741-00	7 - 4	66T-41113-00-1S	2 - 33	66T-42725-30	15 - 9	63D-44316-00	19 - 16	63D-45577-00	19 - 43
6E5-14223-00	5 - 13	63V-15744-00	7 - 10	66T-41114-A0	2 - 35	65W-42726-00	12 - 23		26 - 6	63D-45577-10	19 - 43
66T-14301-22	5 - 1	6F5-15752-00	7 - 18		25 - 8	6H4-42726-00	12 - 21	63D-44322-40	19 - 13	63D-45577-20	19 - 43
66T-14301-32	5 - 1	6F5-15753-00	7 - 19	66T-41131-00-5B	18 - 4	65W-42726-10	12 - 23		26 - 15	63D-45577-30	19 - 43
6E5-14323-03	5 - 12	689-15755-01	7 - 21	66T-41133-A0	18 - 5		15 - 11	66T-44323-40	19 - 14	63D-45577-40	19 - 43
	25 - 21	66T-15758-01	7 - 24		26 - 2	676-42727-00	12 - 20		26 - 16	63D-45577-50	19 - 43
	6 - 25	66T-15762-01	7 - 28	66T-41137-00-5B	18 - 1	66T-42738-00-5B	12 - 6	63D-44341-00	19 - 19	63D-45577-60	19 - 43
6A0-14325-00	5 - 11	66T-15767-00	7 - 8	66T-41237-00	14 - 5	66T-42741-00	12 - 26	6H4-44352-02	19 - 18	663-45587-01	19 - 35
6J8-14334-00	5 - 11	63V-15768-00	7 - 11	66T-41252-00	4 - 22	664-42791-00	12 - 30	66T-44361-00	20 - 1	663-45587-10	19 - 35
66T-14384-01	25 - 19	6F5-15768-00	7 - 20	66T-41256-00	4 - 20	66T-42815-01-4D	12 - 9	663-44366-00	20 - 18	663-45587-20	19 - 35
6E5-14385-02	5 - 18	66T-15770-00	7 - 15	66T-41257-00	4 - 24	66T-42816-00	12 - 13	663-44367-00	20 - 4	663-45587-30	19 - 35

NUMERICAL INDEX
ÍNDICE NUMÉRICO

PART NO. No. PEÇA	REF. NO.	PART NO. No. PEÇA	REF. NO.	PART NO. No. PEÇA	REF. NO.	PART NO. No. PEÇA	REF. NO.	PART NO. No. PEÇA	REF. NO.	PART NO. No. PEÇA	REF. NO.
663-45587-40	19 - 35	703-48236-00	24 - 16	6G1-82151-00	10 - 9	676-W2810-01	6 - 32	90157-05014	16 - 40	90254-03M05	14 - 16
663-45587-50	19 - 35	703-48238-00	24 - 22	6A0-82317-00	9 - 2	90101-08002	2 - 21	90157-05M19	21 - 4	90266-04M01	1 - 7
663-45587-60	19 - 35	703-48243-00	24 - 15	66T-82370-00	9 - 16	90101-08M28	16 - 50	90159-06034	4 - 15	90266-04M04	1 - 5
66T-45611-00	19 - 56	703-48244-00	24 - 21	703-82510-33	24 - 43	90101-08M76	16 - 15	90170-06M30	10 - 2	90269-02M09	13 - 24
66T-45631-00	19 - 51	703-48245-00	24 - 11	66T-82519-00	9 - 20	90101-08M86	17 - 14	90170-09M03	22 - 5	90280-03M03	19 - 17
663-45633-00	19 - 54	703-48246-00	24 - 23	703-82531-00	24 - 45	90101-09M01	22 - 7	90170-12138	19 - 37	90280-05015	8 - 20
66T-45635-00	19 - 55	701-48248-00	24 - 13	703-82540-00	24 - 49	90101-10M58	16 - 53	90170-20137	8 - 21	90338-05M03	12 - 25
663-45930-00-98	20 - 25	703-48252-00	24 - 12	682-82556-00	13 - 43	90105-08M61	19 - 50	90171-16011	20 - 23	90338-07M00	12 - 24
63D-45941-00-EL	20 - 25	703-48261-01	24 - 2		24 - 47	90105-08M76	17 - 3	90179-10M33	17 - 24	90340-08002	19 - 4
663-45941-01-EL	20 - 25	703-48264-00	24 - 6	688-82560-10	9 - 19	90109-06M80	9 - 7	90185-08045	17 - 12	90385-12M04	7 - 34
69W-45943-00-EL	20 - 25	703-48265-00	24 - 9	66T-82575-01	13 - 42		10 - 13	90185-08057	16 - 32	90386-08032	13 - 28
69W-45945-00-EL	20 - 25	703-48268-00	24 - 5	688-82575-01	24 - 46		12 - 29		16 - 52	90386-10M99	16 - 37
69W-45947-00-EL	20 - 25	703-48271-00	24 - 59	703-82577-00	24 - 44		14 - 20	90185-09M01	22 - 4	90386-12M37	12 - 10
663-45949-01-EL	20 - 25	703-48281-00	24 - 30	689-8257Y-00	13 - 44	90109-06M81	9 - 6	90185-10051	17 - 4	90386-12M98	16 - 27
69W-45952-00-EL	20 - 25	703-48282-00	24 - 31	688-82586-21	24 - 48		9 - 9	90185-22043	16 - 24	90386-12MA2	12 - 11
663-45952-02-EL	20 - 25	703-48284-00	24 - 51	66T-82590-00	10 - 14		9 - 13	90201-08M07	16 - 31	90386-22M15	16 - 21
663-45954-01-EL	20 - 25	701-48287-00	24 - 41	703-82591-00	24 - 52		12 - 7	90201-08M54	14 - 11	90386-40M99	13 - 36
663-45956-01-EL	20 - 25	703-48291-10	24 - 38	703-82592-00	24 - 53		14 - 18	90201-10120	15 - 8	90386-40MA0	13 - 32
69W-45958-00-EL	20 - 25	703-48293-10	24 - 40	703-83383-02	24 - 50	90109-06M86	10 - 27		17 - 28	90386-44M03	17 - 9
663-45958-01-EL	20 - 25	701-48320-20	23 - 2	66T-83557-00	10 - 15		12 - 15	90201-10M02	13 - 26	90386-44M99	17 - 11
663-45970-60-98	20 - 25	663-48344-00	14 - 25	6A1-83625-41	7 - 43		13 - 15	90201-10M20	22 - 3	90386-52M02	17 - 8
663-45972-60-98	20 - 25		15 - 2	6E0-83627-41	13 - 45	90109-08M90	16 - 30	90201-10M63	22 - 8	90387-06035	12 - 4
663-45974-60-98	20 - 25	703-48345-01	24 - 19	66T-85515-00	8 - 8	90116-10M28	17 - 5	90201-12426	16 - 55	90387-06119	9 - 3
663-45976-00-98	20 - 25	703-48358-00	24 - 20	66T-85520-00	8 - 10	90119-06M61	12 - 2	90201-12M07	13 - 5	90387-06M60	10 - 23
663-45978-00-98	20 - 25	66T-48501-01	15 - 1	66T-85533-00	8 - 14	90119-06M65	9 - 4	90201-20417	3 - 20	90387-06M66	7 - 27
663-45987-02	20 - 20	65W-48511-00	15 - 7		27 - 2	90119-06M73	12 - 17	90201-21M18	8 - 22	90387-06M80	4 - 16
66T-45997-00	20 - 21		17 - 27	66T-85540-01	9 - 5	90119-06M88	10 - 25	90201-22429	19 - 42	90387-06M86	13 - 3
703-48152-00	24 - 56	6H3-48538-00	14 - 27	66T-8554B-01-94	9 - 1	90119-06MA3	2 - 27	90201-22M03	16 - 22	90387-07M29	16 - 46
703-48153-00	24 - 3		15 - 4	66T-85550-00	8 - 1		2 - 36	90201-27M00	19 - 23	90387-08M05	7 - 35
703-48189-00	24 - 17	65W-61350-00	22 - 1	66T-85560-01	8 - 2	90119-06MA5	2 - 32	90201-43M00	13 - 33	90387-08M16	14 - 3
703-48198-00	24 - 14	65W-61351-00	22 - 2	66T-85561-00	8 - 3	90119-08M03	4 - 12	90202-12031	16 - 28	90387-08M29	16 - 14
703-48203-15	23 - 1	66T-81303-00	27 - 1	66T-85570-00	9 - 10	90119-08M10	7 - 32	90202-12060	20 - 2	90387-10M42	22 - 6
	24 - 1	66T-81328-00	8 - 13	66T-85580-00	8 - 5	90119-08M15	19 - 25	90202-43M57	13 - 35	90389-22M01	20 - 22
703-48211-01	24 - 60	66T-81800-02	11 - 1	66T-85582-00	8 - 7	90119-08M39	11 - 8	90204-06M00	10 - 3	90430-08020	19 - 5
703-48212-00	24 - 57	66T-81820-00	11 - 5	66T-85596-00	8 - 6	90119-08M42	18 - 15	90206-12052	12 - 12		26 - 4
703-48213-00	24 - 58	66T-81826-00	11 - 7	6J4-86111-00	10 - 16	90119-08M44	20 - 5		13 - 6	90430-12072	20 - 3
703-48215-00	24 - 42	66T-81830-00	11 - 4	66T-86112-00	10 - 18	90119-08M51	7 - 33	90206-12M00	16 - 29	90445-07M08	2 - 38
703-48219-00	24 - 29	66T-81840-00	11 - 6	6J4-86116-00	10 - 17	90119-08M52	11 - 9	90206-43M22	13 - 34	90445-07M24	4 - 8
703-48221-00	24 - 55	66T-81850-01	11 - 3	682-86117-00	10 - 21	90119-08M79	18 - 2	90209-27012	3 - 12	90445-07MA4	4 - 9
703-48222-00	24 - 26	66T-81857-00	11 - 2	61J-F4201-00	21 - 1		18 - 11	90209-52M00	17 - 7	90445-09086	6 - 13
703-48223-00	24 - 27	66T-81916-01	9 - 8	66T-W0001-01	25 - 1	90119-08MA5	2 - 24	90243-04007	16 - 5		6 - 30
703-48224-00	24 - 54	6L2-81945-00	10 - 5	66T-W0001-20	26 - 1	90119-10005	2 - 7		16 - 10	90445-09M08	6 - 4
703-48225-00	24 - 28	6G1-8194A-10	10 - 1	66T-W0004-00	4 - 2	90119-10M04	17 - 23	90249-07M32	16 - 45	90445-09M75	2 - 37
703-48226-00	24 - 25	6G1-81952-00	10 - 4	63D-W0070-10	1 - 11	90141-06M00	2 - 19	90249-07M33	16 - 47	90445-11M05	21 - 11
703-48227-00	24 - 24	6G1-81970-61	10 - 8	66T-W0078-0A	26 - 14	90142-05M06	19 - 9	90249-12M34	16 - 33	90445-11M06	21 - 9
703-48232-00	24 - 61	66T-82105-00	10 - 7	66T-W0084-02-4D	13 - 1	90149-05M13	13 - 25	90250-06023	19 - 53	90446-03MA3	9 - 12
703-48234-00	24 - 18	6E5-82117-01	10 - 6	66T-W0090-02-1S	2 - 1	90149-14M12	16 - 2	90254-03M04	14 - 24	90446-10M86	13 - 31
703-48235-00	24 - 4	66T-82127-10	17 - 25	66T-W0093-01	25 - 16		16 - 7		15 - 5	90446-10M87	13 - 30

NUMERICAL INDEX
ÍNDICE NUMÉRICO

PART NO. No. PEÇA	REF. NO.	PART NO. No. PEÇA	REF. NO.	PART NO. No. PEÇA	REF. NO.	PART NO. No. PEÇA	REF. NO.	PART NO. No. PEÇA	REF. NO.	PART NO. No. PEÇA	REF. NO.
90464-12M00	8 - 27	92995-06600	9 - 15	93210-74MG5	26 - 12	97095-06020	2 - 12				
90464-13249	7 - 42		9 - 18	93210-75M51	8 - 17		2 - 16				
90465-15M74	8 - 23		12 - 28		25 - 15	97095-06025	9 - 14				
90465-20M31	10 - 26	92995-08100	17 - 18	93306-001U1	19 - 45	97095-06030	6 - 2				
90465-25M57	12 - 24		20 - 10	93306-306V5	3 - 8	97095-06035	7 - 25				
90467-06016	4 - 10		20 - 17	93306-307U0	3 - 6	97095-06040	6 - 28				
90467-08004	6 - 5	92995-08200	17 - 13	93310-727U0	3 - 13		8 - 18				
	6 - 14	92995-08600	11 - 11	93315-32224	19 - 11	97095-08016	11 - 10				
	6 - 31		18 - 7	93317-22204	19 - 48	97095-08025	20 - 9				
90468-18008	13 - 12	92995-10100	20 - 13	93332-00001	19 - 34	97095-08035	20 - 16				
	14 - 26	92995-10600	16 - 54	93332-00003	19 - 39	97095-08045	14 - 12				
	15 - 3		20 - 14	93332-000UE	3 - 7	97380-05025	24 - 8				
90480-09M21	12 - 3	93101-16001	2 - 10	93430-06024	24 - 10	97380-08030	24 - 32				
90480-10155	10 - 19		25 - 3	93430-10M00	16 - 34	97575-08545	18 - 10				
90480-10M23	10 - 22	93101-22M00	19 - 49	93440-68M03	3 - 14	97575-10570	17 - 22				
90480-10M71	8 - 26		26 - 13	93603-21111	3 - 19	97595-06550	13 - 4				
90480-25161	9 - 11	93101-22M60	19 - 20	93604-08062	19 - 24	97780-50616	1 - 3				
90501-10M84	14 - 6		26 - 7	93606-12019	18 - 3	97802-04006	8 - 16				
90501-15M01	19 - 52	93102-30M56	2 - 9		18 - 14		27 - 4				
90501-23215	13 - 27		25 - 2		20 - 11	97880-05008	10 - 20				
90502-10M06	16 - 51	93102-35008	8 - 4	93608-12063	2 - 6	97880-05030	10 - 10				
90506-16M34	12 - 16		25 - 14	93700-06M03	16 - 19	97880-06035	14 - 7				
90506-30M00	16 - 48	93210-03261	10 - 24	94702-00040	2 - 39	97885-06008	17 - 26				
91490-16012	14 - 22	93210-06ME6	19 - 31	95380-03600	6 - 19	97902-04108	8 - 9				
91490-20010	13 - 20		26 - 10	95380-05600	10 - 12	97902-06125	8 - 15				
91490-20012	16 - 49	93210-08287	21 - 14		19 - 10		27 - 3				
91490-30025	20 - 24		21 - 16		24 - 7	97980-04112	5 - 9				
91690-30018	16 - 13	93210-16275	22 - 10	95380-06600	24 - 39	97980-05125	5 - 26				
91690-40032	4 - 23	93210-32738	6 - 9	95380-06700	14 - 8		25 - 28				
92903-06600	4 - 7		25 - 11		19 - 28	98503-05028	6 - 22				
	7 - 38	93210-33MG4	19 - 30	95380-08600	6 - 11	98580-03015	24 - 37				
	7 - 41		26 - 9		16 - 16	98580-04006	24 - 35				
92990-05100	6 - 23	93210-43MJ0	17 - 10	95380-10600	17 - 10	98580-04010	24 - 34				
92990-05600	5 - 5	93210-46M16	4 - 11	95380-10700	13 - 38	98580-05010	24 - 36				
	10 - 11		25 - 9	95780-06300	13 - 8	99080-08600	16 - 38				
92990-06200	13 - 11		25 - 17	95780-10300	13 - 39	9E471-04305	8 - 12				
92990-06600	19 - 32	93210-48MG8	19 - 22	97013-06014	6 - 12						
92990-08100	16 - 17		26 - 8	97013-06030	7 - 37						
92990-08600	24 - 33	93210-54M54	4 - 14		7 - 40						
92995-06200	13 - 9		25 - 10	97013-06035	4 - 6						
92995-06600	2 - 13		25 - 18	97075-08030	17 - 17						
	2 - 17	93210-59MG7	19 - 15		18 - 6						
	6 - 3		26 - 5	97075-10040	20 - 12						
	6 - 29	93210-65M50	2 - 11	97095-06010	7 - 30						
	7 - 26		25 - 4	97095-06012	9 - 17						
	7 - 31	93210-69MG6	19 - 46	97095-06014	14 - 13						
	8 - 19		26 - 11	97095-06016	8 - 24						
	8 - 25	93210-74MG5	19 - 47		12 - 27						