

**PARTS
CATALOGUE
CATALOGO
DE REPUESTOS**

60FET '02 (6H24)

60FED '02 (6H25)

70BETO '02 (6H31)

FOREWORD

This Parts Catalogue is related to the parts for the model(s) in the below frame. When you are ordering replacement parts, please refer to this Parts Catalogue and quote both part numbers and part names correctly.

60FET'02(6H24), 60FED'02(6H25), 70BETO'02(6H31)

1. Modifications or additions which have been made after issue of the Parts Catalogue will be announced in the Yamaha Parts News.
It is advisable that you make necessary corrections to the Parts Catalogue according to the Yamaha Parts News.

2. Abbreviations

The Following abbreviations are used in this Parts Catalogue.

“UR” Use specified parts number.

“UN” Use as many as needed.

“AP” Alternate Parts

“LM” Local Made

(Parts need to be ordered locally)

“O/S” Over Size

3. Parts, which are to be supplied in an assembly, are listed with a dot(.) in front of the part name as shown below.

EXAMPLE

CARBURETOR ASSY

.JET, PILOT

.NOZZLE, MAIN

4. Number of component for assembly

The numeral appearing to the right of each component part indicates the quantity of parts for each assembly unit.

EXAMPLE

PART NO.	DESCRIPTION	□	▣	▤	▥	REMARKS
6E0-85500-70	C.D.I. MAGNETO ASSY	1				
6E0-85550-70	.ROTOR ASSY	1				
6E0-15723-00-94.	.PULLY, STARTER	1				

5. Quantity Column Information

NAME for Q'TY COLUMN	APPLICABLE MODEL
ED	60FED
ET	60FET
ETO	70BETO

6. Applicable Starting Serial No. and Color Code

1) Engine Starting Sserial No.

60FET	6H2 S : 050482	70BETO	6H3 L : 498526
	6H2 L : 364227		
60FED	6H2 S : 001118		
	6H2 L : 306169		

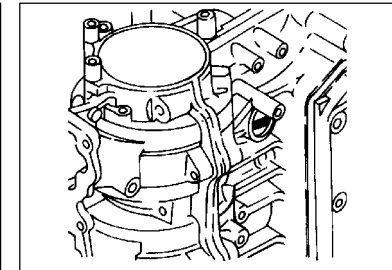
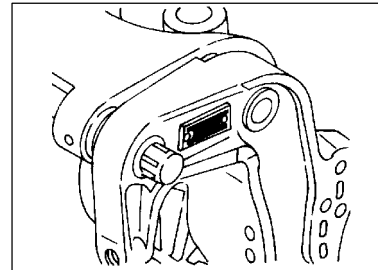

2) Color Code

Color Code	Color Name	Abbreviation
004D	DARK BLUISH GRAY METALLIC 2	DBNM2

7. Note that the illustrations for reference in finding parts numbers, not to be used for assembling. When assembling, please use the applicable service manual.

8. The asterisk (*) before a reference number indicates modification items after the first edition.

CONTENTS

SHEET 1/2

TOP COWLING 1	A4
TOP COWLING 2	A5
CYLINDER. CRANKCASE	A7
CRANKSHAFT. PISTON	B2
INTAKE	B3
CARBURETOR	B4
OIL PUMP	B7
FUEL	C3
GENERATOR	C5
ELECTRICAL	C6
STARTING MOTOR	D1
BOTTOM COWLING	D2
CONTROL	D4
BRACKET 1	D6
BRACKET 2	E2
BRACKET 3	E5
BRACKET 4	E6
POWER TRIM & TILT ASSY 1	F1
POWER TRIM & TILT ASSY 2	F4
UPPER CASING	F7

INDEX

NUMERICAL INDEX	G1
-----------------------	----

SHEET 2/2

LOWER CASING. DRIVE 1	A4*
LOWER CASING. DRIVE 2	B1*
FUEL TANK	B3*
STEERING GUIDE	B4*
REMOTE CONTROL BOX	B5*
REMOTE CONTROL ASSY	B6*
METER 1	C2*
METER 2	C3*
REPAIR KIT 1	C4*
REPAIR KIT 2	C6*

INDEX

NUMERICAL INDEX	G1*
-----------------------	-----

FIG. 1 TOP COWLING 1

SOPORTE SUPERIOR 1

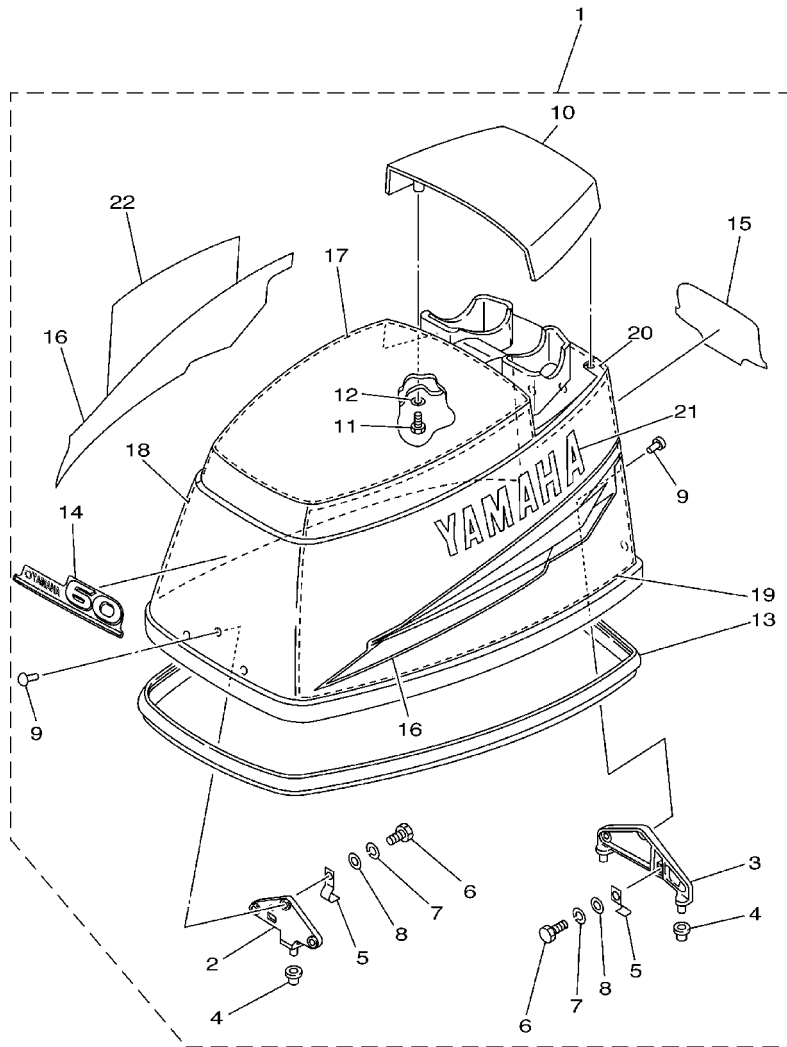

REF. NO.	PART NO. CODIGO NO.	DESCRIPTION DESCRIPTION	ED	ET	ETO	REMARKS OBSERVACION
1	6H2-42610-50-4D	TOP COWLING ASSY SOPORTE SUPERIOR COMPL.	1	1		60F
2	6H3-42647-00-94	.HOLDER, CLAMP BAND .MORDAZA DE ABRAZADERA	1	1		
3	6H3-42649-00-94	.HOLDER, CLAMP BAND .MORDAZA DE ABRAZADERA	1	1		
4	663-42662-00	.DAMPER .AMORTIGUADOR	3	3		
5	6H3-42652-00	.HOOK .GANCHO	2	2		
6	97095-06016	.BOLT .PERNO	2	2		
7	92995-06100	.WASHER, SPRING .ARANDELA	2	2		
8	92995-06600	.WASHER .ARANDELA	2	2		
9	90266-06009	.RIVET .REMACHE	6	6		
10	6H3-42613-01-4D	.MOLDING, AIR DUCT .MOLDURA CONDUCTO AIRE	1	1		
11	97095-06016	.BOLT .PERNO	4	4		
12	92995-06600	.WASHER .ARANDELA	4	4		
13	6H3-42615-00	.SEAL .SELLO	1	1		
14	6H2-42677-50	.GRAPHIC, FRONT .CALCAMONIA FRONTAL	1	1		
15	6H2-42678-30	.GRAPHIC, REAR .CALCAMONIA TRASERA	1	1		
16	6H3-W0070-30	.GRAPHIC SET .JUEGO DE EMBLEMA	1	1		
17	6H3-42617-00	.DAMPER, FORM .HULE DE FORMA	1	1		
18	6H3-42619-00	.DAMPER, FORM .HULE DE FORMA	1	1		
19	6H3-42627-00	.DAMPER, FORM .AMORTIGUADOR FORMA 3	1	1		
20	6H3-42637-00	.DAMPER, FORM .HULE DE FORMA	1	1		
21	6H3-42681-30	.MARK, COWLING .MARCA DE CUBIERTA	1	1		
22	6H3-42682-30	.MARK, COWLING .MARCA DE CUBIERTA	1	1		



6H24200-2010

FIG. 2 TOP COWLING 2

SOPORTE SUPERIOR 2

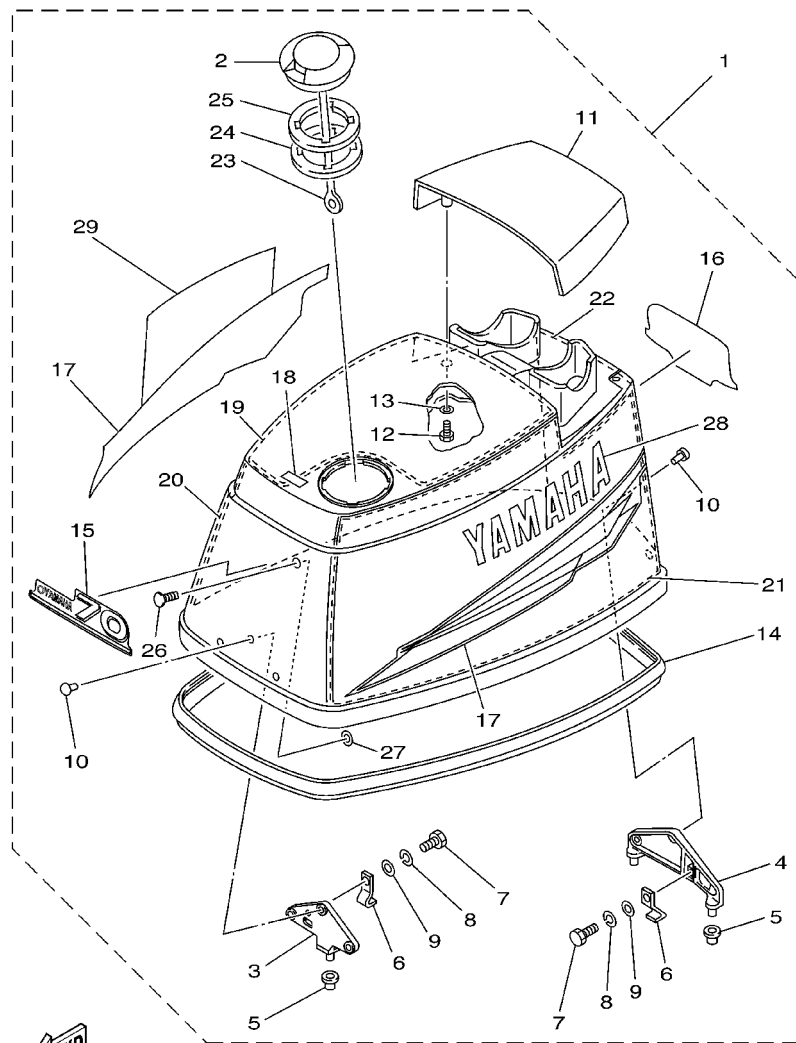

6H23300-2010

REF. NO.	PART NO. CODIGO NO.	DESCRIPTION DESCRIPTION	ED	ET	EIO	REMARKS OBSERVACION
1	6H3-42610-50-4D	TOP COWLING ASSY SOPORTE SUPERIOR COMPL.			1	70B
2	63D-2177H-00	.DISK CAP 2 .TAPA DE DISCO 2			1	
3	6H3-42647-00-94	.HOLDER, CLAMP BAND .MORDAZA DE ABRAZADERA			1	
4	6H3-42649-00-94	.HOLDER, CLAMP BAND .MORDAZA DE ABRAZADERA			1	
5	663-42662-00	.DAMPER AMORTIGUADOR			3	
6	6H3-42652-00	.HOOK .GANCHO			2	
7	97095-06016	.BOLT .PERNO			2	
8	92995-06100	.WASHER, SPRING .ARANDELA			2	
9	92995-06600	.WASHER .ARANDELA			2	
10	90266-06009	.RIVET .REMACHE			6	
11	6H3-42613-01-4D	.MOLDING, AIR DUCT .MOLDURA CONDUCTO AIRE			1	
12	97095-06016	.BOLT .PERNO			4	
13	92995-06600	.WASHER .ARANDELA			4	
14	6H3-42615-00	.SEAL .SELLO			1	
15	6H3-42677-50	.GRAPHIC, FRONT CALCAMONIA FRONTAL			1	
16	6H3-42678-30	.GRAPHIC, REAR .CALCAMONIA TRASERA			1	
17	6H3-W0070-30	.GRAPHIC SET JUEGO DE EMBLEMA			1	
18	6H3-13436-00	.MARK MARCA			1	
19	6H3-42617-10	.DAMPER, FORM HULE DE FORMA			1	
20	6H3-42619-00	.DAMPER, FORM HULE DE FORMA			1	
21	6H3-42627-00	.DAMPER, FORM AMORTIGUADOR FORMA 3			1	
22	6H3-42637-00	.DAMPER, FORM HULE DE FORMA			1	
23	6H1-42694-00	.BAND ABRAZADERA			1	
24	6H3-21732-00	.SEAL 1 .SELLO 1			1	
25	6H3-21735-00	.SEAL 2 .SELLO 2			1	
26	90338-05M03	.PLUG TAPON			1	
27	90183-05M06	.NUT, SPRING .TUERCA DE RESORTE			1	

FIG. 2 TOP COWLING 2

SOPORTE SUPERIOR 2

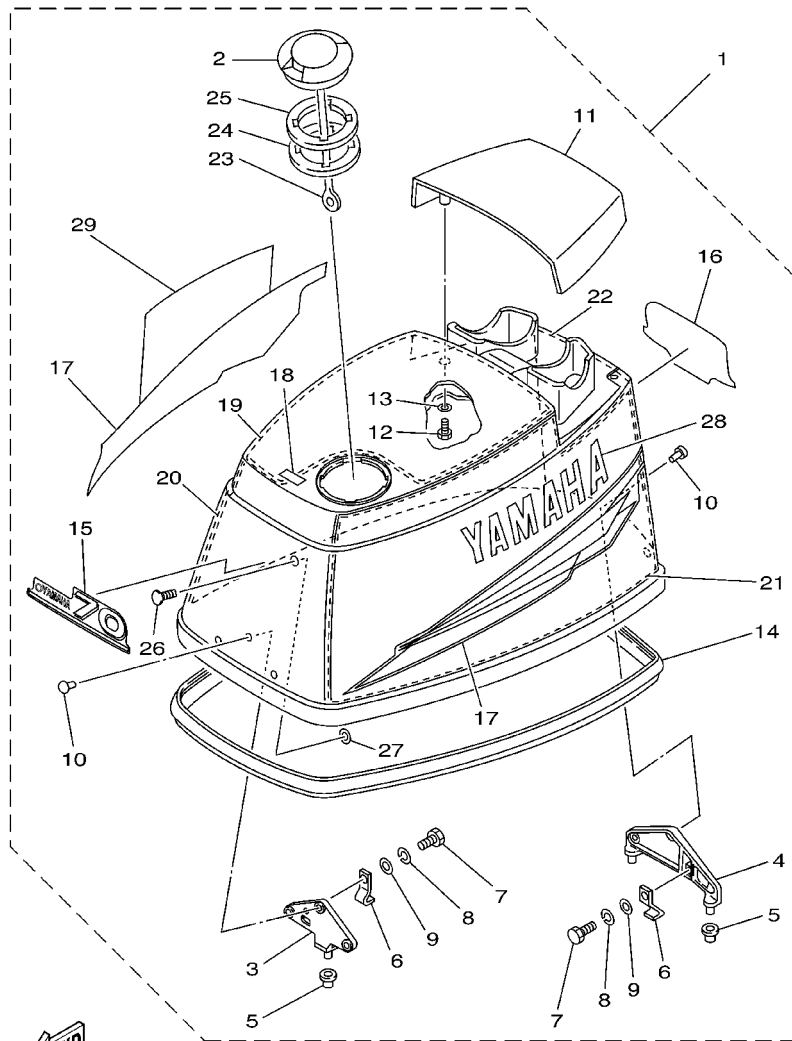

6H23300-2010

REF. NO.	PART NO. CODIGO NO.	DESCRIPTION DESCRIPTION	ED	ET	ETO	REMARKS OBSERVACION
28	6H3-42681-30	.MARK, COWLING .MARCA DE CUBIERTA			1	
29	6H3-42682-30	.MARK, COWLING .MARCA DE CUBIERTA			1	

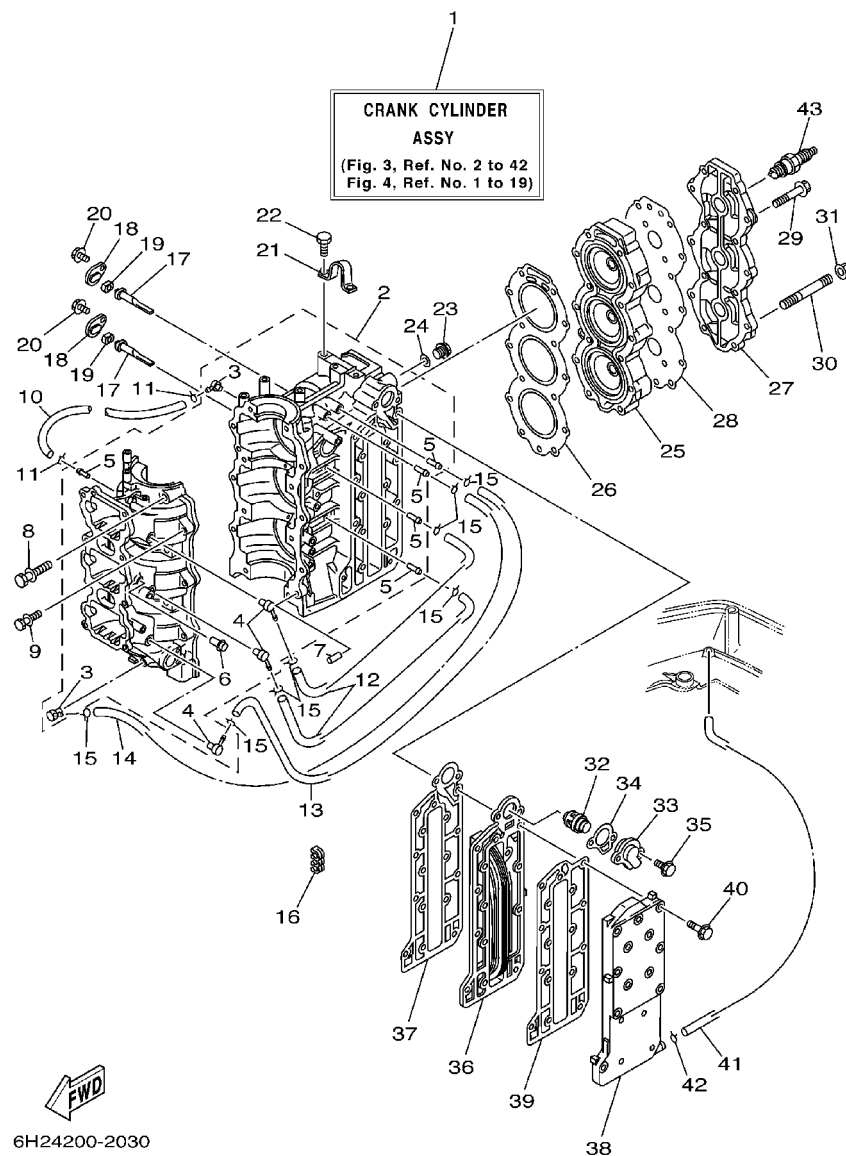

6H24200-2030

FIG. 3 CYLINDER. CRANKCASE CYLINDRO. CARTER

REF. NO.	PART NO. CODIGO NO.	DESCRIPTION DESCRIPTION	ED	ET	EIO	REMARKS OBSERVACION
1	6H3-W0090-43-1S	CRANK CYLINDER ASSY BLOQUE MOTOR COMPLETO			1	70B
	6H3-W0090-08-1S	CRANK CYLINDER ASSY BLOQUE MOTOR COMPLETO	1	1		60F-N.O/I, A/CHOKE
2	6H3-15100-14-1S	CRANKCASE ASSY CARTER COMPLETO			1	70B
	6H3-15100-06-1S	CRANKCASE ASSY CARTER COMPLETO	1	1		60F-N.O/I, A/CHOKE
3	688-11370-00	.CHECK VALVE ASSY .VALVULA DE CONTROL COMPL.	2	2	2	
4	650-11370-00	.CHECK VALVE ASSY .VALVULA DE CONTROL COMPL.	3	3	3	
5	624-14485-00	.PIPE, JOINT .TUBO DE UNION	5	5	5	
6	650-24378-00	.PIPE, JOINT 4 .TUBO DE UNION 4	1	1	1	
7	93608-12063	PIN, DOWEL PASADOR DE CLAVIJA	2	2	2	
8	90119-10005	BOLT, WITH WASHER TORNILLO CON ARANDELA	8	8	8	
9	90119-08M64	BOLT, WITH WASHER TORNILLO CON ARANDELA	6	6	6	
10	90445-07M44	HOSE (L250) TUBO (L250)	1	1	1	
11	90467-06016	CLIP PRESILLA	2	2	2	
12	90445-07M02	HOSE (L167) TUBO (L167)	2	2	2	
13	90445-07M45	HOSE (L340) TUBO (L340)	1	1	1	
14	90445-07M82	HOSE (L440) TUBO (L440)	1	1	1	
15	90467-06016	CLIP PRESILLA	8	8	8	
16	90464-07M05	CLAMP BRIDA	1	1	1	
17	6H3-11325-01	ANODE ANODO	2	2	2	
18	6H3-11327-00-1S	COVER, ANODE CUBIERTA	2	2	2	
19	6H3-11328-00	GROMMET, ANODE TAPON	2	2	2	
20	90119-06023	BOLT, WITH WASHER TORNILLO CON ARANDELA	2	2	2	
21	688-11119-01	HANGER, ENGINE SOPORTE DEL MOTOR	1	1	1	
22	90101-08002	BOLT TORNILLO	2	2	2	
23	90340-14M00	PLUG, STRAIGHT SCREW TORNILLO, DE DRENAJE	1	1	1	
24	90430-14115	GASKET JUNTA	1	1	1	
25	6H3-11111-01-1S	HEAD, CYLINDER 1 CULATA CILINDRO 1	1	1	1	

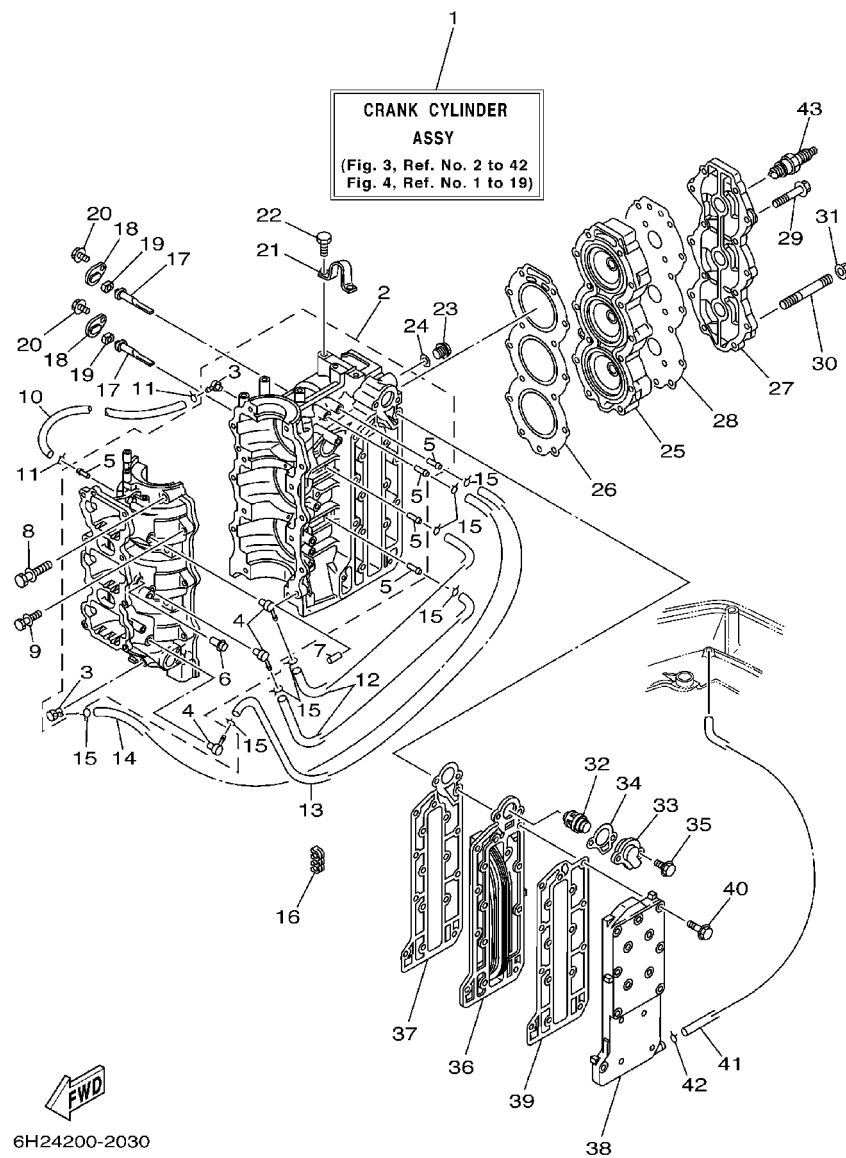

6H24200-2030

FIG. 3 CYLINDER. CRANKCASE CYLINDRO. CARTER

REF. NO.	PART NO. CODIGO NO.	DESCRIPTION DESCRIPTION	ED	ET	EIO	REMARKS OBSERVACION
26	6H3-11181-A1	GASKET, CYLINDER HEAD 1 JUNTA, DE CULATA 1	1	1	1	
27	6H3-11191-00-1S	COVER, CYLINDER HEAD 1 TAPA CULATA DE CILINDRO 1	1	1	1	
28	6H3-11193-A1	GASKET, HEAD COVER 1 EMPAQUE	1	1	1	
29	90119-08MA5	BOLT, WITH WASHER TORNILLO CON ARANDELA	13	13	13	
30	90116-08M69	BOLT, STUD ESPARRAGO	1	1	1	
31	90179-08M34	NUT TUERCA	1	1	1	
32	6H3-12411-10	THERMOSTAT TERMOSTAT	1	1	1	
33	6H3-12413-00-1S	COVER, THERMOSTAT CUBIERTA TERMOSTATO	1	1	1	
34	6H3-12414-A1	GASKET, COVER EMPAQUE	1	1	1	
35	90119-06MA3	BOLT, WITH WASHER TORNILLO CON ARANDELA	2	2	2	
36	6H3-41111-01-1S	INNER COVER, EXHAUST CUBIERTA INTERIOR DE ESCAPE	1	1	1	
37	6H3-41112-A0	GASKET, EXHAUST INNER COVER EMPAQUE	1	1	1	
38	6H3-41113-02-1S	OUTER COVER, EXHAUST CUBOERTA EXTERIOR DE ESCAPE	1	1	1	
39	6H3-41114-A0	GASKET, EXHAUST OUTER COVER EMPAQUE	1	1	1	
40	90119-06MA5	BOLT, WITH WASHER TORNILLO CON ARANDELA	16	16	16	
41	663-24312-01	PIPE 2 TUBO 2	1	1	1	
42	90467-08004	CLIP PRESILLA	1	1	1	
43	94702-00160	PLUG, SPARK (NGK B8HS-10) BUJIA (NGK B8HS-10)	3	3	3	
	94702-00247	PLUG, SPARK (NGK BR8HS-10) BUJIA (NGK BR8HS-10)	3	3		60F-FOR CARIB, CHINA

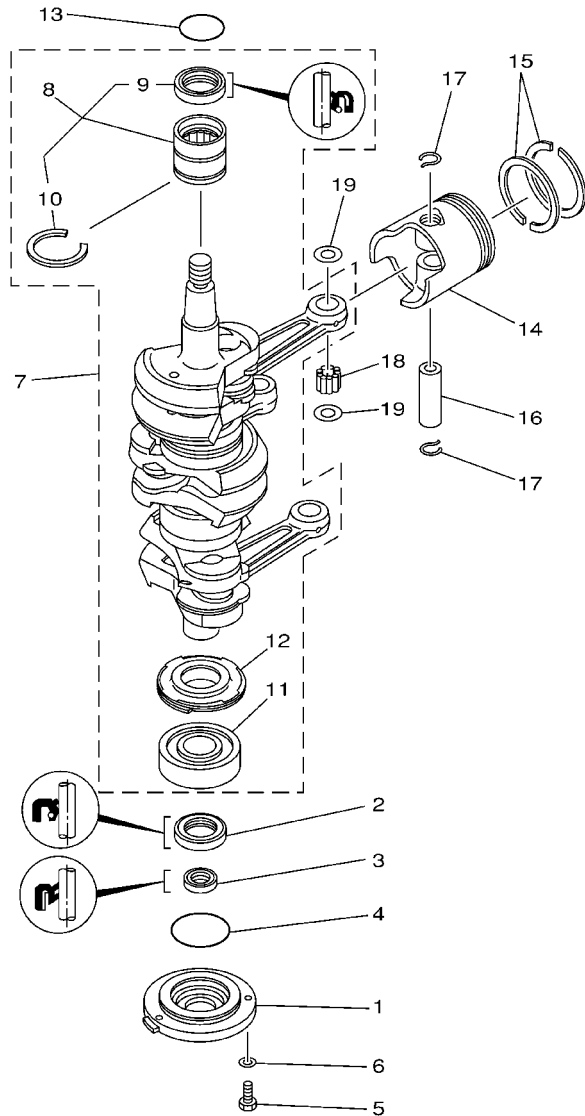

FIG. 4 CRANKSHAFT. PISTON CIGUENAL. PISTON

REF. NO.	PART NO. CODIGO NO.	DESCRIPTION DESCRIPTION	ED	ET	E/O	REMARKS OBSERVACION
1	6H3-15359-00-94	HOUSING, OIL SEAL CAJA DE SELLO DE ACEITE	1	1	1	
2	93102-30M23	OIL SEAL SELLO ACEITE	1	1	1	
3	93106-18M01	OIL SEAL SELLO ACEITE	1	1	1	
4	93210-65M50	O-RING ANILLO O	1	1	1	
5	97095-06020	BOLT PERNO	3	3	3	
6	92995-06600	WASHER ARANDELA	3	3	3	
7	6H3-11400-10	CRANKSHAFT ASSY CIGUENAL COMPLETO			1	70B
	6H3-11400-03	CRANKSHAFT ASSY CIGUENAL COMPLETO	1	1		60F
8	93311-636U6	.BEARING .COJINETE	1	1	1	
9	93102-36M24	..OIL SEAL ..SELLO ACEITE	1	1	1	
10	93440-49M04	..CIRCLIP ..BOLA	1	1	1	
11	93306-306V1	.BEARING .COJINETE	1	1	1	
12	6H3-11536-00	.GEAR, DRIVE .ENGRANAJE TRACCION			1	FOR 6H3-11400-11
13	93210-46M16	O-RING ANILLO O	1	1	1	
14	6H3-11631-01-96	PISTON (STD) PISTON (STD)	3	3	3	
	6H3-11635-01	PISTON (0.25MM O/S) PISTON (0.25MM O/S)	3	3	3	AP
	6H3-11636-01	PISTON (0.50MM O/S) PISTON (0.50MM O/S)	3	3	3	AP
15	6K5-11601-02	PISTON RING SET (STD) JUEGO DE AROS (STD)	3	3	3	
	6K5-11601-12	PISTON RING SET (0.25MM O/S) JUEGO DE AROS (0.25MM O/S)	3	3	3	AP
	6K5-11601-22	PISTON RING SET (0.50MM O/S) JUEGO DE AROS (0.50MM O/S)	3	3	3	AP
16	6H3-11633-00	PIN, PISTON PASADOR, PISTON	3	3	3	
17	688-11634-10	CLIP, PISTON PIN PRESILLA, BULON DE PISTON	6	6	6	
18	93603-18M09	PIN, DOWEL PASADOR DE CLAVIJA	84	84	84	
19	90201-20417	WASHER, PLATE ARANDELA PLANA	6	6	6	



6H30010-9030

FIG. 5 INTAKE

ADMISION

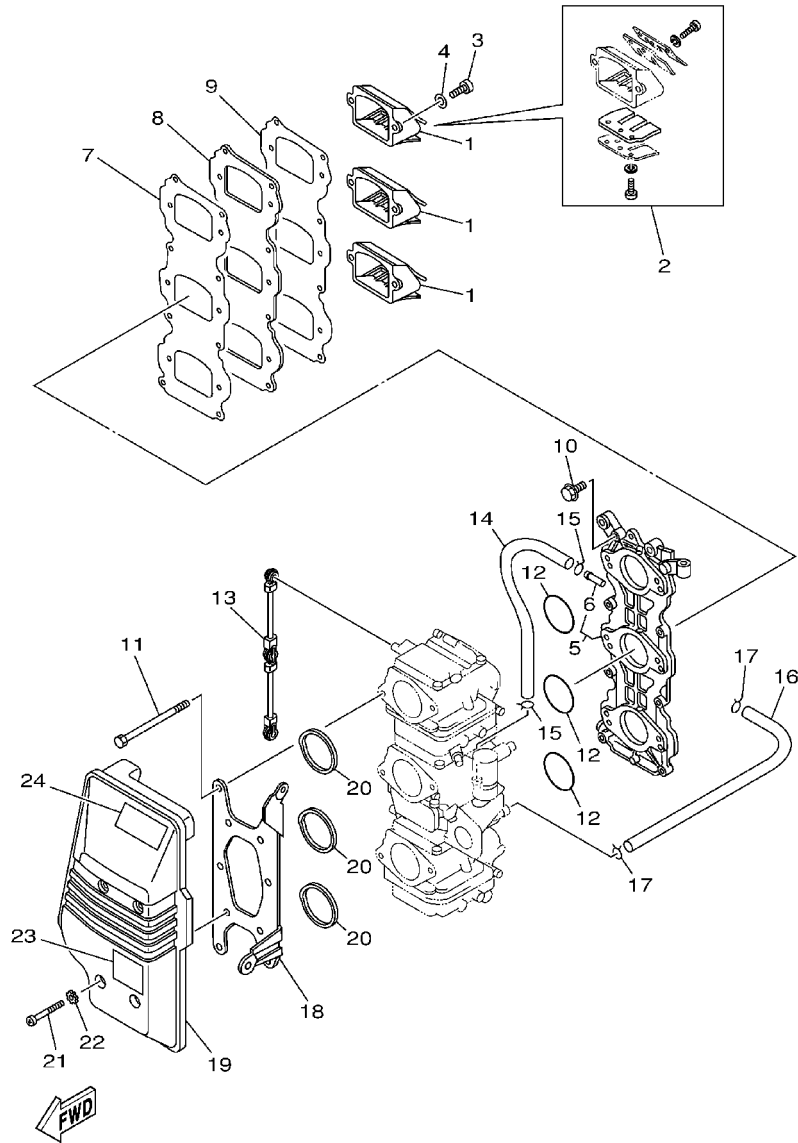

6H31700-2050

REF. NO.	PART NO. CODIGO NO.	DESCRIPTION DESCRIPTION	ED	ET	ETO	REMARKS OBSERVACION
1	6H3-13610-00	REED VALVE ASSY VALVULA DE LAMINAS COMPLETA			3	70B
	6H2-13610-00	REED VALVE ASSY VALVULA DE LAMINAS COMPLETA	3	3		60F
2	688-W0004-00	.REED SET .JUEGO DE VALVULAS DE LENGUETA	1	1	1	
3	97880-05016	SCREW, PAN HEAD TORNILLO DE CABEZA CON PLANA	6	6	6	
4	92990-05600	WASHER, PLATE ARANDELA	6	6	6	
5	6H3-13641-13-94	MANIFOLD 1 MULTIPLE 1			1	70B
	6H3-13641-21-94	MANIFOLD 1 MULTIPLE 1	1	1		60F
6	6H1-14485-00	.PIPE, JOINT .TUBO DE UNION			4	FOR 6H3-13641-13-94
	6H1-14485-00	.PIPE, JOINT .TUBO DE UNION	1	1		FOR 6H3-13641-21-94
7	6H3-13621-A1	GASKET, VALVE SEAT JUNTA, DE VALV,DE EMPAQUE	1	1	1	
8	6H3-13624-00-94	PLATE, REED VALVE PLACA DE VALVULA DE LAMINAS	1	1	1	
9	6H3-13622-A1	GASKET, VALVE SEAT EMPAQUE DE ASIEN TO VALVULA	1	1	1	
10	90119-06MA3	BOLT, WITH WASHER TORNILLO CON ARANDELA	8	8	8	
11	97095-06095	BOLT PERNO	6	6	6	
12	93210-39ME4	O-RING ANILLO O	3	3	3	
13	6H3-41217-00	ROD, ACCEL. LEVER VARILLA PALANCA ACELERADOR	1	1	1	
14	90445-07255	HOSE (L160) TUBO (L160)	1	1	1	
15	90467-06016	CLIP PRESILLA	2	2	2	
16	6H3-14349-00	PIPE TUBO	1	1	1	
17	90467-08004	CLIP PRESILLA	2	2	2	
18	6H3-14413-10	STAY SOPORTE	1	1	1	
19	6H3-14440-02	SILENCER ASSY, INTAKE SILENCIADOR COMPL DE ADMISION	1	1	1	
20	6H3-14457-01	SEAL SELLO	3	3	3	
21	97885-06045	SCREW, PAN HEAD TORNILLO DE CABEZA CON PLANA	4	4	4	
22	90209-06M05	WASHER ARANDELA DE SEPARACION	4	4	4	
23	6H1-85711-60	MARK, CAUTION MARKER	1	1	1	
24	6A1-83625-41	MARK 5 MARCA 5			1	70B-FOR CARIB

FIG. 6 CARBURETOR

CARBURADOR

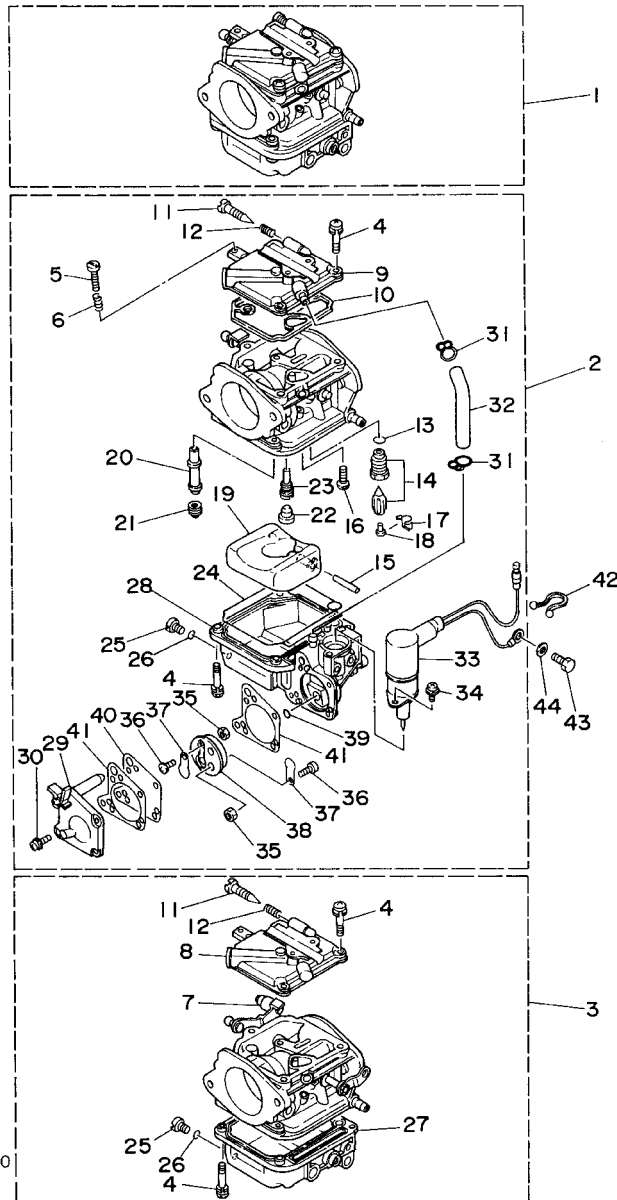

REF. NO.	PART NO. CODIGO NO.	DESCRIPTION DESCRIPTION	ED	ET	EIO	REMARKS OBSERVACION
1	6H3-14301-0A	CARBURETOR ASSY 1 CARBURADOR COMPLETO 1			1	70B
	6H2-14301-0A	CARBURETOR ASSY 1 CARBURADOR COMPLETO 1	1	1		60F
	6H2-14301-20	CARBURETOR ASSY 1 CARBURADOR COMPLETO 1	1	1		60F-FOR BRAZIL
2	6H3-14302-0A	CARBURETOR ASSY 2 CARBURADOR COMPLETO 2			1	70B
	6H2-14302-0A	CARBURETOR ASSY 2 CARBURADOR COMPLETO 2	1	1		60F
	6H2-14302-20	CARBURETOR ASSY 2 CARBURADOR COMPLETO 2	1	1		60F-FOR BRAZIL
3	6H3-14303-0A	CARBURETOR ASSY 3 CARBURADOR COMPLETO 3			1	70B
	6H2-14303-0A	CARBURETOR ASSY 3 CARBURADOR COMPLETO 3	1	1		60F
	6H2-14303-20	CARBURETOR ASSY 3 CARBURADOR COMPLETO 3	1	1		60F-FOR BRAZIL
4	97980-04114	.SCREW, WITH WASHER .TORNILLO, CON ARANDELA	21	21	21	
5	63V-14523-00	.SCREW, STOP .TORNILLO DE TOPE	1	1	1	#2
6	90501-10326	.SPRING, COMPRESSION .RESORTE DE COMPRESION	1	1	1	#2
7	6H2-14578-00	.COLLAR .COLLAR	1	1	1	#3
8	6H4-14146-00	.PLATE .PLACA SOPORTE	2	2	2	#1,3
9	6H3-14146-10	.PLATE .PLACA SOPORTE	1	1	1	#2
10	6H4-14147-00	.O-RING .ANILLO O	3	3	3	
11	692-14923-00	.SCREW, PILOT .TORNILLO DE AJUSTE	3	3	3	
12	697-14555-00	.SPRING .RESORTE	3	3	3	
13	93210-04228	.O-RING .ANILLO O	3	3	3	
14	6H3-14590-00	.NEEDLE VALVE ASSY .VALVULA DE AGUJA COMPLETA	3	3	3	
15	6H4-14548-00	.PIN, FLOAT ARM .PASADOR DE BRAZO DE BOIA	3	3	3	
16	98580-04008	.SCREW, PAN HEAD .TORNILLO DE CABEZA CON PLANA	3	3	3	
17	663-14159-00	.CLIP .PRESILLA	3	3	3	
18	676-14186-00	.PIN, FLOAT .PASADOR DE LA BOYA	3	3	3	
19	6H4-14985-01	.FLOAT .BOIA	3	3	3	
20	6H3-14947-71	.JET, NEEDLE .INJECTOR DE AGUJA			3	70B
	6H2-14947-71	.JET, NEEDLE .INJECTOR DE AGUJA	3	3		60F

FIG. 6 CARBURETOR

CARBURADOR

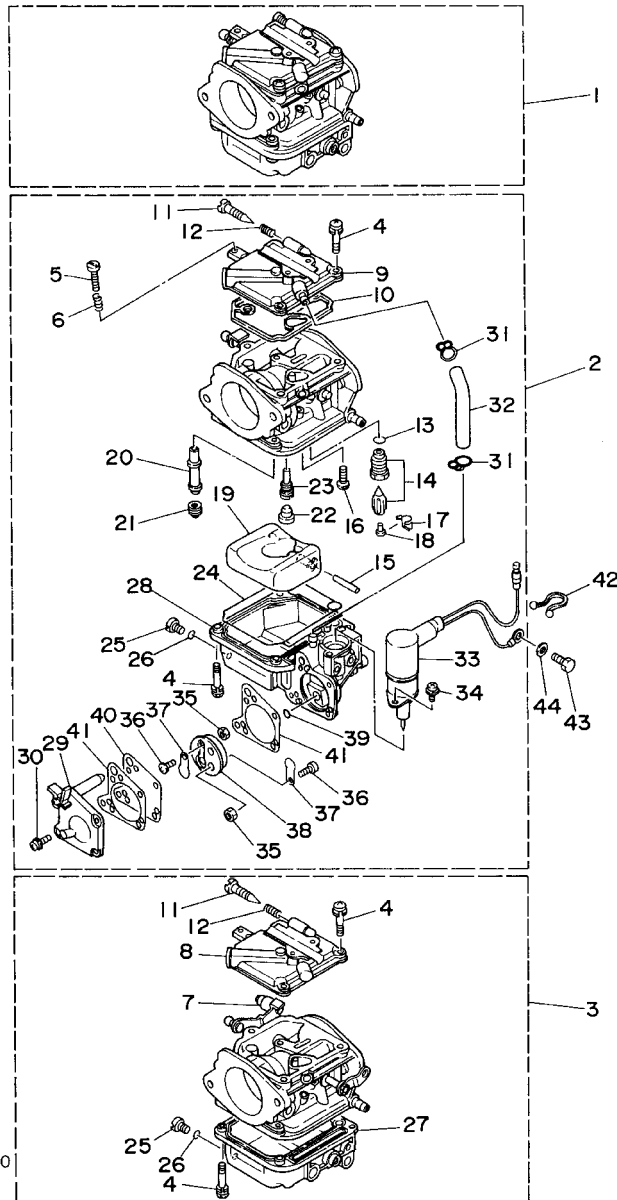

REF. NO.	PART NO. CODIGO NO.	DESCRIPTION DESCRIPTION	ED	ET	EIO	REMARKS OBSERVACION
21	6H3-14943-37	.JET, MAIN (#150) .INYECTOR PRINCIPAL (#150)			3	70B
	6H3-14943-35	.JET, MAIN (#140) .INYECTOR PRINCIPAL (#140)	2	2		60F-#1,2
	6H3-14943-36	.JET, MAIN (#145) .INYECTOR PRINCIPAL (#145)	1	1		60F-#3
	676-14943-38	.JET, MAIN (#155) .INYECTOR PRINCIPAL (#155)	2	2		60F-FOR BRAZIL-#1,2
	6H1-14943-39	.JET, MAIN (#160) .INYECTOR PRINCIPAL (#160)	1	1		60F-FOR BRAZIL-#3
22	676-14966-00	.CAP .TAPA	3	3	3	
23	6H3-14948-17	.JET (#75) .INYECTOR (#75)			3	70B
	6H3-14948-13	.JET (#65) .INYECTOR (#65)	3	3		60F
	6H3-14948-16	.JET (#72) .INYECTOR (#72)	3	3		60F-FOR BRAZIL
24	6H4-14984-00	.GASKET, FLOAT CHAMBER .EMPAQUE CAMARA DE BOIA	3	3	3	
25	6H3-14992-00	.SCREW, DRAIN .TORNILLO, SEGURO	3	3	3	
26	93210-04230	.O-RING .ANILLO O	3	3	3	
27	6H4-14980-00	.BODY, FLOAT CHAMBER .CUERPO CAMARA DE BOIA	2	2	2	#1,3
28	6H3-14980-10	.BODY, FLOAT CHAMBER .CUERPO CAMARA DE BOIA	1	1	1	#2
29	6H3-24452-10	.COVER .CUBIERTA	1	1	1	#2
30	6H4-14567-00	.SCREW .TORNILLO	4	4	4	#2
31	6H3-14137-00	.CLIP .PRESILLA	2	2	2	#2
32	6H3-14349-00	.PIPE .TUBO	1	1	1	#2
33	6H3-14380-00	.STARTER ASSY .ARRANQUE COMPLETO	1	1	1	#2
34	97803-04010	.SCREW, PAN HEAD .TORNILLO DE CABEZA CON PLANA	2	2	2	#2
35	95380-03600	.NUT .TUERCA	2	2	2	#2
36	98980-03006	.SCREW, BIND .TORNILLO DE LIGAR	2	2	2	#2
37	6L5-24421-00	.VALVE, CHECK .VALVULA DE RETENCION	2	2	2	#2
38	6H4-24413-00	.BODY 2 .CUERPO 2	1	1	1	#2
39	6H4-24486-00	.O-RING .ANILLO O	1	1	1	#2
40	6H3-24411-10	.DIAPHRAGM .DIAFRAGMA	1	1	1	#2
41	6H3-24434-10	.GASKET, BODY .EMPAQUE	2	2	2	#2

FIG. 6 CARBURETOR

CARBURADOR

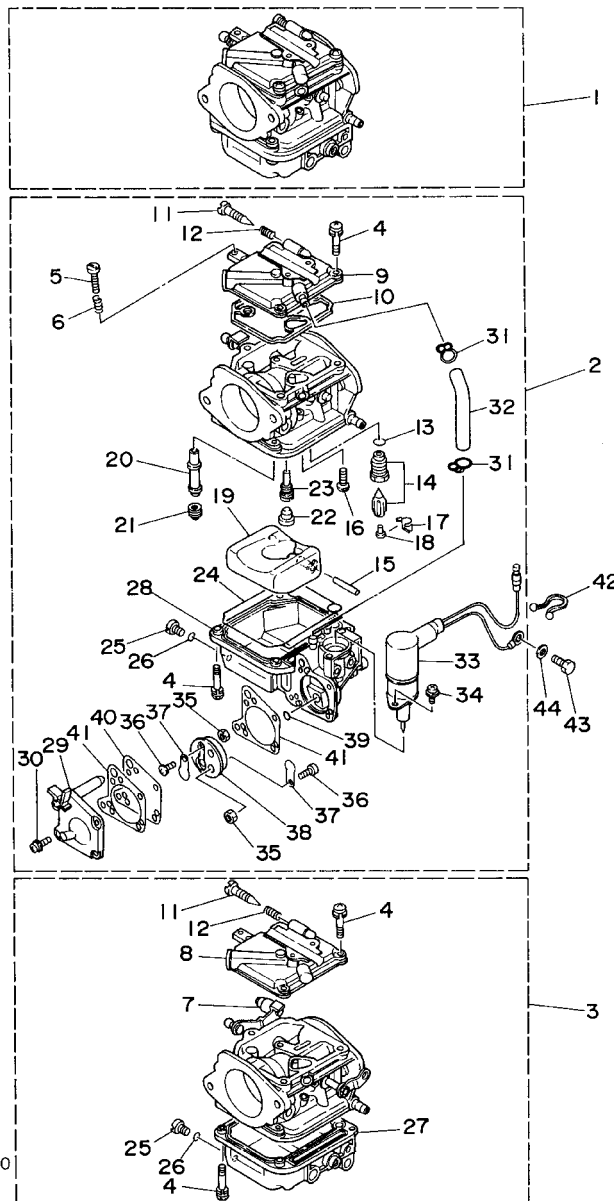

6H30010-4050

REF. NO.	PART NO. CODIGO NO.	DESCRIPTION DESCRIPTION	ED	ET	ETO	REMARKS OBSERVACION
42	90465-18147	CLAMP BRIDA	1	1	1	
43	97013-06012	BOLT PERNO	1	1	1	
44	92903-06600	WASHER, PLATE ARANDELA	1	1	1	

FIG. 7 OIL PUMP

BOMBA DE ACEITE

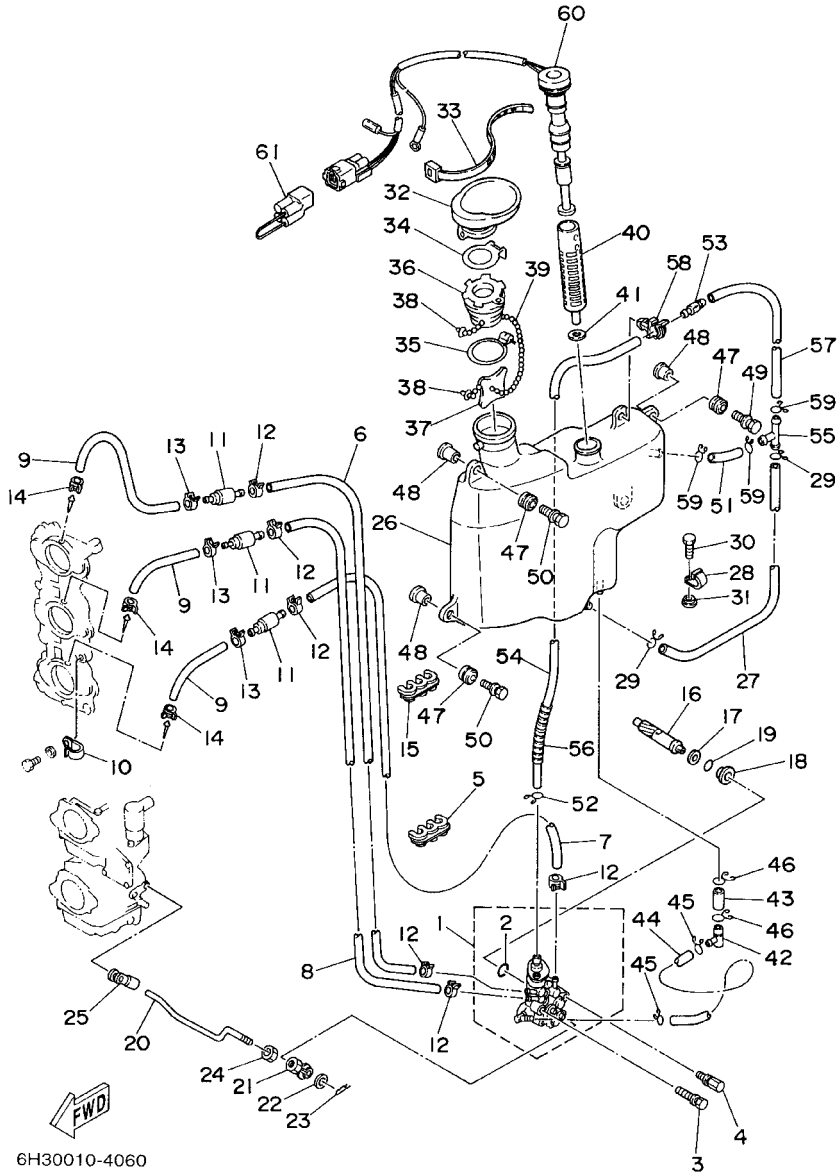

6H30010-4060

REF. NO.	PART NO. CODIGO NO.	DESCRIPTION DESCRIPTION	ED	ET	EIO	REMARKS OBSERVACION
1	6H3-13200-02	OIL INJECTION PUMP ASSY BOMBA DE ACEITE COMPLETA			1	
2	93210-19MA7	.O-RING .ANILLO O			1	
3	90109-06M39	BOLT PERNO			1	
4	90109-06M40	BOLT PERNO			1	
5	90464-07M05	CLAMP BRIDA			1	
6	90445-07M44	HOSE (L250) TUBO (L250)			1	
7	90445-07M23	HOSE (L408) TUBO (L408)			1	
8	90445-07MA5	HOSE (L150) TUBO (L150)			1	
9	90445-07M87	HOSE (L110) TUBO (L110)			3	
10	90465-06M86	CLAMP BRIDA			1	
11	6E9-13183-70	VALVE, CHECK VALVULA DE RETENCION			3	
12	90468-07M02	CLIP PRESILLA			6	
13	90468-07M02	CLIP PRESILLA			3	
14	90468-07M02	CLIP PRESILLA			3	
15	90464-07M05	CLAMP BRIDA			1	
16	6H3-11537-01	GEAR, DRIVEN ENGRANAJE TRACCION			1	
17	90201-08M93	WASHER, PLATE ARANDELA PLANA			1	
18	6H1-13117-01	COLLAR, DISTANCE COLLAR, DISTANCIA			1	
19	93210-13M04	O-RING ANILLO O			1	
20	6H3-41241-01	ROD, LINK VARILLA			1	
21	6H1-41237-00	JOINT, LINK CONECTOR			1	
22	90202-05088	WASHER, PLATE ARANDELA DE PLANA			1	
23	90468-05M03	CLIP PRESILLA			1	
24	95380-05600	NUT TUERCA			1	
25	6E9-41237-00	JOINT, LINK CONECTOR			1	
26	6H3-21707-06	OIL TANK COMP. DEPOSITO DE ACEITE COMP.			1	
27	90445-11M03	HOSE (L330) TUBO (L330)			1	

FIG. 7 OIL PUMP

BOMBA DE ACEITE

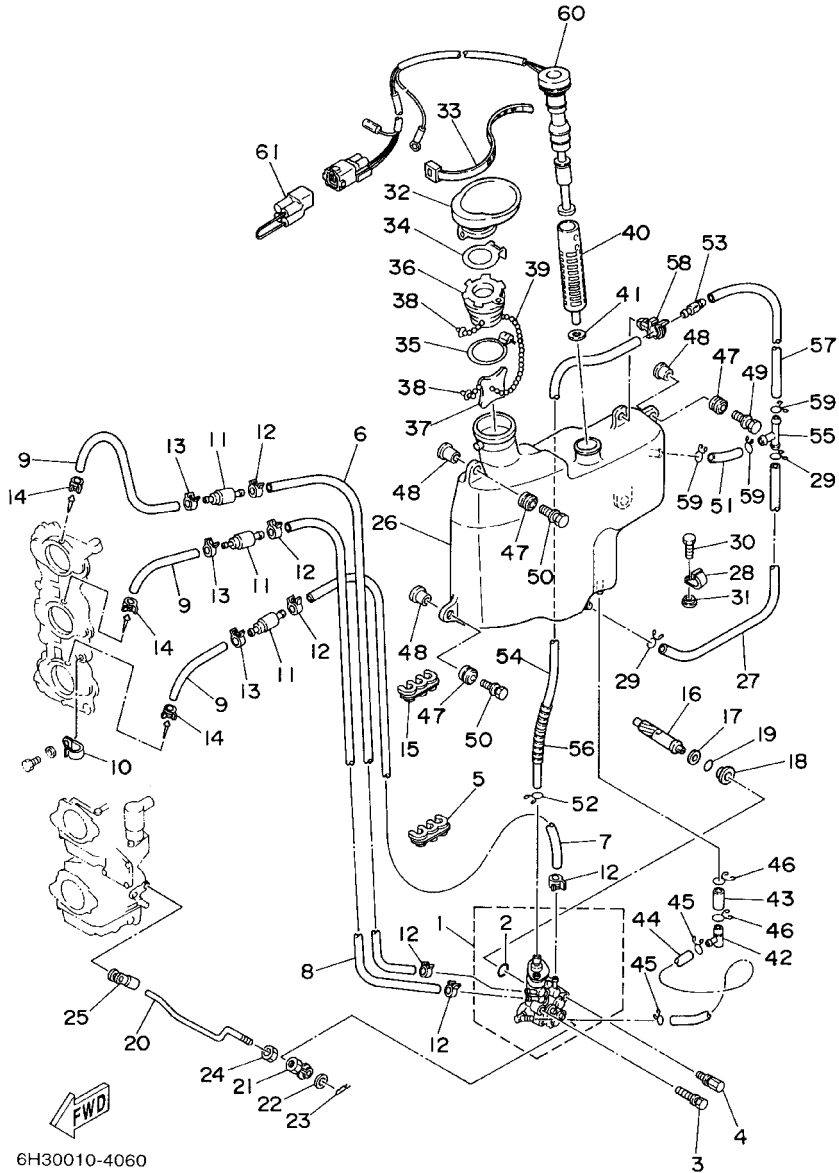

6H30010-4060

REF. NO.	PART NO. CODIGO NO.	DESCRIPTION DESCRIPTION	ED	ET	EIO	REMARKS OBSERVACION
28	90465-11M27	CLAMP BRIDA			1	
29	90467-11M08	CLIP PRESILLA			2	
30	97095-06016	BOLT PERNO			1	
31	90387-06M31	COLLAR COLLAR			1	
32	6H3-21752-00	TUBE, FILLER 1 TUBO DE LLENADOR 1			1	
33	90465-13M30	CLAMP BRIDA			1	
34	63D-2176M-00	HOOK GANCHO			1	
35	63D-2175R-00	HOOK, BAND GANCHO DE CINTA			1	
36	6H4-21770-00	OIL TANK CAP ASSY TAPA DE DEPOSITO DE ACEITE			1	
37	6J8-21758-00	WASHER, SPECIAL 2 ARANDELA ESPECIAL 2			1	
38	6H1-21757-00	WASHER, SPECIAL 1 ARANDELA ESPECIAL 1			2	
39	6H1-24633-00	CHAIN, BALL EMPAQUE			1	
40	6J8-13411-00	STRAINER, OIL FILTRO DE ACEITE			1	
41	6J8-13414-00	GASKET, STRAINER COVER EMPAQUE DE TAPA FILTRO			1	
42	6H1-13435-00	NIPPLE NIPLE			1	
43	90445-08M01	HOSE (L30) TUBO (L30)			1	
44	6H1-21766-01	PIPE, OIL TUBO DEL ACEITE			1	
45	90467-08004	CLIP PRESILLA			2	
46	90467-12M11	CLIP PRESILLA			2	
47	6A0-82317-00	DAMPER, IGNITION COIL AMORTIGUADOR BOBINA ENCENDIDO			4	
48	624-42542-00	PIPE TUBO			4	
49	90119-06M65	BOLT, WITH WASHER TORNILLO CON ARANDELA			2	
50	90119-06M88	BOLT, WITH WASHER TORNILLO CON ARANDELA			2	
51	90445-11M21	HOSE (L40) TUBO (L40)			1	
52	90467-10M04	CLIP PRESILLA			1	
53	6J8-21744-00	BREATHER RESPIRADERO			1	
54	90445-11M15	HOSE (L360) TUBO (L360)			1	

FIG. 7 OIL PUMP

BOMBA DE ACEITE

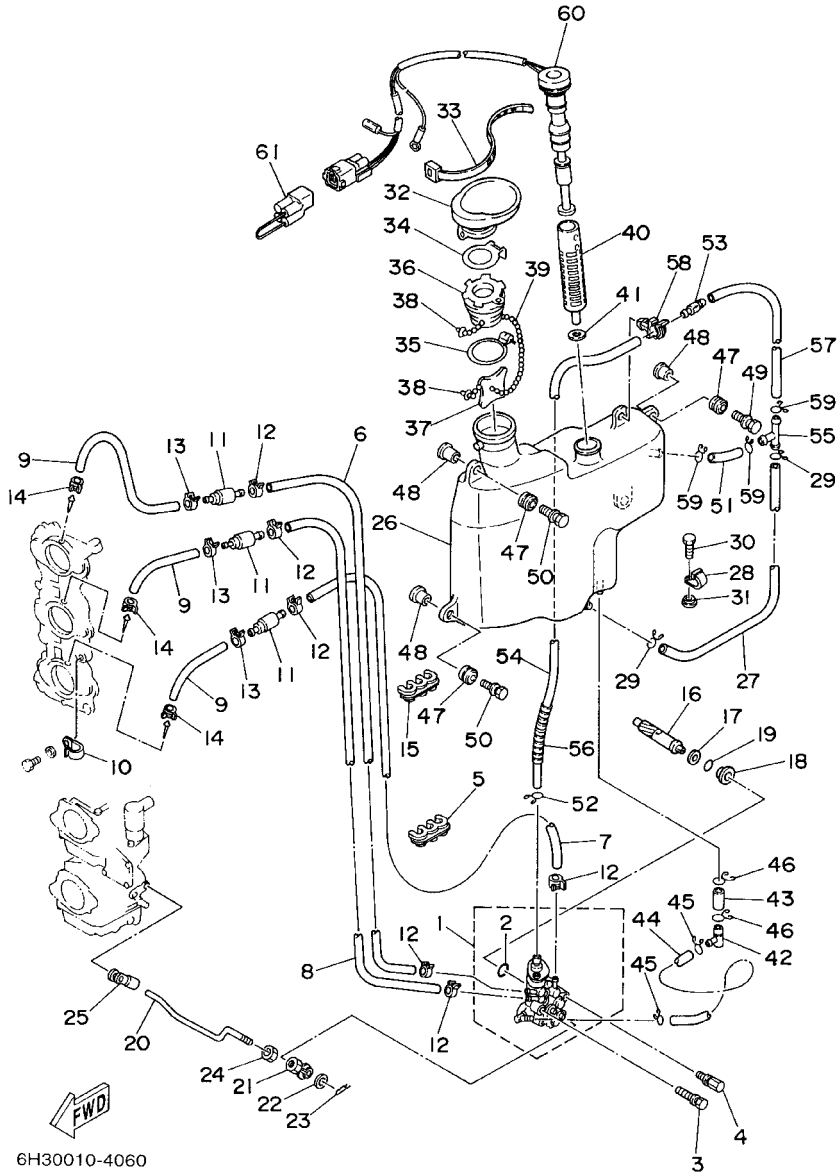

6H30010-4060

REF. NO.	PART NO. CODIGO NO.	DESCRIPTION DESCRIPTION	ED	ET	ETO	REMARKS OBSERVACION
55	6E5-24378-00	PIPE, JOINT 3 TUBO DE UNION 3			1	
56	90446-10M01	HOSE TUBO RESEIRADERO			1	
57	90445-11M02	HOSE (L100) TUBO (L100)			1	
58	90464-11M23	CLAMP BRIDA			1	
59	90467-11M08	CLIP PRESILLA			3	
60	6H3-85720-16	OIL LEVEL GAUGE ASSY MEDIDOR DE NIVEL DE ACEITE			1	
61	6R5-82582-B0	COVER, WIRE HARNESS CUBIERTA DE ARNES DE CABLE			1	AP

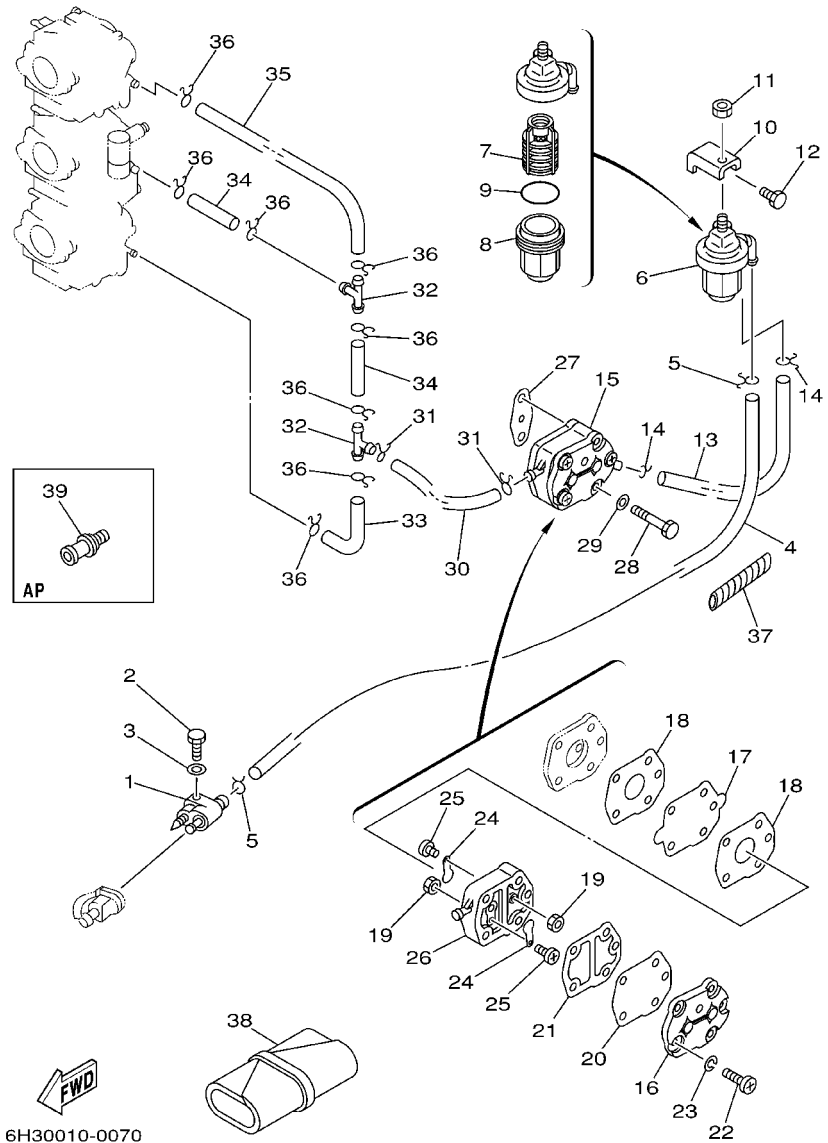

FIG. 8 FUEL

COMBUSTIBLE

REF. NO.	PART NO. CODIGO NO.	DESCRIPTION DESCRIPTION	ED	ET	EIO	REMARKS OBSERVACION
1	6G1-24304-02	FUEL PIPE JOINT COMP. 1 CONECTOR MANGUERA COMBUST.1	1	1	1	
2	97095-06025	BOLT PERNO	1	1	1	
3	92995-06600	WASHER ARANDELA	1	1	1	
4	90445-09M75	HOSE (L370) TUBO (L370)	1	1	1	
5	90467-08004	CLIP PRESILLA	2	2	2	
6	61N-24560-00	FILTER ASSY FILTRO COMPLETO	1	1	1	
7	61N-24563-00	.ELEMENT, FILTER .ELEMENTO DEL FILTRO	1	1	1	
8	61N-24521-00	.CUP, FILTER .COPA DE FILTRO	1	1	1	
9	93210-32738	.O-RING .ANILLO O	1	1	1	
10	648-24566-02	BRACKET, FILTER SOPORTE DEL FILTRO	1	1	1	
11	95380-08600	NUT TUERCA	1	1	1	
12	97013-06014	BOLT PERNO	1	1	1	
13	90445-09072	HOSE (L120) TUBO (L120)	1	1	1	
14	90467-08004	CLIP PRESILLA	2	2	2	
15	692-24410-00	FUEL PUMP ASSY BOMBA DE COMBUSTIBLE COMPLETA	1	1	1	
16	6A0-24413-00	.BODY 2 .CUERPO 2	1	1	1	
17	692-24411-00	.DIAPHRAGM .DIAFRAGMA	1	1	1	
18	648-24434-01	.GASKET, BODY .EMPAQUE	2	2	2	
19	95380-03600	.NUT .TUERCA	2	2	2	
20	663-24411-00	.DIAPHRAGM .DIAFRAGMA	1	1	1	
21	648-24435-02	.GASKET, BODY 2 EMPAQUE	1	1	1	
22	98503-05028	.SCREW, PAN HEAD .TORNILLO DE CABEZA CON PLANA	3	3	3	
23	92990-05100	.WASHER, SPRING .ARANDELA	3	3	3	
24	6A0-24421-01	.VALVE, CHECK .VALVULA DE RETENCION	2	2	2	
25	6A0-14325-00	.SCREW, PAN HEAD .TORNILLO CABEZA REDONDA	2	2	2	
26	6A0-24412-02	.BODY 1 .CUERPO 1	1	1	1	
27	650-24431-A0	GASKET, FUEL PUMP 1 EMPAQUE BOMBA COMBUST 1	1	1	1	

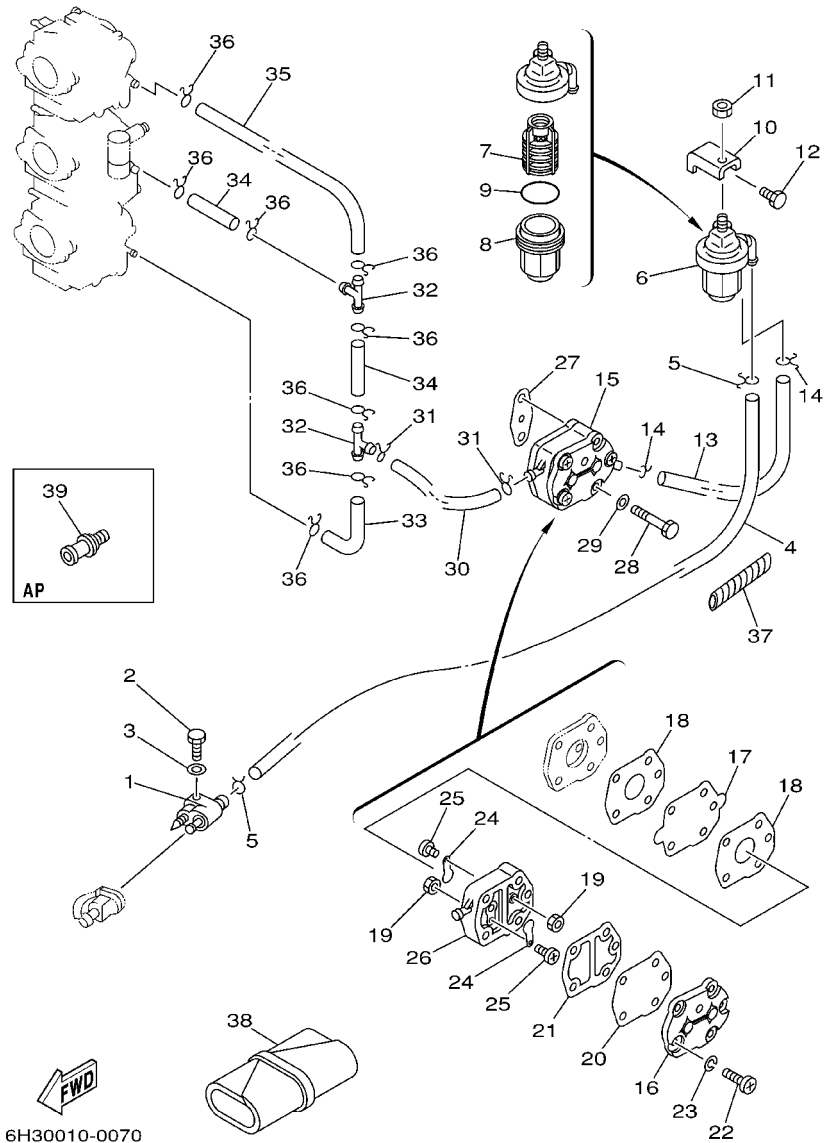

FIG. 8 FUEL

COMBUSTIBLE

REF. NO.	PART NO. CODIGO NO.	DESCRIPTION DESCRIPTION	ED	ET	EIO	REMARKS OBSERVACION
28	97095-06040	BOLT PERNO	2	2	2	
29	92995-06600	WASHER ARANDELA	2	2	2	
30	90445-09072	HOSE (L120) TUBO (L120)	1	1	1	
31	90467-08004	CLIP PRESILLA	2	2	2	
32	688-24378-00	PIPE, JOINT 4 TUBO DE UNION 4.	2	2	2	
33	6H3-24313-00	PIPE 3 TUBO 3	1	1	1	
34	90445-09220	HOSE TUBO	2	2	2	
35	6H3-24314-00	PIPE 4 TUBO 4	1	1	1	
36	90467-08004	CLIP PRESILLA	8	8	8	
37	90446-10M01	HOSE TUBO RESEIRADERO			1	
38	656-W2810-02	TOOL KIT JUEGO DE HERRAMIENTAS	1	1	1	
39	6E0-28193-00-94	PLUG, WATER CHECK TAPON DE CONTROL DE LA AGUA	1	1	1	AP D:12.5MM

FIG. 9 GENERATOR

GENERADOR

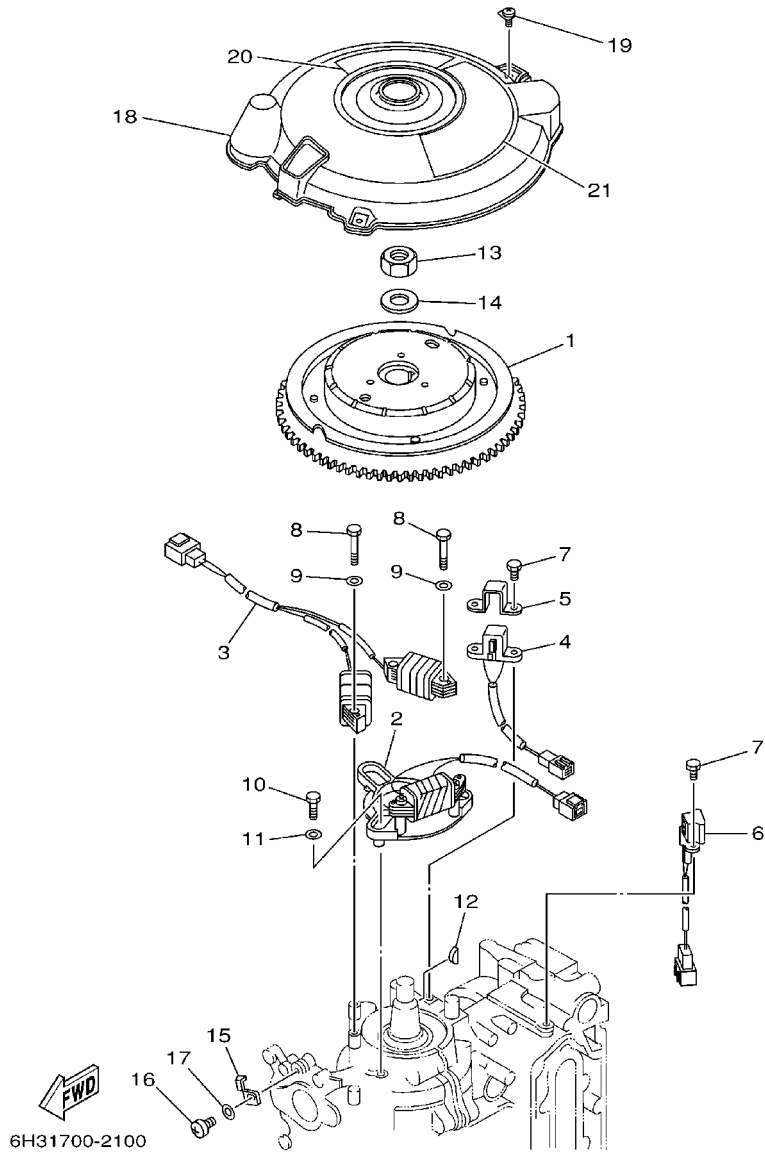

REF. NO.	PART NO. CODIGO NO.	DESCRIPTION DESCRIPTION	ED	ET	EIO	REMARKS OBSERVACION
1	6H2-85550-00	ROTOR ASSY ROTOR COMPLETO	1	1	1	
2	6H2-85520-01	COIL, CHARGE BOBINA DE CARGA	1	1	1	
3	6H2-85533-01	COIL, LIGHTING BOBINA DE LUZ	1	1	1	
4	6H2-85580-01	COIL, PULSER BOBINA DE PULSACION	1	1	1	
5	6H2-85582-00	ATTACHMENT, PULSER SOPORTE DE PULSACION	1	1	1	
6	6H2-85895-01	CRANK POSITION SENDER SENSOR, POSICION DE CIGUENAL	1	1	1	
7	97095-05012	BOLT PERNO	4	4	4	
8	97095-06035	BOLT PERNO	4	4	4	
9	92995-06600	WASHER ARANDELA	4	4	4	
10	97095-06025	BOLT PERNO	3	3	3	
11	92995-06600	WASHER ARANDELA	3	3	3	
12	90280-05015	KEY, WOODRUFF CUNA WOODRUFF	1	1	1	
13	90170-20137	NUT TUERCA	1	1	1	
14	90201-21M18	WASHER, PLATE ARANDELA PLANA	1	1	1	
15	6E5-81332-00	PLATE, TIMING PLACA REGULADOR DE TIEMPO	1	1	1	
16	97885-06010	SCREW, PAN HEAD TORNILLO DE CABEZA CON PLANA	1	1	1	
17	92995-06600	WASHER ARANDELA	1	1	1	
18	6H3-81337-01	COVER, FLYWHEEL CUBIERTA DE VOLANTE	1	1	1	
19	90159-06M23	SCREW, WITH WASHER TORNILLO CON VALONA	3	3	3	
20	6H3-14488-00	LABEL, CAUTION ETIQUETA PRECAUCION	1	1	1	
21	6H3-13437-21	MARK, CAUTION MARKER			1	70B-FOR CARIB

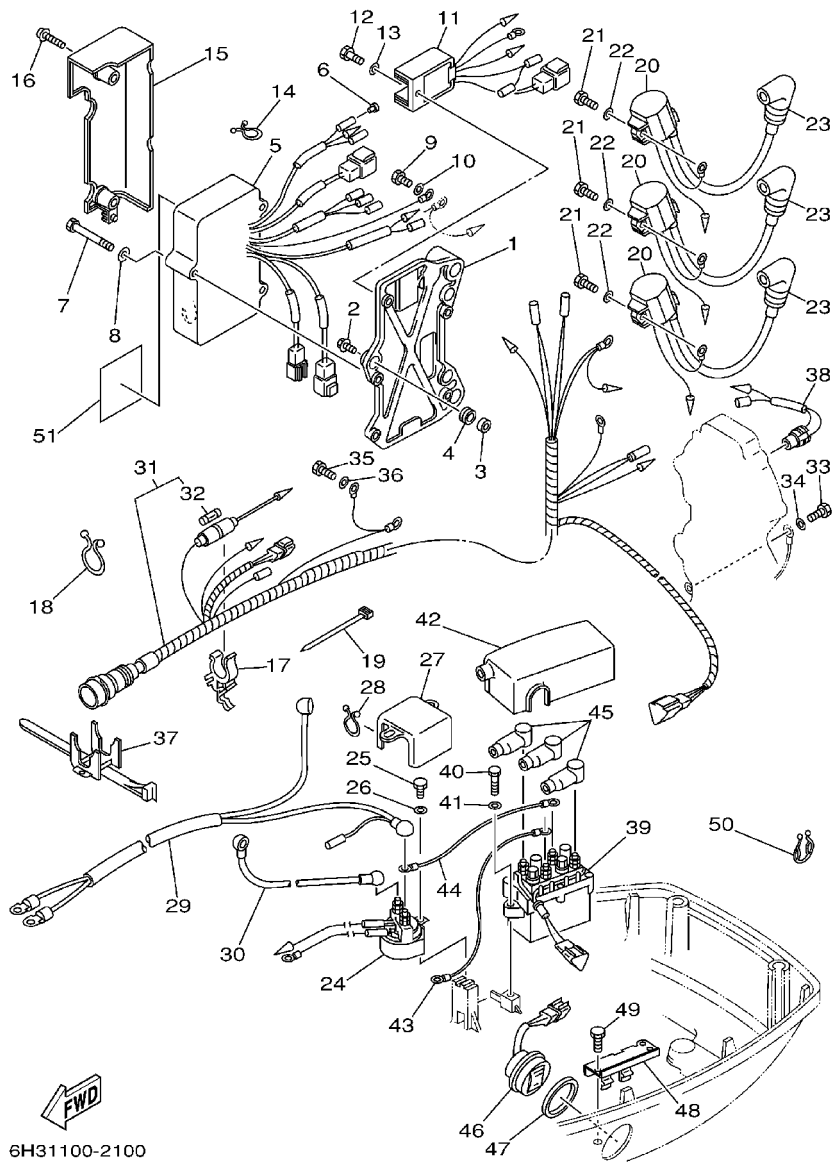

6H31100-2100

FIG. 10 ELECTRICAL

ELECTRICO

REF. NO.	PART NO. CODIGO NO.	DESCRIPTION DESCRIPTION	ED	ET	EIO	REMARKS OBSERVACION
1	6H3-85542-11-94	BRACKET SOPORTE	1	1	1	
2	90105-06M14	BOLT FLANGE TORNILLO	3	3	3	
3	90387-06M43	COLLAR COLLAR	3	3	3	
4	90480-13M54	GROMMET TAPON	3	3	3	
5	6H2-85540-11	C.D.I. UNIT ASSY UNIDAD C.D.I. COMPLETA	1	1	1	
6	703-82119-00	COVER, LEAD WIRE CUBIERTA DE CABLE CONDUCTOR	1	1	1	
7	97095-06045	BOLT PERNO	3	3	3	
8	92995-06600	WASHER ARANDELA	3	3	3	
9	97013-06012	BOLT PERNO	1	1	1	
10	92903-06600	WASHER, PLATE ARANDELA	1	1	1	
11	6H2-81960-10	RECTIFIER & REGULATOR ASSY RECTIFICADOR Y REGULADOR	1	1	1	
12	97095-06016	BOLT PERNO	1	1	1	
13	92995-06600	WASHER ARANDELA	1	1	1	
14	90464-05M16	CLAMP BRIDA	1	1	1	
15	6H3-81916-10	COVER, TERMINAL CUBIERTA DE TERMINAL	1	1	1	
16	90159-06M01	SCREW, WITH WASHER TORNILLO CON VALONA	2	2	2	
17	6G5-82152-00	HOLDER, FUSE PORTA-FUSIBLES	1	1	1	
18	90464-23M22	CLAMP BRIDA	1	1	1	
19	90465-13M11	CLAMP BRIDA	1	1	1	
20	697-85570-00	IGNITION COIL ASSY BOBINA DE IGNICION COMPLETO	3	3	3	
21	97013-06020	BOLT PERNO	3	3	3	
22	92903-06600	WASHER, PLATE ARANDELA	3	3	3	
23	6G1-82370-21	PLUG CAP ASSY TAPON DE BUJIA COMPLT	3	3	3	
24	688-81950-10	RELAY ASSY RELE COMPLETO	1	1	1	
25	97013-06016	BOLT PERNO	1	1	1	
26	92903-06600	WASHER, PLATE ARANDELA	1	1	1	
27	6H3-82164-00	CASE 2 BUJE	1	1	1	

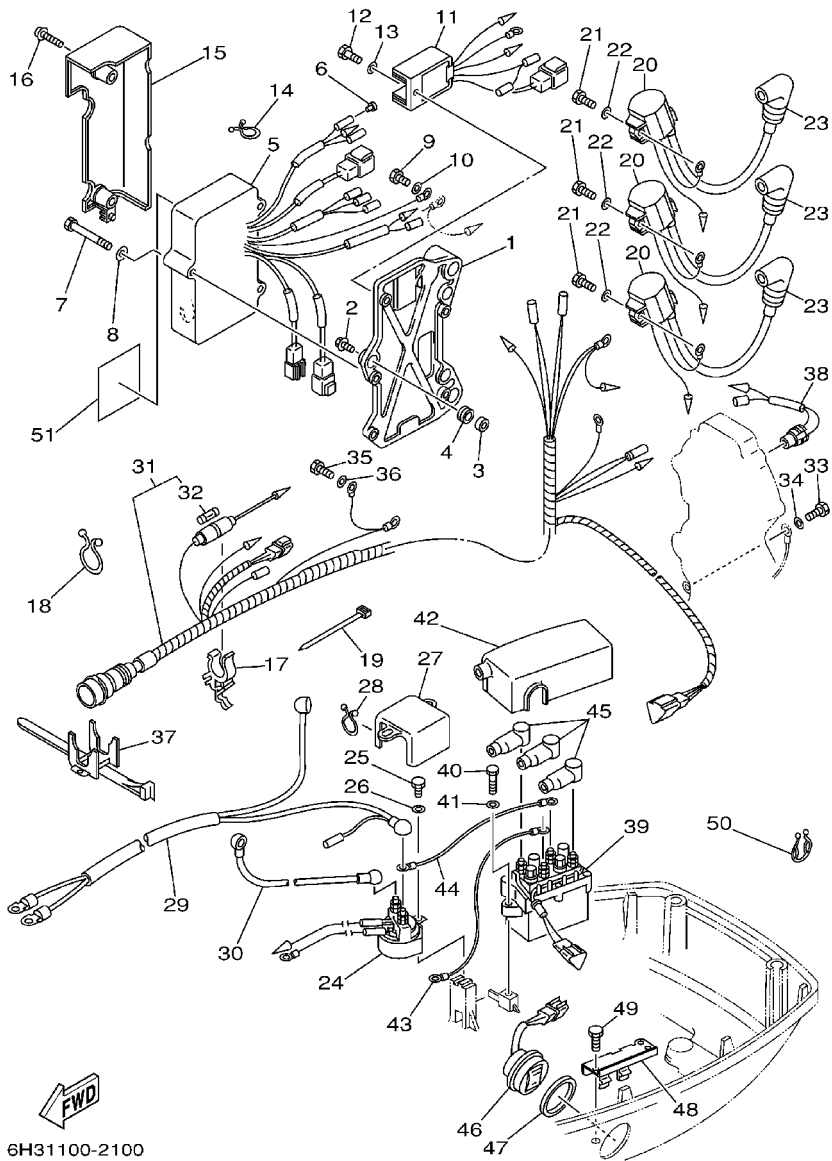

6H31100-2100

FIG. 10 ELECTRICAL

ELECTRICO

REF. NO.	PART NO. CODIGO NO.	DESCRIPTION DESCRIPTION	ED	ET	EIO	REMARKS OBSERVACION
28	90464-15M11	CLAMP BRIDA	1	1	1	
29	6H3-82105-01	WIRE HARNESS ARNES DE CABLES	1	1	1	
30	6H3-82117-00	WIRE, LEAD CABLE CONDUCTOR	1	1	1	
31	6H2-82590-13	WIRE HARNESS ASSY CONJUNTO DE CABLES		1	1	
	6H2-82590-02	WIRE HARNESS ASSY CONJUNTO DE CABLES		1		
32	663-82151-00	.FUSE (12V-20A) .FUSIBLE (12V-20A)	1	1	1	
33	97013-06012	BOLT PERNO	1	1	1	
34	92903-06600	WASHER, PLATE ARANDELA	1	1	1	
35	97013-06012	BOLT PERNO	2	2	2	
36	92903-06600	WASHER, PLATE ARANDELA	2	2	2	
37	688-82594-00	CLAMP GRAMPA	1	1	1	
38	688-82560-10	THERMO SWITCH ASSY INTER. DE TERMO	1	1	1	
39	61A-81950-00	RELAY ASSY RELE COMPLETO		1	1	
40	97095-06025	BOLT PERNO	2	2	2	
41	92995-06600	WASHER ARANDELA		2	2	
42	6H3-82154-11	CASE CAJA		1	1	
43	6H2-81949-11	WIRE, LEAD CABLE CONDUCTOR		1	1	
44	6H2-81949-01	WIRE, LEAD CABLE CONDUCTOR		1	1	
45	682-82119-01	COVER, LEAD WIRE CUBIERTA DE CABLE CONDUCTOR		3	3	
46	6H1-82563-10	TRIM & TILT SWITCH ASSY INTERRUPTOR DE INCLINACION		1	1	"ET"-EXCEPT FOR BRAZIL
47	6E5-82587-00	GASKET EMPAQUETADURA		1	1	"ET"-EXCEPT FOR BRAZIL
48	6E5-83614-01	BRACKET SOPORTE		1	1	"ET"-EXCEPT FOR BRAZIL
49	97095-06016	BOLT PERNO		2	2	"ET"-EXCEPT FOR BRAZIL
50	90464-18M14	CLAMP BRIDA		1	1	"ET"-EXCEPT FOR BRAZIL
51	6R5-85711-60	MARK, CAUTION MARKER		1	1	

FIG. 11 STARTING MOTOR

MOTOR DE ARRANQUE

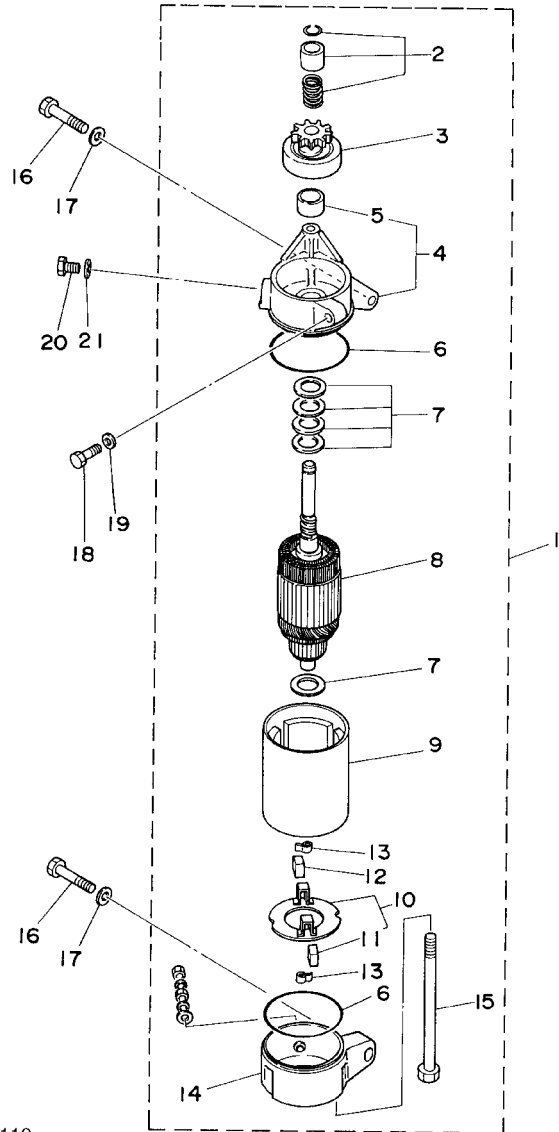

6H30010-4110

REF. NO.	PART NO. CODIGO NO.	DESCRIPTION DESCRIPTION	ED	ET	EIO	REMARKS OBSERVACION
1	6H3-81800-11	STARTING MOTOR ASSY MOTOR DE ARRANQUE COMPLETO	1	1	1	
2	689-81857-11	.PINION STOPPER SET .JUEGO TAPON PINON	1	1	1	
3	6H3-81807-10	.GEAR ASSY, STARTING MOTOR .PINON CONJUNTO	1	1	1	
4	6H3-81830-10	.FRONT BRACKET ASSY .SOPORTE DELANTERO COMPLETO	1	1	1	
5	689-81831-00	..METAL, FRONT ..METAL, DELANTERO	1	1	1	
6	689-81847-11	.O-RING .ANILLO GOMA	2	2	2	
7	689-81809-11	.WASHER KIT .JUEGO DE ARANDELA	1	1	1	
8	689-81850-12	.ARMATURE ASSY .INDUCIDO COMPLETO	1	1	1	
9	6H3-81810-10	.STATOR ASSY .ESTATOR COMPLETO	1	1	1	
10	689-81840-11	.BRUSH HOLDER ASSY .SOSTEN DE ESCOBILLA COMPLETO	1	1	1	
11	689-81812-11	..BRUSH 2 ..ESCOBILLA 2	1	1	1	
12	689-81811-11	.BRUSH 1 .ESCOBILLA 1	1	1	1	
13	689-81813-10	.SPRING, BRUSH .RESORTE DE ESCOBILLA	2	2	2	
14	6H3-81820-11	.REAR BRACKET ASSY .CUBIERTA TRASERA COMPL	1	1	1	
15	689-81826-10	BOLT PERNO	2	2	2	
16	97013-08035	BOLT PERNO	2	2	2	
17	92903-08600	WASHER, PLATE ARANDELA	2	2	2	
18	97013-06025	BOLT PERNO	1	1	1	
19	92903-06600	WASHER, PLATE ARANDELA	1	1	1	
20	97013-08016	BOLT PERNO	1	1	1	
21	92903-08600	WASHER, PLATE ARANDELA	1	1	1	

FIG. 12 BOTTOM COWLING

CUBIERTA INFERIOR

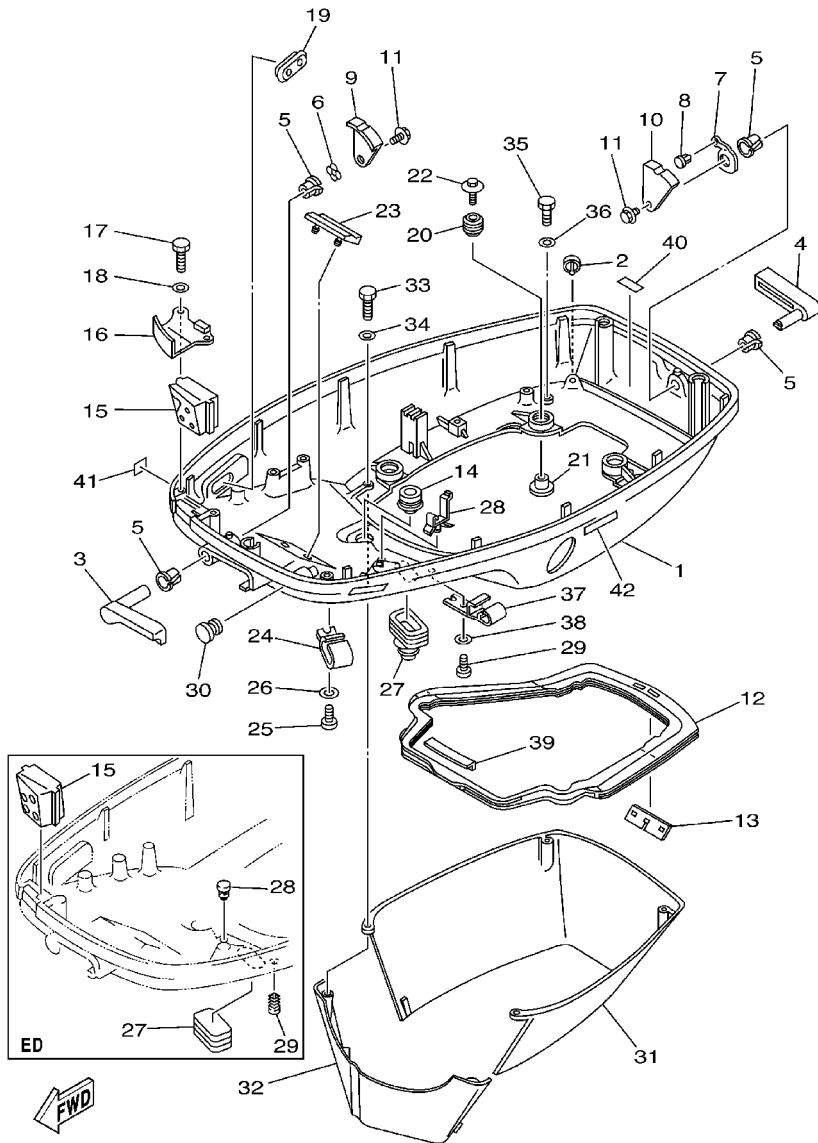

6H24200-2120

REF. NO.	PART NO. CODIGO NO.	DESCRIPTION DESCRIPTION	ED	ET	EIO	REMARKS OBSERVACION
1	6H3-42711-24-4D	COWLING, BOTTOM CUBIERTA INFERIOR		1	1	
	6H3-42711-05-4D	COWLING, BOTTOM CUBIERTA INFERIOR	1	1		"ET"- FOR BRAZIL
2	6H3-44391-01	NIPPLE, HOSE NIPLE MANGUERA	1	1	1	
3	6H3-42815-01-4D	LEVER, CLAMP PALANCA ABRAZADERA	1	1	1	
4	6H3-42817-01-4D	LEVER, CLAMP PALANCA ABRAZADERA	1	1	1	
5	90386-13M38	BUSH BUJE	4	4	4	
6	90206-13M10	WASHER, WAVE ARANDELA ONDULADA	1	1	1	
7	6H3-42813-00	SPRING, CLAMP LEVER RESORTE	1	1	1	
8	90269-04M03	RIVET REMACHE	1	1	1	
9	6H3-42816-00	LEVER, CLAMP PALANCA ABRAZADERA	1	1	1	
10	6H3-42818-00	LEVER, CLAMP PALANCA, ABRAZADERA	1	1	1	
11	90119-06M09	BOLT, WITH WASHER TORNILLO CON ARANDELA	2	2	2	
12	6H3-42716-02	RUBBER, SEAL 1 SELLO DE GOMA 1	1	1	1	
13	6K5-42717-00	RUBBER, SEAL 2 GOMA	1	1	1	
14	6E5-42724-00	GROMMET TAPON	1	1	1	
15	6H3-42725-10	GROMMET TAPON		1	1	
	6H3-42725-00	GROMMET TAPON	1			
16	6H3-42738-01-5B	PLATE, FITTING PLACA DE AJUSTE	1	1	1	
17	97095-06016	BOLT PERNO	2	2	2	
18	92995-06600	WASHER ARANDELA	2	2	2	
19	6H3-42727-00	GROMMET TAPON	1	1	1	
20	90480-09M12	GROMMET TAPON	4	4	4	
21	90387-06M69	COLLAR COLLAR	4	4	4	
22	90119-06M61	BOLT, WITH WASHER TORNILLO CON ARANDELA	4	4	4	
23	6H3-42768-00	DAMPER AMORTIGUADOR	1	1	1	
24	6E5-24367-01	CLAMP, FUEL PIPE 2 GRAMPA DE TUBO DE COMBUST.2	1	1	1	
25	90157-06M01	SCREW, PAN HEAD TORNILLO CABEZA CONICA PLANA	1	1	1	

FIG. 12 BOTTOM COWLING

CUBIERTA INFERIOR

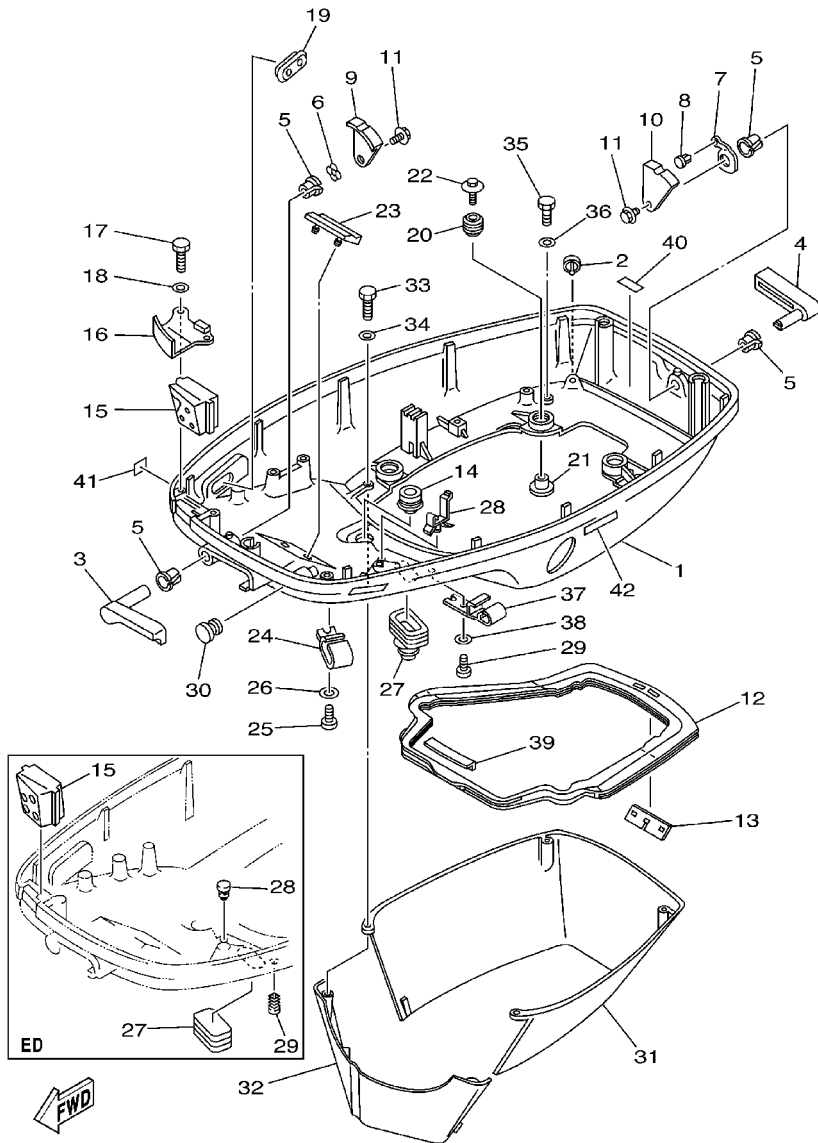

6H24200-2120

REF. NO.	PART NO. CODIGO NO.	DESCRIPTION DESCRIPTION	ED	ET	EIO	REMARKS OBSERVACION
26	92990-06600	WASHER, PLATE ARANDELA	1	1	1	
27	688-42726-10 6H4-42726-00	GROMMET TAPON GROMMET TAPON		1	1	
28	90464-09M13 703-82119-00	CLAMP BRIDA COVER, LEAD WIRE CUBIERTA DE CABLE CONDUCTOR		1	1	
29	90157-06M01 90338-05M03	SCREW, PAN HEAD TORNILLO CABEZA CONICA PLANA PLUG TAPON		1	1	
30	6G1-42748-00	GROMMET TAPON	1	1	1	
31	6H3-42741-01-4D	APRON MANDIL	1	1	1	
32	6H3-42771-01-4D	APRON MANDIL	1	1	1	
33	97095-06025	BOLT PERNO	2	2	2	
34	92995-06600	WASHER ARANDELA	2	2	2	
35	97095-06020	BOLT PERNO	2	2	2	
36	92995-06600	WASHER ARANDELA	2	2	2	
37	6E5-24367-01	CLAMP, FUEL PIPE 2 GRAMPA DE TUBO DE COMBUST.2		1	1	
38	92990-06600	WASHER, PLATE ARANDELA		1	1	
39	6H3-42718-00	RUBBER, SEAL 3 GOMA	1	1	1	
40	6G5-42791-00 6G5-42791-10	MARK 1 MARCA 1 MARK 1 MARCA 1	1	1	1	
41	6A1-28176-00	LABEL, CAUTION ETIQUETA DE PRECAUCION	1			60F-FOR CARIB, CHINA
42	6E3-8257H-00	PLATE, MARK PLACA DE MARCA	1			60F-FOR CARIB, CHINA

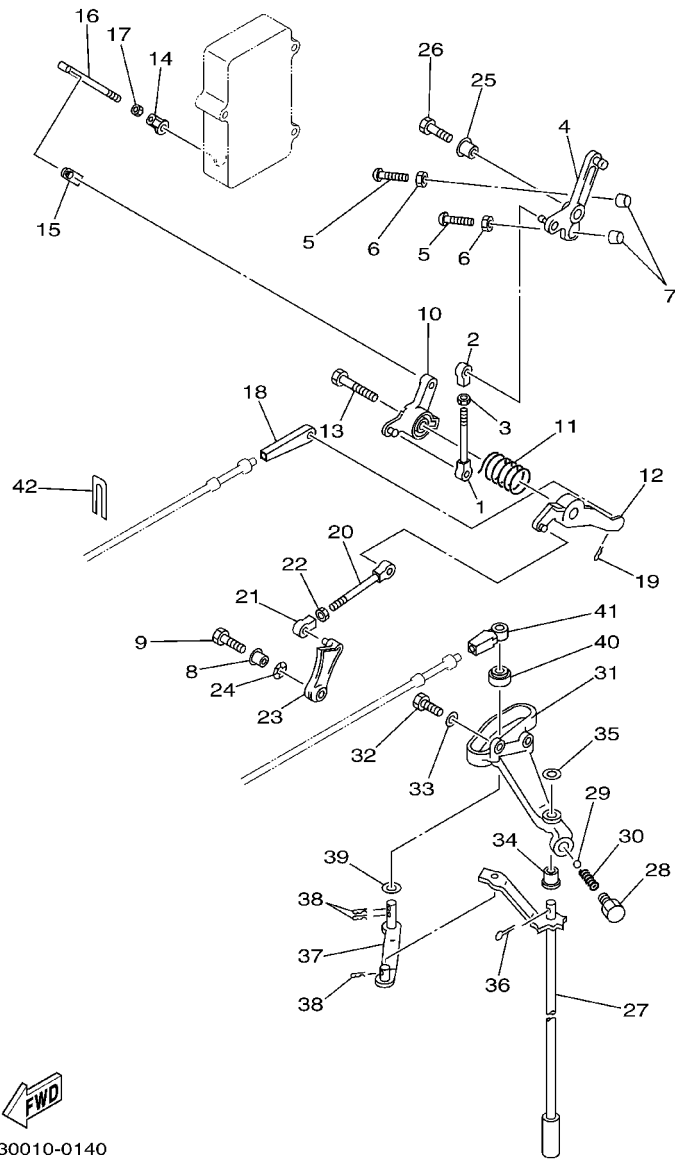

FWD
6H30010-0140

FIG. 13 CONTROL

CONTROL

REF. NO.	PART NO. CODIGO NO.	DESCRIPTION DESCRIPTION	ED	ET	EIO	REMARKS OBSERVACION
1	689-42169-01	JOINT CONECTOR	1	1	1	
2	682-41237-00	JOINT, LINK CONECTOR	1	1	1	
3	95380-05600	NUT TUERCA	1	1	1	
4	6H3-41631-00	LEVER, MAGNETO CONTROL PALANCA DE CONTROL DE MAGNETO	1	1	1	
5	90157-06M13	SCREW, PAN HEAD TORNILLO CABEZA CONICA PLANA	2	2	2	
6	95380-06600	NUT, HEXAGON TUERCA	2	2	2	
7	688-44194-00	CAP TAPA	2	2	2	
8	90387-06M60	COLLAR COLLAR	1	1	1	
9	97095-06025	BOLT PERNO	1	1	1	
10	6H3-41632-20	LEVER, MAGNETO CONTROL PALANCA DE CONTROL DE MAGNETO	1	1	1	
11	90508-26M35	SPRING, TORSION RESORTE DE TORSION	1	1	1	
12	6H3-41633-10	LEVER, MAGNETO CONTROL PALANCA DE CONTROL DE MAGNETO	1	1	1	
13	90109-06M43	BOLT PERNO	1	1	1	
14	6H1-41237-00	JOINT, LINK CONECTOR	1	1	1	
15	6F5-41237-00	JOINT, LINK CONECTOR	1	1	1	
16	6H3-41636-10-94	ROD, MAGNETO CONTROL VARILLA DE CONTROL MAGNETO	1	1	1	
17	95380-05600	NUT TUERCA	1	1	1	
18	6H3-48344-00	CABLE END, REMOTE CONTROL BASE CONTROL	1	1	1	
19	90468-18008	CLIP PRESILLA	1	1	1	
20	689-42169-01	JOINT CONECTOR	1	1	1	
21	6H4-41237-00	JOINT, LINK CONECTOR	1	1	1	
22	95380-05600	NUT TUERCA	1	1	1	
23	6H3-41213-10	CAM, ACCEL. LEVA ACELERADOR	1	1	1	
24	90206-10M04	WASHER, WAVE ARANDELA ONDULADA	1	1	1	
25	90387-06M60	COLLAR COLLAR	1	1	1	
26	97095-06025	BOLT PERNO	1	1	1	
27	6H3-44120-02	HANDLE GEAR SHIFT ASSY MANIJA DE CAMBIO COMPL	1	1		S

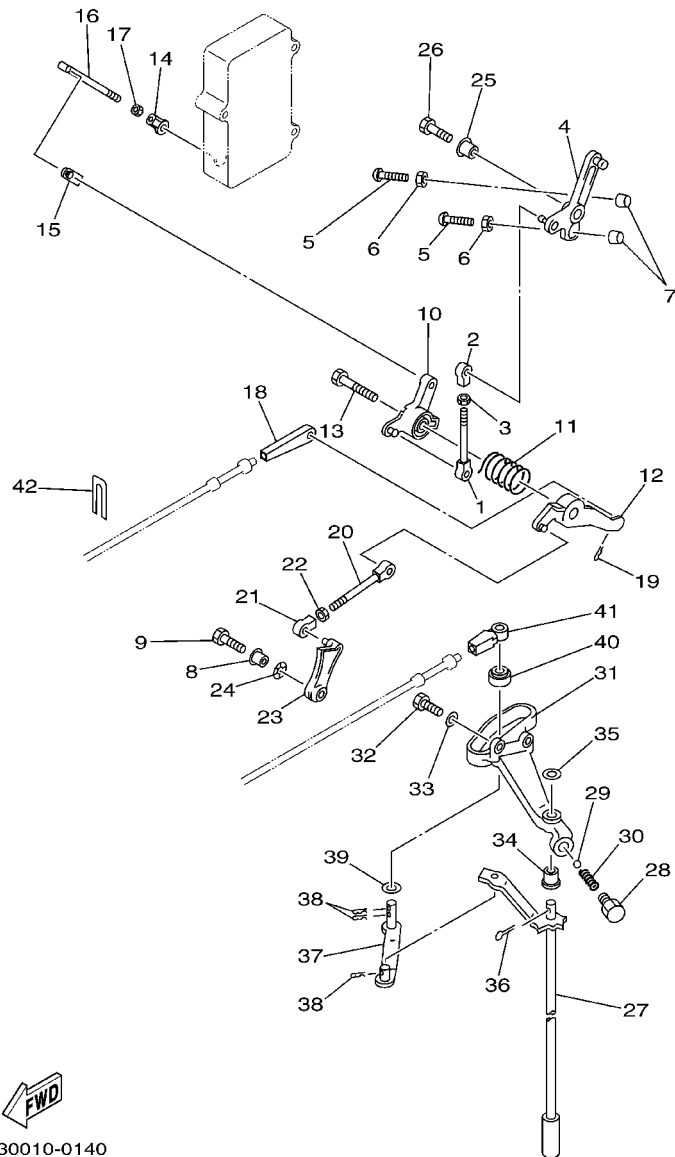

FWD
6H30010-0140

FIG. 13 CONTROL

CONTROL

REF. NO.	PART NO. CODIGO NO.	DESCRIPTION DESCRIPTION	ED	ET	EIO	REMARKS OBSERVACION
27	6H3-44120-12	HANDLE GEAR SHIFT ASSY MANIJA DE CAMBIO COMPL	1	1	1	L
28	648-42715-00	BUSHING BUJE	1	1	1	
29	93501-04M02	BALL BOLA	1	1	1	
30	90501-12082	SPRING, COMPRESSION RESORTE DE COMPRESION	1	1	1	
31	6H3-44117-00-94	BRACKET SOPORTE	1	1	1	
32	97013-06020	BOLT PERNO	2	2	2	
33	92903-06600	WASHER, PLATE ARANDELA	2	2	2	
34	90386-07M58	BUSH BUJE	1	1	1	
35	92990-08200	WASHER, PLAIN ARANDELA	1	1	1	
36	91490-20012	PIN, COTTER PASADOR DE CHAVETA	1	1	1	
37	6H3-44121-01	LEVER, SHIFT ROD PALANCA VARILLA CAMBIOS	1	1	1	
38	90468-18008	CLIP PRESILLA	3	3	3	
39	90202-07M07	WASHER, PLATE ARANDELA DE PLANA	1	1	1	
40	688-44122-00	BUSHING, SHIFT ROD LEVER BUJE PALANCA VARILLA DE CAMBIO	1	1	1	
41	663-48344-00	CABLE END, REMOTE CONTROL BASE CONTROL	1	1	1	
42	6H3-48538-00	CLAMP, CABLE 1 GRAMPA DE CABLE	1	1	1	

FIG. 14 BRACKET 1

SOPORTE 1

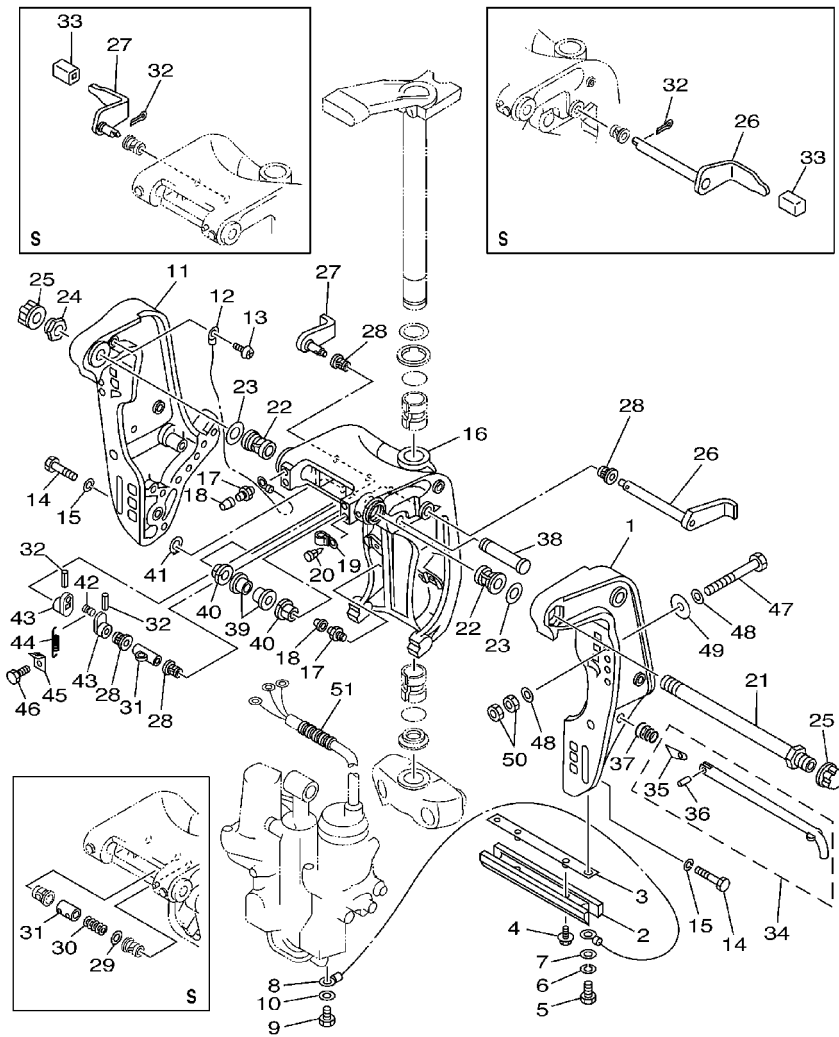

REF. NO.	PART NO. CODIGO NO.	DESCRIPTION DESCRIPTION	ED	ET	EIO	REMARKS OBSERVACION
1	697-43111-05-4D	BRACKET, CLAMP SOPORTE DE LA ABRAZADERA		1		S
	6H1-43111-01-4D	BRACKET, CLAMP SOPORTE DE LA ABRAZADERA		1	1	L
2	6H1-45251-03	ANODE CATODE		1	1	
3	6H1-44526-00	PLATE PLACA 1		1	1	
4	90119-06M29	BOLT, WITH WASHER TORNILLO CON ARANDELA		2	2	
5	97095-06016	BOLT PERNO		2	2	
6	92995-06100	WASHER, SPRING ARANDELA		2	2	
7	92995-06600	WASHER ARANDELA		2	2	
8	6H1-82148-00	WIRE, LEAD 4 CABLE CONDUCTOR 4		1	1	
9	97095-06010	BOLT PERNO		1	1	
10	92995-06600	WASHER ARANDELA		1	1	
11	697-43112-03-4D	BRACKET, CLAMP SOPORTE DE LA ABRAZADERA		1		S
	6H1-43112-00-4D	BRACKET, CLAMP SOPORTE DE LA ABRAZADERA		1	1	L
12	6E5-82148-00	WIRE, LEAD 4 CABLE CONDUCTOR 4		1	1	
13	97880-06012	SCREW, PAN HEAD TORNILLO DE CABEZA CON PLANA		1	1	
14	97095-10045	BOLT PERNO		6	6	
15	92995-10100	WASHER ARANDELA		6	6	
16	697-43311-03-4D	BRACKET, SWIVEL 1 SOPORTE GIRATORIO 1		1		S
	6H1-43311-01-4D	BRACKET, SWIVEL 1 SOPORTE GIRATORIO 1		1	1	L
17	93700-06M03	NIPPLE, GREASE NIPLE DE ENGRASAR		3	3	
18	663-45119-00	CAP, GREASE NIPPLE TAPA DE GRASERA		3	3	AP
19	90465-06M86	CLAMP BRIDA		1		S
	90464-11M18	CLAMP BRIDA		1	1	L
20	90338-05M03	PLUG TAPON		1	1	L
21	688-43131-03	BOLT, CLAMP BRACKET TORNILLO DE ABRAZADERA DEL SOP		1	1	
22	90386-22M15	BUSH BUJE		2	2	
23	90201-22M67	WASHER, PLATE ARANDELA PLANA		2	2	



6H20200-0121

D6

FIG. 14 BRACKET 1

SOPORTE 1

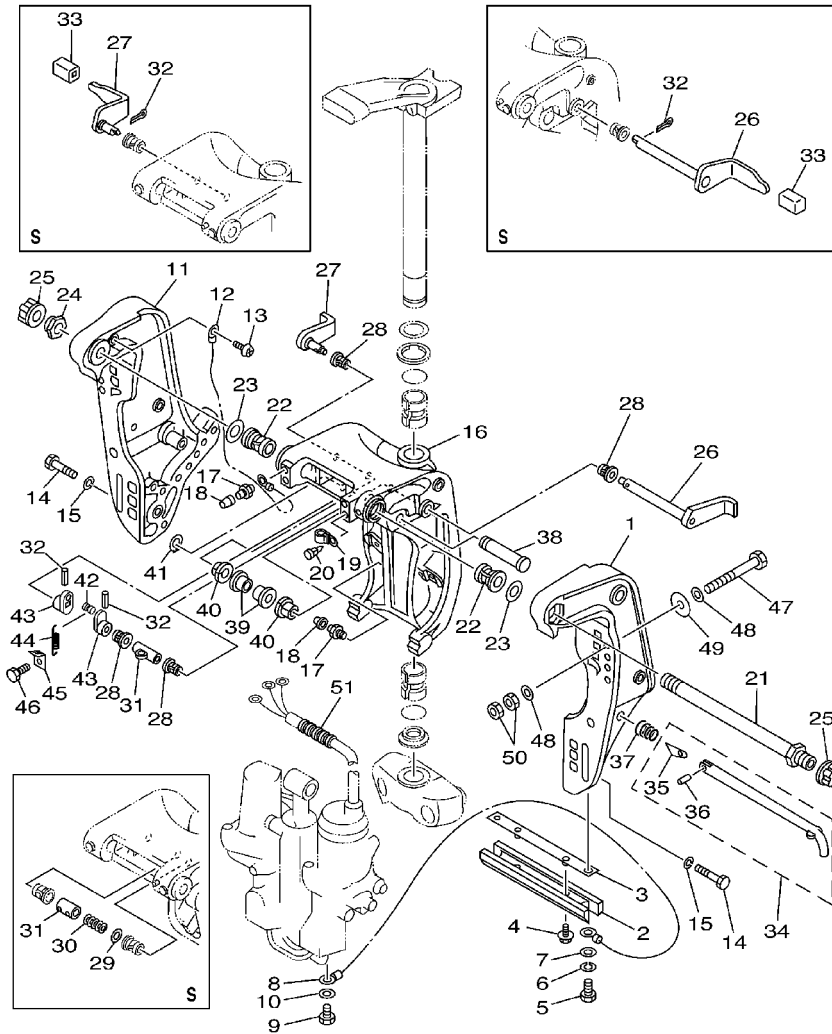

6H20200-0121

REF. NO.	PART NO. CODIGO NO.	DESCRIPTION DESCRIPTION	ED	ET	EIO	REMARKS OBSERVACION
24	90185-22043	NUT, SELF-LOCKING TUERCA AUTOBLOCANTE		1	1	
25	6G5-43145-01	CAP, CLAMP BRACKET TAPA		2	2	
26	688-43181-04	LEVER, TILT STOP PALANCA TOPE INCLINACION		1		S
	6H1-43181-01	LEVER, TILT STOP PALANCA TOPE INCLINACION		1	1	L
27	688-43185-04	LEVER, TILT STOP PALANCA TOPE INCLINACION		1		S
	6H1-43185-01	LEVER, TILT STOP PALANCA TOPE INCLINACION		1	1	L
28	90386-10M16	BUSH BUJE		4	4	
29	92990-10600	WASHER, PLATE ARANDELA		1		S
30	90501-10M21	SPRING, COMPRESSION RESORTE DE COMPRESION		1		S
31	90387-10M38	COLLAR COLLAR		1		S
	90387-10M02	COLLAR COLLAR		1	1	L
32	91490-30025	PIN, COTTER PASADOR DE CHAVETA		2		S
	91690-30020	PIN, SPRING PASADOR DE RESORTE		2	2	L
33	663-43318-00	COVER CUBIERTA		2		S
34	697-43160-00	TILT ROD ASSY VARILLA DE BASCULACION COMPL.		1		S
	688-43160-01	TILT ROD ASSY VARILLA DE BASCULACION COMPL.		1	1	L
35	688-43165-00	.PLATE, TILT LOCK .PLACA DE TOPE, VARILLA SEGUR		1	1	
36	91690-30012	.PIN, SPRING .PASADOR DE RESORTE		1	1	
37	90502-20M03	SPRING, CONICAL RESORTE CONICO		1		S
	90502-16M02	SPRING, CONICAL RESORTE CONICO		1	1	L
38	6E5-43126-02	PIN, UPPER SHOCK MOUNT PASADOR DE AMORTIGUADOR SUPERI		1	1	
39	90386-18M63	BUSH BUJE		2	2	
40	90386-18M35	BUSH BUJE		2	2	
41	93410-18M02	CIRCLIP BOLA		1	1	
42	90249-06M19	PIN PASADOR		1	1	L
43	6G5-43148-00	COLLAR, DISTANCE COLLAR		2	2	L
44	90506-14M24	SPRING, TENSION RESORTE DE TENSION		1	1	L

FIG. 14 BRACKET 1

SOPORTE 1

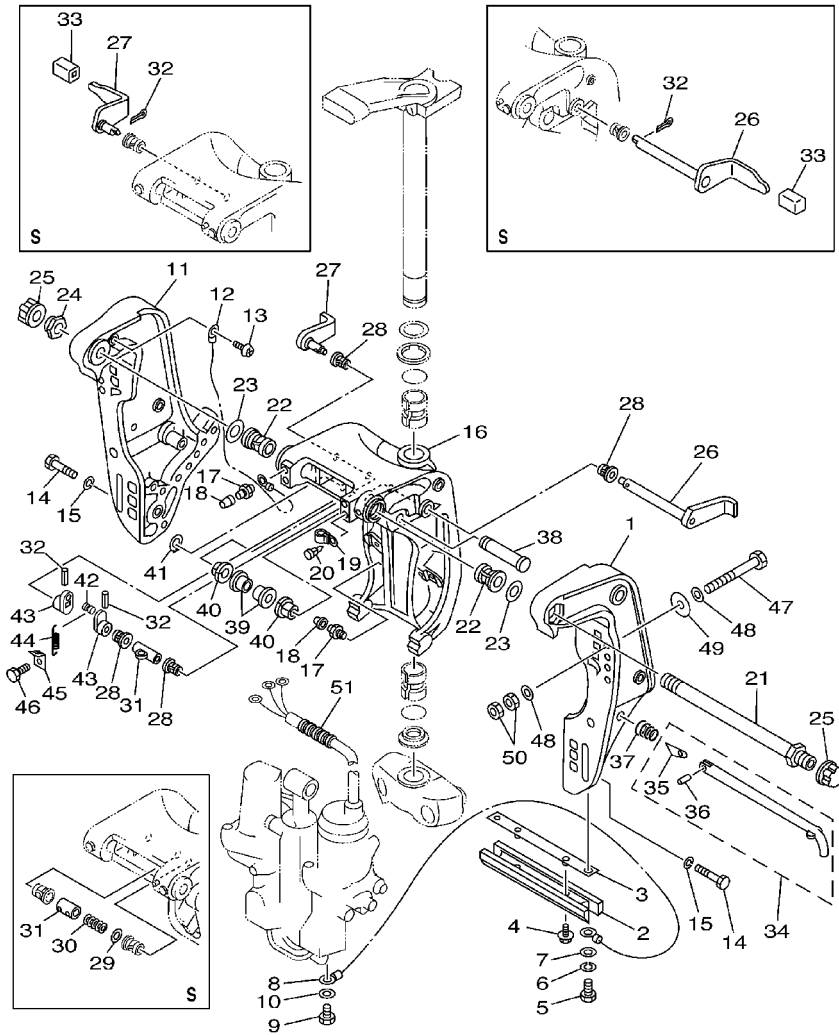

REF. NO.	PART NO. CODIGO NO.	DESCRIPTION DESCRIPTION	ED	ET	ETO	REMARKS OBSERVACION
45	6G5-43144-00	HOOK, SPRING GANCHO		1	1	L
46	97095-06010	BOLT PERNO		1	1	L
47	90101-12M65	BOLT TORNILLO		4	4	
48	92995-12200	WASHER ARANDELA		8	8	
49	90201-12426	WASHER, PLATE ARANDELA PLANA		4	4	
50	95380-12600	NUT TUERCA		8	8	
51	90440-14M00	PIPE TUBO		1	1	



6H20200-0121

FIG. 15 BRACKET 2

SOPORTE 2

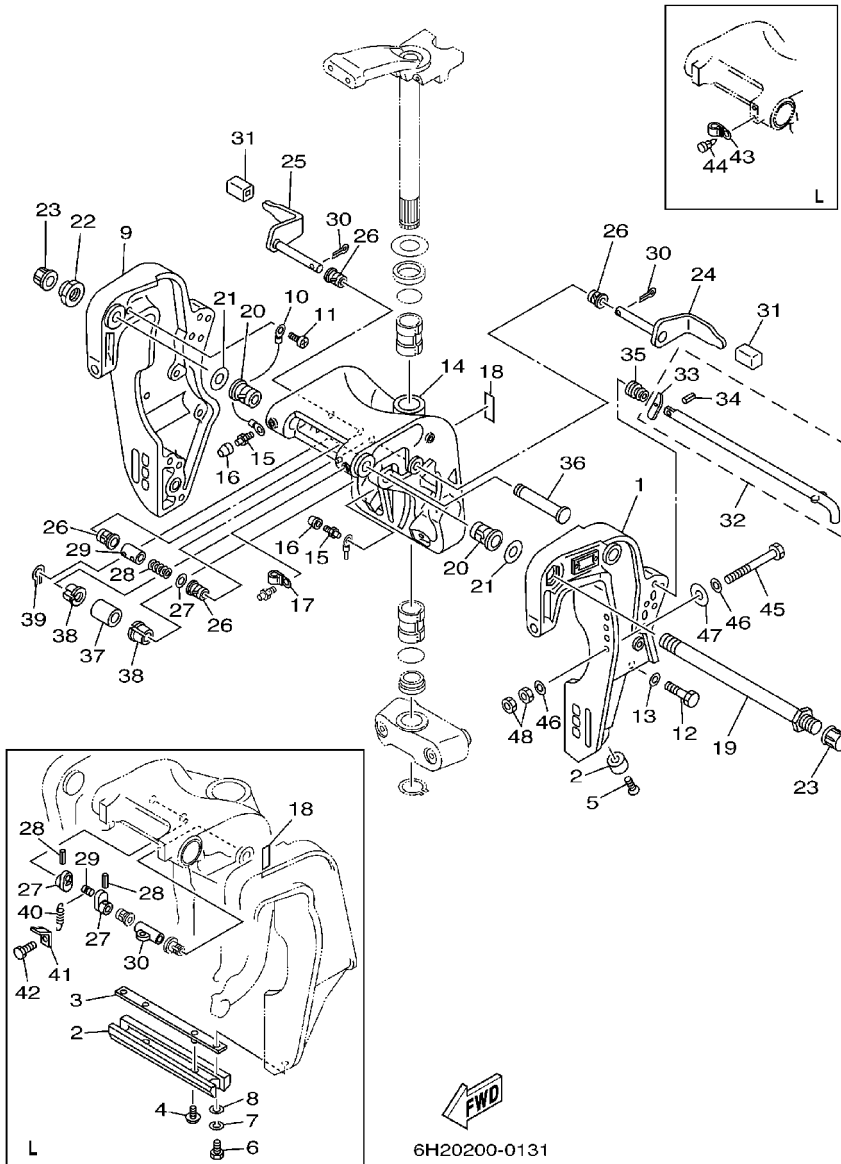

REF. NO.	PART NO. CODIGO NO.	DESCRIPTION DESCRIPTION	ED	ET	ETO	REMARKS OBSERVACION
1	697-43111-05-4D	BRACKET, CLAMP SOPORTE DE LA ABRAZADERA	1			S
	688-43111-13-4D	BRACKET, CLAMP SOPORTE DE LA ABRAZADERA	1			L
2	663-45251-00	ANODE CATODE	2			S
	6H1-45251-03	ANODE CATODE	1			L
3	6H1-44526-00	PLATE PLACA 1	1			L
4	90119-06M29	BOLT, WITH WASHER TORNILLO CON ARANDELA	2			L
5	90152-06M01	SCREW, COUNTERSUNK TORNILLO EMBUTIDO	2			S
6	97095-06016	BOLT PERNO	2			L
7	92995-06100	WASHER, SPRING ARANDELA	2			L
8	92995-06600	WASHER ARANDELA	2			L
9	697-43112-03-4D	BRACKET, CLAMP SOPORTE DE LA ABRAZADERA	1			S
	688-43112-12-4D	BRACKET, CLAMP SOPORTE DE LA ABRAZADERA	1			L
10	6E5-82148-00	WIRE, LEAD 4 CABLE CONDUCTOR 4	1			
11	97880-06012	SCREW, PAN HEAD TORNILLO DE CABEZA CON PLANA	1			
12	97095-10045	BOLT PERNO	6			
13	92995-10100	WASHER ARANDELA	6			
14	697-43311-03-4D	BRACKET, SWIVEL 1 SOPORTE GIRATORIO 1	1			S
	6H1-43311-01-4D	BRACKET, SWIVEL 1 SOPORTE GIRATORIO 1	1			L
15	93700-06M03	NIPPLE, GREASE NIPLE DE ENGRASAR	3			
16	663-45119-00	CAP, GREASE NIPPLE TAPA DE GRASERA	3			AP
17	90465-06M86	CLAMP BRIDA	1			S
18	688-43691-01	INDICATOR, TILT INDICADOR	1			
19	688-43131-03	BOLT, CLAMP BRACKET TORNILLO DE ABRAZADERA DEL SOP	1			
20	90386-22M15	BUSH BUJE	2			
21	90201-22M67	WASHER, PLATE ARANDELA PLANA	2			
22	90185-22043	NUT, SELF-LOCKING TUERCA AUTOBLOCANTE	1			
23	6G5-43145-01	CAP, CLAMP BRACKET TAPA	2			

FIG. 15 BRACKET 2

SOPORTE 2

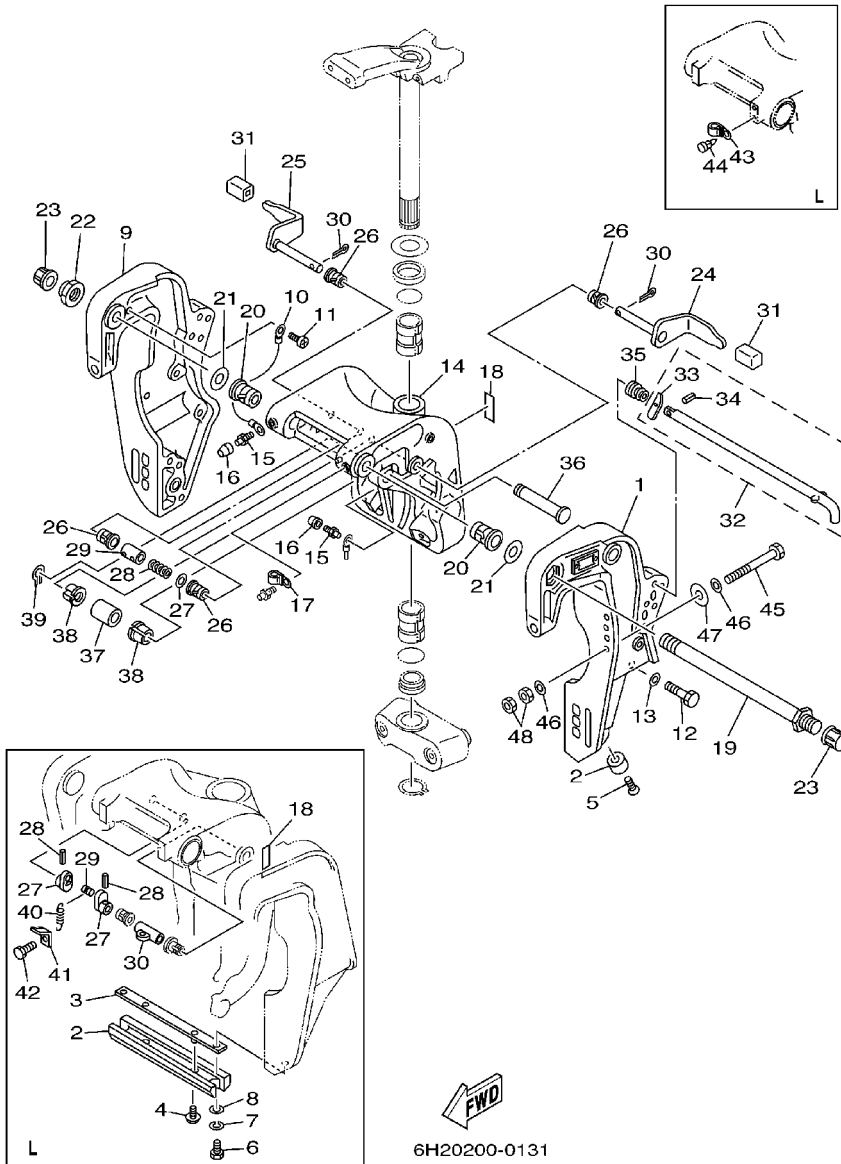

REF. NO.	PART NO. CODIGO NO.	DESCRIPTION DESCRIPTION	ED	ET	ETO	REMARKS OBSERVACION
24	688-43181-04	LEVER, TILT STOP PALANCA TOPE INCLINACION	1			S
	688-43181-10	LEVER, TILT STOP PALANCA TOPE INCLINACION	1			L
25	688-43185-04	LEVER, TILT STOP PALANCA TOPE INCLINACION	1			S
	688-43185-10	LEVER, TILT STOP PALANCA TOPE INCLINACION	1			L
26	90386-10M16	BUSH BUJE	4			
27	92990-10600	WASHER, PLATE ARANDELA	1			S
	6G5-43148-00	COLLAR, DISTANCE COLLAR	2			L
28	90501-10M21	SPRING, COMPRESSION RESORTE DE COMPRESION	1			S
	91690-30020	PIN, SPRING PASADOR DE RESORTE	2			L
29	90387-10M38	COLLAR COLLAR	1			S
	90249-06M19	PIN PASADOR	1			L
30	91490-30025	PIN, COTTER PASADOR DE CHAVETA	2			S
	90387-10M02	COLLAR COLLAR	1			L
31	663-43318-00	COVER CUBIERTA	2			
32	697-43160-00	TILT ROD ASSY VARILLA DE BASCULACION COMPL.	1			S
	688-43160-01	TILT ROD ASSY VARILLA DE BASCULACION COMPL.	1			L
33	688-43165-00	.PLATE, TILT LOCK .PLACA DE TOPE, VARILLA SEGUR	1			
34	91690-30012	.PIN, SPRING .PASADOR DE RESORTE	1			
35	90502-20M03	SPRING, CONICAL RESORTE CONICO	1			S
	90502-16M02	SPRING, CONICAL RESORTE CONICO	1			L
36	6E5-43126-02	PIN, UPPER SHOCK MOUNT PASADOR DE AMORTIGUADOR SUPERI	1			
37	90386-18M21	BUSH BUJE	1			
38	90386-18M35	BUSH BUJE	2			
39	93410-18M02	CIRCLIP BOLA	1			
40	90506-14M24	SPRING, TENSION RESORTE DE TENSION	1			L
41	6G5-43144-00	HÖÖK, SPRING GANCHO	1			L
42	97095-06010	BOLT PERNO	1			L

FIG. 15 BRACKET 2

SOPORTE 2

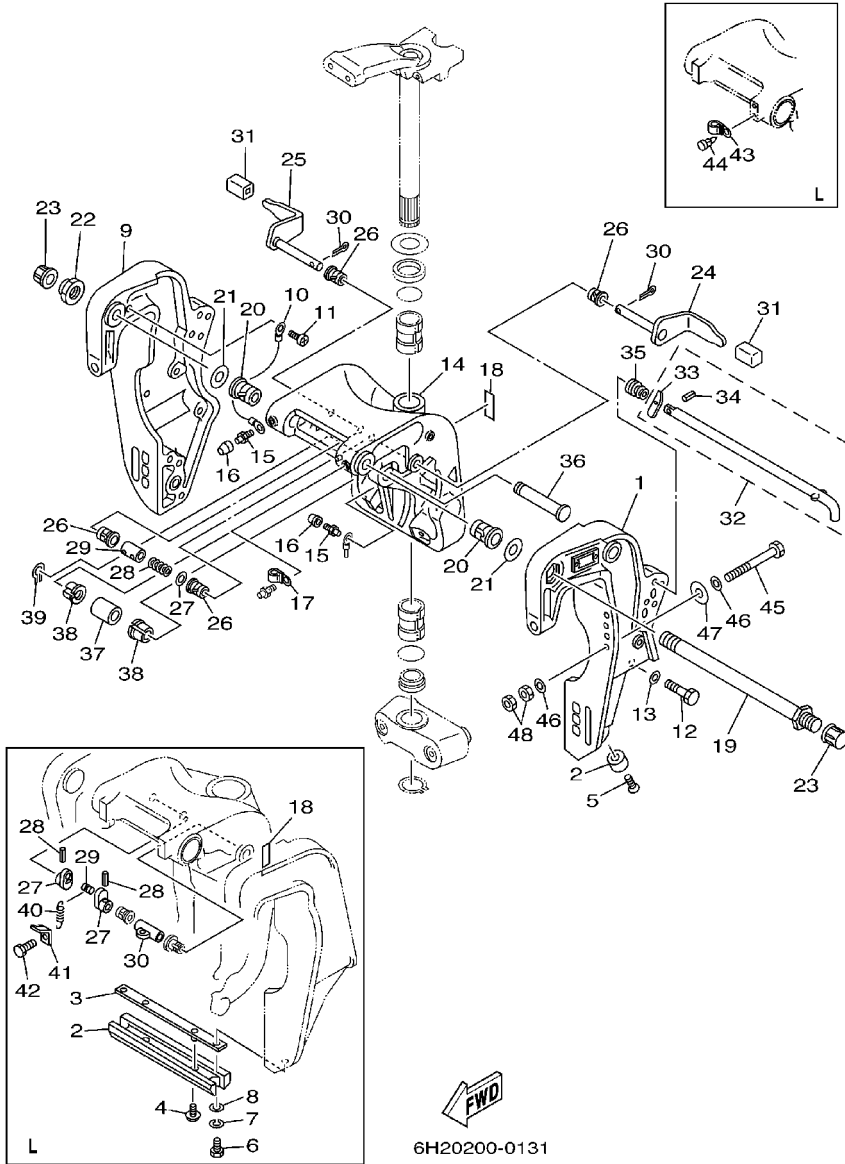

REF. NO.	PART NO. CODIGO NO.	DESCRIPTION DESCRIPTION	ED	ET	ETO	REMARKS OBSERVACION
43	90464-11M18	CLAMP BRIDA	1			L
44	90338-05M03	PLUG TAPON	1			L
45	90101-12M65	BOLT TORNILLO	4			
46	92995-12200	WASHER ARANDELA	8			
47	90201-12426	WASHER, PLATE ARANDELA PLANA	4			
48	95380-12600	NUT TUERCA	8			

FIG. 16 BRACKET 3

SOPORTE 3

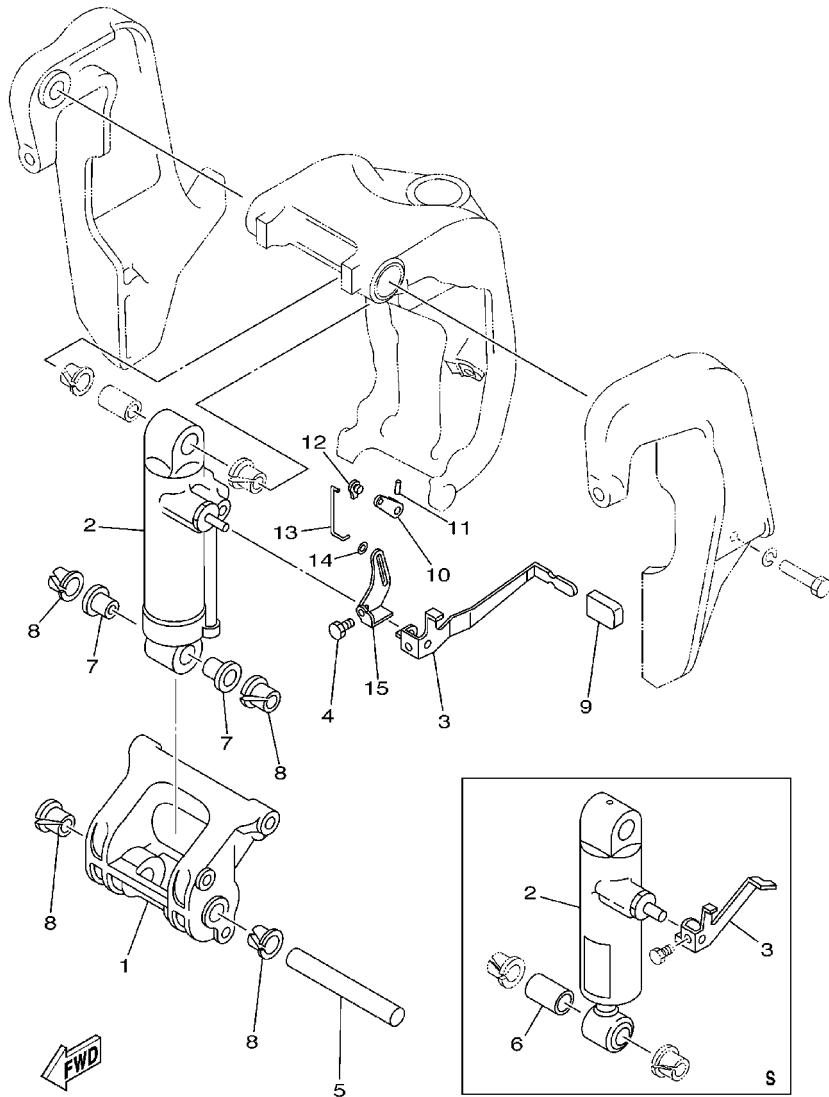

6961200-2160

REF. NO.	PART NO. CODIGO NO.	DESCRIPTION DESCRIPTION	ED	ET	ETO	REMARKS OBSERVACION
1	697-43128-01-4D	SPACER, CLAMP BRACKET ESPACIADOR ABRAZADERA SOPORTE	1			S
	688-43128-01-4D	SPACER, CLAMP BRACKET ESPACIADOR ABRAZADERA SOPORTE	1			L
2	697-43170-03-4D	SHOCK ABSORBER ASSY AMORTIGUADOR COMPL.	1			S
	688-43170-04-4D	SHOCK ABSORBER ASSY AMORTIGUADOR COMPL.	1			L
3	688-43631-00	LEVER, TILT PALANCA DE INCLINACION	1			S
	688-43631-10	LEVER, TILT PALANCA DE INCLINACION	1			L
4	97080-06010	BOLT PERNO	1			
5	688-43124-02	PIN, LOWER SHOCK MOUNT PASADOR DE AMORTIGUADOR INFERI	1			
6	90386-18M21	BUSH BUJE	1			S
7	90386-18M63	BUSH BUJE	2			L
8	90386-18M35	BUSH BUJE	4			
9	682-43318-01	COVER CUBIERTA	1			L
10	688-43186-00	LEVER PALANCA	1			L
11	91690-30020	PIN, SPRING PASADOR DE RESORTE	1			L
12	6J8-41262-00	JOINT, CHOKE LEVER CONECTOR DE AHOGADOR	1			L
13	688-43616-00	ROD, TILT LOCK VARILLA SEGURO DE INCLINACION	1			L
14	90202-03M51	WASHER, PLATE ARANDELA DE PLANA	1			L
15	688-43651-00	LEVER, REVERSE LOCK 1 PALANCA SEGURO DE RESERVA	1			L

FIG. 17 BRACKET 4

SOPORTE 4

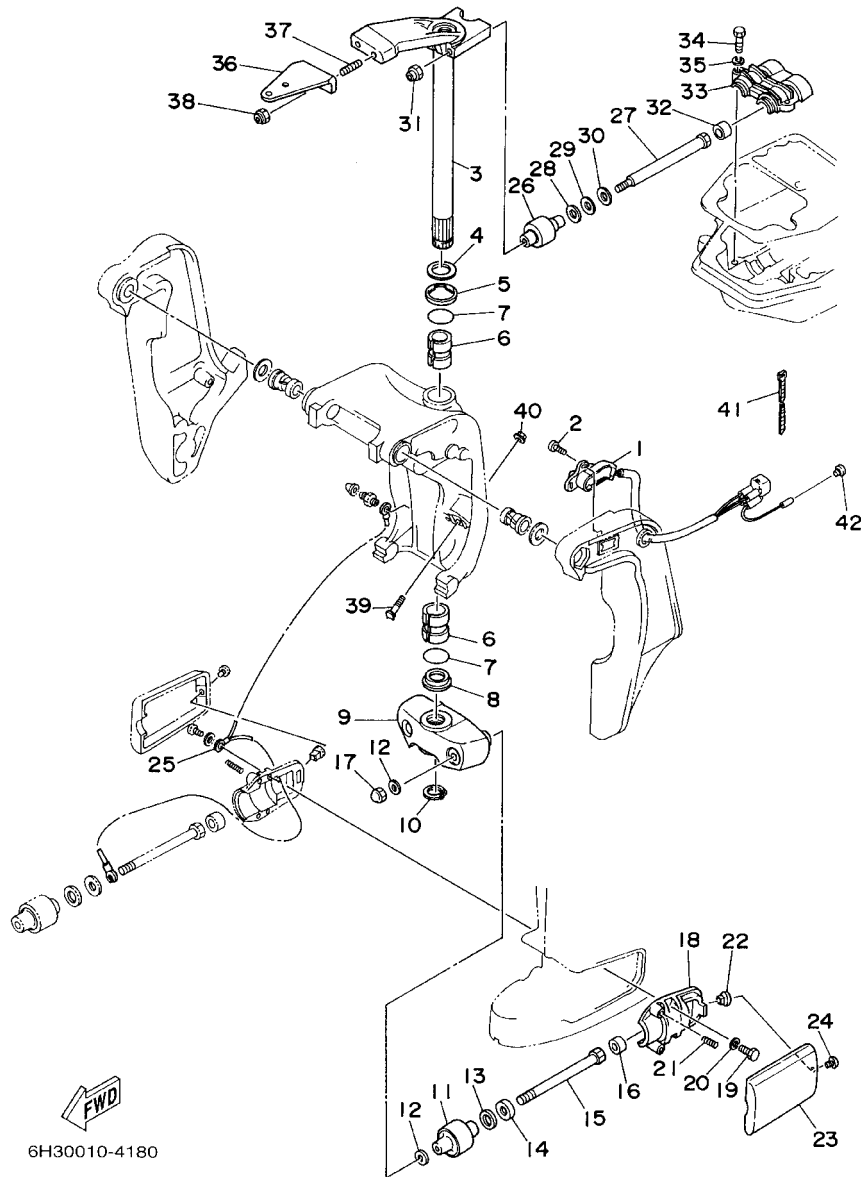

6H30010-4180

REF. NO.	PART NO. CODIGO NO.	DESCRIPTION DESCRIPTION	ED	ET	EIO	REMARKS OBSERVACION
1	6H5-83672-02	TRIM SENDER TRANSMISOR DE INCLINADOR		1		S
	6H1-83672-12	TRIM SENDER TRANSMISOR DE INCLINADOR		1	1	L
2	97885-06016	SCREW, PAN HEAD TORNILLO DE CABEZA CON PLANA		2	2	
3	6H3-42510-02-4D	STEERING BRACKET ASSY SOPORTE DIRECCION COMPL.	1	1		S
	6H3-42510-12-4D	STEERING BRACKET ASSY SOPORTE DIRECCION COMPL.	1	1	1	L
4	90201-30M00	WASHER, PLATE ARANDELA PLANA	1	1	1	
5	90386-30M78	BUSH BUJE	1	1	1	
6	90386-30M77	BUSH BUJE	2	2	2	
7	93210-29M94	O-RING ANILLO O	2	2	2	
8	90386-30M60	BUSH BUJE	1	1	1	
9	6H3-44551-01-4D	HOUSING, LOWER MOUNT RUBBER CAJA AMORTIGUADOR INFERIOR HU	1	1	1	
10	93410-28M06	CIRCLIP BOLA	1	1	1	
11	687-44555-00-94	MOUNT DAMPER, LOWER SIDE AMORTIGUADOR DE HULE LADO INFE	2	2	2	
12	90201-12M16	WASHER, PLATE ARANDELA PLANA	4	4	4	
13	90202-25M04	WASHER, PLATE ARANDELA DE PLANA	2	2	2	
14	90201-13M19	WASHER, PLATE ARANDELA PLANA	2	2	2	
15	90109-12M21	BOLT PERNO	2	2	2	
16	663-44575-00	DAMPER, LOWER MOUNT RUBBER AMORTIGUADOR INFERIOR	2	2	2	
17	95380-12800	NUT, CROWN TUERCA	2	2	2	
18	6H3-44552-03-94	HOUSING, LOWER MOUNT RUBBER CAJA AMORTIGUADOR INFERIOR HU	2	2	2	
19	97075-08025	BOLT PERNO	4	4	4	
20	92995-08100	WASHER ARANDELA	4	4	4	
21	90501-14M08	SPRING, COMPRESSION RESORTE DE COMPRESION	4	4	4	
22	90179-06066	NUT TUERCA	2	2	2	
23	6H3-44553-01-4D	COVER, LOWER MOUNT CUBIERTA, AMORTIGUADOR INFERIOR	2	2	2	
24	97885-06016	SCREW, PAN HEAD TORNILLO DE CABEZA CON PLANA	2	2	2	
25	697-82127-01	WIRE, LEAD 2 CABLE CONDUCTOR 2	1	1		S

FIG. 17 BRACKET 4

SOPORTE 4

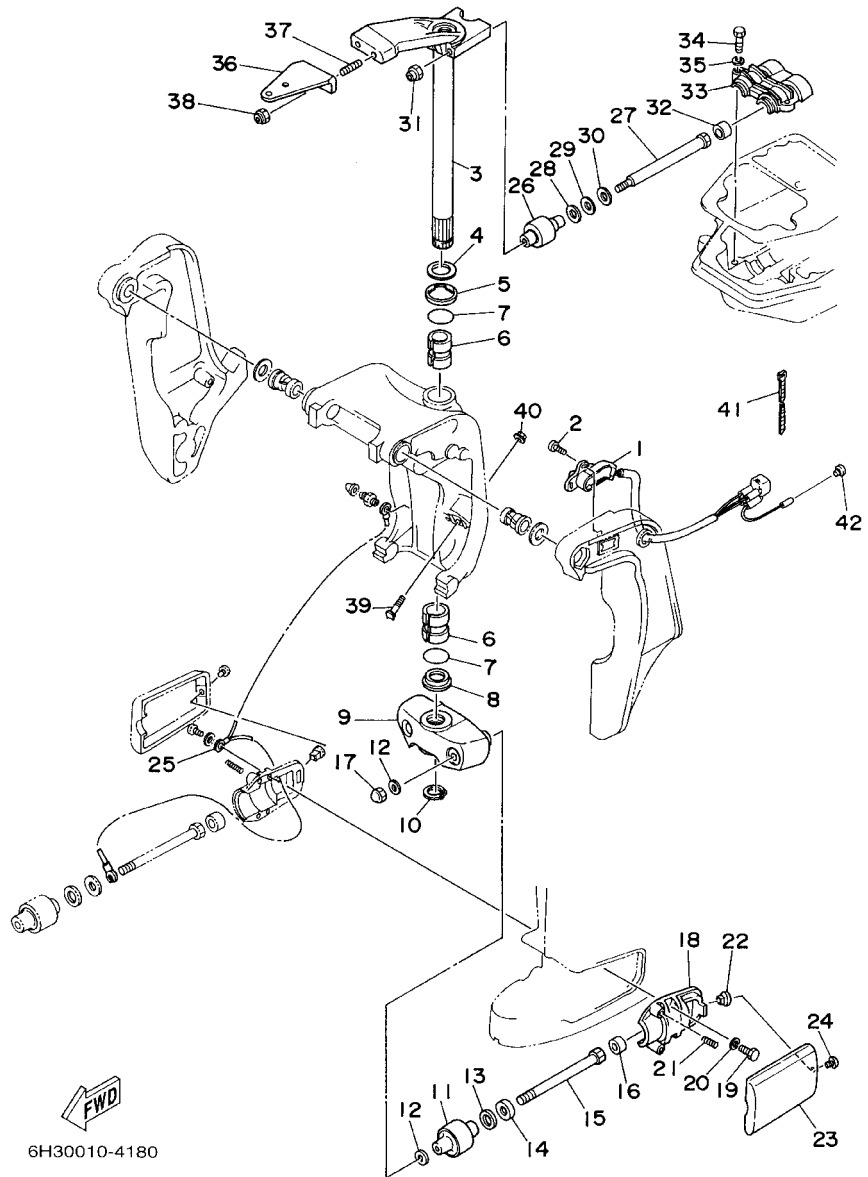

6H30010-4180

REF. NO.	PART NO. CODIGO NO.	DESCRIPTION DESCRIPTION	ED	ET	EIO	REMARKS OBSERVACION
25	688-82127-02	WIRE, LEAD 2 CABLE CONDUCTOR 2	1	1	1	L
26	688-44514-00-94	MOUNT DAMPER, UPPER SIDE AMORTIGUADOR LADO SUPERIOR	2	2	2	
27	90101-10M49	BOLT TORNILLO	2	2	2	
28	90201-20M21	WASHER, PLATE ARANDELA PLANA	2	2	2	
29	90202-20M06	WASHER, PLATE ARANDELA DE PLANA	2	2	2	
30	90201-11M22	WASHER, PLATE ARANDELA PLANA	2	2	2	
31	90185-10051	NUT, SELF-LOCKING TUERCA AUTOBLOCANTE	2	2	2	
32	663-44575-00	DAMPER, LOWER MOUNT RUBBER AMORTIGUADOR INFERIOR	2	2	2	
33	688-44511-00-94	COVER, UPPER MOUNT CUBIERTA AMORTIGUADOR SUPERIOR	1	1	1	
34	97075-08035	BOLT PERNO	3	3	3	
35	92995-08100	WASHER ARANDELA	3	3	3	
36	6H3-48511-51-4D	HOOK, STEERING GANCHO DIRECCION	1	1	1	
37	90116-10175	BOLT, STUD ESPARRAGO			2	70B
	90116-10M28	BOLT, STUD ESPARRAGO	2	2		60F
38	90185-10051	NUT, SELF-LOCKING TUERCA AUTOBLOCANTE	2	2	2	
39	688-43376-01	BOLT, THRUST RECEIVER TORNILLO RECEPTOR		2		S
	6H1-43376-00	BOLT, THRUST RECEIVER TORNILLO RECEPTOR		2	2	L
40	90185-08057	NUT, SELF-LOCKING TUERCA AUTOBLOCANTE		2	2	
41	90465-11M10	CLAMP BRIDA		3	3	
42	703-82119-00	COVER, LEAD WIRE CUBIERTA DE CABLE CONDUCTOR		1	1	

FIG. 18 POWER TRIM & TILT ASSY 1 COMPONER Y PODER VARILLA 1

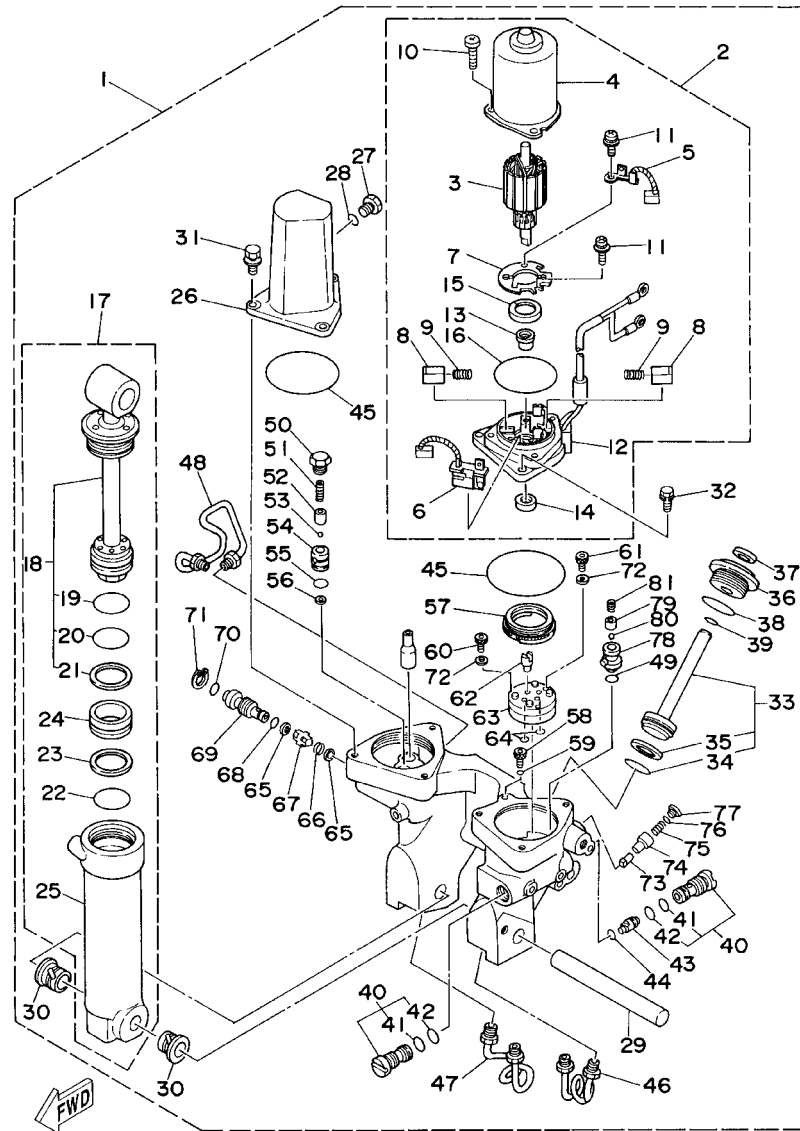

6H20200-4160

REF. NO.	PART NO. CODIGO NO.	DESCRIPTION DESCRIPTION	ED	ET	EIO	REMARKS OBSERVACION
1	6H3-43800-08-4D	POWER TRIM & TILT ASSY ELEVADOR HIDRAULICO COMPL		1		S
2	6H1-43880-02	..MOTOR ASSY ..MOTOR COMPL.		1		
3	6H1-43805-10	..ARMATURE ASSY ..INDUCIDO COMPL.		1		
4	6H1-43804-10	..STATOR ASSY ..ESTATOR COMPL		1		
5	6H1-43891-10	..BRUSH 1 ..ESCOBILLA 1		1		
6	6H1-43892-10	..BRUSH 2 ..ESCOBILLA 2		1		
7	6H1-4380F-10	..PLATE, BRUSH HOLDER ..PLACA		1		
8	6H1-4380J-10	..HOLDER, BRUSH ..PORTAESCOBILLA		2		
9	6H1-4386K-10	..SPRING, BRUSH ..RESORTE, ESCOBILLA		2		
10	97885-05016	..SCREW, PAN HEAD ..TORNILLO DE CABEZA CON PLAN		3		
11	97607-04310	..SCREW, PAN HEAD WITH WASHER ..TORNILLO CAB CON PLANA C/ARA		2		
12	6H1-43881-10	..FRAME, END ..CUADRO EXTERMO		1		
13	6H1-4380H-10	..METAL ..METAL		1		
14	93102-08M43	..OIL SEAL ..SELLO ACEITE		1		
15	6H1-4380G-10	..PLATE ..PLACA		1		
16	6H1-43865-10	..O-RING ..ANILLO EN O 5		1		
17	697-4380E-01	..TILT CYLINDER ASSY ..CILINDRO DE INCLINACION COMPL		1		
18	697-43810-02	..TILT PISTON SUB ASSY ..ELEVADOR SUB-PISTON COMPL		1		
19	6E5-43861-00	..O-RING ..ANILLO EN O 1		1		
20	6E5-43862-00	..O-RING ..ANILLO EN O 2		1		
21	6E5-43872-00	..RING, BACK UP ..ANILLO		1		
22	6E5-43862-00	..O-RING ..ANILLO EN O 2		1		
23	6E5-43872-00	..RING, BACK UP ..ANILLO		1		
24	6E5-43814-01	..PISTON, FREE ..PISTON LIBRE		1		
25	6E5-43813-02	..CYLINDER, TILT ..CILINDRO INCLINACION		1		
26	6E5-43828-00	..BODY, RESERVOIR ..CUERPO DEPOSITO		1		
27	6E5-43829-00	..PLUG, RESERVOIR ..TAPON DEPOSITO		1		

FIG. 18 POWER TRIM & TILT ASSY 1 COMPONER Y PODER VARILLA 1

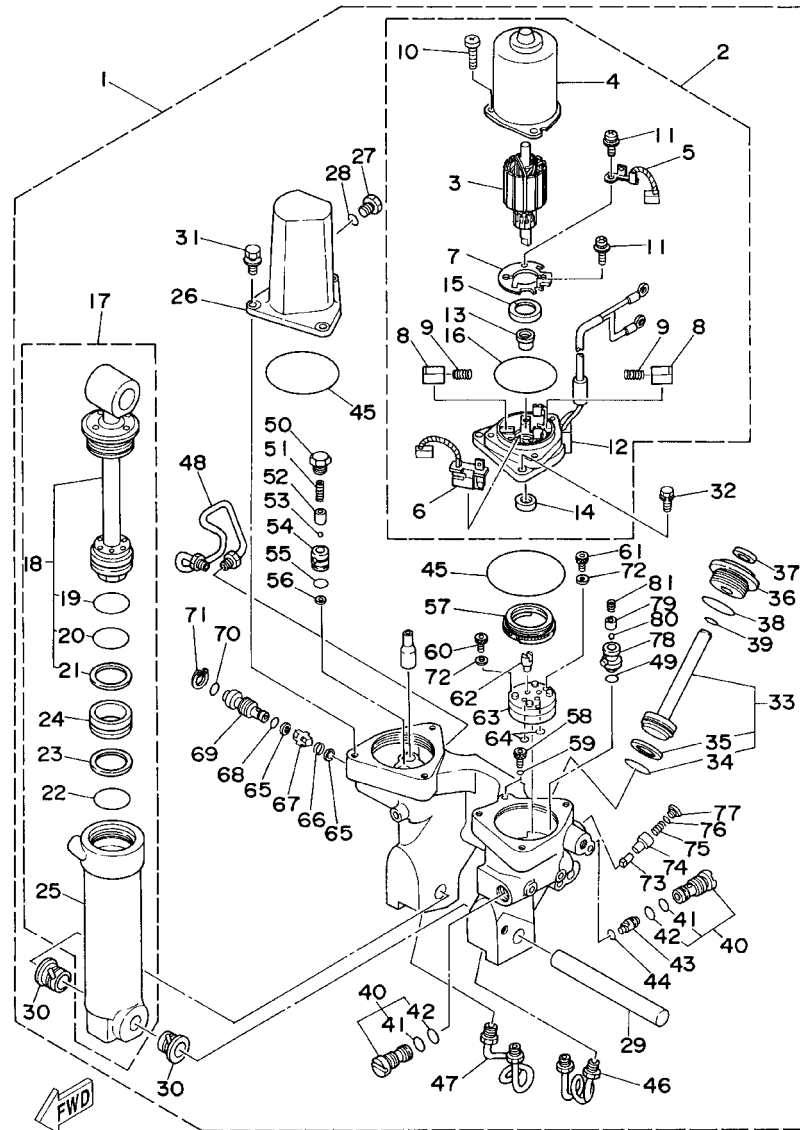

6H20200-4160

REF. NO.	PART NO. CODIGO NO.	DESCRIPTION DESCRIPTION	ED	ET	EIO	REMARKS OBSERVACION
28	6E5-43863-00	.O-RING .ANILLO EN O 3		1		
29	6E5-43818-00	.PIN, LOWER SHOCK MOUNT .PASADOR AMORTIGUADOR INFERIOR		1		
30	90386-18M14	.BUSH .BUJE		2		
31	90119-06M42	.BOLT, WITH WASHER .TORNILLO CON ARANDELA		3		
32	90119-06M71	.BOLT, WITH WASHER .TORNILLO CON ARANDELA		3		
33	6E5-43820-03	.TRIM PISTON SUB ASSY .ELEVADOR PISTON COMPL.		2		
34	6E5-43864-00	.O-RING .ANILLO EN O 4		1		
35	6E5-43874-01	.RING, BACK UP .ANILLO		1		
36	6E5-43821-01	.SCREW, TRIM CYLINDER END .TORNILLO CILINDRO EXTREMO		2		
37	6E5-43822-01	.SEAL, TRIM DUST .SELLO DE POLVO		2		
38	6E5-43862-00	.O-RING .ANILLO EN O 2		2		
39	6E5-43865-00	.O-RING .ANILLO EN O 5		2		
40	6E5-43802-01	.VALVE SUB ASSY .VALVULA PRINCIPAL COMPL.		2		
41	6E5-43866-00	.O-RING .ANILLO EN O 6		1		
42	6E5-43867-00	.O-RING .ANILLO EN O 7		1		
43	6E5-43841-02	.PISTON, SHUTTLE .PISTON		1		
44	6E5-43868-00	.O-RING .ANILLO EN O 8		1		
45	6E5-43869-00	.O-RING .ANILLO EN O 9		2		
46	6E5-43833-01	.PIPE .TUBO 1		1		
47	6E5-43834-01	.PIPE .TUBO 2		1		
48	6E5-43835-00	.PIPE .TUBO 3		1		
49	6E5-43883-00	.O-RING .ANILLO EN O 10		1		
50	6E5-43843-00	.SCREW, VALVE LOCK .TORNILLO		1		
51	6H3-43855-00	.SPRING, UP RELIEF .RESORTE SEGURIDAD SUPERIOR		1		
52	6E5-43859-00	.PIN, VALVE SUPPORT .PASADOR VALVULA SOPORTE		1		
53	6E5-43877-01	.BALL .ESFERA		1		
54	6E5-43895-00	.SEAT, RELIEF VALVE .ASIENTO		1		

FIG. 18 POWER TRIM & TILT ASSY 1 COMPONER Y PODER VARILLA 1

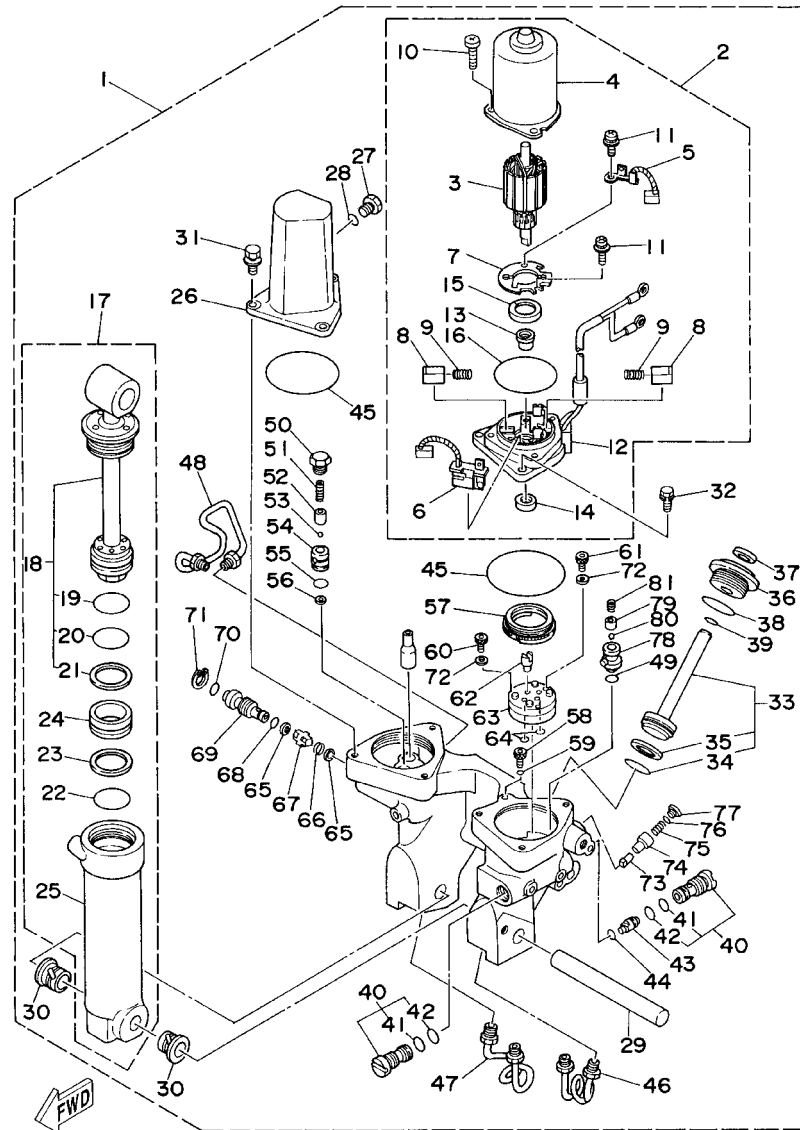

6H20200-4160

REF. NO.	PART NO. CODIGO NO.	DESCRIPTION DESCRIPTION	ED	ET	EIO	REMARKS OBSERVACION
55	6E5-43896-00	.O-RING .ANILLO EN O		1		
56	6E5-43816-10	.FILTER 1 .FILTRO 1		1		
57	6E5-43817-10	.FILTER 2 .FILTRO 2		1		
58	90109-06M21	.BOLT .PERNO		1		
59	6E5-43897-00	.O-RING .ANILLO EN O		1		
60	6E5-43878-01	.BOLT, SOCKET .TORNILLO ENCASTRE		2		
61	6E5-43888-01	.BOLT, SOCKET .TORNILLO ENCASTRE		1		
62	6E5-43831-00	.CONNECTOR, SHAFT .CONEXION EJE		1		
63	6E5-43830-00	.GEAR PUMP ASSY .ENGRANAJE BOMBA COMPL.		1		
64	93210-07M78	.O-RING .ANILLO O		2		
65	6E5-43847-00	.SEAT, MANUAL VALVE .ASIENTO VALVULA MANUAL		2		
66	6E5-43854-01	.SPRING, MANUAL RELEASE .RESORTE DESCOPLO MANUAL		1		
67	6E5-4382A-00	.ADAPTOR 1 .ADAPTADOR 1		1		
68	93210-10M74	.O-RING .ANILLO O		1		
69	6E5-43845-01	.SCREW, MANUAL RELEASE .TORNILLO DESCOPLO MANUAL		1		
70	93210-18M75	.O-RING .ANILLO O		1		
71	6E5-43875-00	.RING, SNAP .ANILLO		1		
72	90201-05M00	.WASHER, PLATE .ARANDELA PLANA		3		
73	6E5-4381A-00	.SHAFT .EJE		1		
74	6E5-43849-01	.PIN, VALVE SUPPORT .PASADOR VALVULA SOPORTE		1		
75	6E5-43824-01	.SPRING, COMPRESSION .RESORTE DE COMPRESION		1		
76	93210-06M77	.O-RING .ANILLO O		1		
77	6E5-43842-00	.SCREW, VALVE SEAT .GRAMPA		1		
78	6G5-43851-00	.SEAT, RELIEF VALVE .ASIENTO VALVULA DE DESCARGA		1		
79	6E5-43844-02	.PIN, VALVE SUPPORT .PASADOR VALVULA SOPORTE		1		
80	6E5-43858-00	.BALL .ESFERA		1		
81	6E5-43856-01	.SPRING, DOWN RELIEF .RESORTE SEGURIDAD		1		

FIG. 19 POWER TRIM & TILT ASSY 2 COMPONER Y PODER VARILLA 2

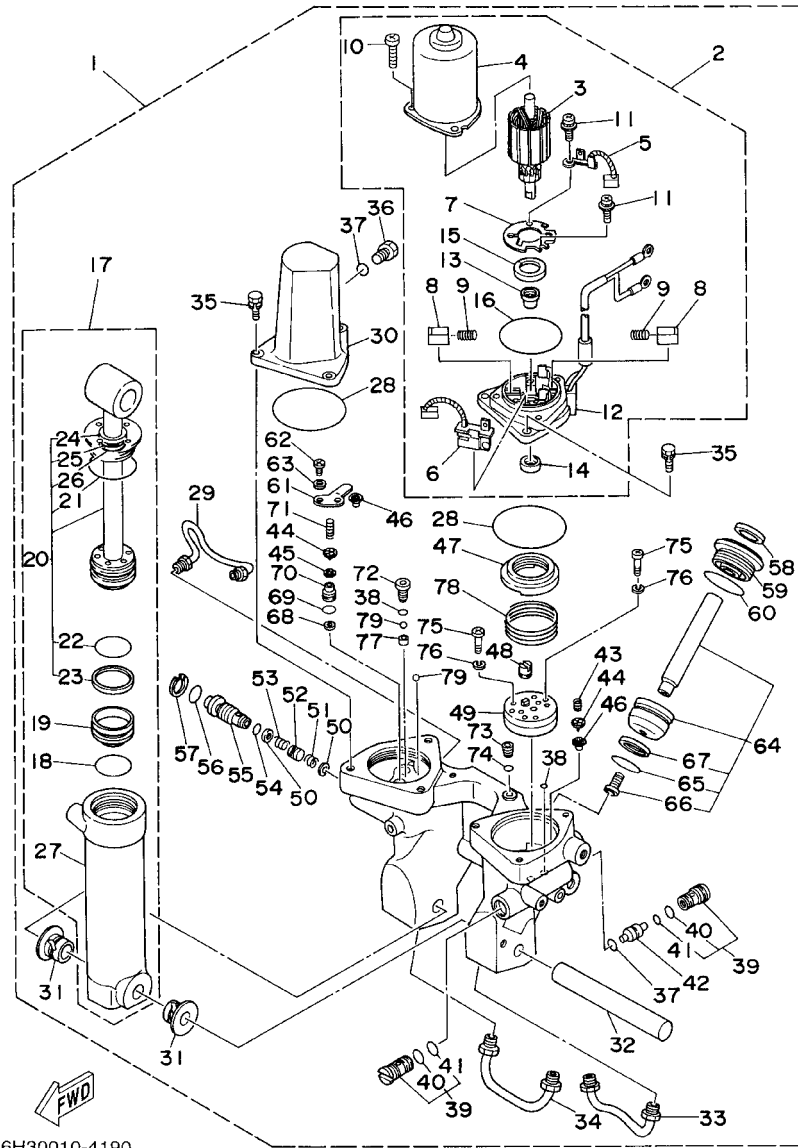

6H30010-4190

REF. NO.	PART NO. CODIGO NO.	DESCRIPTION DESCRIPTION	ED	ET	EIO	REMARKS OBSERVACION
1	6H1-43800-16-4D	POWER TRIM & TILT ASSY ELEVADOR HIDRAULICO COMPL		1	1	L
2	6H1-43880-02	..MOTOR ASSY ..MOTOR COMPL.		1	1	
3	6H1-43805-10	..ARMATURE ASSY ..INDUCIDO COMPL.		1	1	
4	6H1-43804-10	..STATOR ASSY ..ESTATOR COMPL		1	1	
5	6H1-43891-10	..BRUSH 1 ..ESCOBILLA 1		1	1	
6	6H1-43892-10	..BRUSH 2 ..ESCOBILLA 2		1	1	
7	6H1-4380F-10	..PLATE, BRUSH HOLDER ..PLACA		1	1	
8	6H1-4380J-10	..HOLDER, BRUSH ..PORTAESCOBILLA		2	2	
9	6H1-4386K-10	..SPRING, BRUSH ..RESORTE, ESCOBILLA		2	2	
10	97885-05016	..SCREW, PAN HEAD ..TORNILLO DE CABEZA CON PLAN.		3	3	
11	97607-04310	..SCREW, PAN HEAD WITH WASHER ..TORNILLO CAB CON PLANA C/ARA		2	2	
12	6H1-43881-10	..FRAME, END ..CUADRO EXTERMO		1	1	
13	6H1-4380H-10	..METAL ..METAL		1	1	
14	93102-08M43	..OIL SEAL ..SELLO ACEITE		1	1	
15	6H1-4380G-10	..PLATE ..PLACA		1	1	
16	6H1-43865-10	..O-RING ..ANILLO EN O 5		1	1	
17	6H1-43840-11	..POWER TILT ASSY ..CONJUNTO COMPONER		1	1	
18	6H1-43861-10	..O-RING ..ANILLO EN O 1		1	1	
19	6H1-43814-11	..PISTON, FREE ..PISTON LIBRE		1	1	
20	6H1-43810-11	..TILT PISTON SUB ASSY ..ELEVADOR SUB-PISTON COMPL		1	1	
21	6H1-43861-00	..O-RING ..ANILLO EN O 1		1	1	
22	6H1-43861-10	..O-RING ..ANILLO EN O 1		1	1	
23	6H1-43871-10	..RING, BACK UP ..ANILLO		1	1	
24	6H1-43812-00	..SEAL, DUST ..SELLO DE POLVO		1	1	
25	6H1-43872-10	..RING, BACK UP ..ANILLO		1	1	
26	93210-18397	..O-RING ..ANILLO O		1	1	
27	6H1-43813-10	..CYLINDER, TILT ..CILINDRO INCLINACION		1	1	

FIG. 19 POWER TRIM & TILT ASSY 2 COMPONER Y PODER VARILLA 2

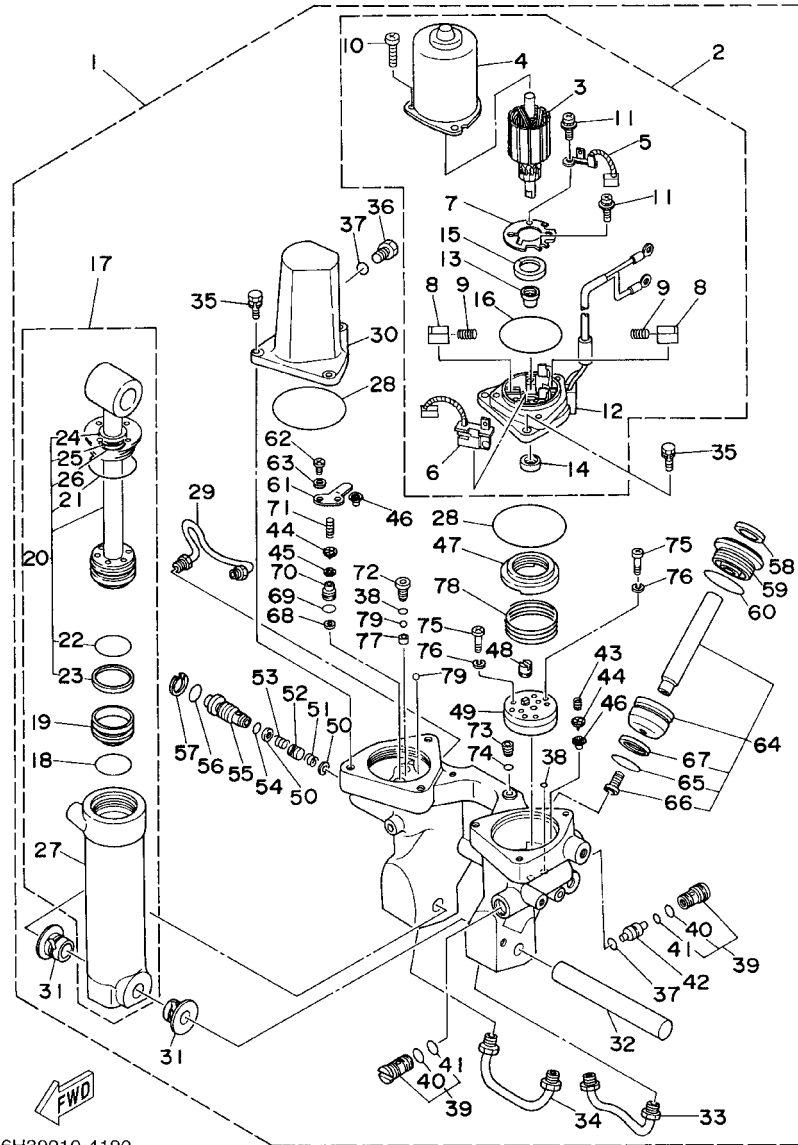

6H30010-4190

REF. NO.	PART NO. CODIGO NO.	DESCRIPTION DESCRIPTION	ED	ET	EIO	REMARKS OBSERVACION
28	93210-64488	.O-RING .ANILLO O		2	2	
29	6H1-43835-10	.PIPE .TUBO 3		1	1	
30	6H1-43828-10	.BODY, RESERVOIR .CUERPO DEPOSITO		1	1	
31	90386-18M14	.BUSH .BUJE		2	2	
32	6E5-43818-00	.PIN, LOWER SHOCK MOUNT .PASADOR AMORTIGUADOR INFERIOR		1	1	
33	6H1-43833-10	.PIPE .TUBO 1		1	1	
34	6H1-43834-00	.PIPE .TUBO 2		1	1	
35	97595-06420	.BOLT, WITH WASHER .PERNO CON ARANDELA RONDELLE		6	6	
36	6H1-43829-00	.PLUG, RESERVOIR .TAPON DEPOSITO		1	1	
37	93210-09165	.O-RING .ANILLO O		2	2	
38	93210-064A5	.O-RING .ANILLO O		3	3	
39	6T4-43802-03	.VALVE SUB ASSY .VALVULA PRINCIPAL COMPL.		2	2	
40	6H1-43866-00	.O-RING .ANILLO EN O 6		1	1	
41	6H1-43867-00	.O-RING .ANILLO EN O 7		1	1	
42	6H1-43841-11	.PISTON, SHUTTLE .PISTON		1	1	
43	6H1-43856-10	.SPRING, DOWN RELIEF .RESORTE SEGURIDAD		1	1	
44	6H1-43844-10	.PIN, VALVE SUPPORT .PASADOR VALVULA SOPORTE		2	2	
45	6H1-4384G-11	.SEAL, RELIEF VALVE .ASIENTO		1	1	
46	6H1-4384F-10	.SEAL, MAIN VALVE .ASIENTO		2	2	
47	6H1-43817-01	.FILTER 2 .FILTRO 2		1	1	
48	6H1-43831-10	.CONNECTOR, SHAFT .CONEXION EJE		1	1	
49	6H1-43830-11	.GEAR PUMP ASSY .ENGRANAJE BOMBA COMPL.		1	1	
50	6H1-43847-00	.SEAT, MANUAL VALVE .ASIENTO VALVULA MANUAL		2	2	
51	6H1-43899-00	.SPRING, MANUAL RELEASE .PLACA		1	1	
52	6H1-4382A-10	.ADAPTOR 1 .ADAPTADOR 1		1	1	
53	6H1-43854-00	.SPRING, MANUAL RELEASE .RESORTE DESCOPLO MANUAL		1	1	
54	93210-10M74	.O-RING .ANILLO O		1	1	

FIG. 19 POWER TRIM & TILT ASSY 2 COMPONER Y PODER VARILLA 2

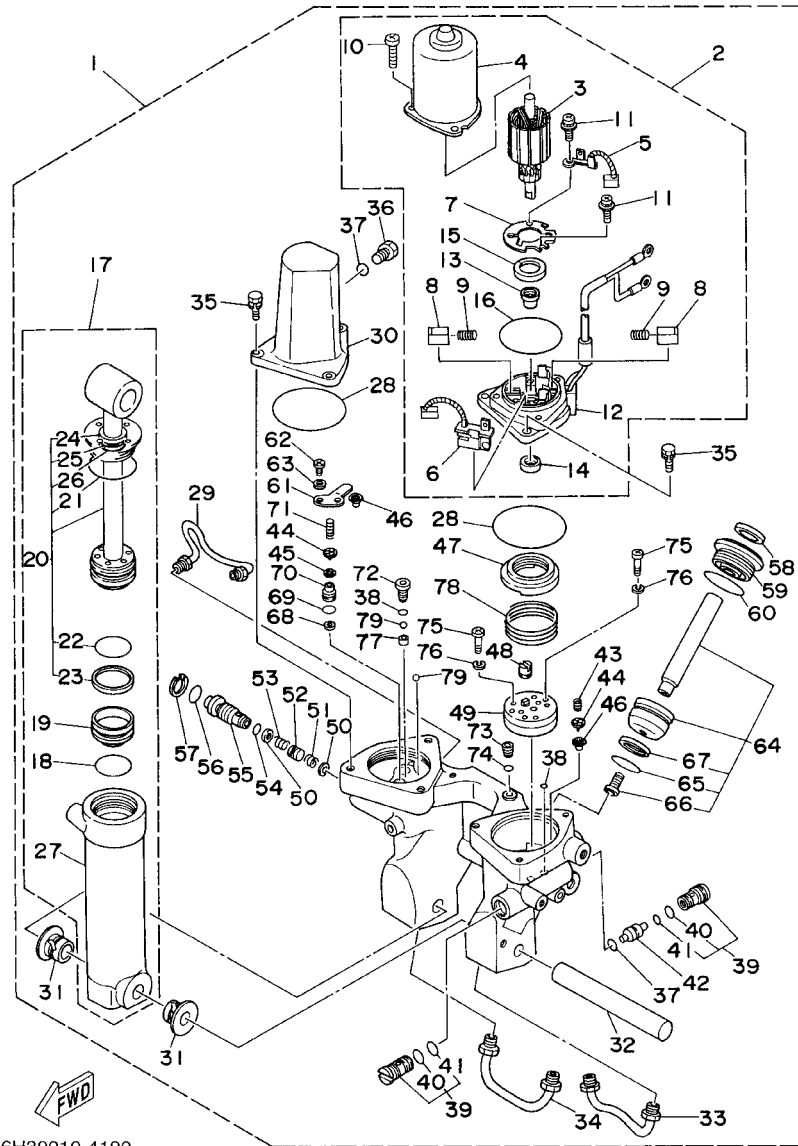

6H30010-4190

REF. NO.	PART NO. CODIGO NO.	DESCRIPTION DESCRIPTION	ED	ET	EIO	REMARKS OBSERVACION
55	6H1-43845-00	.SCREW, MANUAL RELEASE .TORNILLO DESCOPLIO MANUAL		1	1	
56	93210-18M75	.O-RING .ANILLO O		1	1	
57	6H1-43875-00	.RING, SNAP .ANILLO		1	1	
58	6H1-43822-10	.SEAL, TRIM DUST .SELLO DE POLVO		2	2	
59	6H1-43821-11	.SCREW, TRIM CYLINDER END .TORNILLO CILINDURO EXTREMO		2	2	
60	6H1-43861-10	.O-RING .ANILLO EN O 1		2	2	
61	6H1-4384E-20	.SPRING, TRIM .RESORTO		1	1	
62	98501-05010	.SCREW, PAN HEAD .TORNILLO DE CABEZA CON PLANA		2	2	
63	92901-05200	.WASHER, PLAIN .ARANDELA		2	2	
64	6H1-43820-11	.TRIM PISTON SUB ASSY .ELEVADOR PISTON COMPL.		2	2	
65	6H1-43864-00	.O-RING .ANILLO EN O 4		1	1	
66	91318-08016	.BOLT .PERNO		1	1	
67	6H1-43874-00	.RING, BACK UP .ANILLO		1	1	
68	6H1-43816-00	.FILTER 1 .FILTRO 1		1	1	
69	6H1-43896-00	.O-RING .ANILLO EN O		1	1	
70	6H1-43895-12	.SEAT, RELIEF VALVE .ASIENTO		1	1	
71	6H1-43855-11	.SPRING, UP RELIEF .RESORTE SEGURIDAD SUPERIOR		1	1	
72	6H1-43843-11	.SCREW, VALVE LOCK .TORNILLO		1	1	
73	6H1-4388E-11	.PLUG, TAPER SCREW .TAPON		1	1	
74	6H1-43868-00	.O-RING .ANILLO EN O 8		1	1	
75	98501-04025	.SCREW, PAN HEAD .TORNILLO DE CABEZA CON PLANA		4	4	
76	92901-04100	.WASHER, SPRING .ARANDELA		4	4	
77	6H1-4387J-00	.WASHER, SPECIAL 2 .FILTRO2		1	1	
78	6H1-4385H-00	.SPRING, SEAL .RESORTE		1	1	
79	93505-32038	.BALL .BOLA		2	2	

FIG. 20 UPPER CASING

FUNDA SUPERIOR

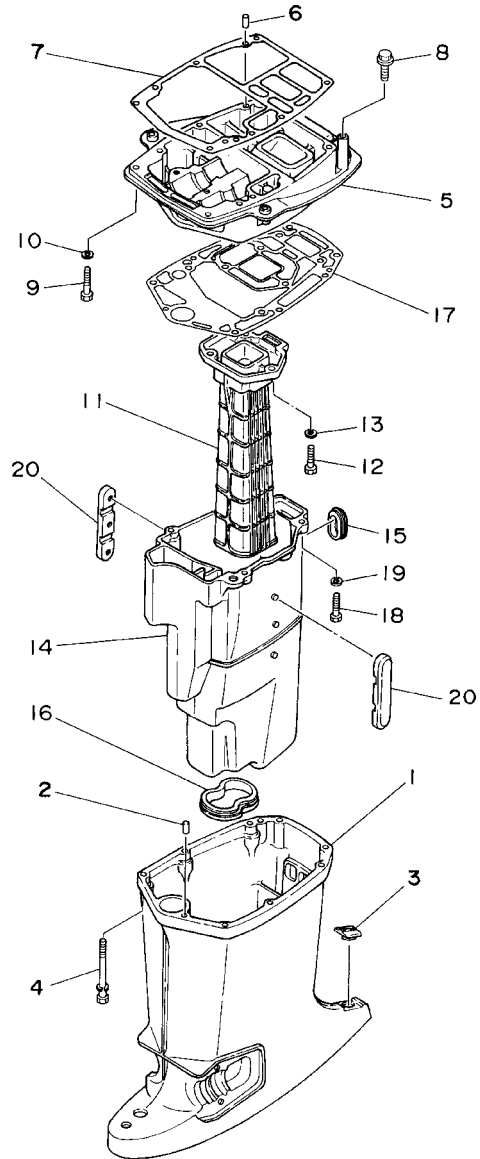

REF. NO.	PART NO. CODIGO NO.	DESCRIPTION DESCRIPTION	ED	ET	EIO	REMARKS OBSERVACION
1	6H3-45111-01-4D	CASING, UPPER CAJA SUPERIOR	1	1		S
	6H3-45111-11-4D	CASING, UPPER CAJA SUPERIOR	1	1	1	L
2	93606-12019	PIN, DOWEL PASADOR DE CLAVIJA	2	2	2	
3	6H3-45155-00	CAP TAPA	1	1	1	
4	90119-08M81	BOLT, WITH WASHER TORNILLO CON ARANDELA	6	6	6	
5	6H3-41137-01-94	GUIDE, EXHAUST GUIA DE ESCAPE	1	1	1	
6	93606-12019	PIN, DOWEL PASADOR DE CLAVIJA	2	2	2	
7	6H3-45113-A0	GASKET, UPPER CASING EMPAQUE	1	1	1	
8	90119-08M79	BOLT, WITH WASHER TORNILLO CON ARANDELA	2	2	2	
9	97075-08035	BOLT PERNO	2	2	2	
10	92995-08100	WASHER ARANDELA	2	2	2	
11	6H3-41131-00-5B	MANIFOLD, EXT. 1 TUBO MULTIPLE DE ESCAPE			1	70B
	6H2-41131-00-5B	MANIFOLD, EXT. 1 TUBO MULTIPLE DE ESCAPE	1	1		60F
12	97075-08030	BOLT PERNO	3	3	3	
13	92995-08100	WASHER ARANDELA	3	3	3	
14	6H3-14711-00-5B	MUFFLER 1 SILENCIADOR 1	1	1		S
	6H3-14711-10-5B	MUFFLER 1 SILENCIADOR 1	1	1	1	L
15	6H3-45127-00	SEAL SELLO DE GOMA	1	1	1	
16	6H3-45123-00	GASKET, MUFFLER EMPAQUE SILENCIADOR	1	1	1	
17	6H3-45114-A1	GASKET, UPPER CASING EMPAQUE	1	1	1	
18	97075-08030	BOLT PERNO	4	4	4	
19	92995-08100	WASHER ARANDELA	4	4	4	
20	6H3-14737-00	DAMPER, MUFFLER AMORTIGUADOR DE SILENCIADOR	2	2		S
	6H3-14737-10	DAMPER, MUFFLER AMORTIGUADOR DE SILENCIADOR	2	2	2	L



6H30100-4190

FIG. 21 LOWER CASING. DRIVE 1

IMPULSOR E INFERIOR 1

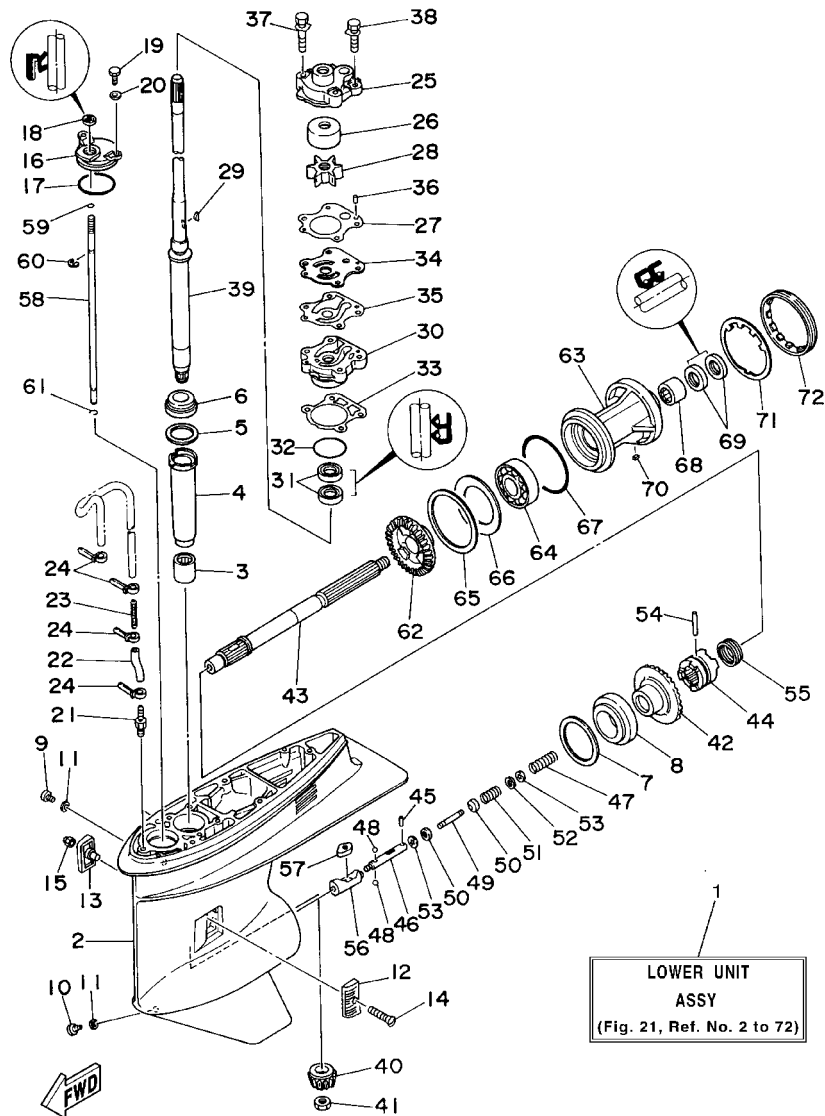

6H20200-1210

REF. NO.	PART NO. CODIGO NO.	DESCRIPTION DESCRIPTION	ED	ET	EIO	REMARKS OBSERVACION
1	6H3-45300-05-4D	LOWER UNIT ASSY CONJUNTO UNIDAD INFERIOR	1	1		S
	6H3-45300-15-4D	LOWER UNIT ASSY CONJUNTO UNIDAD INFERIOR	1	1	1	L
2	6H1-45301-03-4D	CASING, LOWER FUNDA INFERIOR COMPLETA	1	1	1	
3	93315-325V1	BEARING COJINETE	1	1	1	
4	688-45536-01	SLEEVE, DRIVE SHAFT CAMISA EJE DE MANDO	1	1	1	
5	688-45587-01-10	SHIM (T:0.10MM) LAINA (T:0.10MM)	1	1	1	UR
	688-45587-01-12	SHIM (T:0.12MM) LAINA (T:0.12MM)	1	1	1	UR
	688-45587-01-15	SHIM (T:0.15MM) LAINA (T:0.15MM)	1	1	1	UR
	688-45587-01-18	SHIM (T:0.18MM) LAINA (T:0.18MM)	1	1	1	UR
	688-45587-01-30	SHIM (T:0.30MM) LAINA (T:0.30MM)	1	1	1	UR
	688-45587-01-40	SHIM (T:0.40MM) LAINA (T:0.40MM)	1	1	1	UR
	688-45587-01-50	SHIM (T:0.50MM) LAINA (T:0.50MM)	1	1	1	UR
6	93332-000U3	BEARING COJINETE	1	1	1	
7	688-45567-01-10	SHIM (T:0.10MM) LAINA (T:0.10MM)	1	1	1	UR
	688-45567-01-12	SHIM (T:0.12MM) LAINA (T:0.12MM)	1	1	1	UR
	688-45567-01-15	SHIM (T:0.15MM) LAINA (T:0.15MM)	1	1	1	UR
	688-45567-01-18	SHIM (T:0.18MM) LAINA (T:0.18MM)	1	1	1	UR
	688-45567-01-30	SHIM (T:0.30MM) LAINA (T:0.30MM)	1	1	1	UR
	688-45567-01-40	SHIM (T:0.40MM) LAINA (T:0.40MM)	1	1	1	UR
	688-45567-01-50	SHIM (T:0.50MM) LAINA (T:0.50MM)	1	1	1	UR
8	93332-000W7	BEARING COJINETE	1	1	1	
9	90340-08002	PLUG, STRAIGHT SCREW TORNILLO, DE DRENAJE	1	1	1	
10	688-45341-10	PLUG, DRAIN TAPON, DREN	1	1	1	
11	90430-08020	GASKET JUNTA	2	2	2	
12	6H1-45214-00	COVER, WATER INLET CUBIERTA ENTRADA AGUA	1	1	1	
13	6H1-45215-00	COVER, WATER INLET CUBIERTA ENTRADA AGUA	1	1	1	
14	90151-05M00	SCREW, COUNTERSUNK TORNILLO EMBUTIDO	1	1	1	

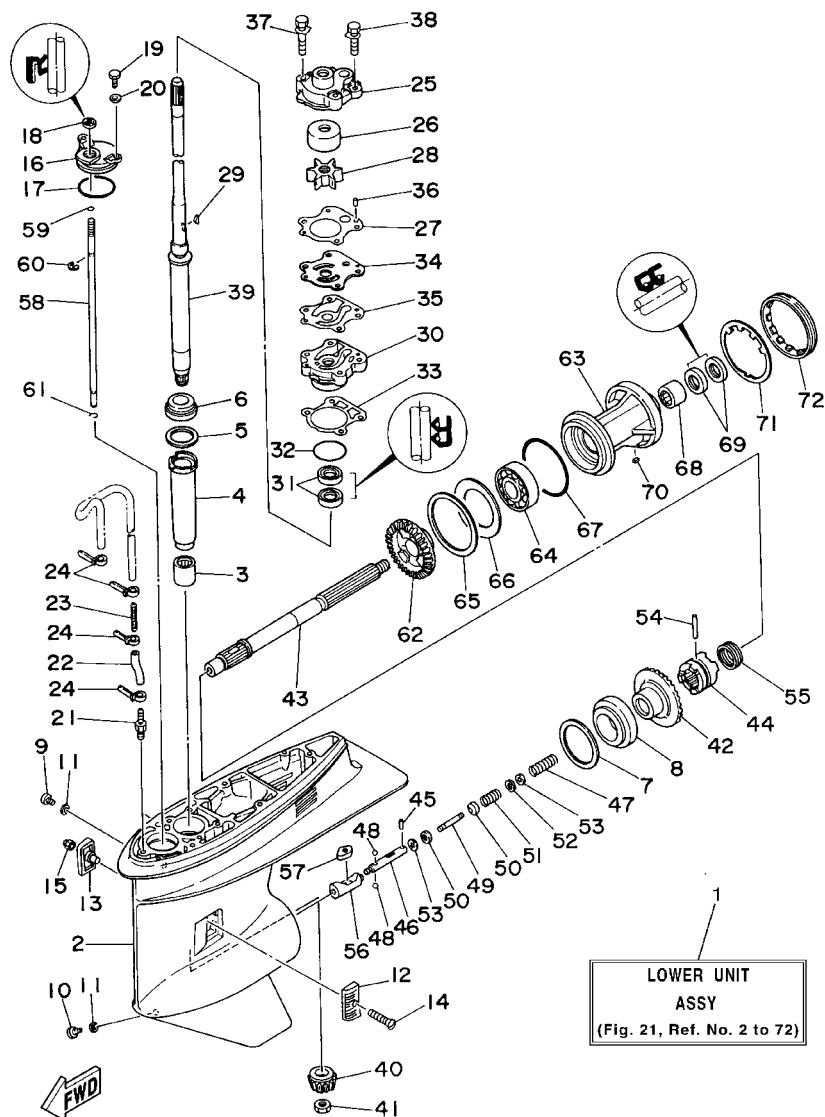

6H20200-1210

FIG. 21 LOWER CASING. DRIVE 1 IMPULSOR E INFERIOR 1

REF. NO.	PART NO. CODIGO NO.	DESCRIPTION DESCRIPTION	ED	ET	EIO	REMARKS OBSERVACION
15	90185-05002	NUT, SELF-LOCKING TUERCA AUTOBLOCANTE	1	1	1	
16	688-45321-00	PLATE PLACA	1	1	1	
17	93210-49046	O-RING ANILLO O	1	1	1	
18	93106-09014	OIL SEAL SELLO ACEITE	1	1	1	
19	97095-06016	BOLT PERNO	2	2	2	
20	92995-06600	WASHER ARANDELA	2	2	2	
21	6E5-45378-00	NIPPLE, HOSE NIPLE MANGUERA	1	1	1	S
22	90445-07ME8	HOSE (L80) TUBO (L80)	1	1	1	L
	90445-07ME9	HOSE (L120) TUBO (L120)	1	1	1	
23	6E5-83558-10	END, NIPPLE EXTREMO DE NIPLE	1	1	1	
24	90465-11M10	CLAMP BRIDA	4	4	4	
25	6H3-44311-00	HOUSING, WATER PUMP CAJA BOMBA DE AGUA	1	1	1	
26	663-44322-00	INSERT, CARTRIDGE CARTUCHO	1	1	1	FOR STD
	663-44322-40	INSERT, CARTRIDGE CARTUCHO	1	1	1	FOR CHROMATE
27	6H3-44315-A0	GASKET, WATER PUMP EMPAQUE	1	1	1	
28	6H3-44352-00	IMPELLER IMPULSOR	1	1	1	
29	90280-03M03	KEY, WOODRUFF CUNA WOODRUFF	1	1	1	
30	6H3-44341-00-94	HOUSING, WATER PUMP CAJA BOMBA DE AGUA	1	1	1	
31	93101-23070	OIL SEAL SELLO ACEITE	2	2	2	
32	93210-46044	O-RING ANILLO O	1	1	1	
33	688-44316-A0	GASKET, WATER PUMP EMPAQUE	1	1	1	
34	6H3-44323-00	OUTER PLATE, CARTRIDGE PLACA EXTERIOR DEL CARTUCHO	1	1	1	FOR STD
	6H3-44323-40	OUTER PLATE, CARTRIDGE PLACA EXTERIOR DEL CARTUCHO	1	1	1	FOR CHROMATE
35	6H3-44324-A0	GASKET, CARTRIDGE EMPAQUE	1	1	1	
36	93604-10M03	PIN, DOWEL PASADOR DE CLAVIJA	2	2	2	
37	90119-08M33	BOLT, WITH WASHER TORNILLO CON ARANDELA	2	2	2	
38	90119-08M14	BOLT, WITH WASHER TORNILLO CON ARANDELA	2	2	2	

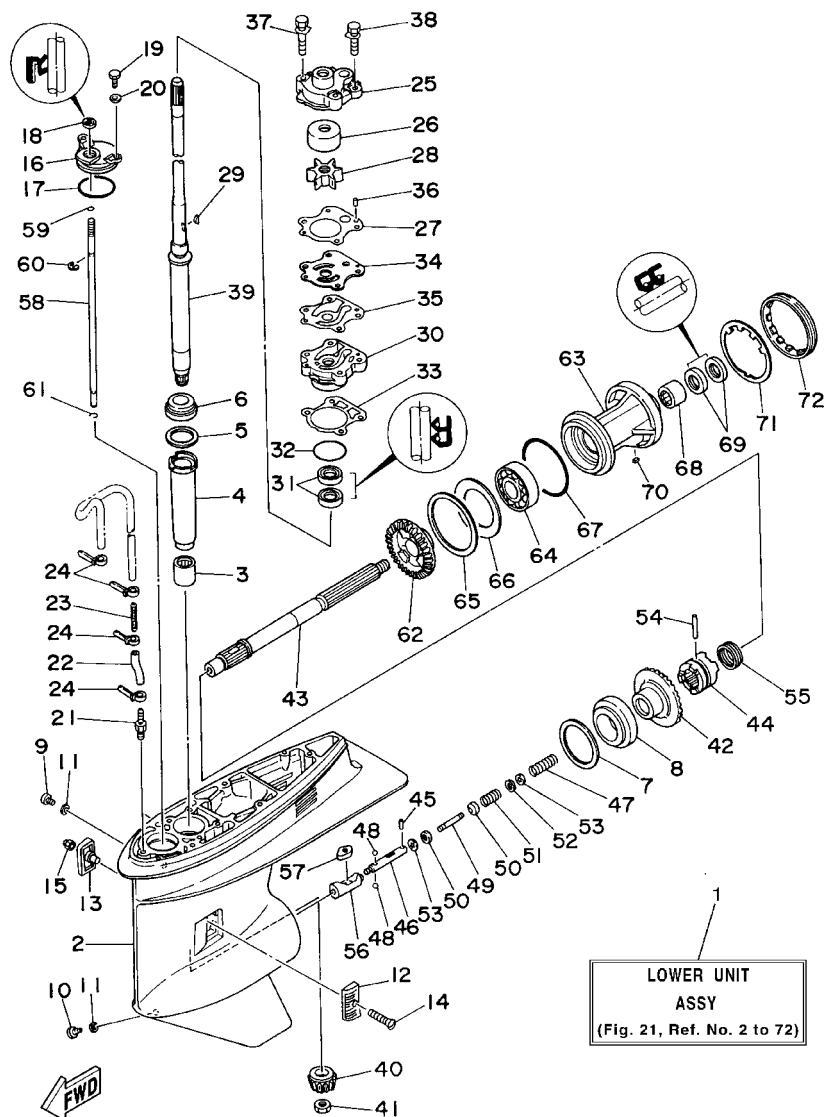

6H20200-1210

FIG. 21 LOWER CASING. DRIVE 1 IMPULSOR E INFERIOR 1

REF. NO.	PART NO. CODIGO NO.	DESCRIPTION DESCRIPTION	ED	ET	EIO	REMARKS OBSERVACION
39	6H3-45501-00	DRIVE SHAFT COMP. EJE DE MANDO COMPL.	1	1		S
	6H3-45501-10	DRIVE SHAFT COMP. EJE DE MANDO COMPL.	1	1	1	L
40	6K5-45551-00	PINION (12T) PINON	1	1	1	
41	90170-16M01	NUT TUERCA	1	1	1	
42	6K5-45560-00	GEAR (28T) ENGRANE COMPLE 1	1	1	1	
43	6H1-45611-01	SHAFT, PROPELLER EJE PROPUSOR	1	1	1	
44	6H1-45631-01	CLUTCH, DOG EMBRAGUE DE GARRA	1	1	1	
45	93603-12M11	PIN, DOWEL PASADOR DE CLAVIJA	1	1	1	
46	6H1-45634-02	SLIDE, SHIFT DESLIZADOR, CAMBIO	1	1	1	
47	90501-16M65	SPRING, COMPRESSION RESORTE DE COMPRESION	1	1	1	
48	93503-16003	BALL BOLA	2	2	2	
49	6H1-45668-00	SHAFT, FREE EJE	1	1	1	
50	6H1-45635-00	PLUNGER, SHIFT EMBOLO DE CAMBIO	2	2	2	
51	90501-12M48	SPRING, COMPRESSION RESORTE DE COMPRESION	1	1	1	
52	90201-03313	WASHER, PLATE ARANDELA PLANA	1	1	1	
53	90183-02M03	NUT, SPRING TUERCA DE RESORTE	2	2	2	
54	90250-07M02	PIN, STRAIGHT PASADOR CILINDRICO	1	1	1	
55	688-45633-00	RING, CROSS PIN ANILLO DE PASADOR	1	1	1	
56	6H1-45641-01	SHIFTER CAMBIO	1	1	1	
57	6H1-44151-00	CAM, SHIFT LEVA DE CAMBIO	1	1	1	
58	6H1-44144-00	ROD, SHIFT VARILLA DE CAMBIO	1	1	1	
59	93210-07003	O-RING ANILLO O	1	1	1	
60	99001-08600	CIRCLIP PRESILLA REDONDA	1	1	1	
61	93450-07M00	CIRCLIP BOLA	1	1	1	
62	6H3-45571-00	GEAR ENGRANAJE	1	1	1	
63	688-45331-00-94	HOUSING, BEARING CAJA DE COJINETE	1	1	1	
64	93306-207U0	BEARING COJINETE	1	1	1	

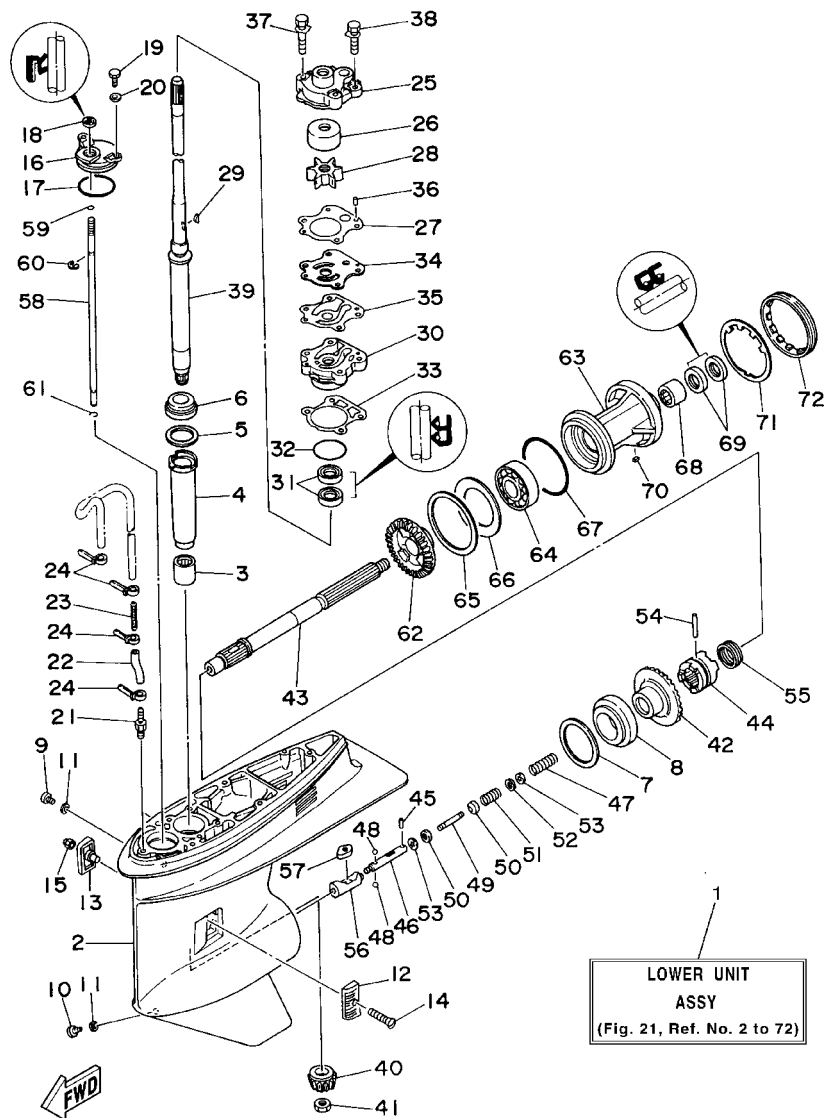

6H20200-1210

FIG. 21 LOWER CASING. DRIVE 1 IMPULSOR E INFERIOR 1

REF. NO.	PART NO. CODIGO NO.	DESCRIPTION DESCRIPTION	ED	ET	EIO	REMARKS OBSERVACION
65	688-45577-01-10	SHIM (T:0.10MM) LAINA (T:0.10MM)	1	1	1	UR
	688-45577-01-12	SHIM (T:0.12MM) LAINA (:0.12MM)	1	1	1	UR
	688-45577-01-15	SHIM (T:0.15MM) LAINA (T:0.15MM)	1	1	1	UR
	688-45577-01-18	SHIM (T:0.18MM) LAINA (T:0.18MM)	1	1	1	UR
	688-45577-01-30	SHIM (T:0.30MM) LAINA (T:0.30MM)	1	1	1	UR
	688-45577-01-40	SHIM (T:0.40MM) LAINA (T:0.40MM)	1	1	1	UR
	688-45577-01-50	SHIM (T:0.50MM) LAINA (T:0.50MM)	1	1	1	UR
66	688-45576-00	WASHER, THRUST ARANDELA DE EMPUJE AXIAL	1	1	1	
67	93210-85M97	O-RING ANILLO O	1	1	1	
68	93317-325U0	BEARING COJINETE	1	1	1	
69	93101-25M03	OIL SEAL SELLO ACEITE	2	2	2	
70	90282-04010	KEY, STRAIGHT CHAVETA, RECTA	1	1	1	
71	688-45383-02	WASHER, CLAW ARANDELA DE UNA	1	1	1	
72	688-45384-00	NUT TUERCA	1	1	1	

FIG. 22 LOWER CASING. DRIVE 2

IMPULSOR E INFERIOR 2

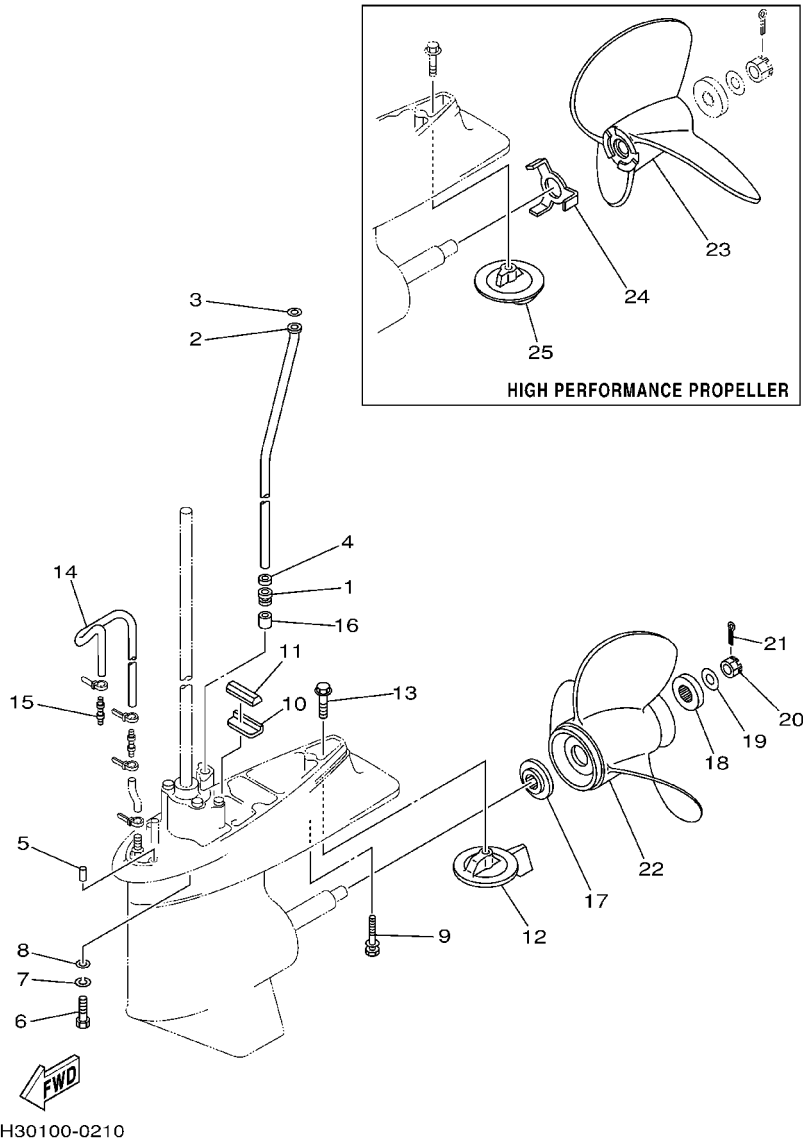

REF. NO.	PART NO. CODIGO NO.	DESCRIPTION DESCRIPTION	ED	ET	EIO	REMARKS OBSERVACION
1	663-44367-00	DAMPER, WATER SEAL GOMA DEL SELLO DE AGUA	1	1	1	
2	6H3-44361-00	TUBE, WATER TUBO DE AGUA	1	1		S
	6H3-44361-10	TUBE, WATER TUBO DE AGUA	1	1	1	L
3	90202-12060	WASHER, PLATE ARANDELA DE PLANA	1	1	1	
4	90430-12072	GASKET JUNTA	1	1	1	
5	93606-12019	PIN, DOWEL PASADOR DE CLAVIJA	2	2	2	
6	97075-10040	BOLT PERNO	4	4	4	
7	92990-10100	WASHER, SPRING ARANDELA	4	4	4	
8	92990-10600	WASHER, PLATE ARANDELA	4	4	4	
9	90119-08M84	BOLT, WITH WASHER TORNILLO CON ARANDELA	1	1	1	
10	663-45376-00-94	GUIDE, SEAL DAMPER GUIA DE SELLO GOMA	1	1	1	
11	688-45375-00	DAMPER, SEAL GOMA DE SELLO	1	1	1	
12	688-45371-02	TAB-TRIM QUILLA ESTABILIZADOR	1	1	1	
13	90105-10M67	BOLT, FLANGE TORNILLO	1	1	1	
14	90445-07MF1	HOSE (L570) TUBO (L570)	1	1	1	
15	6E5-83558-00	END, NIPPLE EXTREMO DE NIPLE	1	1	1	
16	663-44366-00	DAMPER, WATER SEAL GOMA DEL SELLO DE AGUA	1	1	1	
17	688-45987-01	SPACER ESPACIADOR	1	1	1	
18	688-45997-01	SPACER ESPACIADOR	1	1	1	
19	90201-17M00	WASHER, PLATE ARANDELA PLANA	1	1	1	
20	90171-16011	NUT, CASTLE TUERCA ENTALLADA	1	1	1	
21	91490-40025	PIN, COTTER PASADOR DE CHAVETA	1	1	1	
22	6E5-45941-00-EL	PROPELLER (3X13"X19"-K) PROPELA (3X13"X19"-K)	1	1	1	UR
	6E5-45943-00-EL	PROPELLER (3X12-5/8"X21"-K) PROPELA (3X12-5/8"X21"-K)	1	1	1	UR
	6E5-45945-01-EL	PROPELLER (3X13-1/4"X17"-K) PROPELA (3X13-1/4"X17"-K)	1	1	1	UR
	6E5-45947-00-EL	PROPELLER (3X13-1/2"X15"-K) PROPELA (3X13-1/2"X15"-K)	1	1	1	UR
	6E5-45949-00-EL	PROPELLER (3X13-5/8"X13"-K) PROPELA (3X13-5/8"X13"-K)	1	1	1	UR

B1

FIG. 22 LOWER CASING. DRIVE 2

IMPULSOR E INFERIOR 2

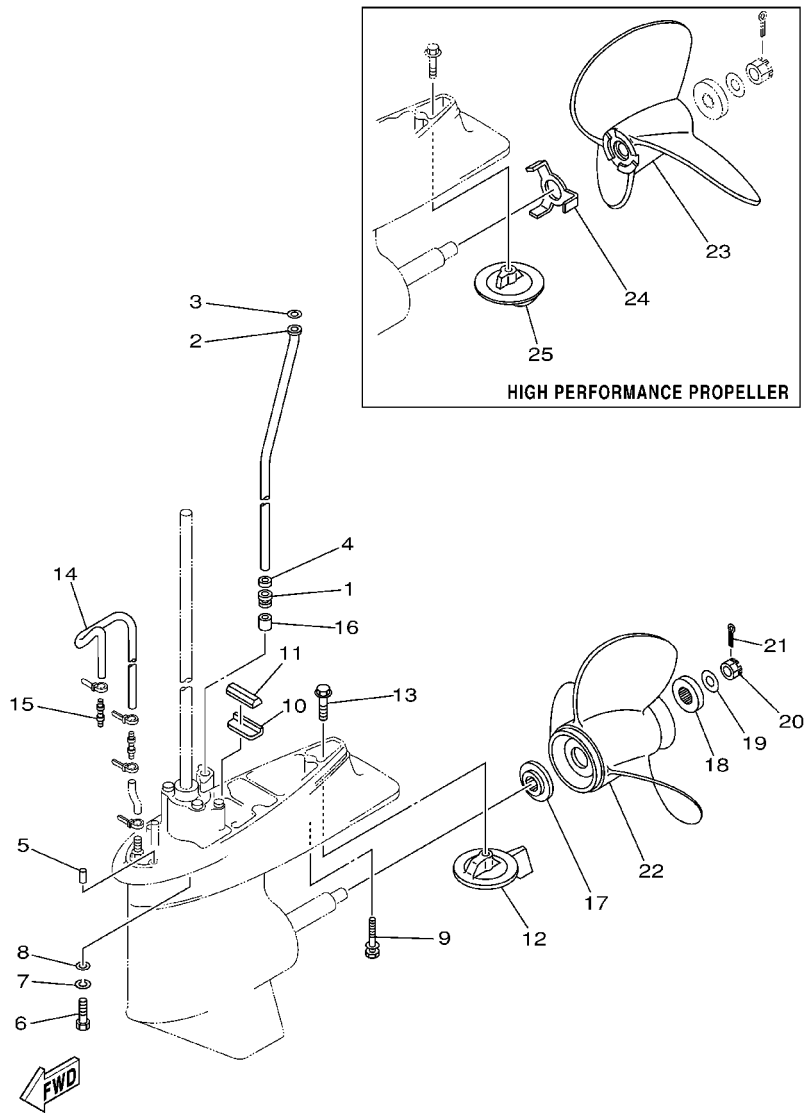

6H30100-0210

REF. NO.	PART NO. CODIGO NO.	DESCRIPTION DESCRIPTION	ED	ET	EIO	REMARKS OBSERVACION
22	6E5-45952-00-EL	PROPELLER (3X13"X23"-K) PROPELA (3X13"X23"-K)	1	1	1	UR
	6E5-45954-00-EL	PROPELLER (3X14"X11"-K) PROPELA (3X14"X11"-K)	1	1	1	UR
	6E5-45956-00-EL	PROPELLER (3X13"X25"-K) PROPELA (3X13"X25"-K)	1	1	1	UR
		STAINLESS STEEL PROPELLER LIMPIO-ACERO DEL PROPELA				
	688-45930-02-98	PROPELLER (3X13"X17"-K) PROPELA (3X13"X17"-K)	1	1	1	UR
	688-45970-03-98	PROPELLER (3X13"X19"-K) PROPELA (3X13"X19"-K)	1	1	1	UR
	688-45972-02-98	PROPELLER (3X13"X21"-K) PROPELA (3X13"X21"-K)	1	1	1	UR
	688-45974-02-98	PROPELLER (3X13"X23"-K) PROPELA (3X13"X23"-K)	1	1	1	UR
	688-45976-01-98	PROPELLER (3X13"X25"-K) PROPELA (3X13"X25"-K)	1	1	1	UR
	688-45932-60-98	PROPELLER (3X13-1/2"X14"-K) PROPELA (3X13-1/2"X14"-K)	1	1	1	UR
	688-45978-60-98	PROPELLER (3X13-1/2"X16"-K) PROPELA (3X13-1/2"X16"-K)	1	1	1	UR
		HIGH PERFORMANCE PROPELLER ALTO COMPOSICION DEL PROPELA				
23	6E5-45970-10	PROPELLER (3X14"X20"-P) PROPELA (3X14"X20"-P)	1	1	1	UR
	6E5-45972-10	PROPELLER (3X14"X24"-P) PROPELA (3X14"X24"-P)	1	1	1	UR
	6E5-45974-10	PROPELLER (3X14"X28"-P) PROPELA (3X14"X28"-P)	1	1	1	UR
	6E5-45976-10	PROPELLER (3X14"X22"-P) PROPELA (3X14"X22"-P)	1	1	1	UR
	6E5-45978-10	PROPELLER (3X14"X26"-P) PROPELA (3X14"X26"-P)	1	1	1	UR
24	6E5-45994-10	PLATE, TOOTH PLACA	1	1	1	
25	6E5-45371-10	TAB-TRIM QUILLA ESTABILIZADOR	1	1	1	

FIG. 23 FUEL TANK

DEPOSITO DE COMBUSTIBLE

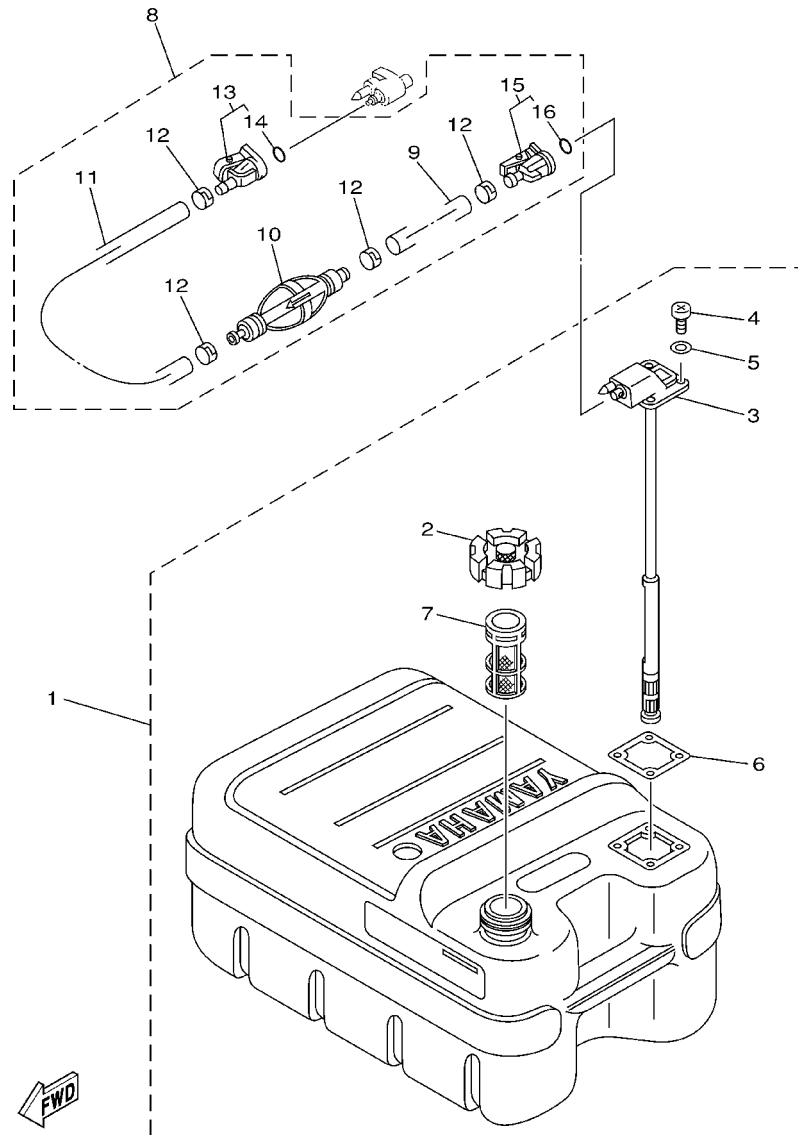

67C0100-9300

REF. NO.	PART NO. CODIGO NO.	DESCRIPTION DESCRIPTION	ED	ET	EIO	REMARKS OBSERVACION
1	6YJ-24201-00	FUEL TANK ASSY (24L)	1	1		AP
	6YJ-24201-10	TANQUE DEL COMBUSTIBLE (24L)		1	1	AP FOR CARIB, CHINA
2	6YJ-24610-01	.CAP ASSY	1	1	1	
		.TAPA COMPLETA				
3	6YJ-24260-00	.FUEL METER ASSY	1	1		
		.MEDIDOR DE COMBUSTIBLE COMPL.				
	6Y1-24260-12	.FUEL METER ASSY		1	1	FOR CARIB, CHINA WITH INDICATOR
		.MEDIDOR DE COMBUSTIBLE COMPL.				
4	98586-05016	.SCREW, PAN HEAD	4	4	4	
		.TORNILLO DE CABEZA CON PLANA				
5	6Y1-24329-00	.SEAL	4	4	4	
		.SELLO				
6	6Y1-24268-00	.GASKET, FUEL METER	1	1	1	
		.EMPAQ MEDIDOR DE COMBUSTIBLE				
7	6YJ-24167-00	.STRAINER	1	1	1	
		.COLADOR				
8	61J-24306-02	FUEL PIPE COMP. 1	1	1	1	AP
		TUBO COMBUST. COMPL 1				
9	90445-11M06	.HOSE (L=2050)	1	1	1	
		.MANGUERA (L=2050)				
10	61J-24360-00	.PRIMER PUMP ASSY	1	1	1	
		.SOPORTE BOMBA				
11	90445-11M05	.HOSE (L=850)	1	1	1	
		.MANGUERA (L=850)				
12	650-24351-51	.BAND 1	4	4	4	
		.ABRAZADERA 1				
13	6G1-24305-03	.FUEL PIPE JOINT COMP. 2	1	1	1	
		.CONECTOR MANGUERA COMBUST.2				
14	93210-08287	.O-RING	1	1	1	
		.ANILLO O				
15	6Y1-24305-04	.FUEL PIPE JOINT COMP. 2	1	1	1	
		.CONECTOR MANGUERA COMBUST.2				
16	93210-08287	.O-RING	1	1	1	
		.ANILLO O				

FIG. 24 STEERING GUIDE

DIRECCIONGUIAR

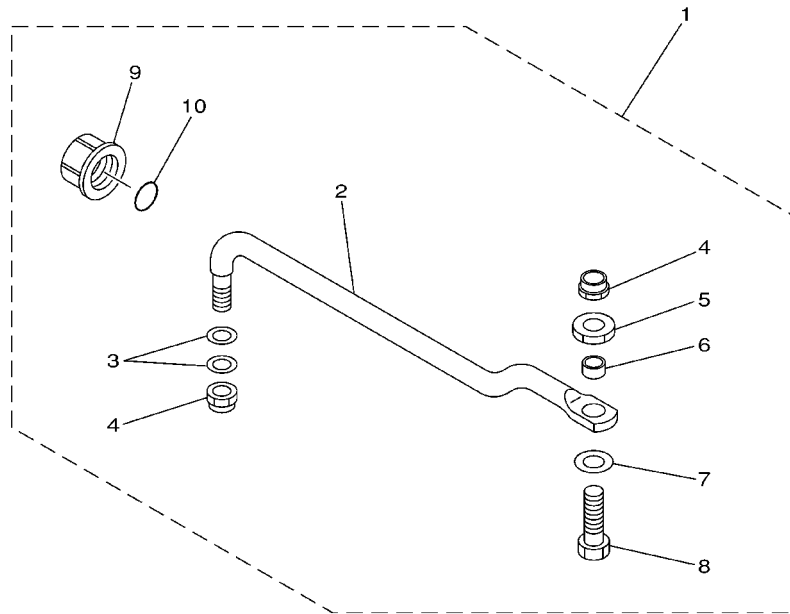

REF. NO.	PART NO. CODIGO NO.	DESCRIPTION DESCRIPTION	ED	ET	E/O	REMARKS OBSERVACION
1	688-61350-10	STEERING GUIDE ATTACHMENT KIT ESTUCHE ADITAMENTO GUIA DE TIM		1	1	AP
2	688-61351-10	.ROD, STEERING LINK .VARILLA ESLABON DIRECCION		1	1	
3	90201-10M20	.WASHER, PLATE .ARANDELA PLANA		2	2	
4	90185-09M01	.NUT, SELF-LOCKING .TUERCA AUTOBLOCANTE		2	2	
5	90170-09M03	.NUT .TUERCA		1	1	
6	90387-10M42	.COLLAR .COLLAR		1	1	
7	90201-10M63	.WASHER, PLATE .ARANDELA PLANA		1	1	
8	6E5-61355-00	.BOLT .TORNILLO		1	1	
9	6E5-43145-01	.CAP, CLAMP BRACKET .TAPA		1	1	
10	93210-16275	.O-RING .ANILLO O		1	1	

6880700-9190

FIG. 25 REMOTE CONTROL BOX CONTROL REMOTO COMPL.

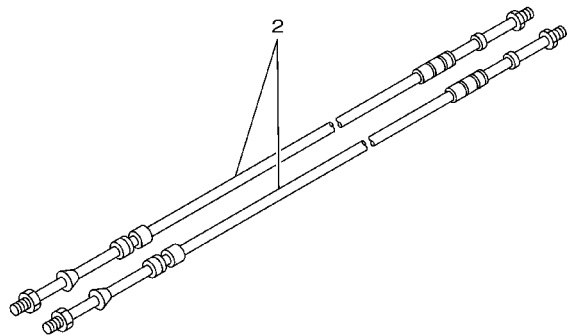
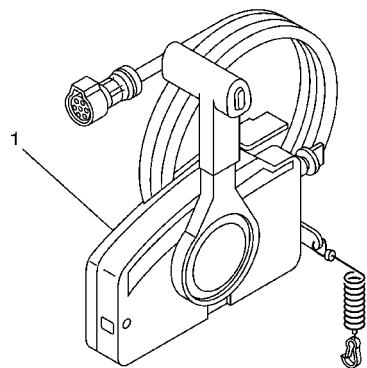

67M0100-8280

REF. NO.	PART NO. CODIGO NO.	DESCRIPTION DESCRIPTION	ED	ET	EIO	REMARKS OBSERVACION
1	703-48205-A4	REMOTE CONTROL ASSY REMOTO CONTROL COMPL.		1	1	AP WITH PT/T SW.
	703-48203-A2	REMOTE CONTROL ASSY REMOTO CONTROL COMPL.	1			AP
2	701-48320-20	CABLE, REMOTE CONTROL L=13F CABLE CONTROL REMOTO L=13F	2	2	2	UR
	701-48320-30	CABLE, REMOTE CONTROL L=14F CABLE CONTROL REMOTO L=14F	2	2	2	UR
	701-48320-50	CABLE, REMOTE CONTROL L=15F CABLE CONTROL REMOTO L=15F	2	2	2	UR

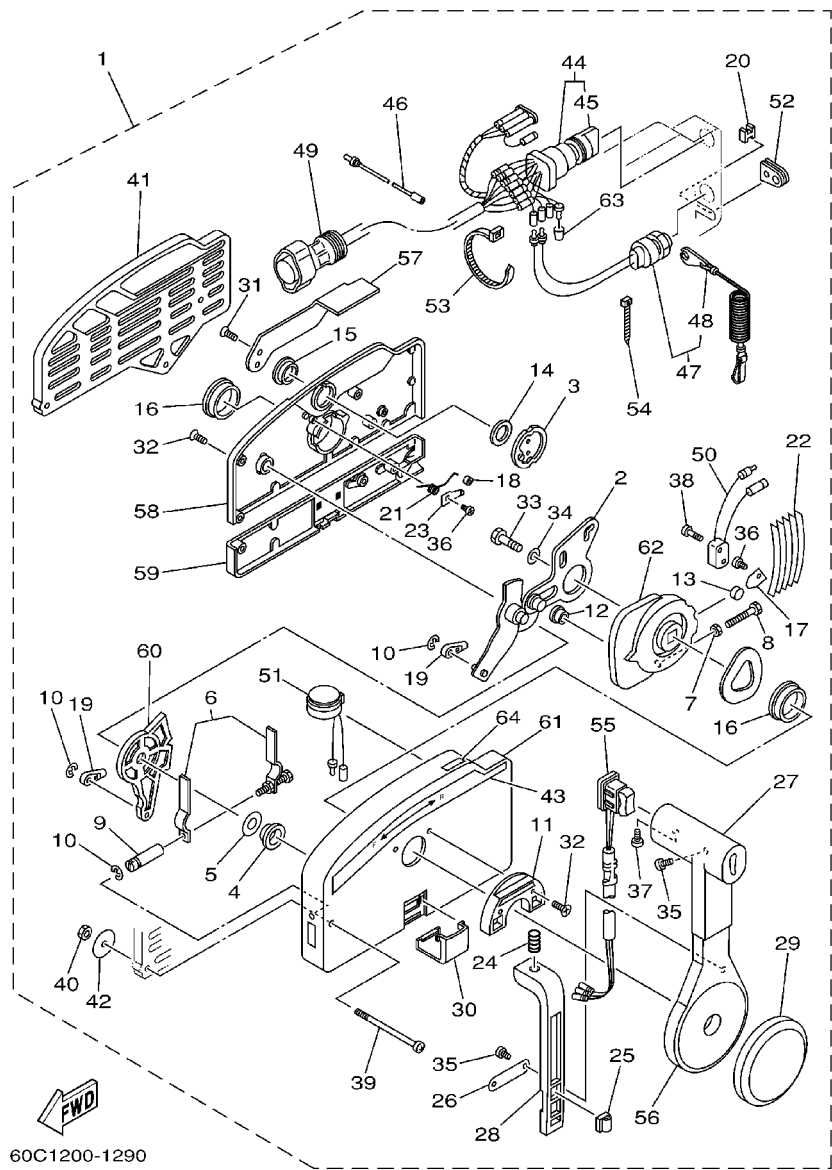

60C1200-1290

FIG. 26 REMOTE CONTROL ASSY CONTROL REMOTO COMPL.

REF. NO.	PART NO. CODIGO NO.	DESCRIPTION DESCRIPTION	ED	ET	EIO	REMARKS OBSERVACION
1	703-48205-A4	REMOTE CONTROL ASSY REMOTO CONTROL COMPL.		1	1	AP WITH PT/T SW.
	703-48203-A2	REMOTE CONTROL ASSY REMOTO CONTROL COMPL.	1			AP
2	703-48261-01	.ARM, THROTTLE .BRAZO ACELERADOR	1	1	1	
3	703-48153-00	.SHAFT, FREE ACCEL. .EJE	1	1	1	
4	703-48235-00	.BUSHING .BUJE	1	1	1	
5	703-48268-00	.SPACER .ESPACIADOR 3	1	1	1	
6	703-48264-00	.THROTTLE, FRICTION .FRICCION ACELERADOR	1	1	1	
7	95380-05600	.NUT .TUERCA	1	1	1	
8	97380-05025	.BOLT .PERNO	1	1	1	
9	703-48265-00	.SHAFT, FRICTION .EJE FRICCION	1	1	1	
10	93430-06024	.CIRCLIP .BOLA	3	3	3	
11	703-48245-00	.PLATE, LOCK .PLACA CERRADURA	1	1	1	
12	703-48252-00	.ROLLER, CAM .RODILLO LEVA	1	1	1	
13	701-48248-00	.ROLLER, FREE ACCEL. .RODILLO ACELERADOR LIBRE	1	1	1	
14	703-48198-00	.WASHER, WAVE .RONDANA ONDULADA 3	1	1	1	
15	703-48243-00	.BUSHING .BUJE 3	1	1	1	
16	703-48236-00	.BUSHING 1 .BUJE	2	2	2	
17	703-48189-00	.RETAINER .RETENEDOR	1	1	1	
18	703-48234-00	.ROLLER, DETENT .RODILLO	1	1	1	
19	703-48345-01	.CABLE END, REMOTE CONTROL 2 .TERMINAL CABLE DE CONTROL REM	2	2	2	
20	703-48358-00	.ANCHOR, CABLE .ABRAZADERA CABLE	1	1	1	
21	703-48244-00	.SPRING, FREE ACCEL. .RESORTE ACELERADOR LIBRE	1	1	1	
22	703-48238-00	.SPRING, DETENT .RESORTE	5	5	5	
23	703-48246-00	.SPACER .ESPACIADOR	1	1	1	
24	703-48227-00	.SPRING, NEUTRAL LOCK .RESORTE DE SEGURO	1	1	1	
25	703-82594-00	.CLAMP .GRAMPA	1	1	1	WITH PT/T SW.
26	703-48226-00	.PLATE, STOPPER .PLACA RETEN	1	1	1	

FIG. 26 REMOTE CONTROL ASSY

CONTROL REMOTO COMPL.

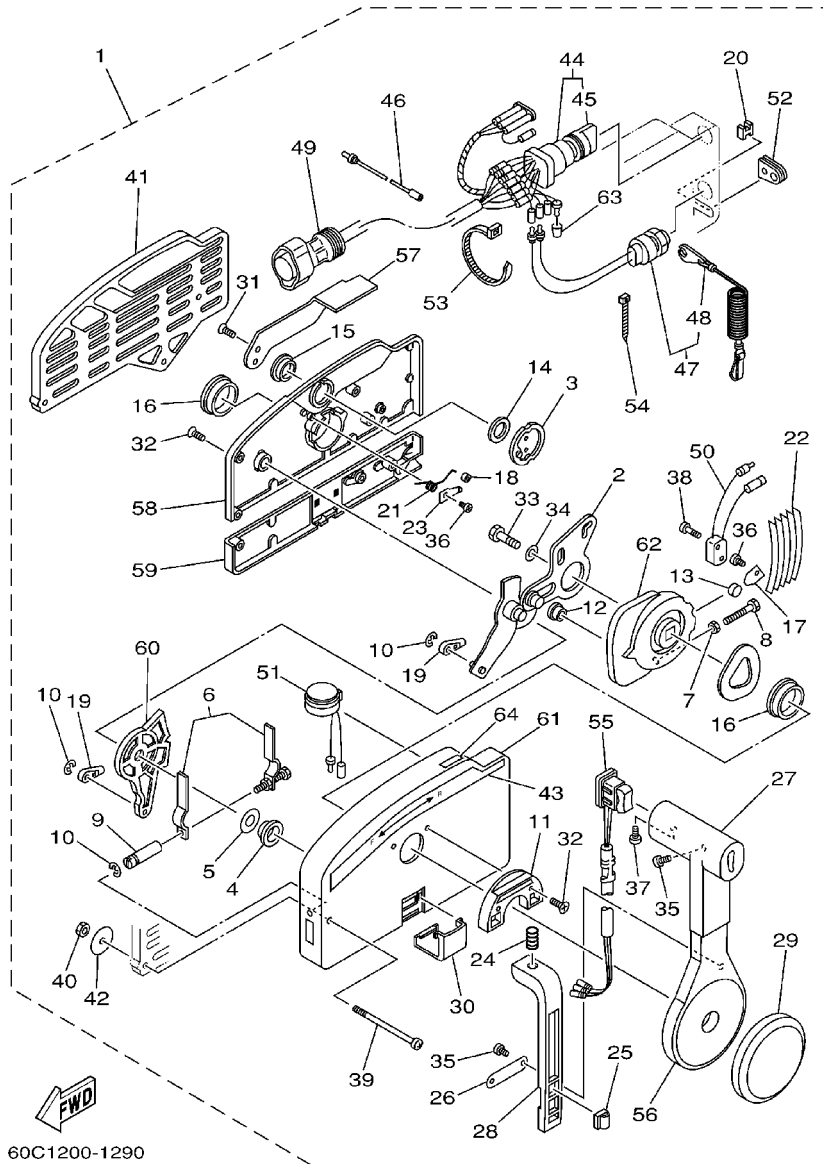

60C1200-1290

REF. NO.	PART NO. CODIGO NO.	DESCRIPTION DESCRIPTION	ED	ET	EIO	REMARKS OBSERVACION
27	703-48222-00	.GRIP, CONTROL LEVER .MANGO DE PALANCA CONTROL	1	1	1	SINGLE
28	703-48223-00	.LOCK, NEUTRAL .CERRADURA NEUTRO	1	1	1	
29	703-48225-00	.COVER .CUBIERTA	1	1	1	
30	703-48219-00	.COVER, LEAD .CUBIERTA	1	1	1	
31	703-48281-00	.SCREW .TORNILLO 1	2	2	2	
32	703-48282-00	.SCREW .TORNILLO 2	7	7	7	
33	97380-08030	.BOLT .PERNO	1	1	1	
34	92990-08600	.WASHER, PLATE .ARANDELA	1	1	1	
35	98580-04010	.SCREW, PAN HEAD .TORNILLO DE CABEZA CON PLANA	3	3	3	
36	98580-04006	.SCREW, PAN HEAD .TORNILLO DE CABEZA CON PLANA	2	2	2	
37	98580-05010	.SCREW, PAN HEAD .TORNILLO DE CABEZA CON PLANA	1	1	1	
38	98580-03015	.SCREW, PAN HEAD .TORNILLO DE CABEZA CON PLANA	2	2	2	
39	703-48291-10	.SCREW (M6) .TORNILLO (M6)	3	3	3	
40	95380-06600	.NUT, HEXAGON .TUERCA	3	3	3	
41	703-48293-10	.SPACER, REMOTE CONTROL .ESPACIADOR	1	1	1	SINGLE
42	701-48287-00	.WASHER .ARANDELA	3	3	3	
43	703-48215-00	.GRAPHIC .CALCOMANIA 1	1	1	1	
44	703-82510-12	.MAIN SWITCH ASSY .CONJUNTO DE LLAVE IGNICION		1	1	FOR PRIME START MODEL
	703-82510-03	.MAIN SWITCH ASSY .CONJUNTO DE LLAVE IGNICION	1			FOR 703-48203-A2
45	676-82577-00	.CAP, KEY .TAPA	1	1	1	
46	703-82531-00	.WIRE, LEAD .CABLE CONDUCTOR	1	1	1	
47	688-82575-01	.ENGINE STOP SWITCH ASSY .INTERRUPTOR DE PARADA COMPL	1	1	1	
48	682-82556-00	.STOPPER .RETENER	1	1	1	
49	688-8258A-20	.EXTENSION, WIRE HARNESS .EXTENSION, ARNES DE CABLES		1	1	L:5M (10P)
	688-82586-21	.EXTENSION, WIRE HARNESS .EXTENSION, CONJ. DE CABLES	1			L:5M (7P)
50	703-82540-00	.NEUTRAL SWITCH ASSY .INTERRUPTOR NEUTRAL COMPL	1	1	1	
51	703-83383-A0	.BUZZER .ZUMBADOR	1	1	1	

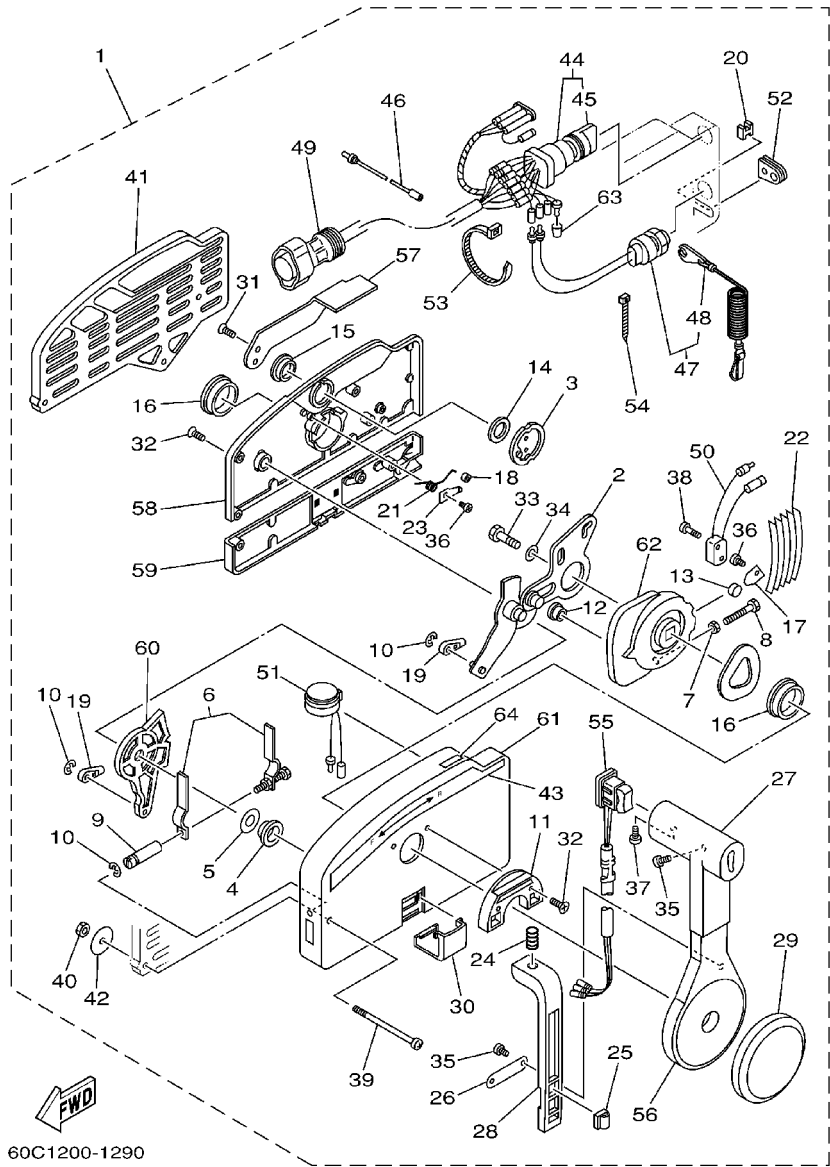

60C1200-1290

FIG. 26 REMOTE CONTROL ASSY CONTROL REMOTO COMPL.

REF. NO.	PART NO. CODIGO NO.	DESCRIPTION DESCRIPTION	ED	ET	EIO	REMARKS OBSERVACION
52	703-48284-00	.GROMMET .TAPON 1	1	1	1	
53	703-82591-00	.BAND .BANDA	1	1	1	
54	703-82592-00	.BAND .BANDA	1	1	1	
55	703-82563-02	.TRIM & TILT SWITCH ASSY .INTERRUPTOR DE INCLINACION		1	1	WITH PT/T SW.
	703-48224-00	.COVER, CONTROL LEVER .CUBIERTA DE PALANCA CONTROL	1			WITHOUT PT/T SW.
56	703-48221-00	.LEVER, CONTROL .PALANCA CONTROL	1	1	1	
57	703-48152-00	.KNOB, FREE ACCEL. .PERILLA	1	1	1	
58	703-48212-00	.BACK PLATE 1 .PLACA TRASERA 1	1	1	1	
59	703-48213-00	.BACK PLATE 2 .PLACA TRASERA 2	1	1	1	
60	703-48271-00	.ARM, SHIFT .BRAZO CAMBIADOR	1	1	1	
61	703-48211-01	.HOUSING,1 .CAJA	1	1	1	
62	703-48232-00	.GEAR .ENGRANAJE 1	1	1	1	
63	703-82542-00	.CAP .TAPA	1	1	1	
64	703-48218-00	.GRAPHIC .CALCAMONIA	1	1	1	

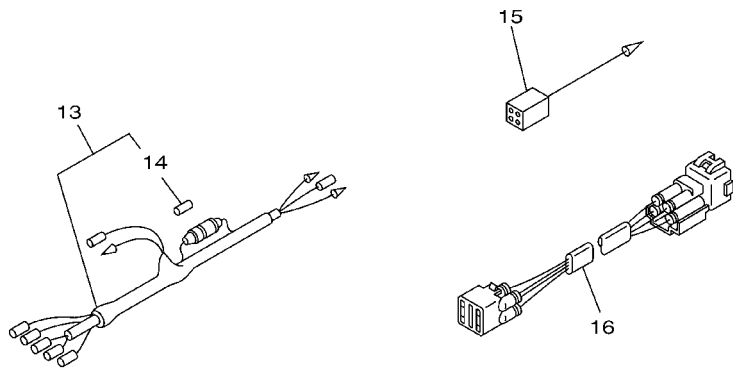
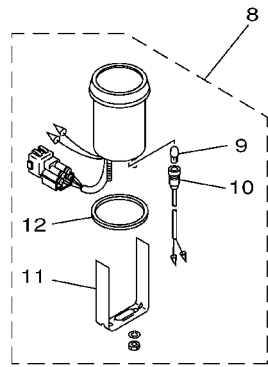
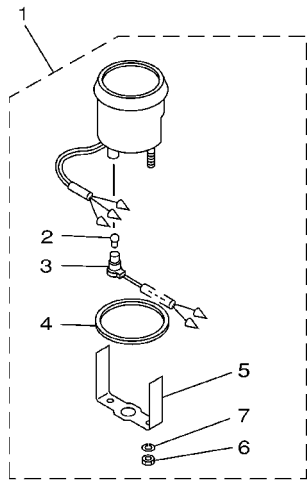

FIG. 27 METER 1

MEDIDOR 1

REF. NO.	PART NO. CODIGO NO.	DESCRIPTION DESCRIPTION	ED	ET	ETO	REMARKS OBSERVACION
1	6Y5-83540-14	TACHOMETER ASSY TACOMETRO COMPLETO		1		AP FOR CHINA WITHOUT OIL LAMP
2	6Y5-83517-00	.BULB (T10, 12V-1.7W)		1		
3	6Y5-83536-10	.BOMBILLA (12V-1.7W, T10)		1		
4	6Y5-83523-00	.SOCKET, METER .ENCASTRE DE MEDIDOR		1		
5	6Y5-83514-00	.DAMPER .AMORTIGUADOR		1		
6	95380-05600	.NUT .TUERCA		2		
7	92990-05100	.WASHER, SPRING .ARANDELA		2		
8	6Y5-83670-12	TRIM METER ASSY. MEDIDOR DE INCLINACION		1		AP
9	6Y5-83518-00	.BULB (12V-1.7W, T6.5)		1		
10	6Y5-83536-00	.BOMBILLA (12V-1.7W, T6.5)		1		
11	6Y5-83544-00	.SOCKET, METER .ENCASTRE DE MEDIDOR		1		
12	688-83664-00	.PLATE, FITTING .PLACA ACCESORIA		1		
13	6Y5-83553-00	.DAMPER .AMORTIGUADOR		1		AP
14	1E6-82151-00	WIRE, LEAD CABLE CONDUCTOR		1		
15	6Y5-82117-00	.FUSE (10A) .FUSIBLE		1		AP FOR CHINA
16	6R3-82553-70	WIRE, LEAD (BLACK) CABLE, CONDUCTOR (NEGRO)		1		AP
		EXTENSION, WIRE LEAD CABLE		1		

6E50200-0280

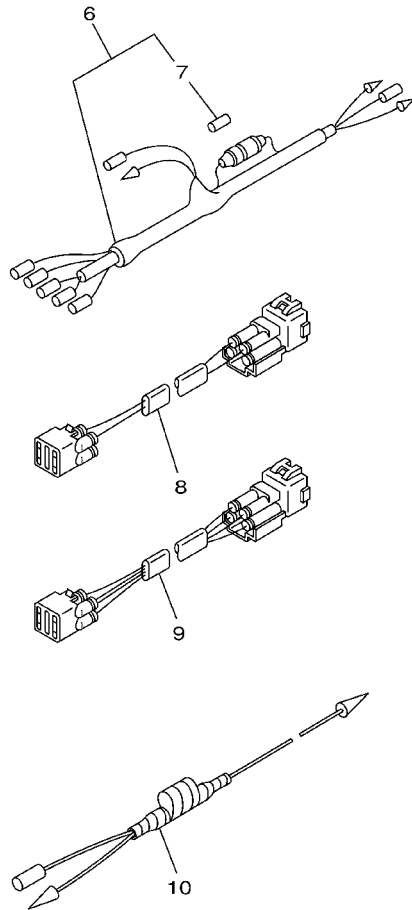
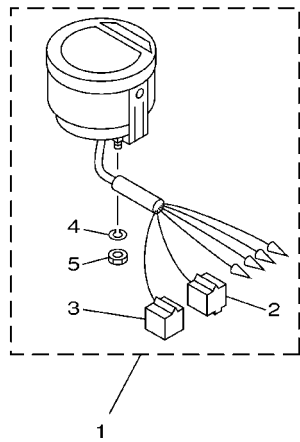

FIG. 28 METER 2

MEDIDOR 2

REF. NO.	PART NO. CODIGO NO.	DESCRIPTION DESCRIPTION	ED	ET	EIO	REMARKS OBSERVACION
1	6Y5-8350T-01	DIGITAL TACHOMETER ASSY TACOMETRO DIGGITAL COMPLETO			1	AP
2	9E450-04433	.CONNECTOR .CONECTOR			1	M-4-W
3	9E450-04533	.CONNECTOR .CONECTOR			1	F-4-W
4	92990-04100	.WASHER, SPRING .ARANDELA			2	
5	95380-04600	.NUT .TUERCA			2	
6	6Y5-83553-00	WIRE, LEAD CABLE CONDUCTOR			1	AP
7	1E6-82151-00	.FUSE (10A) .FUSIBLE			1	
8	6R3-82521-70	WIRE, LEAD CABLE CONDUCTOR			1	AP
9	6R3-82553-70	EXTENSION, WIRE LEAD CABLE			1	AP
10	6H4-81315-11	LEAD WIRE ASSY CABLE CONDUCTOR COMPLETO			1	AP

6H30100-0270

FIG. 29 REPAIR KIT 1

ESTUCHE REPARATION 1

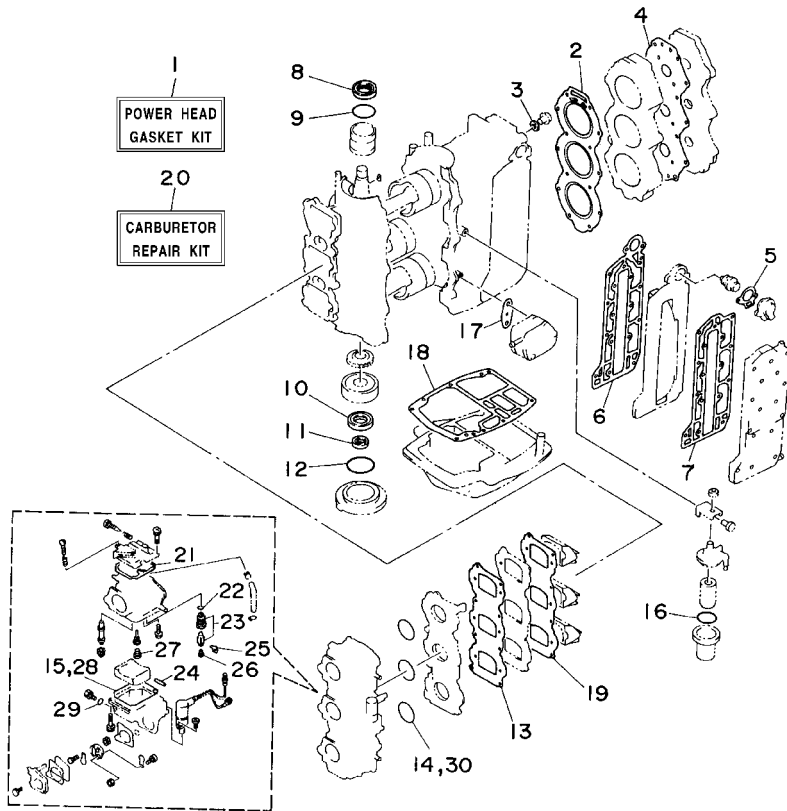

REF. NO.	PART NO. CODIGO NO.	DESCRIPTION DESCRIPTION	ED	ET	EIO	REMARKS OBSERVACION
1	6H3-W0001-02	POWER HEAD GASKET KIT JUEGO DE EMPAQUE	1	1	1	AUTO CHOKE
2	6H3-11181-A1	.GASKET, CYLINDER HEAD 1 .JUNTA, DE CULATA 1	1	1	1	
3	90430-14115	.GASKET .JUNTA	1	1	1	
4	6H3-11193-A1	.GASKET, HEAD COVER 1 .EMPAQUE	1	1	1	
5	6H3-12414-A1	.GASKET, COVER .EMPAQUE	1	1	1	
6	6H3-41112-A0	.GASKET, EXHAUST INNER COVER .EMPAQUE	1	1	1	
7	6H3-41114-A0	.GASKET, EXHAUST OUTER COVER .EMPAQUE	1	1	1	
8	93102-36M24	.OIL SEAL .SELLO ACEITE	1	1	1	
9	93210-46M16	.O-RING .ANILLO O	1	1	1	
10	93102-30M23	.OIL SEAL .SELLO ACEITE	1	1	1	
11	93106-18M01	.OIL SEAL .SELLO ACEITE	1	1	1	
12	93210-65M50	.O-RING .ANILLO O	1	1	1	
13	6H3-13621-A1	.GASKET, VALVE SEAT .JUNTA, DE VALV.DE EMPAQUE	1	1	1	
14	93210-39ME4	.O-RING .ANILLO O	3	3	3	
15	6H4-14984-00	.GASKET, FLOAT CHAMBER .EMPAQUE CAMARA DE BOIA	3	3	3	
16	93210-32738	.O-RING .ANILLO O	1	1	1	
17	650-24431-A0	.GASKET, FUEL PUMP 1 .EMPAQUE BOMBA COMBUST 1	1	1	1	
18	6H3-45113-A0	.GASKET, UPPER CASING .EMPAQUE	1	1	1	
19	6H3-13622-A1	.GASKET, VALVE SEAT .EMPAQUE DE ASIENTO VALVULA	1	1	1	
20	6H2-W0093-10	CARBURETOR REPAIR KIT KIT REPARACION CARBURADOR	1	1	1	AUTO CHOKE
21	6H4-14147-00	.O-RING .ANILLO O	1	1	1	
22	93210-04228	.O-RING .ANILLO O	1	1	1	
23	6H3-14590-00	.NEEDLE VALVE ASSY .VALVULA DE AGUJA COMPLETA	1	1	1	
24	6H4-14548-00	.PIN, FLOAT ARM .PASADOR DE BRAZO DE BOIA	1	1	1	
25	663-14159-00	.CLIP .PRESILLA	1	1	1	
26	676-14186-00	.PIN, FLOAT .PASADOR DE LA BOYA	1	1	1	
27	676-14966-00	.CAP .TAPA	1	1	1	



6H30010-4230

FIG. 30 REPAIR KIT 2

ESTUCHE REPARATION 2

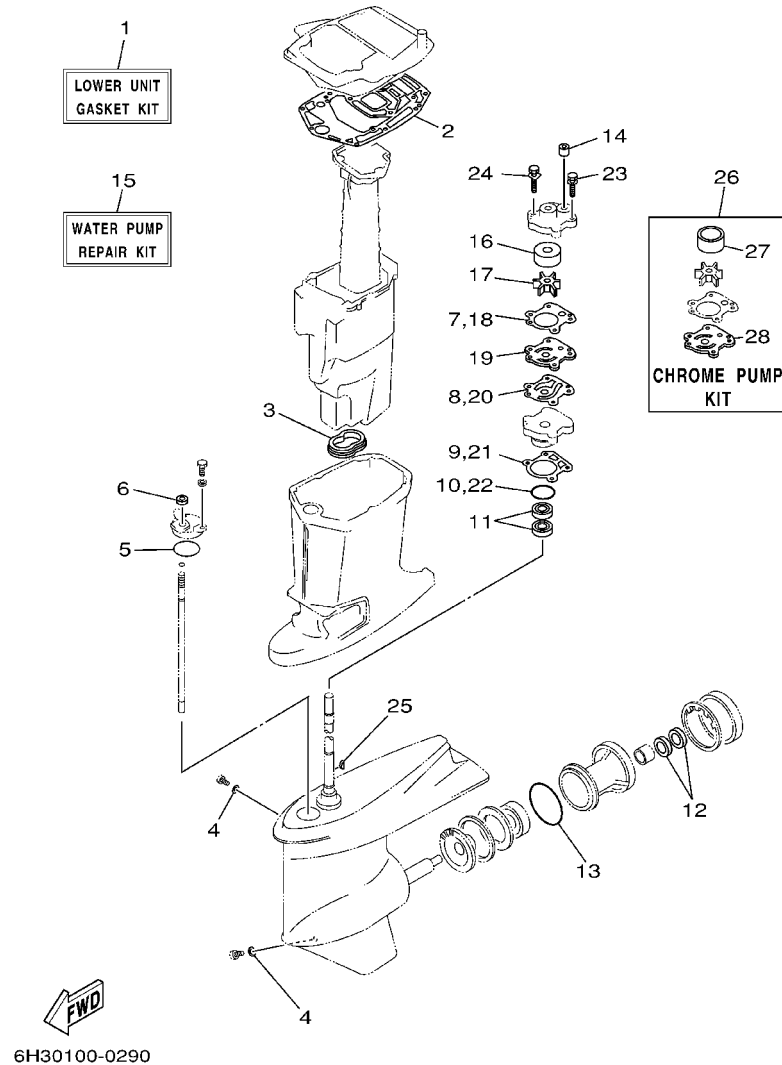

REF. NO.	PART NO. CODIGO NO.	DESCRIPTION DESCRIPTION	ED	ET	EIO	REMARKS OBSERVACION
1	6H3-W0001-22	LOWER UNIT GASKET KIT JUEGO DE JUNTA UNIDAD INFERIOR	1	1	1	
2	6H3-45114-A1	.GASKET, UPPER CASING .EMPAQUE	1	1	1	
3	6H3-45123-00	.GASKET, MUFFLER .EMPAQUE SILENCIADOR	1	1	1	
4	90430-08020	.GASKET JUNTA	2	2	2	
5	93210-49046	.O-RING ANILLO O	1	1	1	
6	93106-09014	.OIL SEAL .SELLO ACEITE	1	1	1	
7	6H3-44315-A0	.GASKET, WATER PUMP .EMPAQUE	1	1	1	
8	6H3-44324-A0	.GASKET, CARTRIDGE .EMPAQUE	1	1	1	
9	688-44316-A0	.GASKET, WATER PUMP .EMPAQUE	1	1	1	
10	93210-46044	.O-RING ANILLO O	1	1	1	
11	93101-23070	.OIL SEAL .SELLO ACEITE	2	2	2	
12	93101-25M03	.OIL SEAL .SELLO ACEITE	2	2	2	
13	93210-85M97	.O-RING ANILLO O	1	1	1	
14	663-44366-00	.DAMPER, WATER SEAL .GOMA DEL SELLO DE AGUA	1	1	1	
15	6H3-W0078-02	WATER PUMP REPAIR KIT ESTUCHE REPARACION BOMBA AGUA	1	1	1	
16	663-44322-00	.INSERT, CARTRIDGE .CARTUCHO	1	1	1	
17	6H3-44352-00	.IMPELLER IMPULSOR	1	1	1	
18	6H3-44315-A0	.GASKET, WATER PUMP .EMPAQUE	1	1	1	
19	6H3-44323-00	.OUTER PLATE, CARTRIDGE .PLACA EXTERIOR DEL CARTUCHO	1	1	1	
20	6H3-44324-A0	.GASKET, CARTRIDGE EMPAQUE	1	1	1	
21	688-44316-A0	.GASKET, WATER PUMP EMPAQUE	1	1	1	
22	93210-46044	.O-RING ANILLO O	1	1	1	
23	90119-08M14	.BOLT, WITH WASHER .TORNILLO CON ARANDELA	2	2	2	
24	90119-08M33	.BOLT, WITH WASHER .TORNILLO CON ARANDELA	2	2	2	
25	90280-03M03	.KEY, WOODRUFF .CUNA WOODRUFF	1	1	1	
26	6H3-W0078-1A	CHROME PUMP KIT ESTUCHE REPARACION BOMBA AGUA	1	1	1	
27	663-44322-40	.INSERT, CARTRIDGE .CARTUCHO	1	1	1	

NUMERICAL INDEX
INDICE NUMERICO

PART NO. CODIGO NO.	REF. NO.	PART NO. CODIGO NO.	REF. NO.	PART NO. CODIGO NO.	REF. NO.	PART NO. CODIGO NO.	REF. NO.	PART NO. CODIGO NO.	REF. NO.	PART NO. CODIGO NO.	REF. NO.
6H3-W0001-02	29 - 1	6H3-13610-00	5 - 1	692-14923-00	6 - 11	6Y1-24329-00	23 - 5	682-41237-00	13 - 2	6H3-42718-00	12 - 39
6H3-W0001-22	30 - 1	6H3-13621-A1	5 - 7	6H1-14943-39	6 - 21	650-24351-51	23 - 12	6H3-41241-01	7 - 20	6E5-42724-00	12 - 14
688-W0004-00	5 - 2		29 - 13	6H3-14943-35	6 - 21	61J-24360-00	23 - 10	6J8-41262-00	16 - 12	6H3-42725-00	12 - 15
6H3-W0070-30	1 - 16	6H3-13622-A1	5 - 9	6H3-14943-36	6 - 21	6E5-24367-01	12 - 24	6H3-41631-00	13 - 4	6H3-42725-10	12 - 15
	2 - 17		29 - 19	6H3-14943-37	6 - 21		12 - 37	6H3-41632-20	13 - 10	6H4-42726-00	12 - 27
6H3-W0078-02	30 - 15	6H3-13624-00-94	5 - 8	676-14943-38	6 - 21	6E5-24378-00	7 - 55	6H3-41633-10	13 - 12	688-42726-10	12 - 27
6H3-W0078-1A	30 - 26	6H3-13641-13-94	5 - 5	6H2-14947-71	6 - 20	650-24378-00	3 - 6	6H3-41636-10-94	13 - 16	6H3-42727-00	12 - 19
6H3-W0090-08-1S	3 - 1	6H3-13641-21-94	5 - 5	6H3-14947-71	6 - 20	688-24378-00	8 - 32	689-42169-01	13 - 1	6H3-42738-01-5B	12 - 16
6H3-W0090-43-1S	3 - 1	6H3-14137-00	6 - 31	6H3-14948-13	6 - 23	692-24410-00	8 - 15		13 - 20	6H3-42741-01-4D	12 - 31
6H2-W0093-10	29 - 20	6H3-14146-10	6 - 9	6H3-14948-16	6 - 23	6H3-24411-10	6 - 40	6H3-42510-02-4D	17 - 3	6G1-42748-00	12 - 30
656-W2810-02	8 - 38	6H4-14146-00	6 - 8	6H3-14948-17	6 - 23	663-24411-00	8 - 20	6H3-42510-12-4D	17 - 3	6H3-42768-00	12 - 23
6H3-11111-01-1S	3 - 25	6H4-14147-00	6 - 10	676-14966-00	6 - 22	692-24411-00	8 - 17	624-42542-00	7 - 48	6H3-42771-01-4D	12 - 32
688-11119-01	3 - 21		29 - 21		29 - 27	6A0-24412-02	8 - 26	6H2-42610-50-4D	1 - 1	6G5-42791-00	12 - 40
6H3-11181-A1	3 - 26	663-14159-00	6 - 17	6H3-14980-10	6 - 28	6A0-24413-00	8 - 16	6H3-42610-50-4D	2 - 1	6G5-42791-10	12 - 40
	29 - 2		29 - 25	6H4-14980-00	6 - 27	6H4-24413-00	6 - 38	6H3-42613-01-4D	1 - 10	6H3-42813-00	12 - 7
6H3-11191-00-1S	3 - 27	676-14186-00	6 - 18	6H4-14984-00	6 - 24	6A0-24421-01	8 - 24		2 - 11	6H3-42815-01-4D	12 - 3
6H3-11193-A1	3 - 28		29 - 26		29 - 15	6L5-24421-00	6 - 37	6H3-42615-00	1 - 13	6H3-42816-00	12 - 9
	29 - 4	6H2-14301-0A	6 - 1		29 - 28	650-24431-A0	8 - 27		2 - 14	6H3-42817-01-4D	12 - 4
6H3-11325-01	3 - 17	6H2-14301-20	6 - 1	6H4-14985-01	6 - 19		29 - 17	6H3-42617-00	1 - 17	6H3-42818-00	12 - 10
6H3-11327-00-1S	3 - 18	6H3-14301-0A	6 - 1	6H3-14992-00	6 - 25	6H3-24434-10	6 - 41	6H3-42617-10	2 - 19	6H1-43111-01-4D	14 - 1
6H3-11328-00	3 - 19	6H2-14302-0A	6 - 2	6H3-15100-06-1S	3 - 2	648-24434-01	8 - 18	6H3-42619-00	1 - 18	688-43111-13-4D	15 - 1
650-11370-00	3 - 4	6H2-14302-20	6 - 2	6H3-15100-14-1S	3 - 2	648-24435-02	8 - 21		2 - 20	697-43111-05-4D	14 - 1
688-11370-00	3 - 3	6H3-14302-0A	6 - 2	6H3-15359-00-94	4 - 1	6H3-24452-10	6 - 29	6H3-42627-00	1 - 19		15 - 1
6H3-11400-03	4 - 7	6H2-14303-0A	6 - 3	6H3-21707-06	7 - 26	6H4-24486-00	6 - 39		2 - 21	6H1-43112-00-4D	14 - 11
6H3-11400-10	4 - 7	6H2-14303-20	6 - 3	6H3-21732-00	2 - 24	61N-24521-00	8 - 8	6H3-42637-00	1 - 20	688-43112-12-4D	15 - 9
6H3-11536-00	4 - 12	6H3-14303-0A	6 - 3	6H3-21735-00	2 - 25	61N-24560-00	8 - 6		2 - 22	697-43112-03-4D	14 - 11
6H3-11537-01	7 - 16	6A0-14325-00	8 - 25	6J8-21744-00	7 - 53	61N-24563-00	8 - 7	6H3-42647-00-94	1 - 2		15 - 9
6K5-11601-02	4 - 15	6H3-14349-00	5 - 16	63D-2175R-00	7 - 35	648-24566-02	8 - 10		2 - 3	688-43124-02	16 - 5
6K5-11601-12	4 - 15		6 - 32	6H3-21752-00	7 - 32	6YJ-24610-01	23 - 2	6H3-42649-00-94	1 - 3	6E5-43126-02	14 - 38
6K5-11601-22	4 - 15	6H3-14380-00	6 - 33	6H1-21757-00	7 - 38	6H1-24633-00	7 - 39		2 - 4		15 - 36
6H3-11631-01-96	4 - 14	6H3-14413-10	5 - 18	6J8-21758-00	7 - 37	6A1-28176-00	12 - 41	6H3-42652-00	1 - 5	688-43128-01-4D	16 - 1
6H3-11633-00	4 - 16	6H3-14440-02	5 - 19	63D-2176M-00	7 - 34	6E0-28193-00-94	8 - 39		2 - 6	697-43128-01-4D	16 - 1
688-11634-10	4 - 17	6H3-14457-01	5 - 20	6H1-21766-01	7 - 44	6H3-41111-01-1S	3 - 36	663-42662-00	1 - 4	688-43131-03	14 - 21
6H3-11635-01	4 - 14	6H1-14485-00	5 - 6	63D-2177H-00	2 - 2	6H3-41112-A0	3 - 37		2 - 5		15 - 19
6H3-11636-01	4 - 14	624-14485-00	3 - 5	6H4-21770-00	7 - 36		29 - 6	6H2-42677-50	1 - 14	6G5-43144-00	14 - 45
6H3-12411-10	3 - 32	6H3-14488-00	9 - 20	6YJ-24167-00	23 - 7	6H3-41113-02-1S	3 - 38	6H3-42677-50	2 - 15		15 - 41
6H3-12413-00-1S	3 - 33	63V-14523-00	6 - 5	6YJ-24201-00	23 - 1	6H3-41114-A0	3 - 39	6H2-42678-30	1 - 15	6E5-43145-01	24 - 9
6H3-12414-A1	3 - 34	6H4-14548-00	6 - 15	6YJ-24201-10	23 - 1		29 - 7	6H3-42678-30	2 - 16	6G5-43145-01	14 - 25
	29 - 5		29 - 24	6YJ-24260-00	23 - 3	6H2-41131-00-5B	20 - 11	6H3-42681-30	1 - 21		15 - 23
6H1-13117-01	7 - 18	697-14555-00	6 - 12	6Y1-24260-12	23 - 3	6H3-41131-00-5B	20 - 11		2 - 28	6G5-43148-00	14 - 43
6E9-13183-70	7 - 11	6H4-14567-00	6 - 30	6Y1-24268-00	23 - 6	6H3-41137-01-94	20 - 5	6H3-42682-30	1 - 22		15 - 27
6H3-13200-02	7 - 1	6H2-14578-00	6 - 7	6G1-24304-02	8 - 1	6H3-41213-10	13 - 23		2 - 29	688-43160-01	14 - 34
6J8-13411-00	7 - 40	6H3-14590-00	6 - 14	6G1-24305-03	23 - 13	6H3-41217-00	5 - 13	6H1-42694-00	2 - 23		15 - 32
6J8-13414-00	7 - 41		29 - 23	6Y1-24305-04	23 - 15	6E9-41237-00	7 - 25	6H3-42711-05-4D	12 - 1	697-43160-00	14 - 34
6H1-13435-00	7 - 42	6H3-14711-00-5B	20 - 14	61J-24306-02	23 - 8	6F5-41237-00	13 - 15	6H3-42711-24-4D	12 - 1		15 - 32
6H3-13436-00	2 - 18	6H3-14711-10-5B	20 - 14	663-24312-01	3 - 41	6H1-41237-00	7 - 21	648-42715-00	13 - 28	688-43165-00	14 - 35
6H3-13437-21	9 - 21	6H3-14737-00	20 - 20	6H3-24313-00	8 - 33		13 - 14	6H3-42716-02	12 - 12		15 - 33
6H2-13610-00	5 - 1	6H3-14737-10	20 - 20	6H3-24314-00	8 - 35	6H4-41237-00	13 - 21	6K5-42717-00	12 - 13	688-43170-04-4D	16 - 2

NUMERICAL INDEX
INDICE NUMERICO

PART NO. CODIGO NO.	REF. NO.	PART NO. CODIGO NO.	REF. NO.	PART NO. CODIGO NO.	REF. NO.	PART NO. CODIGO NO.	REF. NO.	PART NO. CODIGO NO.	REF. NO.	PART NO. CODIGO NO.	REF. NO.
697-43170-03-4D	16 - 2	6H1-43814-11	19 - 19	6E5-43854-01	18 - 66	6E5-43888-01	18 - 61	6H1-44526-00	14 - 3	688-45567-01-40	21 - 7
6H1-43181-01	14 - 26	6E5-43816-10	18 - 56	6H1-43854-00	19 - 53	6H1-43891-10	18 - 5		15 - 3	688-45567-01-50	21 - 7
688-43181-04	14 - 26	6H1-43816-00	19 - 68	6H1-43855-11	19 - 71		19 - 5	6H3-44551-01-4D	17 - 9	6H3-45571-00	21 - 62
	15 - 24	6E5-43817-10	18 - 57	6H3-43855-00	18 - 51	6H1-43892-10	18 - 6	6H3-44552-03-94	17 - 18	688-45576-00	21 - 66
688-43181-10	15 - 24	6H1-43817-01	19 - 47	6E5-43856-01	18 - 81		19 - 6	6H3-44553-01-4D	17 - 23	688-45577-01-10	21 - 65
6H1-43185-01	14 - 27	6E5-43818-00	18 - 29	6H1-43856-10	19 - 43	6E5-43895-00	18 - 54	687-44555-00-94	17 - 11	688-45577-01-12	21 - 65
688-43185-04	14 - 27		19 - 32	6E5-43858-00	18 - 80	6H1-43895-12	19 - 70	663-44575-00	17 - 16	688-45577-01-15	21 - 65
	15 - 25	6E5-4382A-00	18 - 67	6E5-43859-00	18 - 52	6E5-43896-00	18 - 55		17 - 32	688-45577-01-18	21 - 65
688-43185-10	15 - 25	6H1-4382A-10	19 - 52	6H1-4386K-10	18 - 9	6H1-43896-00	19 - 69	6H3-45111-01-4D	20 - 1	688-45577-01-30	21 - 65
688-43186-00	16 - 10	6E5-43820-03	18 - 33		19 - 9	6E5-43897-00	18 - 59	6H3-45111-11-4D	20 - 1	688-45577-01-40	21 - 65
6H1-43311-01-4D	14 - 16	6H1-43820-11	19 - 64	6E5-43861-00	18 - 19	6H1-43899-00	19 - 51	6H3-45113-A0	20 - 7	688-45577-01-50	21 - 65
	15 - 14	6E5-43821-01	18 - 36	6H1-43861-00	19 - 21	6H3-44117-00-94	13 - 31		29 - 18	688-45587-01-10	21 - 5
697-43311-03-4D	14 - 16	6H1-43821-11	19 - 59	6H1-43861-10	19 - 18	6H3-44120-02	13 - 27	6H3-45114-A1	20 - 17	688-45587-01-12	21 - 5
	15 - 14	6E5-43822-01	18 - 37		19 - 22	6H3-44120-12	13 - 27		30 - 2	688-45587-01-15	21 - 5
663-43318-00	14 - 33	6H1-43822-10	19 - 58		19 - 60	6H3-44121-01	13 - 37	663-45119-00	14 - 18	688-45587-01-21	5
	15 - 31	6E5-43824-01	18 - 75	6E5-43862-00	18 - 20	688-44122-00	13 - 40		15 - 16	688-45587-01-30	21 - 5
682-43318-01	16 - 9	6E5-43828-00	18 - 26		18 - 22	6H1-44144-00	21 - 58	6H3-45123-00	20 - 16	688-45587-01-40	21 - 5
6H1-43376-00	17 - 39	6H1-43828-10	19 - 30		18 - 38	6H1-44151-00	21 - 57		30 - 3	688-45587-01-50	21 - 5
688-43376-01	17 - 39	6E5-43829-00	18 - 27	6E5-43863-00	18 - 28	688-44194-00	13 - 7	6H3-45127-00	20 - 15	6H1-45611-01	21 - 43
688-43616-00	16 - 13	6H1-43829-00	19 - 36	6E5-43864-00	18 - 34	6H3-44311-00	21 - 25	6H3-45155-00	20 - 3	6H1-45631-01	21 - 44
688-43631-00	16 - 3	6E5-43830-00	18 - 63	6H1-43864-00	19 - 65	6H3-44315-A0	21 - 27	6H1-45214-00	21 - 12	688-45633-00	21 - 55
688-43631-10	16 - 3	6H1-43830-11	19 - 49	6E5-43865-00	18 - 39		30 - 7	6H1-45215-00	21 - 13	6H1-45634-02	21 - 46
688-43651-00	16 - 15	6E5-43831-00	18 - 62	6H1-43865-10	18 - 16		30 - 18	6H1-45251-03	14 - 2	6H1-45635-00	21 - 50
688-43691-01	15 - 18	6H1-43831-10	19 - 48		19 - 16	688-44316-A0	21 - 33		15 - 2	6H1-45641-01	21 - 56
697-4380E-01	18 - 17	6E5-43833-01	18 - 46	6E5-43866-00	18 - 41		30 - 9	663-45251-00	15 - 2	6H1-45668-00	21 - 49
6H1-4380F-10	18 - 7	6H1-43833-10	19 - 33	6H1-43866-00	19 - 40		30 - 21	6H3-45300-05-4D	21 - 1	688-45930-02-98	22 - 22
	19 - 7	6E5-43834-01	18 - 47	6E5-43867-00	18 - 42	663-44322-00	21 - 26	6H3-45300-15-4D	21 - 1	688-45932-60-98	22 - 22
6H1-4380G-10	18 - 15	6H1-43834-00	19 - 34	6H1-43867-00	19 - 41		30 - 16	6H1-45301-03-4D	21 - 2	6E5-45941-00-EL	22 - 22
	19 - 15	6E5-43835-00	18 - 48	6E5-43868-00	18 - 44	663-44322-40	21 - 26	688-45321-00	21 - 16	6E5-45943-00-EL	22 - 22
6H1-4380H-10	18 - 13	6H1-43835-10	19 - 29	6H1-43868-00	19 - 74		30 - 27	688-45331-00-94	21 - 63	6E5-45945-01-EL	22 - 22
	19 - 13	6H1-4384E-20	19 - 61	6E5-43869-00	18 - 45	6H3-44323-00	21 - 34	688-45341-10	21 - 10	6E5-45947-00-EL	22 - 22
6H1-4380J-10	18 - 8	6H1-4384F-10	19 - 46	6H1-4387J-00	19 - 77		30 - 19	6E5-45371-10	22 - 25	6E5-45949-00-EL	22 - 22
	19 - 8	6H1-4384G-11	19 - 45	6H1-43871-10	19 - 23	6H3-44323-40	21 - 34	688-45371-02	22 - 12	6E5-45952-00-EL	22 - 22
6H1-43800-16-4D	19 - 1	6H1-43840-11	19 - 17	6E5-43872-00	18 - 21		30 - 28	688-45375-00	22 - 11	6E5-45954-00-EL	22 - 22
6H3-43800-08-4D	18 - 1	6E5-43841-02	18 - 43		18 - 23	6H3-44324-A0	21 - 35	663-45376-00-94	22 - 10	6E5-45956-00-EL	22 - 22
6E5-43802-01	18 - 40	6H1-43841-11	19 - 42	6H1-43872-10	19 - 25		30 - 8	6E5-45378-00	21 - 21	6E5-45970-10	22 - 23
6T4-43802-03	19 - 39	6E5-43842-00	18 - 77	6E5-43874-01	18 - 35		30 - 20	688-45383-02	21 - 71	688-45970-03-98	22 - 22
6H1-43804-10	18 - 4	6E5-43843-00	18 - 50	6H1-43874-00	19 - 67	6H3-44341-00-94	21 - 30	688-45384-00	21 - 72	6E5-45972-10	22 - 23
	19 - 4	6H1-43843-11	19 - 72	6E5-43875-00	18 - 71	6H3-44352-00	21 - 28	6H3-45501-00	21 - 39	688-45972-02-98	22 - 22
6H1-43805-10	18 - 3	6E5-43844-02	18 - 79	6H1-43875-00	19 - 57		30 - 17	6H3-45501-10	21 - 39	6E5-45974-10	22 - 23
	19 - 3	6H1-43844-10	19 - 44	6E5-43877-01	18 - 53	6H3-44361-00	22 - 2	688-45536-01	21 - 4	688-45974-02-98	22 - 22
6E5-4381A-00	18 - 73	6E5-43845-01	18 - 69	6E5-43878-01	18 - 60	6H3-44361-10	22 - 2	6K5-45551-00	21 - 40	6E5-45976-10	22 - 23
6H1-43810-11	19 - 20	6H1-43845-00	19 - 55	6H1-4388E-11	19 - 73	6H3-44366-00	22 - 16	6K5-45560-00	21 - 42	688-45976-01-98	22 - 22
697-43810-02	18 - 18	6E5-43847-00	18 - 65	6H1-43880-02	18 - 2		30 - 14	688-45567-01-10	21 - 7	6E5-45978-10	22 - 23
6H1-43812-00	19 - 24	6H1-43847-00	19 - 50		19 - 2	663-44367-00	22 - 1	688-45567-01-12	21 - 7	688-45978-60-98	22 - 22
6E5-43813-02	18 - 25	6E5-43849-01	18 - 74	6H1-43881-10	18 - 12	6H3-44391-01	12 - 2	688-45567-01-15	21 - 7	688-45987-01	22 - 17
6H1-43813-10	19 - 27	6H1-4385H-00	19 - 78		19 - 12	688-44511-00-94	17 - 33	688-45567-01-18	21 - 7	6E5-45994-10	22 - 24
6E5-43814-01	18 - 24	6G5-43851-00	18 - 78	6E5-43883-00	18 - 49	688-44514-00-94	17 - 26	688-45567-01-30	21 - 7	688-45997-01	22 - 18

NUMERICAL INDEX
INDICE NUMERICO

PART NO. CODIGO NO.	REF. NO.	PART NO. CODIGO NO.	REF. NO.	PART NO. CODIGO NO.	REF. NO.	PART NO. CODIGO NO.	REF. NO.	PART NO. CODIGO NO.	REF. NO.	PART NO. CODIGO NO.	REF. NO.
703-48152-00	26 - 57	703-48345-01	26 - 19	6H3-82164-00	10 - 27	6H2-85520-01	9 - 2	90119-08M84	22 - 9	90206-13M10	12 - 6
703-48153-00	26 - 3	703-48358-00	26 - 20	6A0-82317-00	7 - 47	6H2-85533-01	9 - 3	90119-10005	3 - 8	90209-06M05	5 - 22
703-48189-00	26 - 17	6H3-48511-51-4D	17 - 36	6G1-82370-21	10 - 23	6H2-85540-11	10 - 5	90151-05M00	21 - 14	90249-06M19	14 - 42
703-48198-00	26 - 14	6H3-48538-00	13 - 42	703-82510-03	26 - 44	6H3-85542-11-94	10 - 1	90152-06M01	15 - 5		15 - 29
703-48203-A2	25 - 1	688-61350-10	24 - 1	703-82510-12	26 - 44	6H2-85550-00	9 - 1	90157-06M01	12 - 25	90250-07M02	21 - 54
	26 - 1	688-61351-10	24 - 2	6R3-82521-70	28 - 8	697-85570-00	10 - 20		12 - 29	90266-06009	1 - 9
703-48205-A4	25 - 1	6E5-61355-00	24 - 8	703-82531-00	26 - 46	6H2-85580-01	9 - 4	90157-06M13	13 - 5		2 - 10
	26 - 1	6H4-81315-11	28 - 10	703-82540-00	26 - 50	6H2-85582-00	9 - 5	90159-06M01	10 - 16	90269-04M03	12 - 8
703-48211-01	26 - 61	6E5-81332-00	9 - 15	703-82542-00	26 - 63	6H1-85711-60	5 - 23	90159-06M23	9 - 19	90280-03M03	21 - 29
703-48212-00	26 - 58	6H3-81337-01	9 - 18	6R3-82553-70	27 - 16	6R5-85711-60	10 - 51	90170-09M03	24 - 5		30 - 25
703-48213-00	26 - 59	6H3-81800-11	11 - 1		28 - 9	6H3-85720-16	7 - 60	90170-16M01	21 - 41	90280-05015	9 - 12
703-48215-00	26 - 43	6H3-81807-10	11 - 3	682-82556-00	26 - 48	6H2-85895-01	9 - 6	90170-20137	9 - 13	90282-04010	21 - 70
703-48218-00	26 - 64	689-81809-11	11 - 7	688-82560-10	10 - 38	9E450-04433	28 - 2	90171-16011	22 - 20	90338-05M03	2 - 26
703-48219-00	26 - 30	6H3-81810-10	11 - 9	6H1-82563-10	10 - 46	9E450-04533	28 - 3	90179-06066	17 - 22		12 - 29
703-48221-00	26 - 56	689-81811-11	11 - 12	703-82563-02	26 - 55	90101-08002	3 - 22	90179-08M34	3 - 31		14 - 20
703-48222-00	26 - 27	689-81812-11	11 - 11	6E3-8257H-00	12 - 42	90101-10M49	17 - 27	90183-02M03	21 - 53		15 - 44
703-48223-00	26 - 28	689-81813-10	11 - 13	688-82575-01	26 - 47	90101-12M65	14 - 47	90183-05M06	2 - 27	90340-08002	21 - 9
703-48224-00	26 - 55	6H3-81820-11	11 - 14	676-82577-00	26 - 45		15 - 45	90185-05002	21 - 15	90340-14M00	3 - 23
703-48225-00	26 - 29	689-81826-10	11 - 15	688-8258A-20	26 - 49	90105-06M14	10 - 2	90185-08057	17 - 40	90386-07M58	13 - 34
703-48226-00	26 - 26	6H3-81830-10	11 - 4	6R5-82582-B0	7 - 61	90105-10M67	22 - 13	90185-09M01	24 - 4	90386-10M16	14 - 28
703-48227-00	26 - 24	689-81831-00	11 - 5	688-82586-21	26 - 49	90109-06M21	18 - 58	90185-10051	17 - 31		15 - 26
703-48232-00	26 - 62	689-81840-11	11 - 10	6E5-82587-00	10 - 47	90109-06M39	7 - 3		17 - 38	90386-13M38	12 - 5
703-48234-00	26 - 18	689-81847-11	11 - 6	6H2-82590-02	10 - 31	90109-06M40	7 - 4	90185-22043	14 - 24	90386-18M14	18 - 30
703-48235-00	26 - 4	689-81850-12	11 - 8	6H2-82590-13	10 - 31	90109-06M43	13 - 13		15 - 22		19 - 31
703-48236-00	26 - 16	689-81857-11	11 - 2	703-82591-00	26 - 53	90109-12M21	17 - 15	90201-03313	21 - 52	90386-18M21	15 - 37
703-48238-00	26 - 22	6H3-81916-10	10 - 15	703-82592-00	26 - 54	90116-08M69	3 - 30	90201-05M00	18 - 72		16 - 6
703-48243-00	26 - 15	6H2-81949-01	10 - 44	688-82594-00	10 - 37	90116-10M28	17 - 37	90201-08M93	7 - 17	90386-18M35	14 - 40
703-48244-00	26 - 21	6H2-81949-11	10 - 43	703-82594-00	26 - 25	90116-10175	17 - 37	90201-10M20	24 - 3		15 - 38
703-48245-00	26 - 11	61A-81950-00	10 - 39	703-83383-A0	26 - 51	90119-06MA3	3 - 35	90201-10M63	24 - 7		16 - 8
703-48246-00	26 - 23	688-81950-10	10 - 24	6Y5-8350T-01	28 - 1		5 - 10	90201-11M22	17 - 30	90386-18M63	14 - 39
701-48248-00	26 - 13	6H2-81960-10	10 - 11	6Y5-83514-00	27 - 5	90119-06MA5	3 - 40	90201-12M16	17 - 12		16 - 7
703-48252-00	26 - 12	6H3-82105-01	10 - 29	6Y5-83517-00	27 - 2	90119-06M09	12 - 11	90201-12426	14 - 49	90386-22M15	14 - 22
703-48261-01	26 - 2	6H3-82117-00	10 - 30	6Y5-83518-00	27 - 9	90119-06M29	14 - 4		15 - 47		15 - 20
703-48264-00	26 - 6	6Y5-82117-00	27 - 15	6Y5-83523-00	27 - 4		15 - 4	90201-13M19	17 - 14	90386-30M60	17 - 8
703-48265-00	26 - 9	682-82119-01	10 - 45	6Y5-83536-00	27 - 10	90119-06M42	18 - 31	90201-17M00	22 - 19	90386-30M77	17 - 6
703-48268-00	26 - 5	703-82119-00	10 - 6	6Y5-83536-10	27 - 3	90119-06M61	12 - 22	90201-20M21	17 - 28	90386-30M78	17 - 5
703-48271-00	26 - 60		12 - 28	6Y5-83540-14	27 - 1	90119-06M65	7 - 49	90201-20417	4 - 19	90387-06M31	7 - 31
703-48281-00	26 - 31		17 - 42	6Y5-83544-00	27 - 11	90119-06M71	18 - 32	90201-21M18	9 - 14	90387-06M43	10 - 3
703-48282-00	26 - 32	688-82127-02	17 - 25	6Y5-83553-00	27 - 13	90119-06M88	7 - 50	90201-22M67	14 - 23	90387-06M60	13 - 8
703-48284-00	26 - 52	697-82127-01	17 - 25		28 - 6	90119-06023	3 - 20		15 - 21		13 - 25
701-48287-00	26 - 42	6E5-82148-00	14 - 12	6E5-83558-00	22 - 15	90119-08MA5	3 - 29	90201-30M00	17 - 4	90387-06M69	12 - 21
703-48291-10	26 - 39		15 - 10	6E5-83558-10	21 - 23	90119-08M14	21 - 38	90202-03M51	16 - 14	90387-10M02	14 - 31
703-48293-10	26 - 41	6H1-82148-00	14 - 8	6E5-83614-01	10 - 48		30 - 23	90202-05088	7 - 22		15 - 30
701-48320-20	25 - 2	1E6-82151-00	27 - 14	6A1-83625-41	5 - 24	90119-08M33	21 - 37	90202-07M07	13 - 39	90387-10M38	14 - 31
701-48320-30	25 - 2		28 - 7	688-83664-00	27 - 12		30 - 24	90202-12060	22 - 3		15 - 29
701-48320-50	25 - 2	663-82151-00	10 - 32	6Y5-83670-12	27 - 8	90119-08M64	3 - 9	90202-20M06	17 - 29	90387-10M42	24 - 6
6H3-48344-00	13 - 18	6G5-82152-00	10 - 17	6H1-83672-12	17 - 1	90119-08M79	20 - 8	90202-25M04	17 - 13	90430-08020	21 - 11
663-48344-00	13 - 41	6H3-82154-11	10 - 42	6H5-83672-02	17 - 1	90119-08M81	20 - 4	90206-10M04	13 - 24		30 - 4

NUMERICAL INDEX
INDICE NUMERICO

PART NO. CODIGO NO.	REF. NO.	PART NO. CODIGO NO.	REF. NO.	PART NO. CODIGO NO.	REF. NO.	PART NO. CODIGO NO.	REF. NO.	PART NO. CODIGO NO.	REF. NO.	PART NO. CODIGO NO.	REF. NO.
90430-12072	22 - 4	90465-18147	6 - 42	92901-05200	19 - 63	92995-08100	17 - 35	93210-46M16	29 - 9	95380-06600	26 - 40
90430-14115	3 - 24	90467-06016	3 - 11	92903-06600	6 - 44		20 - 10	93210-46044	21 - 32	95380-08600	8 - 11
	29 - 3		3 - 15		10 - 10		20 - 13		30 - 10	95380-12600	14 - 50
90440-14M00	14 - 51		5 - 15		10 - 22		20 - 19		30 - 22		15 - 48
90445-07MA5	7 - 8	90467-08004	3 - 42		10 - 26	92995-10100	14 - 15	93210-49046	21 - 17	95380-12800	17 - 17
90445-07ME8	21 - 22		5 - 17		10 - 34		15 - 13		30 - 5	97013-06012	6 - 43
90445-07ME9	21 - 22		7 - 45		10 - 36	92995-12200	14 - 48	93210-64488	19 - 28		10 - 9
90445-07MF1	22 - 14		8 - 5		11 - 19		15 - 46	93210-65M50	4 - 4		10 - 33
90445-07M02	3 - 12		8 - 14		13 - 33	93101-23070	21 - 31		29 - 12		10 - 35
90445-07M23	7 - 7		8 - 31	92903-08600	11 - 17		30 - 11	93210-85M97	21 - 67	97013-06014	8 - 12
90445-07M44	3 - 10		8 - 36		11 - 21	93101-25M03	21 - 69		30 - 13	97013-06016	10 - 25
	7 - 6	90467-10M04	7 - 52	92990-04100	28 - 4		30 - 12	93306-207U0	21 - 64	97013-06020	10 - 21
90445-07M45	3 - 13	90467-11M08	7 - 29	92990-05100	8 - 23	93102-08M43	18 - 14	93306-306V1	4 - 11		13 - 32
90445-07M82	3 - 14		7 - 59		27 - 7		19 - 14	93311-636U6	4 - 8	97013-06025	11 - 18
90445-07M87	7 - 9	90467-12M11	7 - 46	92990-05600	5 - 4	93102-30M23	4 - 2	93315-325V1	21 - 3	97013-08016	11 - 20
90445-07255	5 - 14	90468-05M03	7 - 23	92990-06600	12 - 26		29 - 10	93317-325U0	21 - 68	97013-08035	11 - 16
90445-08M01	7 - 43	90468-07M02	7 - 12		12 - 38	93102-36M24	4 - 9	93332-000U3	21 - 6	97075-08025	17 - 19
90445-09M75	8 - 4		7 - 13	92990-08200	13 - 35		29 - 8	93332-000W7	21 - 8	97075-08030	20 - 12
90445-09072	8 - 13		7 - 14	92990-08600	26 - 34	93106-09014	21 - 18	93410-18M02	14 - 41		20 - 18
	8 - 30	90468-18008	13 - 19	92990-10100	22 - 7		30 - 6		15 - 39	97075-08035	17 - 34
90445-09220	8 - 34		13 - 38	92990-10600	14 - 29	93106-18M01	4 - 3	93410-28M06	17 - 10		20 - 9
90445-11M02	7 - 57	90480-09M12	12 - 20		15 - 27		29 - 11	93430-06024	26 - 10	97075-10040	22 - 6
90445-11M03	7 - 27	90480-13M54	10 - 4		22 - 8	93210-04228	6 - 13	93440-49M04	4 - 10	97080-06010	16 - 4
90445-11M05	23 - 11	90501-10M21	14 - 30	92995-06100	1 - 7		29 - 22	93450-07M00	21 - 61	97095-05012	9 - 7
90445-11M06	23 - 9		15 - 28		2 - 8	93210-04230	6 - 26	93501-04M02	13 - 29	97095-06010	14 - 9
90445-11M15	7 - 54	90501-10326	6 - 6		14 - 6		29 - 29	93503-16003	21 - 48		14 - 46
90445-11M21	7 - 51	90501-12M48	21 - 51		15 - 7	93210-06M77	18 - 76	93505-32038	19 - 79		15 - 42
90446-10M01	7 - 56	90501-12082	13 - 30	92995-06600	1 - 8	93210-064A5	19 - 38	93603-12M11	21 - 45	97095-06016	1 - 6
	8 - 37	90501-14M08	17 - 21		1 - 12	93210-07M78	18 - 64	93603-18M09	4 - 18		1 - 11
90464-05M16	10 - 14	90501-16M65	21 - 47		2 - 9	93210-07003	21 - 59	93604-10M03	21 - 36		2 - 7
90464-07M05	3 - 16	90502-16M02	14 - 37		2 - 13	93210-08287	23 - 14	93606-12019	20 - 2		2 - 12
	7 - 5		15 - 35		4 - 6		23 - 16		20 - 6		7 - 30
	7 - 15	90502-20M03	14 - 37		8 - 3	93210-09165	19 - 37		22 - 5		10 - 12
90464-09M13	12 - 28		15 - 35		8 - 29	93210-10M74	18 - 68	93608-12063	3 - 7		10 - 49
90464-11M18	14 - 19	90506-14M24	14 - 44		9 - 9		19 - 54	93700-06M03	14 - 17		12 - 17
	15 - 43		15 - 40		9 - 11	93210-13M04	7 - 19		15 - 15		14 - 5
90464-11M23	7 - 58	90508-26M35	13 - 11		9 - 17	93210-16275	24 - 10	94702-00160	3 - 43		15 - 6
90464-15M11	10 - 28	91318-08016	19 - 66		10 - 8	93210-18M75	18 - 70	94702-00247	3 - 43		21 - 19
90464-18M14	10 - 50	91490-20012	13 - 36		10 - 13		19 - 56	95380-03600	6 - 35	97095-06020	4 - 5
90464-23M22	10 - 18	91490-30025	14 - 32		10 - 41		19 - 26		8 - 19		12 - 35
90465-06M86	7 - 10		15 - 30		12 - 18	93210-18397	7 - 2	95380-04600	28 - 5	97095-06025	8 - 2
	14 - 19	91490-40025	22 - 21		12 - 34	93210-19MA7	17 - 7	95380-05600	7 - 24		9 - 10
	15 - 17	91690-30012	14 - 36		12 - 36	93210-29M94	8 - 9		13 - 3		10 - 40
90465-11M10	17 - 41		15 - 34		14 - 7	93210-32738	29 - 16		13 - 17		12 - 33
	21 - 24	91690-30020	14 - 32		14 - 10		5 - 12		13 - 22		13 - 9
90465-11M27	7 - 28		15 - 28		15 - 8	93210-39ME4	29 - 14		26 - 7		13 - 26
90465-13M11	10 - 19		16 - 11		21 - 20		29 - 30		27 - 6	97095-06035	9 - 8
90465-13M30	7 - 33	92901-04100	19 - 76	92995-08100	17 - 20	93210-46M16	4 - 13	95380-06600	13 - 6	97095-06040	8 - 28

NUMERICAL INDEX
INDICE NUMERICO

PART NO. CODIGO NO.	REF. NO.	PART NO. CODIGO NO.	REF. NO.	PART NO. CODIGO NO.	REF. NO.	PART NO. CODIGO NO.	REF. NO.	PART NO. CODIGO NO.	REF. NO.
97095-06045	10 - 7								
97095-06095	5 - 11								
97095-10045	14 - 14								
	15 - 12								
97380-05025	26 - 8								
97380-08030	26 - 33								
97595-06420	19 - 35								
97607-04310	18 - 11								
	19 - 11								
97803-04010	6 - 34								
97880-05016	5 - 3								
97880-06012	14 - 13								
	15 - 11								
97885-05016	18 - 10								
	19 - 10								
97885-06010	9 - 16								
97885-06016	17 - 2								
	17 - 24								
97885-06045	5 - 21								
97980-04114	6 - 4								
98501-04025	19 - 75								
98501-05010	19 - 62								
98503-05028	8 - 22								
98580-03015	26 - 38								
98580-04006	26 - 36								
98580-04008	6 - 16								
98580-04010	26 - 35								
98580-05010	26 - 37								
98586-05016	23 - 4								
98980-03006	6 - 36								
99001-08600	21 - 60								

60FET/60FED/70BETO
PARTS CATALOGUE
E2001 by Yamaha Motor Co., Ltd.
1st Edition, Nov. 2001
All rights reserved.
Any reprinting or unauthorized use
without the written permission of
Yamaha Motor Co., Ltd.
is expressly prohibited.

60FET/60FED/70BETO
CATALOGO DE REPUESTOS
E2001, Yamaha Motor Co., Ltd.
1ªedición, Nov. 2001
Reservados todos los derechos.
Se prohíbe expresamente toda reimpresión
o utilización no autorizada de este manual
sin el consentimiento por escrito de
Yamaha Motor Co., Ltd.