



**PARTS  
CATALOGUE  
CATALOGO  
DE REPUESTOS**

**8CMH'11 (6N0A)**

---



1K6N0-200S1

( )

8CMH  
PARTS CATALOGUE  
©2010 by Yamaha Motor Co., Ltd.  
1st edition, August 2010  
All rights reserved.  
Any reprinting or unauthorized use  
without the written permission of  
Yamaha Motor Co., Ltd.  
is expressly prohibited.  
Printed in Japan.

8CMH  
CATALOGO DE REPUESTOS  
©2010 por Yamaha Motor Co., Ltd.  
1ª edición, agosto 2010  
Todos los derechos reservados.  
Toda reproducción o uso no autorizado  
sin el consentimiento escrito de  
Yamaha Motor Co., Ltd.  
quedan expresamente prohibidos  
Impreso en Japón.

# FOREWORD

This Parts Catalogue is related to the parts for the model(s) on the cover page. When you are ordering replacement parts, please refer to this Parts Catalogue and quote both part numbers and part names correctly.

1. Modifications or additions which have been made after the issue of the Parts Catalogue will be announced in the Parts News.  
It is advisable that you make the necessary corrections to the Parts Catalogue according to the Parts News.

2. Abbreviations

The following abbreviations are used in this Parts Catalogue.

“UR” Use specified parts number.

“UN” Use as many as needed.

“AP” Alternate Parts

“LM” Locally Made (Parts need to be ordered locally)

“F#” Frame No. (Applicable machine No.)

“O/S” Over Size

3. The number of components for assembly

- Parts, which are to be supplied in an assembly, are listed with a dot (.) in front of the part name as shown below.
- The numeral appearing to the right of each component part indicates the quantity of parts for each assembly unit.

PART NO.	DESCRIPTION	Q'TY	REMARKS
2F5-83310-60	FRONT FLASHER LIGHT ASSY	2	
115-83311-60	.BULB (6V-18W)	1	

4. Applicable colours of graphics are represented in the “REMARKS” as shown below.

PART NO.	DESCRIPTION	Q'TY	REMARKS
2N4-24110-00-X5	FUEL TANK COMP.	2	MXR
3J1-24240-10	.GRAPHIC, FUEL TANK	1	FOR MXR

5. Note that the illustrations for reference in finding parts numbers are not to be used for assembling. When assembling, please use the applicable service manual.

6. The asterisk (\*) before a reference number indicates modified items after the first edition.

7. Applicable Serial No.

Engine Serial No.

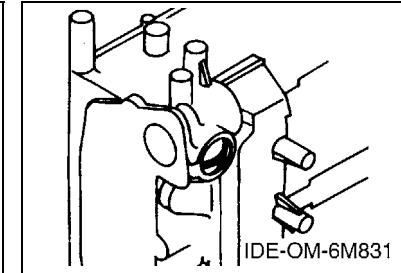
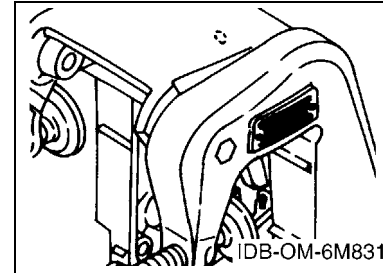

8. Applicable Engine Starting Serial No.

Model	Serial No.	Model	Serial No.
8C	6N0-1034270		

9. Applicable Colour Code

Abbreviation	Colour Name	Colour Code
DBNM2	DARK BLUISH GRAY METALLIC 2	004D

10. Quantity Column Information

Column No.	Name Of Q'ty Column	Applicable Model
1	6N0A	8CMH

# PROLOGO

Este catálogo de repuestos corresponde a las piezas para el o los modelos que figuran en la página de portada. Al formular el pedido de repuestos, se ruega citar este catálogo y especificar correctamente el número y el nombre de las piezas.

- Las modificaciones y agregados que se hayan realizado después de la edición de este Catálogo de Repuestos, serán anunciados en las Informaciones de Recambios. Es recomendable que se hagan las correcciones necesarias en el Catálogo de Repuestos de acuerdo con las Informaciones de Recambios.

## 2. Abreviaciones

En este. Catálogo de Repuestos se emplean las siguientes abreviaciones.

“UR” Usar el número de partes especificado

“UN” Usar la cantidad necesaria

“AP” Piezas sustitutivas

“LM” Fabricación local (Hay que pedir los repuestos en las cercanías)

“F#” N° de bastidor (N° aplicable a la máquina)

“O/S” Sobredimensionado

## 3. La cantidad de componentes para el montaje

- Los componentes, suministrados como conjunto, se describen con un punto (.) que precede al nombre del parte como se indica a continuación.
- La numeración que aparece a la derecha de cada descripción indica la cantidad de partes por cada unidad de conjunto.

CODIGO N°	DESCRIPCION	CANT.	OBSERVACIONES
2F5-83310-60	ENSAMBLAJE DE LA LUZ	2	
115-83311-60	.BOMBILLA (6V-18W)	1	

## 4. Los colores de los componentes se indican como sigue en la columna de “OBSERVACIONES”.

CODIGO N°	DESCRIPCION	CANT.	OBSERVACIONES
2N4-24110-00-X5	COMP. DEL TANQUE	2	MXR
3J1-24240-10	.GRAFICO, DEL TANQUE	1	PARA MXR

- Debe tenerse en cuenta que las ilustraciones sirven como guía para la búsqueda de los números de partes y no deben usarse para el montaje. Durante el montaje, se recomienda usar el manual de taller correspondiente.

- EL asterisco (\*) antes del número de referencia indica los elementos modificados después de la primera edición.

## 7. Números de serie

N° de Serie del motor

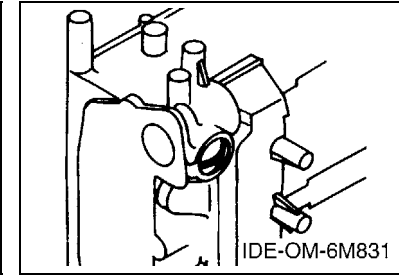
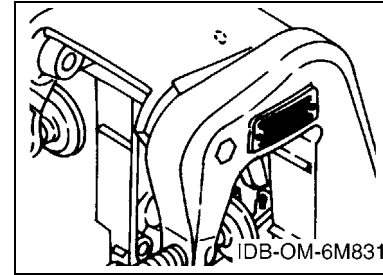

## 8. Números de serie del motor

Modelo	N° de serie	Modelo	N° de serie
8C	6N0-1034270		

## 9. Códigos de color aplicables

Abreviatura	Nombre de color	Código de color
DBNM2	DARK BLUISH GRAY METALLIC 2	004D

## 10. Información para la columna de cantidades

Columna N°	Nombre de la columna de cantidades	Modelo aplicable
1	6N0A	8CMH

# CONTENTS

TOP COWLING .....	1
CYLINDER & CRANKCASE .....	2
CRANKSHAFT & PISTON .....	4
INTAKE .....	5
CARBURETOR .....	6
FUEL .....	8
STARTER .....	9
GENERATOR .....	11
ELECTRICAL .....	12
BOTTOM COWLING .....	13
STEERING .....	14
CONTROL .....	15
BRACKET .....	17
UPPER CASING .....	20
LOWER CASING & DRIVE 1 .....	21
LOWER CASING & DRIVE 2 .....	24
FUEL TANK .....	25
REPAIR KIT .....	26

## INDEX

NUMERICAL INDEX .....	28
-----------------------	----

# CONTENIDO

SOPORTE SUPERIOR .....	1
CYLINDRO & CARTER .....	2
CIGUENAL & PISTON .....	4
ADMISION .....	5
CARBURADOR .....	6
COMBUSTIBLE .....	8
ARRANQUE .....	9
GENERADOR .....	11
ELECTRICO .....	12
CUBIERTA INFERIOR .....	13
DIRECCION .....	14
CONTROL .....	15
SOPORTE .....	17
FUNDA SUPERIOR .....	20
IMPULSOR E INFERIOR 1 .....	21
IMPULSOR E INFERIOR 2 .....	24
DEPOSITO DE COMBUSTIBLE .....	25
ESTUCHE REPARATION .....	26

## INDICE

INDICE NUMERICO .....	28
-----------------------	----

FIG. 1 TOP COWLING

SOPORTE SUPERIOR

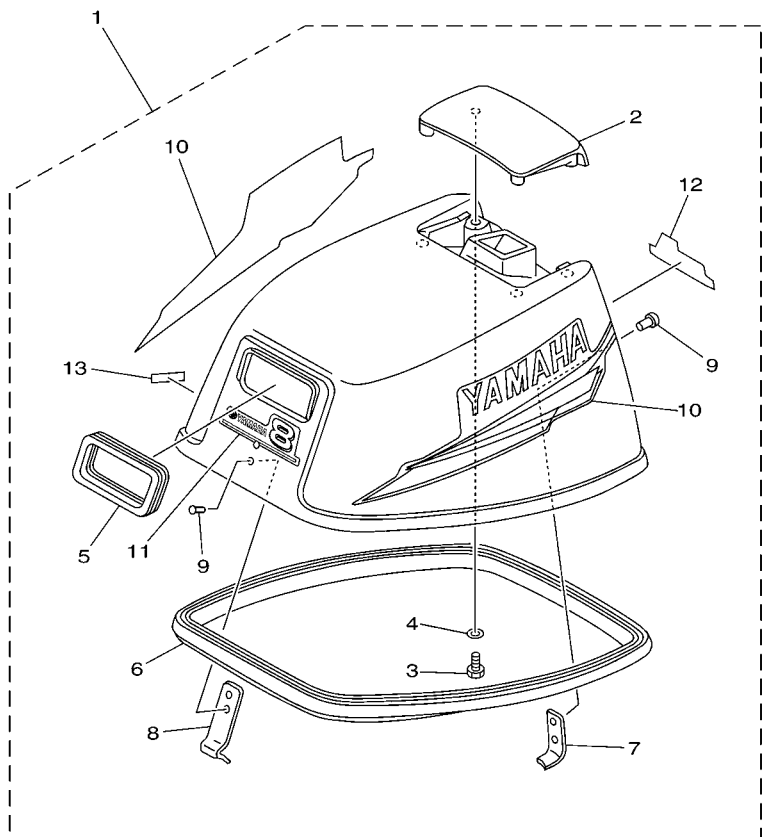

REF. NO.	PART NO. CODIGO Nº	DESCRIPTION DESCRIPCION	QTY	REMARKS OBSERVACIONES
1	6N0-G2610-30-4D	TOP COWLING ASSY SOPORTE SUPERIOR COMPL.	1	
2	6N0-G2613-00-4D	.MOLDING, AIR DUCT .MOLDURA CONDUCTO AIRE	1	
3	97095-06016	.BOLT .PERNO	4	
4	92995-06600	.WASHER .ARANDELA	4	
5	6G1-15761-00	.SEAL, RUBBER 1 .SELLO DE GOMA 1	1	
6	6G1-42615-00	.SEAL .SELLO	1	
7	6G1-42647-00	.HOLDER, CLAMP BAND .MORDAZA DE ABRAZADERA	1	
8	6N0-G2651-00	.HOOK .GANCHO	1	
9	90266-04M00	.RIVET .REMACHE	4	
10	6N0-WG070-10	.GRAPHIC SET .JUEGO DE EMBLEMA	1	
11	6N0-G2677-20	.GRAPHIC, FRONT .CALCAMONIA FRONTAL	1	
12	6N0-G2678-11	.GRAPHIC, REAR .CALCAMONIA TRASERA	1	
13	60R-G4191-00	.INDICATOR, SHIFT .INDICADOR DE CAMBIOS	1	



6N05010-E010

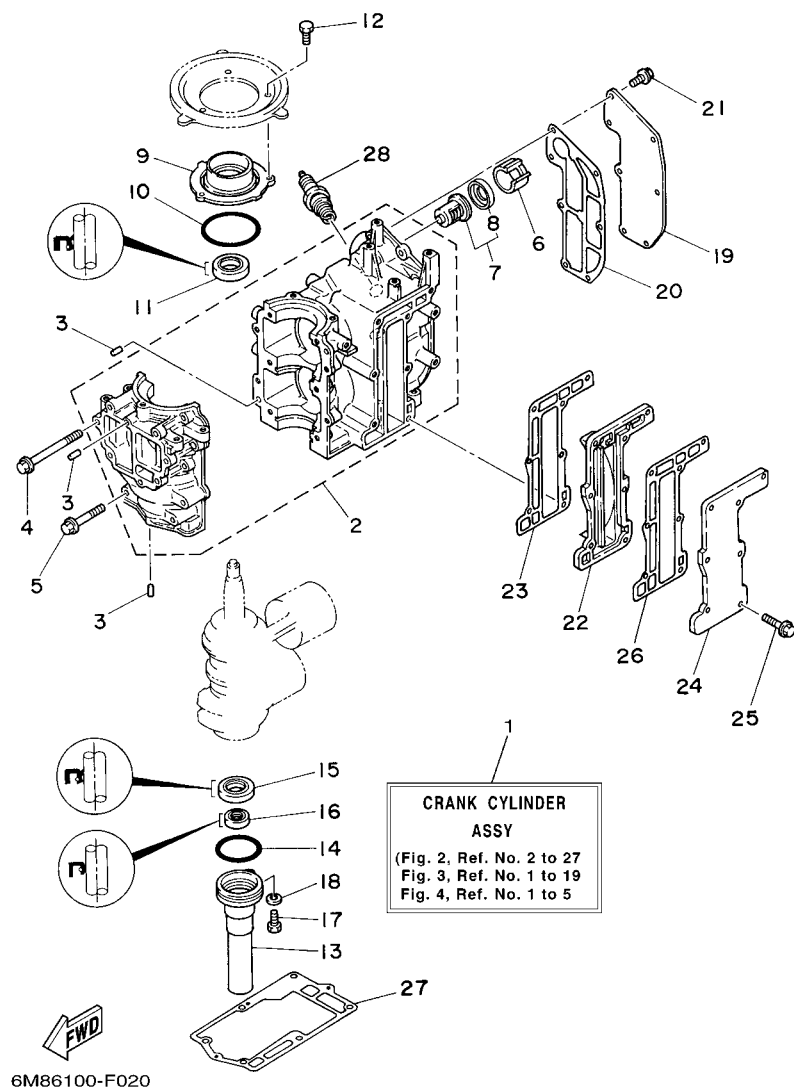
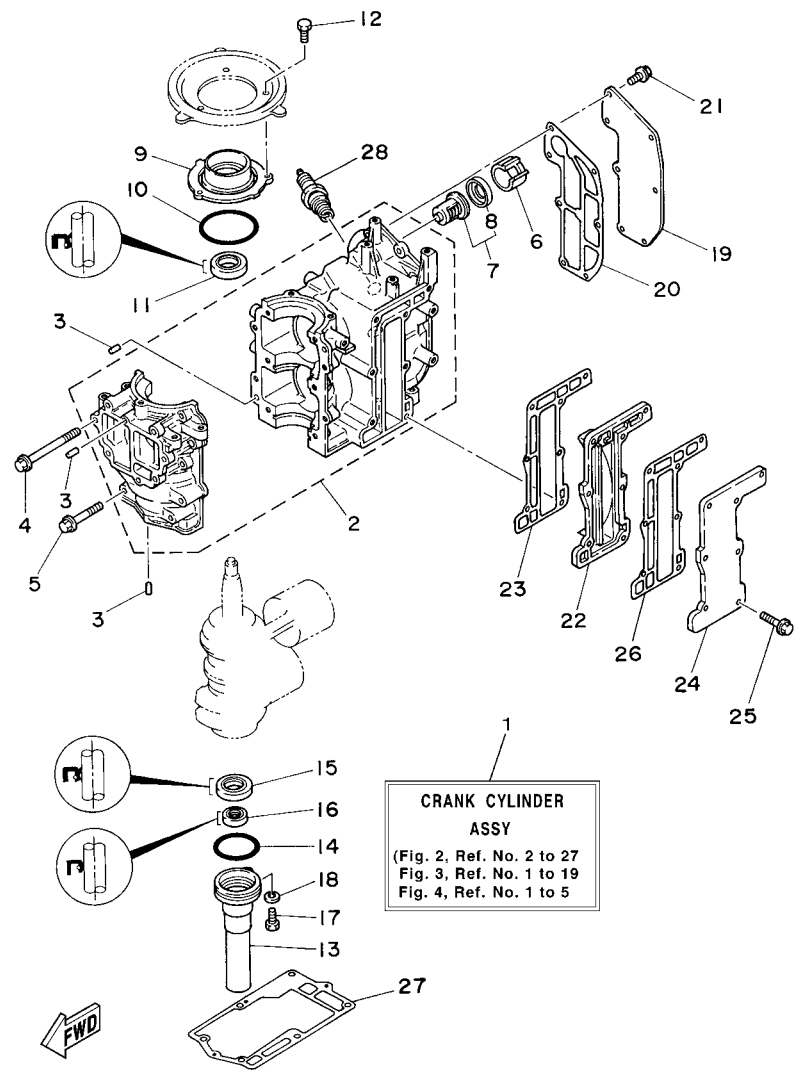

**FIG. 2 CYLINDER & CRANKCASE CYLINDRO & CARTER**

REF. NO.	PART NO. CODIGO Nº	DESCRIPTION DESCRIPCION	QTY	REMARKS OBSERVACIONES
1	6N0-WE090-01-1S	CRANK CYLINDER ASSY BLOQUE MOTOR COMPLETO	1	
2	6N0-E5100-00-1S	CRANKCASE ASSY CARTER COMPLETO	1	
3	93604-08062	PIN, DOWEL PASADOR DE CLAVIJA	4	
4	90105-06M26	BOLT, FLANGE TORNILLO	6	
5	90105-06M25	BOLT, FLANGE TORNILLO	4	
6	90387-22M50	COLLAR ESPACIADOR	1	
7	6E5-12411-02	THERMOSTAT TERMOSTAT	1	
8	6E5-12412-00	.SEAL, THERMOSTAT .SELLO TERMOSTATO	1	
9	6G1-15359-01-94	HOUSING, OIL SEAL CAJA DE SELLO DE ACEITE	1	
10	93210-54M54	O-RING ANILLO O	1	
11	93102-20M25	OIL SEAL SELLO ACEITE	1	
12	97013-06016	BOLT PERNO	3	
13	6G1-15396-02-CA	HOUSING, OIL SEAL CAJA DE SELLO DE ACEITE	1	
14	93210-42159	O-RING ANILLO O	1	
15	93101-20M34	OIL SEAL SELLO ACEITE	1	
16	93101-12M26	OIL SEAL SELLO ACEITE	1	
17	97095-06016	BOLT PERNO	1	
18	92995-06600	WASHER ARANDELA	1	
19	6N0-E1191-00-1S	COVER, CYLINDER HEAD 1 TAPA CULATA DE CILINDRO 1	1	
20	6G1-11193-A1	GASKET, HEAD COVER 1 EMPAQUE	1	
21	90105-06039	BOLT, FLANGE TORNILLO	7	
22	6N0-G1111-00-1S	INNER COVER, EXHAUST CUBIERTA INTERIOR DE ESCAPE	1	
23	6G1-41112-A1	GASKET, EXHAUST INNER COVER EMPAQUE	1	
24	6G1-41113-01-1S	OUTER COVER, EXHAUST CUBOERTA EXTERIOR DE ESCAPE	1	
25	90105-06037	BOLT, FLANGE TORNILLO	7	
26	6G1-41114-A0	GASKET, EXHAUST OUTER COVER EMPAQUE	1	
27	6G1-45113-A1	GASKET, UPPER CASING EMPAQUE	1	

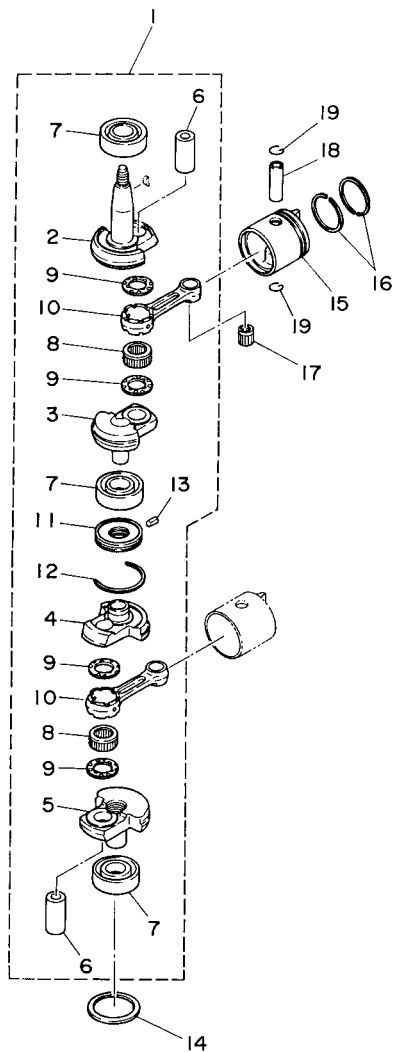

**FIG. 2 CYLINDER & CRANKCASE CYLINDRO & CARTER**



6M86100-F020

REF. NO.	PART NO. CODIGO Nº	DESCRIPTION DESCRIPCION	8NOA					REMARKS OBSERVACIONES
28	94702-00217	PLUG, SPARK (NGK B7HS-10) BUJIA (NGK B7HS-10)	2					



6M80010-4030

FIG. 3 CRANKSHAFT & PISTON

CIGUENAL & PISTON

REF. NO.	PART NO. CODIGO Nº	DESCRIPTION DESCRIPCION	QTY	REMARKS OBSERVACIONES
1	6N0-E1400-00	CRANKSHAFT ASSY CIGUENAL COMPLETO	1	
2	6N0-E1412-00	.CRANK 1 .MANIVELA 1	1	
3	6N0-E1422-00	.CRANK 2 .MANIVELA 2	1	
4	6N0-E1432-00	.CRANK 3 .MANIVELA 3	1	
5	6N0-E1442-00	.CRANK 4 .MANIVELA 4	1	
6	6G1-11681-00	.PIN, CRANK 1 .PASADOR MANIVELA 1	2	
7	93306-204U0	.BEARING .COJINETE	3	
8	93310-418V1	.BEARING .COJINETE DE RODILLOS	2	
9	90209-18112	.WASHER .ARANDELA DE SEPARACION	4	
10	6N0-E1651-00	.ROD, CONNECTING .BIELA	2	
11	6N0-E1515-00	.SEAL, LABYRINTH 1 .SELLO LABERINTO 1	1	
12	93440-47055	.CIRCLIP .SEGURO	1	
13	91609-20008	.PIN, SPRING .PASADOR DE RESORTE	1	
14	90201-41303	WASHER, PLATE ARANDELA PLANA	1	
15	6N0-E1631-00-64	PISTON (STD) PISTON (NORMA)	2	
16	6N0-E1603-00	PISTON RING SET (STD) JUEGO DE ANILLOS (NORMA)	2	
17	93310-112V0	BEARING COJINETE DE RODILLOS	2	
18	6N0-E1633-00	PIN, PISTON PASADOR, PISTON	2	
19	93450-13022	CIRCLIP SEGURO	4	

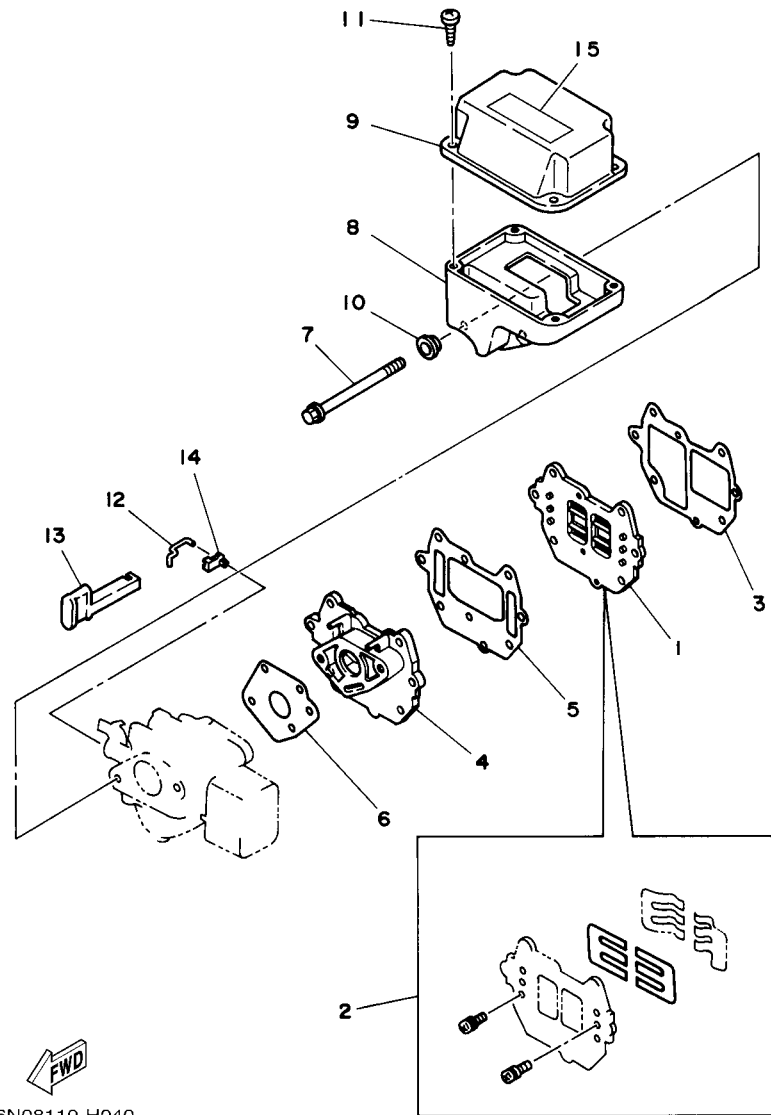

FIG. 4 INTAKE

ADMISION

REF. NO.	PART NO. CODIGO N°	DESCRIPTION DESCRIPCION	QTY	REMARKS OBSERVACIONES
1	6G1-13610-01	REED VALVE ASSY VALVULA DE LAMINAS COMPLETA	1	
2	6G1-W0004-00	.REED SET .JUEGO DE VALVULAS DE LENGUETA	1	
3	6G1-13621-A1	GASKET, VALVE SEAT JUNTA, DE VALV.DE EMPAQUE	1	
4	6N0-E3641-00-94	MANIFOLD 1 MULTIPLE 1	1	
5	6G1-13645-A1	GASKET, MANIFOLD 1 EMPAQUE	1	
6	6G1-14198-A1	GASKET EMPAQUE	1	
7	95895-06085	BOLT, FLANGE TORNILLO DE REBORDE	2	
8	6M8-E4417-00	COVER 1 CUBIERTA 1	1	
9	6M8-E4418-00	COVER 2 CUBIERTA 2	1	
10	90387-06M70	COLLAR ESPACIADOR	2	
11	97780-50514	SCREW, TAPPING TORNILLO DE CABEZA DE CONO ACH	4	
12	6G1-41256-00	ROD, CHOKE 1 VARILLA DE AHOGADOR	1	
13	6G1-41271-00	KNOB, CHOKE PERILLA AHOGADOR	1	
14	661-41262-02	JOINT, CHOKE LEVER CONECTOR DE AHOGADOR	1	
15	6AH-81994-70	LABEL, SAFETY ETIQUETA DE SEGURIDAD	1	

FIG. 5 CARBURETOR

CARBURADOR

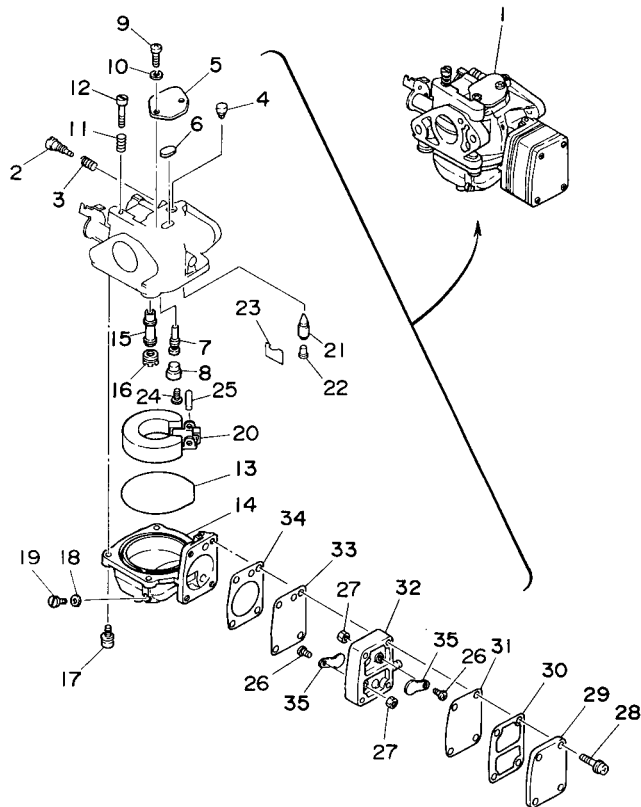

6M80010-4050

REF. NO.	PART NO. CODIGO N°	DESCRIPTION DESCRIPCION	QNTD				REMARKS OBSERVACIONES
1	6N0-14301-10	CARBURETOR ASSY 1 CARBURADOR COMPLETO 1	1				
2	679-14923-00	.SCREW, PILOT .TORNILLO DE AJUSTE	1				
3	679-14555-00	.SPRING .RESORTE	1				
4	6G1-14966-00	.CAP .TAPA	1				
5	6G1-14527-00	.PLATE .PLACA	1				
6	6G1-14126-00	.GASKET .EMPAQUE	1				
7	6G1-14948-06	.JET (#48) .INYECTOR (#48)	1				
8	676-14966-00	.CAP .TAPA	1				
9	97880-04010	.SCREW, PAN HEAD .TORNILLO DE CABEZA CON PLANA	2				
10	92990-04100	.WASHER, SPRING .ARANDELA PLANA	2				
11	90501-10326	.SPRING, COMPRESSION .RESORTE DE COMPRESION	1				
12	63V-14523-00	.SCREW, STOP .TORNILLO DE TOPE	1				
13	6G1-14984-00	.O-RING .EMPAQUE CAMARA DE BOIA	1				
14	6G1-14980-01	.BODY, FLOAT CHAMBER .CUERPO CAMARA DE BOIA	1				
15	6G1-14947-00	.JET, NEEDLE .INYECTOR DE AGUJA	1				
16	6G1-14943-79	.JET, MAIN (#108) .INYECTOR PRINCIPAL (#108)	1				
17	97980-04114	.SCREW, WITH WASHER .TORNILLO, CON ARANDELA	4				
18	6G1-14398-00	.WASHER .EMPAQUE	1				
19	6G1-14992-00	.SCREW, DRAIN .TORNILLO, SEGURO	1				
20	6G1-14985-00	.FLOAT .BOIA	1				
21	62D-14546-01	.VALVE, NEEDLE .VALVULA DE AGUJA	1				
22	676-14186-00	.PIN, FLOAT .PASADOR DE LA BOYA	1				
23	663-14159-00	.CLIP .PRESILLA	1				
24	98580-04008	.SCREW, PAN HEAD .TORNILLO DE CABEZA CRUZADA	1				
25	688-14548-00	.PIN, FLOAT ARM .PASADOR DE BRAZO DE BOIA	1				
26	98980-03006	.SCREW, BIND .TORNILLO DE LIGAR	2				
27	95380-03600	.NUT .TUERCA	2				

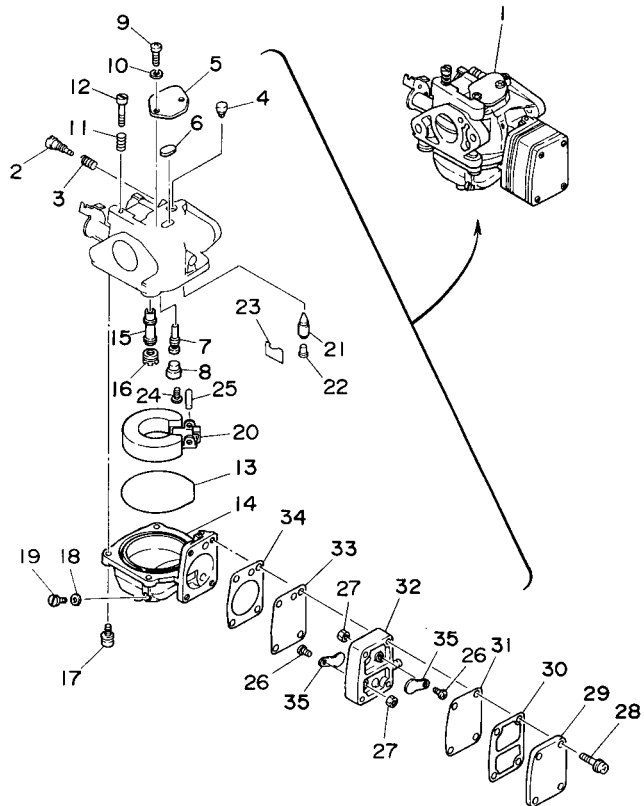

FIG. 5 CARBURETOR

CARBURADOR

REF. NO.	PART NO. CODIGO Nº	DESCRIPTION DESCRIPCION	QTY	REMARKS OBSERVACIONES
28	97980-04125	.SCREW, WITH WASHER .TORNILLO, CON ARANDELA	4	
29	6G1-24452-00	.COVER .CUBIERTA	1	
30	6G1-24432-00	.GASKET, FUEL PUMP 2 .EMPAQUE BOMBA COMBUSTIBLE	1	
31	6G1-24471-00	.DIAPHRAGM .DIAFRAGMA	1	
32	6G1-24412-01	.BODY 1 .CUERPO 1	1	
33	6G1-24411-00	.DIAPHRAGM .DIAFRAGMA	1	
34	6G1-24431-01	.GASKET, FUEL PUMP 1 .EMPAQUE BOMBA COMBUST 1	1	
35	6G1-24421-00	.VALVE, CHECK .VALVULA DE RETENCION	2	



6M80010-4050

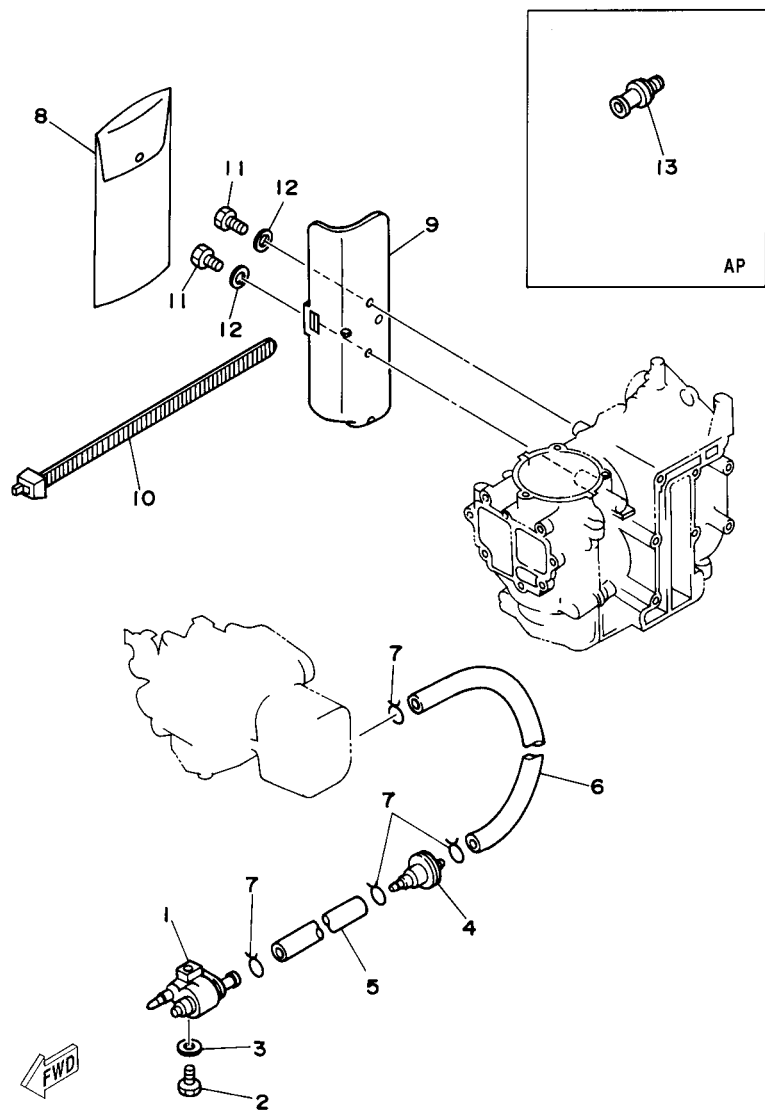
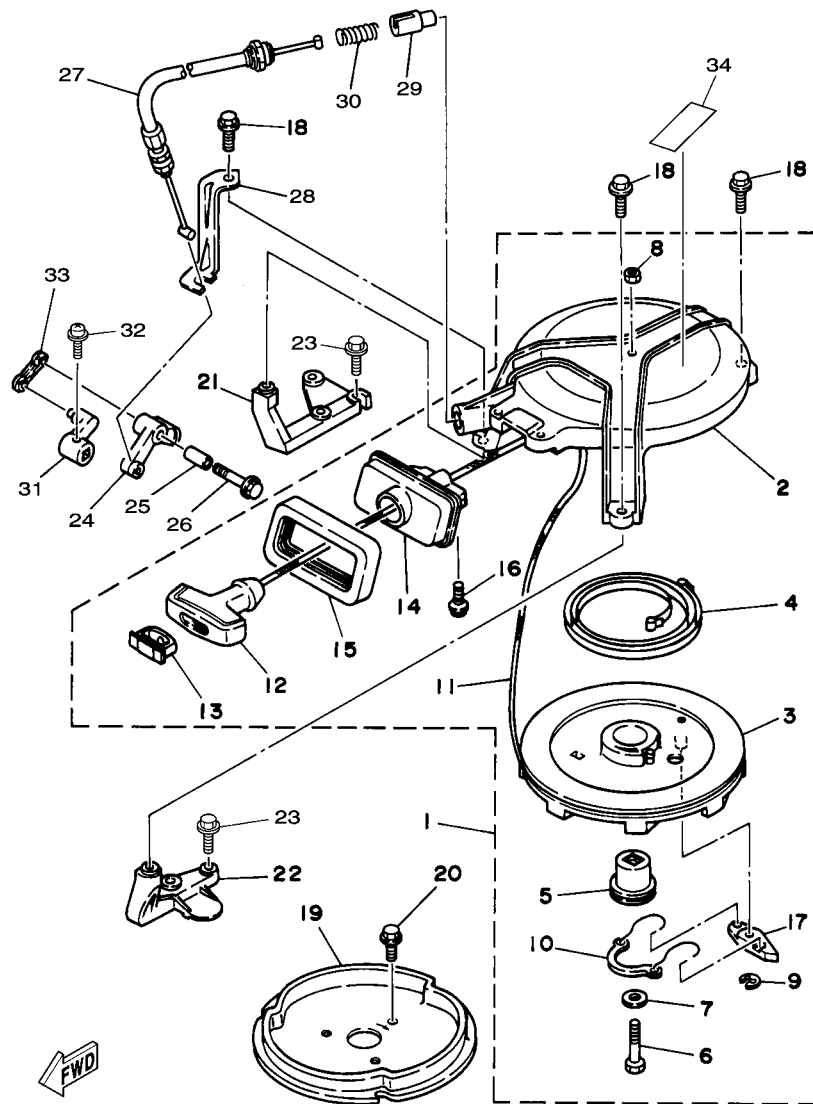

FIG. 6 FUEL

COMBUSTIBLE

REF. NO.	PART NO. CODIGO Nº	DESCRIPTION DESCRIPCION	QNTD			REMARKS OBSERVACIONES
1	6G1-24304-02	FUEL PIPE JOINT COMP. 1 CONECTOR MANGUERA COMBUST.1	1			
2	97095-06025	BOLT PERNO	1			
3	92995-06600	WASHER ARANDELA	1			
4	646-24251-02	STRAINER 1 COLADOR 1	1			
5	90445-09221	HOSE (L205) TUBO (L205)	1			
6	90445-09220	HOSE (L30) TUBO (L30)	1			
7	90467-08004	CLIP PRESILLA	4			
8	6N0-F8100-00	TOOL KIT JUEGO DE HERRAMIENTAS	1			
9	6N0-F8170-00	HOLDER, TOOL SOSTENEDOR, HERRAMIENTA	1			
10	6G1-2811G-00	BAND CINTA	1			
11	97095-06012	BOLT PERNO	2			
12	92995-06600	WASHER ARANDELA	2			
13	6L8-F8193-00	PLUG, WATER CHECK TAPON DE CONTROL DE LA AGUA	1			AP AP



6N0A200-K070

\*1: CUT FROM 50M ROLLS, PART NO. 90890-44372, CUTTING LENGTH 1.85M

\*1: CORTE DE UN RODILLO DE 50M , PARTS NUMERO 90890-44372, LARGO DEL CORTE 1.85M

FIG. 7 STARTER

ARRANQUE

REF. NO.	PART NO. CODIGO N°	DESCRIPTION DESCRIPCION	QTY	REMARKS OBSERVACIONES
1	6M8-E5710-03	STARTER ASSY ARRANQUE COMPLETO	1	
2	6N0-E5711-80-94	.CASE, STARTER .CAJA DE ARRANQUE	1	
3	6M8-E5714-00	.DRUM, SHEAVE .TAMBOR ROLDANA	1	
4	90510-08M03	.SPRING, SPIRAL .RESORTE EN ESPIRAL	1	
5	6G1-15717-00	.SHAFT, STARTER .EJE DE ARRANQUE	1	
6	97013-06035	.BOLT .PERNO	1	
7	90201-06M30	.WASHER, PLATE .ARANDELA PLANA	1	
8	95303-06600	.NUT .TUERCA	1	
9	93430-06M02	.CIRCLIP .SEGURO	1	
10	6G1-15705-00	.SPRING, DRIVE PAWL .RESORTE	1	
11	*	.WIRE (L1850) .CABLE (L1850)	1	*1 *1
12	6G1-15755-00	.HANDLE, STARTER .MANIJA DE ARRANQUE	1	
13	6G1-15779-00	.COVER .CUBIERTA	1	
14	6N0-E5758-00	.GUIDE, ROPE .GUIA DE CUERDA	1	
15	6G1-15762-00	.SEAL, RUBBER 2 .SELLO DE GOMA 2	1	
16	95895-06016	.BOLT, FLANGE .TORNILLO DE REBORDE	2	
17	677-15741-01	.PAWL, DRIVE .TRINQUETE DE TRACCION	1	
18	95895-06020	BOLT, FLANGE TORNILLO DE REBORDE	3	
19	6N0-E5723-00-94	PULLEY, STARTER POLEA DE ARRANQUE	1	
20	90105-06M29	BOLT, FLANGE TORNILLO	3	
21	6N0-E5771-00-94	STAY 1 SOPORTE 1	1	
22	6N0-E5772-00-94	STAY 2 SOPORTE 2	1	
23	97575-06520	BOLT, WITH WASHER PERNO CON ARANDELA	4	
24	6G1-15746-81	ARM BRAZO	1	
25	6G1-15764-00	COLLAR 1 COLLAR 1	1	
26	95895-06025	BOLT, FLANGE TORNILLO DE REBORDE	1	
27	6N0-E5770-90	CABLE COMP., STARTER STOP CABLECOMPL DE SEGURO ARRANQUE	1	

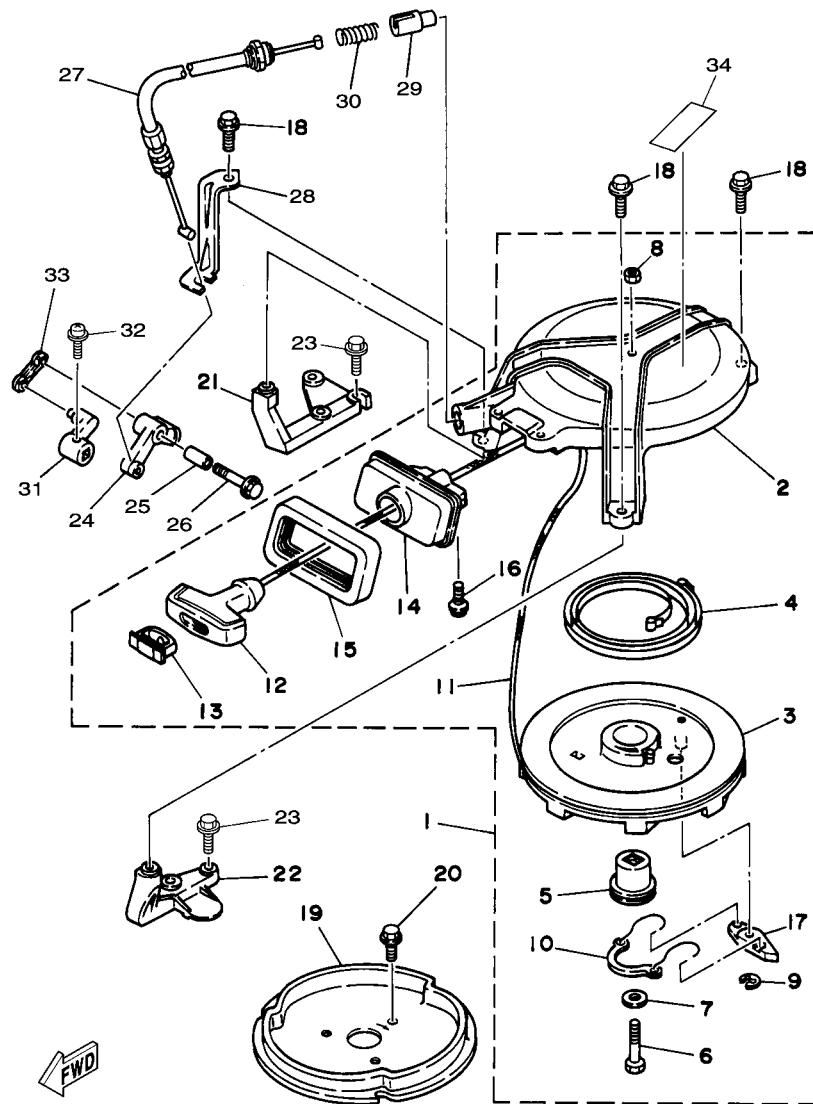

6N0A200-K070

\*1: CUT FROM 50M ROLLS, PART NO. 90890-44372, CUTTING LENGTH 1.85M

\*1: CORTE DE UN RODILLO DE 50M , PARTS NUMERO 90890-44372, LARGO DEL CORTE 1.85M

FIG. 7 STARTER

ARRANQUE

REF. NO.	PART NO. CODIGO Nº	DESCRIPTION DESCRIPCION	6N0A			REMARKS OBSERVACIONES
28	6G1-15774-81	STAY 4 SOPORTE 4	1			
29	656-15748-00	PLUNGER, STARTER STOP EMBOLO SEGURO DE ARRANQUE	1			
30	90501-10227	SPRING, COMPRESSION RESORTE DE COMPRESION	1			
31	6G1-44125-80	LEVER, SHIFT ROD PALANCA VARILLA CAMBIOS	1			
32	97980-05216	SCREW, WITH WASHER TORNILLO, CON ARANDELA	1			
33	6G1-15747-80	LINK ESLABON	1			
34	6AH-81995-70	LABEL, WARNING ETIQUETA DE PRECAUCION	1			



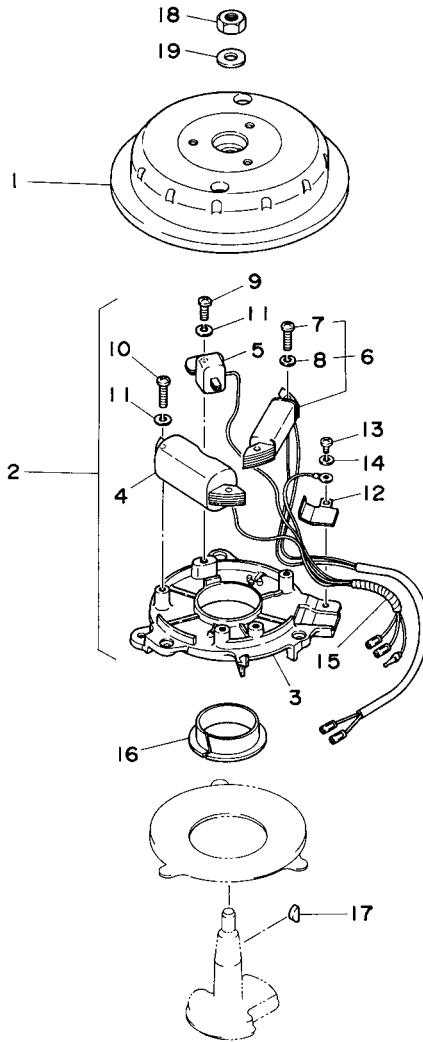

6M80010-4080

FIG. 8 GENERATOR

GENERADOR

REF. NO.	PART NO. CODIGO N°	DESCRIPTION DESCRIPCION	QTY	REMARKS OBSERVACIONES
1	6G1-85550-71	ROTOR ASSY ROTOR COMPLETO	1	
2	6G1-85560-F0	BASE ASSY CONJUNTO BASE	1	
3	6G1-85509-70	.BASE, MAGNETO .BASE DE MAGNETO	1	
4	6E7-85520-70	.COIL, CHARGE .BOBINA DE CARGA	1	
5	6E7-85580-70	.COIL, PULSER .BOBINA DE PULSACION	1	
6	6E7-81303-A0	.LIGHTING COIL ASSY .BOBINA DE ILUMINACION COMPL.	1	
7	97802-05025	..SCREW, PAN HEAD ..TORNILLO	2	
8	92902-05100	..WASHER, SPRING ..ARANDELA	2	
9	97802-05016	.SCREW, PAN HEAD .TORNILLO	1	
10	97802-05020	.SCREW, PAN HEAD .TORNILLO	2	
11	92902-05100	.WASHER, SPRING .ARANDELA	3	
12	6G1-85548-70	.HOLDER .SOSTEN	1	
13	97802-04008	.SCREW, PAN HEAD .TORNILLO	1	
14	92902-04100	.WASHER, SPRING .ARANDELA	1	
15	6G1-85515-70	.LEAD WIRE ASSY .CABLE CONDUCTOR COMPLETO	1	
16	90386-44M42	BUSH BUJE	1	
17	90280-04M06	KEY, WOODRUFF CUNA WOODRUFF	1	
18	90170-10113	NUT TUERCA	1	
19	90201-10126	WASHER, PLATE ARANDELA PLANA	1	

FIG. 9 ELECTRICAL

ELECTRICO

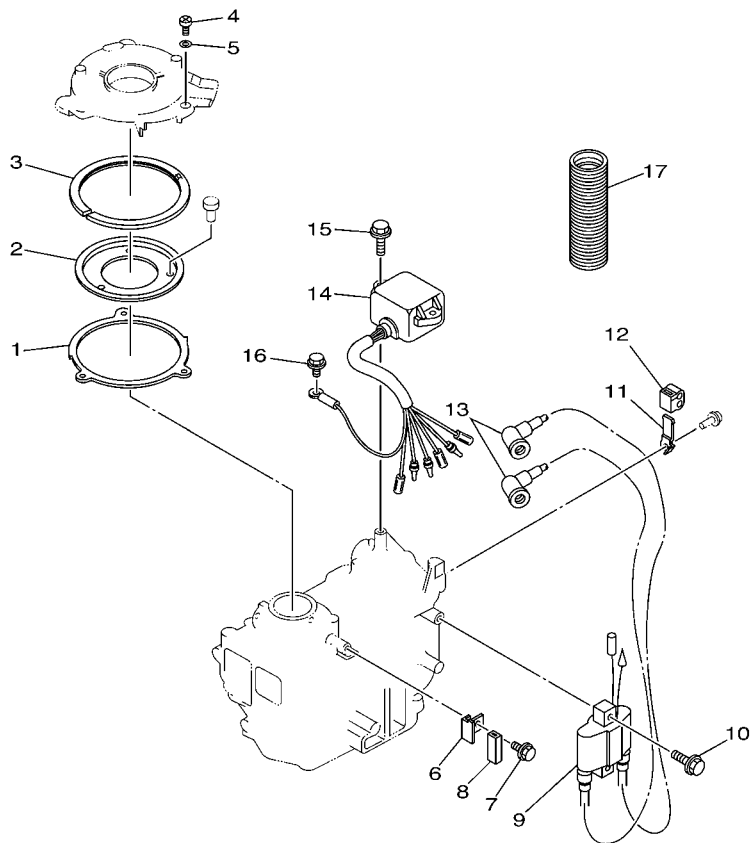

REF. NO.	PART NO. CODIGO Nº	DESCRIPTION DESCRIPCION	QTY	REMARKS OBSERVACIONES
1	6N0-G1611-00	RETAINER, MAGNETO BASE RETENEDOR BASE MAGNETO	1	
2	6G1-41612-00	RETAINER, MAGNETO BASE RETENEDOR BASE MAGNETO	1	
3	6N0-G1613-00	PLATE, BASE FRICTION PLACA DE BASE DE FRICCION	1	
4	97885-05010	SCREW, PAN HEAD TORNILLO A MUESCA	3	
5	92995-05600	WASHER ARANDELA	3	
6	6G1-41615-01	STOPPER, MAGNETO BASE RETENEDOR, BASE MAGNETO	1	
7	95895-06010	BOLT, FLANGE TORNILLO DE REBORDE	1	
8	6G1-44194-00	CAP TAPA	1	
9	6G1-85570-02	IGNITION COIL ASSY BOBINA DE IGNICION COMPLETO	1	
10	95895-06025	BOLT, FLANGE TORNILLO DE REBORDE	2	
11	6M8-82361-00	CLAMP, CORD GRAMPA DE CABLE	1	
12	6M8-82362-00	CLAMP, CORD 2 GRAMPA DE CABLE 2	1	
13	663-82370-01	PLUG CAP ASSY TAPON DE BUJIA COMPLT	2	
14	696-85540-12	C.D.I. UNIT ASSY UNIDAD C.D.I. COMPLETA	1	
15	95895-06020	BOLT, FLANGE TORNILLO DE REBORDE	2	
16	95895-06010	BOLT, FLANGE TORNILLO DE REBORDE	1	
17	6G1-83557-00	TUBE ENCHUFE DE ACEITE	1	

  
6M84100-D100

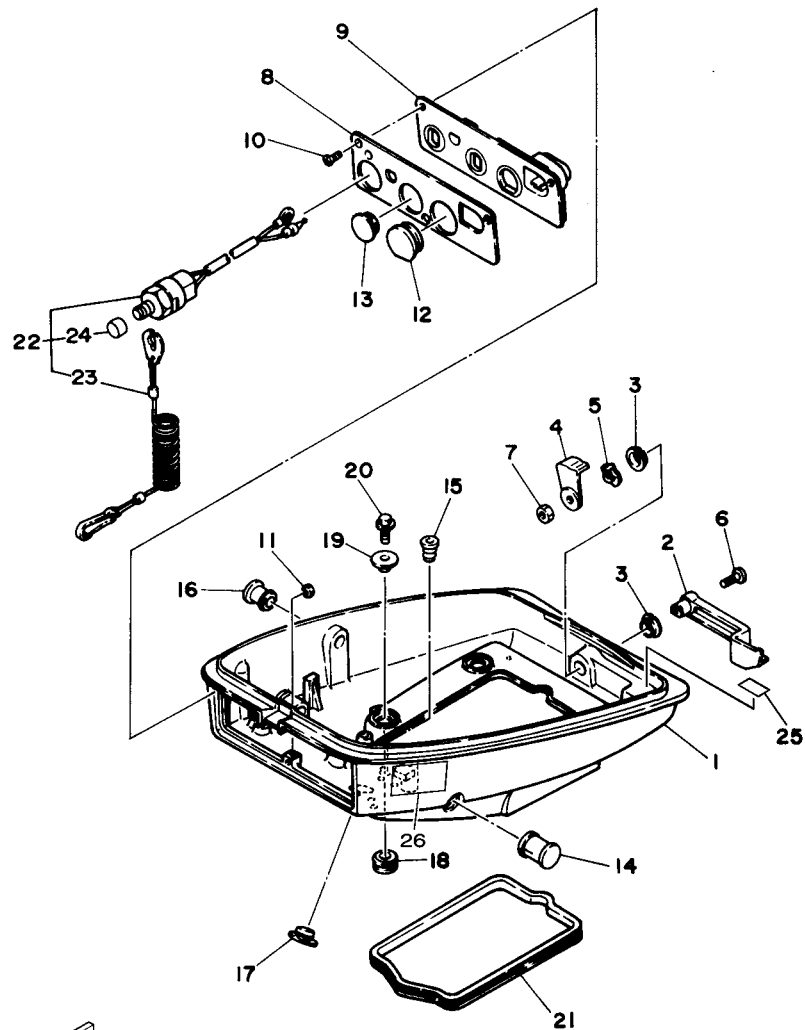

  
 6N08110-H110

FIG. 10 BOTTOM COWLING

CUBIERTA INFERIOR

REF. NO.	PART NO. CODIGO Nº	DESCRIPTION DESCRIPCION	QTY	REMARKS OBSERVACIONES
1	6N0-G2711-00-4D	COWLING, BOTTOM 1 CUBIERTA INFERIOR 1	1	
2	6N0-G2815-00-4D	LEVER, CLAMP PALANCA ABRAZADERA	1	
3	90386-12M45	BUSH BUJE	2	
4	6E0-42816-00	LEVER, CLAMP PALANCA ABRAZADERA	1	
5	90206-12052	WASHER, WAVE ARANDELA ONDULADA	1	
6	97885-06030	SCREW, PAN HEAD TORNILLO A MUESCA	1	
7	95380-06700	NUT TUERCA	1	
8	6N0-G2719-00	PANEL, FRONT LOWER PANEL FRENTE INFERIOR	1	
9	6N0-G2767-00	BRACKET SOPORTE	1	
10	90149-05M02	SCREW TORNILLO DE REGLAJE	3	
11	95380-05700	NUT TUERCA	1	
12	6G1-42724-00	GROMMET TAPON	1	
13	6G1-42725-00	GROMMET TAPON	1	
14	6G1-42726-00	GROMMET TAPON	1	
15	6G1-42727-00	GROMMET TAPON	1	
16	6G1-42748-00	GROMMET TAPON	1	
17	6G1-26326-00	GROMMET TAPON PROTECTOR	1	
18	90480-15M31	GROMMET TAPON	4	
19	90387-06M52	COLLAR ESPACIADOR	4	
20	95895-06020	BOLT, FLANGE TORNILLO DE REBORDE	4	
21	6N0-G2716-00	RUBBER, SEAL 1 SELLO DE GOMA 1	1	
22	6E9-82575-02	ENGINE STOP SWITCH ASSY INTERRUPTOR DE PARADA COMPL	1	
23	682-82556-00	.LANYARD, STOP SWITCH .RETENER	1	
24	689-8257Y-00	.CAP .TAPA	1	
25	6E7-42791-00	MARK 1 MARCA 1	1	
26	6AH-42794-70	LABEL, WARNING (GENERAL) ETIQUETA DE PRECAUCION	1	

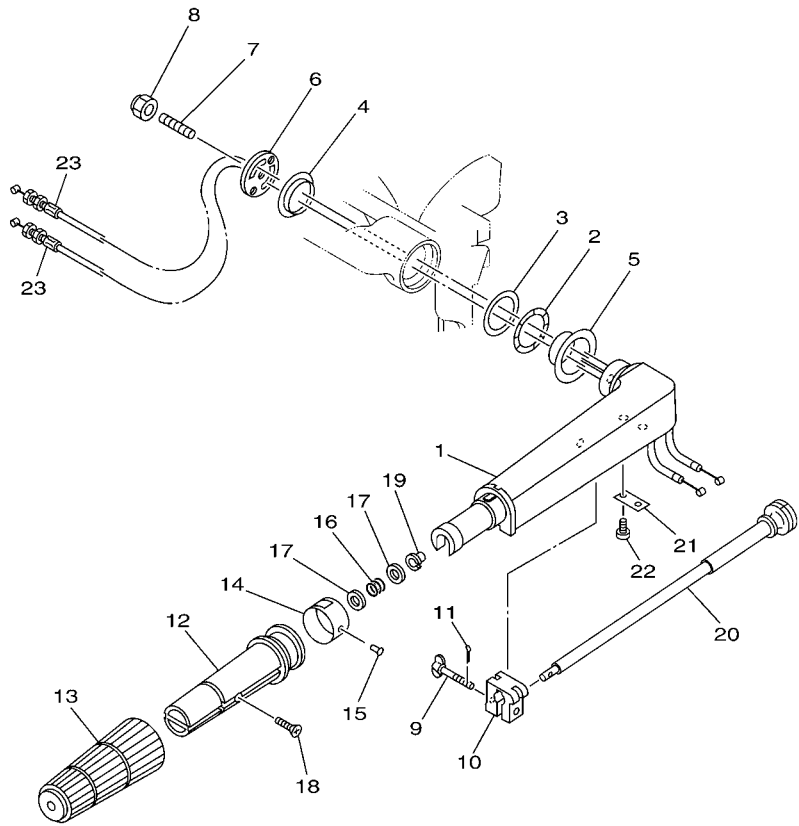

**FWD**  
6M8A100-K110

**FIG. 11 STEERING**

**DIRECCION**

REF. NO.	PART NO. CODIGO Nº	DESCRIPTION DESCRIPCION	QTY	REMARKS OBSERVACIONES
1	6M8-G2111-11-4D	HANDLE, STEERING MANIJA DE DIRECCION	1	
2	90206-36M21	WASHER, WAVE ARANDELA ONDULADA	1	
3	90202-36M55	WASHER, PLATE ARANDELA DE PLANA	1	
4	90386-33M96	BUSH BUJE	1	
5	90386-34M97	BUSH BUJE	1	
6	6G1-42131-02	COVER, HANDLE STEERING CUBIERTA MANIJA DIRRECCION	1	
7	90116-08016	BOLT, STUD ESPARRAGO	1	
8	90185-08057	NUT, SELF-LOCKING TUERCA AUTOBLOCANTE	1	
9	6G1-42125-01	BOLT, FRICTION ADJUSTING TORNILLO FRICCION ADJUSTA	1	
10	6G1-42126-00	FRICTION, STEERING HANDLE GRIP FRICCION DE MANGO DIRECCION	1	
11	91490-16010	PIN, COTTER CHAVETA	1	
12	6M4-G2119-00	GRIP, STEERING HANDLE MANGO, MANIJA DE DIRRECCION	1	
13	6N0-G2177-00	RUBBER, HANDLE HULE DE MANIJA	1	
14	6N0-G2137-10	INDICATOR, THROTTLE INDICADOR ACELERADOR	1	
15	90269-02M09	RIVET REMACHE	1	
16	90501-23215	SPRING, COMPRESSION RESORTE DE COMPRESION	1	
17	90201-10M02	WASHER, PLATE ARANDELA PLANA	2	
18	90152-05011	SCREW, COUNTERSUNK TORNILLO EMBUTIDO	1	
19	90386-08032	BUSH BUJE	1	
20	6G1-42138-01	LEVER, THROTTLE PLANCA DE ACELERACION	1	
21	6E0-42159-02	STAY SOPORTE	1	
22	97885-05012	SCREW, PAN HEAD TORNILLO A MUESCA	2	
23	6N0-F6301-10	THROTTLE CABLE ASSY CABLE DE ACELERADOR COMPLETO	2	

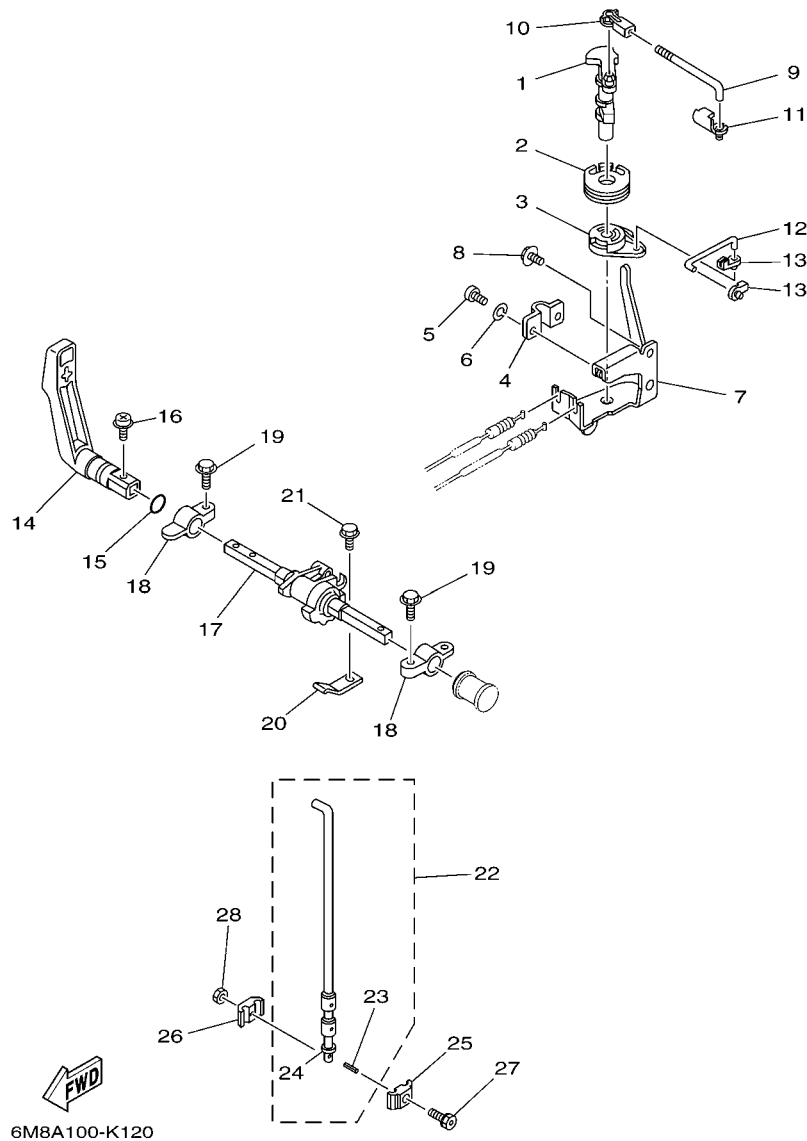

FIG. 12 CONTROL

CONTROL

REF. NO.	PART NO. CODIGO N°	DESCRIPTION DESCRIPCION	QNTD				REMARKS OBSERVACIONES
1	6G1-41631-00	LEVER, MAGNETO CONTROL PALANCA DE CONTROL DE MAGNETO	1				
2	6G1-41638-00	PULLEY POLEA	1				
3	6G1-41283-01	LEVER, FREE ACCEL. PALANCA	1				
4	6G1-41661-00	BRACKET 1 SOPORTE 1	1				
5	97880-05010	SCREW, PAN HEAD TORNILLO DE CABEZA CON PLANA	2				
6	92990-05100	WASHER, SPRING ARANDELA PLANA	2				
7	6G1-14497-81	STAY, THROTTLE WIRE SOPORTE VALVULA DE OBTURACION	1				
8	95895-06010	BOLT, FLANGE TORNILLO DE REBORDE	2				
9	6G1-41238-00	JOINT, LINK CONECTOR	1				
10	662-41237-01	JOINT, LINK CONECTOR	1				
11	6E9-41237-00	JOINT, LINK CONECTOR	1				
12	6G1-41211-00	LINK, ACCEL. ESLABON, ACELERADOR	1				
13	661-41262-02	JOINT, CHOKE LEVER CONECTOR DE AHOGADOR	2				
14	6N0-G4111-00	HANDLE, GEAR SHIFT MANIJA DE CAMBIO DE MARCHAS	1				
15	93210-12327	O-RING ANILLO O	1				
16	97980-05216	SCREW, WITH WASHER TORNILLO, CON ARANDELA	1				
17	6G1-44121-02-94	LEVER, SHIFT ROD PALANCA VARILLA CAMBIOS	1				
18	6G1-41662-01-94	BRACKET 2 SOPORTE 2	2				
19	90105-06M14	BOLT FLANGE TORNILLO	2				
20	6G1-44116-01	SPRING RESORTE	1				
21	95895-06012	BOLT, FLANGE TORNILLO DE REBORDE	1				
22	6N0-G4110-00	SHIFT ROD ASSY VARILLA DE CAMBIO COMPL	1				
23	91690-20010	.PIN, SPRING .PASADOR DE RESORTE	3				
24	92990-05600	.WASHER, PLATE .ARANDELA PLANA	1				
25	6N0-G4145-00	CONNECTOR, SHIFT ROD CONECTOR, VARILLA CAMBIO	1				
26	6N0-G4146-00	CONNECTOR, SHIFT ROD CONECTOR VARILLA DE CAMBIO	1				
27	90109-06M17	BOLT PERNO	1				

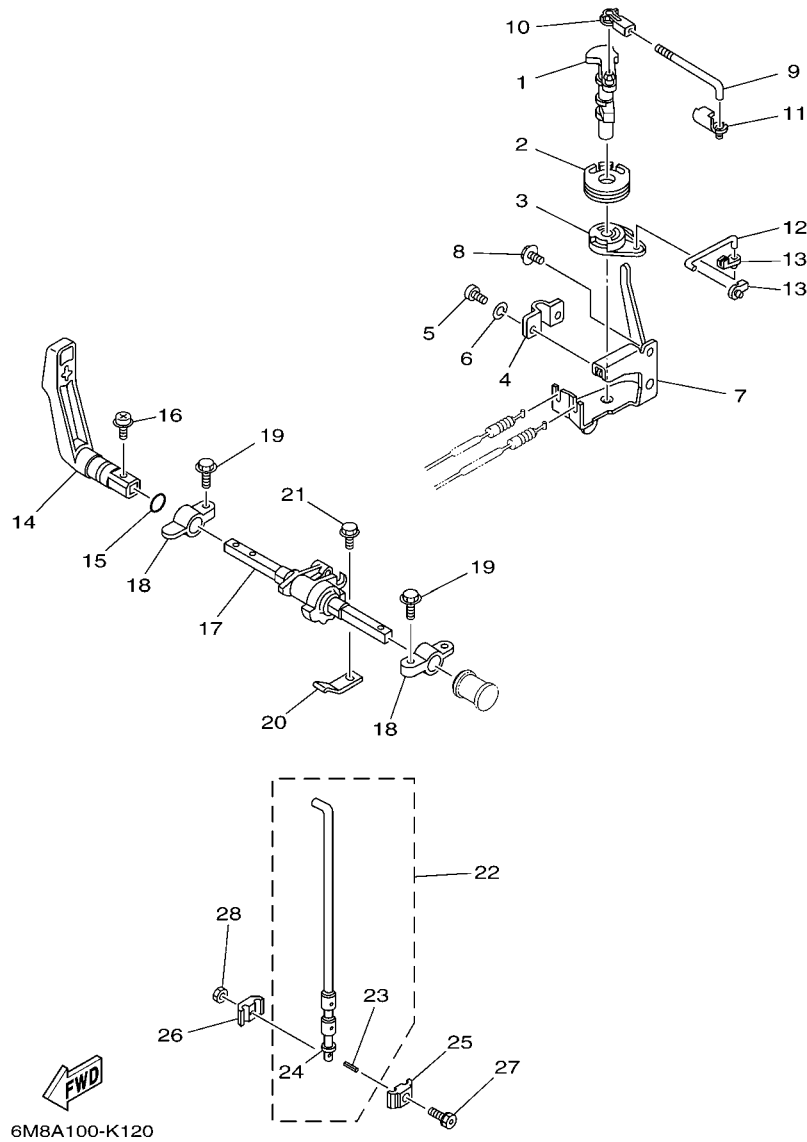
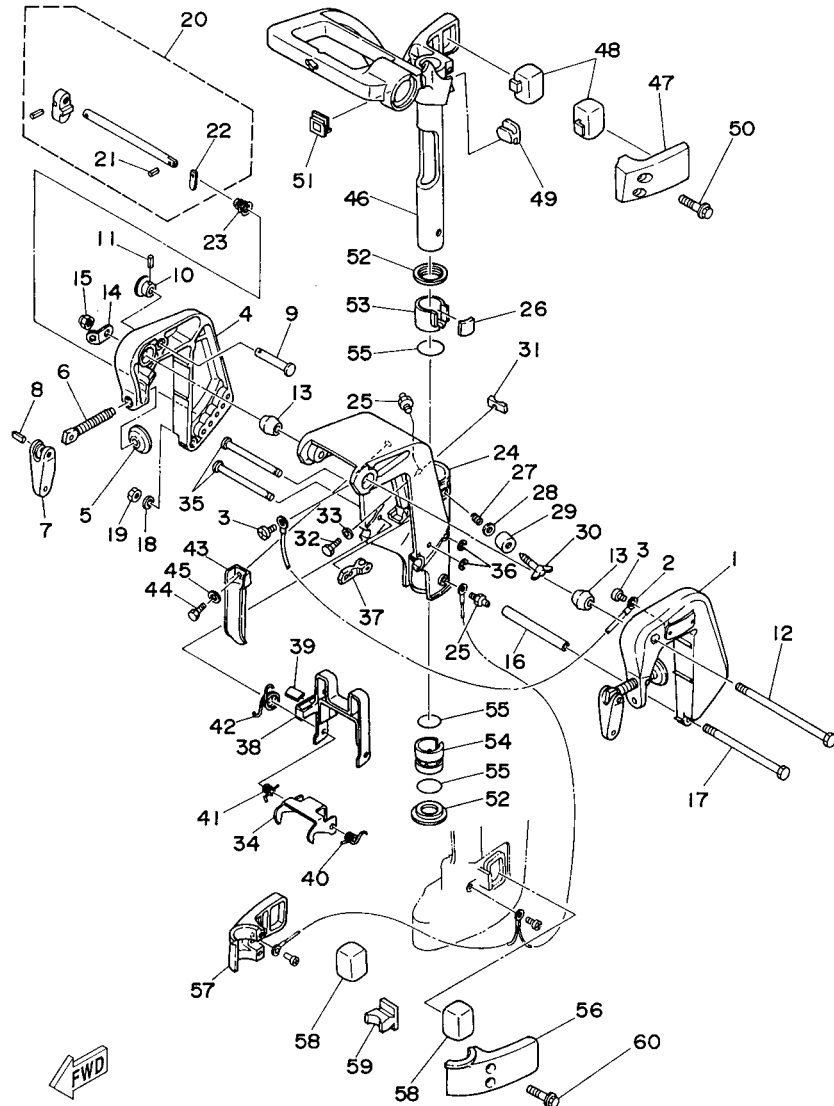

FIG. 12 CONTROL

CONTROL

REF. NO.	PART NO. CODIGO Nº	DESCRIPTION DESCRIPCION	QNTD		REMARKS OBSERVACIONES
28	95380-06600	NUT, HEXAGON TUERCA	1		
-----					
-----					
-----					
-----					
-----					
-----					
-----					
-----					
-----					
-----					
-----					
-----					
-----					
-----					
-----					
-----					
-----					
-----					
-----					
-----					
-----					
-----					



6N00110-4140

FIG. 13 BRACKET

SOPORTE

REF. NO.	PART NO. CODIGO Nº	DESCRIPTION DESCRIPCION	QTY	REMARKS OBSERVACIONES
1	6M8-G3111-02-4D	BRACKET, CLAMP 1 SOPORTE DE LA ABRAZADERA 1	1	
2	6E5-82148-00	WIRE, LEAD 4 CABLE CONDUCTOR 4	1	
3	97885-06008	SCREW, PAN HEAD TORNILLO A MUESCA	2	
4	6M8-G3112-01-4D	BRACKET, CLAMP 2 SOPORTE DE LA ABRAZADERA 2	1	
5	620-43114-00	PAD, TRANSOM CLAMP ARANDELA DE ABRAZADERA	2	
6	6N0-G3116-00	SCREW, TRANSOM CLAMP TORNILLO DE ABRAZADERA	2	
7	6L8-G3118-01	HANDLE, TRANSOM CLAMP MANIJA DE LA ABRAZADERA DEL ES	2	
8	90243-04M01	PIN PASADOR	2	
9	689-43191-00	SHAFT, STOPPER EJE DE TOPE	1	
10	689-43192-01	KNOB, STOPPER PERILLA DE TOPE	1	
11	91690-30016	PIN, SPRING PASADOR DE RESORTE	1	
12	90101-08869	BOLT TORNILLO	1	
13	6G1-43136-00	PIECE, FRICTION PIEZA DE FRICCION	2	
14	6A1-43113-01	PLATE, CLAMP BRACKET PLACA ABRAZADERA SOPORTE	1	
15	90185-08057	NUT, SELF-LOCKING TUERCA AUTOBLOCANTE	1	
16	90387-06M13	COLLAR ESPACIADOR	1	
17	97095-06135	BOLT PERNO	1	
18	92990-06600	WASHER, PLATE ARANDELA PLANA	1	
19	95380-06600	NUT, HEXAGON TUERCA	1	
20	6N0-G3160-00	TILT ROD ASSY VARILLA DE BASCULACION COMPL.	1	
21	91690-30008	.PIN, SPRING .PASADOR DE RESORTE	1	
22	6N0-G3165-00	.PLATE, TILT LOCK .PLACA DE TOPE, VARILLA SEGURID	1	
23	90502-10M06	SPRING, CONICAL RESORTE CONICO	1	
24	6N0-G3311-10-4D	BRACKET, SWIVEL 1 SOPORTE GIRATORIO 1	1	
25	93700-06M03	NIPPLE, GREASE BOQUILLA DE ENGRASAR	2	
26	6G1-42528-00	PLATE, FRICTION PIEZA DE FRICCION	1	
27	90501-18M00	SPRING, COMPRESSION RESORTE DE COMPRESION	1	

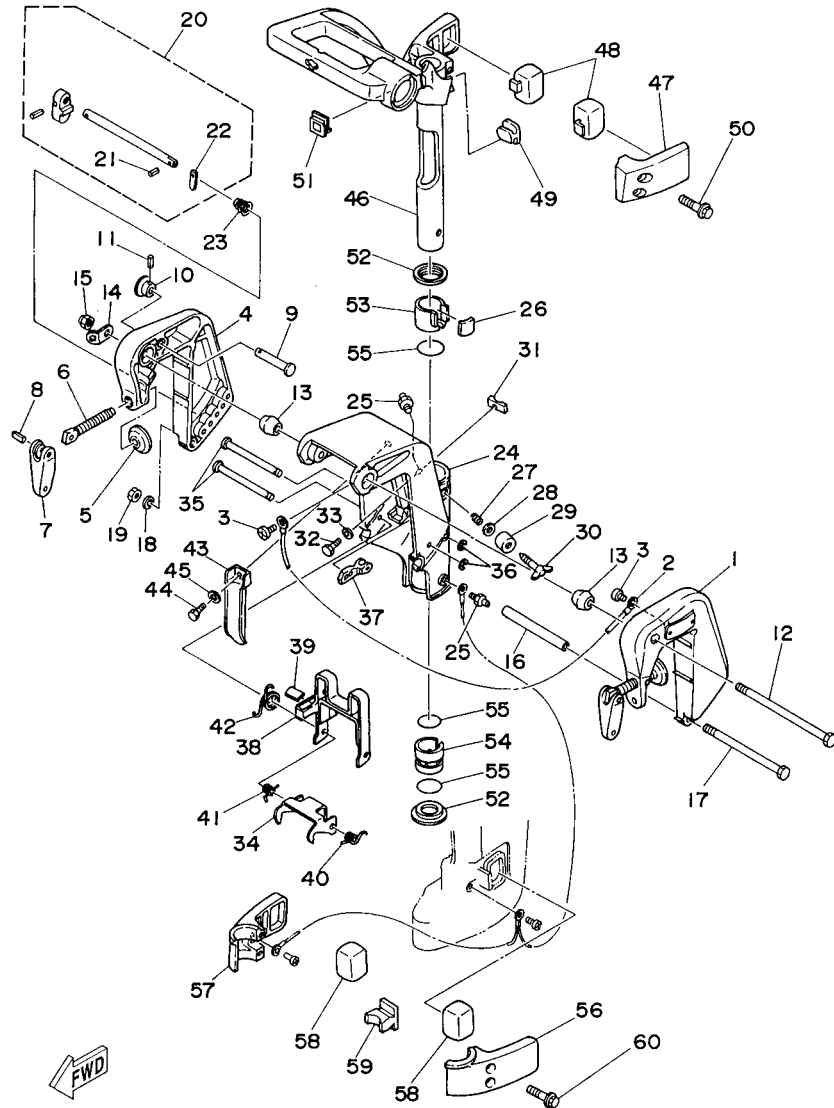

6N00110-4140

FIG. 13 BRACKET

SOPORTE

REF. NO.	PART NO. CODIGO Nº	DESCRIPTION DESCRIPCION	QTY	REMARKS OBSERVACIONES
28	92990-08600	WASHER, PLATE ARANDELA PLANA	1	
29	6G1-43373-00	SEAL, DAMPER SELLO DE GOMA	1	
30	6G1-42529-00	SCREW, FRICTION PIECE TORNILLO PIEZA FRICCION	1	
31	6G1-44532-01	STOPPER, UPPER MOUNT RETEN	1	
32	97095-06010	BOLT PERNO	1	
33	92995-06600	WASHER ARANDELA	1	
34	6N0-G3614-00	PLATE, TILT LOCK PLACA DE SEGURO DE INCLINACION	1	
35	6G1-43659-00	SHAFT, REVERSE LOCK EJE SEGURO DE REVERSA	2	
36	99080-05600	CIRCLIP PRESILLA REDONDA	2	
37	6G1-43615-02	PLATE, TILT LOCK PLACA DE SEGURO DE INCLINACION	1	
38	6G1-43681-00	LEVER, SHALLOW WATER DRIVE 1 PALANCA 1	1	
39	6G1-43318-01	COVER CUBIERTA	1	
40	90508-10M15	SPRING, TORSION RESORTE DE TORSION	1	
41	90508-10M16	SPRING, TORSION RESORTE DE TORSION	1	
42	90508-14M17	SPRING, TORSION RESORTE DE TORSION	1	
43	6N0-G2731-00	CARRYING HANDLE MANIJA	1	
44	97095-08016	BOLT PERNO	1	
45	92995-08600	WASHER ARANDELA	1	
46	6M8-G2511-01-4D	BRACKET, STEERING SOPORTE DE DIRECCION	1	
47	6G1-44511-00-4D	COVER, UPPER MOUNT CUBIERTA AMORTIGUADOR SUPERIOR	1	
48	6N0-G4514-00	MOUNT DAMPER, UPPER SIDE AMORTIGUADOR LADO SUPERIOR	2	
49	6G1-44516-00	MOUNT DAMPER, UPPER FRONT AMORTIGUADOR DE HULE FRENTE SU	1	
50	95895-06035	BOLT, FLANGE TORNILLO DE REBORDE	2	
51	6G1-42551-00	GROMMET TAPON	1	
52	6G1-42535-00	WASHER, THRUST RONDANA EMPUJE	2	
53	6G1-42537-00	BUSHING, PIVOT SHAFT BUJE DEL PIVOTE DE LA FLECHA	1	
54	6G1-42538-01	BUSHING, PIVOT SHAFT BUJE DEL PIVOTE DE LA FLECHA	1	



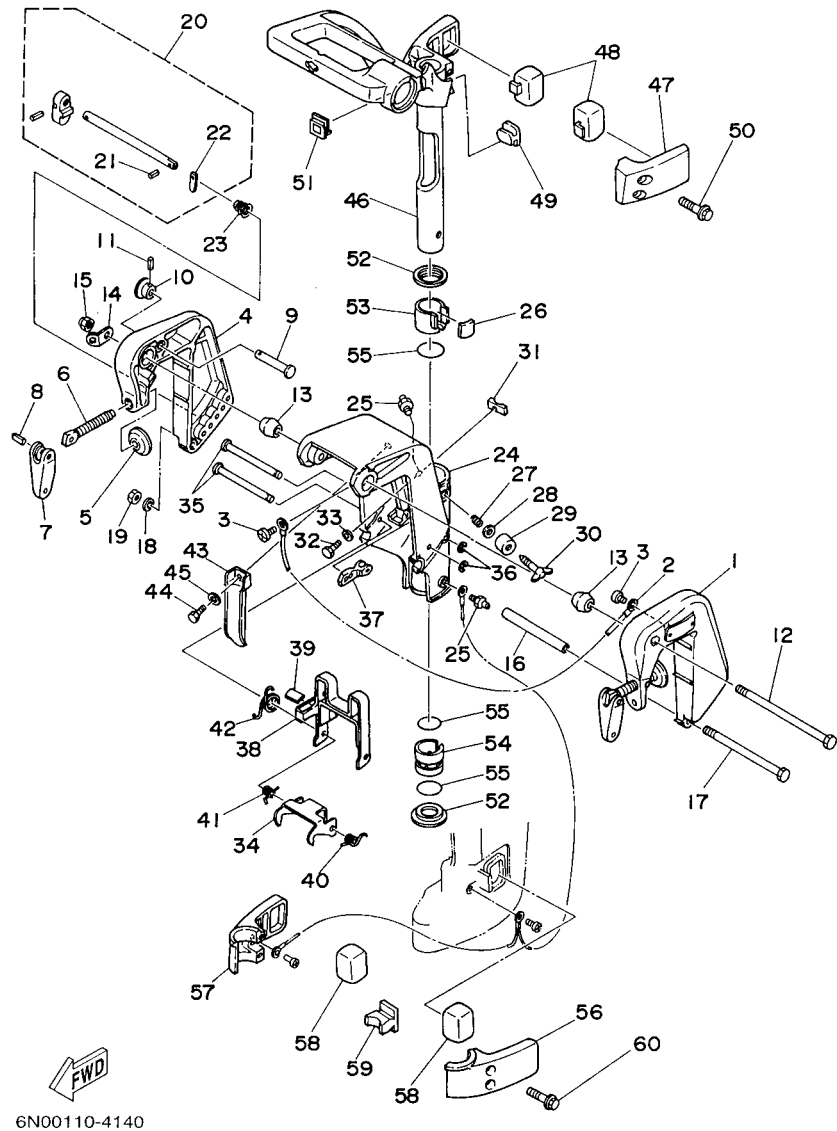

6N00110-4140

FIG. 13 BRACKET

SOPORTE

REF. NO.	PART NO. CODIGO Nº	DESCRIPTION DESCRIPCION	QTY	REMARKS OBSERVACIONES
55	93210-30M31	O-RING ANILLO O	3	
56	6N0-G4551-00-4D	HOUSING, LOWER MOUNT RUBBER 1 CAJA AMORTIGUADOR INFERIOR HU	1	
57	6N0-G4552-00-4D	HOUSING, LOWER MOUNT RUBBER 2 CAJA AMORTIGUADOR INFERIOR HU	1	
58	6N0-G4555-A0	MOUNT DAMPER, LOWER SIDE AMORTIGUADOR DE HULE LADO INFE	2	
59	6N0-G4557-A0	MOUNT DAMPER, LOWER FRONT AMORTIGUADOR DE HULE FRENTE IN	1	
60	95895-06035	BOLT, FLANGE TORNILLO DE REBORDE	2	

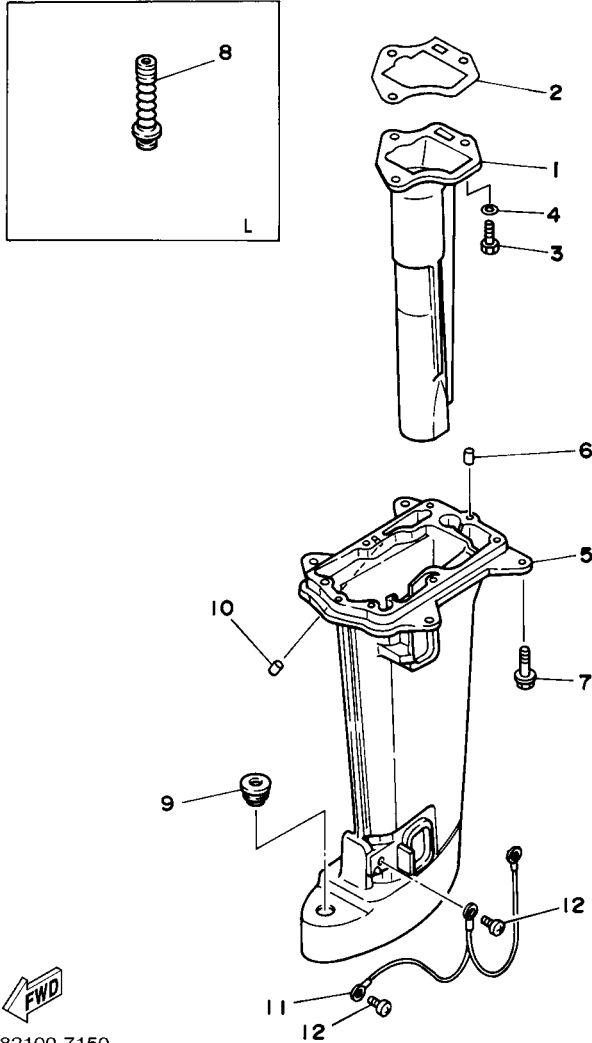

6M82100-7150

FIG. 14 UPPER CASING

FUNDA SUPERIOR

REF. NO.	PART NO. CODIGO Nº	DESCRIPTION DESCRIPCION	QTY	REMARKS OBSERVACIONES
1	6N0-G1131-00-CA	MANIFOLD, EXT. 1 TUBO MULTIPLE DE ESCAPE	1	
2	6G1-41133-A0	GASKET, EXHAUST MANIFOLD 1 EMPAQUE ESCAPE MULTIPLE	1	
3	97095-06020	BOLT PERNO	3	
4	92995-06600	WASHER ARANDELA	3	
5	6N0-G5111-00-4D	CASING, UPPER CAJA SUPERIOR	1	S(17.2") S(17.2")
6	6N0-G5111-10-4D	CASING, UPPER CAJA SUPERIOR	1	L(22.2") L(22.2")
6	93604-08062	PIN, DOWEL PASADOR DE CLAVIJA	2	
7	95895-06030	BOLT, FLANGE TORNILLO DE REBORDE	6	
8	655-44147-00	BOOT, SHIFT ROD HULE DE VARILLA	1	L(22.2") L(22.2")
9	90480-20M29	GROMMET TAPON	1	S(17.2") S(17.2")
10	6G1-45135-00	PIPE TUBO 1	1	
11	6G1-82149-00	WIRE, LEAD 3 CABLE CONDUCTOR 3	1	
12	97885-06008	SCREW, PAN HEAD TORNILLO A MUESCA	2	

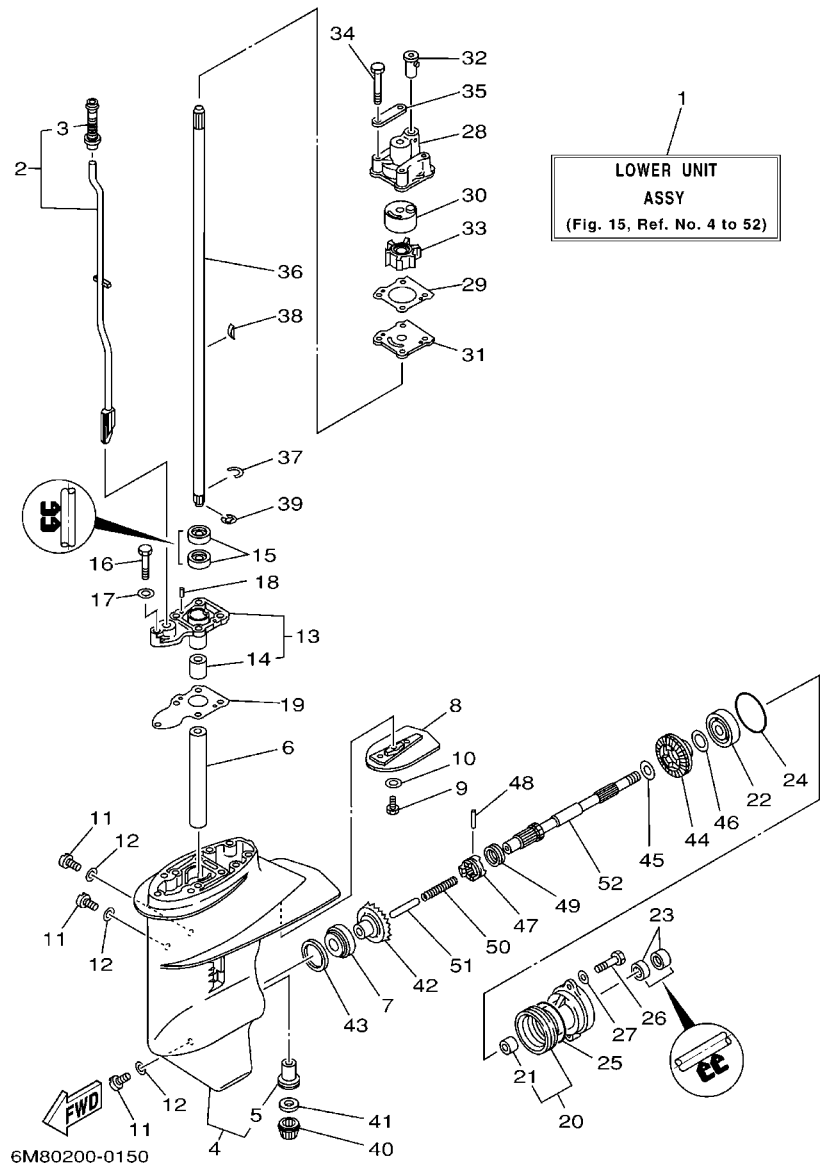

FIG. 15 LOWER CASING & DRIVE 1 IMPULSOR E INFERIOR 1

REF. NO.	PART NO. CODIGO Nº	DESCRIPTION DESCRIPCION	QTY	REMARKS OBSERVACIONES
1	6M8-G5300-00-4D	LOWER UNIT ASSY CONJUNTO UNIDAD INFERIOR	1	S(17.2") S(17.2")
	6M8-G5300-10-4D	LOWER UNIT ASSY CONJUNTO UNIDAD INFERIOR	1	L(22.2") L(22.2")
2	6N0-G4150-00	SHIFT CAM ASSY CONJUNTO EJE LEVA COMPL.	1	S(17.2") S(17.2")
	6N0-G4150-10	SHIFT CAM ASSY CONJUNTO EJE LEVA COMPL.	1	L(22.2") L(22.2")
3	6G1-44147-00	.BOOT, SHIFT ROD .HULE DE VARILLA	1	
4	6N0-G5311-00-4D	CASING, LOWER FUNDA INFERIOR	1	
5	6G1-45317-09	.BUSHING, DRIVE SHAFT .BUJE	1	
6	90387-14M49	COLLAR ESPACIADOR	1	
7	93332-000U4	BEARING COJINETE	1	
8	6N0-G5251-00	ANODE CATODE	1	
9	97095-06016	BOLT PERNO	1	
10	92990-06300	WASHER, INTERNAL TOOTH ARANDELA PLANA	1	
11	90340-08002	PLUG, STRAIGHT SCREW TORNILLO, DE DRENAJE	3	
12	90430-08020	GASKET JUNTA	3	
13	6G1-45331-01-CA	HOUSING, BEARING CAJA DE COJINETE	1	
14	6G1-45316-09	.BUSHING, DRIVE SHAFT .BUJE, EJE DE MANDO	1	
15	93101-11M23	OIL SEAL SELLO ACEITE	2	
16	97095-06030	BOLT PERNO	1	
17	92995-06600	WASHER ARANDELA	1	
18	93604-08062	PIN, DOWEL PASADOR DE CLAVIJA	2	
19	6G1-45315-A0	PACKING, LOWER CASING EMPAQUE	1	
20	6N0-G5361-00-4D	CAP, LOWER CASING FUNDA INFERIOR	1	
21	6G1-45362-09	.BUSHING .BUJE FUNDA INFERIOR TAPA	1	
22	93306-004YH	BEARING COJINETE	1	
23	93101-15074	OIL SEAL SELLO ACEITE	2	
24	93210-49046	O-RING ANILLO O	1	
25	93210-53M08	O-RING ANILLO O	1	

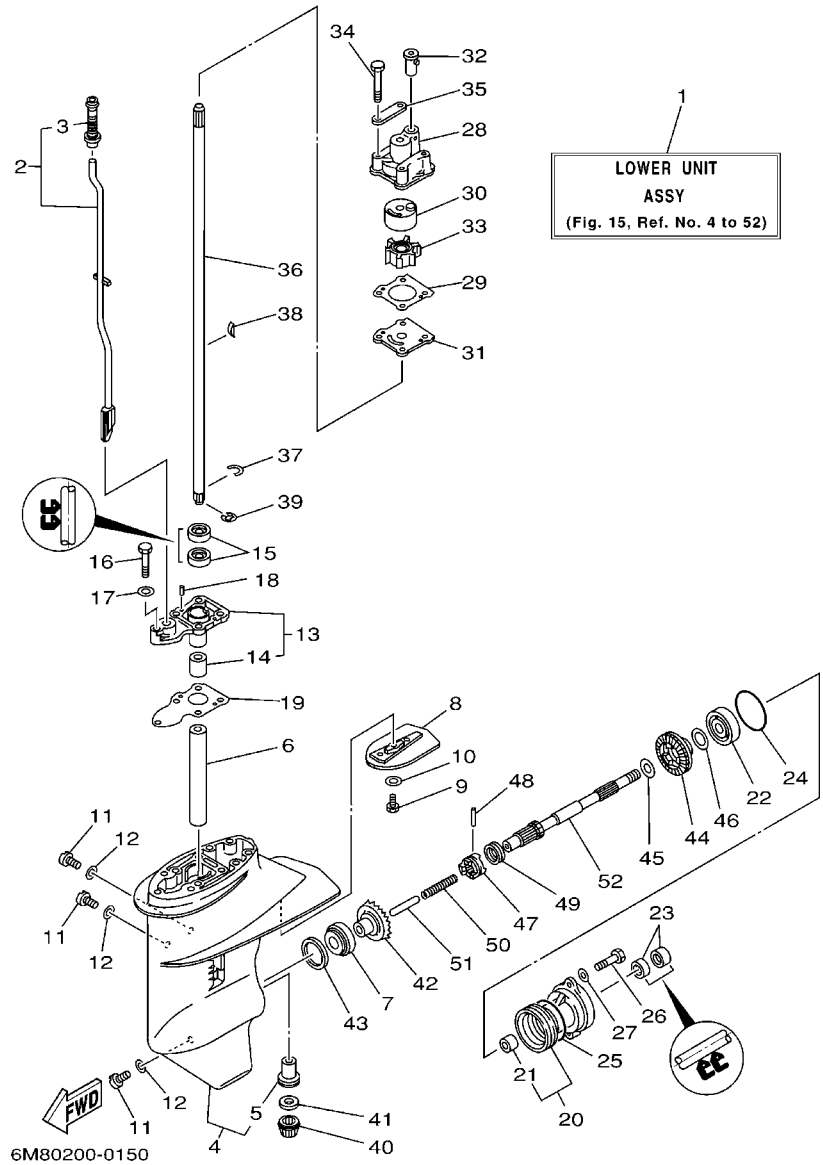

FIG. 15 LOWER CASING & DRIVE 1 IMPULSOR E INFERIOR 1

REF. NO.	PART NO. CODIGO N°	DESCRIPTION DESCRIPCION	QTY	REMARKS OBSERVACIONES
26	97095-06016	BOLT PERNO	2	
27	92995-06600	WASHER ARANDELA	2	
28	6N0-G4311-00	HOUSING, WATER PUMP CAJA BOMBA DE AGUA	1	
29	6G1-44315-A0	GASKET, WATER PUMP EMPAQUE	1	
30	6G1-44322-00	INSERT, CARTRIDGE CARTUCHO	1	
31	6G1-44323-00	OUTER PLATE, CARTRIDGE PLACA EXTERIOR DEL CARTUCHO	1	
32	647-44366-00	DAMPER, WATER SEAL 2 GOMA DEL SELLO DE AGUA 2	1	
33	6G1-44352-00	IMPELLER IMPULSOR	1	
34	97095-06045	BOLT PERNO	4	
35	6G1-44328-00	PLATE PLACA	2	
36	6N0-G5511-00	SHAFT, DRIVE EJE DE MANDO	1	S(17.2")
	6N0-G5511-10	SHAFT, DRIVE EJE DE MANDO	1	L(22.2")
				L(22.2")
37	90467-09M05	CLIP PRESILLA	1	
38	90280-03024	KEY, WOODRUFF CUNA WOODRUFF	1	
39	99001-06600	CIRCLIP PRESILLA REDONDA	1	
40	6N0-G5551-00	PINION (13T) PINON (13T)	1	
41	6G1-45533-00	SHIM (T:1.90MM) LAINA (T:1.90MM)	1	UR
	6G1-45533-10	SHIM (T:2.00MM) LAINA (T:2.00MM)	1	UR
	6G1-45533-20	SHIM (T:2.10MM) LAINA (T:2.10MM)	1	UR
	6G1-45533-30	SHIM (T:2.20MM) LAINA (T:2.20MM)	1	UR
42	6N0-G5560-00	GEAR 1 (27T) ENGRANAJE 1 (27T)	1	
43	664-45587-01	SHIM (T:0.10MM) LAINA (T:0.10MM)	1	UR
	664-45587-10	SHIM (T:0.12MM) LAINA (T:0.12MM)	1	UR
	664-45587-20	SHIM (T:0.15MM) LAINA (T:0.15MM)	1	UR
	664-45587-30	SHIM (T:0.18MM) LAINA (T:0.18MM)	1	UR
	664-45587-40	SHIM (T:0.30MM) LAINA(T:0.30MM)	1	UR
	664-45587-50	SHIM (T:0.40MM) LAINA (T:0.40MM)	1	UR

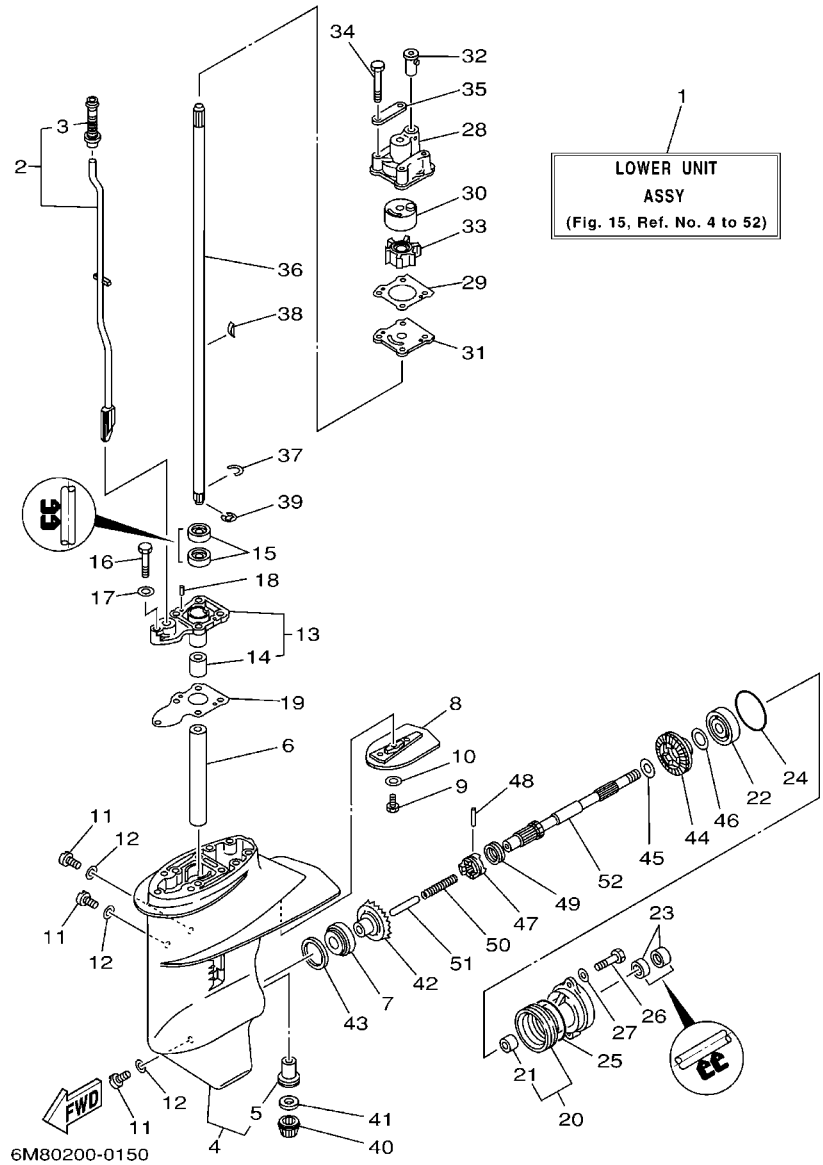
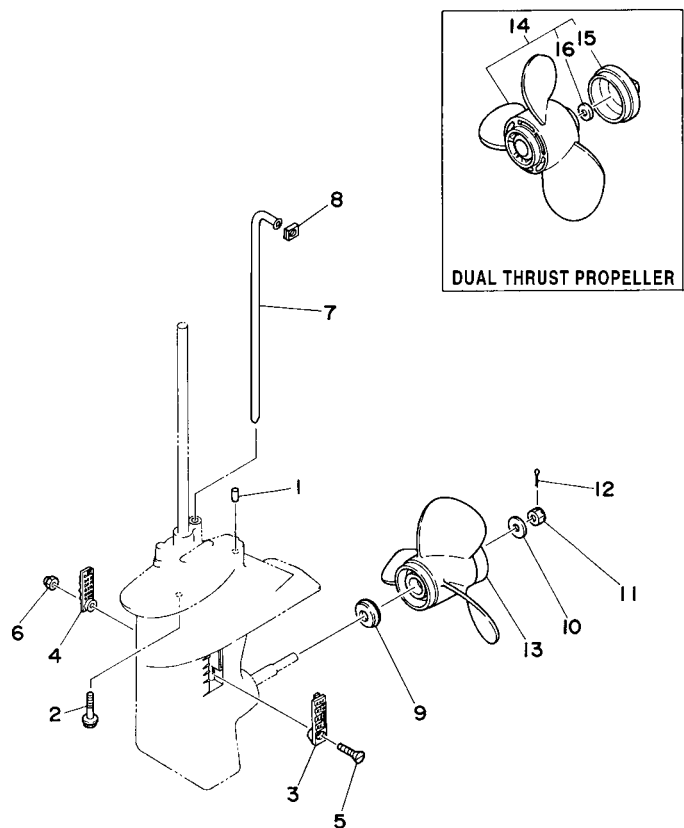

FIG. 15 LOWER CASING & DRIVE 1 IMPULSOR E INFERIOR 1

REF. NO.	PART NO. CODIGO Nº	DESCRIPTION DESCRIPCION	QTY	REMARKS OBSERVACIONES
43	664-45587-60	SHIM (T:0.50MM) LAINA (T:0.50MM)	1	UR
44	6N0-G5571-00	GEAR 2 (27T) ENGRANAJE 2 (27T)	1	UR
45	90201-15M89	WASHER, PLATE ARANDELA PLANA	1	
46	647-45567-00	SHIM (T:0.10MM) LAINA (T:0.10MM)	1	UN
47	6G1-45631-00	CLUTCH, DOG EMBRAGUE DE GARRA	1	
48	6G1-45632-00	PIN, CROSS PASADOR TRANSVERSAL	1	
49	654-45633-00	RING, CROSS PIN ANILLO DE PASADOR	1	
50	90501-12M38	SPRING, COMPRESSION RESORTE DE COMPRESION	1	
51	6G1-45635-00	PLUNGER, SHIFT EMBOLO DE CAMBIO	1	
52	6G1-45611-01	SHAFT, PROPELLER EJE PROPUSOR	1	

FIG. 16 LOWER CASING & DRIVE 2 IMPULSOR E INFERIOR 2



6M80010-7180

REF. NO.	PART NO. CODIGO Nº	DESCRIPTION DESCRIPCION	QTY	REMARKS OBSERVACIONES
1	93604-08062	PIN, DOWEL PASADOR DE CLAVIJA	2	
2	95895-06030	BOLT, FLANGE TORNILLO DE REBORDE	4	
3	6G1-45214-00	COVER, WATER INLET 1 CUBIERTA ENTRADA AGUA 1	1	
4	6G1-45215-00	COVER, WATER INLET 2 CUBIERTA ENTRADA AGUA 2	1	
5	90152-05M03	SCREW, COUNTERSUNK TORNILLO EMBUTIDO	1	
6	90185-05002	NUT, NYLON TUERCA AUTOBLOCANTE	1	
7	6N0-G4361-00	TUBE, WATER 1 TUBO DE AGUA 1	1	S(17.2") S(17.2")
	6N0-G4361-10	TUBE, WATER 1 TUBO DE AGUA 1	1	L(22.2") L(22.2")
8	6G1-44365-00	DAMPER, WATER SEAL 1 HULE DE SELLO DE AGUA 1	1	
9	6N0-G5987-00	SPACER 1 ESPACIADOR 1	1	UR
	6N0-G5987-10	SPACER 1 ESPACIADOR 1	1	UR
10	90201-10M01	WASHER, PLATE ARANDELA PLANA	1	
11	90171-10M01	NUT, CASTLE TUERCA ENTALLADA	1	
12	91490-30020	PIN, COTTER CHAVETA	1	
13	6G1-45941-00-EL	PROPELLER (3X8-1/2"X8-1/2"-N) PROPELA (3X8-1/2"X8-1/2"-N)	1	UR
	6G1-45943-00-EL	PROPELLER (3X8-1/2"X7-1/2"-N) PROPELA (3X8-1/2"X7-1/2"-N)	1	UR
	6G1-45947-00-EL	PROPELLER (3X8-1/2"X6-1/2"-N) PROPELA (3X8-1/2"X6-1/2"-N)	1	UR
14	6G1-W4591-01-EL	PROPELLER (3X9"X7"-N) PROPELA (3X9"X7"-N)	1	UR
	6G1-W4592-00-EL	PROPELLER (3X9"X5"-N) PROPELA (3X9"X5"-N)	1	UR
15	6G1-45616-01	NUT, PROPELLER TUERCA DE HELICE	1	
16	90201-10M02	WASHER, PLATE ARANDELA PLANA	1	

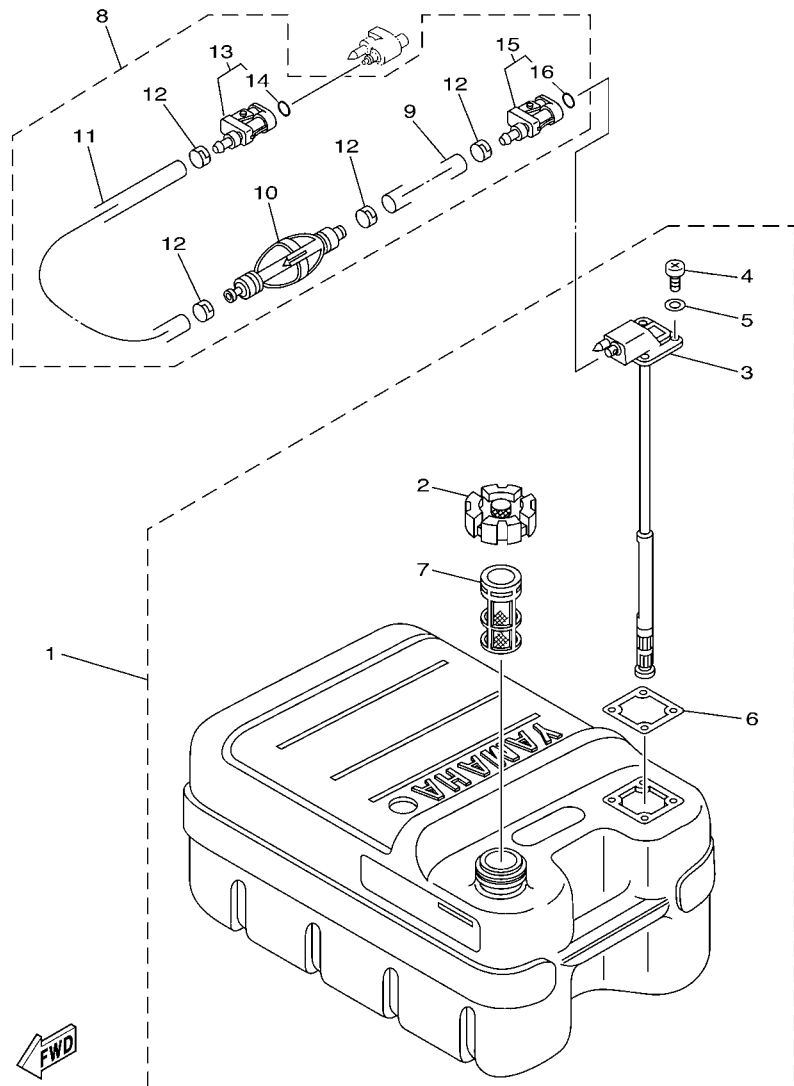
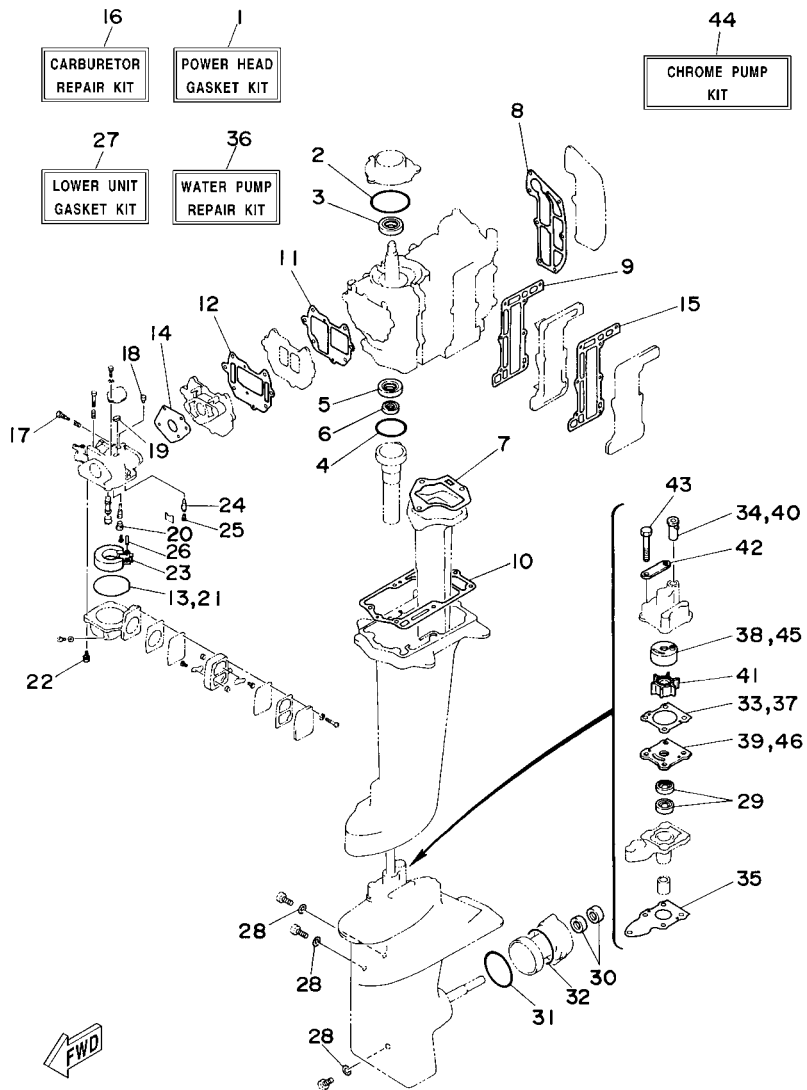

FIG. 17 FUEL TANK

DEPOSITO DE COMBUSTIBLE

REF. NO.	PART NO. CODIGO Nº	DESCRIPTION DESCRIPCION	QTY	REMARKS OBSERVACIONES
1	6YJ-24201-00	FUEL TANK ASSY (24L) TANQUE DEL COMBUSTIBLE (24L)	1	AP
2	6YJ-24610-01	.CAP ASSY .TAPA COMPLETA	1	AP
3	6YJ-24260-00	.FUEL METER ASSY .MEDIDOR DE COMBUSTIBLE COMPL.	1	
4	90157-05M19	.SCREW, PAN HEAD .TORNILLO CABEZA CONICA PLANA	4	
5	6Y1-24329-00	.SEAL .SELLO	4	
6	6Y1-24268-00	.GASKET, FUEL METER .EMPAQ MEDIDOR DE COMBUSTIBLE	1	
7	6YJ-24167-00	.STRAINER .COLADOR	1	
8	61J-24306-04	FUEL PIPE COMP. 1 TUBO COMBUST. COMPL 1	1	AP
9	90445-11M06	.HOSE (L2050) .MANGUERA (L2050)	1	AP
10	61J-24360-00	.PRIMER PUMP ASSY .SOPORTE BOMBA	1	
11	90445-11M05	.HOSE (L850) .MANGUERA (L850)	1	
12	650-24351-01	.BAND 1 .ABRAZADERA 1	4	
13	6G1-24305-05	.FUEL PIPE JOINT COMP. 2 .CONECTOR MANGUERA COMBUST. 2	1	
14	93210-08287	..O-RING ..ANILLO O	1	
15	6Y1-24305-06	.FUEL PIPE JOINT COMP. 2 .CONECTOR MANGUERA COMBUST. 2	1	
16	93210-08287	..O-RING ..ANILLO O	1	



6M80010-7190

FIG. 18 REPAIR KIT

ESTUCHE REPARATION

REF. NO.	PART NO. CODIGO N°	DESCRIPTION DESCRIPCION	QNTD				REMARKS OBSERVACIONES
1	6N0-W0001-A0	POWER HEAD GASKET KIT JUEGO DE EMPAQUE DE MOTOR	1				
2	93210-54M54	.O-RING .ANILLO O	1				
3	93102-20M25	.OIL SEAL .SELLO ACEITE	1				
4	93210-42159	.O-RING .ANILLO O	1				
5	93101-20M34	.OIL SEAL .SELLO ACEITE	1				
6	93101-12M26	.OIL SEAL .SELLO ACEITE	1				
7	6G1-41133-A0	.GASKET, EXHAUST MANIFOLD 1 .EMPAQUE ESCAPE MULTIPLE	1				
8	6G1-11193-A1	.GASKET, HEAD COVER 1 .EMPAQUE	1				
9	6G1-41112-A1	.GASKET, EXHAUST INNER COVER .EMPAQUE	1				
10	6G1-45113-A1	.GASKET, UPPER CASING .EMPAQUE	1				
11	6G1-13621-A1	.GASKET, VALVE SEAT .JUNTA, DE VALV.DE EMPAQUE	1				
12	6G1-13645-A1	.GASKET, MANIFOLD 1 .EMPAQUE	1				
13	6G1-14984-00	.O-RING .EMPAQUE CAMARA DE BOIA	1				
14	6G1-14198-A1	.GASKET .EMPAQUE	1				
15	6G1-41114-A0	.GASKET, EXHAUST OUTER COVER .EMPAQUE	1				
16	6N0-W0093-00	CARBURETOR REPAIR KIT KIT REPARACION CARBURADOR	1				
17	679-14923-00	.SCREW, PILOT .TORNILLO DE AJUSTE	1				
18	6G1-14966-00	.CAP .TAPA	1				
19	6G1-14126-00	.GASKET .EMPAQUE	1				
20	676-14966-00	.CAP .TAPA	1				
21	6G1-14984-00	.O-RING .EMPAQUE CAMARA DE BOIA	1				
22	97980-04114	.SCREW, WITH WASHER .TORNILLO, CON ARANDELA	4				
23	6G1-14985-00	.FLOAT .BOIA	1				
24	6G1-14546-01	.VALVE, NEEDLE .VALVULA DE AGUJA	1				
25	676-14186-00	.PIN, FLOAT .PASADOR DE LA BOYA	1				
26	688-14548-00	.PIN, FLOAT ARM .PASADOR DE BRAZO DE BOIA	1				
27	6N0-W0001-C0	LOWER UNIT GASKET KIT JUEGO DE JUNTA UNIDAD INFERIOR	1				



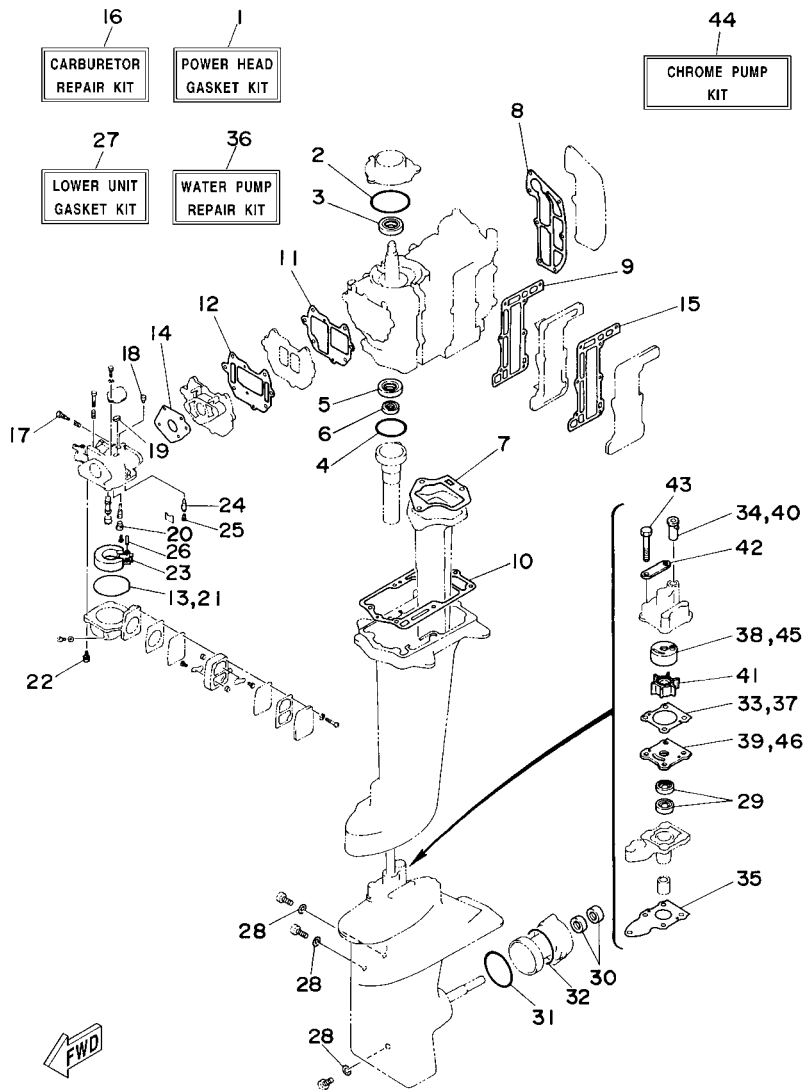

6M80010-7190

FIG. 18 REPAIR KIT

ESTUCHE REPARATION

REF. NO.	PART NO. CODIGO Nº	DESCRIPTION DESCRIPCION	QTY	REMARKS OBSERVACIONES
28	90430-08020	.GASKET .JUNTA	3	
29	93101-11M23	.OIL SEAL .SELLO ACEITE	2	
30	93101-15074	.OIL SEAL .SELLO ACEITE	2	
31	93210-49046	.O-RING .ANILLO O	1	
32	93210-53M08	.O-RING .ANILLO O	1	
33	6G1-44315-A0	.GASKET, WATER PUMP .EMPAQUE	1	
34	647-44366-00	.DAMPER, WATER SEAL 2 .GOMA DEL SELLO DE AGUA 2	1	
35	6G1-45315-A0	.PACKING, LOWER CASING .EMPAQUE	1	
36	6N0-W0078-A0	WATER PUMP REPAIR KIT ESTUCHE REPARACION BOMBA AGUA	1	
37	6G1-44315-A0	.GASKET, WATER PUMP .EMPAQUE	1	
38	6G1-44322-00	.INSERT, CARTRIDGE .CARTUCHO	1	
39	6G1-44323-00	.OUTER PLATE, CARTRIDGE .PLACA EXTERIOR DEL CARTUCHO	1	
40	647-44366-00	.DAMPER, WATER SEAL 2 .GOMA DEL SELLO DE AGUA 2	1	
41	6G1-44352-00	.IMPELLER .IMPULSOR	1	
42	6G1-44328-00	.PLATE .PLACA	2	
43	97095-06045	.BOLT .PERNO	4	
44	6N0-W0078-0A	CHROME PUMP KIT ESTUCHE REPARACION BOMBA AGUA	1	
45	6G1-44322-40	.INSERT, CARTRIDGE .CARTUCHO	1	
46	6G1-44323-40	.OUTER PLATE, CARTRIDGE .PLACA EXTERIOR DEL CARTUCHO	1	

NUMERICAL INDEX  
INDICE NUMERICO

PART NO. CODIGO N°	REF. NO.	PART NO. CODIGO N°	REF. NO.	PART NO. CODIGO N°	REF. NO.	PART NO. CODIGO N°	REF. NO.	PART NO. CODIGO N°	REF. NO.	PART NO. CODIGO N°	REF. NO.
6G1-11193-A1	2 - 20	6G1-15746-81	7 - 24	6G1-41615-01	9 - 6	6G1-44323-00	15 - 31	6AH-81995-70	7 - 34	6N0-G1611-00	9 - 1
	18 - 8	6G1-15747-80	7 - 33	6G1-41631-00	12 - 1		18 - 39	6E5-82148-00	13 - 2	6N0-G1613-00	9 - 3
6G1-11681-00	3 - 6	656-15748-00	7 - 29	6G1-41638-00	12 - 2	6G1-44323-40	18 - 46	6G1-82149-00	14 - 11	6M8-G2111-11-4D	11 - 1
6E5-12411-02	2 - 7	6G1-15755-00	7 - 12	6G1-41661-00	12 - 4	6G1-44328-00	15 - 35	6M8-82361-00	9 - 11	6M4-G2119-00	11 - 12
6E5-12412-00	2 - 8	6G1-15761-00	1 - 5	6G1-41662-01-94	12 - 18		18 - 42	6M8-82362-00	9 - 12	6N0-G2137-10	11 - 14
6G1-13610-01	4 - 1	6G1-15762-00	7 - 15	6G1-42125-01	11 - 9	6G1-44352-00	15 - 33	663-82370-01	9 - 13	6N0-G2177-00	11 - 13
6G1-13621-A1	4 - 3	6G1-15764-00	7 - 25	6G1-42126-00	11 - 10		18 - 41	682-82556-00	10 - 23	6M8-G2511-01-4D	13 - 46
	18 - 11	6G1-15774-81	7 - 28	6G1-42131-02	11 - 6	6G1-44365-00	16 - 8	6E9-82575-02	10 - 22	6N0-G2610-30-4D	1 - 1
6G1-13645-A1	4 - 5	6G1-15779-00	7 - 13	6G1-42138-01	11 - 20	647-44366-00	15 - 32	689-8257Y-00	10 - 24	6N0-G2613-00-4D	1 - 2
	18 - 12	6YJ-24167-00	17 - 7	6E0-42159-02	11 - 21		18 - 34	6G1-83557-00	9 - 17	6N0-G2651-00	1 - 8
6G1-14126-00	5 - 6	6YJ-24201-00	17 - 1	6G1-42528-00	13 - 26		18 - 40	6G1-85509-70	8 - 3	6N0-G2677-20	1 - 11
	18 - 19	646-24251-02	6 - 4	6G1-42529-00	13 - 30	6G1-44511-00-4D	13 - 47	6G1-85515-70	8 - 15	6N0-G2678-11	1 - 12
663-14159-00	5 - 23	6YJ-24260-00	17 - 3	6G1-42535-00	13 - 52	6G1-44516-00	13 - 49	6E7-85520-70	8 - 4	6N0-G2711-00-4D	10 - 1
676-14186-00	5 - 22	6Y1-24268-00	17 - 6	6G1-42537-00	13 - 53	6G1-44532-01	13 - 31	696-85540-12	9 - 14	6N0-G2716-00	10 - 21
	18 - 25	6G1-24304-02	6 - 1	6G1-42538-01	13 - 54	6G1-45113-A1	2 - 27	6G1-85548-70	8 - 12	6N0-G2719-00	10 - 8
6G1-14198-A1	4 - 6	6G1-24305-05	17 - 13	6G1-42551-00	13 - 51		18 - 10	6G1-85550-71	8 - 1	6N0-G2731-00	13 - 43
	18 - 14	6Y1-24305-06	17 - 15	6G1-42615-00	1 - 6	6G1-45135-00	14 - 10	6G1-85560-F0	8 - 2	6N0-G2767-00	10 - 9
6N0-14301-10	5 - 1	61J-24306-04	17 - 8	6G1-42647-00	1 - 7	6G1-45214-00	16 - 3	6G1-85570-02	9 - 9	6N0-G2815-00-4D	10 - 2
6G1-14398-00	5 - 18	6Y1-24329-00	17 - 5	6G1-42724-00	10 - 12	6G1-45215-00	16 - 4	6E7-85580-70	8 - 5	6M8-G3111-02-4D	13 - 1
6G1-14497-81	12 - 7	650-24351-01	17 - 12	6G1-42725-00	10 - 13	6G1-45315-A0	15 - 19	6N0-E1191-00-1S	2 - 19	6M8-G3112-01-4D	13 - 4
63V-14523-00	5 - 12	61J-24360-00	17 - 10	6G1-42726-00	10 - 14		18 - 35	6N0-E1400-00	3 - 1	6N0-G3116-00	13 - 6
6G1-14527-00	5 - 5	6G1-24411-00	5 - 33	6G1-42727-00	10 - 15	6G1-45316-09	15 - 14	6N0-E1412-00	3 - 2	6L8-G3118-01	13 - 7
62D-14546-01	5 - 21	6G1-24412-01	5 - 32	6G1-42748-00	10 - 16	6G1-45317-09	15 - 5	6N0-E1422-00	3 - 3	6N0-G3160-00	13 - 20
6G1-14546-01	18 - 24	6G1-24421-00	5 - 35	6E7-42791-00	10 - 25	6G1-45331-01-CA	15 - 13	6N0-E1432-00	3 - 4	6N0-G3165-00	13 - 22
688-14548-00	5 - 25	6G1-24431-01	5 - 34	6AH-42794-70	10 - 26	6G1-45362-09	15 - 21	6N0-E1442-00	3 - 5	6N0-G3311-10-4D	13 - 24
	18 - 26	6G1-24432-00	5 - 30	6E0-42816-00	10 - 4	6G1-45533-00	15 - 41	6N0-E1515-00	3 - 11	6N0-G3614-00	13 - 34
679-14555-00	5 - 3	6G1-24452-00	5 - 29	6A1-43113-01	13 - 14	6G1-45533-10	15 - 41	6N0-E1603-00	3 - 16	6N0-G4110-00	12 - 22
679-14923-00	5 - 2	6G1-24471-00	5 - 31	620-43114-00	13 - 5	6G1-45533-20	15 - 41	6N0-E1631-00-64	3 - 15	6N0-G4111-00	12 - 14
	18 - 17	6YJ-24610-01	17 - 2	6G1-43136-00	13 - 13	6G1-45533-30	15 - 41	6N0-E1633-00	3 - 18	6N0-G4145-00	12 - 25
6G1-14943-79	5 - 16	6G1-26326-00	10 - 17	689-43191-00	13 - 9	647-45567-00	15 - 46	6N0-E1651-00	3 - 10	6N0-G4146-00	12 - 26
6G1-14947-00	5 - 15	6G1-2811G-00	6 - 10	689-43192-01	13 - 10	664-45587-01	15 - 43	6N0-E3641-00-94	4 - 4	6N0-G4150-00	15 - 2
6G1-14948-06	5 - 7	6G1-41112-A1	2 - 23	6G1-43318-01	13 - 39	664-45587-10	15 - 43	6M8-E4417-00	4 - 8	6N0-G4150-10	15 - 2
676-14966-00	5 - 8		18 - 9	6G1-43373-00	13 - 29	664-45587-20	15 - 43	6M8-E4418-00	4 - 9	60R-G4191-00	1 - 13
	18 - 20	6G1-41113-01-1S	2 - 24	6G1-43615-02	13 - 37	664-45587-30	15 - 43	6N0-E5100-00-1S	2 - 2	6N0-G4311-00	15 - 28
6G1-14966-00	5 - 4	6G1-41114-A0	2 - 26	6G1-43659-00	13 - 35	664-45587-40	15 - 43	6M8-E5710-03	7 - 1	6N0-G4361-00	16 - 7
	18 - 18		18 - 15	6G1-43681-00	13 - 38	664-45587-50	15 - 43	6N0-E5711-80-94	7 - 2	6N0-G4361-10	16 - 7
6G1-14980-01	5 - 14	6G1-41133-A0	14 - 2	6G1-44116-01	12 - 20	664-45587-60	15 - 43	6M8-E5714-00	7 - 3	6N0-G4514-00	13 - 48
6G1-14984-00	5 - 13		18 - 7	6G1-44121-02-94	12 - 17	6G1-45611-01	15 - 52	6N0-E5723-00-94	7 - 19	6N0-G4551-00-4D	13 - 56
	18 - 13	6G1-41211-00	12 - 12	6G1-44125-80	7 - 31	6G1-45616-01	16 - 15	6N0-E5758-00	7 - 14	6N0-G4552-00-4D	13 - 57
	18 - 21	6E9-41237-00	12 - 11	655-44147-00	14 - 8	6G1-45631-00	15 - 47	6N0-E5770-90	7 - 27	6N0-G4555-A0	13 - 58
6G1-14985-00	5 - 20	662-41237-01	12 - 10	6G1-44147-00	15 - 3	6G1-45632-00	15 - 48	6N0-E5771-00-94	7 - 21	6N0-G4557-A0	13 - 59
	18 - 23	6G1-41238-00	12 - 9	6G1-44194-00	9 - 8	654-45633-00	15 - 49	6N0-E5772-00-94	7 - 22	6N0-G5111-00-4D	14 - 5
6G1-14992-00	5 - 19	6G1-41256-00	4 - 12	6G1-44315-A0	15 - 29	6G1-45635-00	15 - 51	6N0-F6301-10	11 - 23	6N0-G5111-10-4D	14 - 5
6G1-15359-01-94	2 - 9	661-41262-02	4 - 14		18 - 33	6G1-45941-00-EL	16 - 13	6N0-F8100-00	6 - 8	6N0-G5251-00	15 - 8
6G1-15396-02-CA	2 - 13		12 - 13		18 - 37	6G1-45943-00-EL	16 - 13	6N0-F8170-00	6 - 9	6M8-G5300-00-4D	15 - 1
6G1-15705-00	7 - 10	6G1-41271-00	4 - 13	6G1-44322-00	15 - 30	6G1-45947-00-EL	16 - 13	6L8-F8193-00	6 - 13	6M8-G5300-10-4D	15 - 1
6G1-15717-00	7 - 5	6G1-41283-01	12 - 3		18 - 38	6E7-81303-A0	8 - 6	6N0-G1111-00-1S	2 - 22	6N0-G5311-00-4D	15 - 4
677-15741-01	7 - 17	6G1-41612-00	9 - 2	6G1-44322-40	18 - 45	6AH-81994-70	4 - 15	6N0-G1131-00-CA	14 - 1	6N0-G5361-00-4D	15 - 20

NUMERICAL INDEX  
INDICE NUMERICO

PART NO. CODIGO N°	REF. NO.	PART NO. CODIGO N°	REF. NO.	PART NO. CODIGO N°	REF. NO.	PART NO. CODIGO N°	REF. NO.	PART NO. CODIGO N°	REF. NO.	PART NO. CODIGO N°	REF. NO.
6N0-G5511-00	15 - 36	90269-02M09	11 - 15	92990-08600	13 - 28	95380-03600	5 - 27	97980-04114	5 - 17		
6N0-G5511-10	15 - 36	90280-03024	15 - 38	92995-05600	9 - 5	95380-05700	10 - 11		18 - 22		
6N0-G5551-00	15 - 40	90280-04M06	8 - 17	92995-06600	1 - 4	95380-06600	12 - 28	97980-04125	5 - 28		
6N0-G5560-00	15 - 42	90340-08002	15 - 11		2 - 18		13 - 19	97980-05216	7 - 32		
6N0-G5571-00	15 - 44	90386-08032	11 - 19		6 - 3	95380-06700	10 - 7		12 - 16		
6N0-G5987-00	16 - 9	90386-12M45	10 - 3		6 - 12	95895-06010	9 - 7	98580-04008	5 - 24		
6N0-G5987-10	16 - 9	90386-33M96	11 - 4		13 - 33		9 - 16	98980-03006	5 - 26		
6N0-W0001-A0	18 - 1	90386-34M97	11 - 5		14 - 4		12 - 8	99001-06600	15 - 39		
6N0-W0001-C0	18 - 27	90386-44M42	8 - 16		15 - 17	95895-06012	12 - 21	99080-05600	13 - 36		
6G1-W0004-00	4 - 2	90387-06M13	13 - 16		15 - 27	95895-06016	7 - 16				
6N0-W0078-OA	18 - 44	90387-06M52	10 - 19	92995-08600	13 - 45	95895-06020	7 - 18				
6N0-W0078-A0	18 - 36	90387-06M70	4 - 10	93101-11M23	15 - 15		9 - 15				
6N0-W0093-00	18 - 16	90387-14M49	15 - 6		18 - 29		10 - 20				
6G1-W4591-01-EL	16 - 14	90387-22M50	2 - 6	93101-12M26	2 - 16	95895-06025	7 - 26				
6G1-W4592-00-EL	16 - 14	90430-08020	15 - 12		18 - 6		9 - 10				
6N0-WE090-01-1S	2 - 1		18 - 28	93101-15074	15 - 23	95895-06030	14 - 7				
6N0-WG070-10	1 - 10	90445-09220	6 - 6		18 - 30		16 - 2				
90101-08869	13 - 12	90445-09221	6 - 5	93101-20M34	2 - 15	95895-06035	13 - 50				
90105-06037	2 - 25	90445-11M05	17 - 11		18 - 5		13 - 60				
90105-06039	2 - 21	90445-11M06	17 - 9	93102-20M25	2 - 11	95895-06085	4 - 7				
90105-06M14	12 - 19	90467-08004	6 - 7		18 - 3	97013-06016	2 - 12				
90105-06M25	2 - 5	90467-09M05	15 - 37	93210-08287	17 - 14	97013-06035	7 - 6				
90105-06M26	2 - 4	90480-15M31	10 - 18		17 - 16	97095-06010	13 - 32				
90105-06M29	7 - 20	90480-20M29	14 - 9	93210-12327	12 - 15	97095-06012	6 - 11				
90109-06M17	12 - 27	90501-10227	7 - 30	93210-30M31	13 - 55	97095-06016	1 - 3				
90116-08016	11 - 7	90501-10326	5 - 11	93210-42159	2 - 14		2 - 17				
90149-05M02	10 - 10	90501-12M38	15 - 50		18 - 4		15 - 9				
90152-05011	11 - 18	90501-18M00	13 - 27	93210-49046	15 - 24		15 - 26				
90152-05M03	16 - 5	90501-23215	11 - 16		18 - 31	97095-06020	14 - 3				
90157-05M19	17 - 4	90502-10M06	13 - 23	93210-53M08	15 - 25	97095-06025	6 - 2				
90170-10113	8 - 18	90508-10M15	13 - 40		18 - 32	97095-06030	15 - 16				
90171-10M01	16 - 11	90508-10M16	13 - 41	93210-54M54	2 - 10	97095-06045	15 - 34				
90185-05002	16 - 6	90508-14M17	13 - 42		18 - 2		18 - 43				
90185-08057	11 - 8	90510-08M03	7 - 4	93306-004YH	15 - 22	97095-06135	13 - 17				
	13 - 15	91490-16010	11 - 11	93306-204U0	3 - 7	97095-08016	13 - 44				
90201-06M30	7 - 7	91490-30020	16 - 12	93310-112V0	3 - 17	97575-06520	7 - 23				
90201-10126	8 - 19	91609-20008	3 - 13	93310-418V1	3 - 8	97780-50514	4 - 11				
90201-10M01	16 - 10	91690-20010	12 - 23	93332-000U4	15 - 7	97802-04008	8 - 13				
90201-10M02	11 - 17	91690-30008	13 - 21	93430-06M02	7 - 9	97802-05016	8 - 9				
	16 - 16	91690-30016	13 - 11	93440-47055	3 - 12	97802-05020	8 - 10				
90201-15M89	15 - 45	92902-04100	8 - 14	93450-13022	3 - 19	97802-05025	8 - 7				
90201-41303	3 - 14	92902-05100	8 - 8	93604-08062	2 - 3	97880-04010	5 - 9				
90202-36M55	11 - 3		8 - 11		14 - 6	97880-05010	12 - 5				
90206-12052	10 - 5	92990-04100	5 - 10		15 - 18	97885-05010	9 - 4				
90206-36M21	11 - 2	92990-05100	12 - 6		16 - 1	97885-05012	11 - 22				
90209-18112	3 - 9	92990-05600	12 - 24	93700-06M03	13 - 25	97885-06008	13 - 3				
90243-04M01	13 - 8	92990-06300	15 - 10	94702-00217	2 - 28		14 - 12				
90266-04M00	1 - 9	92990-06600	13 - 18	95303-06600	7 - 8	97885-06030	10 - 6				