

**PARTS
CATALOGUE
CATALOGO
DE REPUESTOS**

6CMH'03(6M82)

8CMH'03(6N02)

FOREWORD

This Parts Catalogue is related to the parts for the model(s) in the below frame. When you are ordering replacement parts, please refer to this Parts Catalogue and quote both part numbers and part names correctly.

6CMH'03(6M82), 8CMH'03(6N02)

1. Modifications or additions which have been made after issue of the Parts Catalogue will be announced in the Yamaha Parts News.
It is advisable that you make necessary corrections to the Parts Catalogue according to the Yamaha Parts News.

2. Abbreviations
The Following abbreviations are used in this Parts Catalogue.

“UR” Use specified parts number.

“UN” Use as many as needed.

“AP” Alternate Parts

“LM” Local Made
(Parts need to be ordered locally)

“O/S” Over Size

3. Parts, which are to be supplied in an assembly, are listed with a dot(.) in front of the part name as shown below.

EXAMPLE

CARBURETOR ASSY

.JET, PILOT

.NOZZLE, MAIN

4. Number of component for assembly

The numeral appearing to the right of each component part indicates the quantity of parts for each assembly unit.

EXAMPLE

PART NO.	DESCRIPTION	□	□	□	□	□	REMARKS
6E0-85500-70	C.D.I. MAGNETO ASSY	1					
6E0-85550-70	.ROTOR ASSY	1					
6E0-15723-00-94.	PULLY, STARTER	1					

5. Quantity Column Information

NAME for Q'TY COLUMN	APPLICABLE MODEL
6C	6CMH
8C	8CMH

6. Applicable Starting Serial No. and Color Code

1) Engine Starting Serial No.

6CMH S	6M8	: 1000001	8CMH S/L	6N0	: 1000001
--------	-----	-----------	----------	-----	-----------

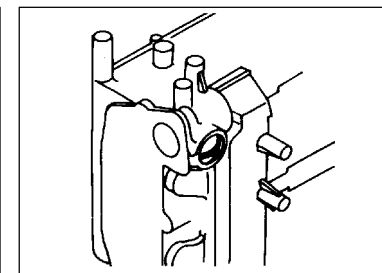
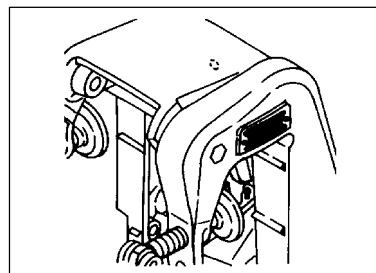

2) Color Code

Color Code	Color Name	Abbreviation
004D	DARK BLUISH GRAY METALLIC 2	DBNM2

7. Note that the illustrations for reference in finding parts numbers, not to be used for assembling. When assembling, please use the applicable service manual.

8. The asterisk (*) before a reference number indicates modification items after the first edition.

PROLOGO

Este Catálogo de Repuestos corresponde a las piezas para el(los) modelo(s) del recuadro siguiente. Al formular el pedido de repuestos, se ruega citar este Catálogo de Repuestos y especificar correctamente los números de parte y los nombres de parte.

6CMH'03(6M82), 8CMH'03(6N02)

1. Las modificaciones y agregados que se hayan realizado después de la edición de este Catálogo de Repuestos, serán anunciados en las Informaciones de Recambios Yamaha.
2. Abreviaciones
En este Catálogo de Repuestos se emplean las siguientes abreviaciones.
 "UR" Usar el número de partes especificado
 "UN" Usar la cantidad necesaria
 "AP" Piezas sustitutivas
 "LM" Fabricación local (Partes necesarias que se pedirán localmente)
 "F#" No. de bastidor aplicable
3. Las piezas suministradas como conjunto se describen con un punto (.) que precede al nombre de la pieza como se indica a continuación.

EJEMPLO

CONJUNTO CARBURADOR

.INYECTOR, piloto

.BOQUILLA, principal

4. Cantidad de componentes de un conjunto
La numeración que aparece a la derecha de cada descripción, indica la cantidad de piezas por cada unidad de conjunto.

EJEMPLO

PIEZAS NO.	DESCRIPTION	u	u	u	OBSERVACION
6E0-85500-70	C.D.I. MAGNETO ASSY	1			
6E0-85550-70	.ROTOR ASSY	1			
6E0-15723-00-94	.PULLY, STARTER	1			

5. Información para columna de Cantidad

NOMBRE PARA COLUMNA DE CANTI.	MODELO APLICABLE
6C	6CMH
8C	8CMH

6. Números de Serie y Códigos de color aplicables

1) No. de Serie del motor.

6CMH S	6M8	: 1000001	8CMH S/L	6N0	: 1000001
--------	-----	-----------	----------	-----	-----------

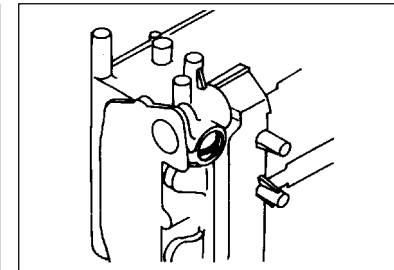
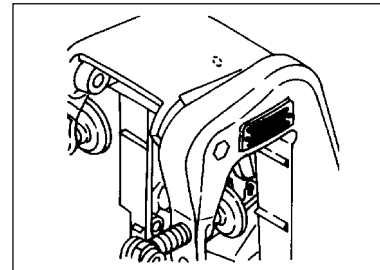

2) Código de color

Código de color	Nombre de color	Abreviación
004D	DARK BLUISH GRAY METALLIC 2	DBNM2

7. Debe tenerse en cuenta que las ilustraciones sirven como guía para la búsqueda de las referencias y no deben usarse para el montaje. Durante el montaje, se recomienda usar el manual de Taller correspondiente.
8. EL asterisco (*) antes del número de referencia indica los elementos modificados después de la primera edición.

CONTENTS

TOP COWLING	A4
CYLINDER. CRANKCASE	A5
CRANKSHAFT. PISTON	A7
INTAKE	B1
CARBURETOR	B2
FUEL	B4
STARTER	B5
GENERATOR	B7
ELECTRICAL	C1
BOTTOM COWLING	C2
STEERING	C4
CONTROL	C5
BRACKET	C7
UPPER CASING	D3
LOWER CASING. DRIVE 1	D4
LOWER CASING. DRIVE 2	D7
FUEL TANK 1	E1
FUEL TANK 2	E2
REPAIR KIT	E3
INDEX	
NUMERICAL INDEX	E5

CONTENIDO

SOPORTE SUPERIOR	A4
CYLINDRO. CARTER	A5
CIGUENAL. PISTON	A7
ADMISION	B1
CARBURADOR	B2
COMBUSTIBLE	B4
ARRANQUE	B5
GENERADOR	B7
ELECTRICO	C1
CUBIERTA INFERIOR	C2
DIRECCION	C4
CONTROL	C5
SOPORTE	C7
FUNDA SUPERIOR	D3
IMPULSOR E INFERIOR 1	D4
IMPULSOR E INFERIOR 2	D7
DEPOSITO DE COMBUSTIBLE 1	E1
DEPOSITO DE COMBUSTIBLE 2	E2
ESTUCHE REPARATION	E3

INDICE

INDICE NUMERICO	E5
-----------------------	----

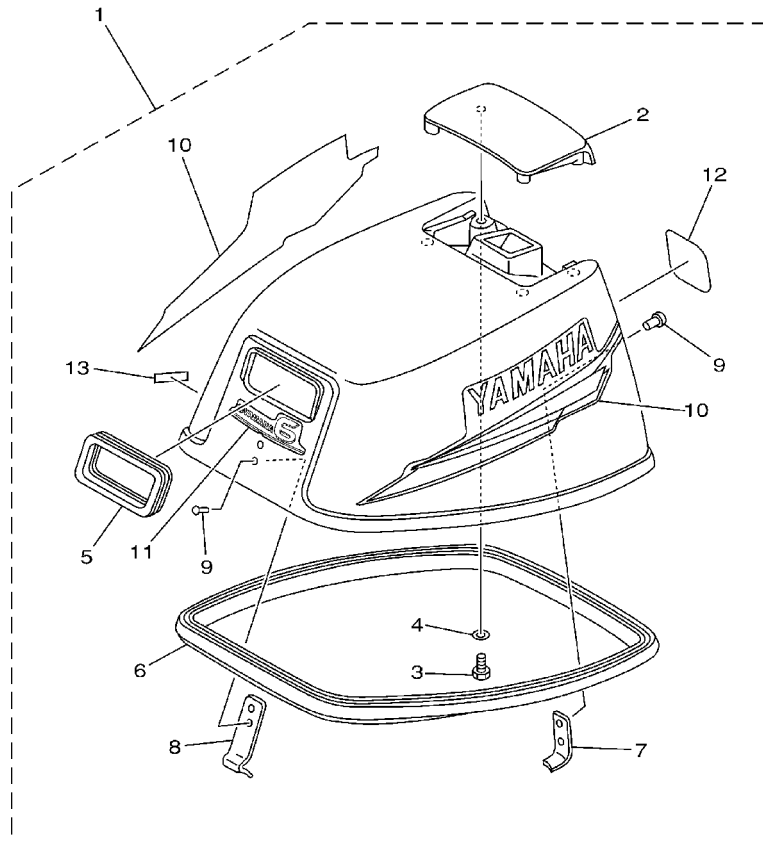

6M81200-2010

FIG. 1 TOP COWLING

SOPORTE SUPERIOR

REF. NO.	PART NO. CODIGO NO.	DESCRIPTION DESCRIPTION	8C	8C				REMARKS OBSERVACION
1	6M8-G2610-30-4D	TOP COWLING ASSY SOPORTE SUPERIOR COMPL.	1					
	6N0-G2610-30-4D	TOP COWLING ASSY SOPORTE SUPERIOR COMPL.		1				
2	6N0-G2613-00-4D	.MOLDING, AIR DUCT .MOLDURA CONDUCTO AIRE	1	1				
3	97095-06016	.BOLT .PERNO	4	4				
4	92995-06600	.WASHER .ARANDELA	4	4				
5	6G1-15761-00	.SEAL, RUBBER 1 .SELLO DE GOMA 1	1	1				
6	6G1-42615-00	.SEAL .SELLO	1	1				
7	6G1-42647-00	.HOLDER, CLAMP BAND .MORDAZA DE ABRAZADERA	1	1				
8	6N0-G2651-00	.HOOK .GANCHO	1	1				
9	90266-04M00	.RIVET .REMACHE	4	4				
10	6N0-WG070-10	.GRAPHIC SET .JUEGO DE EMBLEMA	1	1				
11	6M8-G2677-20	.GRAPHIC, FRONT .CALCAMONIA FRONTAL	1					
	6N0-G2677-20	.GRAPHIC, FRONT .CALCAMONIA FRONTAL		1				
12	6M8-G2678-11	.GRAPHIC, REAR .CALCAMONIA TRASERA	1					
	6N0-G2678-11	.GRAPHIC, REAR .CALCAMONIA TRASERA		1				
13	6E0-44191-11	.INDICATOR, SHIFT .INDICADOR DE CAMBIOS	1	1				

FIG. 2 CYLINDER. CRANKCASE

CYLINDRO. CARTER

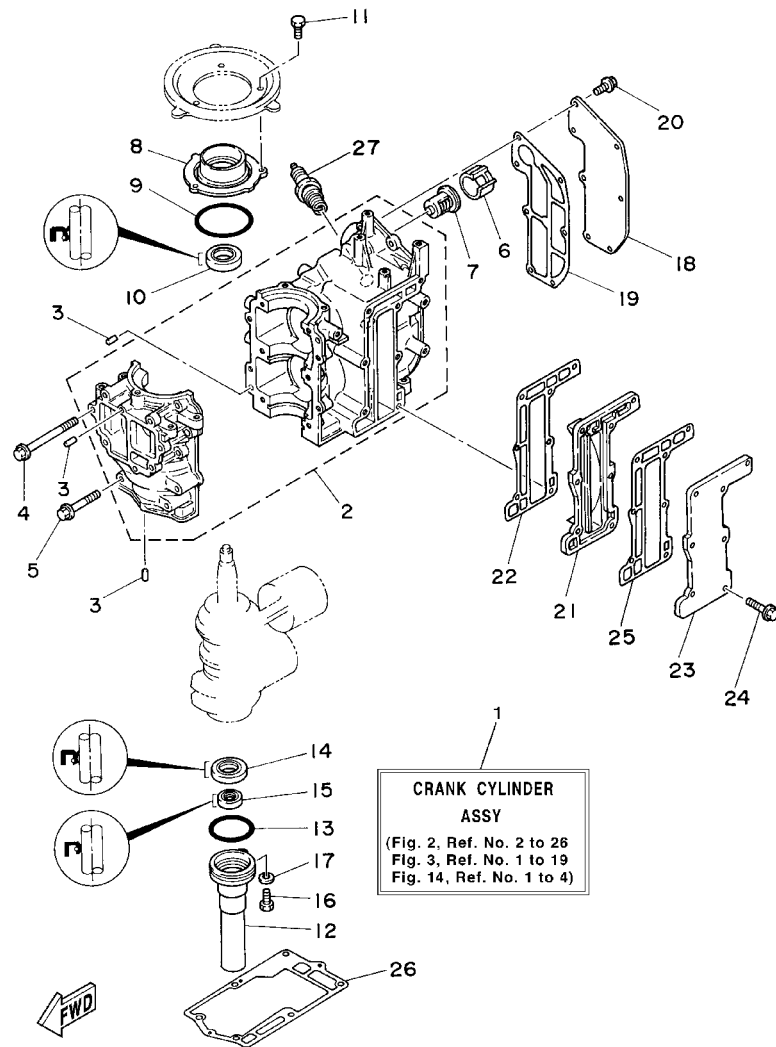

6M82200-7020

REF. NO.	PART NO. CODIGO NO.	DESCRIPTION DESCRIPTION	8C	8C			REMARKS OBSERVACION
1	6N0-WE090-01-4D	CRANK CYLINDER ASSY BLOQUE MOTOR COMPLETO	1	1			
2	6N0-E5100-00-94	CRANKCASE ASSY CARTER COMPLETO	1	1			
3	93604-08062	PIN, DOWEL PASADOR DE CLAVIJA	4	4			
4	90105-06M26	BOLT, FLANGE TORNILLO	6	6			
5	90105-06M25	BOLT, FLANGE TORNILLO	4	4			
6	90387-22M50	COLLAR COLLAR	1	1			
7	6E5-12411-01	THERMOSTAT TERMOSTAT	1	1			
8	6G1-15359-01-94	HOUSING, OIL SEAL CAJA DE SELLO DE ACEITE	1	1			
9	93210-54M54	O-RING JUNTA TORICA	1	1			
10	93102-20M25	OIL SEAL RETEN DE ACEITE	1	1			
11	97013-06016	BOLT PERNO	3	3			
12	6G1-15396-02-5B	HOUSING, OIL SEAL CAJA DE SELLO DE ACEITE	1	1			
13	93210-42159	O-RING JUNTA TORICA	1	1			
14	93101-20M34	OIL SEAL RETEN DE ACEITE	1	1			
15	93101-12M26	OIL SEAL RETEN DE ACEITE	1	1			
16	97095-06016	BOLT PERNO	1	1			
17	92995-06600	WASHER ARANDELA	1	1			
18	6N0-E1191-00-9M	COVER, CYLINDER HEAD 1 TAPA CULATA DE CILINDRO 1	1	1			
19	6G1-11193-A1	GASKET, HEAD COVER 1 EMPAQUE	1	1			
20	90105-06M14	BOLT FLANGE TORNILLO	7	7			
21	6N0-G1111-00-9M	INNER COVER, EXHAUST CUBIERTA INTERIOR DE ESCAPE	1	1			
22	6G1-41112-A1	GASKET, EXHAUST INNER COVER EMPAQUE	1	1			
23	6G1-41113-01-9M	OUTER COVER, EXHAUST CUBOERTA EXTERIOR DE ESCAPE	1	1			
24	90105-06M24	BOLT, FLANGE TORNILLO	7	7			
25	6G1-41114-A0	GASKET, EXHAUST OUTER COVER EMPAQUE	1	1			
26	6G1-45113-A1	GASKET, UPPER CASING EMPAQUE	1	1			
27	94702-00217	PLUG, SPARK (NGK B7HS-10) BUJIA (NGK B7HS-10)	2	2			

FIG. 2 CYLINDER. CRANKCASE CYLINDRO. CARTER

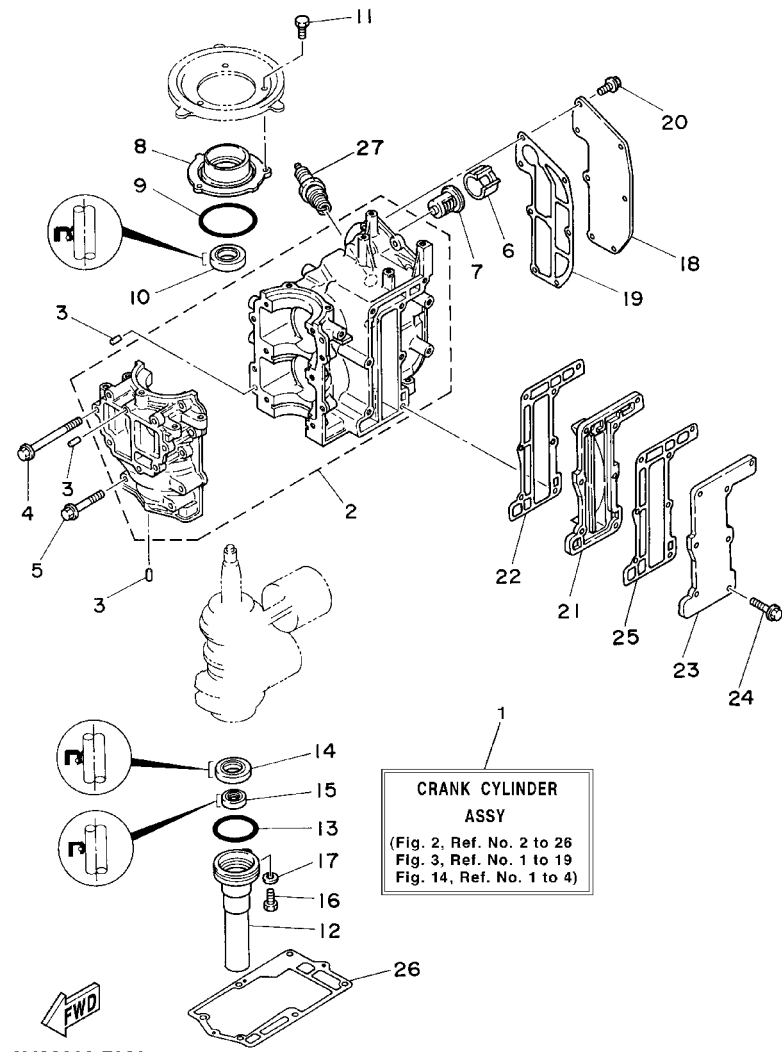

6M82200-7020

REF. NO.	PART NO. CODIGO NO.	DESCRIPTION DESCRIPTION	8C	8C			REMARKS OBSERVACION
27	94702-00271	PLUG, SPARK (NGK BR7HS-10) BUJIA (NGK BR7HS-10)		2			FOR CARIB

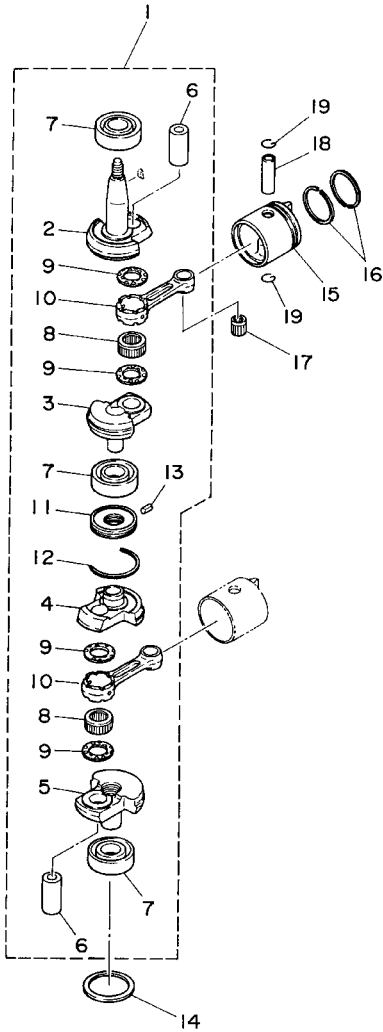

FIG. 3 CRANKSHAFT. PISTON

CIGUENAL. PISTON

REF. NO.	PART NO. CODIGO NO.	DESCRIPTION DESCRIPTION	8C	8C	REMARKS OBSERVACION
1	6N0-E1400-00	CRANKSHAFT ASSY CIGUENAL COMPLETO	1	1	
2	6N0-E1412-00	.CRANK 1 .MANIVELA 1	1	1	
3	6N0-E1422-00	.CRANK 2 .MANIVELA 2	1	1	
4	6N0-E1432-00	.CRANK 3 .MANIVELA 3	1	1	
5	6N0-E1442-00	.CRANK 4 .MANIVELA 4	1	1	
6	6G1-11681-00	.PIN, CRANK 1 .PASADOR MANIVELA 1	2	2	
7	93306-204U0	.BEARING .COJINETE	3	3	
8	93310-418V1	.BEARING .COJINETE DE RODILLOS	2	2	
9	90209-18112	.WASHER .ARANDELA DE SEPARACION	4	4	
10	6N0-E1651-00	.ROD, CONNECTING .BIELA	2	2	
11	6N0-E1515-00	.SEAL, LABYRINTH 1 .SELLO LABERINTO 1	1	1	
12	93440-47055	.CIRCLIP .SEGURO	1	1	
13	91609-20008	.PIN, SPRING .PASADOR DE RESORTE	1	1	
14	90201-41303	WASHER, PLATE ARANDELA PLANA	1	1	
15	6N0-E1631-00-98	PISTON (STD) PISTON (NORMA)	2	2	
16	6N0-E1603-00	PISTON RING SET (STD) JUEGO DE ANILLOS (NORMA)	2	2	
17	93310-112V0	BEARING COJINETE DE RODILLOS	2	2	
18	6N0-E1633-00	PIN, PISTON PASADOR, PISTON	2	2	
19	93450-13022	CIRCLIP SEGURO	4	4	



6M80010-4030

FIG. 4 INTAKE

ADMISION

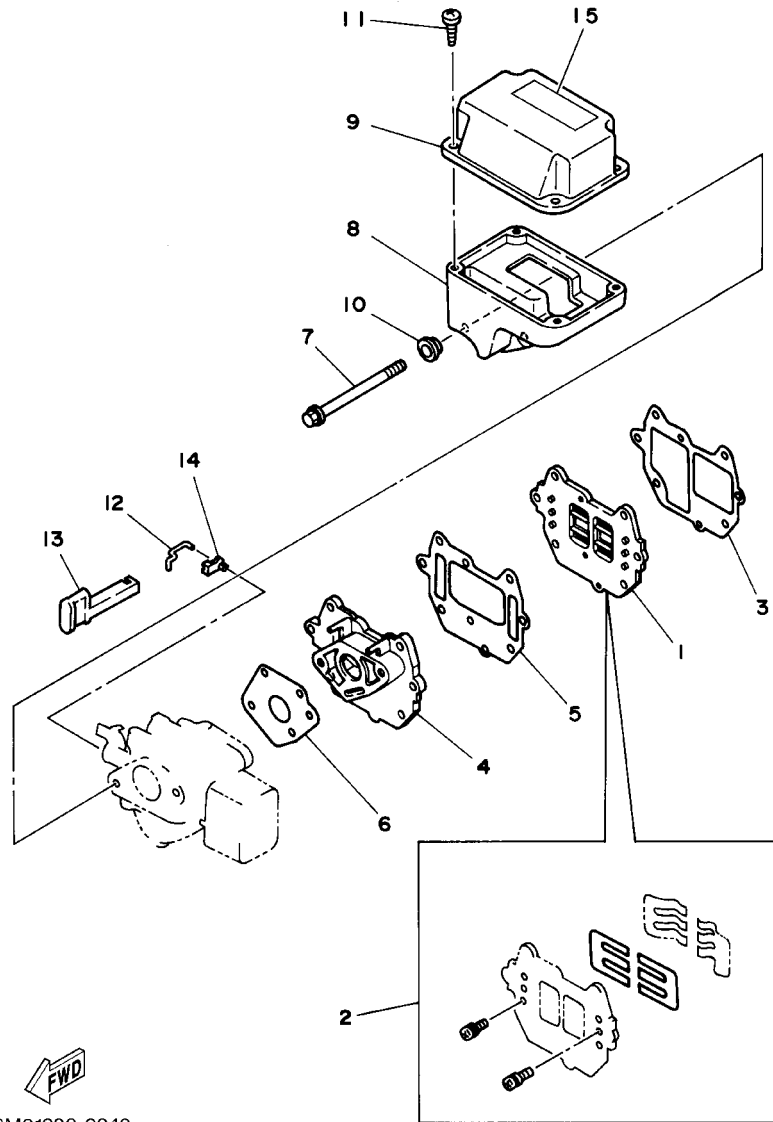



6M81200-2040

REF. NO.	PART NO. CODIGO NO.	DESCRIPTION DESCRIPTION	8C	8C				REMARKS OBSERVACION
1	6G1-13610-01	REED VALVE ASSY VALVULA DE LAMINAS COMPLETA	1	1				
2	6G1-W0004-00	.REED SET .JUEGO DE VALVULAS DE LENGUETA	1	1				
3	6G1-13621-A1	GASKET, VALVE SEAT JUNTA, DE VALV.DE EMPAQUE	1	1				
4	6N0-E3641-00-94	MANIFOLD 1 MULTIPLE 1	1	1				
5	6G1-13645-A1	GASKET, MANIFOLD 1 EMPAQUE	1	1				
6	6G1-14198-A1	GASKET EMPAQUE	1	1				
7	95895-06085	BOLT, FLANGE TORNILLO DE REBORDE	2	2				
8	6M8-E4417-00	COVER 1 CUBIERTA 1	1	1				
9	6M8-E4418-00	COVER 2 CUBIERTA 2	1	1				
10	90387-06M70	COLLAR COLLAR	2	2				
11	97780-50514	SCREW, TAPPING TORNILLO DE CABEZA DE CONO ACH	4	4				
12	6G1-41256-00	ROD, CHOKE 1 VARILLA DE AHOGADOR	1	1				
13	6G1-41271-00	KNOB, CHOKE PERILLA AHOGADOR	1	1				
14	661-41262-02	JOINT, CHOKE LEVER CONECTOR DE AHOGADOR	1	1				
15	6A1-83625-41	MARK 5 MARCA 5	1					FOR CARIB

FIG. 5 CARBURETOR

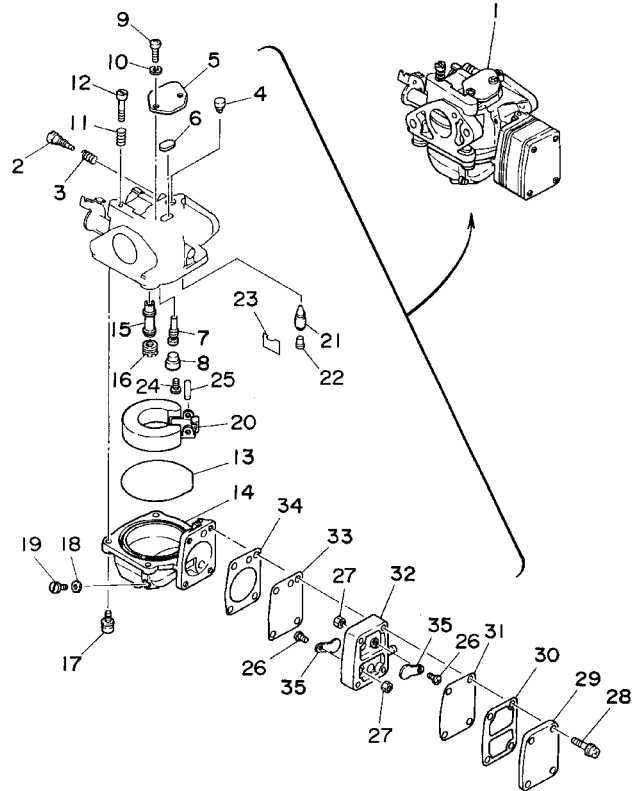
CARBURADOR



REF. NO.	PART NO. CODIGO NO.	DESCRIPTION DESCRIPTION	QTY	QTY		REMARKS OBSERVACION
1	6H6-14301-01	CARBURETOR ASSY 1 CARBURADOR COMPLETO 1	1			
	6G1-14301-01	CARBURETOR ASSY 1 CARBURADOR COMPLETO 1		1		FOR CARIB
	6N0-14301-10	CARBURETOR ASSY 1 CARBURADOR COMPLETO 1		1		FOR BRAZIL
2	679-14923-00	.SCREW, PILOT .TORNILLO DE AJUSTE	1	1		
3	679-14555-00	.SPRING .RESORTE	1	1		
4	6G1-14966-00	.CAP .TAPA	1	1		
5	6G1-14527-00	.PLATE .PLACA	1	1		
6	6G1-14126-00	.GASKET .EMPAQUE	1	1		
7	6G1-14948-05	.JET (#45) .INYECTOR (#45)	1	1		
	6G1-14948-06	.JET (#48) .INYECTOR (#48)		1		FOR BRAZIL
8	676-14966-00	.CAP .TAPA	1	1		
9	97880-04010	.SCREW, PAN HEAD .TORNILLO DE CABEZA CON PLANA	2	2		
10	92990-04100	.WASHER, SPRING .ARANDELA, GROWER	2	2		
11	90501-10326	.SPRING, COMPRESSION .RESORTE DE COMPRESION	1	1		
12	63V-14523-00	.SCREW, STOP .TORNILLO DE TOPE	1	1		
13	6G1-14984-00	.O-RING .EMPAQUE CAMARA DE BOIA	1	1		
14	6G1-14980-01	.BODY, FLOAT CHAMBER .CUERPO CAMARA DE BOIA	1	1		
15	6H6-14947-00	.JET, NEEDLE .INYECTOR DE AGUJA	1			
	6G1-14947-00	.JET, NEEDLE .INYECTOR DE AGUJA		1		
16	676-14943-26	.JET, MAIN (#98) .INYECTOR PRINCIPAL (#98)	1	1		
	6G1-14943-79	.JET, MAIN (#108) .INYECTOR PRINCIPAL (#108)		1		FOR BRAZIL
17	97980-04114	.SCREW, WITH WASHER .TORNILLO, CON ARANDELA	4	4		
18	65W-14398-00	.GASKET .EMPAQUE	1	1		
19	6G1-14992-00	.SCREW, DRAIN .TORNILLO, SEGURO	1	1		
20	6G1-14985-00	.FLOAT .BOIA	1	1		
21	6G1-14546-01	.VALVE, NEEDLE .VALVULA DE AGUJA	1	1		
	62D-14546-01	.VALVE, NEEDLE .VALVULA DE AGUJA		1		FOR BRAZIL



6M80010-4050

FIG. 5 CARBURETOR

CARBURADOR

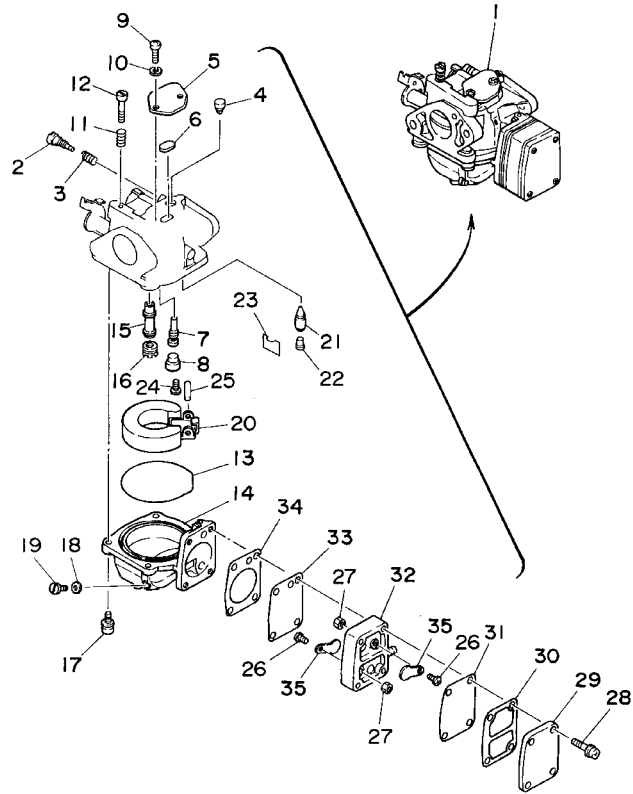

REF. NO.	PART NO. CODIGO NO.	DESCRIPTION DESCRIPTION	QTY	QTY			REMARKS OBSERVACION
22	676-14186-00	.PIN, FLOAT .PASADOR DE LA BOYA	1	1			
23	663-14159-00	.CLIP .PRESILLA	1	1			
24	98580-04008	.SCREW, PAN HEAD .TORNILLO DE CABEZA CRUZADA	1	1			
25	688-14548-00	.PIN, FLOAT ARM .PASADOR DE BRAZO DE BOIA	1	1			
26	98980-03006	.SCREW, BIND .TORNILLO DE AJUSTE	2	2			
27	95380-03600	.NUT .TUERCA	2	2			
28	97980-04125	.SCREW, WITH WASHER .TORNILLO, CON ARANDELA	4	4			
29	6G1-24452-00	.COVER .CUBIERTA	1	1			
30	6G1-24432-00	.GASKET, FUEL PUMP 2 .EMPAQUE BOMBA COMBUSTIBLE	1	1			
31	6G1-24471-00	.DIAPHRAGM .DIAFRAGMA	1	1			
32	6G1-24412-01	.BODY 1 .CUERPO 1	1	1			
33	6G1-24411-00	.DIAPHRAGM .DIAFRAGMA	1	1			
34	6G1-24431-01	.GASKET, FUEL PUMP 1 .EMPAQUE BOMBA COMBUST 1	1	1			
35	6G1-24421-00	.VALVE, CHECK .VALVULA DE RETENCION	2	2			



6M80010-4050

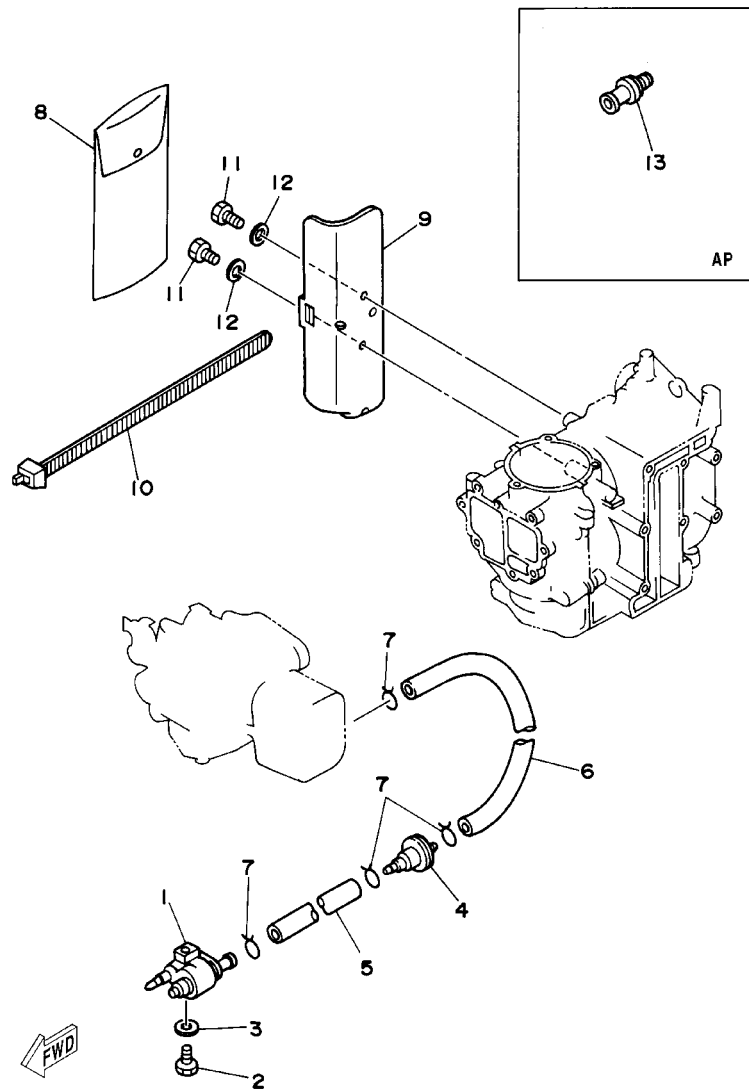

FIG. 6 FUEL

COMBUSTIBLE

REF. NO.	PART NO. CODIGO NO.	DESCRIPTION DESCRIPTION	8C	8C	REMARKS OBSERVACION
1	6G1-24304-02	FUEL PIPE JOINT COMP. 1 CONECTOR MANGUERA COMBUST.1	1	1	
2	97095-06025	BOLT PERNO	1	1	
3	92995-06600	WASHER ARANDELA	1	1	
4	646-24251-02	STRAINER 1 COLADOR 1	1	1	
5	90445-09221	HOSE (L205) TUBO (L205)	1	1	
6	90445-09220	HOSE TUBO	1	1	
7	90467-08004	CLIP PRESILLA	4	4	
8	6N0-F8100-00	TOOL KIT JUEGO DE HERRAMIENTAS	1	1	
9	6N0-F8170-00	TOOL, HOLDER HERRAMIENTA	1	1	
10	6G1-2811G-00	BAND BANDA	1	1	
11	97095-06012	BOLT PERNO	2	2	
12	92995-06600	WASHER ARANDELA	2	2	
13	6L8-F8193-00	PLUG, WATER CHECK TAPON DE CONTROL DE LA AGUA	1	1	AP

FIG. 7 STARTER

ARRANQUE

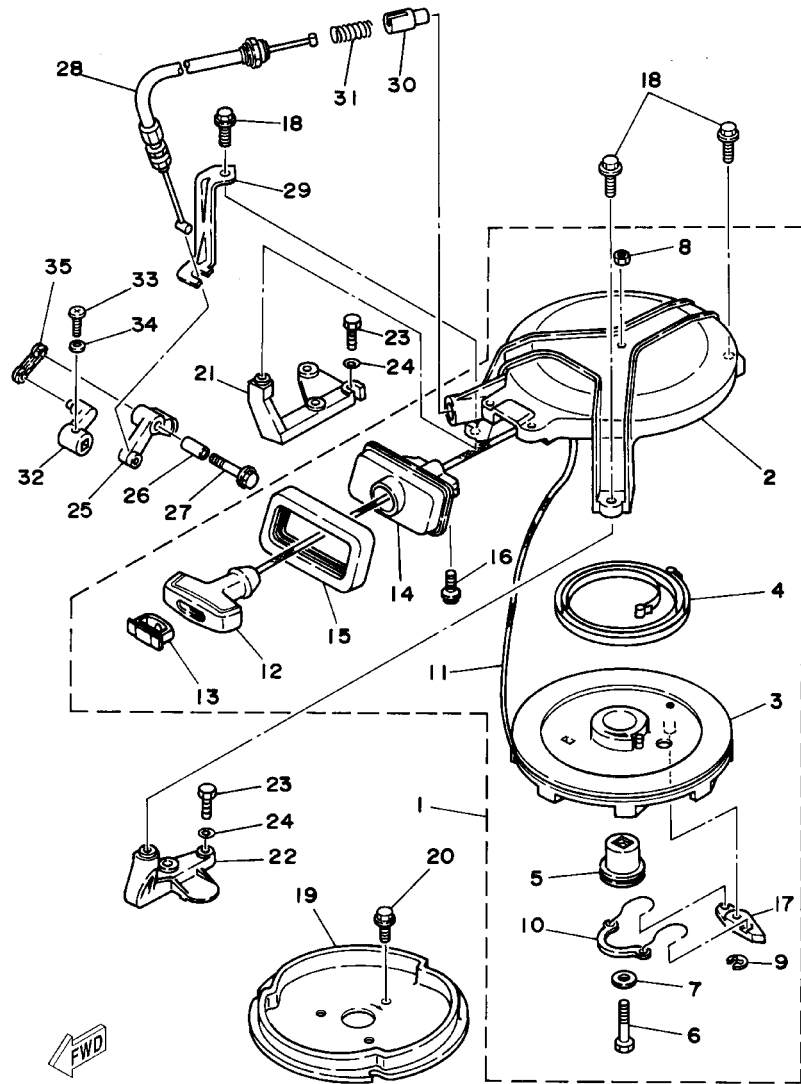

6M80010-7070

REF. NO.	PART NO. CODIGO NO.	DESCRIPTION DESCRIPTION	8C	8C	REMARKS OBSERVACION
1	6M8-E5710-03	STARTER ASSY ARRANQUE COMPLETO	1	1	
2	6N0-E5711-80-94	.CASE, STARTER .CAJA DE ARRANQUE	1	1	
3	6M8-E5714-00	.DRUM, SHEAVE .TAMBOR ROLDANA	1	1	
4	90510-08M03	.SPRING, SPIRAL .RESORTE EN ESPIRAL	1	1	
5	6G1-15717-00	.SHAFT, STARTER .EJE DE ARRANQUE	1	1	
6	97013-06035	.BOLT .PERNO	1	1	
7	90201-06M30	.WASHER, PLATE .ARANDELA PLANA	1	1	
8	95303-06600	.NUT .TUERCA	1	1	
9	93430-06M02	.CIRCLIP .SEGURO	1	1	
10	6G1-15705-00	.SPRING, DRIVE PAWL .RESORTE	1	1	
11	*	.WIRE (L1850) .CABLE (L1850)	1	1	
12	6G1-15755-00	.HANDLE, STARTER .MANIJA DE ARRANQUE	1	1	
13	6G1-15779-00	.COVER .CUBIERTA	1	1	
14	6N0-E5758-00	.GUIDE, ROPE .GUIA DE CUERDA	1	1	
15	6G1-15762-00	.SEAL, RUBBER 2 .SELLO DE GOMA 2	1	1	
16	95895-06016	.BOLT, FLANGE .TORNILLO DE REBORDE	2	2	
17	677-15741-01	.PAWL, DRIVE .TRINQUETE DE TRACCION	1	1	
18	95895-06020	BOLT, FLANGE TORNILLO DE REBORDE	3	3	
19	6N0-E5723-00-94	PULLEY, STARTER POLEA DE ARRANQUE	1	1	
20	90105-06M29	BOLT, FLANGE TORNILLO	3	3	
21	6N0-E5771-00-94	STAY 1 SOPORTE 1	1	1	
22	6N0-E5772-00-94	STAY 2 SOPORTE 2	1	1	
23	97075-06020	BOLT PERNO	4	4	
24	92995-06600	WASHER ARANDELA	4	4	
25	6G1-15746-81	ARM BRAZO	1	1	
<p>* CUT FROM 50M ROLLS, PART NO. 90890-44372, CUTTING LENGTH 1.85M * CORTE DE UN RODILLO DE 50M , PARTS NUMERO 90890-44372, LARGO DEL CORTE 1.85M</p>					

FIG. 7 STARTER

ARRANQUE

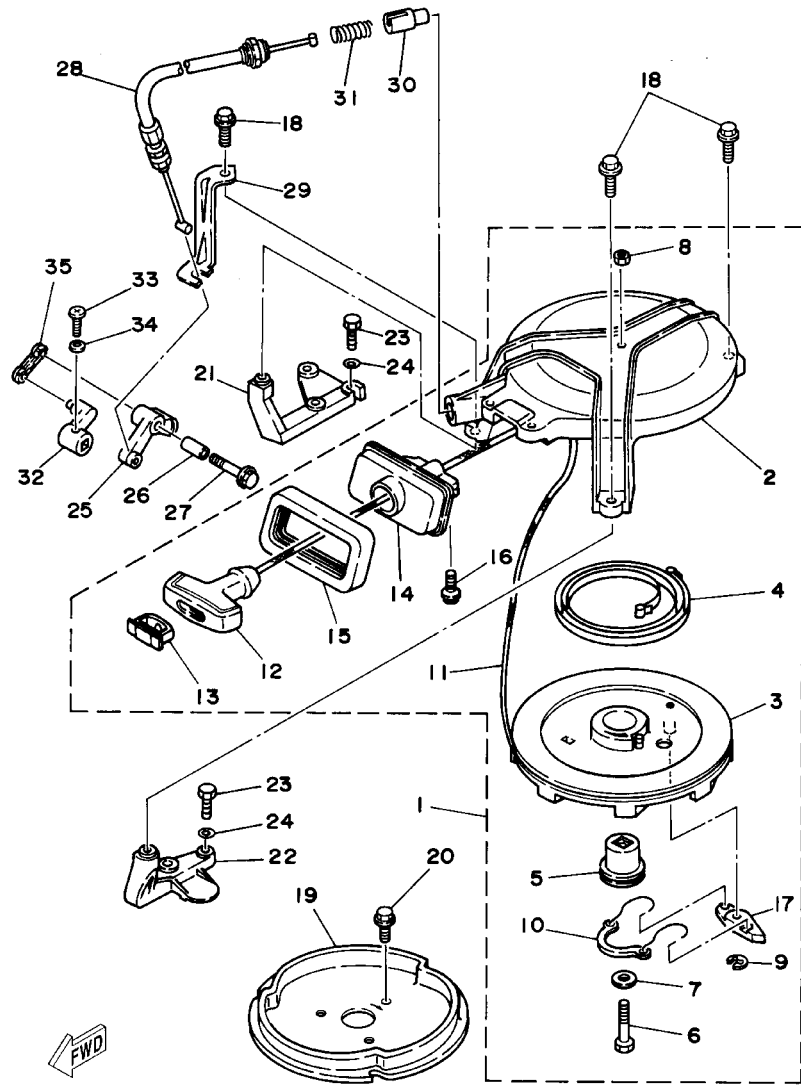

6M80010-7070

REF. NO.	PART NO. CODIGO NO.	DESCRIPTION DESCRIPTION	8C	8C	REMARKS OBSERVACION
25	6G1-15746-10	ARM BRAZO		1	FOR CARIB
26	6G1-15764-00	COLLAR 1 COLLAR 1	1	1	
27	95895-06025	BOLT, FLANGE TORNILLO DE REBORDE	1	1	
28	6N0-E5770-80	CABLE COMP., STARTER STOP CABLECOMPL DE SEGURO ARRANQUE	1	1	
29	6G1-15774-81	STAY 4 SOPORTE 4	1	1	
30	656-15748-00	PLUNGER, STARTER STOP EMBOLO SEGURO DE ARRANQUE	1	1	
31	90501-10227	SPRING, COMPRESSION RESORTE DE COMPRESION	1	1	
32	6G1-44125-80	LEVER, SHIFT ROD PALANCA VARILLA CAMBIOS	1	1	
33	97880-05016	SCREW, PAN HEAD TORNILLO DE CABEZA CON PLANA	1	1	
34	92990-05600	WASHER, PLATE ARANDELA PLANA	1	1	
35	6G1-15747-80	LINK ESLABON	1	1	

FIG. 8 GENERATOR

GENERADOR

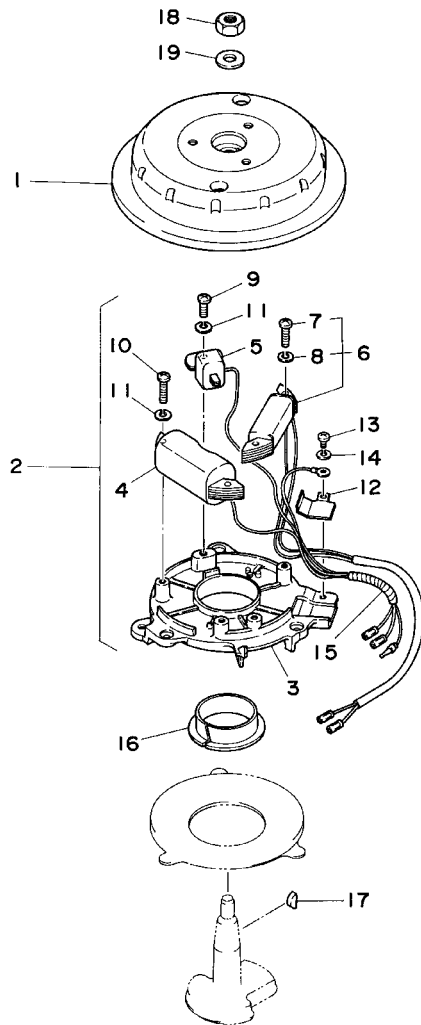

REF. NO.	PART NO. CODIGO NO.	DESCRIPTION DESCRIPTION	8C	8C	REMARKS OBSERVACION
1	6G1-85550-71	ROTOR ASSY ROTOR COMPLETO	1	1	
2	6G1-85560-F0	BASE ASSY CONJUNTO BASE	1	1	
3	6G1-85509-70	.BASE, MAGNETO .BASE DE MAGNETO	1	1	
4	6E7-85520-70	.COIL, CHARGE .BOBINA DE CARGA	1	1	
5	6E7-85580-70	.COIL, PULSER .BOBINA DE PULSACION	1	1	
6	6E7-81303-A0	.LIGHTING COIL ASSY .BOBINA DE ILUMINACION COMPL.	1	1	
7	97802-05025	..SCREW, PAN HEAD ..TORNILLO	2	2	
8	92902-05100	..WASHER, SPRING ..RONDANA SENCILLA	2	2	
9	97802-05016	.SCREW, PAN HEAD .TORNILLO	1	1	
10	97802-05020	.SCREW, PAN HEAD .TORNILLO	2	2	
11	92902-05100	.WASHER, SPRING .RONDANA SENCILLA	3	3	
12	6G1-85548-70	.HOLDER .SOSTEN	1	1	
13	97802-04008	.SCREW, PAN HEAD .TORNILLO	1	1	
14	92902-04100	.WASHER, SPRING .RONDANA SENCILLA	1	1	
15	6G1-85515-70	.LEAD WIRE ASSY .CABLE CONDUCTOR COMPLETO	1	1	
16	90386-44M42	BUSH BUJE	1	1	
17	90280-04M06	KEY, WOODRUFF CUNA WOODRUFF	1	1	
18	90170-10113	NUT TUERCA	1	1	
19	90201-10126	WASHER, PLATE ARANDELA PLANA	1	1	



6M80010-4080

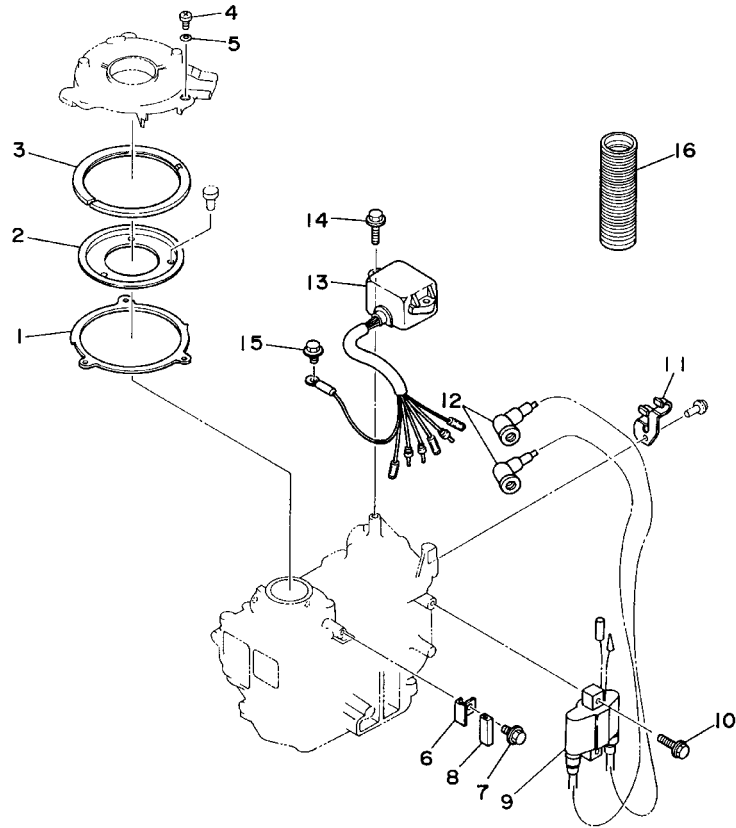

FIG. 9 ELECTRICAL ELECTRICO

REF. NO.	PART NO. CODIGO NO.	DESCRIPTION DESCRIPTION	8C	8C			REMARKS OBSERVACION
1	6N0-G1611-00	RETAINER, MAGNETO BASE RETENEDOR BASE MAGNETO	1	1			
2	6G1-41612-00	RETAINER, MAGNETO BASE RETENEDOR BASE MAGNETO	1	1			
3	6N0-G1613-00	PLATE, BASE FRICTION PLACA DE BASE DE FRICCION	1	1			
4	97885-05010	SCREW, PAN HEAD TORNILLO A MUESCA	3	3			
5	92995-05600	WASHER ARANDELA	3	3			
6	6G1-41615-00	STOPPER, MAGNETO BASE RETENEDOR, BASE MAGNETO	1	1			
7	95895-06010	BOLT, FLANGE TORNILLO DE REBORDE	1	1			
8	6G1-44194-00	CAP TAPA	1	1			
9	6G1-85570-01	IGNITION COIL ASSY BOBINA DE IGNICION COMPLETO	1	1			
10	95895-06025	BOLT, FLANGE TORNILLO DE REBORDE	2	2			
11	90465-08M17	CLAMP BRIDA	1	1			
12	663-82370-01	PLUG CAP ASSY TAPON DE BUJIA COMPLT	2	2			
	6G1-82370-21	PLUG CAP ASSY TAPON DE BUJIA COMPLT		2			FOR CARIB
13	696-85540-11	C.D.I. UNIT ASSY UNIDAD C.D.I. COMPLETA	1	1			
14	95895-06020	BOLT, FLANGE TORNILLO DE REBORDE	2	2			
15	95895-06010	BOLT, FLANGE TORNILLO DE REBORDE	1	1			
16	6G1-83557-00	TUBE ENCHUFE DE ACEITE	1	1			



6M80010-7090

FIG. 10 BOTTOM COWLING

CUBIERTA INFERIOR

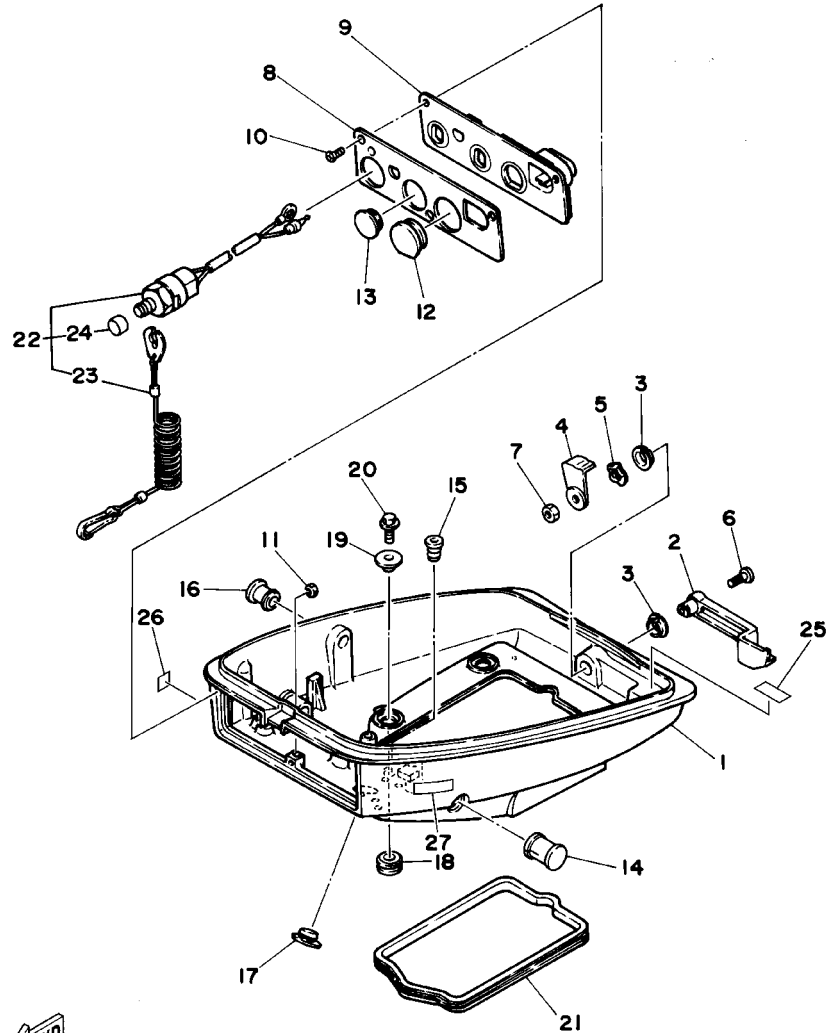

REF. NO.	PART NO. CODIGO NO.	DESCRIPTION DESCRIPTION	8C	8C			REMARKS OBSERVACION
1	6N0-G2711-00-4D	COWLING, BOTTOM CUBIERTA INFERIOR	1	1			
2	6N0-G2815-00-4D	LEVER, CLAMP PALANCA ABRAZADERA	1	1			
3	90386-12M45	BUSH BUJE	2	2			
4	6E0-42816-00	LEVER, CLAMP PALANCA ABRAZADERA	1	1			
5	90206-12052	WASHER, WAVE ARANDELA ONDULADA	1	1			
6	97885-06030	SCREW, PAN HEAD TORNILLO A MUESCA	1	1			
7	95380-06700	NUT TUERCA	1	1			
8	6N0-G2719-00 6N0-G2719-80	PANEL, FRONT LOWER PANEL FRENTE INFERIOR PANEL, FRONT LOWER PANEL FRENTE INFERIOR	1	1 1			FOR CARIB
9	6N0-G2767-00	BRACKET SOPORTE	1	1			
10	90149-05M02	SCREW TORNILLO DE REGLAJE	3	3			
11	95380-05700	NUT TUERCA	1	1			
12	6G1-42724-00	GROMMET TAPON	1	1			
13	6G1-42725-00	GROMMET TAPON	1	1			
14	6G1-42726-00	GROMMET TAPON	1	1			
15	6G1-42727-00	GROMMET TAPON	1	1			
16	6G1-42748-00	GROMMET TAPON	1	1			
17	6G1-26326-00	GROMMET TAPON PROTECTOR	1	1			
18	90480-15M31	GROMMET TAPON	4	4			
19	90387-06M52	COLLAR COLLAR	4	4			
20	95895-06020	BOLT, FLANGE TORNILLO DE REBORDE	4	4			
21	6N0-G2716-00	RUBBER, SEAL 1 SELLO DE GOMA 1	1	1			
22	6E9-82575-02	ENGINE STOP SWITCH ASSY INTERRUPTOR DE PARADA COMPL	1	1			
23	682-82556-00	.STOPPER .RETENER	1	1			
24	689-8257Y-00	.CAP .CASQUILLO	1	1			
25	6E7-42791-00 6E7-42791-10	MARK 1 MARCA 1 MARK 1 MARCA 1	1	1 1			FOR CARIB

6M82200-3100

FIG. 10 BOTTOM COWLING

CUBIERTA INFERIOR

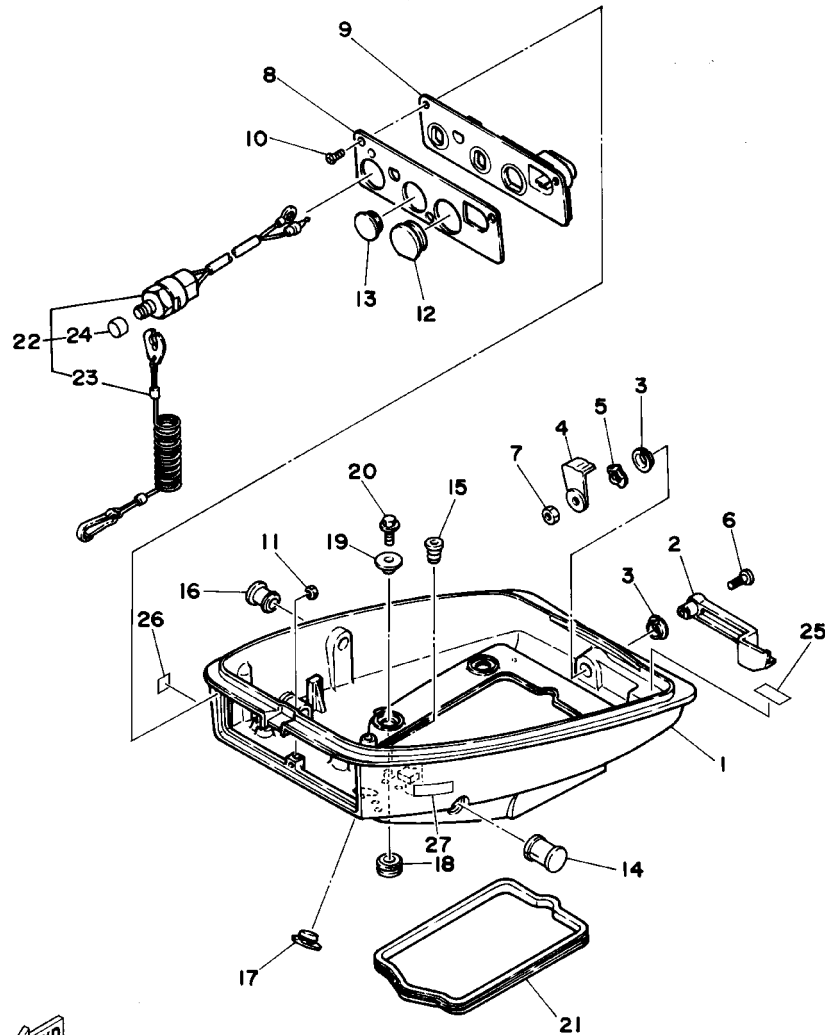

REF. NO.	PART NO. CODIGO NO.	DESCRIPTION DESCRIPTION	8C	8C	REMARKS OBSERVACION
26	6N0-F8176-00	LABEL, CAUTION ETIQUETA DE PRECAUCION		1	FOR CARIB
27	68D-H257H-00	PLATE, MARK PLACA DE MARCA		1	FOR CARIB

6M82200-3100

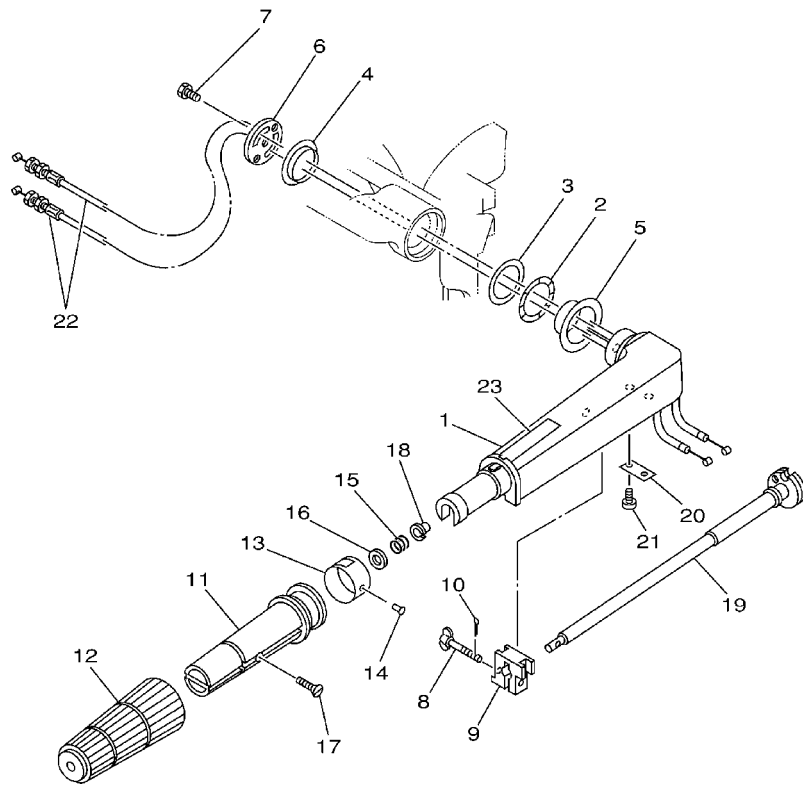

6M81200-2110

FIG. 11 STEERING

DIRECCION

REF. NO.	PART NO. CODIGO NO.	DESCRIPTION DESCRIPTION	8C	8C				REMARKS OBSERVACION
1	6M8-G2111-10-4D	HANDLE, STEERING MANIJA DE DIRECCION	1	1				
2	90206-36M21	WASHER, WAVE ARANDELA ONDULADA	1	1				
3	90202-36M55	WASHER, PLATE ARANDELA DE PLANA	1	1				
4	90386-33M96	BUSH BUJE	1	1				
5	90386-34M97	BUSH BUJE	1	1				
6	6G1-42131-01	COVER, HANDLE STEERING CUBIERTA MANIJA DIRRECCION	1	1				
7	97095-06020	BOLT PERNO	1	1				
8	6G1-42125-01	BOLT, FRICTION ADJUSTING TORNILLO FRICCION ADJUSTA	1	1				
9	6N0-G2126-00	FRICTION, STEERING HANDLE GRIP FRICCION DE MANGO DIRECCION	1	1				
10	91490-16010	PIN, COTTER CHAVETA	1	1				
11	6M4-G2119-00	GRIP, STEERING HANDLE MANGO, MANIJA DE DIRRECCION	1	1				
12	6N0-G2177-00	RUBBER, HANDLE HULE DE MANIJA	1	1				
13	6G1-42137-10	INDICATOR, THROTTLE INDICADOR ACELERADOR	1	1				
14	90269-02M09	RIVET REMACHE	1	1				
15	90501-23215	SPRING, COMPRESSION RESORTE DE COMPRESION	1	1				
16	92903-10600	WASHER, PLATE RONDANA SENCILLA	1	1				
17	90149-05M13	SCREW TORNILLO DE REGLAJE	1	1				
18	90386-08032	BUSH BUJE	1	1				
19	69M-G2138-00	LEVER, THROTTLE PLANCA DE ACELERACION	1	1				
20	6E0-42159-02	STAY SOPORTE	1	1				
21	97885-05012	SCREW, PAN HEAD TORNILLO A MUESCA	2	2				
22	6N0-F6301-00	THROTTLE CABLE ASSY CABLE DE ACELERADOR COMPLETO	2	2				
23	6E0-83627-41	LABEL, CAUTION 7 ETIQUETA DE PRECAUCION 7		1				FOR CARIB

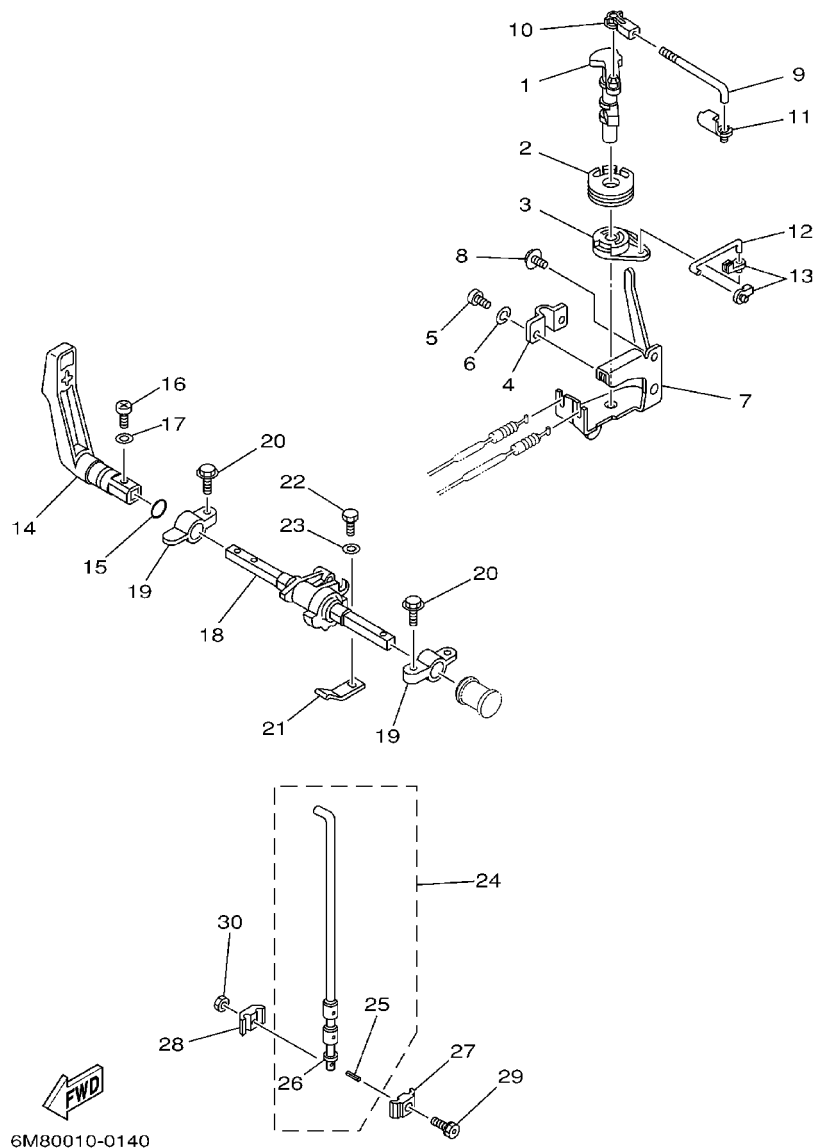

6M80010-0140

FIG. 12 CONTROL

CONTROL

REF. NO.	PART NO. CODIGO NO.	DESCRIPTION DESCRIPTION	8C	8C				REMARKS OBSERVACION
1	6G1-41631-00	LEVER, MAGNETO CONTROL PALANCA DE CONTROL DE MAGNETO	1	1				
2	6G1-41638-00	PULLEY POLEA	1	1				
3	6G1-41283-01	LEVER, FREE ACCEL. PALANCA	1	1				
4	6G1-41661-00	BRACKET SOPORTE	1	1				
5	97880-05010	SCREW, PAN HEAD TORNILLO DE CABEZA CON PLANA	2	2				
6	92990-05100	WASHER, SPRING ARANDELA GROWER	2	2				
7	6G1-14497-80	STAY, THROTTLE WIRE SOPORTE VALVULA DE OBTURACION	1	1				
8	95895-06010	BOLT, FLANGE TORNILLO DE REBORDE	2	2				
9	6G1-41238-00	JOINT, LINK CONECTOR	1	1				
10	662-41237-01	JOINT, LINK CONECTOR	1	1				
11	6E9-41237-00	JOINT, LINK CONECTOR	1	1				
12	6G1-41211-00	LINK, ACCEL. ESLABON, ACELERADOR	1	1				
13	661-41262-02	JOINT, CHOKE LEVER CONECTOR DE AHOGADOR	2	2				
14	6N0-G4111-00	HANDLE, GEAR SHIFT MANIJA DE CAMBIO DE MARCHAS	1	1				
15	93210-12327	O-RING JUNTA TORICA	1	1				
16	97880-05016	SCREW, PAN HEAD TORNILLO DE CABEZA CON PLANA	1	1				
17	92990-05600	WASHER, PLATE ARANDELA PLANA	1	1				
18	6G1-44121-02-94	LEVER, SHIFT ROD PALANCA VARILLA CAMBIOS	1	1				
19	6G1-41662-01-94	BRACKET SOPORTE	2	2				
20	90105-06M14	BOLT FLANGE TORNILLO	2	2				
21	6G1-44116-01	SPRING RESORTE	1	1				
22	97095-06012	BOLT PERNO	1	1				
23	92995-06600	WASHER ARANDELA	1	1				
24	6N0-G4110-00	SHIFT ROD ASSY VARILLA DE CAMBIO COMPL	1	1				
25	91690-20010	.PIN, SPRING .PASADOR DE RESORTE	3	3				
26	92990-05600	.WASHER, PLATE .ARANDELA PLANA	1	1				
27	6N0-G4145-00	CONNECTOR, SHIFT ROD CONECTOR, VARILLA CAMBIO	1	1				UR

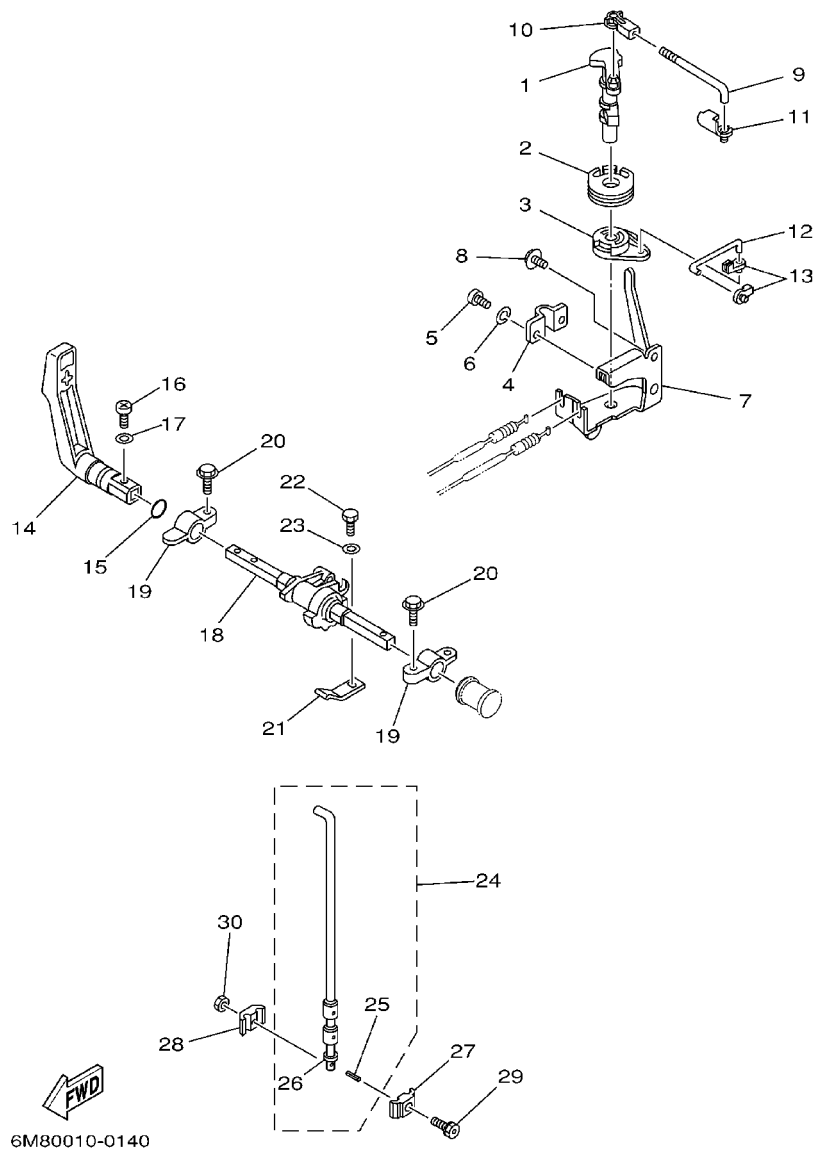
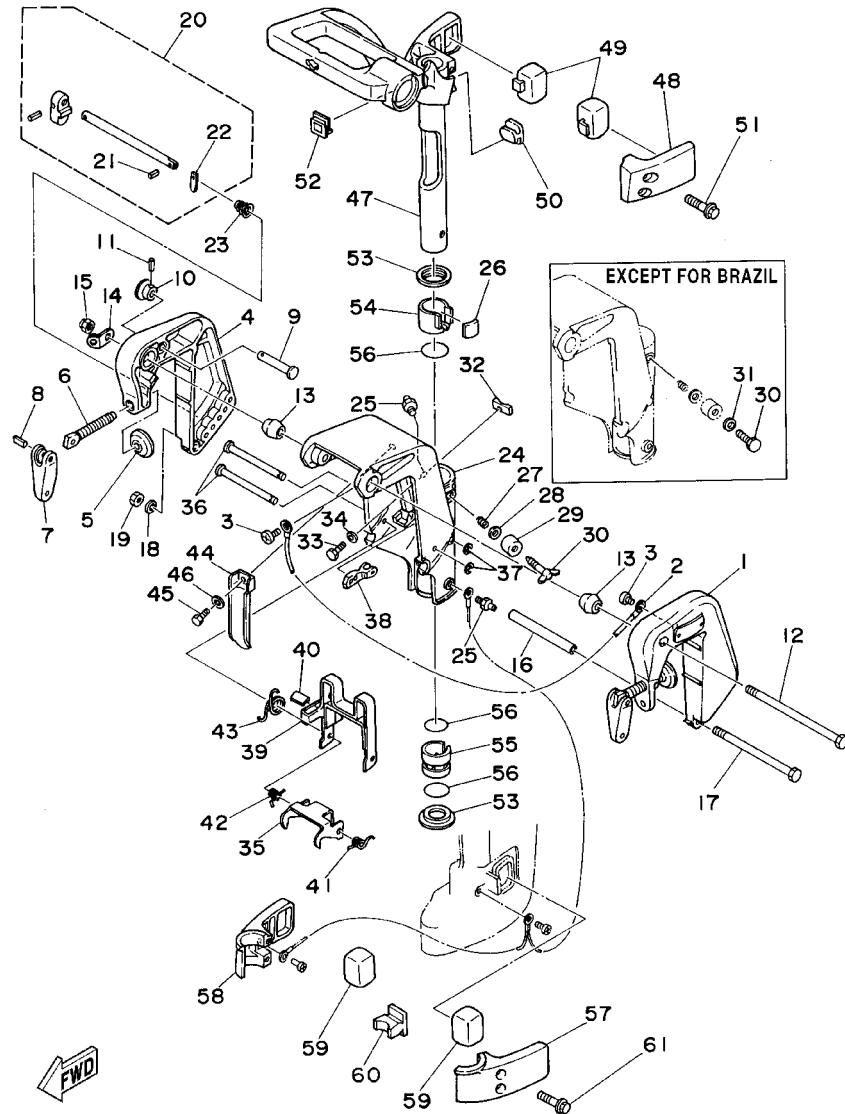

FIG. 12 CONTROL

CONTROL

REF. NO.	PART NO. CODIGO NO.	DESCRIPTION DESCRIPTION	8C	8C				REMARKS OBSERVACION
27	6N0-G4145-10	CONNECTOR, SHIFT ROD CONECTOR, VARILLA CAMBIO	1	1				UR
28	6N0-G4146-00	CONNECTOR, SHIFT ROD CONECTOR VARILLA DE CAMBIO	1	1				UR
	6N0-G4146-10	CONNECTOR, SHIFT ROD CONECTOR VARILLA DE CAMBIO	1	1				UR
29	90109-06M17	BOLT PERNO	1	1				
30	95380-06600	NUT, HEXAGON TUERCA	1	1				



6M80200-7130

FIG. 13 BRACKET

SOPORTE

REF. NO.	PART NO. CODIGO NO.	DESCRIPTION DESCRIPTION	QC	QC	REMARKS OBSERVACION
1	6M8-G3111-02-4D	BRACKET, CLAMP SOPORTE DE LA ABRAZADERA	1	1	
2	6E5-82148-00	WIRE, LEAD 4 CABLE CONDUCTOR 4	1	1	
3	97885-06008	SCREW, PAN HEAD TORNILLO A MUESCA	2	2	
4	6M8-G3112-01-4D	BRACKET, CLAMP SOPORTE DE LA ABRAZADERA	1	1	
5	620-43114-00	PAD, TRANSOM CLAMP ARANDELA DE ABRAZADERA	2	2	
6	6N0-G3116-00	SCREW, TRANSOM CLAMP TORNILLO DE ABRAZADERA	2	2	
7	6L8-G3118-01	HANDLE, TRANSOM CLAMP MANIJA DE LA ABRAZADERA DEL ES	2	2	
8	90243-04M01	PIN PASADOR	2	2	
9	689-43191-00	SHAFT, STOPPER EJE DE TOPE	1	1	
10	689-43192-01	KNOB, STOPPER PERILLA DE TOPE	1	1	
11	91690-30016	PIN, SPRING PASADOR DE RESORTE	1	1	
12	90101-08869	BOLT TORNILLO	1	1	
13	6N0-G3136-00	PIECE, FRICTION PIEZA DE FRICCION	2	2	
14	6A1-43113-01	PLATE, CLAMP BRACKET PLACA ABRAZADERA SOPORTE	1	1	
15	90185-08057	NUT, SELF-LOCKING TUERCA AUTOBLOCANTE	1	1	
16	90387-06M13	COLLAR COLLAR	1	1	
17	97095-06135	BOLT PERNO	1	1	
18	92990-06600	WASHER, PLATE ARANDELA PLANA	1	1	
19	95380-06600	NUT, HEXAGON TUERCA	1	1	
20	6N0-G3160-00	TILT ROD ASSY VARILLA DE BASCULACION COMPL.	1	1	
21	91690-30008	.PIN, SPRING .PASADOR DE RESORTE	1	1	
22	6N0-G3165-00	.PLATE, TILT LOCK .PLACA DE TOPE, VARILLA SEGUR	1	1	
23	90502-10M06	SPRING, CONICAL RESORTE CONICO	1	1	
24	6N0-G3311-10-4D	BRACKET, SWIVEL 1 SOPORTE GIRATORIO 1	1	1	
25	93700-06M03	NIPPLE, GREASE BOQUILLA DE ENGRASAR	2	2	
26	6G1-42528-10	PLATE, FRICTION PIEZA DE FRICCION	1	1	
	6G1-42528-00	PLATE, FRICTION PIEZA DE FRICCION	1		FOR BRAZIL

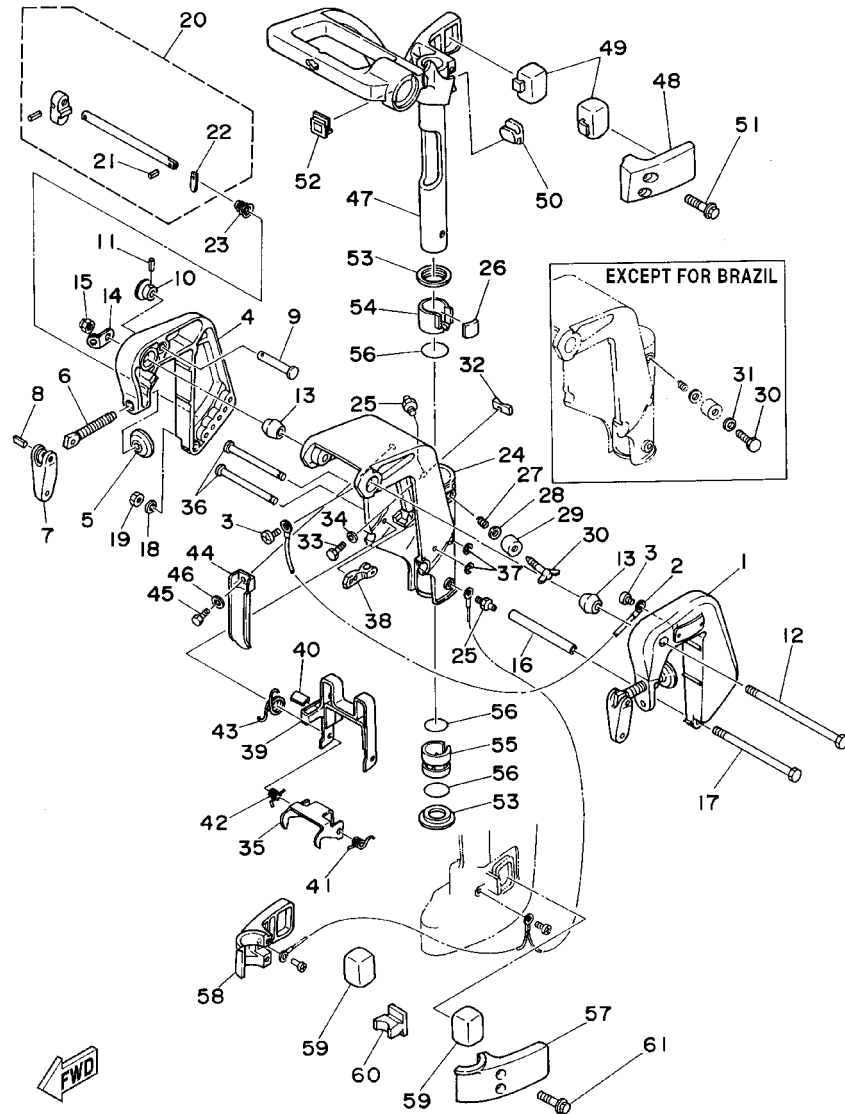

6M80200-7130

FIG. 13 BRACKET

SOPORTE

REF. NO.	PART NO. CODIGO NO.	DESCRIPTION DESCRIPTION	8C	8C	REMARKS OBSERVACION
27	90501-18M00	SPRING, COMPRESSION RESORTE DE COMPRESION	1	1	
28	92990-08600	WASHER, PLATE ARANDELA PLANA	1	1	
29	6G1-43373-00	SEAL, DAMPER SELLO DE GOMA	1	1	
30	97095-08025	BOLT PERNO	1	1	
	6G1-42529-00	SCREW, FRICTION PIECE TORNILLO, PIEZA FRICCION		1	FOR BRAZIL
31	92995-08600	WASHER ARANDELA	1	1	
32	6G1-44532-01	STOPPER, UPPER MOUNT RETEN	1	1	
33	97095-06010	BOLT PERNO	1	1	
34	92995-06600	WASHER ARANDELA	1	1	
35	6N0-G3614-00	PLATE, TILT LOCK PLACA DE SEGURO DE INCLINACION	1	1	
36	6G1-43659-00	SHAFT, REVERSE LOCK EJE SEGURO DE REVERSA	2	2	
37	99080-05600	CIRCLIP PRESILLA REDONDA	2	2	
38	6G1-43615-01	PLATE, TILT LOCK PLACA DE SEGURO DE INCLINACION	1	1	
39	6G1-43681-00	LEVER, SHALLOW WATER DRIVE 1 PALANCA 1	1	1	
40	6G1-43318-01	COVER CUBIERTA	1	1	
41	90508-10M15	SPRING, TORSION RESORTE DE TORSION	1	1	
42	90508-10M16	SPRING, TORSION RESORTE DE TORSION	1	1	
43	90508-14M17	SPRING, TORSION RESORTE DE TORSION	1	1	
44	6N0-G2731-00	CARRYING HANDLE MANIJA	1	1	
45	97095-08016	BOLT PERNO	1	1	
46	92995-08600	WASHER ARANDELA	1	1	
47	6M8-G2511-00-4D	BRACKET, STEERING SOPORTE DE DIRECCION	1	1	
48	6G1-44511-00-4D	COVER, UPPER MOUNT CUBIERTA AMORTIGUADOR SUPERIOR	1	1	
49	6N0-G4514-00	MOUNT DAMPER, UPPER SIDE AMORTIGUADOR LADO SUPERIOR	2	2	
50	6G1-44516-00	MOUNT DAMPER, UPPER FRONT AMORTIGUADOR DE HULE FRENTE SU	1	1	
51	95895-06035	BOLT, FLANGE TORNILLO DE REBORDE	2	2	
52	6G1-42551-00	GROMMET TAPON	1	1	

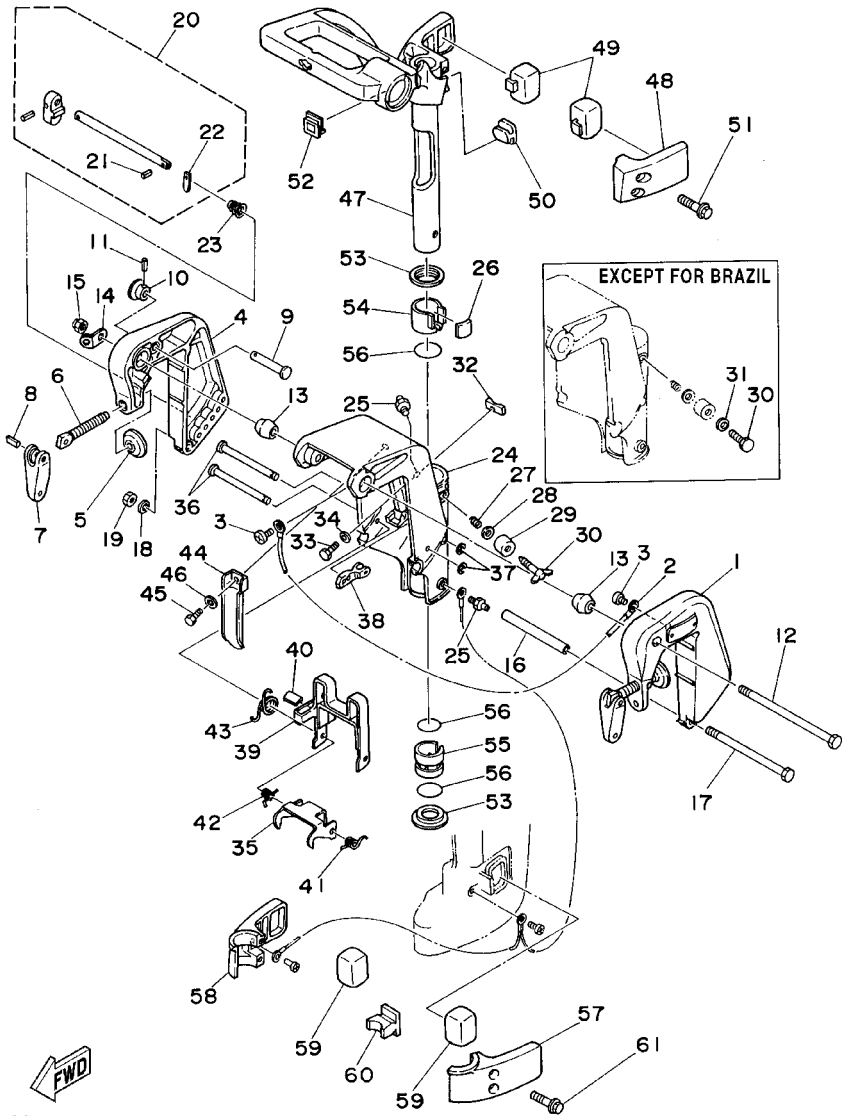

6M80200-7130

FIG. 13 BRACKET

SOPORTE

REF. NO.	PART NO. CODIGO NO.	DESCRIPTION DESCRIPTION	8C	8C	REMARKS OBSERVACION
53	6G1-42535-00	WASHER, THRUST RONDANA EMPUJE	2	2	
54	6G1-42537-10	BUSHING, PIVOT SHAFT BUJE DEL PIVOTE DE LA FLECHA	1	1	
	6G1-42537-00	BUSHING, PIVOT SHAFT BUJE DEL PIVOTE DE LA FLECHA		1	FOR BRAZIL
55	6G1-42538-01	BUSHING, PIVOT SHAFT BUJE DEL PIVOTE DE LA FLECHA	1	1	
56	93210-30M31	O-RING JUNTA TORICA	3	3	
57	6N0-G4551-00-4D	HOUSING, LOWER MOUNT RUBBER CAJA AMORTIGUADOR INFERIOR HU	1	1	
58	6N0-G4552-00-4D	HOUSING, LOWER MOUNT RUBBER CAJA AMORTIGUADOR INFERIOR HU	1	1	
59	6N0-G4555-A0	MOUNT DAMPER, LOWER SIDE AMORTIGUADOR DE HULE LADO INFE	2	2	
60	6N0-G4557-A0	MOUNT DAMPER, LOWER FRONT AMORTIGUADOR DE HULE FRENTE IN	1	1	
61	95895-06035	BOLT, FLANGE TORNILLO DE REBORDE	2	2	

FIG. 14 UPPER CASING

FUNDA SUPERIOR

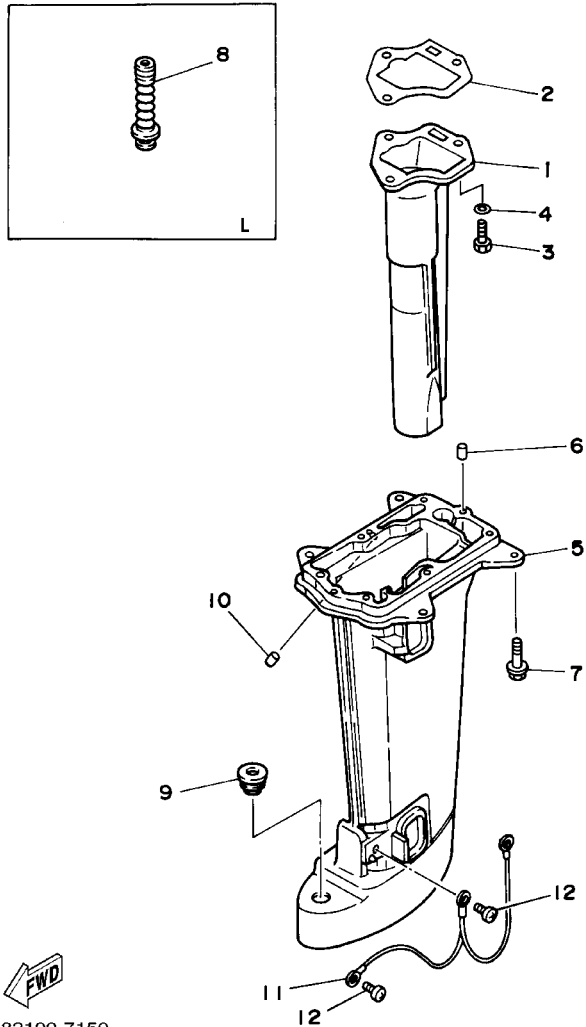

6M82100-7150

REF. NO.	PART NO. CODIGO NO.	DESCRIPTION DESCRIPTION	8C	8C			REMARKS OBSERVACION
1	6M8-G1131-00-5B	MANIFOLD, EXT. 1 TUBO MULTIPLE DE ESCAPE	1				
	6N0-G1131-00-5B	MANIFOLD, EXT. 1 TUBO MULTIPLE DE ESCAPE		1			
2	6G1-41133-A0	GASKET, EXHAUST MANIFOLD 1 EMPAQUE ESCAPE MULTIPLE	1	1			
3	97095-06020	BOLT PERNO	3	3			
4	92995-06600	WASHER ARANDELA	3	3			
5	6N0-G5111-00-4D	CASING, UPPER CAJA SUPERIOR	1	1			S
	6N0-G5111-10-4D	CASING, UPPER CAJA SUPERIOR		1			L
6	93604-08062	PIN, DOWEL PASADOR DE CLAVIJA	2	2			
7	95895-06030	BOLT, FLANGE TORNILLO DE REBORDE	6	6			
8	655-44147-00	BOOT, SHIFT ROD HULE DE VARILLA		1			L
9	90480-20M29	GROMMET TAPON	1	1			S
10	6G1-45135-00	PIPE TUBO 1	1	1			
11	6G1-82149-00	WIRE, LEAD 3 CABLE CONDUCTOR 3	1	1			
12	97885-06008	SCREW, PAN HEAD TORNILLO A MUESCA	2	2			

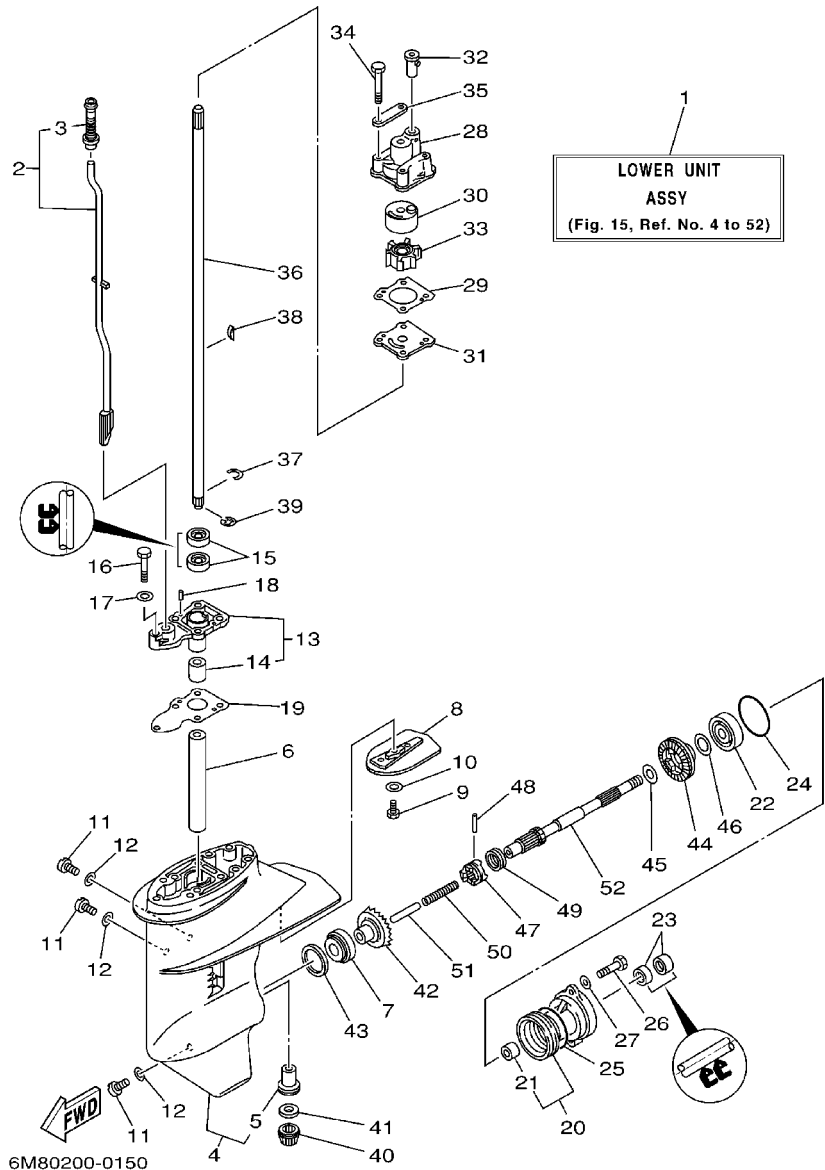

FIG. 15 LOWER CASING. DRIVE 1 IMPULSOR E INFERIOR 1

REF. NO.	PART NO. CODIGO NO.	DESCRIPTION DESCRIPTION	QTY	QTY		REMARKS OBSERVACION
1	6M8-G5300-00-4D	LOWER UNIT ASSY CONJUNTO UNIDAD INFERIOR	1	1		S
	6M8-G5300-10-4D	LOWER UNIT ASSY CONJUNTO UNIDAD INFERIOR		1		L
2	6N0-G4150-00	SHIFT CAM ASSY CONJUNTO EJE LEVA COMPL.	1	1		S
	6N0-G4150-10	SHIFT CAM ASSY CONJUNTO EJE LEVA COMPL.		1		L
3	6G1-44147-00	.BOOT, SHIFT ROD .HULE DE VARILLA	1	1		
4	6N0-G5311-00-4D	CASING, LOWER FUNDA INFERIOR	1	1		
5	6G1-45317-09	.BUSHING, DRIVE SHAFT .BUJE	1	1		
6	90387-14M49	COLLAR COLLAR	1	1		
7	93332-000U4	BEARING COJINETE DE RODILLOS AHUSADO	1	1		
8	6N0-G5251-00	ANODE CATODE	1	1		
9	97095-06016	BOLT PERNO	1	1		
10	92990-06300	WASHER, INTERNAL TOOTH ARANDELA PLANA	1	1		
11	90340-08002	PLUG, STRAIGHT SCREW TORNILLO, DE DRENAJE	3	3		
12	90430-08020	GASKET JUNTA	3	3		
13	6G1-45331-01-5B	HOUSING, BEARING CAJA DE COJINETE	1	1		
14	6G1-45316-09	.BUSHING, DRIVE SHAFT .BUJE, EJE DE MANDO	1	1		
15	93101-11M23	OIL SEAL RETEN DE ACEITE	2	2		
16	97095-06030	BOLT PERNO	1	1		
17	92995-06600	WASHER ARANDELA	1	1		
18	93604-08062	PIN, DOWEL PASADOR DE CLAVIJA	2	2		
19	6G1-45315-A0	PACKING, LOWER CASING EMPAQUE	1	1		
20	6N0-G5361-00-4D	CAP, LOWER CASING FUNDA INFERIOR	1	1		
21	6G1-45362-09	.BUSHING .BUJE FUNDA INFERIOR TAPA	1	1		
22	93306-004U0	BEARING COJINETE	1	1		
23	93101-15074	OIL SEAL RETEN DE ACEITE	2	2		
24	93210-49046	O-RING JUNTA TORICA	1	1		
25	93210-53M08	O-RING JUNTA TORICA	1	1		

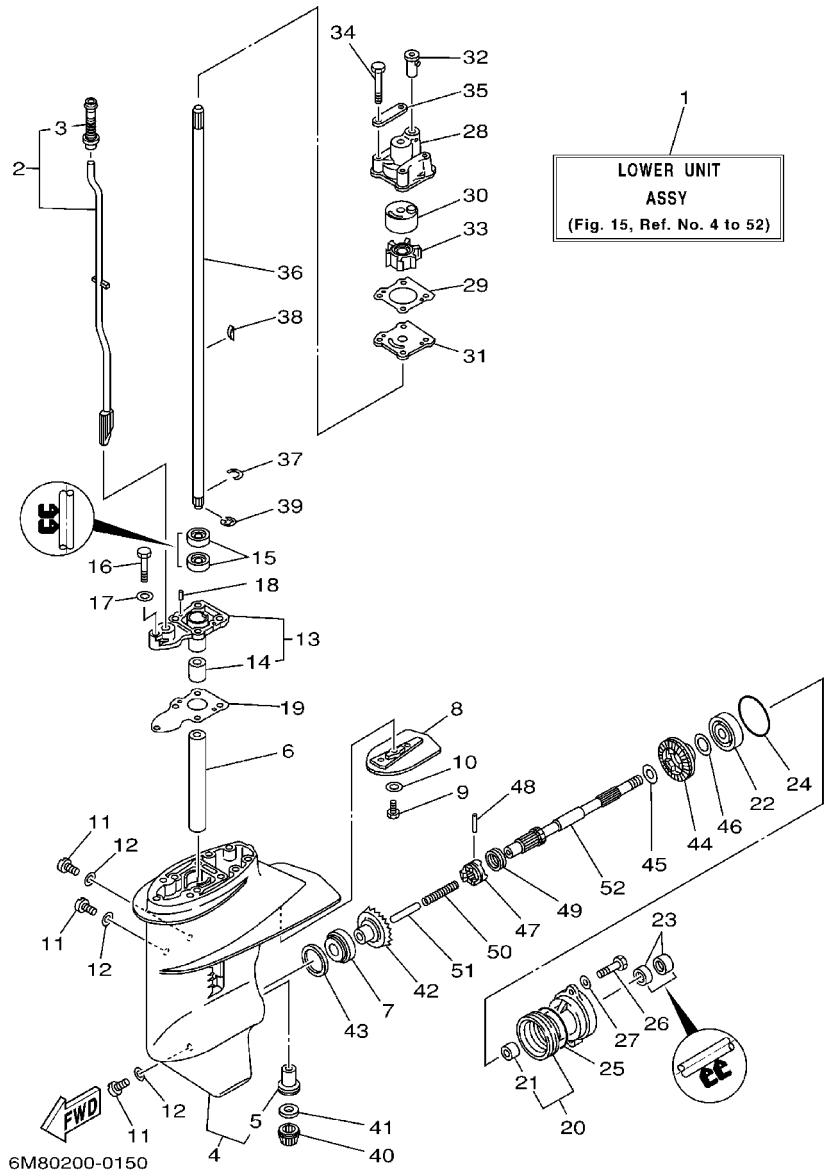

FIG. 15 LOWER CASING. DRIVE 1 IMPULSOR E INFERIOR 1

REF. NO.	PART NO. CODIGO NO.	DESCRIPTION DESCRIPTION	8C	8C			REMARKS OBSERVACION
26	97095-06016	BOLT PERNO	2	2			
27	92995-06600	WASHER ARANDELA	2	2			
28	6N0-G4311-00	HOUSING, WATER PUMP CAJA BOMBA DE AGUA	1	1			
29	6G1-44315-A0	GASKET, WATER PUMP EMPAQUE	1	1			
30	6G1-44322-00	INSERT, CARTRIDGE CARTUCHO		1			
	6G1-44322-40	INSERT, CARTRIDGE CARTUCHO	1				FOR CHROMATE
31	6G1-44323-00	OUTER PLATE, CARTRIDGE PLACA EXTERIOR DEL CARTUCHO		1			
	6G1-44323-40	OUTER PLATE, CARTRIDGE PLACA EXTERIOR DEL CARTUCHO	1				FOR CHROMATE
32	647-44366-00	DAMPER, WATER SEAL GOMA DEL SELLO DE AGUA	1	1			
33	6G1-44352-00	IMPELLER IMPULSOR	1	1			
34	97095-06045	BOLT PERNO	4	4			
35	6G1-44328-00	PLATE PLACA	2	2			
36	6N0-G5511-00	SHAFT, DRIVE EJE DE MANDO	1	1			S
	6N0-G5511-10	SHAFT, DRIVE EJE DE MANDO		1			L
37	90467-09M05	CLIP PRESILLA	1	1			
38	90280-03024	KEY, WOODRUFF CUNA WOODRUFF	1	1			
39	99001-06600	CIRCLIP PRESILLA REDONDA	1	1			
40	6N0-G5551-00	PINION PINON	1	1			
41	6G1-45533-00-19	SHIM (T:1.9MM) LAINA (T:1.9MM)	1	1			UR
	6G1-45533-00-20	SHIM (T:2.0MM) LAINA (T:2.0MM)	1	1			UR
	6G1-45533-00-21	SHIM (T:2.1MM) LAINA (T:2.1MM)	1	1			UR
	6G1-45533-00-22	SHIM (T:2.2MM) LAINA (T:2.2MM)	1	1			UR
42	6N0-G5560-00	GEAR ENGRANE COMPLE 1	1	1			
43	664-45587-01-10	SHIM (T:0.10MM) LAINA (T:0.10MM)	1	1			UR
	664-45587-01-12	SHIM (T:0.12MM) LAINA (T:0.12MM)	1	1			UR
	664-45587-01-15	SHIM (T:0.15MM) LAINA (T:0.15MM)	1	1			UR
	664-45587-01-18	SHIM (T:0.18MM) LAINA (T:0.18MM)	1	1			UR

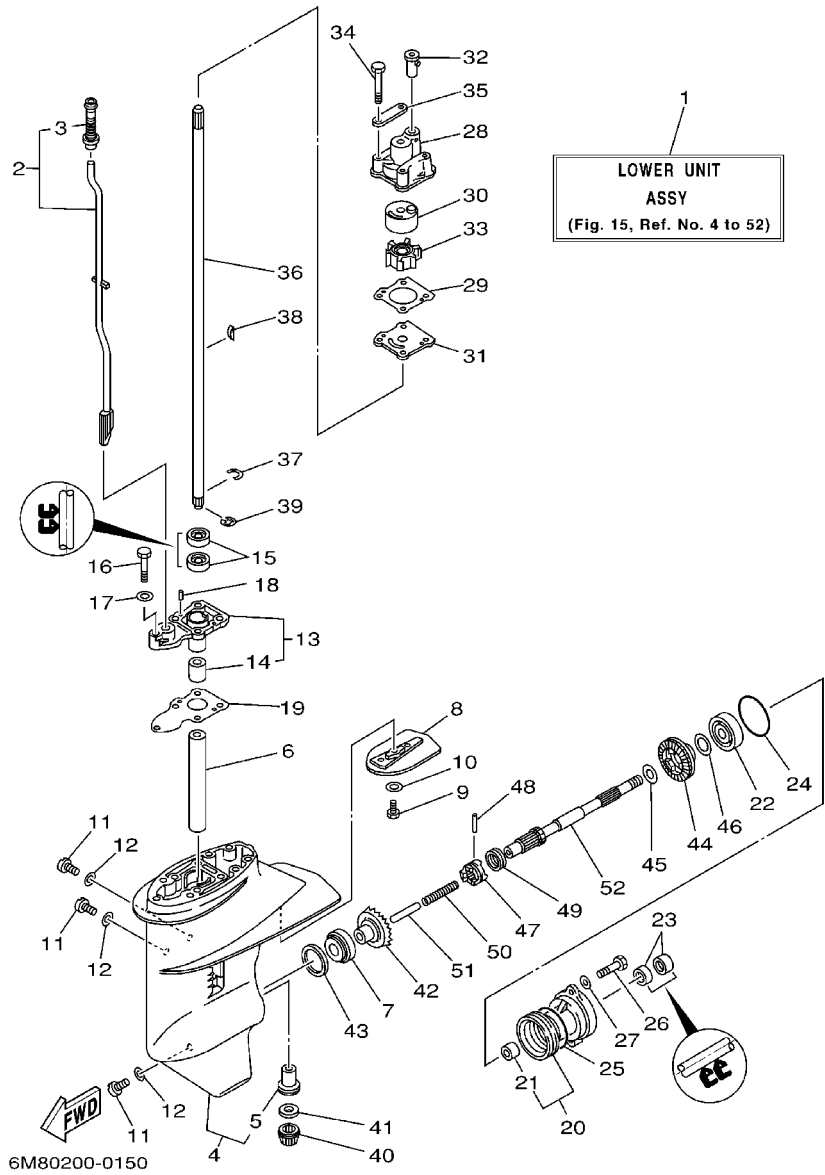
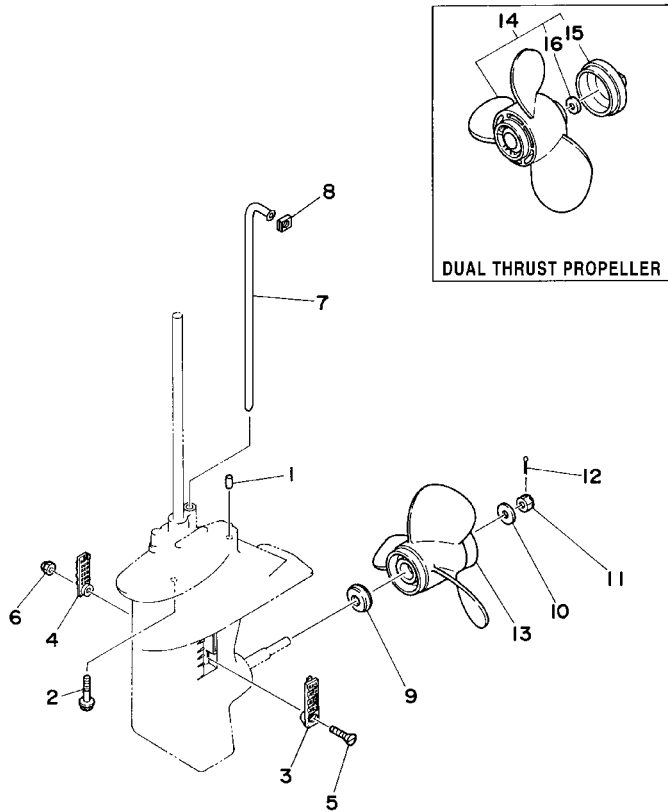

FIG. 15 LOWER CASING. DRIVE 1 IMPULSOR E INFERIOR 1

REF. NO.	PART NO. CODIGO NO.	DESCRIPTION DESCRIPTION	8C	8C	REMARKS OBSERVACION
43	664-45587-01-30	SHIM (T:0.30MM) LAINA(T:0.30MM)	1	1	UR
	664-45587-01-40	SHIM (T:0.40MM) LAINA (T:0.40MM)	1	1	UR
	664-45587-01-50	SHIM (T:0.50MM) LAINA (T:0.50MM)	1	1	UR
44	6N0-G5571-00	GEAR ENGRANAJE	1	1	
45	90201-15M89	WASHER, PLATE ARANDELA PLANA	1	1	
46	647-45567-00	SHIM (T:0.10MM) LAINA (T:0.10MM)	1	1	UN
47	6G1-45631-00	CLUTCH, DOG EMBAGUE DE GARRA	1	1	
48	6G1-45632-00	PIN, CROSS PASADOR TRANSVERSAL	1	1	
49	654-45633-00	RING, CROSS PIN ANILLO DE PASADOR	1	1	
50	90501-12M38	SPRING, COMPRESSION RESORTE DE COMPRESION	1	1	
51	6G1-45635-00	PLUNGER, SHIFT EMBOLO DE CAMBIO	1	1	
52	6G1-45611-01	SHAFT, PROPELLER EJE PROPUSOR	1	1	

FIG. 16 LOWER CASING. DRIVE 2

IMPULSOR E INFERIOR 2



REF. NO.	PART NO. CODIGO NO.	DESCRIPTION DESCRIPTION	8C	8C			REMARKS OBSERVACION
1	93604-08062	PIN, DOWEL PASADOR DE CLAVIJA	2	2			
2	95895-06030	BOLT, FLANGE TORNILLO DE REBORDE	4	4			
3	6G1-45214-00	COVER, WATER INLET CUBIERTA ENTRADA AGUA	1	1			
4	6G1-45215-00	COVER, WATER INLET CUBIERTA ENTRADA AGUA	1	1			
5	90152-05M03	SCREW, COUNTERSUNK TORNILLO EMBUTIDO	1	1			
6	90185-05002	NUT, SELF-LOCKING TUERCA AUTOBLOCANTE	1	1			
7	6N0-G4361-00	TUBE, WATER TUBO DE AGUA	1	1			S
	6N0-G4361-10	TUBE, WATER TUBO DE AGUA		1			L
8	6G1-44365-00	DAMPER, WATER SEAL HULE DE SELLO DE AGUA	1	1			
9	6N0-G5987-00	SPACER ESPACIADOR	1	1			UR
	6N0-G5987-10	SPACER ESPACIADOR		1			UR
10	90201-10M01	WASHER, PLATE ARANDELA PLANA	1	1			
11	90171-10M01	NUT, CASTLE TUERCA ENTALLADA	1	1			
12	91490-30020	PIN, COTTER CHAVETA	1	1			
13	6G1-45941-00-EL	PROPELLER (3X8-1/2"X8-1/2"-N) PROPELA (3X8-1/2"X8-1/2"-N)	1	1			UR
	6G1-45943-00-EL	PROPELLER (3X8-1/2"X7-1/2"-N) PROPELA (3X8-1/2"X7-1/2"-N)		1			UR
	6G1-45945-00-EL	PROPELLER (3X9"X7"-N) PROPELA (3X9"X7"-N)		1			UR
	6G1-45947-00-EL	PROPELLER (3X8-1/2"X6-1/2"-N) PROPELA (3X8-1/2"X6-1/2"-N)		1			UR
14	6G1-W4591-01-EL	PROPELLER (3X9"X7"-N) PROPELA (3X9"X7"-N)	1	1			UR
	6G1-W4592-00-EL	PROPELLER (3X9"X5"-N) PROPELA (3X9"X5"-N)		1			UR
15	6G1-45616-01	NUT, PROPELLER TUERCA DE HELICE	1	1			
16	90201-10M02	WASHER, PLATE ARANDELA PLANA	1	1			



6M80010-7180

FIG. 17 FUEL TANK 1

DEPOSITO DE COMBUSTIBLE 1

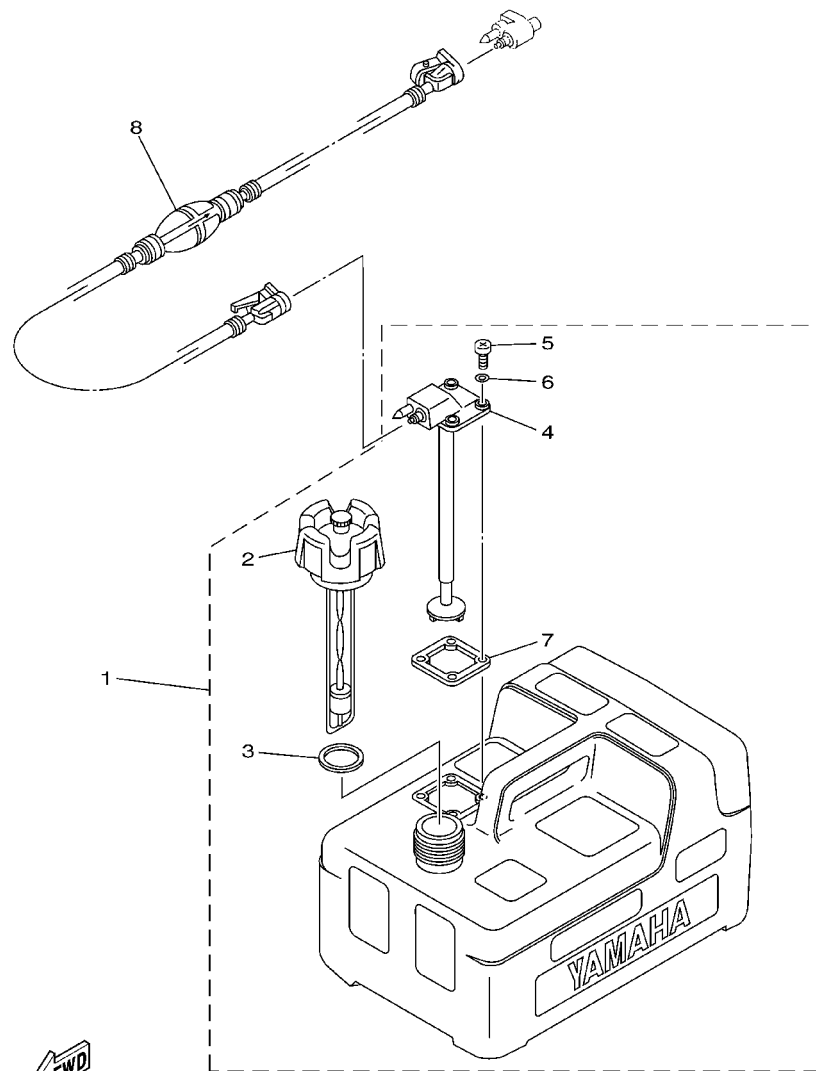

66R0700-9260

REF. NO.	PART NO. CODIGO NO.	DESCRIPTION DESCRIPTION	QTY				REMARKS OBSERVACION
1	6YL-F4201-02	FUEL TANK ASSY TANQUE DEL COMBUSTIBLE COMPL.	1				AP
2	6YL-F4610-00	.CAP ASSY .TAPA COMPLETA	1				
3	6YL-F4641-00	.GASKET, CAP 1 EMPAQUE DE TAPA 1	1				
4	6YL-F4260-01	.FUEL METER ASSY .MEDIDOR DE COMBUSTIBLE COMPL.	1				
5	90157-05811	.SCREW, PAN HEAD .TORNILLO CABEZA CONICA PLANA	4				
6	6YL-F4329-00	.SEAL .SELLO	4				
7	6YL-F4268-01	.GASKET, FUEL METER EMPAQ MEDIDOR DE COMBUSTIBLE	1				
8	6YL-24306-52	FUEL PIPE COMP. 1 TUBO COMBUST. COMPL 1	1				AP

FIG. 18 FUEL TANK 2

DEPOSITO DE COMBUSTIBLE 2

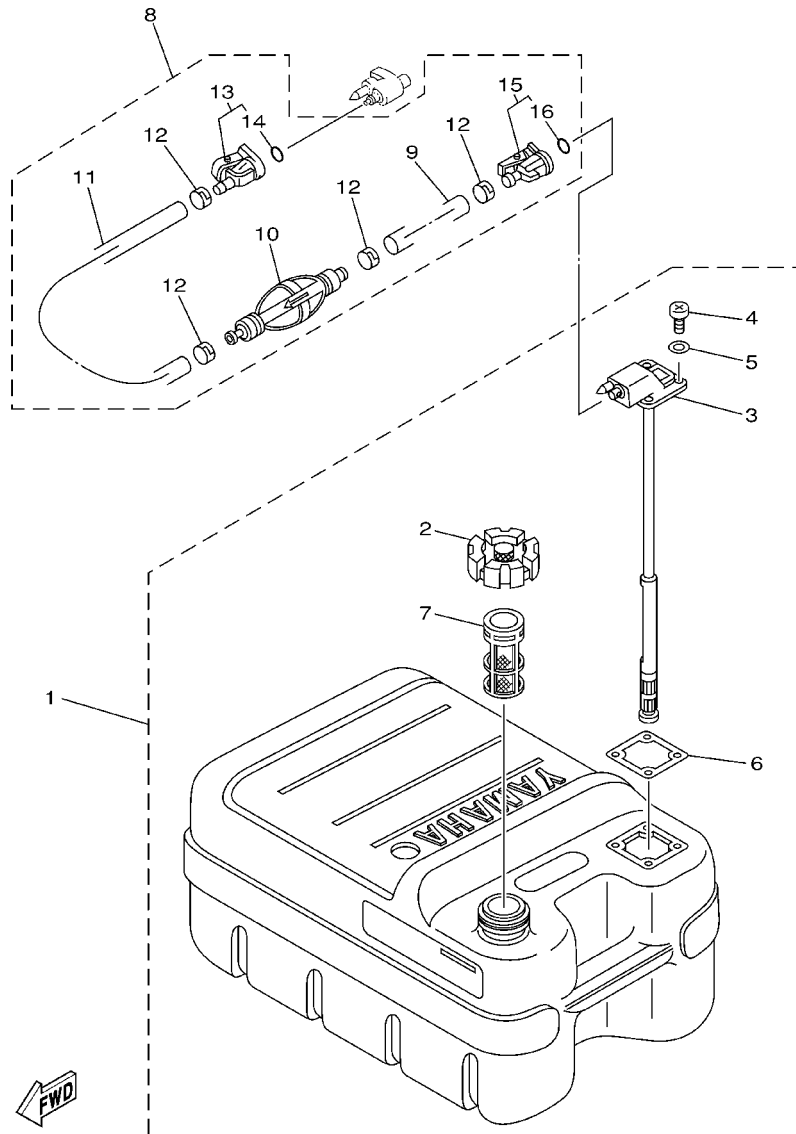

67C0100-9300

REF. NO.	PART NO. CODIGO NO.	DESCRIPTION DESCRIPTION	QTY	QTY	REMARKS OBSERVACION
1	6YJ-24201-10	FUEL TANK ASSY (24L) TANQUE DEL COMBUSTIBLE (24L)		1	AP FOR CARIB
	6M4-F4201-00	FUEL TANK ASSY TANQUE DEL COMBUSTIBLE COMPL.		1	AP FOR BRAZIL
2	6YJ-24610-00	.CAP ASSY .TAPA COMPLETA		1	
3	6Y1-24260-12	.FUEL METER ASSY .MEDIDOR DE COMBUSTIBLE COMPL.		1	FOR CARIB
	6YJ-24260-00	.FUEL METER ASSY .MEDIDOR DE COMBUSTIBLE COMPL.		1	FOR BRAZIL
4	98586-05016	.SCREW, PAN HEAD .TORNILLO DE CABEZA CON PLANA		4	
5	6Y1-24329-00	.SEAL .SELLO		4	
6	6Y1-24268-00	.GASKET, FUEL METER .EMPAQ MEDIDOR DE COMBUSTIBLE		1	
7	6YJ-24167-00	.STRAINER .COLADOR		1	
8	61J-24306-02	FUEL PIPE COMP. 1 TUBO COMBUST. COMPL 1		1	AP
9	90445-11M06	.HOSE (L2050) .MANGUERA (L2050)		1	
10	61J-24360-00	.PRIMER PUMP ASSY .SOPORTE BOMBA		1	
11	90445-11M05	.HOSE (L850) .MANGUERA (L850)		1	
12	650-24351-51	.BAND 1 .ABRAZADERA 1		4	
13	6G1-24305-03	.FUEL PIPE JOINT COMP. 2 .CONECTOR MANGUERA COMBUST. 2		1	
14	93210-08287	..O-RING ..JUNTA TORICA		1	
15	6Y1-24305-04	.FUEL PIPE JOINT COMP. 2 .CONECTOR MANGUERA COMBUST. 2		1	
16	93210-08287	..O-RING ..JUNTA TORICA		1	

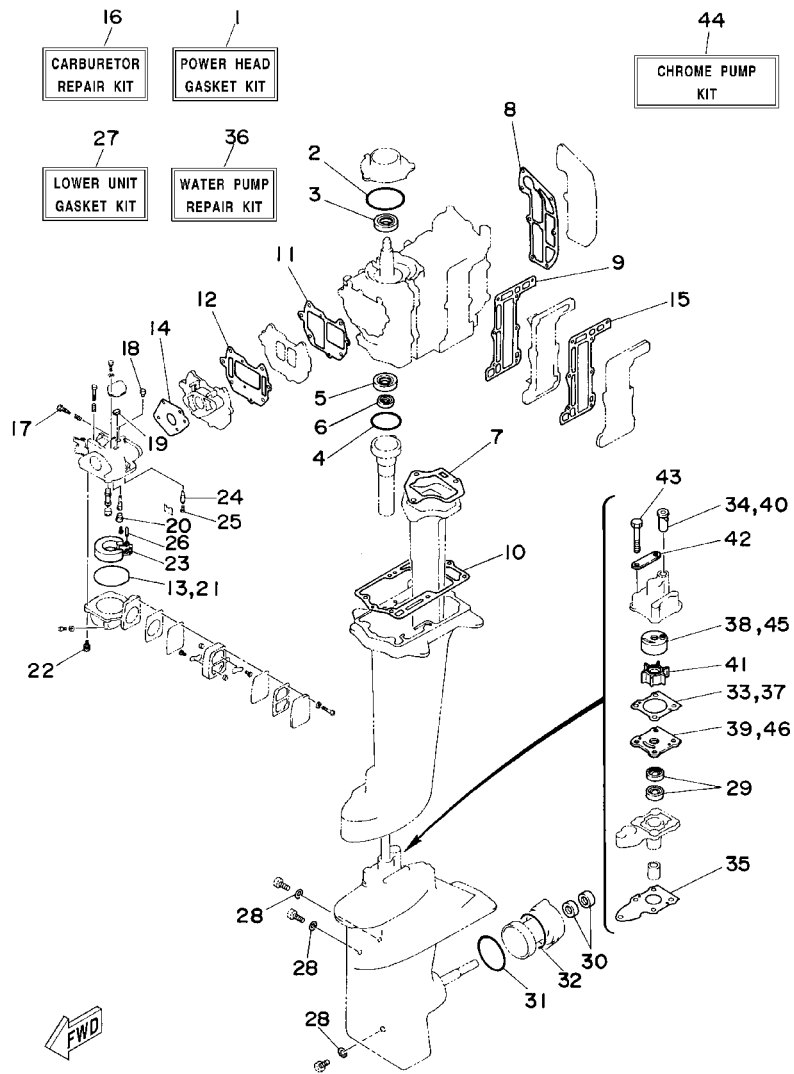

6M80010-7190

FIG. 19 REPAIR KIT

ESTUCHE REPARATION

REF. NO.	PART NO. CODIGO NO.	DESCRIPTION DESCRIPTION	8C	8C			REMARKS OBSERVACION
1	6N0-W0001-A0	POWER HEAD GASKET KIT JUEGO DE EMPAQUE	1	1			
2	93210-54M54	.O-RING .JUNTA TORICA	1	1			
3	93102-20M25	.OIL SEAL .RETEN DE ACEITE	1	1			
4	93210-42159	.O-RING .JUNTA TORICA	1	1			
5	93101-20M34	.OIL SEAL .RETEN DE ACEITE	1	1			
6	93101-12M26	.OIL SEAL .RETEN DE ACEITE	1	1			
7	6G1-41133-A0	.GASKET, EXHAUST MANIFOLD 1 .EMPAQUE ESCAPE MULTIPLE	1	1			
8	6G1-11193-A1	.GASKET, HEAD COVER 1 .EMPAQUE	1	1			
9	6G1-41112-A1	.GASKET, EXHAUST INNER COVER .EMPAQUE	1	1			
10	6G1-45113-A1	.GASKET, UPPER CASING .EMPAQUE	1	1			
11	6G1-13621-A1	.GASKET, VALVE SEAT .JUNTA, DE VALV.DE EMPAQUE	1	1			
12	6G1-13645-A1	.GASKET, MANIFOLD 1 .EMPAQUE	1	1			
13	6G1-14984-00	.O-RING .EMPAQUE CAMARA DE BOIA	1	1			
14	6G1-14198-A1	.GASKET .EMPAQUE	1	1			
15	6G1-41114-A0	.GASKET, EXHAUST OUTER COVER .EMPAQUE	1	1			
16	6N0-W0093-00	CARBURETOR REPAIR KIT KIT REPARACION CARBURADOR	1	1			
17	679-14923-00	.SCREW, PILOT .TORNILLO DE AJUSTE	1	1			
18	6G1-14966-00	.CAP .TAPA	1	1			
19	6G1-14126-00	.GASKET .EMPAQUE	1	1			
20	676-14966-00	.CAP .TAPA	1	1			
21	6G1-14984-00	.O-RING .EMPAQUE CAMARA DE BOIA	1	1			
22	97980-04114	.SCREW, WITH WASHER .TORNILLO, CON ARANDELA	4	4			
23	6G1-14985-00	.FLOAT .BOIA	1	1			
24	6G1-14546-01	.VALVE, NEEDLE .VALVULA DE AGUJA	1	1			
25	676-14186-00	.PIN, FLOAT .PASADOR DE LA BOYA	1	1			
26	688-14548-00	.PIN, FLOAT ARM .PASADOR DE BRAZO DE BOIA	1	1			
27	6N0-W0001-C0	LOWER UNIT GASKET KIT JUEGO DE JUNTA UNIDAD INFERIOR	1	1			

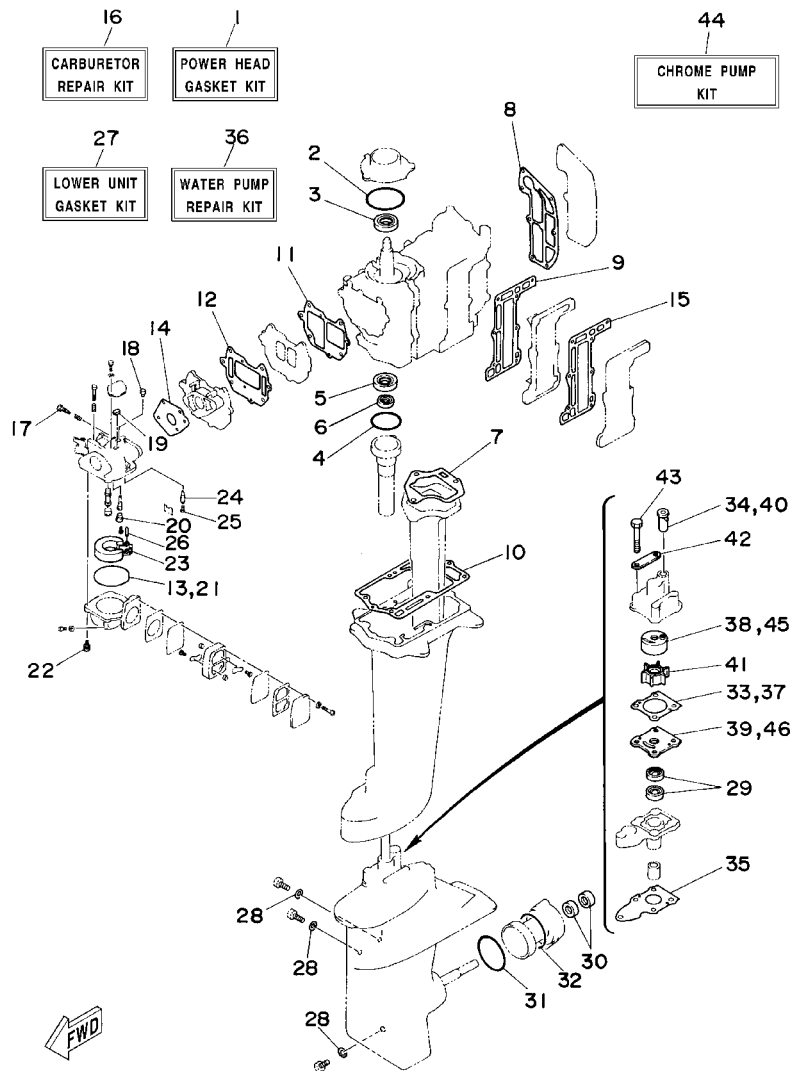

6M80010-7190

FIG. 19 REPAIR KIT

ESTUCHE REPARATION

REF. NO.	PART NO. CODIGO NO.	DESCRIPTION DESCRIPTION	8C	8C		REMARKS OBSERVACION
28	90430-08020	.GASKET .JUNTA	3	3		
29	93101-11M23	.OIL SEAL .RETEN DE ACEITE	2	2		
30	93101-15074	.OIL SEAL .RETEN DE ACEITE	2	2		
31	93210-49046	.O-RING .JUNTA TORICA	1	1		
32	93210-53M08	.O-RING .JUNTA TORICA	1	1		
33	6G1-44315-A0	.GASKET, WATER PUMP .EMPAQUE	1	1		
34	647-44366-00	.DAMPER, WATER SEAL .GOMA DEL SELLO DE AGUA	1	1		
35	6G1-45315-A0	.PACKING, LOWER CASING .EMPAQUE	1	1		
36	6N0-W0078-A0	WATER PUMP REPAIR KIT ESTUCHE REPARACION BOMBA AGUA	1	1		
37	6G1-44315-A0	.GASKET, WATER PUMP .EMPAQUE	1	1		
38	6G1-44322-00	.INSERT, CARTRIDGE .CARTUCHO	1	1		
39	6G1-44323-00	.OUTER PLATE, CARTRIDGE .PLACA EXTERIOR DEL CARTUCHO	1	1		
40	647-44366-00	.DAMPER, WATER SEAL .GOMA DEL SELLO DE AGUA	1	1		
41	6G1-44352-00	.IMPELLER .IMPULSOR	1	1		
42	6G1-44328-00	.PLATE .PLACA	2	2		
43	97095-06045	.BOLT .PERNO	4	4		
44	6N0-W0078-0A	CHROME PUMP KIT ESTUCHE REPARACION BOMBA AGUA	1	1		
45	6G1-44322-40	.INSERT, CARTRIDGE .CARTUCHO	1	1		
46	6G1-44323-40	.OUTER PLATE, CARTRIDGE .PLACA EXTERIOR DEL CARTUCHO	1	1		

NUMERICAL INDEX
INDICE NUMERICO

PART NO. CODIGO NO.	REF. NO.	PART NO. CODIGO NO.	REF. NO.	PART NO. CODIGO NO.	REF. NO.	PART NO. CODIGO NO.	REF. NO.	PART NO. CODIGO NO.	REF. NO.	PART NO. CODIGO NO.	REF. NO.
6N0-E1191-00-9M	2 - 18	6N0-G2613-00-4D	1 - 2	6N0-G5560-00	15 - 42	6G1-14947-00	5 - 15	6G1-24432-00	5 - 30	6E7-42791-10	10 - 25
6N0-E1400-00	3 - 1	6N0-G2651-00	1 - 8	6N0-G5571-00	15 - 44	6H6-14947-00	5 - 15	6G1-24452-00	5 - 29	6E0-42816-00	10 - 4
6N0-E1412-00	3 - 2	6M8-G2677-20	1 - 11	6N0-G5987-00	16 - 9	6G1-14948-05	5 - 7	6G1-24471-00	5 - 31	6A1-43113-01	13 - 14
6N0-E1422-00	3 - 3	6N0-G2677-20	1 - 11	6N0-G5987-10	16 - 9	6G1-14948-06	5 - 7	6YJ-24610-00	18 - 2	6Z0-43114-00	13 - 5
6N0-E1432-00	3 - 4	6M8-G2678-11	1 - 12	68D-H257H-00	10 - 27	6G1-14966-00	5 - 4	6G1-26326-00	10 - 17	689-43191-00	13 - 9
6N0-E1442-00	3 - 5	6N0-G2678-11	1 - 12	6N0-WE090-01-4D	2 - 1		19 - 18	6G1-2811G-00	6 - 10	689-43192-01	13 - 10
6N0-E1515-00	3 - 11	6N0-G2711-00-4D	10 - 1	6N0-WG070-10	1 - 10	676-14966-00	5 - 8	6G1-41112-A1	2 - 22	6G1-43318-01	13 - 40
6N0-E1603-00	3 - 16	6N0-G2716-00	10 - 21	6N0-W0001-A0	19 - 1		19 - 20		19 - 9	6G1-43373-00	13 - 29
6N0-E1631-00-98	3 - 15	6N0-G2719-00	10 - 8	6N0-W0001-C0	19 - 27	6G1-14980-01	5 - 14	6G1-41113-01-9M	2 - 23	6G1-43615-01	13 - 38
6N0-E1633-00	3 - 18	6N0-G2719-80	10 - 8	6G1-W0004-00	4 - 2	6G1-14984-00	5 - 13	6G1-41114-A0	2 - 25	6G1-43659-00	13 - 36
6N0-E1651-00	3 - 10	6N0-G2731-00	13 - 44	6N0-W0078-A0	19 - 36		19 - 13		19 - 15	6G1-43681-00	13 - 39
6N0-E3641-00-94	4 - 4	6N0-G2767-00	10 - 9	6N0-W0078-OA	19 - 44		19 - 21	6G1-41133-A0	14 - 2	6G1-44116-01	12 - 21
6M8-E4417-00	4 - 8	6N0-G2815-00-4D	10 - 2	6N0-W0093-00	19 - 16	6G1-14985-00	5 - 20		19 - 7	6G1-44121-02-94	12 - 18
6M8-E4418-00	4 - 9	6M8-G3111-02-4D	13 - 1	6G1-W4591-01-EL	16 - 14		19 - 23	6G1-41211-00	12 - 12	6G1-44125-80	7 - 32
6N0-E5100-00-94	2 - 2	6M8-G3112-01-4D	13 - 4	6G1-W4592-00-EL	16 - 14	6G1-14992-00	5 - 19	6E9-41237-00	12 - 11	6G1-44147-00	15 - 3
6M8-E5710-03	7 - 1	6N0-G3116-00	13 - 6	6G1-11193-A1	2 - 19	6G1-15359-01-94	2 - 8	662-41237-01	12 - 10	655-44147-00	14 - 8
6N0-E5711-80-94	7 - 2	6L8-G3118-01	13 - 7		19 - 8	6G1-15396-02-5B	2 - 12	6G1-41238-00	12 - 9	6E0-44191-11	1 - 13
6M8-E5714-00	7 - 3	6N0-G3136-00	13 - 13	6G1-11681-00	3 - 6	6G1-15705-00	7 - 10	6G1-41256-00	4 - 12	6G1-44194-00	9 - 8
6N0-E5723-00-94	7 - 19	6N0-G3160-00	13 - 20	6E5-12411-01	2 - 7	6G1-15717-00	7 - 5	661-41262-02	4 - 14	6G1-44315-A0	15 - 29
6N0-E5758-00	7 - 14	6N0-G3165-00	13 - 22	6N0-13610-01	4 - 1	677-15741-01	7 - 17		12 - 13		19 - 33
6N0-E5770-80	7 - 28	6N0-G3311-10-4D	13 - 24	6G1-13621-A1	4 - 3	6G1-15746-10	7 - 25	6G1-41271-00	4 - 13		19 - 37
6N0-E5771-00-94	7 - 21	6N0-G3614-00	13 - 35		19 - 11	6G1-15746-81	7 - 25	6G1-41283-01	12 - 3	6G1-44322-00	15 - 30
6N0-E5772-00-94	7 - 22	6N0-G4110-00	12 - 24	6G1-13645-A1	4 - 5	6G1-15747-80	7 - 35	6G1-41612-00	9 - 2		19 - 38
6M4-F4201-00	18 - 1	6N0-G4111-00	12 - 14		19 - 12	656-15748-00	7 - 30	6G1-41615-00	9 - 6	6G1-44322-40	15 - 30
6YL-F4201-02	17 - 1	6N0-G4145-00	12 - 27	6G1-14126-00	5 - 6	6G1-15755-00	7 - 12	6G1-41631-00	12 - 1		19 - 45
6YL-F4260-01	17 - 4	6N0-G4145-10	12 - 27		19 - 19	6G1-15761-00	1 - 5	6G1-41638-00	12 - 2	6G1-44323-00	15 - 31
6YL-F4268-01	17 - 7	6N0-G4146-00	12 - 28	663-14159-00	5 - 23	6G1-15762-00	7 - 15	6G1-41661-00	12 - 4		19 - 39
6YL-F4329-00	17 - 6	6N0-G4146-10	12 - 28	676-14186-00	5 - 22	6G1-15764-00	7 - 26	6G1-41662-01-94	12 - 19	6G1-44323-40	15 - 31
6YL-F4610-00	17 - 2	6N0-G4150-00	15 - 2		19 - 25	6G1-15774-81	7 - 29	6G1-42125-01	11 - 8		19 - 46
6YL-F4641-00	17 - 3	6N0-G4150-10	15 - 2	6G1-14198-A1	4 - 6	6G1-15779-00	7 - 13	6G1-42131-01	11 - 6	6G1-44328-00	15 - 35
6N0-F6301-00	11 - 22	6N0-G4311-00	15 - 28		19 - 14	6YJ-24167-00	18 - 7	6G1-42137-10	11 - 13		19 - 42
6N0-F8100-00	6 - 8	6N0-G4361-00	16 - 7	6G1-14301-01	5 - 1	6YJ-24201-10	18 - 1	6E0-42159-02	11 - 20	6G1-44352-00	15 - 33
6N0-F8170-00	6 - 9	6N0-G4361-10	16 - 7	6H6-14301-01	5 - 1	646-24251-02	6 - 4	6G1-42528-00	13 - 26		19 - 41
6N0-F8176-00	10 - 26	6N0-G4514-00	13 - 49	6N0-14301-10	5 - 1	6YJ-24260-00	18 - 3	6G1-42528-10	13 - 26	6G1-44365-00	16 - 8
6L8-F8193-00	6 - 13	6N0-G4551-00-4D	13 - 57	65W-14398-00	5 - 18	6Y1-24260-12	18 - 3	6G1-42529-00	13 - 30	647-44366-00	15 - 32
6N0-G1111-00-9M	2 - 21	6N0-G4552-00-4D	13 - 58	6G1-14497-80	12 - 7	6Y1-24268-00	18 - 6	6G1-42535-00	13 - 53		19 - 34
6M8-G1131-00-5B	14 - 1	6N0-G4555-A0	13 - 59	63V-14523-00	5 - 12	6G1-24304-02	6 - 1	6G1-42537-00	13 - 54		19 - 40
6N0-G1131-00-5B	14 - 1	6N0-G4557-A0	13 - 60	6G1-14527-00	5 - 5	6G1-24305-03	18 - 13	6G1-42537-10	13 - 54	6G1-44511-00-4D	13 - 48
6N0-G1611-00	9 - 1	6N0-G5111-00-4D	14 - 5	6G1-14546-01	5 - 21	6Y1-24305-04	18 - 15	6G1-42538-01	13 - 55	6G1-44516-00	13 - 50
6N0-G1613-00	9 - 3	6N0-G5111-10-4D	14 - 5		19 - 24	6YL-24306-52	17 - 8	6G1-42551-00	13 - 52	6G1-44532-01	13 - 32
6M8-G2111-10-4D	11 - 1	6N0-G5251-00	15 - 8	62D-14546-01	5 - 21	61J-24306-02	18 - 8	6G1-42615-00	1 - 6	6G1-45113-A1	2 - 26
6M4-G2119-00	11 - 11	6M8-G5300-00-4D	15 - 1	688-14548-00	5 - 25	6Y1-24329-00	18 - 5	6G1-42647-00	1 - 7		19 - 10
6N0-G2126-00	11 - 9	6M8-G5300-10-4D	15 - 1		19 - 26	650-24351-51	18 - 12	6G1-42724-00	10 - 12	6G1-45135-00	14 - 10
69M-G2138-00	11 - 19	6N0-G5311-00-4D	15 - 4	679-14555-00	5 - 3	61J-24360-00	18 - 10	6G1-42725-00	10 - 13	6G1-45214-00	16 - 3
6N0-G2177-00	11 - 12	6N0-G5361-00-4D	15 - 20	679-14923-00	5 - 2	6G1-24411-00	5 - 33	6G1-42726-00	10 - 14	6G1-45215-00	16 - 4
6M8-G2511-00-4D	13 - 47	6N0-G5511-00	15 - 36		19 - 17	6G1-24412-01	5 - 32	6G1-42727-00	10 - 15	6G1-45315-A0	15 - 19
6M8-G2610-30-4D	1 - 1	6N0-G5511-10	15 - 36	6G1-14943-79	5 - 16	6G1-24421-00	5 - 35	6G1-42748-00	10 - 16		19 - 35
6N0-G2610-30-4D	1 - 1	6N0-G5551-00	15 - 40	676-14943-26	5 - 16	6G1-24431-01	5 - 34	6E7-42791-00	10 - 25	6G1-45316-09	15 - 14

NUMERICAL INDEX
INDICE NUMERICO

PART NO. CODIGO NO.	REF. NO.	PART NO. CODIGO NO.	REF. NO.	PART NO. CODIGO NO.	REF. NO.	PART NO. CODIGO NO.	REF. NO.	PART NO. CODIGO NO.	REF. NO.	PART NO. CODIGO NO.	REF. NO.
6G1-45317-09	15-5	90105-06M24	2-24	90480-15M31	10-18	93101-15074	19-30	95895-06030	16-2		
6G1-45331-01-5B	15-13	90105-06M25	2-5	90480-20M29	14-9	93101-20M34	2-14	95895-06035	13-51		
6G1-45362-09	15-21	90105-06M26	2-4	90501-10227	7-31		19-5		13-61		
6G1-45533-00-19	15-41	90105-06M29	7-20	90501-10326	5-11	93102-20M25	2-10	95895-06085	4-7		
6G1-45533-00-20	15-41	90109-06M17	12-29	90501-12M38	15-50		19-3	97013-06016	2-11		
6G1-45533-00-21	15-41	90149-05M02	10-10	90501-18M00	13-27	93210-08287	18-14	97013-06035	7-6		
6G1-45533-00-22	15-41	90149-05M13	11-17	90501-23215	11-15		18-16	97075-06020	7-23		
647-45567-00	15-46	90152-05M03	16-5	90502-10M06	13-23	93210-12327	12-15	97095-06010	13-33		
664-45587-01-10	15-43	90157-05811	17-5	90508-10M15	13-41	93210-30M31	13-56	97095-06012	6-11		
664-45587-01-12	15-43	90170-10113	8-18	90508-10M16	13-42	93210-42159	2-13		12-22		
664-45587-01-15	15-43	90171-10M01	16-11	90508-14M17	13-43		19-4	97095-06016	1-3		
664-45587-01-18	15-43	90185-05002	16-6	90510-08M03	7-4	93210-49046	15-24		2-16		
664-45587-01-30	15-43	90185-08057	13-15	91490-16010	11-10		19-31		15-9		
664-45587-01-40	15-43	90201-06M30	7-7	91490-30020	16-12	93210-53M08	15-25		15-26		
664-45587-01-50	15-43	90201-10M01	16-10	91609-20008	3-13		19-32	97095-06020	11-7		
6G1-45611-01	15-52	90201-10M02	16-16	91690-20010	12-25	93210-54M54	2-9		14-3		
6G1-45616-01	16-15	90201-10126	8-19	91690-30008	13-21		19-2	97095-06025	6-2		
6G1-45631-00	15-47	90201-15M89	15-45	91690-30016	13-11	93306-004U0	15-22	97095-06030	15-16		
6G1-45632-00	15-48	90201-41303	3-14	92902-04100	8-14	93306-204U0	3-7	97095-06045	15-34		
654-45633-00	15-49	90202-36M55	11-3	92902-05100	8-8	93310-112V0	3-17		19-43		
6G1-45635-00	15-51	90206-12052	10-5		8-11	93310-418V1	3-8	97095-06135	13-17		
6G1-45941-00-EL	16-13	90206-36M21	11-2	92903-10600	11-16	93332-000U4	15-7	97095-08016	13-45		
6G1-45943-00-EL	16-13	90209-18112	3-9	92990-04100	5-10	93430-06M02	7-9	97095-08025	13-30		
6G1-45945-00-EL	16-13	90243-04M01	13-8	92990-05100	12-6	93440-47055	3-12	97780-50514	4-11		
6G1-45947-00-EL	16-13	90266-04M00	1-9	92990-05600	7-34	93450-13022	3-19	97802-04008	8-13		
6E7-81303-A0	8-6	90269-02M09	11-14		12-17	93604-08062	2-3	97802-05016	8-9		
6E5-82148-00	13-2	90280-03024	15-38		12-26		14-6	97802-05020	8-10		
6G1-82149-00	14-11	90280-04M06	8-17	92990-06300	15-10		15-18	97802-05025	8-7		
6G1-82370-21	9-12	90340-08002	15-11	92990-06600	13-18		16-1	97880-04010	5-9		
663-82370-01	9-12	90386-08032	11-18	92990-08600	13-28	93700-06M03	13-25	97880-05010	12-5		
682-82556-00	10-23	90386-12M45	10-3	92995-05600	9-5	94702-00217	2-27	97880-05016	7-33		
689-8257Y-00	10-24	90386-33M96	11-4	92995-06600	1-4	94702-00271	2-27		12-16		
6E9-82575-02	10-22	90386-34M97	11-5		2-17	95303-06600	7-8	97885-05010	9-4		
6G1-83557-00	9-16	90386-44M42	8-16		6-3	95380-03600	5-27	97885-05012	11-21		
6A1-83625-41	4-15	90387-06M13	13-16		6-12	95380-05700	10-11	97885-06008	13-3		
6E0-83627-41	11-23	90387-06M52	10-19		7-24	95380-06600	12-30		14-12		
6G1-85509-70	8-3	90387-06M70	4-10		12-23		13-19	97885-06030	10-6		
6G1-85515-70	8-15	90387-14M49	15-6		13-34	95380-06700	10-7	97980-04114	5-17		
6E7-85520-70	8-4	90387-22M50	2-6		14-4	95895-06010	9-7		19-22		
696-85540-11	9-13	90430-08020	15-12		15-17		9-15	97980-04125	5-28		
6G1-85548-70	8-12		19-28		15-27		12-8	98580-04008	5-24		
6G1-85550-71	8-1	90445-09220	6-6	92995-08600	13-31	95895-06016	7-16	98586-05016	18-4		
6G1-85560-F0	8-2	90445-09221	6-5		13-46	95895-06020	7-18	98980-03006	5-26		
6G1-85570-01	9-9	90445-11M05	18-11	93101-11M23	15-15		9-14	99001-06600	15-39		
6E7-85580-70	8-5	90445-11M06	18-9		19-29		10-20	99080-05600	13-37		
90101-08869	13-12	90465-08M17	9-11	93101-12M26	2-15	95895-06025	7-27				
90105-06M14	2-20	90467-08004	6-7		19-6		9-10				
	12-20	90467-09M05	15-37	93101-15074	15-23	95895-06030	14-7				

6CMH/8CMH
PARTS CATALOGUE
©2002 by Yamaha Motor Co., Ltd.
1st Edition, Sep. 2002
All rights reserved.
Any reprinting or unauthorized use
without the written permission of
Yamaha Motor Co., Ltd.
is expressly prohibited.
Printed in Japan

6CMH/8CMH
CATALOGO DE REPUESTOS
©2002, Yamaha Motor Co., Ltd.
1ª edición, Sept. 2002
Reservados todos los derechos.
Se prohíbe expresamente toda reimpresión
o utilización no autorizada de este manual
sin el consentimiento por escrito de
Yamaha Motor Co., Ltd.
Impreso en Japón