

**PARTS
CATALOGUE
CATALOGO
DE REPUESTOS**

6CMH'01 (6M80)

8CMH'01 (6N00)

FOREWORD

This Parts Catalogue is related to the parts for the model(s) in the below frame. When you are ordering replacement parts, please refer to this Parts Catalogue and quote both part numbers and part names correctly.

6CMH'01(6M80), 8CMH'01(6N00)

1. Modifications or additions which have been made after issue of the Parts Catalogue will be announced in the Yamaha Parts News.
It is advisable that you make necessary corrections to the Parts Catalogue according to the Yamaha Parts News.
2. Abbreviations
The Following abbreviations are used in this Parts Catalogue.
 "UR" Use specified parts number.
 "UN" Use as many as needed.
 "AP" Alternate Parts
 "LM" Local Made
 (Parts need to be ordered locally)
 "O/S" Over Size
3. Parts, which are to be supplied in an assembly, are listed with a dot(.) in front of the part name as shown below.
 EXAMPLE
 CARBURETOR ASSY
 .JET, PILOT
 .NOZZLE, MAIN
4. Number of component for assembly
 The numeral appearing to the right of each component part indicates the quantity of parts for each assembly unit.

EXAMPLE

PART NO.	DESCRIPTION	Q	U	R	T	E	R	E	M	REMARKS
6E0-85500-70	C.D.I. MAGNETO ASSY	1								
6E0-85550-70	.ROTOR ASSY	1								
6E0-15723-00-94.	.PULLY, STARTER	1								

5. Quantity Column Information

NAME for Q'TY COLUMN	APPLICABLE MODEL
6C	6CMH
8C	8CMH

6. Applicable Starting Serial No. and Color Code

1) Engine Starting Serial No.

6CMH S : 014614	8CMH S : 022728 L : 313592
--------------------	----------------------------------

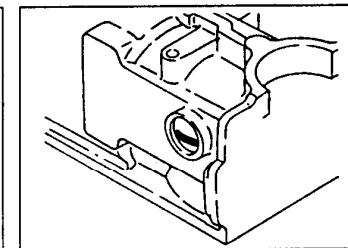
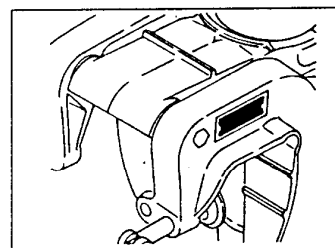

2) Color Code

Color Code	Color Name	Abbreviation
004D	DARK BLUISH GRAY METALLIC 2	DBNM2

7. Note that the illustrations for reference in finding parts numbers, not to be used for assembling. When assembling, please use the applicable service manual.
8. The asterisk (*) before a reference number indicates modification items after the first edition.

PROLOGO

Este Catálogo de Repuestos corresponde a las piezas para el(los) modelo(s) del recuadro siguiente. Al formular el pedido de repuestos, se ruega citar este Catálogo de Repuestos y especificar correctamente los números de parte y los nombres de parte.

6CMH'01(6M80), 8CMH'01(6N00)

1. Las modificaciones y agregados que se hayan realizado después de la edición de este Catálogo de Repuestos, serán anunciados en las Informaciones de Recambios Yamaha.

2. Abreviaciones
En este Catálogo de Repuestos se emplean las siguientes abreviaciones.

- "UR" Usar el número de partes especificado
- "UN" Usar la cantidad necesaria
- "AP" Piezas sustitutivas
- "LM" Fabricación local (Partes necesarias que se pedirán localmente)
- "F#" No. de bastidor aplicable

3. Las piezas suministradas como conjunto se describen con un punto (.) que precede al nombre de la pieza como se indica a continuación.

EJEMPLO

CONJUNTO CARBURADOR

.INYECTOR, piloto

.BOQUILLA, principal

4. Cantidad de componentes de un conjunto

La numeración que aparece a la derecha de cada descripción, indica la cantidad de piezas por cada unidad de conjunto.

EJEMPLO

PIEZAS NO.	DESCRIPTION	w	H			OBSERVACION
			H	H	H	
6E0-85500-70	C.D.I. MAGNETO ASSY	1				
6E0-85550-70	.ROTOR ASSY	1				
6E0-15723-00-94	.PULLY, STARTER	1				

5. Información para columna de Cantidad

NOMBRE PARA COLUMNA DE CANTI.	MODELO APLICABLE
6C	6CMH
8C	8CMH

6. Números de Serie y Códigos de color aplicables

1) No. de Serie del motor.

6CMH S : 014614	8CMH S : 022728 L : 313592
----------------------	------------------------------------

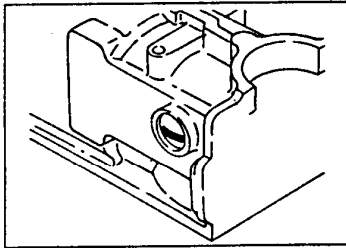
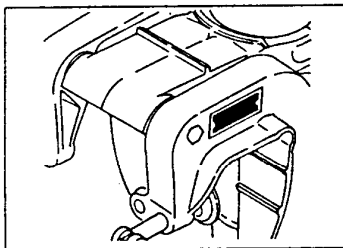

2) Código de color

Código de color	Nombre de color	Abreviación
004D	DARK BLUISH GRAY METALLIC 2	DBNM2

- 7. Debe tenerse en cuenta que las ilustraciones sirven como guía para la búsqueda de las referencias y no deben usarse para el montaje. Durante el montaje, se recomienda usar el manual de Taller correspondiente.
- 8. EL asterisco (*) antes del número de referencia indica los elementos modificados después de la primera edición.

CONTENTS

TOP COWLING	A4
CYLINDER. CRANKCASE	A5
CRANKSHAFT. PISTON	A7
INTAKE	B1
CARBURETOR	B2
FUEL	B4
STARTER	B5
GENERATOR	B7
ELECTRICAL	C1
BOTTOM COWLING	C2
STEERING	C3
CONTROL	C4
BRACKET	C6
UPPER CASING	D2
LOWER CASING. DRIVE 1	D3
LOWER CASING. DRIVE 2	D6
FUEL TANK 1	D7
FUEL TANK 2	E1
REPAIR KIT	E2
INDEX	
NUMERICAL INDEX	E4

CONTENIDO

SOPORTE SUPERIOR	A4
CYLINDRO. CARTER	A5
CIGUENAL. PISTON	A7
ADMISION	B1
CARBURADOR	B2
COMBUSTIBLE	B4
ARRANQUE	B5
GENERADOR	B7
EQUIPO ELECTRICO	C1
CUBIERTA INFERIOR	C2
DIRECCION	C3
CONTROL	C4
SOPORTE	C6
FUNDA SUPERIOR	D2
IMPULSOR E INFERIOR 1	D3
IMPULSOR E INFERIOR 2	D6
DEPOSITO DE COMBUSTIBLE 1	D7
DEPOSITO DE COMBUSTIBLE 2	E1
ESTUCHE REPARATION	E2
INDICE	
INDICE NUMERICO	E4

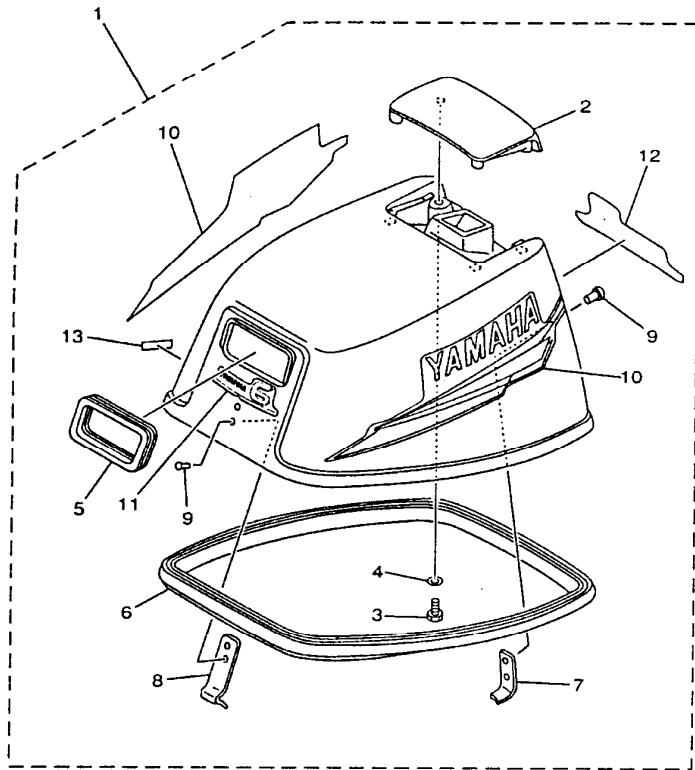
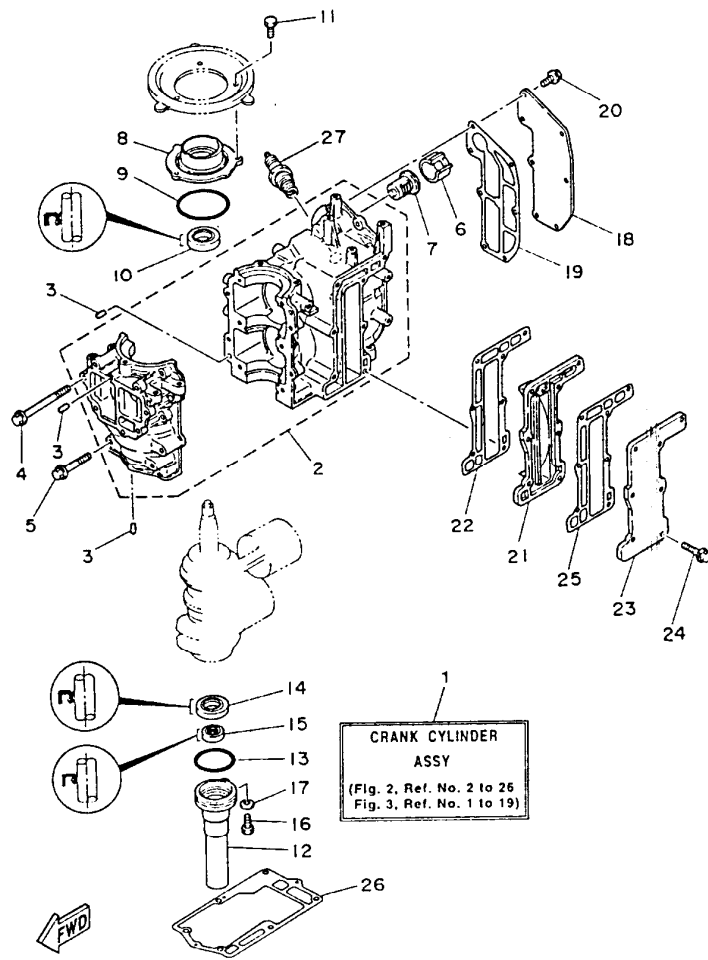

FIG. 1 TOP COWLING

SOPORTE SUPERIOR

REF. NO.	PART NO. CODIGO NO.	DESCRIPTION DESCRIPTION	Q	Q			REMARKS OBSERVACION
1	6M8-G2610-11-4D	TOP COWLING ASSY SOPORTE SUPERIOR COMPL.	1				
	6N0-G2610-11-4D	TOP COWLING ASSY SOPORTE SUPERIOR COMPL.		1			
2	6N0-G2613-00-4D	.MOLDING, AIR DUCT .MOLDURA CONDUCTO AIRE	1	1			
3	97095-06016	.BOLT .PERNO	4	4			
4	92995-06600	.WASHER .ARANDELA	4	4			
5	6G1-15761-00	.SEAL, RUBBER 1 .SELLO DE GOMA 1	1	1			
6	6N0-G2615-00	.SEAL .SELLO	1	1			
7	6G1-42647-00	.HOLDER, CLAMP BAND .MORDAZA DE ABRAZADERA	1	1			
8	6N0-G2651-00	.HOOK .GANCHO	1	1			
9	90266-04M00	.RIVET .REMACHE	4	4			
10	6G1-W0070-14	.GRAPHIC SET JUEGO DE EMBLEMA	1	1			
11	6M8-G2677-11	.GRAPHIC, FRONT .CALCAMONIA FRONTAL	1				
	6N0-G2677-11	.GRAPHIC, FRONT .CALCAMONIA FRONTAL		1			
12	6M8-G2678-11	.GRAPHIC, REAR .CALCAMONIA TRASERA	1				
	6N0-G2678-11	.GRAPHIC, REAR .CALCAMONIA TRASERA		1			
13	6E0-44191-11	.INDICATOR, SHIFT .INDICADOR DE CAMBIOS	1	1			

FWD
6M80010-0010



6M80100-7020

FIG. 2 CYLINDER. CRANKCASE CYLINDRO. CARTER

REF. NO.	PART NO. CODIGO NO.	DESCRIPTION	QTY	QTY	REMARKS OBSERVACION
1	6N0-W0090-00-4D	CRANK CYLINDER ASSY BLOQUE MOTOR COMPLETO	1	1	
2	6N0-E5100-00-94	CRANKCASE ASSY CARTER COMPLETO	1	1	
3	93604-08062	PIN, DOWEL PASADOR DE CLAVIJA	4	4	
4	90105-06M26	BOLT, WASHER BASED TORNILLO CON ARANDELA	6	6	
5	90105-06M25	BOLT, WASHER BASED TORNILLO CON ARANDELA	4	4	
6	90387-22M50	COLLAR CASQUILLO CON VALONA	1	1	
7	6E5-12411-01	THERMOSTAT TERMOSTAT	1	1	
8	6G1-15359-01-94	HOUSING, OIL SEAL CAJA DE SELLO DE ACEITE	1	1	
9	93210-54M54	O-RING ANILLO O	1	1	
10	93102-20M25	OIL SEAL SELLO ACEITE	1	1	
11	97013-06016	BOLT PERNO	3	3	
12	6G1-15396-02-5B	HOUSING, OIL SEAL CAJA DE SELLO DE ACEITE	1	1	
13	93210-42159	O-RING ANILLO O	1	1	
14	93101-20M34	OIL SEAL SELLO ACEITE	1	1	
15	93101-12M26	OIL SEAL SELLO ACEITE	1	1	
16	97095-06016	BOLT PERNO	1	1	
17	92995-06600	WASHER ARANDELA	1	1	
18	6N0-E1191-00-9M	COVER, CYLINDER HEAD 1 TAPA CULATA DE CILINDRO 1	1	1	
19	6G1-11193-A1	GASKET, HEAD COVER 1 EMPAQUE	1	1	
20	90105-06M14	BOLT FLANGE TORNILLO CON ARANDELA	7	7	
21	6N0-G1111-00-9M	INNER COVER, EXHAUST CUBIERTA INTERIOR DE ESCAPE	1	1	
22	6G1-41112-A1	GASKET, EXHAUST INNER COVER EMPAQUE	1	1	
23	6G1-41113-01-9M	OUTER COVER, EXHAUST CUBOERTA EXTERIOR DE ESCAPE	1	1	
24	90105-06M24	BOLT, WASHER BASED TORNILLO CON ARANDELA	7	7	
25	6G1-41114-A0	GASKET, EXHAUST OUTER COVER EMPAQUE	1	1	
26	6G1-45113-A1	GASKET, UPPER CASING EMPAQUE	1	1	
27	94702-00217	PLUG, SPARK (NGK B7HS-10) BUJIA (NGK B7HS-10)	2	2	

FIG. 2 CYLINDER, CRANKCASE CYLINDRO. CARTER

REF. NO.	PART NO. CODIGO NO.	DESCRIPTION DESCRIPTION	Q	Q		REMARKS OBSERVACION
27	94702-00271	PLUG, SPARK (NGK BR7HS-10) BUJIA (NGK BR7HS-10)		2		FOR CARIB

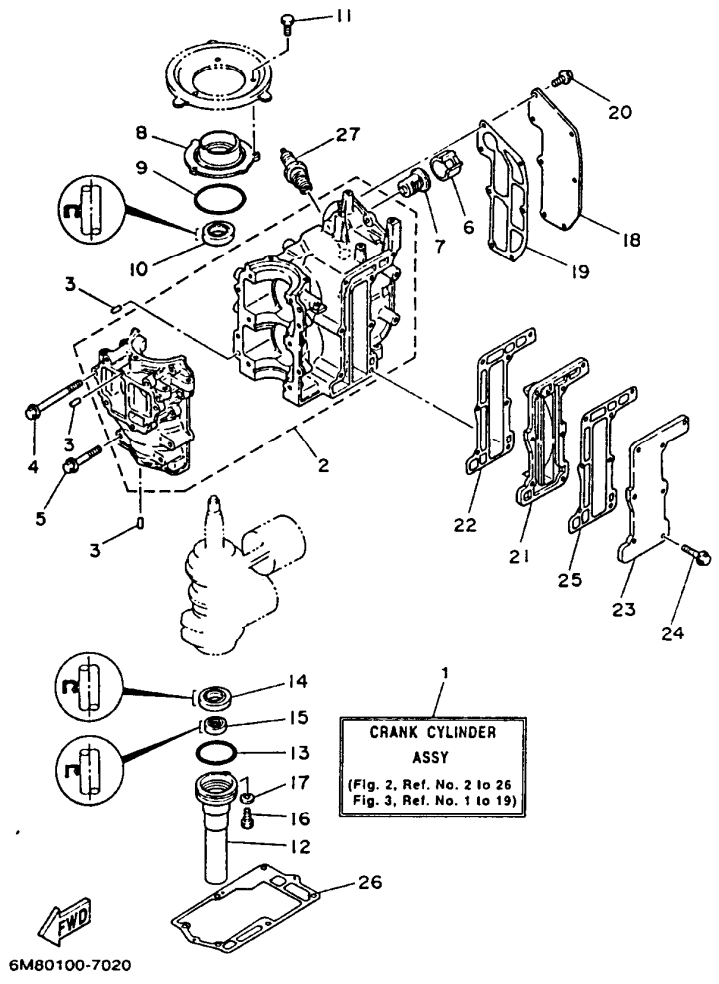

6M80100-7020

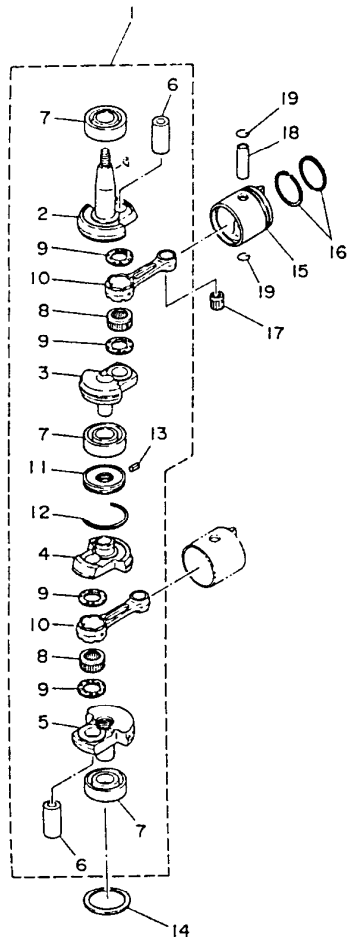

FIG. 3 CRANKSHAFT. PISTON CIGUENAL. PISTON

REF. NO.	PART NO. CODIGO NO.	DESCRIPTION	Q	Q	REMARKS OBSERVACION
1	6N0-E1400-00	CRANKSHAFT ASSY CIGUENAL COMPLETO	1	1	
2	6N0-E1412-00	.CRANK 1 .MANIVELA 1	1	1	
3	6N0-E1422-00	.CRANK 2 .MANIVELA 2	1	1	
4	6N0-E1432-00	.CRANK 3 .MANIVELA 3	1	1	
5	6N0-E1442-00	.CRANK 4 .MANIVELA 4	1	1	
6	6G1-11681-00	.PIN, CRANK 1 .PASADOR MANIVELA 1	2	2	
7	93306-204U0	.BEARING .COJINETE	3	3	
8	93310-418V1	.BEARING .COJINETE	2	2	
9	90209-18112	.WASHER .ARANDELA DE SEPARACION	4	4	
10	6N0-E1651-00	.ROD, CONNECTING .BIELA	2	2	
11	6N0-E1515-00	.SEAL, LABYRINTH 1 .SELLO LABERINTO 1	1	1	
12	93440-47055	.CIRCLIP .BOLA	1	1	
13	91609-20008	.PIN, SPRING .PASADOR DE RESORTE	1	1	
14	90201-41303	.WASHER, PLATE .ARANDELA PLANA	1	1	
15	6G1-11631-00-98	PISTON (STD) PISTON(STD)	2	2	
16	6G1-11603-00	PISTON RING SET (STD) JUEGO DE ANILLOS (STD)	2	2	
17	93310-112V0	BEARING COJINETE	2	2	
18	6G1-11633-00	PIN, PISTON PASADOR, PISTON	2	2	
19	93450-13022	CIRCLIP BOLA	4	4	

FWD
6M80010-4030

FIG. 4 INTAKE

ADMISION

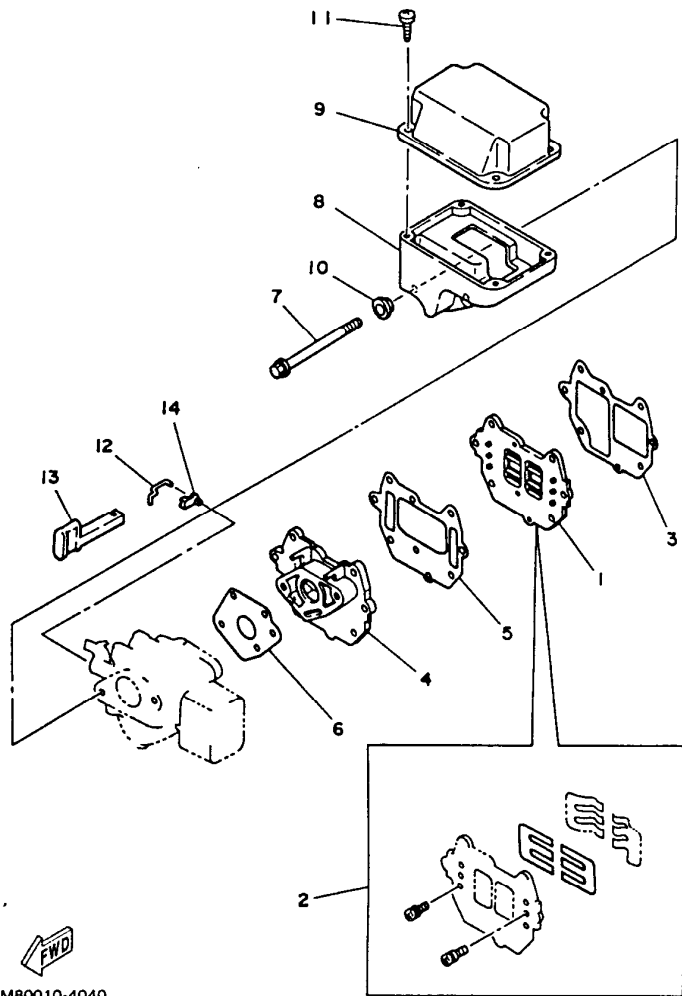

6M80010-4040

REF. NO.	PART NO. CODIGO NO.	DESCRIPTION DESCRIPTION	Q	Q	REMARKS OBSERVACION
1	6G1-13610-01	REED VALVE ASSY VALVULA DE LAMINAS COMPLETA	1	1	
2	6G1-W0004-00	.REED SET .JUEGO DE VALVULAS DE LENGUETA	1	1	
3	6G1-13621-A1	GASKET, VALVE SEAT JUNTA, DE VALV.DE EMPAQUE	1	1	
4	6N0-E3641-00-94	MANIFOLD 1 MULTIPLE 1	1	1	
5	6G1-13645-A1	GASKET, MANIFOLD 1 EMPAQUE	1	1	
6	6G1-14198-A1	GASKET EMPAQUE	1	1	
7	95895-06085	BOLT, FLANGE TUERCA DE REBORDE	2	2	
8	6M8-E4417-00	COVER 1 CUBIERTA 1	1	1	
9	6M8-E4418-00	COVER 2 CUBIERTA 2	1	1	
10	90387-06M70	COLLAR	2	2	
11	97780-50514	CASQUILLO CON VALONA SCREW, TAPPING TORNILLO ROSCA HEMBRA	4	4	
12	6G1-41256-00	ROD, CHOKE 1 VARILLA DE AHOGADOR	1	1	
13	6G1-41271-00	KNOB, CHOKE PERILLA AHOGADOR	1	1	
14	661-41262-02	JOINT, CHOKE LEVER CONECTOR DE AHOGADOR	1	1	

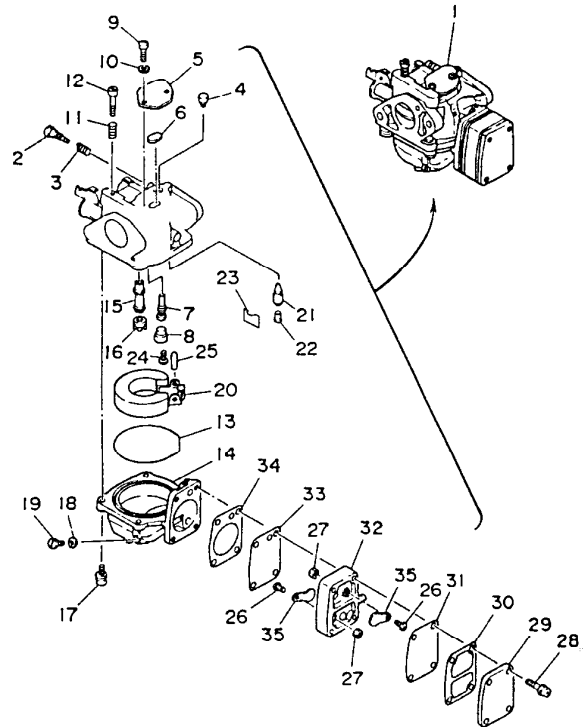

 6M80010-4050

FIG. 5 CARBURETOR

CARBURADOR

REF. NO.	PART NO. CODIGO NO.	DESCRIPTION DESCRIPTION	QU	QU	REMARKS OBSERVACION
1	6H6-14301-01	CARBURETOR ASSY 1 CARBURADOR COMPLETO 1	1		
	6G1-14301-01	CARBURETOR ASSY 1 CARBURADOR COMPLETO 1		1	FOR CARIB
	6N0-14301-10	CARBURETOR ASSY 1 CARBURADOR COMPLETO 1		1	FOR BRAZIL
2	679-14923-00	.SCREW, PILOT .TORNILLO DE AJUSTE	1	1	
3	679-14555-00	.SPRING .RESORTE	1	1	
4	6G1-14966-00	.CAP .TAPA	1	1	
5	6G1-14527-00	.PLATE .PLACA	1	1	
6	6G1-14126-00	.GASKET .EMPAQUE	1	1	
7	6G1-14948-05	.JET (#45) .INYEKTOR (#45)	1	1	
	6N0-14948-06	.JET (#48) .INYEKTOR (#48)		1	FOR 6N0-14301-10
8	676-14966-00	.CAP .TAPA	1	1	
9	97880-04010	.SCREW, PAN HEAD .TORNILLO DE CABEZA CON PLANA	2	2	
10	92990-04100	.WASHER, SPRING .ARANDELA	2	2	
11	90501-10326	.SPRING, COMPRESSION .RESORTE DE COMPRESION	1	1	
12	63V-14523-00	.SCREW, STOP .TORNILLO DE TOPE	1	1	
13	6G1-14984-00	.O-RING .EMPAQUE CAMARA DE BOIA	1	1	
14	6G1-14980-01	.BODY, FLOAT CHAMBER .CUERPO CAMARA DE BOIA	1	1	
15	6H6-14947-00	.JET, NEEDLE .INYEKTOR DE AGUJA	1		
	6G1-14947-00	.JET, NEEDLE .INYEKTOR DE AGUJA		1	
16	676-14943-26	.JET, MAIN (#98) .INYEKTOR PRINCIPAL (#98)	1	1	
	6N0-14943-79	.JET, MAIN (#108) .INYEKTOR PRINCIPAL (#108)		1	FOR 6N0-14301-10
17	97980-04114	.SCREW, WITH WASHER .TORNILLO, CON ARANDELA	4	4	
18	6G1-14398-00	.WASHER .EMPAQUE	1	1	
19	6G1-14992-00	.SCREW, DRAIN .TORNILLO, SEGURO	1	1	
20	6G1-14985-00	.FLOAT .BOIA	1	1	
21	6G1-14546-00	.VALVE, NEEDLE .VALVULA DE AGUJA	1	1	
	620-14546-00	.VALVE, NEEDLE .VALVULA DE AGUJA		1	FOR 6N0-14301-10

B2

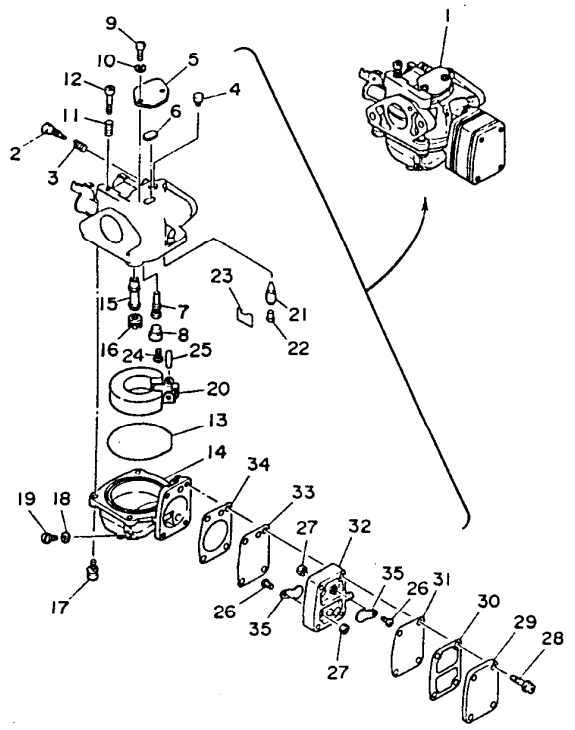
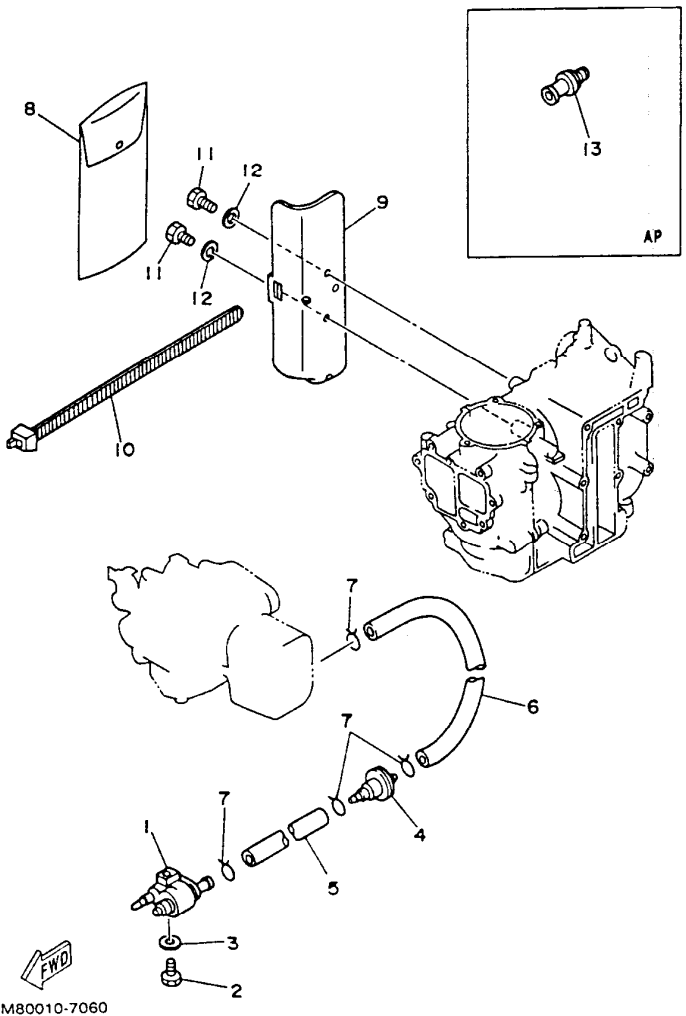

FIG. 5 CARBURETOR CARBURADOR

REF. NO.	PART NO. CODIGO NO.	DESCRIPTION DESCRIPTION	6C	8C	REMARKS OBSERVACION
22	676-14186-00	.PIN, FLOAT .PASADOR DE LA BOYA	1	1	
23	663-14159-00	.CLIP .PRESILLA	1	1	
24	98580-04008	.SCREW, PAN HEAD .TORNILLO DE CABEZA CON PLANA	1	1	
25	688-14548-00	.PIN, FLOAT ARM .PASADOR DE BRAZO DE BOIA	1	1	
26	98580-03006	.SCREW, PAN HEAD .TORNILLO DE CABEZA CON PLANA	2	2	
27	95380-03600	.NUT .TUERCA	2	2	
28	97980-04125	.SCREW, WITH WASHER .TORNILLO, CON ARANDELA	4	4	
29	6G1-24452-00	.COVER .CUBIERTA	1	1	
30	6G1-24432-00	.GASKET, FUEL PUMP 2 .EMPAQUE BOMBA COMBUSTIBLE	1	1	
31	6G1-24471-00	.DIAPHRAGM .DIAFRAGMA	1	1	
32	6G1-24412-01	.BODY 1 .CUERPO 1	1	1	
33	6G1-24411-00	.DIAPHRAGM .DIAFRAGMA	1	1	
34	6G1-24431-01	.GASKET, FUEL PUMP 1 .EMPAQUE BOMBA COMBUST 1	1	1	
35	6G1-24421-00	.VALVE, CHECK .VALVULA DE RETENCION	2	2	

FWD
6M80010-4050



6M80010-7060

FIG. 6 FUEL COMBUSTIBLE

REF. NO.	PART NO. CODIGO NO.	DESCRIPTION DESCRIPTION	QUANTITY	UNIT	REMARKS OBSERVACION
1	6G1-24304-02	FUEL PIPE JOINT COMP. 1 CONECTOR MANGUERA COMBUST.1	1	1	
2	97095-06025	BOLT PERNO	1	1	
3	92995-06600	WASHER ARANDELA	1	1	
4	646-24251-02	STRAINER 1 COLADOR 1	1	1	
5	90445-09221	HOSE (L205) TUBO (L205)	1	1	
6	90445-09220	HOSE TUBO	1	1	
7	90467-08004	CLIP PRESILLA	4	4	
8	6N0-F8100-00	TOOL KIT JUEGO DE HERRAMIENTAS	1	1	
9	6N0-F8170-00	TOOL, HOLDER HERRAMIENTA	1	1	
10	6G1-2811G-00	BAND BANDA	1	1	
11	97095-06012	BOLT PERNO	2	2	
12	92995-06600	WASHER ARANDELA	2	2	
13	6L8-F8193-00	PLUG, WATER CHECK TAPON DE CONTROL DE LA AGUA	1	1	AP

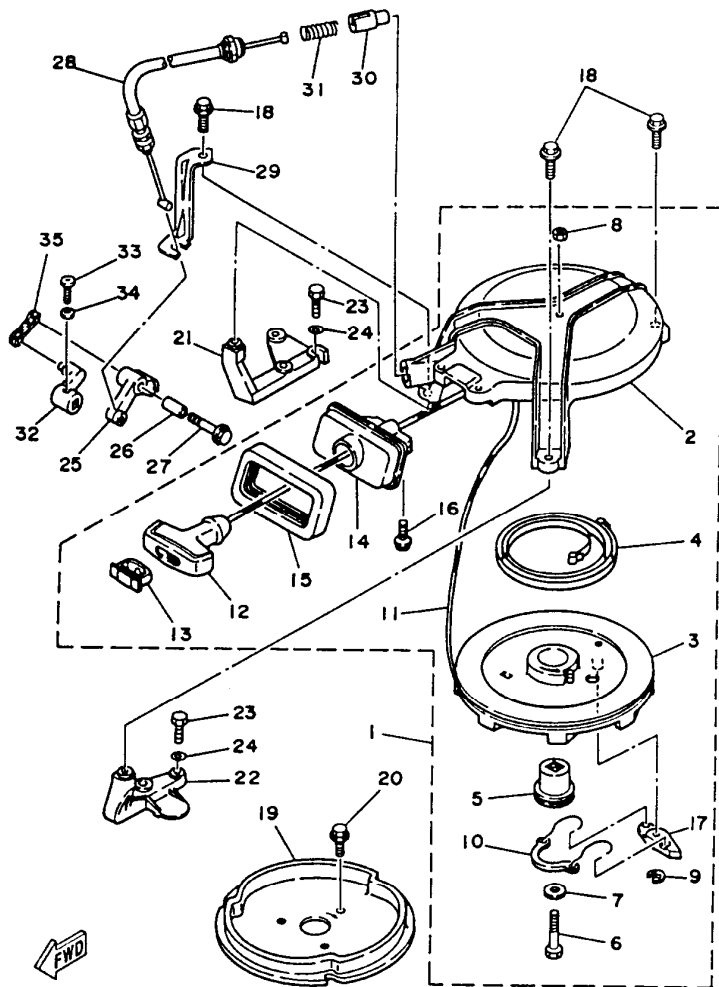

6M80010-7070

FIG. 7 STARTER

ARRANQUE

REF. NO.	PART NO. CODIGO NO.	DESCRIPTION DESCRIPTION	Q	Q	REMARKS OBSERVACION
1	6N0-E5710-00	STARTER ASSY ARRANQUE COMPLETO	1	1	
	6M8-E5710-03	STARTER ASSY ARRANQUE COMPLETO		1	FOR CARIB
2	6N0-E5711-00-94	.CASE, STARTER .CAJA DE ARRANQUE	1	1	
	6N0-E5711-80-94	.CASE, STARTER .CAJA DE ARRANQUE		1	FOR 6M8-E5710-03
3	6M8-E5714-00	.DRUM, SHEAVE .TAMBOR ROLDANA	1	1	
4	90510-08800	.SPRING, SPIRAL .RESORTE EN ESPIRAL	1	1	
5	6G1-15717-00	.SHAFT, STARTER .EJE DE ARRANQUE	1	1	
6	97013-06035	.BOLT .PERNO	1	1	
7	90201-06M30	.WASHER, PLATE .ARANDELA PLANA	1	1	
8	95303-06600	.NUT .TUERCA	1	1	
9	93430-06M02	.CIRCLIP .BOLA	1	1	
10	6G1-15705-00	.SPRING, DRIVE PAWL .RESORTE	1	1	
11	*	.WIRE (L1850) .CABLE	1	1	
12	6G1-15755-00	.HANDLE, STARTER .MANIJA DE ARRANQUE	1	1	
13	6G1-15779-00	.COVER .CUBIERTA	1	1	
14	6N0-E5758-01	.GUIDE, ROPE .GUIA DE CUERDA	1	1	
15	6N0-E5762-00	.SEAL, RUBBER 2 .SELLO DE GOMA 2	1	1	
16	95895-06016	.BOLT, FLANGE .TUERCA DE REBORDE	2	2	
17	677-15741-01	.PAWL, DRIVE .TRINQUETE DE TRACCION	1	1	
18	95895-06020	BOLT, FLANGE TUERCA DE REBORDE	3	3	
19	6N0-E5723-00-94	PULLEY, STARTER POLEA DE ARRANQUE	1	1	
20	90105-06M29	BOLT, WASHER BASED TORNILLO CON ARANDELA	3	3	
21	6N0-E5771-00-94	STAY 1 SOPORTE 1	1	1	
22	6N0-E5772-00-94	STAY 2 SOPORTE 2	1	1	
23	97075-06020	BOLT PERNO	4	4	

* CUT FROM 50M ROLLS, PART NO. 90890-44372, CUTTING LENGTH 1.85M

* CORTE DE UN RODILLO DE 50M, PARTS NUMERO 90890-44372, LARGO DEL CORTE 1.85M

FIG. 7 STARTER

ARRANQUE

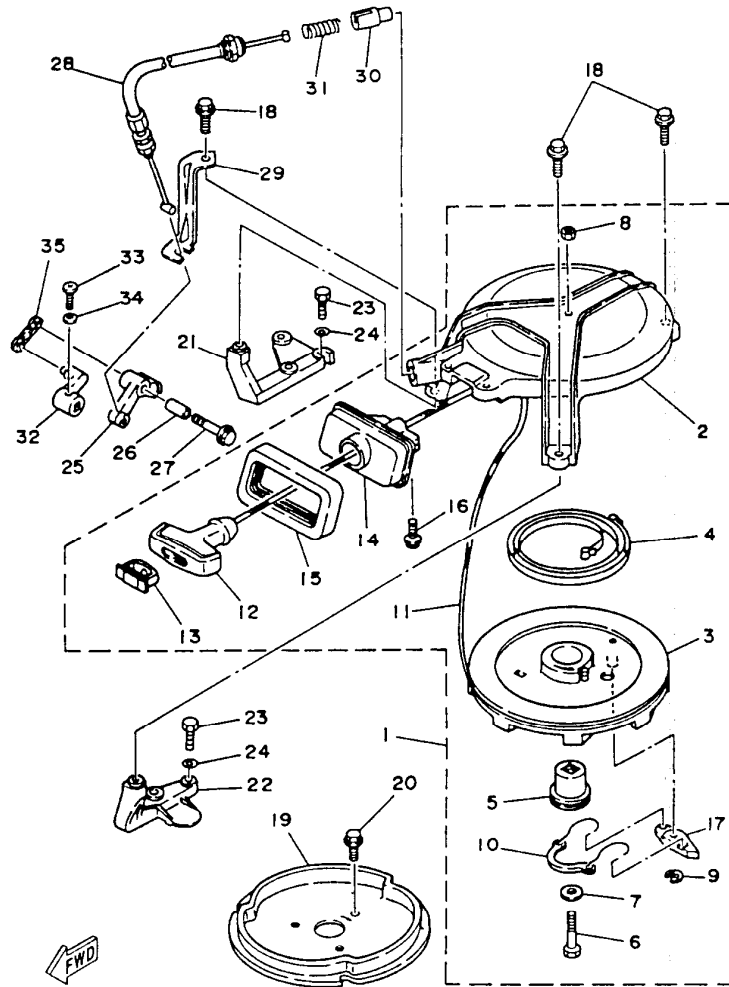

6MB0010-7070

REF. NO.	PART NO. CODIGO NO.	DESCRIPTION DESCRIPTION	6C	8C	REMARKS OBSERVACION
24	92995-06600	WASHER ARANDELA	4	4	
25	6G1-15746-10	ARM BRAZO		1	FOR CARIB
26	6G1-15764-00	COLLAR 1 COLLAR 1		1	FOR CARIB
27	95895-06025	BOLT, FLANGE TUERCA DE REBORDE		1	FOR CARIB
28	6N0-E5770-80	CABLE COMP., STARTER STOP CABLE COMPL. DE SEGURO ARRANQUE		1	FOR CARIB
29	6G1-15774-81	STAY 4 SOPORTE 4		1	FOR CARIB
30	656-15748-00	PLUNGER, STARTER STOP EMBOLO SEGURO DE ARRANQUE		1	FOR CARIB
31	90501-10227	SPRING, COMPRESSION RESORTE DE COMPRESION		1	FOR CARIB
32	6G1-44125-80	LEVER, SHIFT ROD PALANCA VARILLA CAMBIOS		1	FOR CARIB
33	97880-05016	SCREW, PAN HEAD TORNILLO DE CABEZA CON PLANA		1	FOR CARIB
34	92990-05600	WASHER, PLATE ARANDELA		1	FOR CARIB
35	6G1-15747-80	LINK ESLABON		1	FOR CARIB

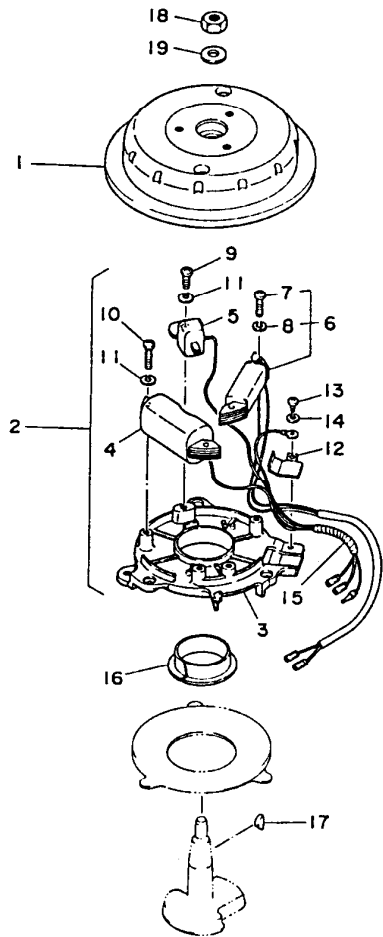

FIG. 8 GENERATOR GENERADOR

REF. NO.	PART NO. CODIGO NO.	DESCRIPTION DESCRIPTION	Q	Q	REMARKS OBSERVACION
1	6G1-85550-71	ROTOR ASSY ROTOR COMPLETO	1	1	
2	6G1-85560-F0	BASE ASSY CONJUNTO BASE	1	1	
3	6G1-85509-70	.BASE, MAGNETO .BASE DE MAGNETO	1	1	
4	6E7-85520-70	.COIL, CHARGE .BOBINA DE CARGA	1	1	
5	6E7-85580-70	.COIL, PULSER .BOBINA DE PULSACION	1	1	
6	6E7-81303-A0	.LIGHTING COIL ASSY .BOBINA DE ILUMINACION COMPL.	1	1	
7	97802-05025	.SCREW, PAN HEAD .TORNILLO DE CABEZA CON PLAN	2	2	
8	92902-05100	.WASHER, SPRING .ARANDELA	2	2	
9	97802-05016	.SCREW, PAN HEAD .TORNILLO DE CABEZA CON PLANA	1	1	
10	97802-05020	.SCREW, PAN HEAD .TORNILLO DE CABEZA CON PLANA	2	2	
11	92902-05100	.WASHER, SPRING .ARANDELA	3	3	
12	6G1-85548-70	.HOLDER .SOSTEN	1	1	
13	97802-04008	.SCREW, PAN HEAD .TORNILLO DE CABEZA CON PLANA	1	1	
14	92902-04100	.WASHER, SPRING .ARANDELA	1	1	
15	6G1-85515-70	.LEAD WIRE ASSY .CABLE CONDUCTOR COMPLETO	1	1	
16	90386-44M42	BUSH BUJE	1	1	
17	90280-04M06	KEY, WOODRUFF CUNA WOODRUFF	1	1	
18	90170-10113	NUT TUERCA	1	1	
19	90201-10126	WASHER, PLATE ARANDELA PLANA	1	1	

FWD
6M80010-4080

B7

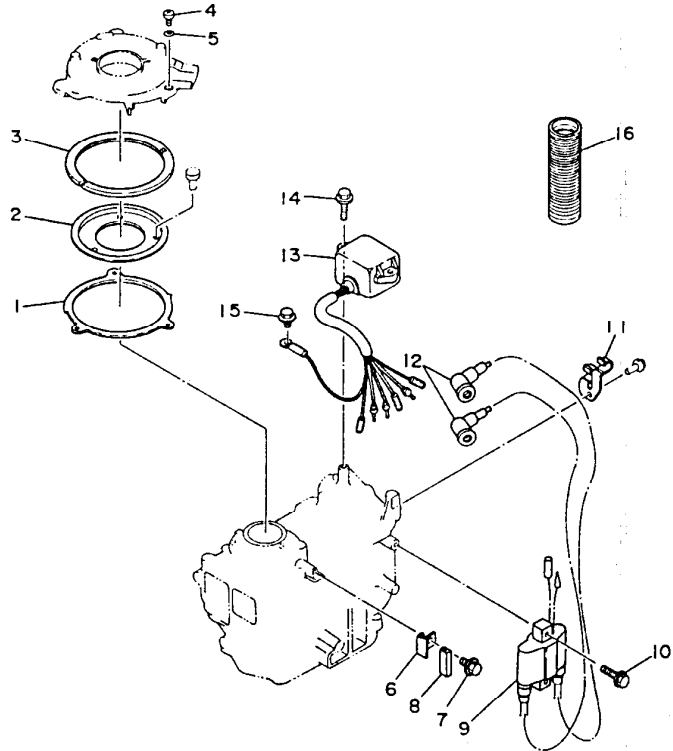

FIG. 9 ELECTRICAL

EQUIPO ELECTRICO

REF. NO.	PART NO. CODIGO NO.	DESCRIPTION DESCRIPTION	Q	Q	REMARKS OBSERVACION
1	6N0-G1611-00	RETAINER, MAGNETO BASE RETENEDOR BASE MAGNETO	1	1	
2	6G1-41612-00	RETAINER, MAGNETO BASE RETENEDOR BASE MAGNETO	1	1	
3	6N0-G1613-00	PLATE, BASE FRICTION PLACA DE BASE DE FRICCION	1	1	
4	97885-05010	SCREW, PAN HEAD TORNILLO DE CABEZA CON PLANA	3	3	
5	92995-05600	WASHER ARANDELA	3	3	
6	6G1-41615-00	STOPPER, MAGNETO BASE RETENEDOR, BASE MAGNETO	1	1	
7	95895-06010	BOLT, FLANGE TUERCA DE REBORDE	1	1	
8	6G1-44194-00	CAP TAPA	1	1	
9	6G1-85570-01	IGNITION COIL ASSY BOBINA DE IGNICION COMPLETO	1	1	
10	95895-06025	BOLT, FLANGE TUERCA DE REBORDE	2	2	
11	90465-08M17	CLAMP BRIDA	1	1	
12	663-82370-01	PLUG CAP ASSY TAPON DE BUJIA COMPLT	2	2	
	6G1-82370-21	PLUG CAP ASSY TAPON DE BUJIA COMPLT		2	FOR CARIB
13	696-85540-11	C.D.I. UNIT ASSY UNIDAD C.D.I. COMPLETA	1	1	
14	95895-06020	BOLT, FLANGE TUERCA DE REBORDE	2	2	
15	95895-06010	BOLT, FLANGE TUERCA DE REBORDE	1	1	
16	6G1-83557-00	TUBE ENCHUFE DE ACEITE	1	1	

FWD
GM80010-7090

C1

FIG. 10 BOTTOM COWLING CUBIERTA INFERIOR

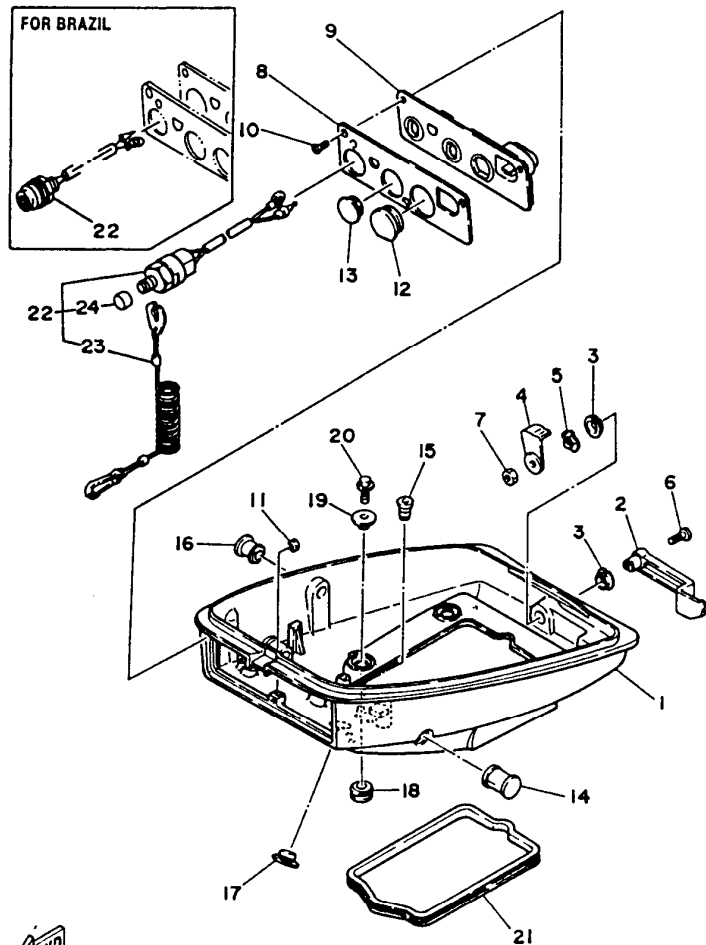

6M80200-7100

REF. NO.	PART NO. CODIGO NO.	DESCRIPTION DESCRIPTION	Q	Q	REMARKS OBSERVACION
1	6N0-G2711-00-4D	COWLING, BOTTOM CUBIERTA INFERIOR	1	1	
2	6N0-G2815-00-4D	LEVER, CLAMP PALANCA ABRAZADERA	1	1	
3	90386-12M45	BUSH BUJE	2	2	
4	6E0-42816-00	LEVER, CLAMP PALANCA ABRAZADERA	1	1	
5	90206-12052	WASHER, WAVE ARANDELA ONDULADA	1	1	
6	97885-06030	SCREW, PAN HEAD TORNILLO DE CABEZA CON PLANA	1	1	
7	95380-06700	NUT TUERCA	1	1	
8	6N0-G2719-00	PANEL, FRONT LOWER PANEL FRENTE INFERIOR	1	1	
	6N0-G2719-80	PANEL, FRONT LOWER PANEL FRENTE INFERIOR		1	FOR CARIB
9	6N0-G2767-00	BRACKET SOPORTE	1	1	
10	90149-05M02	SCREW TORNILLO DE REGLAJE	3	3	
11	95380-05700	NUT TUERCA	1	1	
12	6G1-42724-00	GROMMET TAPON	1	1	
13	6G1-42725-00	GROMMET TAPON	1	1	
14	6G1-42726-00	GROMMET TAPON	1	1	
15	6G1-42727-00	GROMMET TAPON	1	1	
16	6G1-42748-00	GROMMET TAPON	1	1	
17	6G1-26326-00	GROMMET TAPON PROTECTOR	1	1	
18	90480-15M31	GROMMET TAPON	4	4	
19	90387-06M52	COLLAR CASQUILLO CON VALONA	4	4	
20	95895-06020	BOLT, FLANGE TUERCA DE REBORDE	4	4	
21	6N0-G2716-00	RUBBER, SEAL 1 SELLO DE GOMA 1	1	1	
22	6A0-82550-01	ENGINE STOP SWITCH ASSY INTERRUPT. DE PARADA COMPLETO		1	FOR BRAZIL
	6E9-82575-02	ENGINE STOP SWITCH ASSY INTERRUPTOR DE PARADA COMPL	1	1	
23	682-82556-00	STOPPER RETEN	1	1	
24	689-8257Y-00	CAP CASQUILLO	1	1	

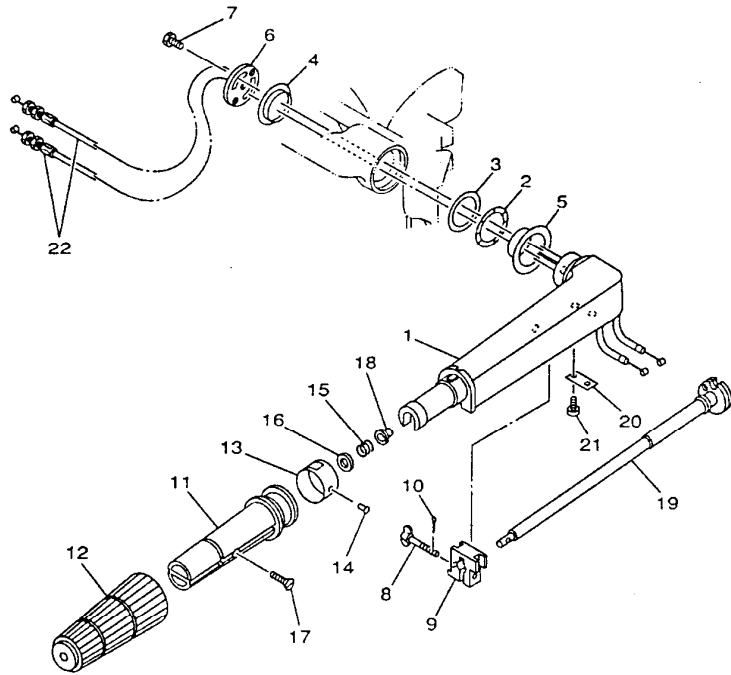

FWD
6M80010-0130

FIG. 11 STEERING DIRECCION

REF. NO.	PART NO. CODIGO NO.	DESCRIPTION DESCRIPTION	Q	Q	REMARKS OBSERVACION
1	6M8-G2111-10-4D	HANDLE, STEERING MANIJA DE DIRECCION	1	1	
2	90206-36M21	WASHER, WAVE ARANDELA ONDULADA	1	1	
3	90202-36M55	WASHER, PLATE ARANDELA DE PLANA	1	1	
4	90386-33M96	BUSH BUJE	1	1	
5	90386-34M97	BUSH BUJE	1	1	
6	6G1-42131-01	COVER, HANDLE STEERING CUBIERTA MANIJA DIRRECCION	1	1	
7	97095-06020	BOLT PERNO	1	1	
8	6N0-G2125-00	BOLT, FRICTION ADJUSTING TORNILLO FRICCION AJUSTA	1	1	
9	6N0-G2126-00	FRICTION, STEERING HANDLE GRIP FRICCION DE MANGO DIRECCION	1	1	
10	91490-16010	PIN, COTTER PASADOR DE CHAVETA	1	1	
11	6M4-G2119-00	GRIP, STEERING HANDLE MANGO, MANIJA DE DIRRECCION	1	1	
12	6N0-G2177-00	RUBBER, HANDLE HULE DE MANIJA	1	1	
13	6G1-42137-10	INDICATOR, THROTTLE INDICADOR ACELERADOR	1	1	
14	90269-02M09	RIVET REMACHE	1	1	
15	90501-23215	SPRING, COMPRESSION RESORTE DE COMPRESION	1	1	
16	92903-10600	WASHER, PLATE ARANDELA	1	1	
17	90149-05M13	SCREW TORNILLO DE REGLAJE	1	1	
18	90386-08032	BUSH BUJE	1	1	
19	6G1-42138-01	LEVER, THROTTLE PLANCA DE ACELERACION	1	1	
20	6E0-42159-02	STAY SOPORTE	1	1	
21	97885-05012	SCREW, PAN HEAD TORNILLO DE CABEZA CON PLANA	2	2	
22	6N0-F6301-00	THROTTLE CABLE ASSY CABLE DE ACELERADOR COMPLETO	2	2	

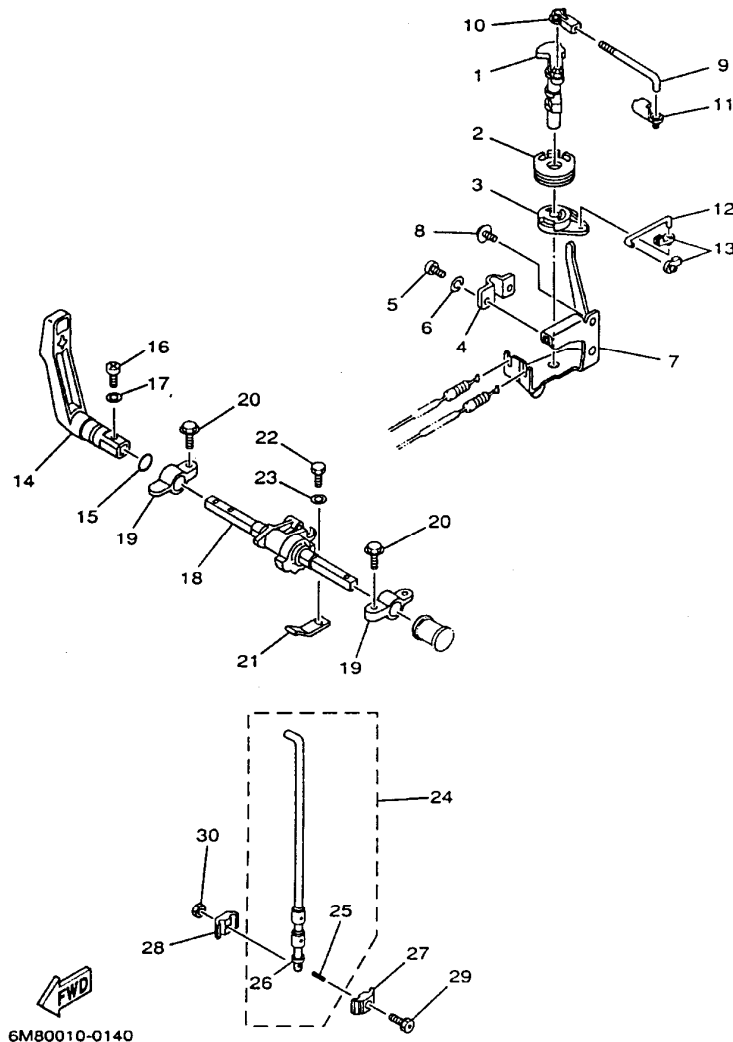

6M80010-0140

FIG. 12 CONTROL

CONTROL

REF. NO.	PART NO. CODIGO NO.	DESCRIPTION	BC	CC	REMARKS OBSERVACION
1	6G1-41631-00	LEVER, MAGNETO CONTROL PALANCA DE CONTROL DE MAGNETO	1	1	
2	6G1-41638-00	PULLEY POLEA	1	1	
3	6G1-41283-01	LEVER, FREE ACCEL. PALANCA	1	1	
4	6G1-41661-00	BRACKET SOPORTE	1	1	
5	97880-05010	SCREW, PAN HEAD TORNILLO DE CABEZA CON PLANA	2	2	
6	92990-05100	WASHER, SPRING ARANDELA	2	2	
7	6G1-14497-00	STAY, THROTTLE WIRE SOPORTE VALVULA DE OBTURACION	1	1	
	6G1-14497-80	STAY, THROTTLE WIRE SOPORTE VALVULA DE OBTURACION		1	FOR CARIB
8	95895-06010	BOLT, FLANGE TUERCA DE REBORDE	2	2	
9	6G1-41238-00	JOINT, LINK CONECTOR	1	1	
10	662-41237-01	JOINT, LINK CONECTOR	1	1	
11	6E9-41237-00	JOINT, LINK CONECTOR	1	1	
12	6G1-41211-00	LINK, ACCEL. ESLABON, ACELERADOR	1	1	
13	661-41262-02	JOINT, CHOKE LEVER CONECTOR DE AHOGADOR	2	2	
14	6N0-G4111-00	HANDLE, GEAR SHIFT MANIJA DE CAMBIO DE MARCHAS	1	1	
15	93210-12327	O-RING ANILLO O	1	1	
16	97880-05016	SCREW, PAN HEAD TORNILLO DE CABEZA CON PLANA	1	1	
17	92990-05600	WASHER, PLATE ARANDELA	1	1	
18	6G1-44121-02-94	LEVER, SHIFT ROD PALANCA VARILLA CAMBIOS	1	1	
19	6G1-41662-01-94	BRACKET SOPORTE	2	2	
20	90105-06M14	BOLT FLANGE TORNILLO CON ARANDELA	2	2	
21	6G1-44116-01	SPRING RESORTE	1	1	
22	97095-06012	BOLT PERNO	1	1	
23	92995-06600	WASHER ARANDELA	1	1	
24	6N0-G4110-00	SHIFT ROD ASSY VARILLA DE CAMBIO COMPL	1	1	
25	91690-20010	PIN, SPRING PASADOR DE RESORTE	1	1	
26	92990-05600	WASHER, PLATE ARANDELA	1	1	

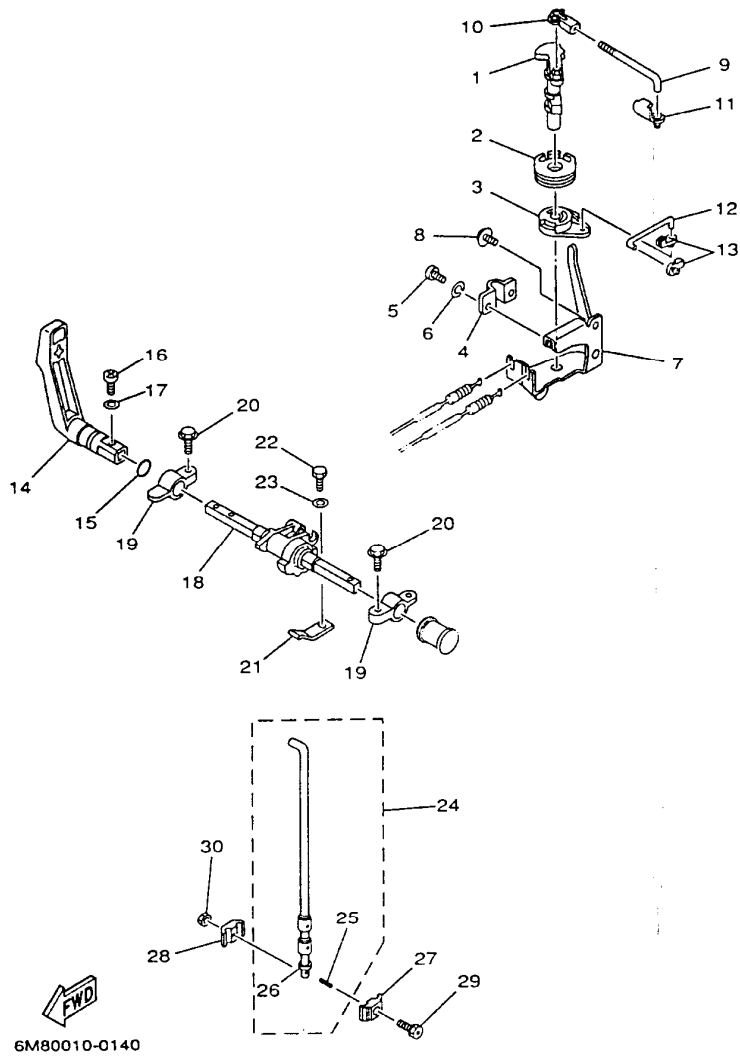
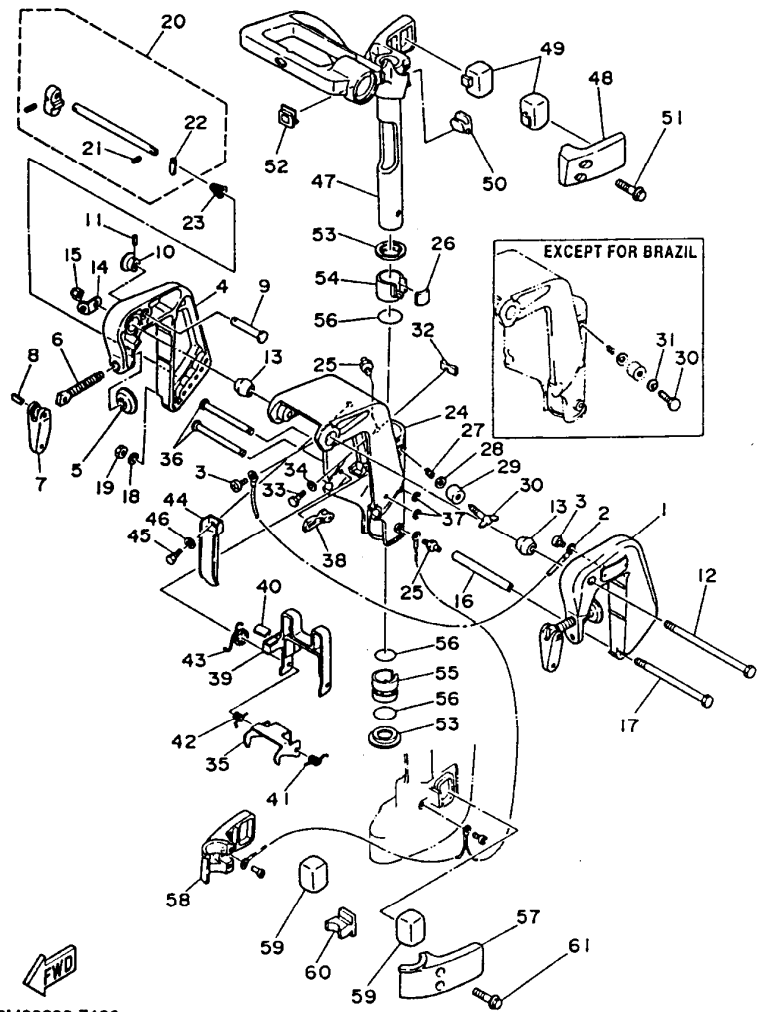

FIG. 12 CONTROL

CONTROL

REF. NO.	PART NO. CODIGO NO.	DESCRIPTION DESCRIPTION	QTY	QTY			REMARKS OBSERVACION
27	6N0-G4145-00	CONNECTOR, SHIFT ROD CONECTOR, VARILLA CAMBIO	1	1			
28	6N0-G4146-00	CONNECTOR, SHIFT ROD CONECTOR VARILLA DE CAMBIO	1	1			
29	90109-06M17	BOLT PERNO	1	1			
30	95380-06600	NUT, HEXAGON TUERCA	1	1			



6M80200-7130

FIG. 13 BRACKET

SOPORTE

REF. NO.	PART NO. CODIGO NO.	DESCRIPTION DESCRIPTION	Q	Q	REMARKS OBSERVACION
1	6M8-G3111-02-4D	BRACKET, CLAMP SOPORTE DE LA ABRAZADERA	1	1	
2	6E5-82148-00	WIRE, LEAD 4 CABLE CONDUCTOR 4	1	1	
3	97885-06008	SCREW, PAN HEAD TORNILLO DE CABEZA CON PLANA	2	2	
4	6M8-G3112-01-4D	BRACKET, CLAMP SOPORTE DE LA ABRAZADERA	1	1	
5	620-43114-00	PAD, TRANSOM CLAMP ARANDELA DE ABRAZADERA	2	2	
6	6N0-G3116-00	SCREW, TRANSOM CLAMP TORNILLO DE ABRAZADERA	2	2	
7	6L8-G3118-01	HANDLE, TRANSOM CLAMP MANIJA DE LA ABRAZADERA DEL ES	2	2	
8	90243-04M01	PIN PASADOR	2	2	
9	689-43191-00	SHAFT, STOPPER EJE DE TOPE	1	1	
10	689-43192-01	KNOB, STOPPER PERILLA DE TOPE	1	1	
11	91690-30016	PIN, SPRING PASADOR DE RESORTE	1	1	
12	90101-08869	BOLT TORNILLO	1	1	
13	6N0-G3136-00	PIECE, FRICTION PIEZA DE FRICCION	2	2	
14	6A1-43113-01	PLATE, CLAMP BRACKET PLACA ABRAZADERA SOPORTE	1	1	
15	90185-08057	NUT, SELF-LOCKING TUERCA AUTOBLOCANTE	1	1	
16	90387-06M13	COLLAR CASQUILLO CON VALONA	1	1	
17	97095-06135	BOLT PERNO	1	1	
18	92990-06600	WASHER, PLATE ARANDELA	1	1	
19	95380-06600	NUT, HEXAGON TUERCA	1	1	
20	6N0-G3160-00	TILT ROD ASSY VARILLA DE BASCULACION COMPL.	1	1	
21	91690-30018	PIN, SPRING PASADOR DE RESORTE	1	1	
22	6N0-G3165-00	PLATE, TILT LOCK PLACA DE TOPE, VARILLA SEGUR	1	1	
23	90502-10M06	SPRING, CONICAL RESORTE CONICO	1	1	
24	6N0-G3311-10-4D	BRACKET, SWIVEL 1 SOPORTE GIRATORIO 1	1	1	
25	93700-06M03	NIPPLE, GREASE NIPLE DE ENGRASAR	2	2	
26	6G1-42528-00	PLATE, FRICTION PIEZA DE FRICCION	1	1	FOR BRAZIL
	6G1-42528-10	PLATE, FRICTION PIEZA DE FRICCION	1	1	

C6

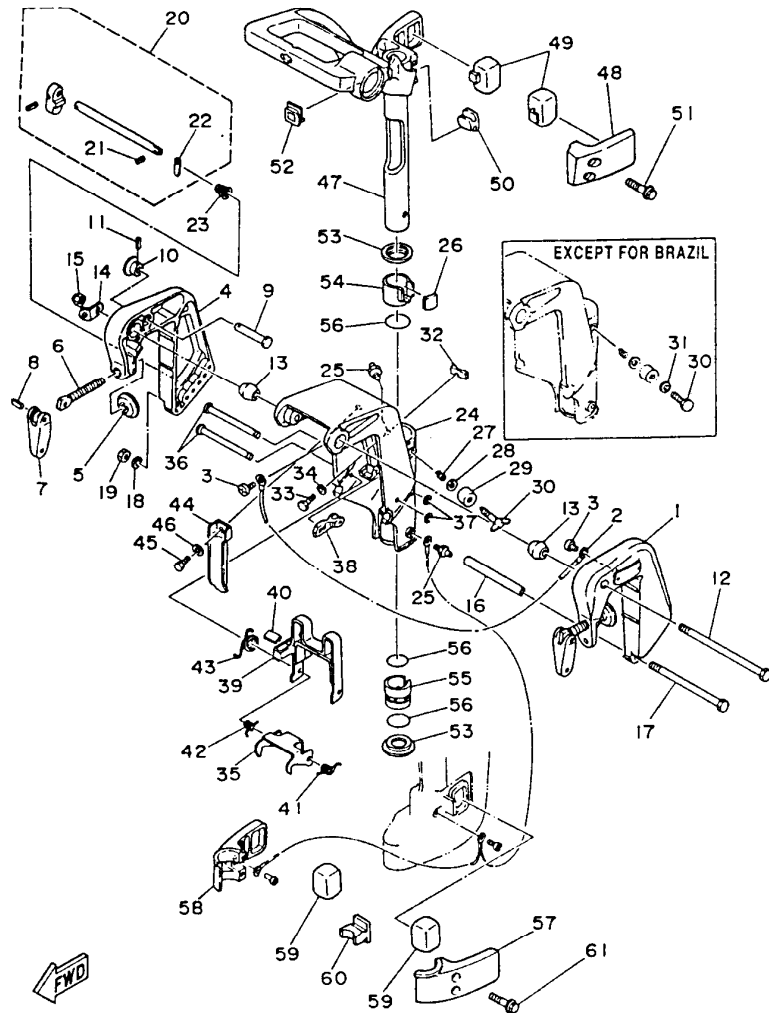

6M80200-7130

FIG. 13 BRACKET

SOPORTE

REF. NO.	PART NO. CODIGO NO.	DESCRIPTION DESCRIPTION	Q	Q	REMARKS OBSERVACION
27	90501-18M00	SPRING, COMPRESSION RESORTE DE COMPRESION	1	1	
28	92990-08600	WASHER, PLATE ARANDELA	1	1	
29	6G1-43373-00	SEAL, DAMPER SELLO DE GOMA	1	1	
30	6G1-42529-00	SCREW, FRICTION PIECE TORNILLO PIEZA FRICCION		1	FOR BRAZIL
	97095-08025	BOLT PERNO	1	1	
31	92995-08600	WASHER ARANDELA	1	1	
32	6G1-44532-00	STOPPER, UPPER MOUNT RETEN	1	1	
33	97095-06010	BOLT PERNO	1	1	
34	92995-06600	WASHER ARANDELA	1	1	
35	6N0-G3614-00	PLATE, TILT LOCK PLACA DE SEGURO DE INCLINACION	1	1	
36	6G1-43659-00	SHAFT, REVERSE LOCK EJE SEGURO DE REVERSA	2	2	
37	93430-05027	CIRCLIP BOLA	2	2	
38	6G1-43615-01	PLATE, TILT LOCK PLACA DE SEGURO DE INCLINACION	1	1	
39	6G1-43681-00	LEVER, SHALLOW WATER DRIVE 1 PALANCA 1	1	1	
40	6G1-43318-01	COVER CUBIERTA	1	1	
41	90508-10M15	SPRING, TORSION RESORTE DE TORSION	1	1	
42	90508-10M16	SPRING, TORSION RESORTE DE TORSION	1	1	
43	90508-14M17	SPRING, TORSION RESORTE DE TORSION	1	1	
44	6N0-G2731-00	CARRYING HANDLE MANIJA	1	1	
45	97095-08016	BOLT PERNO	1	1	
46	92995-08600	WASHER ARANDELA	1	1	
47	6M8-G2511-00-4D	BRACKET, STEERING SOPORTE DE DIRECCION	1	1	
48	6G1-44511-00-4D	COVER, UPPER MOUNT CUBIERTA AMORTIGUADOR SUPERIOR	1	1	
49	6N0-G4514-00	MOUNT DAMPER, UPPER SIDE AMORTIGUADOR LADO SUPERIOR	2	2	
50	6G1-44516-00	MOUNT DAMPER, UPPER FRONT AMORTIGUADOR DE HULE FRENTE SU	1	1	
51	95895-06035	BOLT, FLANGE TUERCA DE REBORDE	2	2	
52	6G1-42551-00	GROMMET TAPON	1	1	

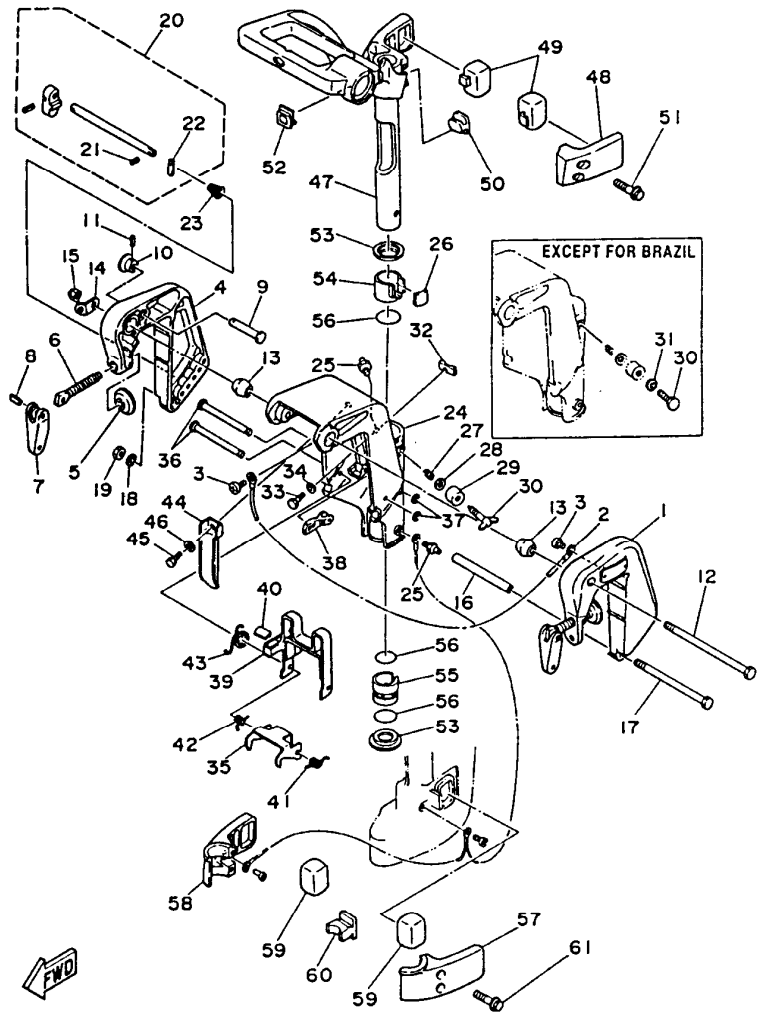

6M80200-7130

FIG. 13 BRACKET

SOPORTE

REF. NO.	PART NO. CODIGO NO.	DESCRIPTION DESCRIPTION	Q	Q	REMARKS OBSERVACION
53	6G1-42535-00	WASHER, THRUST RONDANA EMPUJE	2	2	
54	6G1-42537-00	BUSHING, PIVOT SHAFT BUJE DEL PIVOTE DE LA FLECHA		1	FOR BRAZIL
	6G1-42537-10	BUSHING, PIVOT SHAFT BUJE DEL PIVOTE DE LA FLECHA	1	1	
55	6G1-42538-01	BUSHING, PIVOT SHAFT BUJE DEL PIVOTE DE LA FLECHA	1	1	
56	93210-30M31	O-RING ANILLO O	3	3	
57	6N0-G4551-00-4D	HOUSING, LOWER MOUNT RUBBER CAJA AMORTIGUADOR INFERIOR HU	1	1	
58	6N0-G4552-00-4D	HOUSING, LOWER MOUNT RUBBER CAJA AMORTIGUADOR INFERIOR HU	1	1	
59	6N0-G4555-A0	MOUNT DAMPER, LOWER SIDE AMORTIGUADOR DE HULE LADO INFE	2	2	
60	6N0-G4557-A0	MOUNT DAMPER, LOWER FRONT AMORTIGUADOR DE HULE FRENTE IN	1	1	
61	95895-06035	BOLT, FLANGE TUERCA DE REBORDE	2	2	

FIG. 14 UPPER CASING

FUNDA SUPERIOR

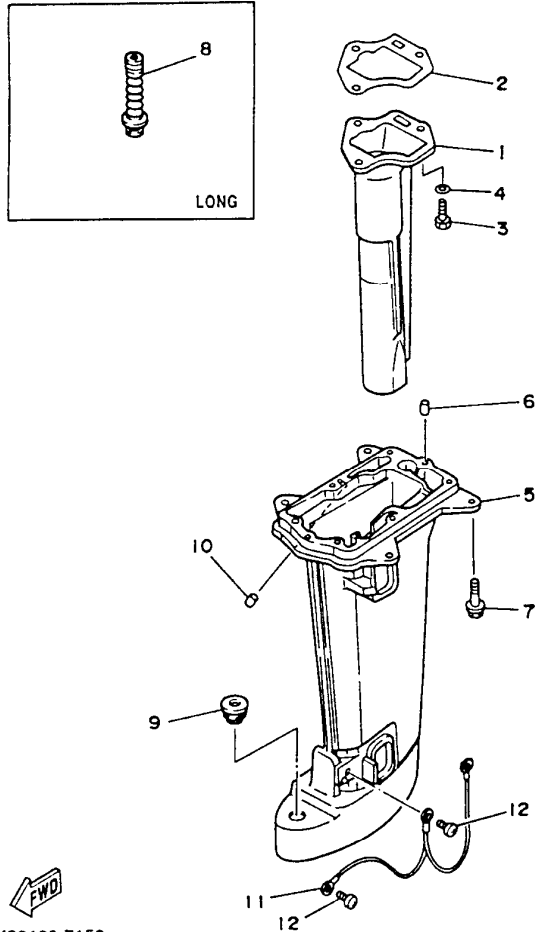

6M80100-7150

REF. NO.	PART NO. CODIGO NO.	DESCRIPTION DESCRIPTION	QUANTITY	UNIT	REMARKS OBSERVACION
1	6M8-G1131-00-5B	MANIFOLD, EXT. 1 TUBO MULTIPLE DE ESCAPE	1		
	6N0-G1131-00-5B	MANIFOLD, EXT. 1 TUBO MULTIPLE DE ESCAPE	1		
2	6G1-41133-A0	GASKET, EXHAUST MANIFOLD 1 EMPAQUE ESCAPE MULTIPLE	1		
3	97095-06020	BOLT PERNO	3		
4	92995-06600	WASHER ARANDELA	3		
5	6N0-G5111-00-4D	CASING, UPPER CAJA SUPERIOR	1		S
	6N0-G5111-10-4D	CASING, UPPER CAJA SUPERIOR	1		L
6	93604-08062	PIN, DOWEL PASADOR DE CLAVIJA	2		
7	95895-06030	BOLT, FLANGE TUERCA DE REBORDE	6		
8	655-44147-00	BOOT, SHIFT ROD HULE DE VARILLA	1		L
9	90480-20M29	GROMMET TAPON	1		
10	6G1-45135-00	PIPE TUBO 1	1		
11	6G1-82149-00	WIRE, LEAD 3 CABLE CONDUCTOR 3	1		
12	97885-06008	SCREW, PAN HEAD TORNILLO DE CABEZA CON PLANA	2		

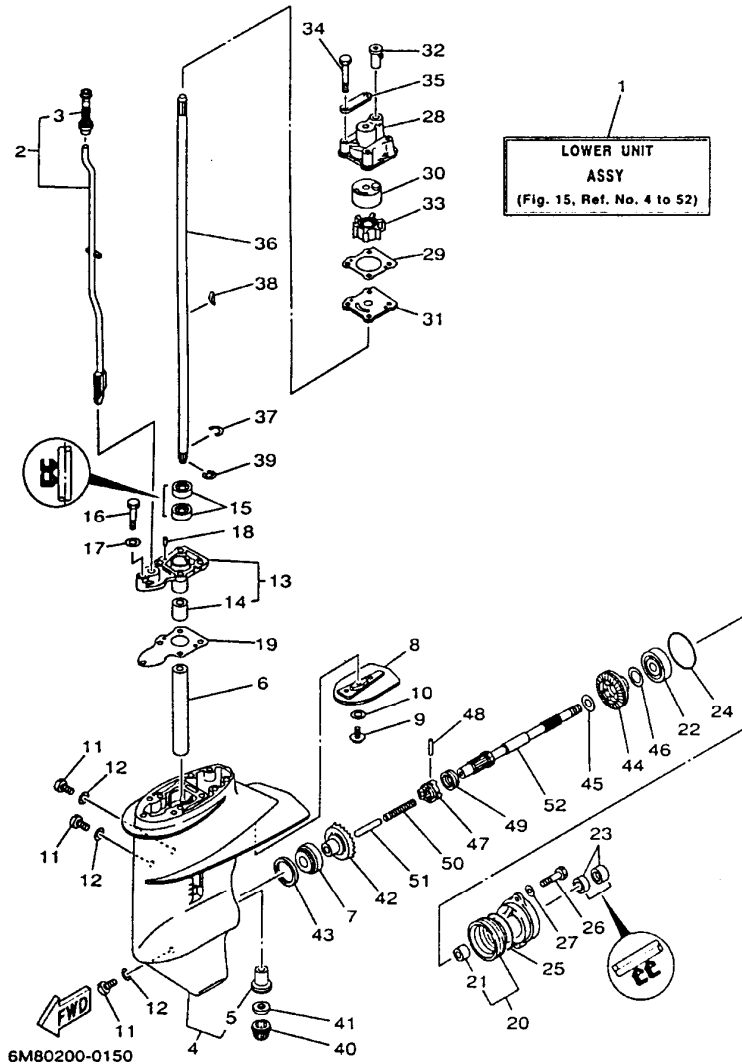

FIG. 15 LOWER CASING, DRIVE 1 IMPULSOR E INFERIOR 1

REF. NO.	PART NO. CODIGO NO.	DESCRIPTION DESCRIPTION	QTY	QTY	REMARKS OBSERVACION
1	6M8-G5300-00-4D	LOWER UNIT ASSY CONJUNTO UNIDAD INFERIOR	1	1	S
	6M8-G5300-10-4D	LOWER UNIT ASSY CONJUNTO UNIDAD INFERIOR		1	L
2	6N0-G4150-00	SHIFT CAM ASSY CONJUNTO EJE LEVA COMPL.	1	1	S
	6N0-G4150-10	SHIFT CAM ASSY CONJUNTO EJE LEVA COMPL.		1	L
3	6G1-44147-00	.BOOT, SHIFT ROD .HULE DE VARILLA	1	1	
4	6N0-G5311-00-4D	CASING, LOWER FUNDA INFERIOR	1	1	
5	6G1-45317-09	.BUSHING, DRIVE SHAFT .BUJE	1	1	
6	90387-14M49	COLLAR CASQUILLO CON VALONA	1	1	
7	93332-000U4	BEARING COJINETE	1	1	
8	6N0-G5251-00	ANODE CATODE	1	1	
9	97095-06016	BOLT PERNO	1	1	
10	92990-06300	WASHER, INTERNAL TOOTH ARANDELA	1	1	
11	90340-08M04	PLUG, STRAIGHT SCREW TORNILLO, DE DRENAJE	3	3	
12	90430-08020	GASKET JUNTA	3	3	
13	6G1-45331-01-5B	HOUSING, BEARING CAJA DE COJINETE	1	1	
14	6G1-45316-09	.BUSHING, DRIVE SHAFT .BUJE, EJE DE MANDO	1	1	
15	93101-11M23	OIL SEAL SELLO ACEITE	2	2	
16	97095-06030	BOLT PERNO	1	1	
17	92995-06600	WASHER ARANDELA	1	1	
18	93604-08062	PIN, DOWEL PASADOR DE CLAVIJA	2	2	
19	6G1-45315-A0	PACKING, LOWER CASING EMPAQUE	1	1	
20	6N0-G5361-00-4D	CAP, LOWER CASING FUNDA INFERIOR	1	1	
21	6G1-45362-09	.BUSHING .BUJE FUNDA INFERIOR TAPA	1	1	
22	93306-004U0	BEARING COJINETE	1	1	
23	93101-15074	OIL SEAL SELLO ACEITE	2	2	
24	93210-49046	O-RING ANILLO O	1	1	
25	93210-53M08	O-RING ANILLO O	1	1	

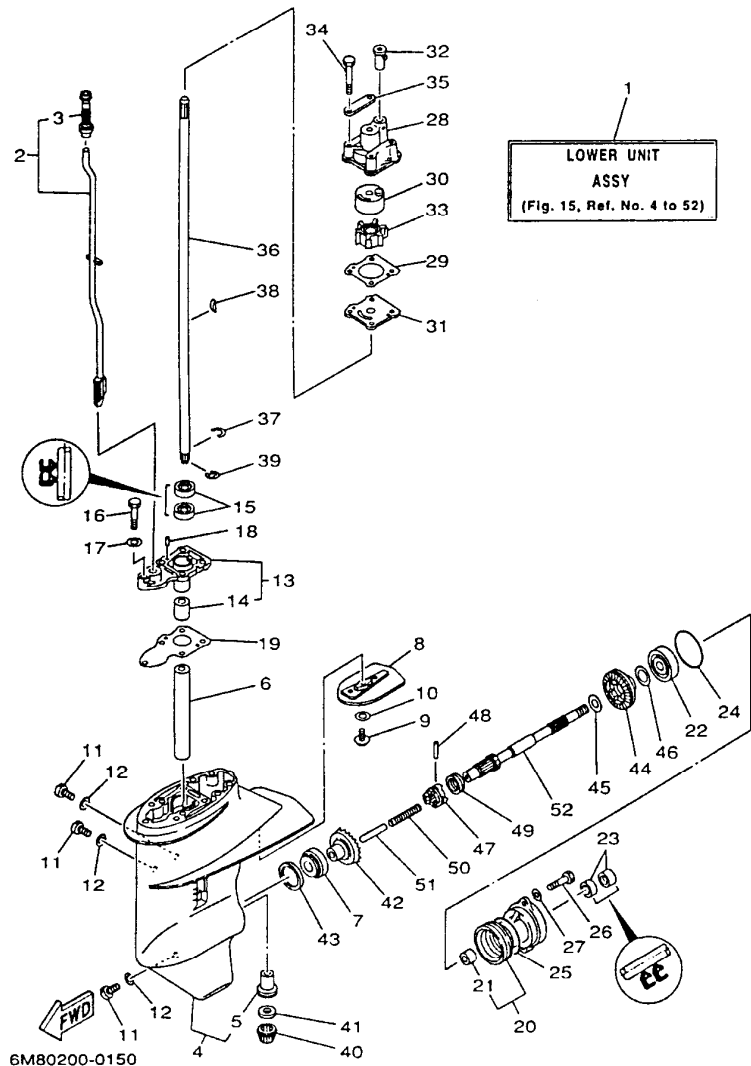

FIG. 15 LOWER CASING. DRIVE 1 IMPULSOR E INFERIOR 1

REF. NO.	PART NO. CODIGO NO.	DESCRIPTION DESCRIPTION	Q	Q	REMARKS OBSERVACION
26	97095-06016	BOLT PERNO	2	2	
27	92995-06600	WASHER ARANDELA	2	2	
28	6N0-G4311-00	HOUSING, WATER PUMP CAJA BOMBA DE AGUA	1	1	
29	6G1-44315-A0	GASKET, WATER PUMP EMPAQUE	1	1	
30	6G1-44322-40	INSERT, CARTRIDGE CARTUCHO	1		FOR CHROMATE
	6G1-44322-00	INSERT, CARTRIDGE CARTUCHO		1	
31	6G1-44323-40	OUTER PLATE, CARTRIDGE PLACA EXTERIOR DEL CARTUCHO	1		FOR CHROMATE
	6G1-44323-00	OUTER PLATE, CARTRIDGE PLACA EXTERIOR DEL CARTUCHO		1	
32	647-44366-00	DAMPER, WATER SEAL GOMA DEL SELLO DE AGUA	1	1	
33	6G1-44352-00	IMPELLER IMPULSOR	1	1	
34	97095-06045	BOLT PERNO	4	4	
35	6G1-44328-00	PLATE PLACA	2	2	
36	6N0-G5511-00	SHAFT, DRIVE EJE DE MANDO	1	1	S
	6N0-G5511-10	SHAFT, DRIVE EJE DE MANDO		1	L
37	90467-09M05	CLIP PRESILLA	1	1	
38	90280-03024	KEY, WOODRUFF CUNA WOODRUFF	1	1	
39	93430-06005	CIRCLIP BOLA	1	1	
40	6N0-G5551-00	PINION PINON	1	1	
41	6G1-45533-00-19	SHIM (T:1.9MM) LAINA (T:1.9MM)	1	1	UR
	6G1-45533-00-20	SHIM (T:2.0MM) LAINA (T:2.0MM)	1	1	UR
	6G1-45533-00-21	SHIM (T:2.1MM) LAINA (T:2.1MM)	1	1	UR
	6G1-45533-00-22	SHIM (T:2.2MM) LAINA (T:2.2MM)	1	1	UR
42	6N0-G5560-00	GEAR ENGRANE COMPLE 1	1	1	
43	664-45587-01-10	SHIM (T:0.10MM) LAINA (T:0.10MM)	1	1	UR
	664-45587-01-12	SHIM (T:0.12MM) LAINA (T:0.12MM)	1	1	UR
	664-45587-01-15	SHIM (T:0.15MM) LAINA (T:0.15MM)	1	1	UR
	664-45587-01-18	SHIM (T:0.18MM) LAINA (T:0.18MM)	1	1	UR

D4

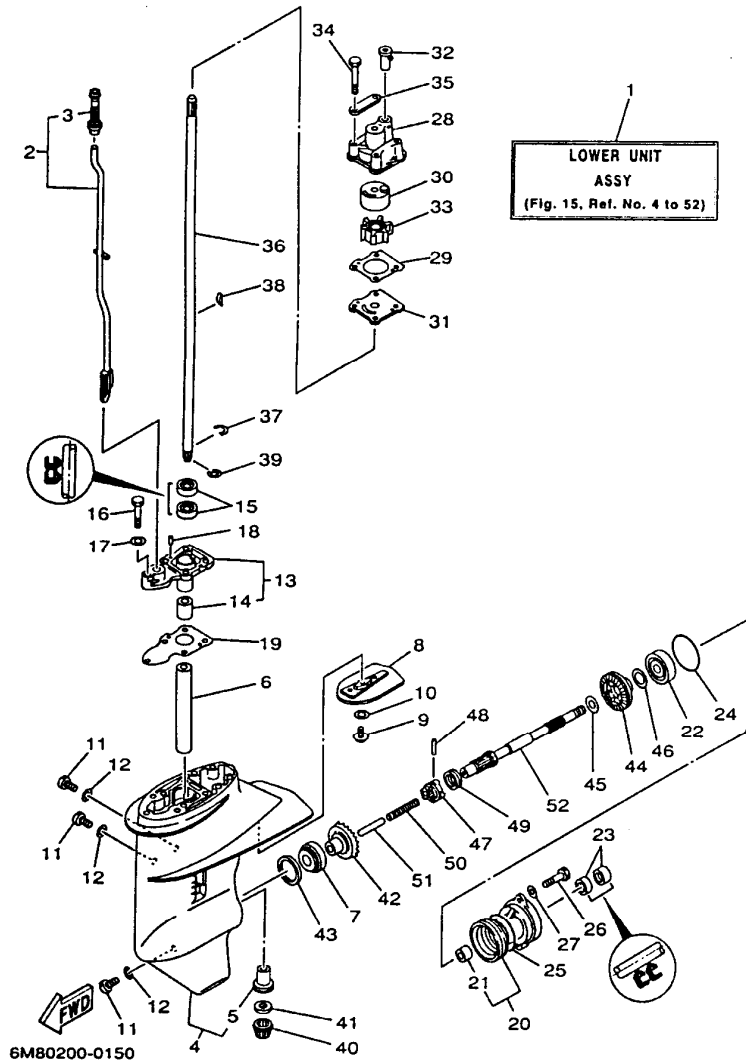
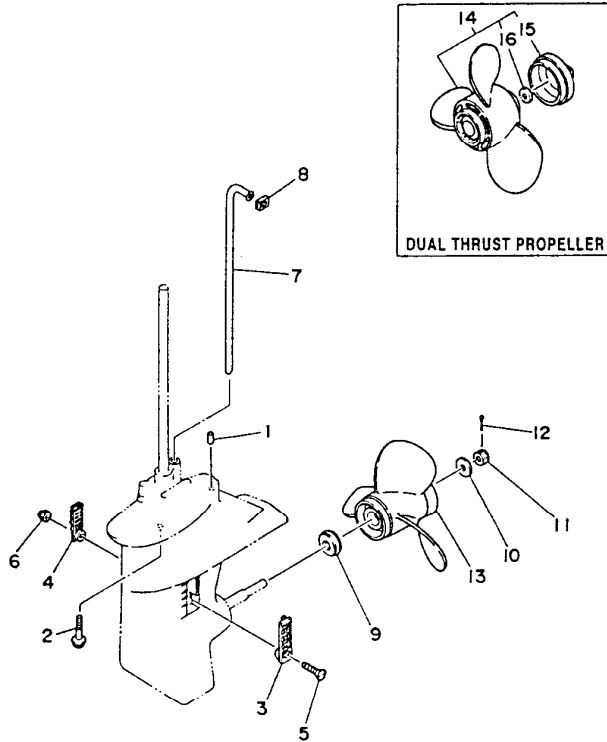

FIG. 15 LOWER CASING, DRIVE 1 IMPULSOR E INFERIOR 1

REF. NO.	PART NO. CODIGO NO.	DESCRIPTION DESCRIPTION	Q	Q			REMARKS OBSERVACION
43	664-45587-01-30	SHIM (T:0.30MM) LAINA (T:0.30MM)	1	1			UR
	664-45587-01-40	SHIM (T:0.40MM) LAINA (T:0.40MM)	1	1			UR
	664-45587-01-50	SHIM (T:0.50MM) LAINA (T:0.50MM)	1	1			UR
44	6N0-G5571-00	GEAR ENGRANAJE	1	1			
45	90201-15M89	WASHER, PLATE ARANDELA PLANA	1	1			
46	647-45567-00	SHIM (T:0.10MM) LAINA (T:0.10MM)	1	1			UN
47	6G1-45631-00	CLUTCH, DOG EMBRAGUE DE GARRA	1	1			
48	6G1-45632-00	PIN, CROSS PASADOR TRANSVERSAL	1	1			
49	654-45633-00	RING, CROSS PIN ANILLO DE PASADOR	1	1			
50	90501-12M38	SPRING, COMPRESSION RESORTE DE COMPRESION	1	1			
51	6G1-45635-00	PLUNGER, SHIFT EMBOLO DE CAMBIO	1	1			
52	6G1-45611-01	SHAFT, PROPELLER EJE PROPUSOR	1	1			

FIG. 16 LOWER CASING. DRIVE 2 IMPULSOR E INFERIOR 2



REF. NO.	PART NO. CODIGO NO.	DESCRIPTION	Q	Q	REMARKS OBSERVACION
1	93604-08062	PIN, DOWEL PASADOR DE CLAVIJA	2	2	
2	95895-06030	BOLT, FLANGE TUERCA DE REBORDE	4	4	
3	6G1-45214-00	COVER, WATER INLET CUBIERTA ENTRADA AGUA	1	1	
4	6G1-45215-00	COVER, WATER INLET CUBIERTA ENTRADA AGUA	1	1	
5	90152-05M03	SCREW, COUNTERSUNK TORNILLO EMBUTIDO	1	1	
6	90185-05002	NUT, SELF-LOCKING TUERCA AUTOBLOCANTE	1	1	
7	6N0-G4361-00	TUBE, WATER TUBO DE AGUA	1	1	S
	6N0-G4361-10	TUBE, WATER TUBO DE AGUA		1	L
8	6G1-44365-00	DAMPER, WATER SEAL HULE DE SELLO DE AGUA	1	1	
9	6N0-G5987-00	SPACER ESPACIADOR	1	1	
10	90201-10M01	WASHER, PLATE ARANDELA PLANA	1	1	
11	90171-10M01	NUT, CASTLE TUERCA ENTALLADA	1	1	
12	91490-30020	PIN, COTTER PASADOR DE CHAVETA	1	1	
13	6G1-45941-00-EL	PROPELLER (3X8-1/2"X8-1/2"-N) PROPELA (3X8-1/2"X8-1/2"-N)	1	1	UR
	6G1-45943-00-EL	PROPELLER (3X8-1/2"X7-1/2"-N) PROPELA (3X8-1/2"X7-1/2"-N)	1	1	UR
	6G1-45947-00-EL	PROPELLER (3X8-1/2"X6-1/2"-N) PROPELA (3X8-1/2"X6-1/2"-N)	1	1	UR
14	6G1-W4591-01-EL	PROPELLER (3X9"X7"-N) PROPELA (3X9"X7"-N)	1	1	UR
	6G1-W4592-00-EL	PROPELLER (3X9"X5"-N) PROPELA (3X9"X5"-N)	1	1	UR
15	6G1-45616-01	NUT, PROPELLER TUERCA DE HELICE	1	1	
16	90201-10M02	WASHER, PLATE ARANDELA PLANA	1	1	

FWD
6M80010-7180

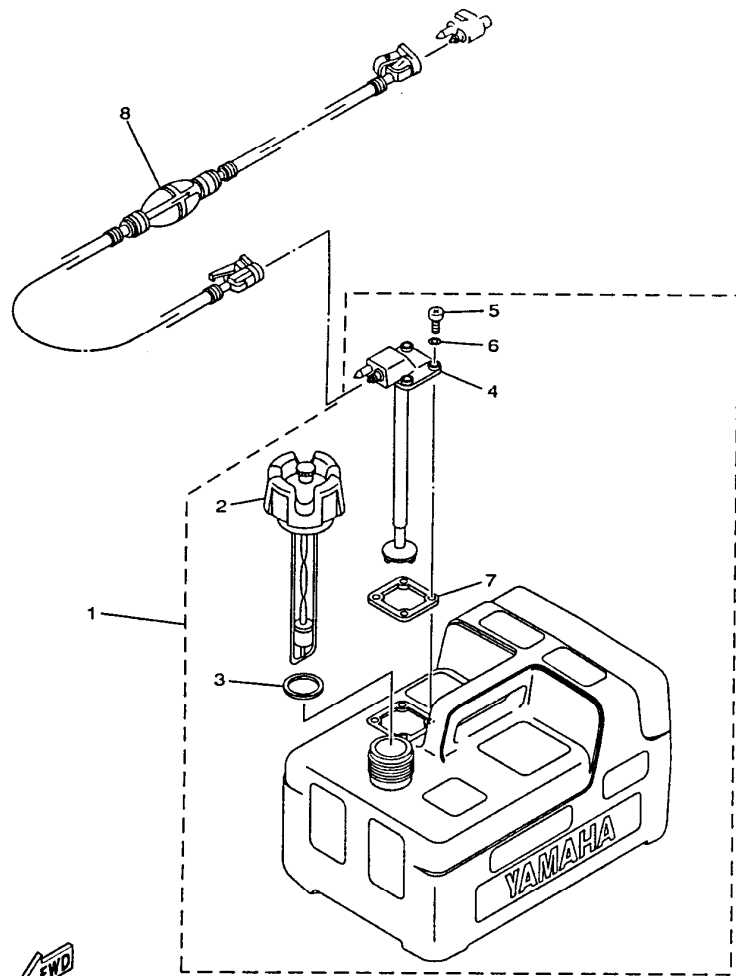

66R0700-9260

FIG. 17 FUEL TANK 1

DEPOSITO DE COMBUSTIBLE 1

REF. NO.	PART NO. CODIGO NO.	DESCRIPTION DESCRIPTION	Q	Q		REMARKS OBSERVACION
1	6YL-F4201-01	FUEL TANK ASSY TANQUE DEL COMBUSTIBLE COMPL.	1			AP
2	6YL-F4610-00	.CAP ASSY .TAPA COMPLETA	1			
3	6YL-F4641-00	.GASKET, CAP 1 .EMPAQUE DE TAPA 1	1			
4	6YL-F4260-01	.FUEL METER ASSY .MEDIDOR DE COMBUSTIBLE COMPL.	1			
5	90157-05811	.SCREW, PAN HEAD .TORNILLO, CABEZA CONICA PLANA	4			
6	6YL-F4329-00	.SEAL .SELLO	4			
7	6YL-F4268-01	.GASKET, FUEL METER .EMPAQ MEDIDOR DE COMBUSTIBLE	1			
8	6YL-24306-52	FUEL PIPE COMP. 1 TUBO COMBUST. COMPL 1	1			AP

FIG. 18 FUEL TANK 2

DEPOSITO DE COMBUSTIBLE 2

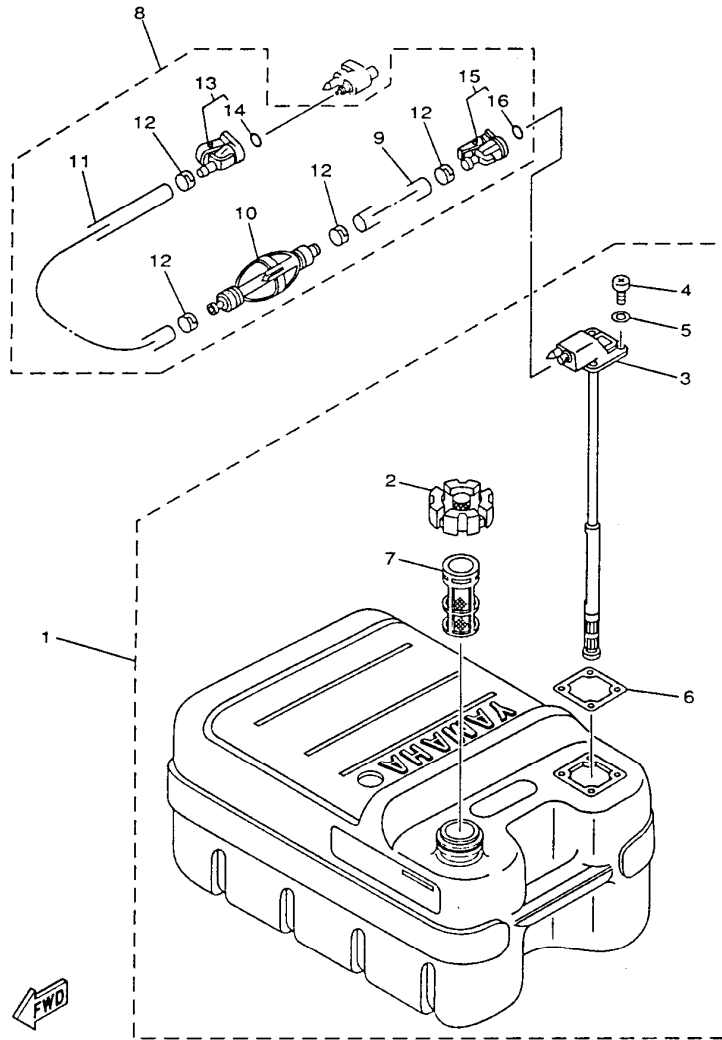

67C0100-9300

REF. NO.	PART NO. CODIGO NO.	DESCRIPTION DESCRIPTION	Q	Q	REMARKS OBSERVACION
1	6YJ-24201-10	FUEL TANK ASSY (24L) TANQUE DEL COMBUSTIBLE (24L)		1	AP FOR CARIB
	6M4-F4201-00	FUEL TANK ASSY TANQUE DEL COMBUSTIBLE COMPL.		1	AP FOR BRAZIL
2	6YJ-24610-01	.CAP ASSY .TAPA COMPLETA		1	
	6YJ-24610-00	.CAP ASSY .TAPA COMPLETA		1	FOR 6M4-F4201-00
3	6Y1-24260-12	.FUEL METER ASSY .MEDIDOR DE COMBUSTIBLE COMPL.		1	WITH INDICATOR
	6Y1-24260-00	.FUEL METER ASSY .MEDIDOR DE COMBUSTIBLE COMPL.		1	FOR 6M4-F4201-00
4	98586-05016	.SCREW, PAN HEAD .TORNILLO DE CABEZA CON PLANA		4	
5	6Y1-24329-00	.SEAL .SELLO		4	
6	6Y1-24268-00	.GASKET, FUEL METER .EMPAQ MEDIDOR DE COMBUSTIBLE		1	
7	6YJ-24167-00	.STRAINER .COLADOR		1	
8	61J-24306-02	FUEL PIPE COMP. 1 TUBO COMBUST. COMPL 1		1	AP
9	90445-11M06	.HOSE (L2050) .MANGUERA (L2050)		1	
10	61J-24360-00	.PRIMER PUMP ASSY .SOPORTE BOMBA		1	
11	90445-11M05	.HOSE (L:850MM) .MANGUERA (L:850MM)		1	
12	650-24351-51	.BAND 1 ABRAZADERA 1		4	
13	6G1-24305-03	.FUEL PIPE JOINT COMP. 2 .CONECTOR MANGUERA COMBUST.2		1	
14	93210-08287	..O-RING ..ANILLO O		1	
15	6Y1-24305-04	FUEL PIPE JOINT COMP. 2 .CONECTOR MANGUERA COMBUST.2		1	
16	93210-08287	..O-RING ..ANILLO O		1	

E1

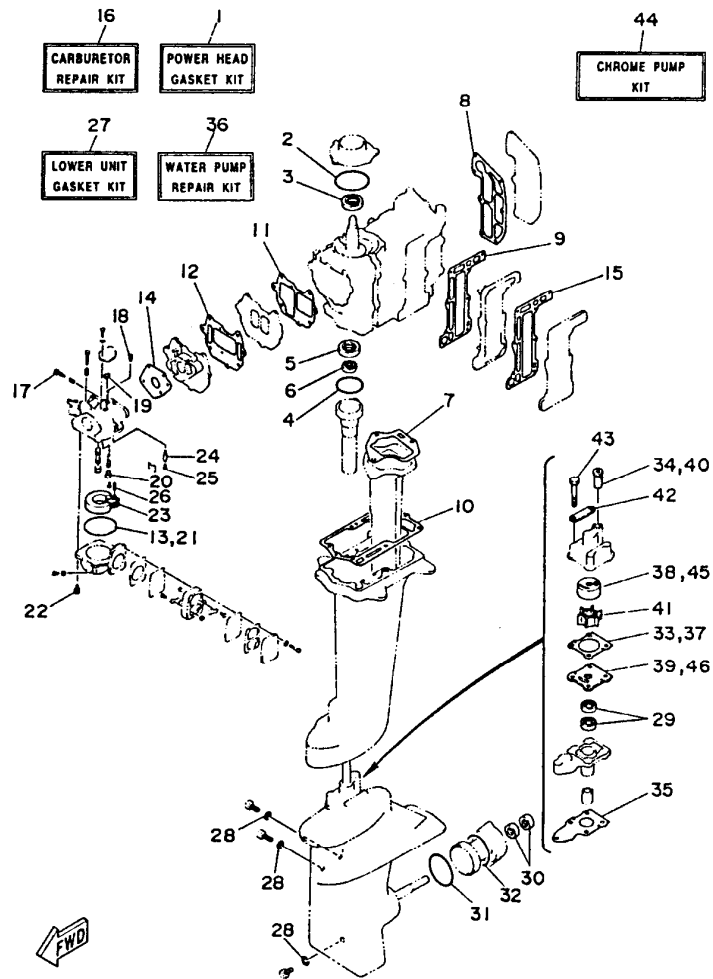

6M80010-7190

FIG. 19 REPAIR KIT

ESTUCHE REPARATION

REF. NO.	PART NO. CODIGO NO.	DESCRIPTION DESCRIPTION	Q	Q		REMARKS OBSERVACION
1	6N0-W0001-A0	POWER HEAD GASKET KIT JUEGO DE EMPAQUE	1	1		
2	93210-54M54	.O-RING .ANILLO O	1	1		
3	93102-20M25	.OIL SEAL .SELLO ACEITE	1	1		
4	93210-42159	.O-RING .ANILLO O	1	1		
5	93101-20M29	.OIL SEAL .SELLO ACEITE	1	1		
6	93101-12M26	.OIL SEAL .SELLO ACEITE	1	1		
7	6G1-41133-A0	.GASKET, EXHAUST MANIFOLD 1 .EMPAQUE ESCAPE MULTIPLE	1	1		
8	6G1-11193-A1	.GASKET, HEAD COVER 1 .EMPAQUE	1	1		
9	6G1-41112-A1	.GASKET, EXHAUST INNER COVER .EMPAQUE	1	1		
10	6G1-41113-A1	.OUTER COVER, EXHAUST .CUBOERTA EXTERIOR DE ESCAPE	1	1		
11	6G1-13621-A1	.GASKET, VALVE SEAT .JUNTA, DE VALV.DE EMPAQUE	1	1		
12	6G1-13645-A1	.GASKET, MANIFOLD 1 .EMPAQUE	1	1		
13	6G1-14984-00	.O-RING .EMPAQUE CAMARA DE BOIA	1	1		
14	6G1-14198-A1	.GASKET .EMPAQUE	1	1		
15	6G1-41114-A0	.GASKET, EXHAUST OUTER COVER .EMPAQUE	1	1		
16	6N0-W0093-00	CARBURETOR REPAIR KIT KIT REPARACION CARBURADOR	1	1		
17	679-14923-00	.SCREW, PILOT .TORNILLO DE AJUSTE	1	1		
18	6G1-14966-00	.CAP .TAPA	1	1		
19	6G1-14126-00	.GASKET .EMPAQUE	1	1		
20	676-14966-00	.CAP .TAPA	1	1		
21	6G1-14984-00	.O-RING .EMPAQUE CAMARA DE BOIA	1	1		
22	97980-04114	.SCREW, WITH WASHER .TORNILLO, CON ARANDELA	4	4		
23	6G1-14985-00	.FLOAT .BOIA	1	1		
24	6G1-14546-00	.VALVE, NEEDLE .VALVULA DE AGUJA	1	1		
25	676-14186-00	.PIN, FLOAT .PASADOR DE LA BOYA	1	1		
26	688-14548-00	.PIN, FLOAT ARM .PASADOR DE BRAZO DE BOIA	1	1		
27	6N0-W0001-C0	LOWER UNIT GASKET KIT JUEGO DE JUNTA UNIDAD INFERIOR	1	1		

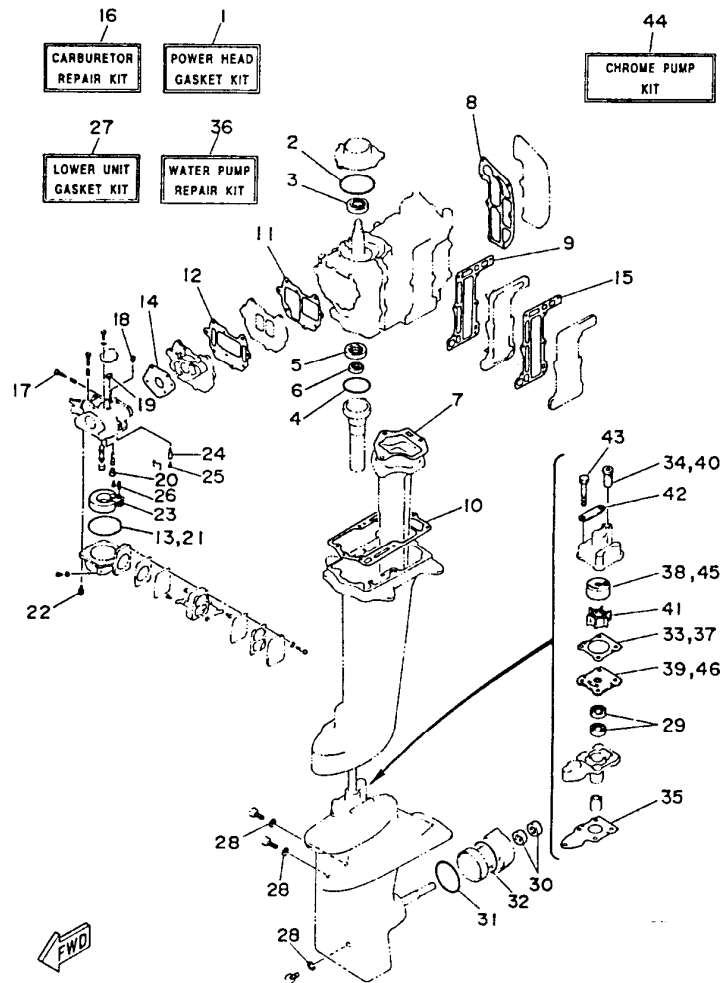

FIG. 19 REPAIR KIT

ESTUCHE REPARATION

REF. NO.	PART NO. CODIGO NO.	DESCRIPTION DESCRIPTION	Q	Q		REMARKS OBSERVACION
28	90430-08020	.GASKET .JUNTA	3	3		
29	93101-11M23	.OIL SEAL .SELLO ACEITE	2	2		
30	93101-15074	.OIL SEAL .SELLO ACEITE	2	2		
31	93210-49046	.O-RING .ANILLO O	1	1		
32	93210-53M08	.O-RING .ANILLO O	1	1		
33	6G1-44315-A0	.GASKET, WATER PUMP .EMPAQUE	1	1		
34	647-44366-00	.DAMPER, WATER SEAL .GOMA DEL SELLO DE AGUA	1	1		
35	6G1-45315-A0	.PACKING, LOWER CASING .EMPAQUE	1	1		
36	6N0-W0078-A0	WATER PUMP REPAIR KIT ESTUCHE REPARACION BOMBA AGUA	1	1		
37	6G1-44315-A0	.GASKET, WATER PUMP .EMPAQUE	1	1		
38	6G1-44322-00	.INSERT, CARTRIDGE .CARTUCHO	1	1		
39	6G1-44323-00	.OUTER PLATE, CARTRIDGE .PLACA EXTERIOR DEL CARTUCHO	1	1		
40	647-44366-00	.DAMPER, WATER SEAL .GOMA DEL SELLO DE AGUA	1	1		
41	6G1-44352-00	.IMPELLER .IMPULSOR	1	1		
42	6G1-44328-00	.PLATE .PLACA	2	2		
43	97095-06045	.BOLT .PERNO	4	4		
44	6N0-W0078-0A	CHROME PUMP KIT ESTUCHE REPARACION BOMBA AGUA	1	1		
45	6G1-44322-40	.INSERT, CARTRIDGE .CARTUCHO	1	1		CHROMATE
46	6G1-44323-40	.OUTER PLATE, CARTRIDGE .PLACA EXTERIOR DEL CARTUCHO	1	1		CHROMATE

6M80010-7190

NUMERICAL INDEX
INDICE NUMERICO

PART NO. CODIGO NO.	REF. NO.	PART NO. CODIGO NO.	REF. NO.	PART NO. CODIGO NO.	REF. NO.	PART NO. CODIGO NO.	REF. NO.	PART NO. CODIGO NO.	REF. NO.	PART NO. CODIGO NO.	REF. NO.
6G1-45533-00-20	15-41	90149-05M13	11-17	90501-23215	11-15	93210-08287	18-16	97013-06016	2-11		
6G1-45533-00-21	15-41	90152-05M03	16-5	90502-10M06	13-23	93210-12327	12-15	97013-06035	7-6		
6G1-45533-00-22	15-41	90157-05811	17-5	90508-10M15	13-41	93210-30M31	13-56	97075-06020	7-23		
647-45567-00	15-46	90170-10113	8-18	90508-10M16	13-42	93210-42159	2-13	97095-06010	13-33		
664-45587-01-10	15-43	90171-10M01	16-11	90508-14M17	13-43		19-4	97095-06012	6-11		
664-45587-01-12	15-43	90185-05002	16-6	90510-08800	7-4	93210-49046	15-24		12-22		
664-45587-01-15	15-43	90185-08057	13-15	91490-16010	11-10		19-31	97095-06016	1-3		
664-45587-01-18	15-43	90201-06M30	7-7	91490-30020	16-12	93210-53M08	15-25		2-16		
664-45587-01-30	15-43	90201-10M01	16-10	91609-20008	3-13		19-32		15-9		
664-45587-01-40	15-43	90201-10M02	16-16	91690-20010	12-25	93210-54M54	2-9		15-26		
664-45587-01-50	15-43	90201-10126	8-19	91690-30016	13-11		19-2	97095-06020	11-7		
6G1-45611-01	15-52	90201-15M89	15-45	91690-30018	13-21	93306-004U0	15-22		14-3		
6G1-45616-01	16-15	90201-41303	3-14	92902-04100	8-14	93306-204U0	3-7	97095-06025	6-2		
6G1-45631-00	15-47	90202-36M55	11-3	92902-05100	8-8	93310-112V0	3-17	97095-06030	15-16		
6G1-45632-00	15-48	90206-12052	10-5		8-11	93310-418V1	3-8	97095-06045	15-34		
654-45633-00	15-49	90206-36M21	11-2	92903-10600	11-16	93332-000U4	15-7		19-43		
6G1-45635-00	15-51	90209-18112	3-9	92990-04100	5-10	93430-05027	13-37	97095-06135	13-17		
6G1-45941-00-EL	16-13	90243-04M01	13-8	92990-05100	12-6	93430-06M02	7-9	97095-08016	13-45		
6G1-45943-00-EL	16-13	90266-04M00	1-9	92990-05600	7-34	93430-06005	15-39	97095-08025	13-30		
6G1-45947-00-EL	16-13	90269-02M09	11-14		12-17	93440-47055	3-12	97780-50514	4-11		
6E7-81303-A0	8-6	90280-03024	15-38		12-26	93450-13022	3-19	97802-04008	8-13		
6E5-82148-00	13-2	90280-04M06	8-17	92990-06300	15-10	93604-08062	2-3	97802-05016	8-9		
6G1-82149-00	14-11	90340-08M04	15-11	92990-06600	13-18		14-6	97802-05020	8-10		
6G1-82370-21	9-12	90386-08032	11-18	92990-08600	13-28		15-18	97802-05025	8-7		
663-82370-01	9-12	90386-12M45	10-3	92995-05600	9-5		16-1	97880-04010	5-9		
6A0-82550-01	10-22	90386-33M96	11-4	92995-06600	1-4	93700-06M03	13-25	97880-05010	12-5		
682-82556-00	10-23	90386-34M97	11-5		2-17	94702-00217	2-27	97880-05016	7-33		
689-8257Y-00	10-24	90386-44M42	8-16		6-3	94702-00271	2-27		12-16		
6E9-82575-02	10-22	90387-06M13	13-16		6-12	95303-06600	7-8	97885-05010	9-4		
6G1-83557-00	9-16	90387-06M52	10-19		7-24	95380-03600	5-27	97885-05012	11-21		
6G1-85509-70	8-3	90387-06M70	4-10		12-23	95380-05700	10-11	97885-06008	13-3		
6G1-85515-70	8-15	90387-14M49	15-6		13-34	95380-06600	12-30		14-12		
6E7-85520-70	8-4	90387-22M50	2-6		14-4		13-19	97885-06030	10-6		
696-85540-11	9-13	90430-08020	15-12		15-17	95380-06700	10-7	97980-04114	5-17		
6G1-85548-70	8-12		19-28		15-27	95895-06010	9-7		19-22		
6G1-85550-71	8-1	90445-09220	6-6	92995-08600	13-31		9-15	97980-04125	5-28		
6G1-85560-F0	8-2	90445-09221	6-5		13-46		12-8	98580-03006	5-26		
6G1-85570-01	9-9	90445-11M05	18-11	93101-11M23	15-15	95895-06016	7-16	98580-04008	5-24		
6E7-85580-70	8-5	90445-11M06	18-9		19-29	95895-06020	7-18	98586-05016	18-4		
90101-08869	13-12	90465-08M17	9-11	93101-12M26	2-15		9-14				
90105-06M14	2-20	90467-08004	6-7		19-6		10-20				
	12-20	90467-09M05	15-37	93101-15074	15-23	95895-06025	7-27				
90105-06M24	2-24	90480-15M31	10-18		19-30		9-10				
90105-06M25	2-5	90480-20M29	14-9	93101-20M29	19-5	95895-06030	14-7				
90105-06M26	2-4	90501-10227	7-31	93101-20M34	2-14		16-2				
90105-06M29	7-20	90501-10326	5-11	93102-20M25	2-10	95895-06035	13-51				
90109-06M17	12-29	90501-12M38	15-50		19-3		13-61				
90149-05M02	10-10	90501-18M00	13-27	93210-08287	18-14	95895-06085	4-7				

— MEMO —

A series of horizontal dotted lines for writing.