

# PARTS CATALOGUE

**90-2011** (6H1D)  
**90AETO'11** (6H1D)

---



2011/5/25

1K6H1-100E1

( )

NEWS NO.	DATE	COMMENT
PE0-OM-110024	May,16,2011	MOD:FIG.14 LIST/ILLUSTRATION REVISION

90/90AETO  
PARTS CATALOGUE  
©2010 by Yamaha Motor Co., Ltd.  
1st edition, May 2010  
All rights reserved.  
Any reprinting or unauthorized use  
without the written permission of  
Yamaha Motor Co., Ltd.  
is expressly prohibited.  
Printed in Japan.

# FOREWORD

This Parts Catalogue is related to the parts for the model(s) on the cover page. When you are ordering replacement parts, please refer to this Parts Catalogue and quote both part numbers and part names correctly.

1. Modifications or additions which have been made after the issue of the Parts Catalogue will be announced in the Parts News.  
It is advisable that you make the necessary corrections to the Parts Catalogue according to the Parts News.

2. Abbreviations

The following abbreviations are used in this Parts Catalogue.

“UR” Use specified parts number.

“UN” Use as many as needed.

“AP” Alternate Parts

“LM” Locally Made (Parts need to be ordered locally)

“F#” Frame No. (Applicable machine No.)

“O/S” Over Size

3. The number of components for assembly

- Parts, which are to be supplied in an assembly, are listed with a dot (.) in front of the part name as shown below.
- The numeral appearing to the right of each component part indicates the quantity of parts for each assembly unit.

PART NO.	DESCRIPTION	Q'TY	REMARKS
2F5-83310-60	FRONT FLASHER LIGHT ASSY	2	
115-83311-60	.BULB (6V-18W)	1	

4. Applicable colours of graphics are represented in the “REMARKS” as shown below.

PART NO.	DESCRIPTION	Q'TY	REMARKS
2N4-24110-00-X5	FUEL TANK COMP.	2	MXR
3J1-24240-10	.GRAPHIC, FUEL TANK	1	FOR MXR

5. Note that the illustrations for reference in finding parts numbers are not to be used for assembling. When assembling, please use the applicable service manual.

6. The asterisk (\*) before a reference number indicates modified items after the first edition.

7. Applicable Serial No.

Engine Serial No.

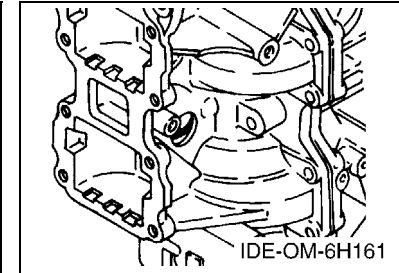
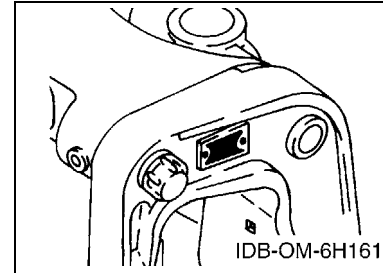

8. Applicable Engine Starting Serial No.

Model	Serial No.	Model	Serial No.
90	6H1-1045543	90A	6H1-1045543

9. Applicable Colour Code

Abbreviation	Colour Name	Colour Code
DBN1	DARK BLUISH GRAY 1	008D

10. Quantity Column Information

Column No.	Name Of Q'ty Column	Applicable Model
1	CAN	90(CANADA)
2	OCE	90AETO(OCEANIA)

# CONTENTS

TOP COWLING .....	1
CYLINDER & CRANKCASE .....	3
CRANKSHAFT & PISTON .....	6
INTAKE .....	8
CARBURETOR .....	9
OIL PUMP .....	11
FUEL 1 .....	13
FUEL 2 .....	15
GENERATOR .....	16
ELECTRICAL .....	17
STARTING MOTOR .....	19
BOTTOM COWLING .....	20
CONTROL .....	22
BRACKET 1 .....	24
BRACKET 2 .....	26
POWER TRIM & TILT ASSY .....	28
UPPER CASING .....	31
LOWER CASING & DRIVE 1 .....	32
LOWER CASING & DRIVE 2 .....	36
STEERING GUIDE .....	38
REMOTE CONTROL BOX .....	39
REMOTE CONTROL ASSY .....	40
METER .....	43
OPTIONAL PARTS .....	44
REPAIR KIT 1 .....	45
REPAIR KIT 2 .....	47

## INDEX

NUMERICAL INDEX .....	49
-----------------------	----

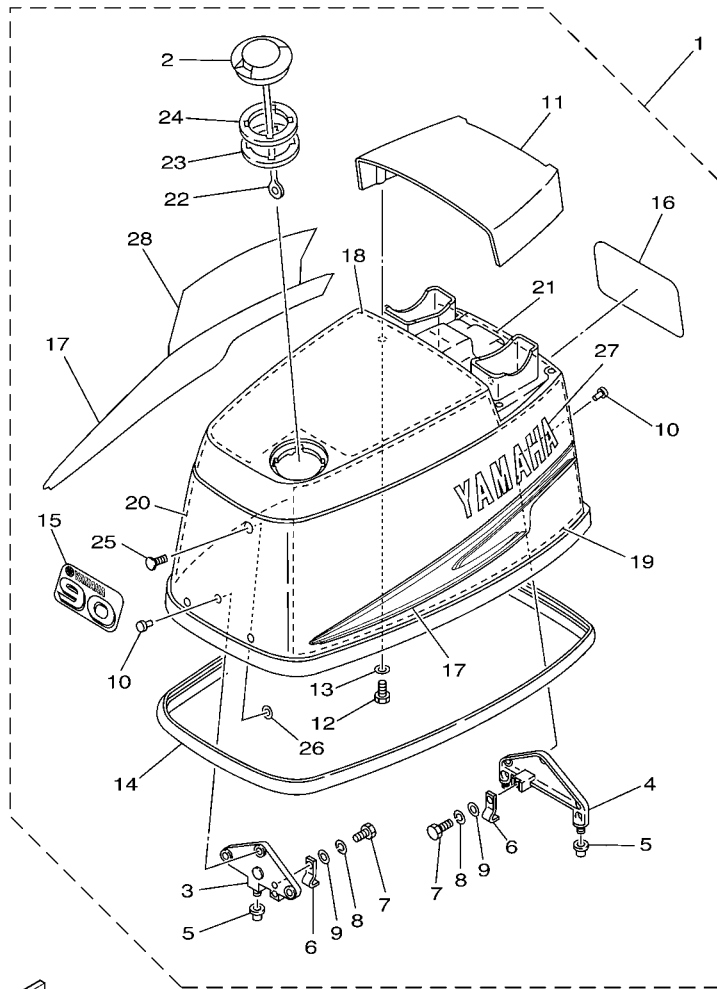

6H14100-3010

FIG. 1 TOP COWLING

REF. NO.	PART NO.	DESCRIPTION	CAN	QTY	REMARKS
1	6H1-42610-80	TOP COWLING ASSY	1	1	
2	63D-2177H-00	.DISK CAP 2	1	1	
3	6H1-42647-00	.HOLDER, CLAMP BAND	1	1	
4	6H1-42649-00	.HOLDER, CLAMP BAND	1	1	
5	663-42662-00	.DAMPER	3	3	
6	688-42652-10	.HOOK	2	2	
7	97095-06016	.BOLT	2	2	
8	92995-06100	.WASHER, SPRING	2	2	
9	92995-06600	.WASHER	2	2	
10	90266-06009	.RIVET	6	6	
11	6H1-42613-01-8D	.MOLDING, AIR DUCT	1	1	
12	97095-06016	.BOLT	4	4	
13	92995-06600	.WASHER	4	4	
14	688-42615-00	.SEAL	1	1	
15	6H1-42677-80	.GRAPHIC, FRONT	1	1	
16	6H1-42678-60	.GRAPHIC, REAR	1	1	
17	6H1-W0070-60	.GRAPHIC SET	1	1	
18	6H1-42617-10	.DAMPER, FORM	1	1	
19	6H1-42619-00	.DAMPER, FORM	1	1	
20	6H1-42627-00	.DAMPER, FORM	1	1	
21	6H1-42637-00	.DAMPER, FORM	1	1	
22	6H1-42694-00	.BAND	1	1	
23	6H3-21732-00	.SEAL 1	1	1	
24	6H3-21735-00	.SEAL 2	1	1	
25	90338-05M12	.PLUG	1	1	
26	90183-05M06	.NUT, SPRING	1	1	
27	6H1-42681-50	.MARK, COWLING	1	1	



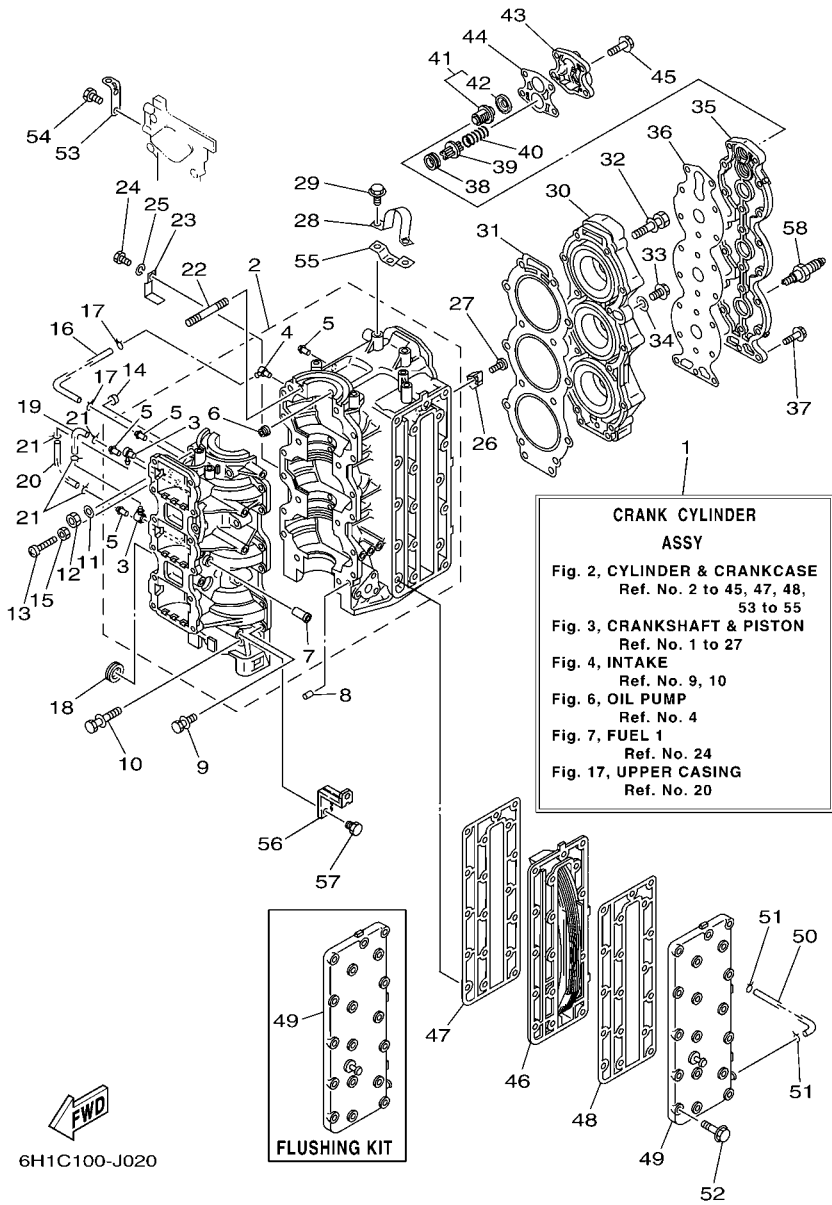

**FIG. 2 CYLINDER & CRANKCASE**

REF. NO.	PART NO.	DESCRIPTION	CAN	QTY	REMARKS
1	6H1-W0090-45-1S	CRANK CYLINDER ASSY (O/I)	1	1	
2	6H1-15100-05	CRANKCASE ASSY (O/I, PRIME ST)	1	1	
3	688-11370-01	.CHECK VALVE ASSY	2	2	
4	650-11370-01	.CHECK VALVE ASSY	1	1	
5	624-14485-00	.PIPE, JOINT	4	4	
6	663-11518-01	.LOCK, BEARING	3	3	
7	650-24378-00	.PIPE, JOINT 4	1	1	
8	99530-08012	PIN, DOWEL	2	2	
9	90119-06M12	BOLT, WITH WASHER	12	12	
10	90119-10005	BOLT, WITH WASHER	6	6	
11	90201-10008	WASHER, PLATE	2	2	
12	95313-10600	NUT	2	2	
13	90157-06014	SCREW, PAN HEAD	1	1	
14	688-44194-00	CAP	1	1	
15	95303-06700	NUT	1	1	
16	90445-07260	HOSE (L276)	1	1	
17	90467-06016	CLIP	2	2	
18	90480-24M04	GROMMET	1	1	
19	90445-07M00	HOSE (L100)	1	1	
20	90445-07M23	HOSE (L408)	1	1	
21	90467-06016	CLIP	4	4	
22	90116-10M06	BOLT, STUD	2	2	
23	90465-12M03	CLAMP	1	1	
24	97095-06014	BOLT	1	1	
25	92995-06100	WASHER, SPRING	1	1	
26	688-11325-00	ANODE	2	2	
27	98780-04015	SCREW, FLAT HEAD	2	2	

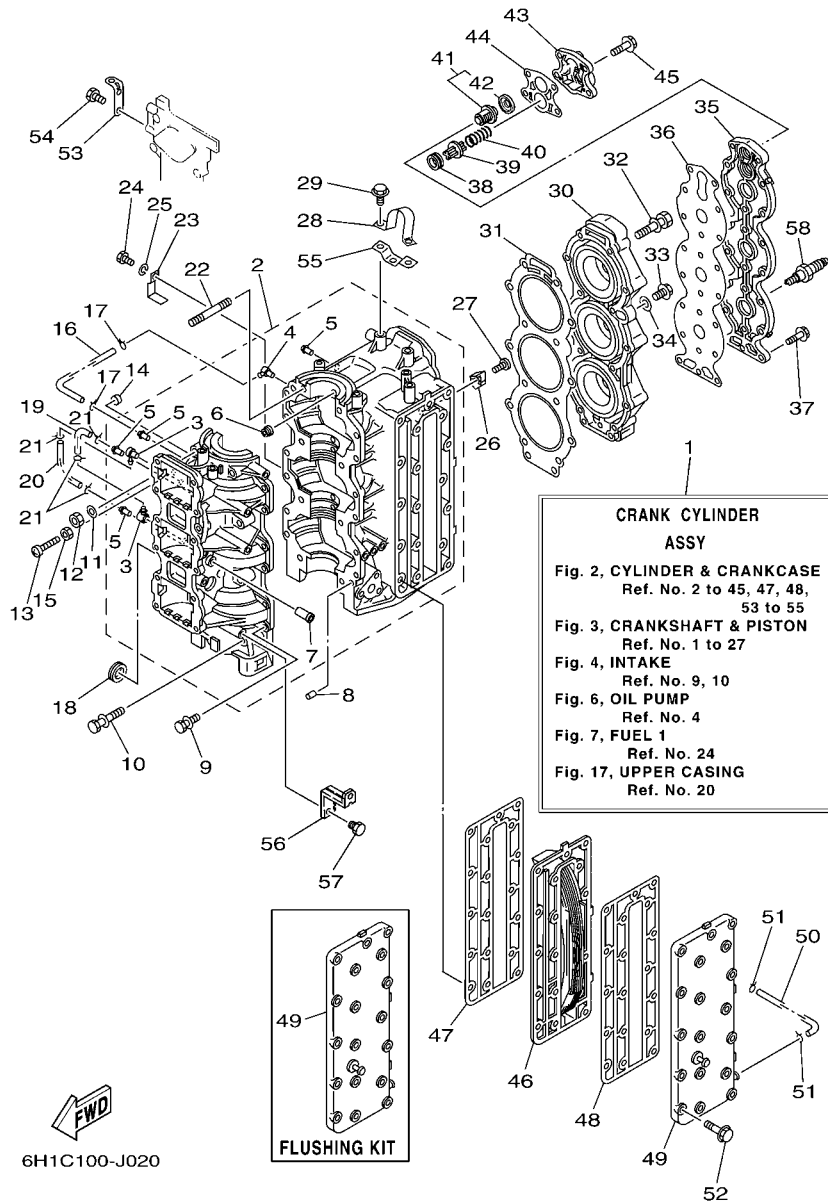

**FIG. 2 CYLINDER & CRANKCASE**

REF. NO.	PART NO.	DESCRIPTION	CAN	QTY	REMARKS
28	688-11119-01	HANGER, ENGINE	1	1	
29	90119-08MA3	BOLT, WITH WASHER	2	2	
30	6H1-11111-01-1S	HEAD, CYLINDER 1	1	1	
31	688-11181-A2	GASKET, CYLINDER HEAD 1	1	1	
32	90119-08MA8	BOLT, WITH WASHER	14	14	
33	90340-14M00	PLUG, STRAIGHT SCREW	1	1	
34	90430-14115	GASKET	1	1	
35	688-11191-00-1S	COVER, CYLINDER HEAD 1	1	1	
36	688-11193-A1	GASKET, HEAD COVER 1	1	1	
37	90119-06MA3	BOLT, WITH WASHER	18	18	
38	90480-20M05	GROMMET	1	1	
39	688-12416-00	VALVE, PRESSURE CONTROL	1	1	
40	90501-16M11	SPRING, COMPRESSION	1	1	
41	688-12411-11	THERMOSTAT	1	1	
42	688-12412-00	.SEAL, THERMOSTAT	1	1	
43	688-12413-00-1S	COVER, THERMOSTAT	1	1	
44	688-12414-A1	GASKET, COVER	1	1	
45	90119-06MA5	BOLT, WITH WASHER	4	4	
46	688-41111-00-1S	INNER COVER, EXHAUST	1	1	
47	688-41112-A0	GASKET, EXHAUST INNER COVER	1	1	
48	688-41114-A0	GASKET, EXHAUST OUTER COVER	1	1	
49	688-41113-00-1S	OUTER COVER, EXHAUST	1	1	FOR STD
	6H1-41113-00-1S	OUTER COVER, EXHAUST	1	1	FLUSHING KIT
50	663-24312-01	PIPE 2	1	1	
51	90467-08004	CLIP	2	2	
52	90119-08020	BOLT, WITH WASHER	18	18	
53	6H1-15772-00	STAY 2	1	1	





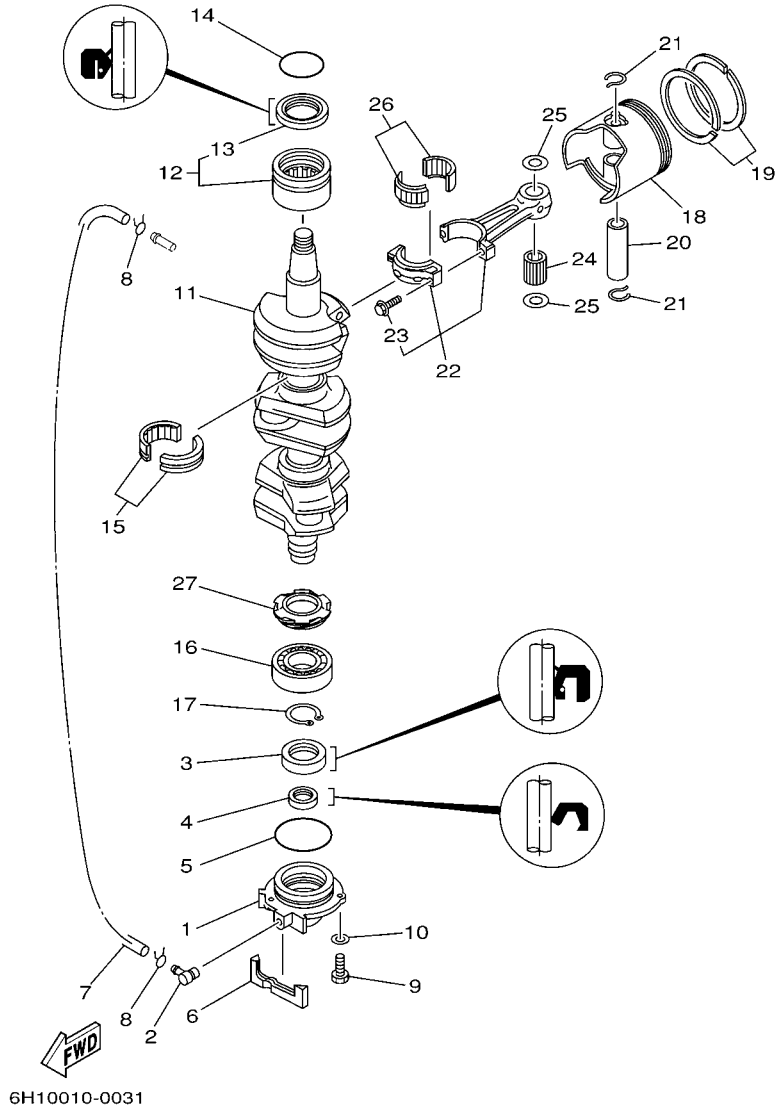

FIG. 3 CRANKSHAFT & PISTON

REF. NO.	PART NO.	DESCRIPTION	CAN	QTY	REMARKS
1	6H1-15359-01-94	HOUSING, OIL SEAL	1	1	
2	688-11370-01	CHECK VALVE ASSY	1	1	
3	93102-30M05	OIL SEAL	1	1	
4	93104-20M02	OIL SEAL	1	1	
5	93210-62269	O-RING	1	1	
6	688-15379-00	SEAL, CRANKCASE	1	1	
7	90445-07M86	HOSE (L460)	1	1	
8	90467-06016	CLIP	2	2	
9	97095-06020	BOLT	3	3	
10	92995-06600	WASHER	3	3	
11	688-11411-01	CRANKSHAFT	1	1	
12	93310-636U4	BEARING	1	1	
13	93102-36M02	.OIL SEAL	1	1	
14	93210-46M16	O-RING	1	1	
15	93310-835U8	BEARING	2	2	
16	93306-206U5	BEARING	1	1	
17	93410-32M00	CIRCLIP	1	1	
18	6H1-11631-03-95	PISTON (STD)	3	3	
	6H1-11635-03	PISTON (0.25MM O/S)	3	3	AP
	6H1-11636-03	PISTON (0.50MM O/S)	3	3	AP
19	688-11603-A0	PISTON RING SET (STD)	3	3	
	688-11604-A0	PISTON RING SET (0.25MM O/S)	3	3	AP
	688-11605-A0	PISTON RING SET (0.50MM O/S)	3	3	AP
20	663-11633-00	PIN, PISTON	3	3	
21	688-11634-10	CLIP, PISTON PIN	6	6	
22	688-11650-03	CONNECTING ROD ASSY	3	3	
23	90109-08022	.BOLT	2	2	



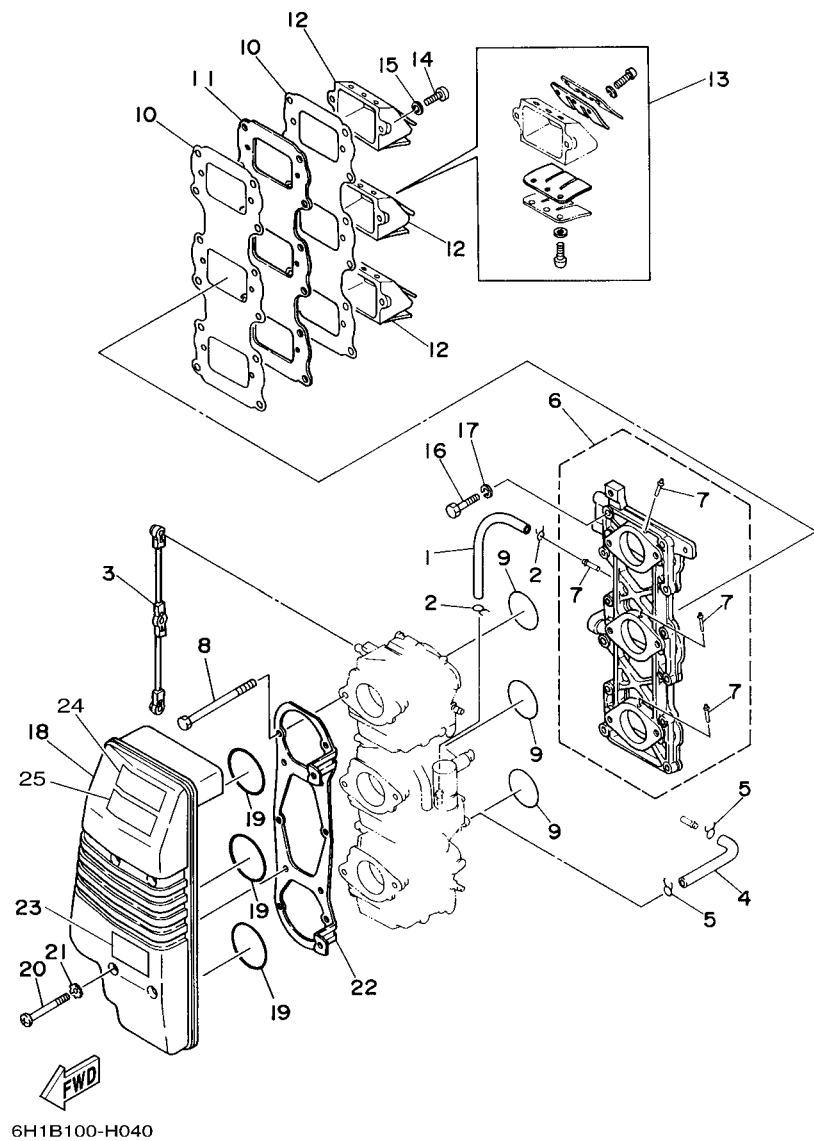
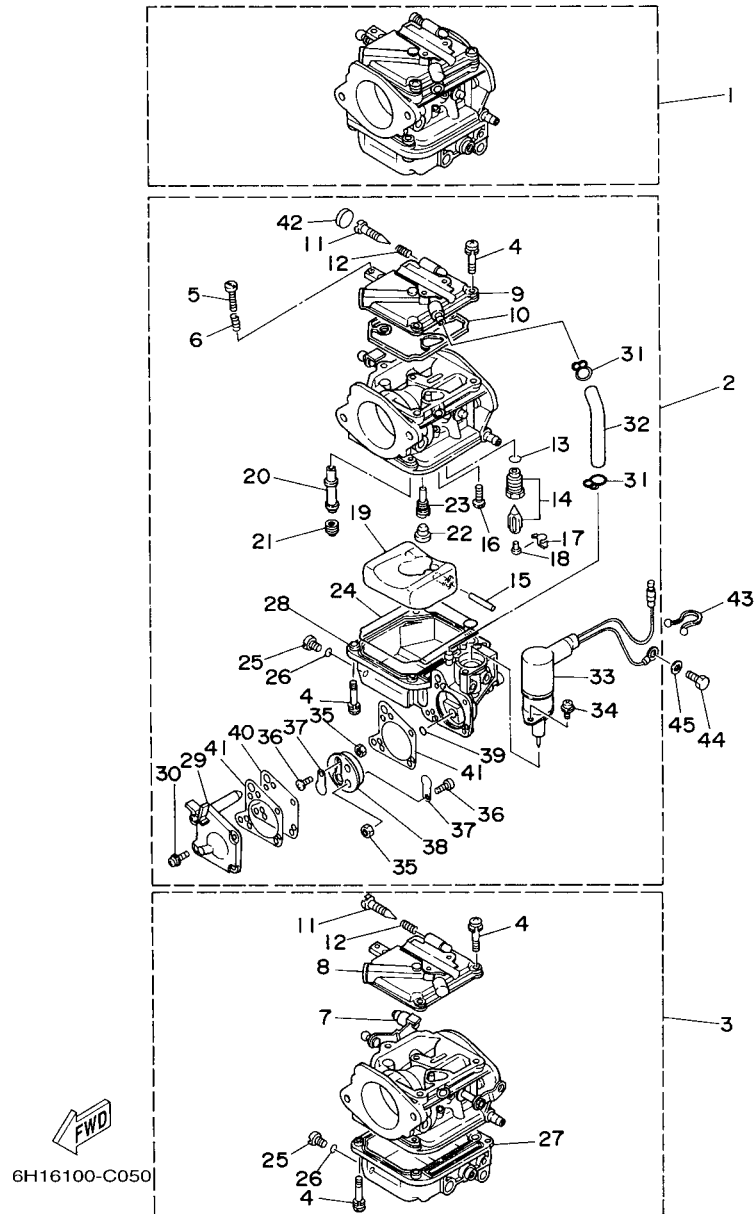

FIG. 4 INTAKE

REF. NO.	PART NO.	DESCRIPTION	CAN	QTY	REMARKS
1	90445-07M23	HOSE (L408)	1	1	
2	90467-06016	CLIP	2	2	
3	688-41217-01	ROD, ACCEL. LEVER	1	1	
4	6H3-14349-00	PIPE	1	1	
5	90467-08004	CLIP	2	2	
6	6H1-13641-02-94	MANIFOLD 1	1	1	
7	6H1-14485-00	.PIPE, JOINT	4	4	
8	97095-06095	BOLT	6	6	
9	93210-39ME4	O-RING	3	3	
10	688-13621-A1	GASKET, VALVE SEAT	2	2	
11	688-13624-00	PLATE, REED VALVE	1	1	
12	688-13610-00	REED VALVE ASSY	3	3	
13	688-W0004-00	.REED SET	1	1	
14	97880-05020	SCREW, PAN HEAD	6	6	
15	92990-05100	WASHER, SPRING	6	6	
16	97013-06030	BOLT	12	12	
17	92903-06100	WASHER, SPRING	12	12	
18	6H1-14440-02	SILENCER ASSY, INTAKE	1	1	
19	93210-46044	O-RING	3	3	
20	97885-06050	SCREW, PAN HEAD	4	4	
21	90209-06M05	WASHER	4	4	
22	6H1-14413-02	STAY	1	1	
23	6H1-85711-60	MARK, CAUTION	1	1	
24	6AH-81994-40	LABEL, SAFETY	1	1	
25	6AH-81994-50	LABEL, SAFETY	1	1	

FIG. 5 CARBURETOR



6H16100-C050

REF. NO.	PART NO.	DESCRIPTION	CAN	OGE		REMARKS
1	6H1-14301-30	CARBURETOR ASSY 1	1			
	6H1-14301-07	CARBURETOR ASSY 1		1		
2	6H1-14302-30	CARBURETOR ASSY 2	1			
	6H1-14302-07	CARBURETOR ASSY 2		1		
3	6H1-14303-30	CARBURETOR ASSY 3	1			
	6H1-14303-07	CARBURETOR ASSY 3		1		
4	97980-04114	.SCREW, WITH WASHER	21	21		
5	63V-14523-00	.SCREW, STOP	1	1		#2
6	90501-10326	.SPRING, COMPRESSION	1	1		#2
7	6H2-14578-00	.COLLAR	1	1		#3
8	6H4-14146-20	.PLATE	2			#1,3
	6H4-14146-00	.PLATE		2		#1,3
9	6H3-14146-20	.PLATE	1			#2
	6H3-14146-10	.PLATE		1		#2
10	6H4-14147-00	.O-RING	3	3		
11	692-14923-00	.SCREW, PILOT	3	3		
12	697-14555-00	.SPRING	3	3		
13	93210-04228	.O-RING	3	3		
14	692-14590-01	.NEEDLE VALVE ASSY	3	3		
15	6H4-14548-00	.PIN, FLOAT ARM	3	3		
16	98580-04008	.SCREW, PAN HEAD	3	3		
17	663-14159-00	.CLIP	3	3		
18	676-14186-00	.PIN, FLOAT	3	3		
19	6H4-14985-01	.FLOAT	3	3		
20	6H1-14947-75	.JET, NEEDLE	3	3		
21	6H1-14943-39	.JET, MAIN (#160)	3	3		
22	676-14966-00	.CAP	3	3		

FIG. 5 CARBURETOR

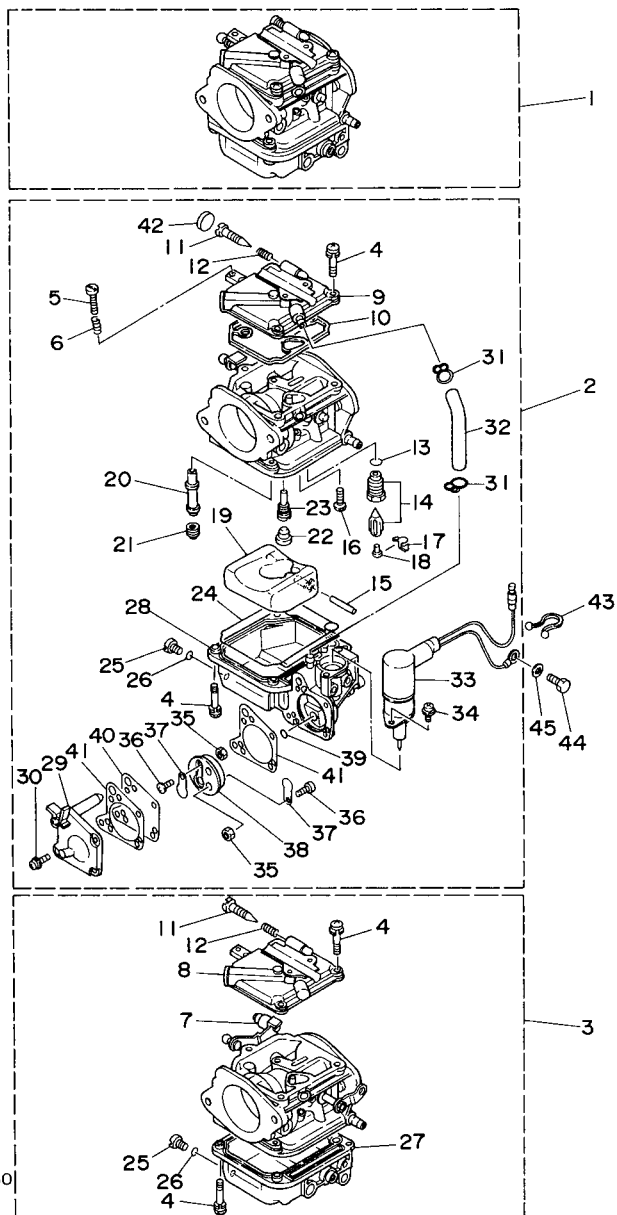

FWD  
6H16100-C050

REF. NO.	PART NO.	DESCRIPTION	CAN	QTY	REMARKS
23	6H1-14948-18	.JET (#78)	3	3	
24	6H4-14984-00	.GASKET, FLOAT CHAMBER	3	3	
25	6H3-14992-00	.SCREW, DRAIN	3	3	
26	93210-04230	.O-RING	3	3	
27	6H4-14980-00	.BODY, FLOAT CHAMBER	2	2	#1,3
28	6H3-14980-10	.BODY, FLOAT CHAMBER	1	1	#2
29	6H3-24452-10	.COVER	1	1	#2
30	6H4-14567-00	.SCREW	4	4	#2
31	6H3-14137-00	.CLIP	2	2	#2
32	6H3-14349-00	.PIPE	1	1	#2
33	6H3-14380-00	.STARTER ASSY	1	1	#2
34	97803-04010	.SCREW, PAN HEAD	2	2	#2
35	95380-03600	.NUT	2	2	#2
36	98980-03006	.SCREW, BIND	2	2	#2
37	6L5-24421-00	.VALVE, CHECK	2	2	#2
38	6H4-24413-00	.BODY 2	1	1	#2
39	6H4-24486-00	.O-RING	1	1	#2
40	6H3-24411-10	.DIAPHRAGM	1	1	#2
41	6H3-24434-10	.GASKET, BODY	2	2	#2
42	67C-1432A-00	.PLUG	3		
43	90465-18147	.CLAMP	1	1	
44	97013-06012	BOLT	1	1	
45	92903-06600	WASHER, PLATE	1	1	

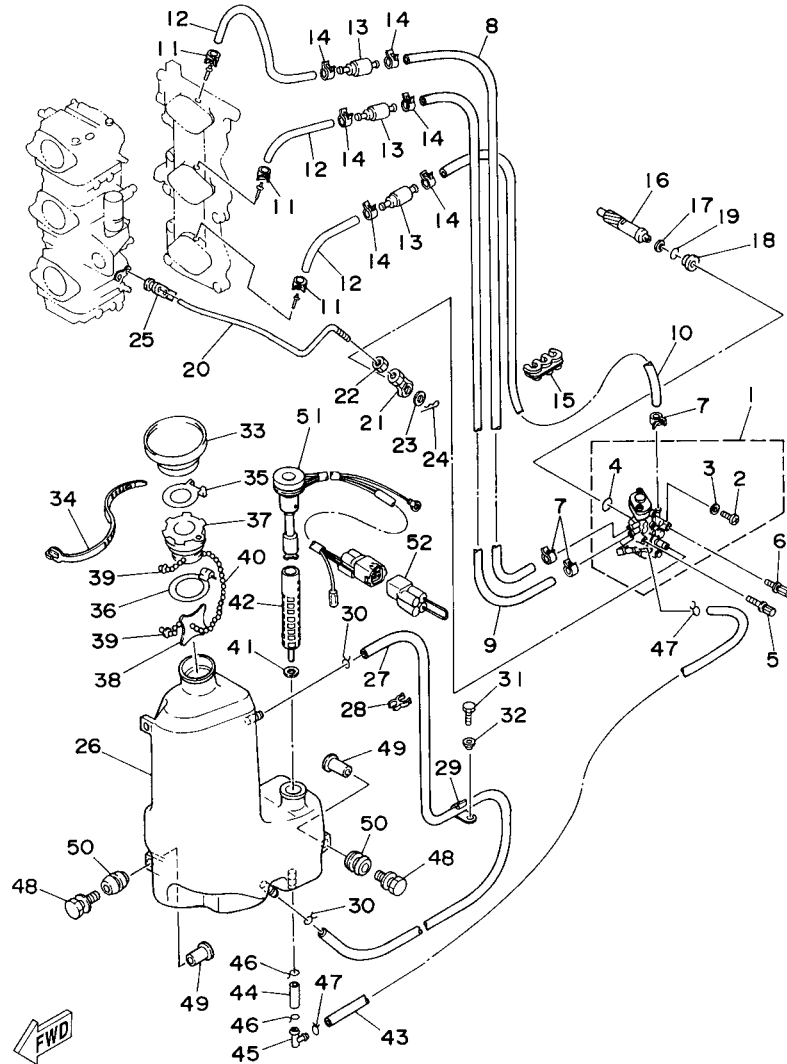

6H10010-0060

FIG. 6 OIL PUMP

REF. NO.	PART NO.	DESCRIPTION	CAN	QTY	REMARKS
1	6H1-13200-02	OIL INJECTION PUMP ASSY	1	1	
2	6R3-13471-00	.PLUG, DRAIN	1	1	
3	6L2-13475-00	.GASKET	1	1	
4	93210-19MA7	.O-RING	1	1	
5	90109-06M39	BOLT	1	1	
6	90109-06M40	BOLT	1	1	
7	90468-07M02	CLIP	3	3	
8	90445-07M90	HOSE (L390)	1	1	
9	90445-07240	HOSE (L330)	1	1	
10	90445-07M44	HOSE (L250)	1	1	
11	90468-07M02	CLIP	3	3	
12	90445-07M87	HOSE (L110)	3	3	
13	6E9-13183-70	VALVE, CHECK	3	3	
14	90468-07M02	CLIP	6	6	
15	90464-07M05	CLAMP	1	1	
16	6H1-11537-01	GEAR, DRIVEN	1	1	
17	90201-08M93	WASHER, PLATE	1	1	
18	6H1-13117-01	COLLAR, DISTANCE	1	1	
19	93210-13M04	O-RING	1	1	
20	6H1-41241-02	ROD, LINK	1	1	
21	6H1-41237-00	JOINT, LINK	1	1	
22	95380-05600	NUT	1	1	
23	90202-05088	WASHER, PLATE	1	1	
24	90468-05M03	CLIP	1	1	
25	6E9-41237-00	JOINT, LINK	1	1	
26	6H1-21707-07	OIL TANK COMP.	1	1	
27	90445-11M09	HOSE (L600)	1	1	

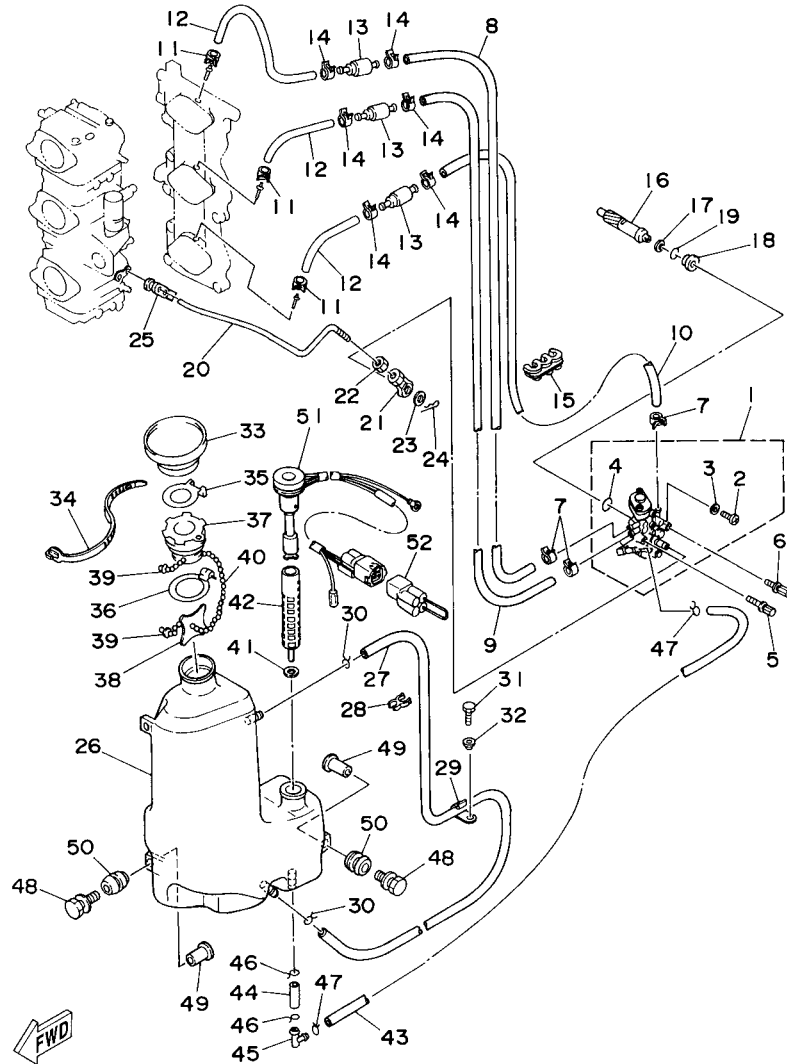

6H10010-0060

FIG. 6 OIL PUMP

REF. NO.	PART NO.	DESCRIPTION	CAN	QTY	REMARKS
28	90464-11M24	CLAMP	1	1	
29	90465-11M27	CLAMP	1	1	
30	90467-11M08	CLIP	2	2	
31	97095-06016	BOLT	1	1	
32	90387-06M31	COLLAR	1	1	
33	6H1-21752-00	TUBE, FILLER 1	1	1	
34	90465-13M30	CLAMP	1	1	
35	63D-2176M-00	HOOK	1	1	
36	63D-2175R-00	HOOK, BAND	1	1	
37	6H4-21770-00	OIL TANK CAP ASSY	1	1	
38	6J8-21758-00	WASHER, SPECIAL 2	1	1	
39	6H1-21757-00	WASHER, SPECIAL 1	2	2	
40	6H1-24633-00	CHAIN, BALL	1	1	
41	6J8-13414-00	GASKET, STRAINER COVER	1	1	
42	6H1-13411-00	STRAINER, OIL	1	1	
43	6H1-21766-01	PIPE, OIL	1	1	
44	90445-08M01	HOSE (L30)	1	1	
45	6H1-13435-00	NIPPLE	1	1	
46	90467-12M11	CLIP	2	2	
47	90467-08004	CLIP	2	2	
48	90119-06M88	BOLT, WITH WASHER	3	3	
49	90387-06119	COLLAR	3	3	
50	6A0-82317-00	DAMPER, IGNITION COIL	3	3	
51	6H1-85720-16	OIL LEVEL GAUGE ASSY	1	1	
52	6R5-82582-B0	COVER, WIRE HARNESS	1	1	AP





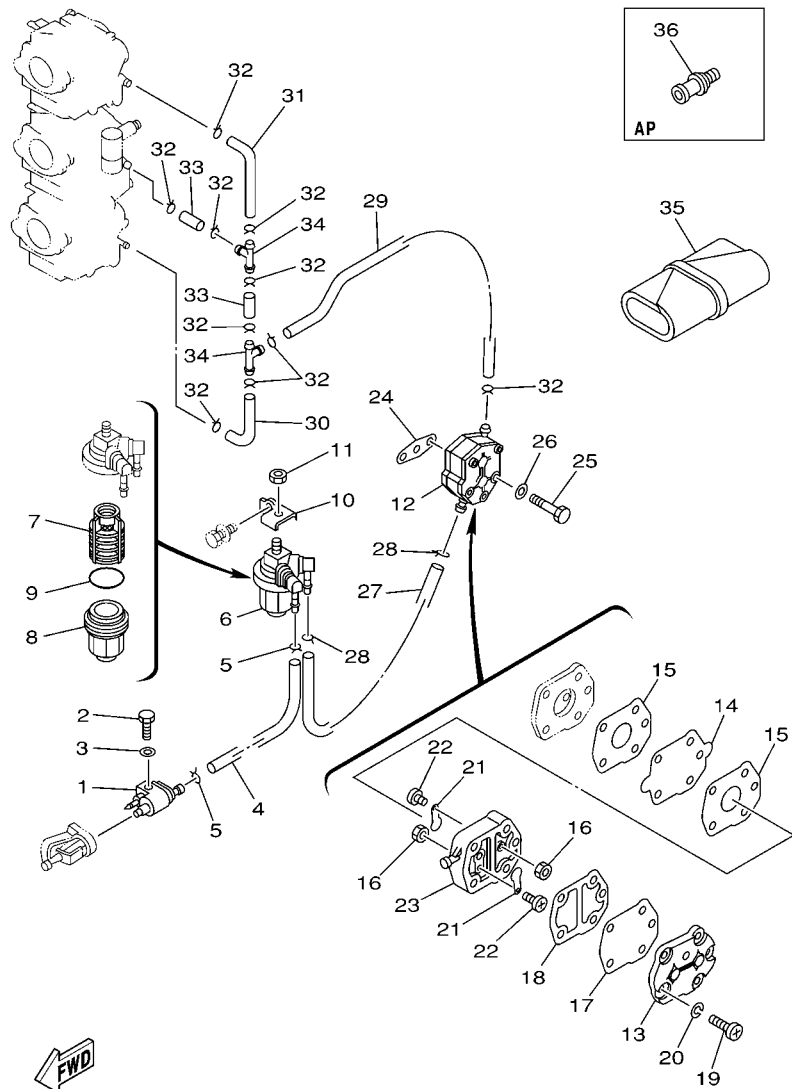

6H10010-0070

FIG. 7 FUEL 1

REF. NO.	PART NO.	DESCRIPTION	CAN	QTY	REMARKS
28	90467-08004	CLIP	2	2	
29	90445-09097	HOSE (L250)	1	1	
30	688-24313-00	PIPE 3	1	1	
31	688-24314-00	PIPE 4	1	1	
32	90467-08004	CLIP	10	10	
33	90445-09220	HOSE (L30)	2	2	
34	688-24378-00	PIPE, JOINT 3	2	2	
35	656-W2810-02	TOOL KIT	1	1	AP
36	6E0-28193-00-94	PLUG, WATER CHECK	1	1	AP D:12.5MM

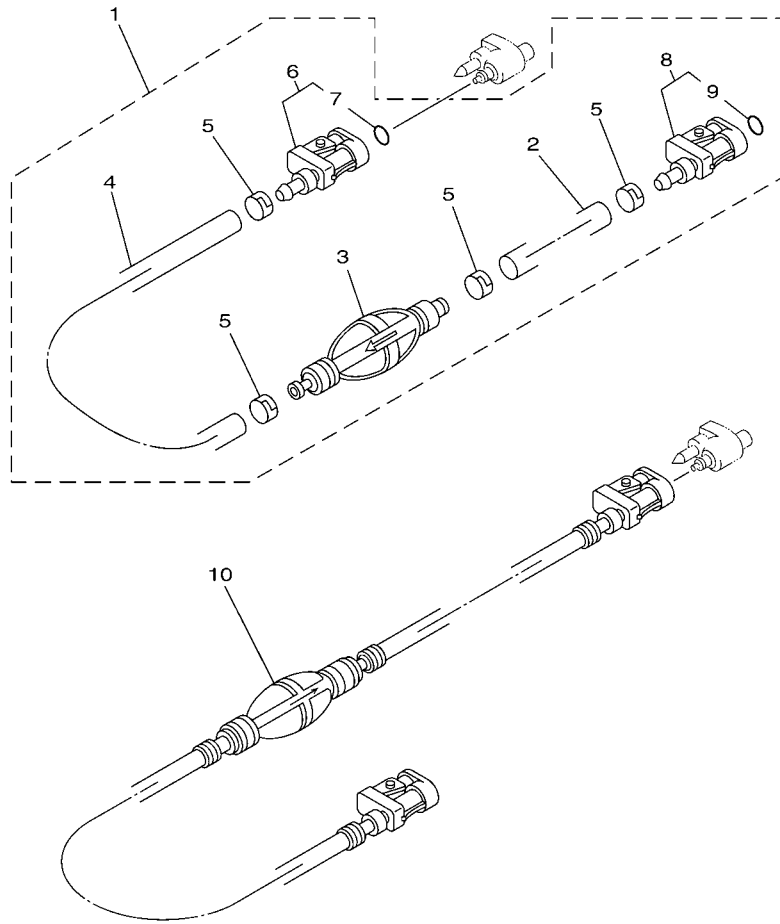

 6H1C100-J080

**FIG. 8 FUEL 2**

REF. NO.	PART NO.	DESCRIPTION	CAN	QTY	REMARKS
1	61J-24306-04	FUEL PIPE COMP. 1		1	AP
2	90445-11M06	.HOSE (L2050)		1	
3	61J-24360-00	.PRIMER PUMP ASSY		1	
4	90445-11M05	.HOSE (L850)		1	
5	650-24351-01	.BAND 1		4	
6	6G1-24305-05	.FUEL PIPE JOINT COMP. 2		1	
7	93210-08287	..O-RING		1	
8	6Y1-24305-06	.FUEL PIPE JOINT COMP. 2		1	
9	93210-08287	..O-RING		1	
10	6YL-24306-60	FUEL PIPE COMP. 1	1		AP

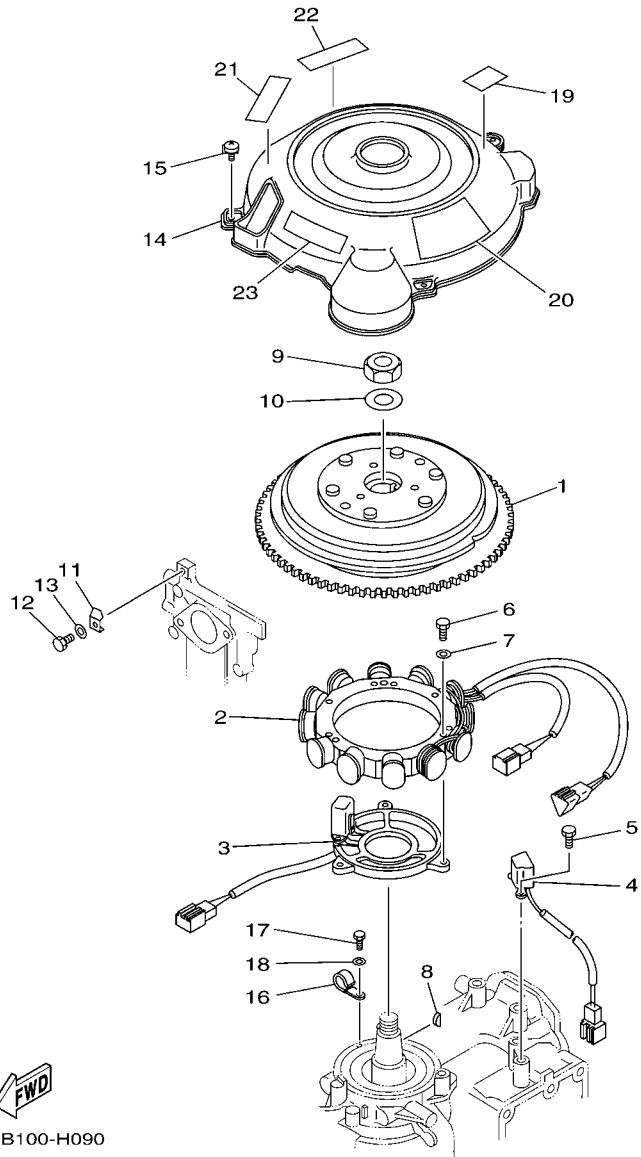

6H1B100-H090

FIG. 9 GENERATOR

REF. NO.	PART NO.	DESCRIPTION	CAN	OCE		REMARKS
1	6H0-85550-00	ROTOR ASSY	1	1		
2	6H0-85510-03	STATOR ASSY	1	1		
3	6H0-85580-01	COIL, PULSER	1	1		
4	6H2-85895-01	CRANK POSITION SENDER	1	1		
5	97095-05012	BOLT	2	2		
6	97095-06040	BOLT	3	3		
7	92995-06600	WASHER	3	3		
8	90280-05015	KEY, WOODRUFF	1	1		
9	90170-20137	NUT	1	1		
10	90201-21M18	WASHER, PLATE	1	1		
11	688-81332-01	PLATE, TIMING	1	1		
12	97095-06010	BOLT	1	1		
13	92995-06600	WASHER	1	1		
14	6H1-81337-01	COVER, FLYWHEEL	1	1		
15	90159-06M20	SCREW, WITH WASHER	3	3		
16	90465-06M90	CLAMP	1	1		
17	97095-06012	BOLT	1	1		
18	92995-06600	WASHER	1	1		
19	6H1-14488-00	LABEL, CAUTION	1	1		
20	6H1-13437-21	MARK, CAUTION	1	1		
21	6AH-81995-40	LABEL, WARNING	1	1		
22	6AH-81995-50	LABEL, WARNING	1	1		
23	6AG-81996-00	MARK	1	1		

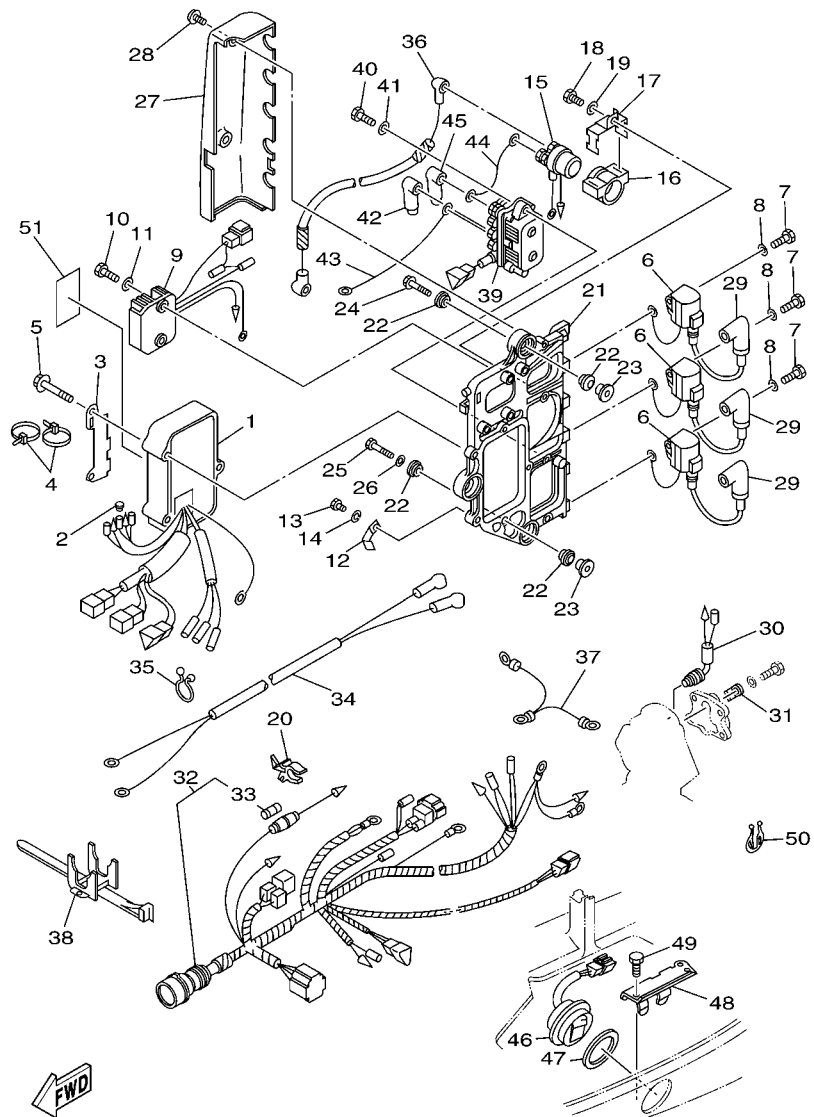

6H19100-F100

FIG. 10 ELECTRICAL

REF. NO.	PART NO.	DESCRIPTION	CAN	QTY	REMARKS
1	6H0-85540-07	C.D.I. UNIT ASSY	1	1	
2	703-82119-00	COVER, LEAD WIRE	1	1	
3	6H1-85542-10	BRACKET	1	1	
4	90465-13M11	CLAMP	2	2	
5	97595-06550	BOLT, WITH WASHER	3	3	
6	697-85570-00	IGNITION COIL ASSY	3	3	
7	97013-06020	BOLT	3	3	
8	92903-06600	WASHER, PLATE	3	3	
9	6H0-81960-10	RECTIFIER & REGULATOR ASSY	1	1	
10	97095-06020	BOLT	2	2	
11	92995-06600	WASHER	2	2	
12	90465-08M23	CLAMP	1	1	
13	97095-06012	BOLT	1	1	
14	92995-06100	WASHER, SPRING	1	1	
15	6G1-81941-10	STARTER RELAY ASSY	1	1	
16	6G1-81952-00	HOLDER, RELAY	1	1	
17	6E9-81945-70	PLATE, SWITCH FITTING	1	1	
18	97013-06016	BOLT	1	1	
19	92903-06600	WASHER, PLATE	1	1	
20	6G5-82152-00	HOLDER, FUSE	1	1	
21	6H1-85542-00-94	BRACKET	1	1	
22	90480-09M25	GROMMET	6	6	
23	90387-06M03	COLLAR	3	3	
24	90119-06M75	BOLT, WITH WASHER	2	2	
25	90109-06M39	BOLT	1	1	
26	90201-06M31	WASHER, PLATE	1	1	
27	6H1-81916-00	COVER, TERMINAL	1	1	

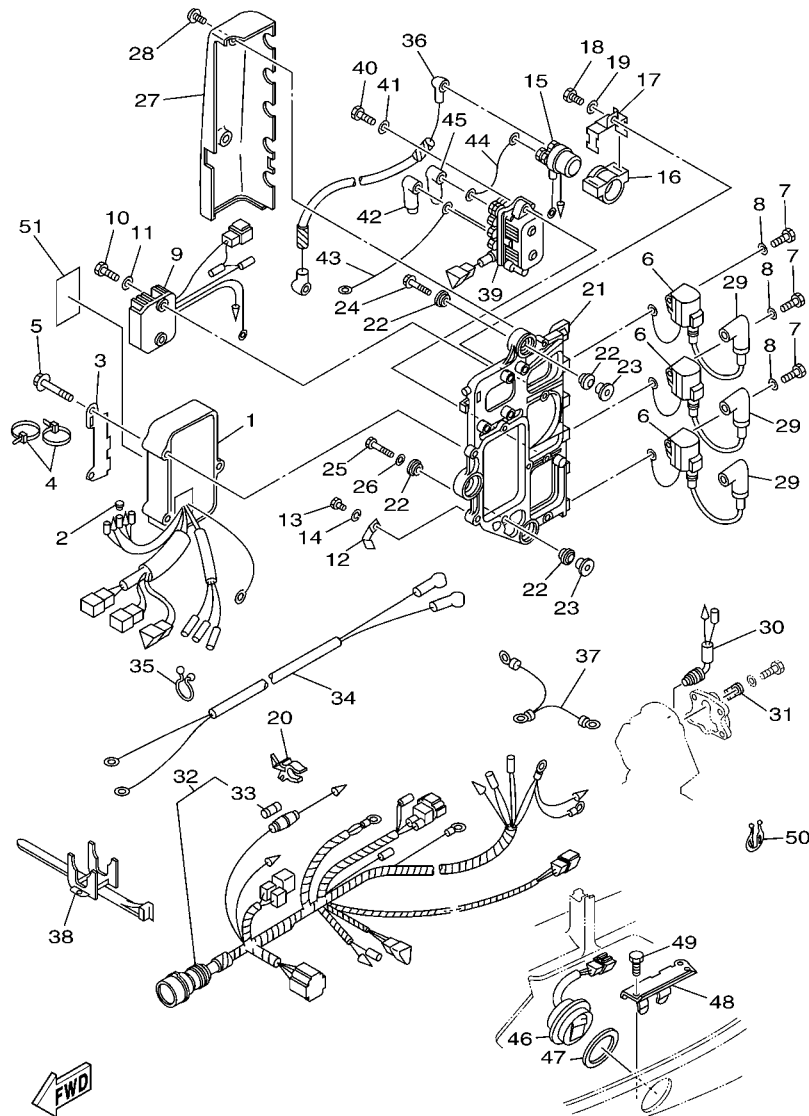

6H19100-F100

FIG. 10 ELECTRICAL

REF. NO.	PART NO.	DESCRIPTION	CAN	QTY	REMARKS
28	90159-06M11	SCREW, WITH WASHER	2	2	
29	6E3-82370-21	PLUG CAP ASSY	3	3	
30	688-82560-10	THERMO SWITCH ASSY	1	1	
31	688-82588-01	PLATE	1	1	
32	6H0-82590-80	WIRE HARNESS ASSY (10P)	1	1	
33	663-82151-00	.FUSE (12V-20A)	1	1	
34	6H0-82105-02	WIRE HARNESS	1	1	
35	90464-23M22	CLAMP	1	1	
36	6H0-82117-00	WIRE, LEAD	1	1	
37	697-82519-00	WIRE, EARTH LEAD	1	1	
38	688-82594-00	CLAMP	1	1	
39	61A-81950-00	RELAY ASSY	1	1	
40	97095-06025	BOLT	2	2	
41	92995-06600	WASHER	2	2	
42	682-82119-01	COVER, LEAD WIRE	2	2	
43	6H0-81949-10	WIRE, LEAD	1	1	
44	6H0-81949-01	WIRE, LEAD	1	1	
45	682-82119-01	COVER, LEAD WIRE	1	1	
46	6H1-82563-10	TRIM & TILT SWITCH ASSY	1	1	
47	6E5-82587-00	GASKET	1	1	
48	6H1-83614-00	BRACKET	1	1	
49	97095-06016	BOLT	1	1	
50	90464-18M14	CLAMP	1	1	
51	6R5-85711-60	MARK, CAUTION	1	1	

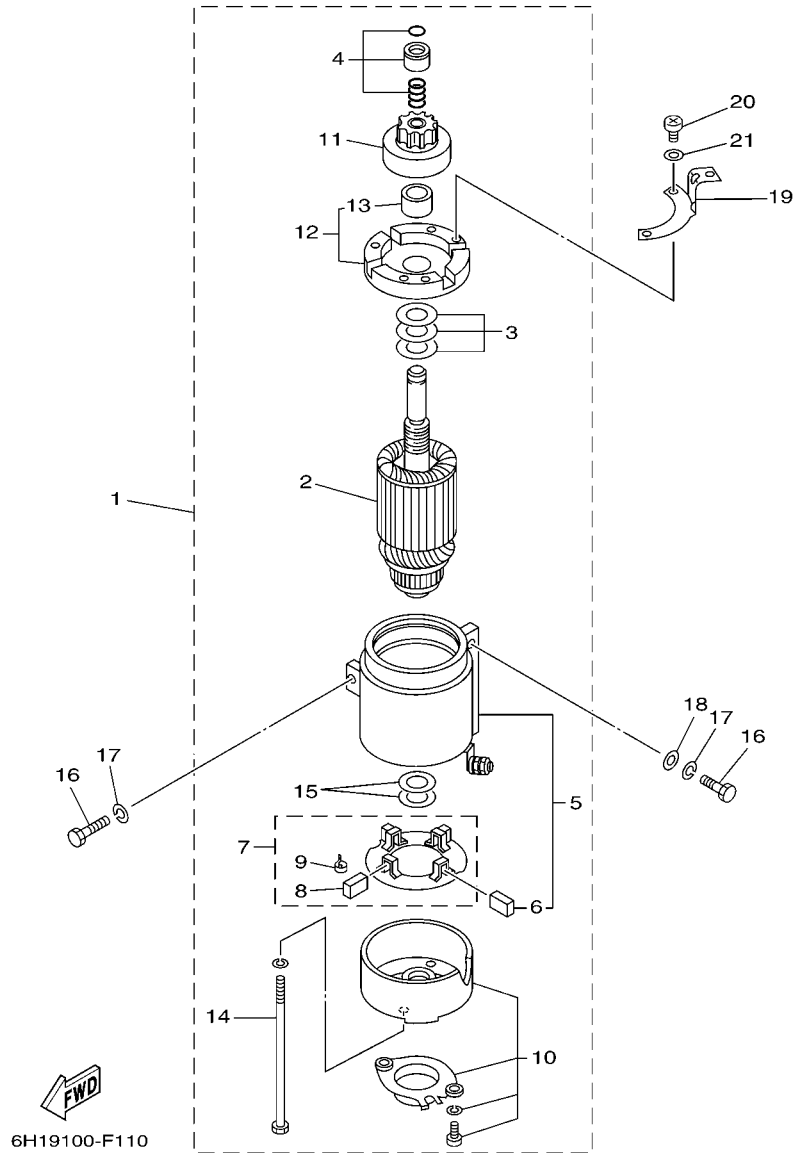

6H19100-F110

FIG. 11 STARTING MOTOR

REF. NO.	PART NO.	DESCRIPTION	CAN	QTY	REMARKS
1	688-81800-12	STARTING MOTOR ASSY	1	1	
2	676-81850-11	.ARMATURE ASSY	1	1	
3	676-81809-10	.WASHER KIT	1	1	
4	676-81857-10	.PINION STOPPER SET	1	1	
5	688-81810-11	.STATOR ASSY	1	1	
6	663-81811-11	..BRUSH 1	2	2	
7	663-81840-11	.BRUSH HOLDER ASSY	1	1	
8	663-81812-11	..BRUSH 2	2	2	
9	663-81813-10	..SPRING, BRUSH	4	4	
10	663-81820-12	.REAR BRACKET ASSY	1	1	
11	663-81832-11	.PINION ASSY	1	1	
12	688-81830-11	.FRONT BRACKET ASSY	1	1	
13	688-81831-00	..METAL, FRONT	1	1	
14	663-81826-10	.BOLT	2	2	
15	688-81824-00	.WASHER 2	2	2	
16	97013-08030	BOLT	3	3	
17	92903-08100	WASHER, SPRING	3	3	
18	92990-08600	WASHER, PLATE	2	2	
19	6H1-15771-00	STAY 1	1	1	
20	97885-04010	SCREW, PAN HEAD	3	3	
21	92995-04600	WASHER	3	3	

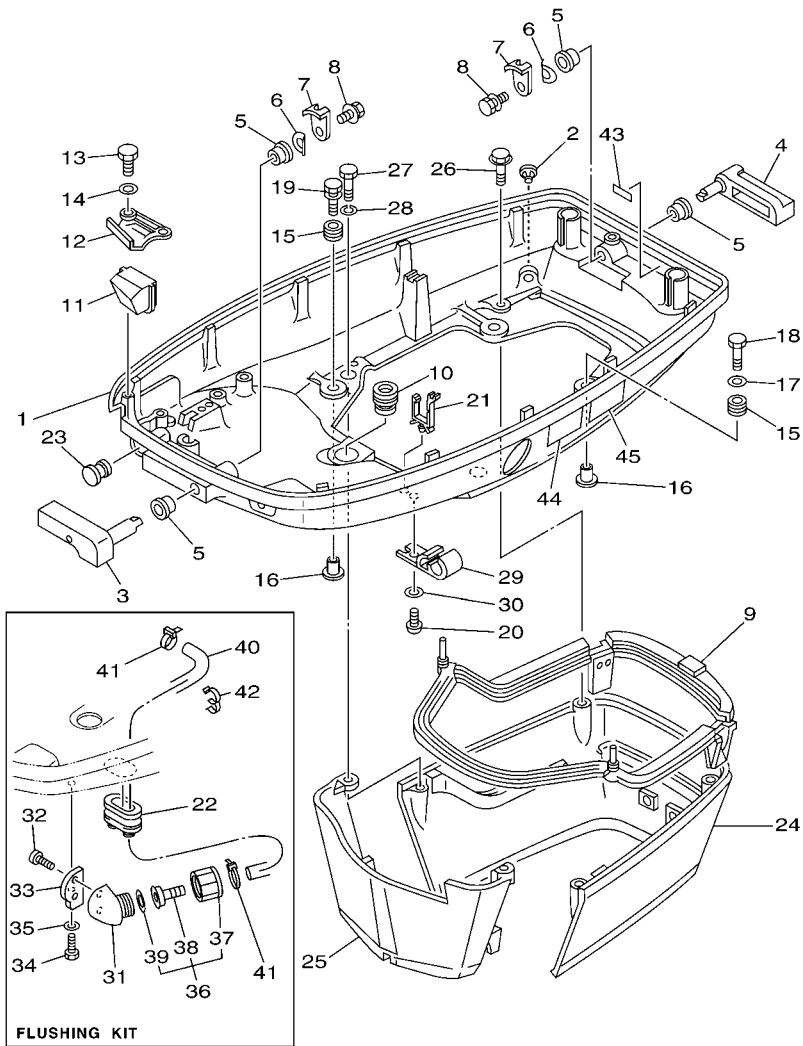

  
 6H1C100-J120

**FIG. 12 BOTTOM COWLING**

REF. NO.	PART NO.	DESCRIPTION	CAN	QTY	REMARKS
1	6H1-42711-01-8D	COWLING, BOTTOM 1	1		
	6H1-42711-10-8D	COWLING, BOTTOM 1		1	FLUSHING KIT
2	6BL-44391-00	NIPPLE, HOSE	1	1	
3	688-42815-01-8D	LEVER, CLAMP	1	1	
4	688-42817-01-8D	LEVER, CLAMP	1	1	
<hr/>					
5	90386-13M38	BUSH	4	4	
6	90206-13019	WASHER, WAVE	2	2	
7	688-42816-00	LEVER, CLAMP	2	2	
8	90119-06M09	BOLT, WITH WASHER	2	2	
9	688-42716-02	RUBBER, SEAL 1	1	1	
<hr/>					
10	663-42724-00	GROMMET	1	1	
11	688-42725-20	GROMMET	1	1	
12	688-42738-01-8D	PLATE, FITTING	1	1	
13	97095-06016	BOLT	2	2	
14	92995-06600	WASHER	2	2	
<hr/>					
15	6BG-42748-00	GROMMET	4	4	
16	90387-06M69	COLLAR	4	4	
17	90201-06416	WASHER, PLATE	1	1	
18	97095-06030	BOLT	1	1	
19	90119-06M61	BOLT, WITH WASHER	3	3	
<hr/>					
20	90157-06M01	SCREW, PAN HEAD	1	1	
21	90464-15M08	CLAMP	1	1	
22	688-42726-10	GROMMET	1		FOR STD
	6H1-42726-21	GROMMET		1	FLUSHING KIT
23	6G1-42748-00	GROMMET	1	1	
<hr/>					
24	688-42741-01-8D	APRON	1	1	
25	688-42771-01-8D	APRON	1	1	



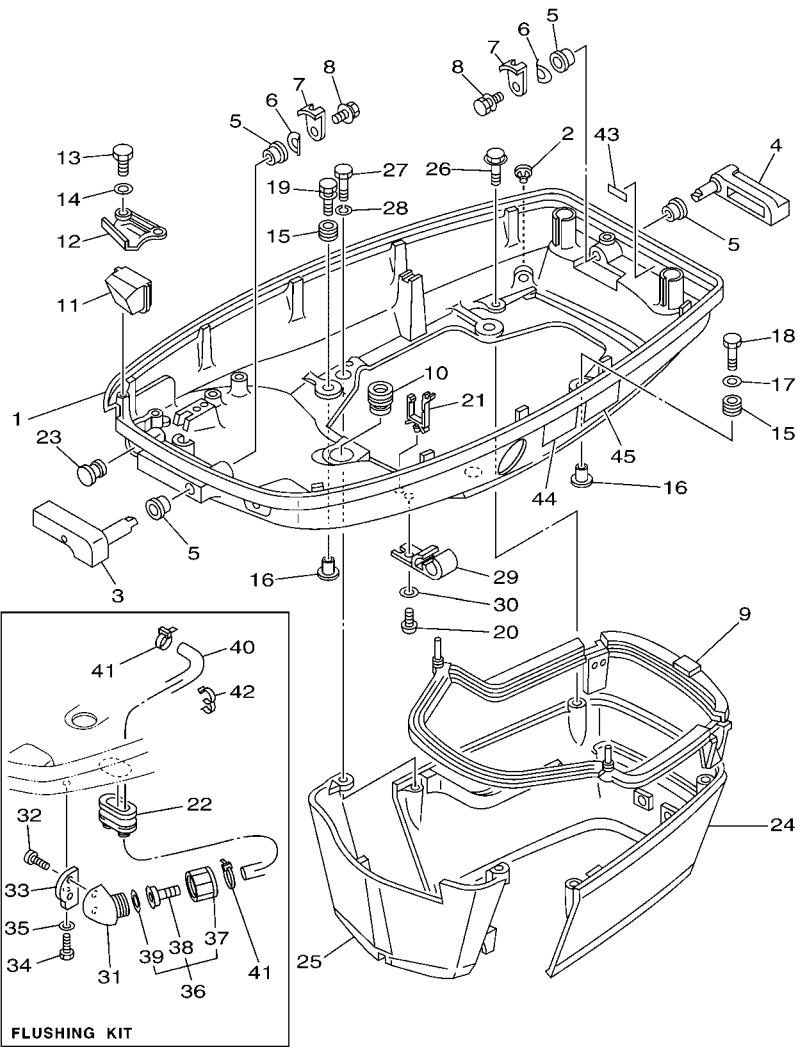

**FWD**  
6H1C100-J120

**FIG. 12 BOTTOM COWLING**

REF. NO.	PART NO.	DESCRIPTION	CAN	QTY	REMARKS
26	97595-06420	BOLT, WITH WASHER	2	2	
27	97095-06030	BOLT	2	2	
28	92995-06100	WASHER, SPRING	2	2	
29	6E5-24367-01	CLAMP, FUEL PIPE 2	1	1	
30	92990-06600	WASHER, PLATE	1	1	
31	68T-12572-00	ADAPTER	1	1	FLUSHING KIT
32	90167-06002	SCREW, TAPPING	2	2	FLUSHING KIT
33	6H1-12535-00	PLATE	1	1	FLUSHING KIT
34	97095-06020	BOLT	1	1	FLUSHING KIT
35	92995-06600	WASHER	1	1	FLUSHING KIT
36	6R3-12580-00	JOINT ASSY	1	1	FLUSHING KIT
37	6R3-12581-00	.JOINT, HOSE 1	1	1	
38	6R3-12582-00	.JOINT, HOSE 2	1	1	
39	6R3-12583-00	.GASKET, HOSE JOINT	1	1	
40	6H1-24312-01	PIPE 2	1	1	FLUSHING KIT
41	90465-11M10	CLAMP	2	2	FLUSHING KIT
42	90464-09M31	CLAMP	1	1	FLUSHING KIT
43	6G5-42791-10	MARK 1	1	1	
44	6AH-42794-40	LABEL, WARNING (GENERAL)	1	1	
45	6AH-42794-50	LABEL, WARNING (GENERAL)	1	1	

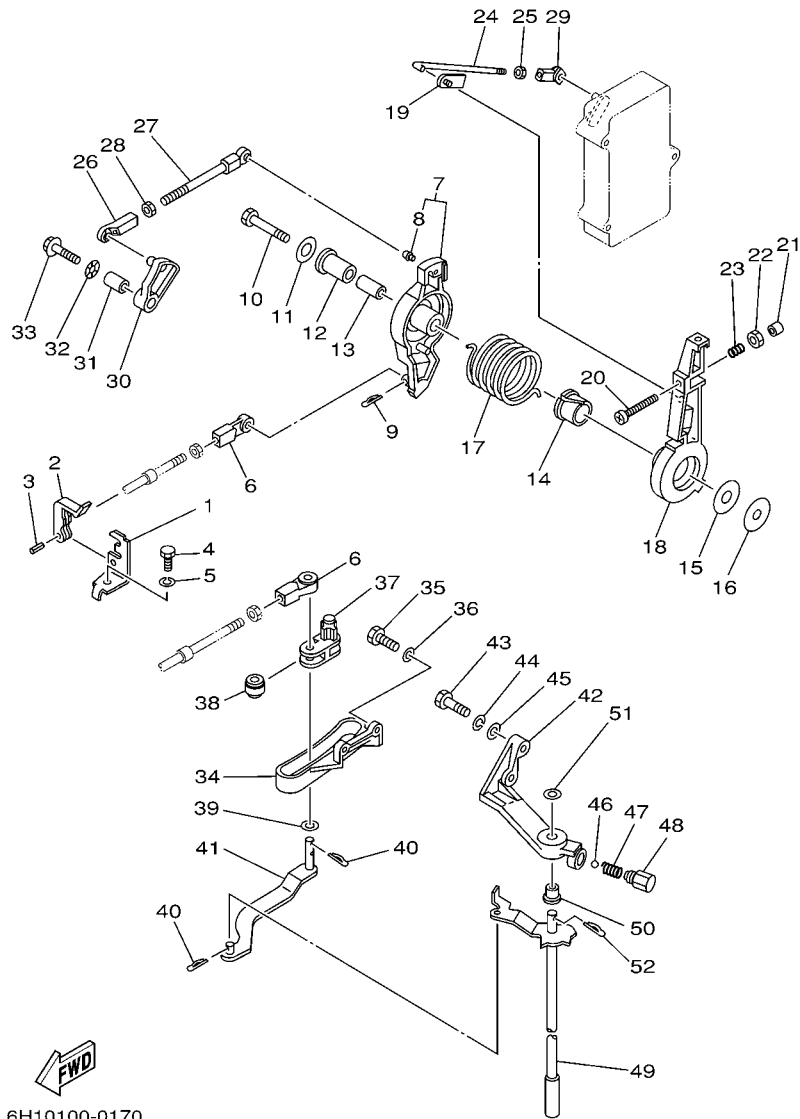

6H10100-0170

FIG. 13 CONTROL

REF. NO.	PART NO.	DESCRIPTION	CAN	QTY	REMARKS
1	663-48531-00	BRACKET, REMOTE CONTROL	1	1	
2	663-48538-00	CLAMP, CABLE 1	1	1	
3	91690-30012	PIN, SPRING	1	1	
4	97095-08016	BOLT	1	1	
5	92995-08100	WASHER	1	1	
6	663-48344-00	CABLE END, REMOTE CONTROL	2	2	
7	688-41632-01-1S	LEVER, MAGNETO CONTROL	1	1	
8	662-41214-01	JOINT 1	1	1	
9	90468-18008	CLIP	1	1	
10	97095-08045	BOLT	1	1	
11	90201-08M23	WASHER, PLATE	1	1	
12	90386-12089	BUSH	1	1	
13	90387-08M16	COLLAR	1	1	
14	90386-22M13	BUSH	1	1	
15	90202-12092	WASHER, PLATE	1	1	
16	90201-08M13	WASHER, PLATE	1	1	
17	90508-29M05	SPRING, TORSION	1	1	
18	688-41631-01-1S	LEVER, MAGNETO CONTROL	1	1	
19	6F5-41237-00	JOINT, LINK	1	1	
20	90157-06013	SCREW, PAN HEAD	1	1	
21	688-44194-00	CAP	1	1	
22	95303-06600	NUT	1	1	
23	90501-16M12	SPRING, COMPRESSION	1	1	
24	6H1-41636-00	ROD, MAGNETO CONTROL	1	1	
25	95380-05600	NUT	1	1	
26	662-41237-01	JOINT, LINK	1	1	
27	688-41211-01	LINK, ACCEL.	1	1	

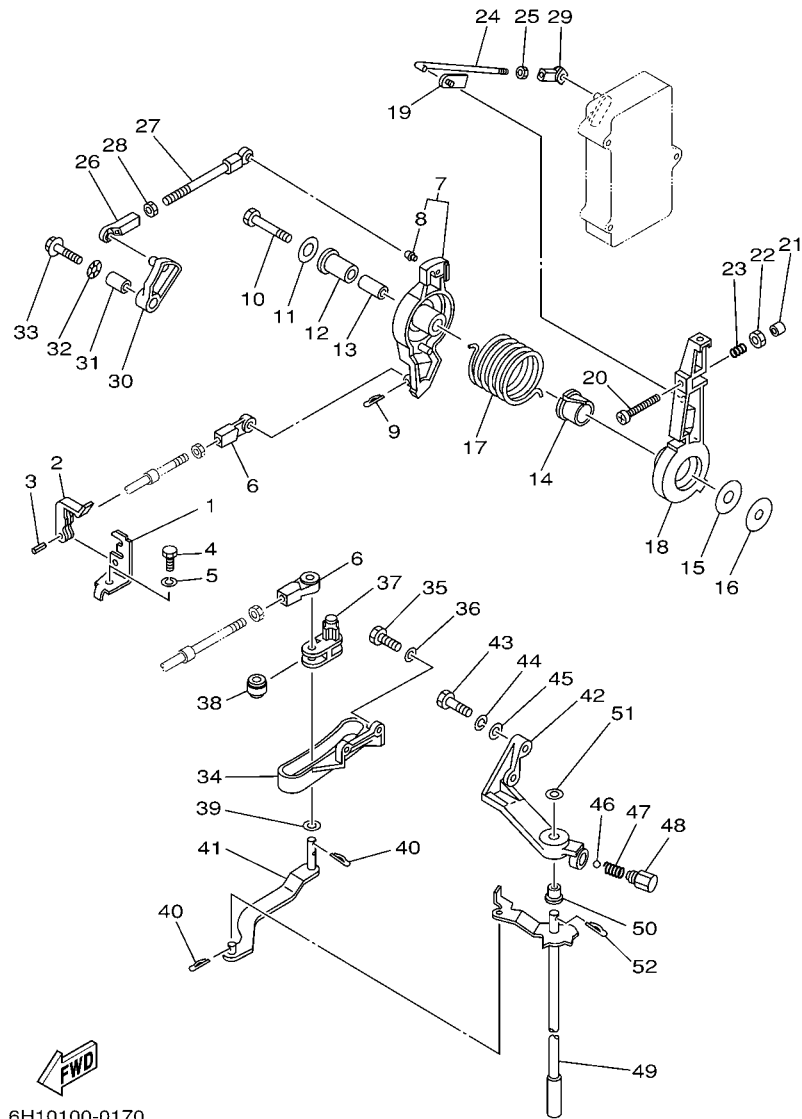

6H10100-0170

FIG. 13 CONTROL

REF. NO.	PART NO.	DESCRIPTION	CAN	QTY	REMARKS
28	95380-05600	NUT	1	1	
29	682-41237-00	JOINT, LINK	1	1	
30	6H1-41213-00	CAM, ACCEL.	1	1	
31	90387-06M17	COLLAR	1	1	
32	90206-10M04	WASHER, WAVE	1	1	
33	90119-06M24	BOLT, WITH WASHER	1	1	
34	688-44117-00-94	BRACKET	1	1	
35	97013-06020	BOLT	2	2	
36	92903-06600	WASHER, PLATE	2	2	
37	688-44124-00	LINK, SHIFT ROD	1	1	
38	688-44122-00	BUSHING, SHIFT ROD LEVER	1	1	
39	90202-07M07	WASHER, PLATE	1	1	
40	90468-18008	CLIP	3	3	
41	6H1-44121-00	LEVER, SHIFT ROD	1	1	
42	688-44118-01-94	BRACKET	1	1	
43	97013-08030	BOLT	2	2	
44	92903-08100	WASHER, SPRING	2	2	
45	92903-08600	WASHER, PLATE	2	2	
46	93501-04M02	BALL	1	1	
47	90501-12082	SPRING, COMPRESSION	1	1	
48	648-42715-00	BUSHING	1	1	
49	6H1-44120-12	HANDLE GEAR SHIFT ASSY	1	1	L(20.3")
	6H1-44120-22	HANDLE GEAR SHIFT ASSY	1	1	X(25.3")
50	90386-07M58	BUSH	1	1	
51	92990-08200	WASHER, PLAIN	1	1	
52	90468-18008	CLIP	1	1	

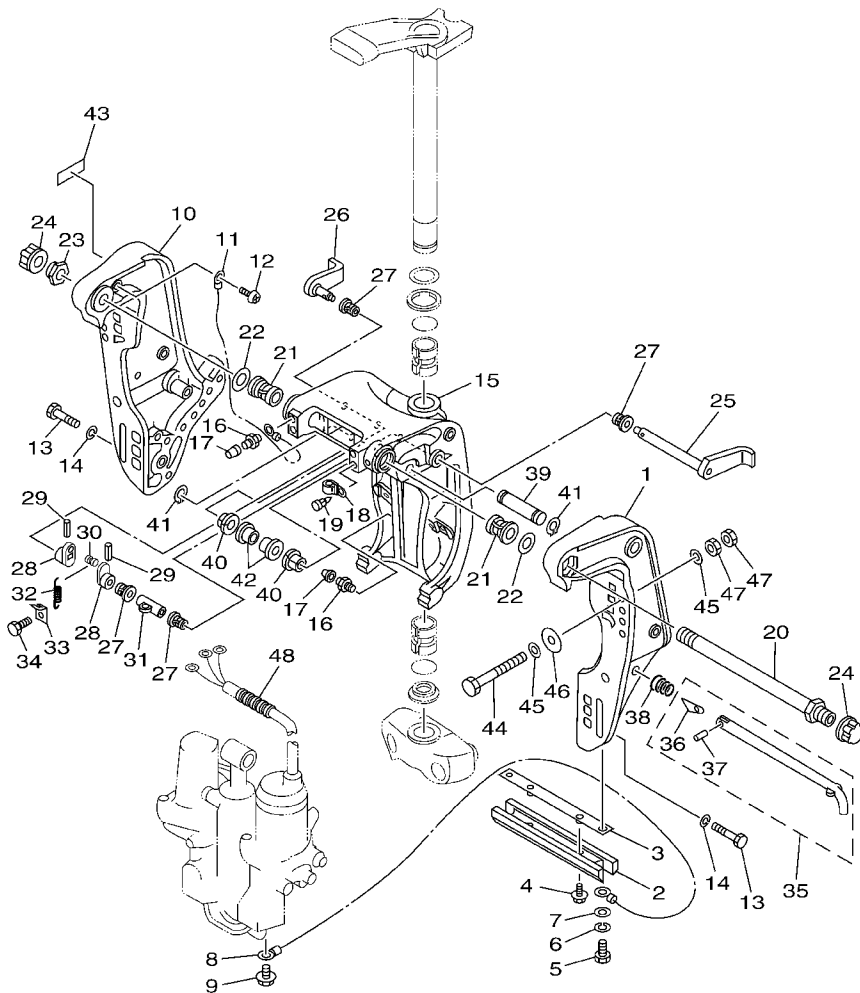

6H19100F1401

FIG. 14 BRACKET 1

REF. NO.	PART NO.	DESCRIPTION	CAN	QTY	REMARKS
1	6H1-43111-01-8D	BRACKET, CLAMP 1	1	1	
2	6H1-45251-03	ANODE	1	1	
3	6H1-44526-00	PLATE	1	1	
4	90119-06M29	BOLT, WITH WASHER	2	2	
5	97095-06016	BOLT	2	2	
6	92995-06100	WASHER, SPRING	2	2	
7	92995-06600	WASHER	2	2	
8	6H1-82148-00	WIRE, LEAD 4	1	1	
9	97595-06510	BOLT, WITH WASHER	1	1	
10	6H1-43112-00-8D	BRACKET, CLAMP 2	1	1	
11	6E5-82148-00	WIRE, LEAD 4	1	1	
12	97880-06012	SCREW, PAN HEAD	1	1	
13	97095-10045	BOLT	6	6	
14	92995-10100	WASHER	6	6	
15	6H1-43311-02-8D	BRACKET, SWIVEL 1	1	1	
16	93700-06M03	NIPPLE, GREASE	3	3	
17	663-45119-00	CAP, GREASE NIPPLE	3	3	
18	90464-11M18	CLAMP	1	1	
19	90338-05M03	PLUG	1	1	
20	688-43131-03	BOLT, CLAMP BRACKET	1	1	
21	90386-22M15	BUSH	2	2	
22	90201-22M67	WASHER, PLATE	2	2	
23	90185-22M11	NUT, SELF-LOCKING	1	1	
24	6G5-43145-01	CAP, CLAMP BRACKET	2	2	
25	6H1-43181-01	LEVER, TILT STOP 1	1	1	
26	6H1-43185-01	LEVER, TILT STOP 2	1	1	
27	90386-10M16	BUSH	4	4	

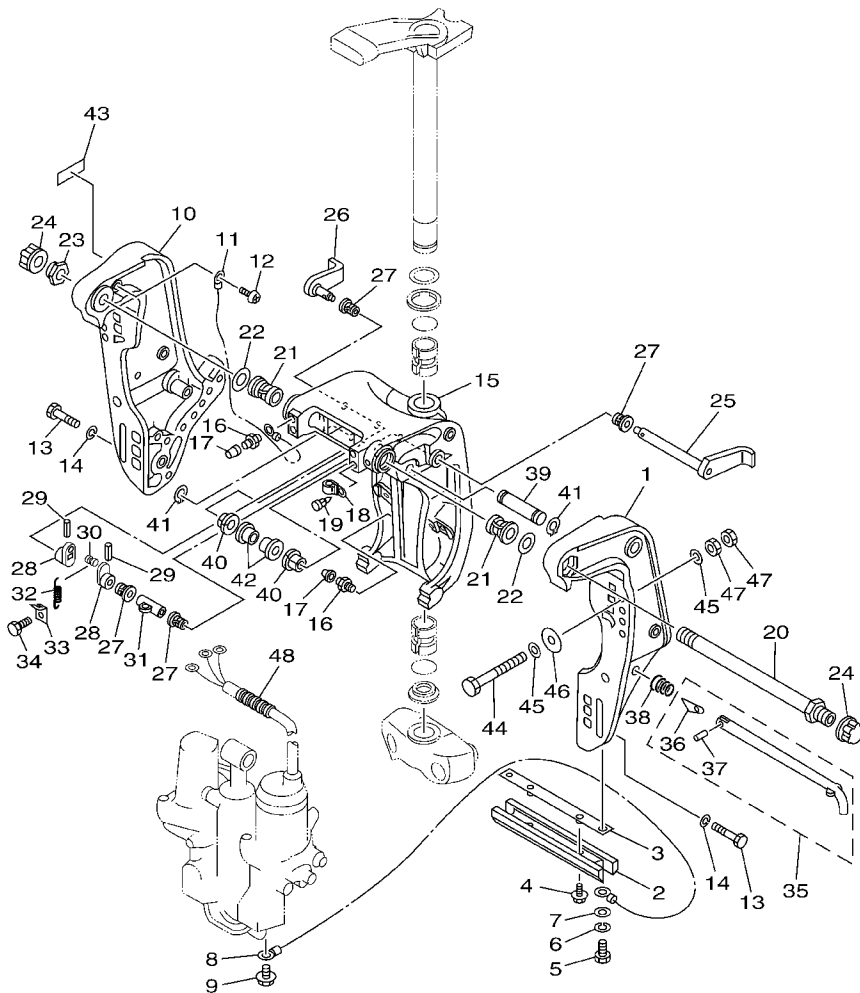

FWD  
6H19100F1401

FIG. 14 BRACKET 1

REF. NO.	PART NO.	DESCRIPTION	CAN	QTY	REMARKS
28	6G5-43148-00	COLLAR, DISTANCE	2	2	
29	91690-30020	PIN, SPRING	2	2	
30	90249-06M19	PIN	1	1	
31	90387-10M02	COLLAR	1	1	
32	90506-14M24	SPRING, TENSION	1	1	
33	6G5-43144-00	HOOK, SPRING	1	1	
34	97095-06010	BOLT	1	1	
35	688-43160-01	TILT ROD ASSY	1	1	
36	688-43165-00	.PLATE, TILT LOCK	1	1	
37	91690-30012	.PIN, SPRING	1	1	
38	90502-16M02	SPRING, CONICAL	1	1	
39	6E5-43126-10	PIN, UPPER SHOCK MOUNT	1	1	Go to P/N:PE0-OM-110024
40	90386-18M35	BUSH	2	2	
41	93410-18M02	CIRCLIP	2	2	Go to P/N:PE0-OM-110024
42	90386-18M63	BUSH	2	2	
43	63V-82377-50	LABEL (SPARK,IGNITION)	1	1	FOR CAN
44	90101-12M65	BOLT	4	4	
45	92995-12200	WASHER	8	8	
46	90201-12426	WASHER, PLATE	4	4	
47	95380-12600	NUT	8	8	
48	90440-14M00	PIPE	1	1	

# PARTS NEWS

News No. PE0-OM-110024

Date: May 16, 2011

Signature: S. Ishibashi

Cause :  Revision Notice  Correction  Sales Unit Change  Others

Model	90, 90AETO (6H1D) / 75CETO (67P9)
Subject	PARTS CATALOGUE CORRECTIONS
CATALOGUE NO.	1K6H1-100E1 / 1K6H1-200S1 / 1K6H1-300F1 / 1K6H1-664E1
Time of YPEC Revision	Text, Illustration --> Jun./20/2011
	PDF Replace --> Jun./20/2011
(YPEC = Yamaha Parts Electrical Catalogue = Website parts catalogue)	

## Applicable Engine Serial No.



MODEL NAME	MODEL CODE	Applicable Engine Serial No.
75C	67P9	692:1052923-
90A	6H1D	6H1:1045966-

### \*1: Interchangeability

A	Old Parts	→	Old Parts
	New Parts	→	New Parts
B	Old Parts	→	Old Parts
	New Parts	→	New Parts
C	Old Parts	→	Old Parts
	New Parts	→	New Parts
		These parts are interchangeable with a set	

## FIG.13 or 14 BRACKET 1

### 1. LIST CORRECTION

Fig. No.	Ref. No.	OLD P/No.	NEW P/No.	PART NAME	Q'TY	*Interchangeability	
						REMARKS	
13 or 14	39	6E5-43126-02	6E5-43126-10	PIN, UPPER SHOCK MOUNT	1		*Part number revision
	41	93410-18M02	-	CIRCLIP	1 --> 2		*Q'TY change

### 2. ILLUSTRATION CORRECTION

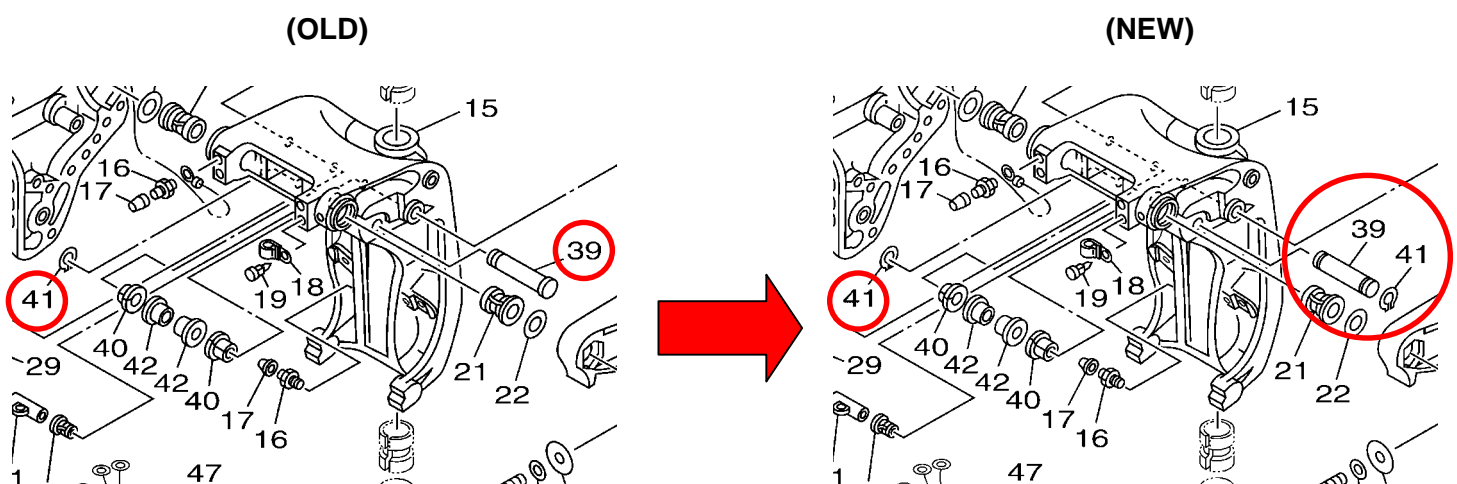

Thank you very much for your cooperation.

Parts  
Manager  
Check

Service  
Manager  
Check

Parts  
Manager  
File

YAMAHA MOTOR CO.,LTD  
2500 Shingai Iwata Shizuoka 438-8501.Japan  
Technical Publication Dept.

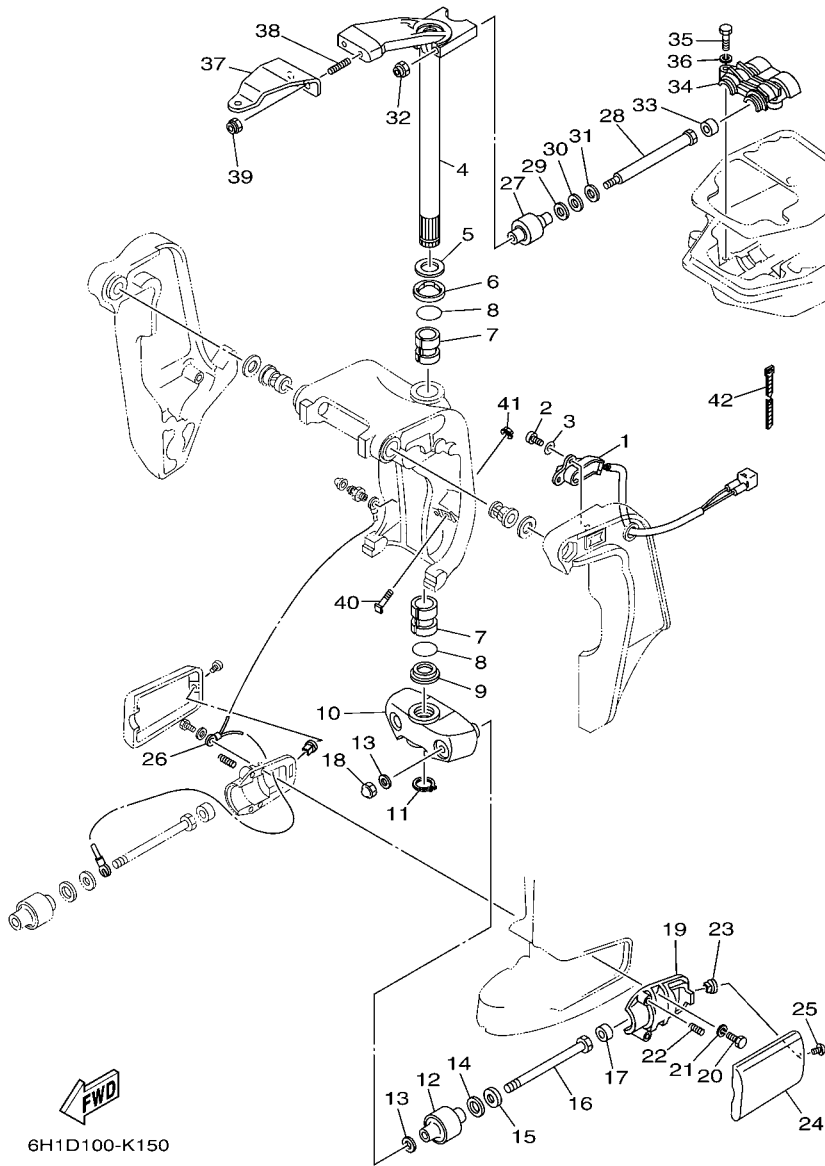

**FIG. 15 BRACKET 2**

REF. NO.	PART NO.	DESCRIPTION	CAN	OGE	REMARKS
1	6H1-83672-21	TRIM SENDER	1	1	
2	97885-06016	SCREW, PAN HEAD	2	2	
3	92995-06600	WASHER	2	2	
4	688-42510-03-8D	STEERING BRACKET ASSY	1	1	
5	90201-30M00	WASHER, PLATE	1	1	
6	90386-30M78	BUSH	1	1	
7	90386-30M77	BUSH	2	2	
8	93210-29M94	O-RING	2	2	
9	90386-30M60	BUSH	1	1	
10	663-44551-02-8D	HOUSING, LOWER MOUNT RUBBER 1	1	1	
11	93410-28M06	CIRCLIP	1	1	
12	687-44555-00	MOUNT DAMPER, LOWER SIDE	2	2	
13	90201-12M16	WASHER, PLATE	4	4	
14	90202-25M04	WASHER, PLATE	2	2	
15	90201-13M19	WASHER, PLATE	2	2	
16	90109-12261	BOLT	2	2	
17	663-44575-00	DAMPER, LOWER MOUNT RUBBER	2	2	
18	95380-12800	NUT, CROWN	2	2	
19	687-44552-02	HOUSING, LOWER MOUNT RUBBER 2	2	2	
20	97075-08025	BOLT	4	4	
21	92995-08100	WASHER	4	4	
22	90501-14M08	SPRING, COMPRESSION	4	4	
23	90179-06066	NUT	2	2	
24	663-44553-01-8D	COVER, LOWER MOUNT	2	2	
25	97885-06016	SCREW, PAN HEAD	2	2	
26	688-82127-02	WIRE, LEAD 2	1	1	
27	688-44514-00	MOUNT DAMPER, UPPER SIDE	2	2	

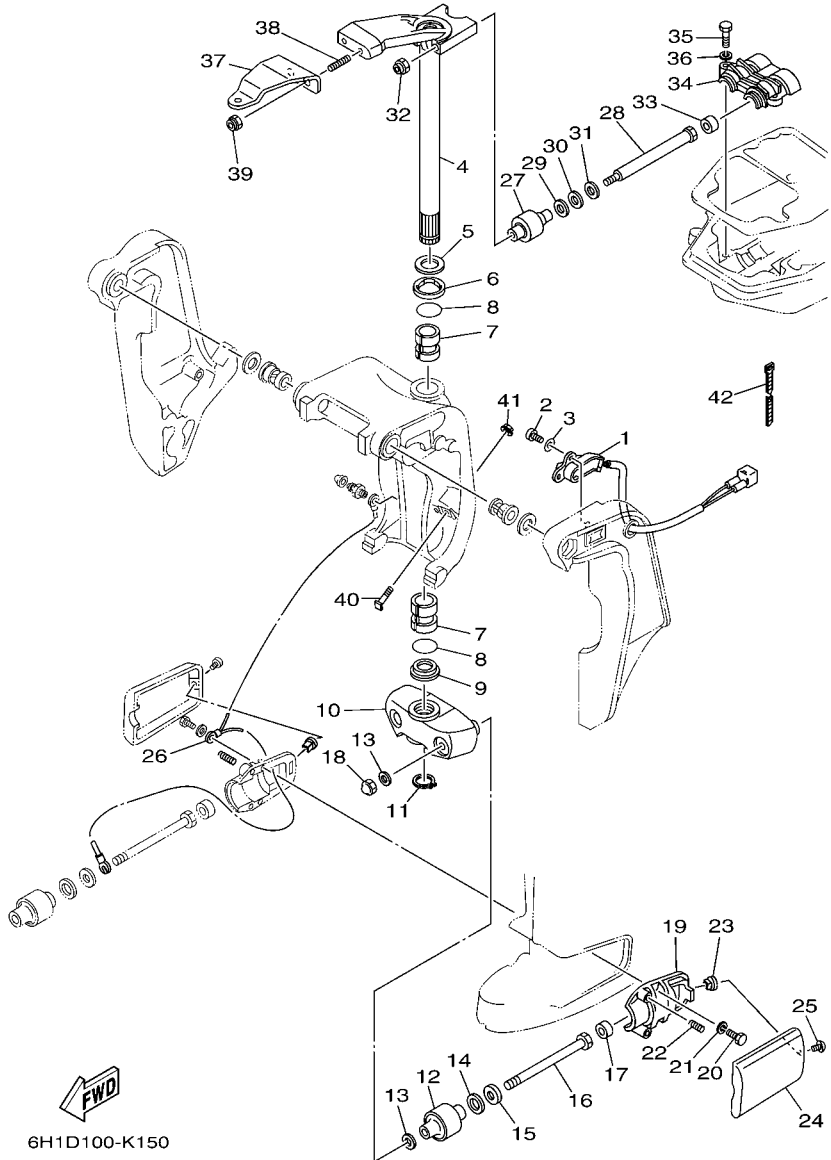

6H1D100-K150

FIG. 15 BRACKET 2

REF. NO.	PART NO.	DESCRIPTION	CAN	QTY	REMARKS
28	90101-10M49	BOLT	2	2	
29	90201-20M21	WASHER, PLATE	2	2	
30	90202-20M06	WASHER, PLATE	2	2	
31	90201-11M22	WASHER, PLATE	2	2	
32	90185-10051	NUT, SELF-LOCKING	2	2	
33	663-44575-00	DAMPER, LOWER MOUNT RUBBER	2	2	
34	688-44511-00	COVER, UPPER MOUNT	1	1	
35	97075-08035	BOLT	3	3	
36	92995-08100	WASHER	3	3	
37	688-48511-30	HOOK, STEERING	1	1	STEERING GUIDE
38	90116-10175	BOLT, STUD	2	2	
39	90185-10051	NUT, SELF-LOCKING	2	2	
40	6H1-43376-00	BOLT, THRUST RECEIVER	2	2	
41	90185-08057	NUT, SELF-LOCKING	2	2	
42	90465-11M10	CLAMP	3	3	



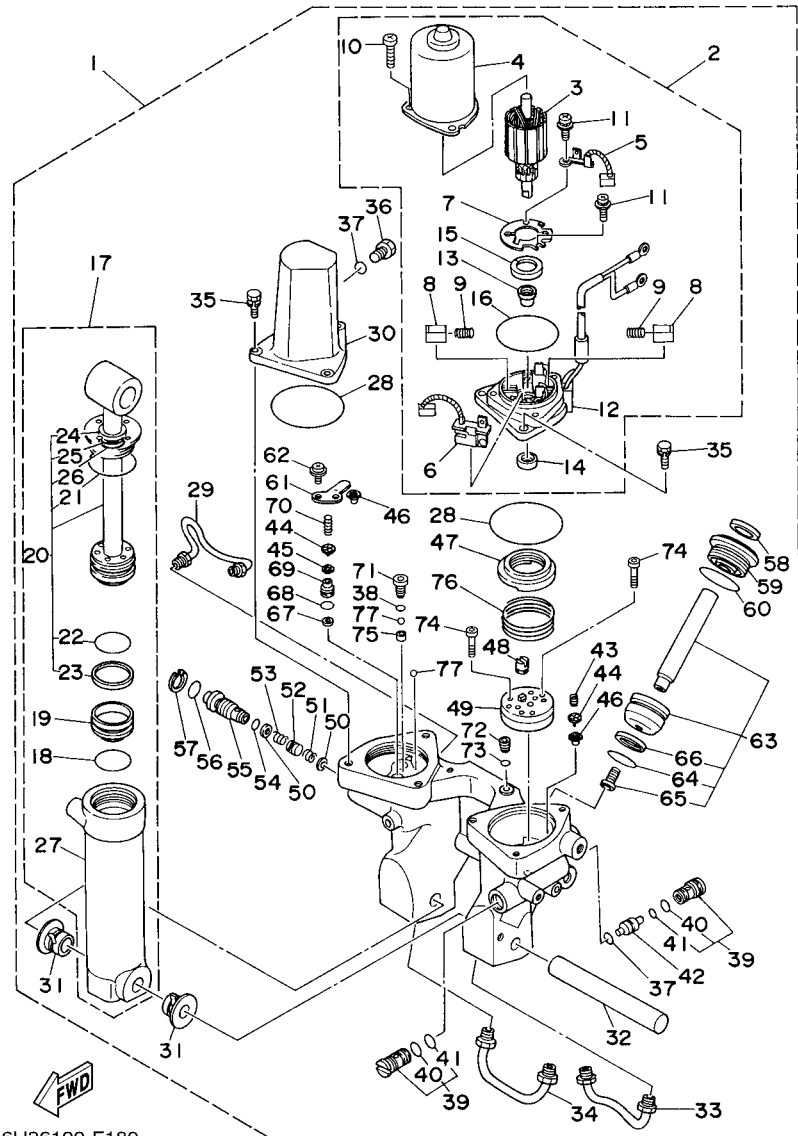

6H36100-F180

FIG. 16 POWER TRIM & TILT ASSY

REF. NO.	PART NO.	DESCRIPTION	CAN	QTY	REMARKS
1	6H1-43800-17-8D	POWER TRIM & TILT ASSY	1	1	
2	6H1-43880-02	..MOTOR ASSY	1	1	
3	6H1-43805-10	..ARMATURE ASSY	1	1	
4	6H1-43804-10	..STATOR ASSY	1	1	
5	6H1-43891-10	..BRUSH 1	1	1	
6	6H1-43892-10	..BREAKER COMP. (BRUSH 2)	1	1	
7	6H1-4380F-10	..PLATE, BRUSH HOLDER	1	1	
8	6H1-4380J-10	..HOLDER, BRUSH	2	2	
9	6H1-4386K-10	..SPRING, BRUSH	2	2	
10	97885-05016	..SCREW, PAN HEAD	3	3	
11	97607-04310	..SCREW,WITH WASHER	2	2	
12	6H1-43881-10	..FRAME, END	1	1	
13	6H1-4380H-10	..METAL	1	1	
14	93102-08M43	..OIL SEAL	1	1	
15	6H1-4380G-10	..PLATE	1	1	
16	6H1-43865-10	..O-RING	1	1	
17	6H1-43840-11	..POWER TILT ASSY	1	1	
18	6H1-43861-10	..O-RING	1	1	
19	6H1-43814-11	..PISTON, FREE	1	1	
20	6H1-43810-11	..TILT PISTON SUB ASSY	1	1	
21	6H1-43861-00	..O-RING	1	1	
22	6H1-43861-10	..O-RING	1	1	
23	6H1-43871-10	..RING, BACK UP	1	1	
24	6H1-43812-00	..SEAL, DUST	1	1	
25	6H1-43872-10	..RING, BACK UP	1	1	
26	93210-18397	..O-RING	1	1	
27	6H1-43813-10	..CYLINDER, TILT	1	1	

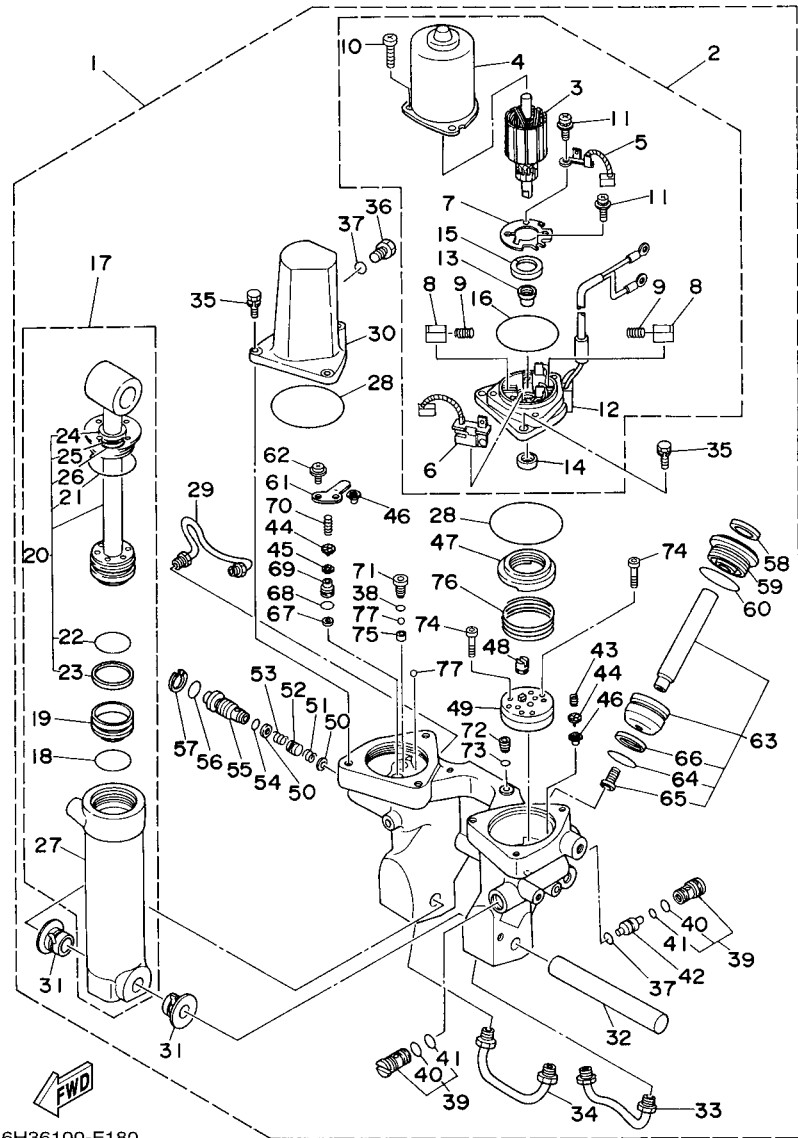

6H36100-F180

FIG. 16 POWER TRIM & TILT ASSY

REF. NO.	PART NO.	DESCRIPTION	CAN	QTY	REMARKS
28	93210-68N50	.O-RING	2	2	
29	6H1-43835-10	.PIPE	1	1	
30	6H1-43828-10	.BODY, RESERVOIR	1	1	
31	90386-18M14	.BUSH	2	2	
32	6E5-43818-00	.PIN, LOWER SHOCK MOUNT	1	1	
33	6H1-43833-10	.PIPE	1	1	
34	6H1-43834-00	.PIPE	1	1	
35	97595-06420	.BOLT, WITH WASHER	6	6	
36	6H1-43829-00	.PLUG, RESERVOIR	1	1	
37	93210-09165	.O-RING	2	2	
38	93210-064A5	.O-RING	1	1	
39	67F-43802-00	.VALVE SUB ASSY	2	2	
40	6H1-43866-00	..O-RING	1	1	
41	6H1-43867-00	..O-RING	1	1	
42	6H1-43841-11	.PISTON, SHUTTLE	1	1	
43	6H1-43856-10	.SPRING, DOWN RELIEF	1	1	
44	6H1-43844-10	.PIN, VALVE SUPPORT	2	2	
45	6H1-4384G-11	.SEAL, RELIEF VALVE	1	1	
46	6H1-4384F-10	.SEAL, MAIN VALVE	2	2	
47	6H1-43817-01	.FILTER 2	1	1	
48	6H1-43831-10	.CONNECTOR, SHAFT	1	1	
49	6H1-43830-11	.GEAR PUMP ASSY	1	1	
50	6H1-43847-00	.SEAT, MANUAL VALVE	2	2	
51	6H1-43899-00	.SPRING, MANUAL RELEASE	1	1	
52	6H1-4382A-10	.ADAPTOR 1	1	1	
53	6H1-43854-00	.SPRING, MANUAL RELEASE	1	1	
54	93210-10M74	.O-RING	1	1	

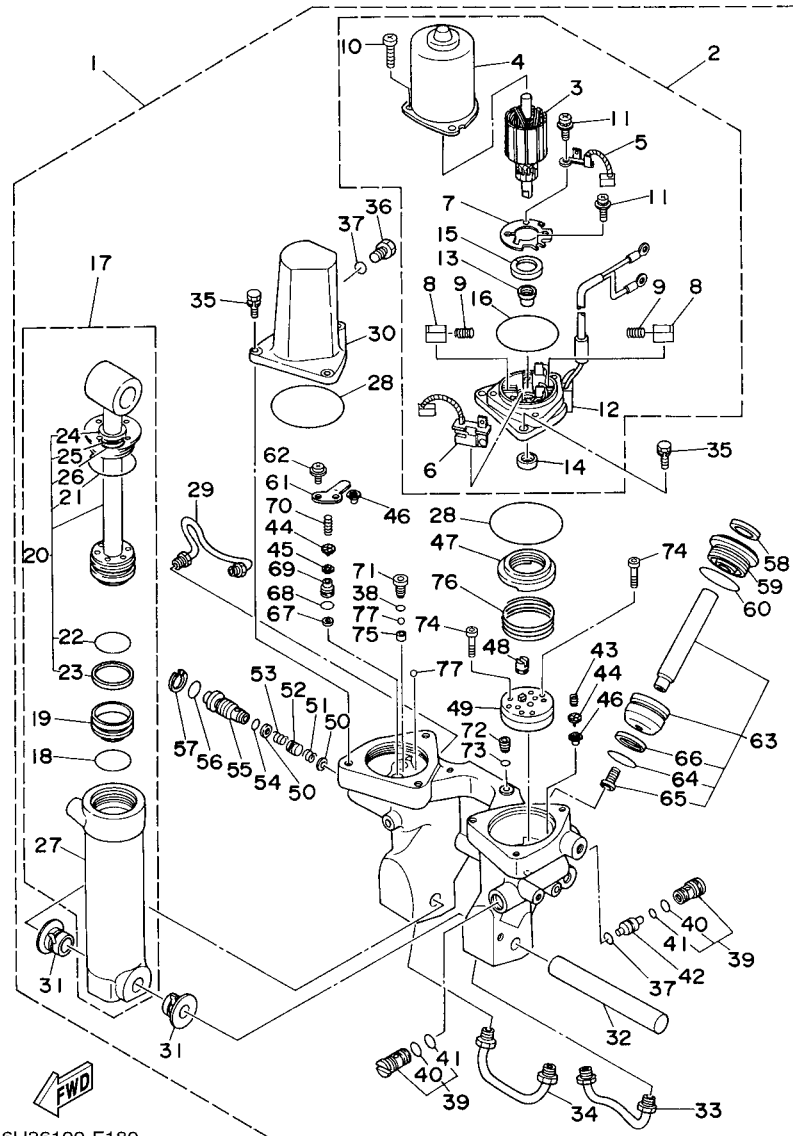

6H36100-F180

FIG. 16 POWER TRIM & TILT ASSY

REF. NO.	PART NO.	DESCRIPTION	CAN	QTY	REMARKS
55	6H1-43845-00	.SCREW, MANUAL RELEASE	1	1	
56	93210-18M75	.O-RING	1	1	
57	6H1-43875-00	.RING, SNAP	1	1	
58	6H1-43822-10	.SEAL, TRIM DUST	2	2	
59	6H1-43821-11	.SCREW, TRIM CYLINDER END	2	2	
60	6H1-43861-10	.O-RING	2	2	
61	6H1-4384E-20	.SPRING, TRIM	1	1	
62	97602-05210	.SCREW, PAN HEAD WITH WASHER	2	2	
63	6H1-43820-11	.TRIM PISTON SUB ASSY	2	2	
64	6H1-43864-00	.O-RING	1	1	
65	91318-08016	.BOLT, SOCKET HEAD	1	1	
66	6H1-43874-00	.RING, BACK UP	1	1	
67	6H1-43816-00	.FILTER 1	1	1	
68	6H1-43896-00	.O-RING	1	1	
69	6H1-43895-12	.SEAT, RELIEF VALVE	1	1	
70	6H1-43855-11	.SPRING, UP RELIEF	1	1	
71	6H1-43843-11	.SCREW, VALVE LOCK	1	1	
72	6H1-4388E-11	.PLUG, TAPER SCREW	1	1	
73	6H1-43868-00	.O-RING	1	1	
74	91318-04025	.BOLT	4	4	
75	6H1-4387J-00	.WASHER, SPECIAL 2	1	1	
76	6H1-4385H-00	.SPRING, SEAL	1	1	
77	93505-32038	.BALL	2	2	

FIG. 17 UPPER CASING

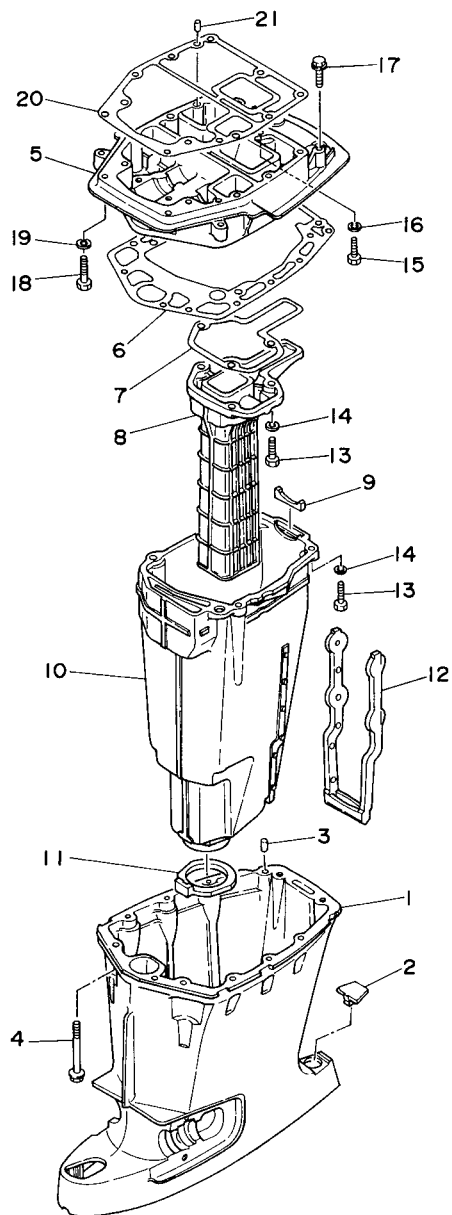
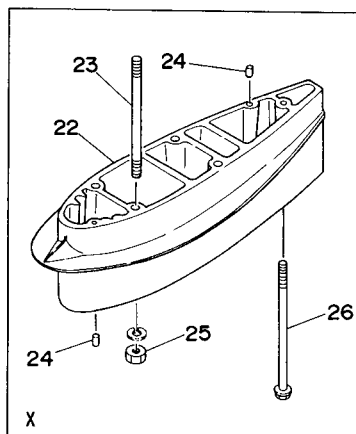

**FWD**  
6H14100-4170

REF. NO.	PART NO.	DESCRIPTION	CAN	QTY	REMARKS
1	688-45111-04-8D	CASING, UPPER	1	1	
2	663-45155-10	CAP	1	1	
3	93606-12019	PIN, DOWEL	2	2	
4	90119-08M80	BOLT, WITH WASHER	8	8	
5	688-41137-03-CA	GUIDE, EXHAUST	1	1	
6	688-45114-A1	GASKET, UPPER CASING	1	1	
7	688-41134-A0	GASKET, EXHAUST MANIFOLD	1	1	
8	688-41131-00-CA	MANIFOLD, EXT. 1	1	1	
9	688-41133-00	GASKET, EXHAUST MANIFOLD 1	1	1	
10	688-14711-01-CA	MUFFLER 1	1	1	
11	688-45123-00	GASKET, MUFFLER	1	1	
12	663-14737-10	DAMPER, MUFFLER	1	1	
13	97075-08030	BOLT	7	7	
14	92995-08100	WASHER	7	7	
15	97075-08025	BOLT	1	1	
16	92995-08100	WASHER	1	1	
17	90119-08102	BOLT, WITH WASHER	2	2	
18	97075-08035	BOLT	2	2	
19	92995-08100	WASHER	2	2	
20	688-45113-A0	GASKET, UPPER CASING	1	1	
21	93606-12019	PIN, DOWEL	2	2	
22	688-45211-01-8D	EXTENSION	1		X(25.3")
23	90116-10M05	BOLT, STUD	4		X(25.3")
24	93606-12019	PIN, DOWEL	4		X(25.3")
25	95380-10600	NUT	4		X(25.3")
26	90119-08M86	BOLT, WITH WASHER	1		X(25.3")

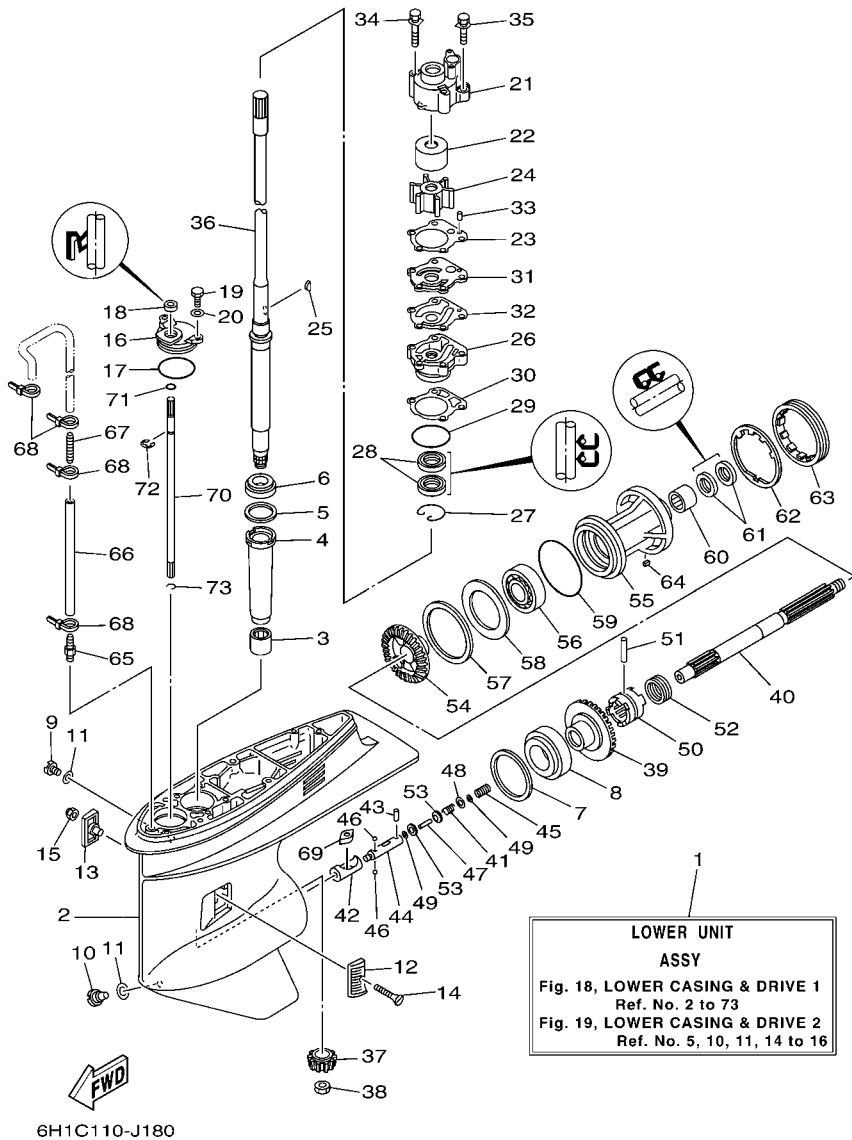

**FIG. 18 LOWER CASING & DRIVE 1**

REF. NO.	PART NO.	DESCRIPTION	CAN	QTY	REMARKS
1	6H1-45300-16-8D	LOWER UNIT ASSY	1	1	L(20.3")
	6H1-45300-26-8D	LOWER UNIT ASSY		1	X(25.3")
2	6H1-45301-03-8D	CASING, LOWER	1	1	
3	93315-325V1	BEARING	1	1	
4	688-45536-01	SLEEVE, DRIVE SHAFT	1	1	
5	688-45587-01	SHIM (T:0.10MM)	1	1	UR
	688-45587-10	SHIM (T:0.12MM)	1	1	UR
	688-45587-20	SHIM (T:0.15MM)	1	1	UR
	688-45587-30	SHIM (T:0.18MM)	1	1	UR
	688-45587-40	SHIM (T:0.30MM)	1	1	UR
	688-45587-50	SHIM (T:0.40MM)	1	1	UR
	688-45587-60	SHIM (T:0.50MM)	1	1	UR
6	93332-000U3	BEARING	1	1	
7	688-45567-01	SHIM (T:0.10MM)	1	1	UR
	688-45567-10	SHIM (T:0.12MM)	1	1	UR
	688-45567-20	SHIM (T:0.15MM)	1	1	UR
	688-45567-30	SHIM (T:0.18MM)	1	1	UR
	688-45567-40	SHIM (T:0.30MM)	1	1	UR
	688-45567-50	SHIM (T:0.40MM)	1	1	UR
	688-45567-60	SHIM (T:0.50MM)	1	1	UR
8	93332-000W7	BEARING	1	1	
9	90340-08002	PLUG, STRAIGHT SCREW	1	1	
10	688-45341-10	PLUG, DRAIN	1	1	
11	90430-08020	GASKET	2	2	
12	6H1-45214-00	COVER, WATER INLET 1	1	1	
13	6H1-45215-00	COVER, WATER INLET 2	1	1	
14	90151-05M00	SCREW, COUNTERSUNK	1	1	

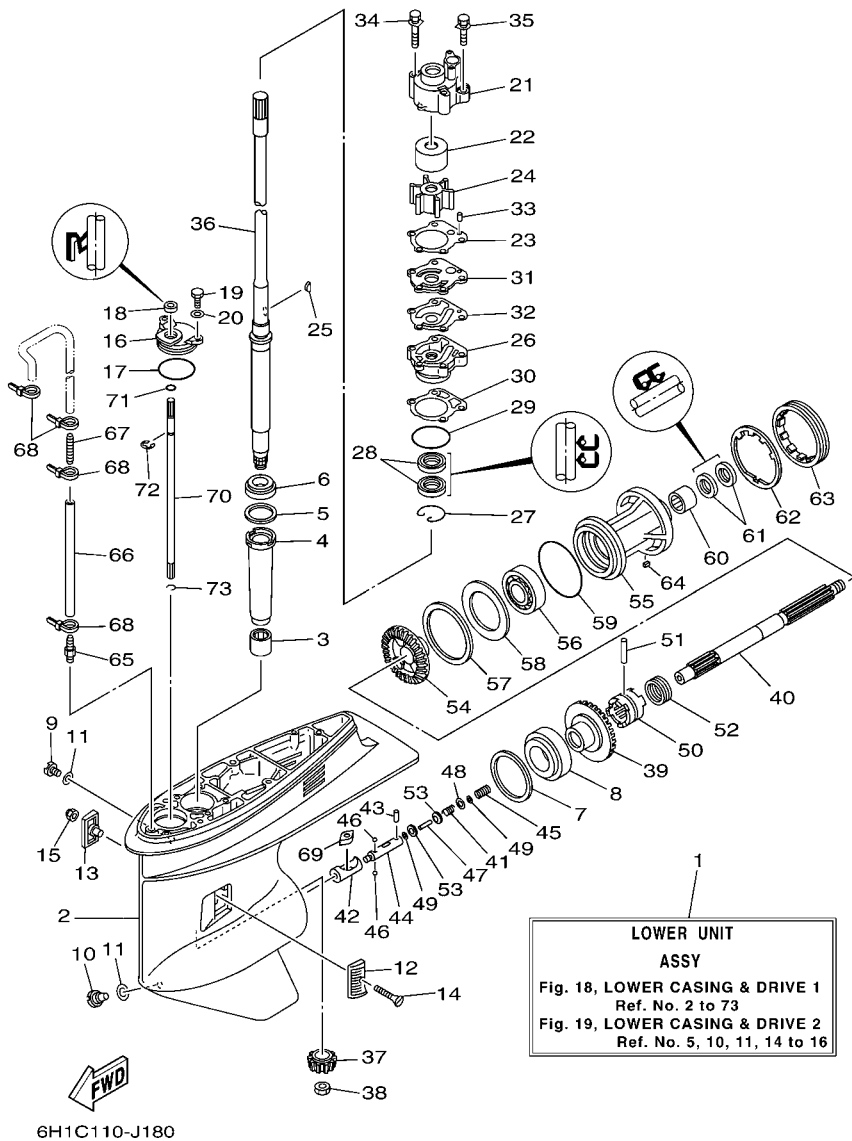

FIG. 18 LOWER CASING & DRIVE 1

REF. NO.	PART NO.	DESCRIPTION	CAN	QTY	REMARKS
15	90185-05002	NUT, NYLON	1	1	
16	688-45321-00	PLATE	1	1	
17	93210-49046	O-RING	1	1	
18	93106-09014	OIL SEAL	1	1	
19	97095-06016	BOLT	2	2	
20	92995-06600	WASHER	2	2	
21	688-44311-01	HOUSING, WATER PUMP	1	1	
22	688-44322-00	INSERT, CARTRIDGE	1	1	
23	688-44315-A0	GASKET, WATER PUMP	1	1	
24	688-44352-03	IMPELLER	1	1	
25	90280-04M04	KEY, WOODRUFF	1	1	
26	6D8-44341-01-CA	HOUSING, WATER PUMP	1	1	
27	93450-44166	CIRCLIP	1	1	
28	93101-25M03	OIL SEAL	2	2	
29	93210-46044	O-RING	1	1	
30	688-44316-A0	GASKET, WATER PUMP	1	1	
31	688-44323-00	OUTER PLATE, CARTRIDGE	1	1	
32	688-44324-A0	GASKET, CARTRIDGE	1	1	
33	93604-10M03	PIN, DOWEL	2	2	
34	90119-08M16	BOLT, WITH WASHER	2	2	
35	90119-08M13	BOLT, WITH WASHER	2	2	
36	6H1-45501-11	DRIVE SHAFT COMP.	1	1	L(20.3")
	688-45501-22	DRIVE SHAFT COMP.		1	X(25.3")
37	688-45551-01	PINION (13T)	1	1	
38	90170-16M01	NUT	1	1	
39	688-45560-00	GEAR 1 (26T)	1	1	
40	6H1-45611-01	SHAFT, PROPELLER	1	1	

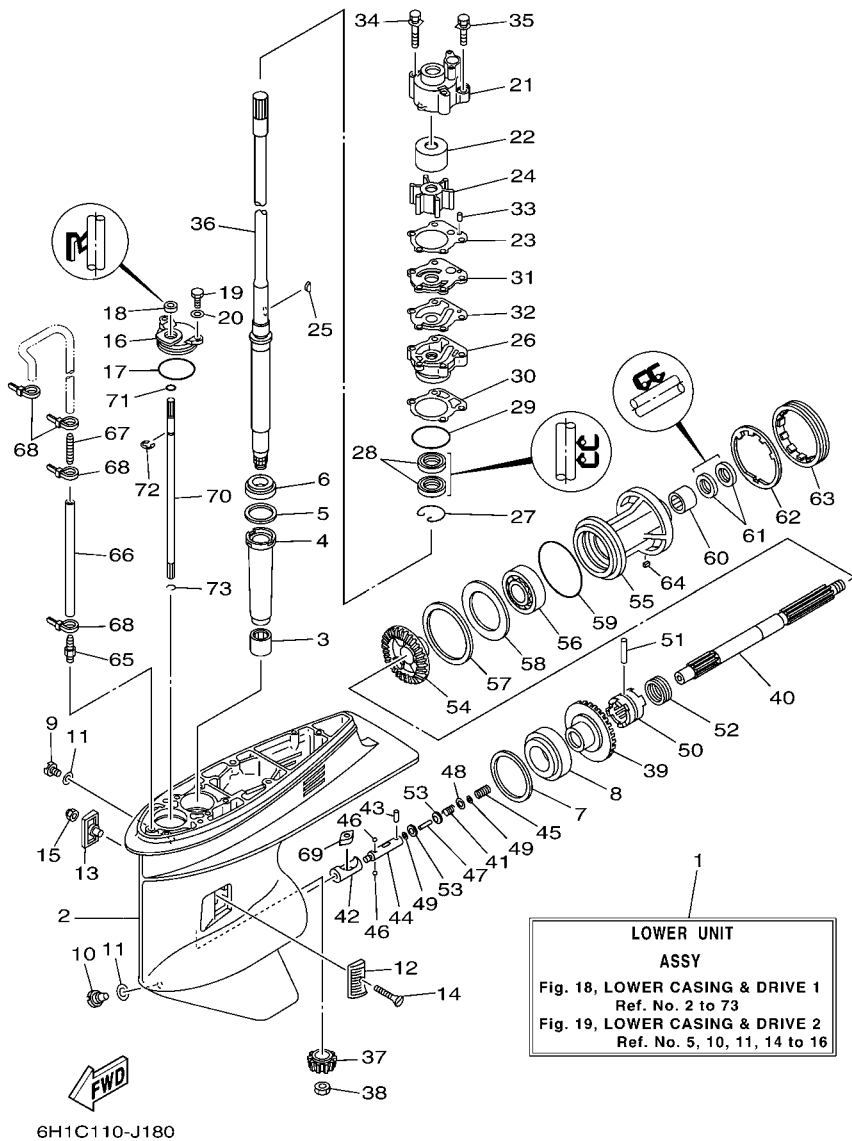
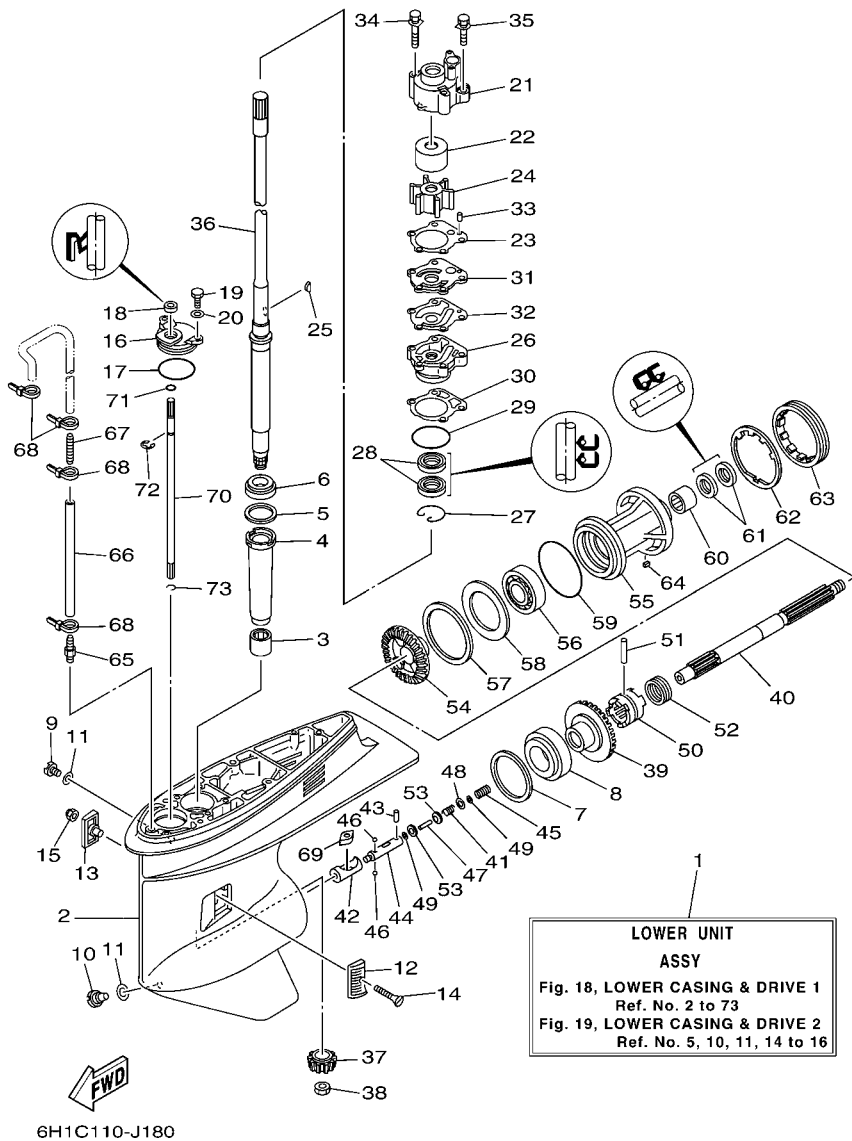

FIG. 18 LOWER CASING & DRIVE 1

REF. NO.	PART NO.	DESCRIPTION	CAN	QTY	REMARKS
41	90501-12M48	SPRING, COMPRESSION	1	1	
42	6H1-45641-01	SHIFTER	1	1	
43	93603-12M11	PIN, DOWEL	1	1	
44	6H1-45634-02	SLIDE, SHIFT	1	1	
45	90501-16M65	SPRING, COMPRESSION	1	1	
46	93503-16003	BALL	2	2	
47	6H1-45668-00	SHAFT, FREE 1	1	1	
48	90201-03313	WASHER, PLATE	1	1	
49	90183-02M03	NUT, SPRING	2	2	
50	6H1-45631-01	CLUTCH, DOG	1	1	
51	90250-07M02	PIN, STRAIGHT	1	1	
52	688-45633-00	RING, CROSS PIN	1	1	
53	6H1-45635-00	PLUNGER, SHIFT	2	2	
54	6H1-45571-00	GEAR 2 (26T)	1	1	
55	688-45331-00-CA	HOUSING, BEARING	1	1	
56	93306-207U0	BEARING	1	1	
57	688-45577-01	SHIM (T:0.10MM)	1	1	UR
	688-45577-10	SHIM (T:0.12MM)	1	1	UR
	688-45577-20	SHIM (T:0.15MM)	1	1	UR
	688-45577-30	SHIM (T:0.18MM)	1	1	UR
	688-45577-40	SHIM (T:0.30MM)	1	1	UR
	688-45577-50	SHIM (T:0.40MM)	1	1	UR
	688-45577-60	SHIM (T:0.50MM)	1	1	UR
58	688-45576-00	WASHER, THRUST 2	1	1	
59	93210-85M97	O-RING	1	1	
60	93317-325U0	BEARING	1	1	
61	93101-25M03	OIL SEAL	2	2	



**FIG. 18 LOWER CASING & DRIVE 1**

REF. NO.	PART NO.	DESCRIPTION	CAN	QTY	REMARKS
62	688-45383-02	WASHER, CLAW	1	1	
63	688-45384-02	NUT	1	1	
64	90282-04010	KEY, STRAIGHT	1	1	
65	6E5-45378-00	NIPPLE, HOSE	1	1	
66	90445-07ME9	HOSE (L120)	1	1	L(20.3")
	90445-07MF2	HOSE (L250)	1	1	X(25.3")
67	6E5-83558-10	END, NIPPLE	1	1	
68	90465-11M10	CLAMP	4	4	
69	6H1-44151-00	CAM, SHIFT	1	1	
70	6H1-44144-00	ROD, SHIFT	1	1	
71	93210-07003	O-RING	1	1	
72	99001-08600	CIRCLIP	1	1	
73	93450-07M00	CIRCLIP	1	1	



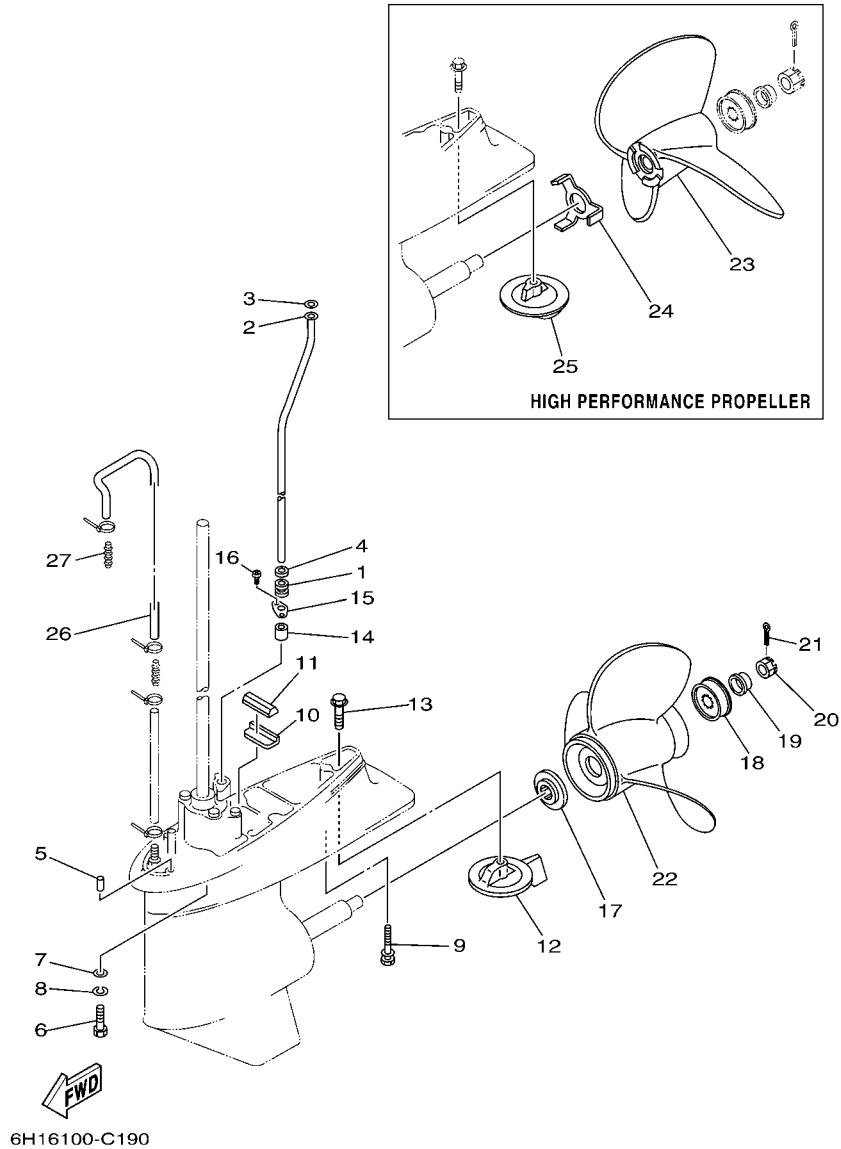
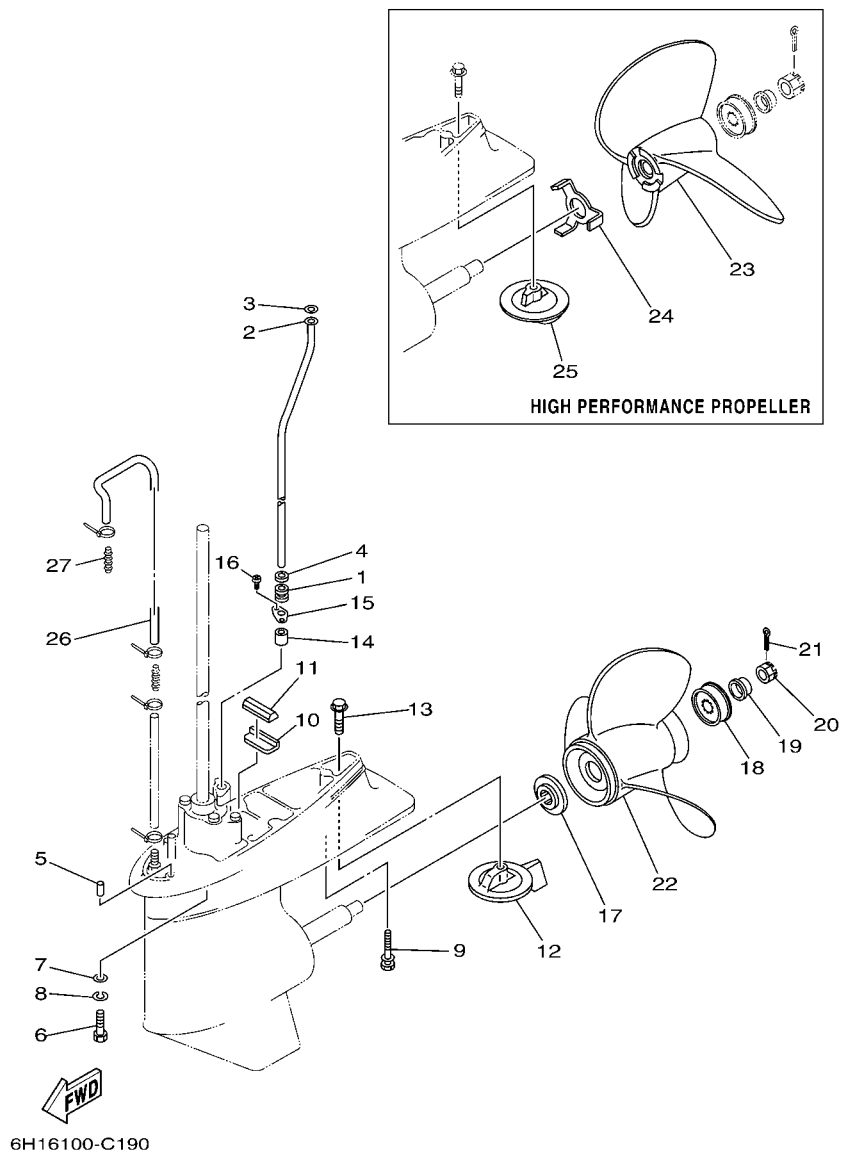

FIG. 19 LOWER CASING & DRIVE 2

REF. NO.	PART NO.	DESCRIPTION	CAN	QTY	REMARKS
1	663-44367-00	DAMPER, WATER SEAL 3	1	1	
2	688-44361-10	TUBE, WATER 1	1	1	L(20.3")
	688-44361-20	TUBE, WATER 1		1	X(25.3")
3	90202-12060	WASHER, PLATE	1	1	
4	90430-12072	GASKET	1	1	
5	93606-12019	PIN, DOWEL	2	2	L(20.3")
6	97075-10040	BOLT	4	4	L(20.3")
7	92995-10600	WASHER	4	4	
8	92990-10100	WASHER, SPRING	4	4	
9	90119-08M84	BOLT, WITH WASHER	1	1	L(20.3")
10	663-45376-00	GUIDE, SEAL DAMPER	1	1	
11	688-45375-00	DAMPER, SEAL	1	1	
12	688-45371-02	TAB-TRIM	1	1	
13	90105-10M67	BOLT, FLANGE	1	1	
14	663-44366-00	DAMPER, WATER SEAL 2	1	1	
15	90480-19M06	GROMMET	1	1	
16	90160-04006	SCREW, ROUND TAPPING	2	2	
17	688-45987-01	SPACER 1	1	1	
18	67F-45997-00	SPACER 2	1	1	
19	90389-25M00	BUSH	1	1	
20	90171-16011	NUT, CASTLE	1	1	
21	91490-40025	PIN. COTTER	1	1	
22	6E5-45941-00-EL	PROPELLER (3X13"X19"-K)	1	1	UR
	6E5-45943-00-EL	PROPELLER (3X12-5/8"X21"-K)	1	1	UR
	6E5-45945-01-EL	PROPELLER (3X13-1/4"X17"-K)	1	1	UR
	6E5-45947-00-EL	PROPELLER (3X13-1/2"X15"-K)	1	1	UR
	6E5-45949-00-EL	PROPELLER (3X13-5/8"X13"-K)	1	1	UR



**FIG. 19 LOWER CASING & DRIVE 2**

REF. NO.	PART NO.	DESCRIPTION	CAN	OCE	REMARKS
22	6E5-45952-00-EL	PROPELLER (3X13"X23"-K)	1	1	UR
	6E5-45954-00-EL	PROPELLER (3X14"X11"-K)	1	1	UR
	6E5-45956-00-EL	PROPELLER (3X13"X25"-K)	1	1	UR
	688-45930-02-98	PROPELLER (3X13"X17"-K)	1	1	UR
	688-45970-03-98	PROPELLER (3X13"X19"-K)	1	1	UR
---	688-45972-02-98	PROPELLER (3X13"X21"-K)	1	1	UR
	688-45974-02-98	PROPELLER (3X13"X23"-K)	1	1	UR
	688-45976-01-98	PROPELLER (3X13"X25"-K)	1	1	UR
	688-45932-60-98	PROPELLER (3X13-1/2"X14"-K)	1	1	UR
	688-45978-60-98	PROPELLER (3X13-1/2"X16"-K)	1	1	UR
---	23	6E5-45970-10	1	1	UR
	6E5-45972-10	PROPELLER (3X14"X24"-P)	1	1	UR
	6E5-45974-10	PROPELLER (3X14"X28"-P)	1	1	UR
	6E5-45976-10	PROPELLER (3X14"X22"-P)	1	1	UR
	6E5-45978-10	PROPELLER (3X14"X26"-P)	1	1	UR
---	24	6E5-45994-10	1	1	PLATE, TOOTH
	25	6E5-45371-10	1	1	TAB-TRIM
	26	90445-07MF1	1	1	HOSE (L570)
	27	6E5-83558-00	1	1	END, NIPPLE
---					
---					
---					





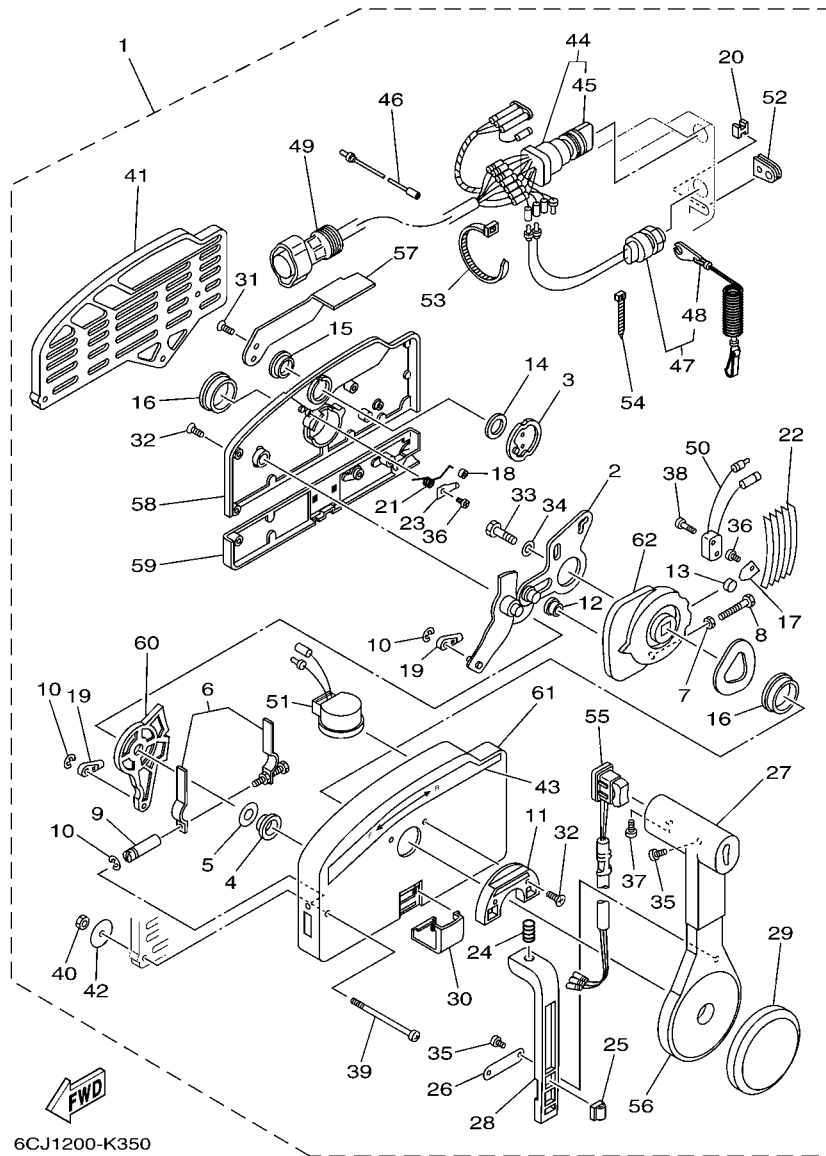

FIG. 22 REMOTE CONTROL ASSY

REF. NO.	PART NO.	DESCRIPTION	CAN	OGE	REMARKS
1	703-48205-18	REMOTE CONTROL ASSY (10P)		1	AP WITH PT/T SW.
2	703-48261-01	.ARM, THROTTLE		1	
3	703-48153-00	.SHAFT, FREE ACCEL.		1	
4	703-48235-00	.BUSHING		1	
5	703-48268-00	.SPACER		1	
6	703-48264-00	.FRICTION, THROTTLE		1	
7	95380-05600	.NUT		1	
8	97380-05025	.BOLT		1	
9	703-48265-00	.SHAFT, FRICTION		1	
10	93430-06024	.CIRCLIP		3	
11	703-48245-00	.PLATE, LOCK		1	
12	703-48252-00	.ROLLER, CAM		1	
13	701-48248-00	.ROLLER, FREE ACCEL.		1	
14	703-48198-00	.WASHER, WAVE		1	
15	703-48243-00	.BUSHING		1	
16	703-48236-00	.BUSHING 1		2	
17	703-48189-00	.RETAINER		1	
18	703-48234-00	.ROLLER, DETENT		1	
19	703-48345-01	.CABLE END, REMOTE CONTROL 2		2	
20	703-48358-00	.ANCHOR, CABLE		1	
21	703-48244-00	.SPRING, FREE ACCEL.		1	
22	703-48238-00	.SPRING, DETENT		5	
23	703-48246-00	.SPACER		1	
24	703-48227-00	.SPRING, NEUTRAL LOCK		1	
25	703-82594-00	.CLAMP		1	WITH PT/T SW.
26	703-48226-00	.PLATE, STOPPER		1	
27	703-48222-00	.GRIP, CONTROL LEVER		1	SINGLE

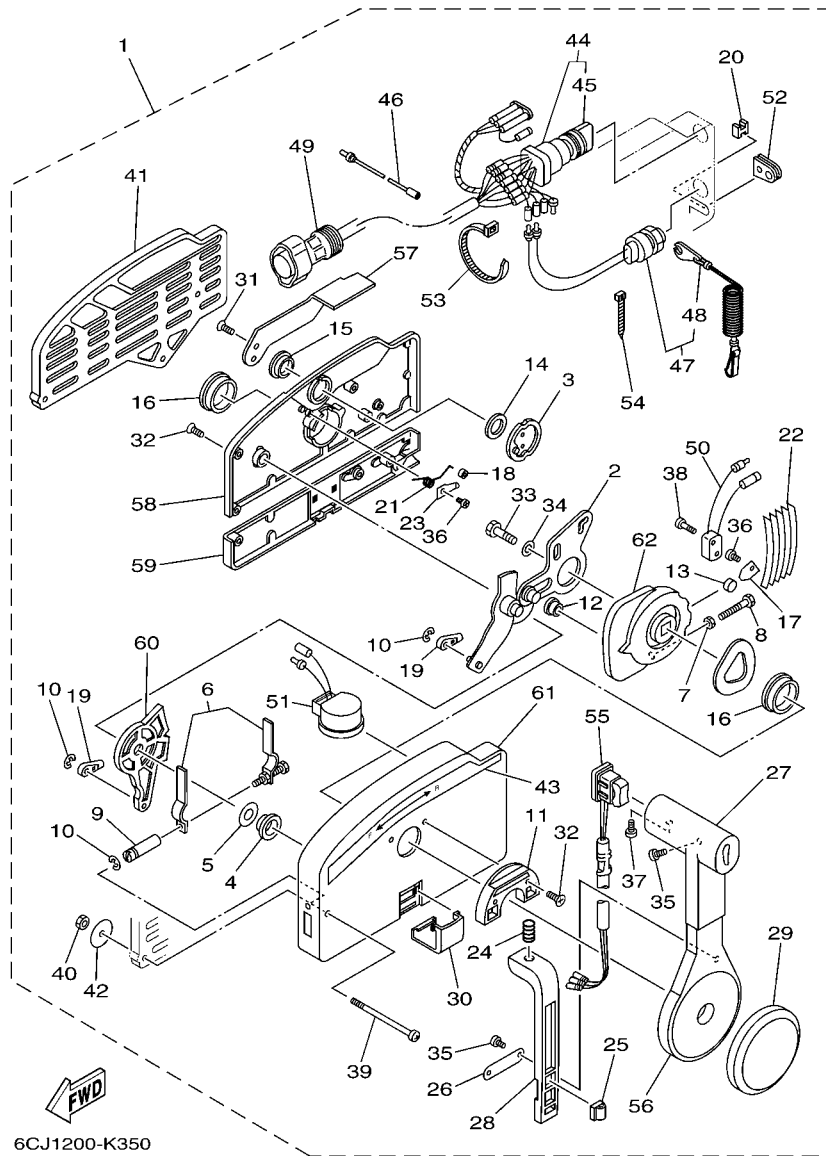
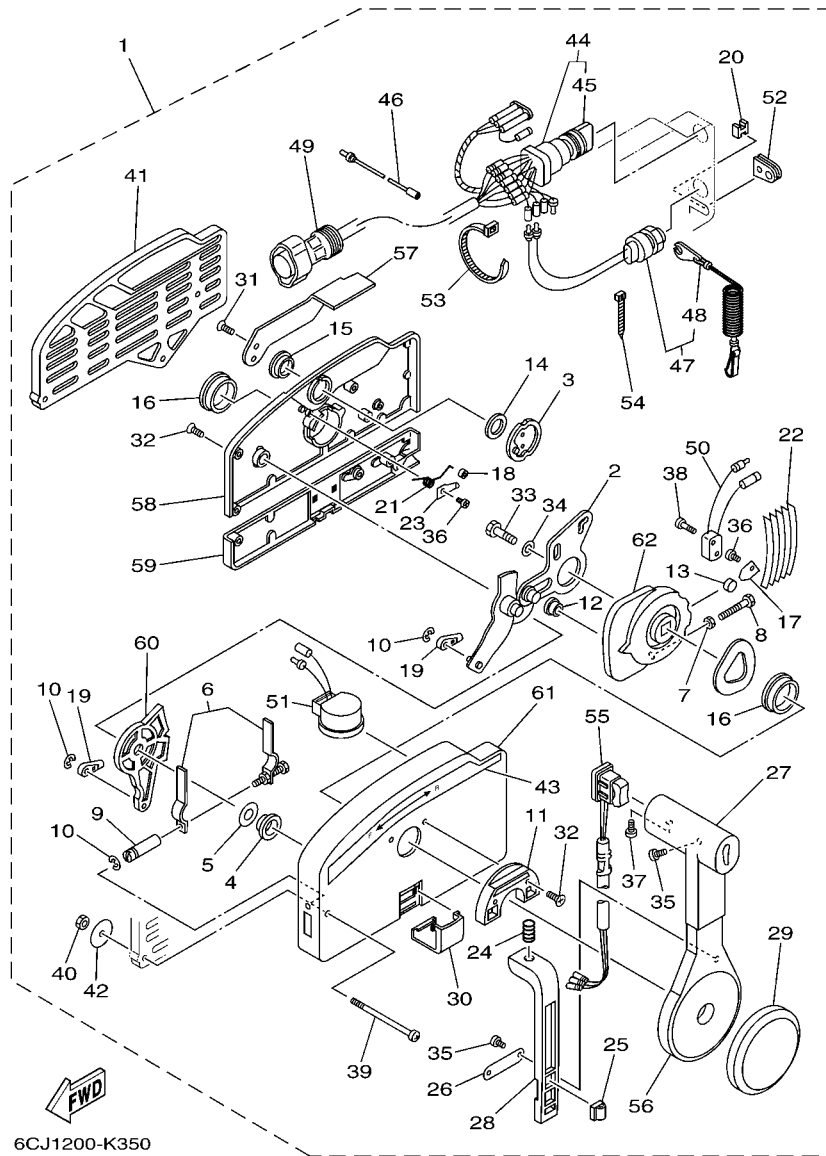

FIG. 22 REMOTE CONTROL ASSY

REF. NO.	PART NO.	DESCRIPTION	CAN	QTY	REMARKS
28	703-48223-00	.LOCK, NEUTRAL		1	
29	703-48225-00	.COVER		1	
30	703-48219-00	.COVER, LEAD		1	
31	703-48281-00	.SCREW		2	
32	703-48282-00	.SCREW		7	
33	97380-08030	.BOLT		1	
34	92990-08600	.WASHER, PLATE		1	
35	98580-04010	.SCREW, PAN HEAD		3	
36	98580-04006	.SCREW, PAN HEAD		2	
37	98580-05010	.SCREW, PAN HEAD		1	
38	98580-03015	.SCREW, PAN HEAD		2	
39	703-48291-10	.SCREW (M6)		3	
40	95380-06600	.NUT, HEXAGON		3	
41	703-48293-10	.SPACER, REMOTE CONTROL		1	SINGLE
42	701-48287-00	.WASHER		3	
43	703-48215-00	.GRAPHIC		1	
44	703-82510-43	.MAIN SWITCH ASSY		1	
45	703-82577-00	.CAP, KEY		1	
46	703-82531-00	.WIRE, LEAD (L70)		1	
47	688-82575-01	.ENGINE STOP SWITCH ASSY		1	
48	682-82556-00	.LANYARD, STOP SWITCH		1	
49	688-8258A-20	.EXTENSION, WIRE HARNESS (4.9M)		1	(10P)
50	703-82540-00	.NEUTRAL SWITCH ASSY		1	
51	703-83383-10	.BUZZER		1	
52	703-48284-00	.GROMMET		1	
53	703-82591-00	.BAND		1	
54	703-82592-00	.BAND		1	



**FIG. 22 REMOTE CONTROL ASSY**

REF. NO.	PART NO.	DESCRIPTION	CAN	QTY	REMARKS
55	703-82563-02	.TRIM & TILT SWITCH ASSY		1	WITH PT/T SW.
56	703-48221-00	.LEVER, CONTROL		1	
57	703-48152-00	.KNOB, FREE ACCEL.		1	
58	703-48212-00	.BACK PLATE 1		1	
59	703-48213-00	.BACK PLATE 2		1	
60	703-48271-00	.ARM, SHIFT		1	
61	703-48211-02	.HOUSING,1		1	
62	703-48232-00	.GEAR		1	

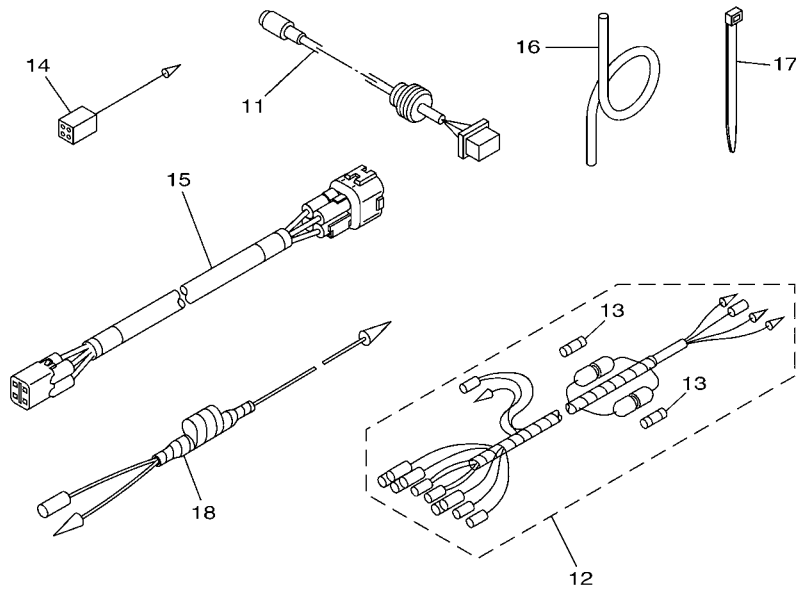
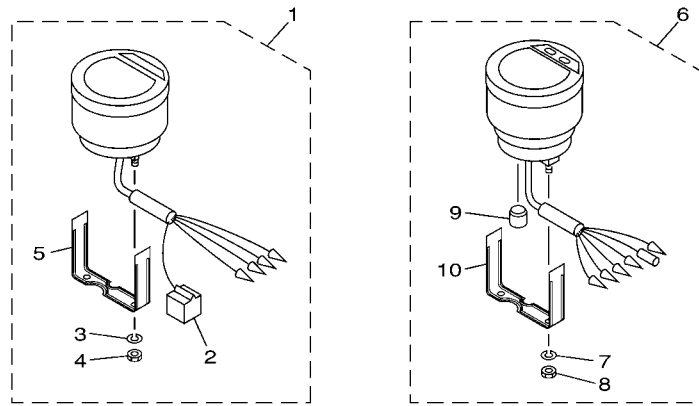

62XE100-G310

FIG. 23 METER

REF. NO.	PART NO.	DESCRIPTION	CAN	QTY	REMARKS
1	6Y5-8350T-90	DIGITAL TACHOMETER ASSY		1	AP
2	9E450-04533	.CONNECTOR		1	F-4-W
3	92990-04100	.WASHER, SPRING		2	
4	95380-04600	.NUT		2	
5	6Y5-8355X-T1	.BRACKET, METER 1		1	
6	6Y5-83570-S5	SPEEDOMETER ASSY		1	AP
7	92990-04100	.WASHER, SPRING		2	
8	95380-04600	.NUT		2	
9	6Y5-83533-T2	.GROMMET		1	
10	6Y5-8355X-T1	.BRACKET, METER 1		1	
11	6Y5-87122-S0	CORD ASSY 1		1	AP
12	6Y5-83553-M0	WIRE, LEAD (L=2.5M)		1	AP
13	1E6-82151-00	.FUSE (10A)		2	
14	6Y5-82117-00	WIRE, LEAD (BLACK) (L300)		1	AP
15	6Y5-83653-30	WIRE, LEAD (L=8.0M)		1	AP 4P,8M
16	6Y5-83557-10	TUBE (8M)		1	AP
17	90465-11M10	CLAMP		2	AP
18	6H4-81315-11	LEAD WIRE ASSY	1	1	AP





FIG. 25 REPAIR KIT 1

REF. NO.	PART NO.	DESCRIPTION	CAN	QTY	REMARKS
1	6H1-W0001-02	POWER HEAD GASKET KIT	1	1	
2	93210-46044	.O-RING	3	3	
3	93210-39ME4	.O-RING	3	3	
4	688-13621-A1	.GASKET, VALVE SEAT	2	2	
5	6H4-14984-00	.GASKET, FLOAT CHAMBER	3	3	
6	688-11181-A2	.GASKET, CYLINDER HEAD 1	1	1	
7	90430-14115	.GASKET	1	1	
8	688-11193-A1	.GASKET, HEAD COVER 1	1	1	
9	688-12414-A1	.GASKET, COVER	1	1	
10	688-41112-A0	.GASKET, EXHAUST INNER COVER	1	1	
11	688-41114-A0	.GASKET, EXHAUST OUTER COVER	1	1	
12	93210-46M16	.O-RING	1	1	
13	93102-36M02	.OIL SEAL	1	1	
14	93102-30M05	.OIL SEAL	1	1	
15	93104-20M02	.OIL SEAL	1	1	
16	93210-62269	.O-RING	1	1	
17	688-45113-A0	.GASKET, UPPER CASING	1	1	
18	93210-32738	.O-RING	1	1	
19	650-24431-A0	.GASKET, FUEL PUMP 1	1	1	
20	6H1-W0093-10	CARBURETOR REPAIR KIT	1	1	
21	6H4-14147-00	.O-RING	1	1	
22	93210-04228	.O-RING	1	1	
23	692-14590-01	.NEEDLE VALVE ASSY	1	1	
24	6H4-14548-00	.PIN, FLOAT ARM	1	1	
25	663-14159-00	.CLIP	1	1	
26	676-14186-00	.PIN, FLOAT	1	1	
27	676-14966-00	.CAP	1	1	

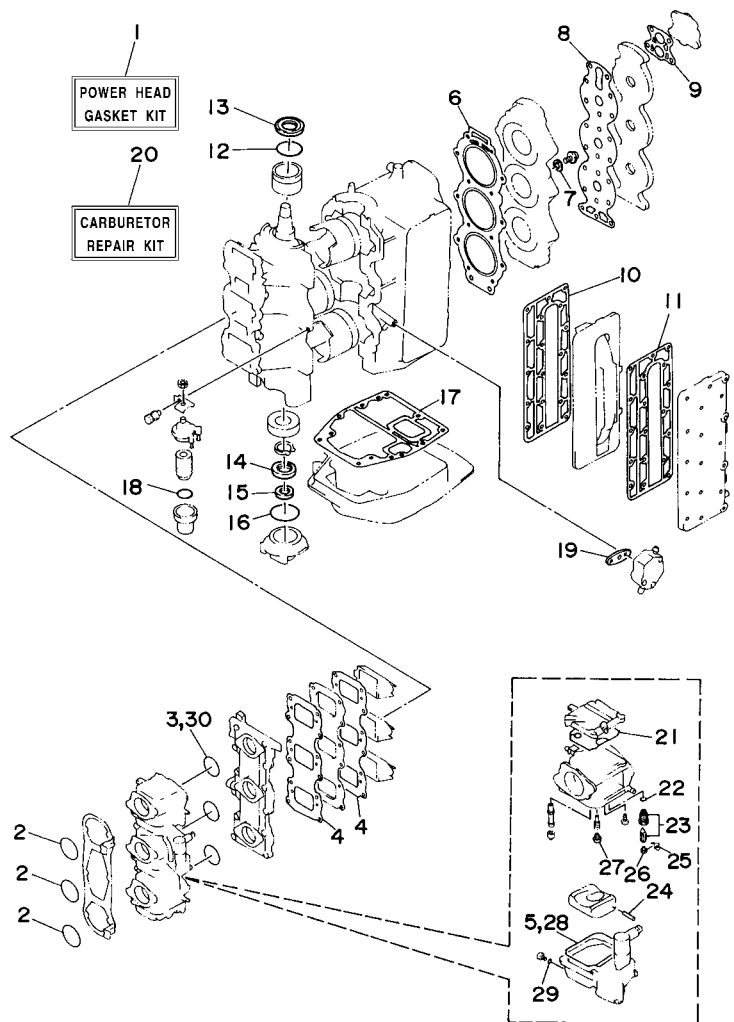

6H10010-4230



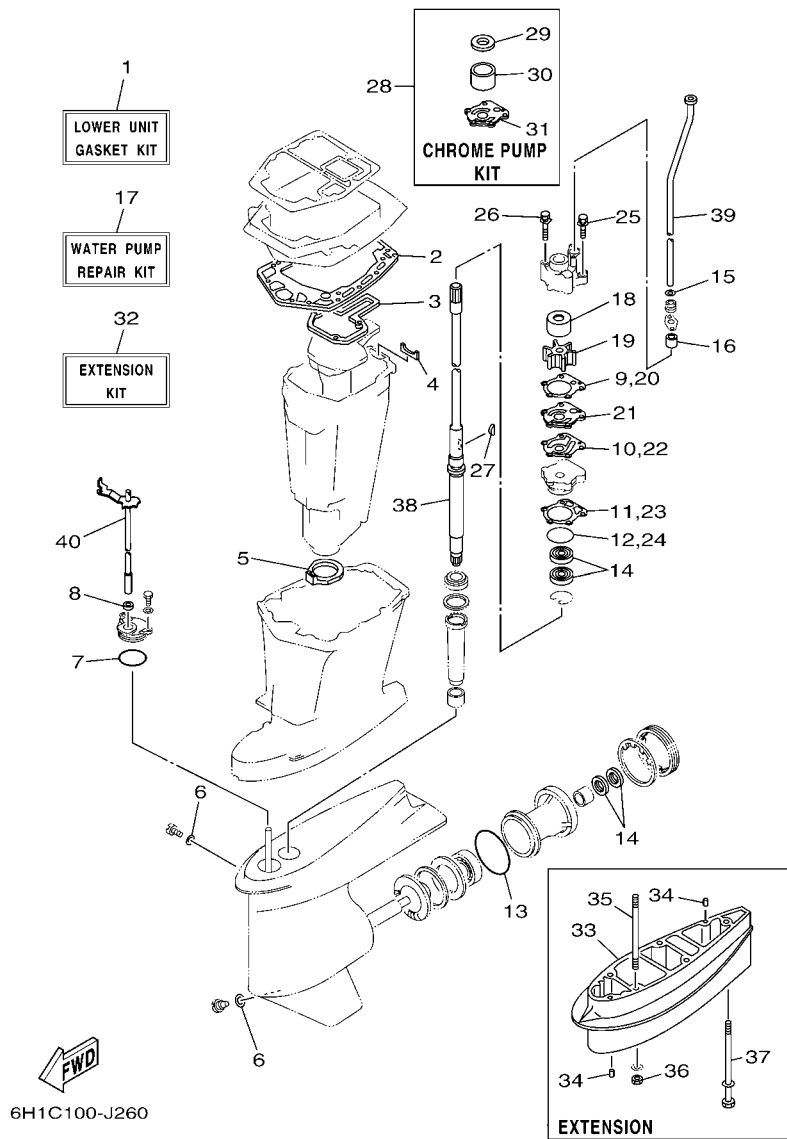

FIG. 26 REPAIR KIT 2

REF. NO.	PART NO.	DESCRIPTION	CAN	QTY	REMARKS
1	688-W0001-22	LOWER UNIT GASKET KIT	1	1	
2	688-45114-A1	.GASKET, UPPER CASING	1	1	
3	688-41134-A0	.GASKET, EXHAUST MANIFOLD	1	1	
4	688-41133-00	.GASKET, EXHAUST MANIFOLD 1	1	1	
5	688-45123-00	.GASKET, MUFFLER	1	1	
6	90430-08020	.GASKET	2	2	
7	93210-49046	.O-RING	1	1	
8	93106-09014	.OIL SEAL	1	1	
9	688-44315-A0	.GASKET, WATER PUMP	1	1	
10	688-44324-A0	.GASKET, CARTRIDGE	1	1	
11	688-44316-A0	.GASKET, WATER PUMP	1	1	
12	93210-46044	.O-RING	1	1	
13	93210-85M97	.O-RING	1	1	
14	93101-25M03	.OIL SEAL	4	4	
15	90430-12072	.GASKET	1	1	
16	663-44366-00	.DAMPER, WATER SEAL 2	1	1	
17	692-W0078-02	WATER PUMP REPAIR KIT	1	1	
18	688-44322-00	.INSERT, CARTRIDGE	1	1	
19	688-44352-03	.IMPELLER	1	1	
20	688-44315-A0	.GASKET, WATER PUMP	1	1	
21	688-44323-00	.OUTER PLATE, CARTRIDGE	1	1	
22	688-44324-A0	.GASKET, CARTRIDGE	1	1	
23	688-44316-A0	.GASKET, WATER PUMP	1	1	
24	93210-46044	.O-RING	1	1	
25	90119-08M13	.BOLT, WITH WASHER	2	2	
26	90119-08M16	.BOLT, WITH WASHER	2	2	
27	90280-04M04	.KEY, WOODRUFF	1	1	

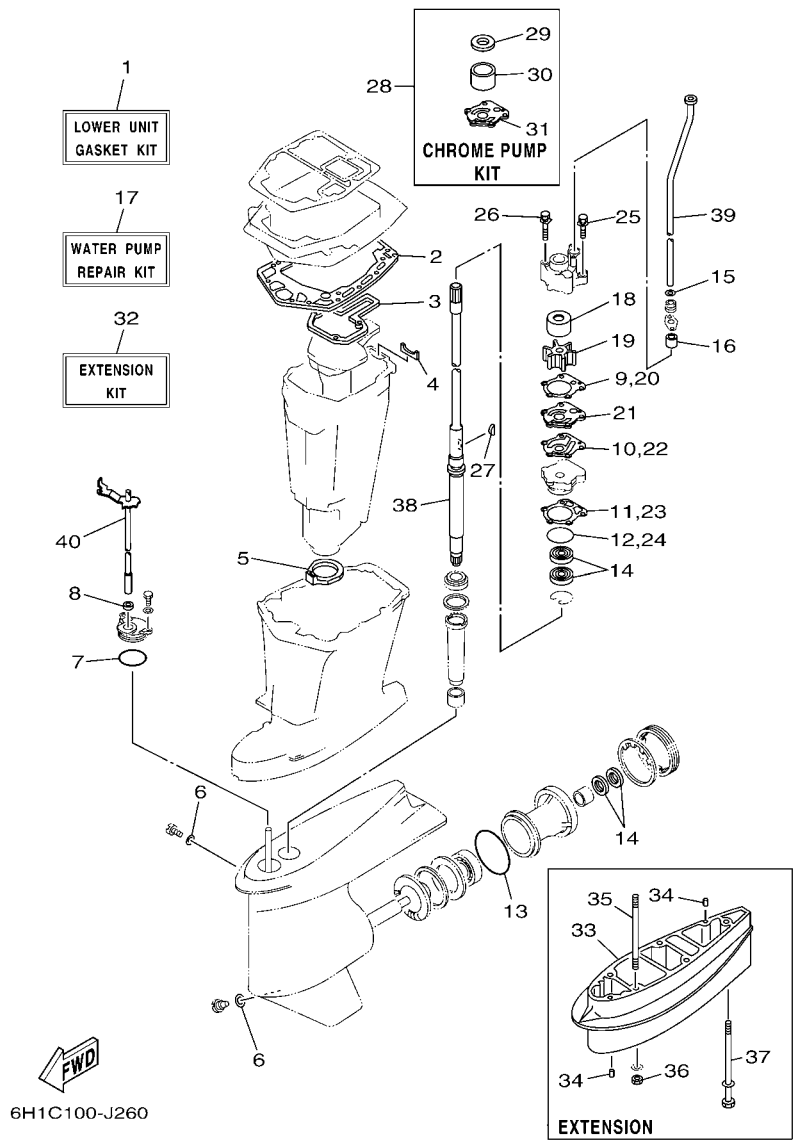

FIG. 26 REPAIR KIT 2

REF. NO.	PART NO.	DESCRIPTION	CAN	QTY	REMARKS
28	688-W0078-1A	CHROME PUMP KIT	1	1	
29	688-44321-41	.INNER PLATE, CARTRIDGE	1	1	
30	688-44322-41	.INSERT, CARTRIDGE	1	1	
31	688-44323-40	.OUTER PLATE, CARTRIDGE	1	1	
32	6H1-W0072-02-8D	EXTENSION KIT		1	X(25.3")
33	688-45211-01-8D	.EXTENSION		1	
34	93606-12019	.PIN, DOWEL		4	
35	90116-10M05	.BOLT, STUD		4	
36	95380-10600	.NUT		4	
37	90119-08M86	.BOLT, WITH WASHER		1	
38	688-45501-22	.DRIVE SHAFT COMP.		1	
39	688-44361-20	.TUBE, WATER 1		1	
40	6H1-44120-22	.HANDLE GEAR SHIFT ASSY		1	

NUMERICAL INDEX

PART NO.	REF. NO.	PART NO.	REF. NO.	PART NO.	REF. NO.	PART NO.	REF. NO.	PART NO.	REF. NO.	PART NO.	REF. NO.
6H1-11111-01-1S	2 - 30	6H1-13435-00	6 - 45	688-14711-01-CA	17 - 10	692-24410-00	7 - 12	688-42510-03-8D	15 - 4	6H1-43311-02-8D	14 - 15
688-11119-01	2 - 28	6H1-13437-21	9 - 20	663-14737-10	17 - 12	663-24411-00	7 - 17	6H1-42610-80	1 - 1	6H1-43376-00	15 - 40
688-11181-A2	2 - 31	6R3-13471-00	6 - 2	692-14923-00	5 - 11	692-24411-00	7 - 14	6H1-42613-01-8D	1 - 11	6H1-43800-17-8D	16 - 1
	25 - 6	6L2-13475-00	6 - 3	6H1-14943-39	5 - 21	6H3-24411-10	5 - 40	688-42615-00	1 - 14	67F-43802-00	16 - 39
688-11191-00-1S	2 - 35	688-13610-00	4 - 12	6A0-24412-02	5 - 20	6A0-24412-02	7 - 23	6H1-42617-10	1 - 18	6H1-43804-10	16 - 4
688-11193-A1	2 - 36	688-13621-A1	4 - 10	6H1-14948-18	5 - 23	6A0-24413-00	7 - 13	6H1-42619-00	1 - 19	6H1-43805-10	16 - 3
	25 - 8		25 - 4	676-14966-00	5 - 22	6H4-24413-00	5 - 38	6H1-42627-00	1 - 20	6H1-4380F-10	16 - 7
688-11325-00	2 - 26	688-13624-00	4 - 11		25 - 27	6L5-24421-00	5 - 37	6H1-42637-00	1 - 21	6H1-4380G-10	16 - 15
650-11370-01	2 - 4	6H1-13641-02-94	4 - 6	6H4-14980-00	5 - 27	6A0-24421-01	7 - 21	6H1-42647-00	1 - 3	6H1-4380H-10	16 - 13
688-11370-01	2 - 3	6H3-14137-00	5 - 31	6H3-14980-10	5 - 28	650-24431-A0	7 - 24	6H1-42649-00	1 - 4	6H1-4380J-10	16 - 8
	3 - 2	6H4-14146-00	5 - 8	6H4-14984-00	5 - 24		25 - 19	688-42652-10	1 - 6	6H1-43810-11	16 - 20
688-11411-01	3 - 11	6H3-14146-10	5 - 9		25 - 5	648-24434-01	7 - 15	663-42662-00	1 - 5	6H1-43812-00	16 - 24
663-11518-01	2 - 6	6H3-14146-20	5 - 9		25 - 28	6H3-24434-10	5 - 41	6H1-42677-80	1 - 15	6H1-43813-10	16 - 27
6H1-11536-00	3 - 27	6H4-14146-20	5 - 8	6H4-14985-01	5 - 19	648-24435-02	7 - 18	6H1-42678-60	1 - 16	6H1-43814-11	16 - 19
6H1-11537-01	6 - 16	6H3-14146-50	24 - 13	6H3-14992-00	5 - 25	6H3-24452-10	5 - 29	6H1-42681-50	1 - 27	6H1-43816-00	16 - 67
688-11603-A0	3 - 19	6H4-14146-50	24 - 12	6H1-15100-05	2 - 2	6H4-24486-00	5 - 39	6H1-42682-50	1 - 28	6H1-43817-01	16 - 47
688-11604-A0	3 - 19	6H4-14147-00	5 - 10	6H1-15359-01-94	3 - 1	61N-24521-00	7 - 8	6H1-42694-00	1 - 22	6E5-43818-00	16 - 32
688-11605-A0	3 - 19		25 - 21	688-15379-00	3 - 6	61N-24560-00	7 - 6	6H1-42711-01-8D	12 - 1	6H1-43820-11	16 - 63
6H1-11631-03-95	3 - 18	663-14159-00	5 - 17	6H1-15771-00	11 - 19	61N-24563-00	7 - 7	6H1-42711-10-8D	12 - 1	6H1-43821-11	16 - 59
663-11633-00	3 - 20		25 - 25	6H1-15772-00	2 - 53	6H1-24566-01	7 - 10	648-42715-00	13 - 48	6H1-43822-10	16 - 58
688-11634-10	3 - 21	676-14186-00	5 - 18	6H1-15773-01	2 - 55	6H1-24633-00	6 - 40	688-42716-02	12 - 9	6H1-43828-10	16 - 30
6H1-11635-03	3 - 18		25 - 26	6H1-21707-07	6 - 26	6E0-28193-00-94	7 - 36	663-42724-00	12 - 10	6H1-43829-00	16 - 36
6H1-11636-03	3 - 18	6H1-14301-07	5 - 1	6H3-21732-00	1 - 23	688-41111-00-1S	2 - 46	688-42725-20	12 - 11	6H1-4382A-10	16 - 52
688-11650-03	3 - 22	6H1-14301-30	5 - 1	6H3-21735-00	1 - 24	688-41112-A0	2 - 47	688-42726-10	12 - 22	6H1-43830-11	16 - 49
688-12411-11	2 - 41	6H1-14302-07	5 - 2	6H1-21752-00	6 - 33		25 - 10	6H1-42726-21	12 - 22	6H1-43831-10	16 - 48
688-12412-00	2 - 42	6H1-14302-30	5 - 2	6H1-21757-00	6 - 39	688-41113-00-1S	2 - 49	688-42738-01-8D	12 - 12	6H1-43833-10	16 - 33
688-12413-00-1S	2 - 43	6H1-14303-07	5 - 3	6J8-21758-00	6 - 38	6H1-41113-00-1S	2 - 49	688-42741-01-8D	12 - 24	6H1-43834-00	16 - 34
6H1-12413-50	24 - 2	6H1-14303-30	5 - 3	63D-2175R-00	6 - 36	688-41114-A0	2 - 48	6BG-42748-00	12 - 15	6H1-43835-10	16 - 29
6H1-12414-50	24 - 3	6A0-14325-00	7 - 22	6H1-21766-01	6 - 43		25 - 11	6G1-42748-00	12 - 23	6H1-43840-11	16 - 17
688-12414-A1	2 - 44	67C-1432A-00	5 - 42	63D-2176M-00	6 - 35	688-41131-00-CA	17 - 8	688-42771-01-8D	12 - 25	6H1-43841-11	16 - 42
	25 - 9	6H1-14348-51	24 - 5	6H4-21770-00	6 - 37	688-41133-00	17 - 9	6G5-42791-10	12 - 43	6H1-43843-11	16 - 71
688-12416-00	2 - 39	6H3-14349-00	4 - 4	63D-2177H-00	1 - 2		26 - 4	6AH-42794-40	12 - 44	6H1-43844-10	16 - 44
6H1-12440-52	24 - 1		5 - 32	6H1-21796-00	2 - 56	688-41134-A0	17 - 7	6AH-42794-50	12 - 45	6H1-43845-00	16 - 55
6H1-12443-50	24 - 7	6H1-14349-50	24 - 9	6G1-24304-02	7 - 1		26 - 3	688-42815-01-8D	12 - 3	6H1-43847-00	16 - 50
6H1-12466-A0	24 - 8	6H3-14380-00	5 - 33	6G1-24305-05	8 - 6	688-41137-03-CA	17 - 5	688-42816-00	12 - 7	6H1-4384E-20	16 - 61
6H1-12466-B0	24 - 10	6H1-14413-02	4 - 22	6Y1-24305-06	8 - 8	688-41211-01	13 - 27	688-42817-01-8D	12 - 4	6H1-4384F-10	16 - 46
6E5-12481-00	24 - 11	6H1-14440-02	4 - 18	61J-24306-04	8 - 1	6H1-41213-00	13 - 30	6H1-43111-01-8D	14 - 1	6H1-4384G-11	16 - 45
6H1-12535-00	12 - 33	624-14485-00	2 - 5	6YL-24306-60	8 - 10	662-41214-01	13 - 8	6H1-43112-00-8D	14 - 10	6H1-43854-00	16 - 53
68T-12572-00	12 - 31	6H1-14485-00	4 - 7	663-24312-01	2 - 50	688-41217-01	4 - 3	6E5-43126-02	14 - 39	6H1-43855-11	16 - 70
6R3-12580-00	12 - 36	6H1-14488-00	9 - 19	6H1-24312-01	12 - 40	682-41237-00	13 - 29	688-43131-03	14 - 20	6H1-43856-10	16 - 43
6R3-12581-00	12 - 37	63V-14523-00	5 - 5	688-24313-00	7 - 30	6E9-41237-00	6 - 25	6G5-43144-00	14 - 33	6H1-4385H-00	16 - 76
6R3-12582-00	12 - 38	6H4-14548-00	5 - 15	688-24314-00	7 - 31	6F5-41237-00	13 - 19	6E5-43145-01	20 - 9	6H1-43861-00	16 - 21
6R3-12583-00	12 - 39		25 - 24	6H1-24314-00	7 - 27	6H1-41237-00	6 - 21	6G5-43145-01	14 - 24	6H1-43861-10	16 - 18
6H1-13117-01	6 - 18	697-14555-00	5 - 12	650-24351-01	8 - 5	662-41237-01	13 - 26	6G5-43148-00	14 - 28		16 - 22
6E9-13183-70	6 - 13	6H4-14567-00	5 - 30	61J-24360-00	8 - 3	6H1-41241-02	6 - 20	688-43160-01	14 - 35		16 - 60
6H1-13200-02	6 - 1	6H2-14578-00	5 - 7	6E5-24367-01	12 - 29	688-41631-01-1S	13 - 18	688-43165-00	14 - 36	6H1-43864-00	16 - 64
6H1-13411-00	6 - 42	692-14590-01	5 - 14	650-24378-00	2 - 7	688-41632-01-1S	13 - 7	6H1-43181-01	14 - 25	6H1-43865-10	16 - 16
6J8-13414-00	6 - 41		25 - 23	688-24378-00	7 - 34	6H1-41636-00	13 - 24	6H1-43185-01	14 - 26	6H1-43866-00	16 - 40

NUMERICAL INDEX

PART NO.	REF. NO.	PART NO.	REF. NO.	PART NO.	REF. NO.	PART NO.	REF. NO.	PART NO.	REF. NO.	PART NO.	REF. NO.
6H1-43867-00	16 - 41	688-44361-10	19 - 2	688-45560-00	18 - 39	6E5-45976-10	19 - 23	701-48320-50	21 - 2	682-82119-01	10 - 45
6H1-43868-00	16 - 73	688-44361-20	19 - 2	688-45567-01	18 - 7	6E5-45978-10	19 - 23	701-48320-60	21 - 2	688-82127-02	15 - 26
6H1-4386K-10	16 - 9		26 - 39	688-45567-10	18 - 7	688-45978-60-98	19 - 22	701-48320-80	21 - 2	6E5-82148-00	14 - 11
6H1-43871-10	16 - 23	663-44366-00	19 - 14	688-45567-20	18 - 7	688-45987-01	19 - 17	663-48344-00	13 - 6	6H1-82148-00	14 - 8
6H1-43872-10	16 - 25		26 - 16	688-45567-30	18 - 7	6E5-45994-10	19 - 24	6E5-45994-01	22 - 19	1E6-82151-00	23 - 13
6H1-43874-00	16 - 66	663-44367-00	19 - 1	688-45567-40	18 - 7	67F-45997-00	19 - 18	703-48358-00	22 - 20	663-82151-00	10 - 33
6H1-43875-00	16 - 57	6BL-44391-00	12 - 2	688-45567-50	18 - 7	703-48152-00	22 - 57	688-48511-30	15 - 37	6G5-82152-00	10 - 20
6H1-4387J-00	16 - 75	688-44511-00	15 - 34	688-45567-60	18 - 7	703-48153-00	22 - 3	663-48531-00	13 - 1	6A0-82317-00	6 - 50
6H1-43880-02	16 - 2	688-44514-00	15 - 27	6H1-45571-00	18 - 54	703-48189-00	22 - 17	663-48538-00	13 - 2	6E3-82370-21	10 - 29
6H1-43881-10	16 - 12	6H1-44526-00	14 - 3	688-45576-00	18 - 58	703-48198-00	22 - 14	688-61350-10	20 - 1	63V-82377-50	14 - 43
6H1-4388E-11	16 - 72	663-44551-02-8D	15 - 10	688-45577-01	18 - 57	703-48205-18	21 - 1	688-61351-10	20 - 2	703-82510-43	22 - 44
6H1-43891-10	16 - 5	687-44552-02	15 - 19	688-45577-10	18 - 57		22 - 1	6E5-61355-00	20 - 8	697-82519-00	10 - 37
6H1-43892-10	16 - 6	663-44553-01-8D	15 - 24	688-45577-20	18 - 57	703-48211-02	22 - 61	6H4-81315-11	23 - 18	703-82531-00	22 - 46
6H1-43895-12	16 - 69	687-44555-00	15 - 12	688-45577-30	18 - 57	703-48212-00	22 - 58	688-81332-01	9 - 11	703-82540-00	22 - 50
6H1-43896-00	16 - 68	663-44575-00	15 - 17	688-45577-40	18 - 57	703-48213-00	22 - 59	6H1-81337-01	9 - 14	682-82556-00	22 - 48
6H1-43899-00	16 - 51		15 - 33	688-45577-50	18 - 57	703-48215-00	22 - 43	688-81800-12	11 - 1	688-82560-10	10 - 30
688-44117-00-94	13 - 34	688-45111-04-8D	17 - 1	688-45577-60	18 - 57	703-48219-00	22 - 30	703-82563-02	11 - 3	703-82563-02	22 - 55
688-44118-01-94	13 - 42	688-45113-A0	17 - 20	688-45587-01	18 - 5	703-48221-00	22 - 56	688-81810-11	11 - 5	6H1-82563-10	10 - 46
6H1-44120-12	13 - 49		25 - 17	688-45587-10	18 - 5	703-48222-00	22 - 27	663-81811-11	11 - 6	688-82575-01	22 - 47
6H1-44120-22	13 - 49	688-45114-A1	17 - 6	688-45587-20	18 - 5	703-48223-00	22 - 28	663-81812-11	11 - 8	703-82577-00	22 - 45
	26 - 40		26 - 2	688-45587-30	18 - 5	703-48225-00	22 - 29	663-81813-10	11 - 9	6R5-82582-B0	6 - 52
6H1-44121-00	13 - 41	663-45119-00	14 - 17	688-45587-40	18 - 5	703-48226-00	22 - 26	663-81820-12	11 - 10	6E5-82587-00	10 - 47
688-44122-00	13 - 38	688-45123-00	17 - 11	688-45587-50	18 - 5	703-48227-00	22 - 24	688-81824-00	11 - 15	688-82588-01	10 - 31
688-44124-00	13 - 37		26 - 5	688-45587-60	18 - 5	703-48232-00	22 - 62	663-81826-10	11 - 14	688-8258A-20	22 - 49
6H1-44144-00	18 - 70	663-45155-10	17 - 2	6H1-45611-01	18 - 40	703-48234-00	22 - 18	688-81830-11	11 - 12	6H0-82590-80	10 - 32
6H1-44151-00	18 - 69	688-45211-01-8D	17 - 22	6H1-45631-01	18 - 50	703-48235-00	22 - 4	688-81831-00	11 - 13	703-82591-00	22 - 53
688-44194-00	2 - 14		26 - 33	688-45633-00	18 - 52	703-48236-00	22 - 16	663-81832-11	11 - 11	703-82592-00	22 - 54
	13 - 21	6H1-45214-00	18 - 12	6H1-45634-02	18 - 44	703-48238-00	22 - 22	663-81840-11	11 - 7	688-82594-00	10 - 38
688-44311-01	18 - 21	6H1-45215-00	18 - 13	6H1-45635-00	18 - 53	703-48243-00	22 - 15	676-81850-11	11 - 2	703-82594-00	22 - 25
688-44315-A0	18 - 23	6H1-45251-03	14 - 2	6H1-45641-01	18 - 42	703-48244-00	22 - 21	676-81857-10	11 - 4	703-83383-10	22 - 51
	26 - 9	6H1-45300-16-8D	18 - 1	6H1-45668-00	18 - 47	703-48245-00	22 - 11	6H1-81916-00	10 - 27	6Y5-8350T-90	23 - 1
	26 - 20	6H1-45300-26-8D	18 - 1	688-45930-02-98	19 - 22	703-48246-00	22 - 23	6G1-81941-10	10 - 15	6Y5-83533-T2	23 - 9
688-44316-A0	18 - 30	6H1-45301-03-8D	18 - 2	688-45932-60-98	19 - 22	701-48248-00	22 - 13	6E9-81945-70	10 - 17	6Y5-83553-M0	23 - 12
	26 - 11	688-45321-00	18 - 16	6E5-45941-00-EL	19 - 22	703-48252-00	22 - 12	6H0-81949-01	10 - 44	6Y5-83557-10	23 - 16
	26 - 23	688-45331-00-CA	18 - 55	6E5-45943-00-EL	19 - 22	703-48261-01	22 - 2	6H0-81949-10	10 - 43	6E5-83558-00	19 - 27
688-44321-41	26 - 29	688-45341-10	18 - 10	6E5-45945-01-EL	19 - 22	703-48264-00	22 - 6	61A-81950-00	10 - 39	6E5-83558-10	18 - 67
688-44322-00	18 - 22	688-45371-02	19 - 12	6E5-45947-00-EL	19 - 22	703-48265-00	22 - 9	6G1-81952-00	10 - 16	6Y5-8355X-T1	23 - 5
	26 - 18	6E5-45371-10	19 - 25	6E5-45949-00-EL	19 - 22	703-48268-00	22 - 5	6H0-81960-10	10 - 9		23 - 10
688-44322-41	26 - 30	688-45375-00	19 - 11	6E5-45952-00-EL	19 - 22	703-48271-00	22 - 60	6AH-81994-40	4 - 24	6Y5-83570-S5	23 - 6
688-44323-00	18 - 31	663-45376-00	19 - 10	6E5-45954-00-EL	19 - 22	703-48281-00	22 - 31	6AH-81994-50	4 - 25	6H1-83614-00	10 - 48
	26 - 21	6E5-45378-00	18 - 65	6E5-45956-00-EL	19 - 22	703-48282-00	22 - 32	6AH-81995-40	9 - 21	6Y5-83653-30	23 - 15
688-44323-40	26 - 31	688-45383-02	18 - 62	688-45970-03-98	19 - 22	703-48284-00	22 - 52	6AH-81995-50	9 - 22	6H1-83672-21	15 - 1
688-44324-A0	18 - 32	688-45384-02	18 - 63	6E5-45970-10	19 - 23	701-48287-00	22 - 42	6AG-81996-00	9 - 23	6H0-85510-03	9 - 2
	26 - 10	6H1-45501-11	18 - 36	688-45972-02-98	19 - 22	703-48291-10	22 - 39	6H0-82105-02	10 - 34	6H0-85540-07	10 - 1
	26 - 22	688-45501-22	18 - 36	6E5-45972-10	19 - 23	703-48293-10	22 - 41	6H0-82117-00	10 - 36	6H1-85542-00-94	10 - 21
6D8-44341-01-CA	18 - 26		26 - 38	688-45974-02-98	19 - 22	701-48320-00	21 - 2	6Y5-82117-00	23 - 14	6H1-85542-10	10 - 3
688-44352-03	18 - 24	688-45536-01	18 - 4	6E5-45974-10	19 - 23	701-48320-20	21 - 2	703-82119-00	10 - 2	6H0-85550-00	9 - 1
	26 - 19	688-45551-01	18 - 37	688-45976-01-98	19 - 22	701-48320-30	21 - 2	682-82119-01	10 - 42	697-85570-00	10 - 6

NUMERICAL INDEX

PART NO.	REF. NO.	PART NO.	REF. NO.	PART NO.	REF. NO.	PART NO.	REF. NO.	PART NO.	REF. NO.	PART NO.	REF. NO.	PART NO.	REF. NO.
6H0-85580-01	9 - 3	90119-08MA8	2 - 32	90206-13019	12 - 6	90445-07M87	6 - 12	90468-18008	13 - 40	92995-06600	7 - 3		
6H1-85711-60	4 - 23	90119-10005	2 - 10	90209-06M05	4 - 21	90445-07M90	6 - 8		13 - 52		7 - 26		
6R5-85711-60	10 - 51	90151-05M00	18 - 14	90249-06M19	14 - 30	90445-07ME9	18 - 66	90480-09M25	10 - 22		9 - 7		
6H1-85720-16	6 - 51	90157-06013	13 - 20	90250-07M02	18 - 51	90445-07MF1	19 - 26	90480-19M06	19 - 15		9 - 13		
6H2-85895-01	9 - 4	90157-06014	2 - 13	90266-06009	1 - 10	90445-07MF2	18 - 66	90480-20M05	2 - 38		9 - 18		
6Y5-87122-S0	23 - 11	90157-06M01	12 - 20	90280-04M04	18 - 25	90445-08M01	6 - 44	90480-24M04	2 - 18		10 - 11		
6H1-W0001-02	25 - 1	90159-06M11	10 - 28		26 - 27	90445-09097	7 - 29	90501-10326	5 - 6		10 - 41		
688-W0001-22	26 - 1	90159-06M20	9 - 15	90280-05015	9 - 8	90445-09104	7 - 4	90501-12082	13 - 47		12 - 14		
688-W0004-00	4 - 13	90160-04006	19 - 16	90282-04010	18 - 64	90445-09220	7 - 33	90501-12M48	18 - 41		12 - 35		
6H1-W0070-60	1 - 17	90167-06002	12 - 32	90338-05M03	14 - 19	90445-11M05	8 - 4	90501-14M08	15 - 22		14 - 7		
6H1-W0072-02-8D	26 - 32	90170-09M03	20 - 5	90338-05M12	1 - 25	90445-11M06	8 - 2	90501-16M11	2 - 40		15 - 3		
692-W0078-02	26 - 17	90170-16M01	18 - 38	90340-08002	18 - 9	90445-11M09	6 - 27	90501-16M12	13 - 23		18 - 20		
688-W0078-1A	26 - 28	90170-20137	9 - 9	90340-14M00	2 - 33	90464-07M05	6 - 15	90501-16M65	18 - 45	92995-08100	13 - 5		
6H1-W0090-45-1S	2 - 1	90171-16011	19 - 20	90386-07M58	13 - 50	90464-09M31	12 - 42	90502-16M02	14 - 38		15 - 21		
6H1-W0093-10	25 - 20	90179-06066	15 - 23	90386-10M16	14 - 27	90464-11M18	14 - 18	90506-14M24	14 - 32		15 - 36		
656-W2810-02	7 - 35	90183-02M03	18 - 49	90386-12089	13 - 12	90464-11M24	6 - 28	90508-29M05	13 - 17		17 - 14		
90101-10M49	15 - 28	90183-05M06	1 - 26	90386-13M38	12 - 5	90464-15M08	12 - 21	91318-04025	16 - 74		17 - 16		
90101-12M65	14 - 44	90185-05002	18 - 15	90386-18M14	16 - 31	90464-18M14	10 - 50	91318-08016	16 - 65		17 - 19		
90105-10M67	19 - 13	90185-08057	15 - 41	90386-18M35	14 - 40	90464-23M22	10 - 35	91490-40025	19 - 21	92995-10100	14 - 14		
90109-06M39	6 - 5	90185-09M01	20 - 4	90386-18M63	14 - 42	90465-06M90	9 - 16	91690-30012	13 - 3	92995-10600	19 - 7		
	10 - 25	90185-10051	15 - 32	90386-22M13	13 - 14	90465-08M23	10 - 12		14 - 37	92995-12200	14 - 45		
	6 - 6		15 - 39	90386-22M15	14 - 21	90465-11M10	12 - 41	91690-30020	14 - 29	93101-25M03	18 - 28		
90109-08022	3 - 23	90185-22M11	14 - 23	90386-30M60	15 - 9		15 - 42	92903-06100	4 - 17		18 - 61		
90109-12261	15 - 16	90201-03313	18 - 48	90386-30M77	15 - 7		18 - 68	92903-06600	5 - 45		26 - 14		
90116-10175	15 - 38	90201-06416	12 - 17	90386-30M78	15 - 6		23 - 17		10 - 8	93102-08M43	16 - 14		
90116-10M05	17 - 23	90201-06M31	10 - 26	90387-06119	6 - 49	90465-11M27	6 - 29		10 - 19	93102-30M05	3 - 3		
	26 - 35	90201-08M13	13 - 16	90387-06M03	10 - 23	90465-12M03	2 - 23		13 - 36		25 - 14		
90116-10M06	2 - 22	90201-08M23	13 - 11	90387-06M17	13 - 31	90465-13M11	10 - 4	92903-08100	11 - 17	93102-36M02	3 - 13		
90119-06M09	12 - 8	90201-08M93	6 - 17	90387-06M31	6 - 32	90465-13M30	6 - 34		13 - 44		25 - 13		
90119-06M12	2 - 9	90201-10008	2 - 11	90387-06M69	12 - 16	90465-18147	5 - 43	92903-08600	13 - 45	93104-20M02	3 - 4		
90119-06M24	13 - 33	90201-10M20	20 - 3	90387-08M16	13 - 13	90467-06016	2 - 17	92990-04100	23 - 3		25 - 15		
90119-06M29	14 - 4	90201-10M63	20 - 7	90387-10M02	14 - 31		2 - 21		23 - 7	93106-09014	18 - 18		
90119-06M61	12 - 19	90201-11M22	15 - 31	90387-10M42	20 - 6		3 - 8	92990-05100	4 - 15		26 - 8		
90119-06M75	10 - 24	90201-12426	14 - 46	90389-25M00	19 - 19		4 - 2		7 - 20	93210-04228	5 - 13		
90119-06M88	6 - 48	90201-12M16	15 - 13	90430-08020	18 - 11	90467-08004	2 - 51	92990-06600	12 - 30		25 - 22		
90119-06MA3	2 - 37	90201-13M19	15 - 15		26 - 6		4 - 5	92990-08200	13 - 51	93210-04230	5 - 26		
90119-06MA5	2 - 45	90201-20417	3 - 25	90430-12072	19 - 4		6 - 47	92990-08600	11 - 18		25 - 29		
90119-08020	2 - 52	90201-20M21	15 - 29		26 - 15		7 - 5		22 - 34	93210-064A5	16 - 38		
90119-08102	17 - 17	90201-21M18	9 - 10	90430-14115	2 - 34		7 - 28	92990-10100	19 - 8	93210-07003	18 - 71		
90119-08M13	18 - 35	90201-22M67	14 - 22		25 - 7		7 - 32	92995-04600	11 - 21	93210-08287	8 - 7		
	26 - 25	90201-30M00	15 - 5	90440-14M00	14 - 48	90467-10M04	24 - 4	92995-06100	1 - 8		8 - 9		
90119-08M16	18 - 34	90202-05088	6 - 23	90445-07240	6 - 9	90467-11M08	6 - 30		2 - 25	93210-09165	16 - 37		
	26 - 26	90202-07M07	13 - 39	90445-07260	2 - 16	90467-12M11	6 - 46		10 - 14	93210-10M74	16 - 54		
90119-08M80	17 - 4	90202-12060	19 - 3	90445-07M00	2 - 19	90468-05M03	6 - 24		12 - 28	93210-13M04	6 - 19		
90119-08M84	19 - 9	90202-12092	13 - 15	90445-07M23	2 - 20	90468-07M02	6 - 7		14 - 6	93210-16275	20 - 10		
90119-08M86	17 - 26	90202-20M06	15 - 30		4 - 1		6 - 11	92995-06600	1 - 9	93210-18397	16 - 26		
	26 - 37	90202-25M04	15 - 14	90445-07M44	6 - 10		6 - 14		1 - 13	93210-18M75	16 - 56		
90119-08MA3	2 - 29	90206-10M04	13 - 32	90445-07M86	3 - 7	90468-18008	13 - 9		3 - 10	93210-19MA7	6 - 4		



NUMERICAL INDEX

PART NO.	REF. NO.	PART NO.	REF. NO.	PART NO.	REF. NO.	PART NO.	REF. NO.	PART NO.	REF. NO.	PART NO.	REF. NO.
93210-29M94	15 - 8	95303-06600	13 - 22	97095-06025	10 - 40						
93210-32738	7 - 9	95303-06700	2 - 15	97095-06030	12 - 18						
	25 - 18	95313-10600	2 - 12		12 - 27						
93210-39ME4	4 - 9	95380-03600	5 - 35	97095-06040	7 - 25						
	25 - 3		7 - 16		9 - 6						
	25 - 30	95380-04600	23 - 4	97095-06095	4 - 8						
93210-46044	4 - 19		23 - 8	97095-08012	2 - 57						
	18 - 29	95380-05600	6 - 22	97095-08016	13 - 4						
	25 - 2		13 - 25	97095-08045	13 - 10						
	26 - 12		13 - 28	97095-10045	14 - 13						
	26 - 24		22 - 7	97380-05025	22 - 8						
93210-46M16	3 - 14	95380-06600	22 - 40	97380-08030	22 - 33						
	25 - 12	95380-08600	7 - 11	97595-06420	12 - 26						
93210-49046	18 - 17	95380-10600	17 - 25		16 - 35						
	26 - 7		26 - 36	97595-06510	14 - 9						
93210-62269	3 - 5	95380-12600	14 - 47	97595-06550	10 - 5						
	25 - 16	95380-12800	15 - 18	97602-05210	16 - 62						
93210-68N50	16 - 28	97013-06012	5 - 44	97607-04310	16 - 11						
93210-85M97	18 - 59	97013-06016	10 - 18	97803-04010	5 - 34						
	26 - 13	97013-06020	10 - 7	97880-04006	24 - 6						
93306-206U5	3 - 16		13 - 35	97880-05020	4 - 14						
93306-207U0	18 - 56	97013-06030	4 - 16	97880-06012	14 - 12						
93310-636U4	3 - 12	97013-08030	11 - 16	97885-04010	11 - 20						
93310-730V8	3 - 26		13 - 43	97885-05016	16 - 10						
93310-835U8	3 - 15	97075-08025	15 - 20	97885-06016	15 - 2						
93315-325V1	18 - 3		17 - 15		15 - 25						
93317-325U0	18 - 60	97075-08030	17 - 13	97885-06050	4 - 20						
93332-000U3	18 - 6	97075-08035	15 - 35	97980-04114	5 - 4						
93332-000W7	18 - 8		17 - 18	98503-05028	7 - 19						
93410-18M02	14 - 41	97075-10040	19 - 6	98580-03015	22 - 38						
93410-28M06	15 - 11	97095-05012	9 - 5	98580-04006	22 - 36						
93410-32M00	3 - 17	97095-06010	9 - 12	98580-04008	5 - 16						
93430-06024	22 - 10		14 - 34	98580-04010	22 - 35						
93450-07M00	18 - 73	97095-06012	2 - 54	98580-05010	22 - 37						
93450-44166	18 - 27		9 - 17	98780-04015	2 - 27						
93501-04M02	13 - 46		10 - 13	98980-03006	5 - 36						
93503-16003	18 - 46	97095-06014	2 - 24	99001-08600	18 - 72						
93505-32038	16 - 77	97095-06016	1 - 7	99530-08012	2 - 8						
93603-12M11	18 - 43		1 - 12	9E450-04533	23 - 2						
93603-21111	3 - 24		6 - 31								
93604-10M03	18 - 33		10 - 49								
93606-12019	17 - 3		12 - 13								
	17 - 21		14 - 5								
	17 - 24		18 - 19								
	19 - 5	97095-06020	3 - 9								
	26 - 34		7 - 2								
93700-06M03	14 - 16		10 - 10								
94702-00247	2 - 58		12 - 34								