



**PARTS  
CATALOGUE  
CATÁLOGO  
DE PEÇAS**

**F90BET'13 (6EJ2)**

---



1M6EJ-280P1

( )

F90BET  
PARTS CATALOGUE  
©2013 by Yamaha Motor Co., Ltd.  
1st edition, July 2013  
All rights reserved.  
Any reprinting or unauthorized use  
without the written permission of  
Yamaha Motor Co., Ltd.  
is expressly prohibited.

F90BET  
CATÁLOGO DE PEÇAS  
©2013, Yamaha Motor Co., Ltd.  
1ª edição, Julho 2013  
Todos os direitos reservados.  
É proibida expressamente toda e qualquer  
reimpressão ou utilização sem a autorização  
por escrita da  
Yamaha Motor Co., Ltd.

# FOREWORD

This Parts Catalogue is related to the parts for the model(s) on the cover page. When you are ordering replacement parts, please refer to this Parts Catalogue and quote both part numbers and part names correctly.

1. Modifications or additions which have been made after the issue of the Parts Catalogue will be announced in the Parts News.  
It is advisable that you make the necessary corrections to the Parts Catalogue according to the Parts News.

2. Abbreviations

The following abbreviations are used in this Parts Catalogue.

“UR” Use specified parts number.

“UN” Use as many as needed.

“AP” Alternate Parts

“LM” Locally Made (Parts need to be ordered locally)

“F#” Frame No. (Applicable machine No.)

“O/S” Over Size

3. The number of components for assembly

- Parts, which are to be supplied in an assembly, are listed with a dot (.) in front of the part name as shown below.
- The numeral appearing to the right of each component part indicates the quantity of parts for each assembly unit.

PART NO.	DESCRIPTION	Q'TY	REMARKS
2F5-83310-60	FRONT FLASHER LIGHT ASSY	2	
115-83311-60	.BULB (6V-18W)	1	

4. Applicable colours of graphics are represented in the “REMARKS” as shown below.

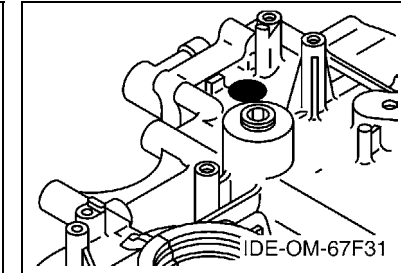
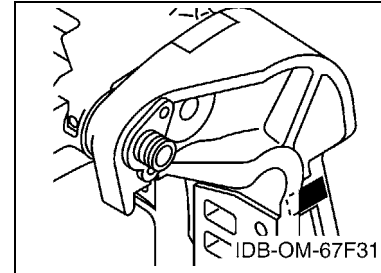
PART NO.	DESCRIPTION	Q'TY	REMARKS
2N4-24110-00-X5	FUEL TANK COMP.	2	MXR
3J1-24240-10	.GRAPHIC, FUEL TANK	1	FOR MXR

5. Note that the illustrations for reference in finding parts numbers are not to be used for assembling. When assembling, please use the applicable service manual.

6. The asterisk (\*) before a reference number indicates modified items after the first edition.

7. Applicable Serial No.

Engine Serial No.



8. Applicable Engine Starting Serial No.

Model	Serial No.	Model	Serial No.
F90B	6EJL-1000431		

9. Applicable Colour Code

Abbreviation	Colour Name	Colour Code
DBNM2	DARK BLUISH GRAY METALLIC 2	004D

10. Quantity Column Information

Column No.	Name Of Q'ty Column	Applicable Model
1	6EJ2	F90BET

# PREFÁCIO

Este Catálogo de Peças se refere as Peças dos modelos relacionados na capa. Quando for solicitar peças de reposição para estes Modelos, recorra a este Catálogo de Peças e especifique corretamente os códigos e Nomes das Peças.

1. As Modificações ou adições que tenham sido efetuadas após a publicação deste Catálogo de Peças, serão comunicadas a Rede de Concessionárias através das informações de Modificação de Peças (Parts News).

2. Abreviaturas  
Seguem abaixo as abreviaturas utilizadas neste Catálogo de Peças:

“UR” Uso Restrito para o Código da Peça

“UN” Uso Necessário

“AP” Peça Alternativa

“LM” Fabricação Local (A peça pode ser pedida localmente)

“F#” No. de Série do Chassi (Aplicação do Número de Série)

“O/S” Tamanho Maior

3. Peças componentes de conjuntos

- As peças que são fornecidas dentro de conjuntos estão listadas com um ponto de identificação (.) como segue abaixo.
- O número que aparece a direita da descrição da Peça indica o número de Peças usado em cada Conjunto Individual.

No. PEÇA	DESCRIÇÃO	QTDE	OBSERVAÇÕES
2F5-83310-60	PISCA DIANTEIRO CONJ.	2	
115-83311-60	.LÂMPADA (6V-18W)	1	

4. Os gráficos que são Aplicados em Peças Coloridas estão representados na coluna “OBSERVAÇÕES”, como segue abaixo.

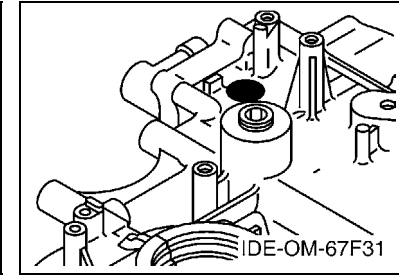
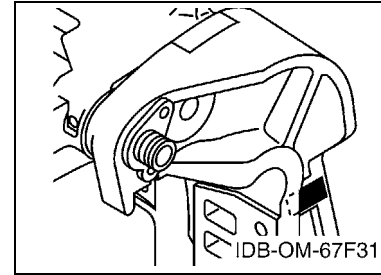
No. PEÇA	DESCRIÇÃO	QTDE	OBSERVAÇÕES
2N4-24110-00-X5	TANQUE DE COMBUSTÍVEL COMPL.	2	MXR
3J1-24240-10	.GRÁFICO, TANQUE DE COMB.	1	PARA MXR

5. Observe que as ilustrações são referentes apenas a indicação dos códigos das peças, e não para montagem. Para montagem, por favor utilize o Manual de Montagem apropriado.

6. O asterisco (\*) antes do Número de referência da peça indica a modificação ocorrida após a primeira edição.

7. Aplicação do Número de Série

No. de Série do Motor



8. Aplicação do No. de Série Inicial

Modelo	No. Série	Modelo	No. Série
F90B	6EJL-1000431		

9. Aplicação do Código de Cor

Abreviação	Nome da Cor	Código da Cor
DBNM2	DARK BLUISH GRAY METALLIC 2	004D

10. Informação na Coluna de Quantidade

No. da Coluna	Nome na Coluna de Qtde	Modelo Aplicável
1	6EJ2	F90BET

# CONTENTS

SCHEDULED SERVICE PARTS .....	1
TOP COWLING .....	2
CYLINDER & CRANKCASE 1 .....	3
CRANKSHAFT & PISTON .....	5
CYLINDER & CRANKCASE 2 .....	6
VALVE .....	8
INTAKE 1 .....	10
INTAKE 2 .....	11
INTAKE 3 .....	12
FUEL INJECTION PUMP 1 .....	14
FUEL INJECTION PUMP 2 .....	15
FUEL 1 .....	16
FUEL 2 .....	18
GENERATOR .....	19
ELECTRICAL 1 .....	20
ELECTRICAL 2 .....	22
ELECTRICAL 3 .....	24
ELECTRICAL 4 .....	26
STARTING MOTOR .....	27
BOTTOM COWLING .....	29
CONTROL .....	31
BRACKET 1 .....	33
BRACKET 2 .....	35
OPTIONAL PARTS .....	37
POWER TRIM & TILT ASSY 1 .....	38
POWER TRIM & TILT ASSY 2 .....	42
UPPER CASING .....	43
OIL PAN .....	45
LOWER CASING & DRIVE 1 .....	46
LOWER CASING & DRIVE 2 .....	49
STEERING GUIDE .....	51
REMOTE CONTROL BOX .....	52
REMOTE CONTROL ASSY .....	53
METER .....	56
REPAIR KIT 1 .....	57
REPAIR KIT 2 .....	58
<b>INDEX</b>	
NUMERICAL INDEX .....	60

# ÍNDICE GERAL

PECAS DE MANUTENCAO PROGRAMADA .....	1
CAPO SUPERIOR .....	2
CARCACA DO CILINDRO 1 .....	3
VIRABREQUIM E PISTAO .....	5
CARCACA DO CILINDRO 2 .....	6
VALVULA .....	8
ADMISSAO 1 .....	10
ADMISSAO 2 .....	11
ADMISSAO 3 .....	12
BOMBA DE INJECAO COMBUSTIVEL 1 .....	14
BOMBA DE INJECAO COMBUSTIVEL 2 .....	15
COMBUSTIVEL .....	16
COMBUSTIVEL 2 .....	18
GERADOR .....	19
SISTEMA ELETRICO 1 .....	20
SISTEMA ELETRICO 2 .....	22
SISTEMA ELETRICO 3 .....	24
SISTEMA ELETRICO 4 .....	26
MOTOR DE PARTIDA .....	27
BANDEJA DO CAPO .....	29
CONTROLE .....	31
SUPORTE 1 .....	33
SUPORTE 2 .....	35
PECAS OPCIONAIS .....	37
SISTEMA INCLINACAO 1 .....	38
SISTEMA INCLINACAO 2 .....	42
CAPA INFERIOR .....	43
BANDEJA DE OLEO .....	45
CARCACA INF. E TRANSMISSAO 1 .....	46
CARCACA INF. E TRANSMISSAO 2 .....	49
HASTE DA DIRECAO .....	51
CAIXA DO CONTROLE REMOTO .....	52
CONTROLE REMOTO CONJ. ....	53
MEDIDOR .....	56
KIT DE REPARO 1 .....	57
KIT DE REPARO 2 .....	58
<b>ÍNDICE GERAL</b>	
ÍNDICE NUMÉRICO .....	60

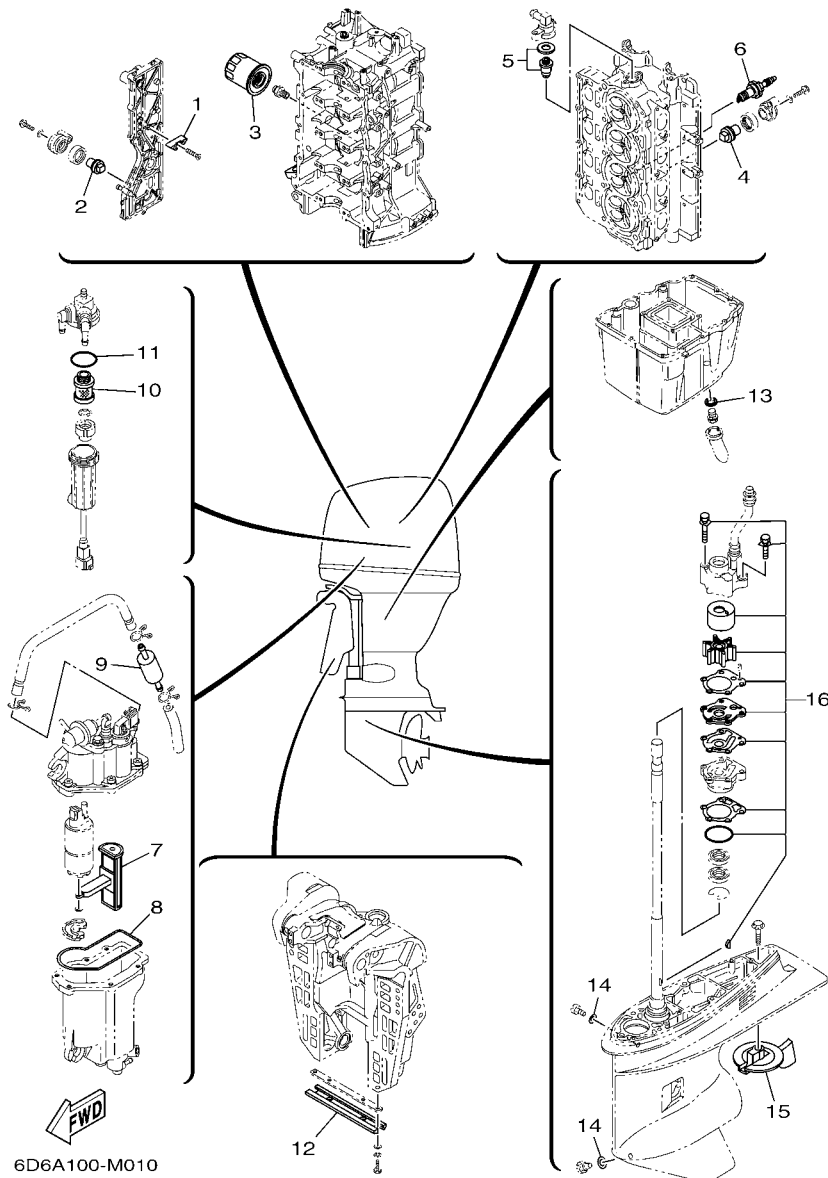


FIG. 1 SCHEDULED SERVICE PARTS PECAS DE MANUTENCAO PROGRAMADA

REF. NO.	PART NO. No. PEÇA	DESCRIPTION DESCRIÇÃO	QTY	REMARKS OBSERVAÇÕES
1	6E5-11325-00	ANODE ANODO	3	
2	67F-11325-01	ANODE ANODO	1	
3	5GH-13440-30	ELEMENT ASSY, OIL CLEANER ELEMENTO DO FILTRO DE OLEO CJ	1	
4	67F-11325-01	ANODE ANODO	2	
5	67F-12411-01	THERMOSTAT TERMOSTATO	1	
6	94702-00391	PLUG, SPARK (NGK LFR5A-11) VELA DE IGNICAO (NGK LFR5A-11)	4	
7	6C5-13915-00	FILTER FILTRO	1	
8	6C5-14984-00	GASKET, FLOAT CHAMBER GAXETA DA CAMARA DA BOIA.	1	
9	6C5-24251-00	STRAINER 1 FILTRO 1	1	
10	6D8-24563-00	ELEMENT, FILTER ELEMENTO DO FILTRO	1	
11	6D8-24564-00	GASKET GAXETA	1	
12	6H1-45251-03	ANODE ANODO	1	
13	90430-14M09	GASKET GAXETA	1	
14	90430-08020	GASKET GAXETA	2	
15	67F-45371-00	TAB-TRIM ESTABILIZADOR DE DIRECAO	1	
16	67F-W0078-00	WATER PUMP REPAIR KIT JOGO DE REPARO DA BOMBA D'AGUA	1	

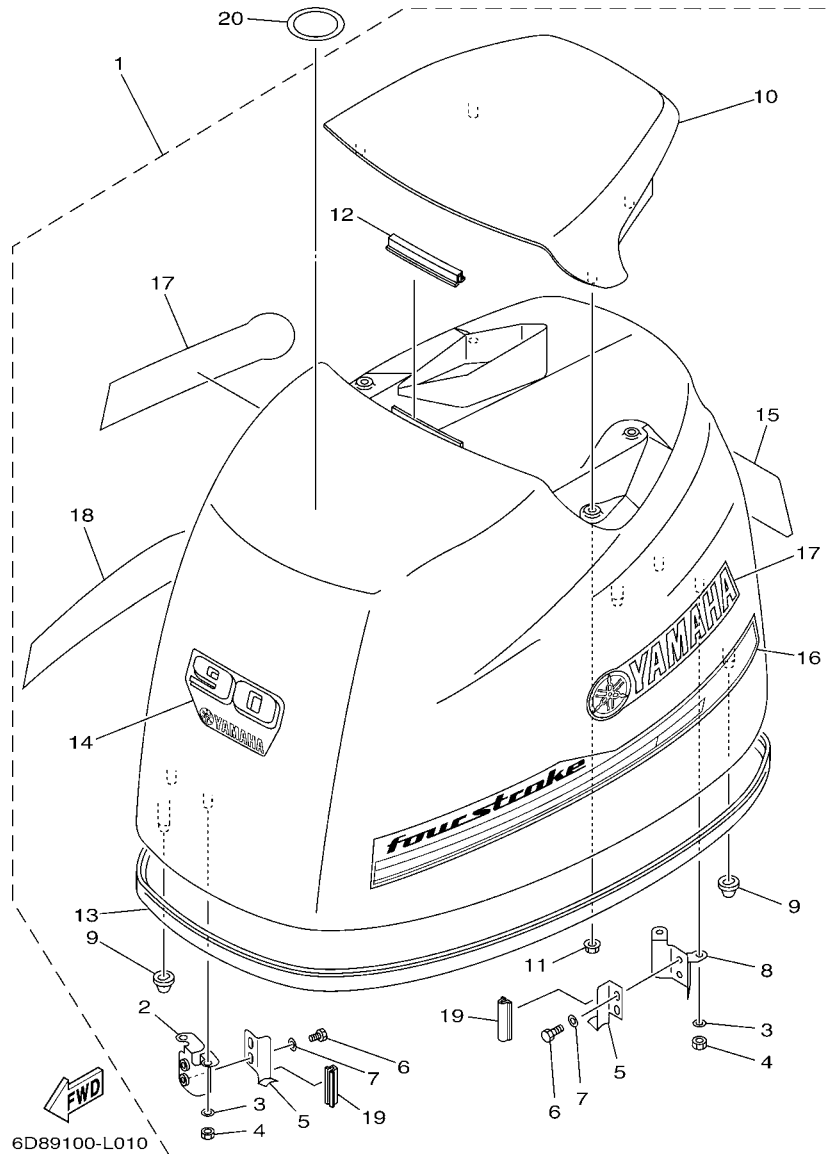


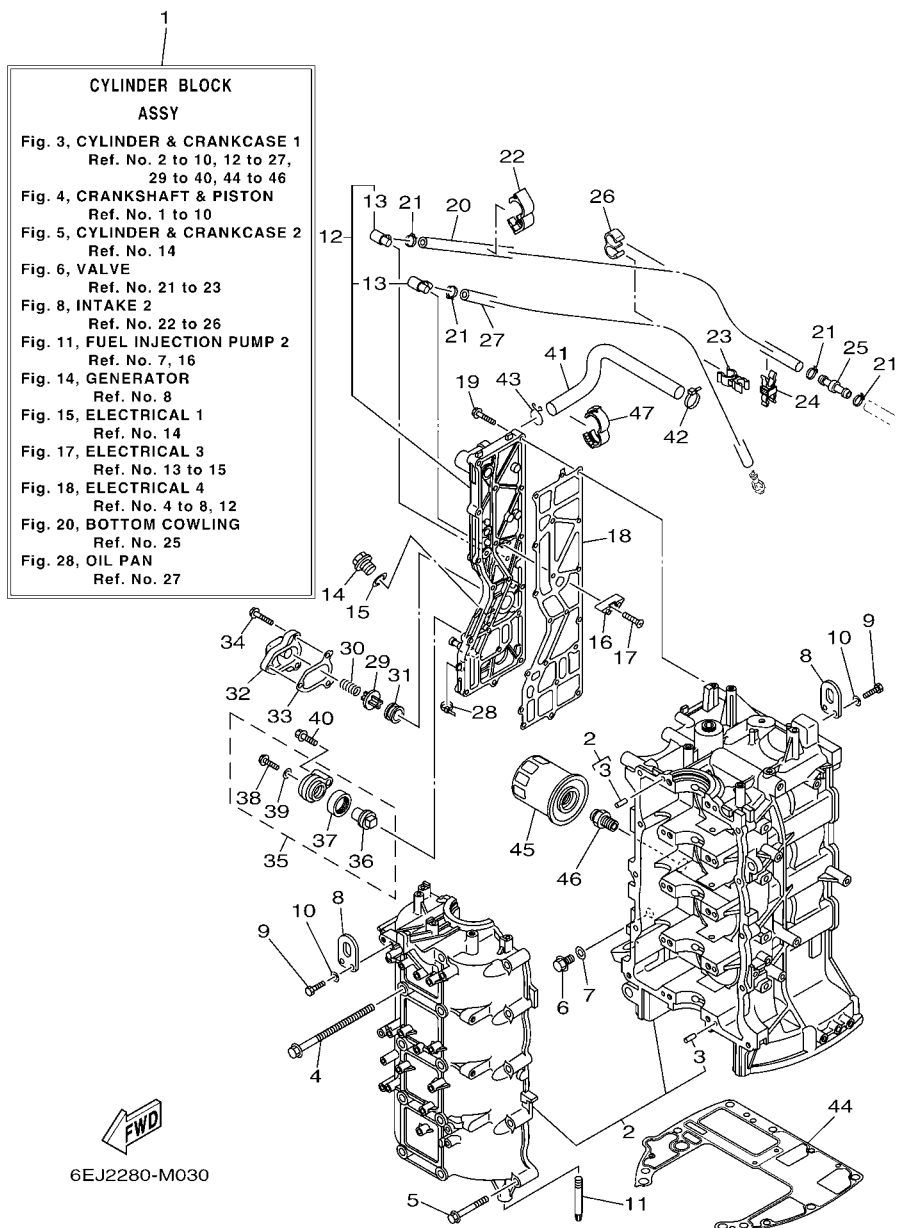
FIG. 2 TOP COWLING

CAPO SUPERIOR

REF. NO.	PART NO. No. PEÇA	DESCRIPTION DESCRIÇÃO	QTY	REMARKS OBSERVAÇÕES
1	6D8-42610-30	TOP COWLING ASSY CAPO SUPERIOR CONJ.	1	
2	67F-42647-00	.HOLDER, CLAMP BAND .SUPORTE DA BRACADEIRA	1	
3	92990-06100	.WASHER, SPRING .ARRUELA COM MOLA	4	
4	95380-06600	.NUT, HEXAGON .PORCA SEXTAVADA	4	
5	68V-42652-00	.HOOK .GANCHO	2	
6	97095-06012	.BOLT .PARAFUSO	4	
7	92995-06600	.WASHER .ARRUELA	4	
8	67F-42649-00	.HOLDER, CLAMP BAND .SUPORTE DA BRACADEIRA	1	
9	67F-42662-00	.DAMPER .AMORTIZADOR	3	
10	67F-42613-00-4D	.MOLDING, AIR DUCT .MOLDURA DO DUTO DE AR	1	
11	90179-06M24	.NUT .PORCA	4	
12	61N-42628-00	.SEAL .VEDACAO	1	
13	67F-42615-00	.SEAL .VEDACAO	1	
14	6D8-42677-20	.GRAPHIC, FRONT .GRAFICO DIANTEIRO	1	
15	6D8-42678-30	.GRAPHIC, REAR .GRAFICO TRASEIRO	1	
16	6D6-42675-00	.GRAPHIC, SIDE 1 .GRAFICO LATERAL	1	
17	6D6-42681-00	.MARK, COWLING .MARCA DO CAPO (ADESIVO)	2	
18	6D6-42676-00	.GRAPHIC, SIDE 2 .GRAFICO LATERAL	1	
19	67F-42628-00	.SEAL .VEDACAO	2	
20	67F-13434-20	LABEL, CAUTION ETIQUETA DE ADVERTENCIA	1	



**FIG. 3 CYLINDER & CRANKCASE 1 CARCACA DO CILINDRO 1**



REF. NO.	PART NO. No. PEÇA	DESCRIPTION DESCRIÇÃO	6EJ2				REMARKS OBSERVAÇÕES
1	6D8-W009B-07-9S	CYLINDER BLOCK ASSY GRUPO DE FORÇA CONJUNTO	1				
2	6D8-15100-02	CRANKCASE ASSY CARCACA DO MOTOR COMPLETA	1				
3	93606-12019	.PIN, DOWEL .PINO GUIA	10				
4	90119-10M88	BOLT, WITH WASHER PARAFUSO COM ARRUELA	10				
5	90119-08M66	BOLT, WITH WASHER PARAFUSO COM ARRUELA	10				
6	90340-14M06	PLUG, STRAIGHT SCREW TAMPAO DO DRENO	1				
7	90430-14115	GASKET GAXETA	1				
8	62Y-11119-00	HANGER, ENGINE ALCA DO MOTOR	2				
9	97095-06020	BOLT PARAFUSO	4				
10	92995-06600	WASHER ARRUELA	4				
11	67F-15142-00	GUIDE 1 GUIA 1	2				
12	6D8-41113-50-9S	OUTER COVER, EXHAUST TAMPA EXTERNA DO ESCAPE	1				
13	676-11372-00	.NIPPLE, HOSE .JUNCAO DA MANGUEIRA	2				
14	90340-18M09	PLUG, STRAIGHT SCREW TAMPAO DO DRENO	1				
15	90430-18130	GASKET GAXETA	1				
16	6E5-11325-00	ANODE ANODO	3				
17	98780-04016	SCREW, FLAT HEAD PARAFUSO CABECA PLANA	3				
18	67F-41114-A2	GASKET, EXHAUST OUTER COVER GAXETA TAMPA EXTERNA DO ESCAPE	1				
19	90119-06MA4	BOLT, WITH WASHER PARAFUSO COM ARRUELA	18				
20	6D8-42541-00	PIPE 1 TUBO 1	1				
21	90465-11M10	CLAMP BRACADEIRA	4				
22	90464-18004	CLAMP BRACADEIRA	1				
23	90464-10010	CLAMP BRACADEIRA	1				
24	90464-11009	CLAMP BRACADEIRA	1				
25	6D8-24378-00	PIPE, JOINT 3 JUNCAO DO TUBO 3	1				
26	90464-09M31	CLAMP BRACADEIRA	1				
27	68V-42541-20	PIPE 1 TUBO 1	1				

**FIG. 3 CYLINDER & CRANKCASE 1 CARCACA DO CILINDRO 1**

REF. NO.	PART NO. No. PEÇA	DESCRIPTION DESCRIÇÃO	6EJ2				REMARKS OBSERVAÇÕES
28	90465-11M10	CLAMP BRACADEIRA	1				
29	6G5-12416-00	VALVE, PRESSURE CONTROL VALVULA DO CONTROLE PRESSAO	1				
30	90501-16M11	SPRING, COMPRESSION MOLA DE COMPRESSAO	1				
31	90480-20M05	GROMMET ILHO DE BORRACHA	1				
32	67F-1246A-01-9S	COVER 1 TAPPAO 1	1				
33	67F-12435-A0	GASKET GAXETA	1				
34	90119-06MA2	BOLT, WITH WASHER PARAFUSO COM ARRUELA	3				
35	69J-11301-00	ANODE COVER ASSY CAPA DO ANODO C.J.	1				
36	67F-11325-01	.ANODE .ANODO	1				
37	67F-11328-00	.GROMMET, ANODE .ILHO DO ANODO	1				
38	90105-06M07	.BOLT, FLANGE .PARAFUSO FLANGE	1				
39	90430-06M03	.GASKET .GAXETA	1				
40	97575-08540	BOLT, WITH WASHER PARAFUSO COM ARRUELA	1				
41	67F-1243A-00	HOSE 1 MANGUEIRA 1	1				
42	90465-11M59	CLAMP BRACADEIRA	1				
43	90467-20M15	CLIP PRESILHA	1				
44	68V-11351-00	GASKET, CYLINDER GAXETA DO CILINDRO	1				
45	5GH-13440-30	ELEMENT ASSY, OIL CLEANER ELEMENTO DO FILTRO DE OLEO C.J.	1				
46	90401-20007	BOLT, UNION PARAFUSO DE UNIAO	1				
47	90464-16001	CLAMP BRACADEIRA	1				

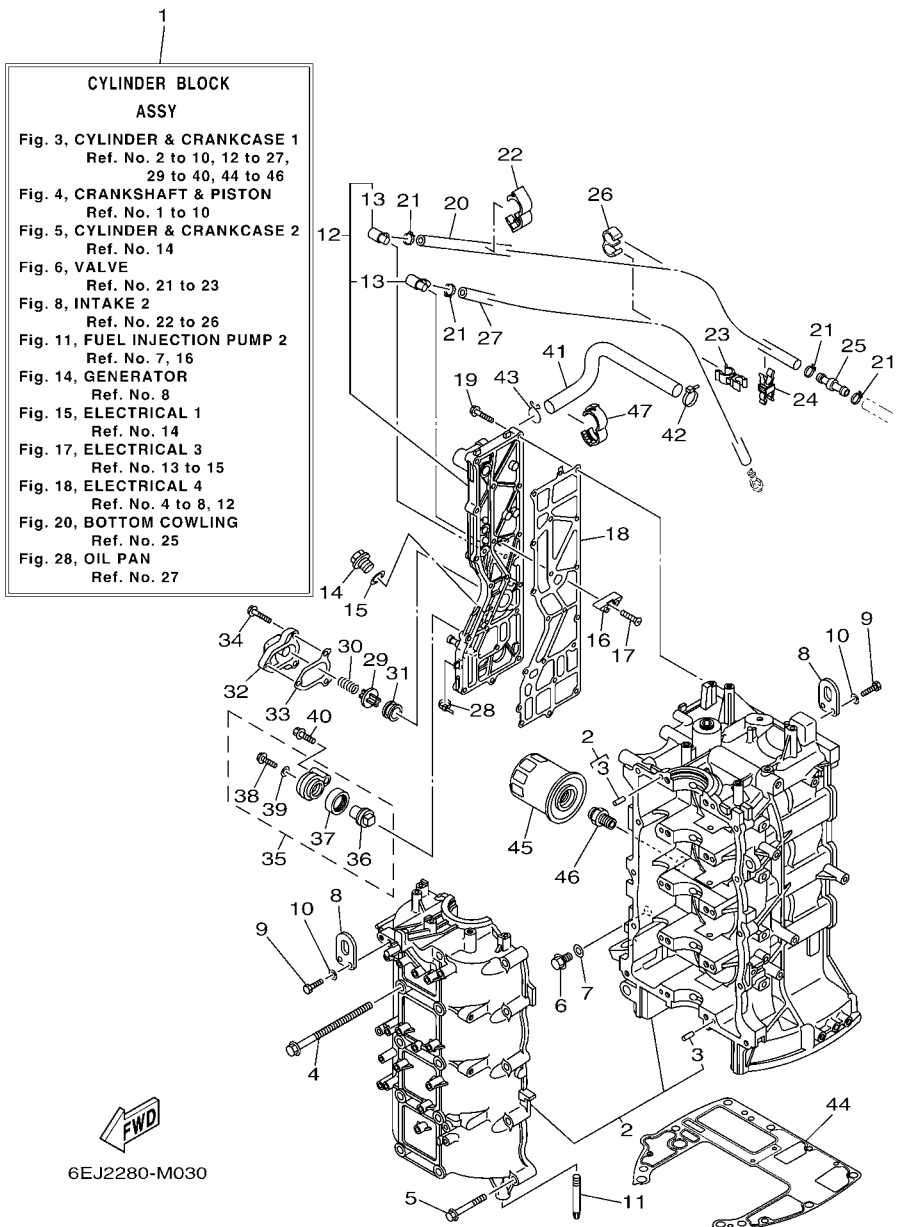
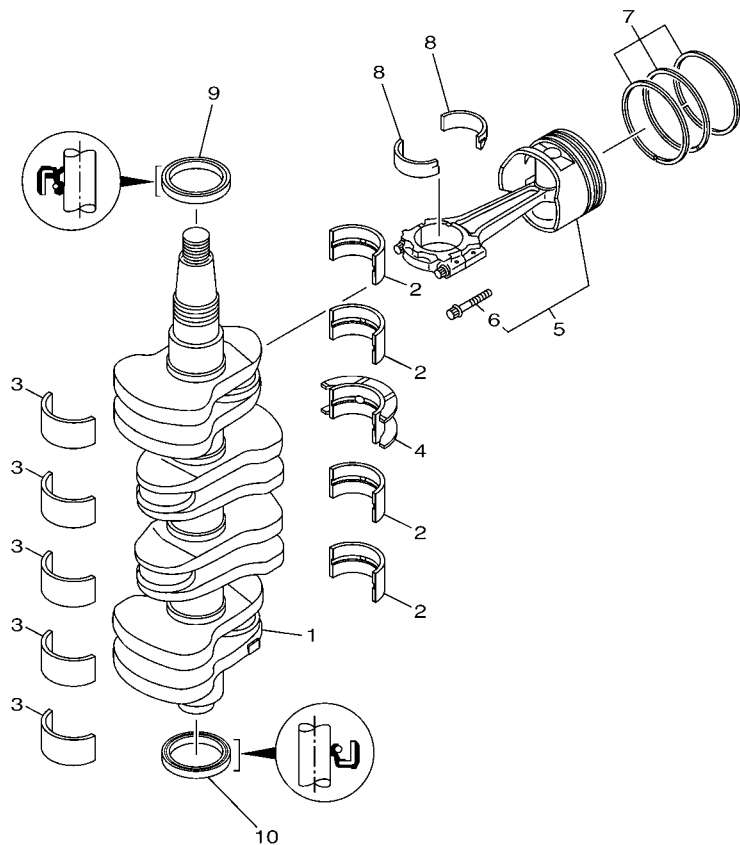


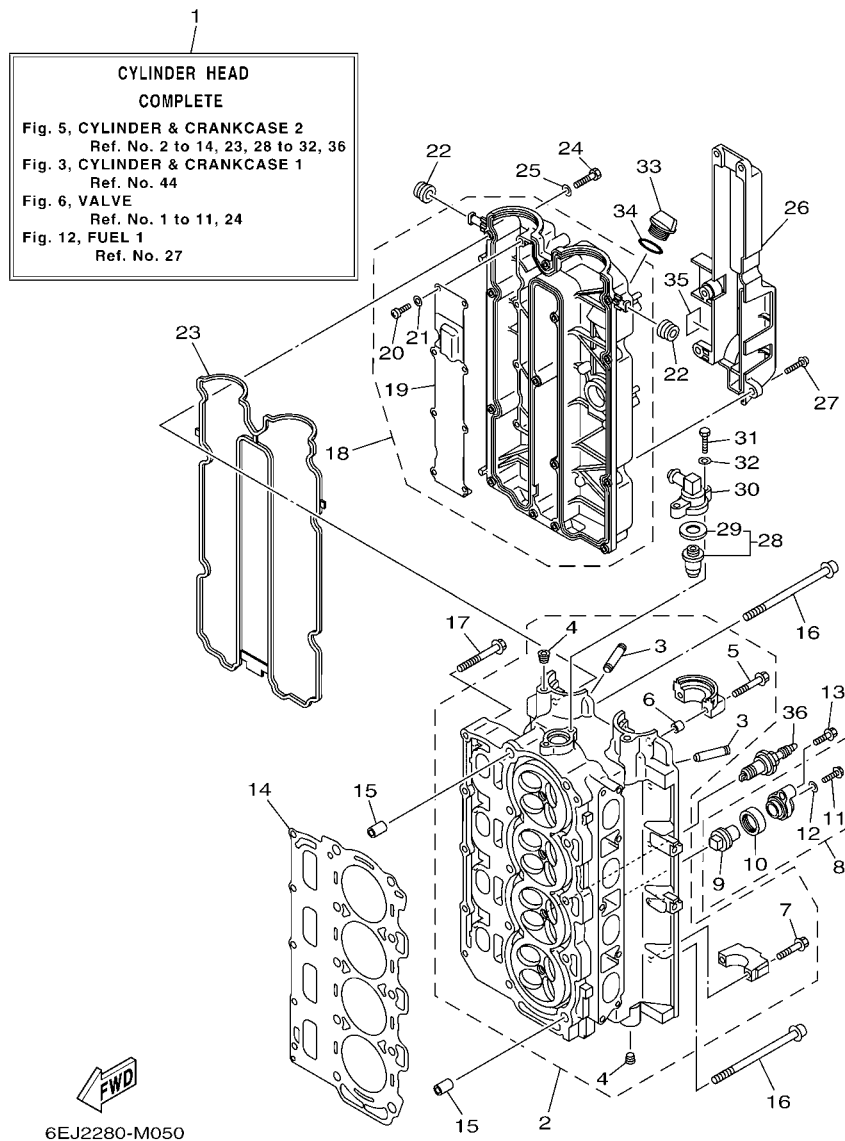
FIG. 4 CRANKSHAFT & PISTON

VIRABREQUIM E PISTAO



6D67110-K030

REF. NO.	PART NO. No. PEÇA	DESCRIPTION DESCRIÇÃO	QTD				REMARKS OBSERVAÇÕES
1	6D8-11411-01	CRANKSHAFT VIRABREQUIM	1				
2	6D8-11416-00	PLANE BEARING, CRANKSHAFT 1 ROLAMENTO PLANO DO VIRABREQ. 1	4				UR GREEN UR GREEN
	6D8-11416-10	PLANE BEARING, CRANKSHAFT 1 ROLAMENTO PLANO DO VIRABREQ. 1	4				UR BLUE UR BLUE
	6D8-11416-20	PLANE BEARING, CRANKSHAFT 1 ROLAMENTO PLANO DO VIRABREQ. 1	4				UR RED UR RED
3	6D8-11417-00	PLANE BEARING, CRANKSHAFT 2 BRONZINA PLANA DO VIRABREQUIM	5				UR YELLOW UR YELLOW
	6D8-11417-10	PLANE BEARING, CRANKSHAFT 2 BRONZINA PLANA DO VIRABREQUIM	5				UR GREEN UR GREEN
	6D8-11417-20	PLANE BEARING, CRANKSHAFT 2 BRONZINA PLANA DO VIRABREQUIM	5				UR BLUE UR BLUE
	6D8-11417-30	PLANE BEARING, CRANKSHAFT 2 BRONZINA PLANA DO VIRABREQUIM	5				UR RED UR RED
4	6D8-11418-00	PLANE BEARING, CRANKSHAFT 3 BRONZINA PLANA DO VIRABREQUIM	1				UR GREEN UR GREEN
	6D8-11418-10	PLANE BEARING, CRANKSHAFT 3 BRONZINA PLANA DO VIRABREQUIM	1				UR BLUE UR BLUE
	6D8-11418-20	PLANE BEARING, CRANKSHAFT 3 BRONZINA PLANA DO VIRABREQUIM	1				UR RED UR RED
5	6D8-W1164-21	PISTON/CON-ROD ASSY(STD) KIT PISTAO BIELA MOTOR (STD)	4				
	6D8-W1164-31	PISTON/CON-ROD ASSY(0.25MM OS) KIT PISTAO BIELA (0.25MM OS)	4				AP AP
6	K1C-A3275-00	.BOLT, CONNECTING ROD .PARAFUSO DA BIELA	2				
7	6D8-11603-10	PISTON RING SET (STD) JOGO DE ANEIS (STD)	4				
	6D8-11604-10	PISTON RING SET (0.25MM O/S) JOGO DE ANEIS (0.25MM O/S)	4				AP AP
8	6D8-11656-00	PLANE BEARING, CONNECTING ROD BRONZINA PLANA DA BIELA	8				UR YELLOW UR YELLOW
	6D8-11656-10	PLANE BEARING, CONNECTING ROD BRONZINA PLANA DA BIELA	8				UR GREEN UR GREEN
	6D8-11656-20	PLANE BEARING, CONNECTING ROD BRONZINA PLANA DA BIELA	8				UR BLUE UR BLUE
	6D8-11656-30	PLANE BEARING, CONNECTING ROD BRONZINA PLANA DA BIELA	8				UR RED UR RED
9	93102-48017	OIL SEAL RETENTOR DE OLEO	1				
10	93101-48001	OIL SEAL RETENTOR DE OLEO	1				

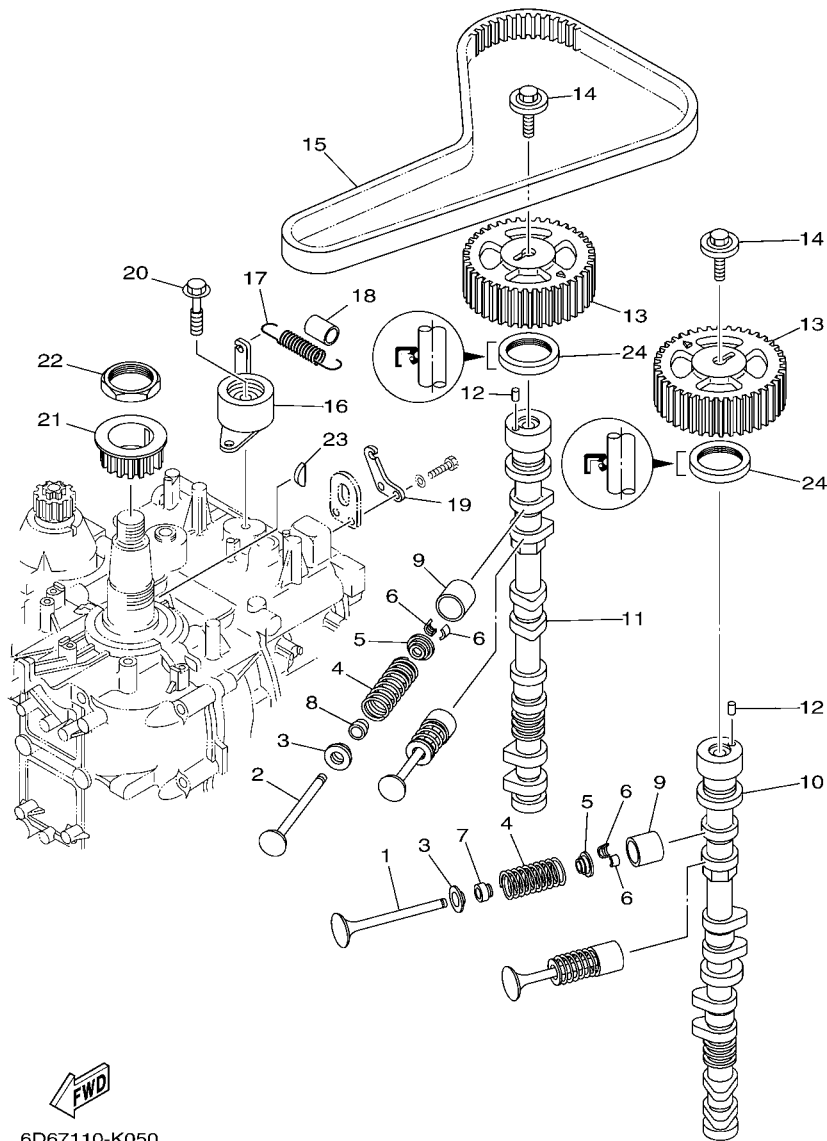


6EJ2280-M050

FIG. 5 CYLINDER & CRANKCASE 2 CARCACA DO CILINDRO 2

REF. NO.	PART NO. No. PEÇA	DESCRIPTION DESCRIÇÃO	6EJ2				REMARKS OBSERVAÇÕES
1	6D8-W009A-04-9S	CYLINDER HEAD COMPLETE CABECOTE DO CILINDRO CONJ	1				
2	6D8-11110-20-9S	CYLINDER HEAD ASSY CABECOTE DO CILINDRO CONJ.	1				
3	67F-11133-10	.GUIDE, VALVE 1 .GUIA DA VALVULA 1	16				
4	90344-51019	.PLUG, TAPER SCREW .TAMPAO DO PARAFUSO	4				
5	90119-07235	.BOLT/WASHER-CAM CAPS .PARAFUSO COM ARRUELA	4				
6	91809-08006	.PIN, DOWEL .PINO GUIA	4				
7	90119-07234	.BOLT, WITH WASHER .PARAFUSO COM ARRUELA	16				
8	69J-11301-00	ANODE COVER ASSY CAPA DO ANODO CJ.	2				
9	67F-11325-01	.ANODE .ANODO	1				
10	67F-11328-00	.GROMMET, ANODE .ILHO DO ANODO	1				
11	90105-06M07	.BOLT, FLANGE .PARAFUSO FLANGE	1				
12	90430-06M03	.GASKET .GAXETA	1				
13	97575-08540	BOLT, WITH WASHER PARAFUSO COM ARRUELA	2				
14	67F-11181-03	GASKET, CYLINDER HEAD 1 GAXETA CABECOTE DO CILINDRO 1	1				
15	99530-14016	PIN, DOWEL PINO GUIA	2				
16	90155-10005	SCREW, FLAT FILLISTER PARAFUSO	10				
17	90119-08M91	BOLT, WITH WASHER PARAFUSO COM ARRUELA	5				
18	6D8-11191-01-9S	COVER, CYLINDER HEAD 1 TAMPA, CABECOTE DO CILINDRO 1	1				
19	67F-11168-00	.COVER, BREATHER .TAMPA DE RESPIRO	1				
20	98507-04008	.SCREW, PAN HEAD .PARAFUSO	8				
21	92907-04600	.WASHER .ARRUELA	8				
22	90480-12072	GROMMET ILHO DE BORRACHA	2				
23	6D8-11356-01	SEAL, CYLINDER 2 VEDACAO DO CILINDRO 2	1				
24	97095-06030	BOLT PARAFUSO	14				
25	92995-06600	WASHER ARRUELA	14				
26	67F-11192-01	COVER, CYLINDER HEAD 2 TAMPA, CABECOTE DO CILINDRO 2	1				
27	90119-06M79	BOLT, WITH WASHER PARAFUSO COM ARRUELA	5				



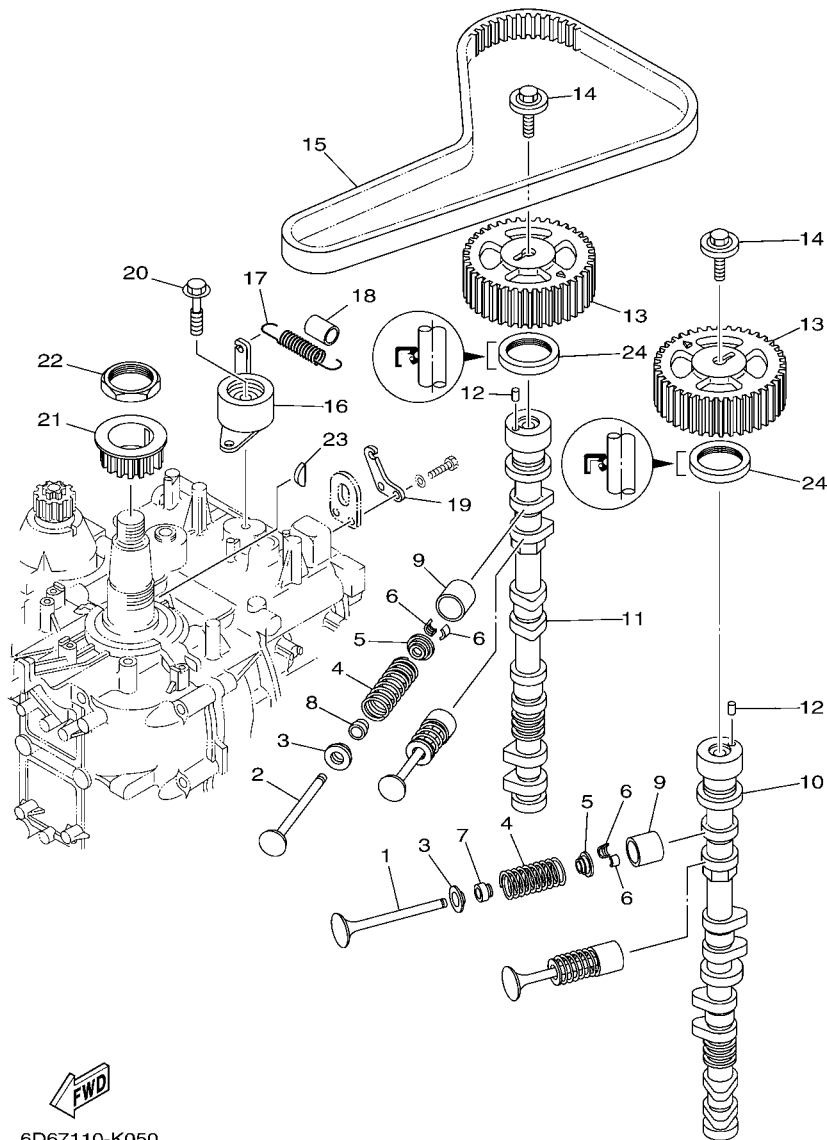


6D67110-K050

FIG. 6 VALVE

VALVULA

REF. NO.	PART NO. No. PEÇA	DESCRIPTION DESCRIÇÃO	QTD			REMARKS OBSERVAÇÕES
1	6D8-12111-00	VALVE, INTAKE VALVULA DE ADMISSAO	8			
2	6D8-12121-10	VALVE, EXHAUST VALVULA DE ESCAPE	8			
3	6D8-12116-00	SEAT, VALVE SPRING ASSENTO INFERIOR DA MOLA	16			
4	6D8-12113-00	SPRING, VALVE INNER MOLA DA VALVULA INTERNA	16			
5	26H-12117-00	RETAINER, VALVE SPRING ASSENTO SUPERIOR DA MOLA	16			
6	4G0-12118-00	LOCK, VALVE SPRING RETAINER TRAVA DA VALVULA	32			
7	K0A-A3721-00	SEAL, VALVE STEM RETENTOR DA HASTE DA VALVULA	8			
8	K0A-A3722-00	SEAL, VALVE STEM 2 RETENTOR DA HASTE DA VALVULA 2	8			
9	6D8-12153-00	LIFTER, VALVE (12) LEVANTADOR DA VALVULA (12)	16			UR
	6D8-12153-10	LIFTER, VALVE (14) LEVANTADOR DA VALVULA (14)	16			UR
	6D8-12153-20	LIFTER, VALVE (16) LEVANTADOR DA VALVULA (16)	16			UR
	6D8-12153-30	LIFTER, VALVE (18) LEVANTADOR DA VALVULA (18)	16			UR
	6D8-12153-40	LIFTER, VALVE (20) LEVANTADOR DA VALVULA (20)	16			UR
	6D8-12153-50	LIFTER, VALVE (22) LEVANTADOR DA VALVULA (22)	16			UR
	6D8-12153-60	LIFTER, VALVE (24) LEVANTADOR DA VALVULA (24)	16			UR
	6D8-12153-70	LIFTER, VALVE (26) LEVANTADOR DA VALVULA (26)	16			UR
	6D8-12153-80	LIFTER, VALVE (28) LEVANTADOR DA VALVULA (28)	16			UR
	6D8-12153-90	LIFTER, VALVE (30) LEVANTADOR DA VALVULA (30)	16			UR
	6D8-12153-A0	LIFTER, VALVE (32) LEVANTADOR DA VALVULA (32)	16			UR
	6D8-12153-B0	LIFTER, VALVE (34) LEVANTADOR DA VALVULA (34)	16			UR
	6D8-12153-C0	LIFTER, VALVE (36) LEVANTADOR DA VALVULA (36)	16			UR
	6D8-12153-D0	LIFTER, VALVE (38) LEVANTADOR DA VALVULA (38)	16			UR
	6D8-12153-E0	LIFTER, VALVE (40) LEVANTADOR DA VALVULA (40)	16			UR
	6D8-12153-F0	LIFTER, VALVE (42) LEVANTADOR DA VALVULA (42)	16			UR
	6D8-12153-G0	LIFTER, VALVE (44) LEVANTADOR DA VALVULA (44)	16			UR
	6D8-12153-H0	LIFTER, VALVE (46) LEVANTADOR DA VALVULA (46)	16			UR
	6D8-12153-J0	LIFTER, VALVE (48) LEVANTADOR DA VALVULA (48)	16			UR



6D67110-K050

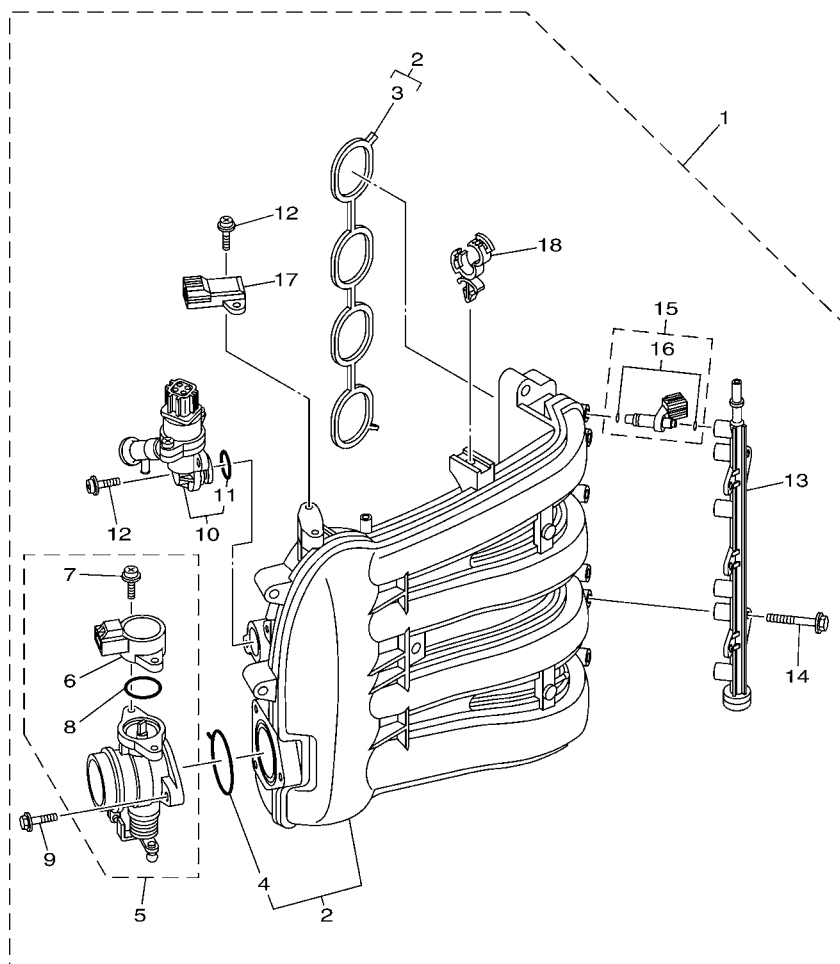
FIG. 6 VALVE

VALVULA

REF. NO.	PART NO. No. PEÇA	DESCRIPTION DESCRIÇÃO	QTY			REMARKS OBSERVAÇÕES
9	6D8-12153-K0	LIFTER, VALVE (50) LEVANTADOR DA VALVULA (50)	16			UR
	6D8-12153-L0	LIFTER, VALVE (52) LEVANTADOR DA VALVULA (52)	16			UR
	6D8-12153-M0	LIFTER, VALVE (54) LEVANTADOR DA VALVULA (54)	16			UR
	6D8-12153-N0	LIFTER, VALVE (56) LEVANTADOR DA VALVULA (56)	16			UR
	6D8-12153-P0	LIFTER, VALVE (58) LEVANTADOR DA VALVULA (58)	16			UR
	6D8-12153-R0	LIFTER, VALVE (60) LEVANTADOR DA VALVULA (60)	16			UR
	6D8-12153-S0	LIFTER, VALVE (62) LEVANTADOR DA VALVULA (62)	16			UR
	6D8-12153-T0	LIFTER, VALVE (64) LEVANTADOR DA VALVULA (64)	16			UR
	6D8-12153-U0	LIFTER, VALVE (66) LEVANTADOR DA VALVULA (66)	16			UR
	6D8-12153-V0	LIFTER, VALVE (68) LEVANTADOR DA VALVULA (68)	16			UR
10	6D8-12171-00	CAMSHAFT 1 EIXO DE COMANDO 1	1			
11	6D8-12181-00	CAMSHAFT 2 EIXO DE COMANDO 2	1			
12	93605-10108	PIN, DOWEL PINO	2			
13	67F-11537-00	GEAR, DRIVEN ENGRENAGEM MOTRIZ	2			
14	90119-10050	BOLT, WITH WASHER PARAFUSO COM ARRUELA	2			
15	67F-46241-00	BELT CINTO	1			
16	67F-11590-00	TENSIONER ASSY TENSIONADOR CONJUNTO	1			
17	90506-16M39	SPRING, TENSION MOLA DE TENSÃO	1			
18	90445-15M03	HOSE (L23) TUBO (L23)	1			
19	67F-11595-00	PLATE, VALVE PLACA DA VALVULA	1			
20	90119-10M72	BOLT, WITH WASHER PARAFUSO COM ARRUELA	1			
21	6D8-11536-01	GEAR, DRIVE ENGRENAGEM MOTORA	1			
22	90170-40008	NUT PORCA	1			
23	90280-04008	KEY, WOODRUFF CHAVETA MEIA LUA	1			
24	93102-38008	OIL SEAL RETENTOR DE OLEO	2			

FIG. 7 INTAKE 1

ADMISSAO 1



FWD  
6D81100-D060

REF. NO.	PART NO. No. PEÇA	DESCRIPTION DESCRIÇÃO	QTY	REMARKS OBSERVAÇÕES
1	6D8-14200-00	INTAKE ASSY INJECÃO CONJUNTO	1	
2	6D8-13641-00	..MANIFOLD, INTAKE 1 ..TUBO MULTIPLA DE ADMISSÃO 1	1	
3	6D8-13645-00	..GASKET, MANIFOLD 1 ..GAXETA DO TUBO MULTIPLA 1	1	
4	6D8-13557-00	..GASKET ..GAXETA	1	
5	6D8-13750-00	..THROTTLE BODY ASSY ..CONJ. DE VALVULA DE ACELERAÇÃO	1	
6	6C5-85885-00	..THROTTLE SENSOR ASSY ..SENSOR ACELERAÇÃO CONJ.	1	
7	6C5-81145-00	..SCREW 1 ..PARAFUSO 1	2	
8	6C5-8182L-00	..O-RING 1 ..ANEL DE BORRACHA	1	
9	6C5-14496-00	..BOLT ..PARAFUSO	3	
10	6D8-13105-01	..CONTROL VALVE ASSY ..CONTROLADOR DA VALVULA CJ	1	
11	6C5-1319C-00	..O-RING ..ANEL DE BORRACHA	1	
12	6C5-81146-10	..SCREW 2 ..PARAFUSO 2	4	
13	6D8-13161-00	..PIPE, DELIVERY 1 ..TUBO DE DELIBERAÇÃO 1	1	
14	6C5-14446-00	..BOLT ..PARAFUSO	2	
15	6D8-13761-00	..INJECTOR ..INJETOR CONJUNTO	4	
16	6C5-1410B-00	..PACKING KIT ..KIT DE JUNTAS	1	
17	68F-83688-00	..SENSOR ASSY ..SENSOR CONJUNTO	1	
18	90464-18246	..CLAMP ..BRACADEIRA	1	



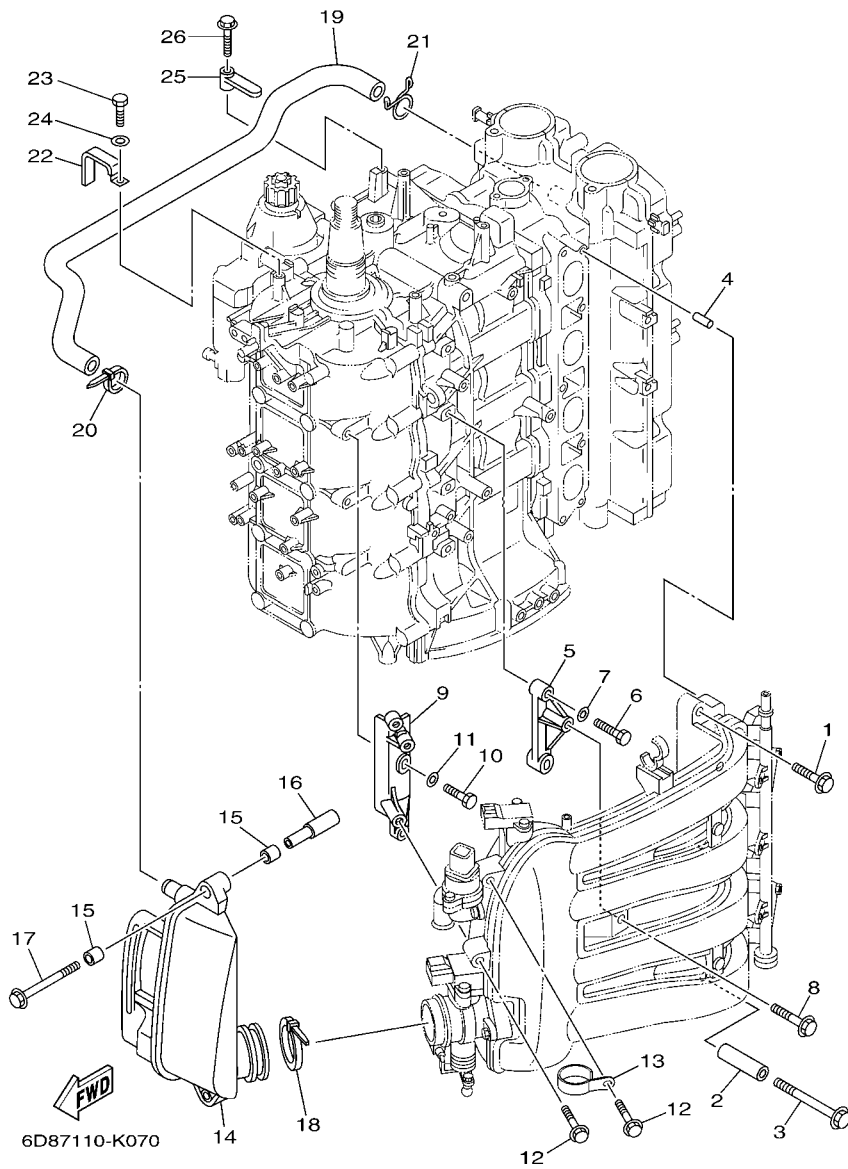


FIG. 8 INTAKE 2

ADMISSAO 2

REF. NO.	PART NO. No. PEÇA	DESCRIPTION DESCRIÇÃO	6E12				REMARKS OBSERVAÇÕES
1	90119-08069	BOLT, WITH WASHER PARAFUSO COM ARRUELA	4				
2	90387-08033	COLLAR ESPACADOR	1				
3	90119-08M03	BOLT, WITH WASHER PARAFUSO COM ARRUELA	1				
4	91690-50014	PIN, SPRING PINO MOLA	2				
5	6D8-14291-00	BRACKET 1 SUPORTE 1	1				
6	97095-06030	BOLT PARAFUSO	2				
7	92995-06600	WASHER ARRUELA	2				
8	90119-06087	BOLT, WITH WASHER PARAFUSO COM ARRUELA	1				
9	6D8-14292-00	BRACKET 2 SUPORTE DA INJECAO 2	1				
10	97095-06020	BOLT PARAFUSO	2				
11	92995-06600	WASHER ARRUELA	2				
12	90119-06087	BOLT, WITH WASHER PARAFUSO COM ARRUELA	2				
13	6D8-13782-00	STAY FIXADOR	1				
14	6D8-14440-01	SILENCER ASSY, INTAKE SILENCIADOR DA ADMISSAO CONJ.	1				
15	90386-08001	BUSH BUCHA	4				
16	90387-07013	COLLAR ESPACADOR	2				
17	90119-06113	BOLT, WITH WASHER PARAFUSO COM ARRUELA	2				
18	90464-76001	CLAMP BRACADEIRA	1				
19	6D8-15373-00	PIPE, BREATHER TUBO DO RESPIRO	1				
20	90465-11M59	CLAMP BRACADEIRA	1				
21	90467-20M15	CLIP PRESILHA	1				
22	90465-12M03	CLAMP BRACADEIRA	1				
23	97095-06012	BOLT PARAFUSO	1				
24	92995-06600	WASHER ARRUELA	1				
25	6D8-82544-00	CLAMP BRACADEIRA	1				
26	95895-06025	BOLT, FLANGE PARAFUSO FLANGE	1				

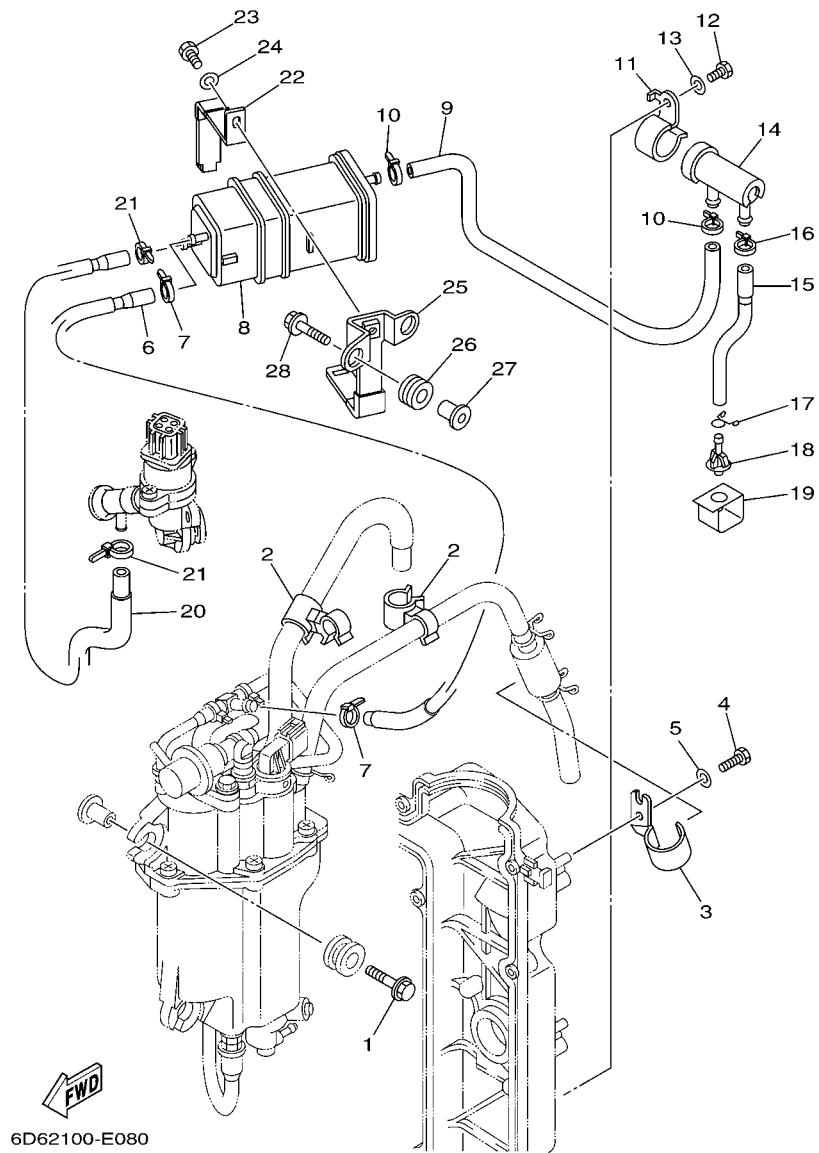


FIG. 9 INTAKE 3

ADMISSAO 3

REF. NO.	PART NO. No. PEÇA	DESCRIPTION DESCRIÇÃO	QTD				REMARKS OBSERVAÇÕES
1	90119-06M08	BOLT, WITH WASHER PARAFUSO COM ARRUELA	3				
2	90464-15007	CLAMP BRACADEIRA	2				
3	6D8-13428-01	BRACKET, STRAINER 1 SUPORTE DO FILTRO 1	1				
4	97095-06012	BOLT PARAFUSO	1				
5	92995-06600	WASHER ARRUELA	1				
6	6D8-24314-01	PIPE 4 TUBO 4	1				
7	90465-11M10	CLAMP BRACADEIRA	2				
8	69J-24170-00	CANISTER ASSY BOMBA DE COMBUSTIVEL	1				
9	6D8-24315-00	PIPE 5 TUBO 5	1				
10	90465-11M10	CLAMP BRACADEIRA	2				
11	6D8-2417H-01	CLAMP 1 BRACADEIRA 1	1				
12	97095-06010	BOLT PARAFUSO	1				
13	92995-06600	WASHER ARRUELA	1				
14	69J-24502-00	FILTER, FUEL FILTRO DE COMBUSTIVEL	1				
15	6D8-24316-00	PIPE 6 TUBO 6	1				
16	90465-11M10	CLAMP BRACADEIRA	1				
17	90467-09M03	CLIP PRESILHA	1				
18	69J-44391-00	NIPPLE, HOSE JUNCAO DO TUBO	1				
19	6D8-2413X-01	PLATE PLACA	1				
20	6D8-24317-01	PIPE 7 TUBO 7	1				
21	90465-11M10	CLAMP BRACADEIRA	2				
22	69J-2419A-01	HOLDER FIXADOR	1				
23	97095-06016	BOLT PARAFUSO	1				
24	92995-06600	WASHER ARRUELA	1				
25	6D8-2134X-00	BRACKET, CANISTER SUPORTE	1				
26	90480-10M23	GROMMET ILHO DE BORRACHA	2				
27	90387-06M60	COLLAR ESPACADOR	2				



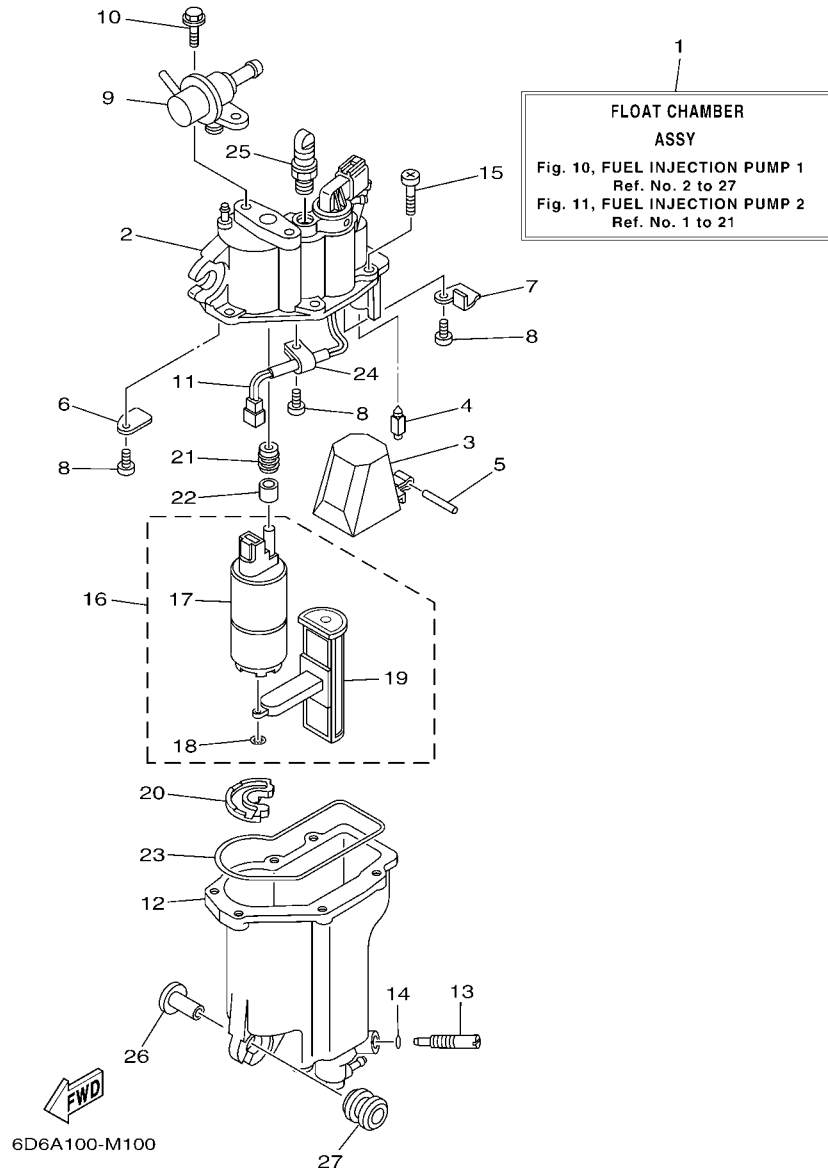


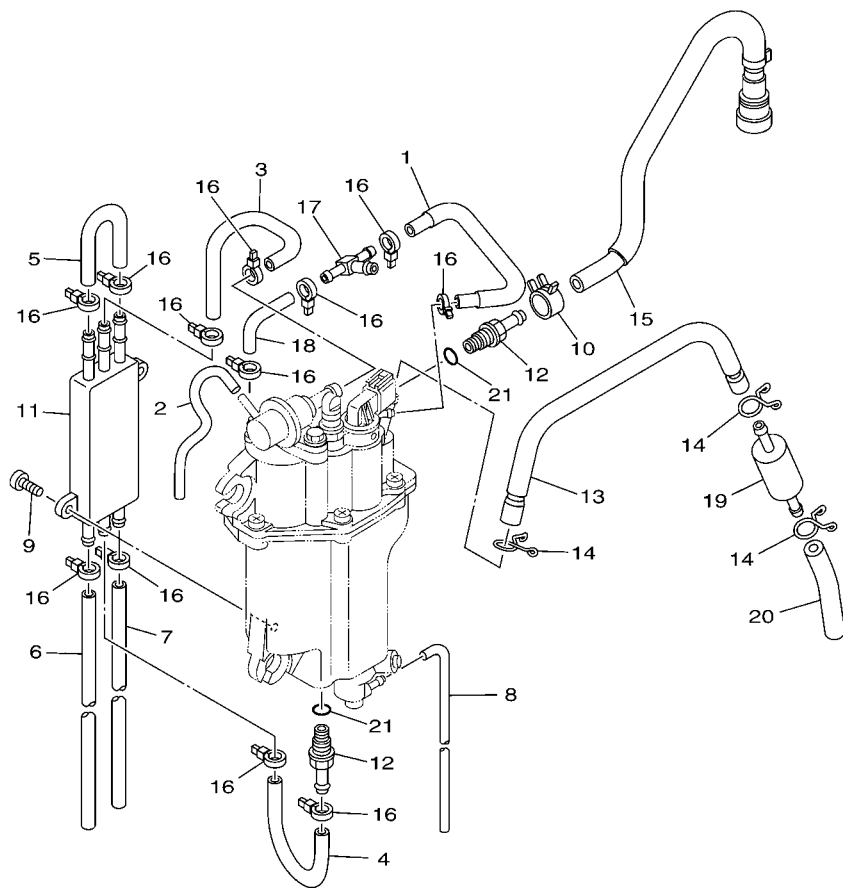
FIG. 10 FUEL INJECTION PUMP 1

BOMBA DE INJECÃO COMBUSTÍVEL 1

REF. NO.	PART NO. No. PEÇA	DESCRIPTION DESCRIÇÃO	QTY				REMARKS OBSERVAÇÕES
1	6D8-14180-40	FLOAT CHAMBER ASSY CAMARA DA BOIA CJ	1				
2	6D8-14182-10	COVER, FLOAT CHAMBER TAMPA DA CAMARA DA BOIA	1				
3	6C5-14985-00	FLOAT BOIA	1				
4	6C5-14546-10	VALVE, NEEDLE VALVULA DA AGULHA	1				
5	6C5-14386-00	PIN, FLOAT PINO DA BOIA	1				
6	6C5-2441R-10	PLATE, BAFFLE 1 PLACA DEFLETORA 1	1				
7	6C5-2441T-10	PLATE, BAFFLE 2 PLACA DEFLETORA 2	1				
8	6C5-24453-00	SCREW PARAFUSO	3				
9	6C5-13906-01	REGULATOR, PRESSURE REGULADOR DE PRESSAO	1				
10	6C5-24592-00	BOLT PARAFUSO	2				
11	6C5-87226-00	WIRE HARNESS ASSY CHICOTE PRINCIPAL COMPLETO	1				
12	6D8-14960-10	BODY ASSY COBERTURA CONJUNTO	1				
13	6C5-14191-00	PLUG, DRAIN TAMPAO DE DRENO	1				
14	6C5-14397-00	O-RING TUBO DE RESPIRO	1				
15	6C5-14567-00	SCREW PARAFUSO	6				
16	6C5-13910-10	FUEL PUMP ASSY BOMBA DE COMBUSTIVEL COMPLETA	1				
17	6C5-13907-00	.FUEL PUMP COMP. .BOMBA DE COMBUSTIVEL COMPLETA	1				
18	6C5-14127-10	.CLIP .CLIPE	1				
19	6C5-13915-00	.FILTER .FILTRO	1				
20	6C5-13593-00	DAMPER AMORTIZADOR	1				
21	6C5-13781-00	DAMPÉR, PUMP AMORTIZADOR DA BOMBA	1				
22	6C5-13716-00	COLLAR ESPACADOR	1				
23	6C5-14984-00	GASKET, FLOAT CHAMBER GAXETA DA CAMARA DA BOIA.	1				
24	6C5-21337-10	CLAMP, CABLE BRACAIDEIRA DE CABOS	1				
25	6C5-14225-00	CAP CAPA	1				
26	90387-06M69	COLLAR ESPACADOR	3				
27	90480-09M12	GROMMET ILHO DE BORRACHA	3				

FIG. 11 FUEL INJECTION PUMP 2

BOMBA DE INJECÃO COMBUSTIVEL 2



6D67110-K100

REF. NO.	PART NO. No. PEÇA	DESCRIPTION DESCRIÇÃO	QTY				REMARKS OBSERVAÇÕES
1	6D8-13546-01	HOSE 2 MANGUEIRA 2	1				
2	6D8-13542-01	HOSE, VACUUM SENSING 1 TUBO DE VACUO 1	1				
3	6C5-24321-20	PIPE 10 TUBO 10	1				
4	6C5-24322-20	PIPE 11 TUBO 11	1				
5	6C5-24323-00	PIPE 12 TUBO 12	1				
6	6D8-24324-01	PIPE 13 TUBO 13	1				
7	6D8-24325-10	PIPE 14 TUBO 14	1				
8	6BG-14149-00	PIPE TUBO	1				
9	6C5-24444-00	SCREW PARAFUSO	2				
10	6C5-13577-00	CLIP PRESILHA	1				
11	6C5-21841-00	COOLER REFRIGERADOR	1				
12	6C5-14251-00	NIPPLE NIPLÉ	2				
13	6D8-14148-20	PIPE TUBO	1				
14	6C5-24387-00	CLIP PRESILHA	3				
15	6D8-13974-00	PIPE, FUEL 4 TUBO DE COMBUSTIVEL 4	1				
16	90465-11M10	CLAMP BRACADEIRA	12				
17	6C5-24379-00	PIPE, JOINT 4 JUNCAO DO TUBO 4	1				
18	6C5-13545-00	HOSE 1 MANGUEIRA 1	1				
19	6C5-24251-00	STRAINER 1 FILTRO 1	1				
20	6D8-2451B-20	HOSE, FUEL INLET TUBO DE ENTRADA DO COMBUSTIVEL	1				
21	6C5-13739-00	O-RING ANEL DE BORRACHA	2				

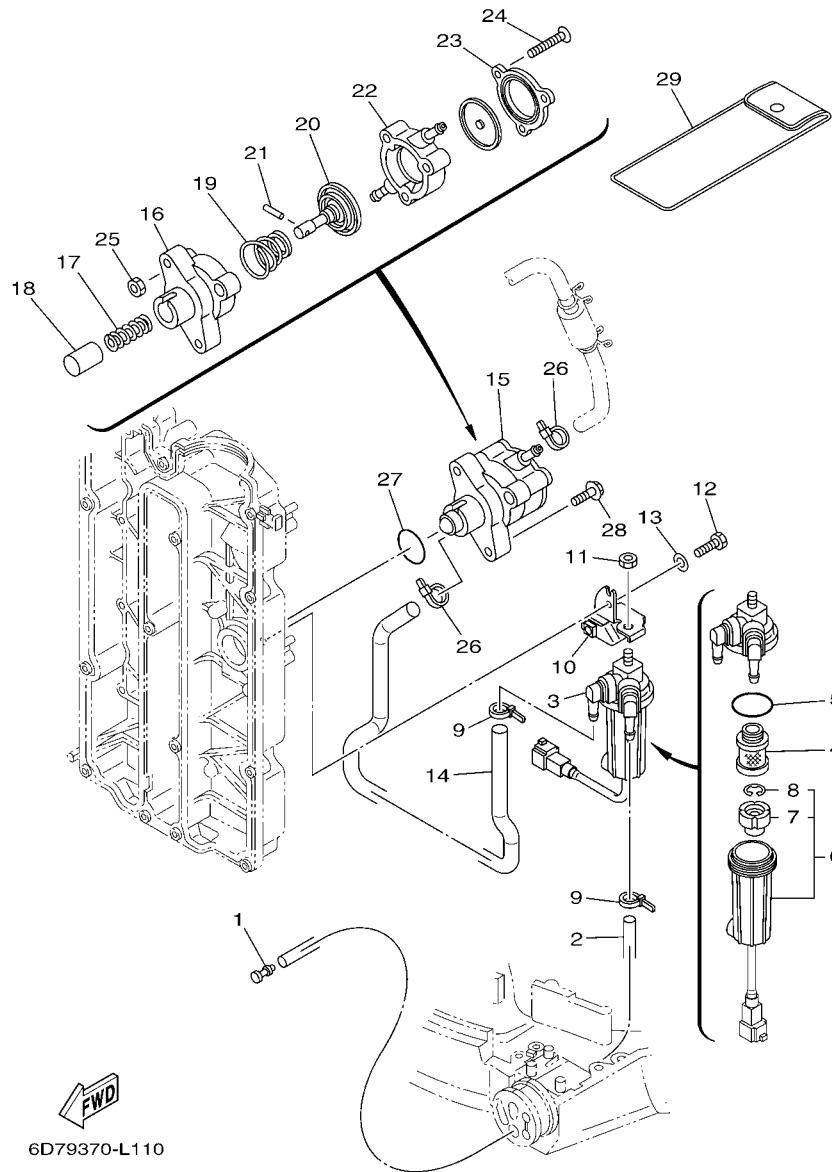


FIG. 12 FUEL 1

COMBUSTIVEL

REF. NO.	PART NO. No. PEÇA	DESCRIPTION DESCRIÇÃO	QTY	REMARKS OBSERVAÇÕES
1	689-85547-00	DAMPER AMORTIZADOR	1	
2	90445-13M37	HOSE (L2300) TUBO (L2300)	1	
3	6D8-24560-00	FILTER ASSY FILTRO DE COMBUSTIVEL CONJ.	1	
4	6D8-24563-00	.ELEMENT, FILTER .ELEMENTO DO FILTRO	1	
5	6D8-24564-00	.GASKET .GAXETA	1	
6	6D8-24562-00	.CUP, FILTER .COPO DO FILTRO	1	
7	6D8-24469-00	..FLOAT, WATER LEVEL ..BOIA DO NIVEL D'AGUA	1	
8	6D8-24519-00	..CLIP ..PRESILHA	1	
9	90465-11M10	CLAMP BRACADEIRA	2	
10	6D8-24566-00	BRACKET, FILTER SUPORTE DO FILTRO	1	
11	95380-08600	NUT PORCA	1	
12	97095-06016	BOLT PARAFUSO	1	
13	92995-06600	WASHER ARRUELA	1	
14	6D8-24311-00	PIPE, FUEL 1 TUBO DE COMBUSTIVEL 1	1	
15	6D8-24410-10	FUEL PUMP ASSY BOMBA DE COMBUSTIVEL CONJ.	1	
16	68V-24412-00	.BODY 1 .CARCACA 1	1	
17	68V-24454-00	.SPRING .MOLA	1	
18	63P-13131-00	.PLUNGER .ESPACADOR	1	
19	68V-24423-00	.SPRING, DIAPHRAGM .MOLA DO DIAFRAGMA	1	
20	68V-24411-00	.DIAPHRAGM .DIAFRAGMA	1	
21	68V-24374-00	.PIN .PINO	1	
22	68V-24413-10	.BODY 2 .CARCACA 2	1	
23	6D8-24414-00	.BODY 3 .COBERTURA 3	1	
24	68V-24444-00	.SCREW .PARAFUSO	3	
25	68V-24149-00	.NUT .PORCA	3	
26	90465-11M10	CLAMP BRACADEIRA	2	
27	93210-30682	O-RING ANEL DE BORRACHA	1	

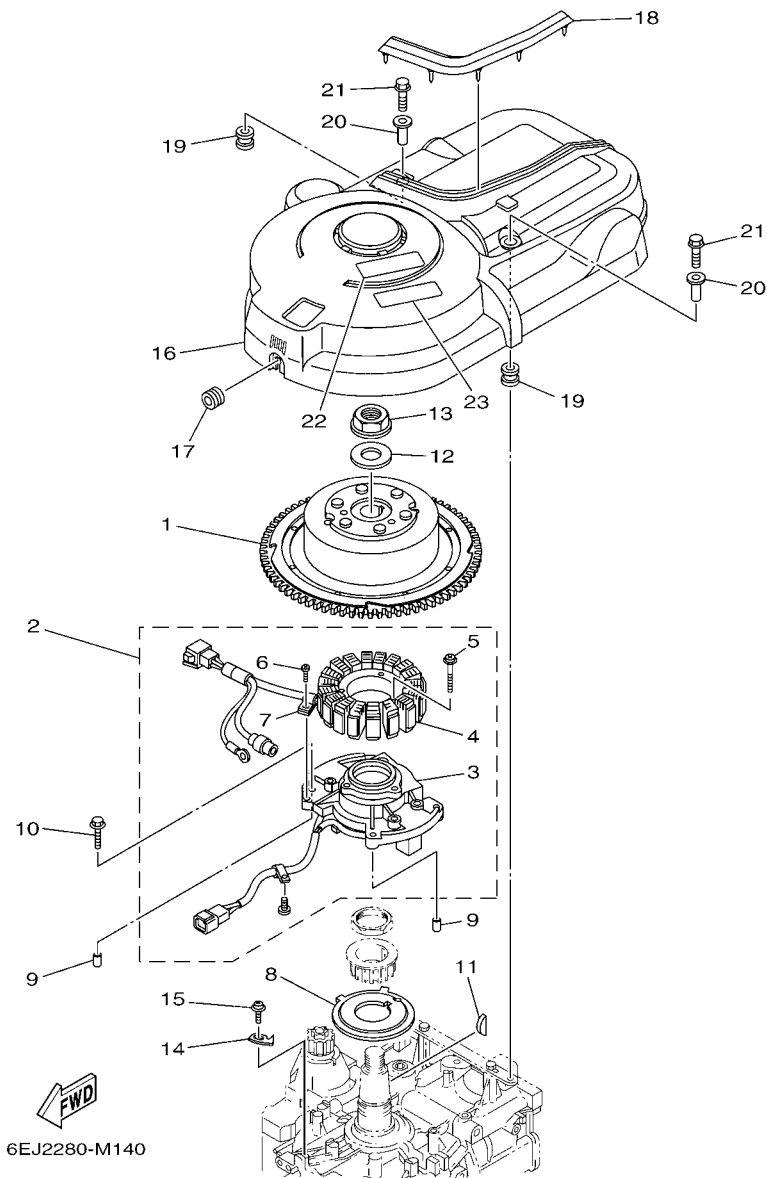






FIG. 14 GENERATOR

GERADOR

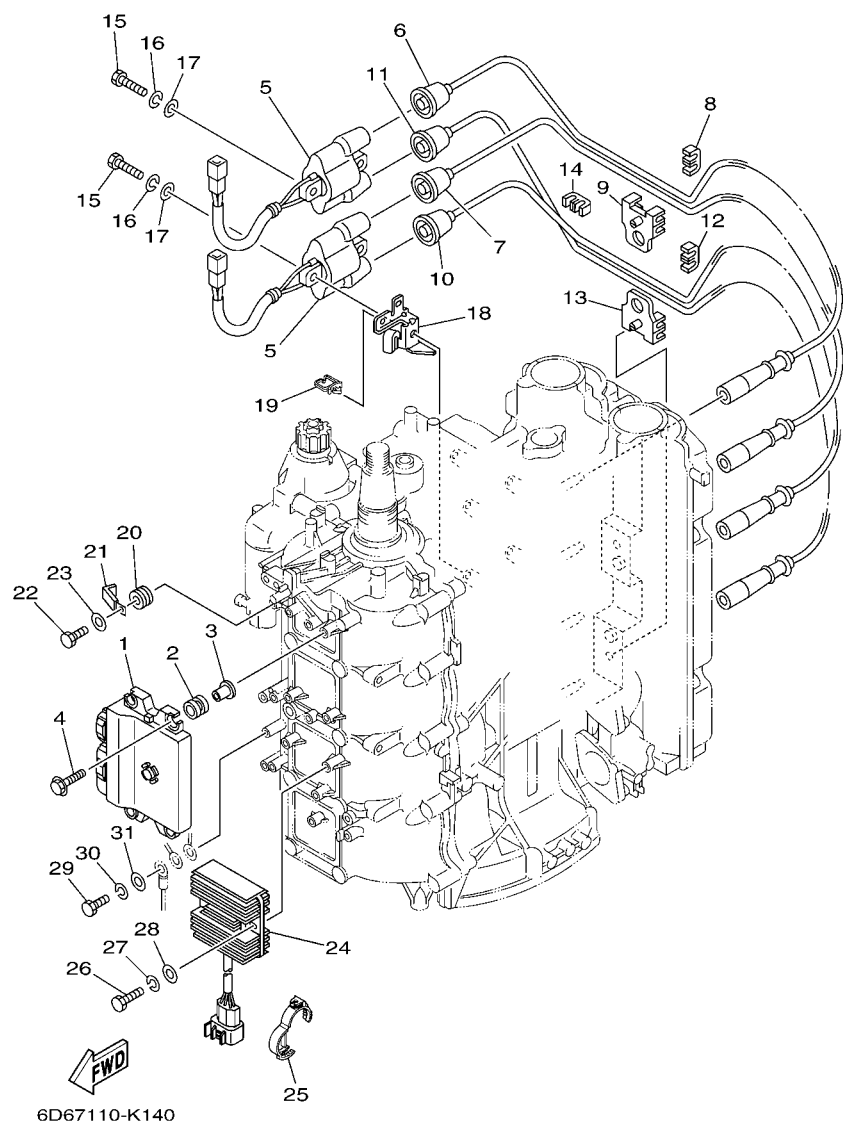


6EJ2280-M140

REF. NO.	PART NO. No. PEÇA	DESCRIPTION DESCRIÇÃO	6EJ2				REMARKS OBSERVAÇÕES
1	6D8-81450-00	ROTOR ASSY ROTOR DO MAGNETO CONJ.	1				
2	6D8-81460-00	BASE ASSY BASE CONJUNTO	1				
3	6D8-85580-00	.COIL, PULSER .BOBINA DE PULSO CONJUNTO	1				
4	6D8-81410-00	.STATOR ASSY .ESTATOR CONJ.	1				
5	63D-81345-20	.SCREW, WITH WASHER (M6X30) .PARAFUSO COM ARRUELA	3				
6	97607-04110	.SCREW, WITH WASHER .PARAFUSO	1				
7	445-81328-20	.CLAMP .BRACADEIRA	1				
8	68V-81673-10	ROTOR ROTOR CONJ.	1				
9	99530-08012	PIN, DOWEL PINO GUIA	2				
10	97595-06630	BOLT, WITH WASHER PARAFUSO COM ARRUELA	4				
11	90280-05015	KEY, WOODRUFF CHAVETA MEIA LUA	1				
12	90201-24014	WASHER, PLATE ARRUELA PLANA	1				
13	90179-24002	NUT PORCA	1				
14	6D8-81332-00	PLATE, TIMING PLACA DO REGULADORA	1				
15	97985-06210	SCREW, WITH WASHER PARAFUSO	1				
16	6D8-81337-00	COVER, FLYWHEEL TAMPA DO ROTOR	1				
17	90480-12314	GROMMET ILHO DE BORRACHA	1				
18	6D8-85547-00	DAMPER AMORTIZADOR	1				
19	663-82317-01	DAMPER, IGNITION COIL AMORTIZADOR BOBINA DE IGNICAO	2				
20	90387-06119	COLLAR ESPACADOR	2				
21	95895-06020	BOLT, FLANGE PARAFUSO FLANGE	2				
22	6AH-81995-70	LABEL, WARNING ETIQUETA ADVERTENCIA	1				
23	6AH-81994-70	LABEL, SAFETY ETIQUETA DE SEGURANCA	1				

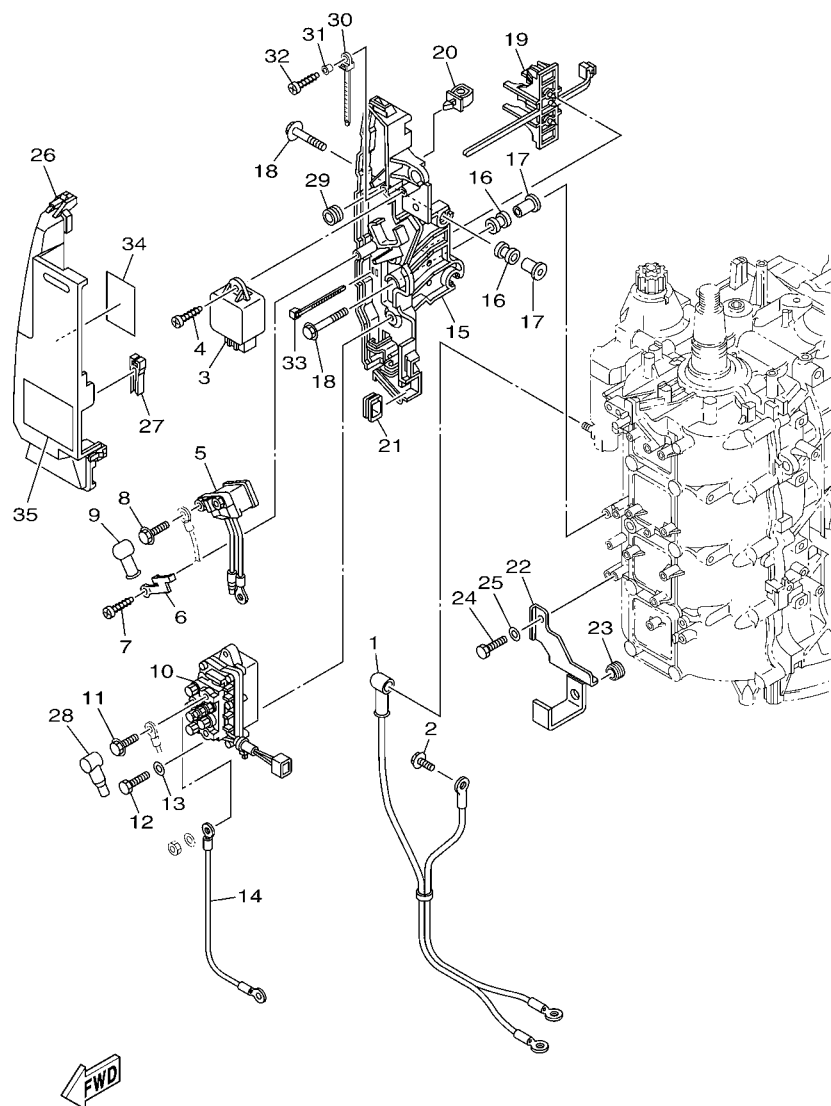
FIG. 15 ELECTRICAL 1

SISTEMA ELETRICO 1



REF. NO.	PART NO. No. PEÇA	DESCRIPTION DESCRIÇÃO	QTY	REMARKS OBSERVAÇÕES
1	6D8-8591A-24	ENGINE CONTROL UNIT ASSY UNIDADE DE CONTROLE MOTORA CJ	1	
2	68V-82317-00	DAMPER, IGNITION COIL AMORTIZADOR BOBINA DE IGNICAO	4	
3	90387-06119	COLLAR ESPACADOR	4	
4	90119-06M59	BOLT, WITH WASHER PARAFUSO COM ARRUELA	4	
5	63P-82310-01	IGNITION COIL ASSY BOBINA DE IGNICAO CONJ.	2	
6	67F-82341-00	CORD, HIGH TENSION 1 CABO DE ALTA TENSAO 1	1	#1
7	67F-82342-00	CORD, HIGH TENSION 2 CABO DE ALTA TENSAO 2	1	#2
8	67F-82361-00	CLAMP, CORD GRAMPO FIXADOR DO TUBO	1	
9	67F-82362-00	CLAMP, CORD 2 SUPORTE DOS CABOS 2	1	
10	67F-82343-00	CORD, HIGH TENSION 3 CABO DE ALTA TENSAO 3	1	#3
11	67F-82344-00	CORD, HIGH TENSION 4 CABO DE ALTA TENSAO 4	1	#4
12	67F-82361-00	CLAMP, CORD GRAMPO FIXADOR DO TUBO	1	
13	67F-82362-00	CLAMP, CORD 2 SUPORTE DOS CABOS 2	1	
14	67F-82361-00	CLAMP, CORD GRAMPO FIXADOR DO TUBO	1	
15	97095-06025	BOLT PARAFUSO	4	
16	92995-06100	WASHER, SPRING ARRUELA COM MOLA	4	
17	92995-06600	WASHER ARRUELA	4	
18	6D8-82388-01	PLATE PLACA	2	
19	90464-08004	CLAMP BRACAIDEIRA	2	
20	90480-14329	GROMMET ILHO DE BORRACHA	1	
21	90465-08M23	CLAMP BRACAIDEIRA	1	
22	97095-06014	BOLT PARAFUSO	1	
23	92995-06600	WASHER ARRUELA	1	
24	6D8-81960-10	RECTIFIER & REGULATOR ASSY RETIFICADOR & REGULADOR CONJ.	1	
25	90464-30003	CLAMP BRACAIDEIRA	1	
26	97095-06025	BOLT PARAFUSO	2	
27	92995-06100	WASHER, SPRING ARRUELA COM MOLA	2	





6D79700-L150

FIG. 16 ELECTRICAL 2

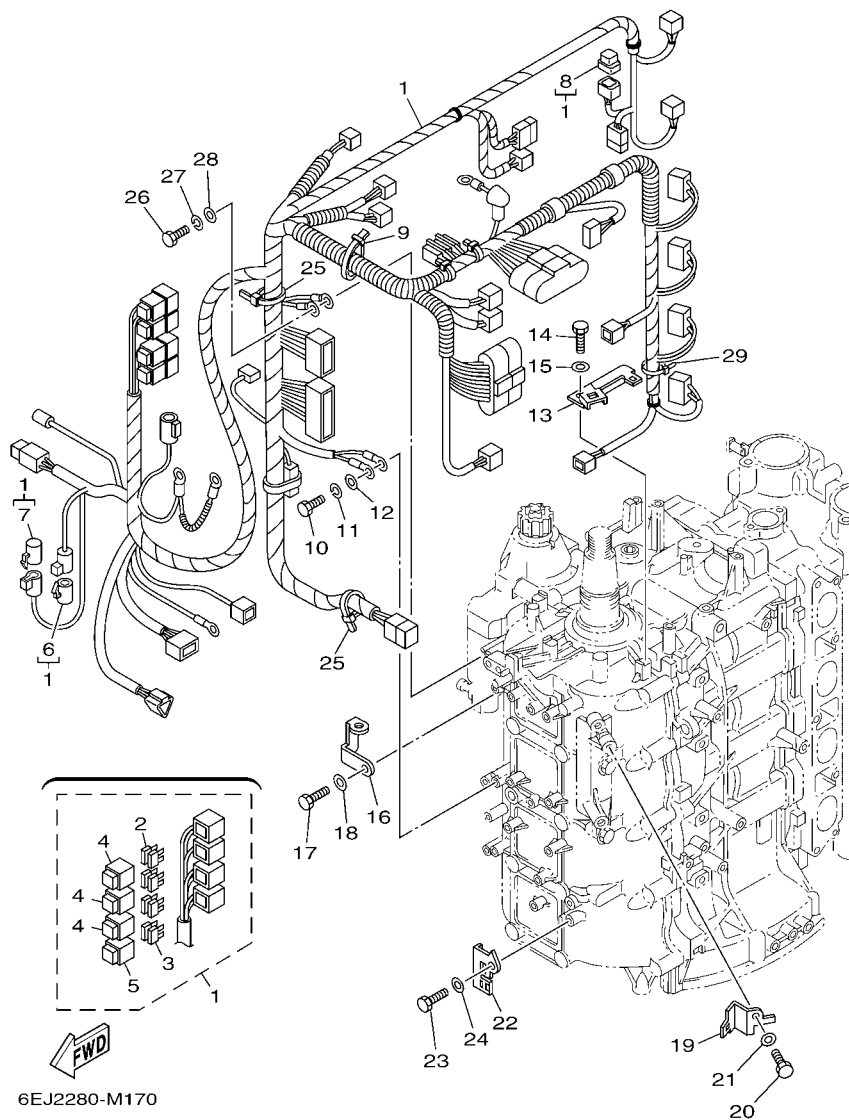
SISTEMA ELETRICO 2

REF. NO.	PART NO. No. PEÇA	DESCRIPTION DESCRIÇÃO	6E12				REMARKS OBSERVAÇÕES
1	68V-82105-00	BATTERY CABLE CABO DE BATERIA	1				
2	90105-06M14	BOLT FLANGE PARAFUSO FLANGE	1				
3	60E-81950-00	RELAY ASSY RELE CONJUNTO	1				
4	97780-60625	SCREW, TAPPING PARAFUSO	1				
5	68V-8194A-00	RELAY RELE	1				
6	68V-81953-00	STAY, RELAY FIXADOR DO RELE	1				
7	97780-60620	SCREW, TAPPING PARAFUSO	1				
8	97595-06610	BOLT, WITH WASHER PARAFUSO COM ARRUELA	2				
9	6G5-82119-00	COVER, LEAD WIRE TAMPA DO FIO DA BATERIA	2				
10	63P-81950-00	RELAY ASSY RELE CONJUNTO	1				
11	97595-06610	BOLT, WITH WASHER PARAFUSO COM ARRUELA	2				
12	97013-06020	BOLT PARAFUSO	2				
13	92903-06600	WASHER, PLATE ARRUELA PLANA	2				
14	61A-81949-00	WIRE, LEAD CHICOTE DE FIOS	1				
15	68V-81948-02	BRACKET SUPORTE	1				
16	6A0-82317-00	DAMPER, IGNITION COIL AMORTIZADOR BOBINA DE IGNICAO	5				
17	90387-06119	COLLAR ESPACADOR	5				
18	90119-06M59	BOLT, WITH WASHER PARAFUSO COM ARRUELA	5				
19	68V-82594-00	CLAMP GRAMPO DO CHICOTE	1				
20	90464-12M58	CLAMP BRACADEIRA	1				
21	6D8-81518-00	GROMMET ILHO DE BORRACHA	1				
22	6D8-81528-02	CLAMP 1 GRAMPO 1	1				
23	90480-13M24	GROMMET ILHO DE BORRACHA	1				
24	97095-06014	BOLT PARAFUSO	1				
25	92995-06600	WASHER ARRUELA	1				
26	68V-81942-03	COVER TAMPA	1				
27	67F-2812A-00	PULLER, FUSE PINCA DO FUSIVEL	1				



FIG. 17 ELECTRICAL 3

SISTEMA ELETRICO 3

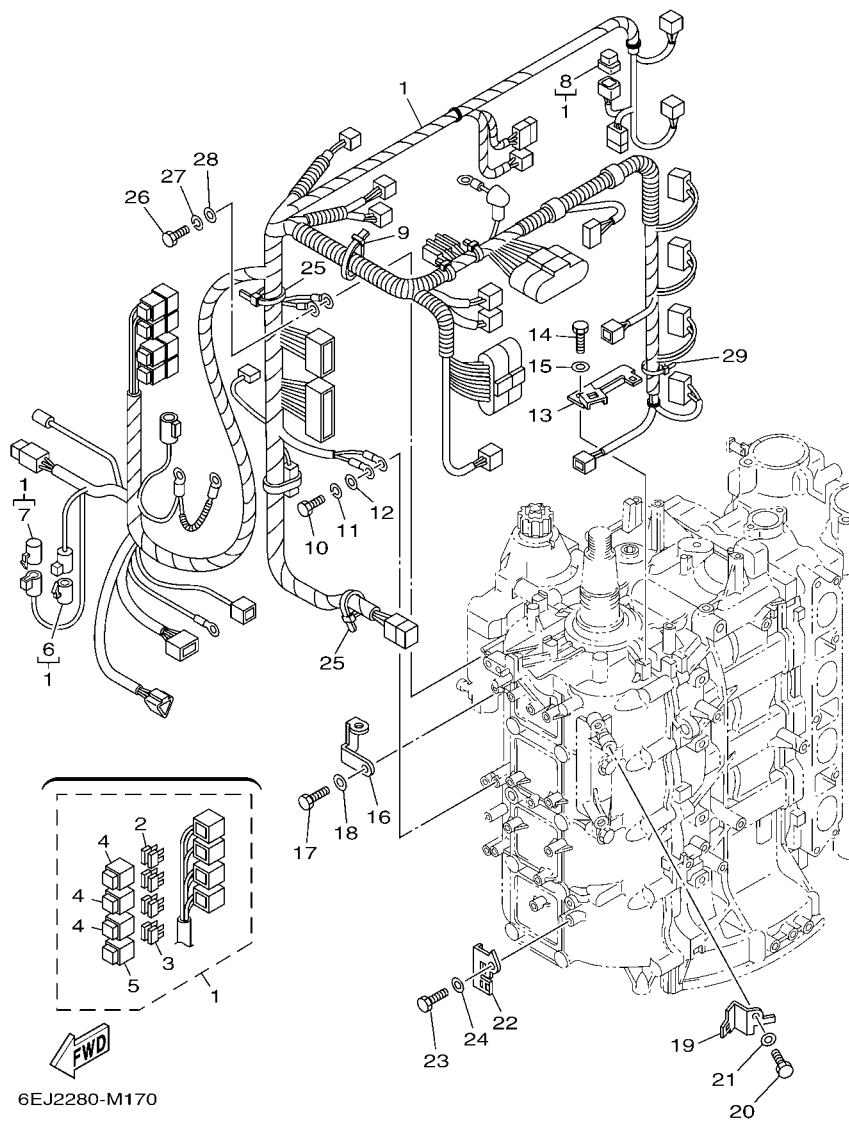


6EJ2280-M170

REF. NO.	PART NO. No. PEÇA	DESCRIPTION DESCRIÇÃO	6EJ2				REMARKS OBSERVAÇÕES
1	6D8-82590-31	WIRE HARNESS ASSY CHICOTE PRINCIPAL COMPLETO	1				
2	67F-82151-00	.FUSE (20A) .FUSIVEL (20A)	6				
3	67F-82151-10	.FUSE (30A) .FUSIVEL (30A)	2				
4	67F-8215B-10	.CAP (YELLOW) .TAMPAO	3				
5	67F-8215B-20	.CAP (GREEN) .TAMPAO	1				
6	6DA-82582-00	.CAP 1 (FEMALE) .TAMPAO 1	1				
7	6DA-82582-10	.CAP 1 (MALE) .TAMPAO 1	1				
8	6Y8-82582-11	.CAP 1 (4PIN) .TAMPA DA CHICOTE	1				
9	90464-76001	CLAMP BRACADEIRA	1				
10	97095-06016	BOLT PARAFUSO	1				
11	92995-06100	WASHER, SPRING ARRUELA COM MOLA	1				
12	92995-06600	WASHER ARRUELA	1				
13	6D8-82588-01	PLATE PLACA	1				
14	97095-06012	BOLT PARAFUSO	1				
15	92995-06600	WASHER ARRUELA	1				
16	6D8-82581-01	STAY, CORD CLAMP FIXADOR DO CHICOTE DA LAMPADA	1				
17	97095-06014	BOLT PARAFUSO	1				
18	92995-06600	WASHER ARRUELA	1				
19	6D8-82389-01	PLATE 2 PLACA 2	1				
20	97095-06012	BOLT PARAFUSO	1				
21	92995-06600	WASHER ARRUELA	1				
22	6D8-82398-01	PLATE 3 PLACA 3	1				
23	97095-06012	BOLT PARAFUSO	1				
24	92995-06600	WASHER ARRUELA	1				
25	90465-13M18	CLAMP BRACADEIRA	2				
26	97095-06016	BOLT PARAFUSO	1				
27	92995-06100	WASHER, SPRING ARRUELA COM MOLA	1				

FIG. 17 ELECTRICAL 3

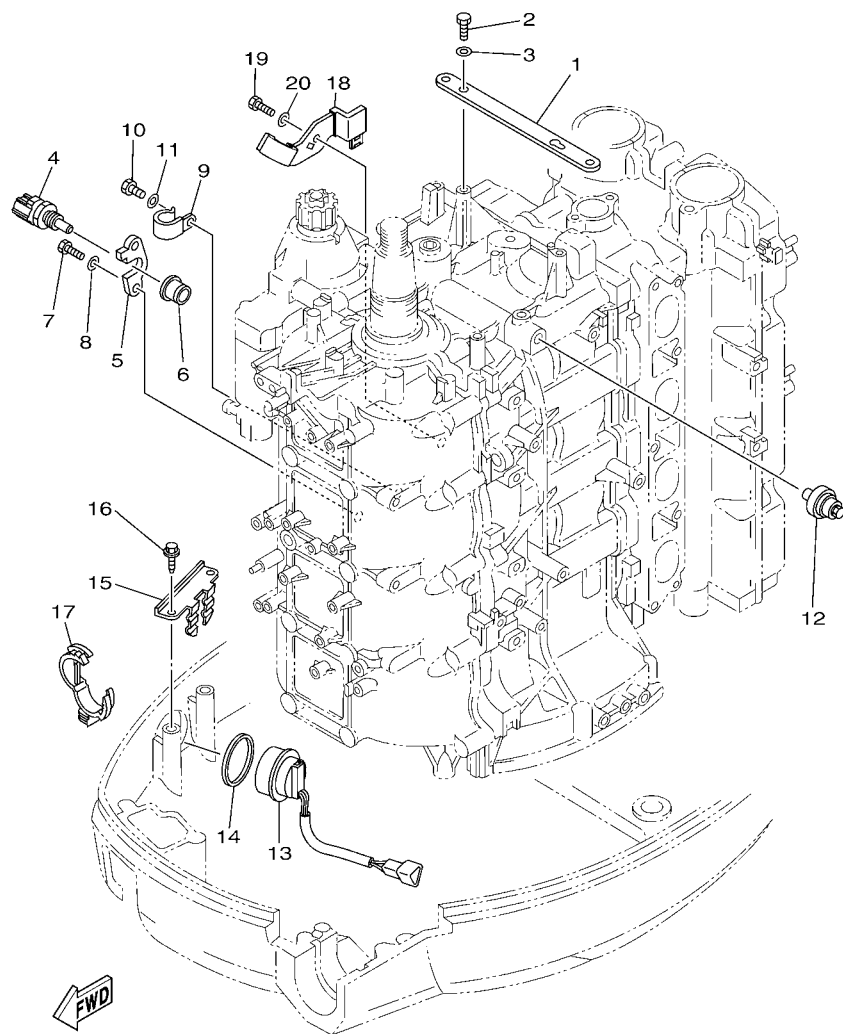
SISTEMA ELETRICO 3



REF. NO.	PART NO. No. PEÇA	DESCRIPTION DESCRIÇÃO	6EJ2				REMARKS OBSERVAÇÕES
28	92995-06600	WASHER ARRUELA	1				
29	90465-13M11	CLAMP BRACADEIRA	1				
-----							
-----							
-----							
-----							
-----							
-----							
-----							
-----							
-----							
-----							

FIG. 18 ELECTRICAL 4

SISTEMA ELETRICO 4



6D6A100-M170

REF. NO.	PART NO. No. PEÇA	DESCRIPTION DESCRIÇÃO	QTY	REMARKS OBSERVAÇÕES
1	6D8-8132G-10	PLATE PLACA	1	
2	97095-06016	BOLT PARAFUSO	2	
3	92995-06600	WASHER ARRUELA	2	
4	67F-85790-00	THERMOSENSOR ASSY TERMOSTATO	1	
5	67F-85757-00	RETAINER RETENTOR DO SENSOR	1	
6	68V-85753-00	GASKET, SENDER UNIT GAXETA DO SENSOR	1	
7	97095-06016	BOLT PARAFUSO	2	
8	92995-06600	WASHER ARRUELA	2	
9	90465-06M86	CLAMP BRACADEIRA	1	
10	97095-06012	BOLT PARAFUSO	1	
11	92995-06600	WASHER ARRUELA	1	
12	68V-82504-00	OIL PRESSURE SWITCH ASSY SENSOR DE PRESSAO DO OLEO	1	
13	63D-82563-10	TRIM & TILT SWITCH ASSY INTERRUPTOR TRIM & TILT CONJ.	1	
14	6E5-82587-00	GASKET GAXETA	1	
15	67F-83614-00	BRACKET SUPORTE	1	
16	90109-06M86	BOLT PARAFUSO	2	
17	90464-30003	CLAMP BRACADEIRA	2	
18	6D8-8252H-01	PLATE, HOLDER PLACA DO SUPORTE	1	
19	97095-06012	BOLT PARAFUSO	1	
20	92995-06600	WASHER ARRUELA	1	



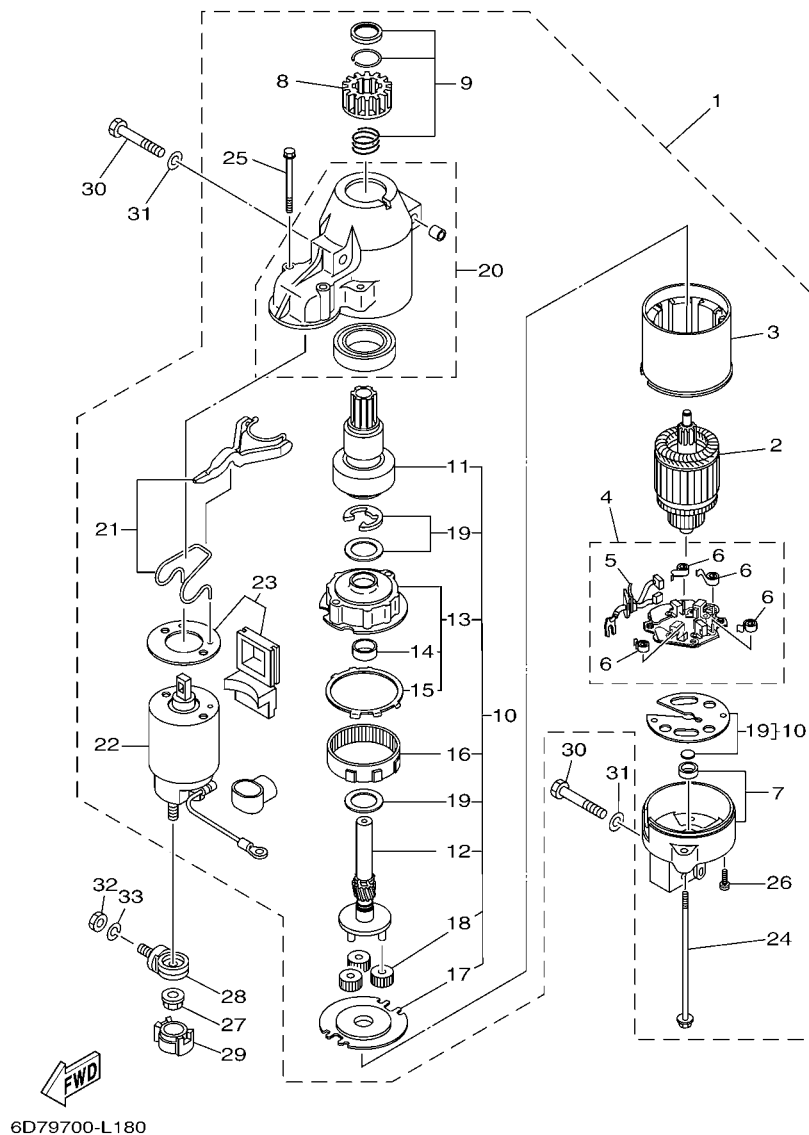


FIG. 19 STARTING MOTOR

MOTOR DE PARTIDA

REF. NO.	PART NO. No. PEÇA	DESCRIPTION DESCRIÇÃO	QTY	REMARKS OBSERVAÇÕES
1	68V-81800-02	STARTING MOTOR ASSY MOTOR DE PARTIDA COMPLETO	1	
2	67F-81850-00	.ARMATURE ASSY .INDUZIDO CONJ.	1	
3	67F-81810-00	.STATOR ASSY .ESTATOR CONJTO	1	
4	69J-81840-00	.BRUSH HOLDER ASSY .FIXADOR DAS ESCOVAS CONJ.	1	
5	69J-81801-00	..BRUSH SET ..JOGO DE ESCOVAS	1	
6	67F-81813-00	..SPRING, BRUSH ..MOLA DO ESCOVA	4	
7	68F-81820-00	.REAR BRACKET ASSY .SUPORTE TRASEIRO CONJ.	1	
8	67F-81808-00	.PINION ASSY .PINHAO CONJUNTO	1	
9	67F-81857-00	.PINION STOPPER SET .JOGO LIMITADOR DO PINHAO	1	
10	67F-81807-00	.GEAR ASSY, STARTING MOTOR .ENGRENAGEM DO MOTOR ARRANQUE	1	
11	67F-81832-00	..CLUTCH, OVER RUN ..PINHAO DA EMBREAGEM	1	
12	67F-81836-00	..SHAFT, PINION ..MOLA DA ALAVANCA	1	
13	67F-81821-00	..BRACKET, CENTER 1 ..SUPORTE DO CENTRO 1	1	
14	67F-81841-00	..BEARING ..ROLAMENTO	1	
15	67F-8183R-00	..GASKET ..GAXETA	1	
16	67F-81891-00	..GEAR, RING ..ANEL DA ENGRENAGEM	1	WITH 67F-8183R-00 WITH 67F-8183R-00
17	67F-81830-00	..BRACKET, CENTER 2 ..SUPORTE DIANTEIRO CONJ.	1	
18	60V-8183T-00	..GEAR, IDLER ..ENGRENAGEM LOUCA	3	
19	67F-81809-00	..WASHER KIT ..ARRUELAS JOGO	1	
20	60X-81842-00	.COVER .TAMPA	1	
21	6C5-81839-00	.LEVER ASSY .ALAVANCA CONJUNTO	1	
22	68V-81941-02	.STARTER RELAY ASSY .RELE DE PARTIDA CONJ	1	
23	6C5-81869-00	.COVER, DUST .TAMPA DO RELE DE PARTIDA	1	
24	6K7-81826-11	.BOLT .PARAFUSO	2	
25	69J-81828-00	.SCREW 2 .PARAFUSO 2	2	
26	67F-81846-00	.SCREW .PARAFUSO	2	
27	90179-08003	NUT PORCA	1	



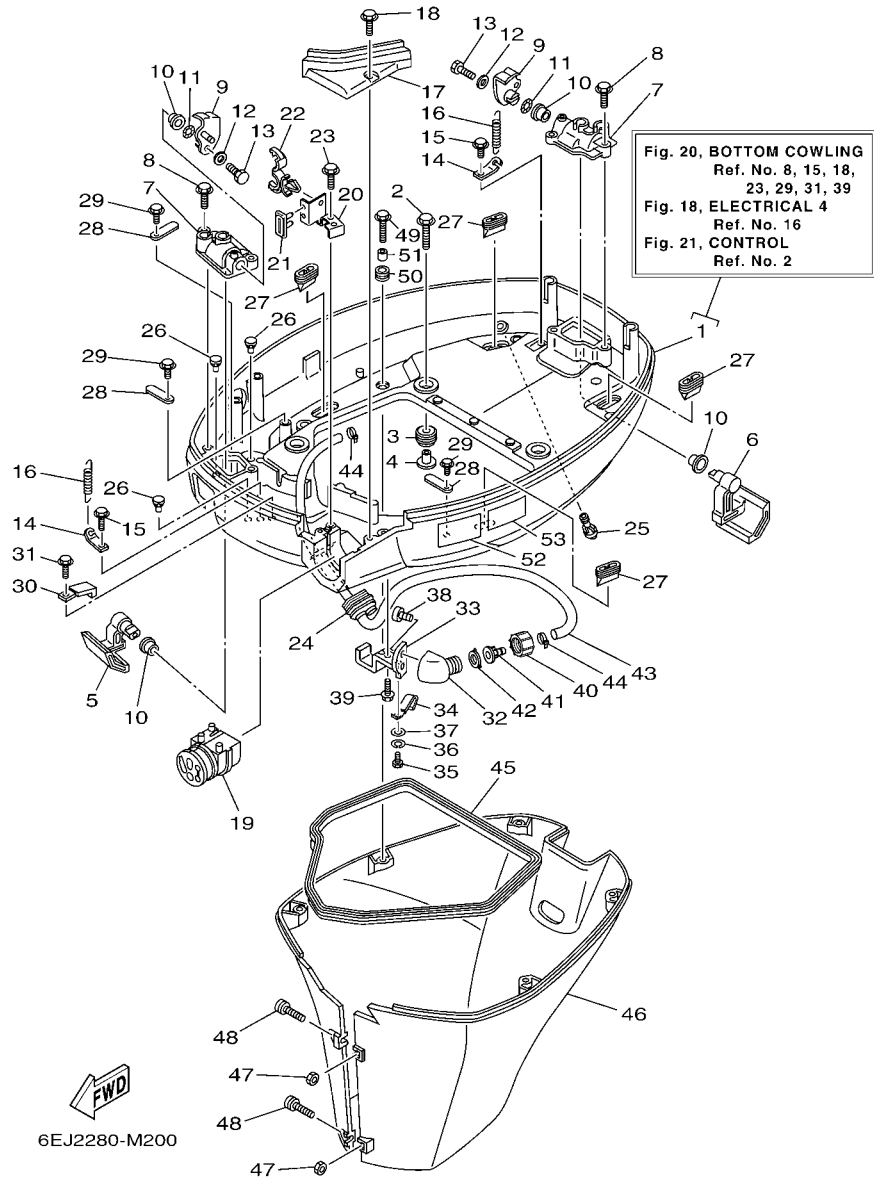


FIG. 20 BOTTOM COWLING

BANDEJA DO CAPO

REF. NO.	PART NO. No. PEÇA	DESCRIPTION DESCRIÇÃO	6EJ2			REMARKS OBSERVAÇÕES
1	6D8-42710-00-4D	BOTTOM COWLING ASSY BASE DO CAPO CONJ.	1			
2	90119-08M22	BOLT, WITH WASHER PARAFUSO COM ARRUELA	4			
3	90480-22M15	GROMMET ILHO DE BORRACHA	4			
4	90387-08M37	COLLAR ESPACADOR	4			
5	67F-42815-00-4D	LEVER, CLAMP ALAVANCA DA BRACADEIRA	1			
6	67F-42816-00-4D	LEVER, CLAMP ALAVANCA DA BRACADEIRA	1			
7	67F-42828-00-9S	PLATE, CLAMP PLACA DA BRACADEIRA	2			
8	90109-06M82	BOLT PARAFUSO	4			
9	68V-42818-01	LEVER, CLAMP ALAVANCA DA BRACADEIRA	2			
10	90386-15M73	BUSH BUCHA	4			
11	90206-15M18	WASHER, WAVE ARRUELA ONDULADA	2			
12	90201-06068	WASHER, PLATE ARRUELA PLANA	2			
13	97095-06016	BOLT PARAFUSO	2			
14	64D-43144-00	HOOK, SPRING GANCHO DA MOLA	2			
15	90109-06M86	BOLT PARAFUSO	2			
16	90506-16M34	SPRING, TENSION MOLA DE TENSÃO	2			
17	67F-42738-00-8D	PLATE, FITTING PLACA DA FIXADORA	1			
18	90109-06M96	BOLT PARAFUSO	2			
19	68V-42725-00	GROMMET ILHO	1			
20	6D8-42756-02	STAY, CLAMP SUPPORTO FIXADOR	1			
21	6D8-42717-00	RUBBER, SEAL 2 BORRACHA DE VEDACAO 2	1			
22	90464-18246	CLAMP BRACADEIRA	1			
23	90109-06M86	BOLT PARAFUSO	1			
24	6H1-42726-21	GROMMET ILHO	1			FLUSHING KIT FLUSHING KIT
25	6BL-44391-00	NIPPLE, HOSE JUNCAO DO TUBO	1			
26	6H4-42748-00	GROMMET ILHO	3			
27	67F-42717-00	RUBBER, SEAL 2 BORRACHA DE VEDACAO 2	4			

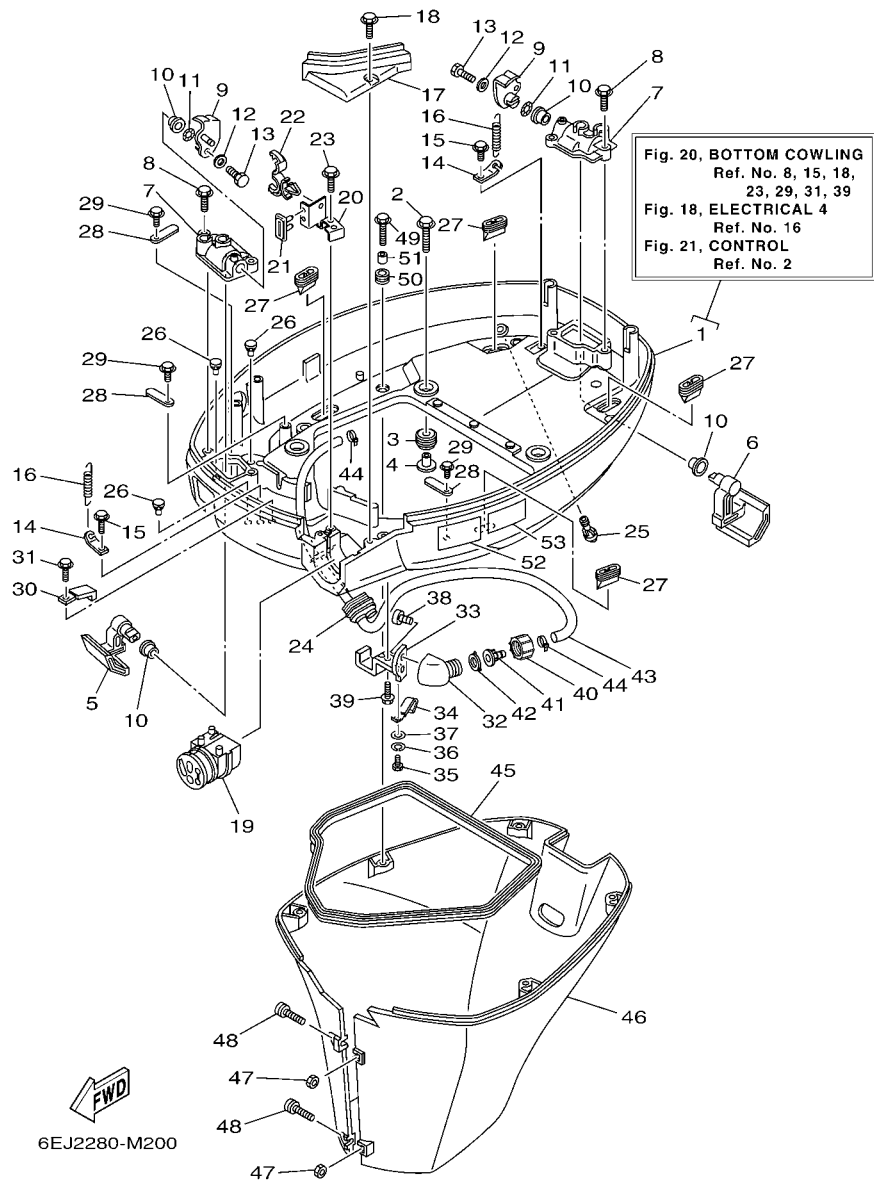
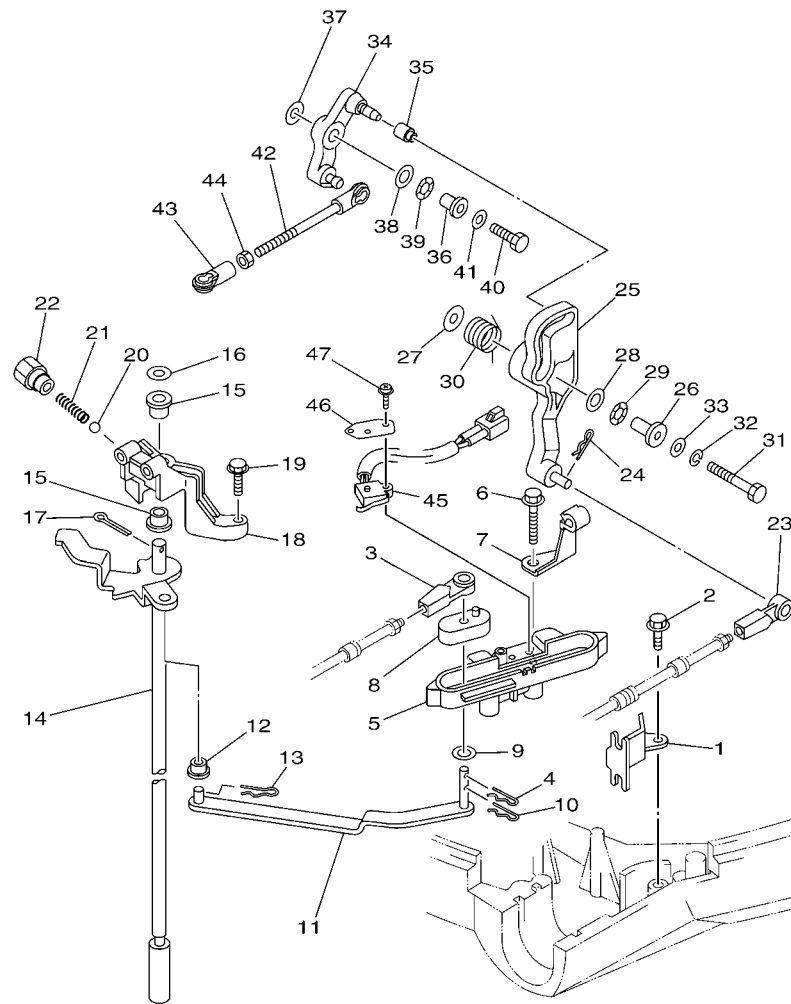


FIG. 20 BOTTOM COWLING

BANDEJA DO CAPO

REF. NO.	PART NO. No. PEÇA	DESCRIPTION DESCRIÇÃO	6EJ2			REMARKS OBSERVAÇÕES
28	6E5-82588-00	PLATE PLACA	3			
29	90109-06M81	BOLT PARAFUSO	3			
30	90465-08M23	CLAMP BRACADEIRA	1			
31	90109-06M86	BOLT PARAFUSO	1			
32	68T-12572-00	ADAPTER ADAPTADOR	1			FLUSHING KIT FLUSHING KIT
33	67F-12535-01	PLATE PLACA	1			FLUSHING KIT FLUSHING KIT
34	90462-06018	CLAMP BRACADEIRA	1			FLUSHING KIT FLUSHING KIT
35	97095-06008	BOLT PARAFUSO	1			FLUSHING KIT FLUSHING KIT
36	92995-06100	WASHER, SPRING ARRUELA COM MOLLA	1			FLUSHING KIT FLUSHING KIT
37	92995-06200	WASHER ARRUELA	1			FLUSHING KIT FLUSHING KIT
38	90167-06002	SCREW, TAPPING PARAFUSO	2			FLUSHING KIT FLUSHING KIT
39	90109-06M86	BOLT PARAFUSO	1			FLUSHING KIT FLUSHING KIT
40	6R3-12581-00	JOINT, HOSE 1 JUNCAO DA MANGUEIRA 1	1			FLUSHING KIT FLUSHING KIT
41	6R3-12582-00	JOINT, HOSE 2 JUNCAO DA MANGUEIRA 2	1			FLUSHING KIT FLUSHING KIT
42	6R3-12583-00	GASKET, HOSE JOINT GAXETA DA JUNCAO DA MANGUEIRA	1			FLUSHING KIT FLUSHING KIT
43	67F-24312-00	PIPE 2 TUBO 2	1			FLUSHING KIT FLUSHING KIT
44	90465-11M10	CLAMP BRACADEIRA	2			FLUSHING KIT FLUSHING KIT
45	61A-42716-00	RUBBER, SEAL 1 BORRACHA DE VEDACAO 1	1			
46	67F-42741-01-4D	APRON ABA	1			
47	95380-06600	NUT, HEXAGON PORCA SEXTAVADA	2			
48	90159-06M28	SCREW, WITH WASHER PARAFUSO COM ARRUELA	2			
49	90109-06M80	BOLT PARAFUSO	5			
50	90480-13M24	GROMMET ILHO DE BORRACHA	5			
51	90387-06M43	COLLAR ESPACADOR	5			
52	6AH-42794-70	LABEL, WARNING (GENERAL) ETIQUETA ADVERTENCIA	1			
53	4VW-F111M-04	LABEL, MADE IN ETIQUETA DE FABRICACAO LOCAL	1			

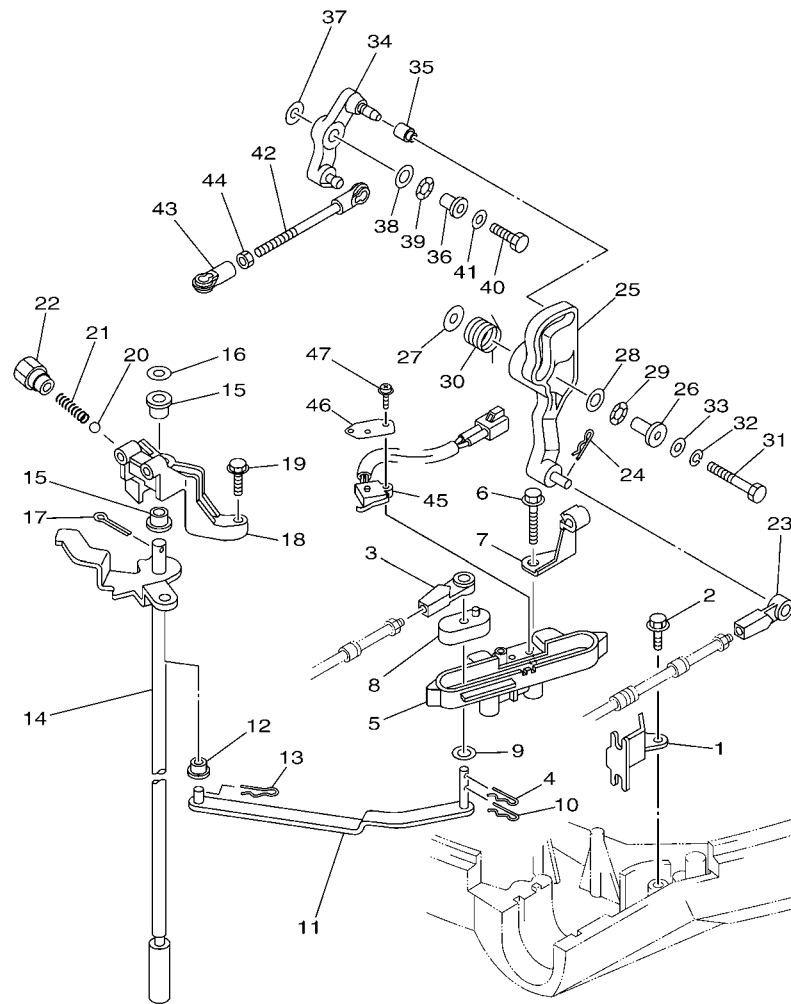


6D67110-K200

FIG. 21 CONTROL

CONTROLE

REF. NO.	PART NO. No. PEÇA	DESCRIPTION DESCRIÇÃO	QTY	REMARKS OBSERVAÇÕES
1	67F-48538-00	CLAMP, CABLE 1 GRAMPO DO CABO 1	1	
2	90109-06M86	BOLT PARAFUSO	1	
3	663-48344-00	CABLE END, REMOTE CONTROL TERMINAL DO CABO DE CONTROL	1	
4	90468-18008	CLIP PRESILHA	1	
5	6D8-44117-00-94	BRACKET SUPORTE	1	
6	97595-06550	BOLT, WITH WASHER PARAFUSO COM ARRUELA	2	
7	90462-10027	CLAMP BRACADEIRA	1	
8	68V-44122-01	BUSHING, SHIFT ROD LEVER BUCHA DA ALAVANCA DE MUDANCA	1	
9	90202-07M07	WASHER, PLATE ARRUELA PLANA	1	
10	90468-18008	CLIP PRESILHA	1	
11	67F-44121-00	LEVER, SHIFT ROD ALAVANCA DA HASTE DE MUDANCA	1	
12	90386-06M12	BUSH BUCHA	1	
13	90468-18008	CLIP PRESILHA	1	
14	67F-44120-10	HANDLE GEAR SHIFT ASSY ALAVANCA DE MUDANCA CONJ.	1	L(21.1")
15	90386-90M90	BUSH BUCHA	2	L(21.1")
16	90201-09M02	WASHER, PLATE ARRUELA PLANA	1	
17	91490-20015	PIN, COTTER CONTRAPINO	1	
18	67F-44118-00-94	BRACKET SUPORTE	1	
19	97575-06525	BOLT, WITH WASHER PARAFUSO COM ARRUELA	2	
20	93501-04M02	BALL ESFERA	1	
21	90501-12082	SPRING, COMPRESSION MOLA DE COMPRESSAO	1	
22	648-42715-00	BUSHING BUCHA	1	
23	663-48344-00	CABLE END, REMOTE CONTROL TERMINAL DO CABO DE CONTROL	1	
24	90468-18008	CLIP PRESILHA	1	
25	6D8-42154-00	LEVER, THROTTLE CONTROL ALAVANCA ACELERACAO	1	
26	90387-06M21	COLLAR ESPACADOR	1	
27	90201-06M62	WASHER, PLATE ARRUELA PLANA	1	



6D67110-K200

FIG. 21 CONTROL

CONTROLE

REF. NO.	PART NO. No. PEÇA	DESCRIPTION DESCRIÇÃO	QTY	REMARKS OBSERVAÇÕES
28	90201-10M02	WASHER, PLATE ARRUELA PLANA	1	
29	90206-10M04	WASHER, WAVE ARRUELA ONDULADA	1	
30	67F-44135-00	SPRING MOLA	1	
31	97095-06035	BOLT PARAFUSO	1	
32	92995-06100	WASHER, SPRING ARRUELA COM MOLA	1	
33	92995-06600	WASHER ARRUELA	1	
34	6D8-42157-00	LEVER, THROTTLE ALAVANCA DE ACELERACAO	1	
35	68V-42171-00	BUSHING BUCHA	1	
36	90387-06013	COLLAR ESPACADOR	1	
37	90201-06M31	WASHER, PLATE ARRUELA PLANA	1	
38	90201-10M02	WASHER, PLATE ARRUELA PLANA	1	
39	90206-10M04	WASHER, WAVE ARRUELA ONDULADA	1	
40	97095-06025	BOLT PARAFUSO	1	
41	92995-06600	WASHER ARRUELA	1	
42	6D8-41237-00	JOINT, LINK JUNCAO DO ARTICULADOR	1	
43	682-41237-00	JOINT, LINK JUNCAO DO ARTICULADOR	1	
44	95380-05600	NUT PORCA	1	
45	60V-8259F-00	SWITCH ASSY INTERRUPTOR DE COMANDO CONJ.	1	
46	61A-82588-01	PLATE PLACA	1	
47	97985-04116	SCREW, WITH WASHER PARAFUSO	2	

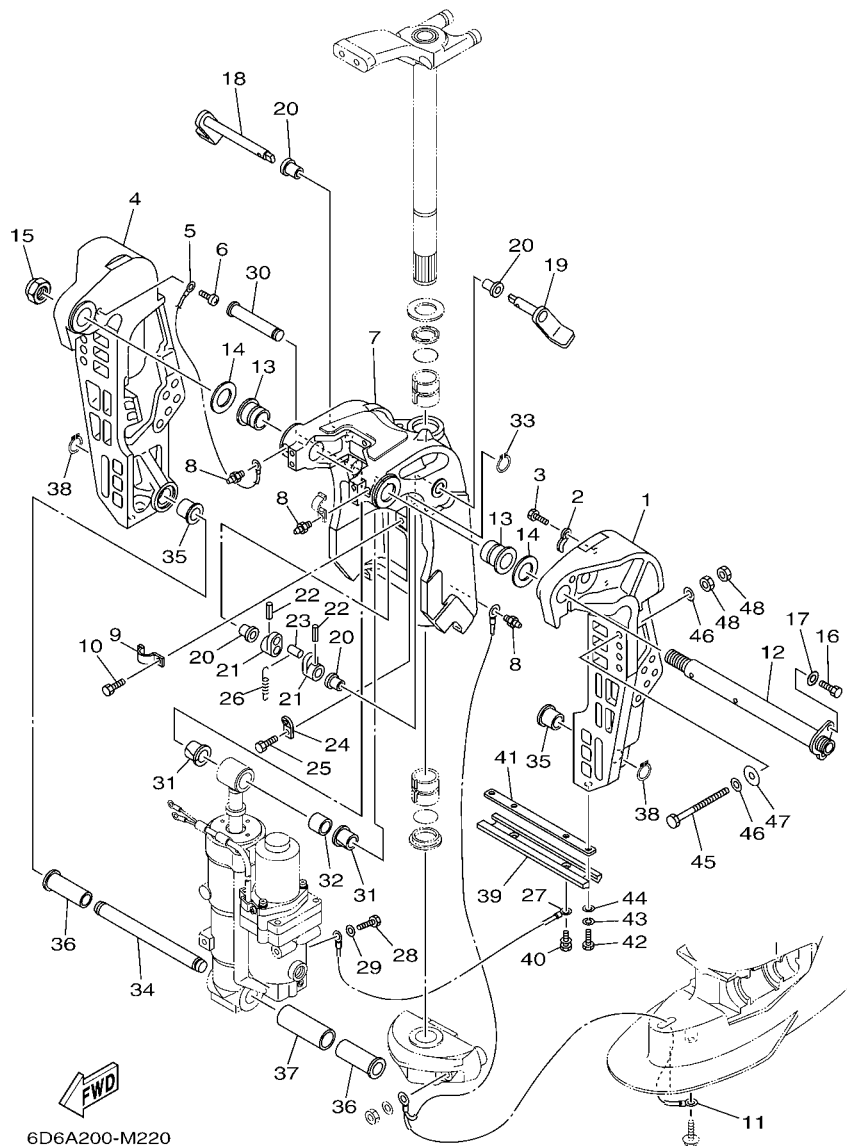


FIG. 22 BRACKET 1

SUPORTE 1

REF. NO.	PART NO. No. PEÇA	DESCRIPTION DESCRIÇÃO	QTY	REMARKS OBSERVAÇÕES
1	67F-43111-00-4D	BRACKET, CLAMP 1 SUPORTE DA BRACADEIRA 1	1	
2	90465-10M77	CLAMP BRACADEIRA	2	
3	97095-06010	BOLT PARAFUSO	2	
4	67F-43112-00-4D	BRACKET, CLAMP 2 SUPORTE DA BRACADEIRA 2	1	
5	6E5-82148-00	WIRE, LEAD 4 FIO CONDUTOR 4	1	
6	97880-06012	SCREW, PAN HEAD PARAFUSO	1	
7	6D8-43311-01-4D	BRACKET, SWIVEL 1 SUPORTE DO EIXO GIRATORIO	1	
8	93700-06M03	NIPPLE, GREASE NIPLE DE GRAXA	3	
9	90465-08M63	CLAMP BRACADEIRA	1	
10	97095-06010	BOLT PARAFUSO	1	
11	67F-82127-00	WIRE, LEAD 2 FIO CONDUTOR 2	1	
12	64E-43131-01	BOLT, CLAMP BRACKET PARAFUSO DE ACO	1	
13	90386-25M31	BUSH BUCHA	2	
14	90201-26M59	WASHER, PLATE ARRUELA PLANA	2	
15	90185-22M11	NUT, SELF-LOCKING PORCA AUTOTRAVANTE	1	
16	97095-08020	BOLT PARAFUSO	1	
17	92995-08600	WASHER ARRUELA	1	
18	6D8-43181-00	LEVER, TILT STOP 1 ALAVANCA LIMITADORA INCLINAC 1	1	
19	6D8-43185-00	LEVER, TILT STOP 2 ALAVANCA LIMITADORA INCLINAC 2	1	
20	90386-10M16	BUSH BUCHA	4	
21	6G5-43148-00	COLLAR, DISTANCE COLAR DE DISTANCIA	2	
22	91690-30020	PIN, SPRING PINO MOLA	2	
23	90249-06M19	PIN PINO	1	
24	66T-43144-00	HOOK, SPRING GANCHO DA MOLA	1	
25	97095-06010	BOLT PARAFUSO	1	
26	90506-14M24	SPRING, TENSION MOLA DE TENSÃO	1	
27	6D8-82148-00	WIRE, LEAD 4 FIO CONDUTOR 4	1	

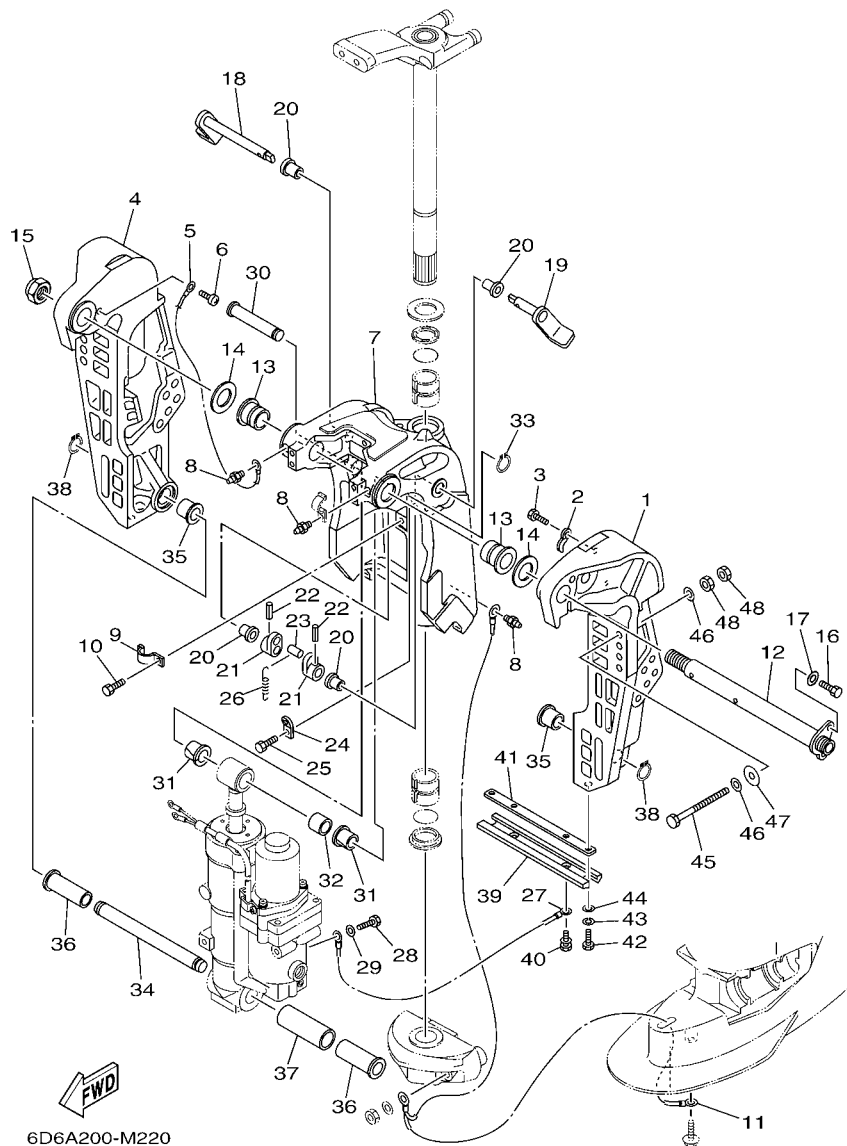
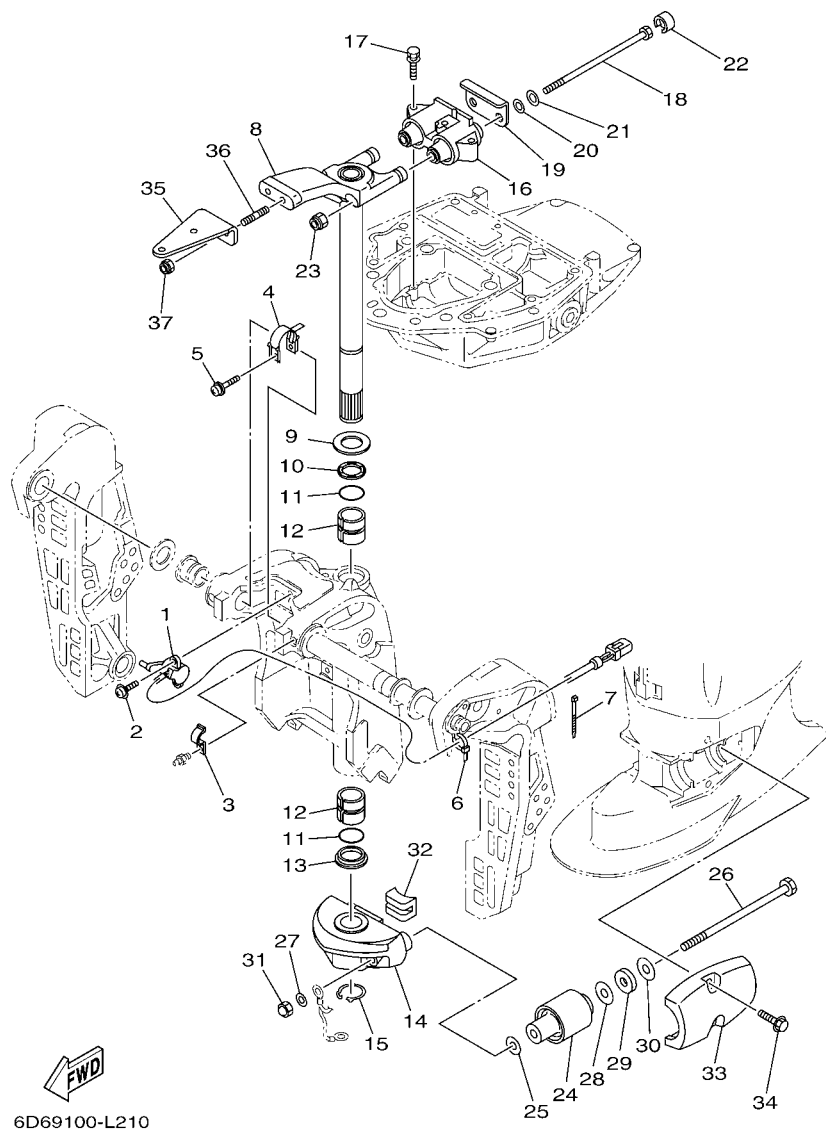


FIG. 22 BRACKET 1

SUPORTE 1

REF. NO.	PART NO. No. PEÇA	DESCRIPTION DESCRIÇÃO	QTY				REMARKS OBSERVAÇÕES
28	97095-06010	BOLT PARAFUSO	1				
29	92995-06600	WASHER ARRUELA	1				
30	6D8-43126-00	PIN, UPPER SHOCK MOUNT PINO DO AMORTIZADOR SUPERIOR	1				
31	90386-18M35	BUSH BUCHA	2				
32	90386-18001	BUSH BUCHA	1				
33	93410-18M05	CIRCLIP ANEL TRAVA	1				
34	67F-43818-00	PIN, LOWER SHOCK MOUNT PINO DO INFERIOR DE MONTAGEM	1				
35	90387-18M01	COLLAR ESPACADOR	2				
36	90386-18MA0	BUSH BUCHA	2				
37	90387-22M01	COLLAR ESPACADOR	1				
38	93410-18M05	CIRCLIP ANEL TRAVA	2				
39	6H1-45251-03	ANODE ANODO	1				
40	90119-06M81	BOLT, WITH WASHER PARAFUSO COM ARRUELA	2				
41	6H1-44526-00	PLATE PLACA	1				
42	97095-06016	BOLT PARAFUSO	2				
43	92995-06100	WASHER, SPRING ARRUELA COM MOLA	2				
44	92995-06600	WASHER ARRUELA	2				
45	90101-12M03	BOLT (L:115MM) PARAFUSO (L:115MM)	4				
46	90201-13M01	WASHER, PLATE ARRUELA PLANA	8				
47	90201-12426	WASHER, PLATE ARRUELA PLANA	4				
48	95380-12600	NUT PORCA	8				





6D69100-L210

FIG. 23 BRACKET 2

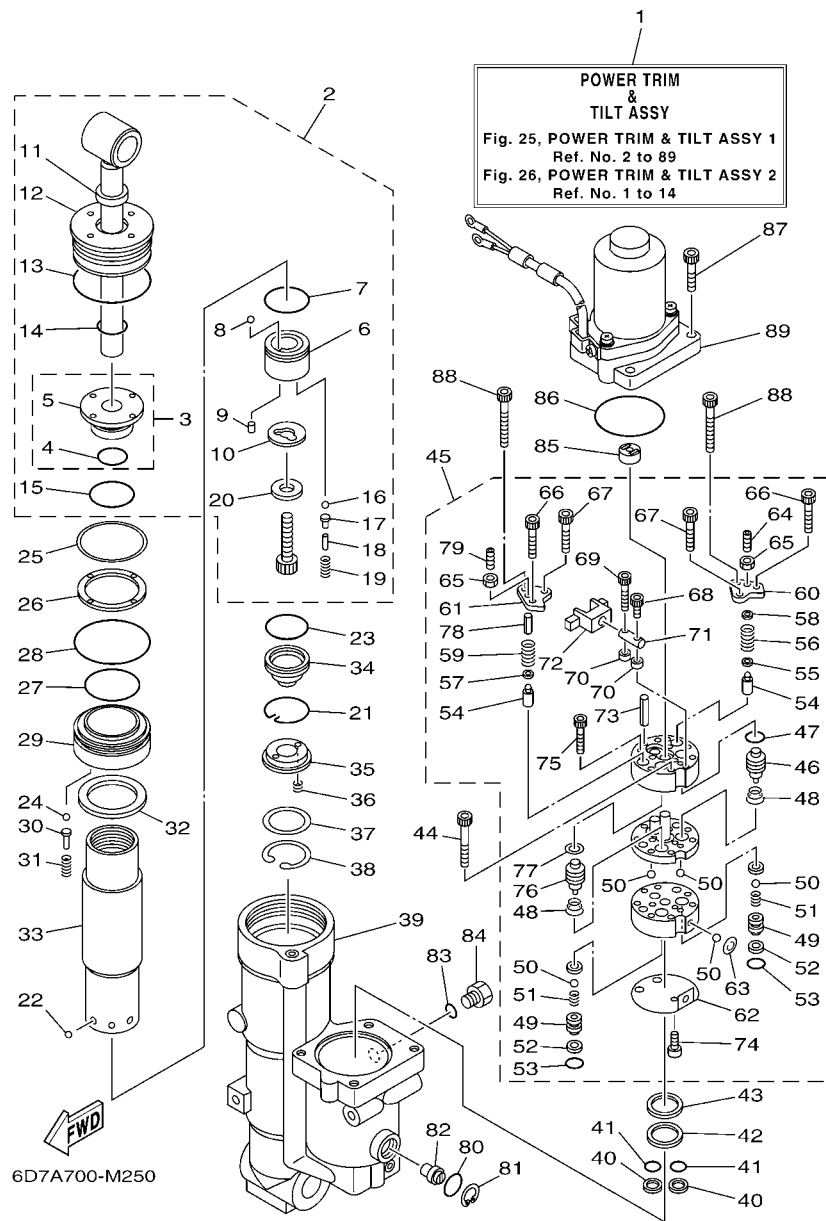
SUPOORTE 2

REF. NO.	PART NO. No. PEÇA	DESCRIPTION DESCRIÇÃO	QTY	REMARKS OBSERVAÇÕES
1	67H-83672-01	TRIM SENDER SENSOR DO TRIM	1	
2	97985-06216	SCREW, WITH WASHER PARAFUSO	2	
3	90465-08M63	CLAMP BRACADEIRA	1	
4	64E-43139-10	CAM, TRIM SENDER SENDOR DE ELEVACAO TRIM	1	
5	90159-05059	SCREW, WITH WASHER PARAFUSO COM ARRUELA	1	
6	90465-11M10	CLAMP BRACADEIRA	1	
7	90465-11M10	CLAMP BRACADEIRA	3	
8	67F-42510-11-4D	STEERING BRACKET ASSY SUPOORTE DIRECIONAL CONJ.	1	
9	90201-30M00	WASHER, PLATE ARRUELA PLANA	1	
10	90386-30M78	BUSH BUCHA	1	
11	93210-29M94	O-RING ANEL DE BORRACHA	2	
12	90386-30M77	BUSH BUCHA	2	
13	90386-30M60	BUSH BUCHA	1	
14	67F-44551-00-4D	HOUSING, LOWER MOUNT RUBBER 1 ALOJAMENTO DO SUPORTE INFERIOR	1	
15	93410-28M06	CIRCLIP ANEL TRAVA	1	
16	67F-44514-01	MOUNT DAMPER, UPPER SIDE AMORTIZADOR SUPERIOR	1	
17	90119-08091	BOLT, WITH WASHER PARAFUSO COM ARRUELA	3	
18	90109-12007	BOLT PARAFUSO	2	
19	67F-44526-00	PLATE PLACA	1	
20	90201-12M16	WASHER, PLATE ARRUELA PLANA	2	
21	90201-13M01	WASHER, PLATE ARRUELA PLANA	2	
22	67F-44533-00	DAMPER, UPPER MOUNT RUBBER AMORTIZADOR SUPERIOR	2	
23	95780-12300	NUT, FLANGE PORCA FLANGE	2	
24	67F-44555-00	MOUNT DAMPER, LOWER SIDE AMORTIZADOR INFERIOR	2	
25	90201-13M03	WASHER, PLATE ARRUELA PLANA	2	
26	90109-12012	BOLT PARAFUSO	2	
27	90201-12M16	WASHER, PLATE ARRUELA PLANA	2	





FIG. 25 POWER TRIM & TILT ASSY 1 SISTEMA INCLINACAO 1

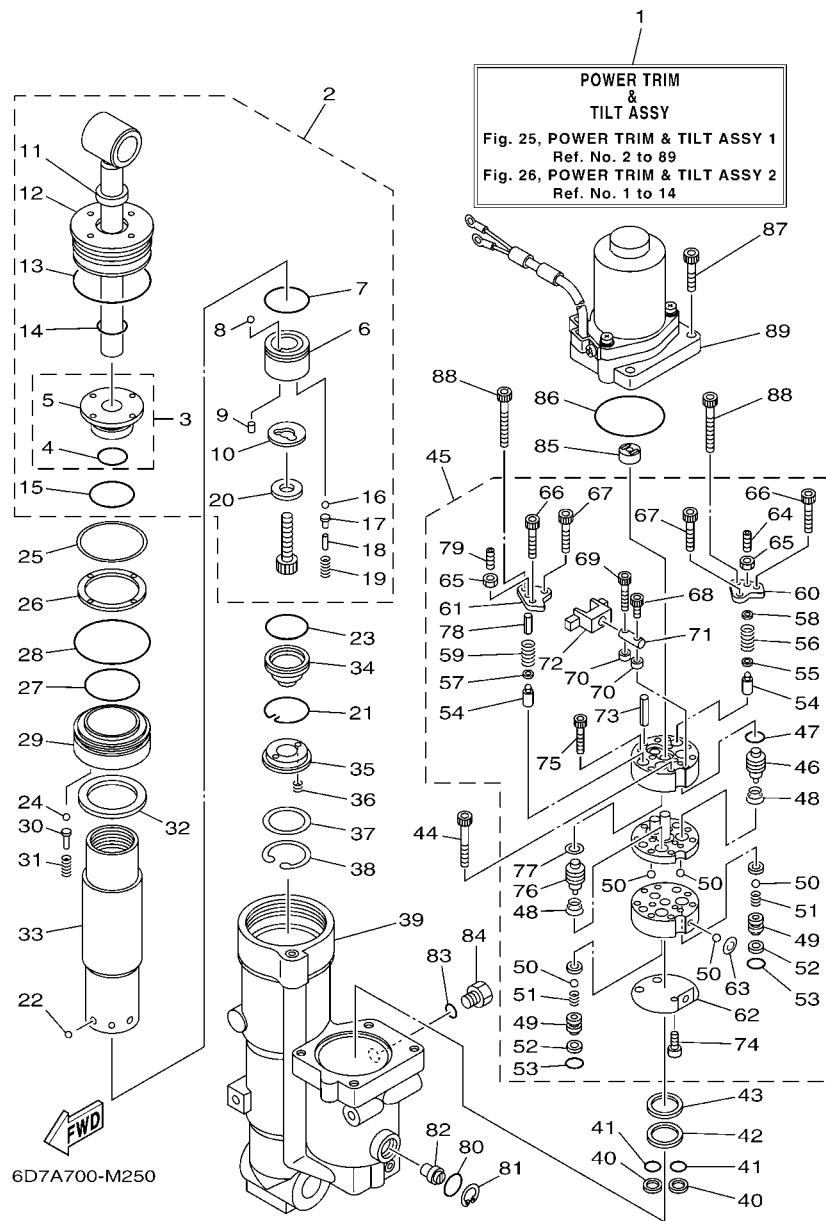


REF. NO.	PART NO. No. PEÇA	DESCRIPTION DESCRIÇÃO	QTY	REMARKS OBSERVAÇÕES
1	6D8-43800-10-8D	POWER TRIM & TILT ASSY SISTEMA INCLINACAO (TRIM/TILT)	1	
2	67F-43810-02	TILT PISTON SUB ASSY PISTAO SUB CONJ.	1	
3	67F-4380R-01	.CYLINDER END SUB ASSY .TERMINAL DO CILINDRO SUB COMJ.	1	
4	6D8-43861-00	..O-RING ..ANEL DE BORRACHA	1	
5	67F-43811-01	..SCREW, CYLINDER END ..PARAFUSO TERMINACAO CILINDRO	1	
6	67F-4385A-02	.PISTON, TILT .PISTAO DO SISTEMA INCLINACAO	1	
7	67F-43863-00	.O-RING .ANEL DE BORRACHA	1	
8	93501-08001	.BALL .ESFERA	1	
9	93602-07244	.PIN, DOWEL .PINO GUIA	2	
10	67F-22435-00	.PLATE, VALVE 2 .PLACA DA VALVULA 2	1	
11	6H1-43812-00	.SEAL, DUST .VEDADOR PROTETOR	1	
12	67F-43821-01	.SCREW, TRIM CYLINDER END .PARAFUSO TERMINACAO CILINDRO	1	
13	67F-43861-00	.O-RING .ANEL DE BORRACHA	1	
14	6D8-43861-00	.O-RING .ANEL DE BORRACHA	1	
15	62X-43862-00	.O-RING .ANEL DE BORRACHA	1	
16	93501-08001	.BALL .ESFERA	2	
17	65W-4386A-00	.PIN, ABSORBER VALVE .PINO	2	
18	688-4386F-00	.PIN, STRAIGHT .PINO DE ACO	2	
19	65W-43853-00	.SPRING, MAIN VALVE .MOLA MESTRE DA VALVULA	2	
20	67F-43893-00	.WASHER .ARRUELA	1	
21	67F-43875-00	RING, SNAP ANEL TRAVA DO RETENTOR	1	
22	93503-16003	BALL ESFERA	6	
23	67F-43863-00	O-RING ANEL DE BORRACHA	1	
24	93501-08001	BALL ESFERA	5	
25	67F-43899-00	PLATE STOPPER PLACA DO LIMITADOR	1	
26	67F-43816-00	FILTER 1 FILTRO 1	1	
27	67F-43862-00	SCREW, CYLINDER END PARAFUSO TERMINACAO CILINDRO	1	



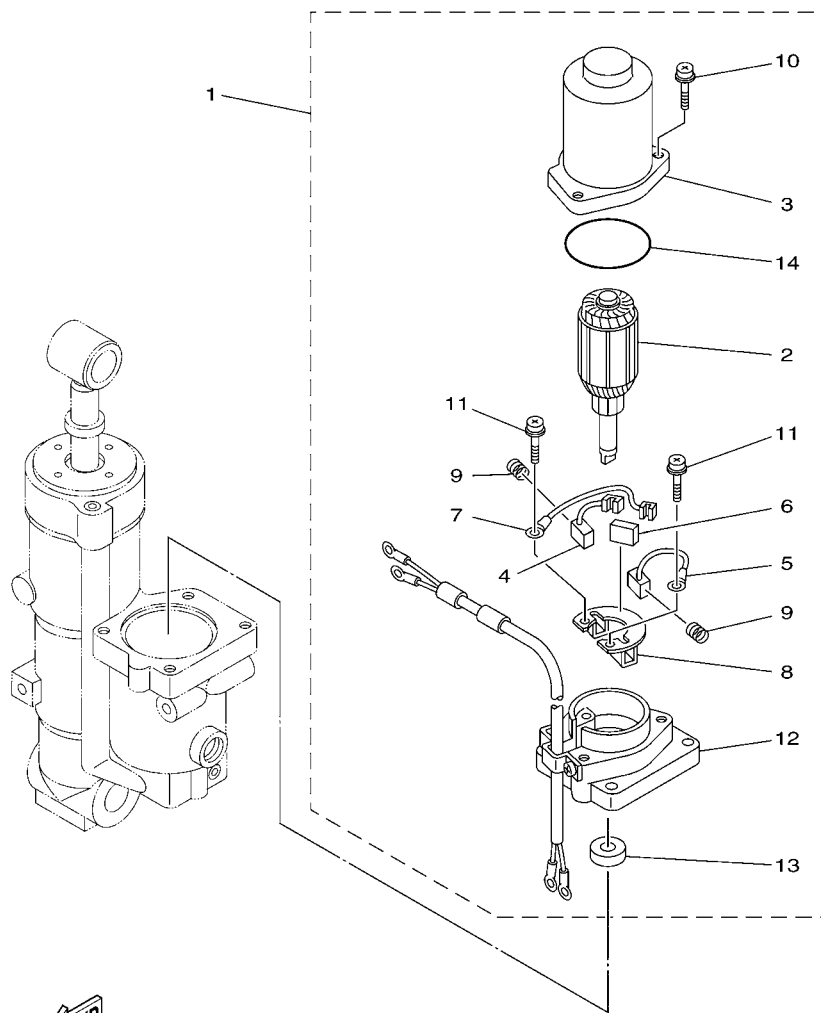


FIG. 25 POWER TRIM & TILT ASSY 1 SISTEMA INCLINACAO 1



REF. NO.	PART NO. No. PEÇA	DESCRIPTION DESCRIÇÃO	QTY	REMARKS OBSERVAÇÕES
82	6D8-43845-00	SCREW, MANUAL RELEASE PARAFUSO DO REGULAGEM MANUAL	1	
83	93210-09165	O-RING ANEL DE BORRACHA	1	
84	6H1-43829-00	PLUG, RESERVOIR TAMPAO DO RESERVATORIO	1	
85	6D8-43831-00	CONNECTOR, SHAFT CONECTOR DO EIXO	1	
86	93210-64488	O-RING ANEL DE BORRACHA	1	
87	91380-06020	BOLT PARAFUSO	4	
88	91318-05050	BOLT PARAFUSO	2	
89	6D8-43880-01	MOTOR ASSY MOTOR CONJ.	1	REFER TO FIG.26 REFER TO FIG.26

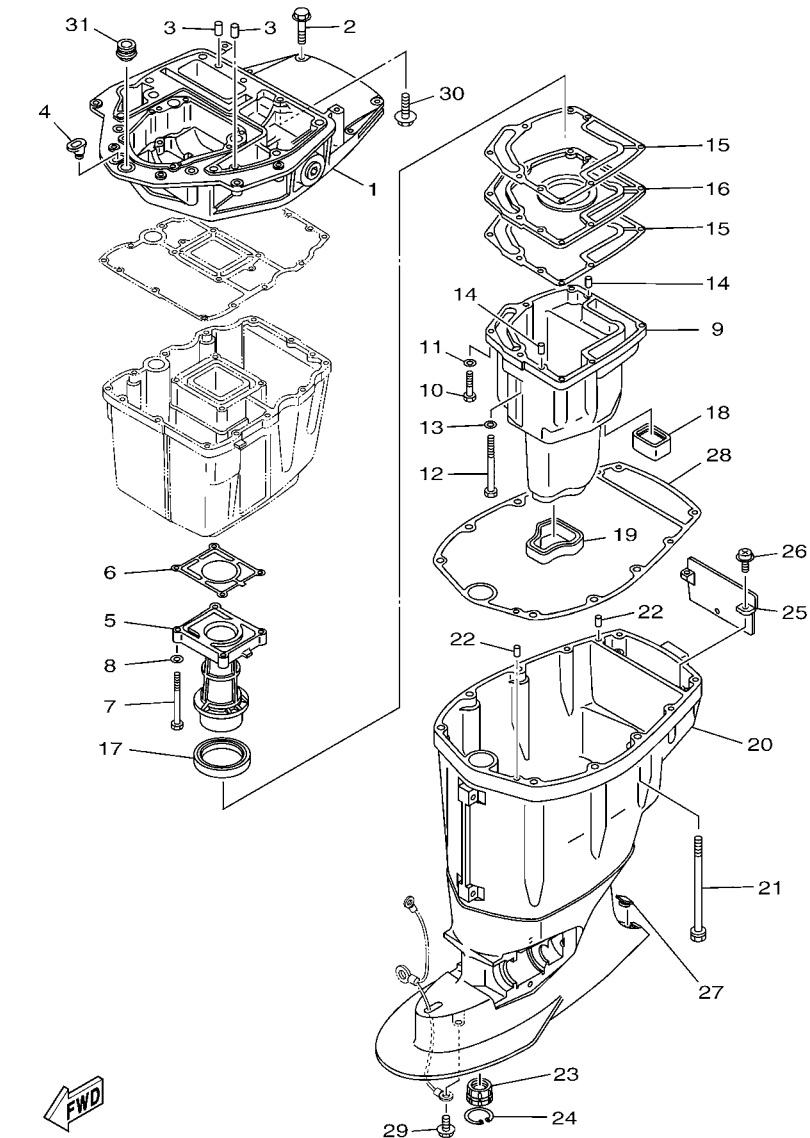
FIG. 26 POWER TRIM & TILT ASSY 2 SISTEMA INCLINACAO 2



  
6D63100-F250

REF. NO.	PART NO. No. PEÇA	DESCRIPTION DESCRIÇÃO	QTY				REMARKS OBSERVAÇÕES
1	6D8-43880-01	MOTOR ASSY MOTOR CONJ.	1				
2	6D8-43805-01	.ARMATURE ASSY .ARMADURA CONJUNTO	1				
3	6D8-43804-01	.STATOR ASSY .ESTATOR CONJUNTO	1				
4	6H1-43891-11	.BRUSH 1 .ESCOVA 1	1				
5	6H1-43892-11	.BRUSH 2 .ESCOVA 2	1				
6	6H1-82181-10	.CIRCUIT BREAKER COMP. .CIRCUITODO FREIO COMPLETO	1				
7	62X-43807-00	.WIRE SUB ASSY .CHICOTE SUB CONJ.	1				
8	6H1-4380F-11	.PLATE, BRUSH HOLDER .SUPORTE ESCOVA	1				
9	62X-4386K-00	.SPRING, BRUSH .MOLA DAS ESCOVAS	2				
10	97980-05225	.SCREW, WITH WASHER .PARAFUSO	3				
11	97602-04216	.SCREW, PAN HEAD WITH WASHER .PARAFUSO	2				
12	6D8-43881-01	.FRAME, END .BASE DE TERMINACAO DO MOTOR	1				
13	93102-08414	.OIL SEAL .RETENTOR DE OLEO	1				
14	93210-554A9	.O-RING .ANEL DE BORRACHA	1				





6D67110-K260

FIG. 27 UPPER CASING

CAPA INFERIOR

REF. NO.	PART NO. No. PEÇA	DESCRIPTION DESCRIÇÃO	QTD			REMARKS OBSERVAÇÕES
1	6D8-41137-00-CA	GUIDE, EXHAUST GUIA DO ESCAPE	1			
2	97575-08540	BOLT, WITH WASHER PARAFUSO COM ARRUELA	4			
3	93608-16M16	PIN, DOWEL PINO	2			
4	6G1-42727-00	GROMMET ILHO	1			
5	67F-41131-01-CA	MANIFOLD, EXT. 1 TUBO MULTIPLO DE ESCAPE 1	1			
6	67F-41133-A1	GASKET, EXHAUST MANIFOLD 1 GAXETA DO MULTIPLO DE ESCAPE 1	1			
7	97075-06070	BOLT PARAFUSO	4			
8	92995-06600	WASHER ARRUELA	4			
9	67F-14711-00-CA	MUFFLER 1 SILENCIADOR 1	1			
10	97075-06030	BOLT PARAFUSO	6			
11	92995-06600	WASHER ARRUELA	6			
12	97075-06050	BOLT PARAFUSO	1			
13	92995-06600	WASHER ARRUELA	1			
14	93606-19M23	PIN, DOWEL PINO GUIA	2			
15	67F-41134-A0	GASKET, EXHAUST MANIFOLD GAXETA DO MULTIPLO DE ESCAPE	2			
16	67F-45181-00-CA	PLATE PLACA	1			
17	67F-41138-00	SEAL, EXT. 1 VEDACAO DO ESCAPE 1	1			
18	67F-45127-00	SEAL RETENTOR DE BORRACHA	1			
19	67F-45123-00	GASKET, MUFFLER GAXETA DO SILENCIADOR	1			
20	67F-45111-11-4D	CASING, UPPER CAIXA SUPERIOR	1			
21	90119-10M08	BOLT, WITH WASHER PARAFUSO COM ARRUELA	6			
22	93608-16M16	PIN, DOWEL PINO	2			
23	67F-45318-00	BUSHING, DRIVE SHAFT BUCHA DO EIXO DE DIRECAO	1			
24	93420-36M01	CIRCLIP ANEL TRAVA	1			
25	67F-45151-00	COVER, UPPER CASING TAMPA DA CAIXA SUPERIOR	1			
26	97980-06216	SCREW, WITH WASHER PARAFUSO	2			
27	67F-45155-00	CAP CAPA	1			

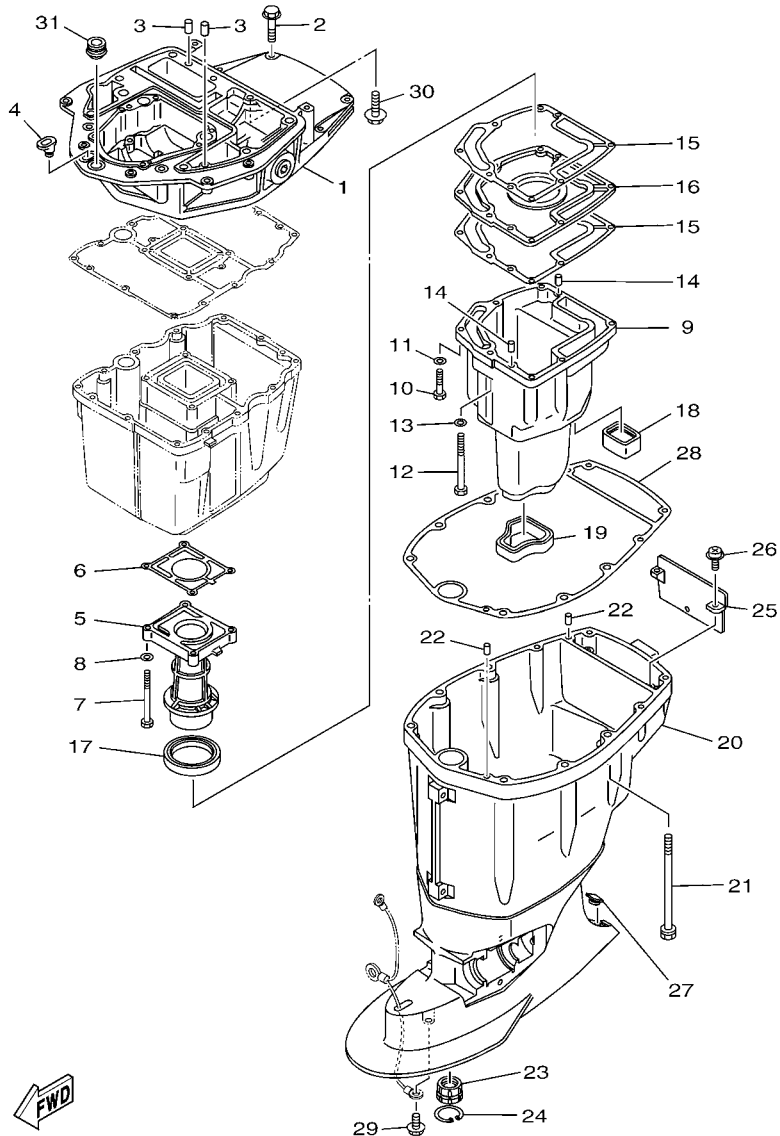
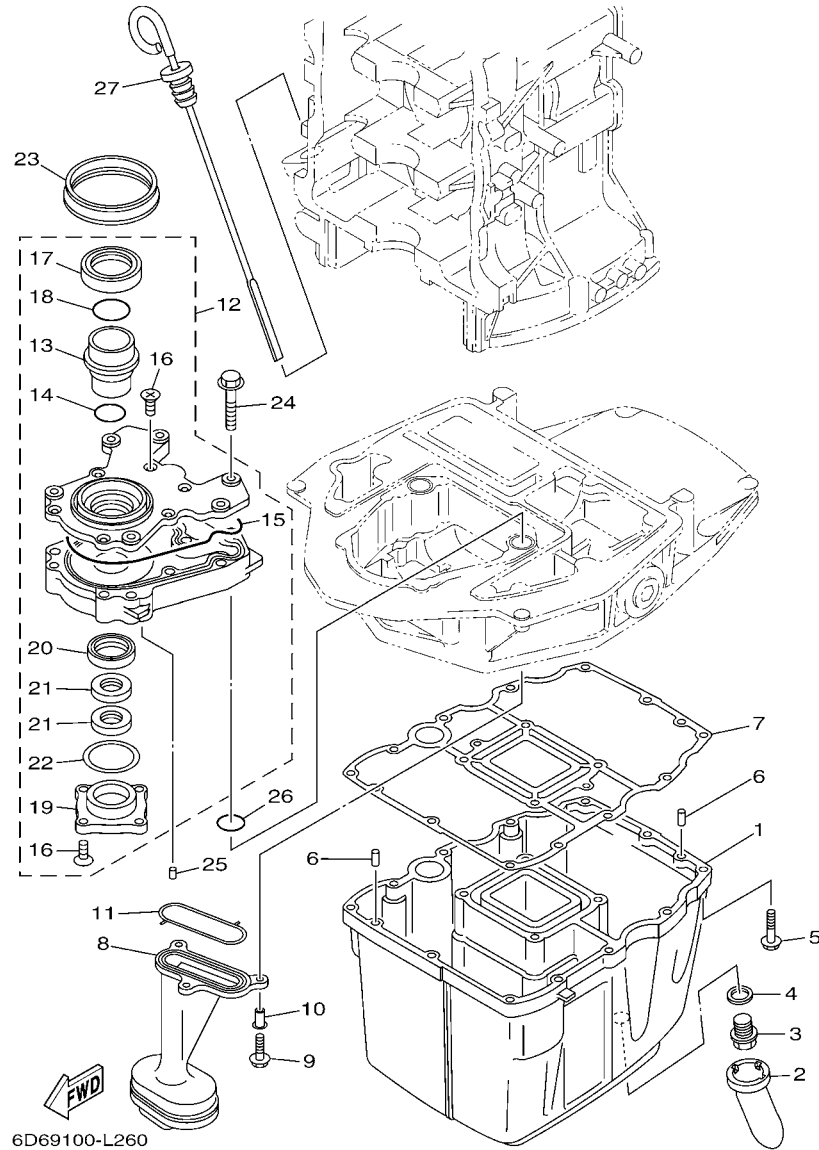


FIG. 27 UPPER CASING

CAPA INFERIOR

REF. NO.	PART NO. No. PEÇA	DESCRIPTION DESCRIÇÃO	6E12				REMARKS OBSERVAÇÕES
28	67F-45113-00	GASKET, UPPER CASING GAXETA DA CAIXA SUPERIOR	1				
29	95895-08014	BOLT, FLANGE PARAFUSO FLANGE	1				
30	90119-08M58	BOLT, WITH WASHER PARAFUSO COM ARRUELA	2				
31	67F-42724-00	GROMMET ILHO	1				
-----							
-----							
-----							
-----							
-----							
-----							
-----							
-----							
-----							

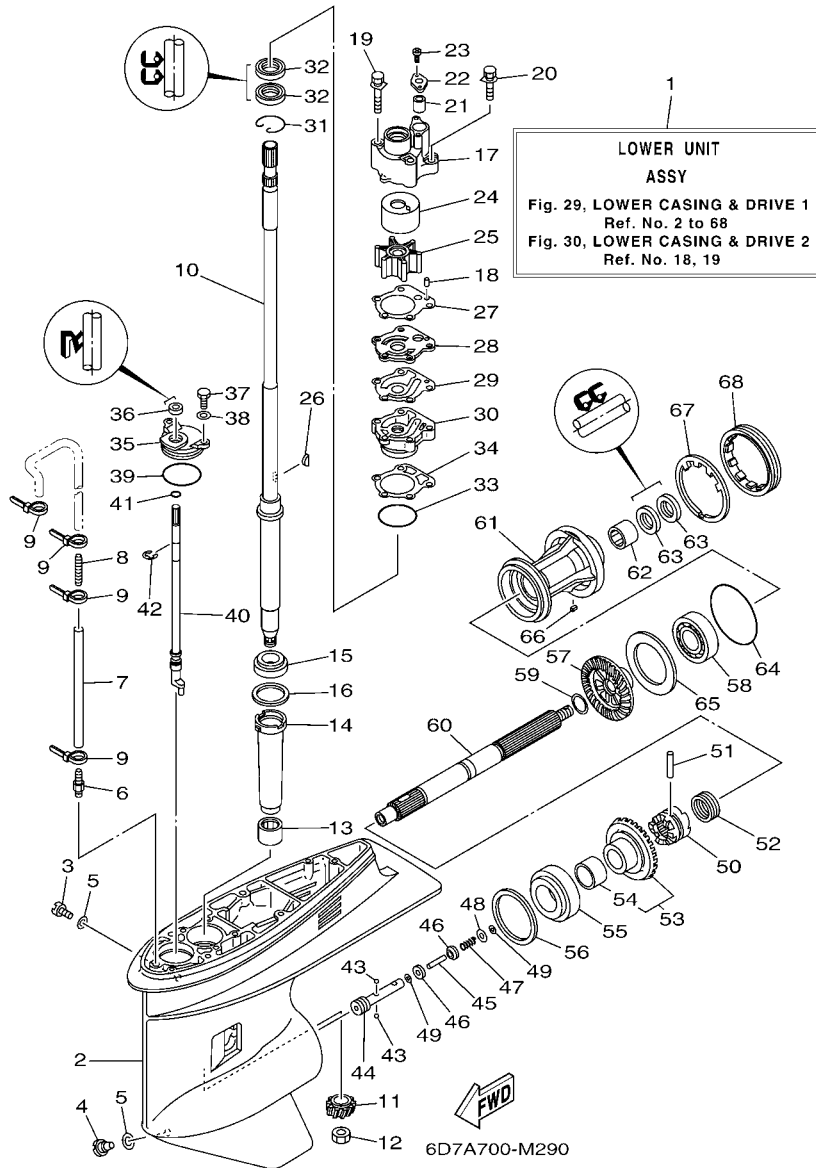


6D69100-L260

FIG. 28 OIL PAN

BANDEJA DE OLEO

REF. NO.	PART NO. No. PEÇA	DESCRIPTION DESCRIÇÃO	QTY	REMARKS OBSERVAÇÕES
1	67F-15311-03-CA	OIL PAN CARTER DO OLEO	1	
2	63P-15316-00	DAMPER 1 AMORTIZADOR 1	1	
3	90340-14M06	PLUG, STRAIGHT SCREW TAMPAO DO DRENO	1	
4	90430-14M09	GASKET GAXETA	1	
5	97575-06525	BOLT, WITH WASHER PARAFUSO COM ARRUELA	12	
6	93606-12019	PIN, DOWEL PINO GUIA	2	
7	68V-15312-00	GASKET, OIL PAN GAXETA DA CAPA DO OLEO	1	
8	67F-13411-00	STRAINER, OIL FILTRADOR DE OLEO	1	
9	95812-06025	BOLT, FLANGE PARAFUSO FLANGE	3	
10	90387-06263	COLLAR ESPADADOR	3	
11	67F-13415-00	SEAL, OIL STRAINER VEDACAO DO FILTRADOR DE OLEO	1	
12	67F-13300-10	OIL PUMP ASSY BOMBA DE OLEO COMPLETA	1	
13	67F-13314-02	.SHAFT, PUMP .EIXO BOMBA DE OLEO	1	
14	67F-13473-01	.O-RING .ANEL DE BORRACHA	1	
15	67F-13329-00	.GASKET, PUMP COVER .GAXETA DA TAMPA DA BOMBA	1	
16	67F-13495-00	.SCREW .PARAFUSO	10	
17	67F-13119-01	.OIL SEAL .RETENTOR DE OLEO	1	
18	67F-13769-00	.O-RING .ANEL DE BORRACHA	1	
19	67F-13914-00	.HOUSING, PUMP .ALOJAMENTO DA BOMBA	1	
20	67F-13631-03	.OIL SEAL .RETENTOR DE OLEO	1	
21	67F-13149-00	.OIL SEAL .RETENTOR DE OLEO	2	
22	67F-13339-00	.GASKET, PUMP COVER .GAXETA DA TAMPA DA BOMBA	1	
23	67F-13338-00	SEAL VEDACAO	1	
24	97595-06545	BOLT, WITH WASHER PARAFUSO COM ARRUELA	6	
25	93604-12M07	PIN, DOWEL PINO GUIA	2	
26	93210-19MJ1	O-RING ANEL DE BORRACHA	2	
27	6D8-15362-00	PLUG, OIL LEVEL TAMPAO DO NIVEL DE OLEO	1	



**FIG. 29 LOWER CASING & DRIVE 1 CARCACA INF. E TRANSMISSAO 1**

REF. NO.	PART NO. No. PEÇA	DESCRIPTION DESCRIÇÃO	QTD	REMARKS OBSERVAÇÕES
1	6D9-45300-13-4D	LOWER UNIT ASSY UNIDADE DA RABETA INFERIOR CJ.	1	L(21.1") L(21.1")
2	67F-45301-00-4D	CASING, LOWER RABETA INFERIOR	1	
3	90340-08002	PLUG, STRAIGHT SCREW TAMPAO DO DRENO	1	
4	688-45341-10	PLUG, DRAIN TAMPAO DE ESGOTO	1	
5	90430-08020	GASKET GAXETA	2	
6	6E5-45378-00	NIPPLE, HOSE NIPLE DO TUBO	1	
7	90445-07M31	HOSE (L200) TUBO (L200)	1	L(21.1") L(21.1")
8	6E5-83558-10	END, NIPPLE TERMINAL CONEXAO	1	
9	90465-11M10	CLAMP BRACADEIRA	4	
10	67F-45501-10	DRIVE SHAFT COMP. EIXO DE DIRECIONAL COMPL.	1	L(21.1") L(21.1")
11	6D9-45551-10	PINION (11T) PINHAO (11D)	1	
12	90170-16M01	NUT PORCA	1	
13	93315-52563	BEARING ROLAMENTO	1	
14	688-45536-01	SLEEVE, DRIVE SHAFT PROTETOR DO EIXO DE DIRECIONAL	1	
15	93332-000U3	BEARING ROLAMENTO	1	
16	688-45587-01	SHIM (T:0.10MM) ARRUELA CALCO (T:0.10MM)	1	UR
	688-45587-10	SHIM (T:0.12MM) ARRUELA CALCO (T:0.12MM)	1	UR
	688-45587-20	SHIM (T:0.15MM) ARRUELA CALCO (T:0.15MM)	1	UR
	688-45587-30	SHIM (T:0.18MM) ARRUELA CALCO (T:0.18MM)	1	UR
	688-45587-40	SHIM (T:0.30MM) ARRUELA CALCO (T:0.30MM)	1	UR
	688-45587-50	SHIM (T:0.40MM) ARRUELA CALCO (T:0.40MM)	1	UR
	688-45587-60	SHIM (T:0.50MM) ARRUELA CALCO (T:0.50MM)	1	UR
17	67F-44311-01	HOUSING, WATER PUMP ALOJAMENTO DA BOMBA D'AGUA	1	
18	93604-10M03	PIN, DOWEL PINO GUIA	2	
19	90119-08M87	BOLT, WITH WASHER PARAFUSO COM ARRUELA	2	
20	90119-08M13	BOLT, WITH WASHER PARAFUSO COM ARRUELA	2	
21	663-44366-00	DAMPER, WATER SEAL 2 AMORTIZADOR DE BORRACHA 2	1	

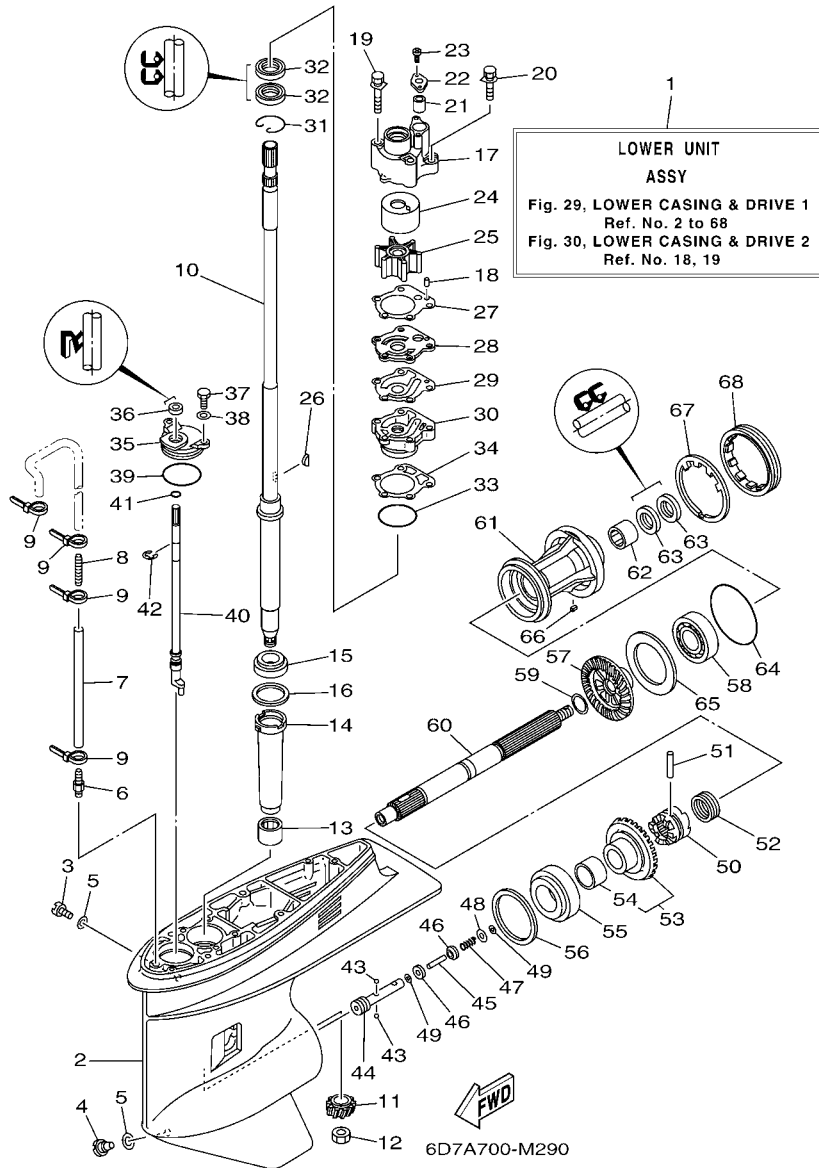


FIG. 29 LOWER CASING & DRIVE 1 CARCACA INF. E TRANSMISSAO 1

REF. NO.	PART NO. No. PEÇA	DESCRIPTION DESCRIÇÃO	QTY	REMARKS OBSERVAÇÕES
22	90480-19M06	GROMMET ILHO DE BORRACHA	1	
23	90160-04006	SCREW, ROUND TAPPING PARAFUSO	2	
24	67F-44322-00	INSERT, CARTRIDGE INSERTO DA BOMBA D'AGUA	1	
25	67F-44352-00	IMPELLER IMPULSOR	1	
26	90280-04M04	KEY, WOODRUFF CHAVETA MEIA LUA	1	
27	688-44315-A0	GASKET, WATER PUMP GAXETA DA BOMBA D'AGUA	1	
28	67F-44323-00	OUTER PLATE, CARTRIDGE PLACA DA EXTERNA DA BOMBA	1	
29	688-44324-A0	GASKET, CARTRIDGE GAXETA DO CARTUCHO	1	
30	6D8-44341-01-CA	HOUSING, WATER PUMP CAIXA DA BOMBA D'AGUA 2	1	
31	93450-44166	CIRCLIP ANEL TRAVA	1	
32	93101-25M03	OIL SEAL RETENTOR DE OLEO	2	
33	93210-46044	O-RING ANEL DE BORRACHA	1	
34	688-44316-A0	GASKET, WATER PUMP GAXETA DA BOMBA D'AGUA	1	
35	688-45321-00	PLATE PLACA	1	
36	93106-09014	OIL SEAL RETENTOR DE OLEO	1	
37	97095-06016	BOLT PARAFUSO	2	
38	92995-06600	WASHER ARRUELA	2	
39	93210-49046	O-RING ANEL DE BORRACHA	1	
40	67F-44150-01	SHIFT CAM ASSY CAME DE MUDANCA CONJ.	1	
41	93210-07003	O-RING ANEL DE BORRACHA	1	
42	99001-08600	CIRCLIP ANEL TRAVA	1	
43	93503-16003	BALL ESFERA	2	
44	67F-45634-00	SLIDE, SHIFT LAMINA DE MUDANCA	1	
45	6H1-45668-00	SHAFT, FREE 1 EIXO DE LIVRE 1	1	
46	6H1-45635-00	PLUNGER, SHIFT ACIONADOR DE MUDANCA	2	
47	90501-12M48	SPRING, COMPRESSION MOLA DE COMPRESSAO	1	
48	90201-03313	WASHER, PLATE ARRUELA PLANA	1	

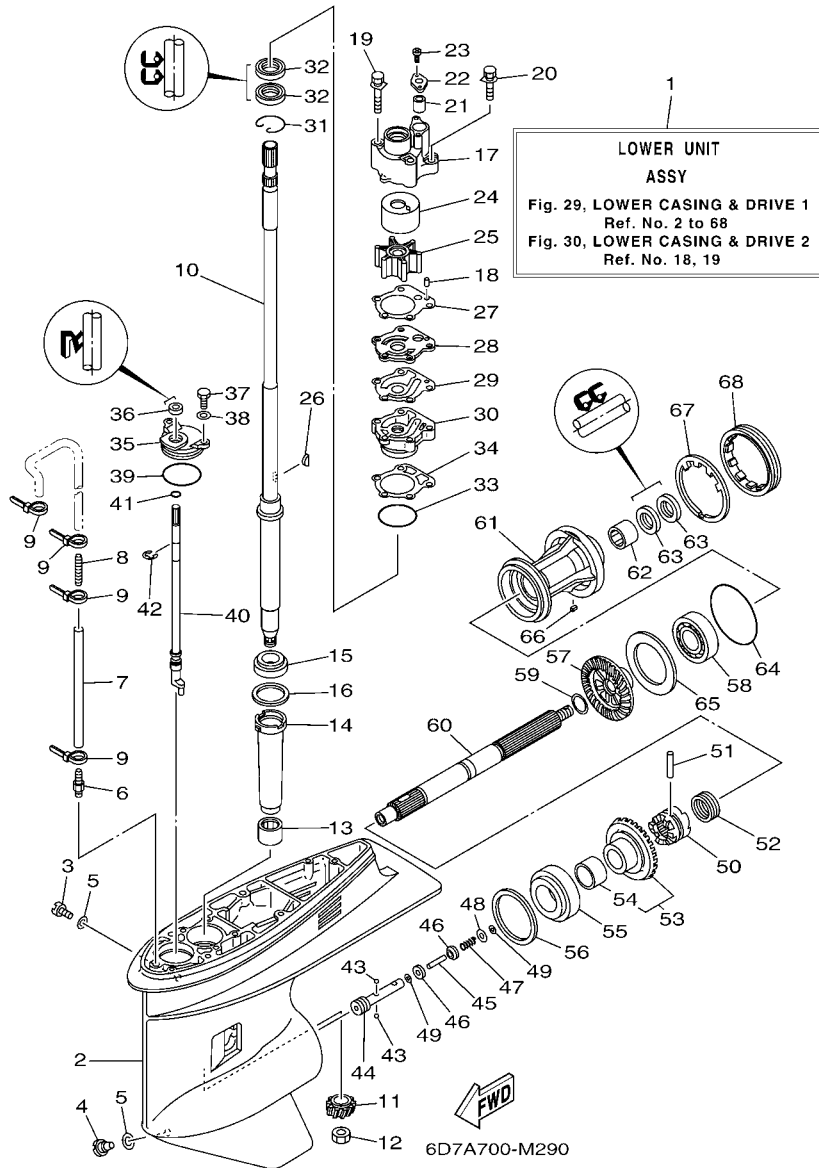
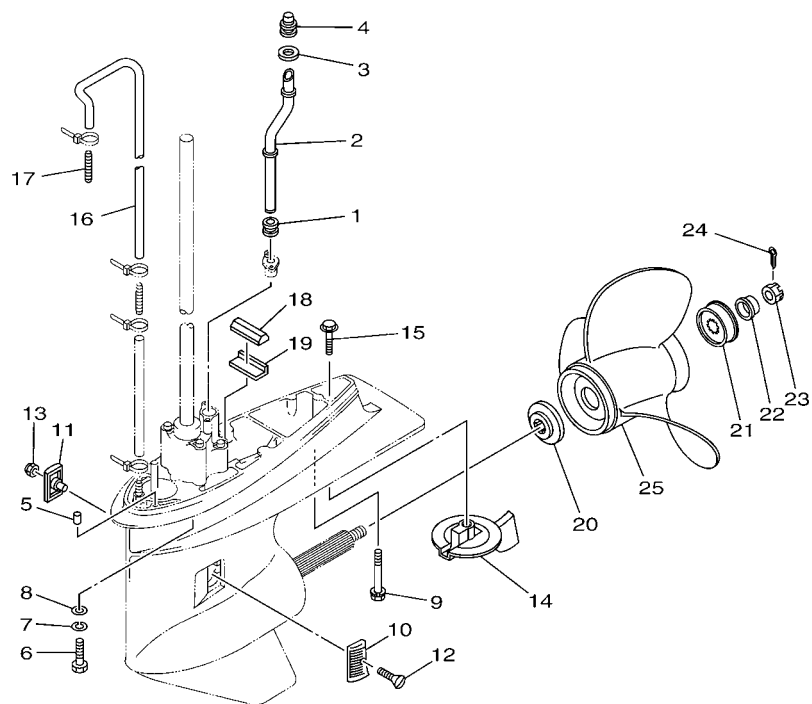


FIG. 29 LOWER CASING & DRIVE 1 CARCACA INF. E TRANSMISSAO 1

REF. NO.	PART NO. No. PEÇA	DESCRIPTION DESCRIÇÃO	QTY	REMARKS OBSERVAÇÕES
49	90183-02M03	NUT, SPRING PORCA MOLLA	2	
50	6D8-45631-00	CLUTCH, DOG ENGATE DA ENGRENAGEM	1	
51	90250-07M02	PIN, STRAIGHT PINO DIRECTO	1	
52	688-45633-00	RING, CROSS PIN ANEL DE FIXACAO DO PINHAO	1	
53	6D9-45560-10	GEAR 1 (25T) ENGRENAGEM 1 (25D)	1	
54	93317-322V0	BEARING ROLAMENTO	1	
55	93332-000UD	BEARING ROLAMENTO	1	
56	688-45567-01	SHIM (T:0.10MM) ARRUELA CALCO (T:0.10MM)	1	UR
	688-45567-10	SHIM (T:0.12MM) ARRUELA CALCO (T:0.12MM)	1	UR
	688-45567-20	SHIM (T:0.15MM) ARRUELA CALCO (T:0.15MM)	1	UR
	688-45567-30	SHIM (T:0.18MM) ARRUELA CALCO (T:0.18MM)	1	UR
	688-45567-40	SHIM (T:0.30MM) ARRUELA CALCO (T:0.30MM)	1	UR
	688-45567-50	SHIM (T:0.40MM) ARRUELA CALCO (T:0.40MM)	1	UR
	688-45567-60	SHIM (T:0.50MM) ARRUELA CALCO (T:0.50MM)	1	UR
57	6D9-45571-10	GEAR 2 (25T) ENGRENAGEM FRONTAL 2 (25D)	1	
58	93306-207U0	BEARING ROLAMENTO	1	
59	90201-25M05	WASHER, PLATE ARRUELA PLANA	1	
60	67F-45611-01	SHAFT, PROPELLER EIXO DA HELICE	1	
61	67F-45331-00-CA	HOUSING, BEARING ALOJAMENTO DO ROLAMENTO	1	
62	93317-325U0	BEARING ROLAMENTO	1	
63	93101-25M03	OIL SEAL RETENTOR DE OLEO	2	
64	93210-86M39	O-RING ANEL DE BORRACHA	1	
65	67F-45576-00	WASHER, THRUST 2 ARRUELA DE ACO 2	1	
66	90282-04010	KEY, STRAIGHT CHAVETA RETA	1	
67	688-45383-02	WASHER, CLAW ARRUELA	1	
68	688-45384-02	NUT PORCA	1	

FIG. 30 LOWER CASING & DRIVE 2 CARCACA INF. E TRANSMISSAO 2



6D81100-D320

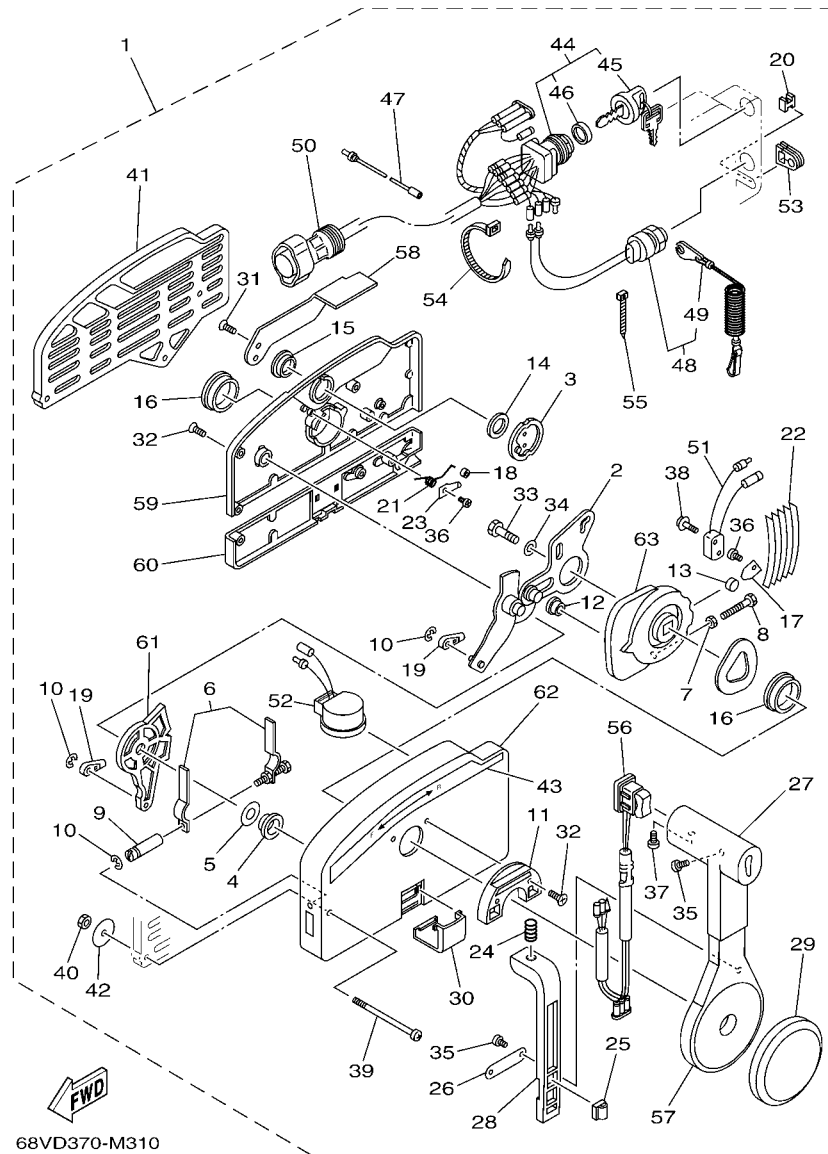
REF. NO.	PART NO. No. PEÇA	DESCRIPTION DESCRIÇÃO	6E12				REMARKS OBSERVAÇÕES
1	663-44367-00	DAMPER, WATER SEAL 3 AMORTIZADOR DE BORRACHA 3	1				
2	6D8-44361-00	TUBE, WATER 1 TUBO DE AGUA 1	1				L(21.1") L(21.1")
3	6D8-44314-00	SPACER ESPACADOR	1				
4	67F-44365-00	DAMPER, WATER SEAL 1 AMORTIZADOR DE BORRACHA 1	1				
5	93606-12019	PIN, DOWEL PINO GUIA	2				
6	97075-10040	BOLT PARAFUSO	4				L(21.1") L(21.1")
7	92995-10100	WASHER ARRUELA	4				L(21.1") L(21.1")
8	92995-10600	WASHER ARRUELA	4				L(21.1") L(21.1")
9	90119-08M84	BOLT, WITH WASHER PARAFUSO COM ARRUELA	1				L(21.1") L(21.1")
10	6H1-45214-00	COVER, WATER INLET 1 TAMPA DA ENTRADA DE AGUA 1	1				
11	6H1-45215-00	COVER, WATER INLET 2 TAMPA DA ENTRADA DE AGUA 2	1				
12	90151-05M00	SCREW, COUNTERSUNK PARAFUSO TRAMBULADOR	1				
13	90185-05002	NUT, NYLON PORCA AUTOTRAVANTE	1				
14	67F-45371-00	TAB-TRIM ESTABILIZADOR DE DIRECAO	1				
15	90105-10M67	BOLT, FLANGE PARAFUSO FLANGE	1				
16	90445-07ME0	HOSE (L1220) TUBO (L1220)	1				
17	6E5-83558-00	END, NIPPLE TERMINAL DE LIGACAO	1				
18	688-45375-00	DAMPER, SEAL AMORTIZADOR DE VEDACAO	1				
19	663-45376-00	GUIDE, SEAL DAMPER GUIA DE AMORTIZADOR DE VEDACAO	1				
20	688-45987-01	SPACER 1 ESPACADOR 1	1				
21	67F-45997-00	SPACER 2 ESPACADOR 2	1				
22	90389-25M00	BUSH BUCHA	1				
23	90171-16011	NUT, CASTLE PORCA CASTELO	1				
24	91490-40030	PIN, COTTER CONTRAPINO	1				
25	6E5-45941-00	PROPELLER (3X13"X19"-K) HELICE (3X13"X19"-K)	1				UR UR
	6E5-45943-00	PROPELLER (3X12-5/8"X21"-K) HELICE (3X12-5/8"X21"-K)	1				UR UR
	6E5-45945-01	PROPELLER (3X13-1/4"X17"-K) HELICE (3X13-1/4"X17"-K)	1				UR UR







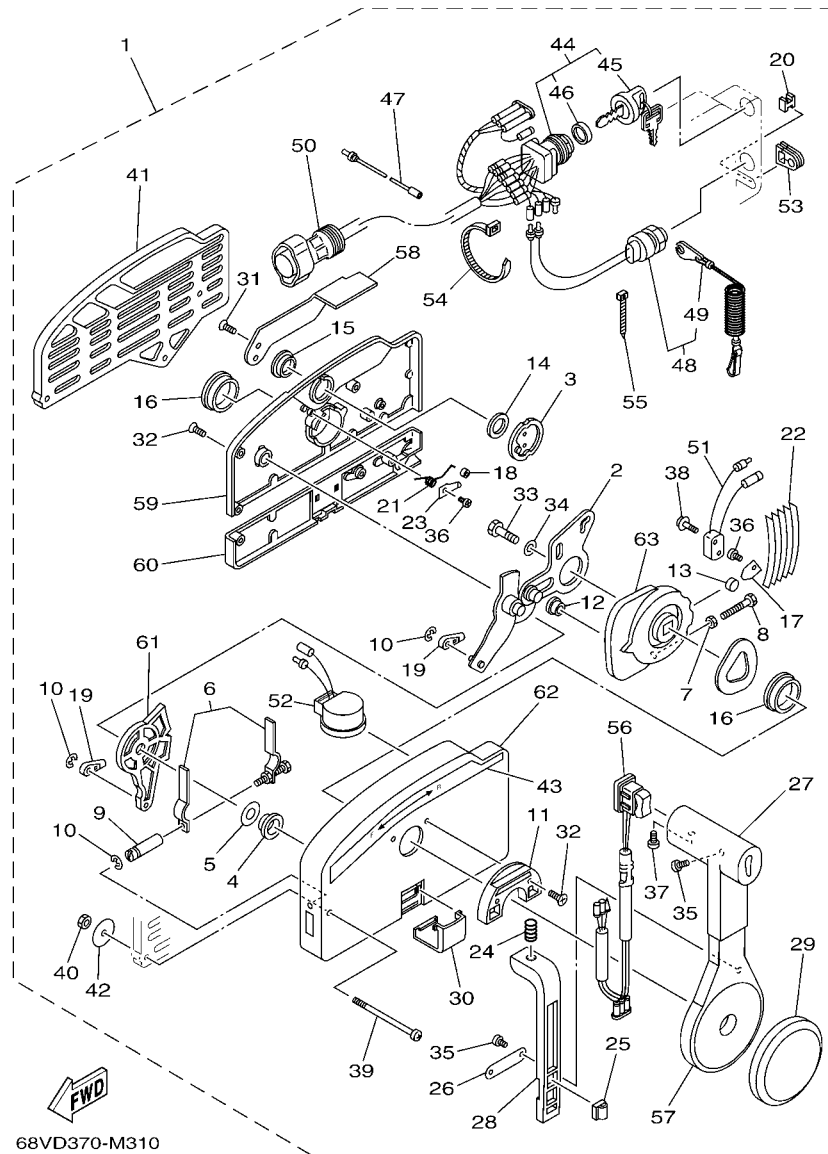




68VD370-M310

FIG. 33 REMOTE CONTROL ASSY CONTROLE REMOTO CONJ.

REF. NO.	PART NO. No. PEÇA	DESCRIPTION DESCRIÇÃO	QTY	REMARKS OBSERVAÇÕES
1	703-48207-1B	REMOTE CONTROL ASSY (10P) CONTROLE REMOTO CONJUNTO (10P)	1	AP WITH PT/T SW. AP WITH PT/T SW.
2	703-48261-01	.ARM, THROTTLE .BRACO DE ACELERACAO	1	
3	703-48153-00	.SHAFT, FREE ACCEL. .EIXO DE ACELERACAO LIVRE	1	
4	703-48235-00	.BUSHING .ROLAMENTO	1	
5	703-48268-00	.SPACER .ESPACADOR 3	1	
6	703-48264-00	.FRICTION, THROTTLE .ACELERADOR, FRICCAO	1	
7	95380-05600	.NUT .PORCA	1	
8	97380-05025	.BOLT .PARAFUSO	1	
9	703-48265-00	.SHAFT, FRICTION .EIXO FRICCAO	1	
10	93430-06024	.CIRCLIP .ANEL TRAVA	3	
11	703-48245-00	.PLATE, LOCK .PLACA TRAVA	1	
12	703-48252-00	.ROLLER, CAM .ROLETE	1	
13	701-48248-00	.ROLLER, FREE ACCEL. .ROLETE	1	
14	703-48198-00	.WASHER, WAVE .ARRUELA ONDULADA 3	1	
15	703-48243-00	.BUSHING .BUCHA 3	1	
16	703-48236-00	.BUSHING 1 .ROLETE	2	
17	703-48189-00	.RETAINER .RETENTOR	1	
18	703-48234-00	.ROLLER, DETENT .ROLETE	1	
19	703-48345-01	.CABLE END, REMOTE CONTROL 2 .TERMINAL DO CABO	2	
20	703-48358-00	.ANCHOR, CABLE .CABO DA ANCORA	1	
21	703-48244-00	.SPRING, FREE ACCEL. .MOLA DO COMANDO	1	
22	703-48238-00	.SPRING, DETENT .MOLA	5	
23	703-48246-00	.SPACER .ESPACADOR	1	
24	703-48227-00	.SPRING, NEUTRAL LOCK .MOLA DO PONTO NEUTRO	1	
25	703-82594-00	.CLAMP .GRAMPO DO CHICOTE	1	WITH PT/T SW. WITH PT/T SW.
26	703-48226-00	.PLATE, STOPPER .PLACA LIMITADORA	1	
27	703-48222-00	.GRIP, CONTROL LEVER .TRAVA, ALAVANCA DE CONTROLE	1	SINGLE SINGLE



68VD370-M310

FIG. 33 REMOTE CONTROL ASSY CONTROLE REMOTO CONJ.

REF. NO.	PART NO. No. PEÇA	DESCRIPTION DESCRIÇÃO	QTY	REMARKS OBSERVAÇÕES
28	703-48223-00	.LOCK, NEUTRAL .TRAVA DO NEUTRO	1	
29	703-48225-00	.COVER .TAMPA	1	
30	703-48219-00	.COVER, LEAD .TAMPA DE MOLDURA	1	
31	703-48281-00	.SCREW .PARAFUSO 1	2	
32	703-48282-00	.SCREW .PARAFUSO 2	7	
33	97380-08030	.BOLT .PARAFUSO	1	
34	92990-08600	.WASHER, PLATE .ARRUELA PLANA	1	
35	98580-04010	.SCREW, PAN HEAD .PARAFUSO	3	
36	98580-04006	.SCREW, PAN HEAD .PARAFUSO	2	
37	98580-05010	.SCREW, PAN HEAD .PARAFUSO	1	
38	703-48129-00	.SCREW 3 .PARAFUSO 3	2	
39	703-48291-10	.SCREW (M6) .PARAFUSO	3	
40	95380-06600	.NUT, HEXAGON .PORCA SEXTAVADA	3	
41	703-48293-10	.SPACER, REMOTE CONTROL .ESPACADOR	1	SINGLE SINGLE
42	701-48287-00	.WASHER .ARRUELA	3	
43	703-48215-00	.GRAPHIC .GRAFICO 1	1	
44	703-82510-44	.MAIN SWITCH ASSY .INTERRUPTOR PRINCIPAL. CONJ.	1	
45	703-82577-00	.CAP, KEY .CAPA DA CHAVE	1	
46	6K1-82532-00	.CAP .TAMPA	1	
47	703-82531-00	.WIRE, LEAD (L70) .FIO CONDUTOR (L70)	1	
48	688-82575-01	.ENGINE STOP SWITCH ASSY .INTERRUPTOR DE PARADA CJ.	1	
49	682-82556-00	.LANYARD, STOP SWITCH .PULSEIRA DE PARADA AUTOMATICA	1	
50	688-8258A-20	.EXTENSION, WIRE HARNESS (4.9M) .EXTENSAO CHICOTE FIOS (4.9M)	1	(10P) (10P)
51	703-82540-00	.NEUTRAL SWITCH ASSY .INTERRUPTOR NEUTRO CONJ.	1	
52	703-83383-11	.BUZZER .ALARME	1	
53	703-48284-10	.GROMMET .ILHO	1	
54	703-82591-00	.BAND .BRACADEIRA	3	

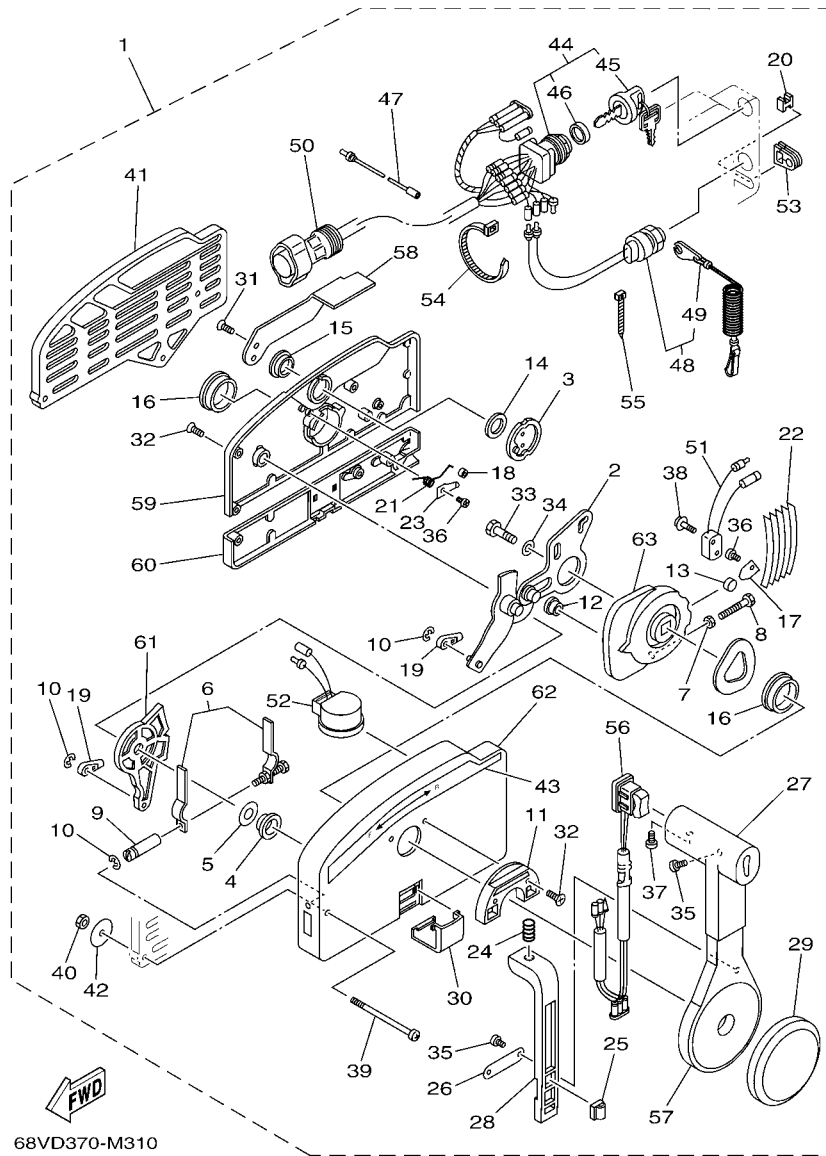
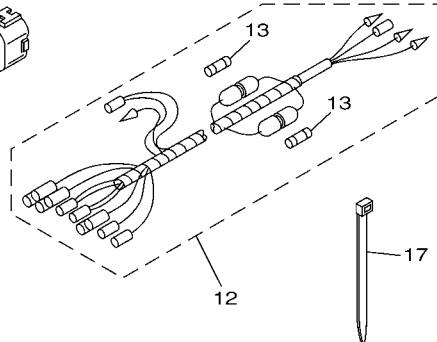
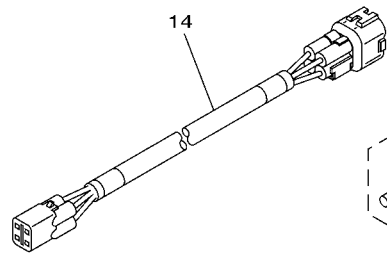
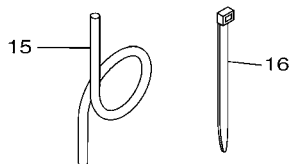
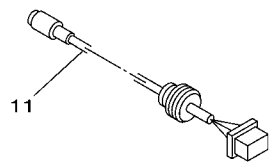
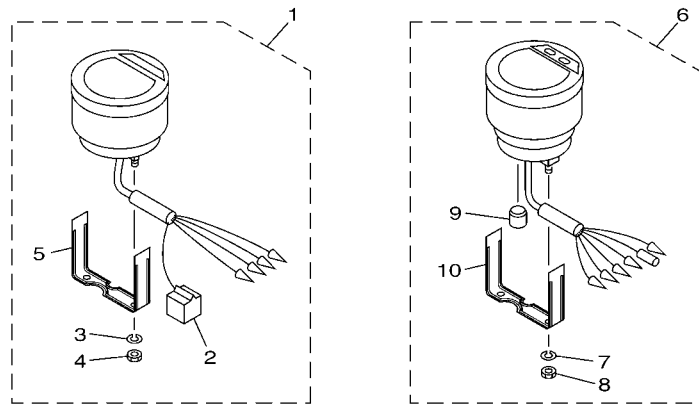


FIG. 33 REMOTE CONTROL ASSY      CONTROLE REMOTO CONJ.

REF. NO.	PART NO. No. PEÇA	DESCRIPTION DESCRIÇÃO	QTY	REMARKS OBSERVAÇÕES
55	703-82592-00	.BAND .BRACADEIRA	1	
56	703-82563-12	.TRIM & TILT SWITCH ASSY .INTERRUPTOR TRIM & TILT CONJ.	1	WITH PT/T SW. WITH PT/T SW.
57	703-48221-00	.LEVER, CONTROL .ALAVANCA DO CONTROLE REMOTO	1	
58	703-48152-00	.KNOB, FREE ACCEL. .ALAVANCA DE ACELERAÇÃO	1	
59	703-48212-00	.BACK PLATE 1 .TAMPA DO COMANDO 1	1	
60	703-48213-00	.BACK PLATE 2 .TAMPA DO COMANDO 2	1	
61	703-48271-00	.ARM, SHIFT .BRACO DO CAMBIO	1	
62	703-48211-02	.HOUSING, 1 .CORPO DO COMANDO	1	
63	703-48232-00	.GEAR .ENGRENAGEM DO COMANDO	1	



6EJ1280-L330

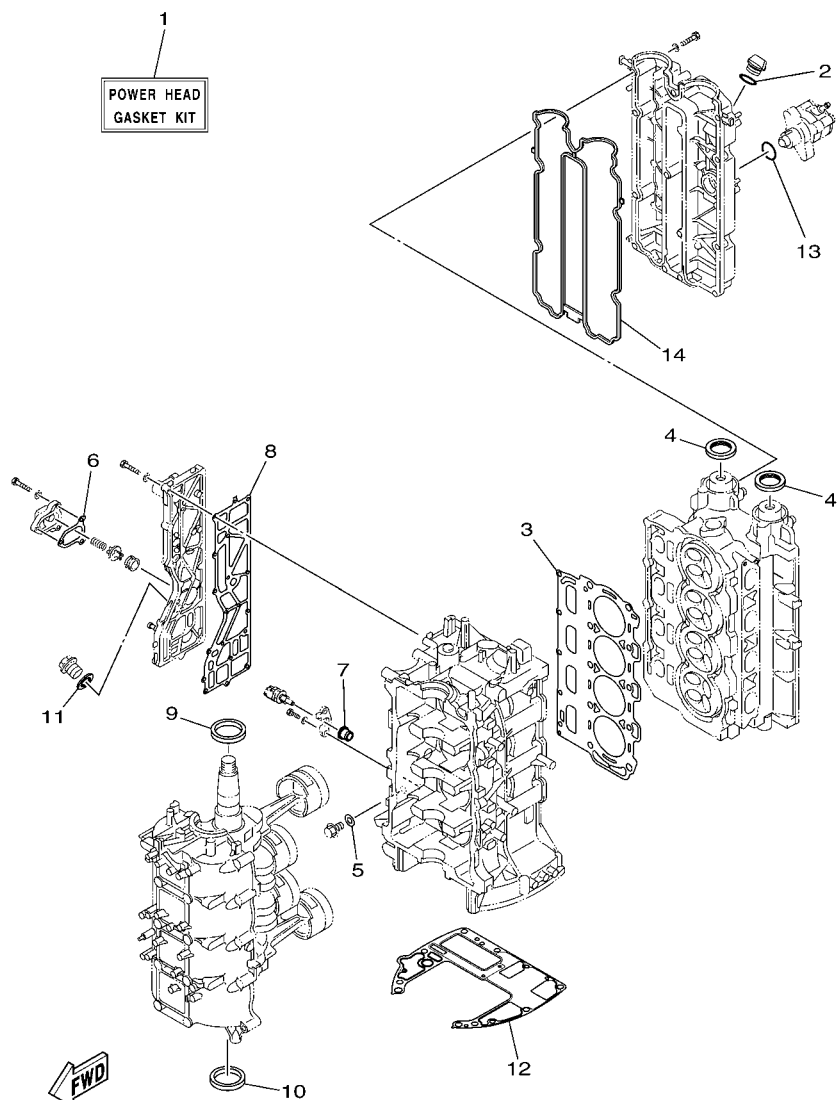
FIG. 34 METER

MEDIDOR

REF. NO.	PART NO. No. PEÇA	DESCRIPTION DESCRIÇÃO	6EJ2				REMARKS OBSERVAÇÕES
1	6Y5-8350T-91	DIGITAL TACHOMETER ASSY TACOMETRO DIGITAL CONJUNTO	1				AP
2	9E450-04533	.CONNECTOR .CONECTOR	1				F-4-W F-4-W
3	92990-04100	.WASHER, SPRING .ARRUELA COM MOLA	2				
4	95380-04600	.NUT .PORCA	2				
5	6Y5-8355X-T1	.BRACKET, METER 1 .SUPORTE DOS MEDIDORES 1	1				
6	6Y5-83570-S6	SPEEDOMETER ASSY VELOCIMETRO CONJUNTO	1				AP AP
7	92990-04100	.WASHER, SPRING .ARRUELA COM MOLA	2				
8	95380-04600	.NUT .PORCA	2				
9	6Y5-83533-T2	.GROMMET .ILHO DE BORRACHA	1				
10	6Y5-8355X-T1	.BRACKET, METER 1 .SUPORTE DOS MEDIDORES 1	1				
11	6Y5-87122-S0	CORD ASSY 1 CHICOTE COMPLETO 1	1				AP AP
12	6Y5-83553-M0	WIRE, LEAD (L=2.5M) FIO CONDUTOR (L=2.5M)	1				AP AP AP
13	1E6-82151-00	.FUSE (10A) .FUSIVEL (10A)	2				
14	6Y5-83653-30	WIRE, LEAD (L=8.0M) CHICOTE DO PAINEL (L=8.0M)	1				AP 4P,8M AP 4P,8M
15	6Y5-83557-10	TUBE (8M) TUBO (8M)	1				AP AP
16	90465-11M10	CLAMP BRACADEIRA	2				AP AP
17	90465-13M18	CLAMP BRACADEIRA	10				AP AP

FIG. 35 REPAIR KIT 1

KIT DE REPARO 1



6D67110-K320

REF. NO.	PART NO. No. PEÇA	DESCRIPTION DESCRIÇÃO	QTY				REMARKS OBSERVAÇÕES
1	6D8-W0001-03	POWER HEAD GASKET KIT KIT DE GAXETAS DO CABECOTE	1				
2	93210-24M79	.O-RING .ANEL DE BORRACHA	1				
3	67F-11181-03	.GASKET, CYLINDER HEAD 1 .GAXETA CABECOTE DO CILINDRO 1	1				
4	93102-38008	.OIL SEAL .RETENTOR DE OLEO	2				
5	90430-14115	.GASKET .GAXETA	1				
6	67F-12435-A0	.GASKET .GAXETA	1				
7	68V-85753-00	.GASKET, SENDER UNIT .GAXETA DO SENSOR	1				
8	67F-41114-A2	.GASKET, EXHAUST OUTER COVER .GAXETA TAMPA EXTERNA DO ESCAPE	1				
9	93102-48017	.OIL SEAL .RETENTOR DE OLEO	1				
10	93101-48001	.OIL SEAL .RETENTOR DE OLEO	1				
11	90430-18130	.GASKET .GAXETA	1				
12	68V-11351-00	.GASKET, CYLINDER .GAXETA DO CILINDRO	1				
13	93210-30682	.O-RING .ANEL DE BORRACHA	1				
14	6D8-11356-01	.SEAL, CYLINDER 2 .VEDACAO DO CILINDRO 2	1				

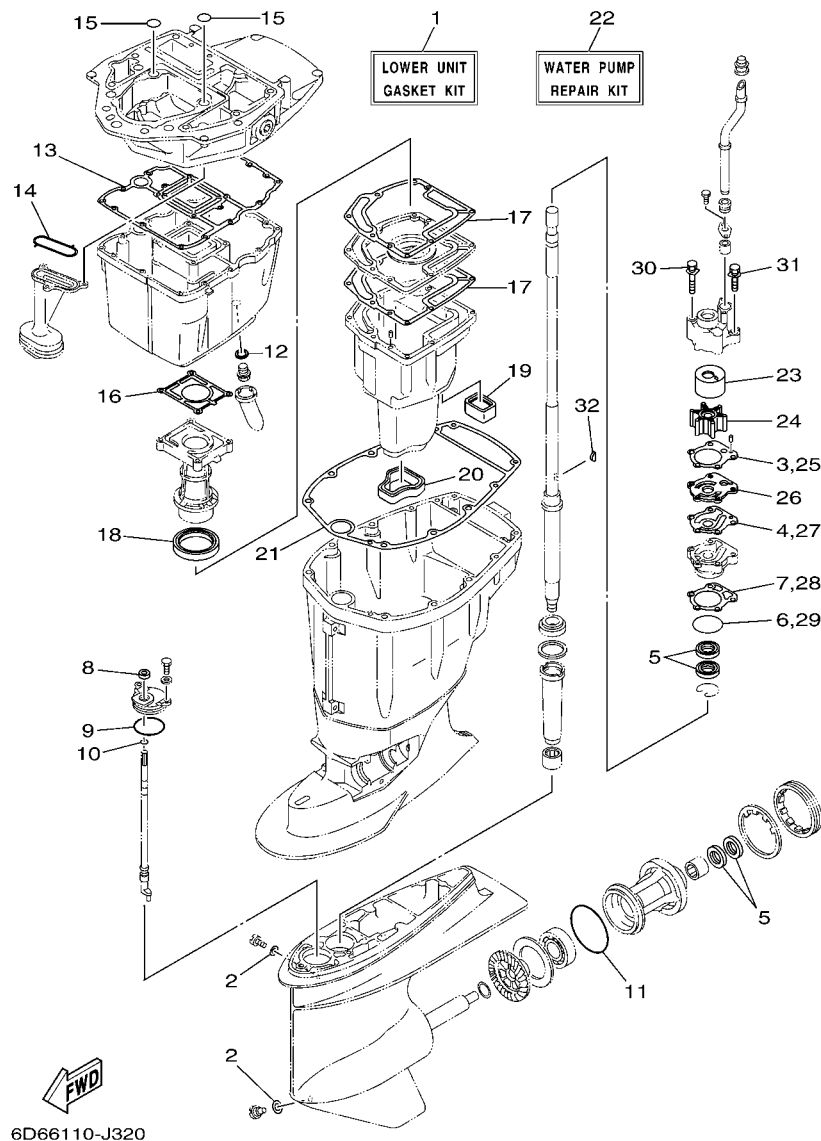


FIG. 36 REPAIR KIT 2

KIT DE REPARO 2

REF. NO.	PART NO. No. PEÇA	DESCRIPTION DESCRIÇÃO	QTY	REMARKS OBSERVAÇÕES
1	67F-W0001-21	LOWER UNIT GASKET KIT KIT DE GAXETAS UNIDADE INF.	1	
2	90430-08020	.GASKET .GAXETA	2	
3	688-44315-A0	.GASKET, WATER PUMP .GAXETA DA BOMBA D'AGUA	1	
4	688-44324-A0	.GASKET, CARTRIDGE .GAXETA DO CARTUCHO	1	
5	93101-25M03	.OIL SEAL .RETENTOR DE OLEO	4	
6	93210-46044	.O-RING .ANEL DE BORRACHA	1	
7	688-44316-A0	.GASKET, WATER PUMP .GAXETA DA BOMBA D'AGUA	1	
8	93106-09014	.OIL SEAL .RETENTOR DE OLEO	1	
9	93210-49046	.O-RING .ANEL DE BORRACHA	1	
10	93210-07003	.O-RING .ANEL DE BORRACHA	1	
11	93210-86M39	.O-RING .ANEL DE BORRACHA	1	
12	90430-14M09	.GASKET .GAXETA	1	
13	68V-15312-00	.GASKET, OIL PAN .GAXETA DA CAPA DO OLEO	1	
14	67F-13415-00	.SEAL, OIL STRAINER .VEDACAO DO FILTRADOR DE OLEO	1	
15	93210-19MJ1	.O-RING .ANEL DE BORRACHA	2	
16	67F-41133-A1	.GASKET, EXHAUST MANIFOLD 1 .GAXETA DO MULTIPLO DE ESCAPE 1	1	
17	67F-41134-A0	.GASKET, EXHAUST MANIFOLD .GAXETA DO MULTIPLO DE ESCAPE	2	
18	67F-41138-00	.SEAL, EXT. 1 .VEDACAO DO ESCAPE 1	1	
19	67F-45127-00	.SEAL .RETENTOR DE BORRACHA	1	
20	67F-45123-00	.GASKET, MUFFLER .GAXETA DO SILENCIADOR	1	
21	67F-45113-00	.GASKET, UPPER CASING .GAXETA DA CAIXA SUPERIOR	1	
22	67F-W0078-00	WATER PUMP REPAIR KIT JOGO DE REPARO DA BOMBA D'AGUA	1	
23	67F-44322-00	.INSERT, CARTRIDGE .INSERTO DA BOMBA D'AGUA	1	
24	67F-44352-00	.IMPELLER .IMPULSOR	1	
25	688-44315-A0	.GASKET, WATER PUMP .GAXETA DA BOMBA D'AGUA	1	
26	67F-44323-00	.OUTER PLATE, CARTRIDGE .PLACA DA EXTERNA DA BOMBA	1	
27	688-44324-A0	.GASKET, CARTRIDGE .GAXETA DO CARTUCHO	1	





NUMERICAL INDEX  
ÍNDICE NUMÉRICO

PART NO. No. PEÇA	REF. NO.	PART NO. No. PEÇA	REF. NO.	PART NO. No. PEÇA	REF. NO.	PART NO. No. PEÇA	REF. NO.	PART NO. No. PEÇA	REF. NO.	PART NO. No. PEÇA	REF. NO.
6D8-11110-20-9S	5 - 2	4G0-12118-00	6 - 6	67F-13119-01	28 - 17	6C5-14191-00	10 - 13	6C5-24322-20	11 - 4	6D8-41237-00	21 - 42
62Y-11119-00	3 - 8	6D8-12121-10	6 - 2	63P-13131-00	12 - 18	6D8-14200-00	7 - 1	6C5-24323-00	11 - 5	6D8-42154-00	21 - 25
67F-11133-10	5 - 3	6D8-12153-00	6 - 9	67F-13149-00	28 - 21	6C5-14225-00	10 - 25	6D8-24324-01	11 - 6	6D8-42157-00	21 - 34
67F-11168-00	5 - 19	6D8-12153-10	6 - 9	6D8-13161-00	7 - 13	6C5-14251-00	11 - 12	6D8-24325-10	11 - 7	68V-42171-00	21 - 35
67F-11181-03	5 - 14	6D8-12153-20	6 - 9	6C5-1319C-00	7 - 11	6D8-14291-00	8 - 5	6D8-24351-51	13 - 3	67F-42510-11-4D	23 - 8
	35 - 3	6D8-12153-30	6 - 9	67F-13300-10	28 - 12	6D8-14292-00	8 - 9	6Y2-24360-60	13 - 5	6D8-42541-00	3 - 20
6D8-11191-01-9S	5 - 18	6D8-12153-40	6 - 9	67F-13314-02	28 - 13	6C5-14386-00	10 - 5	68V-24374-00	12 - 21	68V-42541-20	3 - 27
67F-11192-01	5 - 26	6D8-12153-50	6 - 9	67F-13329-00	28 - 15	6C5-14397-00	10 - 14	6D8-24378-00	3 - 25	6D8-42610-30	2 - 1
69J-11301-00	3 - 35	6D8-12153-60	6 - 9	67F-13338-00	28 - 23	6D8-14440-01	8 - 14	6C5-24379-00	11 - 17	67F-42613-00-4D	2 - 10
	5 - 8	6D8-12153-70	6 - 9	67F-13339-00	28 - 22	6C5-14446-00	7 - 14	6C5-24387-00	11 - 14	67F-42615-00	2 - 13
6E5-11325-00	1 - 1	6D8-12153-80	6 - 9	67F-13411-00	28 - 8	6C5-14496-00	7 - 9	6C5-24410-10	12 - 15	61N-42628-00	2 - 12
	3 - 16	6D8-12153-90	6 - 9	67F-13415-00	28 - 11	6C5-14546-10	10 - 4	68V-24411-00	12 - 20	67F-42628-00	2 - 19
67F-11325-01	1 - 2	6D8-12153-A0	6 - 9		36 - 14	6C5-14567-00	10 - 15	68V-24412-00	12 - 16	67F-42647-00	2 - 2
	1 - 4	6D8-12153-B0	6 - 9	6D8-13428-01	9 - 3	67F-14711-00-CA	27 - 9	68V-24413-10	12 - 22	67F-42649-00	2 - 8
	3 - 36	6D8-12153-C0	6 - 9	67F-13434-20	2 - 20	6D8-14960-10	10 - 12	6D8-24414-00	12 - 23	68V-42652-00	2 - 5
	5 - 9	6D8-12153-D0	6 - 9	5GH-13440-30	1 - 3	6C5-14984-00	1 - 8	6C5-24411R-10	10 - 6	67F-42662-00	2 - 9
67F-11328-00	3 - 37	6D8-12153-E0	6 - 9		3 - 45		10 - 23	6C5-2441T-10	10 - 7	6D6-42675-00	2 - 16
	5 - 10	6D8-12153-F0	6 - 9	67F-13473-01	28 - 14	6C5-14985-00	10 - 3	68V-24423-00	12 - 19	6D6-42676-00	2 - 18
68V-11351-00	3 - 44	6D8-12153-G0	6 - 9	67F-13495-00	28 - 16	6D8-15100-02	3 - 2	68V-24444-00	12 - 24	6D8-42677-20	2 - 14
	35 - 12	6D8-12153-H0	6 - 9	6D8-13542-01	11 - 2	67F-15142-00	3 - 11	6C5-24444-00	11 - 9	6D8-42678-30	2 - 15
6D8-11356-01	5 - 23	6D8-12153-J0	6 - 9	6C5-13545-00	11 - 18	67F-15311-03-CA	28 - 1	6C5-24453-00	10 - 8	6D6-42681-00	2 - 17
	35 - 14	6D8-12153-K0	6 - 9	6D8-13546-01	11 - 1	68V-15312-00	28 - 7	68V-24454-00	12 - 17	6D8-42710-00-4D	20 - 1
676-11372-00	3 - 13	6D8-12153-L0	6 - 9	6D8-13557-00	7 - 4		36 - 13	6D8-24469-00	12 - 7	648-42715-00	21 - 22
6D8-11411-01	4 - 1	6D8-12153-M0	6 - 9	6C5-13577-00	11 - 10	63P-15316-00	28 - 2	69J-24502-00	9 - 14	61A-42716-00	20 - 45
6D8-11416-00	4 - 2	6D8-12153-N0	6 - 9	6C5-13593-00	10 - 20	6D8-15362-00	28 - 27	6D8-24519-00	12 - 8	67F-42717-00	20 - 27
6D8-11416-10	4 - 2	6D8-12153-P0	6 - 9	67F-13631-03	28 - 20	6G8-15363-00	5 - 33	6D8-2451B-20	11 - 20	6D8-42717-00	20 - 21
6D8-11416-20	4 - 2	6D8-12153-R0	6 - 9	6D8-13641-00	7 - 2	6D8-15373-00	8 - 19	6D8-24560-00	12 - 3	67F-42724-00	27 - 31
6D8-11417-00	4 - 3	6D8-12153-S0	6 - 9	6D8-13645-00	7 - 3	6C5-21337-10	10 - 24	6D8-24562-00	12 - 6	68V-42725-00	20 - 19
6D8-11417-10	4 - 3	6D8-12153-T0	6 - 9	6C5-13716-00	10 - 22	6D8-2134X-00	9 - 25	6D8-24563-00	1 - 10	6H1-42726-21	20 - 24
6D8-11417-20	4 - 3	6D8-12153-U0	6 - 9	6C5-13739-00	11 - 21	6C5-21841-00	11 - 11		12 - 4	6G1-42727-00	27 - 4
6D8-11417-30	4 - 3	6D8-12153-V0	6 - 9	6D8-13750-00	7 - 5	1UF-22434-00	25 - 37	6D8-24564-00	1 - 11	67F-42738-00-8D	20 - 17
6D8-11418-00	4 - 4	6D8-12171-00	6 - 10	6D8-13761-00	7 - 15	67F-22435-00	25 - 10		12 - 5	67F-42741-01-4D	20 - 46
6D8-11418-10	4 - 4	6D8-12181-00	6 - 11	67F-13769-00	28 - 18	67F-22471-01	25 - 33	6D8-24566-00	12 - 10	6H4-42748-00	20 - 26
6D8-11418-20	4 - 4	67F-12411-01	1 - 5	6C5-13781-00	10 - 21	6D8-2413X-01	9 - 19	6C5-24592-00	10 - 10	6D8-42756-02	20 - 20
6D8-11536-01	6 - 21		5 - 28	6D8-13782-00	8 - 13	68V-24149-00	12 - 25	67F-28100-01	12 - 29	6AH-42794-70	20 - 52
67F-11537-00	6 - 13	67F-12412-00	5 - 29	6C5-13906-01	10 - 9	69J-24170-00	9 - 8	67F-2812A-00	16 - 27	67F-42815-00-4D	20 - 5
67F-11590-00	6 - 16	68V-12413-00-9S	5 - 30	6C5-13907-00	10 - 17	6D8-2417H-01	9 - 11	6D8-41113-50-9S	3 - 12	67F-42816-00-4D	20 - 6
67F-11595-00	6 - 19	6G5-12416-00	3 - 29	6C5-13910-10	10 - 16	69J-2419A-01	9 - 22	67F-41114-A2	3 - 18	68V-42818-01	20 - 9
6D8-11603-10	4 - 7	67F-12435-A0	3 - 33	67F-13914-00	28 - 19	6C5-24251-00	1 - 9		35 - 8	67F-42828-00-9S	20 - 7
6D8-11604-10	4 - 7		35 - 6	6C5-13915-00	1 - 7		11 - 19	67F-41131-01-CA	27 - 5	67F-43111-00-4D	22 - 1
6D8-11656-00	4 - 8	67F-1243A-00	3 - 41		10 - 19	6Y2-24307-50	13 - 1	67F-41133-A1	27 - 6	67F-43112-00-4D	22 - 4
6D8-11656-10	4 - 8	67F-1246A-01-9S	3 - 32	6D8-13974-00	11 - 15	6D8-24311-00	12 - 14		36 - 16	6D8-43126-00	22 - 30
6D8-11656-20	4 - 8	67F-12535-01	20 - 33	6C5-1410B-00	7 - 16	67F-24312-00	20 - 43	67F-41134-A0	27 - 15	64E-43131-01	22 - 12
6D8-11656-30	4 - 8	68T-12572-00	20 - 32	6C5-14127-10	10 - 18	6D8-24314-01	9 - 6		36 - 17	64E-43139-10	23 - 4
6D8-12111-00	6 - 1	6R3-12581-00	20 - 40	6D8-14148-20	11 - 13	6D8-24315-00	9 - 9	6D8-41137-00-CA	27 - 1	64D-43144-00	20 - 14
6D8-12113-00	6 - 4	6R3-12582-00	20 - 41	6BG-14149-00	11 - 8	6D8-24316-00	9 - 15	67F-41138-00	27 - 17	66T-43144-00	22 - 24
6D8-12116-00	6 - 3	6R3-12583-00	20 - 42	6D8-14180-40	10 - 1	6D8-24317-01	9 - 20		36 - 18	6E5-43145-01	31 - 8
26H-12117-00	6 - 5	6D8-13105-01	7 - 10	6D8-14182-10	10 - 2	6C5-24321-20	11 - 3	682-41237-00	21 - 43	6G5-43148-00	22 - 21

NUMERICAL INDEX  
ÍNDICE NUMÉRICO

PART NO. No. PEÇA	REF. NO.	PART NO. No. PEÇA	REF. NO.	PART NO. No. PEÇA	REF. NO.	PART NO. No. PEÇA	REF. NO.	PART NO. No. PEÇA	REF. NO.	PART NO. No. PEÇA	REF. NO.
6D8-43181-00	22 - 18	6D8-43863-00	25 - 80	67F-44323-00	29 - 28	688-45383-02	29 - 67	703-48152-00	33 - 58	6C5-81146-10	7 - 12
6D8-43185-00	22 - 19	67F-43865-00	25 - 28	67F-43865-00	36 - 26	688-45384-02	29 - 68	703-48153-00	33 - 3	445-81328-20	14 - 7
6D8-43311-01-4D	22 - 7	65W-4386A-00	25 - 17	688-44324-A0	29 - 29	67F-45501-10	29 - 10	703-48189-00	33 - 17	6D8-8132G-10	18 - 1
6D8-43800-10-8D	25 - 1	6T4-4386A-00	25 - 30		36 - 4	688-45536-01	29 - 14	703-48198-00	33 - 14	6D8-81332-00	14 - 14
6D8-43804-01	26 - 3	6C6-4386E-00	25 - 72		36 - 27	6D9-45551-10	29 - 11	703-48207-1B	32 - 1	6D8-81337-00	14 - 16
6D8-43805-01	26 - 2	688-4386F-00	25 - 18	6D8-44341-01-CA	29 - 30	6D9-45560-10	29 - 53		33 - 1	63D-81345-20	14 - 5
62X-43807-00	26 - 7	6C6-4386G-00	25 - 71	67F-44352-00	29 - 25	688-45567-01	29 - 56	703-48211-02	33 - 62	6D8-81410-00	14 - 4
6H1-4380F-11	26 - 8	62X-4386K-00	26 - 9		36 - 24	688-45567-10	29 - 56	703-48212-00	33 - 59	6D8-81450-00	14 - 1
6C5-4380G-00	25 - 43	6C5-43872-00	25 - 77	6D8-44361-00	30 - 2	688-45567-20	29 - 56	703-48213-00	33 - 60	6D8-81460-00	14 - 2
6D8-4380K-01	25 - 39	62X-43875-00	25 - 38	67F-44365-00	30 - 4	688-45567-30	29 - 56	703-48215-00	33 - 43	6D8-81518-00	16 - 21
67F-4380R-01	25 - 3	67F-43875-00	25 - 21	663-44366-00	29 - 21	688-45567-40	29 - 56	703-48219-00	33 - 30	6D8-81528-02	16 - 22
67F-43810-02	25 - 2	6H1-43875-00	25 - 81	663-44367-00	30 - 1	688-45567-50	29 - 56	703-48221-00	33 - 57	68V-81673-10	14 - 8
67F-43811-01	25 - 5	6C6-4387G-00	25 - 52	69J-44391-00	9 - 18	688-45567-60	29 - 56	703-48222-00	33 - 27	68V-81800-02	19 - 1
6H1-43812-00	25 - 11	6D8-43880-01	25 - 89	6BL-44391-00	20 - 25	6D9-45571-10	29 - 57	703-48223-00	33 - 28	69J-81801-00	19 - 5
67F-43816-00	25 - 26		26 - 1	67F-44514-01	23 - 16	67F-45576-00	29 - 65	703-48225-00	33 - 29	67F-81807-00	19 - 10
6C5-43816-00	25 - 42	6D8-43881-01	26 - 12	67F-44526-00	23 - 19	688-45587-01	29 - 16	703-48226-00	33 - 26	67F-81808-00	19 - 8
6C6-43817-00	25 - 40	6H1-43883-00	25 - 47	6H1-44526-00	22 - 41	688-45587-10	29 - 16	703-48227-00	33 - 24	67F-81809-00	19 - 19
67F-43818-00	22 - 34	67F-4388A-01	25 - 29	67F-44533-00	23 - 22	688-45587-20	29 - 16	703-48232-00	33 - 63	67F-81810-00	19 - 3
67F-4381B-00	25 - 34	6C6-4388E-00	25 - 69	67F-44551-00-4D	23 - 14	688-45587-30	29 - 16	703-48234-00	33 - 18	67F-81813-00	19 - 6
6D8-4381G-00	25 - 78	6C6-4388F-00	25 - 70	67F-44553-00-4D	23 - 33	688-45587-40	29 - 16	703-48235-00	33 - 4	68F-81820-00	19 - 7
67F-4381J-00	25 - 32	6H1-43891-11	26 - 4	67F-44555-00	23 - 24	688-45587-50	29 - 16	703-48236-00	33 - 16	67F-81821-00	19 - 13
6C5-4381K-00	25 - 58	6H1-43892-11	26 - 5	67F-44575-00	23 - 32	688-45587-60	29 - 16	703-48238-00	33 - 22	6KJ-81826-11	19 - 24
67F-43821-01	25 - 12	67F-43893-00	25 - 20	67F-45111-11-4D	27 - 20	67F-45611-01	29 - 60	703-48243-00	33 - 15	69J-81828-00	19 - 25
6H1-43829-00	25 - 84	6C5-43893-00	25 - 55	67F-45113-00	27 - 28	6D8-45631-00	29 - 50	703-48244-00	33 - 21	6C5-8182L-00	7 - 8
6C6-4382E-00	25 - 49	6C6-43893-00	25 - 57		36 - 21	688-45633-00	29 - 52	703-48245-00	33 - 11	67F-81830-00	19 - 17
6C5-4382K-00	25 - 60	6C6-43894-00	25 - 48	67F-45123-00	27 - 19	67F-45634-00	29 - 44	703-48246-00	33 - 23	67F-81832-00	19 - 11
6C5-4382L-00	25 - 61	6C5-43895-00	25 - 62		36 - 20	6H1-45635-00	29 - 46	701-48248-00	33 - 13	67F-81836-00	19 - 12
6D8-43830-00	25 - 45	62X-43899-00	25 - 35	67F-45127-00	27 - 18	6H1-45668-00	29 - 45	703-48252-00	33 - 12	6C5-81839-00	19 - 21
6D8-43831-00	25 - 85	67F-43899-00	25 - 25		36 - 19	688-45930-02	30 - 25	703-48261-01	33 - 2	67F-8183R-00	19 - 15
6C5-43841-00	25 - 76	69J-4389J-00	25 - 41	67F-45151-00	27 - 25	688-45932-60	30 - 25	703-48264-00	33 - 6	60V-8183T-00	19 - 18
6C6-43841-00	25 - 46		25 - 53	67F-45155-00	27 - 27	6E5-45941-00	30 - 25	703-48265-00	33 - 9	69J-81840-00	19 - 4
6D8-43845-00	25 - 82	6D8-44117-00-94	21 - 5	67F-45180-00-4D	24 - 1	6E5-45943-00	30 - 25	703-48268-00	33 - 5	67F-81841-00	19 - 14
62X-4384H-00	25 - 36	67F-44118-00-94	21 - 18	67F-45181-00-CA	27 - 16	6E5-45945-01	30 - 25	703-48271-00	33 - 61	60X-81842-00	19 - 20
6C5-43851-00	25 - 54	67F-44120-10	21 - 14	6H1-45214-00	30 - 10	6E5-45947-00	30 - 25	703-48281-00	33 - 31	67F-81846-00	19 - 26
65W-43853-00	25 - 19	67F-44121-00	21 - 11	6H1-45215-00	30 - 11	6E5-45949-00	30 - 25	703-48282-00	33 - 32	67F-81850-00	19 - 2
6C6-43853-00	25 - 51	68V-44122-01	21 - 8	6H1-45251-03	1 - 12	6E5-45952-00	30 - 25	703-48284-10	33 - 53	67F-81857-00	19 - 9
6C5-43854-00	25 - 63	67F-44135-00	21 - 30		22 - 39	6E5-45954-00	30 - 25	701-48287-00	33 - 42	6C5-81869-00	19 - 23
6D8-43855-00	25 - 56	67F-44150-01	29 - 40	6D9-45300-13-4D	29 - 1	6E5-45956-00	30 - 25	703-48291-10	33 - 39	67F-81891-00	19 - 16
6D8-43856-00	25 - 59	67F-44311-01	29 - 17	67F-45301-00-4D	29 - 2	6E5-45958-00	30 - 25	703-48293-10	33 - 41	6D8-81919-00	16 - 34
67F-43857-00	25 - 31	6D8-44314-00	30 - 3	67F-45318-00	27 - 23	688-45970-03	30 - 25	701-48320-30	32 - 2	6D8-81919-10	16 - 35
67F-4385A-02	25 - 6	688-44315-A0	29 - 27	688-45321-00	29 - 35	688-45972-02	30 - 25	663-48344-00	21 - 3	60V-81925-00	19 - 28
67F-43861-00	25 - 13		36 - 3	67F-45331-00-CA	29 - 61	688-45974-02	30 - 25		21 - 23	68V-81941-02	19 - 22
6D8-43861-00	25 - 4		36 - 25	688-45341-10	29 - 4	688-45976-01	30 - 25	703-48345-01	33 - 19	68V-81942-03	16 - 26
	25 - 14	688-44316-A0	29 - 34	67F-45371-00	1 - 15	688-45978-60	30 - 25	703-48358-00	33 - 20	68V-81948-02	16 - 15
62X-43862-00	25 - 15		36 - 7		30 - 14	688-45987-01	30 - 20	67F-48511-01	23 - 35	61A-81949-00	16 - 14
67F-43862-00	25 - 27		36 - 28	688-45375-00	30 - 18	67F-45997-00	30 - 21	67F-48538-00	21 - 1	68V-8194A-00	16 - 5
67F-43863-00	25 - 7	67F-44322-00	29 - 24	663-45376-00	30 - 19	67F-46241-00	6 - 15	67F-61350-00	31 - 1	60E-81950-00	16 - 3
	25 - 23		36 - 23	6E5-45378-00	29 - 6	703-48129-00	33 - 38	6C5-81145-00	7 - 7	63P-81950-00	16 - 10

NUMERICAL INDEX  
ÍNDICE NUMÉRICO

PART NO. No. PEÇA	REF. NO.	PART NO. No. PEÇA	REF. NO.	PART NO. No. PEÇA	REF. NO.	PART NO. No. PEÇA	REF. NO.	PART NO. No. PEÇA	REF. NO.	PART NO. No. PEÇA	REF. NO.
68V-81953-00	16 - 6	6DA-82582-10	17 - 7	6D8-W009B-07-9S	3 - 1	90119-08M91	5 - 17	90206-10M04	21 - 29	90430-08020	29 - 5
6D8-81960-10	15 - 24	6Y8-82582-11	17 - 8	6D8-W1164-21	4 - 5	90119-10050	6 - 14		21 - 39		36 - 2
6AH-81994-70	14 - 23	6E5-82587-00	18 - 14	6D8-W1164-31	4 - 5	90119-10M08	27 - 21	90206-15M18	20 - 11	90430-14115	3 - 7
6AH-81995-70	14 - 22	6E5-82588-00	20 - 28	90101-09M01	31 - 7	90119-10M72	6 - 20	90249-06M19	22 - 23		35 - 5
68V-82105-00	16 - 1	61A-82588-01	21 - 46	90101-12M03	22 - 45	90119-10M88	3 - 4	90250-07M02	29 - 51	90430-14M09	1 - 13
6G5-82119-00	16 - 9	6D8-82588-01	17 - 13	90105-06M07	3 - 38	90151-05M00	30 - 12	90280-04008	6 - 23		28 - 4
682-82119-01	16 - 28	688-8258A-20	33 - 50		5 - 11	90155-10005	5 - 16	90280-04M04	29 - 26		36 - 12
67F-82127-00	22 - 11	6D8-82590-31	17 - 1	90105-06M14	16 - 2	90159-05059	23 - 5		36 - 32	90430-18130	3 - 15
6D8-82148-00	22 - 27	703-82591-00	33 - 54	90105-10M67	30 - 15	90159-06M28	20 - 48	90280-05015	14 - 11		35 - 11
6E5-82148-00	22 - 5	703-82592-00	33 - 55	90109-06M80	20 - 49	90160-04006	29 - 23	90282-04010	29 - 66	90445-07M31	29 - 7
1E6-82151-00	34 - 13	68V-82594-00	16 - 19	90109-06M81	20 - 29	90167-06002	20 - 38	90340-08002	29 - 3	90445-07ME0	30 - 16
67F-82151-00	17 - 2	703-82594-00	33 - 25	90109-06M82	20 - 8	90170-09M03	31 - 4	90340-14M06	3 - 6	90445-13M01	13 - 2
67F-82151-10	17 - 3	60V-8259F-00	21 - 45	90109-06M86	18 - 16	90170-16M01	29 - 12		28 - 3	90445-13M37	12 - 2
67F-8215B-10	17 - 4	703-83383-11	33 - 52		20 - 15	90170-40008	6 - 22	90340-18M09	3 - 14	90445-15M03	6 - 18
67F-8215B-20	17 - 5	6Y5-8350T-91	34 - 1		20 - 23	90171-16011	30 - 23	90344-51019	5 - 4	90462-06018	20 - 34
6H1-82181-10	26 - 6	6Y5-83533-T2	34 - 9		20 - 31	90179-06M24	2 - 11	90386-06M12	21 - 12	90462-10027	21 - 7
63P-82310-01	15 - 5	6Y5-83553-M0	34 - 12		20 - 39	90179-08003	19 - 27	90386-08001	8 - 15	90464-08004	15 - 19
68V-82317-00	15 - 2	6Y5-83557-10	34 - 15		21 - 2	90179-24002	14 - 13	90386-10M16	22 - 20	90464-09M31	3 - 26
6A0-82317-00	16 - 16	6E5-83558-00	30 - 17	90109-06M96	20 - 18	90183-02M03	29 - 49	90386-15M73	20 - 10	90464-10010	3 - 23
	16 - 29	6E5-83558-10	29 - 8	90109-12007	23 - 18	90185-05002	30 - 13	90386-18001	22 - 32	90464-11009	3 - 24
663-82317-01	14 - 19	6Y5-8355X-T1	34 - 5	90109-12012	23 - 26	90185-09M01	31 - 3	90386-18M35	22 - 31	90464-12M58	16 - 20
67F-82341-00	15 - 6		34 - 10	90110-12M00	24 - 4	90185-10051	23 - 37	90386-18MA0	22 - 36	90464-15007	9 - 2
67F-82342-00	15 - 7	6Y5-83570-S6	34 - 6	90116-10175	23 - 36	90185-22M11	22 - 15	90386-25M31	22 - 13	90464-16001	3 - 47
67F-82343-00	15 - 10	67F-83614-00	18 - 15	90119-06087	8 - 8	90201-03313	29 - 48	90386-30M60	23 - 13	90464-18004	3 - 22
67F-82344-00	15 - 11	6D8-83626-00	5 - 35		8 - 12	90201-06068	20 - 12	90386-30M77	23 - 12	90464-18246	7 - 18
67F-82361-00	15 - 8	6Y5-83653-30	34 - 14	90119-06113	8 - 17	90201-06M31	21 - 37	90386-30M78	23 - 10		20 - 22
	15 - 12	67H-83672-01	23 - 1	90119-06M08	9 - 1	90201-06M62	21 - 27	90386-90M90	21 - 15	90464-30003	15 - 25
	15 - 14	68F-83688-00	7 - 17	90119-06M59	9 - 28	90201-09M02	21 - 16	90387-06013	21 - 36		18 - 17
67F-82362-00	15 - 9	689-85547-00	12 - 1		15 - 4	90201-10M02	21 - 28	90387-06119	14 - 20	90464-76001	8 - 18
	15 - 13	6D8-85547-00	14 - 18		16 - 18		21 - 38		15 - 3		17 - 9
6D8-82388-01	15 - 18	6D8-85580-00	14 - 3	90119-06M79	5 - 27	90201-10M20	31 - 2		16 - 17	90465-06M86	18 - 9
6D8-82389-01	17 - 19	68V-85753-00	18 - 6	90119-06M81	22 - 40	90201-10M63	31 - 6	90387-06263	28 - 10	90465-08M23	15 - 21
6D8-82398-01	17 - 22		35 - 7	90119-06M83	12 - 28	90201-12426	22 - 47	90387-06M05	16 - 31		20 - 30
68V-82504-00	18 - 12	67F-85757-00	18 - 5	90119-06MA2	3 - 34	90201-12M01	24 - 2	90387-06M21	21 - 26	90465-08M63	22 - 9
703-82510-44	33 - 44	67F-85790-00	18 - 4	90119-06MA4	3 - 19	90201-12M16	23 - 20	90387-06M43	20 - 51		23 - 3
6D8-8252H-01	18 - 18	6C5-85885-00	7 - 6	90119-07234	5 - 7		23 - 27	90387-06M60	9 - 27	90465-10M77	22 - 2
703-82531-00	33 - 47	6D8-8591A-24	15 - 1	90119-07235	5 - 5		24 - 5	90387-06M69	10 - 26	90465-11M10	3 - 21
6K1-82532-00	33 - 46	6Y5-87122-S0	34 - 11	90119-08069	8 - 1	90201-13M01	22 - 46	90387-07013	8 - 16		3 - 28
703-82540-00	33 - 51	6C5-87226-00	10 - 11	90119-08091	23 - 17		23 - 21	90387-08033	8 - 2		9 - 7
6D8-82544-00	8 - 25	K1C-A3275-00	4 - 6	90119-08M03	8 - 3	90201-13M03	23 - 25	90387-08M37	20 - 4		9 - 10
682-82556-00	33 - 49	K0A-A3721-00	6 - 7	90119-08M13	29 - 20	90201-13M19	23 - 30	90387-10M42	31 - 5		9 - 16
63D-82563-10	18 - 13	K0A-A3722-00	6 - 8		36 - 31	90201-24014	14 - 12	90387-18M01	22 - 35		9 - 21
703-82563-12	33 - 56	4VW-F111M-04	20 - 53	90119-08M22	20 - 2	90201-24M02	23 - 28	90387-22M01	22 - 37		11 - 16
688-82575-01	33 - 48	6D8-W0001-03	35 - 1	90119-08M58	27 - 30	90201-25M05	29 - 59	90389-25M00	30 - 22		12 - 9
703-82577-00	33 - 45	67F-W0001-21	36 - 1	90119-08M66	3 - 5	90201-26M59	22 - 14	90401-20007	3 - 46		12 - 26
6D8-82581-01	17 - 16	67F-W0078-00	1 - 16	90119-08M84	30 - 9	90201-30M00	23 - 9	90430-06M03	3 - 39		20 - 44
68F-82582-00	19 - 29		36 - 22	90119-08M87	29 - 19	90202-07M07	21 - 9		5 - 12		23 - 6
6DA-82582-00	17 - 6	6D8-W009A-04-9S	5 - 1		36 - 30	90202-25M04	23 - 29	90430-08020	1 - 14		23 - 7

NUMERICAL INDEX  
ÍNDICE NUMÉRICO

PART NO. No. PEÇA	REF. NO.	PART NO. No. PEÇA	REF. NO.	PART NO. No. PEÇA	REF. NO.	PART NO. No. PEÇA	REF. NO.	PART NO. No. PEÇA	REF. NO.	PART NO. No. PEÇA	REF. NO.
90465-11M10	29 - 9	92903-06600	16 - 13	92995-06600	27 - 11	93410-28M06	23 - 15	97075-10040	30 - 6	97595-06610	16 - 8
	34 - 16	92903-08100	19 - 33		27 - 13	93420-36M01	27 - 24	97095-06008	20 - 35		16 - 11
90465-11M59	3 - 42	92903-08600	19 - 31		29 - 38	93430-06024	33 - 10	97095-06010	9 - 12	97595-06630	14 - 10
	8 - 20	92907-04600	5 - 21	92995-08600	22 - 17	93450-44166	29 - 31		22 - 3	97602-04216	26 - 11
90465-12M03	8 - 22	92990-04100	34 - 3	92995-10100	30 - 7	93501-04M02	21 - 20		22 - 10	97607-04110	14 - 6
90465-12M53	16 - 30		34 - 7	92995-10600	30 - 8	93501-08001	25 - 8		22 - 25	97780-60620	16 - 7
90465-13M11	17 - 29	92990-06100	2 - 3	92A08-03012	25 - 79		25 - 16		22 - 28	97780-60625	16 - 4
90465-13M18	16 - 33	92990-08600	33 - 34	92A08-03110	25 - 64		25 - 24	97095-06012	2 - 6		16 - 32
	17 - 25	92995-06100	15 - 16	93101-25M03	29 - 32	93503-16003	25 - 22		8 - 23	97880-06012	22 - 6
	34 - 17		15 - 27		29 - 63		29 - 43		9 - 4	97980-05225	26 - 10
90467-09M03	9 - 17		15 - 30		36 - 5	93505-32038	25 - 50		17 - 14	97980-06216	27 - 26
90467-20M15	3 - 43		17 - 11	93101-48001	4 - 10	93602-07244	25 - 9		17 - 20	97985-04116	21 - 47
	8 - 21		17 - 27		35 - 10	93604-10M03	29 - 18		17 - 23	97985-06210	14 - 15
90468-18008	21 - 4		20 - 36	93102-08414	26 - 13	93604-12M07	28 - 25		18 - 10	97985-06216	23 - 2
	21 - 10		21 - 32	93102-38008	6 - 24	93605-10108	6 - 12		18 - 19	98507-04008	5 - 20
	21 - 13		22 - 43		35 - 4	93606-12019	3 - 3	97095-06014	15 - 22	98580-04006	33 - 36
	21 - 24	92995-06200	20 - 37	93102-48017	4 - 9		28 - 6		16 - 24	98580-04010	33 - 35
90480-06M19	13 - 4	92995-06600	2 - 7		35 - 9		30 - 5		17 - 17	98580-05010	33 - 37
90480-09M12	10 - 27		3 - 10	93106-09014	29 - 36	93606-19M23	27 - 14	97095-06016	9 - 23	98780-04016	3 - 17
90480-10M23	9 - 26		5 - 25		36 - 8	93608-16M16	27 - 3		12 - 12	99001-08600	29 - 42
90480-12072	5 - 22		5 - 32	93210-07003	29 - 41		27 - 22		15 - 29	99530-08012	14 - 9
90480-12314	14 - 17		8 - 7		36 - 10	93700-06M03	22 - 8		17 - 10	99530-14016	5 - 15
90480-13M24	16 - 23		8 - 11	93210-09165	25 - 83	94702-00391	1 - 6		17 - 26	9E450-04533	34 - 2
	20 - 50		8 - 24	93210-16275	31 - 9		5 - 36		18 - 2		
90480-14329	15 - 20		9 - 5	93210-19MJ1	28 - 26	95302-03600	25 - 65		18 - 7		
90480-19M06	29 - 22		9 - 13		36 - 15	95333-08600	19 - 32		20 - 13		
90480-20M05	3 - 31		9 - 24	93210-24M79	5 - 34	95380-04600	34 - 4		22 - 42		
90480-22M15	20 - 3		12 - 13		35 - 2		34 - 8		29 - 37		
90501-12082	21 - 21		15 - 17	93210-29M94	23 - 11	95380-05600	21 - 44	97095-06020	3 - 9		
90501-12M48	29 - 47		15 - 23	93210-30682	12 - 27		33 - 7		8 - 10		
90501-16M11	3 - 30		15 - 28		35 - 13	95380-06600	2 - 4	97095-06025	5 - 31		
90506-14M24	22 - 26		15 - 31	93210-46044	29 - 33		20 - 47		15 - 15		
90506-16M34	20 - 16		16 - 25		36 - 6		33 - 40		15 - 26		
90506-16M39	6 - 17		17 - 12		36 - 29	95380-08600	12 - 11		21 - 40		
91318-03005	25 - 74		17 - 15	93210-49046	29 - 39	95380-12600	22 - 48	97095-06030	5 - 24		
91318-03016	25 - 68		17 - 18		36 - 9	95380-12700	24 - 3		8 - 6		
91318-04030	25 - 67		17 - 21	93210-554A9	26 - 14	95380-12800	23 - 31	97095-06035	21 - 31		
91318-05025	25 - 75		17 - 24	93210-64488	25 - 86	95780-12300	23 - 23	97095-08020	22 - 16		
91318-05030	25 - 66		17 - 28	93210-86M39	29 - 64		24 - 6	97380-05025	33 - 8		
91318-05045	25 - 44		18 - 3		36 - 11	95812-06025	28 - 9	97380-08030	33 - 33		
91318-05050	25 - 88		18 - 8	93306-207U0	29 - 58	95895-06020	14 - 21	97575-06525	21 - 19		
91380-06020	25 - 87		18 - 11	93315-52563	29 - 13	95895-06025	8 - 26		28 - 5		
91490-20015	21 - 17		18 - 20	93317-322V0	29 - 54	95895-08014	27 - 29	97575-08540	3 - 40		
91490-40030	30 - 24		21 - 33	93317-325U0	29 - 62	97013-06020	16 - 12		5 - 13		
91609-50028	25 - 73		21 - 41	93332-000U3	29 - 15	97013-08045	19 - 30		27 - 2		
91690-30020	22 - 22		22 - 29	93332-000UD	29 - 55	97075-06030	27 - 10	97575-10540	23 - 34		
91690-50014	8 - 4		22 - 44	93410-18M05	22 - 33	97075-06050	27 - 12	97595-06545	28 - 24		
91809-08006	5 - 6		27 - 8		22 - 38	97075-06070	27 - 7	97595-06550	21 - 6		