

**PARTS
CATALOGUE
CATALOGO
DE REPUESTOS**

(E)40XMH '01 (66T0)

(E)40XWH '01 (66T1)

(E)40XW '01 (66T1)

(E)40XWT '01 (66T1)

FOREWORD

This Parts Catalogue is related to the parts for the model(s) in the below frame. When you are ordering replacement parts, please refer to this Parts Catalogue and quote both part numbers and part names correctly.

(E)40XMH'01(66T0), (E)40XWH'01(66T1),
(E)40XW'01(66T1), (E)40XWT'01(66T1)

1. Modifications or additions which have been made after issue of the Parts Catalogue will be announced in the Yamaha Parts News.
It is advisable that you make necessary corrections to the Parts Catalogue according to the Yamaha Parts News.

2. Abbreviations

The Following abbreviations are used in this Parts Catalogue.

- "UR" Use specified parts number.
- "UN" Use as many as needed.
- "AP" Alternate Parts
- "LM" Local Made
(Parts need to be ordered locally)
- "O/S" Over Size

3. Parts, which are to be supplied in an assembly, are listed with a dot(.) in front of the part name as shown below.

EXAMPLE
CARBURETOR ASSY
.JET, PILOT
.NOZZLE, MAIN

4. Number of component for assembly

The numeral appearing to the right of each component part indicates the quantity of parts for each assembly unit.

EXAMPLE

PART NO.	DESCRIPTION	E	EH	EHT	L	LH	LHT	REMARKS
6E0-85500-70	C.D.I. MAGNETO ASSY	1						
6E0-85550-70	.ROTOR ASSY	1						
6E0-15723-00-94.	.PULLY, STARTER	1						

5. Quantity Column Information

NAME for Q'TY COLUMN	APPLICABLE MODEL
MH	40XMH, E40XMH
WH	40XWH, E40XWH
W	40XW, E40XW
WT	40XWT, E40XWT

6. Applicable Starting Serial No. and Color Code

1) Engine Starting Sserial No.

40XMH	S : 005649	E40XMH	S : 005649
	L : 217613		L : 217613
40XWH	L : 351867		X : 701095
40XW	S : 121235	E40XWH	L : 351867
	L : 402073	E40XW	S : 121235
40XWT	L : 452288		L : 402073
		E40XWT	L : 452288

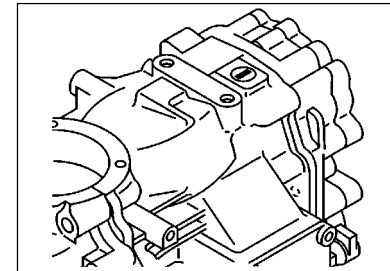
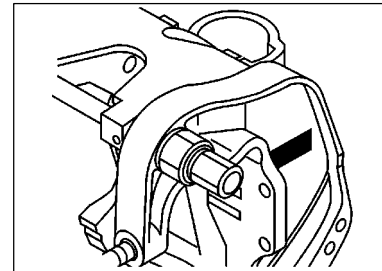

2) Color Code

Color Code	Color Name	Abbreviation
004D	DARK BLUISH GRAY METALLIC 2	DBNM2

7. Note that the illustrations for reference in finding parts numbers, not to be used for assembling. When assembling, please use the applicable service manual.

8. The asterisk (*) before a reference number indicates modification items after the first edition.

CONTENTS

SHEET 1/2

TOP COWLING	A4
CYLINDER. CRANKCASE	A5
CRANKSHAFT. PISTON	A7
INTAKE	B1
CARBURETOR	B2
FUEL	B4
STARTER	B6
GENERATOR	C1
ELECTRICAL 1	C3
ELECTRICAL 2	C4
ELECTRICAL 3	C6
STARTING MOTOR	C7
BOTTOM COWLING	D1
STEERING	D3
STEERING FRICTION	D5
CONTROL	D6
REMOTO CONTROL ATTACHMENT	E1
BRACKET 1	E2
BRACKET 2	E6
BRACKET 3	F1
POWER TRIM & TILT ASSY	F3
UPPER CASING	F6
LOWER CASING. DRIVE 1	F7

INDEX

NUMERICAL INDEX	G1
-----------------------	----

SHEET 2/2

LOWER CASING. DRIVE 1	A4*
LOWER CASING. DRIVE 2	A7*
FUEL TANK	B2*
STEERING GUIDE	B3*
REMOTE CONTROL BOX	B4*
REMOTE CONTROL ASSY	B5*
REPAIR KIT 1	C1*
REPAIR KIT 2	C3*
REPAIR KIT 3	C4*

INDEX

NUMERICAL INDEX	G1*
-----------------------	-----

FIG. 1 TOP COWLING

SOPORTE SUPERIOR

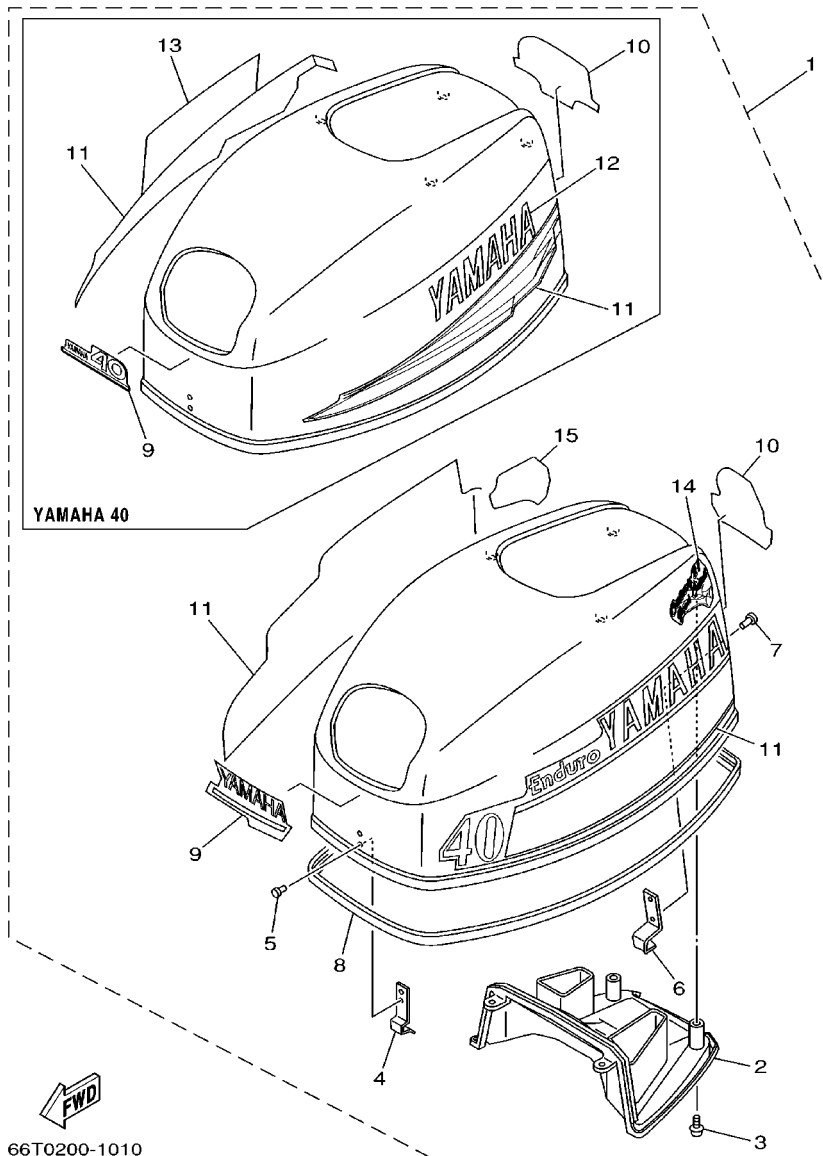

66T0200-1010

REF. NO.	PART NO. CODIGO NO.	DESCRIPTION DESCRIPTION	MH	WH	W	WT	REMARKS OBSERVACION
1	66T-42610-H1-4D	TOP COWLING ASSY SOPORTE SUPERIOR COMPL.	1	1	1	1	ENDURO
	66T-42610-Y0-4D	TOP COWLING ASSY SOPORTE SUPERIOR COMPL.	1	1			ENDURO FOR YEMEN
	66T-42610-11-4D	TOP COWLING ASSY SOPORTE SUPERIOR COMPL.	1	1	1		YAMAHA 40
2	66T-42613-01	.MOLDING, AIR DUCT .MOLDURA CONDUCTO AIRE	1	1	1	1	
3	97780-50616	.SCREW, TAPPING .TORNILLO, ROSCA HEMBRA	4	4	4	4	
4	6E0-42651-02	.HOOK .GANCHO	1	1	1	1	
5	90266-04M04	.RIVET .REMACHE	2	2	2	2	
6	6F5-42652-01	.HOOK .GANCHO	1	1	1	1	
7	90266-04M01	.RIVET .REMACHE	2	2	2	2	
8	66T-42615-02	.SEAL .SELLO	1	1	1	1	
9	61N-42677-H0	.GRAPHIC, FRONT .CALCAMONIA FRONTAL	1	1	1	1	ENDURO
	63D-42677-11	.GRAPHIC, FRONT .CALCAMONIA FRONTAL	1	1	1	1	YAMAHA 40
10	6J4-42678-H0	.GRAPHIC, REAR .CALCAMONIA TRASERA	1	1	1	1	ENDURO
	63D-42678-11	.GRAPHIC, REAR .CALCAMONIA TRASERA	1	1	1	1	YAMAHA 40
11	66T-W0070-H0	.GRAPHIC SET .JUEGO DE EMBLEMA	1	1	1	1	ENDURO
	63D-W0070-10	.GRAPHIC SET .JUEGO DE EMBLEMA	1	1	1	1	YAMAHA 40
12	63D-42681-10	.MARK, COWLING .MARCA DE CUBIERTA	1	1	1	1	YAMAHA 40
13	63D-42682-10	.MARK, COWLING .MARCA DE CUBIERTA	1	1	1	1	YAMAHA 40
14	66T-42681-Y0	.MARK, COWLING .MARCA DE CUBIERTA	1	1			ENDURO FOR YEMEN
15	66T-42682-Y0	.MARK, COWLING .MARCA DE CUBIERTA	1	1			ENDURO FOR YEMEN

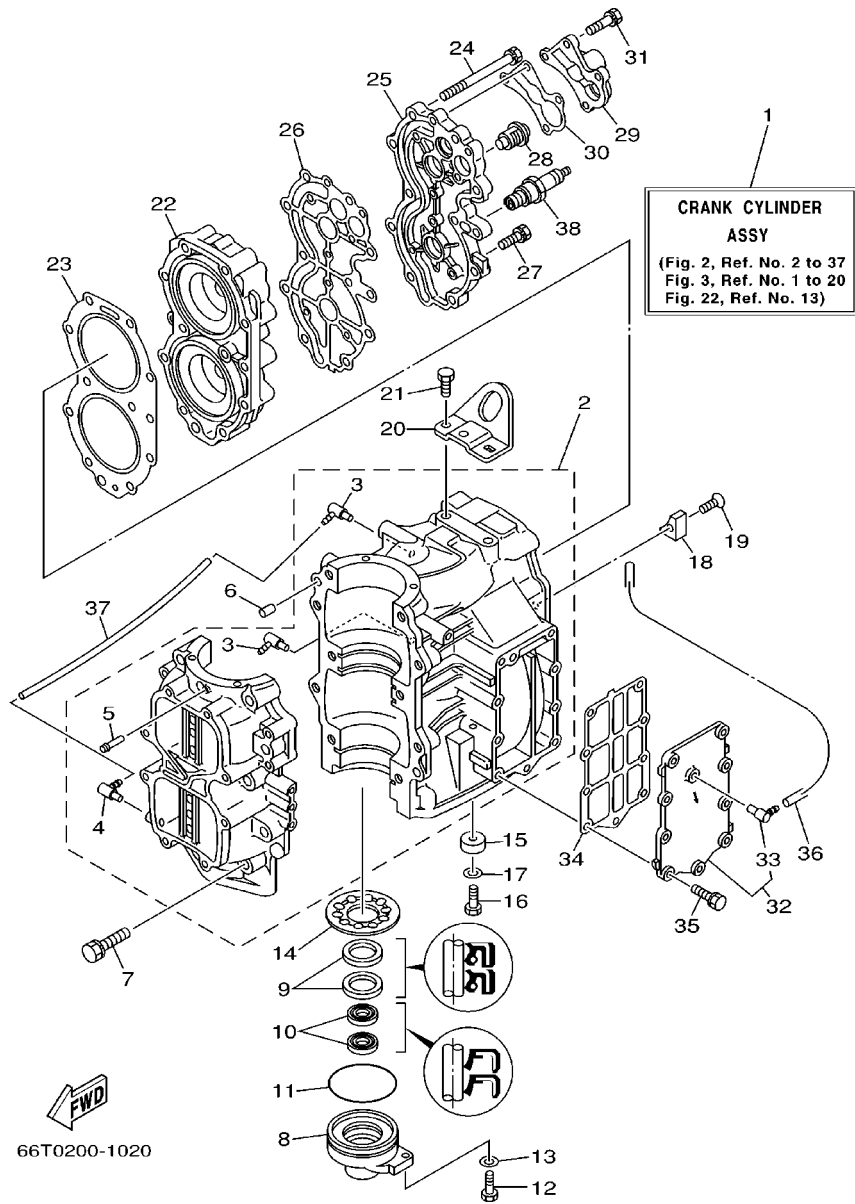

FIG. 2 CYLINDER. CRANKCASE CYLINDRO. CARTER

REF. NO.	PART NO. CODIGO NO.	DESCRIPTION DESCRIPTION	MH	WH	W	WT	REMARKS OBSERVACION
1	66T-W0090-02-1S	CRANK CYLINDER ASSY BLOQUE MOTOR COMPLETO	1	1	1	1	
2	66T-15100-02-1S	CRANKCASE ASSY CARTER COMPLETO	1	1	1	1	
3	6E5-13552-00	.NOZZLE .BOQUILLA	2	2	2	2	
4	6E5-13552-00	.NOZZLE .BOQUILLA	1	1	1	1	
5	624-14485-00	.PIPE, JOINT .TUBO DE UNION	1	1	1	1	
6	93608-12063	PIN, DOWEL PASADOR DE CLAVIJA	2	2	2	2	
7	90119-10005	BOLT, WITH WASHER TORNILLO CON ARANDELA	10	10	10	10	
8	66T-15396-01-94	HOUSING, OIL SEAL CAJA DE SELLO DE ACEITE	1	1	1	1	
9	93102-30M56	OIL SEAL SELLO ACEITE	2	2	2	2	
10	93101-16001	OIL SEAL SELLO ACEITE	2	2	2	2	
11	93210-65M50	O-RING ANILLO O	1	1	1	1	
12	97095-06020	BOLT PERNO	1	1	1	1	
13	92995-06600	WASHER ARANDELA	1	1	1	1	
14	66T-11565-00	WASHER, BEARING COVER ARANDELA CUBIERTA DE COJINETE	1	1	1	1	
15	676-45251-00	ANODE CATODE	1	1	1	1	
16	97095-06020	BOLT PERNO	1	1	1	1	
17	92995-06600	WASHER ARANDELA	1	1	1	1	
18	676-11325-00	ANODE ANODO	1	1	1	1	
19	90141-06M00	SCREW, COUNTERSUNK TORNILLO RANURADO	1	1	1	1	
20	66T-11119-00	HANGER, ENGINE SOPORTE DEL MOTOR	1	1	1	1	
21	90101-08002	BOLT TORNILLO	2	2	2	2	
22	66T-11111-01-94	HEAD, CYLINDER 1 CULATA CILINDRO 1	1	1	1	1	
23	66T-11181-A2	GASKET, CYLINDER HEAD 1 JUNTA, DE CULATA 1	1	1	1	1	
24	90119-08MA5	BOLT, WITH WASHER TORNILLO CON ARANDELA	11	11	11	11	
25	66T-11191-00-9M	COVER, CYLINDER HEAD 1 TAPA CULATA DE CILINDRO 1	1	1	1	1	
26	66T-11193-A2	GASKET, HEAD COVER 1 EMPAQUE	1	1	1	1	
27	90119-06MA3	BOLT, WITH WASHER TORNILLO CON ARANDELA	4	4	4	4	

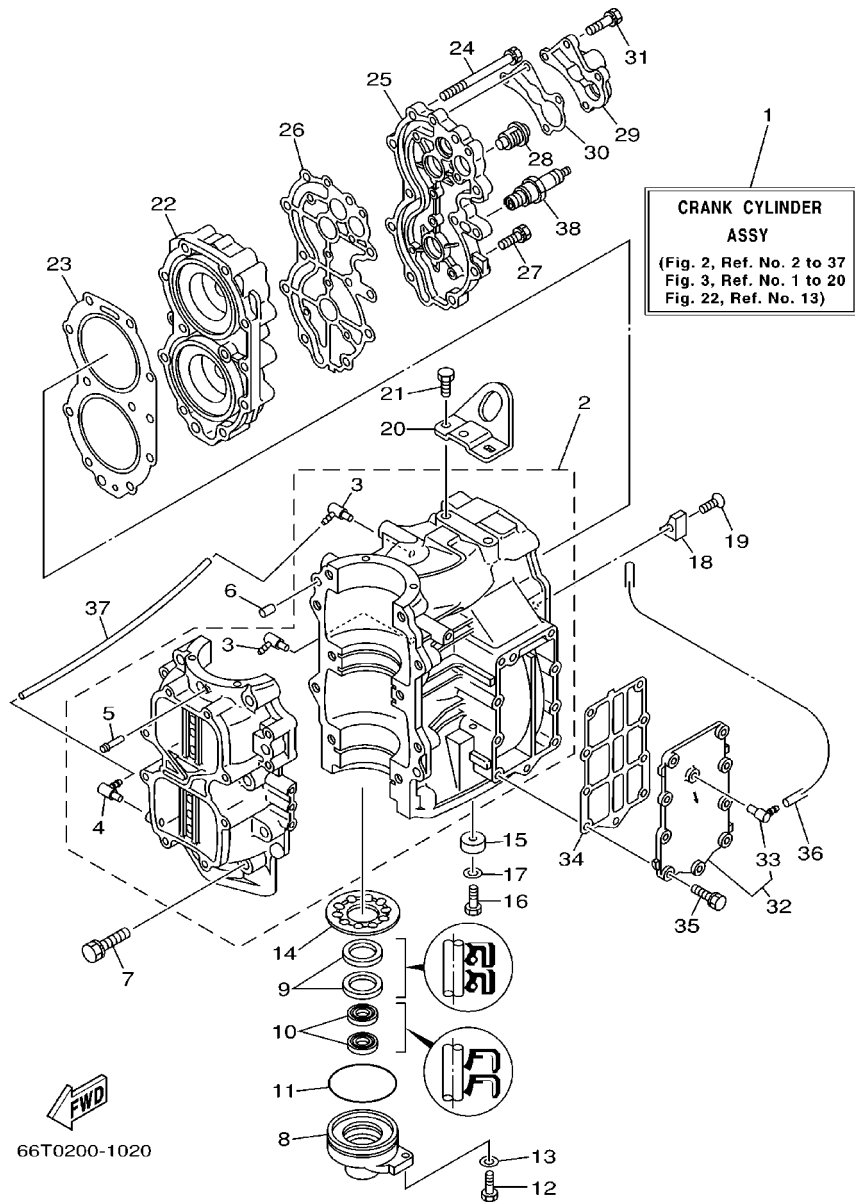

FIG. 2 CYLINDER, CRANKCASE CYLINDRO, CARTER

REF. NO.	PART NO. CODIGO NO.	DESCRIPTION DESCRIPTION	MH	WH	W	WT	REMARKS OBSERVACION
28	6E5-12411-01	THERMOSTAT TERMOSTAT	1	1	1	1	
29	676-12413-00-9M	COVER, THERMOSTAT CUBIERTA TERMOSTATO	1	1	1	1	
30	676-12414-A0	GASKET, COVER EMPAQUE	1	1	1	1	
31	90119-06MA5	BOLT, WITH WASHER TORNILLO CON ARANDELA	4	4	4	4	
32	66T-41113-00-9M	OUTER COVER, EXHAUST CUBOERTA EXTERIOR, DE ESCAPE	1	1	1	1	
33	676-11372-00	.NIPPLE, HOSE .NIPLE DE MANGUERA	1	1	1	1	
34	66T-41114-A0	GASKET, EXHAUST OUTER COVER EMPAQUE	1	1	1	1	
35	90119-06MA3	BOLT, WITH WASHER TORNILLO CON ARANDELA	9	9	9	9	
36	90445-09M75	HOSE (L370) TUBO (L370)	1	1	1	1	
37	90445-07M08	HOSE (L220) TUBO (L220)	1	1	1	1	
38	94702-00040	PLUG, SPARK (NGK B7HS) BUJIA (NGK B7HS)	2	2	2	2	
	94702-00272	PLUG, SPARK (NGK BR7HS) BUJIA (NGK BR7HS)	2	2	2	2	FOR CARIB, CHINA, TAIWAN

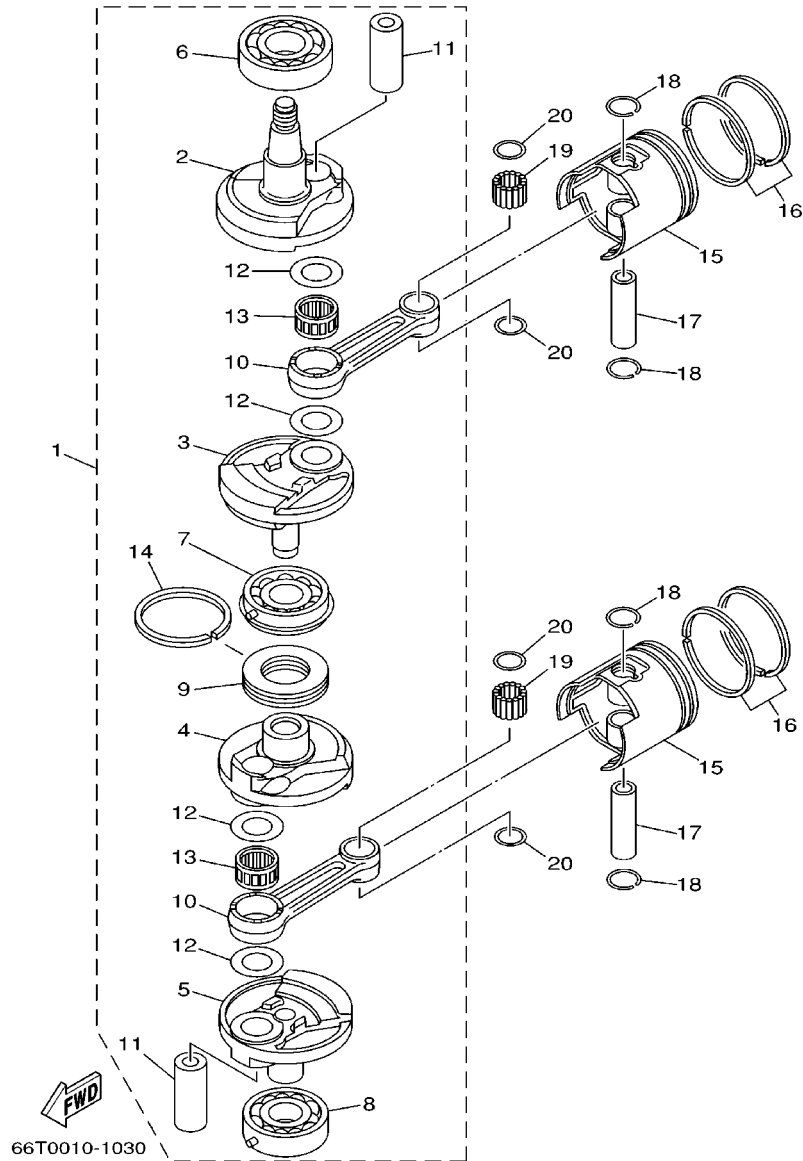

FIG. 3 CRANKSHAFT. PISTON

CIGUENAL. PISTON

REF. NO.	PART NO. CODIGO NO.	DESCRIPTION DESCRIPTION	MH	WH	W	WT	REMARKS OBSERVACION
1	66T-11400-01	CRANKSHAFT ASSY CIGUENAL COMPLETO	1	1	1	1	
2	66T-11412-00	.CRANK 1 .MANIVELA 1	1	1	1	1	
3	66T-11422-00	.CRANK 2 .MANIVELA 2	1	1	1	1	
4	66T-11432-00	.CRANK 3 .MANIVELA 3	1	1	1	1	
5	66T-11442-00	.CRANK 4 .MANIVELA 4	1	1	1	1	
6	93306-307U0	.BEARING .COJINETE	1	1	1	1	
7	93332-000UE	.BEARING .COJINETE	1	1	1	1	
8	93306-306V5	.BEARING .COJINETE	1	1	1	1	
9	6F5-11515-00	.SEAL, LABYRINTH 1 .SELLO LABERINTO 1	1	1	1	1	
10	6F5-11651-00	.ROD, CONNECTING .BIELA	2	2	2	2	
11	66T-11681-00	.PIN, CRANK 1 .PASADOR MANIVELA 1	2	2	2	2	
12	90209-27M07	.WASHER .ARANDELA DE SEPARACION	4	4	4	4	
13	93310-727U0	.BEARING .COJINETE	2	2	2	2	
14	93440-68M03	.CIRCLIP .BOLA	1	1	1	1	
15	66T-11631-00-93	PISTON (STD) PISTON (STD)	2	2	2	2	
	66T-11635-00	PISTON (0.25MM O/S)	2	2	2	2	AP
	66T-11636-00	PISTON (0.50MM O/S)	2	2	2	2	AP
16	66T-11603-00	PISTON RING SET (STD) JUEGO DE ANILLOS (STD)	2	2	2	2	
	66T-11604-00	PISTON RING SET (0.25MM O/S) JUEGO DE ANILLOS (0.25MM O/S)	2	2	2	2	AP
	66T-11605-00	PISTON RING SET (0.50MM O/S) JUEGO DE ANILLOS (0.50MM O/S)	2	2	2	2	AP
17	6F5-11633-00	.PIN, PISTON .PASADOR, PISTON	2	2	2	2	
18	663-11634-00	.CLIP, PISTON PIN .PRESILLA, BULON DE PISTON	4	4	4	4	
19	93603-21111	.PIN, DOWEL .PASADOR DE CLAVIJA	56	56	56	56	
20	90201-20417	.WASHER, PLATE .ARANDELA PLANA	4	4	4	4	

FIG. 4 INTAKE

ADMISION

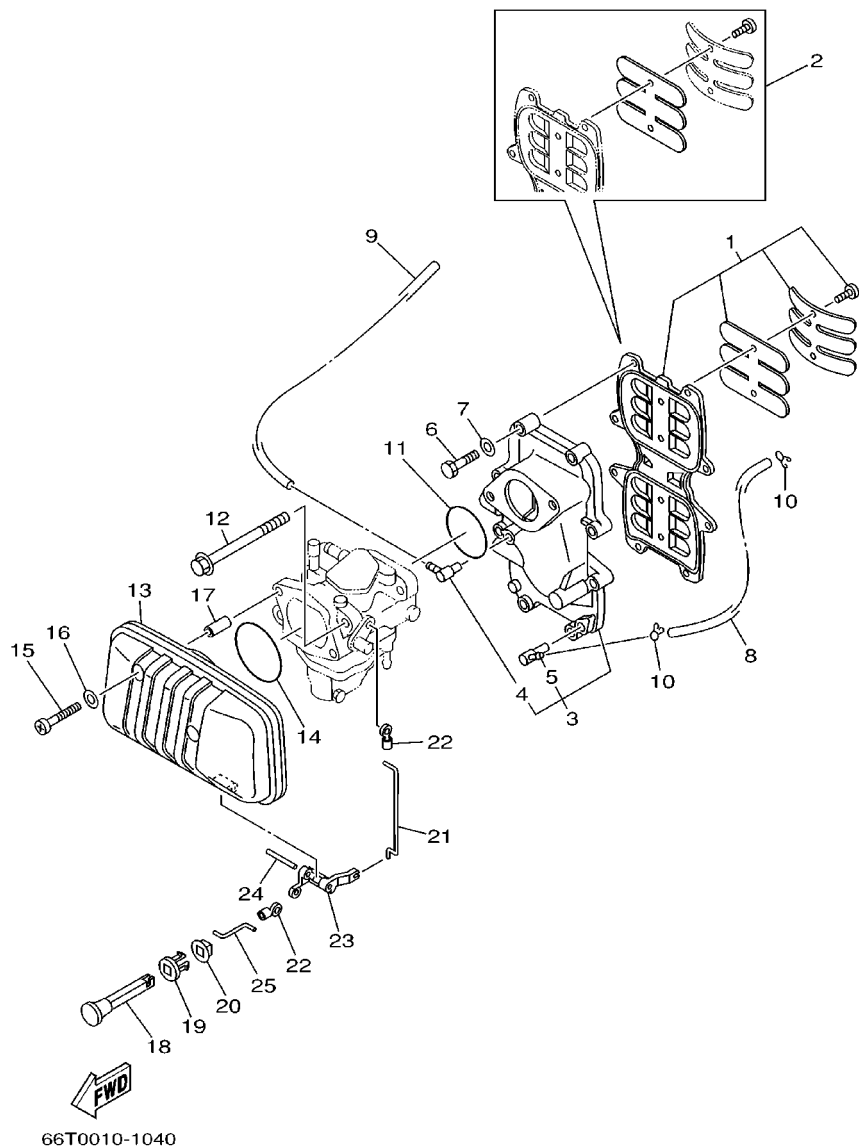

REF. NO.	PART NO. CODIGO NO.	DESCRIPTION DESCRIPTION	MH	WH	W	WT	REMARKS OBSERVACION
1	66T-13610-00	REED VALVE ASSY VALVULA DE LAMINAS COMPLETA	1	1	1	1	
2	66T-W0004-00	.REED SET .JUEGO DE VALVULAS DE LENGUETA	1	1	1	1	
3	66T-13641-02-94	MANIFOLD 1 MULTIPLE 1	1	1	1	1	
4	6E5-13552-00	.NOZZLE .BOQUILLA	1	1	1	1	
5	650-11372-00	.NIPPLE, HOSE .NIPLE DE MANGUERA	1	1	1	1	
6	97013-06035	BOLT PERNO	8	8	8	8	
7	92903-06600	WASHER, PLATE ARANDELA	8	8	8	8	
8	90445-07M24	HOSE (L240) TUBO (L240)	1	1	1	1	
9	90445-07MA4	HOSE (L280) TUBO (L280)	1	1	1	1	
10	90467-06016	CLIP PRESILLA	2	2	2	2	
11	93210-46M16	O-RING ANILLO O	1	1	1	1	
12	90119-08M03	BOLT, WITH WASHER TORNILLO CON ARANDELA	2	2	2	2	
13	66T-14440-00	SILENCER ASSY, INTAKE SILENCIADOR COMPL DE ADMISION	1	1	1	1	
14	93210-54M54	O-RING ANILLO O	1	1	1	1	
15	97885-06040	SCREW, PAN HEAD TORNILLO DE CABEZA CON PLANA	2	2	2	2	
16	92995-06600	WASHER ARANDELA	2	2	2	2	
17	90387-06M80	COLLAR COLLAR	2	2	2	2	
18	6H4-41271-01	KNOB, CHOKE PERILLA AHOGADOR	1	1	1	1	
19	689-41273-00	GROMMET TAPON PROTECTOR	1	1	1	1	
20	6J8-41274-00	GROMMET 2 TAPON 2	1	1	1	1	
21	66T-41256-00	ROD, CHOKE 1 VARILLA DE AHOGADOR	1	1	1	1	
22	661-41262-02	JOINT, CHOKE LEVER CONECTOR DE AHOGADOR	2	2	2	2	
23	66T-41252-00	LEVER, CHOKE 1 PALANCA AHOGADOR 1	1	1	1	1	
24	91690-40032	PIN, SPRING PASADOR DE RESORTE	1	1	1	1	
25	66T-41257-00	ROD, CHOKE 2 VARILLA DE AHOGADOR	1	1	1	1	

FIG. 5 CARBURETOR

CARBURADOR

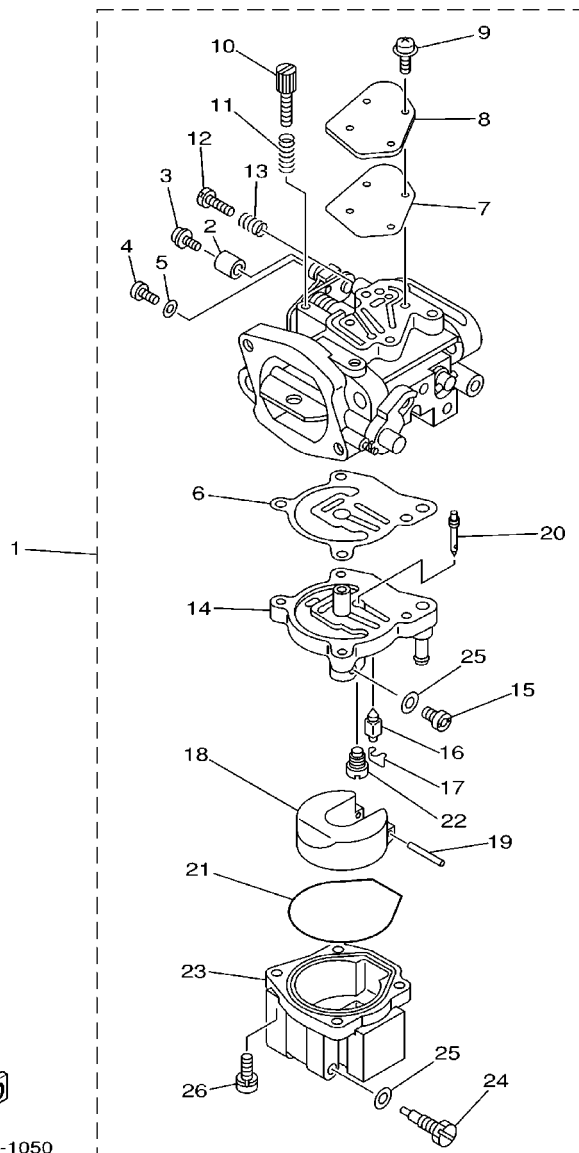

66T0010-1050

REF. NO.	PART NO. CODIGO NO.	DESCRIPTION DESCRIPTION	MH	WH	W	WT	REMARKS OBSERVACION
1	66T-14301-02	CARBURETOR ASSY 1 CARBURADOR COMPLETO 1	1	1			
	66T-14301-12	CARBURETOR ASSY 1 CARBURADOR COMPLETO 1			1	1	
	66T-14301-22	CARBURETOR ASSY 1 CARBURADOR COMPLETO 1	1				FOR BRAZIL
	66T-14301-32	CARBURETOR ASSY 1 CARBURADOR COMPLETO 1			1		FOR BRAZIL
2	66T-14578-00	.COLLAR .COLLAR	1	1	1	1	
3	66T-14584-00	.STOPPER .RETENER	1	1	1	1	
4	6J8-14592-01	.SCREW .TORNILLO	1	1	1	1	
5	92990-05600	.WASHER, PLATE .ARANDELA	1	1	1	1	
6	66T-14384-01	.GASKET, FLOAT CHAMBER .EMPAQUE DE CAMARA DE BOIA	1	1	1	1	
7	66T-14536-00	.GASKET .EMPAQUE	1	1	1	1	
8	66T-14527-00	.PLATE .PLACA	1	1	1	1	
9	97980-04112	.SCREW, WITH WASHER .TORNILLO, CON ARANDELA	4	4	4	4	
10	66T-14523-00	.SCREW, STOP .TORNILLO DE TOPE	1	1	1	1	
11	6J8-14334-00	.SPRING, THROTTLE .RESORTE DE AJUSTADOR DE AIRE	1	1	1	1	
12	6E5-14323-03	.SCREW, AIR ADJUSTING .TORNILLO DE AJUSTE DE AIRE	1	1	1	1	
13	6E5-14223-00	.SPRING, AIR ADJUSTING .RESORTE, AJUSTE DE AIRE	1	1	1	1	
14	66T-14945-02	.SPACER ASSY (#38) .BRIDA DE ESPACIADOR 1 (#38)	1	1	1	1	
15	61A-1492E-85	.JET, MAIN (#170) .INJECTOR, PRINCIPAL (#170)	1	1	1	1	
	61A-1492E-88	.JET, MAIN (#176) .INJECTOR, PRINCIPAL (#176)	1	1			FOR BRAZIL
16	6E5-14546-00	.VALVE, NEEDLE .VALVULA DE AGUJA	1	1	1	1	
17	6E5-14159-00	.CLIP .PRESILLA	1	1	1	1	
18	6E5-14385-02	.FLOAT BOIA	1	1	1	1	
19	6E5-14386-02	.PIN, FLOAT .PASADOR DE BOIA	1	1	1	1	
20	66T-1492F-35	.JET, AIR SLOW (#70) .ESPREA (#70)	1	1	1	1	
	66T-1492F-37	.JET, AIR SLOW (#74) .ESPREA (#74)	1	1			FOR BRAZIL
21	66T-14984-00	.GASKET, FLOAT CHAMBER .EMPAQUE CAMARA DE BOIA	1	1	1	1	
22	66T-14992-00	.PLUG .TAPON	1	1	1	1	

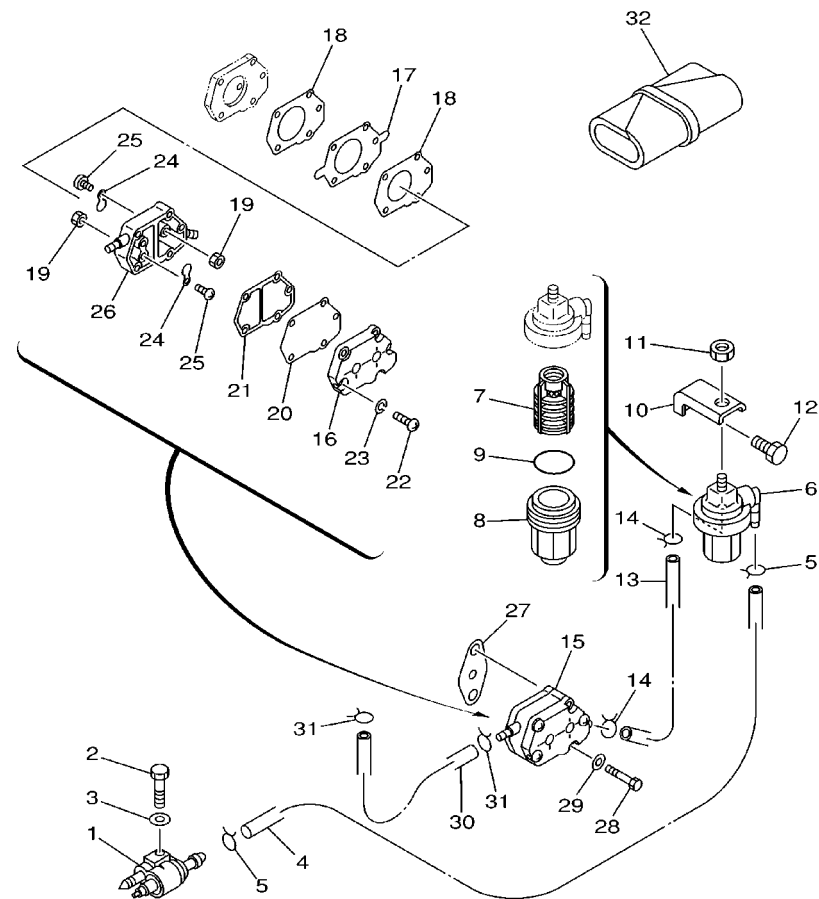

66T0010-1060

FIG. 6 FUEL

COMBUSTIBLE

REF. NO.	PART NO. CODIGO NO.	DESCRIPTION DESCRIPTION	MH	WH	W	WT	REMARKS OBSERVACION
1	6G1-24304-02	FUEL PIPE JOINT COMP. 1 CONECTOR MANGUERA COMBUST.1	1	1	1	1	
2	97095-06030	BOLT PERNO	1	1	1	1	
3	92995-06600	WASHER ARANDELA	1	1	1	1	
4	90445-09M08	HOSE (L550) TUBO (L550)	1	1	1	1	
5	90467-08004	CLIP PRESILLA	2	2	2	2	
6	61N-24560-00	FILTER ASSY FILTRO COMPLETO	1	1	1	1	
7	61N-24563-00	.ELEMENT, FILTER .ELEMENTO DEL FILTRO	1	1	1	1	
8	61N-24521-00	.CUP, FILTER .COPA DE FILTRO	1	1	1	1	
9	93210-32738	.O-RING .ANILLO O	1	1	1	1	
10	648-24566-02	BRACKET, FILTER SOPORTE DEL FILTRO	1	1	1	1	
11	95380-08600	NUT TUERCA	1	1	1	1	
12	97013-06014	BOLT PERNO	1	1	1	1	
13	90445-09086	HOSE (L170) TUBO (L170)	1	1	1	1	
14	90467-08004	CLIP PRESILLA	2	2	2	2	
15	692-24410-00	FUEL PUMP ASSY BOMBA DE COMBUSTIBLE COMPLETA	1	1	1	1	
16	6A0-24413-00	BODY 2 .CUERPO 2	1	1	1	1	
17	692-24411-00	.DIAPHRAGM .DIAFRAGMA	1	1	1	1	
18	648-24434-01	.GASKET, BODY EMPAQUE	2	2	2	2	
19	95380-03600	.NUT .TUERCA	2	2	2	2	
20	663-24411-00	.DIAPHRAGM .DIAFRAGMA	1	1	1	1	
21	648-24435-02	.GASKET, BODY 2 EMPAQUE	1	1	1	1	
22	98503-05028	.SCREW, PAN HEAD .TORNILLO DE CABEZA CON PLANA	3	3	3	3	
23	92990-05100	.WASHER, SPRING ARANDELA	3	3	3	3	
24	6A0-24421-01	.VALVE, CHECK .VALVULA DE RETENCION	2	2	2	2	
25	6A0-14325-00	.SCREW, PAN HEAD .TORNILLO CABEZA REDONDA	2	2	2	2	
26	6A0-24412-02	BODY 1 .CUERPO 1	1	1	1	1	
27	650-24431-A0	GASKET, FUEL PUMP 1 EMPAQUE BOMBA COMBUST 1	1	1	1	1	

B4

COMBUSTIBLE

FIG. 6 FUEL

REF. NO.	PART NO. CODIGO NO.	DESCRIPTION DESCRIPTION	MH	WH	W	WT	REMARKS OBSERVACION
28	97095-06040	BOLT PERNO	2	2	2	2	
29	92995-06600	WASHER ARANDELA	2	2	2	2	
30	90445-09086	HOSE (L170) TUBO (L170)	1	1	1	1	
31	90467-08004	CLIP PRESILLA	2	2	2	2	
32	676-W2810-01	TOOL KIT JUEGO DE HERRAMIENTAS	1	1	1	1	

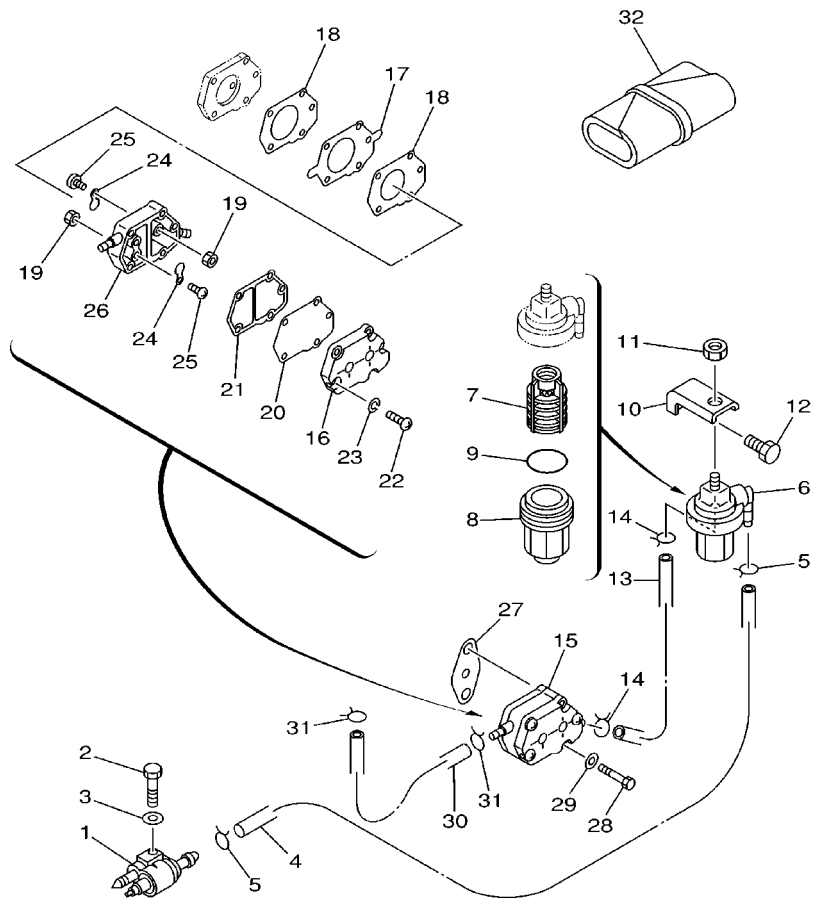

66T0010-1060

FIG. 7 STARTER

ARRANQUE

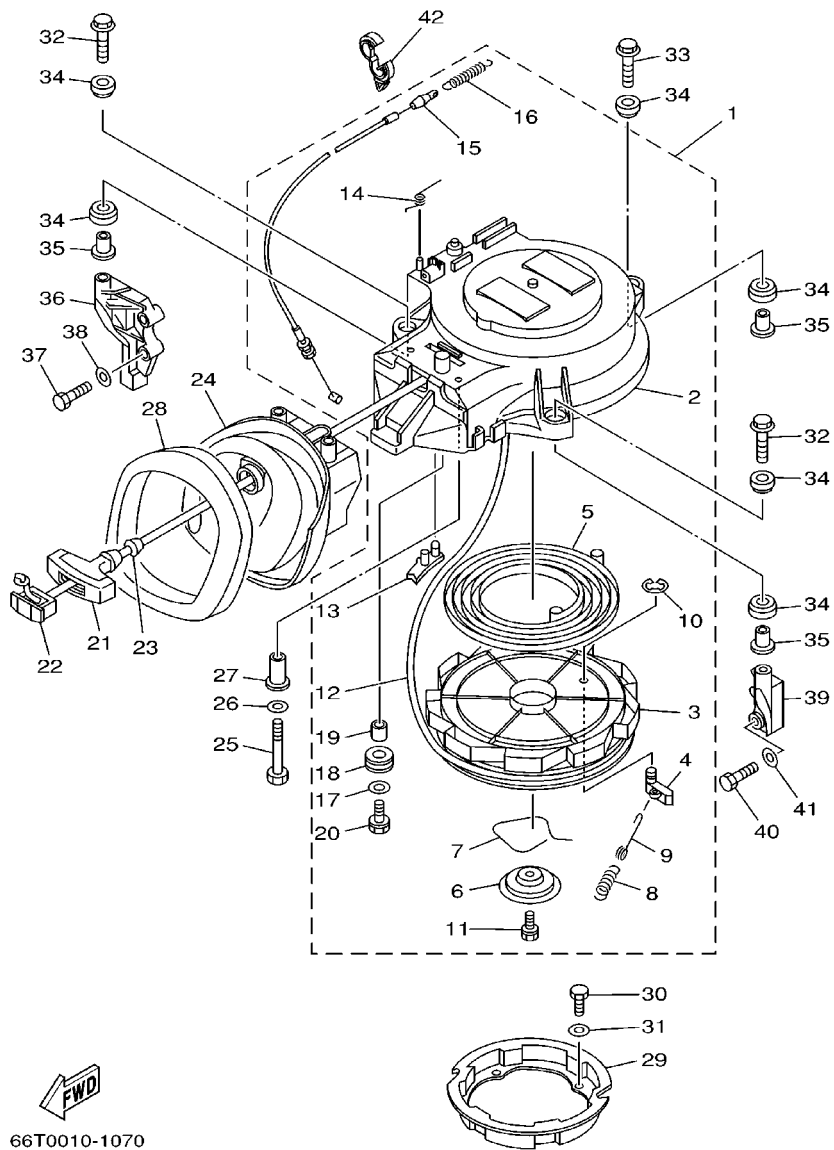

REF. NO.	PART NO. CODIGO NO.	DESCRIPTION DESCRIPTION	MH	WH	W	WT	REMARKS OBSERVACION
1	66T-15710-00	STARTER ASSY ARRANQUE COMPLETO	1	1	1	1	
2	66T-15711-00	.CASE, STARTER .CAJA DE ARRANQUE	1	1	1	1	
3	66T-15714-00	.DRUM, SHEAVE .TAMBOR ROLDANA	1	1	1	1	
4	63V-15741-00	.PAWL, DRIVE .TRINQUETE DE TRACCION	1	1	1	1	
5	66T-15713-00	.SPRING, STARTER .RESORTE DE ARRANQUE	1	1	1	1	
6	66T-15716-00	.PLATE, DRIVE .PLACA DE TRACCION	1	1	1	1	
7	66T-15705-00	.SPRING, DRIVE PAWL .RESORTE	1	1	1	1	
8	66T-15767-00	.SPRING .RESORTE	1	1	1	1	
9	66T-15784-00	.SPRING, RETURN .RESORTE DE RETORNO	1	1	1	1	
10	63V-15744-00	.CIRCLIP .SEGURO	1	1	1	1	
11	63V-15768-00	.BOLT .TORNILLO	1	1	1	1	
12	*	.WIRE, STARTER (1.8M) .CUERDA DE ARRANQUE (1,8M)	1	1	1	1	
13	66T-15794-00	.STOPPER .TOPE	1	1	1	1	
14	66T-15734-00	.SPRING, RETURN .RESORTE DE RETORNO	1	1	1	1	
15	66T-15770-00	.CABLE COMP., STARTER STOP .CABLE COMPL DE SEGURO ARRANQUE	1	1	1	1	
16	66T-15731-00	.SPRING, RETURN .RESORTE DE RETORNO	1	1	1	1	
17	6F5-15791-00	.WASHER, LOCK .EMBLEMA	1	1	1	1	
18	6F5-15752-00	.ROLLER, WIRE .RODILLO DE CUERDA	1	1	1	1	
19	6F5-15753-00	.BUSH .BUJE	1	1	1	1	
20	6F5-15768-00	.BOLT .TORNILLO	1	1	1	1	
21	689-15755-01	.HANDLE, STARTER .MANIJA DE ARRANQUE	1	1	1	1	
22	6F5-15779-02	.COVER .CUBIERTA	1	1	1	1	
23	697-15789-00	.DAMPER .AMORTIGUADOR	1	1	1	1	
24	66T-15758-01	.GUIDE, ROPE .GUIA DE CUERDA	1	1	1	1	
25	97095-06035	.PERNO	2	2	2	2	
<p>* CUT FROM 50M ROLLS, PART NO. 90890-44374, CUTTING LENGTH 1.8M * CORTE DE UN RODILLO DE 50M, PARTS NUMERO 90890-44374, LARGO DEL CORTE 1.8M</p>							

FWD
66T0010-1070

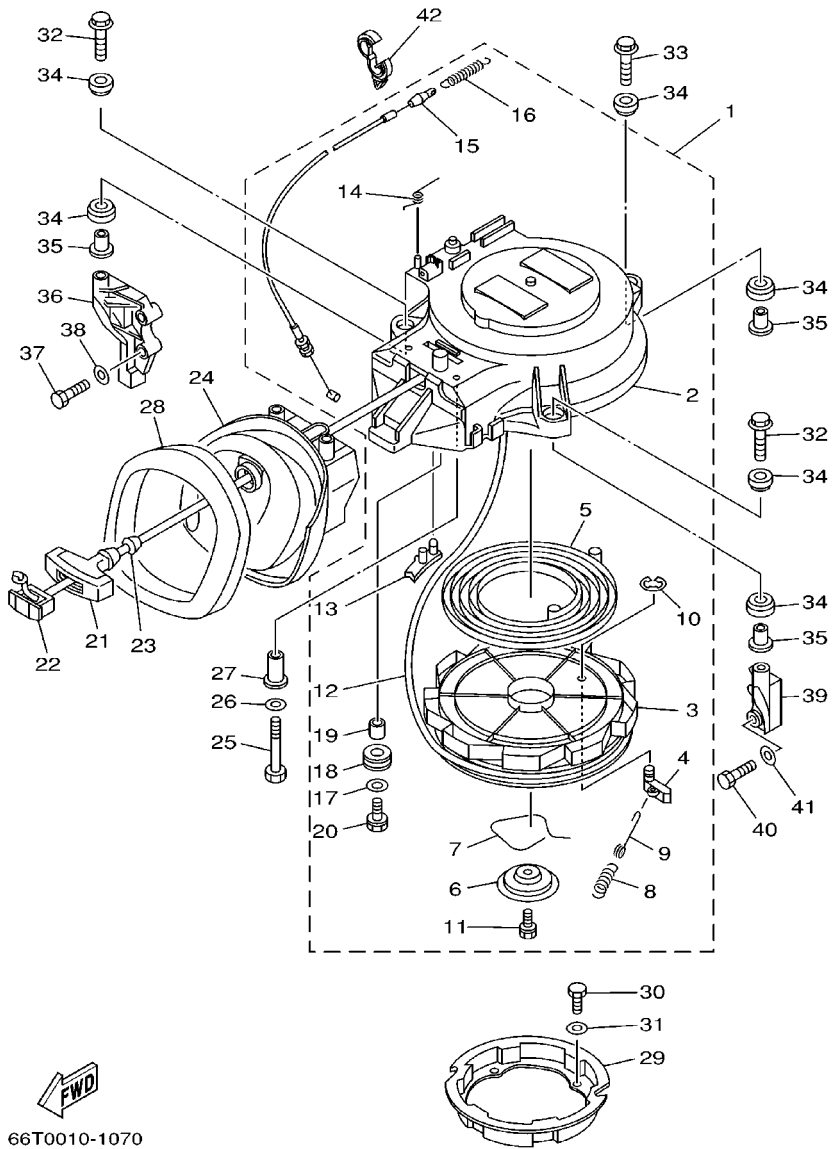

FIG. 7 STARTER

ARRANQUE

REF. NO.	PART NO. CODIGO NO.	DESCRIPTION DESCRIPTION	MH	WH	W	WT	REMARKS OBSERVACION
26	92995-06600	WASHER ARANDELA	2	2	2	2	
27	90387-06M66	COLLAR COLLAR	2	2	2	2	
28	66T-15762-01	SEAL, RUBBER 2 SELLO DE GOMA 2	1	1	1	1	
29	66T-15723-00	PULLEY, STARTER POLEA DE ARRANQUE	1	1	1	1	
30	97095-06010	BOLT PERNO	4	4	4	4	
31	92995-06600	WASHER ARANDELA	4	4	4	4	
32	90119-08M10	BOLT, WITH WASHER TORNILLO CON ARANDELA	2	2	2	2	
33	90119-08M51	BOLT, WITH WASHER TORNILLO CON ARANDELA	1	1	1	1	
34	90385-12M04	BUSH BUJE	6	6	6	6	
35	90387-08M05	COLLAR COLLAR	3	3	3	3	
36	66T-15771-00-94	STAY 1 SOPORTE 1	1	1	1	1	
37	97013-06030	BOLT PERNO	2	2	2	2	
38	92903-06600	WASHER, PLATE ARANDELA	2	2	2	2	
39	66T-15772-00-94	STAY 2 SOPORTE 2	1	1	1	1	
40	97013-06030	BOLT PERNO	2	2	2	2	
41	92903-06600	WASHER, PLATE ARANDELA	2	2	2	2	
42	90464-13249	CLAMP BRIDA	1	1	1	1	

FIG. 8 GENERATOR

GENERADOR

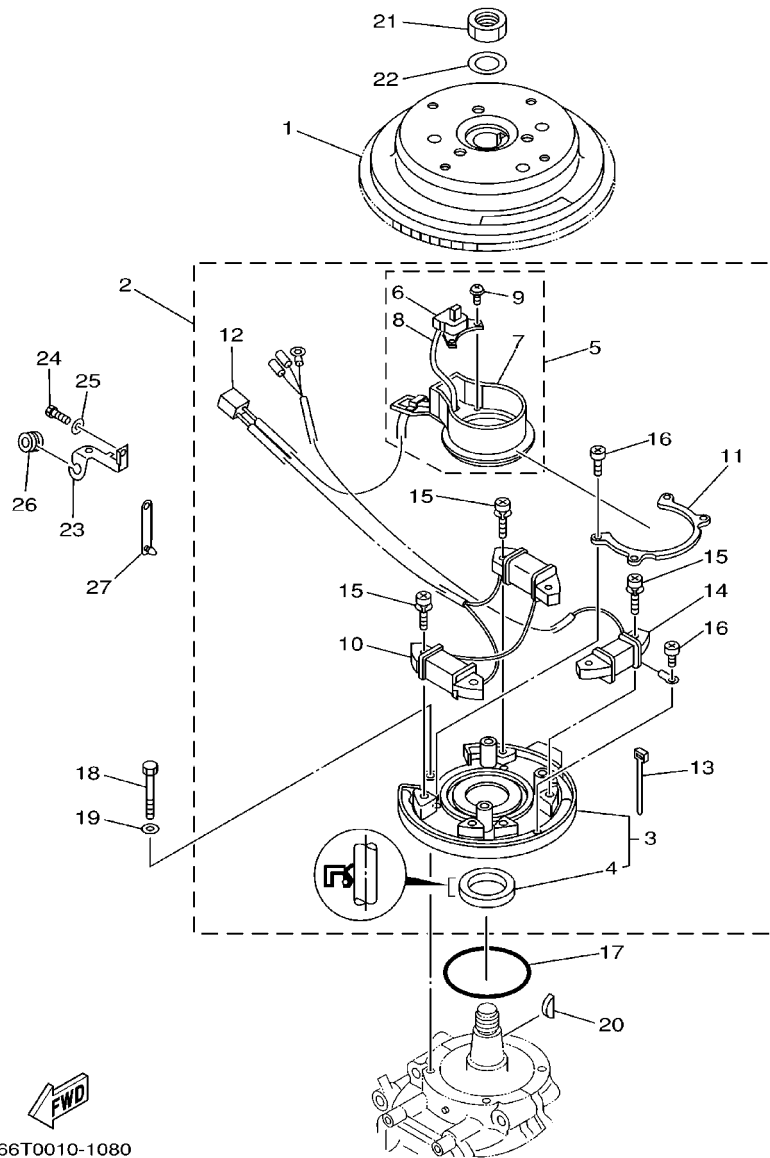

66T0010-1080

REF. NO.	PART NO. CODIGO NO.	DESCRIPTION DESCRIPTION	MH	WH	W	WT	REMARKS OBSERVACION
1	66T-85550-00	ROTOR ASSY ROTOR COMPLETO		1	1	1	
	66T-85550-10	ROTOR ASSY (W/LIGHTING COIL) ROTOR COMPLETO (C/BOBINA DE LUZ)	1				
2	66T-85560-01	BASE ASSY CONJUNTO BASE	1	1	1	1	
	66T-85560-11	BASE ASSY CONJUNTO BASE	1				
3	66T-85561-00	BASE, MAGNETO BASE DE MAGNETO	1	1	1	1	
4	93102-35008	OIL SEAL SELLO ACEITE	1	1	1	1	
5	66T-85580-00	PULSER COIL ASSY BOBINA DE PULSACION COMPLETA	1	1	1	1	
6	66T-85596-00	COIL, PULSER 1 BOBINA DE PULSACION 1	1	1	1	1	
7	66T-85582-00	ATTACHMENT, PULSER IMPLEMENTO DE PULSACION	1	1	1	1	
8	66T-85515-00	LEAD WIRE ASSY CABLE CONDUCTOR COMPLETO	1	1	1	1	
9	97902-04108	SCREW, WITH WASHER TORNILLO, CON ARANDELA	2	2	2	2	
10	66T-85520-00	COIL, CHARGE BOBINA DE CARGA	1	1	1	1	
11	66T-41611-00	RETAINER, MAGNETO BASE RETENEDOR BASE MAGNETO	1	1	1	1	
12	9E471-04305	CONNECTOR CONECTOR	1	1	1	1	
13	66T-81328-00	CLAMP GRAMPA	1	1	1	1	
14	66T-85533-00	COIL, LIGHTING BOBINA DE LUZ	1	1	1	1	FOR 66T-85560-01
15	97902-06125	SCREW, WITH WASHER TORNILLO, CON ARANDELA	6	6	6	6	FOR 66T-85560-01
	97902-06125	SCREW, WITH WASHER TORNILLO, CON ARANDELA	4				FOR 66T-85560-11
16	97802-04006	SCREW, PAN HEAD TORNILLO DE CABEZA CON PLANA	5	5	5	5	FOR 66T-85560-01
	97802-04006	SCREW, PAN HEAD TORNILLO DE CABEZA CON PLANA	4				FOR 66T-85560-11
17	93210-75M51	O-RING ANILLO O	1	1	1	1	
18	97095-06040	BOLT PERNO	4	4	4	4	
19	92995-06600	WASHER ARANDELA	4	4	4	4	
20	90280-05015	KEY, WOODRUFF CUNA WOODRUFF	1	1	1	1	
21	90170-20137	NUT TUERCA	1	1	1	1	
22	90201-21M18	WASHER, PLATE ARANDELA PLANA	1	1	1	1	
23	90465-15M74	CLAMP BRIDA	1	1	1	1	

C1

FIG. 8 GENERATOR

GENERADOR

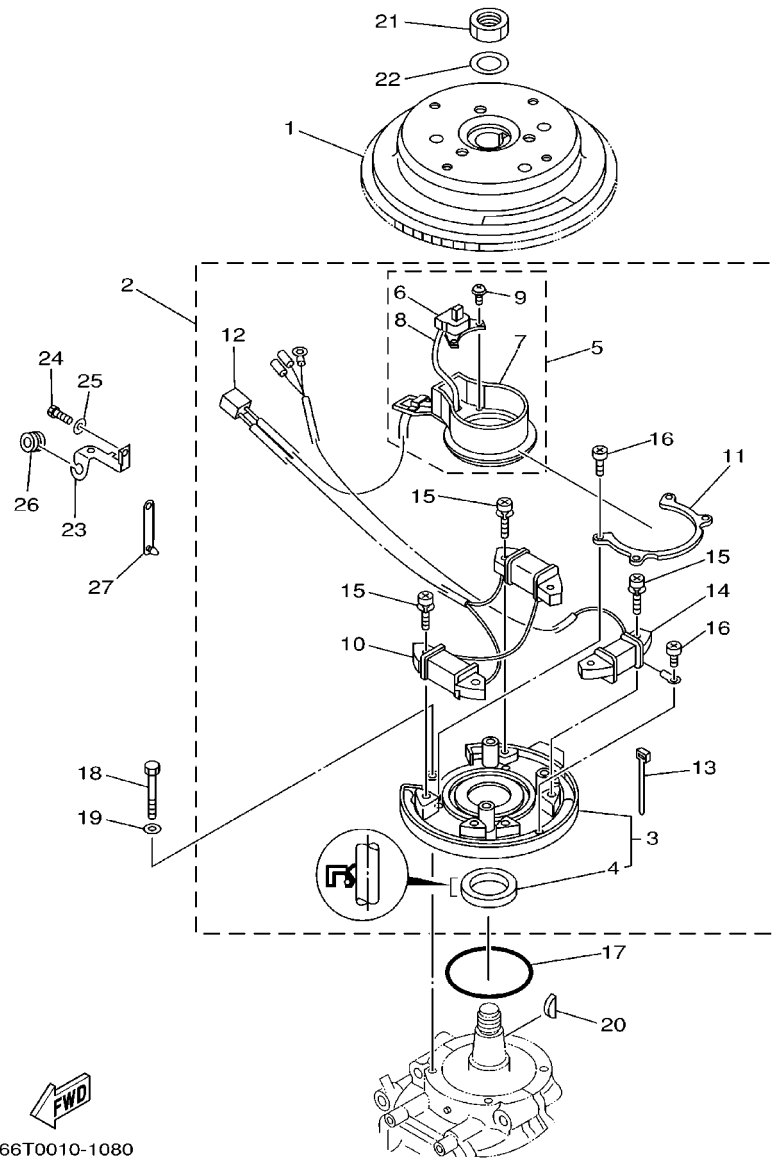

REF. NO.	PART NO. CODIGO NO.	DESCRIPTION DESCRIPTION	MH	WH	W	WT	REMARKS OBSERVACION
24	97095-06016	BOLT PERNO	1	1	1	1	
25	92995-06600	WASHER ARANDELA	1	1	1	1	
26	90480-10M71	GROMMET TAPON	1	1	1	1	
27	90464-12M00	CLAMP BRIDA	1	1	1	1	

66T0010-1080

FIG. 9 ELECTRICAL 1

EQUIPO ELECTRICO 1

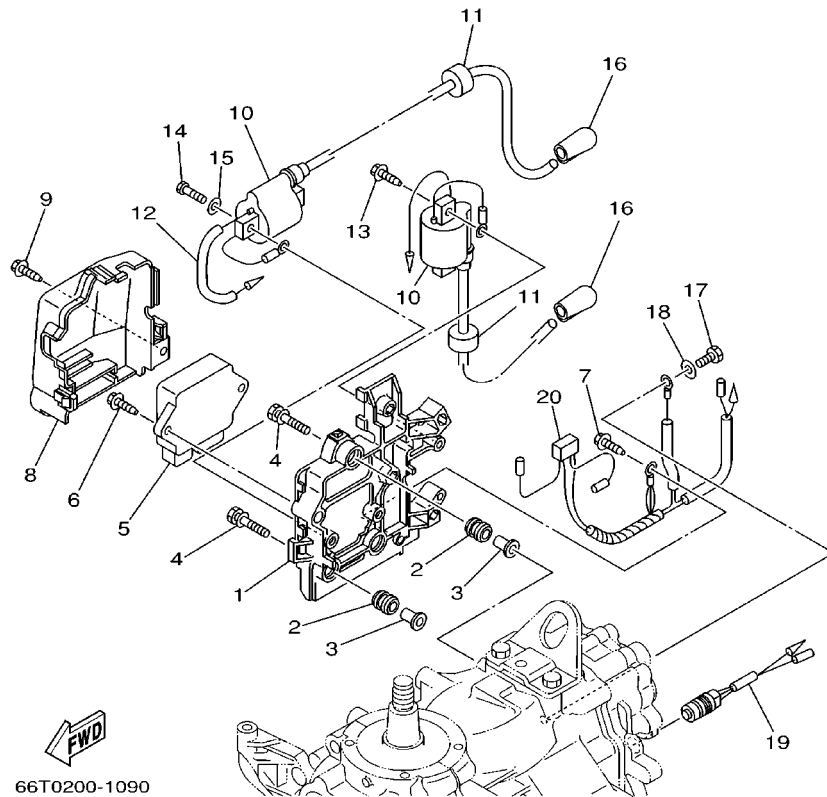
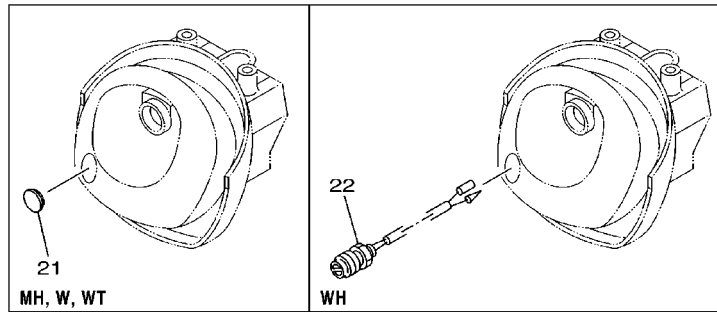

66T0200-1090

REF. NO.	PART NO. CODIGO NO.	DESCRIPTION DESCRIPTION	MH	WH	W	WT	REMARKS OBSERVACION
1	66T-8554B-01-94	BRACKET SOPORTE (REF.NO. 6, 7, 9, 13, FIG.10, REF.NO. 13)	1	1	1	1	
2	6A0-82317-00	DAMPER, IGNITION COIL AMORTIGUADOR BOBINA ENCENDIDO	3	3	3	3	
3	624-42542-00	PIPE TUBO	3	3	3	3	
4	90119-06M65	BOLT, WITH WASHER TORNILLO CON ARANDELA	3	3	3	3	
5	66T-85540-00	C.D.I. UNIT ASSY UNIDAD C.D.I. COMPLETA	1	1	1	1	
6	90109-06M81	BOLT PERNO	2	2	2	2	
7	90109-06M80	BOLT PERNO	1	1	1	1	
8	66T-81916-01	COVER, TERMINAL CUBIERTA DE TERMINAL	1	1	1	1	
9	90109-06M81	BOLT PERNO	1	1	1	1	
10	66T-85570-00	IGNITION COIL ASSY BOBINA DE IGNICION COMPLETO	2	2	2	2	
11	90480-25161	GROMMET TAPON	2	2	2	2	
12	90446-03MA3	HOSE TUBO RESEIRADERO	1	1	1	1	
13	90109-06M81	BOLT PERNO	2	2	2	2	
14	97095-06025	BOLT PERNO	2	2	2	2	
15	92995-06600	WASHER ARANDELA	2	2	2	2	
16	66T-82370-00	PLUG CAP ASSY TAPON DE BUJIA COMPLT	2	2	2	2	
	6E3-82370-21	PLUG CAP ASSY TAPON DE BUJIA COMPLT	2	2	2	2	FOR CARIB
17	97095-06012	BOLT PERNO	1	1	1	1	
18	92995-06600	WASHER ARANDELA	1	1	1	1	
19	688-82560-10	THERMO SWITCH ASSY INTER. DE TERMO	1	1	1	1	
20	66T-82519-00	WIRE, EARTH LEAD CABLE CONDUCTOR A TIERRA	1	1			
21	6G1-42725-00	GROMMET TAPON	1		1	1	
22	689-81870-00	STARTING SWITCH ASSY INTERRUPTOR DE ARRANQUE COMPL.		1			

FIG. 10 ELECTRICAL 2

EQUIPO ELECTRICO 2

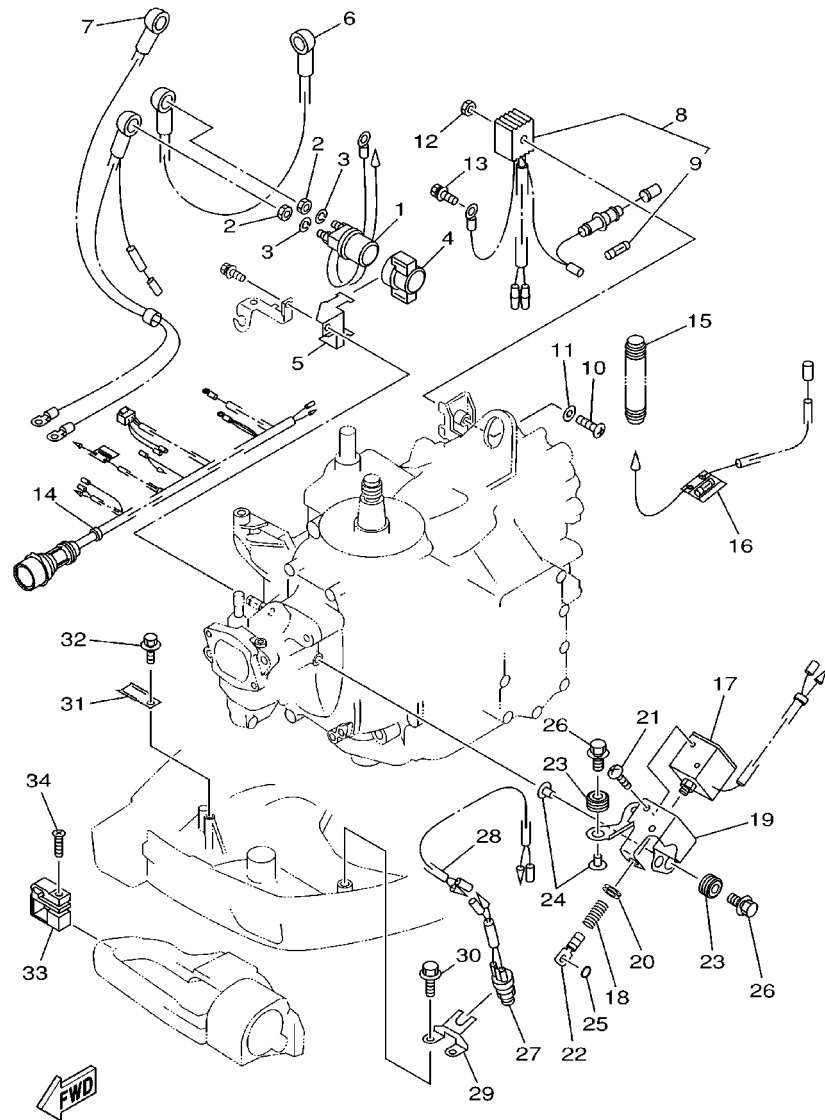

66T0200-1100

REF. NO.	PART NO. CODIGO NO.	DESCRIPTION DESCRIPTION	MH	WH	W	WT	REMARKS OBSERVACION
1	6G1-8194A-10	RELAY RELE		1	1	1	
2	90170-06M30	NUT TUERCA		2	2	2	
3	90204-06M00	WASHER, SPRING ARANDELA DE RESORTE		2	2	2	
4	6G1-81952-00	HOLDER, RELAY SOSTEN DE RELE		1	1	1	
5	6L2-81945-00	PLATE, SWITCH FITTING PLACA ACCESORIA DE INTERRUP.		1	1		
6	6E5-82117-01	WIRE, LEAD CABLE CONDUCTOR		1	1	1	
7	66T-82105-00	WIRE HARNESS ARNES DE CABLES		1	1	1	
8	6G1-81970-61	RECTIFIER ASSY RECTIFICADOR COMPLETO		1	1	1	
9	6G1-82151-00	.FUSE .FUSIBLE		1	1	1	
10	97880-05030	SCREW, PAN HEAD TORNILLO DE CABEZA CON PLANA		1	1	1	
11	92990-05600	WASHER, PLATE ARANDELA		1	1	1	
12	95380-05600	NUT TUERCA		1	1	1	
13	90109-06M80	BOLT PERNO		1	1	1	
14	66T-82590-00	WIRE HARNESS ASSY CONJUNTO DE CABLES			1		
15	66T-83557-00	TUBE ENCHUFE DE ACEITE		1	1		I.DIA.: 13MM
	6N7-83557-00	TUBE ENCHUFE DE ACEITE				1	I.DIA.: 22MM
16	66T-82115-00	WIRE, PLUS LEAD CABLE CONDUCTOR POSITIVO		1			
17	6J4-86111-00	COIL, SOLENOID CONJUNTO BOBINA SOLENOIDE			1	1	
18	6J4-86116-00	WIRE, PULL ALAMBRE-JALADOR			1	1	
19	66T-86112-00	STAY, SOLENOID SOPORTE SOLENOIDE			1	1	
20	90480-10155	GROMMET TAPON			1	1	
21	97880-05008	SCREW, PAN HEAD TORNILLO DE CABEZA CON PLANA			4	4	
22	682-86117-00	HOOK, WIRE PULL GANCHO JALADOR DE ALAMBRE			1	1	
23	90480-10M23	GROMMET TAPON			3	3	
24	90387-06M60	COLLAR COLLAR			3	3	
25	93210-03261	O-RING ANILLO O			1	1	
26	90119-06M88	BOLT, WITH WASHER TORNILLO CON ARANDELA			3	3	

FIG. 10 ELECTRICAL 2

EQUIPO ELECTRICO 2

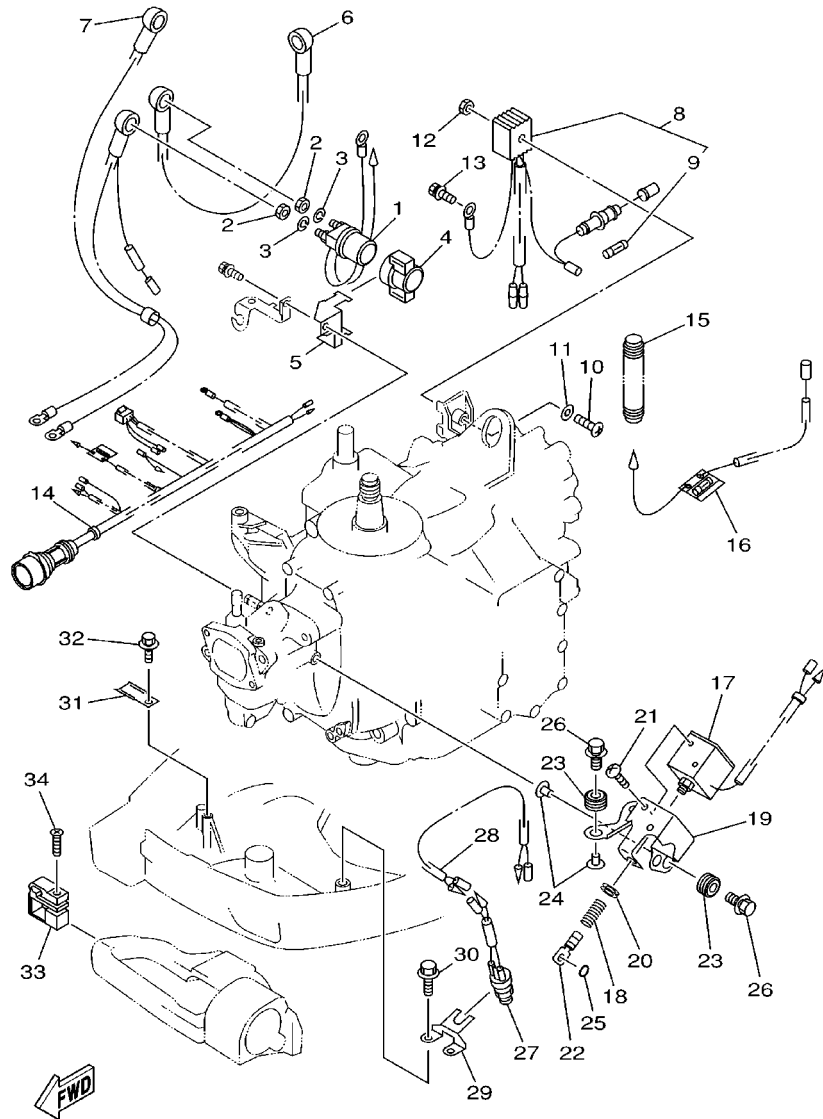

66T0200-1100

REF. NO.	PART NO. CODIGO NO.	DESCRIPTION DESCRIPTION	MH	WH	W	WT	REMARKS OBSERVACION
27	6F5-82540-00	NEUTRAL SWITCH ASSY INTERRUPTOR NEUTRAL COMPL		1			
28	66T-82553-00	EXTENSION, WIRE LEAD CABLE		1			
29	66T-82554-00	STAY, NEUTRAL SWITCH SOPORTE INTERRUPTOR DE NEUTRAL		1			
30	90109-06M86	BOLT PERNO		2			
31	90465-20M31	CLAMP BRIDA		1	1	1	
32	90109-06M86	BOLT PERNO		1	1	1	
33	65W-82594-00	CLAMP GRAMPA		1			
34	90161-06M00	SCREW, TAPPING TORNILLO DE CABEZA PLANA		1			

FIG. 11 ELECTRICAL 3

EQUIPO ELECTRICO 3

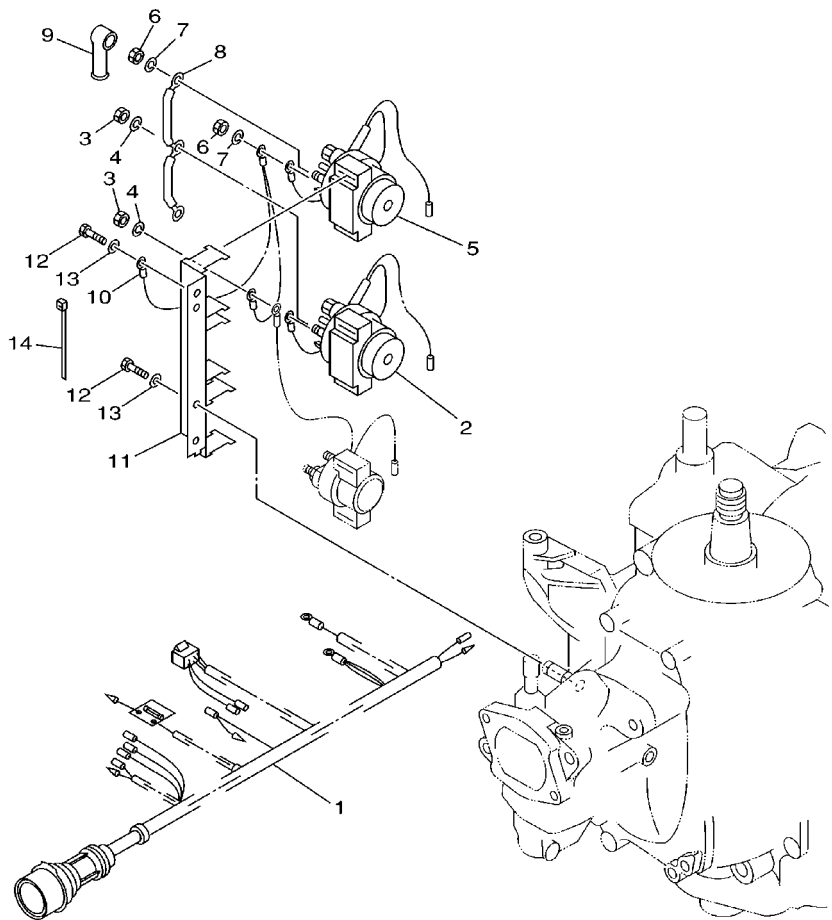

REF. NO.	PART NO. CODIGO NO.	DESCRIPTION DESCRIPTION	MH	WH	W	WT	REMARKS OBSERVACION
1	66T-82590-20	WIRE HARNESS ASSY CONJUNTO DE CABLES				1	
2	6E5-8195B-01	RELAY ASSY RELE COMPLETO				1	
3	90170-06M30	NUT TUERCA				3	
4	90204-06M00	WASHER, SPRING ARANDELA DE RESORTE				3	
5	6E5-8195C-01	RELAY ASSY RELE COMPLETO				1	
6	90170-06M30	NUT TUERCA				3	
7	90204-06M00	WASHER, SPRING ARANDELA DE RESORTE				3	
8	66T-87149-00	CONNECTOR CONECTOR				1	
9	6G5-82119-00	COVER, LEAD WIRE CUBIERTA DE CABLE CONDUCTOR				4	
10	6E5-82116-00	WIRE, MINUS LEAD CABLE CONDUCTOR NEGATIVO				1	
11	66T-81948-00	BRACKET SOPORTE				1	
12	97095-06016	BOLT PERNO				1	
13	92995-06600	WASHER ARANDELA				1	
14	90465-11M10	CLAMP BRIDA				1	



66T0010-1110

FIG. 12 STARTING MOTOR

MOTOR DE ARRANQUE

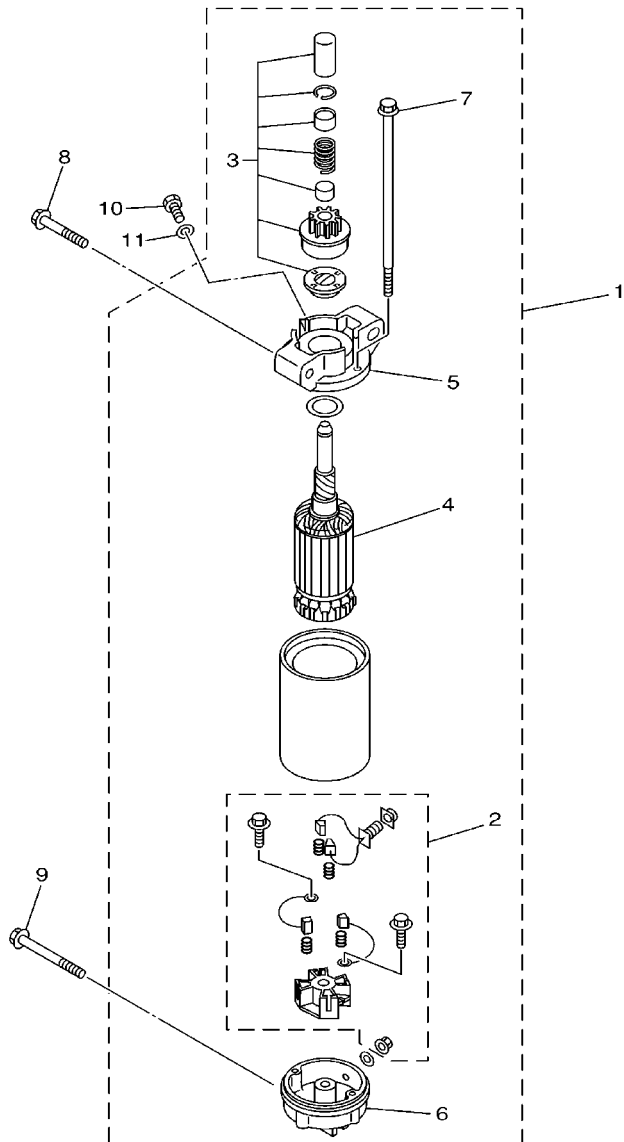

66T0010-1120

REF. NO.	PART NO. CODIGO NO.	DESCRIPTION DESCRIPTION	MH	WH	W	WT	REMARKS OBSERVACION
1	66T-81800-00	STARTING MOTOR ASSY MOTOR DE ARRANQUE COMPLETO		1	1	1	
2	66T-81840-00	.BRUSH HOLDER ASSY .SOSTEN DE ESCOBILLA COMPLETO		1	1	1	
3	66T-81857-00	.PINION STOPPER SET .JUEGO TAPON PINON		1	1	1	
4	66T-81850-00	.ARMATURE ASSY .INDUCIDO COMPLETO		1	1	1	
5	66T-81830-00	.FRONT BRACKET ASSY .SOPORTE DELANTERO COMPLETO		1	1	1	
6	66T-81820-00	.REAR BRACKET ASSY .CUBIERTA TRASERA COMPL		1	1	1	
7	66T-81826-00	.BOLT .PERNO		1	1	1	
8	90119-08M39	BOLT, WITH WASHER TORNILLO CON ARANDELA		2	2	2	
9	90119-08M52	BOLT, WITH WASHER TORNILLO CON ARANDELA		1	1	1	
10	97095-08016	BOLT PERNO		1	1	1	
11	92995-08600	WASHER ARANDELA		1	1	1	

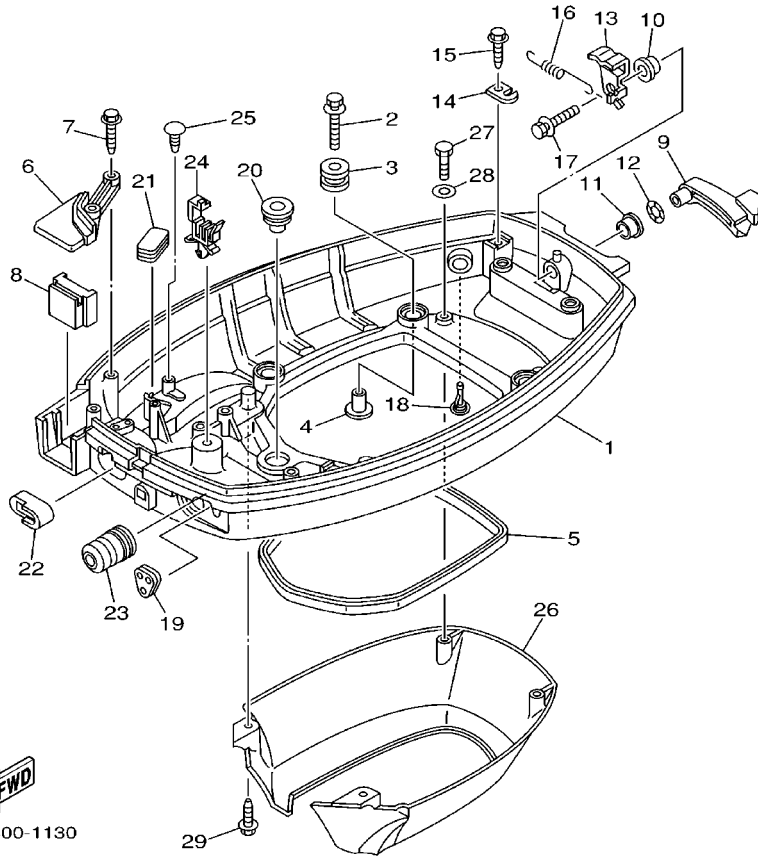
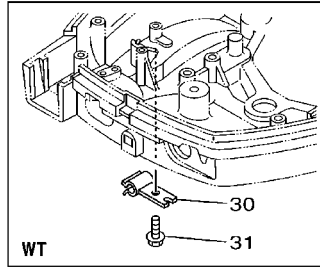
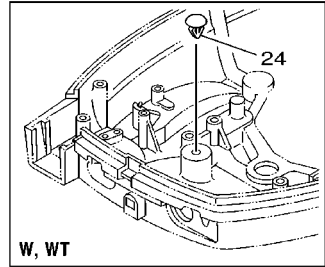

FIG. 13 BOTTOM COWLING

CUBIERTA INFERIOR

REF. NO.	PART NO. CODIGO NO.	DESCRIPTION DESCRIPTION	MH	WH	W	WT	REMARKS OBSERVACION
1	66T-42710-01-4D	BOTTOM COWLING ASSY CUBIERTA INFERIOR COMPL. (REF.NO. 7, 15, 29, 31 FIG.10, REF.NO. 30, 32 FIG.16, REF.NO. 18, 20)	1	1	1	1	
2	90119-06M61	BOLT, WITH WASHER TORNILLO CON ARANDELA	4	4	4	4	
3	90480-09M21	GROMMET TAPON	4	4	4	4	
4	90387-06035	COLLAR COLLAR	4	4	4	4	
5	66T-42716-00	RUBBER, SEAL 1 SELLO DE GOMA 1	1	1	1	1	
6	66T-42738-00-5B	PLATE, FITTING PLACA DE AJUSTE	1	1	1	1	
7	90109-06M81	BOLT PERNO	2	2	2	2	
8	66T-42725-00	GROMMET TAPON	1				
	66T-42725-10	GROMMET TAPON		1			
	66T-42725-20	GROMMET TAPON			1	1	
9	66T-42815-01-4D	LEVER, CLAMP PALANCA ABRAZADERA	1	1	1	1	
10	90386-12M37	BUSH BUJE	1	1	1	1	
11	90386-12MA2	BUSH BUJE	1	1	1	1	
12	90206-12052	WASHER, WAVE ARANDELA ONDULADA	1	1	1	1	
13	66T-42816-00	LEVER, CLAMP PALANCA ABRAZADERA	1	1	1	1	
14	66T-43144-00	HOOK, SPRING GANCHO	1	1	1	1	
15	90109-06M86	BOLT PERNO	1	1	1	1	
16	90506-16M34	SPRING, TENSION RESORTE DE TENSION	1	1	1	1	
17	90119-06M73	BOLT, WITH WASHER TORNILLO CON ARANDELA	1	1	1	1	
18	6E5-44391-00	NIPPLE, HOSE NIPLE MANGUERA	1	1	1	1	
19	65W-26326-00	GROMMET TAPON PROTECTOR	1	1			
	65W-26326-10	GROMMET TAPON PROTECTOR			1	1	
20	676-42727-00	GROMMET TAPON	1	1	1	1	
21	6H4-42726-00	GROMMET TAPON	1	1	1		
	6H1-42726-10	GROMMET TAPON				1	

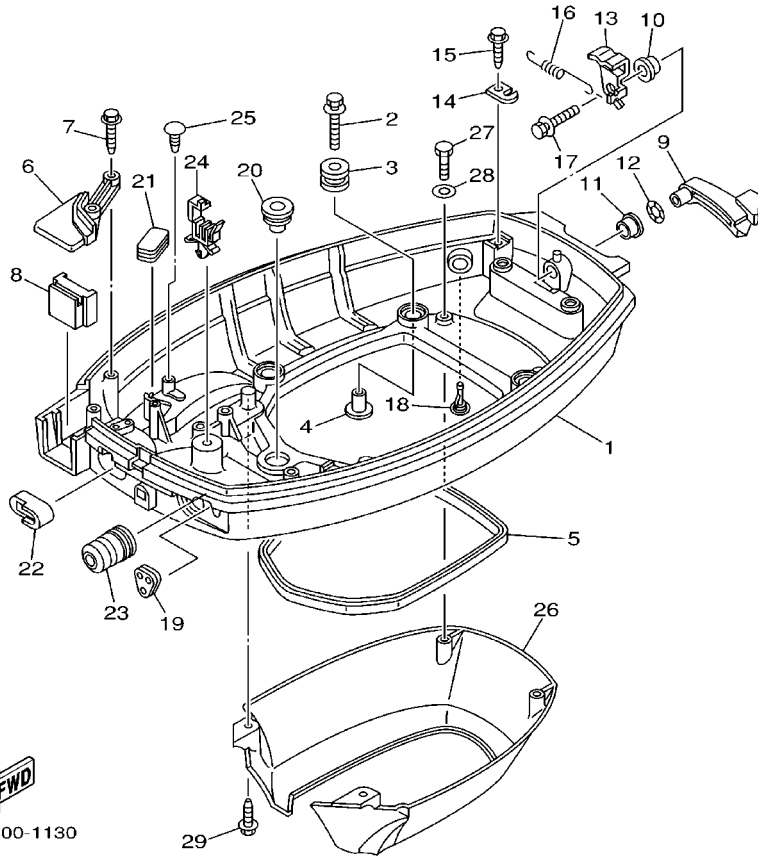
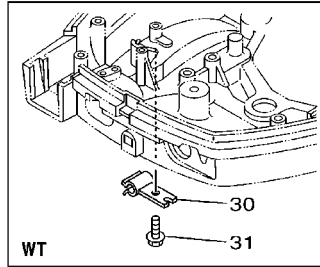
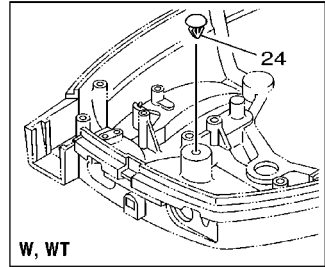

FIG. 13 BOTTOM COWLING

CUBIERTA INFERIOR

REF. NO.	PART NO. CODIGO NO.	DESCRIPTION DESCRIPTION	MH	WH	W	WT	REMARKS OBSERVACION
22	66T-24329-00	SEAL SELLO	1	1	1	1	
23	65W-42726-00	GROMMET TAPON	1	1			
	65W-42726-10	GROMMET TAPON			1	1	
24	90465-25M57	CLAMP BRIDA	1	1			
	90338-07M00	PLUG TAPON			1	1	
25	90338-05M03	PLUG TAPON	1	1	1		
26	66T-42741-00	APRON MANDIL	1	1	1	1	
27	97095-06016	BOLT PERNO	2	2	2	2	
28	92995-06600	WASHER ARANDELA	2	2	2	2	
29	90109-06M80	BOLT PERNO	2	2	2	2	
30	90464-09M49	CLAMP BRIDA				1	
31	90109-06M80	BOLT PERNO				1	

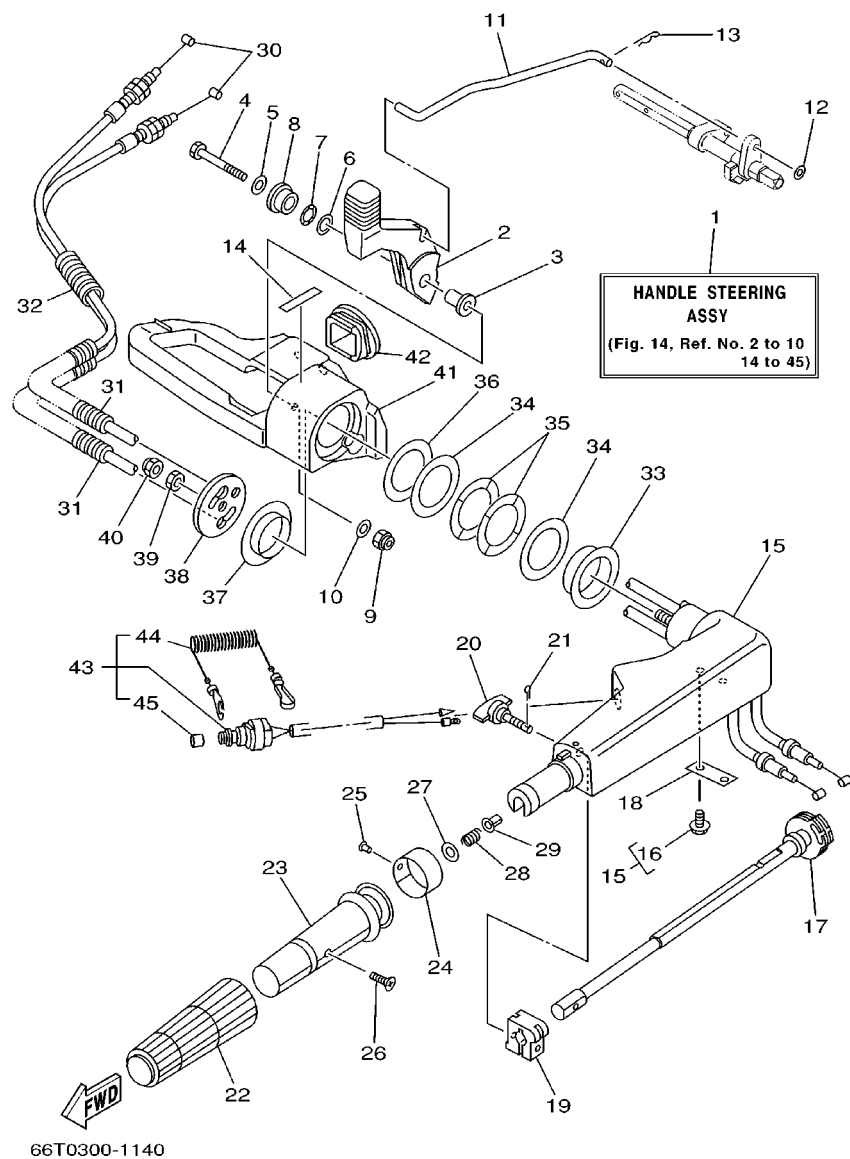
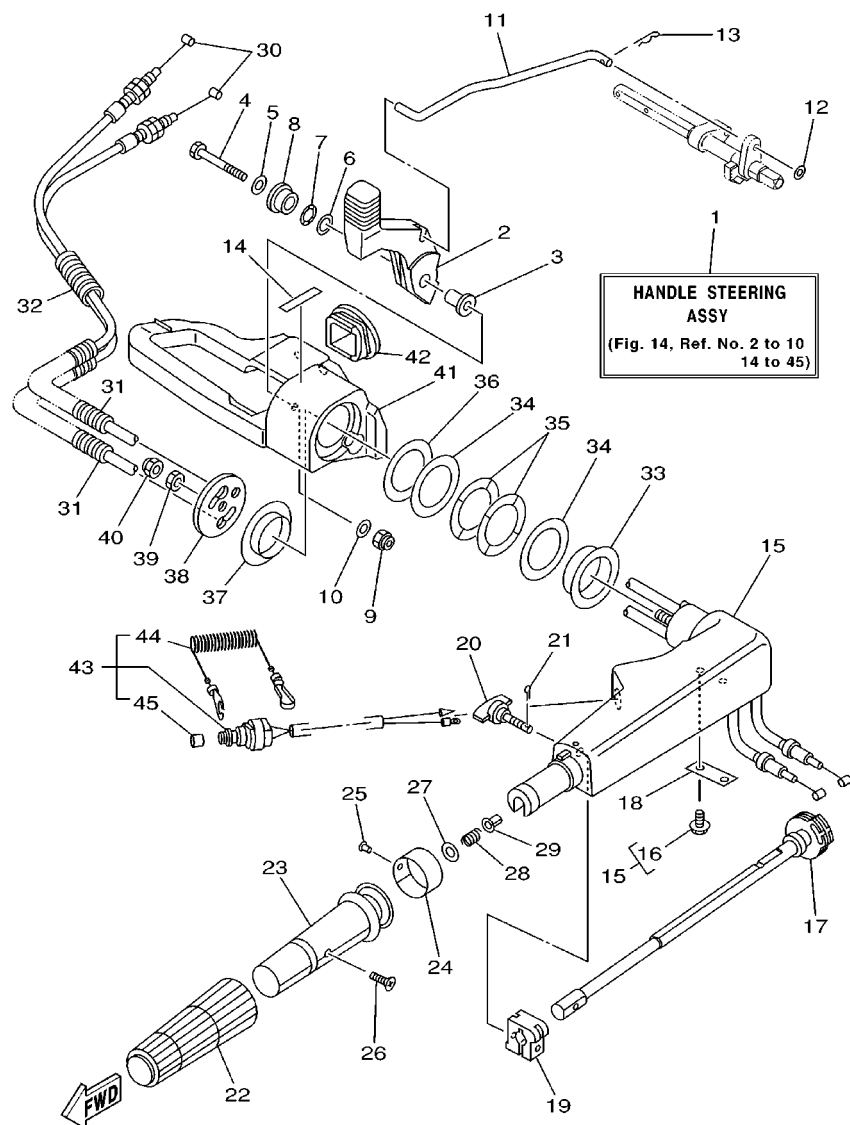

FIG. 14 STEERING

DIRECCION

REF. NO.	PART NO. CODIGO NO.	DESCRIPTION DESCRIPTION	MH	WH	W	WT	REMARKS OBSERVACION
1	66T-W0084-02-4D	HANDLE STEERING ASSY CONJUNTO DE MANIJA	1	1			
2	66T-44111-02	HANDLE, GEAR SHIFT MANIJA DE CAMBIO DE MARCHAS	1	1			
3	90387-06M86	COLLAR COLLAR	1	1			
4	97095-06050	BOLT PERNO	1	1			
5	92995-06600	WASHER ARANDELA	1	1			
6	90201-12M07	WASHER, PLATE ARANDELA PLANA	1	1			
7	90206-12052	WASHER, WAVE ARANDELA ONDULADA	1	1			
8	66T-42123-00	BOLT, HANDLE JOINT TORNILLO CONEXION DE LA MANIJA	1	1			
9	95780-06300	NUT, FLANGE TUERCA DE BRIDA	1	1			
10	92995-06200	WASHER ARANDELA	1	1			
11	66T-44124-00	LINK, SHIFT ROD ESLABON	1	1			
12	92990-06200	WASHER, PLAIN ARANDELA	1	1			
13	90468-18008	CLIP PRESILLA	1	1			
14	6E0-44191-11	INDICATOR, SHIFT INDICADOR DE CAMBIOS	1	1			
15	65W-42101-01-4D	HANDLE, STEERING MANIJA DE DIRECCION	1	1			
16	90109-06M86	BOLT PERNO	2	2			
17	65W-42138-00	LEVER, THROTTLE PLANCA DE ACELERACION	1	1			
18	65W-42159-00	STAY SOPORTE	1	1			
19	6G1-42126-00	FRICTION, STEERING HANDLE GRIP FRICCION DE MANGO DIRECCION	1	1			
20	65W-42125-00	BOLT, FRICTION ADJUSTING TORNILLO FRICCION ADJUSTA	1	1			
21	91490-20010	PIN, COTTER PASADOR DE CHAVETA	1	1			
22	6F6-42177-A0	RUBBER, HANDLE HULE DE MANIJA	1	1			
23	664-42119-00	GRIP, STEERING HANDLE MANGO, MANIJA DE DIRRECCION	1	1			
24	6G1-42137-10	INDICATOR, THROTTLE INDICADOR ACELERADOR	1	1			
25	90269-02M09	RIVET REMACHE	1	1			
26	90149-05M13	SCREW TORNILLO DE REGLAJE	1	1			
27	92903-10600	WASHER, PLATE ARANDELA	1	1			



66T0300-1140

FIG. 14 STEERING

DIRECCION

REF. NO.	PART NO. CODIGO NO.	DESCRIPTION DESCRIPTION	MH	WH	W	WT	REMARKS OBSERVACION
28	90501-23215	SPRING, COMPRESSION RESORTE DE COMPRESION	1	1			
29	90386-08032	BUSH BUJE	1	1			
30	66T-26301-00	THROTTLE CABLE ASSY CABLE DE ACELERADOR COMPLETO	2	2			
31	90446-10M87	HOSE TUBO RESEIRADERO	2	2			
32	90446-10M86	HOSE TUBO RESEIRADERO	2	2			
33	90386-40MA0	BUSH BUJE	1	1			
34	90201-43M00	WASHER, PLATE ARANDELA PLANA	2	2			
35	90206-43M22	WASHER, WAVE ARANDELA ONDULADA	2	2			
36	90202-43M57	WASHER, PLATE ARANDELA DE PLANA	1	1			
37	90386-40M99	BUSH BUJE	1	1			
38	65W-42131-01	COVER, HANDLE STEERING CUBIERTA MANIJA DIRRECCION	1	1			
39	95380-10700	NUT TUERCA	1	1			
40	95780-10300	NUT, FLANGE TUERCA DE BRIDA	1	1			
41	65W-42121-01-4D	BRACKET SOPORTE	1	1			
42	66T-41273-00	GROMMET TAPON PROTECTOR	1	1			
43	66T-82575-01	ENGINE STOP SWITCH ASSY INTERRUPTOR DE PARADA COMPL	1	1			
44	682-82556-00	.STOPPER .RETENER	1	1			
45	689-8257Y-00	.CAP .CASQUILLO	1	1			

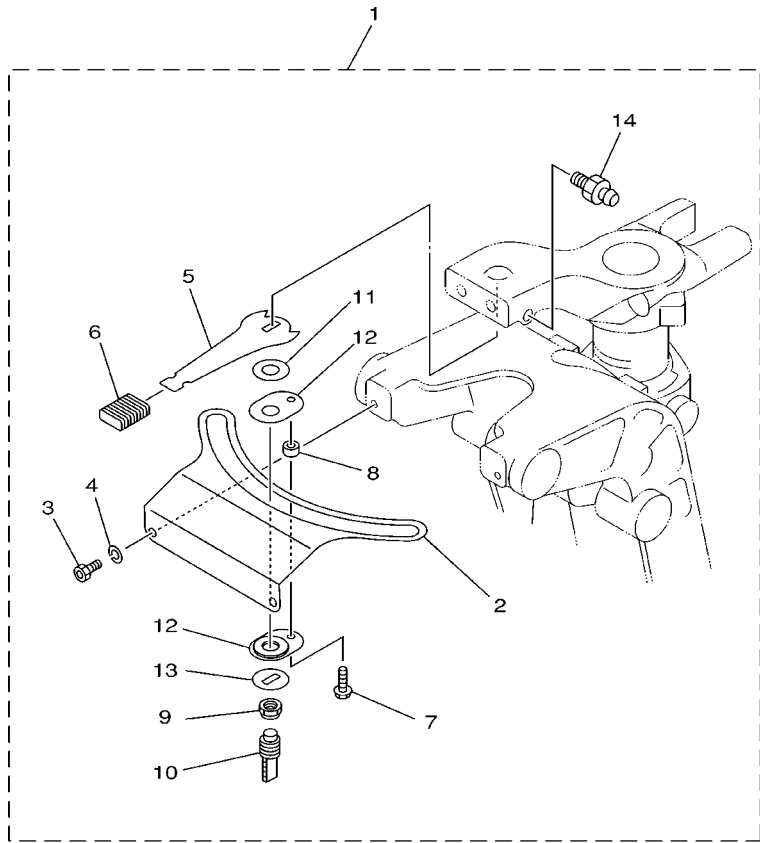

FIG. 15 STEERING FRICTION

FRICCION DE DIRECCION

REF. NO.	PART NO. CODIGO NO.	DESCRIPTION DESCRIPTION	MH	WH	W	WT	REMARKS OBSERVACION
1	65W-42508-00	STEERING FRICTION ASSY DIRECCION FRICCION COMP.	1				
2	65W-42527-00	.PLATE, FRICTION .PLACA DE FRICCION	1				
3	90109-06M50	.BOLT .PERNO	2				
4	92990-06100	.WASHER, SPRING .ARANDELA	2				
5	65W-42561-00	.KNOB, STEERING LOCK .PERILLA	1				
6	689-43633-00	.COVER, TILT LEVER .CUBIERTA PALANCA DE INCLINAC	1				
7	97595-05516	.BOLT, WITH WASHER .PERNO CON ARANDELA RONDELLE	1				
8	90387-05M11	.COLLAR .COLLAR	1				
9	90185-10M14	.NUT, SELF-LOCKING .TUERCA AUTOBLOCANTE	1				
10	65W-42562-00	.SHAFT, STEERING LOCK .EJE CERRADURA DE DIRECCION	1				
11	90202-10M56	.WASHER, PLATE .ARANDELA DE PLANA	1				
12	65W-42528-00	.PLATE, FRICTION .PIEZA DE FRICCION	2				
13	90209-10M26	.WASHER .ARANDELA DE SEPARACION	1				
14	93700-06M03	.NIPPLE, GREASE .NIPLE DE ENGRASAR	1				



65W0010-8180

FIG. 16 CONTROL

CONTROL

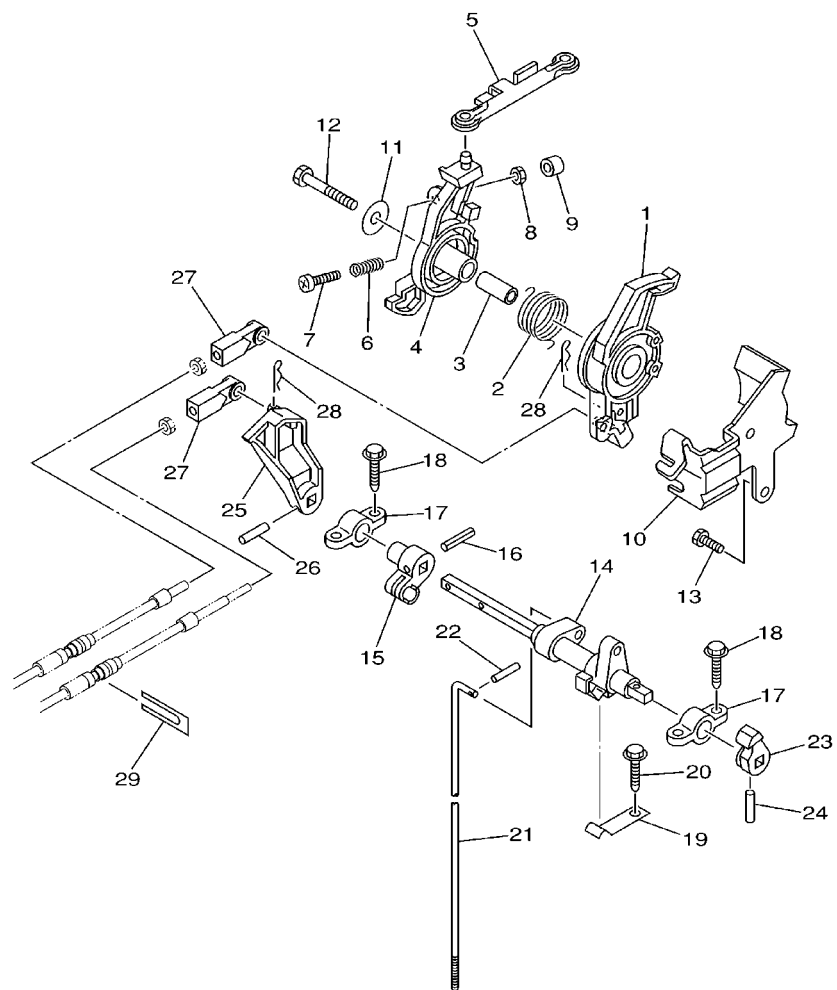

REF. NO.	PART NO. CODIGO NO.	DESCRIPTION DESCRIPTION	MH	WH	W	WT	REMARKS OBSERVACION
1	66T-41638-00	PULLEY POLEA	1	1	1	1	
2	66T-42167-00	SPRING 1 RESORTE 1	1	1	1	1	
3	90387-08M16	COLLAR COLLAR	1	1	1	1	
4	66T-41631-01	LEVER, MAGNETO CONTROL PALANCA DE CONTROL DE MAGNETO	1	1	1	1	
5	66T-41237-00	JOINT, LINK CONECTOR	1	1	1	1	
6	90501-10M84	SPRING, COMPRESSION RESORTE DE COMPRESION	1	1	1	1	
7	97880-06035	SCREW, PAN HEAD TORNILLO DE CABEZA CON PLANA	1	1	1	1	
8	95380-06700	NUT TUERCA	1	1	1	1	
9	688-44194-00	CAP TAPA	1	1	1	1	
10	66T-14497-00	STAY, THROTTLE WIRE SOPORTE VALVULA DE OBTURACION	1	1	1	1	
11	90201-08M54	WASHER, PLATE ARANDELA PLANA	1	1	1	1	
12	97095-08045	BOLT PERNO	1	1	1	1	
13	97095-06014	BOLT PERNO	1	1	1	1	
14	66T-44121-00	LEVER, SHIFT ROD PALANCA VARILLA CAMBIOS	1	1	1	1	
15	66M-44122-00	BUSHING, SHIFT ROD LEVER BUJE PALANCA VARILLA DE CAMBIO	1	1	1	1	
16	90254-03M05	PIN, SPRING PASADOR DE TIPO A RESORTE	1	1	1	1	
17	6F5-41662-00	BRACKET SOPORTE	2	2	2	2	
18	90109-06M81	BOLT PERNO	4	4	4	4	
19	682-44116-01	SPRING RESORTE	1	1	1	1	
20	90109-06M86	BOLT PERNO	1	1	1	1	
21	66T-44143-00	ROD, SHIFT VARILLA DE CAMBIO	1	1			S
	66T-44143-10	ROD, SHIFT VARILLA DE CAMBIO	1	1	1	1	L/X
22	91490-16012	PIN, COTTER PASADOR DE CHAVETA	1	1	1	1	
23	65W-44173-00	LEVER, SHIFT CONTROL PALANCA CONTROL CAMBIOS		1			
24	90254-03M04	PIN, SPRING PASADOR DE TIPO A RESORTE		1			
25	66T-44125-01	LEVER, SHIFT ROD PALANCA VARILLA CAMBIOS	1	1	1	1	
26	90254-03M04	PIN, SPRING PASADOR DE TIPO A RESORTE	1	1	1	1	



66T0010-1160

D6

FIG. 17 REMOTE CONTROL ATTACHMENT

CONJUNTO ADITAMENTO

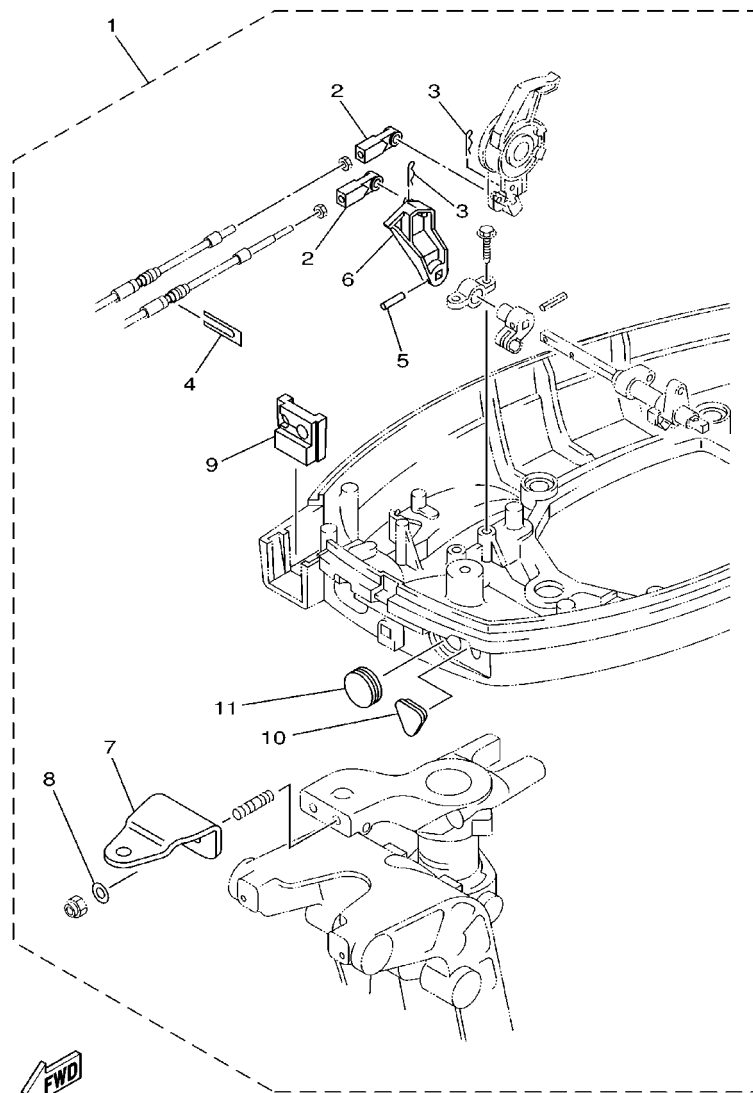

66T0010-1170

REF. NO.	PART NO. CODIGO NO.	DESCRIPTION DESCRIPTION	MH	WH	W	WT	REMARKS OBSERVACION
1	66T-48501-01	REMOTE CONT. ATTACHMENT ASSY. CONJUNTO ADITAMENTO	1	1	1	1	AP
2	663-48344-00	.CABLE END, REMOTE CONTROL .BASE CONTROL	2	2	2	2	
3	90468-18008	.CLIP .PRESILLA	2	2	2	2	
4	6H3-48538-00	.CLAMP, CABLE 1 .GRAMPA DE CABLE	1	1	1	1	
5	90254-03M04	.PIN, SPRING .PASADOR DE TIPO A RESORTE	1	1	1	1	
6	66T-44125-01	.LEVER, SHIFT ROD .PALANCA VARILLA CAMBIOS	1	1	1	1	
7	65W-48511-00	.HOOK, STEERING .GANCHO DIRECCION	1	1	1	1	
8	90201-10120	.WASHER, PLATE .ARANDELA PLANA	2	2	2	2	
9	66T-42725-30	.GROMMET .TAPON	1	1	1	1	
10	65W-26326-10	.GROMMET .TAPON PROTECTOR	1	1	1	1	
11	65W-42726-10	.GROMMET .TAPON	1	1	1	1	

FIG. 18 BRACKET 1

SOPORTE 1

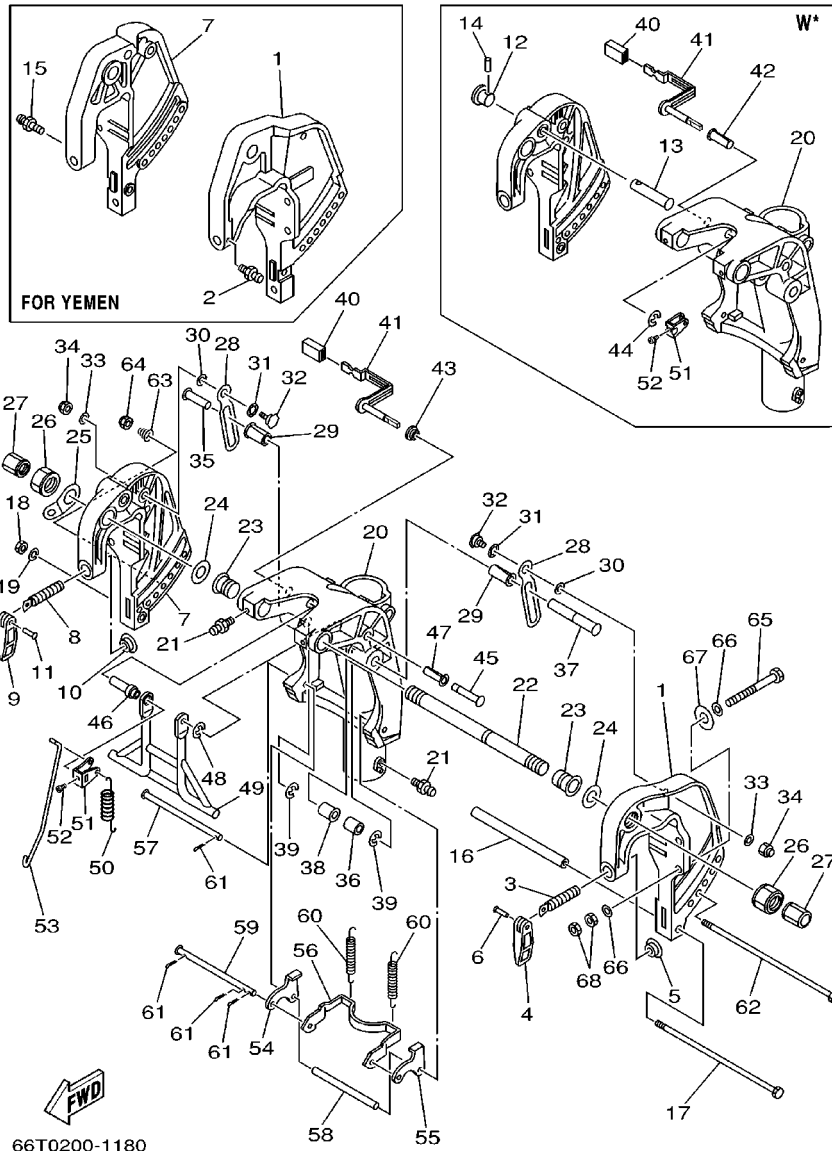

REF. NO.	PART NO. CODIGO NO.	DESCRIPTION DESCRIPTION	MH	WH	W	WT	REMARKS OBSERVACION
1	66T-43111-01-4D	BRACKET, CLAMP SOPORTE DE LA ABRAZADERA	1	1	1		
	66T-43111-Y0-4D	BRACKET, CLAMP SOPORTE DE LA ABRAZADERA	1	1			FOR YEMEN
2	93700-06M03	NIPPLE, GREASE NIPLE DE ENGRASAR	1	1			FOR YEMEN
3	90149-14M12	SCREW TORNILLO DE REGLAJE	1	1	1		
4	663-43118-01-4D	HANDLE, TRANSOM CLAMP MANIJA DE LA ABRAZADERA DEL ES	1	1	1		
5	648-43114-01	PAD, TRANSOM CLAMP ARANDELA DE ABRAZADERA	1	1	1		
6	90243-04007	PIN PASADOR	1	1	1		
7	66T-43112-01-4D	BRACKET, CLAMP SOPORTE DE LA ABRAZADERA	1	1	1		
	66T-43112-Y0-4D	BRACKET, CLAMP SOPORTE DE LA ABRAZADERA	1	1			FOR YEMEN
8	90149-14M12	SCREW TORNILLO DE REGLAJE	1	1	1		
9	663-43118-01-4D	HANDLE, TRANSOM CLAMP MANIJA DE LA ABRAZADERA DEL ES	1	1	1		
10	648-43114-01	PAD, TRANSOM CLAMP ARANDELA DE ABRAZADERA	1	1	1		
11	90243-04007	PIN PASADOR	1	1	1		
12	65W-43192-00	KNOB, STOPPER PERILLA DE TOPE	1	1	1		W*
13	65W-43191-00	SHAFT, STOPPER EJE DE TOPE	1	1	1		W*
14	91690-30018	PIN, SPRING PASADOR DE RESORTE	1	1	1		W*
15	93700-06M03	NIPPLE, GREASE NIPLE DE ENGRASAR	1	1			FOR YEMEN
16	90387-08M29	COLLAR COLLAR	1	1	1		
17	90101-08M76	BOLT TORNILLO	1	1	1		
18	95380-08600	NUT TUERCA	1	1	1		
19	92990-08100	WASHER, SPRING ARANDELA	1	1	1		
20	65W-43311-00-4D	BRACKET, SWIVEL 1 SOPORTE GIRATORIO 1	1	1			S
	65W-43311-10-4D	BRACKET, SWIVEL 1 SOPORTE GIRATORIO 1	1	1	1		L/X

W*: WITHOUT SHALLOW WATER DRIVE
W*: SIN NAVEGACION EN AGUAS POCO PROFUNDAS

FIG. 18 BRACKET 1

SOPORTE 1

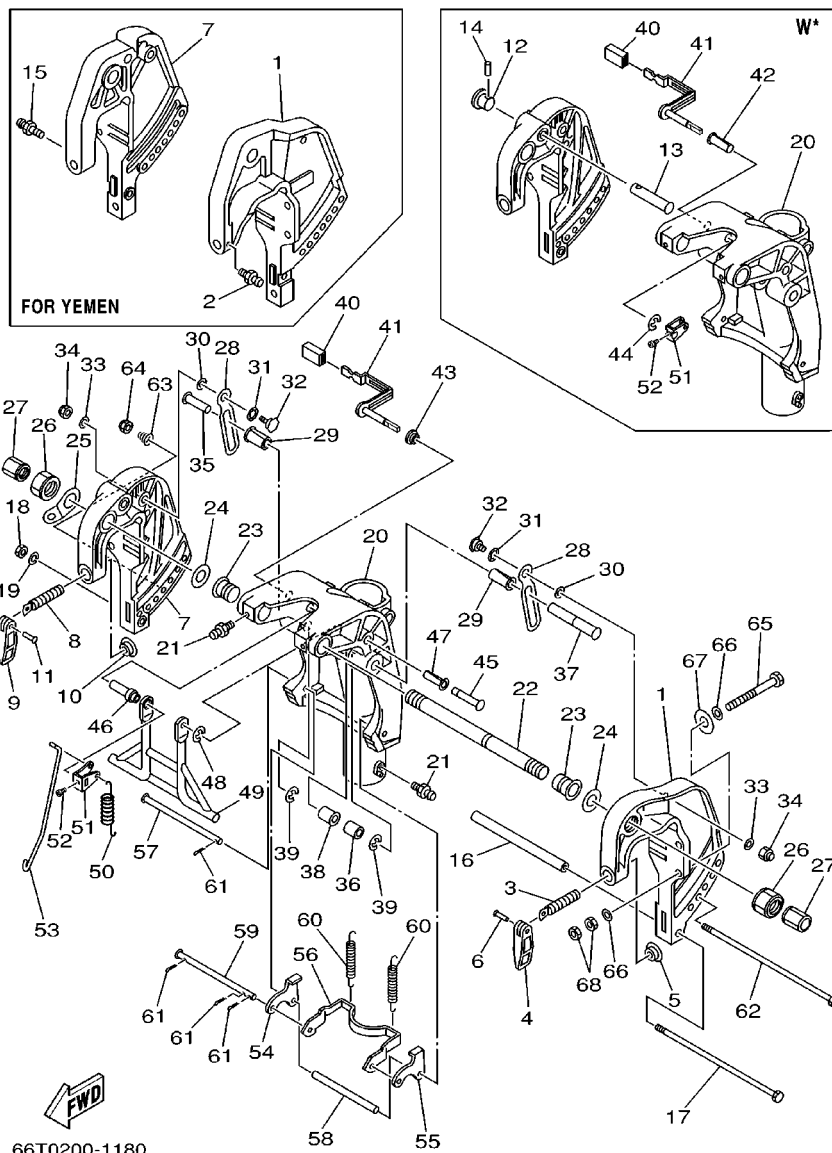

REF. NO.	PART NO. CODIGO NO.	DESCRIPTION DESCRIPTION	MH	WH	W	WT	REMARKS OBSERVACION
21	93700-06M03	NIPPLE, GREASE NIPLE DE ENGRASAR	1				WITH STEERING FRICTION
	93700-06M03	NIPPLE, GREASE NIPLE DE ENGRASAR	3	3	3		
22	63D-43131-01	BOLT, CLAMP BRACKET TORNILLO DE ABRAZADERA DEL SOP	1	1	1		
23	90386-22M15	BUSH BUJE	2	2	2		
24	90201-22M03	WASHER, PLATE ARANDELA PLANA	2	2	2		
25	6J8-43113-01	PLATE, CLAMP BRACKET PLACA ABRAZADERA SOPORTE	1	1	1		
26	90185-22043	NUT, SELF-LOCKING TUERCA AUTOBLOCANTE	2	2	2		
27	6G5-43145-01	CAP, CLAMP BRACKET TAPA	2	2	2		
28	66T-43627-00	STOPPER RETEN	2	2	2		
29	90386-12M98	BUSH BUJE	2	2	2		
30	90202-12031	WASHER, PLATE ARANDELA DE PLANA	2	2	2		
31	90206-12M00	WASHER, WAVE ARANDELA ONDULADA	2	2	2		
32	90109-08M90	BOLT PERNO	2	2	2		
33	90201-08M07	WASHER, PLATE ARANDELA PLANA	2	2	2		
34	90185-08057	NUT, SELF-LOCKING TUERCA AUTOBLOCANTE	2	2	2		
35	90249-12M34	PIN PASADOR	1	1	1		
36	90387-12M04	COLLAR COLLAR	1	1	1		D*
37	90249-12M39	PIN PASADOR	1	1	1		D*
	90249-12M34	PIN PASADOR	1	1	1		W*
38	90386-12MA0	BUSH BUJE	1	1	1		D*
39	93430-10M00	CIRCLIP BOLA	2	2	2		
40	682-43318-01	COVER CUBIERTA	1	1	1		
41	65W-43630-11	TILT LEVER ASSY PLANCA DE INCLINACION COMPL	1	1	1		

D*: FOR SHALLOW WATER DRIVE
D*: PARA NAVEGACION EN AGUAS POCO PROFUNDAS

W*: WITHOUT SHALLOW WATER DRIVE
W*: SIN NAVEGACION EN AGUAS POCO PROFUNDAS

FIG. 18 BRACKET 1

SOPORTE 1

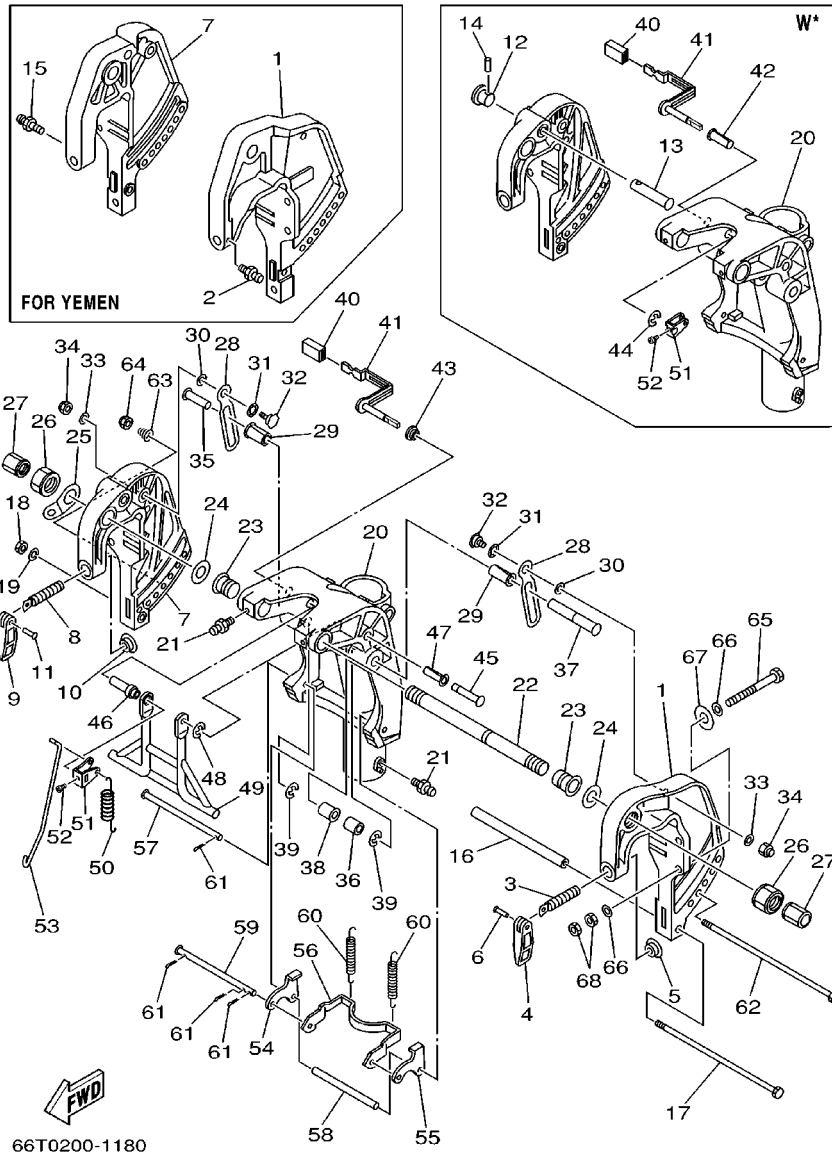

REF. NO.	PART NO. CODIGO NO.	DESCRIPTION DESCRIPTION	MH	WH	W	WT	REMARKS OBSERVACION
41	65W-43630-02	TILT LEVER ASSY PLANCA DE INCLINACION COMPL	1	1	1		W*
42	90386-10M99	BUSH BUJE	1	1	1		W*
43	90386-07MA2	BUSH BUJE	1	1	1		D*
44	99080-08600	CIRCLIP PRESILLA REDONDA	1	1	1		W*
45	90249-10M31	PIN PASADOR	1	1	1		D*
46	90387-07M05	COLLAR COLLAR	1	1	1		D*
47	90386-10M99	BUSH BUJE	1	1	1		D*
48	99080-08600	CIRCLIP PRESILLA REDONDA	1	1	1		D*
49	66T-43350-02	RECEIVER ASSY RECIBIDOR COMPL	1	1	1		D*
50	90506-20M37	SPRING, TENSION RESORTE DE TENSION	1	1	1		D*
51	66T-43631-11	LEVER, TILT PALANCA DE INCLINACION	1	1	1		D*
	66T-43631-01	LEVER, TILT PALANCA DE INCLINACION	1	1	1		W*
52	90149-05M17	SCREW TORNILLO DE REGLAJE	1	1	1		
53	65W-43616-00	ROD, TILT LOCK VARILLA SEGURO DE INCLINACION	1	1	1		
54	65W-43614-01	PLATE, TILT LOCK PLACA DE SEGURO DE INCLINACION	1	1	1		
55	65W-43615-01	PLATE, TILT LOCK PLACA DE SEGURO DE INCLINACION	1	1	1		
56	65W-43613-00	ARM, TILT LOCK BRAZO DE SEGURO DE INCLINACION	1	1	1		
57	90249-07M32	PIN PASADOR	1	1	1		
58	90387-07M29	COLLAR COLLAR	1	1	1		
59	90249-07M33	PIN PASADOR	1	1	1		
60	90506-30M00	SPRING, TENSION RESORTE DE TENSION	2	2	2		
61	91490-20015	PIN, COTTER PASADOR DE CHAVETA	4	4	4		
62	90101-08M28	BOLT TORNILLO	1	1	1		

D*: FOR SHALLOW WATER DRIVE
D*: PARA NAVEGACION EN AGUAS POCO PROFUNDAS

W*: WITHOUT SHALLOW WATER DRIVE
W*: SIN NAVEGACION EN AGUAS POCO PROFUNDAS

FIG. 18 BRACKET 1

SOPORTE 1

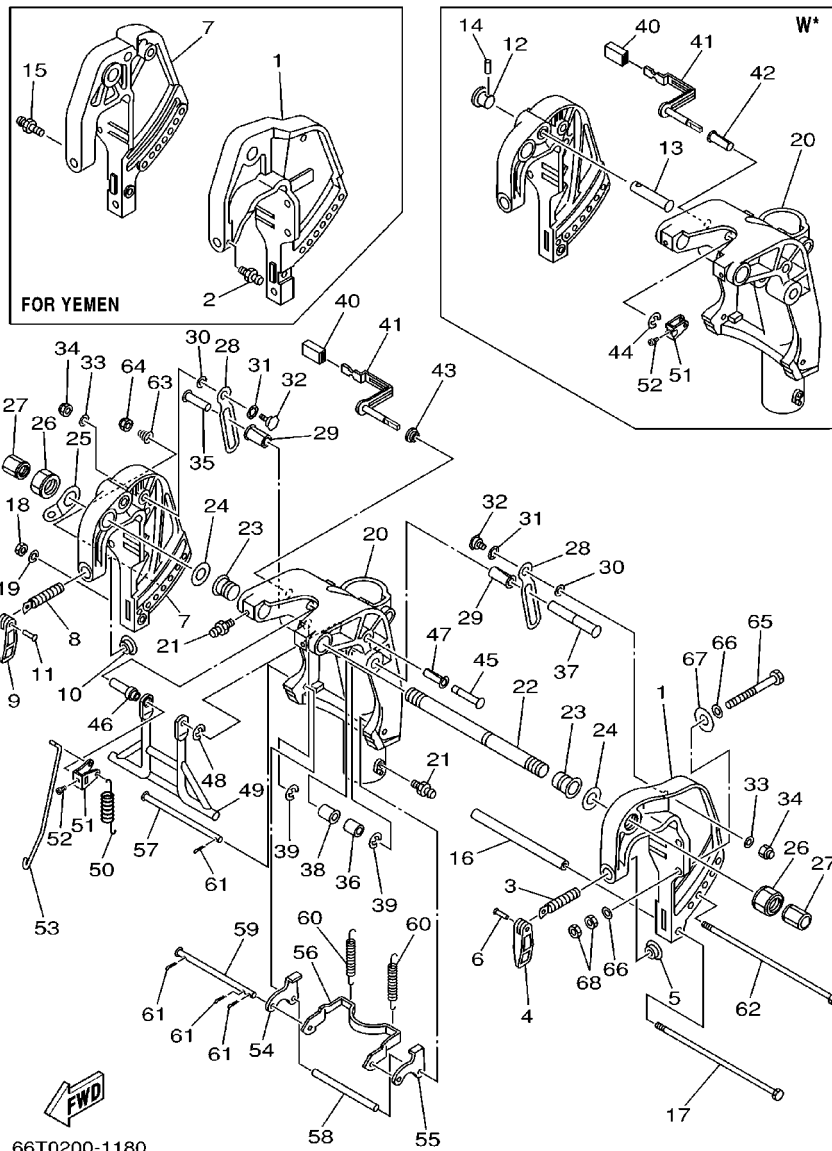

REF. NO.	PART NO. CODIGO NO.	DESCRIPTION DESCRIPTION	MH	WH	W	WT	REMARKS OBSERVACION
63	90502-10M06	SPRING, CONICAL RESORTE CONICO	1	1	1		
64	90185-08057	NUT, SELF-LOCKING TUERCA AUTOBLOCANTE	1	1	1		
65	90101-10M58	BOLT TORNILLO	4	4	4		
66	92995-10600	WASHER ARANDELA	8	8	8		
67	90201-12426	WASHER, PLATE ARANDELA PLANA	4	4	4		
68	95380-10600	NUT TUERCA	8	8	8		

FIG. 19 BRACKET 2

SOPORTE 2

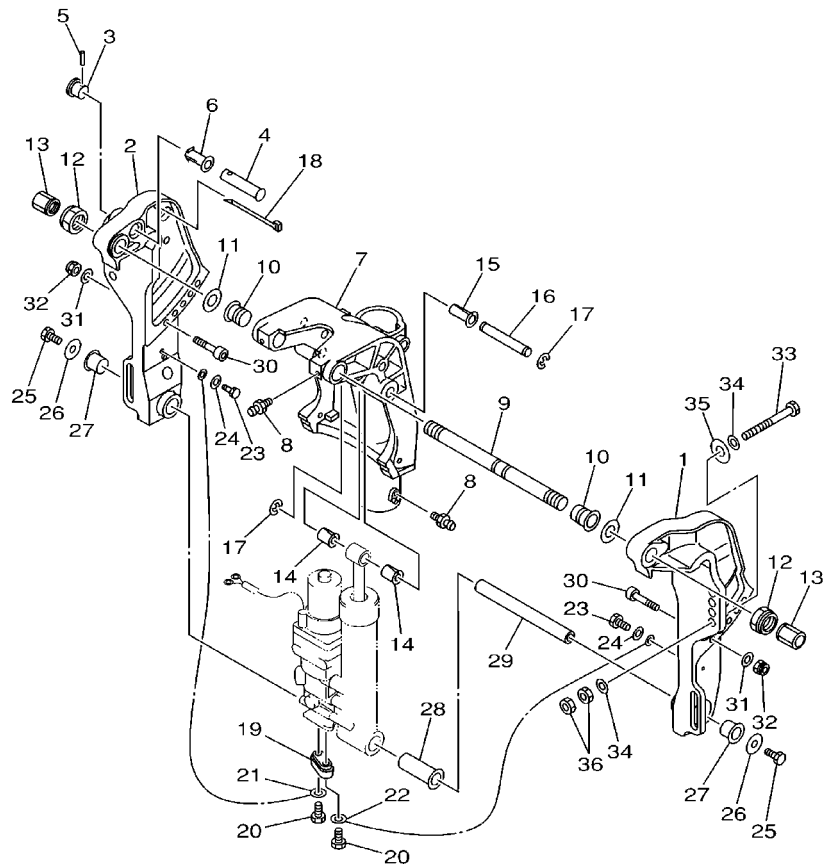

REF. NO.	PART NO. CODIGO NO.	DESCRIPTION DESCRIPTION	MH	WH	W	WT	REMARKS OBSERVACION
1	65W-43111-10-4D	BRACKET, CLAMP SOPORTE DE LA ABRAZADERA				1	
2	65W-43112-10-4D	BRACKET, CLAMP SOPORTE DE LA ABRAZADERA				1	
3	65W-43192-00	KNOB, STOPPER PERILLA DE TOPE				1	
4	65W-43191-00	SHAFT, STOPPER EJE DE TOPE				1	
5	91690-30018	PIN, SPRING PASADOR DE RESORTE				1	
6	90386-14MA1	BUSH BUJE				1	
7	65W-43311-10-4D	BRACKET, SWIVEL 1 SOPORTE GIRATORIO 1				1	L
8	93700-06M03	NIPPLE, GREASE NIPLE DE ENGRASAR				3	
9	63D-43131-01	BOLT, CLAMP BRACKET TORNILLO DE ABRAZADERA DEL SOP				1	
10	90386-22M15	BUSH BUJE				2	
11	90201-22M03	WASHER, PLATE ARANDELA PLANA				2	
12	90185-22M11	NUT, SELF-LOCKING TUERCA AUTOBLOCANTE				2	
13	6G5-43145-01	CAP, CLAMP BRACKET TAPA				2	
14	90386-12MA0	BUSH BUJE				2	
15	90386-12M98	BUSH BUJE				1	
16	90249-12M38	PIN PASADOR				1	
17	93430-10M00	CIRCLIP BOLA				2	
18	90465-13M11	CLAMP BRIDA				2	
19	65W-45251-00	ANODE CATODE				1	
20	90101-06020	BOLT TORNILLO				2	
21	6H1-82148-00	WIRE, LEAD 4 CABLE CONDUCTOR 4				1	
22	6U0-82127-00	WIRE, LEAD 2 CABLE CONDUCTOR 2				1	
23	97095-06014	BOLT PERNO				2	
24	92995-06600	WASHER ARANDELA				2	
25	97080-08016	BOLT PERNO				2	
26	90201-08M00	WASHER, PLATE ARANDELA PLANA				2	
27	90386-18M44	BUSH BUJE				2	



65W0010-1230

FIG. 20 BRACKET 3

SOPORTE 3

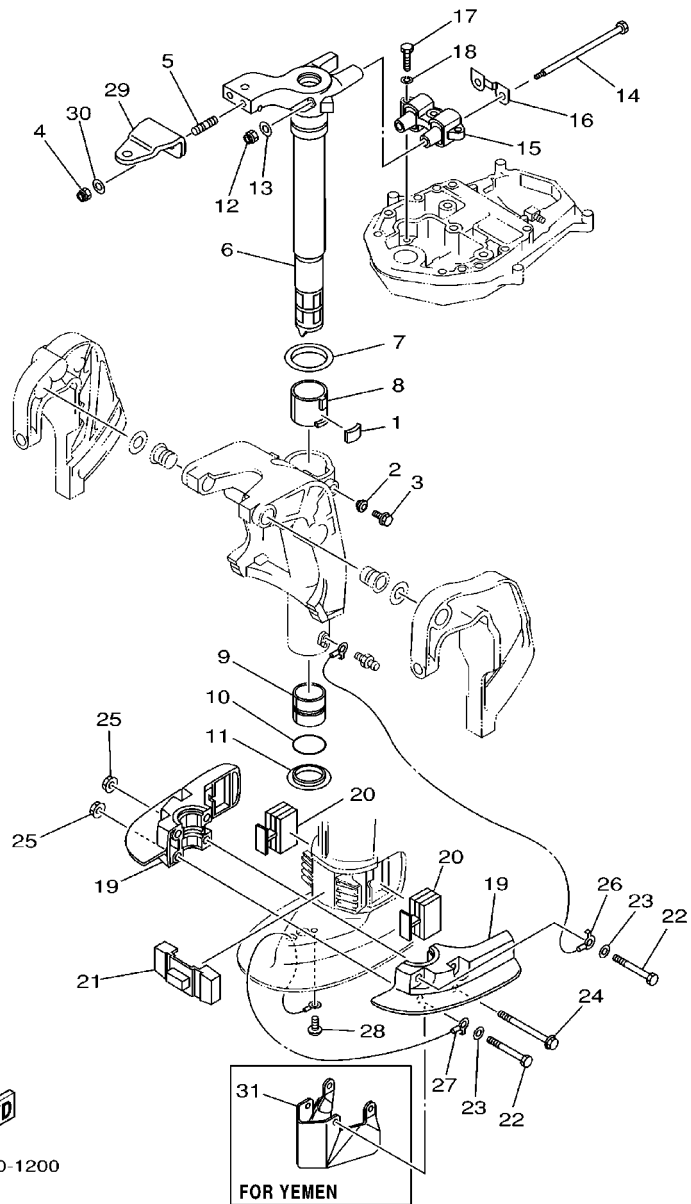

66T0200-1200

REF. NO.	PART NO. CODIGO NO.	DESCRIPTION DESCRIPTION	MH	WH	W	WT	REMARKS OBSERVACION
1	648-42528-00	PLATE, FRICTION PIEZA DE FRICCIÓN	1	1	1	1	
2	65W-43373-00	SEAL, DAMPER SELLO DE GOMA	1	1	1	1	
3	90105-08M76	BOLT, WASHER BASED TORNILLO CON ARANDELA	1	1	1	1	
4	90185-10051	NUT, SELF-LOCKING TUERCA AUTOBLOCANTE	2	2	2	2	
5	90116-10M28	BOLT, STUD ESPARRAGO	2	2	2	2	
6	65W-42511-00-4D	BRACKET, STEERING SOPORTE DE DIRECCION	1	1			S
	65W-42511-10-4D	BRACKET, STEERING SOPORTE DE DIRECCION	1	1	1	1	L/X
7	90209-52M00	WASHER ARANDELA DE SEPARACION	1	1	1	1	
8	90386-52M02	BUSH BUJE	1	1	1	1	
9	90386-44M03	BUSH BUJE	1	1	1	1	
10	93210-43MJ0	O-RING ANILLO O	1	1	1	1	
11	90386-44M99	BUSH BUJE	1	1	1	1	
12	90185-08045	NUT, SELF-LOCKING TUERCA AUTOBLOCANTE	2	2	2	2	
13	92995-08200	WASHER ARANDELA	2	2	2	2	
14	90101-08M86	BOLT TORNILLO	2	2	2	2	
15	66T-44514-00-4D	MOUNT DAMPER, UPPER SIDE AMORTIGUADOR LADO SUPERIOR	1	1	1	1	S/L
	66T-44514-30-4D	MOUNT DAMPER, UPPER SIDE AMORTIGUADOR LADO SUPERIOR	1				X
16	66T-44526-00	PLATE PLACA 1	1	1	1	1	S/L
	66T-44526-30	PLATE PLACA 1	1				X
17	97075-08030	BOLT PERNO	3	3	3	3	
18	92995-08100	WASHER ARANDELA	3	3	3	3	
19	65W-44551-00-4D	HOUSING, LOWER MOUNT RUBBER CAJA AMORTIGUADOR INFERIOR HU	2	2	2	2	
20	65W-44555-10	MOUNT DAMPER, LOWER SIDE AMORTIGUADOR DE HULE LADO INFE	2	2	2	2	
21	66T-44575-00	DAMPER, LOWER MOUNT RUBBER AMORTIGUADOR INFERIOR	1	1	1	1	
22	97075-10070	BOLT PERNO	2	2	2	2	
23	92995-10600	WASHER ARANDELA	2	2	2	2	
24	90119-10M04	BOLT, WITH WASHER TORNILLO CON ARANDELA	2	2	2	2	

FIG. 21 POWER TRIM & TILT ASSY COMPONER Y PODER VARILLA

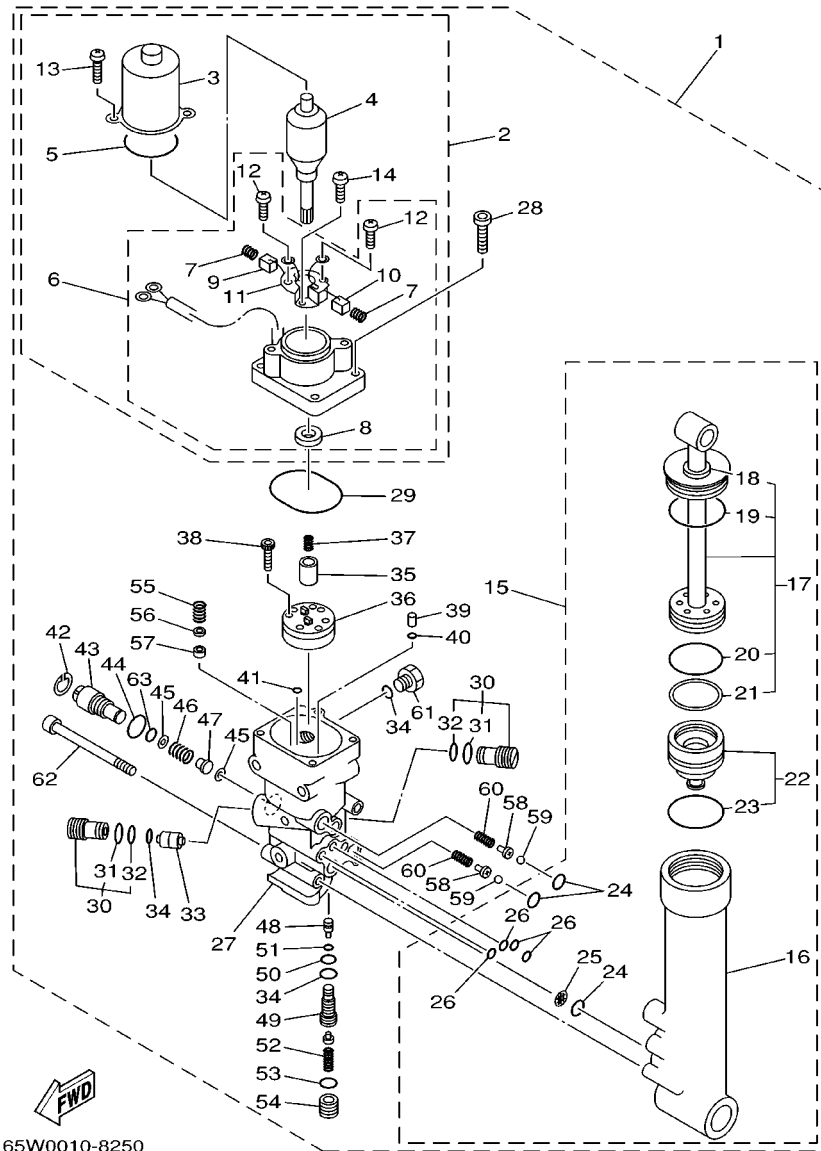

65W0010-8250

REF. NO.	PART NO. CODIGO NO.	DESCRIPTION DESCRIPTION	MH	WH	W	WT	REMARKS OBSERVACION
1	65W-43800-02-4D	POWER TRIM & TILT ASSY ELEVADOR HIDRAULICO COMPL				1	
2	65W-43880-00	.MOTOR ASSY .MOTOR COMPL.				1	
3	65W-43804-00	..STATOR ASSY ..ESTATOR COMPL				1	
4	65W-43805-00	..ARMATURE ASSY ..INDUCIDO COMPL.				1	
5	65W-43869-00	..O-RING ..ANILLO EN O 9				1	
6	65W-43881-00	..FRAME, END ..CUADRO EXTERMO				1	
7	65W-4386K-00	...SPRING, BRUSH ...RESORTE, ESCOBILLA				2	
8	65W-43882-00	...OIL SEAL ...SELLO ACEITE				1	
9	65W-43892-00	...BRUSH 2 ...ESCOBILLA 2				1	
10	65W-43891-00	...BRUSH 1 ...ESCOBILLA 1				1	
11	65W-4380F-00	...PLATE, BRUSH HOLDER ...PLACA				1	
12	65W-43879-00	...SCREW, WITH WASHER ...TORNILLO CON RONDANA				2	
13	65W-43887-00	..BOLT, THROUGH ..TORNILLO				2	
14	65W-4388E-00	..BOLT ..PERNO				1	
15	65W-43840-00	..POWER TILT ASSY ..CONJUNTO COMPONER				1	
16	65W-4380K-00	..CYLINDER, TILT SUB ASSY ..CILINDRO, INCLINACION				1	
17	65W-43810-00	..PISTON SUB ASSY ..SUB-PISTON COMPL				1	
18	65W-43812-00	...SEAL, DUST ...SELLO DE POLVO				1	
19	65W-43865-00	...O-RING ...ANILLO EN O 5				1	
20	6H1-43861-10	...O-RING ...ANILLO EN O 1				1	
21	65W-43871-00	...RING, BACK UP ...ANILLO				1	
22	65W-4381B-00	..FREE PISTON SUB ASSY ..SUB-PISTON COMPL				1	
23	6H1-43861-10	...O-RING ...ANILLO EN O 1				1	
24	93210-11368	..O-RING ..ANILLO O				3	
25	6H1-43816-00	..FILTER 1 ..FIELTRO 1				1	
26	93210-064A5	..O-RING ..ANILLO O				4	
27	65W-4380L-00	..HOUSING, TRIM & TILT SUB ASSY ..CAJA, INCLINACION Y ADRNO				1	

FIG. 21 POWER TRIM & TILT ASSY COMONER Y PODER VARILLA

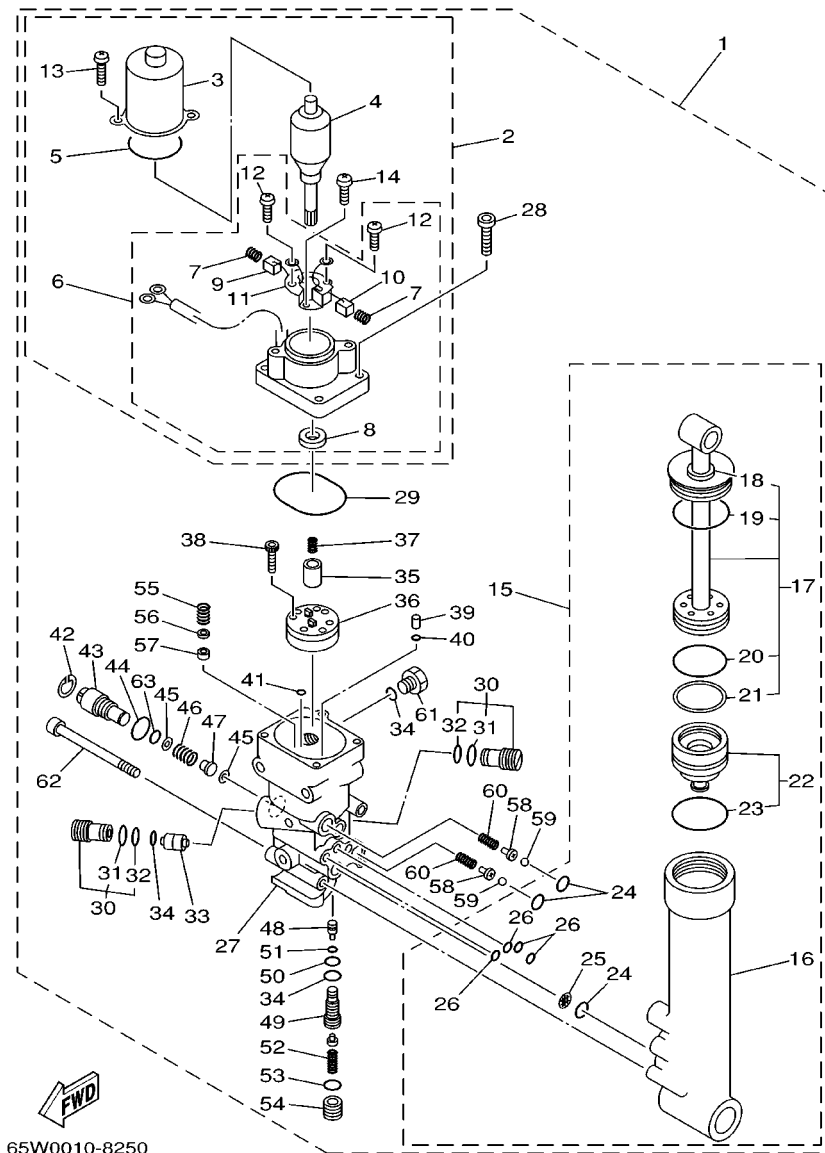

65W0010-8250

REF. NO.	PART NO. CODIGO NO.	DESCRIPTION DESCRIPTION	MH	WH	W	WT	REMARKS OBSERVACION
28	65W-43888-00	.BOLT, SOCKET .TORNILLO ENCASTRE				4	
29	93210-50768	.O-RING .ANILLO O				1	
30	6T4-43802-03	.VALVE SUB ASSY .VALVULA PRINCIPAL COMPL.				2	
31	6H1-43866-00	.O-RING .ANILLO EN O 6				1	
32	6H1-43867-00	.O-RING .ANILLO EN O 7				1	
33	62X-43841-00	.PISTON, SHUTTLE .PISTON				1	
34	93210-09165	.O-RING .ANILLO O				3	
35	65W-43831-00	.CONNECTOR, SHAFT .CONEXION EJE				1	
36	65W-43830-00	.GEAR PUMP ASSY .ENGRANAJE BOMBA COMPL.				1	
37	6T4-43853-00	.SPRING, MAIN VALVE .RESORTE				1	
38	91318-04025	.BOLT .PERNO				4	
39	65W-43817-00	.FILTER 2 .FILTRO 2				2	
40	65W-43861-00	.O-RING .ANILLO EN O 1				2	
41	65W-43862-00	.O-RING .ANILLO EN O 2				2	
42	6H1-43875-00	.RING, SNAP .ANILLO				1	
43	6H1-43845-00	.SCREW, MANUAL RELEASE .TORNILLO DESCOPLO MANUAL				1	
44	93210-18397	.O-RING .ANILLO O				1	
45	6H1-43847-00	.SEAT, MANUAL VALVE .ASIENTO VALVULA MANUAL				2	
46	65W-43854-00	.SPRING, MANUAL RELEASE .RESORTE DESCOPLO MANUAL				1	
47	65W-4382A-00	.ADAPTOR 1 .ADAPTADOR 1				1	
48	65W-43844-00	.PIN, VALVE SUPPORT .PASADOR VALVULA SOPORTE				1	
49	65W-43851-00	.SEAT, RELIEF VALVE .ASIENTO VALVULA DE DESCARGA				1	
50	93210-08006	.O-RING .ANILLO O				1	
51	93210-03478	.O-RING .ANILLO O				1	
52	65W-43855-00	.SPRING, UP RELIEF .RESORTE SEGURIDAD SUPERIOR				1	
53	93210-11073	.O-RING .ANILLO O				1	
54	65W-43843-00	.SCREW, VALVE LOCK .TORNILLO				1	

FIG. 22 UPPER CASING

FUNDA SUPERIOR

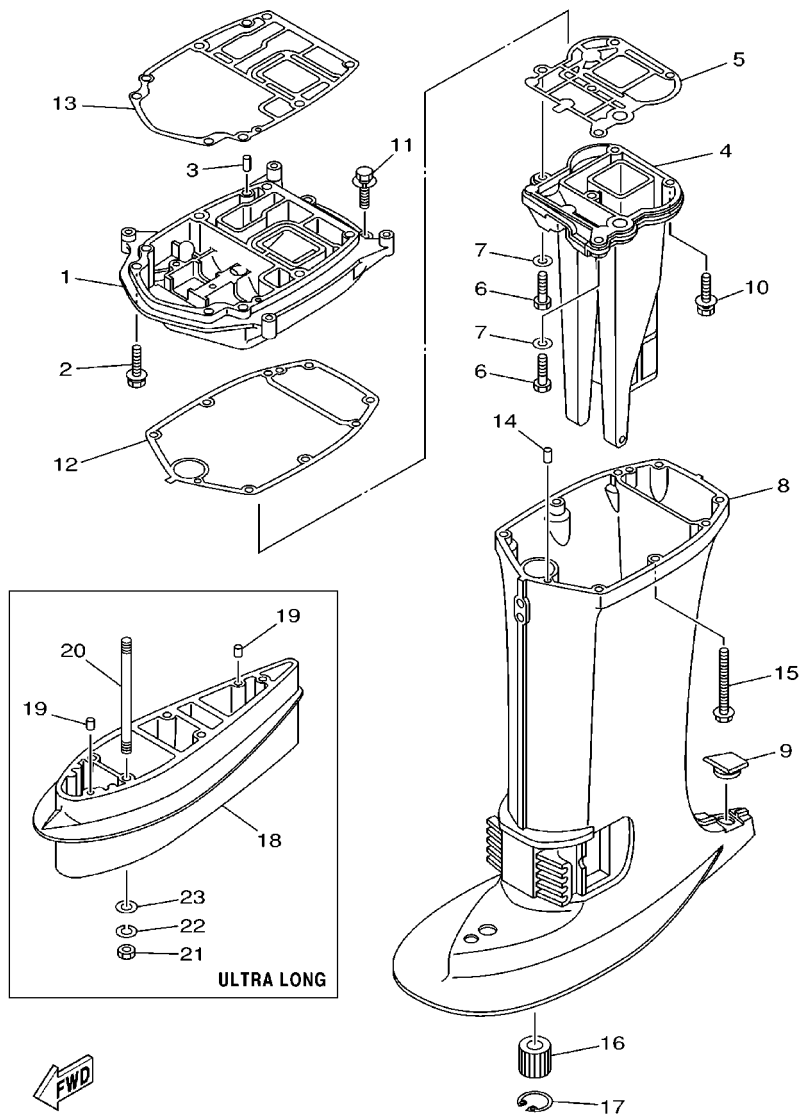

66T0200-1220

REF. NO.	PART NO. CODIGO NO.	DESCRIPTION DESCRIPTION	MH	WH	W	WT	REMARKS OBSERVACION
1	66T-41137-00-94	GUIDE, EXHAUST GUIA DE ESCAPE	1	1	1	1	
2	90119-08M79	BOLT, WITH WASHER TORNILLO CON ARANDELA	2	2	2	2	
3	93606-12019	PIN, DOWEL PASADOR DE CLAVIJA	2	2	2	2	
4	66T-41131-00-5B	MANIFOLD, EXT. 1 TUBO MULTIPLE DE ESCAPE	1	1			S
	66T-41131-10-5B	MANIFOLD, EXT. 1 TUBO MULTIPLE DE ESCAPE	1	1	1	1	L/X
5	66T-41133-A0	GASKET, EXHAUST MANIFOLD 1 EMPAQUE ESCAPE MULTIPLE	1	1	1	1	
6	97075-08030	BOLT PERNO	2	2	2	2	
7	92995-08600	WASHER ARANDELA	2	2	2	2	
8	66T-45111-00-4D	CASING, UPPER CAJA SUPERIOR	1	1			S
	66T-45111-10-4D	CASING, UPPER CAJA SUPERIOR	1	1	1	1	L/X
9	63D-45155-00	CAP TAPA	1	1	1	1	
10	97575-08545	BOLT, WITH WASHER PERNO CON ARANDELA RONDELLE	3	3	3	3	
11	90119-08M79	BOLT, WITH WASHER TORNILLO CON ARANDELA	2	2	2	2	
12	66T-45114-A0	GASKET, UPPER CASING EMPAQUE	1	1	1	1	
13	66T-45113-A0	GASKET, UPPER CASING EMPAQUE	1	1	1	1	
14	93606-12019	PIN, DOWEL PASADOR DE CLAVIJA	2	2	2	2	
15	90119-08M42	BOLT, WITH WASHER TORNILLO CON ARANDELA	6	6	6	6	
16	679-45318-00	BUSHING, DRIVE SHAFT BUJE, EJE DE MANDO	1	1	1	1	L/X
17	93420-30042	CIRCLIP BOLA	1	1	1	1	L/X
18	66T-45211-00-4D	EXTENSION EXTENSION	1				X
19	93606-12019	PIN, DOWEL PASADOR DE CLAVIJA	2				X
20	90116-10M23	BOLT, STUD ESPARRAGO	4				X
21	95380-10600	NUT TUERCA	4				X
22	92990-10100	WASHER, SPRING ARANDELA	4				X
23	92990-10600	WASHER, PLATE ARANDELA	4				X

FIG. 23 LOWER CASING, DRIVE 1

IMPULSOR E INFERIOR 1

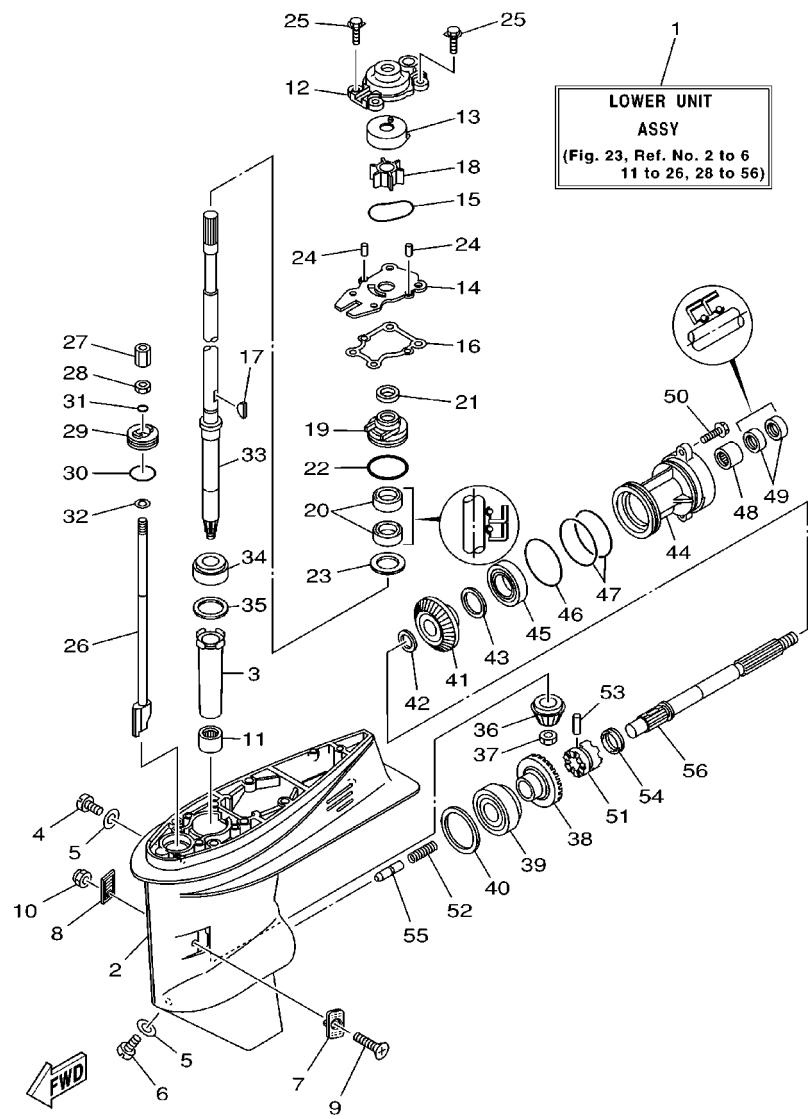

66T0200-1230

REF. NO.	PART NO. CODIGO NO.	DESCRIPTION DESCRIPTION	MH	WH	W	WT	REMARKS OBSERVACION
1	66T-45300-01-4D	LOWER UNIT ASSY CONJUNTO UNIDAD INFERIOR	1		1		S
	66T-45300-11-4D	LOWER UNIT ASSY CONJUNTO UNIDAD INFERIOR	1	1	1	1	L
	66T-45300-31-4D	LOWER UNIT ASSY CONJUNTO UNIDAD INFERIOR	1				X
2	66T-45311-01-4D	CASING, LOWER FUNDA INFERIOR	1	1	1	1	
3	6H4-45536-00	SLEEVE, DRIVE SHAFT CAMISA EJE DE MANDO	1	1	1	1	
4	90340-08M04	PLUG, STRAIGHT SCREW TORNILLO, DE DRENAJE	1	1	1	1	
5	90430-08020	GASKET JUNTA	2	2	2	2	
6	688-45341-00	PLUG, DRAIN TAPON, DREN	1	1	1	1	
7	63D-45214-00	COVER, WATER INLET CUBIERTA ENTRADA AGUA	1	1	1	1	
8	63D-45215-00	COVER, WATER INLET CUBIERTA ENTRADA AGUA	1	1	1	1	
9	90142-05M06	SCREW, COUNTERSUNK TORNILLO EMBUTIDO	1	1	1	1	
10	95380-05600	NUT TUERCA	1	1	1	1	
11	93315-32224	BEARING COJINETE	1	1	1	1	
12	66T-44311-00	HOUSING, WATER PUMP CAJA BOMBA DE AGUA	1	1	1	1	
13	63D-44322-00	INSERT, CARTRIDGE CARTUCHO				1	FOR STD
	63D-44322-40	INSERT, CARTRIDGE CARTUCHO	1	1	1	1	FOR CHROMATE
14	66T-44323-00	OUTER PLATE, CARTRIDGE PLACA EXTERIOR DEL CARTUCHO				1	FOR STD
	66T-44323-40	OUTER PLATE, CARTRIDGE PLACA EXTERIOR DEL CARTUCHO	1	1	1	1	FOR CHROMATE
15	93210-59MG7	O-RING ANILLO O	1	1	1	1	
16	63D-44316-00	GASKET, WATER PUMP EMPAQUE	1	1	1	1	
17	90280-03M03	KEY, WOODRUFF CUNA WOODRUFF	1	1	1	1	
18	6H4-44352-02	IMPELLER IMPULSOR	1	1	1	1	
19	63D-44341-00	HOUSING, WATER PUMP CAJA BOMBA DE AGUA	1	1	1	1	
20	93101-22M60	OIL SEAL SELLO ACEITE	2	2	2	2	
21	66T-45344-01	COVER, OIL SEAL CUBIERTA SELLO ACEITE	1	1	1	1	
22	93210-48MG8	O-RING ANILLO O	1	1	1	1	
23	90201-27M00	WASHER, PLATE ARANDELA PLANA	1	1	1	1	

FIG. 23 LOWER CASING. DRIVE 1

IMPULSOR E INFERIOR 1

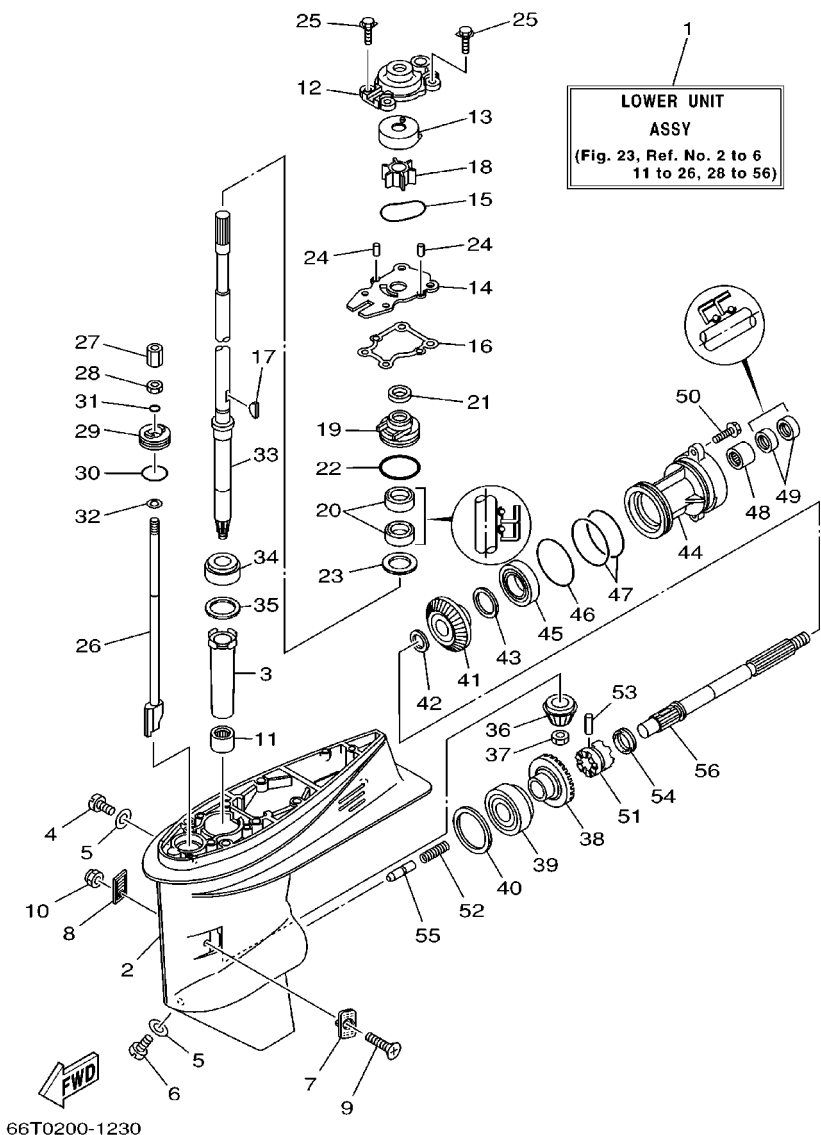

66T0200-1230

REF. NO.	PART NO. CODIGO NO.	DESCRIPTION DESCRIPTION	MH	WH	W	WT	REMARKS OBSERVACION
24	93604-08062	PIN, DOWEL PASADOR DE CLAVIJA	2	2	2	2	
25	90119-08M15	BOLT, WITH WASHER TORNILLO CON ARANDELA	4	4	4	4	
26	66T-44150-01	SHIFT CAM ASSY CONJUNTO EJE LEVA COMPL.	1		1		S
	66T-44150-11	SHIFT CAM ASSY CONJUNTO EJE LEVA COMPL.	1	1	1	1	L
	66T-44150-21	SHIFT CAM ASSY CONJUNTO EJE LEVA COMPL.	1				X
27	61N-44146-00	CONNECTOR, SHIFT ROD CONECTOR VARILLA DE CAMBIO	1	1	1	1	
28	95380-06700	NUT TUERCA	1	1	1	1	
29	66T-45321-00	PLATE PLACA	1	1	1	1	
30	93210-33MG4	O-RING ANILLO O	1	1	1	1	
31	93210-06ME6	O-RING ANILLO O	1	1	1	1	
32	92990-06600	WASHER, PLATE ARANDELA	1	1	1	1	
33	66T-45501-01	DRIVE SHAFT COMP. EJE DE MANDO COMPL.	1		1		S
	66T-45501-11	DRIVE SHAFT COMP. EJE DE MANDO COMPL.	1	1	1	1	L
	66T-45501-21	DRIVE SHAFT COMP. EJE DE MANDO COMPL.	1				X
34	93332-00001	BEARING COJINETE	1	1	1	1	
35	663-45587-01-10	SHIM (T:0.10MM) LAINA (T:0.10MM)	1	1	1	1	UR
	663-45587-01-12	SHIM (T:0.12MM) LAINA (T:0.12MM)	1	1	1	1	UR
	663-45587-01-15	SHIM (T:0.15MM) LAINA (T:0.15MM)	1	1	1	1	UR
	663-45587-01-18	SHIM (T:0.18MM) LAINA (T:0.18MM)	1	1	1	1	UR
	663-45587-01-30	SHIM (T:0.30MM) LAINA (T:0.30MM)	1	1	1	1	UR
	663-45587-01-40	SHIM (T:0.40MM) LAINA (T:0.40MM)	1	1	1	1	UR
	663-45587-01-50	SHIM (T:0.50MM) LAINA (T:0.50MM)	1	1	1	1	UR
36	66T-45551-00	PINION PINON	1	1	1	1	
37	90170-12138	NUT TUERCA	1	1	1	1	
38	66T-45560-01	GEAR ENGRANE COMPLE 1	1	1	1	1	
39	93332-00003	BEARING COJINETE	1	1	1	1	
40	663-45567-01-10	SHIM (T:0.10MM) LAINA (T:0.10MM)	1	1	1	1	UR

FIG. 23 LOWER CASING, DRIVE 1

IMPULSOR E INFERIOR 1

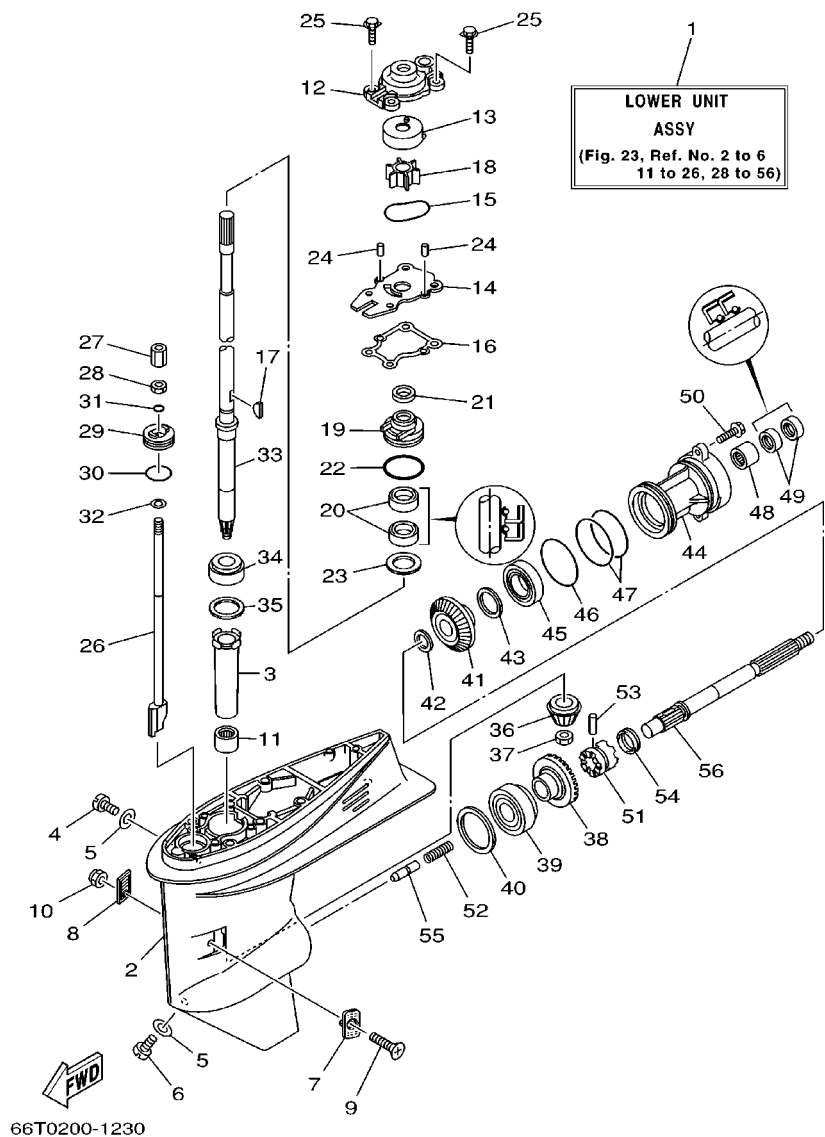

REF. NO.	PART NO. CODIGO NO.	DESCRIPTION DESCRIPTION	MH	WH	W	WT	REMARKS OBSERVACION
40	663-45567-01-12	SHIM (T:0.12MM) LAINA (T:0.12MM)	1	1	1	1	UR
	663-45567-01-15	SHIM (T:0.15MM) LAINA (T:0.15MM)	1	1	1	1	UR
	663-45567-01-18	SHIM (T:0.18MM) LAINA (T:0.18MM)	1	1	1	1	UR
	663-45567-01-30	SHIM (T:0.30MM) LAINA (T:0.30MM)	1	1	1	1	UR
	663-45567-01-40	SHIM (T:0.40MM) LAINA (T:0.40MM)	1	1	1	1	UR
	663-45567-01-50	SHIM (T:0.50MM) LAINA (T:0.50MM)	1	1	1	1	UR
41	66T-45571-00	GEAR ENGRANAJE	1	1	1	1	
42	90201-22429	WASHER, PLATE ARANDELA PLANA	1	1	1	1	
43	63D-45577-00-10	SHIM (T:0.10MM) LAINA (T:0.10MM)	1	1	1	1	UR
	63D-45577-00-12	SHIM (T:0.12MM) LAINA (T:0.12MM)	1	1	1	1	UR
	63D-45577-00-15	SHIM (T:0.15MM) LAINA (T:0.15MM)	1	1	1	1	UR
	63D-45577-00-18	SHIM (T:0.18MM) LAINA (T:0.18MM)	1	1	1	1	UR
	63D-45577-00-30	SHIM (T:0.30MM) LAINA (T:0.30MM)	1	1	1	1	UR
	63D-45577-00-40	SHIM (T:0.40MM) LAINA (T:0.40MM)	1	1	1	1	UR
	63D-45577-00-50	SHIM (T:0.50MM) LAINA (T:0.50MM)	1	1	1	1	UR
44	63D-45361-02-4D	CAP, LOWER CASING FUNDA INFERIOR	1	1	1	1	
45	93306-001U1	BEARING COJINETE	1	1	1	1	
46	93210-69MG6	O-RING ANILLO O	1	1	1	1	
47	93210-74MG5	O-RING ANILLO O	2	2	2	2	
48	93317-22204	BEARING COJINETE	1	1	1	1	
49	93101-22M00	OIL SEAL SELLO ACEITE	2	2	2	2	
50	90105-08M61	BOLT, WASHER BASED TORNILLO CON ARANDELA	2	2	2	2	
51	66T-45631-00	CLUTCH, DOG EMBRAGUE DE GARRA	1	1	1	1	
52	90501-15M01	SPRING, COMPRESSION RESORTE DE COMPRESION	1	1	1	1	
53	90250-06023	PIN, STRAIGHT PASADOR CILINDRICO	1	1	1	1	
54	663-45633-00	RING, CROSS PIN ANILLO DE PASADOR	1	1	1	1	
55	66T-45635-00	PLUNGER, SHIFT EMBOLO DE CAMBIO	1	1	1	1	

FIG. 23 LOWER CASING. DRIVE 1

IMPULSOR E INFERIOR 1

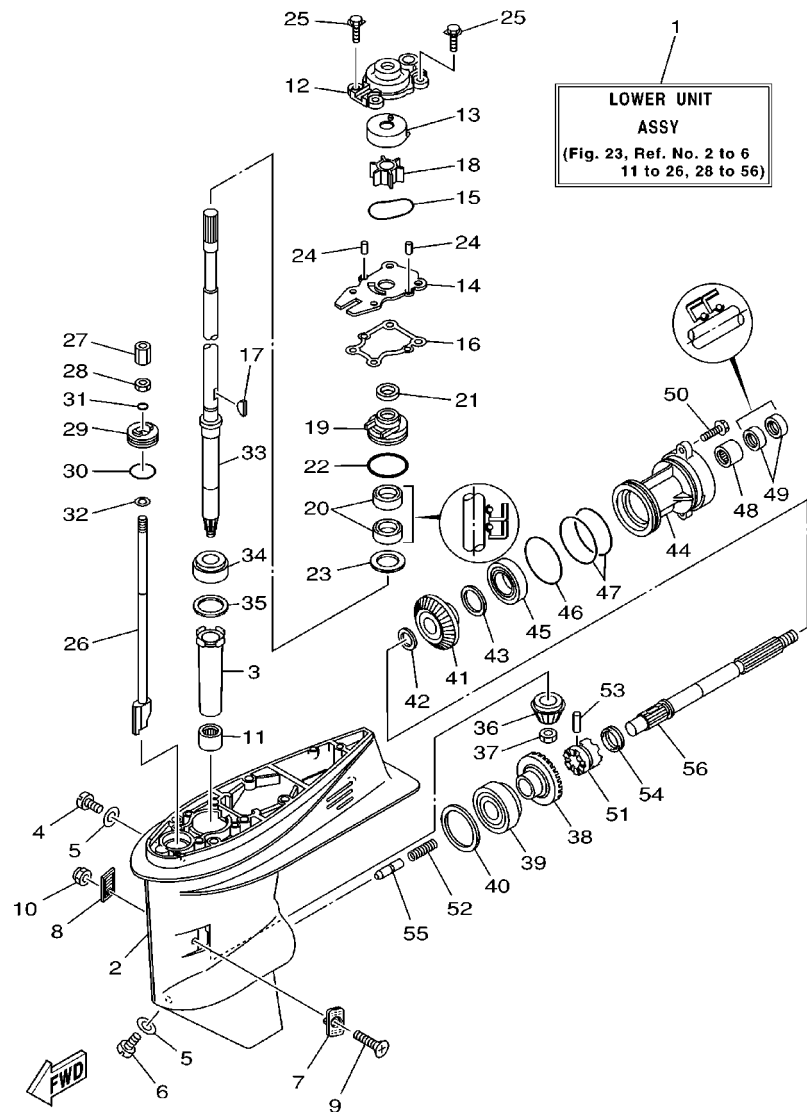

66T0200-1230

REF. NO.	PART NO. CODIGO NO.	DESCRIPTION DESCRIPTION	MH	WH	W	WT	REMARKS OBSERVACION
56	66T-45611-00	SHAFT, PROPELLER EJE PROPUSOR	1	1	1	1	

FIG. 24 LOWER CASING. DRIVE 2

IMPULSOR E INFERIOR 2

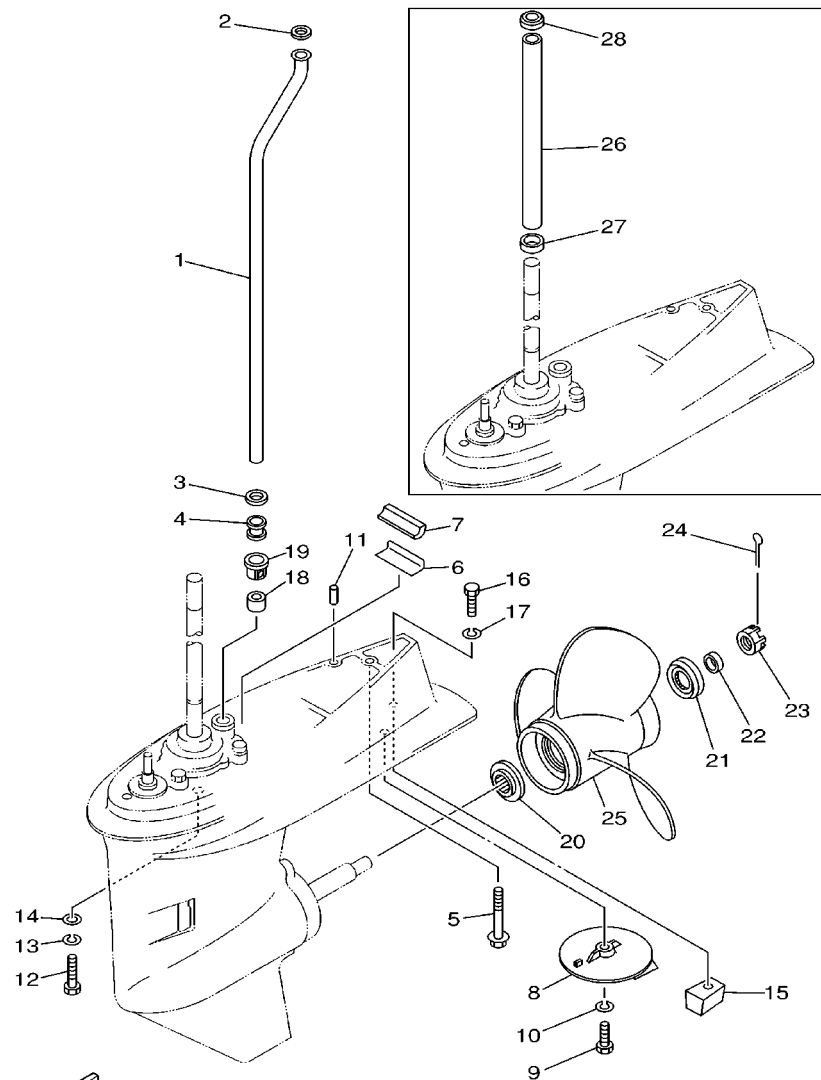

66T0010-1240

REF. NO.	PART NO. CODIGO NO.	DESCRIPTION DESCRIPTION	MH	WH	W	WT	REMARKS OBSERVACION
1	66T-44361-00	TUBE, WATER TUBO DE AGUA	1		1		S
	66T-44361-10	TUBE, WATER TUBO DE AGUA	1	1	1	1	L
	66T-44361-20	TUBE, WATER TUBO DE AGUA	1				X
2	90202-12060	WASHER, PLATE ARANDELA DE PLANA	1	1	1	1	
3	90430-12072	GASKET JUNTA	1	1	1	1	
4	663-44367-00	DAMPER, WATER SEAL GOMA DEL SELLO DE AGUA	1	1	1	1	
5	90119-08M44	BOLT, WITH WASHER TORNILLO CON ARANDELA	1	1	1	1	S/L
	90119-08M43	BOLT, WITH WASHER TORNILLO CON ARANDELA	1				X
6	663-45376-00	GUIDE, SEAL DAMPER GUIA DE SELLO GOMA	1	1	1	1	
7	63D-45375-00	DAMPER, SEAL GOMA DE SELLO	1	1	1	1	
8	664-45371-01	TAB-TRIM QUILLA ESTABILIZADOR	1	1	1	1	
9	97095-08025	BOLT PERNO	1	1	1	1	
10	92995-08100	WASHER ARANDELA	1	1	1	1	
11	93606-12019	PIN, DOWEL PASADOR DE CLAVIJA	2	2	2	2	
12	97075-10040	BOLT PERNO	4	4	4	4	S/L
13	92995-10100	WASHER ARANDELA	4	4	4	4	S/L
14	92995-10600	WASHER ARANDELA	4	4	4	4	S/L
15	67C-45251-00	ANODE CATODE	1	1	1	1	
16	97095-08035	BOLT PERNO	1	1	1	1	
17	92995-08100	WASHER ARANDELA	1	1	1	1	
18	663-44366-00	DAMPER, WATER SEAL GOMA DEL SELLO DE AGUA	1	1	1	1	
19	63D-44312-00	COVER, WATER PUMP HOUSING CUBIERTA CAJA BOMBA DE AGUA	1	1	1	1	
20	663-45987-02	SPACER ESPACIADOR	1	1	1	1	
21	66T-45997-00	SPACER ESPACIADOR	1	1	1	1	
22	90389-22M01	BUSH BUJE	1	1	1	1	
23	90171-16011	NUT, CASTLE TUERCA ENTALLADA	1	1	1	1	
24	91490-30025	PIN, COTTER PASADOR DE CHAVETA	1	1	1	1	

FIG. 24 LOWER CASING, DRIVE 2 IMPULSOR E INFERIOR 2

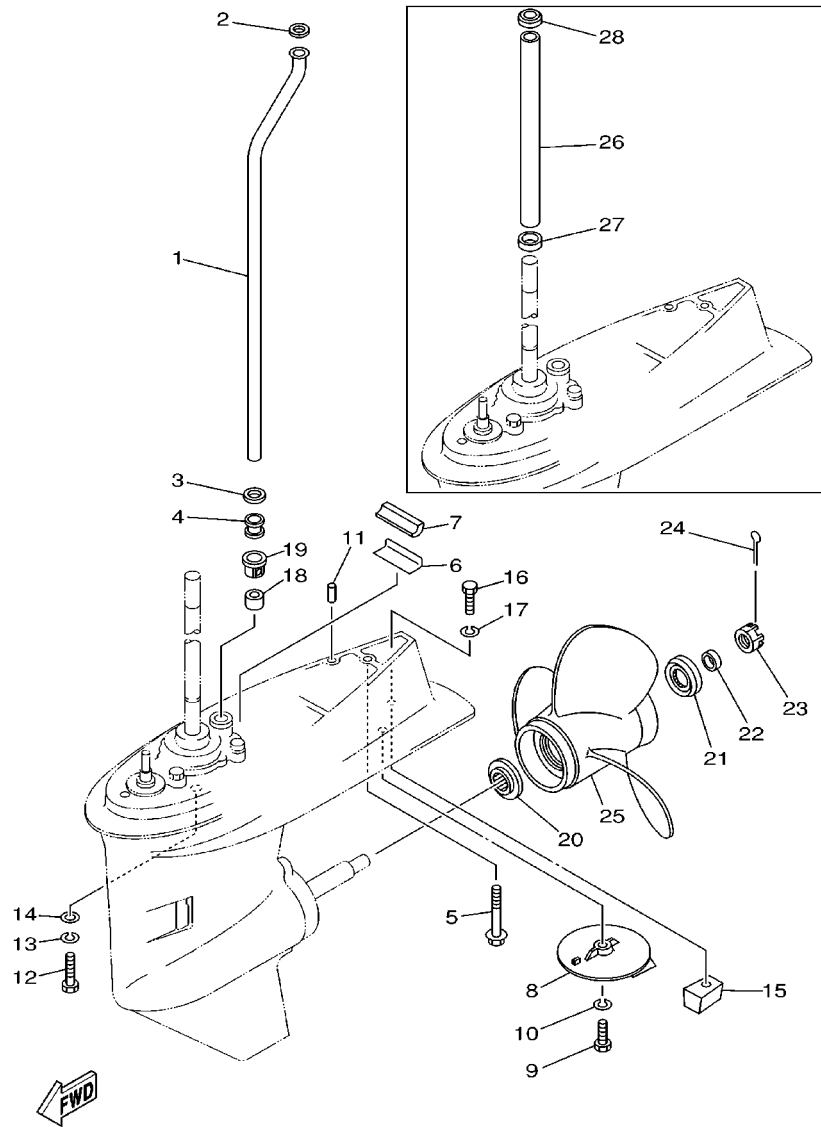

66T0010-1240

REF. NO.	PART NO. CODIGO NO.	DESCRIPTION DESCRIPTION	MH	WH	W	WT	REMARKS OBSERVACION
25	63D-45941-00-EL	PROPELLER (3X12-1/4"X8"-G) PROPELA (3X12-1/4"X8"-G)	1	1	1	1	UR
	663-45930-00-98	PROPELLER (3X10-1/4"X14"-G) PROPELA (3X10-1/4"X14"-G)	1	1	1	1	UR
	663-45941-01-EL	PROPELLER (3X10-3/4"X17"-G) PROPELA (3X10-3/4"X17"-G)	1	1	1	1	UR
	663-45943-02-EL	PROPELLER (3X11"X15"-G) PROPELA (3X11"X15"-G)	1	1	1	1	UR
	663-45945-02-EL	PROPELLER (3X11-1/8"X13"-G) PROPELA (3X11-1/8"X13"-G)	1	1	1	1	UR
	663-45947-02-EL	PROPELLER (3X11-5/8"X11"-G) PROPELA (3X11-5/8"X11"-G)	1	1	1	1	UR
	663-45949-01-EL	PROPELLER (3X10-3/4"X16"-G) PROPELA (3X10-3/4"X16"-G)	1	1	1	1	UR
	663-45952-02-EL	PROPELLER (3X11-3/8"X12"-G) PROPELA (3X11-3/8"X12"-G)	1	1	1	1	UR
	663-45954-01-EL	PROPELLER (3X11-3/4"X10"-G) PROPELA (3X11-3/4"X10"-G)	1	1	1	1	UR
	663-45956-01-EL	PROPELLER (3X12-1/4"X9"-G) PROPELA (3X12-1/4"X9"-G)	1	1	1	1	UR
	663-45958-01-EL	PROPELLER (3X11-1/4"X14"-G) PROPELA (3X11-1/4"X14"-G)	1	1	1	1	UR
	663-45976-00-98	PROPELLER (3X10-1/4"X15"-G) PROPELA (3X10-1/4"X15"-G)	1	1	1	1	UR
	663-45978-00-98	PROPELLER (3X10-1/4"X16"-G) PROPELA (3X10-1/4"X16"-G)	1	1	1	1	UR
	663-45970-60-98	PROPELLER (3X11-3/4"X12"-G) PROPELA (3X11-3/4"X12"-G)	1	1	1	1	UR
	663-45972-60-98	PROPELLER (3X12"X11"-G) PROPELA (3X12"X11"-G)	1	1	1	1	UR
	663-45974-60-98	PROPELLER (3X11-1/2"X13"-G) PROPELA (3X11-1/2"X13"-G)	1	1	1	1	UR
26	66T-44362-10	TUBE, WATER TUBO DE AGUA	1	1	1	1	L
	66T-44362-20	TUBE, WATER TUBO DE AGUA	1				X
27	90480-25M70	GROMMET TAPON	1	1	1	1	
28	90480-30M71	GROMMET TAPON	1	1	1	1	

B1

FIG. 25 FUEL TANK

DEPOSITO DE COMBUSTIBLE

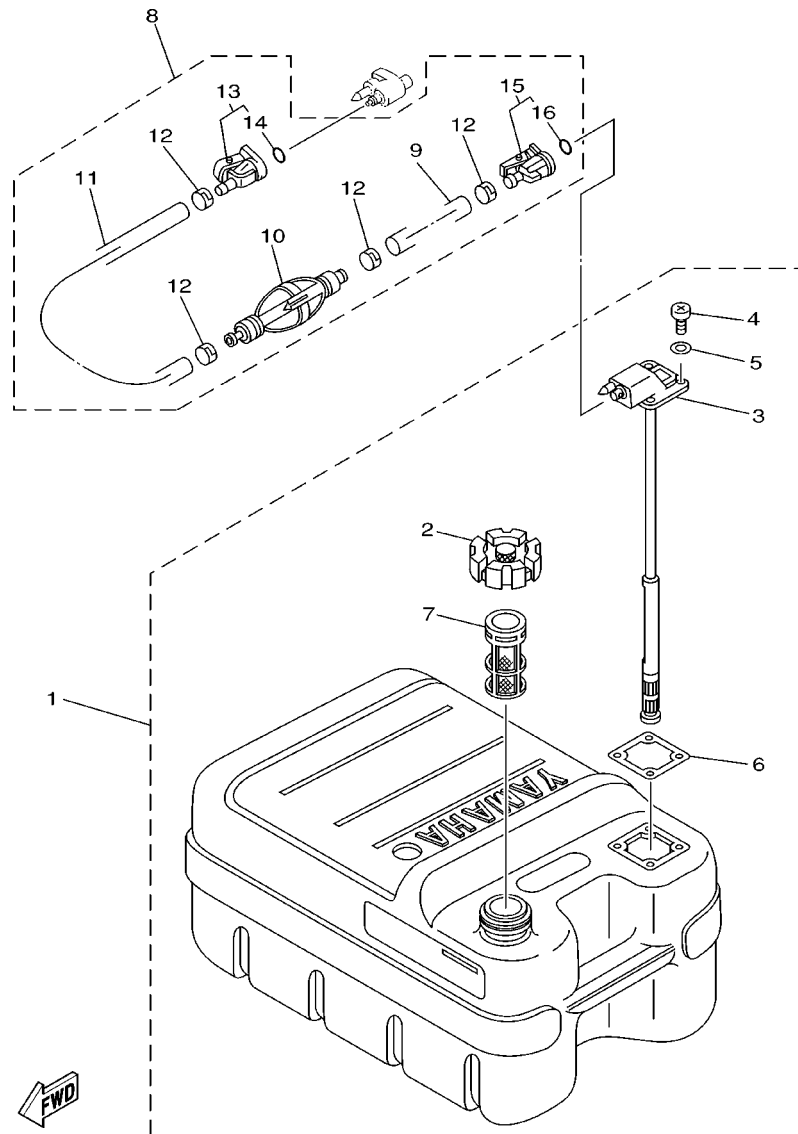

66T0100-9240

REF. NO.	PART NO. CODIGO NO.	DESCRIPTION DESCRIPTION	MH	WH	W	WT	REMARKS OBSERVACION
1	6YJ-24201-00	FUEL TANK ASSY (24L) TANQUE DEL COMBUSTIBLE (24L)	1	1	1	1	AP
	6YJ-24201-10	FUEL TANK ASSY (24L) TANQUE DEL COMBUSTIBLE (24L)	1	1	1	1	AP FOR CHINA, TAIWAN
2	6YJ-24610-01	.CAP ASSY .TAPA COMPLETA	1	1	1	1	
3	6YJ-24260-00	.FUEL METER ASSY .MEDIDOR DE COMBUSTIBLE COMPL.	1	1	1	1	
	6Y1-24260-12	.FUEL METER ASSY .MEDIDOR DE COMBUSTIBLE COMPL.	1	1	1	1	FOR CHINA, TAIWAN
4	98586-05016	.SCREW, PAN HEAD .TORNILLO DE CABEZA CON PLANA	4	4	4	4	
5	6Y1-24329-00	.SEAL .SELLO	4	4	4	4	
6	6Y1-24268-00	.GASKET, FUEL METER .EMPAQ MEDIDOR DE COMBUSTIBLE	1	1	1	1	
7	6YJ-24167-00	.STRAINER .COLADOR	1	1	1	1	
8	61J-24306-02	FUEL PIPE COMP. 1 TUBO COMBUST. COMPL 1	1	1	1	1	AP
9	90445-11M06	.HOSE (L2050) .MANGUERA (L2050)	1	1	1	1	
10	61J-24360-00	.PRIMER PUMP ASSY .SOPORTE BOMBA	1	1	1	1	
11	90445-11M05	.HOSE (L:850MM) .MANGUERA (L:850MM)	1	1	1	1	
12	650-24351-51	BAND 1 .ABRAZADERA 1	4	4	4	4	
13	6G1-24305-03	FUEL PIPE JOINT COMP. 2 CONECTOR MANGUERA COMBUST.2	1	1	1	1	
14	93210-08287	.O-RING .ANILLO O	1	1	1	1	
15	6Y1-24305-04	FUEL PIPE JOINT COMP. 2 CONECTOR MANGUERA COMBUST.2	1	1	1	1	
16	93210-08287	.O-RING .ANILLO O	1	1	1	1	

FIG. 26 STEERING GUIDE

DIRECCIONGUIAR

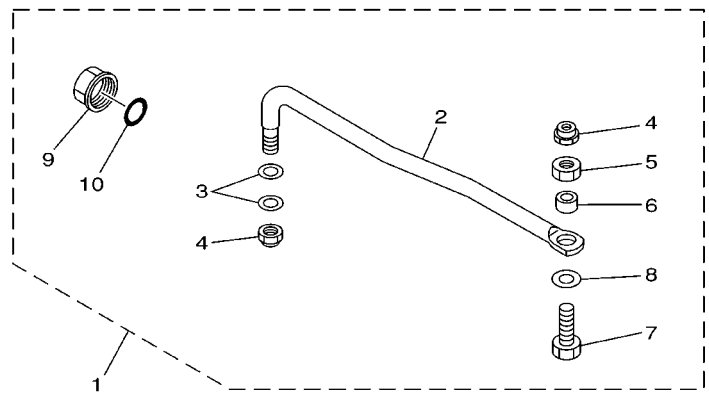

REF. NO.	PART NO. CODIGO NO.	DESCRIPTION DESCRIPTION	MH	WH	W	WT	REMARKS OBSERVACION
1	65W-61350-00	STEERING GUIDE ATTACHMENT KIT ESTUCHE ADITAMENTO GUIA DE TIM			1	1	AP FOR CHINA
2	65W-61351-00	.ROD, STEERING LINK .VARILLA ESLABON DIRECCION			1	1	
3	90201-10M20	.WASHER, PLATE .ARANDELA PLANA			2	2	
4	90185-09M01	.NUT, SELF-LOCKING .TUERCA AUTOBLOCANTE			2	2	
5	90170-09M03	.NUT .TUERCA			1	1	
6	90387-10M42	.COLLAR .COLLAR			1	1	
7	90101-09M01	.BOLT .TORNILLO			1	1	
8	90201-10M63	.WASHER, PLATE .ARANDELA PLANA			1	1	
9	6E5-43145-01	.CAP, CLAMP BRACKET .TAPA			1	1	
10	93210-16275	.O-RING .ANILLO O			1	1	

65W0010-8210

FIG. 27 REMOTE CONTROL BOX CONTROL REMOTO COMPL.

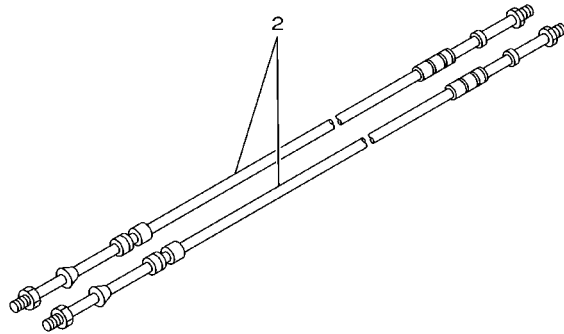
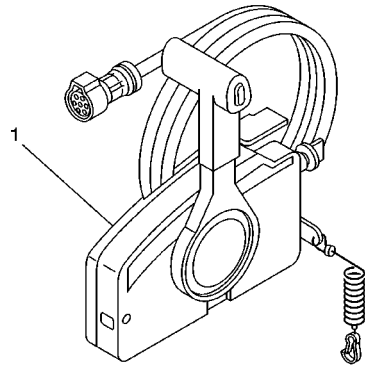

67M0100-8280

REF. NO.	PART NO. CODIGO NO.	DESCRIPTION DESCRIPTION	MH	WH	W	WT	REMARKS OBSERVACION
1	703-48205-16	REMOTE CONTROL ASSY REMOTO CONTROL COMPL.				1	AP WITH PT/T SW.
	703-48203-14	REMOTE CONTROL ASSY (7P) REMOTO CONTROL COMPL.(7P)			1		AP
2	701-48320-00	CABLE, REMOTE CONTROL L=12F CABLE CONTROL REMOTO L=12F			2	2	UR
	701-48320-20	CABLE, REMOTE CONTROL L=13F CABLE CONTROL REMOTO L=13F			2	2	UR
	701-48320-50	CABLE, REMOTE CONTROL L=15F CABLE CONTROL REMOTO L=15F			2	2	UR

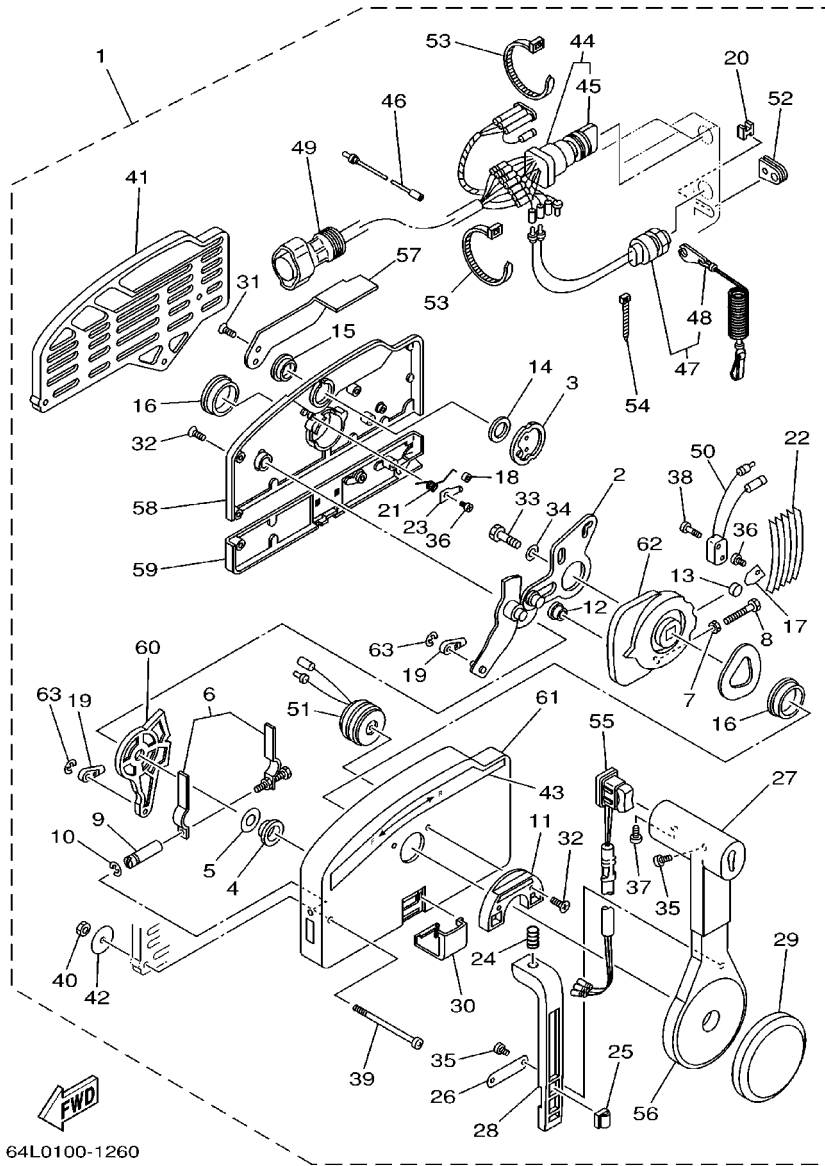

64L0100-1260

FIG. 28 REMOTE CONTROL ASSY CONTROL REMOTO COMPL.

REF. NO.	PART NO. CODIGO NO.	DESCRIPTION DESCRIPTION	MH	WH	W	WT	REMARKS OBSERVACION
1	703-48205-16	REMOTE CONTROL ASSY				1	AP WITH PT/T SW.
	703-48203-14	REMOTE CONTROL COMPL.					
	703-48203-14	REMOTE CONTROL ASSY (7P)			1		AP
	703-48203-14	REMOTE CONTROL COMPL.(7P)					
2	703-48261-01	.ARM, THROTTLE			1	1	
		.BRAZO ACELERADOR					
3	703-48153-00	.SHAFT, FREE ACCEL.			1	1	
		.EJE					
4	703-48235-00	.BUSHING			1	1	
		.BUJE					
5	703-48268-00	.SPACER			1	1	
		.ESPACIADOR 3					
6	703-48264-00	.THROTTLE, FRICTION			1	1	
		.FRICCION ACELERADOR					
7	95380-05600	.NUT			1	1	
		.TUERCA					
8	97380-05025	.BOLT			1	1	
		.PERNO					
9	703-48265-00	.SHAFT, FRICTION			1	1	
		.EJE FRICCION					
10	93430-06024	.CIRCLIP			3	3	
		.BOLA					
11	703-48245-00	.PLATE, LOCK			1	1	
		.PLACA CERRADURA					
12	703-48252-00	.ROLLER, CAM			1	1	
		.RODILLO LEVA					
13	701-48248-00	.ROLLER, FREE ACCEL.			1	1	
		.RODILLO ACELERADOR LIBRE					
14	703-48198-00	.WASHER, WAVE			1	1	
		.RONDANA ONDULADA 3					
15	703-48243-00	.BUSHING			1	1	
		.BUJE 3					
16	703-48236-00	.BUSHING 1			2	2	
		.BUJE					
17	703-48189-00	.RETAINER			1	1	
		.RETENEDOR					
18	703-48234-00	.ROLLER, DETENT			1	1	
		.RODILLO					
19	703-48345-01	.CABLE END,REMOTE CONTROL 2			2	2	
		.TERMINAL CABLE DE CONTROL REM					
20	703-48358-00	.ANCHOR, CABLE			1	1	
		.ABRAZADERA CABLE					
21	703-48244-00	.SPRING, FREE ACCEL.			1	1	
		.RESORTE ACELERADOR LIBRE					
22	703-48238-00	.SPRING, DETENT			5	5	
		.RESORTE					
23	703-48246-00	.SPACER			1	1	
		.ESPACIADOR					
24	703-48227-00	.SPRING, NEUTRAL LOCK			1	1	
		.RESORTE DE SEGURO					
25	703-82594-00	.CLAMP			1		WITH PT/T SW.
		.GRAMPA					
26	703-48226-00	.PLATE, STOPPER			1	1	
		.PLACA RETEN					

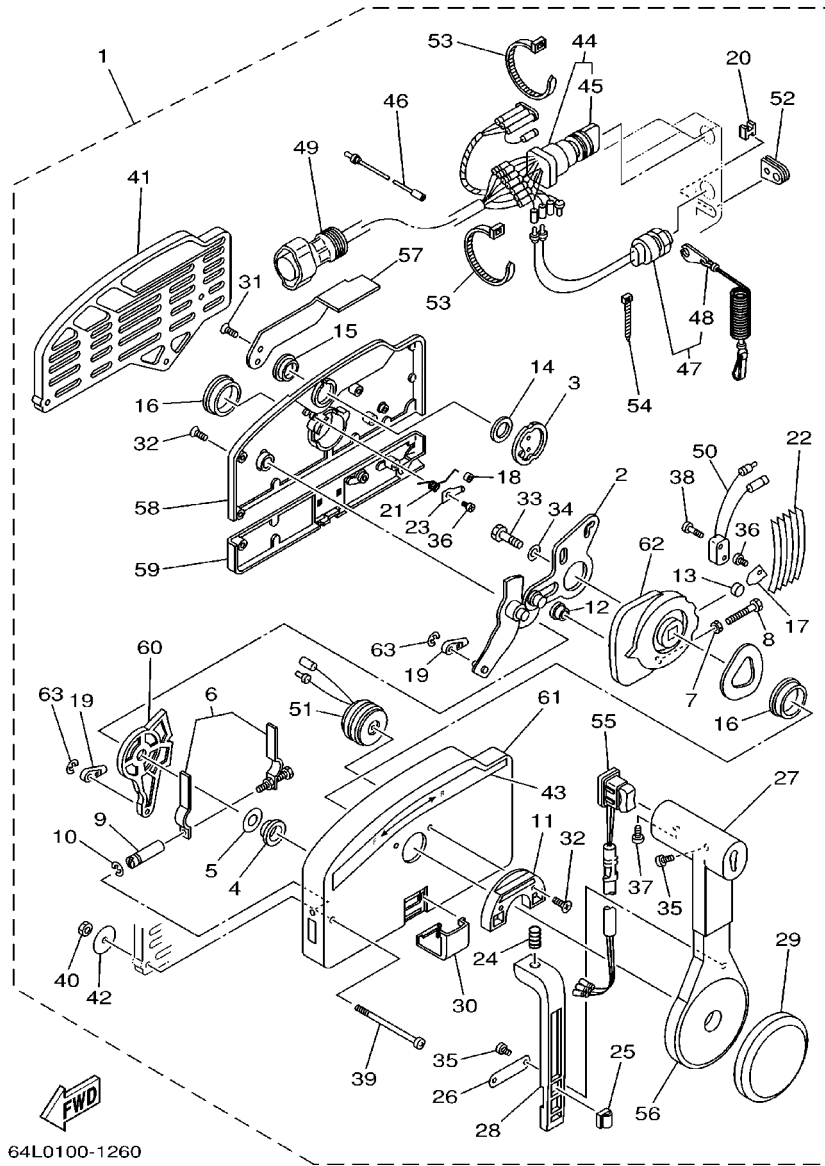

64L0100-1260

FIG. 28 REMOTE CONTROL ASSY CONTROL REMOTO COMPL.

REF. NO.	PART NO. CODIGO NO.	DESCRIPTION DESCRIPTION	MH	WH	W	WT	REMARKS OBSERVACION
27	703-48222-00	.GRIP, CONTROL LEVER .MANGO DE PALANCA CONTROL			1	1	SINGLE
28	703-48223-00	.LOCK, NEUTRAL .CERRADURA NEUTRO			1	1	
29	703-48225-00	.COVER .CUBIERTA			1	1	
30	703-48219-00	.COVER, LEAD .CUBIERTA			1	1	
31	703-48281-00	.SCREW .TORNILLO 1			2	2	
32	703-48282-00	.SCREW .TORNILLO 2			7	7	
33	97095-08030	.BOLT .PERNO			1	1	
34	92990-08600	.WASHER, PLATE .ARANDELA			1	1	
35	98580-04010	.SCREW, PAN HEAD .TORNILLO DE CABEZA CON PLANA			3	3	
36	98580-04006	.SCREW, PAN HEAD .TORNILLO DE CABEZA CON PLANA			2	2	
37	98580-05010	.SCREW, PAN HEAD .TORNILLO DE CABEZA CON PLANA			1	1	
38	98580-03015	.SCREW, PAN HEAD .TORNILLO DE CABEZA CON PLANA			2	2	
39	703-48291-10	.SCREW (M6) .TORNILLO (M6)			3	3	
40	95380-06600	.NUT, HEXAGON .TUERCA			3	3	
41	703-48293-10	.SPACER, REMOTE CONTROL .ESPACIADOR			1	1	SINGLE
42	701-48287-00	.WASHER .ARANDELA			3	3	
43	703-48215-00	.GRAPHIC .CALCOMANIA 1			1	1	
44	703-82510-42	.MAIN SWITCH ASSY .CONJUNTO DE LLAVE IGNICION			1	1	
	703-82510-31	.MAIN SWITCH ASSY (7P) .CONJUNTO DE LLAVE IGNICION (7P)			1	1	
45	676-82577-00	.CAP, KEY .TAPA			1	1	
46	703-82531-00	.WIRE, LEAD .CABLE CONDUCTOR			1	1	
47	688-82575-01	.ENGINE STOP SWITCH ASSY .INTERRUPTOR DE PARADA COMPL			1	1	
48	682-82556-00	.STOPPER .RETENER			1	1	
49	688-8258A-20	.EXTENSION, WIRE HARNESS .EXTENSION, ARNES DE CABLES			1	1	L:5M (10P)
	688-82586-21	.EXTENSION, WIRE HARNESS .EXTENSION, CONJ. DE CABLES			1	1	L:5M (7P)
50	703-82540-00	.NEUTRAL SWITCH ASSY .INTERRUPTOR NEUTRAL COMPL			1	1	
51	703-83383-02	.BUZZER .ZUMBADOR			1	1	

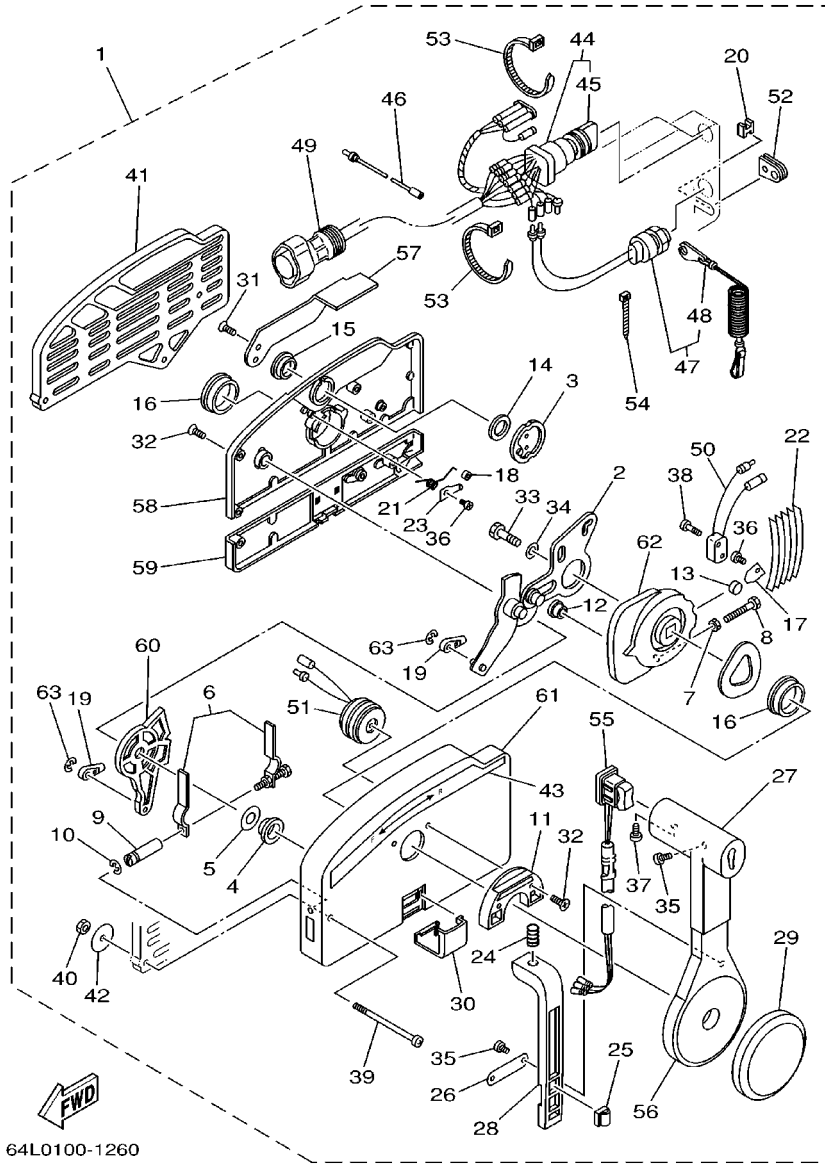

64L0100-1260

FIG. 28 REMOTE CONTROL ASSY CONTROL REMOTO COMPL.

REF. NO.	PART NO. CODIGO NO.	DESCRIPTION DESCRIPTION	MH	WH	W	WT	REMARKS OBSERVACION
52	703-48284-00	.GROMMET .TAPON 1			1	1	
53	703-82591-00	.BAND .BANDA			2	2	
54	703-82592-00	.BAND .BANDA			1	1	
55	703-82563-02	.TRIM & TILT SWITCH ASSY .INTERRUPTOR DE INCLINACION				1	
	703-48224-00	.COVER, CONTROL LEVER .CUBIERTA DE PALANCA CONTROL			1		WITHOUT PT/T SW.
56	703-48221-00	.LEVER, CONTROL .PALANCA CONTROL			1	1	
57	703-48152-00	.KNOB, FREE ACCEL. .PERILLA			1	1	
58	703-48212-00	.BACK PLATE 1 .PLACA TRASERA 1			1	1	
59	703-48213-00	.BACK PLATE 2 .PLACA TRASERA 2			1	1	
60	703-48271-00	.ARM, SHIFT .BRAZO CAMBIADOR			1	1	
61	703-48211-01	.HOUSING, 1 .CAJA			1	1	
62	703-48232-00	.GEAR .ENGRANAJE 1			1	1	
63	93430-06024	.CIRCLIP .BOLA			2	2	

FIG. 29 REPAIR KIT 1

ESTUCHE REPARATION 1

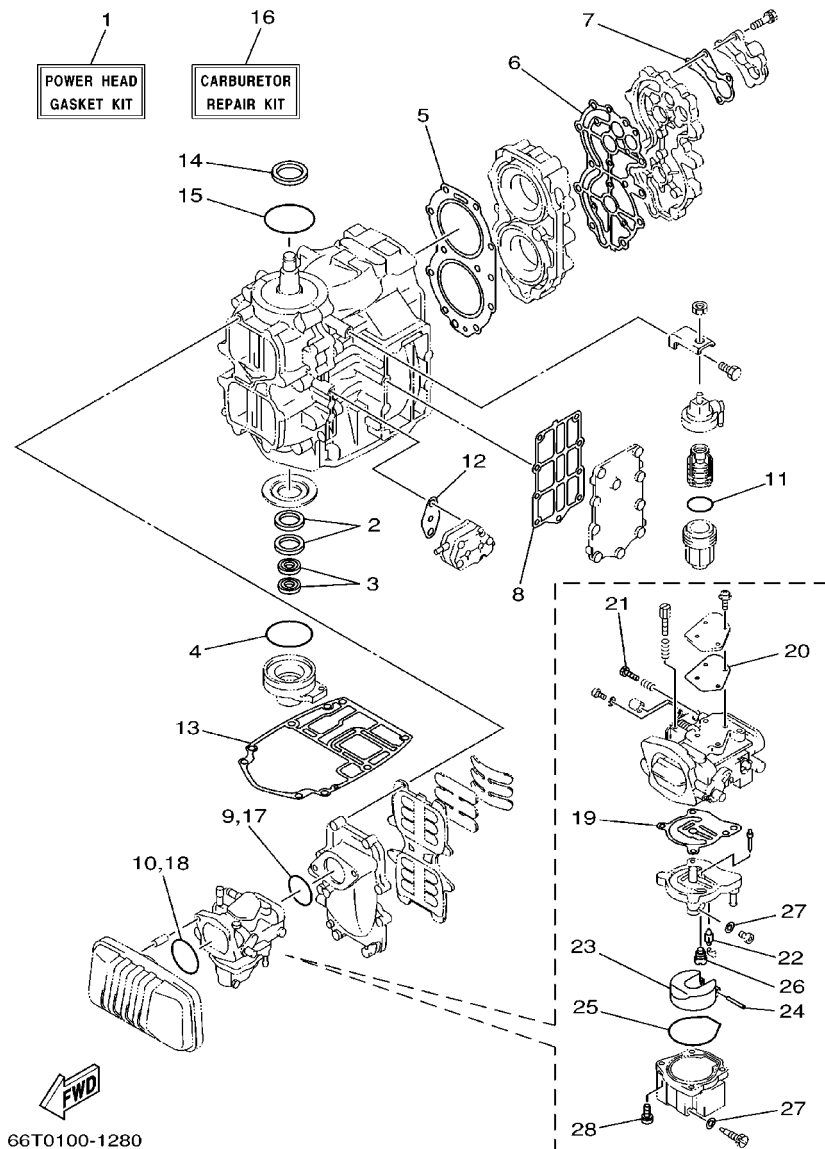

REF. NO.	PART NO. CODIGO NO.	DESCRIPTION DESCRIPTION	MH	WH	W	WT	REMARKS OBSERVACION
1	66T-W0001-01	POWER HEAD GASKET KIT JUEGO DE EMPAQUE MOTOR	1	1	1	1	
2	93102-30M56	.OIL SEAL .SELLO ACEITE	2	2	2	2	
3	93101-16001	.OIL SEAL .SELLO ACEITE	2	2	2	2	
4	93210-65M50	.O-RING ANILLO O	1	1	1	1	
5	66T-11181-A2	.GASKET, CYLINDER HEAD 1 JUNTA, DE CULATA 1	1	1	1	1	
6	66T-11193-A2	.GASKET, HEAD COVER 1 EMPAQUE	1	1	1	1	
7	676-12414-A0	.GASKET, COVER EMPAQUE	1	1	1	1	
8	66T-41114-A0	.GASKET, EXHAUST OUTER COVER EMPAQUE	1	1	1	1	
9	93210-46M16	.O-RING ANILLO O	1	1	1	1	
10	93210-54M54	.O-RING ANILLO O	1	1	1	1	
11	93210-32738	.O-RING ANILLO O	1	1	1	1	
12	650-24431-A0	.GASKET, FUEL PUMP 1 EMPAQUE BOMBA COMBUST 1	1	1	1	1	
13	66T-45113-A0	.GASKET, UPPER CASING EMPAQUE	1	1	1	1	
14	93102-35008	.OIL SEAL .SELLO ACEITE	1	1	1	1	
15	93210-75M51	.O-RING ANILLO O	1	1	1	1	
16	66T-W0093-01	CARBURETOR REPAIR KIT KIT REPARACION CARBURADOR	1	1	1	1	
17	93210-46M16	.O-RING ANILLO O	1	1	1	1	
18	93210-54M54	.O-RING ANILLO O	1	1	1	1	
19	66T-14384-01	.GASKET, FLOAT CHAMBER EMPAQUE DE CAMARA DE BOIA	1	1	1	1	
20	66T-14536-00	.GASKET EMPAQUE	1	1	1	1	
21	6E5-14323-03	.SCREW, AIR ADJUSTING .TORNILLO DE AJUSTE DE AIRE	1	1	1	1	
22	6E5-14546-00	.VALVE, NEEDLE .VALVULA DE AGUJA	1	1	1	1	
23	6E5-14385-02	.FLOAT BOIA	1	1	1	1	
24	6E5-14386-02	.PIN, FLOAT .PASADOR DE BOIA	1	1	1	1	
25	66T-14984-00	.GASKET, FLOAT CHAMBER EMPAQUE CAMARA DE BOIA	1	1	1	1	
26	66T-14992-00	.PLUG .TAPON	1	1	1	1	
27	66T-14959-00	.GASKET EMPAQUE	2	2	2	2	

FIG. 30 REPAIR KIT 2

ESTUCHE REPARATION 2

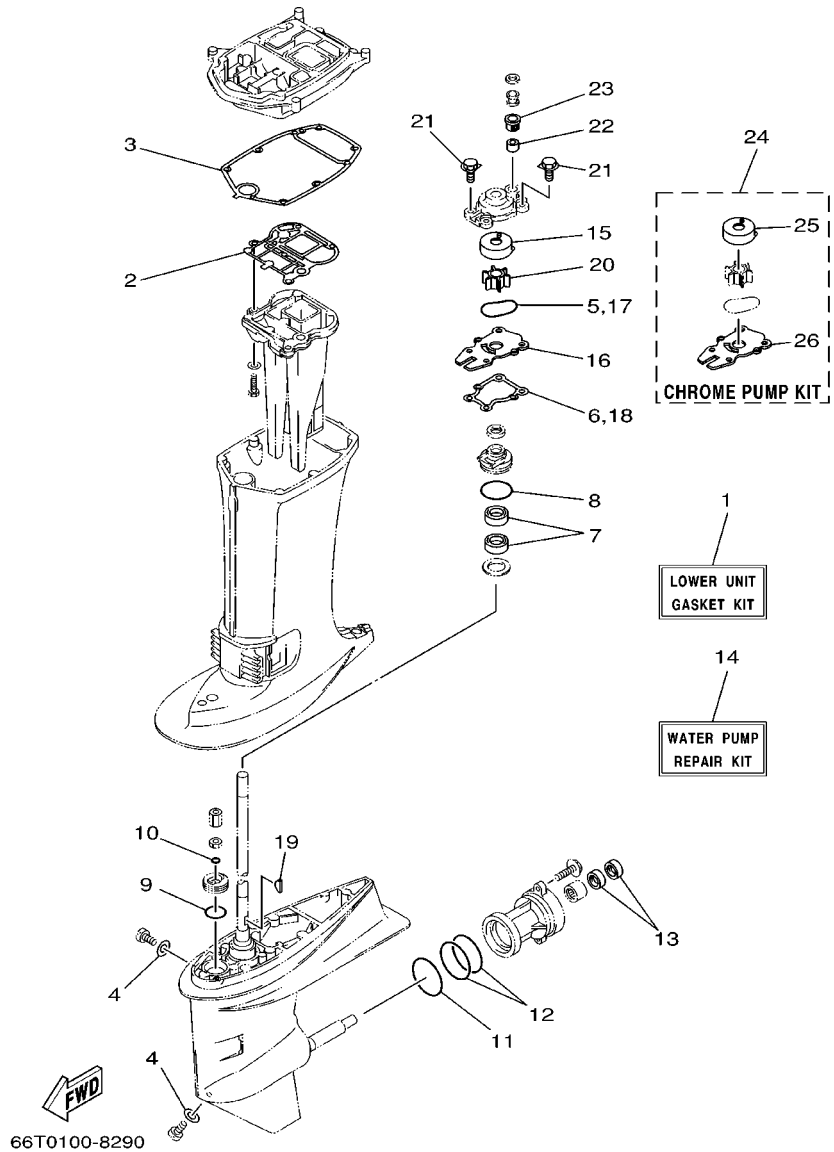

REF. NO.	PART NO. CODIGO NO.	DESCRIPTION DESCRIPTION	MH	WH	W	WT	REMARKS OBSERVACION
1	66T-W0001-20	LOWER UNIT GASKET KIT JUEGO DE EMPAQUE UNIDAD INFER	1	1	1	1	
2	66T-41133-A0	.GASKET, EXHAUST MANIFOLD 1 .EMPAQUE ESCAPE MULTIPLE	1	1	1	1	
3	66T-45114-A0	.GASKET, UPPER CASING .EMPAQUE	1	1	1	1	
4	90430-08020	.GASKET JUNTA	2	2	2	2	
5	93210-59MG7	.O-RING .ANILLO O	1	1	1	1	
6	63D-44316-00	.GASKET, WATER PUMP .EMPAQUE	1	1	1	1	
7	93101-22M60	.OIL SEAL .SELLO ACEITE	2	2	2	2	
8	93210-48MG8	.O-RING .ANILLO O	1	1	1	1	
9	93210-33MG4	.O-RING .ANILLO O	1	1	1	1	
10	93210-06ME6	.O-RING .ANILLO O	1	1	1	1	
11	93210-69MG6	.O-RING .ANILLO O	1	1	1	1	
12	93210-74MG5	.O-RING .ANILLO O	2	2	2	2	
13	93101-22M00	.OIL SEAL .SELLO ACEITE	2	2	2	2	
14	66T-W0078-00	WATER PUMP REPAIR KIT ESTUCHE REPARACION BOMBA AGUA	1	1	1	1	
15	63D-44322-00	.INSERT, CARTRIDGE .CARTUCHO	1	1	1	1	
16	66T-44323-00	.OUTER PLATE, CARTRIDGE .PLACA EXTERIOR DEL CARTUCHO	1	1	1	1	
17	93210-59MG7	.O-RING .ANILLO O	1	1	1	1	
18	63D-44316-00	.GASKET, WATER PUMP .EMPAQUE	1	1	1	1	
19	90280-03M03	.KEY, WOODRUFF .CUNA WOODRUFF	1	1	1	1	
20	6H4-44352-02	.IMPELLER .IMPULSOR	1	1	1	1	
21	90119-08M15	.BOLT, WITH WASHER .TORNILLO CON ARANDELA	4	4	4	4	
22	663-44366-00	.DAMPER, WATER SEAL .GOMA DEL SELLO DE AGUA	1	1	1	1	
23	63D-44312-00	.COVER, WATER PUMP HOUSING .CUBIERTA CAJA BOMBA DE AGUA	1	1	1	1	
24	66T-W0078-0A	CHROME PUMP KIT ESTUCHE REPARACION BOMBA AGUA	1	1	1	1	
25	63D-44322-40	.INSERT, CARTRIDGE .CARTUCHO	1	1	1	1	
26	66T-44323-40	.OUTER PLATE, CARTRIDGE .PLACA EXTERIOR DEL CARTUCHO	1	1	1	1	

NUMERICAL INDEX
INDICE NUMERICO

PART NO. CODIGO NO.	REF. NO.	PART NO. CODIGO NO.	REF. NO.	PART NO. CODIGO NO.	REF. NO.	PART NO. CODIGO NO.	REF. NO.	PART NO. CODIGO NO.	REF. NO.	PART NO. CODIGO NO.	REF. NO.
66T-W0001-01	29 - 1	6E5-14223-00	5 - 13	66T-15723-00	7 - 29	648-24566-02	6 - 10	66T-42610-H1-4D	1 - 1	6G5-43145-01	19 - 13
66T-W0001-20	30 - 1	66T-14301-02	5 - 1	66T-15731-00	7 - 16	6YJ-24610-01	25 - 2	66T-42610-Y0-4D	1 - 1	65W-43191-00	18 - 13
66T-W0004-00	4 - 2	66T-14301-12	5 - 1	66T-15734-00	7 - 14	66T-26301-00	14 - 30	66T-42610-11-4D	1 - 1		19 - 4
63D-W0070-10	1 - 11	66T-14301-22	5 - 1	63V-15741-00	7 - 4	65W-26326-00	13 - 19	66T-42613-01	1 - 2	65W-43192-00	18 - 12
66T-W0070-H0	1 - 11	66T-14301-32	5 - 1	63V-15744-00	7 - 10	65W-26326-10	13 - 19	66T-42615-02	1 - 8		19 - 3
66T-W0078-0A	30 - 24	6E5-14323-03	5 - 12	6F5-15752-00	7 - 18		17 - 10	6E0-42651-02	1 - 4	65W-43311-00-4D	18 - 20
66T-W0078-00	30 - 14		29 - 21	6F5-15753-00	7 - 19	66T-41113-00-9M	2 - 32	6F5-42652-01	1 - 6	65W-43311-10-4D	18 - 20
66T-W0084-02-4D	14 - 1	6A0-14325-00	6 - 25	689-15755-01	7 - 21	66T-41114-A0	2 - 34	61N-42677-H0	1 - 9		19 - 7
66T-W0090-02-1S	2 - 1	6J8-14334-00	5 - 11	66T-15758-01	7 - 24		29 - 8	63D-42677-11	1 - 9	682-43318-01	18 - 40
66T-W0093-01	29 - 16	66T-14384-01	5 - 6	66T-15762-01	7 - 28	66T-41131-00-5B	22 - 4	6J4-42678-H0	1 - 10	66T-43350-02	18 - 49
676-W2810-01	6 - 32		29 - 19	66T-15767-00	7 - 8	66T-41131-10-5B	22 - 4	63D-42678-11	1 - 10	65W-43373-00	20 - 2
66T-11111-01-94	2 - 22	6E5-14385-02	5 - 18	6F5-15768-00	7 - 20	66T-41133-A0	22 - 5	63D-42681-10	1 - 12	65W-43613-00	18 - 56
66T-11119-00	2 - 20		29 - 23	63V-15768-00	7 - 11		30 - 2	66T-42681-Y0	1 - 14	65W-43614-01	18 - 54
66T-11181-A2	2 - 23	6E5-14386-02	5 - 19	66T-15770-00	7 - 15	66T-41137-00-94	22 - 1	63D-42682-10	1 - 13	65W-43615-01	18 - 55
	29 - 5		29 - 24	66T-15771-00-94	7 - 36	66T-41237-00	16 - 5	66T-42682-Y0	1 - 15	65W-43616-00	18 - 53
66T-11191-00-9M	2 - 25	66T-14440-00	4 - 13	66T-15772-00-94	7 - 39	66T-41252-00	4 - 23	66T-42710-01-4D	13 - 1	66T-43627-00	18 - 28
66T-11193-A2	2 - 26	624-14485-00	2 - 5	6F5-15779-02	7 - 22	66T-41256-00	4 - 21	66T-42716-00	13 - 5	65W-43630-02	18 - 41
	29 - 6	66T-14497-00	16 - 10	66T-15784-00	7 - 9	66T-41257-00	4 - 25	6G1-42725-00	9 - 21	65W-43630-11	18 - 41
676-11325-00	2 - 18	66T-14523-00	5 - 10	697-15789-00	7 - 23	661-41262-02	4 - 22	66T-42725-00	13 - 8	66T-43631-01	18 - 51
650-11372-00	4 - 5	66T-14527-00	5 - 8	6F5-15791-00	7 - 17	6H4-41271-01	4 - 18	66T-42725-10	13 - 8	66T-43631-11	18 - 51
676-11372-00	2 - 33	66T-14536-00	5 - 7	66T-15794-00	7 - 13	66T-41273-00	14 - 42	66T-42725-20	13 - 8	689-43633-00	15 - 6
66T-11400-01	3 - 1		29 - 20	6YJ-24167-00	25 - 7	689-41273-00	4 - 19	66T-42725-30	17 - 9	65W-4380F-00	21 - 11
66T-11412-00	3 - 2	6E5-14546-00	5 - 16	6YJ-24201-00	25 - 1	6J8-41274-00	4 - 20	6H1-42726-10	13 - 21	65W-4380K-00	21 - 16
66T-11422-00	3 - 3		29 - 22	6YJ-24201-10	25 - 1	66T-41611-00	8 - 11	6H4-42726-00	13 - 21	65W-4380L-00	21 - 27
66T-11432-00	3 - 4	66T-14578-00	5 - 2	6YJ-24260-00	25 - 3	66T-41631-01	16 - 4	65W-42726-00	13 - 23	65W-43800-02-4D	21 - 1
66T-11442-00	3 - 5	66T-14584-00	5 - 3	6Y1-24260-12	25 - 3	66T-41638-00	16 - 1	65W-42726-10	13 - 23	6T4-43802-03	21 - 30
6F5-11515-00	3 - 9	6J8-14592-01	5 - 4	6Y1-24268-00	25 - 6	6F5-41662-00	16 - 17		17 - 11	65W-43804-00	21 - 3
66T-11565-00	2 - 14	61A-1492E-85	5 - 15	6G1-24304-02	6 - 1	65W-42101-01-4D	14 - 15	676-42727-00	13 - 20	65W-43805-00	21 - 4
66T-11603-00	3 - 16	61A-1492E-88	5 - 15	6G1-24305-03	25 - 13	664-42119-00	14 - 23	66T-42738-00-5B	13 - 6	65W-4381B-00	21 - 22
66T-11604-00	3 - 16	66T-1492F-35	5 - 20	6Y1-24305-04	25 - 15	65W-42121-01-4D	14 - 41	66T-42741-00	13 - 26	65W-43810-00	21 - 17
66T-11605-00	3 - 16	66T-1492F-37	5 - 20	61J-24306-02	25 - 8	66T-42123-00	14 - 8	66T-42815-01-4D	13 - 9	65W-43812-00	21 - 18
66T-11631-00-93	3 - 15	66T-14945-02	5 - 14	6Y1-24329-00	25 - 5	65W-42125-00	14 - 20	66T-42816-00	13 - 13	6H1-43816-00	21 - 25
6F5-11633-00	3 - 17	66T-14959-00	5 - 25	66T-24329-00	13 - 22	6G1-42126-00	14 - 19	65W-43111-10-4D	19 - 1	65W-43817-00	21 - 39
663-11634-00	3 - 18		29 - 27	650-24351-51	25 - 12	65W-42131-01	14 - 38	66T-43111-Y0-4D	18 - 1	65W-4382A-00	21 - 47
66T-11635-00	3 - 15	66T-14981-00	5 - 23	61J-24360-00	25 - 10	6G1-42137-10	14 - 24	66T-43111-01-4D	18 - 1	6H1-43829-00	21 - 61
66T-11636-00	3 - 15	66T-14984-00	5 - 21	692-24410-00	6 - 15	65W-42138-00	14 - 17	65W-43112-10-4D	19 - 2	65W-43830-00	21 - 36
6F5-11651-00	3 - 10		29 - 25	663-24411-00	6 - 20	65W-42159-00	14 - 18	66T-43112-Y0-4D	18 - 7	65W-43831-00	21 - 35
66T-11681-00	3 - 11	66T-14991-00	5 - 24	692-24411-00	6 - 17	66T-42167-00	16 - 2	66T-43112-01-4D	18 - 7	6H1-4384F-10	21 - 57
6E5-12411-01	2 - 28	66T-14992-00	5 - 22	6A0-24412-02	6 - 26	6F6-42177-A0	14 - 22	6J8-43113-01	18 - 25	65W-43840-00	21 - 15
676-12413-00-9M	2 - 29		29 - 26	6A0-24413-00	6 - 16	65W-42508-00	15 - 1	648-43114-01	18 - 5	62X-43841-00	21 - 33
676-12414-A0	2 - 30	66T-15100-02-1S	2 - 2	6A0-24421-01	6 - 24	65W-42511-00-4D	20 - 6		18 - 10	65W-43843-00	21 - 54
	29 - 7	66T-15396-01-94	2 - 8	650-24431-A0	6 - 27	65W-42511-10-4D	20 - 6	663-43118-01-4D	18 - 4	6H1-43844-10	21 - 56
6E5-13552-00	2 - 3	66T-15705-00	7 - 7		29 - 12	65W-42527-00	15 - 2		18 - 9	65W-43844-00	21 - 48
	2 - 4	66T-15710-00	7 - 1	648-24434-01	6 - 18	648-42528-00	20 - 1	63D-43131-01	18 - 22	6H1-43845-00	21 - 43
	4 - 4	66T-15711-00	7 - 2	648-24435-02	6 - 21	65W-42528-00	15 - 12		19 - 9	6H1-43847-00	21 - 45
66T-13610-00	4 - 1	66T-15713-00	7 - 5	61N-24521-00	6 - 8	624-42542-00	9 - 3	66T-43144-00	13 - 14	65W-43851-00	21 - 49
66T-13641-02-94	4 - 3	66T-15714-00	7 - 3	61N-24560-00	6 - 6	65W-42561-00	15 - 5	6E5-43145-01	26 - 9	6T4-43853-00	21 - 37
6E5-14159-00	5 - 17	66T-15716-00	7 - 6	61N-24563-00	6 - 7	65W-42562-00	15 - 10	6G5-43145-01	18 - 27	65W-43853-00	21 - 60

NUMERICAL INDEX
INDICE NUMERICO

PART NO. CODIGO NO.	REF. NO.	PART NO. CODIGO NO.	REF. NO.	PART NO. CODIGO NO.	REF. NO.	PART NO. CODIGO NO.	REF. NO.	PART NO. CODIGO NO.	REF. NO.	PART NO. CODIGO NO.	REF. NO.
65W-43854-00	21 - 46	63D-44322-00	30 - 15	63D-45361-02-4D	23 - 44	663-45972-60-98	24 - 25	701-48320-00	27 - 2	703-82531-00	28 - 46
65W-43855-00	21 - 52	63D-44322-40	23 - 13	664-45371-01	24 - 8	663-45974-60-98	24 - 25	701-48320-20	27 - 2	6F5-82540-00	10 - 27
6H1-43856-10	21 - 55		30 - 25	63D-45375-00	24 - 7	663-45976-00-98	24 - 25	701-48320-50	27 - 2	703-82540-00	28 - 50
65W-4386A-00	21 - 58	66T-44323-00	23 - 14	663-45376-00	24 - 6	663-45978-00-98	24 - 25	663-48344-00	16 - 27	66T-82553-00	10 - 28
65W-4386K-00	21 - 7		30 - 16	66T-45501-01	23 - 33	663-45987-02	24 - 20		17 - 2	66T-82554-00	10 - 29
6H1-43861-10	21 - 20	66T-44323-40	23 - 14	66T-45501-11	23 - 33	66T-45997-00	24 - 21	703-48345-01	28 - 19	682-82556-00	14 - 44
	21 - 23		30 - 26	66T-45501-21	23 - 33	703-48152-00	28 - 57	703-48358-00	28 - 20		28 - 48
65W-43861-00	21 - 40	63D-44341-00	23 - 19	6H4-45536-00	23 - 3	703-48153-00	28 - 3	66T-48501-01	17 - 1	688-82560-10	9 - 19
65W-43862-00	21 - 41	6H4-44352-02	23 - 18	66T-45551-00	23 - 36	703-48189-00	28 - 17	65W-48511-00	17 - 7	703-82563-02	28 - 55
65W-43865-00	21 - 19		30 - 20	66T-45560-01	23 - 38	703-48198-00	28 - 14		20 - 29	689-8257Y-00	14 - 45
6H1-43866-00	21 - 31	66T-44361-00	24 - 1	663-45567-01-10	23 - 40	703-48203-14	27 - 1	6H3-48538-00	16 - 29	66T-82575-01	14 - 43
6H1-43867-00	21 - 32	66T-44361-10	24 - 1	663-45567-01-12	23 - 40		28 - 1		17 - 4	688-82575-01	28 - 47
65W-43869-00	21 - 5	66T-44361-20	24 - 1	663-45567-01-15	23 - 40	703-48205-16	27 - 1	65W-61350-00	26 - 1	676-82577-00	28 - 45
65W-43871-00	21 - 21	66T-44362-10	24 - 26	663-45567-01-18	23 - 40		28 - 1	65W-61351-00	26 - 2	688-8258A-20	28 - 49
6H1-43875-00	21 - 42	66T-44362-20	24 - 26	663-45567-01-30	23 - 40	703-48211-01	28 - 61	66T-81303-00	31 - 1	688-82586-21	28 - 49
62X-43878-00	21 - 62	663-44366-00	24 - 18	663-45567-01-40	23 - 40	703-48212-00	28 - 58	66T-81328-00	8 - 13	66T-82590-00	10 - 14
65W-43879-00	21 - 12		30 - 22	663-45567-01-50	23 - 40	703-48213-00	28 - 59	66T-81800-00	12 - 1	66T-82590-20	11 - 1
65W-4388E-00	21 - 14	663-44367-00	24 - 4	66T-45571-00	23 - 41	703-48215-00	28 - 43	66T-81820-00	12 - 6	703-82591-00	28 - 53
65W-43880-00	21 - 2	6E5-44391-00	13 - 18	63D-45577-00-10	23 - 43	703-48219-00	28 - 30	66T-81826-00	12 - 7	703-82592-00	28 - 54
65W-43881-00	21 - 6	66T-44514-00-4D	20 - 15	63D-45577-00-12	23 - 43	703-48221-00	28 - 56	66T-81830-00	12 - 5	65W-82594-00	10 - 33
65W-43882-00	21 - 8	66T-44514-30-4D	20 - 15	63D-45577-00-15	23 - 43	703-48222-00	28 - 27	66T-81840-00	12 - 2	703-82594-00	28 - 25
65W-43887-00	21 - 13	66T-44526-00	20 - 16	63D-45577-00-18	23 - 43	703-48223-00	28 - 28	66T-81850-00	12 - 4	703-83383-02	28 - 51
65W-43888-00	21 - 28	66T-44526-30	20 - 16	63D-45577-00-30	23 - 43	703-48224-00	28 - 55	66T-81857-00	12 - 3	6N7-83557-00	10 - 15
65W-43891-00	21 - 10	65W-44551-00-4D	20 - 19	63D-45577-00-40	23 - 43	703-48225-00	28 - 29	689-81870-00	9 - 22	66T-83557-00	10 - 15
65W-43892-00	21 - 9	65W-44555-10	20 - 20	63D-45577-00-50	23 - 43	703-48226-00	28 - 26	66T-81916-01	9 - 8	66T-85515-00	8 - 8
66T-44111-02	14 - 2	66T-44575-00	20 - 21	663-45587-01-10	23 - 35	703-48227-00	28 - 24	6G1-8194A-10	10 - 1	66T-85520-00	8 - 10
682-44116-01	16 - 19	66T-45111-00-4D	22 - 8	663-45587-01-12	23 - 35	703-48232-00	28 - 62	6L2-81945-00	10 - 5	66T-85533-00	8 - 14
66T-44121-00	16 - 14	66T-45111-10-4D	22 - 8	663-45587-01-15	23 - 35	703-48234-00	28 - 18	66T-81948-00	11 - 11		31 - 2
66M-44122-00	16 - 15	66T-45113-A0	22 - 13	663-45587-01-18	23 - 35	703-48235-00	28 - 4	6E5-8195B-01	11 - 2	66T-8554B-01-94	9 - 1
66T-44124-00	14 - 11		29 - 13	663-45587-01-30	23 - 35	703-48236-00	28 - 16	6E5-8195C-01	11 - 5	66T-85540-00	9 - 5
66T-44125-01	16 - 25	66T-45114-A0	22 - 12	663-45587-01-40	23 - 35	703-48238-00	28 - 22	6G1-81952-00	10 - 4	66T-85550-00	8 - 1
	17 - 6		30 - 3	663-45587-01-50	23 - 35	703-48243-00	28 - 15	6G1-81970-61	10 - 8	66T-85550-10	8 - 1
66T-44143-00	16 - 21	66T-45151-00-4D	20 - 31	66T-45611-00	23 - 56	703-48244-00	28 - 21	66T-82105-00	10 - 7	66T-85560-01	8 - 2
66T-44143-10	16 - 21	63D-45155-00	22 - 9	66T-45631-00	23 - 51	703-48245-00	28 - 11	66T-82115-00	10 - 16	66T-85560-11	8 - 2
61N-44146-00	23 - 27	66T-45211-00-4D	22 - 18	663-45633-00	23 - 54	703-48246-00	28 - 23	6E5-82116-00	11 - 10	66T-85561-00	8 - 3
66T-44150-01	23 - 26	63D-45214-00	23 - 7	66T-45635-00	23 - 55	701-48248-00	28 - 13	6E5-82117-01	10 - 6	66T-85570-00	9 - 10
66T-44150-11	23 - 26	63D-45215-00	23 - 8	663-45930-00-98	24 - 25	703-48252-00	28 - 12	6G5-82119-00	11 - 9	66T-85580-00	8 - 5
66T-44150-21	23 - 26	65W-45251-00	19 - 19	63D-45941-00-EL	24 - 25	703-48261-01	28 - 2	6U0-82127-00	19 - 22	66T-85582-00	8 - 7
65W-44173-00	16 - 23	67C-45251-00	24 - 15	663-45941-01-EL	24 - 25	703-48264-00	28 - 6	66T-82127-00	20 - 26	66T-85596-00	8 - 6
6E0-44191-11	14 - 14	676-45251-00	2 - 15	663-45943-02-EL	24 - 25	703-48265-00	28 - 9	66T-82127-10	20 - 27	6J4-86111-00	10 - 17
688-44194-00	16 - 9	66T-45300-01-4D	23 - 1	663-45945-02-EL	24 - 25	703-48268-00	28 - 5	6H1-82148-00	19 - 21	66T-86112-00	10 - 19
66T-44311-00	23 - 12	66T-45300-11-4D	23 - 1	663-45947-02-EL	24 - 25	703-48271-00	28 - 60	6G1-82151-00	10 - 9	6J4-86116-00	10 - 18
63D-44312-00	24 - 19	66T-45300-31-4D	23 - 1	663-45949-01-EL	24 - 25	703-48281-00	28 - 31	6A0-82317-00	9 - 2	682-86117-00	10 - 22
	30 - 23	66T-45311-01-4D	23 - 2	663-45952-02-EL	24 - 25	703-48282-00	28 - 32	6E3-82370-21	9 - 16	66T-87149-00	11 - 8
63D-44316-00	23 - 16	679-45318-00	22 - 16	663-45954-01-EL	24 - 25	703-48284-00	28 - 52	66T-82370-00	9 - 16	9E471-04305	8 - 12
	30 - 6	66T-45321-00	23 - 29	663-45956-01-EL	24 - 25	703-48287-00	28 - 42	703-82510-31	28 - 44	90101-06020	19 - 20
	30 - 18	688-45341-00	23 - 6	663-45958-01-EL	24 - 25	703-48291-10	28 - 39	703-82510-42	28 - 44	90101-08M28	18 - 62
63D-44322-00	23 - 13	66T-45344-01	23 - 21	663-45970-60-98	24 - 25	703-48293-10	28 - 41	66T-82519-00	9 - 20	90101-08M76	18 - 17

NUMERICAL INDEX
INDICE NUMERICO

PART NO. CODIGO NO.	REF. NO.	PART NO. CODIGO NO.	REF. NO.	PART NO. CODIGO NO.	REF. NO.	PART NO. CODIGO NO.	REF. NO.	PART NO. CODIGO NO.	REF. NO.	PART NO. CODIGO NO.	REF. NO.
90101-08M86	20 - 14	90141-06M00	2 - 19	90206-12M00	18 - 31	90386-40M99	14 - 37	90480-09M21	13 - 3	92995-06600	11 - 13
90101-08002	2 - 21	90142-05M06	23 - 9	90206-12052	13 - 12	90386-44M03	20 - 9	90480-10M23	10 - 23		13 - 28
90101-09M01	26 - 7	90149-05M13	14 - 26		14 - 7	90386-44M99	20 - 11	90480-10M71	8 - 26		14 - 5
90101-10M58	18 - 65	90149-05M17	18 - 52	90206-43M22	14 - 35	90386-52M02	20 - 8	90480-10155	10 - 20		19 - 24
90101-12M65	19 - 33	90149-14M12	18 - 3	90209-10M26	15 - 13	90387-05M11	15 - 8	90480-25M70	24 - 27	92995-08100	20 - 18
90105-08M61	23 - 50		18 - 8	90209-27M07	3 - 12	90387-06M60	10 - 24	90480-25161	9 - 11		24 - 10
90105-08M76	20 - 3	90161-06M00	10 - 34	90209-52M00	20 - 7	90387-06M66	7 - 27	90480-30M71	24 - 28		24 - 17
90109-06M50	15 - 3	90170-06M30	10 - 2	90243-04007	18 - 6	90387-06M80	4 - 17	90501-10M84	16 - 6	92995-08200	20 - 13
90109-06M80	9 - 7		11 - 3		18 - 11	90387-06M86	14 - 3	90501-15M01	23 - 52	92995-08600	12 - 11
	10 - 13		11 - 6	90249-07M32	18 - 57	90387-06035	13 - 4	90501-23215	14 - 28		22 - 7
	13 - 29	90170-09M03	26 - 5	90249-07M33	18 - 59	90387-07M05	18 - 46	90502-10M06	18 - 63	92995-10100	24 - 13
	13 - 31	90170-12138	23 - 37	90249-10M31	18 - 45	90387-07M29	18 - 58	90506-16M34	13 - 16	92995-10600	18 - 66
90109-06M81	9 - 6	90170-20137	8 - 21	90249-12M34	18 - 35	90387-08M05	7 - 35	90506-20M37	18 - 50		19 - 31
	9 - 9	90171-16011	24 - 23		18 - 37	90387-08M16	16 - 3	90506-30M00	18 - 60		20 - 23
	9 - 13	90179-10M33	20 - 25	90249-12M38	19 - 16	90387-08M29	18 - 16	91318-04025	21 - 38		24 - 14
	13 - 7	90185-08045	20 - 12	90249-12M39	18 - 37	90387-10M42	26 - 6	91490-16012	16 - 22	92995-12200	19 - 34
	16 - 18	90185-08057	18 - 34	90249-18M35	19 - 29	90387-12M04	18 - 36	91490-20010	14 - 21	93101-16001	2 - 10
90109-06M86	10 - 30		18 - 64	90250-06023	23 - 53	90389-22M01	24 - 22	91490-20015	18 - 61		29 - 3
	10 - 32	90185-09M01	26 - 4	90254-03M04	16 - 24	90430-08020	23 - 5	91490-30025	24 - 24	93101-22M00	23 - 49
	13 - 15	90185-10M13	19 - 32		16 - 26		30 - 4	91690-30018	18 - 14		30 - 13
	14 - 16	90185-10M14	15 - 9		17 - 5	90430-12072	24 - 3		19 - 5	93101-22M60	23 - 20
	16 - 20	90185-10051	20 - 4	90254-03M05	16 - 16	90445-07MA4	4 - 9	91690-40032	4 - 24		30 - 7
90109-08M90	18 - 32	90185-22M11	19 - 12	90266-04M01	1 - 7	90445-07M08	2 - 37	92903-06600	4 - 7	93102-30M56	2 - 9
90110-10M02	19 - 30	90185-22043	18 - 26	90266-04M04	1 - 5	90445-07M24	4 - 8		7 - 38		29 - 2
90116-10M23	22 - 20	90201-08M00	19 - 26	90269-02M09	14 - 25	90445-09M08	6 - 4		7 - 41	93102-35008	8 - 4
90116-10M28	20 - 5	90201-08M07	18 - 33	90280-03M03	23 - 17	90445-09M75	2 - 36	92903-10600	14 - 27		29 - 14
90119-06MA3	2 - 27	90201-08M54	16 - 11		30 - 19	90445-09086	6 - 13	92990-05100	6 - 23	93210-03261	10 - 25
	2 - 35	90201-10M20	26 - 3	90280-05015	8 - 20		6 - 30	92990-05600	5 - 5	93210-03478	21 - 51
90119-06MA5	2 - 31	90201-10M63	26 - 8	90338-05M03	13 - 25	90445-11M05	25 - 11		10 - 11	93210-06ME6	23 - 31
90119-06M61	13 - 2	90201-10120	17 - 8	90338-07M00	13 - 24	90445-11M06	25 - 9	92990-06100	15 - 4		30 - 10
90119-06M65	9 - 4		20 - 30	90340-08M04	23 - 4	90446-03MA3	9 - 12	92990-06200	14 - 12	93210-064A5	21 - 26
90119-06M73	13 - 17	90201-12M07	14 - 6	90385-12M04	7 - 34	90446-10M86	14 - 32	92990-06600	23 - 32	93210-08006	21 - 50
90119-06M88	10 - 26	90201-12426	18 - 67	90386-07MA2	18 - 43	90446-10M87	14 - 31	92990-08100	18 - 19	93210-08287	25 - 14
90119-08MA5	2 - 24		19 - 35	90386-08032	14 - 29	90464-09M49	13 - 30	92990-08600	28 - 34		25 - 16
90119-08M03	4 - 12	90201-20417	3 - 20	90386-10M99	18 - 42	90464-12M00	8 - 27	92990-10100	22 - 22	93210-09165	21 - 34
90119-08M10	7 - 32	90201-21M18	8 - 22		18 - 47	90464-13249	7 - 42	92990-10600	22 - 23	93210-10M74	21 - 63
90119-08M15	23 - 25	90201-22M03	18 - 24	90386-12MA0	18 - 38	90465-11M10	11 - 14	92995-06200	14 - 10	93210-11073	21 - 53
	30 - 21		19 - 11		19 - 14	90465-13M11	19 - 18	92995-06600	2 - 13	93210-11368	21 - 24
90119-08M39	12 - 8	90201-22429	23 - 42	90386-12MA2	13 - 11	90465-15M74	8 - 23		2 - 17	93210-16275	26 - 10
90119-08M42	22 - 15	90201-27M00	23 - 23	90386-12M37	13 - 10	90465-20M31	10 - 31		4 - 16	93210-18397	21 - 44
90119-08M43	24 - 5	90201-43M00	14 - 34	90386-12M98	18 - 29	90465-25M57	13 - 24		6 - 3	93210-32738	6 - 9
90119-08M44	24 - 5	90202-10M56	15 - 11		19 - 15	90467-06016	4 - 10		6 - 29		29 - 11
90119-08M51	7 - 33	90202-12031	18 - 30	90386-14MA1	19 - 6	90467-08004	6 - 5		7 - 26	93210-33MG4	23 - 30
90119-08M52	12 - 9	90202-12060	24 - 2	90386-18MA0	19 - 28		6 - 14		7 - 31		30 - 9
90119-08M79	22 - 2	90202-43M57	14 - 36	90386-18M44	19 - 27		6 - 31		8 - 19	93210-43MJ0	20 - 10
	22 - 11	90204-06M00	10 - 3	90386-22M15	18 - 23	90468-18008	14 - 13		8 - 25	93210-46M16	4 - 11
90119-10M04	20 - 24		11 - 4		19 - 10		16 - 28		9 - 15		29 - 9
90119-10005	2 - 7		11 - 7	90386-40MA0	14 - 33		17 - 3		9 - 18		29 - 17

NUMERICAL INDEX
INDICE NUMERICO

PART NO. CODIGO NO.	REF. NO.	PART NO. CODIGO NO.	REF. NO.	PART NO. CODIGO NO.	REF. NO.	PART NO. CODIGO NO.	REF. NO.	PART NO. CODIGO NO.	REF. NO.	PART NO. CODIGO NO.	REF. NO.
93210-48MG8	23 - 22	95380-05600	10 - 12	97802-04006	31 - 4						
	30 - 8		23 - 10	97880-05008	10 - 21						
93210-50768	21 - 29		28 - 7	97880-05030	10 - 10						
93210-54M54	4 - 14	95380-06600	28 - 40	97880-06035	16 - 7						
	29 - 10	95380-06700	16 - 8	97885-06008	20 - 28						
	29 - 18		23 - 28	97885-06040	4 - 15						
93210-59MG7	23 - 15	95380-08600	6 - 11	97902-04108	8 - 9						
	30 - 5		18 - 18	97902-06125	8 - 15						
	30 - 17	95380-10600	18 - 68		31 - 3						
93210-65M50	2 - 11		22 - 21	97980-04112	5 - 9						
	29 - 4	95380-10700	14 - 39	97980-05125	5 - 26						
93210-69MG6	23 - 46	95380-12600	19 - 36		29 - 28						
	30 - 11	95780-06300	14 - 9	98503-05028	6 - 22						
93210-74MG5	23 - 47	95780-10300	14 - 40	98580-03015	28 - 38						
	30 - 12	97013-06014	6 - 12	98580-04006	28 - 36						
93210-75M51	8 - 17	97013-06030	7 - 37	98580-04010	28 - 35						
	29 - 15		7 - 40	98580-05010	28 - 37						
93306-001U1	23 - 45	97013-06035	4 - 6	98586-05016	25 - 4						
93306-306V5	3 - 8	97075-08030	20 - 17	99080-08600	18 - 44						
93306-307U0	3 - 6		22 - 6		18 - 48						
93310-727U0	3 - 13	97075-10040	24 - 12								
93315-32224	23 - 11	97075-10070	20 - 22								
93317-22204	23 - 48	97080-08016	19 - 25								
93332-000UE	3 - 7	97095-06010	7 - 30								
93332-00001	23 - 34	97095-06012	9 - 17								
93332-00003	23 - 39	97095-06014	16 - 13								
93420-30042	22 - 17		19 - 23								
93430-06024	28 - 10	97095-06016	8 - 24								
	28 - 63		11 - 12								
93430-10M00	18 - 39		13 - 27								
	19 - 17	97095-06020	2 - 12								
93440-68M03	3 - 14		2 - 16								
93501-08001	21 - 59	97095-06025	9 - 14								
93603-21111	3 - 19	97095-06030	6 - 2								
93604-08062	23 - 24	97095-06035	7 - 25								
93606-12019	22 - 3	97095-06040	6 - 28								
	22 - 14		8 - 18								
	22 - 19	97095-06050	14 - 4								
	24 - 11	97095-08016	12 - 10								
93608-12063	2 - 6	97095-08025	24 - 9								
93700-06M03	15 - 14	97095-08030	28 - 33								
	18 - 2	97095-08035	24 - 16								
	18 - 15	97095-08045	16 - 12								
	18 - 21	97380-05025	28 - 8								
	19 - 8	97575-08545	22 - 10								
94702-00040	2 - 38	97595-05516	15 - 7								
94702-00272	2 - 38	97780-50616	1 - 3								
95380-03600	6 - 19	97802-04006	8 - 16								

(E)40XMH/(E)40XWH/(E)40XW/(E)40XWT
PARTS CATALOGUE
©2000 by Yamaha Motor Co., Ltd.
1st Edition, Nov. 2000
All rights reserved.
Any reprinting or unauthorized use
without the written permission of
Yamaha Motor Co., Ltd.
is expressly prohibited.

(E)40XMH/(E)40XWH/(E)40XW/(E)40XWT
CATALOGO DE REPUESTOS
©2000, Yamaha Motor Co., Ltd.
1ª edición, Nov. 2000
Reservados todos los derechos.
Se prohíbe expresamente toda reimpresión
o utilización no autorizada de este manual
sin el consentimiento por escrito de
Yamaha Motor Co., Ltd.