

PARTS CATALOGUE

F50'06 (6C12)

F60'06 (6C52)

F50F'06 (6C12)

F60C'06 (6C52)



2010/3/31

1E6C1-100E1

(2E6C1-100E1)

NEWS NO.	DATE	COMMENT
PE0-OM-050016	Sep.,23,2005	COR:FIG.8 ILLUSTRATION CORRECTION
PE0-OM-090022	Mar.,2,2009	MOD:FIG.27 PTT(6C5-43800-01-8D) P/No. REVISION
PE0-OM-100028	Mar.,30,2010	MOD:FIG.21 STEERING 1 LIST/ILLUSTRATION REVISION

FOREWORD

This Parts Catalogue is related to the parts for the model(s) on the cover page. When you are ordering replacement parts, please refer to this Parts Catalogue and quote both part numbers and part names correctly.

1. Modifications or additions which have been made after the issue of the Parts Catalogue will be announced in the Parts News.
It is advisable that you make the necessary corrections to the Parts Catalogue according to the Parts News.

2. Abbreviations

The following abbreviations are used in this Parts Catalogue.

“UR” Use specified parts number.

“UN” Use as many as needed.

“AP” Alternate Parts

“LM” Locally Made (Parts need to be ordered locally)

“F#” Frame No. (Applicable machine No.)

“O/S” Over Size

3. The number of components for assembly

- Parts, which are to be supplied in an assembly, are listed with a dot (.) in front of the part name as shown below.
- The numeral appearing to the right of each component part indicates the quantity of parts for each assembly unit.

PART NO.	DESCRIPTION	Q'TY	REMARKS
2F5-83310-60	FRONT FLASHER LIGHT ASSY	2	
115-83311-60	.BULB (6V-18W)	1	

4. Applicable colours of graphics are represented in the “REMARKS” as shown below.

PART NO.	DESCRIPTION	Q'TY	REMARKS
2N4-24110-00-X5	FUEL TANK COMP.	2	MXR
3J1-24240-10	.GRAPHIC, FUEL TANK	1	FOR MXR

5. Note that the illustrations for reference in finding parts numbers are not to be used for assembling. When assembling, please use the applicable service manual.

6. The asterisk (*) before a reference number indicates modified items after the first edition.

7. Applicable Serial No.

Engine Serial No.

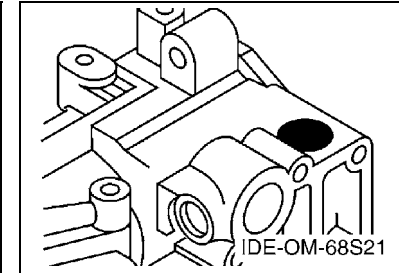
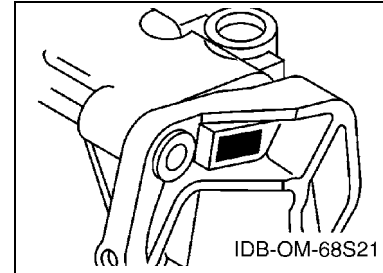

8. Applicable Engine Starting Serial No.

Model	Serial No.	Model	Serial No.
F50	6C1-1006292	F50F	6C1-1006292
F60	6C5-1007597	F60C	6C5-1007597

9. Applicable Colour Code

Abbreviation	Colour Name	Colour Code
DBNM2	DARK BLUISH GRAY METALLIC 2	004D

10. Quantity Column Information

Column No.	Name Of Q'ty Column	Applicable Model
1	EHT	F50/F60TH,F50F/F60CEHT
2	ET	F50/F60TR,F50F/F60CET

CONTENTS

SHEET1/2

TOP COWLING	A4
CYLINDER & CRANKCASE 1	A5
CRANKSHAFT & PISTON	A7
CYLINDER & CRANKCASE 2	B1
VALVE	B3
INTAKE 1	B4
INTAKE 2	B5
FUEL INJECTION PUMP 1	B6
FUEL INJECTION PUMP 2	B7
OIL PUMP	C1
FUEL 1	C2
FUEL 2	C4
GENERATOR	C5
ELECTRICAL 1	C6
ELECTRICAL 2	C7
ELECTRICAL 3	D2
ELECTRICAL 4	D4
STARTING MOTOR	D5
BOTTOM COWLING 1	D6
BOTTOM COWLING 2	E1
STEERING 1	E2
STEERING 2	E5
STEERING FRICTION	E6
CONTROL	E7
BRACKET 1	F2
BRACKET 2	F4
POWER TRIM & TILT ASSY 1	F6

INDEX

NUMERICAL INDEX	G1
-----------------------	----

SHEET2/2

POWER TRIM & TILT ASSY 1	A4*
POWER TRIM & TILT ASSY 2	A5*
UPPER CASING	A6*
OIL PAN	A7*
LOWER CASING & DRIVE 1	B1*
LOWER CASING & DRIVE 2	B4*
FUEL TANK	B6*
STEERING GUIDE	B7*
REMOTE CONTROL BOX	C1*
REMOTE CONTROL ASSY	C2*
METER	C5*
OPTIONAL PARTS	C6*
REPAIR KIT 1	C7*
REPAIR KIT 2	D1*

INDEX

NUMERICAL INDEX	G1*
-----------------------	-----

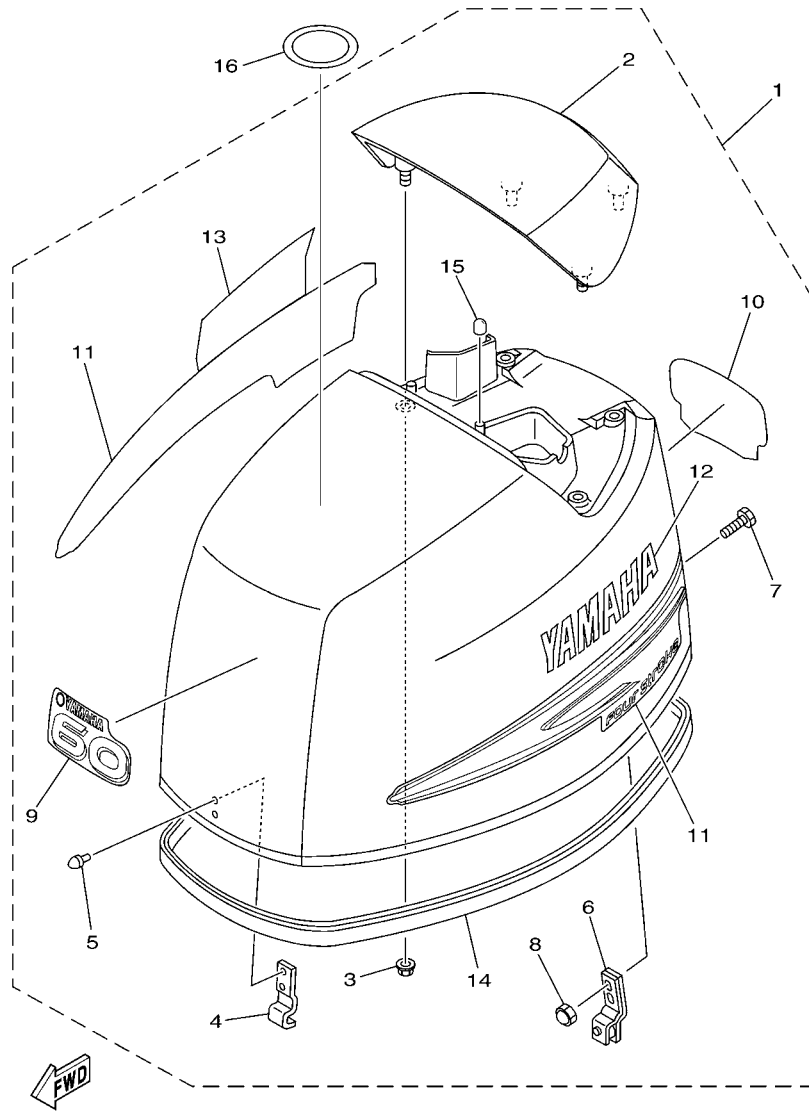

6C11010-D010

FIG. 1 TOP COWLING

REF. NO.	PART NO.	DESCRIPTION	EHT	ET			REMARKS
1	6C1-42610-00-4D	TOP COWLING ASSY	1	1			F50,F50F
	6C5-42610-00-4D	TOP COWLING ASSY	1	1			F60,F60C
	6C5-42610-A0-4D	TOP COWLING ASSY		1			F60TJR
2	67C-42613-00-4D	.MOLDING, AIR DUCT	1	1			
3	90179-06029	.NUT	4	4			
4	6C5-42651-00	.HOOK	1	1			
5	90266-06M02	.RIVET	2	2			
6	67C-42652-01	.HOOK	1	1			
7	90109-06047	.BOLT	2	2			
8	90185-06M05	.NUT, SELF-LOCKING	2	2			
9	62Y-42677-30	.GRAPHIC, FRONT	1	1			F50,F50F
	69W-42677-00	.GRAPHIC, FRONT	1	1			F60,F60C
	69W-42677-A0	.GRAPHIC, FRONT		1			F60TJR
10	6C1-42678-00	.GRAPHIC, REAR	1	1			F50,F50F
	6C5-42678-00	.GRAPHIC, REAR	1	1			F60,F60C
	6C5-42678-A0	.GRAPHIC, REAR		1			F60TJR
11	69W-W0070-00	.GRAPHIC SET	1	1			
12	69W-42681-00	.MARK, COWLING	1	1			
13	69W-42682-00	.MARK, COWLING	1	1			
14	6C5-42615-00	.SEAL	1	1			
15	69W-13448-00	.CAP	2	2			
16	67F-13434-03	LABEL, CAUTION	1	1			

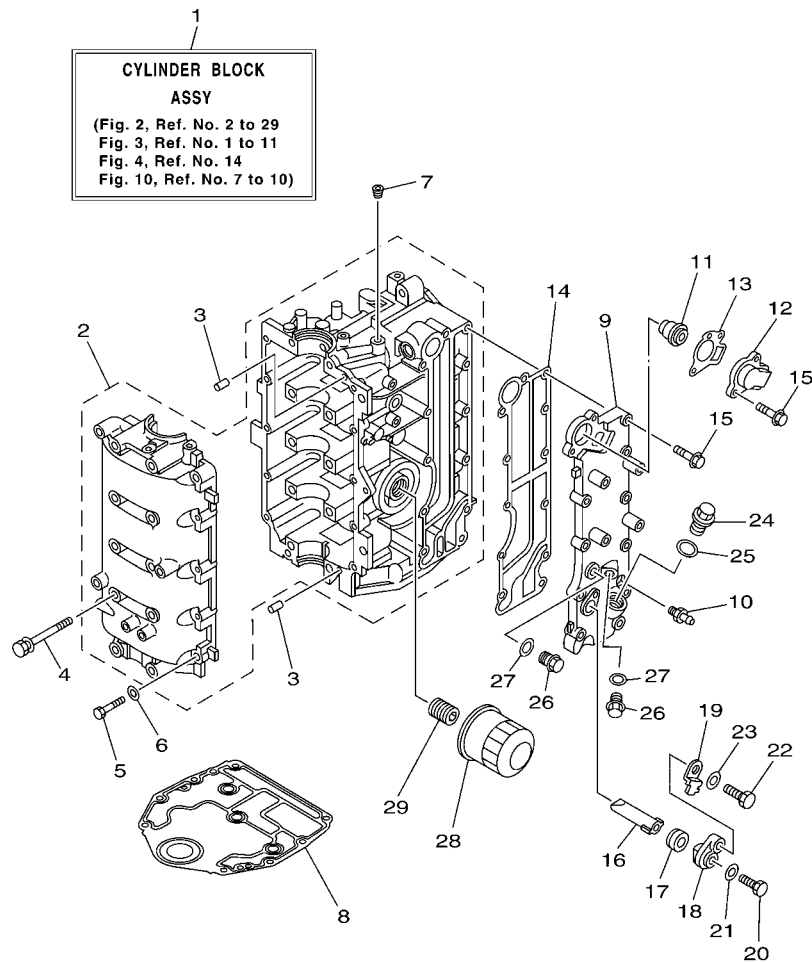

6C12100-E020

FIG. 2 CYLINDER & CRANKCASE 1

REF. NO.	PART NO.	DESCRIPTION	EHT	ET			REMARKS
1	6C5-W009B-01-1S	CYLINDER BLOCK ASSY	1	1			
2	6C5-15100-00-1S	CRANKCASE ASSY	1	1			
3	93606-12019	PIN, DOWEL	4	4			
4	90119-08M01	BOLT, WITH WASHER	10	10			
5	97013-06035	BOLT	10	10			
6	92903-06600	WASHER, PLATE	10	10			
7	90344-51003	PLUG, TAPER SCREW	1	1			
8	67C-11351-01	GASKET, CYLINDER	1	1			
9	6C5-41113-00-1S	OUTER COVER, EXHAUST	1	1			
10	62Y-12481-10	PIPE 1	1	1			
11	6G8-12411-03	THERMOSTAT	1	1			
12	6H3-12413-00-1S	COVER, THERMOSTAT	1	1			
13	62Y-12414-00	GASKET, COVER	1	1			
14	6C5-41114-00	GASKET, EXHAUST OUTER COVER	1	1			
15	90119-06MA5	BOLT, WITH WASHER	12	12			
16	62Y-11325-00	ANODE	1	1			
17	66M-11328-00	GROMMET, ANODE	1	1			
18	66M-11327-00-94	COVER, ANODE	1	1			
19	66M-12535-00	PLATE	1	1			
20	97095-05012	BOLT	1	1			
21	92995-05600	WASHER	1	1			
22	97095-06020	BOLT	1	1			
23	92995-06600	WASHER	1	1			
24	90340-18M09	PLUG, STRAIGHT SCREW	1	1			
25	90430-18130	GASKET	1	1			
26	90340-14M06	PLUG, STRAIGHT SCREW	2	2			
27	90430-14115	GASKET	2	2			

FIG. 2 CYLINDER & CRANKCASE 1

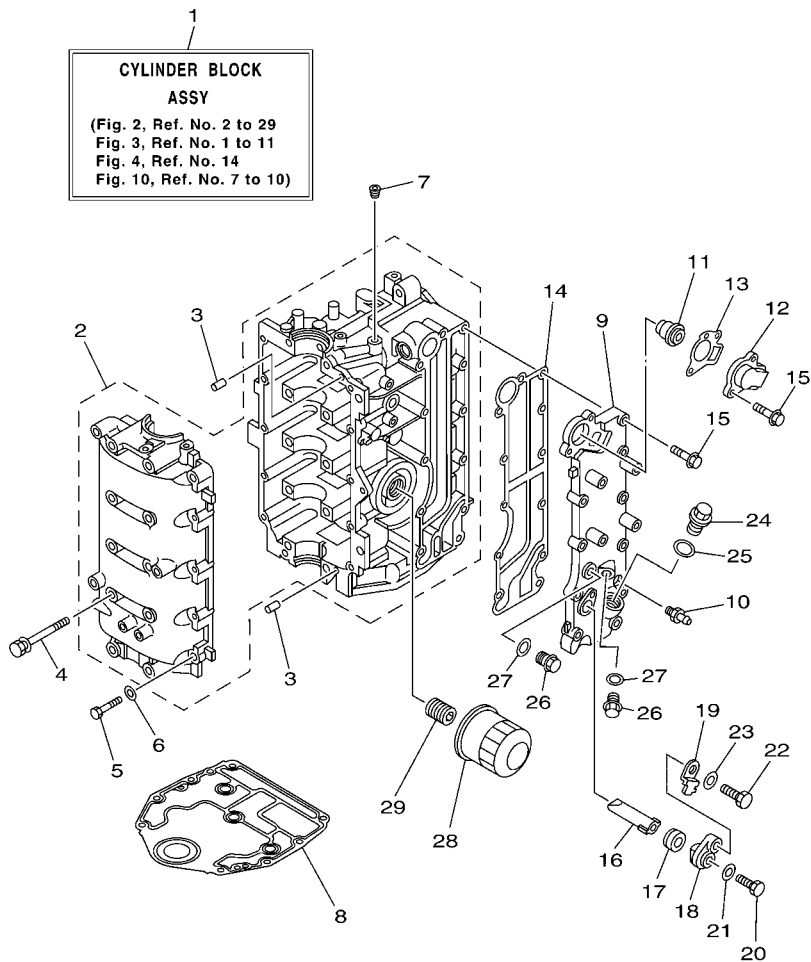

1
**CYLINDER BLOCK
 ASSY**
 (Fig. 2, Ref. No. 2 to 29
 Fig. 3, Ref. No. 1 to 11
 Fig. 4, Ref. No. 14
 Fig. 10, Ref. No. 7 to 10)

REF. NO.	PART NO.	DESCRIPTION	EHT	ET				REMARKS
28	5GH-13440-20	ELEMENT ASSY, OIL CLEANER	1	1				
29	6C5-12858-00	BOLT, UNION	1	1				

 6C12100-E020

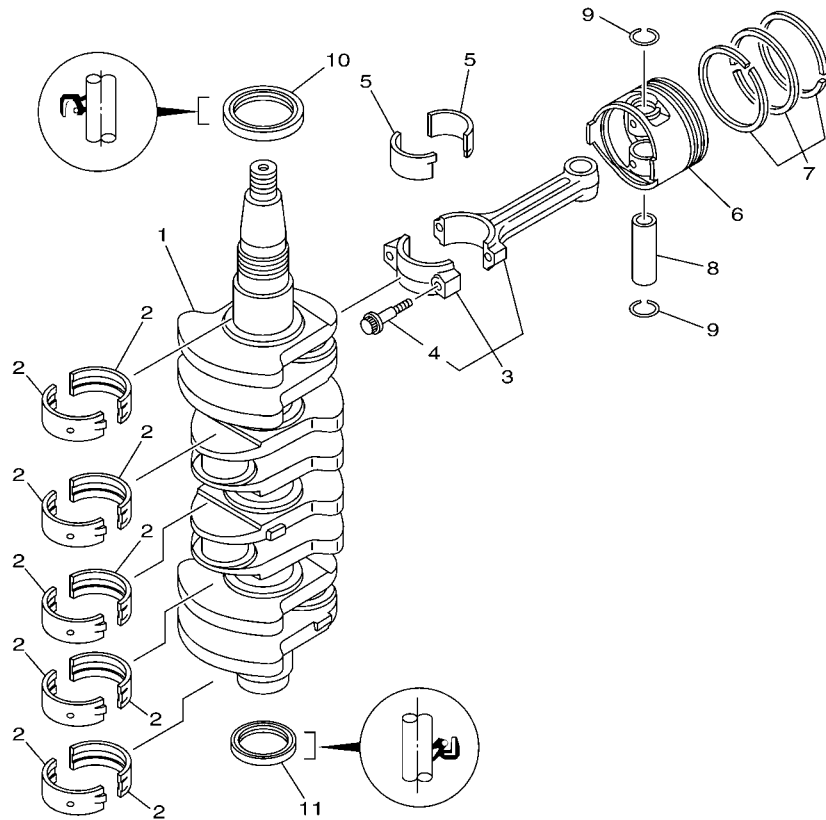

FWD
6C11010-D030

FIG. 3 CRANKSHAFT & PISTON

REF. NO.	PART NO.	DESCRIPTION	EHT	ET		REMARKS
1	6C5-11411-00	CRANKSHAFT	1	1		
2	6C5-11416-00	PLANE BEARING, CRANKSHAFT 1	10	10		UR YELLOW
	6C5-11416-10	PLANE BEARING, CRANKSHAFT 1	10	10		UR RED
	6C5-11416-20	PLANE BEARING, CRANKSHAFT 1	10	10		UR PINK
	6C5-11416-30	PLANE BEARING, CRANKSHAFT 1	10	10		UR GREEN
3	6C5-11650-00	CONNECTING ROD ASSY	4	4		
4	6C5-11654-00	.BOLT, CONNECTING ROD	2	2		
5	6C5-11656-00	PLANE BEARING, CONNECTING ROD	8	8		UR YELLOW
	6C5-11656-10	PLANE BEARING, CONNECTING ROD	8	8		UR RED
	6C5-11656-20	PLANE BEARING, CONNECTING ROD	8	8		UR PINK
	6C5-11656-30	PLANE BEARING, CONNECTING ROD	8	8		UR GREEN
6	69W-11631-00-97	PISTON (STD)	4	4		
	69W-11635-00	PISTON (0.25MM O/S)	4	4		AP
	69W-11636-00	PISTON (0.50MM O/S)	4	4		AP
7	67C-11603-00	PISTON RING SET (STD)	4	4		
	67C-11604-00	PISTON RING SET (0.25MM O/S)	4	4		AP
	67C-11605-00	PISTON RING SET (0.50MM O/S)	4	4		AP
8	62Y-11633-00	PIN, PISTON	4	4		
9	93450-17129	CIRCLIP	8	8		
10	93102-43M42	OIL SEAL	1	1		
11	93101-35002	OIL SEAL	1	1		

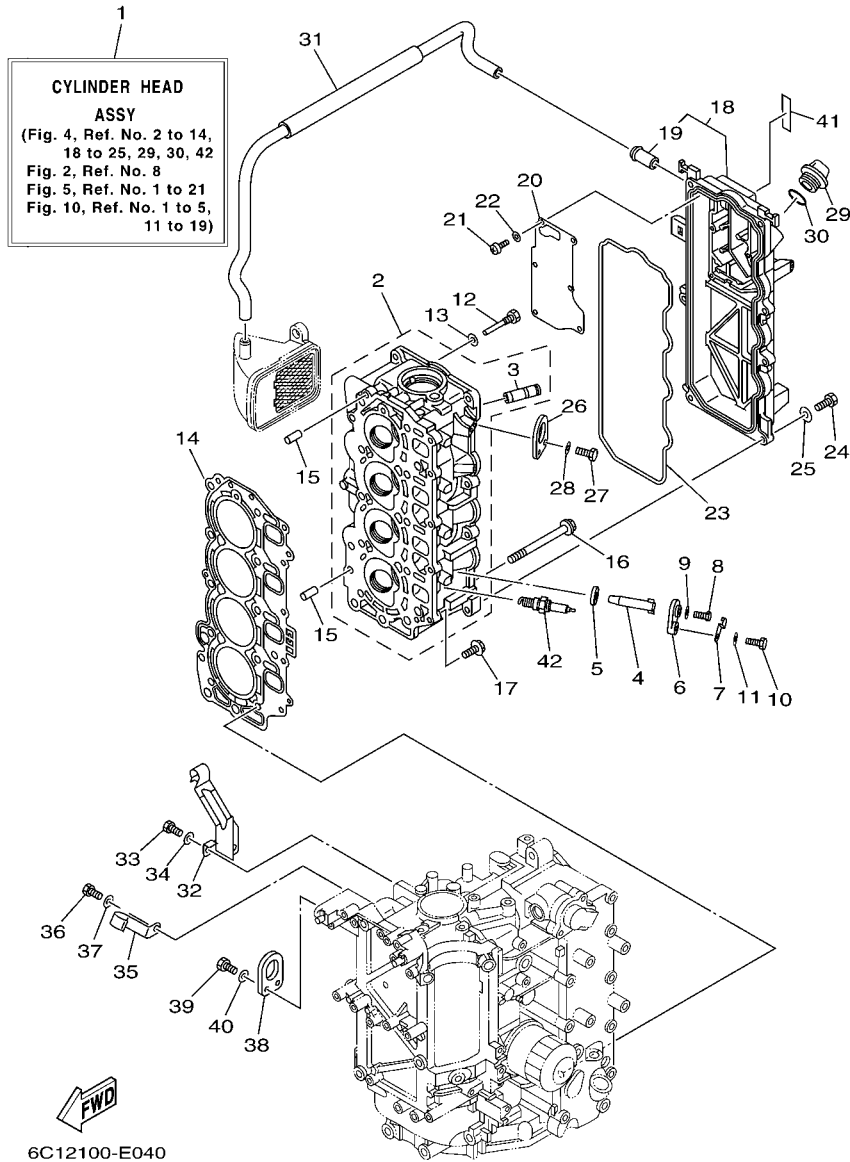

FIG. 4 CYLINDER & CRANKCASE 2

REF. NO.	PART NO.	DESCRIPTION	EHT	ET	REMARKS
1	6C5-W009A-01-1S	CYLINDER HEAD ASSY	1	1	
2	6C5-11111-00-1S	HEAD, CYLINDER 1	1	1	
3	62Y-11133-30	.GUIDE, VALVE 1	8	8	
4	62Y-11325-00	ANODE	4	4	
5	66M-11328-00	GROMMET, ANODE	4	4	
6	66M-11327-00-94	COVER, ANODE	4	4	
7	66M-12535-00	PLATE	4	4	
8	97095-05012	BOLT	4	4	
9	92995-05600	WASHER	4	4	
10	97095-06020	BOLT	4	4	
11	92995-06600	WASHER	4	4	
12	90109-06M65	BOLT	1	1	
13	90430-06014	GASKET	1	1	
14	6C5-11181-01	GASKET, CYLINDER HEAD 1	1	1	
15	99530-08012	PIN, DOWEL	2	2	
16	90105-09005	BOLT, FLANGE	10	10	
17	90119-06MA3	BOLT, WITH WASHER	5	5	
18	6C5-11191-01-1S	COVER, CYLINDER HEAD 1	1	1	
19	62Y-14485-00	.PIPE, JOINT	1	1	
20	6C5-11168-00	COVER, BREATHER	1	1	
21	98507-04010	SCREW, PAN HEAD	6	6	
22	92907-04600	WASHER	6	6	
23	62Y-11356-00	SEAL, CYLINDER 2	1	1	
24	97095-06020	BOLT	7	7	
25	92995-06600	WASHER	7	7	
26	62Y-11119-00	HANGER, ENGINE	1	1	
27	97095-06020	BOLT	2	2	

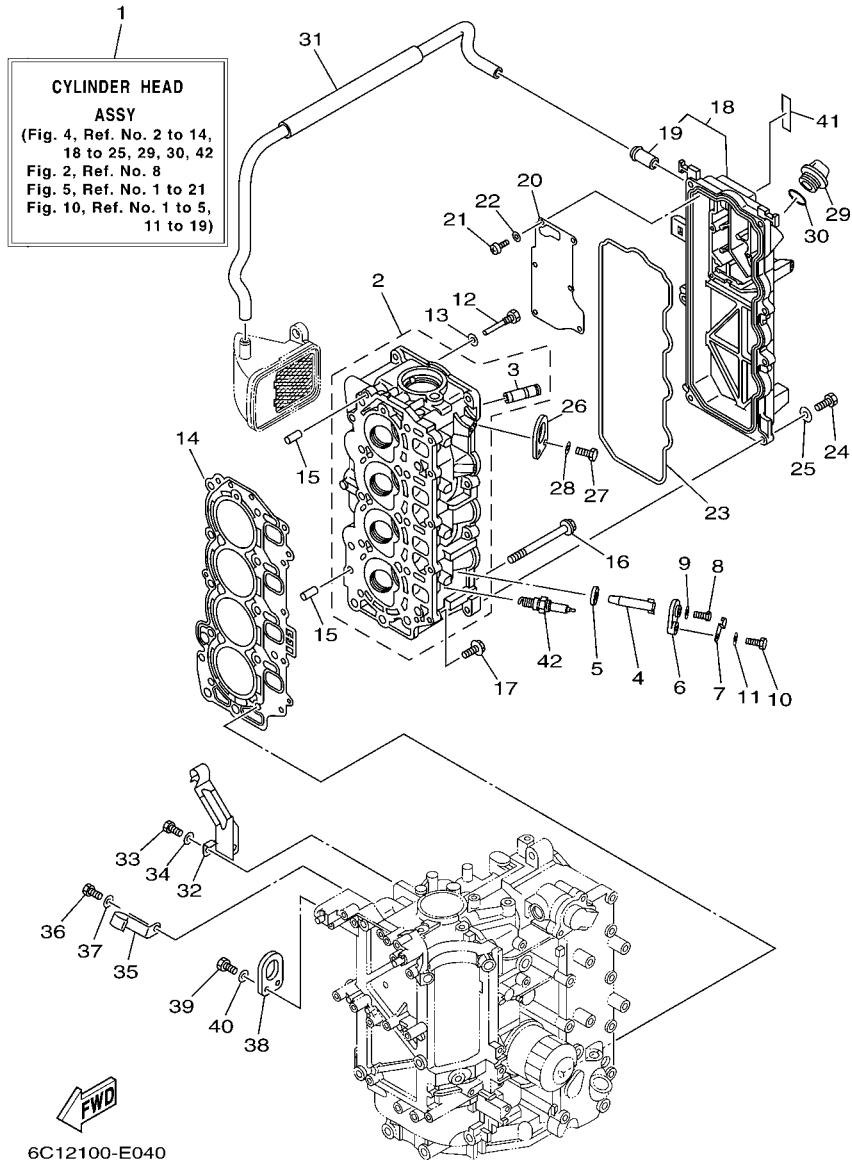
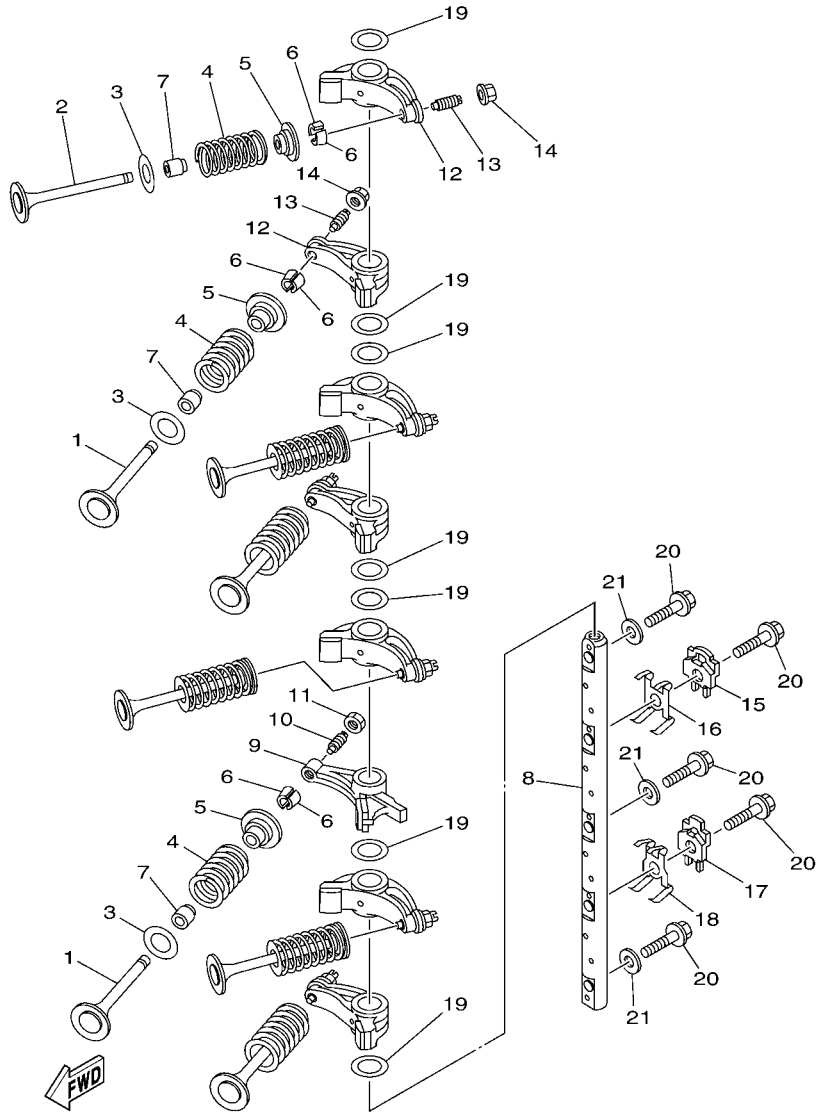

FIG. 4 CYLINDER & CRANKCASE 2

REF. NO.	PART NO.	DESCRIPTION	EHT	ET	REMARKS
28	92995-06600	WASHER	2	2	
29	6G8-15363-00	PLUG, OIL	1	1	
30	93210-24M79	O-RING	1	1	
31	6C5-1531A-01	HOSE, BREATHER 1	1	1	
32	6C5-15378-00	HOLDER	1	1	
33	97095-06014	BOLT	1	1	
34	92995-06600	WASHER	1	1	
35	6C5-15378-11	HOLDER	1	1	
36	97095-06014	BOLT	1	1	
37	92995-06600	WASHER	1	1	
38	62Y-11119-00	HANGER, ENGINE	1	1	
39	97095-06020	BOLT	2	2	
40	92995-06600	WASHER	2	2	
41	62Y-12138-40	MARK, CAUTION	1	1	FOR USA,OCE
	62Y-12138-50	MARK, CAUTION	1	1	FOR CAN
42	94702-00418	PLUG, SPARK (NGK DPR6EB)	4	4	



6C12100-E050

FIG. 5 VALVE

REF. NO.	PART NO.	DESCRIPTION	EHT	ET			REMARKS
1	69W-12111-00	VALVE, INTAKE	4	4			
2	69W-12121-00	VALVE, EXHAUST	4	4			
3	62Y-12116-00	SEAT, VALVE SPRING	8	8			
4	51Y-12114-00	SPRING, VALVE OUTER	8	8			
5	30X-12117-00	RETAINER, VALVE SPRING	8	8			
6	30X-12118-00	COTTER, VALVE	16	16			
7	51Y-12119-00	SEAL, VALVE STEM	8	8			
8	6C5-12146-00	SHAFT, ROCKER	1	1			
9	62Y-12151-00	ARM, VALVE ROCKER	1	1			
10	64J-12159-00	SCREW, VALVE ADJUSTING	1	1			
11	62Y-12158-00	NUT, LOCK	1	1			
12	6C5-12151-00	ARM, VALVE ROCKER	7	7			
13	6C5-12159-00	SCREW, VALVE ADJUSTING	7	7			
14	6C5-12158-00	NUT, LOCK	7	7			
15	6C5-12231-00	GUIDE, STOPPER 1	1	1			
16	6C5-12233-00	PLATE, GUIDE STOPPER 1	1	1			
17	6C5-12241-00	GUIDE, STOPPER 2	1	1			
18	6C5-12243-00	PLATE, GUIDE STOPPER 2	1	1			
19	90201-16014	WASHER, PLATE	7	7			
20	90105-08060	BOLT, FLANGE	5	5			
21	92990-08200	WASHER, PLAIN	3	3			

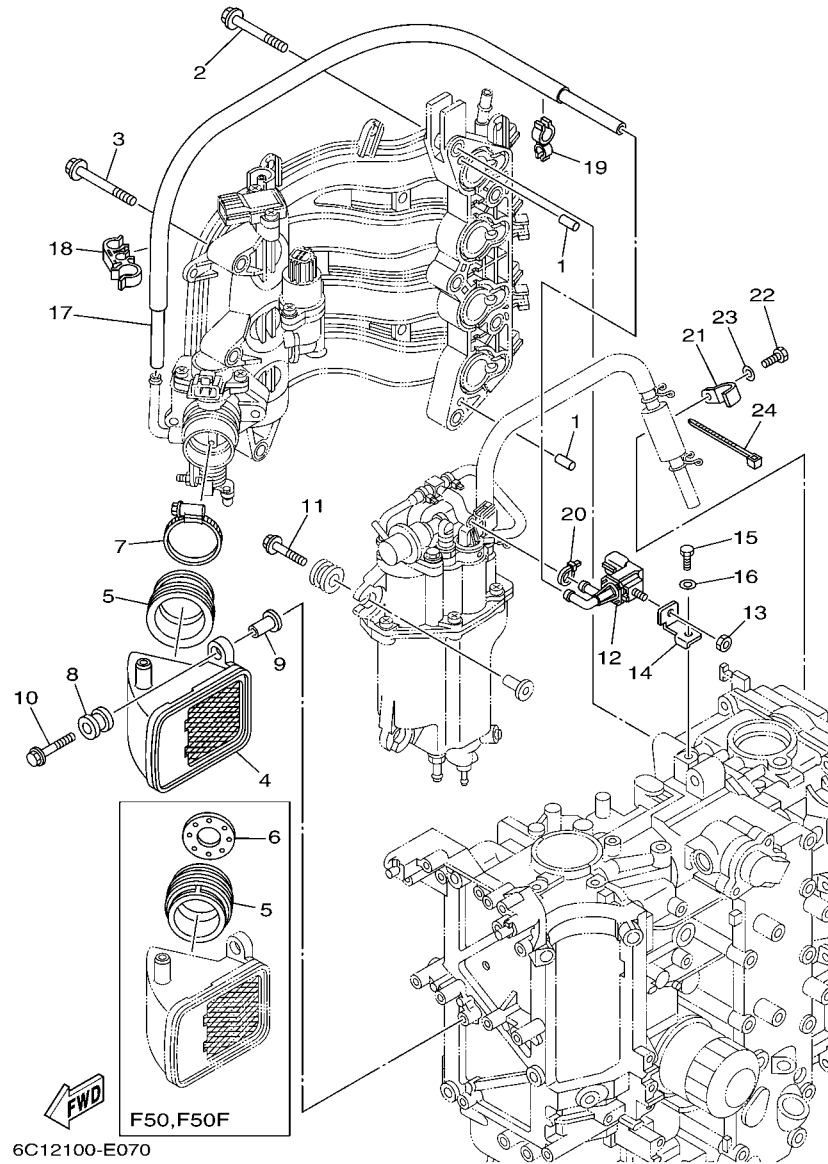

FIG. 7 INTAKE 2

REF. NO.	PART NO.	DESCRIPTION	EHT	ET	REMARKS
1	93608-12M05	PIN, DOWEL	2	2	
2	90119-08069	BOLT, WITH WASHER	5	5	
3	90119-06087	BOLT, WITH WASHER	3	3	
4	6C5-14440-00	SILENCER ASSY, INTAKE	1	1	
5	6C1-14453-01	JOINT, AIR CLEANER 1	1	1	F50,F50F
6	6C5-14453-01	JOINT, AIR CLEANER 1	1	1	F60,F60C
6	6C1-14477-00	PLATE	1	1	F50,F50F
7	90450-50001	HOSE CLAMP ASSY	1	1	
8	6A0-82317-00	DAMPER, IGNITION COIL	2	2	
9	90387-06119	COLLAR	2	2	
10	90119-06106	BOLT, WITH WASHER	2	2	
11	90119-06M08	BOLT, WITH WASHER	3	3	
12	6C5-86120-00	SOLENOID VALVE ASSY	1	1	
13	95380-06600	NUT, HEXAGON	1	1	
14	6C5-86112-00	STAY, SOLENOID	1	1	
15	97095-06016	BOLT	1	1	
16	92995-06600	WASHER	1	1	
17	6C5-12576-00	HOSE 1	1	1	
18	90464-15008	CLAMP	1	1	
19	90464-12006	CLAMP	1	1	
20	90465-11M10	CLAMP	1	1	
21	6C5-13428-00	BRACKET, STRAINER 1	1	1	
22	97095-06016	BOLT	1	1	
23	92995-06600	WASHER	1	1	
24	90465-13M18	CLAMP	1	1	FOR USA,CAN

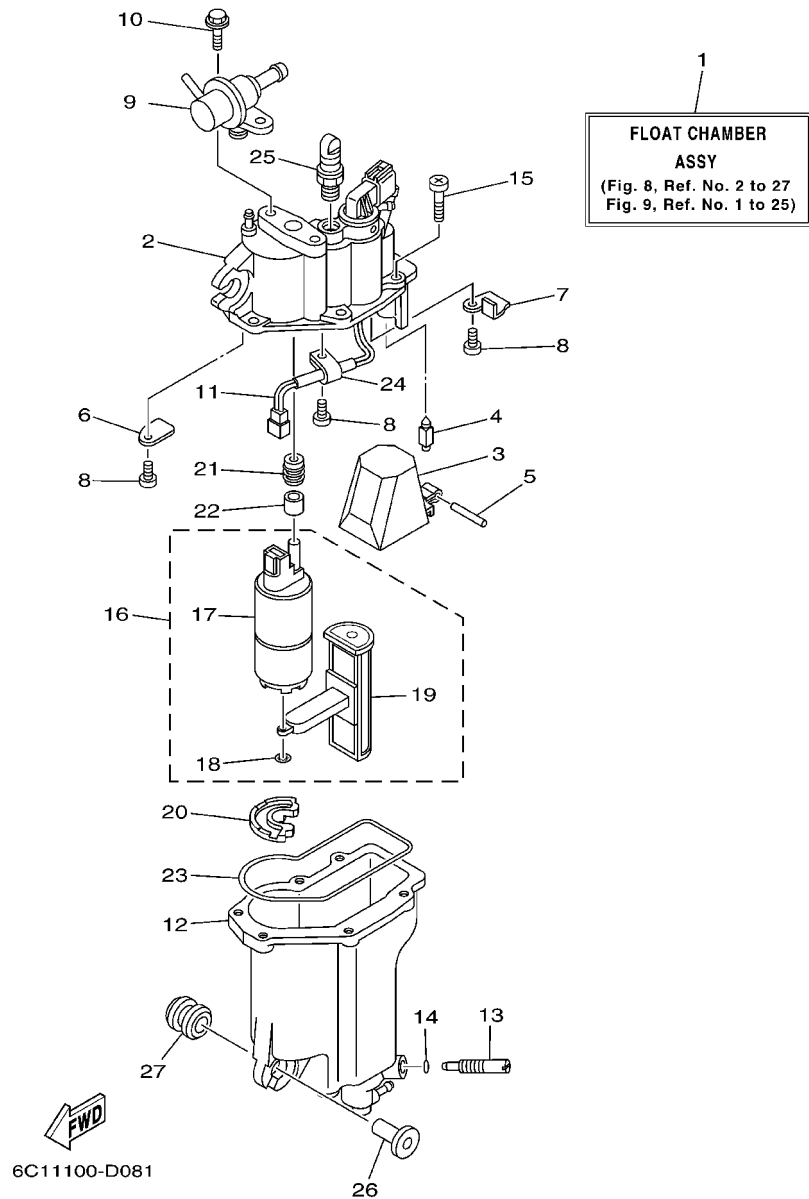
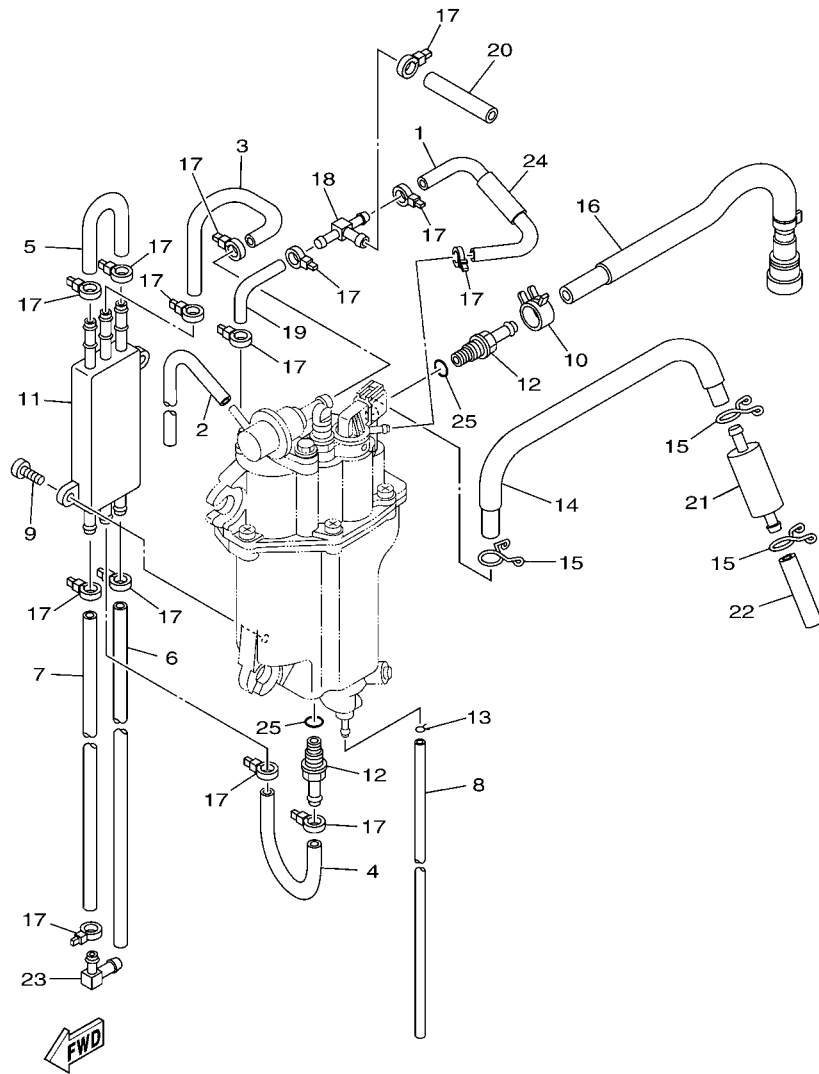

FIG. 8 FUEL INJECTION PUMP 1

REF. NO.	PART NO.	DESCRIPTION	EHT	ET				REMARKS
1	6C5-14180-00	FLOAT CHAMBER ASSY	1	1				
2	6C5-14182-00	COVER, FLOAT CHAMBER	1	1				
3	6C5-14985-00	FLOAT	1	1				
4	6C5-14546-00	VALVE, NEEDLE	1	1				
5	6C5-14386-00	PIN, FLOAT	1	1				
6	6C5-2441R-00	PLATE, BAFFLE 1	1	1				
7	6C5-2441T-00	PLATE, BAFFLE 2	1	1				
8	6C5-24453-00	SCREW	3	3				
9	6C5-13906-00	REGULATOR, PRESSURE	1	1				
10	6C5-24592-00	BOLT	2	2				
11	6C5-87226-00	WIRE HARNESS ASSY	1	1				
12	6C5-14960-00	BODY ASSY	1	1				
13	6C5-14191-00	PLUG, DRAIN	1	1				
14	6C5-14397-00	O-RING	1	1				
15	6C5-14567-00	SCREW	6	6				
16	6C5-13910-00	FUEL PUMP ASSY	1	1				
17	6C5-13907-00	.FUEL PUMP COMP.	1	1				
18	6C5-14127-00	.CLIP	1	1				
19	6C5-13915-00	.FILTER	1	1				
20	6C5-13593-00	DAMPER	1	1				
21	6C5-13781-00	DAMPER, PUMP	1	1				
22	6C5-13716-00	COLLAR	1	1				
23	6C5-14984-00	GASKET, FLOAT CHAMBER	1	1				
24	6C5-21337-00	CLAMP, CABLE	1	1				
25	6C5-14225-00	CAP	1	1				
26	90387-06M69	COLLAR	3	3				
27	90480-09M12	GROMMET	3	3				



6C11010-D090

FIG. 9 FUEL INJECTION PUMP 2

REF. NO.	PART NO.	DESCRIPTION	EHT	ET				REMARKS
1	6C5-13546-00	HOSE 2	1	1				
2	6C5-13542-00	HOSE, VACUUM SENSING 1	1	1				
3	6C5-24321-00	PIPE 10	1	1				
4	6C5-24322-00	PIPE 11	1	1				
5	6C5-24323-00	PIPE 12	1	1				
6	6C5-24324-00	PIPE 13 (L150)	1	1				
7	6C5-24325-00	PIPE 14 (L110)	1	1				
8	6C5-14149-00	PIPE (L200)	1	1				
9	6C5-24444-00	SCREW	2	2				
10	6C5-13577-00	CLIP	1	1				
11	6C5-21841-00	COOLER	1	1				
12	6C5-14251-00	NIPPLE	2	2				
13	6C5-2411M-00	CLIP	1	1				
14	6C5-14148-00	PIPE	1	1				
15	6C5-24387-00	CLIP	3	3				
16	6C5-13974-00	PIPE, FUEL 4	1	1				
17	90465-11M10	CLAMP	14	14				
18	6C5-24379-00	PIPE, JOINT 4	1	1				
19	6C5-13545-00	HOSE 1	1	1				
20	6C5-13547-00	HOSE 3	1	1				
21	6C5-24251-00	STRAINER 1	1	1				
22	6C5-2451B-00	HOSE, FUEL INLET	1	1				
23	6C5-1410F-00	CONNECTOR	1	1				
24	6C5-13548-00	HOSE, AIR 4	1	1				
25	6C5-13739-00	O-RING	2	2				

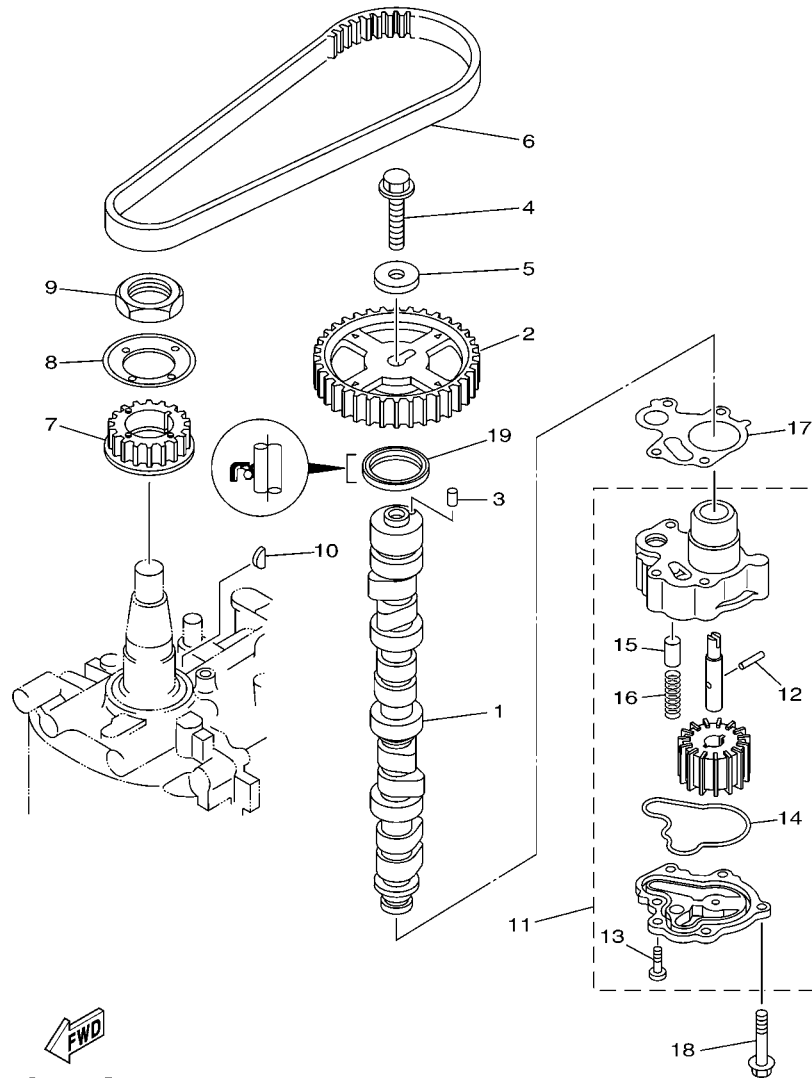

6C11010-D100

FIG. 10 OIL PUMP

REF. NO.	PART NO.	DESCRIPTION	EHT	ET	REMARKS
1	6C5-12171-00	CAMSHAFT 1	1	1	
2	6C5-11537-00	GEAR, DRIVEN	1	1	
3	93605-17002	PIN, DOWEL	1	1	
4	95817-10035	BOLT, FLANGE	1	1	
5	90201-10144	WASHER, PLATE	1	1	
6	6C5-46241-00	V-BELT	1	1	
7	6C5-11536-00	GEAR, DRIVE	1	1	
8	62Y-11557-00	WASHER 1	1	1	
9	90170-35008	NUT	1	1	
10	90280-03M01	KEY, WOODRUFF	1	1	
11	6C5-13300-00	OIL PUMP ASSY	1	1	
12	93603-17070	.PIN, DOWEL	1	1	
13	98580-06016	.SCREW, PAN HEAD	2	2	
14	6C5-13142-00	.GASKET	1	1	
15	6G8-11577-00	.PLUNGER, RELIEF	1	1	
16	90501-6C500	.SPRING, COMPRESSION	1	1	
17	6C5-13329-00	GASKET, PUMP COVER	1	1	
18	90119-06025	BOLT, WITH WASHER	4	4	
19	93102-37M40	OIL SEAL	1	1	

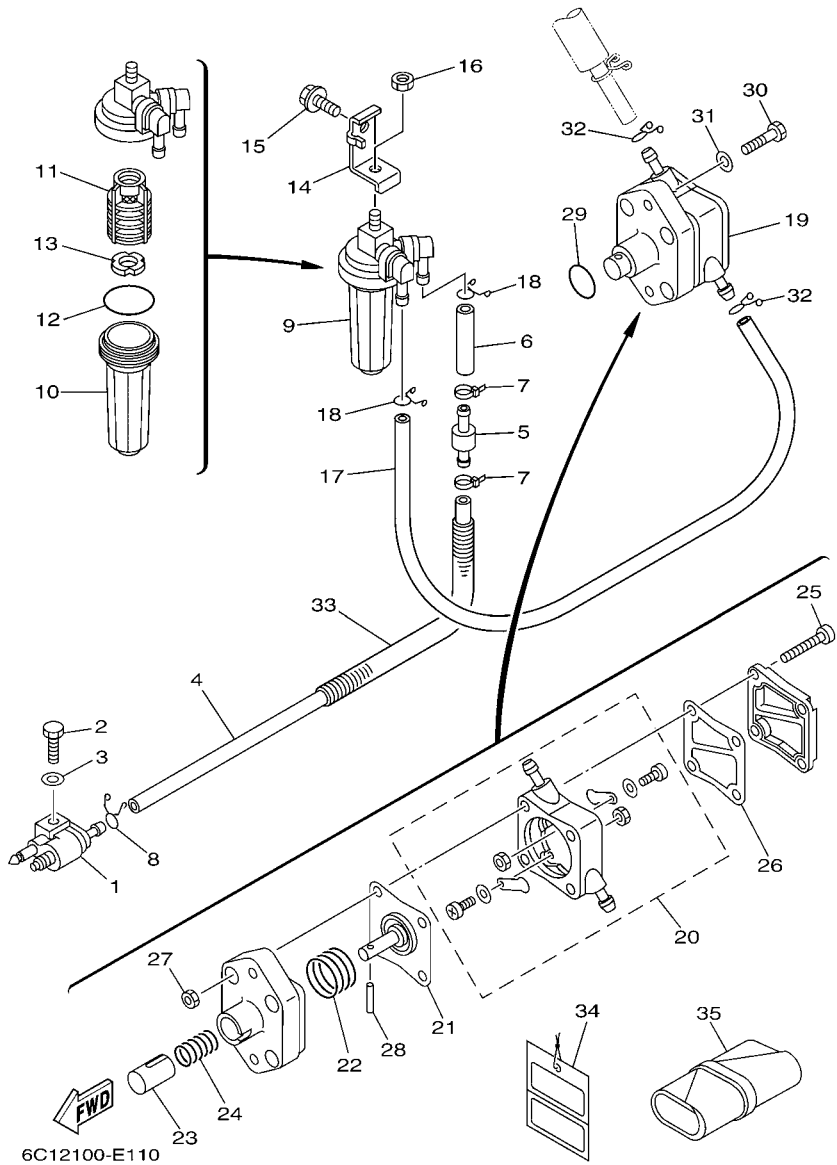
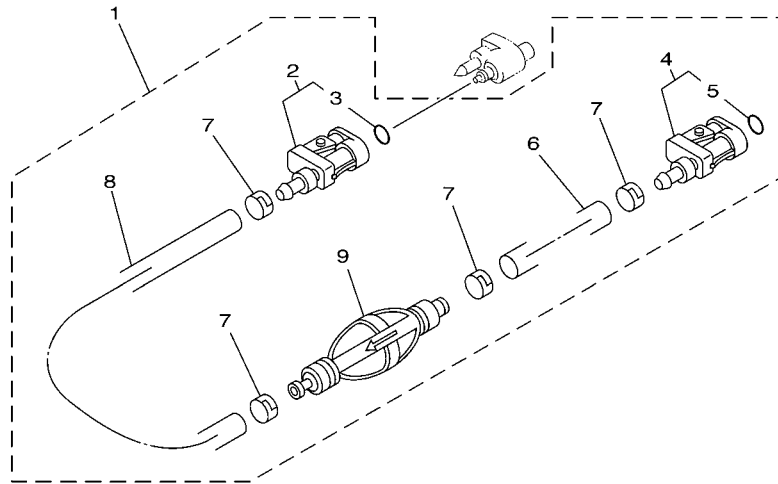

FIG. 11 FUEL 1

REF. NO.	PART NO.	DESCRIPTION	EHT	ET				REMARKS
1	6G1-24304-02	FUEL PIPE JOINT COMP. 1	1	1				
2	97095-06025	BOLT	1	1				
3	92995-06600	WASHER	1	1				
4	6C5-2247A-00	HOSE 1	1	1				
5	67F-24377-00	PIPE, JOINT 3	1	1				
6	90445-13M02	HOSE (L40)	1	1				
7	90465-11M10	CLAMP	2	2				
8	90467-09M17	CLIP	1	1				
9	68V-24560-01	FILTER ASSY	1	1				
10	68V-24521-01	.CUP, FILTER	1	1				
11	68V-24563-00	.ELEMENT, FILTER	1	1				
12	93210-32738	.O-RING	1	1				
13	68V-24469-01	.FLOAT, WATER LEVEL	1	1				
14	6C5-24566-01	BRACKET, FILTER	1	1				
15	95895-08016	BOLT, FLANGE	1	1				
16	95380-08600	NUT	1	1				
17	90445-13M36	HOSE (L350)	1	1				
18	90467-10M04	CLIP	2	2				
19	6C5-24410-00	FUEL PUMP ASSY	1	1				
20	6C5-24415-00	.BODY 4	1	1				
21	62Y-24411-02	.DIAPHRAGM	1	1				
22	62Y-24423-00	.SPRING, DIAPHRAGM	1	1				
23	62Y-13131-00	.PLUNGER	1	1				
24	62Y-24454-00	.SPRING	1	1				
25	62Y-24444-01	.SCREW	4	4				
26	6C5-24471-00	.DIAPHRAGM	1	1				
27	95380-05600	.NUT	4	4				

FIG. 12 FUEL 2



REF. NO.	PART NO.	DESCRIPTION	EHT	ET		REMARKS
1	6Y2-24306-56	FUEL PIPE COMP. 1		1		AP FOR USA
	6Y1-24306-54	FUEL PIPE COMP. 1	1	1		AP FOR CAN
2	6E5-24305-06	.FUEL PIPE JOINT COMP. 2		1		FOR 6Y2-24306-56
	6G1-24305-04	.FUEL PIPE JOINT COMP. 2	1	1		FOR 6Y1-24306-54
3	93210-08287	..O-RING	1	1		
4	6Y2-24305-06	.FUËL PIPE JOINT COMP. 2		1		FOR 6Y2-24306-56
	6Y1-24305-05	.FUËL PIPE JOINT COMP. 2	1	1		FOR 6Y1-24306-54
5	93210-08287	..O-RING	1	1		
6	90445-13M01	.HOSE (L2050)		1		FOR 6Y2-24306-56
	90445-11M06	.HOSE (L2050)	1	1		FOR 6Y1-24306-54
7	6E5-24351-51	.BAND 1		4		FOR 6Y2-24306-56
	650-24351-51	.BAND 1	4	4		FOR 6Y1-24306-54
8	90445-13M00	.HOSE (L850)		1		FOR 6Y2-24306-56
	90445-11M05	.HOSE (L850)	1	1		FOR 6Y1-24306-54
9	6Y2-24360-60	.PRIMER PUMP ASSY		1		FOR 6Y2-24306-56
	6Y1-24360-52	.PRIMER PUMP ASSY	1	1		FOR 6Y1-24306-54



68R3100-C100

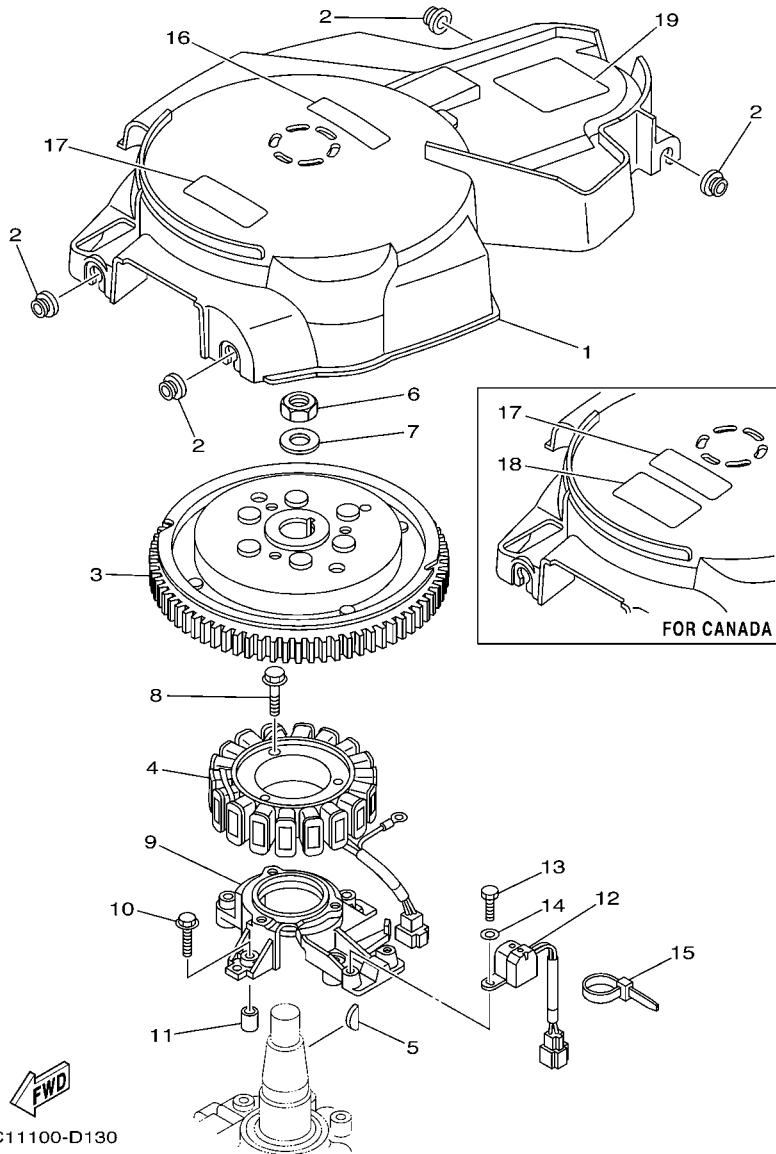

FIG. 13 GENERATOR

REF. NO.	PART NO.	DESCRIPTION	EHT	ET		REMARKS
1	6C5-81337-00	COVER, FLYWHEEL	1	1		
2	90480-12072	GROMMET	4	4		
3	6C5-81450-00	ROTOR ASSY	1	1		
4	6C5-81410-00	STATOR ASSY	1	1		
5	6H4-11545-00	KEY, WOODRUFF	1	1		
6	90170-20137	NUT	1	1		
7	90201-21M18	WASHER, PLATE	1	1		
8	95023-06030	BOLT	3	3		
9	6C5-85561-00-94	BASE, MAGNETO	1	1		
10	95023-06030	BOLT	4	4		
11	99530-08012	PIN, DOWEL	2	2		
12	62Y-85580-00	COIL, PULSER	1	1		
13	97095-05012	BOLT	2	2		
14	92995-05600	WASHER	2	2		
15	90465-13M97	CLAMP	1	1		
16	6C5-13437-41	MARK, CAUTION	1	1		FOR USA,OCE
	6C5-13437-51	MARK, CAUTION	1	1		FOR CAN
17	6A1-83625-41	MARK 5	1	1		
18	6A1-83625-51	MARK 5	1	1		FOR CAN
19	62Y-83626-00	MARK 6	1	1		

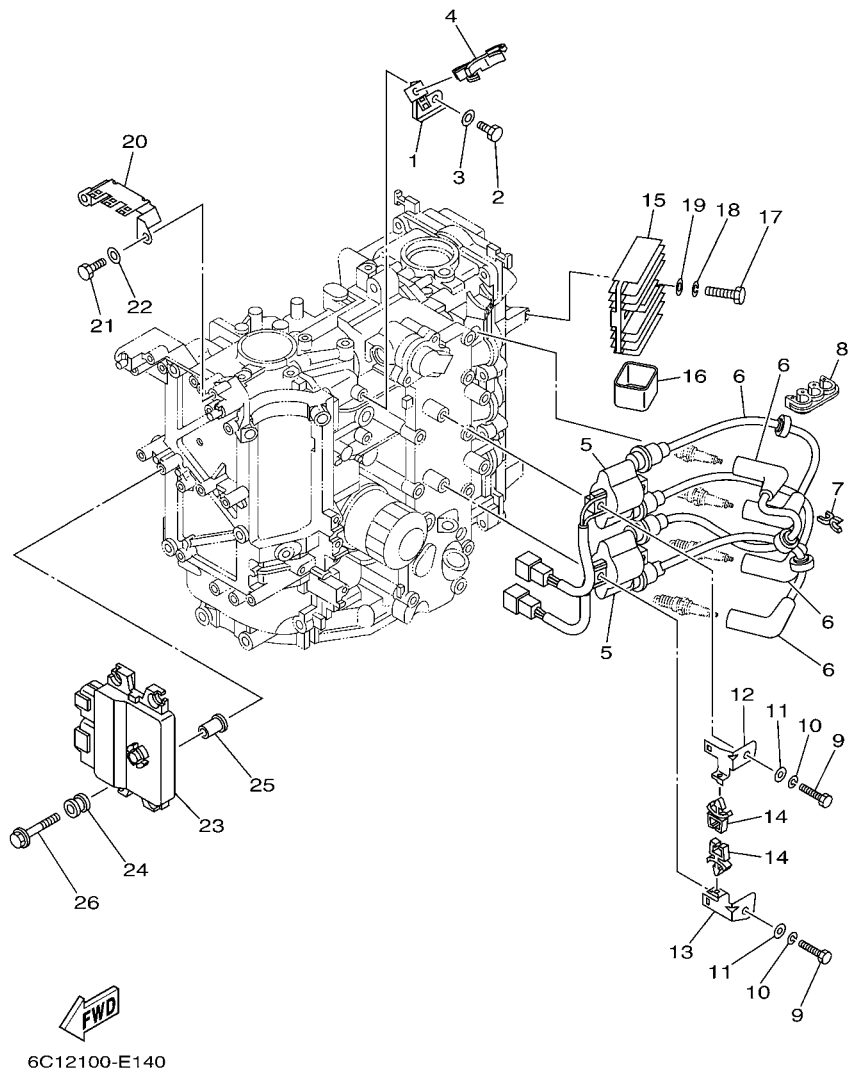
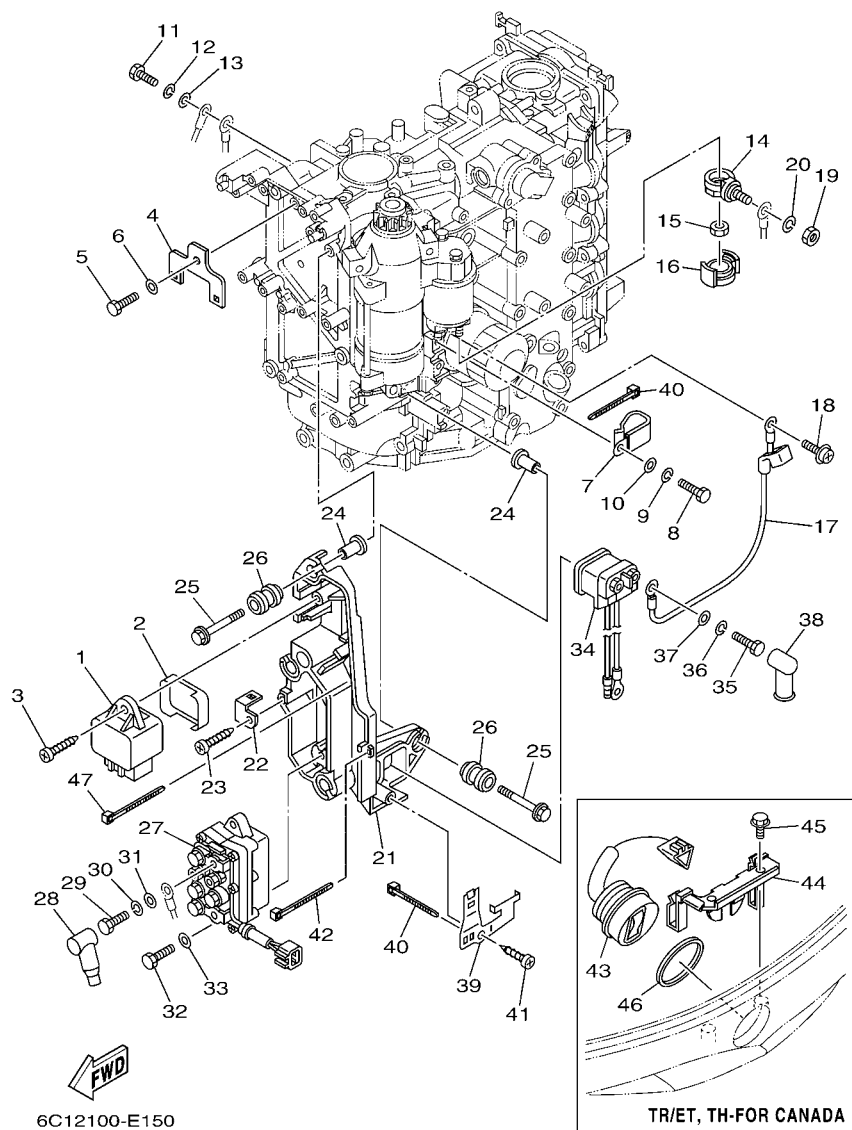

FIG. 14 ELECTRICAL 1

REF. NO.	PART NO.	DESCRIPTION	EHT	ET			REMARKS
1	6C5-85525-00	COVER	1	1			
2	97095-06014	BOLT	1	1			
3	92995-06600	WASHER	1	1			
4	90464-18246	CLAMP	1	1			
5	63P-82310-01	IGNITION COIL ASSY	2	2			
6	6C5-82340-01	HIGH TENSION CORD ASSY 1	4	4			
7	90464-07M41	CLAMP	2	2			
8	90464-07M05	CLAMP	1	1			
9	97095-06030	BOLT	4	4			
10	92995-06100	WASHER, SPRING	4	4			
11	92995-06600	WASHER	4	4			
12	6C5-82316-01	BRACKET, IGNITION COIL	1	1			
13	6C5-82316-11	BRACKET, IGNITION COIL	1	1			
14	90464-06001	CLAMP	2	2			
15	68V-81960-00	RECTIFIER & REGULATOR ASSY	1	1			
16	6C5-81961-00	COVER	1	1			
17	97095-06025	BOLT	2	2			
18	92995-06100	WASHER, SPRING	2	2			
19	92995-06600	WASHER	2	2			
20	6C5-82171-00	STAY, FUSE BOX	1	1			
21	97095-06014	BOLT	2	2			
22	92995-06600	WASHER	2	2			
23	6C1-8591A-30	ENGINE CONTROL UNIT ASSY	1	1			F50,F50F
	6C5-8591A-30	ENGINE CONTROL UNIT ASSY	1	1			F60,F60C
24	6C5-82317-00	DAMPER, IGNITION COIL	4	4			
25	90387-06119	COLLAR	4	4			
26	90119-06M59	BOLT, WITH WASHER	4	4			

C6

FIG. 15 ELECTRICAL 2



REF. NO.	PART NO.	DESCRIPTION	EHT	ET	REMARKS
1	60E-81950-00	RELAY ASSY	1	1	
2	6C5-81336-00	GROMMET	1	1	
3	97780-60620	SCREW, TAPPING	1	1	
4	6C5-8257V-00	PLATE, CONNECTOR	1	1	
5	97095-06014	BOLT	1	1	
6	92995-06600	WASHER	1	1	
7	90465-05M87	CLAMP	1	1	
8	97095-06020	BOLT	4	4	
9	92995-06100	WASHER, SPRING	4	4	
10	92995-06600	WASHER	4	4	
11	97095-06020	BOLT	1	1	
12	92995-06100	WASHER, SPRING	1	1	
13	92995-06600	WASHER	1	1	
14	60V-81925-00	TERMINAL	1	1	
15	90179-08003	NUT	1	1	
16	68F-82582-00	COVER, WIRE HARNESS	1	1	
17	6C5-81815-00	CORD, STARTER MOTOR	1	1	
18	90159-04005	SCREW, WITH WASHER	1	1	
19	95333-08600	NUT	1	1	
20	92903-08100	WASHER, SPRING	1	1	
21	6C5-81948-00	BRACKET	1	1	
22	6C5-85548-00	HOLDER	1	1	
23	97780-60620	SCREW, TAPPING	1	1	
24	90387-06119	COLLAR	4	4	
25	90119-06M59	BOLT, WITH WASHER	4	4	
26	6A0-82317-00	DAMPER, IGNITION COIL	4	4	
27	63P-81950-00	RELAY ASSY	1	1	

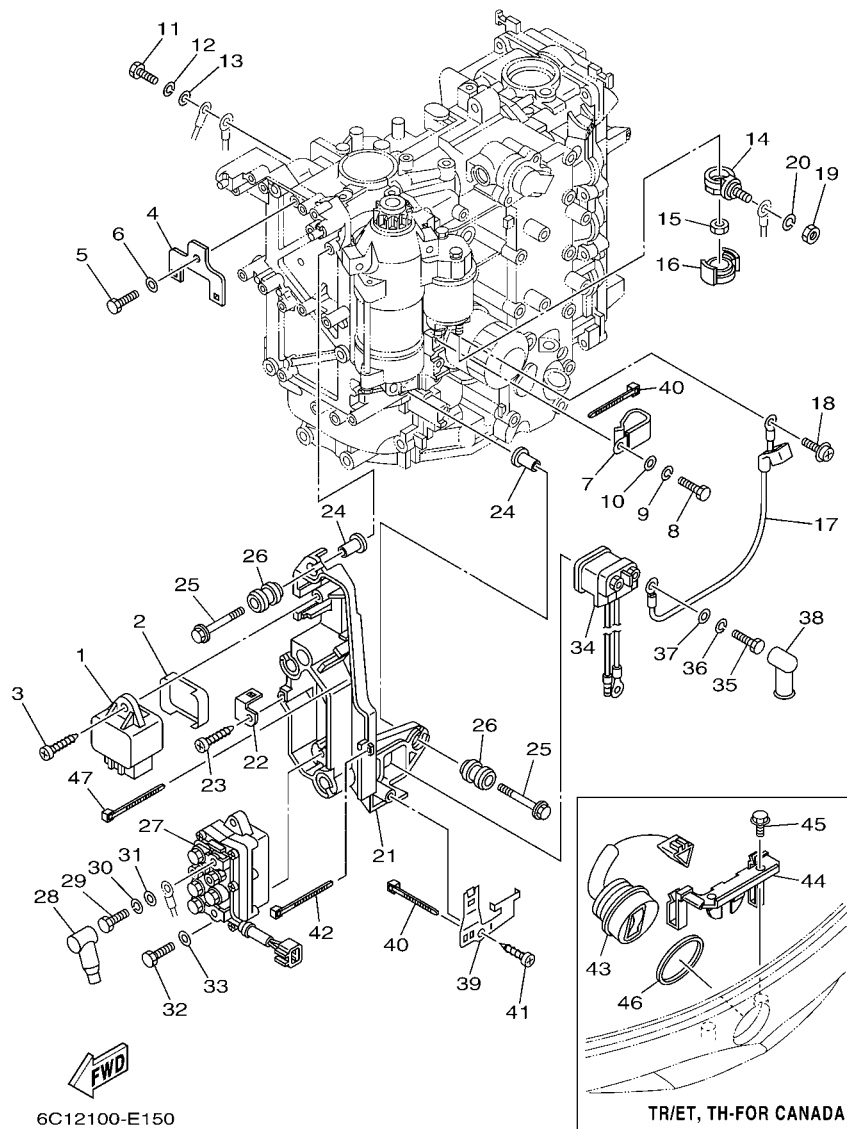

FIG. 15 ELECTRICAL 2

REF. NO.	PART NO.	DESCRIPTION	EHT	ET			REMARKS
28	682-82119-01	COVER, LEAD WIRE	2	2			
29	97095-06010	BOLT	2	2			
30	92995-06100	WASHER, SPRING	2	2			
31	92995-06600	WASHER	2	2			
32	97013-06020	BOLT	2	2			
33	92903-06600	WASHER, PLATE	2	2			
34	68V-8194A-00	RELAY	1	1			
35	97095-06010	BOLT	2	2			
36	92995-06100	WASHER, SPRING	2	2			
37	92995-06600	WASHER	2	2			
38	6G5-82119-00	COVER, LEAD WIRE	2	2			
39	6C5-81953-00	STAY, RELAY	1	1			
40	90465-11M10	CLAMP	2	2			
41	97780-60620	SCREW, TAPPING	1	1			
42	90465-13M97	CLAMP	1	1			
43	63D-82563-10	TRIM & TILT SWITCH ASSY	1	1			EHT-FOR CAN
44	6C5-83614-01	BRACKET	1	1			EHT-FOR CAN
45	90109-06M86	BOLT	2	2			EHT-FOR CAN
46	6E5-82587-00	GASKET	1	1			EHT-FOR CAN
47	90465-13M97	CLAMP	1	1			

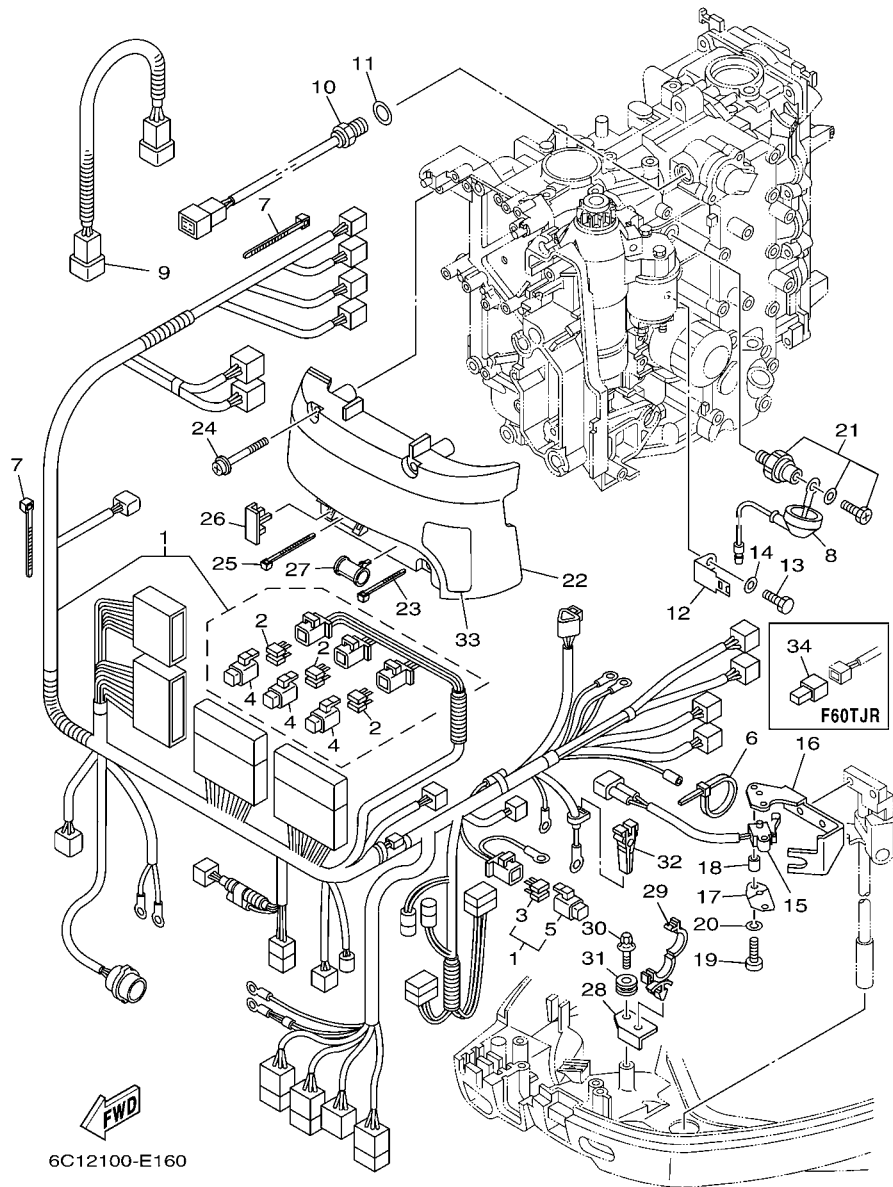
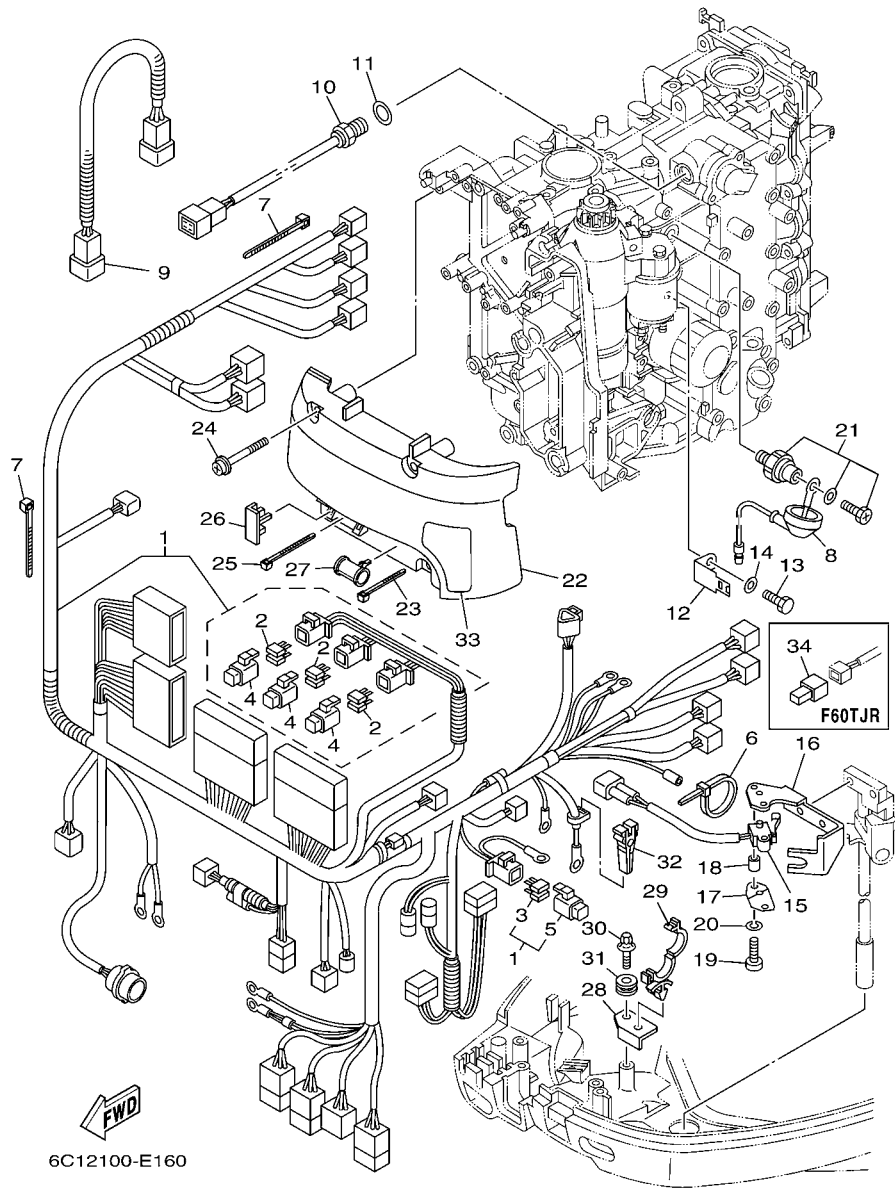

FIG. 16 ELECTRICAL 3

REF. NO.	PART NO.	DESCRIPTION	EHT	ET	REMARKS
1	6C5-82590-30	WIRE HARNESS ASSY	1	1	FOR USA,CAN
	6C5-82590-11	WIRE HARNESS ASSY	1	1	FOR OCE
2	67F-82151-00	.FUSE (20A)	6	6	
3	67F-82151-10	.FUSE (30A)	2	2	
4	67F-8215B-10	.CAP (YELLOW)	3	3	
5	67F-8215B-20	.CAP (GREEN)	1	1	
6	90465-13M24	CLAMP	1	1	
7	90465-13M11	CLAMP	2	2	
8	68V-81315-00	LEAD WIRE ASSY	1	1	
9	6C5-82553-00	EXTENSION, WIRE LEAD	1	1	
10	6C5-85790-00	THERMOSENSOR ASSY	1	1	
11	90430-14115	GASKET	1	1	
12	6C5-82388-00	PLATE	1	1	
13	97095-06014	BOLT	1	1	
14	92995-06600	WASHER	1	1	
15	60V-8259F-00	SWITCH ASSY	1	1	EXCEPT F60TJR
16	6C5-82554-01	STAY, NEUTRAL SWITCH	1	1	
17	61A-82588-01	PLATE	1	1	EXCEPT F60TJR
18	90387-04001	COLLAR	1	1	EXCEPT F60TJR
19	97885-04016	SCREW, PAN HEAD	2	2	EXCEPT F60TJR
20	92995-04100	WASHER	2	2	EXCEPT F60TJR
21	64J-82504-00	OIL PRESSURE SWITCH ASSY	1	1	
22	6C5-81942-00	COVER	1	1	
23	90465-13M39	CLAMP	1	1	
24	90159-06M14	SCREW, WITH WASHER	4	4	
25	90465-13M24	CLAMP	1	1	
26	6C5-82176-00	DAMPER	2	2	



6C12100-E160

FIG. 16 ELECTRICAL 3

REF. NO.	PART NO.	DESCRIPTION	EHT	ET	REMARKS
27	6C5-8252R-00	DAMPER	1	1	
28	6C5-42811-00	STAY	1	1	
29	90464-18007	CLAMP	1	1	
30	90119-06077	BOLT, WITH WASHER	1	1	
31	90480-13598	GROMMET	1	1	
32	67F-2812A-00	PULLER, FUSE	1	1	
33	6C5-81919-00	GRAPHIC, REGULATOR	1	1	
34	68V-82582-10	COVER, WIRE HARNESS		1	F60TJR

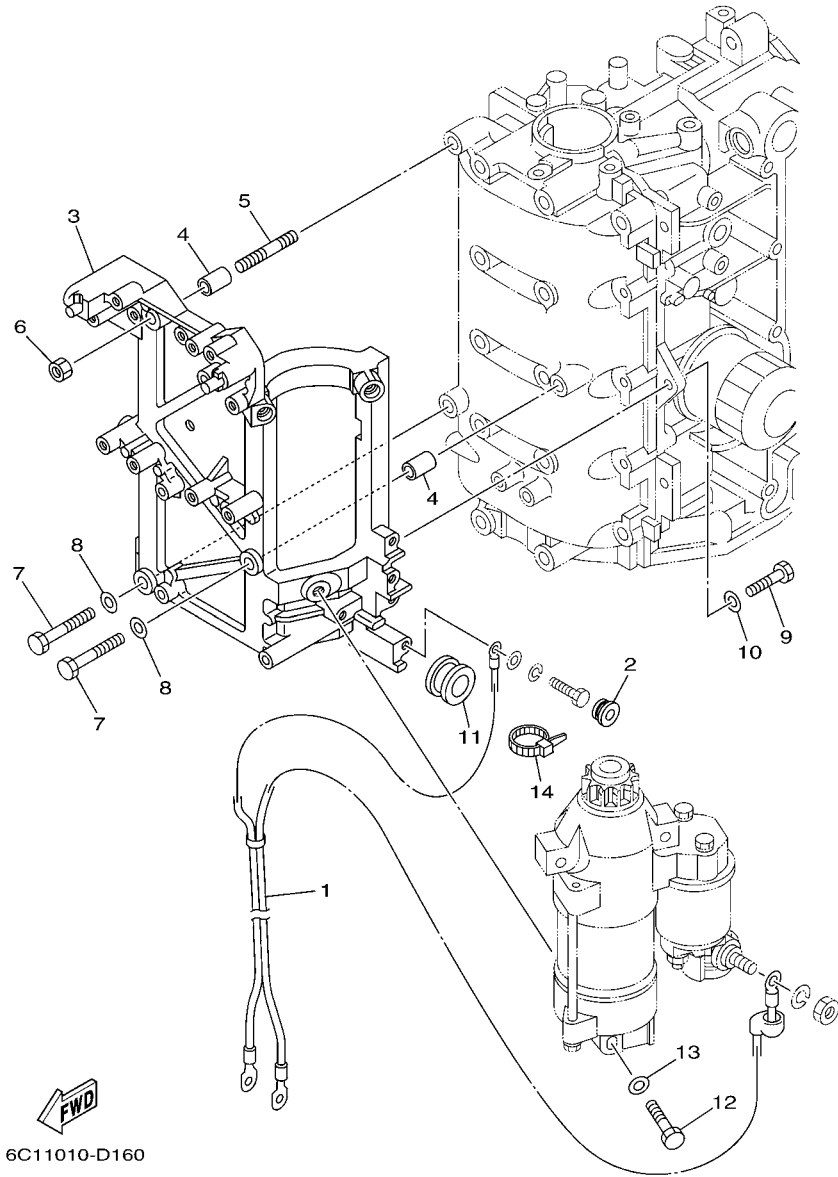
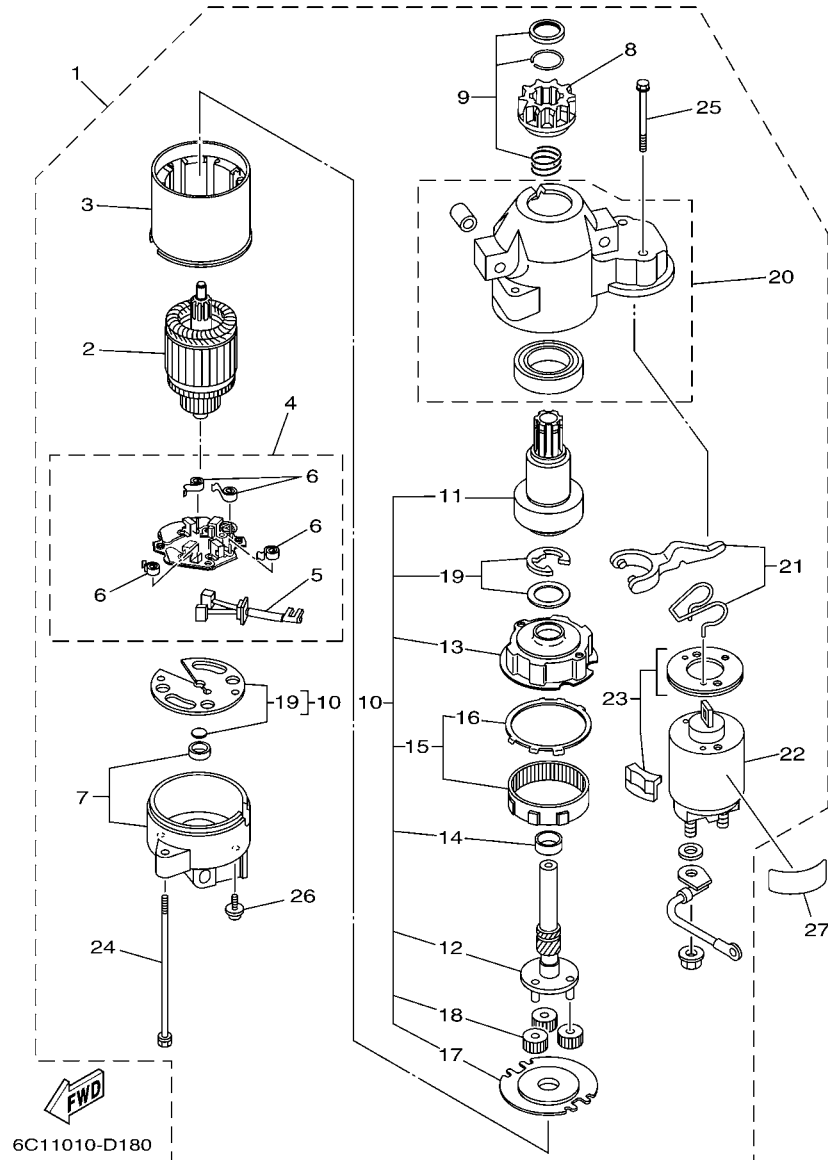

FIG. 17 ELECTRICAL 4

REF. NO.	PART NO.	DESCRIPTION	EHT	ET	REMARKS
1	6C5-82105-U0	WIRE HARNESS	1	1	FOR USA,OCE
	6C5-82105-00	WIRE HARNESS	1	1	FOR CAN
2	90480-12072	GROMMET	1	1	
3	6C5-81822-00-94	BRACKET, STARTING MOTOR	1	1	
4	99590-10114	PIN, DOWEL	2	2	
5	95680-08330	BOLT, STUD	1	1	
6	95380-08600	NUT	1	1	
7	97095-08035	BOLT	2	2	
8	92995-08600	WASHER	2	2	
9	97095-08025	BOLT	2	2	
10	92995-08600	WASHER	2	2	
11	90480-24003	GROMMET	1	1	
12	97013-08045	BOLT	3	3	
13	92903-08600	WASHER, PLATE	3	3	
14	90465-13M18	CLAMP	1	1	



6C11010-D180

FIG. 18 STARTING MOTOR

REF. NO.	PART NO.	DESCRIPTION	EHT	ET	REMARKS
1	6C5-81800-00	STARTING MOTOR ASSY	1	1	
2	67F-81850-00	.ARMATURE ASSY	1	1	
3	67F-81810-00	.STATOR ASSY	1	1	
4	69J-81840-00	.BRUSH HOLDER ASSY	1	1	
5	69J-81801-00	..BRUSH SET	1	1	
6	67F-81813-00	..SPRING, BRUSH	4	4	
7	68F-81820-00	.REAR BRACKET ASSY	1	1	
8	67F-81808-00	.PINION ASSY	1	1	
9	67F-81857-00	.PINION STOPPER SET	1	1	
10	67F-81807-00	.GEAR ASSY, STARTING MOTOR	1	1	
11	67F-81832-00	..CLUTCH, OVER RUN	1	1	
12	67F-81836-00	..SHAFT, PINION	1	1	
13	67F-81821-00	..BRACKET, CENTER 1	1	1	
14	67F-81841-00	..BEARING	1	1	
15	67F-81891-00	..GEAR, RING	1	1	
16	67F-8183R-00	...GASKET	1	1	
17	67F-81830-00	..BRACKET, CENTER 2	1	1	
18	60V-8183T-00	..GEAR, IDLER	3	3	
19	67F-81809-00	..WASHER KIT	1	1	
20	6C5-81842-00	.COVER	1	1	
21	69J-81839-00	.LEVER ASSY	1	1	
22	6C5-81941-00	.STARTER RELAY ASSY	1	1	
23	69J-81869-00	.COVER, DUST	1	1	
24	6K7-81826-10	.BOLT	2	2	
25	69J-81828-00	.BOLT 2	2	2	
26	67F-81846-00	.SCREW	2	2	
27	67F-83627-01	LABEL, CAUTION 7	1	1	

FIG. 19 BOTTOM COWLING 1

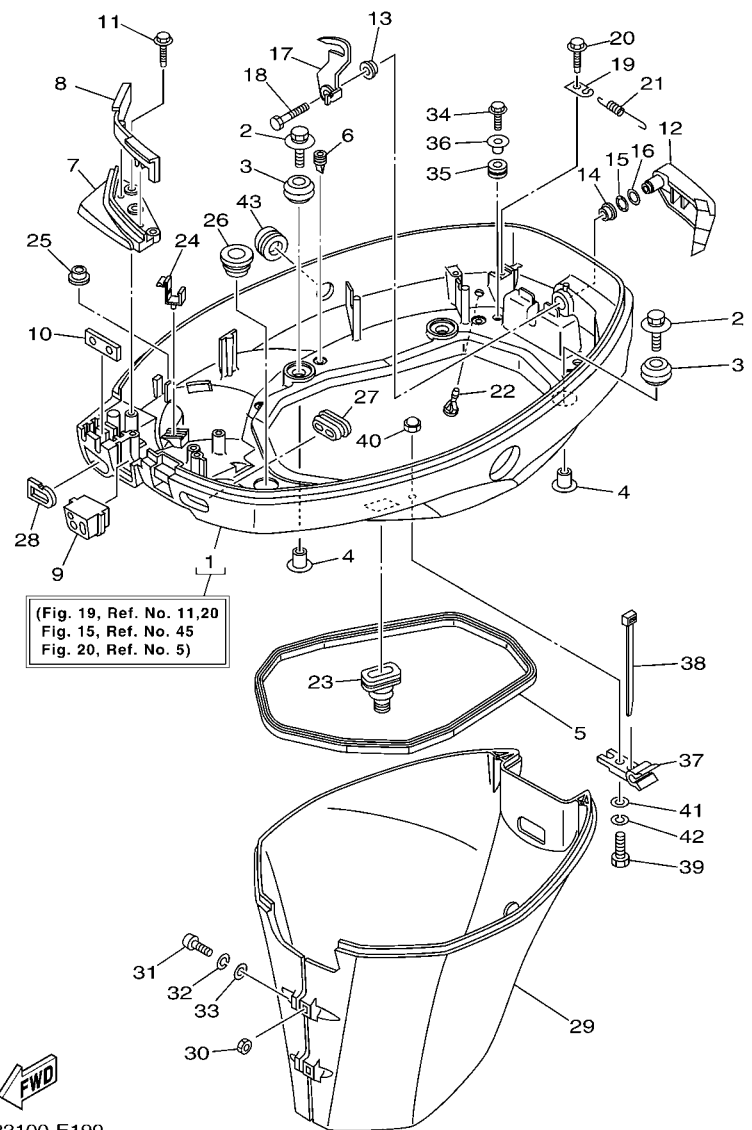

REF. NO.	PART NO.	DESCRIPTION	EHT	ET			REMARKS
1	6C5-42710-00-4D	BOTTOM COWLING ASSY	1				FOR OCE
	6C5-42710-10-4D	BOTTOM COWLING ASSY	1	1			EHT-FOR CAN
2	90119-06M08	BOLT, WITH WASHER	4	4			
3	90480-09M12	GROMMET	4	4			
4	90387-06060	COLLAR	4	4			
5	62Y-42716-00	RUBBER, SEAL 1	1	1			
6	65W-42717-00	RUBBER, SEAL 2	4	4			
7	6C5-42738-00-4D	PLATE, FITTING	1	1			
8	6C5-42718-00	RUBBER, SEAL 3	1	1			
9	6C5-42725-30	GROMMET	1	1			
10	62Y-42727-00	GROMMET	1	1			
11	90109-06M81	BOLT	3	3			
12	67C-42815-00-4D	LEVER, CLAMP	1	1			
13	90386-12M37	BUSH	1	1			
14	90386-12MA2	BUSH	1	1			
15	90206-12052	WASHER, WAVE	1	1			
16	90201-12M07	WASHER, PLATE	1	1			
17	67C-42816-01	LEVER, CLAMP	1	1			
18	97095-06014	BOLT	1	1			
19	66T-43144-00	HOOK, SPRING	1	1			
20	90109-06M86	BOLT	1	1			
21	90506-18M40	SPRING, TENSION	1	1			
22	6H3-44391-01	NIPPLE, HOSE	1	1			
23	6C5-42724-00	GROMMET	1	1			
24	90464-09M13	CLAMP	1	1			
25	6E7-82317-00	DAMPER, IGNITION COIL	1	1			
26	68U-42727-00	GROMMET	1	1			

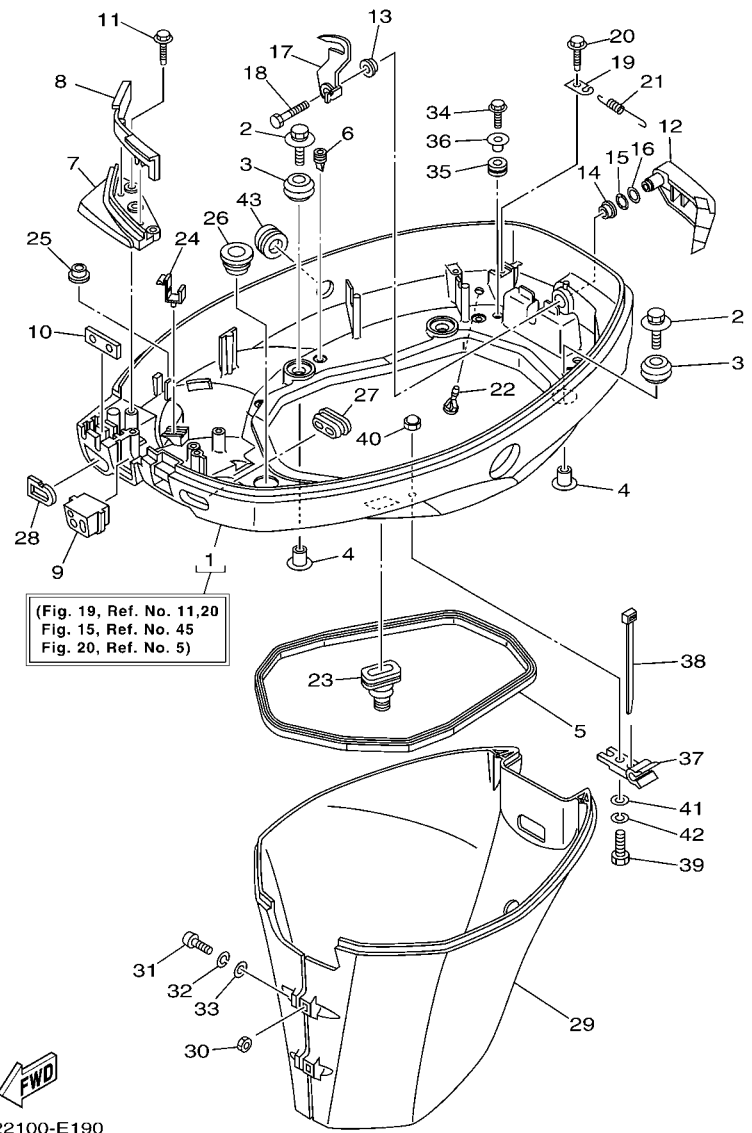

6C22100-E190

FIG. 19 BOTTOM COWLING 1

REF. NO.	PART NO.	DESCRIPTION	EHT	ET	REMARKS
27	6H3-42727-00	GROMMET	1	1	
28	61N-24329-00	SEAL	1	1	
29	67C-42741-10-4D	APRON	1	1	
30	95380-06600	NUT, HEXAGON	2	2	
31	97880-06025	SCREW, PAN HEAD	2	2	
32	92990-06100	WASHER, SPRING	2	2	
33	92990-06600	WASHER, PLATE	2	2	
34	90109-06M80	BOLT	2	2	
35	90480-13M24	GROMMET	2	2	
36	90387-06M43	COLLAR	2	2	
37	90464-09M49	CLAMP	1	1	
38	90465-11M10	CLAMP	2	2	
39	97095-06020	BOLT	1	1	
40	95380-06800	NUT	1	1	
41	92990-06600	WASHER, PLATE	1	1	
42	92995-06100	WASHER, SPRING	1	1	
43	6C5-42726-00	GROMMET	1	1	

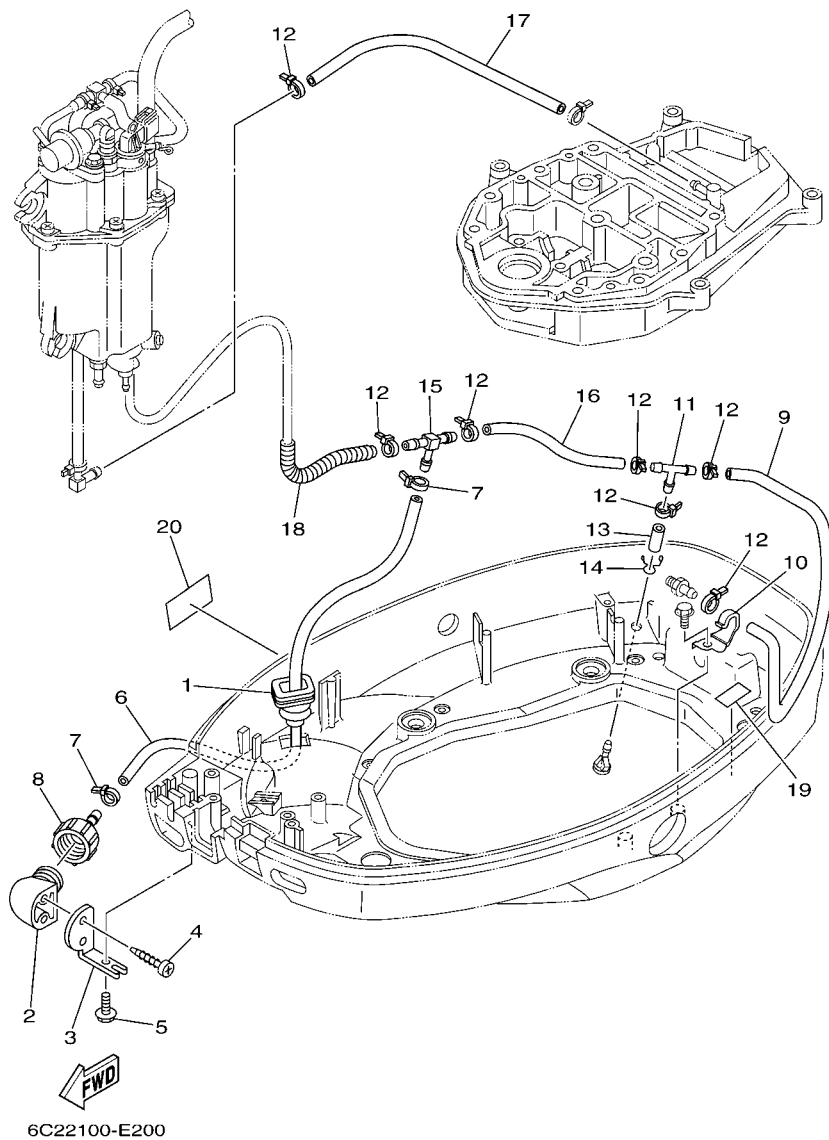

FIG. 20 BOTTOM COWLING 2

REF. NO.	PART NO.	DESCRIPTION	EHT	ET	REMARKS
1	65W-42724-10	GROMMET	1	1	
2	68T-12572-00	ADAPTER	1	1	
3	69W-12535-00	PLATE	1	1	
4	90167-06002	SCREW, TAPPING	2	2	
5	90109-06M80	BOLT	1	1	
6	6C5-24312-00	PIPE 2	1	1	
7	90465-11M10	CLAMP	2	2	
8	6R3-12580-00	JOINT ASSY	1	1	
9	90445-09226	HOSE (L390)	1	1	
10	90462-08031	CLAMP	1	1	
11	688-24378-00	PIPE, JOINT 4	1	1	
12	90465-11M10	CLAMP	7	7	
13	90445-09220	HOSE (L30)	1	1	
14	90467-08M18	CLIP	1	1	
15	6C5-24378-00	PIPE, JOINT 4	1	1	
16	90445-09091	HOSE (L135)	1	1	
17	90445-09104	HOSE (L300)	1	1	
18	90447-10006	HOSE, WITH SPRING	1	1	
19	6C5-82377-00	LABEL	1	1	
20	62Y-13444-40	MARK	1	1	FOR USA,OCE
	62Y-13444-50	MARK	1	1	FOR CAN

FIG. 21 STEERING 1

REF. NO.	PART NO.	DESCRIPTION	EHT	ET	REMARKS
1	6X4-42101-J0-4D	HANDLE, STEERING	1		
2	6X4-42111-00-4D	HANDLE, STEERING	1		
3	93700-06M03	NIPPLE, GREASE	1		
4	6X4-48215-00	GRAPHIC	1		
5	6X4-42119-00	GRIP, STEERING HANDLE	1		
6	6X4-42177-00	RUBBER, HANDLE	1		
7	6X4-42137-00	INDICATOR, THROTTLE	1		
8	6X4-41291-00	BUSHING	1		
9	6X4-44139-00	COLLAR	1		
10	90142-05001	SCREW, COUNTERSUNK	1		
11	91490-20010	PIN, COTTER	1		
12	6X4-44177-00	WASHER	2		
13	6X4-42128-00	COLLAR, DISTANCE 1	1		
14	90501-23215	SPRING, COMPRESSION	1		
15	6X4-44188-00	WASHER	2		
16	90386-08032	BUSH	1		
17	63D-42126-00	FRICION, STEERING HANDLE GRIP	1		
18	6X4-48154-00	KNOB, THROTTLE	1		
19	95380-06600	NUT, HEXAGON	1		
20	91490-20010	PIN, COTTER	1		
21	6X4-44100-00	SHIFT LINK ASSY	1		
22	6X4-42115-00	.SHAFT, STEERING HANDLE	1		
23	6X4-44102-00	.SHIFT ASSIST ASSY.	1		
24	6X4-14137-00	.CLIP	1		
25	69W-48261-00	.ARM, THROTTLE	1		
26	6X4-82540-00	.NEUTRAL SWITCH ASSY	1		
27	6A5-48129-10	.SCREW 3	2		

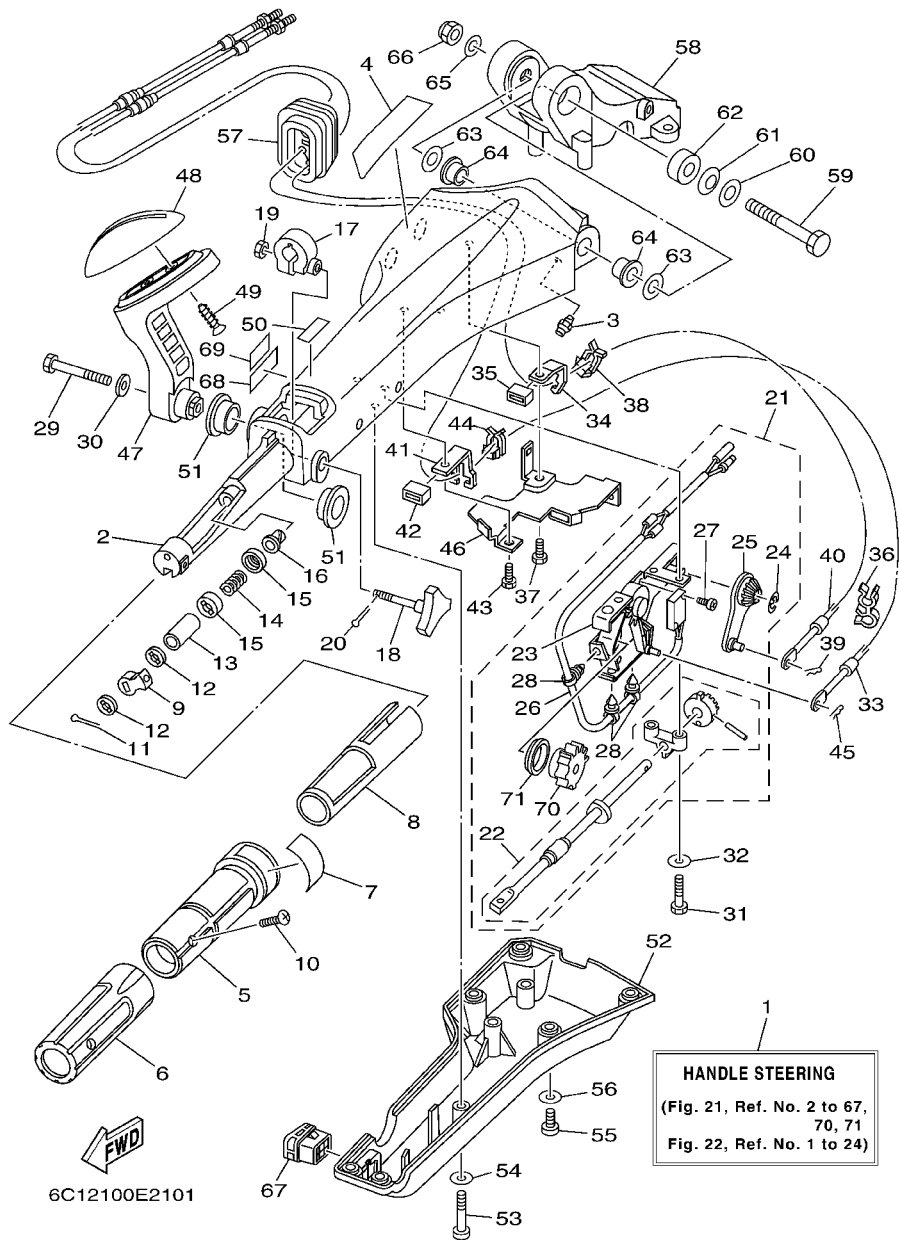

FIG. 21 STEERING 1

REF. NO.	PART NO.	DESCRIPTION	EHT	ET	REMARKS
28	6X4-42821-00	.BAND, CLAMP	3		
29	97095-08040	BOLT	1		
30	92995-08600	WASHER	1		
31	97095-06030	BOLT	2		
32	92995-06600	WASHER	2		
33	67C-48321-10	CABLE	1		
34	6X4-48538-00	CLAMP, CABLE 1	1		
35	6X4-26367-00	PROTECTOR	1		
36	90464-09M42	CLAMP	1		
37	97095-06014	BOLT	1		
38	63D-48538-00	CLAMP, CABLE 1	1		
39	90468-10005	CLIP	1		
40	69W-26301-00	THROTTLE CABLE ASSY	1		
41	6X4-48538-10	CLAMP, CABLE 1	1		
42	6X4-26367-00	PROTECTOR	1		
43	97095-06014	BOLT	1		
44	63D-48538-00	CLAMP, CABLE 1	1		
45	90468-10005	CLIP	1		
46	6X4-42159-00	STAY	1		
47	6X4-44159-00-4D	HANDLE, GEAR SHIFT	1		
48	6X4-44173-00	LEVER, SHIFT CONTROL	1		
49	97780-60920	SCREW, TAPPING	2		
50	6G8-44191-00	INDICATOR, SHIFT	1		
51	90386-26MA3	BUSH	2		
52	6X4-42131-10	COVER, HANDLE STEERING	1		
53	97885-06040	SCREW, PAN HEAD	1		
54	92995-06600	WASHER	1		

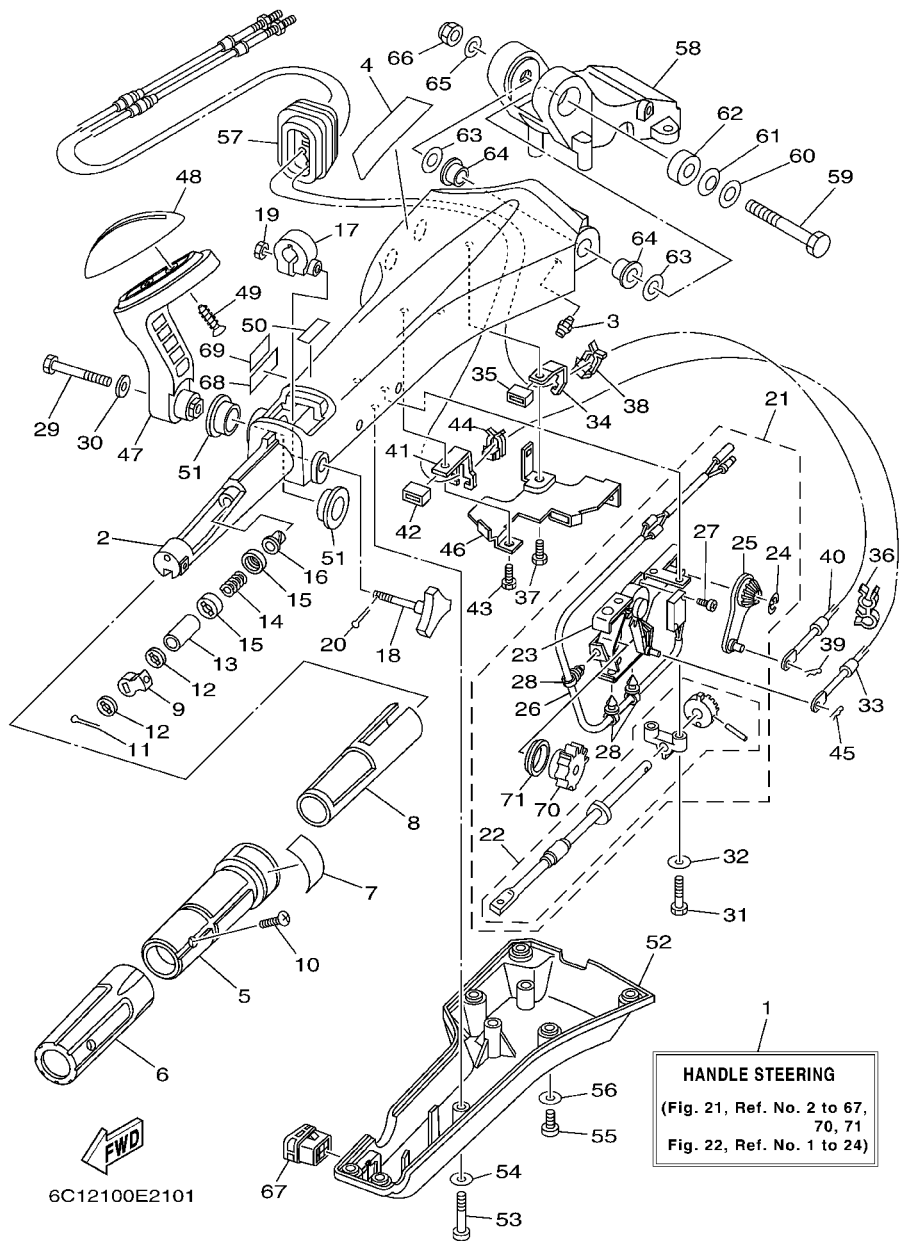

FIG. 21 STEERING 1

REF. NO.	PART NO.	DESCRIPTION	EHT	ET	REMARKS
55	97885-06016	SCREW, PAN HEAD	6		
56	92995-06600	WASHER	6		
57	6X4-42725-00	GROMMET	1		
58	63D-42121-22-4D	BRACKET	1		
59	90101-12014	BOLT	1		
60	92990-12200	WASHER, PLAIN	1		
61	90206-12M22	WASHER, WAVE	1		
62	90387-12M02	COLLAR	1		
63	90201-12035	WASHER, PLATE	2		
64	90386-12003	BUSH	2		
65	92990-12600	WASHER, PLATE	1		
66	90185-12M12	NUT, SELF-LOCKING	1		
67	6X4-42728-10	CAP	1		
68	6E0-83627-41	LABEL, CAUTION 7	1		
69	6E0-83627-51	LABEL, CAUTION 7	1		FOR CAN
70	6X4-47731-00	.GEAR, DRIVE	1		
71	6X4-44132-00	.BUSHING	1		

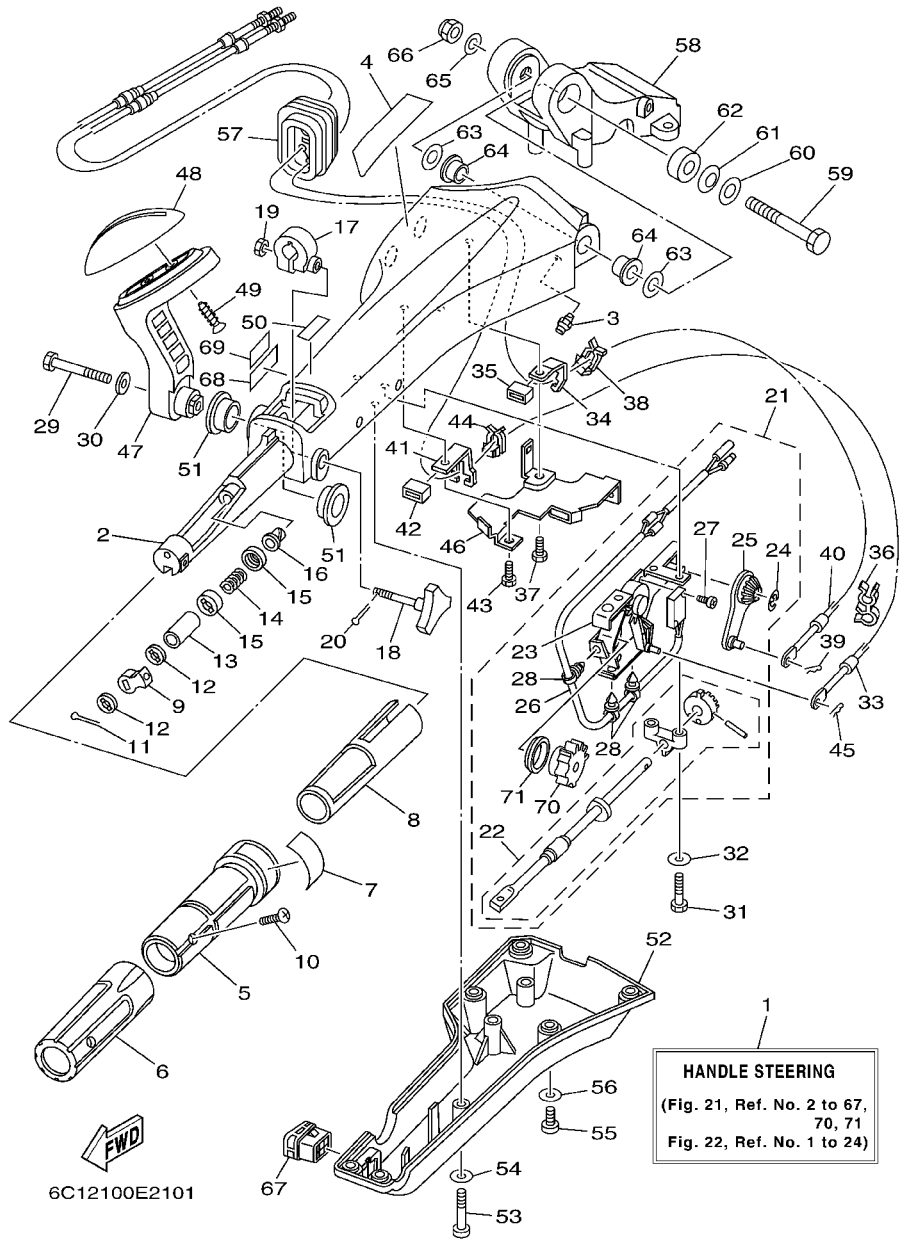
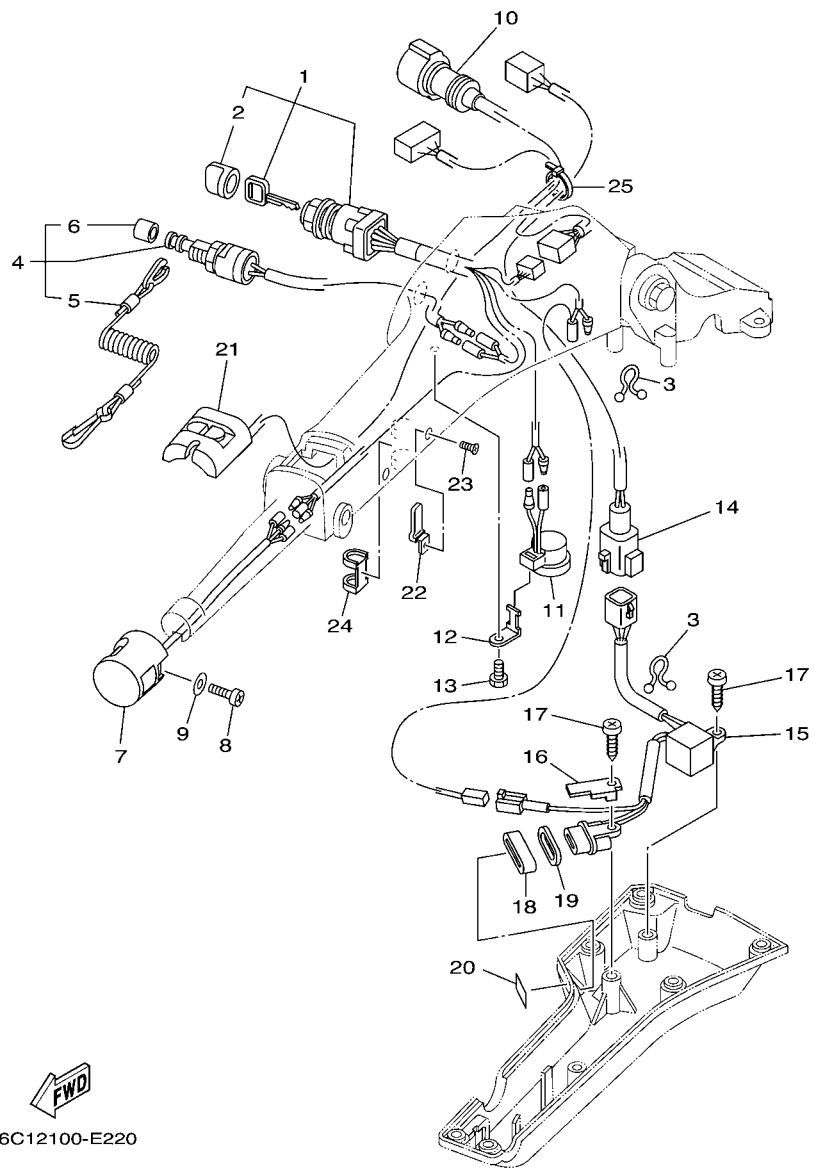

FIG. 22 STEERING 2



6C12100-E220

REF. NO.	PART NO.	DESCRIPTION	EHT	ET	REMARKS
1	6X4-82510-10	MAIN SWITCH ASSY	1		
2	676-82577-00	.CAP, KEY	1		
3	90464-08M07	CLAMP	2		
4	69W-82575-00	ENGINE STOP SWITCH ASSY	1		
5	682-82556-00	.STOPPER	1		
6	689-8257Y-00	.CAP	1		
7	6X4-82563-00	TRIM & TILT SWITCH ASSY	1		
8	97880-06016	SCREW, PAN HEAD	1		
9	92990-06600	WASHER, PLATE	1		
10	6X4-82586-10	EXT., WIRE HARNESS (L: 950MM)	1		
11	6X4-83383-00	BUZZER	1		
12	6X4-83386-00	STAY, BUZZER	1		
13	97095-06014	BOLT	1		
14	6X4-83653-20	WIRE, LEAD (L: 700MM)	1		
15	6C5-84301-00	PILOT LIGHT ASSY 1	1		
16	6X4-44114-00	STOPPER	1		
17	97780-60620	SCREW, TAPPING	2		
18	6X4-42727-00	GROMMET	1		
19	6H4-83589-00	GASKET	1		
20	6X4-85415-00	MARK, SIGNAL LAMP	1		
21	6X4-81860-00	SWITCH ASSY	1		
22	6X4-44554-00	PLATE	2		
23	90152-04015	SCREW, COUNTERSUNK	2		
24	6X4-42724-00	GROMMET	1		
25	90465-13M36	CLAMP	1		

FIG. 23 STEERING FRICTION

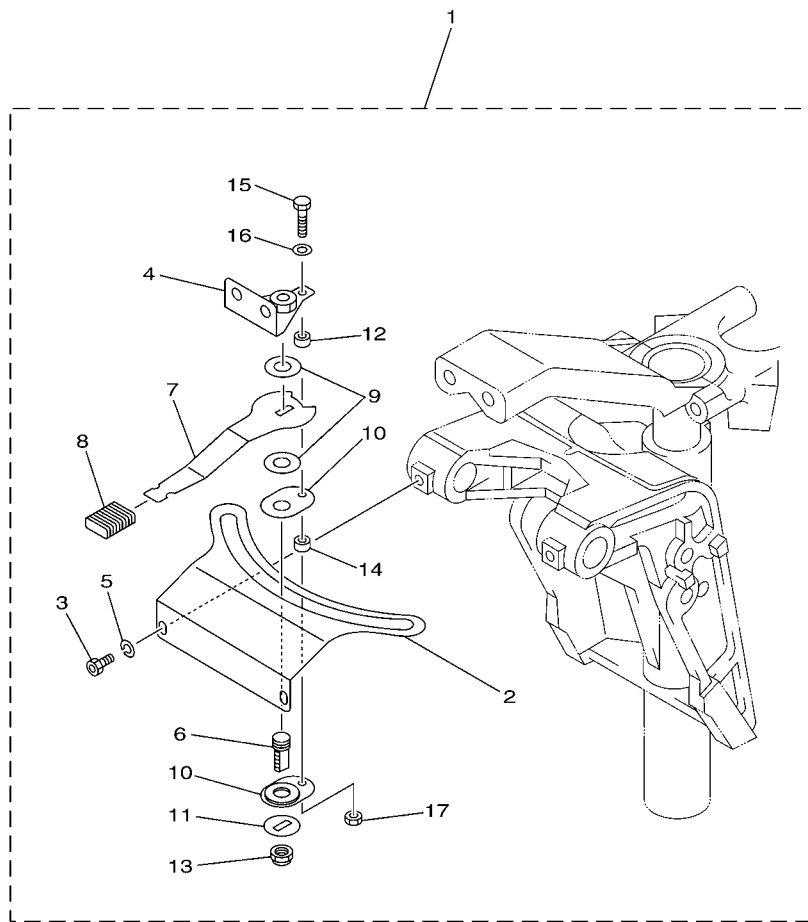

REF. NO.	PART NO.	DESCRIPTION	EHT	ET				REMARKS
1	6C5-42508-00	STEERING FRICTION ASSY	1					
2	6C5-42527-00	.PLATE, FRICTION	1					
3	90109-06M88	.BOLT	2					
4	67C-42525-00	.PLATE, FRICTION	1					
5	92990-06100	.WASHER, SPRING	2					
6	67C-42562-00	.SHAFT, STEERING LOCK	1					
7	67C-42561-00	.KNOB, STEERING LOCK	1					
8	689-43633-00	.COVER, TILT LEVER	1					
9	90202-10M56	.WASHER, PLATE	2					
10	65W-42528-00	.PLATE, FRICTION	2					
11	90209-10M26	.WASHER	1					
12	90387-05M05	.COLLAR	1					
13	90185-10M14	.NUT, SELF-LOCKING	1					
14	90387-05M11	.COLLAR	1					
15	97095-05020	.BOLT	1					
16	92995-05600	.WASHER	1					
17	95380-05600	.NUT	1					

 6C11010-D220

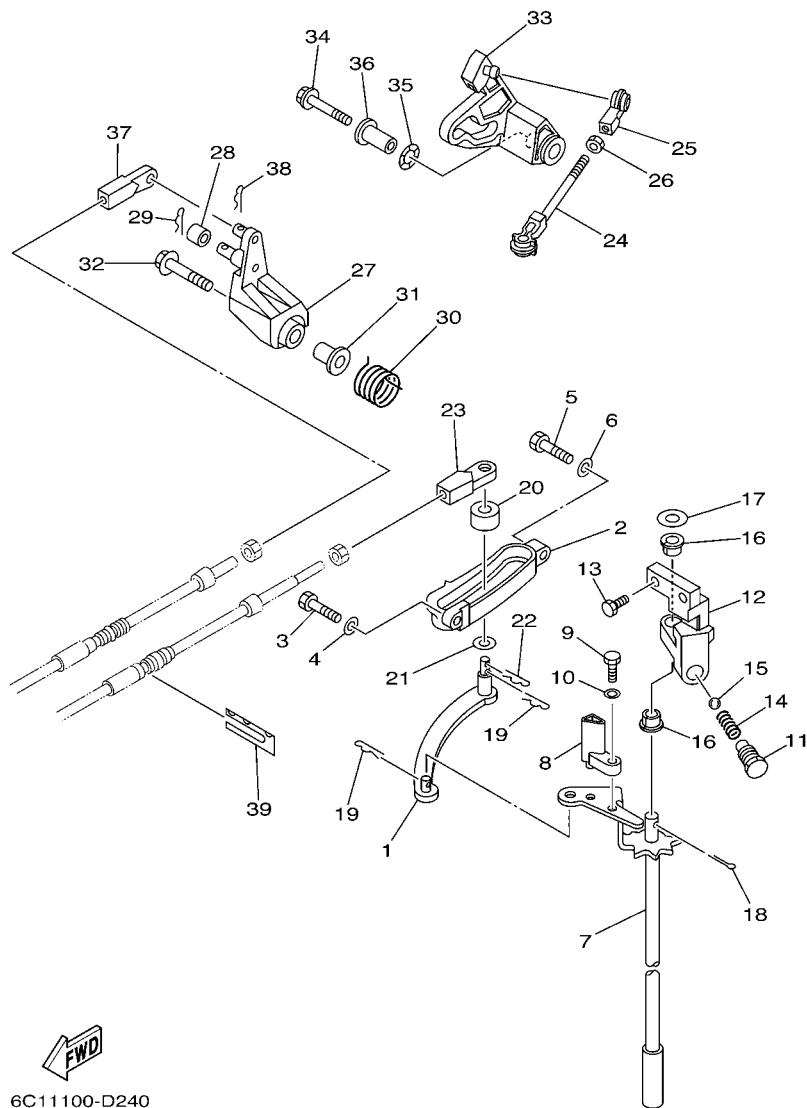

6C11100-D240

FIG. 24 CONTROL

REF. NO.	PART NO.	DESCRIPTION	EHT	ET	REMARKS
1	69W-44121-00	LEVER, SHIFT ROD	1	1	
2	62Y-44117-01-4D	BRACKET	1	1	
3	97095-06020	BOLT	1	1	
4	92995-06600	WASHER	1	1	
5	97095-06025	BOLT	1	1	
6	92995-06600	WASHER	1	1	
7	6C5-44120-01	HANDLE GEAR SHIFT ASSY	1	1	L (20.7")
8	6C5-44122-00	BUSHING, SHIFT ROD LEVER	1	1	EXCEPT F60TJR
9	97095-05014	BOLT	1	1	EXCEPT F60TJR
10	92995-05600	WASHER	1	1	EXCEPT F60TJR
11	62Y-42715-01	BUSHING	1	1	
12	62Y-44118-00	BRACKET	1	1	
13	97095-06020	BOLT	2	2	
14	90501-12082	SPRING, COMPRESSION	1	1	
15	93501-04M02	BALL	1	1	
16	90386-90M90	BUSH	2	2	
17	90201-10M20	WASHER, PLATE	1	1	
18	91490-20015	PIN, COTTER	1	1	
19	90468-18008	CLIP	2	2	
20	688-44122-00	BUSHING, SHIFT ROD LEVER	1	1	
21	90202-07M07	WASHER, PLATE	1	1	
22	90468-18008	CLIP	1	1	
23	69W-48344-00	CABLE END, REMOTE CONTROL	1	1	
24	688-41211-01	LINK, ACCEL.	1	1	
25	6H4-41237-00	JOINT, LINK	1	1	
26	95380-05700	NUT	1	1	
27	62Y-42154-00	LEVER, THROTTLE CONTROL	1	1	

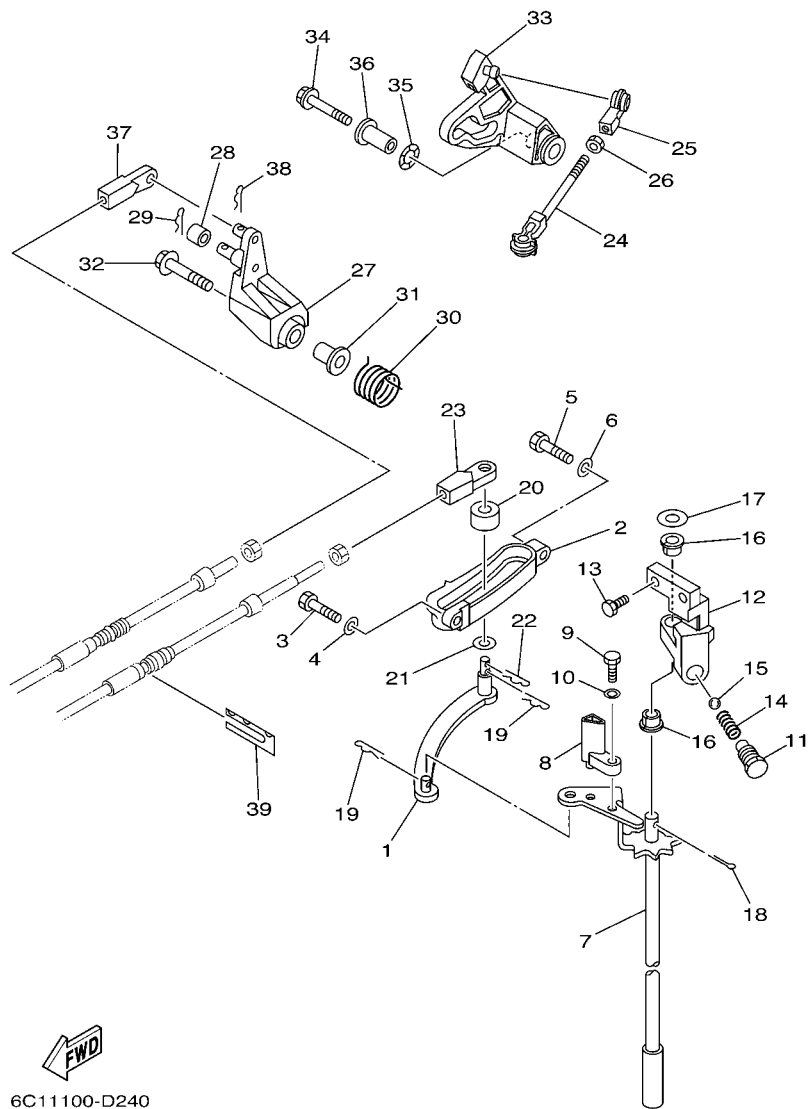

6C11100-D240

FIG. 24 CONTROL

REF. NO.	PART NO.	DESCRIPTION	EHT	ET	REMARKS
28	6C5-42171-00	BUSHING	1	1	
29	91490-16010	PIN, COTTER	1	1	
30	62Y-44135-00	SPRING	1	1	
31	90387-06M45	COLLAR	1	1	
32	90119-06106	BOLT, WITH WASHER	1	1	
33	6C5-42335-00	LEVER, ACCEL. CONTROL	1	1	
34	95895-06035	BOLT, FLANGE	1	1	
35	90206-10M04	WASHER, WAVE	1	1	
36	90387-06M82	COLLAR	1	1	
37	69W-48344-00	CABLE END, REMOTE CONTROL	1	1	
38	90468-18008	CLIP	1	1	
39	62Y-48538-00	CLAMP, CABLE 1	1	1	

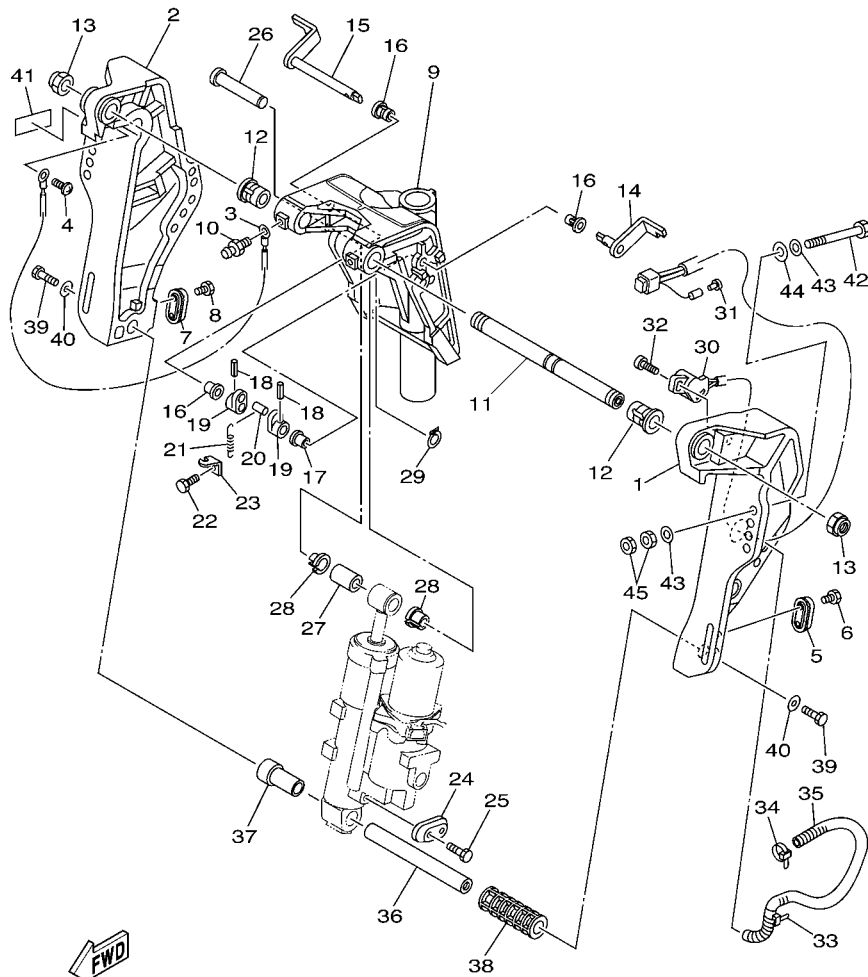

6C11100-D250

FIG. 25 BRACKET 1

REF. NO.	PART NO.	DESCRIPTION	EHT	ET				REMARKS
1	6C5-43111-00-4D	BRACKET, CLAMP 1	1	1				
2	6C5-43112-00-4D	BRACKET, CLAMP 2	1	1				
3	6E5-82148-00	WIRE, LEAD 4	1	1				
4	97885-06008	SCREW, PAN HEAD	1	1				
5	65W-45251-00	ANODE	1	1				
6	90101-06020	BOLT	2	2				
7	65W-45251-00	ANODE	1	1				
8	90101-06020	BOLT	2	2				
9	6C5-43311-00-4D	BRACKET, SWIVEL 1	1	1				
10	93700-06M03	NIPPLE, GREASE	1					
	93700-06M03	NIPPLE, GREASE		3				
11	63D-43131-01	BOLT, CLAMP BRACKET	1	1				
12	90386-22MA4	BUSH	2	2				
13	90185-22M11	NUT, SELF-LOCKING	2	2				
14	6C5-43181-00	LEVER, TILT STOP	1	1				
15	6C5-43185-00	LEVER, TILT STOP	1	1				
16	90386-10M16	BUSH	3	3				
17	90386-10025	BUSH	1	1				
18	91690-30020	PIN, SPRING	2	2				
19	6G5-43148-00	COLLAR, DISTANCE	2	2				
20	90249-06M19	PIN	1	1				
21	90506-14M24	SPRING, TENSION	1	1				
22	97095-06010	BOLT	1	1				
23	6G5-43144-00	HOOK, SPRING	1	1				
24	65W-45251-00	ANODE	1	1				
25	90101-06020	BOLT	2	2				
26	6E5-43126-02	PIN, UPPER SHOCK MOUNT	1	1				

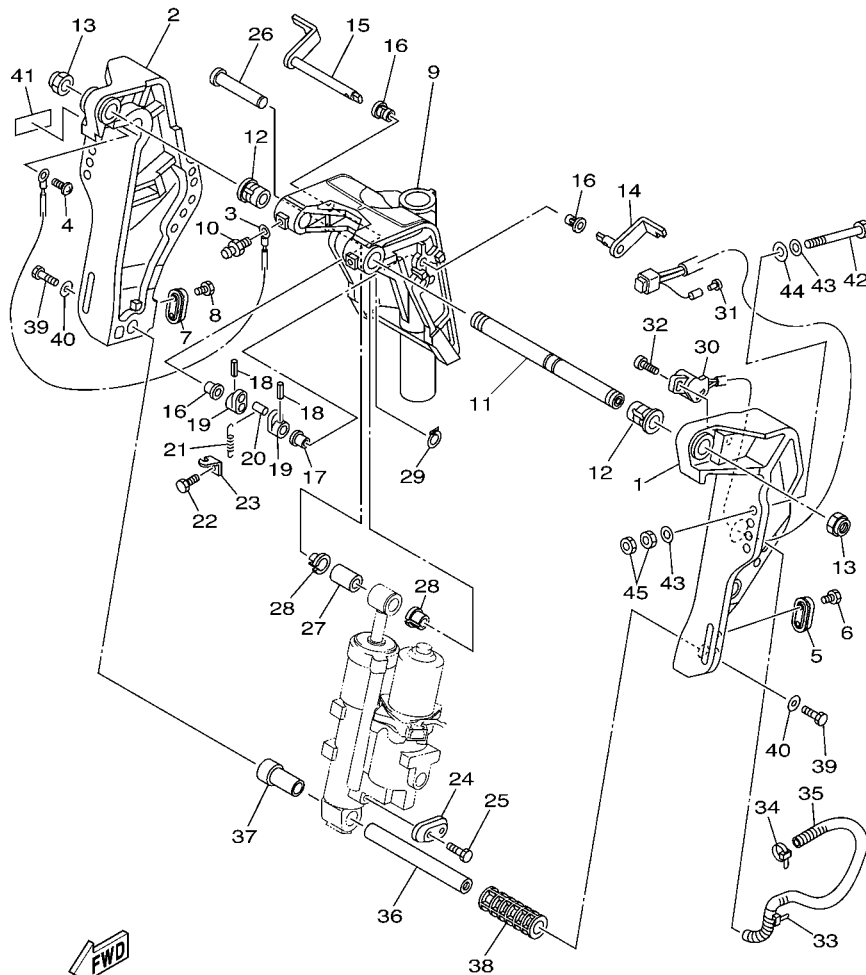

6C11100-D250

FIG. 25 BRACKET 1

REF. NO.	PART NO.	DESCRIPTION	EHT	ET	REMARKS
27	90386-18M92	BUSH	1	1	
28	90386-18M35	BUSH	2	2	
29	93410-18M02	CIRCLIP	1	1	
30	63D-83672-10	TRIM SENDER	1	1	FOR USA,CAN
	63D-83672-01	TRIM SENDER		1	FOR OCE
31	703-82119-00	COVER, LEAD WIRE		1	FOR OCE
32	97885-06016	SCREW, PAN HEAD	2	2	EHT-FOR CAN
33	90464-76001	CLAMP	1	1	
34	90465-11M10	CLAMP	1	1	EHT-FOR CAN
35	90447-13010	HOSE, WITH SPRING	1	1	FOR OCE,F60TJR
	90447-19009	HOSE, WITH SPRING	1	1	EXCEPT OCE,F60TJR
36	6C5-43818-00	PIN, LOWER SHOCK MOUNT	1	1	
37	6C5-43833-00	PIPE	1	1	
38	6C5-43834-00	PIPE	1	1	
39	97080-08020	BOLT	2	2	
40	90201-08M14	WASHER, PLATE	2	2	
41	63V-82377-50	LABEL (SPARK,IGNITION)	1	1	FOR CAN
42	90101-12M65	BOLT	4	4	
43	92995-12200	WASHER	8	8	
44	90201-12426	WASHER, PLATE	4	4	
45	95380-12600	NUT	8	8	

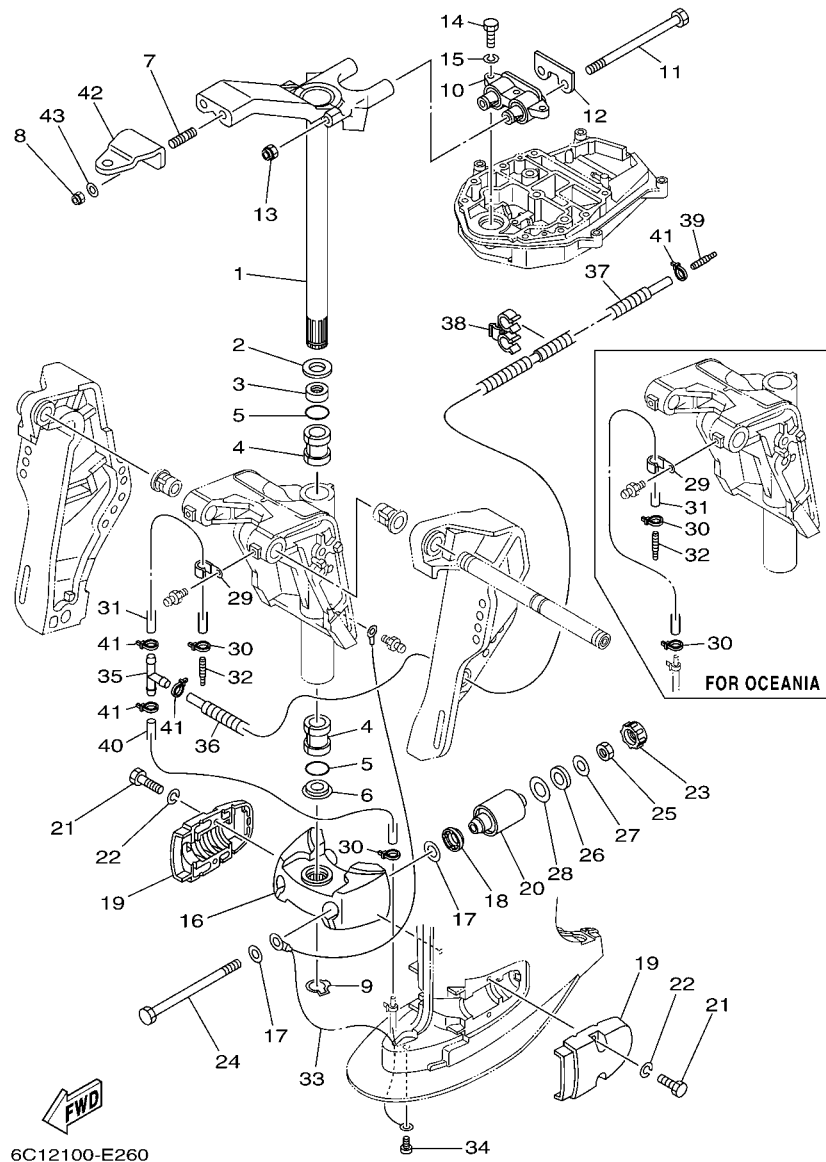

FIG. 26 BRACKET 2

REF. NO.	PART NO.	DESCRIPTION	EHT	ET	REMARKS
1	69W-42510-01-4D	STEERING BRACKET ASSY	1	1	
2	90201-30M00	WASHER, PLATE	1	1	
3	90386-30M78	BUSH	1	1	
4	90386-30M77	BUSH	2	2	
5	93210-29M94	O-RING	2	2	
6	90386-30M60	BUSH	1	1	
7	90116-10M28	BOLT, STUD	2	2	
8	90185-10051	NUT, SELF-LOCKING	2	2	
9	93410-28M06	CIRCLIP	1	1	
10	69W-44514-00-4D	MOUNT DAMPER, UPPER SIDE	1	1	
11	90101-08M15	BOLT	2	2	
12	69W-44526-01	PLATE	1	1	
13	90185-08045	NUT, SELF-LOCKING	2	2	
14	97075-08030	BOLT	3	3	
15	92995-08100	WASHER	3	3	
16	6C5-44551-00-4D	HOUSING, LOWER MOUNT RUBBER	1	1	
17	90201-12M16	WASHER, PLATE	4	4	
18	6C5-43885-00	GROMMET	2	2	
19	6C5-44552-00-4D	HOUSING, LOWER MOUNT RUBBER	2	2	
20	69W-44555-00-4D	MOUNT DAMPER, LOWER SIDE	2	2	
21	97075-08030	BOLT	4	4	
22	92995-08100	WASHER	4	4	
23	6C5-44575-00	DAMPER, LOWER MOUNT RUBBER	2	2	
24	90109-12MA3	BOLT	2	2	
25	95380-12700	NUT	2	2	
26	90202-21100	WASHER, PLATE	2	2	
27	90201-13M19	WASHER, PLATE	2	2	

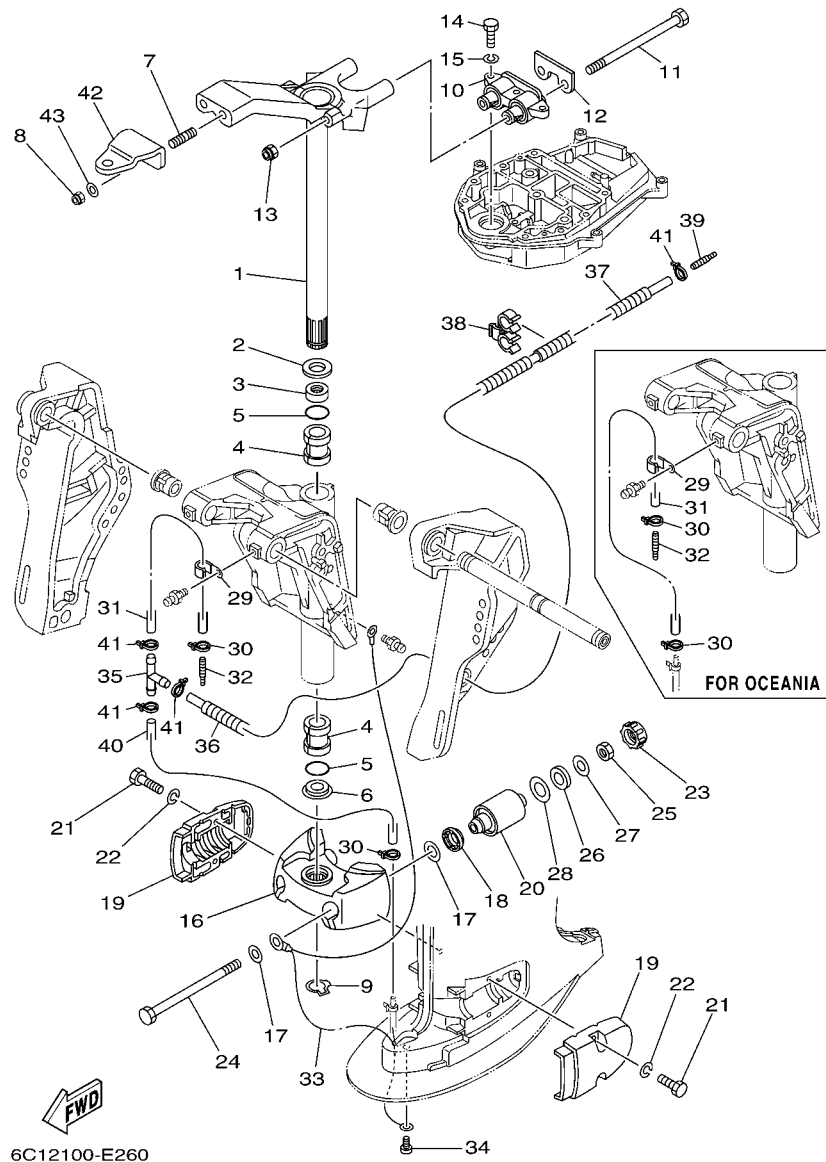
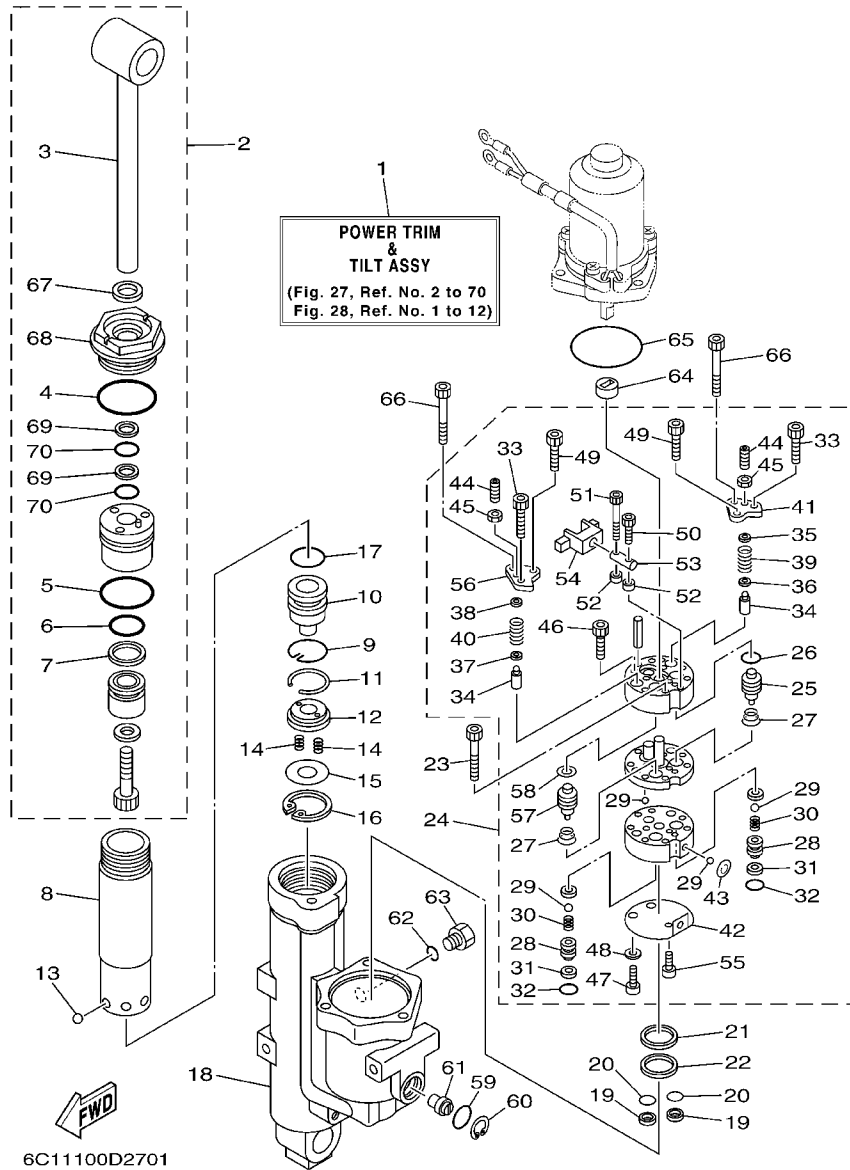

FIG. 26 BRACKET 2

REF. NO.	PART NO.	DESCRIPTION	EHT	ET	REMARKS
28	90201-22M05	WASHER, PLATE	2	2	
29	90465-06M86	CLAMP	1	1	EXCEPT F60TJR
30	90465-11M10	CLAMP	2	2	EXCEPT F60TJR
31	90445-07M53	HOSE (L700)	1	1	FOR OCE
	90445-07MF2	HOSE (L250)	1	1	EXCEPT OCE,F60TJR
32	6E5-83558-00	END, NIPPLE	1	1	EXCEPT F60TJR
33	67C-82127-10	WIRE, LEAD 2	1	1	
34	97885-06008	SCREW, PAN HEAD	1	1	
35	90413-05014	WAY 3	1	1	EXCEPT OCE,F60TJR
36	6C5-44385-00	HOSE, WATER 1	1	1	EXCEPT OCE,F60TJR
37	90447-07001	HOSE, WITH SPRING (L400)	1	1	EXCEPT OCE,F60TJR
38	90464-10006	CLAMP	1	1	EXCEPT OCE,F60TJR
39	6E5-83558-00	END, NIPPLE	1	1	EXCEPT OCE,F60TJR
40	90445-07M30	HOSE (L450)	1	1	EXCEPT OCE,F60TJR
41	90465-11M10	CLAMP	4	4	EXCEPT OCE,F60TJR
42	65W-48511-00	HOOK, STEERING	1		
43	90201-10120	WASHER, PLATE		2	



6C11100D2701

FIG. 27 POWER TRIM & TILT ASSY 1

REF. NO.	PART NO.	DESCRIPTION	EHT	ET	REMARKS
1	6C5-43800-01-8D	POWER TRIM & TILT ASSY	1	1	
2	6C5-43810-00	TILT PISTON SUB ASSY	1	1	
3	6C5-43801-00	.ROD	1	1	
4	62Y-43863-00	.O-RING	1	1	
5	6C5-43862-00	.O-RING	1	1	
6	6C5-43861-00	.O-RING	1	1	
7	6C5-43871-00	.RING, BACK UP	1	1	
8	6C5-22471-00	CYLINDER, SHOCK ABSORBER	1	1	
9	6C5-43875-00	RING, SNAP	1	1	
10	6C5-4381B-00	FREE PISTON SUB ASSY	1	1	
11	93450-32116	CIRCLIP	1	1	
12	6C5-43899-00	PLATE STOPPER	1	1	
13	93503-16003	BALL	6	6	
14	62X-4384H-00	SPRING	2	2	
15	6C5-22435-00	PLATE, VALVE 2	1	1	
16	99009-32500	CIRCLIP	1	1	
17	6C5-43861-00	O-RING	1	1	
18	6C5-4380K-00	CYLINDER, TILT SUB ASSY	1	1	
19	6C5-43817-10	FILTER 2	2	2	
20	69J-4389J-00	O-RING	2	2	
21	6C5-43816-00	FILTER 1	1	1	
22	6C5-4380G-00	PLATE	1	1	
23	91312-05045	BOLT	2	2	
24	6C5-43830-00	GEAR PUMP ASSY	1	1	
25	6C6-43841-00	.PISTON, SHUTTLE	1	1	
26	6H1-43883-00	.O-RING	1	1	
27	6C6-43894-00	.SPRING, SHUTTLE RETURN	2	2	

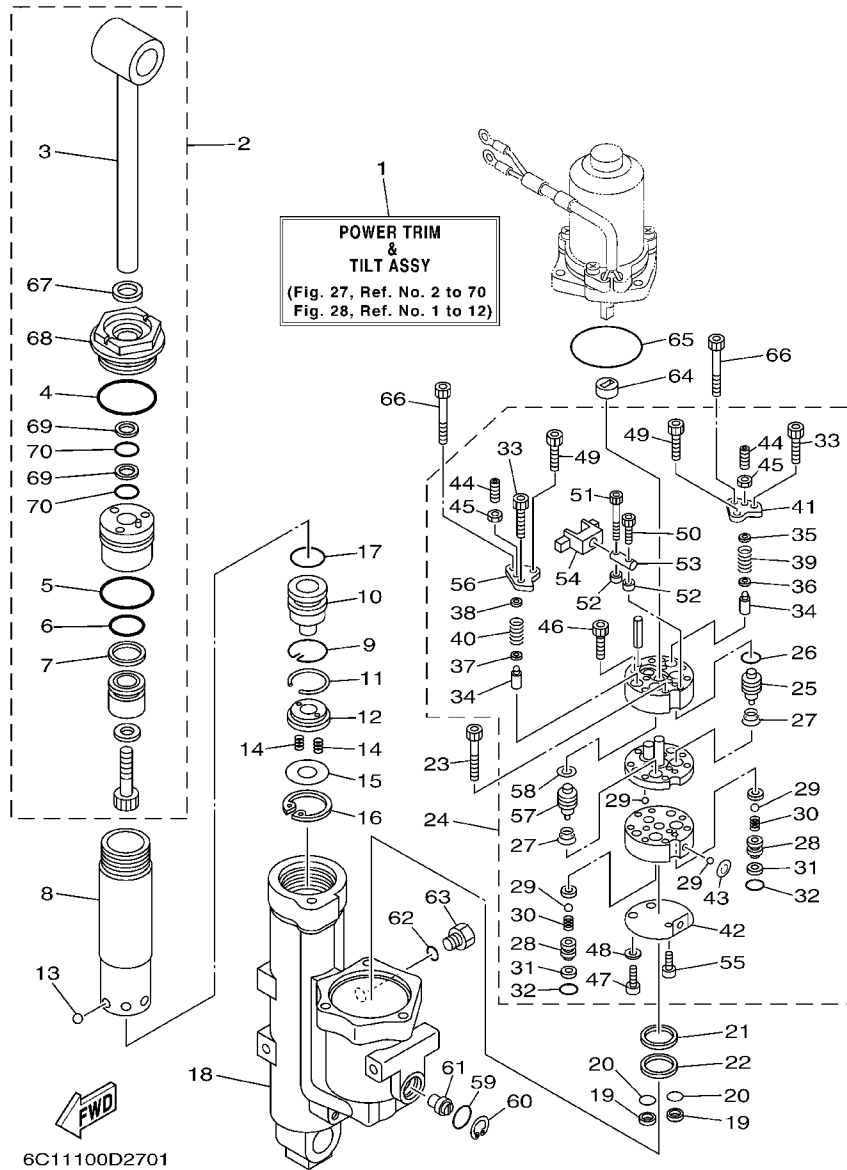

FIG. 27 POWER TRIM & TILT ASSY 1

REF. NO.	PART NO.	DESCRIPTION	EHT	ET	REMARKS
28	6C6-4382E-00	.ADAPTOR 2	2	2	
29	93505-32038	.BALL	6	6	
30	6C6-43853-00	.SPRING, MAIN VALVE	2	2	
31	6C6-4387G-00	.WASHER	2	2	
32	69J-4389J-00	.O-RING	2	2	
33	91312-05030	.BOLT	2	2	
34	6C5-43851-00	.SEAT, RELIEF VALVE	2	2	
35	6C5-4381K-00	.HOLDER	1	1	
36	6C5-43893-00	.WASHER	1	1	
37	6C6-43893-00	.WASHER	1	1	
38	6C6-4381K-00	.HOLDER	1	1	
39	6C5-43855-00	.SPRING, UP RELIEF	1	1	
40	6C5-43856-00	.SPRING, DOWN RELIEF	1	1	
41	6C5-4382K-00	.CAP, RELIEF VALVE	1	1	
42	6C5-43895-00	.SEAT, RELIEF VALVE	1	1	
43	6C5-43854-00	.SPRING, MANUAL RELEASE	1	1	
44	92A08-03110	.SCREW SET	2	2	
45	95302-03600	.NUT	2	2	
46	91312-05025	.BOLT	2	2	
47	6C6-43878-00	.BOLT, SOCKET	2	2	
48	62Y-4387G-00	.WASHER	2	2	
49	91312-04030	.BOLT	2	2	
50	91312-03016	.BOLT	1	1	
51	6C6-4388E-00	.PLUG, TAPER SCREW	1	1	
52	6C6-4388F-00	.SPACER	2	2	
53	6C6-4386G-00	.PIN, STRAIGHT 2	1	1	
54	6C6-4386E-00	.LEVER 1	1	1	

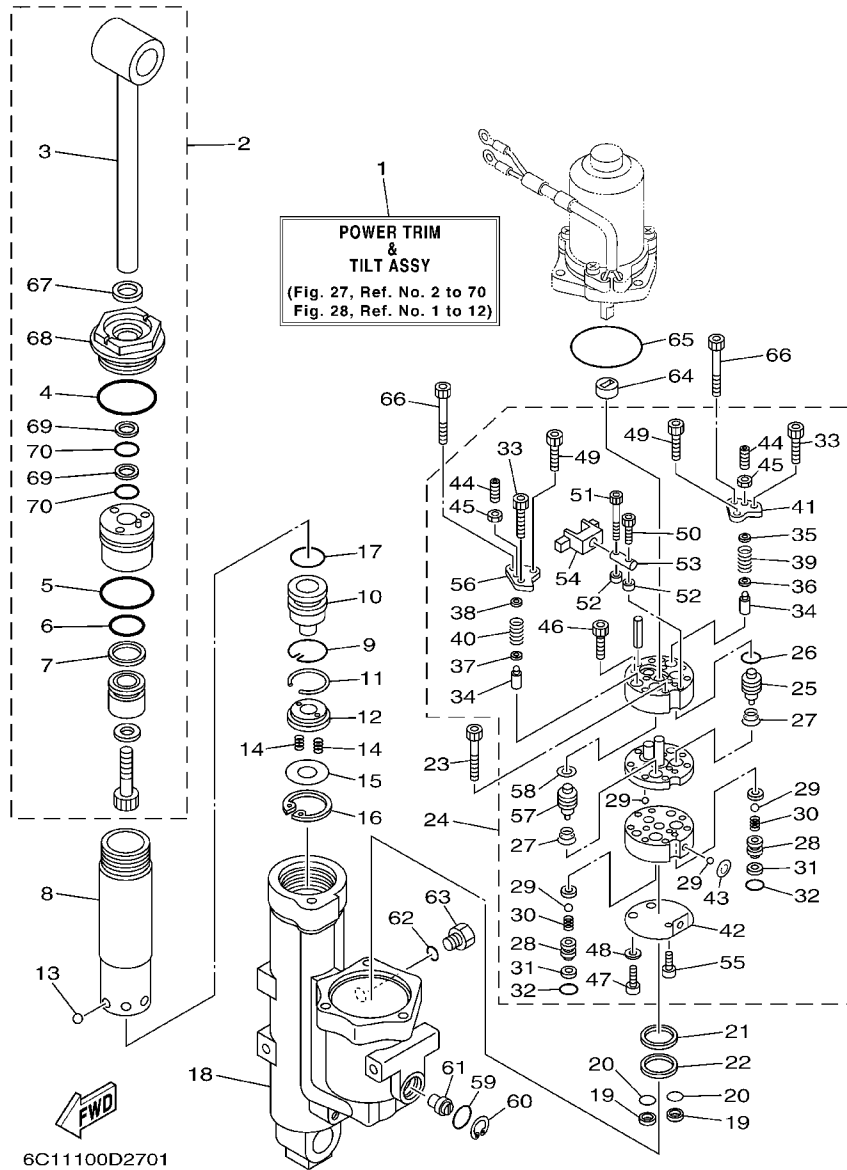
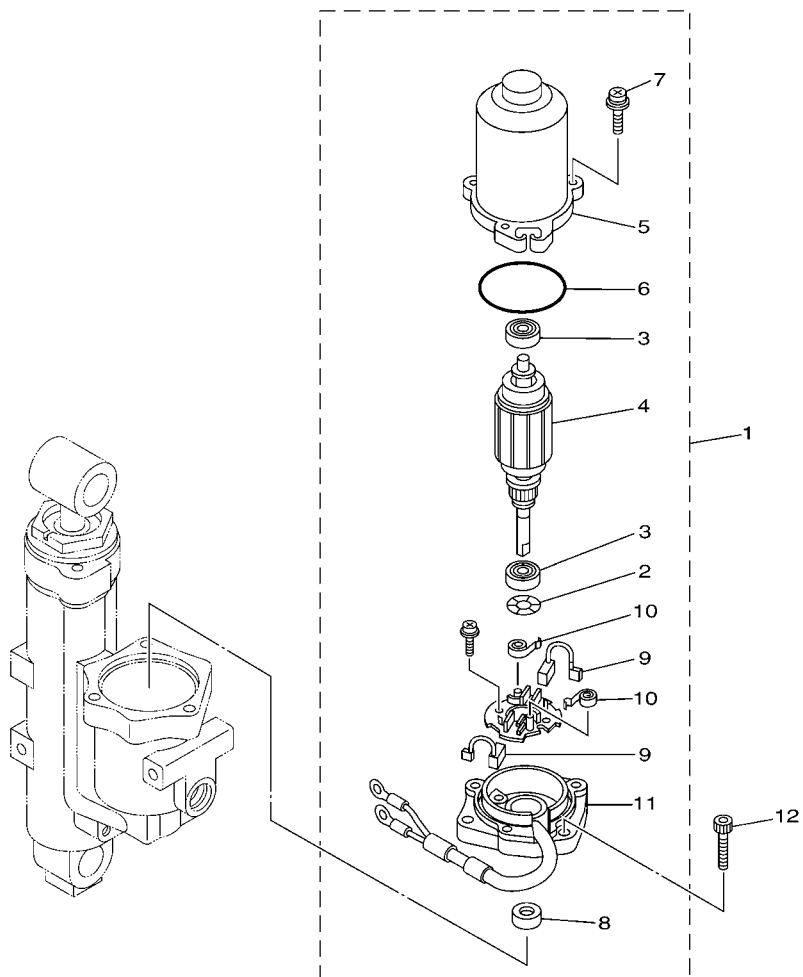

FIG. 27 POWER TRIM & TILT ASSY 1

REF. NO.	PART NO.	DESCRIPTION	EHT	ET	REMARKS
55	91312-03005	.BOLT	1	1	
56	6C5-4382L-00	.CAP, RELIEF VALVE	1	1	
57	6C5-43841-00	.PISTON, SHUTTLE	1	1	
58	6C5-43872-00	.RING, BACK UP	1	1	
59	93210-18397	O-RING	1	1	
60	6H1-43875-00	RING, SNAP	1	1	
61	6C5-43845-00	SCREW, MANUAL RELEASE	1	1	
62	93210-09165	O-RING	1	1	
63	6H1-43829-00	PLUG, RESERVOIR	1	1	
64	6C5-43831-00	CONNECTOR, SHAFT	1	1	
65	93210-64488	O-RING	1	1	
66	91312-05050	BOLT	2	2	
67	62Y-43822-00	.SEAL, TRIM DUST	1	1	
68	6C5-43821-00	.SCREW, TRIM CYLINDER END	1	1	
69	62X-43872-00	.RING, BACK UP	2	2	
70	6C5-43863-00	.O-RING	2	2	

FIG. 28 POWER TRIM & TILT ASSY 2



REF. NO.	PART NO.	DESCRIPTION	EHT	ET	REMARKS
1	6C5-43880-01	MOTOR ASSY	1	1	
2	90206-08N51	.WASHER, WAVE	1	1	
3	93399-999T8	.BEARING	2	2	
4	6C5-43805-00	.ARMATURE ASSY	1	1	
5	6C5-43804-01	.STATOR ASSY	1	1	
6	6C5-43869-00	.O-RING	1	1	
7	6C5-43879-00	.SCREW, WITH WASHER	3	3	
8	6C5-43882-00	.OIL SEAL	1	1	
9	6C5-43891-00	.BRUSH 1	2	2	
10	6C5-4386K-00	.SPRING, BRUSH	2	2	
11	6C5-43881-01	.FRAME, END	1	1	
12	62X-43888-00	BOLT, SOCKET	3	3	

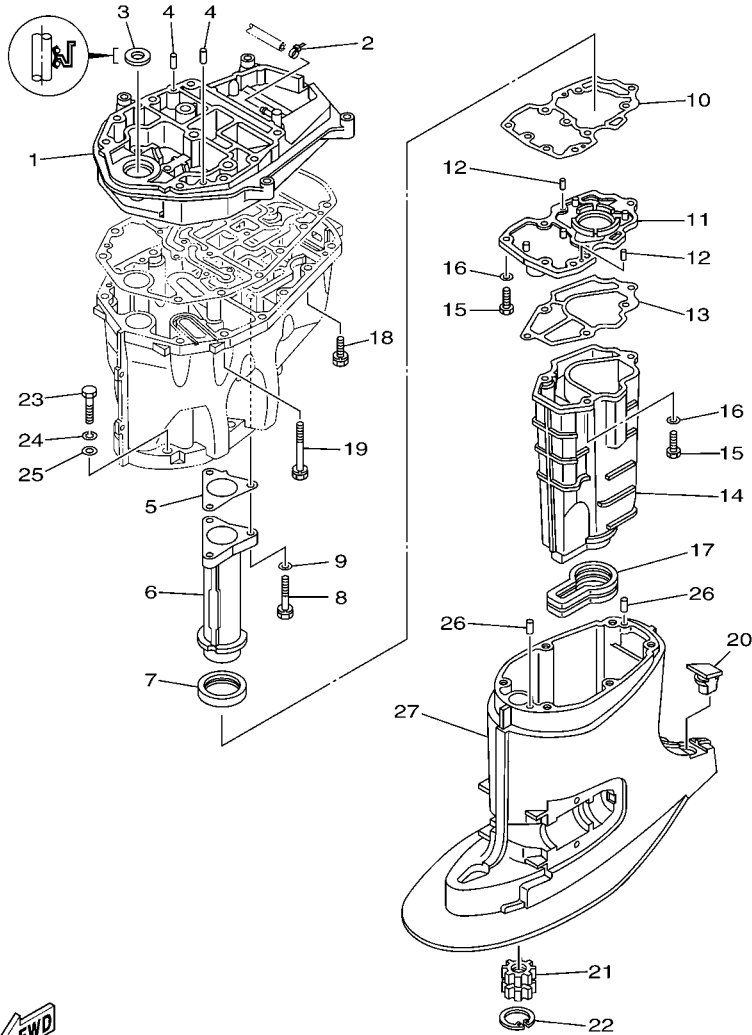

6C11010-D280



6C11010-D290

FIG. 29 UPPER CASING

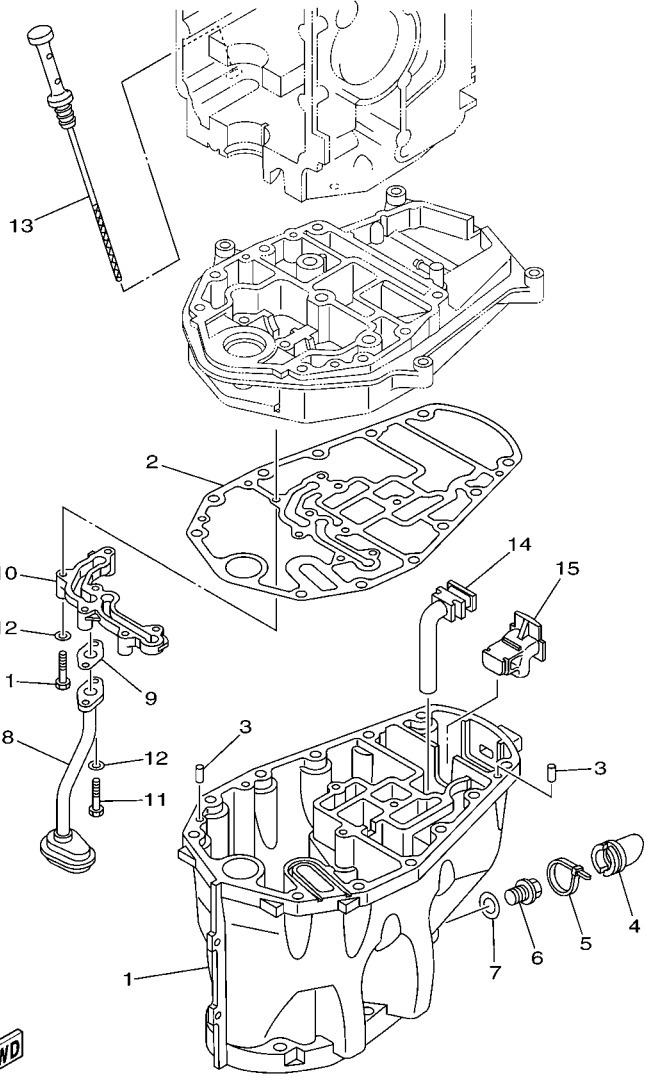
REF. NO.	PART NO.	DESCRIPTION	EHT	ET				REMARKS
1	6C5-41137-00-94	GUIDE, EXHAUST	1	1				
2	90465-11M10	CLAMP	1	1				
3	93103-18011	OIL SEAL	1	1				
4	93608-12M05	PIN, DOWEL	2	2				
5	6C5-41133-00	GASKET, EXHAUST MANIFOLD 1	1	1				
6	6C5-41131-00-5B	MANIFOLD, EXT. 1	1	1				
7	6C5-46132-00	GASKET 1	1	1				
8	90119-06120	BOLT, WITH WASHER	3	3				
9	90201-06015	WASHER, PLATE	3	3				
10	6C5-41134-00	GASKET, EXHAUST MANIFOLD	1	1				
11	6C5-45181-00-5B	PLATE	1	1				
12	93604-10M03	PIN, DOWEL	2	2				
13	6C5-41135-00	GASKET, EXHAUST MANIFOLD	1	1				
14	6C5-14711-00-5B	MUFFLER 1	1	1				
15	97075-06025	BOLT	6	6				
16	92995-06600	WASHER	6	6				
17	6C5-45123-00	GASKET, MUFFLER	1	1				
18	90119-08M79	BOLT, WITH WASHER	4	4				
19	90119-08M82	BOLT, WITH WASHER	8	8				
20	6C5-45155-00	CAP	1	1				
21	69W-45318-00	BUSHING, DRIVE SHAFT	1	1				
22	93420-36M01	CIRCLIP	1	1				
23	97075-10045	BOLT	6	6				
24	92995-10100	WASHER	6	6				
25	92995-10600	WASHER	6	6				
26	93606-12019	PIN, DOWEL	2	2				
27	6C5-45111-00-4D	CASING, UPPER	1	1				



6C11010-D300

FIG. 30 OIL PAN

REF. NO.	PART NO.	DESCRIPTION	EHT	ET				REMARKS
1	6C5-15311-00-5B	OIL PAN	1	1				
2	6C5-15312-00	GASKET, OIL PAN	1	1				
3	93606-12019	PIN, DOWEL	2	2				
4	6C5-15316-00	DAMPER, ENGINE MOUNT 1	1	1				
5	90465-11M59	CLAMP	1	1				
6	90340-14M06	PLUG, STRAIGHT SCREW	1	1				
7	90430-14M09	GASKET	1	1				
8	6C5-13411-00	STRAINER, OIL	1	1				
9	6C5-13414-00	GASKET, STRAINER COVER	1	1				
10	6C5-15333-00	COVER	1	1				
11	97013-06030	BOLT	6	6				
12	92903-06600	WASHER, PLATE	6	6				
13	6C5-15362-00	PLUG, OIL LEVEL	1	1				
14	6C5-45135-01	PIPE	1	1				
15	6C5-45136-01	PIPE	1	1				

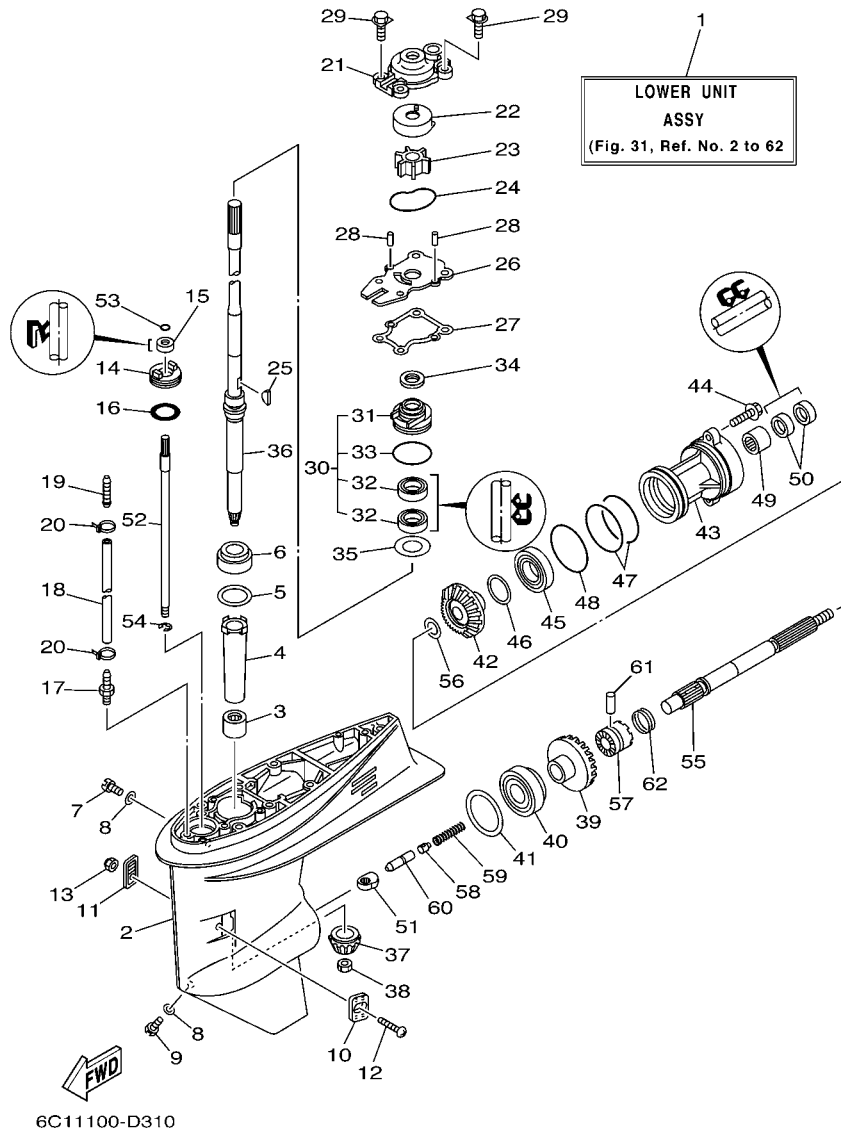

FIG. 31 LOWER CASING & DRIVE 1

REF. NO.	PART NO.	DESCRIPTION	EHT	ET		REMARKS
1	69W-45300-00-4D	LOWER UNIT ASSY	1	1		L (20.7")
2	69W-45301-00-4D	CASING, LOWER	1	1		
3	93315-32224	BEARING	1	1		
4	6H4-45536-00	SLEEVE, DRIVE SHAFT	1	1		
5	663-45587-01	SHIM (T:0.10MM)	1	1		UR
6	663-45587-10	SHIM (T:0.12MM)	1	1		UR
7	663-45587-20	SHIM (T:0.15MM)	1	1		UR
8	663-45587-30	SHIM (T:0.18MM)	1	1		UR
9	663-45587-40	SHIM (T:0.30MM)	1	1		UR
10	663-45587-50	SHIM (T:0.40MM)	1	1		UR
11	663-45587-60	SHIM (T:0.50MM)	1	1		UR
12	93332-00001	BEARING	1	1		
13	90340-08002	PLUG, STRAIGHT SCREW	1	1		
14	90430-08020	GASKET	2	2		
15	688-45341-10	PLUG, DRAIN	1	1		
16	63D-45214-00	COVER, WATER INLET 1	1	1		
17	63D-45215-00	COVER, WATER INLET 2	1	1		
18	90142-05M06	SCREW, COUNTERSUNK	1	1		
19	95380-05600	NUT	1	1		
20	63D-45321-00	PLATE	1	1		
21	93106-09014	OIL SEAL	1	1		
22	93210-33MG4	O-RING	1	1		
23	6E5-45378-00	NIPPLE, HOSE	1	1		
24	90445-07ME8	HOSE (L80)	1	1		L (20.7")
25	6E5-83558-10	END, NIPPLE	1	1		
26	90465-11M10	CLAMP	2	2		
27	63D-44311-00	HOUSING, WATER PUMP	1	1		

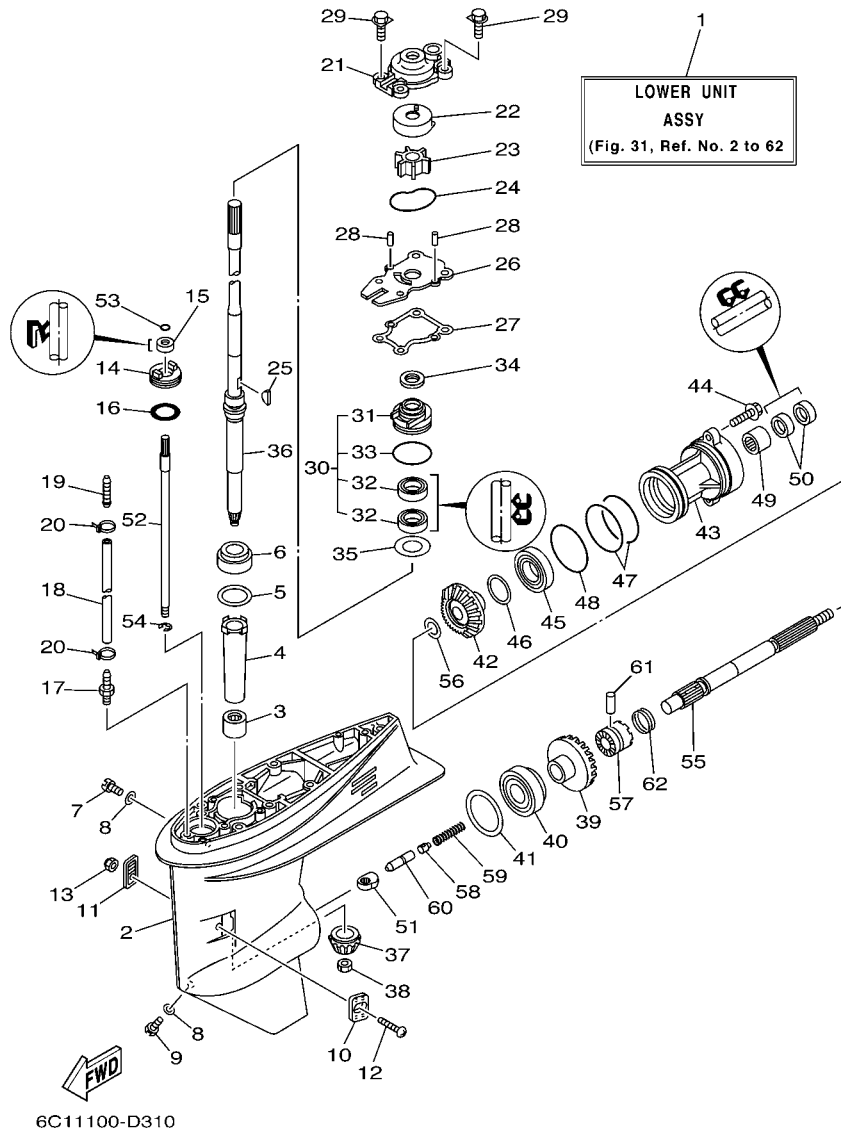

FIG. 31 LOWER CASING & DRIVE 1

REF. NO.	PART NO.	DESCRIPTION	EHT	ET	REMARKS
22	63D-44322-00	INSERT, CARTRIDGE	1	1	
23	6H3-44352-00	IMPELLER	1	1	
24	93210-59MG7	O-RING	1	1	
25	90280-03024	KEY, WOODRUFF	1	1	
26	63D-44323-00	OUTER PLATE, CARTRIDGE	1	1	
27	63D-44316-00	GASKET, WATER PUMP	1	1	
28	93604-08062	PIN, DOWEL	2	2	
29	90119-08M15	BOLT, WITH WASHER	4	4	
30	63D-W4434-00	WATER PUMP HOUSING ASSY	1	1	
31	63D-44341-00	.HOUSING, WATER PUMP	1	1	
32	93101-25M57	.OIL SEAL	2	2	
33	93210-48MG8	.O-RING	1	1	
34	63D-45344-00	COVER, OIL SEAL	1	1	
35	90201-27M00	WASHER, PLATE	1	1	
36	69W-45501-00	DRIVE SHAFT COMP.	1	1	L (20.7")
37	69W-45551-00	PINION (13T)	1	1	
38	90170-12138	NUT	1	1	
39	69W-45560-00	GEAR 1 (24T)	1	1	
40	93332-00092	BEARING	1	1	
41	663-45567-01	SHIM (T:0.10MM)	1	1	UR
	663-45567-10	SHIM (T:0.12MM)	1	1	UR
	663-45567-20	SHIM (T:0.15MM)	1	1	UR
	663-45567-30	SHIM (T:0.18MM)	1	1	UR
	663-45567-40	SHIM (T:0.30MM)	1	1	UR
	663-45567-50	SHIM (T:0.40MM)	1	1	UR
	663-45567-60	SHIM (T:0.50MM)	1	1	UR
42	62Y-45571-00	GEAR 2 (24T)	1	1	

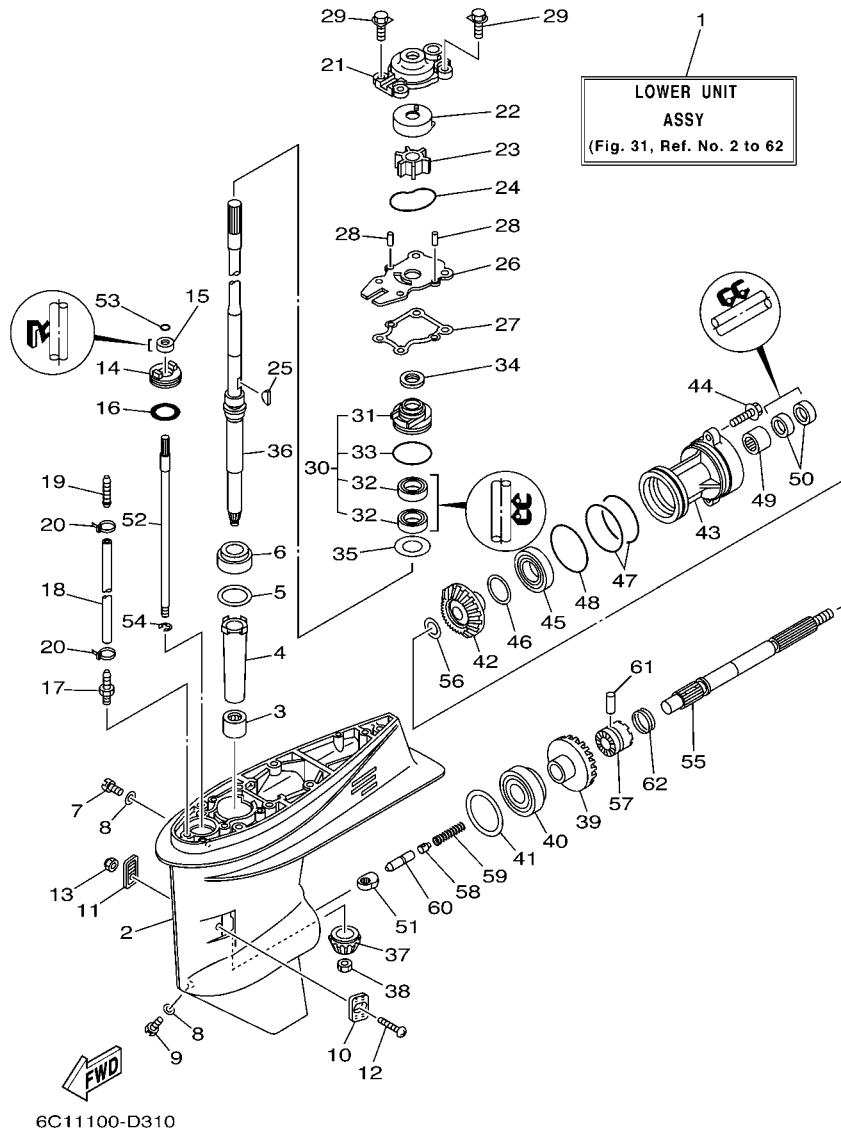
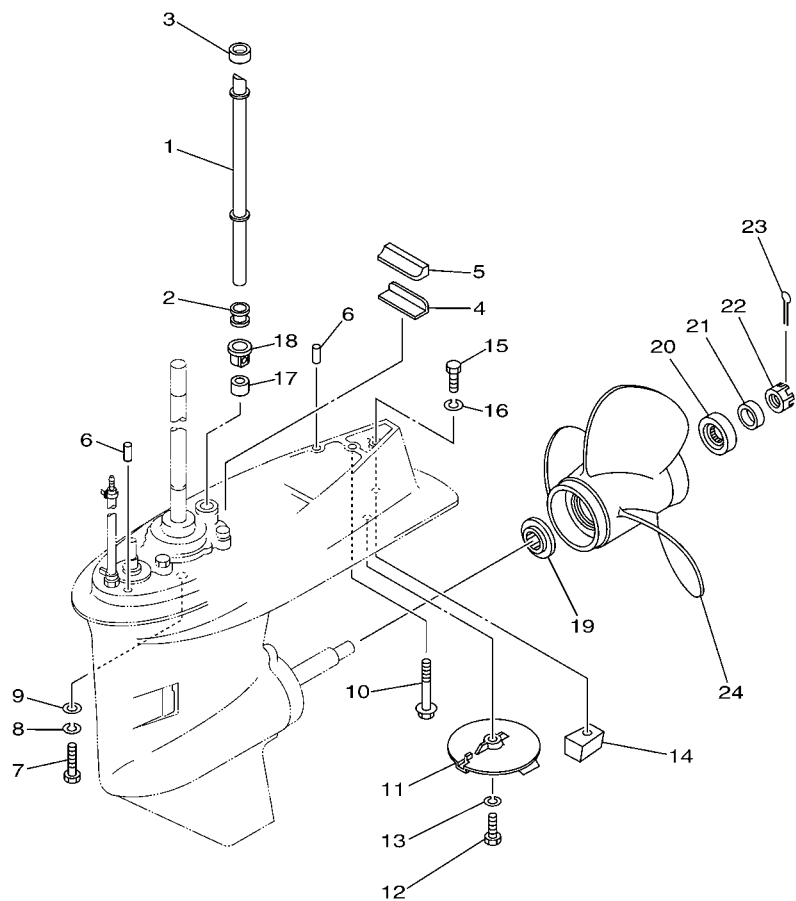

FIG. 31 LOWER CASING & DRIVE 1

REF. NO.	PART NO.	DESCRIPTION	EHT	ET	REMARKS
43	63D-45361-02-4D	CAP, LOWER CASING	1	1	
44	90105-08M61	BOLT, FLANGE	2	2	
45	93306-001U1	BEARING	1	1	
46	63D-45577-00	SHIM (T:0.10MM)	1	1	UR
	63D-45577-10	SHIM (T:0.12MM)	1	1	UR
	63D-45577-20	SHIM (T:0.15MM)	1	1	UR
	63D-45577-30	SHIM (T:0.18MM)	1	1	UR
	63D-45577-40	SHIM (T:0.30MM)	1	1	UR
	63D-45577-50	SHIM (T:0.40MM)	1	1	UR
	63D-45577-60	SHIM (T:0.50MM)	1	1	UR
47	93210-74MG5	O-RING	2	2	
48	93210-69MG6	O-RING	1	1	
49	93317-22204	BEARING	1	1	
50	93101-22M00	OIL SEAL	2	2	
51	62Y-44151-00	CAM, SHIFT	1	1	
52	63D-44144-00	ROD, SHIFT	1	1	
53	93210-07003	O-RING	1	1	
54	99001-08600	CIRCLIP	1	1	
55	63D-45611-00	SHAFT, PROPELLER	1	1	
56	90201-22008	WASHER, PLATE	1	1	
57	62Y-45631-00	CLUTCH, DOG	1	1	
58	663-45634-00	SLIDE, SHIFT	1	1	
59	90501-18001	SPRING, COMPRESSION	1	1	
60	63D-45635-00	PLUNGER, SHIFT	1	1	
61	90250-06023	PIN, STRAIGHT	1	1	
62	67C-45633-00	RING, CROSS PIN	1	1	

FIG. 32 LOWER CASING & DRIVE 2



6C11010-D320

REF. NO.	PART NO.	DESCRIPTION	EHT	ET		REMARKS
1	6C5-44361-00	TUBE, WATER	1	1		L (20.7")
2	663-44367-00	DAMPER, WATER SEAL	1	1		
3	663-44366-00	DAMPER, WATER SEAL	1	1		
4	663-45376-00-94	GUIDE, SEAL DAMPER	1	1		
5	63D-45375-00	DAMPER, SEAL	1	1		
6	93606-12019	PIN, DOWEL	2	2		
7	97075-10040	BOLT	4	4		L (20.7")
8	92995-10100	WASHER	4	4		L (20.7")
9	92995-10600	WASHER	4	4		L (20.7")
10	90119-08M84	BOLT, WITH WASHER	1	1		L (20.7")
11	67C-45371-00	TAB-TRIM	1	1		
12	97095-08025	BOLT	1	1		
13	92995-08100	WASHER	1	1		
14	67C-45251-00	ANODE	1	1		
15	97095-08035	BOLT	1	1		
16	92995-08100	WASHER	1	1		
17	663-44366-00	DAMPER, WATER SEAL	1	1		
18	63D-44312-00	COVER, WATER PUMP HOUSING	1	1		
19	663-45987-02	SPACER	1	1		
20	66T-45997-00	SPACER	1	1		
21	90389-22M01	BUSH	1	1		
22	90171-16011	NUT, CASTLE	1	1		
23	91490-30025	PIN, COTTER	1	1		
24	69W-45943-00-EL	PROPELLER (3X11"X15"-G)	1	1		UR
	69W-45945-00-EL	PROPELLER (3X11-1/8"X13"-G)	1	1		UR
	69W-45947-00-EL	PROPELLER (3X11-5/8"X11"-G)	1	1		UR
	69W-45952-00-EL	PROPELLER (3X11-3/8"X12"-G)	1	1		UR

B4

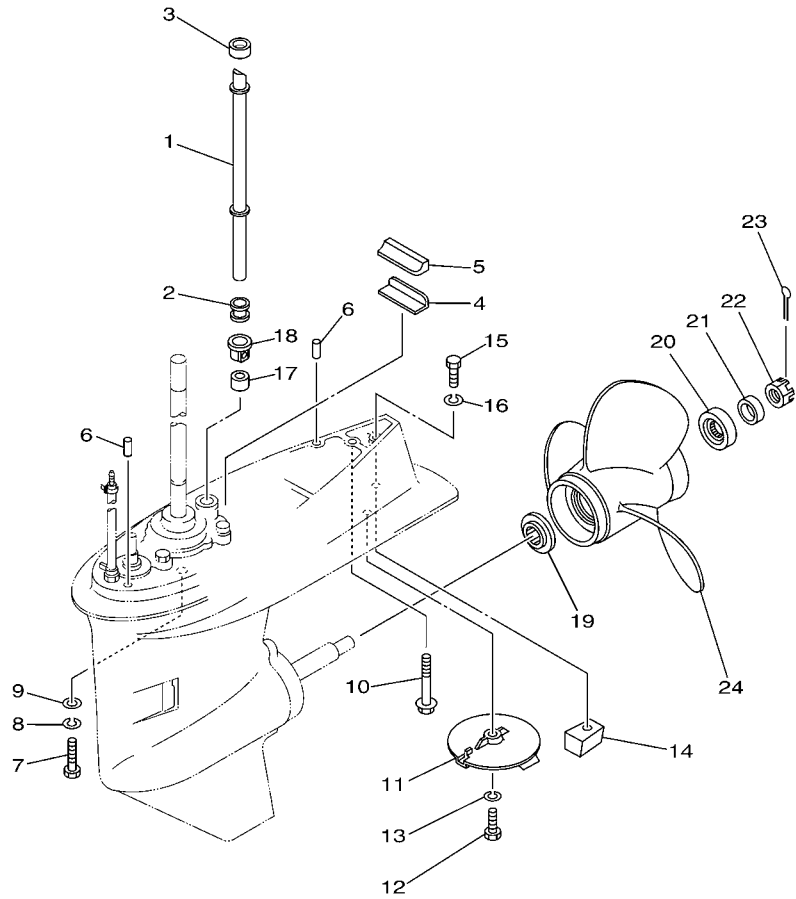

6C11010-D320

FIG. 32 LOWER CASING & DRIVE 2

REF. NO.	PART NO.	DESCRIPTION	EHT	ET		REMARKS
24	663-45941-01-EL	PROPELLER (3X10-3/4"X17"-G)	1	1		UR
	663-45949-01-EL	PROPELLER (3X10-3/4"X16"-G)	1	1		UR
	663-45952-02-EL	PROPELLER (3X11-3/8"X12"-G)	1	1		UR
	663-45956-01-EL	PROPELLER (3X12-1/4"X9"-G)	1	1		UR
	663-45958-01-EL	PROPELLER (3X11-1/4"X14"-G)	1	1		UR
	6H5-45943-00-EL	PROPELLER (3X10"X15"-G)	1	1		UR WITH LIP CUP
	6H5-45945-00-EL	PROPELLER (3X10-3/8"X13"-G)	1	1		UR WITH LIP CUP
	6H5-45952-00-EL	PROPELLER (3X10-5/8"X12"-G)	1	1		UR WITH LIP CUP
	6H5-45958-00-EL	PROPELLER (3X10-1/4"X14"-G)	1	1		UR WITH LIP CUP
	663-45970-60-98	PROPELLER (3X11-3/4"X12"-G)	1	1		UR
	663-45972-60-98	PROPELLER (3X12"X11"-G)	1	1		UR
	663-45974-60-98	PROPELLER (3X11-1/2"X13"-G)	1	1		UR
	697-45970-00-98	PROPELLER (3X11-1/4"X14"-G)	1	1		UR
	663-45930-00-98	PROPELLER (3X10-1/4"X14"-G)	1	1		UR
	663-45974-02-98	PROPELLER (3X10-5/8"X13"-G)	1	1		UR
	663-45976-00-98	PROPELLER (3X10-1/4"X15"-G)	1	1		UR
	663-45978-00-98	PROPELLER (3X10-1/4"X16"-G)	1	1		UR

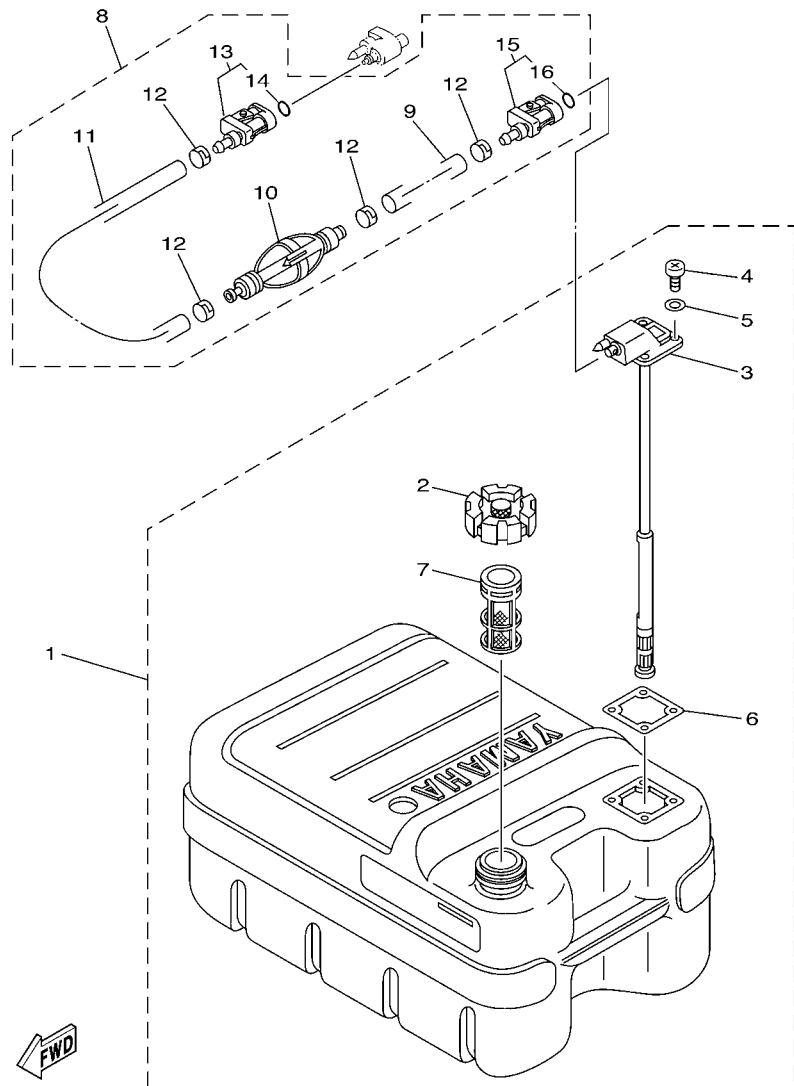

68U3100-C240

FIG. 33 FUEL TANK

REF. NO.	PART NO.	DESCRIPTION	EHT	ET	REMARKS
1	6YJ-24201-10	FUEL TANK ASSY (24L)	1	1	AP FOR OCE
2	6YJ-24610-01	.CAP ASSY	1	1	
3	6Y1-24260-12	.FUEL METER ASSY	1	1	WITH INDICATOR
4	98586-05016	.SCREW, PAN HEAD	4	4	
5	6Y1-24329-00	.SEAL	4	4	
6	6Y1-24268-00	.GASKET, FUEL METER	1	1	
7	6YJ-24167-00	.STRAINER	1	1	
8	61J-24306-04	FUEL PIPE COMP. 1	1	1	AP FOR OCE
9	90445-11M06	.HOSE (L2050)	1	1	
10	61J-24360-00	.PRIMER PUMP ASSY	1	1	
11	90445-11M05	.HOSE (L850)	1	1	
12	650-24351-01	.BAND 1	4	4	
13	6G1-24305-05	.FUEL PIPE JOINT COMP. 2	1	1	
14	93210-08287	..O-RING	1	1	
15	6Y1-24305-06	.FUEL PIPE JOINT COMP. 2	1	1	
16	93210-08287	..O-RING	1	1	

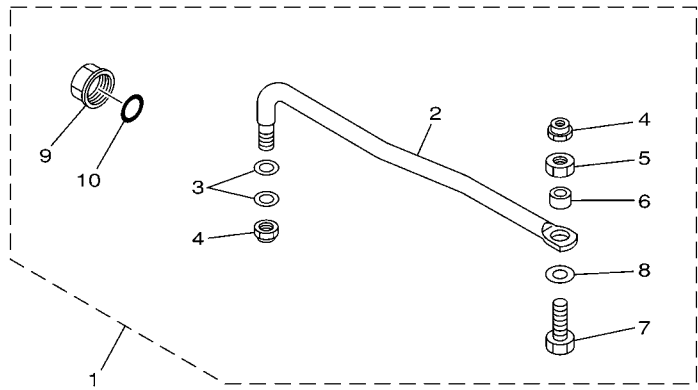

65W0010-8210

FIG. 34 STEERING GUIDE

REF. NO.	PART NO.	DESCRIPTION	EHT	ET		REMARKS
1	65W-61350-00	STEERING GUIDE ATTACHMENT KIT		1		AP
2	65W-61351-00	.ROD, STEERING LINK		1		
3	90201-10M20	.WASHER, PLATE		2		
4	90185-09M01	.NUT, SELF-LOCKING		2		
5	90170-09M03	.NUT		1		
6	90387-10M42	.COLLAR		1		
7	90101-09M01	.BOLT		1		
8	90201-10M63	.WASHER, PLATE		1		
9	6E5-43145-01	.CAP, CLAMP BRACKET		1		
10	93210-16275	.O-RING		1		

B7

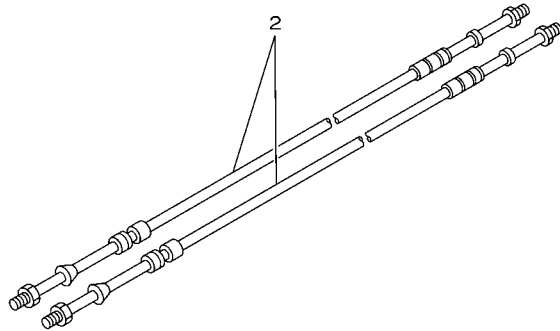
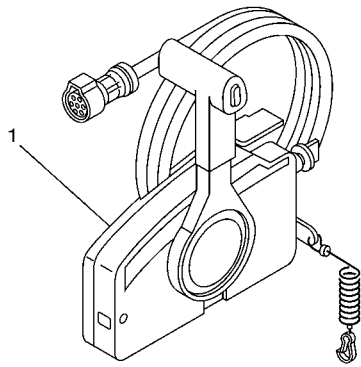

67M0100-8280

FIG. 35 REMOTE CONTROL BOX

REF. NO.	PART NO.	DESCRIPTION	EHT	ET		REMARKS
1	703-48205-17	REMOTE CONTROL ASSY (10P)		1		AP WITH PT/T SW.
2	701-48310-90	CABLE, REMOTE CONTROL L=11F		2		UR
	701-48320-00	CABLE, REMOTE CONTROL L=12F		2		UR
	701-48320-20	CABLE, REMOTE CONTROL L=13F		2		UR
	701-48320-50	CABLE, REMOTE CONTROL L=15F		2		UR

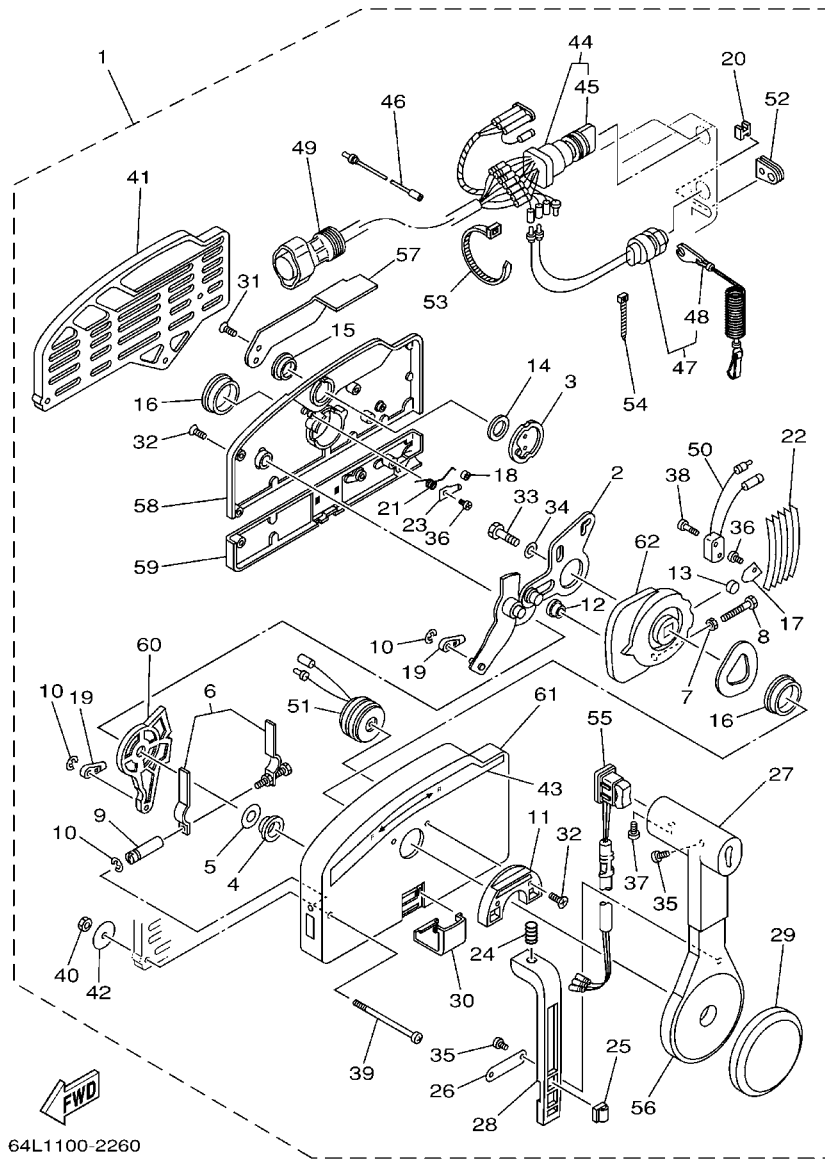

64L1100-2260

FIG. 36 REMOTE CONTROL ASSY

REF. NO.	PART NO.	DESCRIPTION	EHT	ET	REMARKS
1	703-48205-17	REMOTE CONTROL ASSY (10P)		1	AP WITH PT/T SW.
2	703-48261-01	.ARM, THROTTLE		1	
3	703-48153-00	.SHAFT, FREE ACCEL.		1	
4	703-48235-00	.BUSHING		1	
5	703-48268-00	.SPACER		1	
6	703-48264-00	.FRICTION, THROTTLE		1	
7	95380-05600	.NUT		1	
8	97380-05025	.BOLT		1	
9	703-48265-00	.SHAFT, FRICTION		1	
10	93430-06024	.CIRCLIP		3	
11	703-48245-00	.PLATE, LOCK		1	
12	703-48252-00	.ROLLER, CAM		1	
13	701-48248-00	.ROLLER, FREE ACCEL.		1	
14	703-48198-00	.WASHER, WAVE		1	
15	703-48243-00	.BUSHING		1	
16	703-48236-00	.BUSHING 1		2	
17	703-48189-00	.RETAINER		1	
18	703-48234-00	.ROLLER, DETENT		1	
19	703-48345-01	.CABLE END, REMOTE CONTROL 2		2	
20	703-48358-00	.ANCHOR, CABLE		1	
21	703-48244-00	.SPRING, FREE ACCEL.		1	
22	703-48238-00	.SPRING, DETENT		5	
23	703-48246-00	.SPACER		1	
24	703-48227-00	.SPRING, NEUTRAL LOCK		1	
25	703-82594-00	.CLAMP		1	WITH PT/T SW.
26	703-48226-00	.PLATE, STOPPER		1	
27	703-48222-00	.GRIP, CONTROL LEVER		1	SINGLE

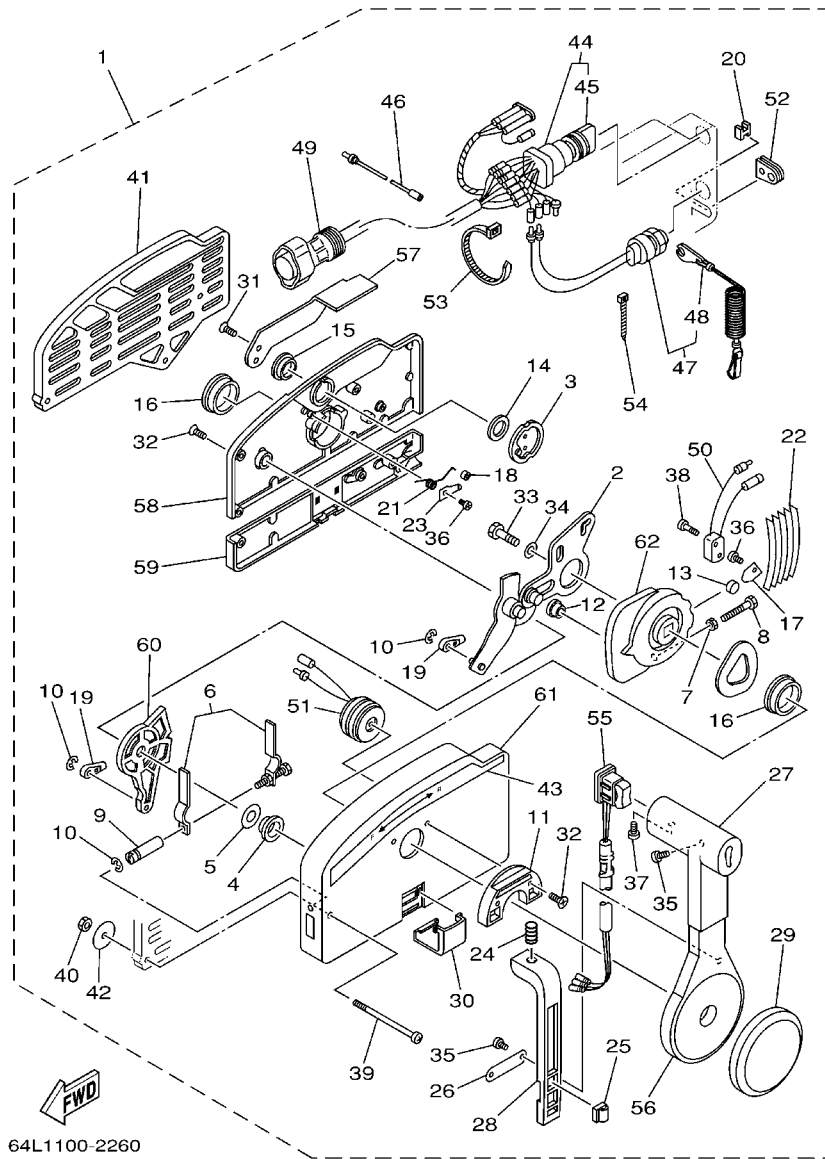

64L1100-2260

FIG. 36 REMOTE CONTROL ASSY

REF. NO.	PART NO.	DESCRIPTION	EHT	ET	REMARKS
28	703-48223-00	.LOCK, NEUTRAL		1	
29	703-48225-00	.COVER		1	
30	703-48219-00	.COVER, LEAD		1	
31	703-48281-00	.SCREW		2	
32	703-48282-00	.SCREW		7	
33	97380-08030	.BOLT		1	
34	92990-08600	.WASHER, PLATE		1	
35	98580-04010	.SCREW, PAN HEAD		3	
36	98580-04006	.SCREW, PAN HEAD		2	
37	98580-05010	.SCREW, PAN HEAD		1	
38	98580-03015	.SCREW, PAN HEAD		2	
39	703-48291-10	.SCREW (M6)		3	
40	95380-06600	.NUT, HEXAGON		3	
41	703-48293-10	.SPACER, REMOTE CONTROL		1	SINGLE
42	701-48287-00	.WASHER		3	
43	703-48215-00	.GRAPHIC		1	
44	703-82510-43	.MAIN SWITCH ASSY		1	
45	703-82577-00	..CAP, KEY		1	
46	703-82531-00	.WIRE, LEAD		1	
47	688-82575-01	.ENGINE STOP SWITCH ASSY		1	
48	682-82556-00	..STOPPER		1	
49	688-8258A-20	.EXTENSION, WIRE HARNESS		1	L:5M (10P)
50	703-82540-00	.NEUTRAL SWITCH ASSY		1	
51	703-83383-02	.BUZZER		1	
52	703-48284-00	.GROMMET		1	
53	703-82591-00	.BAND		1	
54	703-82592-00	.BAND		1	

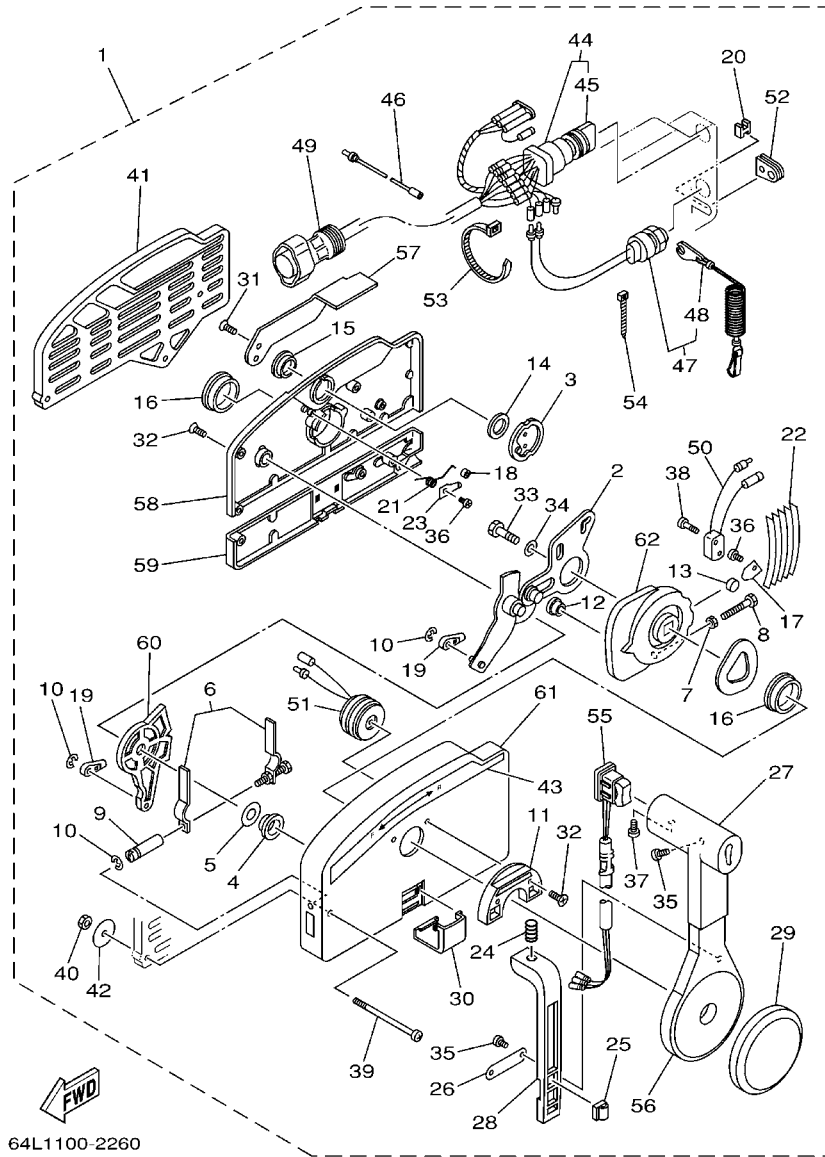

64L1100-2260

FIG. 36 REMOTE CONTROL ASSY

REF. NO.	PART NO.	DESCRIPTION	EHT	ET	REMARKS
55	703-82563-02	.TRIM & TILT SWITCH ASSY		1	WITH PT/T SW.
56	703-48221-00	.LEVER, CONTROL		1	
57	703-48152-00	.KNOB, FREE ACCEL.		1	
58	703-48212-00	.BACK PLATE 1		1	
59	703-48213-00	.BACK PLATE 2		1	
60	703-48271-00	.ARM, SHIFT		1	
61	703-48211-01	.HOUSING,1		1	
62	703-48232-00	.GEAR		1	

FIG. 37 METER

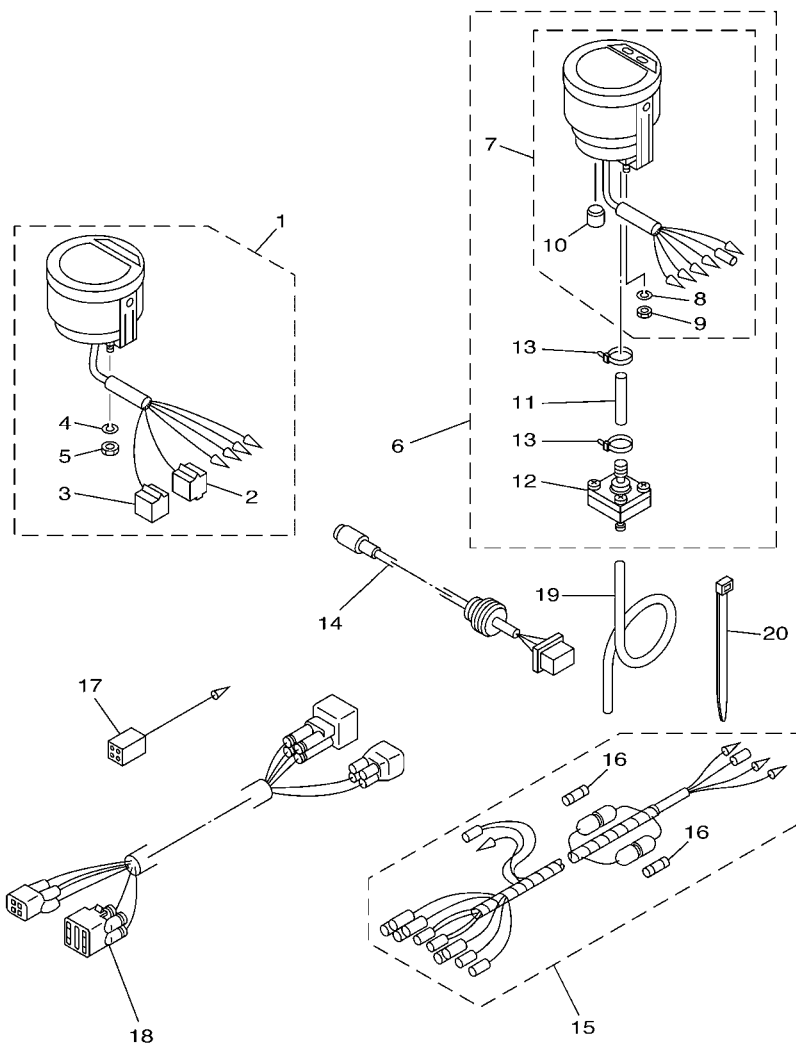

61A1700-2290

REF. NO.	PART NO.	DESCRIPTION	EHT	ET	REMARKS
1	6Y5-8350T-03	DIGITAL TACHOMETER ASSY		1	AP FOR OCE
2	9E450-04433	.CONNECTOR		1	M-4-W
3	9E450-04533	.CONNECTOR		1	F-4-W
4	92990-04100	.WASHER, SPRING		2	
5	95380-04600	.NUT		2	
6	6Y5-83500-S5	DIGITAL SPEEDOMETER ASSY		1	AP FOR OCE
7	6Y5-83570-S5	.SPEEDOMETER ASSY		1	
8	92990-04100	..WASHER, SPRING		2	
9	95380-04600	..NUT		2	
10	6Y5-83533-T2	..GROMMET		1	
11	6Y5-83557-31	.TUBE		1	
12	6Y5-83728-00	.CONNECTOR ASSY		1	
13	90465-11M10	.CLAMP		2	
14	6Y5-87122-S0	CORD ASSY 1		1	AP FOR OCE
15	6Y5-83553-M0	WIRE, LEAD (L=2.5M)		1	AP FOR OCE
16	1E6-82151-00	.FUSE (10A)		2	
17	6Y5-82117-00	WIRE, LEAD (BLACK)		1	AP FOR OCE
18	68F-82553-80	EXTENSION, WIRE LEAD (L=8.0M)		1	AP FOR OCE
19	6Y5-83557-10	TUBE (8M)		1	AP FOR OCE
20	90465-11M10	CLAMP		2	AP FOR OCE

FIG. 38 OPTIONAL PARTS

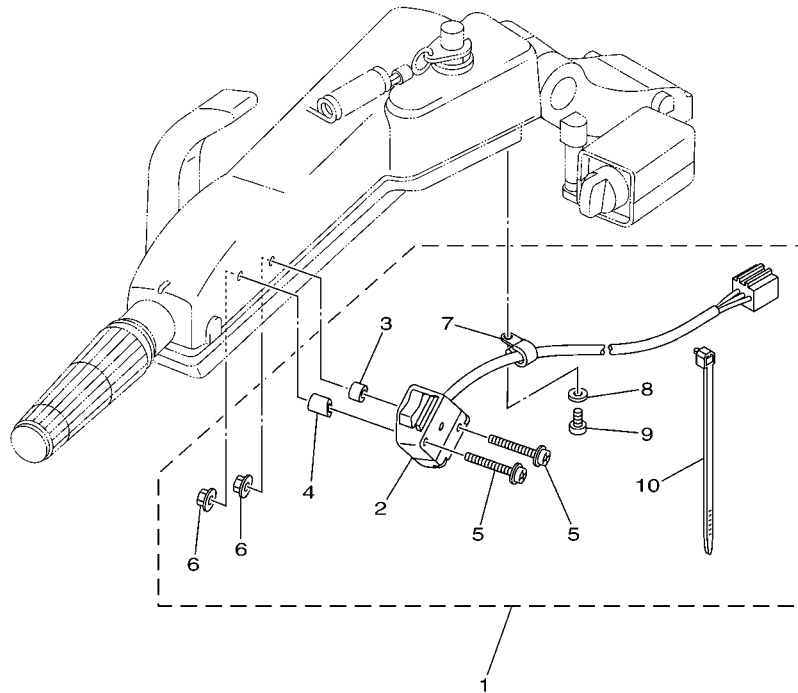

REF. NO.	PART NO.	DESCRIPTION	EHT	ET		REMARKS
1	6C5-W8186-00	VARIABLE TROLLING RPM SW. KIT	1	1		AP ET-FOR USA
2	6C5-81860-00	.SWITCH ASSY	1	1		
3	6C5-23448-00	.SPACER	1	1		
4	6C5-23448-10	.SPACER	1	1		
5	90159-06018	.SCREW, WITH WASHER	2	2		
6	95780-06300	.NUT, FLANGE	2	2		
7	90465-06M86	.CLAMP	2	2		
8	90201-06028	.WASHER, PLATE	2	2		
9	97885-06016	.SCREW, PAN HEAD	2	2		
10	90465-13M24	.CLAMP	4	4		

6C11010-D330

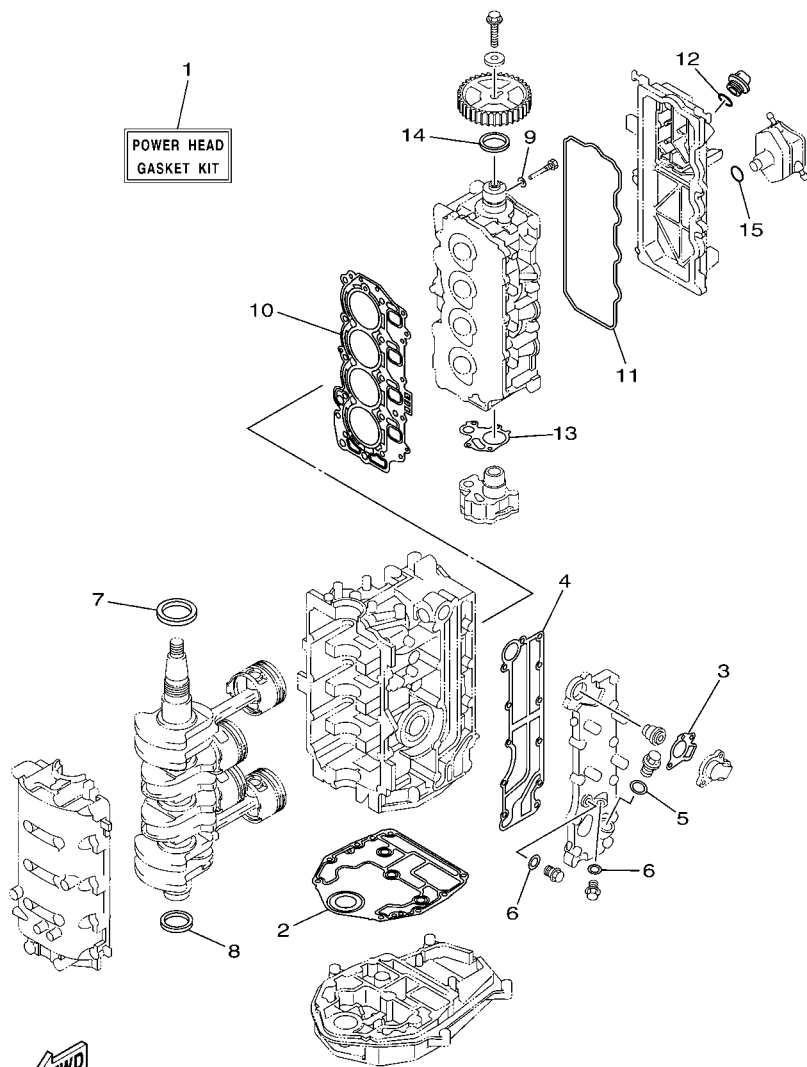

6C11100-D390



FIG. 39 REPAIR KIT 1

REF. NO.	PART NO.	DESCRIPTION	EHT	ET	REMARKS
1	6C5-W0001-00	POWER HEAD GASKET KIT	1	1	
2	67C-11351-01	.GASKET, CYLINDER	1	1	
3	62Y-12414-00	.GASKET, COVER	1	1	
4	6C5-41114-00	.GASKET, EXHAUST OUTER COVER	1	1	
5	90430-18130	.GASKET	1	1	
6	90430-14115	.GASKET	2	2	
7	93102-43M42	.OIL SEAL	1	1	
8	93101-35002	.OIL SEAL	1	1	
9	90430-06014	.GASKET	1	1	
10	6C5-11181-01	.GASKET, CYLINDER HEAD 1	1	1	
11	62Y-11356-00	.SEAL, CYLINDER 2	1	1	
12	93210-24M79	.O-RING	1	1	
13	6C5-13329-00	.GASKET, PUMP COVER	1	1	
14	93102-37M40	.OIL SEAL	1	1	
15	93210-24M79	.O-RING	1	1	

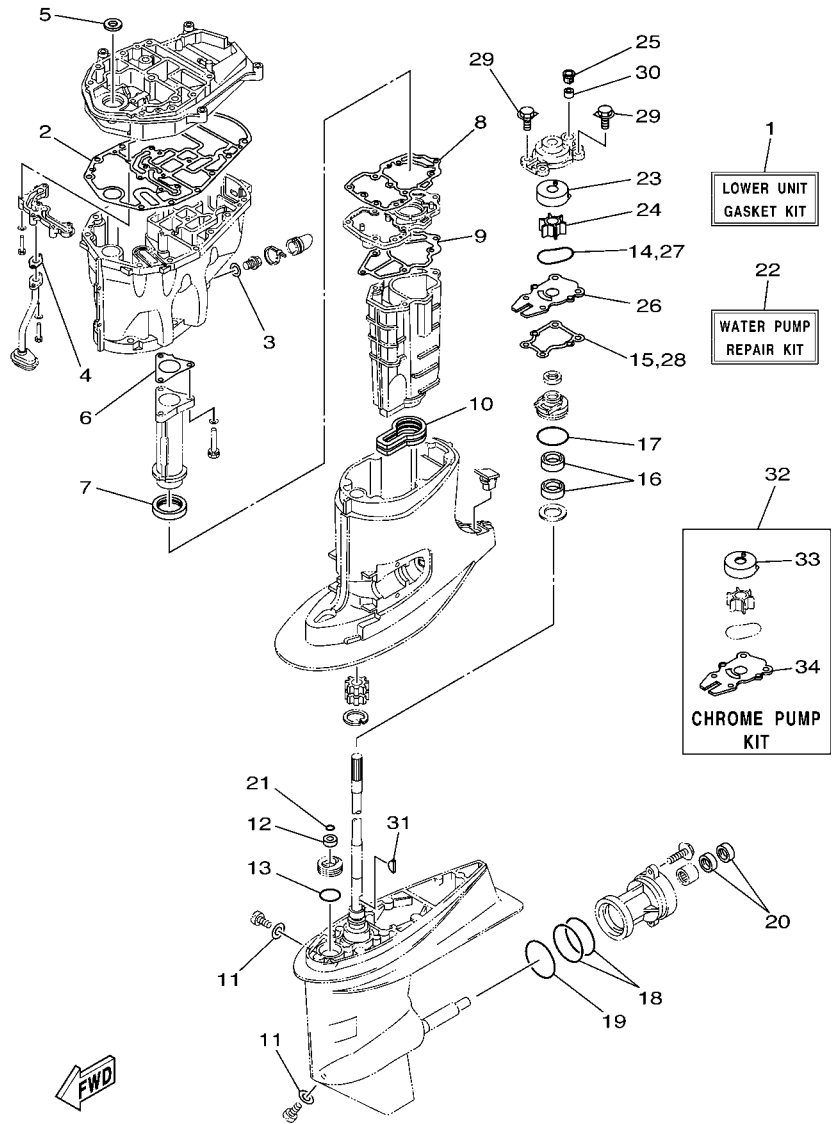

FIG. 40 REPAIR KIT 2

REF. NO.	PART NO.	DESCRIPTION	EHT	ET	REMARKS
1	6C5-W0001-20	LOWER UNIT GASKET KIT	1	1	
2	6C5-15312-00	.GASKET, OIL PAN	1	1	
3	90430-14M09	.GASKET	1	1	
4	6C5-13414-00	.GASKET, STRAINER COVER	1	1	
5	93103-18011	.OIL SEAL	1	1	
6	6C5-41133-00	.GASKET, EXHAUST MANIFOLD 1	1	1	
7	6C5-46132-00	.GASKET 1	1	1	
8	6C5-41134-00	.GASKET, EXHAUST MANIFOLD	1	1	
9	6C5-41135-00	.GASKET, EXHAUST MANIFOLD	1	1	
10	6C5-45123-00	.GASKET, MUFFLER	1	1	
11	90430-08020	.GASKET	2	2	
12	93106-09014	.OIL SEAL	1	1	
13	93210-33MG4	.O-RING	1	1	
14	93210-59MG7	.O-RING	1	1	
15	63D-44316-00	.GASKET, WATER PUMP	1	1	
16	93101-25M57	.OIL SEAL	2	2	
17	93210-48MG8	.O-RING	1	1	
18	93210-74MG5	.O-RING	2	2	
19	93210-69MG6	.O-RING	1	1	
20	93101-22M00	.OIL SEAL	2	2	
21	93210-07003	.O-RING	1	1	
22	63D-W0078-01	WATER PUMP REPAIR KIT	1	1	
23	63D-44322-00	.INSERT, CARTRIDGE	1	1	
24	6H3-44352-00	.IMPELLER	1	1	
25	63D-44312-00	.COVER, WATER PUMP HOUSING	1	1	
26	63D-44323-00	.OUTER PLATE, CARTRIDGE	1	1	
27	93210-59MG7	.O-RING	1	1	

NUMERICAL INDEX

PART NO.	REF. NO.	PART NO.	REF. NO.	PART NO.	REF. NO.	PART NO.	REF. NO.	PART NO.	REF. NO.	PART NO.	REF. NO.
6C5-11111-00-1S	4 - 2	62Y-12138-50	4 - 41	6C5-13557-00	6 - 4	6C5-1531A-01	4 - 31	6C5-24387-00	9 - 15	62Y-42154-00	24 - 27
62Y-11119-00	4 - 26	6C5-12146-00	5 - 8	6C5-13577-00	9 - 10	6C5-15333-00	30 - 10	6C5-24410-00	11 - 19	6X4-42159-00	21 - 46
62Y-11133-30	4 - 3	62Y-12151-00	5 - 9	6C5-13593-00	8 - 20	6C5-15362-00	30 - 13	62Y-24411-02	11 - 21	6C5-42171-00	24 - 28
6C5-11168-00	4 - 20	6C5-12151-00	5 - 12	6C5-13641-00	6 - 2	6G8-15363-00	4 - 29	6C5-24415-00	11 - 20	6X4-42177-00	21 - 6
6C5-11181-01	4 - 14	62Y-12158-00	5 - 11	6C5-13645-00	6 - 3	6C5-15378-00	4 - 32	6C5-2441R-00	8 - 6	6C5-42335-00	24 - 33
	39 - 10	6C5-12158-00	5 - 14	6C5-13716-00	8 - 22	6C5-15378-11	4 - 35	6C5-2441T-00	8 - 7	6C5-42508-00	23 - 1
6C5-11191-01-1S	4 - 18	64J-12159-00	5 - 10	6C5-13739-00	9 - 25	6C5-21337-00	8 - 24	62Y-24423-00	11 - 22	69W-42510-01-4D	26 - 1
62Y-11325-00	2 - 16	6C5-12159-00	5 - 13	6C5-13750-00	6 - 5	6C5-21841-00	9 - 11	6C5-24444-00	9 - 9	67C-42525-00	23 - 4
	4 - 4	6C5-12171-00	10 - 1	6C5-13761-00	6 - 16	6C5-22435-00	27 - 15	62Y-24444-01	11 - 25	6C5-42527-00	23 - 2
66M-11327-00-94	2 - 18	6C5-12231-00	5 - 15	6C5-13781-00	8 - 21	6C5-22471-00	27 - 8	6C5-24453-00	8 - 8	65W-42528-00	23 - 10
	4 - 6	6C5-12233-00	5 - 16	6C5-13906-00	8 - 9	6C5-2247A-00	11 - 4	62Y-24454-00	11 - 24	67C-42561-00	23 - 7
66M-11328-00	2 - 17	6C5-12241-00	5 - 17	6C5-13907-00	8 - 17	6C5-23448-00	38 - 3	68V-24469-01	11 - 13	67C-42562-00	23 - 6
	4 - 5	6C5-12243-00	5 - 18	6C5-13910-00	8 - 16	6C5-23448-10	38 - 4	6C5-24471-00	11 - 26	6C1-42610-00-4D	1 - 1
67C-11351-01	2 - 8	6G8-12411-03	2 - 11	6C5-13915-00	8 - 19	6C5-2411M-00	9 - 13	6C5-2441B-00	9 - 22	6C5-42610-00-4D	1 - 1
	39 - 2	6H3-12413-00-1S	2 - 12	6C5-13974-00	9 - 16	6YJ-24167-00	33 - 7	68V-24521-01	11 - 10	6C5-42610-A0-4D	1 - 1
62Y-11356-00	4 - 23	62Y-12414-00	2 - 13	6C5-1410B-00	6 - 17	6YJ-24201-10	33 - 1	68V-24560-01	11 - 9	67C-42613-00-4D	1 - 2
	39 - 11		39 - 3	6C5-1410F-00	9 - 23	6C5-24251-00	9 - 21	68V-24563-00	11 - 11	6C5-42615-00	1 - 14
6C5-11411-00	3 - 1	62Y-12481-10	2 - 10	6C5-14127-00	8 - 18	6Y1-24260-12	33 - 3	6C5-24566-01	11 - 14	6C5-42651-00	1 - 4
6C5-11416-00	3 - 2	66M-12535-00	2 - 19	6X4-14137-00	21 - 24	6Y1-24268-00	33 - 6	6C5-24592-00	8 - 10	67C-42652-01	1 - 6
6C5-11416-10	3 - 2		4 - 7	6C5-14148-00	9 - 14	6G1-24304-02	11 - 1	6YJ-24610-01	33 - 2	69W-42677-00	1 - 9
6C5-11416-20	3 - 2	69W-12535-00	20 - 3	6C5-14149-00	9 - 8	6G1-24305-04	12 - 2	69W-26301-00	21 - 40	62Y-42677-30	1 - 9
6C5-11416-30	3 - 2	68T-12572-00	20 - 2	6C5-14180-00	8 - 1	6G1-24305-05	33 - 13	6X4-26367-00	21 - 35	69W-42677-A0	1 - 9
6C5-11536-00	10 - 7	6C5-12576-00	7 - 17	6C5-14182-00	8 - 2	6Y1-24305-05	12 - 4	6C5-28100-00	11 - 35	6C1-42678-00	1 - 10
6C5-11537-00	10 - 2	6R3-12580-00	20 - 8	6C5-14191-00	8 - 13	6E5-24305-06	12 - 2	67F-2812A-00	16 - 32	6C5-42678-00	1 - 10
6H4-11545-00	13 - 5	6C5-12858-00	2 - 29	6C5-14200-00	6 - 1	6Y1-24305-06	33 - 15	61H-2819R-31	11 - 34	6C5-42678-A0	1 - 10
62Y-11557-00	10 - 8	6C5-13105-01	6 - 10	6C5-14225-00	8 - 25	6Y2-24305-06	12 - 4	6C5-41113-00-1S	2 - 9	69W-42681-00	1 - 12
6G8-11577-00	10 - 15	62Y-13131-00	11 - 23	6C5-14251-00	9 - 12	61J-24306-04	33 - 8	6C5-41114-00	2 - 14	69W-42682-00	1 - 13
67C-11603-00	3 - 7	6C5-13142-00	10 - 14	6C5-14386-00	8 - 5	6Y1-24306-54	12 - 1		39 - 4	6C5-42710-00-4D	19 - 1
67C-11604-00	3 - 7	6C5-13161-00	6 - 13	6C5-14397-00	6 - 11	6Y2-24306-56	12 - 1	6C5-41131-00-5B	29 - 6	6C5-42710-10-4D	19 - 1
67C-11605-00	3 - 7	6C5-13300-00	10 - 11		8 - 14	6C5-24312-00	20 - 6	6C5-41133-00	29 - 5	62Y-42715-01	24 - 11
69W-11631-00-97	3 - 6	6C5-13329-00	10 - 17	6C5-14440-00	7 - 4	6C5-24321-00	9 - 3		40 - 6	62Y-42716-00	19 - 5
62Y-11633-00	3 - 8		39 - 13	6C5-14446-00	6 - 15	6C5-24322-00	9 - 4	6C5-41134-00	29 - 10	65W-42717-00	19 - 6
69W-11635-00	3 - 6	6C5-13411-00	30 - 8	6C1-14453-01	7 - 5	6C5-24323-00	9 - 5		40 - 8	6C5-42718-00	19 - 8
69W-11636-00	3 - 6	6C5-13414-00	30 - 9	6C5-14453-01	7 - 5	6C5-24324-00	9 - 6	6C5-41135-00	29 - 13	6C5-42724-00	19 - 23
6C5-11650-00	3 - 3		40 - 4	6C1-14477-00	7 - 6	6C5-24325-00	9 - 7		40 - 9	6X4-42724-00	22 - 24
6C5-11654-00	3 - 4	6C5-13428-00	7 - 21	62Y-14485-00	4 - 19	61N-24329-00	19 - 28		29 - 1	65W-42724-10	20 - 1
6C5-11656-00	3 - 5	67F-13434-03	1 - 16	6C5-14496-00	6 - 9	6Y1-24329-00	33 - 5	6C5-41137-00-94	29 - 1	6X4-42725-00	21 - 57
6C5-11656-10	3 - 5	6C5-13437-41	13 - 16	6C5-14546-00	8 - 4	650-24351-01	33 - 12	688-41211-01	24 - 24	6C5-42725-30	19 - 9
6C5-11656-20	3 - 5	6C5-13437-51	13 - 16	6C5-14567-00	8 - 15	650-24351-51	12 - 7	6H4-41237-00	24 - 25	6C5-42726-00	19 - 43
6C5-11656-30	3 - 5	5GH-13440-20	2 - 28	6C5-14711-00-5B	29 - 14	6E5-24351-51	12 - 7	6X4-41291-00	21 - 8	6X4-42101-J0-4D	21 - 1
69W-12111-00	5 - 1	62Y-13444-40	20 - 20	6C5-14960-00	8 - 12	6Y1-24360-00	33 - 10	6X4-42111-00-4D	21 - 2	68U-42727-00	19 - 26
51Y-12114-00	5 - 4	62Y-13444-50	20 - 20	6C5-14984-00	8 - 23	6Y1-24360-52	12 - 9	6X4-42115-00	21 - 22	6H3-42727-00	19 - 27
62Y-12116-00	5 - 3	69W-13448-00	1 - 15	6C5-14985-00	8 - 3	6Y2-24360-60	12 - 9	6X4-42119-00	21 - 5	6X4-42727-00	22 - 18
30X-12117-00	5 - 5	6C5-13542-00	9 - 2	6C5-15100-00-1S	2 - 2	62Y-24374-01	11 - 28	63D-42121-22-4D	21 - 58	6X4-42728-10	21 - 67
30X-12118-00	5 - 6	6C5-13545-00	9 - 19	6C5-15311-00-5B	30 - 1	67F-24377-00	11 - 5	63D-42126-00	21 - 17	6C5-42738-00-4D	19 - 7
51Y-12119-00	5 - 7	6C5-13546-00	9 - 1	6C5-15312-00	30 - 2	688-24378-00	20 - 11	6X4-42128-00	21 - 13	67C-42741-10-4D	19 - 29
69W-12121-00	5 - 2	6C5-13547-00	9 - 20		40 - 2	6C5-24378-00	20 - 15	6X4-42131-10	21 - 52	6C5-42811-00	16 - 28
62Y-12138-40	4 - 41	6C5-13548-00	9 - 24	6C5-15316-00	30 - 4	6C5-24379-00	9 - 18	6X4-42137-00	21 - 7	67C-42815-00-4D	19 - 12

NUMERICAL INDEX

PART NO.	REF. NO.	PART NO.	REF. NO.	PART NO.	REF. NO.	PART NO.	REF. NO.	PART NO.	REF. NO.	PART NO.	REF. NO.
67C-42816-01	19 - 17	6C6-4386E-00	27 - 54	63D-44316-00	40 - 15	69W-45560-00	31 - 39	663-45978-00-98	32 - 24	703-48293-10	36 - 41
6X4-42821-00	21 - 28	6C6-4386G-00	27 - 53	63D-44322-00	31 - 22	663-45567-01	31 - 41	663-45987-02	32 - 19	701-48310-90	35 - 2
6C5-43111-00-4D	25 - 1	6C5-4386K-00	28 - 10		40 - 23	663-45567-10	31 - 41	66T-45997-00	32 - 20	701-48320-00	35 - 2
6C5-43112-00-4D	25 - 2	6C5-43871-00	27 - 7	63D-44322-40	40 - 33	663-45567-20	31 - 41	6C5-46132-00	29 - 7	701-48320-20	35 - 2
6E5-43126-02	25 - 26	6C5-43872-00	27 - 58	63D-44323-00	31 - 26	663-45567-30	31 - 41		40 - 7	701-48320-50	35 - 2
63D-43131-01	25 - 11	6C5-43875-00	27 - 9		40 - 26	663-45567-40	31 - 41	6C5-46241-00	10 - 6	67C-48321-10	21 - 33
66T-43144-00	19 - 19	6H1-43875-00	27 - 60	63D-44323-40	40 - 34	663-45567-50	31 - 41	6A5-48129-10	21 - 27	69W-48344-00	24 - 23
6G5-43144-00	25 - 23	6C6-43878-00	27 - 47	63D-44341-00	31 - 31	663-45567-60	31 - 41	703-48152-00	36 - 57	703-48345-01	36 - 19
6E5-43145-01	34 - 9	6C5-43879-00	28 - 7	6H3-44352-00	31 - 23	62Y-45571-00	31 - 42	703-48153-00	36 - 3	703-48358-00	36 - 20
6G5-43148-00	25 - 19	62Y-4387G-00	27 - 48		40 - 24	63D-45577-00	31 - 46	6X4-48154-00	21 - 18	65W-48511-00	26 - 42
6C5-43181-00	25 - 14	6C6-4387G-00	27 - 31	6C5-44361-00	32 - 1	63D-45577-10	31 - 46	703-48189-00	36 - 17	62Y-48538-00	24 - 39
6C5-43185-00	25 - 15	6C5-43880-01	28 - 1	663-44366-00	32 - 3	63D-45577-20	31 - 46	703-48198-00	36 - 14	63D-48538-00	21 - 38
6C5-43311-00-4D	25 - 9	6C5-43881-01	28 - 11		40 - 30	63D-45577-30	31 - 46	703-48205-17	35 - 1	6X4-48538-00	21 - 34
689-43633-00	23 - 8	6C5-43882-00	28 - 8	663-44367-00	32 - 2	63D-45577-40	31 - 46		36 - 1	6X4-48538-10	21 - 41
6C5-43800-01-4D	27 - 1	6H1-43883-00	27 - 26	6C5-44385-00	26 - 36	63D-45577-50	31 - 46	703-48211-01	36 - 61	65W-61350-00	34 - 1
6C5-43801-00	27 - 3	6C5-43885-00	26 - 18	6H3-44391-01	19 - 22	63D-45577-60	31 - 46	703-48212-00	36 - 58	65W-61351-00	34 - 2
6C5-43804-01	28 - 5	62X-43888-00	28 - 12	69W-44514-00-4D	26 - 10	663-45587-01	31 - 5	703-48213-00	36 - 59	6C5-81145-00	6 - 7
6C5-43805-00	28 - 4	6C6-4388E-00	27 - 51	69W-44526-01	26 - 12	663-45587-10	31 - 5	6X4-48215-00	21 - 4	6C5-81146-00	6 - 12
6C5-4380G-00	27 - 22	6C6-4388F-00	27 - 52	6C5-44551-00-4D	26 - 16	663-45587-20	31 - 5	703-48215-00	36 - 43	68V-81315-00	16 - 8
6C5-4380K-00	27 - 18	6C5-43891-00	28 - 9	6C5-44552-00-4D	26 - 19	663-45587-30	31 - 5	703-48219-00	36 - 30	6C5-81336-00	15 - 2
6C5-43810-00	27 - 2	6C5-43893-00	27 - 36	6X4-44554-00	22 - 22	663-45587-40	31 - 5	703-48221-00	36 - 56	6C5-81337-00	13 - 1
6C5-43816-00	27 - 21	6C6-43893-00	27 - 37	69W-44555-00-4D	26 - 20	663-45587-50	31 - 5	703-48222-00	36 - 27	6C5-81410-00	13 - 4
6C5-43817-10	27 - 19	6C6-43894-00	27 - 27	6C5-44575-00	26 - 23	663-45587-60	31 - 5	703-48223-00	36 - 28	6C5-81450-00	13 - 3
6C5-43818-00	25 - 36	6C5-43895-00	27 - 42	6C5-45111-00-4D	29 - 27	63D-45611-00	31 - 55	703-48225-00	36 - 29	6C5-81800-00	18 - 1
6C5-4381B-00	27 - 10	6C5-43899-00	27 - 12	6C5-45123-00	29 - 17	62Y-45631-00	31 - 57	703-48226-00	36 - 26	69J-81801-00	18 - 5
6C5-4381K-00	27 - 35	69J-4389J-00	27 - 20		40 - 10	67C-45633-00	31 - 62	703-48227-00	36 - 24	67F-81807-00	18 - 10
6C6-4381K-00	27 - 38	6X4-44100-00	21 - 21	6C5-45135-01	30 - 14	663-45634-00	31 - 58	703-48232-00	36 - 62	67F-81808-00	18 - 8
6H1-43829-00	27 - 63	6X4-44102-00	21 - 23	6C5-45136-01	30 - 15	63D-45635-00	31 - 60	703-48234-00	36 - 18	67F-81809-00	18 - 19
6C6-4382E-00	27 - 28	6X4-44114-00	22 - 16	6C5-45155-00	29 - 20	663-45930-00-98	32 - 24	703-48235-00	36 - 4	67F-81810-00	18 - 3
6C5-4382K-00	27 - 41	62Y-44117-01-4D	24 - 2	6C5-45181-00-5B	29 - 11	663-45941-01-EL	32 - 24	703-48236-00	36 - 16	67F-81813-00	18 - 6
6C5-4382L-00	27 - 56	62Y-44118-00	24 - 12	63D-45214-00	31 - 10	69W-45943-00-EL	32 - 24	703-48238-00	36 - 22	6C5-81815-00	15 - 17
6C5-43830-00	27 - 24	6C5-44120-01	24 - 7	63D-45215-00	31 - 11	6H5-45943-00-EL	32 - 24	703-48243-00	36 - 15	68F-81820-00	18 - 7
6C5-43831-00	27 - 64	69W-44121-00	24 - 1	65W-45251-00	25 - 5	69W-45945-00-EL	32 - 24	703-48244-00	36 - 21	67F-81821-00	18 - 13
6C5-43833-00	25 - 37	688-44122-00	24 - 20	67C-45251-00	32 - 14	6H5-45945-00-EL	32 - 24	703-48245-00	36 - 11	6C5-81822-00-94	17 - 3
6C5-43834-00	25 - 38	6C5-44122-00	24 - 8	69W-45300-00-4D	31 - 1	69W-45947-00-EL	32 - 24	703-48246-00	36 - 23	6K7-81826-10	18 - 24
6C5-43841-00	27 - 57	62Y-44135-00	24 - 30	69W-45301-00-4D	31 - 2	663-45949-01-EL	32 - 24	701-48248-00	36 - 13	69J-81828-00	18 - 25
6C6-43841-00	27 - 25	6X4-44139-00	21 - 9	69W-45318-00	29 - 21	69W-45952-00-EL	32 - 24	703-48252-00	36 - 12	6C5-8182L-00	6 - 8
6C5-43845-00	27 - 61	63D-44144-00	31 - 52	63D-45321-00	31 - 14	6H5-45952-00-EL	32 - 24	69W-48261-00	21 - 25	67F-81830-00	18 - 17
62X-4384H-00	27 - 14	62Y-44151-00	31 - 51	688-45341-10	31 - 9	663-45952-02-EL	32 - 24	703-48261-01	36 - 2	67F-81832-00	18 - 11
6C5-43851-00	27 - 34	6X4-44159-00-4D	21 - 47	63D-45344-00	31 - 34	663-45956-01-EL	32 - 24	703-48264-00	36 - 6	67F-81836-00	18 - 12
6C6-43853-00	27 - 30	6X4-44173-00	21 - 48	63D-45361-02-4D	31 - 43	6H5-45958-00-EL	32 - 24	703-48265-00	36 - 9	69J-81839-00	18 - 21
6C5-43854-00	27 - 43	6X4-44177-00	21 - 12	67C-45371-00	32 - 11	663-45958-01-EL	32 - 24	703-48268-00	36 - 5	67F-8183R-00	18 - 16
6C5-43855-00	27 - 39	6X4-44188-00	21 - 15	63D-45375-00	32 - 5	697-45970-00-98	32 - 24	703-48271-00	36 - 60	60V-8183T-00	18 - 18
6C5-43856-00	27 - 40	6G8-44191-00	21 - 50	663-45376-00-94	32 - 4	663-45970-60-98	32 - 24	703-48281-00	36 - 31	69J-81840-00	18 - 4
6C5-43861-00	27 - 6	63D-44311-00	31 - 21	6E5-45378-00	31 - 17	663-45972-60-98	32 - 24	703-48282-00	36 - 32	67F-81841-00	18 - 14
6C5-43862-00	27 - 5	63D-44312-00	32 - 18	69W-45501-00	31 - 36	663-45974-02-98	32 - 24	703-48284-00	36 - 52	6C5-81842-00	18 - 20
62Y-43863-00	27 - 4		40 - 25	6H4-45536-00	31 - 4	663-45974-60-98	32 - 24	701-48287-00	36 - 42	67F-81846-00	18 - 26
6C5-43869-00	28 - 6	63D-44316-00	31 - 27	69W-45551-00	31 - 37	663-45976-00-98	32 - 24	703-48291-10	36 - 39	67F-81850-00	18 - 2

NUMERICAL INDEX

PART NO.	REF. NO.	PART NO.	REF. NO.	PART NO.	REF. NO.	PART NO.	REF. NO.	PART NO.	REF. NO.	PART NO.	REF. NO.
67F-81857-00	18 - 9	703-82540-00	36 - 50	63D-83672-01	25 - 30	90119-06106	7 - 10	90201-12M16	26 - 17	90387-06M43	19 - 36
6C5-81860-00	38 - 2	6C5-82553-00	16 - 9	63D-83672-10	25 - 30		24 - 32	90201-13M19	26 - 27	90387-06M45	24 - 31
6X4-81860-00	22 - 21	68F-82553-80	37 - 18	68F-83688-00	6 - 18	90119-06120	29 - 8	90201-16014	5 - 19	90387-06M69	8 - 26
69J-81869-00	18 - 23	6C5-82554-01	16 - 16	6Y5-83728-00	37 - 12	90119-06M08	7 - 11	90201-21M18	13 - 7	90387-06M82	24 - 36
67F-81891-00	18 - 15	682-82556-00	22 - 5	6C5-84301-00	22 - 15		19 - 2	90201-22008	31 - 56	90387-10M42	34 - 6
6C5-81919-00	16 - 33		36 - 48	6X4-85415-00	22 - 20	90119-06M59	14 - 26	90201-22M05	26 - 28	90387-12M02	21 - 62
60V-81925-00	15 - 14	6X4-82563-00	22 - 7	6C5-85525-00	14 - 1		15 - 25	90201-27M00	31 - 35	90389-22M01	32 - 21
6C5-81941-00	18 - 22	703-82563-02	36 - 55	6C5-85548-00	15 - 22	90119-06MA3	4 - 17	90201-30M00	26 - 2	90413-05014	26 - 35
6C5-81942-00	16 - 22	63D-82563-10	15 - 43	6C5-85561-00-94	13 - 9	90119-06MA5	2 - 15	90202-07M07	24 - 21	90430-06014	4 - 13
6C5-81948-00	15 - 21	69W-82575-00	22 - 4	62Y-85580-00	13 - 12	90119-08069	7 - 2	90202-10M56	23 - 9		39 - 9
68V-8194A-00	15 - 34	688-82575-01	36 - 47	6C5-85790-00	16 - 10	90119-08M01	2 - 4	90202-21100	26 - 26	90430-08020	31 - 8
60E-81950-00	15 - 1	676-82577-00	22 - 2	6C5-85885-00	6 - 6	90119-08M15	31 - 29	90206-08N51	28 - 2		40 - 11
63P-81950-00	15 - 27	703-82577-00	36 - 45	6C1-8591A-30	14 - 23		40 - 29	90206-10M04	24 - 35	90430-14115	2 - 27
6C5-81953-00	15 - 39	6C5-8257V-00	15 - 4	6C5-8591A-30	14 - 23	90119-08M79	29 - 18	90206-12052	19 - 15		16 - 11
68V-81960-00	14 - 15	689-8257Y-00	22 - 6	6C5-86112-00	7 - 14	90119-08M82	29 - 19	90206-12M22	21 - 61		39 - 6
6C5-81961-00	14 - 16	68F-82582-00	15 - 16	6C5-86120-00	7 - 12	90119-08M84	32 - 10	90209-10M26	23 - 11	90430-14M09	30 - 7
6C5-82105-00	17 - 1	68V-82582-10	16 - 34	6Y5-87122-S0	37 - 14	90142-05001	21 - 10	90249-06M19	25 - 20		40 - 3
6C5-82105-U0	17 - 1	6X4-82586-10	22 - 10	6C5-87226-00	8 - 11	90142-05M06	31 - 12	90250-06023	31 - 61	90430-18130	2 - 25
6Y5-82117-00	37 - 17	6E5-82587-00	15 - 46	6C5-W0001-00	39 - 1	90152-04015	22 - 23	90266-06M02	1 - 5		39 - 5
6G5-82119-00	15 - 38	61A-82588-01	16 - 17	6C5-W0001-20	40 - 1	90159-04005	15 - 18	90280-03024	31 - 25	90445-07M30	26 - 40
703-82119-00	25 - 31	688-8258A-20	36 - 49	69W-W0070-00	1 - 11	90159-06018	38 - 5		40 - 31	90445-07M53	26 - 31
682-82119-01	15 - 28	6C5-82590-11	16 - 1	63D-W0078-01	40 - 22	90159-06M14	16 - 24	90280-03M01	10 - 10	90445-07ME8	31 - 18
67C-82127-10	26 - 33	6C5-82590-30	16 - 1	63D-W0078-0A	40 - 32	90167-06002	20 - 4	90340-08002	31 - 7	90445-07MF2	26 - 31
6E5-82148-00	25 - 3	703-82591-00	36 - 53	6C5-W009A-01-1S	4 - 1	90170-09M03	34 - 5	90340-14M06	2 - 26	90445-09091	20 - 16
1E6-82151-00	37 - 16	703-82592-00	36 - 54	6C5-W009B-01-1S	2 - 1	90170-12138	31 - 38		30 - 6	90445-09104	20 - 17
67F-82151-00	16 - 2	703-82594-00	36 - 25	63D-W4434-00	31 - 30	90170-20137	13 - 6	90340-18M09	2 - 24	90445-09220	20 - 13
67F-82151-10	16 - 3	60V-8259F-00	16 - 15	6C5-W8186-00	38 - 1	90170-35008	10 - 9	90344-51003	2 - 7	90445-09226	20 - 9
67F-8215B-10	16 - 4	6X4-83383-00	22 - 11	90101-06020	25 - 6	90171-16011	32 - 22	90386-08032	21 - 16	90445-11M05	12 - 8
67F-8215B-20	16 - 5	703-83383-02	36 - 51	90101-08M15	26 - 11	90179-06029	1 - 3	90386-10025	25 - 17		33 - 11
6C5-82171-00	14 - 20	6X4-83386-00	22 - 12	90101-09M01	34 - 7	90179-08003	15 - 15	90386-10M16	25 - 16	90445-11M06	12 - 6
6C5-82176-00	16 - 26	6Y5-83500-S5	37 - 6	90101-12014	21 - 59	90185-06M05	1 - 8	90386-12003	21 - 64		33 - 9
63P-82310-01	14 - 5	6Y5-8350T-03	37 - 1	90101-12M65	25 - 42	90185-08045	26 - 13	90386-12M37	19 - 13	90445-13M00	12 - 8
6C5-82316-01	14 - 12	6Y5-83533-T2	37 - 10	90105-08060	5 - 20	90185-09M01	34 - 4	90386-12MA2	19 - 14	90445-13M01	12 - 6
6C5-82316-11	14 - 13	6Y5-83553-M0	37 - 15	90105-08M61	31 - 44	90185-10051	26 - 8	90386-18M35	25 - 28	90445-13M02	11 - 6
6A0-82317-00	7 - 8	6Y5-83557-10	37 - 19	90105-09005	4 - 16	90185-10M14	23 - 13	90386-18M92	25 - 27	90445-13M36	11 - 17
	15 - 26	6Y5-83557-31	37 - 11	90109-06047	1 - 7	90185-12M12	21 - 66	90386-22MA4	25 - 12	90446-14M62	11 - 33
6C5-82317-00	14 - 24	6E5-83558-00	26 - 32	90109-06M65	4 - 12	90185-22M11	25 - 13	90386-26MA3	21 - 51	90447-07001	26 - 37
6E7-82317-00	19 - 25	6E5-83558-10	31 - 19	90109-06M80	19 - 34	90201-06015	29 - 9	90386-30M60	26 - 6	90447-10006	20 - 18
6C5-82340-01	14 - 6	6Y5-83570-S5	37 - 7		20 - 5	90201-06028	38 - 8	90386-30M77	26 - 4	90447-13010	25 - 35
6C5-82377-00	20 - 19	6H4-83589-00	22 - 19	90109-06M81	19 - 11	90201-08M14	25 - 40	90386-30M78	26 - 3	90447-19009	25 - 35
63V-82377-50	25 - 41	6C5-83614-01	15 - 44	90109-06M86	15 - 45	90201-10120	26 - 43	90386-90M90	24 - 16	90450-50001	7 - 7
6C5-82388-00	16 - 12	6A1-83625-41	13 - 17		19 - 20	90201-10144	10 - 5	90387-04001	16 - 18	90462-08031	20 - 10
64J-82504-00	16 - 21	6A1-83625-51	13 - 18	90109-06M88	23 - 3	90201-10M20	24 - 17	90387-05M05	23 - 12	90464-06001	14 - 14
6X4-82510-10	22 - 1	62Y-83626-00	13 - 19	90109-12MA3	26 - 24		34 - 3	90387-05M11	23 - 14	90464-07M05	14 - 8
703-82510-43	36 - 44	67F-83627-01	18 - 27	90116-10M28	26 - 7	90201-10M63	34 - 8	90387-06060	19 - 4	90464-07M41	14 - 7
6C5-8252R-00	16 - 27	6E0-83627-41	21 - 68	90119-06025	10 - 18	90201-12035	21 - 63	90387-06119	7 - 9	90464-07M56	6 - 14
703-82531-00	36 - 46	6E0-83627-51	21 - 69	90119-06077	16 - 30	90201-12426	25 - 44		14 - 25	90464-08M07	22 - 3
6X4-82540-00	21 - 26	6X4-83653-20	22 - 14	90119-06087	7 - 3	90201-12M07	19 - 16		15 - 24	90464-09M13	19 - 24

NUMERICAL INDEX

PART NO.	REF. NO.	PART NO.	REF. NO.	PART NO.	REF. NO.	PART NO.	REF. NO.	PART NO.	REF. NO.	PART NO.	REF. NO.
90464-09M42	21 - 36	90506-14M24	25 - 21	92995-08100	26 - 15	93315-32224	31 - 3	95895-06035	24 - 34	97880-06025	19 - 31
90464-09M49	19 - 37	90506-18M40	19 - 21		32 - 13	93317-22204	31 - 49	95895-08016	11 - 15	97885-04016	16 - 19
90464-10006	26 - 38	91317-03005	27 - 55	92995-08600	17 - 8	93332-00001	31 - 6	97013-06020	15 - 32	97885-06008	25 - 4
90464-12006	7 - 19	91317-03016	27 - 50		21 - 30	93332-00092	31 - 40	97013-06030	30 - 11		26 - 34
90464-15008	7 - 18	91317-04030	27 - 49	92995-10100	29 - 24	93399-999T8	28 - 3	97013-06035	2 - 5	97885-06016	21 - 55
90464-18007	16 - 29	91317-05025	27 - 46		32 - 8	93410-18M02	25 - 29	97013-08045	17 - 12		25 - 32
90464-18246	14 - 4	91317-05030	27 - 33	92995-10600	29 - 25	93410-28M06	26 - 9	97075-06025	29 - 15		38 - 9
90464-76001	25 - 33	91317-05045	27 - 23		32 - 9	93420-36M01	29 - 22	97075-08030	26 - 14	97885-06040	21 - 53
90465-05M87	15 - 7	91317-05050	27 - 66	92995-12200	25 - 43	93430-06024	36 - 10	97075-10040	32 - 7	98507-04010	4 - 21
90465-06M86	26 - 29	91490-16010	24 - 29	92A08-03110	27 - 44	93450-17129	3 - 9	97075-10045	29 - 23	98580-03015	36 - 38
	38 - 7	91490-20010	21 - 11	93101-22M00	31 - 50	93450-32116	27 - 11	97080-08020	25 - 39	98580-04006	36 - 36
90465-11M10	7 - 20	91490-20015	24 - 18		40 - 20	93501-04M02	24 - 15	97095-05012	2 - 20	98580-04010	36 - 35
	9 - 17	91490-30025	32 - 23	93101-25M57	31 - 32	93503-16003	27 - 13		4 - 8	98580-05010	36 - 37
	11 - 7	91690-30020	25 - 18		40 - 16	93505-32038	27 - 29		13 - 13	98580-06016	10 - 13
	15 - 40	92903-06600	2 - 6	93101-35002	3 - 11	93603-17070	10 - 12	97095-05014	24 - 9	98586-05016	33 - 4
	19 - 38		15 - 33		39 - 8	93604-08062	31 - 28	97095-05020	23 - 15	99001-08600	31 - 54
	20 - 7		30 - 12	93102-37M40	10 - 19	93604-10M03	29 - 12	97095-06010	15 - 29	99009-32500	27 - 16
	25 - 34	92903-08100	15 - 20		39 - 14	93605-17002	10 - 3		25 - 22	99530-08012	4 - 15
	26 - 30	92903-08600	17 - 13	93102-43M42	3 - 10	93606-12019	2 - 3	97095-06014	4 - 33		13 - 11
	29 - 2	92907-04600	4 - 22		39 - 7		29 - 26		14 - 2	99590-10114	17 - 4
	31 - 20	92990-04100	37 - 4	93103-18011	29 - 3		30 - 3		15 - 5	9E450-04433	37 - 2
	37 - 13	92990-06100	19 - 32		40 - 5		32 - 6		16 - 13	9E450-04533	37 - 3
90465-11M59	30 - 5		23 - 5	93106-09014	31 - 15	93608-12M05	7 - 1		19 - 18		
90465-13M11	16 - 7	92990-06600	19 - 33		40 - 12		29 - 4		21 - 37		
90465-13M18	7 - 24		22 - 9	93210-07003	31 - 53	93700-06M03	21 - 3		22 - 13		
	17 - 14	92990-08200	5 - 21		40 - 21		25 - 10	97095-06016	7 - 15		
90465-13M24	16 - 6	92990-08600	36 - 34	93210-08287	12 - 3	94702-00418	4 - 42	97095-06020	2 - 22		
	38 - 10	92990-12200	21 - 60		33 - 14	95023-06030	13 - 8		4 - 10		
90465-13M36	22 - 25	92990-12600	21 - 65	93210-09165	27 - 62	95307-03600	27 - 45		15 - 8		
90465-13M39	16 - 23	92995-04100	16 - 20	93210-16275	34 - 10	95333-08600	15 - 19		19 - 39		
90465-13M97	13 - 15	92995-05600	2 - 21	93210-18397	27 - 59	95380-04600	37 - 5		24 - 3		
	15 - 42		4 - 9	93210-24M79	4 - 30	95380-05600	11 - 27	97095-06025	11 - 2		
90467-08M18	20 - 14		13 - 14		11 - 29		23 - 17		14 - 17		
90467-09M17	11 - 8		23 - 16		39 - 12		31 - 13		24 - 5		
90467-10M04	11 - 18		24 - 10	93210-29M94	26 - 5		36 - 7	97095-06030	11 - 30		
90468-10005	21 - 39	92995-06100	14 - 10	93210-32738	11 - 12	95380-05700	24 - 26		14 - 9		
90468-18008	24 - 19		15 - 9	93210-33MG4	31 - 16	95380-06600	7 - 13		21 - 31		
90480-09M12	8 - 27		19 - 42		40 - 13		19 - 30	97095-08025	17 - 9		
	19 - 3	92995-06600	2 - 23	93210-48MG8	31 - 33		21 - 19		32 - 12		
90480-12072	13 - 2		4 - 11		40 - 17		36 - 40	97095-08035	17 - 7		
	17 - 2		7 - 16	93210-59MG7	31 - 24	95380-06800	19 - 40		32 - 15		
90480-13598	16 - 31		11 - 3		40 - 14	95380-08600	11 - 16	97095-08040	21 - 29		
90480-13M24	19 - 35		14 - 3	93210-64488	27 - 65		17 - 6	97380-05025	36 - 8		
90480-24003	17 - 11		15 - 6	93210-69MG6	31 - 48	95380-12600	25 - 45	97380-08030	36 - 33		
90501-12082	24 - 14		16 - 14		40 - 19	95380-12700	26 - 25	97780-60620	15 - 3		
90501-18001	31 - 59		21 - 32	93210-74MG5	31 - 47	95680-08330	17 - 5		22 - 17		
90501-23215	21 - 14		24 - 4		40 - 18	95780-06300	38 - 6	97780-60920	21 - 49		
90501-6C500	10 - 16		29 - 16	93306-001U1	31 - 45	95817-10035	10 - 4	97880-06016	22 - 8		



F50/F60
F50F/F60C
PARTS CATALOGUE
©2005 by Yamaha Motor Co., Ltd.
1st edition, April 2005
All rights reserved.
Any reprinting or unauthorized use
without the written permission of
Yamaha Motor Co., Ltd.
is expressly prohibited.
Printed in Japan.