



PARTS CATALOGUE

F50 (6C15)

F60 (6C55)

F50F'09 (6C15)

F60C'09 (6C55)



2009/3/31

1H6C1-100E1

()

NEWS NO.	DATE	COMMENT
PE0-OM-090025	March,2,2009	MOD:FIG.27 PTT(6C5-43800-01-8D) P/No. REVISION

F50/F60
F50F/F60C
PARTS CATALOGUE
©2008 by Yamaha Motor Co., Ltd.
1st edition, March 2008
All rights reserved.
Any reprinting or unauthorized use
without the written permission of
Yamaha Motor Co., Ltd.
is expressly prohibited.
Printed in Japan.

FOREWORD

This Parts Catalogue is related to the parts for the model(s) on the cover page. When you are ordering replacement parts, please refer to this Parts Catalogue and quote both part numbers and part names correctly.

1. Modifications or additions which have been made after the issue of the Parts Catalogue will be announced in the Parts News.
It is advisable that you make the necessary corrections to the Parts Catalogue according to the Parts News.

2. Abbreviations

The following abbreviations are used in this Parts Catalogue.

“UR” Use specified parts number.

“UN” Use as many as needed.

“AP” Alternate Parts

“LM” Locally Made (Parts need to be ordered locally)

“F#” Frame No. (Applicable machine No.)

“O/S” Over Size

3. The number of components for assembly

- Parts, which are to be supplied in an assembly, are listed with a dot (.) in front of the part name as shown below.
- The numeral appearing to the right of each component part indicates the quantity of parts for each assembly unit.

PART NO.	DESCRIPTION	Q'TY	REMARKS
2F5-83310-60	FRONT FLASHER LIGHT ASSY	2	
115-83311-60	.BULB (6V-18W)	1	

4. Applicable colours of graphics are represented in the “REMARKS” as shown below.

PART NO.	DESCRIPTION	Q'TY	REMARKS
2N4-24110-00-X5	FUEL TANK COMP.	2	MXR
3J1-24240-10	.GRAPHIC, FUEL TANK	1	FOR MXR

5. Note that the illustrations for reference in finding parts numbers are not to be used for assembling. When assembling, please use the applicable service manual.

6. The asterisk (*) before a reference number indicates modified items after the first edition.

7. Applicable Serial No.

Engine Serial No.

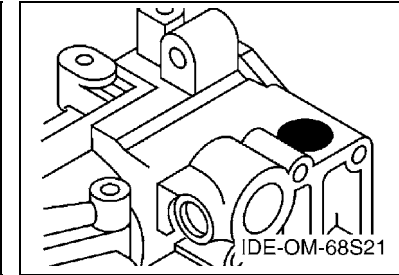
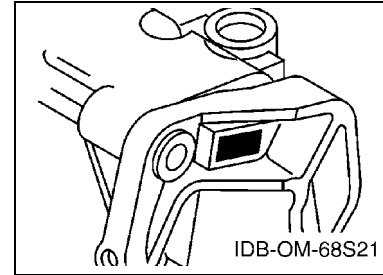

8. Applicable Engine Starting Serial No.

Model	Serial No.	Model	Serial No.
F50	6C1-1026054	F50F	6C1-1026054
F60	6C5-1032264	F60C	6C5-1032264

9. Applicable Colour Code

Abbreviation	Colour Name	Colour Code
DBN1	DARK BLUISH GRAY 1	008D

10. Quantity Column Information

Column No.	Name Of Q'ty Column	Applicable Model
1	EHT	F50/F60THH,F50F/F60CEHT
2	ET	F50/F60TRH,F50F/F60CET

CONTENTS

TOP COWLING	1
CYLINDER & CRANKCASE 1	2
CRANKSHAFT & PISTON	4
CYLINDER & CRANKCASE 2	5
VALVE	7
INTAKE 1	8
INTAKE 2	9
FUEL INJECTION PUMP 1	10
FUEL INJECTION PUMP 2	12
OIL PUMP	14
FUEL 1	15
FUEL 2	17
GENERATOR	18
ELECTRICAL 1	19
ELECTRICAL 2	21
ELECTRICAL 3	23
ELECTRICAL 4	25
STARTING MOTOR	26
BOTTOM COWLING 1	27
BOTTOM COWLING 2	29
STEERING 1	30
STEERING 2	33
STEERING FRICTION	34
CONTROL	35
BRACKET 1	37
BRACKET 2	39
POWER TRIM & TILT ASSY 1	41
POWER TRIM & TILT ASSY 2	44
UPPER CASING	45
OIL PAN	46
LOWER CASING & DRIVE 1	47
LOWER CASING & DRIVE 2	50
FUEL TANK	52
STEERING GUIDE	53
REMOTE CONTROL BOX	54
REMOTE CONTROL ASSY	55
METER	58
REPAIR KIT 1	59
REPAIR KIT 2	60

INDEX

NUMERICAL INDEX	62
-----------------------	----

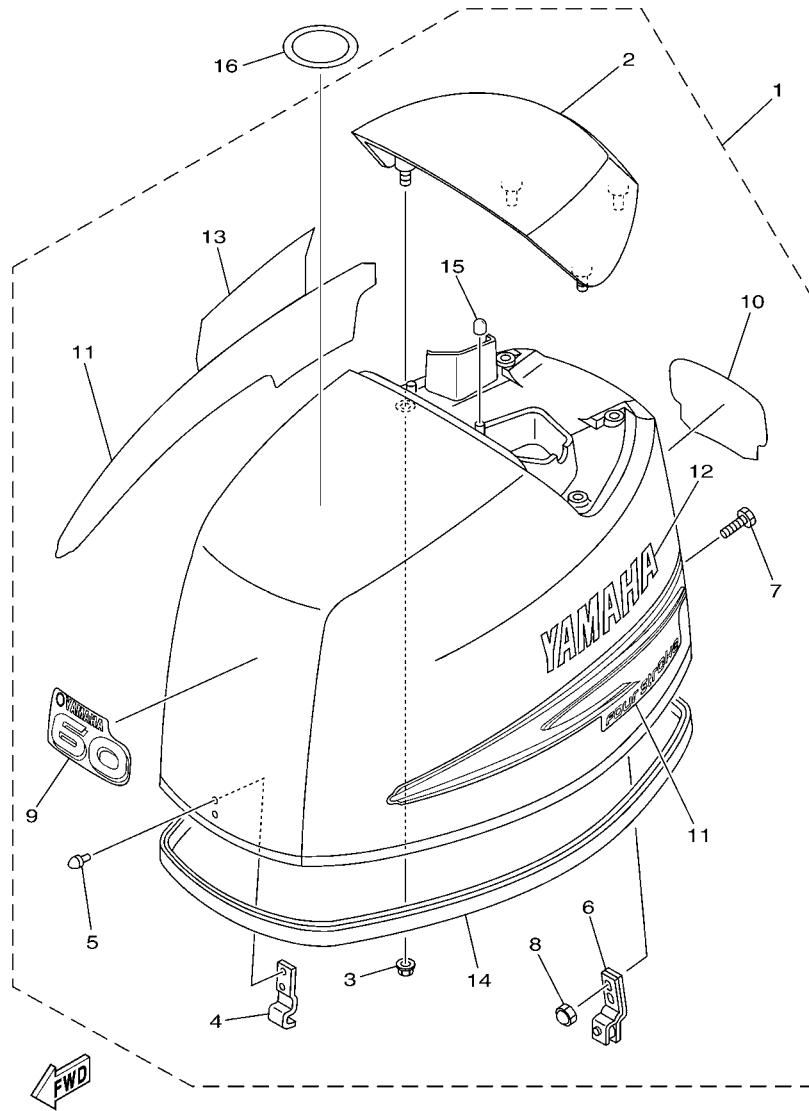

6C11010-D010

FIG. 1 TOP COWLING

REF. NO.	PART NO.	DESCRIPTION	EHT	ET			REMARKS
1	6C1-42610-00-8D	TOP COWLING ASSY	1	1			F50,F50F
	6C5-42610-00-8D	TOP COWLING ASSY	1	1			F60,F60C
	6C5-42610-A0-8D	TOP COWLING ASSY		1			F60TJR
2	67C-42613-00-8D	.MOLDING, AIR DUCT	1	1			
3	90179-06029	.NUT	4	4			
4	6C5-42651-00	.HOOK	1	1			
5	90266-06M02	.RIVET	2	2			
6	67C-42652-02	.HOOK	1	1			
7	90109-06047	.BOLT	2	2			
8	90185-06M05	.NUT, SELF-LOCKING	2	2			
9	62Y-42677-30	.GRAPHIC, FRONT	1	1			F50,F50F
	69W-42677-00	.GRAPHIC, FRONT	1	1			F60,F60C
	69W-42677-A0	.GRAPHIC, FRONT		1			F60TJR
10	6C1-42678-00	.GRAPHIC, REAR	1	1			F50,F50F
	6C5-42678-00	.GRAPHIC, REAR	1	1			F60,F60C
	6C5-42678-A0	.GRAPHIC, REAR		1			F60TJR
11	69W-W0070-00	.GRAPHIC SET	1	1			
12	69W-42681-00	.MARK, COWLING	1	1			
13	69W-42682-00	.MARK, COWLING	1	1			
14	6C5-42615-00	.SEAL	1	1			
15	69W-13448-00	.CAP	2	2			
16	67F-13434-10	LABEL, CAUTION	1	1			

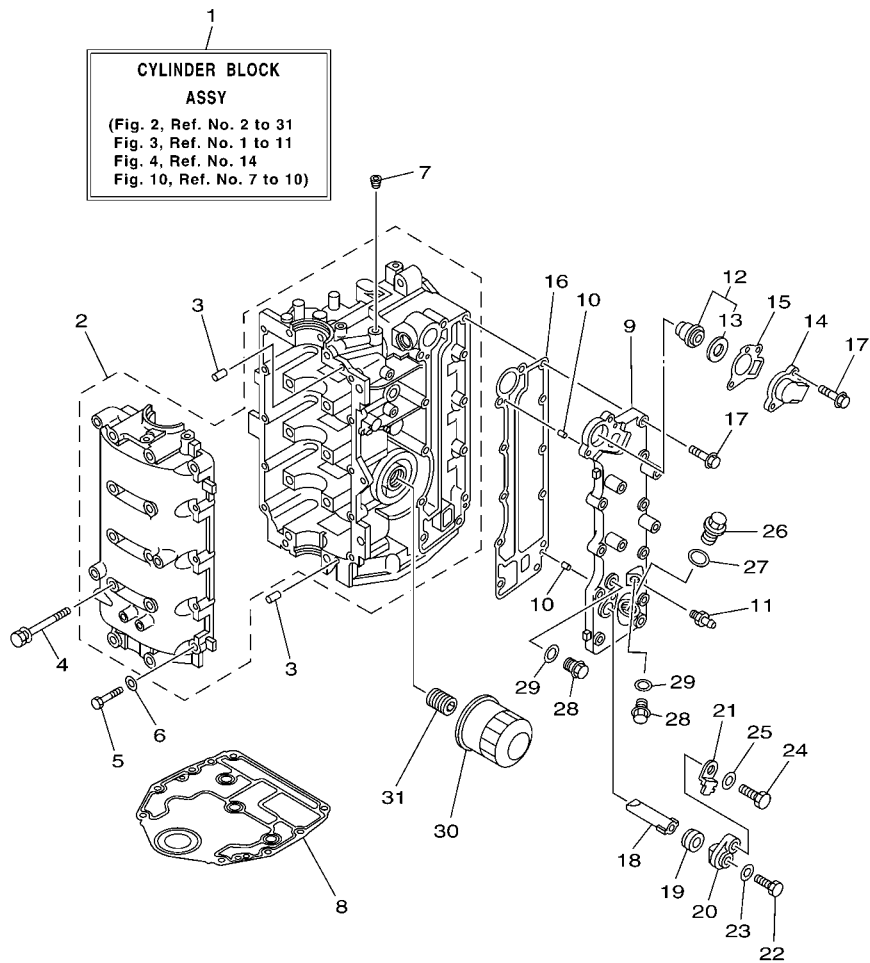

6C13100-F020

FIG. 2 CYLINDER & CRANKCASE 1

REF. NO.	PART NO.	DESCRIPTION	EHT	ET	REMARKS
1	6C5-W009B-02-9S	CYLINDER BLOCK ASSY	1	1	
2	6C5-15100-10-9S	CRANKCASE ASSY	1	1	
3	93606-12019	PIN, DOWEL	4	4	
4	90119-08M01	BOLT, WITH WASHER	10	10	
5	97013-06035	BOLT	10	10	
6	92903-06600	WASHER, PLATE	10	10	
7	90344-51003	PLUG, TAPER SCREW	1	1	
8	67C-11351-01	GASKET, CYLINDER	1	1	
9	6C5-41113-11-9S	OUTER COVER, EXHAUST	1	1	
10	93604-10M03	PIN, DOWEL	2	2	
11	62Y-12481-10	PIPE 1	1	1	
12	6G8-12411-03	THERMOSTAT	1	1	
13	688-12412-00	.SEAL, THERMOSTAT	1	1	
14	6C5-12413-00-9S	COVER, THERMOSTAT	1	1	
15	62Y-12414-00	GASKET, COVER	1	1	
16	6C5-41114-10	GASKET, EXHAUST OUTER COVER	1	1	
17	90119-06MA5	BOLT, WITH WASHER	12	12	
18	62Y-11325-00	ANODE	1	1	
19	66M-11328-00	GROMMET, ANODE	1	1	
20	66M-11327-00-94	COVER, ANODE	1	1	
21	66M-12535-00	PLATE	1	1	
22	97095-05012	BOLT	1	1	
23	92995-05600	WASHER	1	1	
24	97095-06020	BOLT	1	1	
25	92995-06600	WASHER	1	1	
26	90340-18M09	PLUG, STRAIGHT SCREW	1	1	
27	90430-18130	GASKET	1	1	

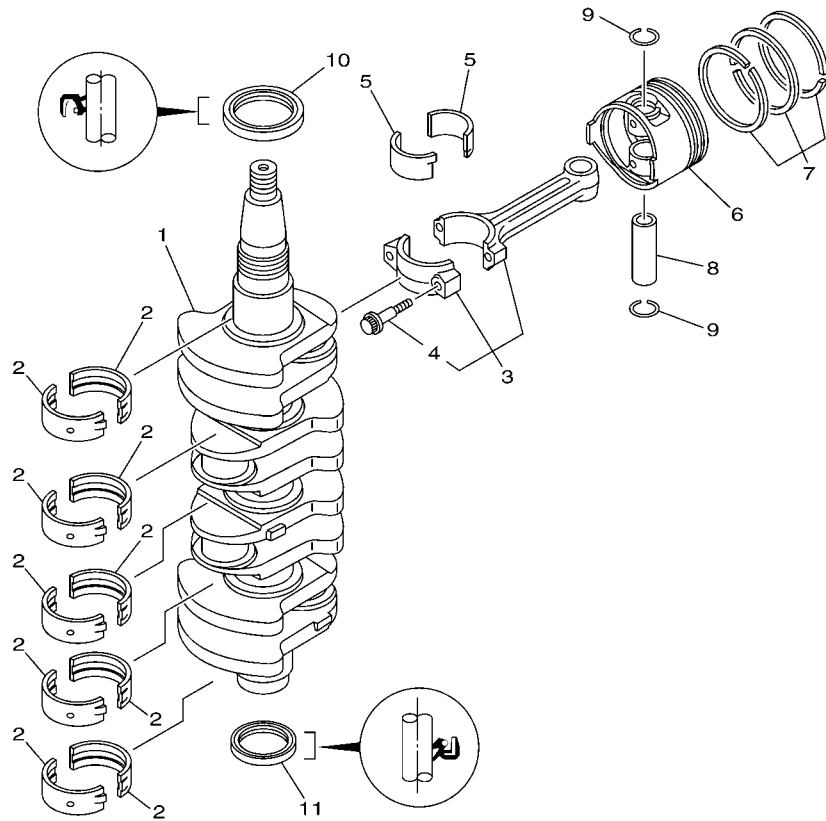

6C11010-D030

FIG. 3 CRANKSHAFT & PISTON

REF. NO.	PART NO.	DESCRIPTION	EHT	ET		REMARKS
1	6C5-11411-00	CRANKSHAFT	1	1		
2	6C5-11416-00	PLANE BEARING, CRANKSHAFT 1	10	10		UR YELLOW
	6C5-11416-10	PLANE BEARING, CRANKSHAFT 1	10	10		UR RED
	6C5-11416-20	PLANE BEARING, CRANKSHAFT 1	10	10		UR PINK
	6C5-11416-30	PLANE BEARING, CRANKSHAFT 1	10	10		UR GREEN
3	6C5-11650-00	CONNECTING ROD ASSY	4	4		
4	6C5-11654-00	.BOLT, CONNECTING ROD	2	2		
5	6C5-11656-00	PLANE BEARING, CONNECTING ROD	8	8		UR YELLOW
	6C5-11656-10	PLANE BEARING, CONNECTING ROD	8	8		UR RED
	6C5-11656-20	PLANE BEARING, CONNECTING ROD	8	8		UR PINK
	6C5-11656-30	PLANE BEARING, CONNECTING ROD	8	8		UR GREEN
6	69W-11631-00-97	PISTON (STD)	4	4		
	69W-11635-00	PISTON (0.25MM O/S)	4	4		AP
	69W-11636-00	PISTON (0.50MM O/S)	4	4		AP
7	67C-11603-00	PISTON RING SET (STD)	4	4		
	67C-11604-00	PISTON RING SET (0.25MM O/S)	4	4		AP
	67C-11605-00	PISTON RING SET (0.50MM O/S)	4	4		AP
8	62Y-11633-00	PIN, PISTON	4	4		
9	93450-17129	CIRCLIP	8	8		
10	93102-43M42	OIL SEAL	1	1		
11	93101-35002	OIL SEAL	1	1		

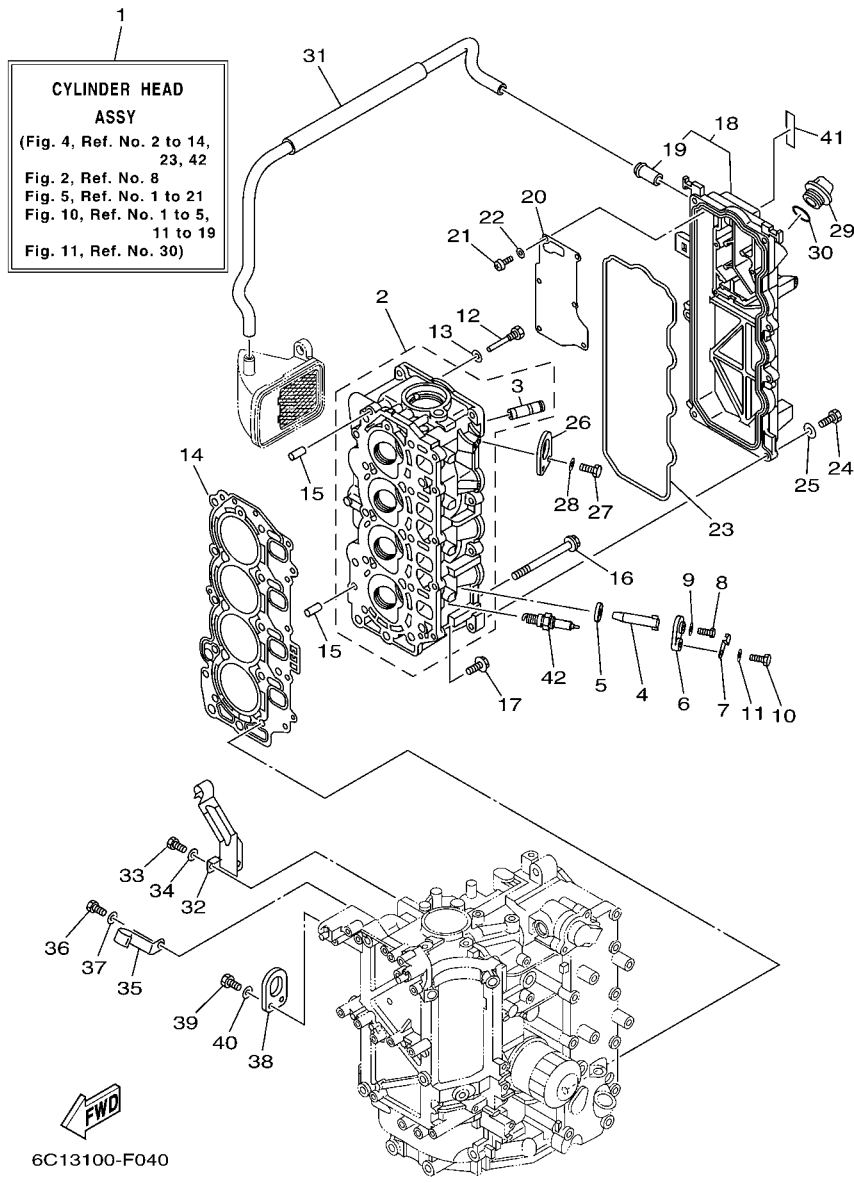

FIG. 4 CYLINDER & CRANKCASE 2

REF. NO.	PART NO.	DESCRIPTION	EHT	ET	REMARKS
1	6C5-W009A-11-9S	CYLINDER HEAD ASSY	1	1	
2	6C5-11111-00-9S	HEAD, CYLINDER 1	1	1	
3	62Y-11133-30	.GUIDE, VALVE 1	8	8	
4	62Y-11325-00	ANODE	4	4	
5	66M-11328-00	GROMMET, ANODE	4	4	
6	66M-11327-00-94	COVER, ANODE	4	4	
7	66M-12535-00	PLATE	4	4	
8	97095-05012	BOLT	4	4	
9	92995-05600	WASHER	4	4	
10	97095-06020	BOLT	4	4	
11	92995-06600	WASHER	4	4	
12	90109-06M65	BOLT	1	1	
13	90430-06014	GASKET	1	1	
14	6C5-11181-01	GASKET, CYLINDER HEAD 1	1	1	
15	99530-08012	PIN, DOWEL	2	2	
16	90105-09005	BOLT, FLANGE	10	10	
17	90119-06MA3	BOLT, WITH WASHER	5	5	
18	6C5-11191-01-9S	COVER, CYLINDER HEAD 1	1	1	
19	62Y-14485-00	.PIPE, JOINT	1	1	
20	6C5-11168-00	COVER, BREATHER	1	1	
21	98507-04010	SCREW, PAN HEAD	6	6	
22	92907-04600	WASHER	6	6	
23	62Y-11356-00	SEAL, CYLINDER 2	1	1	
24	97095-06020	BOLT	7	7	
25	92995-06600	WASHER	7	7	
26	62Y-11119-00	HANGER, ENGINE	1	1	
27	97095-06020	BOLT	2	2	

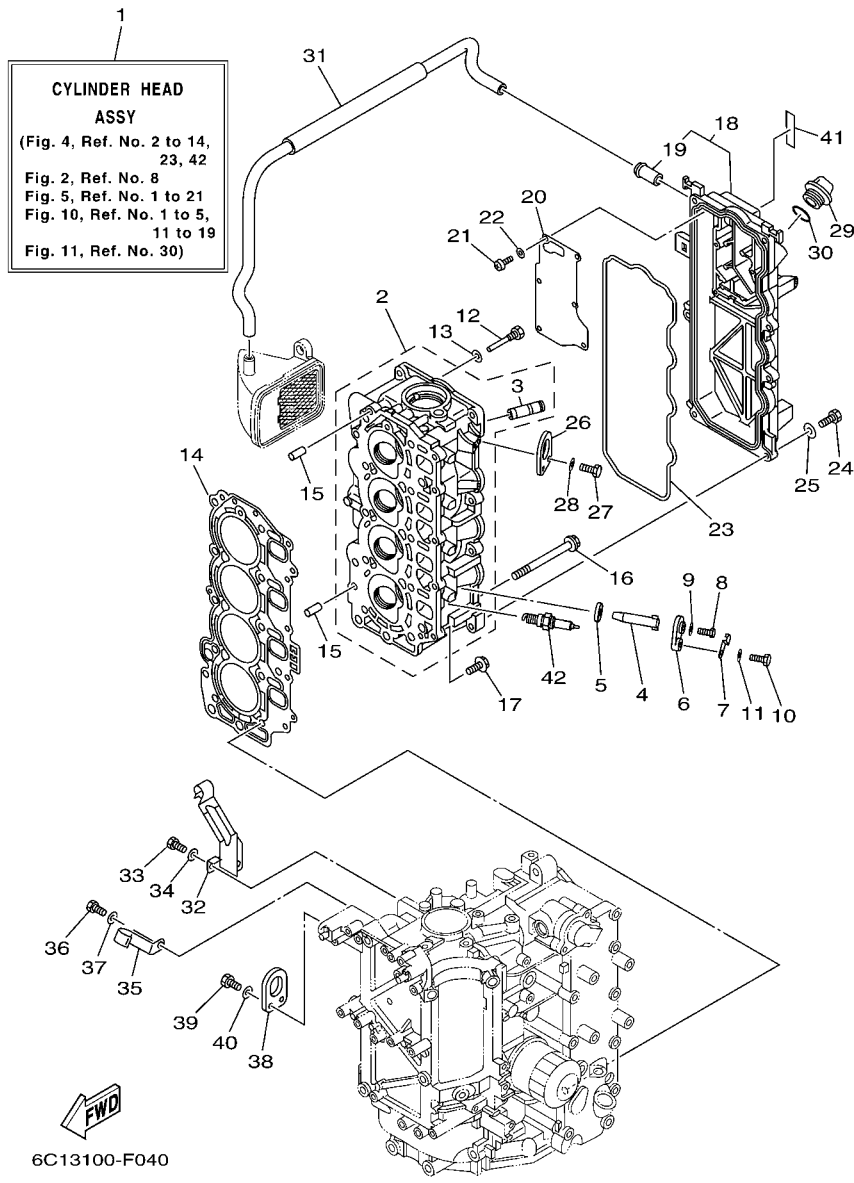

FIG. 4 CYLINDER & CRANKCASE 2

REF. NO.	PART NO.	DESCRIPTION	EHT	ET	REMARKS
28	92995-06600	WASHER	2	2	
29	6G8-15363-00	PLUG, OIL	1	1	
30	93210-24M79	O-RING	1	1	
31	6C5-1531A-01	HOSE, BREATHER 1	1	1	
32	6C5-15378-00	HOLDER	1	1	
33	97095-06014	BOLT	1	1	
34	92995-06600	WASHER	1	1	
35	6C5-15378-11	HOLDER	1	1	
36	97095-06014	BOLT	1	1	
37	92995-06600	WASHER	1	1	
38	62Y-11119-00	HANGER, ENGINE	1	1	
39	97095-06020	BOLT	2	2	
40	92995-06600	WASHER	2	2	
41	62Y-12138-40	MARK, CAUTION	1	1	FOR OCE
	62Y-12138-50	MARK, CAUTION	1	1	FOR CAN
	62Y-12138-60	MARK, CAUTION	1	1	FOR BRA
42	94702-00418	PLUG, SPARK (NGK DPR6EB)	4	4	

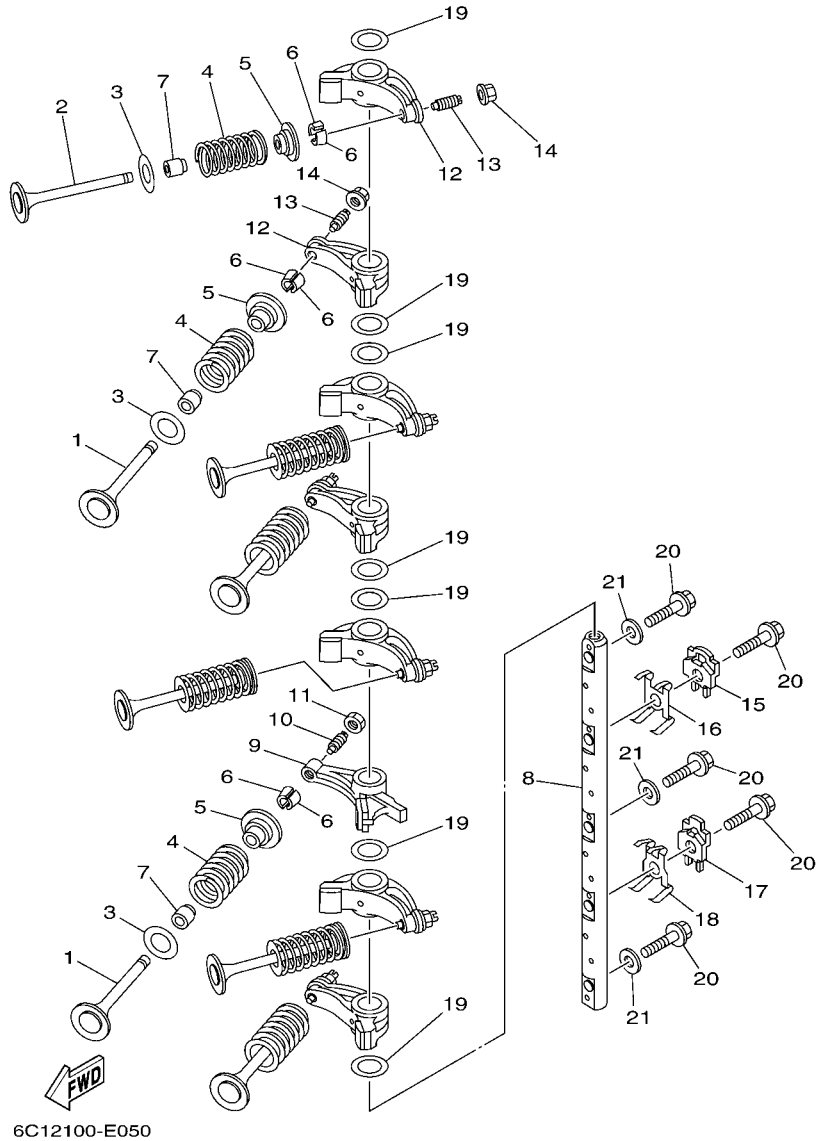

FIG. 5 VALVE

REF. NO.	PART NO.	DESCRIPTION	EHT	ET			REMARKS
1	69W-12111-00	VALVE, INTAKE	4	4			
2	69W-12121-00	VALVE, EXHAUST	4	4			
3	62Y-12116-00	SEAT, VALVE SPRING	8	8			
4	51Y-12114-00	SPRING, VALVE OUTER	8	8			
5	30X-12117-00	RETAINER, VALVE SPRING	8	8			
6	30X-12118-00	COTTER, VALVE	16	16			
7	51Y-12119-00	SEAL, VALVE STEM	8	8			
8	6C5-12146-00	SHAFT, ROCKER	1	1			
9	62Y-12151-00	ARM, VALVE ROCKER	1	1			
10	64J-12159-00	SCREW, VALVE ADJUSTING	1	1			
11	62Y-12158-00	NUT, LOCK	1	1			
12	6C5-12151-00	ARM, VALVE ROCKER	7	7			
13	6C5-12159-00	SCREW, VALVE ADJUSTING	7	7			
14	6C5-12158-00	NUT, LOCK	7	7			
15	6C5-12231-00	GUIDE, STOPPER 1	1	1			
16	6C5-12233-00	PLATE, GUIDE STOPPER 1	1	1			
17	6C5-12241-00	GUIDE, STOPPER 2	1	1			
18	6C5-12243-00	PLATE, GUIDE STOPPER 2	1	1			
19	90201-16014	WASHER, PLATE	7	7			
20	90105-08060	BOLT, FLANGE	5	5			
21	92990-08200	WASHER, PLAIN	3	3			

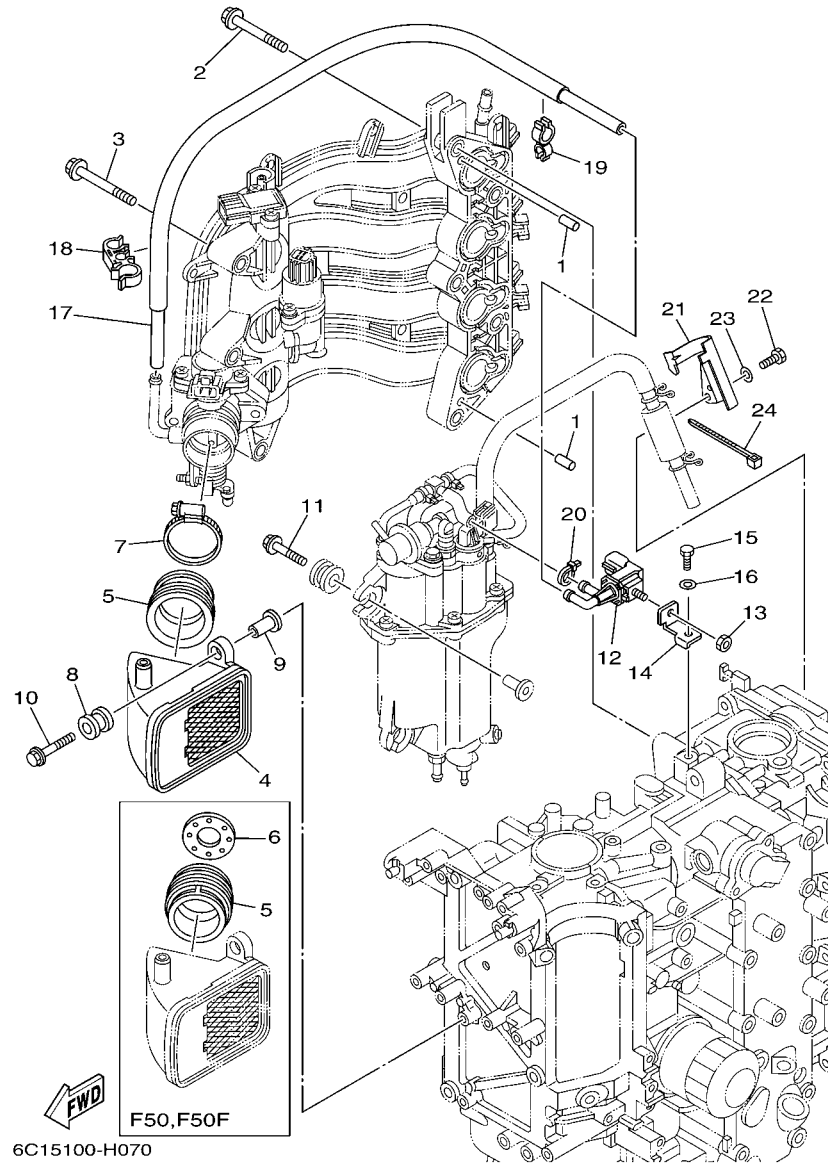

FIG. 7 INTAKE 2

REF. NO.	PART NO.	DESCRIPTION	EHT	ET			REMARKS
1	93608-12M05	PIN, DOWEL	2	2			
2	90119-08069	BOLT, WITH WASHER	5	5			
3	90119-06087	BOLT, WITH WASHER	3	3			
4	6C5-14440-00	SILENCER ASSY, INTAKE	1	1			
5	6C1-14453-01	JOINT, AIR CLEANER 1	1	1			F50, F50F
	6C5-14453-01	JOINT, AIR CLEANER 1	1	1			F60, F60C
6	6C1-14477-00	PLATE	1	1			F50, F50F
7	90450-50001	HOSE CLAMP ASSY	1	1			
8	6A0-82317-00	DAMPER, IGNITION COIL	2	2			
9	90387-06119	COLLAR	2	2			
10	90119-06106	BOLT, WITH WASHER	2	2			
11	90119-06M08	BOLT, WITH WASHER	3	3			
12	6C5-86120-00	SOLENOID VALVE ASSY	1	1			
13	95380-06600	NUT, HEXAGON	1	1			
14	6C5-86112-00	STAY, SOLENOID	1	1			
15	97095-06016	BOLT	1	1			
16	92995-06600	WASHER	1	1			
17	6C5-12576-00	HOSE 1	1	1			
18	90464-15008	CLAMP	1	1			
19	90464-12006	CLAMP	1	1			
20	90465-11M10	CLAMP	1	1			
21	6C5-13428-01	BRACKET, STRAINER 1	1	1			
22	97095-06016	BOLT	1	1			
23	92995-06600	WASHER	1	1			
24	90465-13M18	CLAMP	1	1			

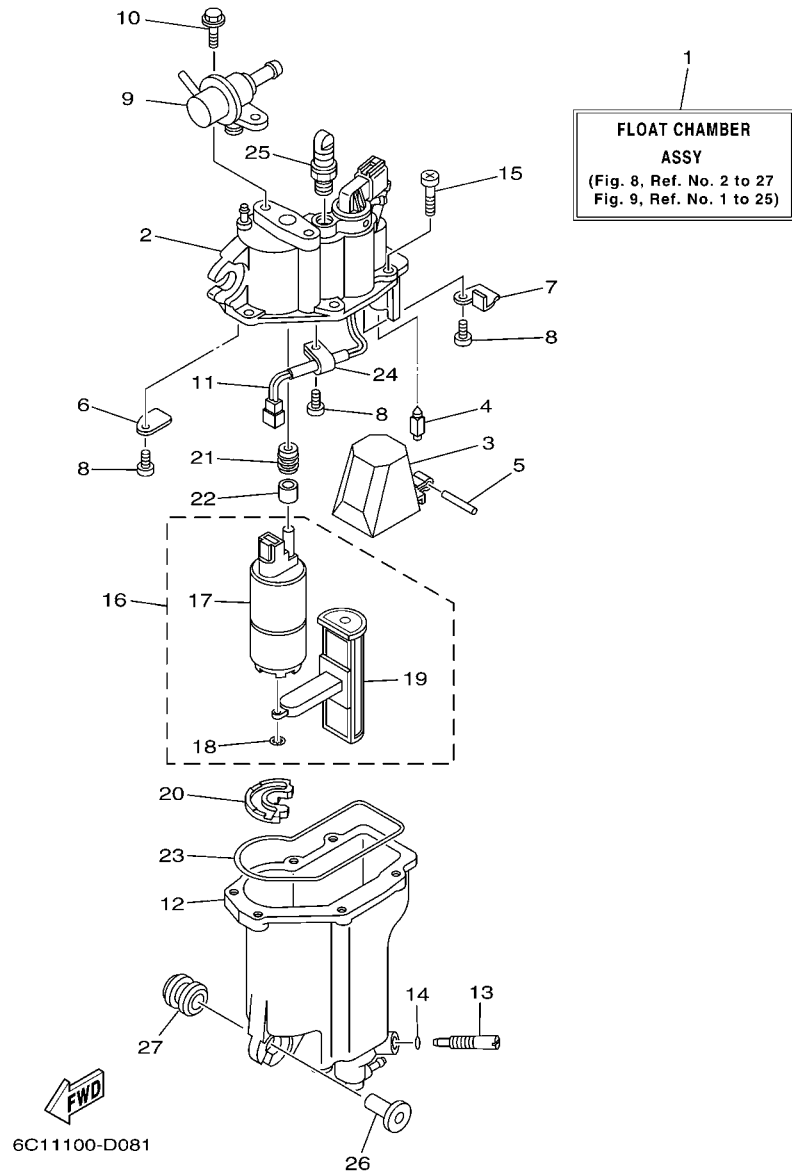

FIG. 8 FUEL INJECTION PUMP 1

REF. NO.	PART NO.	DESCRIPTION	EHT	ET		REMARKS
1	6C5-14180-00	FLOAT CHAMBER ASSY	1	1		FOR CAN,OCE
	6C5-14180-10	FLOAT CHAMBER ASSY		1		FOR BRA
2	6C5-14182-00	COVER, FLOAT CHAMBER	1	1		FOR CAN,OCE
	6C5-14182-10	COVER, FLOAT CHAMBER		1		FOR BRA
3	6C5-14985-00	FLOAT	1	1		
4	6C5-14546-00	VALVE, NEEDLE	1	1		FOR CAN,OCE
	6C5-14546-10	VALVE, NEEDLE		1		FOR BRA
5	6C5-14386-00	PIN, FLOAT	1	1		
6	6C5-2441R-00	PLATE, BAFFLE 1	1	1		FOR CAN,OCE
	6C5-2441R-10	PLATE, BAFFLE 1		1		FOR BRA
7	6C5-2441T-00	PLATE, BAFFLE 2	1	1		FOR CAN,OCE
	6C5-2441T-10	PLATE, BAFFLE 2		1		FOR BRA
8	6C5-24453-00	SCREW	3	3		
9	6C5-13906-01	REGULATOR, PRESSURE	1	1		
10	6C5-24592-00	BOLT	2	2		
11	6C5-87226-00	WIRE HARNESS ASSY	1	1		
12	6C5-14960-00	BODY ASSY	1	1		FOR CAN,OCE
	6C5-14960-10	BODY ASSY		1		FOR BRA
13	6C5-14191-00	PLUG, DRAIN	1	1		
14	6C5-14397-00	O-RING	1	1		
15	6C5-14567-00	SCREW	6	6		
16	6C5-13910-00	FUEL PUMP ASSY	1	1		FOR CAN,OCE
	6C5-13910-10	FUEL PUMP ASSY		1		FOR BRA
17	6C5-13907-00	.FUEL PUMP COMP.	1	1		
18	6C5-14127-00	.CLIP	1	1		FOR CAN,OCE
	6C5-14127-10	.CLIP		1		FOR BRA
19	6C5-13915-00	.FILTER	1	1		

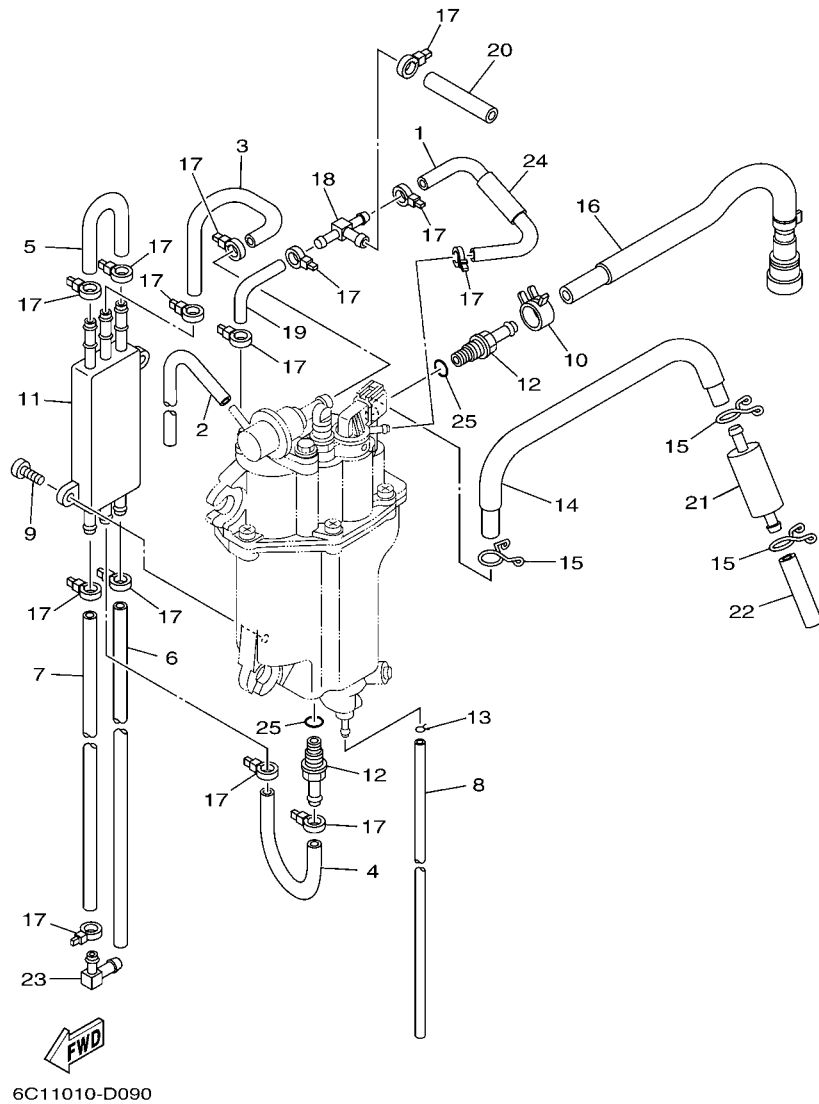
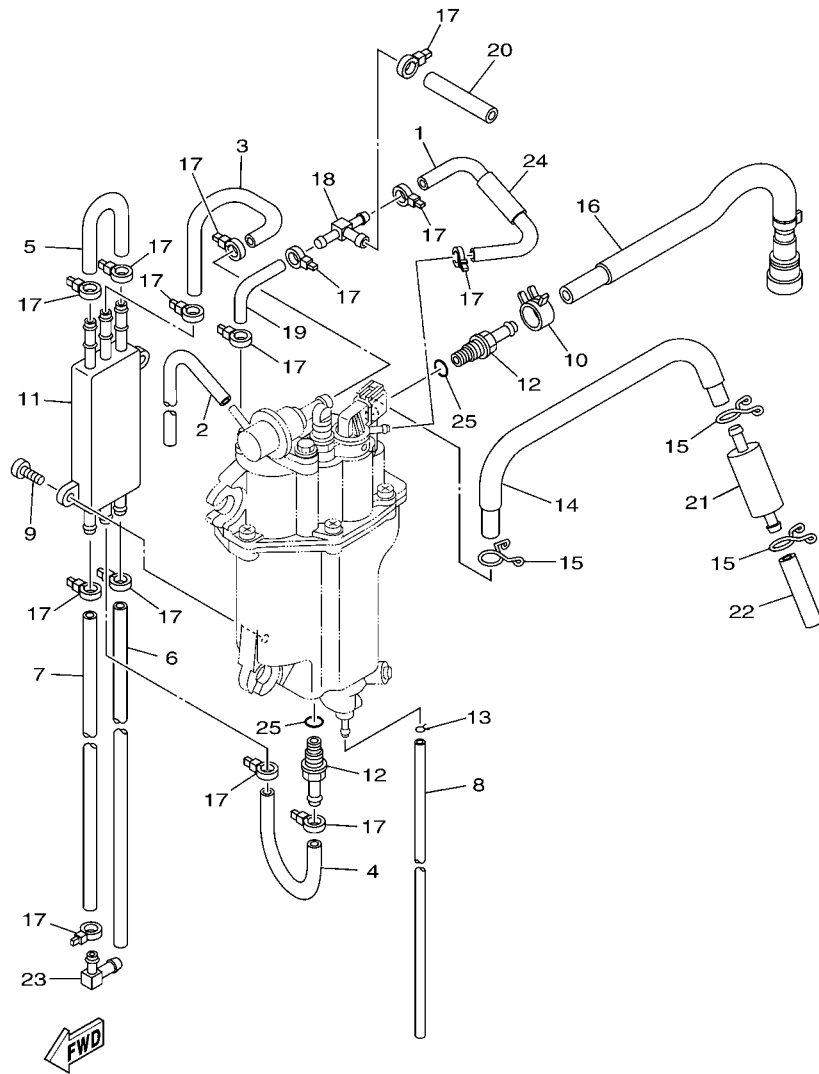

FIG. 9 FUEL INJECTION PUMP 2

REF. NO.	PART NO.	DESCRIPTION	EHT	ET	REMARKS
1	6C5-13546-00	HOSE 2	1	1	FOR CAN,OCE
	6C5-13546-10	HOSE 2		1	FOR BRA
2	6C5-13542-00	HOSE, VACUUM SENSING 1	1	1	
3	6C5-24321-00	PIPE 10	1	1	FOR CAN,OCE
	6C5-24321-10	PIPE 10		1	FOR BRA
4	6C5-24322-00	PIPE 11	1	1	FOR CAN,OCE
	6C5-24322-10	PIPE 11		1	FOR BRA
5	6C5-24323-00	PIPE 12	1	1	
6	6C5-24324-00	PIPE 13 (L150)	1	1	
7	6C5-24325-00	PIPE 14 (L110)	1	1	
8	6C5-14149-00	PIPE (L200)	1	1	
9	6C5-24444-00	SCREW	2	2	
10	6C5-13577-00	CLIP	1	1	
11	6C5-21841-00	COOLER	1	1	
12	6C5-14251-00	NIPPLE	2	2	
13	6C5-2411M-00	CLIP	1	1	
14	6C5-14148-00	PIPE	1	1	FOR CAN,OCE
	6C5-14148-10	PIPE		1	FOR BRA
15	6C5-24387-00	CLIP	3	3	
16	6C5-13974-00	PIPE, FUEL 4	1	1	
17	90465-11M10	CLAMP	14	14	
18	6C5-24379-00	PIPE, JOINT 4	1	1	
19	6C5-13545-00	HOSE 1	1	1	FOR CAN,OCE
	6C5-13545-10	HOSE 1		1	FOR BRA
20	6C5-13547-00	HOSE 3	1	1	FOR CAN,OCE
	6C5-13547-10	HOSE 3		1	FOR BRA
21	6C5-24251-00	STRAINER 1	1	1	



6C11010-D090

FIG. 9 FUEL INJECTION PUMP 2

REF. NO.	PART NO.	DESCRIPTION	EHT	ET			REMARKS
22	6C5-2451B-00	HOSE, FUEL INLET	1	1			FOR CAN,OCE
	6C5-2451B-10	HOSE, FUEL INLET		1			FOR BRA
23	6C5-1410F-00	CONNECTOR	1	1			
24	6C5-13548-00	HOSE, AIR 4	1	1			
25	6C5-13739-00	O-RING	2	2			
<hr style="border-top: 1px dashed black;"/>							
<hr style="border-top: 1px dashed black;"/>							
<hr style="border-top: 1px dashed black;"/>							
<hr style="border-top: 1px dashed black;"/>							
<hr style="border-top: 1px dashed black;"/>							
<hr style="border-top: 1px dashed black;"/>							
<hr style="border-top: 1px dashed black;"/>							
<hr style="border-top: 1px dashed black;"/>							
<hr style="border-top: 1px dashed black;"/>							

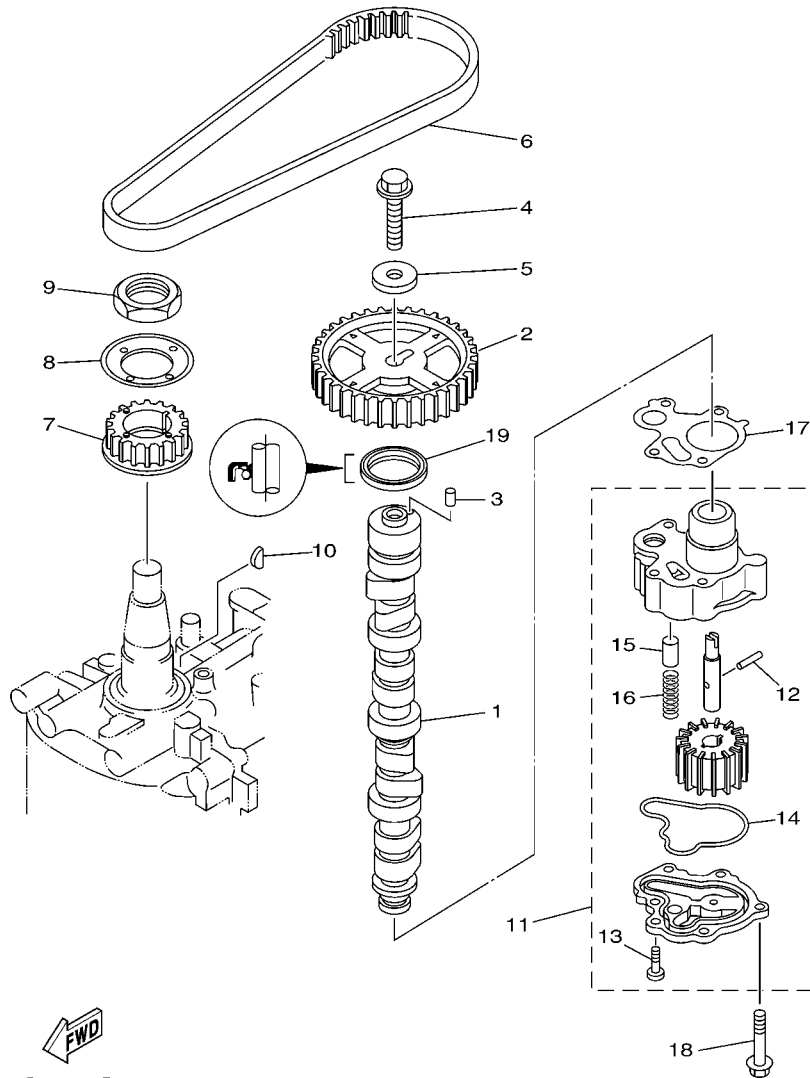

 6C11010-D100

FIG. 10 OIL PUMP

REF. NO.	PART NO.	DESCRIPTION	EHT	ET	REMARKS
1	6C5-12171-00	CAMSHAFT 1	1	1	
2	6C5-11537-00	GEAR, DRIVEN	1	1	
3	93605-17002	PIN, DOWEL	1	1	
4	95817-10035	BOLT, FLANGE	1	1	
5	90201-10144	WASHER, PLATE	1	1	
6	6C5-46241-00	V-BELT	1	1	
7	6C5-11536-00	GEAR, DRIVE	1	1	
8	62Y-11557-00	WASHER 1	1	1	
9	90170-35008	NUT	1	1	
10	90280-03M01	KEY, WOODRUFF	1	1	
11	6C5-13300-00	OIL PUMP ASSY	1	1	
12	93603-17070	.PIN, DOWEL	1	1	
13	98580-06016	.SCREW, PAN HEAD	2	2	
14	6C5-13142-00	.GASKET	1	1	
15	6G8-11577-00	.PLUNGER, RELIEF	1	1	
16	90501-6C500	.SPRING, COMPRESSION	1	1	
17	6C5-13329-00	GASKET, PUMP COVER	1	1	
18	90119-06025	BOLT, WITH WASHER	4	4	
19	93102-37M40	OIL SEAL	1	1	

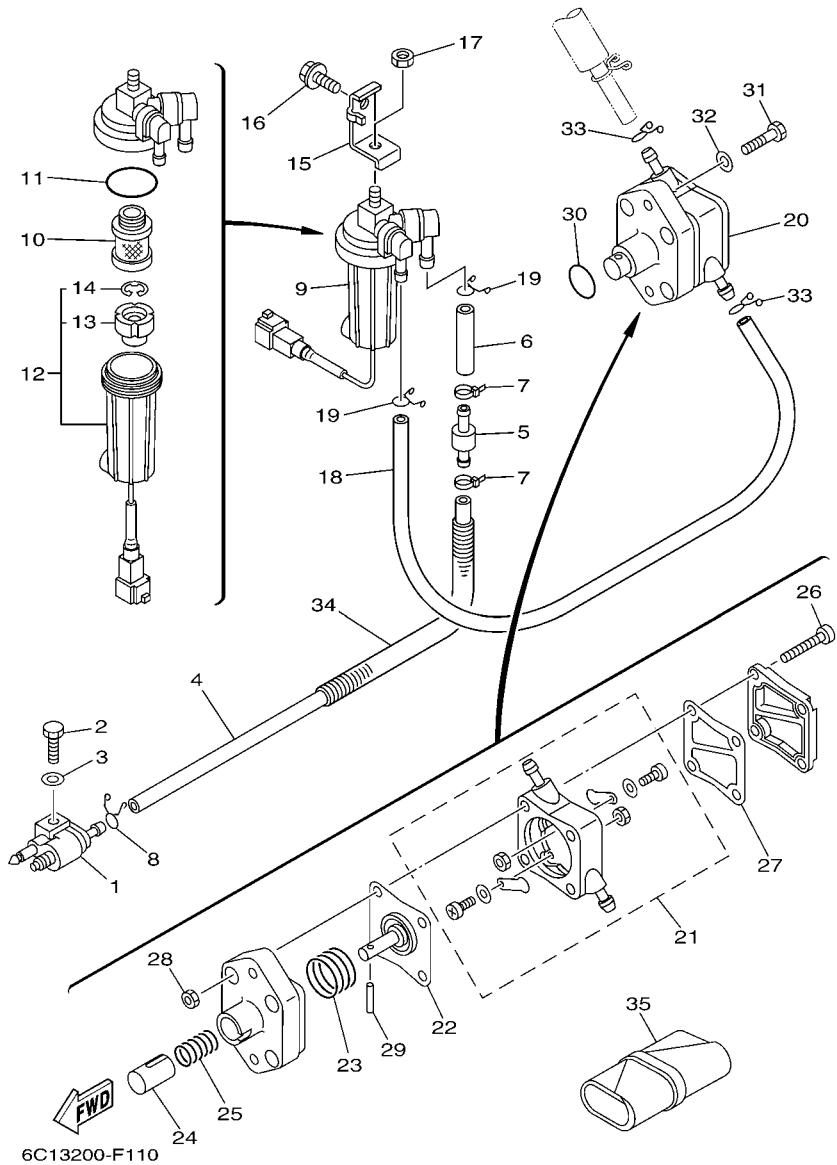
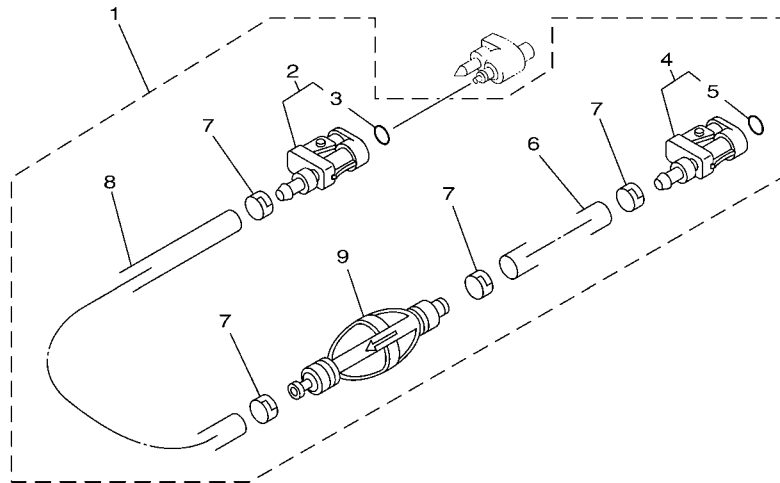

FIG. 11 FUEL 1

REF. NO.	PART NO.	DESCRIPTION	EHT	ET				REMARKS
1	6G1-24304-02	FUEL PIPE JOINT COMP. 1	1	1				
2	97095-06025	BOLT	1	1				
3	92995-06600	WASHER	1	1				
4	6C5-2247A-00	HOSE 1	1	1				
5	67F-24377-00	PIPE, JOINT 2	1	1				
6	90445-13M02	HOSE (L40)	1	1				
7	90465-11M10	CLAMP	2	2				
8	90467-09M17	CLIP	1	1				
9	6D8-24560-00	FILTER ASSY	1	1				
10	6D8-24563-00	.ELEMENT, FILTER	1	1				
11	6D8-24564-00	.GASKET	1	1				
12	6D8-24562-00	.CUP, FILTER	1	1				
13	6D8-24469-00	..FLOAT, WATER LEVEL	1	1				
14	6D8-24519-00	..CLIP	1	1				
15	6C5-24566-01	BRACKET, FILTER	1	1				
16	95895-08016	BOLT, FLANGE	1	1				
17	95380-08600	NUT	1	1				
18	90445-13M36	HOSE (L350)	1	1				
19	90467-10M04	CLIP	2	2				
20	6C5-24410-00	FUEL PUMP ASSY	1	1				
21	6C5-24415-00	.BODY 4	1	1				
22	62Y-24411-02	.DIAPHRAGM	1	1				
23	62Y-24423-00	.SPRING, DIAPHRAGM	1	1				
24	62Y-13131-00	.PLUNGER	1	1				
25	62Y-24454-00	.SPRING	1	1				
26	62Y-24444-01	.SCREW	4	4				
27	6C5-24471-00	.DIAPHRAGM	1	1				

FIG. 12 FUEL 2



REF. NO.	PART NO.	DESCRIPTION	EHT	ET		REMARKS
1	6Y2-24306-56	FUEL PIPE COMP. 1		1		AP *1
	6Y1-24306-55	FUEL PIPE COMP. 1	1	1		AP *2
	61J-24306-04	FUEL PIPE COMP. 1		1		AP *3
2	6E5-24305-06	.FUEL PIPE JOINT COMP. 2		1		*1
	6G1-24305-05	.FUEL PIPE JOINT COMP. 2	1	1		*2,3
3	93210-08287	..O-RING	1	1		
4	6Y2-24305-06	.FUEL PIPE JOINT COMP. 2		1		*1
	6Y1-24305-06	.FUEL PIPE JOINT COMP. 2	1	1		*2,3
5	93210-08287	..O-RING	1	1		
6	90445-13M01	.HOSE (L2050)		1		*1
	90445-11M06	.HOSE (L2050)	1	1		*2,3
7	6E5-24351-51	.BAND 1		4		*1
	650-24351-51	.BAND 1	4	4		*2
	650-24351-01	.BAND 1		4		*3
8	90445-13M00	.HOSE (L850)		1		*1
	90445-11M05	.HOSE (L850)	1	1		*2,3
9	6Y2-24360-60	.PRIMER PUMP ASSY		1		*1
	6Y1-24360-52	.PRIMER PUMP ASSY	1	1		*2
	61J-24360-00	.PRIMER PUMP ASSY		1		*3



6C15100-H120

*1: FOR CANADA (F60TJR)
 *2: FOR CANADA (EXCEPT F60TJR)
 *3: FOR BRAZIL

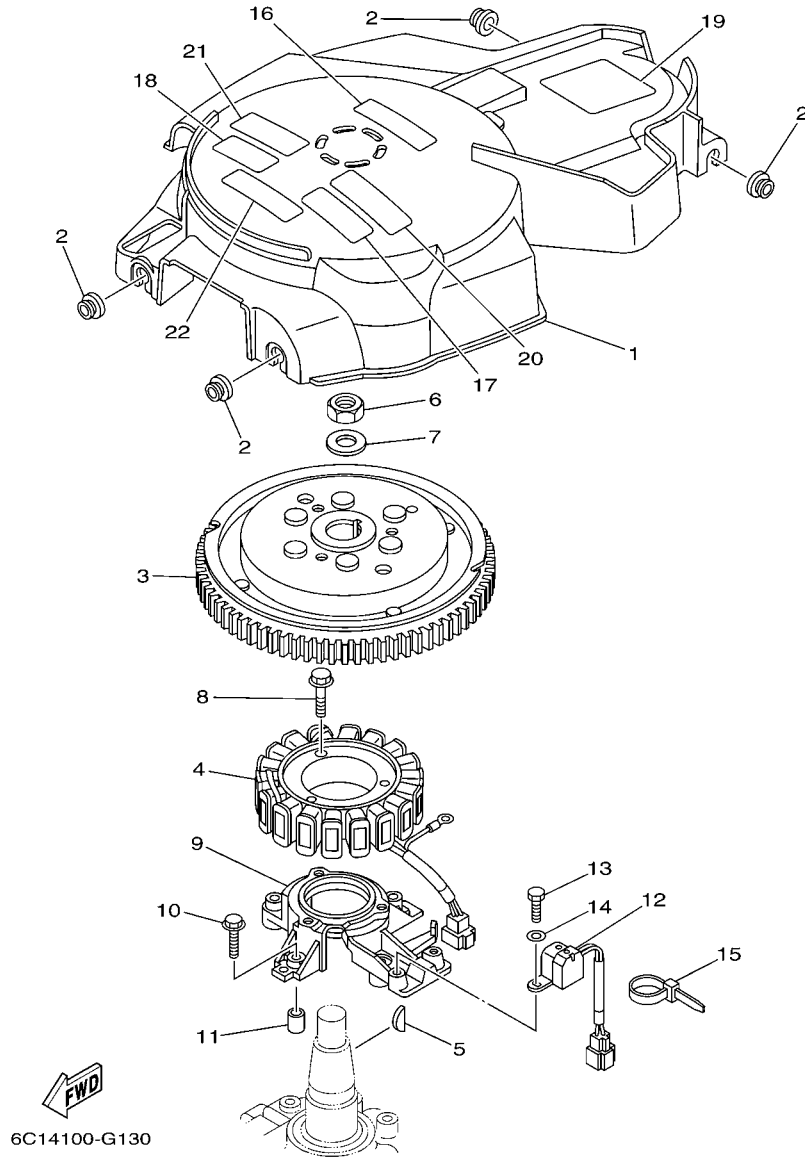

FIG. 13 GENERATOR

REF. NO.	PART NO.	DESCRIPTION	EHT	ET		REMARKS
1	6C5-81337-00	COVER, FLYWHEEL	1	1		
2	90480-12072	GROMMET	4	4		
3	6C5-81450-00	ROTOR ASSY	1	1		
4	6C5-81410-00	STATOR ASSY	1	1		
5	6H4-11545-00	KEY, WOODRUFF	1	1		
6	90170-20137	NUT	1	1		
7	90201-21M18	WASHER, PLATE	1	1		
8	95023-06030	BOLT	3	3		
9	6C5-85561-00-94	BASE, MAGNETO	1	1		
10	95023-06030	BOLT	4	4		
11	99530-08012	PIN, DOWEL	2	2		
12	62Y-85580-00	COIL, PULSER	1	1		
13	97095-05012	BOLT	2	2		
14	92995-05600	WASHER	2	2		
15	90465-13M97	CLAMP	1	1		
16	6C5-13437-41	MARK, CAUTION	1	1		FOR OCE
	6C5-13437-51	MARK, CAUTION	1	1		FOR CAN
	6C5-13437-61	MARK, CAUTION	1	1		FOR BRA
17	6AH-81995-40	LABEL, WARNING	1	1		
18	6AH-81995-50	LABEL, WARNING	1	1		FOR CAN,BRA
19	62Y-83626-00	MARK 6	1	1		
20	6AH-81994-40	LABEL, SAFETY	1	1		
21	6AH-81994-50	LABEL, SAFETY	1	1		FOR CAN,BRA
22	6AG-81996-00	MARK	1	1		

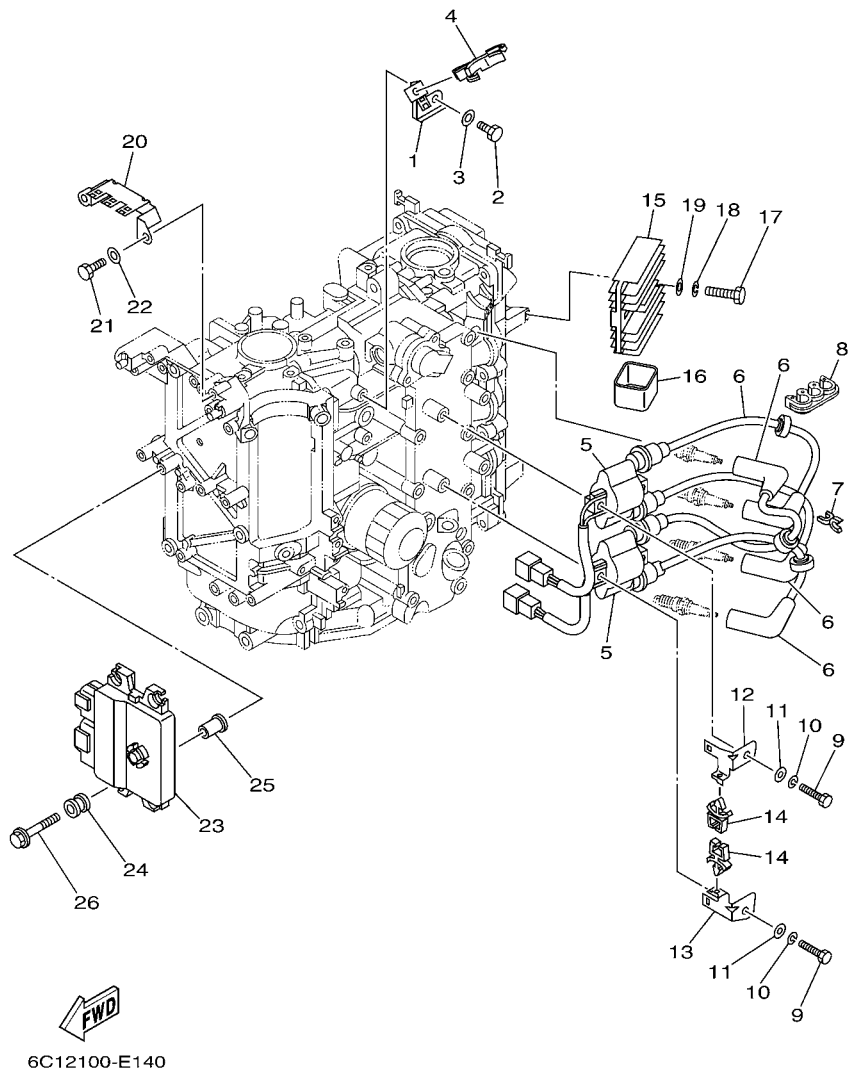
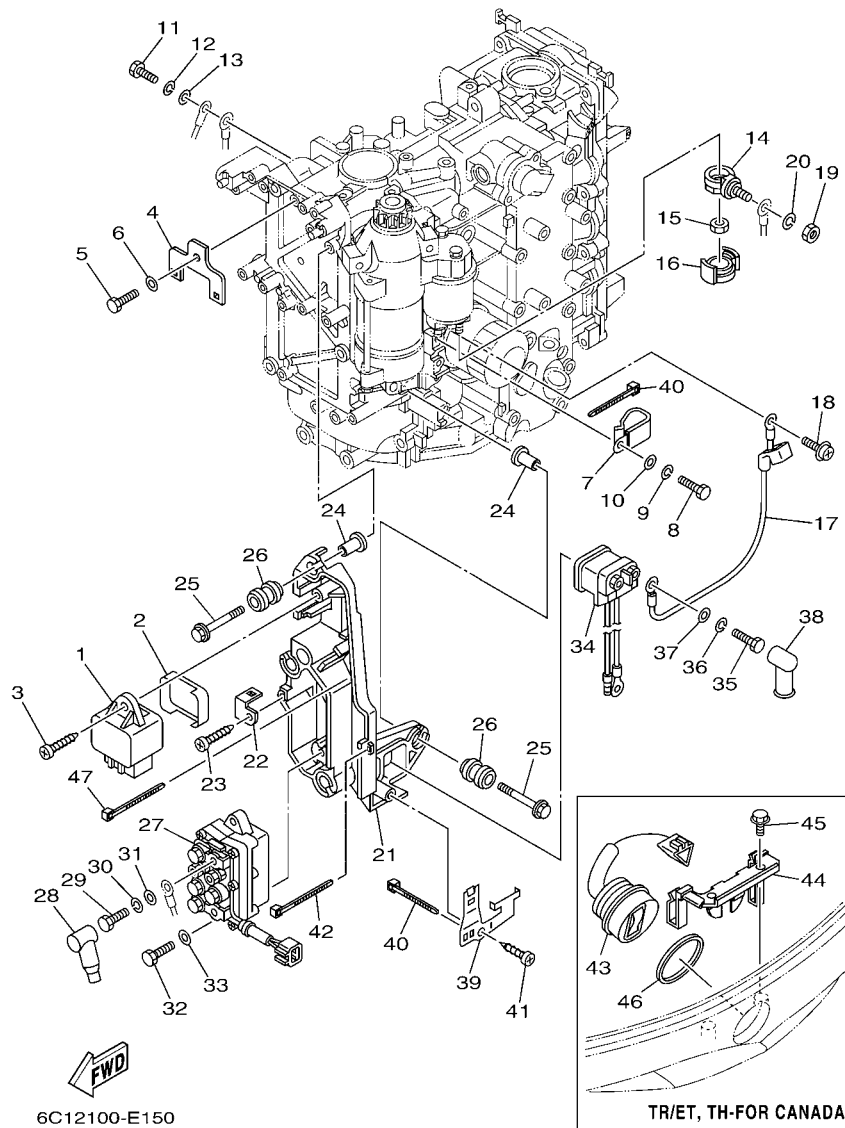

FIG. 14 ELECTRICAL 1

REF. NO.	PART NO.	DESCRIPTION	EHT	ET		REMARKS
1	6C5-85525-00	COVER	1	1		
2	97095-06014	BOLT	1	1		
3	92995-06600	WASHER	1	1		
4	90464-18246	CLAMP	1	1		
5	63P-82310-01	IGNITION COIL ASSY	2	2		
6	6C5-82340-01	HIGH TENSION CORD ASSY 1	4	4		
7	90464-07M41	CLAMP	2	2		
8	90464-07M05	CLAMP	1	1		
9	97095-06030	BOLT	4	4		
10	92995-06100	WASHER, SPRING	4	4		
11	92995-06600	WASHER	4	4		
12	6C5-82316-01	BRACKET, IGNITION COIL	1	1		
13	6C5-82316-11	BRACKET, IGNITION COIL	1	1		
14	90464-06001	CLAMP	2	2		
15	6D3-81960-00	RECTIFIER & REGULATOR ASSY	1	1		
16	6C5-81961-00	COVER	1	1		
17	97095-06025	BOLT	2	2		
18	92995-06100	WASHER, SPRING	2	2		
19	92995-06600	WASHER	2	2		
20	6C5-82171-00	STAY, FUSE BOX	1	1		
21	97095-06014	BOLT	2	2		
22	92995-06600	WASHER	2	2		
23	6C1-8591A-31	ENGINE CONTROL UNIT ASSY	1	1		F50,F50F
	6C5-8591A-31	ENGINE CONTROL UNIT ASSY	1	1		F60,F60C
	6C5-8591A-41	ENGINE CONTROL UNIT ASSY	1	1		F60C-FOR BRA
24	6C5-82317-00	DAMPER, IGNITION COIL	4	4		
25	90387-06119	COLLAR	4	4		



6C12100-E150

FIG. 15 ELECTRICAL 2

REF. NO.	PART NO.	DESCRIPTION	EHT	ET	REMARKS
1	60E-81950-00	RELAY ASSY	1	1	
2	6C5-81336-00	GROMMET	1	1	
3	97780-60620	SCREW, TAPPING	1	1	
4	6C5-8257V-00	PLATE, CONNECTOR	1	1	
5	97095-06014	BOLT	1	1	
6	92995-06600	WASHER	1	1	
7	90465-05M87	CLAMP	1	1	
8	97095-06020	BOLT	4	4	
9	92995-06100	WASHER, SPRING	4	4	
10	92995-06600	WASHER	4	4	
11	97095-06020	BOLT	1	1	
12	92995-06100	WASHER, SPRING	1	1	
13	92995-06600	WASHER	1	1	
14	60V-81925-00	TERMINAL	1	1	
15	90179-08003	NUT	1	1	
16	68F-82582-00	COVER, WIRE HARNESS	1	1	
17	6C5-81815-00	CORD, STARTER MOTOR	1	1	
18	90159-04005	SCREW, WITH WASHER	1	1	
19	95333-08600	NUT	1	1	
20	92903-08100	WASHER, SPRING	1	1	
21	6C5-81948-00	BRACKET	1	1	
22	6C5-85548-00	HOLDER	1	1	
23	97780-60620	SCREW, TAPPING	1	1	
24	90387-06119	COLLAR	4	4	
25	90119-06M59	BOLT, WITH WASHER	4	4	
26	6A0-82317-00	DAMPER, IGNITION COIL	4	4	
27	63P-81950-00	RELAY ASSY	1	1	

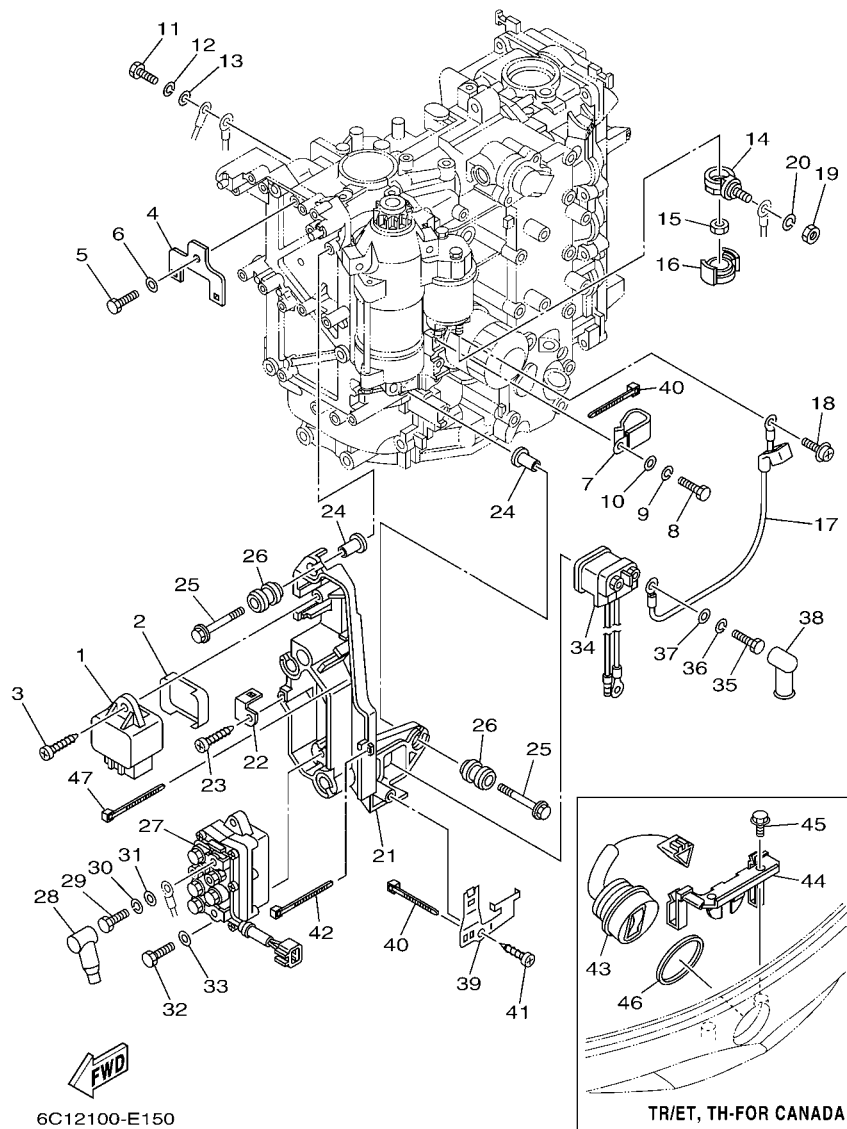
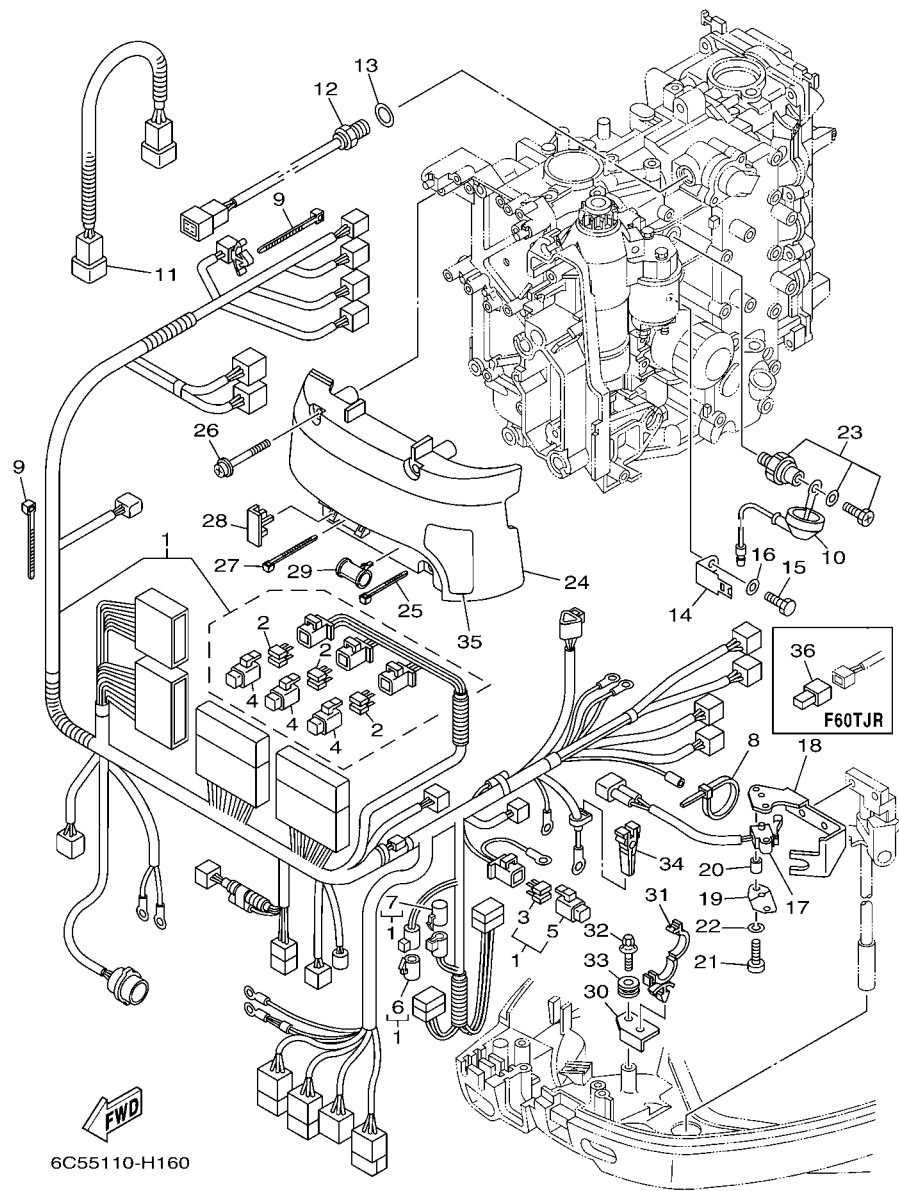

FIG. 15 ELECTRICAL 2

REF. NO.	PART NO.	DESCRIPTION	EHT	ET		REMARKS
28	682-82119-01	COVER, LEAD WIRE	2	2		
29	97095-06010	BOLT	2	2		
30	92995-06100	WASHER, SPRING	2	2		
31	92995-06600	WASHER	2	2		
32	97013-06020	BOLT	2	2		
33	92903-06600	WASHER, PLATE	2	2		
34	68V-8194A-00	RELAY	1	1		
35	97095-06010	BOLT	2	2		
36	92995-06100	WASHER, SPRING	2	2		
37	92995-06600	WASHER	2	2		
38	6G5-82119-00	COVER, LEAD WIRE	2	2		
39	6C5-81953-00	STAY, RELAY	1	1		
40	90465-11M10	CLAMP	2	2		
41	97780-60620	SCREW, TAPPING	1	1		
42	90465-13M97	CLAMP	1	1		
43	63D-82563-10	TRIM & TILT SWITCH ASSY	1	1		EHT-FOR CAN
44	6C5-83614-01	BRACKET	1	1		EHT-FOR CAN
45	90109-06M86	BOLT	2	2		EHT-FOR CAN
46	6E5-82587-00	GASKET	1	1		EHT-FOR CAN
47	90465-13M97	CLAMP	2	2		



6C55110-H160

FIG. 16 ELECTRICAL 3

REF. NO.	PART NO.	DESCRIPTION	EHT	ET		REMARKS
1	6C5-82590-40	WIRE HARNESS ASSY	1	1		
	6C5-82590-60	WIRE HARNESS ASSY	1			FOR OCE
2	67F-82151-00	.FUSE (20A)	6	6		
3	67F-82151-10	.FUSE (30A)	2	2		
4	67F-8215B-10	.CAP (YELLOW)	3	3		
5	67F-8215B-20	.CAP (GREEN)	1	1		
6	6P2-82582-00	.CAP 1 (FEMALE)	1	1		
7	6P2-82582-10	.CAP 1 (MALE)	1	1		
8	90465-13M24	CLAMP	1	1		
9	90465-13M11	CLAMP	2	2		
10	68V-81315-00	LEAD WIRE ASSY	1	1		
11	6C5-82553-00	EXTENSION, WIRE LEAD	1	1		
12	6C5-85790-00	THERMOSENSOR ASSY	1	1		
13	90430-14115	GASKET	1	1		
14	6C5-82388-00	PLATE	1	1		
15	97095-06014	BOLT	1	1		
16	92995-06600	WASHER	1	1		
17	60V-8259F-00	SWITCH ASSY	1	1		EXCEPT F60TJR
18	6C5-82554-01	STAY, NEUTRAL SWITCH	1	1		
19	61A-82588-01	PLATE	1	1		EXCEPT F60TJR
20	90387-04001	COLLAR	1	1		EXCEPT F60TJR
21	97885-04016	SCREW, PAN HEAD	2	2		EXCEPT F60TJR
22	92995-04100	WASHER	2	2		EXCEPT F60TJR
23	64J-82504-00	OIL PRESSURE SWITCH ASSY	1	1		
24	6C5-81942-00	COVER	1	1		
25	90465-13M39	CLAMP	1	1		
26	90159-06M14	SCREW, WITH WASHER	4	4		

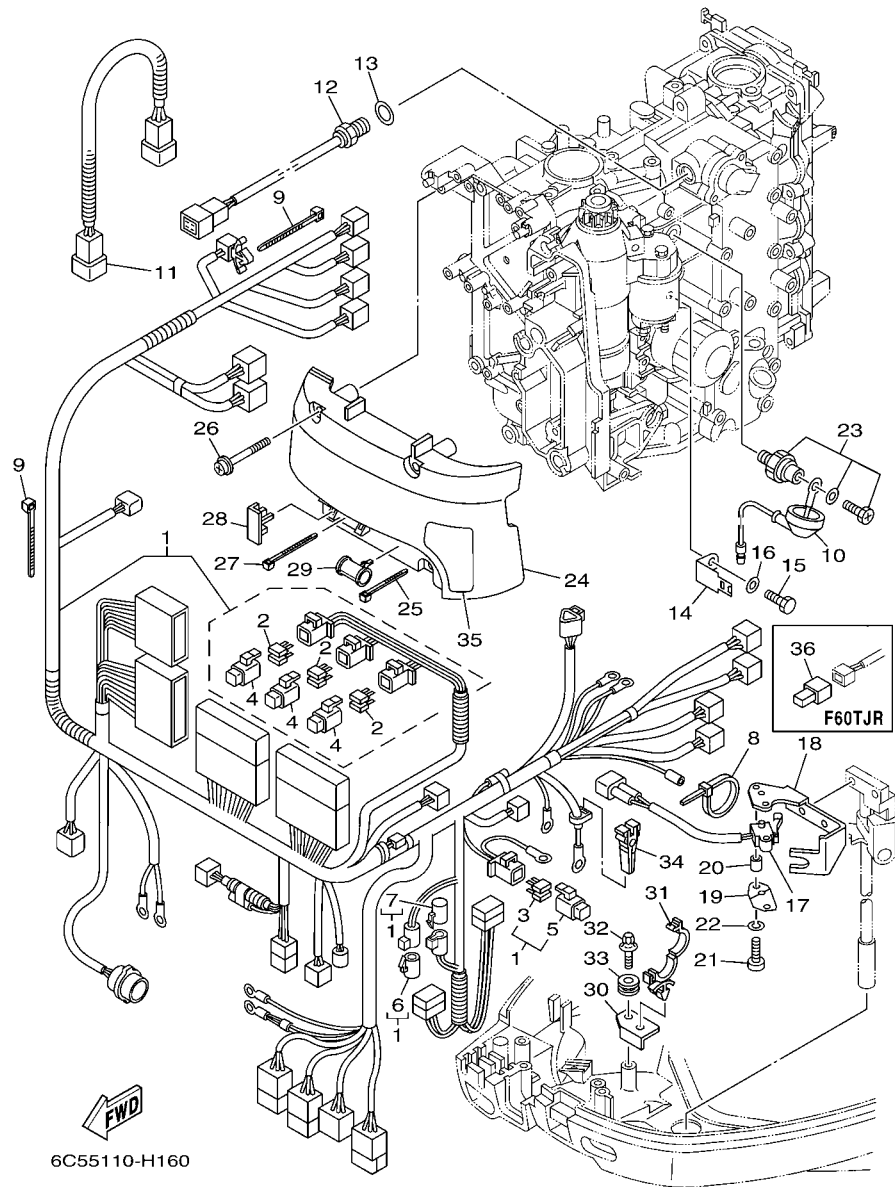

6C55110-H160

FIG. 16 ELECTRICAL 3

REF. NO.	PART NO.	DESCRIPTION	EHT	ET	REMARKS
27	90465-13M24	CLAMP	1	1	
28	6C5-82176-00	DAMPER	2	2	
29	6C5-8252R-00	DAMPER	1	1	
30	6C5-42811-00	STAY	1	1	
31	90464-18007	CLAMP	1	1	
32	90119-06077	BOLT, WITH WASHER	1	1	
33	90480-13598	GROMMET	1	1	
34	67F-2812A-00	PULLER, FUSE	1	1	
35	6C5-81919-00	GRAPHIC, REGULATOR	1	1	
36	68V-82582-10	COVER, WIRE HARNESS	1		FOR F60TJR

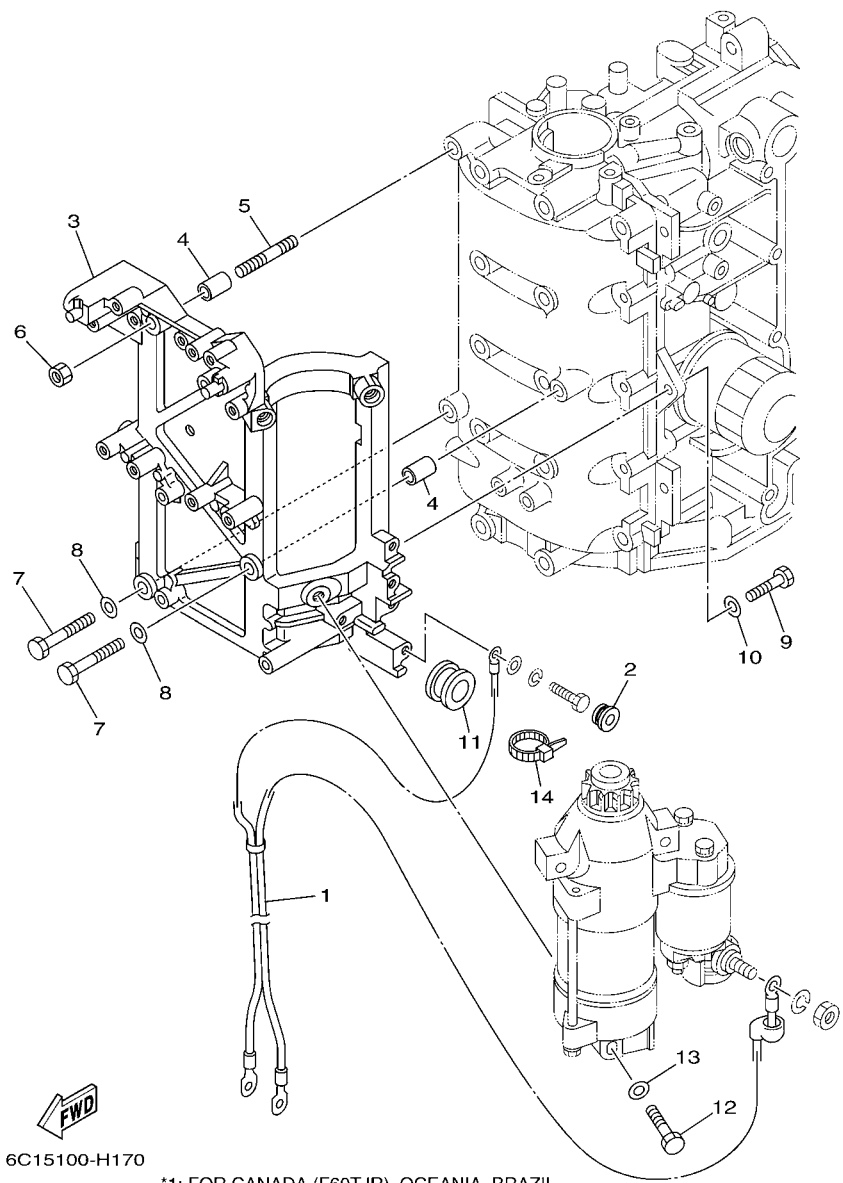

6C15100-H170

*1: FOR CANADA (F60TJR), OCEANIA, BRAZIL
 *2: FOR CANADA (EXCEPT F60TJR)

FIG. 17 ELECTRICAL 4

REF. NO.	PART NO.	DESCRIPTION	EHT	ET	REMARKS
1	6C5-82105-U0	WIRE HARNESS	1	1	*1
	6C5-82105-00	WIRE HARNESS	1	1	*2
2	90480-12072	GROMMET	1	1	
3	6C5-81822-00-94	BRACKET, STARTING MOTOR	1	1	
4	99590-10114	PIN, DOWEL	2	2	
5	95680-08330	BOLT, STUD	1	1	
6	95380-08600	NUT	1	1	
7	97095-08035	BOLT	2	2	
8	92995-08600	WASHER	2	2	
9	97095-08025	BOLT	2	2	
10	92995-08600	WASHER	2	2	
11	90480-24003	GROMMET	1	1	
12	97013-08045	BOLT	3	3	
13	92903-08600	WASHER, PLATE	3	3	
14	90465-13M18	CLAMP	1	1	

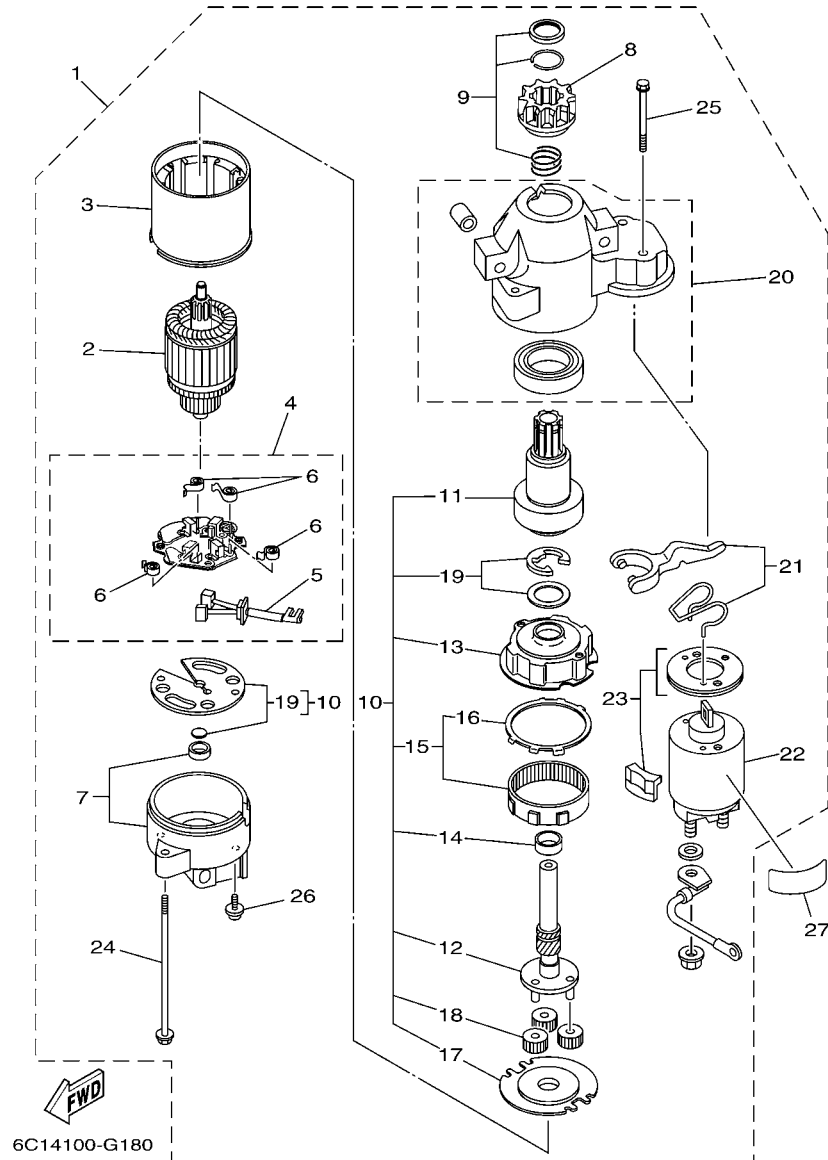

FIG. 18 STARTING MOTOR

REF. NO.	PART NO.	DESCRIPTION	EHT	ET	REMARKS
1	6C5-81800-00	STARTING MOTOR ASSY	1	1	
2	67F-81850-00	.ARMATURE ASSY	1	1	
3	67F-81810-00	.STATOR ASSY	1	1	
4	69J-81840-00	.BRUSH HOLDER ASSY	1	1	
5	69J-81801-00	..BRUSH SET	1	1	
6	67F-81813-00	..SPRING, BRUSH	4	4	
7	68F-81820-00	.REAR BRACKET ASSY	1	1	
8	67F-81808-00	.PINION ASSY	1	1	
9	67F-81857-00	.PINION STOPPER SET	1	1	
10	67F-81807-00	.GEAR ASSY, STARTING MOTOR	1	1	
11	67F-81832-00	..CLUTCH, OVER RUN	1	1	
12	67F-81836-00	..SHAFT, PINION	1	1	
13	67F-81821-00	..BRACKET, CENTER 1	1	1	
14	67F-81841-00	..BEARING	1	1	
15	67F-81891-00	..GEAR, RING	1	1	
16	67F-8183R-00	...GASKET	1	1	
17	67F-81830-00	..BRACKET, CENTER 2	1	1	
18	60V-8183T-00	..GEAR, IDLER	3	3	
19	67F-81809-00	..WASHER KIT	1	1	
20	60X-81842-00	.COVER	1	1	
21	69J-81839-00	.LEVER ASSY	1	1	
22	6C5-81941-00	.STARTER RELAY ASSY	1	1	
23	69J-81869-00	.COVER, DUST	1	1	
24	6K7-81826-11	.BOLT	2	2	
25	69J-81828-00	.BOLT 2	2	2	
26	67F-81846-00	.SCREW	2	2	
27	67F-83627-01	LABEL, CAUTION 7	1	1	

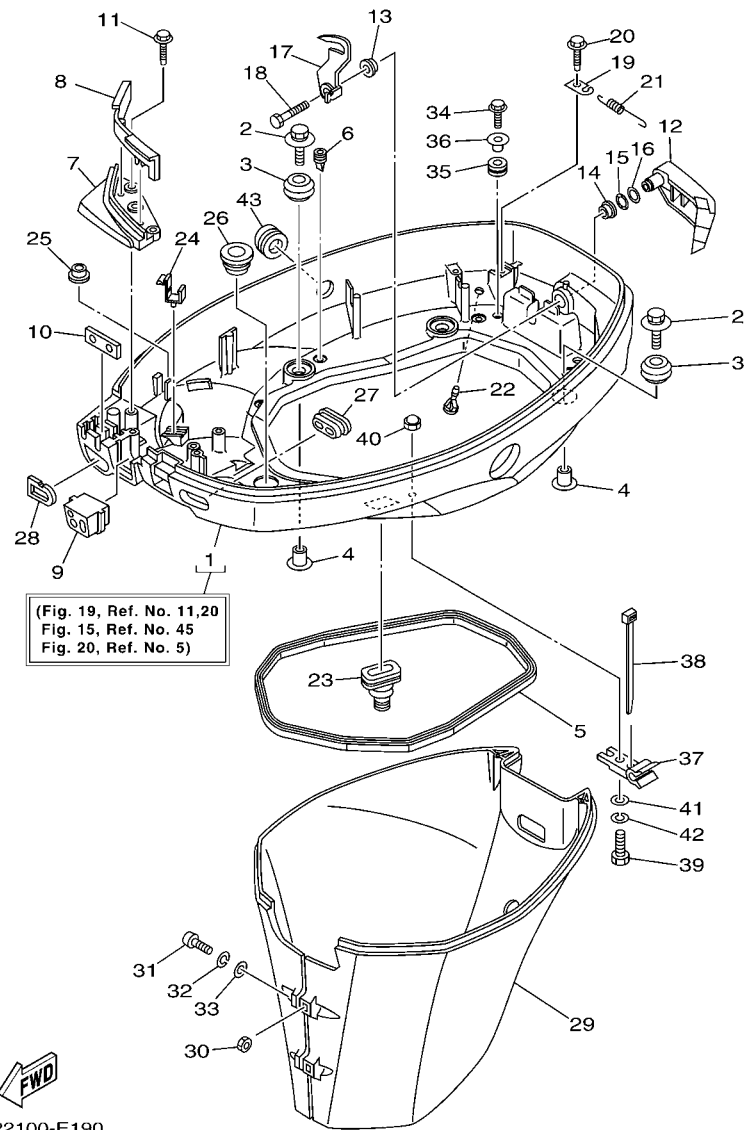
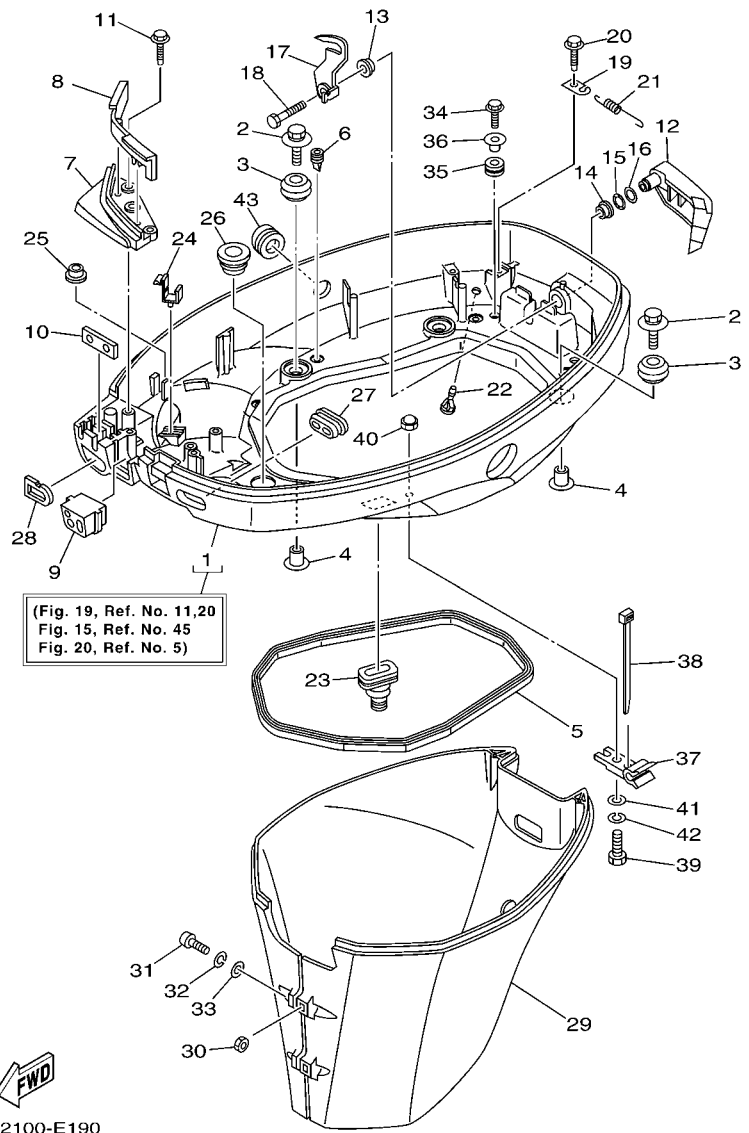

FIG. 19 BOTTOM COWLING 1

REF. NO.	PART NO.	DESCRIPTION	EHT	ET	REMARKS
1	6C5-42710-00-8D	BOTTOM COWLING ASSY	1		FOR OCE
	6C5-42710-10-8D	BOTTOM COWLING ASSY	1	1	EHT-FOR CAN
2	90119-06M08	BOLT, WITH WASHER	4	4	
3	90480-09M12	GROMMET	4	4	
4	90387-06060	COLLAR	4	4	
5	62Y-42716-00	RUBBER, SEAL 1	1	1	
6	65W-42717-00	RUBBER, SEAL 2	4	4	
7	6C5-42738-00-8D	PLATE, FITTING	1	1	
8	6C5-42718-00	RUBBER, SEAL 3	1	1	
9	6C5-42725-30	GROMMET	1	1	
10	62Y-42727-00	GROMMET	1	1	
11	90109-06M81	BOLT	3	3	
12	67C-42815-00-8D	LEVER, CLAMP	1	1	
13	90386-12M37	BUSH	1	1	
14	90386-12MA2	BUSH	1	1	
15	90206-12052	WASHER, WAVE	1	1	
16	90201-12M07	WASHER, PLATE	1	1	
17	67C-42816-01	LEVER, CLAMP	1	1	
18	97095-06014	BOLT	1	1	
19	66T-43144-00	HOOK, SPRING	1	1	
20	90109-06M86	BOLT	1	1	
21	90506-18M40	SPRING, TENSION	1	1	
22	6H3-44391-01	NIPPLE, HOSE	1	1	
23	6C5-42724-00	GROMMET	1	1	
24	90464-09M13	CLAMP	1	1	
25	6E7-82317-00	DAMPER, IGNITION COIL	1	1	
26	68U-42727-00	GROMMET	1	1	



6C22100-E190

FIG. 19 BOTTOM COWLING 1

REF. NO.	PART NO.	DESCRIPTION	EHT	ET			REMARKS
27	6H3-42727-00	GROMMET	1	1			
28	61N-24329-00	SEAL	1	1			
29	67C-42741-10-8D	APRON	1	1			
30	95380-06600	NUT, HEXAGON	2	2			
31	97880-06025	SCREW, PAN HEAD	2	2			
32	92990-06100	WASHER, SPRING	2	2			
33	92990-06600	WASHER, PLATE	2	2			
34	90109-06M80	BOLT	2	2			
35	90480-13M24	GROMMET	2	2			
36	90387-06M43	COLLAR	2	2			
37	90464-09M49	CLAMP	1	1			
38	90465-11M10	CLAMP	2	2			
39	97095-06020	BOLT	1	1			
40	95380-06800	NUT	1	1			
41	92990-06600	WASHER, PLATE	1	1			
42	92995-06100	WASHER, SPRING	1	1			
43	6C5-42726-00	GROMMET	1	1			

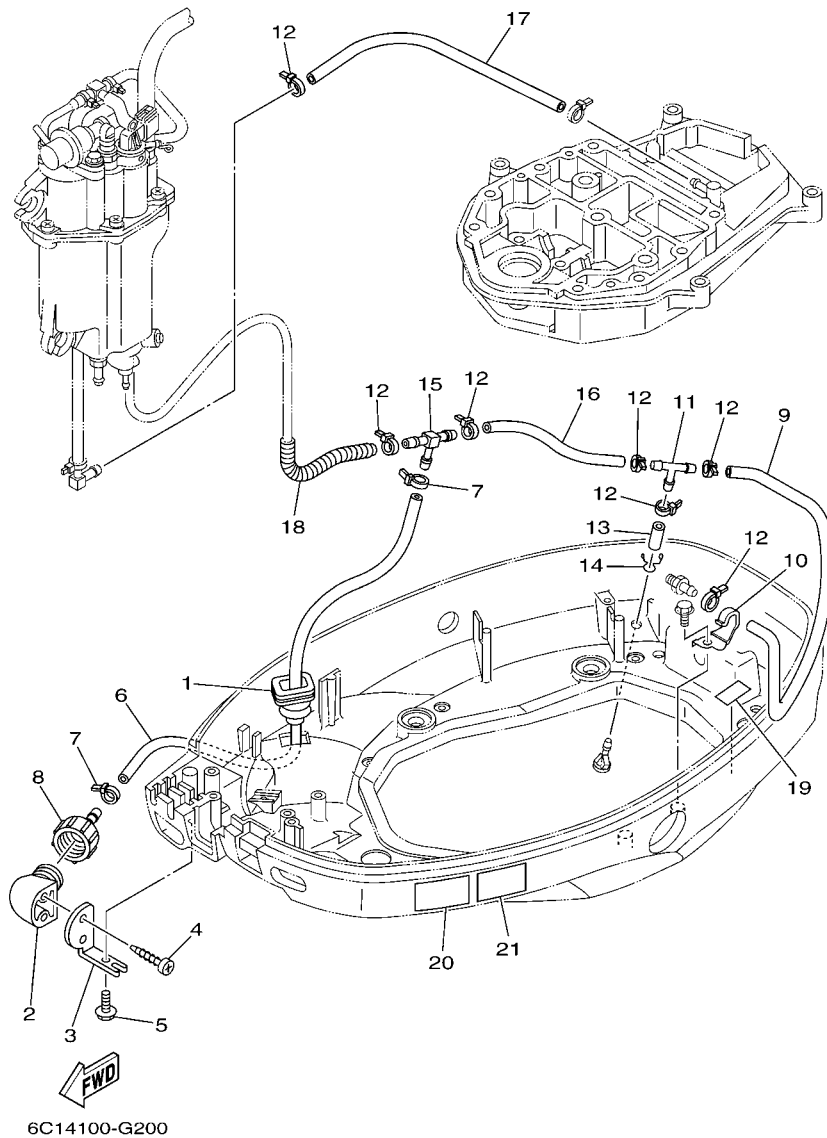

FIG. 20 BOTTOM COWLING 2

REF. NO.	PART NO.	DESCRIPTION	EHT	ET			REMARKS
1	65W-42724-10	GROMMET	1	1			
2	68T-12572-00	ADAPTER	1	1			
3	69W-12535-00	PLATE	1	1			
4	90167-06002	SCREW, TAPPING	2	2			
5	90109-06M80	BOLT	1	1			
6	6C5-24312-00	PIPE 2	1	1			
7	90465-11M10	CLAMP	2	2			
8	6R3-12580-00	JOINT ASSY	1	1			
9	90445-09226	HOSE (L390)	1	1			
10	90462-08031	CLAMP	1	1			
11	688-24378-00	PIPE, JOINT 3	1	1			
12	90465-11M10	CLAMP	7	7			
13	90445-09220	HOSE (L30)	1	1			
14	90467-08M18	CLIP	1	1			
15	6C5-24378-00	PIPE, JOINT 3	1	1			
16	90445-09091	HOSE (L135)	1	1			
17	90445-09104	HOSE (L300)	1	1			
18	90447-10006	TUBE	1	1			
19	6C5-82377-00	LABEL	1	1			
20	6AH-42794-40	LABEL, WARNING (GENERAL)	1	1			
21	6AH-42794-50	LABEL, WARNING (GENERAL)	1	1			FOR CAN,BRA

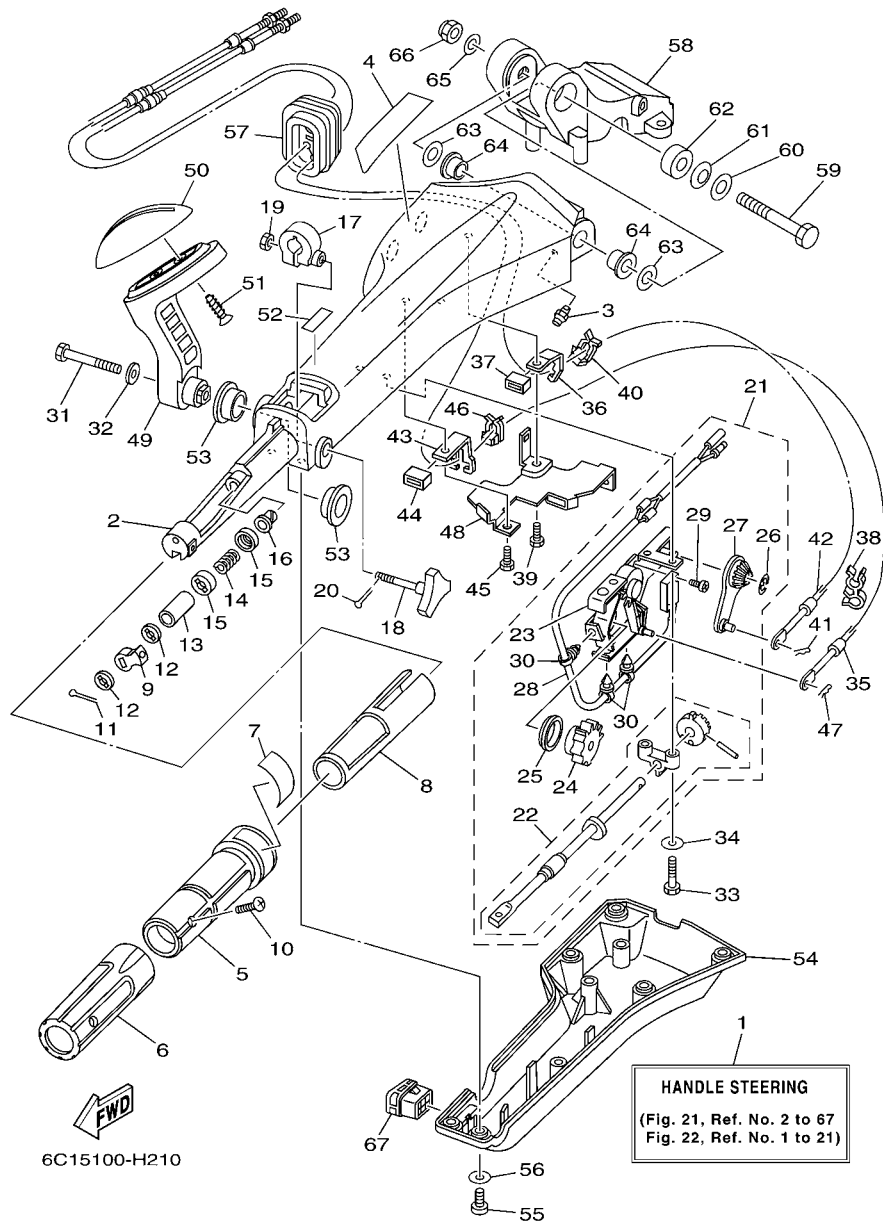

FIG. 21 STEERING 1

REF. NO.	PART NO.	DESCRIPTION	EHT	ET	REMARKS
1	6X4-42101-J2-4D	HANDLE, STEERING	1		
2	6X4-42111-01-4D	HANDLE, STEERING	1		
3	93700-06M03	NIPPLE, GREASE	1		
4	6X4-48215-00	GRAPHIC	1		
5	6X4-42119-00	GRIP, STEERING HANDLE	1		
6	6X4-42177-00	RUBBER, HANDLE	1		
7	6X4-42137-00	INDICATOR, THROTTLE	1		
8	6X4-41291-00	BUSHING	1		
9	6X4-44139-00	COLLAR	1		
10	90142-05001	SCREW, COUNTERSUNK	1		
11	91490-20010	PIN. COTTER	1		
12	6X4-44177-00	WASHER	2		
13	6X4-42128-00	COLLAR, DISTANCE 1	1		
14	90501-23215	SPRING, COMPRESSION	1		
15	6X4-44188-00	WASHER	2		
16	90386-08032	BUSH	1		
17	63D-42126-00	FRICION, STEERING HANDLE GRIP	1		
18	6X4-48154-00	KNOB, THROTTLE	1		
19	95380-06600	NUT, HEXAGON	1		
20	91490-20010	PIN. COTTER	1		
21	6X4-44100-00	SHIFT LINK ASSY	1		
22	6X4-42115-00	.SHAFT, STEERING HANDLE	1		
23	6X4-44102-00	.SHIFT ASSIST ASSY.	1		
24	6X4-47731-00	.GEAR, DRIVE	1		
25	6X4-44132-00	.BUSHING	1		
26	6X4-14137-00	.CLIP	1		
27	6X4-48261-00	.ARM, THROTTLE	1		

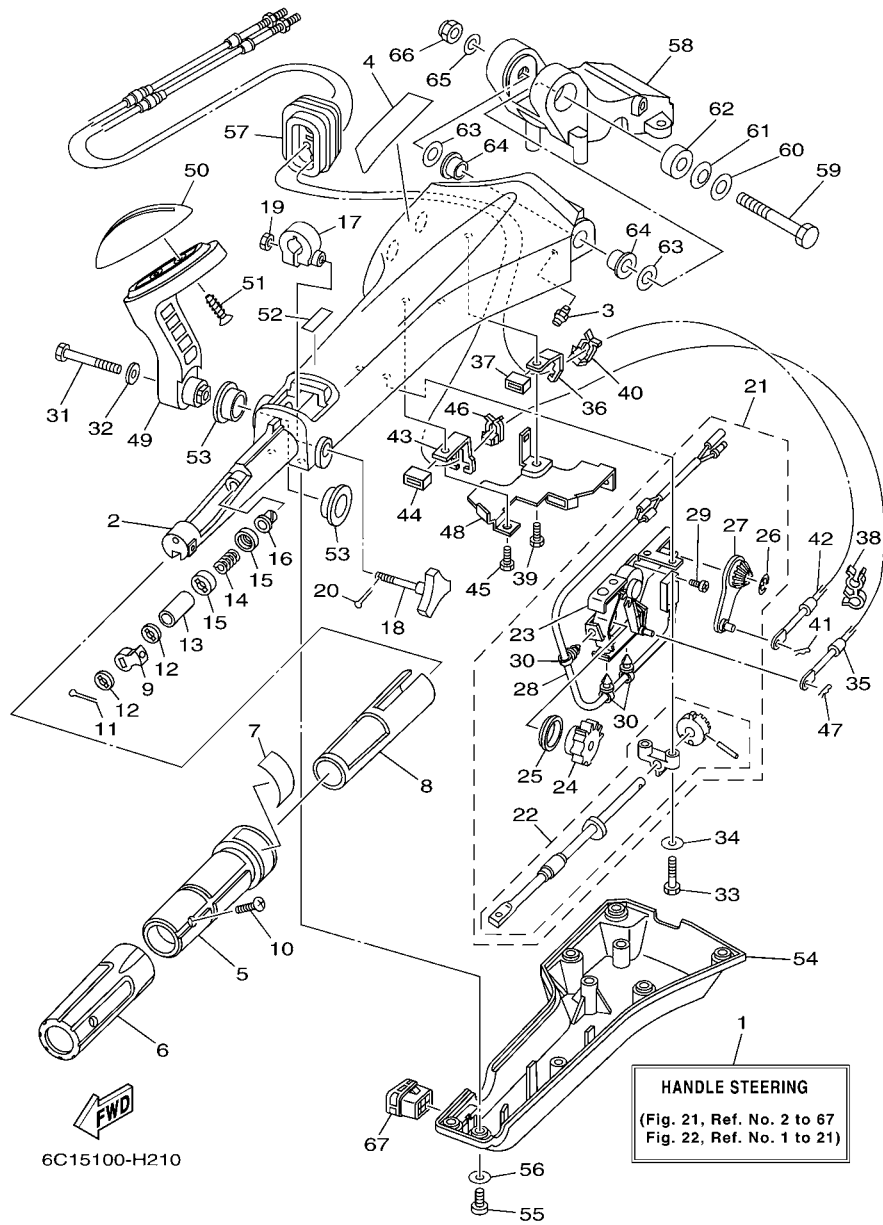

FIG. 21 STEERING 1

REF. NO.	PART NO.	DESCRIPTION	EHT	ET				REMARKS
28	6X4-82540-00	.NEUTRAL SWITCH ASSY	1					
29	6A5-48129-10	.SCREW 3	2					
30	6X4-42821-00	.BAND, CLAMP	3					
31	97095-08040	BOLT	1					
32	92995-08600	WASHER	1					
33	97095-06030	BOLT	2					
34	92995-06600	WASHER	2					
35	67C-48321-11	CABLE	1					
36	6X4-48538-00	CLAMP, CABLE 1	1					
37	6X4-26367-00	PROTECTOR	1					
38	90464-09M42	CLAMP	1					
39	97095-06014	BOLT	1					
40	63D-48538-00	CLAMP, CABLE 1	1					
41	90468-10005	CLIP	1					
42	69W-26301-00	THROTTLE CABLE ASSY	1					
43	6X4-48538-10	CLAMP, CABLE 1	1					
44	6X4-26367-00	PROTECTOR	1					
45	97095-06014	BOLT	1					
46	63D-48538-00	CLAMP, CABLE 1	1					
47	90468-10005	CLIP	1					
48	6X4-42159-00	STAY	1					
49	6X4-44159-00-4D	HANDLE, GEAR SHIFT	1					
50	6X4-44173-00	LEVER, SHIFT CONTROL	1					
51	97780-60920	SCREW, TAPPING	2					
52	6G8-44191-00	INDICATOR, SHIFT	1					
53	90386-26MA3	BUSH	2					
54	6X4-42131-11	COVER, HANDLE STEERING	1					

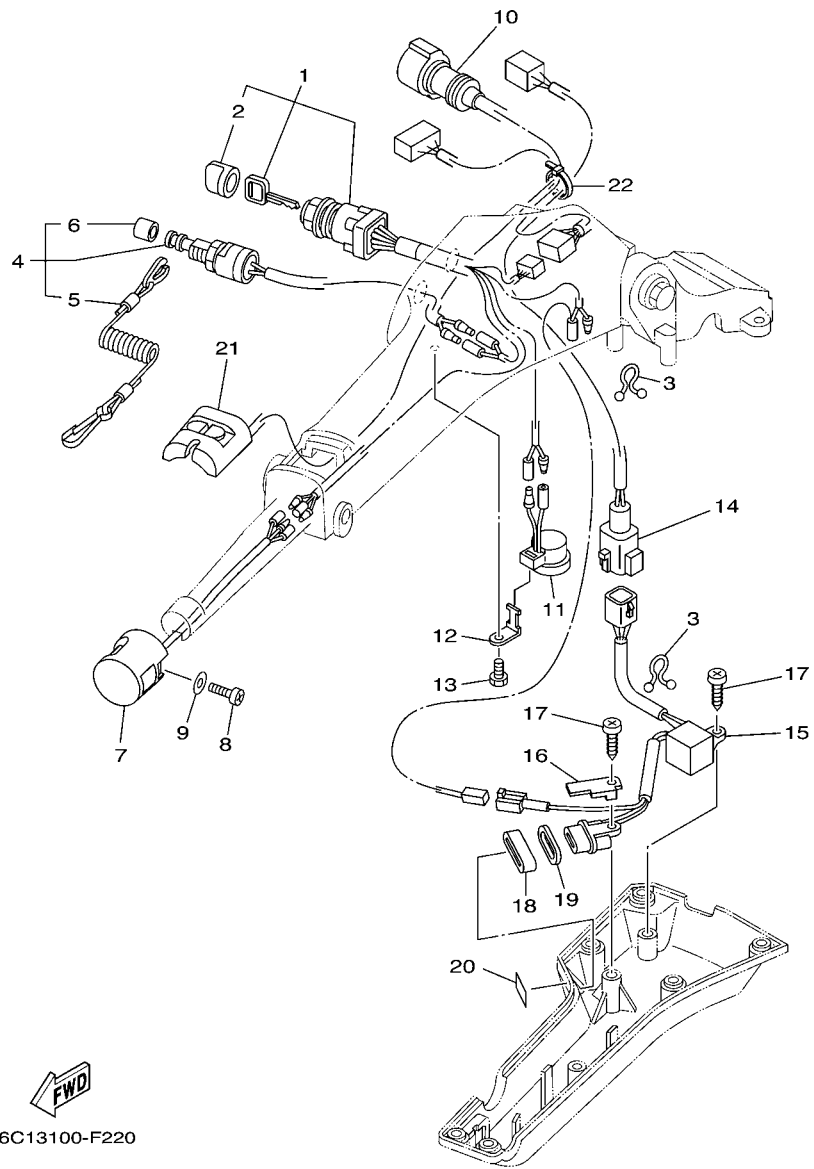
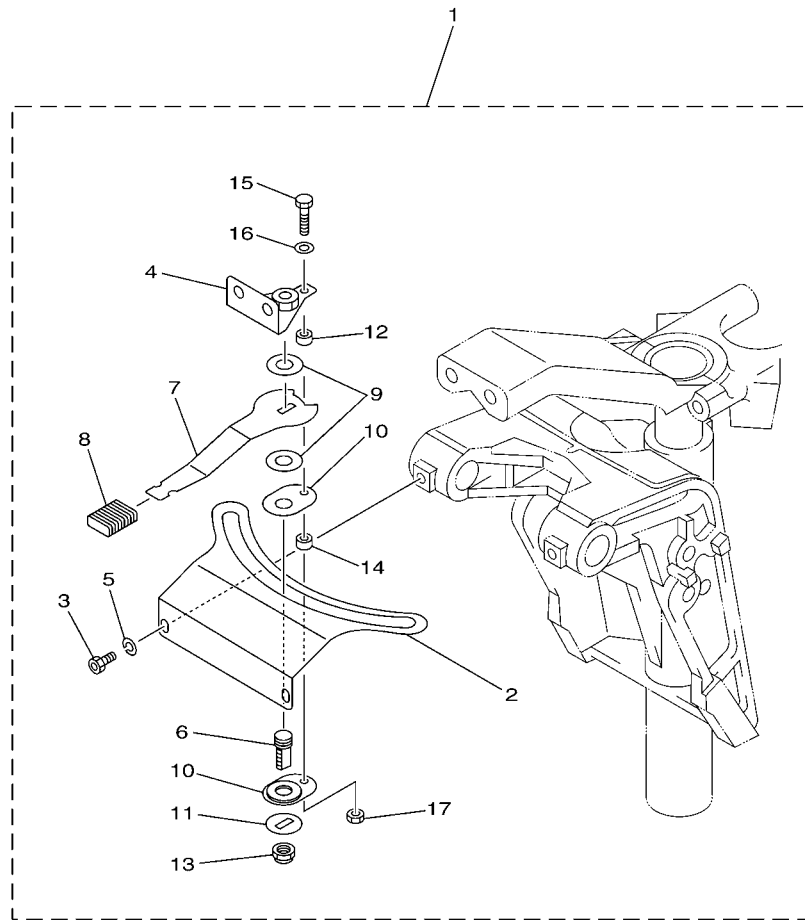

FIG. 22 STEERING 2

REF. NO.	PART NO.	DESCRIPTION	EHT	ET			REMARKS
1	6X4-82510-10	MAIN SWITCH ASSY	1				
2	676-82577-00	.CAP, KEY	1				
3	90464-08M07	CLAMP	2				
4	69W-82575-00	ENGINE STOP SWITCH ASSY	1				
5	682-82556-00	.LANYARD, STOP SWITCH	1				
6	689-8257Y-00	.CAP	1				
7	6X4-82563-00	TRIM & TILT SWITCH ASSY	1				
8	97880-06016	SCREW, PAN HEAD	1				
9	92990-06600	WASHER, PLATE	1				
10	6X4-82586-10	EXT., WIRE HARNESS (L: 950MM)	1				
11	6X4-83383-00	BUZZER	1				
12	6X4-83386-00	STAY, BUZZER	1				
13	97095-06014	BOLT	1				
14	6X4-83653-20	WIRE, LEAD (L: 700MM)	1				
15	6C5-84301-00	PILOT LIGHT ASSY 1	1				
16	6X4-44114-00	STOPPER	1				
17	97780-60620	SCREW, TAPPING	2				
18	6X4-42727-00	GROMMET	1				
19	6H4-83589-00	GASKET	1				
20	6X4-85415-00	MARK, SIGNAL LAMP	1				
21	6X4-81860-00	SWITCH ASSY	1				
22	90465-13M36	CLAMP	1				



 6C11010-D220

FIG. 23 STEERING FRICTION

REF. NO.	PART NO.	DESCRIPTION	EHT	ET			REMARKS
1	6C5-42508-00	STEERING FRICTION ASSY	1				
2	6C5-42527-00	.PLATE, FRICTION	1				
3	90109-06M88	.BOLT	2				
4	67C-42525-00	.PLATE, FRICTION	1				
5	92990-06100	.WASHER, SPRING	2				
6	67C-42562-00	.SHAFT, STEERING LOCK	1				
7	67C-42561-00	.KNOB, STEERING LOCK	1				
8	689-43633-00	.COVER, TILT LEVER	1				
9	90202-10M56	.WASHER, PLATE	2				
10	65W-42528-00	.PLATE, FRICTION	2				
11	90209-10M26	.WASHER	1				
12	90387-05M05	.COLLAR	1				
13	90185-10M14	.NUT, SELF-LOCKING	1				
14	90387-05M11	.COLLAR	1				
15	97095-05020	.BOLT	1				
16	92995-05600	.WASHER	1				
17	95380-05600	.NUT	1				

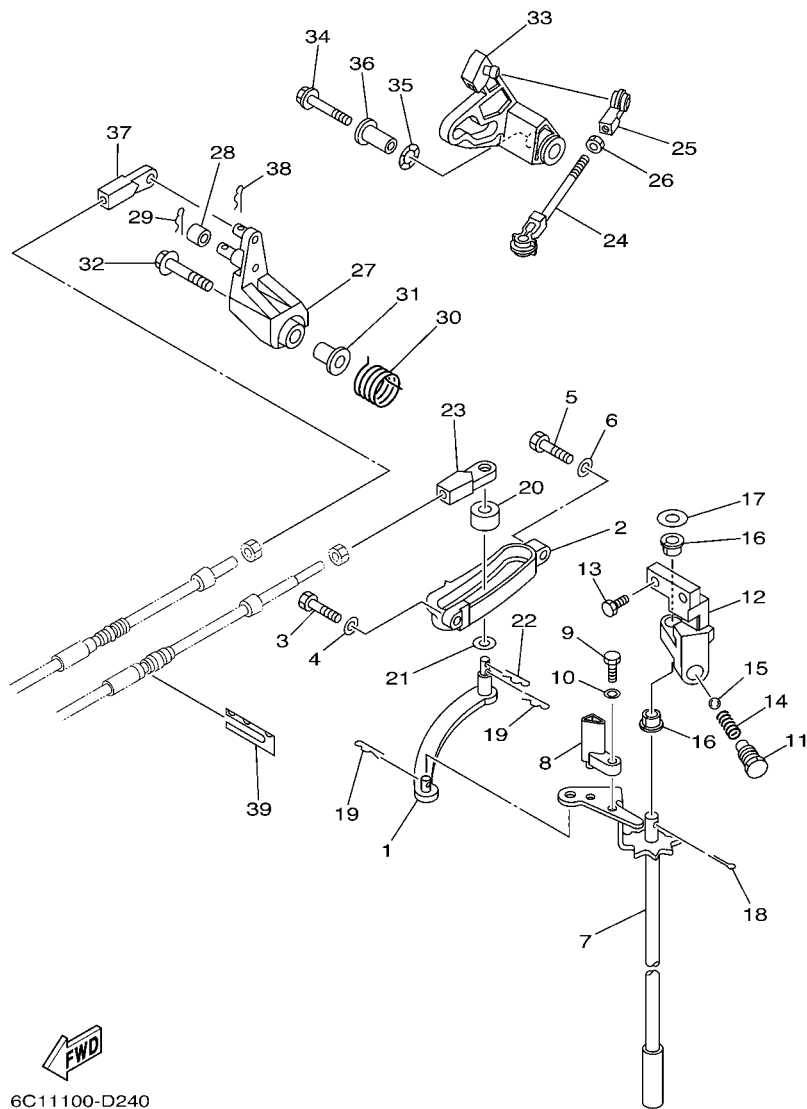

6C11100-D240

FIG. 24 CONTROL

REF. NO.	PART NO.	DESCRIPTION	EHT	ET	REMARKS
1	69W-44121-00	LEVER, SHIFT ROD	1	1	
2	62Y-44117-01-9S	BRACKET	1	1	
3	97095-06020	BOLT	1	1	
4	92995-06600	WASHER	1	1	
5	97095-06025	BOLT	1	1	
6	92995-06600	WASHER	1	1	
7	6C5-44120-01	HANDLE GEAR SHIFT ASSY	1	1	L(20.7")
8	6C5-44122-00	BUSHING, SHIFT ROD LEVER	1	1	EXCEPT F60TJR
9	97095-05014	BOLT	1	1	EXCEPT F60TJR
10	92995-05600	WASHER	1	1	EXCEPT F60TJR
11	62Y-42715-01	BUSHING	1	1	
12	62Y-44118-00	BRACKET	1	1	
13	90101-06054	BOLT	2	2	
14	90501-12082	SPRING, COMPRESSION	1	1	
15	93501-04M02	BALL	1	1	
16	90386-90M90	BUSH	2	2	
17	90201-10M20	WASHER, PLATE	1	1	
18	91490-20015	PIN. COTTER	1	1	
19	90468-18008	CLIP	2	2	
20	688-44122-00	BUSHING, SHIFT ROD LEVER	1	1	
21	90202-07M07	WASHER, PLATE	1	1	
22	90468-18008	CLIP	1	1	
23	69W-48344-00	CABLE END, REMOTE CONTROL	1	1	
24	688-41211-01	LINK, ACCEL.	1	1	
25	6H4-41237-00	JOINT, LINK	1	1	
26	95380-05700	NUT	1	1	
27	62Y-42154-00	LEVER, THROTTLE CONTROL	1	1	

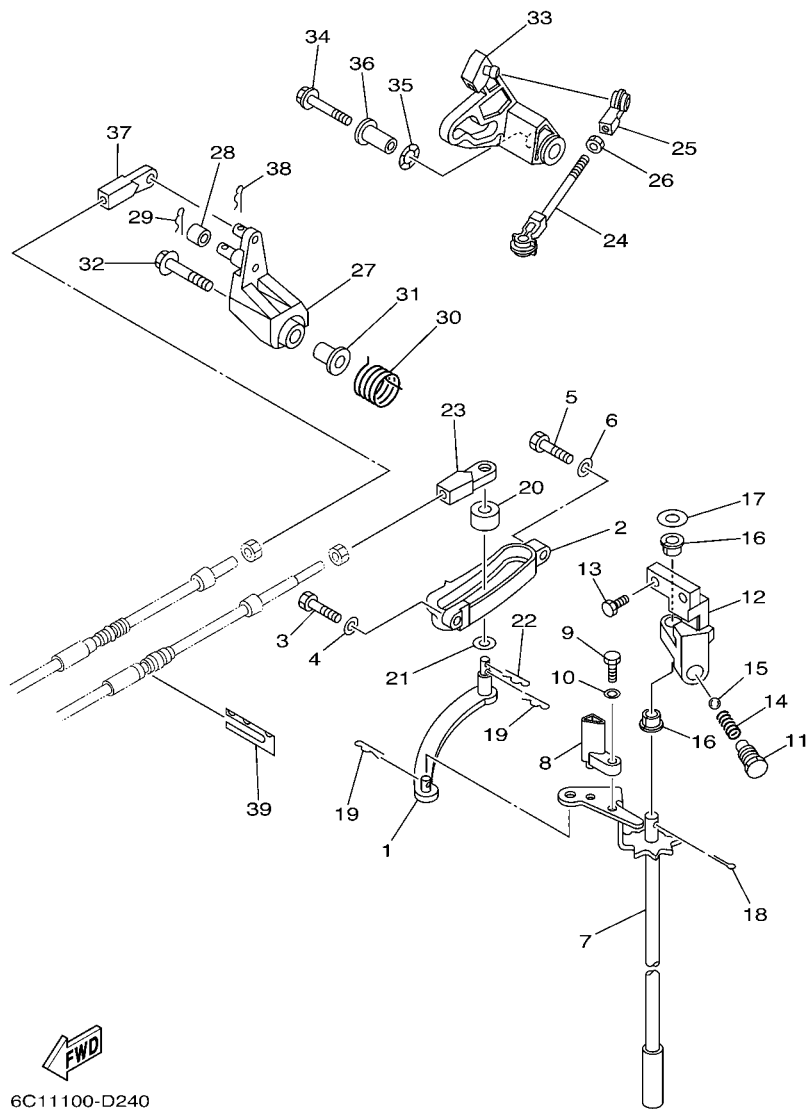

6C11100-D240

FIG. 24 CONTROL

REF. NO.	PART NO.	DESCRIPTION	EHT	ET	REMARKS
28	6C5-42171-00	BUSHING	1	1	
29	91490-16010	PIN. COTTER	1	1	
30	62Y-44135-00	SPRING	1	1	
31	90387-06M45	COLLAR	1	1	
32	90119-06106	BOLT, WITH WASHER	1	1	
33	6C5-42335-00	LEVER, ACCEL. CONTROL	1	1	
34	95895-06035	BOLT, FLANGE	1	1	
35	90206-10M04	WASHER, WAVE	1	1	
36	90387-06M82	COLLAR	1	1	
37	69W-48344-00	CABLE END, REMOTE CONTROL	1	1	
38	90468-18008	CLIP	1	1	
39	62Y-48538-00	CLAMP, CABLE 1	1	1	

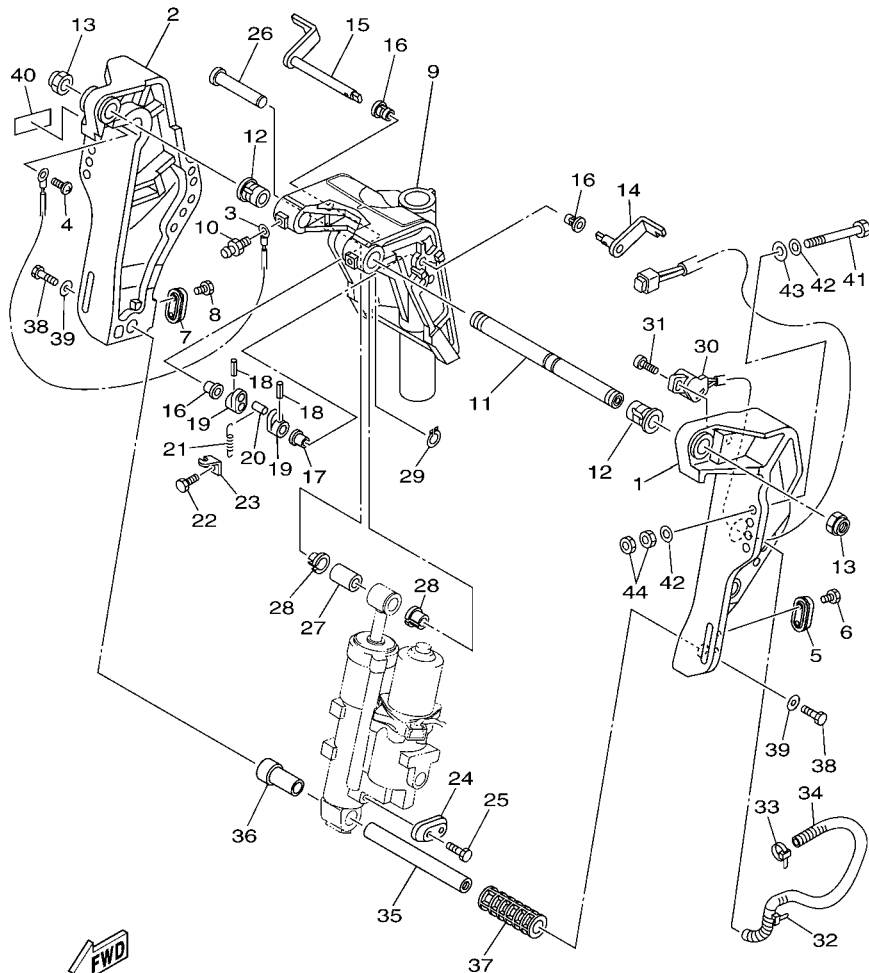

6C13100-F250

FIG. 25 BRACKET 1

REF. NO.	PART NO.	DESCRIPTION	EHT	ET	REMARKS
1	6C5-43111-00-8D	BRACKET, CLAMP 1	1	1	
2	6C5-43112-00-8D	BRACKET, CLAMP 2	1	1	
3	6E5-82148-00	WIRE, LEAD 4	1	1	
4	97885-06008	SCREW, PAN HEAD	1	1	
5	65W-45251-00	ANODE	1	1	
6	90101-06020	BOLT	2	2	
7	65W-45251-00	ANODE	1	1	
8	90101-06020	BOLT	2	2	
9	6C5-43311-00-8D	BRACKET, SWIVEL 1	1	1	
10	93700-06M03	NIPPLE, GREASE	1		
	93700-06M03	NIPPLE, GREASE		3	
11	63D-43131-10	BOLT, CLAMP BRACKET	1	1	
12	90386-22MA4	BUSH	2	2	
13	90185-22007	NUT, SELF-LOCKING	2	2	
14	6C5-43181-10	LEVER, TILT STOP	1	1	
15	6C5-43185-10	LEVER, TILT STOP	1	1	
16	90386-10M16	BUSH	3	3	
17	90386-10025	BUSH	1	1	
18	91690-30020	PIN, SPRING	2	2	
19	6G5-43148-00	COLLAR, DISTANCE	2	2	
20	90249-06M19	PIN	1	1	
21	90506-14M24	SPRING, TENSION	1	1	
22	97095-06010	BOLT	1	1	
23	6G5-43144-00	HOOK, SPRING	1	1	
24	65W-45251-00	ANODE	1	1	
25	90101-06020	BOLT	2	2	
26	6E5-43126-02	PIN, UPPER SHOCK MOUNT	1	1	

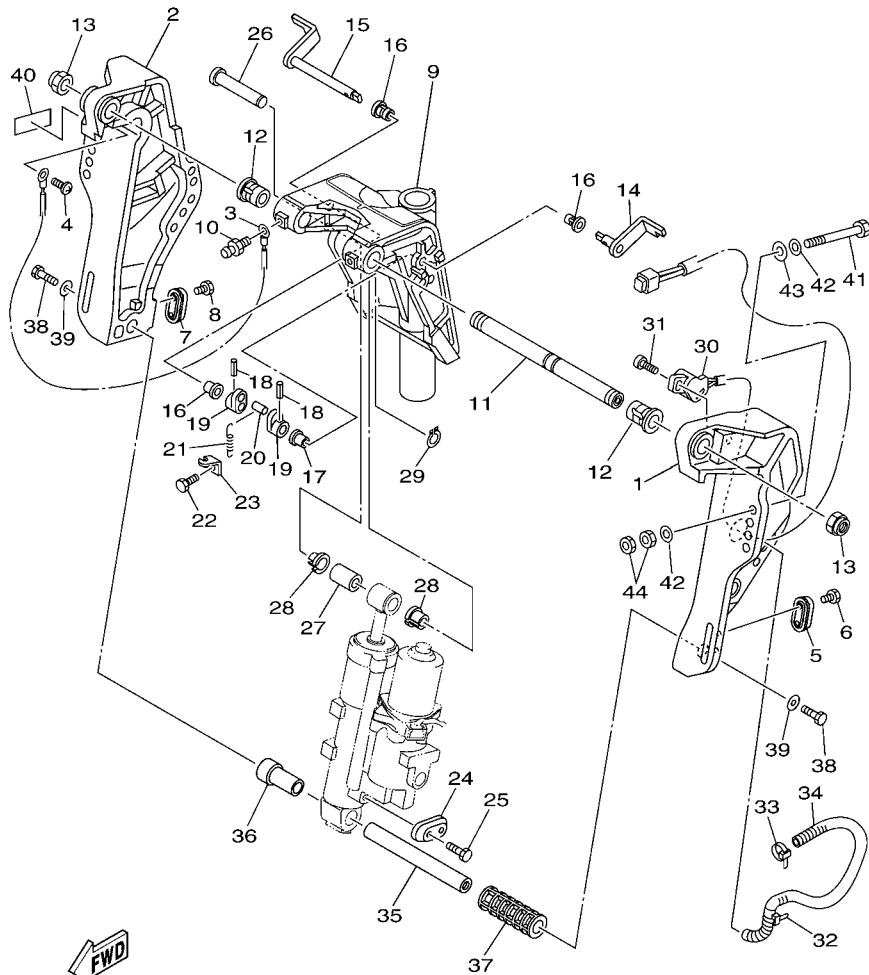

6C13100-F250

FIG. 25 BRACKET 1

REF. NO.	PART NO.	DESCRIPTION	EHT	ET		REMARKS
27	90386-18M92	BUSH	1	1		
28	90386-18M35	BUSH	2	2		
29	93410-18M02	CIRCLIP	1	1		
30	63D-83672-10	TRIM SENDER	1	1		EHT-FOR CAN
31	97885-06016	SCREW, PAN HEAD	2	2		EHT-FOR CAN
32	90464-76001	CLAMP	1	1		
33	90465-11M10	CLAMP	1	1		EHT-FOR CAN
34	90447-19009	TUBE	1	1		EXCEPT F60TJR
	90447-13010	TUBE		1		FOR F60TJR
35	6C5-43818-00	PIN, LOWER SHOCK MOUNT	1	1		
36	6C5-43833-00	PIPE	1	1		
37	6C5-43834-00	PIPE	1	1		
38	90101-08016	BOLT	2	2		
39	90201-08064	WASHER, PLATE	2	2		
40	63V-82377-50	LABEL (SPARK,IGNITION)	1	1		FOR CAN
41	90101-12M65	BOLT	4	4		
42	92995-12200	WASHER	8	8		
43	90201-12426	WASHER, PLATE	4	4		
44	95380-12600	NUT	8	8		

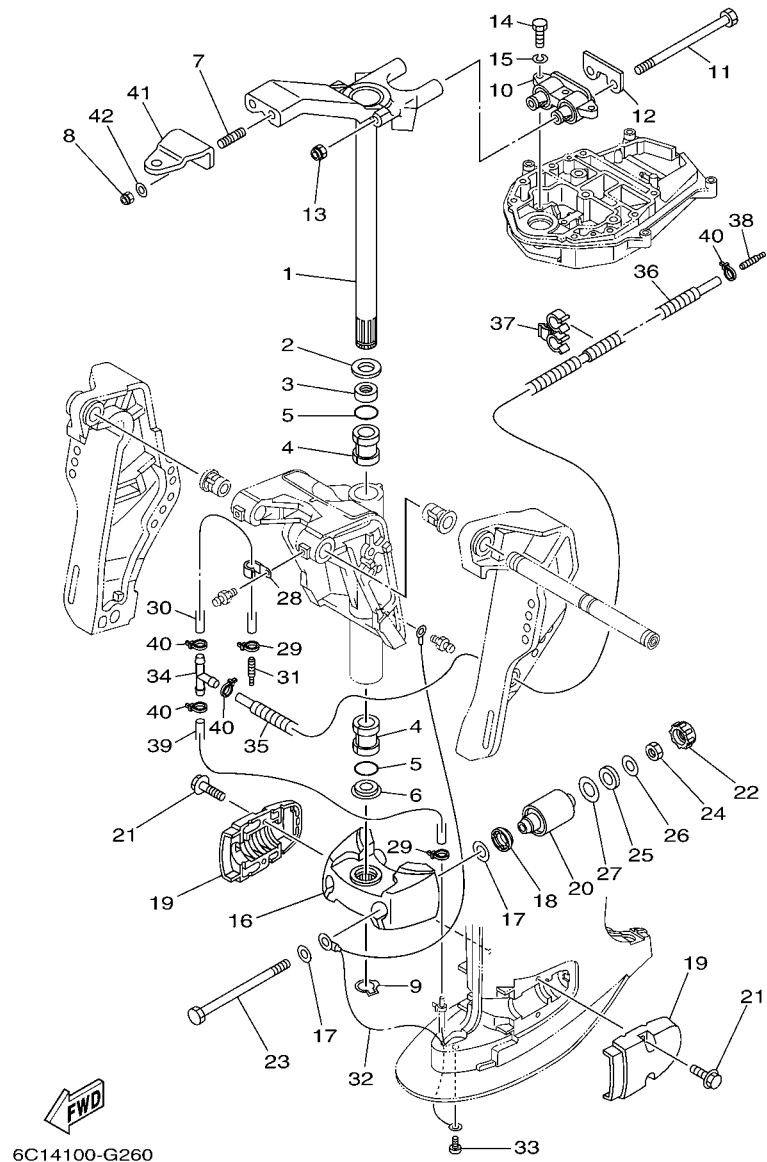

FIG. 26 BRACKET 2

REF. NO.	PART NO.	DESCRIPTION	EHT	ET	REMARKS
1	69W-42510-01-8D	STEERING BRACKET ASSY	1	1	
2	90201-30M00	WASHER, PLATE	1	1	
3	90386-30M78	BUSH	1	1	
4	90386-30M77	BUSH	2	2	
5	93210-29M94	O-RING	2	2	
6	90386-30M60	BUSH	1	1	
7	90116-10038	BOLT, STUD	2	2	
8	90185-10015	NUT, SELF-LOCKING	2	2	
9	93410-28M06	CIRCLIP	1	1	
10	69W-44514-00-4D	MOUNT DAMPER, UPPER SIDE	1	1	L(20.7")
11	90109-08103	BOLT	2	2	
12	69W-44526-01	PLATE	1	1	
13	90185-08010	NUT, SELF-LOCKING	2	2	
14	97075-08030	BOLT	3	3	
15	92995-08100	WASHER	3	3	
16	6C5-44551-00-8D	HOUSING, LOWER MOUNT RUBBER	1	1	
17	90201-12041	WASHER, PLATE	4	4	
18	6C5-43885-00	GROMMET	2	2	
19	6C5-44552-00-8D	HOUSING, LOWER MOUNT RUBBER	2	2	
20	69W-44555-00-4D	MOUNT DAMPER, LOWER SIDE	2	2	
21	90119-08101	BOLT, WITH WASHER	4	4	
22	6C5-44575-00	DAMPER, LOWER MOUNT RUBBER	2	2	
23	90109-12013	BOLT	2	2	
24	95380-12700	NUT	2	2	
25	90202-21100	WASHER, PLATE	2	2	
26	90201-13M19	WASHER, PLATE	2	2	
27	90201-22M05	WASHER, PLATE	2	2	

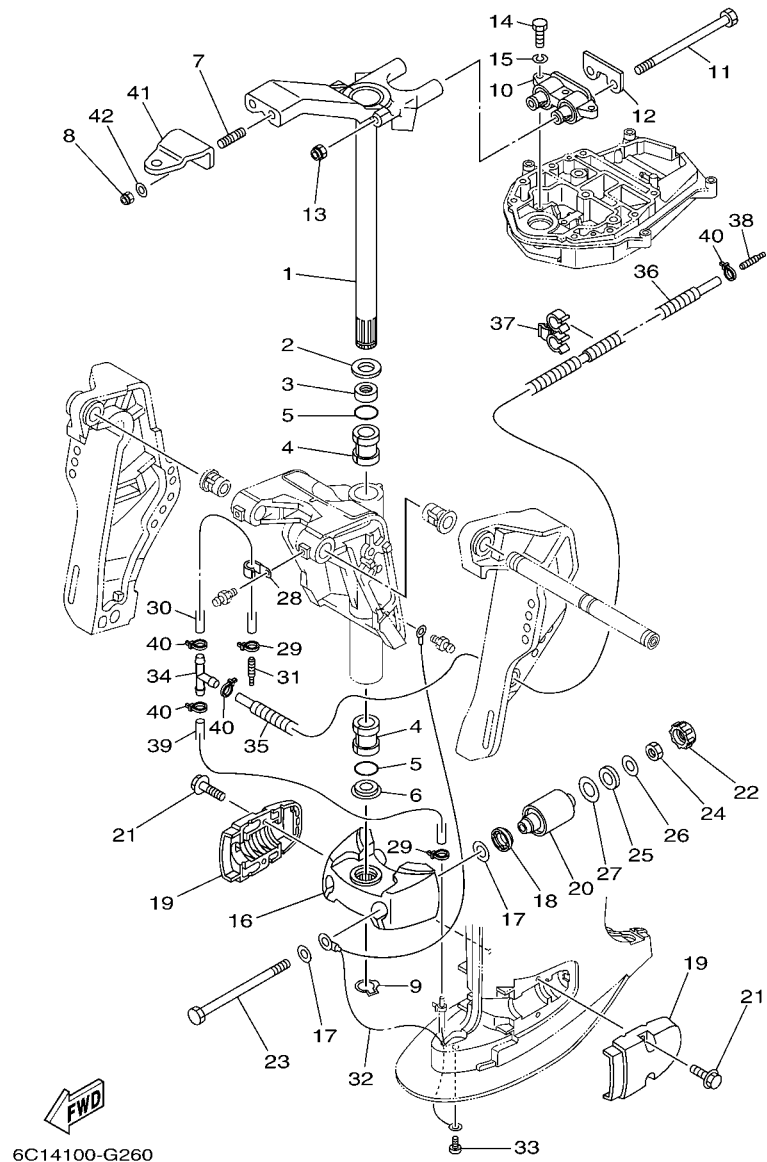

FIG. 26 BRACKET 2

REF. NO.	PART NO.	DESCRIPTION	EHT	ET		REMARKS
28	90465-06M86	CLAMP	1	1		EXCEPT F60TJR
29	90465-11M10	CLAMP	2	2		EXCEPT F60TJR
30	90445-07MF2	HOSE (L250)	1	1		EXCEPT F60TJR
31	6E5-83558-00	END, NIPPLE	1	1		EXCEPT F60TJR
32	67C-82127-10	WIRE, LEAD 2	1	1		
33	97885-06008	SCREW, PAN HEAD	1	1		
34	90413-05014	WAY 3	1	1		EXCEPT F60TJR
35	6C5-44385-00	HOSE, WATER 1	1	1		EXCEPT F60TJR
36	90447-07001	HOSE, WITH SPRING (L400)	1	1		EXCEPT F60TJR
37	90464-10006	CLAMP	1	1		EXCEPT F60TJR
38	6E5-83558-00	END, NIPPLE	1	1		EXCEPT F60TJR
39	90445-07M30	HOSE (L450)	1	1		EXCEPT F60TJR
40	90465-11M10	CLAMP	4	4		EXCEPT F60TJR
41	65W-48511-10	HOOK, STEERING		1		
42	90201-10049	WASHER, PLATE		2		

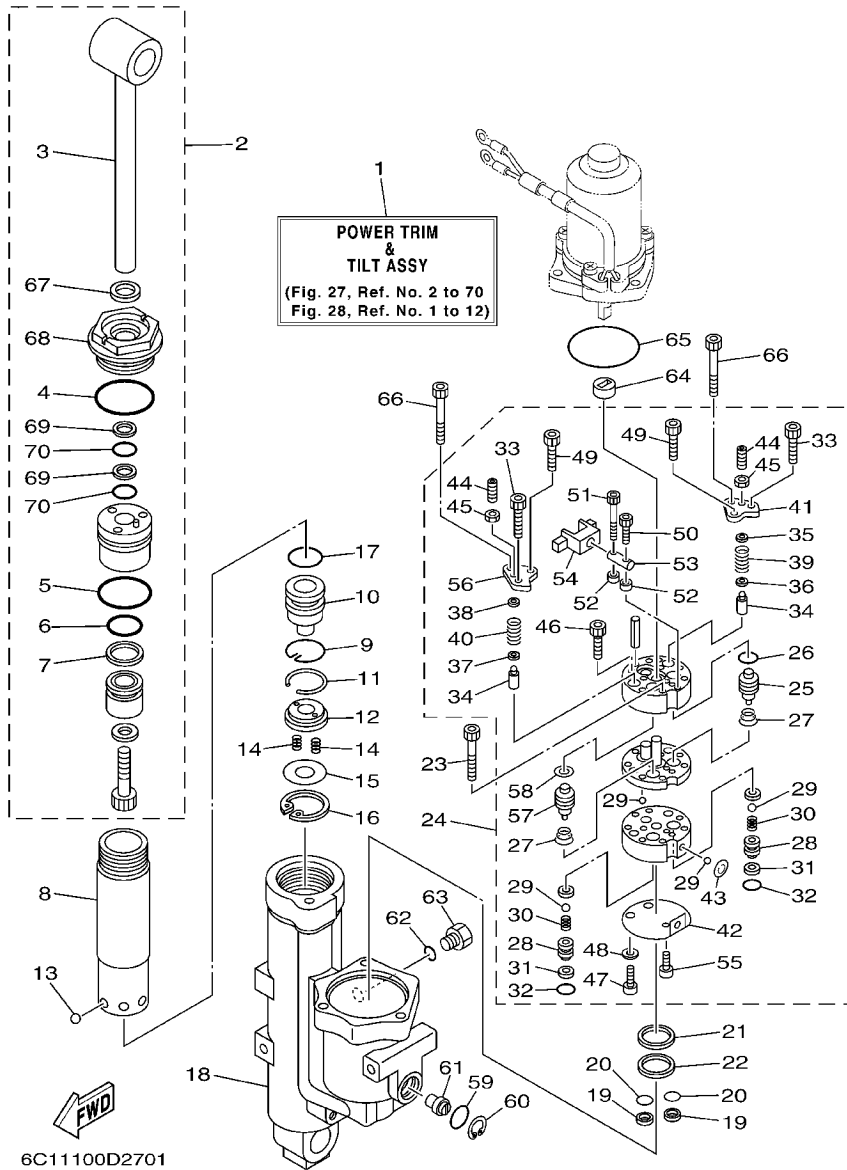

FIG. 27 POWER TRIM & TILT ASSY 1

REF. NO.	PART NO.	DESCRIPTION	EHT	ET	REMARKS
1	6C5-43800-01-8D	POWER TRIM & TILT ASSY	1	1	
2	6C5-43810-00	TILT PISTON SUB ASSY	1	1	
3	6C5-43801-00	.ROD	1	1	
4	62Y-43863-00	.O-RING	1	1	
5	6C5-43862-00	.O-RING	1	1	
6	6C5-43861-00	.O-RING	1	1	
7	6C5-43871-00	.RING, BACK UP	1	1	
8	6C5-22471-00	CYLINDER, SHOCK ABSORBER	1	1	
9	6C5-43875-00	RING, SNAP	1	1	
10	6C5-4381B-00	FREE PISTON SUB ASSY	1	1	
11	93450-32116	CIRCLIP	1	1	
12	6C5-43899-00	PLATE STOPPER	1	1	
13	93503-16003	BALL	6	6	
14	62X-4384H-00	SPRING	2	2	
15	6C5-22435-00	PLATE, VALVE 2	1	1	
16	99009-32500	CIRCLIP	1	1	
17	6C5-43861-00	O-RING	1	1	
18	6C5-4380K-00	CYLINDER, TILT SUB ASSY	1	1	
19	6C5-43817-10	FILTER 2	2	2	
20	69J-4389J-00	O-RING	2	2	
21	6C5-43816-00	FILTER 1	1	1	
22	6C5-4380G-00	PLATE	1	1	
23	91312-05045	BOLT	2	2	
24	6C5-43830-00	GEAR PUMP ASSY	1	1	
25	6C6-43841-00	.PISTON, SHUTTLE	1	1	
26	6H1-43883-00	.O-RING	1	1	
27	6C6-43894-00	.SPRING, SHUTTLE RETURN	2	2	

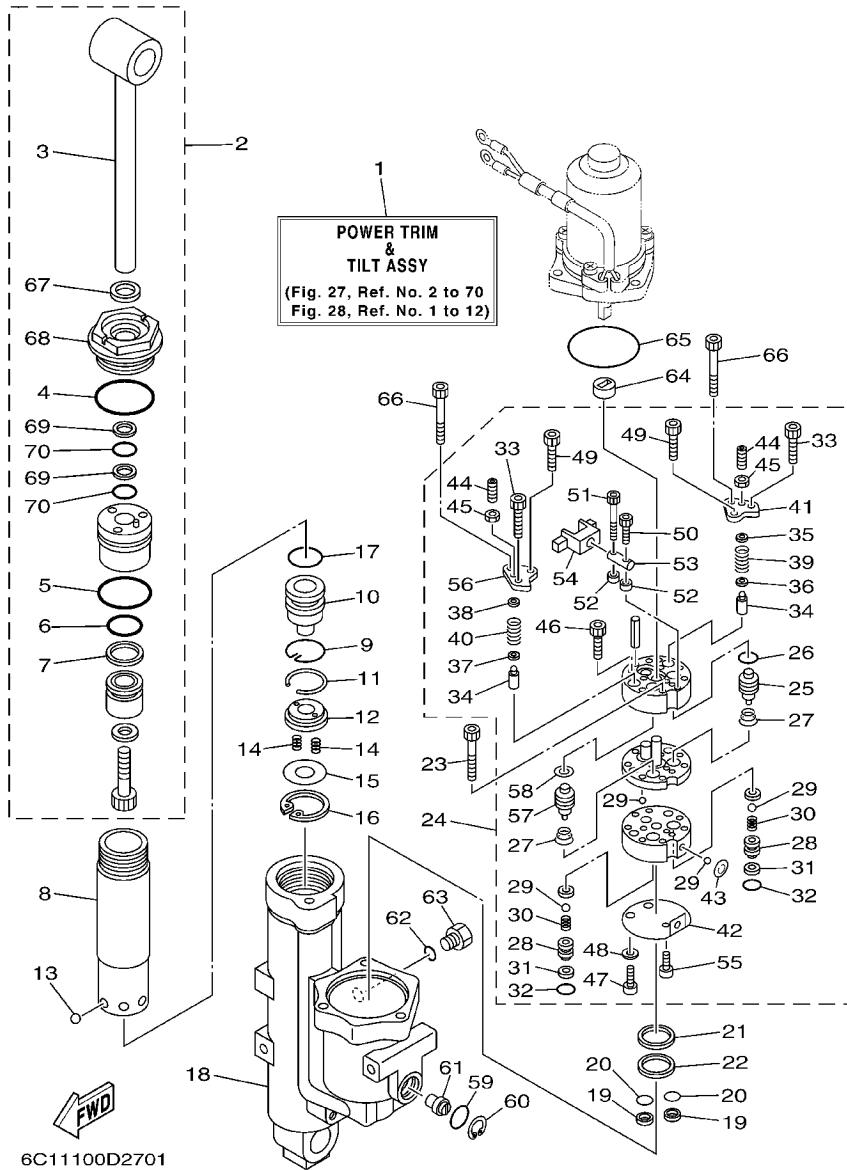
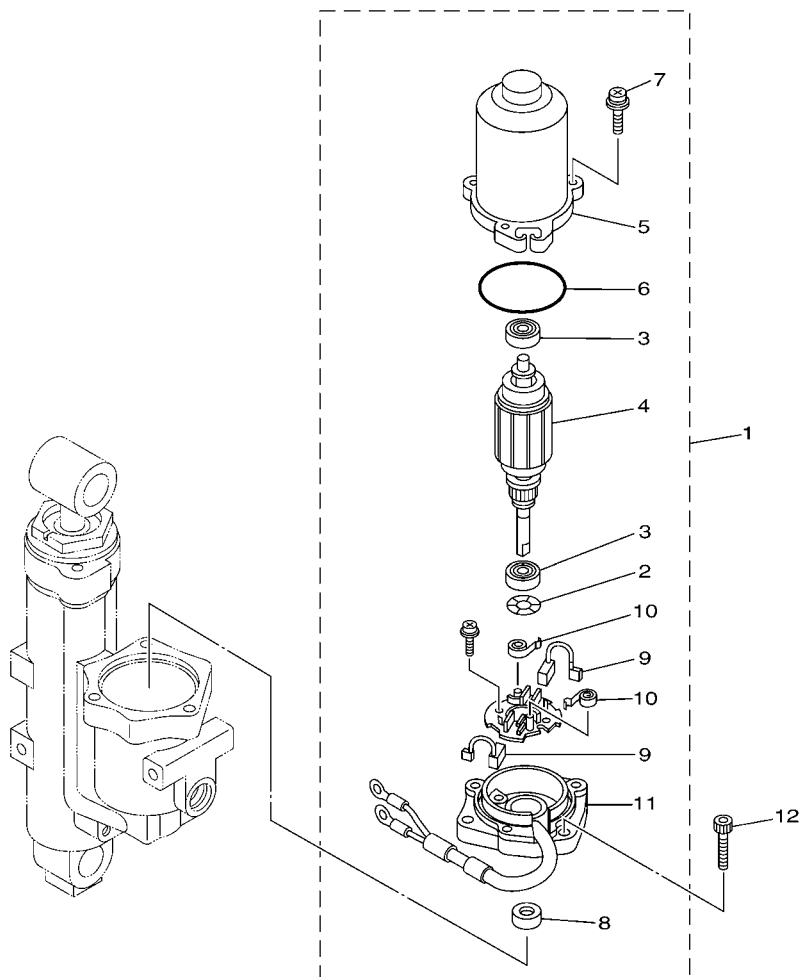

FIG. 27 POWER TRIM & TILT ASSY 1

REF. NO.	PART NO.	DESCRIPTION	EHT	ET	REMARKS
55	91312-03005	.BOLT	1	1	
56	6C5-4382L-00	.CAP, RELIEF VALVE	1	1	
57	6C5-43841-00	.PISTON, SHUTTLE	1	1	
58	6C5-43872-00	.RING, BACK UP	1	1	
59	93210-18397	O-RING	1	1	
60	6H1-43875-00	RING, SNAP	1	1	
61	6C5-43845-00	SCREW, MANUAL RELEASE	1	1	
62	93210-09165	O-RING	1	1	
63	6H1-43829-00	PLUG, RESERVOIR	1	1	
64	6C5-43831-00	CONNECTOR, SHAFT	1	1	
65	93210-64488	O-RING	1	1	
66	91312-05050	BOLT	2	2	
67	62Y-43822-00	.SEAL, TRIM DUST	1	1	
68	6C5-43821-00	.SCREW, TRIM CYLINDER END	1	1	
69	62X-43872-00	.RING, BACK UP	2	2	
70	6C5-43863-00	.O-RING	2	2	

FIG. 28 POWER TRIM & TILT ASSY 2



REF. NO.	PART NO.	DESCRIPTION	EHT	ET			REMARKS
1	6C5-43880-01	MOTOR ASSY	1	1			
2	90206-08N51	.WASHER, WAVE	1	1			
3	93399-999T8	.BEARING	2	2			
4	6C5-43805-00	.ARMATURE ASSY	1	1			
5	6C5-43804-01	.STATOR ASSY	1	1			
6	6C5-43869-00	.O-RING	1	1			
7	6C5-43879-00	.SCREW, WITH WASHER	3	3			
8	6C5-43882-00	.OIL SEAL	1	1			
9	6C5-43891-00	.BRUSH 1	2	2			
10	6C5-4386K-00	.SPRING, BRUSH	2	2			
11	6C5-43881-01	.FRAME, END	1	1			
12	62X-43888-00	BOLT, SOCKET	3	3			

6C11010-D280

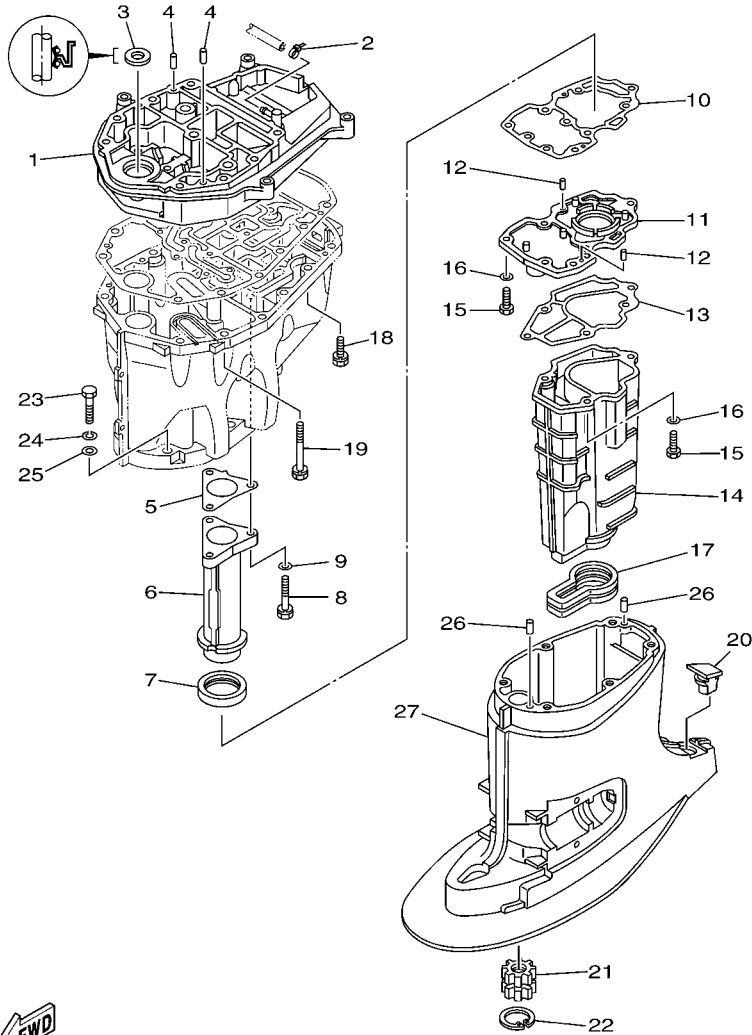

6C11010-D290

FIG. 29 UPPER CASING

REF. NO.	PART NO.	DESCRIPTION	EHT	ET				REMARKS
1	6C5-41137-00-8D	GUIDE, EXHAUST	1	1				
2	90465-11M10	CLAMP	1	1				
3	93103-18011	OIL SEAL	1	1				
4	93608-12M05	PIN, DOWEL	2	2				
5	6C5-41133-00	GASKET, EXHAUST MANIFOLD 1	1	1				
6	6C5-41131-00-5B	MANIFOLD, EXT. 1	1	1				
7	6C5-46132-00	GASKET 1	1	1				
8	90119-06120	BOLT, WITH WASHER	3	3				
9	90201-06015	WASHER, PLATE	3	3				
10	6C5-41134-00	GASKET, EXHAUST MANIFOLD	1	1				
11	6C5-45181-00-5B	PLATE	1	1				
12	93604-10M03	PIN, DOWEL	2	2				
13	6C5-41135-00	GASKET, EXHAUST MANIFOLD	1	1				
14	6C5-14711-00-5B	MUFFLER 1	1	1				
15	97075-06025	BOLT	6	6				
16	92995-06600	WASHER	6	6				
17	6C5-45123-00	GASKET, MUFFLER	1	1				
18	90119-08M79	BOLT, WITH WASHER	4	4				
19	90119-08M82	BOLT, WITH WASHER	8	8				
20	6C5-45155-00	CAP	1	1				
21	69W-45318-00	BUSHING, DRIVE SHAFT	1	1				
22	93420-36M01	CIRCLIP	1	1				
23	97075-10045	BOLT	6	6				
24	92995-10100	WASHER	6	6				
25	92995-10600	WASHER	6	6				
26	93606-12019	PIN, DOWEL	2	2				
27	6C5-45111-00-8D	CASING, UPPER	1	1				

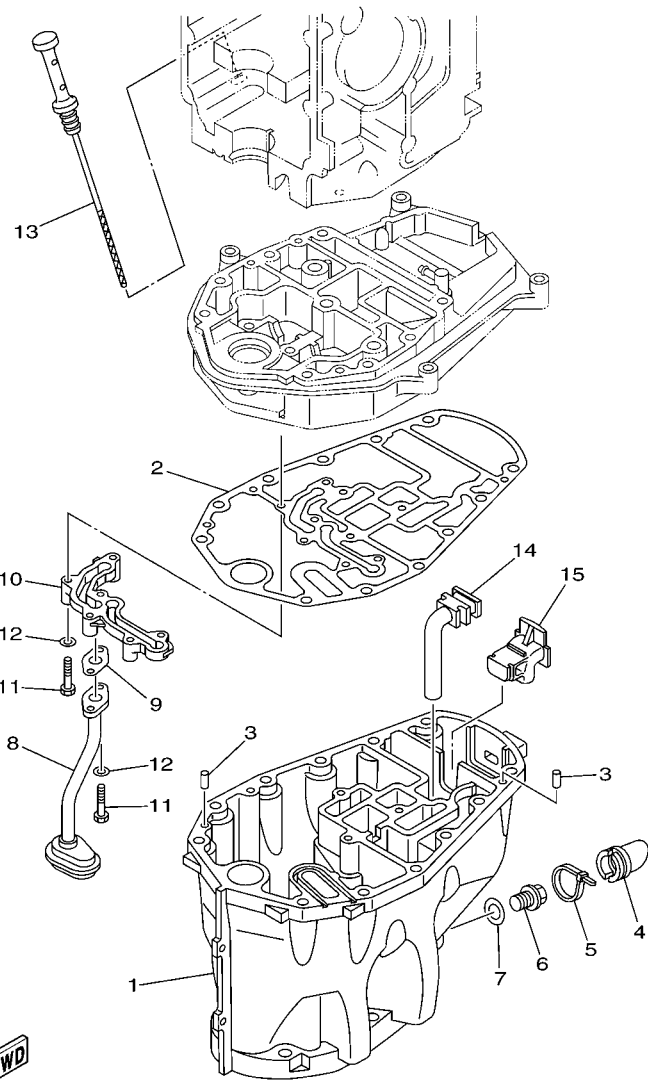

6C11010-D300

FIG. 30 OIL PAN

REF. NO.	PART NO.	DESCRIPTION	EHT	ET	REMARKS
1	6C5-15311-00-8D	OIL PAN	1	1	
2	6C5-15312-00	GASKET, OIL PAN	1	1	
3	93606-12019	PIN, DOWEL	2	2	
4	6C5-15316-00	DAMPER 1	1	1	
5	90465-11M59	CLAMP	1	1	
6	90340-14M06	PLUG, STRAIGHT SCREW	1	1	
7	90430-14M09	GASKET	1	1	
8	6C5-13411-00	STRAINER, OIL	1	1	
9	6C5-13414-00	GASKET, STRAINER COVER	1	1	
10	6C5-15333-00	COVER	1	1	
11	97013-06030	BOLT	6	6	
12	92903-06600	WASHER, PLATE	6	6	
13	6C5-15362-00	PLUG, OIL LEVEL	1	1	
14	6C5-45135-01	PIPE	1	1	
15	6C5-45136-01	PIPE	1	1	

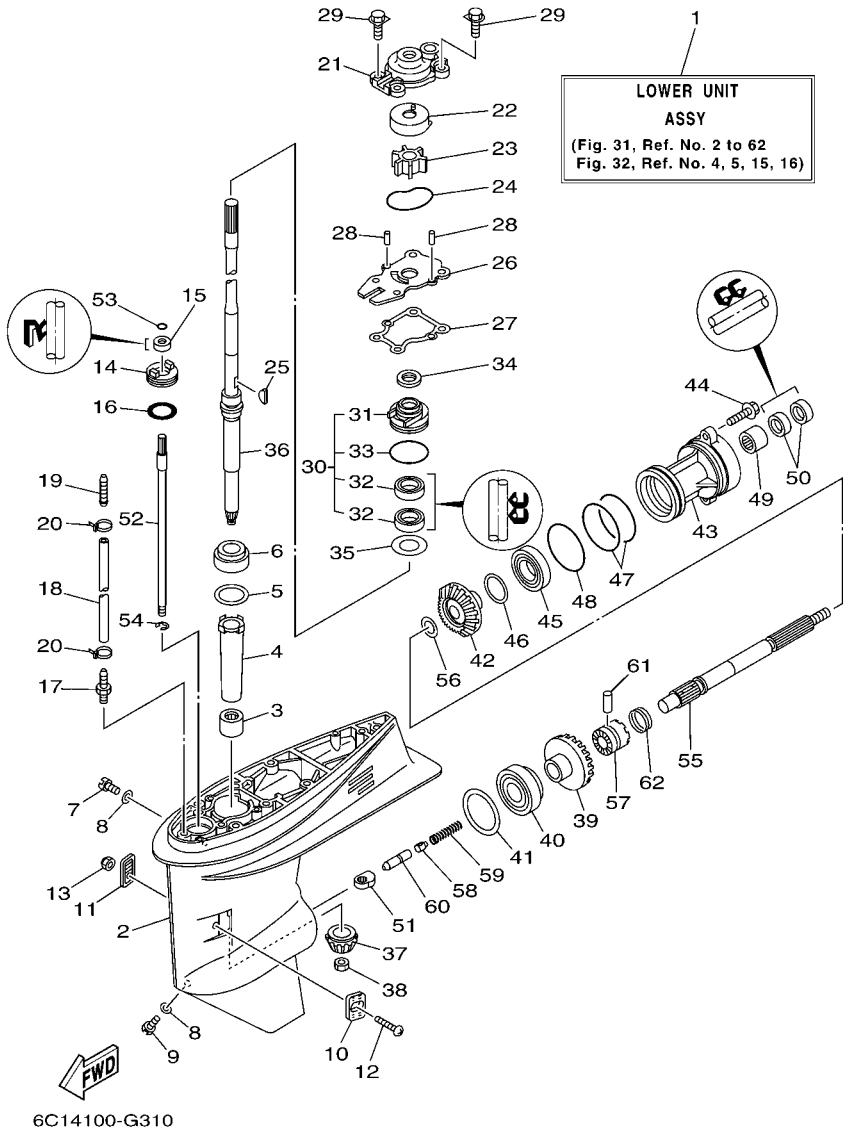

FIG. 31 LOWER CASING & DRIVE 1

REF. NO.	PART NO.	DESCRIPTION	EHT	ET	REMARKS
1	69W-45300-00-8D	LOWER UNIT ASSY	1	1	L(20.7")
2	69W-45301-00-8D	CASING, LOWER	1	1	
3	93315-32224	BEARING	1	1	
4	6H4-45536-00	SLEEVE, DRIVE SHAFT	1	1	
5	663-45587-01	SHIM (T:0.10MM)	1	1	UR
6	663-45587-10	SHIM (T:0.12MM)	1	1	UR
7	663-45587-20	SHIM (T:0.15MM)	1	1	UR
8	663-45587-30	SHIM (T:0.18MM)	1	1	UR
9	663-45587-40	SHIM (T:0.30MM)	1	1	UR
10	663-45587-50	SHIM (T:0.40MM)	1	1	UR
11	663-45587-60	SHIM (T:0.50MM)	1	1	UR
12	93332-00001	BEARING	1	1	
13	90340-08002	PLUG, STRAIGHT SCREW	1	1	
14	90430-08020	GASKET	2	2	
15	688-45341-10	PLUG, DRAIN	1	1	
16	63D-45214-00	COVER, WATER INLET 1	1	1	
17	63D-45215-00	COVER, WATER INLET 2	1	1	
18	90142-05M06	SCREW, COUNTERSUNK	1	1	
19	95380-05600	NUT	1	1	
20	63D-45321-00	PLATE	1	1	
21	93106-09014	OIL SEAL	1	1	
22	93210-33MG4	O-RING	1	1	
23	6E5-45378-00	NIPPLE, HOSE	1	1	
24	90445-07ME8	HOSE (L80)	1	1	L(20.7")
25	6E5-83558-10	END, NIPPLE	1	1	
26	90465-11M10	CLAMP	2	2	
27	63D-44311-00	HOUSING, WATER PUMP	1	1	

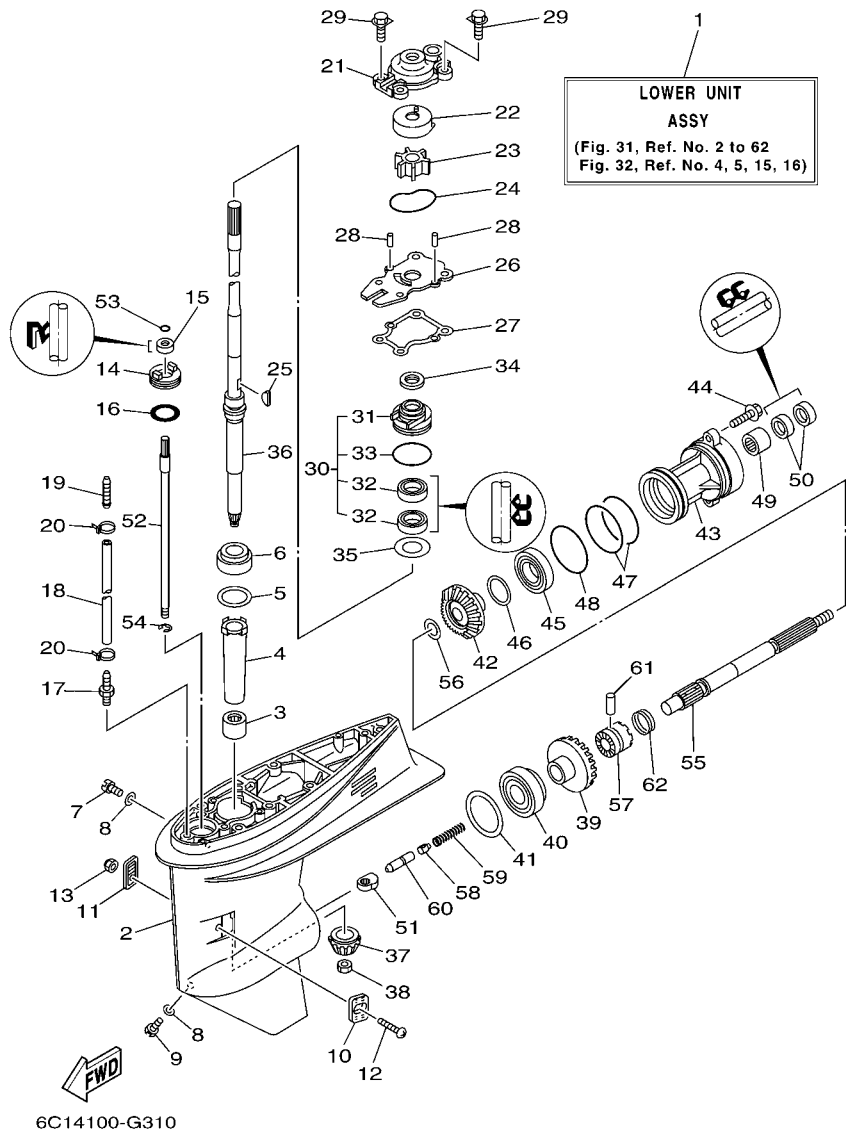

FIG. 31 LOWER CASING & DRIVE 1

REF. NO.	PART NO.	DESCRIPTION	EHT	ET	REMARKS
22	63D-44322-00	INSERT, CARTRIDGE	1	1	
23	6H3-44352-00	IMPELLER	1	1	
24	93210-59MG7	O-RING	1	1	
25	90280-03024	KEY, WOODRUFF	1	1	
26	63D-44323-00	OUTER PLATE, CARTRIDGE	1	1	
27	63D-44316-00	GASKET, WATER PUMP	1	1	
28	93604-08062	PIN, DOWEL	2	2	
29	90119-08M15	BOLT, WITH WASHER	4	4	
30	63D-W4434-00	WATER PUMP HOUSING ASSY	1	1	
31	63D-44341-00	.HOUSING, WATER PUMP	1	1	
32	93101-25M57	.OIL SEAL	2	2	
33	93210-48MG8	.O-RING	1	1	
34	63D-45344-00	COVER, OIL SEAL	1	1	
35	90201-27M00	WASHER, PLATE	1	1	
36	69W-45501-00	DRIVE SHAFT COMP.	1	1	L(20.7")
37	69W-45551-00	PINION (13T)	1	1	
38	90170-12138	NUT	1	1	
39	69W-45560-00	GEAR 1 (24T)	1	1	
40	93332-00092	BEARING	1	1	
41	663-45567-01	SHIM (T:0.10MM)	1	1	UR
	663-45567-10	SHIM (T:0.12MM)	1	1	UR
	663-45567-20	SHIM (T:0.15MM)	1	1	UR
	663-45567-30	SHIM (T:0.18MM)	1	1	UR
	663-45567-40	SHIM (T:0.30MM)	1	1	UR
	663-45567-50	SHIM (T:0.40MM)	1	1	UR
	663-45567-60	SHIM (T:0.50MM)	1	1	UR
42	62Y-45571-00	GEAR 2 (24T)	1	1	

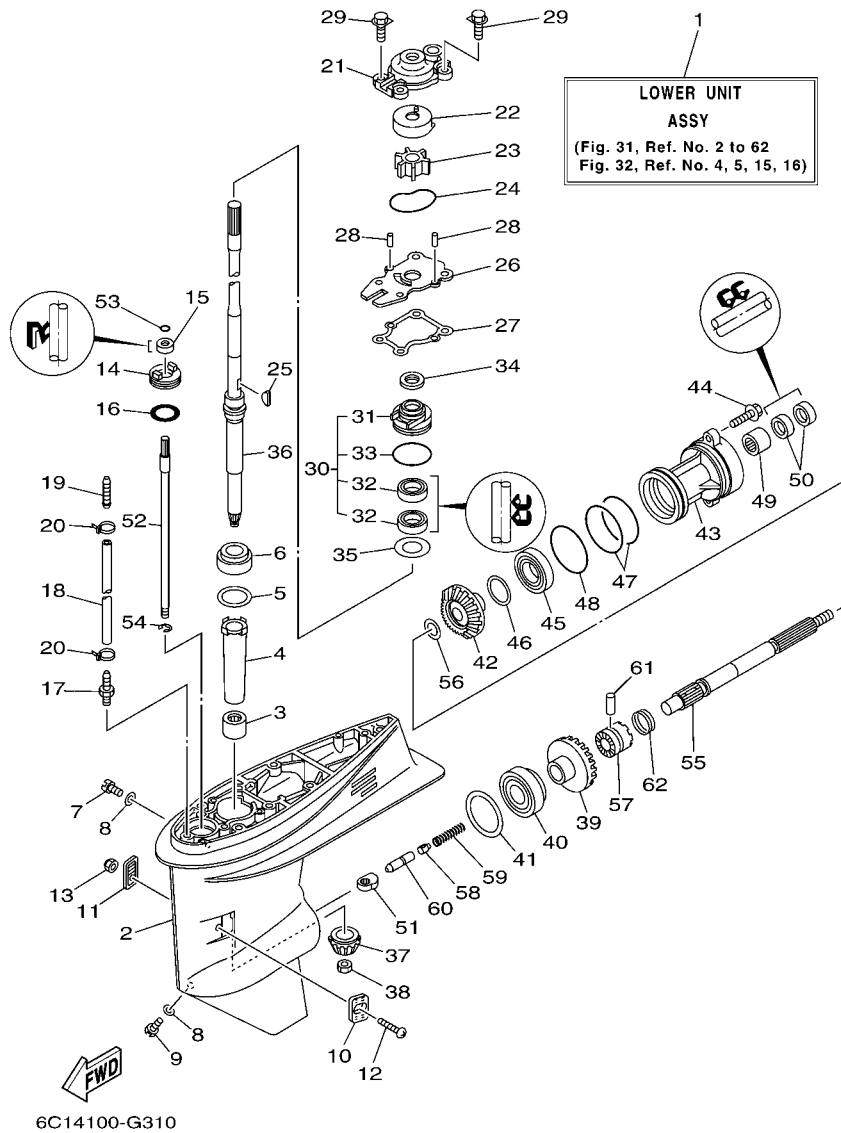
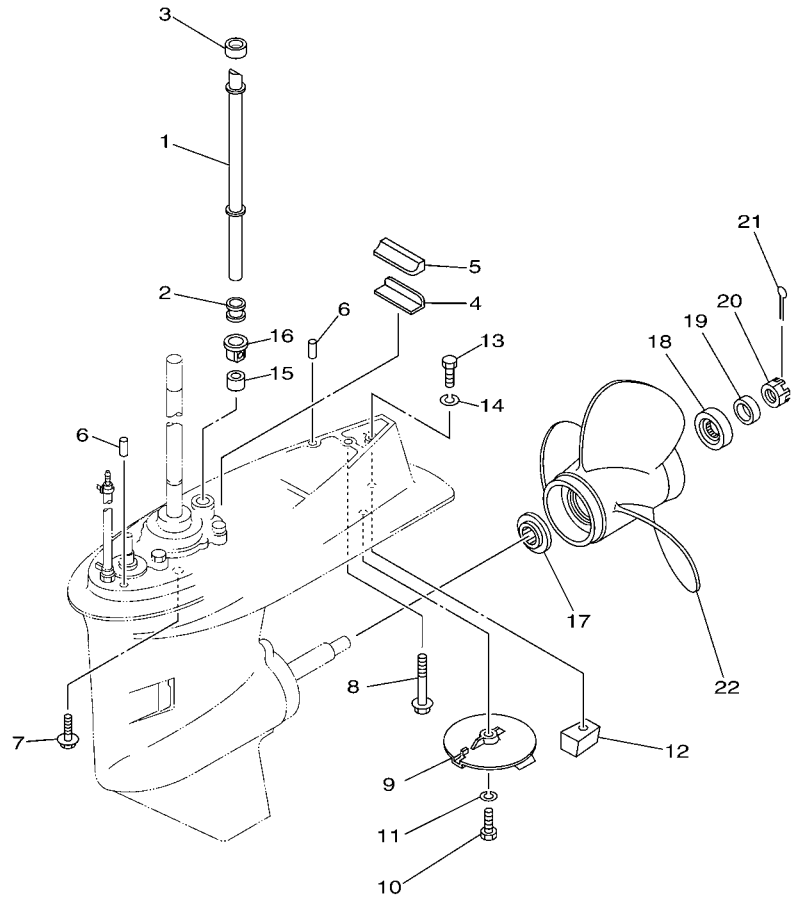

FIG. 31 LOWER CASING & DRIVE 1

REF. NO.	PART NO.	DESCRIPTION	EHT	ET	REMARKS
43	63D-45361-02-8D	CAP, LOWER CASING	1	1	
44	90105-08148	BOLT, FLANGE	2	2	
45	93306-001U1	BEARING	1	1	
46	63D-45577-00	SHIM (T:0.10MM)	1	1	UR
	63D-45577-10	SHIM (T:0.12MM)	1	1	UR
	63D-45577-20	SHIM (T:0.15MM)	1	1	UR
	63D-45577-30	SHIM (T:0.18MM)	1	1	UR
	63D-45577-40	SHIM (T:0.30MM)	1	1	UR
	63D-45577-50	SHIM (T:0.40MM)	1	1	UR
	63D-45577-60	SHIM (T:0.50MM)	1	1	UR
47	93210-74MG5	O-RING	2	2	
48	93210-69MG6	O-RING	1	1	
49	93317-22204	BEARING	1	1	
50	93101-22M00	OIL SEAL	2	2	
51	62Y-44151-00	CAM, SHIFT	1	1	
52	63D-44144-00	ROD, SHIFT	1	1	
53	93210-07003	O-RING	1	1	
54	99001-08600	CIRCLIP	1	1	
55	63D-45611-00	SHAFT, PROPELLER	1	1	
56	90201-22008	WASHER, PLATE	1	1	
57	62Y-45631-00	CLUTCH, DOG	1	1	
58	663-45634-00	SLIDE, SHIFT	1	1	
59	90501-18001	SPRING, COMPRESSION	1	1	
60	63D-45635-00	PLUNGER, SHIFT	1	1	
61	90250-06023	PIN, STRAIGHT	1	1	
62	67C-45633-00	RING, CROSS PIN	1	1	



FWD
6C14100-G321

FIG. 32 LOWER CASING & DRIVE 2

REF. NO.	PART NO.	DESCRIPTION	EHT	ET	REMARKS
1	6C5-44361-00	TUBE, WATER	1	1	L(20.7")
2	663-44367-00	DAMPER, WATER SEAL	1	1	
3	663-44366-00	DAMPER, WATER SEAL	1	1	
4	663-45376-00-94	GUIDE, SEAL DAMPER	1	1	
5	63D-45375-00	DAMPER, SEAL	1	1	
6	93606-12019	PIN, DOWEL	2	2	
7	90119-10030	BOLT, WITH WASHER	4	4	L(20.7")
8	90119-08M84	BOLT, WITH WASHER	1	1	L(20.7")
9	67C-45371-00	TAB-TRIM	1	1	
10	97095-08025	BOLT	1	1	
11	92995-08100	WASHER	1	1	
12	67C-45251-00	ANODE	1	1	
13	97095-08035	BOLT	1	1	
14	92995-08100	WASHER	1	1	
15	663-44366-00	DAMPER, WATER SEAL	1	1	
16	63D-44312-00	COVER, WATER PUMP HOUSING	1	1	
17	663-45987-02	SPACER	1	1	
18	66T-45997-00	SPACER	1	1	
19	90389-22M01	BUSH	1	1	
20	90171-16011	NUT, CASTLE	1	1	
21	91490-30025	PIN, COTTER	1	1	
22	69W-45943-00-EL	PROPELLER (3X11"X15"-G)	1	1	UR
	69W-45945-00-EL	PROPELLER (3X11-1/8"X13"-G)	1	1	UR
	69W-45947-00-EL	PROPELLER (3X11-5/8"X11"-G)	1	1	UR
	69W-45952-00-EL	PROPELLER (3X11-3/8"X12"-G)	1	1	UR
	663-45941-01-EL	PROPELLER (3X10-3/4"X17"-G)	1	1	UR
	663-45949-01-EL	PROPELLER (3X10-3/4"X16"-G)	1	1	UR

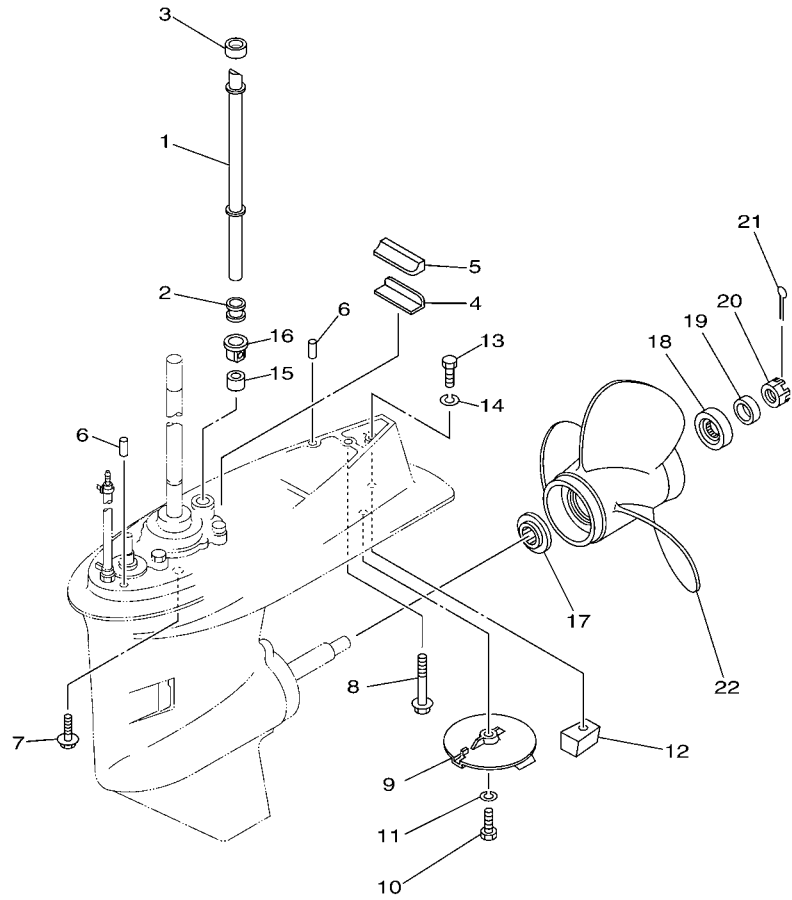

6C14100-G321

FIG. 32 LOWER CASING & DRIVE 2

REF. NO.	PART NO.	DESCRIPTION	EHT	ET		REMARKS
22	663-45952-02-EL	PROPELLER (3X11-3/8"X12"-G)	1	1		UR
	663-45956-01-EL	PROPELLER (3X12-1/4"X9"-G)	1	1		UR
	663-45958-01-EL	PROPELLER (3X11-1/4"X14"-G)	1	1		UR
	6H5-45943-00-EL	PROPELLER (3X10"X15"-G)	1	1		UR WITH LIP CUP
	6H5-45945-00-EL	PROPELLER (3X10-3/8"X13"-G)	1	1		UR WITH LIP CUP
	6H5-45952-00-EL	PROPELLER (3X10-5/8"X12"-G)	1	1		UR WITH LIP CUP
	6H5-45958-00-EL	PROPELLER (3X10-1/4"X14"-G)	1	1		UR WITH LIP CUP
	663-45970-60-98	PROPELLER (3X11-3/4"X12"-G)	1	1		UR
	663-45972-60-98	PROPELLER (3X12"X11"-G)	1	1		UR
	663-45974-60-98	PROPELLER (3X11-1/2"X13"-G)	1	1		UR
	697-45970-00-98	PROPELLER (3X11-1/4"X14"-G)	1	1		UR
	663-45930-00-98	PROPELLER (3X10-1/4"X14"-G)	1	1		UR
	663-45974-02-98	PROPELLER (3X10-5/8"X13"-G)	1	1		UR
	663-45976-00-98	PROPELLER (3X10-1/4"X15"-G)	1	1		UR
	663-45978-00-98	PROPELLER (3X10-1/4"X16"-G)	1	1		UR

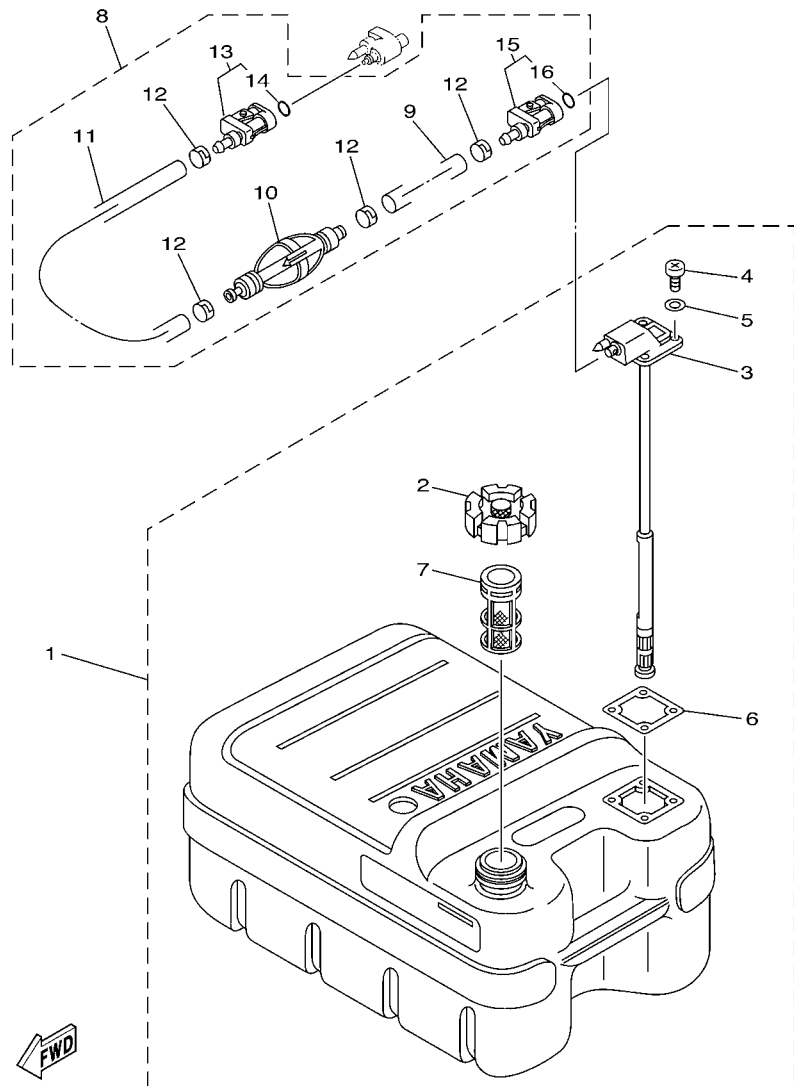
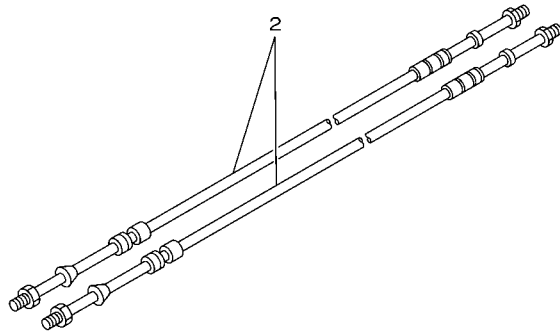
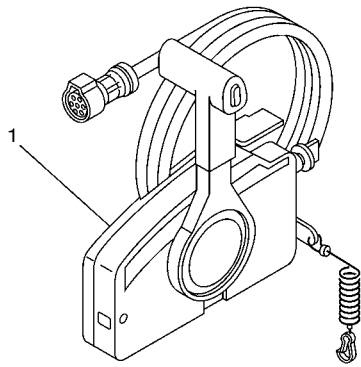

FIG. 33 FUEL TANK

REF. NO.	PART NO.	DESCRIPTION	EHT	ET	REMARKS
1	6YJ-24201-10	FUEL TANK ASSY (24L)	1	1	AP FOR OCE
2	6YJ-24610-01	.CAP ASSY	1	1	
3	6Y1-24260-12	.FUEL METER ASSY	1	1	WITH INDICATOR
4	90157-05M19	.SCREW, PAN HEAD	4	4	
5	6Y1-24329-00	.SEAL	4	4	
6	6Y1-24268-00	.GASKET, FUEL METER	1	1	
7	6YJ-24167-00	.STRAINER	1	1	
8	61J-24306-04	FUEL PIPE COMP. 1	1	1	AP FOR OCE
9	90445-11M06	.HOSE (L2050)	1	1	
10	61J-24360-00	.PRIMER PUMP ASSY	1	1	
11	90445-11M05	.HOSE (L850)	1	1	
12	650-24351-01	.BAND 1	4	4	
13	6G1-24305-05	.FUEL PIPE JOINT COMP. 2	1	1	
14	93210-08287	..O-RING	1	1	
15	6Y1-24305-06	.FUEL PIPE JOINT COMP. 2	1	1	
16	93210-08287	..O-RING	1	1	



67M0100-8280

FIG. 35 REMOTE CONTROL BOX

REF. NO.	PART NO.	DESCRIPTION	EHT	ET		REMARKS
1	703-48205-17	REMOTE CONTROL ASSY (10P)		1		AP WITH PT/T SW.
2	701-48310-90	CABLE, REMOTE CONTROL L=11F		2		UR
	701-48320-00	CABLE, REMOTE CONTROL L=12F		2		UR
	701-48320-20	CABLE, REMOTE CONTROL L=13F		2		UR
	701-48320-50	CABLE, REMOTE CONTROL L=15F		2		UR

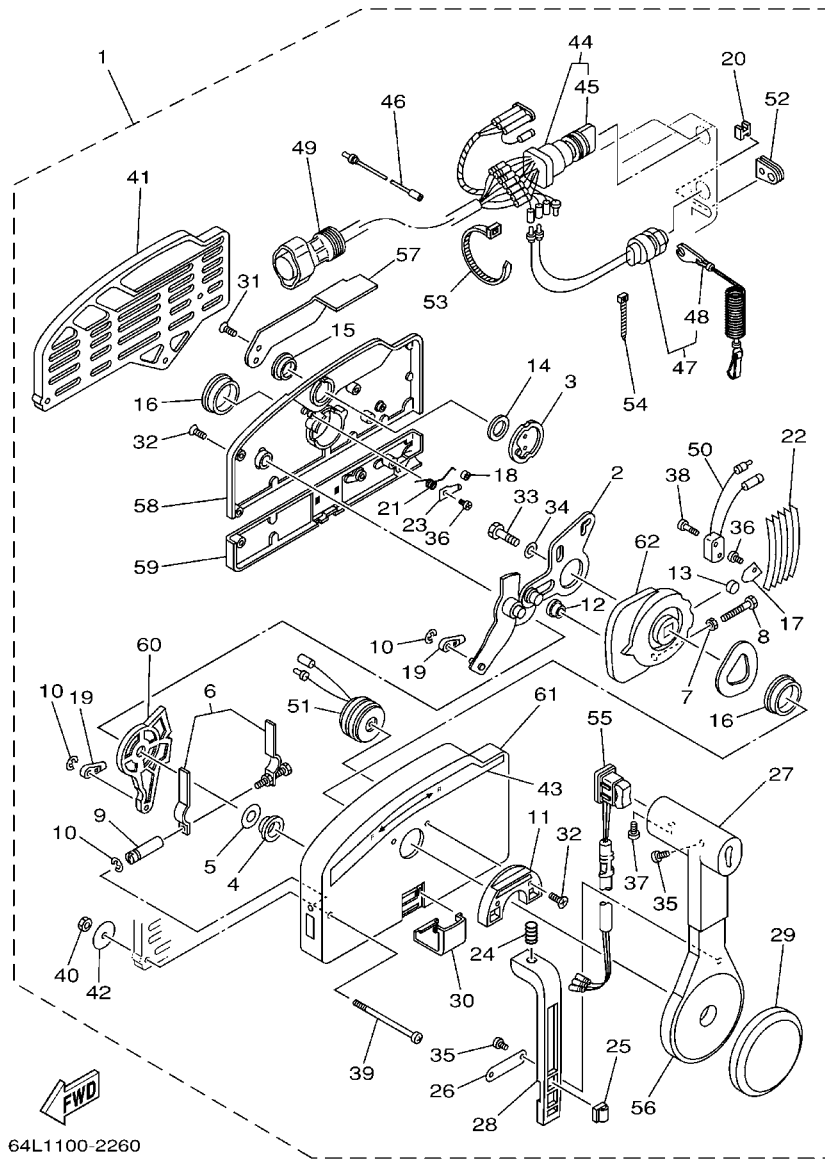

64L1100-2260

FIG. 36 REMOTE CONTROL ASSY

REF. NO.	PART NO.	DESCRIPTION	EHT	ET	REMARKS
1	703-48205-17	REMOTE CONTROL ASSY (10P)		1	AP WITH PT/T SW.
2	703-48261-01	.ARM, THROTTLE		1	
3	703-48153-00	.SHAFT, FREE ACCEL.		1	
4	703-48235-00	.BUSHING		1	
5	703-48268-00	.SPACER		1	
6	703-48264-00	.FRICTION, THROTTLE		1	
7	95380-05600	.NUT		1	
8	97380-05025	.BOLT		1	
9	703-48265-00	.SHAFT, FRICTION		1	
10	93430-06024	.CIRCLIP		3	
11	703-48245-00	.PLATE, LOCK		1	
12	703-48252-00	.ROLLER, CAM		1	
13	701-48248-00	.ROLLER, FREE ACCEL.		1	
14	703-48198-00	.WASHER, WAVE		1	
15	703-48243-00	.BUSHING		1	
16	703-48236-00	.BUSHING 1		2	
17	703-48189-00	.RETAINER		1	
18	703-48234-00	.ROLLER, DETENT		1	
19	703-48345-01	.CABLE END, REMOTE CONTROL 2		2	
20	703-48358-00	.ANCHOR, CABLE		1	
21	703-48244-00	.SPRING, FREE ACCEL.		1	
22	703-48238-00	.SPRING, DETENT		5	
23	703-48246-00	.SPACER		1	
24	703-48227-00	.SPRING, NEUTRAL LOCK		1	
25	703-82594-00	.CLAMP		1	WITH PT/T SW.
26	703-48226-00	.PLATE, STOPPER		1	
27	703-48222-00	.GRIP, CONTROL LEVER		1	SINGLE

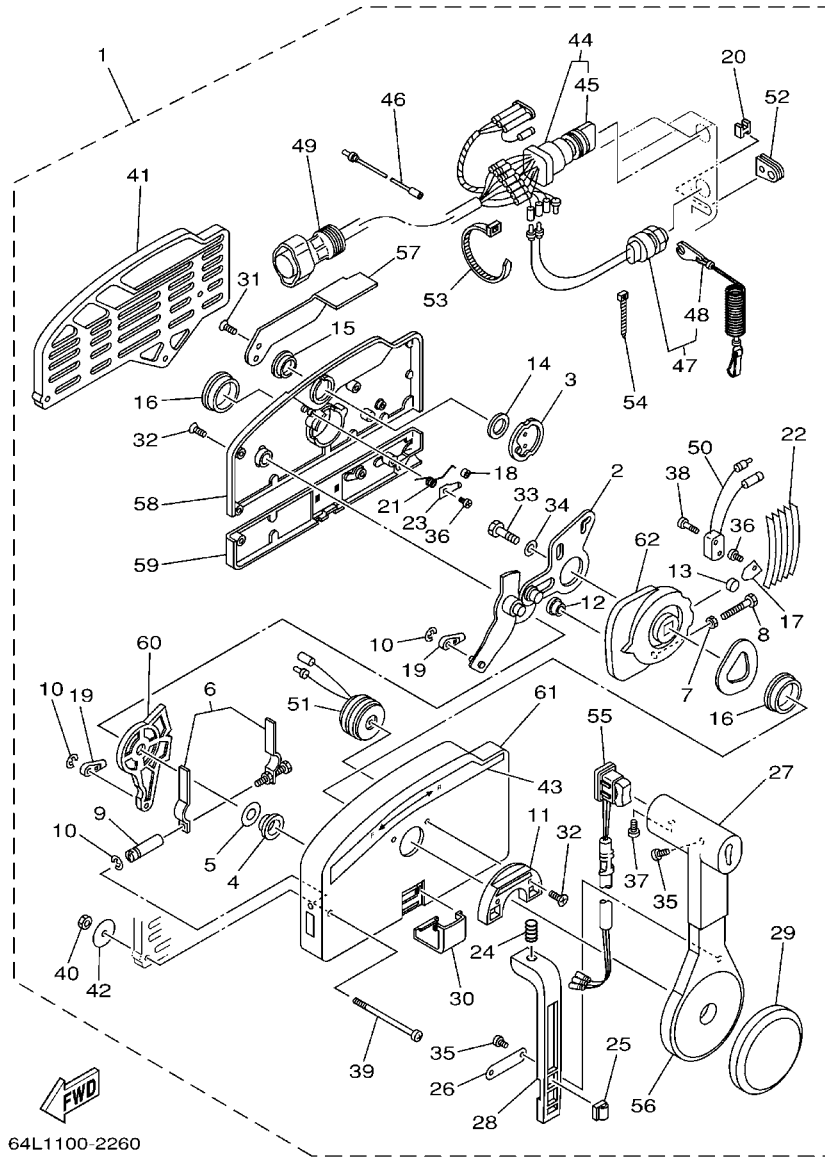

64L1100-2260

FIG. 36 REMOTE CONTROL ASSY

REF. NO.	PART NO.	DESCRIPTION	EHT	ET	REMARKS
28	703-48223-00	.LOCK, NEUTRAL		1	
29	703-48225-00	.COVER		1	
30	703-48219-00	.COVER, LEAD		1	
31	703-48281-00	.SCREW		2	
32	703-48282-00	.SCREW		7	
33	97380-08030	.BOLT		1	
34	92990-08600	.WASHER, PLATE		1	
35	98580-04010	.SCREW, PAN HEAD		3	
36	98580-04006	.SCREW, PAN HEAD		2	
37	98580-05010	.SCREW, PAN HEAD		1	
38	98580-03015	.SCREW, PAN HEAD		2	
39	703-48291-10	.SCREW (M6)		3	
40	95380-06600	.NUT, HEXAGON		3	
41	703-48293-10	.SPACER, REMOTE CONTROL		1	SINGLE
42	701-48287-00	.WASHER		3	
43	703-48215-00	.GRAPHIC		1	
44	703-82510-43	.MAIN SWITCH ASSY		1	
45	703-82577-00	.CAP, KEY		1	
46	703-82531-00	.WIRE, LEAD (L70)		1	
47	688-82575-01	.ENGINE STOP SWITCH ASSY		1	
48	682-82556-00	.LANYARD, STOP SWITCH		1	
49	688-8258A-20	.EXTENSION, WIRE HARNESS (4.9M)		1	(10P)
50	703-82540-00	.NEUTRAL SWITCH ASSY		1	
51	703-83383-02	.BUZZER		1	
52	703-48284-00	.GROMMET		1	
53	703-82591-00	.BAND		1	
54	703-82592-00	.BAND		1	

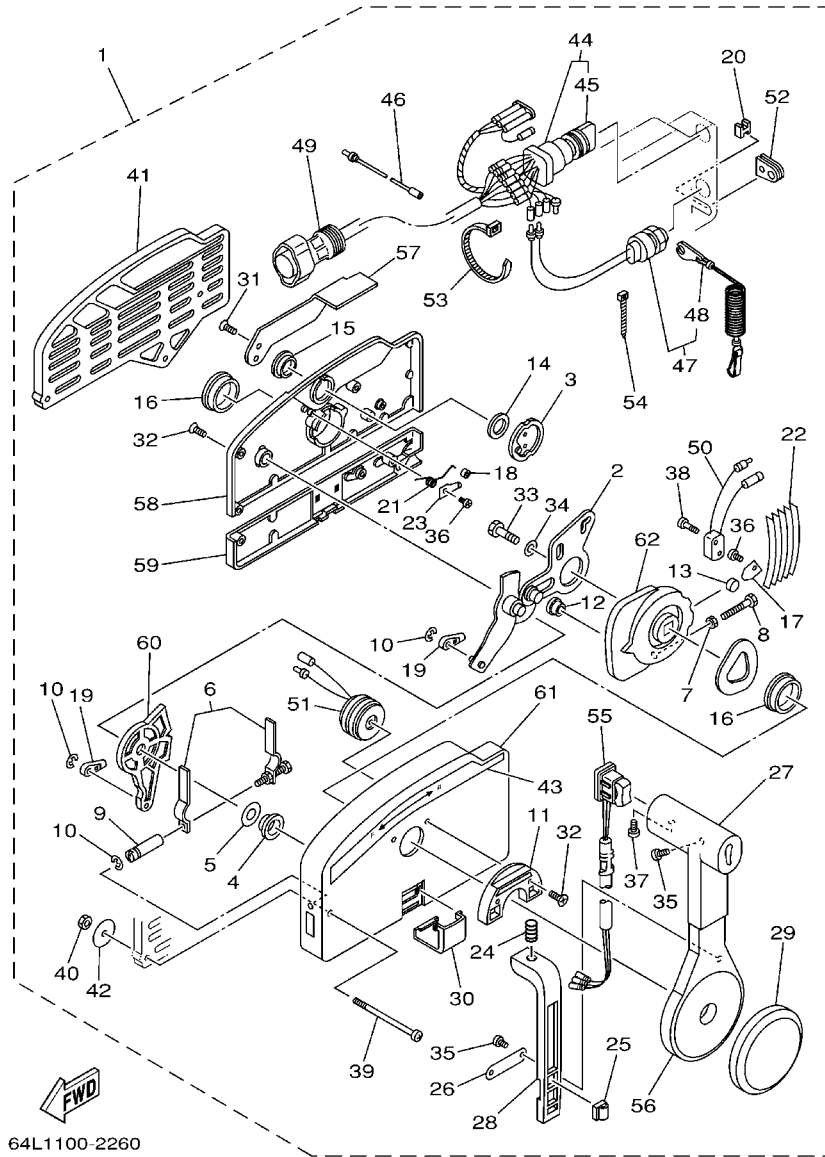
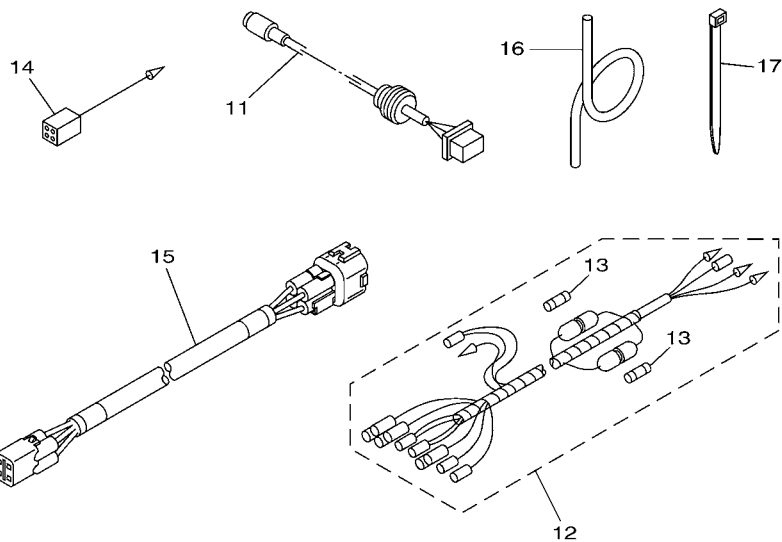
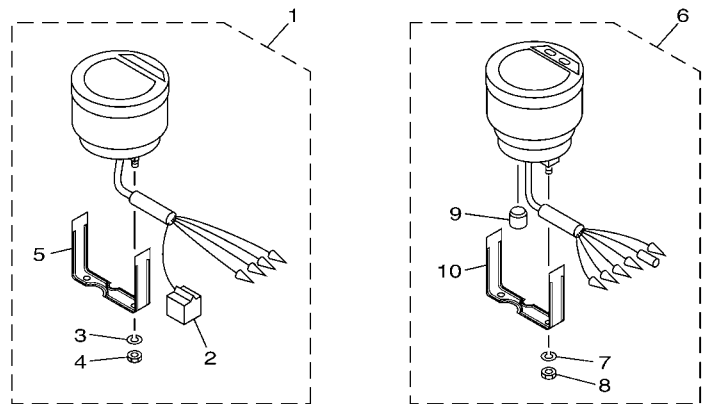

FIG. 36 REMOTE CONTROL ASSY

REF. NO.	PART NO.	DESCRIPTION	EHT	ET	REMARKS
55	703-82563-02	.TRIM & TILT SWITCH ASSY		1	WITH PT/T SW.
56	703-48221-00	.LEVER, CONTROL		1	
57	703-48152-00	.KNOB, FREE ACCEL.		1	
58	703-48212-00	.BACK PLATE 1		1	
59	703-48213-00	.BACK PLATE 2		1	
60	703-48271-00	.ARM, SHIFT		1	
61	703-48211-01	.HOUSING,1		1	
62	703-48232-00	.GEAR		1	



6C14100-G370

FIG. 37 METER

REF. NO.	PART NO.	DESCRIPTION	EHT	ET	REMARKS
1	6Y5-8350T-90	DIGITAL TACHOMETER ASSY		1	AP FOR OCE,BRA
2	9E450-04533	.CONNECTOR		1	F-4-W
3	92990-04100	.WASHER, SPRING		2	
4	95380-04600	.NUT		2	
5	6Y5-8355X-T1	.BRACKET, METER 1		1	
6	6Y5-83570-S5	SPEEDOMETER ASSY		1	AP FOR OCE
7	92990-04100	.WASHER, SPRING		2	
8	95380-04600	.NUT		2	
9	6Y5-83533-T2	.GROMMET		1	
10	6Y5-8355X-T1	.BRACKET, METER 1		1	
11	6Y5-87122-S0	CORD ASSY 1		1	AP FOR OCE
12	6Y5-83553-M0	WIRE, LEAD (L=2.5M)		1	AP FOR OCE
	6Y5-83553-00	WIRE, LEAD (L=2.5M)		1	AP FOR BRA
13	1E6-82151-00	.FUSE (10A)		2	FOR 6Y5-83553-M0
	1E6-82151-00	.FUSE (10A)		1	FOR 6Y5-83553-00
14	6Y5-82117-00	WIRE, LEAD (BLACK) (L300)		1	AP FOR OCE
15	6Y5-83653-30	WIRE, LEAD (L=8.0M)		1	AP FOR OCE 4P,8M
	6Y5-83653-20	WIRE, LEAD (L=7.0M)		1	AP FOR BRA 4P,7M
16	6Y5-83557-10	TUBE (8M)		1	AP FOR OCE
17	90465-11M10	CLAMP		2	AP FOR OCE

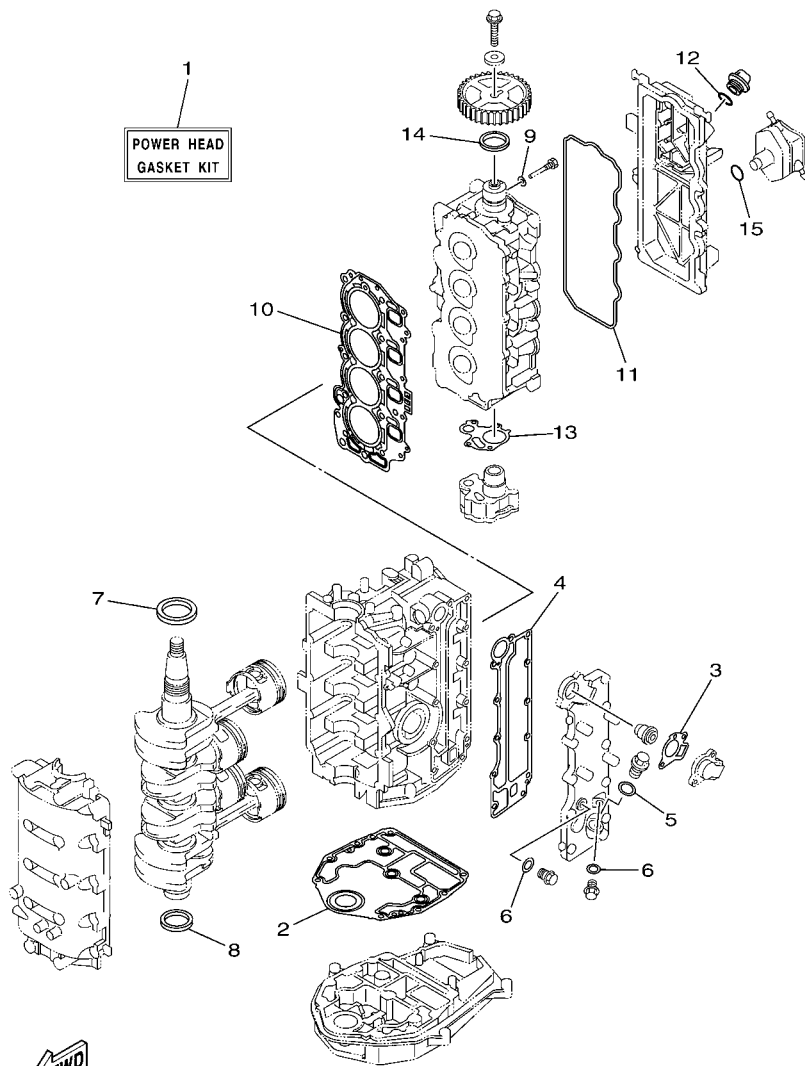

6C13100-F380

FIG. 38 REPAIR KIT 1

REF. NO.	PART NO.	DESCRIPTION	EHT	ET			REMARKS
1	6C5-W0001-01	POWER HEAD GASKET KIT	1	1			
2	67C-11351-01	.GASKET, CYLINDER	1	1			
3	62Y-12414-00	.GASKET, COVER	1	1			
4	6C5-41114-10	.GASKET, EXHAUST OUTER COVER	1	1			
5	90430-18130	.GASKET	1	1			
6	90430-14115	.GASKET	2	2			
7	93102-43M42	.OIL SEAL	1	1			
8	93101-35002	.OIL SEAL	1	1			
9	90430-06014	.GASKET	1	1			
10	6C5-11181-01	.GASKET, CYLINDER HEAD 1	1	1			
11	62Y-11356-00	.SEAL, CYLINDER 2	1	1			
12	93210-24M79	.O-RING	1	1			
13	6C5-13329-00	.GASKET, PUMP COVER	1	1			
14	93102-37M40	.OIL SEAL	1	1			
15	93210-24M79	.O-RING	1	1			

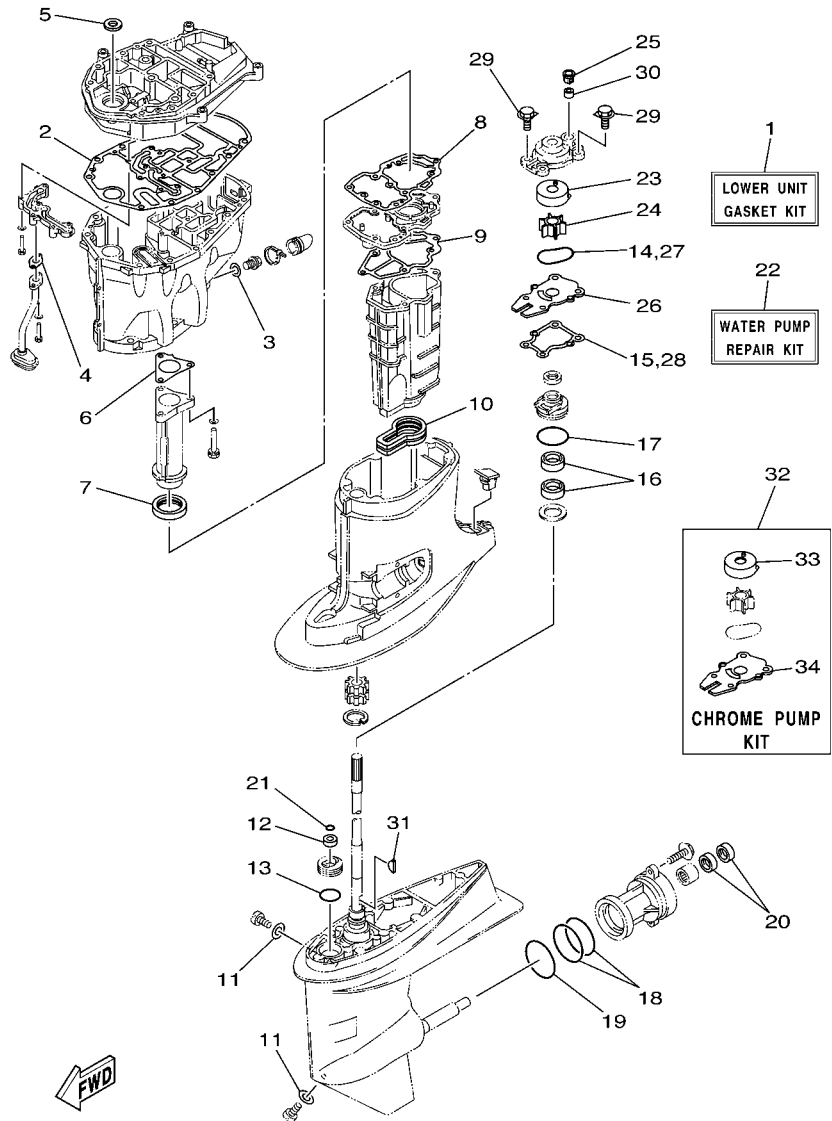

6C11100-D400

FIG. 39 REPAIR KIT 2

REF. NO.	PART NO.	DESCRIPTION	EHT	ET			REMARKS
1	6C5-W0001-20	LOWER UNIT GASKET KIT	1	1			
2	6C5-15312-00	.GASKET, OIL PAN	1	1			
3	90430-14M09	.GASKET	1	1			
4	6C5-13414-00	.GASKET, STRAINER COVER	1	1			
5	93103-18011	.OIL SEAL	1	1			
6	6C5-41133-00	.GASKET, EXHAUST MANIFOLD 1	1	1			
7	6C5-46132-00	.GASKET 1	1	1			
8	6C5-41134-00	.GASKET, EXHAUST MANIFOLD	1	1			
9	6C5-41135-00	.GASKET, EXHAUST MANIFOLD	1	1			
10	6C5-45123-00	.GASKET, MUFFLER	1	1			
11	90430-08020	.GASKET	2	2			
12	93106-09014	.OIL SEAL	1	1			
13	93210-33MG4	.O-RING	1	1			
14	93210-59MG7	.O-RING	1	1			
15	63D-44316-00	.GASKET, WATER PUMP	1	1			
16	93101-25M57	.OIL SEAL	2	2			
17	93210-48MG8	.O-RING	1	1			
18	93210-74MG5	.O-RING	2	2			
19	93210-69MG6	.O-RING	1	1			
20	93101-22M00	.OIL SEAL	2	2			
21	93210-07003	.O-RING	1	1			
22	63D-W0078-01	WATER PUMP REPAIR KIT	1	1			
23	63D-44322-00	.INSERT, CARTRIDGE	1	1			
24	6H3-44352-00	.IMPELLER	1	1			
25	63D-44312-00	.COVER, WATER PUMP HOUSING	1	1			
26	63D-44323-00	.OUTER PLATE, CARTRIDGE	1	1			
27	93210-59MG7	.O-RING	1	1			

NUMERICAL INDEX

PART NO.	REF. NO.	PART NO.	REF. NO.	PART NO.	REF. NO.	PART NO.	REF. NO.	PART NO.	REF. NO.	PART NO.	REF. NO.
6C5-11111-00-9S	4 - 2	62Y-12138-40	4 - 41	6C5-13546-00	9 - 1	6C5-14546-10	8 - 4	6C5-24325-00	9 - 7	6C5-41114-10	38 - 4
62Y-11119-00	4 - 26	62Y-12138-50	4 - 41	6C5-13546-10	9 - 1	6C5-14567-00	8 - 15	61N-24329-00	19 - 28	6C5-41131-00-5B	29 - 6
	4 - 38	62Y-12138-60	4 - 41	6C5-13547-00	9 - 20	6C5-14711-00-5B	29 - 14	6Y1-24329-00	33 - 5	6C5-41133-00	29 - 5
62Y-11133-30	4 - 3	6C5-12146-00	5 - 8	6C5-13547-10	9 - 20	6C5-14960-00	8 - 12	650-24351-01	12 - 7		39 - 6
6C5-11168-00	4 - 20	62Y-12151-00	5 - 9	6C5-13548-00	9 - 24	6C5-14960-10	8 - 12		33 - 12	6C5-41134-00	29 - 10
6C5-11181-01	4 - 14	6C5-12151-00	5 - 12	6C5-13557-00	6 - 4	6C5-14984-00	8 - 23	650-24351-51	12 - 7		39 - 8
	38 - 10	62Y-12158-00	5 - 11	6C5-13577-00	9 - 10	6C5-14985-00	8 - 3	6E5-24351-51	12 - 7	6C5-41135-00	29 - 13
6C5-11191-01-9S	4 - 18	6C5-12158-00	5 - 14	6C5-13593-00	8 - 20	6C5-15100-10-9S	2 - 2	61J-24360-00	12 - 9		39 - 9
62Y-11325-00	2 - 18	64J-12159-00	5 - 10	6C5-13641-00	6 - 2	6C5-15311-00-8D	30 - 1		33 - 10	6C5-41137-00-8D	29 - 1
	4 - 4	6C5-12159-00	5 - 13	6C5-13645-00	6 - 3	6C5-15312-00	30 - 2	6Y1-24360-52	12 - 9	688-41211-01	24 - 24
66M-11327-00-94	2 - 20	6C5-12171-00	10 - 1	6C5-13716-00	8 - 22		39 - 2	6Y2-24360-60	12 - 9	6H4-41237-00	24 - 25
	4 - 6	6C5-12231-00	5 - 15	6C5-13739-00	9 - 25	6C5-15316-00	30 - 4	62Y-24374-01	11 - 29	6X4-41291-00	21 - 8
66M-11328-00	2 - 19	6C5-12233-00	5 - 16	6C5-13750-00	6 - 5	6C5-1531A-01	4 - 31	67F-24377-00	11 - 5	6X4-42101-J2-4D	21 - 1
	4 - 5	6C5-12241-00	5 - 17	6C5-13761-00	6 - 16	6C5-15333-00	30 - 10	688-24378-00	20 - 11	6X4-42111-01-4D	21 - 2
67C-11351-01	2 - 8	6C5-12243-00	5 - 18	6C5-13781-00	8 - 21	6C5-15362-00	30 - 13	6C5-24378-00	20 - 15	6X4-42115-00	21 - 22
	38 - 2	6G8-12411-03	2 - 12	6C5-13906-01	8 - 9	6G8-15363-00	4 - 29	6C5-24379-00	9 - 18	6X4-42119-00	21 - 5
62Y-11356-00	4 - 23	688-12412-00	2 - 13	6C5-13907-00	8 - 17	6C5-15378-00	4 - 32	6C5-24387-00	9 - 15	63D-42121-22-4D	21 - 58
	38 - 11	6C5-12413-00-9S	2 - 14	6C5-13910-00	8 - 16	6C5-15378-11	4 - 35	6C5-24410-00	11 - 20	63D-42126-00	21 - 17
6C5-11411-00	3 - 1	62Y-12414-00	2 - 15	6C5-13910-10	8 - 16	6C5-21337-00	8 - 24	62Y-24411-02	11 - 22	6X4-42128-00	21 - 13
6C5-11416-00	3 - 2		38 - 3	6C5-13915-00	8 - 19	6C5-21337-10	8 - 24	6C5-24415-00	11 - 21	6X4-42131-11	21 - 54
6C5-11416-10	3 - 2	62Y-12481-10	2 - 11	6C5-13974-00	9 - 16	6C5-21841-00	9 - 11	6C5-2441R-00	8 - 6	6X4-42137-00	21 - 7
6C5-11416-20	3 - 2	66M-12535-00	2 - 21	6C5-1410B-00	6 - 17	6C5-22435-00	27 - 15	6C5-2441R-10	8 - 6	62Y-42154-00	24 - 27
6C5-11416-30	3 - 2		4 - 7	6C5-1410F-00	9 - 23	6C5-22471-00	27 - 8	6C5-2441T-00	8 - 7	6X4-42159-00	21 - 48
6C5-11536-00	10 - 7	69W-12535-00	20 - 3	6C5-14127-00	8 - 18	6C5-2247A-00	11 - 4	6C5-2441T-10	8 - 7	6C5-42171-00	24 - 28
6C5-11537-00	10 - 2	68T-12572-00	20 - 2	6C5-14127-10	8 - 18	6C5-2411M-00	9 - 13	62Y-24423-00	11 - 23	6X4-42177-00	21 - 6
6H4-11545-00	13 - 5	6C5-12576-00	7 - 17	6X4-14137-00	21 - 26	6YJ-24167-00	33 - 7	6C5-24444-00	9 - 9	6C5-42335-00	24 - 33
62Y-11557-00	10 - 8	6R3-12580-00	20 - 8	6C5-14148-00	9 - 14	6YJ-24201-10	33 - 1	6C5-24444-01	11 - 26	6C5-42508-00	23 - 1
6G8-11577-00	10 - 15	6C5-12858-00	2 - 31	6C5-14148-10	9 - 14	6C5-24251-00	9 - 21	6C5-24453-00	8 - 8	69W-42510-01-8D	26 - 1
67C-11603-00	3 - 7	6C5-13105-01	6 - 10	6C5-14149-00	9 - 8	6Y1-24260-12	33 - 3	62Y-24454-00	11 - 25	67C-42525-00	23 - 4
67C-11604-00	3 - 7	62Y-13131-00	11 - 24	6C5-14180-00	8 - 1	6Y1-24268-00	33 - 6	6D8-24469-00	11 - 13	6C5-42527-00	23 - 2
67C-11605-00	3 - 7	6C5-13142-00	10 - 14	6C5-14180-10	8 - 1	6G1-24304-02	11 - 1	6C5-24471-00	11 - 27	65W-42528-00	23 - 10
69W-11631-00-97	3 - 6	6C5-13161-00	6 - 13	6C5-14182-00	8 - 2	6G1-24305-05	12 - 2	6D8-24519-00	11 - 14	67C-42561-00	23 - 7
62Y-11633-00	3 - 8	6C5-13300-00	10 - 11	6C5-14182-10	8 - 2		33 - 13	6C5-2451B-00	9 - 22	67C-42562-00	23 - 6
69W-11635-00	3 - 6	6C5-13329-00	10 - 17	6C5-14191-00	8 - 13	6E5-24305-06	12 - 2	6C5-2451B-10	9 - 22	6C1-42610-00-8D	1 - 1
69W-11636-00	3 - 6		38 - 13	6C5-14200-00	6 - 1	6Y1-24305-06	12 - 4	6D8-24560-00	11 - 9	6C5-42610-00-8D	1 - 1
6C5-11650-00	3 - 3	6C5-13411-00	30 - 8	6C5-14225-00	8 - 25		33 - 15	6D8-24562-00	11 - 12	6C5-42610-A0-8D	1 - 1
6C5-11654-00	3 - 4	6C5-13414-00	30 - 9	6C5-14251-00	9 - 12	6Y2-24305-06	12 - 4	6D8-24563-00	11 - 10	67C-42613-00-8D	1 - 2
6C5-11656-00	3 - 5		39 - 4	6C5-14386-00	8 - 5	61J-24306-04	12 - 1	6D8-24564-00	11 - 11	6C5-42615-00	1 - 14
6C5-11656-10	3 - 5	6C5-13428-01	7 - 21	6C5-14397-00	6 - 11		33 - 8	6C5-24566-01	11 - 15	6C5-42651-00	1 - 4
6C5-11656-20	3 - 5	67F-13434-10	1 - 16		8 - 14	6Y1-24306-55	12 - 1	6C5-24592-00	8 - 10	67C-42652-02	1 - 6
6C5-11656-30	3 - 5	6C5-13437-41	13 - 16	6C5-14440-00	7 - 4	6Y2-24306-56	12 - 1	6YJ-24610-01	33 - 2	69W-42677-00	1 - 9
69W-12111-00	5 - 1	6C5-13437-51	13 - 16	6C5-14446-00	6 - 15	6C5-24312-00	20 - 6	69W-26301-00	21 - 42	62Y-42677-30	1 - 9
51Y-12114-00	5 - 4	6C5-13437-61	13 - 16	6C1-14453-01	7 - 5	6C5-24321-00	9 - 3	6X4-26367-00	21 - 37	69W-42677-A0	1 - 9
62Y-12116-00	5 - 3	5GH-13440-20	2 - 30	6C5-14453-01	7 - 5	6C5-24321-10	9 - 3		21 - 44	6C1-42678-00	1 - 10
30X-12117-00	5 - 5	69W-13448-00	1 - 15	6C1-14477-00	7 - 6	6C5-24322-00	9 - 4	6C5-28100-00	11 - 35	6C5-42678-00	1 - 10
30X-12118-00	5 - 6	6C5-13542-00	9 - 2	62Y-14485-00	4 - 19	6C5-24322-10	9 - 4	67F-2812A-00	16 - 34	6C5-42678-A0	1 - 10
51Y-12119-00	5 - 7	6C5-13545-00	9 - 19	6C5-14496-00	6 - 9	6C5-24323-00	9 - 5	6C5-41113-11-9S	2 - 9	69W-42681-00	1 - 12
69W-12121-00	5 - 2	6C5-13545-10	9 - 19	6C5-14546-00	8 - 4	6C5-24324-00	9 - 6	6C5-41114-10	2 - 16	69W-42682-00	1 - 13

NUMERICAL INDEX

PART NO.	REF. NO.	PART NO.	REF. NO.	PART NO.	REF. NO.	PART NO.	REF. NO.	PART NO.	REF. NO.	PART NO.	REF. NO.
6C5-42710-00-8D	19 - 1	6C6-4381K-00	27 - 38	69J-4389J-00	27 - 20	6C5-44575-00	26 - 22	663-45587-40	31 - 5	703-48219-00	36 - 30
6C5-42710-10-8D	19 - 1	6H1-43829-00	27 - 63		27 - 32	6C5-45111-00-8D	29 - 27	663-45587-50	31 - 5	703-48221-00	36 - 56
62Y-42715-01	24 - 11	6C6-4382E-00	27 - 28	6X4-44100-00	21 - 21	6C5-45123-00	29 - 17	663-45587-60	31 - 5	703-48222-00	36 - 27
62Y-42716-00	19 - 5	6C5-4382K-00	27 - 41	6X4-44102-00	21 - 23		39 - 10	63D-45611-00	31 - 55	703-48223-00	36 - 28
65W-42717-00	19 - 6	6C5-4382L-00	27 - 56	6X4-44114-00	22 - 16	6C5-45135-01	30 - 14	62Y-45631-00	31 - 57	703-48225-00	36 - 29
6C5-42718-00	19 - 8	6C5-43830-00	27 - 24	62Y-44117-01-9S	24 - 2	6C5-45136-01	30 - 15	67C-45633-00	31 - 62	703-48226-00	36 - 26
6C5-42724-00	19 - 23	6C5-43831-00	27 - 64	62Y-44118-00	24 - 12	6C5-45155-00	29 - 20	663-45634-00	31 - 58	703-48227-00	36 - 24
65W-42724-10	20 - 1	6C5-43833-00	25 - 36	6C5-44120-01	24 - 7	6C5-45181-00-5B	29 - 11	63D-45635-00	31 - 60	703-48232-00	36 - 62
6X4-42725-00	21 - 57	6C5-43834-00	25 - 37	69W-44121-00	24 - 1	63D-45214-00	31 - 10	663-45930-00-98	32 - 22	703-48234-00	36 - 18
6C5-42725-30	19 - 9	6C5-43841-00	27 - 57	688-44122-00	24 - 20	63D-45215-00	31 - 11	663-45941-01-EL	32 - 22	703-48235-00	36 - 4
6C5-42726-00	19 - 43	6C6-43841-00	27 - 25	6C5-44122-00	24 - 8	65W-45251-00	25 - 5	69W-45943-00-EL	32 - 22	703-48236-00	36 - 16
62Y-42727-00	19 - 10	6C5-43845-00	27 - 61	6X4-44132-00	21 - 25		25 - 7	6H5-45943-00-EL	32 - 22	703-48238-00	36 - 22
68U-42727-00	19 - 26	62X-4384H-00	27 - 14	62Y-44135-00	24 - 30		25 - 24	69W-45945-00-EL	32 - 22	703-48243-00	36 - 15
6H3-42727-00	19 - 27	6C5-43851-00	27 - 34	6X4-44139-00	21 - 9	67C-45251-00	32 - 12	6H5-45945-00-EL	32 - 22	703-48244-00	36 - 21
6X4-42727-00	22 - 18	6C6-43853-00	27 - 30	63D-44144-00	31 - 52	69W-45300-00-8D	31 - 1	69W-45947-00-EL	32 - 22	703-48245-00	36 - 11
6X4-42728-10	21 - 67	6C5-43854-00	27 - 43	62Y-44151-00	31 - 51	69W-45301-00-8D	31 - 2	663-45949-01-EL	32 - 22	703-48246-00	36 - 23
6C5-42738-00-8D	19 - 7	6C5-43855-00	27 - 39	6X4-44159-00-4D	21 - 49	69W-45318-00	29 - 21	69W-45952-00-EL	32 - 22	701-48248-00	36 - 13
67C-42741-10-8D	19 - 29	6C5-43856-00	27 - 40	6X4-44173-00	21 - 50	63D-45321-00	31 - 14	6H5-45952-00-EL	32 - 22	703-48252-00	36 - 12
6AH-42794-40	20 - 20	6C5-43861-00	27 - 6	6X4-44177-00	21 - 12	688-45341-10	31 - 9	663-45952-02-EL	32 - 22	6X4-48261-00	21 - 27
6AH-42794-50	20 - 21		27 - 17	6X4-44188-00	21 - 15	63D-45344-00	31 - 34	663-45956-01-EL	32 - 22	703-48261-01	36 - 2
6C5-42811-00	16 - 30	6C5-43862-00	27 - 5	6G8-44191-00	21 - 52	63D-45361-02-8D	31 - 43	6H5-45958-00-EL	32 - 22	703-48264-00	36 - 6
67C-42815-00-8D	19 - 12	62Y-43863-00	27 - 4	63D-44311-00	31 - 21	67C-45371-00	32 - 9	663-45958-01-EL	32 - 22	703-48265-00	36 - 9
67C-42816-01	19 - 17	6C5-43869-00	28 - 6	63D-44312-00	32 - 16	63D-45375-00	32 - 5	697-45970-00-98	32 - 22	703-48268-00	36 - 5
6X4-42821-00	21 - 30	6C6-4386E-00	27 - 54		39 - 25	663-45376-00-94	32 - 4	663-45970-60-98	32 - 22	703-48271-00	36 - 60
6C5-43111-00-8D	25 - 1	6C6-4386G-00	27 - 53	63D-44316-00	31 - 27	6E5-45378-00	31 - 17	663-45972-60-98	32 - 22	703-48281-00	36 - 31
6C5-43112-00-8D	25 - 2	6C5-4386K-00	28 - 10		39 - 15	69W-45501-00	31 - 36	663-45974-02-98	32 - 22	703-48282-00	36 - 32
6E5-43126-02	25 - 26	6C5-43871-00	27 - 7		39 - 28	6H4-45536-00	31 - 4	663-45974-60-98	32 - 22	703-48284-00	36 - 52
63D-43131-10	25 - 11	6C5-43872-00	27 - 58	63D-44322-00	31 - 22	69W-45551-00	31 - 37	663-45976-00-98	32 - 22	701-48287-00	36 - 42
66T-43144-00	19 - 19	6C5-43875-00	27 - 9		39 - 23	69W-45560-00	31 - 39	663-45978-00-98	32 - 22	703-48291-10	36 - 39
6G5-43144-00	25 - 23	6H1-43875-00	27 - 60	63D-44322-40	39 - 33	663-45567-01	31 - 41	663-45987-02	32 - 17	703-48293-10	36 - 41
6E5-43145-01	34 - 9	6C6-43878-00	27 - 47	63D-44323-00	31 - 26	663-45567-10	31 - 41	66T-45997-00	32 - 18	701-48310-90	35 - 2
6G5-43148-00	25 - 19	6C5-43879-00	28 - 7		39 - 26	663-45567-20	31 - 41	6C5-46132-00	29 - 7	701-48320-00	35 - 2
6C5-43181-10	25 - 14	62Y-4387G-00	27 - 48	63D-44323-40	39 - 34	663-45567-30	31 - 41		39 - 7	701-48320-20	35 - 2
6C5-43185-10	25 - 15	6C6-4387G-00	27 - 31	63D-44341-00	31 - 31	663-45567-40	31 - 41	6C5-46241-00	10 - 6	701-48320-50	35 - 2
6C5-43311-00-8D	25 - 9	6C5-43880-01	28 - 1	6H3-44352-00	31 - 23	663-45567-50	31 - 41	6X4-47731-00	21 - 24	67C-48321-11	21 - 35
689-43633-00	23 - 8	6C5-43881-01	28 - 11		39 - 24	663-45567-60	31 - 41	6A5-48129-10	21 - 29	69W-48344-00	24 - 23
6C5-43800-01-8D	27 - 1	6C5-43882-00	28 - 8	6C5-44361-00	32 - 1	62Y-45571-00	31 - 42	703-48152-00	36 - 57		24 - 37
6C5-43801-00	27 - 3	6H1-43883-00	27 - 26	663-44366-00	32 - 3	63D-45577-00	31 - 46	703-48153-00	36 - 3	703-48345-01	36 - 19
6C5-43804-01	28 - 5	6C5-43885-00	26 - 18		32 - 15	63D-45577-10	31 - 46	6X4-48154-00	21 - 18	703-48358-00	36 - 20
6C5-43805-00	28 - 4	62X-43888-00	28 - 12		39 - 30	63D-45577-20	31 - 46	703-48189-00	36 - 17	65W-48511-10	26 - 41
6C5-4380G-00	27 - 22	6C6-4388E-00	27 - 51	663-44367-00	32 - 2	63D-45577-30	31 - 46	703-48198-00	36 - 14	62Y-48538-00	24 - 39
6C5-4380K-00	27 - 18	6C6-4388F-00	27 - 52	6C5-44385-00	26 - 35	63D-45577-40	31 - 46	703-48205-17	35 - 1	63D-48538-00	21 - 40
6C5-43810-00	27 - 2	6C5-43891-00	28 - 9	6H3-44391-01	19 - 22	63D-45577-50	31 - 46		36 - 1		21 - 46
6C5-43816-00	27 - 21	6C5-43893-00	27 - 36	69W-44514-00-4D	26 - 10	63D-45577-60	31 - 46	703-48211-01	36 - 61	6X4-48538-00	21 - 36
6C5-43817-10	27 - 19	6C6-43893-00	27 - 37	69W-44526-01	26 - 12	663-45587-01	31 - 5	703-48212-00	36 - 58	6X4-48538-10	21 - 43
6C5-43818-00	25 - 35	6C6-43894-00	27 - 27	6C5-44551-00-8D	26 - 16	663-45587-10	31 - 5	703-48213-00	36 - 59	65W-61350-00	34 - 1
6C5-4381B-00	27 - 10	6C5-43895-00	27 - 42	6C5-44552-00-8D	26 - 19	663-45587-20	31 - 5	6X4-48215-00	21 - 4	65W-61351-00	34 - 2
6C5-4381K-00	27 - 35	6C5-43899-00	27 - 12	69W-44555-00-4D	26 - 20	663-45587-30	31 - 5	703-48215-00	36 - 43	6C5-81145-00	6 - 7

NUMERICAL INDEX

PART NO.	REF. NO.	PART NO.	REF. NO.	PART NO.	REF. NO.	PART NO.	REF. NO.	PART NO.	REF. NO.	PART NO.	REF. NO.
6C5-81146-00	6 - 12	6AH-81995-40	13 - 17	689-8257Y-00	22 - 6	6C5-8591A-41	14 - 23	90119-08101	26 - 21	90202-21100	26 - 25
68V-81315-00	16 - 10	6AH-81995-50	13 - 18	68F-82582-00	15 - 16	6C5-86112-00	7 - 14	90119-08M01	2 - 4	90206-08N51	28 - 2
6C5-81336-00	15 - 2	6AG-81996-00	13 - 22	6P2-82582-00	16 - 6	6C5-86120-00	7 - 12	90119-08M15	31 - 29	90206-10M04	24 - 35
6C5-81337-00	13 - 1	6C5-82105-00	17 - 1	68V-82582-10	16 - 36	6Y5-87122-S0	37 - 11		39 - 29	90206-12052	19 - 15
6C5-81410-00	13 - 4	6C5-82105-U0	17 - 1	6P2-82582-10	16 - 7	6C5-87226-00	8 - 11	90119-08M79	29 - 18	90206-12M22	21 - 61
6C5-81450-00	13 - 3	6Y5-82117-00	37 - 14	6X4-82586-10	22 - 10	6C5-W0001-01	38 - 1	90119-08M82	29 - 19	90209-10M26	23 - 11
6C5-81800-00	18 - 1	6G5-82119-00	15 - 38	6E5-82587-00	15 - 46	6C5-W0001-20	39 - 1	90119-08M84	32 - 8	90249-06M19	25 - 20
69J-81801-00	18 - 5	682-82119-01	15 - 28	61A-82588-01	16 - 19	69W-W0070-00	1 - 11		32 - 7	90250-06023	31 - 61
67F-81807-00	18 - 10	67C-82127-10	26 - 32	688-8258A-20	36 - 49	63D-W0078-01	39 - 22	90142-05001	21 - 10	90266-06M02	1 - 5
67F-81808-00	18 - 8	6E5-82148-00	25 - 3	6C5-82590-40	16 - 1	63D-W0078-0A	39 - 32	90142-05M06	31 - 12	90280-03024	31 - 25
67F-81809-00	18 - 19	1E6-82151-00	37 - 13	6C5-82590-60	16 - 1	6C5-W009A-11-9S	4 - 1	90157-05M19	33 - 4		39 - 31
67F-81810-00	18 - 3		37 - 13	703-82591-00	36 - 53	6C5-W009B-02-9S	2 - 1	90159-04005	15 - 18	90280-03M01	10 - 10
67F-81813-00	18 - 6	67F-82151-00	16 - 2	703-82592-00	36 - 54	63D-W4434-00	31 - 30	90159-06M14	16 - 26	90340-08002	31 - 7
6C5-81815-00	15 - 17	67F-82151-10	16 - 3	703-82594-00	36 - 25	90101-06020	25 - 6	90167-06002	20 - 4	90340-14M06	2 - 28
68F-81820-00	18 - 7	67F-8215B-10	16 - 4	60V-8259F-00	16 - 17		25 - 8	90170-09M03	34 - 5		30 - 6
67F-81821-00	18 - 13	67F-8215B-20	16 - 5	6X4-83383-00	22 - 11		25 - 25	90170-12138	31 - 38	90340-18M09	2 - 26
6C5-81822-00-94	17 - 3	6C5-82171-00	14 - 20	703-83383-02	36 - 51	90101-06054	24 - 13	90170-20137	13 - 6	90344-51003	2 - 7
6K7-81826-11	18 - 24	6C5-82176-00	16 - 28	6X4-83386-00	22 - 12	90101-08016	25 - 38	90170-35008	10 - 9	90386-08032	21 - 16
69J-81828-00	18 - 25	63P-82310-01	14 - 5	6Y5-8350T-90	37 - 1	90101-09M01	34 - 7	90171-16011	32 - 20	90386-10025	25 - 17
6C5-8182L-00	6 - 8	6C5-82316-01	14 - 12	6Y5-83533-T2	37 - 9	90101-12014	21 - 59	90179-06029	1 - 3	90386-10M16	25 - 16
67F-81830-00	18 - 17	6C5-82316-11	14 - 13	6Y5-83553-00	37 - 12	90101-12M65	25 - 41	90179-08003	15 - 15	90386-12003	21 - 64
67F-81832-00	18 - 11	6A0-82317-00	7 - 8	6Y5-83553-M0	37 - 12	90105-08060	5 - 20	90185-06M05	1 - 8	90386-12M37	19 - 13
67F-81836-00	18 - 12		15 - 26	6Y5-83557-10	37 - 16	90105-08148	31 - 44	90185-08010	26 - 13	90386-12MA2	19 - 14
69J-81839-00	18 - 21	6C5-82317-00	14 - 24	6E5-83558-00	26 - 31	90105-09005	4 - 16	90185-09M01	34 - 4	90386-18M35	25 - 28
67F-8183R-00	18 - 16	6E7-82317-00	19 - 25		26 - 38	90109-06047	1 - 7	90185-10015	26 - 8	90386-18M92	25 - 27
60V-8183T-00	18 - 18	6C5-82340-01	14 - 6	6E5-83558-10	31 - 19	90109-06M65	4 - 12	90185-10M14	23 - 13	90386-22MA4	25 - 12
69J-81840-00	18 - 4	6C5-82377-00	20 - 19	6Y5-8355X-T1	37 - 5	90109-06M80	19 - 34	90185-12M12	21 - 66	90386-26MA3	21 - 53
67F-81841-00	18 - 14	63V-82377-50	25 - 40		37 - 10		20 - 5	90185-22007	25 - 13	90386-30M60	26 - 6
60X-81842-00	18 - 20	6C5-82388-00	16 - 14	6Y5-83570-S5	37 - 6	90109-06M81	19 - 11	90201-06015	29 - 9	90386-30M77	26 - 4
67F-81846-00	18 - 26	64J-82504-00	16 - 23	6H4-83589-00	22 - 19	90109-06M86	15 - 45	90201-08064	25 - 39	90386-30M78	26 - 3
67F-81850-00	18 - 2	6X4-82510-10	22 - 1	6C5-83614-01	15 - 44		19 - 20	90201-10049	26 - 42	90386-90M90	24 - 16
67F-81857-00	18 - 9	703-82510-43	36 - 44	62Y-83626-00	13 - 19	90109-06M88	23 - 3	90201-10144	10 - 5	90387-04001	16 - 20
6X4-81860-00	22 - 21	6C5-8252R-00	16 - 29	67F-83627-01	18 - 27	90109-08103	26 - 11	90201-10M20	24 - 17	90387-05M05	23 - 12
69J-81869-00	18 - 23	703-82531-00	36 - 46	6X4-83653-20	22 - 14	90109-12013	26 - 23		34 - 3	90387-05M11	23 - 14
67F-81891-00	18 - 15	6X4-82540-00	21 - 28	6Y5-83653-20	37 - 15	90116-10038	26 - 7	90201-10M63	34 - 8	90387-06060	19 - 4
6C5-81919-00	16 - 35	703-82540-00	36 - 50	6Y5-83653-30	37 - 15	90119-06025	10 - 18	90201-12035	21 - 63	90387-06119	7 - 9
60V-81925-00	15 - 14	6C5-82553-00	16 - 11	63D-83672-10	25 - 30	90119-06077	16 - 32	90201-12041	26 - 17		14 - 25
6C5-81941-00	18 - 22	6C5-82554-01	16 - 18	68F-83688-00	6 - 18	90119-06087	7 - 3	90201-12426	25 - 43		15 - 24
6C5-81942-00	16 - 24	682-82556-00	22 - 5	6C5-84301-00	22 - 15	90119-06106	7 - 10	90201-12M07	19 - 16	90387-06M43	19 - 36
6C5-81948-00	15 - 21		36 - 48	6X4-85415-00	22 - 20		24 - 32	90201-13M19	26 - 26	90387-06M45	24 - 31
68V-8194A-00	15 - 34	6X4-82563-00	22 - 7	6C5-85525-00	14 - 1	90119-06120	29 - 8	90201-16014	5 - 19	90387-06M69	8 - 26
60E-81950-00	15 - 1	703-82563-02	36 - 55	6C5-85548-00	15 - 22	90119-06M08	7 - 11	90201-21M18	13 - 7	90387-06M82	24 - 36
63P-81950-00	15 - 27	63D-82563-10	15 - 43	6C5-85561-00-94	13 - 9		19 - 2	90201-22008	31 - 56	90387-10M42	34 - 6
6C5-81953-00	15 - 39	69W-82575-00	22 - 4	62Y-85580-00	13 - 12	90119-06M59	14 - 26	90201-22M05	26 - 27	90387-12M02	21 - 62
6D3-81960-00	14 - 15	688-82575-01	36 - 47	6C5-85790-00	16 - 12		15 - 25	90201-27M00	31 - 35	90389-22M01	32 - 19
6C5-81961-00	14 - 16	676-82577-00	22 - 2	6C5-85885-00	6 - 6	90119-06MA3	4 - 17	90201-30M00	26 - 2	90413-05014	26 - 34
6AH-81994-40	13 - 20	703-82577-00	36 - 45	6C1-8591A-31	14 - 23	90119-06MA5	2 - 17	90202-07M07	24 - 21	90430-06014	4 - 13
6AH-81994-50	13 - 21	6C5-8257V-00	15 - 4	6C5-8591A-31	14 - 23	90119-08069	7 - 2	90202-10M56	23 - 9		38 - 9

NUMERICAL INDEX

PART NO.	REF. NO.	PART NO.	REF. NO.	PART NO.	REF. NO.	PART NO.	REF. NO.	PART NO.	REF. NO.	PART NO.	REF. NO.
90430-08020	31 - 8	90465-11M10	9 - 17	91312-05025	27 - 46	92995-06600	7 - 23	93210-09165	27 - 62	93700-06M03	25 - 10
	39 - 11		11 - 7	91312-05030	27 - 33		11 - 3	93210-16275	34 - 10	94702-00418	4 - 42
90430-14115	2 - 29		15 - 40	91312-05045	27 - 23		11 - 32	93210-18397	27 - 59	95023-06030	13 - 8
	16 - 13		19 - 38	91312-05050	27 - 66		14 - 3	93210-24M79	4 - 30		13 - 10
	38 - 6		20 - 7	91490-16010	24 - 29		14 - 11		11 - 30	95302-03600	27 - 45
90430-14M09	30 - 7		20 - 12	91490-20010	21 - 11		14 - 19		38 - 12	95333-08600	15 - 19
	39 - 3		25 - 33		21 - 20		14 - 22		38 - 15	95380-04600	37 - 4
90430-18130	2 - 27		26 - 29	91490-20015	24 - 18		15 - 6	93210-29M94	26 - 5		37 - 8
	38 - 5		26 - 40	91490-30025	32 - 21		15 - 10	93210-33MG4	31 - 16	95380-05600	11 - 28
90445-07M30	26 - 39		29 - 2	91690-30020	25 - 18		15 - 13		39 - 13		23 - 17
90445-07ME8	31 - 18		31 - 20	92903-06600	2 - 6		15 - 31	93210-48MG8	31 - 33		31 - 13
90445-07MF2	26 - 30		37 - 17		15 - 33		15 - 37		39 - 17		36 - 7
90445-09091	20 - 16	90465-11M59	30 - 5		30 - 12		16 - 16	93210-59MG7	31 - 24	95380-05700	24 - 26
90445-09104	20 - 17	90465-13M11	16 - 9	92903-08100	15 - 20		21 - 34		39 - 14	95380-06600	7 - 13
90445-09220	20 - 13	90465-13M18	7 - 24	92903-08600	17 - 13		21 - 56		39 - 27		19 - 30
90445-09226	20 - 9		17 - 14	92907-04600	4 - 22		24 - 4	93210-64488	27 - 65		21 - 19
90445-11M05	12 - 8	90465-13M24	16 - 8	92990-04100	37 - 3		24 - 6	93210-69MG6	31 - 48		36 - 40
	33 - 11		16 - 27		37 - 7		29 - 16		39 - 19	95380-06800	19 - 40
90445-11M06	12 - 6	90465-13M36	22 - 22	92990-06100	19 - 32	92995-08100	26 - 15	93210-74MG5	31 - 47	95380-08600	11 - 17
	33 - 9	90465-13M39	16 - 25		23 - 5		32 - 11		39 - 18		17 - 6
90445-13M00	12 - 8	90465-13M97	13 - 15	92990-06600	19 - 33		32 - 14	93306-001U1	31 - 45	95380-12600	25 - 44
90445-13M01	12 - 6		15 - 42		19 - 41	92995-08600	17 - 8	93315-32224	31 - 3	95380-12700	26 - 24
90445-13M02	11 - 6		15 - 47		22 - 9		17 - 10	93317-22204	31 - 49	95680-08330	17 - 5
90445-13M36	11 - 18	90467-08M18	20 - 14	92990-08200	5 - 21		21 - 32	93332-00001	31 - 6	95817-10035	10 - 4
90446-14M62	11 - 34	90467-09M17	11 - 8	92990-08600	36 - 34	92995-10100	29 - 24	93332-00092	31 - 40	95895-06035	24 - 34
90447-07001	26 - 36	90467-10M04	11 - 19	92990-12200	21 - 60	92995-10600	29 - 25	93399-999T8	28 - 3	95895-08016	11 - 16
90447-10006	20 - 18		11 - 33	92990-12600	21 - 65	92995-12200	25 - 42	93410-18M02	25 - 29	97013-06020	15 - 32
90447-13010	25 - 34	90468-10005	21 - 41	92995-04100	16 - 22	92A08-03110	27 - 44	93410-28M06	26 - 9	97013-06030	30 - 11
90447-19009	25 - 34		21 - 47	92995-05600	2 - 23	93101-22M00	31 - 50	93420-36M01	29 - 22	97013-06035	2 - 5
90450-50001	7 - 7	90468-18008	24 - 19		4 - 9		39 - 20	93430-06024	36 - 10	97013-08045	17 - 12
90462-08031	20 - 10		24 - 22		13 - 14	93101-25M57	31 - 32	93450-17129	3 - 9	97075-06025	29 - 15
90464-06001	14 - 14		24 - 38		23 - 16		39 - 16	93450-32116	27 - 11	97075-08030	26 - 14
90464-07M05	14 - 8	90480-09M12	8 - 27		24 - 10	93101-35002	3 - 11	93501-04M02	24 - 15	97075-10045	29 - 23
90464-07M41	14 - 7		19 - 3	92995-06100	14 - 10		38 - 8	93503-16003	27 - 13	97095-05012	2 - 22
90464-07M56	6 - 14	90480-12072	13 - 2		14 - 18	93102-37M40	10 - 19	93505-32038	27 - 29		4 - 8
90464-08M07	22 - 3		17 - 2		15 - 9		38 - 14	93603-17070	10 - 12		13 - 13
90464-09M13	19 - 24	90480-13598	16 - 33		15 - 12	93102-43M42	3 - 10	93604-08062	31 - 28	97095-05014	24 - 9
90464-09M42	21 - 38	90480-13M24	19 - 35		15 - 30		38 - 7	93604-10M03	2 - 10	97095-05020	23 - 15
90464-09M49	19 - 37	90480-24003	17 - 11		15 - 36	93103-18011	29 - 3		29 - 12	97095-06010	15 - 29
90464-10006	26 - 37	90501-12082	24 - 14		19 - 42		39 - 5	93605-17002	10 - 3		15 - 35
90464-12006	7 - 19	90501-18001	31 - 59	92995-06600	2 - 25	93106-09014	31 - 15	93606-12019	2 - 3		25 - 22
90464-15008	7 - 18	90501-23215	21 - 14		4 - 11		39 - 12		29 - 26	97095-06014	4 - 33
90464-18007	16 - 31	90501-6C500	10 - 16		4 - 25	93210-07003	31 - 53		30 - 3		4 - 36
90464-18246	14 - 4	90506-14M24	25 - 21		4 - 28		39 - 21		32 - 6		14 - 2
90464-76001	25 - 32	90506-18M40	19 - 21		4 - 34	93210-08287	12 - 3	93608-12M05	7 - 1		14 - 21
90465-05M87	15 - 7	91312-03005	27 - 55		4 - 37		12 - 5		29 - 4		15 - 5
90465-06M86	26 - 28	91312-03016	27 - 50		4 - 40		33 - 14	93700-06M03	21 - 3		16 - 15
90465-11M10	7 - 20	91312-04030	27 - 49		7 - 16		33 - 16		25 - 10		19 - 18

NUMERICAL INDEX

PART NO.	REF. NO.	PART NO.	REF. NO.	PART NO.	REF. NO.	PART NO.	REF. NO.	PART NO.	REF. NO.	PART NO.	REF. NO.
97095-06014	21 - 39 21 - 45 22 - 13	99530-08012 99590-10114 9E450-04533	13 - 11 17 - 4 37 - 2								
97095-06016	7 - 15 7 - 22										
97095-06020	2 - 24 4 - 10 4 - 24 4 - 27 4 - 39 15 - 8 15 - 11 19 - 39 24 - 3										
97095-06025	11 - 2 14 - 17 24 - 5										
97095-06030	11 - 31 14 - 9 21 - 33										
97095-08025	17 - 9 32 - 10										
97095-08035	17 - 7 32 - 13										
97095-08040	21 - 31										
97380-05025	36 - 8										
97380-08030	36 - 33										
97780-60620	15 - 3 15 - 23 15 - 41 22 - 17										
97780-60920	21 - 51										
97880-06016	22 - 8										
97880-06025	19 - 31										
97885-04016	16 - 21										
97885-06008	25 - 4 26 - 33										
97885-06016	21 - 55 25 - 31										
98507-04010	4 - 21										
98580-03015	36 - 38										
98580-04006	36 - 36										
98580-04010	36 - 35										
98580-05010	36 - 37										
98580-06016	10 - 13										
99001-08600	31 - 54										
99009-32500	27 - 16										
99530-08012	4 - 15										