

PARTS CATALOGUE

VF150A-2014 (6EH2)



1N6EH-100E1

()

VF150A
PARTS CATALOGUE
©2014 by Yamaha Motor Co., Ltd.
1st edition, February 2014
All rights reserved.
Any reprinting or unauthorized use
without the written permission of
Yamaha Motor Co., Ltd.
is expressly prohibited.
Printed in Japan.

FOREWORD

This Parts Catalogue is related to the parts for the model(s) on the cover page. When you are ordering replacement parts, please refer to this Parts Catalogue and quote both part numbers and part names correctly.

1. Modifications or additions which have been made after the issue of the Parts Catalogue will be announced in the Parts News.
It is advisable that you make the necessary corrections to the Parts Catalogue according to the Parts News.

2. Abbreviations

The following abbreviations are used in this Parts Catalogue.

“UR” Use specified parts number.

“UN” Use as many as needed.

“AP” Alternate Parts

“LM” Locally Made (Parts need to be ordered locally)

“F#” Frame No. (Applicable machine No.)

“O/S” Over Size

3. The number of components for assembly

- Parts, which are to be supplied in an assembly, are listed with a dot (.) in front of the part name as shown below.
- The numeral appearing to the right of each component part indicates the quantity of parts for each assembly unit.

PART NO.	DESCRIPTION	Q'TY	REMARKS
2F5-83310-60	FRONT FLASHER LIGHT ASSY	2	
115-83311-60	.BULB (6V-18W)	1	

4. Applicable colours of graphics are represented in the “REMARKS” as shown below.

PART NO.	DESCRIPTION	Q'TY	REMARKS
2N4-24110-00-X5	FUEL TANK COMP.	2	MXR
3J1-24240-10	.GRAPHIC, FUEL TANK	1	FOR MXR

5. Note that the illustrations for reference in finding parts numbers are not to be used for assembling. When assembling, please use the applicable service manual.

6. The asterisk (*) before a reference number indicates modified items after the first edition.

7. Applicable Serial No.

Engine Serial No.

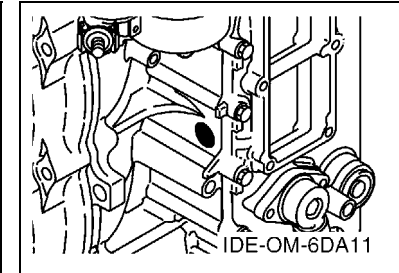
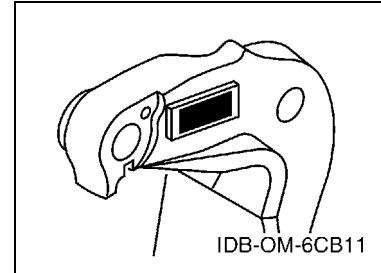

8. Applicable Engine Starting Serial No.

Model	Serial No.	Model	Serial No.
VF150A	6EH-1000872		

9. Applicable Colour Code

Abbreviation	Colour Name	Colour Code
SBL	SHINY BLACK	00NA

10. Quantity Column Information

Column No.	Name Of Q'ty Column	Applicable Model
1	6EH2	VF150LA

CONTENTS

SCHEDULED SERVICE PARTS	1
TOP COWLING	2
CYLINDER & CRANKCASE 1	3
CRANKSHAFT & PISTON	5
CYLINDER & CRANKCASE 2	6
CYLINDER & CRANKCASE 3	7
CYLINDER & CRANKCASE 4	9
VALVE	10
INTAKE 1	13
INTAKE 2	14
INTAKE 3	16
FUEL INJECTION PUMP 1	17
FUEL INJECTION PUMP 2	19
FUEL 1	20
FUEL 2	21
GENERATOR	22
ELECTRICAL 1	24
ELECTRICAL 2	26
ELECTRICAL 3	27
ELECTRICAL 4	28
ELECTRICAL 5	29
STARTING MOTOR	30
BOTTOM COWLING 1	31
BOTTOM COWLING 2	33
BOTTOM COWLING 3	34
CONTROL	35
BRACKET 1	37
BRACKET 2	39
POWER TRIM & TILT ASSY 1	41
POWER TRIM & TILT ASSY 2	43
UPPER CASING	45
OIL PAN	47
LOWER CASING & DRIVE 1	48
LOWER CASING & DRIVE 2	52
STEERING GUIDE	53
OPTIONAL PARTS 1	54
OPTIONAL PARTS 2	55
REPAIR KIT 1	56
REPAIR KIT 2	57

INDEX

NUMERICAL INDEX	59
-----------------------	----

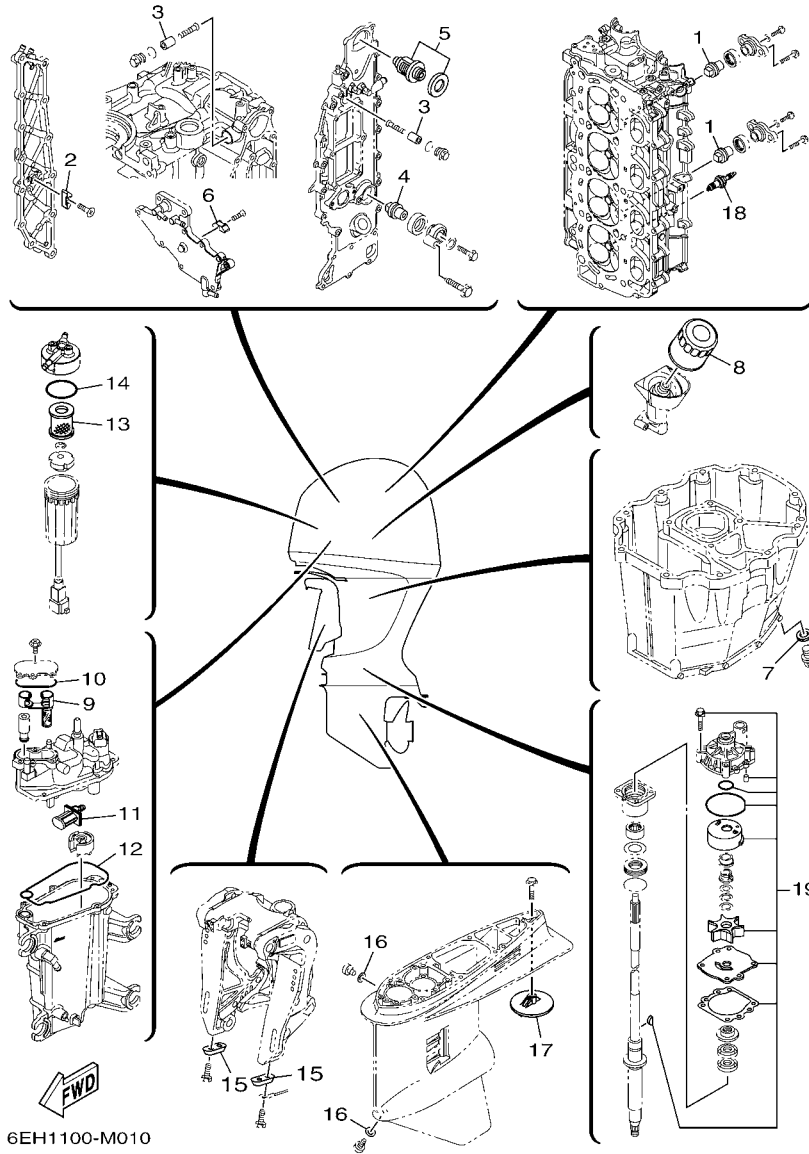

FIG. 1 SCHEDULED SERVICE PARTS

REF. NO.	PART NO.	DESCRIPTION	6EH2				REMARKS
1	67F-11325-01	ANODE	2				
2	6E5-11325-00	ANODE	1				
3	68T-11325-00	ANODE	2				
4	67F-11325-01	ANODE	1				
5	6DA-12411-00	THERMOSTAT	1				
6	6E5-11325-00	ANODE	1				
7	90430-14M09	GASKET	1				
8	69J-13440-03	ELEMENT ASSY, OIL CLEANER	1				
9	6CB-24501-01	FILTER, FUEL	1				
10	6CB-13016-00	O-RING	1				
11	63P-13915-00	FILTER	1				
12	6CB-14984-00	GASKET, FLOAT CHAMBER	1				
13	6P3-24563-01	ELEMENT, FILTER	1				
14	6P3-24564-00	GASKET	1				
15	65W-45251-00	ANODE	2				
16	90430-08020	GASKET	2				
17	6EH-45371-00	TAB-TRIM	1				
18	94702-00400	PLUG, SPARK (NGK LFR6A-11)	4				
19	61A-W0078-A3	WATER PUMP REPAIR KIT	1				

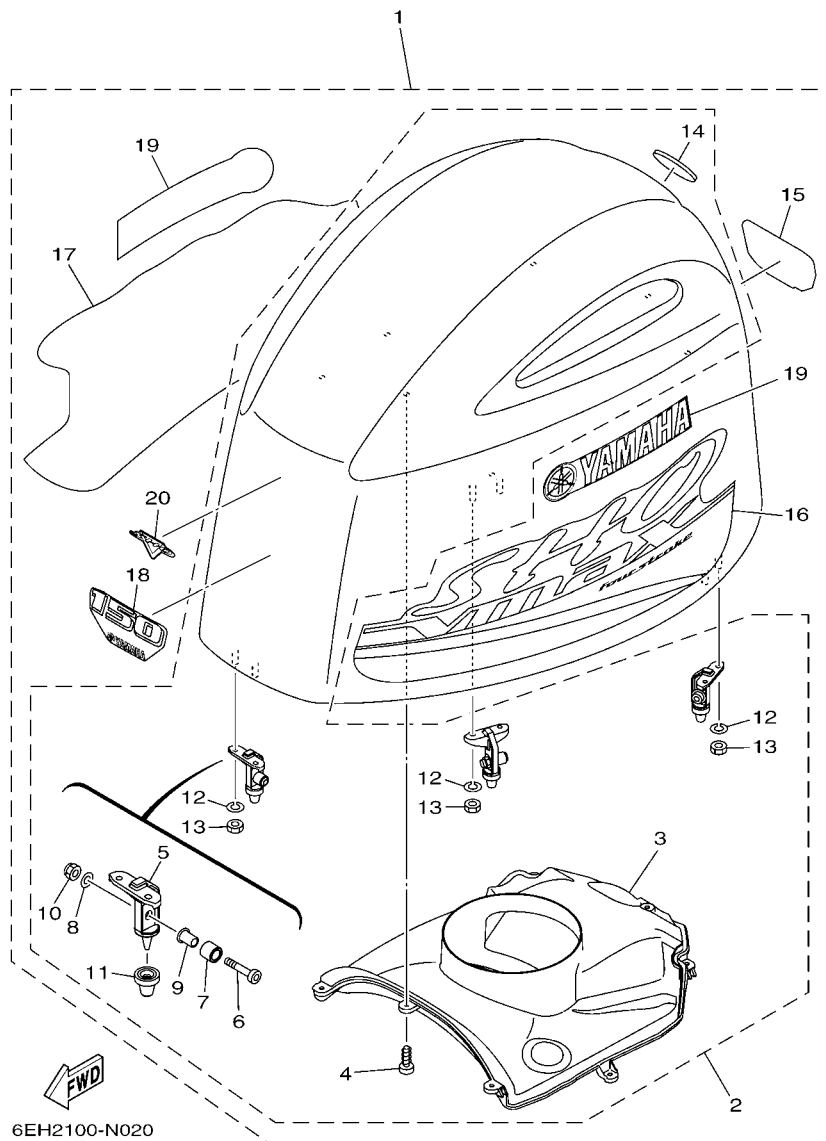

FIG. 2 TOP COWLING

REF. NO.	PART NO.	DESCRIPTION	6EH2				REMARKS
1	6EH-42610-01	TOP COWLING ASSY	1				
2	6EH-4261A-00	.TOP COWLING COMPLETE	1				
3	6DA-42613-00	..MOLDING, AIR DUCT	1				
4	90167-05017	..SCREW, TAPPING	8				
5	6CB-42647-00	..HOLDER, CLAMP BAND	3				
6	90111-08078	..BOLT,HEX. SOCKET BUTTON	3				
7	90387-10094	..COLLAR	3				
8	92990-08600	..WASHER, PLATE	3				
9	90387-08M45	..COLLAR	3				
10	95780-08300	..NUT, FLANGE	3				
11	6AW-42663-00	..DAMPER	3				
12	92990-06100	..WASHER, SPRING	6				
13	95380-06600	..NUT, HEXAGON	6				
14	6DA-42697-00	..TUNING FORK MARK	1				
15	6EH-42678-00	.GRAPHIC, REAR	1				
16	6CB-42675-10	.GRAPHIC, SIDE 1	1				
17	6CB-42676-10	.GRAPHIC, SIDE 2	1				
18	63P-42677-40	.GRAPHIC, FRONT	1				
19	6D6-42681-00	.MARK, COWLING	2				
20	6EH-42682-00	.MARK, COWLING	1				

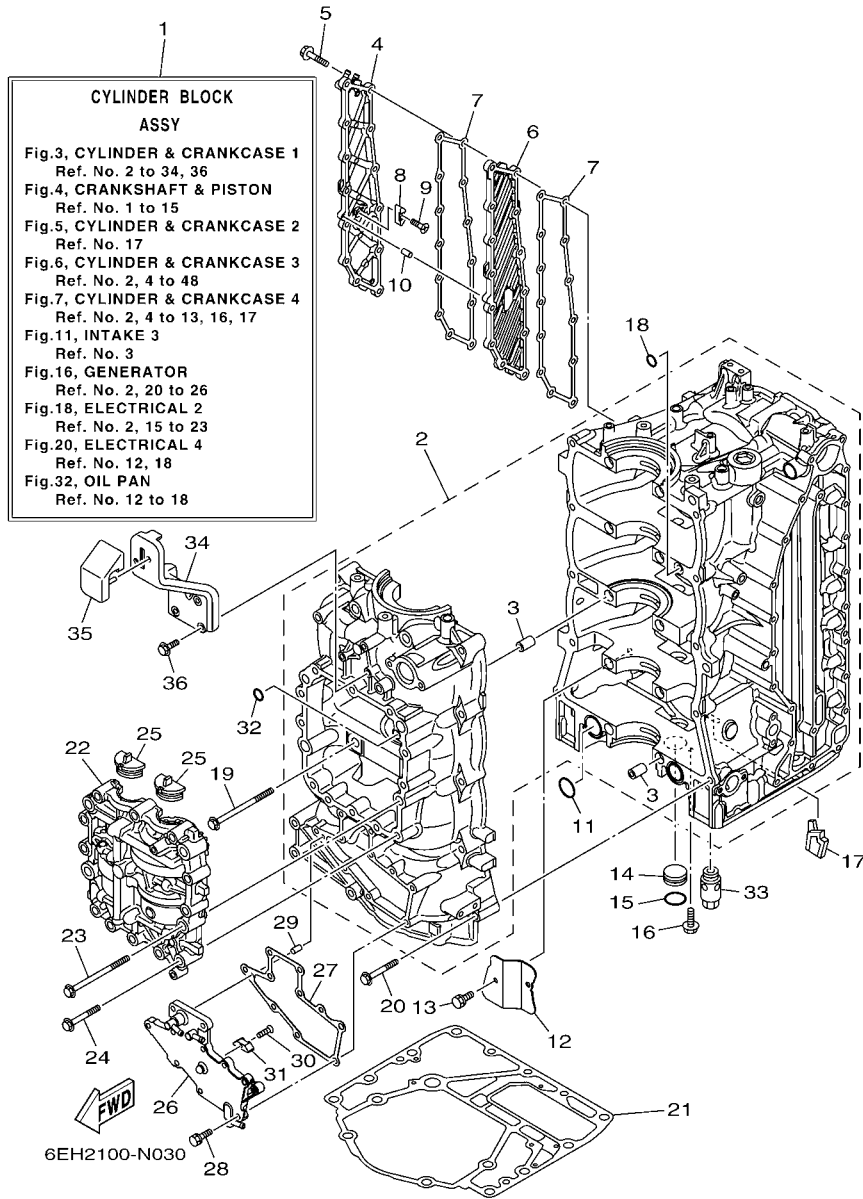
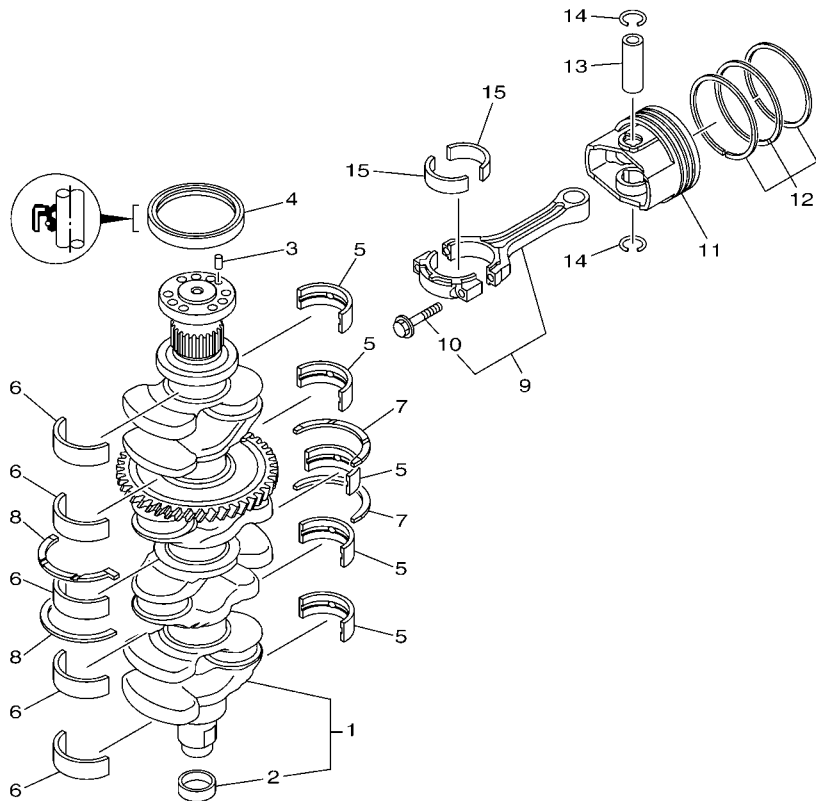

FIG. 3 CYLINDER & CRANKCASE 1

REF. NO.	PART NO.	DESCRIPTION	6EH2				REMARKS
1	6DA-W009B-01-9S	CYLINDER BLOCK ASSY	1				
2	6DA-15109-00-9S	CRANKCASE ASSY	1				
3	91814-18002	.PIN, DOWEL	10				
4	6DA-15414-00-9S	COVER, AIR CLEANER	1				
5	90105-06028	BOLT, FLANGE	13				
6	6DA-15423-00-9S	COVER 2	1				
7	6DA-15353-00	GASKET, DRAIN	2				
8	6E5-11325-00	ANODE	1				
9	98780-04016	SCREW, FLAT HEAD	1				
10	91690-40010	PIN, SPRING	1				
11	93210-25552	O-RING	2				
12	6DA-15412-00	COVER, OIL PUMP	1				
13	90119-06023	BOLT, WITH WASHER	2				
14	90338-25004	PLUG	1				
15	93210-25647	O-RING	1				
16	90119-06M81	BOLT, WITH WASHER	1				
17	6DA-14664-00	GROMMET, WATER SHUT	1				
18	93210-12648	O-RING	1				
19	90105-10406	BOLT, FLANGE	10				
20	90119-08M66	BOLT, WITH WASHER	10				
21	63P-11351-01	GASKET, CYLINDER	1				
22	6DA-11500-00	BALANCER ASSY	1				
23	90105-10406	BOLT, FLANGE	4				
24	90105-08175	BOLT, FLANGE	12				
25	63P-11512-00	SEAL, CRANK COVER	2				
26	6DA-15411-00-9S	COVER, CRANKCASE 1	1				
27	6DA-15451-00	GASKET, CRANKCASE COVER 1	1				



 6DA1100-M040

FIG. 4 CRANKSHAFT & PISTON

REF. NO.	PART NO.	DESCRIPTION	QTY	REMARKS
1	6DA-11410-00	CRANKSHAFT	1	
2	6CB-11478-00	.COLLAR	1	
3	93606-12019	PIN, DOWEL	1	
4	93102-85008	OIL SEAL	1	
5	6DA-11416-00	PLANE BEARING, CRANKSHAFT 1	5	UR YELLOW
6	6DA-11416-10	PLANE BEARING, CRANKSHAFT 1	5	UR GREEN
6	6DA-11416-20	PLANE BEARING, CRANKSHAFT 1	5	UR BLUE
6	6DA-11417-00	PLANE BEARING, CRANKSHAFT 2	5	UR YELLOW
6	6DA-11417-10	PLANE BEARING, CRANKSHAFT 2	5	UR GREEN
6	6DA-11417-20	PLANE BEARING, CRANKSHAFT 2	5	UR BLUE
7	6DA-11426-00	BEARING, THRUST 1	2	
8	6DA-11427-00	BEARING, THRUST 2	2	
9	6CB-W1165-00	CONNECTING ROD ASSY	4	
10	6CB-11654-00	.BOLT, CONNECTING ROD	2	
11	6DA-11631-00-94	PISTON (STD)	4	
12	6CB-11603-00	PISTON RING SET (STD)	4	
13	6CB-11633-00	PIN, PISTON	4	
14	K0F-A3233-00	RING,HOLE SNAP	8	
15	6CB-11656-00	PLANE BEARING, CONNECTING ROD	8	UR YELLOW
	6CB-11656-10	PLANE BEARING, CONNECTING ROD	8	UR GREEN
	6CB-11656-20	PLANE BEARING, CONNECTING ROD	8	UR BLUE

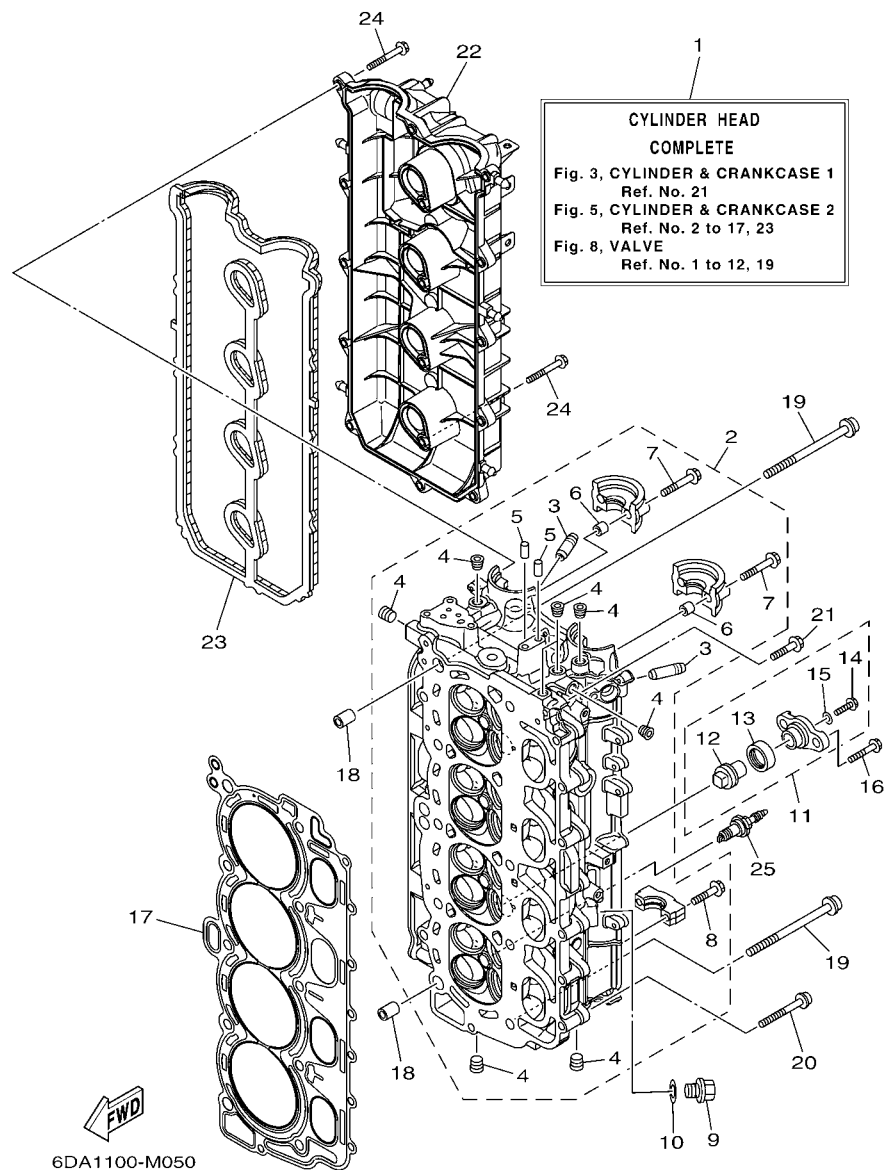

FIG. 5 CYLINDER & CRANKCASE 2

REF. NO.	PART NO.	DESCRIPTION	QTY	REMARKS
1	6DA-W009A-00-9S	CYLINDER HEAD COMPLETE	1	
2	6DA-11110-00-9S	CYLINDER HEAD ASSY	1	
3	6DA-11133-10	.GUIDE, VALVE 1	16	
4	90344-51019	.PLUG, TAPER SCREW	8	
5	93606-12019	.PIN, DOWEL	2	
6	91809-08006	.PIN, DOWEL	4	
7	90119-07001	.BOLT, WITH WASHER	4	
8	90119-07234	.BOLT, WITH WASHER	16	
9	90340-14M06	PLUG, STRAIGHT SCREW	1	
10	90430-14115	GASKET	1	
11	67F-11301-00	ANODE COVER ASSY	2	
12	67F-11325-01	.ANODE	1	
13	67F-11328-00	.GROMMET, ANODE	1	
14	90105-06M07	.BOLT, FLANGE	1	
15	90430-06M03	.GASKET	1	
16	95885-08025	BOLT, FLANGE	4	
17	6DA-11181-00	GASKET, CYLINDER HEAD 1	1	
18	90387-11005	COLLAR	2	
19	90155-11002	SCREW, FLAT FILLISTER	10	
20	90105-08175	BOLT, FLANGE	8	
21	90105-06151	BOLT, FLANGE	1	
22	6DA-11191-00	COVER, CYLINDER HEAD 1	1	
23	6DA-11193-00	GASKET, HEAD COVER 1	1	
24	95895-06030	BOLT, FLANGE	16	
25	94702-00400	PLUG, SPARK (NGK LFR6A-11)	4	

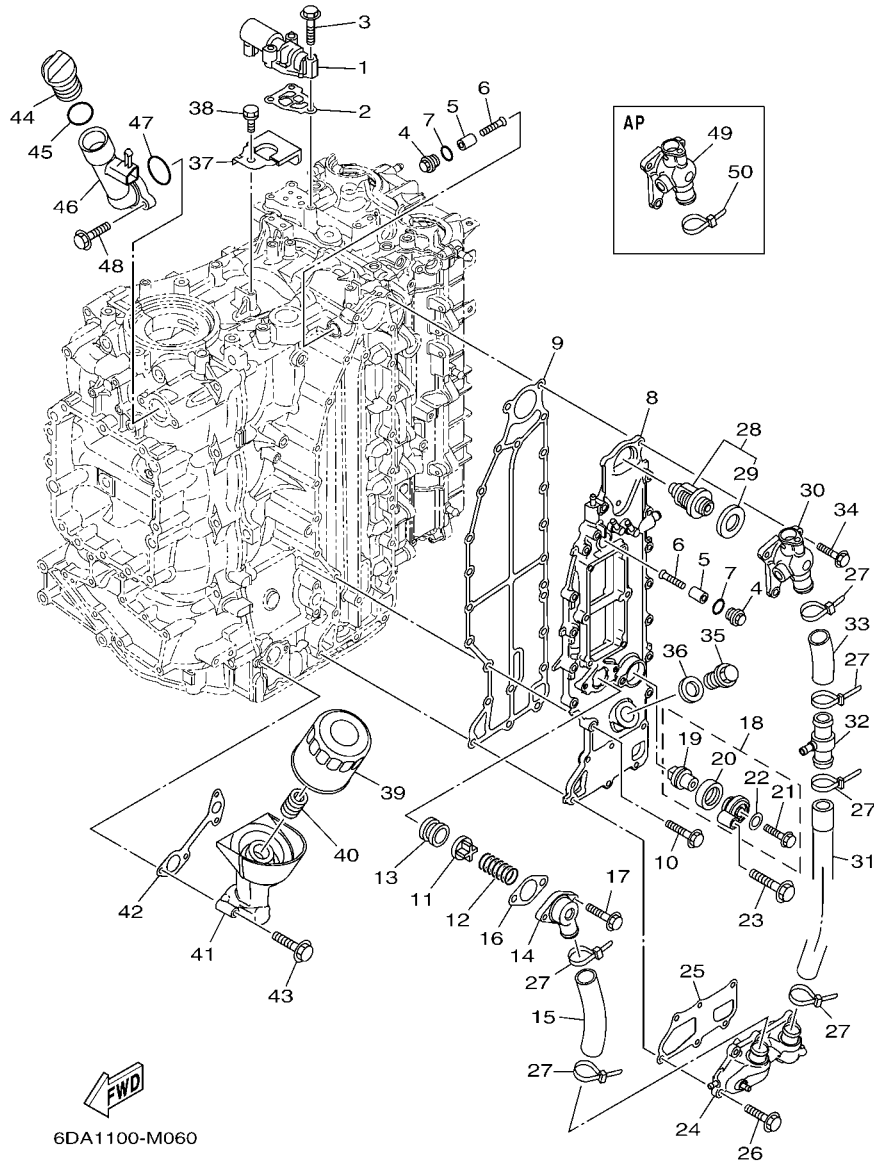

FIG. 6 CYLINDER & CRANKCASE 3

REF. NO.	PART NO.	DESCRIPTION	QTY	REMARKS
1	6CB-86120-00	SOLENOID VALVE ASSY	1	
2	6CB-1242F-00	GASKET, FILTER	1	
3	90105-06035	BOLT, FLANGE	3	
4	6G8-11197-01	PLUG, BLIND	2	
5	68T-11325-00	ANODE	2	
6	90151-05M05	SCREW, COUNTERSUNK	2	
7	93210-13M63	O-RING	2	
8	6DA-41113-00-9S	OUTER COVER, EXHAUST	1	
9	6DA-41114-00	GASKET, EXHAUST OUTER COVER	1	
10	90105-06028	BOLT, FLANGE	14	
11	60H-12416-00	VALVE, PRESSURE CONTROL	1	
12	90501-16M11	SPRING, COMPRESSION	1	
13	90480-20M05	GROMMET	1	
14	6G5-11372-00	COVER, BYPASS 2	1	
15	6DA-1243A-00	HOSE 1	1	
16	60V-11382-A0	GASKET 2	1	
17	90119-06MA3	BOLT, WITH WASHER	2	
18	69J-11301-00	ANODE COVER ASSY	1	
19	67F-11325-01	.ANODE	1	
20	67F-11328-00	.GROMMET, ANODE	1	
21	90105-06M07	.BOLT, FLANGE	1	
22	90430-06M03	.GASKET	1	
23	97575-08540	BOLT, WITH WASHER	1	
24	6DA-12527-00-9S	COVER, WATER BY-PASS	1	
25	6DA-11381-00	GASKET 1	1	
26	90105-06028	BOLT, FLANGE	6	
27	90465-11M59	CLAMP	6	

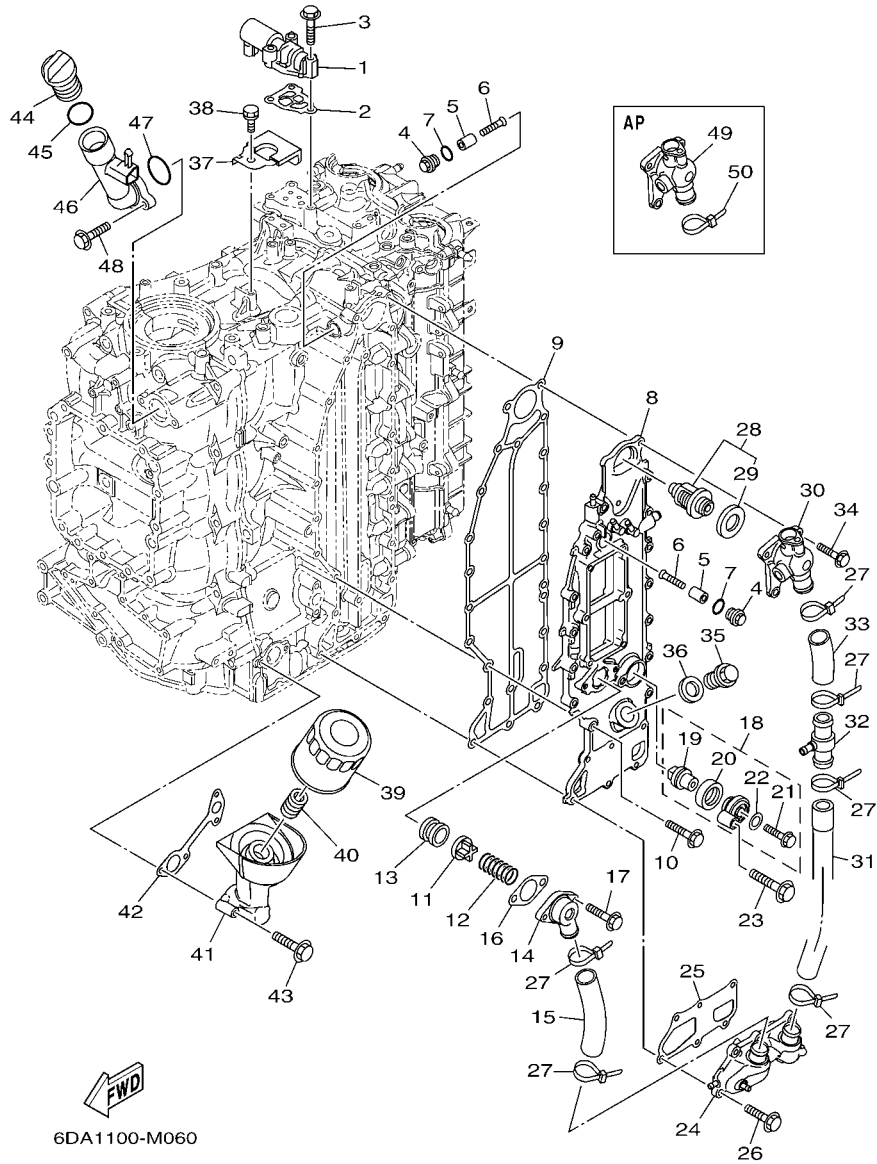
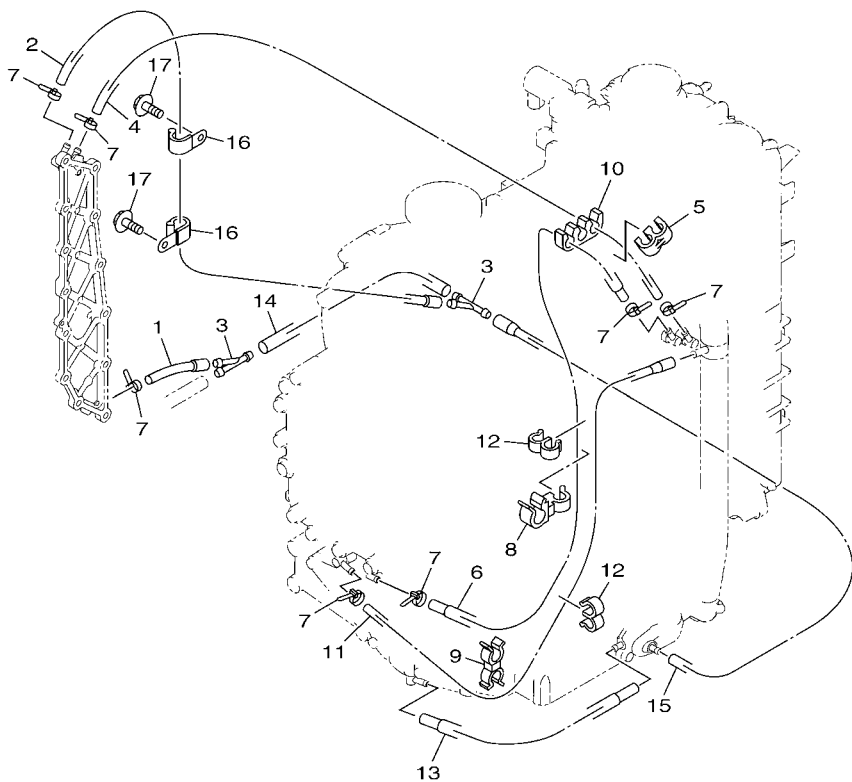

FIG. 6 CYLINDER & CRANKCASE 3

REF. NO.	PART NO.	DESCRIPTION	QTY	REMARKS
28	6DA-12411-00	THERMOSTAT	1	
29	6AW-12412-00	.SEAL, THERMOSTAT	1	
30	6DA-12413-00-9S	COVER, THERMOSTAT	1	
31	6DA-1243E-00	HOSE 2	1	
32	6CE-24378-00	PIPE, JOINT 3	1	
33	6DA-1244H-00	HOSE 5	1	
34	90105-06028	BOLT, FLANGE	3	
35	90340-18M09	PLUG, STRAIGHT SCREW	1	
36	90430-18130	GASKET	1	
37	6P2-12491-00	CLAMP 1	1	
38	90119-06078	BOLT, WITH WASHER	1	
39	69J-13440-03	ELEMENT ASSY, OIL CLEANER	1	
40	6S5-12858-00	BOLT, UNION	1	
41	6DA-13446-00	CONNECTOR	1	
42	6DA-13475-00	GASKET	1	
43	90105-06151	BOLT, FLANGE	4	
44	6G8-15363-00	PLUG, OIL	1	
45	93210-24M79	O-RING	1	
46	6DA-15319-00	JOINT	1	
47	93210-357A3	O-RING	1	
48	90105-06037	BOLT, FLANGE	2	
49	6DA-1241B-00-9S	COVER, THERMOSTAT 2	1	AP WATER TEMP SENSOR
50	90465-11M59	CLAMP	1	AP WATER TEMP SENSOR

FIG. 7 CYLINDER & CRANKCASE 4



FWD
6DA1100-M070

REF. NO.	PART NO.	DESCRIPTION	QTY	REMARKS
1	6DA-12576-00	HOSE 1	1	
2	6DA-12589-00	HOSE 6	1	
3	6CE-24377-00	PIPE, JOINT 2	2	
4	90445-09008	HOSE (L470)	1	
5	90464-09M21	CLAMP	1	
6	6DA-12578-00	HOSE 3	1	
7	90465-11M10	CLAMP	7	
8	90464-12010	CLAMP	1	
9	90464-09142	CLAMP	1	
10	90464-09020	CLAMP	1	
11	6DA-12579-00	HOSE 4	1	
12	90464-09M31	CLAMP	2	
13	6DA-12552-00	HOSE 8	1	
14	90445-10057	HOSE (L170)	1	
15	6DA-12589-00	HOSE 6	1	
16	90465-08M83	CLAMP	2	
17	95895-06012	BOLT, FLANGE	2	

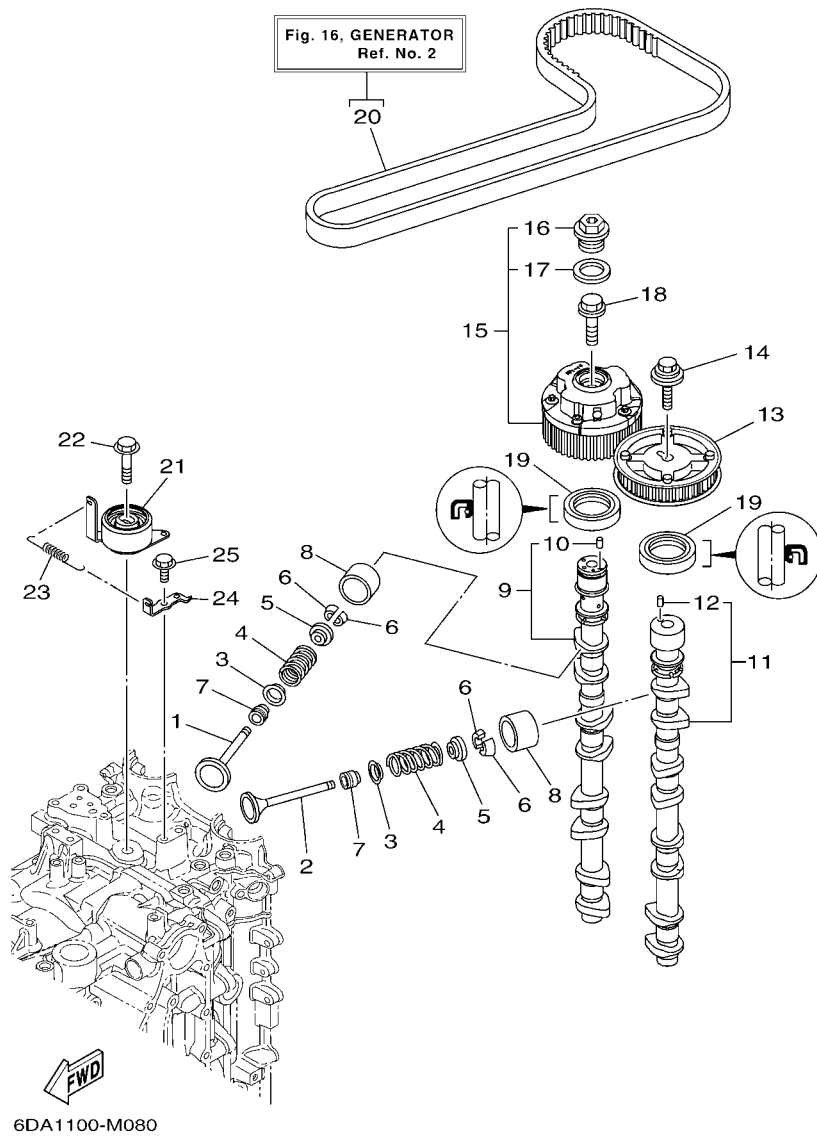

FIG. 8 VALVE

REF. NO.	PART NO.	DESCRIPTION	BEH2				REMARKS
1	6CB-12111-00	VALVE, INTAKE	8				
2	6DA-12121-00	VALVE, EXHAUST	8				
3	K0F-A3743-00	SEAT, VALVE SPRING	16				
4	6CB-12113-00	SPRING, VALVE INNER	16				
5	K0F-A3741-00	RETAINER, VALVE SPRING	16				
6	K0F-A3742-00	LOCK, VALVE SPRING RETAINER	32				
7	51Y-12119-00	SEAL, VALVE STEM	16				
8	K0F-A3751-00	LIFTER, VALVE (3.000)	16				UR
	K0F-A3751-10	LIFTER, VALVE (3.025)	16				UR
	K0F-A3751-20	LIFTER, VALVE (3.050)	16				UR
	K0F-A3751-30	LIFTER, VALVE (3.075)	16				UR
	K0F-A3751-40	LIFTER, VALVE (3.100)	16				UR
	K0F-A3751-50	LIFTER, VALVE (3.122)	16				UR
	K0F-A3751-60	LIFTER, VALVE (3.142)	16				UR
	K0F-A3751-70	LIFTER, VALVE (3.162)	16				UR
	K0F-A3751-80	LIFTER, VALVE (3.182)	16				UR
	K0F-A3751-90	LIFTER, VALVE (3.202)	16				UR
	K0F-A3751-A0	LIFTER, VALVE (3.222)	16				UR
	K0F-A3751-B0	LIFTER, VALVE (3.242)	16				UR
	K0F-A3751-C0	LIFTER, VALVE (3.262)	16				UR
	K0F-A3751-D0	LIFTER, VALVE (3.282)	16				UR
	K0F-A3751-E0	LIFTER, VALVE (3.302)	16				UR
	K0F-A3751-F0	LIFTER, VALVE (3.322)	16				UR
	K0F-A3751-G0	LIFTER, VALVE (3.342)	16				UR
	K0F-A3751-H0	LIFTER, VALVE (3.362)	16				UR
	K0F-A3751-J0	LIFTER, VALVE (3.382)	16				UR
	K0F-A3751-K0	LIFTER, VALVE (3.402)	16				UR

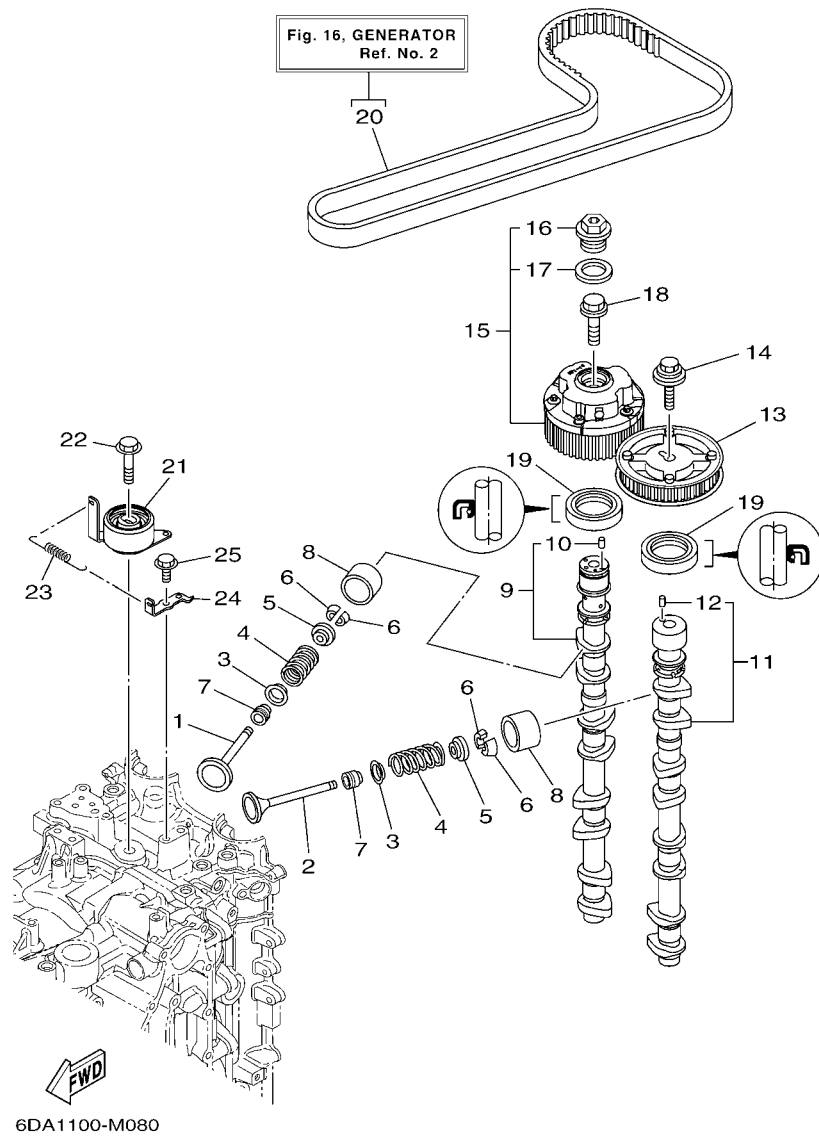

FIG. 8 VALVE

REF. NO.	PART NO.	DESCRIPTION	QTY	REMARKS
8	K0F-A3751-L0	LIFTER, VALVE (3.422)	16	UR
	K0F-A3751-M0	LIFTER, VALVE (3.442)	16	UR
	K0F-A3751-N0	LIFTER, VALVE (3.462)	16	UR
	K0F-A3751-P0	LIFTER, VALVE (3.482)	16	UR
	K0F-A3751-R0	LIFTER, VALVE (3.502)	16	UR
	K0F-A3751-S0	LIFTER, VALVE (3.522)	16	UR
	K0F-A3751-T0	LIFTER, VALVE (3.542)	16	UR
	K0F-A3753-00	LIFTER, VALVE (3.562)	16	UR
	K0F-A3753-10	LIFTER, VALVE (3.582)	16	UR
	K0F-A3753-20	LIFTER, VALVE (3.602)	16	UR
	K0F-A3753-30	LIFTER, VALVE (3.625)	16	UR
	K0F-A3753-40	LIFTER, VALVE (3.650)	16	UR
	K0F-A3753-50	LIFTER, VALVE (3.675)	16	UR
	K0F-A3753-60	LIFTER, VALVE (3.700)	16	UR
	K0F-A3753-70	LIFTER, VALVE (3.725)	16	UR
9	6DA-12171-00	CAMSHAFT 1	1	
10	93605-10108	.PIN, DOWEL	1	
11	6DA-12181-00	CAMSHAFT 2	1	
12	93605-10108	.PIN, DOWEL	1	
13	6DA-115A0-00	DRIVEN GEAR ASSY	1	
14	90119-10050	BOLT, WITH WASHER	1	
15	6P2-12645-20	PULLEY ASSY 1	1	
16	6P2-12623-00	.BOLT	1	
17	6P2-12663-00	.GASKET	1	
18	6P2-12615-00	BOLT	1	
19	93102-38008	OIL SEAL	2	
20	6DA-W4624-00	BELT (WITH ROTOR BOLTS)	1	

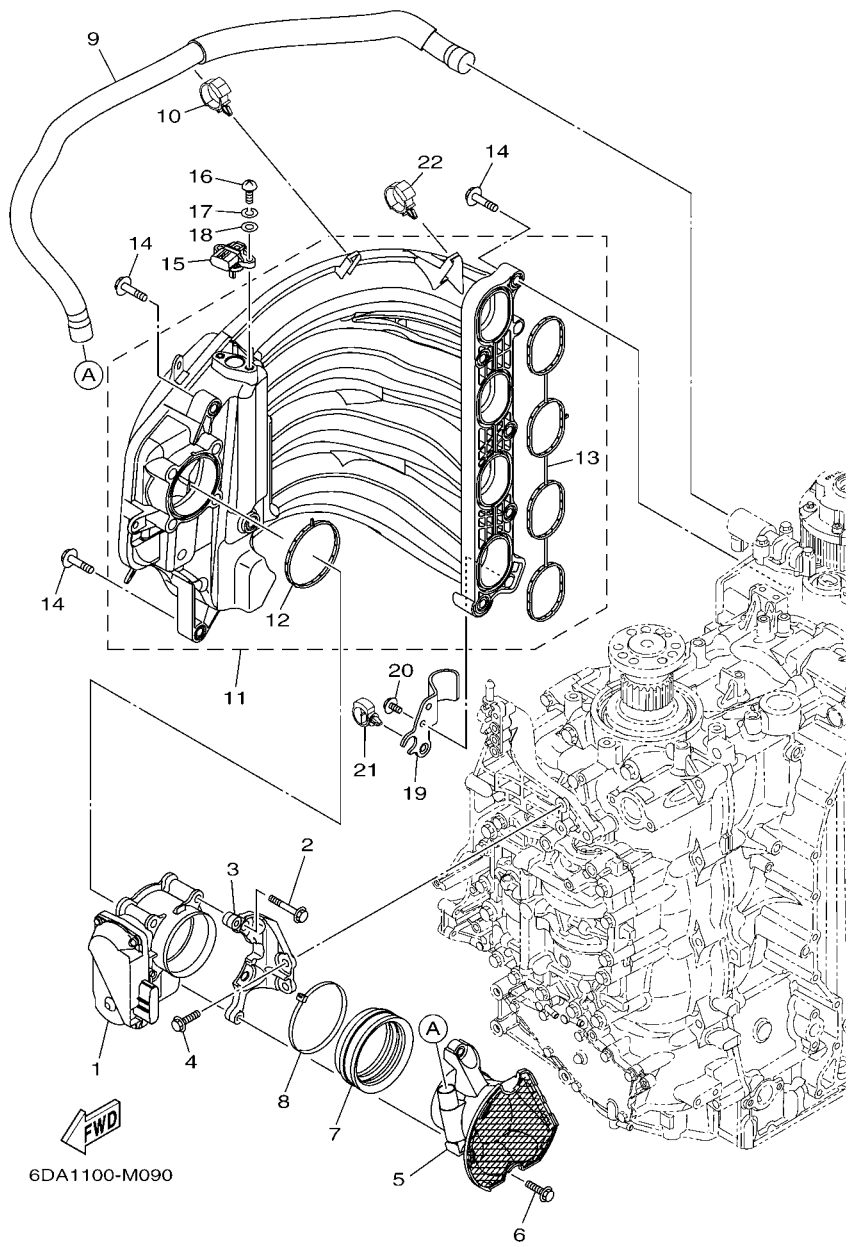
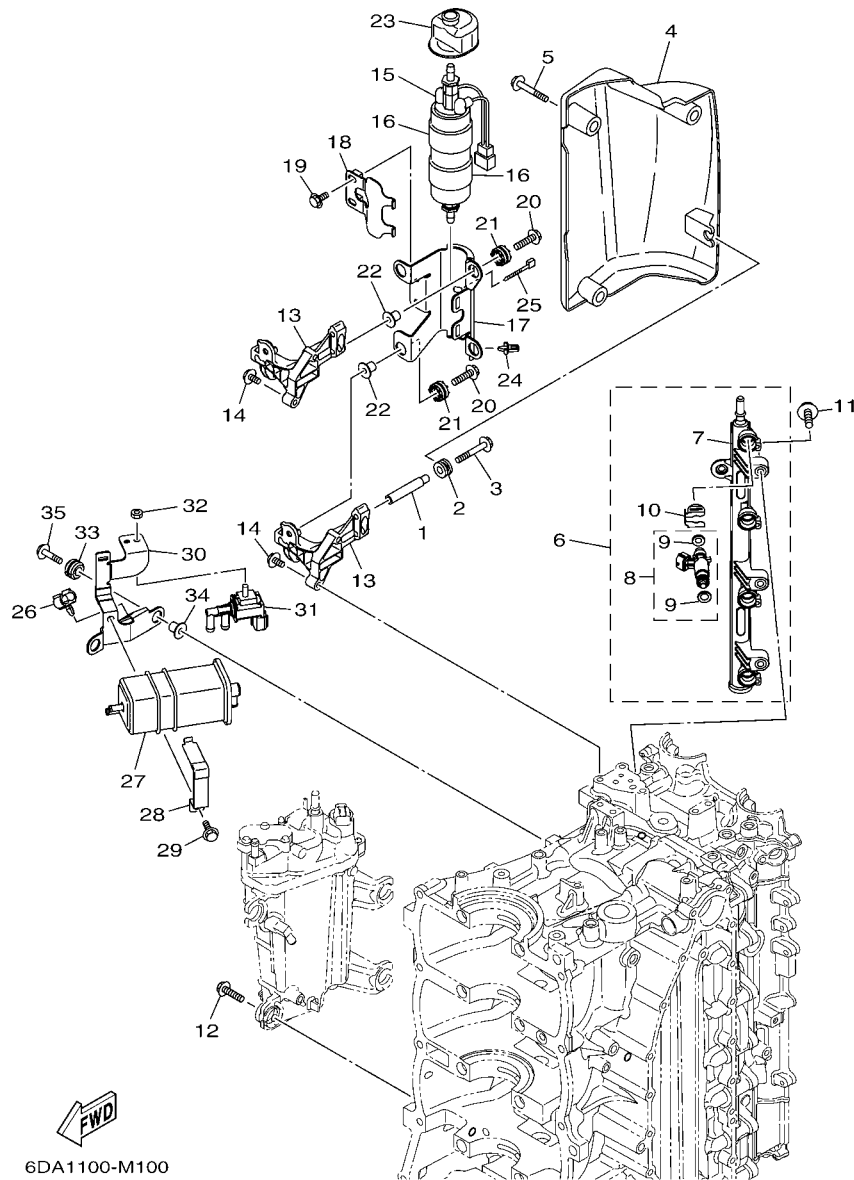

FIG. 9 INTAKE 1

REF. NO.	PART NO.	DESCRIPTION	QTY	REMARKS
1	6DA-13751-00	BODY, THROTTLE 1	1	
2	97575-08560	BOLT, WITH WASHER	4	
3	6DA-13152-00	STAY 2	1	
4	95875-06025	BOLT, FLANGE	2	
5	6DA-14440-00	SILENCER ASSY, INTAKE	1	
6	95875-06025	BOLT, FLANGE	2	
7	6P2-1441J-00	PIPE, SILENCER	1	
8	90464-99004	CLAMP	1	
9	6DA-15373-00	PIPE, BREATHER	1	
10	90464-12183	CLAMP	1	
11	6DA-13641-00	MANIFOLD, INTAKE 1	1	
12	6DA-13646-00	.GASKET, MANIFOLD 2	1	
13	6DA-13645-00	.GASKET, MANIFOLD 1	1	
14	90119-08020	BOLT, WITH WASHER	9	
15	68F-83688-10	SENSOR ASSY	1	
16	97885-05016	SCREW, PAN HEAD	2	
17	92995-05100	WASHER	2	
18	92995-05600	WASHER	2	
19	6DA-13881-00	COVER 1	1	
20	95895-06012	BOLT, FLANGE	2	
21	90464-20181	CLAMP	1	
22	90464-12183	CLAMP	1	



6DA1100-M100

FIG. 10 INTAKE 2

REF. NO.	PART NO.	DESCRIPTION	6EH2				REMARKS
1	90387-06283	COLLAR	1				
2	90480-12314	GROMMET	1				
3	90105-06054	BOLT, FLANGE	1				
4	6DA-13564-00	COVER, MANIFOLD	1				
5	95875-06020	BOLT, FLANGE	3				
6	6DA-13160-00	DELIVERY PIPE ASSY 1	1				
7	6DA-13161-00	.PIPE, DELIVERY 1	1				
8	6DA-13761-00	.INJECTOR	4				
9	6AW-1410B-00	..PACKING KIT	1				
10	6AW-13577-10	.CLIP	4				
11	90105-06M08	BOLT, FLANGE	3				
12	90119-06M24	BOLT, WITH WASHER	4				
13	6DA-24425-00	BRACKET, FUEL PUMP 1	2				
14	90105-06M08	BOLT, FLANGE	4				
15	6CB-24410-00	FUEL PUMP ASSY	1				
16	6DA-24492-00	BUSH, FUEL PUMP	2				
17	6DA-24491-00	BRACKET, FUEL PUMP	1				
18	6DA-24426-00	BRACKET, FUEL PUMP 2	1				
19	95895-06012	BOLT, FLANGE	2				
20	90119-06M17	BOLT, WITH WASHER	4				
21	60V-85516-00	SPACER	4				
22	90387-06289	COLLAR	4				
23	6DA-24462-00	CAP, BLIND	1				
24	90464-06001	CLAMP	1				
25	90465-11M10	CLAMP	1				
26	90464-09130	CLAMP	1				
27	6P2-24170-00	CANISTER ASSY	1				

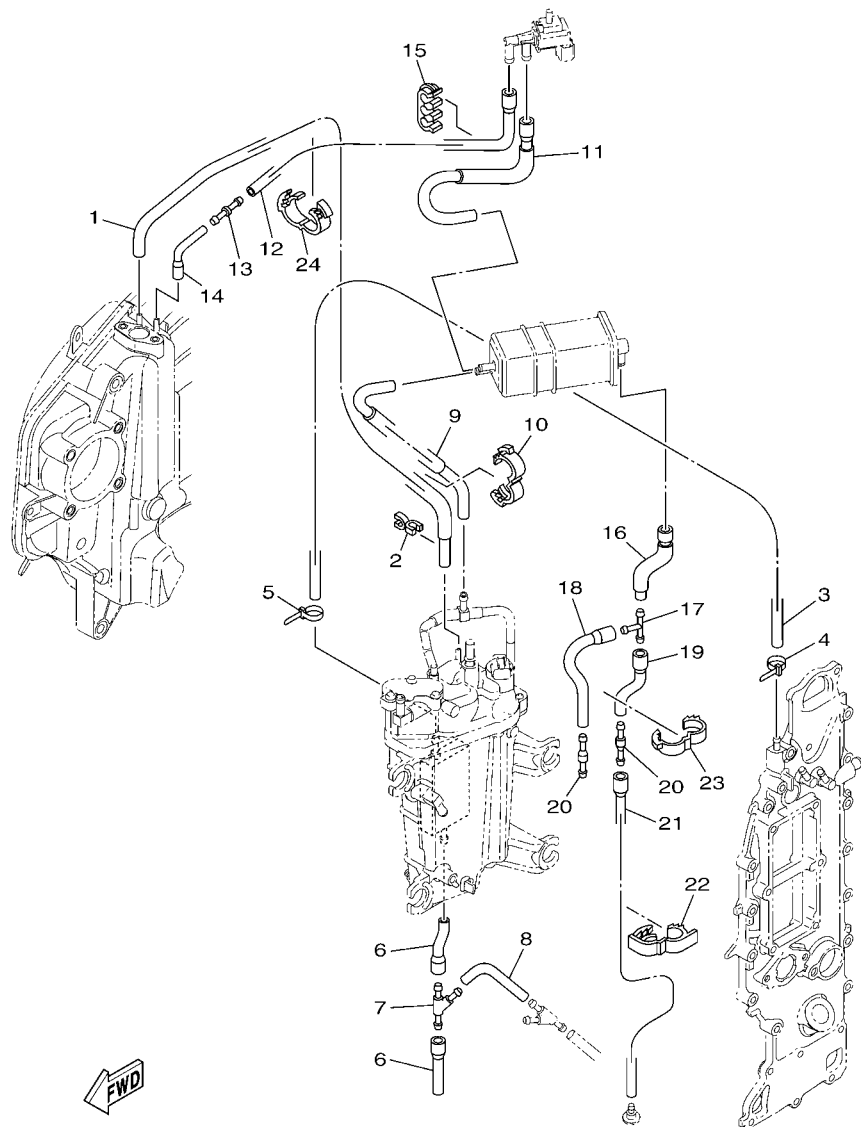

6DA1100-M110

FIG. 11 INTAKE 3

REF. NO.	PART NO.	DESCRIPTION	6EH2				REMARKS
1	6DA-13532-00	HOSE, VACUUM SENSING 3	1				
2	90464-07M41	CLAMP	1				
3	90445-09120	HOSE (L600)	1				
4	90465-11M10	CLAMP	1				
5	90465-11M10	CLAMP	1				
6	6DA-12576-00	HOSE 1	2				
7	6CE-24377-00	PIPE, JOINT 2	1				
8	90445-10056	HOSE (L85)	1				
9	6DA-1475A-00	PIPE 1	1				
10	90464-16001	CLAMP	1				
11	6DA-1475F-00	PIPE 3	1				
12	6DA-2416A-00	HOSE	1				
13	6CB-14989-00	ORIFICE, AIR VENT	1				
14	6DA-1475G-00	PIPE 4	1				
15	90464-10011	CLAMP	1				
16	6DA-13545-00	HOSE 1	1				
17	688-24378-00	PIPE, JOINT 3	1				
18	68V-13546-10	HOSE 2	1				
19	6DA-13548-00	HOSE, AIR 4	1				
20	6E5-21744-00	BREATHER	2				
21	6DA-13547-00	HOSE 3	1				
22	90464-18004	CLAMP	1				
23	90464-16001	CLAMP	1				
24	90464-16001	CLAMP	1				

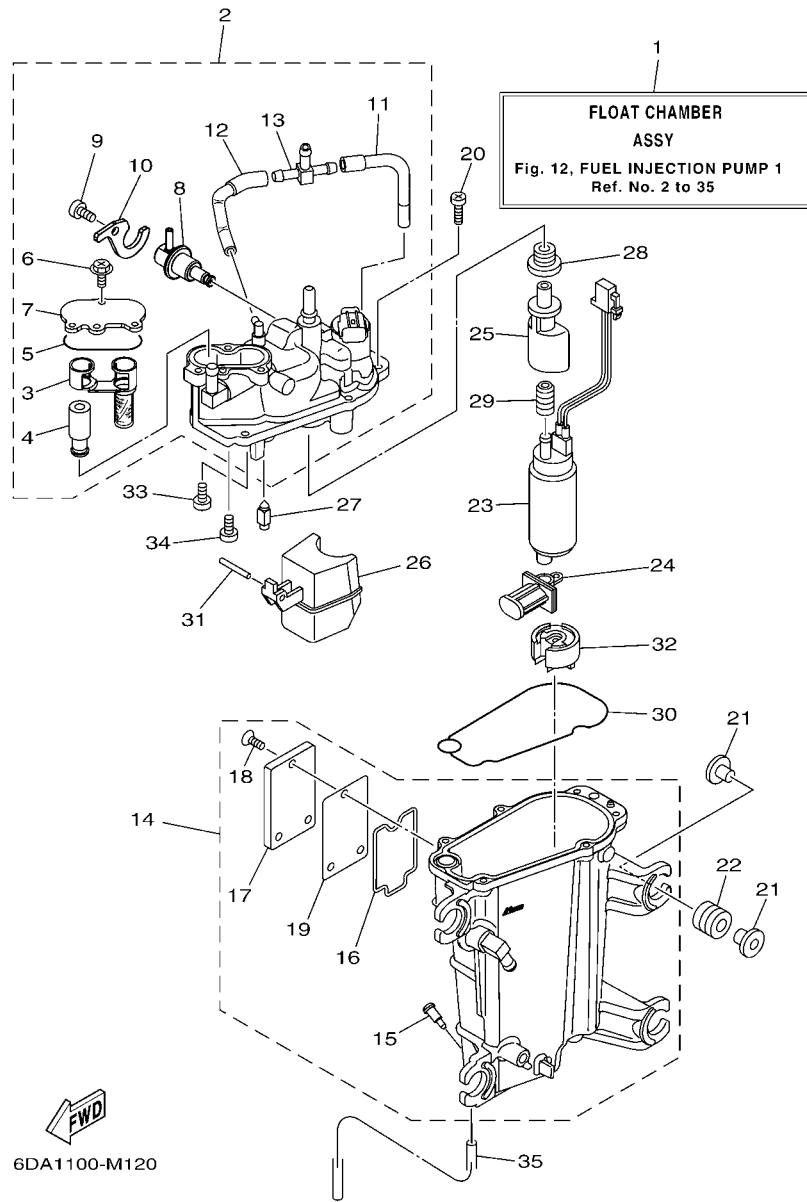

6DA1100-M120

FIG. 12 FUEL INJECTION PUMP 1

REF. NO.	PART NO.	DESCRIPTION	QTY	REMARKS
1	6DA-14180-00	FLOAT CHAMBER ASSY	1	
2	6DA-14182-00	COVER, FLOAT CHAMBER	1	
3	6CB-24501-01	.FILTER, FUEL	1	
4	6CB-24460-00	.RELIEF VALVE ASSY	1	
5	6CB-13016-00	.O-RING	1	
6	6CB-14216-00	.SCREW	3	
7	6CB-24217-00	.COVER	1	
8	6CB-13906-01	.REGULATOR, PRESSURE	1	
9	6CB-14564-00	.SCREW	1	
10	6DA-14146-00	.PLATE	1	
11	6DA-13892-00	.HOSE, AIR 2	1	
12	6DA-13893-00	.HOSE, AIR 3	1	
13	69J-24379-00	.PIPE, JOINT 4	1	
14	6DA-14181-00	BODY, FLOAT CHAMBER 1	1	
15	6P2-14191-00	.PLUG, DRAIN	1	
16	6CB-14239-00	.SEAL	1	
17	6CB-24452-10	.COVER	1	
18	6CB-14429-01	.SCREW	3	
19	6CB-24482-00	.GASKET 1	1	
20	63P-14567-00	SCREW	6	
21	69J-13716-00	COLLAR	8	
22	6CB-13593-00	DAMPER	4	
23	6P2-13907-20	FUEL PUMP COMP.	1	
24	63P-13915-00	FILTER	1	
25	6AW-13132-00	JOINT	1	
26	6CB-14985-00	FLOAT	1	
27	6CB-14546-00	VALVE, NEEDLE	1	

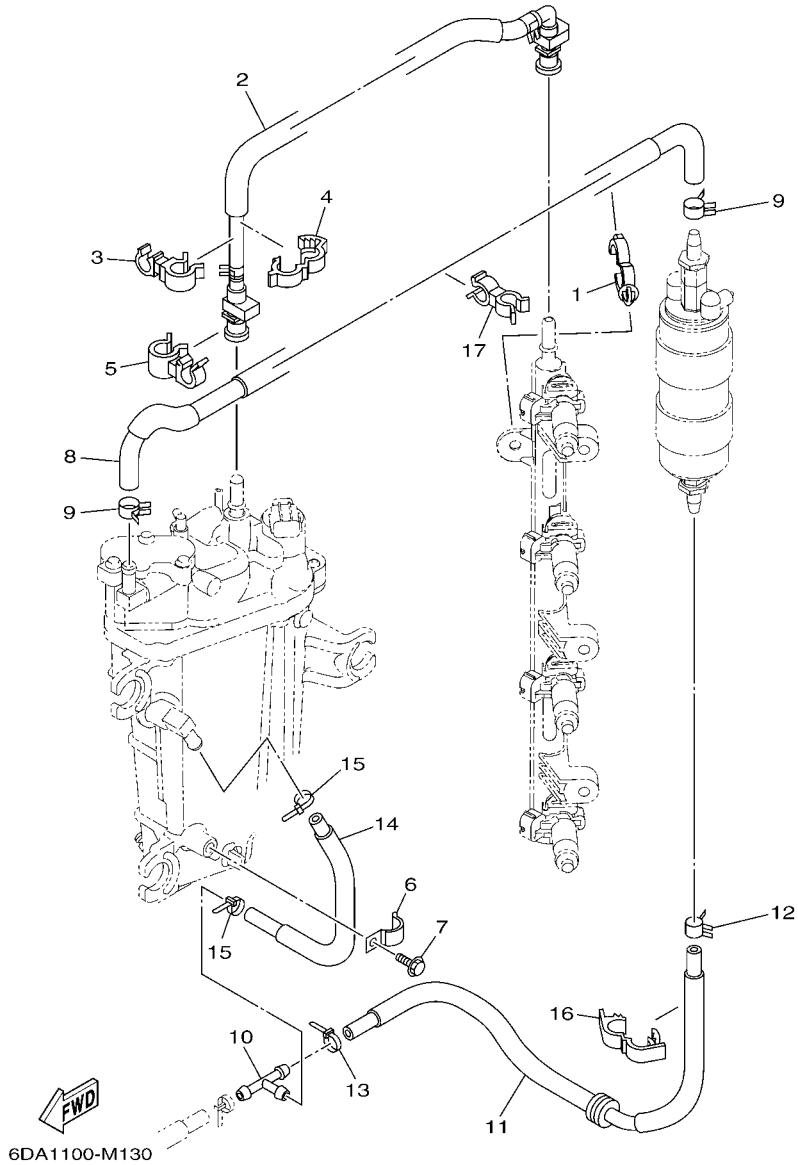
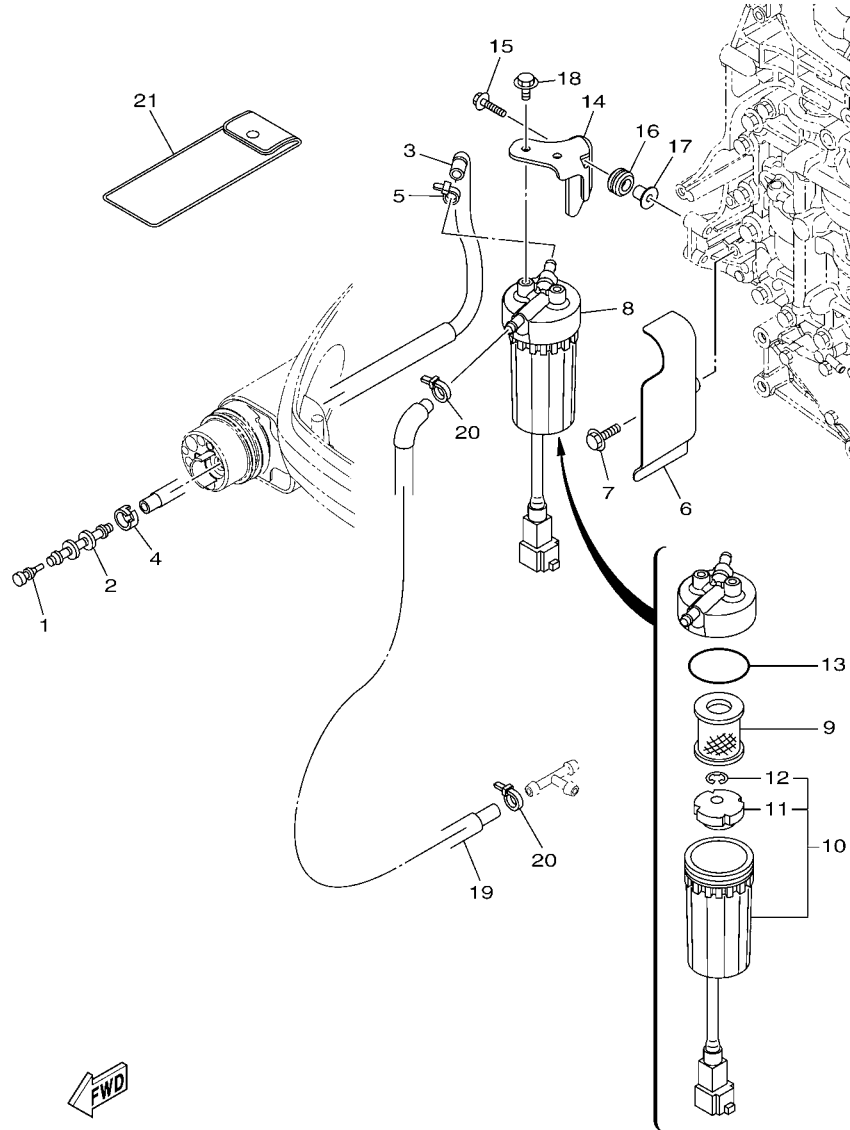

FIG. 13 FUEL INJECTION PUMP 2

REF. NO.	PART NO.	DESCRIPTION	6EH2				REMARKS
1	90464-20181	CLAMP	1				
2	6DA-24310-00	FUEL PIPE ASSY	1				
3	90464-12010	CLAMP	1				
4	90464-16003	CLAMP	1				
5	90464-15007	CLAMP	1				
6	90465-08M63	CLAMP	1				
7	95895-06010	BOLT, FLANGE	1				
8	6DA-24324-00	PIPE 13	1				
9	90467-120A7	CLIP	2				
10	6E5-24378-00	PIPE, JOINT 3	1				
11	6DA-24317-00	PIPE 7	1				
12	90467-120A7	CLIP	1				
13	90465-11M10	CLAMP	1				
14	6DA-24323-00	PIPE 12	1				
15	90465-11M10	CLAMP	2				
16	90464-18004	CLAMP	1				
17	90464-13260	CLAMP	1				



6DA1100-M140

FIG. 14 FUEL 1

REF. NO.	PART NO.	DESCRIPTION	QTY	REMARKS
1	689-85547-00	DAMPER	1	
2	6AW-24377-01	PIPE, JOINT 2	1	
3	6DA-24314-00	PIPE 4	1	
4	6E5-24351-51	BAND 1	1	
5	90465-11M10	CLAMP	1	
6	6DA-24596-00	COVER	1	
7	95895-06025	BOLT, FLANGE	2	
8	6P3-24560-03	FILTER ASSY	1	
9	6P3-24563-01	.ELEMENT, FILTER	1	
10	6P3-24562-03	.CUP, FILTER	1	
11	6P3-24469-00	..FLOAT, WATER LEVEL	1	
12	6P3-24519-00	..CLIP	1	
13	6P3-24564-00	.GASKET	1	
14	6DA-24566-00	BRACKET, FILTER	1	
15	90119-06M17	BOLT, WITH WASHER	2	
16	90480-15013	GROMMET	2	
17	90387-06289	COLLAR	2	
18	95895-06012	BOLT, FLANGE	2	
19	6DA-24313-00	PIPE 3	1	
20	90465-11M10	CLAMP	2	
21	69J-28100-01	TOOL KIT	1	AP

FIG. 15 FUEL 2

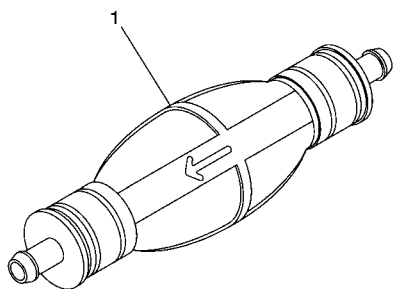

 68VC100-L120

REF. NO.	PART NO.	DESCRIPTION	68H2				REMARKS
1	6YK-24360-73	PRIMER PUMP ASSY	1				AP

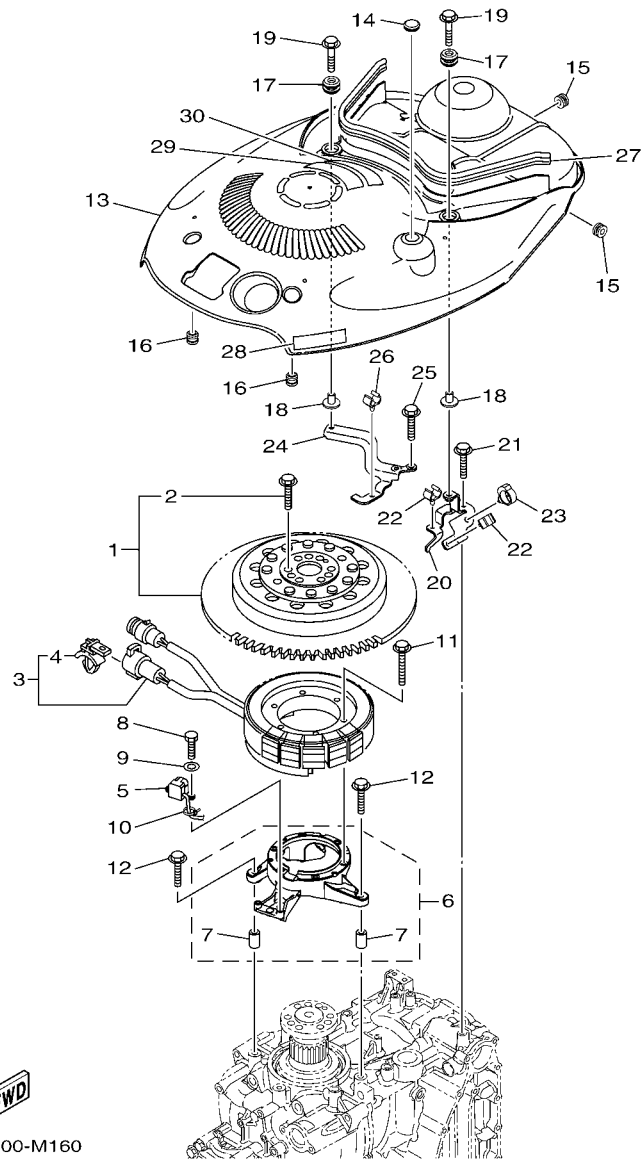

FIG. 16 GENERATOR

REF. NO.	PART NO.	DESCRIPTION	QTY	REMARKS
1	6DA-W8145-00	ROTOR ASSY WITH BOLTS	1	
2	6AW-W9011-00	.BOLT SET (FOR ROTOR ASSY)	1	
3	6DA-81410-00	STATOR ASSY	1	
4	90464-12002	.CLAMP	1	
5	6CB-85580-00	COIL, PULSER	1	
6	6DA-85561-00	BASE, MAGNETO	1	
7	99590-08012	.PIN, DOWEL	2	
8	97095-05020	BOLT	2	
9	92995-05600	WASHER	2	
10	90465-13M97	CLAMP	1	
11	95022-06035	BOLT, FLANGE	6	
12	95895-06030	BOLT, FLANGE	4	
13	6DA-81337-00	COVER, FLYWHEEL	1	
14	90480-16025	GROMMET	1	
15	90480-12314	GROMMET	2	
16	6A0-82317-00	DAMPER, IGNITION COIL	2	
17	6BG-42748-00	GROMMET	2	
18	90387-06M69	COLLAR	2	
19	90119-06M61	BOLT, WITH WASHER	2	
20	6DA-8132G-00	PLATE	1	
21	95895-06016	BOLT, FLANGE	1	
22	90464-09130	CLAMP	2	
23	90464-20181	CLAMP	1	
24	6DA-82398-00	PLATE 3	1	
25	95895-06016	BOLT, FLANGE	2	
26	90464-09130	CLAMP	1	
27	6DA-42617-00	DAMPER, FORM	1	

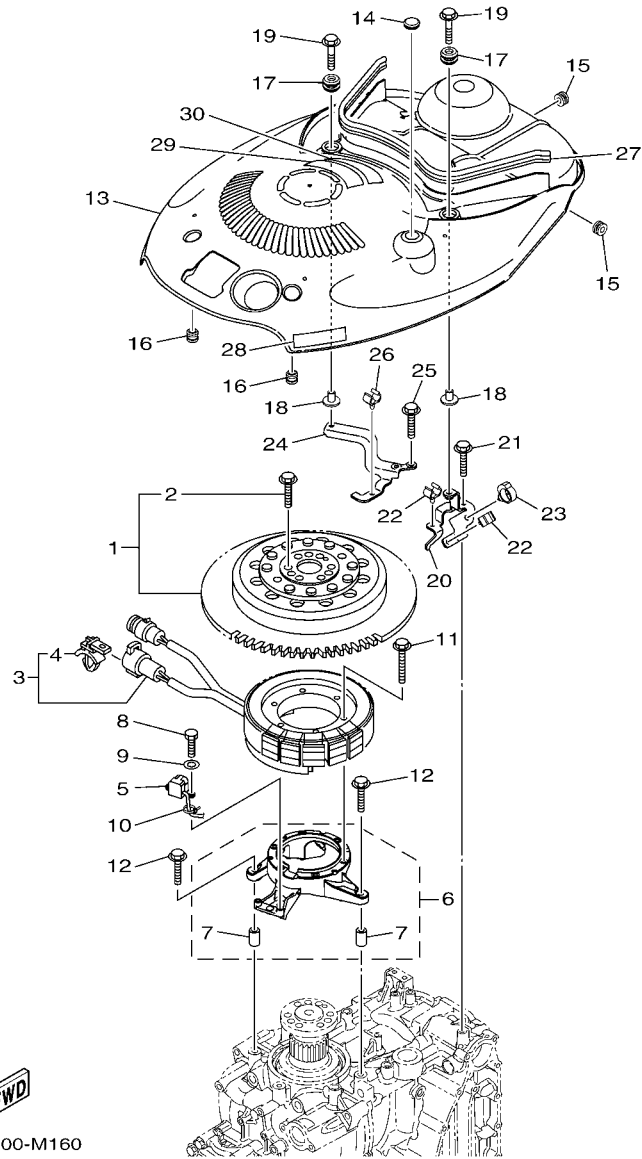

FIG. 16 GENERATOR

REF. NO.	PART NO.	DESCRIPTION	6EH2				REMARKS
28	63P-13437-52	MARK, CAUTION	1				
29	6AH-81994-40	LABEL, SAFETY	1				
30	6AH-81994-50	LABEL, SAFETY	1				

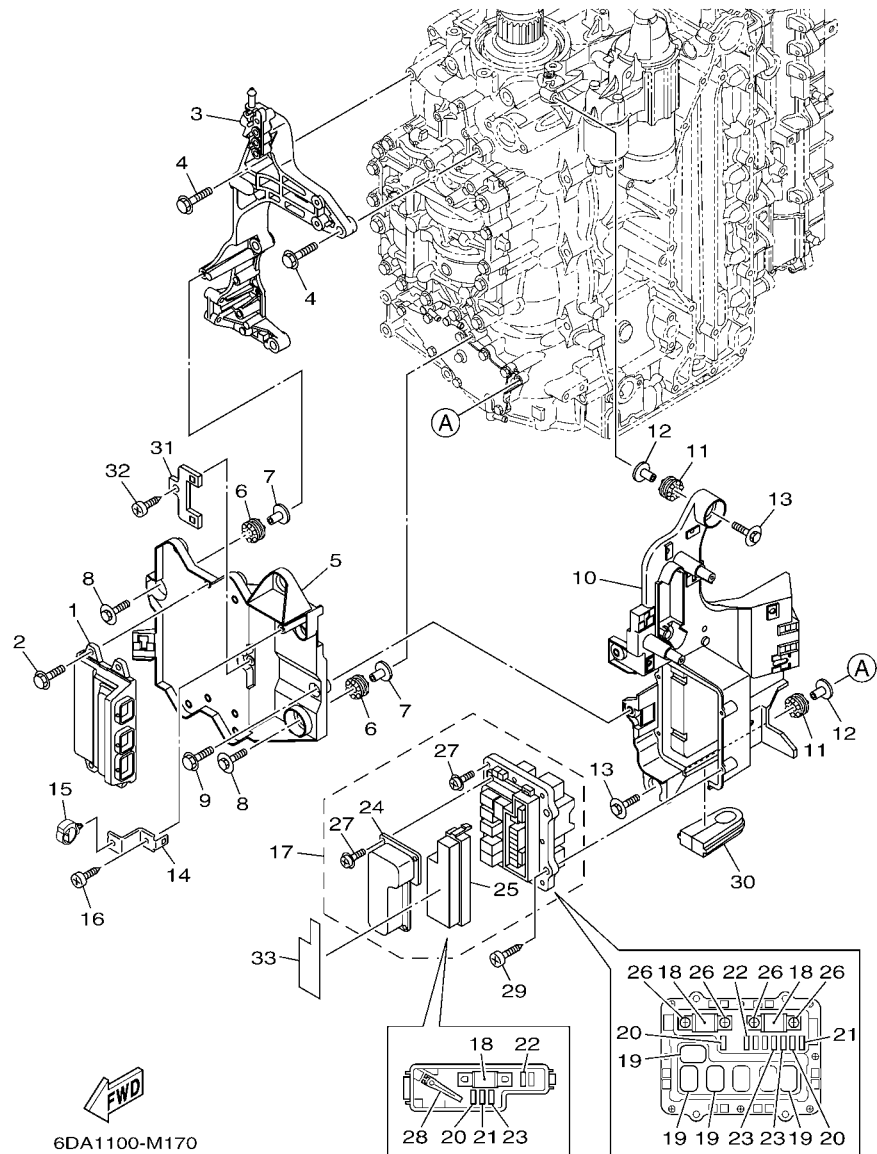

FIG. 17 ELECTRICAL 1

REF. NO.	PART NO.	DESCRIPTION	QTY	REMARKS
1	6EH-8591A-01	ENGINE CONTROL UNIT ASSY	1	
2	95895-06020	BOLT, FLANGE	4	
3	6DA-85991-00	BRACKET, UNIT	1	
4	95875-08035	BOLT, FLANGE	4	
5	6DA-81948-00	BRACKET	1	
6	68F-85516-01	SPACER	3	
7	90387-06176	COLLAR	3	
8	68F-85119-00	BOLT	3	
9	95895-06016	BOLT, FLANGE	2	
10	6DA-81952-00	HOLDER, RELAY	1	
11	68F-85516-01	SPACER	3	
12	90387-06176	COLLAR	3	
13	68F-85119-00	BOLT	3	
14	6DA-85548-00	HOLDER	1	
15	90464-20181	CLAMP	1	
16	97780-60620	SCREW, TAPPING	1	
17	6DA-82170-00	FUSE BOX ASSY	1	
18	6P2-82151-00	.FUSE (60A)	3	
19	68F-8195A-00	.RELAY ASSY	4	
20	67F-82151-40	.FUSE (10A)	3	
21	67F-82151-50	.FUSE (15A)	2	
22	67F-82151-00	.FUSE (20A)	2	
23	67F-82151-10	.FUSE (30A)	3	
24	6CB-81639-00	.COVER	1	
25	6CB-85544-00	.CASE	1	
26	68F-82846-00	.SCREW, PAN HEAD (M5)	4	
27	6P2-82113-00	.SCREW	13	

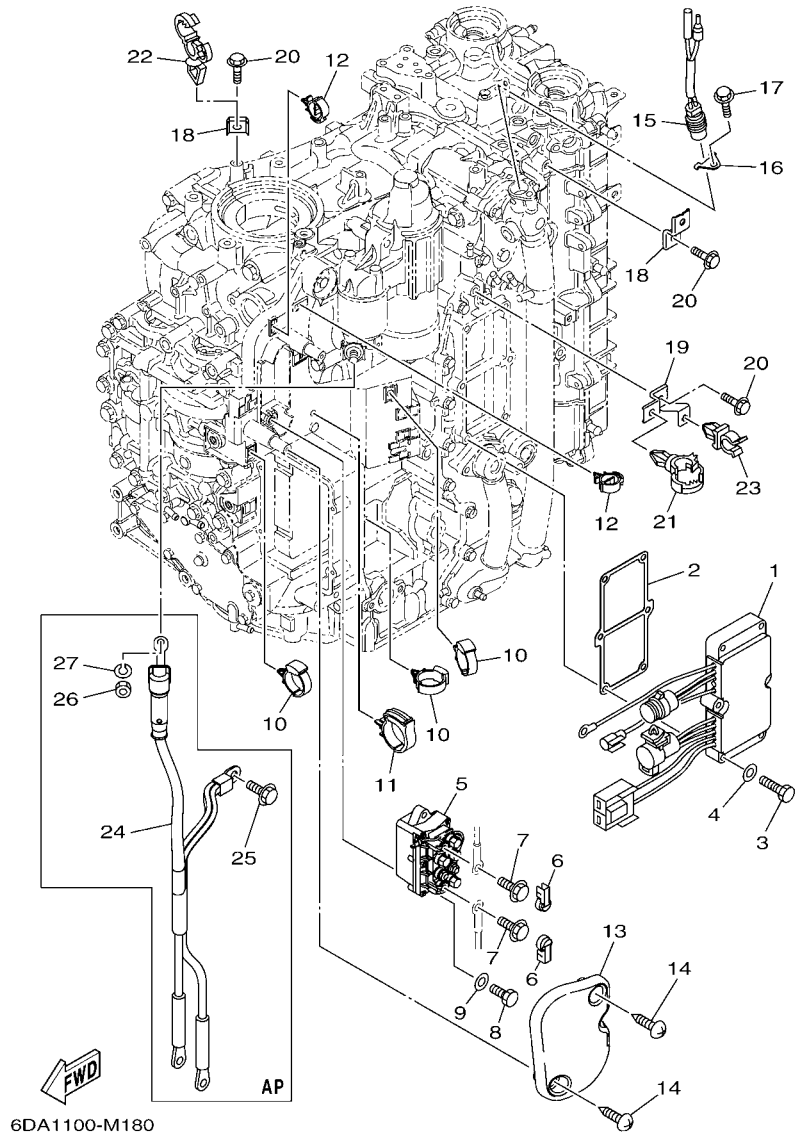

FIG. 18 ELECTRICAL 2

REF. NO.	PART NO.	DESCRIPTION	6EH2				REMARKS
1	6DA-81960-00	RECTIFIER & REGULATOR ASSY	1				
2	6DA-81975-00	PLATE, RECTIFIER FITTING	1				
3	97095-06035	BOLT	6				
4	92995-06600	WASHER	6				
5	63P-81950-00	RELAY ASSY	1				
6	6P2-8183X-00	CAP, TERMINAL	2				
7	97595-06610	BOLT, WITH WASHER	2				
8	97095-06020	BOLT	2				
9	92995-06600	WASHER	2				
10	90464-12183	CLAMP	3				
11	90464-32002	CLAMP	1				
12	90464-18246	CLAMP	2				
13	6DA-81942-00	COVER	1				
14	90169-05M00	SCREW, TRUSS HEAD TAPPING	2				
15	6P2-82560-01	THERMO SWITCH ASSY	1				
16	6E9-82588-00	PLATE	1				
17	95895-06012	BOLT, FLANGE	1				
18	6DA-82388-00	PLATE	2				
19	6DA-82389-00	PLATE 2	1				
20	95895-06016	BOLT, FLANGE	3				
21	90464-20181	CLAMP	1				
22	90464-13249	CLAMP	1				
23	90464-09008	CLAMP	1				
24	6DA-82105-01	BATTERY CABLE	1				AP
25	95895-08016	BOLT, FLANGE	1				AP
26	95333-08600	NUT	1				AP
27	92903-08100	WASHER, SPRING	1				AP

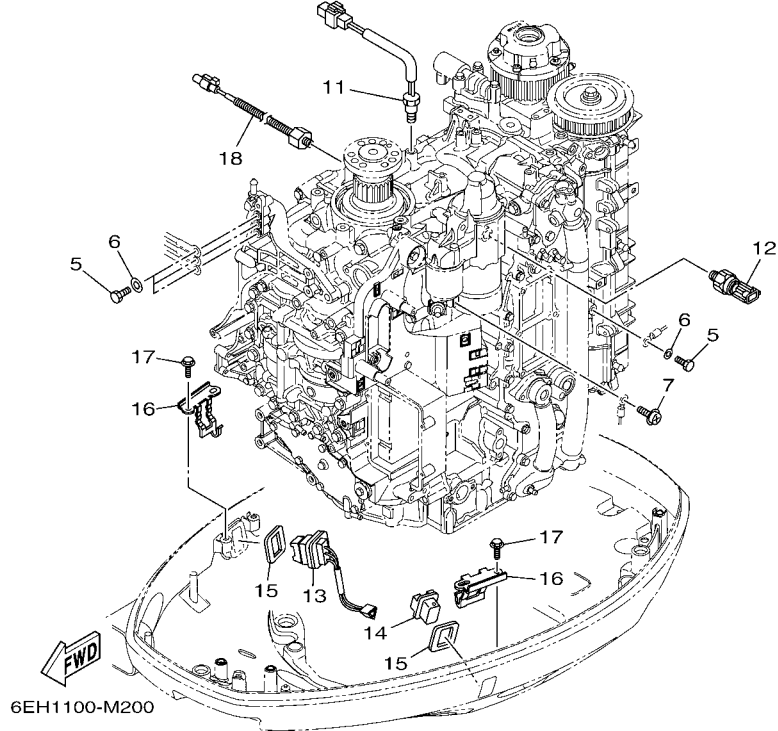
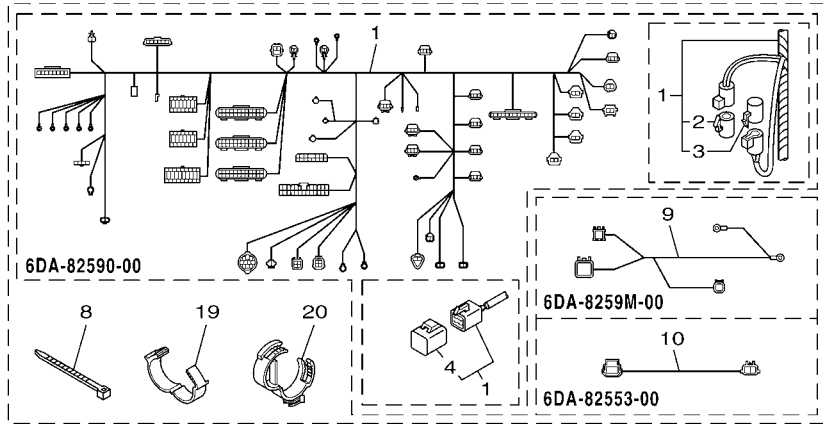
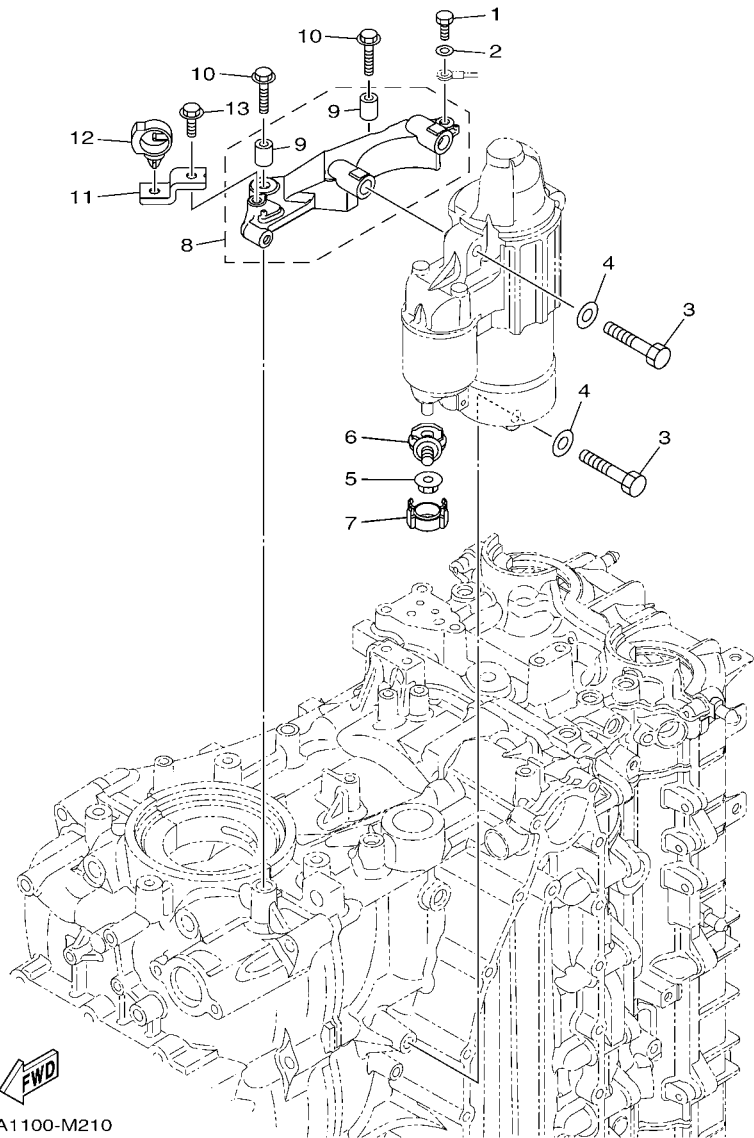

FIG. 20 ELECTRICAL 4

REF. NO.	PART NO.	DESCRIPTION	6EH2				REMARKS
1	6DA-82590-00	WIRE HARNESS ASSY	1				
2	6DA-82582-00	.CAP 1 (FEMALE)	1				
3	6DA-82582-10	.CAP 1 (MALE)	1				
4	6Y8-82582-11	.CAP 1 (4PIN)	1				
5	97095-06016	BOLT	4				
6	92995-06600	WASHER	4				
7	97985-04308	SCREW, WITH WASHER	1				
8	90465-11M59	CLAMP	1				
9	6DA-8259M-00	WIRE HARNESS ASSY 2	1				
10	6DA-82553-00	EXTENSION, WIRE LEAD	1				
11	6CB-85790-00	THERMOSENSOR ASSY	1				
12	6AW-83651-00	SENDER, OIL PRESSURE	1				
13	69J-82563-00	TRIM & TILT SWITCH ASSY	1				
14	69J-42723-01	COVER, BOTTOM	1				
15	69J-82587-00	GASKET	2				
16	63P-83614-01	BRACKET	2				
17	95895-06012	BOLT, FLANGE	4				
18	6CJ-85780-00	SENSOR, KNOCK	1				
19	90464-26001	CLAMP	5				
20	90464-30003	CLAMP	2				



6DA1100-M210

FIG. 21 ELECTRICAL 5

REF. NO.	PART NO.	DESCRIPTION	6EH2				REMARKS
1	97095-06016	BOLT	1				
2	92995-06600	WASHER	1				
3	97013-08045	BOLT	3				
4	92903-08600	WASHER, PLATE	3				
5	90179-08003	NUT	1				
6	60V-81925-00	TERMINAL	1				
7	68F-82582-00	COVER, WIRE HARNESS	1				
8	6DA-81822-00	BRACKET, STARTING MOTOR	1				
9	99590-10114	.PIN, DOWEL	2				
10	90105-08M87	BOLT, FLANGE	2				
11	6DA-82388-00	PLATE	1				
12	90464-20181	CLAMP	1				
13	95895-06016	BOLT, FLANGE	1				

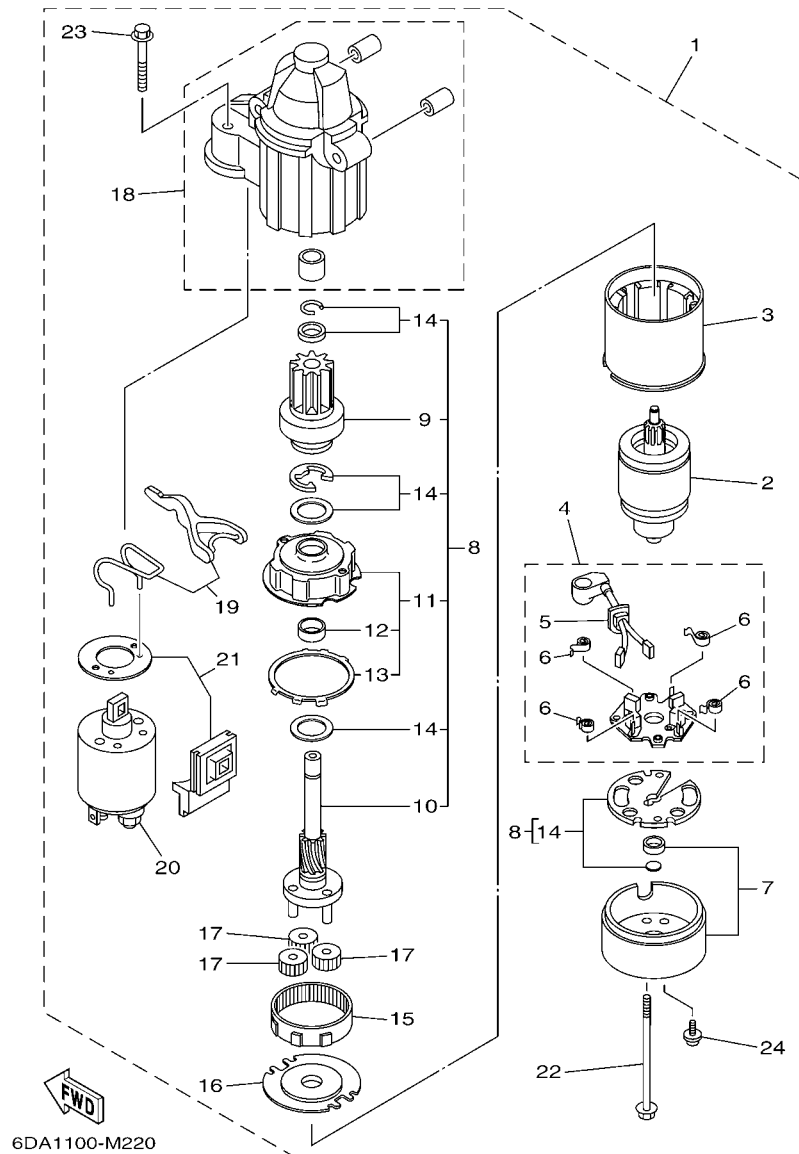

6DA1100-M220

FIG. 22 STARTING MOTOR

REF. NO.	PART NO.	DESCRIPTION	6EH2				REMARKS
1	6CB-81800-00	STARTING MOTOR ASSY	1				
2	67F-81850-00	.ARMATURE ASSY	1				
3	67F-81810-00	.STATOR ASSY	1				
4	69J-81840-00	.BRUSH HOLDER ASSY	1				
5	69J-81801-00	..BRUSH SET	1				
6	67F-81813-00	..SPRING, BRUSH	4				
7	6CB-81820-00	.REAR BRACKET ASSY	1				
8	6CB-81807-00	.GEAR ASSY, STARTING MOTOR	1				
9	6CB-81832-00	..CLUTCH, OVER RUN	1				
10	6CB-81836-00	..SHAFT, PINION	1				
11	67F-81821-00	..BRACKET, CENTER 1	1				
12	67F-81841-00	...BEARING	1				
13	67F-8183R-00	...GASKET	1				
14	6CB-81809-00	..WASHER KIT	1				
15	67F-81891-00	.GEAR, RING	1				WITH 67F-8183R-00
16	67F-81830-00	.BRACKET, CENTER 2	1				
17	60V-8183T-00	.GEAR, IDLER	3				
18	6CB-81842-00	.COVER	1				
19	6C5-81839-00	.LEVER ASSY	1				
20	6C5-81941-00	.STARTER RELAY ASSY	1				
21	6C5-81869-00	.COVER, DUST	1				
22	6CB-81826-00	.BOLT	2				
23	69J-81828-00	.SCREW 2	2				
24	67F-81846-00	.SCREW	2				

FIG. 23 BOTTOM COWLING 1

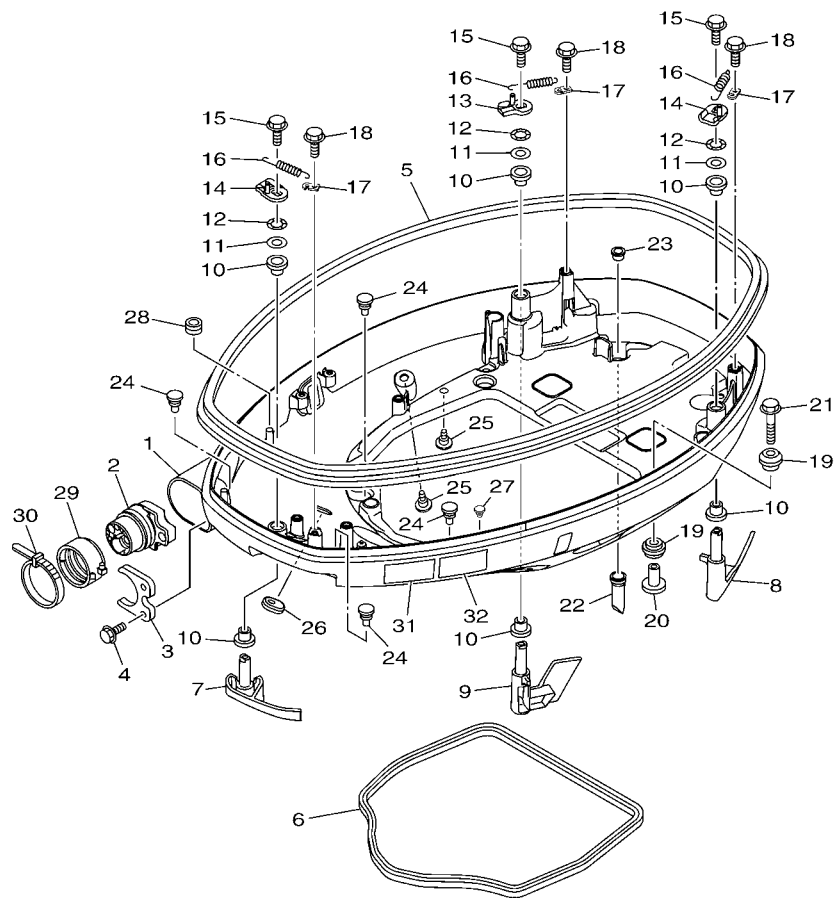

FWD
6DA1100-M230

REF. NO.	PART NO.	DESCRIPTION	QTY	REMARKS
1	6DA-42710-00-8D	BOTTOM COWLING ASSY	1	
2	6DA-42725-00	GROMMET	1	
3	6CB-42761-00	STOPPER	1	
4	95895-06014	BOLT, FLANGE	2	
5	6DA-42615-00	SEAL	1	
6	63P-42716-00	RUBBER, SEAL 1	1	
7	6DA-42815-00-8D	LEVER, CLAMP	1	
8	6DA-42816-00-8D	LEVER, CLAMP	1	
9	6DA-42817-00-8D	LEVER, CLAMP	1	
10	90386-15M73	BUSH	6	
11	90201-156J2	WASHER, PLATE	3	
12	90206-15M18	WASHER, WAVE	3	
13	6CB-42818-00	LEVER, CLAMP	1	
14	6CB-42819-00	LEVER, CLAMP	2	
15	95880-08012	BOLT, FLANGE	3	
16	90506-22001	SPRING, TENSION	3	
17	66T-43144-00	HOOK, SPRING	3	
18	95895-06012	BOLT, FLANGE	3	
19	90480-22M81	GROMMET	8	
20	90387-08M37	COLLAR	4	
21	90119-08M22	BOLT, WITH WASHER	4	
22	6DA-42717-00	RUBBER, SEAL 2	4	
23	6DA-42384-00	SEAL, CAP	4	
24	6H4-42748-00	GROMMET	4	
25	6P2-44391-00	NIPPLE, HOSE	2	
26	61A-42727-00	GROMMET	1	
27	90269-07003	RIVET	1	

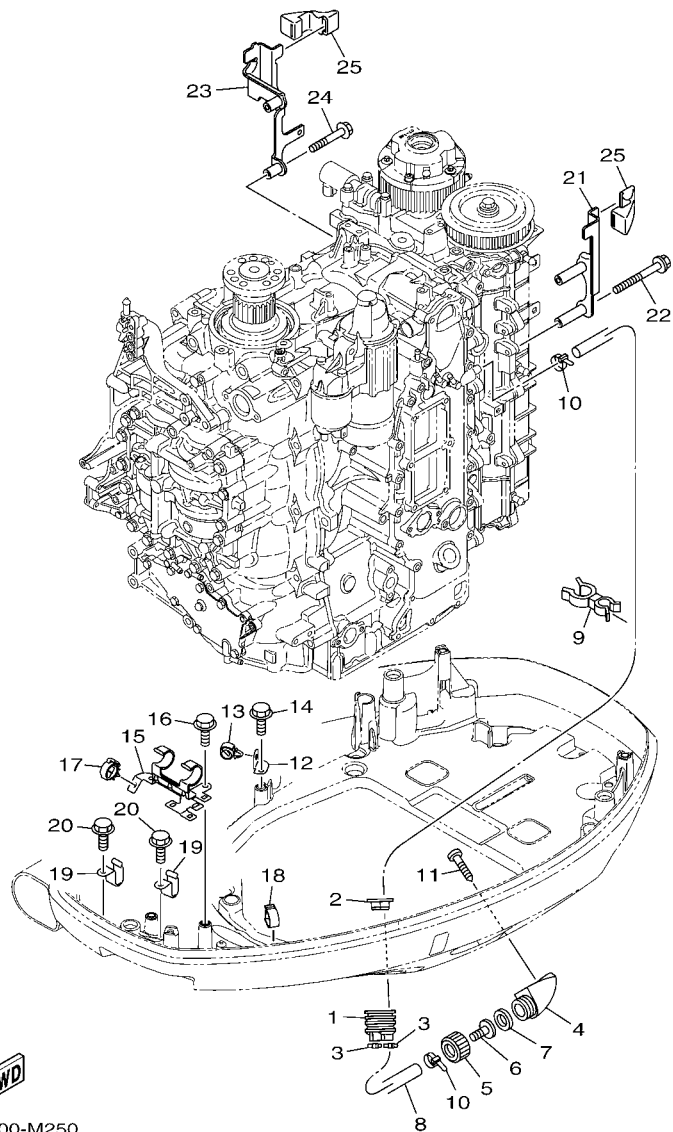

6EH1100-M250

FIG. 25 BOTTOM COWLING 3

REF. NO.	PART NO.	DESCRIPTION	6EH2				REMARKS
1	6H1-42726-21	GROMMET	1				
2	6BG-42384-00	SEAL, CAP	1				
3	90465-11M10	CLAMP	2				
4	6AW-12572-00	ADAPTER	1				
5	6R3-12581-00	JOINT, HOSE 1	1				
6	6AW-12582-00	JOINT, HOSE 2	1				
7	6R3-12583-00	GASKET, HOSE JOINT	1				
8	6DA-42541-00	PIPE 1	1				
9	90464-21256	CLAMP	1				
10	90465-11M10	CLAMP	2				
11	97780-60520	SCREW, TAPPING	2				
12	63P-42756-00	STAY, CLAMP	1				
13	90464-13249	CLAMP	1				
14	95895-06012	BOLT, FLANGE	1				
15	6DA-8366G-00	BRACKET 3	1				
16	95895-06012	BOLT, FLANGE	2				
17	90464-18246	CLAMP	1				
18	90464-18004	CLAMP	1				
19	90462-12013	CLAMP	2				
20	95895-06012	BOLT, FLANGE	2				
21	6DA-11998-00	BRACKET 1	1				
22	95895-06065	BOLT, FLANGE	2				
23	6DA-11999-00	BRACKET 2	1				
24	95895-06040	BOLT, FLANGE	2				
25	6CB-42662-00	DAMPER	2				

FIG. 26 CONTROL

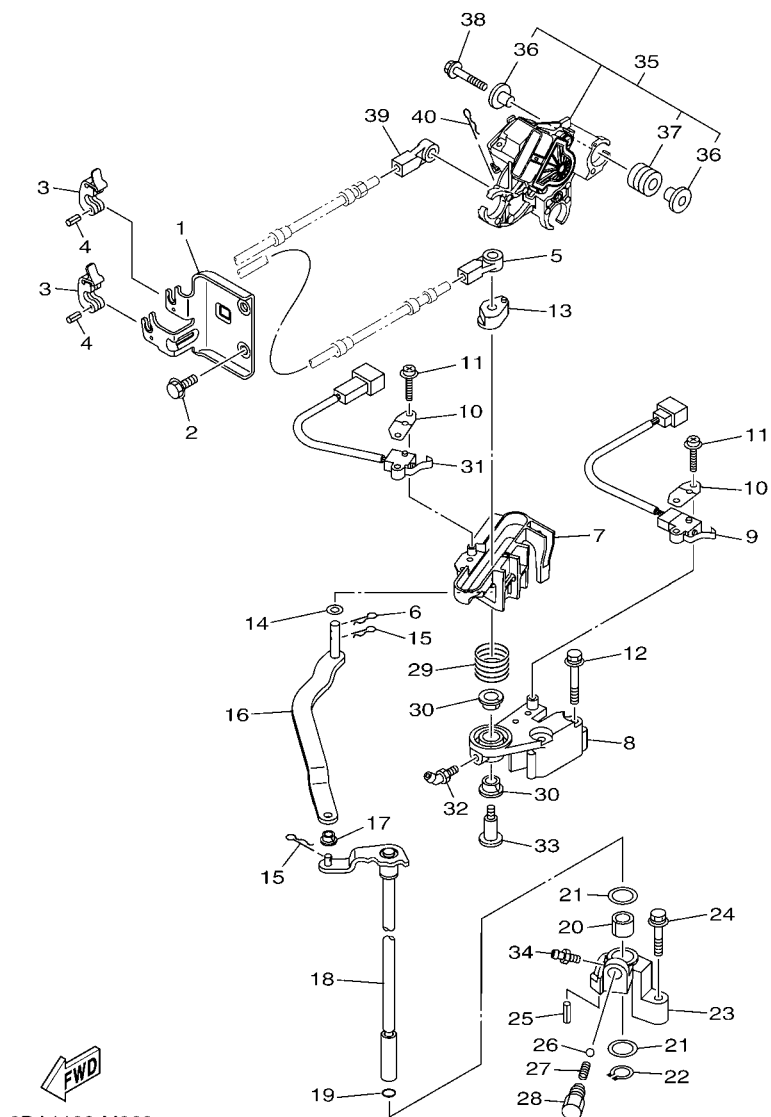

6DA1100-M260

REF. NO.	PART NO.	DESCRIPTION	QTY	REMARKS
1	6DA-48531-00	BRACKET, REMOTE CONTROL 1	1	
2	95895-08020	BOLT, FLANGE	2	
3	6E5-48538-00	CLAMP, CABLE	2	
4	91690-30010	PIN, SPRING	2	
5	6E5-48344-00	CABLE END, REMOTE CONTROL	1	
6	90468-18008	CLIP	1	
7	6DA-44176-00	BRACKET	1	
8	63P-44117-01	BRACKET	1	
9	69J-8259F-00	SWITCH ASSY	1	
10	61A-82588-01	PLATE	2	
11	97985-04116	SCREW, WITH WASHER	4	
12	97595-06550	BOLT, WITH WASHER	2	
13	63P-44122-00	BUSHING, SHIFT ROD LEVER	1	
14	90202-08M20	WASHER, PLATE	1	
15	90468-18008	CLIP	2	
16	6DA-44121-00	LEVER, SHIFT ROD	1	
17	90386-06M12	BUSH	1	
18	6DA-44120-11	HANDLE GEAR SHIFT ASSY	1	L(20.3")
19	93210-09165	O-RING	1	
20	90386-16M66	BUSH	1	
21	90202-16061	WASHER, PLATE	2	
22	93410-16006	CIRCLIP	1	
23	63P-44118-00	BRACKET	1	
24	97575-06535	BOLT, WITH WASHER	1	
25	91690-30010	PIN, SPRING	1	
26	93501-04M02	BALL	1	
27	90501-12082	SPRING, COMPRESSION	1	

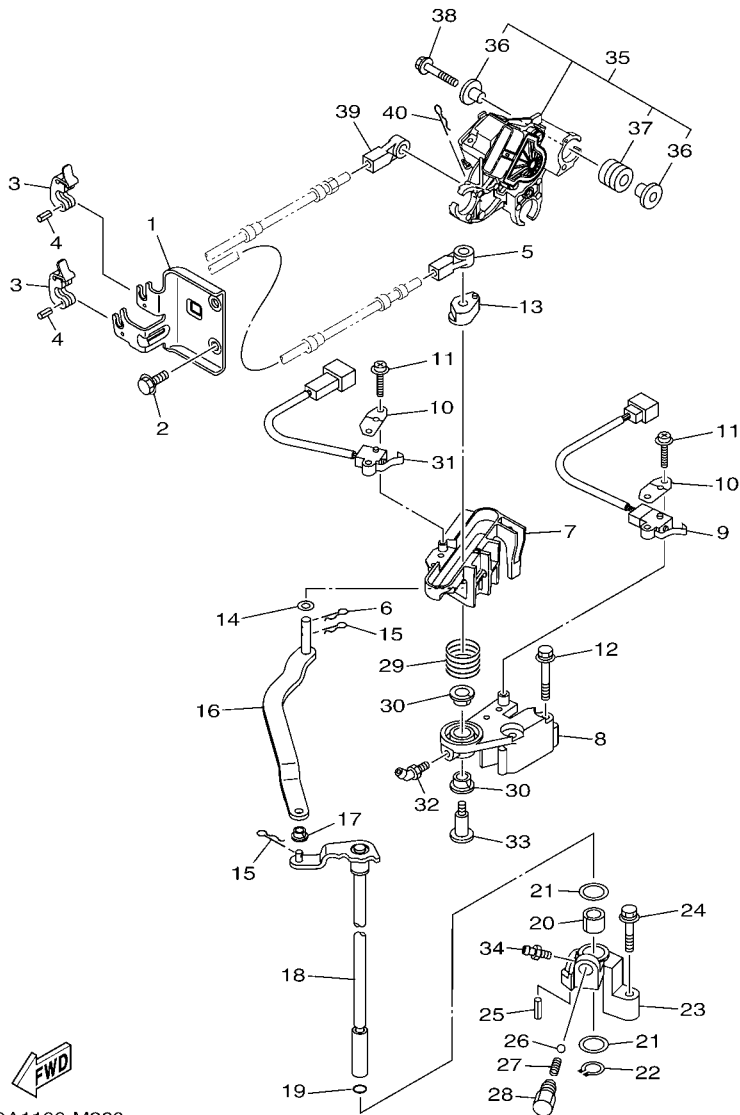

6DA1100-M260

FIG. 26 CONTROL

REF. NO.	PART NO.	DESCRIPTION	QTY	REMARKS
28	648-42715-00	BUSHING	1	
29	90508-20M31	SPRING, TORSION	1	
30	90386-12069	BUSH	2	
31	60V-8259F-00	SWITCH ASSY	1	
32	93700-06M01	NIPPLE, GREASE	1	
33	90109-08019	BOLT	1	
34	93700-06M03	NIPPLE, GREASE	1	
35	6DA-8A410-00	SENSOR UNIT	1	
36	69J-13716-00	.COLLAR	6	
37	6CB-13593-00	.DAMPER	3	
38	90119-06126	BOLT, WITH WASHER	3	
39	6E5-48344-00	CABLE END, REMOTE CONTROL	1	
40	90468-18008	CLIP	1	

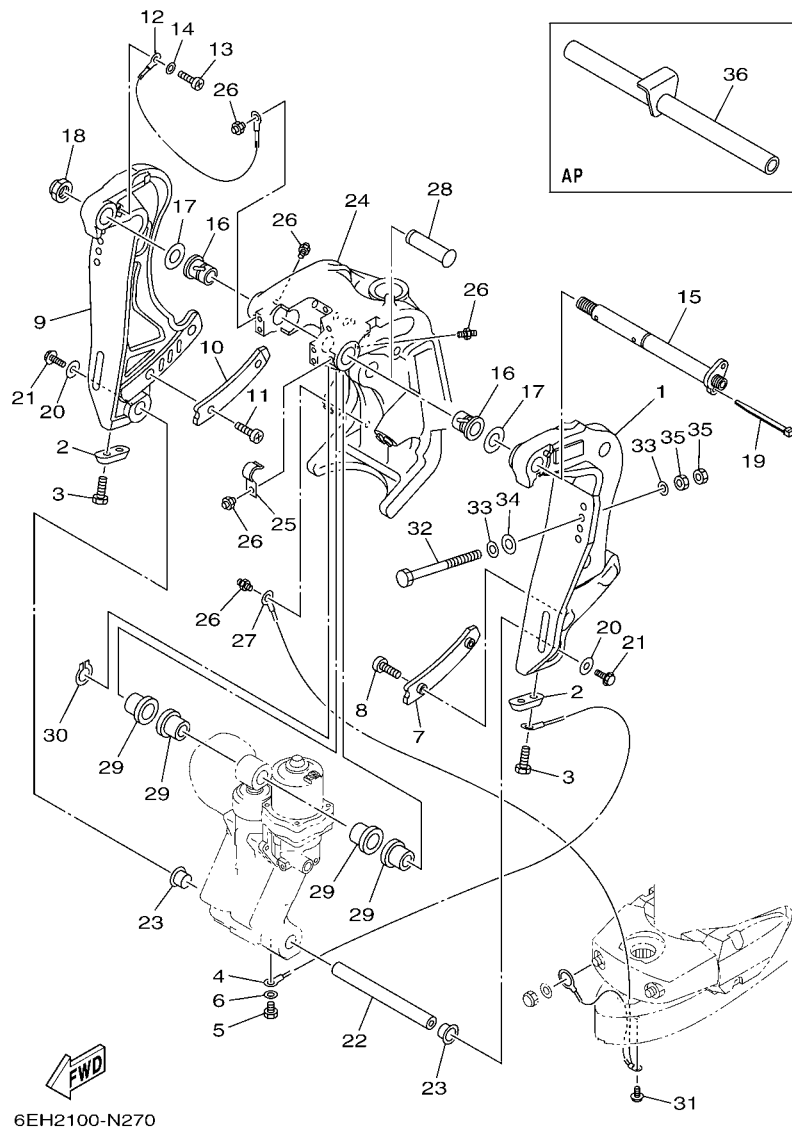

FIG. 27 BRACKET 1

REF. NO.	PART NO.	DESCRIPTION	6EH2				REMARKS
1	6CB-43111-02-8D	BRACKET, CLAMP 1	1				
2	65W-45251-00	ANODE	2				
3	90101-06020	BOLT	4				
4	6E5-82148-00	WIRE, LEAD 4	1				
5	97095-06010	BOLT	1				
6	92995-06600	WASHER	1				
7	61A-43132-00	WASHER, FRICTION	1				
8	97885-06010	SCREW, PAN HEAD	2				
9	6CB-43112-01-8D	BRACKET, CLAMP 2	1				
10	61A-43133-00	WASHER, FRICTION	1				
11	97885-06010	SCREW, PAN HEAD	2				
12	6E5-82148-00	WIRE, LEAD 4	1				
13	97885-06012	SCREW, PAN HEAD	1				
14	92995-06600	WASHER	1				
15	64E-43131-30	BOLT, CLAMP BRACKET	1				
16	90386-25M31	BUSH	2				
17	90201-26M59	WASHER, PLATE	2				
18	90185-22M11	NUT, SELF-LOCKING	1				
19	90465-11M10	CLAMP	1				
20	90201-10060	WASHER, PLATE	2				
21	97575-10530	BOLT, WITH WASHER	2				
22	6BC-43818-00	PIN, LOWER SHOCK MOUNT	1				
23	90386-22M98	BUSH	2				
24	64E-43311-10-8D	BRACKET, SWIVEL 1	1				
25	90465-08M63	CLAMP	1				
26	93700-06M03	NIPPLE, GREASE	5				
27	66K-82149-00	WIRE, LEAD 3	1				

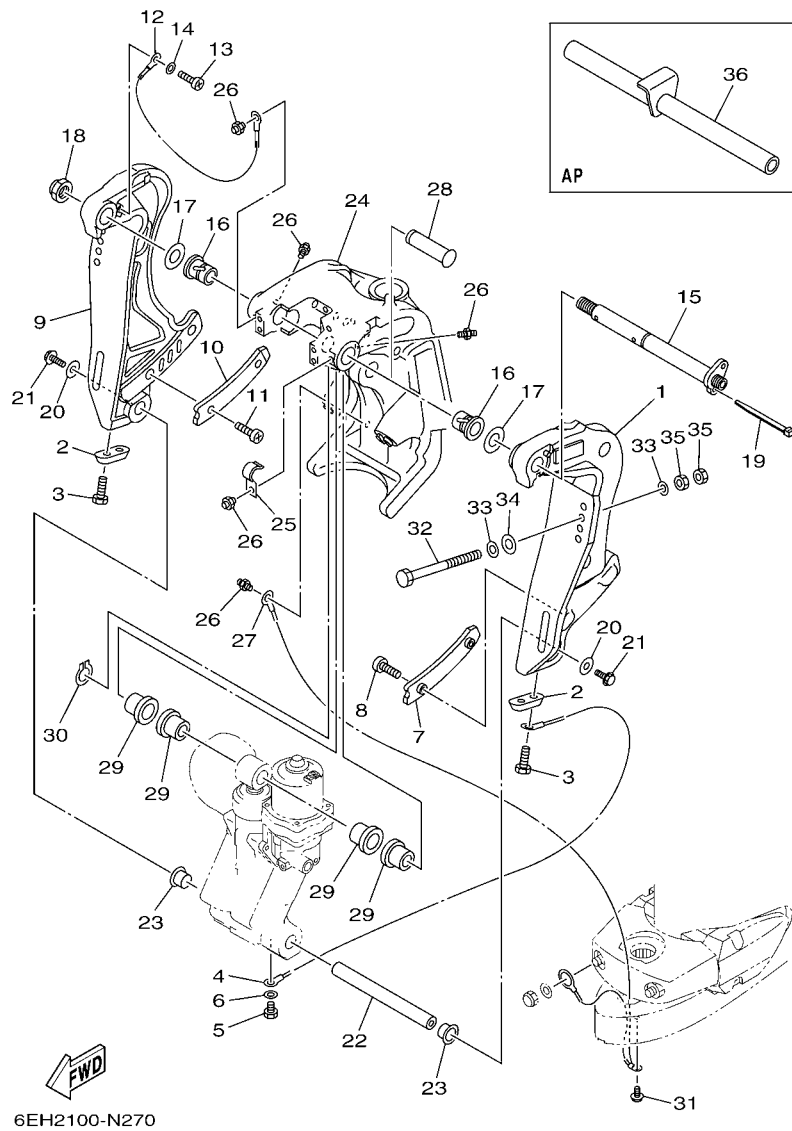
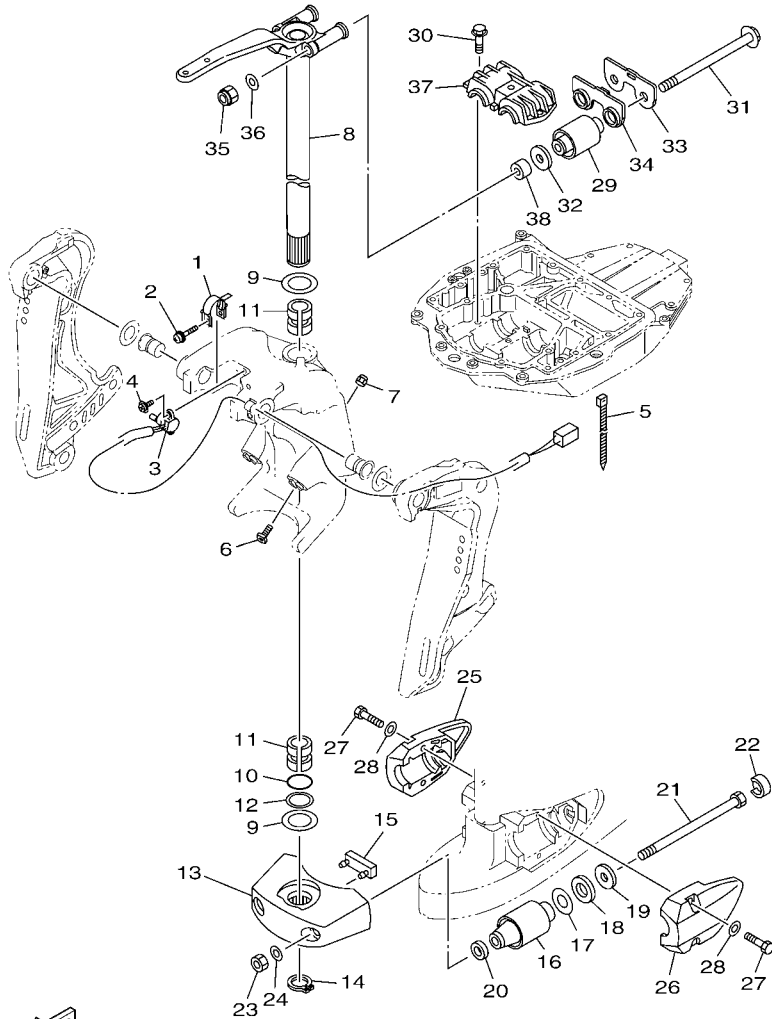

FIG. 27 BRACKET 1

REF. NO.	PART NO.	DESCRIPTION	6EH2				REMARKS
28	64E-43126-00	PIN, UPPER SHOCK MOUNT	1				
29	90386-22M98	BUSH	4				
30	93410-22M11	CIRCLIP	1				
31	95895-06010	BOLT, FLANGE	1				
32	90101-12M05	BOLT (L:130MM)	4				
33	90201-13M01	WASHER, PLATE	8				
34	90201-12426	WASHER, PLATE	4				
35	95380-12600	NUT	8				
36	6CB-43611-00	SHAFT, TILT LOCK	1				AP



6EH1100-M280

FIG. 28 BRACKET 2

REF. NO.	PART NO.	DESCRIPTION	6EH2				REMARKS
1	64E-43139-10	CAM, TRIM SENDER	1				
2	90159-05059	SCREW, WITH WASHER	1				
3	67H-83672-01	TRIM SENDER	1				
4	97985-06216	SCREW, WITH WASHER	2				
5	90465-11M10	CLAMP	3				
6	61A-43376-00	BOLT, THRUST RECEIVER	2				
7	95780-10300	NUT, FLANGE	2				
8	6DA-42510-10-8D	STEERING BRACKET ASSY	1				
9	90201-38M60	WASHER, PLATE	2				
10	93210-37MH7	O-RING	1				
11	90386-38M32	BUSH	2				
12	90202-40M47	WASHER, PLATE	1				
13	68V-44551-00-8D	HOUSING, LOWER MOUNT RUBBER 1	1				
14	93410-37M04	CIRCLIP	1				
15	61A-44575-00	DAMPER, LOWER MOUNT RUBBER	1				
16	60V-44555-00	MOUNT DAMPER, LOWER SIDE	2				
17	90201-35008	WASHER, PLATE	2				
18	90202-32M19	WASHER, PLATE	2				
19	90201-16M55	WASHER, PLATE	2				
20	90201-15M58	WASHER, PLATE	2				
21	90101-14004	BOLT	2				
22	69J-44533-00	DAMPER, UPPER MOUNT RUBBER	2				
23	95380-14600	NUT	2				
24	92995-14600	WASHER	2				
25	63P-44553-00-8D	COVER, LOWER MOUNT	1				
26	63P-44556-00-8D	COVER, LOWER MOUNT 2	1				
27	97075-10040	BOLT	4				

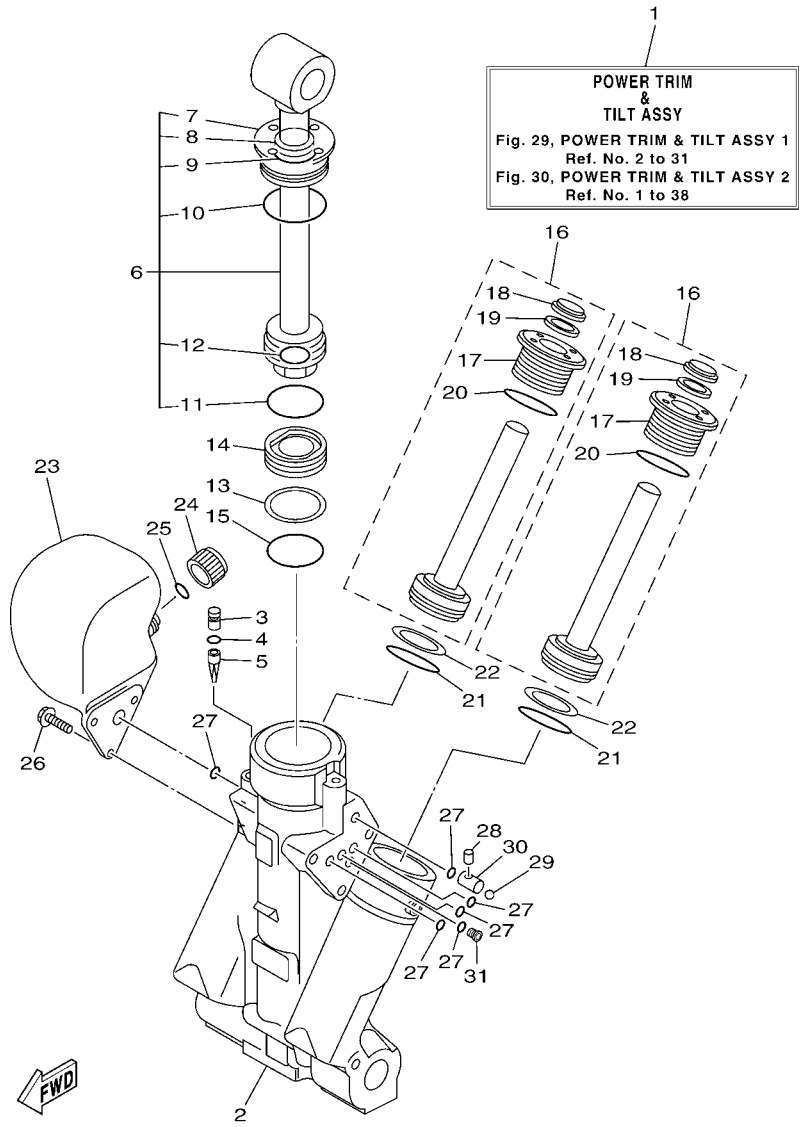

6DA1100-M290

FIG. 29 POWER TRIM & TILT ASSY 1

REF. NO.	PART NO.	DESCRIPTION	6EH2				REMARKS
1	6CB-43800-02-8D	POWER TRIM & TILT ASSY	1				
2	6CB-43825-00	HOUSING, TRIM & TILT	1				
3	6AW-4388J-00	PLUG 2	1				
4	93210-10M74	O-RING	1				
5	64E-43817-00	FILTER 2	1				
6	63P-43810-02	TILT PISTON SUB ASSY	1				
7	64E-43811-02	.SCREW, CYLINDER END	1				
8	64E-43898-00	.SEAL, DUST 2	1				
9	64E-43867-00	.O-RING	1				
10	64E-43866-00	.O-RING	1				
11	6E5-43862-00	.O-RING	1				
12	64E-43883-00	.O-RING	1				
13	6E5-43872-00	RING, BACK UP	1				
14	6E5-43814-02	PISTON, FREE	1				
15	6E5-43862-00	O-RING	1				
16	6CB-43820-01	TRIM PISTON SUB ASSY	2				
17	64E-43821-03	.SCREW, TRIM CYLINDER END	1				
18	64E-43822-00	.SEAL, TRIM DUST	1				
19	64E-4384J-00	.SEAL, TRIM DOWN	1				
20	6G5-43864-00	.O-RING	1				
21	6E5-43864-00	O-RING	2				
22	6E5-43874-01	RING, BACK UP	2				
23	64E-43828-01	BODY, RESERVOIR	1				
24	64E-43829-01	PLUG, RESERVOIR	1				
25	64E-43897-00	O-RING	1				
26	64E-4388E-01	BOLT ,SCREW (L:14MM)	3				
27	64E-43869-00	O-RING	6				

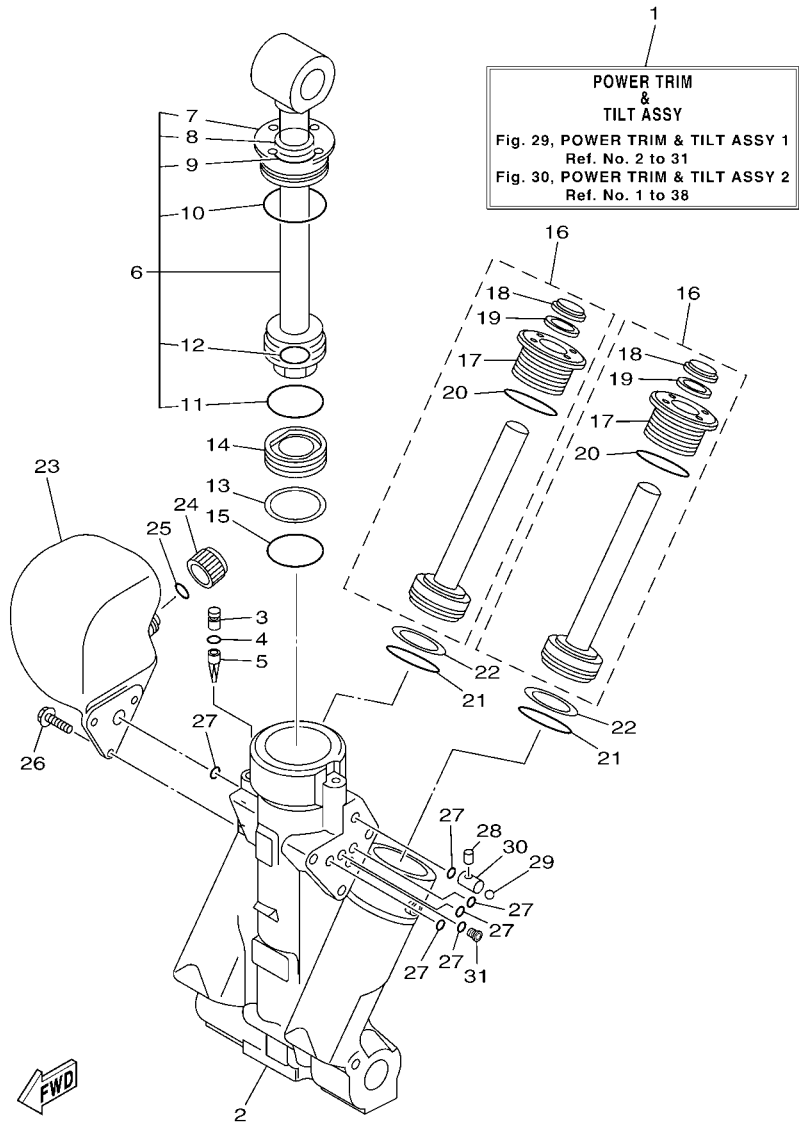

6DA1100-M290

FIG. 29 POWER TRIM & TILT ASSY 1

REF. NO.	PART NO.	DESCRIPTION	6EH2				REMARKS
28	64E-4381G-00	PIN	1				
29	6E5-43858-00	BALL	1				
30	64E-4382G-00	VALVE, SEAT	1				
31	64E-4384N-00	PLUG, ORIFICE	1				

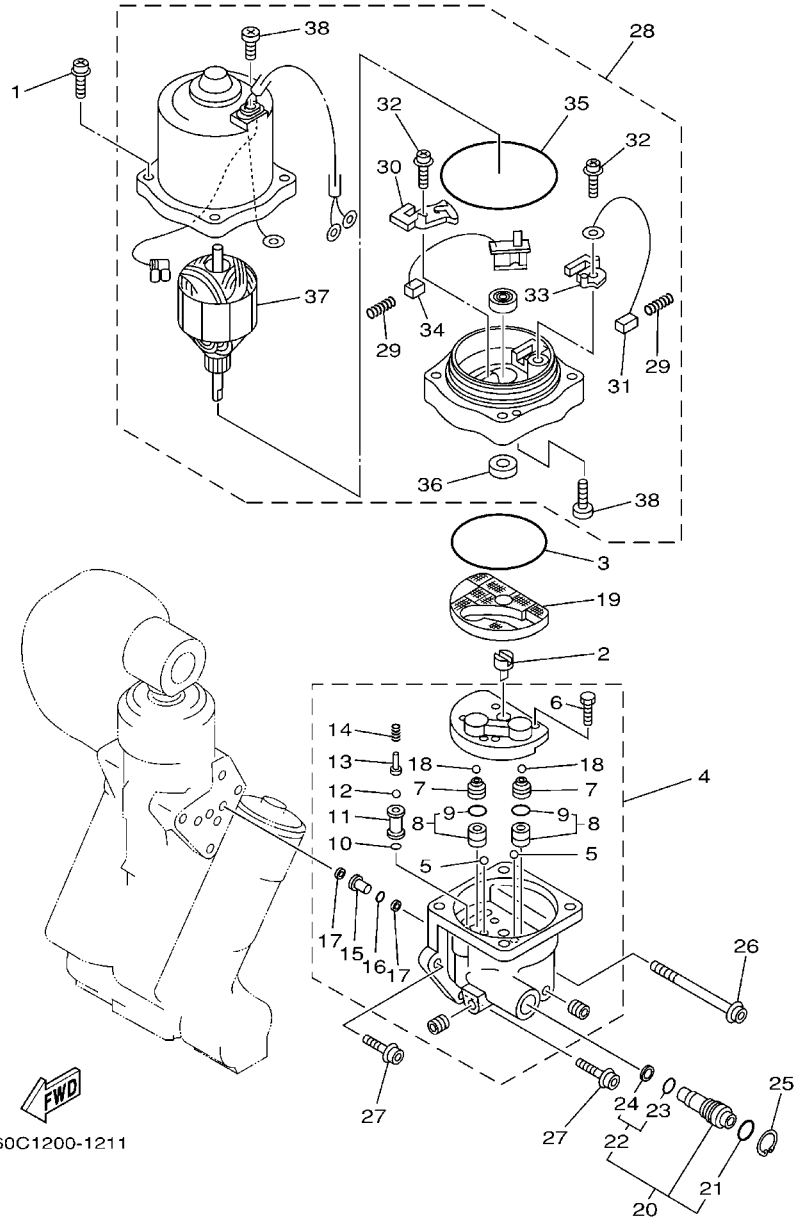

60C1200-1211

FIG. 30 POWER TRIM & TILT ASSY 2

REF. NO.	PART NO.	DESCRIPTION	QTY	REMARKS
1	64E-4388E-11	BOLT ,SCREW (L:34.7MM)	4	
2	64E-43831-00	CONNECTOR, SHAFT	1	
3	64E-43868-00	O-RING	1	
4	6CB-43830-00	GEAR PUMP ASSY	1	
5	72X-43858-00	.BALL	2	
6	64E-43843-00	.SCREW, VALVE LOCK	4	
7	6AW-43841-00	.PISTON, SHUTTLE	2	
8	64E-43802-00	.VALVE SUB ASSY	2	
9	6E5-43896-00	..O-RING	1	
10	6G5-43863-00	.O-RING	1	
11	64E-43851-00	.SEAT, RELIEF VALVE	1	
12	64E-43858-00	.BALL	1	
13	64E-43859-00	.PIN, VALVE SUPPORT	1	
14	64E-43855-00	.SPRING, UP RELIEF	1	
15	64E-43850-00	.VALVE SUB ASSY	1	
16	64E-43865-00	.O-RING	1	
17	64E-43816-00	.FILTER 1	2	
18	6AW-43858-00	.BALL	2	
19	64E-43817-11	FILTER 2	1	
20	64E-43860-01	MANUAL VALVE SUB-ASSY	1	
21	72X-85075-L0	.O-RING	1	
22	64E-43827-00	.RING SET	1	
23	64E-4387A-00	..O-RING	1	
24	64E-43873-00	..RING, BACK UP	1	
25	6AW-43875-00	RING, SNAP	1	
26	64E-43879-11	SCREW, WITH WASHER	1	
27	64E-43879-01	SCREW, WITH WASHER	2	

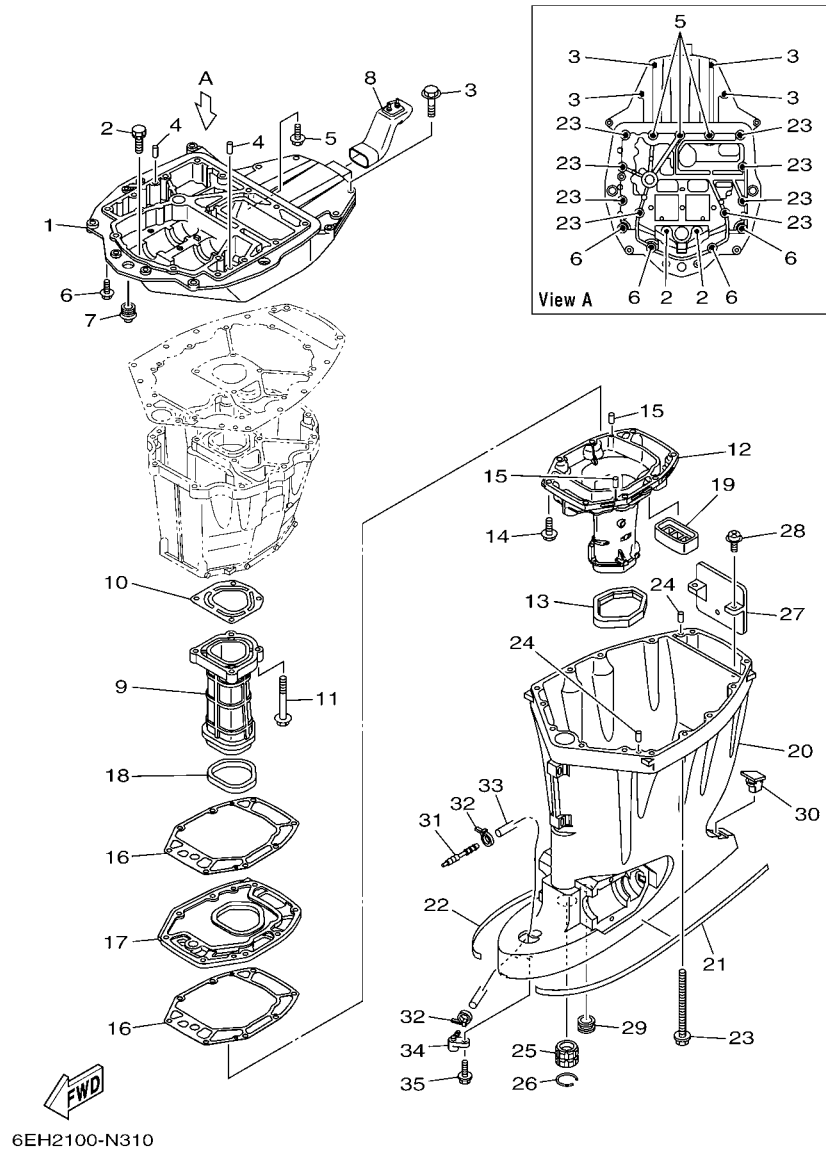
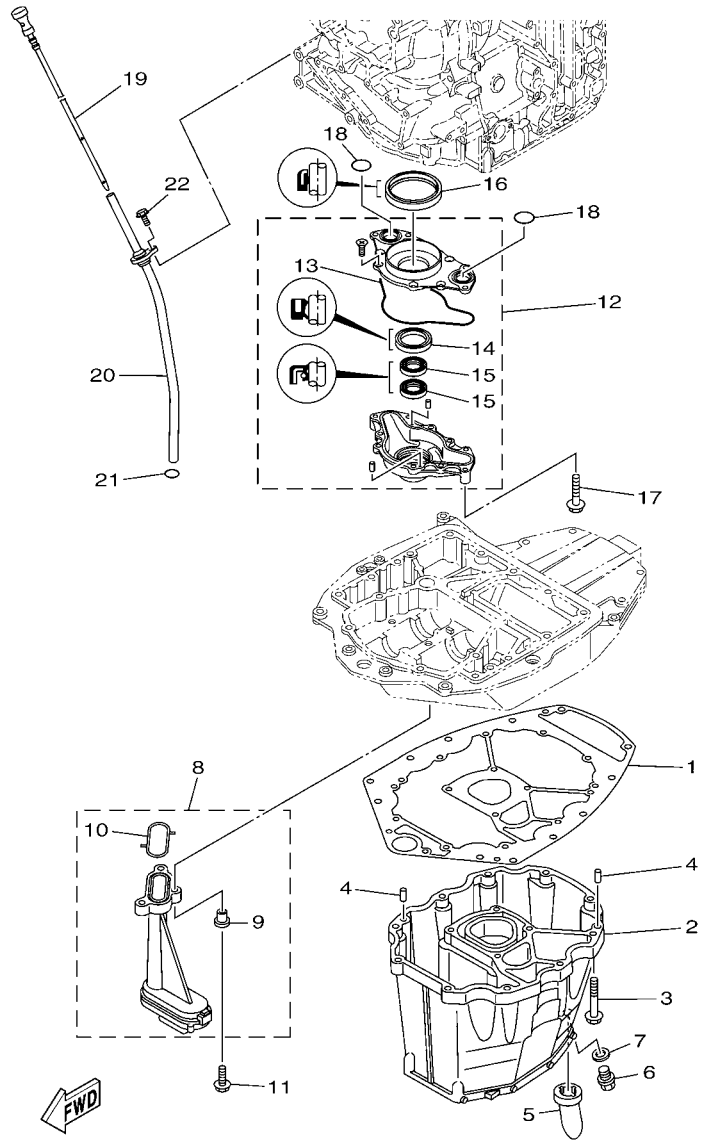

FIG. 31 UPPER CASING

REF. NO.	PART NO.	DESCRIPTION	6EH2				REMARKS
1	63P-41137-04-CA	GUIDE, EXHAUST	1				
2	90119-08102	BOLT, WITH WASHER	2				
3	97575-10545	BOLT, WITH WASHER	4				
4	93608-16M16	PIN, DOWEL	2				
5	90119-08M58	BOLT, WITH WASHER	3				
6	97575-10535	BOLT, WITH WASHER	4				
7	6E5-42724-00	GROMMET	1				
8	6DA-42769-00	SEAL, RUBBER	1				
9	63P-41131-01-9S	MANIFOLD, EXT. 1	1				
10	63P-41133-A0	GASKET, EXHAUST MANIFOLD 1	1				
11	97575-08560	BOLT, WITH WASHER	4				
12	6DA-14711-10-9S	MUFFLER 1	1				
13	69J-45123-00	GASKET, MUFFLER	1				
14	97575-08535	BOLT, WITH WASHER	8				
15	93606-19M23	PIN, DOWEL	2				
16	63P-41134-A1	GASKET, EXHAUST MANIFOLD	2				
17	63P-45181-01-9S	PLATE	1				
18	63P-41138-00	SEAL, EXT. 1	1				
19	69J-45127-00	SEAL	1				
20	6DA-45111-10-8D	CASING, UPPER	1				
21	6N9-42791-40	MARK 1	1				
22	6N9-42792-40	MARK 2	1				
23	90119-10007	BOLT, WITH WASHER	8				
24	93608-16M16	PIN, DOWEL	2				
25	6E5-45318-00	BUSHING, DRIVE SHAFT	1				
26	93420-36M01	CIRCLIP	1				
27	69J-14624-01	COVER, EXHAUST	1				



6EH1100-M320

FIG. 32 OIL PAN

REF. NO.	PART NO.	DESCRIPTION	6EH2				REMARKS
1	63P-15312-01	GASKET, OIL PAN	1				
2	63P-15311-02-CA	OIL PAN	1				
3	97575-08535	BOLT, WITH WASHER	10				
4	93608-16M16	PIN, DOWEL	2				
5	63P-15316-00	DAMPER 1	1				
6	90340-14M06	PLUG, STRAIGHT SCREW	1				
7	90430-14M09	GASKET	1				
8	63P-13411-00	STRAINER, OIL	1				
9	90387-06263	.COLLAR	3				
10	63P-13415-00	.SEAL, OIL STRAINER	1				
11	95812-06025	BOLT, FLANGE	3				
12	6DA-13300-00	OIL PUMP ASSY	1				
13	6DA-13329-00	.GASKET, PUMP COVER	1				
14	6AW-13119-00	.OIL SEAL	1				
15	69J-13631-00	.OIL SEAL	2				
16	6CB-11355-00	SEAL, CYLINDER 1	1				
17	97575-06540	BOLT, WITH WASHER	4				
18	93210-25552	O-RING	2				
19	6DA-15362-00	PLUG, OIL LEVEL	1				
20	6DA-15377-00	GUIDE, INLET	1				
21	93210-19MJ3	O-RING	1				
22	95895-06016	BOLT, FLANGE	1				

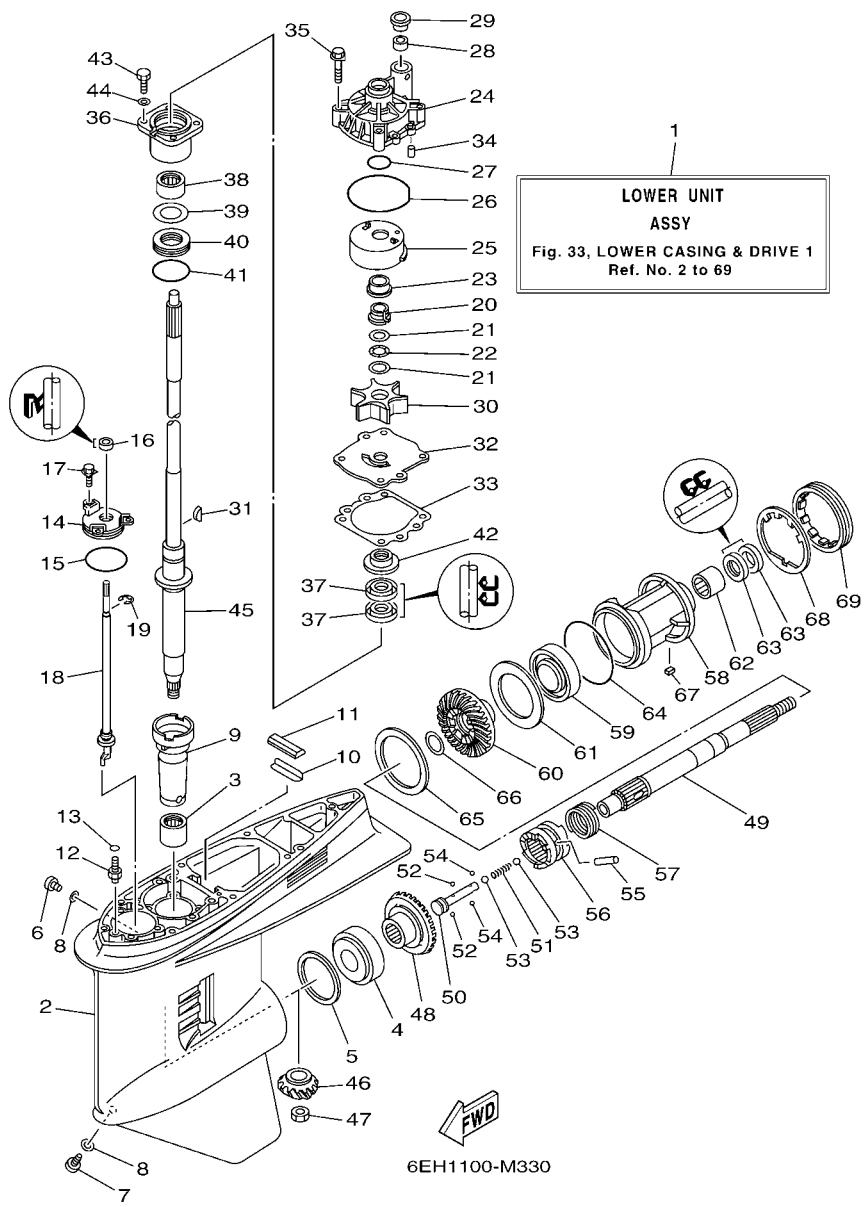

FIG. 33 LOWER CASING & DRIVE 1

REF. NO.	PART NO.	DESCRIPTION	6EH2				REMARKS
1	6EH-45300-00-NA	LOWER UNIT ASSY	1				
2	6J9-45301-07-NA	CASING, LOWER	1				
3	93311-928U5	BEARING	1				
4	93332-000V3	BEARING	1				
5	6G5-45567-01	SHIM (T:0.10MM)	1				UR
6	6G5-45567-10	SHIM (T:0.12MM)	1				UR
7	6G5-45567-20	SHIM (T:0.15MM)	1				UR
8	6G5-45567-30	SHIM (T:0.18MM)	1				UR
9	6G5-45567-40	SHIM (T:0.30MM)	1				UR
10	6G5-45567-50	SHIM (T:0.40MM)	1				UR
11	6G5-45567-60	SHIM (T:0.50MM)	1				UR
12	90340-08002	PLUG, STRAIGHT SCREW	1				
13	688-45341-10	PLUG, DRAIN	1				
14	90430-08020	GASKET	2				
15	6G5-45536-01	SLEEVE, DRIVE SHAFT	1				
16	663-45376-00	GUIDE, SEAL DAMPER	1				
17	688-45375-00	DAMPER, SEAL	1				
18	63P-45378-00	NIPPLE, HOSE	1				
19	93210-07003	O-RING	1				
20	6E5-45321-00	PLATE	1				
21	93210-58144	O-RING	1				
22	93106-09014	OIL SEAL	1				
23	90119-06M10	BOLT, WITH WASHER	3				
24	63P-44150-01	SHIFT CAM ASSY	1				
25	99001-08600	CIRCLIP	1				
26	61A-45538-00	SPACER 1	1				
27	90201-22M01	WASHER, PLATE	2				

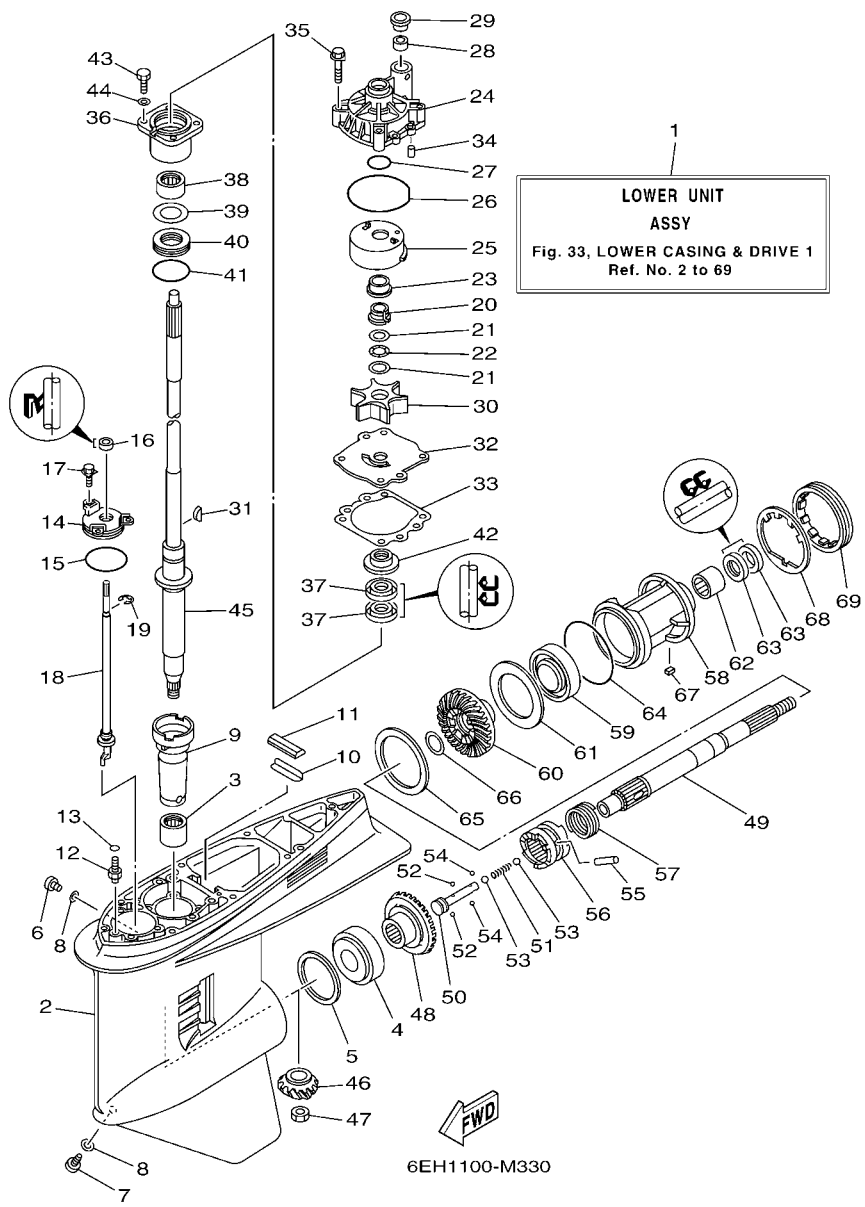

FIG. 33 LOWER CASING & DRIVE 1

REF. NO.	PART NO.	DESCRIPTION	6EH2				REMARKS
22	90206-22M19	WASHER, WAVE	1				
23	61A-45527-00	COLLAR, DRIVE SHAFT	1				
24	61A-44311-01	HOUSING, WATER PUMP	1				
25	61A-44322-02	INSERT, CARTRIDGE	1				
26	93210-86M38	O-RING	1				
27	93210-37160	O-RING	1				
28	6E5-44365-00	DAMPER, WATER SEAL 1	1				
29	6E5-44312-00	COVER, WATER PUMP HOUSING	1				
30	6E5-44352-01	IMPELLER	1				
31	90280-04M05	KEY, WOODRUFF	1				
32	6G5-44323-01	OUTER PLATE, CARTRIDGE	1				
33	6E5-44315-A0	GASKET, WATER PUMP	1				
34	93606-12019	PIN, DOWEL	2				
35	90119-08M14	BOLT, WITH WASHER	4				
36	6E5-45331-00-9S	HOUSING, BEARING	1				
37	93101-28M16	OIL SEAL	2				
38	93317-330U2	BEARING	1				
39	6E5-45587-01	SHIM (T:0.10MM)	1				UR
	6E5-45587-10	SHIM (T:0.12MM)	1				UR
	6E5-45587-20	SHIM (T:0.15MM)	1				UR
	6E5-45587-30	SHIM (T:0.18MM)	1				UR
	6E5-45587-40	SHIM (T:0.30MM)	1				UR
	6E5-45587-50	SHIM (T:0.40MM)	1				UR
	6E5-45587-60	SHIM (T:0.50MM)	1				UR
40	93341-930V2	BEARING	1				
41	93210-55M14	O-RING	1				
42	6E5-45344-00	COVER, OIL SEAL	1				

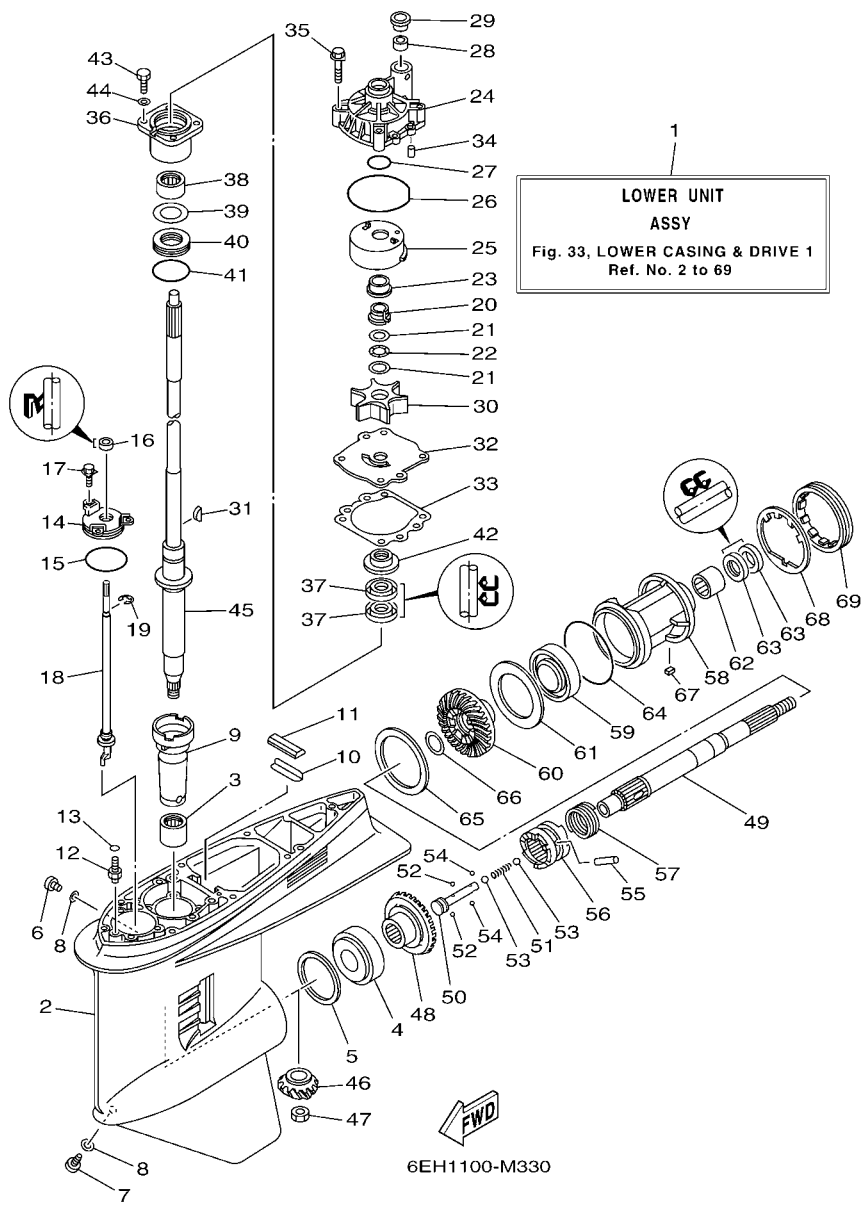
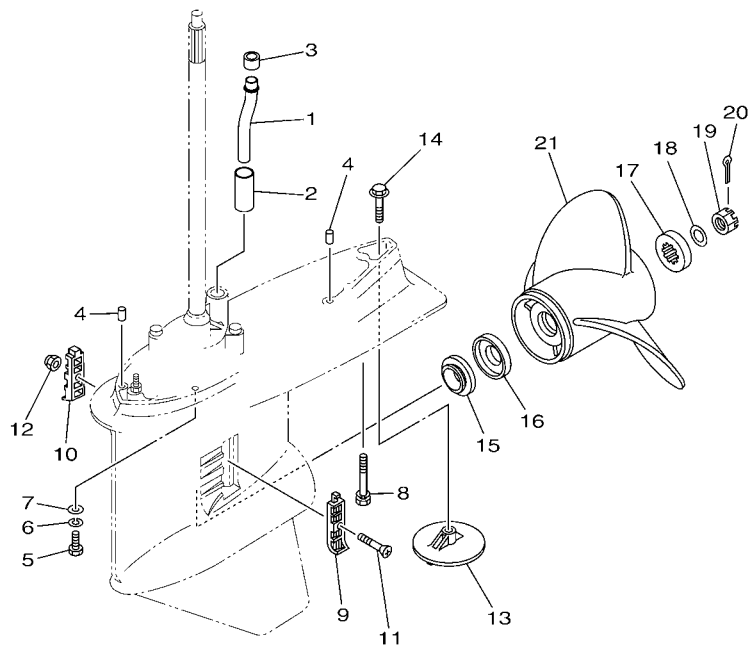

FIG. 33 LOWER CASING & DRIVE 1

REF. NO.	PART NO.	DESCRIPTION	6EH2				REMARKS
43	97095-08025	BOLT	4				
44	92995-08600	WASHER	4				
45	63P-45501-01	DRIVE SHAFT COMP.	1				
46	63P-45551-00	PINION (14T)	1				
47	90170-16M01	NUT	1				
48	6EH-45560-00	GEAR 1 (28T)	1				
49	6J9-45611-01	SHAFT, PROPELLER	1				
50	6E5-45634-02	SLIDE, SHIFT	1				
51	90501-16M37	SPRING, COMPRESSION	1				
52	93507-32009	BALL	2				
53	93511-32017	BALL	2				
54	93503-16003	BALL	2				
55	90250-08M07	PIN, STRAIGHT	1				
56	6DA-45631-00	CLUTCH, DOG	1				
57	6E5-45633-01	RING, CROSS PIN	1				
58	6J9-45332-00-CA	HOUSING, BEARING	1				
59	93306-209U0	BEARING	1				
60	6EH-45571-00	GEAR 2 (28T)	1				
61	6G5-45576-10	WASHER, THRUST 2	1				
62	93315-43061	BEARING	1				
63	93101-30M17	OIL SEAL	2				
64	93210-97M55	O-RING	1				
65	6G5-45577-02	SHIM (T:0.10MM)	1				UR
	6G5-45577-10	SHIM (T:0.12MM)	1				UR
	6G5-45577-20	SHIM (T:0.15MM)	1				UR
	6G5-45577-30	SHIM (T:0.18MM)	1				UR
	6G5-45577-40	SHIM (T:0.30MM)	1				UR



6EH1100-M340

FIG. 34 LOWER CASING & DRIVE 2

REF. NO.	PART NO.	DESCRIPTION	6EH2				REMARKS
1	6DA-44361-10	TUBE, WATER 1	1				
2	90445-23002	HOSE (L59)	1				
3	6E5-44365-00	DAMPER, WATER SEAL 1	1				
4	93608-16M16	PIN, DOWEL	2				
5	97095-10045	BOLT	6				
6	92995-10100	WASHER	6				
7	92995-10600	WASHER	6				
8	90119-10MA2	BOLT, WITH WASHER	1				
9	6J9-45214-00	COVER, WATER INLET 1	1				
10	6J9-45215-00	COVER, WATER INLET 2	1				
11	90152-05M08	SCREW, COUNTERSUNK	1				
12	90185-05002	NUT, NYLON	1				
13	6EH-45371-00	TAB-TRIM	1				
14	90105-10M00	BOLT, FLANGE	1				
15	60X-45987-10	SPACER 1	1				
16	60X-45995-00	SPACER 3	1				
17	688-45997-01	SPACER 2	1				
18	92990-18200	WASHER	1				
19	90171-18M04	NUT, CASTLE	1				
20	91490-40030	PIN, COTTER	1				
21	6CB-45932-10	PROPELLER (3X15-1/8"X22"-T1)	1				UR
	6CB-45974-10	PROPELLER (3X15-1/8"X23"-T1)	1				UR

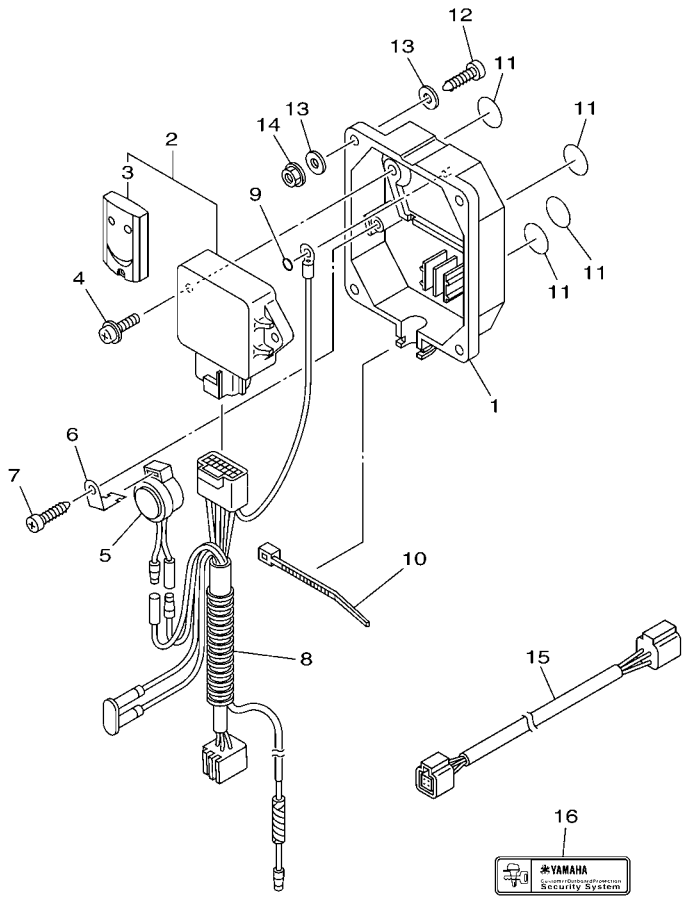

6CJ1100-K370

FIG. 36 OPTIONAL PARTS 1

REF. NO.	PART NO.	DESCRIPTION	QTY	REMARKS
1	6Y8-86267-00	CASE COMPLETE 1	1	
2	6Y8-86260-12	REMOTE CONTROL UNIT ASSY	1	
3	6AA-86261-22	.TRANSMITTER COMP	2	
4	97980-06216	SCREW, WITH WASHER	2	
5	6X4-83383-00	BUZZER	1	
6	6X4-83386-00	STAY, BUZZER	1	
7	97780-60620	SCREW, TAPPING	1	
8	6Y8-82509-10	WIRE, SUB LEAD	1	
9	93210-04279	O-RING	1	
10	90465-11M10	CLAMP	1	
11	6Y8-8454G-00	PATCH 1	4	
12	90167-06M00	SCREW, TAPPING	4	UR
	97880-06035	SCREW, PAN HEAD	4	UR
13	90201-06M30	WASHER, PLATE	8	
14	95780-06300	NUT, FLANGE	4	
15	6Y8-82521-11	2FT PIGTAIL BUS	1	
16	6Y8-48277-00	STICKER 1	4	

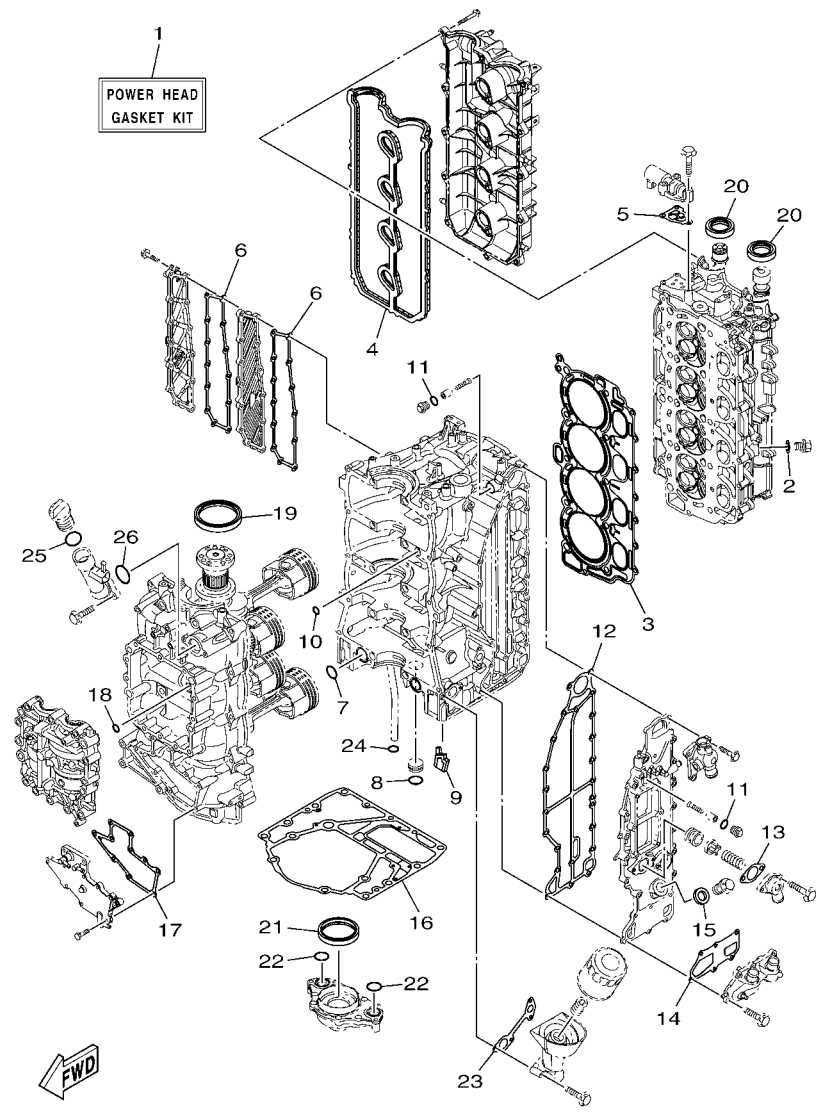

6DA1100-M380

FIG. 38 REPAIR KIT 1

REF. NO.	PART NO.	DESCRIPTION	QTY	REMARKS
1	6DA-W0001-00	POWER HEAD GASKET KIT	1	
2	90430-14115	.GASKET	1	
3	6DA-11181-00	.GASKET, CYLINDER HEAD 1	1	
4	6DA-11193-00	.GASKET, HEAD COVER 1	1	
5	6CB-1242F-00	.GASKET, FILTER	1	
6	6DA-15353-00	.GASKET, DRAIN	2	
7	93210-25552	.O-RING	2	
8	93210-25647	.O-RING	1	
9	6DA-14664-00	.GROMMET, WATER SHUT	1	
10	93210-12648	.O-RING	1	
11	93210-13M63	.O-RING	2	
12	6DA-41114-00	.GASKET, EXHAUST OUTER COVER	1	
13	60V-11382-A0	.GASKET 2	1	
14	6DA-11381-00	.GASKET 1	1	
15	90430-18130	.GASKET	1	
16	63P-11351-01	.GASKET, CYLINDER	1	
17	6DA-15451-00	.GASKET, CRANKCASE COVER 1	1	
18	93210-08001	.O-RING	1	
19	93102-85008	.OIL SEAL	1	
20	93102-38008	.OIL SEAL	2	
21	6CB-11355-00	.SEAL, CYLINDER 1	1	
22	93210-25552	.O-RING	2	
23	6DA-13475-00	.GASKET	1	
24	93210-19MJ3	.O-RING	1	
25	93210-24M79	.O-RING	1	
26	93210-357A3	.O-RING	1	

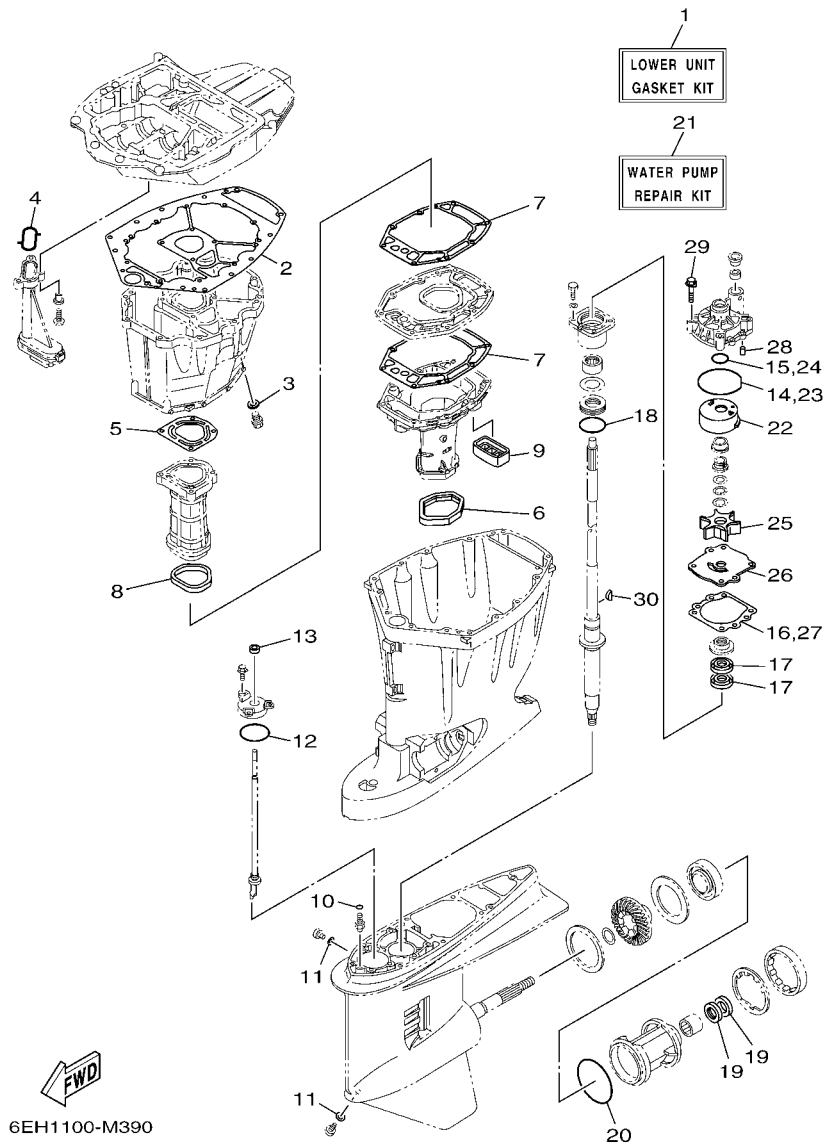

FIG. 39 REPAIR KIT 2

REF. NO.	PART NO.	DESCRIPTION	6EH2				REMARKS
1	63P-W0001-21	LOWER UNIT GASKET KIT	1				
2	63P-15312-01	.GASKET, OIL PAN	1				
3	90430-14M09	.GASKET	1				
4	63P-13415-00	.SEAL, OIL STRAINER	1				
5	63P-41133-A0	.GASKET, EXHAUST MANIFOLD 1	1				
6	69J-45123-00	.GASKET, MUFFLER	1				
7	63P-41134-A1	.GASKET, EXHAUST MANIFOLD	2				
8	63P-41138-00	.SEAL, EXT. 1	1				
9	69J-45127-00	.SEAL	1				
10	93210-07003	.O-RING	2				
11	90430-08020	.GASKET	2				
12	93210-58144	.O-RING	1				
13	93106-09014	.OIL SEAL	1				
14	93210-86M38	.O-RING	1				
15	93210-37160	.O-RING	1				
16	6E5-44315-A0	.GASKET, WATER PUMP	1				
17	93101-28M16	.OIL SEAL	2				
18	93210-55M14	.O-RING	1				
19	93101-30M17	.OIL SEAL	2				
20	93210-97M55	.O-RING	1				
21	61A-W0078-A3	WATER PUMP REPAIR KIT	1				
22	61A-44322-02	.INSERT, CARTRIDGE	1				
23	93210-86M38	.O-RING	1				
24	93210-37160	.O-RING	1				
25	6E5-44352-01	.IMPELLER	1				
26	6G5-44323-01	.OUTER PLATE, CARTRIDGE	1				
27	6E5-44315-A0	.GASKET, WATER PUMP	1				

NUMERICAL INDEX

PART NO.	REF. NO.	PART NO.	REF. NO.	PART NO.	REF. NO.	PART NO.	REF. NO.	PART NO.	REF. NO.	PART NO.	REF. NO.
6DA-11110-00-9S	5 - 2	6CB-11633-00	4 - 13	6DA-13161-00	10 - 7	6P2-14386-00	12 - 31	6DA-24324-00	13 - 8	6DA-42541-00	25 - 8
6DA-11133-10	5 - 3	6CB-11654-00	4 - 10	6DA-13300-00	32 - 12	6P2-1441J-00	9 - 7	6E5-24351-51	14 - 4	6EH-42610-01	2 - 1
6DA-11181-00	5 - 17	6CB-11656-00	4 - 15	6DA-13329-00	32 - 13	6CB-14429-01	12 - 18	6YK-24360-73	15 - 1	6DA-42613-00	2 - 3
	38 - 3	6CB-11656-10	4 - 15	63P-13411-00	32 - 8	6DA-14440-00	9 - 5	6CE-24377-00	7 - 3	6DA-42615-00	23 - 5
6DA-11191-00	5 - 22	6CB-11656-20	4 - 15	63P-13415-00	32 - 10	6CB-1447B-00	12 - 28		11 - 7	6DA-42617-00	16 - 27
6DA-11193-00	5 - 23	6DA-11998-00	25 - 21		39 - 4	6CB-14546-00	12 - 27	6AW-24377-01	14 - 2	6EH-4261A-00	2 - 2
	38 - 4	6DA-11999-00	25 - 23	63P-13437-52	16 - 28	6CB-14564-00	12 - 9	688-24378-00	11 - 17	6CB-42647-00	2 - 5
6G8-11197-01	6 - 4	6CB-12111-00	8 - 1	69J-13440-03	1 - 8	63P-14567-00	12 - 20	6CE-24378-00	6 - 32	6CB-42662-00	25 - 25
67F-11301-00	5 - 11	6CB-12113-00	8 - 4		6 - 39	69J-14624-01	31 - 27	6E5-24378-00	13 - 10	6DA-42662-00	3 - 35
69J-11301-00	6 - 18	51Y-12119-00	8 - 7	6DA-13446-00	6 - 41	6DA-14664-00	3 - 17	69J-24379-00	12 - 13	6AW-42663-00	2 - 11
68T-11325-00	1 - 3	6DA-12121-00	8 - 2	6DA-13475-00	6 - 42		38 - 9	6CB-24410-00	10 - 15	6CB-42675-10	2 - 16
	6 - 5	6DA-12171-00	8 - 9		38 - 23	6DA-14711-10-9S	31 - 12	6DA-24425-00	10 - 13	6CB-42676-10	2 - 17
6E5-11325-00	1 - 2	6DA-12181-00	8 - 11	63P-13490-00	3 - 33	6DA-1475A-00	11 - 9	6DA-24426-00	10 - 18	63P-42677-40	2 - 18
	1 - 6	6DA-12411-00	1 - 5	6DA-13532-00	11 - 1	6DA-1475F-00	11 - 11	6CB-24452-10	12 - 17	6EH-42678-00	2 - 15
	3 - 8		6 - 28	6DA-13545-00	11 - 16	6DA-1475G-00	11 - 14	4SV-24453-00	12 - 33	6D6-42681-00	2 - 19
	3 - 31	6AW-12412-00	6 - 29	68V-13546-10	11 - 18	6CB-14984-00	1 - 12	6CB-24460-00	12 - 4	6EH-42682-00	2 - 20
67F-11325-01	1 - 1	6DA-12413-00-9S	6 - 30	6DA-13547-00	11 - 21	6DA-24462-00	12 - 30	6DA-24462-00	10 - 23	6DA-42710-00-8D	23 - 1
	1 - 4	60H-12416-00	6 - 11	6DA-13548-00	11 - 19	6CB-14985-00	12 - 26	6P3-24469-00	14 - 11	6DA-42710-00	26 - 28
	5 - 12	6DA-1241B-00-9S	6 - 49	6DA-13564-00	10 - 4	6CB-14989-00	11 - 13	6CB-24482-00	12 - 19	648-42715-00	23 - 6
	6 - 19	6CB-1242F-00	6 - 2	6AW-13577-10	10 - 10	6DA-15109-00-9S	3 - 2	6DA-24491-00	10 - 17	63P-42716-00	23 - 22
67F-11328-00	5 - 13		38 - 5	6CB-13593-00	12 - 22	63P-15311-02-CA	32 - 2	6DA-24492-00	10 - 16	69J-42723-01	20 - 14
	6 - 20	6DA-1243A-00	6 - 15		26 - 37	63P-15312-01	32 - 1	6CB-24501-01	1 - 9	6E5-42724-00	31 - 7
63P-11351-01	3 - 21	6DA-1243E-00	6 - 31	69J-13631-00	32 - 15		39 - 2		12 - 3	6DA-42725-00	23 - 2
	38 - 16	6DA-1244H-00	6 - 33	6DA-13641-00	9 - 11	63P-15316-00	32 - 5	6P3-24519-00	14 - 12	6H1-42726-21	25 - 1
6CB-11355-00	32 - 16	6P2-12491-00	6 - 37	6DA-13645-00	9 - 13	6DA-15319-00	6 - 46	6P3-24560-03	14 - 8	61A-42727-00	23 - 26
	38 - 21	6DA-12527-00-9S	6 - 24	6DA-13646-00	9 - 12	6DA-15353-00	3 - 7	6P3-24562-03	14 - 10	6DA-42741-10-8D	24 - 1
6G5-11372-00	6 - 14	6DA-12552-00	7 - 13	69J-13716-00	12 - 21		38 - 6	6P3-24563-01	1 - 13	6DA-42744-00	3 - 34
6DA-11381-00	6 - 25	6AW-12572-00	25 - 4		26 - 36	6DA-15362-00	32 - 19		14 - 9	6BG-42748-00	16 - 17
	38 - 14	6DA-12576-00	7 - 1	6DA-13751-00	9 - 1	6G8-15363-00	6 - 44	6P3-24564-00	1 - 14	6H4-42748-00	23 - 24
60V-11382-A0	6 - 16		11 - 6	6DA-13761-00	10 - 8	6DA-15373-00	9 - 9		14 - 13	68F-42753-00	23 - 29
	38 - 13	6DA-12578-00	7 - 6	6AW-13781-00	12 - 29	6DA-15377-00	32 - 20	6DA-24566-00	14 - 14	63P-42756-00	25 - 12
6DA-11410-00	4 - 1	6DA-12579-00	7 - 11	6AW-13784-00	12 - 32	6DA-15411-00-9S	3 - 26	6DA-24596-00	14 - 6	6CB-42761-00	23 - 3
6DA-11416-00	4 - 5	6R3-12581-00	25 - 5	6DA-13881-00	9 - 19	6DA-15412-00	3 - 12	69J-28100-01	14 - 21	6DA-42769-00	31 - 8
6DA-11416-10	4 - 5	6AW-12582-00	25 - 6	6DA-13892-00	12 - 11	6DA-15414-00-9S	3 - 4	67F-2812A-00	17 - 28	6N9-42791-40	31 - 21
6DA-11416-20	4 - 5	6R3-12583-00	25 - 7	6DA-13893-00	12 - 12	6DA-15423-00-9S	3 - 6	6DA-41113-00-9S	6 - 8	6N9-42792-40	31 - 22
6DA-11417-00	4 - 6	6DA-12589-00	7 - 2	6CB-13906-01	12 - 8	6DA-15451-00	3 - 27	6DA-41114-00	6 - 9	6AH-42794-40	23 - 31
6DA-11417-10	4 - 6		7 - 15	6P2-13907-20	12 - 23		38 - 17		38 - 12	6AH-42794-50	23 - 32
6DA-11417-20	4 - 6	6P2-12615-00	8 - 18	63P-13915-00	1 - 11	6DA-2134X-00	10 - 30	63P-41131-01-9S	31 - 9	6DA-42815-00-8D	23 - 7
6DA-11426-00	4 - 7	6P2-12623-00	8 - 16		12 - 24	6E5-21744-00	11 - 20	63P-41133-A0	31 - 10	6DA-42816-00-8D	23 - 8
6DA-11427-00	4 - 8	6P2-12645-20	8 - 15	6AW-1410B-00	10 - 9	6DA-2416A-00	11 - 12		39 - 5	6DA-42817-00-8D	23 - 9
6CB-11478-00	4 - 2	6P2-12663-00	8 - 17	6DA-14146-00	12 - 10	6P2-24170-00	10 - 27	63P-41134-A1	31 - 16	6CB-42818-00	23 - 13
6DA-11500-00	3 - 22	6S5-12858-00	6 - 40	6P2-14149-00	12 - 35	63P-2419A-01	10 - 28		39 - 7	6CB-42819-00	23 - 14
63P-11512-00	3 - 25	6CB-13016-00	1 - 10	6DA-14180-00	12 - 1	6CB-24217-00	12 - 7	63P-41137-04-CA	31 - 1	6CB-43111-02-8D	27 - 1
6DA-11590-00	8 - 21		12 - 5	6DA-14181-00	12 - 14	6DA-24310-00	13 - 2	63P-41138-00	31 - 18	6CB-43112-01-8D	27 - 9
6DA-11595-00	8 - 24	6AW-13119-00	32 - 14	6DA-14182-00	12 - 2	6DA-24313-00	14 - 19		39 - 8	64E-43126-00	27 - 28
6DA-115A0-00	8 - 13	6AW-13132-00	12 - 25	6P2-14191-00	12 - 15	6DA-24314-00	14 - 3	6BG-42384-00	25 - 2	64E-43131-30	27 - 15
6CB-11603-00	4 - 12	6DA-13152-00	9 - 3	6CB-14216-00	12 - 6	6DA-24317-00	13 - 11	6DA-42384-00	23 - 23	6DA-42510-10-8D	27 - 7
6DA-11631-00-94	4 - 11	6DA-13160-00	10 - 6	6CB-14239-00	12 - 16	6DA-24323-00	13 - 14		28 - 8		

NUMERICAL INDEX

PART NO.	REF. NO.	PART NO.	REF. NO.	PART NO.	REF. NO.	PART NO.	REF. NO.	PART NO.	REF. NO.	PART NO.	REF. NO.
61A-43133-00	27 - 10	6G5-43864-00	29 - 20	63P-44511-00	28 - 37	6G5-45567-50	33 - 5	6DA-81822-00	21 - 8	6Y8-82509-10	36 - 8
64E-43139-10	28 - 1	64E-43865-00	30 - 16	6DA-44514-00	28 - 29	6G5-45567-60	33 - 5	6CB-81826-00	22 - 22	6Y8-82521-11	36 - 15
66T-43144-00	23 - 17	6G5-43865-01	30 - 35	6DA-44526-00	28 - 33	6EH-45571-00	33 - 60	69J-81828-00	22 - 23	6DA-82553-00	20 - 10
6E5-43145-01	35 - 8	64E-43866-00	29 - 10	6DA-44532-00	28 - 34	6G5-45576-10	33 - 61	67F-81830-00	22 - 16	6P2-82560-01	18 - 15
64E-43311-10-8D	27 - 24	64E-43867-00	29 - 9	69J-44533-00	28 - 22	6G5-45577-02	33 - 65	6CB-81832-00	22 - 9	69J-82563-00	20 - 13
61A-43376-00	28 - 6	64E-43868-00	30 - 3	68V-44551-00-8D	28 - 13	6G5-45577-10	33 - 65	6CB-81836-00	22 - 10	6C5-8257V-00	17 - 31
6CB-43611-00	27 - 36	64E-43869-00	29 - 27	63P-44553-00-8D	28 - 25	6G5-45577-20	33 - 65	6C5-81839-00	22 - 19	68F-82582-00	21 - 7
6CB-43800-02-8D	29 - 1	6H1-4386K-10	30 - 29	60V-44555-00	28 - 16	6G5-45577-30	33 - 65	67F-8183R-00	22 - 13	6DA-82582-00	20 - 2
64E-43802-00	30 - 8	6E5-43872-00	29 - 13	63P-44556-00-8D	28 - 26	6G5-45577-40	33 - 65	60V-8183T-00	22 - 17	6DA-82582-10	20 - 3
64E-43805-01	30 - 37	64E-43873-00	30 - 24	61A-44575-00	28 - 15	6G5-45577-50	33 - 65	6P2-8183X-00	18 - 6	6Y8-82582-11	20 - 4
64E-4380F-00	30 - 33	6E5-43874-01	29 - 22	6DA-45111-10-8D	31 - 20	6G5-45577-60	33 - 65	69J-81840-00	22 - 4	69J-82587-00	20 - 15
64E-4380J-00	30 - 30	6AW-43875-00	30 - 25	69J-45123-00	31 - 13	6E5-45587-01	33 - 39	67F-81841-00	22 - 12	6E9-82588-00	18 - 16
63P-43810-02	29 - 6	64E-43879-01	30 - 27		39 - 6	6E5-45587-10	33 - 39	6CB-81842-00	22 - 18	61A-82588-01	26 - 10
64E-43811-02	29 - 7	64E-43879-11	30 - 26	69J-45127-00	31 - 19	6E5-45587-20	33 - 39	67F-81846-00	22 - 24	6DA-82590-00	20 - 1
6E5-43814-02	29 - 14	64E-4387A-00	30 - 23		39 - 9	6E5-45587-30	33 - 39	67F-81850-00	22 - 2	60V-8259F-00	26 - 31
64E-43816-00	30 - 17	67H-43880-10	30 - 28	6C5-45155-00	31 - 30	6E5-45587-40	33 - 39	6C5-81869-00	22 - 21	69J-8259M-00	26 - 9
64E-43817-00	29 - 5	64E-43883-00	29 - 12	63P-45181-01-9S	31 - 17	6E5-45587-50	33 - 39	67F-81891-00	22 - 15	6DA-82599-00	20 - 9
64E-43817-11	30 - 19	64E-4388E-01	29 - 26	6J9-45214-00	34 - 9	6E5-45587-60	33 - 39	6DA-81919-00	17 - 33	63P-825E0-01	37 - 1
6BC-43818-00	27 - 22	64E-4388E-11	30 - 1	6J9-45215-00	34 - 10	6J9-45611-01	33 - 49	60V-81925-00	21 - 6	68F-82846-00	17 - 26
64E-4381G-00	29 - 28	6AW-4388J-00	29 - 3	65W-45251-00	1 - 15	6DA-45631-00	33 - 56	6C5-81941-00	22 - 20	6X4-83383-00	36 - 5
6CB-43820-01	29 - 16	64E-43891-00	30 - 31		27 - 2	6E5-45633-01	33 - 57	6DA-81942-00	18 - 13	6X4-83386-00	36 - 6
64E-43821-03	29 - 17	64E-43892-00	30 - 34	6EH-45300-00-NA	33 - 1	6E5-45634-02	33 - 50	6DA-81948-00	17 - 5	6E5-83558-00	31 - 31
64E-43822-00	29 - 18	6E5-43896-00	30 - 9	6J9-45301-07-NA	33 - 2	6CB-45932-10	34 - 21	63P-81950-00	18 - 5	63P-83614-01	20 - 16
6CB-43825-00	29 - 2	64E-43897-00	29 - 25	6E5-45318-00	31 - 25	6CB-45974-10	34 - 21	6DA-81952-00	17 - 10	6AW-83651-00	20 - 12
64E-43827-00	30 - 22	64E-43898-00	29 - 8	6E5-45321-00	33 - 14	60X-45987-10	34 - 15	68F-8195A-00	17 - 19	6DA-8366G-00	25 - 15
64E-43828-01	29 - 23	63P-44117-01	26 - 8	6E5-45331-00-9S	33 - 36	60X-45995-00	34 - 16	6DA-81960-00	18 - 1	67H-83672-01	28 - 3
64E-43829-01	29 - 24	63P-44118-00	26 - 23	6J9-45332-00-CA	33 - 58	688-45997-01	34 - 17	6DA-81975-00	18 - 2	68F-83688-10	9 - 15
64E-4382G-00	29 - 30	6DA-44120-11	26 - 18	688-45341-10	33 - 7	6Y8-48277-00	36 - 16	6AH-81994-40	16 - 29	6Y8-8454G-00	36 - 11
6CB-43830-00	30 - 4	6DA-44121-00	26 - 16	6E5-45344-00	33 - 42	6E5-48344-00	26 - 5	6AH-81994-50	16 - 30	6P2-85075-00	19 - 10
64E-43831-00	30 - 2	63P-44122-00	26 - 13	6EH-45371-00	1 - 17		26 - 39	6DA-82105-01	18 - 24	72X-85075-L0	30 - 21
6AW-43841-00	30 - 7	63P-44150-01	33 - 18		34 - 13	6DA-48531-00	26 - 1	6P2-82113-00	17 - 27	68F-85119-00	17 - 8
64E-43843-00	30 - 6	6DA-44176-00	26 - 7	688-45375-00	33 - 11	6E5-48538-00	26 - 3	6E5-82148-00	27 - 4		17 - 13
64E-43843-10	30 - 38	61A-44311-01	33 - 24	663-45376-00	33 - 10	6E5-61350-02	35 - 1		27 - 12	60V-85516-00	10 - 21
64E-4384J-00	29 - 19	6E5-44312-00	33 - 29	63P-45378-00	33 - 12	6E5-61351-01	35 - 2	66K-82149-00	27 - 27	68F-85516-01	17 - 6
64E-4384N-00	29 - 31	6E5-44315-A0	33 - 33	63P-45379-00	31 - 34	6E5-61355-00	35 - 5	67F-82151-00	17 - 22		17 - 11
64E-43850-00	30 - 15		39 - 16	6G5-45383-01	33 - 68	6DA-8132G-00	16 - 20	6P2-82151-00	17 - 18	6CB-85544-00	17 - 25
64E-43851-00	30 - 11		39 - 27	6G5-45384-02	33 - 69	6DA-81336-00	17 - 30	67F-82151-10	17 - 23	689-85547-00	14 - 1
64E-43855-00	30 - 14	61A-44322-02	33 - 25	63P-45501-01	33 - 45	6DA-81337-00	16 - 13	67F-82151-40	17 - 20	6DA-85548-00	17 - 14
64E-43858-00	30 - 12		39 - 22	61A-45527-00	33 - 23	6DA-81410-00	16 - 3	67F-82151-50	17 - 21	6DA-85561-00	16 - 6
6AW-43858-00	30 - 18	6G5-44323-01	33 - 32	6G5-45536-01	33 - 9	6CB-81639-00	17 - 24	6DA-82170-00	17 - 17	6CB-85580-00	16 - 5
6E5-43858-00	29 - 29		39 - 26	61A-45538-00	33 - 20	6CB-81800-00	22 - 1	6CB-82310-00	19 - 5	6CJ-85780-00	20 - 18
72X-43858-00	30 - 5	6E5-44352-01	33 - 30	63P-45551-00	33 - 46	69J-81801-00	22 - 5	6CB-82314-00	19 - 7	6CB-85790-00	20 - 11
64E-43859-00	30 - 13		39 - 25	6EH-45560-00	33 - 48	6CB-81807-00	22 - 8	6A0-82317-00	16 - 16	6P2-85896-00	19 - 9
64E-43860-01	30 - 20	6DA-44361-10	34 - 1	6G5-45567-01	33 - 5	6CB-81809-00	22 - 14	6DA-82388-00	18 - 18	6EH-8591A-01	17 - 1
6E5-43862-00	29 - 11	6E5-44365-00	33 - 28	6G5-45567-10	33 - 5	67F-81810-00	22 - 3		21 - 11	6DA-85991-00	17 - 3
	29 - 15		34 - 3	6G5-45567-20	33 - 5	67F-81813-00	22 - 6	6DA-82389-00	18 - 19	6C5-86120-00	10 - 31
6G5-43863-00	30 - 10	6E5-44366-00	31 - 29	6G5-45567-30	33 - 5	6CB-81820-00	22 - 7	6D8-82389-01	19 - 1	6CB-86120-00	6 - 1
6E5-43864-00	29 - 21	6P2-44391-00	23 - 25	6G5-45567-40	33 - 5	67F-81821-00	22 - 11	6DA-82398-00	16 - 24	6Y8-86260-12	36 - 2

NUMERICAL INDEX

PART NO.	REF. NO.	PART NO.	REF. NO.	PART NO.	REF. NO.	PART NO.	REF. NO.	PART NO.	REF. NO.	PART NO.	REF. NO.
6AA-86261-22	36 - 3	6CB-W1165-00	4 - 9	90119-08M14	39 - 29	90269-07003	23 - 27	90445-09120	11 - 3	90464-99004	9 - 8
6Y8-86267-00	36 - 1	6DA-W4624-00	8 - 20	90119-08M22	23 - 21	90280-04M05	33 - 31	90445-10056	11 - 8	90465-08M63	13 - 6
6DA-8A410-00	26 - 35	6DA-W8145-00	16 - 1	90119-08M58	31 - 5		39 - 30	90445-10057	7 - 14		27 - 25
K0F-A3233-00	4 - 14	6AW-W9011-00	16 - 2	90119-08M66	3 - 20	90282-04M00	33 - 67	90445-23002	34 - 2	90465-08M83	7 - 16
K0F-A3741-00	8 - 5	90101-06020	27 - 3	90119-10007	31 - 23	90338-25004	3 - 14	90462-12013	25 - 19	90465-11M10	7 - 7
K0F-A3742-00	8 - 6	90101-12M05	27 - 32	90119-10024	28 - 30	90340-08002	33 - 6	90464-06001	10 - 24		10 - 25
K0F-A3743-00	8 - 3	90101-14004	28 - 21	90119-10050	8 - 14	90340-14M06	5 - 9	90464-07M41	11 - 2		11 - 4
K0F-A3751-00	8 - 8	90105-06028	3 - 5	90119-10M07	8 - 22		32 - 6	90464-09008	18 - 23		11 - 5
K0F-A3751-10	8 - 8		6 - 10	90119-10MA2	34 - 8	90340-18M09	6 - 35	90464-09020	7 - 10		13 - 13
K0F-A3751-20	8 - 8		6 - 26	90151-05M05	6 - 6	90344-51019	5 - 4	90464-09130	10 - 26		13 - 15
K0F-A3751-30	8 - 8		6 - 34	90152-05M08	34 - 11	90386-06M12	26 - 17		16 - 22		14 - 5
K0F-A3751-40	8 - 8	90105-06035	6 - 3	90155-11002	5 - 19	90386-12069	26 - 30		16 - 26		14 - 20
K0F-A3751-50	8 - 8	90105-06037	6 - 48	90159-05059	28 - 2	90386-15M73	23 - 10	90464-09142	7 - 9		25 - 3
K0F-A3751-60	8 - 8	90105-06054	10 - 3		37 - 4	90386-16M66	26 - 20	90464-09M21	7 - 5		25 - 10
K0F-A3751-70	8 - 8	90105-06151	5 - 21	90159-06053	24 - 5	90386-22M98	27 - 23	90464-09M31	7 - 12		27 - 19
K0F-A3751-80	8 - 8		6 - 43	90159-06M28	24 - 2		27 - 29	90464-10011	11 - 15		28 - 5
K0F-A3751-90	8 - 8	90105-06196	3 - 36	90167-05017	2 - 4	90386-25M31	27 - 16	90464-12002	16 - 4		31 - 32
K0F-A3751-A0	8 - 8	90105-06M07	5 - 14	90167-06M00	36 - 12	90386-38M32	28 - 11	90464-12010	7 - 8		36 - 10
K0F-A3751-B0	8 - 8		6 - 21	90169-05M00	18 - 14	90387-05004	37 - 5		13 - 3		37 - 6
K0F-A3751-C0	8 - 8	90105-06M08	10 - 11	90170-16M01	33 - 47	90387-06176	17 - 7	90464-12183	9 - 10	90465-11M59	6 - 27
K0F-A3751-D0	8 - 8		10 - 14	90171-18M04	34 - 19		17 - 12		9 - 22		6 - 50
K0F-A3751-E0	8 - 8	90105-08175	3 - 24	90179-08003	21 - 5	90387-06263	32 - 9		18 - 10		20 - 8
K0F-A3751-F0	8 - 8		5 - 20	90183-061A6	24 - 4	90387-06283	10 - 1	90464-13249	18 - 22	90465-13M97	16 - 10
K0F-A3751-G0	8 - 8	90105-08M87	21 - 10	90185-05002	34 - 12	90387-06289	10 - 22		19 - 4	90467-120A7	13 - 9
K0F-A3751-H0	8 - 8	90105-10406	3 - 19	90185-09M01	35 - 6		10 - 34		25 - 13		13 - 12
K0F-A3751-J0	8 - 8		3 - 23	90185-14M00	28 - 35		14 - 17	90464-13260	13 - 17	90468-18008	26 - 6
K0F-A3751-K0	8 - 8	90105-10M00	34 - 14	90185-22M11	27 - 18	90387-06M43	24 - 7	90464-15007	13 - 5		26 - 15
K0F-A3751-L0	8 - 8	90105-14009	28 - 31	90201-06M30	36 - 13	90387-06M69	16 - 18	90464-16001	11 - 10		26 - 40
K0F-A3751-M0	8 - 8	90109-08019	26 - 33	90201-10060	27 - 20	90387-08M37	23 - 20		11 - 23	90480-12314	10 - 2
K0F-A3751-N0	8 - 8	90111-08078	2 - 6	90201-10M20	35 - 7	90387-08M45	2 - 9		11 - 24		16 - 15
K0F-A3751-P0	8 - 8	90119-06023	3 - 13	90201-12426	27 - 34	90387-10094	2 - 7	90464-16003	13 - 4		19 - 8
K0F-A3751-R0	8 - 8	90119-06078	6 - 38	90201-13M01	27 - 33	90387-10M61	35 - 3	90464-18004	11 - 22	90480-13163	23 - 28
K0F-A3751-S0	8 - 8	90119-06126	26 - 38	90201-156J2	23 - 11	90387-11005	5 - 18		13 - 16	90480-13M24	24 - 6
K0F-A3751-T0	8 - 8	90119-06M10	33 - 17	90201-15M58	28 - 20	90387-14004	28 - 38		25 - 18	90480-14031	10 - 33
K0F-A3753-00	8 - 8	90119-06M17	10 - 20	90201-16M01	28 - 32	90430-06M03	5 - 15	90464-18246	18 - 12	90480-15013	14 - 16
K0F-A3753-10	8 - 8		10 - 35	90201-16M55	28 - 19		6 - 22		25 - 17	90480-16025	16 - 14
K0F-A3753-20	8 - 8		14 - 15	90201-22M01	33 - 21	90430-08020	1 - 16	90464-20181	9 - 21	90480-20M05	6 - 13
K0F-A3753-30	8 - 8	90119-06M18	31 - 35	90201-26M59	27 - 17		33 - 8		13 - 1	90480-22M81	23 - 19
K0F-A3753-40	8 - 8	90119-06M24	10 - 12	90201-30M92	33 - 66		39 - 11		16 - 23	90501-12082	26 - 27
K0F-A3753-50	8 - 8	90119-06M61	16 - 19	90201-35008	28 - 17	90430-14115	5 - 10		17 - 15	90501-16M11	6 - 12
K0F-A3753-60	8 - 8	90119-06M81	3 - 16	90201-38M60	28 - 9		38 - 2		18 - 21	90501-16M37	33 - 51
K0F-A3753-70	8 - 8	90119-06MA3	3 - 28	90202-08M20	26 - 14	90430-14M09	1 - 7		19 - 3	90506-18025	8 - 23
6DA-W0001-00	38 - 1		6 - 17	90202-16061	26 - 21		32 - 7		21 - 12	90506-22001	23 - 16
63P-W0001-21	39 - 1	90119-07001	5 - 7	90202-32M19	28 - 18		39 - 3	90464-20258	23 - 30	90508-20M31	26 - 29
61A-W0078-A3	1 - 19	90119-07234	5 - 8	90202-40M47	28 - 12	90430-18130	6 - 36	90464-21256	25 - 9	90560-12M01	35 - 4
	39 - 21	90119-08020	9 - 14	90206-15M18	23 - 12		38 - 15	90464-26001	20 - 19	91490-40030	34 - 20
6DA-W009A-00-9S	5 - 1	90119-08102	31 - 2	90206-22M19	33 - 22	90445-07010	31 - 33	90464-30003	20 - 20	91690-30010	26 - 4
6DA-W009B-01-9S	3 - 1	90119-08M14	33 - 35	90250-08M07	33 - 55	90445-09008	7 - 4	90464-32002	18 - 11		26 - 25

NUMERICAL INDEX

PART NO.	REF. NO.	PART NO.	REF. NO.	PART NO.	REF. NO.	PART NO.	REF. NO.	PART NO.	REF. NO.	PART NO.	REF. NO.
91690-40010	3 - 10	93210-16275	35 - 9	93608-16M16	31 - 24	95895-06025	19 - 6	98507-04008	12 - 34		
	3 - 29	93210-19MJ3	32 - 21		32 - 4	95895-06030	5 - 24	98780-04016	3 - 9		
91809-08006	5 - 6		38 - 24		34 - 4		16 - 12		3 - 30		
91814-18002	3 - 3	93210-24M79	6 - 45	93700-06M01	26 - 32	95895-06040	25 - 24	99001-08600	33 - 19		
92903-08100	18 - 27		38 - 25	93700-06M03	26 - 34	95895-06065	25 - 22	99590-08012	16 - 7		
92903-08600	21 - 4	93210-25552	3 - 11		27 - 26	95895-08016	18 - 25	99590-10114	21 - 9		
92990-06100	2 - 12		32 - 18	94702-00400	1 - 18	95895-08020	26 - 2				
92990-08600	2 - 8		38 - 7		5 - 25	97013-08045	21 - 3				
92990-18200	34 - 18		38 - 22	95022-06035	16 - 11	97075-10040	28 - 27				
92995-05100	9 - 17	93210-25647	3 - 15	95333-08600	18 - 26	97095-05020	16 - 8				
92995-05600	9 - 18		38 - 8	95380-06600	2 - 13	97095-06010	27 - 5				
	16 - 9	93210-357A3	6 - 47		10 - 32	97095-06016	20 - 5				
92995-06600	18 - 4		38 - 26		24 - 3		21 - 1				
	18 - 9	93210-37160	33 - 27	95380-12600	27 - 35		37 - 2				
	19 - 12		39 - 15	95380-14600	28 - 23	97095-06020	18 - 8				
	20 - 6		39 - 24	95780-06300	36 - 14		19 - 11				
	21 - 2	93210-37MH7	28 - 10	95780-08300	2 - 10	97095-06035	18 - 3				
	27 - 6	93210-55M14	33 - 41	95780-10300	28 - 7	97095-08025	33 - 43				
	27 - 14		39 - 18	95812-06025	32 - 11	97095-10045	34 - 5				
	37 - 3	93210-58144	33 - 15	95875-06020	10 - 5	97575-06516	8 - 25				
92995-08600	33 - 44		39 - 12	95875-06025	9 - 4	97575-06535	26 - 24				
92995-10100	34 - 6	93210-86M38	33 - 26		9 - 6	97575-06540	32 - 17				
92995-10600	28 - 28		39 - 14	95875-08035	17 - 4	97575-08535	31 - 14				
	34 - 7		39 - 23	95880-08012	23 - 15		32 - 3				
92995-14600	28 - 24	93210-97M55	33 - 64	95885-08025	5 - 16	97575-08540	6 - 23				
	28 - 36		39 - 20	95895-06010	13 - 7	97575-08560	9 - 2				
93101-28M16	33 - 37	93306-209U0	33 - 59		27 - 31		31 - 11				
	39 - 17	93311-928U5	33 - 3	95895-06012	7 - 17	97575-10530	27 - 21				
93101-30M17	33 - 63	93315-43061	33 - 62		9 - 20	97575-10535	31 - 6				
	39 - 19	93317-330U2	33 - 38		10 - 19	97575-10545	31 - 3				
93102-08M43	30 - 36	93332-000V3	33 - 4		14 - 18	97595-06550	26 - 12				
93102-38008	8 - 19	93341-930V2	33 - 40		18 - 17	97595-06610	18 - 7				
	38 - 20	93410-16006	26 - 22		19 - 2	97607-04310	30 - 32				
93102-85008	4 - 4	93410-22M11	27 - 30		20 - 17	97780-50620	17 - 29				
	38 - 19	93410-37M04	28 - 14		23 - 18	97780-60520	25 - 11				
93106-09014	33 - 16	93420-36M01	31 - 26		25 - 14	97780-60620	17 - 16				
	39 - 13	93501-04M02	26 - 26		25 - 16		17 - 32				
93210-04279	36 - 9	93503-16003	33 - 54		25 - 20		36 - 7				
93210-07003	33 - 13	93507-32009	33 - 52	95895-06014	23 - 4	97880-06035	36 - 12				
	39 - 10	93511-32017	33 - 53	95895-06016	10 - 29	97885-05016	9 - 16				
93210-08001	3 - 32	93605-10108	8 - 10		16 - 21	97885-06010	27 - 8				
	38 - 18		8 - 12		16 - 25		27 - 11				
93210-09165	26 - 19	93606-12019	4 - 3		17 - 9	97885-06012	27 - 13				
93210-10M74	29 - 4		5 - 5		18 - 20	97980-06216	31 - 28				
93210-12648	3 - 18		33 - 34		21 - 13		36 - 4				
	38 - 10		39 - 28		32 - 22	97985-04116	26 - 11				
93210-13M63	6 - 7	93606-19M23	31 - 15	95895-06020	17 - 2	97985-04308	20 - 7				
	38 - 11	93608-16M16	31 - 4	95895-06025	14 - 7	97985-06216	28 - 4				