

# PARTS CATALOGUE

## VF200A-2014 (6CD6)

---



1N6CD-100E1

( )

VF200A  
PARTS CATALOGUE  
©2014 by Yamaha Motor Co., Ltd.  
1st edition, February 2014  
All rights reserved.  
Any reprinting or unauthorized use  
without the written permission of  
Yamaha Motor Co., Ltd.  
is expressly prohibited.  
Printed in Japan.

# FOREWORD

This Parts Catalogue is related to the parts for the model(s) on the cover page. When you are ordering replacement parts, please refer to this Parts Catalogue and quote both part numbers and part names correctly.

1. Modifications or additions which have been made after the issue of the Parts Catalogue will be announced in the Parts News.  
It is advisable that you make the necessary corrections to the Parts Catalogue according to the Parts News.

2. Abbreviations

The following abbreviations are used in this Parts Catalogue.

“UR” Use specified parts number.

“UN” Use as many as needed.

“AP” Alternate Parts

“LM” Locally Made (Parts need to be ordered locally)

“F#” Frame No. (Applicable machine No.)

“O/S” Over Size

3. The number of components for assembly

- Parts, which are to be supplied in an assembly, are listed with a dot (.) in front of the part name as shown below.
- The numeral appearing to the right of each component part indicates the quantity of parts for each assembly unit.

PART NO.	DESCRIPTION	Q'TY	REMARKS
2F5-83310-60	FRONT FLASHER LIGHT ASSY	2	
115-83311-60	.BULB (6V-18W)	1	

4. Applicable colours of graphics are represented in the “REMARKS” as shown below.

PART NO.	DESCRIPTION	Q'TY	REMARKS
2N4-24110-00-X5	FUEL TANK COMP.	2	MXR
3J1-24240-10	.GRAPHIC, FUEL TANK	1	FOR MXR

5. Note that the illustrations for reference in finding parts numbers are not to be used for assembling. When assembling, please use the applicable service manual.

6. The asterisk (\*) before a reference number indicates modified items after the first edition.

7. Applicable Serial No.

Engine Serial No.

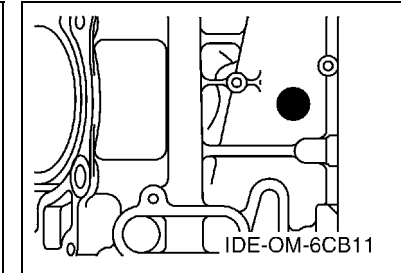
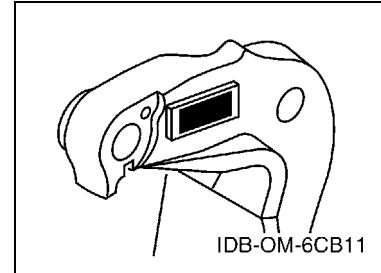

8. Applicable Engine Starting Serial No.

Model	Serial No.	Model	Serial No.
VF200A	6CD-1002622		

9. Applicable Colour Code

Abbreviation	Colour Name	Colour Code
SBL	SHINY BLACK	00NA

10. Quantity Column Information

Column No.	Name Of Q'ty Column	Applicable Model
1	6CD6	VF200LA

# CONTENTS

SCHEDULED SERVICE PARTS .....	1
TOP COWLING .....	2
CYLINDER & CRANKCASE 1 .....	4
CRANKSHAFT & PISTON .....	6
CYLINDER & CRANKCASE 2 .....	7
CYLINDER & CRANKCASE 3 .....	9
CYLINDER & CRANKCASE 4 .....	10
VALVE .....	11
INTAKE 1 .....	14
INTAKE 2 .....	15
THROTTLE BODY ASSY 1 .....	17
THROTTLE BODY ASSY 2 .....	18
FUEL INJECTION PUMP 1 .....	19
FUEL INJECTION PUMP 2 .....	21
FUEL 1 .....	22
FUEL 2 .....	23
GENERATOR .....	24
ELECTRICAL 1 .....	25
ELECTRICAL 2 .....	27
ELECTRICAL 3 .....	28
ELECTRICAL 4 .....	30
ELECTRICAL 5 .....	32
STARTING MOTOR .....	33
BOTTOM COWLING 1 .....	34
BOTTOM COWLING 2 .....	36
BOTTOM COWLING 3 .....	38
CONTROL .....	39
BRACKET 1 .....	41
BRACKET 2 .....	43
POWER TRIM & TILT ASSY 1 .....	45
POWER TRIM & TILT ASSY 2 .....	47
UPPER CASING .....	49
OIL PAN .....	51
LOWER CASING & DRIVE 1 .....	52
LOWER CASING & DRIVE 2 .....	56
OPTIONAL PARTS 1 .....	58
OPTIONAL PARTS 2 .....	59
REPAIR KIT 1 .....	60
REPAIR KIT 2 .....	61

## INDEX

NUMERICAL INDEX .....	63
-----------------------	----

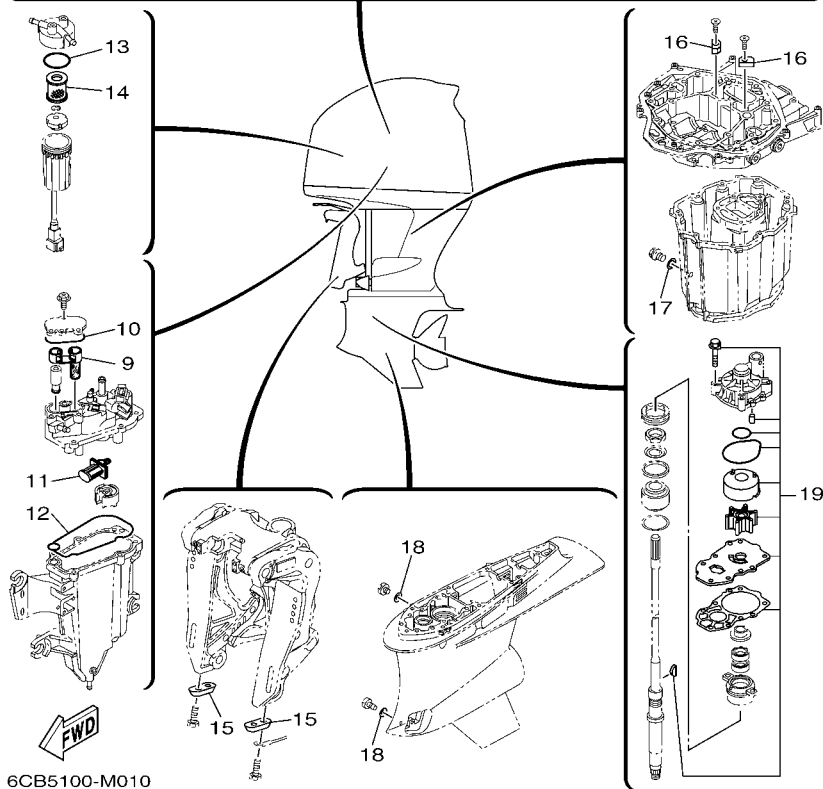
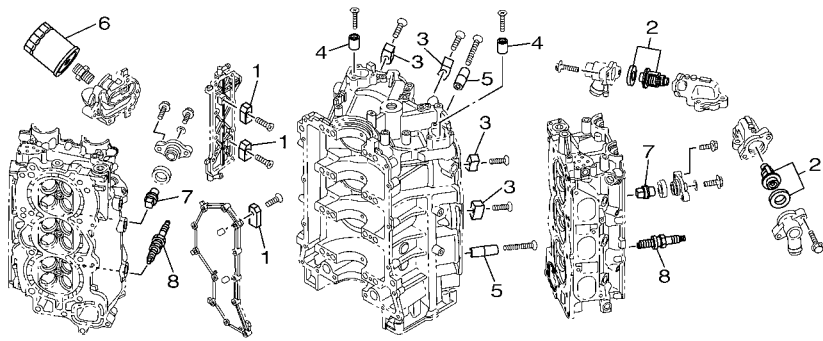

FIG. 1 SCHEDULED SERVICE PARTS

REF. NO.	PART NO.	DESCRIPTION	6CD6				REMARKS
1	63P-11325-01	ANODE	4				
2	6CB-12411-10	THERMOSTAT	2				
3	6AW-1132P-00	ANODE 5	4				
4	68T-11325-00	ANODE	2				
5	6AW-1132N-01	ANODE 4	2				
6	N26-13440-02	ELEMENT ASSY, OIL CLEANER	1				
7	67F-11325-01	ANODE	8				
8	94702-00400	PLUG, SPARK (NGK LFR6A-11)	6				
9	6CB-24501-01	FILTER, FUEL	1				
10	6CB-13016-00	O-RING	1				
11	63P-13915-00	FILTER	1				
12	6CB-14984-00	GASKET, FLOAT CHAMBER	1				
13	6P3-24564-00	GASKET	1				
14	6P3-24563-01	ELEMENT, FILTER	1				
15	65W-45251-00	ANODE	2				
16	63P-11325-11	ANODE	2				
17	90430-14M09	GASKET	1				
18	90430-08020	GASKET	2				
19	6CB-W0078-00	WATER PUMP REPAIR KIT	1				

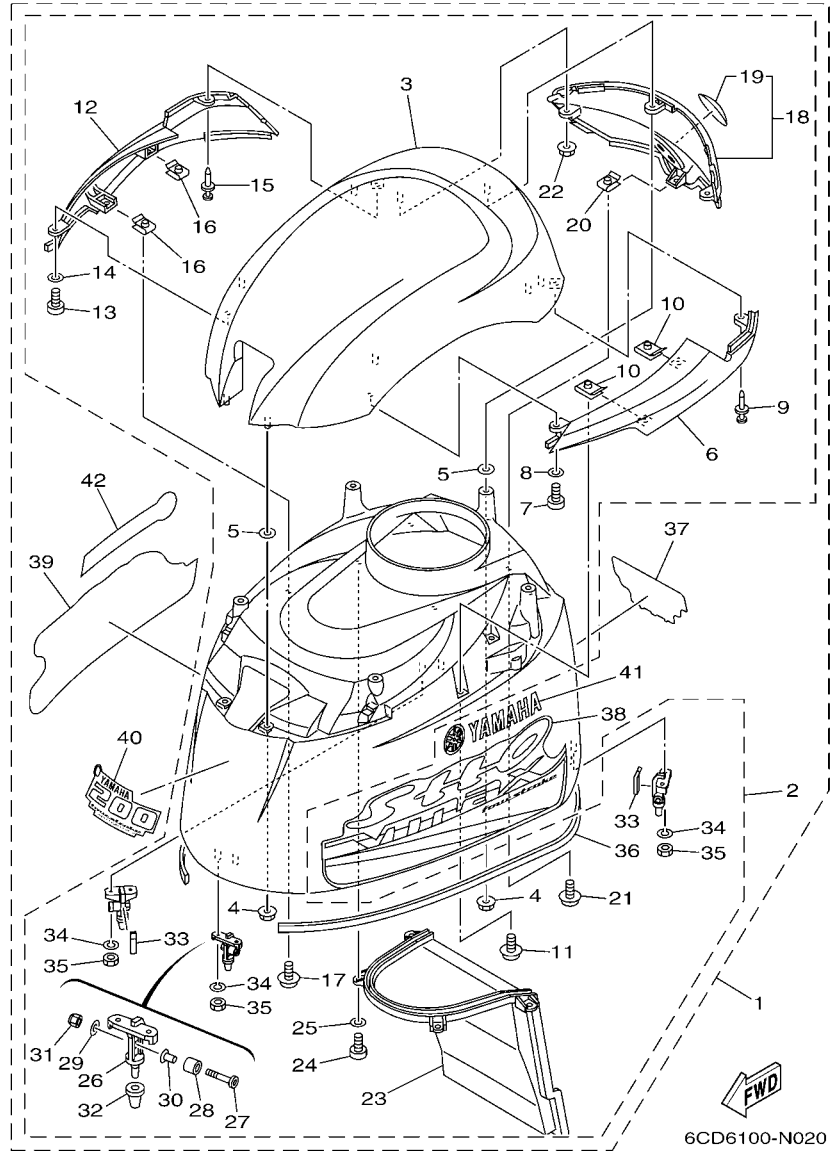

FIG. 2 TOP COWLING

REF. NO.	PART NO.	DESCRIPTION	6CD6				REMARKS
1	6CD-42610-01	TOP COWLING ASSY	1				
2	6CB-4261A-00	..TOP COWLING COMPLETE	1				
3	6CB-42613-00-NA	..MOLDING, AIR DUCT	1				
4	90179-06029	..NUT	7				
5	6CB-42545-00	..WASHER, PLAIN	7				
6	6CB-42626-00-NA	..LOUVER, 1	1				
7	97780-60616	..SCREW, TAPPING	1				
8	92990-06200	..WASHER, PLAIN	1				
9	90269-05005	..RIVET	1				
10	90183-051A5	..NUT, SPRING	2				
11	97980-05214	..SCREW, WITH WASHER	2				
12	6CB-42636-00-NA	..LOUVER 2	1				
13	97780-60616	..SCREW, TAPPING	1				
14	92990-06200	..WASHER, PLAIN	1				
15	90269-05005	..RIVET	1				
16	90183-051A5	..NUT, SPRING	2				
17	97980-05214	..SCREW, WITH WASHER	2				
18	6CB-Y426J-00	..REAR PANEL ASSY	1				
19	6AW-42697-10	...TUNING FORK MARK	1				
20	90183-051A5	..NUT, SPRING	1				
21	97980-05214	..SCREW, WITH WASHER	1				
22	90179-06029	..NUT	2				
23	6CB-42635-00	..DUCT, WATER SEPARATOR	1				
24	97780-60616	..SCREW, TAPPING	4				
25	92990-06200	..WASHER, PLAIN	4				
26	6CB-42647-00	..HOLDER, CLAMP BAND	3				
27	90111-08078	..BOLT,HEX. SOCKET BUTTON	3				

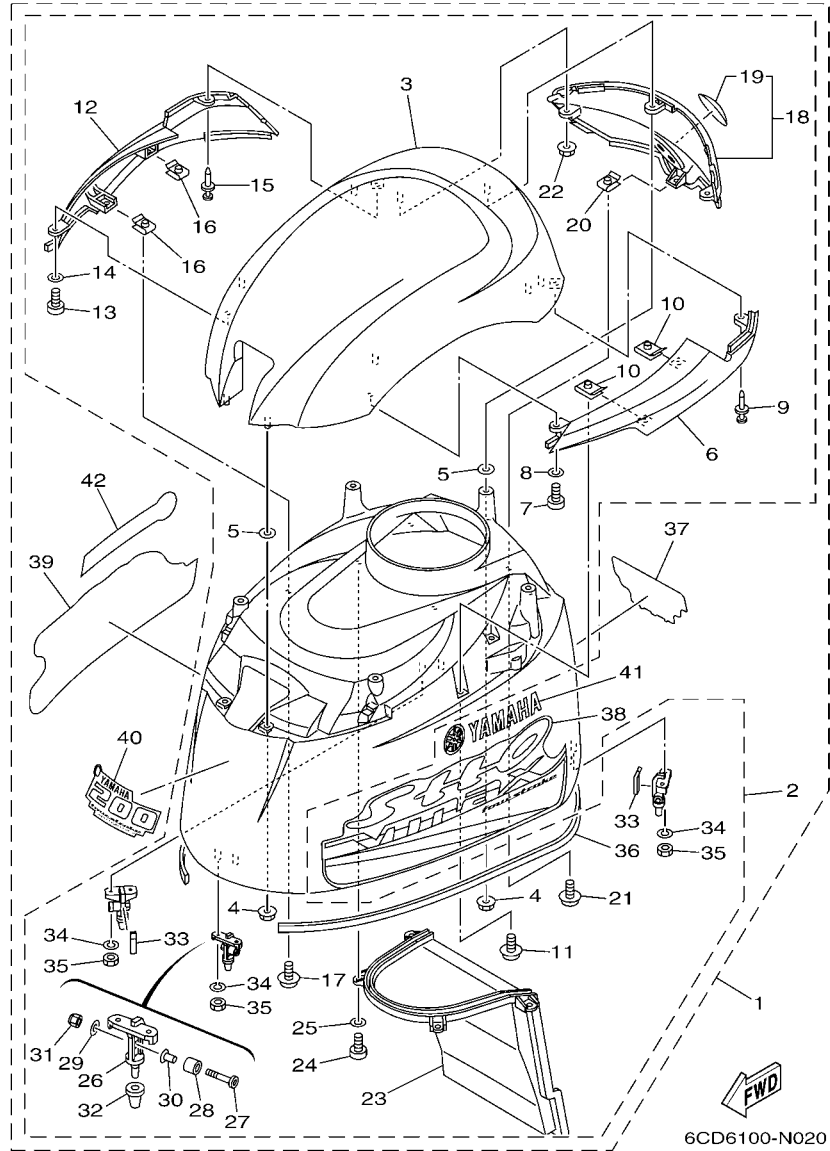
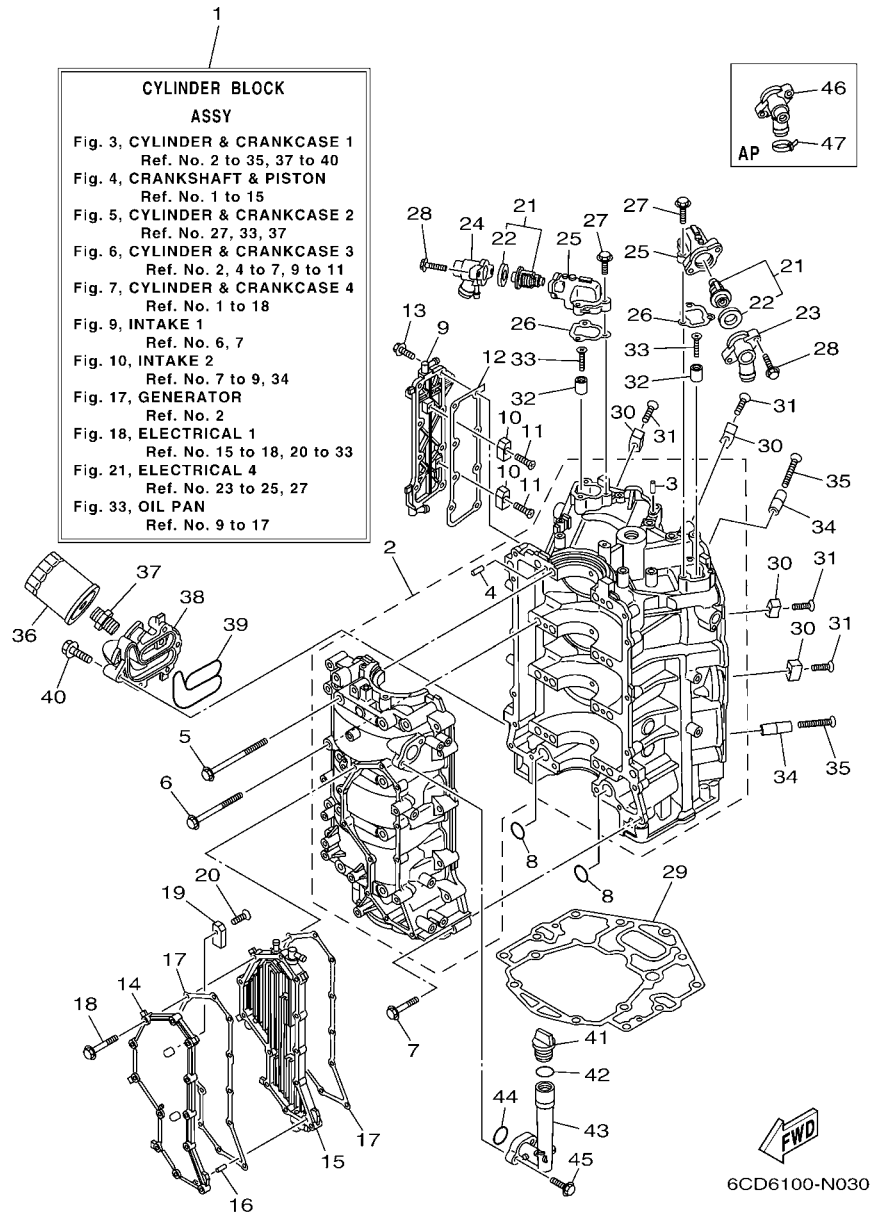

FIG. 2 TOP COWLING

REF. NO.	PART NO.	DESCRIPTION	6CD6				REMARKS
28	90387-10094	..COLLAR	3				
29	92990-08600	..WASHER, PLATE	3				
30	90387-08M45	..COLLAR	3				
31	95780-08300	..NUT, FLANGE	3				
32	6AW-42663-00	..DAMPER	3				
33	6CB-42134-00	..COVER	2				
34	92990-06100	..WASHER, SPRING	6				
35	95380-06600	..NUT, HEXAGON	6				
36	6CB-42628-00	..SEAL	1				
37	6CD-42678-00	.GRAPHIC, REAR	1				
38	6CB-42675-10	.GRAPHIC, SIDE 1	1				
39	6CB-42676-10	.GRAPHIC, SIDE 2	1				
40	6CD-42677-00	.GRAPHIC, FRONT	1				
41	6CB-42681-01	.MARK, COWLING	1				
42	6CB-42682-01	.MARK, COWLING	1				



**FIG. 3 CYLINDER & CRANKCASE 1**

REF. NO.	PART NO.	DESCRIPTION	6CD6				REMARKS
1	6CB-W009B-06	CYLINDER BLOCK ASSY	1				
2	6CB-15100-10	CRANKCASE ASSY	1				
3	93606-12019	.PIN, DOWEL	3				
4	93606-12019	.PIN, DOWEL	8				
5	6CB-15187-00	BOLT	8				
6	6CB-15481-00	BOLT 1	8				
7	90105-08175	BOLT, FLANGE	16				
8	93210-26658	O-RING	2				
9	6CB-1131C-00	COVER, JOINT	1				
10	63P-11325-01	ANODE	2				
11	90151-06M02	SCREW, COUNTERSUNK	2				
12	6CB-1131B-00	GASKET, COVER	1				
13	90105-06M07	BOLT, FLANGE	8				
14	6CB-15411-00	COVER, CRANKCASE 1	1				
15	6CB-15421-10	COVER, CRANKCASE 2	1				
16	91690-40010	PIN, SPRING	1				
17	6CB-15451-00	GASKET, CRANKCASE COVER 1	2				
18	90105-06151	BOLT, FLANGE	12				
19	63P-11325-01	ANODE	2				
20	90151-06M02	SCREW, COUNTERSUNK	2				
21	6CB-12411-10	THERMOSTAT	2				
22	67F-12412-00	.SEAL, THERMOSTAT	1				
23	6CB-12413-20	COVER, THERMOSTAT	1				
24	6CB-12413-11	COVER, THERMOSTAT	1				
25	6CB-12422-10-9S	COVER, HOUSING	2				
26	6CB-12427-10	GASKET, HOUSING COVER 1	2				
27	95027-06025	BOLT, FLANGE	6				



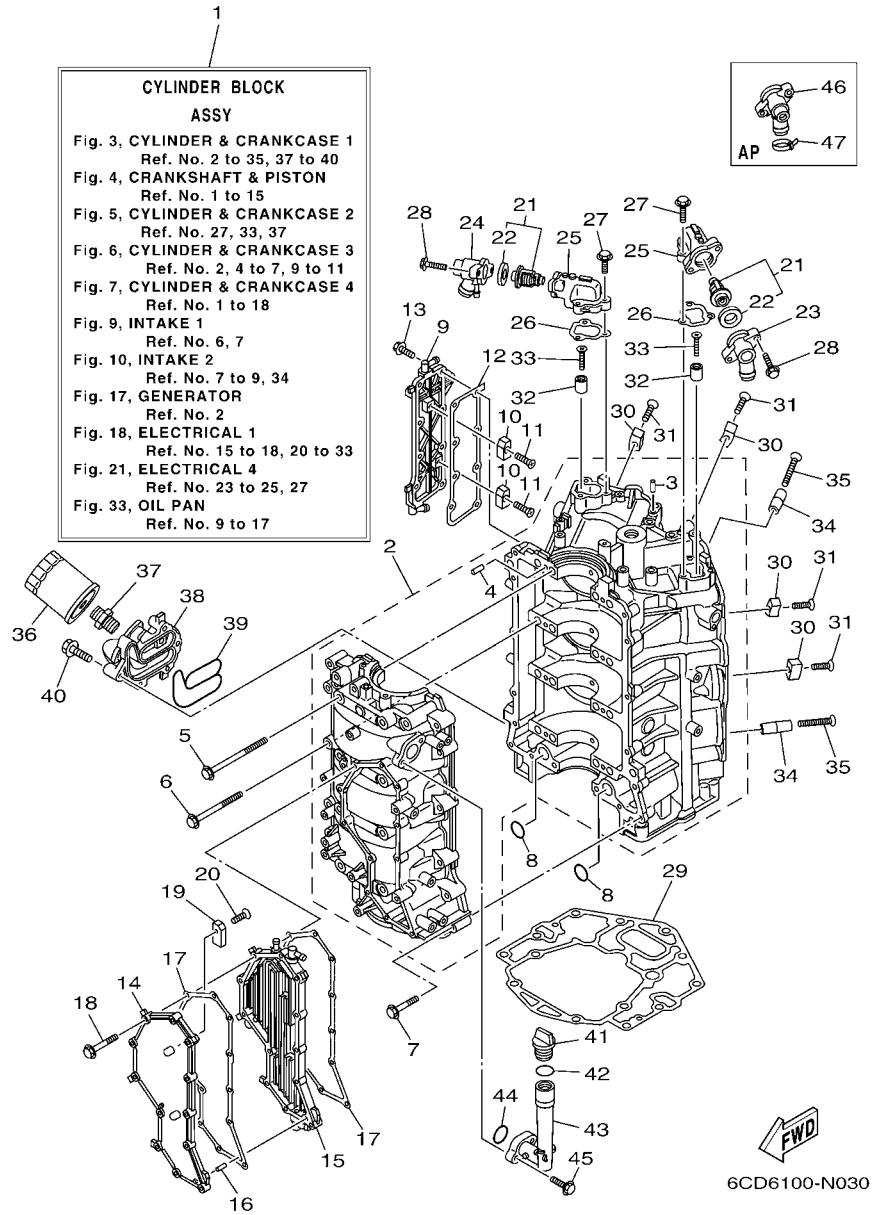

**FIG. 3 CYLINDER & CRANKCASE 1**

REF. NO.	PART NO.	DESCRIPTION	6CD6				REMARKS
28	90105-06037	BOLT, FLANGE	4				
29	6CB-11351-00	GASKET, CYLINDER	1				
30	6AW-1132P-00	ANODE 5	4				
31	98780-06530	SCREW, FLAT HEAD	4				
32	68T-11325-00	ANODE	2				
33	90151-05M05	SCREW, COUNTERSUNK	2				
34	6AW-1132N-01	ANODE 4	2				
35	98780-06550	SCREW, FLAT HEAD	2				
36	N26-13440-02	ELEMENT ASSY, OIL CLEANER	1				
37	90401-19001	BOLT, UNION	1				
38	6CB-13446-00	CONNECTOR	1				
39	6CB-13477-00	GASKET	1				
40	90105-06151	BOLT, FLANGE	5				
41	6G8-15363-00	PLUG, OIL	1				
42	93210-24M79	O-RING	1				
43	6CB-15319-00	JOINT	1				
44	93210-27370	O-RING	1				
45	90105-06037	BOLT, FLANGE	2				
46	6CB-1241B-01	COVER, THERMOSTAT 2	1				AP WATER TEMP SENSOR
47	90465-11M59	CLAMP	1				AP WATER TEMP SENSOR

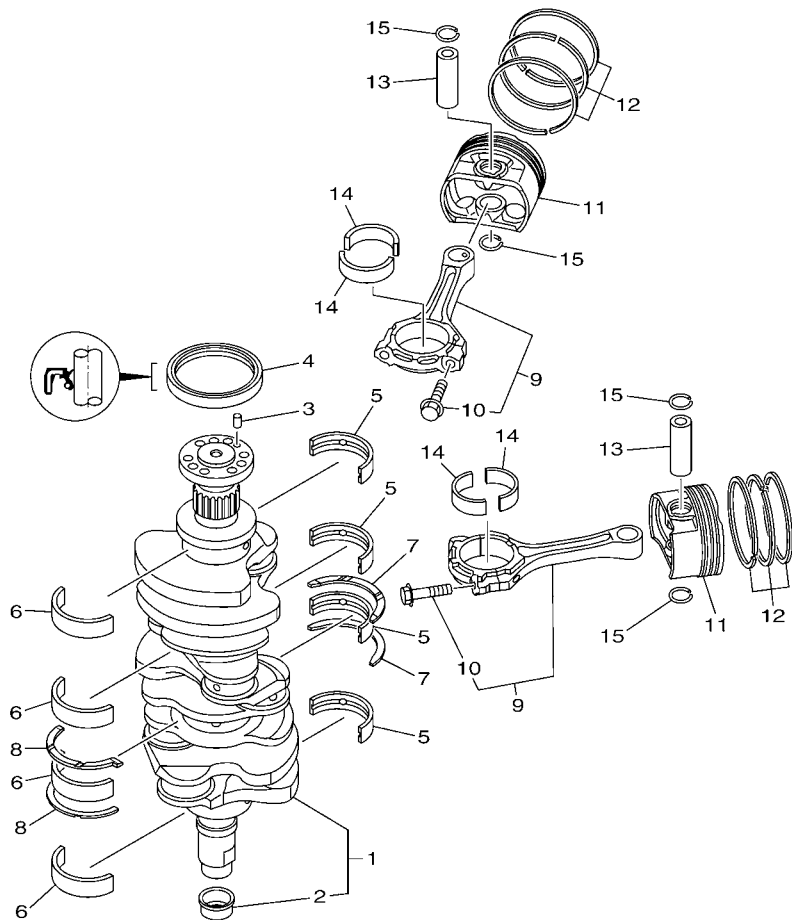

  
 6CB3110-L030

**FIG. 4 CRANKSHAFT & PISTON**

REF. NO.	PART NO.	DESCRIPTION	6CD6	REMARKS
1	6CB-11410-00	CRANKSHAFT	1	
2	6CB-11478-00	.COLLAR	1	
3	93606-12019	PIN, DOWEL	1	
4	93102-85008	OIL SEAL	1	
5	6CB-11416-00	PLANE BEARING, CRANKSHAFT 1	4	UR PURPLE
6	6CB-11416-10	PLANE BEARING, CRANKSHAFT 1	4	UR YELLOW
6	6CB-11416-20	PLANE BEARING, CRANKSHAFT 1	4	UR RED
6	6CB-11416-30	PLANE BEARING, CRANKSHAFT 1	4	UR GREEN
6	6CB-11416-40	PLANE BEARING, CRANKSHAFT 1	4	UR BROWN
6	6CB-11417-00	PLANE BEARING, CRANKSHAFT 2	4	UR PURPLE
6	6CB-11417-10	PLANE BEARING, CRANKSHAFT 2	4	UR YELLOW
6	6CB-11417-20	PLANE BEARING, CRANKSHAFT 2	4	UR RED
6	6CB-11417-30	PLANE BEARING, CRANKSHAFT 2	4	UR GREEN
6	6CB-11417-40	PLANE BEARING, CRANKSHAFT 2	4	UR BROWN
7	6CB-11426-03	BEARING, THRUST 1	2	
8	6CB-11427-03	BEARING, THRUST 2	2	
9	6CB-W1165-00	CONNECTING ROD ASSY	6	
10	6CB-11654-00	.BOLT, CONNECTING ROD	2	
11	6CE-11631-00	PISTON (STD)	6	
12	6CB-11603-00	PISTON RING SET (STD)	6	
13	6CB-11633-00	PIN, PISTON	6	
14	6CB-11656-00	PLANE BEARING, CONNECTING ROD	12	UR YELLOW
14	6CB-11656-10	PLANE BEARING, CONNECTING ROD	12	UR GREEN
14	6CB-11656-20	PLANE BEARING, CONNECTING ROD	12	UR BLUE
15	K0F-A3233-00	RING,HOLE SNAP	12	

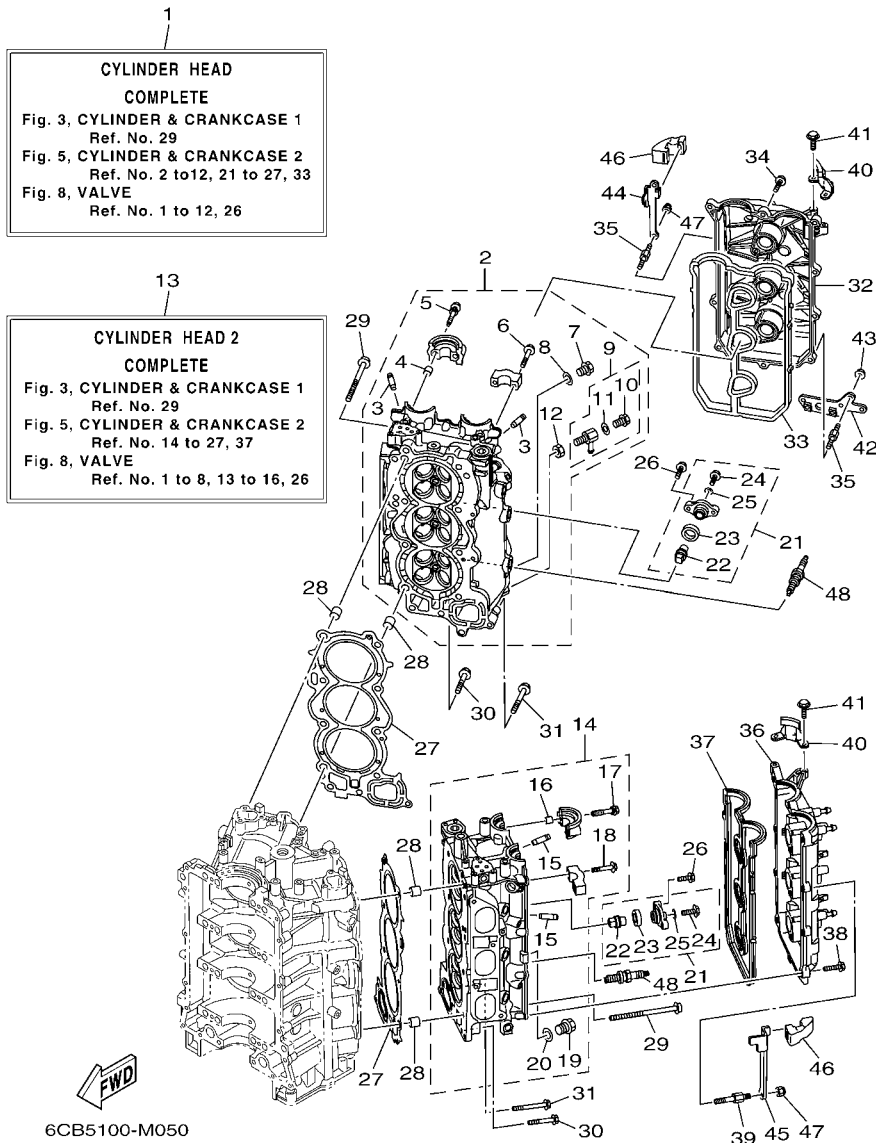
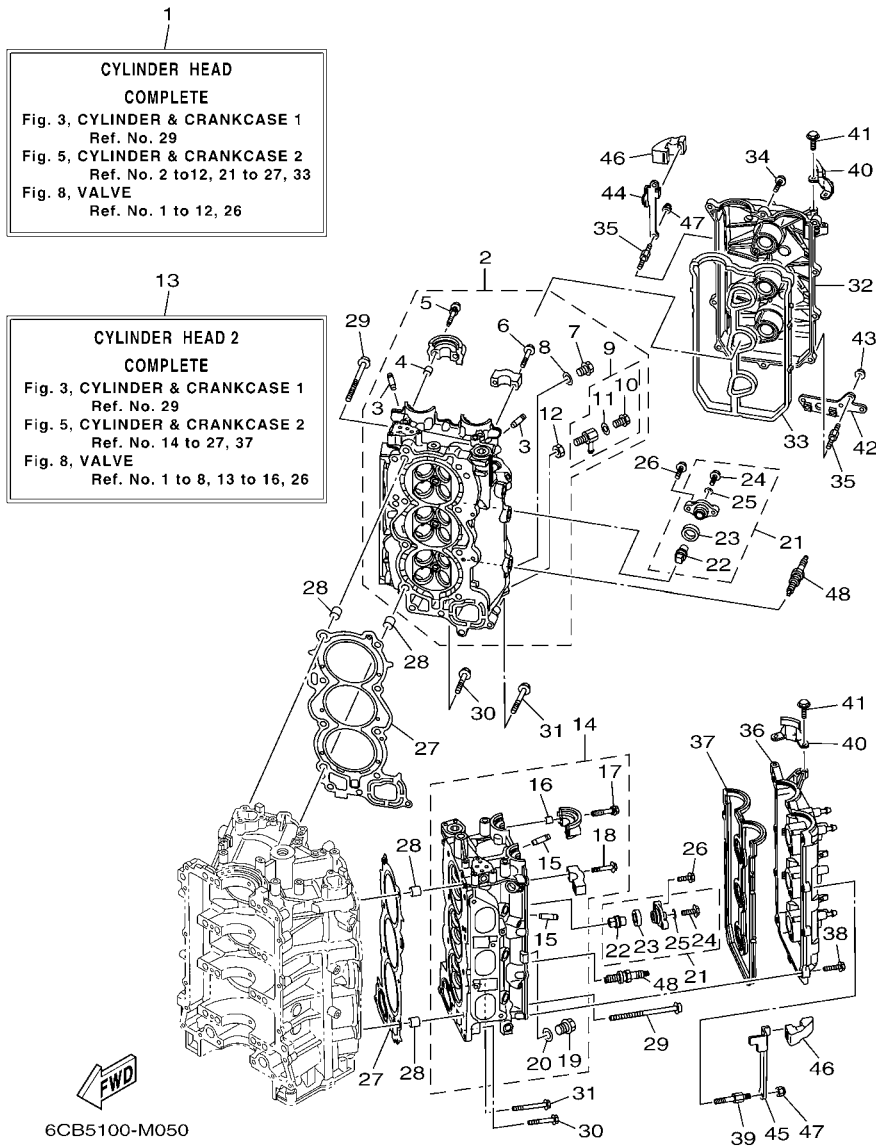

FIG. 5 CYLINDER & CRANKCASE 2

REF. NO.	PART NO.	DESCRIPTION	6CD6				REMARKS
1	6CB-W009A-00	CYLINDER HEAD COMPLETE	1				
2	6CB-11110-00	CYLINDER HEAD ASSY	1				
3	6S5-11133-10	.GUIDE, VALVE 1	12				
4	91809-08006	.PIN, DOWEL	4				
5	90119-07001	.BOLT, WITH WASHER	4				
6	90119-07234	.BOLT, WITH WASHER	12				
7	90340-18M09	.PLUG, STRAIGHT SCREW	1				
8	90430-18130	.GASKET	1				
9	6CB-83609-00	.CONNECTOR ASSY	1				
10	90340-14M06	..PLUG, STRAIGHT SCREW	1				
11	90430-14115	..GASKET	1				
12	95380-14700	.NUT	1				
13	6CB-W009C-00	CYLINDER HEAD 2 COMPLETE	1				
14	6CB-11120-00	CYLINDER HEAD ASSY 2	1				
15	6S5-11133-10	.GUIDE, VALVE 1	12				
16	91809-08006	.PIN, DOWEL	4				
17	90119-07001	.BOLT, WITH WASHER	4				
18	90119-07234	.BOLT, WITH WASHER	12				
19	90340-18M09	.PLUG, STRAIGHT SCREW	1				
20	90430-18130	.GASKET	1				
21	67F-11301-00	ANODE COVER ASSY	8				
22	67F-11325-01	.ANODE	1				
23	67F-11328-00	.GROMMET, ANODE	1				
24	90105-06M07	.BOLT, FLANGE	1				
25	90430-06M03	.GASKET	1				
26	95885-08025	BOLT, FLANGE	16				
27	6CB-11181-00	GASKET, CYLINDER HEAD 1	2				



**FIG. 5 CYLINDER & CRANKCASE 2**

REF. NO.	PART NO.	DESCRIPTION	6CD6				REMARKS
28	90387-11005	COLLAR	4				
29	90155-11002	SCREW, FLAT FILLISTER	16				
30	90105-08175	BOLT, FLANGE	4				
31	90105-08220	BOLT, FLANGE	2				
32	6CB-11191-02	COVER, CYLINDER HEAD 1	1				
33	6CB-11193-00	GASKET, HEAD COVER 1	1				
34	95895-06030	BOLT, FLANGE	9				
35	90109-06277	BOLT	4				
36	6CB-11192-02	COVER, CYLINDER HEAD 2	1				
37	6CB-11194-00	GASKET, HEAD COVER 2	1				
38	95895-06030	BOLT, FLANGE	11				
39	90109-06277	BOLT	2				
40	6AW-15142-00	GUIDE 1	2				
41	95885-06014	BOLT, FLANGE	4				
42	6CB-2134V-00	BRACKET	1				
43	90179-06M28	NUT	2				
44	6CB-11998-00	BRACKET 1	1				
45	6CB-11999-00	BRACKET 2	1				
46	6CB-42662-00	DAMPER	2				
47	90185-06M07	NUT, SELF-LOCKING	4				
48	94702-00400	PLUG, SPARK (NGK LFR6A-11)	6				

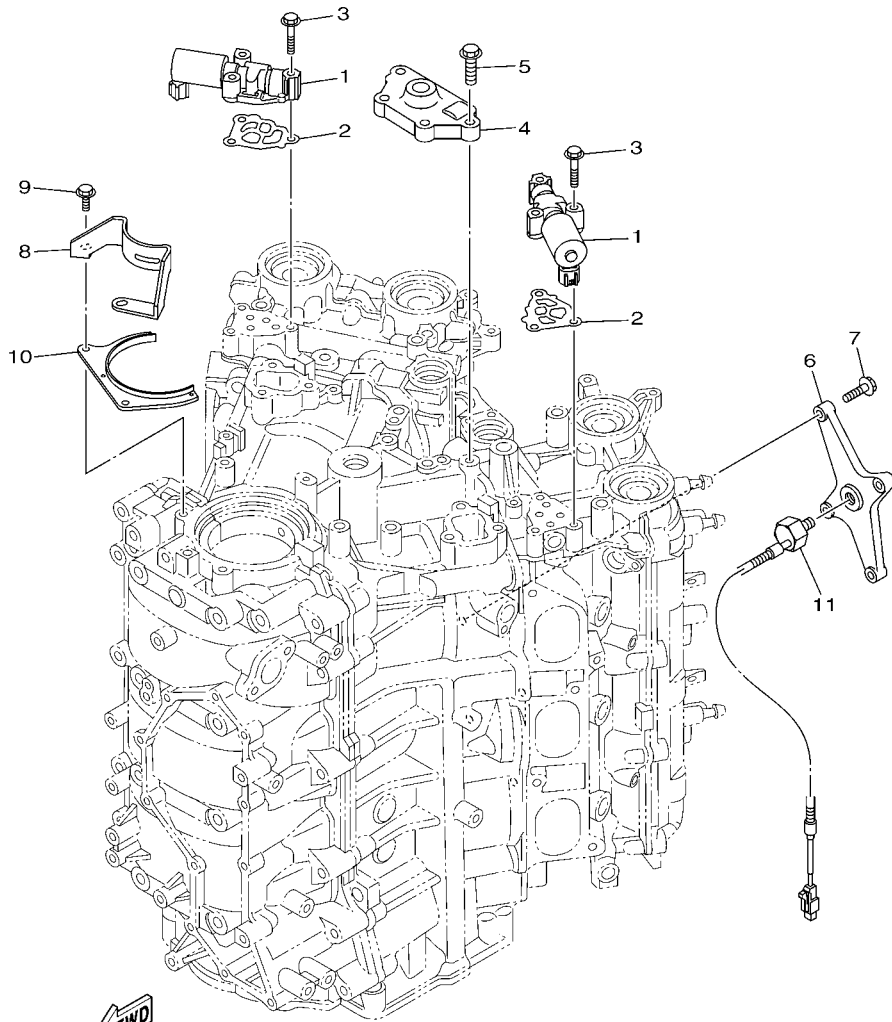

6CD6100-N060

FIG. 6 CYLINDER & CRANKCASE 3

REF. NO.	PART NO.	DESCRIPTION	6CD6				REMARKS
1	6CB-86120-00	SOLENOID VALVE ASSY	2				
2	6CB-1242F-00	GASKET, FILTER	2				
3	90105-06035	BOLT, FLANGE	6				
4	6CB-15544-00	STAY 1	1				
5	90105-08178	BOLT, FLANGE	4				
6	6CB-1135A-00	BRACKET	1				
7	90105-06037	BOLT, FLANGE	4				
8	6CB-15142-00	GUIDE 1	1				
9	95875-06016	BOLT, FLANGE	2				
10	6CB-1149A-00	PLATE 1	1				
11	6P2-85780-00	SENSOR, KNOCK	1				

FIG. 7 CYLINDER & CRANKCASE 4

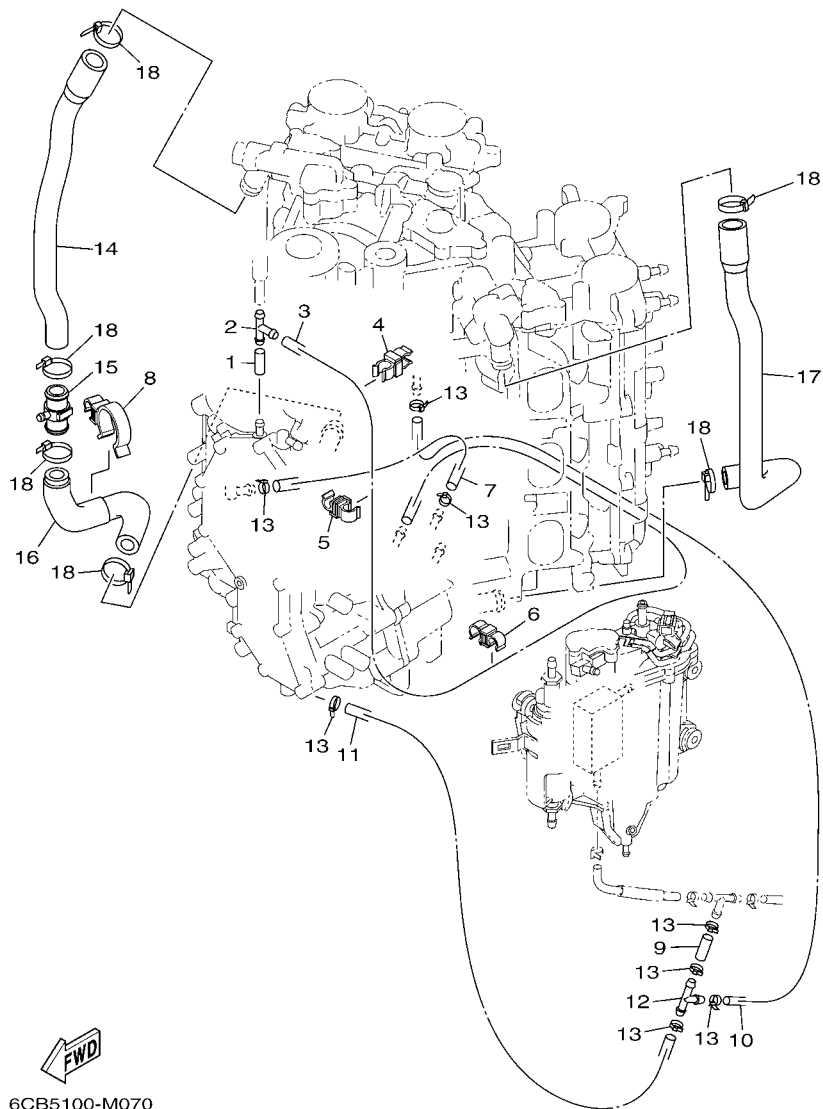

REF. NO.	PART NO.	DESCRIPTION	6CD6				REMARKS
1	90445-09220	HOSE (L30)	1				
2	688-24378-00	PIPE, JOINT 3	1				
3	6CB-12576-10	HOSE 1	1				
4	90464-10M59	CLAMP	1				
5	90464-09013	CLAMP	1				
6	90464-12010	CLAMP	1				
7	6CB-12577-00	HOSE 2	1				
8	90464-26002	CLAMP	1				
9	90445-09220	HOSE (L30)	1				
10	90445-09124	HOSE (L675)	1				
11	90445-096H2	HOSE (L280)	1				
12	688-24378-00	PIPE, JOINT 3	1				
13	90465-11M10	CLAMP	8				
14	6CE-1244G-00	HOSE, 4	1				
15	6CE-24378-00	PIPE, JOINT 3	1				
16	6CE-1244H-00	HOSE 5	1				
17	6CB-1243E-00	HOSE 2	1				
18	90465-11M59	CLAMP	6				

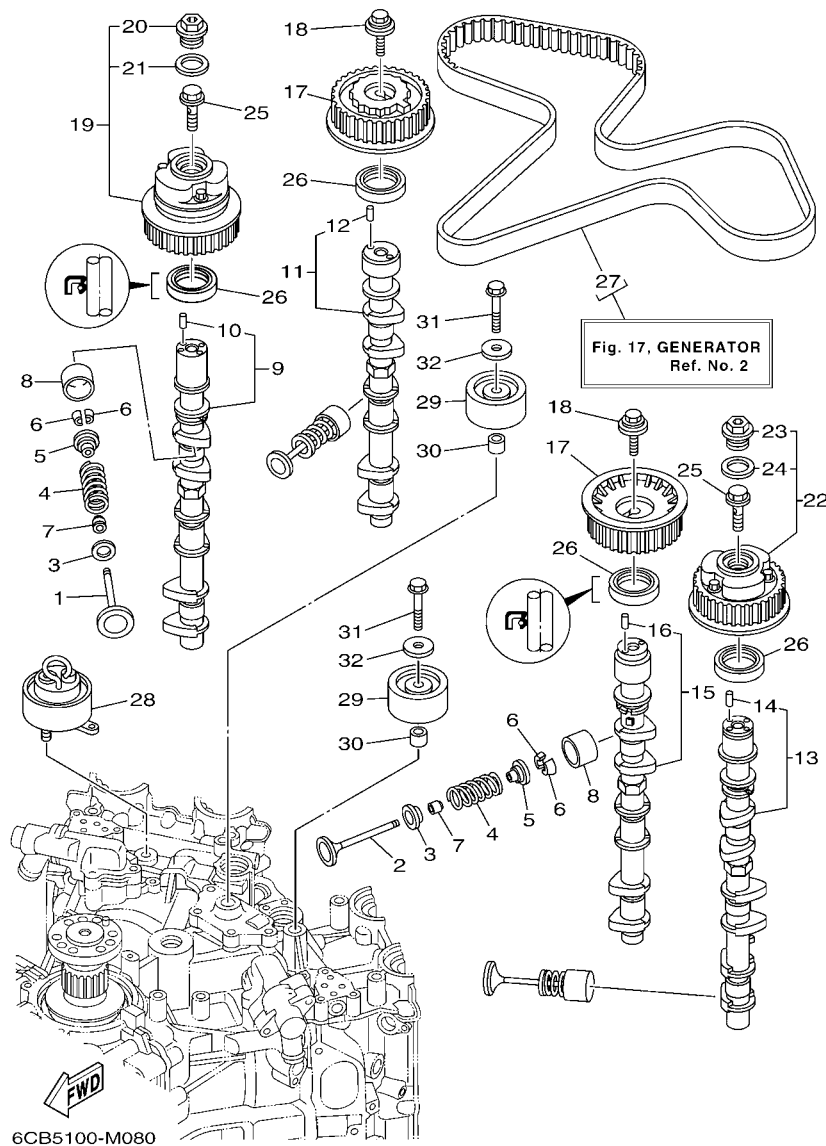

FIG. 8 VALVE

REF. NO.	PART NO.	DESCRIPTION	6CD6				REMARKS
1	6CB-12111-00	VALVE, INTAKE	12				
2	6CB-12121-00	VALVE, EXHAUST	12				
3	K0F-A3743-00	SEAT, VALVE SPRING	24				
4	6CB-12113-00	SPRING, VALVE INNER	24				
5	K0F-A3741-00	RETAINER, VALVE SPRING	24				
6	K0F-A3742-00	LOCK, VALVE SPRING RETAINER	48				
7	51Y-12119-00	SEAL, VALVE STEM	24				
8	K0F-A3751-00	LIFTER, VALVE (3.000)	24				UR
	K0F-A3751-10	LIFTER, VALVE (3.025)	24				UR
	K0F-A3751-20	LIFTER, VALVE (3.050)	24				UR
	K0F-A3751-30	LIFTER, VALVE (3.075)	24				UR
	K0F-A3751-40	LIFTER, VALVE (3.100)	24				UR
	K0F-A3751-50	LIFTER, VALVE (3.122)	24				UR
	K0F-A3751-60	LIFTER, VALVE (3.142)	24				UR
	K0F-A3751-70	LIFTER, VALVE (3.162)	24				UR
	K0F-A3751-80	LIFTER, VALVE (3.182)	24				UR
	K0F-A3751-90	LIFTER, VALVE (3.202)	24				UR
	K0F-A3751-A0	LIFTER, VALVE (3.222)	24				UR
	K0F-A3751-B0	LIFTER, VALVE (3.242)	24				UR
	K0F-A3751-C0	LIFTER, VALVE (3.262)	24				UR
	K0F-A3751-D0	LIFTER, VALVE (3.282)	24				UR
	K0F-A3751-E0	LIFTER, VALVE (3.302)	24				UR
	K0F-A3751-F0	LIFTER, VALVE (3.322)	24				UR
	K0F-A3751-G0	LIFTER, VALVE (3.342)	24				UR
	K0F-A3751-H0	LIFTER, VALVE (3.362)	24				UR
	K0F-A3751-J0	LIFTER, VALVE (3.382)	24				UR
	K0F-A3751-K0	LIFTER, VALVE (3.402)	24				UR

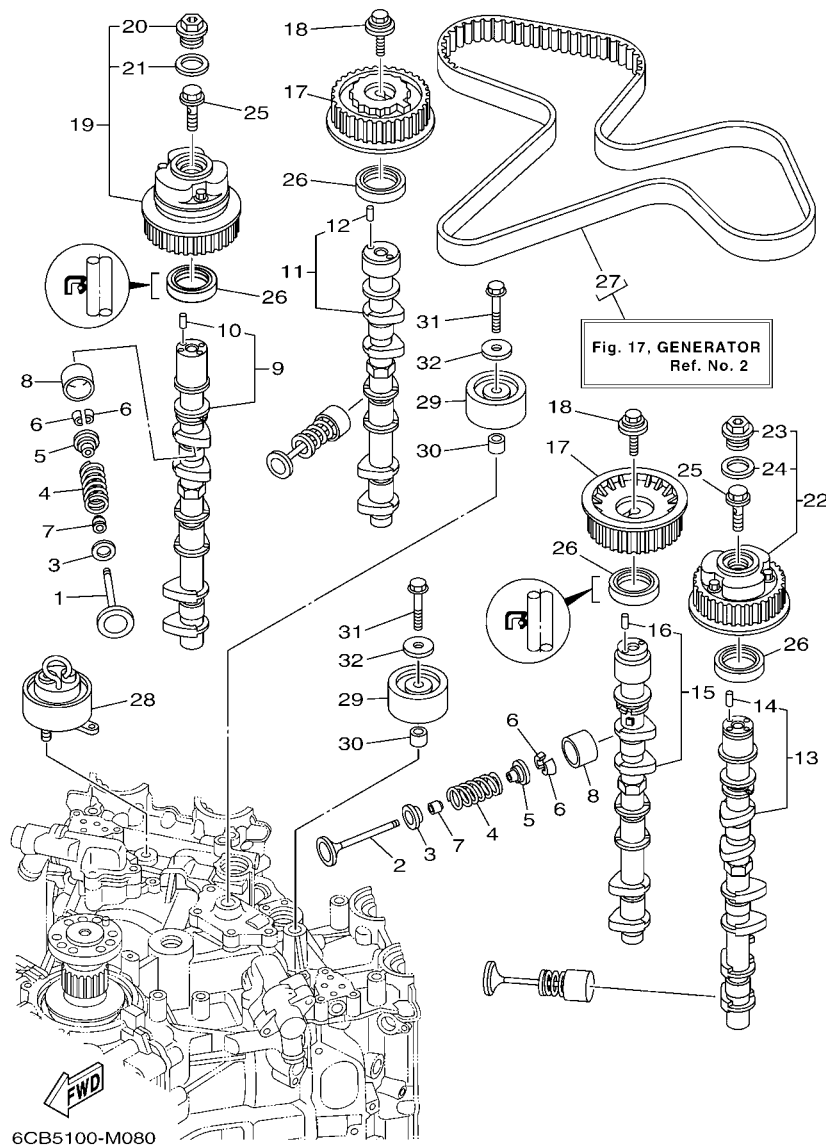

FIG. 8 VALVE

REF. NO.	PART NO.	DESCRIPTION	6CD6			REMARKS
8	K0F-A3751-L0	LIFTER, VALVE (3.422)	24			UR
	K0F-A3751-M0	LIFTER, VALVE (3.442)	24			UR
	K0F-A3751-N0	LIFTER, VALVE (3.462)	24			UR
	K0F-A3751-P0	LIFTER, VALVE (3.482)	24			UR
	K0F-A3751-R0	LIFTER, VALVE (3.502)	24			UR
	K0F-A3751-S0	LIFTER, VALVE (3.522)	24			UR
	K0F-A3751-T0	LIFTER, VALVE (3.542)	24			UR
	K0F-A3753-00	LIFTER, VALVE (3.562)	24			UR
	K0F-A3753-10	LIFTER, VALVE (3.582)	24			UR
	K0F-A3753-20	LIFTER, VALVE (3.602)	24			UR
	K0F-A3753-30	LIFTER, VALVE (3.625)	24			UR
	K0F-A3753-40	LIFTER, VALVE (3.650)	24			UR
	K0F-A3753-50	LIFTER, VALVE (3.675)	24			UR
	K0F-A3753-60	LIFTER, VALVE (3.700)	24			UR
	K0F-A3753-70	LIFTER, VALVE (3.725)	24			UR
9	6CB-12171-00	CAMSHAFT 1	1			
10	93605-10108	.PIN, DOWEL	1			
11	6CB-12181-00	CAMSHAFT 2	1			
12	93605-10108	.PIN, DOWEL	1			
13	6CB-12172-00	CAMSHAFT 3	1			
14	93605-10108	.PIN, DOWEL	1			
15	6CB-12182-00	CAMSHAFT 4	1			
16	93605-10108	.PIN, DOWEL	1			
17	6CB-11567-00	GEAR, DRIVEN 2	2			
18	90119-10050	BOLT, WITH WASHER	2			
19	6CB-12645-01	PULLEY ASSY 1	1			
20	6P2-12623-00	.BOLT	1			



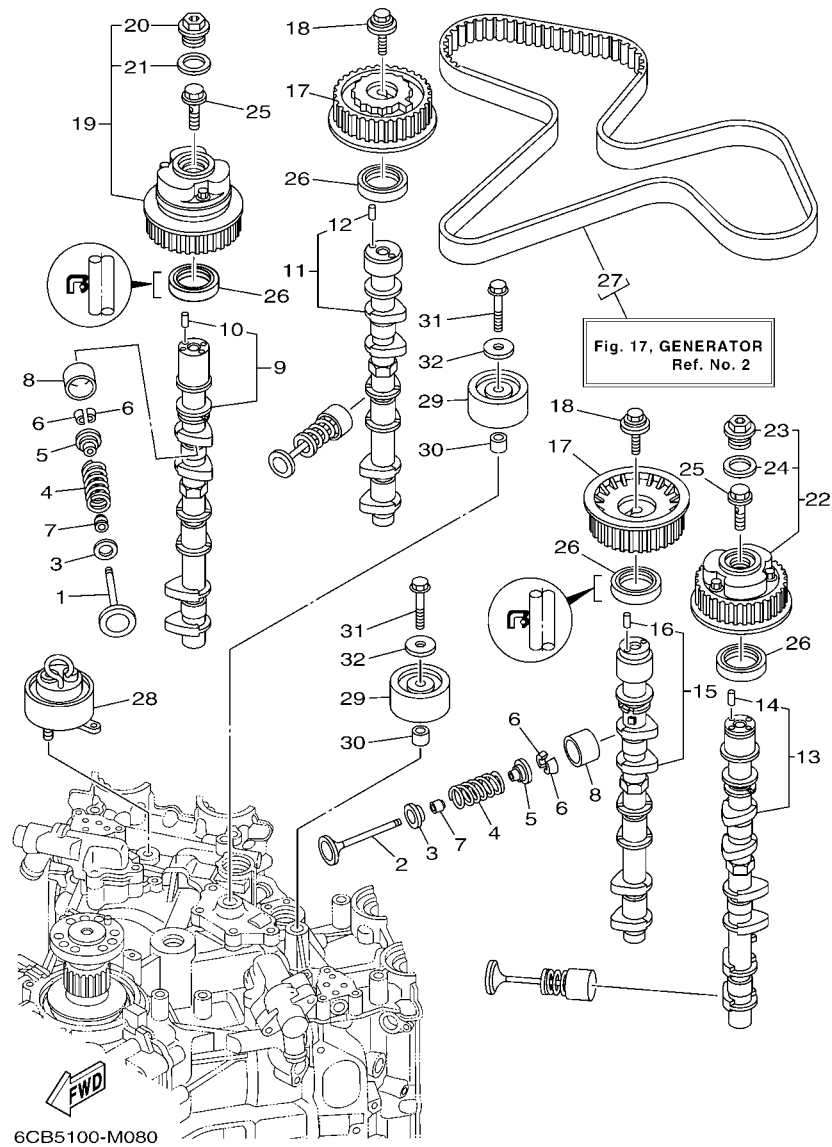

FIG. 8 VALVE

REF. NO.	PART NO.	DESCRIPTION	6CD6				REMARKS
21	6P2-12663-00	.GASKET	1				
22	6CB-1264A-01	PULLEY ASSY 2	1				
23	6P2-12623-00	.BOLT	1				
24	6P2-12663-00	.GASKET	1				
25	6P2-12615-00	BOLT	2				
26	93102-38008	OIL SEAL	4				
27	6CB-W4624-00	BELT (WITH ROTOR BOLTS)	1				
28	6CB-11590-01	TENSIONER ASSY	1				
29	6CB-15512-00	GEAR, IDLER 1	2				
30	99530-14016	PIN, DOWEL	2				
31	90119-10M07	BOLT, WITH WASHER	2				
32	90201-10M01	WASHER, PLATE	2				

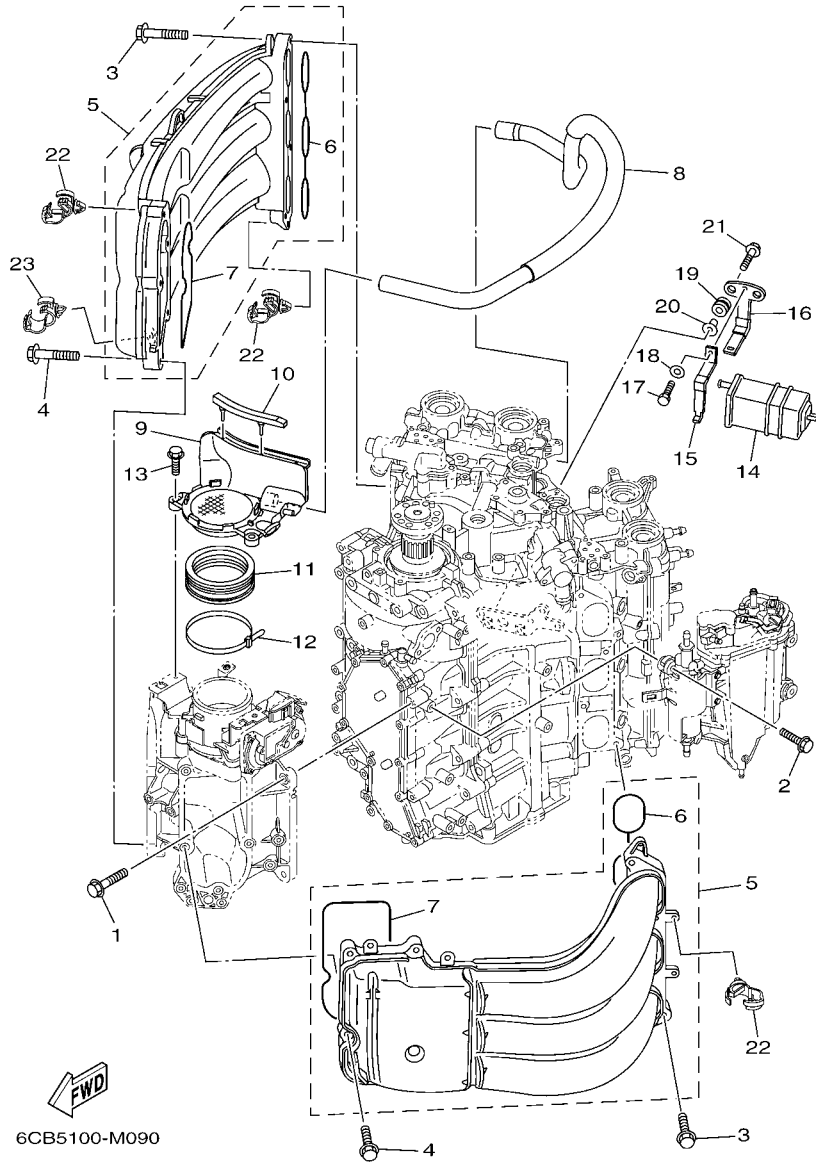
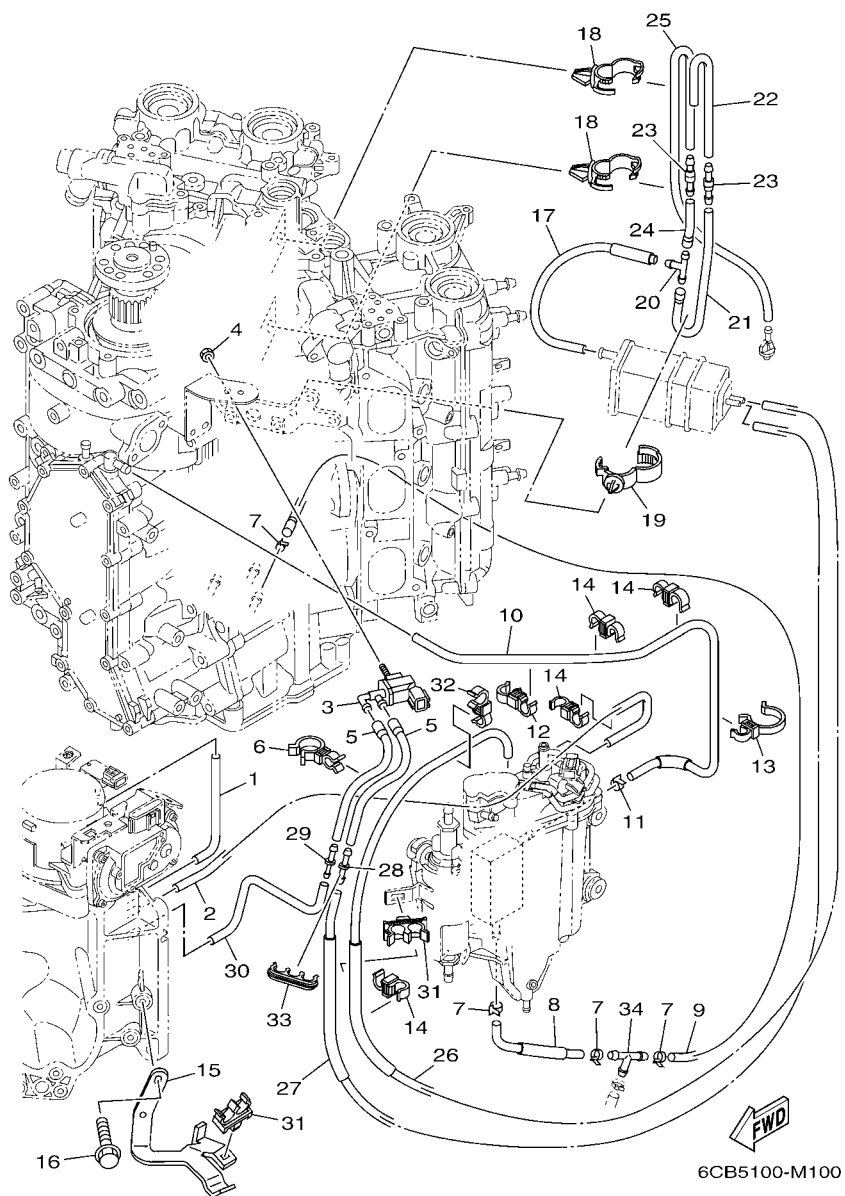

FIG. 9 INTAKE 1

REF. NO.	PART NO.	DESCRIPTION	6CD6				REMARKS
1	95875-08030	BOLT, FLANGE	4				
2	90119-06M24	BOLT, WITH WASHER	4				
3	90119-08020	BOLT, WITH WASHER	8				
4	90105-06035	BOLT, FLANGE	10				
5	6CB-13641-00	MANIFOLD, INTAKE 1	2				
6	6CB-13645-00	.GASKET, MANIFOLD 1	1				
7	6CB-13646-00	.GASKET, MANIFOLD 2	1				
8	6CB-15373-00	PIPE, BREATHER	1				
9	6CB-14440-01	SILENCER ASSY, INTAKE	1				
10	6CB-85547-00	DAMPER	1				
11	6AW-1441J-00	PIPE, SILENCER	1				
12	90464-99004	CLAMP	1				
13	95895-06020	BOLT, FLANGE	2				
14	69J-24170-00	CANISTER ASSY	1				
15	69J-2419A-01	HOLDER	1				
16	69J-2134X-00	BRACKET, CANISTER	1				
17	97095-06016	BOLT	1				
18	92995-06600	WASHER	1				
19	90480-10M23	GROMMET	2				
20	90387-06289	COLLAR	2				
21	90119-06M17	BOLT, WITH WASHER	2				
22	90464-13249	CLAMP	8				
23	90464-20181	CLAMP	1				

FIG. 10 INTAKE 2



REF. NO.	PART NO.	DESCRIPTION	6CD6				REMARKS
1	6CB-13533-00	HOSE, VACUUM SENSING 4	1				
2	6CB-13532-10	HOSE, VACUUM SENSING 3	1				
3	6C5-86120-00	SOLENOID VALVE ASSY	1				
4	95380-06600	NUT, HEXAGON	1				
5	6CB-2416A-00	HOSE	2				
6	90464-23001	CLAMP	2				
7	90465-11M10	CLAMP	4				
8	6CE-12482-10	PIPE 2	1				
9	90445-097F7	HOSE (L780)	1				
10	6CB-12484-00	PIPE 4	1				
11	90465-11M10	CLAMP	1				
12	90464-12010	CLAMP	1				
13	90464-26002	CLAMP	1				
14	90464-09013	CLAMP	4				
15	6CB-13782-00	STAY	1				
16	95895-06016	BOLT, FLANGE	2				
17	6CB-13545-00	HOSE 1	1				
18	90464-20181	CLAMP	2				
19	90464-07209	CLAMP	1				
20	688-24378-00	PIPE, JOINT 3	1				
21	6CB-13546-00	HOSE 2	1				
22	6CB-13547-00	HOSE 3	1				
23	6E5-21744-00	BREATHER	2				
24	6CB-13548-00	HOSE, AIR 4	1				
25	6CB-12483-00	PIPE 3	1				
26	6CB-1475A-00	PIPE 1	1				
27	6CB-1475F-00	PIPE 3	1				

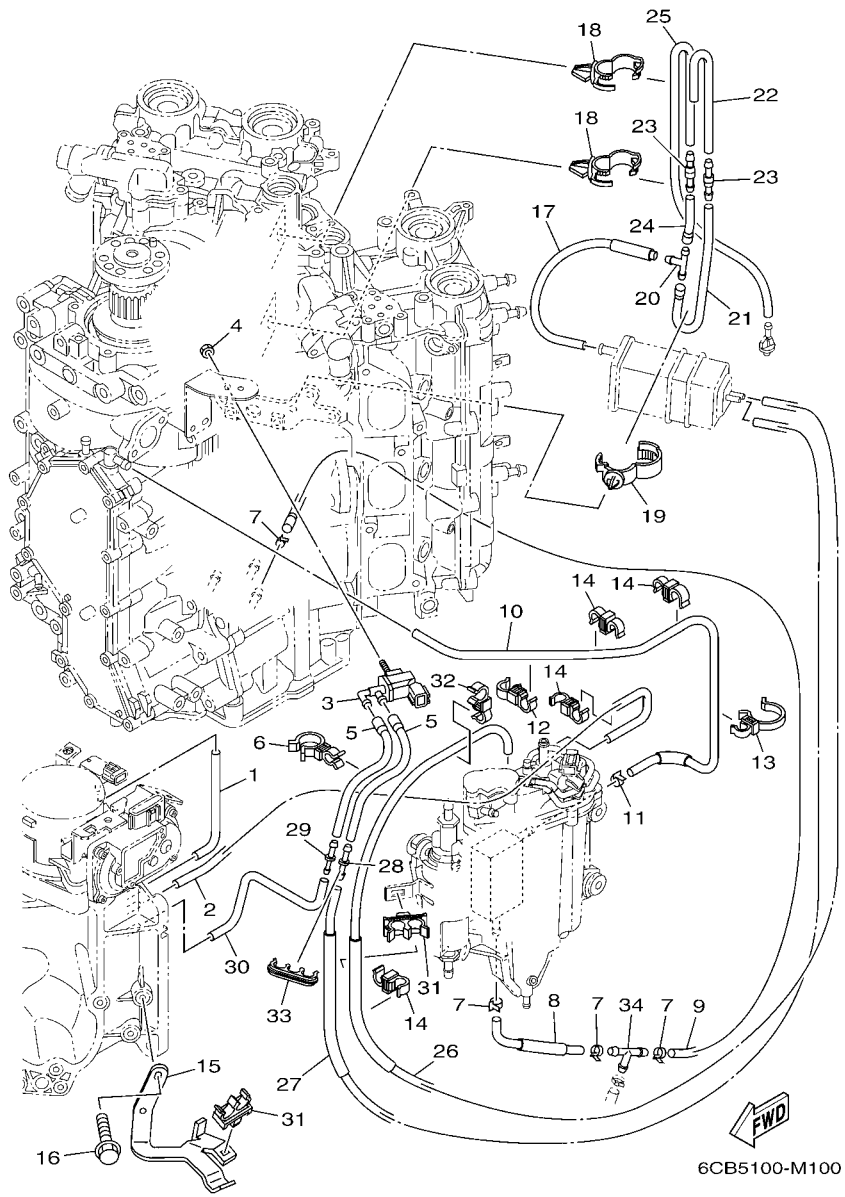

**FIG. 10 INTAKE 2**

REF. NO.	PART NO.	DESCRIPTION	6CD6				REMARKS
28	6G8-24376-00	PIPE, JOINT 1	1				
29	6CB-14989-00	ORIFICE, AIR VENT	1				
30	6CB-1475G-00	PIPE 4	1				
31	90464-11012	CLAMP	2				
32	90464-12010	CLAMP	1				
33	90464-10011	CLAMP	1				
34	688-24378-00	PIPE, JOINT 3	1				
-----							
-----							
-----							
-----							
-----							
-----							
-----							
-----							
-----							

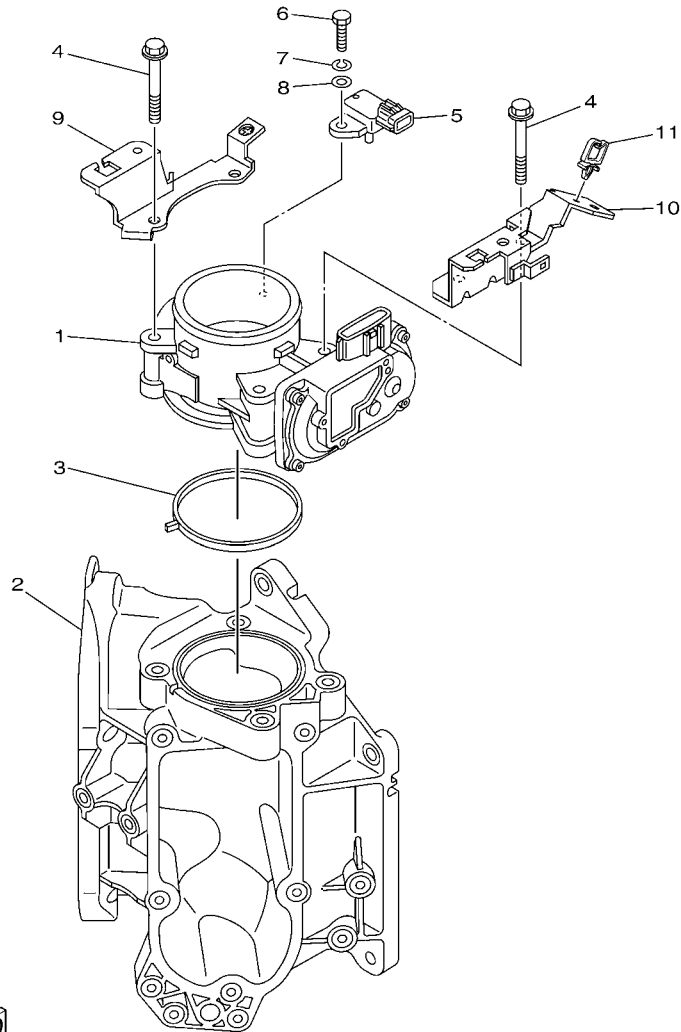

  
 6CB3110-L100

**FIG. 11 THROTTLE BODY ASSY 1**

REF. NO.	PART NO.	DESCRIPTION	6CD6				REMARKS
1	6CB-13751-00	BODY, THROTTLE 1	1				
2	6CB-13711-00	MIXING BODY	1				
3	6CB-13556-00	GASKET, MANIFOLD	1				
4	95875-08060	BOLT, FLANGE	4				
5	6P2-82380-00	SENSOR, PRESSURE	1				
6	97075-06020	BOLT	1				
7	92995-06100	WASHER, SPRING	1				
8	92995-06600	WASHER	1				
9	6CB-13898-00	HOLDER	1				
10	6CB-13898-10	HOLDER	1				
11	90464-08004	CLAMP	1				

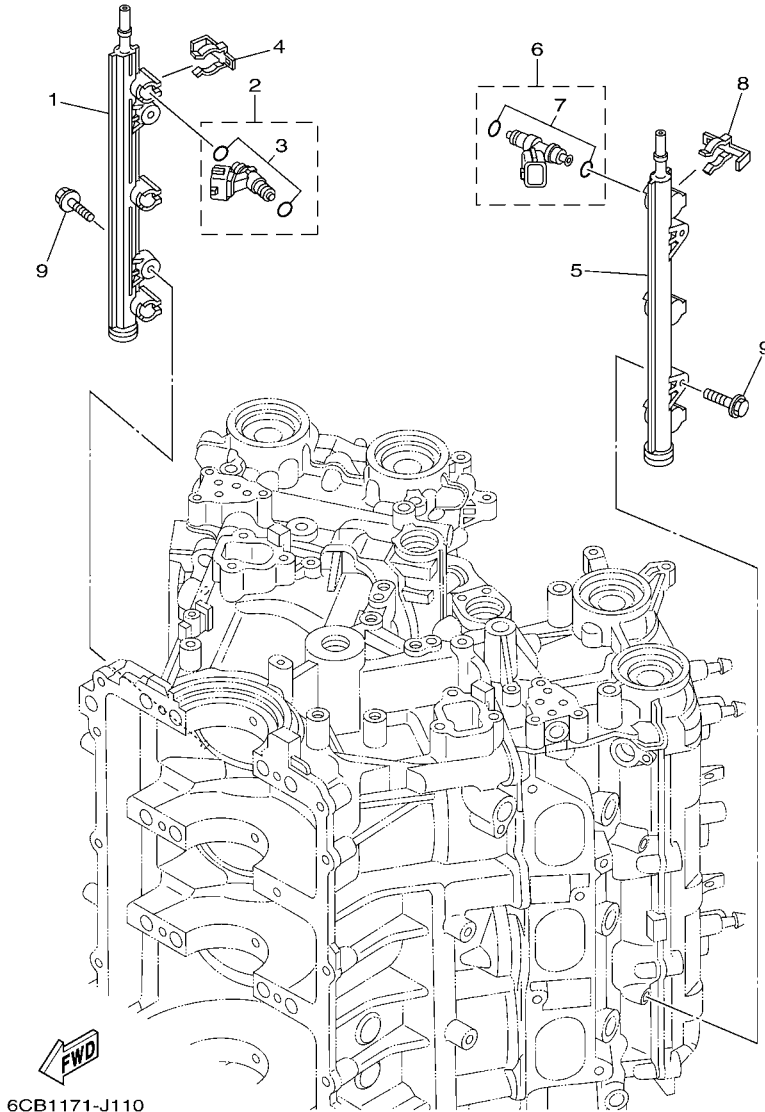

**FIG. 12 THROTTLE BODY ASSY 2**

REF. NO.	PART NO.	DESCRIPTION	6CD6				REMARKS
1	6CB-13161-00	PIPE, DELIVERY 1	1				
2	6AW-13761-00	INJECTOR	3				
3	6AW-1410B-00	.PACKING KIT	1				
4	6CB-13577-00	CLIP	3				
5	6CB-13171-00	PIPE, DELIVERY 2	1				
6	6AW-13761-00	INJECTOR	3				
7	6AW-1410B-00	.PACKING KIT	1				
8	6CB-13577-00	CLIP	3				
9	90105-06M08	BOLT, FLANGE	4				
-----							
-----							
-----							
-----							
-----							

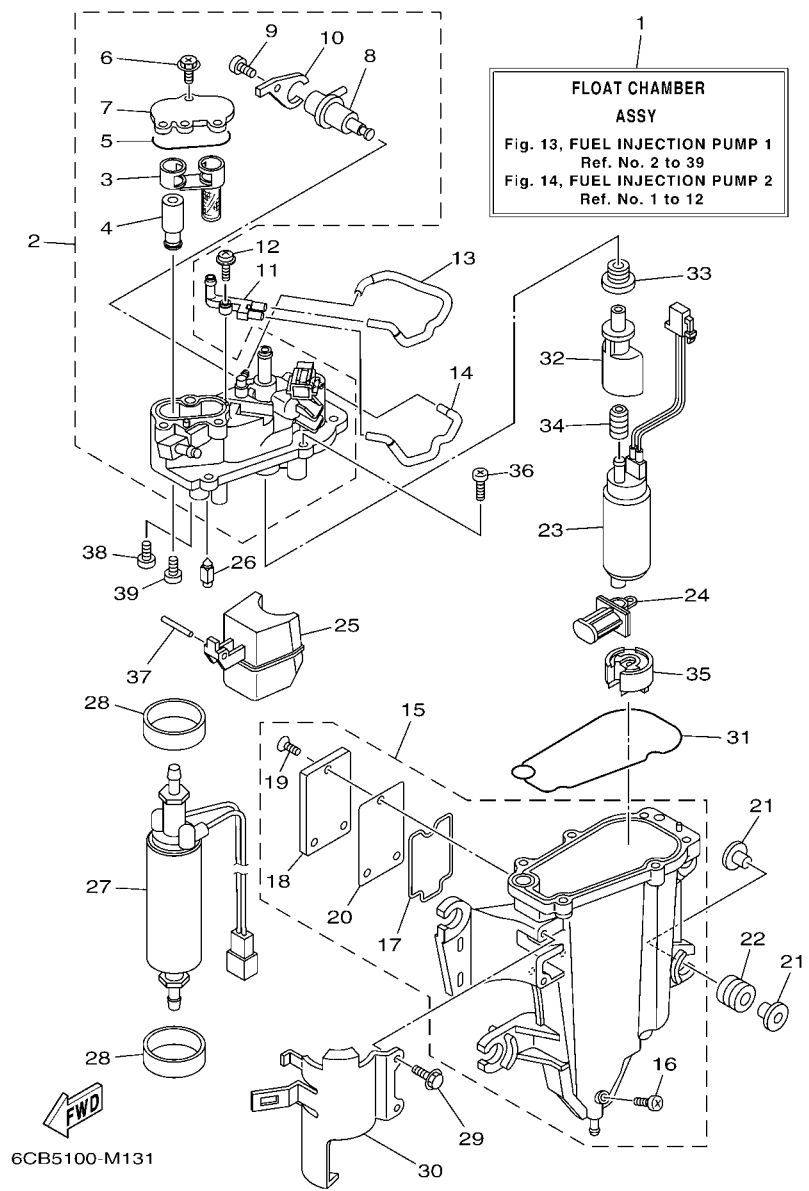

6CB5100-M131

FIG. 13 FUEL INJECTION PUMP 1

REF. NO.	PART NO.	DESCRIPTION	6CD6				REMARKS
1	6CB-14180-05	FLOAT CHAMBER ASSY	1				
2	6CB-14182-02	COVER, FLOAT CHAMBER	1				
3	6CB-24501-01	.FILTER, FUEL	1				
4	6CB-24460-00	.RELIEF VALVE ASSY	1				
5	6CB-13016-00	.O-RING	1				
6	6CB-14216-00	.SCREW	3				
7	6CB-24217-00	.COVER	1				
8	6CB-13906-01	.REGULATOR, PRESSURE	1				
9	6CB-14564-00	.SCREW	1				
10	6CB-14146-00	.PLATE	1				
11	68V-24379-10	PIPE, JOINT 4	1				
12	68V-14216-00	SCREW	1				
13	6CB-1475H-00	PIPE 5	1				
14	6CB-1475J-00	PIPE 6	1				
15	6CB-14181-01	BODY, FLOAT CHAMBER 1	1				
16	6P2-14191-00	.PLUG, DRAIN	1				
17	6CB-14239-00	.SEAL	1				
18	6CB-24452-10	.COVER	1				
19	6CB-14429-01	.SCREW	3				
20	6CB-24482-00	.GASKET 1	1				
21	69J-13716-00	COLLAR	8				
22	6CB-13593-00	DAMPER	4				
23	6CB-13907-10	FUEL PUMP COMP.	1				
24	63P-13915-00	FILTER	1				
25	6CB-14985-00	FLOAT	1				
26	6CB-14546-00	VALVE, NEEDLE	1				
27	6CB-24410-00	FUEL PUMP ASSY	1				

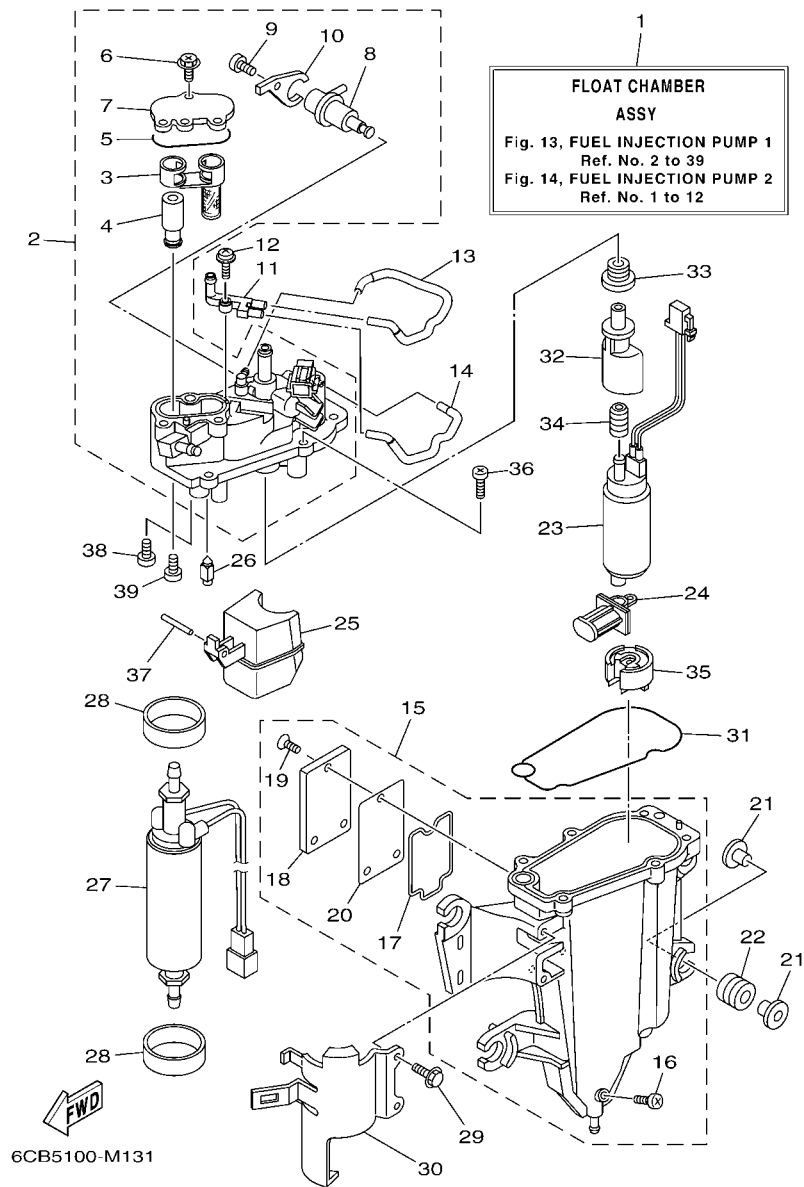
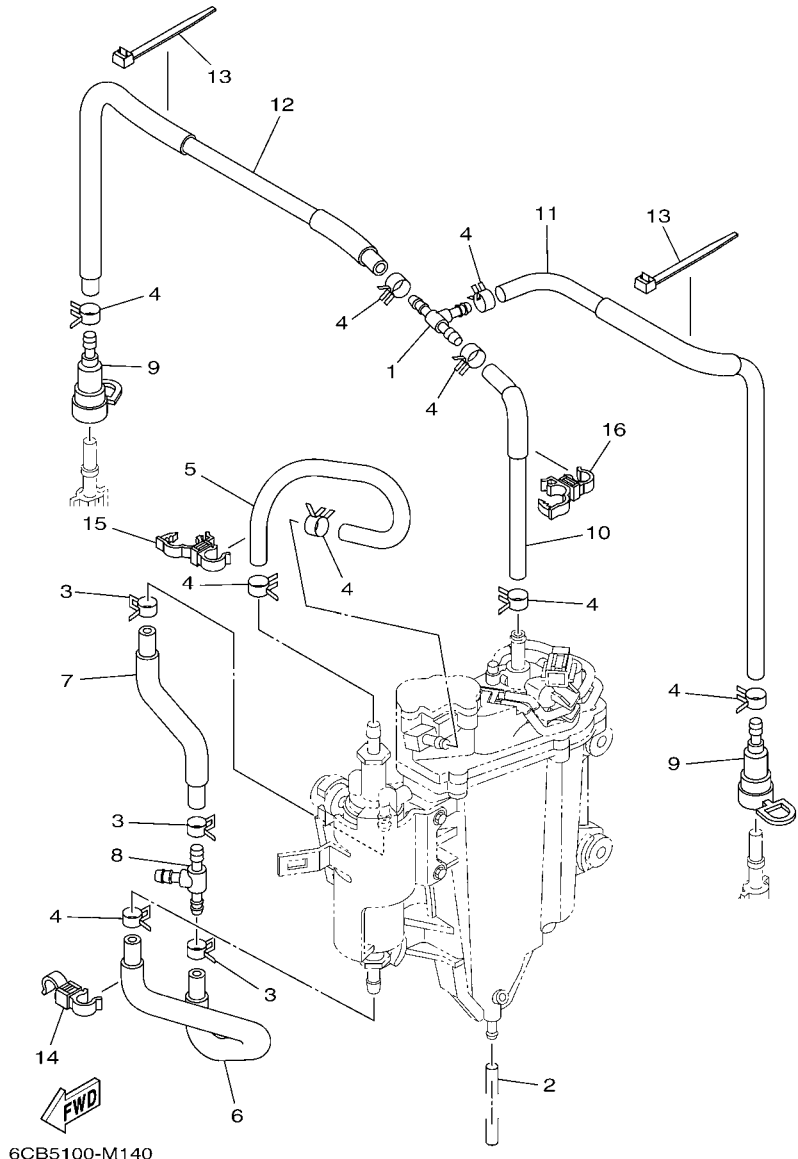

FIG. 13 FUEL INJECTION PUMP 1

REF. NO.	PART NO.	DESCRIPTION	6CD6				REMARKS
28	6CB-24492-00	BUSH, FUEL PUMP	2				
29	6CB-24592-00	BOLT	2				
30	6CB-24491-00	BRACKET, FUEL PUMP	1				
31	6CB-14984-00	GASKET, FLOAT CHAMBER	1				
32	6AW-13132-00	JOINT	1				
33	6CB-1447B-00	BUSH 1	1				
34	6AW-13781-00	DAMPER, PUMP	1				
35	6AW-13784-00	COVER, PUMP	1				
36	63P-14567-00	SCREW	6				
37	6P2-14386-00	PIN, FLOAT	1				
38	4SV-24453-00	SCREW	1				
39	98507-04008	SCREW, PAN HEAD	1				





**FIG. 14 FUEL INJECTION PUMP 2**

REF. NO.	PART NO.	DESCRIPTION	6CD6				REMARKS
1	6CB-24461-00	PIPE, JOINT	1				
2	6P2-14149-00	PIPE	1				
3	69J-14137-00	CLIP	3				
4	68V-13577-00	CLIP	9				
5	6CB-24324-00	PIPE 13	1				
6	6CB-24317-00	PIPE 7	1				
7	6CB-24323-00	PIPE 12	1				
8	6E5-24378-00	PIPE, JOINT 3	1				
9	60E-24300-01	FUEL PIPE JOINT	2				
10	6CB-13971-01	PIPE, FUEL 1	1				
11	6CB-13974-01	PIPE, FUEL 4	1				
12	6CB-13972-00	PIPE, FUEL 2	1				
13	90465-14M66	CLAMP	2				
14	90464-12009	CLAMP	1				
15	90464-12012	CLAMP	1				
16	90464-12012	CLAMP	1				

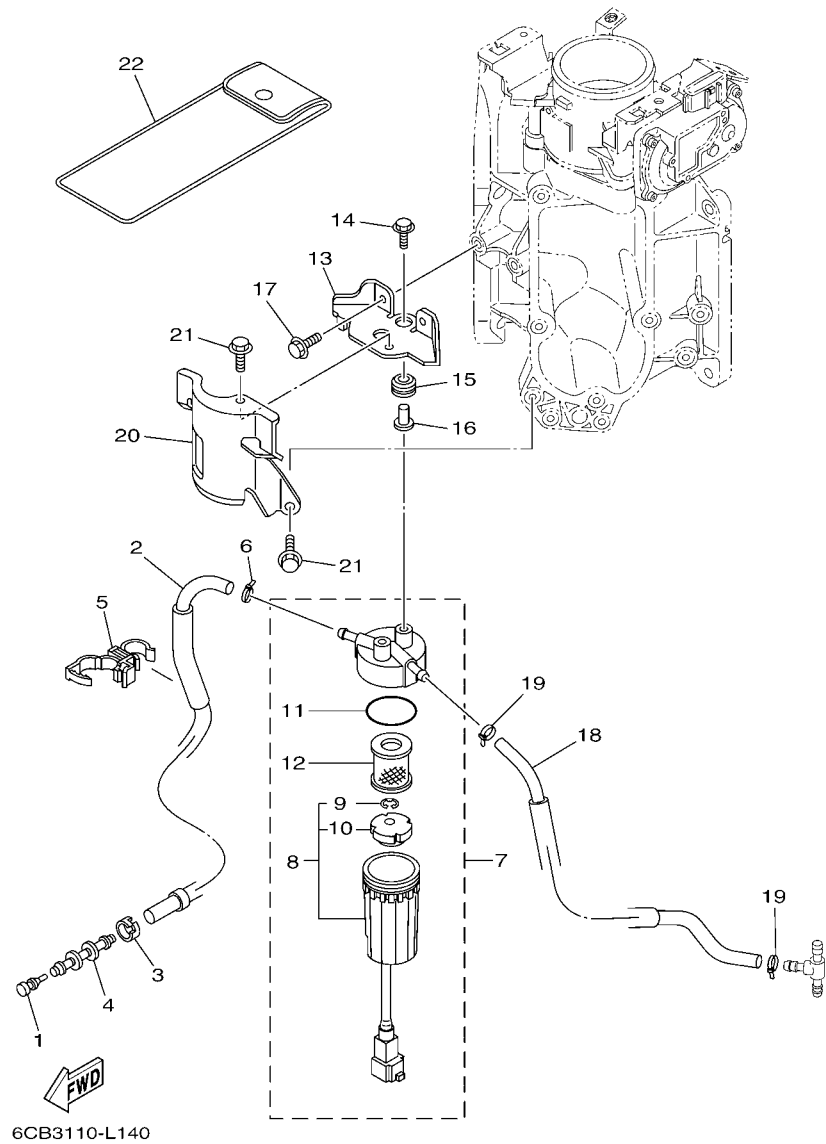
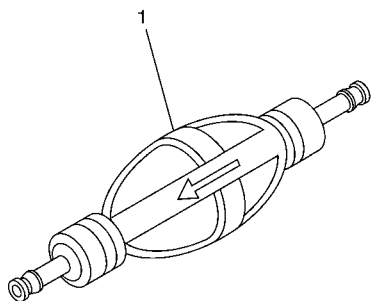

FIG. 15 FUEL 1

REF. NO.	PART NO.	DESCRIPTION	6CD6				REMARKS
1	689-85547-00	DAMPER	1				
2	6CB-24314-11	PIPE 4	1				
3	6E5-24351-51	BAND 1	1				
4	6AW-24377-01	PIPE, JOINT 2	1				
5	90464-12012	CLAMP	1				
6	90465-11M10	CLAMP	1				
7	6P3-24560-22	FILTER ASSY	1				
8	6P3-24562-21	.CUP, FILTER	1				
9	6P3-24519-00	..CLIP	1				
10	6P3-24469-00	..FLOAT, WATER LEVEL	1				
11	6P3-24564-00	.GASKET	1				
12	6P3-24563-01	.ELEMENT, FILTER	1				
13	6CB-24566-00	BRACKET, FILTER	1				
14	90119-06M17	BOLT, WITH WASHER	2				
15	90480-10M23	GROMMET	2				
16	90387-06289	COLLAR	2				
17	95895-06016	BOLT, FLANGE	2				
18	6CB-24313-10	PIPE 3	1				
19	90465-11M10	CLAMP	2				
20	6CB-24596-01	COVER	1				
21	95895-06014	BOLT, FLANGE	2				
22	69J-28100-01	TOOL KIT	1				AP

FIG. 16 FUEL 2



REF. NO.	PART NO.	DESCRIPTION	6CD6					REMARKS
1	6AW-24360-01	PRIMER PUMP ASSY	1					AP

  
68V9110-J110

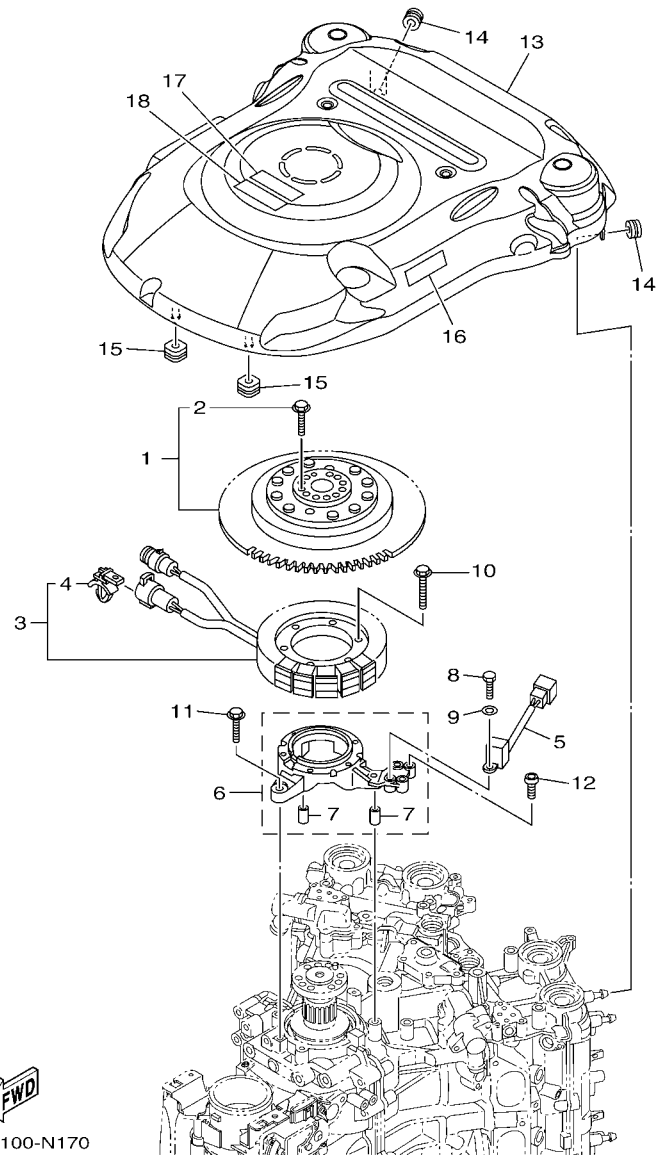

FIG. 17 GENERATOR

REF. NO.	PART NO.	DESCRIPTION	6CD6				REMARKS
1	6CB-W8145-00	ROTOR ASSY WITH BOLTS	1				
2	6AW-W9011-00	.BOLT SET (FOR ROTOR ASSY)	1				
3	6CB-81410-00	STATOR ASSY	1				
4	90464-12002	.CLAMP	1				
5	6CB-85580-00	COIL, PULSER	1				
6	6CB-85561-00	BASE, MAGNETO	1				
7	99530-08012	.PIN, DOWEL	2				
8	97095-05020	BOLT	2				
9	92995-05600	WASHER	2				
10	95022-06030	BOLT, FLANGE	6				
11	95895-06030	BOLT, FLANGE	4				
12	92014-05012	BOLT, BUTTON HEAD	1				
13	6CB-81337-01	COVER, FLYWHEEL	1				
14	90480-12314	GROMMET	2				
15	6CB-85516-00	SPACER	2				
16	6CB-13437-50	MARK, CAUTION	1				
17	6AH-81994-40	LABEL, SAFETY	1				
18	6AH-81994-50	LABEL, SAFETY	1				

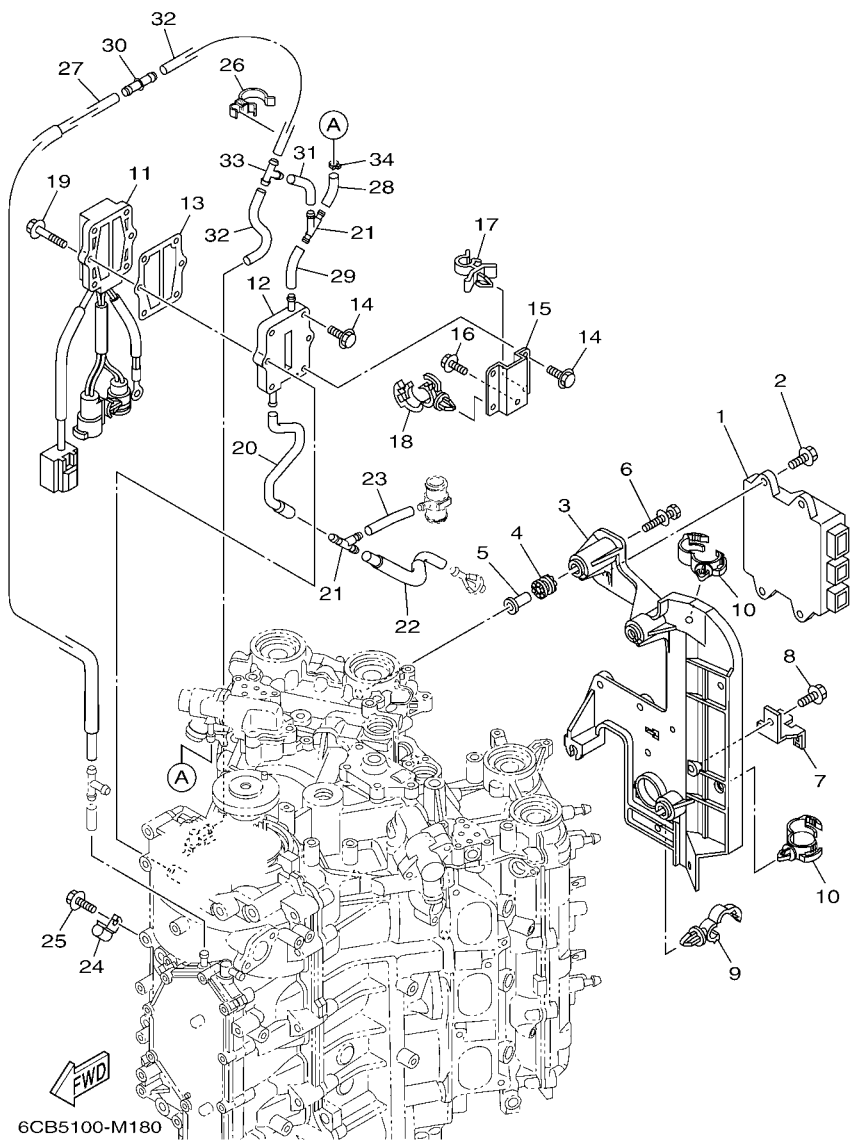

FIG. 18 ELECTRICAL 1

REF. NO.	PART NO.	DESCRIPTION	6CD6				REMARKS
1	6CD-8591A-04	ENGINE CONTROL UNIT ASSY	1				
2	95895-06020	BOLT, FLANGE	4				
3	6CB-82316-01	BRACKET, IGNITION COIL	1				
4	64J-85516-00	SPACER	4				
5	69M-42758-01	COLLAR	4				
6	90119-06M56	BOLT, WITH WASHER	4				
7	6BR-81845-00	PLATE	1				
8	95895-06012	BOLT, FLANGE	1				
9	90464-13249	CLAMP	1				
10	90464-20181	CLAMP	2				
11	6CB-81960-00	RECTIFIER & REGULATOR ASSY	1				
12	6CB-81972-00-9S	COVER, RECTIFIER	1				
13	69J-81975-A0	PLATE, RECTIFIER FITTING	1				
14	90119-06MA4	BOLT, WITH WASHER	4				
15	6CB-81975-00	PLATE, RECTIFIER FITTING	1				
16	95895-06014	BOLT, FLANGE	1				
17	90464-09129	CLAMP	1				
18	90464-20181	CLAMP	1				
19	90119-06MA5	BOLT, WITH WASHER	2				
20	6CB-1248E-10	PIPE 9	1				
21	6CE-24377-00	PIPE, JOINT 2	2				
22	6CE-12483-00	PIPE 3	1				
23	90445-107A5	HOSE (L30)	1				
24	90462-06013	CLAMP	1				
25	95023-06012	BOLT	1				
26	90464-26002	CLAMP	1				
27	6CE-12481-10	PIPE 1	1				

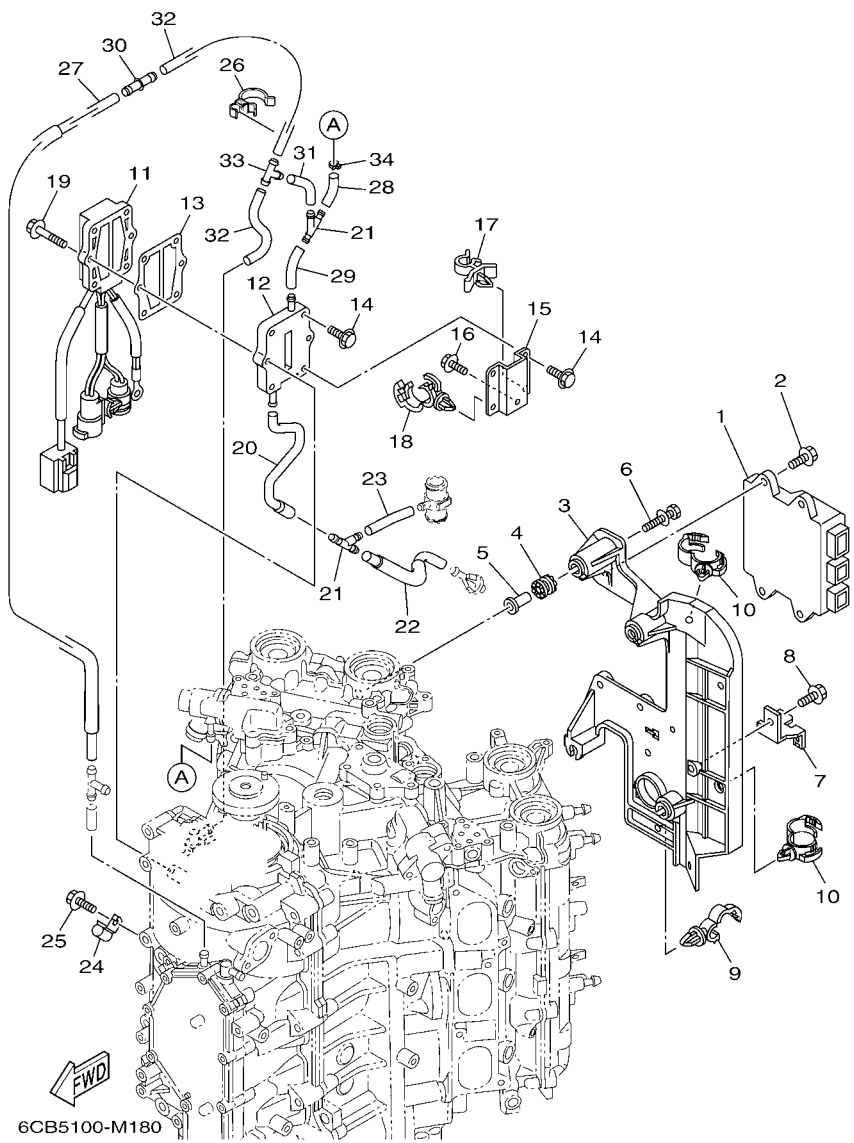
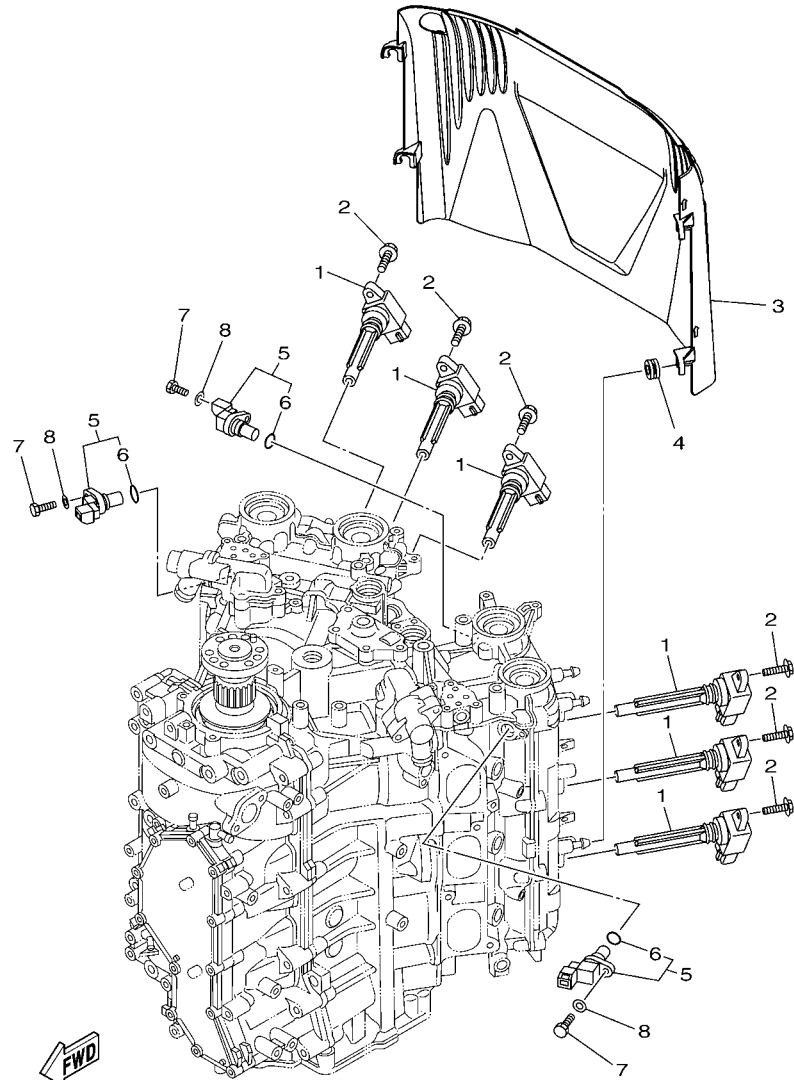

FIG. 18 ELECTRICAL 1

REF. NO.	PART NO.	DESCRIPTION	6CD6				REMARKS
28	6CE-14872-00	PIPE 2	1				
29	6CE-14872-00	PIPE 2	1				
30	6CE-24376-00	PIPE, JOINT 1	1				
31	6CE-14872-00	PIPE 2	1				
32	90445-09068	HOSE (L110)	2				
33	688-24378-00	PIPE, JOINT 3	1				
34	90465-11M10	CLAMP	1				
-----							
-----							
-----							
-----							
-----							
-----							
-----							
-----							
-----							
-----							



6CB2110-K180

FIG. 19 ELECTRICAL 2

REF. NO.	PART NO.	DESCRIPTION	6CD6				REMARKS
1	6CB-82310-00	IGNITION COIL ASSY	6				
2	95895-06025	BOLT, FLANGE	6				
3	6CB-82314-00	COVER, IGNITION COIL	1				
4	90480-12314	GROMMET	4				
5	6P2-85896-00	SENSOR, CAM POSITION	3				
6	6P2-85075-00	.O-RING	1				
7	97095-06020	BOLT	3				
8	92995-06600	WASHER	3				

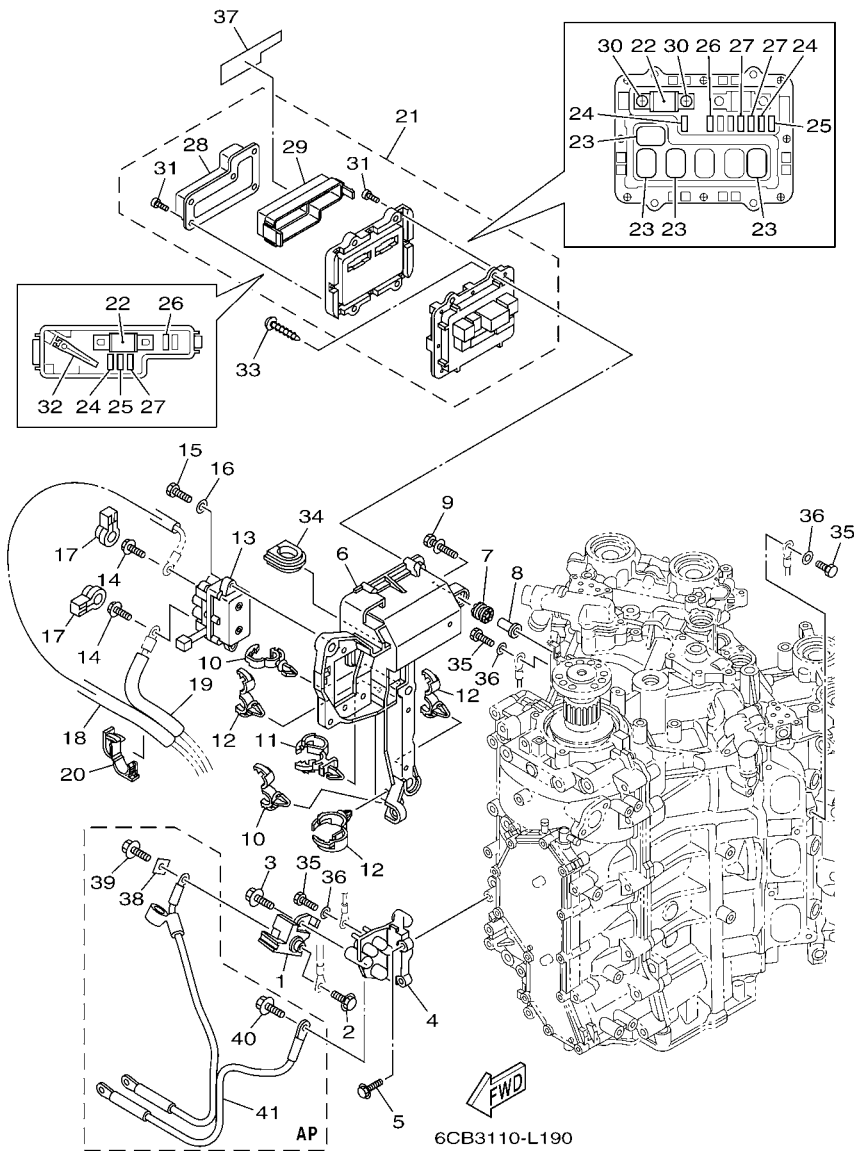

FIG. 20 ELECTRICAL 3

REF. NO.	PART NO.	DESCRIPTION	6CD6				REMARKS
1	6P2-81925-01	TERMINAL	1				
2	95895-08016	BOLT, FLANGE	1				
3	95814-08020	BOLT, FLANGE	1				
4	6CB-81929-00	BRACKET, TERMINAL	1				
5	95895-06020	BOLT, FLANGE	2				
6	6CB-81948-01	BRACKET	1				
7	64J-85516-00	SPACER	5				
8	69M-42758-01	COLLAR	5				
9	90119-06M56	BOLT, WITH WASHER	5				
10	90464-13249	CLAMP	2				
11	90464-12183	CLAMP	1				
12	90464-20181	CLAMP	3				
13	63P-81950-00	RELAY ASSY	1				
14	97595-06610	BOLT, WITH WASHER	2				
15	97013-06020	BOLT	2				
16	92903-06600	WASHER, PLATE	2				
17	6P2-8183X-00	CAP, TERMINAL	2				
18	90446-15005	HOSE (L200)	1				
19	90446-15M07	HOSE (L60)	1				
20	90464-18004	CLAMP	1				
21	6CB-82170-00	FUSE BOX ASSY	1				
22	6P2-82151-00	.FUSE (60A)	2				
23	68F-8195A-00	.RELAY ASSY	4				
24	67F-82151-40	.FUSE (10A)	3				
25	67F-82151-50	.FUSE (15A)	2				
26	67F-82151-00	.FUSE (20A)	2				
27	67F-82151-10	.FUSE (30A)	3				



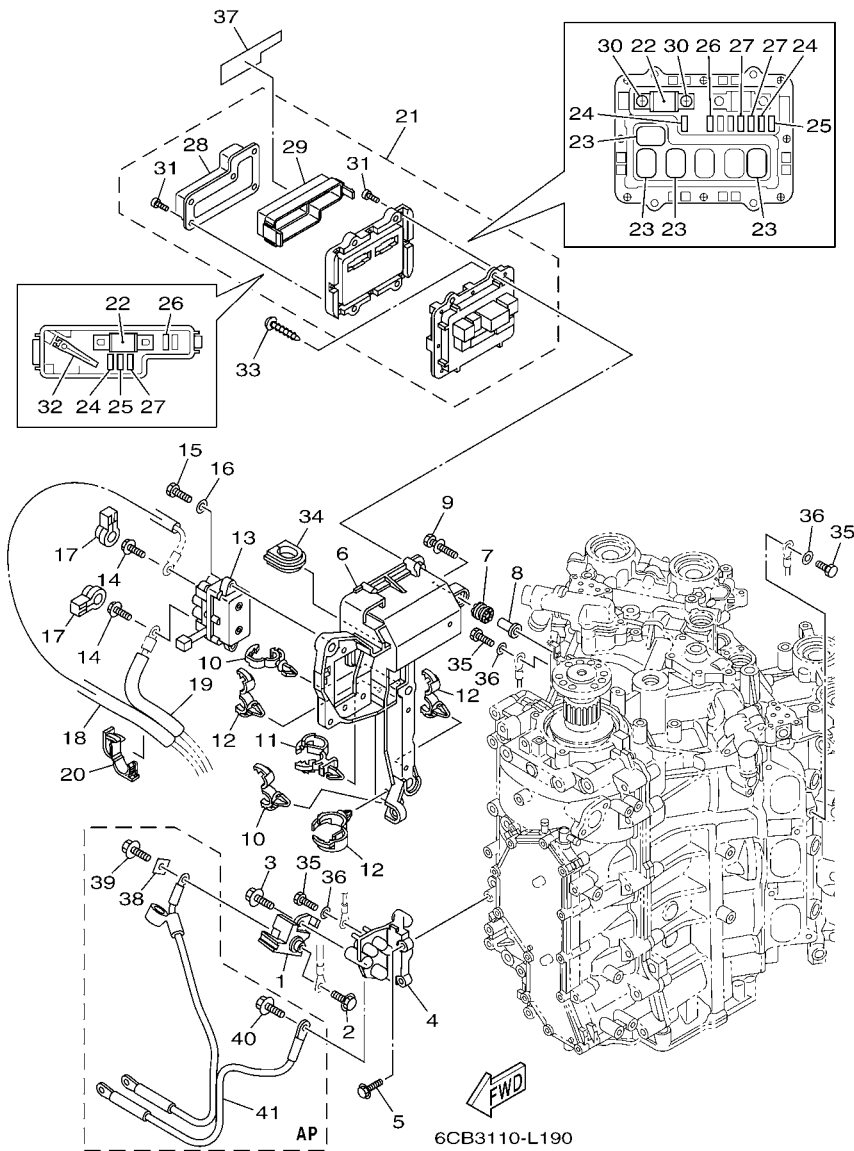

FIG. 20 ELECTRICAL 3

REF. NO.	PART NO.	DESCRIPTION	6CD6				REMARKS
28	6CB-81639-00	.COVER	1				
29	6CB-85544-00	.CASE	1				
30	68F-82846-00	.SCREW, PAN HEAD (M5)	2				
31	6P2-82113-00	.SCREW	13				
32	67F-2812A-00	.PULLER, FUSE	1				
33	97780-50620	SCREW, TAPPING	4				
34	6P2-81336-00	GROMMET	1				
35	97095-06016	BOLT	5				
36	92995-06600	WASHER	5				
37	6CB-81919-20	GRAPHIC, REGULATOR	1				
38	6CB-81923-00	WASHER	1				AP
39	95895-08016	BOLT, FLANGE	1				AP
40	95895-08016	BOLT, FLANGE	1				AP
41	6CB-82105-01	BATTERY CABLE	1				AP

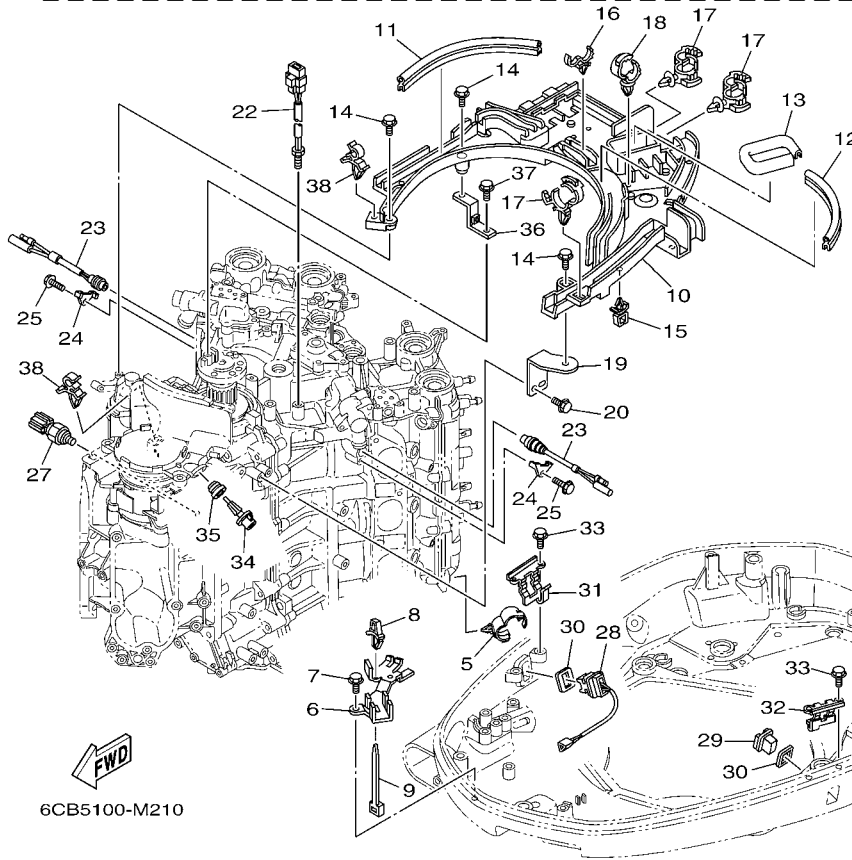
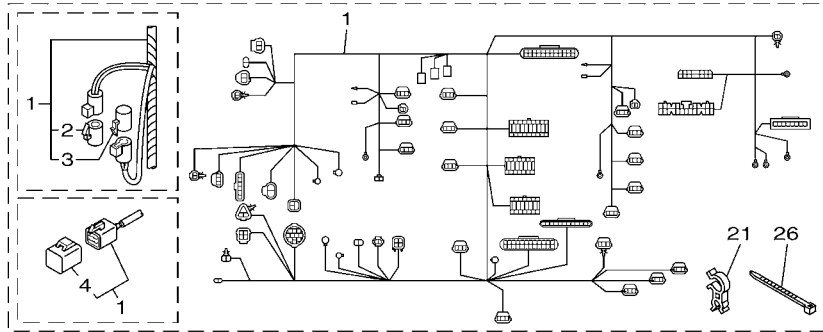
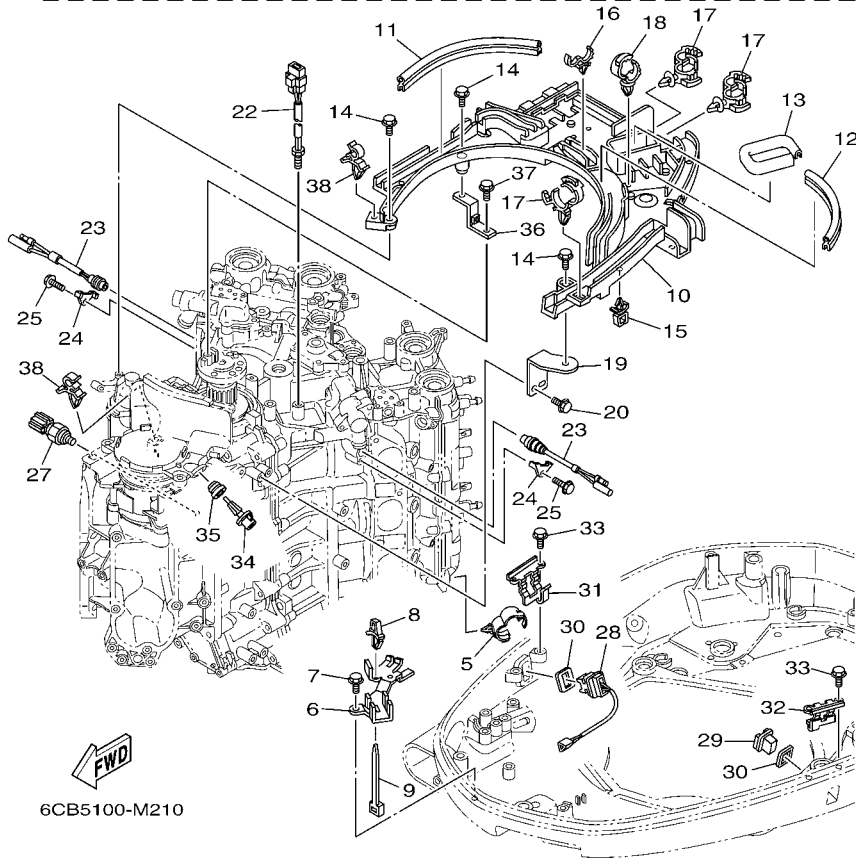
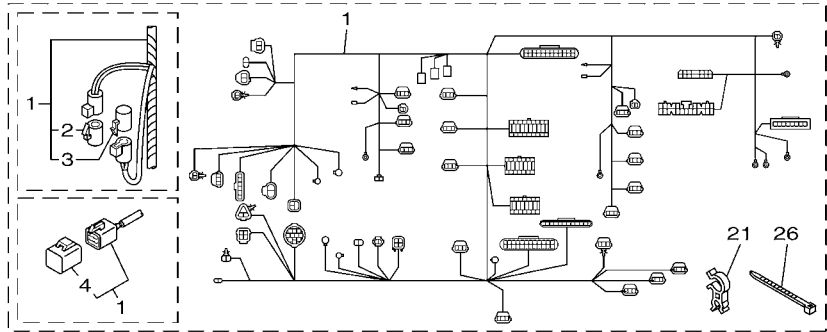

FIG. 21 ELECTRICAL 4

REF. NO.	PART NO.	DESCRIPTION	6CD6				REMARKS
1	6CB-82590-02	WIRE HARNESS ASSY	1				
2	6P2-82582-00	.CAP 1 (FEMALE)	1				
3	6P2-82582-10	.CAP 1 (MALE)	1				
4	6Y8-82582-11	.CAP 1 (4PIN)	1				
5	90464-20181	CLAMP	4				
6	6CB-82594-00	CLAMP	1				
7	95895-06012	BOLT, FLANGE	2				
8	90464-06001	CLAMP	1				
9	90465-13M24	CLAMP	1				
10	6CB-82589-01	PROTECTOR, WIRE HARNESS	1				
11	6BG-42617-00	DAMPER, FORM	1				
12	6CB-42617-00	DAMPER, FORM	1				
13	6CB-42629-00	SEAL	1				
14	95895-06020	BOLT, FLANGE	5				
15	90464-11121	CLAMP	1				
16	90464-18246	CLAMP	1				
17	90464-12183	CLAMP	4				
18	90464-20181	CLAMP	2				
19	6CB-82388-00	PLATE	1				
20	95895-06016	BOLT, FLANGE	2				
21	90464-23001	CLAMP	1				
22	6CB-85790-00	THERMOSENSOR ASSY	1				
23	6P2-82560-01	THERMO SWITCH ASSY	2				
24	6E9-82588-00	PLATE	2				
25	95895-06012	BOLT, FLANGE	2				
26	90465-14M66	CLAMP	1				
27	6AW-83651-00	SENDER, OIL PRESSURE	1				



**FIG. 21 ELECTRICAL 4**

REF. NO.	PART NO.	DESCRIPTION	6CD6				REMARKS
28	69J-82563-00	TRIM & TILT SWITCH ASSY	1				
29	69J-42723-01	COVER, BOTTOM	1				
30	69J-82587-00	GASKET	2				
31	63P-83614-01	BRACKET	1				
32	63P-83614-01	BRACKET	1				
33	95895-06012	BOLT, FLANGE	4				
34	63P-85886-00	SENSOR, AIR TEMPERATURE	1				
35	63P-14435-00	GROMMET	1				
36	6CB-81952-00	HOLDER, RELAY	1				
37	95895-06016	BOLT, FLANGE	1				
38	90464-09129	CLAMP	2				

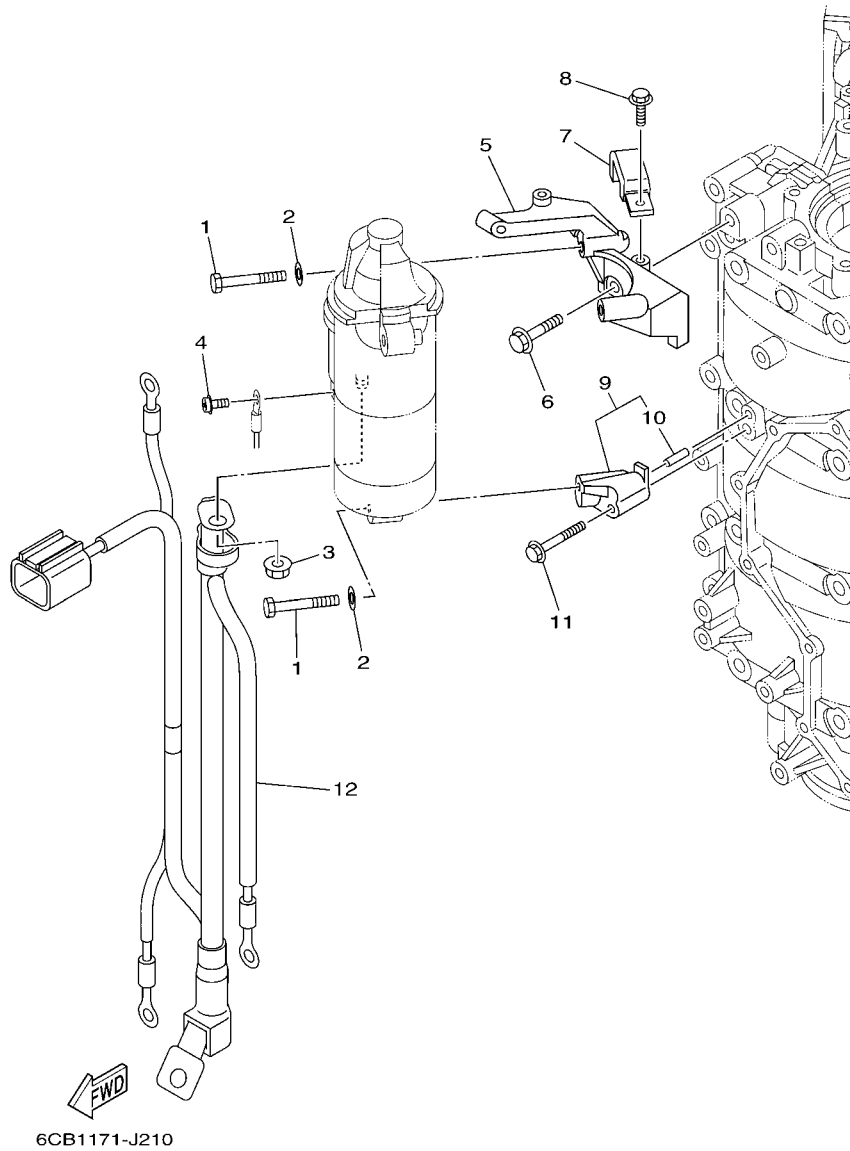

FIG. 22 ELECTRICAL 5

REF. NO.	PART NO.	DESCRIPTION	6CD6				REMARKS
1	97013-08045	BOLT	3				
2	92903-08600	WASHER, PLATE	3				
3	90179-08003	NUT	1				
4	97985-04308	SCREW, WITH WASHER	1				
5	6CB-81822-02	BRACKET, STARTING MOTOR	1				
6	90105-08M87	BOLT, FLANGE	2				
7	6CB-81443-00	CLAMP, LEAD 1	1				
8	95895-06016	BOLT, FLANGE	1				
9	6CB-81823-00	STAY, STARTING MOTOR	1				
10	93606-12019	.PIN, DOWEL	1				
11	90105-06151	BOLT, FLANGE	1				
12	6CB-8259M-00	WIRE HARNESS ASSY 2	1				

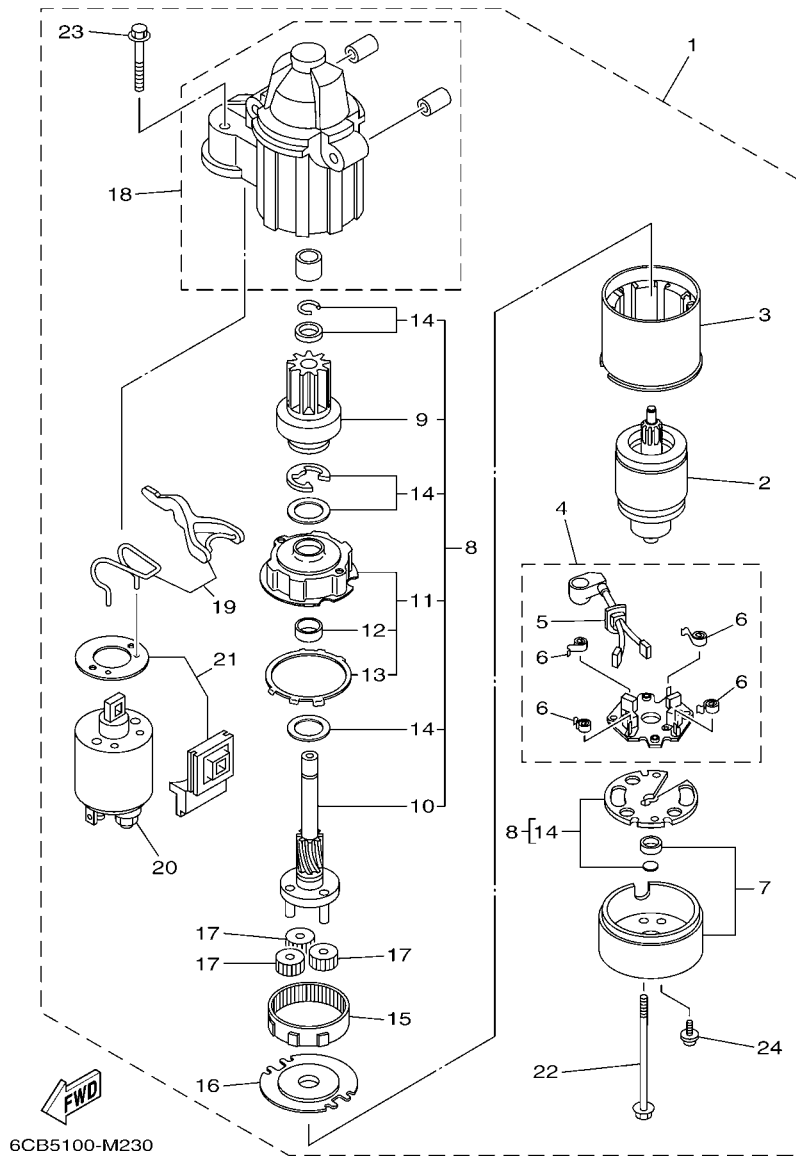
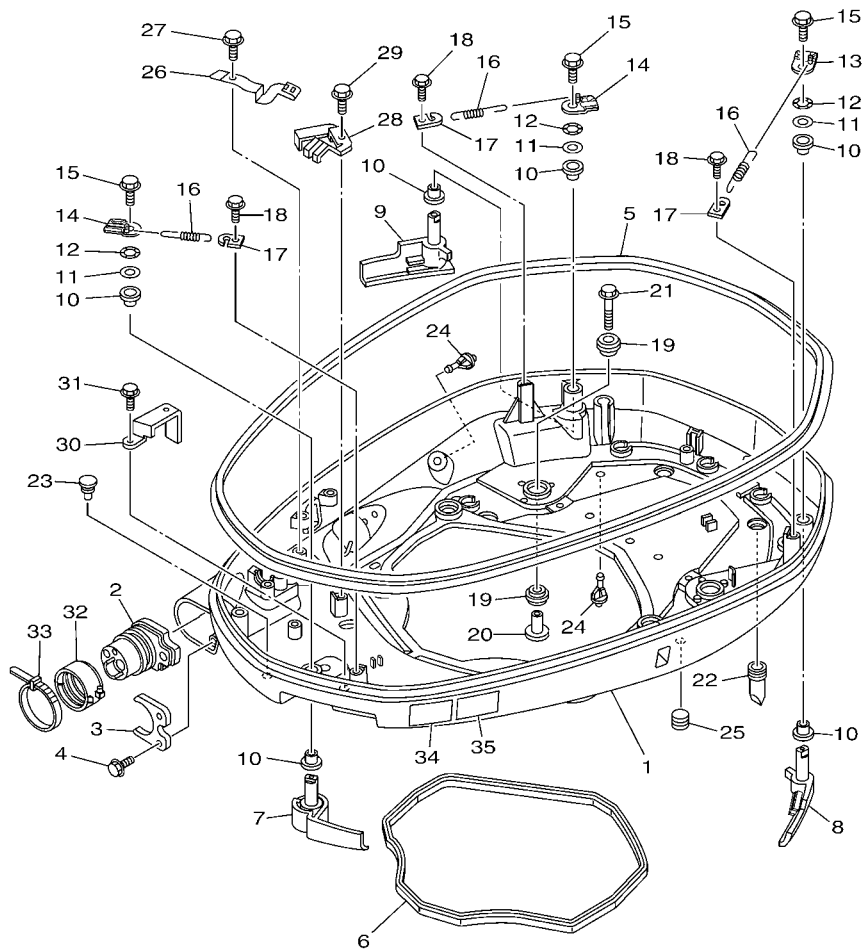

FIG. 23 STARTING MOTOR

REF. NO.	PART NO.	DESCRIPTION	6CD6				REMARKS
1	6CB-81800-00	STARTING MOTOR ASSY	1				
2	67F-81850-00	.ARMATURE ASSY	1				
3	67F-81810-00	.STATOR ASSY	1				
4	69J-81840-00	.BRUSH HOLDER ASSY	1				
5	69J-81801-00	..BRUSH SET	1				
6	67F-81813-00	..SPRING, BRUSH	4				
7	6CB-81820-00	.REAR BRACKET ASSY	1				
8	6CB-81807-00	.GEAR ASSY, STARTING MOTOR	1				
9	6CB-81832-00	..CLUTCH, OVER RUN	1				
10	6CB-81836-00	..SHAFT, PINION	1				
11	67F-81821-00	..BRACKET, CENTER 1	1				
12	67F-81841-00	...BEARING	1				
13	67F-8183R-00	...GASKET	1				
14	6CB-81809-00	..WASHER KIT	1				
15	67F-81891-00	.GEAR, RING	1				WITH 67F-8183R-00
16	67F-81830-00	.BRACKET, CENTER 2	1				
17	60V-8183T-00	.GEAR, IDLER	3				
18	6CB-81842-00	.COVER	1				
19	6C5-81839-00	.LEVER ASSY	1				
20	6C5-81941-00	.STARTER RELAY ASSY	1				
21	6C5-81869-00	.COVER, DUST	1				
22	6CB-81826-00	.BOLT	2				
23	69J-81828-00	.SCREW 2	2				
24	67F-81846-00	.SCREW	2				



6CD4100-L230

FIG. 24 BOTTOM COWLING 1

REF. NO.	PART NO.	DESCRIPTION	6CD6			REMARKS
1	6CB-42711-01-8D	COWLING, BOTTOM 1	1			
2	6CB-42725-01	GROMMET	1			
3	6CB-42761-00	STOPPER	1			
4	95895-06014	BOLT, FLANGE	2			
5	6CB-42615-00	SEAL	1			
6	6CB-42716-00	RUBBER, SEAL 1	1			
7	6CB-42815-01-8D	LEVER, CLAMP	1			
8	6CB-42816-01-8D	LEVER, CLAMP	1			
9	6CB-42817-01-8D	LEVER, CLAMP	1			
10	90386-15M73	BUSH	6			
11	90201-156J2	WASHER, PLATE	3			
12	90206-15M18	WASHER, WAVE	3			
13	6CB-42818-00	LEVER, CLAMP	1			
14	6CB-42819-00	LEVER, CLAMP	2			
15	95880-08012	BOLT, FLANGE	3			
16	90506-22001	SPRING, TENSION	3			
17	66T-43144-00	HOOK, SPRING	3			
18	95895-06012	BOLT, FLANGE	3			
19	90480-22M81	GROMMET	12			
20	90387-08M37	COLLAR	6			
21	90119-08M22	BOLT, WITH WASHER	6			
22	6D0-42717-00	RUBBER, SEAL 2	4			
23	6H4-42748-00	GROMMET	1			
24	6P2-44391-00	NIPPLE, HOSE	2			
25	90338-11007	PLUG	2			
26	6CB-42743-00	BRACKET	1			
27	95895-06012	BOLT, FLANGE	1			

**FIG. 24 BOTTOM COWLING 1**

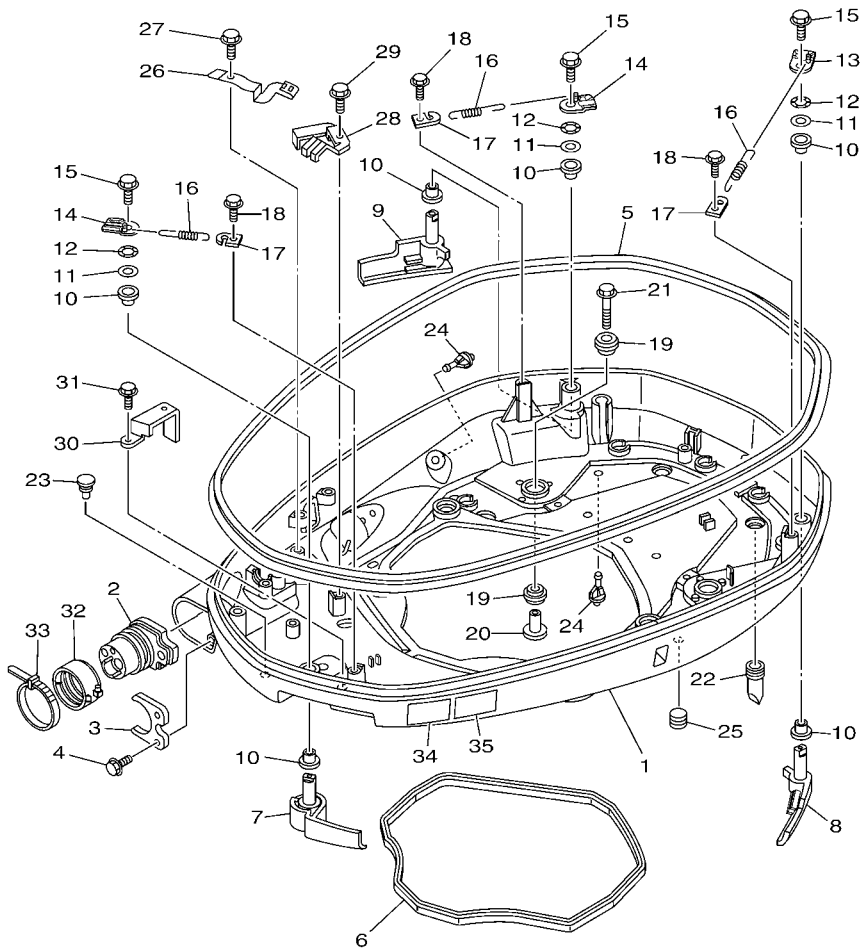

6CD4100-L230

REF. NO.	PART NO.	DESCRIPTION	6CD6			REMARKS
28	6CB-42766-00	BRACKET 2	1			
29	95895-06012	BOLT, FLANGE	1			
30	6CB-42756-00	STAY, CLAMP	1			
31	95895-06012	BOLT, FLANGE	1			
32	68F-42753-00	FASTNER	1			AP
33	90464-20258	CLAMP	1			AP
34	6AH-42794-40	LABEL, WARNING (GENERAL)	1			
35	6AH-42794-50	LABEL, WARNING (GENERAL)	1			
<hr/>						
<hr/>						
<hr/>						
<hr/>						
<hr/>						
<hr/>						
<hr/>						
<hr/>						

**FIG. 25 BOTTOM COWLING 2**

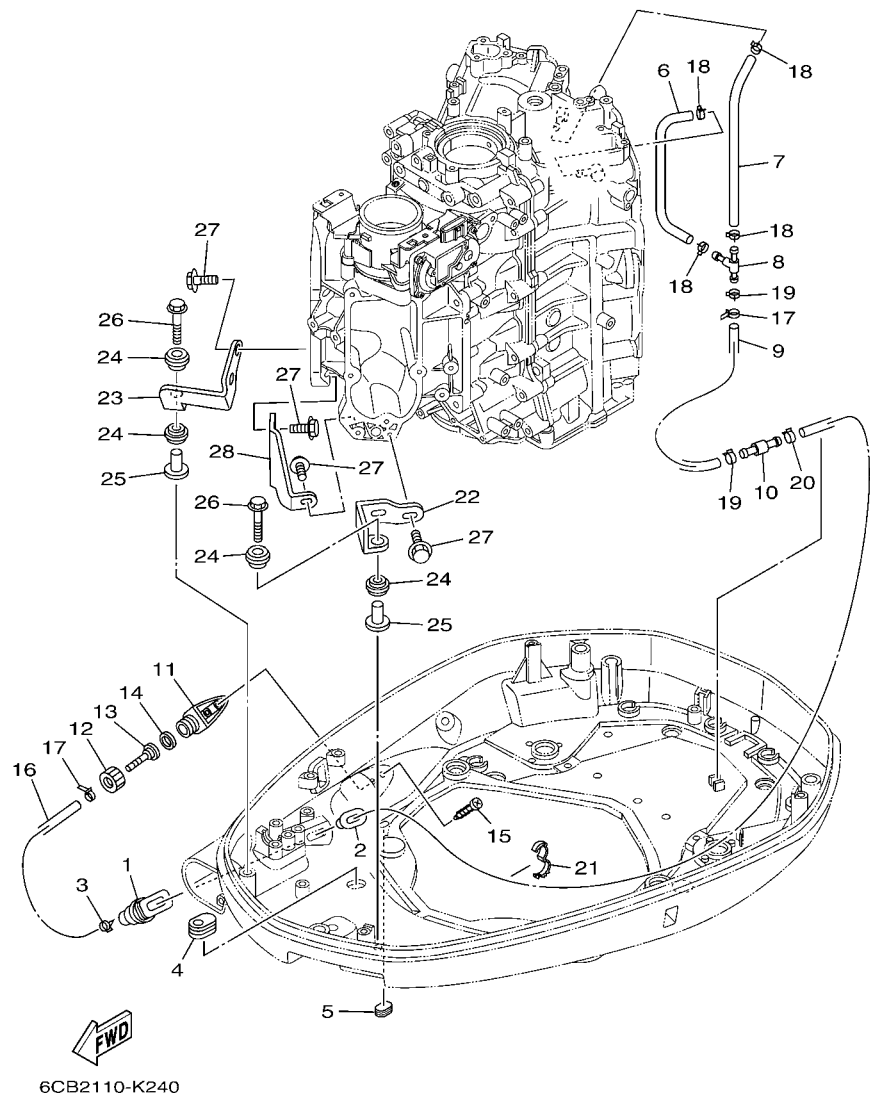

REF. NO.	PART NO.	DESCRIPTION	6CD6				REMARKS
1	6BG-42724-00	GROMMET	2				
2	6BG-42384-00	SEAL, CAP	2				
3	90465-11M10	CLAMP	2				
4	61A-42727-00	GROMMET	1				
5	64G-42727-00	GROMMET	1				
6	6CB-24315-00	PIPE 5	1				
7	90445-14021	HOSE (L185)	1				
8	6AW-42169-00	JOINT	1				
9	90445-16015	HOSE (L300)	1				
10	6AW-42785-00	PIPE	1				
11	6AW-12572-00	ADAPTER	1				
12	6R3-12581-00	JOINT, HOSE 1	1				
13	6AW-12582-00	JOINT, HOSE 2	1				
14	6R3-12583-00	GASKET, HOSE JOINT	1				
15	97780-60520	SCREW, TAPPING	2				
16	90445-14019	HOSE (L1460)	1				
17	90465-11M10	CLAMP	2				
18	90467-130A5	CLIP	4				
19	90467-140A8	CLIP	2				
20	90467-140A9	CLIP	1				
21	90464-16001	CLAMP	2				
22	6CB-42643-00	PLATE, CLAMP	1				
23	6CB-42644-00	PLATE, CLAMP 2	1				
24	90480-14029	GROMMET	4				
25	90387-06M03	COLLAR	2				
26	90119-06M61	BOLT, WITH WASHER	2				
27	90105-06039	BOLT, FLANGE	6				



**FIG. 25 BOTTOM COWLING 2**

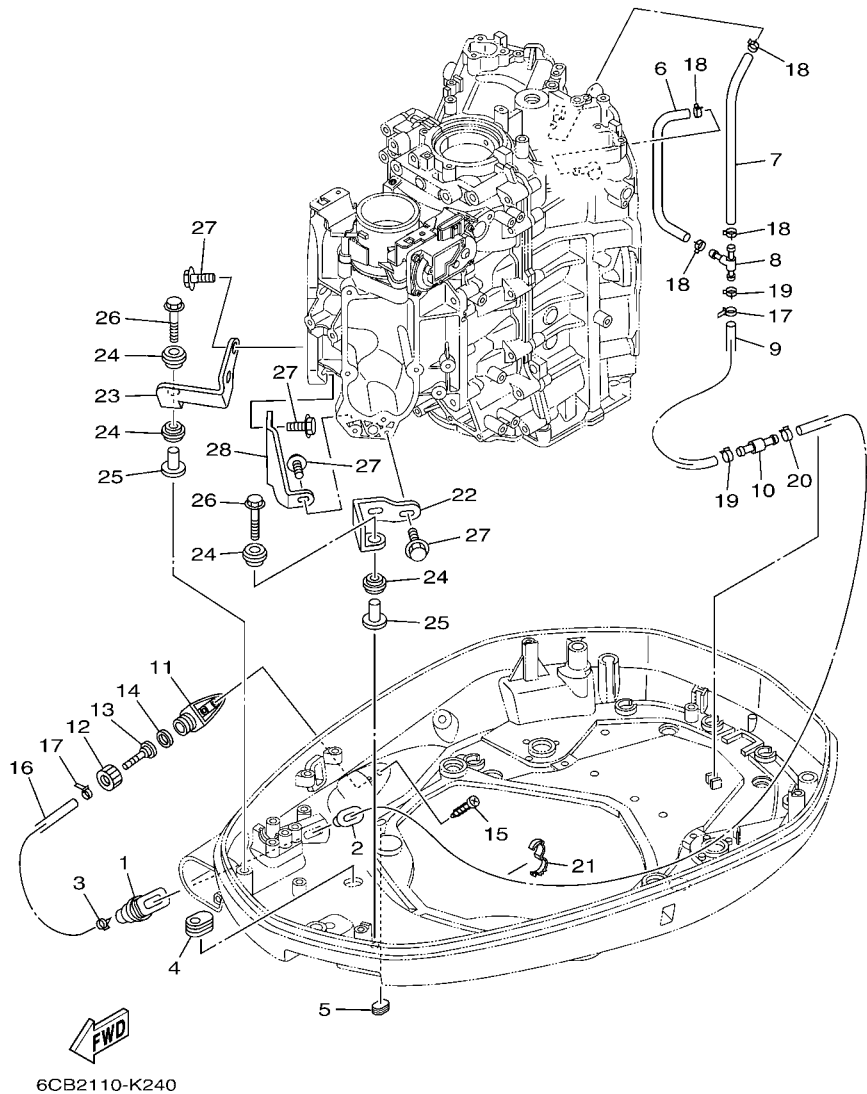

REF. NO.	PART NO.	DESCRIPTION	6CD6					REMARKS
28	6CB-42744-00	STAY	1					

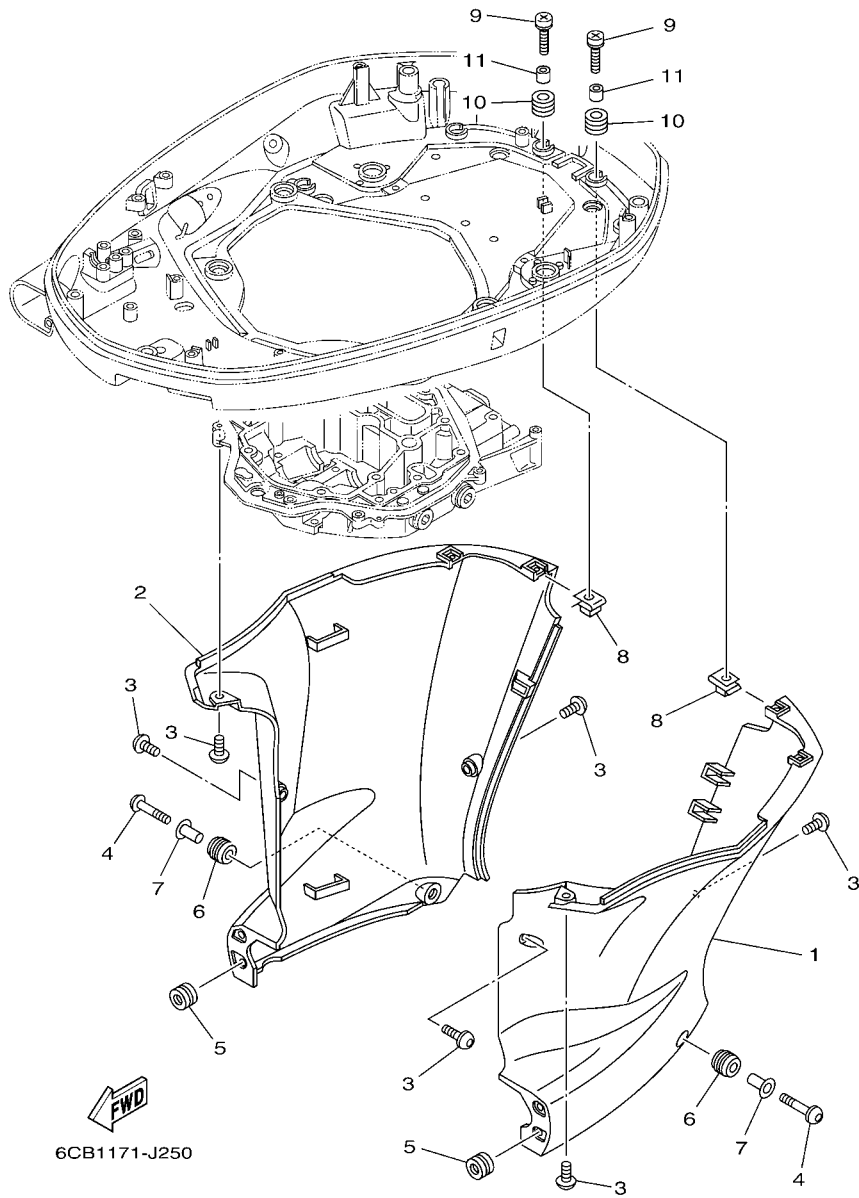
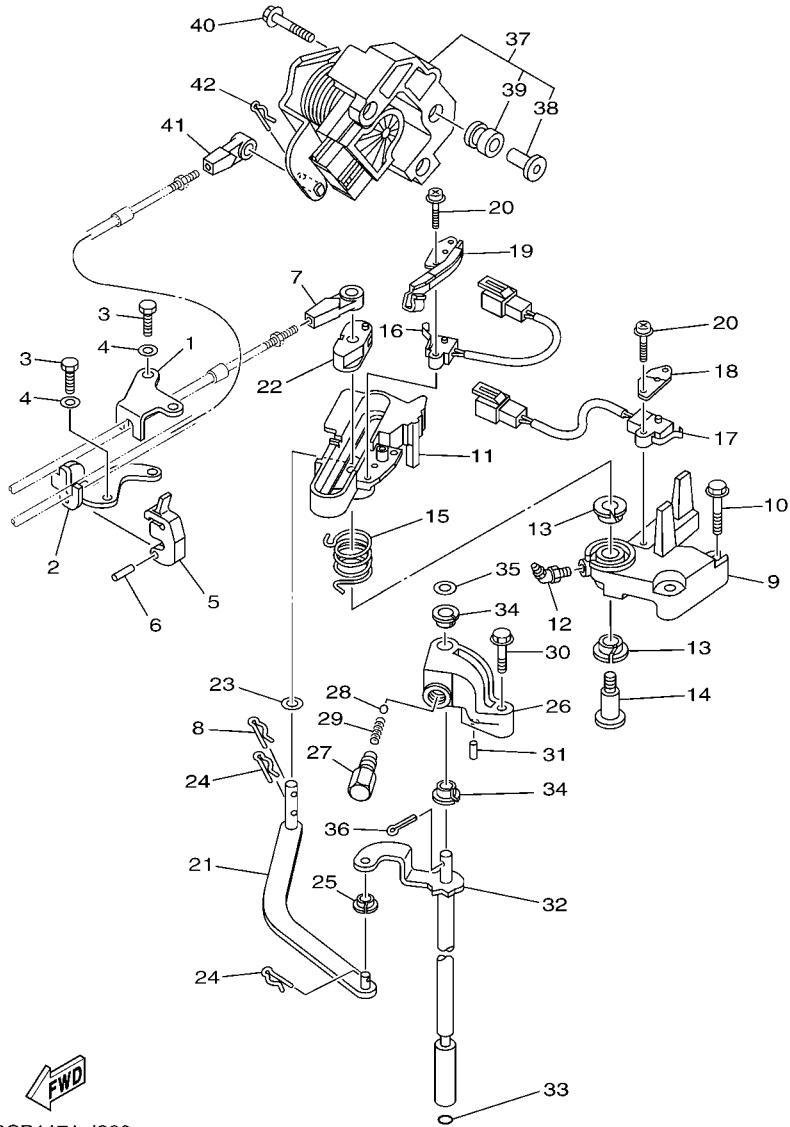

FIG. 26 BOTTOM COWLING 3

REF. NO.	PART NO.	DESCRIPTION	6CD6		REMARKS
1	6CB-42741-00-8D	APRON	1		
2	6CB-42771-00-8D	APRON	1		
3	90111-06144	BOLT,HEX. SOCKET BUTTON	6		
4	90111-06142	BOLT,HEX. SOCKET BUTTON	2		
5	90480-11012	GROMMET	4		
6	90480-16009	GROMMET	2		
7	90387-07028	COLLAR	2		
8	90183-061A6	NUT, SPRING	4		
9	90159-06053	SCREW, WITH WASHER	4		
10	90480-13M24	GROMMET	4		
11	90387-06M43	COLLAR	4		



6CB1171-J260

FIG. 27 CONTROL

REF. NO.	PART NO.	DESCRIPTION	6CD6				REMARKS
1	6CB-48531-00	BRACKET, REMOTE CONTROL 1	1				
2	6CB-48532-00	BRACKET, REMOTE CONTROL 2	1				
3	97095-06016	BOLT	4				
4	92995-06600	WASHER	4				
5	6E5-48538-00	CLAMP, CABLE	1				
6	91690-30010	PIN, SPRING	1				
7	6E5-48344-00	CABLE END, REMOTE CONTROL	1				
8	90468-18008	CLIP	1				
9	6CB-44117-00	BRACKET	1				
10	95895-06035	BOLT, FLANGE	2				
11	69J-44176-01	BRACKET	1				
12	93700-06M01	NIPPLE, GREASE	1				
13	90386-12069	BUSH	2				
14	90109-08019	BOLT	1				
15	90508-20052	SPRING, TORSION	1				
16	60V-8259F-00	SWITCH ASSY	1				
17	69J-8259F-00	SWITCH ASSY	1				
18	61A-82588-01	PLATE	1				
19	6CB-82588-00	PLATE	1				
20	97985-04116	SCREW, WITH WASHER	4				
21	6CB-44121-00	LEVER, SHIFT ROD	1				
22	69J-44122-00	BUSHING, SHIFT ROD LEVER	1				
23	90202-08M20	WASHER, PLATE	1				
24	90468-18008	CLIP	2				
25	90386-06M12	BUSH	1				
26	69J-44118-00	BRACKET	1				
27	648-42715-00	BUSHING	1				

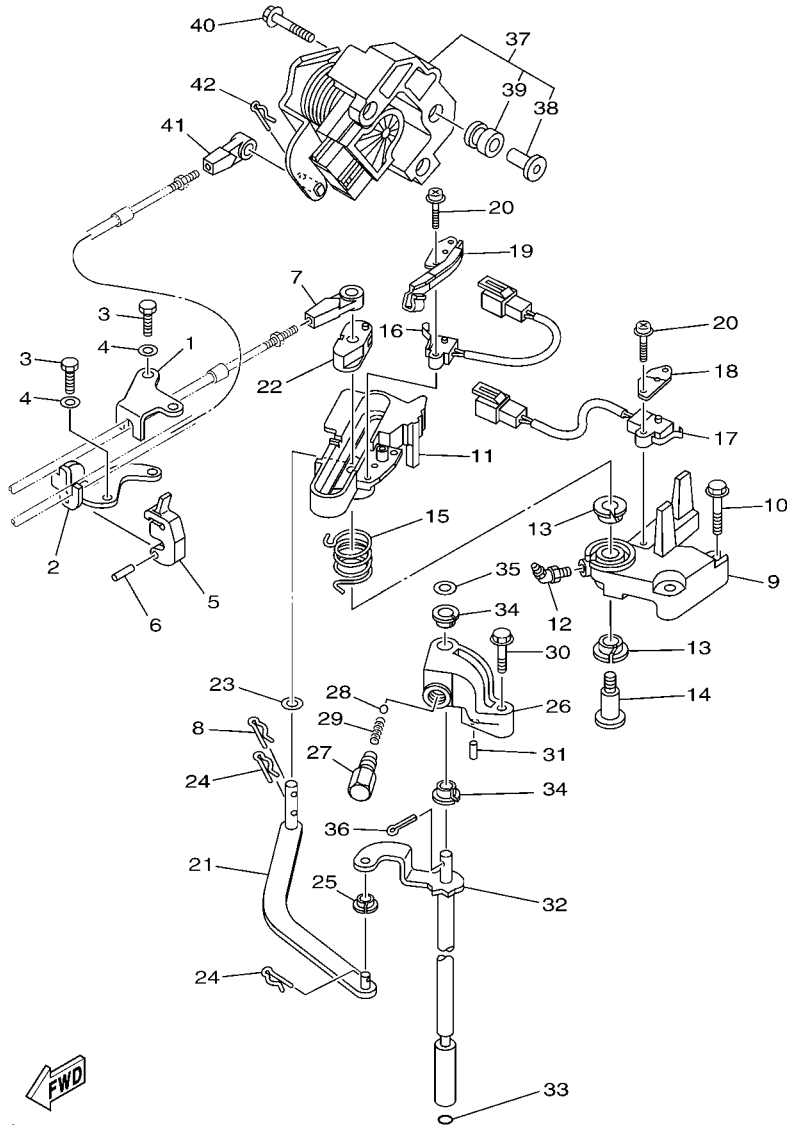

6CB1171-J260

FIG. 27 CONTROL

REF. NO.	PART NO.	DESCRIPTION	6CD6				REMARKS
28	93501-04M02	BALL	1				
29	90501-12082	SPRING, COMPRESSION	1				
30	97575-06535	BOLT, WITH WASHER	1				
31	91690-30010	PIN, SPRING	1				
32	6CB-44120-01	HANDLE GEAR SHIFT ASSY	1				
33	93210-09165	O-RING	1				
34	90386-90M90	BUSH	2				
35	90201-09M02	WASHER, PLATE	1				
36	91490-20015	PIN, COTTER	1				
37	6CB-8A410-00	SENSOR UNIT	1				
38	6P2-44139-00	.COLLAR	3				
39	6CB-41273-00	.GROMMET	3				
40	90119-06126	BOLT, WITH WASHER	3				
41	6E5-48344-00	CABLE END, REMOTE CONTROL	1				
42	90468-18008	CLIP	1				

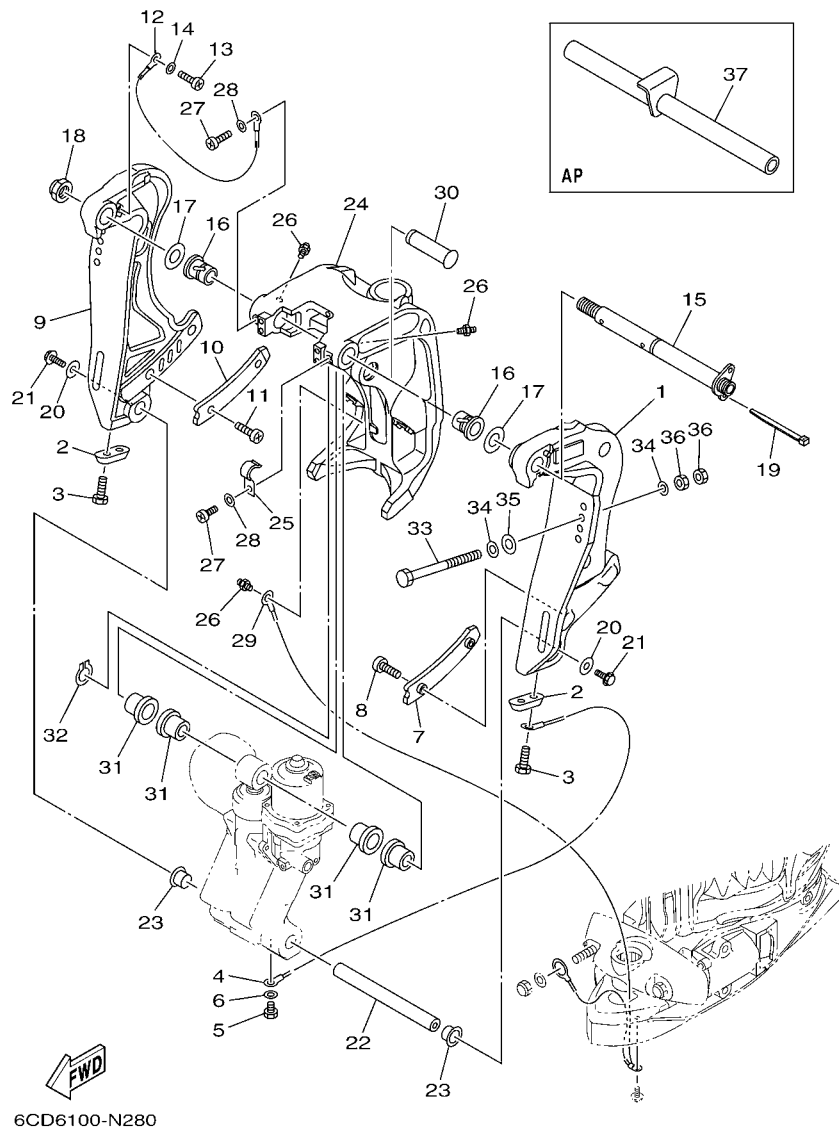

FIG. 28 BRACKET 1

REF. NO.	PART NO.	DESCRIPTION	6CD6				REMARKS
1	6CB-43111-02-8D	BRACKET, CLAMP 1	1				
2	65W-45251-00	ANODE	2				
3	90101-06020	BOLT	4				
4	6E5-82148-00	WIRE, LEAD 4	1				
5	97095-06010	BOLT	1				
6	92995-06600	WASHER	1				
7	61A-43132-00	WASHER, FRICTION	1				
8	97885-06010	SCREW, PAN HEAD	2				
9	6CB-43112-01-8D	BRACKET, CLAMP 2	1				
10	61A-43133-00	WASHER, FRICTION	1				
11	97885-06010	SCREW, PAN HEAD	2				
12	6E5-82148-00	WIRE, LEAD 4	1				
13	97885-06012	SCREW, PAN HEAD	1				
14	92995-06600	WASHER	1				
15	64E-43131-30	BOLT, CLAMP BRACKET	1				
16	90386-25M31	BUSH	2				
17	90201-26M59	WASHER, PLATE	2				
18	90185-22M11	NUT, SELF-LOCKING	1				
19	90465-11M10	CLAMP	1				
20	90201-10060	WASHER, PLATE	2				
21	90119-10054	BOLT, WITH WASHER	2				
22	6BC-43818-00	PIN, LOWER SHOCK MOUNT	1				
23	90386-22M98	BUSH	2				
24	6CB-43311-00-8D	BRACKET, SWIVEL 1	1				
25	90465-08M63	CLAMP	1				
26	93700-06M03	NIPPLE, GREASE	3				
27	98504-06010	SCREW, PAN HEAD	2				

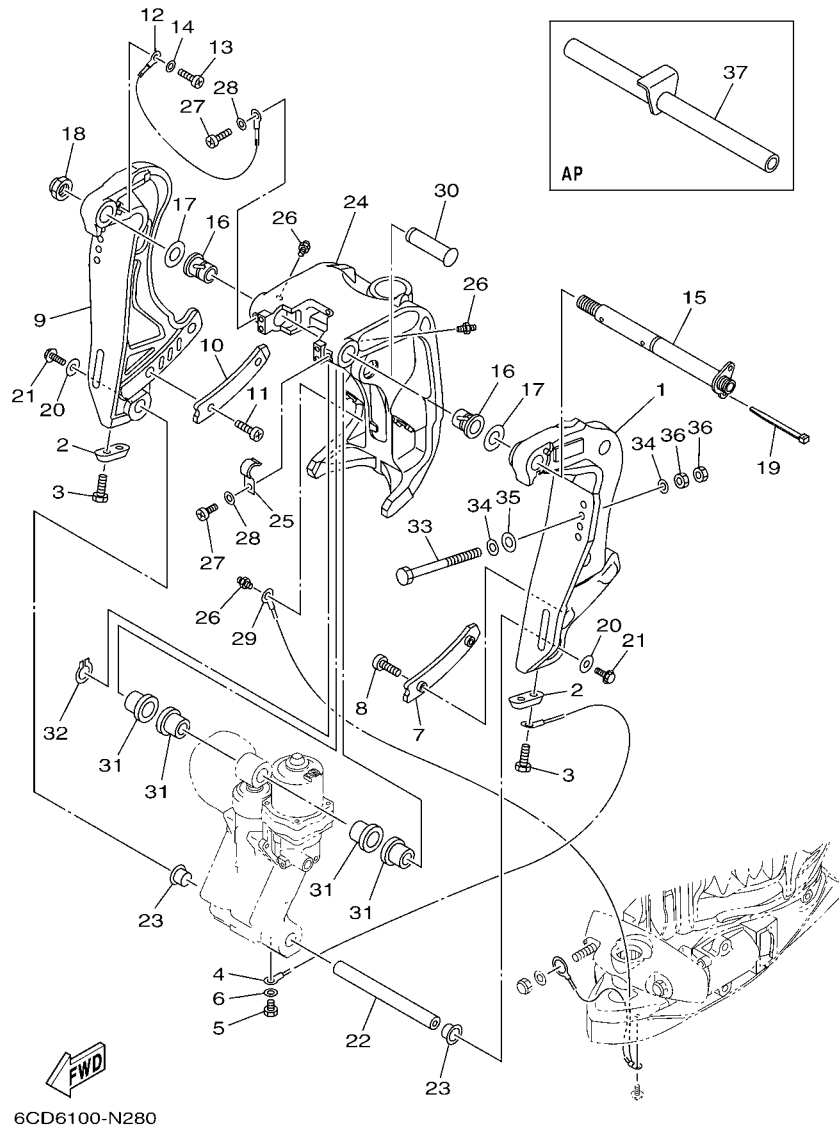
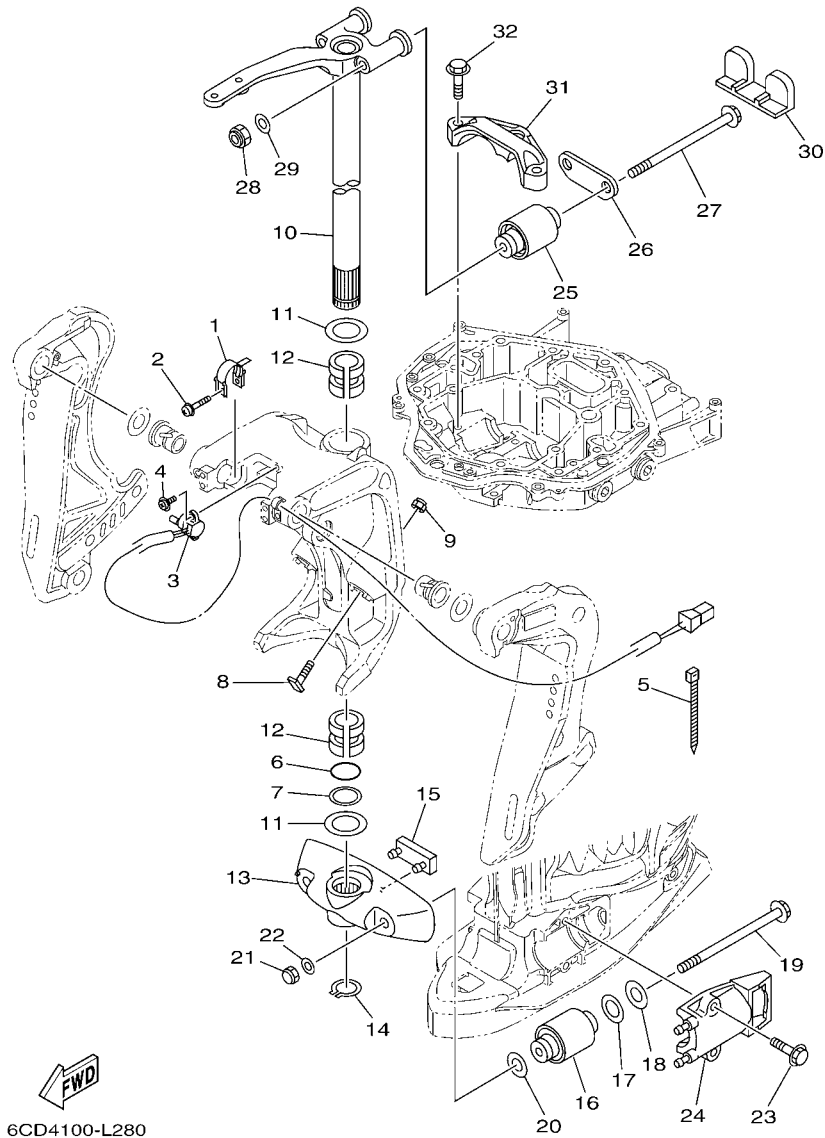

FIG. 28 BRACKET 1

REF. NO.	PART NO.	DESCRIPTION	6CD6				REMARKS
28	92903-06600	WASHER, PLATE	2				
29	66K-82149-00	WIRE, LEAD 3	1				
30	64E-43126-00	PIN, UPPER SHOCK MOUNT	1				
31	90386-22M98	BUSH	4				
32	93410-22M11	CIRCLIP	1				
33	90101-12M05	BOLT (L:130MM)	4				
34	90201-13M01	WASHER, PLATE	8				
35	90201-12426	WASHER, PLATE	4				
36	95380-12600	NUT	8				
37	6CB-43611-00	SHAFT, TILT LOCK	1				AP



6CD4100-L280

FIG. 29 BRACKET 2

REF. NO.	PART NO.	DESCRIPTION	6CD6				REMARKS
1	64E-43139-10	CAM, TRIM SENDER	1				
2	90159-05059	SCREW, WITH WASHER	1				
3	67H-83672-01	TRIM SENDER	1				
4	97985-06216	SCREW, WITH WASHER	2				
5	90465-11M10	CLAMP	3				
6	93210-37MH7	O-RING	1				
7	90202-40M47	WASHER, PLATE	1				
8	64E-43376-00	BOLT, THRUST RECEIVER	2				
9	95780-10300	NUT, FLANGE	2				
10	6CB-42510-00-8D	STEERING BRACKET ASSY	1				
11	90201-38M60	WASHER, PLATE	2				
12	90386-38M89	BUSH	2				
13	6CB-44551-01-8D	HOUSING, LOWER MOUNT RUBBER 1	1				
14	93410-37M04	CIRCLIP	1				
15	6E5-44575-00	DAMPER, LOWER MOUNT RUBBER	1				
16	60X-44555-00	MOUNT DAMPER, LOWER SIDE	2				
17	90202-32M19	WASHER, PLATE	2				
18	90201-16M55	WASHER, PLATE	2				
19	90105-14007	BOLT, FLANGE	2				
20	90201-15M58	WASHER, PLATE	2				
21	95380-14800	NUT	2				
22	92995-14600	WASHER	2				
23	90119-10024	BOLT, WITH WASHER	4				
24	61A-44552-01-CA	HOUSING, LOWER MOUNT RUBBER 2	2				
25	6CB-44514-00	MOUNT DAMPER, UPPER SIDE	2				
26	6CB-44526-00	PLATE	1				
27	90105-14007	BOLT, FLANGE	2				

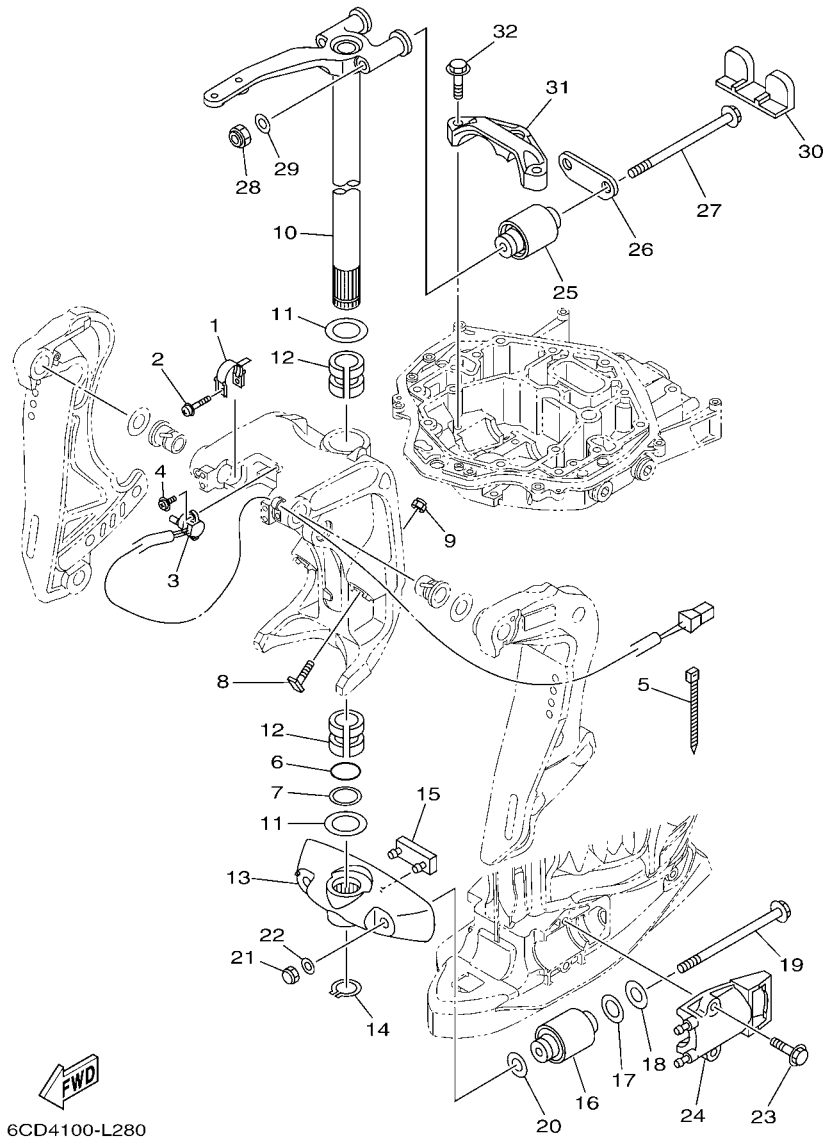

**FIG. 29 BRACKET 2**

REF. NO.	PART NO.	DESCRIPTION	6CD6				REMARKS
28	90185-14M00	NUT, SELF-LOCKING	2				
29	92995-14600	WASHER	2				
30	6CB-44533-00	DAMPER, UPPER MOUNT RUBBER	1				
31	6CB-44511-00	COVER, UPPER MOUNT	1				
32	90119-10024	BOLT, WITH WASHER	3				
-----							
-----							
-----							
-----							
-----							
-----							
-----							
-----							
-----							



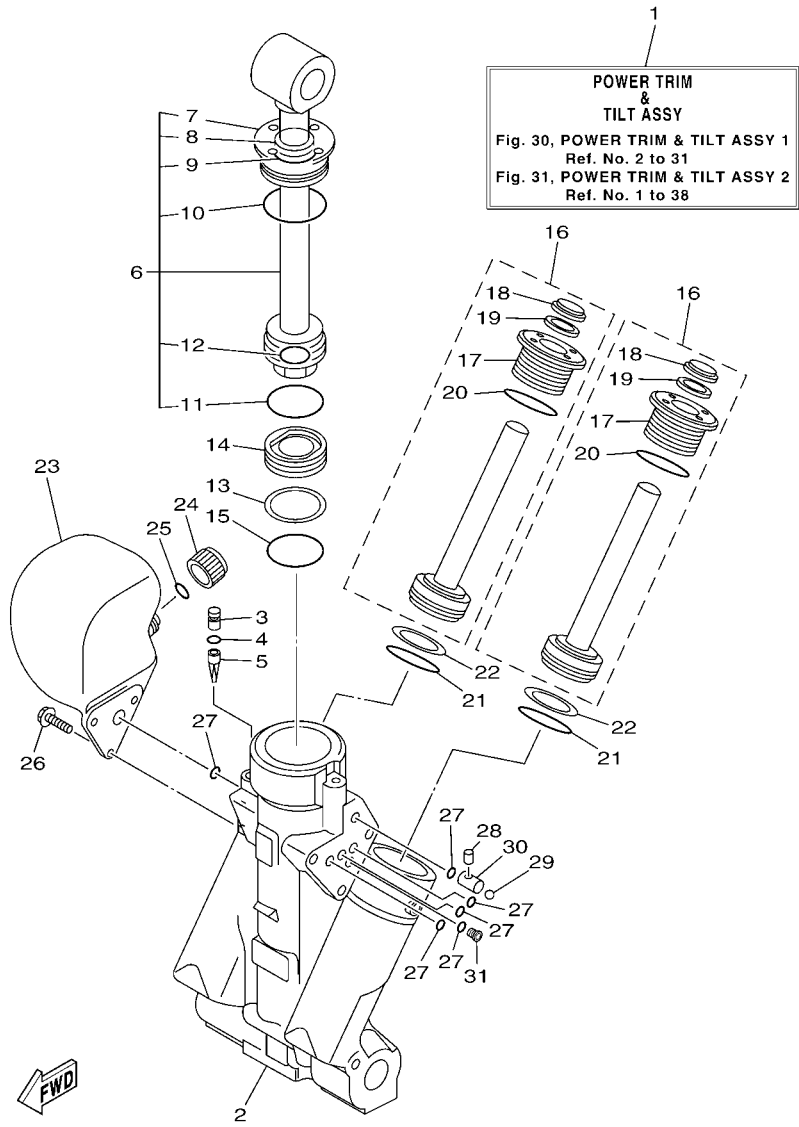

6CB5100-M300

FIG. 30 POWER TRIM & TILT ASSY 1

REF. NO.	PART NO.	DESCRIPTION	6CD6				REMARKS
1	6CB-43800-02-8D	POWER TRIM & TILT ASSY	1				
2	6CB-43825-00	HOUSING, TRIM & TILT	1				
3	6AW-4388J-00	PLUG 2	1				
4	93210-10M74	O-RING	1				
5	64E-43817-00	FILTER 2	1				
6	63P-43810-02	TILT PISTON SUB ASSY	1				
7	64E-43811-02	.SCREW, CYLINDER END	1				
8	64E-43898-00	.SEAL, DUST 2	1				
9	64E-43867-00	.O-RING	1				
10	64E-43866-00	.O-RING	1				
11	6E5-43862-00	.O-RING	1				
12	64E-43883-00	.O-RING	1				
13	6E5-43872-00	RING, BACK UP	1				
14	6E5-43814-02	PISTON, FREE	1				
15	6E5-43862-00	O-RING	1				
16	6CB-43820-01	TRIM PISTON SUB ASSY	2				
17	64E-43821-03	.SCREW, TRIM CYLINDER END	1				
18	64E-43822-00	.SEAL, TRIM DUST	1				
19	64E-4384J-00	.SEAL, TRIM DOWN	1				
20	6G5-43864-00	.O-RING	1				
21	6E5-43864-00	O-RING	2				
22	6E5-43874-01	RING, BACK UP	2				
23	64E-43828-01	BODY, RESERVOIR	1				
24	64E-43829-01	PLUG, RESERVOIR	1				
25	64E-43897-00	O-RING	1				
26	64E-4388E-01	BOLT ,SCREW (L:14MM)	3				
27	64E-43869-00	O-RING	6				

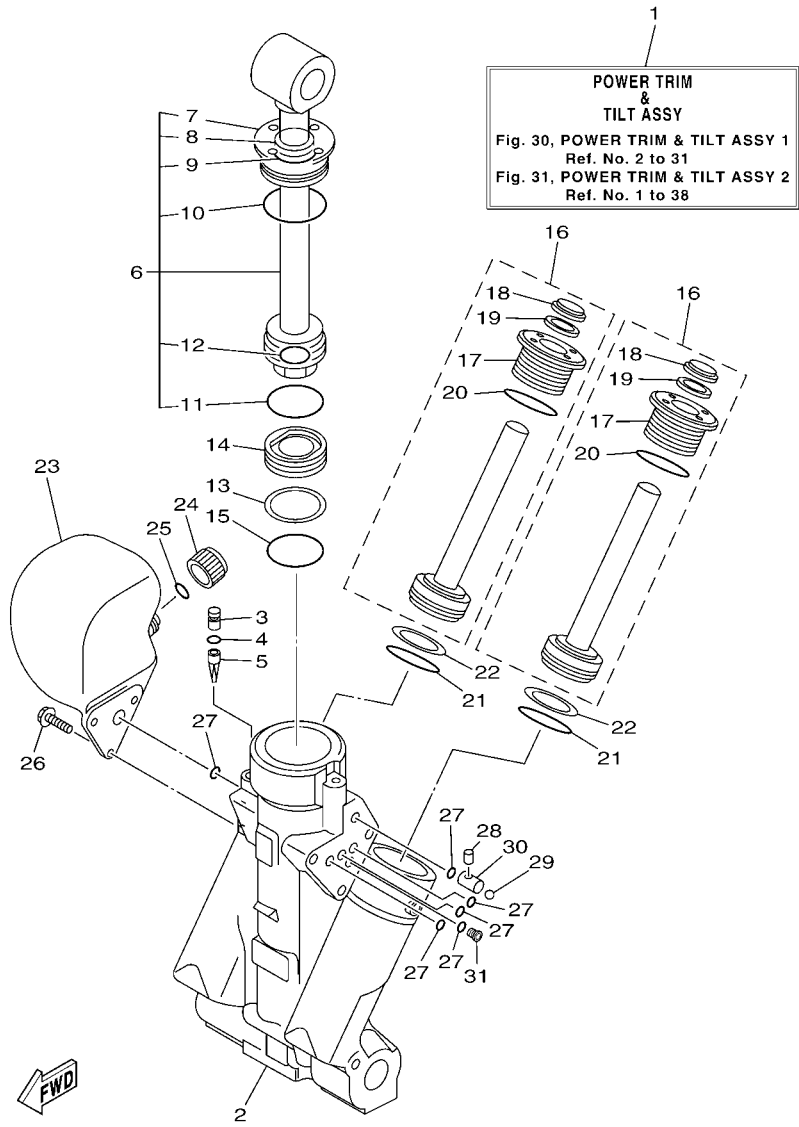

6CB5100-M300

FIG. 30 POWER TRIM & TILT ASSY 1

REF. NO.	PART NO.	DESCRIPTION	6CD6				REMARKS
28	64E-4381G-00	PIN	1				
29	6E5-43858-00	BALL	1				
30	64E-4382G-00	VALVE, SEAT	1				
31	64E-4384N-00	PLUG, ORIFICE	1				
-----							
-----							
-----							
-----							
-----							
-----							
-----							
-----							
-----							
-----							

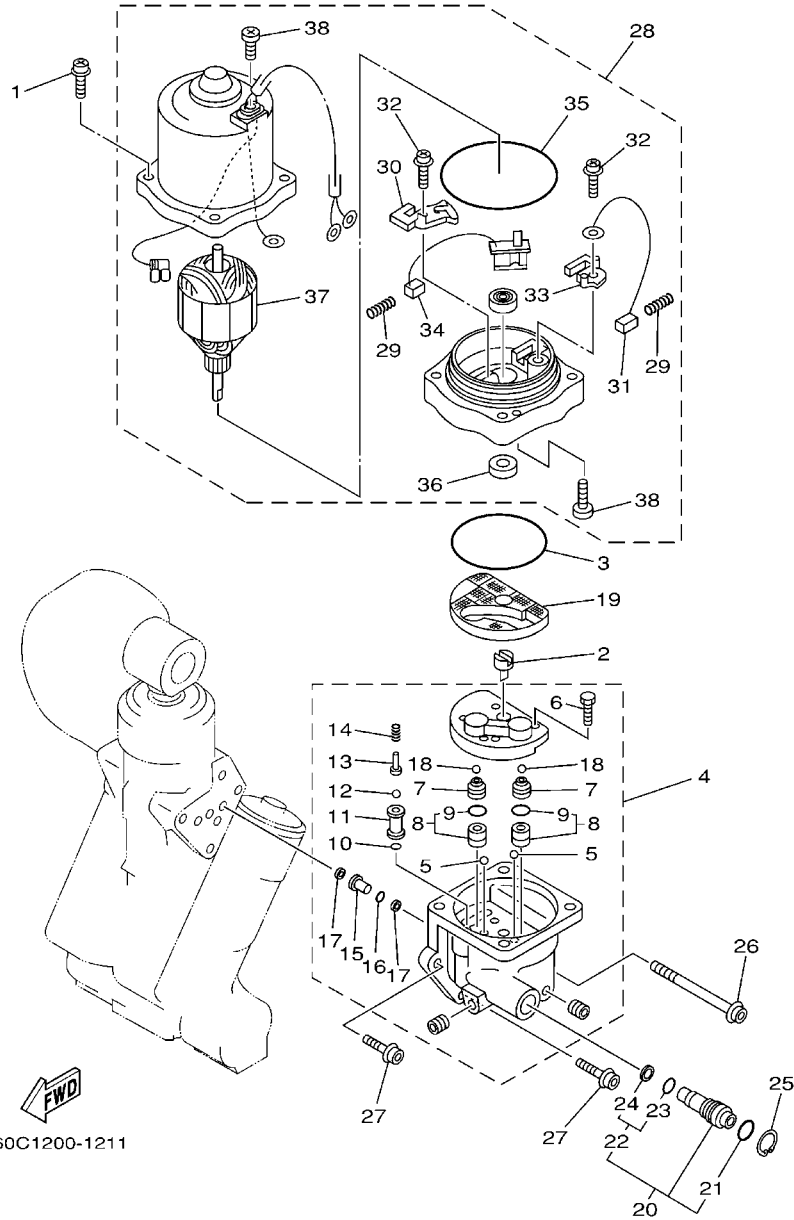
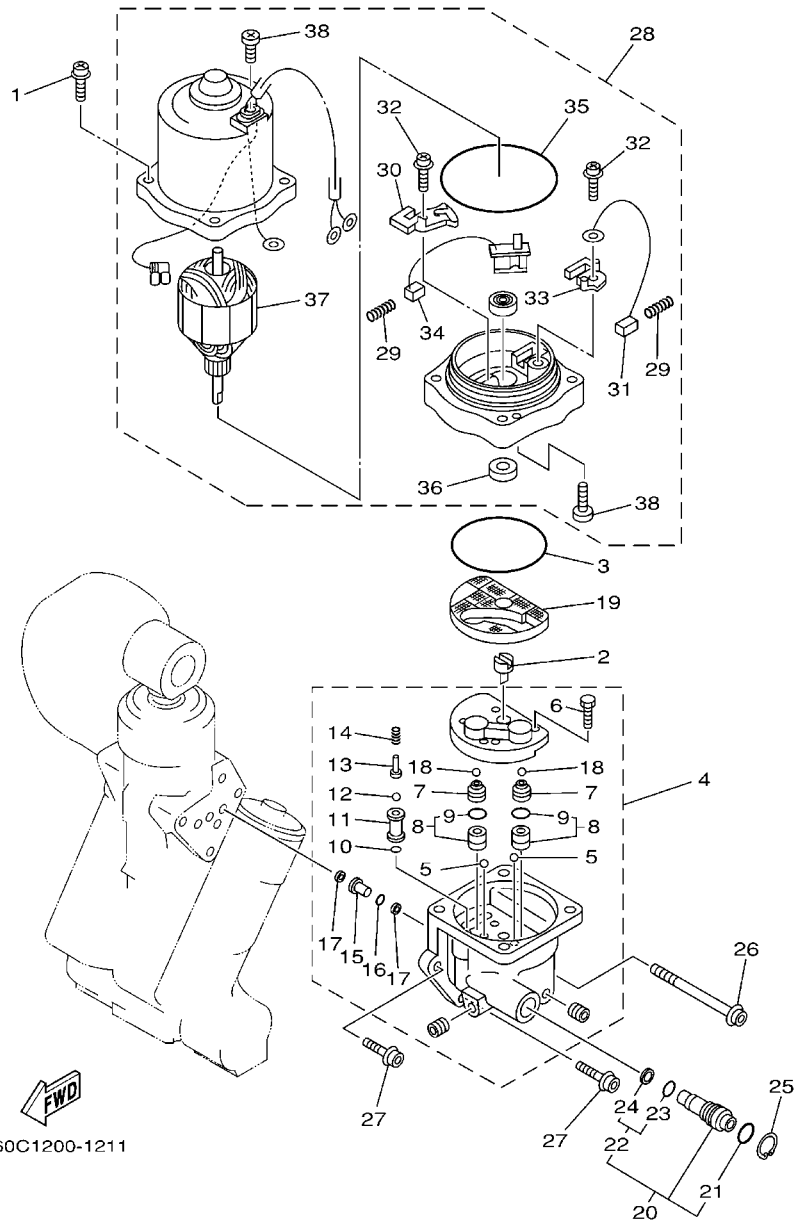

FIG. 31 POWER TRIM & TILT ASSY 2

REF. NO.	PART NO.	DESCRIPTION	6CD6				REMARKS
1	64E-4388E-11	BOLT ,SCREW (L:34.7MM)	4				
2	64E-43831-00	CONNECTOR, SHAFT	1				
3	64E-43868-00	O-RING	1				
4	6CB-43830-00	GEAR PUMP ASSY	1				
5	72X-43858-00	.BALL	2				
6	64E-43843-00	.SCREW, VALVE LOCK	4				
7	6AW-43841-00	.PISTON, SHUTTLE	2				
8	64E-43802-00	.VALVE SUB ASSY	2				
9	6E5-43896-00	..O-RING	1				
10	6G5-43863-00	.O-RING	1				
11	64E-43851-00	.SEAT, RELIEF VALVE	1				
12	64E-43858-00	.BALL	1				
13	64E-43859-00	.PIN, VALVE SUPPORT	1				
14	64E-43855-00	.SPRING, UP RELIEF	1				
15	64E-43850-00	.VALVE SUB ASSY	1				
16	64E-43865-00	.O-RING	1				
17	64E-43816-00	.FILTER 1	2				
18	6AW-43858-00	.BALL	2				
19	64E-43817-11	FILTER 2	1				
20	64E-43860-01	MANUAL VALVE SUB-ASSY	1				
21	72X-85075-L0	.O-RING	1				
22	64E-43827-00	.RING SET	1				
23	64E-4387A-00	..O-RING	1				
24	64E-43873-00	..RING, BACK UP	1				
25	6AW-43875-00	RING, SNAP	1				
26	64E-43879-11	SCREW, WITH WASHER	1				
27	64E-43879-01	SCREW, WITH WASHER	2				



60C1200-1211

**FIG. 31 POWER TRIM & TILT ASSY 2**

REF. NO.	PART NO.	DESCRIPTION	6CD6			REMARKS
28	67H-43880-10	MOTOR ASSY	1			
29	6H1-4386K-10	.SPRING, BRUSH	2			
30	64E-4380J-00	.HOLDER, BRUSH	1			
31	64E-43891-00	.BRUSH 1	1			
32	97607-04310	.SCREW, WITH WASHER	2			
33	64E-4380F-00	.HOLDER, BRUSH 2	1			
34	64E-43892-00	.BREAKER COMP. (BRUSH 2)	1			
35	6G5-43865-01	.O-RING	1			
36	93102-08M43	.OIL SEAL	1			
37	64E-43805-01	.ARMATURE ASSY	1			
38	64E-43843-10	.SCREW, VALVE LOCK	3			
-----						
-----						
-----						
-----						
-----						

**FIG. 32 UPPER CASING**

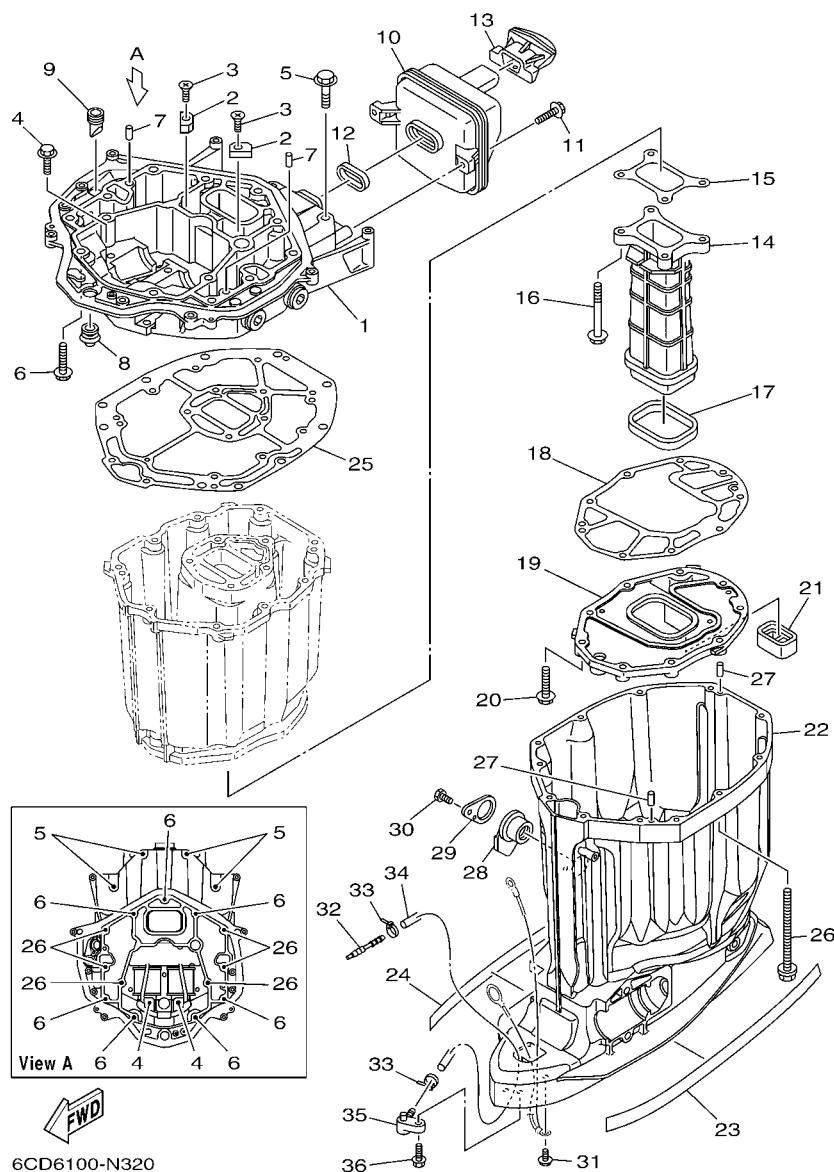

REF. NO.	PART NO.	DESCRIPTION	6CD6				REMARKS
1	6CB-41137-00-CA	GUIDE, EXHAUST	1				
2	63P-11325-11	ANODE	2				
3	90151-06M02	SCREW, COUNTERSUNK	2				
4	90119-08102	BOLT, WITH WASHER	2				
5	97575-10545	BOLT, WITH WASHER	4				
6	97575-10535	BOLT, WITH WASHER	7				
7	93608-16M16	PIN, DOWEL	2				
8	6E5-42724-00	GROMMET	1				
9	61A-42717-00	RUBBER, SEAL 2	1				
10	6CB-14750-00	SILENCER ASSY	1				
11	95875-06020	BOLT, FLANGE	2				
12	6CB-14755-00	GASKET, SILENCER	1				
13	6CB-42769-01	SEAL, RUBBER	1				
14	6CB-41132-00-9S	MANIFOLD, EXHAUST	1				
15	6CB-41134-00	GASKET, EXHAUST MANIFOLD	1				
16	97575-08560	BOLT, WITH WASHER	4				
17	6CB-41138-00	SEAL, EXT. 1	1				
18	6CB-41135-00	GASKET, EXHAUST MANIFOLD	1				
19	6CB-45181-00-CA	PLATE	1				
20	97575-08535	BOLT, WITH WASHER	9				
21	6CB-45127-00	SEAL	1				
22	6CB-45111-00-8D	CASING, UPPER	1				
23	6CB-42791-00	MARK 1	1				
24	6CB-42792-00	MARK 2	1				
25	6CB-45113-00	GASKET, UPPER CASING	1				
26	90119-10007	BOLT, WITH WASHER	6				
27	93608-16M16	PIN, DOWEL	2				

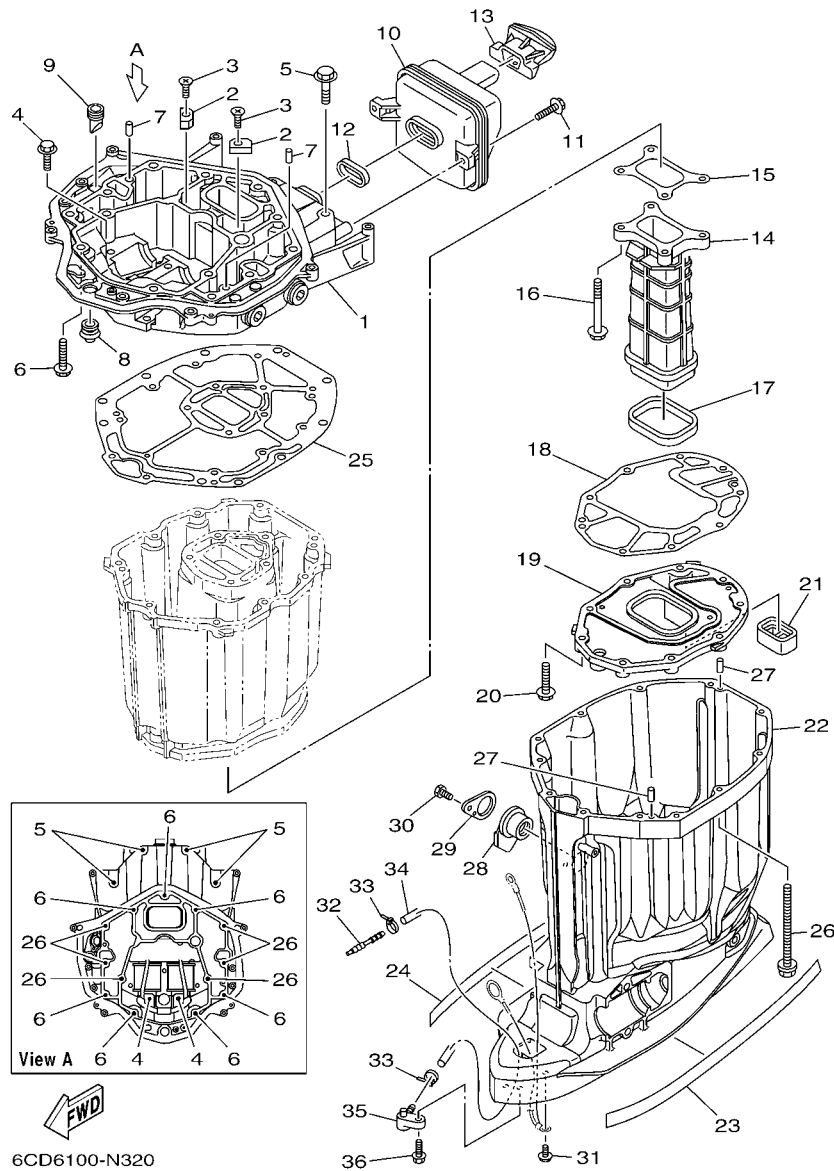

**FIG. 32 UPPER CASING**

REF. NO.	PART NO.	DESCRIPTION	6CD6				REMARKS
28	6BB-15316-00	DAMPER 1	1				
29	6BB-45152-01	COVER, UPPER CASING 2	1				
30	97095-06012	BOLT	1				
31	95895-06010	BOLT, FLANGE	1				
32	6E5-83558-00	END, NIPPLE	1				
33	90465-11M10	CLAMP	2				
34	90445-07012	HOSE (L1457)	1				
35	63P-45379-00	NIPPLE, HOSE	1				
36	90119-06M18	BOLT, WITH WASHER	1				
-----							
-----							
-----							
-----							
-----							
-----							
-----							
-----							
-----							

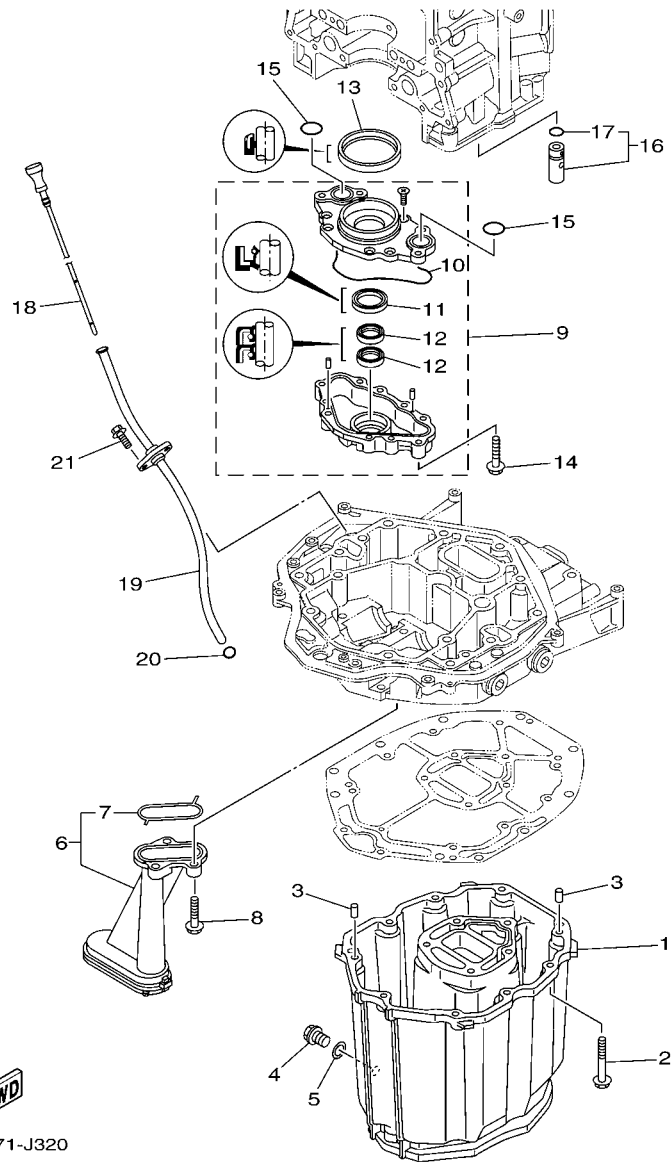

6CB1171-J320

FIG. 33 OIL PAN

REF. NO.	PART NO.	DESCRIPTION	6CD6			REMARKS
1	6CB-15311-00-CA	OIL PAN	1			
2	97575-08535	BOLT, WITH WASHER	10			
3	93608-16M16	PIN, DOWEL	2			
4	90340-14M06	PLUG, STRAIGHT SCREW	1			
5	90430-14M09	GASKET	1			
6	6CB-13411-00	STRAINER, OIL	1			
7	6AW-13415-00	.SEAL, OIL STRAINER	1			
8	95812-06025	BOLT, FLANGE	3			
9	6CB-13300-00	OIL PUMP ASSY	1			
10	6CB-13329-00	.GASKET, PUMP COVER	1			
11	6AW-13119-00	.OIL SEAL	1			
12	69J-13631-00	.OIL SEAL	2			
13	6CB-11355-00	SEAL, CYLINDER 1	1			
14	95875-06040	BOLT, FLANGE	4			
15	93210-26658	O-RING	2			
16	6CB-13490-00	RELIEF VALVE ASSY	1			
17	6CB-13473-00	.O-RING	1			
18	6CB-15362-00	PLUG, OIL LEVEL	1			
19	6CB-15377-00	GUIDE, INLET	1			
20	93210-19MJ3	O-RING	1			
21	95875-06016	BOLT, FLANGE	2			

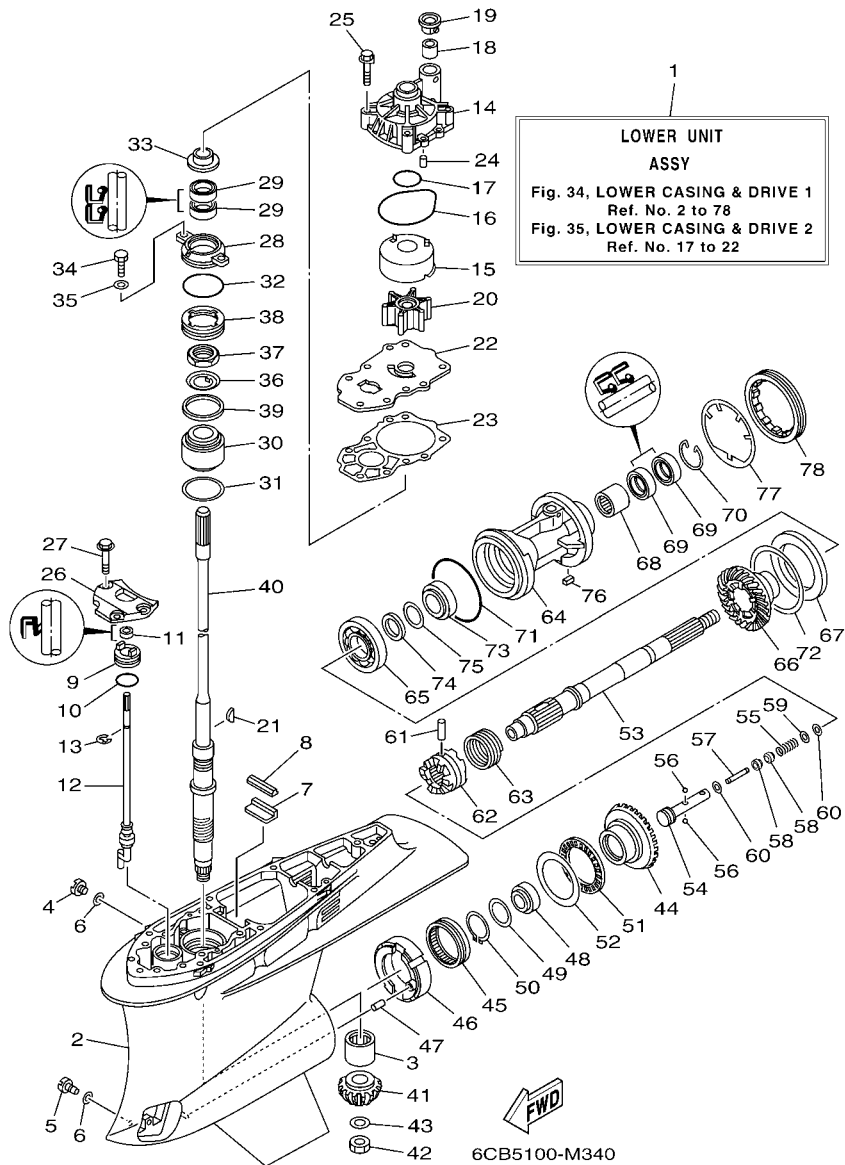

**FIG. 34 LOWER CASING & DRIVE 1**

REF. NO.	PART NO.	DESCRIPTION	6CD6				REMARKS
1	6CB-45300-01-NA	LOWER UNIT ASSY	1				
2	6CB-45311-01-NA	CASING, LOWER	1				
3	93311-928U5	BEARING	1				
4	90340-08002	PLUG, STRAIGHT SCREW	1				
5	688-45341-10	PLUG, DRAIN	1				
6	90430-08020	GASKET	2				
7	663-45376-00	GUIDE, SEAL DAMPER	1				
8	688-45375-00	DAMPER, SEAL	1				
9	65N-45321-00	PLATE	1				
10	93210-33M49	O-RING	1				
11	93106-09014	OIL SEAL	1				
12	6CB-44150-00	SHIFT CAM ASSY	1				
13	99001-08600	CIRCLIP	1				
14	61A-44311-01	HOUSING, WATER PUMP	1				
15	61A-44322-02	INSERT, CARTRIDGE	1				
16	93210-86M38	O-RING	1				
17	93210-37160	O-RING	1				
18	6E5-44365-00	DAMPER, WATER SEAL 1	1				
19	6E5-44312-00	COVER, WATER PUMP HOUSING	1				
20	6E5-44352-01	IMPELLER	1				
21	90280-04002	KEY, WOODRUFF	1				
22	6CB-44323-00	OUTER PLATE, CARTRIDGE	1				
23	6CB-44315-00	GASKET, WATER PUMP	1				
24	93606-12019	PIN, DOWEL	2				
25	90119-08M14	BOLT, WITH WASHER	4				
26	6CB-44312-00	COVER, WATER PUMP HOUSING	1				
27	90119-08M32	BOLT, WITH WASHER	3				



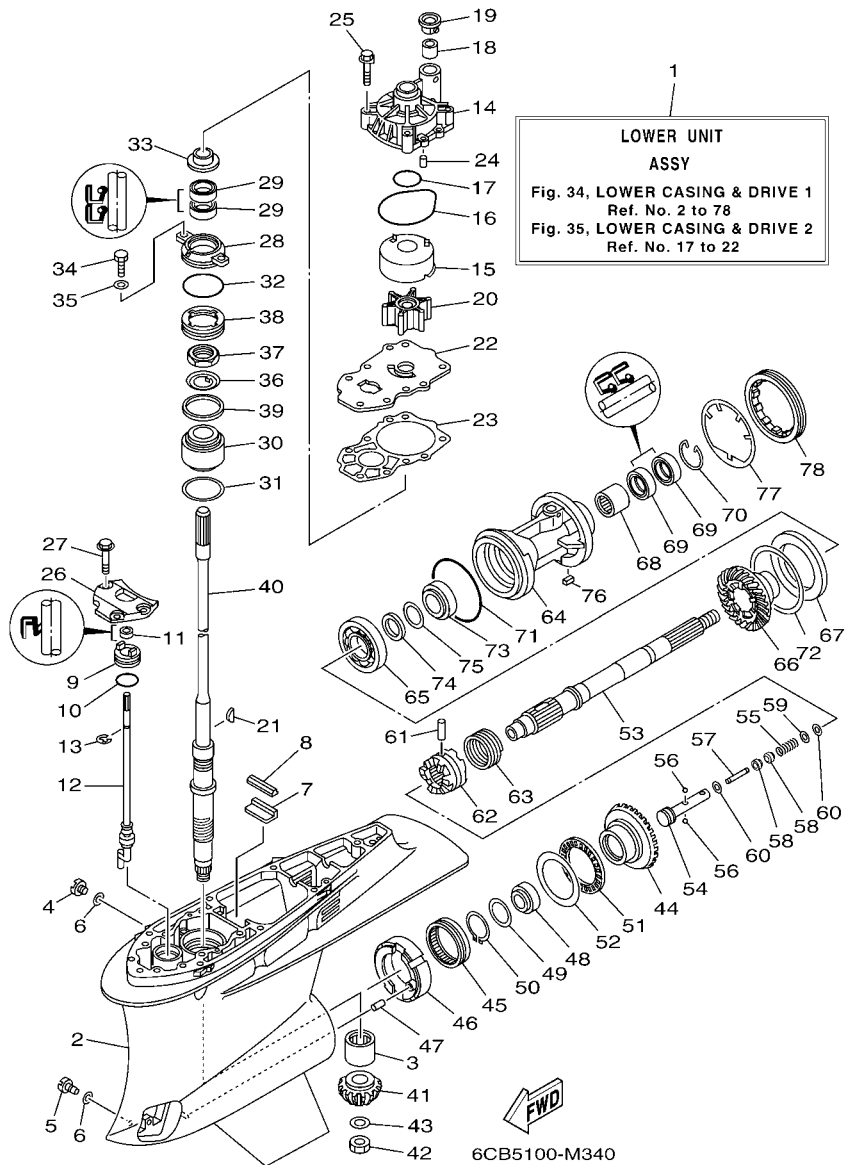

**FIG. 34 LOWER CASING & DRIVE 1**

REF. NO.	PART NO.	DESCRIPTION	6CD6				REMARKS
28	6CB-45335-00-9S	HOUSING, OIL SEAL	1				
29	93101-28M16	OIL SEAL	2				
30	93332-000A3	BEARING	1				
31	6CB-45587-00	SHIM (T:0.10MM)	1				UR
	6CB-45587-10	SHIM (T:0.12MM)	1				UR
	6CB-45587-20	SHIM (T:0.15MM)	1				UR
	6CB-45587-30	SHIM (T:0.18MM)	1				UR
	6CB-45587-40	SHIM (T:0.30MM)	1				UR
	6CB-45587-50	SHIM (T:0.40MM)	1				UR
	6CB-45587-60	SHIM (T:0.50MM)	1				UR
32	93210-58144	O-RING	1				
33	6E5-45344-00	COVER, OIL SEAL	1				
34	97095-08020	BOLT	2				
35	92995-08600	WASHER	2				
36	90214-30003	WASHER, CLAW	1				
37	90170-30M18	NUT	1				
38	6CB-45244-00	NUT	1				
39	6CB-45539-00	SPACER 2	1				
40	6CB-45501-01	DRIVE SHAFT COMP.	1				
41	6CB-45551-00	PINION (12T)	1				
42	90170-16M19	NUT	1				
43	90201-16M00	WASHER, PLATE	1				
44	6CB-45561-00	GEAR 1 (21T)	1				
45	93311-85894	BEARING	1				
46	6CB-45824-00	ADAPTER	1				
47	93608-16M16	PIN, DOWEL	1				
48	93332-000A4	BEARING	1				

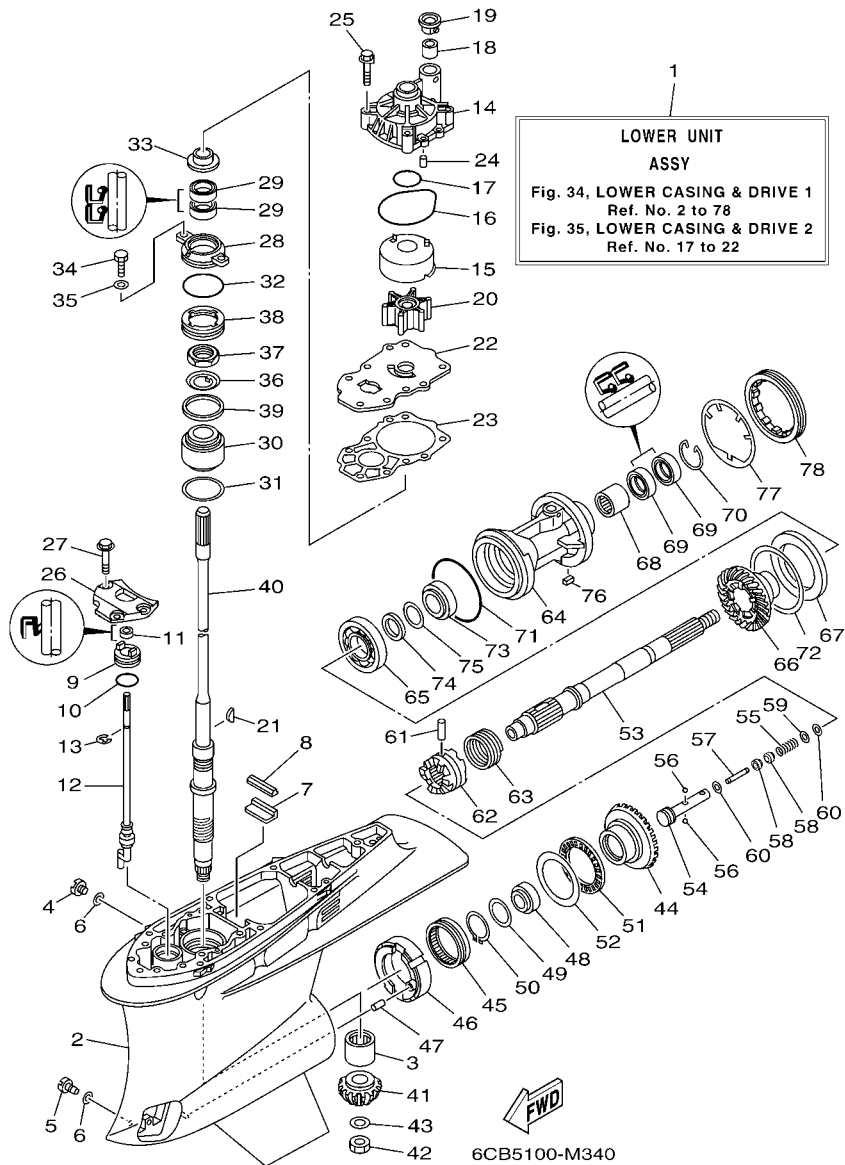

**FIG. 34 LOWER CASING & DRIVE 1**

REF. NO.	PART NO.	DESCRIPTION	6CD6				REMARKS
49	90201-41008	WASHER, PLATE	1				
50	99009-47500	CIRCLIP	1				
51	93340-67011	BEARING	1				
52	6CB-45567-00	SHIM (T:2.00MM)	1				UR
	6CB-45567-10	SHIM (T:2.03MM)	1				UR
	6CB-45567-20	SHIM (T:2.06MM)	1				UR
	6CB-45567-30	SHIM (T:2.09MM)	1				UR
	6CB-45567-40	SHIM (T:2.12MM)	1				UR
	6CB-45567-50	SHIM (T:2.15MM)	1				UR
53	6CB-45611-00	SHAFT, PROPELLER	1				
54	6CB-45634-00	SLIDE, SHIFT	1				
55	90501-10M77	SPRING, COMPRESSION	1				
56	93501-04011	BALL	2				
57	6H1-45668-00	SHAFT, FREE 1	1				
58	61A-45635-00	PLUNGER, SHIFT	2				
59	90201-02M00	WASHER, PLATE	1				
60	90183-02M03	NUT, SPRING	2				
61	90250-08M07	PIN, STRAIGHT	1				
62	6CB-45631-00	CLUTCH, DOG	1				
63	6E5-45633-01	RING, CROSS PIN	1				
64	6CB-45332-00-CA	HOUSING, BEARING	1				
65	93306-209U0	BEARING	1				
66	6CB-45571-00	GEAR 2 (21T)	1				
67	6CB-45576-00	WASHER, THRUST 2	1				
68	93315-43061	BEARING	1				
69	93101-30M17	OIL SEAL	2				
70	93450-45M02	CIRCLIP	1				

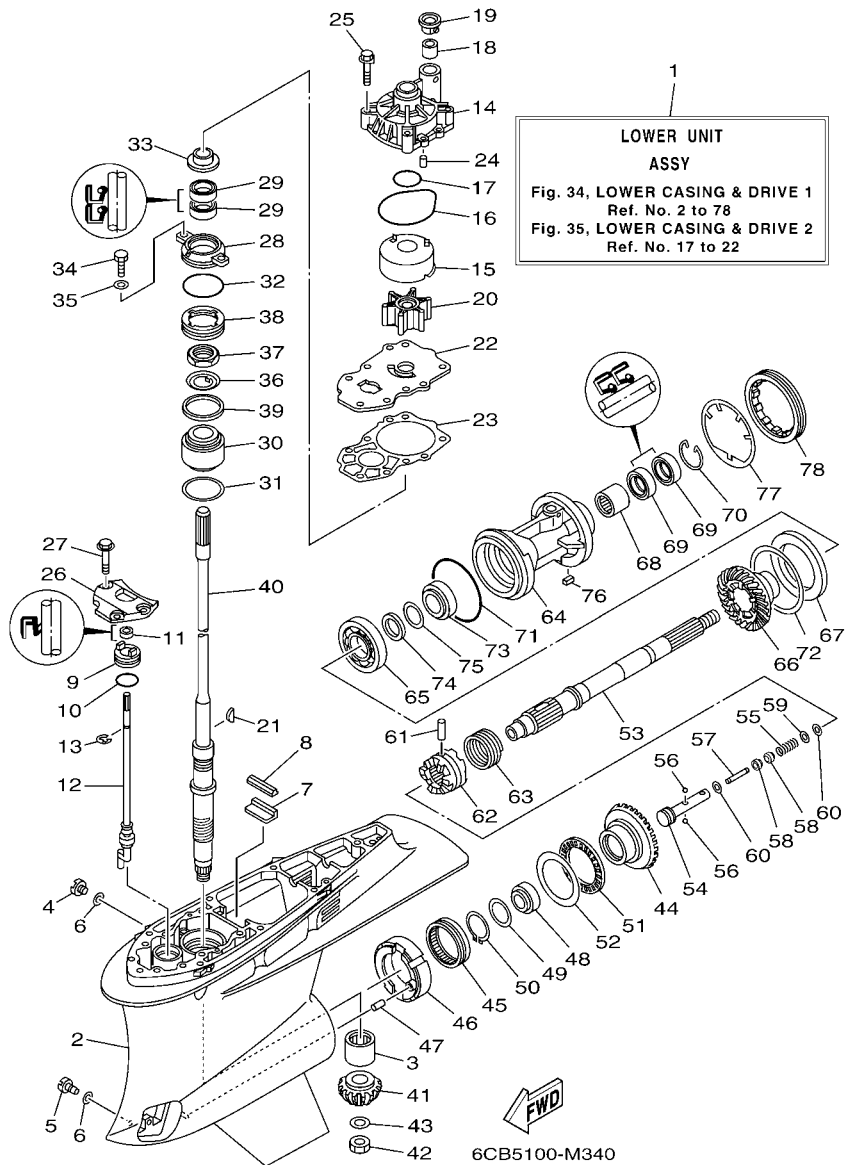

**FIG. 34 LOWER CASING & DRIVE 1**

REF. NO.	PART NO.	DESCRIPTION	6CD6				REMARKS
71	93211-02001	O-RING	1				
72	6CB-45577-00	SHIM (T:0.10MM)	1				UR
	6CB-45577-10	SHIM (T:0.12MM)	1				UR
	6CB-45577-20	SHIM (T:0.15MM)	1				UR
	6CB-45577-30	SHIM (T:0.18MM)	1				UR
	6CB-45577-40	SHIM (T:0.30MM)	1				UR
	6CB-45577-50	SHIM (T:0.40MM)	1				UR
	6CB-45577-60	SHIM (T:0.50MM)	1				UR
73	93332-000A5	BEARING	1				
74	90201-32008	WASHER, PLATE	1				
75	676-45567-00	SHIM (T:0.7MM)	1				UR
	676-45567-10	SHIM (T:0.8MM)	1				UR
	676-45567-20	SHIM (T:0.9MM)	1				UR
	676-45567-30	SHIM (T:1.0MM)	1				UR
	676-45567-40	SHIM (T:1.1MM)	1				UR
	676-45567-50	SHIM (T:1.2MM)	1				UR
76	90282-05008	KEY, STRAIGHT	1				
77	6CB-45383-00	WASHER, CLAW	1				
78	6CB-45384-00	NUT	1				

**FIG. 35 LOWER CASING & DRIVE 2**

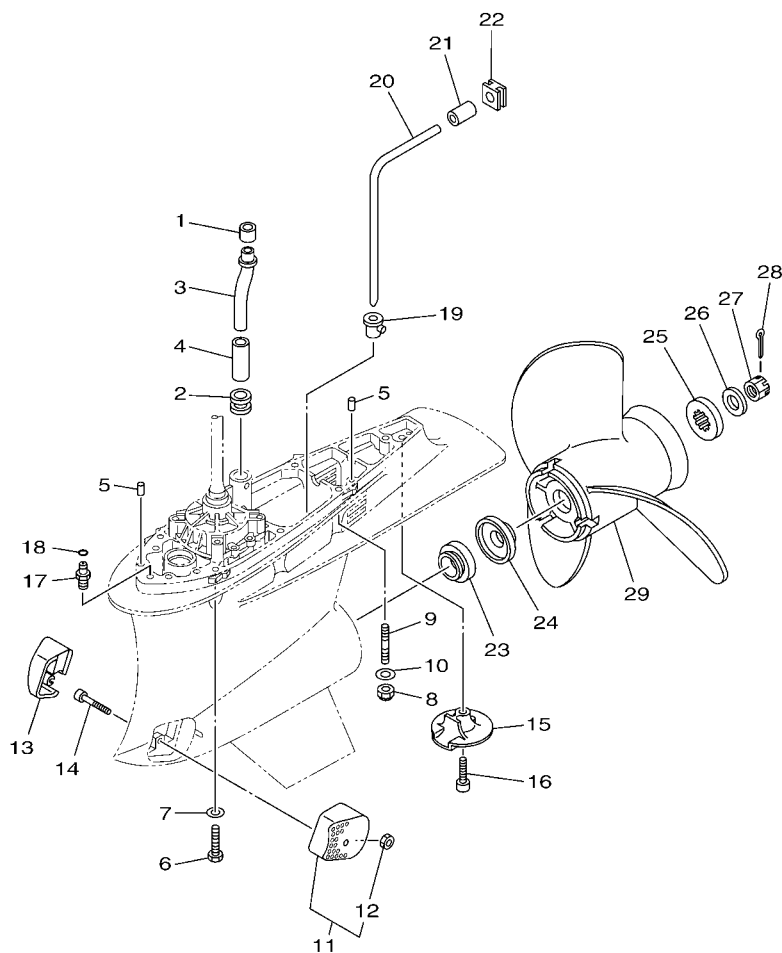

6CB3110-L340

REF. NO.	PART NO.	DESCRIPTION	6CD6				REMARKS
1	6E5-44365-00	DAMPER, WATER SEAL 1	1				
2	6E5-44366-00	DAMPER, WATER SEAL 2	1				
3	6CB-44361-00	TUBE, WATER 1	1				
4	90445-23002	HOSE (L59)	1				
5	93608-16M16	PIN, DOWEL	2				
6	97095-10045	BOLT	3				
7	92995-10600	WASHER	3				
8	95780-10300	NUT, FLANGE	4				
9	90116-10021	BOLT, STUD	4				
10	92995-10600	WASHER	4				
11	6CB-45214-20	COVER, WATER INLET 1	1				
12	90185-05002	.NUT, NYLON	1				
13	6CB-45215-20	COVER, WATER INLET 2	1				
14	90110-05039	BOLT, HEXAGON SOCKET HEAD	1				
15	6AW-45619-00	CAP	1				
16	90110-10018	BOLT, HEXAGON SOCKET HEAD	1				
17	63P-45378-00	NIPPLE, HOSE	1				
18	93210-07003	O-RING	1				
19	6D0-44367-00	DAMPER, WATER SEAL 3	1				
20	6CB-44362-00	TUBE, WATER 2	1				
21	6D0-44365-00	DAMPNER, WATER SEAL 1	1				
22	6D0-44366-00	DAMPER, WATER SEAL 2	1				
23	60X-45987-10	SPACER 1	1				
24	60X-45995-00	SPACER 3	1				
25	688-45997-01	SPACER 2	1				
26	92990-18200	WASHER	1				
27	90171-18M04	NUT, CASTLE	1				

FIG. 35 LOWER CASING & DRIVE 2

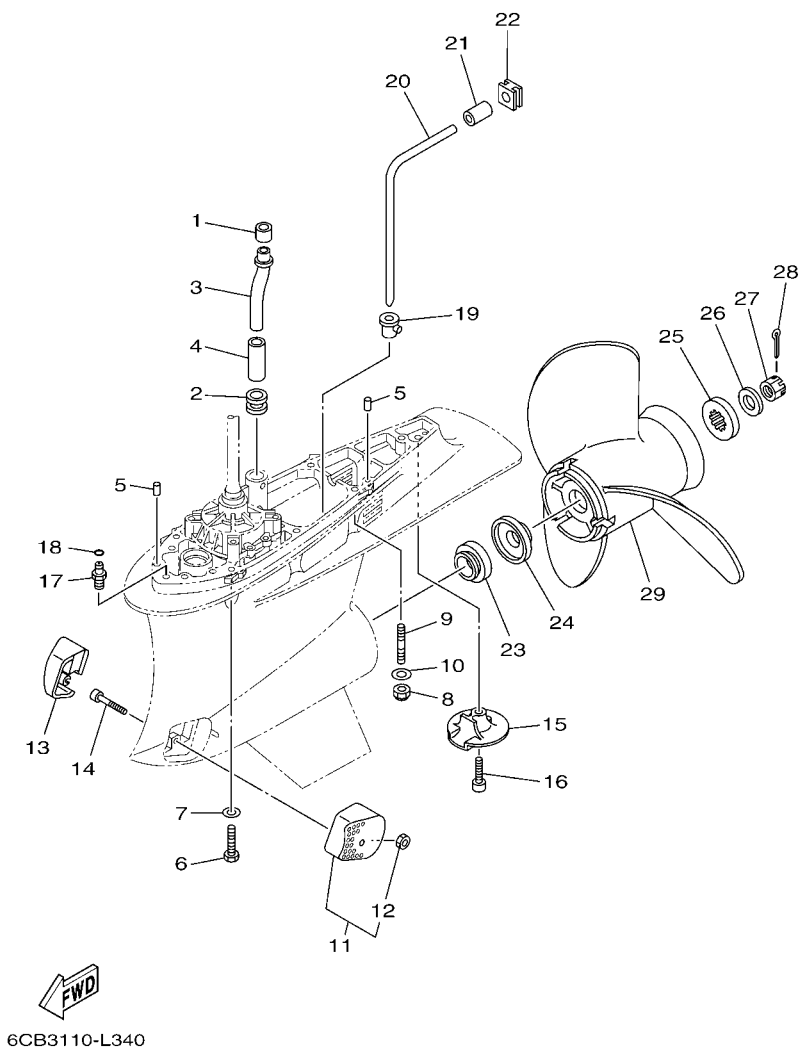

REF. NO.	PART NO.	DESCRIPTION	6CD6				REMARKS
28	91490-40030	PIN. COTTER	1				
29	6CB-45970-00	PROPELLER (3X15-1/8"X27"-T1)	1				UR
	6CB-45972-00	PROPELLER (3X15-1/8"X25"-T1)	1				UR
	6CB-45974-00	PROPELLER (3X14-1/2"X23"-T1)	1				UR
	6CB-45976-00	PROPELLER (3X14-3/4"X29"-T1)	1				UR
-----							
-----							
-----							
-----							
-----							
-----							
-----							
-----							

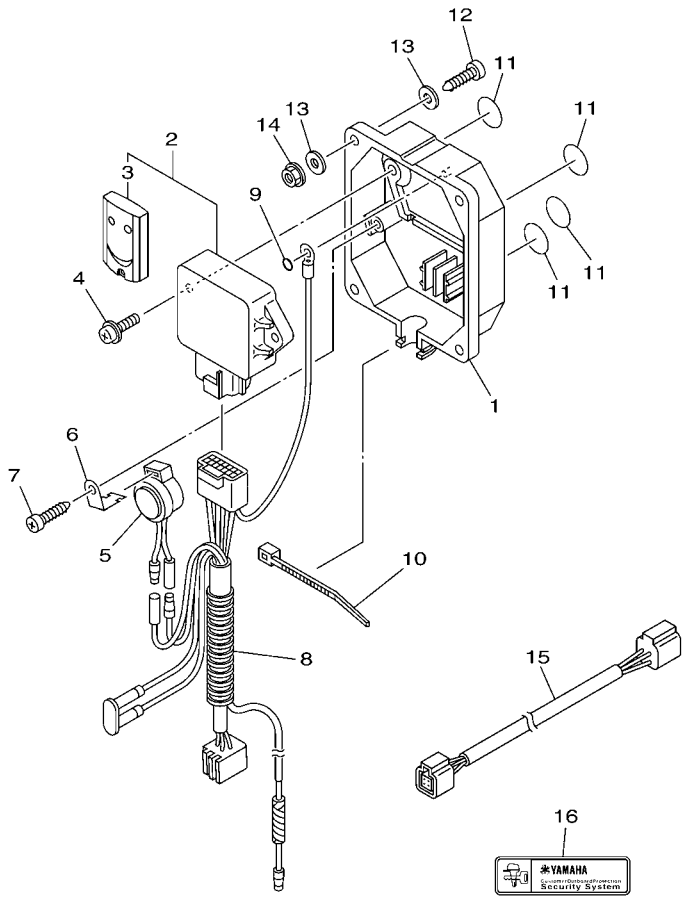

6CJ1100-K370

FIG. 36 OPTIONAL PARTS 1

REF. NO.	PART NO.	DESCRIPTION	6CD6				REMARKS
1	6Y8-86267-00	CASE COMPLETE 1	1				
2	6Y8-86260-12	REMOTE CONTROL UNIT ASSY	1				
3	6AA-86261-22	.TRANSMITTER COMP	2				
4	97980-06216	SCREW, WITH WASHER	2				
5	6X4-83383-00	BUZZER	1				
6	6X4-83386-00	STAY, BUZZER	1				
7	97780-60620	SCREW, TAPPING	1				
8	6Y8-82509-10	WIRE, SUB LEAD	1				
9	93210-04279	O-RING	1				
10	90465-11M10	CLAMP	1				
11	6Y8-8454G-00	PATCH 1	4				
12	90167-06M00	SCREW, TAPPING	4				UR
	97880-06035	SCREW, PAN HEAD	4				UR
13	90201-06M30	WASHER, PLATE	8				
14	95780-06300	NUT, FLANGE	4				
15	6Y8-82521-11	2FT PIGTAIL BUS	1				
16	6Y8-48277-00	STICKER 1	4				

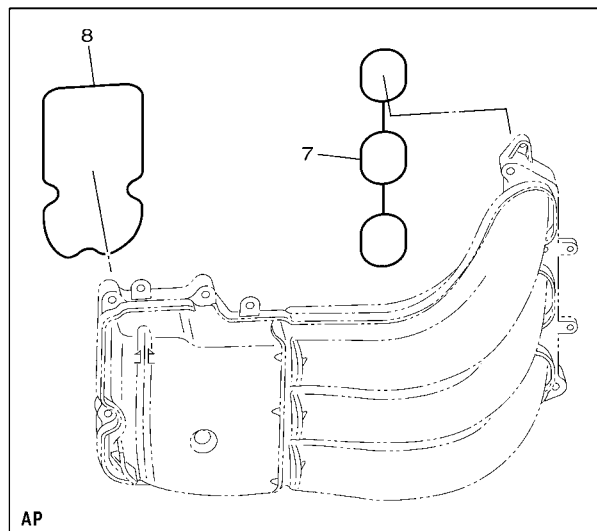
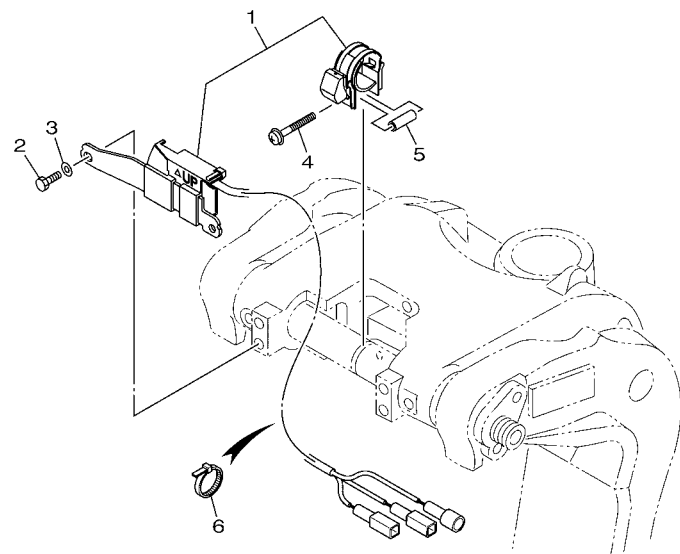

**FWD**  
6CB3110-L360

FIG. 37 OPTIONAL PARTS 2

REF. NO.	PART NO.	DESCRIPTION	6CD6				REMARKS
1	63P-825E0-01	TILT LIMIT SWITCH ASSY	1				
2	97095-06016	BOLT	2				
3	92995-06600	WASHER	2				
4	90159-05059	SCREW, WITH WASHER	1				
5	90387-05004	COLLAR	1				
6	90465-11M10	CLAMP	5				
7	6CB-13645-00	GASKET, MANIFOLD 1	1				AP
8	6CB-13646-00	GASKET, MANIFOLD 2	1				AP

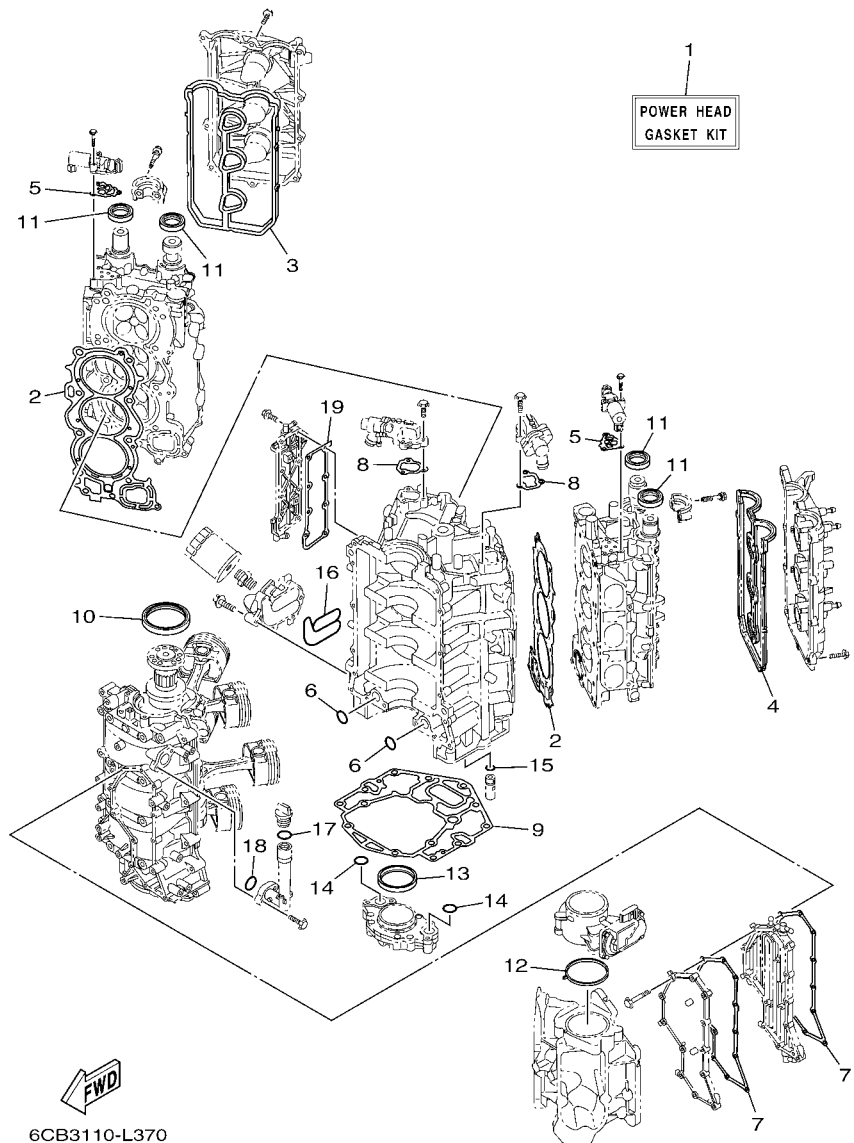

**FIG. 38 REPAIR KIT 1**

REF. NO.	PART NO.	DESCRIPTION	6CD6				REMARKS
1	6CB-W0001-02	POWER HEAD GASKET KIT	1				
2	6CB-11181-00	.GASKET, CYLINDER HEAD 1	2				
3	6CB-11193-00	.GASKET, HEAD COVER 1	1				
4	6CB-11194-00	.GASKET, HEAD COVER 2	1				
5	6CB-1242F-00	.GASKET, FILTER	2				
6	93210-26658	.O-RING	2				
7	6CB-15451-00	.GASKET, CRANKCASE COVER 1	2				
8	6CB-12427-10	.GASKET, HOUSING COVER 1	2				
9	6CB-11351-00	.GASKET, CYLINDER	1				
10	93102-85008	.OIL SEAL	1				
11	93102-38008	.OIL SEAL	4				
12	6CB-13556-00	.GASKET, MANIFOLD	1				
13	6CB-11355-00	.SEAL, CYLINDER 1	1				
14	93210-26658	.O-RING	2				
15	6CB-13473-00	.O-RING	1				
16	6CB-13477-00	.GASKET	1				
17	93210-24M79	.O-RING	1				
18	93210-27370	.O-RING	1				
19	6CB-1131B-00	.GASKET, COVER	1				



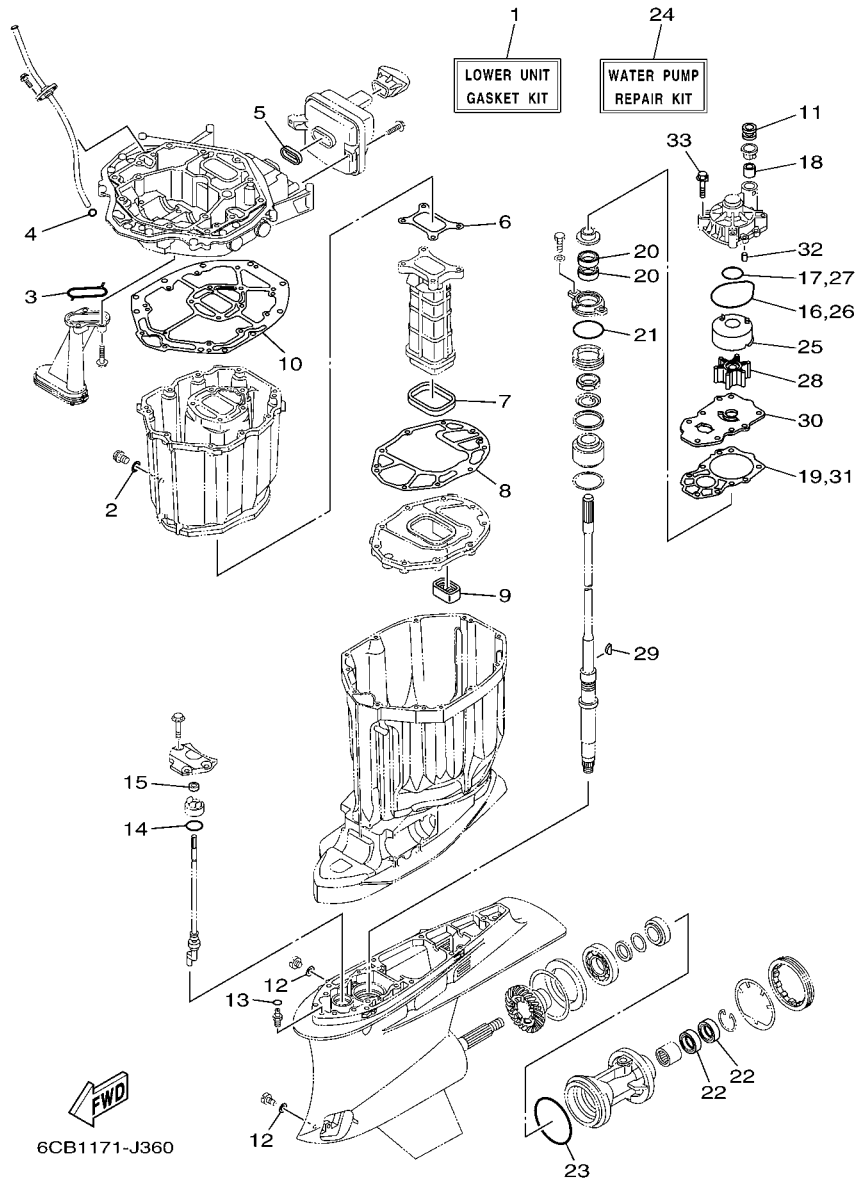

FIG. 39 REPAIR KIT 2

REF. NO.	PART NO.	DESCRIPTION	6CD6				REMARKS
1	6CB-W0001-20	LOWER UNIT GASKET KIT	1				
2	90430-14M09	.GASKET	1				
3	6AW-13415-00	.SEAL, OIL STRAINER	1				
4	93210-19MJ3	.O-RING	1				
5	6CB-14755-00	.GASKET, SILENCER	1				
6	6CB-41134-00	.GASKET, EXHAUST MANIFOLD	1				
7	6CB-41138-00	.SEAL, EXT. 1	1				
8	6CB-41135-00	.GASKET, EXHAUST MANIFOLD	1				
9	6CB-45127-00	.SEAL	1				
10	6CB-45113-00	.GASKET, UPPER CASING	1				
11	6E5-44366-00	.DAMPER, WATER SEAL 2	1				
12	90430-08020	.GASKET	2				
13	93210-07003	.O-RING	1				
14	93210-33M49	.O-RING	1				
15	93106-09014	.OIL SEAL	1				
16	93210-86M38	.O-RING	1				
17	93210-37160	.O-RING	1				
18	6E5-44365-00	.DAMPER, WATER SEAL 1	1				
19	6CB-44315-00	.GASKET, WATER PUMP	1				
20	93101-28M16	.OIL SEAL	2				
21	93210-58144	.O-RING	1				
22	93101-30M17	.OIL SEAL	2				
23	93211-02001	.O-RING	1				
24	6CB-W0078-00	WATER PUMP REPAIR KIT	1				
25	61A-44322-02	.INSERT, CARTRIDGE	1				
26	93210-86M38	.O-RING	1				
27	93210-37160	.O-RING	1				



NUMERICAL INDEX

PART NO.	REF. NO.	PART NO.	REF. NO.	PART NO.	REF. NO.	PART NO.	REF. NO.	PART NO.	REF. NO.	PART NO.	REF. NO.
6CB-11110-00	5 - 2	6CB-11478-00	4 - 2	6P2-12623-00	8 - 20	6AW-13761-00	12 - 6	6CB-14989-00	10 - 29	6CB-24452-10	13 - 18
6CB-11120-00	5 - 14	6CB-1149A-00	6 - 10		8 - 23	6AW-13781-00	13 - 34	6CB-15100-10	3 - 2	4SV-24453-00	13 - 38
6S5-11133-10	5 - 3	6CB-11567-00	8 - 17	6CB-12645-01	8 - 19	6CB-13782-00	10 - 15	6AW-15142-00	5 - 40	6CB-24460-00	13 - 4
	5 - 15	6CB-11590-01	8 - 28	6CB-1264A-01	8 - 22	6AW-13784-00	13 - 35	6CB-15142-00	6 - 8	6CB-24461-00	14 - 1
6CB-11181-00	5 - 27	6CB-11603-00	4 - 12	6P2-12663-00	8 - 21	6CB-13898-00	11 - 9	6CB-15187-00	3 - 5	6P3-24469-00	15 - 10
	38 - 2	6CE-11631-00	4 - 11		8 - 24	6CB-13898-10	11 - 10	6CB-15311-00-CA	33 - 1	6CB-24482-00	13 - 20
6CB-11191-02	5 - 32	6CB-11633-00	4 - 13	6CB-13016-00	1 - 10	6CB-13906-01	13 - 8	6BB-15316-00	32 - 28	6CB-24491-00	13 - 30
6CB-11192-02	5 - 36	6CB-11654-00	4 - 10		13 - 5	6CB-13907-10	13 - 23	6CB-15319-00	3 - 43	6CB-24492-00	13 - 28
6CB-11193-00	5 - 33	6CB-11656-00	4 - 14	6AW-13119-00	33 - 11	63P-13915-00	1 - 11	6CB-15362-00	33 - 18	6CB-24501-01	1 - 9
	38 - 3	6CB-11656-10	4 - 14	6AW-13132-00	13 - 32		13 - 24	6G8-15363-00	3 - 41		13 - 3
6CB-11194-00	5 - 37	6CB-11656-20	4 - 14	6CB-13161-00	12 - 1	6CB-13971-01	14 - 10	6CB-15373-00	9 - 8	6P3-24519-00	15 - 9
	38 - 4	6CB-11998-00	5 - 44	6CB-13171-00	12 - 5	6CB-13972-00	14 - 12	6CB-15377-00	33 - 19	6P3-24560-22	15 - 7
67F-11301-00	5 - 21	6CB-11999-00	5 - 45	6CB-13300-00	33 - 9	6CB-13974-01	14 - 11	6CB-15411-00	3 - 14	6P3-24562-21	15 - 8
6CB-1131B-00	3 - 12	6CB-12111-00	8 - 1	6CB-13329-00	33 - 10	6AW-1410B-00	12 - 3	6CB-15421-10	3 - 15	6P3-24563-01	1 - 14
	38 - 19	6CB-12113-00	8 - 4	6CB-13411-00	33 - 6		12 - 7	6CB-15451-00	3 - 17		15 - 12
6CB-1131C-00	3 - 9	51Y-12119-00	8 - 7	6AW-13415-00	33 - 7	69J-14137-00	14 - 3		38 - 7	6P3-24564-00	1 - 13
68T-11325-00	1 - 4	6CB-12121-00	8 - 2		39 - 3	6CB-14146-00	13 - 10	6CB-15481-00	3 - 6		15 - 11
	3 - 32	6CB-12171-00	8 - 9	6CB-13437-50	17 - 16	6P2-14149-00	14 - 2	6CB-15512-00	8 - 29	6CB-24566-00	15 - 13
63P-11325-01	1 - 1	6CB-12172-00	8 - 13	N26-13440-02	1 - 6	6CB-14180-05	13 - 1	6CB-15544-00	6 - 4	6CB-24592-00	13 - 29
	3 - 10	6CB-12181-00	8 - 11		3 - 36	6CB-14181-01	13 - 15	6CB-2134V-00	5 - 42	6CB-24596-01	15 - 20
	3 - 19	6CB-12182-00	8 - 15	6CB-13446-00	3 - 38	6CB-14182-02	13 - 2	69J-28100-00	9 - 16	69J-28100-01	15 - 22
67F-11325-01	1 - 7	6CB-12411-10	1 - 2	6CB-13473-00	33 - 17	6P2-14191-00	13 - 16	6E5-21744-00	10 - 23	67F-2812A-00	20 - 32
	5 - 22		3 - 21		38 - 15	68V-14216-00	13 - 12	6CB-2416A-00	10 - 5	6CB-41132-00-9S	32 - 14
63P-11325-11	1 - 16	67F-12412-00	3 - 22	6CB-13477-00	3 - 39	6CB-14216-00	13 - 6	69J-24170-00	9 - 14	6CB-41134-00	32 - 15
	32 - 2	6CB-12413-11	3 - 24		38 - 16	6CB-14239-00	13 - 17	69J-2419A-01	9 - 15		39 - 6
67F-11328-00	5 - 23	6CB-12413-20	3 - 23	6CB-13490-00	33 - 16	6P2-14386-00	13 - 37	6CB-24217-00	13 - 7	6CB-41135-00	32 - 18
6AW-1132N-01	1 - 5	6CB-1241B-01	3 - 46	6CB-13532-10	10 - 2	6AW-1441J-00	9 - 11	60E-24300-01	14 - 9		39 - 8
	3 - 34	6CB-12422-10-9S	3 - 25	6CB-13533-00	10 - 1	6CB-14429-01	13 - 19	6CB-24313-10	15 - 18	6CB-41137-00-CA	32 - 1
6AW-1132P-00	1 - 3	6CB-12427-10	3 - 26	6CB-13545-00	10 - 17	63P-14435-00	21 - 35	6CB-24314-11	15 - 2	6CB-41138-00	32 - 17
	3 - 30		38 - 8	6CB-13546-00	10 - 21	6CB-14440-01	9 - 9	6CB-24315-00	25 - 6		39 - 7
6CB-11351-00	3 - 29	6CB-1242F-00	6 - 2	6CB-13547-00	10 - 22	6CB-1447B-00	13 - 33	6CB-24317-00	14 - 6	6CB-41273-00	27 - 39
	38 - 9		38 - 5	6CB-13548-00	10 - 24	6CB-14546-00	13 - 26	6CB-24323-00	14 - 7	6CB-42134-00	2 - 33
6CB-11355-00	33 - 13	6CB-1243E-00	7 - 17	6CB-13556-00	11 - 3	6CB-14564-00	13 - 9	6CB-24324-00	14 - 5	6AW-42169-00	25 - 8
	38 - 13	6CE-1244G-00	7 - 14		38 - 12	63P-14567-00	13 - 36	6E5-24351-51	15 - 3	6BG-42384-00	25 - 2
6CB-1135A-00	6 - 6	6CE-1244H-00	7 - 16	68V-13577-00	14 - 4	6CB-14750-00	32 - 10	6AW-24360-01	16 - 1	6CB-42510-00-8D	29 - 10
6CB-11410-00	4 - 1	6CE-12481-10	18 - 27	6CB-13577-00	12 - 4	6CE-24376-00	32 - 12	6CE-24376-00	18 - 30	6CB-42545-00	2 - 5
6CB-11416-00	4 - 5	6CE-12482-10	10 - 8		12 - 8		39 - 5	6G8-24376-00	10 - 28	6CD-42610-01	2 - 1
6CB-11416-10	4 - 5	6CB-12483-00	10 - 25		13 - 22	6CB-1475A-00	10 - 26	6CE-24377-00	18 - 21	6CB-42613-00-NA	2 - 3
6CB-11416-20	4 - 5	6CE-12483-00	18 - 22	6CB-13593-00	33 - 12	6CB-1475F-00	10 - 27	6AW-24377-01	15 - 4	6CB-42615-00	24 - 5
6CB-11416-30	4 - 5	6CB-12484-00	10 - 10	6CB-13641-00	9 - 5	6CB-1475G-00	10 - 30	688-24378-00	7 - 2	6BG-42617-00	21 - 11
6CB-11416-40	4 - 5	6CB-1248E-10	18 - 20	6CB-13645-00	9 - 6	6CB-1475H-00	13 - 13		7 - 12	6CB-42617-00	21 - 12
6CB-11417-00	4 - 6	6AW-12572-00	25 - 11		37 - 7	6CB-1475J-00	13 - 14		10 - 20	6CB-4261A-00	2 - 2
6CB-11417-10	4 - 6	6CB-12576-10	7 - 3	6CB-13646-00	9 - 7	6CE-14872-00	18 - 28		10 - 34	6CB-42626-00-NA	2 - 6
6CB-11417-20	4 - 6	6CB-12577-00	7 - 7		37 - 8		18 - 29		18 - 33	6CB-42628-00	2 - 36
6CB-11417-30	4 - 6	6R3-12581-00	25 - 12	6CB-13711-00	11 - 2		18 - 31	6CE-24378-00	7 - 15	6CB-42629-00	21 - 13
6CB-11417-40	4 - 6	6AW-12582-00	25 - 13	69J-13716-00	13 - 21	6CB-14984-00	1 - 12	6E5-24378-00	14 - 8	6CB-42635-00	2 - 23
6CB-11426-03	4 - 7	6R3-12583-00	25 - 14	6CB-13751-00	11 - 1		13 - 31	68V-24379-10	13 - 11	6CB-42636-00-NA	2 - 12
6CB-11427-03	4 - 8	6P2-12615-00	8 - 25	6AW-13761-00	12 - 2	6CB-14985-00	13 - 25	6CB-24410-00	13 - 27	6CB-42643-00	25 - 22

NUMERICAL INDEX

PART NO.	REF. NO.	PART NO.	REF. NO.	PART NO.	REF. NO.	PART NO.	REF. NO.	PART NO.	REF. NO.	PART NO.	REF. NO.
6CB-42644-00	25 - 23	61A-43132-00	28 - 7	6G5-43864-00	30 - 20	6E5-44365-00	34 - 18	6CB-45567-10	34 - 52	6CB-81410-00	17 - 3
6CB-42647-00	2 - 26	61A-43133-00	28 - 10	64E-43865-00	31 - 16		35 - 1	676-45567-20	34 - 75	6CB-81443-00	22 - 7
6CB-42662-00	5 - 46	64E-43139-10	29 - 1	6G5-43865-01	31 - 35		39 - 18	6CB-45567-20	34 - 52	6CB-81639-00	20 - 28
6AW-42663-00	2 - 32	66T-43144-00	24 - 17	64E-43866-00	30 - 10	6D0-44366-00	35 - 22	676-45567-30	34 - 75	6CB-81800-00	23 - 1
6CB-42675-10	2 - 38	6CB-43311-00-8D	28 - 24	64E-43867-00	30 - 9	6E5-44366-00	35 - 2	6CB-45567-30	34 - 52	69J-81801-00	23 - 5
6CB-42676-10	2 - 39	64E-43376-00	29 - 8	64E-43868-00	31 - 3		39 - 11	676-45567-40	34 - 75	6CB-81807-00	23 - 8
6CD-42677-00	2 - 40	6CB-43611-00	28 - 37	64E-43869-00	30 - 27	6D0-44367-00	35 - 19	6CB-45567-40	34 - 52	6CB-81809-00	23 - 14
6CD-42678-00	2 - 37	6CB-43800-02-8D	30 - 1	6H1-4386K-10	31 - 29	6P2-44391-00	24 - 24	676-45567-50	34 - 75	67F-81810-00	23 - 3
6CB-42681-01	2 - 41	64E-43802-00	31 - 8	6E5-43872-00	30 - 13	6CB-44511-00	29 - 31	6CB-45567-50	34 - 52	67F-81813-00	23 - 6
6CB-42682-01	2 - 42	64E-43805-01	31 - 37	64E-43873-00	31 - 24	6CB-44514-00	29 - 25	6CB-45571-00	34 - 66	6CB-81820-00	23 - 7
6AW-42697-10	2 - 19	64E-4380F-00	31 - 33	6E5-43874-01	30 - 22	6CB-44526-00	29 - 26	6CB-45576-00	34 - 67	67F-81821-00	23 - 11
6CB-42711-01-8D	24 - 1	64E-4380J-00	31 - 30	6AW-43875-00	31 - 25	6CB-44533-00	29 - 30	6CB-45577-00	34 - 72	6CB-81822-02	22 - 5
648-42715-00	27 - 27	63P-43810-02	30 - 6	64E-43879-01	31 - 27	6CB-44551-01-8D	29 - 13	6CB-45577-10	34 - 72	6CB-81823-00	22 - 9
6CB-42716-00	24 - 6	64E-43811-02	30 - 7	64E-43879-11	31 - 26	61A-44552-01-CA	29 - 24	6CB-45577-20	34 - 72	6CB-81826-00	23 - 22
61A-42717-00	32 - 9	6E5-43814-02	30 - 14	64E-4387A-00	31 - 23	60X-44555-00	29 - 16	6CB-45577-30	34 - 72	69J-81828-00	23 - 23
6D0-42717-00	24 - 22	64E-43816-00	31 - 17	67H-43880-10	31 - 28	6E5-44575-00	29 - 15	6CB-45577-40	34 - 72	67F-81830-00	23 - 16
69J-42723-01	21 - 29	64E-43817-00	30 - 5	64E-43883-00	30 - 12	6CB-45111-00-8D	32 - 22	6CB-45577-50	34 - 72	6CB-81832-00	23 - 9
6BG-42724-00	25 - 1	64E-43817-11	31 - 19	64E-4388E-01	30 - 26	6CB-45113-00	32 - 25	6CB-45577-60	34 - 72	6CB-81836-00	23 - 10
6E5-42724-00	32 - 8	6BC-43818-00	28 - 22	64E-4388E-11	31 - 1		39 - 10	6CB-45587-00	34 - 31	6C5-81839-00	23 - 19
6CB-42725-01	24 - 2	64E-4381G-00	30 - 28	6AW-4388J-00	30 - 3	6CB-45127-00	32 - 21	6CB-45587-10	34 - 31	67F-8183R-00	23 - 13
61A-42727-00	25 - 4	6CB-43820-01	30 - 16	64E-43891-00	31 - 31		39 - 9	6CB-45587-20	34 - 31	60V-8183T-00	23 - 17
64G-42727-00	25 - 5	64E-43821-03	30 - 17	64E-43892-00	31 - 34	6BB-45152-01	32 - 29	6CB-45587-30	34 - 31	6P2-8183X-00	20 - 17
6CB-42741-00-8D	26 - 1	64E-43822-00	30 - 18	6E5-43896-00	31 - 9	6CB-45181-00-CA	32 - 19	6CB-45587-40	34 - 31	69J-81840-00	23 - 4
6CB-42743-00	24 - 26	6CB-43825-00	30 - 2	64E-43897-00	30 - 25	6CB-45214-20	35 - 11	6CB-45587-50	34 - 31	67F-81841-00	23 - 12
6CB-42744-00	25 - 28	64E-43827-00	31 - 22	64E-43898-00	30 - 8	6CB-45215-20	35 - 13	6CB-45587-60	34 - 31	6CB-81842-00	23 - 18
6H4-42748-00	24 - 23	64E-43828-01	30 - 23	6CB-44117-00	27 - 9	6CB-45244-00	34 - 38	6CB-45611-00	34 - 53	6BR-81845-00	18 - 7
68F-42753-00	24 - 32	64E-43829-01	30 - 24	69J-44118-00	27 - 26	65W-45251-00	1 - 15	6AW-45619-00	35 - 15	67F-81846-00	23 - 24
6CB-42756-00	24 - 30	64E-4382G-00	30 - 30	6CB-44120-01	27 - 32		28 - 2	6CB-45631-00	34 - 62	67F-81850-00	23 - 2
69M-42758-01	18 - 5	6CB-43830-00	31 - 4	6CB-44121-00	27 - 21	6CB-45300-01-NA	34 - 1	6E5-45633-01	34 - 63	6C5-81869-00	23 - 21
		64E-43831-00	31 - 2	69J-44122-00	27 - 22	6CB-45311-01-NA	34 - 2	6CB-45634-00	34 - 54	67F-81891-00	23 - 15
6CB-42761-00	24 - 3	6AW-43841-00	31 - 7	6P2-44139-00	27 - 38	65N-45321-00	34 - 9	61A-45635-00	34 - 58	6CB-81919-20	20 - 37
6CB-42766-00	24 - 28	64E-43843-00	31 - 6	6CB-44150-00	34 - 12	6CB-45332-00-CA	34 - 64	6H1-45668-00	34 - 57	6CB-81923-00	20 - 38
6CB-42769-01	32 - 13	64E-43843-10	31 - 38	69J-44176-01	27 - 11	6CB-45335-00-9S	34 - 28	6CB-45824-00	34 - 46	6P2-81925-01	20 - 1
6CB-42771-00-8D	26 - 2	64E-4384J-00	30 - 19	61A-44311-01	34 - 14	688-45341-10	34 - 5	6CB-45970-00	35 - 29	6CB-81929-00	20 - 4
6AW-42785-00	25 - 10	64E-4384N-00	30 - 31	6CB-44312-00	34 - 26	6E5-45344-00	34 - 33	6CB-45972-00	35 - 29	6C5-81941-00	23 - 20
6CB-42791-00	32 - 23	64E-43850-00	31 - 15	6E5-44312-00	34 - 19	688-45375-00	34 - 8	6CB-45974-00	35 - 29	6CB-81948-01	20 - 6
6CB-42792-00	32 - 24	64E-43851-00	31 - 11	6CB-44315-00	34 - 23	663-45376-00	34 - 7	6CB-45976-00	35 - 29	63P-81950-00	20 - 13
6AH-42794-40	24 - 34	64E-43855-00	31 - 14		39 - 19	63P-45378-00	35 - 17	60X-45987-10	35 - 23	6CB-81952-00	21 - 36
6AH-42794-50	24 - 35	64E-43858-00	31 - 12		39 - 31	63P-45379-00	32 - 35	60X-45995-00	35 - 24	68F-8195A-00	20 - 23
6CB-42815-01-8D	24 - 7	6AW-43858-00	31 - 18	61A-44322-02	34 - 15	6CB-45383-00	34 - 77	688-45997-01	35 - 25	6CB-81960-00	18 - 11
6CB-42816-01-8D	24 - 8	6E5-43858-00	30 - 29		39 - 25	6CB-45384-00	34 - 78	6Y8-48277-00	36 - 16	6CB-81972-00-9S	18 - 12
6CB-42817-01-8D	24 - 9	72X-43858-00	31 - 5	6CB-44323-00	34 - 22	6CB-45501-01	34 - 40	6E5-48344-00	27 - 7	6CB-81975-00	18 - 15
6CB-42818-00	24 - 13	64E-43859-00	31 - 13		39 - 30	6CB-45539-00	34 - 39		27 - 41	69J-81975-A0	18 - 13
6CB-42819-00	24 - 14	64E-43860-01	31 - 20	6E5-44352-01	34 - 20	6CB-45551-00	34 - 41	6CB-48531-00	27 - 1	6AH-81994-40	17 - 17
6CB-43111-02-8D	28 - 1	6E5-43862-00	30 - 11		39 - 28	6CB-45561-00	34 - 44	6CB-48532-00	27 - 2	6AH-81994-50	17 - 18
6CB-43112-01-8D	28 - 9		30 - 15	6CB-44361-00	35 - 3	676-45567-00	34 - 75	6E5-48538-00	27 - 5	6CB-82105-01	20 - 41
64E-43126-00	28 - 30	6G5-43863-00	31 - 10	6CB-44362-00	35 - 20	6CB-45567-00	34 - 52	6P2-81336-00	20 - 34	6P2-82113-00	20 - 31
64E-43131-30	28 - 15	6E5-43864-00	30 - 21	6D0-44365-00	35 - 21	676-45567-10	34 - 75	6CB-81337-01	17 - 13	6E5-82148-00	28 - 4

NUMERICAL INDEX

PART NO.	REF. NO.	PART NO.	REF. NO.	PART NO.	REF. NO.	PART NO.	REF. NO.	PART NO.	REF. NO.	PART NO.	REF. NO.
6E5-82148-00	28 - 12	6CB-85547-00	9 - 10	K0F-A3753-30	8 - 8	90119-06M17	9 - 21	90185-14M00	29 - 28	90387-08M37	24 - 20
66K-82149-00	28 - 29	6CB-85561-00	17 - 6	K0F-A3753-40	8 - 8		15 - 14	90185-22M11	28 - 18	90387-08M45	2 - 30
67F-82151-00	20 - 26	6CB-85580-00	17 - 5	K0F-A3753-50	8 - 8	90119-06M18	32 - 36	90201-02M00	34 - 59	90387-10094	2 - 28
6P2-82151-00	20 - 22	6P2-85780-00	6 - 11	K0F-A3753-60	8 - 8	90119-06M24	9 - 2	90201-06M30	36 - 13	90387-11005	5 - 28
67F-82151-10	20 - 27	6CB-85790-00	21 - 22	K0F-A3753-70	8 - 8	90119-06M56	18 - 6	90201-09M02	27 - 35	90401-19001	3 - 37
67F-82151-40	20 - 24	63P-85886-00	21 - 34	6CB-W0001-02	38 - 1		20 - 9	90201-10060	28 - 20	90430-06M03	5 - 25
67F-82151-50	20 - 25	6P2-85896-00	19 - 5	6CB-W0001-20	39 - 1	90119-06M61	25 - 26	90201-10M01	8 - 32	90430-08020	1 - 18
6CB-82170-00	20 - 21	6CD-8591A-04	18 - 1	6CB-W0078-00	1 - 19	90119-06MA4	18 - 14	90201-12426	28 - 35		34 - 6
6CB-82310-00	19 - 1	6C5-86120-00	10 - 3		39 - 24	90119-06MA5	18 - 19	90201-13M01	28 - 34		39 - 12
6CB-82314-00	19 - 3	6CB-86120-00	6 - 1	6CB-W009A-00	5 - 1	90119-07001	5 - 5	90201-156J2	24 - 11	90430-14115	5 - 11
6CB-82316-01	18 - 3	6Y8-86260-12	36 - 2	6CB-W009B-06	3 - 1		5 - 17	90201-15M58	29 - 20	90430-14M09	1 - 17
6P2-82380-00	11 - 5	6AA-86261-22	36 - 3	6CB-W009C-00	5 - 13	90119-07234	5 - 6	90201-16M00	34 - 43		33 - 5
6CB-82388-00	21 - 19	6Y8-86267-00	36 - 1	6CB-W1165-00	4 - 9		5 - 18	90201-16M55	29 - 18		39 - 2
6Y8-82509-10	36 - 8	6CB-8A410-00	27 - 37	6CB-W4624-00	8 - 27	90119-08020	9 - 3	90201-26M59	28 - 17	90430-18130	5 - 8
6Y8-82521-11	36 - 15	K0F-A3233-00	4 - 15	6CB-W8145-00	17 - 1	90119-08102	32 - 4	90201-32008	34 - 74		5 - 20
6P2-82560-01	21 - 23	K0F-A3741-00	8 - 5	6AW-W9011-00	17 - 2	90119-08M14	34 - 25	90201-38M60	29 - 11	90445-07012	32 - 34
69J-82563-00	21 - 28	K0F-A3742-00	8 - 6	6CB-Y426J-00	2 - 18		39 - 33	90201-41008	34 - 49	90445-09068	18 - 32
6P2-82582-00	21 - 2	K0F-A3743-00	8 - 3	90101-06020	28 - 3	90119-08M22	24 - 21	90202-08M20	27 - 23	90445-09124	7 - 10
6P2-82582-10	21 - 3	K0F-A3751-00	8 - 8	90101-12M05	28 - 33	90119-08M32	34 - 27	90202-32M19	29 - 17	90445-09220	7 - 1
6Y8-82582-11	21 - 4	K0F-A3751-10	8 - 8	90105-06035	6 - 3	90119-10007	32 - 26	90202-40M47	29 - 7		7 - 9
69J-82587-00	21 - 30	K0F-A3751-20	8 - 8		9 - 4	90119-10024	29 - 23	90206-15M18	24 - 12	90445-096H2	7 - 11
6CB-82588-00	27 - 19	K0F-A3751-30	8 - 8	90105-06037	3 - 28		29 - 32	90214-30003	34 - 36	90445-097F7	10 - 9
6E9-82588-00	21 - 24	K0F-A3751-40	8 - 8		3 - 45	90119-10050	8 - 18	90250-08M07	34 - 61	90445-107A5	18 - 23
61A-82588-01	27 - 18	K0F-A3751-50	8 - 8		6 - 7	90119-10054	28 - 21	90269-05005	2 - 9	90445-14019	25 - 16
6CB-82589-01	21 - 10	K0F-A3751-60	8 - 8	90105-06039	25 - 27	90119-10M07	8 - 31		2 - 15	90445-14021	25 - 7
6CB-82590-02	21 - 1	K0F-A3751-70	8 - 8	90105-06151	3 - 18	90151-05M05	3 - 33	90280-04002	34 - 21	90445-16015	25 - 9
6CB-82594-00	21 - 6	K0F-A3751-80	8 - 8		3 - 40	90151-06M02	3 - 11		39 - 29	90445-23002	35 - 4
60V-8259F-00	27 - 16	K0F-A3751-90	8 - 8		22 - 11		3 - 20	90282-05008	34 - 76	90446-15005	20 - 18
69J-8259F-00	27 - 17	K0F-A3751-A0	8 - 8	90105-06M07	3 - 13		32 - 3	90338-11007	24 - 25	90446-15M07	20 - 19
6CB-8259M-00	22 - 12	K0F-A3751-B0	8 - 8		5 - 24	90155-11002	5 - 29	90340-08002	34 - 4	90462-06013	18 - 24
63P-825E0-01	37 - 1	K0F-A3751-C0	8 - 8	90105-06M08	12 - 9	90159-05059	29 - 2	90340-14M06	5 - 10	90464-06001	21 - 8
68F-82846-00	20 - 30	K0F-A3751-D0	8 - 8	90105-08175	3 - 7		37 - 4		33 - 4	90464-07209	10 - 19
6X4-83383-00	36 - 5	K0F-A3751-E0	8 - 8		5 - 30	90159-06053	26 - 9	90340-18M09	5 - 7	90464-08004	11 - 11
6X4-83386-00	36 - 6	K0F-A3751-F0	8 - 8	90105-08178	6 - 5	90167-06M00	36 - 12		5 - 19	90464-09013	7 - 5
6E5-83558-00	32 - 32	K0F-A3751-G0	8 - 8	90105-08220	5 - 31	90170-16M19	34 - 42	90386-06M12	27 - 25		10 - 14
6CB-83609-00	5 - 9	K0F-A3751-H0	8 - 8	90105-08M87	22 - 6	90170-30M18	34 - 37	90386-12069	27 - 13	90464-09129	18 - 17
63P-83614-01	21 - 31	K0F-A3751-J0	8 - 8	90105-14007	29 - 19	90171-18M04	35 - 27	90386-15M73	24 - 10		21 - 38
	21 - 32	K0F-A3751-K0	8 - 8		29 - 27	90179-06029	2 - 4	90386-22M98	28 - 23	90464-10011	10 - 33
6AW-83651-00	21 - 27	K0F-A3751-L0	8 - 8	90109-06277	5 - 35		2 - 22		28 - 31	90464-10M59	7 - 4
67H-83672-01	29 - 3	K0F-A3751-M0	8 - 8		5 - 39	90179-06M28	5 - 43	90386-25M31	28 - 16	90464-11012	10 - 31
6Y8-8454G-00	36 - 11	K0F-A3751-N0	8 - 8	90109-08019	27 - 14	90179-08003	22 - 3	90386-38M89	29 - 12	90464-11121	21 - 15
6P2-85075-00	19 - 6	K0F-A3751-P0	8 - 8	90110-05039	35 - 14	90183-02M03	34 - 60	90386-90M90	27 - 34	90464-12002	17 - 4
72X-85075-L0	31 - 21	K0F-A3751-R0	8 - 8	90110-10018	35 - 16	90183-051A5	2 - 10	90387-05004	37 - 5	90464-12009	14 - 14
64J-85516-00	18 - 4	K0F-A3751-S0	8 - 8	90111-06142	26 - 4		2 - 16	90387-06289	9 - 20	90464-12010	7 - 6
	20 - 7	K0F-A3751-T0	8 - 8	90111-06144	26 - 3		2 - 20		15 - 16		10 - 12
6CB-85516-00	17 - 15	K0F-A3753-00	8 - 8	90111-08078	2 - 27	90183-061A6	26 - 8	90387-06M03	25 - 25		10 - 32
6CB-85544-00	20 - 29	K0F-A3753-10	8 - 8	90116-10021	35 - 9	90185-05002	35 - 12	90387-06M43	26 - 11	90464-12012	14 - 15
689-85547-00	15 - 1	K0F-A3753-20	8 - 8	90119-06126	27 - 40	90185-06M07	5 - 47	90387-07028	26 - 7		14 - 16

NUMERICAL INDEX

PART NO.	REF. NO.	PART NO.	REF. NO.	PART NO.	REF. NO.	PART NO.	REF. NO.	PART NO.	REF. NO.	PART NO.	REF. NO.
90464-12012	15 - 5	90480-10M23	9 - 19	93101-30M17	39 - 22	93501-04M02	27 - 28	95895-06012	24 - 18	97780-60616	2 - 13
90464-12183	20 - 11		15 - 15	93102-08M43	31 - 36	93605-10108	8 - 10		24 - 27		2 - 24
	21 - 17	90480-11012	26 - 5	93102-38008	8 - 26		8 - 12		24 - 29	97780-60620	36 - 7
90464-13249	9 - 22	90480-12314	17 - 14		38 - 11		8 - 14		24 - 31	97880-06035	36 - 12
	18 - 9		19 - 4	93102-85008	4 - 4		8 - 16	95895-06014	15 - 21	97885-06010	28 - 8
	20 - 10	90480-13M24	26 - 10		38 - 10	93606-12019	3 - 3		18 - 16		28 - 11
90464-16001	25 - 21	90480-14029	25 - 24	93106-09014	34 - 11		3 - 4		24 - 4	97885-06012	28 - 13
90464-18004	20 - 20	90480-16009	26 - 6		39 - 15		4 - 3	95895-06016	10 - 16	97980-05214	2 - 11
90464-18246	21 - 16	90480-22M81	24 - 19	93210-04279	36 - 9		22 - 10		15 - 17		2 - 17
90464-20181	9 - 23	90501-10M77	34 - 55	93210-07003	35 - 18		34 - 24		21 - 20		2 - 21
	10 - 18	90501-12082	27 - 29		39 - 13		39 - 32		21 - 37	97980-06216	36 - 4
	18 - 10	90506-22001	24 - 16	93210-09165	27 - 33	93608-16M16	32 - 7		22 - 8	97985-04116	27 - 20
	18 - 18	90508-20052	27 - 15	93210-10M74	30 - 4		32 - 27	95895-06020	9 - 13	97985-04308	22 - 4
	20 - 12	91490-20015	27 - 36	93210-19MJ3	33 - 20		33 - 3		18 - 2	97985-06216	29 - 4
	21 - 5	91490-40030	35 - 28		39 - 4		34 - 47		20 - 5	98504-06010	28 - 27
	21 - 18	91690-30010	27 - 6	93210-24M79	3 - 42		35 - 5		21 - 14	98507-04008	13 - 39
90464-20258	24 - 33		27 - 31		38 - 17	93700-06M01	27 - 12	95895-06025	19 - 2	98780-06530	3 - 31
90464-23001	10 - 6	91690-40010	3 - 16	93210-26658	3 - 8	93700-06M03	28 - 26	95895-06030	5 - 34	98780-06550	3 - 35
	21 - 21	91809-08006	5 - 4		33 - 15	94702-00400	1 - 8		5 - 38	99001-08600	34 - 13
90464-26002	7 - 8		5 - 16		38 - 6		5 - 48		17 - 11	99009-47500	34 - 50
	10 - 13	92014-05012	17 - 12		38 - 14	95022-06030	17 - 10	95895-06035	27 - 10	99530-08012	17 - 7
	18 - 26	92903-06600	20 - 16	93210-27370	3 - 44	95023-06012	18 - 25	95895-08016	20 - 2	99530-14016	8 - 30
90464-99004	9 - 12		28 - 28		38 - 18	95027-06025	3 - 27		20 - 39		
90465-08M63	28 - 25	92903-08600	22 - 2	93210-33M49	34 - 10	95380-06600	2 - 35		20 - 40		
90465-11M10	7 - 13	92990-06100	2 - 34		39 - 14		10 - 4	97013-06020	20 - 15		
	10 - 7	92990-06200	2 - 8	93210-37160	34 - 17	95380-12600	28 - 36	97013-08045	22 - 1		
	10 - 11		2 - 14		39 - 17	95380-14700	5 - 12	97075-06020	11 - 6		
	15 - 6		2 - 25		39 - 27	95380-14800	29 - 21	97095-05020	17 - 8		
	15 - 19	92990-08600	2 - 29	93210-37MH7	29 - 6	95780-06300	36 - 14	97095-06010	28 - 5		
	18 - 34	92990-18200	35 - 26	93210-58144	34 - 32	95780-08300	2 - 31	97095-06012	32 - 30		
	25 - 3	92995-05600	17 - 9		39 - 21	95780-10300	29 - 9	97095-06016	9 - 17		
	25 - 17	92995-06100	11 - 7	93210-86M38	34 - 16		35 - 8		20 - 35		
	28 - 19	92995-06600	9 - 18		39 - 16	95812-06025	33 - 8		27 - 3		
	29 - 5		11 - 8		39 - 26	95814-08020	20 - 3		37 - 2		
	32 - 33		19 - 8	93211-02001	34 - 71	95875-06016	6 - 9	97095-06020	19 - 7		
	36 - 10		20 - 36		39 - 23		33 - 21	97095-08020	34 - 34		
	37 - 6		27 - 4	93306-209U0	34 - 65	95875-06020	32 - 11	97095-10045	35 - 6		
90465-11M59	3 - 47		28 - 6	93311-85894	34 - 45	95875-06040	33 - 14	97575-06535	27 - 30		
	7 - 18		28 - 14	93311-928U5	34 - 3	95875-08030	9 - 1	97575-08535	32 - 20		
90465-13M24	21 - 9		37 - 3	93315-43061	34 - 68	95875-08060	11 - 4		33 - 2		
90465-14M66	14 - 13	92995-08600	34 - 35	93332-000A3	34 - 30	95880-08012	24 - 15	97575-08560	32 - 16		
	21 - 26	92995-10600	35 - 7	93332-000A4	34 - 48	95885-06014	5 - 41	97575-10535	32 - 6		
90467-130A5	25 - 18		35 - 10	93332-000A5	34 - 73	95885-08025	5 - 26	97575-10545	32 - 5		
90467-140A8	25 - 19	92995-14600	29 - 22	93340-67011	34 - 51	95895-06010	32 - 31	97595-06610	20 - 14		
90467-140A9	25 - 20		29 - 29	93410-22M11	28 - 32	95895-06012	18 - 8	97607-04310	31 - 32		
90468-18008	27 - 8	93101-28M16	34 - 29	93410-37M04	29 - 14		21 - 7	97780-50620	20 - 33		
	27 - 24		39 - 20	93450-45M02	34 - 70		21 - 25	97780-60520	25 - 15		
	27 - 42	93101-30M17	34 - 69	93501-04011	34 - 56		21 - 33	97780-60616	2 - 7		