



# PARTS CATALOGUE

**YFM7FGPW (3B43) EUROPE**  
**YFM7FGPW (3B44) OCEANIA**



2009/5/20

1F3B4-300E1

( 2F3B4-300E1 )

NEWS NO.	DATE	COMMENT
PE0-MC-060105	Sep., 7,2006	FIG.1/12/19 LIST/ILLUSTRATION REVISION
PE0-MC-060108	Sep.,29,2006	FIG.40 REAR MASTER CYLINDER LIST CORRECTION
PE0-MC-060129	Dec.,22,2006	FIG.10/33/36 ILLUSTRATION CORRECTION
PE0-MC-080004	Jan.,23,2008	FIG.10 THROTTLE BODY ASSY 1 LIST/ILLUSTRATION REVISION
PE0-MC-080025	May,22,2008	FIG.23 SIDE COVER ILLUSTRATION CORRECTION

2009/5/20

NEWS NO.	DATE	COMMENT
PE0-MC-080037	June,30,2008	FIG.35/36 REAR WHEEL LIST CORRECTION
PE0-MC-090005	Jan.,30,2009	MOD:FIG.48 ELECTRICAL 1 LIST REVISION
PE0-MC-090023	Apr.,28,2009	FIG.16 TRANSMISSION LIST/ILLUST. REVISION

YFM7FGPW  
PARTS CATALOGUE  
©2006 by Yamaha Motor Co., Ltd.  
1st edition, June 2006  
All rights reserved.  
Any reprinting or unauthorized use  
without the written permission of  
Yamaha Motor Co., Ltd.  
is expressly prohibited.

**A3**



**A4**

# FOREWORD

This Parts Catalogue is related to the parts for the model(s) on the cover page. When you are ordering replacement parts, please refer to this Parts Catalogue and quote both part numbers and part names correctly.

1. Modifications or additions which have been made after the issue of the Parts Catalogue will be announced in the Parts News.

It is advisable that you make the necessary corrections to the Parts Catalogue according to the Parts News.

2. Abbreviations

The following abbreviations are used in this Parts Catalogue.

“UR” Use specified parts number.

“UN” Use as many as needed.

“AP” Alternate Parts

“LM” Locally Made (Parts need to be ordered locally)

“F#” Frame No. (Applicable machine No.)

“O/S” Over Size

3. The number of components for assembly

- Parts, which are to be supplied in an assembly, are listed with a dot (.) in front of the part name as shown below.
- The numeral appearing to the right of each component part indicates the quantity of parts for each assembly unit.

PART NO.	DESCRIPTION	Q'TY	REMARKS
2F5-83310-60	FRONT FLASHER LIGHT ASSY	2	
115-83311-60	.BULB (6V-18W)	1	

4. Applicable colours of graphics are represented in the “REMARKS” as shown below.

PART NO.	DESCRIPTION	Q'TY	REMARKS
2N4-24110-00-X5	FUEL TANK COMP.	2	MXR
3J1-24240-10	.GRAPHIC, FUEL TANK	1	FOR MXR

5. Note that the illustrations for reference in finding parts numbers are not to be used for assembling. When assembling, please use the applicable service manual.

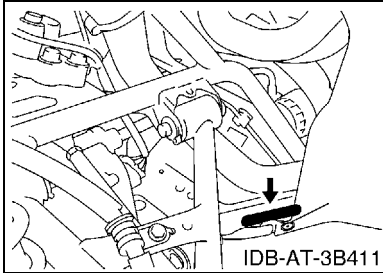
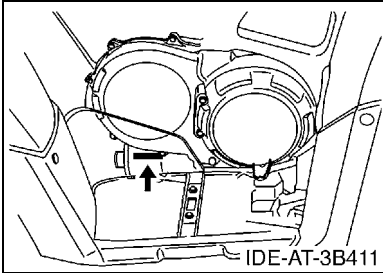
6. The asterisk (\*) before a reference number indicates modified items after the first edition.

# FOREWORD

7. Applicable Serial No.

Engine Serial No.

Frame Serial No.



8. Applicable Colour Code (The (\*) mark shows Model colour.)

Abbreviation	Colour Name	Colour Code
DPBSE(*)	DEEP PURPLISH BLUE SOLID E	0583
PDG(*)	PASTEL DEEP GREEN	00K0
RTR(*)	ROMANTIQUE ROUGE	00TR

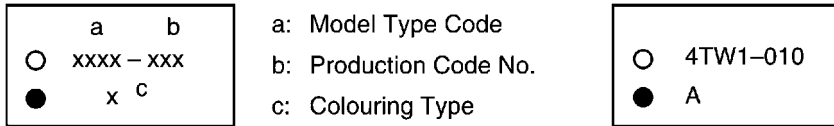
9. Quantity Column Information

Column No.	Name Of Q'ty Column	Destination
1	EUR	EUROPE
2	OCE	OCEANIA

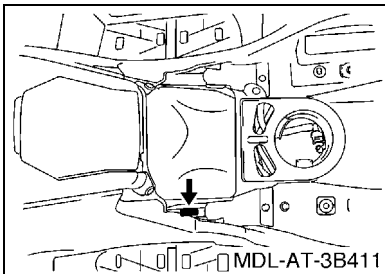
# MODEL LABEL

(1) A label called “Model Label” is affixed in the location as indicated in (3) below. When using this parts catalogue, please be sure to cross-reference the “model code – production code No.” in the catalogue with the “model code – production code No.” indicated on the Model Label affixed onto the product concerned.

(2) “Model Label” Indication



(3) Model Label Affixing Location



(4) Colouring Information

Model Code	Colouring Type Code	Colour Code	Colour Name	Abbreviation
3B43	A	00K0	PASTEL DEEP GREEN	PDG
	B	00TR	ROMANTIQUE ROUGE	RTR
	D	0583	DEEP PURPLISH BLUE SOLID E	DPBSE
3B44	D	0583	DEEP PURPLISH BLUE SOLID E	DPBSE

(5) Model Code – Production Code Number of Model Listed in This Parts Catalogue

Model Code	Production Code No.	Country (destination)	Model Code	Production Code No.	Country (destination)
3B43	010	EUROPE			
3B44	010	AUSTRALIA			
		NEW ZEALAND			

# CONTENTS

## ENGINE

CYLINDER HEAD .....	B2
CYLINDER .....	B3
CRANKSHAFT & PISTON .....	B4
VALVE .....	B6
CAMSHAFT & CHAIN .....	B7
WATER PUMP .....	B8
RADIATOR & HOSE .....	B9
OIL PUMP .....	B10
INTAKE .....	B11
THROTTLE BODY ASSY 1 .....	B12
EXHAUST .....	B14
CRANKCASE .....	C2
CRANKCASE COVER 1 .....	C3
STARTER CLUTCH .....	C5
CLUTCH .....	C6
TRANSMISSION .....	C8
MIDDLE DRIVE GEAR .....	C10
SHIFT CAM & FORK .....	C12
SHIFT SHAFT .....	C14

## CHASSIS

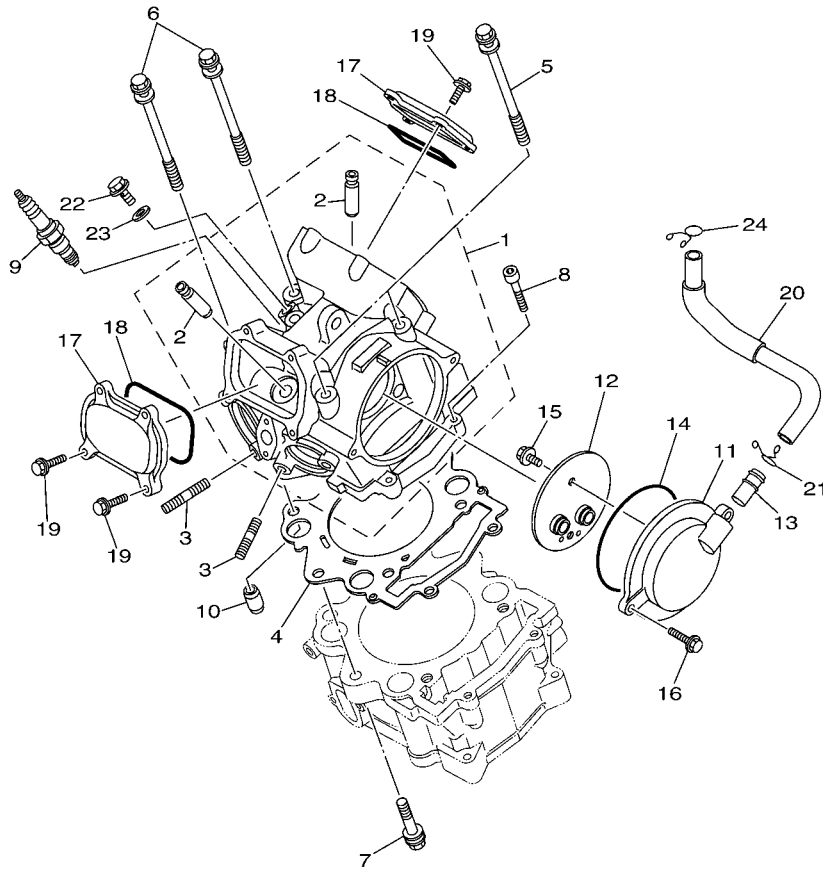
FRAME .....	D2
FRONT FENDER .....	D3
REAR FENDER .....	D6
SIDE COVER .....	D7
REAR ARM .....	D9
REAR SUSPENSION .....	D10
DRIVE SHAFT .....	D11
FRONT DIFFERENTIAL .....	D14
STEERING .....	E2
FRONT SUSPENSION & WHEEL .....	E4
FUEL TANK .....	E5
SEAT .....	E6
FRONT WHEEL .....	E7
FRONT WHEEL 2 .....	E9
FRONT BRAKE CALIPER .....	E11
REAR WHEEL .....	E13
REAR WHEEL 2 .....	E15
REAR BRAKE CALIPER .....	F3
STEERING HANDLE & CABLE .....	F5
FRONT MASTER CYLINDER .....	F7

REAR MASTER CYLINDER .....	F8
STAND & FOOTREST .....	F10
GUARD .....	F11
GENERATOR .....	F12
STARTING MOTOR .....	F13
METER .....	F14
HEADLIGHT .....	F15
TAILLIGHT .....	G2
ELECTRICAL 1 .....	G3
ELECTRICAL 2 .....	G6
GRAPHICS .....	G7
EMBLEM & LABEL 1 .....	G8
EMBLEM & LABEL 2 .....	G9

## INDEX

NUMERICAL INDEX .....	M1
-----------------------	----





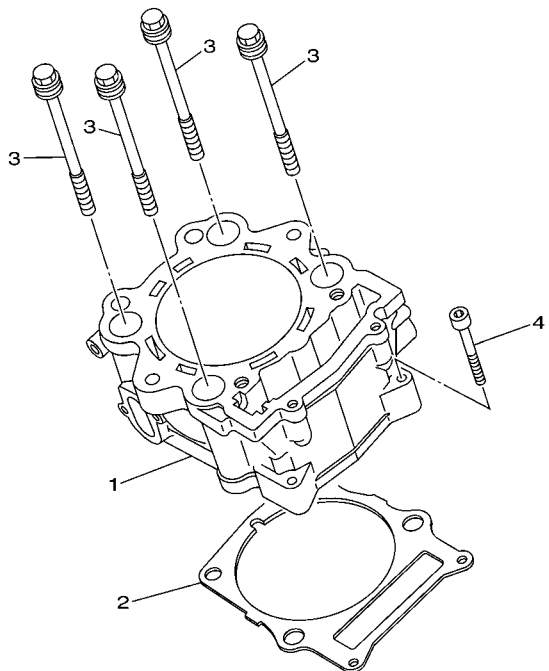
  
 3B41100-F010

**FIG. 1 CYLINDER HEAD**

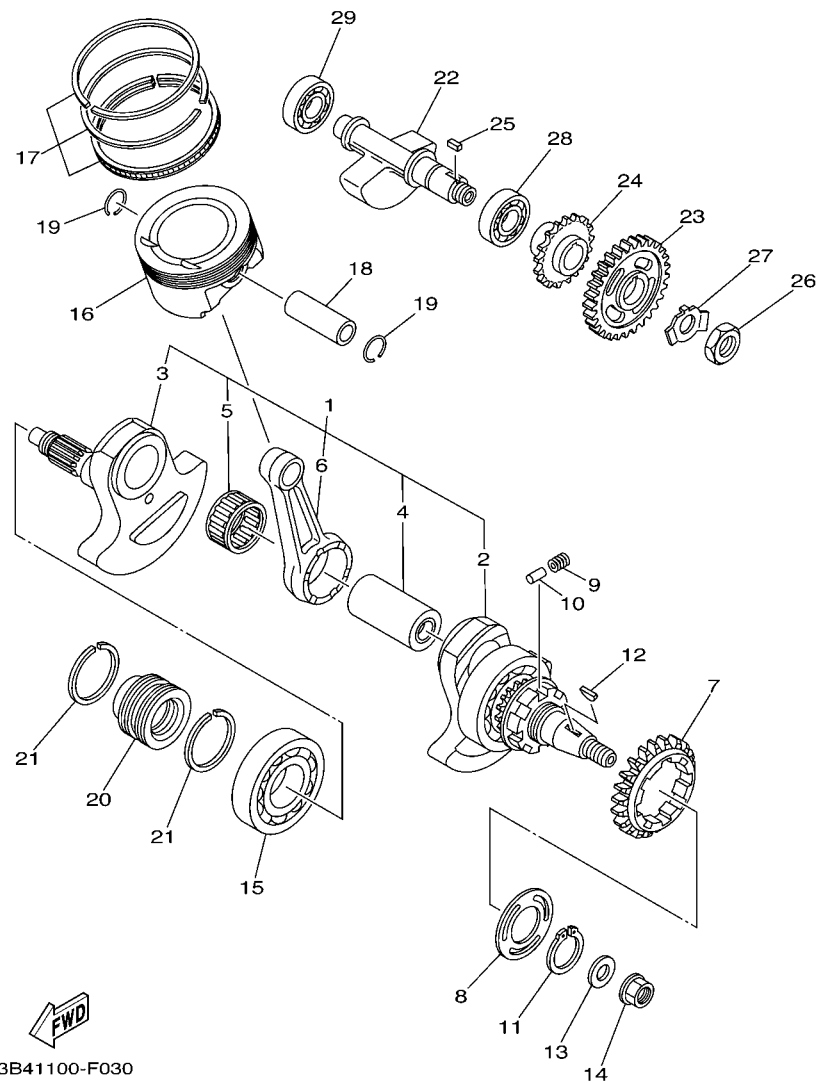
REF. NO.	PART NO.	DESCRIPTION	EUR	OCF			REMARKS
1	3B4-11101-00	CYLINDER HEAD ASSY	1	1			
2	4G0-11133-11	.GUIDE, VALVE 1	4	4			
3	95612-08625	BOLT, STUD	4	4			
4	3B4-11181-00	GASKET, CYLINDER HEAD 1	1	1			
5	90109-09003	BOLT	2	2			
6	90109-09002	BOLT	2	2			
7	90109-09005	BOLT	2	2			
8	91312-06030	BOLT	2	2			
9	94701-00420	PLUG, SPARK (NGK CPR7EA)	1	1			
10	93612-16254	PIN, DOWEL	2	2			
11	3B4-11185-00	COVER, CYLINDER HEAD SIDE 1	1	1			
12	3B4-11165-00	PLATE, BREATHER	1	1			
13	371-11167-01	PIPE, BREATHER 2	1	1			
14	93210-96601	O-RING	1	1			
15	95022-06012	BOLT, FLANGE	2	2			
16	95022-06020	BOLT, FLANGE	2	2			
17	1S3-11186-00	COVER, CYLINDER HEAD SIDE 2	2	2			
18	93210-78544	O-RING	2	2			
19	95022-06020	BOLT, FLANGE	8	8			
20	3B4-11166-00	PIPE, BREATHER 1	1	1			
21	90467-14015	CLIP	1	1			
22	90401-08004	BOLT, UNION	1	1			
23	90430-08119	GASKET	1	1			
24	90467-150A2	CLIP	1	1			

**FIG. 2 CYLINDER**

REF. NO.	PART NO.	DESCRIPTION	EUR	OCE	REMARKS
1	3B4-11311-00	CYLINDER 1	1	1	
2	1S3-11351-00	GASKET, CYLINDER	1	1	
3	90119-10023	BOLT, WITH WASHER	4	4	
4	91312-06040	BOLT	2	2	
-----					
-----					
-----					
-----					
-----					
-----					
-----					
-----					
-----					



  
3B41100-F020



**FIG. 3 CRANKSHAFT & PISTON**

REF. NO.	PART NO.	DESCRIPTION	EUR	QCE		REMARKS
1	3B4-11400-00	CRANKSHAFT ASSY	1	1		
2	3B4-11401-09	.CRANK SUB ASSY 1	1	1		
3	3B4-11402-09	.CRANK SUB ASSY 2	1	1		
4	1S3-11681-00	.PIN, CRANK 1	1	1		
5	93310-84017	.BEARING	1	1		
6	1S3-11651-00	.ROD, CONNECTING	1	1		
7	5KM-11536-10	GEAR, DRIVE (46T)	1	1		
8	5KM-11565-00	WASHER, BEARING COVER	1	1		
9	90501-220A1	SPRING, COMPRESSION	8	8		
10	93606-09002	PIN, DOWEL	4	4		
11	99009-35400	CIRCLIP	1	1		
12	90280-05001	KEY, WOODRUFF	1	1		
13	90201-165H4	WASHER, PLATE	1	1		
14	90179-16004	NUT	1	1		
15	93306-30810	BEARING	1	1		
16	1S3-11631-10	PISTON (STD)	1	1		
17	1S3-11603-10	PISTON RING SET (STD)	1	1		
18	5VK-11633-00	PIN, PISTON	1	1		
19	93450-24154	CIRCLIP	2	2		
20	3B4-16181-00	SPACER 1	1	1		
21	3B4-11447-00	SEAL, CRANK	2	2		
22	3B4-11454-00	WEIGHT 1	1	1		
23	3B4-11531-00	GEAR, BALANCE WEIGHT	1	1		
24	3B4-13354-00	SPROCKET, DRIVE	1	1		
25	90282-05007	KEY, STRAIGHT	1	1		
26	90170-18003	NUT	1	1		
27	90215-18001	WASHER, LOCK	1	1		

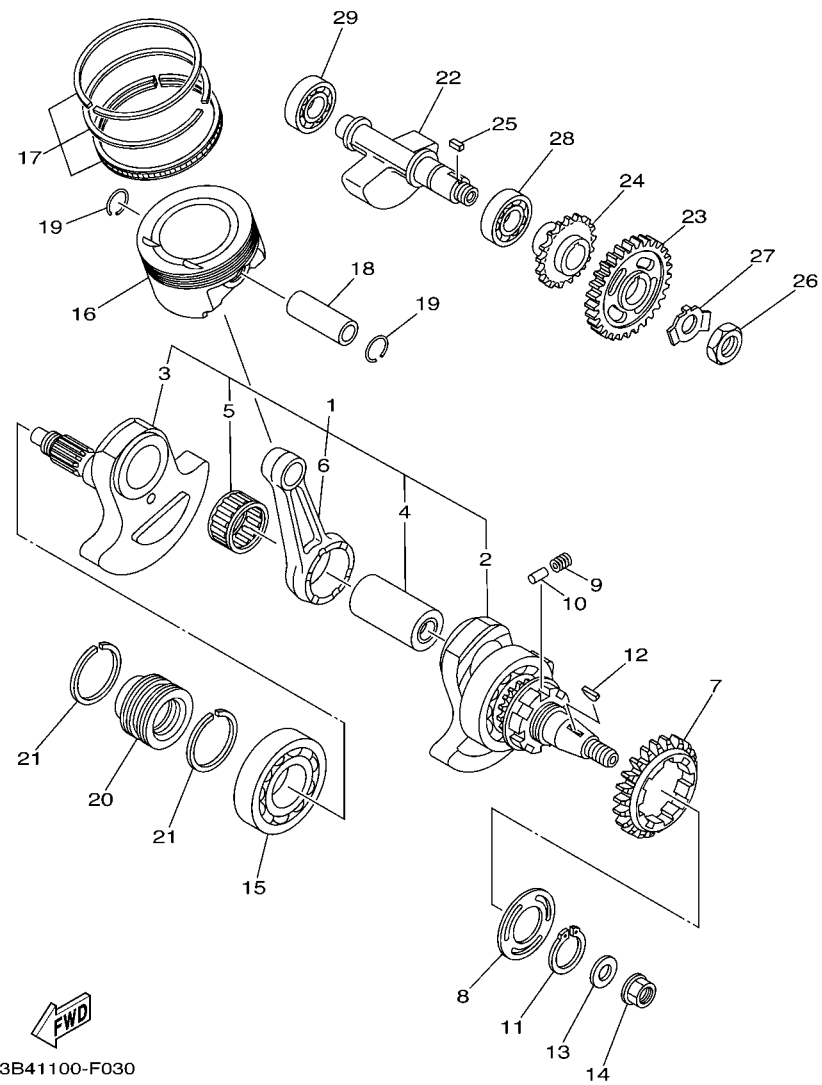


FIG. 3 CRANKSHAFT & PISTON

REF. NO.	PART NO.	DESCRIPTION	EUR	OCE				REMARKS
28	93306-30534	BEARING	1	1				
29	93306-30438	BEARING	1	1				
-----								
-----								
-----								
-----								
-----								
-----								
-----								
-----								
-----								

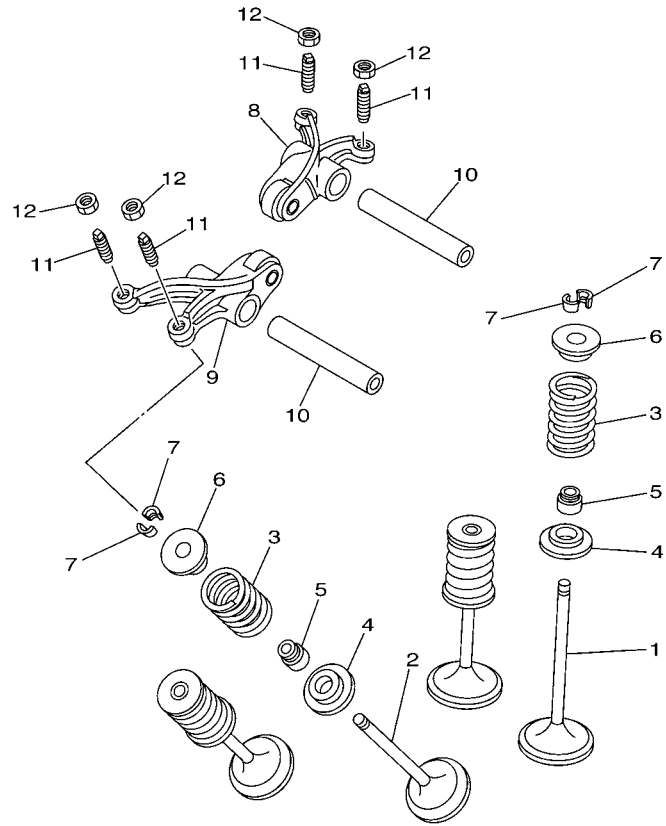
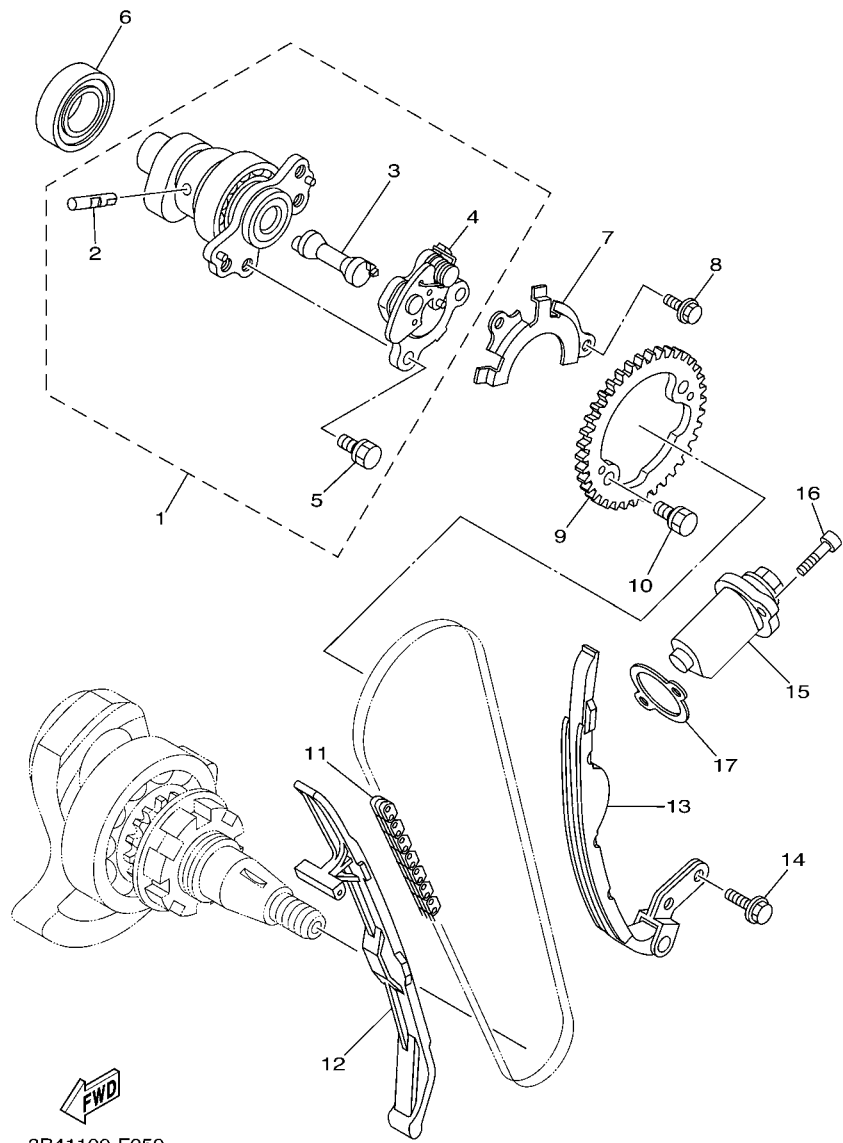


FIG. 4 VALVE

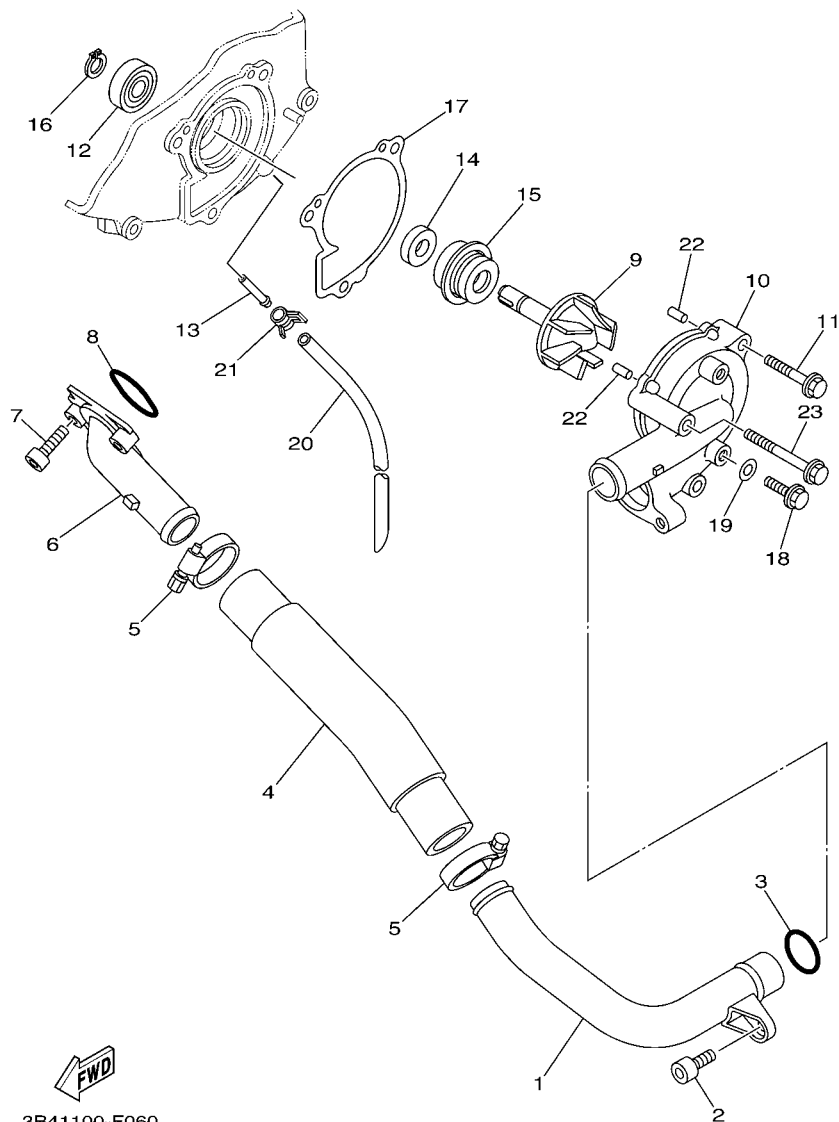
REF. NO.	PART NO.	DESCRIPTION	EUR	OCE	REMARKS
1	5VK-12111-00	VALVE, INTAKE	2	2	
2	5VK-12121-00	VALVE, EXHAUST	2	2	
3	1S3-12113-00	SPRING, VALVE INNER	4	4	
4	3YF-12116-00	SEAT, VALVE SPRING	4	4	
5	5H0-12119-00	SEAL, VALVE STEM	4	4	
6	3YF-12117-01	RETAINER, VALVE SPRING	4	4	
7	4G0-12118-00	COTTER, VALVE	8	8	
8	5VK-12151-00	ARM, VALVE ROCKER	1	1	
9	5VK-12161-00	ARM, VALVE ROCKER 2	1	1	
10	5VK-12146-00	SHAFT, ROCKER	2	2	
11	5XT-12159-00	SCREW, VALVE ADJUSTING	4	4	
12	90170-06128	NUT	4	4	

  
1S31100-E040



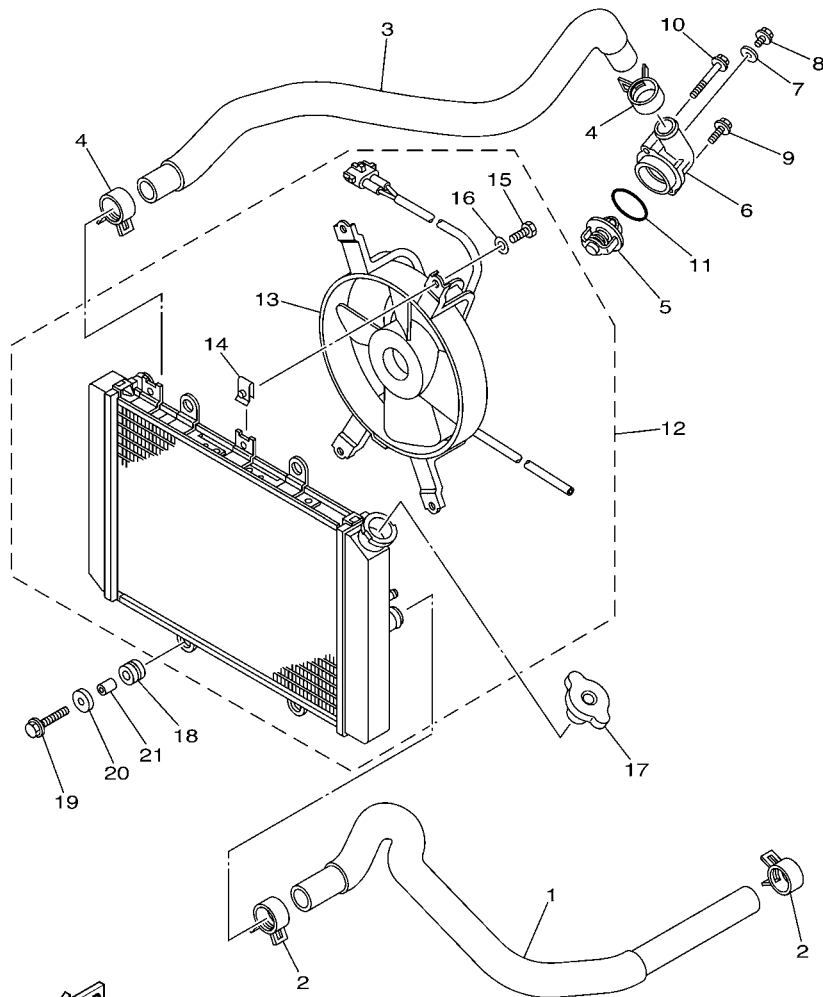
**FIG. 5 CAMSHAFT & CHAIN**

REF. NO.	PART NO.	DESCRIPTION	EUR	OCE	REMARKS
1	3B4-12170-00	CAMSHAFT ASSY 1	1	1	
2	5VK-12284-00	.PIN, DECOMPRESSION LEVER	1	1	
3	1S3-12290-00	.LEVER, DECOMPRESSION SPRING	1	1	
4	1S3-12280-00	.DECOMPRESSION ASSY	1	1	
5	90105-07004	.BOLT, FLANGE	2	2	
6	93306-07209	BEARING	1	1	
7	5VK-1111F-00	PLATE	1	1	
8	90105-06078	BOLT, FLANGE	2	2	
9	1S3-12176-00	SPROCKET, CAM CHAIN	1	1	
10	90105-07004	BOLT, FLANGE	2	2	
11	94591-57126	CHAIN (98XRH2010-126M)	1	1	
12	3B4-12231-01	GUIDE, STOPPER 1	1	1	
13	3B4-12241-00	GUIDE, STOPPER 2	1	1	
14	90105-06082	BOLT, FLANGE	2	2	
15	3TB-12210-00	TENSIONER ASSY, CAM CHAIN	1	1	
16	91312-06025	BOLT	2	2	
17	4DW-12213-00	GASKET, TENSIONER CASE	1	1	



**FIG. 6 WATER PUMP**

REF. NO.	PART NO.	DESCRIPTION	EUR	OCE			REMARKS
1	3B4-12481-00	PIPE 1	1	1			
2	91312-06012	BOLT	1	1			
3	93210-21190	O-RING	1	1			
4	3B4-12577-00	HOSE 2	1	1			
5	90450-32015	HOSE CLAMP ASSY	2	2			
6	5KM-12469-00	JOINT 1	1	1			
7	91312-06020	BOLT	2	2			
8	93210-33786	O-RING	1	1			
9	3B4-12450-00	IMPELLER SHAFT ASSY	1	1			
10	3B4-12422-00	COVER, HOUSING	1	1			
11	95022-06030	BOLT, FLANGE	1	1			
12	93306-00006	BEARING	1	1			
13	5D3-1243K-00	PIPE, DRAIN	1	1			
14	93101-10090	OIL SEAL	1	1			
15	11H-12438-10	SEAL, MECHANICAL	1	1			
16	99009-10400	CIRCLIP	1	1			
17	3B4-12428-00	GASKET, HOUSING COVER 2	1	1			
18	95022-06010	BOLT, FLANGE	2	2			
19	90430-06014	GASKET	2	2			
20	90445-07340	HOSE (L310)	1	1			
21	90467-07093	CLIP	1	1			
22	93604-10011	PIN, DOWEL	2	2			
23	95022-06050	BOLT, FLANGE	1	1			



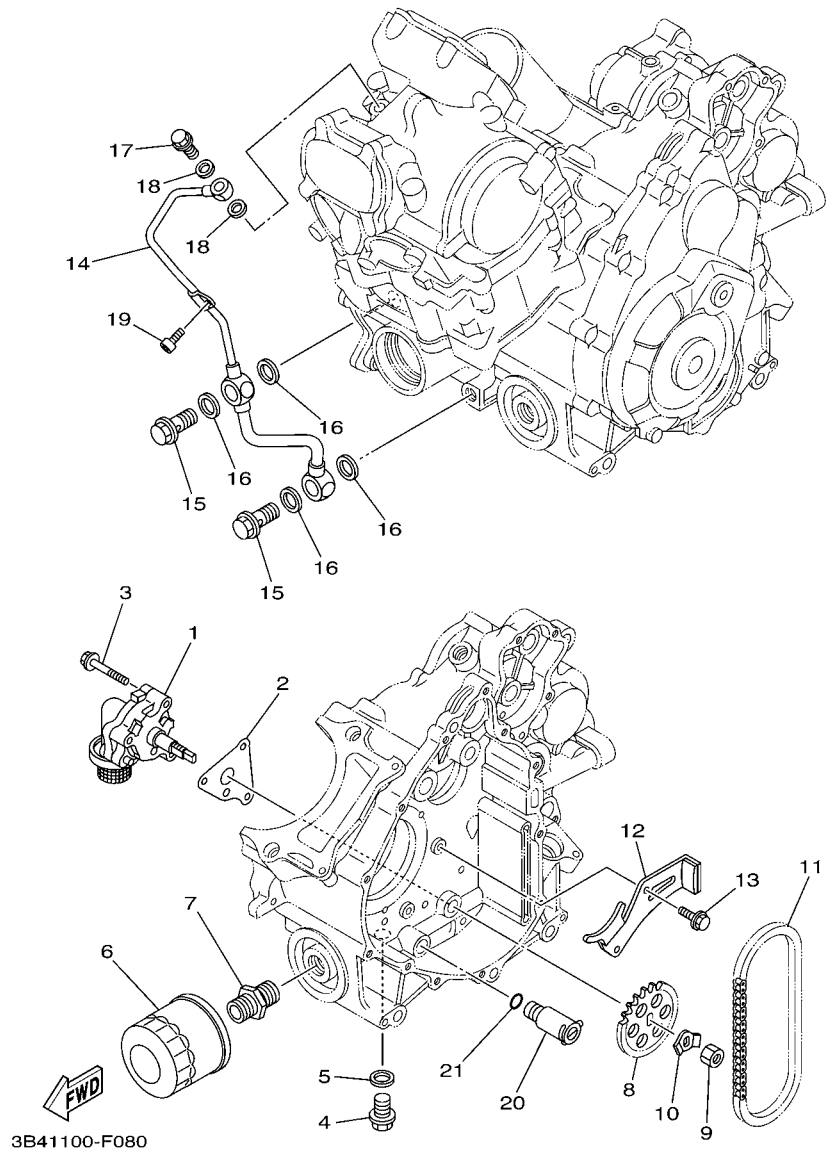
3B41100-F070

FIG. 7 RADIATOR & HOSE

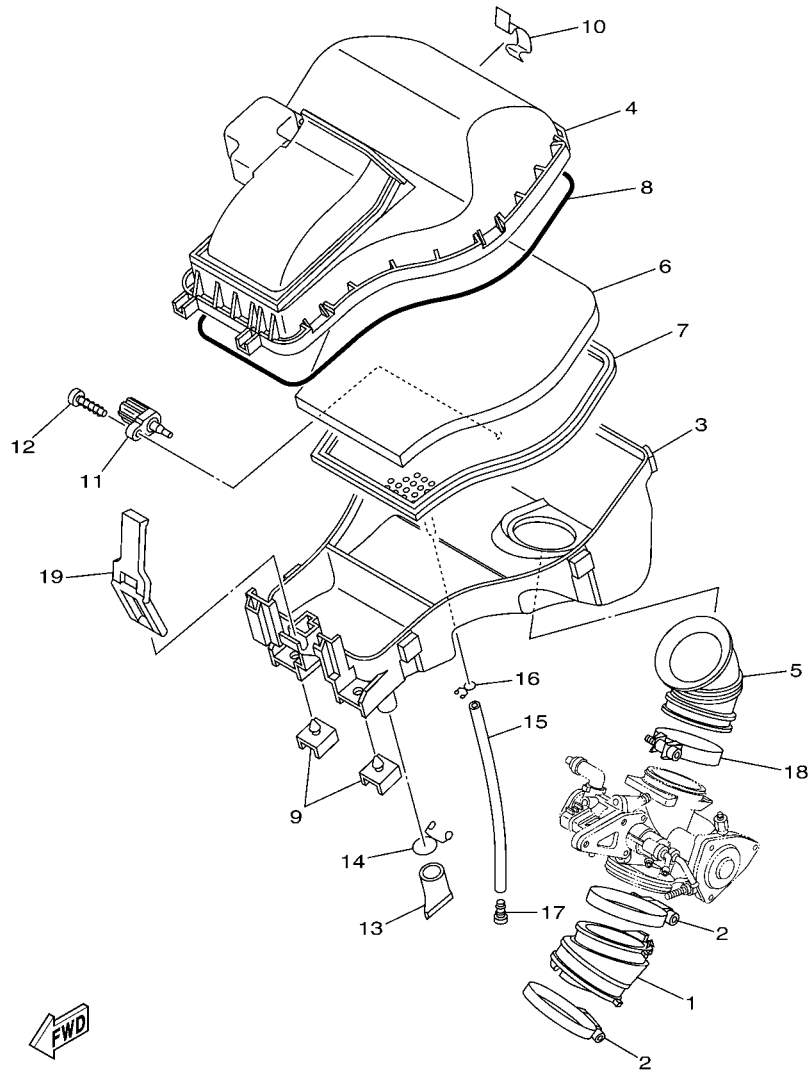
REF. NO.	PART NO.	DESCRIPTION	EUR	QCE	REMARKS
1	3B4-12576-00	HOSE 1	1	1	
2	90467-26189	CLIP	2	2	
3	3B4-12578-00	HOSE 3	1	1	
4	90467-26189	CLIP	2	2	
5	3B4-12411-00	THERMOSTAT	1	1	
6	1S3-12413-00	COVER, THERMOSTAT	1	1	
7	90430-06014	GASKET	1	1	
8	95022-06010	BOLT, FLANGE	1	1	
9	95022-06020	BOLT, FLANGE	1	1	
10	95022-06045	BOLT, FLANGE	1	1	
11	93210-41042	O-RING	1	1	
12	3B4-1240A-00	RADIATOR ASSY	1	1	
13	3B4-12405-00	.BLOWER ASSY	1	1	
14	1AA-12535-00	.PLATE	1	1	
15	97017-06010	.BOLT	4	4	
16	92907-06600	.WASHER, PLATE	4	4	
17	22W-12462-00	CAP, RADIATOR	1	1	
18	90480-15235	GROMMET	4	4	
19	95802-06020	BOLT, FLANGE	2	2	
20	90209-06012	WASHER	2	2	
21	90387-060A7	COLLAR	2	2	



FIG. 8 OIL PUMP



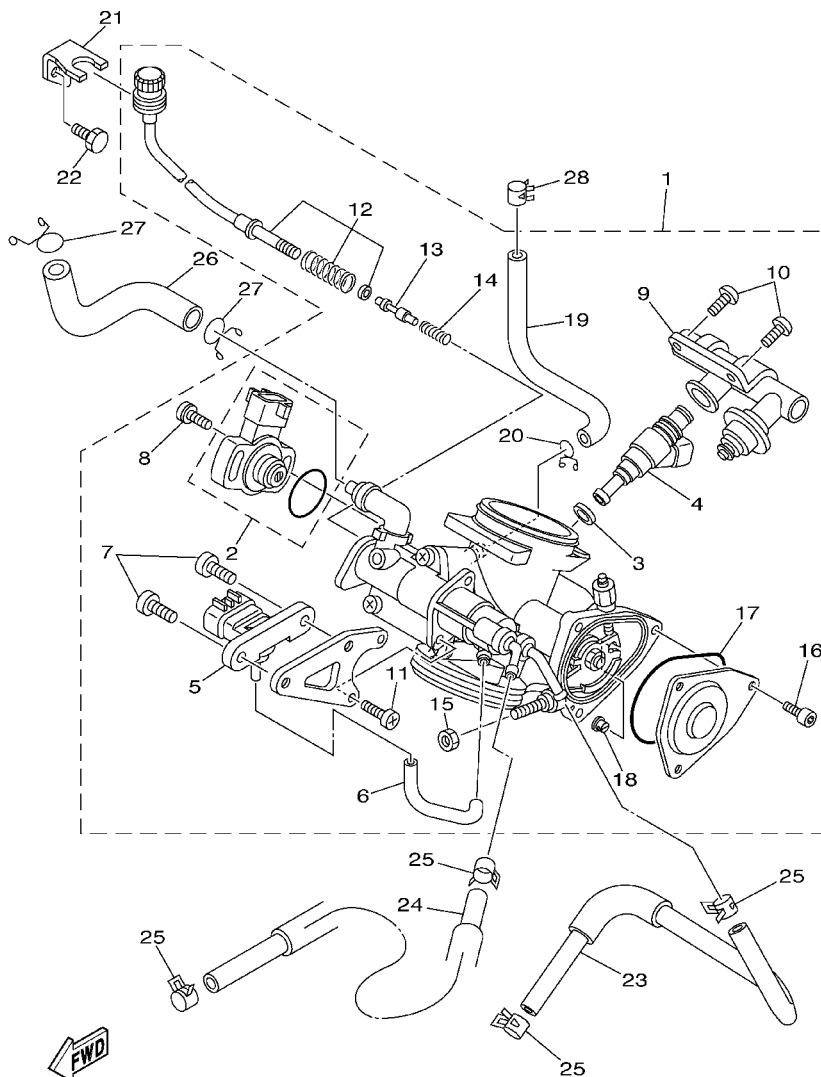
REF. NO.	PART NO.	DESCRIPTION	EUR	OCE			REMARKS
1	3B4-13300-00	OIL PUMP ASSY	1	1			
2	3B4-13329-00	GASKET, PUMP COVER	1	1			
3	95022-06040	BOLT, FLANGE	3	3			
4	90340-14132	PLUG, STRAIGHT SCREW	1	1			
5	214-11198-01	GASKET	1	1			
6	5GH-13440-20	ELEMENT ASSY, OIL CLEANER	1	1			
7	90401-20145	BOLT, UNION	1	1			
8	3B4-13355-00	SPROCKET, DRIVEN	1	1			
9	95312-10600	NUT	1	1			
10	90215-10008	WASHER, LOCK	1	1			
11	94580-31074	CHAIN	1	1			
12	3B4-12221-00	GUIDE, STOPPER 3	1	1			
13	90105-06082	BOLT, FLANGE	2	2			
14	3B4-13171-00	PIPE, DELIVERY 2	1	1			
15	90401-14118	BOLT, UNION	2	2			
16	90430-14043	GASKET	4	4			
17	90401-10015	BOLT, UNION	1	1			
18	90430-10188	GASKET	2	2			
19	91312-06012	BOLT	1	1			
20	25G-13490-00	RELIEF VALVE ASSY	1	1			
21	93210-10096	O-RING	1	1			



3B41100-F090

FIG. 9 INTAKE

REF. NO.	PART NO.	DESCRIPTION	EUR	OCE	REMARKS
1	3B4-13586-00	JOINT, CARBURETOR 1	1	1	
2	90450-72002	HOSE CLAMP ASSY	2	2	
3	3B4-14411-00	CASE, AIR CLEANER 1	1	1	
4	3B4-14402-00	CAP CASE ASSY	1	1	
5	3B4-14453-00	JOINT, AIR CLEANER 1	1	1	
6	3B4-14451-00	ELEMENT, AIR CLEANER	1	1	
7	3B4-14472-00	PLATE, ELEMENT	1	1	
8	3B4-14457-00	SEAL	1	1	
9	3B4-14409-00	DAMPER	2	2	
10	3B4-14424-00	CLIP, CAP FITTING	6	6	
11	8FP-85886-00	SENSOR, AIR TEMPERATURE	1	1	
12	97702-50520	SCREW, TAPPING	1	1	
13	59V-14457-00	SEAL	1	1	
14	90467-220A1	CLIP	1	1	
15	91A20-07020	TUBE, FLEXIBLE VINYL	1	1	
16	90467-10041	CLIP	1	1	
17	90338-08174	PLUG	1	1	
18	90450-59006	HOSE CLAMP ASSY	1	1	
19	3B4-14455-00	BAND	1	1	

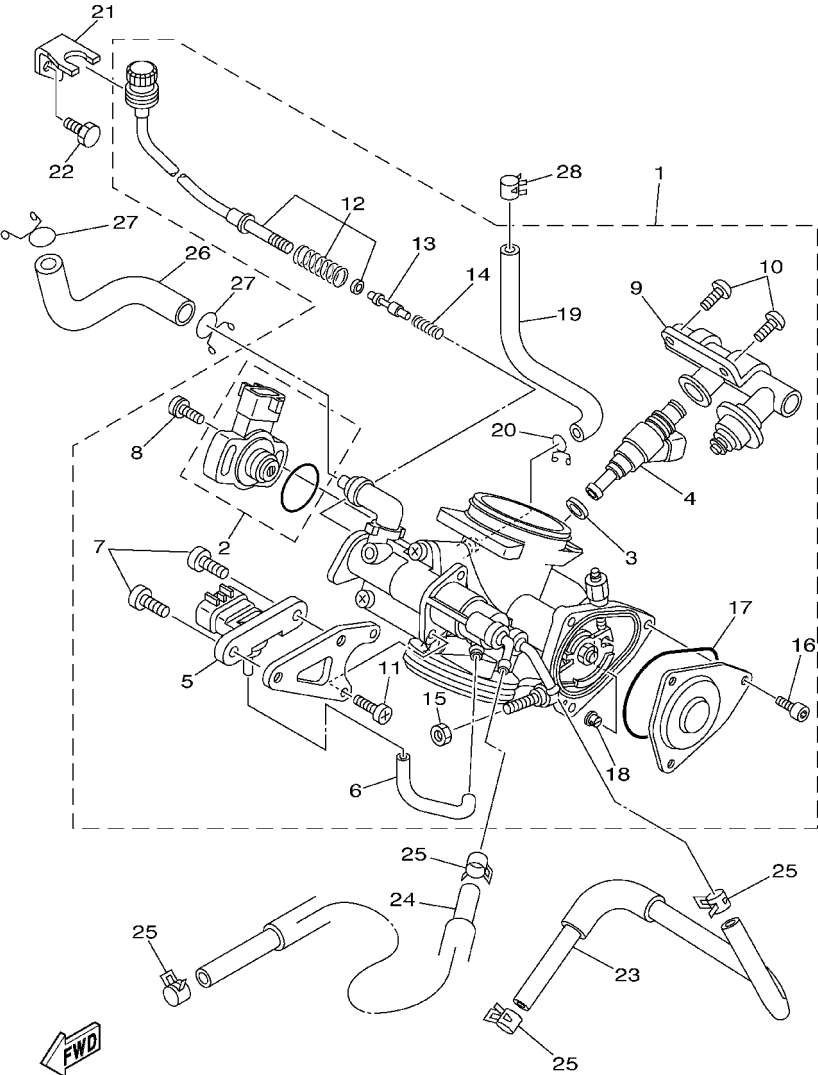


3B41100F1011

FIG. 10 THROTTLE BODY ASSY 1

REF. NO.	PART NO.	DESCRIPTION	EUR	QTY	REMARKS
1	3B4-13750-00	THROTTLE BODY ASSY	1	1	
2	3B4-W8588-00	.THROTTLE SENSOR SET	1	1	
3	8FP-13556-00	.GASKET, MANIFOLD	1	1	
4	3B4-13761-00	.INJECTOR ASSY	1	1	
5	1C7-82380-00	.SENSOR, PRESSURE	1	1	
6	5JW-14348-00	.PIPE 1	1	1	
7	98507-06010	.SCREW, PAN HEAD	2	2	
8	8CC-14216-10	.SCREW	2	2	
9	3B4-13160-00	.DELIVERY PIPE ASSY 1	1	1	
10	98507-06012	.SCREW, PAN HEAD	2	2	
11	98507-05012	.SCREW, PAN HEAD	2	2	
12	3B4-14503-00	.ADJUST SCREW SET	1	1	
13	1S3-13493-00	.PLUNGER	1	1	
14	4BH-14134-00	.SPRING, AIR ADJUSTING	1	1	
15	1S3-14161-00	.NUT, CABLE ADJUSTING	1	1	
16	91312-04006	.BOLT	3	3	
17	5LP-14147-00	.O-RING	1	1	
18	1UY-14155-00	.GUIDE, CABLE	1	1	
19	3B4-13543-00	.HOSE, AIR	1	1	
20	90467-09006	.CLIP	1	1	
21	3B4-14413-00	STAY	1	1	
22	97002-06012	BOLT	1	1	
23	3B4-1243A-00	HOSE 1	1	1	
24	90445-12006	HOSE (L630)	1	1	
25	90467-110A2	CLIP	4	4	
26	3B4-13545-00	HOSE 1	1	1	
27	90467-140A4	CLIP	2	2	

FIG. 10 THROTTLE BODY ASSY 1



3B41100F1011

REF. NO.	PART NO.	DESCRIPTION	EUR	OCÉ		REMARKS
28	90467-090A3	CLIP	1	1		

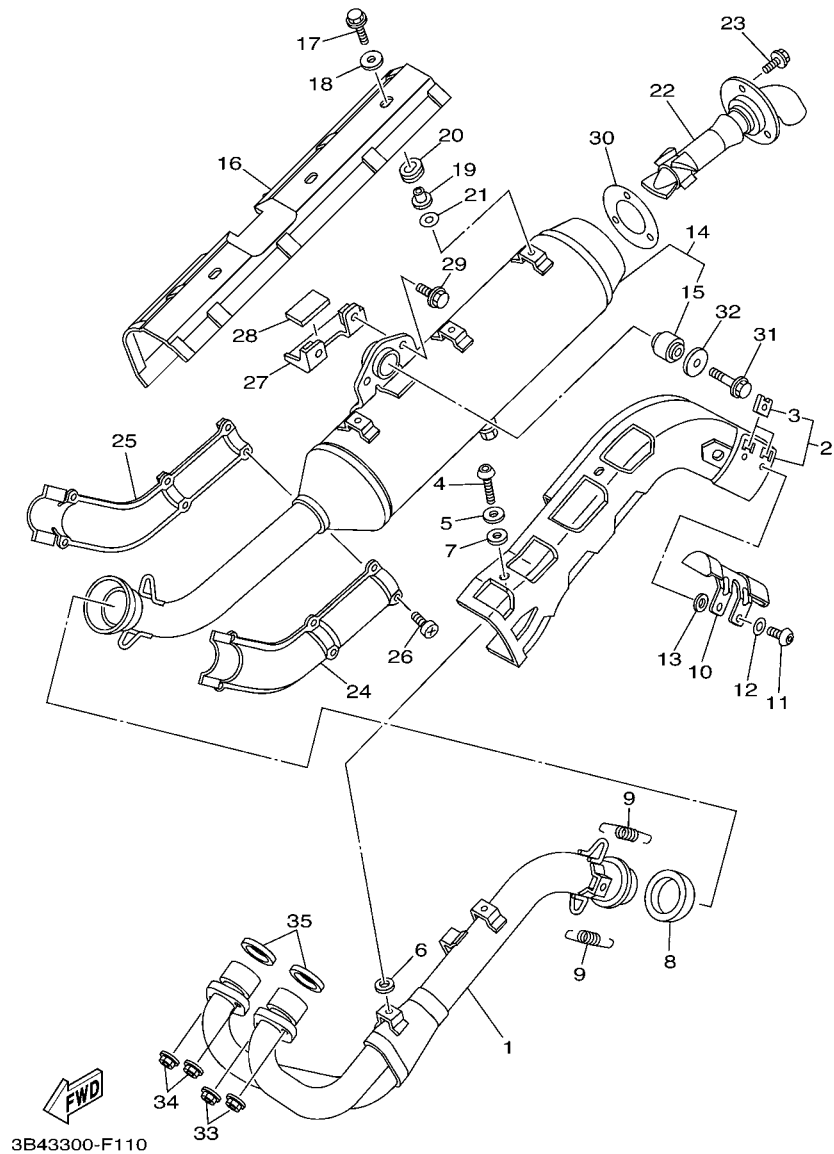


FIG. 11 EXHAUST

REF. NO.	PART NO.	DESCRIPTION	EUR	OCF		REMARKS
1	3B4-14611-00	PIPE, EXHAUST 1	1	1		
2	3B4-14627-00	COVER, EXHAUST	1	1		
3	90183-060A2	.NUT, SPRING	2	2		
4	92012-06016	BOLT, BUTTON HEAD	4	4		
5	90201-06036	WASHER, PLATE	4	4		
6	90201-05022	WASHER, PLATE	4	4		
7	90201-05019	WASHER, PLATE	4	4		
8	3B4-14714-00	GASKET, MUFFLER	1	1		
9	90506-26010	SPRING, TENSION	2	2		
10	3B4-14758-00	PROTECTOR, SILENCER	1	1		
11	92012-06012	BOLT, BUTTON HEAD	2	2		
12	92902-06200	WASHER	2	2		
13	90201-05015	WASHER, PLATE	2	2		
14	3B4-W1471-00	MUFFLER COMP. 1	1	1		
15	3B4-27414-00	.DAMPER, FOOTREST	1	1		
16	3B4-14718-00	PROTECTOR, MUFFLER 1	1	1		
17	95822-06016	BOLT, FLANGE	6	6		
18	90201-06036	WASHER, PLATE	6	6		
19	90387-06140	COLLAR	6	6		
20	90480-01021	GROMMET	6	6		
21	90201-05037	WASHER, PLATE	6	6		
22	3B4-14752-00	PIPE, OUTLET	1	1		
23	95022-06008	BOLT, FLANGE	3	3		
24	3B4-1471C-00	PROTECTOR ASSY 1	1	1		
25	3B4-1472C-00	PROTECTOR ASSY., 2	1	1		
26	98502-06016	SCREW, PAN HEAD	6	6		
27	3B4-1477U-00	STOPPER 1	1	1		

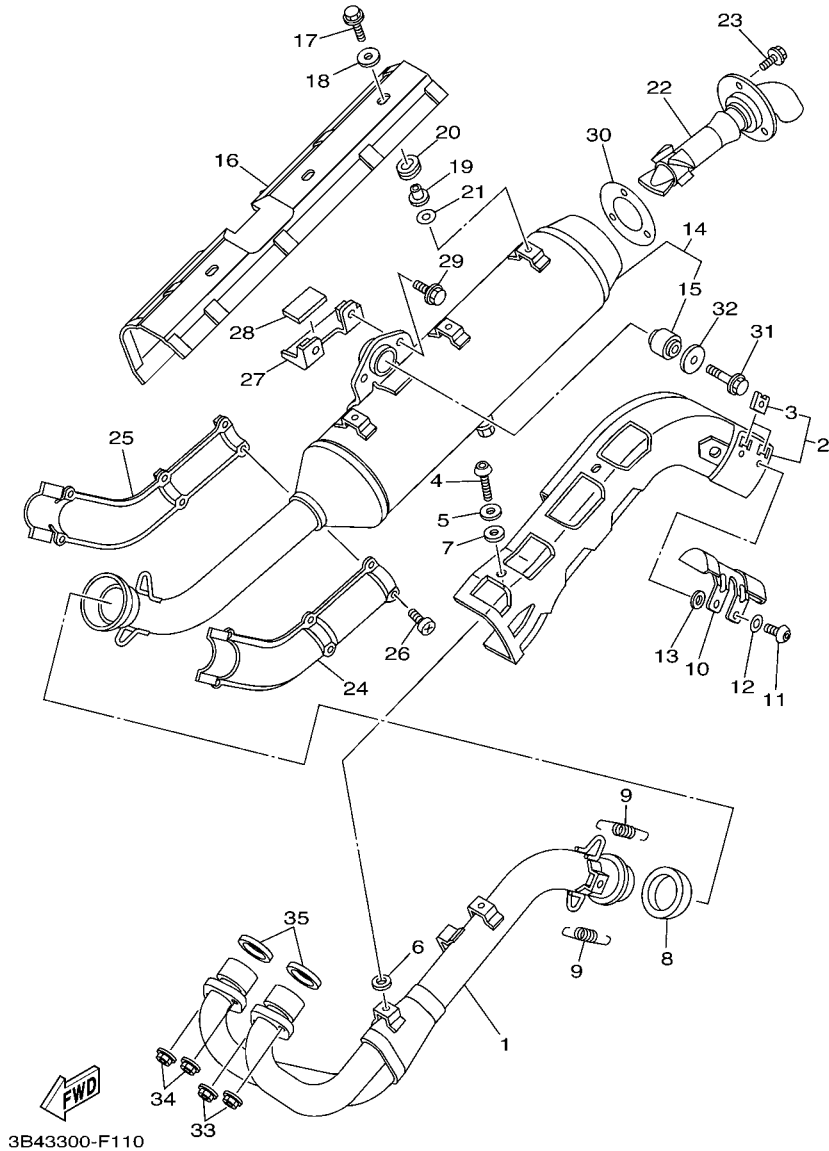
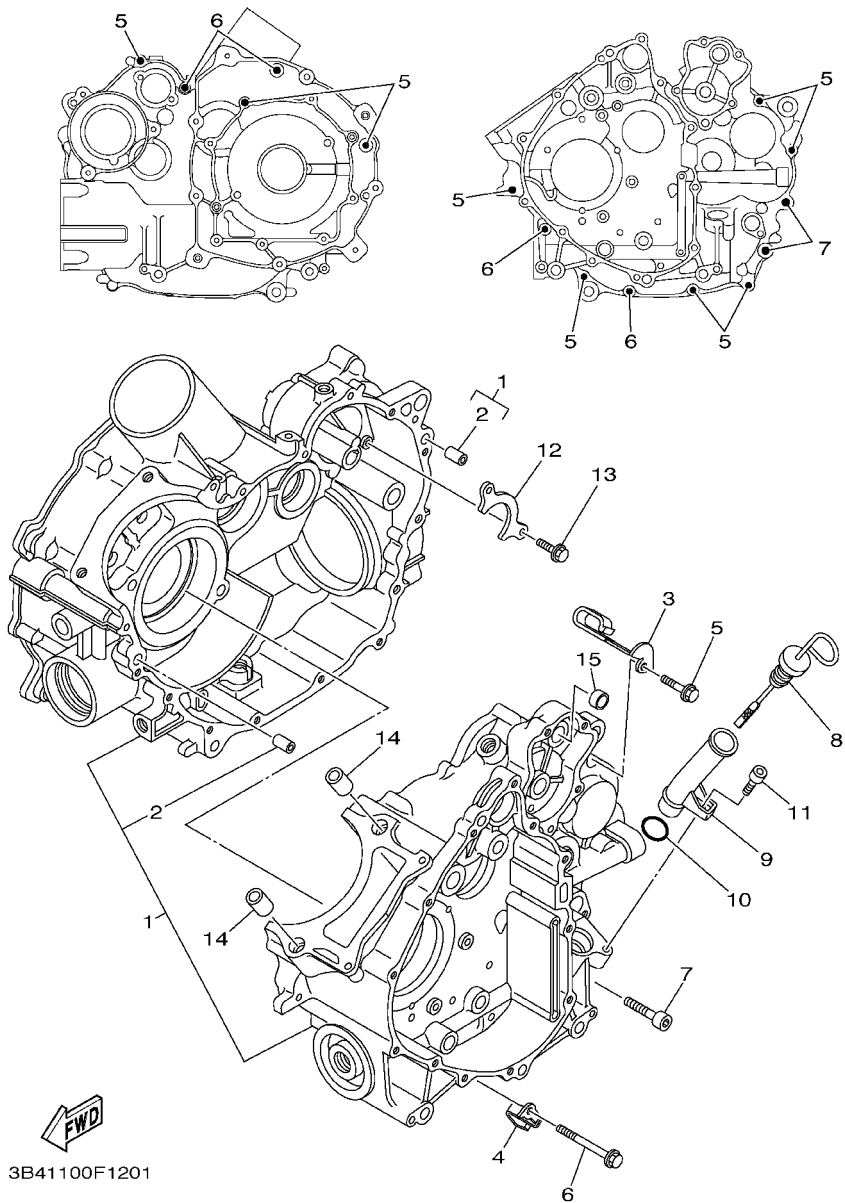


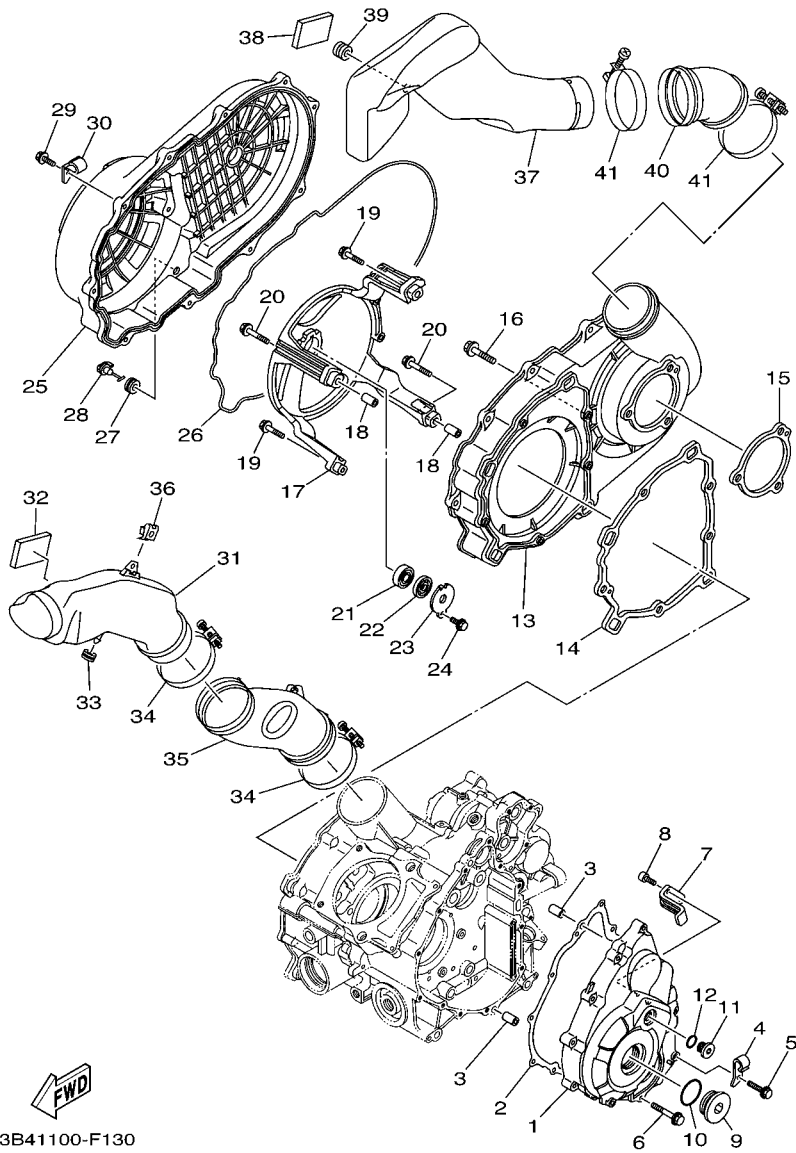
FIG. 11 EXHAUST

REF. NO.	PART NO.	DESCRIPTION	EUR	OCÉ		REMARKS
28	3B4-14733-00	MAT 1	1	1		
29	95822-08012	BOLT, FLANGE	2	2		
30	3B4-14755-00	GASKET, SILENCER	1	1		
31	95812-08040	BOLT, FLANGE	1	1		
32	90201-080E4	WASHER, PLATE	1	1		
33	90179-08023	NUT	2	2		
34	95702-08500	NUT, FLANGE	2	2		
35	3YF-14613-01	GASKET, EXHAUST PIPE	2	2		

FIG. 12 CRANKCASE



REF. NO.	PART NO.	DESCRIPTION	EUR	QTY	REMARKS
1	3B4-15100-02	CRANKCASE ASSY	1	1	
2	99530-10116	.PIN, DOWEL	2	2	
3	90462-10041	CLAMP	1	1	
4	90462-08049	CLAMP	1	1	
5	95022-06030	BOLT, FLANGE	9	9	
6	95022-06060	BOLT, FLANGE	4	4	
7	91312-08040	BOLT	2	2	
8	3B4-15362-00	PLUG, OIL LEVEL	1	1	
9	3B4-15112-00	PIPE, OIL	1	1	
10	93210-21631	O-RING	1	1	
11	91312-06012	BOLT	1	1	
12	3B4-15388-00	PLATE, BEARING COVER	1	1	
13	90105-06082	BOLT, FLANGE	2	2	
14	99530-14016	PIN, DOWEL	2	2	
15	3B4-18581-00	SPACER 1	1	1	

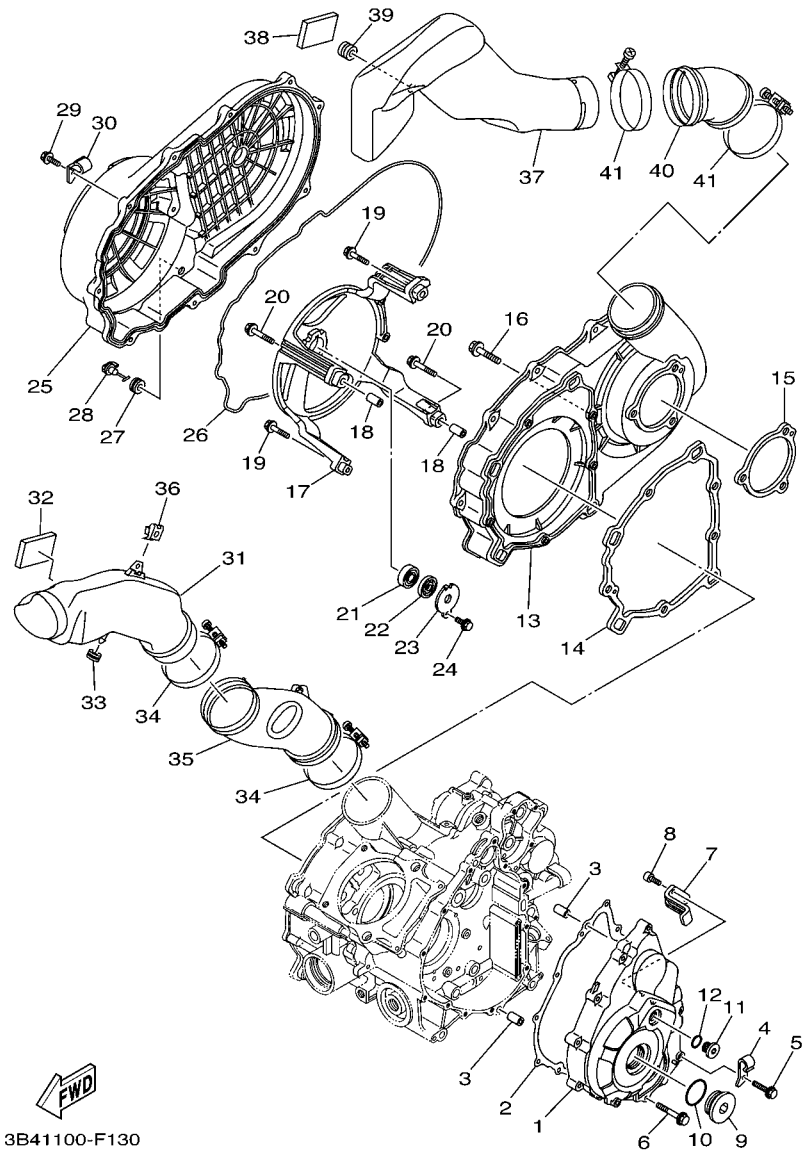


3B41100-F130

FIG. 13 CRANKCASE COVER 1

REF. NO.	PART NO.	DESCRIPTION	EUR	QTY	REMARKS
1	3B4-15411-00	COVER, CRANKCASE 1	1	1	
2	3B4-15451-00	GASKET, CRANKCASE COVER 1	1	1	
3	99530-10116	PIN, DOWEL	2	2	
4	90462-08050	CLAMP	1	1	
5	95022-06030	BOLT, FLANGE	11	11	
6	95022-06050	BOLT, FLANGE	1	1	
7	3B4-15113-00	PLATE	1	1	
8	90110-05031	BOLT, HEXAGON SOCKET HEAD	2	2	
9	90340-36002	PLUG, STRAIGHT SCREW	1	1	
10	93210-357A3	O-RING	1	1	
11	90340-14011	PLUG, STRAIGHT SCREW	1	1	
12	93210-14369	O-RING	1	1	
13	3B4-15421-00	COVER, CRANKCASE 2	1	1	
14	3B4-15453-00	GASKET	1	1	
15	3B4-15315-00	SEAL, CRANKCASE	1	1	
16	95822-06030	BOLT, FLANGE	8	8	
17	3B4-15442-00	HOUSING, BEARING	1	1	
18	99530-10116	PIN, DOWEL	2	2	
19	95822-06030	BOLT, FLANGE	2	2	
20	95822-06040	BOLT, FLANGE	2	2	
21	93306-20120	BEARING	1	1	
22	93101-12168	OIL SEAL	1	1	
23	4WV-15381-00	PLATE, BEARING COVER	1	1	
24	95022-06016	BOLT, FLANGE	1	1	
25	3B4-15431-00	COVER, CRANKCASE 3	1	1	
26	3B4-15379-00	SEAL, CRANKCASE	1	1	
27	90480-13018	GROMMET	1	1	



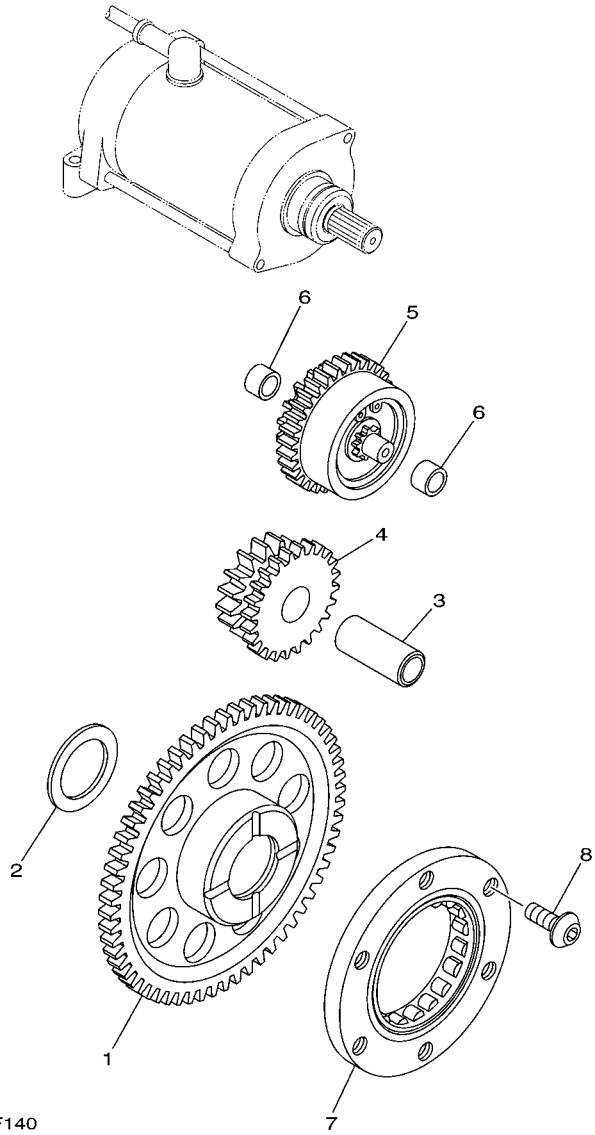


3B41100-F130

**FIG. 13 CRANKCASE COVER 1**

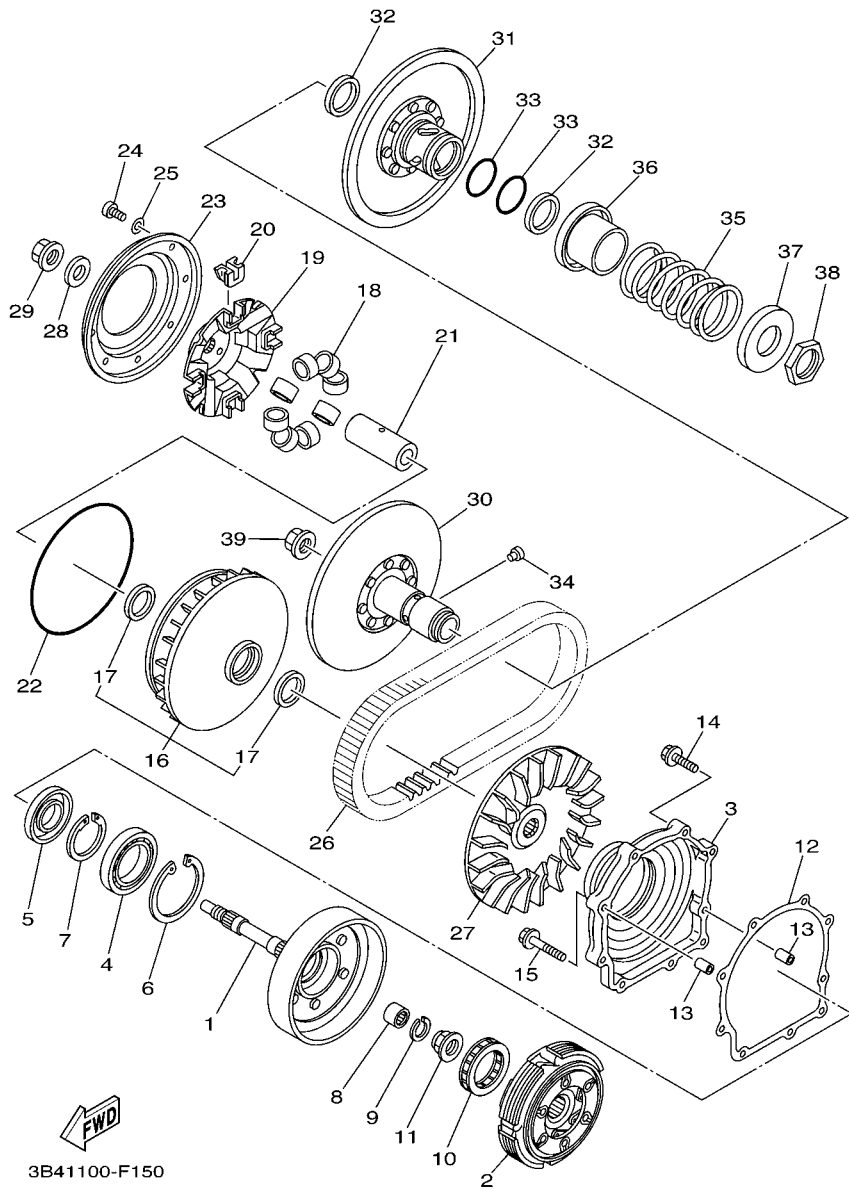
REF. NO.	PART NO.	DESCRIPTION	EUR	QCE		REMARKS
28	5KM-15351-00	PLUG, DRAIN	1	1		
29	95822-06020	BOLT, FLANGE	12	12		
30	90462-08055	CLAMP	1	1		
31	3B4-15471-00	DUCT, AIR	1	1		
32	5EJ-2414H-00	DAMPER, PLATE 1	1	1		
33	90480-13567	GROMMET	1	1		
34	90460-85135	CLAMP, HOSE	2	2		
35	3B4-15472-00	SEAL, AIR DUCT	1	1		
36	90183-060A5	NUT, SPRING	1	1		
37	3B4-15473-00	DUCT, AIR	1	1		
38	1S3-82123-00	SEAT, BATTERY	2	2		
39	90480-13398	GROMMET	1	1		
40	3B4-15474-00	SEAL, AIR DUCT	1	1		
41	90460-85135	CLAMP, HOSE	2	2		

**FIG. 14 STARTER CLUTCH**



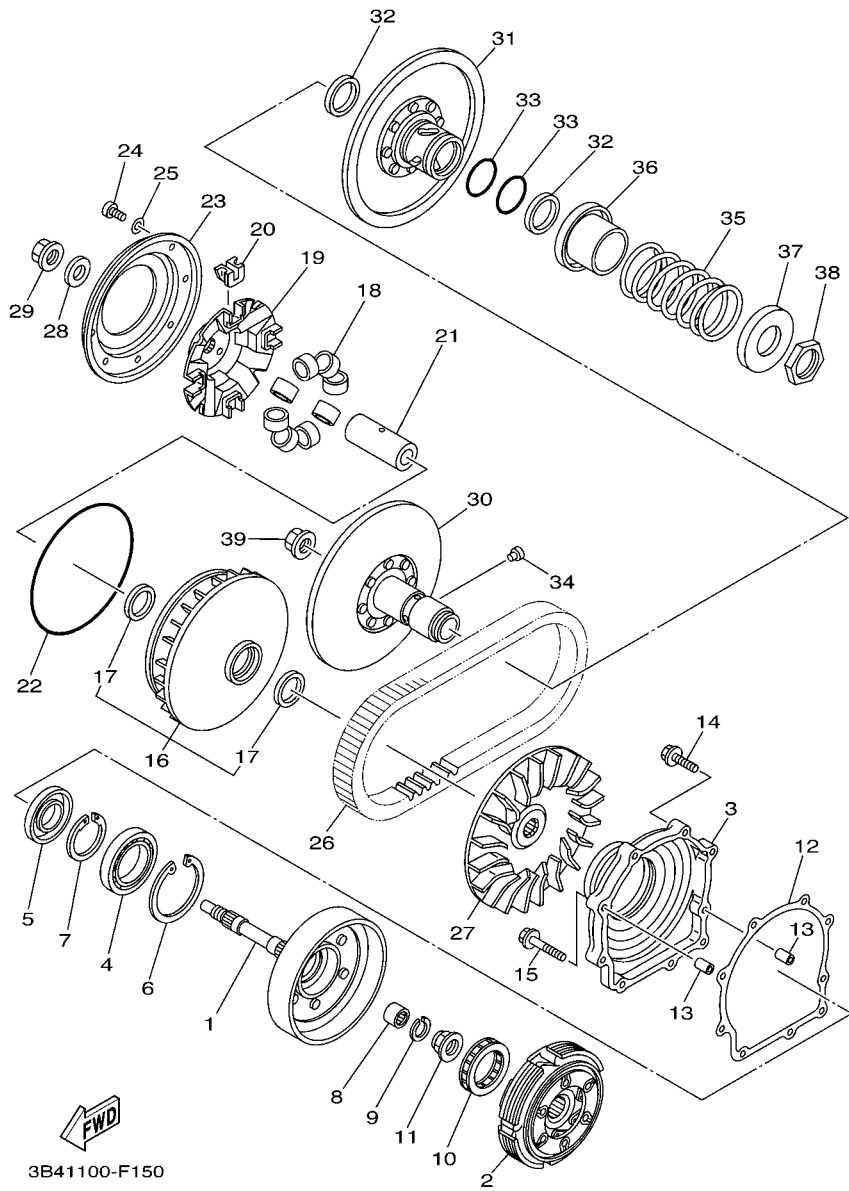
3B41100-F140

REF. NO.	PART NO.	DESCRIPTION	EUR	QCE	REMARKS
1	3B4-15515-00	GEAR 3 (49T)	1	1	
2	90201-286K9	WASHER, PLATE	1	1	
3	3B4-15522-00	SHAFT 2	1	1	
4	3B4-15517-00	GEAR, IDLER 2 (25T/15T)	1	1	
5	1S3-15560-00	DAMPER ASSY	1	1	
6	90380-10002	BUSH, SOLID	2	2	
7	5KM-15590-00	STARTER ONE-WAY ASSY	1	1	
8	90149-08018	SCREW	3	3	
<hr/>					
<hr/>					
<hr/>					
<hr/>					
<hr/>					
<hr/>					



**FIG. 15 CLUTCH**

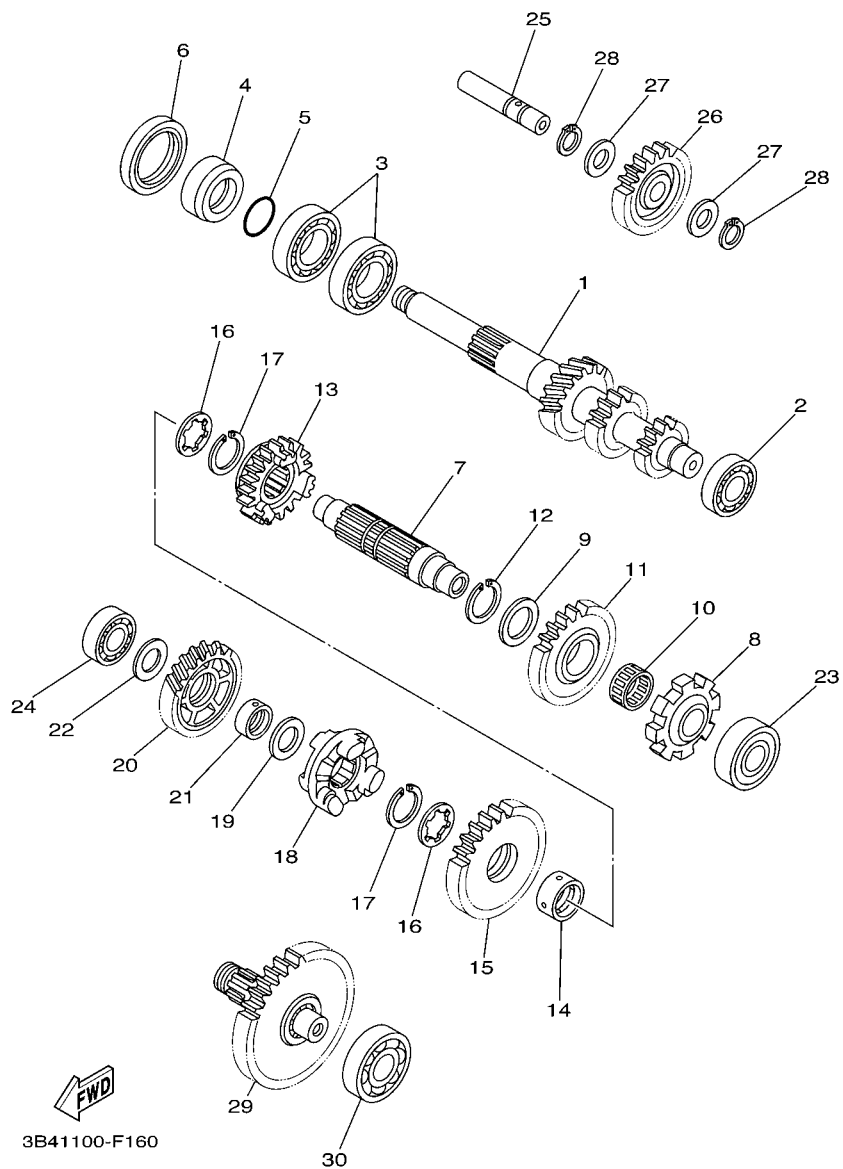
REF. NO.	PART NO.	DESCRIPTION	EUR	OCÉ	REMARKS
1	3B4-16611-00	CLUTCH HOUSING COMP.	1	1	
2	3B4-16620-00	CLUTCH CARRIER ASSY	1	1	
3	3B4-15163-00	HOUSING, BEARING 1	1	1	
4	93316-01003	BEARING	1	1	
5	93102-35004	OIL SEAL	1	1	
6	99009-80500	CIRCLIP	1	1	
7	93410-46079	CIRCLIP	1	1	
8	93315-21813	BEARING	1	1	
9	93450-24062	CIRCLIP	1	1	
10	4SH-16664-00	BEARING, ONE WAY	1	1	
11	90179-22021	NUT	1	1	
12	3B4-15463-00	GASKET, COVER PINION 2	1	1	
13	99530-10116	PIN, DOWEL	2	2	
14	95022-06030	BOLT, FLANGE	7	7	
15	95022-06040	BOLT, FLANGE	2	2	
16	3B4-17606-00	PRIMARY SLIDING SHEAVE COMP.	1	1	
17	93101-35001	OIL SEAL	2	2	
18	3B4-17632-00	WEIGHT	8	8	
19	3B4-17623-00	CAM	1	1	
20	3B4-17653-00	SLIDER	4	4	
21	3B4-17645-00	COLLAR	1	1	
22	93211-594A4	O-RING	1	1	
23	4WV-17639-10	STOPPER	1	1	
24	90157-04006	SCREW, PAN HEAD	8	8	
25	90201-047R9	WASHER, PLATE	8	8	
26	3B4-17641-00	V-BELT	1	1	
27	3B4-17611-00	SHEAVE, PRIMARY FIXED	1	1	



**FIG. 15 CLUTCH**

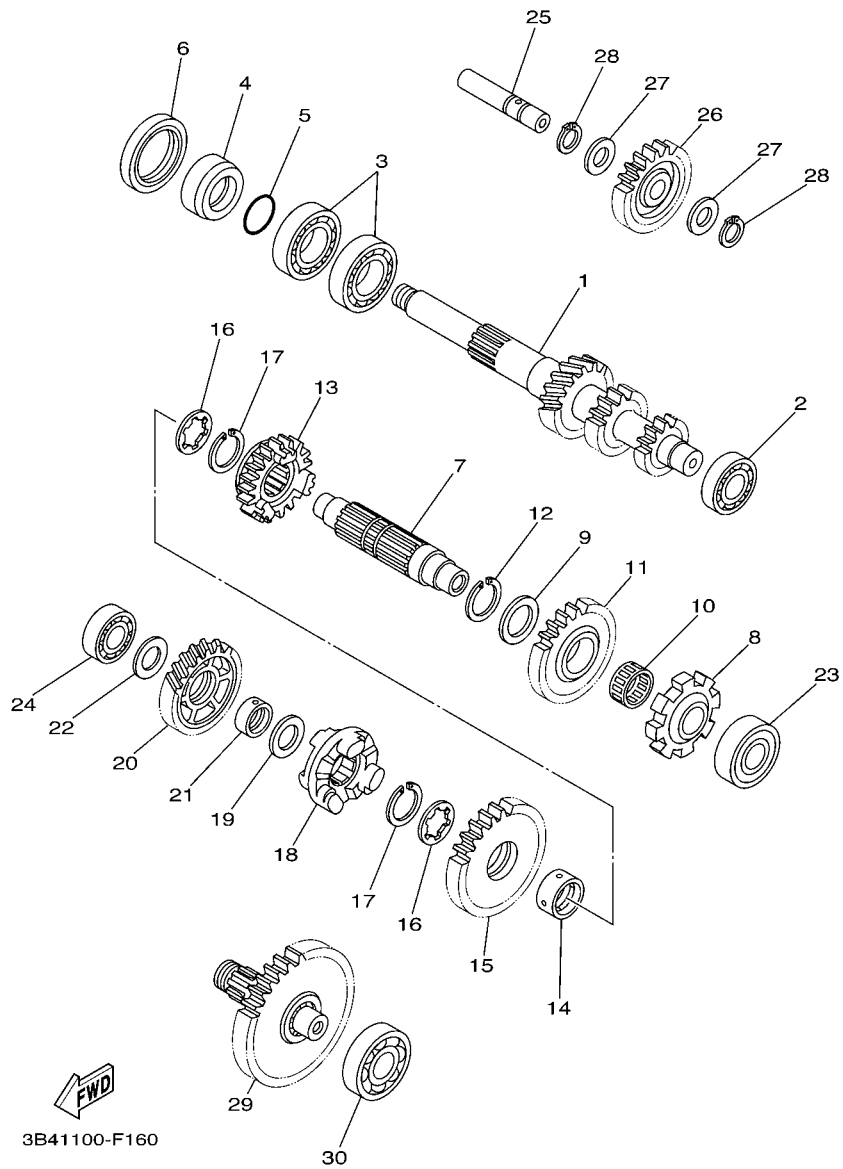
REF. NO.	PART NO.	DESCRIPTION	EUR	QCE	REMARKS
28	90201-190T7	WASHER, PLATE	1	1	
29	90179-16005	NUT	1	1	
30	3B4-17660-00	SECONDARY FIXED SHEAVE COMP.	1	1	
31	3B4-17670-00	SECONDARY SLIDING SHEAVE	1	1	
32	93104-41119	OIL SEAL	2	2	
33	93210-44545	O-RING	2	2	
34	4CW-17664-00	PIN, GUIDE	4	4	
35	90501-650A0	SPRING, COMPRESSION	1	1	
36	4WV-17684-00	SEAT, SECONDARY SPRING	1	1	
37	4WV-17644-00	SEAT, SPRING	1	1	
38	90170-36279	NUT	1	1	
39	90179-16005	NUT	1	1	

FIG. 16 TRANSMISSION



REF. NO.	PART NO.	DESCRIPTION	EUR	OCF	REMARKS
1	3B4-17681-00	SHAFT, SECONDARY	1	1	
2	93306-00426	BEARING	1	1	
3	93306-07801	BEARING	2	2	
4	90387-26001	COLLAR	1	1	
5	93210-26001	O-RING	1	1	
6	93102-42004	OIL SEAL	1	1	
7	3B4-17421-00	AXLE, DRIVE	1	1	
8	3B4-17473-00	STOPPER	1	1	
9	90201-25290	WASHER, PLATE	1	1	
10	93310-32590	BEARING	1	1	
11	3B4-17253-00	GEAR, REVERSE WHEEL 2 (28T)	1	1	
12	93440-25084	CIRCLIP	1	1	
13	3B4-17582-00	GEAR, MIDDLE DRIVE (21T)	1	1	
14	90387-250R3	COLLAR	1	1	
15	3B4-17233-00	GEAR, LOW WHEEL (31T)	1	1	
16	90209-22082	WASHER (T=0.5)	2	2	
17	93440-25084	CIRCLIP	2	2	
18	3B4-17285-01	CLUTCH, DOG	1	1	
19	90201-20278	WASHER, PLATE	1	1	
20	3B4-17223-01	GEAR, HIGH WHEEL (29T)	1	1	
21	90387-20021	COLLAR	1	1	
22	90201-170U8	WASHER, PLATE	1	1	
23	93306-20464	BEARING	1	1	
24	93306-20309	BEARING	1	1	
25	3B4-17432-00	AXLE, IDLE	1	1	
26	3B4-17243-00	GEAR, REVERSE WHEEL 1 (23T)	1	1	Go to P/N : PE0-MC-090023
27	90201-150U6	WASHER, PLATE	2	2	

FIG. 16 TRANSMISSION



REF. NO.	PART NO.	DESCRIPTION	EUR	OCE	REMARKS
28	93440-15012	CIRCLIP	2	2	
29	3B4-17520-00	DRIVE PINION ASSY (41T)	1	1	Go to P/N : PE0-MC-090023
30	93306-30438	BEARING	1	1	
-----					
-----					
-----					
-----					
-----					
-----					
-----					

# PARTS NEWS

Date: Apr./28/2009

Signature: M.Saito

News No. PE0-MC-090023 1/2

Cause  Revision Notice  Correction  Sales Unit Change  Others

Model	See the "List of Models and CATALOGUE No's below."	
Subject	PARTS CATALOGUE CORRECTIONS	
CATALOGUE NO.	See the "List of Models and CATALOGUE No's below."	
Time of YPEC Revision	Text, Illustration --> May./20/2009	PDF Replace --> May./20/2009
(YPEC = Yamaha Parts Electrical Catalogue = Website parts catalogue)		

## FIG.16 TRANSMISSION SECTION

### 1. LIST CORRECTION

Ref.No.	OLD PART No.	NEW PART No.	PART NAME	Q'TY	INTERCHANGE ABILITY	REMARKS
25	3B4-17432-00	<b>3B4-17432-01</b>	AXLE, IDLE	1	○	
26	3B4-17243-00	<b>16B-17243-00</b>	GEAR, REVERSE WHEEL	1	○	<b>Note-1</b>
27	90201-150U6	<b>90201-15029</b>	WASHER, PLATE	2-->1	○	
28	90344-15012	-----	CIRCLIP	2	○	<b>Delete</b>
31	-----	<b>93310-31576</b>	BEARING	1	○	<b>Add.</b>
32	-----	<b>90387-15017</b>	COLLAR	1	○	<b>Add.</b>

\* These changes are applied from initial production.

\* The parts marked with ○ indicates interchangeability with a set.

Note-1; As for 3B4-17243-00, parts supply is discontinued.

Old Gear reverse wheel is not interchangeable with new Gear reverse wheel.

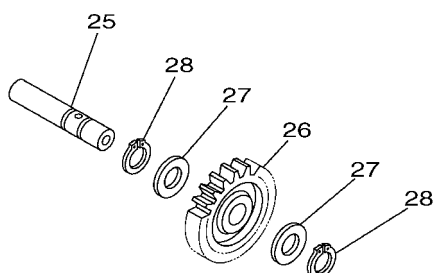
When you exchange old Gear reverse wheel, please exchange in Gear reverse wheel set (99999-03870).

\*\*Components parts of Gear reverse wheel set : 99999-03870

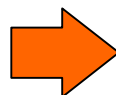
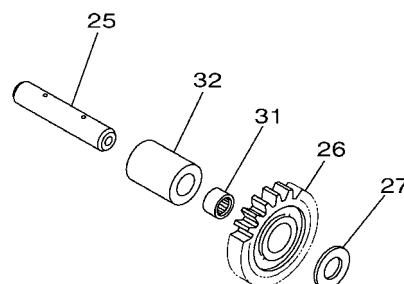
Part No.	Part Name	Q'ty
3B4-17432-01	AXLE, IDEL	1
16B-17243-00	GEAR, REVERSE WHEEL	1
90201-15029	WASHER, PLATE	1
93310-31576	BEARING	1
90387-15017	COLLOR	1

### 2. ILLUSTRATION CORRECTION

#### OLD type



#### NEW type



Thank you very much for your cooperation.

Parts  
Manager  
Check

Service  
Manager  
Check

Parts  
Manager  
File

YAMAHA MOTOR CO.,LTD  
2500 Shingai Iwata Shizuoka 438-8501.Japan  
Technical Publication Dept.

# PARTS NEWS



Date: Apr./28/2009

Signature: M.Saito

News No. PE0-MC-090023 2/2

Cause  Revision Notice  Correction  Sales Unit Change  Others

Model	See the"List of Models and CATALOGUE No's below."
Subject	PARTS CATALOGUE CORRECTIONS
CATALOGUE NO.	See the"List of Models and CATALOGUE No's below."
Time of YPEC Revision	Text, Illustration --> May./20/2009 PDF Replace --> May./20/2009 (YPEC = Yamaha Parts Electrical Catalogue = Website parts catalogue)

### 3. LIST of Models and CATALOG No's

MODEL YEAR	MODEL NAME	MODEL CODE	CATALOG No.
2007	YFM7FGPW	3B41 / 3B42	1F3B4-100E1
2007	YFM7FGPW	3B43 / 3B44	1F3B4-300E1
2007	YFM7FGPW	3B45 / 3B46 / 3B47	1F3B4-100EA
2007	YFM7FGPW	3B48	1F3B4-110E1
2007	YFM7FGPW	3B4A / 3B4B / 3B4C / 3B4D	1F3B4-100EK
2008	YFM7FGPX	3B49 / 3B4E / 3B4F / 3B4G	1G3B4-100E1
2008	YFM7FGPX	3B4H / 3B4J / 3B4K	1G3B4-100EA
2008	YFM7FGPX	3B4L	1G3B4-110E1
2008	YFM7FGPX	3B4M / 3B4N / 3B4P / 3B4R	1G3B4-100EK
2008	YFM7FGPX	3B4S	1G3B4-171E1
2008	YFM7FGPX	3B4T	1G3B4-171EA
2008	YFM7FGX	5C01 / 5C02 / 5C04	1G5C0-100E1
2008	YFM7FGX	5C05 / 5C06	1G5C0-100EA
2009	YFM7FGPY	43P1	1H43P-110E1
2009	YFM7FGPY	43P2 / 43P3 / 43P4	1H43P-100E1
2009	YFM7FGPY	43P5	1H43P-110EA
2009	YFM7FGPY	43P6 / 43P7	1H43P-100EA
2009	YFM7FGPY	43P8	1H43P-110EK
2009	YFM7FGPY	43P9	1H43P-171E1
2009	YFM7FGPY	43PA	1H43P-110EY
2009	YFM7FGPY	43PB / 43PC / 43PD	1H43P-100EK
2009	YFM7FGPY	43PE / 43PF	1H43P-100EY
2009	YFM7FGY	5C0A	1H5C0-110E1
2009	YFM7FGY	5C0B	1H5C0-171E1
2009	YFM7FGY	5C0C	1H5C0-110EA
2009	YFM7FGY	5C0D	1H5C0-171EA
2009	YFM5FGY	28P1	1H28P-110E1
2009	YFM5FGY	28P2 / 28P3 / 28P4	1H28P-100E1
2009	YFM5FGY	28P5	1H28P-110EA
2009	YFM5FGY	28P6	1H28P-171E1
2009	YFM5FGY	34D1	1H34D-110E1
2009	YFM5FGPY	34D2 / 34D3 / 34D4	1H34D-100E1
2009	YFM5FGPY	34D5	1H34D-110E1
2009	YFM5FGPY	34D6 / 34D7	1H34D-100EA
2009	YFM5FGPSEY	34D8	1H34D-110EK
2009	YFM5FGPSEY	34D9 / 34DA / 34DB	1H34D-100EK

Thank you very much for your cooperation.

Parts  
Manager  
Check

Service  
Manager  
Check

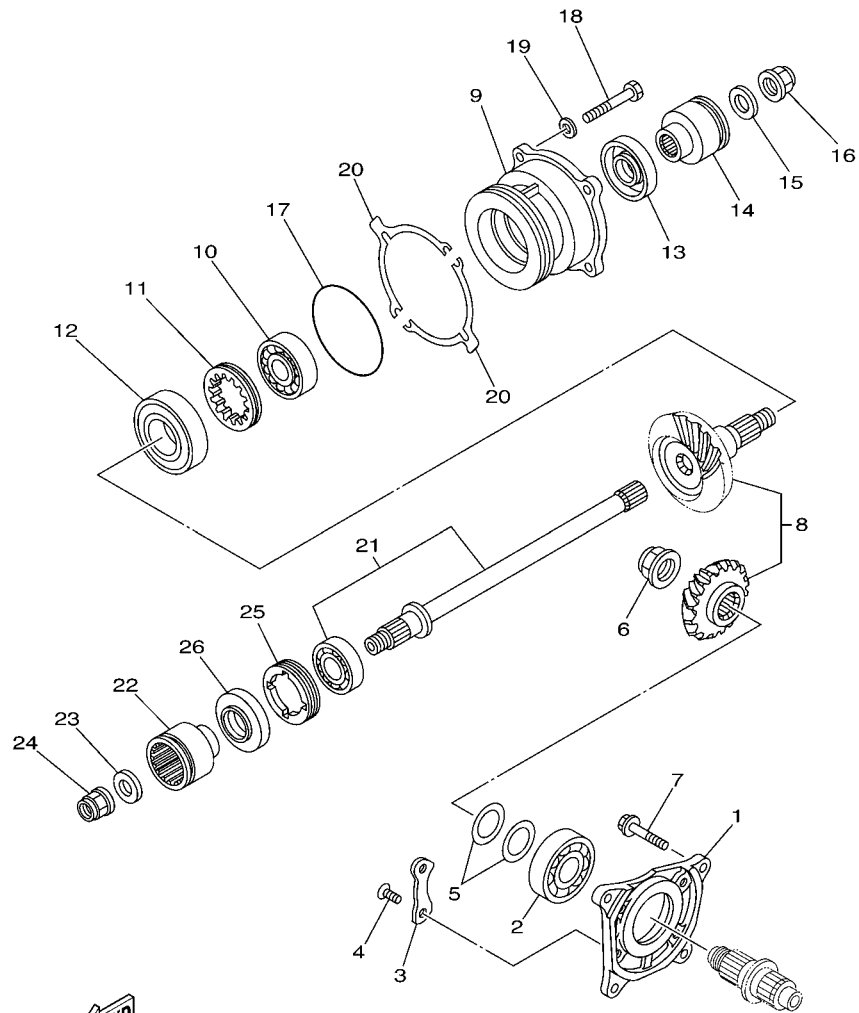
Parts  
Manager  
File

YAMAHA MOTOR CO.,LTD  
2500 Shingai Iwata Shizuoka 438-8501.Japan  
Technical Publication Dept.





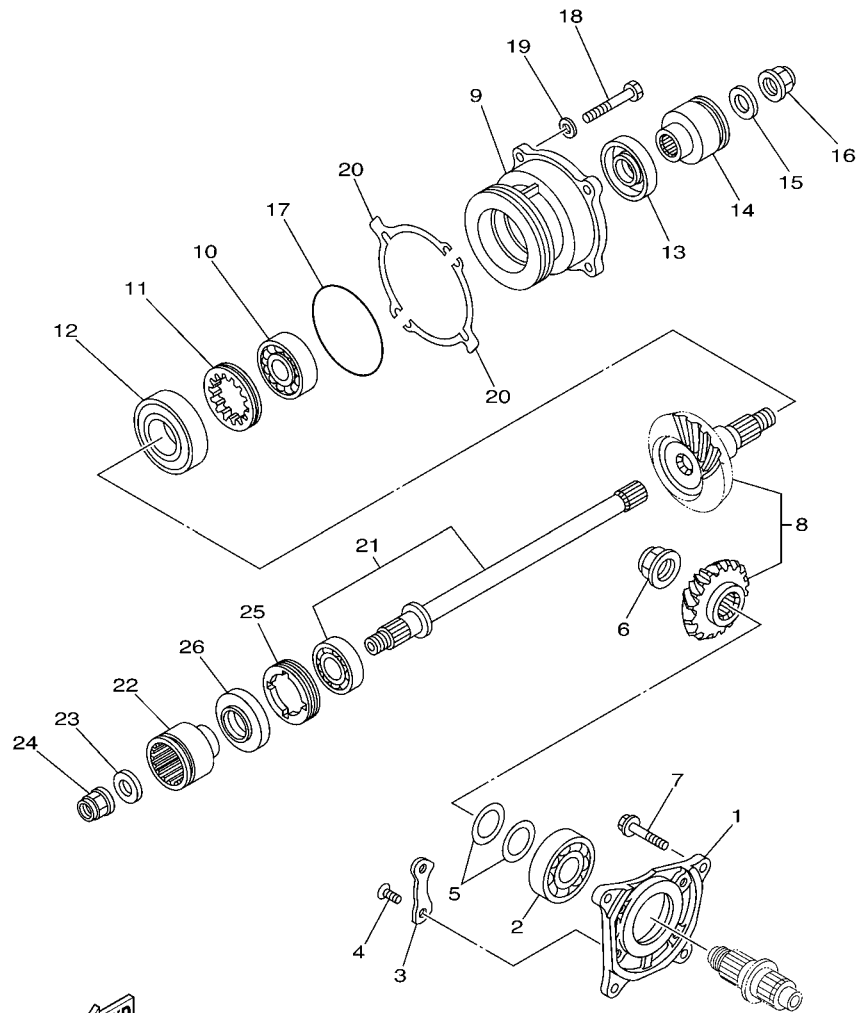
FIG. 17 MIDDLE DRIVE GEAR



3B41100-F170

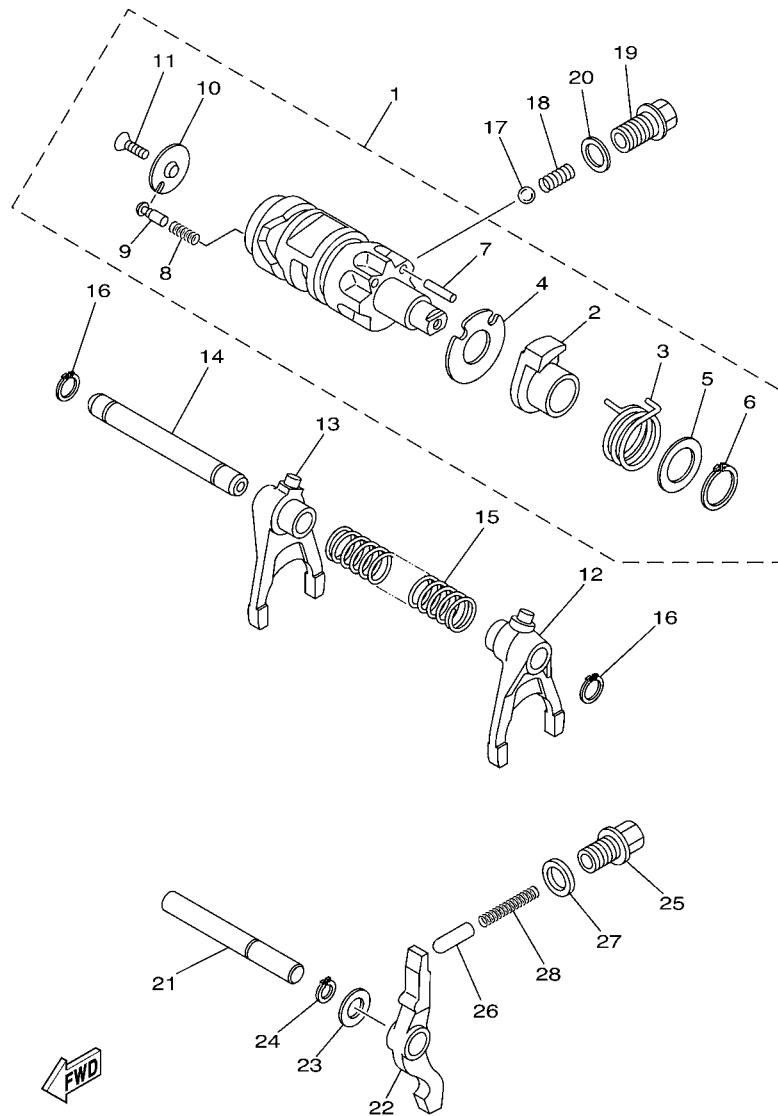
REF. NO.	PART NO.	DESCRIPTION	EUR	QCE	REMARKS
1	3B4-17521-00	HOUSING, BEARING	1	1	
2	93306-30537	BEARING	1	1	
3	11H-15383-02	PLATE, BEARING COVER	2	2	
4	90149-08013	SCREW	4	4	
5	5KM-17531-50	SHIM, PINION (0.5T)	2	2	UR
5KM-17531-60	SHIM, PINION (0.55T)	2	2	UR	
5KM-17531-70	SHIM, PINION (0.6T)	2	2	UR	
5KM-17531-80	SHIM, PINION (0.7T)	2	2	UR	
5KM-17531-90	SHIM, PINION (0.8T)	2	2	UR	
5KM-17531-A0	SHIM, PINION (0.9T)	2	2	UR	
5KM-17531-B0	SHIM, PINION (1.0T)	2	2	UR	
6	90179-22013	NUT	1	1	
7	90105-08129	BOLT, FLANGE	4	4	
8	3B4-17530-00	PINION SET	1	1	
9	3B4-17551-00	HOUSING, BEARING	1	1	
10	93306-37206	BEARING	1	1	
11	90179-60001	NUT	1	1	
12	93306-20654	BEARING	1	1	
13	93102-30010	OIL SEAL	1	1	
14	3B4-17832-00	COUPLING	1	1	
15	90201-16021	WASHER, PLATE	1	1	
16	90179-16006	NUT	1	1	
17	93210-78544	O-RING	1	1	
18	97022-08030	BOLT	4	4	
19	92902-08600	WASHER, PLATE	4	4	
20	3B4-17531-00	SHIM, PINION (0.1T)	2	2	UR
3B4-17531-10	SHIM, PINION (0.15T)	2	2	UR	

FIG. 17 MIDDLE DRIVE GEAR



3B41100-F170

REF. NO.	PART NO.	DESCRIPTION	EUR	OCF		REMARKS
20	3B4-17531-20	SHIM, PINION (0.2T)	2	2		UR
	3B4-17531-30	SHIM, PINION (0.3T)	2	2		UR
	3B4-17531-40	SHIM, PINION (0.4T)	2	2		UR
	3B4-17531-50	SHIM, PINION (0.5T)	2	2		UR
	3B4-17531-60	SHIM, PINION (0.6T)	2	2		UR
21	3B4-1755A-00	MIDDLE DRIVEN SHAFT ASSY	1	1		
22	3B4-17832-00	COUPLING	1	1		
23	90201-16021	WASHER, PLATE	1	1		
24	90179-16006	NUT	1	1		
25	90179-55660	NUT	1	1		
26	93102-30010	OIL SEAL	1	1		

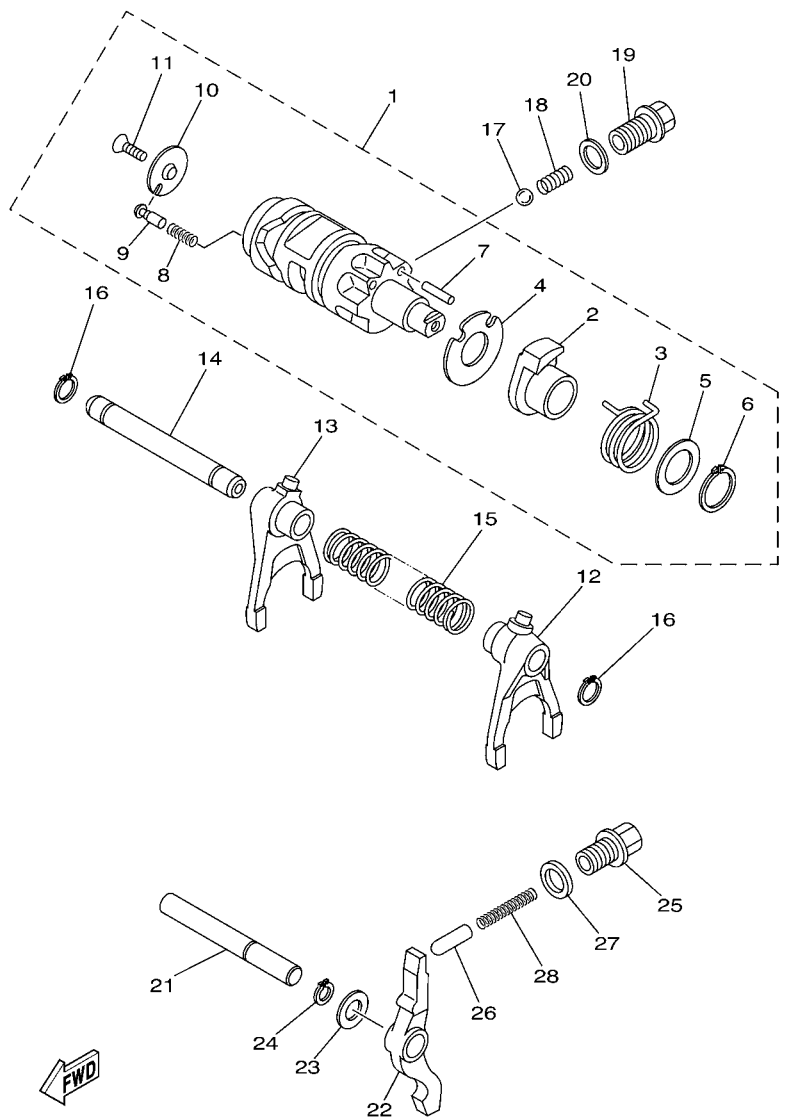


3B41100-F180

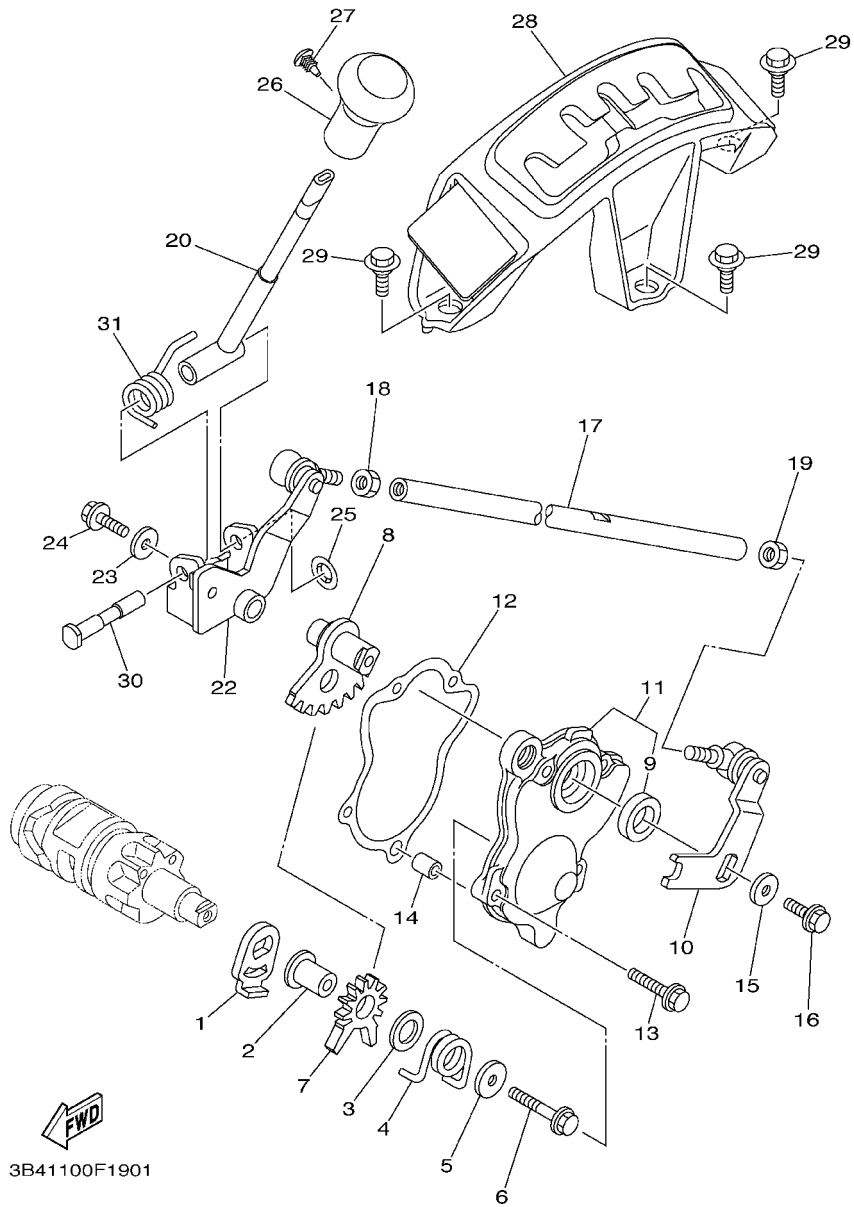
FIG. 18 SHIFT CAM & FORK

REF. NO.	PART NO.	DESCRIPTION	EUR	OCE	REMARKS
1	3B4-18540-00	SHIFT CAM ASSY	1	1	
2	5KM-18171-00	.CAM, LEVER	1	1	
3	90508-32018	.SPRING, TORSION	1	1	
4	3B4-18331-00	.PLATE, SHIFT CAM	1	1	
5	90201-20792	.WASHER, PLATE	1	1	
6	93410-20038	.CIRCLIP	1	1	
7	93604-18100	.PIN, DOWEL	1	1	
8	90501-06022	.SPRING, COMPRESSION	1	1	
9	5KM-18542-00	.POINT, NEUTRAL	1	1	
10	4UN-18566-00	.PLATE, SIDE 2	1	1	
11	90149-05016	.SCREW	1	1	
12	3B4-18511-00	FORK, SHIFT 1	1	1	
13	3B4-18512-00	FORK, SHIFT 2	1	1	
14	3B4-18531-00	BAR, SHIFT FORK GUIDE 1	1	1	
15	90501-120A6	SPRING, COMPRESSION	1	1	
16	99009-12400	CIRCLIP	2	2	
17	93503-08007	BALL	1	1	
18	90501-10353	SPRING, COMPRESSION	1	1	
19	90105-14003	BOLT, FLANGE	1	1	
20	90430-14194	GASKET	1	1	
21	3B4-18318-00	SHAFT, SHIFTER	1	1	
22	3B4-18148-00	LEVER, STOPPER	1	1	
23	90201-127J6	WASHER, PLATE	1	1	
24	99009-12400	CIRCLIP	1	1	
25	90109-14002	BOLT	1	1	
26	1J7-18547-00	STOPPER, CAM	1	1	
27	90430-14043	GASKET	1	1	

FIG. 18 SHIFT CAM & FORK



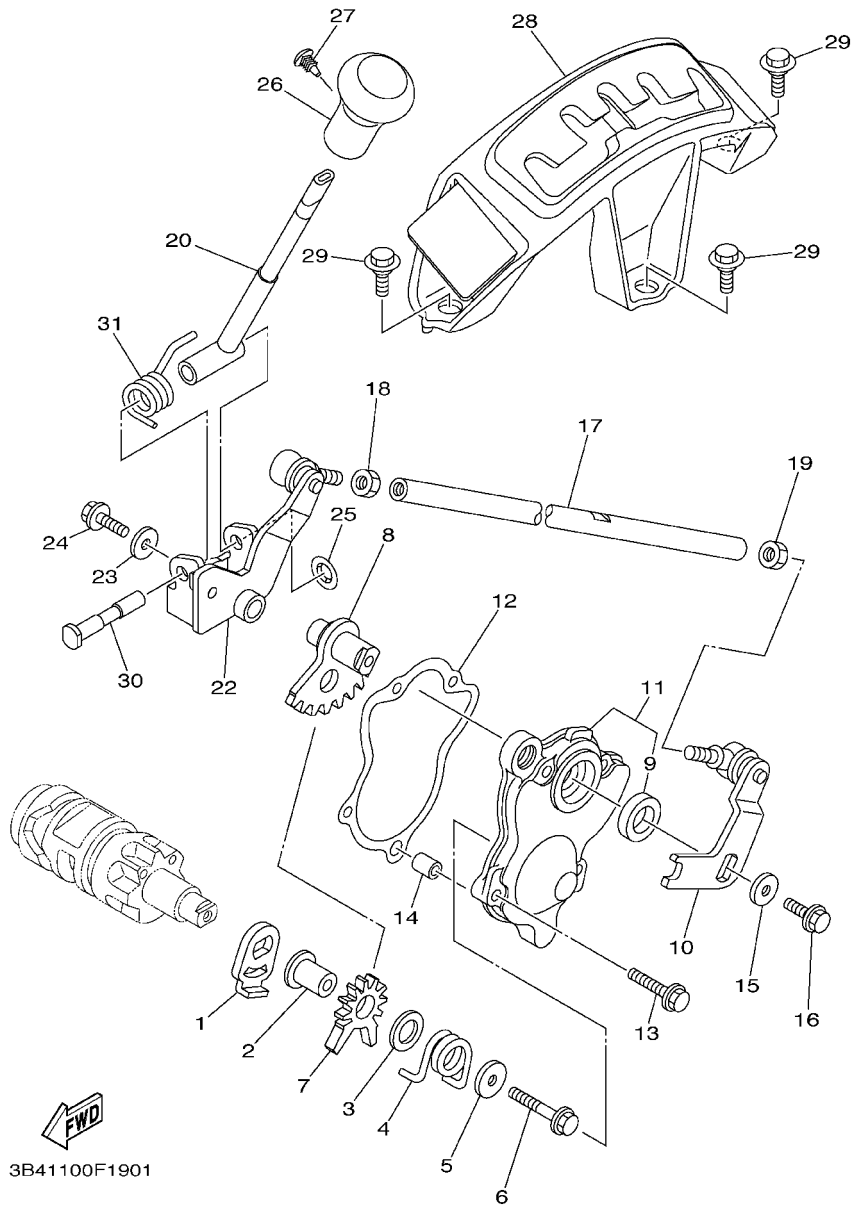
REF. NO.	PART NO.	DESCRIPTION	EUR	OCÉ			REMARKS
28	90501-12004	SPRING, COMPRESSION	1	1			



3B41100F1901

FIG. 19 SHIFT SHAFT

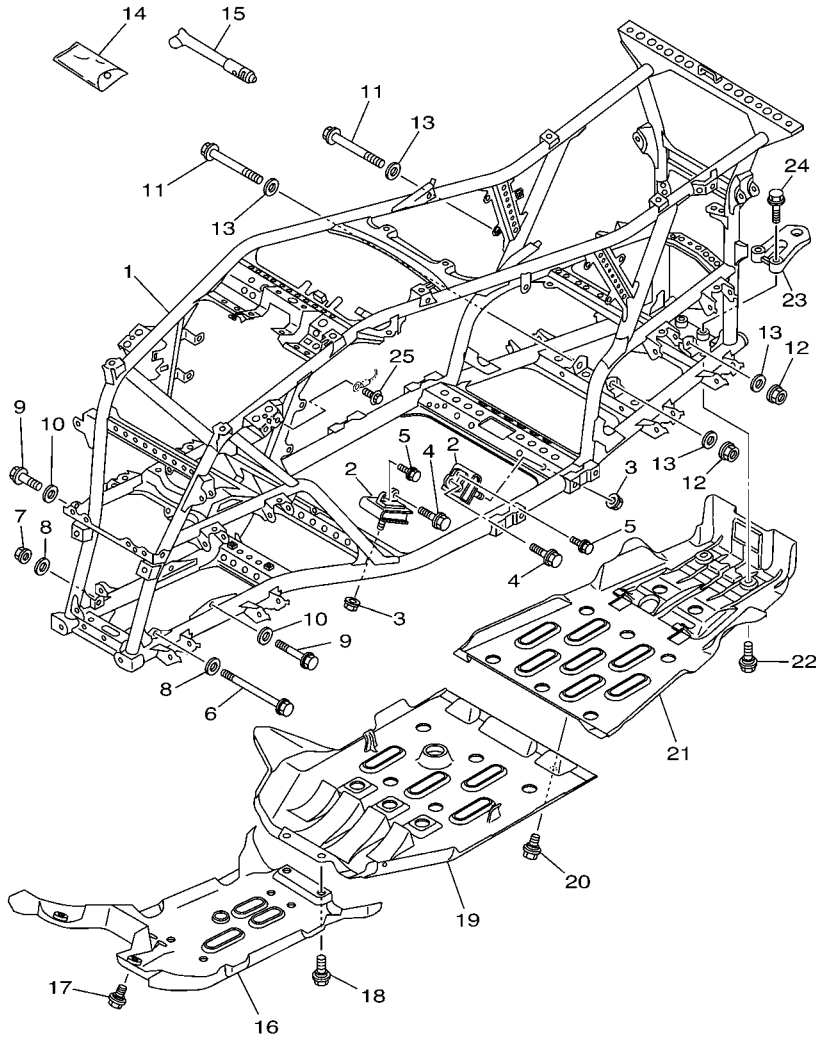
REF. NO.	PART NO.	DESCRIPTION	EUR	OCE	REMARKS
1	4SH-18198-00	LEVER	1	1	
2	90387-0613B	COLLAR	1	1	
3	90201-132G5	WASHER, PLATE	1	1	
4	90508-35764	SPRING, TORSION	1	1	
5	90201-06036	WASHER, PLATE	1	1	
6	95812-06035	BOLT, FLANGE	1	1	
7	5KM-18191-00	LEVER	1	1	
8	3B4-18103-10	SHIFT SHAFT COMP.	1	1	
9	93102-15212	.OIL SEAL	1	1	
10	3B4-18104-20	SHIFT GUIDE COMP.	1	1	
11	3B4-18380-00	SHIFTER BRKT, ASSY	1	1	
12	3B4-18146-00	GASKET	1	1	
13	95022-06020	BOLT, FLANGE	4	4	
14	99530-08012	PIN, DOWEL	1	1	
15	90201-06036	WASHER, PLATE	1	1	
16	95812-06016	BOLT, FLANGE	1	1	
17	3B4-18115-00	ROD, SHIFT	1	1	
18	90170-08358	NUT	1	1	
19	95302-08700	NUT	1	1	
20	3B4-18190-01	LEVER COMP. 1	1	1	
22	3B4-18169-01	ARM, SHIFT 2	1	1	
23	90201-06036	WASHER, PLATE	1	1	
24	95812-06016	BOLT, FLANGE	1	1	
25	90183-080A1	NUT, SPRING	1	1	
26	3B4-18174-00	KNOB, SHIFT LEVER	1	1	
27	90269-05055	RIVET	1	1	



3B41100F1901

FIG. 19 SHIFT SHAFT

REF. NO.	PART NO.	DESCRIPTION	EUR	OCÉ	REMARKS
28	3B4-18160-00	SHIFT GUIDE ASSY	1	1	
29	90109-063F1	BOLT	3	3	
30	3B4-18125-00	SHAFT, SHIFT	1	1	
31	3B4-18196-00	SPRING, RETURN	1	1	
-----					
-----					
-----					
-----					
-----					
-----					
-----					
-----					
-----					

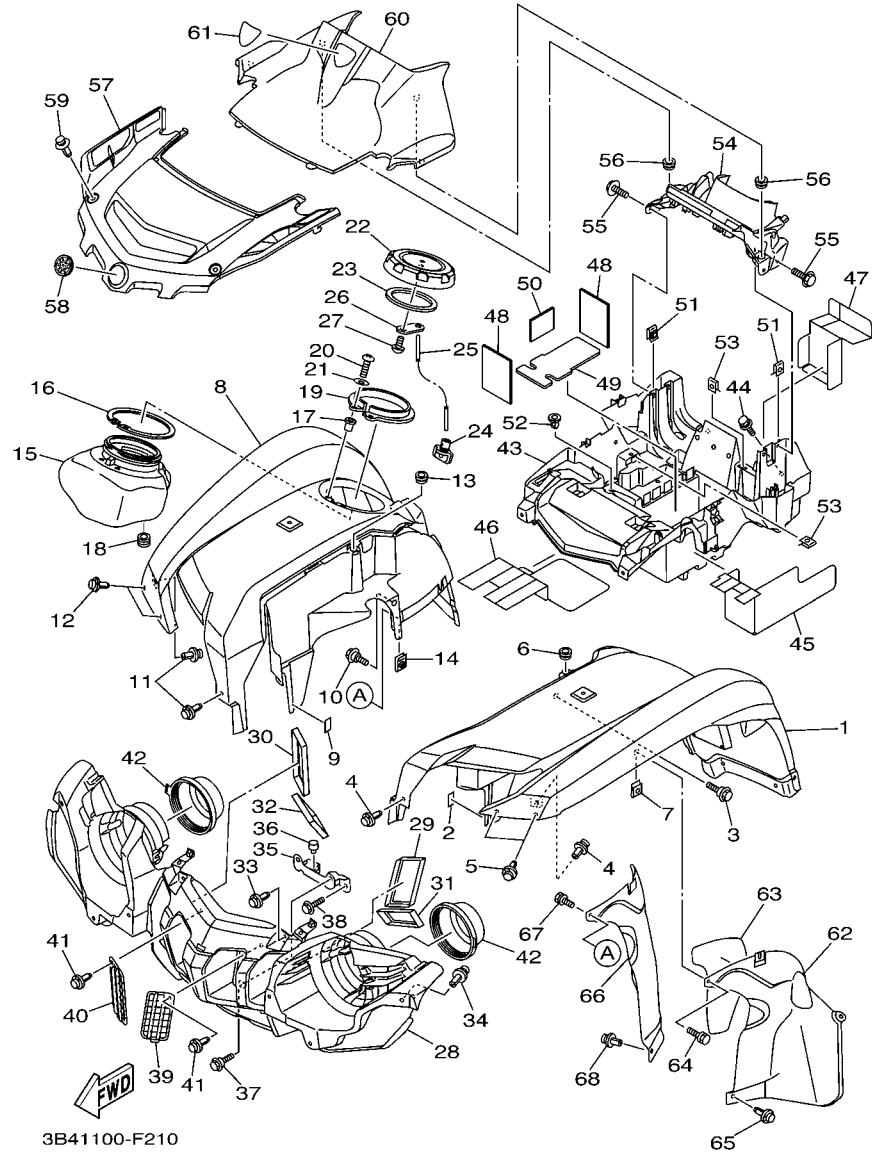


3B41100-F200

FIG. 20 FRAME

REF. NO.	PART NO.	DESCRIPTION	EUR	QCE	REMARKS
1	3B4-21110-10	FRAME COMP.	1	1	
2	3B4-21485-00	DAMPER, RUBBER 1	4	4	
3	95602-10200	NUT, U FLANGE	4	4	
4	95812-10035	BOLT, FLANGE	4	4	
5	90105-06639	BOLT, FLANGE	4	4	
6	90105-10110	BOLT, FLANGE	1	1	
7	90185-10011	NUT, SELF-LOCKING	1	1	
8	90201-101J1	WASHER, PLATE	2	2	
9	90105-10061	BOLT, FLANGE	2	2	
10	90201-101J1	WASHER, PLATE	2	2	
11	90105-10073	BOLT, FLANGE	2	2	
12	90185-10011	NUT, SELF-LOCKING	2	2	
13	90201-101J1	WASHER, PLATE	4	4	
14	5TG-28100-00	TOOL KIT	1	1	
15	1NV-2811A-01	GAUGE, AIR	1	1	
16	3B4-2147A-00	GUARD, ENGINE 1	1	1	
17	90109-06086	BOLT	2	2	
18	90109-063F5	BOLT	2	2	
19	3B4-2147E-00	GUARD, ENGINE 2	1	1	
20	90109-063F5	BOLT	2	2	
21	3B4-2147F-00	GUARD, ENGINE 3	1	1	
22	90109-06086	BOLT	2	2	
23	3B4-28488-00	HOOK	1		
	3B4-28488-10	HOOK		1	
24	95817-10035	BOLT, FLANGE	2	2	
25	95802-06012	BOLT, FLANGE	1	1	

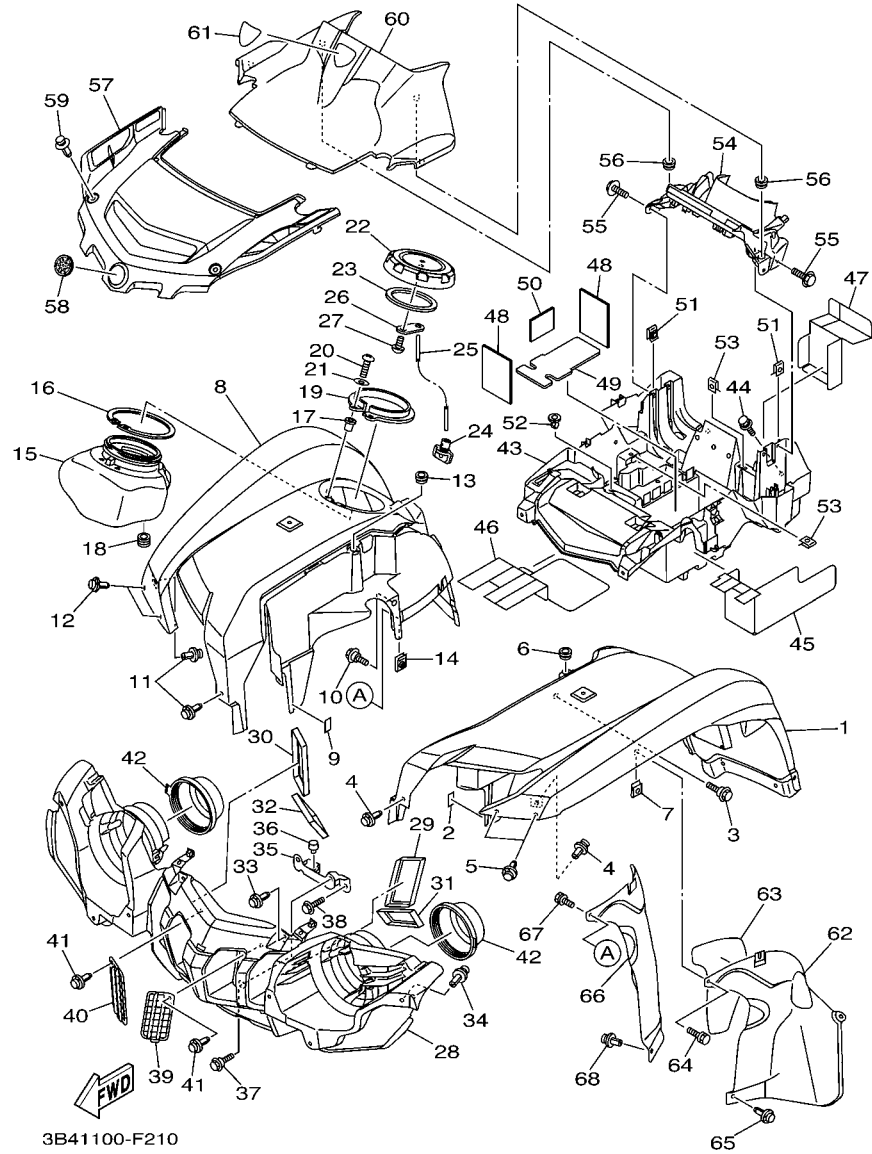
FIG. 21 FRONT FENDER



REF. NO.	PART NO.	DESCRIPTION	EUR	QTY	REMARKS
1	3B4-W215B-00	FRONT FENDER COMP. 2	1		UR FOR PDG
	3B4-W215B-10	FRONT FENDER COMP. 2	1		UR FOR RTR
	3B4-W215B-30	FRONT FENDER COMP. 2	1		UR FOR DPBSE
	3B4-W215E-30	FRONT FENDER COMP.		1	FOR DPBSE
2	3B4-21541-00	DAMPER 1	1	1	
3	90109-063F1	BOLT	1	1	
4	90269-07010	RIVET	2	2	
5	90269-07010	RIVET	2	2	
6	90480-13398	GROMMET	1	1	
7	90183-06053	NUT, SPRING	1	1	
8	3B4-21556-00	FENDER, FRONT 2	1		UR FOR PDG
	3B4-21556-10	FENDER, FRONT 2	1		UR FOR RTR
	3B4-21556-30	FENDER, FRONT 2	1		UR FOR DPBSE
	3B4-21556-30	FENDER, FRONT 2		1	FOR DPBSE
9	3B4-21541-00	DAMPER 1	1	1	
10	90109-063F1	BOLT	1	1	
11	90269-07010	RIVET	2	2	
12	90269-07010	RIVET	2	2	
13	90480-13398	GROMMET	1	1	
14	90183-06053	NUT, SPRING	1	1	
15	3B4-2838K-00	BOX 1	1	1	
16	3B4-2838M-00	SEAL, BOX 1	1	1	
17	90179-05523	NUT	2	2	
18	90480-13004	GROMMET	1	1	
19	3B4-2839N-00	HOLDER	1	1	
20	98502-05016	SCREW, PAN HEAD	2	2	
21	92902-05600	WASHER, PLATE	2	2	



**FIG. 21 FRONT FENDER**



REF. NO.	PART NO.	DESCRIPTION	EUR	QTY	REMARKS
22	3B4-2151B-00	CAP	1	1	
23	3B4-28307-00	SEAL	1	1	
24	3B4-215A1-00	PLUG, DRAIN	1	1	
25	3B4-2845L-00	STOPPER, OPEN	1	1	
26	3B4-28487-00	PLATE 2	1	1	
27	97702-50512	SCREW, TAPPING	1	1	
28	3B4-28309-00	GRILLE, FRONT	1	1	
29	3B4-28217-00	DAMPER 1	1	1	
30	3B4-28227-00	DAMPER 2	1	1	
31	3B4-28237-00	DAMPER 3	1	1	
32	3B4-28247-00	DAMPER 4	1	1	
33	90269-07010	RIVET	2	2	
34	90269-07077	RIVET	2	2	
35	3B4-28332-00	STAY, LEG SHIELD	1	1	
36	5RU-24768-00	STOPPER	2	2	
37	90109-063F1	BOLT	2	2	
38	95802-06012	BOLT, FLANGE	2	2	
39	3B4-2837N-00	GRILL, AIR INTAKE 1	1	1	
40	3B4-2837R-00	GRILL, AIR INTAKE 2	1	1	
41	90269-07077	RIVET	2	2	
42	3B4-28349-00	CAP	2	2	
43	3B4-21523-00	PLATE 1	1	1	
44	90119-06056	BOLT, WITH WASHER	3	3	
45	3B4-8253E-00	INSULATOR 1	1	1	
46	3B4-8253F-00	INSULATOR 2	1	1	
47	3B4-8254E-00	INSULATOR	1	1	
48	3B4-8233W-00	INSU.	2	2	

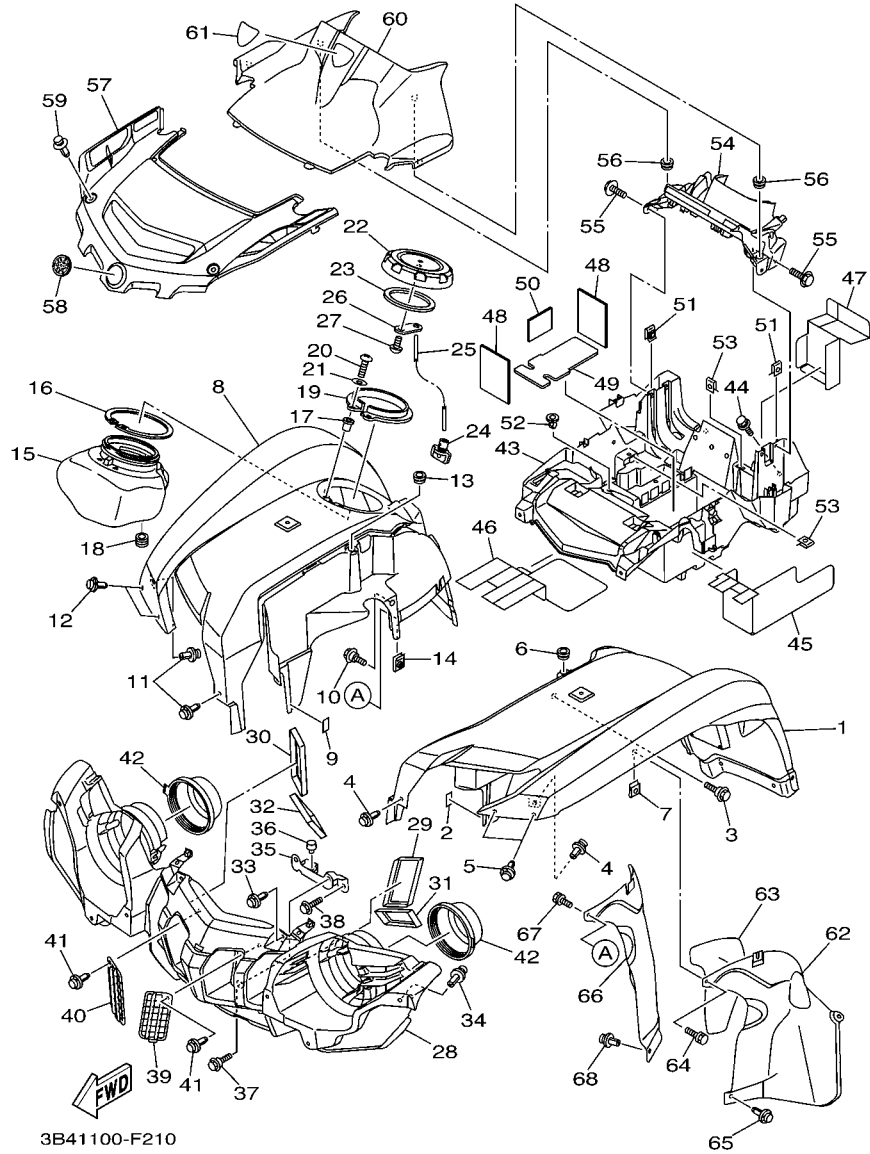
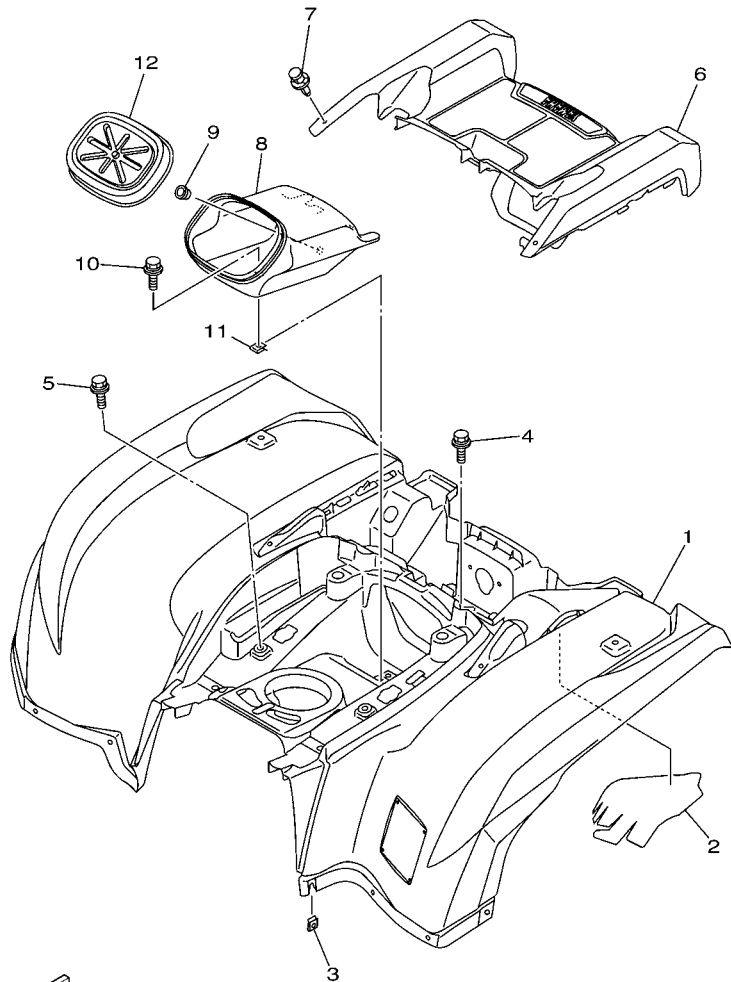


FIG. 21 FRONT FENDER

REF. NO.	PART NO.	DESCRIPTION	EUR	QCE	REMARKS
49	3B4-82122-00	SEAT, BATTERY	1	1	
50	1S3-82123-00	SEAT, BATTERY	1	1	
51	90183-06053	NUT, SPRING	5	5	
52	90338-08226	PLUG	2	2	
53	90183-05008	NUT, SPRING	2	2	
54	3B4-2837L-00	PANEL, CONSOLE 1	1	1	
55	90119-06056	BOLT, WITH WASHER	4	4	
56	90480-13567	GROMMET	2	2	
57	3B4-23391-00	PANEL, FRONT	1	1	
58	5KM-2175B-00	TUNING FORK MARK	1	1	
59	90269-07010	RIVET	2	2	
60	3B4-28313-00	LID	1	1	
61	3B4-26232-00	EMBLEM 3D	1	1	
62	3B4-21552-00	FENDER, INNER	1	1	
63	3B4-21575-00	SEAL 1	1	1	
64	90119-06056	BOLT, WITH WASHER	1	1	
65	90269-07010	RIVET	1	1	
66	3B4-21553-00	FENDER, INNER 2	1	1	
67	90119-06056	BOLT, WITH WASHER	1	1	
68	90269-07010	RIVET	2	2	

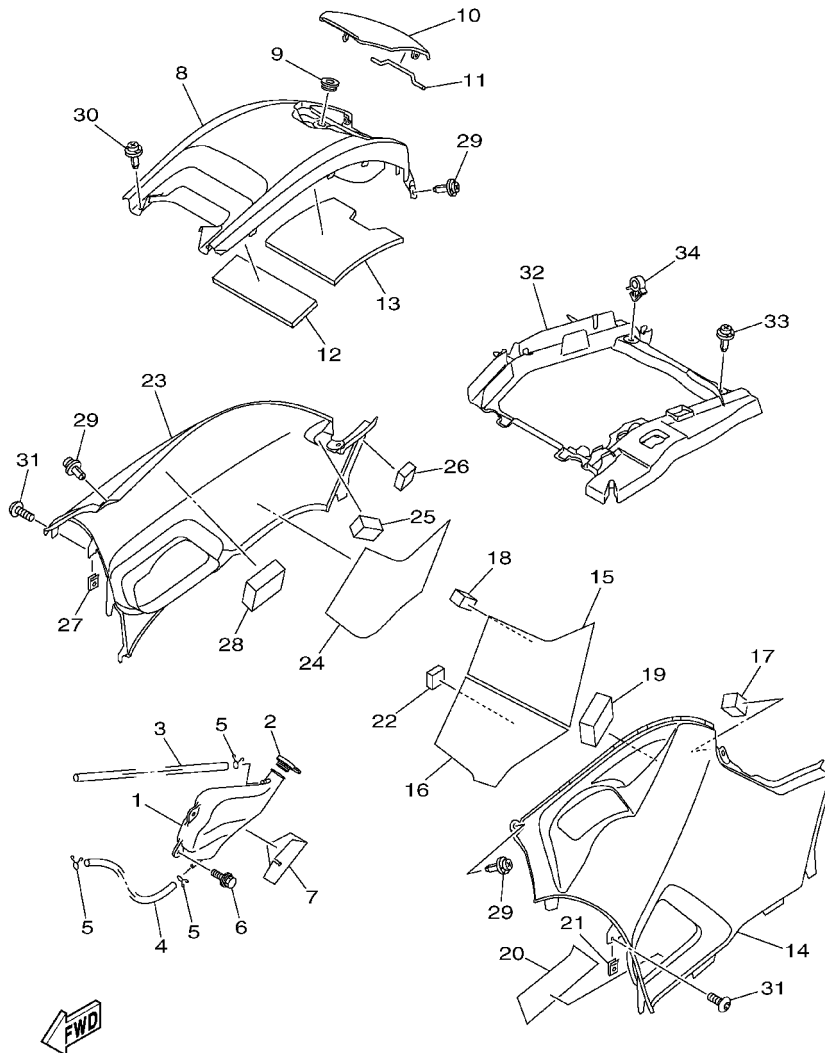


3B41100-F220

FIG. 22 REAR FENDER

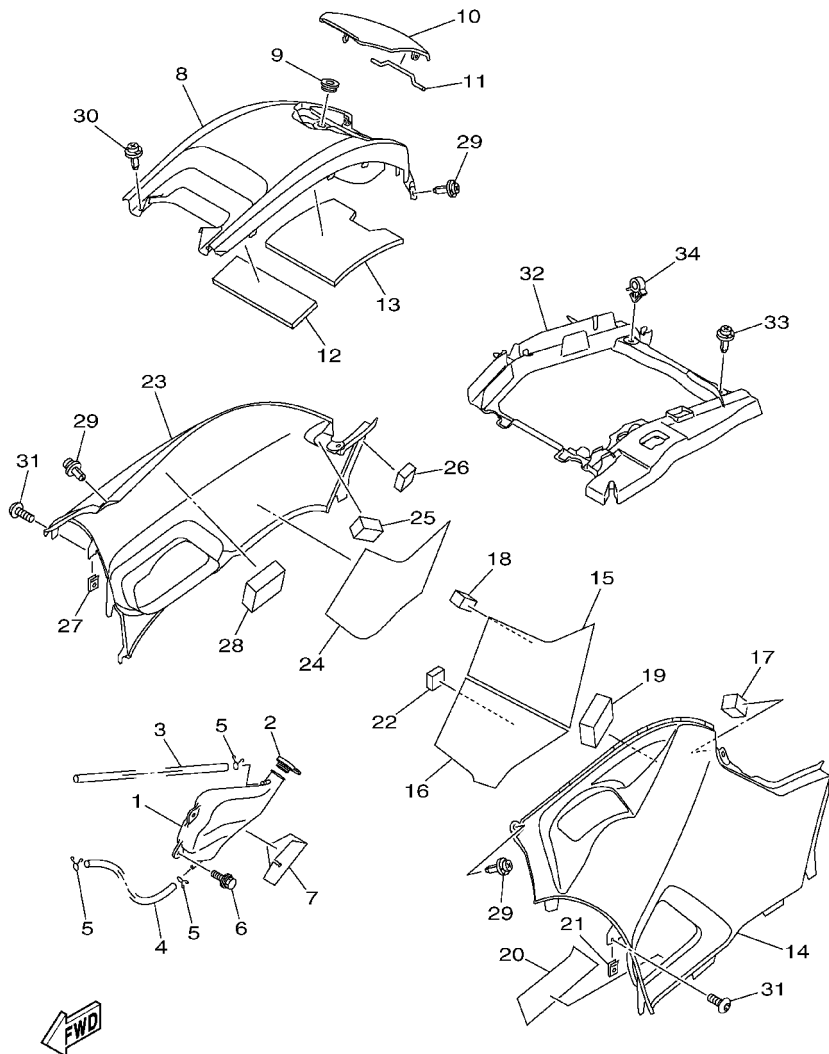
REF. NO.	PART NO.	DESCRIPTION	EUR	OCE			REMARKS
1	3B4-W216B-00	REAR FENDER COMP.2	1				UR FOR PDG
	3B4-W216B-10	REAR FENDER COMP.2	1				UR FOR RTR
	3B4-W216B-30	REAR FENDER COMP.2	1				UR FOR DPBSE
	3B4-W216E-30	REAR FENDER COMP.		1			FOR DPBSE
2	3B4-21652-00	PROTECTOR	1	1			
3	90183-06053	NUT, SPRING	1	1			
4	90119-06056	BOLT, WITH WASHER	2	2			
5	90119-06056	BOLT, WITH WASHER	2	2			
6	3B4-21651-00	COVER, REAR FENDER	1	1			
7	90269-07010	RIVET	2	2			
8	3B4-2160E-00	BOX	1	1			
9	90338-09130	PLUG	1	1			
10	90119-06056	BOLT, WITH WASHER	1	1			
11	90183-06053	NUT, SPRING	1	1			
12	3B4-2160F-00	LID	1	1			

**FIG. 23 SIDE COVER**



3B41100F2301

REF. NO.	PART NO.	DESCRIPTION	EUR	OCE	REMARKS
1	3B4-21871-00	TANK, RECOVERY	1	1	
2	1S3-21875-00	CAP	1	1	
3	90445-09117	HOSE (L540)	1	1	
4	90445-09110	HOSE (L420)	1	1	
5	90467-08003	CLIP	3	3	
6	90119-06056	BOLT, WITH WASHER	2	2	
7	3B4-2176E-00	PLATE	1	1	
8	3B4-2171A-00	COVER, TOP	1	1	
9	90480-01558	GROMMET	1	1	
10	3B4-2177B-00	LID, COVER	1	1	
11	3B4-2177K-00	PIN, HINGE	1	1	
12	3B4-21746-00	DAMPER	1	1	
13	3B4-21747-00	DAMPER	1	1	
14	3B4-21711-00	COVER, SIDE 1	1		UR FOR PDG
	3B4-21711-10	COVER, SIDE 1	1		UR FOR RTR
	3B4-21711-30	COVER, SIDE 1	1		UR FOR DPBSE
	3B4-21711-30	COVER, SIDE 1		1	FOR DPBSE
15	3B4-2174A-00	INSULATOR, SIDE COVER	1	1	
16	3B4-2173N-00	SEAL 4	1	1	
17	3B4-21717-00	DAMPER	1	1	
18	3B4-2174X-00	DAMPER	1	1	
19	3B4-2174Y-00	DAMPER	1	1	
20	3B4-2173M-00	SEAL 3	1	1	
21	90183-06053	NUT, SPRING	1	1	
22	3B4-2177N-00	DAMPER, LOCATING 4	1	1	
23	3B4-21721-00	COVER, SIDE 2	1		UR FOR PDG
	3B4-21721-10	COVER, SIDE 2	1		UR FOR RTR



3B41100F2301

FIG. 23 SIDE COVER

REF. NO.	PART NO.	DESCRIPTION	EUR	OCÉ	REMARKS
23	3B4-21721-30	COVER, SIDE 2	1		UR FOR DPBSE
	3B4-21721-30	COVER, SIDE 2		1	FOR DPBSE
24	3B4-2174T-00	INSULATOR, SIDE COVER 2	1	1	
25	3B4-21717-00	DAMPER	1	1	
26	3B4-2174X-00	DAMPER	1	1	
27	90183-06053	NUT, SPRING	1	1	
28	3B4-2174Y-00	DAMPER	1	1	
29	90269-07076	RIVET	4	4	
30	90269-06081	RIVET	2	2	
31	90110-06090	BOLT, HEXAGON SOCKET HEAD	2	2	
32	3B4-2414H-00	DAMPER, PLATE 1	1	1	
33	90269-07010	RIVET	1	1	
34	90464-16012	CLAMP	1	1	

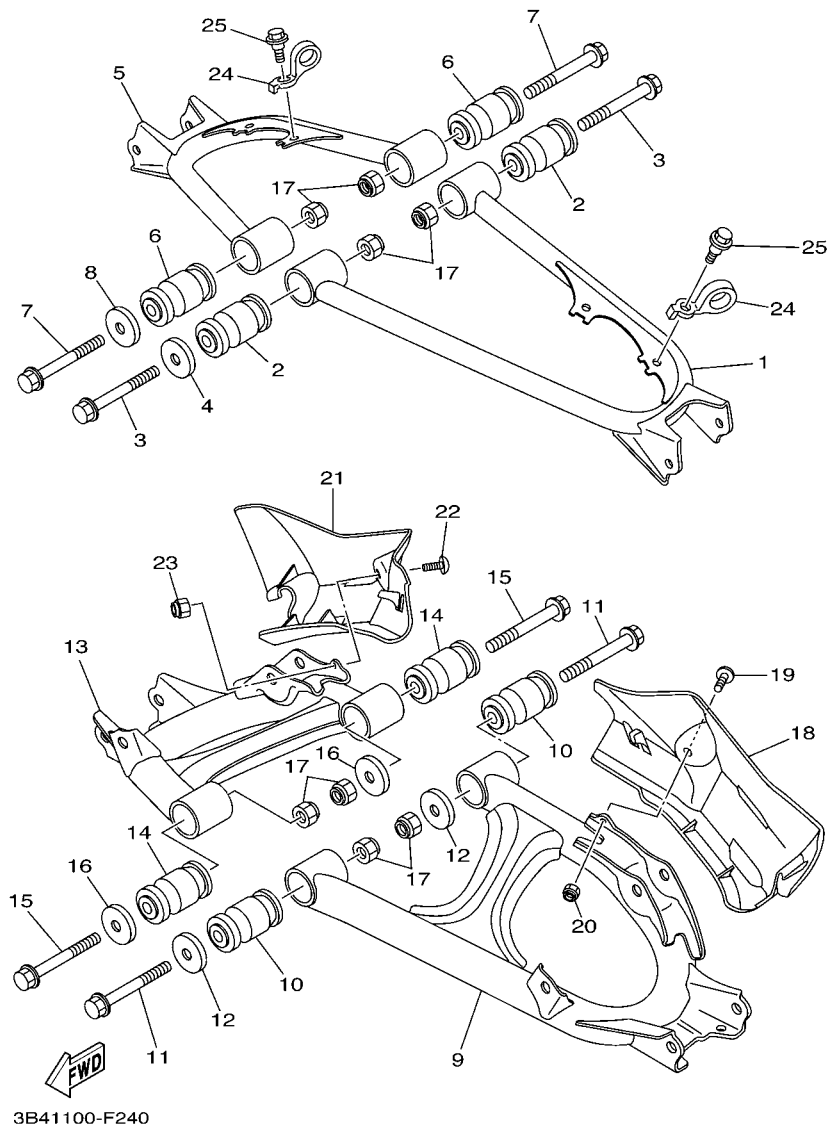
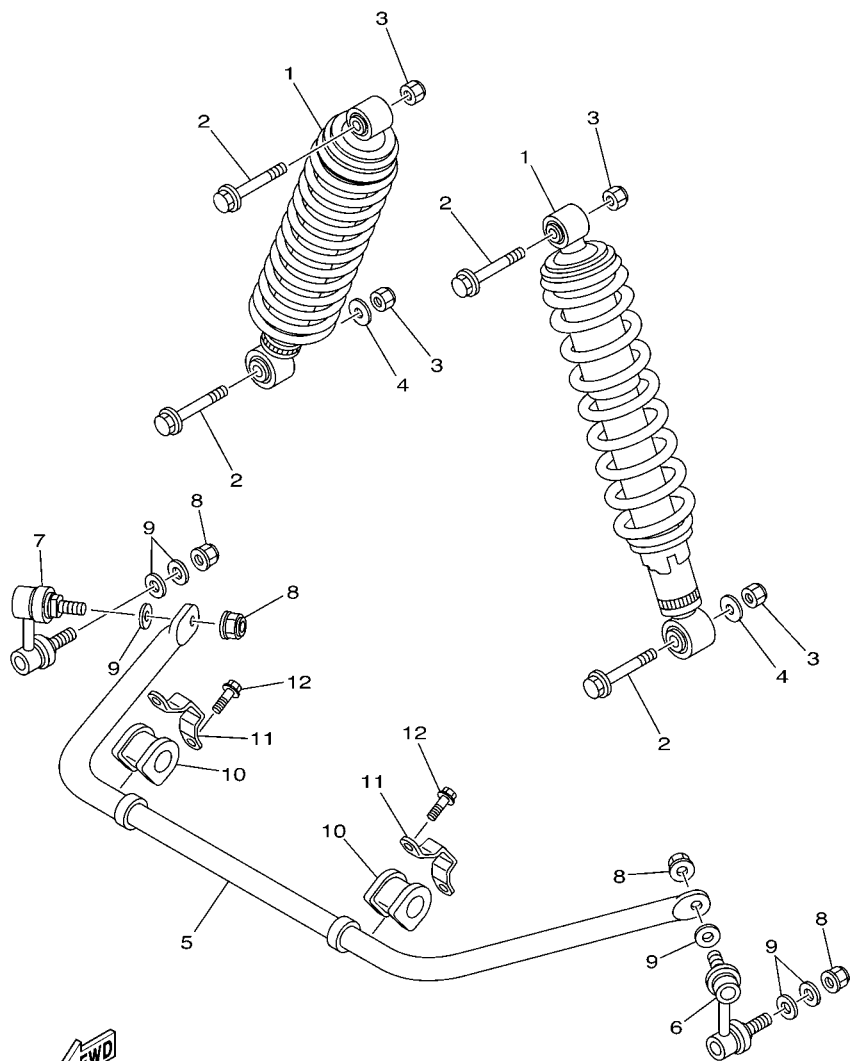


FIG. 24 REAR ARM

REF. NO.	PART NO.	DESCRIPTION	EUR	QTY	REMARKS
1	3B4-22171-10	ARM, REAR 1	1	1	
2	5KM-23526-10	BUSH	2	2	
3	90105-10222	BOLT, FLANGE	2	2	
4	5KM-22149-00	WASHER	1	1	
5	3B4-22172-10	ARM, REAR 2	1	1	
6	5KM-23526-10	BUSH	2	2	
7	90105-10222	BOLT, FLANGE	2	2	
8	5KM-22149-00	WASHER	1	1	
9	3B4-2217M-10	ARM 1	1	1	
10	5KM-23526-10	BUSH	2	2	
11	90105-10222	BOLT, FLANGE	2	2	
12	5KM-22149-00	WASHER	2	2	
13	3B4-2217N-10	ARM 2	1	1	
14	5KM-23526-10	BUSH	2	2	
15	90105-10222	BOLT, FLANGE	2	2	
16	5KM-22149-00	WASHER	2	2	
17	90185-10060	NUT, SELF-LOCKING	8	8	
18	3B4-22128-00	COVER, THRUST 1	1	1	
19	90110-06200	BOLT, HEXAGON SOCKET HEAD	1	1	
20	95707-06300	NUT, NYLON	1	1	
21	3B4-22129-00	COVER, THRUST 2	1	1	
22	90110-06200	BOLT, HEXAGON SOCKET HEAD	1	1	
23	95707-06300	NUT, NYLON	1	1	
24	3B4-25875-00	HOLDER, BRAKE HOSE 1	4	4	
25	90109-063F1	BOLT	4	4	

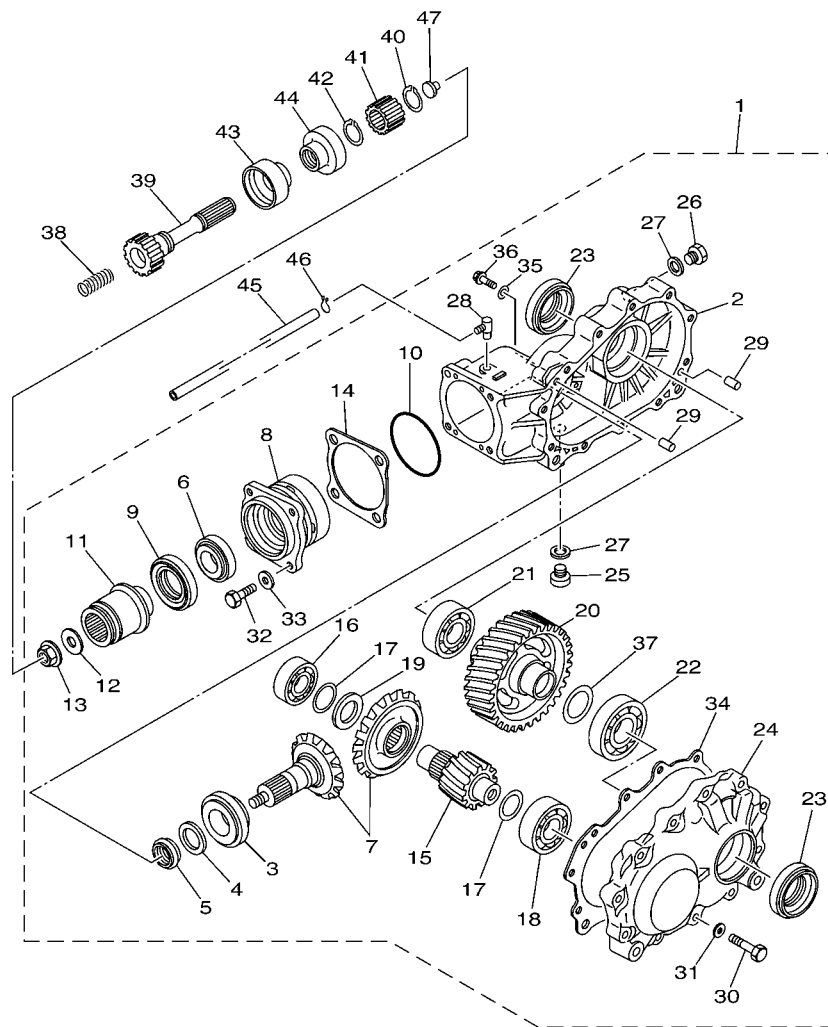
**FIG. 25 REAR SUSPENSION**



3B41100-F250

REF. NO.	PART NO.	DESCRIPTION	EUR	QCE	REMARKS
1	3B4-22210-00	SHOCK ABSORBER ASSY, REAR	2	2	
2	90105-10388	BOLT, FLANGE	4	4	
3	90185-10060	NUT, SELF-LOCKING	4	4	
4	90201-101J1	WASHER, PLATE	2	2	
5	3B4-47491-00	BAR, STABILIZER	1	1	
6	5KM-2385L-01	JOINT, STABILIZER 1	1	1	
7	5KM-2385M-01	JOINT, STABILIZER 2	1	1	
8	95602-10200	NUT, U FLANGE	4	4	
9	90201-101J1	WASHER, PLATE	6	6	
10	3B4-2386G-00	BUSH, STABILIZER FRONT	2	2	
11	3B4-2386H-00	COVER, STABILIZER FRONT	2	2	
12	95812-08014	BOLT, FLANGE	4	4	

**D10**

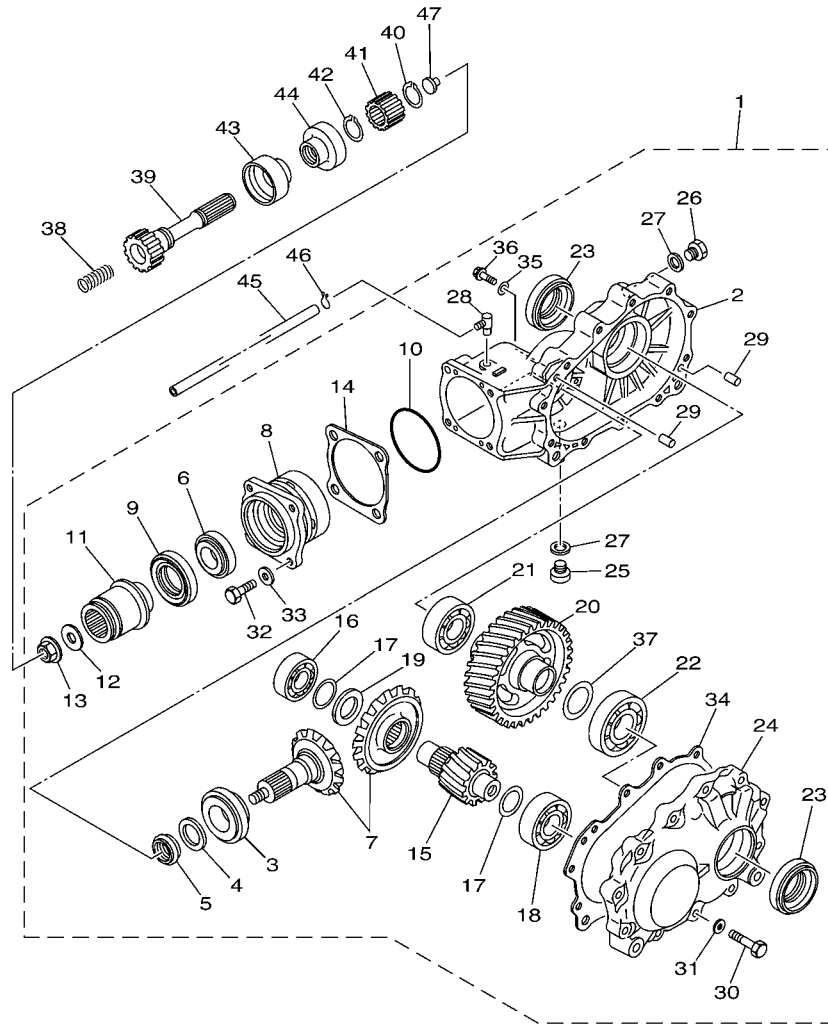


**FWD**  
3B41100-F260

**FIG. 26 DRIVE SHAFT**

REF. NO.	PART NO.	DESCRIPTION	EUR	QTY	REMARKS
1	3B4-46101-00	REAR AXLE GEAR CASE ASSY	1	1	
2	3B4-46151-00	.HOUSING, DRIVE SHAFT	1	1	
3	93332-00046	.BEARING	1	1	
4	90201-25634	.WASHER, PLATE	1	1	
5	3B4-46129-00	.SPACER, EXPANSION	1	1	
6	93332-00053	.BEARING	1	1	
7	3B4-461A0-00	.RING GEAR SET	1	1	
8	3B4-46144-00	.HOUSING, PINION BEARING	1	1	
9	93102-35009	.OIL SEAL	1	1	
10	93210-626A7	.O-RING	1	1	
11	3B4-46126-00	.COUPLING	1	1	
12	90201-12029	.WASHER, PLATE	1	1	
13	90179-12005	.NUT	1	1	
14	2HR-46127-00-25	.SHIM, DRIVE PISTON (0.25T)	1	1	UR
	2HR-46127-00-30	.SHIM, DRIVE PISTON (0.30T)	1	1	UR
	2HR-46127-00-35	.SHIM, DRIVE PISTON (0.35T)	1	1	UR
	2HR-46127-00-40	.SHIM, DRIVE PISTON (0.40T)	1	1	UR
	2HR-46127-00-45	.SHIM, DRIVE PISTON (0.45T)	1	1	UR
	2HR-46127-00-50	.SHIM, DRIVE PISTON (0.50T)	1	1	UR
15	3B4-46316-00	.GEAR, PINION 1	1	1	
16	93306-205U0	.BEARING	1	1	
17	3B4-46119-00	.SHIM, THRUST (0.25T)	2	2	UR
	3B4-46119-10	.SHIM, THRUST (0.30T)	2	2	UR
	3B4-46119-20	.SHIM, THRUST (0.35T)	2	2	UR
	3B4-46119-30	.SHIM, THRUST (0.40T)	2	2	UR
	3B4-46119-40	.SHIM, THRUST (0.45T)	2	2	UR
	3B4-46119-50	.SHIM, THRUST (0.50T)	2	2	UR





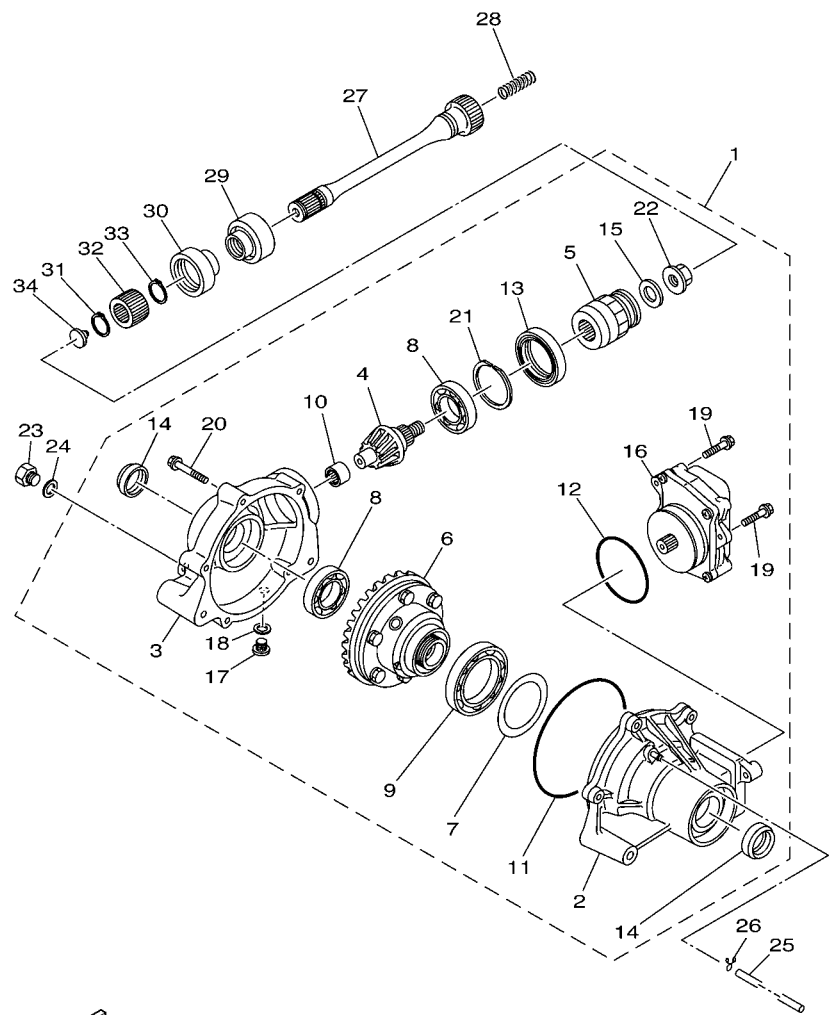
  
 3B41100-F260

**FIG. 26 DRIVE SHAFT**

REF. NO.	PART NO.	DESCRIPTION	EUR	QTY	REMARKS
18	93306-30523	.BEARING	1	1	
19	3B4-4621F-00	.SHIM, THRUST (4.5T)	1	1	UR
	3B4-4621F-10	.SHIM, THRUST (4.8T)	1	1	UR
	3B4-4621F-20	.SHIM, THRUST (5.1T)	1	1	UR
	3B4-4621F-30	.SHIM, THRUST (5.4T)	1	1	UR
20	3B4-46326-00	.GEAR, WHEEL 1	1	1	
21	93306-00704	.BEARING	1	1	
22	93306-207U0	.BEARING	1	1	
23	93102-35009	.OIL SEAL	2	2	
24	3B4-46152-00	.HOUSING, BEARING	1	1	
25	90340-14002	.PLUG, STRAIGHT SCREW	1	1	
26	90340-14029	.PLUG, STRAIGHT SCREW	1	1	
27	214-11198-01	.GASKET	2	2	
28	5UG-15371-00	.BREATHER	1	1	
29	99530-10014	.PIN, DOWEL	2	2	
30	97022-08035	.BOLT	11	11	
31	92902-08600	.WASHER, PLATE	11	11	
32	97022-08025	.BOLT	4	4	
33	92902-08600	.WASHER, PLATE	4	4	
34	3B4-4631A-00	.GSKT., CASE	1	1	
35	90201-08087	.WASHER, PLATE	1	1	
36	95022-08012	.BOLT, FLANGE	1	1	
37	3B4-46344-00	.SHIM (0.25T)	1	1	UR
	3B4-46344-10	.SHIM (0.30T)	1	1	UR
	3B4-46344-20	.SHIM (0.35T)	1	1	UR
	3B4-46344-30	.SHIM (0.40T)	1	1	UR
	3B4-46344-40	.SHIM (0.45T)	1	1	UR



FIG. 27 FRONT DIFFERENTIAL



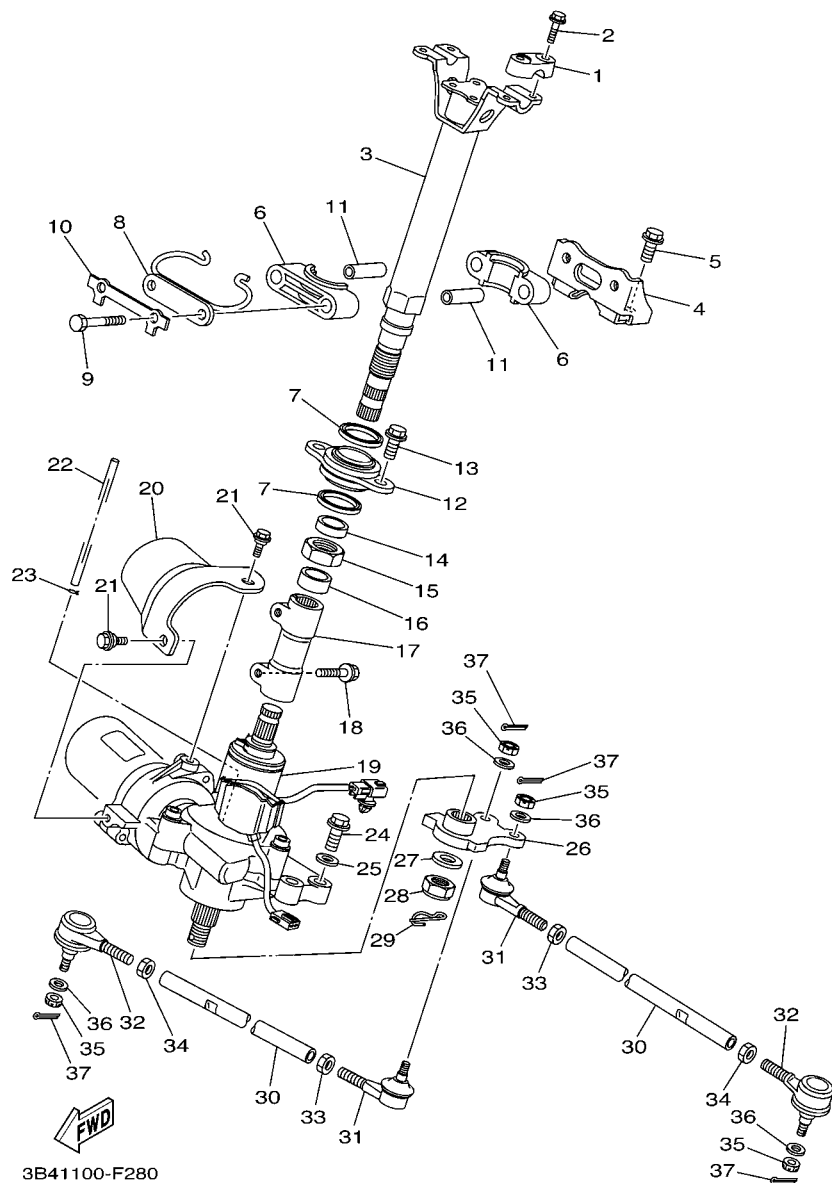
3B41100-F270

REF. NO.	PART NO.	DESCRIPTION	EUR	OCE	REMARKS
1	3B4-46160-00	FRONT AXLE GEAR CASE COMP.	1	1	
2	3B4-46162-00	.HOUSING, BEARING 2	1	1	
3	3B4-46161-00	.HOUSING, SHAFT DRIVE 2	1	1	
4	3B4-46141-00	.PINION, DRIVE 2	1	1	
5	3B4-67839-00	.CUPLING	1	1	
6	3B4-46470-00	.LIMITED SLIP DIFF. ASSY	1	1	
7	3B4-46117-00	.SHIM, RING GEAR (0.1T)	1	1	UR
	3B4-46117-10	.SHIM, RING GEAR (0.2T)	1	1	UR
	3B4-46117-20	.SHIM, RING GEAR (0.3T)	1	1	UR
	3B4-46117-30	.SHIM, RING GEAR (0.4T)	1	1	UR
8	93306-00613	.BEARING	2	2	
9	3B4-46164-00	.BEARING 1	1	1	
10	3B4-46166-00	.BEARING 3	1	1	
11	3B4-46134-00	.O-RING 1	1	1	
12	3B4-46135-00	.O-RING 2	1	1	
13	93105-46001	.OIL SEAL	1	1	
14	3B4-46163-00	.SEAL,OIL 1	2	2	
15	3B4-47359-00	.WASHER	1	1	
16	3B4-4616A-00	.SERVO MOTOR COMP	1	1	
17	90340-10001	.PLUG, STRAIGHT SCREW	1	1	
18	90430-10003	.GASKET	1	1	
19	95812-06014	.BOLT, FLANGE	3	3	
20	95812-08040	.BOLT, FLANGE	5	5	
21	3B4-46142-00	.RING,HOLE SNAP 1	1	1	
22	4WV-46145-10	.NUT 1	1	1	
23	90340-14012	PLUG, STRAIGHT SCREW	1	1	
24	214-11198-01	GASKET	1	1	

D14



FIG. 28 STEERING



REF. NO.	PART NO.	DESCRIPTION	EUR	QTY	REMARKS
1	8K1-23814-00	HOLDER, HANDLE	2	2	
2	95827-08030	BOLT, FLANGE	4	4	
3	3B4-23813-00	COLUMN, STEERING 2	1	1	
4	3B4-22517-00	SUPT., STRG. COLUMN	1	1	
5	90105-10109	BOLT, FLANGE	2	2	
6	1UY-23812-00	PLANE BEARING, STEERING	2	2	
7	93112-31011	OIL SEAL	2	2	
8	5GH-23868-00	BRACKET, STEERING LOWER	1	1	
9	97027-08060	BOLT	2	2	
10	1UY-23894-01	WASHER, LOCK 1	1	1	
11	90387-090R0	COLLAR	2	2	
12	3B4-23875-00	PLANE BEARING, STEERING LOWER	1	1	
13	90105-10109	BOLT, FLANGE	2	2	
14	90387-22014	COLLAR	1	1	
15	90185-22008	NUT, SELF-LOCKING	1	1	
16	90387-22591	COLLAR	1	1	
17	3B4-2381B-00	JOINT	1	1	
18	90119-08106	BOLT, WITH WASHER	2	2	
19	3B4-238B0-00	POWER STRG. ACTUATOR ASSY	1	1	
20	3B4-238B6-00	COVER, MOTOR	1	1	
21	90109-063F1	BOLT	2	2	
22	90445-070F1	HOSE (L950)	1	1	
23	90467-07029	CLIP	1	1	
24	90105-08153	BOLT, FLANGE	4	4	
25	90201-08326	WASHER, PLATE	4	4	
26	3B4-23816-00	ARM, PITMAN	1	1	
27	90201-170M2	WASHER, PLATE	1	1	

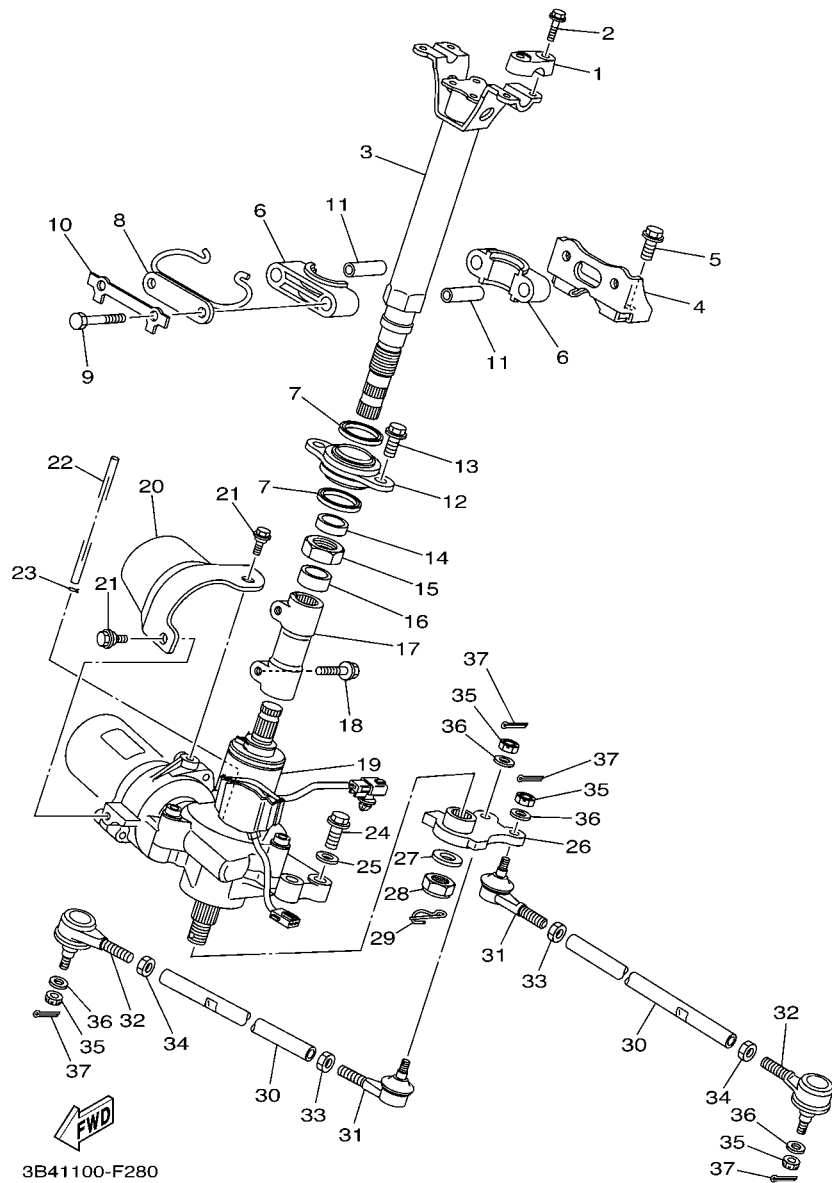
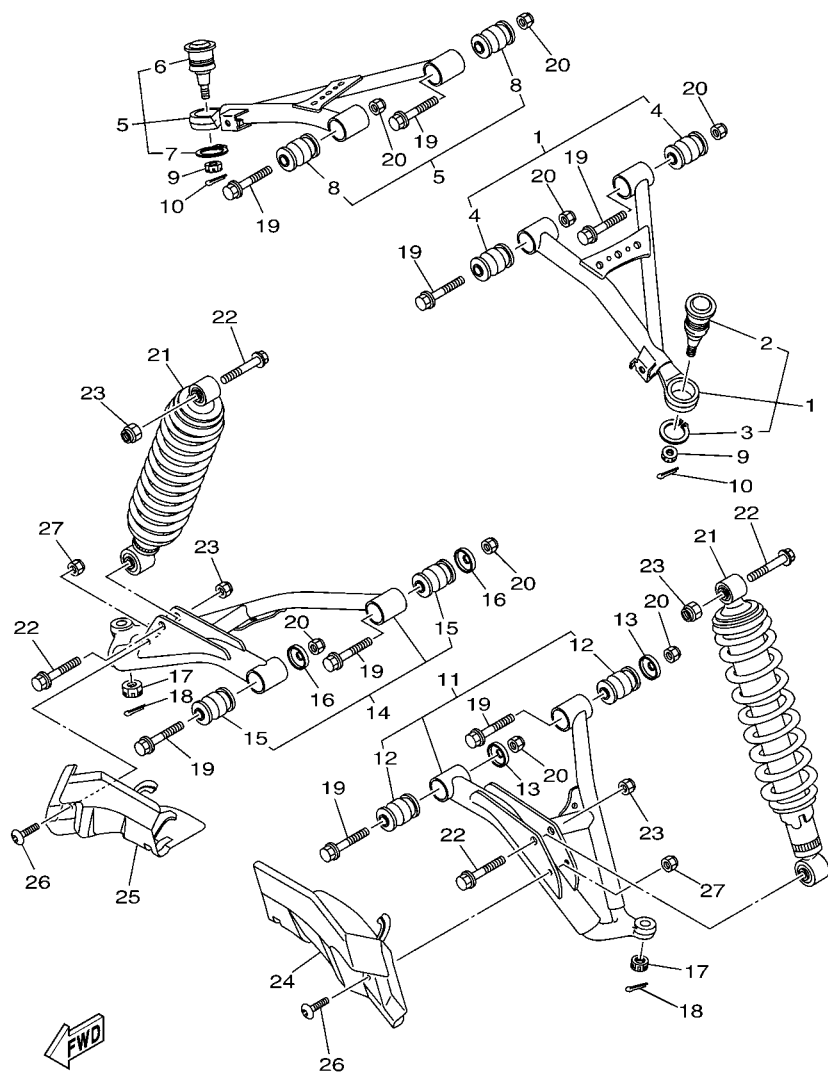


FIG. 28 STEERING

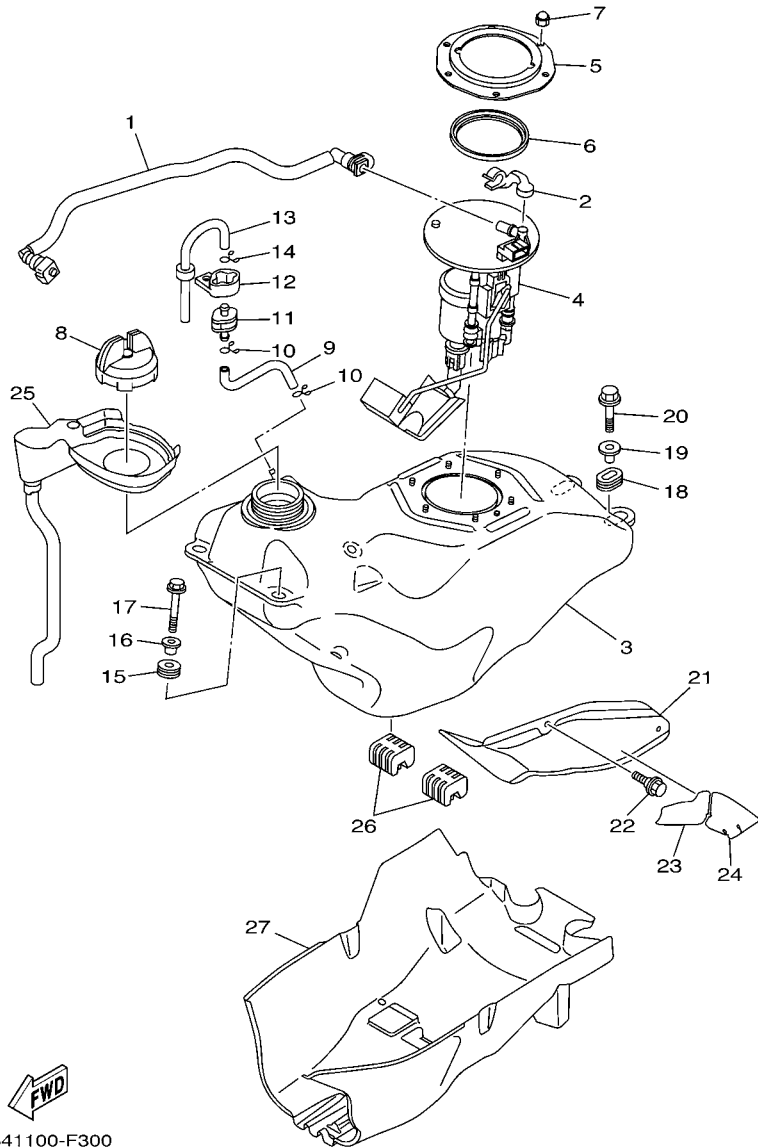
REF. NO.	PART NO.	DESCRIPTION	EUR	QCE	REMARKS
28	95612-16100	NUT, U	1	1	
29	90468-18195	CLIP	1	1	
30	5KM-23831-00	ROD, TIE	2	2	
31	1UY-23841-01	JOINT, UNIVERSAL 1	2	2	
32	1UY-23845-01	JOINT, UNIVERSAL 2	2	2	
33	95307-10700	NUT	2	2	
34	90170-10186	NUT	2	2	(L.H. THREAD)
35	90171-10001	NUT, CASTLE	4	4	
36	90209-10229	WASHER	4	4	
37	91401-20020	PIN, COTTER	4	4	

**FIG. 29 FRONT SUSPENSION & WHEEL**



3B41100-F290

REF. NO.	PART NO.	DESCRIPTION	EUR	QTY	REMARKS
1	3B4-23540-10	FRONT UPPER ARM COMP. (LEFT)	1	1	
2	5LP-23579-00	.BALL JOINT 2	1	1	
3	99009-30400	.CIRCLIP	1	1	
4	5KM-23526-10	.BUSH	2	2	
5	3B4-23550-10	FRONT UPPER ARM COMP. (RIGHT)	1	1	
6	5LP-23579-00	.BALL JOINT 2	1	1	
7	99009-30400	.CIRCLIP	1	1	
8	5KM-23526-10	.BUSH	2	2	
9	90171-10001	NUT, CASTLE	2	2	
10	91401-20020	PIN, COTTER	2	2	
11	3B4-23570-10	FRONT LOWER ARM COMP. (LEFT)	1	1	
12	5KM-23526-10	.BUSH	2	2	
13	5KM-22149-00	WASHER	2	2	
14	3B4-23580-10	FRONT LOWER ARM COMP. (RIGHT)	1	1	
15	5KM-23526-10	.BUSH	2	2	
16	5KM-22149-00	WASHER	2	2	
17	90171-12039	NUT, CASTLE	2	2	
18	91490-25020	PIN, COTTER	2	2	
19	90105-10222	BOLT, FLANGE	8	8	
20	90185-10060	NUT, SELF-LOCKING	8	8	
21	3B4-23350-00	SHOCK ABSORBER ASSY	2	2	
22	90105-10388	BOLT, FLANGE	4	4	
23	90185-10060	NUT, SELF-LOCKING	4	4	
24	3B4-23123-00	COVER, LOWER 1	1	1	
25	3B4-23133-00	COVER, LOWER 2	1	1	
26	90110-06200	BOLT, HEXAGON SOCKET HEAD	2	2	
27	95707-06300	NUT, NYLON	2	2	



3B41100-F300

FIG. 30 FUEL TANK

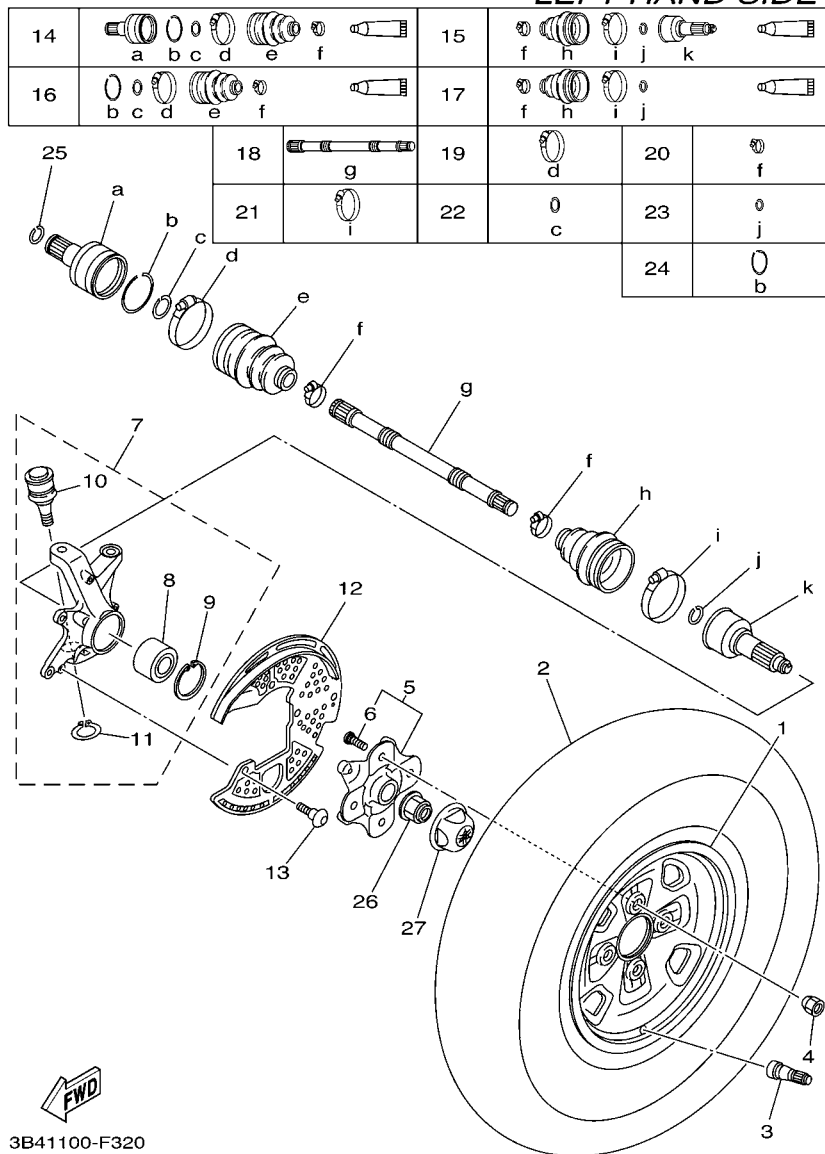
REF. NO.	PART NO.	DESCRIPTION	EUR	OCF	REMARKS
1	3B4-13971-00	PIPE, FUEL 1	1	1	
2	90464-14004	CLAMP	1	1	
3	3B4-24110-00	FUEL TANK COMP.	1	1	
4	3B4-13907-00	FUEL PUMP COMP.	1	1	
5	3B4-24491-00	BRACKET, FUEL PUMP	1	1	
6	1S3-24486-00	O-RING	1	1	
7	95307-06800	NUT	6	6	
8	3B4-24610-00	CAP ASSY	1	1	
9	3B4-24312-00	PIPE 2	1	1	
10	90467-09006	CLIP	2	2	
11	3B4-24380-00	PIPE JOINT ASSY	1	1	
12	3B4-24398-00	BAND 1	1	1	
13	3B4-24313-00	PIPE 3	1	1	
14	90467-09006	CLIP	1	1	
15	90480-18290	GROMMET	2	2	
16	90387-066J1	COLLAR	2	2	
17	95807-06030	BOLT, FLANGE	2	2	
18	90480-01400	GROMMET	2	2	
19	90387-075H4	COLLAR	2	2	
20	95807-06030	BOLT, FLANGE	2	2	
21	3B4-24129-00	COVER, SIDE 1	1	1	
22	90109-063F1	BOLT	2	2	
23	3B4-2414J-00	DAMPER, PLATE 2	1	1	
24	3B4-2414K-00	DAMPER, PLATE 3	1	1	
25	3B4-2414F-00	COVER, FILLER COMP.	1	1	
26	3B4-24181-00	DAMPER, LOCATING 1	2	2	
27	3B4-24141-00	PROTECTOR, FUEL TANK	1	1	





FIG. 32 FRONT WHEEL

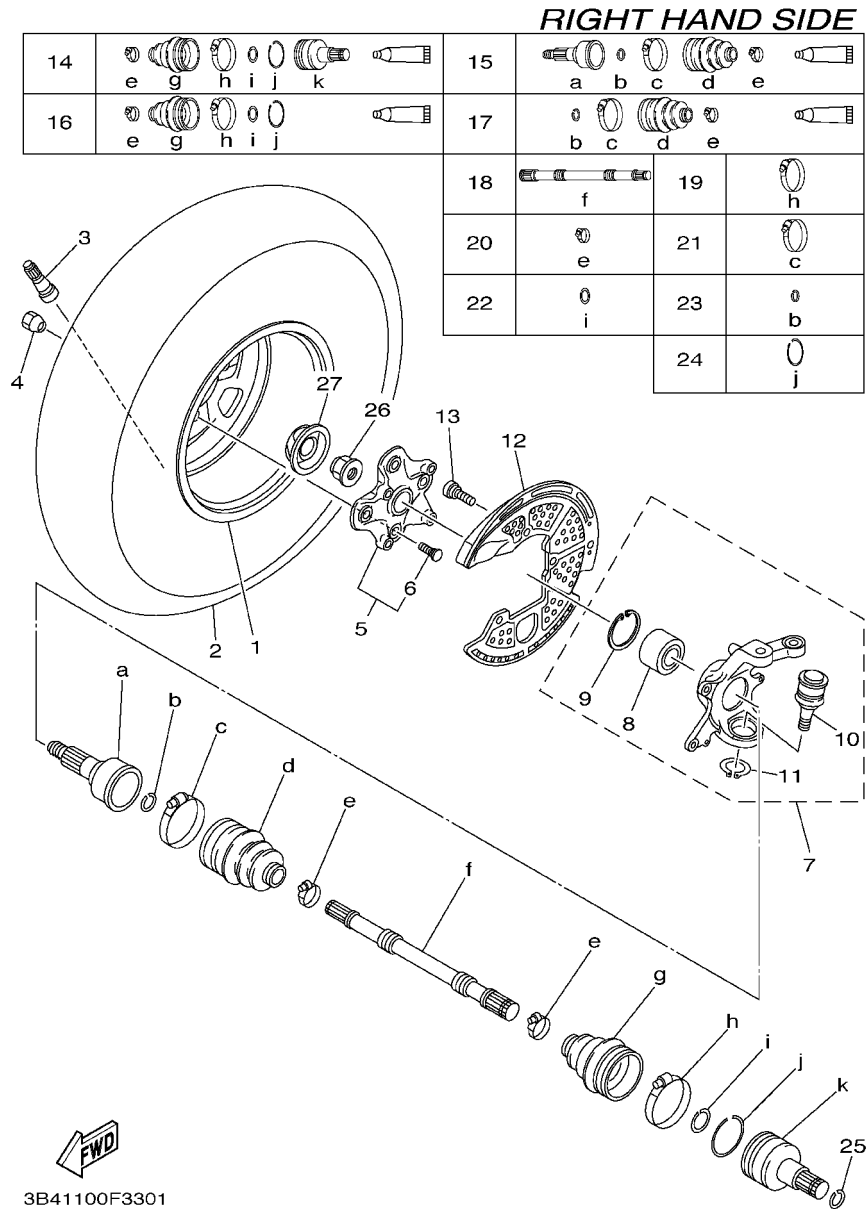
LEFT HAND SIDE



REF. NO.	PART NO.	DESCRIPTION	EUR	OCE	REMARKS
1	3B4-25180-00	WHEEL COMP.	1	1	
2	94108-12012	TIRE (AT25X8-12** KT421 T/L N)	1		DUNLOP
	94108-12008	TIRE(AT25X8-12,C828 4P/TL)		1	CHENG SHIN
3	93900-00030	VALVE, RIM (TR412)	1	1	TAIHEIYO
4	90179-10007	NUT	4	4	
5	3B4-25111-00	HUB, FRONT	1	1	
6	90114-10010	.BOLT, SERRATION	4	4	
7	3B4-23501-00	STEERING KNUCKLE ASSY (LEFT)	1	1	
8	93305-00602	.BEARING	1	1	
9	99009-55500	.CIRCLIP	1	1	
10	3B4-23579-00	.BALL JOINT 2	1	1	
11	99009-30400	.CIRCLIP	1	1	
12	3B4-2514A-00	RING, WHEEL 1 (LEFT)	1	1	
13	90154-06014	SCREW, BINDING	3	3	
14	3B4-2510J-00	DOUBLE OFF SET JOINT	1	1	
15	3B4-2510F-00	BALL JOINT SET	1	1	
16	3B4-2510H-00	BOOT SET(DOUBLE OFFSET JOINT)	1	1	
17	3B4-2510G-00	BOOT SET (BALL JOINT)	1	1	
18	3B4-2518E-00	SHAFT	1	1	
19	3B4-2511H-00	BOOT BAND(DOUBLE OFFSET JOINT)	1	1	
20	3B4-2512G-00	BOOT BAND (SMALL)	2	2	
21	3B4-2511G-00	BOOT BAND (BALL JOINT)	1	1	
22	3B4-2512J-00	SNAP RING	1	1	
23	3B4-2512H-00	CIRCLIP	1	1	
24	3B4-25182-00	CIRCLIP	1	1	
25	93450-22119	CIRCLIP	1	1	
26	90179-20006	NUT	1	1	



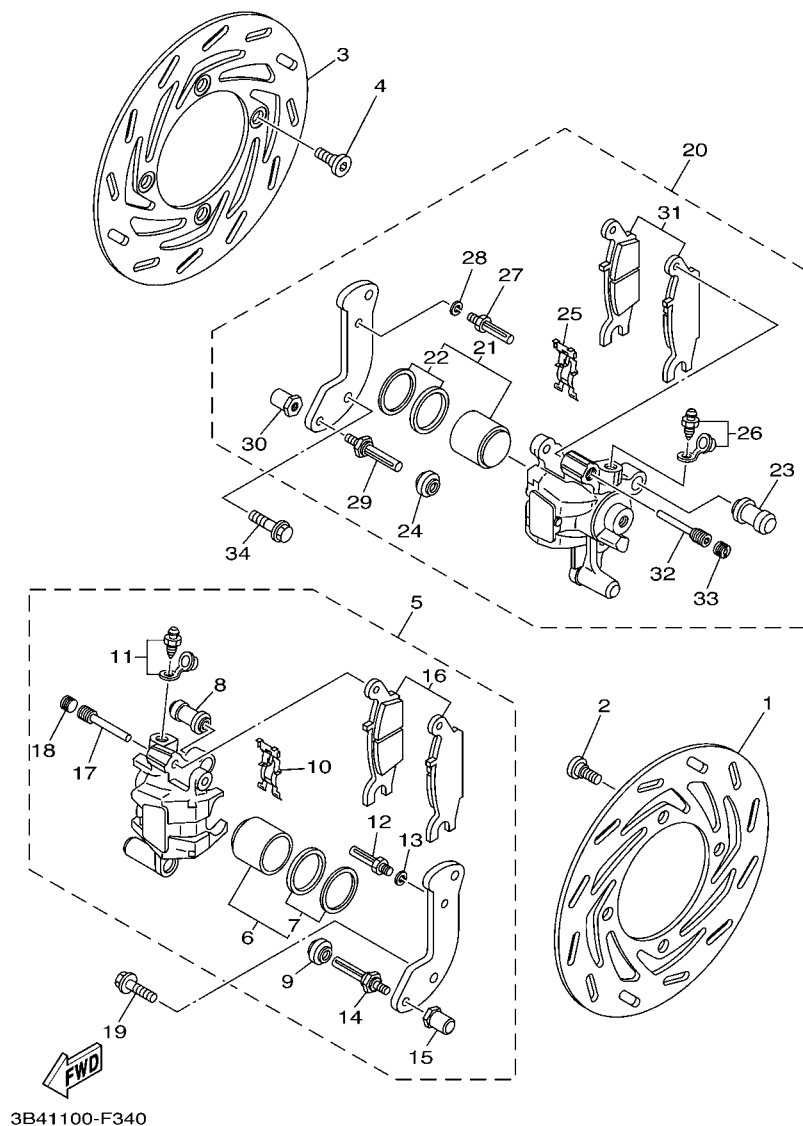
FIG. 33 FRONT WHEEL 2



REF. NO.	PART NO.	DESCRIPTION	EUR	OCE	REMARKS
1	3B4-25180-00	WHEEL COMP.	1	1	
2	94108-12012	TIRE (AT25X8-12** KT421 T/L N)	1		DUNLOP
	94108-12008	TIRE(AT25X8-12,C828 4P/TL)		1	CHENG SHIN
3	93900-00030	VALVE, RIM (TR412)	1	1	TAIHEIYO
4	90179-10007	NUT	4	4	
5	3B4-25111-00	HUB, FRONT	1	1	
6	90114-10010	.BOLT, SERRATION	4	4	
7	3B4-23502-00	STEERING KNUCKLE ASSY (RIGHT)	1	1	
8	93305-00602	.BEARING	1	1	
9	99009-55500	.CIRCLIP	1	1	
10	3B4-23579-00	.BALL JOINT 2	1	1	
11	99009-30400	.CIRCLIP	1	1	
12	3B4-2515A-00	RING, WHEEL 2 (RIGHT)	1	1	
13	90154-06014	SCREW, BINDING	3	3	
14	3B4-2510J-00	DOUBLE OFF SET JOINT	1	1	
15	3B4-2510F-00	BALL JOINT SET	1	1	
16	3B4-2510H-00	BOOT SET(DOUBLE OFFSET JOINT)	1	1	
17	3B4-2510G-00	BOOT SET (BALL JOINT)	1	1	
18	3B4-2518E-00	SHAFT	1	1	
19	3B4-2511H-00	BOOT BAND(DOUBLE OFFSET JOINT)	1	1	
20	3B4-2512G-00	BOOT BAND (SMALL)	2	2	
21	3B4-2511G-00	BOOT BAND (BALL JOINT)	1	1	
22	3B4-2512J-00	SNAP RING	1	1	
23	3B4-2512H-00	CIRCLIP	1	1	
24	3B4-25182-00	CIRCLIP	1	1	
25	93450-22119	CIRCLIP	1	1	
26	90179-20006	NUT	1	1	



**FIG. 34 FRONT BRAKE CALIPER**



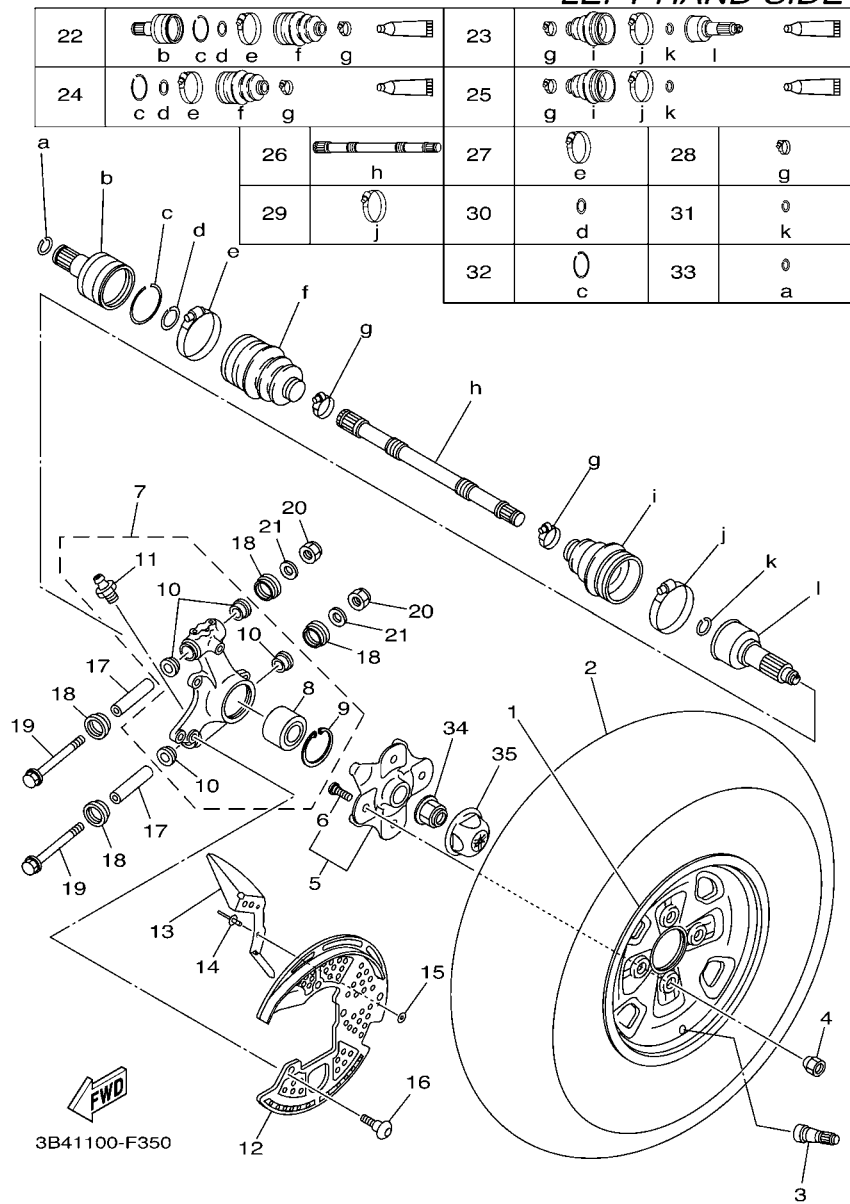
3B41100-F340

REF. NO.	PART NO.	DESCRIPTION	EUR	QTY	REMARKS
1	3B4-2582T-01	DISC, BRAKE (LEFT)	1	1	
2	90109-08101	BOLT	4	4	
3	3B4-2582T-01	DISC, BRAKE (LEFT)	1	1	
4	90109-08101	BOLT	4	4	
5	3B4-2580T-00	CALIPER ASSY (LEFT)	1	1	
6	3B4-W0057-00	.PISTON ASSY, CALIPER	1	1	
7	3B4-W0047-00	..CALIPER SEAL KIT	1	1	
8	1UY-25937-51	.BOOT 2	1	1	
9	3JD-25917-00	.BOOT, CALIPER	1	1	
10	5DH-25919-00	.SUPPORT, PAD	1	1	
11	1UY-W0048-50	.BLEED SCREW KIT	1	1	
12	1UY-25926-51	.BOLT	1	1	
13	1UY-25938-51	.WASHER, SPRING	1	1	
14	3JD-25926-00	.BOLT	1	1	
15	3JD-25961-00	.NUT	1	1	
16	3B4-W0045-00	.BRAKE PAD KIT	1	1	
17	5DH-25933-00	.PIN, PAD	1	1	
18	5DH-25916-00	.PLUG	1	1	
19	90105-08538	BOLT, FLANGE	2	2	
20	3B4-2580U-00	CALIPER ASSY (RIGHT)	1	1	
21	3B4-W0057-00	.PISTON ASSY, CALIPER	1	1	
22	3B4-W0047-00	..CALIPER SEAL KIT	1	1	
23	1UY-25937-51	.BOOT 2	1	1	
24	3JD-25917-00	.BOOT, CALIPER	1	1	
25	5DH-25919-00	.SUPPORT, PAD	1	1	
26	1UY-W0048-50	.BLEED SCREW KIT	1	1	
27	1UY-25926-51	.BOLT	1	1	



FIG. 35 REAR WHEEL

LEFT HAND SIDE

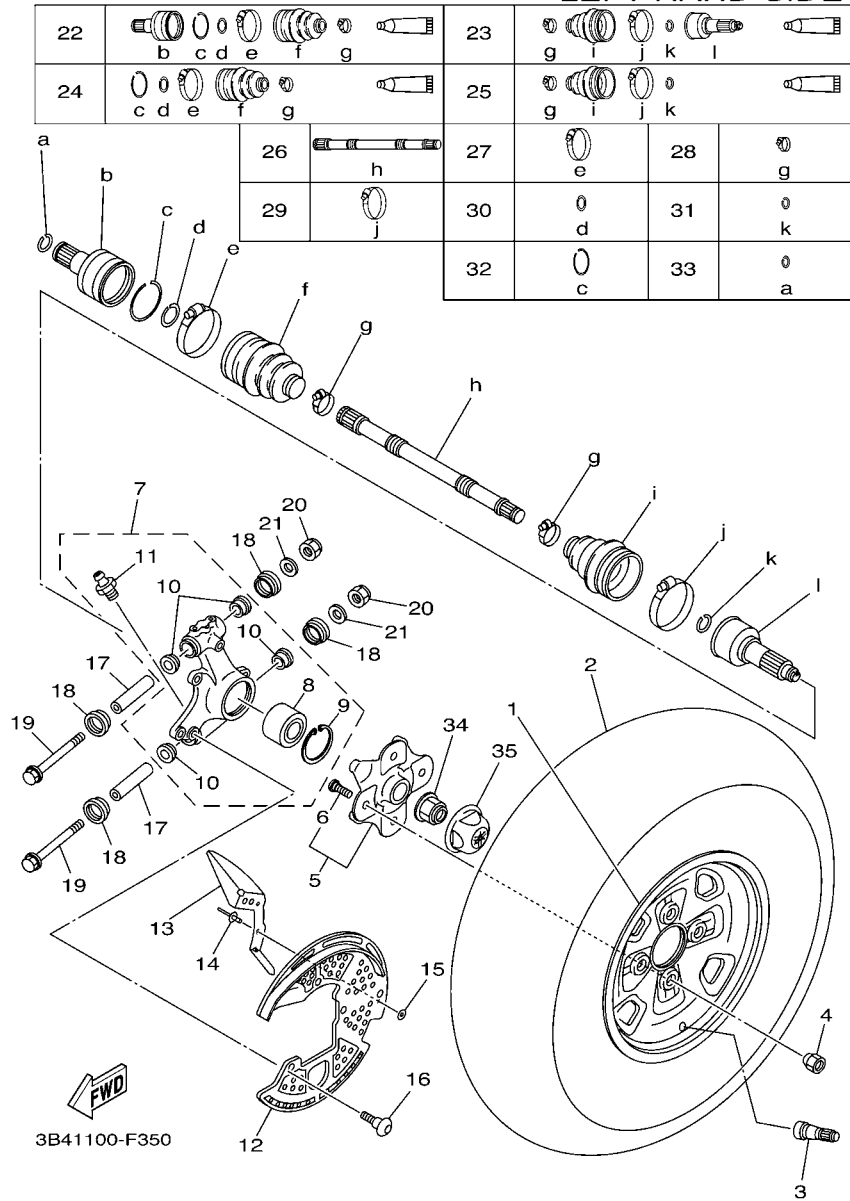


REF. NO.	PART NO.	DESCRIPTION	EUR	QTY	REMARKS
1	3B4-25390-00	REAR WHEEL COMP.	1	1	
2	94110-12012	TIRE (AT25X10-12** KT425T/L N)	1		DUNLOP
	94110-12008	TIRE(AT25X10-12,C828 4P/TL)		1	CHENG SHIN
3	93900-00030	VALVE, RIM (TR412)	1	1	TAIHEIYO
4	90179-10007	NUT	4	4	
5	3B4-25111-00	HUB, FRONT	1	1	
6	90114-10010	.BOLT, SERRATION	4	4	
7	3B4-2530F-00	REAR KNUCKLE ASSY	1	1	
8	93305-00602	.BEARING	1	1	
9	99009-55500	.CIRCLIP	1	1	
10	90381-17067	.BUSH, SOLID	4	4	
11	93700-06004	.NIPPLE, GREASE	2	2	
12	3B4-2514A-00	RING, WHEEL 1 (LEFT)	1	1	
13	3B4-2539F-00	PLATE 1	1	1	
14	90267-47187	RIVET, BLIND	2	2	
15	90201-04325	WASHER, PLATE	2	2	
16	90154-06014	SCREW, BINDING	3	3	
17	5KM-23448-00	SPACER	2	2	
18	2NL-23517-00	COVER, THRUST 1	4	4	
19	90105-10480	BOLT, FLANGE	2	2	
20	90185-10060	NUT, SELF-LOCKING	2	2	
21	90201-101J1	WASHER, PLATE	2	2	
22	3B4-2530V-00	DOUBLE OFF SET JOINT	1	1	
23	3B4-2510F-00	BALL JOINT SET	1	1	
24	3B4-2510H-00	BOOT SET(DOUBLE OFFSET JOINT)	1	1	
25	3B4-2510G-00	BOOT SET (BALL JOINT)	1	1	
26	3B4-2518E-10	SHAFT	1	1	



FIG. 35 REAR WHEEL

LEFT HAND SIDE

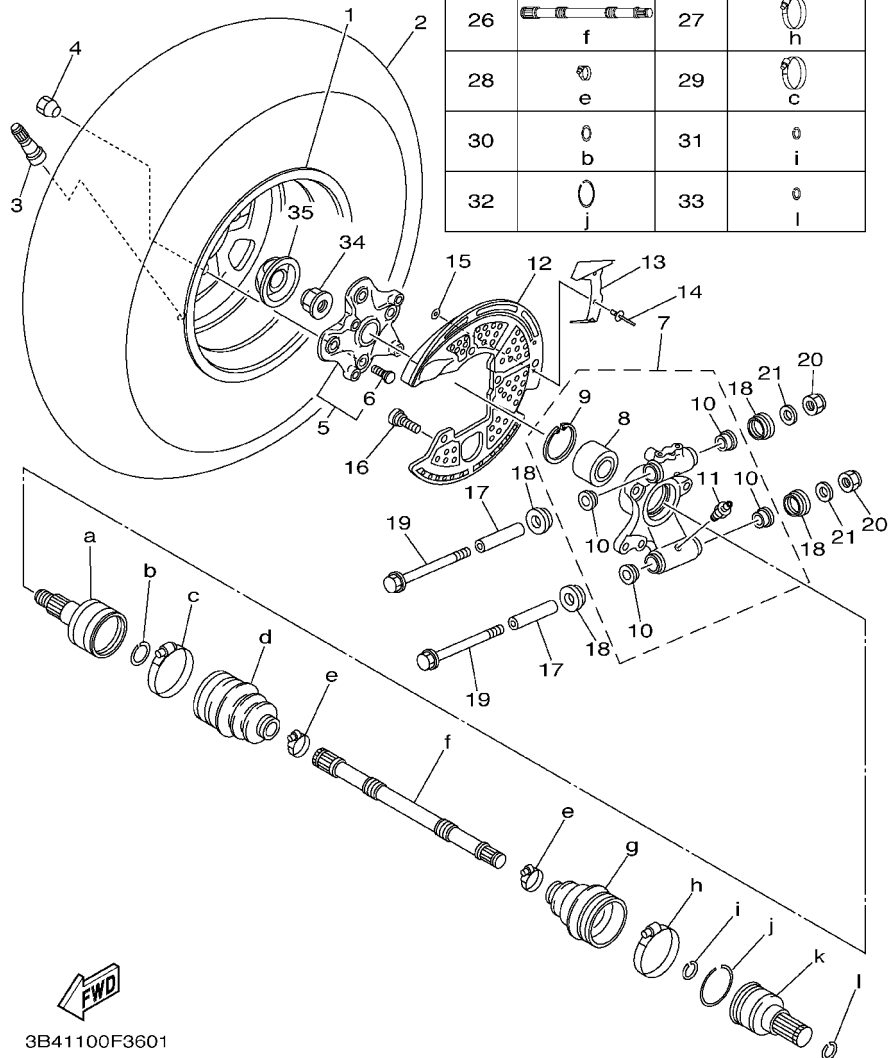


REF. NO.	PART NO.	DESCRIPTION	EUR	OCF	REMARKS
27	3B4-2511H-00	BOOT BAND(DOUBLE OFFSET JOINT)	1	1	
28	3B4-2512G-00	BOOT BAND (SMALL)	2	2	
29	3B4-2511G-00	BOOT BAND (BALL JOINT)	1	1	
30	3B4-2512J-00	SNAP RING	1	1	
31	3B4-2512H-00	CIRCLIP	1	1	
32	3B4-25182-00	CIRCLIP	1	1	
33	3B4-2536E-00	CLIP, SPRING	1	1	
34	90179-20006	NUT	1	1	
35	3B4-2512A-00	CAP, WHEEL	1	1	

FIG. 36 REAR WHEEL 2

RIGHT HAND SIDE

22		23	
24		25	
26		27	
28		29	
30		31	
32		33	



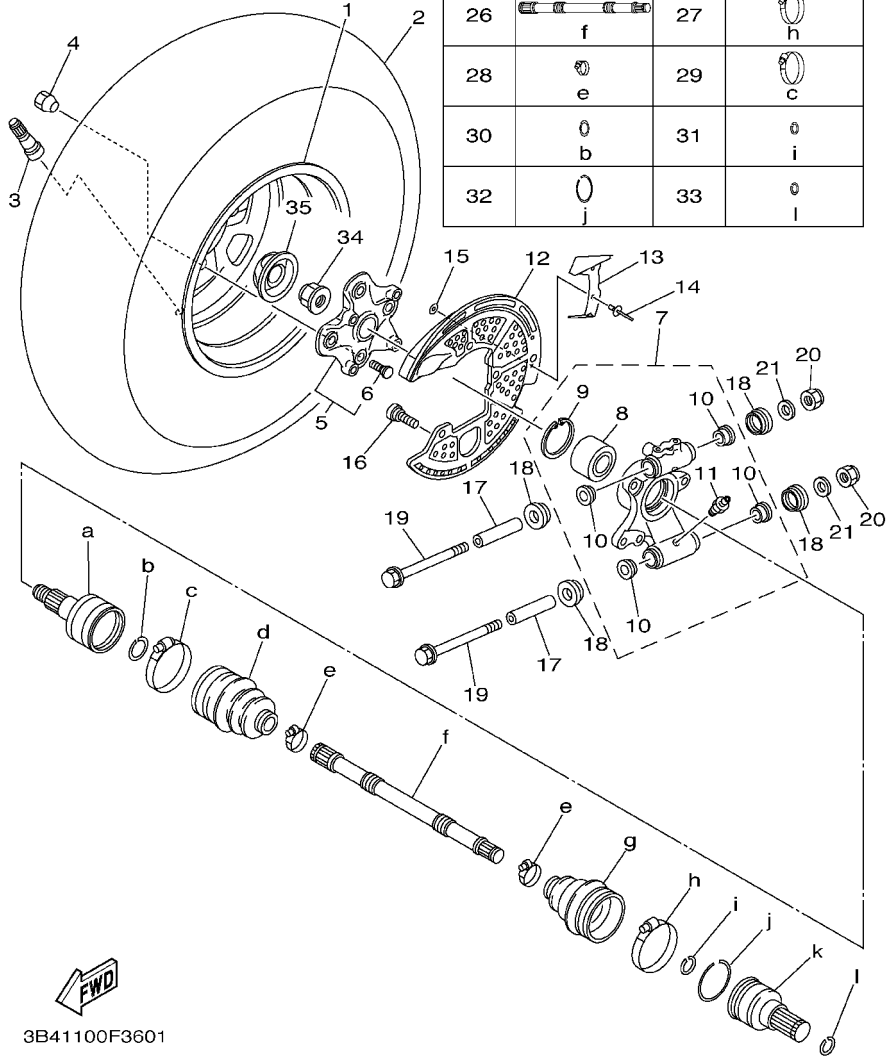
3B41100F3601

REF. NO.	PART NO.	DESCRIPTION	EUR	OCE	REMARKS
1	3B4-25390-00	REAR WHEEL COMP.	1	1	
2	94110-12012	TIRE (AT25X10-12** KT425T/L N)	1		DUNLOP
	94110-12008	TIRE(AT25X10-12,C828 4P/TL)		1	CHENG SHIN
3	93900-00030	VALVE, RIM (TR412)	1	1	TAIHEIYO
4	90179-10007	NUT	4	4	
5	3B4-25111-00	HUB, FRONT	1	1	
6	90114-10010	.BOLT, SERRATION	4	4	
7	3B4-2532F-00	REAR KNUCKLE ASSY.,2	1	1	
8	93305-00602	.BEARING	1	1	
9	99009-55500	.CIRCLIP	1	1	
10	90381-17067	.BUSH, SOLID	4	4	
11	93700-06004	.NIPPLE, GREASE	2	2	
12	3B4-2515A-00	RING, WHEEL 2 (RIGHT)	1	1	
13	3B4-2539G-00	PLATE 2	1	1	
14	90267-47187	RIVET, BLIND	2	2	
15	90201-04325	WASHER, PLATE	2	2	
16	90154-06014	SCREW, BINDING	3	3	
17	5KM-23448-00	SPACER	2	2	
18	2NL-23517-00	COVER, THRUST 1	4	4	
19	90105-10480	BOLT, FLANGE	2	2	
20	90185-10060	NUT, SELF-LOCKING	2	2	
21	90201-101J1	WASHER, PLATE	2	2	
22	3B4-2530V-00	DOUBLE OFF SET JOINT	1	1	
23	3B4-2510F-00	BALL JOINT SET	1	1	
24	3B4-2510H-00	BOOT SET(DOUBLE OFFSET JOINT)	1	1	
25	3B4-2510G-00	BOOT SET (BALL JOINT)	1	1	
26	3B4-2518E-10	SHAFT	1	1	

FIG. 36 REAR WHEEL 2

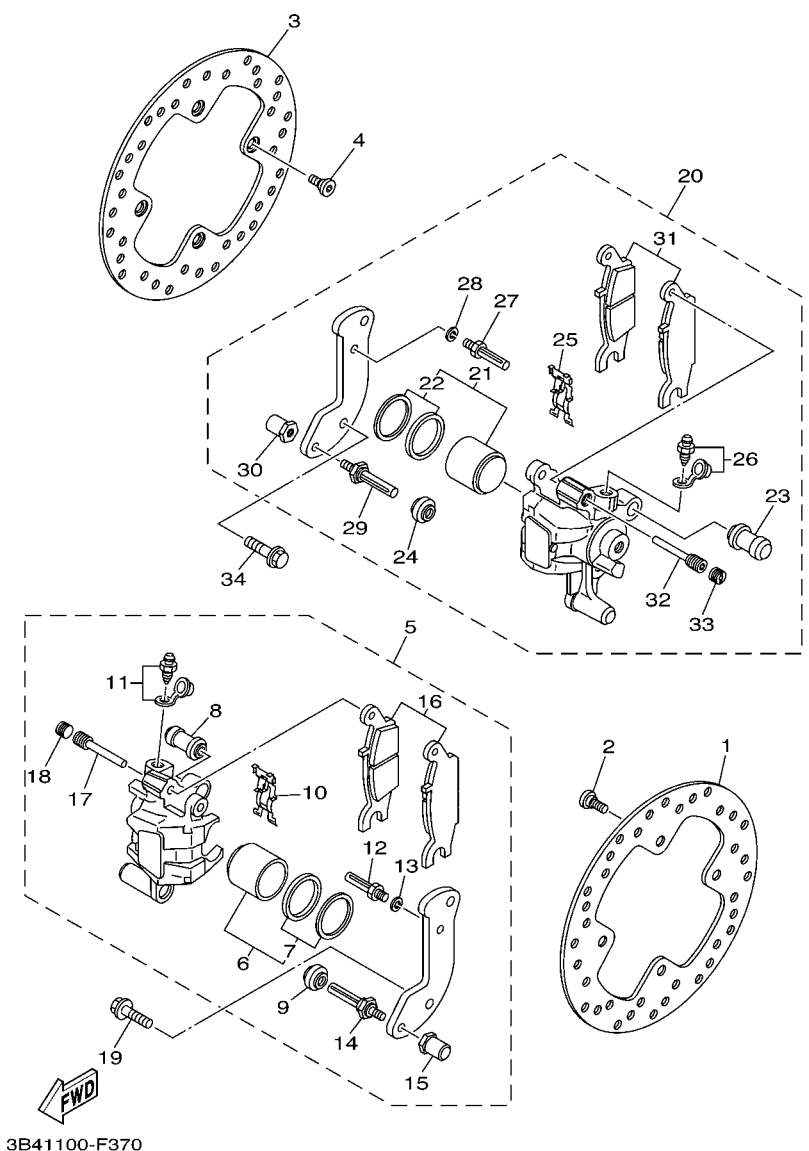
RIGHT HAND SIDE

22		23	
24		25	
26		27	
28		29	
30		31	
32		33	



3B41100F3601

REF. NO.	PART NO.	DESCRIPTION	EUR	OCE	REMARKS
27	3B4-2511H-00	BOOT BAND(DOUBLE OFFSET JOINT)	1	1	
28	3B4-2512G-00	BOOT BAND (SMALL)	2	2	
29	3B4-2511G-00	BOOT BAND (BALL JOINT)	1	1	
30	3B4-2512J-00	SNAP RING	1	1	
31	3B4-2512H-00	CIRCLIP	1	1	
32	3B4-25182-00	CIRCLIP	1	1	
33	3B4-2536E-00	CLIP, SPRING	1	1	
34	90179-20006	NUT	1	1	
35	3B4-2512A-00	CAP, WHEEL	1	1	

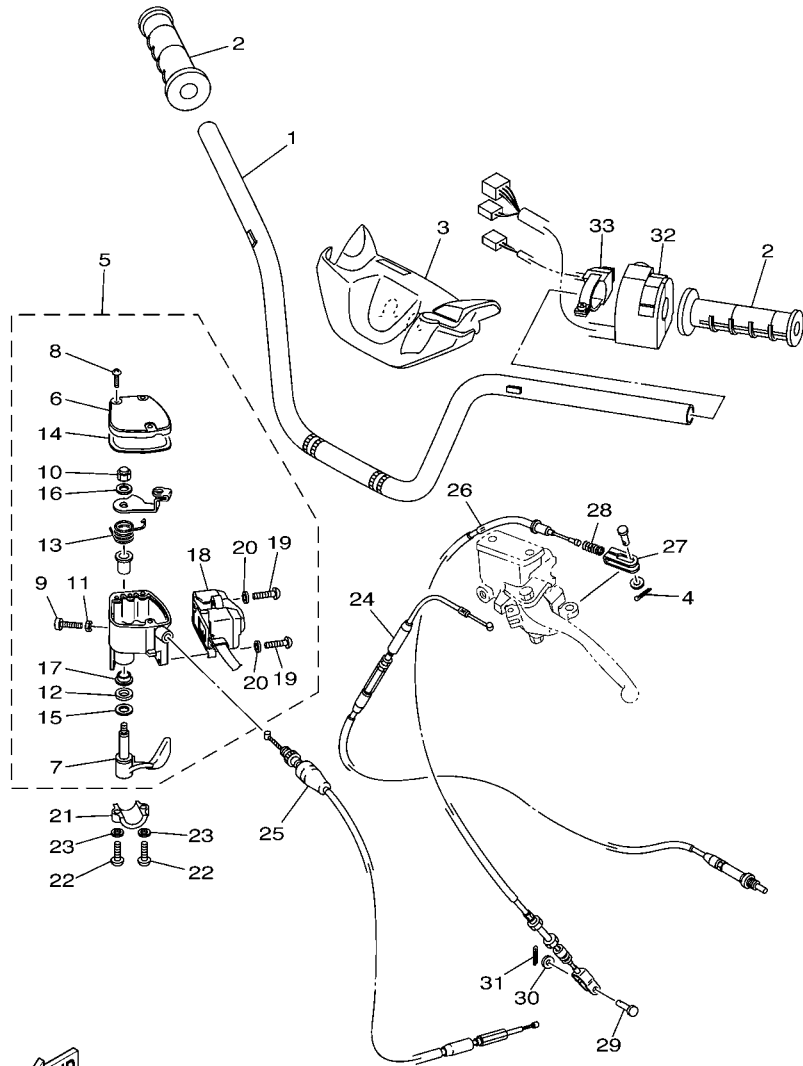


**FIG. 37 REAR BRAKE CALIPER**

REF. NO.	PART NO.	DESCRIPTION	EUR	QCE	REMARKS
1	3B4-2582V-00	DISC, REAR BRAKE 1	1	1	
2	90109-08101	BOLT	4	4	
3	3B4-2582V-00	DISC, REAR BRAKE 1	1	1	
4	90109-08101	BOLT	4	4	
5	3B4-2580V-00	CALIPER ASSY, REAR 1	1	1	
6	3B4-W0057-10	.PISTON ASSY, CALIPER	1	1	
7	3B4-W0047-00	..CALIPER SEAL KIT	1	1	
8	1UY-25937-51	.BOOT 2	1	1	
9	3JD-25917-00	.BOOT, CALIPER	1	1	
10	5DH-25919-50	.SUPPORT, PAD	1	1	
11	1UY-W0048-50	.BLEED SCREW KIT	1	1	
12	1UY-25926-51	.BOLT	1	1	
13	1UY-25938-51	.WASHER, SPRING	1	1	
14	3JD-25926-00	.BOLT	1	1	
15	3JD-25961-00	.NUT	1	1	
16	3B4-W0046-00	.BRAKE PAD KIT 2	1	1	
17	3GD-25933-00	.PIN, PAD	1	1	
18	5DH-25916-00	.PLUG	1	1	
19	90105-08538	BOLT, FLANGE	2	2	
20	3B4-2580W-00	CALIPER ASSY, REAR 2	1	1	
21	3B4-W0057-10	.PISTON ASSY, CALIPER	1	1	
22	3B4-W0047-00	..CALIPER SEAL KIT	1	1	
23	1UY-25937-51	.BOOT 2	1	1	
24	3JD-25917-00	.BOOT, CALIPER	1	1	
25	5DH-25919-50	.SUPPORT, PAD	1	1	
26	1UY-W0048-50	.BLEED SCREW KIT	1	1	
27	1UY-25926-51	.BOLT	1	1	



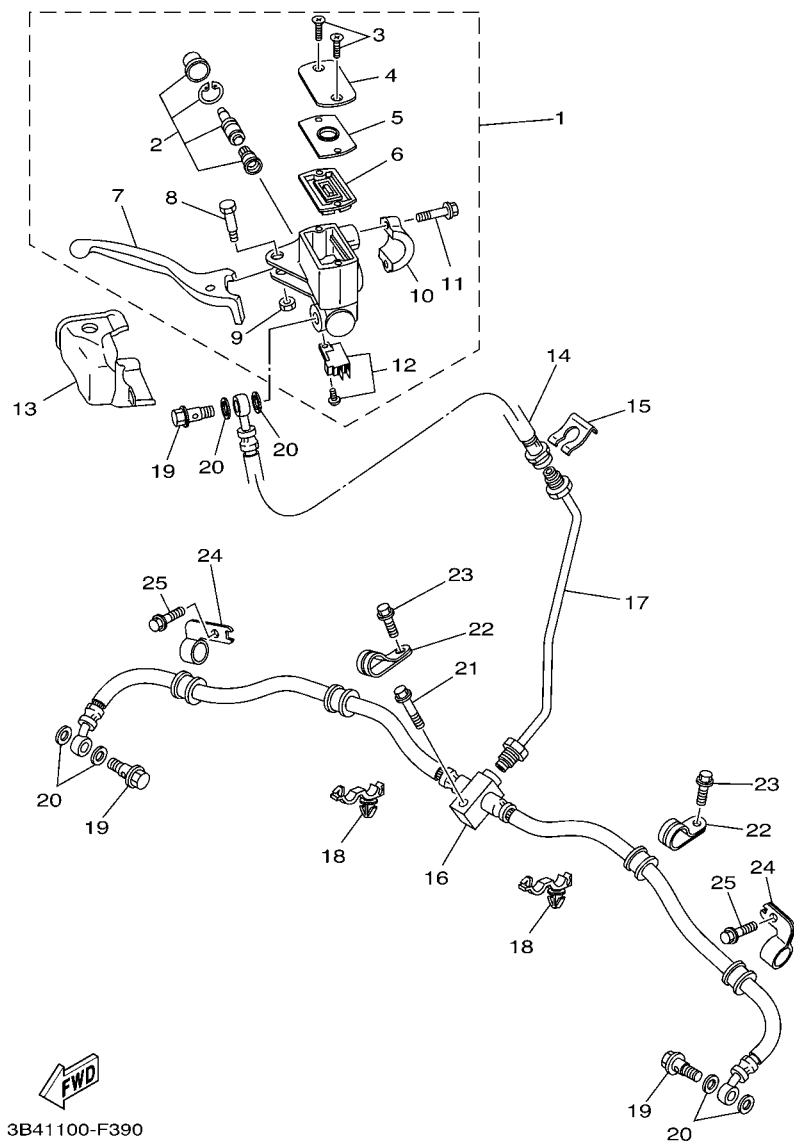
FIG. 38 STEERING HANDLE & CABLE



  
3B43300-F380

REF. NO.	PART NO.	DESCRIPTION	EUR	OCE	REMARKS
1	3B4-26111-00	HANDLEBAR	1	1	
2	5LP-26241-00	GRIP	2	2	
3	3B4-26124-00	PROTECTOR, HANDLEBAR	1	1	
4	91401-16012	PIN, COTTER	1	1	
5	5KM-26250-10	THROTTLE LEVER ASSY	1	1	
6	4KB-2628F-10	.CAP, GEAR	1	1	
7	1NV-2625G-01	.LEVER, THROTTLE	1	1	
8	90149-04278	.SCREW	3	3	
9	98507-05020	.SCREW, PAN HEAD	1	1	
10	95607-05100	.NUT, U	1	1	
11	95307-05700	.NUT	1	1	
12	93104-09025	.OIL SEAL	1	1	
13	1NV-26304-00	.SPRING	1	1	
14	4KB-2628G-00	.GASKET	1	1	
15	1NV-26129-00	.WASHER	1	1	
16	1NV-26398-00	.WASHER	1	1	
17	1NV-2625K-00	.COLLAR	1	1	
18	5KM-83976-10	.SWITCH, HANDLE 1	1	1	
19	98507-04016	.SCREW, PAN HEAD	2	2	
20	92907-04600	.WASHER	2	2	
21	4V4-82913-00	HOLDER, LEVER LOWER 1	1	1	
22	98502-05020	SCREW, PAN HEAD	2	2	
23	92902-05600	WASHER, PLATE	2	2	
24	3B4-2637F-00	CABLE, CONTROL 2	1	1	
25	3B4-26311-00	CABLE, THROTTLE 1	1	1	
26	3B4-26341-00	CABLE, BRAKE	1	1	
27	3B4-26347-00	JOINT, CABLE	1	1	



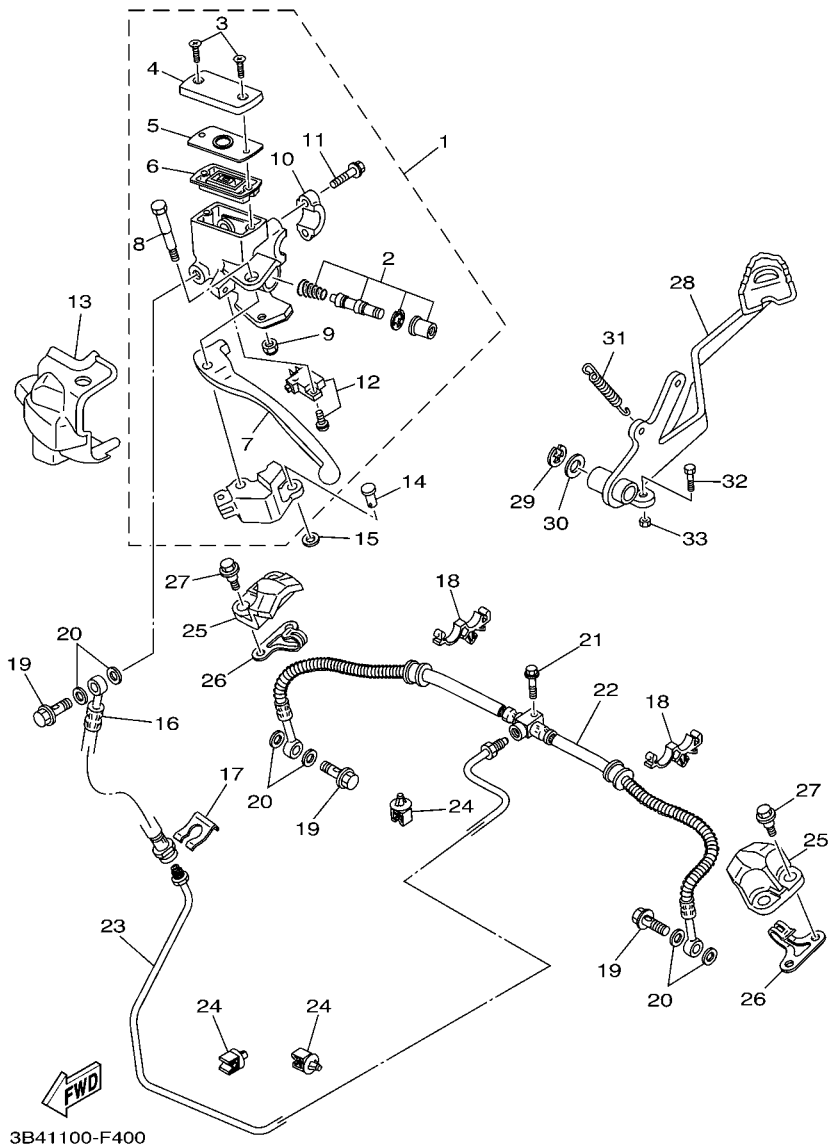


**FIG. 39 FRONT MASTER CYLINDER**

REF. NO.	PART NO.	DESCRIPTION	EUR	QTY	REMARKS
1	3B4-2583T-00	MASTER CYLINDER ASSY	1	1	
2	5LP-W0041-00	.CYLINDER KIT, MASTER	1	1	
3	98706-04012	.SCREW, FLAT HEAD	2	2	
4	3GM-25852-22	.CAP, RESERVOIR	1	1	
5	3B4-2585B-00	.PLATE, DIAPHRAGM	1	1	
6	4TT-25854-00	.DIAPHRAGM, RESERVOIR	1	1	
7	3B4-83922-00	.LEVER 2	1	1	
8	3B4-2589F-00	.BOLT, LEVER	1	1	
9	95604-06100	.NUT, U	1	1	
10	56A-25867-00	.BRACKET, MASTER CYLINDER	1	1	
11	5EB-26332-00	.BOLT	2	2	
12	4HM-83980-00	.FRONT STOP SWITCH ASSY	1	1	
13	3B4-2637A-00	COVER, HANDLE LEVER 2	1	1	
14	3B4-25872-00	HOSE, BRAKE 1	1	1	
15	2GU-25866-00	CIRCLIP	1	1	
16	3B4-25873-00	HOSE, BRAKE 2	1	1	
17	3B4-25871-00	PIPE, BRAKE	1	1	
18	90464-20010	CLAMP	2	2	
19	90401-10159	BOLT, UNION	3	3	
20	90201-10118	WASHER, PLATE	6	6	
21	95822-06025	BOLT, FLANGE	1	1	
22	3B4-25886-00	HOLDER, BRAKE HOSE	2	2	
23	95802-06012	BOLT, FLANGE	2	2	
24	3B4-25876-00	HOLDER, BRAKE HOSE 2	2	2	
25	95802-06012	BOLT, FLANGE	2	2	



**FIG. 40 REAR MASTER CYLINDER**

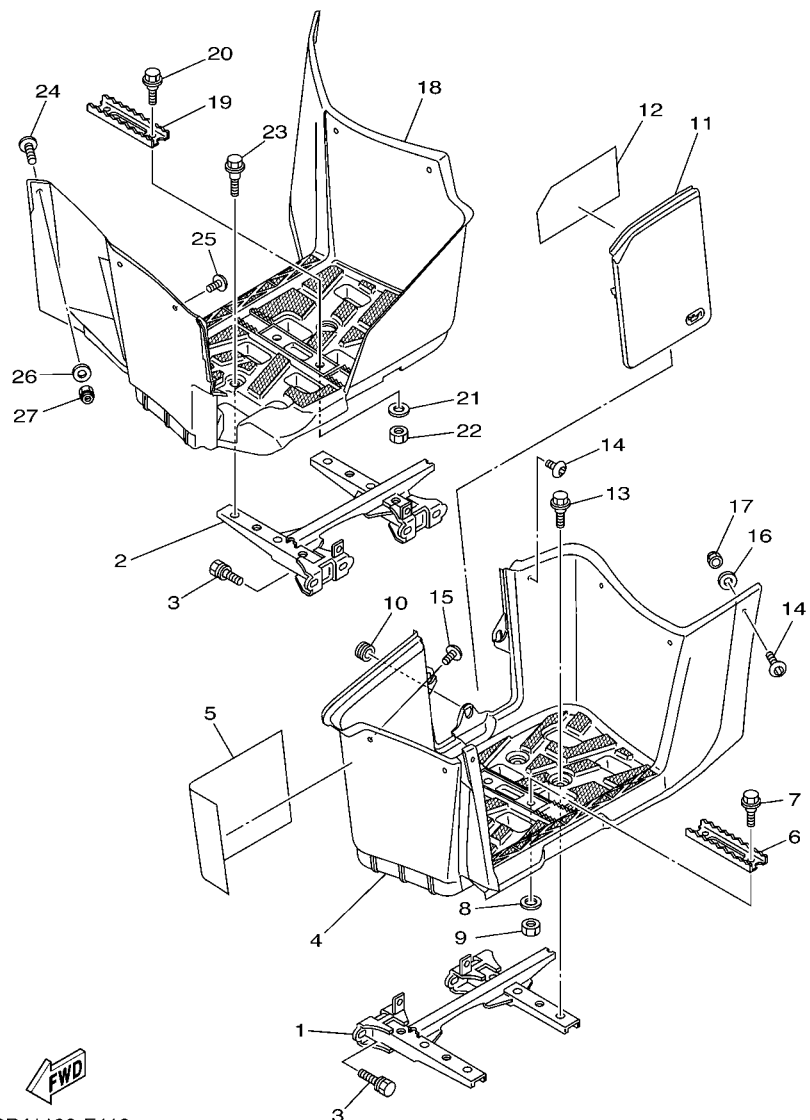


3B41100-F400

REF. NO.	PART NO.	DESCRIPTION	EUR	QTY	REMARKS
1	3B4-2583V-00	RR. MASTER CYLINDER ASSY.	1	1	
2	5LP-W0041-00	.CYLINDER KIT, MASTER	1	1	
3	98706-04012	.SCREW, FLAT HEAD	2	2	
4	3GM-25852-22	.CAP, RESERVOIR	1	1	
5	3B4-2585B-00	.PLATE, DIAPHRAGM	1	1	
6	4TT-25854-00	.DIAPHRAGM, RESERVOIR	1	1	
7	3B4-83912-00	.LEVER 1	1	1	
8	3B4-2589F-10	.BOLT, LEVER	1	1	
9	3B4-26294-00	.NUT 1	1	1	
10	56A-25867-00	.BRACKET, MASTER CYLINDER	1	1	
11	5EB-26332-00	.BOLT	2	2	
12	3B4-83980-00	.FRONT STOP SWITCH ASSY	1	1	
13	3B4-26372-00	COVER, HANDLE LEVER 1	1	1	
14	90240-08013	PIN, CLEVIS	1	1	
15	90201-08083	WASHER, PLATE	1	1	
16	3B4-25872-00	HOSE, BRAKE 1	1	1	
17	2GU-25866-00	CIRCLIP	1	1	
18	90464-16006	CLAMP	2	2	
19	90401-10159	BOLT, UNION	3	3	
20	90201-10118	WASHER, PLATE	6	6	
21	95822-06025	BOLT, FLANGE	1	1	
22	3B4-25874-00	HOSE, BRAKE	1	1	
23	3B4-25882-00	PIPE, BRAKE 2	1	1	
24	5KM-81677-00	CLAMP 1	4	4	
25	3B4-25715-00	COVER 1	2	2	
26	3B4-2588F-00	HOLDER, BRAKE HOSE 5	2	2	
27	90109-063F1	BOLT	4	4	

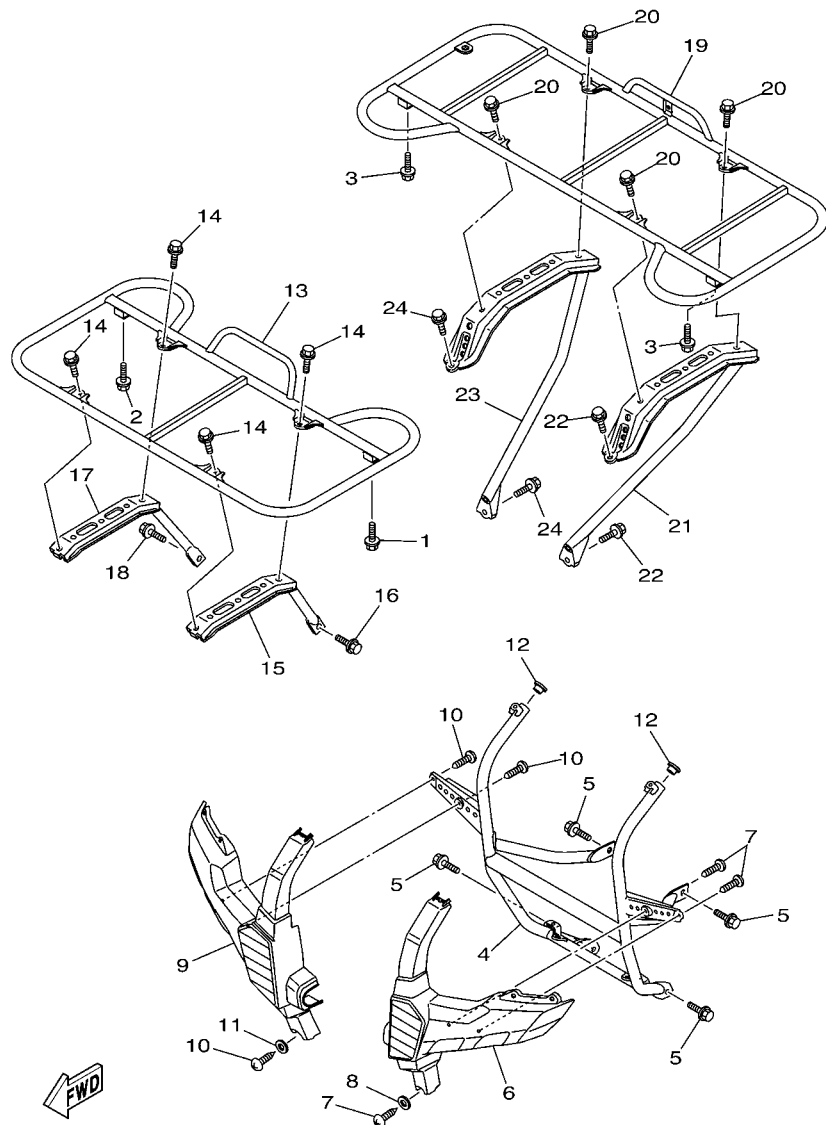


FIG. 41 STAND & FOOTREST



3B41100-F410

REF. NO.	PART NO.	DESCRIPTION	EUR	QTY	REMARKS
1	3B4-27452-00	BRACKET, FOOTREST 1	1	1	
2	3B4-27462-00	BRACKET, FOOTREST 2	1	1	
3	90119-10033	BOLT, WITH WASHER	8	8	
4	3B4-27453-00	COVER 1	1	1	
5	3B4-21732-00	SEAL 1	1	1	
6	5GH-2741A-00	ARM 1	1	1	
7	90109-063F5	BOLT	2	2	
8	90201-06071	WASHER, PLATE	2	2	
9	95312-06600	NUT	2	2	
10	90480-14532	GROMMET	1	1	
11	3B4-28239-00	COVER 3	1	1	
12	3B4-21735-00	SEAL 2	1	1	
13	90109-063F1	BOLT	4	4	
14	90110-06200	BOLT, HEXAGON SOCKET HEAD	5	5	
15	90110-06104	BOLT, HEXAGON SOCKET HEAD	1	1	
16	90201-06557	WASHER, PLATE	6	6	
17	95707-06300	NUT, NYLON	6	6	
18	3B4-27463-00	COVER 2	1	1	
19	5GH-2741A-00	ARM 1	1	1	
20	90109-063F5	BOLT	2	2	
21	90201-06071	WASHER, PLATE	2	2	
22	95312-06600	NUT	2	2	
23	90109-063F1	BOLT	4	4	
24	90110-06200	BOLT, HEXAGON SOCKET HEAD	5	5	
25	90110-06104	BOLT, HEXAGON SOCKET HEAD	1	1	
26	90201-06557	WASHER, PLATE	6	6	
27	95707-06300	NUT, NYLON	6	6	

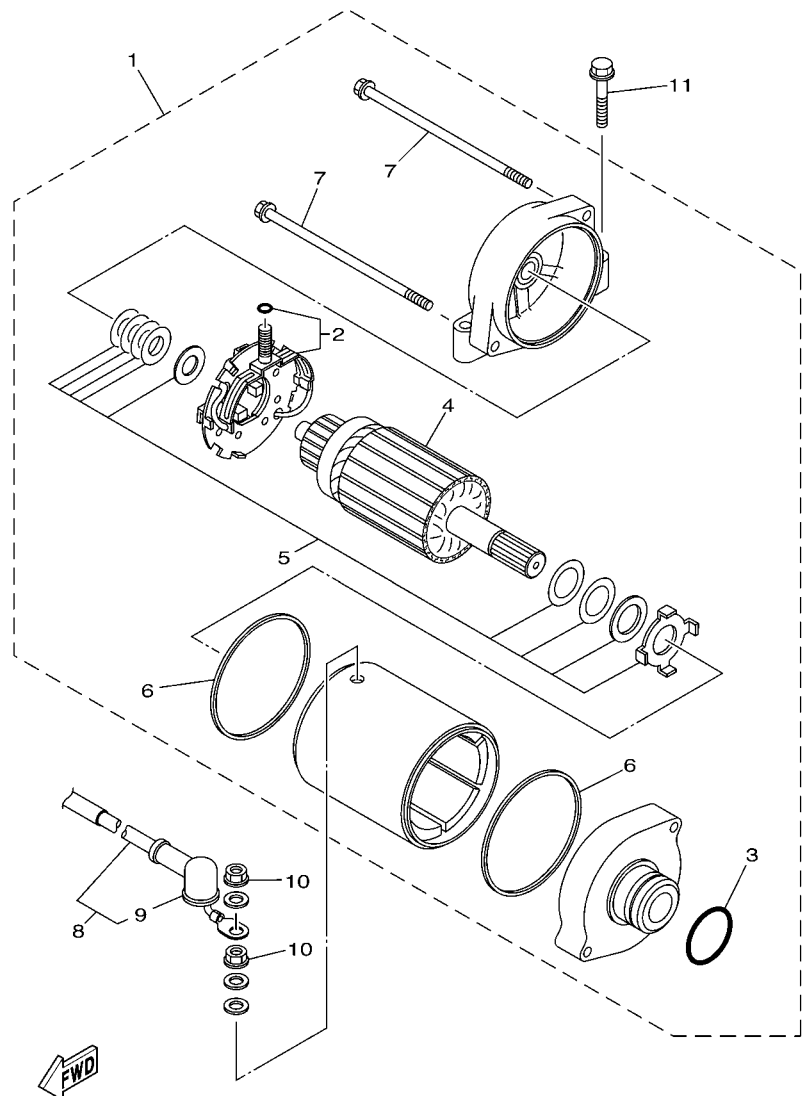


3B41100-F420

FIG. 42 GUARD

REF. NO.	PART NO.	DESCRIPTION	EUR	QCE	REMARKS
1	90119-06056	BOLT, WITH WASHER	1	1	
2	90119-06056	BOLT, WITH WASHER	1	1	
3	90119-06056	BOLT, WITH WASHER	2	2	
4	3B4-2845N-00	BAR, CARRY FRONT	1	1	
5	95817-08014	BOLT, FLANGE	4	4	
6	3B4-2842M-00	COVER 1	1	1	
7	97702-50516	SCREW, TAPPING	3	3	
8	92902-05200	WASHER	1	1	
9	3B4-2842N-00	COVER 2	1	1	
10	97702-50516	SCREW, TAPPING	3	3	
11	92902-05200	WASHER	1	1	
12	90338-18122	PLUG	2	2	
13	3B4-24841-00	CARRIER, FRONT	1	1	
14	95817-08014	BOLT, FLANGE	4	4	
15	3B4-24821-00	STAY, FRONT CARRIER 1	1	1	
16	95817-08014	BOLT, FLANGE	1	1	
17	3B4-24822-00	STAY, FRONT CARRIER 2	1	1	
18	95817-08014	BOLT, FLANGE	1	1	
19	3B4-24842-00	CARRIER, REAR	1	1	
20	95817-08014	BOLT, FLANGE	4	4	
21	3B4-2482J-00	FRAME, CARRIER 1	1	1	
22	90119-10033	BOLT, WITH WASHER	2	2	
23	3B4-2482K-00	FRAME, CARRIER 2	1	1	
24	90119-10033	BOLT, WITH WASHER	2	2	





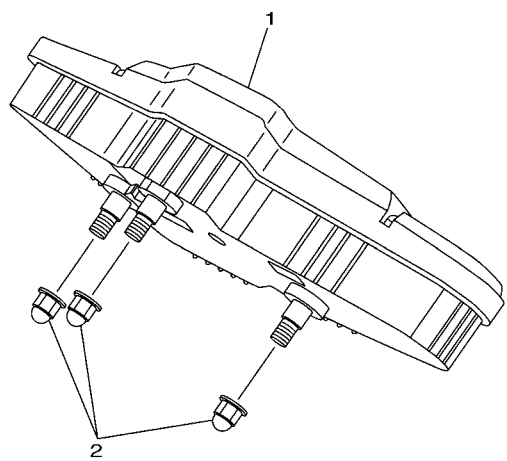
3B41100-F440

FIG. 44 STARTING MOTOR

REF. NO.	PART NO.	DESCRIPTION	EUR	OCÉ	REMARKS
1	1S3-81890-00	MOTOR ASSY	1	1	
2	3AJ-81801-00	.BRUSH SET	1	1	
3	1FK-81847-00	.O-RING	1	1	
4	4NK-81850-00	.ARMATURE ASSY	1	1	
5	3KS-81809-00	.WASHER KIT	1	1	
6	11H-81844-00	.GASKET	2	2	
7	3AJ-81826-00	.BOLT	2	2	
8	3B4-81815-00	CORD, STARTER MOTOR	1	1	
9	4G0-81871-00	.CAP	1	1	
10	4XV-8182A-00	NUT	2	2	
11	95022-06030	BOLT, FLANGE	2	2	

FIG. 45 METER

REF. NO.	PART NO.	DESCRIPTION	EUR	OCÉ			REMARKS
1	3B4-83500-10	SPEEDOMETER COMPLETE	1	1			KM/H
2	90176-05003	NUT, CROWN	3	3			



  
3B41100-F450







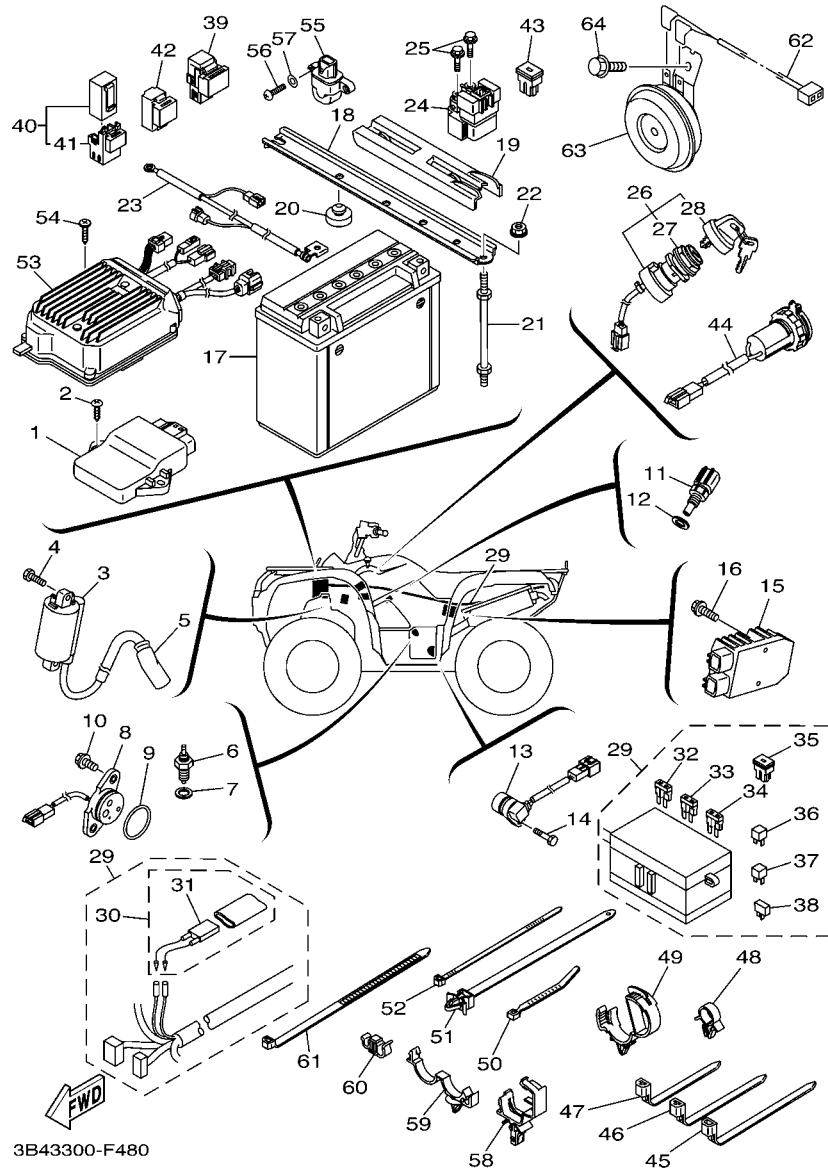


FIG. 48 ELECTRICAL 1

REF. NO.	PART NO.	DESCRIPTION	EUR	OCE	REMARKS
1	3B4-8591A-01	ENGINE CONTROL UNIT ASSY	1	1	
2	97702-60025	SCREW, TAPPING	2	2	
3	2UJ-82310-01	IGNITION COIL ASSY	1	1	
4	97007-05020	BOLT	2	2	
5	5VK-82370-00	PLUG CAP ASSY	1	1	
6	3GB-82540-01	NEUTRAL SWITCH ASSY	1	1	
7	90430-10148	GASKET	1	1	
8	3B4-82540-00	NEUTRAL SWITCH ASSY	1	1	
9	93210-29196	O-RING	1	1	
10	90119-06137	BOLT, WITH WASHER	2	2	
11	8CC-85790-01	THERMOSENSOR ASSY	1	1	
12	90430-12202	GASKET	1	1	
13	3B4-83755-00	SENSOR, SPEED	1	1	
14	91312-06020	BOLT	1	1	
15	1D7-81960-00	RECTIFIER & REGULATOR ASSY	1	1	
16	95802-06020	BOLT, FLANGE	2	2	
17	4SH-82100-22	BATTERY ASSY (YUASA YTX20L-BS)	1	1	
18	3B4-82128-00	BRACKET, BATTERY	1	1	
19	3B4-82129-00	COVER, BATTERY	1	1	
20	22W-24741-00	PAD, SEAT	2	2	
21	3B4-82133-00	SCREW, FITTING	2	2	
22	95702-06500	NUT, FLANGE	2	2	
23	3B4-82116-00	WIRE, MINUS LEAD	1	1	
24	3B4-81940-00	STARTER RELAY ASSY	1	1	
25	95022-06008	BOLT, FLANGE	2	2	
26	3B4-82510-00	MAIN SWITCH ASSY	1	1	
27	3HN-82569-00	.NUT, MAIN SWITCH	1	1	

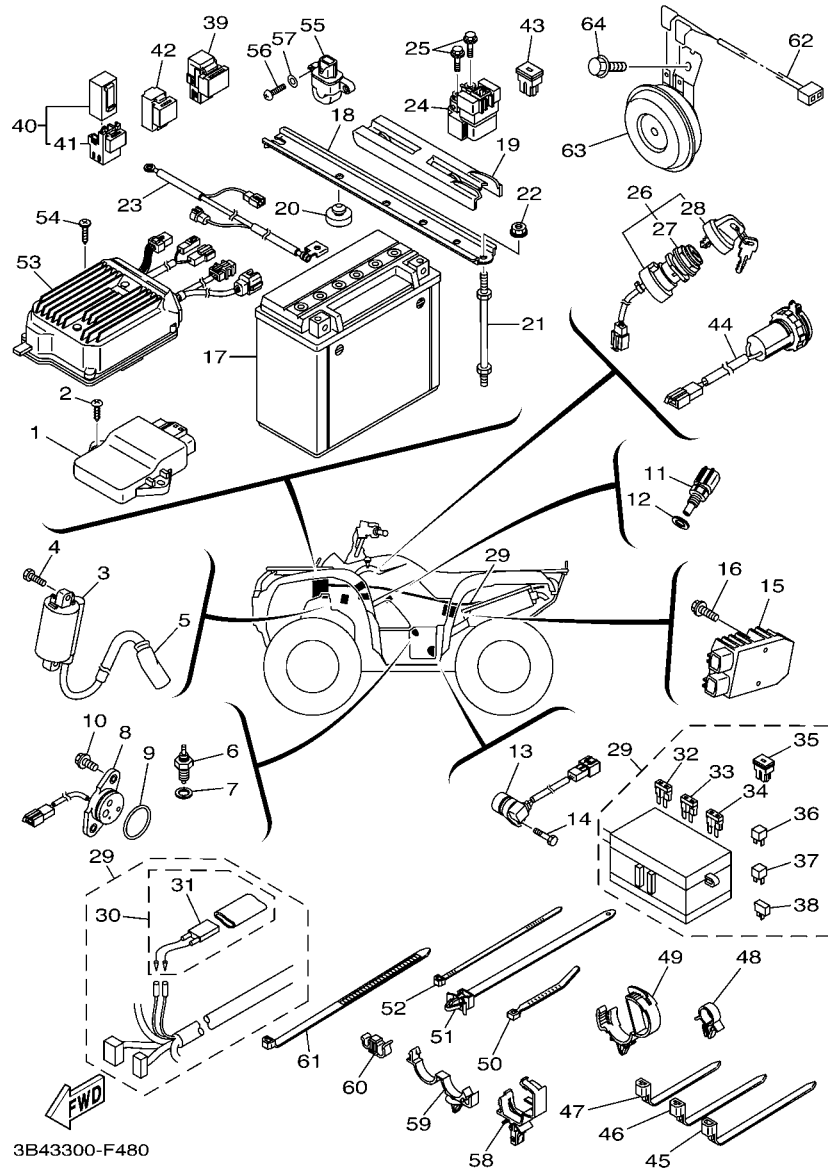


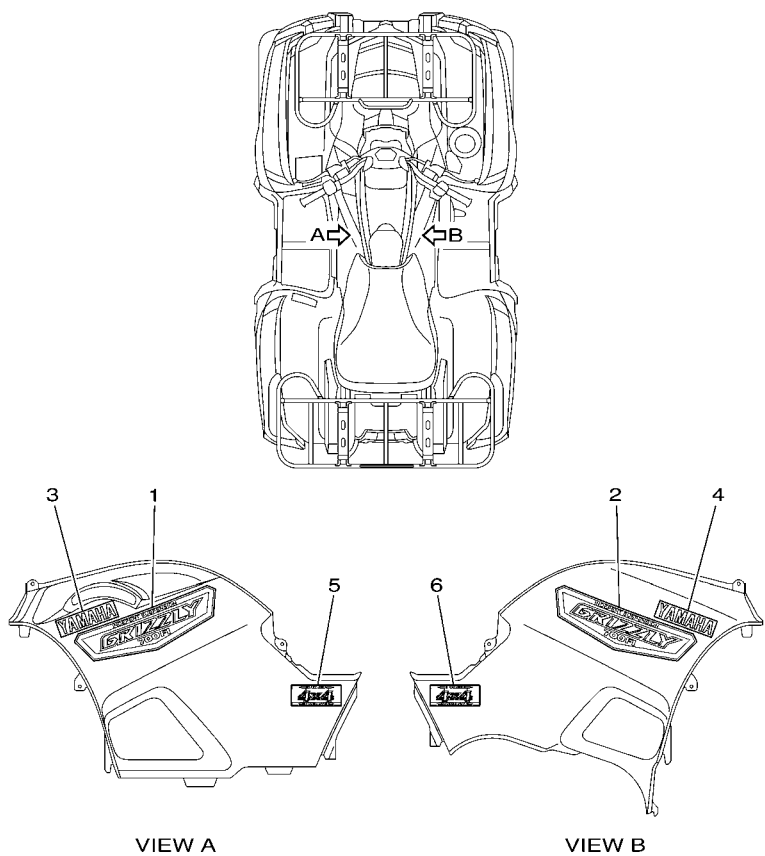
FIG. 48 ELECTRICAL 1

REF. NO.	PART NO.	DESCRIPTION	EUR	OCE	REMARKS
28	3HN-82579-00	.CAP, KEY	1	1	
29	3B4-82590-10	WIRE HARNESS ASSY	1	1	
30	4GB-82180-00	.CIRCUIT BREAKER ASSY	1	1	
31	4GB-82560-00	..THERMO SWITCH ASSY	1	1	
32	5JJ-82151-10	.FUSE (15A-BL)	3	3	
33	5JJ-82151-30	.FUSE (10A-BL)	4	4	
34	5JJ-82151-90	.FUSE (5A-BL)	2	2	
35	5PS-82151-00	.FUSE (40A)	2	2	
36	4WA-81980-00	.DIODE ASSY	1	1	
37	5TJ-81980-00	.DIODE ASSY	1	1	
38	5VG-81980-00	.DIODE ASSY	1	1	
39	5DM-81950-00	RELAY ASSY	3	3	
40	5EA-81950-20	RELAY ASSY	4	4	
41	5EA-81952-00	.HOLDER, RELAY	1	1	
42	29U-81950-93	RELAY ASSY	1	1	
43	5PS-82151-00	FUSE (40A)	1	1	
44	3B4-8254B-00	TERMINAL COMP.	1	1	
45	90464-15195	CLAMP	2	2	
46	90464-13073	CLAMP	4	4	
47	90464-25004	CLAMP	4	4	
48	90464-15157	CLAMP	4	4	
49	90464-20181	CLAMP	2	2	
50	90465-10098	CLAMP	1	1	
51	90464-10112	CLAMP	1	1	
52	5Y9-12491-00	CLAMP 1	2	2	
53	3B4-859A0-00	POWER STRG. CONT. UNIT ASSY	1	1	
54	98902-06020	SCREW, BIND	1	1	





FIG. 50 GRAPHICS



3B41100-F510

REF. NO.	PART NO.	DESCRIPTION	EUR	OCE		REMARKS
1	3B4-2173E-00	GRAPHIC 1	1	1		
2	3B4-2173E-00	GRAPHIC 1	1	1		
3	5KM-2173B-00	EMBLEM 3D	1	1		
4	5KM-2173B-00	EMBLEM 3D	1	1		
5	2C6-2163G-00	EMBLEM 1	1			UR FOR PDG
	2C6-2163G-10	EMBLEM 1	1			UR FOR RTR
	2C6-2163G-30	EMBLEM 1	1	1		UR FOR DPBSE
6	2C6-2163G-00	EMBLEM 1	1			UR FOR PDG
	2C6-2163G-10	EMBLEM 1	1			UR FOR RTR
	2C6-2163G-30	EMBLEM 1	1	1		UR FOR DPBSE

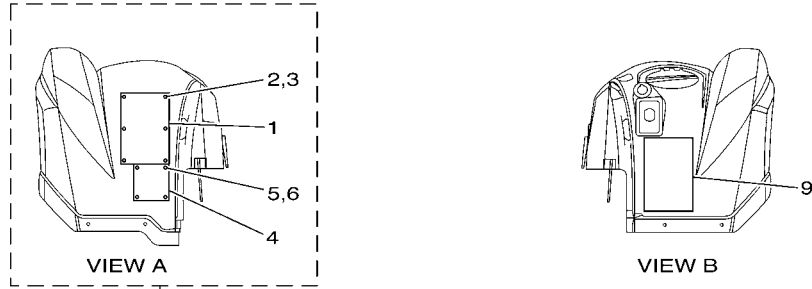


FIG.21-1

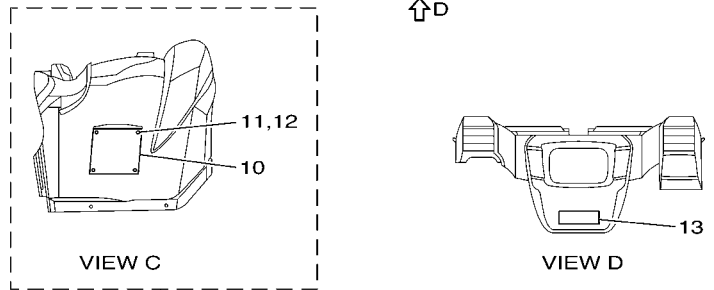
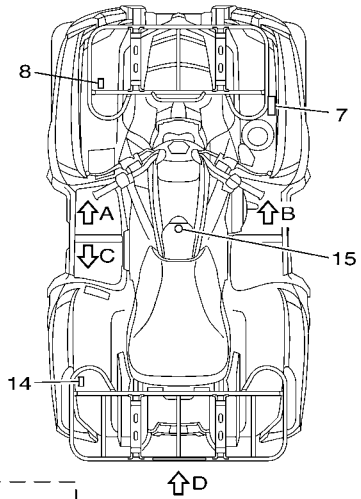
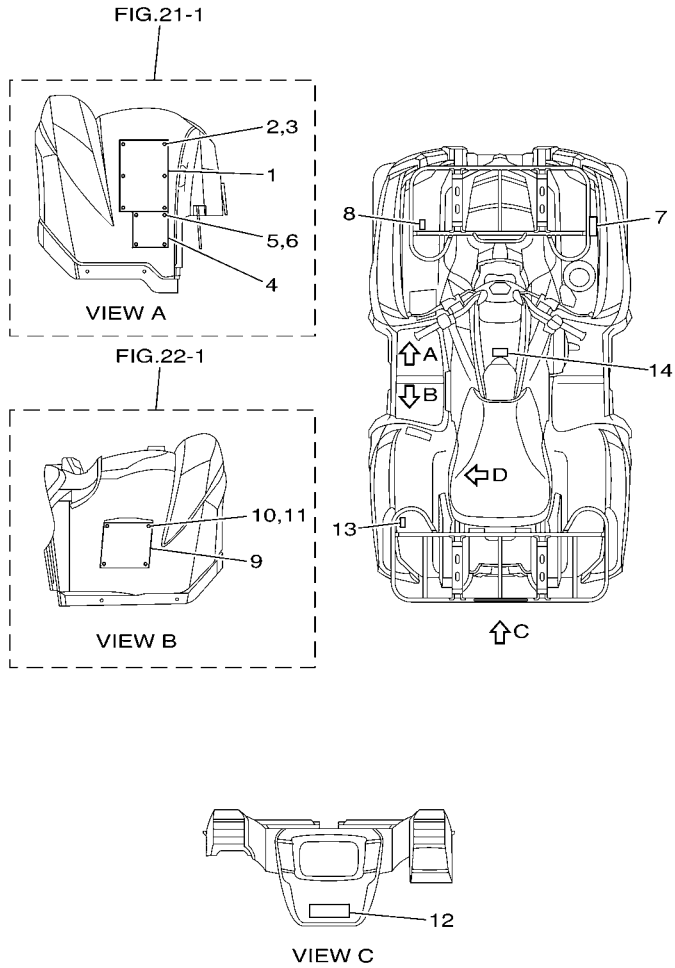


FIG.22-1

3B43300-F510

FIG. 51 EMBLEM & LABEL 1

REF. NO.	PART NO.	DESCRIPTION	EUR	OCÉ		REMARKS
1	5FK-21568-00	LABEL, WARNING	1			
2	90267-32004	RIVET, BLIND	6			
3	90201-03313	WASHER, PLATE	6			
4	5FK-21697-00	LABEL, CAUTION 2	1			
5	90267-32004	RIVET, BLIND	4			
6	90201-03313	WASHER, PLATE	4			
7	3B4-24877-A0	LABEL, CAUTION	1			ENGLISH
8	3GC-24877-A0	LABEL, CAUTION	1			ENGLISH
9	5KM-21558-20	LABEL, WARNING 2	1			
10	5KM-21696-M0	LABEL, CAUTION	1			
11	90267-32004	RIVET, BLIND	4			
12	90201-03313	WASHER, PLATE	4			
13	5KM-2151K-00	LABEL 7	1			ENGLISH
14	4WV-24877-A0	LABEL, CAUTION	1			ENGLISH
15	3ME-2415E-01	LABEL, CAUTION	1			



3B43300-F520

FIG. 52 EMBLEM & LABEL 2

REF. NO.	PART NO.	DESCRIPTION	EUR	OCE	REMARKS
1	5FE-21568-11	LABEL, WARNING		1	ENGLISH
2	90267-32004	RIVET, BLIND		6	
3	90201-03313	WASHER, PLATE		6	
4	5FE-21697-01	LABEL, CAUTION 2		1	ENGLISH
5	90267-32004	RIVET, BLIND		4	
6	90201-03313	WASHER, PLATE		4	
7	3B4-2151F-00	LABEL 3		1	ENGLISH
8	3GC-24877-A0	LABEL, CAUTION		1	ENGLISH
9	5KM-21696-00	LABEL, CAUTION		1	ENGLISH
10	90267-32004	RIVET, BLIND		4	
11	90201-03313	WASHER, PLATE		4	
12	5KM-2151K-00	LABEL 7		1	ENGLISH
13	4WV-24877-A0	LABEL, CAUTION		1	ENGLISH
14	5KM-21558-00	LABEL, WARNING 2		1	ENGLISH



NUMERICAL INDEX

PART NO.	GRID NO.	PART NO.	GRID NO.	PART NO.	GRID NO.	PART NO.	GRID NO.	PART NO.	GRID NO.	PART NO.	GRID NO.
3B4-11101-00	B - 2	3B4-12405-00	B - 9	3B4-14455-00	B - 11	4SH-16664-00	C - 6	3B4-18129-00	C - 14	3B4-21651-00	D - 6
5VK-1111F-00	B - 7	3B4-1240A-00	B - 9	3B4-14457-00	B - 11	3B4-17223-01	C - 8	3B4-18146-00	C - 14	3B4-21652-00	D - 6
4G0-11133-11	B - 2	3B4-12411-00	B - 9	59V-14457-00	B - 11	3B4-17233-00	C - 8	3B4-18148-00	C - 12	5KM-21696-00	G - 9
3B4-11165-00	B - 2	1S3-12413-00	B - 9	3B4-14472-00	B - 11	3B4-17243-00	C - 8	3B4-18160-00	C - 15	5KM-21696-M0	G - 8
3B4-11166-00	B - 2	3B4-12422-00	B - 8	3B4-14503-00	B - 12	3B4-17253-00	C - 8	3B4-18169-00	C - 14	5FK-21697-00	G - 8
371-11167-01	B - 2	3B4-12428-00	B - 8	3B4-14611-00	B - 14	3B4-17285-01	C - 8	5KM-18171-00	C - 12	5FE-21697-01	G - 9
3B4-11181-00	B - 2	11H-12438-10	B - 8	3YF-14613-01	B - 15	3B4-17421-00	C - 8	3B4-18174-00	C - 14	3B4-21711-00	D - 7
3B4-11185-00	B - 2	3B4-1243A-00	B - 12	3B4-14627-00	B - 14	3B4-17432-00	C - 8	3B4-18181-00	C - 14	3B4-21711-10	D - 7
1S3-11186-00	B - 2	5D3-1243K-00	B - 8	3B4-14714-00	B - 14	3B4-17473-00	C - 8	3B4-18190-00	C - 14	3B4-21711-30	D - 7
214-11198-01	B - 10	3B4-12450-00	B - 8	3B4-14718-00	B - 14	3B4-17520-00	C - 9	5KM-18191-00	C - 14	3B4-21717-00	D - 7
	D - 12	22W-12462-00	B - 9	3B4-1471C-00	B - 14	3B4-17521-00	C - 10	3B4-18196-00	C - 15	3B4-2171A-00	D - 7
	D - 14	5KM-12469-00	B - 8	3B4-1472C-00	B - 14	3B4-17530-00	C - 10	4SH-18198-00	C - 14	3B4-21721-00	D - 7
3B4-11311-00	B - 3	3B4-12481-00	B - 8	3B4-14733-00	B - 15	3B4-17531-00	C - 10	3B4-18318-00	C - 12	3B4-21721-10	D - 7
1S3-11351-00	B - 3	5Y9-12491-00	G - 4	3B4-14752-00	B - 14	3B4-17531-10	C - 10	3B4-18331-00	C - 12	3B4-21721-30	D - 8
3B4-11400-00	B - 4	1AA-12535-00	B - 9	3B4-14755-00	B - 15	3B4-17531-20	C - 11	3B4-18511-00	C - 12	3B4-21732-00	F - 10
3B4-11401-09	B - 4	3B4-12576-00	B - 9	3B4-14758-00	B - 14	3B4-17531-30	C - 11	3B4-18512-00	C - 12	3B4-21735-00	F - 10
3B4-11402-09	B - 4	3B4-12577-00	B - 8	3B4-1477U-00	B - 14	3B4-17531-40	C - 11	3B4-18531-00	C - 12	5KM-2173B-00	G - 7
3B4-11447-00	B - 4	3B4-12578-00	B - 9	3B4-15100-01	C - 2	3B4-17531-50	C - 11	3B4-18540-00	C - 12	3B4-2173E-00	G - 7
3B4-11454-00	B - 4	3B4-13160-00	B - 12	3B4-15112-00	C - 2	5KM-17531-50	C - 10	5KM-18542-00	C - 12	3B4-2173M-00	D - 7
3B4-11531-00	B - 4	3B4-13171-00	B - 10	3B4-15113-00	C - 3	3B4-17531-60	C - 11	1J7-18547-00	C - 12	3B4-2173N-00	D - 7
5KM-11536-10	B - 4	3B4-13300-00	B - 10	3B4-15163-00	C - 6	5KM-17531-60	C - 10	4UN-18566-00	C - 12	3B4-21746-00	D - 7
5KM-11565-00	B - 4	3B4-13329-00	B - 10	3B4-15315-00	C - 3	5KM-17531-70	C - 10	3B4-21110-10	D - 2	3B4-21747-00	D - 7
1S3-11603-10	B - 4	3B4-13354-00	B - 4	5KM-15351-00	C - 4	5KM-17531-80	C - 10	3B4-2147A-00	D - 2	3B4-2174A-00	D - 7
1S3-11631-10	B - 4	3B4-13355-00	B - 10	3B4-15362-00	C - 2	5KM-17531-90	C - 10	3B4-2147E-00	D - 2	3B4-2174T-00	D - 8
5VK-11633-00	B - 4	5GH-13440-20	B - 10	5UG-15371-00	D - 12	5KM-17531-A0	C - 10	3B4-2147F-00	D - 2	3B4-2174X-00	D - 7
1S3-11651-00	B - 4	25G-13490-00	B - 10	3B4-15379-00	C - 3	5KM-17531-B0	C - 10	3B4-21485-00	D - 2	3B4-2174Y-00	D - 7
1S3-11681-00	B - 4	1S3-13493-00	B - 12	4VVV-15381-00	C - 3	3B4-17551-00	C - 10	3B4-2151B-00	D - 4	5KM-2175B-00	D - 5
5VK-12111-00	B - 6	3B4-13543-00	B - 12	11H-15383-02	C - 10	3B4-1755A-00	C - 11	3B4-2151F-00	G - 9	3B4-2176E-00	D - 7
1S3-12113-00	B - 6	3B4-13545-00	B - 12	3B4-15388-00	C - 2	3B4-17582-00	C - 8	5KM-2151K-00	G - 8	3B4-2177B-00	D - 7
3YF-12116-00	B - 6	8FP-13556-00	B - 12	3B4-15411-00	C - 3	3B4-17606-00	C - 6		G - 9	3B4-2177K-00	D - 7
3YF-12117-01	B - 6	3B4-13586-00	B - 11	3B4-15421-00	C - 3	3B4-17611-00	C - 6	3B4-21523-00	D - 4	3B4-2177N-00	D - 7
4G0-12118-00	B - 6	3B4-13750-00	B - 12	3B4-15431-00	C - 3	3B4-17623-00	C - 6	3B4-21541-00	D - 3	3B4-21871-00	D - 7
5H0-12119-00	B - 6	3B4-13761-00	B - 12	3B4-15442-00	C - 3	3B4-17632-00	C - 6	3B4-21552-00	D - 5	1S3-21875-00	D - 7
5VK-12121-00	B - 6	3B4-13907-00	E - 5	3B4-15451-00	C - 3	4WV-17639-10	C - 6	3B4-21553-00	D - 5	3B4-22128-00	D - 9
5VK-12146-00	B - 6	3B4-13971-00	E - 5	3B4-15453-00	C - 3	3B4-17641-00	C - 6	3B4-21556-00	D - 3	3B4-22129-00	D - 9
5VK-12151-00	B - 6	4BH-14134-00	B - 12	3B4-15463-00	C - 6	4WV-17644-00	C - 7	3B4-21556-10	D - 3	5KM-22149-00	D - 9
5XT-12159-00	B - 6	5LP-14147-00	B - 12	3B4-15471-00	C - 4	3B4-17645-00	C - 6	3B4-21556-30	D - 3		E - 4
5VK-12161-00	B - 6	1UY-14155-00	B - 12	3B4-15472-00	C - 4	3B4-17653-00	C - 6	5KM-21558-00	G - 9	3B4-22171-10	D - 9
3B4-12170-00	B - 7	1S3-14161-00	B - 12	3B4-15473-00	C - 4	3B4-17660-00	C - 7	5KM-21558-20	G - 8	3B4-22172-10	D - 9
1S3-12176-00	B - 7	8CC-14216-10	B - 12	3B4-15474-00	C - 4	4CW-17664-00	C - 7	5FK-21568-00	G - 8	3B4-2217M-10	D - 9
3TB-12210-00	B - 7	5JW-14348-00	B - 12	3B4-15515-00	C - 5	3B4-17670-00	C - 7	5FE-21568-11	G - 9	3B4-2217N-10	D - 9
4DW-12213-00	B - 7	3B4-14402-00	B - 11	3B4-15517-00	C - 5	3B4-17681-00	C - 8	3B4-21575-00	D - 5	3B4-22210-00	D - 10
3B4-12221-00	B - 10	3B4-14409-00	B - 11	3B4-15522-00	C - 5	4WV-17684-00	C - 7	3B4-215A1-00	D - 4	3B4-22517-00	E - 2
3B4-12231-01	B - 7	3B4-14411-00	B - 11	1S3-15560-00	C - 5	3B4-17832-00	C - 10	3B4-2160E-00	D - 6	3B4-23123-00	E - 4
3B4-12241-00	B - 7	3B4-14413-00	B - 12	5KM-15590-00	C - 5	3B4-18103-00	C - 14	3B4-2160F-00	D - 6	3B4-23133-00	E - 4
1S3-12280-00	B - 7	3B4-14424-00	B - 11	3B4-16181-00	B - 4	3B4-18104-00	C - 14	2C6-2163G-00	G - 7	3B4-23350-00	E - 4
5VK-12284-00	B - 7	3B4-14451-00	B - 11	3B4-16611-00	C - 6	3B4-18115-00	C - 14	2C6-2163G-10	G - 7	3B4-23391-00	D - 5
1S3-12290-00	B - 7	3B4-14453-00	B - 11	3B4-16620-00	C - 6	3B4-18125-00	C - 15	2C6-2163G-30	G - 7	5KM-23448-00	E - 13

NUMERICAL INDEX

PART NO.	GRID NO.	PART NO.	GRID NO.	PART NO.	GRID NO.	PART NO.	GRID NO.	PART NO.	GRID NO.	PART NO.	GRID NO.
5KM-23448-00	E - 15	3B4-2470F-10	E - 6	3B4-2512A-00	E - 10	3GM-25852-22	F - 7	4KB-2628F-10	F - 5	3B4-46117-30	D - 14
3B4-23501-00	E - 7	3B4-2470F-20	E - 6		E - 14		F - 8	4KB-2628G-00	F - 5	3B4-46119-00	D - 11
3B4-23502-00	E - 9	3B4-2470F-30	E - 6		F - 2	4TT-25854-00	F - 7	1NV-26304-00	F - 5	3B4-46119-10	D - 11
2NL-23517-00	E - 13	3B4-24710-10	E - 6	3B4-2512G-00	E - 7		F - 8	3B4-26311-00	F - 5	3B4-46119-20	D - 11
	E - 15	3B4-24710-20	E - 6		E - 9	3B4-2585B-00	F - 7	5EB-26332-00	F - 7	3B4-46119-30	D - 11
5KM-23526-10	D - 9	3B4-24710-30	E - 6		E - 14		F - 8		F - 8	3B4-46119-40	D - 11
	E - 4	3B4-24725-00	E - 6		F - 2	2GU-25866-00	F - 7	3B4-26341-00	F - 5	3B4-46119-50	D - 11
3B4-23540-10	E - 4	22W-24741-00	E - 6	3B4-2512H-00	E - 7		F - 8	3B4-26347-00	F - 5	3B4-46126-00	D - 11
3B4-23550-10	E - 4		G - 3		E - 9	56A-25867-00	F - 7	3B4-26372-00	F - 8	5KM-46126-00	D - 13
3B4-23570-10	E - 4	5RU-24768-00	D - 4		E - 14		F - 8	3B4-2637A-00	F - 7		D - 15
3B4-23579-00	E - 7	3B4-24821-00	F - 11		F - 2	3B4-25871-00	F - 7	3B4-2637F-00	F - 5	2HR-46127-00-25	D - 11
	E - 9	3B4-24822-00	F - 11	3B4-2512J-00	E - 7	3B4-25872-00	F - 7	1NV-26398-00	F - 5	2HR-46127-00-30	D - 11
5LP-23579-00	E - 4	3B4-2482J-00	F - 11		E - 9		F - 8	3B4-27211-00	F - 9	2HR-46127-00-35	D - 11
3B4-23580-10	E - 4	3B4-2482K-00	F - 11		E - 14	3B4-25873-00	F - 7	3B4-27414-00	B - 14	2HR-46127-00-40	D - 11
1UY-23812-00	E - 2	3B4-24841-00	F - 11		F - 2	3B4-25874-00	F - 8	5GH-2741A-00	F - 10	2HR-46127-00-45	D - 11
3B4-23813-00	E - 2	3B4-24842-00	F - 11	3B4-2514A-00	E - 7	3B4-25875-00	D - 9	3B4-27452-00	F - 10	2HR-46127-00-50	D - 11
8K1-23814-00	E - 2	3B4-24877-A0	G - 8		E - 13	3B4-25876-00	F - 7	3B4-27453-00	F - 10	3B4-46129-00	D - 11
3B4-23816-00	E - 2	3GC-24877-A0	G - 8	3B4-2515A-00	E - 9	3B4-25882-00	F - 8	3B4-27462-00	F - 10	3B4-46134-00	D - 14
3B4-2381B-00	E - 2		G - 9		E - 15	3B4-25886-00	F - 7	3B4-27463-00	F - 10	3B4-46135-00	D - 14
5KM-23831-00	E - 3	4WV-24877-A0	G - 8	3B4-25180-00	E - 7	3B4-2588F-00	F - 8	5TG-28100-00	D - 2	5KM-46136-00	D - 13
1UY-23841-01	E - 3		G - 9		E - 9	3B4-2589F-00	F - 7	1NV-2811A-01	D - 2		D - 15
1UY-23845-01	E - 3	3B4-2510F-00	E - 7	3B4-25182-00	E - 7	3B4-2589F-10	F - 8	3B4-28217-00	D - 4	5KM-46137-00	D - 13
5KM-2385L-01	D - 10		E - 9		E - 9	5DH-25916-00	E - 11	3B4-28227-00	D - 4		D - 15
5KM-2385M-01	D - 10		E - 13		E - 14		F - 3	3B4-28237-00	D - 4	3B4-46141-00	D - 14
5GH-23868-00	E - 2		E - 15		F - 2	3JD-25917-00	E - 11	3B4-28239-00	F - 10	3B4-46142-00	D - 14
3B4-2386G-00	D - 10	3B4-2510G-00	E - 7	3B4-2518E-00	E - 7		F - 3	3B4-28247-00	D - 4	3B4-46144-00	D - 11
3B4-2386H-00	D - 10		E - 9		E - 9	5DH-25919-00	E - 11	3B4-28307-00	D - 4	4WV-46145-10	D - 14
3B4-23875-00	E - 2		E - 13	3B4-2518E-10	E - 13	5DH-25919-50	F - 3	3B4-28309-00	D - 4	3B4-46151-00	D - 11
1UY-23894-01	E - 2		E - 15		E - 15	3JD-25926-00	E - 11	3B4-28313-00	D - 5	3B4-46152-00	D - 12
3B4-238B0-00	E - 2	3B4-2510H-00	E - 7	3B4-2530F-00	E - 13		F - 3	3B4-28332-00	D - 4	3B4-46160-00	D - 14
3B4-238B6-00	E - 2		E - 9	3B4-2530V-00	E - 13	1UY-25926-51	E - 11	3B4-28349-00	D - 4	3B4-46161-00	D - 14
3B4-24110-00	E - 5		E - 13		E - 15		F - 3	3B4-2837L-00	D - 5	3B4-46162-00	D - 14
3B4-24129-00	E - 5		E - 15	3B4-2532F-00	E - 15	3GD-25933-00	F - 3	3B4-2837N-00	D - 4	3B4-46163-00	D - 14
3B4-24141-00	E - 5	3B4-2510J-00	E - 7	3B4-2536E-00	E - 14	5DH-25933-00	E - 11	3B4-2837R-00	D - 4	3B4-46164-00	D - 14
3B4-2414F-00	E - 5		E - 9		F - 2	1UY-25937-51	E - 11	3B4-2838K-00	D - 3	3B4-46166-00	D - 14
3B4-2414H-00	D - 8	3B4-25111-00	E - 7	3B4-25390-00	E - 13		F - 3	3B4-2838M-00	D - 3	3B4-4616A-00	D - 14
5EJ-2414H-00	C - 4		E - 9		E - 15	1UY-25938-51	E - 11	3B4-2839N-00	D - 3	3B4-46172-00	D - 13
3B4-2414J-00	E - 5		E - 13	3B4-2539F-00	E - 13		F - 3	3B4-2842M-00	F - 11	3B4-46173-00	D - 15
3B4-2414K-00	E - 5		E - 15	3B4-2539G-00	E - 15	3JD-25961-00	E - 11	3B4-2842N-00	F - 11	3B4-461A0-00	D - 11
3ME-2415E-01	G - 8	3B4-2511G-00	E - 7	3B4-25715-00	F - 8		F - 3	3B4-2845L-00	D - 4	3B4-4621F-00	D - 12
3B4-24181-00	E - 5		E - 9	3B4-2580T-00	E - 11	3B4-26111-00	F - 5	3B4-2845N-00	F - 11	3B4-4621F-10	D - 12
3B4-24312-00	E - 5		E - 14	3B4-2580U-00	E - 11	3B4-26124-00	F - 5	3B4-28487-00	D - 4	3B4-4621F-20	D - 12
3B4-24313-00	E - 5		F - 2	3B4-2580V-00	F - 3	1NV-26129-00	F - 5	3B4-28488-00	D - 2	3B4-4621F-30	D - 12
3B4-24380-00	E - 5	3B4-2511H-00	E - 7	3B4-2580W-00	F - 3	3B4-26232-00	D - 5	3B4-28488-10	D - 2	3B4-46316-00	D - 11
3B4-24398-00	E - 5		E - 9	3B4-2582T-01	E - 11	5LP-26241-00	F - 5	3B4-46101-00	D - 11	3B4-4631A-00	D - 12
1S3-24486-00	E - 5		E - 14	3B4-2582V-00	F - 3	5KM-26250-10	F - 5	3B4-46117-00	D - 14	3B4-46326-00	D - 12
3B4-24491-00	E - 5		F - 2	3B4-2583T-00	F - 7	1NV-2625G-01	F - 5	3B4-46117-10	D - 14	3B4-46344-00	D - 12
3B4-24610-00	E - 5	3B4-2512A-00	E - 8	3B4-2583V-00	F - 8	1NV-2625K-00	F - 5	3B4-46117-20	D - 14	3B4-46344-10	D - 12

NUMERICAL INDEX

PART NO.	GRID NO.	PART NO.	GRID NO.	PART NO.	GRID NO.	PART NO.	GRID NO.	PART NO.	GRID NO.	PART NO.	GRID NO.
3B4-46344-20	D - 12	5VK-82370-00	G - 3	3B4-W0057-00	E - 11	90110-05031	C - 3	90179-16005	C - 7	90201-101J1	E - 15
3B4-46344-30	D - 12	1C7-82380-00	B - 12	3B4-W0057-10	F - 3		F - 12	90179-16006	C - 10	90201-12029	D - 11
3B4-46344-40	D - 12	3B4-82510-00	G - 3	3B4-W1471-00	B - 14	90110-06090	D - 8	90179-20006	E - 7	90201-127J6	C - 12
3B4-46344-50	D - 13	3B4-8253E-00	D - 4	3B4-W215B-00	D - 3	90110-06104	F - 10		E - 9	90201-132G5	C - 14
3B4-46470-00	D - 14	3B4-8253F-00	D - 4	3B4-W215B-10	D - 3	90110-06200	D - 9		E - 14	90201-144J2	F - 9
5KM-46559-00	D - 13	3B4-82540-00	G - 3	3B4-W215B-30	D - 3		E - 4		F - 2	90201-150U6	C - 8
	D - 15	5LP-82540-01	G - 3	3B4-W215E-30	D - 3		F - 10	90179-22013	C - 10	90201-16021	C - 10
3B4-47359-00	D - 14	3B4-8254B-00	G - 4	3B4-W216B-00	D - 6	90114-10010	E - 7	90179-22021	C - 6	90201-165H4	B - 4
3B4-47491-00	D - 10	3B4-8254E-00	D - 4	3B4-W216B-10	D - 6		E - 9	90179-55660	C - 11	90201-170M2	E - 2
3B4-67839-00	D - 14	4GB-82560-00	G - 4	3B4-W216B-30	D - 6		E - 13	90179-60001	C - 10	90201-170U8	C - 8
3B4-81410-00	F - 12	3HN-82569-00	G - 3	3B4-W216E-30	D - 6		E - 15	90183-05008	D - 5	90201-190T7	C - 7
3B4-81450-00	F - 12	3B4-82576-00	G - 5	90105-06078	B - 7	90119-06056	D - 4		F - 15	90201-20278	C - 8
5KM-81677-00	F - 8	3HN-82579-00	G - 4	90105-06082	B - 7		D - 6	90183-06053	D - 3	90201-20792	C - 12
3AJ-81801-00	F - 13	3B4-82590-10	G - 4		B - 10		D - 7		D - 6	90201-25290	C - 8
3KS-81809-00	F - 13	4V4-82913-00	F - 5		C - 2		F - 11		D - 7	90201-25634	D - 11
3B4-81815-00	F - 13	3B4-83371-00	G - 5	90105-06639	D - 2	90119-06137	G - 3	90183-060A2	B - 14	90201-286K9	C - 5
3AJ-81826-00	F - 13	3B4-83500-10	F - 14	90105-07004	B - 7	90119-08106	E - 2	90183-060A5	C - 4	90209-06012	B - 9
4XV-8182A-00	F - 13	3B4-83755-00	G - 3	90105-08129	C - 10	90119-10023	B - 3	90183-080A1	C - 14	90209-10229	E - 3
11H-81844-00	F - 13	3B4-83912-00	F - 8	90105-08153	E - 2	90119-10033	F - 10	90185-10011	D - 2	90209-22082	C - 8
1FK-81847-00	F - 13	3B4-83922-00	F - 7	90105-08538	E - 11		F - 11	90185-10060	D - 9	90215-10008	B - 10
4NK-81850-00	F - 13	3B4-83972-00	F - 6		F - 3	90149-04278	F - 5		D - 10	90215-18001	B - 4
4G0-81871-00	F - 13	3B4-83976-00	F - 6	90105-10061	D - 2	90149-05016	C - 12		E - 4	90240-06076	F - 6
1S3-81890-00	F - 13	5KM-83976-10	F - 5	90105-10073	D - 2	90149-08013	C - 10		E - 13	90240-08013	F - 8
3B4-81940-00	G - 3	3B4-83980-00	F - 8	90105-10109	E - 2	90149-08018	C - 5		E - 15	90267-32004	G - 8
5DM-81950-00	G - 4	4HM-83980-00	F - 7	90105-10110	D - 2	90154-05021	F - 15	90185-22008	E - 2		G - 9
5EA-81950-20	G - 4	3B4-84300-00	F - 15	90105-10222	D - 9	90154-06014	E - 7	90201-03313	G - 8	90267-47187	E - 13
29U-81950-93	G - 4	3B4-84314-00	F - 15		E - 4		E - 9		G - 9		E - 15
5EA-81952-00	G - 4	2GU-84334-00	F - 15	90105-10388	D - 10		E - 13	90201-04325	E - 13	90269-05055	C - 14
1D7-81960-00	G - 3	3B4-84340-00	F - 15		E - 4		E - 15		E - 15	90269-06081	D - 8
4WA-81980-00	G - 4	5GH-84703-00	F - 15	90105-10480	E - 13	90157-04006	C - 6	90201-047R9	C - 6	90269-07010	D - 3
5TJ-81980-00	G - 4	3FA-84710-00	G - 2		E - 15	90159-05022	F - 15	90201-05015	B - 14		D - 6
5VG-81980-00	G - 4	1A2-84714-41	G - 2	90105-14003	C - 12	90170-06128	B - 6	90201-05019	B - 14		D - 8
4SH-82100-22	G - 3	3Y6-85130-02	G - 6	90109-06086	D - 2	90170-08358	C - 14	90201-05022	B - 14	90269-07076	D - 8
3B4-82116-00	G - 3	8CC-85790-01	G - 3	90109-063F1	C - 15	90170-10186	E - 3	90201-05037	B - 14	90269-07077	D - 4
3B4-82122-00	D - 5	5FL-85885-02	B - 12		D - 3	90170-18003	B - 4	90201-06036	B - 14	90280-05001	B - 4
1S3-82123-00	C - 4	8FP-85886-00	B - 11		D - 9	90170-36279	C - 7		C - 14	90282-05007	B - 4
	D - 5	3B4-8591A-01	G - 3		E - 2	90171-10001	E - 3	90201-06071	F - 10	90338-08174	B - 11
3B4-82128-00	G - 3	3B4-859A0-00	G - 4		E - 5		E - 4	90201-06074	G - 2	90338-08226	D - 5
3B4-82129-00	G - 3	5LP-W0041-00	F - 7		F - 8	90171-12039	E - 4	90201-06557	F - 10	90338-09130	D - 6
3B4-82133-00	G - 3		F - 8		F - 10	90176-05003	F - 14	90201-08083	F - 8	90338-18122	F - 11
5PS-82151-00	G - 4	3B4-W0045-00	E - 11	90109-063F5	D - 2	90179-05523	D - 3	90201-08087	D - 12	90340-10001	D - 14
5JJ-82151-10	G - 4	3B4-W0045-10	E - 12		F - 10	90179-08023	B - 15	90201-080E4	B - 15	90340-14002	D - 12
5JJ-82151-30	G - 4	3B4-W0046-00	F - 3	90109-08101	E - 11	90179-10007	E - 7	90201-08326	E - 2	90340-14011	C - 3
5JJ-82151-90	G - 4	3B4-W0046-10	F - 4		F - 3		E - 9	90201-10118	F - 7	90340-14012	D - 14
4GB-82180-00	G - 4	3B4-W0047-00	E - 11	90109-09002	B - 2		E - 13		F - 8	90340-14029	D - 12
3B4-82309-00	G - 5		F - 3	90109-09003	B - 2		E - 15	90201-101J1	D - 2	90340-14132	B - 10
2UJ-82310-01	G - 3	1UY-W0048-50	E - 11	90109-09005	B - 2	90179-12005	D - 11		D - 10	90340-36002	C - 3
3B4-8233W-00	D - 4		F - 3	90109-14002	C - 12	90179-16004	B - 4		E - 13	90380-10002	C - 5

NUMERICAL INDEX

PART NO.	GRID NO.	PART NO.	GRID NO.	PART NO.	GRID NO.	PART NO.	GRID NO.	PART NO.	GRID NO.	PART NO.	GRID NO.
90381-17067	E - 13	90464-13073	G - 4	90501-220A1	B - 4	93210-10096	B - 10	93440-15012	C - 9	95022-08012	D - 12
	E - 15	90464-14004	E - 5	90501-650A0	C - 7	93210-14369	C - 3	93440-25084	C - 8	95302-05600	G - 6
90387-060A7	B - 9	90464-15157	G - 4	90506-16318	F - 9	93210-21190	B - 8	93450-22119	E - 7	95302-08700	C - 14
90387-0613B	C - 14	90464-15195	G - 4	90506-26010	B - 14	93210-21631	C - 2		E - 9	95307-05700	F - 5
90387-06140	B - 14	90464-16006	F - 8	90508-32018	C - 12	93210-26001	C - 8	93450-24062	C - 6	95307-06800	E - 5
90387-066J1	E - 5	90464-16012	D - 8	90508-35764	C - 14	93210-29196	G - 3	93450-24154	B - 4	95307-10700	E - 3
90387-075H4	E - 5	90464-20010	F - 7	91312-04006	B - 12	93210-33786	B - 8	93503-08007	C - 12	95312-06600	F - 9
90387-090R0	E - 2		G - 5	91312-06012	B - 8	93210-357A3	C - 3	93604-10011	B - 8		F - 10
90387-20021	C - 8	90464-20181	G - 4		B - 10	93210-41042	B - 9	93604-18100	C - 12	95312-10600	B - 10
90387-22014	E - 2	90464-20237	G - 5		C - 2	93210-44545	C - 7	93606-09002	B - 4	95602-10200	D - 2
90387-22591	E - 2	90464-25004	G - 4	91312-06020	B - 8	93210-626A7	D - 11	93612-16254	B - 2		D - 10
90387-250R3	C - 8	90465-10098	G - 4		G - 3	93210-78544	B - 2	93700-06004	E - 13	95604-06100	F - 7
90387-26001	C - 8	90467-07029	D - 13	91312-06025	B - 7		C - 10		E - 15		F - 8
90401-08004	B - 2		D - 15	91312-06030	B - 2	93210-96601	B - 2	93900-00030	E - 7	95607-05100	F - 5
90401-10015	B - 10		E - 2	91312-06040	B - 3	93211-594A4	C - 6		E - 9	95612-08625	B - 2
90401-10159	F - 7	90467-07093	B - 8	91312-08040	C - 2	93305-00602	E - 7		E - 13	95612-16100	E - 3
	F - 8	90467-08003	D - 7	91401-16012	F - 5		E - 9		E - 15	95702-06300	G - 2
90401-14118	B - 10	90467-09006	B - 12	91401-20012	F - 6		E - 13	94108-12008	E - 7	95702-06500	G - 3
90401-20145	B - 10		E - 5	91401-20020	E - 3		E - 15		E - 9	95702-08500	B - 15
90430-06014	B - 8	90467-090A3	B - 13		E - 4	93306-00006	B - 8	94108-12012	E - 7	95707-06300	D - 9
	B - 9	90467-10041	B - 11	91490-25020	E - 4	93306-00426	C - 8		E - 9		E - 4
90430-08119	B - 2	90467-110A2	B - 12	91A20-07020	B - 11	93306-00613	D - 14	94110-12008	E - 13		F - 10
90430-10003	D - 14	90467-14015	B - 2	92012-06012	B - 14	93306-00704	D - 12		E - 15	95802-06012	D - 2
90430-10148	G - 3	90467-140A4	B - 12	92012-06016	B - 14	93306-07209	B - 7	94110-12012	E - 13		D - 4
90430-10188	B - 10	90467-150A2	B - 2	92012-06030	F - 12	93306-07801	C - 8		E - 15		F - 7
90430-12202	G - 3	90467-220A1	B - 11	92902-05200	F - 11	93306-20120	C - 3	94580-31074	B - 10	95802-06020	B - 9
90430-14043	B - 10	90467-26189	B - 9		G - 6	93306-20309	C - 8	94591-57126	B - 7		G - 3
	C - 12	90468-18195	E - 3	92902-05600	D - 3	93306-20464	C - 8	94701-00330	B - 2	95807-06030	E - 5
90430-14194	C - 12	90480-01021	B - 14		F - 5	93306-205U0	D - 11	95022-06008	B - 14	95812-06014	D - 14
90445-070F1	D - 15	90480-01400	E - 5		G - 5	93306-20654	C - 10		G - 3	95812-06016	C - 14
	E - 2	90480-01558	D - 7	92902-06200	B - 14	93306-207U0	D - 12	95022-06010	B - 8	95812-06035	C - 14
90445-07340	B - 8	90480-13004	D - 3	92902-08600	C - 10	93306-30438	B - 5		B - 9	95812-08014	D - 10
90445-074F6	D - 13	90480-13018	C - 3		D - 12		C - 9	95022-06012	B - 2	95812-08040	B - 15
90445-09110	D - 7	90480-13398	C - 4	92907-04600	F - 5	93306-30523	D - 12	95022-06016	C - 3		D - 14
90445-09117	D - 7		D - 3	92907-06200	F - 6	93306-30534	B - 5	95022-06020	B - 2	95812-10035	D - 2
90445-09220	G - 2	90480-13567	C - 4	92907-06600	B - 9	93306-30537	C - 10		B - 9	95817-06012	G - 5
90445-12006	B - 12		D - 5	93101-10090	B - 8	93306-30810	B - 4		C - 14	95817-08014	F - 11
90450-32015	B - 8	90480-14532	F - 10	93101-12168	C - 3	93306-37206	C - 10	95022-06030	B - 8	95817-10035	D - 2
90450-59006	B - 11	90480-15235	B - 9	93101-35001	C - 6	93310-32590	C - 8		C - 2	95822-06016	B - 14
90450-72002	B - 11	90480-18290	E - 5	93102-15212	C - 14	93310-84017	B - 4		C - 3	95822-06020	C - 4
90460-85135	C - 4	90501-05764	F - 15	93102-30010	C - 10	93315-21813	C - 6		C - 6	95822-06025	F - 7
90462-08049	C - 2	90501-06022	C - 12	93102-35004	C - 6	93316-01003	C - 6		F - 13		F - 8
90462-08050	C - 3	90501-08665	F - 6	93102-35009	D - 11	93332-00046	D - 11	95022-06040	B - 10	95822-06030	C - 3
90462-08055	C - 4	90501-10353	C - 12	93102-42004	C - 8	93332-00053	D - 11		C - 6	95822-06040	C - 3
90462-10041	C - 2	90501-12004	C - 13	93104-09025	F - 5	93410-20038	C - 12	95022-06045	B - 9	95822-08012	B - 15
90464-09013	G - 5	90501-120A6	C - 12	93104-41119	C - 7	93410-22039	D - 13	95022-06050	B - 8	95827-08030	E - 2
90464-10112	G - 4	90501-18002	D - 13	93105-46001	D - 14		D - 15		C - 3	97002-05016	G - 5
90464-12045	G - 5		D - 15	93112-31011	E - 2	93410-46079	C - 6	95022-06060	C - 2	97002-06012	B - 12

NUMERICAL INDEX

PART NO.	GRID NO.	PART NO.	GRID NO.	PART NO.	GRID NO.	PART NO.	GRID NO.	PART NO.	GRID NO.	PART NO.	GRID NO.
97007-05020	G - 3										
97017-06010	B - 9										
97022-06014	F - 9										
97022-08025	D - 12										
97022-08030	C - 10										
97022-08035	D - 12										
97027-08060	E - 2										
97702-50512	D - 4										
97702-50516	F - 11										
97702-50520	B - 11										
97702-60025	G - 3										
98502-03530	F - 15										
98502-05016	D - 3										
98502-05020	F - 5										
98502-06016	B - 14										
98507-04016	F - 5										
98507-05012	B - 12										
98507-05020	F - 5										
98507-06010	B - 12										
98507-06012	B - 12										
98706-04012	F - 7										
	F - 8										
98902-06020	G - 4										
99001-10600	F - 9										
99009-10400	B - 8										
99009-12400	C - 12										
99009-19400	D - 13										
	D - 15										
99009-30400	E - 4										
	E - 7										
	E - 9										
99009-35400	B - 4										
99009-55500	E - 7										
	E - 9										
	E - 13										
	E - 15										
99009-80500	C - 6										
99530-08012	C - 14										
99530-10014	D - 12										
99530-10116	C - 2										
	C - 3										
	C - 6										
99530-14016	C - 2										