



PARTS CATALOGUE

YFZ450X (5D3B) U.S.A.

YFZ450X (5D3C) CANADA

YFZ450X (5D3D) EUROPE

YFZ450X (5D3B) OCEANIA

YFZ450 (5D3B) JAPAN



2009/1/27

1G5D3-100E1

(2G5D3-100E1)

NEWS NO.	DATE	COMMENT
PE0-MC-080062	Oct.,27,2008	FIG.9 CARBURETOR LIST REVISION

YFZ450X/YFM450
PARTS CATALOGUE
©2007 by Yamaha Motor Co., Ltd.
1st edition, May 2007
All rights reserved.
Any reprinting or unauthorized use
without the written permission of
Yamaha Motor Co., Ltd.
is expressly prohibited.

A3

FOREWORD

This Parts Catalogue is related to the parts for the model(s) on the cover page. When you are ordering replacement parts, please refer to this Parts Catalogue and quote both part numbers and part names correctly.

1. Modifications or additions which have been made after the issue of the Parts Catalogue will be announced in the Parts News.

It is advisable that you make the necessary corrections to the Parts Catalogue according to the Parts News.

2. Abbreviations

The following abbreviations are used in this Parts Catalogue.

“UR” Use specified parts number.

“UN” Use as many as needed.

“AP” Alternate Parts

“LM” Locally Made (Parts need to be ordered locally)

“F#” Frame No. (Applicable machine No.)

“O/S” Over Size

3. The number of components for assembly

- Parts, which are to be supplied in an assembly, are listed with a dot (.) in front of the part name as shown below.
- The numeral appearing to the right of each component part indicates the quantity of parts for each assembly unit.

PART NO.	DESCRIPTION	Q'TY	REMARKS
2F5-83310-60	FRONT FLASHER LIGHT ASSY	2	
115-83311-60	.BULB (6V-18W)	1	

4. Applicable colours of graphics are represented in the “REMARKS” as shown below.

PART NO.	DESCRIPTION	Q'TY	REMARKS
2N4-24110-00-X5	FUEL TANK COMP.	2	MXR
3J1-24240-10	.GRAPHIC, FUEL TANK	1	FOR MXR

5. Note that the illustrations for reference in finding parts numbers are not to be used for assembling. When assembling, please use the applicable service manual.

6. The asterisk (*) before a reference number indicates modified items after the first edition.

FOREWORD

7. Applicable Serial No.

Engine Serial No.

Frame Serial No.

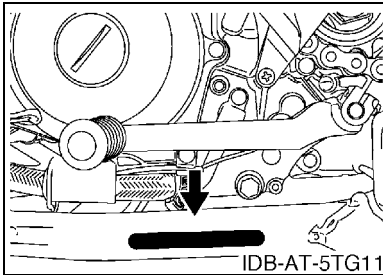
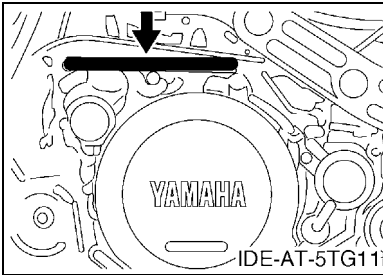

8. Applicable Colour Code (The (*) mark shows Model colour.)

Abbreviation	Colour Name	Colour Code
DPBSE(*)	DEEP PURPLISH BLUE SOLID E	0583
PGD(*)	PASTEL DARK GRAY	003E

9. Quantity Column Information

Column No.	Name Of Q'ty Column	Destination
1	USA	U.S.A.
2	CAN	CANADA
3	EUR	EUROPE
4	OCE	OCEANIA
5	JPN	JAPAN

CONTENTS

ENGINE

CYLINDER	B2
CRANKSHAFT & PISTON	B4
VALVE	B5
CAMSHAFT & CHAIN	B7
WATER PUMP	B8
RADIATOR & HOSE	B9
OIL PUMP	B10
INTAKE	B12
CARBURETOR	B14
EXHAUST	C4
CRANKCASE	C5
CRANKCASE COVER 1	C6
STARTER	C8
CLUTCH	C9
TRANSMISSION	C11
SHIFT CAM & FORK	C13

CHASSIS

FRAME	C14
FRONT FENDER	D2
REAR FENDER	D3
OIL TANK	D5
REAR ARM	D7
REAR SUSPENSION	D10
STEERING	D11
FRONT SUSPENSION & WHEEL	D12
FUEL TANK	D15
SEAT	E3
FRONT WHEEL	E4
FRONT BRAKE CALIPER	E5
REAR WHEEL	E7
REAR BRAKE CALIPER	E8
STEERING HANDLE & CABLE	E9
FRONT MASTER CYLINDER	E10
STAND & FOOTREST	E11
REAR MASTER CYLINDER	E12
GUARD	E14
GENERATOR	E15
STARTING MOTOR	F2
HEADLIGHT	F3
TAILLIGHT	F4

TAILLIGHT 2	F5
HANDLE SWITCH & LEVER	F6
ELECTRICAL 1	F7
ELECTRICAL 2	F10
EMBLEM & LABEL 1	F11
EMBLEM & LABEL 2	F12
EMBLEM & LABEL 3	F14
EMBLEM & LABEL 4	F15
EMBLEM & LABEL 5	G2

INDEX

NUMERICAL INDEX	M1
-----------------------	----

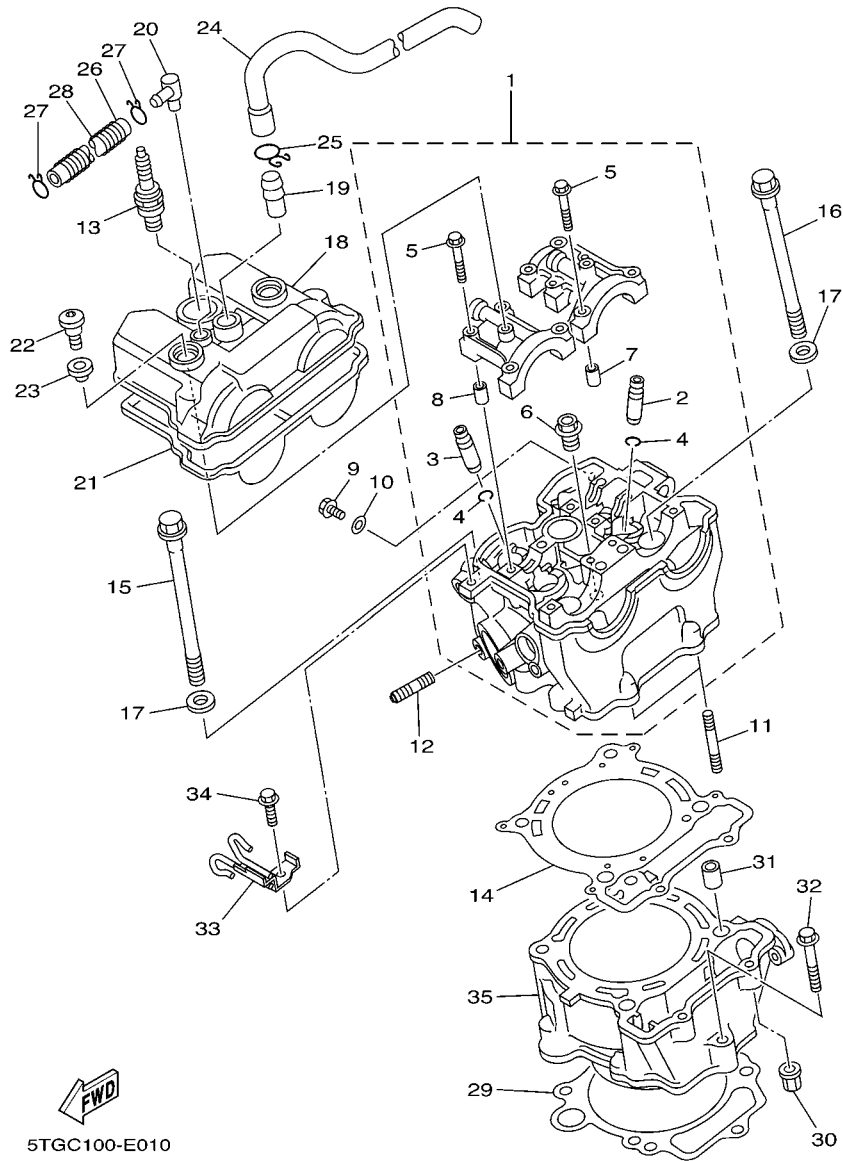

5TGC100-E010

FIG. 1 CYLINDER

REF. NO.	PART NO.	DESCRIPTION	USA	CAN	EUR	OCE	JPN	REMARKS
1	5D3-11102-00	CYLINDER HEAD ASSY	1	1	1	1	1	
2	5TA-11133-10	.GUIDE, VALVE 1	3	3	3	3	3	
3	5TA-11134-10	.GUIDE, VALVE 2	2	2	2	2	2	
4	93440-10153	.CIRCLIP	5	5	5	5	5	
5	90105-06027	.BOLT, FLANGE	10	10	10	10	10	
6	90340-12007	.PLUG, STRAIGHT SCREW	1	1	1	1	1	
7	91808-16023	.PIN, DOWEL	2	2	2	2	2	
8	91808-16023	.PIN, DOWEL	2	2	2	2	2	
9	95022-06010	BOLT, FLANGE	1	1	1	1	1	
10	90430-06014	GASKET	1	1	1	1	1	
11	95612-06635	BOLT, STUD	2	2	2	2	2	
12	90116-08022	BOLT, STUD	2	2	2	2	2	
13	94701-00411	PLUG, SPARK (NGK R CR8E)	1	1	1	1	1	
	94703-00411	PLUG, SPARK (NGK R CR8E)					1	
14	5TA-11181-00	GASKET, CYLINDER HEAD 1	1	1	1	1	1	
15	90105-104A7	BOLT, FLANGE	2	2	2	2	2	
16	90105-106A3	BOLT, FLANGE	2	2	2	2	2	
17	90201-10025	WASHER, PLATE	4	4	4	4	4	
18	5TG-11191-00	COVER, CYLINDER HEAD 1	1	1	1	1	1	
19	371-11167-01	PIPE, BREATHER 2	1	1	1	1	1	
20	5D3-11167-00	PIPE, BREATHER 2	1	1	1	1	1	
21	5TA-11193-00	GASKET, HEAD COVER 1	1	1	1	1	1	
22	90109-06203	BOLT	2	2	2	2	2	
23	4KG-1111G-00	RUBBER, MOUNT 1	2	2	2	2	2	
24	5TG-11166-00	PIPE, BREATHER 1	1	1	1	1	1	
25	90467-140A4	CLIP	1	1	1	1	1	
26	90445-11182	HOSE (L300)	1	1	1	1	1	

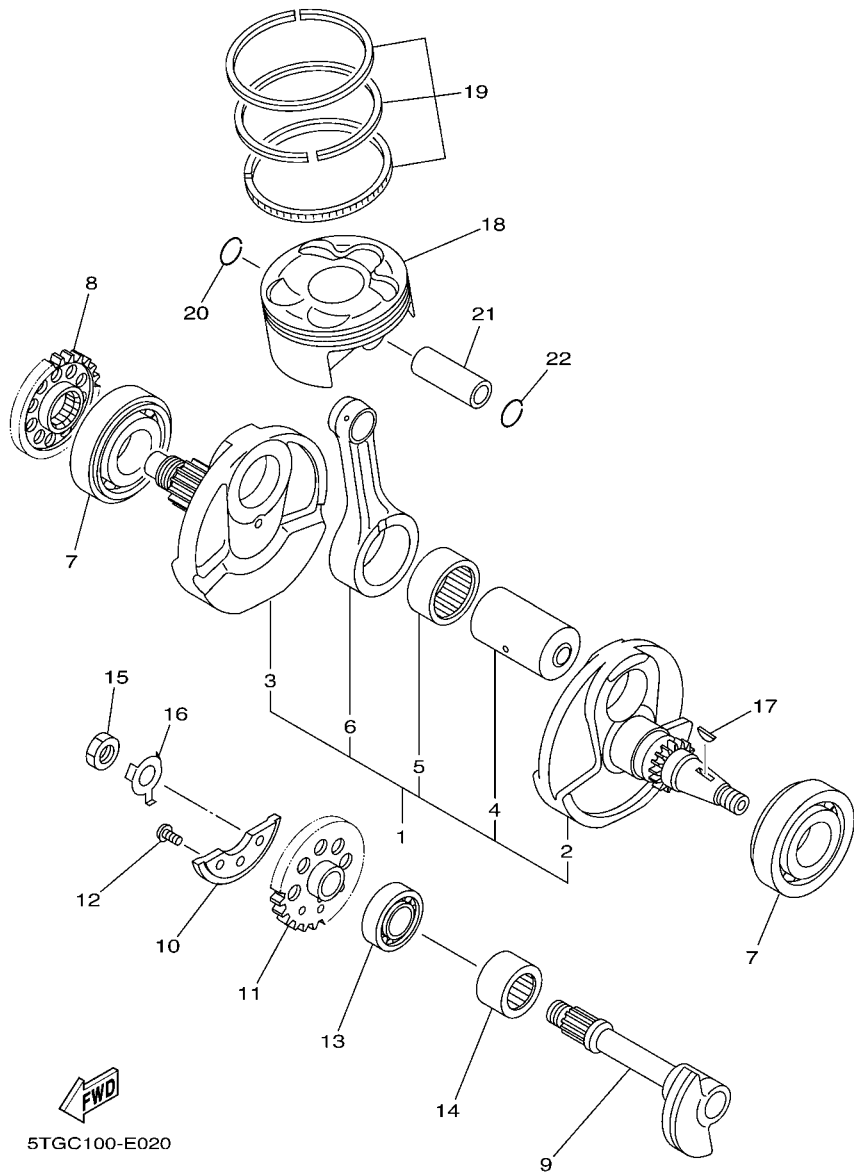
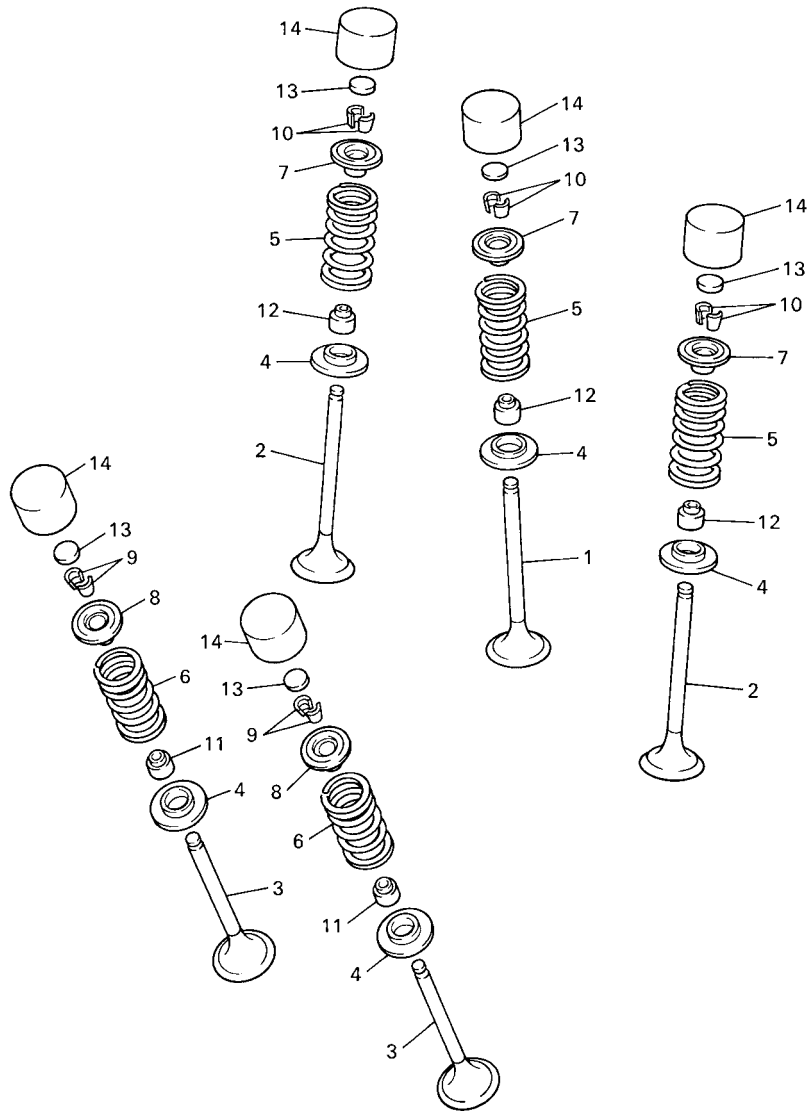

FIG. 2 CRANKSHAFT & PISTON

REF. NO.	PART NO.	DESCRIPTION	USA	CAN	EUR	OCE	JPN	REMARKS
1	5TG-11400-30	CRANKSHAFT ASSY	1	1	1	1	1	
2	5TG-11412-30	.CRANK 1	1	1	1	1	1	
3	5TG-11422-30	.CRANK 2	1	1	1	1	1	
4	5TG-11681-00	.PIN, CRANK 1	1	1	1	1	1	
5	93310-63458	.BEARING	1	1	1	1	1	
6	5D3-11651-00	.ROD, CONNECTING	1	1	1	1	1	
7	93306-30633	BEARING	2	2	2	2	2	
8	5TA-11536-00	GEAR, DRIVE	1	1	1	1	1	
9	5TA-11455-11	SHAFT 1	1	1	1	1	1	
10	5BE-11454-00	WEIGHT 1	1	1	1	1	1	
11	5TA-11531-01	GEAR, BALANCE WEIGHT	1	1	1	1	1	
12	90149-06084	SCREW	3	3	3	3	3	
13	93306-20335	BEARING	1	1	1	1	1	
14	93311-62574	BEARING	1	1	1	1	1	
15	90170-14171	NUT	1	1	1	1	1	
16	90215-14287	WASHER, LOCK	1	1	1	1	1	
17	90280-03006	KEY, WOODRUFF	1	1	1	1	1	
18	5TG-11631-11	PISTON (STD)	1	1	1	1	1	
19	5TG-11603-00	PISTON RING SET (STD)	1	1	1	1	1	
20	93450-22027	CIRCLIP	1	1	1	1	1	
21	5TG-11633-10	PIN, PISTON	1	1	1	1	1	
22	93450-22027	CIRCLIP	1	1	1	1	1	



5BE100-8030

FIG. 3 VALVE

REF. NO.	PART NO.	DESCRIPTION	USA	CAN	EUR	OCE	JPN	REMARKS
1	5TA-12111-00	VALVE, INTAKE	1	1	1	1	1	
2	5TA-12112-00	VALVE, INTAKE 2	2	2	2	2	2	
3	5TA-12121-00	VALVE, EXHAUST	2	2	2	2	2	
4	3GM-12126-00	SEAT, VALVE SPRING 2	5	5	5	5	5	
5	5TA-12113-00	SPRING, VALVE INNER	3	3	3	3	3	
6	5TA-12114-00	SPRING, VALVE OUTER	2	2	2	2	2	
7	5BE-12117-00	RETAINER, VALVE SPRING	3	3	3	3	3	
8	4GY-12117-00	RETAINER, VALVE SPRING	2	2	2	2	2	
9	1AA-12118-00	COTTER, VALVE	4	4	4	4	4	
10	1WG-12118-00	COTTER, VALVE	6	6	6	6	6	
11	33M-12119-00	SEAL, VALVE STEM	2	2	2	2	2	
12	4SV-12119-00	SEAL, VALVE STEM	3	3	3	3	3	
13	3LD-12168-00	PAD, ADJUSTING (1.20)	5	5	5	5	5	UR
	3LD-12168-20	PAD, ADJUSTING (1.25)	5	5	5	5	5	UR
	3LD-12168-40	PAD, ADJUSTING (1.30)	5	5	5	5	5	UR
	3LD-12168-60	PAD, ADJUSTING (1.35)	5	5	5	5	5	UR
	3LD-12168-80	PAD, ADJUSTING (1.40)	5	5	5	5	5	UR
	3LD-12168-A0	PAD, ADJUSTING (1.45)	5	5	5	5	5	UR
	3LD-12168-F0	PAD, ADJUSTING (1.50)	5	5	5	5	5	UR
	3LD-12168-H1	PAD, ADJUSTING (1.55)	5	5	5	5	5	UR
	3LD-12168-K1	PAD, ADJUSTING (1.60)	5	5	5	5	5	UR
	3LD-12168-M1	PAD, ADJUSTING (1.65)	5	5	5	5	5	UR
	3LD-12168-R1	PAD, ADJUSTING (1.70)	5	5	5	5	5	UR
	3LD-12168-U1	PAD, ADJUSTING (1.75)	5	5	5	5	5	UR
	3LD-12168-W1	PAD, ADJUSTING (1.80)	5	5	5	5	5	UR
	3LD-12168-Y1	PAD, ADJUSTING (1.85)	5	5	5	5	5	UR
	3LD-12169-11	PAD, ADJUSTING (1.90)	5	5	5	5	5	UR

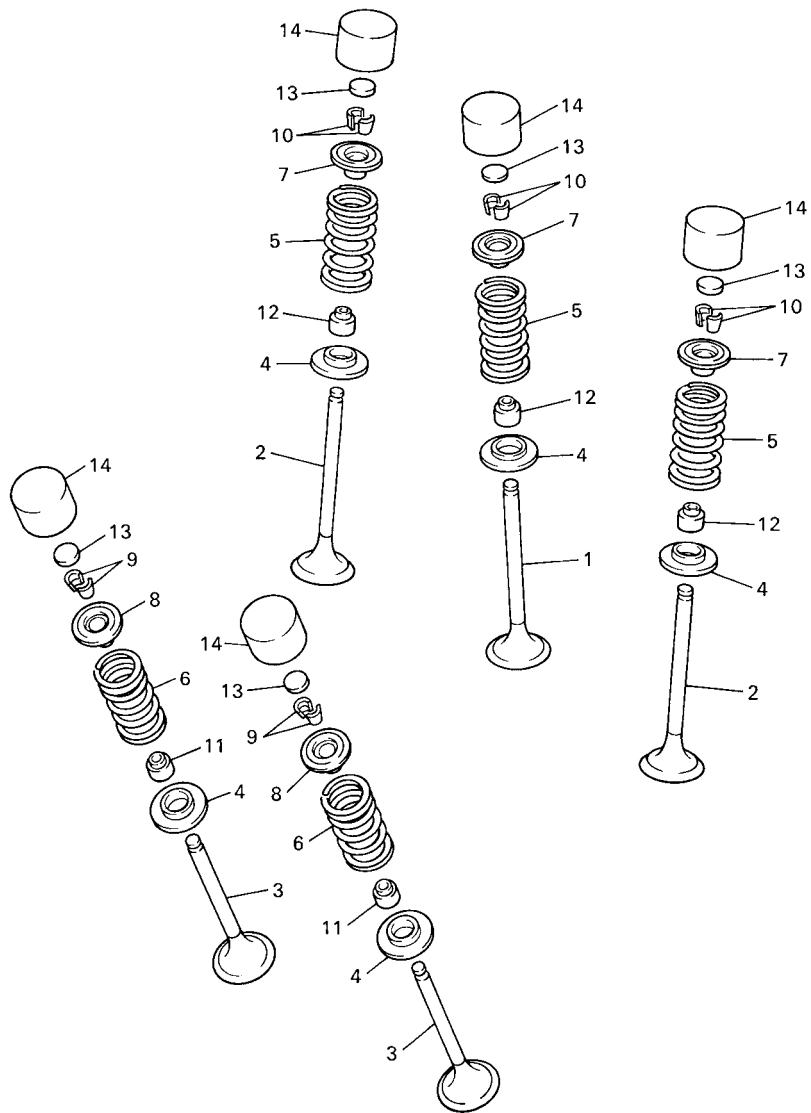

5BE100-8030

FIG. 3 VALVE

REF. NO.	PART NO.	DESCRIPTION	USA	CAN	EUR	OCE	JPN	REMARKS
13	3LD-12169-31	PAD, ADJUSTING (1.95)	5	5	5	5	5	UR
	3LD-12169-50	PAD, ADJUSTING (2.00)	5	5	5	5	5	UR
	3LD-12169-70	PAD, ADJUSTING (2.05)	5	5	5	5	5	UR
	3LD-12169-90	PAD, ADJUSTING (2.10)	5	5	5	5	5	UR
	3LD-12169-E0	PAD, ADJUSTING (2.15)	5	5	5	5	5	UR
	3LD-12169-G0	PAD, ADJUSTING (2.20)	5	5	5	5	5	UR
	3LD-12169-J0	PAD, ADJUSTING (2.25)	5	5	5	5	5	UR
	3LD-12169-L0	PAD, ADJUSTING (2.30)	5	5	5	5	5	UR
	3LD-12169-N0	PAD, ADJUSTING (2.35)	5	5	5	5	5	UR
	3LD-12169-T0	PAD, ADJUSTING (2.40)	5	5	5	5	5	UR
14	3FV-12153-10	LIFTER, VALVE	5	5	5	5	5	YELLOW

FIG. 5 WATER PUMP

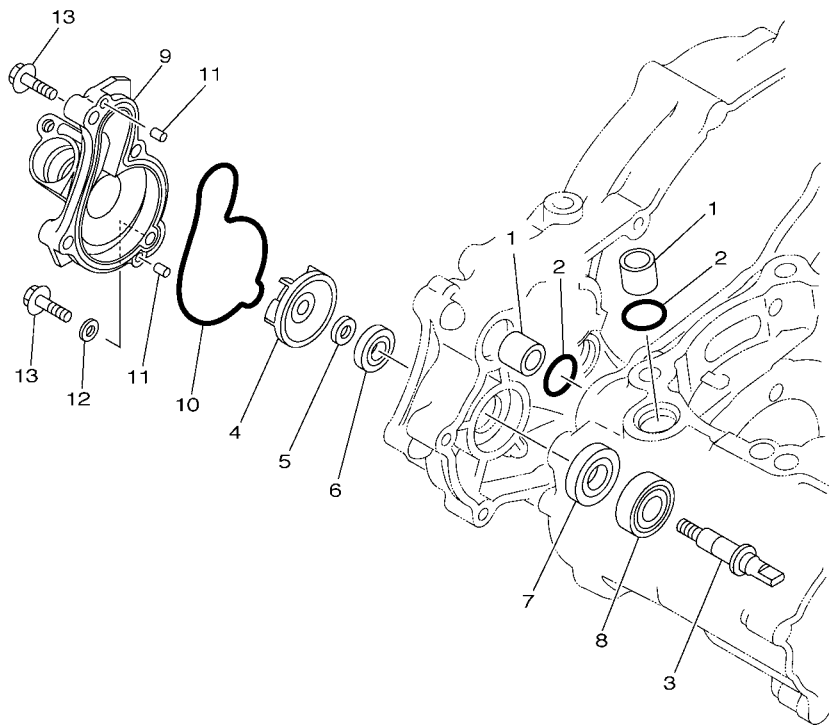

REF. NO.	PART NO.	DESCRIPTION	USA	CAN	EUR	OCE	JPN	REMARKS
1	5BE-12564-00	PIPE, WATER	2	2	2	2	2	
2	93210-19758	O-RING	2	2	2	2	2	
3	5GR-12458-00	SHAFT, IMPELLER	1	1	1	1	1	
4	5DJ-12451-00	IMPELLER, WATER PUMP	1	1	1	1	1	
5	90201-08512	WASHER, PLATE	1	1	1	1	1	
6	93102-11008	OIL SEAL	1	1	1	1	1	
7	93102-12106	OIL SEAL (SD 12-22-5 HS)	1	1	1	1	1	
8	93306-00105	BEARING	1	1	1	1	1	
9	5TG-12422-00	COVER, HOUSING	1	1	1	1	1	
10	5TG-12439-00	O-RING	1	1	1	1	1	
11	93604-10011	PIN, DOWEL	2	2	2	2	2	
12	90430-06014	GASKET	1	1	1	1	1	
13	95022-06030	BOLT, FLANGE	4	4	4	4	4	



5TG1100-C050

FIG. 6 RADIATOR & HOSE

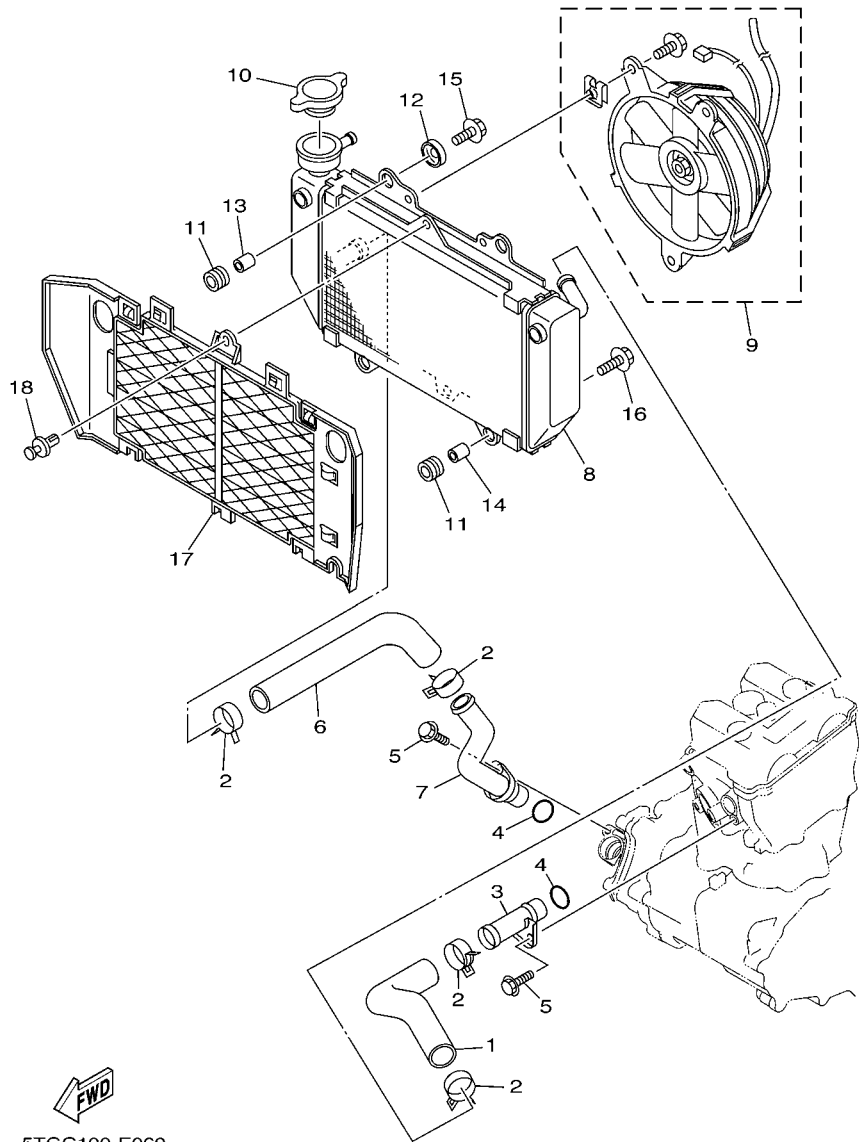

5TGC100-E060

REF. NO.	PART NO.	DESCRIPTION	USA	CAN	EUR	OCE	JPN	REMARKS
1	5TG-12576-00	HOSE 1	1	1	1	1	1	
2	90467-23109	CLIP	4	4	4	4	4	
3	5TG-12481-00	PIPE 1	1	1	1	1	1	
4	93210-16500	O-RING	2	2	2	2	2	
5	95022-06012	BOLT, FLANGE	2	2	2	2	2	
6	5TG-12577-00	HOSE 2	1	1	1	1	1	
7	5TG-12482-00	PIPE 2	1	1	1	1	1	
8	5TG-12461-10	RADIATOR ASSY	1	1	1	1	1	
9	5TG-12405-00	BLOWER ASSY	1	1	1	1	1	
10	5SL-12462-00	CAP, RADIATOR	1	1	1	1	1	
11	90480-15235	GROMMET	4	4	4	4	4	
12	90209-06012	WASHER	2	2	2	2	2	
13	90387-06113	COLLAR	2	2	2	2	2	
14	90387-07020	COLLAR	2	2	2	2	2	
15	95802-06020	BOLT, FLANGE	2	2	2	2	2	
16	95802-06025	BOLT, FLANGE	2	2	2	2	2	
17	5TG-12467-10	COVER, RADIATOR	1	1	1	1	1	
18	90269-07076	RIVET	1	1	1	1	1	

FIG. 7 OIL PUMP

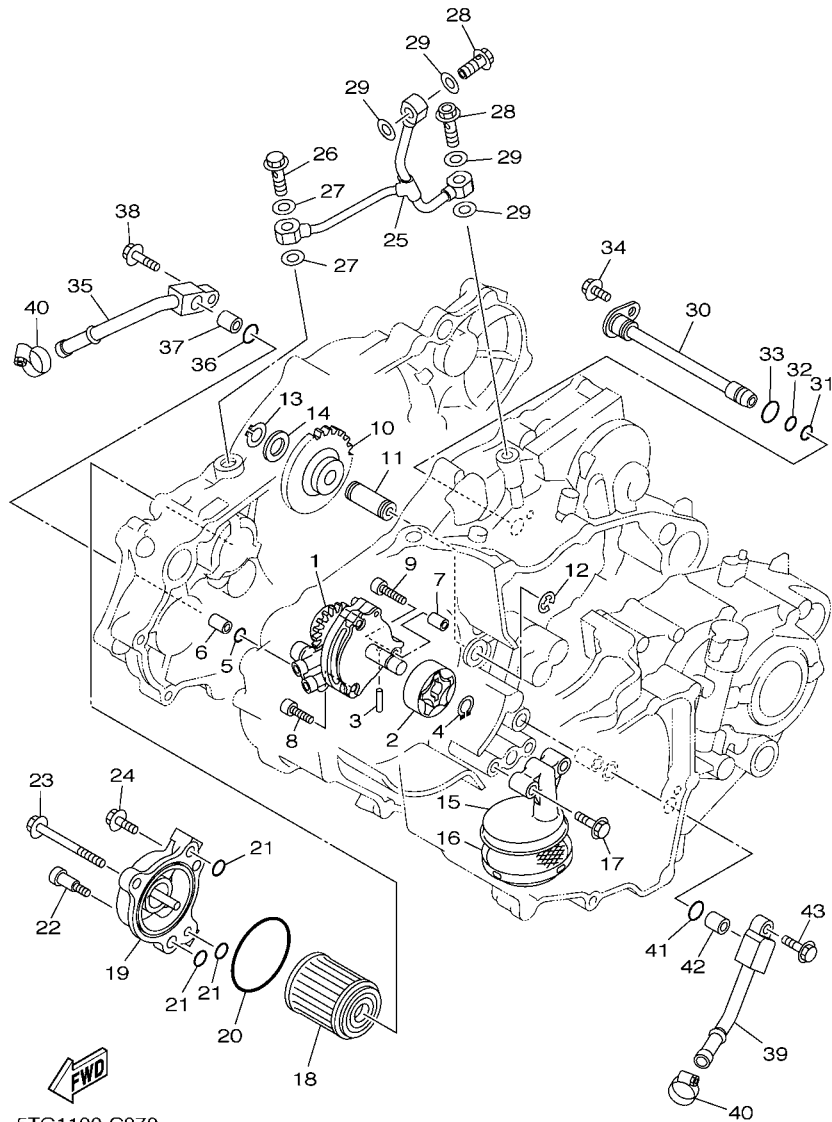

5TG1100-C070

REF. NO.	PART NO.	DESCRIPTION	USA	CAN	EUR	OCE	JPN	REMARKS
1	5D3-13300-00	OIL PUMP ASSY	1	1	1	1	1	
2	5TA-13320-00	ROTOR ASSY 2	1	1	1	1	1	
3	93603-16219	PIN, DOWEL	1	1	1	1	1	
4	93440-10153	CIRCLIP	1	1	1	1	1	
5	93210-10197	O-RING	1	1	1	1	1	
6	99530-10114	PIN, DOWEL	1	1	1	1	1	
7	99530-08012	PIN, DOWEL	1	1	1	1	1	
8	91312-06025	BOLT	2	2	2	2	2	
9	91312-06030	BOLT	1	1	1	1	1	
10	5TA-13341-00	GEAR, OIL PUMP IDLE	1	1	1	1	1	
11	5BE-13342-00	SHAFT, IDLE GEAR	1	1	1	1	1	
12	99002-08600	CIRCLIP	1	1	1	1	1	
13	99009-12400	CIRCLIP	1	1	1	1	1	
14	90201-12166	WASHER, PLATE	1	1	1	1	1	
15	5TA-13412-00	HOUSING, STRAINER	1	1	1	1	1	
16	5BE-13411-00	STRAINER, OIL	1	1	1	1	1	
17	95022-06025	BOLT, FLANGE	2	2	2	2	2	
18	5D3-13440-00	ELEMENT ASSY, OIL CLEANER	1	1	1	1	1	
19	5BE-13447-10	COVER, OIL ELEMENT	1	1	1	1	1	
20	93210-47675	O-RING	1	1	1	1	1	
21	93210-07135	O-RING	3	3	3	3	3	
22	90110-06228	BOLT, HEXAGON SOCKET HEAD	1	1	1	1	1	
23	91312-06065	BOLT	1	1	1	1	1	
24	91312-06020	BOLT	1	1	1	1	1	
25	5TJ-13161-00	PIPE, DELIVERY 1	1	1	1	1	1	
26	90401-10015	BOLT, UNION	1	1	1	1	1	
27	90430-10188	GASKET	2	2	2	2	2	

FIG. 7 OIL PUMP

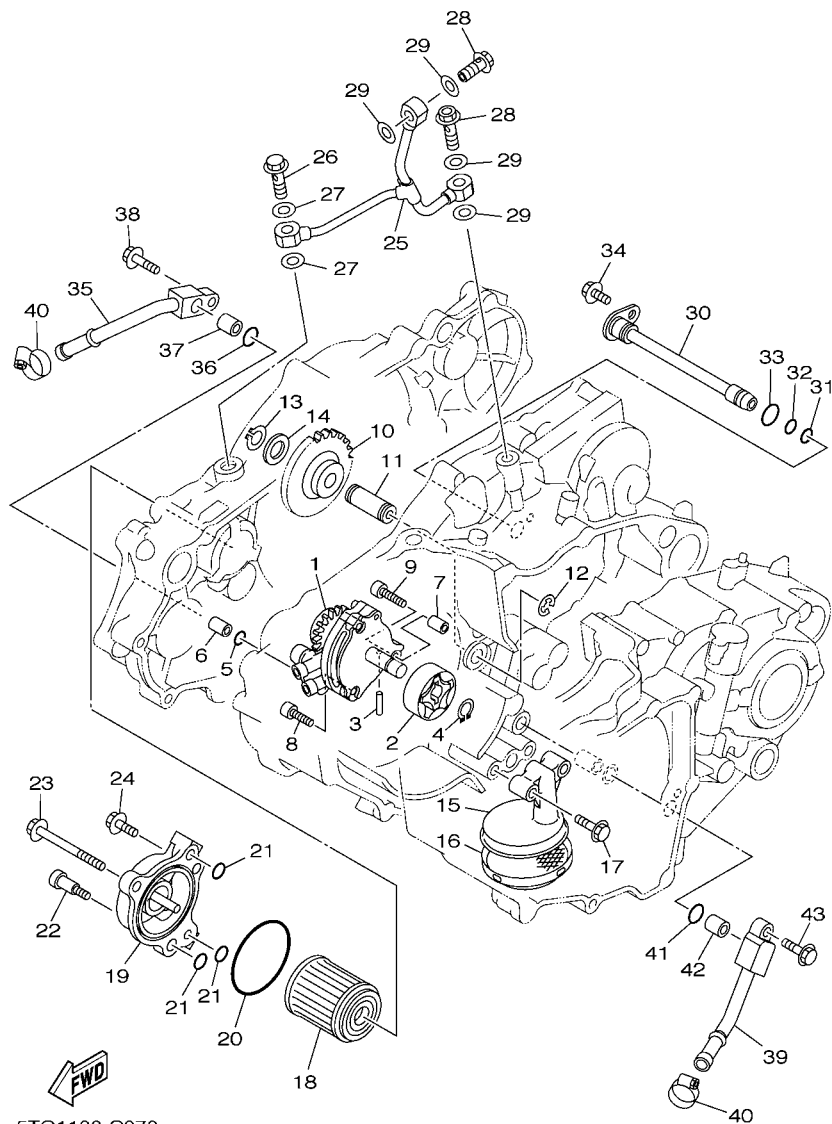

5TG1100-C070

REF. NO.	PART NO.	DESCRIPTION	USA	CAN	EUR	OCE	JPN	REMARKS
28	90401-08006	BOLT, UNION	2	2	2	2	2	
29	90430-08119	GASKET	4	4	4	4	4	
30	5TG-13171-00	PIPE, DELIVERY 2	1	1	1	1	1	
31	93210-07003	O-RING	1	1	1	1	1	
32	93210-09008	O-RING	1	1	1	1	1	
33	93210-12759	O-RING	1	1	1	1	1	
34	95022-06012	BOLT, FLANGE	1	1	1	1	1	
35	5TG-13416-10	PIPE, OIL 1	1	1	1	1	1	
36	93210-10197	O-RING	1	1	1	1	1	
37	99530-10114	PIN, DOWEL	1	1	1	1	1	
38	95022-06025	BOLT, FLANGE	1	1	1	1	1	
39	5TG-13418-10	PIPE, OIL 2	1	1	1	1	1	
40	90450-22001	HOSE CLAMP ASSY	2	2	2	2	2	
41	93210-10197	O-RING	1	1	1	1	1	
42	99530-10114	PIN, DOWEL	1	1	1	1	1	
43	95022-06025	BOLT, FLANGE	1	1	1	1	1	

FIG. 8 INTAKE

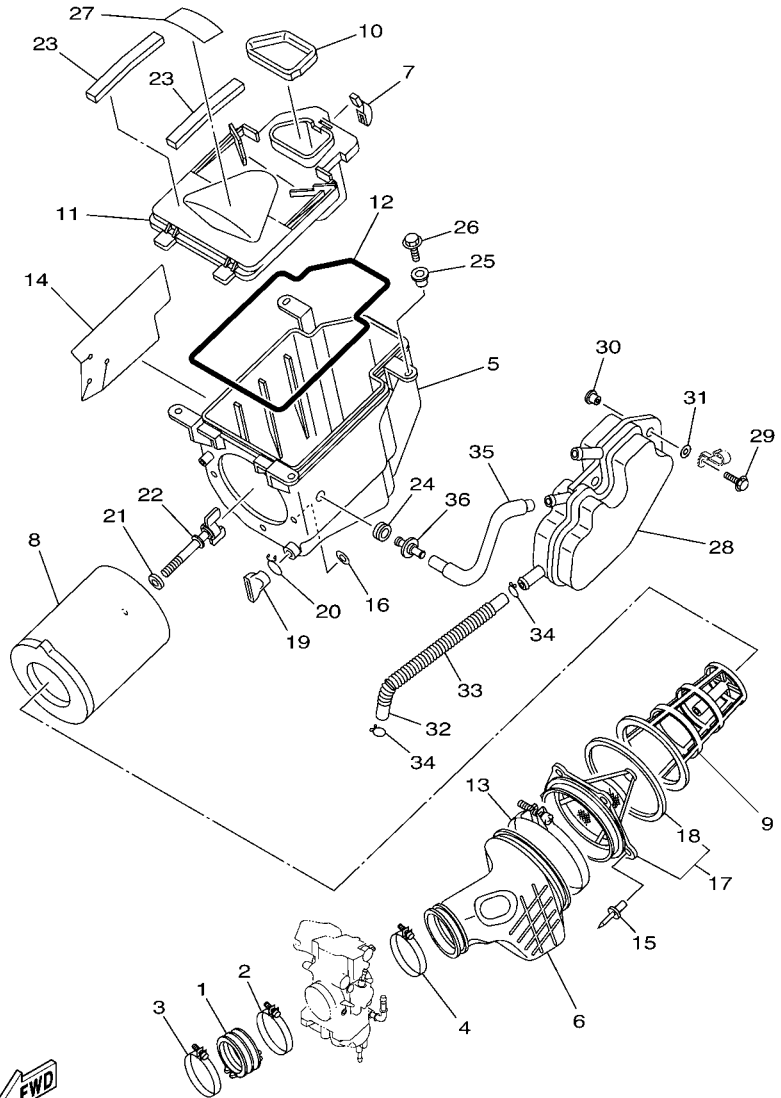

5TG7100-D080

REF. NO.	PART NO.	DESCRIPTION	USA	CAN	EUR	OCE	JPN	REMARKS
1	5XD-13597-10	JOINT, CARBURETOR 3	1	1	1	1	1	
2	90450-57013	HOSE CLAMP ASSY	1	1	1	1	1	
3	90450-59005	HOSE CLAMP ASSY	1	1	1	1	1	
4	90450-61002	HOSE CLAMP ASSY	1	1	1	1	1	
5	5TG-14411-00	CASE, AIR CLEANER 1	1	1	1	1	1	
6	5TG-14453-01	JOINT, AIR CLEANER 1	1	1	1	1	1	
7	5GH-14436-00	HOOK	3	3	3	3	3	
8	5TG-14451-00	ELEMENT, AIR CLEANER	1	1	1	1	1	
9	5TG-14458-00	GUIDE	1	1	1	1	1	
10	5TG-14479-00	FUNNEL	1	1	1	1	1	
11	5TG-14412-01	CAP, CLEANER CASE 1	1	1	1	1	1	
12	4FU-14452-00	SEAL	1	1	1	1	1	
13	90450-99007	HOSE CLAMP ASSY	1	1	1	1	1	
14	5TG-1442F-00	PROTECTOR	1	1	1	1	1	
15	90267-48138	RIVET, BLIND	5	5	5	5	5	
16	90201-04028	WASHER, PLATE	5	5	5	5	5	
17	5D3-14459-00	HOLDER, GUIDE	1	1	1	1	1	
18	4ES-14462-00	.SEAL	1	1	1	1	1	
19	59V-14457-00	SEAL	1	1	1	1	1	
20	90467-220A1	CLIP	1	1	1	1	1	
21	90209-06014	WASHER	1	1	1	1	1	
22	90122-06010	BOLT, WING	1	1	1	1	1	
23	5TG-14409-00	DAMPER	2	2	2	2	2	
24	31A-14435-00	GROMMET	1	1	1	1	1	
25	90387-08073	COLLAR	4	4	4	4	4	
26	90105-06084	BOLT, FLANGE	4	4	4	4	4	
27	5D3-2177C-10	PLATE, EPA OFFROAD ATV 1	1					

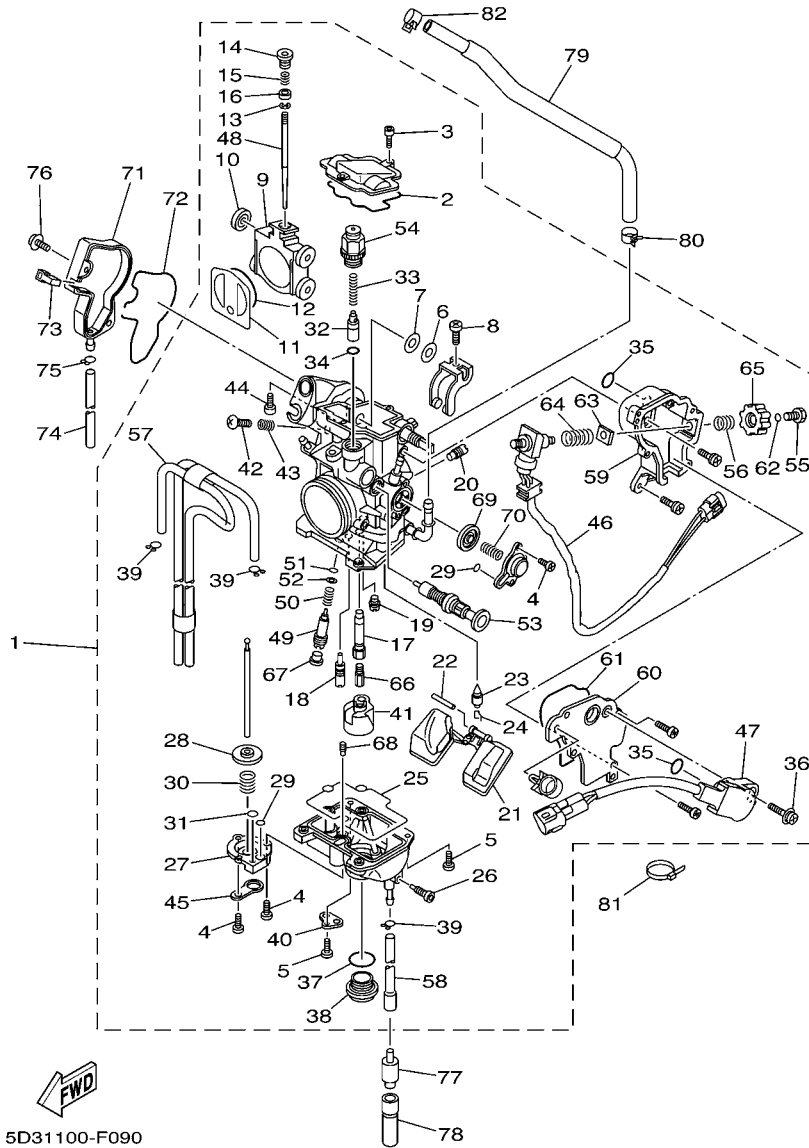

5D31100-F090

FIG. 9 CARBURETOR

REF. NO.	PART NO.	DESCRIPTION	USA	CAN	EUR	OC	JPN	REMARKS
1	5TG-14101-31	CARBURETOR ASSY 1	1	1				
	5TG-14101-21	CARBURETOR ASSY 1			1	1	1	
2	5JG-14959-00	.GASKET	1	1	1	1	1	
3	91316-04012	.BOLT	2	2	2	2	2	
4	688-14592-00	.SCREW	5	5	5	5	5	
5	98502-04012	.SCREW, PAN HEAD	4	4	4	4	4	
6	90202-08045	.WASHER, PLATE	1	1	1	1	1	
7	5JG-14951-00	.WASHER	1	1	1	1	1	
8	5JG-14522-00	.SCREW, ADJUST	1	1	1	1	1	
9	5JG-14388-00	.VALVE, VACUUM CONTROL	1	1	1	1	1	
10	3TJ-14267-40	.ROLLER	1	1	1	1	1	
11	5JG-14546-01	.VALVE, NEEDLE	1	1	1	1	1	
12	4FN-14997-00	.SEAL	1	1	1	1	1	
13	3TJ-14159-40	.CLIP	1	1	1	1	1	
14	5JG-14521-00	.SCREW, ADJUST	1	1	1	1	1	
15	5JG-14275-00	.SPRING	1	1	1	1	1	
16	5JG-14264-00	.COLLAR	1	1	1	1	1	
17	5JG-14947-00	.NOZZLE, MAIN	1	1	1	1	1	
18	4MX-14948-06	.JET, SLOW (#48)	1	1	1	1	1	
19	3TJ-1494F-23	.JET (#90)	1	1	1	1	1	
20	5TA-14943-15	.JET, MAIN (#70)	1	1	1	1	1	
21	4SR-14985-00	.FLOAT	1	1	1	1	1	
22	676-14548-00	.PIN, FLOAT ARM	1	1	1	1	1	
23	4MX-14392-00	.VALVE, NEEDLE	1	1	1	1	1	
24	633-14159-00	.CLIP	1	1	1	1	1	
25	5JG-14984-00	.GASKET, FLOAT CHAMBER	1	1	1	1	1	
26	3TJ-14191-40	.PLUG, DRAIN	1	1	1	1	1	

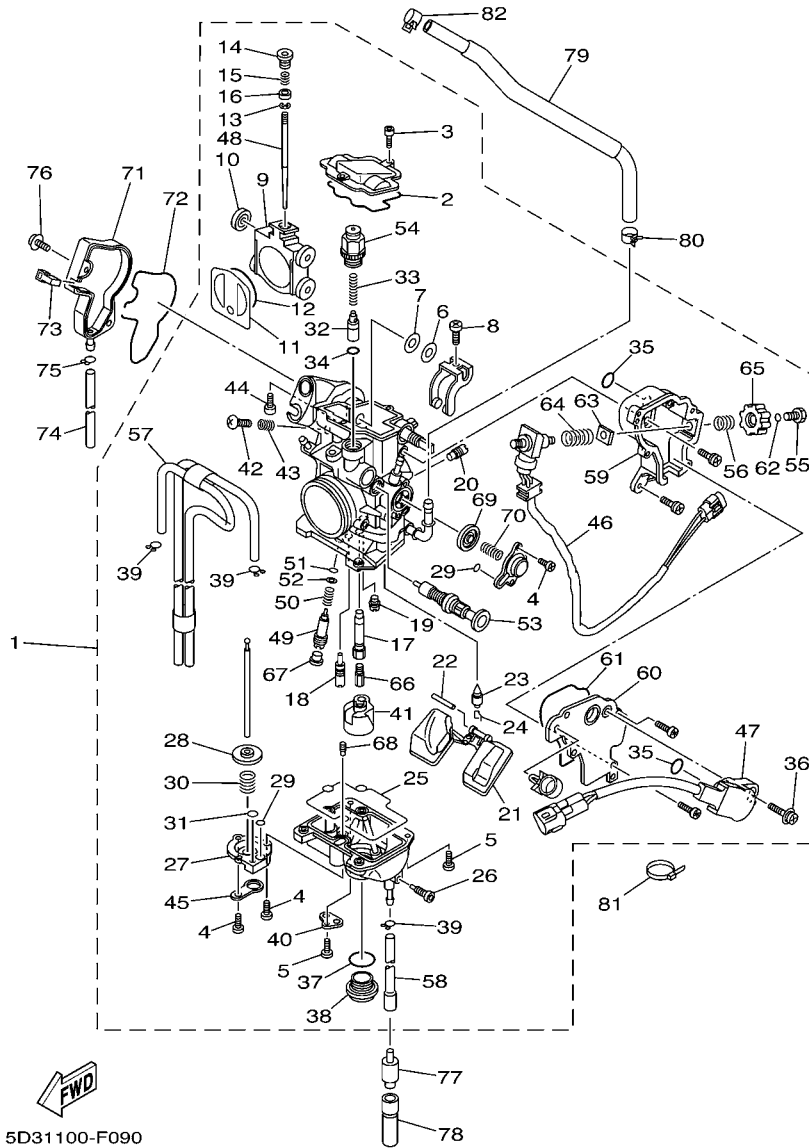

5D31100-F090

FIG. 9 CARBURETOR

REF. NO.	PART NO.	DESCRIPTION	USA	CAN	EUR	OCE	JPN	REMARKS
27	3TJ-14293-40	.COVER 1	1	1	1	1	1	
28	5JG-14940-17	.DIAPHRAGM ASSY	1	1	1	1	1	
29	3TJ-14536-40	.GASKET	2	2	2	2	2	
30	3TJ-14933-40	.SPRING, DIAPHRAGM	1	1	1	1	1	
31	6H4-14561-00	.O-RING	1	1	1	1	1	
32	5TA-14371-00	.PLUNGER, STARTER	1	1	1	1	1	
33	5TA-14335-00	.SPRING, PLUNGER	1	1	1	1	1	
34	5TA-14997-00	.SEAL	1	1	1	1	1	
35	5NX-14562-00	.O-RING	2	2	2	2	2	
36	5NX-14216-00	.SCREW	1	1	1	1	1	
37	4MX-14561-00	.O-RING	1	1	1	1	1	
38	4MX-14115-00	.PLUG, SCREW	1	1	1	1	1	
39	3TJ-14137-40	.CLIP	3	3	3	3	3	
40	5BE-14146-00	.PLATE	1	1	1	1	1	
41	5JG-14346-00	.PLATE	1	1	1	1	1	
42	5JG-14565-00	.SCREW	1	1	1	1	1	
43	5JG-14531-00	.SPRING, ADJUST SCREW	1	1	1	1	1	
44	5JG-14591-00	.SCREW	1	1	1	1	1	
45	5PA-14146-00	.PLATE	1	1	1	1	1	
46	5TG-8259A-00	.SWITCH, CARBURETOR	1	1	1	1	1	
47	5TG-85885-00	.THROTTLE SENSOR ASSY	1	1	1	1	1	
48	5TG-14916-GR	.NEEDLE	1	1				
	5BE-14916-DR	.NEEDLE (#DVR)			1	1	1	
49	3TJ-14923-40	.SCREW, PILOT	1	1	1	1	1	
50	3TJ-14160-40	.COIL, SPRING	1	1	1	1	1	
51	3TJ-14562-40	.O-RING	1	1	1	1	1	
52	3TJ-14952-40	.WASHER	1	1	1	1	1	

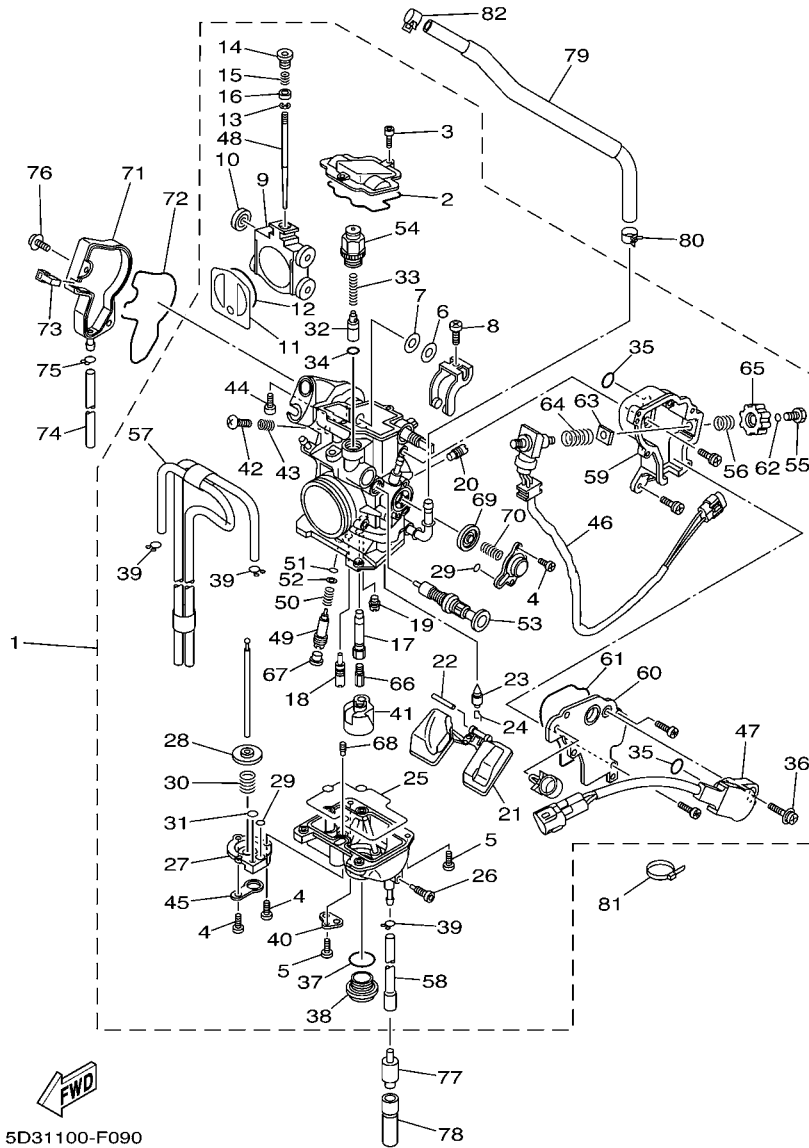

5D31100-F090

FIG. 9 CARBURETOR

REF. NO.	PART NO.	DESCRIPTION	USA	CAN	EUR	OCE	JPN	REMARKS
53	5TG-14171-00	.PLUNGER, STARTER	1	1	1	1	1	
54	5TG-14225-00	.CAP	1	1	1	1	1	
55	5TG-14591-00	.SCREW	1	1	1	1	1	
56	5TG-14935-00	.SPRING	1	1	1	1	1	
57	5TG-14197-00	.PIPE	1	1	1	1	1	
58	5TG-14987-00	.HOSE	1	1	1	1	1	
59	5TG-14417-00	.COVER 1	1	1	1	1	1	
60	5TG-14418-00	.COVER 2	1	1	1	1	1	
61	5TG-14959-00	.GASKET	1	1	1	1	1	
62	5TG-14561-00	.O-RING	1	1	1	1	1	
63	5TG-14255-00	.PLATE	1	1	1	1	1	
64	5TG-14335-00	.SPRING, PLUNGER	1	1	1	1	1	
65	5TG-14261-00	.HOLDER	1	1	1	1	1	
66	4MX-14943-38	.JET, MAIN (#155)	1	1	1	1	1	
67	5TJ-14118-00	.CAP	1	1				
68	4JT-1494F-03	.JET (#40)	1	1	1	1	1	
69	5GS-14940-00	.DIAPHRAGM ASSY	1	1	1	1	1	
70	5GS-14933-00	.SPRING, DIAPHRAGM	1	1	1	1	1	
71	5TA-14293-00	COVER 1	1	1	1	1	1	
72	5TA-14227-00	GASKET	1	1	1	1	1	
73	5TA-14239-00	SEAL	1	1	1	1	1	
74	5TA-14987-00	HOSE	1	1	1	1	1	
75	3TJ-14137-40	CLIP	1	1	1	1	1	
76	90110-05038	BOLT, HEXAGON SOCKET HEAD	2	2	2	2	2	
77	24W-14193-00	PIPE	1	1	1	1	1	
78	91A20-07004	TUBE, FLEXIBLE VINYL	1	1	1	1	1	
79	5TG-24311-20	PIPE, FUEL 1	1	1				

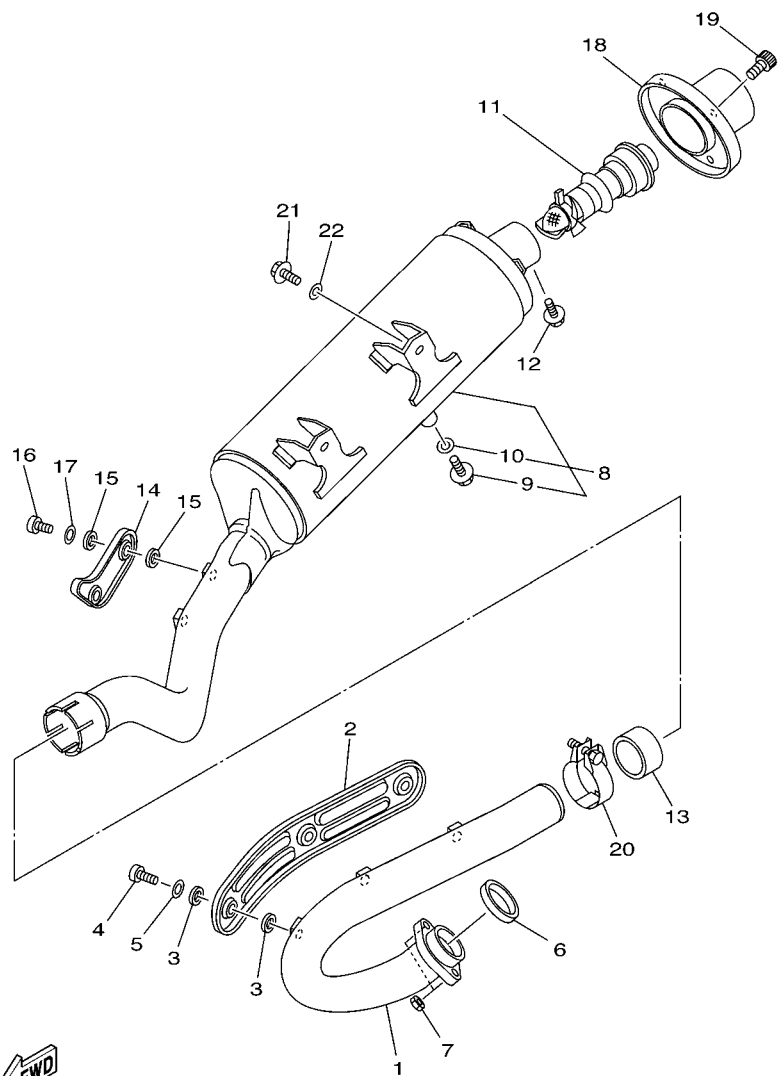

5TGC100-E100

FIG. 10 EXHAUST

REF. NO.	PART NO.	DESCRIPTION	USA	CAN	EUR	OCE	JPN	REMARKS
1	5TG-14611-11	PIPE, EXHAUST 1	1	1	1	1	1	
2	5TG-14628-10	PROTECTOR, EXHAUST PIPE	1	1	1	1	1	
3	90201-05015	WASHER, PLATE	6	6	6	6	6	
4	98980-06010	SCREW, BIND	3	3	3	3	3	
5	92990-06200	WASHER, PLAIN	3	3	3	3	3	
6	3VD-14613-01	GASKET, EXHAUST PIPE	1	1	1	1	1	
7	95702-08500	NUT, WITH WASHER	2	2	2	2	2	
8	5TG-14711-01	MUFFLER 1	1	1	1	1	1	
9	90105-10147	.BOLT, FLANGE	1	1	1	1	1	
10	92990-10600	.WASHER, PLATE	1	1	1	1	1	
11	5TG-14752-00	PIPE, OUTLET	1	1	1	1	1	
12	95022-06008	BOLT, FLANGE	1	1	1	1	1	
13	8FA-14714-10	GASKET, MUFFLER	1	1	1	1	1	
14	5TG-14718-00	PROTECTOR, MUFFLER 1	1	1	1	1	1	
15	90201-05015	WASHER, PLATE	4	4	4	4	4	
16	98902-06010	SCREW, BIND	2	2	2	2	2	
17	92902-06200	WASHER	2	2	2	2	2	
18	5TG-14787-00	CAP, SILENCER	1	1	1	1	1	
19	90110-06134	BOLT, HEXAGON SOCKET HEAD	3	3	3	3	3	
20	5BE-14788-00	BAND, SILENCER	1	1	1	1	1	
21	90105-08129	BOLT, FLANGE	2	2	2	2	2	
22	90201-08048	WASHER, PLATE	2	2	2	2	2	

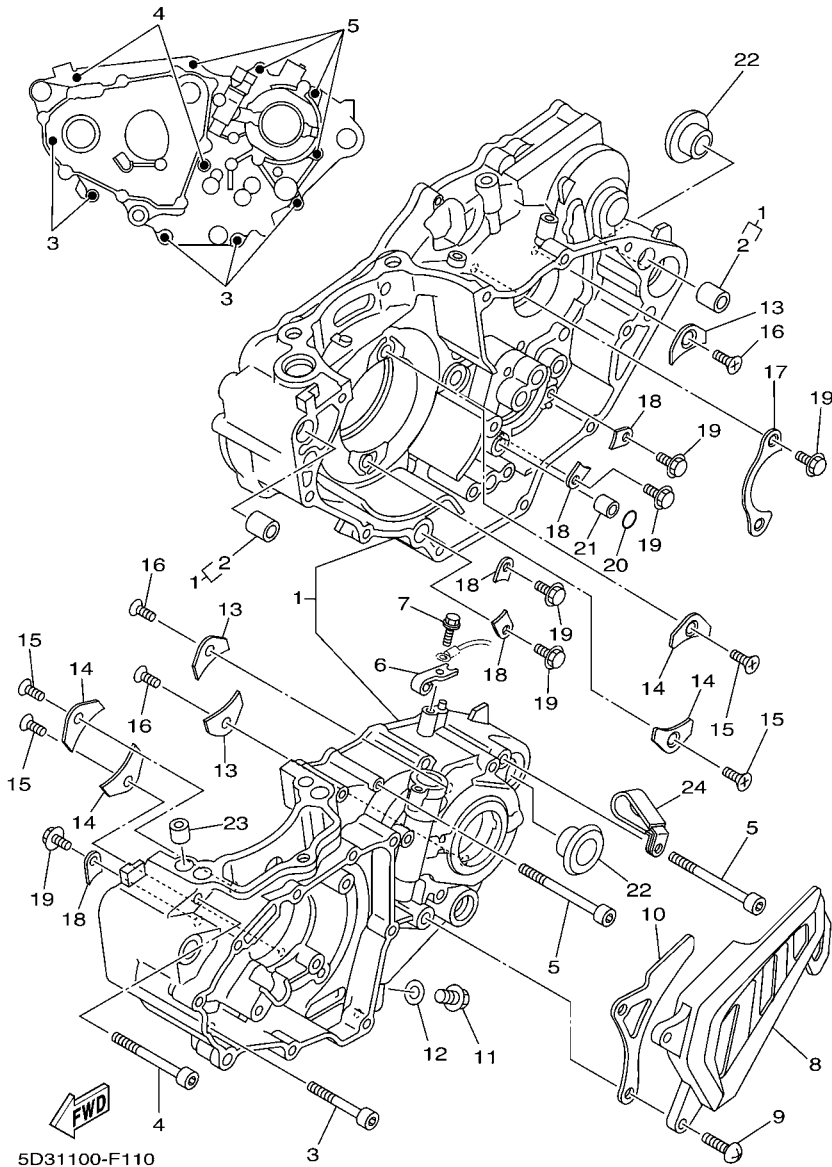
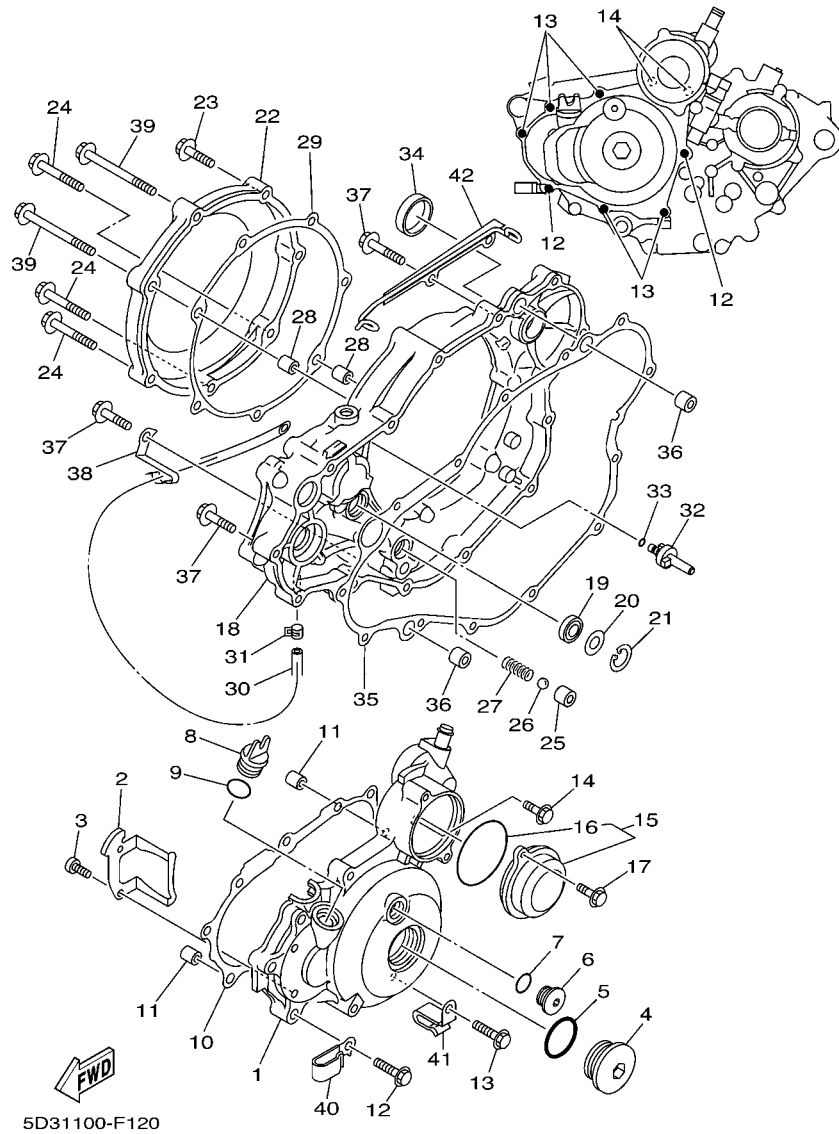

FIG. 11 CRANKCASE

REF. NO.	PART NO.	DESCRIPTION	USA	CAN	EUR	OCE	JPN	REMARKS
1	5TG-15100-01	CRANKCASE ASSY	1	1	1	1	1	
2	99530-14016	.PIN, DOWEL	2	2	2	2	2	
3	91314-06050	BOLT	5	5	5	5	5	
4	91314-06060	BOLT	2	2	2	2	2	
5	91314-06075	BOLT	4	4	4	4	4	
6	5D3-15441-00	HOLDER, CLUTCH CABLE	1	1	1	1	1	
7	95022-06016	BOLT, FLANGE	1	1	1	1	1	
8	5TA-15421-10	COVER, CRANKCASE 2	1	1	1	1	1	
9	98512-06025	SCREW, PAN HEAD	2	2	2	2	2	
10	5TA-17466-00	GUIDE, CHAIN	1	1	1	1	1	
11	95022-10016	BOLT, FLANGE	1	1	1	1	1	
12	90430-10148	GASKET	1	1	1	1	1	
13	4JT-15381-01	PLATE, BEARING COVER	3	3	3	3	3	
14	5BE-15383-01	PLATE, BEARING COVER	4	4	4	4	4	
15	90151-06044	SCREW, COUNTERSUNK	4	4	4	4	4	
16	90149-06074	SCREW	3	3	3	3	3	
17	4L0-17471-00	PLATE, COVER	1	1	1	1	1	
18	5DH-18562-00	PLATE, STOPPER 2	5	5	5	5	5	
19	90105-06081	BOLT, FLANGE	7	7	7	7	7	
20	93210-10197	O-RING	1	1	1	1	1	
21	99530-10114	PIN, DOWEL	1	1	1	1	1	
22	90387-164N2	COLLAR	2	2	2	2	2	
23	99530-10116	PIN, DOWEL	2	2	2	2	2	
24	90461-10011	CLAMP	1	1	1	1	1	

FIG. 12 CRANKCASE COVER 1



REF. NO.	PART NO.	DESCRIPTION	USA	CAN	EUR	OCE	JPN	REMARKS
1	5TG-15411-10	COVER, CRANKCASE 1	1	1	1	1	1	
2	90465-10017	CLAMP	1	1	1	1	1	
3	91312-05012	BOLT	2	2	2	2	2	
4	90340-27003	PLUG, STRAIGHT SCREW	1	1	1	1	1	
5	93210-27370	O-RING	1	1	1	1	1	
6	90340-14003	PLUG, STRAIGHT SCREW	1	1	1	1	1	
7	93210-14369	O-RING	1	1	1	1	1	
8	3Y1-15363-00	PLUG, OIL	1	1	1	1	1	
9	93210-19123	O-RING	1	1	1	1	1	
10	5TG-15451-00	GASKET, CRANKCASE COVER 1	1	1	1	1	1	
11	99530-08016	PIN, DOWEL	2	2	2	2	2	
12	95022-06040	BOLT, FLANGE	2	2	2	2	2	
13	95022-06030	BOLT, FLANGE	5	5	5	5	5	
14	95022-06020	BOLT, FLANGE	2	2	2	2	2	
15	5TG-1549B-10	COVER ASSY 2	1	1	1	1	1	
16	93210-60426	O-RING	1	1	1	1	1	
17	95022-06016	BOLT, FLANGE	2	2	2	2	2	
18	5D3-15431-00	COVER, CRANKCASE 3	1	1	1	1	1	
19	93101-14164	OIL SEAL	1	1	1	1	1	
20	90201-15701	WASHER, PLATE (T=1.0)	1	1	1	1	1	
21	99009-22500	CIRCLIP	1	1	1	1	1	
22	5TG-15415-00	COVER, GENERATOR	1	1	1	1	1	
23	95022-06030	BOLT, FLANGE	2	2	2	2	2	
24	95022-06040	BOLT, FLANGE	3	3	3	3	3	
25	583-13113-00	SEAT, CHECK BALL	1	1	1	1	1	
26	93503-08007	BALL	1	1	1	1	1	
27	90501-043E0	SPRING, COMPRESSION	1	1	1	1	1	

FIG. 12 CRANKCASE COVER 1

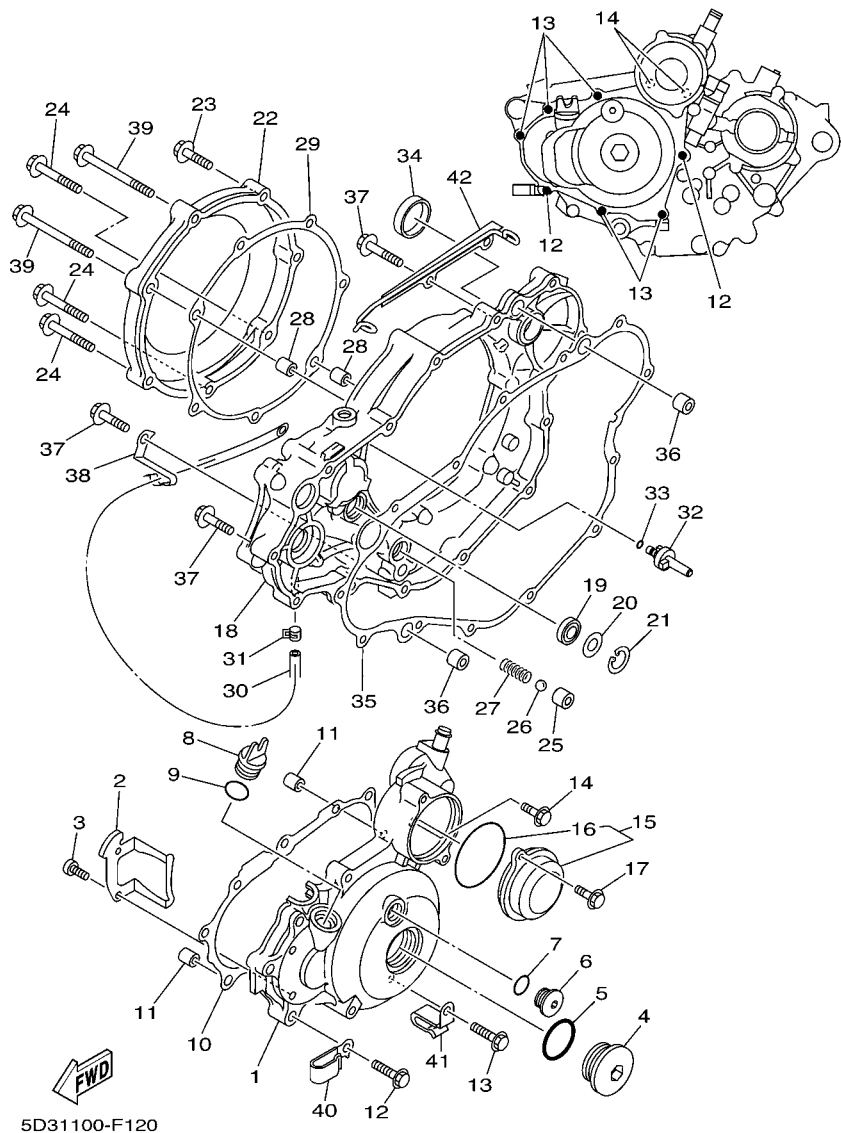

REF. NO.	PART NO.	DESCRIPTION	USA	CAN	EUR	OCE	JPN	REMARKS
28	99530-08016	PIN, DOWEL	2	2	2	2	2	
29	5TA-15453-00	GASKET	1	1	1	1	1	
30	90445-07340	HOSE (L310)	1	1	1	1	1	
31	90467-070A0	CLIP	1	1	1	1	1	
32	5D3-15155-00	NOZZLE 3	1	1	1	1	1	
33	93210-05098	O-RING	1	1	1	1	1	
34	90338-30096	PLUG	1	1	1	1	1	
35	5TG-15462-02	GASKET, CRANKCASE COVER 3	1	1	1	1	1	
36	91812-16001	PIN, DOWEL	2	2	2	2	2	
37	95022-06030	BOLT, FLANGE	10	10	10	10	10	
38	90462-08049	CLAMP	1	1	1	1	1	
39	95022-06080	BOLT, FLANGE	2	2	2	2	2	
40	90462-08044	CLAMP	1	1	1	1	1	
41	90462-10034	CLAMP	1	1	1	1	1	
42	5TG-15484-10	CLAMP 2	1	1	1	1	1	

FIG. 13 STARTER

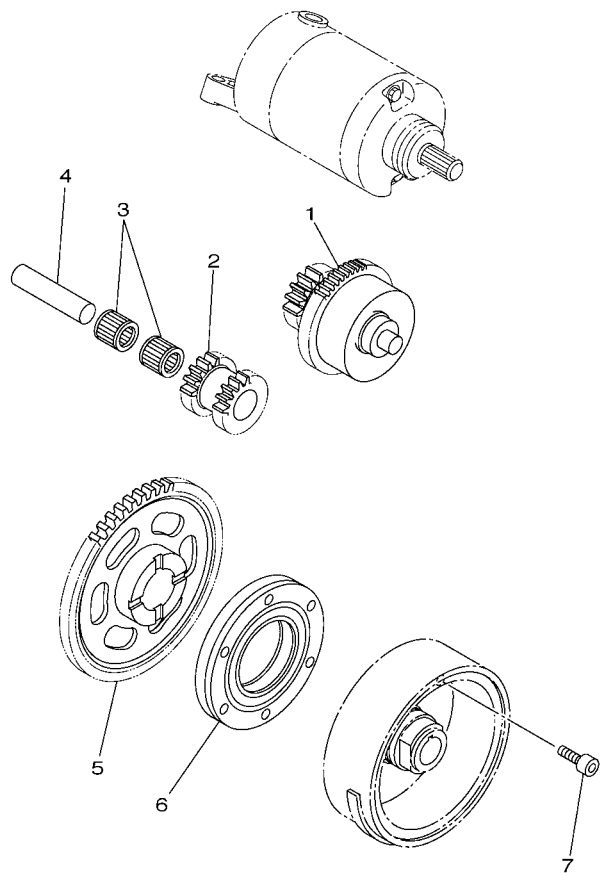

REF. NO.	PART NO.	DESCRIPTION	USA	CAN	EUR	OCE	JPN	REMARKS
1	5TG-15560-00	DAMPER ASSY	1	1	1	1	1	
2	5TG-15517-00	GEAR, IDLER 2	1	1	1	1	1	
3	93310-212L6	BEARING	2	2	2	2	2	
4	5H0-15521-00	SHAFT 1	1	1	1	1	1	
5	5TG-15515-01	GEAR 3	1	1	1	1	1	
6	5TG-15590-00	STARTER ONE-WAY ASSY	1	1	1	1	1	
7	90110-06168	BOLT, HEXAGON SOCKET HEAD	6	6	6	6	6	

5TG1100-C130

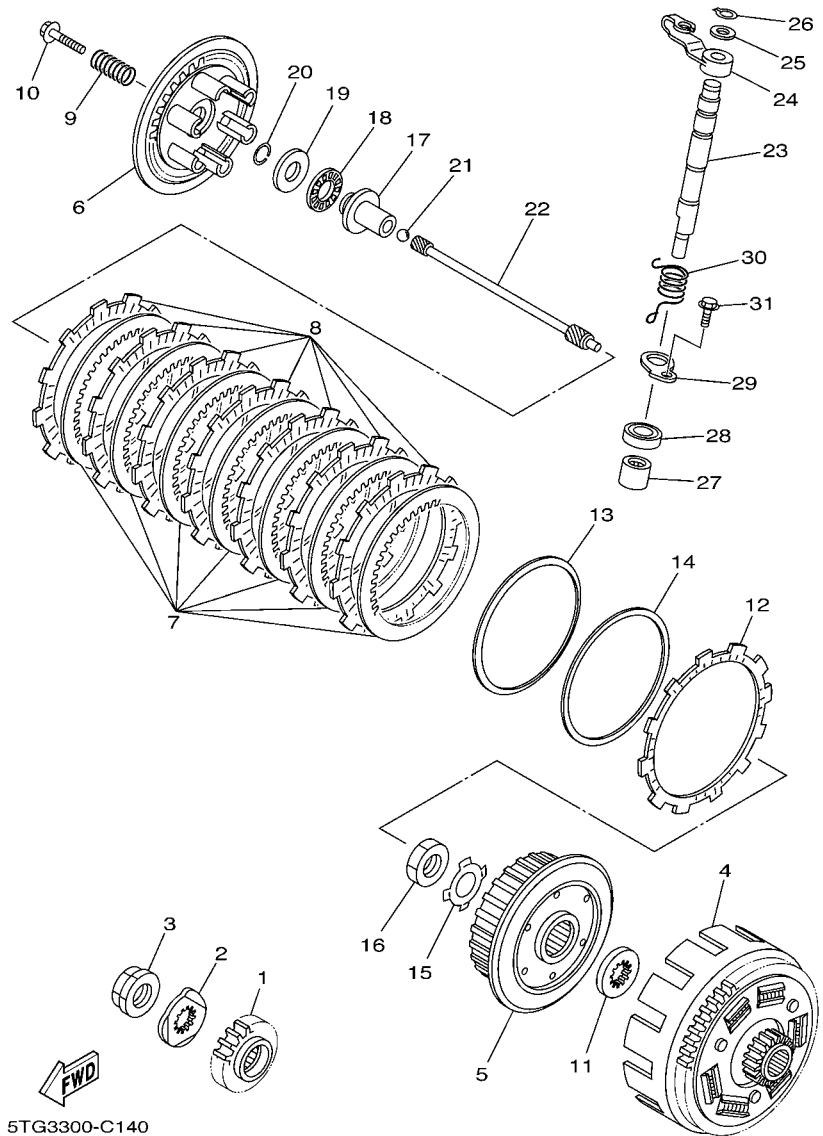

FIG. 14 CLUTCH

REF. NO.	PART NO.	DESCRIPTION	USA	CAN	EUR	OCE	JPN	REMARKS
1	5TG-16111-00	GEAR, PRIMARY DRIVE	1	1	1	1	1	
2	90215-21003	WASHER, LOCK	1	1	1	1	1	
3	90179-20001	NUT	1	1	1	1	1	
4	5D3-16150-00	PRIMARY DRIVEN GEAR COMP.	1	1	1	1	1	
5	5TA-16371-10	BOSS, CLUTCH	1	1	1	1	1	
6	5TG-16351-00	PLATE, PRESSURE 1	1	1	1	1	1	
7	4X7-16325-00	PLATE, CLUTCH 2	7	7	7	7	7	
8	5TA-16321-00	PLATE, FRICTION	7	7	7	7	7	
9	90501-231E9	SPRING, COMPRESSION	6	6	6	6	6	
10	90159-06010	SCREW, WITH WASHER	6	6	6	6	6	
11	2JN-16154-00	PLATE, THRUST 1	1	1	1	1	1	
12	5JG-16321-00	PLATE, FRICTION	1	1	1	1	1	
13	5JG-16383-00	SPRING, CLUTCH BOSS	1	1	1	1	1	
14	5JG-16384-00	PLATE, SEAT	1	1	1	1	1	
15	90215-20005	WASHER, LOCK	1	1	1	1	1	
16	90170-20327	NUT	1	1	1	1	1	
17	5TG-16356-00	ROD, PUSH 1	1	1	1	1	1	
18	93340-21505	BEARING	1	1	1	1	1	
19	90201-125L6	WASHER, PLATE	1	1	1	1	1	
20	93440-10085	CIRCLIP	1	1	1	1	1	
21	93515-32029	BALL	1	1	1	1	1	
22	5TG-16357-00	ROD, PUSH 2	1	1	1	1	1	
23	5TG-16382-10	AXLE, PUSH LEVER	1	1	1	1	1	
24	5TG-16342-00	LEVER, PUSH	1	1	1	1	1	
25	90201-10032	WASHER, PLATE	1	1	1	1	1	
26	99009-10400	CIRCLIP	1	1	1	1	1	
27	93317-11287	BEARING	1	1	1	1	1	

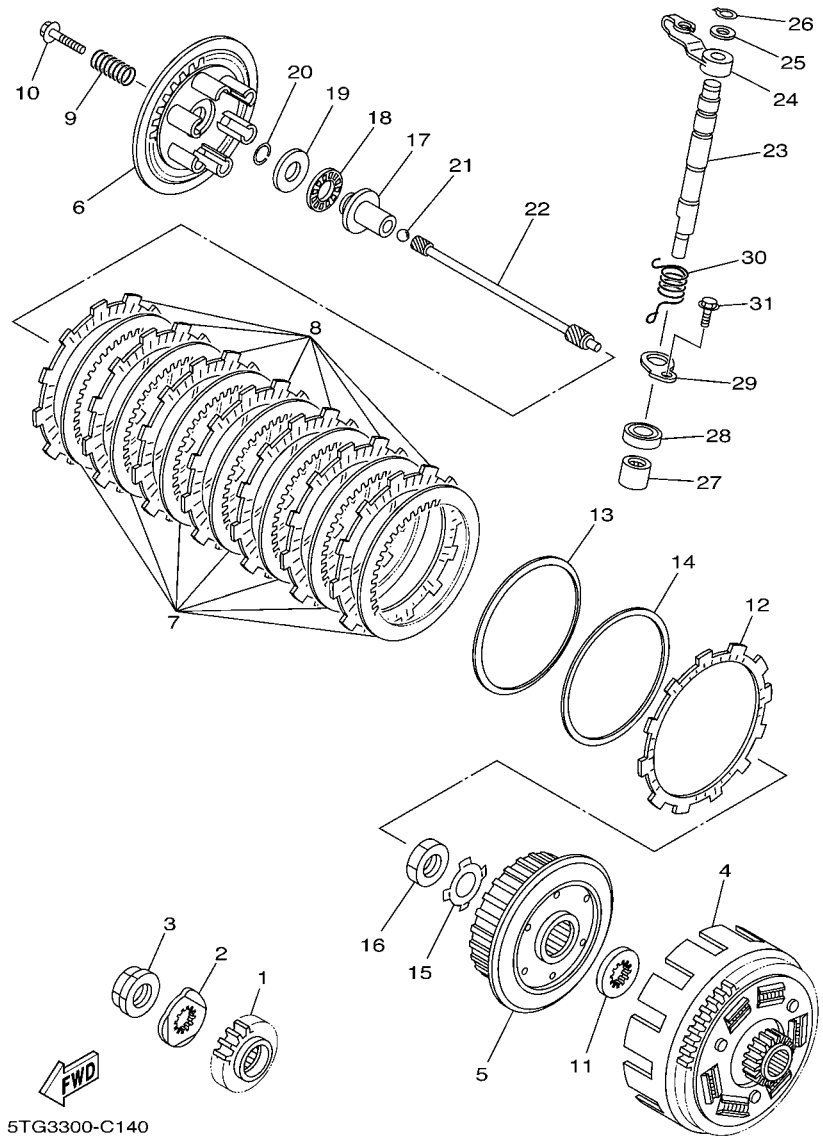
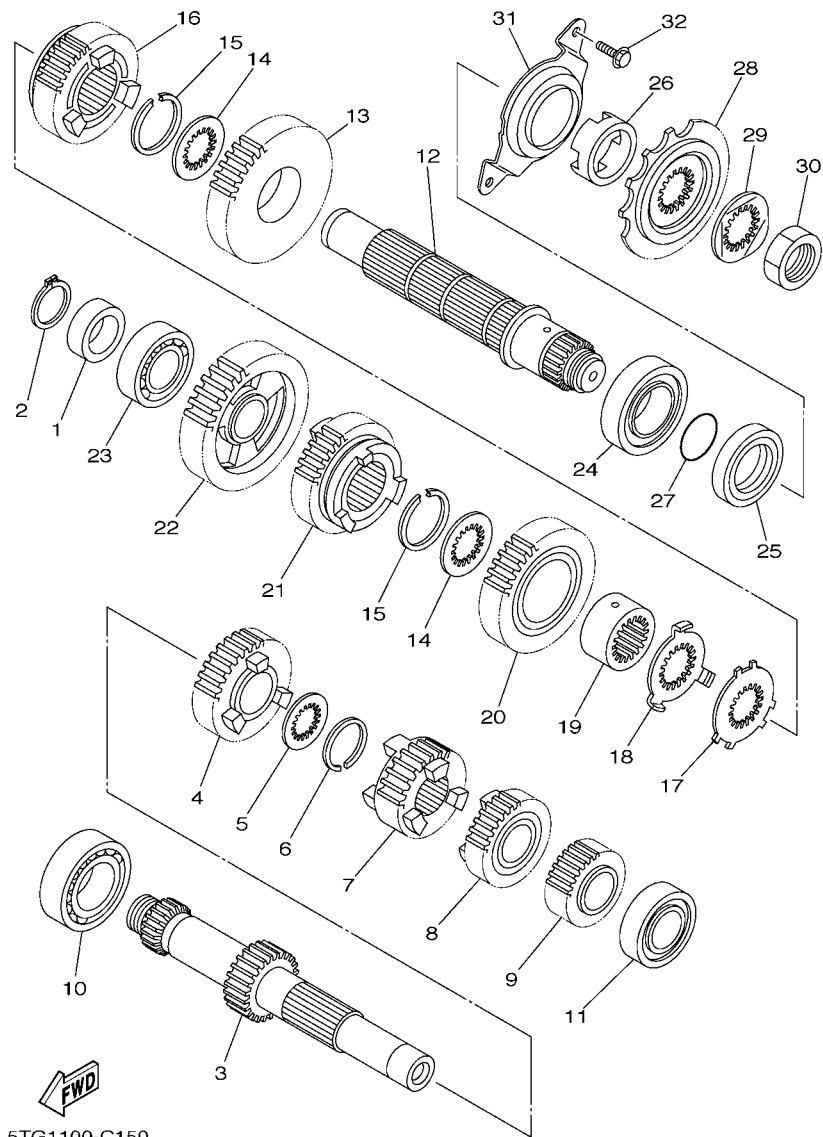

FIG. 14 CLUTCH

REF. NO.	PART NO.	DESCRIPTION	USA	CAN	EUR	OCE	JPN	REMARKS
28	93102-12224	OIL SEAL	1	1	1	1	1	
29	5D3-16384-00	PLATE, SEAT	1	1	1	1	1	
30	90508-16054	SPRING, TORSION	1	1	1	1	1	
31	95022-06012	BOLT, FLANGE	1	1	1	1	1	



5TG1100-C150

FIG. 15 TRANSMISSION

REF. NO.	PART NO.	DESCRIPTION	USA	CAN	EUR	OCE	JPN	REMARKS
1	90387-20030	COLLAR	1	1	1	1	1	
2	99009-20400	CIRCLIP	1	1	1	1	1	
3	5TG-17411-00	AXLE, MAIN	1	1	1	1	1	
4	5TG-17151-00	GEAR, 5TH PINION (20T)	1	1	1	1	1	
5	90209-21332	WASHER	1	1	1	1	1	
6	93440-25084	CIRCLIP	1	1	1	1	1	
7	5TG-17131-00	GEAR, 3RD PINION (16T)	1	1	1	1	1	
8	5TG-17141-00	GEAR, 4TH PINION (18T)	1	1	1	1	1	
9	5TG-17121-00	GEAR, 2ND PINION (14T)	1	1	1	1	1	
10	93306-20532	BEARING	1	1	1	1	1	
11	93306-00431	BEARING	1	1	1	1	1	
12	5TG-17402-00	DRIVE AXLE ASSY	1	1	1	1	1	
13	5TG-17221-00	GEAR, 2ND WHEEL (27T)	1	1	1	1	1	
14	90209-25342	WASHER	2	2	2	2	2	
15	93440-28062	CIRCLIP	2	2	2	2	2	
16	5TG-17241-00	GEAR, 4TH WHEEL (23T)	1	1	1	1	1	
17	90209-25349	WASHER	1	1	1	1	1	
18	90209-25350	WASHER	1	1	1	1	1	
19	90387-2810U	COLLAR	1	1	1	1	1	
20	5TG-17231-00	GEAR, 3RD WHEEL (25T)	1	1	1	1	1	
21	5TG-17251-00	GEAR, 5TH WHEEL (21T)	1	1	1	1	1	
22	5BF-17211-00	GEAR, 1ST WHEEL (29T)	1	1	1	1	1	
23	93306-00426	BEARING	1	1	1	1	1	
24	93306-20593	BEARING	1	1	1	1	1	
25	93102-32480	OIL SEAL	1	1	1	1	1	
26	90387-2513F	COLLAR	1	1	1	1	1	
27	93210-22164	O-RING	1	1	1	1	1	

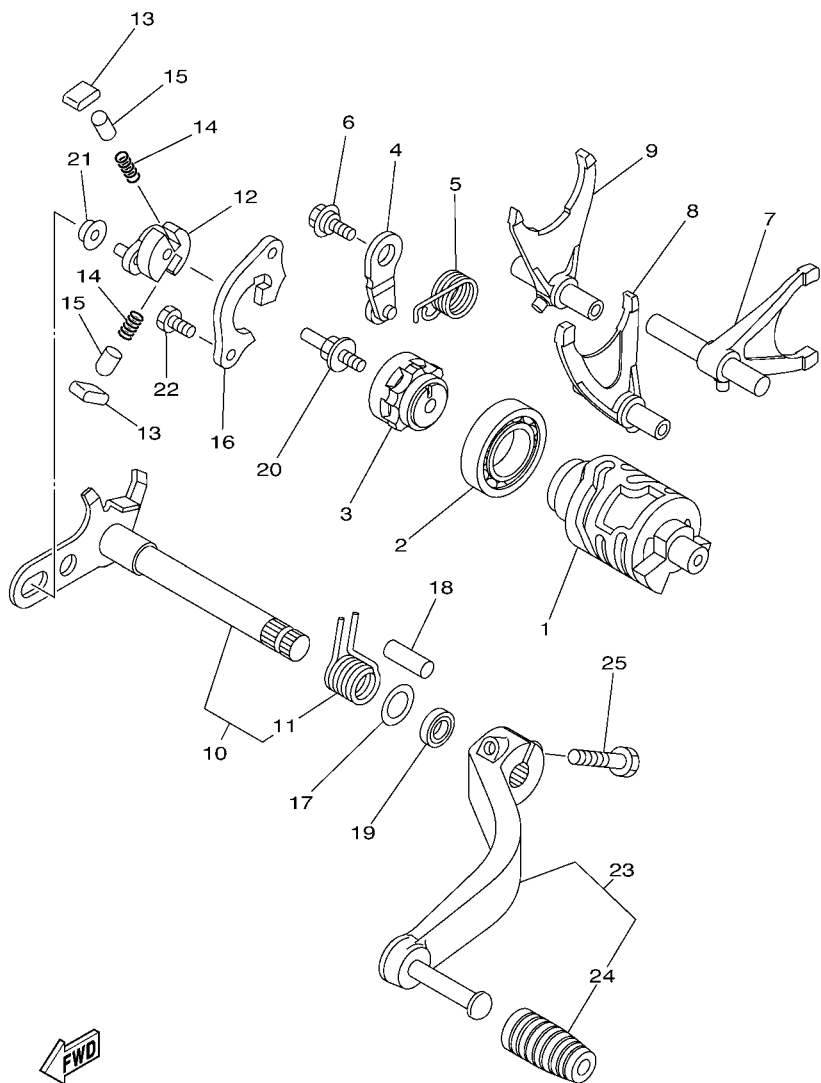

5TG7100-D162

FIG. 16 SHIFT CAM & FORK

REF. NO.	PART NO.	DESCRIPTION	USA	CAN	EUR	OCE	JPN	REMARKS
1	5TG-18541-00	CAM, SHIFT	1	1	1	1	1	
2	93306-90509	BEARING	1	1	1	1	1	
3	4EW-18185-00	SEGMENT	1	1	1	1	1	
4	3XK-18140-00	STOPPER LEVER ASSY	1	1	1	1	1	
5	90508-26561	SPRING, TORSION	1	1	1	1	1	
6	90109-06193	BOLT	1	1	1	1	1	
7	5TG-18501-00	FORK, SHIFT 1	1	1	1	1	1	
8	5TG-18502-00	FORK, SHIFT 2	1	1	1	1	1	
9	5TG-18503-00	FORK, SHIFT 3	1	1	1	1	1	
10	5TG-18101-10	SHIFT SHAFT ASSY	1	1	1	1	1	
11	90508-35015	.SPRING, TORSION	1	1	1	1	1	
12	5MW-18122-01	LEVER, SHIFT 2	1	1	1	1	1	
13	3XJ-18182-00	PAWL, SHIFTER	2	2	2	2	2	
14	90501-052G5	SPRING, COMPRESSION	2	2	2	2	2	
15	3XJ-18184-00	PIN, PAWL	2	2	2	2	2	
16	5BE-18172-00	GUIDE, SHIFT	1	1	1	1	1	
17	90201-12166	WASHER, PLATE	1	1	1	1	1	
18	93608-33002	PIN, DOWEL	1	1	1	1	1	
19	93102-12224	OIL SEAL	1	1	1	1	1	
20	3XJ-18173-10	PIN, SHIFT	1	1	1	1	1	
21	3XJ-18178-00	ROLLER, SHIFT LEVER	1	1	1	1	1	
22	90101-06041	BOLT	2	2	2	2	2	
23	5TG-18110-10	SHIFT PEDAL ASSY	1	1	1	1	1	
24	5YT-18113-00	.COVER, SHIFT PEDAL	1	1	1	1	1	
25	90109-06031	BOLT	1	1	1	1	1	

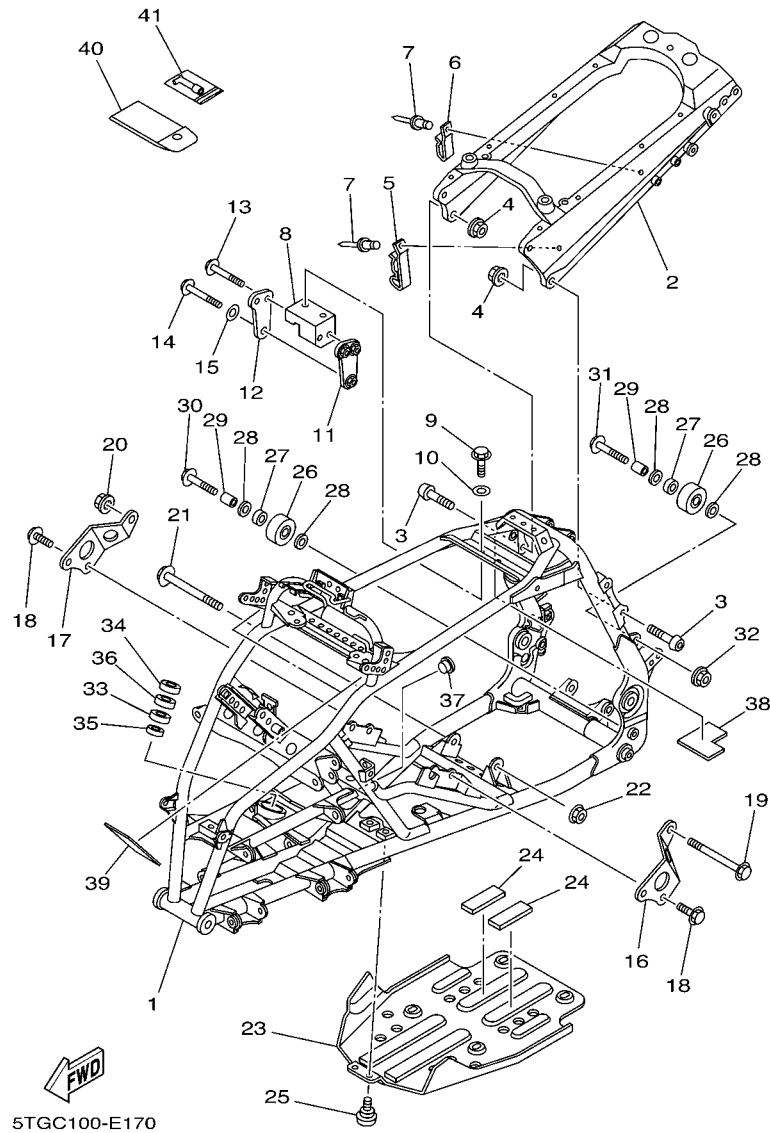

FIG. 17 FRAME

REF. NO.	PART NO.	DESCRIPTION	USA	CAN	EUR	OCE	JPN	REMARKS
1	5TG-21101-49	FRONT FRAME COMP.	1	1	1	1	1	UR FOR DPBSE
	5D3-21101-19	FRONT FRAME COMP.	1	1	1	1	1	UR FOR PGD
2	5TG-21190-08	REAR FRAME COMP.	1	1	1	1	1	UR FOR DPBSE
	5TG-21190-18	REAR FRAME COMP.	1	1	1	1	1	UR FOR PGD
3	90111-10031	BOLT,HEX. SOCKET BUTTON	4	4	4	4	4	
4	90185-10011	NUT, SELF-LOCKING	4	4	4	4	4	
5	90462-12003	CLAMP	1	1	1	1	1	
6	90462-12005	CLAMP	1	1	1	1	1	
7	90267-48088	RIVET, BLIND	2	2	2	2	2	
8	5TG-21315-00	STAY, ENGINE 1	1	1	1	1	1	
9	95812-08020	BOLT, FLANGE	2	2	2	2	2	
10	90201-08053	WASHER, PLATE	2	2	2	2	2	
11	5TG-21318-10	STAY, ENGINE 5	1	1	1	1	1	
12	5TG-21314-10	STAY, ENGINE 5	1	1	1	1	1	
13	95812-08050	BOLT, FLANGE	2	2	2	2	2	
14	95812-10055	BOLT, FLANGE	1	1	1	1	1	
15	90201-10036	WASHER, PLATE	1	1	1	1	1	
16	5D3-21316-00	STAY, ENGINE 3	1	1	1	1	1	
17	5D3-21317-00	STAY, ENGINE 3	1	1	1	1	1	
18	95812-08016	BOLT, FLANGE	4	4	4	4	4	
19	95812-10165	BOLT, FLANGE	1	1	1	1	1	
20	90185-10011	NUT, SELF-LOCKING	1	1	1	1	1	
21	90105-10148	BOLT, FLANGE	1	1	1	1	1	
22	90185-10011	NUT, SELF-LOCKING	1	1	1	1	1	
23	5TG-21471-00	PROTECTOR, ENGINE	1	1	1	1	1	
24	41R-21717-00	DAMPER	2	2	2	2	2	
25	90109-06198	BOLT	6	6	6	6	6	

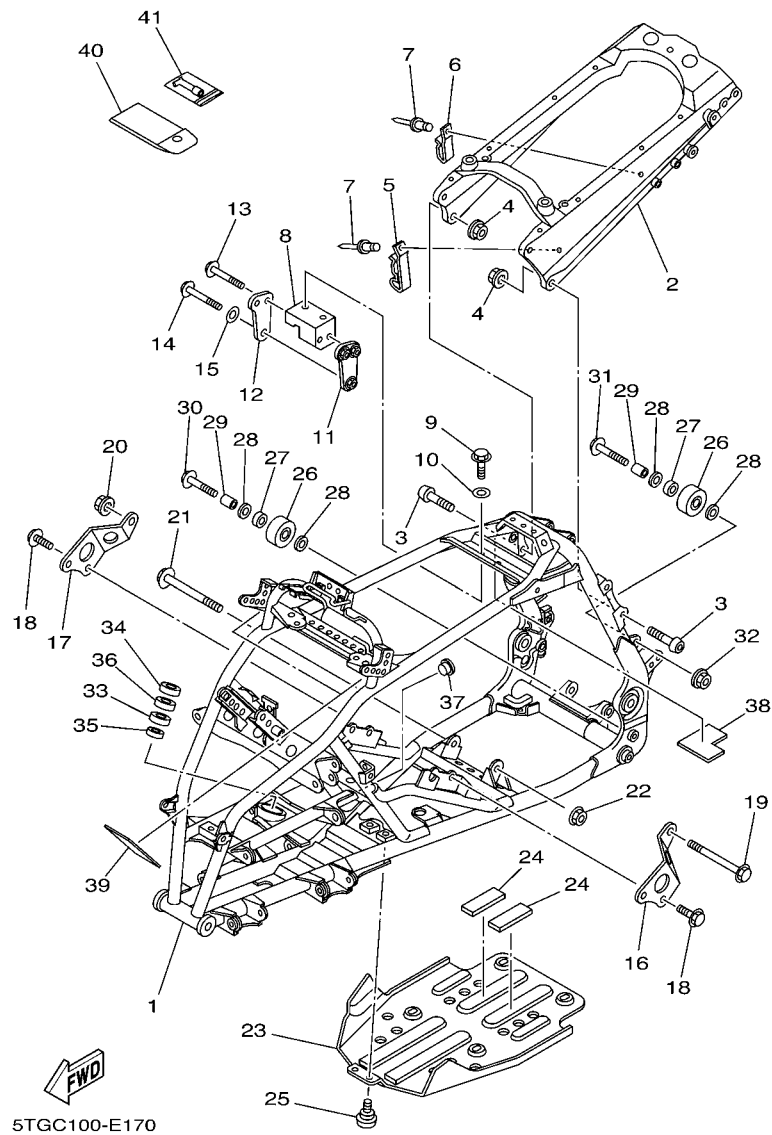
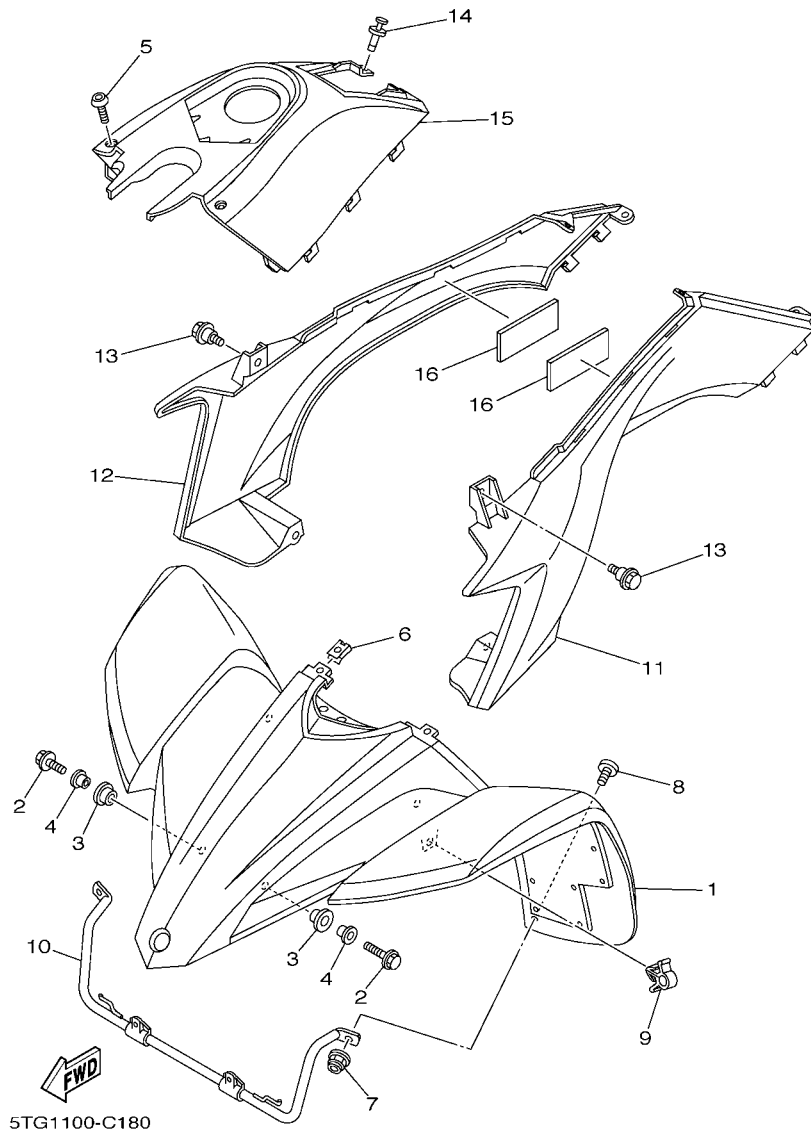

FIG. 17 FRAME

REF. NO.	PART NO.	DESCRIPTION	USA	CAN	EUR	OCE	JPN	REMARKS
26	5TG-22178-00	TENSIONER	2	2	2	2	2	
27	93300-60804	BEARING	2	2	2	2	2	
28	90201-08043	WASHER, PLATE	4	4	4	4	4	
29	90387-086N4	COLLAR	2	2	2	2	2	
30	95022-08040	BOLT, FLANGE	1	1	1	1	1	
31	90105-08112	BOLT, FLANGE	1	1	1	1	1	
32	95602-08200	NUT, SELF-LOCKING	1	1	1	1	1	
33	93306-20352	BEARING	1	1	1	1	1	
34	93102-25081	OIL SEAL	1	1	1	1	1	
35	93102-25099	OIL SEAL	1	1	1	1	1	
36	5GT-23872-00	HOLDER, BEARING	1	1	1	1	1	
37	90338-18122	PLUG	2	2	2	2	2	
38	5TG-25897-00	DAMPER	1	1	1	1	1	
39	5TG-84163-00	DAMPER	2	2	2	2	2	
40	5TG-28100-10	TOOL KIT	1	1	1	1	1	
41	1NV-2811A-01	GAUGE, AIR	1	1	1	1	1	

FIG. 18 FRONT FENDER



REF. NO.	PART NO.	DESCRIPTION	USA	CAN	EUR	OCE	JPN	REMARKS
1	5TG-W2151-00	FRONT FENDER COMP.	1					UR FOR DPBSE
	5TG-W2151-50	FRONT FENDER COMP.	1					UR FOR PGD
	5TG-W215C-00	FRONT FENDER COMP.2		1				UR FOR DPBSE
	5TG-W215C-50	FRONT FENDER COMP.2		1				UR FOR PGD
	5TG-W215B-00	FRONT FENDER COMP. 2			1			UR FOR DPBSE
	5TG-W215B-50	FRONT FENDER COMP. 2			1			UR FOR PGD
	5TG-W215D-00	FRONT FENDER COMP. 2				1		UR FOR DPBSE
	5TG-W215D-50	FRONT FENDER COMP. 2				1		UR FOR PGD
	5TG-W215E-00	FRONT FENDER COMP.					1	FOR DPBSE
2	95802-06016	BOLT, FLANGE	4	4	4	4	4	
3	90480-15006	GROMMET	4	4	4	4	4	
4	90387-061F9	COLLAR	4	4	4	4	4	
5	90110-05201	BOLT, HEXAGON SOCKET HEAD	2	2	2	2	2	
6	90183-05008	NUT, SPRING	2	2	2	2	2	
7	95602-06200	NUT, SELF-LOCKING	2	2	2	2	2	
8	90111-06038	BOLT,HEX. SOCKET BUTTON	2	2	2	2	2	
9	90464-48174	CLAMP	1	1	1	1	1	
10	5TG-21513-10	STAY, FENDER 1	1	1	1	1	1	
11	5TG-21711-00	COVER, SIDE 1	1	1	1	1	1	UR FOR DPBSE
	5TG-21711-50	COVER, SIDE 1	1	1	1	1	1	UR FOR PGD
12	5TG-21721-00	COVER, SIDE 2	1	1	1	1	1	UR FOR DPBSE
	5TG-21721-50	COVER, SIDE 2	1	1	1	1	1	UR FOR PGD
13	90109-06172	BOLT	4	4	4	4	4	
14	90269-06002	RIVET	2	2	2	2	2	
15	5TG-2171A-00	COVER, TOP	1	1	1	1	1	UR FOR DPBSE
	5TG-2171A-50	COVER, TOP	1	1	1	1	1	UR FOR PGD
16	5TG-21541-00	DAMPER 1	2	2	2	2	2	

FIG. 19 REAR FENDER

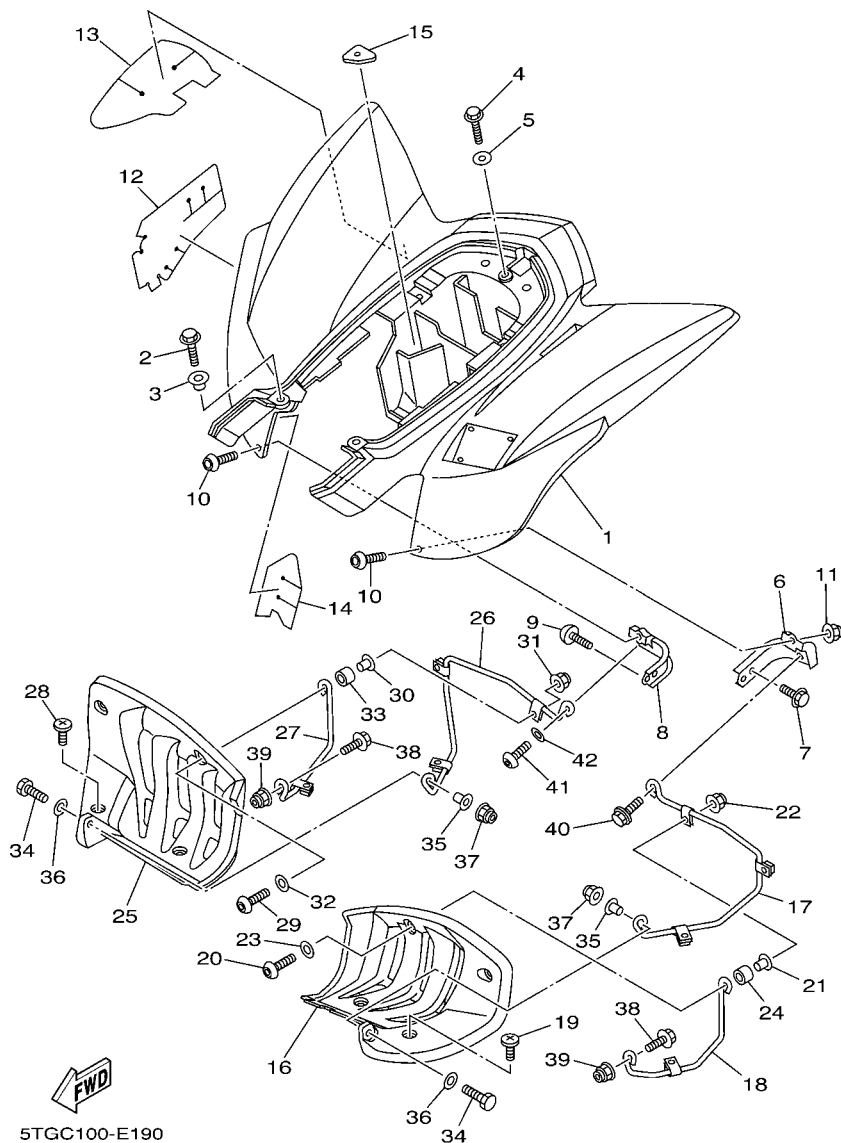

REF. NO.	PART NO.	DESCRIPTION	USA	CAN	EUR	OCE	JPN	REMARKS	
1	5TG-W2161-02	REAR FENDER COMP.	1				1	1	UR FOR DPBSE
	5TG-W2161-52	REAR FENDER COMP.	1				1		UR FOR PGD
	5TG-W216C-02	REAR FENDER COMP.2			1				UR FOR DPBSE
	5TG-W216C-52	REAR FENDER COMP.2			1				UR FOR PGD
	5TG-W216B-02	REAR FENDER COMP.2				1			UR FOR DPBSE
	5TG-W216B-52	REAR FENDER COMP.2				1			UR FOR PGD
2	90105-06084	BOLT, FLANGE	2	2	2	2	2	2	
3	90387-06146	COLLAR	2	2	2	2	2	2	
4	90105-06084	BOLT, FLANGE	1	1	1	1	1	1	
5	90201-06087	WASHER, PLATE	1	1	1	1	1	1	
6	5TG-21643-10	STAY, REAR	1	1	1	1	1	1	
7	95822-08012	BOLT, FLANGE	2	2	2	2	2	2	
8	5TG-21644-20	STAY, REAR	1	1	1	1	1	1	
9	92012-08012	BOLT, BUTTON HEAD	2	2	2	2	2	2	
10	90111-06038	BOLT,HEX. SOCKET BUTTON	2	2	2	2	2	2	
11	95602-06200	NUT, SELF-LOCKING	1	1	1	1	1	1	
12	5TG-2163A-01	COVER, REAR FENDER 1	1	1	1	1	1	1	
13	5TG-2163E-10	COVER, REAR FENDER 2	1	1	1	1	1	1	
14	5TG-2163F-10	COVER, REAR FENDER 3	1	1	1	1	1	1	
15	5TG-21639-00	DAMPER 2	1	1	1	1	1	1	
16	5TG-21621-00	FLAP	1	1	1	1	1	1	
17	5D3-2164F-10	STAY 1	1	1	1	1	1	1	
18	5D3-2164H-10	STAY 3	1	1	1	1	1	1	
19	90154-05013	SCREW, BINDING	3	3	3	3	3	3	
20	92012-06035	BOLT, BUTTON HEAD	1	1	1	1	1	1	
21	90560-06201	SPACER	1	1	1	1	1	1	
22	95602-06200	NUT, SELF-LOCKING	1	1	1	1	1	1	

FIG. 19 REAR FENDER

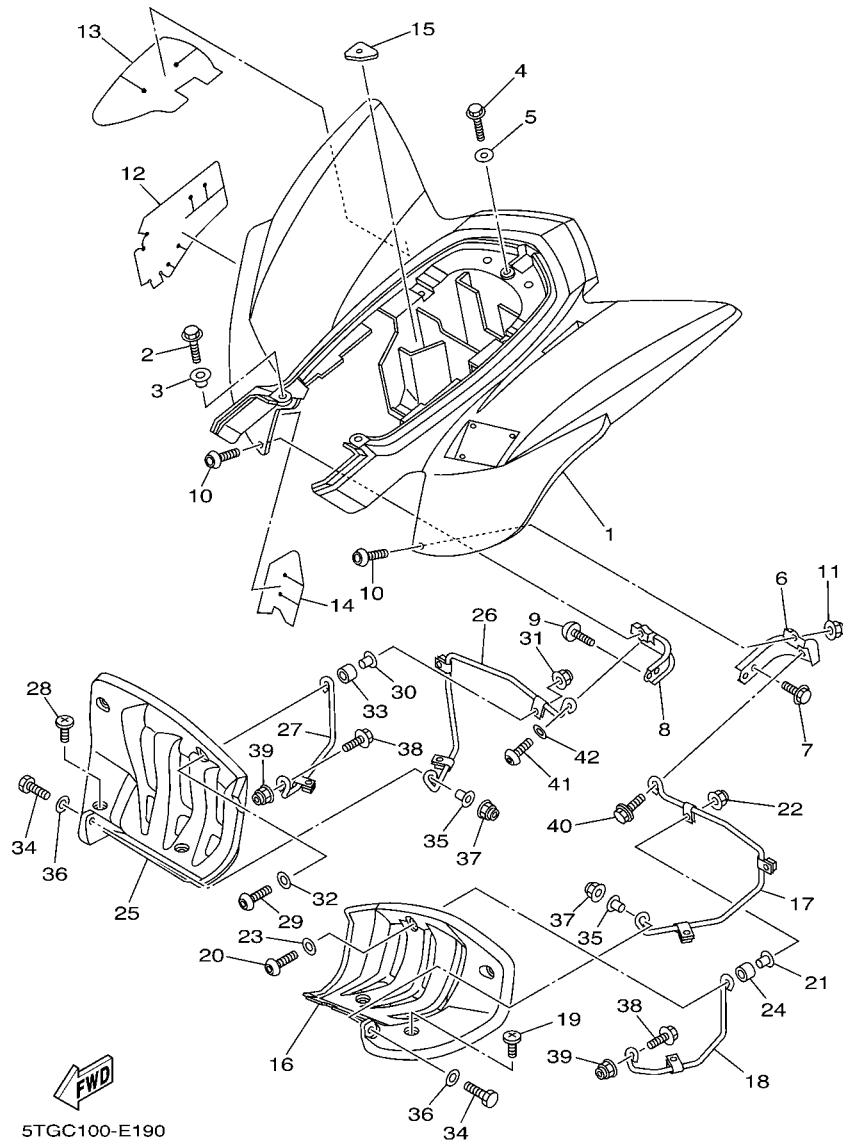

REF. NO.	PART NO.	DESCRIPTION	USA	CAN	EUR	OCE	JPN	REMARKS
23	90201-06076	WASHER, PLATE	1	1	1	1	1	
24	90387-06197	COLLAR	1	1	1	1	1	
25	5TG-21691-00	FLAP	1	1	1	1	1	
26	5D3-2164G-10	STAY 2	1	1	1	1	1	
27	5D3-2164J-10	STAY 4	1	1	1	1	1	
28	90154-05013	SCREW, BINDING	3	3	3	3	3	
29	92012-06035	BOLT, BUTTON HEAD	1	1	1	1	1	
30	90560-06201	SPACER	1	1	1	1	1	
31	95602-06200	NUT, SELF-LOCKING	1	1	1	1	1	
32	90201-06076	WASHER, PLATE	1	1	1	1	1	
33	90387-06197	COLLAR	1	1	1	1	1	
34	97012-06025	BOLT	2	2	2	2	2	
35	90387-06204	COLLAR	2	2	2	2	2	
36	90201-06093	WASHER, PLATE	2	2	2	2	2	
37	95602-06200	NUT, SELF-LOCKING	2	2	2	2	2	
38	95822-08020	BOLT, FLANGE	2	2	2	2	2	
39	95602-08200	NUT, SELF-LOCKING	2	2	2	2	2	
40	95822-08016	BOLT, FLANGE	1	1	1	1	1	
41	92012-08020	BOLT, BUTTON HEAD	1	1	1	1	1	
42	90201-08043	WASHER, PLATE	1	1	1	1	1	

FIG. 20 OIL TANK

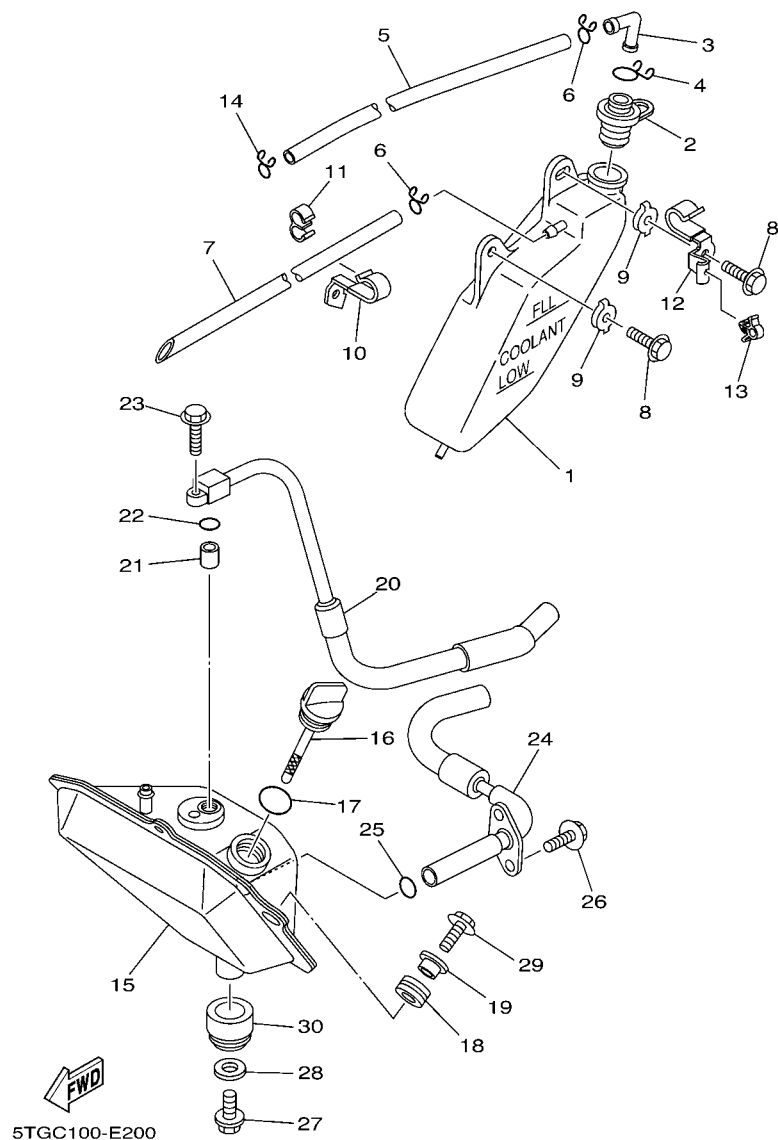

REF. NO.	PART NO.	DESCRIPTION	USA	CAN	EUR	OC	JPN	REMARKS
1	5TG-21871-00	TANK, RECOVERY	1	1	1	1	1	
2	5TG-21875-00	CAP	1	1	1	1	1	
3	26H-21828-00	ELBOW	1	1	1	1	1	
4	90467-11019	CLIP	1	1	1	1	1	
5	90445-090F7	HOSE (L1150)	1	1	1	1	1	
6	90467-08003	CLIP	2	2	2	2	2	
7	90445-09020	HOSE (L600)	1	1	1	1	1	
8	90105-06084	BOLT, FLANGE	2	2	2	2	2	
9	5TG-21715-00	WASHER, SPECIAL 1	2	2	2	2	2	
10	90465-08047	CLAMP	1	1	1	1	1	
11	90464-09M31	CLAMP	1	1	1	1	1	
12	90465-08044	CLAMP	1	1	1	1	1	
13	90464-13133	CLAMP	1	1	1	1	1	
14	90467-08003	CLIP	1	1	1	1	1	
15	5TG-21750-00	OIL TANK ASSY	1	1	1	1	1	
16	5LP-21761-01	GAUGE, LEVEL	1	1	1	1	1	
17	93210-21190	O-RING	1	1	1	1	1	
18	90480-10289	GROMMET	2	2	2	2	2	
19	90387-06150	COLLAR	2	2	2	2	2	
20	5TG-13465-00	HOSE, OIL 2	1	1	1	1	1	
21	99530-10114	PIN, DOWEL	1	1	1	1	1	
22	93210-10197	O-RING	1	1	1	1	1	
23	95022-06025	BOLT, FLANGE	1	1	1	1	1	
24	5D3-13464-00	HOSE, OIL 1	1	1	1	1	1	
25	93210-16629	O-RING	1	1	1	1	1	
26	91312-06016	BOLT	2	2	2	2	2	
27	95802-08016	BOLT, FLANGE	1	1	1	1	1	

FIG. 20 OIL TANK

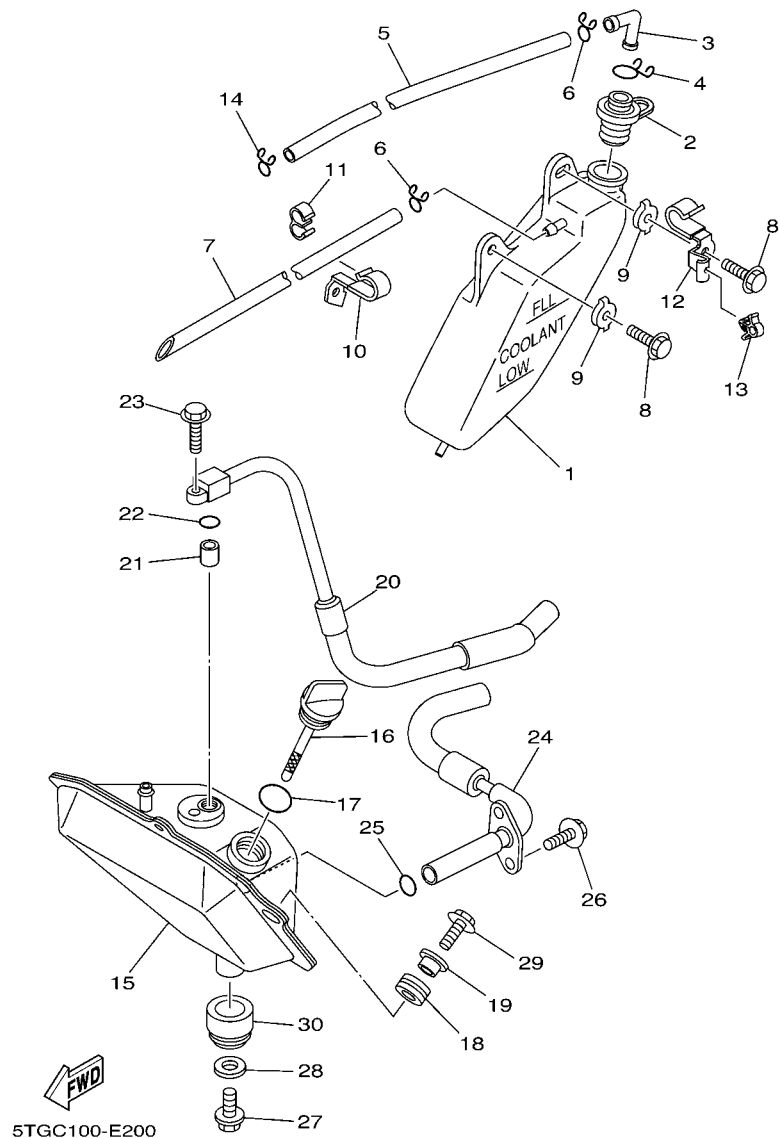

REF. NO.	PART NO.	DESCRIPTION	USA	CAN	EUR	OCE	JPN	REMARKS
28	90201-082A6	WASHER, PLATE	1	1	1	1	1	
29	95822-06020	BOLT, FLANGE	2	2	2	2	2	
30	90480-24001	GROMMET	1	1	1	1	1	

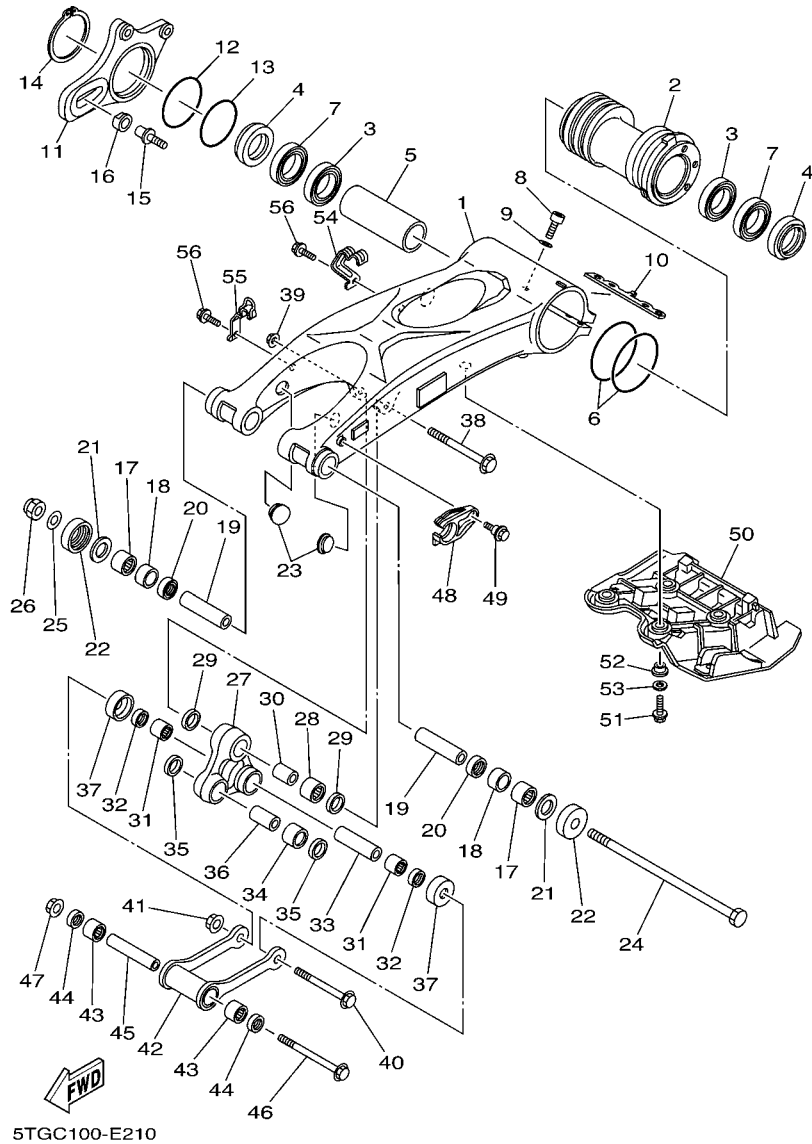

FIG. 21 REAR ARM

REF. NO.	PART NO.	DESCRIPTION	USA	CAN	EUR	OCE	JPN	REMARKS
1	5TG-22110-20	REAR ARM COMP.	1	1	1	1	1	
2	5TG-25311-20	HUB, REAR	1	1	1	1	1	
3	93306-90804	BEARING	2	2	2	2	2	
4	93106-46003	OIL SEAL	2	2	2	2	2	
5	5TG-25317-00	SPACER, BEARING	1	1	1	1	1	
6	1S3-23147-01	O-RING	2	2	2	2	2	
7	93306-90805	BEARING	2	2	2	2	2	
8	91314-08040	BOLT	4	4	4	4	4	
9	92903-08600	WASHER, PLATE	4	4	4	4	4	
10	5TG-22475-00	SEAL, DUST	1	1	1	1	1	
11	5TG-25721-20	BRACKET, CALIPER	1	1	1	1	1	
12	93210-71001	O-RING	1	1	1	1	1	
13	93210-66001	O-RING	1	1	1	1	1	
14	93410-67085	CIRCLIP	1	1	1	1	1	
15	90110-12001	BOLT, HEXAGON SOCKET HEAD	1	1	1	1	1	
16	90387-16014	COLLAR	1	1	1	1	1	
17	93317-22237	BEARING	2	2	2	2	2	
18	90380-22111	BUSH, SOLID	2	2	2	2	2	
19	90387-160W0	COLLAR	2	2	2	2	2	
20	93106-22019	OIL SEAL (DC 22-28-8)	2	2	2	2	2	
21	3YF-22149-00	WASHER	2	2	2	2	2	
22	4X7-22129-00	COVER, THRUST 2	2	2	2	2	2	
23	90338-23004	PLUG	2	2	2	2	2	
24	5LP-22141-00	SHAFT, PIVOT	1	1	1	1	1	
25	90201-16018	WASHER, PLATE	1	1	1	1	1	
26	90185-16002	NUT, SELF-LOCKING	1	1	1	1	1	
27	5TG-2217A-10	ARM, RELAY	1	1	1	1	1	

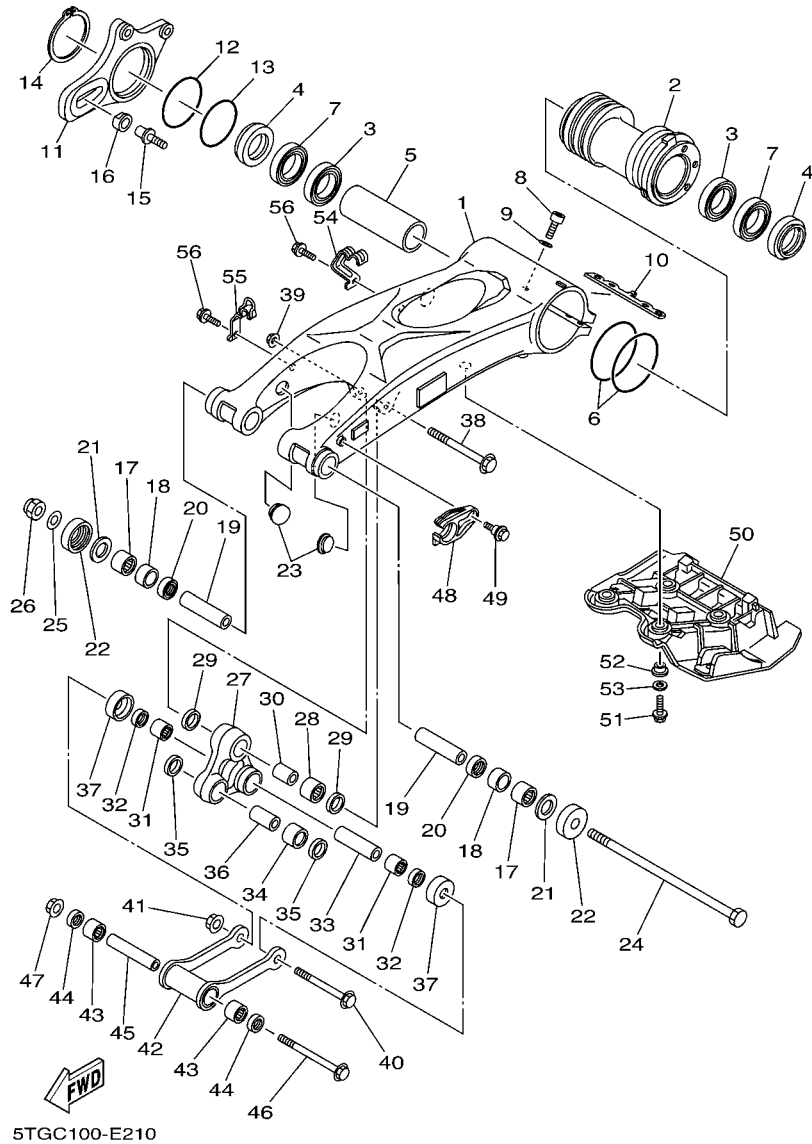
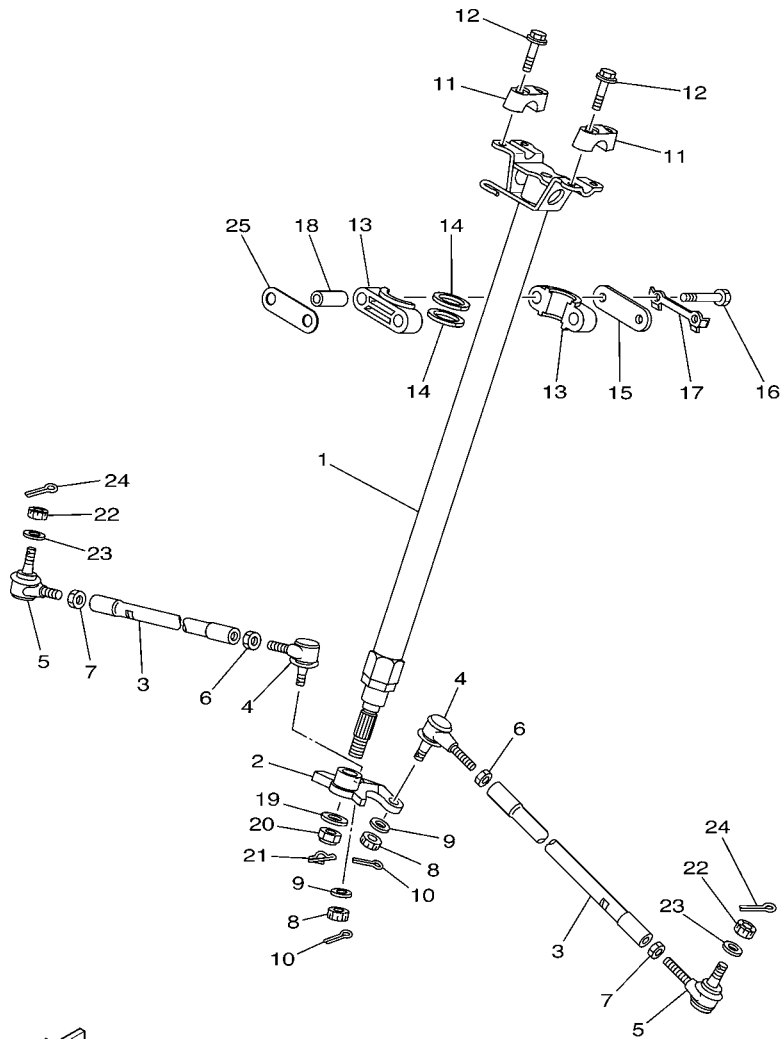

FIG. 21 REAR ARM

REF. NO.	PART NO.	DESCRIPTION	USA	CAN	EUR	OCE	JPN	REMARKS
28	93315-32057	BEARING	1	1	1	1	1	
29	93109-20001	OIL SEAL	2	2	2	2	2	
30	90387-123M3	COLLAR	1	1	1	1	1	
31	93315-31758	BEARING	2	2	2	2	2	
32	93109-17071	OIL SEAL	2	2	2	2	2	
33	90387-12030	COLLAR	1	1	1	1	1	
34	93315-32052	BEARING	1	1	1	1	1	
35	93109-20001	OIL SEAL	2	2	2	2	2	
36	90387-12020	COLLAR	1	1	1	1	1	
37	5TG-22128-00	COVER, THRUST 1	2	2	2	2	2	
38	90105-12038	BOLT, FLANGE	1	1	1	1	1	
39	90185-12002	NUT, SELF-LOCKING	1	1	1	1	1	
40	90105-12040	BOLT, FLANGE	1	1	1	1	1	
41	90185-12002	NUT, SELF-LOCKING	1	1	1	1	1	
42	5D3-2217F-00	ROD, CONNECTING 1	1	1	1	1	1	
43	93315-31758	BEARING	2	2	2	2	2	
44	93109-17071	OIL SEAL	2	2	2	2	2	
45	90387-12019	COLLAR	1	1	1	1	1	
46	90105-12039	BOLT, FLANGE	1	1	1	1	1	
47	90185-12002	NUT, SELF-LOCKING	1	1	1	1	1	
48	5TG-22151-00	SEAL, GUARD	1	1	1	1	1	
49	90109-06172	BOLT	1	1	1	1	1	
50	5TG-22360-11	GUARD SUB ASSY	1	1	1	1	1	
51	95802-06025	BOLT, FLANGE	4	4	4	4	4	
52	90387-06151	COLLAR	4	4	4	4	4	
53	90201-06088	WASHER, PLATE	4	4	4	4	4	
54	5TG-25886-10	HOLDER, BRAKE HOSE	1	1	1	1	1	

FIG. 23 STEERING



5D31100-F230

REF. NO.	PART NO.	DESCRIPTION	USA	CAN	EUR	OCE	JPN	REMARKS
1	5D3-23813-10	COLUMN, STEERING 2	1	1	1	1	1	
2	5TG-23816-10	ARM, PITMAN	1	1	1	1	1	
3	1S3-23831-20	ROD, TIE	2	2	2	2	2	
4	1S3-23841-20	JOINT, UNIVERSAL 1	2	2	2	2	2	
5	1S3-23845-20	JOINT, UNIVERSAL 2	2	2	2	2	2	
6	90170-12055	NUT	2	2	2	2	2	
7	90170-12054	NUT	2	2	2	2	2	(RH. THREAD)
8	90171-10001	NUT, CASTLE	2	2	2	2	2	
9	90209-10229	WASHER	2	2	2	2	2	
10	91402-20020	PIN, COTTER	2	2	2	2	2	
11	5XC-23441-90	HOLDER, HANDLE UPPER	2	2	2	2	2	
12	95022-08035	BOLT, FLANGE	4	4	4	4	4	
13	1UY-23812-00	PLANE BEARING, STEERING	2	2	2	2	2	
14	93112-31011	OIL SEAL	2	2	2	2	2	
15	1UY-23868-01	BRACKET, STEERING LOWER	1	1	1	1	1	
16	97022-08060	BOLT	2	2	2	2	2	
17	1UY-23894-01	WASHER, LOCK 1	1	1	1	1	1	
18	90387-09011	COLLAR	2	2	2	2	2	
19	90201-14021	WASHER, PLATE	1	1	1	1	1	
20	90185-14009	NUT, SELF-LOCKING	1	1	1	1	1	
21	90468-16191	CLIP	1	1	1	1	1	
22	90171-10001	NUT, CASTLE	2	2	2	2	2	
23	90209-10229	WASHER	2	2	2	2	2	
24	91402-20020	PIN, COTTER	2	2	2	2	2	
25	5D3-23858-00	SPACER	1	1	1	1	1	

FIG. 24 FRONT SUSPENSION & WHEEL

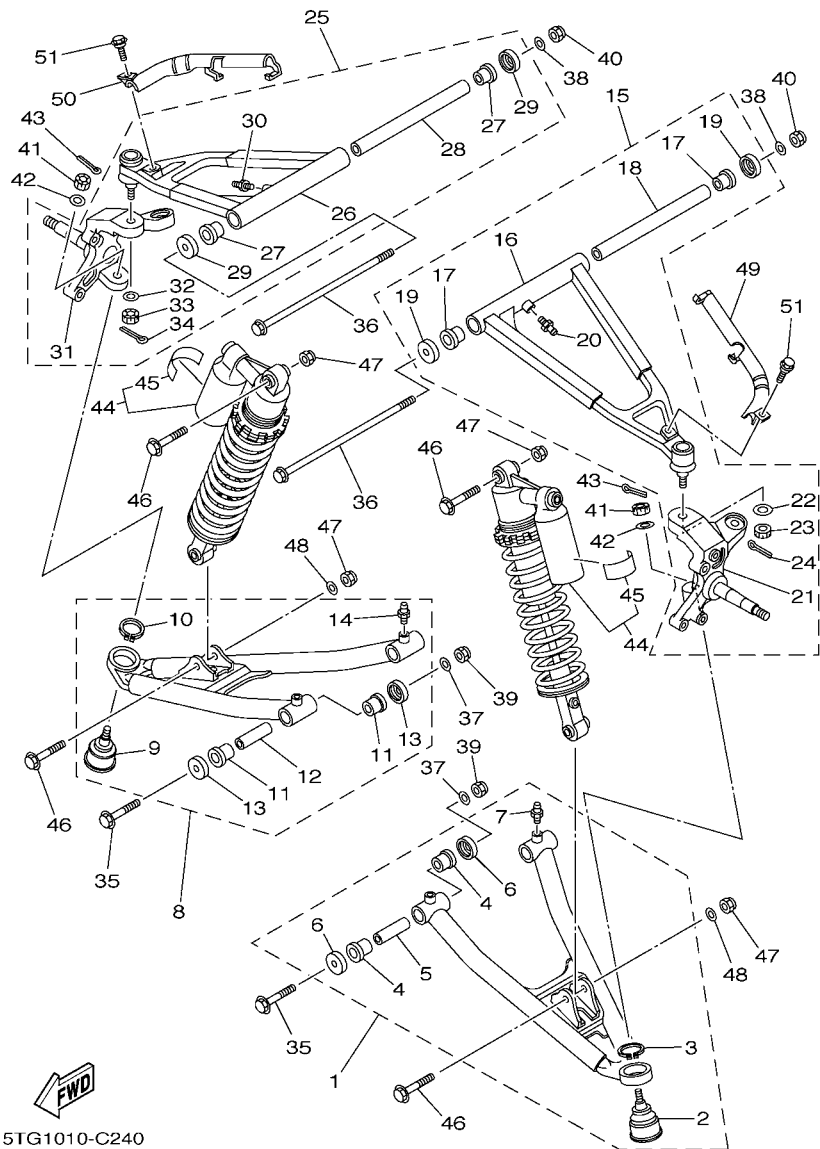

5TG1010-C240

REF. NO.	PART NO.	DESCRIPTION	USA	CAN	EUR	OCE	JPN	REMARKS
1	5TG-23507-20	FRONT LOWER ARM SUB-ASSY (L.H)	1	1	1	1	1	UR FOR DPBSE
	5TG-23507-00	FRONT LOWER ARM SUB-ASSY (L.H)	1	1	1	1	1	UR FOR PGD
2	5LP-23579-00	.BALL JOINT 2	1	1	1	1	1	
3	99009-30400	.CIRCLIP	1	1	1	1	1	
4	90381-15088	.BUSH, SOLID	4	4	4	4	4	
5	90387-101R3	.COLLAR	2	2	2	2	2	
6	5YT-23517-00	.COVER, THRUST 1	4	4	4	4	4	
7	93700-06004	.NIPPLE, GREASE	2	2	2	2	2	
8	5TG-23508-20	FRONT LOWER ARM SUB-ASSY (R.H)	1	1	1	1	1	UR FOR DPBSE
	5TG-23508-00	FRONT LOWER ARM SUB-ASSY (R.H)	1	1	1	1	1	UR FOR PGD
9	5LP-23579-00	.BALL JOINT 2	1	1	1	1	1	
10	99009-30400	.CIRCLIP	1	1	1	1	1	
11	90381-15088	.BUSH, SOLID	4	4	4	4	4	
12	90387-101R3	.COLLAR	2	2	2	2	2	
13	5YT-23517-00	.COVER, THRUST 1	4	4	4	4	4	
14	93700-06004	.NIPPLE, GREASE	2	2	2	2	2	
15	5TG-23505-20	FRONT UPPER ARM SUB ASSY LH	1	1	1	1	1	UR FOR DPBSE
	5TG-23505-30	FRONT UPPER ARM SUB ASSY LH	1	1	1	1	1	UR FOR PGD
16	5TG-23540-20	.FRONT UPPER ARM COMP. (LEFT)	1	1	1	1	1	UR FOR DPBSE
	5TG-23540-00	.FRONT UPPER ARM COMP. (LEFT)	1	1	1	1	1	UR FOR PGD
17	90381-15088	.BUSH, SOLID	2	2	2	2	2	
18	90387-100Y6	.COLLAR	1	1	1	1	1	
19	5YT-23517-00	.COVER, THRUST 1	2	2	2	2	2	
20	93700-06004	.NIPPLE, GREASE	1	1	1	1	1	
21	1S3-23501-00	.STEERING KNUCKLE ASSY (LEFT)	1	1	1	1	1	
22	90209-10229	.WASHER	1	1	1	1	1	
23	90171-10001	.NUT, CASTLE	1	1	1	1	1	

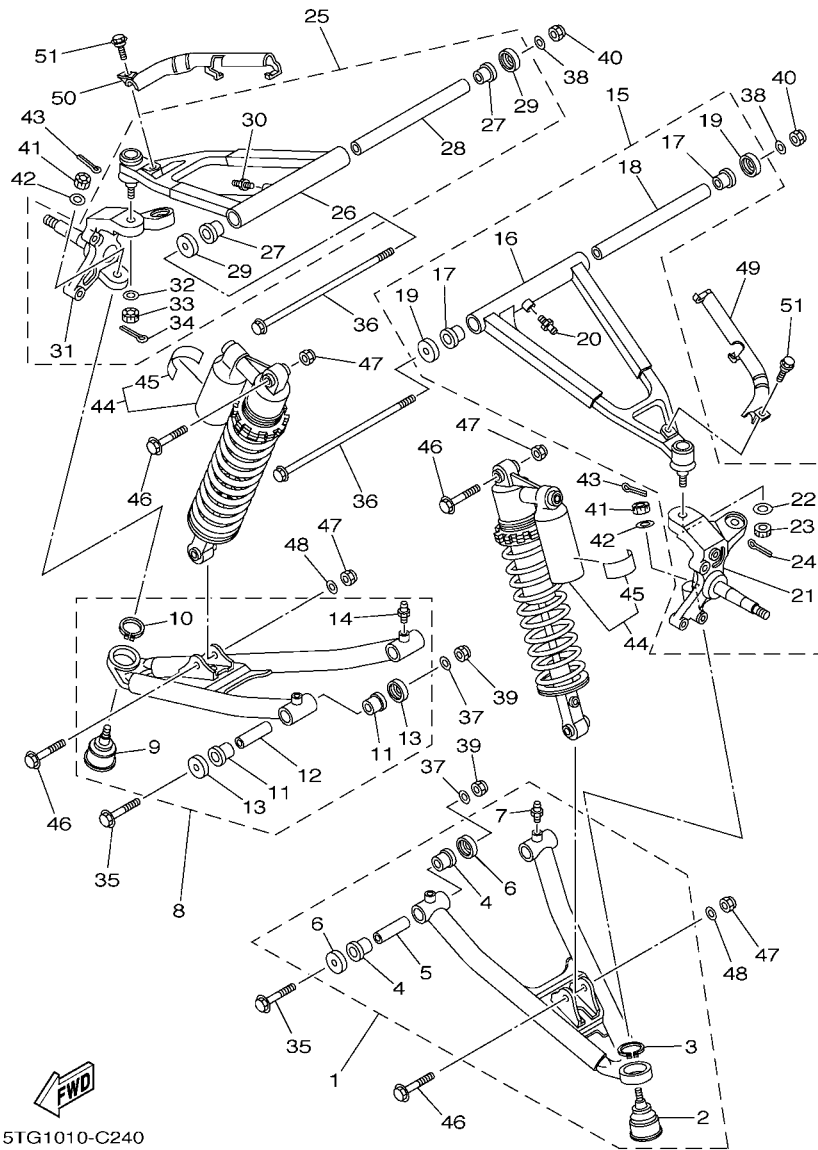

5TG1010-C240

FIG. 24 FRONT SUSPENSION & WHEEL

REF. NO.	PART NO.	DESCRIPTION	USA	CAN	EUR	OCE	JPN	REMARKS
24	91402-20020	.PIN, COTTER	1	1	1	1	1	
25	5TG-23506-20	FRONT UPPER ARM SUB ASSY RH	1	1	1	1	1	UR FOR DPBSE
	5TG-23506-30	FRONT UPPER ARM SUB ASSY RH	1	1	1	1	1	UR FOR PGD
26	5TG-23550-20	.FRONT UPPER ARM COMP. (RIGHT)	1	1	1	1	1	UR FOR DPBSE
	5TG-23550-00	.FRONT UPPER ARM COMP. (RIGHT)	1	1	1	1	1	UR FOR PGD
27	90381-15088	.BUSH, SOLID	2	2	2	2	2	
28	90387-100Y6	.COLLAR	1	1	1	1	1	
29	5YT-23517-00	.COVER, THRUST 1	2	2	2	2	2	
30	93700-06004	.NIPPLE, GREASE	1	1	1	1	1	
31	1S3-23502-00	.STEERING KNUCKLE ASSY (RIGHT)	1	1	1	1	1	
32	90209-10229	.WASHER	1	1	1	1	1	
33	90171-10001	.NUT, CASTLE	1	1	1	1	1	
34	91402-20020	.PIN, COTTER	1	1	1	1	1	
35	90105-10135	BOLT, FLANGE	4	4	4	4	4	
36	90105-10132	BOLT, FLANGE	2	2	2	2	2	
37	90201-10037	WASHER, PLATE	4	4	4	4	4	
38	90201-10037	WASHER, PLATE	2	2	2	2	2	
39	90185-10012	NUT, SELF-LOCKING	4	4	4	4	4	
40	90185-10012	NUT, SELF-LOCKING	2	2	2	2	2	
41	90171-10001	NUT, CASTLE	2	2	2	2	2	
42	90209-10229	WASHER	2	2	2	2	2	
43	91402-20020	PIN, COTTER	2	2	2	2	2	
44	5D3-23350-30	SHOCK ABSORBER ASSY	2					UR FOR DPBSE
	5D3-23350-70	SHOCK ABSORBER ASSY	2					UR FOR PGD
	5D3-23350-40	SHOCK ABSORBER ASSY		2				UR FOR DPBSE
	5D3-23350-80	SHOCK ABSORBER ASSY		2				UR FOR PGD
	5D3-23350-50	SHOCK ABSORBER ASSY			2	2		UR FOR DPBSE

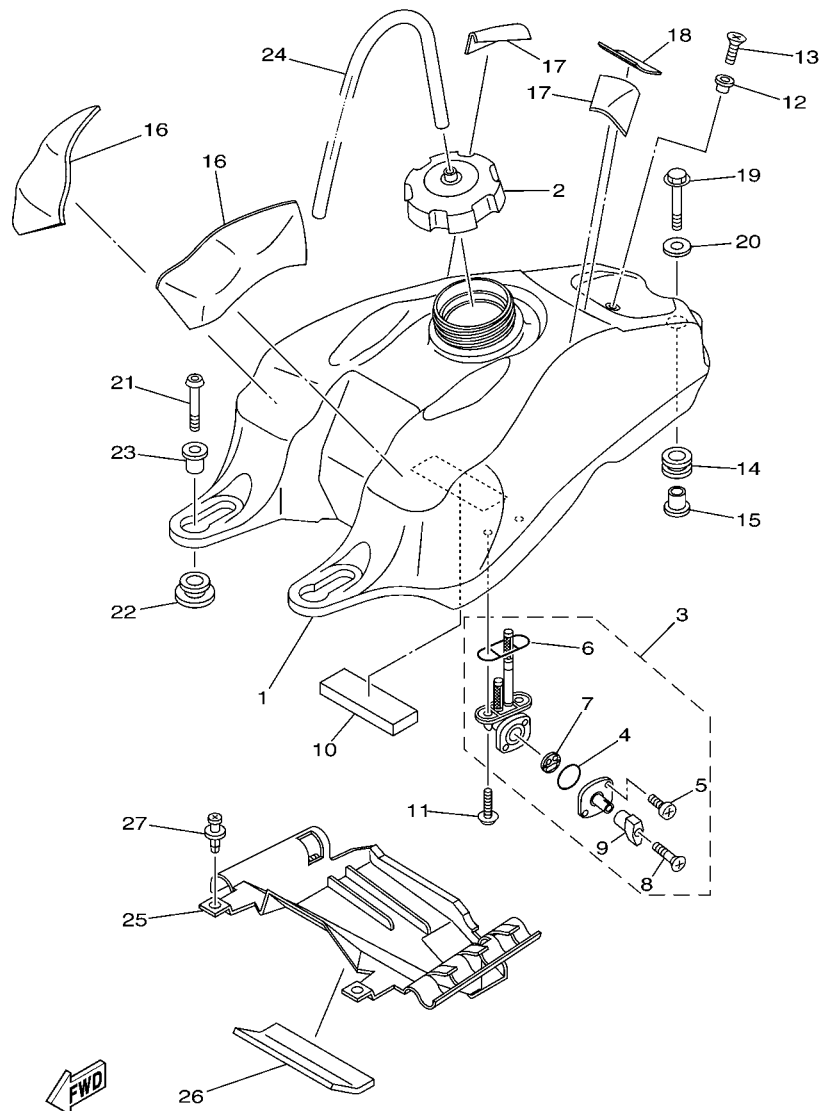

5TG7100-D250

FIG. 25 FUEL TANK

REF. NO.	PART NO.	DESCRIPTION	USA	CAN	EUR	OCE	JPN	REMARKS
1	5TG-24110-10	FUEL TANK COMP.	1	1				
	5TG-24110-00	FUEL TANK COMP.			1	1	1	
2	5KM-24610-00	CAP ASSY	1	1	1	1	1	
3	5TG-24500-01	FUEL COCK ASSY 1	1	1	1	1	1	
4	3AJ-24534-01	.SEAL, COCK	1	1	1	1	1	
5	98507-03008	.SCREW, PAN HEAD	2	2	2	2	2	
6	4X8-24512-00	.O-RING	1	1	1	1	1	
7	3AC-24523-00	.VALVE PACKING	1	1	1	1	1	
8	98606-04018	.SCREW, OVAL HEAD	1	1	1	1	1	
9	4HM-24524-00	.LEVER, COCK	1	1	1	1	1	
10	5TG-24181-00	DAMPER, LOCATING 1	1	1	1	1	1	
11	90149-06108	SCREW	2	2	2	2	2	
12	4EW-2412F-00	BRACKET, SEAT	1	1	1	1	1	
13	98702-06025	SCREW, FLAT HEAD	1	1	1	1	1	
14	90480-18290	GROMMET	1	1	1	1	1	
15	90387-066J1	COLLAR	1	1	1	1	1	
16	12R-21747-00	DAMPER	2	2	2	2	2	
17	M12-T133A-00	SEAT, DAMPER A	2	2	2	2	2	
18	22F-2139X-00	DAMPER	1	1	1	1	1	
19	95822-06030	BOLT, FLANGE	1	1	1	1	1	
20	90201-06033	WASHER, PLATE	1	1	1	1	1	
21	92012-06025	BOLT, BUTTON HEAD	2	2	2	2	2	
22	90480-18004	GROMMET	2	2	2	2	2	
23	90387-066J1	COLLAR	2	2	2	2	2	
24	90445-08026	HOSE (L220)	1	1	1	1	1	
25	5TG-2414H-00	DAMPER, PLATE 1	1	1	1	1	1	
26	12R-21747-00	DAMPER	1	1	1	1	1	

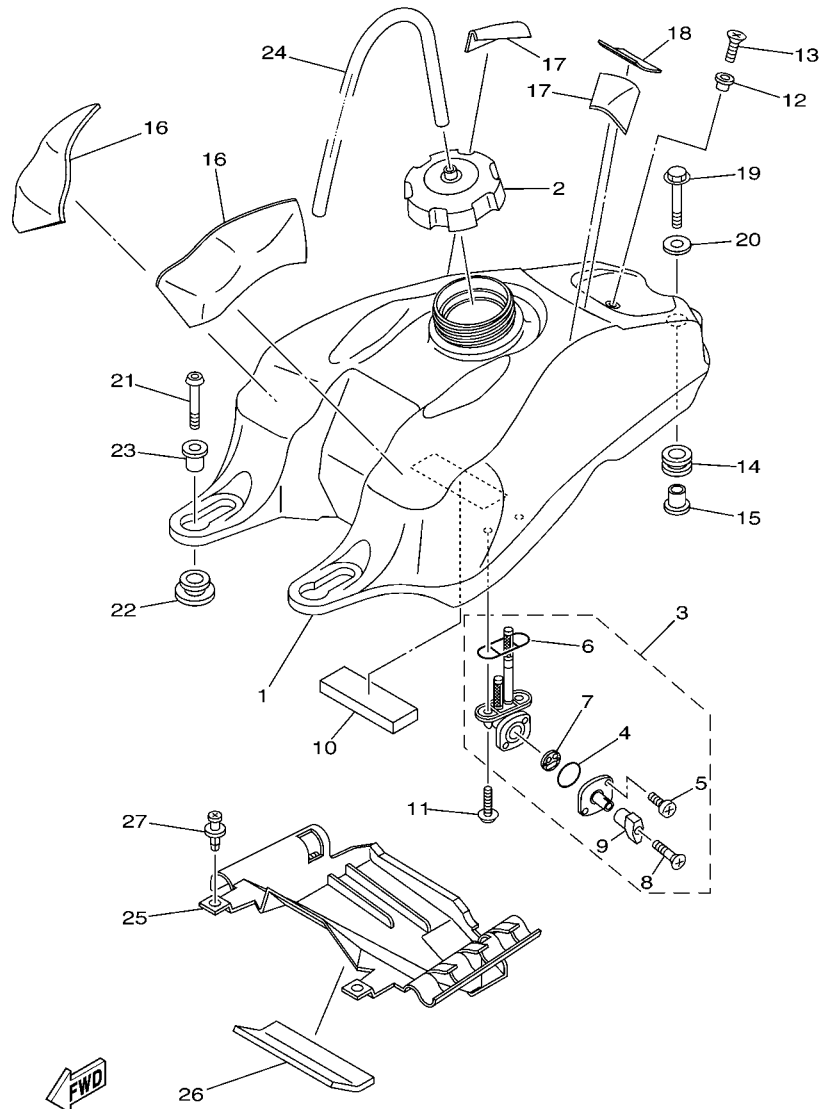

5TG7100-D250

FIG. 25 FUEL TANK

REF. NO.	PART NO.	DESCRIPTION	USA	CAN	EUR	OCE	JPN	REMARKS
27	90269-06002	RIVET	2	2	2	2	2	

FIG. 27 FRONT WHEEL

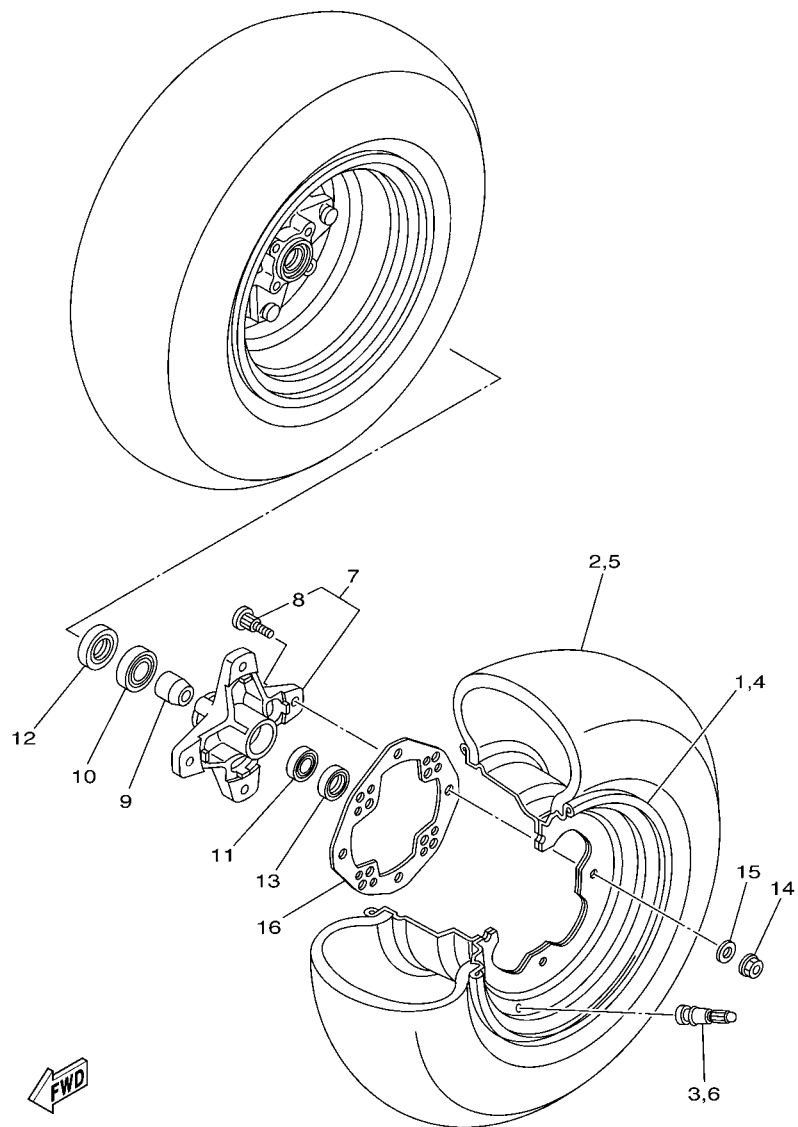

REF. NO.	PART NO.	DESCRIPTION	USA	CAN	EUR	OCE	JPN	REMARKS
1	5LP-25180-20	WHEEL COMP.	1	1	1	1	1	
2	94107-10015	TIRE (AT21X7R10 KT341 T/L N)	1	1	1	1	1	DUNLOP
3	93900-00030	VALVE, RIM (TR412)	1	1	1	1	1	TAIHEIYO
4	5LP-25180-20	WHEEL COMP.	1	1	1	1	1	
5	94107-10015	TIRE (AT21X7R10 KT341 T/L N)	1	1	1	1	1	DUNLOP
6	93900-00030	VALVE, RIM (TR412)	1	1	1	1	1	TAIHEIYO
7	1S3-25111-00	HUB, FRONT	2	2	2	2	2	
8	90114-10006	.BOLT, SERRATION	4	4	4	4	4	
9	5LP-25117-00	SPACER, BEARING	2	2	2	2	2	
10	93306-00446	BEARING	2	2	2	2	2	
11	93306-20231	BEARING	2	2	2	2	2	
12	93105-26026	OIL SEAL	2	2	2	2	2	
13	93102-22216	OIL SEAL	2	2	2	2	2	
14	95702-10500	NUT, WITH WASHER	8	8	8	8	8	
15	92902-10200	WASHER	8	8	8	8	8	
16	1S3-25127-00	COVER, PLATE	2	2	2	2	2	

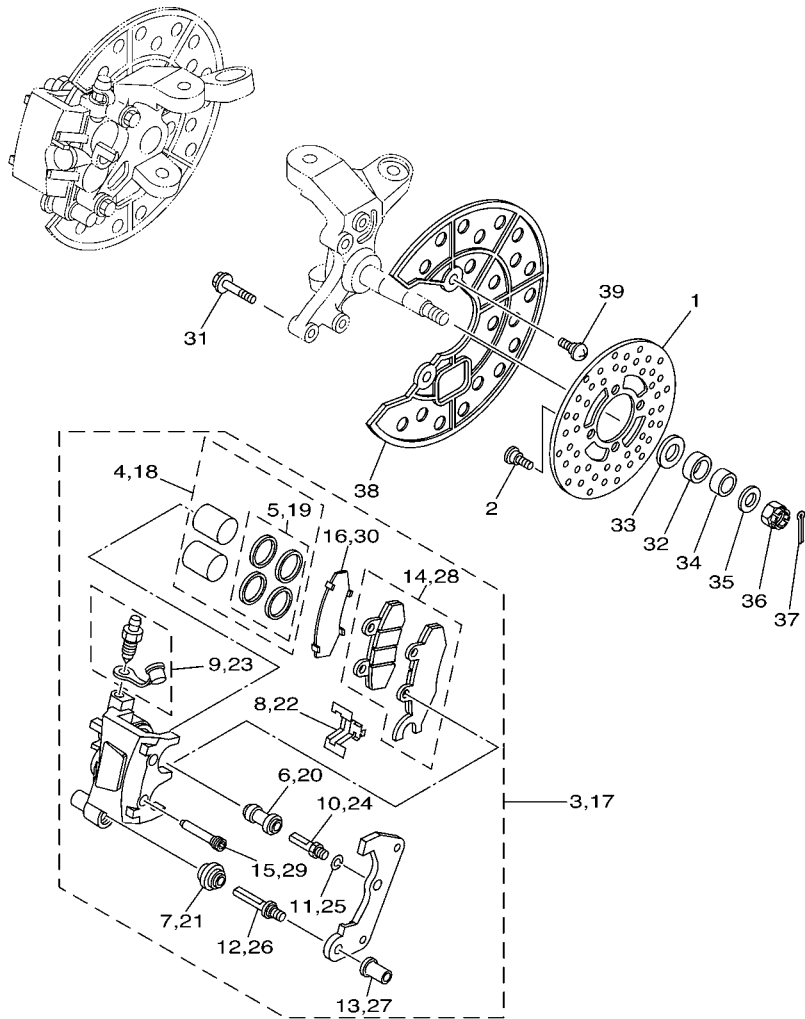

1S31100-E290

FIG. 28 FRONT BRAKE CALIPER

REF. NO.	PART NO.	DESCRIPTION	USA	CAN	EUR	OCE	JPN	REMARKS
1	3GD-2582T-10	DISC, BRAKE (LEFT)	2	2	2	2	2	
2	90109-08082	BOLT	8	8	8	8	8	
3	5TG-2580T-11	CALIPER ASSY (LEFT)	1	1	1	1	1	
4	5TG-W0057-00	.PISTON ASSY, CALIPER	1	1	1	1	1	
5	3LC-W0047-50	..CALIPER SEAL KIT	1	1	1	1	1	
6	1UY-25937-51	.BOOT 2	1	1	1	1	1	
7	3JD-25917-00	.BOOT, CALIPER	1	1	1	1	1	
8	3JD-25919-00	.SUPPORT, PAD	1	1	1	1	1	
9	1UY-W0048-50	.BLEED SCREW KIT	1	1	1	1	1	
10	1UY-25926-51	.BOLT	1	1	1	1	1	
11	1UY-25938-51	.WASHER, SPRING	1	1	1	1	1	
12	3JD-25926-00	.BOLT	1	1	1	1	1	
13	3JD-25961-00	.NUT	1	1	1	1	1	
14	5TG-W0045-20	.BRAKE PAD KIT	1	1	1	1	1	
15	5TG-25924-00	.PIN, PAD	2	2	2	2	2	
16	1S3-25828-00	.SHIM, CALIPER	1	1	1	1	1	
17	5TG-2580U-11	CALIPER ASSY (RIGHT)	1	1	1	1	1	
18	5TG-W0057-00	.PISTON ASSY, CALIPER	1	1	1	1	1	
19	3LC-W0047-50	..CALIPER SEAL KIT	1	1	1	1	1	
20	1UY-25937-51	.BOOT 2	1	1	1	1	1	
21	3JD-25917-00	.BOOT, CALIPER	1	1	1	1	1	
22	3JD-25919-00	.SUPPORT, PAD	1	1	1	1	1	
23	1UY-W0048-50	.BLEED SCREW KIT	1	1	1	1	1	
24	1UY-25926-51	.BOLT	1	1	1	1	1	
25	1UY-25938-51	.WASHER, SPRING	1	1	1	1	1	
26	3JD-25926-00	.BOLT	1	1	1	1	1	
27	3JD-25961-00	.NUT	1	1	1	1	1	

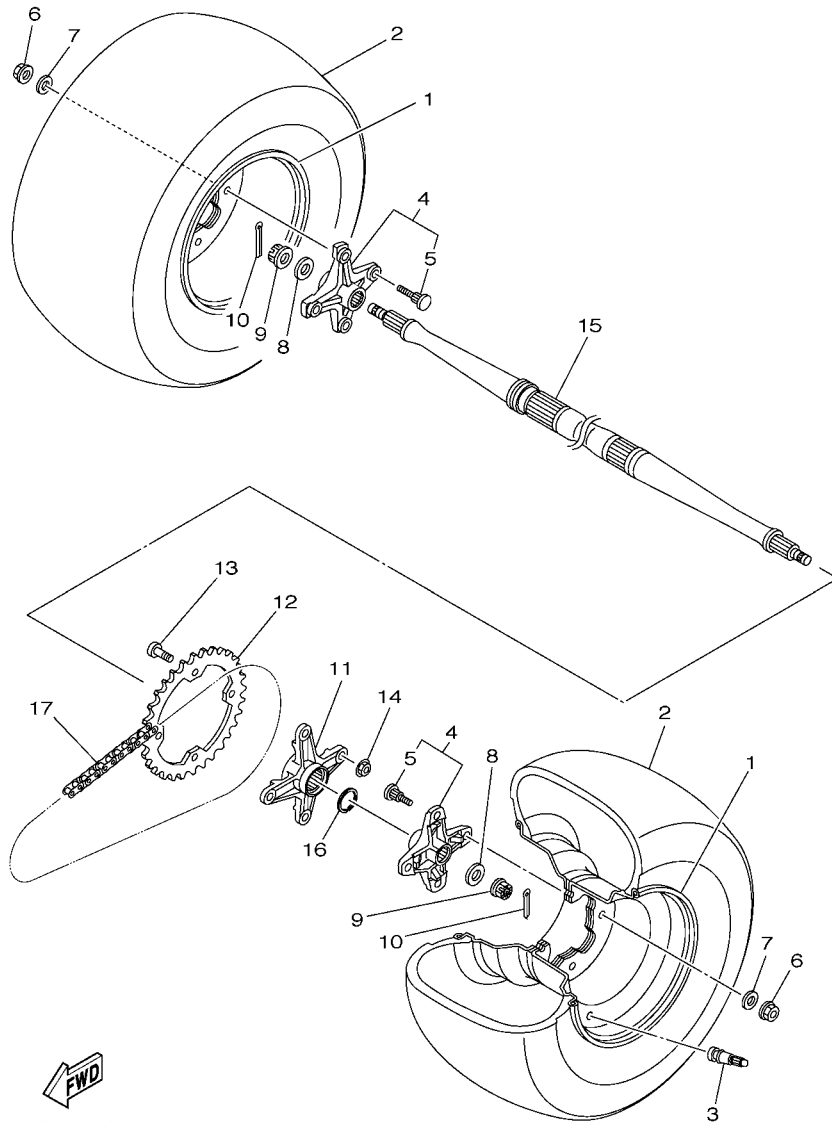

FIG. 29 REAR WHEEL

REF. NO.	PART NO.	DESCRIPTION	USA	CAN	EUR	OCE	JPN	REMARKS
1	5LP-25390-20	REAR WHEEL COMP.	2	2	2	2	2	
2	94110-09015	TIRE (AT20X10R9 KT355 TL)	2	2	2	2	2	DUNLOP
3	93900-00022	VALVE, RIM (TR413)	2	2	2	2	2	TAIHEIYO
4	1S3-25383-20	COLLAR, WHEEL	2	2	2	2	2	
5	90114-10013	.BOLT, SERRATION	4	4	4	4	4	
6	95702-10500	NUT, WITH WASHER	8	8	8	8	8	
7	92902-10200	WASHER	8	8	8	8	8	
8	90201-16023	WASHER, PLATE	2	2	2	2	2	
9	90171-16002	NUT, CASTLE	2	2	2	2	2	
10	90252-03001	PIN, COTTER	2	2	2	2	2	
11	1S3-25386-00	COLLAR, SPROCKET AXLE	1	1	1	1	1	
12	5TG-25438-10	SPROCKET, DRIVEN (38T)	1	1	1	1	1	
13	90109-10013	BOLT	4	4	4	4	4	
14	90185-10011	NUT, SELF-LOCKING	4	4	4	4	4	
15	5D3-25381-00	AXLE, WHEEL	1	1	1	1	1	
16	1S3-25415-00	CIRCLIP	1	1	1	1	1	
17	94582-13096	CHAIN (DID520MXV)	1	1	1	1	1	

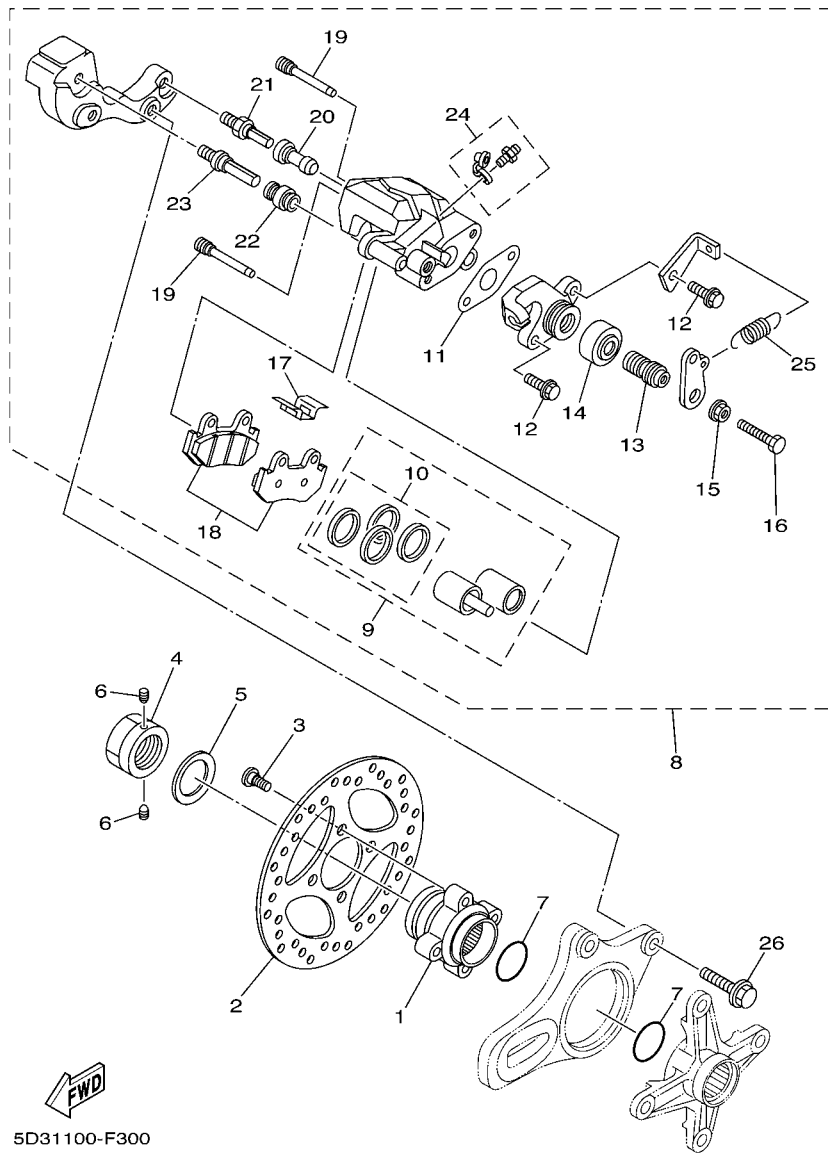

FIG. 30 REAR BRAKE CALIPER

REF. NO.	PART NO.	DESCRIPTION	USA	CAN	EUR	OC	JPN	REMARKS
1	1S3-25712-00	BRACKET, DISC	1	1	1	1	1	
2	1S3-2582W-10	DISK, REAR BRAKE 2	1	1	1	1	1	
3	90109-08076	BOLT	4	4	4	4	4	
4	90179-36003	NUT	1	1	1	1	1	
5	90208-37001	WASHER, CONICAL SPRING	1	1	1	1	1	
6	90113-06055	BOLT, SET	2	2	2	2	2	
7	93210-36769	O-RING	2	2	2	2	2	
8	5TG-2580W-20	CALIPER ASSY, REAR 2	1	1	1	1	1	
9	5TG-W0057-10	.PISTON ASSY, CALIPER	1	1	1	1	1	
10	5TG-W0047-00	..CALIPER SEAL KIT	1	1	1	1	1	
11	5TG-25975-00	.RUBBER, BUSHING	1	1	1	1	1	
12	5UG-25833-00	.BOLT, FITTING	2	2	2	2	2	
13	5TG-25978-00	.SHAFT L	1	1	1	1	1	
14	1UY-25974-51	.BOOT	1	1	1	1	1	
15	1UY-25973-51	.NUT	1	1	1	1	1	
16	5TG-25972-00	.ADJUSTBOLT	1	1	1	1	1	
17	3LD-25934-01	.SPRING, PAD	1	1	1	1	1	
18	5TG-W0046-10	.BRAKE PAD KIT 2	1	1	1	1	1	
19	5DH-25933-00	.PIN, PAD	2	2	2	2	2	
20	1UY-25937-51	.BOOT 2	1	1	1	1	1	
21	3SP-25914-51	.PIN, SLIDE	1	1	1	1	1	
22	3JD-25917-00	.BOOT, CALIPER	1	1	1	1	1	
23	3SP-25926-51	.BOLT	1	1	1	1	1	
24	1UY-W0048-50	.BLEED SCREW KIT	1	1	1	1	1	
25	5TG-25977-50	.SPRING, RETURN	1	1	1	1	1	
26	90105-101A9	BOLT, FLANGE	2	2	2	2	2	

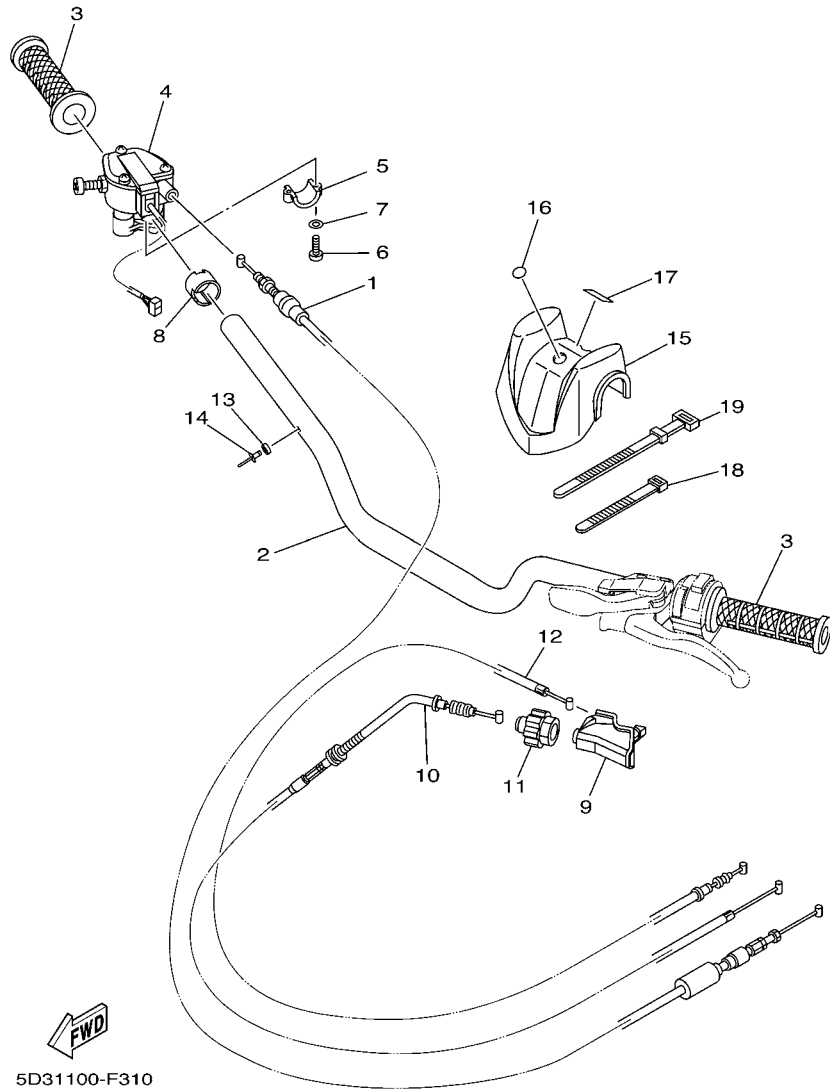

FIG. 31 STEERING HANDLE & CABLE

REF. NO.	PART NO.	DESCRIPTION	USA	CAN	EUR	OCE	JPN	REMARKS
1	5TG-26311-00	CABLE, THROTTLE 1	1	1	1	1	1	
2	5D3-26111-10	HANDLEBAR	1	1	1	1	1	
3	5LP-26241-00	GRIP	2	2	2	2	2	
4	5TG-26250-10	THROTTLE LEVER ASSY	1	1	1	1	1	
5	4V4-82913-00	HOLDER, LEVER LOWER 1	1	1	1	1	1	
6	98502-05020	SCREW, PAN HEAD	2	2	2	2	2	
7	92902-05100	WASHER, SPRING	2	2	2	2	2	
8	1UY-26259-00	COLLAR	1	1	1	1	1	
9	5TG-26372-00	COVER, HANDLE LEVER 1	1	1	1	1	1	
10	5TG-26335-30	CABLE, CLUTCH	1	1	1	1	1	
11	1C3-26342-50	BOOT, CABLE	1	1	1	1	1	
12	5TG-26341-20	WIRE, BRAKE 1	1	1	1	1	1	
13	90387-02001	COLLAR	1	1	1	1	1	
14	90267-24143	RIVET, BLIND	1	1	1	1	1	
15	5D3-26124-00	PROTECTOR, HANDLEBAR	1	1	1	1	1	
16	5GT-2836B-10	TUNING FORK MARK	1	1	1	1	1	
17	5D3-26219-10	EMBLEM	1	1	1	1	1	
18	437-83936-01	BAND, SWITCH CORD	2	2	2	2	2	
19	3TB-83936-00	BAND, SWITCH CORD	2	2	2	2	2	

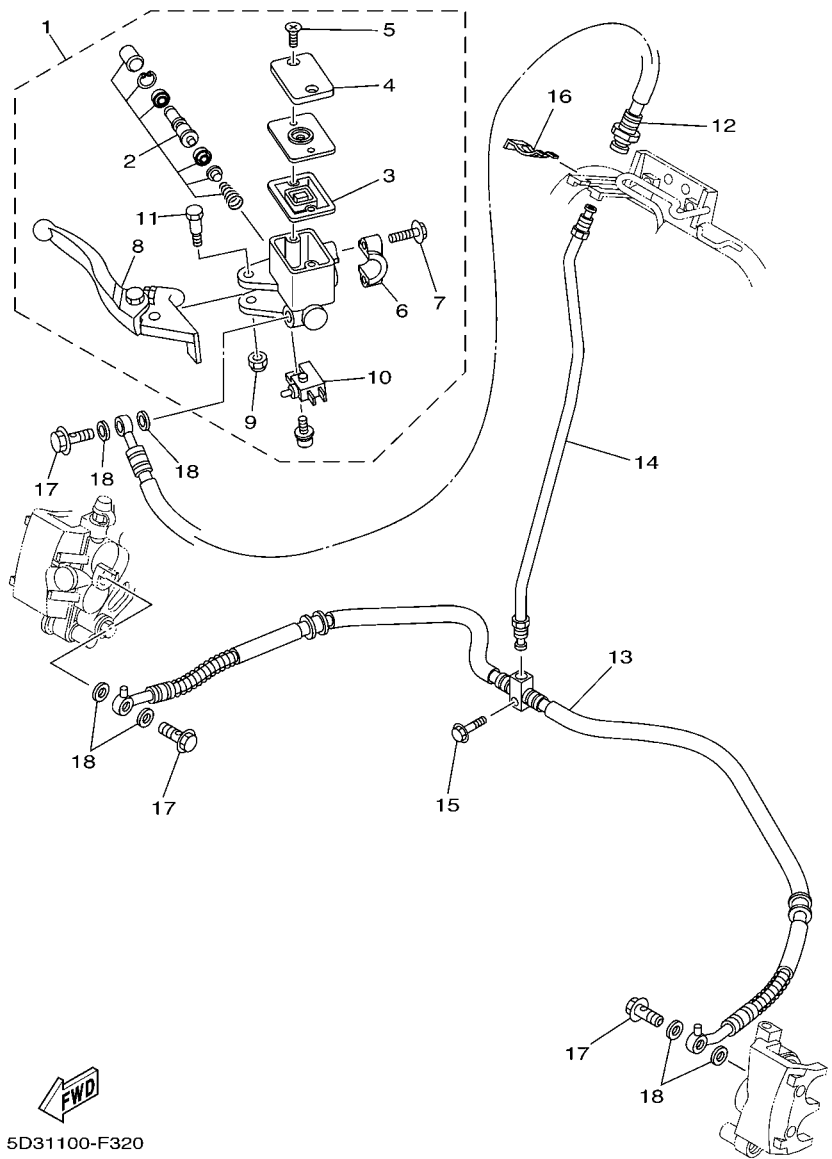
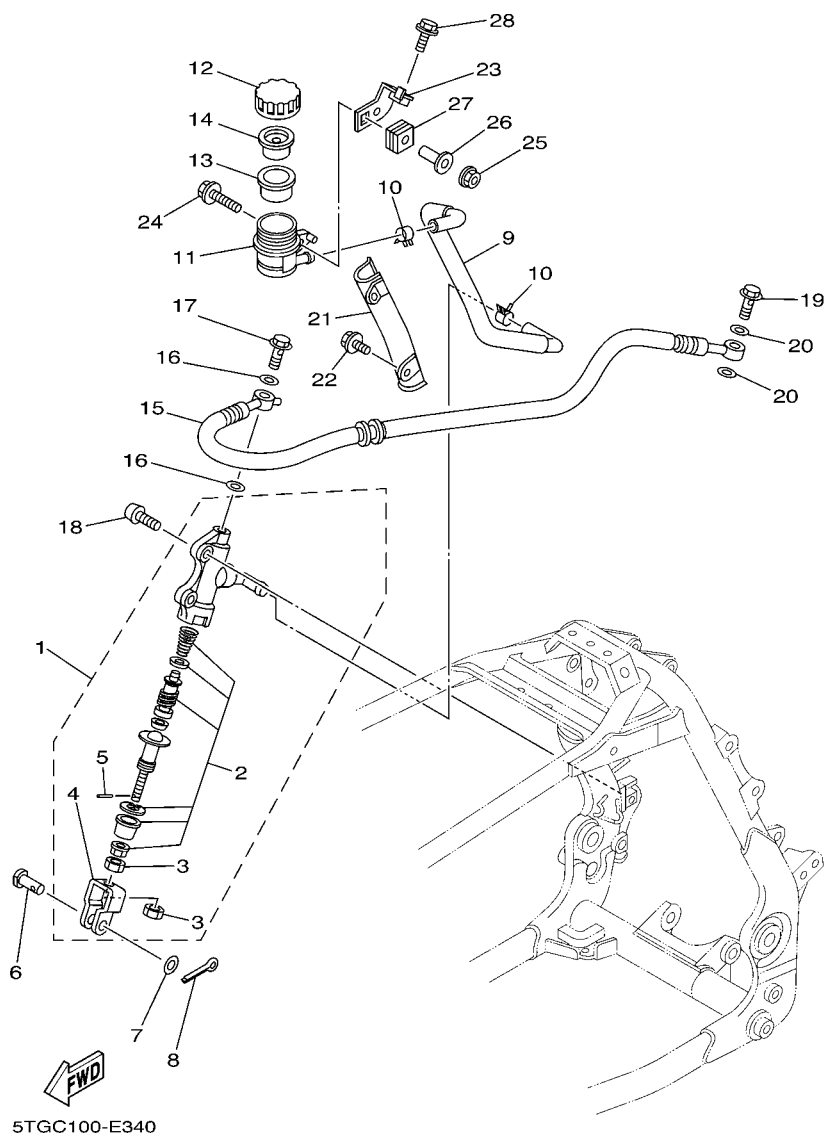

FIG. 32 FRONT MASTER CYLINDER

REF. NO.	PART NO.	DESCRIPTION	USA	CAN	EUR	OCE	JPN	REMARKS
1	5D3-2583T-00	MASTER CYLINDER ASSY	1	1	1	1	1	
2	5D3-W0041-00	.CYLINDER KIT, MASTER	1	1	1	1	1	
3	4TT-25854-00	.DIAPHRAGM, RESERVOIR	1	1	1	1	1	
4	5D3-25852-00	.CAP, RESERVOIR	1	1	1	1	1	
5	4NK-2589H-00	.SCREW	2	2	2	2	2	
6	5LP-25867-00	.BRACKET, MASTER CYLINDER	1	1	1	1	1	
7	5MV-25833-00	.BOLT, FITTING	2	2	2	2	2	
8	5D3-83922-00	.LEVER 2	1	1	1	1	1	
9	95604-06100	.NUT, U	1	1	1	1	1	
10	5D3-83980-00	.FRONT STOP SWITCH ASSY	1	1	1	1	1	
11	5MV-2589F-00	.BOLT, LEVER	1	1	1	1	1	
12	5TG-25872-10	HOSE, BRAKE 1	1	1	1	1	1	
13	5TG-25873-10	HOSE, BRAKE 2	1	1	1	1	1	
14	5TG-25871-10	PIPE, BRAKE	1	1	1	1	1	
15	95822-06025	BOLT, FLANGE	1	1	1	1	1	
16	2GU-25866-00	CIRCLIP	1	1	1	1	1	
17	90401-10015	BOLT, UNION	3	3	3	3	3	
18	90201-10118	WASHER, PLATE	6	6	6	6	6	

FIG. 34 REAR MASTER CYLINDER



REF. NO.	PART NO.	DESCRIPTION	USA	CAN	EUR	OCE	JPN	REMARKS
1	5TG-2580E-20	REAR MASTER CYLINDER ASSY	1	1	1	1	1	
2	5TG-W0042-50	.CYLINDER KIT, MASTER	1	1	1	1	1	
3	4SS-27218-00	.NUT	2	2	2	2	2	
4	2YK-27222-00	.JOINT	1	1	1	1	1	
5	3KW-27234-00	.PIN, BRAKE ROD	1	1	1	1	1	
6	90240-08124	PIN, CLEVIS	1	1	1	1	1	
7	90201-08083	WASHER, PLATE	1	1	1	1	1	
8	91401-16012	PIN, COTTER	1	1	1	1	1	
9	5TG-25895-10	HOSE, RESERVOIR	1	1	1	1	1	
10	90467-11044	CLIP	2	2	2	2	2	
11	5TG-25894-00	TANK, RESERVOIR	1	1	1	1	1	
12	3XP-25852-50	CAP, RESERVOIR	1	1	1	1	1	
13	2VN-25854-00	DIAPHRAGM, RESERVOIR	1	1	1	1	1	
14	2VN-25855-00	BUSH,DIAPHRAGM	1	1	1	1	1	
15	5TG-25874-30	HOSE, BRAKE	1	1	1	1	1	
16	90201-10118	WASHER, PLATE	2	2	2	2	2	
17	90401-10015	BOLT, UNION	1	1	1	1	1	
18	92012-08025	BOLT, BUTTON HEAD	2	2	2	2	2	
19	90401-10015	BOLT, UNION	1	1	1	1	1	
20	90201-10118	WASHER, PLATE	2	2	2	2	2	
21	5TG-2587A-00	HOLDER, BRAKE HOSE	1	1	1	1	1	
22	95022-06010	BOLT, FLANGE	2	2	2	2	2	
23	5TG-21228-10	BRACKET, RESERVE TANK	1	1	1	1	1	
24	90105-05331	BOLT, FLANGE	1	1	1	1	1	
25	95602-05200	NUT, SELF-LOCKING	1	1	1	1	1	
26	90387-05016	COLLAR	1	1	1	1	1	
27	90480-10011	GROMMET	1	1	1	1	1	

FIG. 34 REAR MASTER CYLINDER

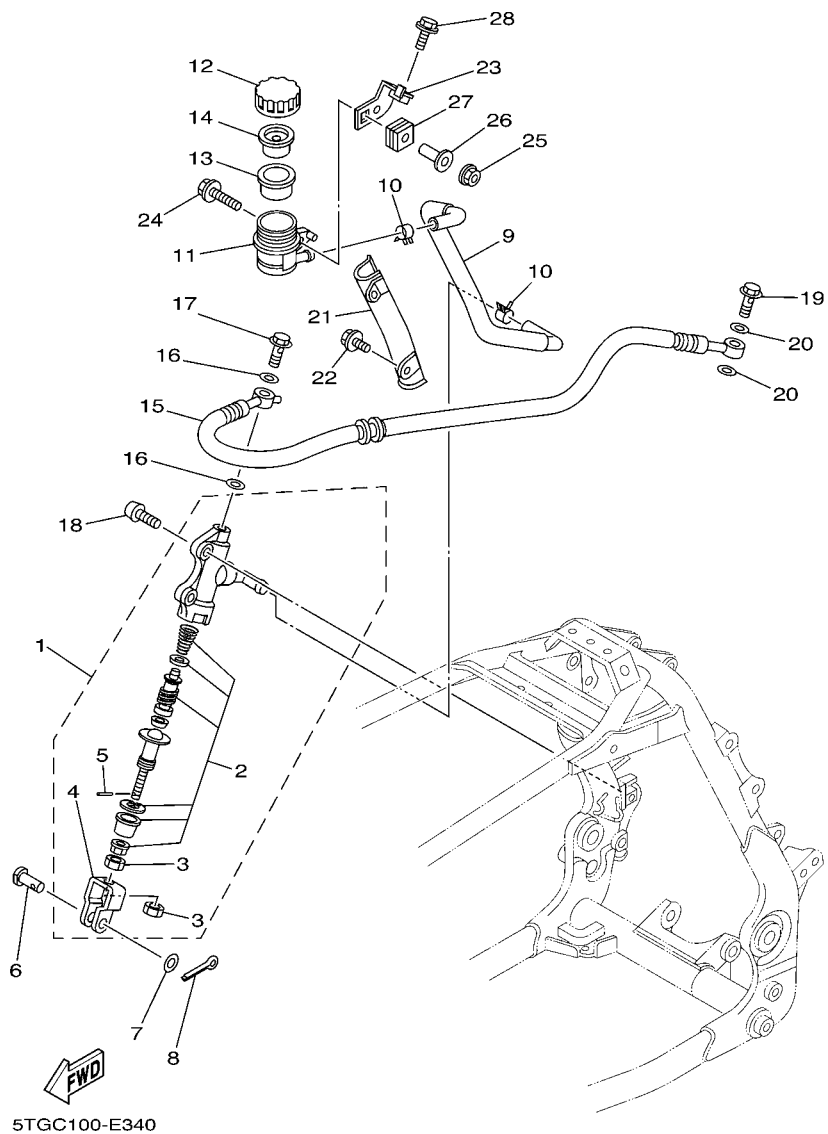

REF. NO.	PART NO.	DESCRIPTION	USA	CAN	EUR	OCE	JPN	REMARKS
28	95802-06012	BOLT, FLANGE	1	1	1	1	1	

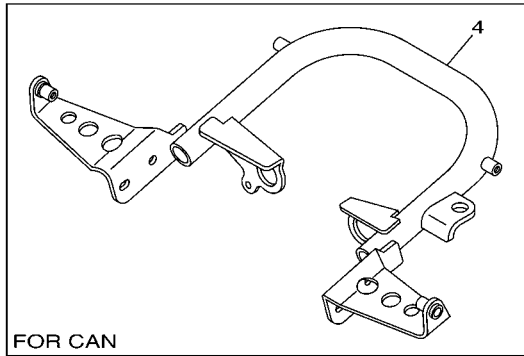

FOR CAN

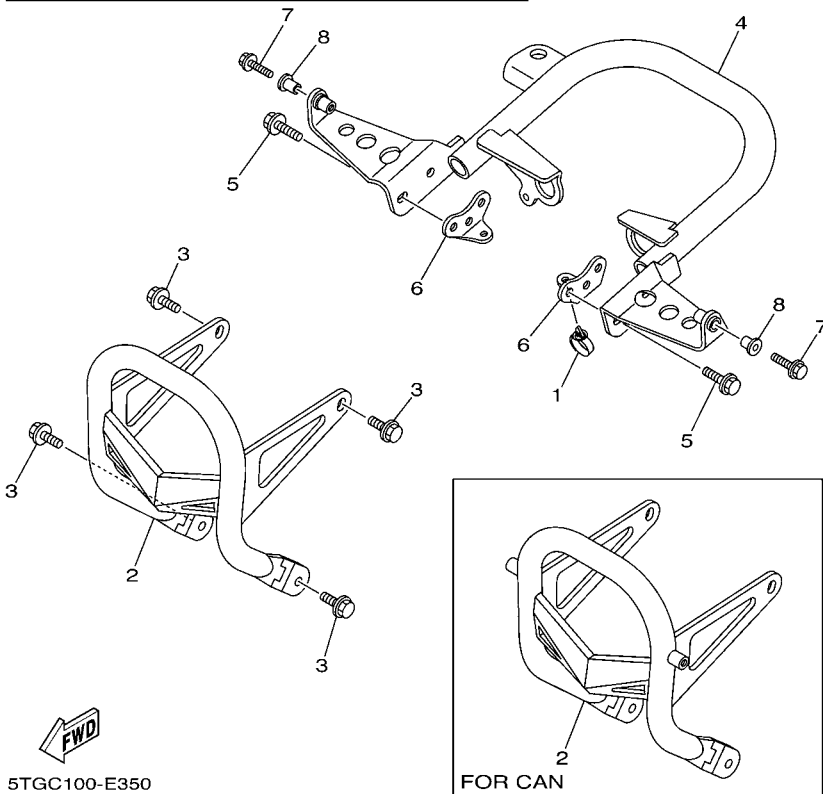

FOR CAN

5TGC100-E350

FIG. 35 GUARD

REF. NO.	PART NO.	DESCRIPTION	USA	CAN	EUR	OCE	JPN	REMARKS
1	90464-20181	CLAMP	1	1	1	1	1	
2	5D3-2845N-00	BAR, CARRY FRONT	1		1	1	1	
	5D3-2845N-10	BAR, CARRY FRONT		1				
3	95812-08014	BOLT, FLANGE	4	4	4	4	4	
4	5D3-2845R-00	BAR, CARRY REAR	1		1	1	1	
	5D3-2845R-10	BAR, CARRY REAR		1				
5	95812-08020	BOLT, FLANGE	4	4	4	4	4	
6	5TG-28215-00	WASHER, SPECIAL	2	2	2	2	2	
7	95802-06020	BOLT, FLANGE	2	2	2	2	2	
8	90387-06153	COLLAR	2	2	2	2	2	

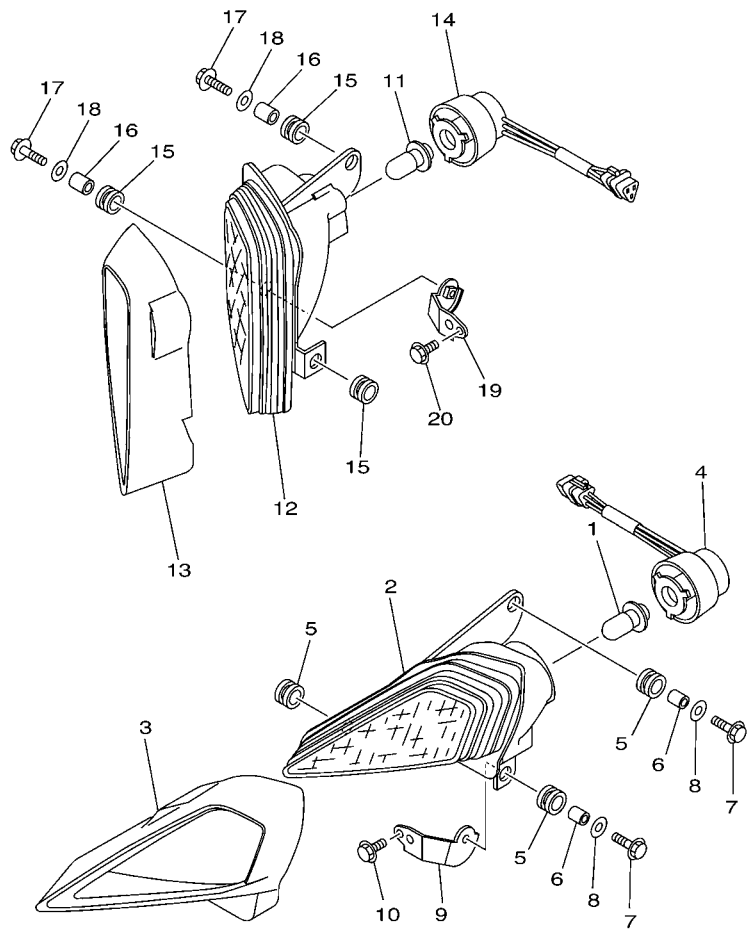

5TG1100-C381

FIG. 38 HEADLIGHT

REF. NO.	PART NO.	DESCRIPTION	USA	CAN	EUR	OCE	JPN	REMARKS
1	4KB-84314-01	BULB (12V-30/30W)	1	1	1	1	1	
2	5TG-84110-03	HEADLIGHT UNIT ASSY	1	1	1	1	1	
3	5TG-84165-01	RIM, HEADLIGHT COVER 1	1	1	1	1	1	
4	5TG-84140-01	SOCKET CORD ASSY	1	1	1	1	1	
5	90480-14102	GROMMET	3	3	3	3	3	
6	90387-07598	COLLAR	2	2	2	2	2	
7	95802-06025	BOLT, FLANGE	2	2	2	2	2	
8	90201-06078	WASHER, PLATE	2	2	2	2	2	
9	5TG-84118-10	STAY, HEADLIGHT 1	1	1	1	1	1	
10	95812-06014	BOLT, FLANGE	1	1	1	1	1	
11	4KB-84314-01	BULB (12V-30/30W)	1	1	1	1	1	
12	5TG-84310-03	HEADLIGHT UNIT ASSY	1	1	1	1	1	
13	5TG-84166-01	RIM, HEADLIGHT COVER 2	1	1	1	1	1	
14	5TG-84340-01	SOCKET CORD ASSY 1	1	1	1	1	1	
15	90480-14102	GROMMET	3	3	3	3	3	
16	90387-07598	COLLAR	2	2	2	2	2	
17	95802-06025	BOLT, FLANGE	2	2	2	2	2	
18	90201-06078	WASHER, PLATE	2	2	2	2	2	
19	5TG-84119-10	STAY, HEADLIGHT 2	1	1	1	1	1	
20	95812-06014	BOLT, FLANGE	1	1	1	1	1	

FIG. 39 TAILLIGHT

REF. NO.	PART NO.	DESCRIPTION	USA	CAN	EUR	OCE	JPN	REMARKS
1	5TG-84710-20	TAILLIGHT UNIT ASSY	1			1	1	
2	90480-25001	GROMMET	2			2	2	
3	97702-50016	SCREW, TAPPING	2			2	2	
4	90201-05023	WASHER, PLATE	2			2	2	

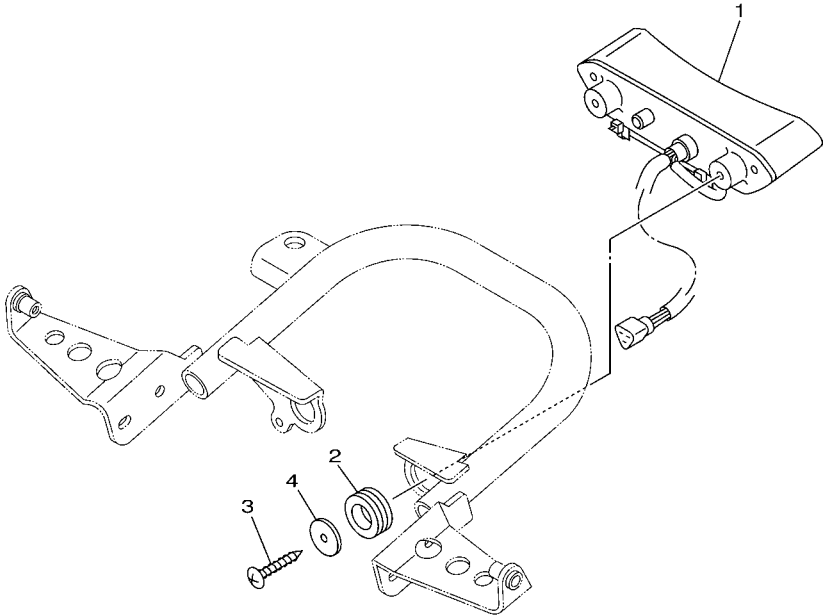

FWD
5TGC100-E390

FIG. 41 HANDLE SWITCH & LEVER

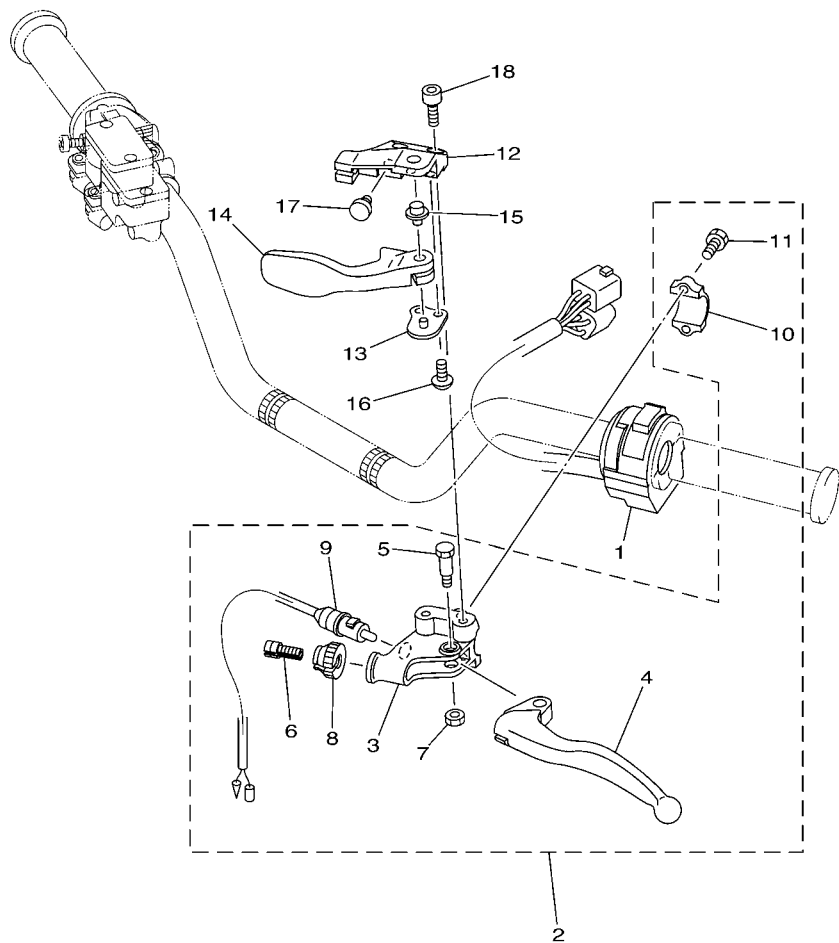

REF. NO.	PART NO.	DESCRIPTION	USA	CAN	EUR	OCE	JPN	REMARKS
1	4KB-83973-00	SWITCH, HANDLE 3	1	1	1	1	1	
2	5TG-82910-00	LEVER HOLDER ASSY (LEFT)	1	1	1	1	1	
3	5TG-82911-00	.HOLDER, LEVER 1	1	1	1	1	1	
4	5TJ-83912-00	.LEVER 1	1	1	1	1	1	
5	90109-06034	.BOLT	1	1	1	1	1	
6	5TA-26337-00	.BOLT, ADJUSTING	1	1	1	1	1	
7	95602-06100	.NUT, U	1	1	1	1	1	
8	5HD-83951-00	.BOLT, CABLE ADJUSTING	1	1	1	1	1	
9	1UY-82917-00	.SWITCH	1	1	1	1	1	
10	5TG-82913-00	.HOLDER, LEVER LOWER 1	1	1	1	1	1	
11	97002-05016	.BOLT	2	2	2	2	2	
12	5TG-25727-00	BRACKET, LEVER	1	1	1	1	1	
13	5D3-25689-00	PLATE, GUIDE	1	1	1	1	1	
14	5TG-25726-00	LEVER, BRAKE	1	1	1	1	1	
15	5TG-83923-00	COLLAR, LEVER 2	1	1	1	1	1	
16	92012-06014	BOLT, BUTTON HEAD	2	2	2	2	2	
17	90338-07007	PLUG	1	1	1	1	1	
18	92014-06016	BOLT, BUTTON HEAD	2	2	2	2	2	

 5TGC100-E410

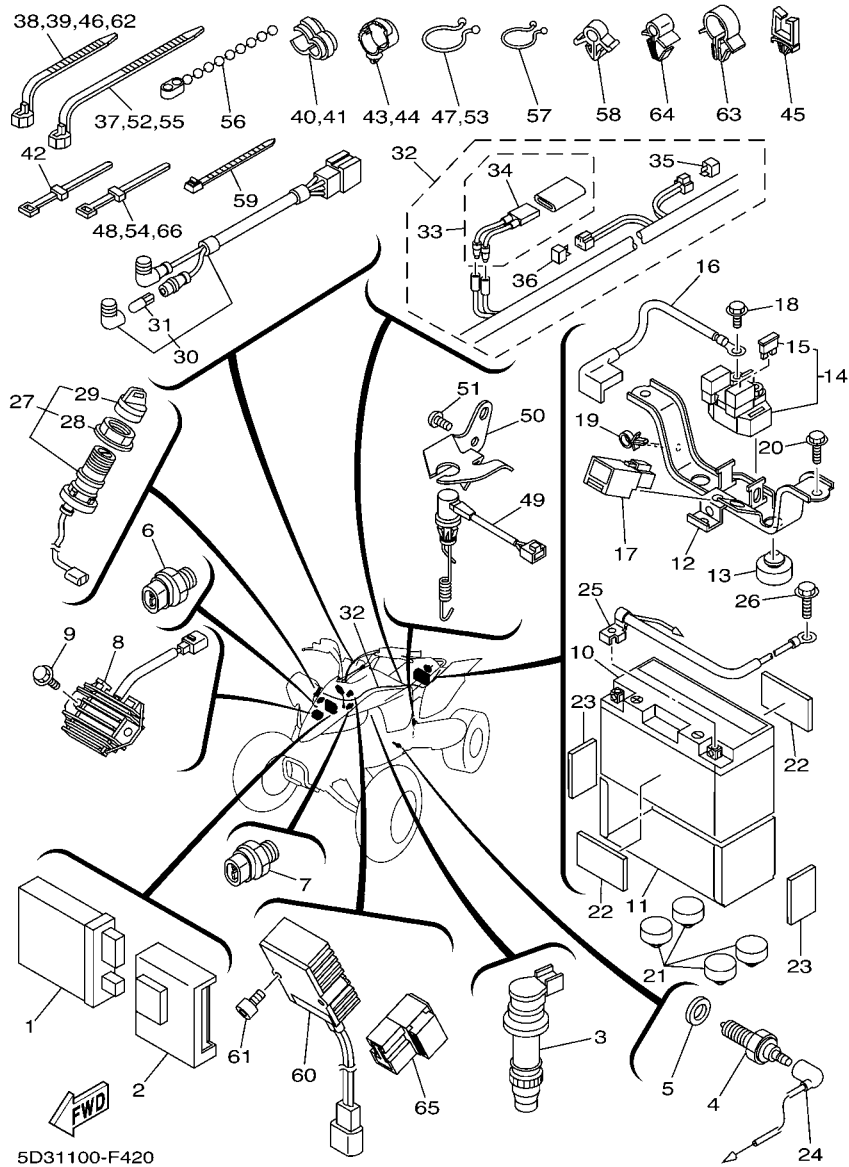

FIG. 42 ELECTRICAL 1

REF. NO.	PART NO.	DESCRIPTION	USA	CAN	EUR	OCE	JPN	REMARKS
1	5TG-85540-10	C.D.I. UNIT ASSY	1	1	1	1	1	
2	5TG-85546-00	BAND	1	1	1	1	1	
3	5TA-82310-10	IGNITION COIL ASSY	1	1	1	1	1	
4	3GB-82540-01	NEUTRAL SWITCH ASSY	1	1	1	1	1	
5	90430-10148	GASKET	1	1	1	1	1	
6	5EB-82560-00	THERMO SWITCH ASSY	1	1	1	1	1	
7	5LP-82560-00	THERMO SWITCH ASSY	1	1	1	1	1	
8	5TG-81960-00	RECTIFIER & REGULATOR ASSY	1	1	1	1	1	
9	95022-06020	BOLT, FLANGE	2	2	2	2	2	
10	4UC-82100-01	BATTERY (GS GT7B-4)	1	1	1	1	1	
	4GY-82100-01	BATTERY (GS GT7B-4)					1	
11	5D3-82122-00	SEAT, BATTERY	1	1	1	1	1	
12	5TG-82128-10	BRACKET, BATTERY	1	1	1	1	1	
13	5TG-82121-10	PAD, BATTERY	2	2	2	2	2	
14	5JW-81940-02	STARTER RELAY ASSY	1	1	1	1	1	
15	36Y-82151-00	.FUSE (15A-BL)	2	2	2	2	2	
16	5TG-82115-00	WIRE, PLUS LEAD	1	1	1	1	1	
17	1RL-81950-92	RELAY ASSY	1	1	1	1	1	
18	95022-06008	BOLT, FLANGE	1	1	1	1	1	
19	90464-15157	CLAMP	1	1	1	1	1	
20	90105-06084	BOLT, FLANGE	2	2	2	2	2	
21	5TG-82121-10	PAD, BATTERY	4	4	4	4	4	
22	5D3-82123-00	SEAT, BATTERY	2	2	2	2	2	
23	22F-2139X-00	DAMPER	2	2	2	2	2	
24	5TG-82541-00	WIRE, LEAD	1	1	1	1	1	
25	5TG-82116-00	WIRE, MINUS LEAD	1	1	1	1	1	
26	95022-06008	BOLT, FLANGE	1	1	1	1	1	

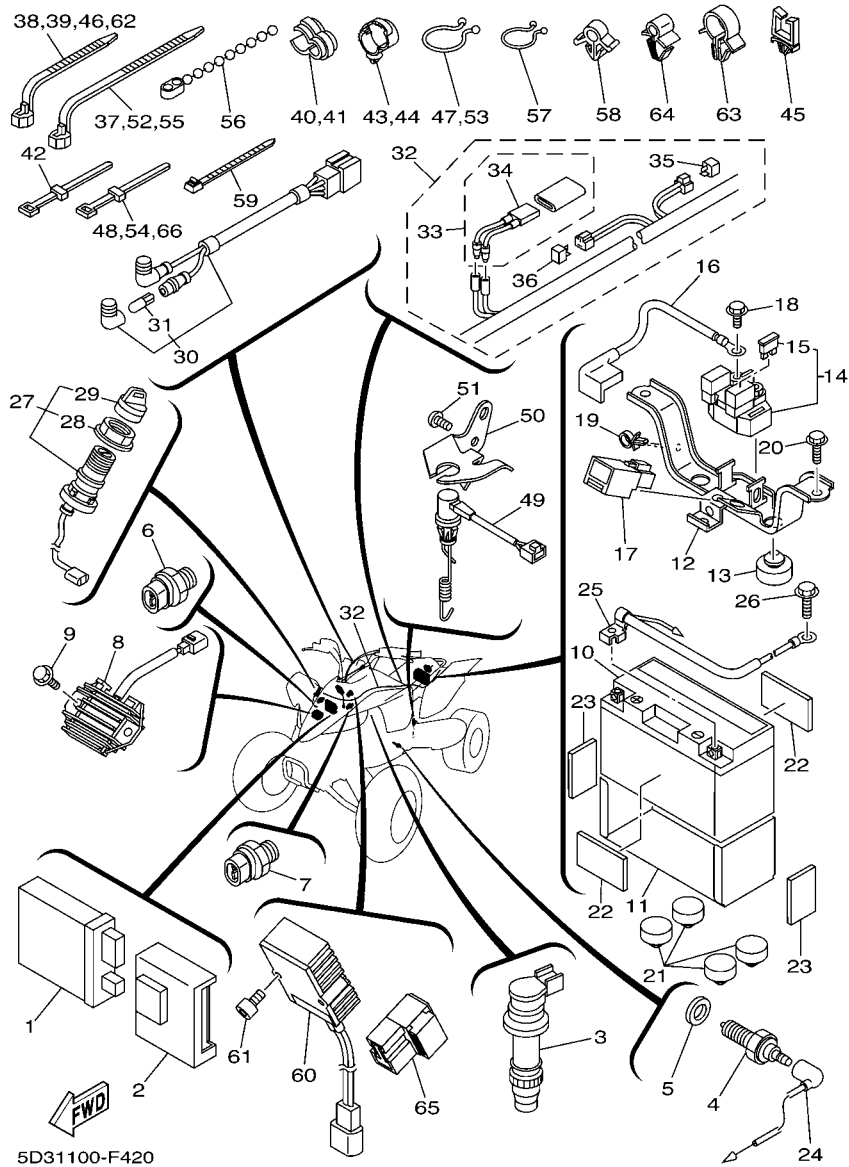

FIG. 42 ELECTRICAL 1

REF. NO.	PART NO.	DESCRIPTION	USA	CAN	EUR	OCE	JPN	REMARKS
27	5TG-82510-00	MAIN SWITCH ASSY	1	1	1	1	1	
28	3HN-82569-00	.NUT, MAIN SWITCH	1	1	1	1	1	
29	3HN-82579-00	.CAP, KEY	1	1	1	1	1	
30	5TG-83530-00	PILOT LIGHT ASSY	1	1	1	1	1	RED, GREEN LENS
31	5GH-83516-00	.BULB (14V-1.7W)	2	2	2	2	2	
32	5D3-82590-00	WIRE HARNESS ASSY	1	1	1	1	1	
33	5ND-82180-00	.CIRCUIT BREAKER ASSY	1	1	1	1	1	
34	5ND-82560-00	..THERMO SWITCH ASSY	1	1	1	1	1	
35	4WA-81980-00	.DIODE ASSY	1	1	1	1	1	
36	3WP-81980-00	.DIODE ASSY	1	1	1	1	1	
37	90464-15195	CLAMP	1	1	1	1	1	
38	90464-13073	CLAMP	2	2	2	2	2	
39	90464-13073	CLAMP	1	1	1	1	1	
40	90464-15065	CLAMP	1	1	1	1	1	
41	90464-15065	CLAMP	1	1	1	1	1	
42	437-83936-01	BAND, SWITCH CORD	1	1	1	1	1	
43	90464-20181	CLAMP	1	1	1	1	1	
44	90464-20181	CLAMP	1	1	1	1	1	
45	90464-20159	CLAMP	1	1	1	1	1	
46	90464-13073	CLAMP	1	1	1	1	1	
47	90464-30040	CLAMP	1	1	1	1	1	
48	3TB-83936-00	BAND, SWITCH CORD	1	1	1	1	1	
49	5TG-82530-10	STOP SWITCH ASSY	1	1	1	1	1	
50	5TG-2144G-10	STAY, STOP SWITCH	1	1	1	1	1	
51	98902-06012	SCREW, BIND	2	2	2	2	2	
52	90464-15195	CLAMP	1	1	1	1	1	
53	90464-30040	CLAMP	1	1	1	1	1	

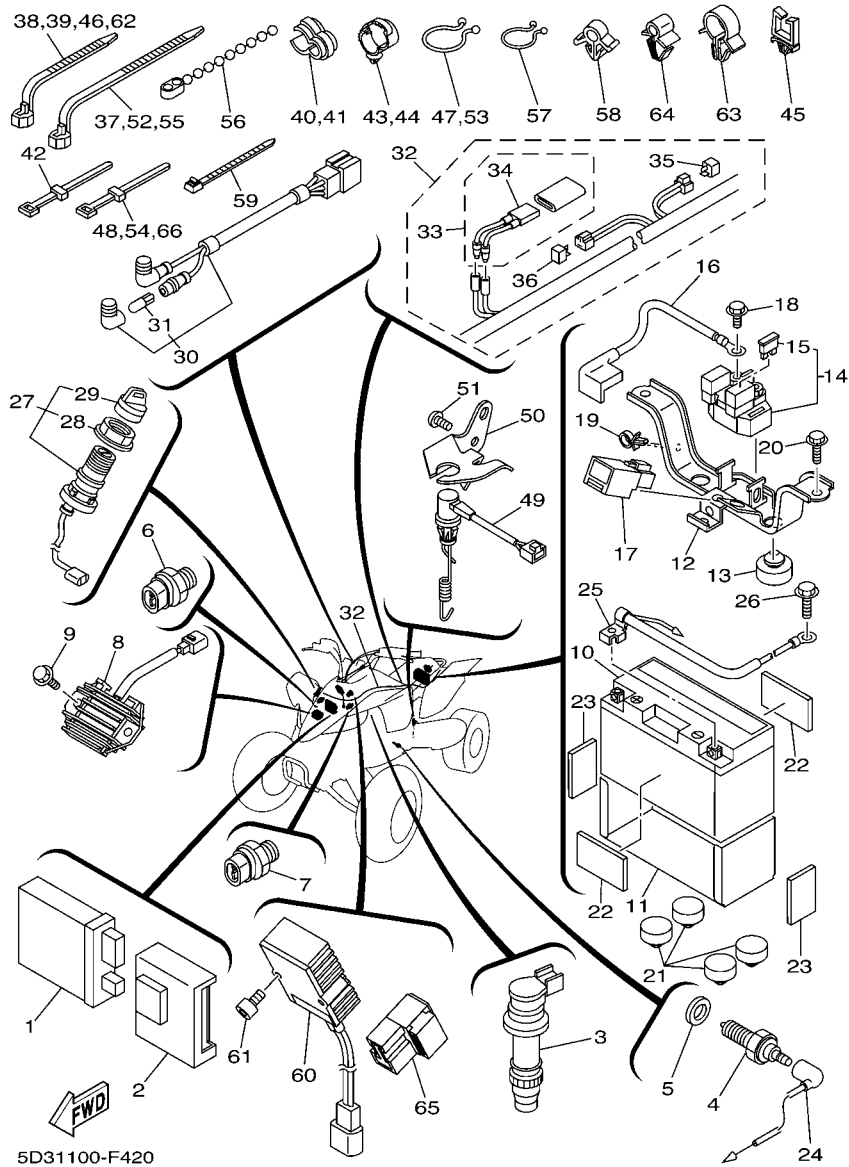

FIG. 42 ELECTRICAL 1

REF. NO.	PART NO.	DESCRIPTION	USA	CAN	EUR	OCE	JPN	REMARKS
54	3TB-83936-00	BAND, SWITCH CORD	1	1	1	1	1	
55	90464-15195	CLAMP	1	1	1	1	1	
56	90464-20031	CLAMP	1	1	1	1	1	
57	90464-23041	CLAMP	1	1	1	1	1	
58	90464-48174	CLAMP	1	1	1	1	1	
59	90465-13M11	CLAMP	1	1	1	1	1	
60	5TG-85370-00	RESISTOR ASSY	1	1	1	1	1	
61	91312-05010	BOLT	2	2	2	2	2	
62	90464-13073	CLAMP	2	2	2	2	2	
63	90464-15157	CLAMP	1	1	1	1	1	
64	90464-48174	CLAMP	1	1	1	1	1	
65	5DM-81950-00	RELAY ASSY (G8HN-1C4T-DJ-Y52)	2	2	2	2	2	
66	3TB-83936-00	BAND, SWITCH CORD	1	1	1	1	1	

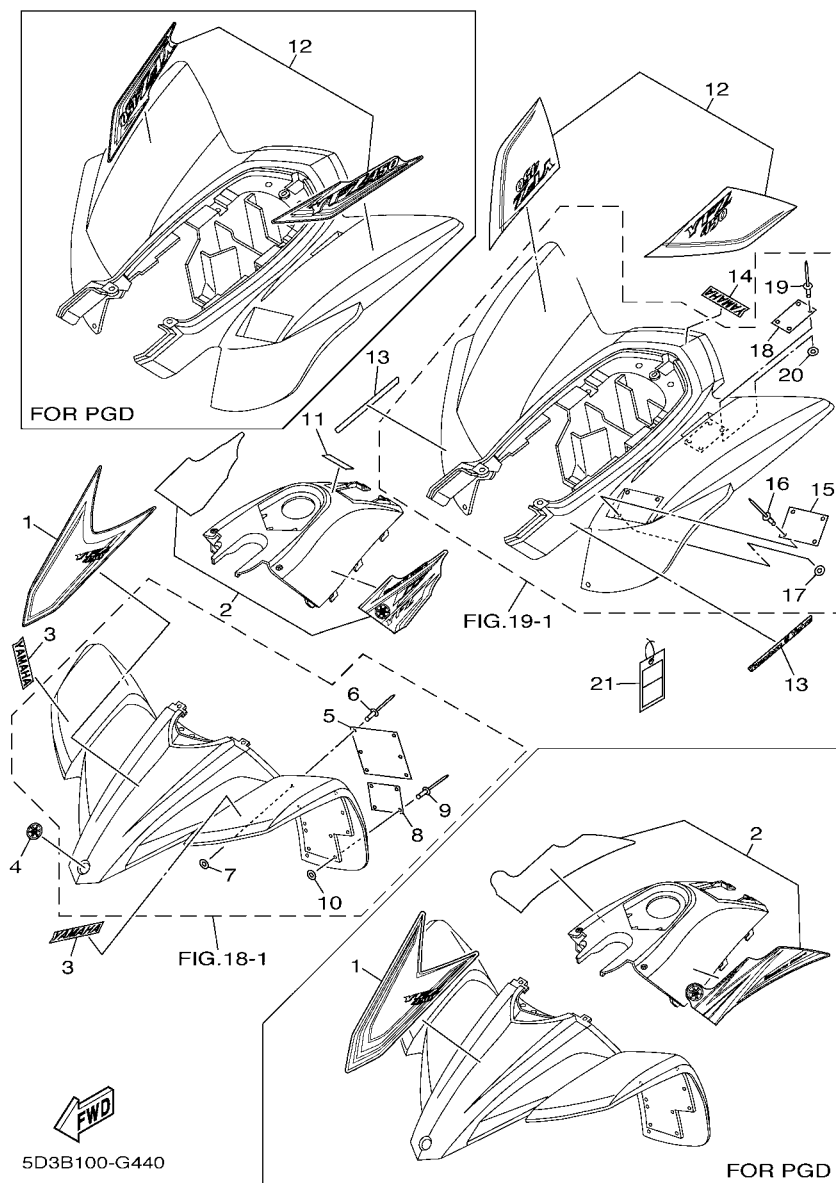

FIG. 44 EMBLEM & LABEL 1

REF. NO.	PART NO.	DESCRIPTION	USA	CAN	EUR	OCE	JPN	REMARKS
1	5D3-21569-40	GRAPHIC 1	1					UR FOR DPBSE
	5D3-21569-50	GRAPHIC 1	1					UR FOR PGD
2	5D3-24250-40	GRAPHIC SET	1					UR FOR DPBSE
	5D3-24250-50	GRAPHIC SET	1					UR FOR PGD
3	3GD-2153E-00	EMBLEM, YAMAHA	2					UR FOR DPBSE
	3GD-2153E-20	EMBLEM, YAMAHA	2					UR FOR PGD
4	4KN-2836B-10	TUNING FORK MARK	1					
5	5FE-21568-01	LABEL, WARNING	1					ENGLISH
6	90267-32004	RIVET, BLIND	6					
7	90201-03008	WASHER, PLATE	6					
8	5FE-21697-01	LABEL, CAUTION 2	1					ENGLISH
9	90267-32004	RIVET, BLIND	4					
10	90201-03008	WASHER, PLATE	4					
11	5PW-2415E-11	LABEL, CAUTION	1					ENGLISH
12	5D3-2165A-40	GRAPHIC SET, REAR FENDER	1					UR FOR DPBSE
	5D3-2165A-50	GRAPHIC SET, REAR FENDER	1					UR FOR PGD
13	5D3-2163G-00	EMBLEM 1	2					UR FOR DPBSE
	5D3-2163G-10	EMBLEM 1	2					UR FOR PGD
14	4ES-2153E-40	EMBLEM, YAMAHA	1					UR FOR DPBSE
	4ES-2153E-30	EMBLEM, YAMAHA	1					UR FOR PGD
15	5TG-21696-30	LABEL, CAUTION	1					
16	90267-32004	RIVET, BLIND	4					
17	90201-03008	WASHER, PLATE	4					
18	5FE-2151H-01	LABEL 5	1					ENGLISH
19	90267-32004	RIVET, BLIND	4					
20	90201-03008	WASHER, PLATE	4					
21	5LP-2819R-00	TAG, WARNING	1					

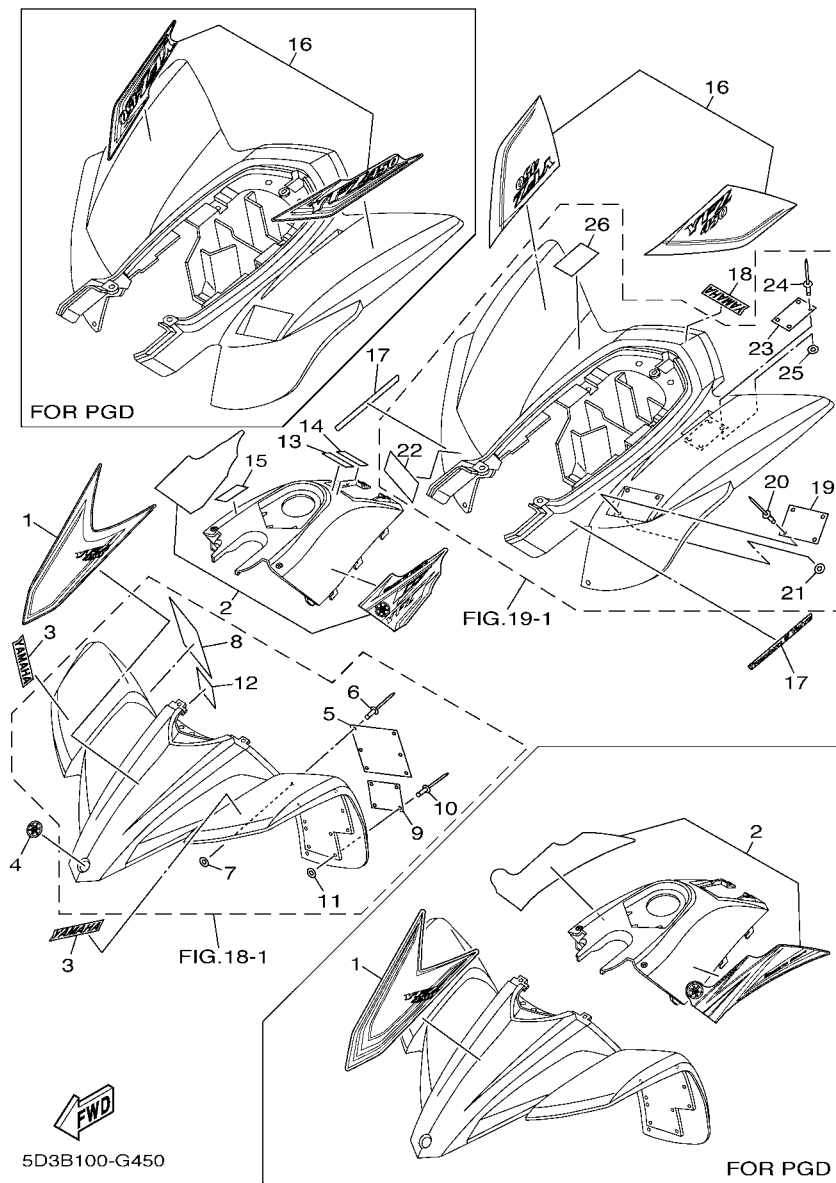

FIG. 45 EMBLEM & LABEL 2

REF. NO.	PART NO.	DESCRIPTION	USA	CAN	EUR	OCE	JPN	REMARKS
1	5D3-21569-40	GRAPHIC 1		1				UR FOR DPBSE
	5D3-21569-50	GRAPHIC 1		1				UR FOR PGD
2	5D3-24250-40	GRAPHIC SET		1				UR FOR DPBSE
	5D3-24250-50	GRAPHIC SET		1				UR FOR PGD
3	3GD-2153E-00	EMBLEM, YAMAHA		2				UR FOR DPBSE
	3GD-2153E-20	EMBLEM, YAMAHA		2				UR FOR PGD
4	4KN-2836B-10	TUNING FORK MARK		1				
5	5FE-21568-01	LABEL, WARNING		1				ENGLISH
6	90267-32004	RIVET, BLIND		6				
7	90201-03008	WASHER, PLATE		6				
8	4WU-21568-10	LABEL, WARNING		1				FRENCH
9	5FE-21697-01	LABEL, CAUTION 2		1				ENGLISH
10	90267-32004	RIVET, BLIND		4				
11	90201-03008	WASHER, PLATE		4				
12	3JM-21697-10	LABEL, CAUTION 2		1				FRENCH
13	5PW-2415E-11	LABEL, CAUTION		1				ENGLISH
14	5PW-2415E-31	LABEL, CAUTION		1				
15	4SH-2416E-00	LABEL, CAUTION CANADA		1				ENGLISH
16	5D3-2165A-40	GRAPHIC SET, REAR FENDER		1				UR FOR DPBSE
	5D3-2165A-50	GRAPHIC SET, REAR FENDER		1				UR FOR PGD
17	5D3-2163G-00	EMBLEM 1		2				UR FOR DPBSE
	5D3-2163G-10	EMBLEM 1		2				UR FOR PGD
18	4ES-2153E-40	EMBLEM, YAMAHA		1				UR FOR DPBSE
	4ES-2153E-30	EMBLEM, YAMAHA		1				UR FOR PGD
19	5TG-21696-30	LABEL, CAUTION		1				
20	90267-32004	RIVET, BLIND		4				
21	90201-03008	WASHER, PLATE		4				

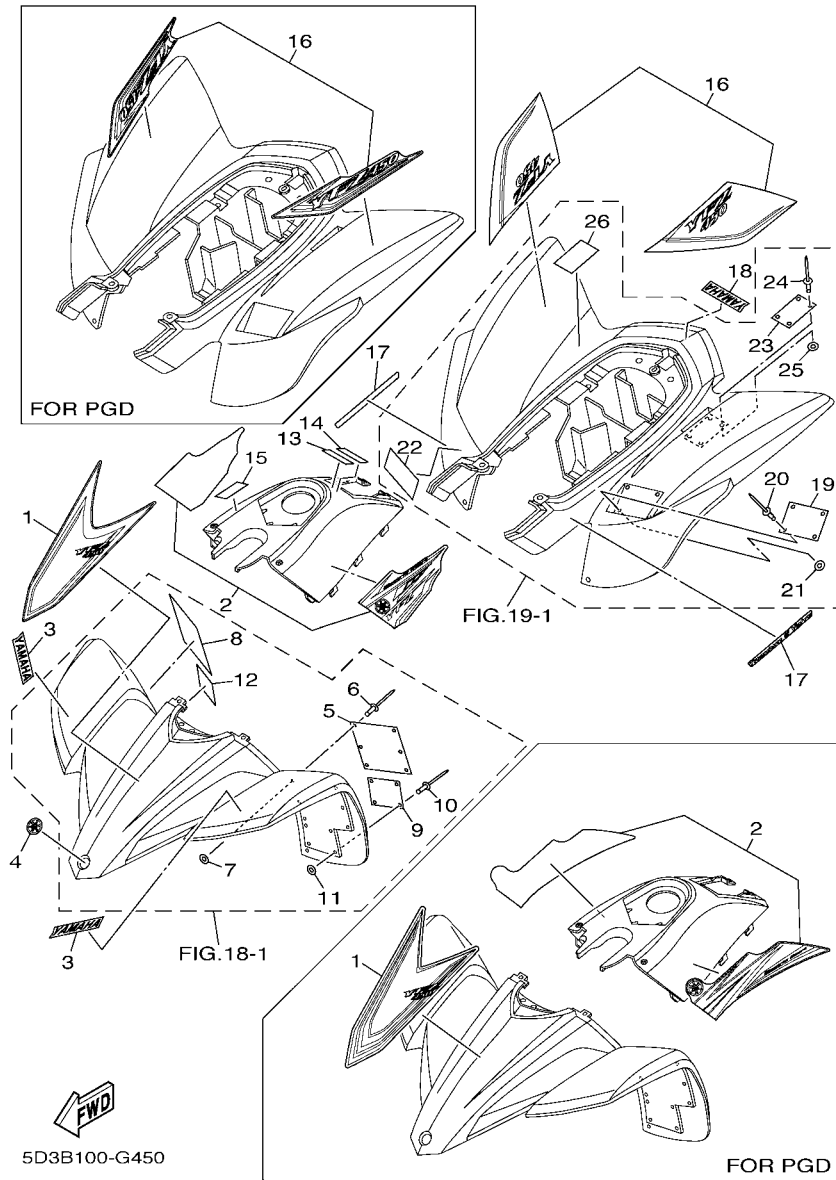

FIG. 45 EMBLEM & LABEL 2

REF. NO.	PART NO.	DESCRIPTION	USA	CAN	EUR	OCE	JPN	REMARKS
22	5TG-21696-50	LABEL, CAUTION			1			
23	5FE-2151H-01	LABEL 5			1			ENGLISH
24	90267-32004	RIVET, BLIND			4			
25	90201-03008	WASHER, PLATE			4			
26	4WU-2151H-10	LABEL 5			1			FRENCH

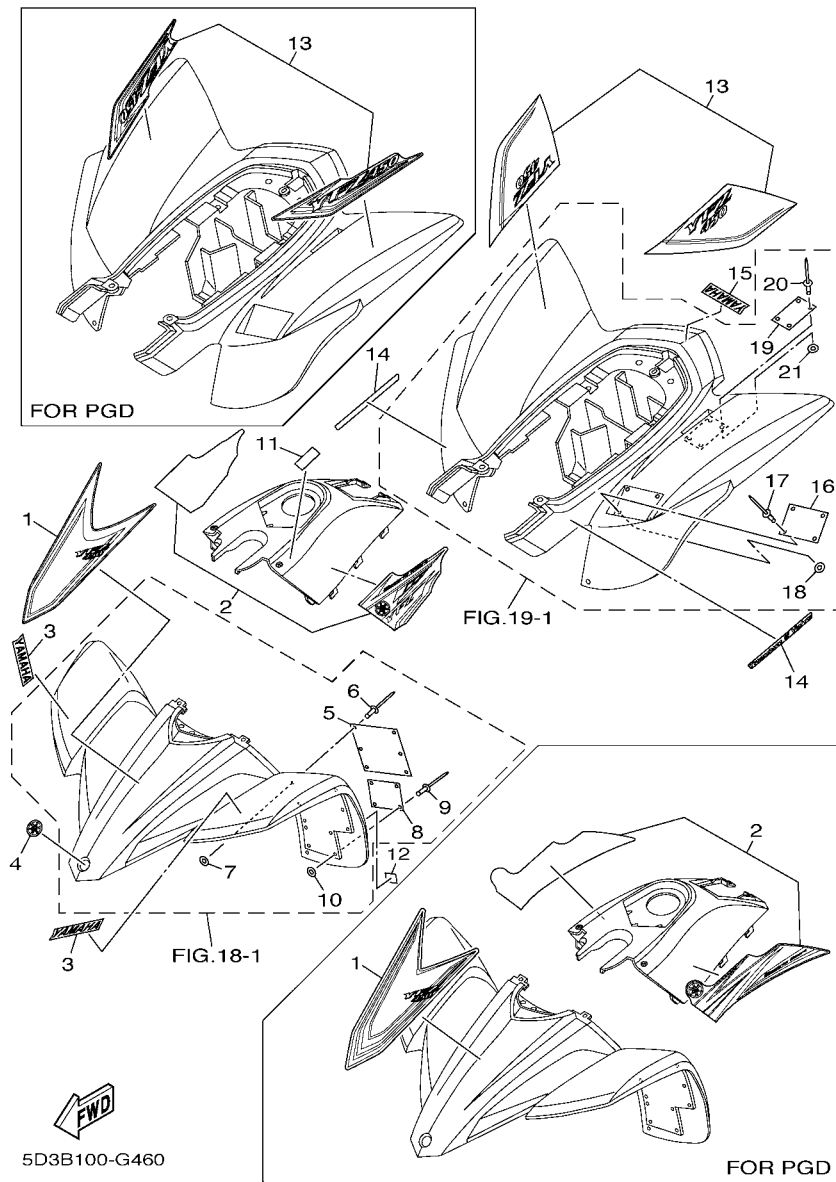

FIG. 46 EMBLEM & LABEL 3

REF. NO.	PART NO.	DESCRIPTION	USA	CAN	EUR	OCE	JPN	REMARKS
1	5D3-21569-40	GRAPHIC 1			1			UR FOR DPBSE
	5D3-21569-50	GRAPHIC 1			1			UR FOR PGD
2	5D3-24250-40	GRAPHIC SET			1			UR FOR DPBSE
	5D3-24250-50	GRAPHIC SET			1			UR FOR PGD
3	3GD-2153E-00	EMBLEM, YAMAHA			2			UR FOR DPBSE
	3GD-2153E-20	EMBLEM, YAMAHA			2			UR FOR PGD
4	4KN-2836B-10	TUNING FORK MARK			1			
5	5FK-21568-00	LABEL, WARNING			1			
6	90267-32004	RIVET, BLIND			6			
7	90201-03008	WASHER, PLATE			6			
8	5FK-21697-00	LABEL, CAUTION 2			1			
9	90267-32004	RIVET, BLIND			4			
10	90201-03008	WASHER, PLATE			4			
11	5TG-2415E-00	LABEL, CAUTION			1			
12	4GB-2155A-00	MARK, EC			1			
13	5D3-2165A-40	GRAPHIC SET, REAR FENDER			1			UR FOR DPBSE
	5D3-2165A-50	GRAPHIC SET, REAR FENDER			1			UR FOR PGD
14	5D3-2163G-00	EMBLEM 1			2			UR FOR DPBSE
	5D3-2163G-10	EMBLEM 1			2			UR FOR PGD
15	4ES-2153E-40	EMBLEM, YAMAHA			1			UR FOR DPBSE
	4ES-2153E-30	EMBLEM, YAMAHA			1			UR FOR PGD
16	5TG-21696-40	LABEL, CAUTION			1			
17	90267-32004	RIVET, BLIND			4			
18	90201-03008	WASHER, PLATE			4			
19	5FK-2151H-00	LABEL 5			1			
20	90267-32004	RIVET, BLIND			4			
21	90201-03008	WASHER, PLATE			4			

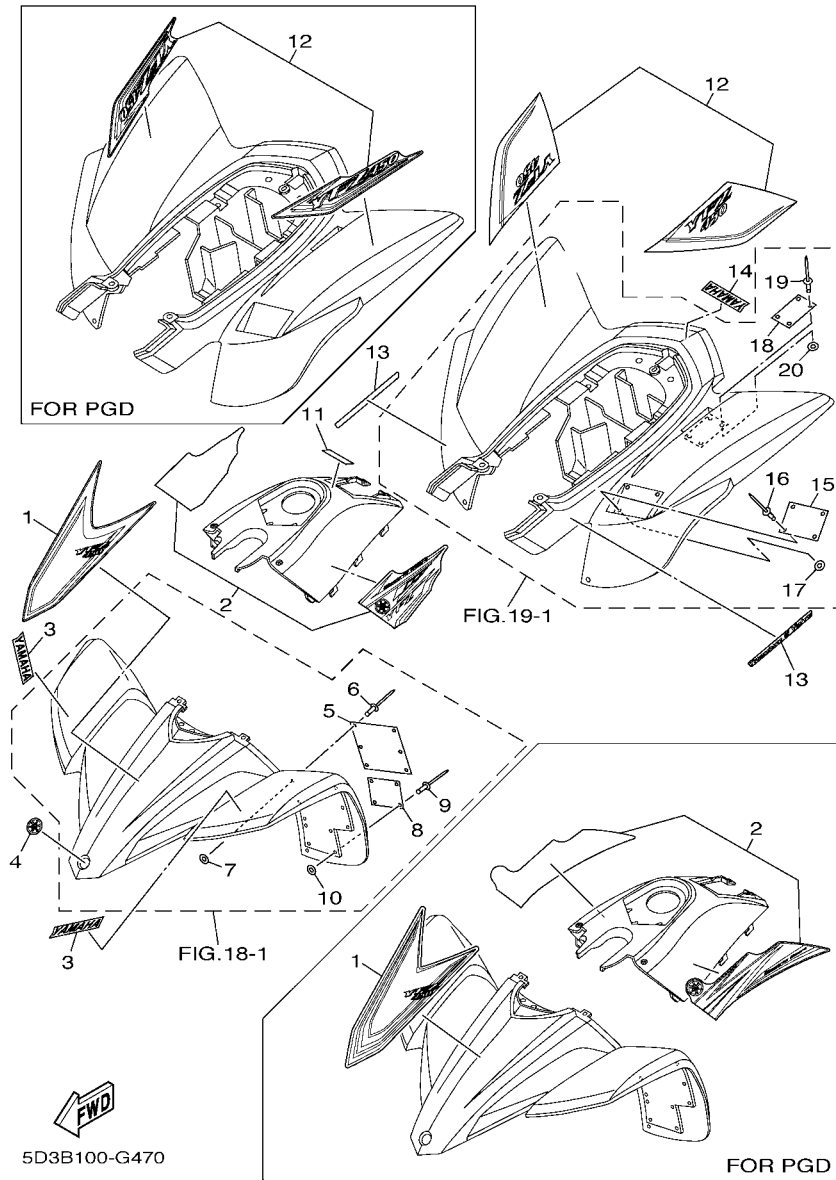
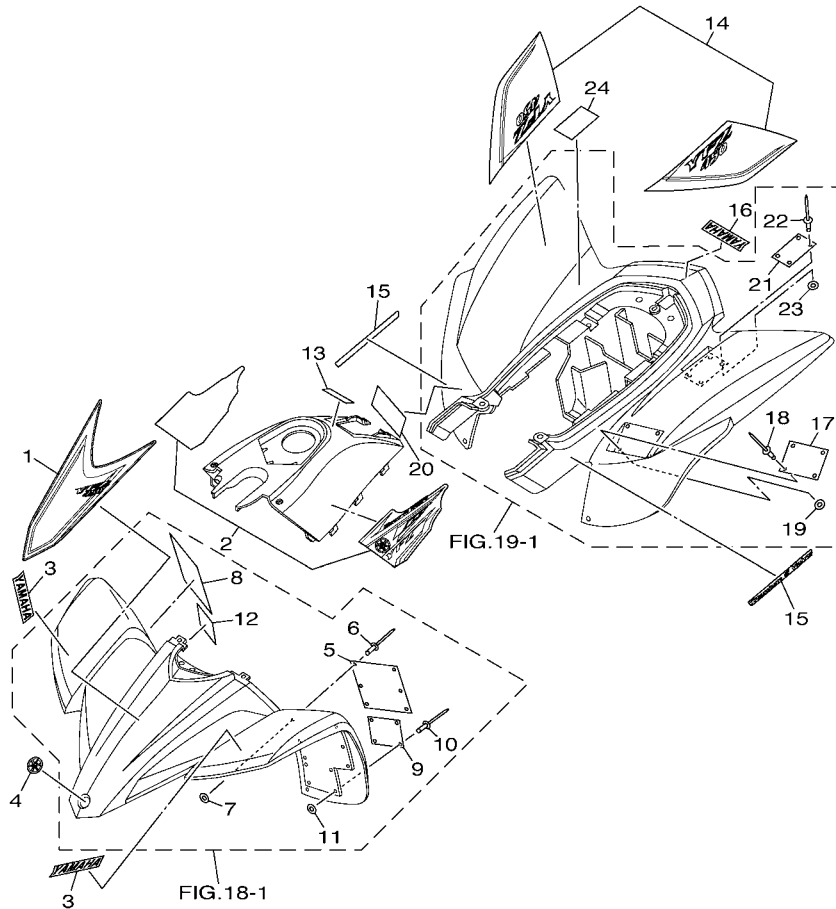

FIG. 47 EMBLEM & LABEL 4

REF. NO.	PART NO.	DESCRIPTION	USA	CAN	EUR	OCE	JPN	REMARKS
1	5D3-21569-40	GRAPHIC 1					1	UR FOR DPBSE
	5D3-21569-50	GRAPHIC 1					1	UR FOR PGD
2	5D3-24250-40	GRAPHIC SET					1	UR FOR DPBSE
	5D3-24250-50	GRAPHIC SET					1	UR FOR PGD
3	3GD-2153E-00	EMBLEM, YAMAHA					2	UR FOR DPBSE
	3GD-2153E-20	EMBLEM, YAMAHA					2	UR FOR PGD
4	4KN-2836B-10	TUNING FORK MARK					1	
5	5FE-21568-11	LABEL, WARNING					1	ENGLISH
6	90267-32004	RIVET, BLIND					6	
7	90201-03008	WASHER, PLATE					6	
8	5FE-21697-01	LABEL, CAUTION 2					1	ENGLISH
9	90267-32004	RIVET, BLIND					4	
10	90201-03008	WASHER, PLATE					4	
11	5TG-2415E-10	LABEL, CAUTION					1	
12	5D3-2165A-40	GRAPHIC SET, REAR FENDER					1	UR FOR DPBSE
	5D3-2165A-50	GRAPHIC SET, REAR FENDER					1	UR FOR PGD
13	5D3-2163G-00	EMBLEM 1					2	UR FOR DPBSE
	5D3-2163G-10	EMBLEM 1					2	UR FOR PGD
14	4ES-2153E-40	EMBLEM, YAMAHA					1	UR FOR DPBSE
	4ES-2153E-30	EMBLEM, YAMAHA					1	UR FOR PGD
15	5TG-21696-30	LABEL, CAUTION					1	
16	90267-32004	RIVET, BLIND					4	
17	90201-03008	WASHER, PLATE					4	
18	5FE-2151H-01	LABEL 5					1	ENGLISH
19	90267-32004	RIVET, BLIND					4	
20	90201-03008	WASHER, PLATE					4	



FWD
5D3B100-G480

FIG. 48 EMBLEM & LABEL 5

REF. NO.	PART NO.	DESCRIPTION	USA	CAN	EUR	OCE	JPN	REMARKS
1	5D3-21569-40	GRAPHIC 1					1	
2	5D3-24250-40	GRAPHIC SET					1	
3	3GD-2153E-00	EMBLEM, YAMAHA					2	
4	4KN-2836B-10	TUNING FORK MARK					1	
5	5FE-21568-11	LABEL, WARNING					1	ENGLISH
6	90267-32004	RIVET, BLIND					6	
7	90201-03008	WASHER, PLATE					6	
8	4SH-21568-00	LABEL, WARNING					1	JAPANESE
9	5FE-21697-01	LABEL, CAUTION 2					1	ENGLISH
10	90267-32004	RIVET, BLIND					4	
11	90201-03008	WASHER, PLATE					4	
12	4SH-21697-00	LABEL, CAUTION 2					1	JAPANESE
13	3FB-2415E-C1	LABEL, CAUTION					1	
14	5D3-2165A-40	GRAPHIC SET, REAR FENDER					1	
15	5D3-2163G-00	EMBLEM 1					2	
16	4ES-2153E-40	EMBLEM, YAMAHA					1	
17	5TG-21696-30	LABEL, CAUTION					1	
18	90267-32004	RIVET, BLIND					4	
19	90201-03008	WASHER, PLATE					4	
20	5TG-21696-60	LABEL, CAUTION					1	
21	5FE-2151H-01	LABEL 5					1	ENGLISH
22	90267-32004	RIVET, BLIND					4	
23	90201-03008	WASHER, PLATE					4	
24	4LB-2151H-02	LABEL 5					1	

NUMERICAL INDEX

PART NO.	GRID NO.	PART NO.	GRID NO.	PART NO.	GRID NO.	PART NO.	GRID NO.	PART NO.	GRID NO.	PART NO.	GRID NO.
5D3-11102-00	B - 2	3LD-12168-R1	B - 5	5BE-13447-10	B - 10	5TG-14458-00	B - 12	5TA-14987-00	C - 2	5TG-17231-00	C - 11
4KG-1111G-00	B - 2	3LD-12168-U1	B - 5	5D3-13464-00	D - 5	5D3-14459-00	B - 12	5TG-14987-00	C - 2	5TG-17241-00	C - 11
5TA-11133-10	B - 2	3LD-12168-W1	B - 5	5TG-13465-00	D - 5	4ES-14462-00	B - 12	4FN-14997-00	B - 14	5TG-17251-00	C - 11
5TA-11134-10	B - 2	3LD-12168-Y1	B - 5	5XD-13597-10	B - 12	5TG-14479-00	B - 12	5TA-14997-00	B - 15	5TG-17402-00	C - 11
5TG-11166-00	B - 2	3LD-12169-11	B - 5	5TG-14101-20	B - 14	5JG-14521-00	B - 14	5TG-15100-01	C - 5	5TG-17411-00	C - 11
5D3-11167-00	B - 2	3LD-12169-31	B - 6	5TG-14101-30	B - 14	5JG-14522-00	B - 14	5D3-15155-00	C - 7	5NG-17460-00	C - 12
371-11167-01	B - 2	3LD-12169-50	B - 6	4MX-14115-00	B - 15	5JG-14531-00	B - 15	5TG-1531A-00	B - 13	5TA-17466-00	C - 5
5TA-11181-00	B - 2	3LD-12169-70	B - 6	5TJ-14118-00	C - 2	3TJ-14536-40	B - 15	5TG-1532A-00	B - 13	4LO-17471-00	C - 5
5TG-11191-00	B - 2	3LD-12169-90	B - 6	3TJ-14137-40	B - 15	5JG-14546-01	B - 14	3Y1-15363-00	C - 6	5GR-17471-10	C - 12
5TA-11193-00	B - 2	3LD-12169-E0	B - 6	5BE-14146-00	B - 15	676-14548-00	B - 14	5TG-15370-00	B - 13	5TG-18101-10	C - 13
5TA-11311-10	B - 3	3LD-12169-G0	B - 6	5PA-14146-00	B - 15	4MX-14561-00	B - 15	4JT-15381-01	C - 5	5TG-18110-10	C - 13
5TA-11351-00	B - 3	3LD-12169-J0	B - 6	633-14159-00	B - 14	5TG-14561-00	C - 2	5BE-15383-01	C - 5	5YT-18113-00	C - 13
5D3-11395-00	B - 3	3LD-12169-L0	B - 6	3TJ-14159-40	B - 14	6H4-14561-00	B - 15	5TG-15411-10	C - 6	5MW-18122-01	C - 13
5TG-11400-30	B - 4	3LD-12169-N0	B - 6	3TJ-14160-40	B - 15	5NX-14562-00	B - 15	5TG-15415-00	C - 6	3XK-18140-00	C - 13
5TG-11412-30	B - 4	3LD-12169-T0	B - 6	5TG-14171-00	C - 2	3TJ-14562-40	B - 15	5TA-15421-10	C - 5	5BE-18172-00	C - 13
5TG-11422-30	B - 4	5TA-12170-10	B - 7	3TJ-14191-40	B - 14	5JG-14565-00	B - 15	5D3-15431-00	C - 6	3XJ-18173-10	C - 13
5BE-11454-00	B - 4	5TG-12180-20	B - 7	24W-14193-00	C - 2	5JG-14591-00	B - 15	5D3-15441-00	C - 5	3XJ-18178-00	C - 13
5TA-11455-11	B - 4	5TA-12210-00	B - 7	5TG-14197-00	C - 2	5TG-14591-00	C - 2	5TG-15451-00	C - 6	3XJ-18182-00	C - 13
5TA-11531-01	B - 4	4FM-12213-00	B - 7	5NX-14216-00	B - 15	688-14592-00	B - 14	5TA-15453-00	C - 7	3XJ-18184-00	C - 13
5TA-11536-00	B - 4	5BE-12241-00	B - 7	5TG-14225-00	C - 2	5TG-14611-11	C - 4	5TG-15462-02	C - 7	4EW-18185-00	C - 13
5TG-11603-00	B - 4	5TA-12251-01	B - 7	5TA-14227-00	C - 2	3VD-14613-01	C - 4	5TG-15484-10	C - 7	5TG-18501-00	C - 13
5TG-11631-11	B - 4	5TA-12252-00	B - 7	5TA-14239-00	C - 2	5TG-14628-10	C - 4	5TG-1549B-10	C - 6	5TG-18502-00	C - 13
5TG-11633-10	B - 4	5TG-12299-00	B - 7	5TG-14255-00	C - 2	5TG-14711-01	C - 4	5TG-15515-01	C - 8	5TG-18503-00	C - 13
5D3-11651-00	B - 4	5TG-12405-00	B - 9	5TG-14261-00	C - 2	8FA-14714-10	C - 4	5TG-15517-00	C - 8	5TG-18541-00	C - 13
5TG-11681-00	B - 4	5TG-12422-00	B - 8	5JG-14264-00	B - 14	5TG-14718-00	C - 4	5H0-15521-00	C - 8	5DH-18562-00	C - 5
5TA-12111-00	B - 5	5TG-12439-00	B - 8	3TJ-14267-40	B - 14	5TG-14752-00	C - 4	5TG-15560-00	C - 8	5D3-21101-19	C - 14
5TA-12112-00	B - 5	5DJ-12451-00	B - 8	5JG-14275-00	B - 14	5TG-14787-00	C - 4	5TG-15590-00	C - 8	5TG-21101-49	C - 14
5TA-12113-00	B - 5	5GR-12458-00	B - 8	5TA-14293-00	C - 2	5BE-14788-00	C - 4	5TG-16111-00	C - 9	5TG-21190-08	C - 14
5TA-12114-00	B - 5	5TG-12461-10	B - 9	3TJ-14293-40	B - 15	5BE-14916-DR	B - 15	5D3-16150-00	C - 9	5TG-21190-18	C - 14
4GY-12117-00	B - 5	5SL-12462-00	B - 9	5TA-14335-00	B - 15	5TG-14916-GR	B - 15	2JN-16154-00	C - 9	5TG-21228-10	E - 12
5BE-12117-00	B - 5	5TG-12467-10	B - 9	5TG-14335-00	C - 2	3TJ-14923-40	B - 15	5JG-16321-00	C - 9	5TG-21314-10	C - 14
1AA-12118-00	B - 5	5TG-12481-00	B - 9	5JG-14346-00	B - 15	5GS-14933-00	C - 2	5TA-16321-00	C - 9	5TG-21315-00	C - 14
1WG-12118-00	B - 5	5TG-12482-00	B - 9	5TA-14371-00	B - 15	3TJ-14933-40	B - 15	4X7-16325-00	C - 9	5D3-21316-00	C - 14
33M-12119-00	B - 5	5BE-12564-00	B - 8	5JG-14388-00	B - 14	5TG-14935-00	C - 2	5TG-16342-00	C - 9	5D3-21317-00	C - 14
4SV-12119-00	B - 5	5TG-12576-00	B - 9	4MX-14392-00	B - 14	5GS-14940-00	C - 2	5TG-16351-00	C - 9	5TG-21318-10	C - 14
5TA-12121-00	B - 5	5TG-12577-00	B - 9	5TG-14409-00	B - 12	5JG-14940-17	B - 15	5TG-16356-00	C - 9	22F-2139X-00	D - 15
3GM-12126-00	B - 5	583-13113-00	C - 6	5TG-14411-00	B - 12	5TA-14943-15	B - 14	5TG-16357-00	C - 9		F - 7
3FV-12153-10	B - 6	5TJ-13161-00	B - 10	5TG-14412-01	B - 12	4MX-14943-38	C - 2	5TA-16371-10	C - 9	5TG-2144G-10	F - 8
3LD-12168-00	B - 5	5TG-13171-00	B - 11	5TG-14417-00	C - 2	5JG-14947-00	B - 14	5TG-16382-10	C - 9	5TG-21471-00	C - 14
3LD-12168-20	B - 5	5D3-13300-00	B - 10	5TG-14418-00	C - 2	4MX-14948-04	B - 14	5JG-16383-00	C - 9	5TG-21513-10	D - 2
3LD-12168-40	B - 5	5TA-13320-00	B - 10	5TG-14419-00	B - 13	4JT-1494F-03	C - 2	5D3-16384-00	C - 10	5FK-2151H-00	F - 14
3LD-12168-60	B - 5	5TA-13341-00	B - 10	5TG-1442F-00	B - 12	3TJ-1494F-23	B - 14	5JG-16384-00	C - 9	5FE-2151H-01	F - 11
3LD-12168-80	B - 5	5BE-13342-00	B - 10	31A-14435-00	B - 12	5JG-14951-00	B - 14	5TG-17121-00	C - 11		F - 13
3LD-12168-A0	B - 5	5BE-13411-00	B - 10	5GH-14436-00	B - 12	3TJ-14952-40	B - 15	5TG-17131-00	C - 11		F - 15
3LD-12168-F0	B - 5	5TA-13412-00	B - 10	5TG-14451-00	B - 12	5JG-14959-00	B - 14	5TG-17141-00	C - 11		G - 2
3LD-12168-H1	B - 5	5TG-13416-10	B - 11	4FU-14452-00	B - 12	5TG-14959-00	C - 2	5TG-17151-00	C - 11	4LB-2151H-02	G - 2
3LD-12168-K1	B - 5	5TG-13418-10	B - 11	5TG-14453-01	B - 12	5JG-14984-00	B - 14	5BF-17211-00	C - 11	4WU-2151H-10	F - 13
3LD-12168-M1	B - 5	5D3-13440-00	B - 10	59V-14457-00	B - 12	4SR-14985-00	B - 14	5TG-17221-00	C - 11	3GD-2153E-00	F - 11

NUMERICAL INDEX

PART NO.	GRID NO.	PART NO.	GRID NO.	PART NO.	GRID NO.	PART NO.	GRID NO.	PART NO.	GRID NO.	PART NO.	GRID NO.
3GD-2153E-00	F - 12	5D3-2163G-10	F - 15	4X7-22129-00	D - 7	1S3-23845-20	D - 11	5D3-25381-00	E - 7	1UY-25926-51	E - 5
	F - 14	5TG-21643-10	D - 3	5LP-22141-00	D - 7	5D3-23858-00	D - 11	1S3-25383-20	E - 7	3SP-25926-51	E - 8
	F - 15	5TG-21644-20	D - 3	3YF-22149-00	D - 7	1UY-23868-01	D - 11	1S3-25386-00	E - 7	5DH-25933-00	E - 8
	G - 2	5D3-2164F-10	D - 3	5TG-22151-00	D - 8	5GT-23872-00	C - 15	5LP-25390-20	E - 7	3LD-25934-01	E - 8
3GD-2153E-20	F - 11	5D3-2164G-10	D - 4	5TG-22178-00	C - 15	1UY-23894-01	D - 11	1S3-25415-00	E - 7	1UY-25937-51	E - 5
	F - 12	5D3-2164H-10	D - 3	5TG-2217A-10	D - 7	5TG-24110-00	D - 15	5TG-25438-10	E - 7		E - 8
	F - 14	5D3-2164J-10	D - 4	5D3-2217F-00	D - 8	5TG-24110-10	D - 15	5D3-25689-00	F - 6	1UY-25938-51	E - 5
	F - 15	5D3-2165A-40	F - 11	5D3-22210-30	D - 10	4EW-2412F-00	D - 15	1S3-25712-00	E - 8	3JD-25961-00	E - 5
4ES-2153E-30	F - 11		F - 12	5D3-22210-40	D - 10	5TG-2414H-00	D - 15	5TG-25721-20	D - 7	5TG-25972-00	E - 8
	F - 12		F - 14	5D3-22210-50	D - 10	5TG-2415E-00	F - 14	5TG-25726-00	F - 6	1UY-25973-51	E - 8
	F - 14		F - 15	5D3-22210-60	D - 10	5TG-2415E-10	F - 15	5TG-25727-00	F - 6	1UY-25974-51	E - 8
	F - 15		G - 2	5D3-22210-70	D - 10	5PW-2415E-11	F - 11	5TG-2580E-20	E - 12	5TG-25975-00	E - 8
4ES-2153E-40	F - 11	5D3-2165A-50	F - 11	5D3-22210-80	D - 10		F - 12	5TG-2580T-11	E - 5	5TG-25977-50	E - 8
	F - 12		F - 12	5D3-22210-90	D - 10	5PW-2415E-31	F - 12	5TG-2580U-11	E - 5	5TG-25978-00	E - 8
	F - 14		F - 14	4AA-22259-50	D - 10	3FB-2415E-C1	G - 2	5TG-2580W-20	E - 8	5D3-26111-10	E - 9
	F - 15		F - 15		D - 14	4SH-2416E-00	F - 12	1S3-25828-00	E - 5	5D3-26124-00	E - 9
	G - 2	5TG-21691-00	D - 4	5TG-22360-11	D - 8	5TG-24181-00	D - 15	3GD-2582T-10	E - 5	5D3-26219-10	E - 9
5TG-21541-00	D - 2	5TG-21696-30	F - 11	5TG-22475-00	D - 7	5D3-24250-40	F - 11	1S3-2582W-10	E - 8	5LP-26241-00	E - 9
4GB-2155A-00	F - 14		F - 12	1S3-23147-01	D - 7		F - 12	5MV-25833-00	E - 10	5TG-26250-10	E - 9
4SH-21568-00	G - 2		F - 15	5D3-23350-30	D - 13		F - 14	5UG-25833-00	E - 8	1UY-26259-00	E - 9
5FK-21568-00	F - 14		G - 2	5D3-23350-40	D - 13		F - 15	5D3-2583T-00	E - 10	5TG-26311-00	E - 9
5FE-21568-01	F - 11	5TG-21696-40	F - 14	5D3-23350-50	D - 13		G - 2	5D3-25852-00	E - 10	5TG-26335-30	E - 9
	F - 12	5TG-21696-50	F - 13	5D3-23350-60	D - 14	5D3-24250-50	F - 11	3XP-25852-50	E - 12	5TA-26337-00	F - 6
4WU-21568-10	F - 12	5TG-21696-60	G - 2	5D3-23350-70	D - 13		F - 12	2VN-25854-00	E - 12	5TG-26341-20	E - 9
5FE-21568-11	F - 15	4SH-21697-00	G - 2	5D3-23350-80	D - 13		F - 14	4TT-25854-00	E - 10	1C3-26342-50	E - 9
	G - 2	5FK-21697-00	F - 14	5D3-23350-90	D - 14		F - 15	2VN-25855-00	E - 12	5TG-26372-00	E - 9
5D3-21569-40	F - 11	5FE-21697-01	F - 11	5XC-23441-90	D - 11	5TG-24311-10	C - 3	2GU-25866-00	E - 10	371-27114-00	E - 3
	F - 12		F - 12	1S3-23501-00	D - 12	5TG-24311-20	C - 2	5LP-25867-00	E - 10	5TG-27211-10	E - 11
	F - 14		F - 15	1S3-23502-00	D - 13	5TG-24500-01	D - 15	5TG-25871-10	E - 10	4SS-27218-00	E - 12
	F - 15		G - 2	5TG-23505-20	D - 12	4X8-24512-00	D - 15	5TG-25872-10	E - 10	2YK-27222-00	E - 12
	G - 2	3JM-21697-10	F - 12	5TG-23505-30	D - 12	3AC-24523-00	D - 15	5TG-25873-10	E - 10	3KW-27234-00	E - 12
5D3-21569-50	F - 11	5TG-21711-00	D - 2	5TG-23506-20	D - 13	4HM-24524-00	D - 15	5TG-25874-30	E - 12	5TG-27411-10	E - 11
	F - 12	5TG-21711-50	D - 2	5TG-23506-30	D - 13	3AJ-24534-01	D - 15	5TG-25875-00	D - 14	5TG-27421-10	E - 11
	F - 14	5TG-21715-00	D - 5	5TG-23507-00	D - 12	5KM-24610-00	D - 15	5TG-25876-00	D - 14	5TG-27813-10	E - 11
	F - 15	41R-21717-00	C - 14	5TG-23507-20	D - 12	5TG-2470F-40	E - 3	5TG-2587A-00	E - 12	5TG-28100-10	C - 15
5TG-21621-00	D - 3	5TG-2171A-00	D - 2	5TG-23508-00	D - 12	5D3-24710-00	E - 3	5TG-25886-10	D - 8	1NV-2811A-01	C - 15
5TG-21639-00	D - 3	5TG-2171A-50	D - 2	5TG-23508-20	D - 12	214-24724-00	E - 3	5TG-25887-10	D - 9	5LP-2819R-00	F - 11
5TG-2163A-01	D - 3	5TG-21721-00	D - 2	5YT-23517-00	D - 12	5TG-24725-00	E - 3	5TG-25894-00	E - 12	5TG-28215-00	E - 14
5TG-2163E-10	D - 3	5TG-21721-50	D - 2	5TG-23540-00	D - 12	5D3-24737-00	E - 3	5TG-25895-10	E - 12	4KN-2836B-10	F - 11
5TG-2163F-10	D - 3	12R-21747-00	D - 15	5TG-23540-20	D - 12	22W-24741-00	E - 3	5TG-25897-00	C - 15		F - 12
5D3-2163G-00	F - 11	5TG-21750-00	D - 5	5TG-23550-00	D - 13	5TG-2481M-10	F - 5	5MV-2589F-00	E - 10		F - 14
	F - 12	5LP-21761-01	D - 5	5TG-23550-20	D - 13	1S3-25111-00	E - 4	4NK-2589H-00	E - 10		F - 15
	F - 14	5D3-2177C-10	B - 12	5LP-23579-00	D - 12	5LP-25117-00	E - 4	3SP-25914-51	E - 8		G - 2
	F - 15	26H-21828-00	D - 5	1UY-23812-00	D - 11	1S3-25127-00	E - 4	3JD-25917-00	E - 5	5GT-2836B-10	E - 9
	G - 2	5TG-21871-00	D - 5	5D3-23813-10	D - 11	5TG-2514A-00	E - 6		E - 8	5D3-2845N-00	E - 14
5D3-2163G-10	F - 11	5TG-21875-00	D - 5	5TG-23816-10	D - 11	5LP-25180-20	E - 4	3JD-25919-00	E - 5	5D3-2845N-10	E - 14
	F - 12	5TG-22110-20	D - 7	1S3-23831-20	D - 11	5TG-25311-20	D - 7	5TG-25924-00	E - 5	5D3-2845R-00	E - 14
	F - 14	5TG-22128-00	D - 8	1S3-23841-20	D - 11	5TG-25317-00	D - 7	3JD-25926-00	E - 5	5D3-2845R-10	E - 14

NUMERICAL INDEX

PART NO.	GRID NO.	PART NO.	GRID NO.	PART NO.	GRID NO.	PART NO.	GRID NO.	PART NO.	GRID NO.	PART NO.	GRID NO.
5TG-81410-02	E - 15	5TG-83923-00	F - 6	5TG-W215D-50	D - 2	90110-12001	D - 7	90201-06033	D - 15	90240-08124	E - 12
5TG-81450-01	E - 15	3TB-83936-00	E - 9	5TG-W215E-00	D - 2	90111-06038	D - 2	90201-06076	D - 4	90252-03001	E - 7
5TG-81801-00	F - 2		F - 8	5TG-W2161-02	D - 3		D - 3	90201-06078	B - 13	90267-24143	E - 9
3AJ-81809-00	F - 2	437-83936-01	E - 9	5TG-W2161-52	D - 3	90111-10031	C - 14		F - 3	90267-32004	F - 11
5TG-81815-00	F - 2		F - 8	5TG-W216B-02	D - 3	90113-06055	E - 8	90201-06087	D - 3		F - 12
4WP-81826-00	F - 2	5HD-83951-00	F - 6	5TG-W216B-52	D - 3	90114-10006	E - 4	90201-06088	D - 8		F - 14
4XV-8182A-00	F - 2	4KB-83973-00	F - 6	5TG-W216C-02	D - 3	90114-10013	E - 7	90201-06093	D - 4		F - 15
4WP-81844-00	F - 2	5D3-83980-00	E - 10	5TG-W216C-52	D - 3	90116-08022	B - 2	90201-06103	F - 5		G - 2
1FK-81847-00	F - 2	5TG-84110-03	F - 3	90101-06041	C - 13	90122-06010	B - 12	90201-08043	C - 15	90267-48088	C - 14
4G0-81871-00	F - 2	5TG-84118-10	F - 3	90101-12024	D - 10	90149-05024	E - 15		D - 4	90267-48138	B - 12
5TG-81890-00	F - 2	5TG-84119-10	F - 3	90102-12003	D - 10	90149-06074	C - 5	90201-08048	C - 4	90269-06002	D - 2
5JW-81940-02	F - 7	5TG-84140-01	F - 3	90105-05331	E - 12	90149-06084	B - 4	90201-08053	C - 14		E - 2
5DM-81950-00	F - 9	5TG-84163-00	C - 15	90105-06027	B - 2	90149-06108	D - 15	90201-08083	E - 12	90269-07076	B - 9
1RL-81950-92	F - 7	5TG-84165-01	F - 3	90105-06081	C - 5	90151-06044	C - 5	90201-082A6	D - 6	90280-03006	B - 4
5TG-81960-00	F - 7	5TG-84166-01	F - 3	90105-06084	B - 12	90154-05013	D - 3	90201-08512	B - 8	90338-07007	F - 6
3WP-81980-00	F - 8	5TG-84310-03	F - 3		D - 3	90154-06014	E - 6	90201-10025	B - 2	90338-18122	C - 15
4WA-81980-00	F - 8	4KB-84314-01	F - 3		D - 5	90159-06010	C - 9	90201-10032	C - 9	90338-23004	D - 7
4GY-82100-01	F - 7	5TG-84340-01	F - 3		F - 7	90170-12054	D - 11	90201-10035	D - 14	90338-30096	C - 7
4UC-82100-01	F - 7	5TG-84551-10	F - 5	90105-08112	C - 15	90170-12055	D - 11	90201-10036	C - 14	90340-12007	B - 2
5TG-82115-00	F - 7	5TG-84553-00	F - 5	90105-08129	C - 4	90170-14171	B - 4	90201-10037	D - 13	90340-14003	C - 6
5TG-82116-00	F - 7	5TG-84710-20	F - 4	90105-08184	E - 6	90170-20327	C - 9	90201-10118	E - 10	90340-27003	C - 6
5TG-82121-10	F - 7		F - 5	90105-10131	D - 14	90171-10001	D - 11		E - 12	90380-22111	D - 7
5D3-82122-00	F - 7	2EK-85111-00	F - 10	90105-10132	D - 13		D - 12	90201-12020	E - 15	90381-15088	D - 12
5D3-82123-00	F - 7	3Y6-85130-02	F - 10	90105-10135	D - 13	90171-14002	E - 6	90201-12033	D - 10	90387-02001	E - 9
5TG-82128-10	F - 7	449-85131-02	F - 10	90105-10147	C - 4	90171-16002	E - 7	90201-12034	D - 10	90387-05016	E - 12
36Y-82151-00	F - 7	5TG-85370-00	F - 9	90105-10148	C - 14	90176-06041	F - 5	90201-12166	B - 10	90387-06113	B - 9
5ND-82180-00	F - 8	5TG-85540-10	F - 7	90105-101A9	E - 8	90179-06033	B - 3		C - 13	90387-06146	D - 3
5TA-82310-10	F - 7	5TG-85546-00	F - 7	90105-104A7	B - 2	90179-12657	E - 15	90201-125L6	C - 9	90387-06150	D - 5
5TG-82510-00	F - 8	5TG-85885-00	B - 15	90105-106A3	B - 2	90179-20001	C - 9	90201-14021	D - 11	90387-06151	D - 8
5TG-82530-10	F - 8	M12-T133A-00	D - 15	90105-12038	D - 8		C - 12	90201-14586	E - 6	90387-06153	E - 14
3GB-82540-01	F - 7	5D3-W0041-00	E - 10	90105-12039	D - 8	90179-36003	E - 8	90201-15701	C - 6	90387-06197	D - 4
5TG-82541-00	F - 7	5TG-W0042-50	E - 12	90105-12040	D - 8	90183-05008	D - 2	90201-16018	D - 7	90387-061F9	D - 2
5EB-82560-00	F - 7	5TG-W0045-20	E - 5	90109-06031	C - 13	90185-10011	C - 14	90201-16023	E - 7	90387-06204	D - 4
5LP-82560-00	F - 7	5TG-W0045-30	E - 6	90109-06034	F - 6		E - 7	90201-20022	E - 6	90387-066J1	D - 15
5ND-82560-00	F - 8	5TG-W0046-10	E - 8	90109-06172	D - 2	90185-10012	D - 13	90202-08045	B - 14	90387-07018	B - 13
3HN-82569-00	F - 8	5TG-W0047-00	E - 8		D - 8	90185-12002	D - 8	90208-37001	E - 8	90387-07020	B - 9
3HN-82579-00	F - 8	3LC-W0047-50	E - 5	90109-06193	C - 13	90185-12007	D - 10	90209-06012	B - 9	90387-07598	F - 3
5D3-82590-00	F - 8	1UY-W0048-50	E - 5	90109-06198	C - 14	90185-14009	D - 11	90209-06014	B - 12	90387-08073	B - 12
5TG-8259A-00	B - 15		E - 8	90109-06203	B - 2	90185-16002	D - 7	90209-10229	D - 11	90387-086N4	C - 15
5TG-82910-00	F - 6	5TG-W0057-00	E - 5	90109-067F4	D - 14	90201-03008	F - 11		D - 12	90387-09011	D - 11
5TG-82911-00	F - 6	5TG-W0057-10	E - 8	90109-08076	E - 8		F - 12	90209-21332	C - 11	90387-100Y6	D - 12
4V4-82913-00	E - 9	5TG-W2151-00	D - 2	90109-08082	E - 5		F - 14	90209-25342	C - 11	90387-101R3	D - 12
5TG-82913-00	F - 6	5TG-W2151-50	D - 2	90109-10013	E - 7		F - 15	90209-25349	C - 11	90387-12019	D - 8
1UY-82917-00	F - 6	5TG-W215B-00	D - 2	90110-05038	C - 2		G - 2	90209-25350	C - 11	90387-12020	D - 8
5GH-83516-00	F - 8	5TG-W215B-50	D - 2	90110-05201	D - 2	90201-04028	B - 12	90215-14287	B - 4	90387-12030	D - 8
5TG-83530-00	F - 8	5TG-W215C-00	D - 2	90110-06134	C - 4	90201-05015	C - 4	90215-20005	C - 9	90387-123M3	D - 8
5TJ-83912-00	F - 6	5TG-W215C-50	D - 2	90110-06168	C - 8	90201-05023	F - 4	90215-21003	C - 9	90387-150R1	E - 6
5D3-83922-00	E - 10	5TG-W215D-00	D - 2	90110-06228	B - 10		F - 5		C - 12	90387-16014	D - 7

NUMERICAL INDEX

PART NO.	GRID NO.	PART NO.	GRID NO.	PART NO.	GRID NO.	PART NO.	GRID NO.	PART NO.	GRID NO.	PART NO.	GRID NO.
90387-160W0	D - 7	90465-08047	D - 5	91401-16012	E - 12	93210-14369	C - 6	93608-33002	C - 13	95702-10500	E - 7
90387-164N2	C - 5	90465-10017	C - 6	91402-20020	D - 11	93210-16500	B - 9	93612-16254	B - 3	95802-06012	E - 13
90387-20005	E - 6	90465-13M11	F - 9		D - 13	93210-16629	D - 5	93700-06004	D - 12	95802-06016	D - 2
90387-20030	C - 11	90467-070A0	C - 7	91402-30025	D - 10	93210-19123	C - 6	93900-00022	E - 7	95802-06020	B - 9
90387-2513F	C - 11	90467-08003	D - 5		E - 6	93210-19758	B - 8	93900-00030	E - 4		E - 14
90387-2810U	C - 11	90467-100A2	C - 3	91808-16023	B - 2	93210-21190	D - 5	94107-10015	E - 4	95802-06025	B - 9
90401-08006	B - 11	90467-11019	D - 5	91812-16001	C - 7	93210-22164	C - 11	94110-09015	E - 7		D - 8
90401-10015	B - 10	90467-11044	E - 12	91A20-07004	C - 2	93210-27370	C - 6	94582-13096	E - 7		F - 3
	E - 10	90467-110A3	B - 3	92012-06014	F - 6	93210-36769	E - 8	94591-57118	B - 7	95802-08016	D - 5
	E - 12	90467-120A5	C - 3	92012-06016	F - 5	93210-47675	B - 10	94701-00411	B - 2	95812-06014	B - 3
90430-06014	B - 2	90467-140A4	B - 2	92012-06025	D - 15	93210-60426	C - 6	94703-00411	B - 2		F - 3
	B - 8		B - 13	92012-06035	D - 3	93210-66001	D - 7	95022-06008	C - 4	95812-08014	E - 14
90430-08119	B - 11	90467-220A1	B - 12	92012-08012	D - 3	93210-71001	D - 7		F - 7	95812-08016	C - 14
90430-10148	C - 5	90467-23109	B - 9	92012-08020	D - 4	93300-60804	C - 15	95022-06010	B - 2	95812-08020	C - 14
	F - 7	90468-16191	D - 11	92012-08025	E - 12	93306-00105	B - 8		E - 12		E - 14
90430-10188	B - 10	90480-10011	E - 12	92014-06016	F - 6	93306-00426	C - 11	95022-06012	B - 9	95812-08050	C - 14
90445-07340	C - 7	90480-10289	D - 5	92902-05100	E - 9	93306-00431	C - 11		B - 11	95812-10025	E - 11
90445-08026	D - 15	90480-14102	F - 3		F - 10	93306-00446	E - 4		C - 10	95812-10035	E - 11
90445-09020	D - 5	90480-15006	D - 2	92902-05200	F - 10	93306-20231	E - 4		D - 9	95812-10055	C - 14
90445-090F7	D - 5	90480-15235	B - 9	92902-06200	C - 4	93306-20335	B - 4	95022-06016	C - 5	95812-10165	C - 14
90445-11182	B - 2	90480-18004	D - 15	92902-10200	E - 4	93306-20352	C - 15		C - 6	95822-06020	D - 6
90450-22001	B - 11	90480-18290	D - 15		E - 7	93306-20532	C - 11		C - 12	95822-06025	E - 10
90450-57013	B - 12	90480-24001	D - 6	92903-08600	D - 7	93306-20593	C - 11	95022-06020	C - 6	95822-06030	D - 15
90450-59005	B - 12	90480-25001	F - 4	92990-06200	C - 4	93306-30633	B - 4		F - 7	95822-08012	D - 3
90450-61002	B - 12		F - 5	92990-10600	C - 4	93306-90509	C - 13	95022-06025	B - 7	95822-08016	D - 4
90450-99007	B - 12	90501-043E0	C - 6	93101-14164	C - 6	93306-90804	D - 7		B - 10	95822-08020	D - 4
90461-10011	C - 5	90501-052G5	C - 13	93102-11008	B - 8	93306-90805	D - 7		D - 5	97002-05016	F - 6
90462-08044	C - 7	90501-080A5	B - 3	93102-12106	B - 8	93310-212L6	C - 8		F - 2	97012-06025	D - 4
90462-08049	C - 7	90501-100A2	B - 13	93102-12224	C - 10	93310-63458	B - 4	95022-06030	B - 8	97022-08060	D - 11
90462-10034	C - 7	90501-231E9	C - 9		C - 13	93311-62574	B - 4		C - 6	97702-50016	F - 4
90462-12003	C - 14	90506-20380	E - 11	93102-22216	E - 4	93315-31758	D - 8	95022-06035	B - 3		F - 5
90462-12005	C - 14	90508-16054	C - 10	93102-25081	C - 15	93315-32052	D - 8	95022-06040	C - 6	98502-04012	B - 14
90464-09M31	D - 5	90508-26561	C - 13	93102-25099	C - 15	93315-32057	D - 8	95022-06080	C - 7	98502-05020	E - 9
90464-13073	F - 8	90508-35015	C - 13	93102-32480	C - 11	93317-11287	C - 9	95022-08035	D - 11	98507-03008	D - 15
90464-13133	C - 3	90560-06201	D - 3	93105-26026	E - 4	93317-22237	D - 7	95022-08040	C - 15	98512-06025	C - 5
	D - 5	91312-05010	F - 9	93106-22019	D - 7	93340-21505	C - 9	95022-10016	C - 5	98606-04018	D - 15
90464-15065	F - 8	91312-05012	C - 6	93106-46003	D - 7	93410-67085	D - 7	95302-05600	F - 10	98702-06025	D - 15
90464-15157	F - 7	91312-06014	E - 15	93109-17071	D - 8	93440-10085	C - 9	95602-05200	E - 12	98902-06010	C - 4
90464-15195	F - 8	91312-06016	D - 5	93109-20001	D - 8	93440-10153	B - 2	95602-06100	F - 6	98902-06012	F - 8
90464-20031	F - 9	91312-06020	B - 10	93112-31011	D - 11		B - 10	95602-06200	D - 2	98980-06010	C - 4
90464-20159	F - 8	91312-06025	B - 10	93210-05098	C - 7	93440-25084	C - 11		D - 3	99002-08600	B - 10
90464-20181	E - 14	91312-06030	B - 10	93210-07003	B - 11	93440-28062	C - 11		E - 11	99009-10400	C - 9
	F - 8	91312-06065	B - 10	93210-07135	B - 10	93440-41178	B - 7	95602-08200	C - 15	99009-12400	B - 10
90464-23041	F - 9	91314-06050	C - 5	93210-09008	B - 11	93450-22027	B - 4		D - 4	99009-20400	C - 11
90464-30040	F - 8	91314-06060	C - 5	93210-10197	B - 10	93503-08007	C - 6	95604-06100	E - 10	99009-22500	C - 6
90464-48174	D - 2	91314-06075	C - 5		C - 5	93515-32029	C - 9	95612-06635	B - 2	99009-30400	D - 12
	F - 9	91314-08040	D - 7		D - 5	93603-16219	B - 10	95702-08500	C - 4	99530-08012	B - 10
90465-08044	D - 5	91316-04012	B - 14	93210-12759	B - 11	93604-10011	B - 8	95702-10500	E - 4	99530-08016	C - 6

NUMERICAL INDEX

PART NO.	GRID NO.	PART NO.	GRID NO.	PART NO.	GRID NO.	PART NO.	GRID NO.	PART NO.	GRID NO.	PART NO.	GRID NO.
99530-10114	B - 10										
	C - 5										
	D - 5										
99530-10116	C - 5										
99530-14016	C - 5										