

PARTS CATALOGUE

YZ450FT (5XD5) U.S.A.

YZ450F (5XD6) EUROPE

YZ450F (5XD7) JAPAN

YZ450FT (5XD8) CANADA, OCEANIA, SOUTH AFRICA

YZ450FT/YZ450F
PARTS CATALOGUE
©2004 by Yamaha Motor Co., Ltd.
1st edition, July 2004
All rights reserved.
Any reprinting or unauthorized use
without the written permission of
Yamaha Motor Co., Ltd.
is expressly prohibited.
Printed in Japan.

A3

YZ450FT/YZ450F



A4

FOREWORD

This Parts Catalogue is related to the parts for the model(s) on the cover page. When you are ordering replacement parts, please refer to this Parts Catalogue and quote both part numbers and part names correctly.

1. Modifications or additions which have been made after the issue of the Parts Catalogue will be announced in the Parts News.

It is advisable that you make the necessary corrections to the Parts Catalogue according to the Parts News.

2. Abbreviations

The following abbreviations are used in this Parts Catalogue.

“UR” Use specified parts number.

“UN” Use as many as needed.

“AP” Alternate Parts

“LM” Locally Made (Parts need to be ordered locally)

“F#” Frame No. (Applicable machine No.)

“O/S” Over Size

3. The number of components for assembly

- Parts, which are to be supplied in an assembly, are listed with a dot (.) in front of the part name as shown below.
- The numeral appearing to the right of each component part indicates the quantity of parts for each assembly unit.

PART NO.	DESCRIPTION	Q'TY	REMARKS
2F5-83310-60	FRONT FLASHER LIGHT ASSY	2	
115-83311-60	.BULB (6V-18W)	1	

4. Applicable colours of graphics are represented in the “REMARKS” as shown below.

PART NO.	DESCRIPTION	Q'TY	REMARKS
2N4-24110-00-X5	FUEL TANK COMP.	2	MXR
3J1-24240-10	.GRAPHIC, FUEL TANK	1	FOR MXR

5. Note that the illustrations for reference in finding parts numbers are not to be used for assembling. When assembling, please use the applicable service manual.

6. The asterisk (*) before a reference number indicates modified items after the first edition.

FOREWORD

7. Applicable Serial No.

Engine Serial No.

Frame Serial No.

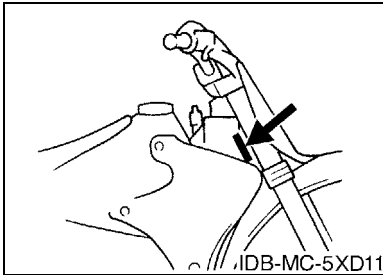
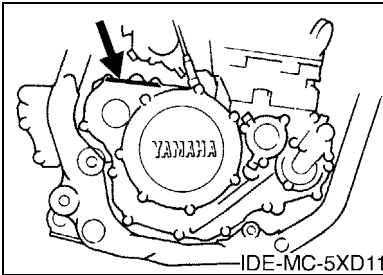

8. Applicable Colour Code (The (*) mark shows Model colour.)

Abbreviation	Colour Name	Colour Code
DPBSE(*)	DEEP PURPLISH BLUE SOLID E	0583

CONTENTS

ENGINE

CYLINDER	B2
CRANKSHAFT & PISTON	B4
VALVE	B5
CAMSHAFT & CHAIN	B7
WATER PUMP	B8
RADIATOR & HOSE	B9
OIL PUMP	B10
OIL CLEANER	B11
INTAKE	B12
CARBURETOR	B13
EXHAUST	C3
CRANKCASE	C4
CRANKCASE COVER 1	C5
STARTER	C7
CLUTCH	C8
TRANSMISSION	C9
SHIFT CAM & FORK	C11
SHIFT SHAFT	C12

CHASSIS

FRAME	C13
FENDER	C15
SIDE COVER	D2
REAR ARM	D3
REAR SUSPENSION	D5
STEERING	D7
FRONT FORK	D8
FUEL TANK	D10
SEAT	D12
FRONT WHEEL	D13
FRONT BRAKE CALIPER	D14
REAR WHEEL	D15
REAR BRAKE CALIPER	E3
STEERING HANDLE & CABLE	E4
FRONT MASTER CYLINDER	E5
STAND & FOOTREST	E6
REAR MASTER CYLINDER	E7
GENERATOR	E8
HANDLE SWITCH & LEVER	E9
ELECTRICAL 1	E10
ALTERNATE FOR CHASSIS	E11

ALTERNATE DECOMPRESSION KIT	E12
-----------------------------------	-----

INDEX

NUMERICAL INDEX	M1
-----------------------	----

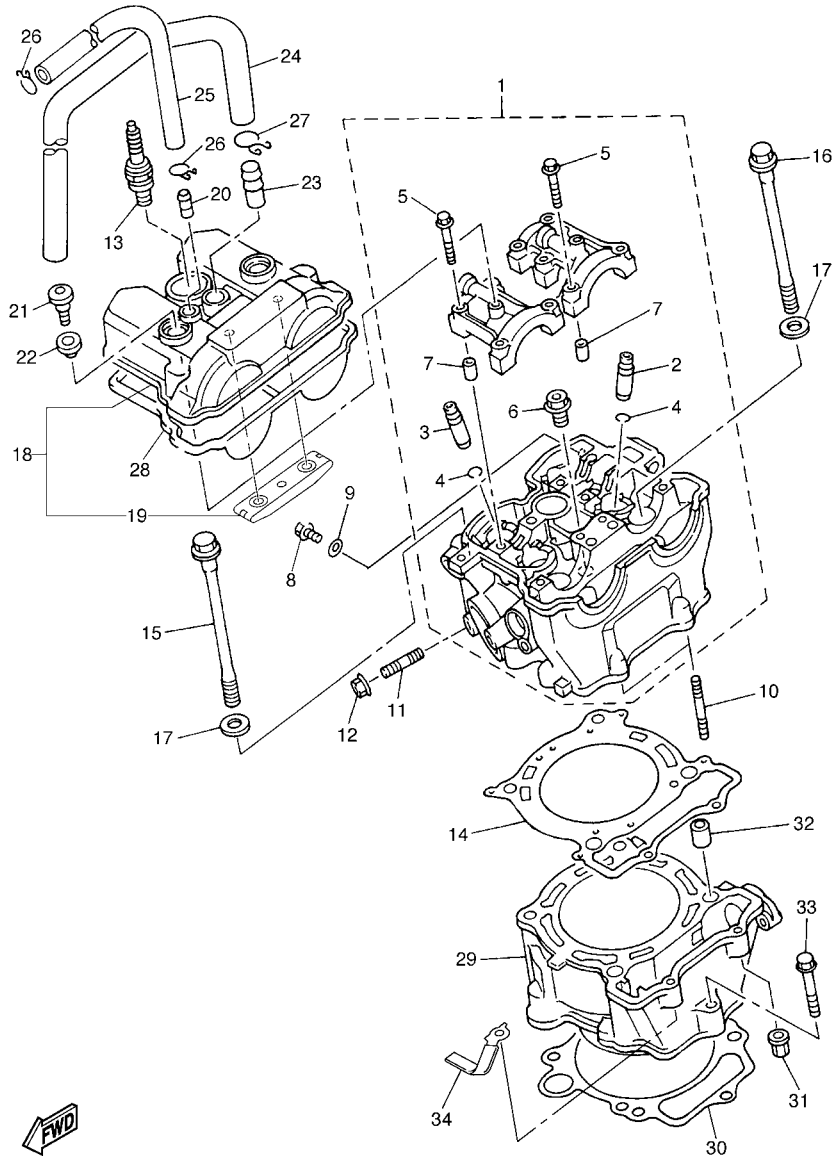

5XD5100-D010

FIG. 1 CYLINDER

REF. NO.	PART NO.	DESCRIPTION	5XD5	5XD6	5XD7	5XD8	REMARKS
1	5XD-11102-00	CYLINDER HEAD ASSY	1	1	1	1	
2	5TA-11133-10	.GUIDE, VALVE 1	3	3	3	3	
3	5TA-11134-10	.GUIDE, VALVE 2	2	2	2	2	
4	93440-10153	.CIRCLIP	5	5	5	5	
5	90105-06027	.BOLT, FLANGE	10	10	10	10	
6	90340-12112	.PLUG, STRAIGHT SCREW	1	1	1	1	
7	91808-16023	.PIN, DOWEL	4	4	4	4	
8	95027-06010	BOLT, FLANGE	1	1	1	1	
9	90430-06014	GASKET	1	1	1	1	
10	95617-06635	BOLT, STUD	2	2	2	2	
11	95617-08620	BOLT, STUD	1	1	1	1	
12	95707-08500	NUT, FLANGE	1	1	1	1	
13	94701-00411	PLUG, SPARK (NGK R CR8E)	1	1		1	STD
	94703-00411	PLUG, SPARK (NGK R CR8E)			1		STD
	94701-00410	PLUG, SPARK (NGK R CR9E)	1	1		1	AP
	94703-00410	PLUG, SPARK (NGK R CR9E)			1		AP
14	5TA-11181-00	GASKET, CYLINDER HEAD 1	1	1	1	1	
15	90105-104A7	BOLT, FLANGE	2	2	2	2	
16	90105-106A3	BOLT, FLANGE	2	2	2	2	
17	90201-10025	WASHER, PLATE	4	4	4	4	
18	5TG-11190-10	COVER, CYLINDER HEAD 1	1	1	1	1	
19	5BE-12241-00	.GUIDE, STOPPER 2	1	1	1	1	
20	5BE-11167-00	PIPE, BREATHER 2	1	1	1	1	
21	90109-066F0	BOLT	2	2	2	2	
22	4KG-1111G-00	RUBBER, MOUNT 1	2	2	2	2	
23	371-11167-01	PIPE, BREATHER 2	1	1	1	1	
24	5TA-11166-00	PIPE, BREATHER 1	1	1	1	1	

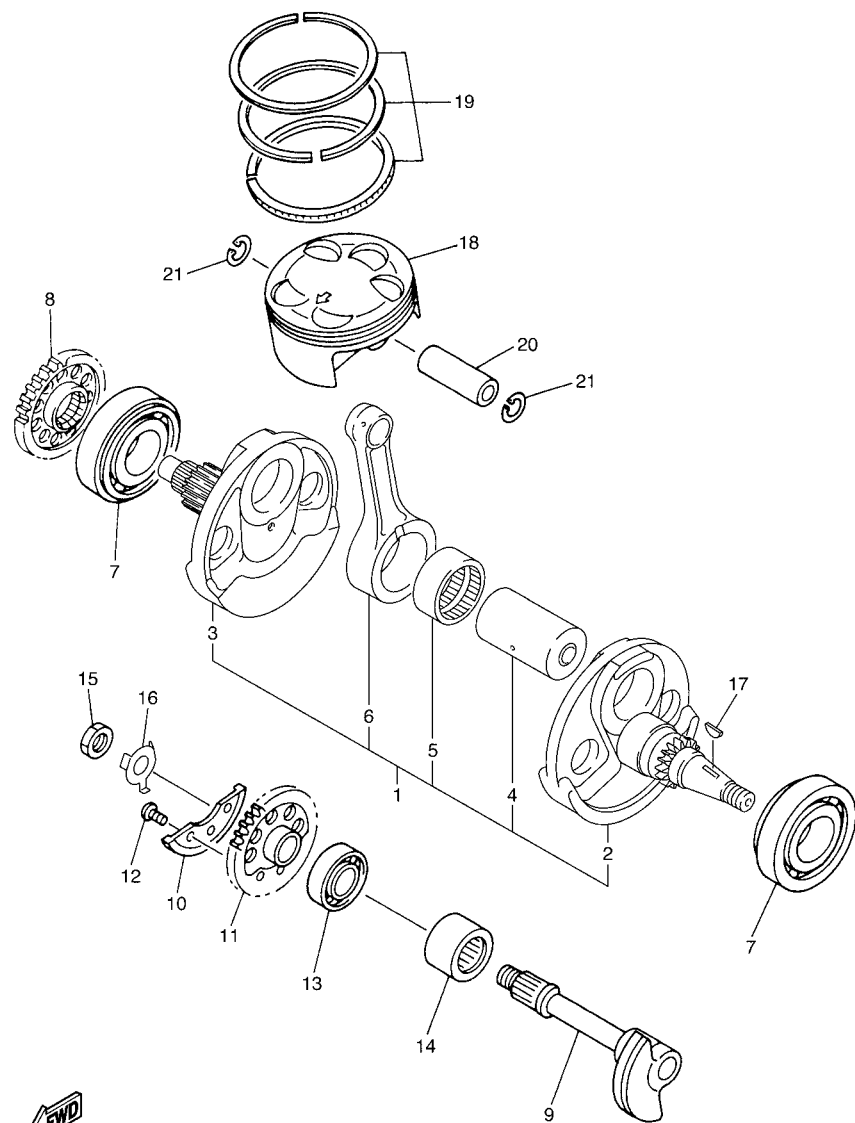

5TA1100-B020

FIG. 2 CRANKSHAFT & PISTON

REF. NO.	PART NO.	DESCRIPTION	5XD5	5XD6	5XD7	5XD8	REMARKS
1	5XD-11400-00	CRANKSHAFT ASSY	1	1	1	1	
2	5TA-11412-00	.CRANK 1	1	1	1	1	
3	5TA-11422-00	.CRANK 2	1	1	1	1	
4	5TA-11681-00	.PIN, CRANK 1	1	1	1	1	
5	93310-63417	.BEARING	1	1	1	1	
6	5XD-11651-00	.ROD, CONNECTING	1	1	1	1	
7	93306-30633	BEARING	2	2	2	2	
8	5TA-11536-00	GEAR, DRIVE	1	1	1	1	
9	5TA-11455-11	SHAFT 1	1	1	1	1	
10	5BE-11454-00	WEIGHT 1	1	1	1	1	
11	5TA-11531-01	GEAR, BALANCE WEIGHT	1	1	1	1	
12	90149-06250	SCREW	3	3	3	3	
13	93306-20335	BEARING	1	1	1	1	
14	93311-62574	BEARING	1	1	1	1	
15	90170-14171	NUT	1	1	1	1	
16	90215-14287	WASHER, LOCK	1	1	1	1	
17	90280-03001	KEY, WOODRUFF	1	1	1	1	
18	5TJ-11631-00	PISTON (STD)	1	1	1	1	
19	5JG-11603-00	PISTON RING SET (STD)	1	1	1	1	
20	5TA-11633-00	PIN, PISTON	1	1	1	1	
21	93420-18082	CIRCLIP	2	2	2	2	

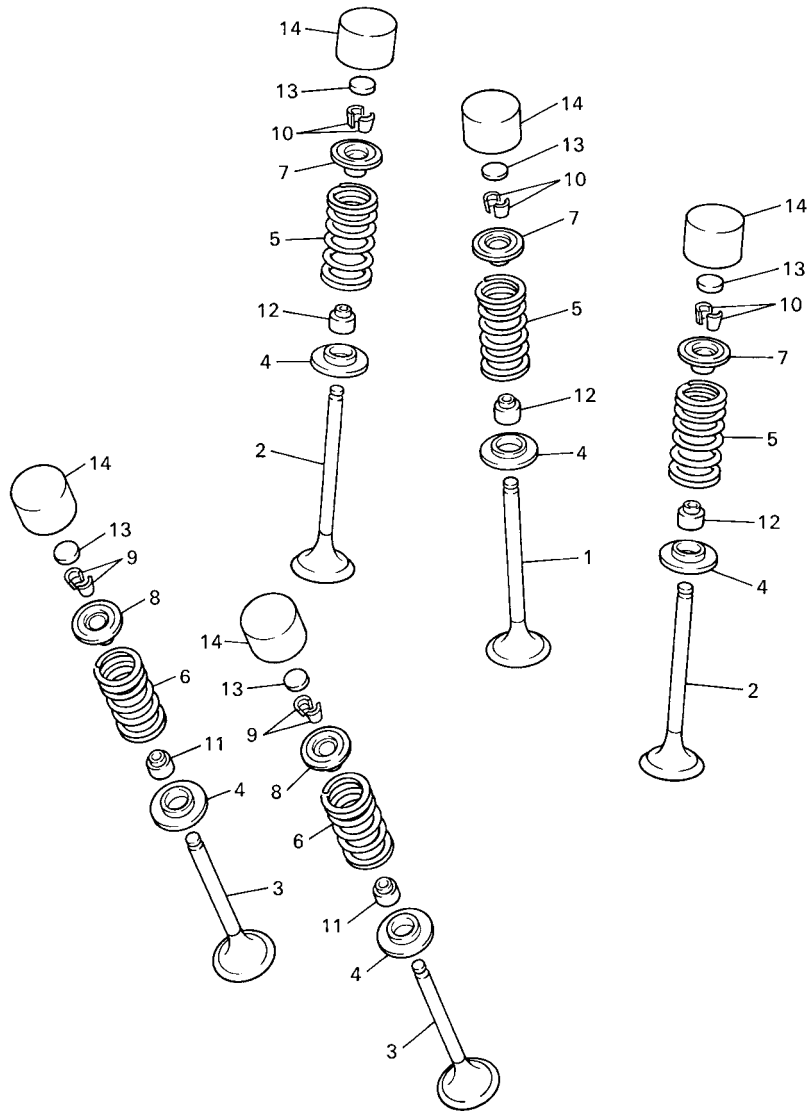

5BE100-8030

FIG. 3 VALVE

REF. NO.	PART NO.	DESCRIPTION	5XD5	5XD6	5XD7	5XD8	REMARKS
1	5TA-12111-00	VALVE, INTAKE	1	1	1	1	
2	5TA-12112-00	VALVE, INTAKE 2	2	2	2	2	
3	5TA-12121-00	VALVE, EXHAUST	2	2	2	2	
4	3GM-12126-00	SEAT, VALVE SPRING 2	5	5	5	5	
5	5TA-12113-00	SPRING, VALVE INNER	3	3	3	3	
6	5TA-12114-00	SPRING, VALVE OUTER	2	2	2	2	
7	5BE-12117-00	RETAINER, VALVE SPRING	3	3	3	3	
8	4GY-12117-00	RETAINER, VALVE SPRING	2	2	2	2	
9	1AA-12118-00	COTTER, VALVE	4	4	4	4	
10	1WG-12118-00	COTTER, VALVE	6	6	6	6	
11	33M-12119-00	SEAL, VALVE STEM	2	2	2	2	
12	4SV-12119-00	SEAL, VALVE STEM	3	3	3	3	
13	3LD-12168-00	PAD, ADJUSTING (1.20)	5	5	5	5	UR
	3LD-12168-20	PAD, ADJUSTING (1.25)	5	5	5	5	UR
	3LD-12168-40	PAD, ADJUSTING (1.30)	5	5	5	5	UR
	3LD-12168-60	PAD, ADJUSTING (1.35)	5	5	5	5	UR
	3LD-12168-80	PAD, ADJUSTING (1.40)	5	5	5	5	UR
	3LD-12168-A0	PAD, ADJUSTING (1.45)	5	5	5	5	UR
	3LD-12168-F0	PAD, ADJUSTING (1.50)	5	5	5	5	UR
	3LD-12168-H1	PAD, ADJUSTING (1.55)	5	5	5	5	UR
	3LD-12168-K1	PAD, ADJUSTING (1.60)	5	5	5	5	UR
	3LD-12168-M1	PAD, ADJUSTING (1.65)	5	5	5	5	UR
	3LD-12168-R1	PAD, ADJUSTING (1.70)	5	5	5	5	UR
	3LD-12168-U1	PAD, ADJUSTING (1.75)	5	5	5	5	UR
	3LD-12168-W1	PAD, ADJUSTING (1.80)	5	5	5	5	UR
	3LD-12168-Y1	PAD, ADJUSTING (1.85)	5	5	5	5	UR
	3LD-12169-11	PAD, ADJUSTING (1.90)	5	5	5	5	UR

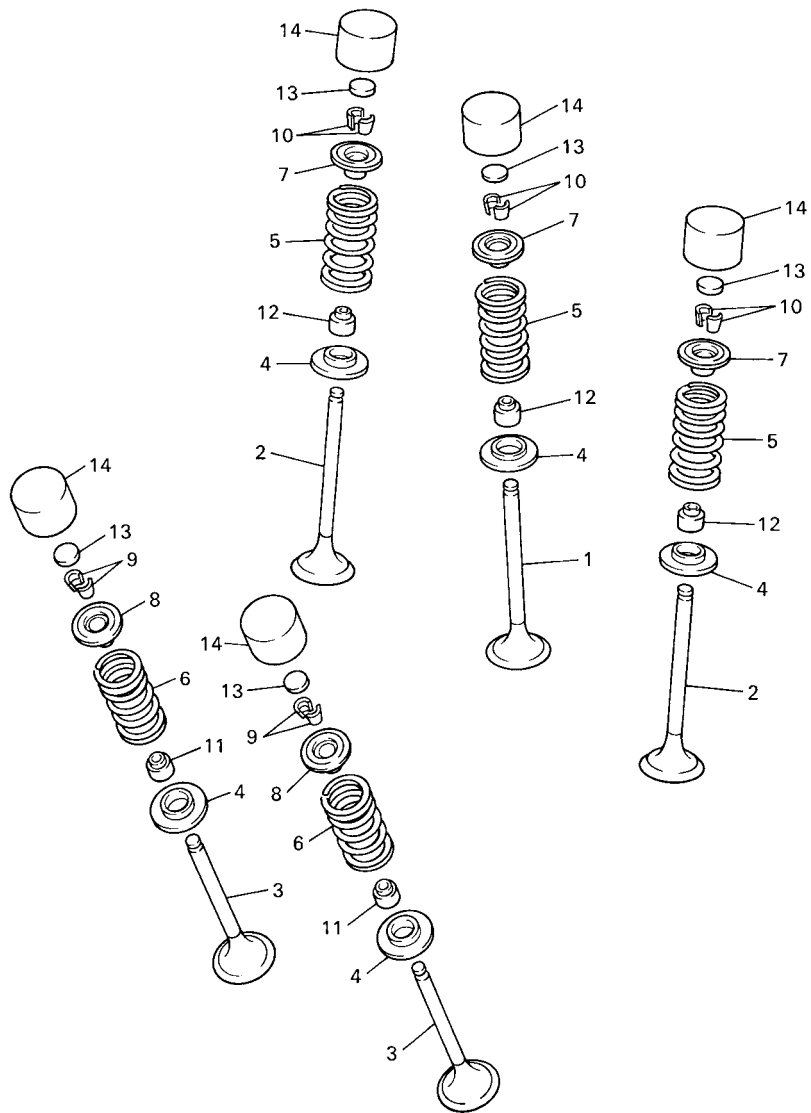

5BE100-8030

FIG. 3 VALVE

REF. NO.	PART NO.	DESCRIPTION	SXD5	SXD6	SXD7	SXD8	REMARKS
13	3LD-12169-31	PAD, ADJUSTING (1.95)	5	5	5	5	UR
	3LD-12169-50	PAD, ADJUSTING (2.00)	5	5	5	5	UR
	3LD-12169-70	PAD, ADJUSTING (2.05)	5	5	5	5	UR
	3LD-12169-90	PAD, ADJUSTING (2.10)	5	5	5	5	UR
	3LD-12169-E0	PAD, ADJUSTING (2.15)	5	5	5	5	UR
	3LD-12169-G0	PAD, ADJUSTING (2.20)	5	5	5	5	UR
	3LD-12169-J0	PAD, ADJUSTING (2.25)	5	5	5	5	UR
	3LD-12169-L0	PAD, ADJUSTING (2.30)	5	5	5	5	UR
	3LD-12169-N0	PAD, ADJUSTING (2.35)	5	5	5	5	UR
	3LD-12169-T0	PAD, ADJUSTING (2.40)	5	5	5	5	UR
14	3FV-12153-10	LIFTER, VALVE	5	5	5	5	UR YELLOW

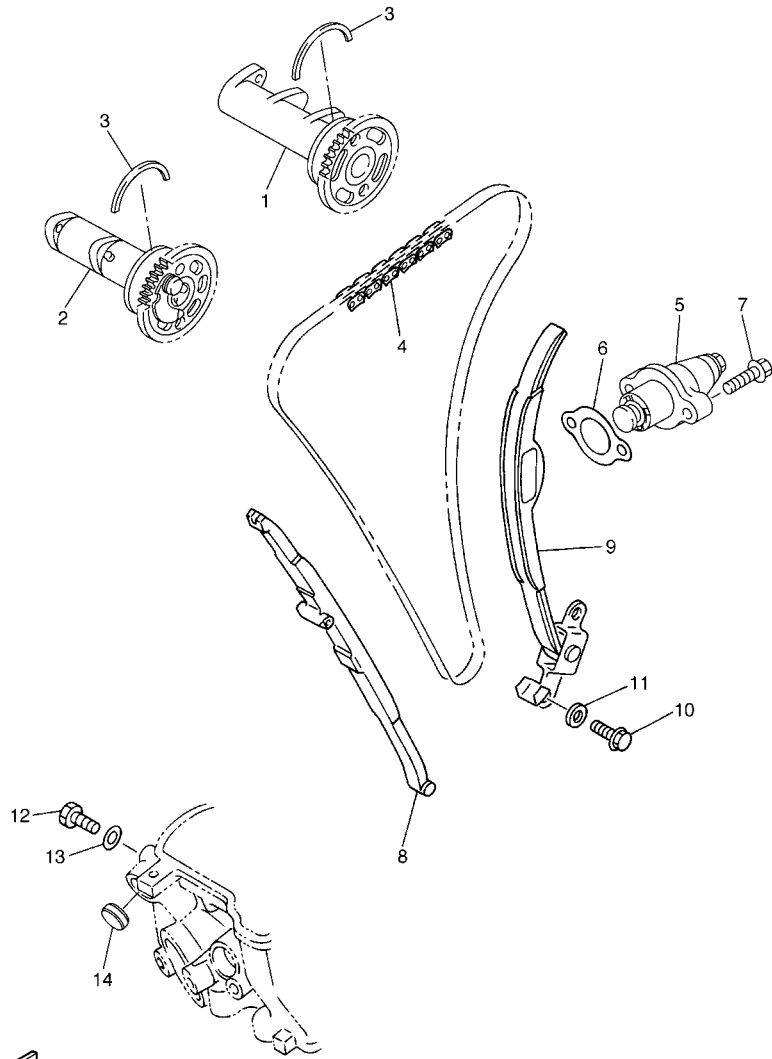

5XD5100-D040

FIG. 4 CAMSHAFT & CHAIN

REF. NO.	PART NO.	DESCRIPTION	5XD5	5XD6	5XD7	5XD8	REMARKS
1	5TA-12170-00	CAMSHAFT ASSY 1	1	1	1	1	
2	5TA-12180-00	CAMSHAFT ASSY 2	1	1	1	1	
3	93440-41178	CIRCLIP	2	2	2	2	
4	94591-57118	CHAIN (98XRH2010-118M)	1	1	1	1	
5	5TA-12210-00	TENSIONER ASSY, CAM CHAIN	1	1	1	1	
6	4FM-12213-00	GASKET, TENSIONER CASE	1	1	1	1	
7	95027-06025	BOLT, FLANGE	2	2	2	2	
8	5TA-12251-01	DAMPER, CHAIN 1	1	1	1	1	
9	5TA-12252-00	DAMPER, CHAIN 2	1	1	1	1	
10	97027-06016	BOLT	2	2	2	2	
11	92907-06600	WASHER, PLATE	2	2	2	2	
12	90109-06418	BOLT	1	1	1	1	
13	90430-06014	GASKET	1	1	1	1	
14	90338-18004	PLUG	1	1	1	1	

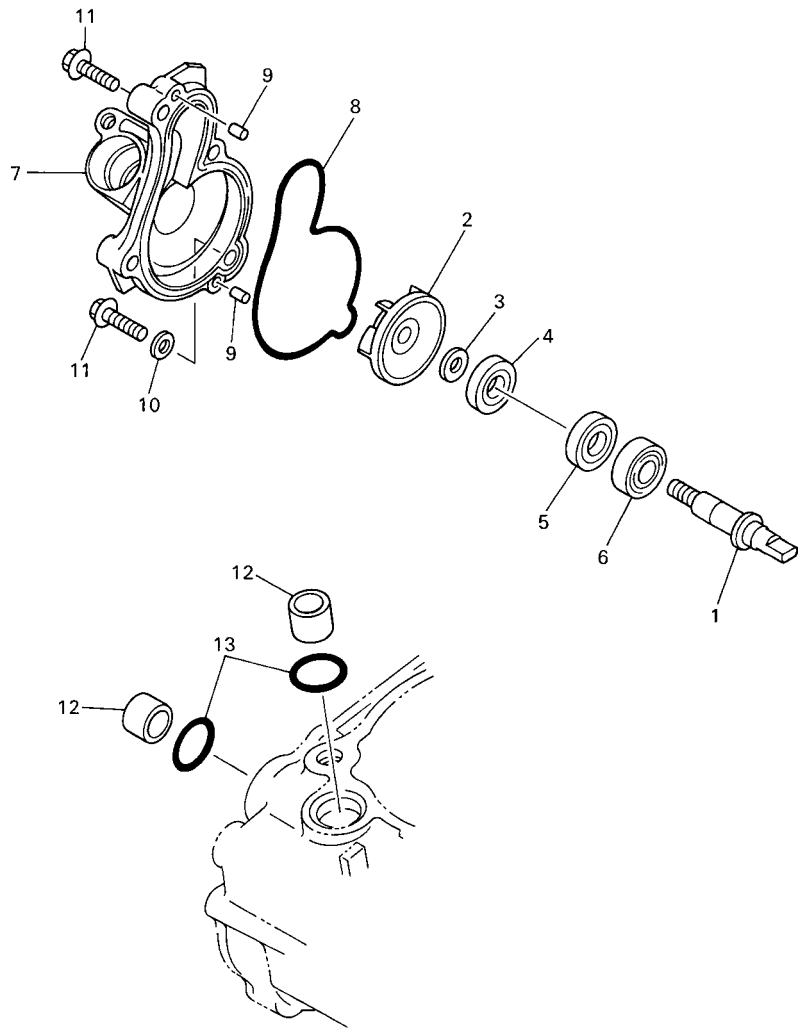

FIG. 5 WATER PUMP

REF. NO.	PART NO.	DESCRIPTION	5XD5	5XD6	5XD7	5XD8	REMARKS
1	5GR-12458-00	SHAFT, IMPELLER	1	1	1	1	
2	5DJ-12451-00	IMPELLER, WATER PUMP	1	1	1	1	
3	90201-08512	WASHER, PLATE	1	1	1	1	
4	93109-11073	OIL SEAL	1	1	1	1	
5	93102-12106	OIL SEAL (SD 12-22-5 HS)	1	1	1	1	
6	93306-00105	BEARING (B6001)	1	1	1	1	
7	5BE-12422-20	COVER, HOUSING	1	1	1	1	
8	5BE-12439-00	O-RING	1	1	1	1	
9	93604-10011	PIN, DOWEL	2	2	2	2	
10	90430-06014	GASKET	1	1	1	1	
11	95027-06030	BOLT, FLANGE	4	4	4	4	
12	5BE-12564-00	PIPE, WATER	2	2	2	2	
13	93210-19758	O-RING	2	2	2	2	



5BE100-8050

FIG. 6 RADIATOR & HOSE

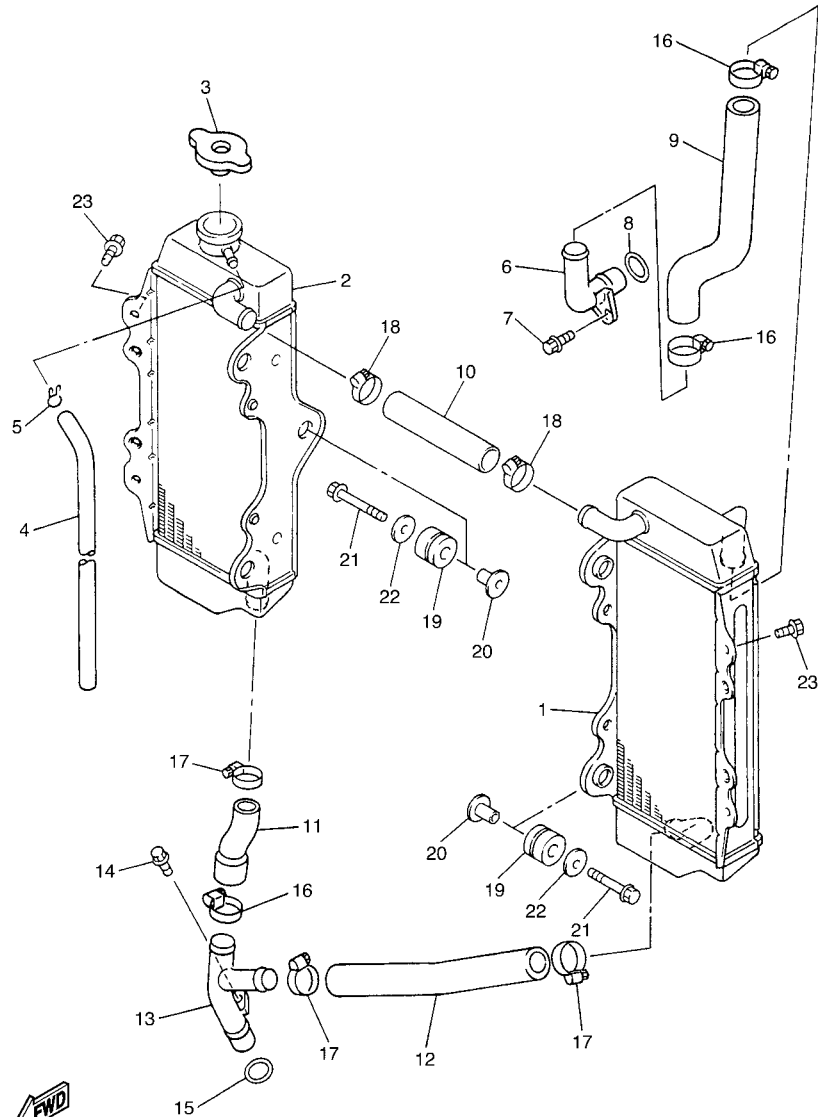

5TA1100-B060

REF. NO.	PART NO.	DESCRIPTION	5XD5	5XD6	5XD7	5XD8	REMARKS
1	5TA-1240A-00	RADIATOR ASSY	1	1	1	1	
2	5TA-12461-00	RADIATOR ASSY	1	1	1	1	
3	5HD-12462-00	CAP, RADIATOR	1	1	1	1	
4	91A20-05065	TUBE, FLEXIBLE VINYL	1	1	1	1	
5	90467-09006	CLIP	1	1	1	1	
6	5TA-12481-00	PIPE 1	1	1	1	1	
7	91317-06012	BOLT	1	1	1	1	
8	93210-16500	O-RING	1	1	1	1	
9	5TA-12576-00	HOSE 1	1	1	1	1	
10	5SG-12579-00	HOSE 4	1	1	1	1	
11	5TA-12578-00	HOSE 3	1	1	1	1	
12	5TA-12579-00	HOSE 4	1	1	1	1	
13	5TA-12482-00	PIPE 2	1	1	1	1	
14	95027-06012	BOLT, FLANGE	1	1	1	1	
15	93210-16500	O-RING	1	1	1	1	
16	90450-28014	HOSE CLAMP ASSY	3	3	3	3	
17	90450-25037	HOSE CLAMP ASSY	3	3	3	3	
18	90450-22017	HOSE CLAMP ASSY	2	2	2	2	
19	90480-15528	GROMMET	6	6	6	6	
20	90387-06065	COLLAR	6	6	6	6	
21	95027-06025	BOLT, FLANGE	6	6	6	6	
22	90201-06571	WASHER, PLATE	6	6	6	6	
23	95827-06010	BOLT, FLANGE	2	2	2	2	

FIG. 7 OIL PUMP

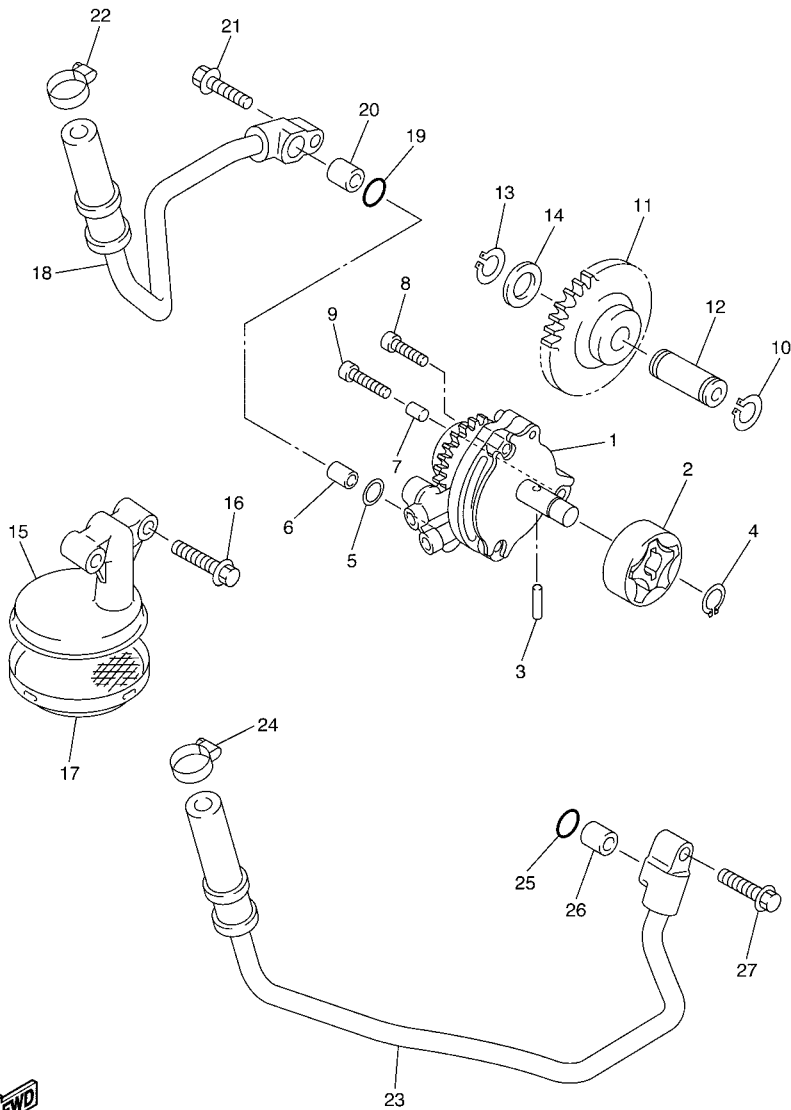

5TA1100-B070

REF. NO.	PART NO.	DESCRIPTION	5XD5	5XD6	5XD7	5XD8	REMARKS
1	5TA-13300-00	OIL PUMP ASSY	1	1	1	1	
2	5TA-13320-00	ROTOR ASSY 2	1	1	1	1	
3	93603-16219	PIN, DOWEL	1	1	1	1	
4	93440-10153	CIRCLIP	1	1	1	1	
5	93210-10197	O-RING	1	1	1	1	
6	99530-10114	PIN, DOWEL	1	1	1	1	
7	99530-08012	PIN, DOWEL	1	1	1	1	
8	90110-06058	BOLT, HEXAGON SOCKET HEAD	2	2	2	2	
9	91314-06030	BOLT	1	1	1	1	
10	99001-08600	CIRCLIP	1	1	1	1	
11	5TA-13341-00	GEAR, OIL PUMP IDLE	1	1	1	1	
12	5BE-13342-00	SHAFT, IDLE GEAR	1	1	1	1	
13	99009-12400	CIRCLIP	1	1	1	1	
14	90201-12166	WASHER, PLATE	1	1	1	1	
15	5TA-13412-00	HOUSING, STRAINER	1	1	1	1	
16	95027-06025	BOLT, FLANGE	2	2	2	2	
17	5BE-13411-00	STRAINER, OIL	1	1	1	1	
18	5TA-13464-00	HOSE, OIL 1	1	1	1	1	
19	93210-10197	O-RING	1	1	1	1	
20	99530-10114	PIN, DOWEL	1	1	1	1	
21	95027-06025	BOLT, FLANGE	1	1	1	1	
22	90450-22017	HOSE CLAMP ASSY	1	1	1	1	
23	5TA-13465-00	HOSE, OIL 2	1	1	1	1	
24	90450-22017	HOSE CLAMP ASSY	1	1	1	1	
25	93210-10197	O-RING	1	1	1	1	
26	99530-10114	PIN, DOWEL	1	1	1	1	
27	95027-06025	BOLT, FLANGE	1	1	1	1	

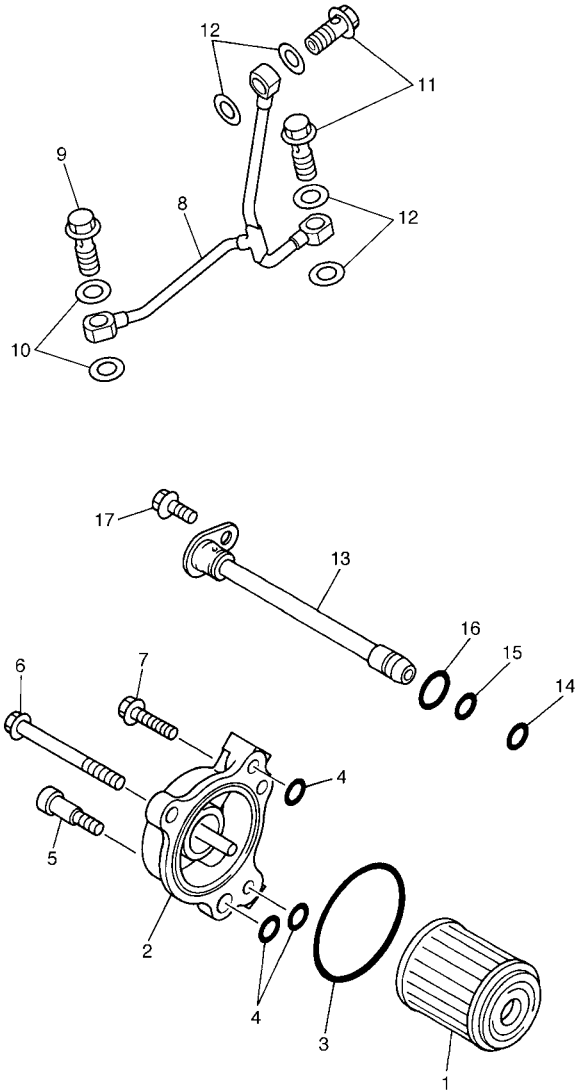

FIG. 8 OIL CLEANER

REF. NO.	PART NO.	DESCRIPTION	5XD5	5XD6	5XD7	5XD8	REMARKS
1	5TA-13440-00	ELEMENT ASSY, OIL CLEANER	1	1	1	1	
2	5BE-13447-10	COVER, OIL ELEMENT	1	1	1	1	
3	93210-47675	O-RING	1	1	1	1	
4	93210-07135	O-RING	3	3	3	3	
5	90109-065G2	BOLT	1	1	1	1	
6	91317-06065	BOLT	1	1	1	1	
7	91317-06020	BOLT	1	1	1	1	
8	5TG-13161-00	PIPE, DELIVERY 1	1	1	1	1	
9	90401-10159	BOLT, UNION	1	1	1	1	
10	90430-10188	GASKET	2	2	2	2	
11	90401-08038	BOLT, UNION	2	2	2	2	
12	90430-08119	GASKET	4	4	4	4	
13	5TA-13171-00	PIPE, DELIVERY 2	1	1	1	1	
14	93210-07003	O-RING	1	1	1	1	
15	93210-09008	O-RING	1	1	1	1	
16	93210-12759	O-RING	1	1	1	1	
17	95027-06012	BOLT, FLANGE	1	1	1	1	



5XD1100-C080

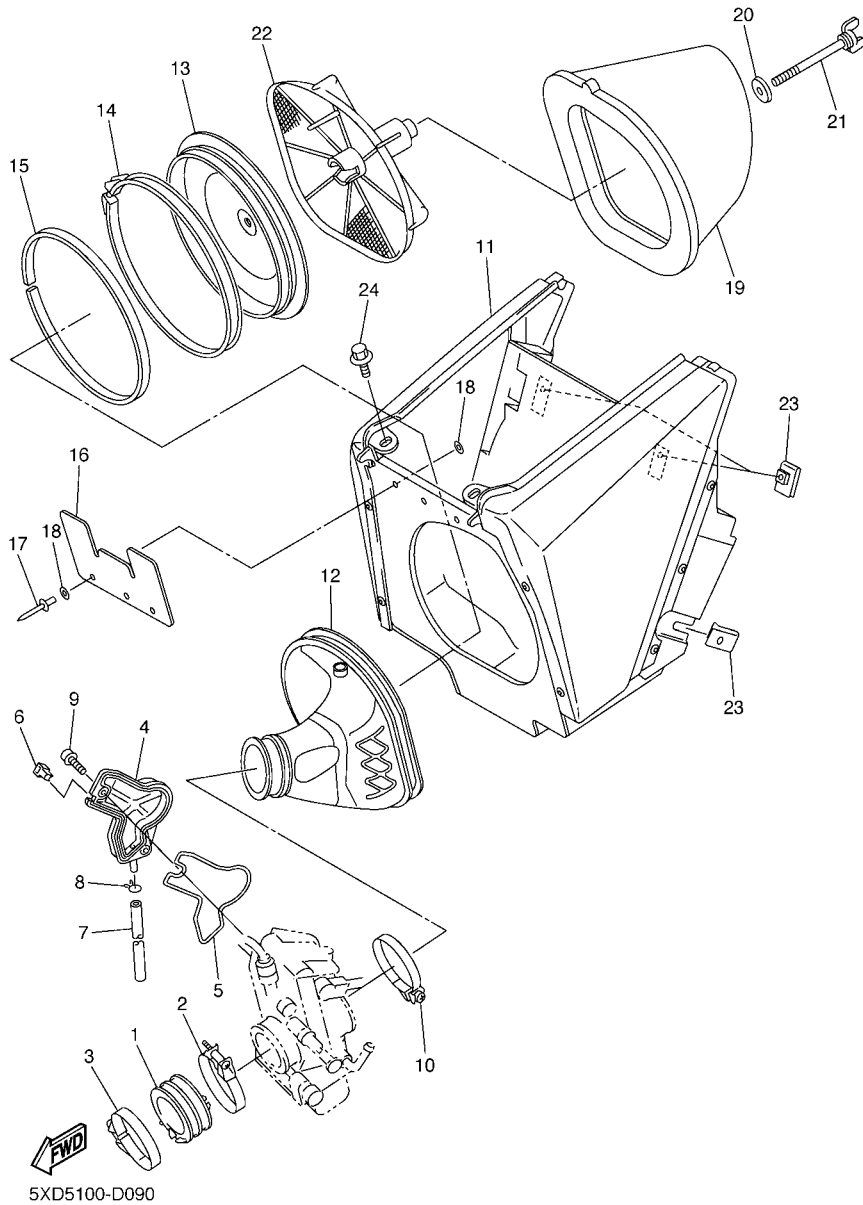
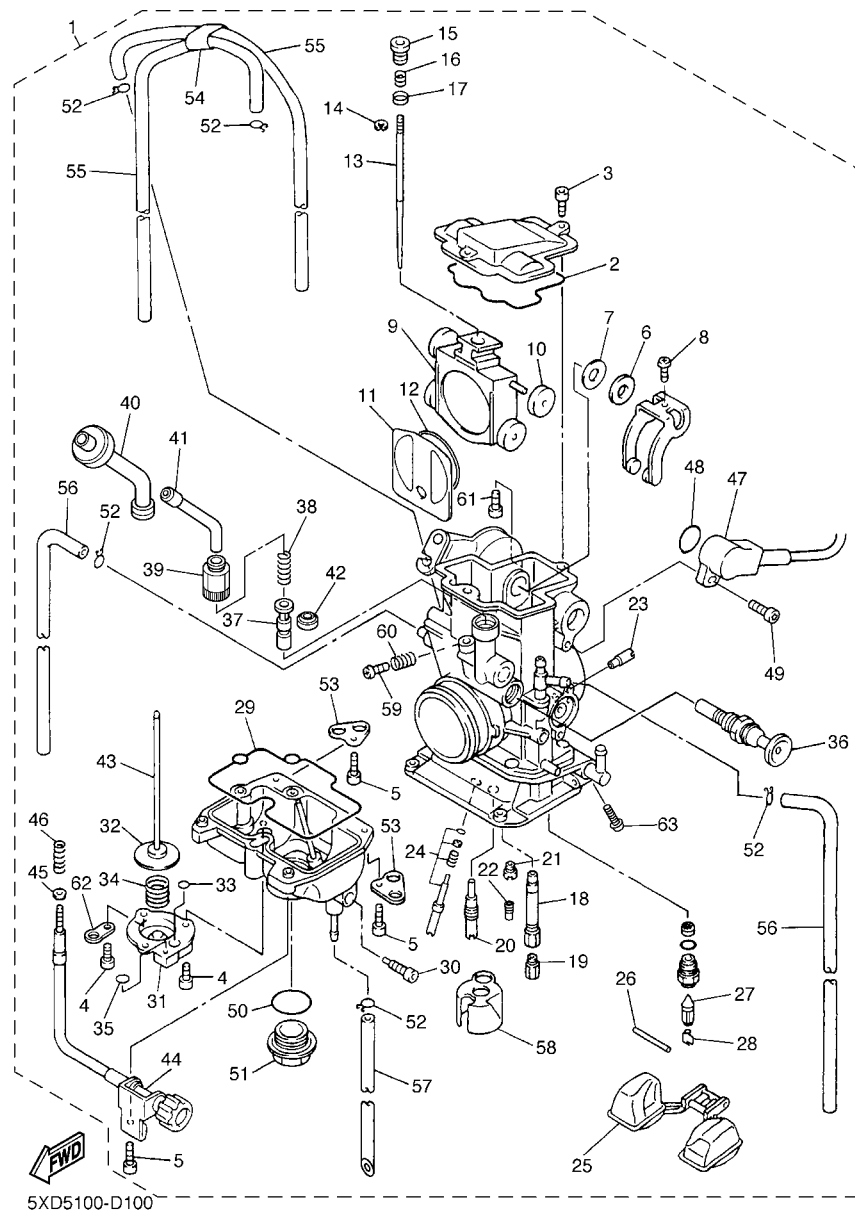

FIG. 9 INTAKE

REF. NO.	PART NO.	DESCRIPTION	5XD5	5XD6	5XD7	5XD8	REMARKS
1	5XD-13597-10	JOINT, CARBURETOR 3	1	1	1	1	
2	90450-57009	HOSE CLAMP ASSY	1	1	1	1	
3	90450-59002	HOSE CLAMP ASSY	1	1	1	1	
4	5TA-14293-00	COVER 1	1	1	1	1	
5	5TA-14227-00	GASKET	1	1	1	1	
6	5TA-14239-00	SEAL	1	1	1	1	
7	5TA-14987-00	HOSE	1	1	1	1	
8	3TJ-14137-40	CLIP	1	1	1	1	
9	5TA-14428-00	BOLT	2	2	2	2	
10	90450-61001	HOSE CLAMP ASSY	1	1	1	1	
11	5TA-14401-01	AIR CLEANER CASE ASSY	1	1	1	1	
12	5XD-14453-00	JOINT, AIR CLEANER 1	1	1	1	1	
13	5NY-14459-00	HOLDER, GUIDE	1	1	1	1	
14	5NY-14455-10	BAND	1	1	1	1	
15	5NY-14442-00	SPACER	1	1	1	1	
16	5XD-14417-00	COVER 1	1	1	1	1	
17	90267-32070	RIVET, BLIND	3	3	3	3	
18	90201-03313	WASHER, PLATE	6	6	6	6	
19	4XM-14451-00	ELEMENT, AIR CLEANER	1	1	1	1	
20	90209-06096	WASHER	1	1	1	1	
21	90122-06035	BOLT, WING	1	1	1	1	
22	5BE-14458-00	GUIDE	1	1	1	1	
23	90183-06023	NUT, SPRING	3	3	3	3	
24	90109-067F4	BOLT	2	2	2	2	



5XD5100-D100

FIG. 10 CARBURETOR

REF. NO.	PART NO.	DESCRIPTION	5XD5	5XD6	5XD7	5XD8	REMARKS
1	5XD-14101-50	CARBURETOR ASSY 1	1	1	1	1	
2	5JG-14959-00	.GASKET	1	1	1	1	
3	91316-04012	.BOLT	2	2	2	2	
4	688-14592-00	.SCREW	3	3	3	3	
5	98502-04012	.SCREW, PAN HEAD	4	4	4	4	
6	90202-08045	.WASHER, PLATE	1	1	1	1	
7	5JG-14951-00	.WASHER	1	1	1	1	
8	5JG-14522-00	.SCREW, ADJUST	1	1	1	1	
9	5JG-14388-00	.VALVE, VACUUM CONTROL	1	1	1	1	
10	3TJ-14267-40	.ROLLER	1	1	1	1	
11	5JG-14546-01	.VALVE, NEEDLE	1	1	1	1	
12	4FN-14997-00	.SEAL	1	1	1	1	
13	5TA-14916-LR	.NEEDLE (#NFLR)	1	1	1	1	STD
	5TA-14916-LN	.NEEDLE (#NFLN)	1	1	1	1	AP
	5TA-14916-LP	.NEEDLE (#NFLP)	1	1	1	1	AP
	5TA-14916-L1	.NEEDLE (#NFLQ)	1	1	1	1	AP
	5TA-14916-LS	.NEEDLE (#NFLS)	1	1	1	1	AP
	5TA-14916-LT	.NEEDLE (#NFLT)	1	1	1	1	AP
	5TA-14916-LU	.NEEDLE (#NFLU)	1	1	1	1	AP
	5TA-14916-PN	.NEEDLE (#NFPP)	1	1	1	1	AP
	5TA-14916-PP	.NEEDLE (#NFPP)	1	1	1	1	AP
	5TA-14916-P1	.NEEDLE (#NFPP)	1	1	1	1	AP
	5TA-14916-PR	.NEEDLE (#NFPR)	1	1	1	1	AP
	5TA-14916-PS	.NEEDLE (#NFPS)	1	1	1	1	AP
	5TA-14916-PT	.NEEDLE (#NFPT)	1	1	1	1	AP
	5TA-14916-PU	.NEEDLE (#NFPU)	1	1	1	1	AP
14	3TJ-14159-40	.CLIP	1	1	1	1	

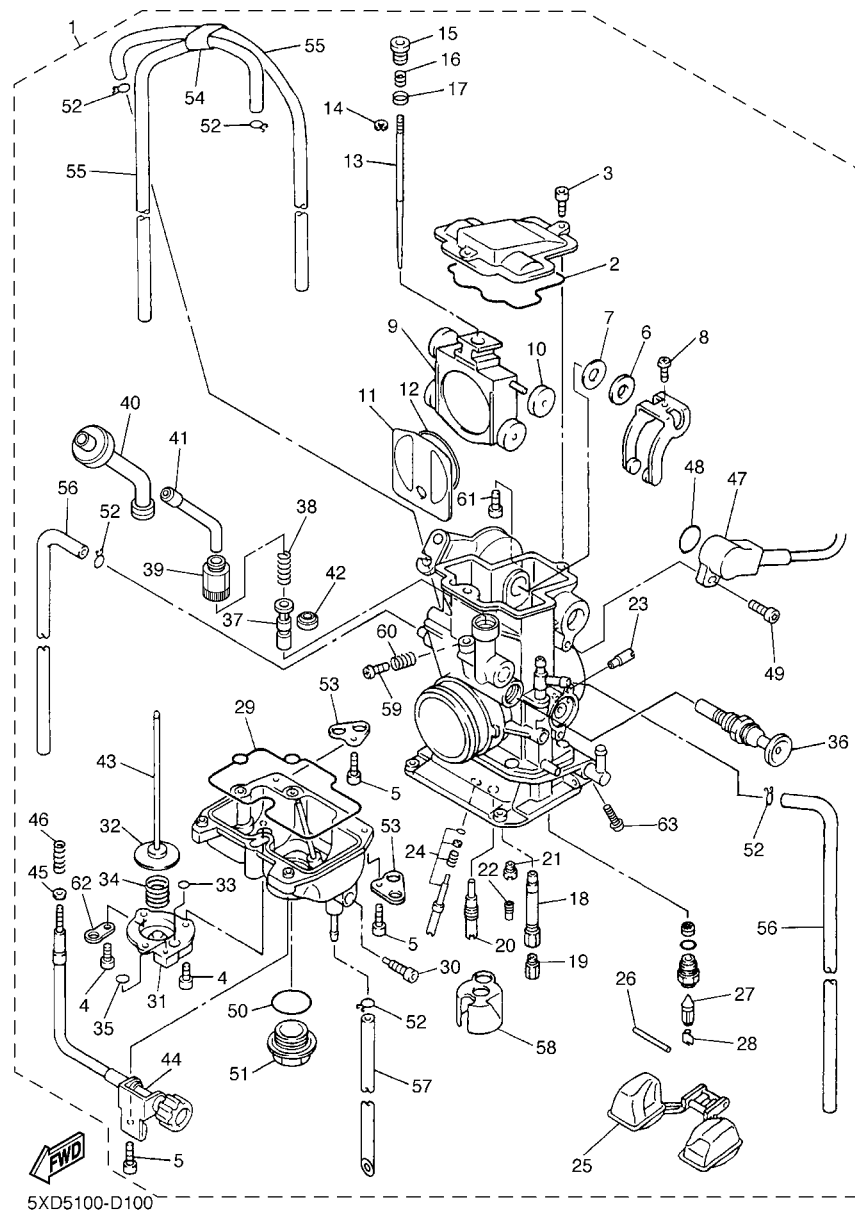

5XD5100-D100

FIG. 10 CARBURETOR

REF. NO.	PART NO.	DESCRIPTION	5XD5	5XD6	5XD7	5XD8	REMARKS
15	5JG-14521-00	.SCREW, ADJUST	1	1	1	1	
16	5JG-14275-00	.SPRING	1	1	1	1	
17	5JG-14264-00	.COLLAR	1	1	1	1	
18	5XD-14947-00	.JET, NEEDLE	1	1	1	1	
19	4MX-14943-40	.JET, MAIN (#165)	1	1	1	1	STD
	4MX-14943-88	.JET, MAIN (#152)	1	1	1	1	AP
	4MX-14943-38	.JET, MAIN (#155)	1	1	1	1	AP
	4MX-14943-89	.JET, MAIN (#158)	1	1	1	1	AP
	4MX-14943-39	.JET, MAIN (#160)	1	1	1	1	AP
	4MX-14943-90	.JET, MAIN (#162)	1	1	1	1	AP
	4MX-14943-91	.JET, MAIN (#168)	1	1	1	1	AP
	4MX-14943-41	.JET, MAIN (#170)	1	1	1	1	AP
	4MX-14943-92	.JET, MAIN (#172)	1	1	1	1	AP
	4MX-14943-42	.JET, MAIN (#175)	1	1	1	1	AP
	4MX-14943-93	.JET, MAIN (#178)	1	1	1	1	AP
20	4MX-14948-05	.JET, SLOW (#45)	1	1	1	1	STD
	4MX-14948-02	.JET, SLOW (#38)	1	1	1	1	AP
	4MX-14948-03	.JET, SLOW (#40)	1	1	1	1	AP
	4MX-14948-04	.JET, SLOW (#42)	1	1	1	1	AP
	4MX-14948-06	.JET, SLOW (#48)	1	1	1	1	AP
	4MX-14948-07	.JET, SLOW (#50)	1	1	1	1	AP
	4MX-14948-08	.JET, SLOW (#52)	1	1	1	1	AP
21	3TJ-1494F-16	.JET (#72)	1	1	1	1	STD
	3TJ-1494F-14	.JET (#68)	1	1	1	1	AP
	3TJ-1494F-15	.JET (#70)	1	1	1	1	AP
	3TJ-1494F-17	.JET (#75)	1	1	1	1	AP
	3TJ-1494F-18	.JET (#78)	1	1	1	1	AP

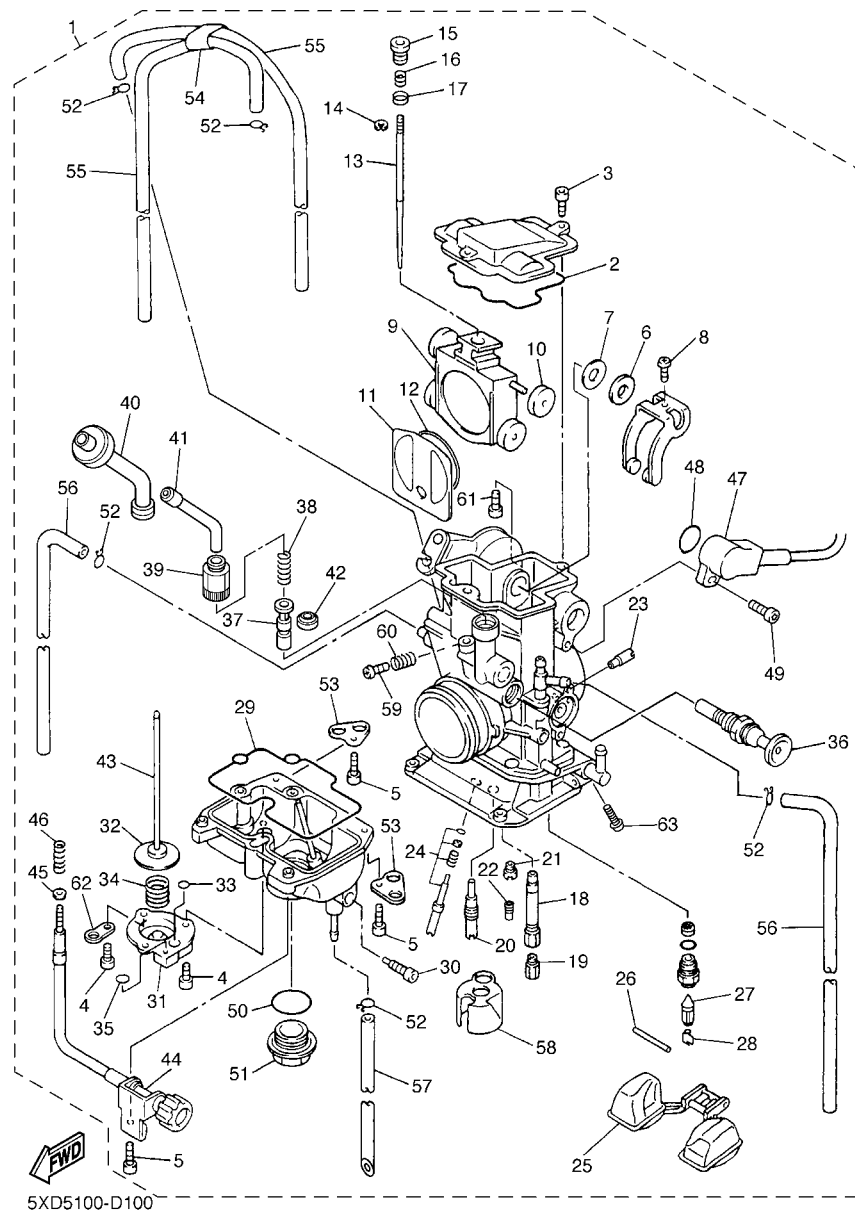

5XD5100-D100

FIG. 10 CARBURETOR

REF. NO.	PART NO.	DESCRIPTION	5XD5	5XD6	5XD7	5XD8	REMARKS
22	4TJ-1494F-03	.JET (#40)	1	1	1	1	STD
	4TJ-1494F-01	.JET (#35)	1	1	1	1	AP
	4TJ-1494F-05	.JET (#45)	1	1	1	1	AP
	4TJ-1494F-07	.JET (#50)	1	1	1	1	AP
	4TJ-1494F-09	.JET (#55)	1	1	1	1	AP
23	5TA-14943-27	.JET, MAIN (#100)	1	1	1	1	
24	5NL-14105-00	.PILOT SCREW SET	1	1	1	1	
25	4SR-14985-00	.FLOAT	1	1	1	1	
26	676-14548-00	.PIN, FLOAT ARM	1	1	1	1	
27	4MX-14392-00	.VALVE, NEEDLE	1	1	1	1	
28	633-14159-00	.CLIP	1	1	1	1	
29	5JG-14984-00	.GASKET, FLOAT CHAMBER	1	1	1	1	
30	3TJ-14191-40	.PLUG, DRAIN	1	1	1	1	
31	3TJ-14293-40	.COVER 1	1	1	1	1	
32	5JG-14940-17	.DIAPHRAGM ASSY	1	1	1	1	STD
	5JG-14940-16	.DIAPHRAGM ASSY	1	1	1	1	AP
	5JG-14940-18	.DIAPHRAGM ASSY	1	1	1	1	AP
33	3TJ-14536-40	.GASKET	1	1	1	1	
34	3TJ-14933-40	.SPRING, DIAPHRAGM	1	1	1	1	
35	6H4-14561-00	.O-RING	1	1	1	1	
36	5TA-14171-00	.PLUNGER, STARTER	1	1	1	1	
37	5TA-14371-00	.PLUNGER, STARTER	1	1	1	1	
38	5TA-14335-00	.SPRING, PLUNGER	1	1	1	1	
39	5TA-14991-00	.SCREW	1	1	1	1	
40	5TA-14374-00	.CAP, PLUNGER	1	1	1	1	
41	5TA-14155-00	.GUIDE, CABLE	1	1	1	1	
42	5TA-14997-00	.SEAL	1	1	1	1	

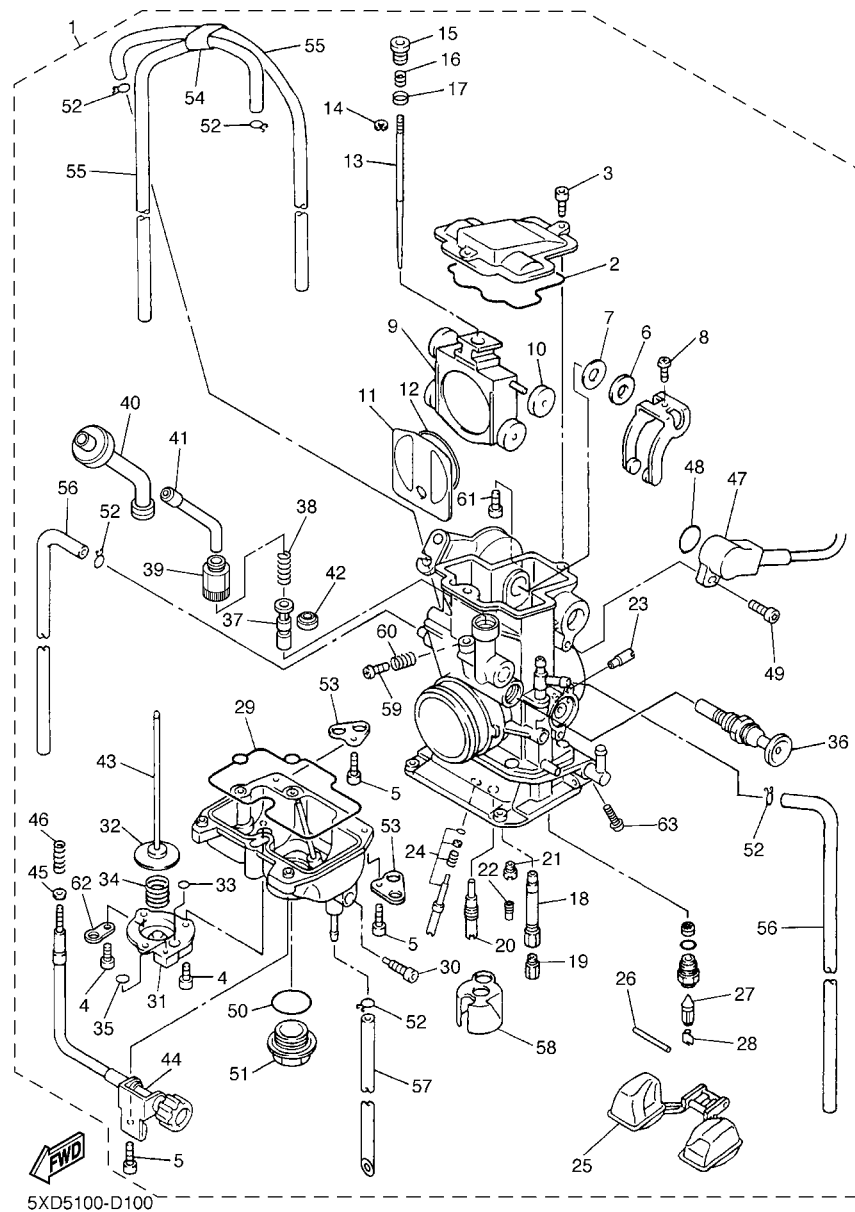

5XD5100-D100

FIG. 10 CARBURETOR

REF. NO.	PART NO.	DESCRIPTION	5XD5	5XD6	5XD7	5XD8	REMARKS
43	5JG-14379-00	.ROD, STARTER	1	1	1	1	
44	5JG-14922-00	.SCREW, THROTTLE	1	1	1	1	
45	90201-08410	.WASHER, PLATE	1	1	1	1	
46	5TA-14934-00	.SPRING, THROTTLE STOP	1	1	1	1	
47	5TA-85885-00	.THROTTLE SENSOR ASSY	1	1	1	1	
48	5NX-14562-00	.O-RING	1	1	1	1	
49	5NX-14216-00	.SCREW	1	1	1	1	
50	4MX-14561-00	.O-RING	1	1	1	1	
51	4MX-14115-00	.PLUG, SCREW	1	1	1	1	
52	3TJ-14137-40	.CLIP	5	5	5	5	
53	5BE-14146-00	.PLATE	2	2	2	2	
54	5TA-14261-00	.HOLDER	1	1	1	1	
55	5TA-14196-00	.PIPE	2	2	2	2	
56	5TA-14197-00	.PIPE	2	2	2	2	
57	5TJ-14987-00	.HOSE	1	1	1	1	
58	5JG-14346-00	.PLATE	1	1	1	1	
59	5JG-14565-00	.SCREW	1	1	1	1	
60	5JG-14531-00	.SPRING, ADJUST SCREW	1	1	1	1	
61	5JG-14591-00	.SCREW	1	1	1	1	
62	5PA-14146-00	.PLATE	1	1	1	1	
63	5XD-14325-00	.SCREW, PAN HEAD	1	1	1	1	

FIG. 12 CRANKCASE

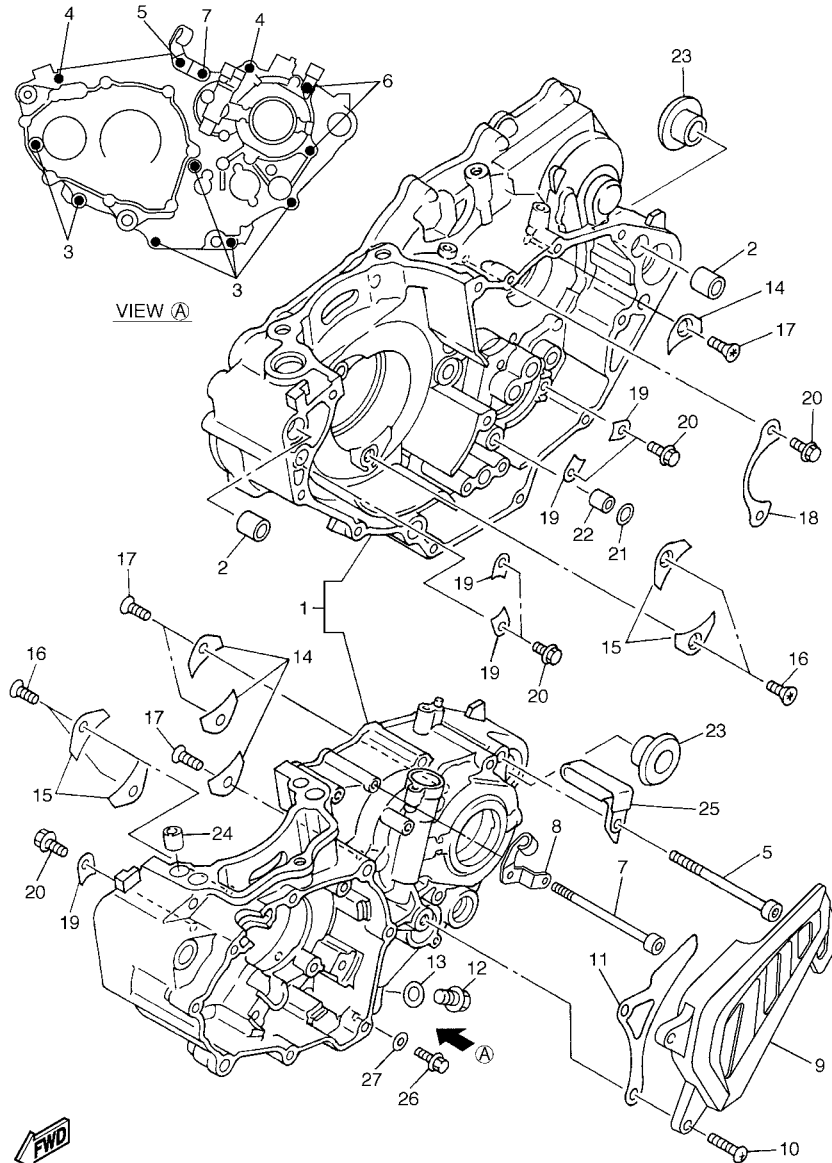

5XD1100-C120

REF. NO.	PART NO.	DESCRIPTION	5XD5	5XD6	5XD7	5XD8	REMARKS
1	5TA-15150-11	CRANKCASE ASSY	1	1	1	1	
2	99530-14016	PIN, DOWEL	2	2	2	2	
3	91317-06050	BOLT	6	6	6	6	
4	91317-06060	BOLT	2	2	2	2	
5	91314-06065	BOLT	1	1	1	1	
6	91317-06075	BOLT	2	2	2	2	
7	91314-06080	BOLT	1	1	1	1	
8	5XD-15441-00	HOLDER, CLUTCH CABLE	1	1	1	1	
9	5TA-15421-00	COVER, CRANKCASE 2	1	1	1	1	
10	98507-06025	SCREW, PAN HEAD	2	2	2	2	
11	5TA-17466-00	GUIDE, CHAIN	1	1	1	1	
12	95027-10016	BOLT, FLANGE	1	1	1	1	
13	90430-10188	GASKET	1	1	1	1	
14	4JT-15381-01	PLATE, BEARING COVER	4	4	4	4	
15	5BE-15383-01	PLATE, BEARING COVER	4	4	4	4	
16	90149-06126	SCREW	4	4	4	4	
17	90149-06326	SCREW	4	4	4	4	
18	4L0-17471-00	PLATE, COVER	1	1	1	1	
19	5DH-18562-00	PLATE, STOPPER 2	5	5	5	5	
20	90105-06553	BOLT, FLANGE	7	7	7	7	
21	93210-10197	O-RING	1	1	1	1	
22	99530-10114	PIN, DOWEL	1	1	1	1	
23	90387-18007	COLLAR	2	2	2	2	
24	99530-10116	PIN, DOWEL	2	2	2	2	
25	90461-10136	CLAMP	1	1	1	1	
26	95024-06010	BOLT, FLANGE	1	1	1	1	
27	90430-06014	GASKET	1	1	1	1	

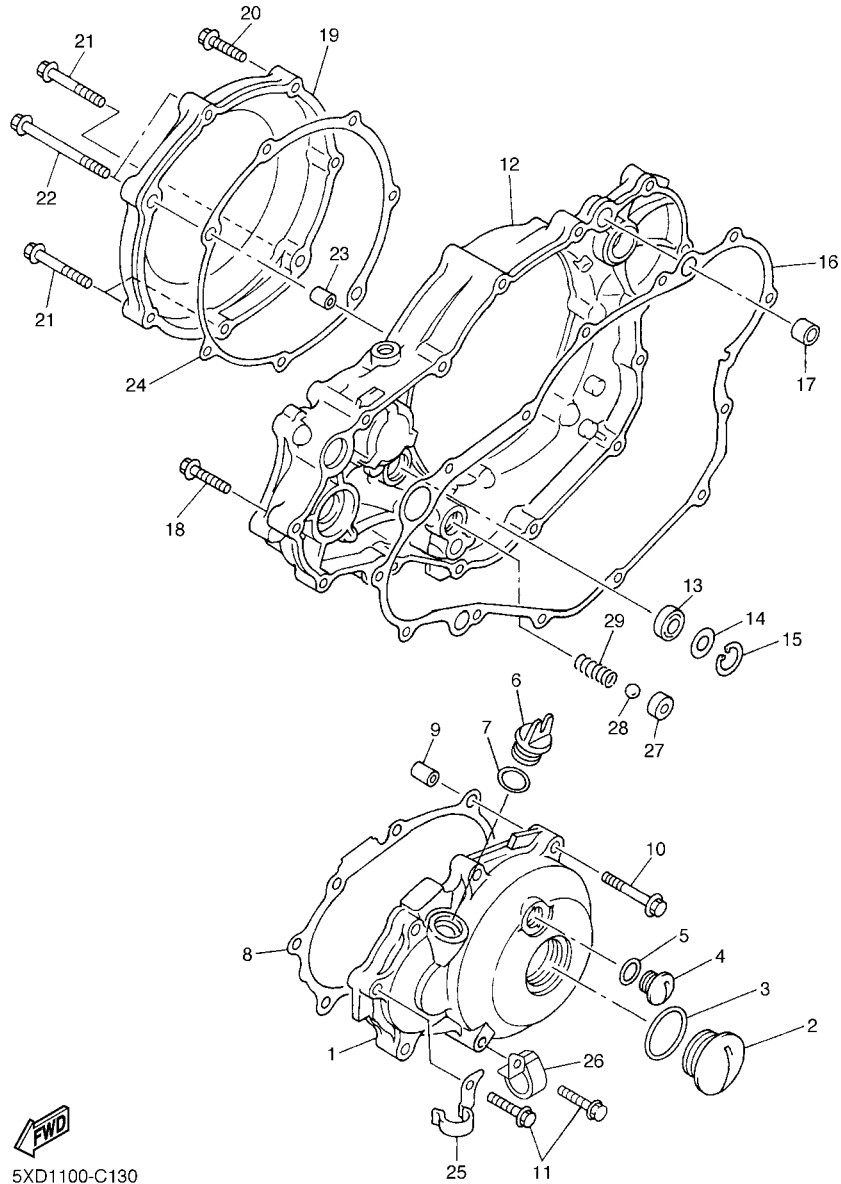

5XD1100-C130

FIG. 13 CRANKCASE COVER 1

REF. NO.	PART NO.	DESCRIPTION	5XD5	5XD6	5XD7	5XD8	REMARKS
1	5TA-15411-10	COVER, CRANKCASE 1	1	1	1	1	
2	90340-32123	PLUG, STRAIGHT SCREW	1	1	1	1	
3	93210-32172	O-RING	1	1	1	1	
4	90340-14128	PLUG, STRAIGHT SCREW	1	1	1	1	
5	93210-14369	O-RING	1	1	1	1	
6	3Y1-15363-00	PLUG, OIL	1	1	1	1	
7	93210-19123	O-RING	1	1	1	1	
8	5TA-15451-00	GASKET, CRANKCASE COVER 1	1	1	1	1	
9	99530-08016	PIN, DOWEL	2	2	2	2	
10	95027-06040	BOLT, FLANGE	2	2	2	2	
11	95027-06030	BOLT, FLANGE	6	6	6	6	
12	5XD-15431-00	COVER, CRANKCASE 3	1	1	1	1	
13	93101-14164	OIL SEAL	1	1	1	1	
14	90201-15701	WASHER, PLATE (T=1.0)	1	1	1	1	
15	99009-22500	CIRCLIP	1	1	1	1	
16	5TA-15462-00	GASKET, CRANKCASE COVER 3	1	1	1	1	
17	91812-16001	PIN, DOWEL	2	2	2	2	
18	95027-06030	BOLT, FLANGE	10	10	10	10	
19	5TA-15415-10	COVER, GENERATOR	1	1	1	1	
20	95027-06030	BOLT, FLANGE	2	2	2	2	
21	95027-06040	BOLT, FLANGE	3	3	3	3	
22	95027-06080	BOLT, FLANGE	2	2	2	2	
23	99530-08016	PIN, DOWEL	2	2	2	2	
24	5TA-15453-00	GASKET	1	1	1	1	
25	90462-10241	CLAMP	1	1	1	1	
26	5XD-15378-00	HOLDER	1	1	1	1	
27	583-13113-00	SEAT, CHECK BALL	1	1	1	1	

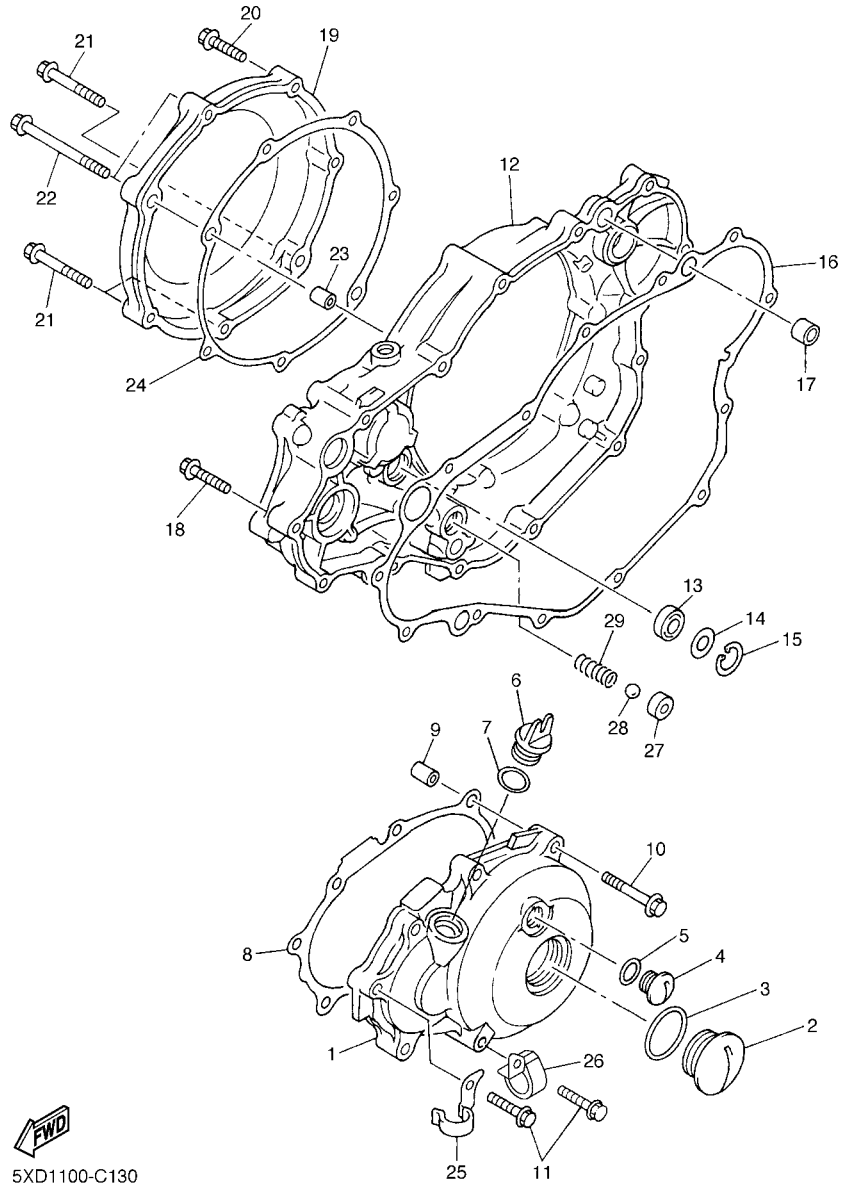

5XD1100-C130

FIG. 13 CRANKCASE COVER 1

REF. NO.	PART NO.	DESCRIPTION	5XD5	5XD6	5XD7	5XD8	REMARKS
28	93503-08007	BALL	1	1	1	1	
29	90501-043E0	SPRING, COMPRESSION	1	1	1	1	

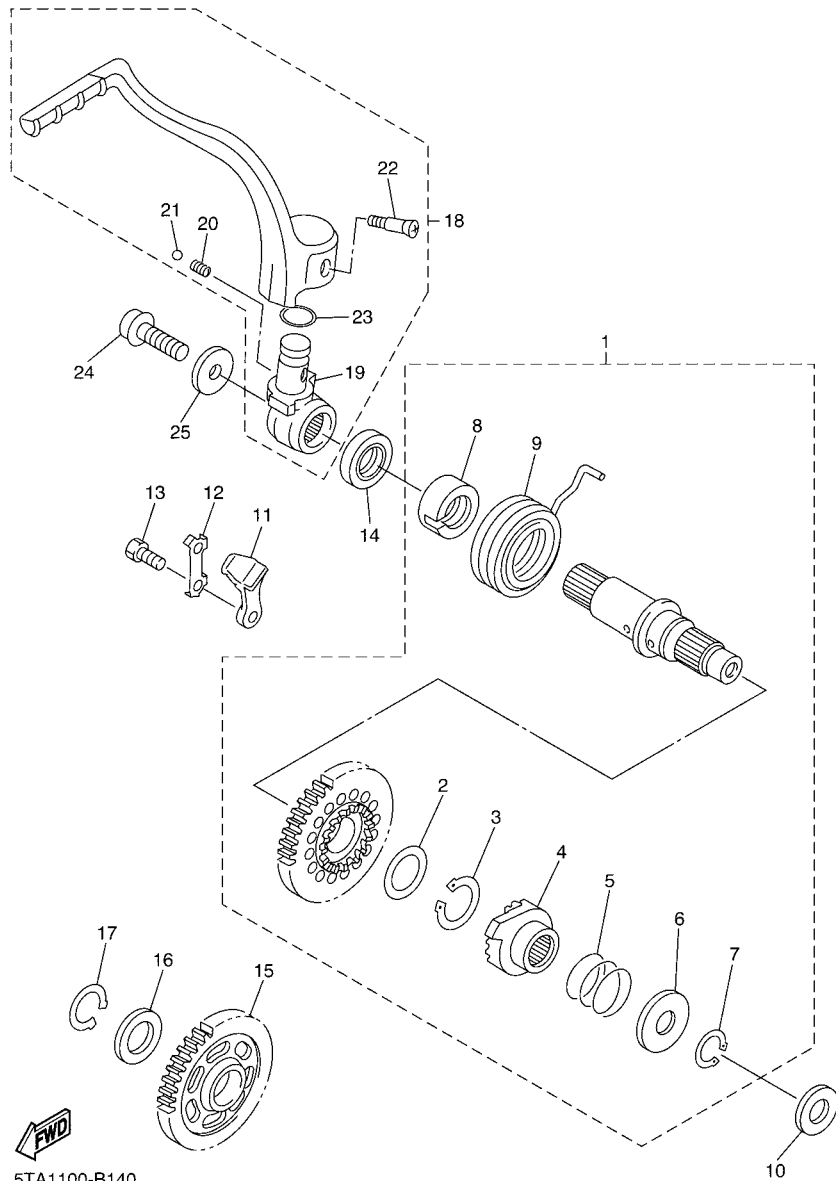

5TA1100-B140

FIG. 14 STARTER

REF. NO.	PART NO.	DESCRIPTION	5XD5	5XD6	5XD7	5XD8	REMARKS
1	5XD-15601-00	KICK SHAFT ASSY	1	1	1	1	
2	90201-20685	.WASHER, PLATE (T=0.5)	1	1	1	1	
3	93410-20038	.CIRCLIP	1	1	1	1	
4	4GY-15671-00	.WHEEL, RATCHET	1	1	1	1	
5	90501-16016	.SPRING, COMPRESSION	1	1	1	1	
6	90201-167P7	.WASHER, PLATE	1	1	1	1	
7	99009-16400	.CIRCLIP	1	1	1	1	
8	5GR-15664-00	.GUIDE, SPRING	1	1	1	1	
9	90508-305B0	.SPRING, TORSION	1	1	1	1	
10	90201-162H4	WASHER, PLATE	1	1	1	1	
11	5SG-15668-00	STOPPER	1	1	1	1	
12	214-15686-00	WASHER, LOCK	1	1	1	1	
13	90101-06001	BOLT	2	2	2	2	
14	93102-20108	OIL SEAL	1	1	1	1	
15	5TA-15651-00	GEAR, KICK IDLE	1	1	1	1	
16	90201-20276	WASHER, PLATE (T=1.0)	1	1	1	1	
17	99009-20400	CIRCLIP	1	1	1	1	
18	5XD-15620-00	KICK CRANK ASSY	1	1	1	1	
19	5XD-15621-00	.BOSS, KICK CRANK	1	1	1	1	
20	90501-147A5	.SPRING, COMPRESSION	1	1	1	1	
21	93507-32009	.BALL	1	1	1	1	
22	90152-06010	.SCREW, COUNTERSUNK	1	1	1	1	
23	93210-17570	.O-RING	1	1	1	1	
24	90110-08035	BOLT, HEXAGON SOCKET HEAD	1	1	1	1	
25	90201-087A9	WASHER, PLATE	1	1	1	1	

FIG. 15 CLUTCH

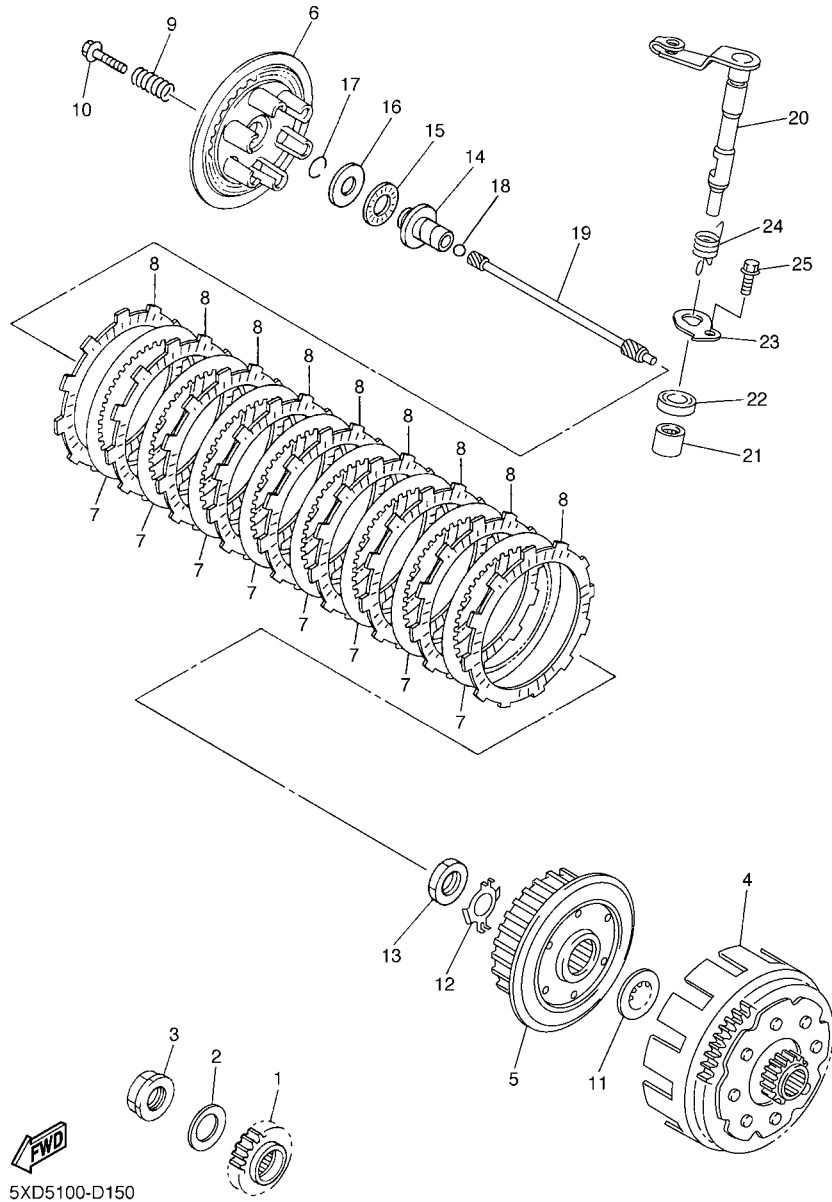

REF. NO.	PART NO.	DESCRIPTION	5XD5	5XD6	5XD7	5XD8	REMARKS
1	5XD-16111-00	GEAR, PRIMARY DRIVE	1	1	1	1	
2	90208-25045	WASHER, CONICAL SPRING	1	1	1	1	
3	90179-20009	NUT	1	1	1	1	
4	5XD-16150-50	PRIMARY DRIVEN GEAR COMP.	1	1	1	1	
5	5TA-16371-10	BOSS, CLUTCH	1	1	1	1	
6	5JG-16351-00	PLATE, PRESSED 1	1	1	1	1	
7	5JG-16325-00	PLATE, CLUTCH 2	8	8	8	8	
8	5TA-16321-00	PLATE, FRICTION	9	9	9	9	
9	90501-231E9	SPRING, COMPRESSION	6	6	6	6	
10	90159-06092	SCREW, WITH WASHER	6	6	6	6	
11	5XD-16154-00	PLATE, THRUST 1	1	1	1	1	
12	90215-20005	WASHER, LOCK	1	1	1	1	
13	90170-20327	NUT	1	1	1	1	
14	5JG-16356-00	ROD, PUSH 1	1	1	1	1	
15	93340-21505	BEARING	1	1	1	1	
16	90201-125L6	WASHER, PLATE	1	1	1	1	
17	93440-10085	CIRCLIP	1	1	1	1	
18	93511-32027	BALL	1	1	1	1	
19	5TA-16357-10	ROD, PUSH 2	1	1	1	1	
20	5XD-16381-00	PUSH LEVER COMP.	1	1	1	1	
21	93317-11287	BEARING	1	1	1	1	
22	93102-12224	OIL SEAL	1	1	1	1	
23	5TA-16384-01	PLATE, SEAT	1	1	1	1	
24	90508-12007	SPRING, TORSION	1	1	1	1	
25	95027-06012	BOLT, FLANGE	1	1	1	1	

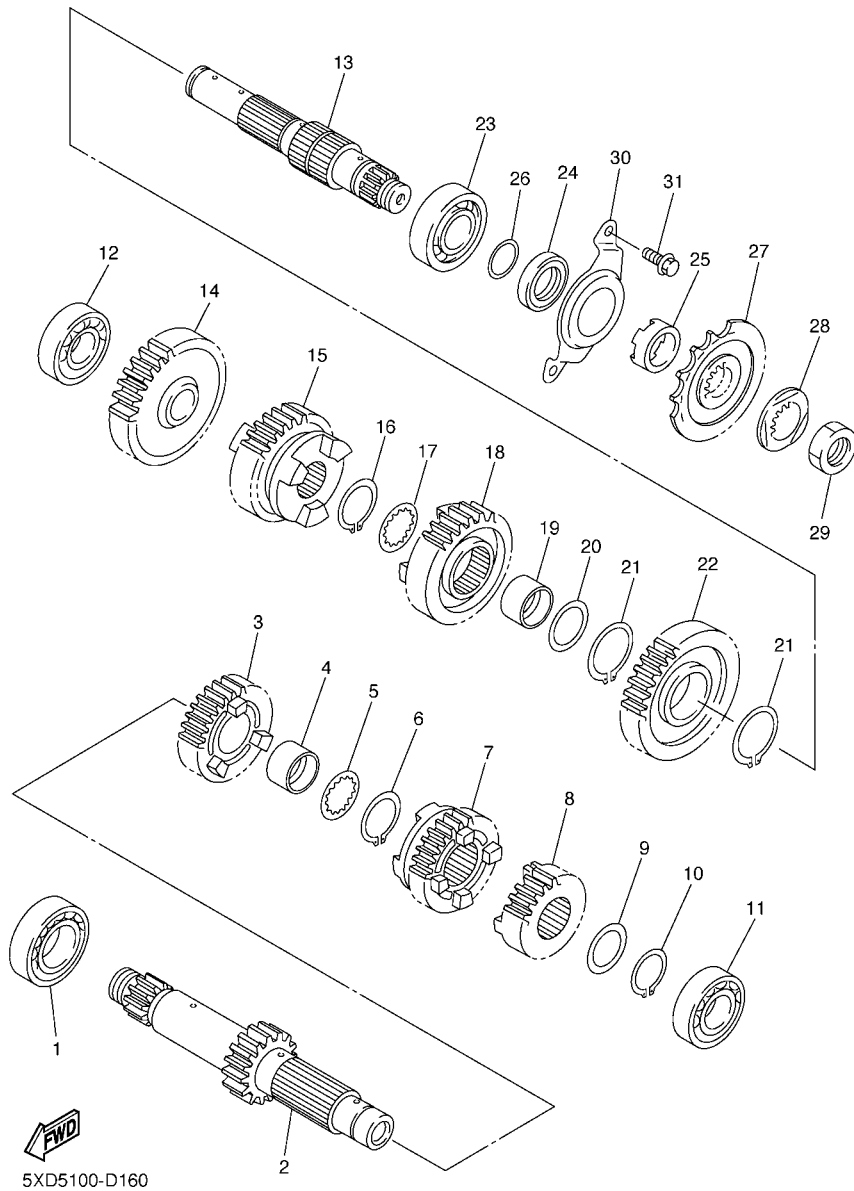
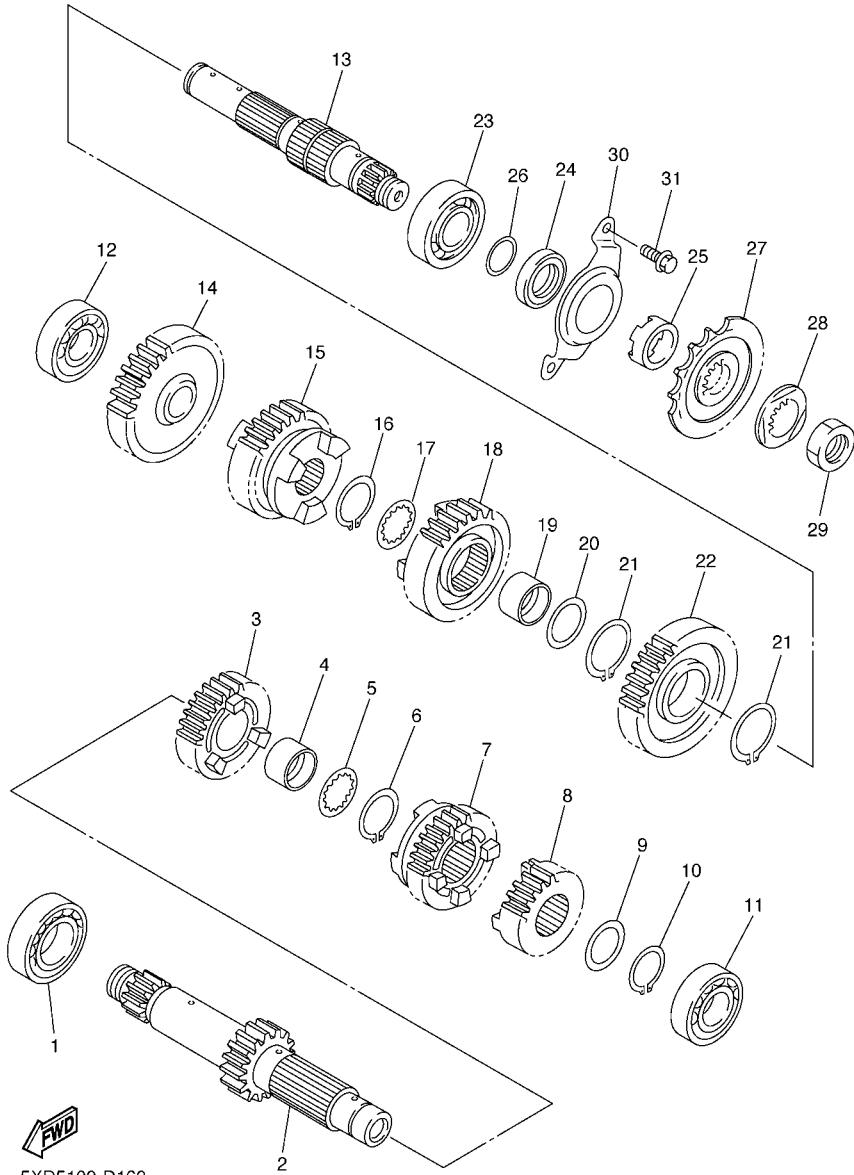

FIG. 16 TRANSMISSION

REF. NO.	PART NO.	DESCRIPTION	5XD5	5XD6	5XD7	5XD8	REMARKS
1	93306-20532	BEARING	1	1	1	1	
2	5TA-17411-20	AXLE, MAIN (14T)	1	1	1	1	
3	5TA-17141-20	GEAR, 4TH PINION (20T)	1	1	1	1	
4	90387-25008	COLLAR	1	1	1	1	
5	90209-21332	WASHER	1	1	1	1	
6	93440-25084	CIRCLIP	1	1	1	1	
7	5TA-17131-20	GEAR, 3RD PINION (18T)	1	1	1	1	
8	5TA-17121-10	GEAR, 2ND PINION (16T)	1	1	1	1	
9	90201-206L6	WASHER, PLATE	1	1	1	1	
10	99009-20400	CIRCLIP	1	1	1	1	
11	93306-00431	BEARING	1	1	1	1	
12	93306-00426	BEARING	1	1	1	1	
13	5TA-17402-10	DRIVE AXLE ASSY	1	1	1	1	
14	5TA-17211-10	GEAR, 1ST WHEEL (27T)	1	1	1	1	
15	5TA-17241-10	GEAR, 4TH WHEEL (21T)	1	1	1	1	
16	93440-25084	CIRCLIP	1	1	1	1	
17	90209-21332	WASHER	1	1	1	1	
18	5TA-17231-10	GEAR, 3RD WHEEL (23T)	1	1	1	1	
19	90387-25013	COLLAR	1	1	1	1	
20	90201-253G3	WASHER, PLATE	1	1	1	1	
21	93440-30077	CIRCLIP	2	2	2	2	
22	5TA-17221-10	GEAR, 2ND WHEEL (25T)	1	1	1	1	
23	93306-20593	BEARING	1	1	1	1	
24	93102-32480	OIL SEAL	1	1	1	1	
25	90387-2513F	COLLAR	1	1	1	1	
26	93210-22164	O-RING	1	1	1	1	
27	9383E-14215	SPROCKET, DRIVE (14T)	1	1	1	1	



5XD5100-D160

FIG. 16 TRANSMISSION

REF. NO.	PART NO.	DESCRIPTION	5XD5	5XD6	5XD7	5XD8	REMARKS
28	90215-21003	WASHER, LOCK	1	1	1	1	
29	90179-20001	NUT	1	1	1	1	
30	5GR-17471-00	PLATE, COVER	1	1	1	1	
31	90105-06553	BOLT, FLANGE	2	2	2	2	

FIG. 18 SHIFT SHAFT

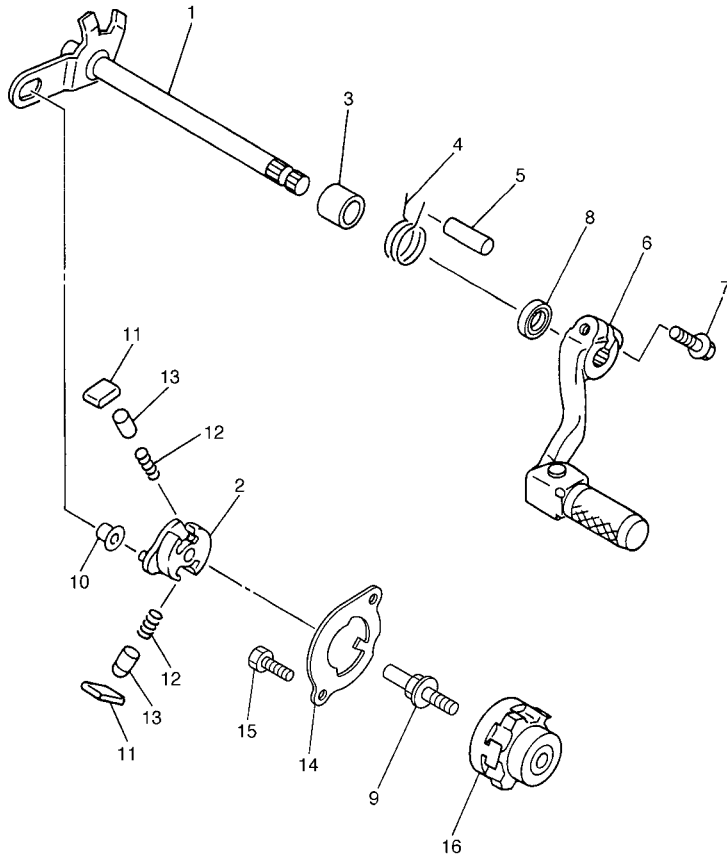

REF. NO.	PART NO.	DESCRIPTION	5XD5	5XD6	5XD7	5XD8	REMARKS
1	5TJ-18101-00	SHIFT SHAFT ASSY	1	1	1	1	
2	5MW-18122-01	LEVER, SHIFT 2	1	1	1	1	
3	90387-124F4	COLLAR	1	1	1	1	
4	90508-291A8	SPRING, TORSION	1	1	1	1	
5	93608-33002	PIN, DOWEL	1	1	1	1	
6	5TA-18110-00	SHIFT PEDAL ASSY	1	1	1	1	
7	95027-06020	BOLT, FLANGE	1	1	1	1	
8	93102-12224	OIL SEAL	1	1	1	1	
9	3XJ-18173-10	PIN, SHIFT	1	1	1	1	
10	3XJ-18178-00	ROLLER, SHIFT LEVER	1	1	1	1	
11	3XJ-18182-00	PAWL, SHIFTER	2	2	2	2	
12	90501-052G5	SPRING, COMPRESSION	2	2	2	2	
13	3XJ-18184-00	PIN, PAWL	2	2	2	2	
14	5TJ-18172-00	GUIDE, SHIFT	1	1	1	1	
15	90101-06034	BOLT	2	2	2	2	
16	4EW-18185-00	SEGMENT	1	1	1	1	



5TJ5100-C190

C12

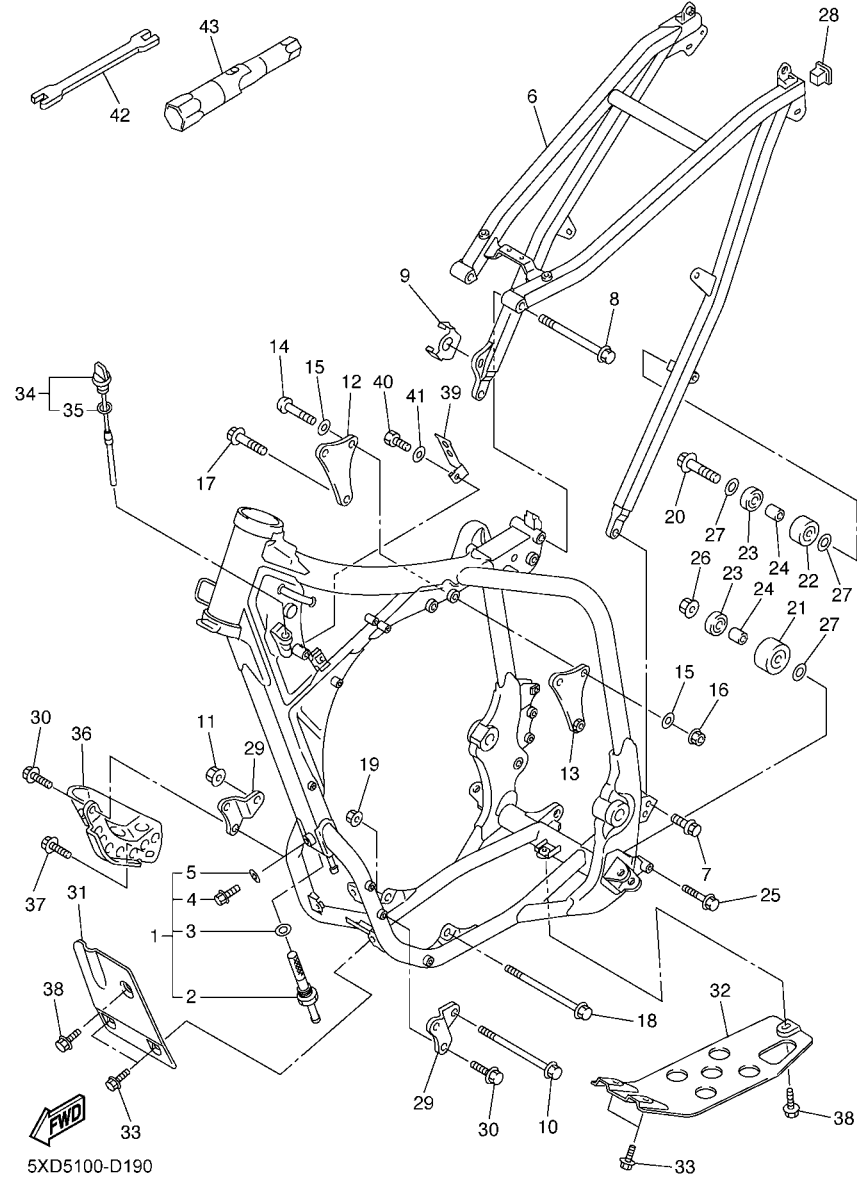

5XD5100-D190

FIG. 19 FRAME

REF. NO.	PART NO.	DESCRIPTION	5XD5	5XD6	5XD7	5XD8	REMARKS
1	5XD-21101-50	FRONT FRAME COMP.	1	1	1	1	
2	5TA-21756-00	.NET, FILTER	1	1	1	1	
3	90201-145M4	.WASHER, PLATE	1	1	1	1	
4	95827-08012	.BOLT, FLANGE	1	1	1	1	
5	90430-08119	.GASKET	1	1	1	1	
6	5XD-21190-50	REAR FRAME COMP.	1	1	1	1	
7	90105-08057	BOLT, FLANGE	2	2	2	2	
8	90105-08120	BOLT, FLANGE	1	1	1	1	
9	5XD-21455-60	PLATE, PATCH	1	1	1	1	
10	90105-10099	BOLT, FLANGE	1	1	1	1	
11	90179-10658	NUT	1	1	1	1	
12	5XD-21425-00	BRACKET, REAR UPPER 1	1	1	1	1	
13	5XD-21425-10	BRACKET, REAR UPPER 1	1	1	1	1	
14	92017-10060	BOLT, BUTTON HEAD	2	2	2	2	
15	90201-104R2	WASHER, PLATE	4	4	4	4	
16	90179-10658	NUT	2	2	2	2	
17	95817-10055	BOLT, FLANGE	1	1	1	1	
18	90105-10733	BOLT, FLANGE	1	1	1	1	
19	90179-10658	NUT	1	1	1	1	
20	95027-08040	BOLT, FLANGE	1	1	1	1	
21	3JD-22178-20	TENSIONER	1	1	1	1	
22	4EW-22178-01	TENSIONER	1	1	1	1	
23	93300-60804	BEARING	2	2	2	2	
24	90387-086N4	COLLAR	2	2	2	2	
25	95027-08065	BOLT, FLANGE	1	1	1	1	
26	95707-08500	NUT, FLANGE	1	1	1	1	
27	90201-086P8	WASHER, PLATE	3	3	3	3	

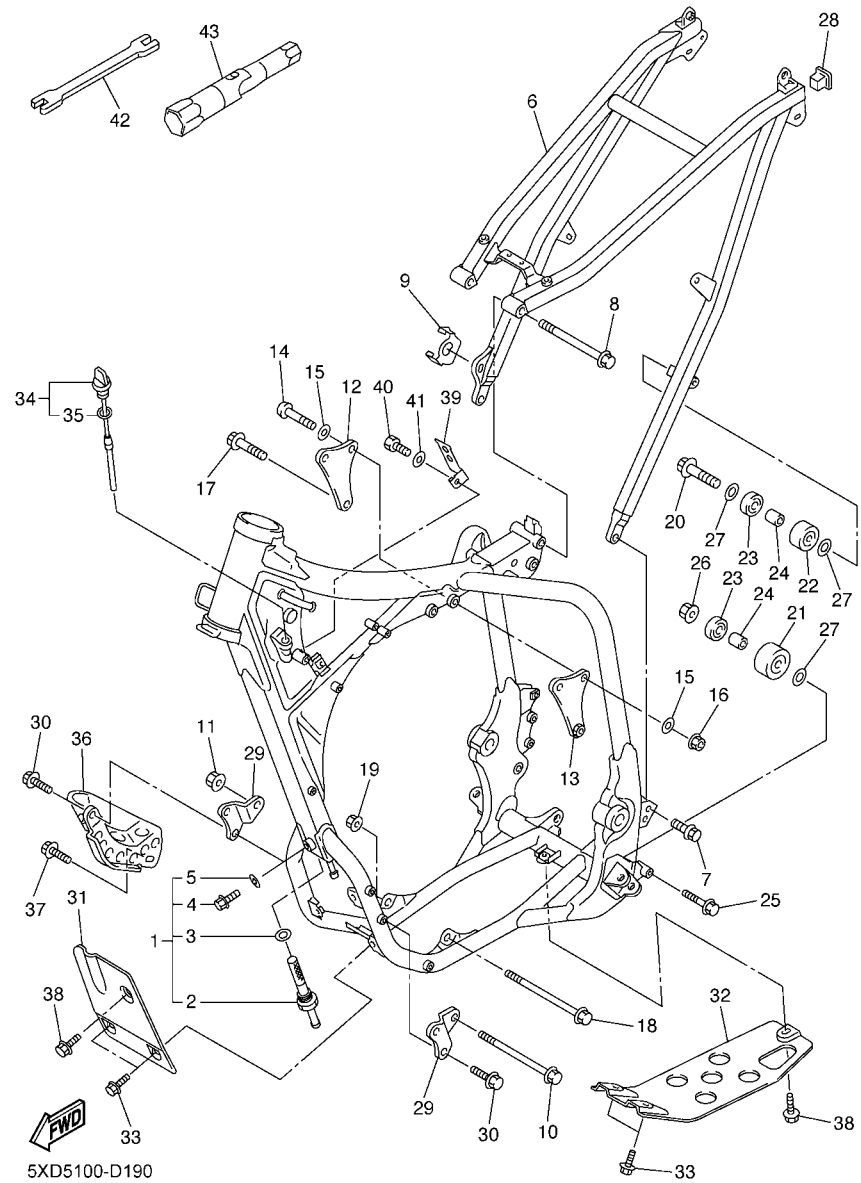

5XD5100-D190

FIG. 19 FRAME

REF. NO.	PART NO.	DESCRIPTION	5XD5	5XD6	5XD7	5XD8	REMARKS
28	90338-18176	PLUG	1	1	1	1	
29	5XD-21417-50	BRACKET, FRONT LOWER 1	2	2	2	2	
30	95817-08016	BOLT, FLANGE	4	4	4	4	
31	5TA-21471-00	PROTECTOR, ENGINE	1	1	1	1	
32	5TA-2147E-00	GUARD, ENGINE 2	1	1	1	1	
33	95027-06012	BOLT, FLANGE	4	4	4	4	
34	5TA-15362-01	PLUG, OIL LEVEL	1	1	1	1	
35	93210-08001	.O-RING	1	1	1	1	
36	5TA-2147A-00	GUARD, ENGINE 1	1	1	1	1	
37	95817-08012	BOLT, FLANGE	1	1	1	1	
38	90119-06001	BOLT, WITH WASHER	2	2	2	2	
39	5XD-21274-00	BRACKET, C.D.I. UNIT	1	1	1	1	
40	97027-06012	BOLT	1	1	1	1	
41	92907-06600	WASHER, PLATE	1	1	1	1	
42	5ET-28166-00	WRENCH, HEXAGON	1	1	1	1	
43	5TA-2814F-00	BOX, SPARK PLUG	1	1	1	1	

FIG. 20 FENDER

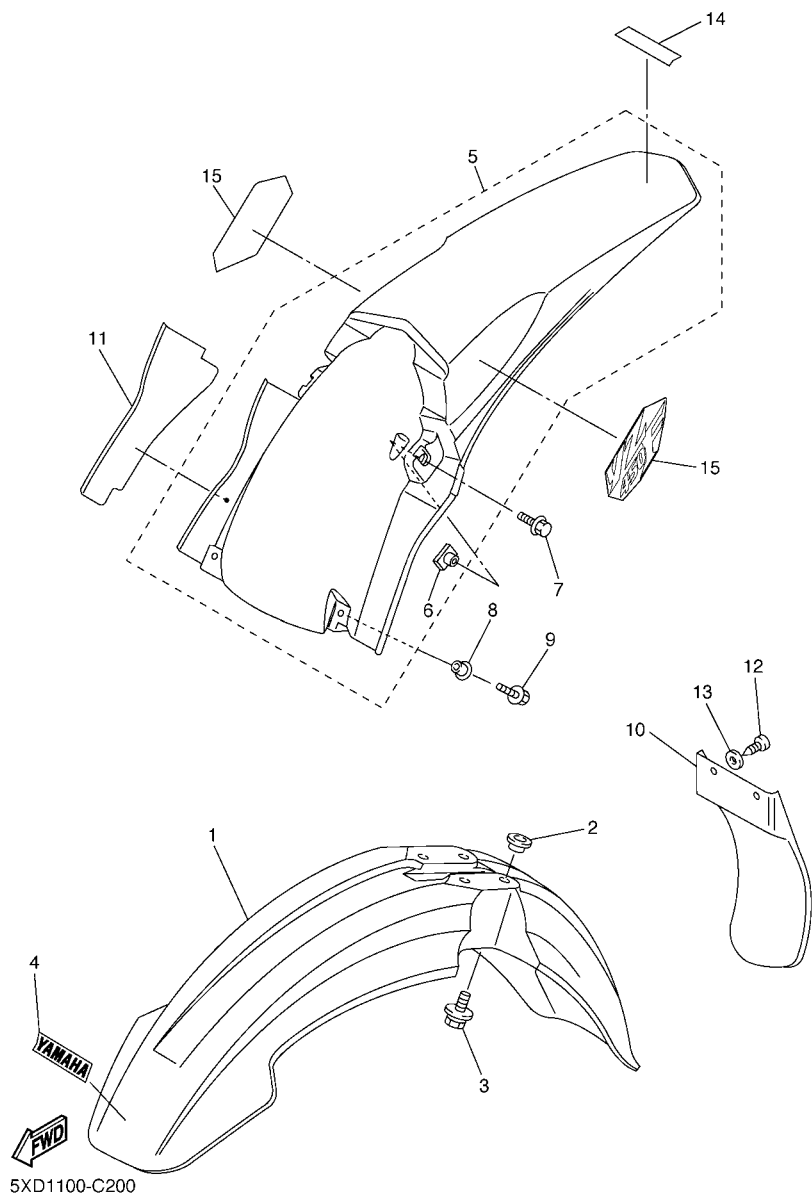

REF. NO.	PART NO.	DESCRIPTION	5XD5	5XD6	5XD7	5XD8	REMARKS
1	5HD-21511-00	FENDER, FRONT	1	1	1	1	
2	90387-06090	COLLAR	4	4	4	4	
3	90119-06096	BOLT, WITH WASHER	4	4	4	4	
4	4ES-2153E-01	EMBLEM, YAMAHA	1	1	1	1	
5	5XD-21610-00	REAR FENDER COMP.	1	1	1	1	
6	5XD-21635-00	.NUT, REAR FENDER	2	2	2	2	
7	90119-06192	BOLT, WITH WASHER	2	2	2	2	
8	90387-06009	COLLAR	2	2	2	2	
9	90119-06225	BOLT, WITH WASHER	2	2	2	2	
10	5TA-21642-00	GUARD, FLAP	1	1	1	1	
11	5TA-2174T-00	INSULATOR, SIDE COVER 2	1	1	1	1	
12	97707-60016	SCREW, TAPPING	2	2	2	2	
13	90201-06557	WASHER, PLATE	2	2	2	2	
14	4ES-2153E-01	EMBLEM, YAMAHA	1	1	1	1	
15	5XD-2163G-00	EMBLEM 1	2	2	2	2	

FIG. 21 SIDE COVER

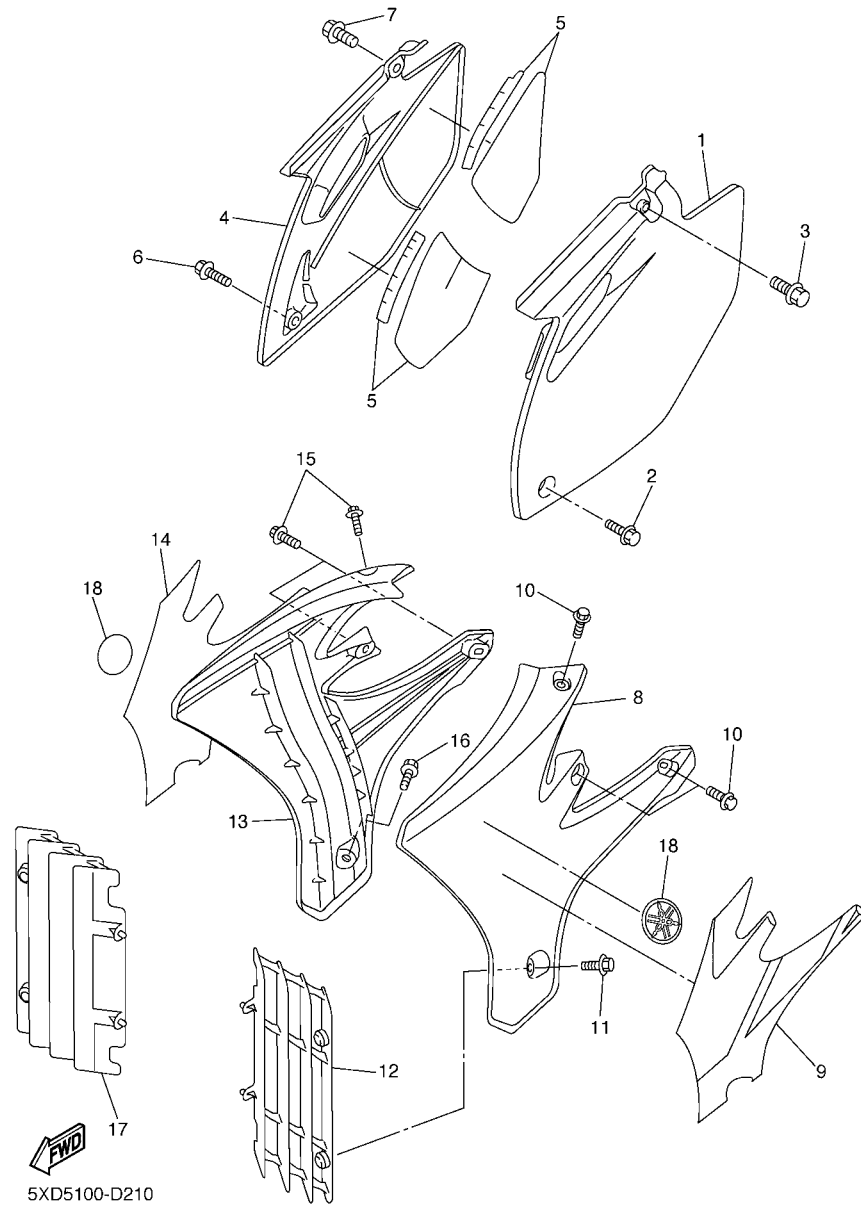

REF. NO.	PART NO.	DESCRIPTION	5XD5	5XD6	5XD7	5XD8	REMARKS
1	5TA-21711-00	COVER, SIDE 1	1	1	1	1	
2	95827-06016	BOLT, FLANGE	1	1	1	1	
3	90119-08238	BOLT, WITH WASHER	1	1	1	1	
4	5TA-21721-00	COVER, SIDE 2	1	1	1	1	
5	5TA-2174A-00	INSULATOR, SIDE COVER	1	1	1	1	
6	95827-06016	BOLT, FLANGE	1	1	1	1	
7	90119-08238	BOLT, WITH WASHER	1	1	1	1	
8	5TA-21730-00	SIDE COVER ASSY 3	1	1	1	1	
9	5XD-2173E-10	GRAPHIC 1	1	1	1	1	
10	90105-06055	BOLT, FLANGE	3	3	3	3	
11	90159-06078	SCREW, WITH WASHER	1	1	1	1	
12	5TA-2172A-00	PANEL 1	1	1	1	1	
13	5TA-21740-00	SIDE COVER ASSY 4	1	1	1	1	
14	5XD-2173F-10	GRAPHIC 2	1	1	1	1	
15	90105-06055	BOLT, FLANGE	3	3	3	3	
16	90159-06078	SCREW, WITH WASHER	1	1	1	1	
17	5TA-2172A-00	PANEL 1	1	1	1	1	
18	5MV-2175C-00	TUNING FORK MARK	2	2	2	2	

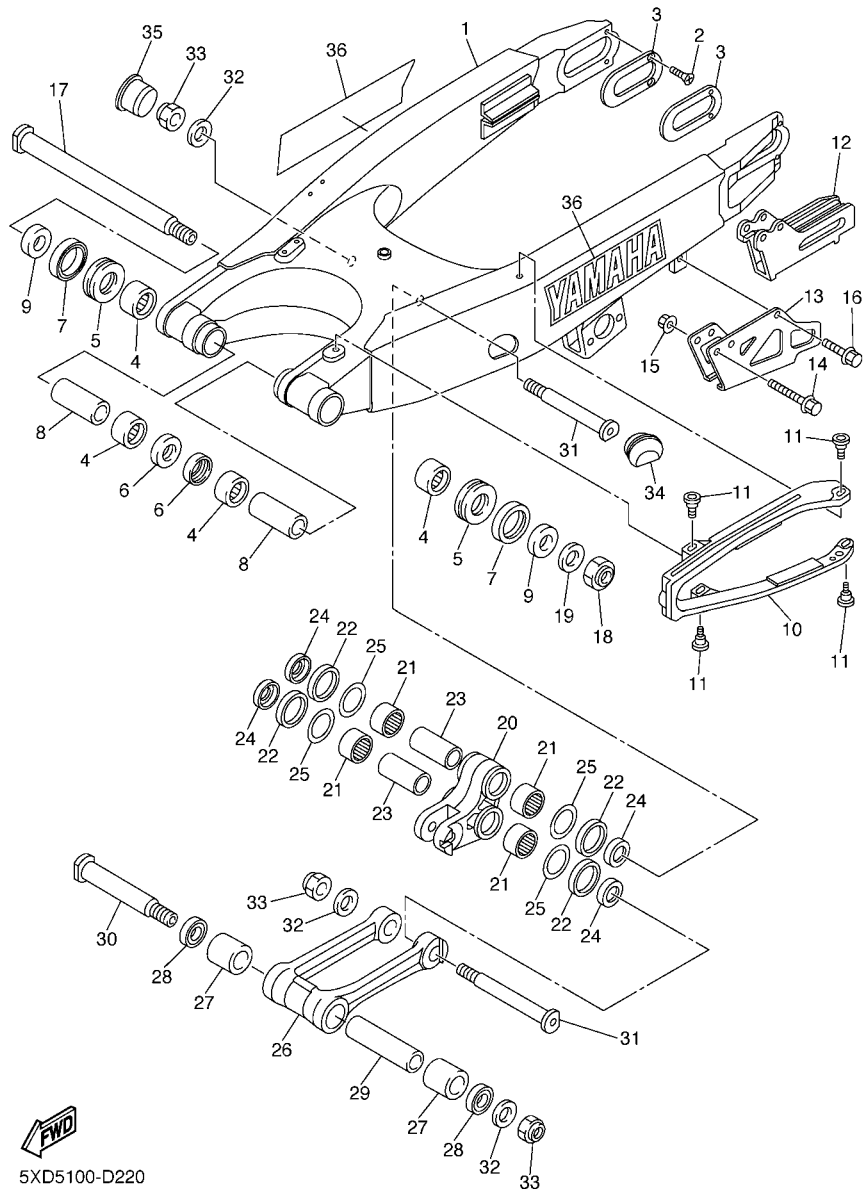
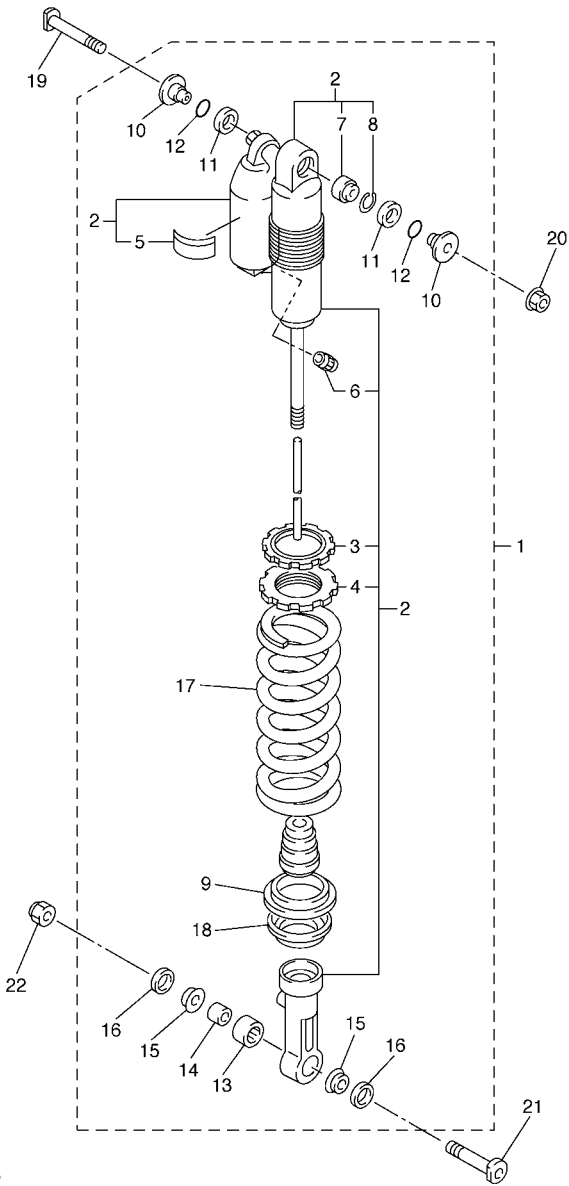

FIG. 22 REAR ARM

REF. NO.	PART NO.	DESCRIPTION	5XD5	5XD6	5XD7	5XD8	REMARKS
1	1C3-22110-00	REAR ARM COMP.	1	1	1	1	
2	90151-04001	SCREW, COUNTERSUNK	4	4	4	4	
3	1P8-22355-00	PATCH	2	2	2	2	
4	93317-22262	BEARING	4	4	4	4	
5	93342-22217	BEARING	2	2	2	2	
6	93106-22019	OIL SEAL (DC 22-28-8)	2	2	2	2	
7	93109-28043	OIL SEAL	2	2	2	2	
8	90387-18004	COLLAR	2	2	2	2	
9	90387-18009	COLLAR	2	2	2	2	
10	1C3-22151-00	SEAL, GUARD	1	1	1	1	
11	1C3-22969-00	SCREW, 1	4	4	4	4	
12	1C3-22199-00	SUPPORT, CHAIN	1	1	1	1	
13	1C3-22128-00	COVER, THRUST 1	1	1	1	1	
14	95027-06050	BOLT, FLANGE	2	2	2	2	
15	90179-06568	NUT	2	2	2	2	
16	95027-06010	BOLT, FLANGE	1	1	1	1	
17	5XD-22141-50	SHAFT, PIVOT	1	1	1	1	
18	90185-16127	NUT, SELF-LOCKING	1	1	1	1	
19	90201-160F6	WASHER, PLATE	1	1	1	1	
20	1C3-2217A-00	ARM, RELAY	1	1	1	1	
21	93315-32166	BEARING	4	4	4	4	
22	93109-25001	OIL SEAL	4	4	4	4	
23	90387-16010	COLLAR	2	2	2	2	
24	90209-16008	WASHER	4	4	4	4	
25	90201-21013	WASHER, PLATE	4	4	4	4	
26	1C3-2217F-00	ROD, CONNECTING 1	1	1	1	1	
27	93315-32165	BEARING	2	2	2	2	



5XD1100-C230

FIG. 23 REAR SUSPENSION

REF. NO.	PART NO.	DESCRIPTION	5XD5	5XD6	5XD7	5XD8	REMARKS
1	5XD-22210-50	SHOCK ABSORBER ASSY, REAR	1				
	5XD-22210-60	SHOCK ABSORBER ASSY, REAR		1			
	5XD-22210-70	SHOCK ABSORBER ASSY, REAR			1		
	5XD-22210-80	SHOCK ABSORBER ASSY, REAR				1	UR FOR CAN
	5XD-22210-90	SHOCK ABSORBER ASSY, REAR				1	UR FOR OCE,ZAF
2	5XD-22201-50	.DAMPER SUB ASSY	1				
	5XD-22201-60	.DAMPER SUB ASSY		1			
	5XD-22201-70	.DAMPER SUB ASSY			1		
	5XD-22201-80	.DAMPER SUB ASSY				1	UR FOR CAN
	5XD-22201-90	.DAMPER SUB ASSY				1	UR FOR OCE,ZAF
3	3SP-22234-00	..GUIDE, SPRING 3	1	1	1	1	
4	3SP-22213-00	..SEAT, SPRING UPPER	1	1	1	1	
5	4AA-22259-80	..LABEL, WARNING	1				
	4AA-22259-40	..LABEL, WARNING		1			
	4AA-22259-50	..LABEL, WARNING			1		
	4AA-22259-60	..LABEL, WARNING				1	UR FOR CAN
	4AA-22259-40	..LABEL, WARNING				1	UR FOR OCE,ZAF
6	509-23184-L0	..CAP, AIR VALVE	1	1	1	1	
7	4JX-22226-00	..BUSH, SHOCK ABSORBER LOWER	1	1	1	1	
8	5DH-23183-00	..CIRCLIP	1	1	1	1	
9	5MV-22224-00	.GUIDE, SPRING 2	1	1	1	1	
10	1C3-22253-00	.COLLAR, DISTANCE	2	2	2	2	
11	3JE-22475-00	.SEAL, DUST	2	2	2	2	
12	4EW-22474-00	.SEAL, RING	2	2	2	2	
13	5UN-22176-00	.BEARING	1	1	1	1	
14	5MV-22184-00	.BUSH	1	1	1	1	
15	5MV-22253-00	.COLLAR, DISTANCE	2	2	2	2	

D5

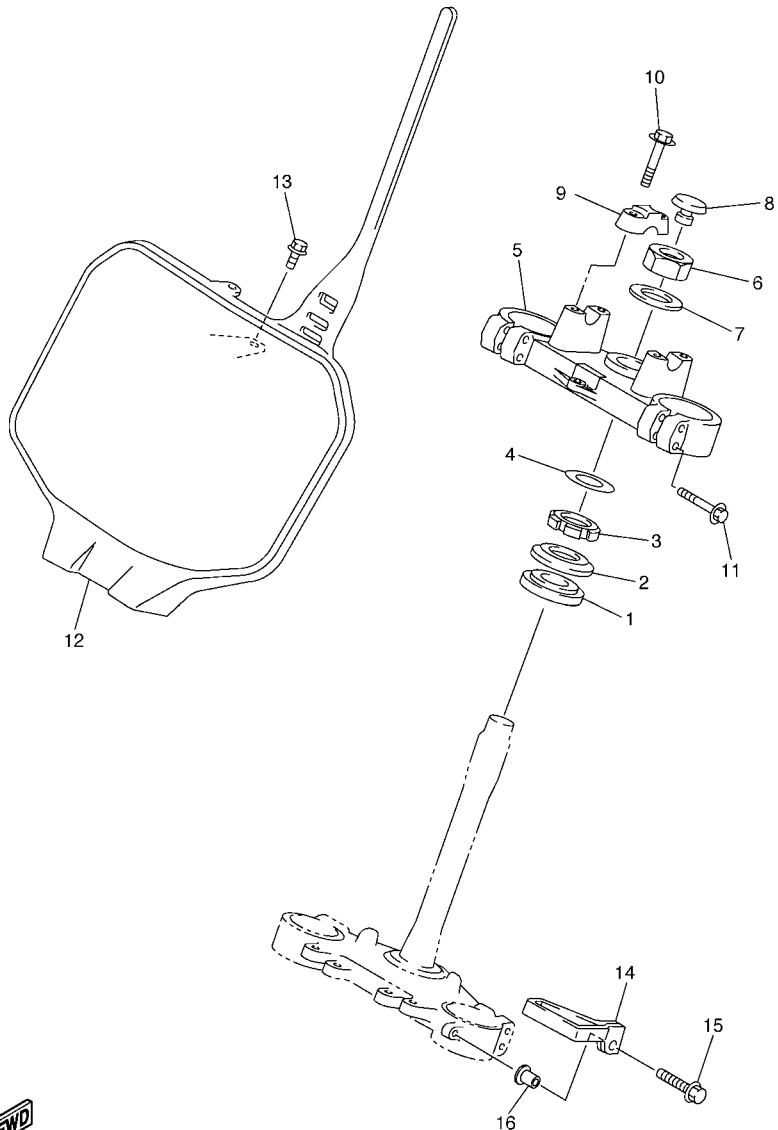

FWD
5XD5100-D240

FIG. 24 STEERING

REF. NO.	PART NO.	DESCRIPTION	5XD5	5XD6	5XD7	5XD8	REMARKS
1	93332-00068	BEARING	1	1	1	1	
2	4EW-23416-00	COVER, BALL RACE 2	1	1	1	1	
3	90179-28003	NUT	1	1	1	1	
4	90201-286K9	WASHER, PLATE	1	1	1	1	
5	5XE-23435-20	CROWN, HANDLE	1	1	1	1	
6	5TA-23357-00	NUT	1	1	1	1	
7	90201-247L2	WASHER, PLATE	1	1	1	1	
8	5TJ-2319U-00	CAP	1	1	1	1	
9	5XE-23441-00	HOLDER, HANDLE UPPER	2	2	2	2	
10	95027-08035	BOLT, FLANGE	4	4	4	4	
11	95027-08040	BOLT, FLANGE	4	4	4	4	
12	1C3-23485-00	PLATE, NUMBER	1	1	1	1	
13	95027-06014	BOLT, FLANGE	1	1	1	1	
14	5XE-23389-00	GUIDE, CABLE	1	1	1	1	
15	95027-06020	BOLT, FLANGE	1	1	1	1	
16	5XE-23113-00	COLLAR	1	1	1	1	

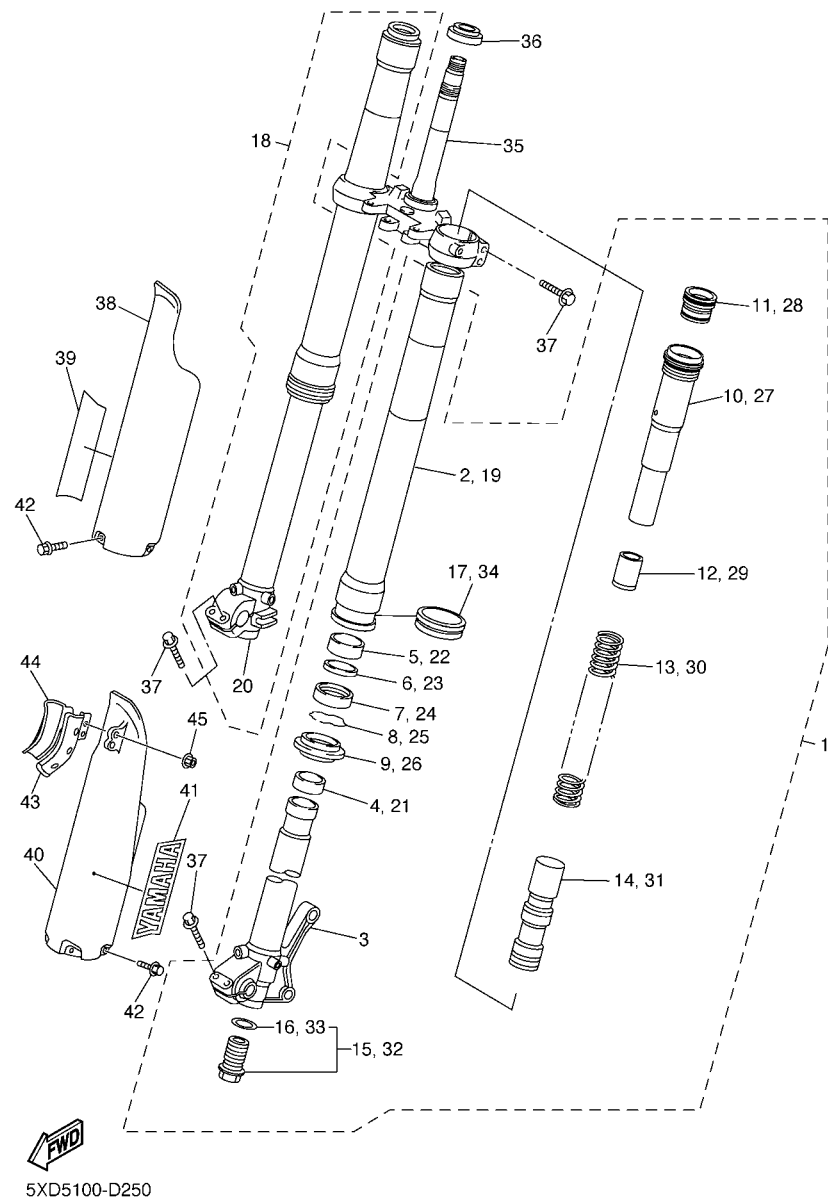

FIG. 25 FRONT FORK

REF. NO.	PART NO.	DESCRIPTION	5XD5	5XD6	5XD7	5XD8	REMARKS
1	5XD-23102-50	FRONT FORK ASSY (L.H)	1		1	1	
	5XD-23102-60	FRONT FORK ASSY (L.H)		1			
2	1C3-23136-L0	.TUBE, OUTER	1	1	1	1	
3	1P8-23120-L0	.INNER TUBE COMP.2	1	1	1	1	
4	5XE-23171-L0	.PISTON, FRONT FORK	1	1	1	1	
5	5XE-23125-L0	.METAL, SLIDE 1	1	1	1	1	
6	5XE-23146-L0	.WASHER, OIL SEAL	1	1	1	1	
7	1C3-23145-L0	.OIL SEAL	1	1	1	1	
8	5XE-23153-L0	.RING, SNAP	1	1	1	1	
9	5XE-23144-L0	.SEAL, DUST	1	1	1	1	
10	5XD-23170-N0	.CYLINDER COMP., FRONT FORK	1		1	1	
	5XD-23170-P0	.CYLINDER COMP., FRONT FORK		1			
11	5XD-2316A-N0	.VALVE COMP.	1		1	1	
	5XD-2316A-P0	.VALVE COMP.		1			
12	1C3-23118-L0	.SPACER	1	1	1	1	
13	5XD-23141-N0	.SPRING (K=4.5N/MM)	1		1	1	
	5XD-23141-P0	.SPRING (K=4.4N/MM)		1			
14	1C3-2316E-L0	.SPACER	1	1	1	1	
15	1C3-23111-L0	.BOLT, CAP	1	1	1	1	
16	2HH-23158-L0	.GASKET	1	1	1	1	
17	1C3-2314F-L0	.PROTECTOR GUIDE COMP., 1	1	1	1	1	
18	5XD-23103-50	FRONT FORK ASSY (R.H)	1		1	1	
	5XD-23103-60	FRONT FORK ASSY (R.H)		1			
19	1C3-23136-L0	.TUBE, OUTER	1	1	1	1	
20	1P8-23110-L0	.INNER TUBE COMP.1	1	1	1	1	
21	5XE-23171-L0	.PISTON, FRONT FORK	1	1	1	1	
22	5XE-23125-L0	.METAL, SLIDE 1	1	1	1	1	

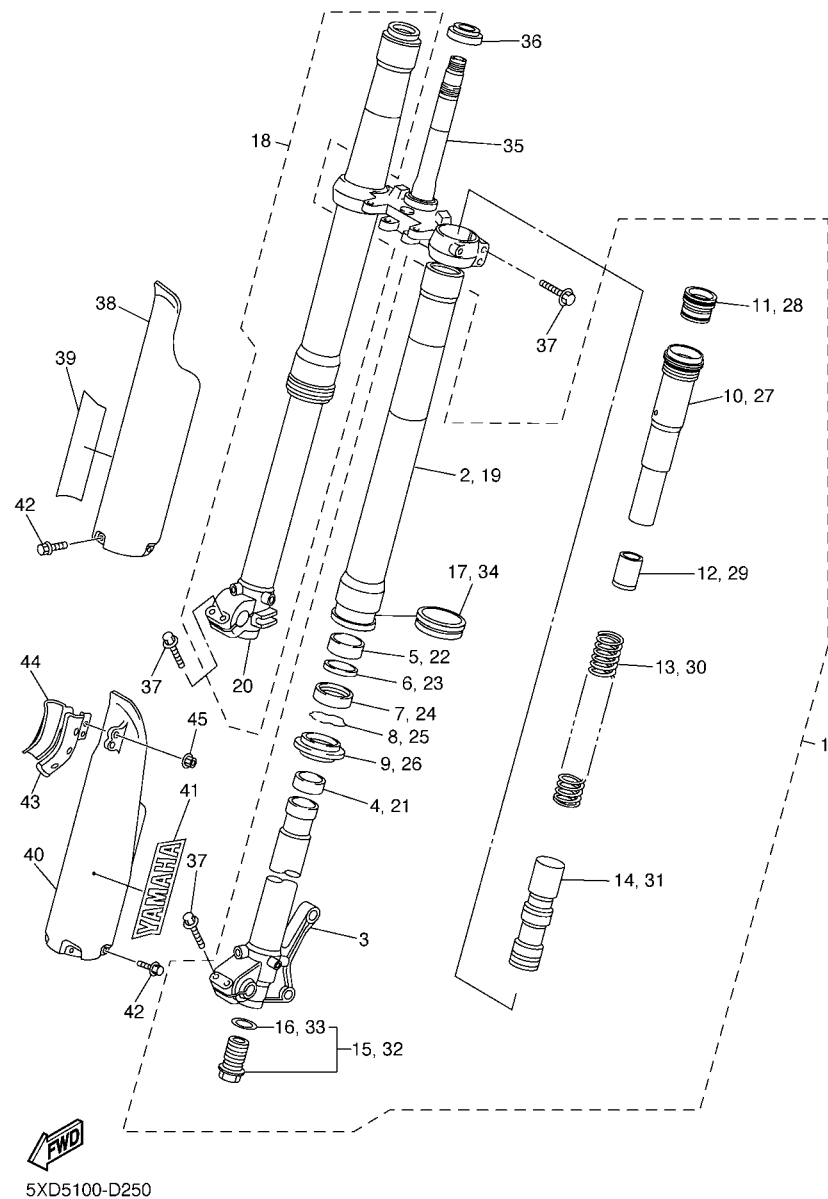
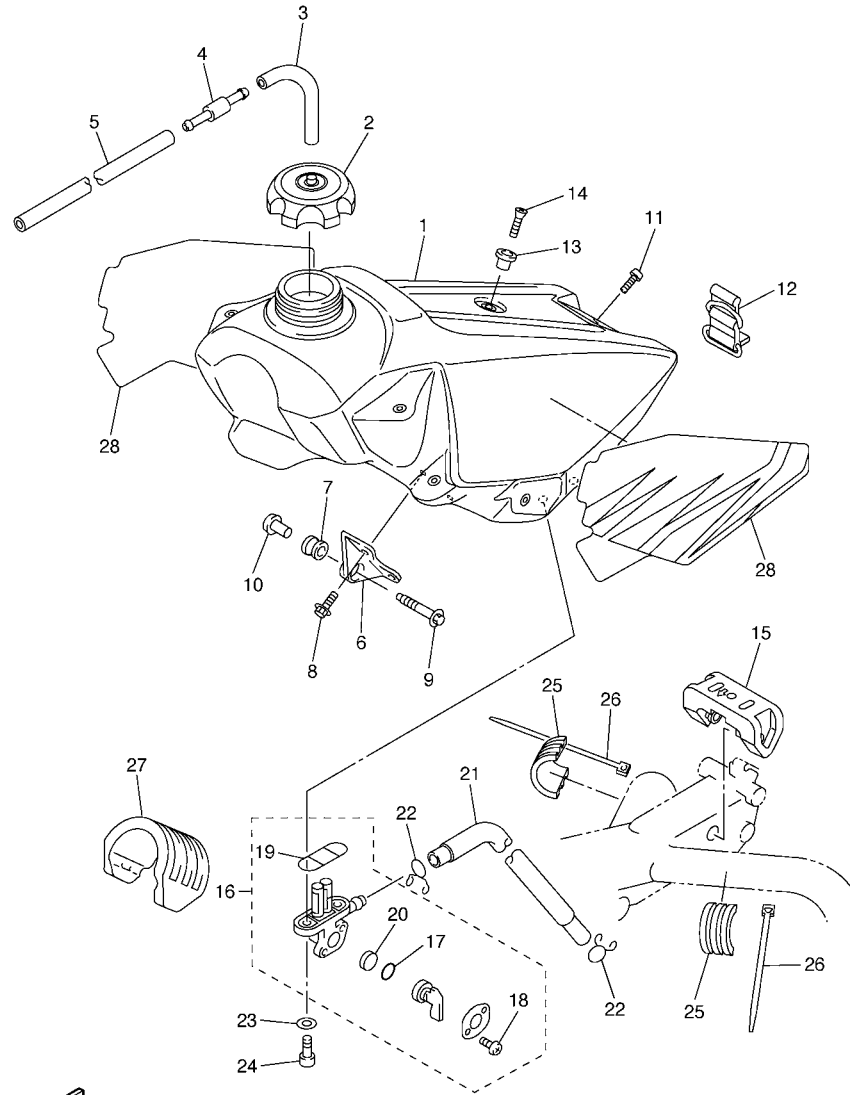

FIG. 25 FRONT FORK

REF. NO.	PART NO.	DESCRIPTION	5XD5	5XD6	5XD7	5XD8	REMARKS
23	5XE-23146-L0	.WASHER, OIL SEAL	1	1	1	1	
24	1C3-23145-L0	.OIL SEAL	1	1	1	1	
25	5XE-23153-L0	.RING, SNAP	1	1	1	1	
26	5XE-23144-L0	.SEAL, DUST	1	1	1	1	
27	5XD-23170-N0	.CYLINDER COMP., FRONT FORK	1		1	1	
	5XD-23170-P0	.CYLINDER COMP., FRONT FORK		1			
28	5XD-2316A-N0	.VALVE COMP.	1		1	1	
	5XD-2316A-P0	.VALVE COMP.		1			
29	1C3-23118-L0	.SPACER	1	1	1	1	
30	5XD-23141-N0	.SPRING (K=4.5N/MM)	1		1	1	
	5XD-23141-P0	.SPRING (K=4.4N/MM)		1			
31	1C3-2316E-L0	.SPACER	1	1	1	1	
32	1C3-23111-L0	.BOLT, CAP	1	1	1	1	
33	2HH-23158-L0	..GASKET	1	1	1	1	
34	1C3-2314F-L0	.PROTECTOR GUIDE COMP., 1	1	1	1	1	
35	5XD-23340-M0	UNDER BRACKET COMP.	1	1	1	1	
36	93332-00081	BEARING	1	1	1	1	
37	5NY-23346-L0	BOLT 1	8	8	8	8	
38	1C3-2315J-00	PROTECTOR 2	1	1	1	1	
39	4XL-2153A-10	EMBLEM, YAMAHA	1	1	1	1	
40	1C3-2315H-00	PROTECTOR 1	1	1	1	1	
41	4XL-2153A-10	EMBLEM, YAMAHA	1	1	1	1	
42	3SP-23356-L0	BOLT 2	6	6	6	6	
43	1C3-23466-00	CLAMP	1	1	1	1	
44	1C3-23467-00	CLAMP	1	1	1	1	
45	95707-06500	NUT, FLANGE	2	2	2	2	



5XD5100-D260

FIG. 26 FUEL TANK

REF. NO.	PART NO.	DESCRIPTION	5XD5	5XD6	5XD7	5XD8	REMARKS
1	5XD-24110-01	FUEL TANK COMP.	1	1	1	1	
2	5NY-24610-00	CAP ASSY	1	1	1	1	
3	90445-09220	HOSE (L30)	1	1	1	1	
4	3XJ-24380-00	PIPE JOINT ASSY	1	1	1	1	
5	90445-09095	HOSE (L215)	1	1	1	1	
6	5XE-24144-00	HOLDER, DAMPER	2	2	2	2	
7	90480-18549	GROMMET	2	2	2	2	
8	95027-06016	BOLT, FLANGE	4	4	4	4	
9	5XE-24176-00	BOLT 1	2	2	2	2	
10	5NY-24186-00	WASHER, SPECIAL	2	2	2	2	
11	98907-06025	SCREW, BIND	1	1	1	1	
12	5SF-24173-00	BAND, TANK FITTING 1	1	1	1	1	
13	4EW-2412F-00	BRACKET, SEAT	1	1	1	1	
14	98707-06025	SCREW, FLAT HEAD	1	1	1	1	
15	4SS-24181-00	DAMPER, LOCATING 1	1	1	1	1	
16	4DP-24500-01	FUEL COCK ASSY 1	1	1	1	1	
17	3AJ-24534-01	.SEAL, COCK	1	1	1	1	
18	98507-03008	.SCREW, PAN HEAD	2	2	2	2	
19	4X8-24512-00	.O-RING	1	1	1	1	
20	3AC-24523-00	.VALVE PACKING	1	1	1	1	
21	90445-11185	HOSE	1	1	1	1	
22	90467-10008	CLIP	2	2	2	2	
23	90202-05193	WASHER, PLATE	2	2	2	2	
24	90149-06011	SCREW	2	2	2	2	
25	5NY-24183-00	DAMPER, LOCATING 3	2	2	2	2	
26	90465-13152	CLAMP	2	2	2	2	
27	5BE-24182-00	DAMPER, LOCATING 2	1	1	1	1	

D10

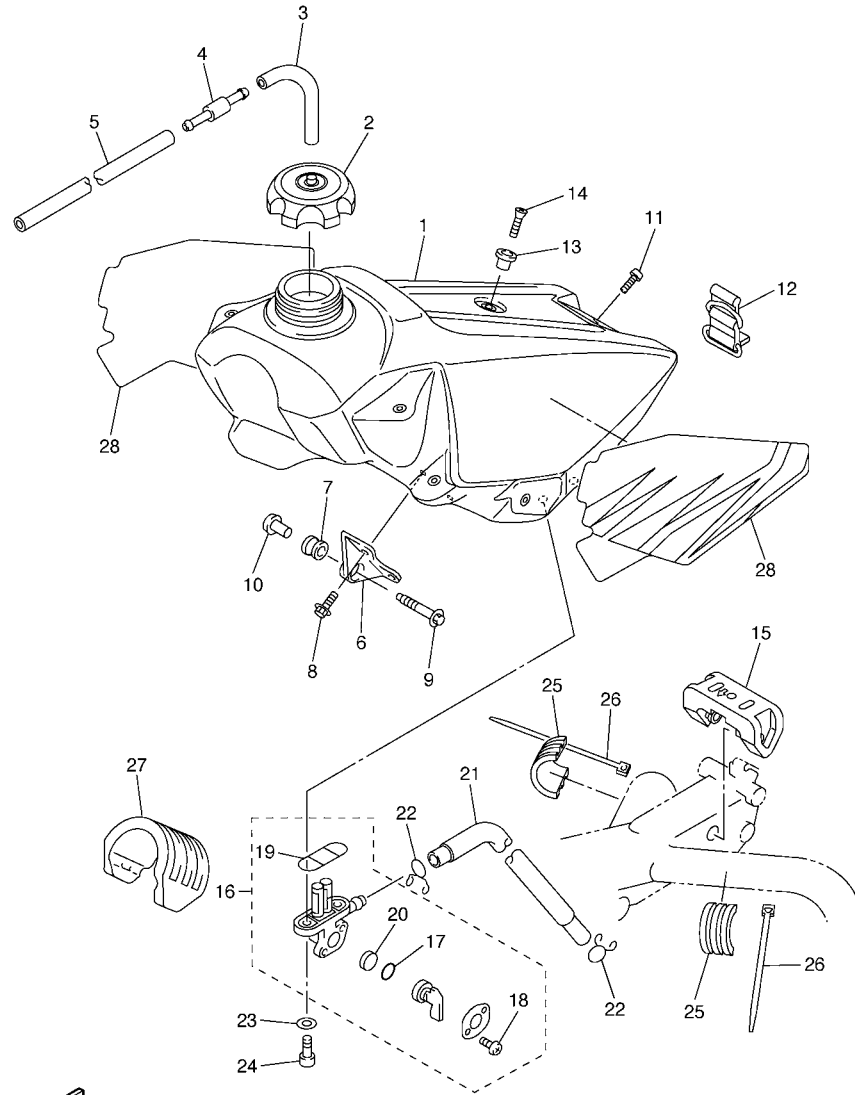

5XD5100-D260

FIG. 26 FUEL TANK

REF. NO.	PART NO.	DESCRIPTION	5XD5	5XD6	5XD7	5XD8	REMARKS
28	5XD-24240-10	GRAPHIC SET	1	1	1	1	

FIG. 27 SEAT

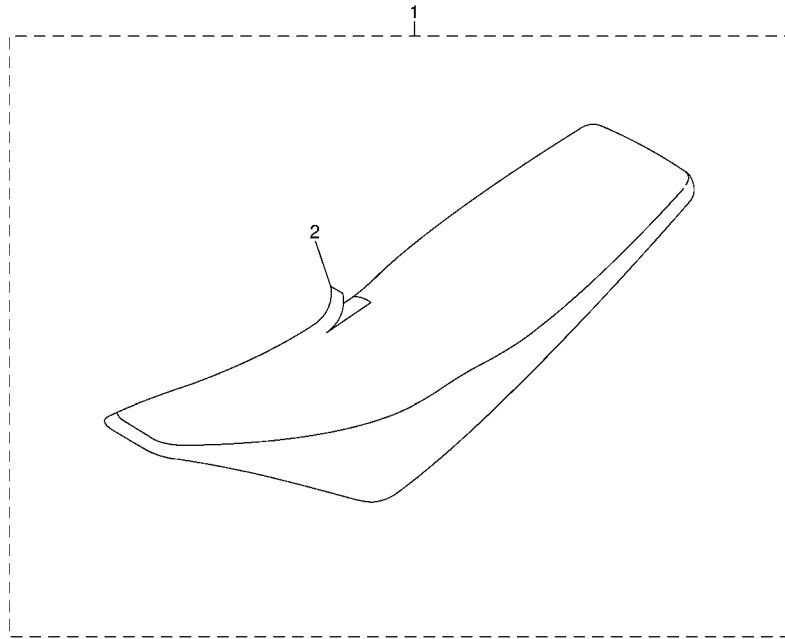

REF. NO.	PART NO.	DESCRIPTION	5XD5	5XD6	5XD7	5XD8	REMARKS
1	5XD-24710-00	SINGLE SEAT ASSY	1	1	1	1	
2	5XD-2470F-00	.SEAT COVER COMP.	1	1	1	1	



5XD1100-C270

FIG. 28 FRONT WHEEL

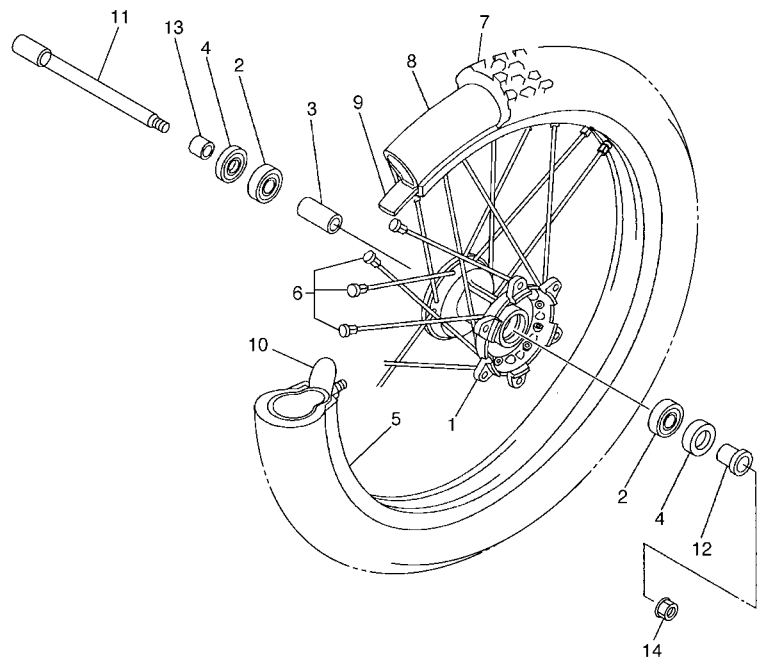

REF. NO.	PART NO.	DESCRIPTION	5XD5	5XD6	5XD7	5XD8	REMARKS
1	5NY-25111-00	HUB, FRONT	1	1	1	1	
2	93306-90403	BEARING	2	2	2	2	
3	5NY-25117-00	SPACER, BEARING	1	1	1	1	
4	93102-26468	OIL SEAL	2	2	2	2	
5	94416-21003	RIM (1.60-21)	1	1	1	1	
6	5NY-25104-00	SPOKE SET, FRONT	1	1	1	1	
7	94108-21015	TIRE (80/100-21 51M D739FA)	1			1	DUNLOP
	94108-2112Y	TIRE (80/100-21 51M D755F)		1		1	DUNLOP (FRA,CAN)
	*	TIRE (80/100-21 51R MT320)		1			LM PIRELLI
	94108-21012	TIRE(80/100-21 51M M601)			1		BRIDGESTONE
8	94227-21101	TUBE (80/100-21 M/C TR4)	1	1		1	DUNLOP FOR FRA
	*	TUBE (80/100-21)		1			LM PIRELLI
	94209-21229	TUBE (80/100-21 M/C TR4)			1		BRIDGESTONE
9	94309-21161	BAND, RIM (1.60-21)	1	1		1	DUNLOP FOR FRA
	*	BAND, RIM (80/100-21)		1			LM PIRELLI
	94330-21084	BAND,RIM (1.60-21)			1		BRIDGESTONE
10	5SF-25394-00	SPACER, BEAD	1	1	1	1	
11	1C3-25181-00	AXLE, WHEEL	1	1	1	1	
12	5NY-25183-00	COLLAR, WHEEL	1	1	1	1	
13	5NY-25186-00	COLLAR, WHEEL	1	1	1	1	
14	90179-16002	NUT	1	1	1	1	



5XD5100-D280

FIG. 29 FRONT BRAKE CALIPER

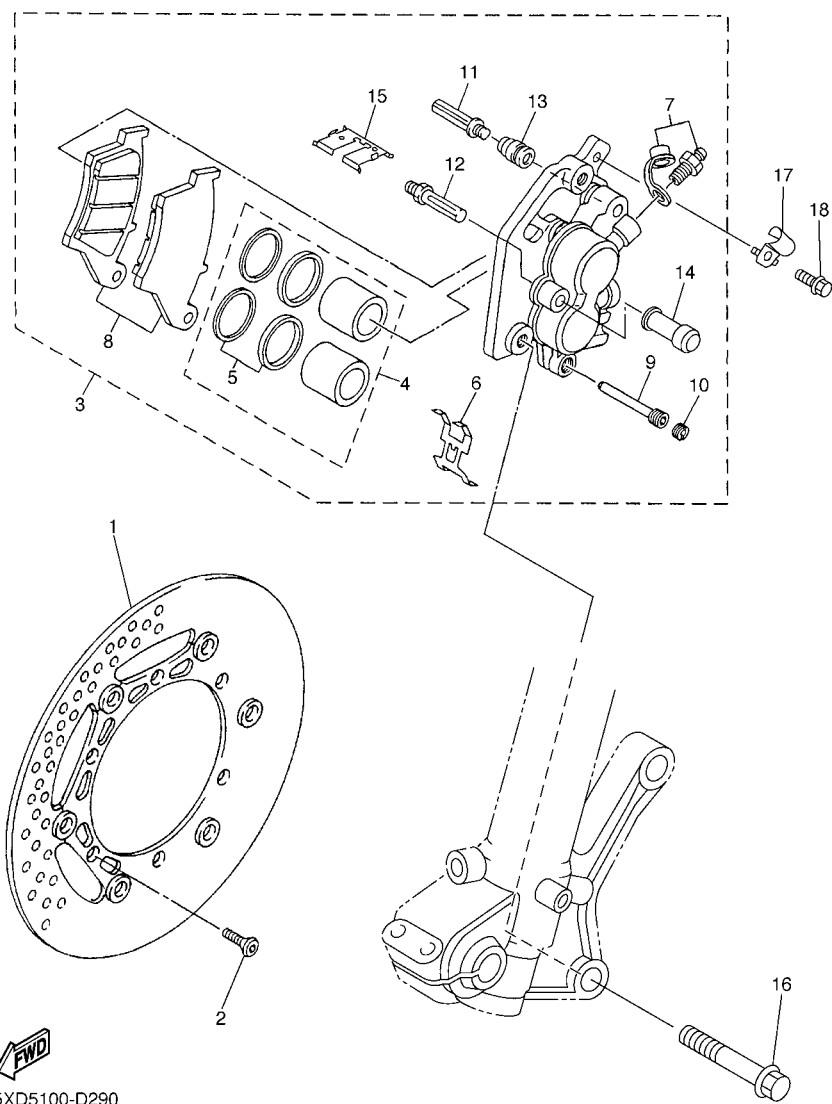

REF. NO.	PART NO.	DESCRIPTION	5XD5	5XD6	5XD7	5XD8	REMARKS
1	5MV-2581T-00	DISK BRAKE ASSY	1	1	1	1	
2	90149-06327	SCREW	6	6	6	6	
3	1C3-2580T-00	CALIPER ASSY (LEFT)	1	1	1	1	
4	5UN-W0057-00	.PISTON ASSY, CALIPER	1	1	1	1	
5	3JD-W0047-00	..CALIPER SEAL KIT	1	1	1	1	
6	5DH-25919-00	.SUPPORT, PAD	1	1	1	1	
7	1UY-W0048-50	.BLEED SCREW KIT	1	1	1	1	
8	5MV-W0045-01	.BRAKE PAD KIT	1	1	1	1	
9	5DH-25933-00	.PIN, PAD	1	1	1	1	
10	5DH-25916-00	.PLUG	1	1	1	1	
11	3SP-25926-51	.BOLT	1	1	1	1	
12	3SP-25914-51	.PIN, SLIDE	1	1	1	1	
13	3JD-25917-00	.BOOT, CALIPER	1	1	1	1	
14	1UY-25937-51	.BOOT 2	1	1	1	1	
15	5DH-25849-00	.RETAINER, CALIPER	1	1	1	1	
16	90105-08659	BOLT, FLANGE	2	2	2	2	
17	1C3-25875-00	HOLDER, BRAKE HOSE 1	1	1	1	1	
18	95027-06010	BOLT, FLANGE	1	1	1	1	

FIG. 30 REAR WHEEL

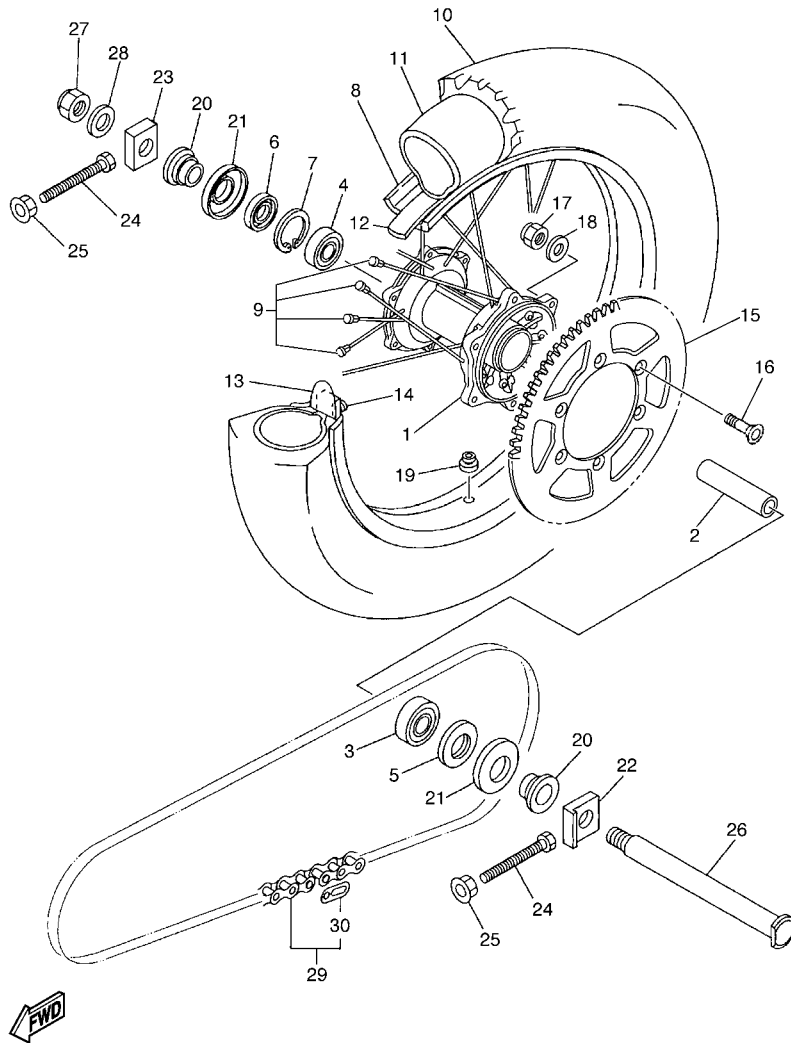

5XD5100-D300

REF. NO.	PART NO.	DESCRIPTION	5XD5	5XD6	5XD7	5XD8	REMARKS
1	5ET-25311-00	HUB, REAR	1	1	1	1	
2	5ET-25317-00	SPACER, BEARING	1	1	1	1	
3	93306-27205	BEARING	1	1	1	1	
4	93306-07202	BEARING	1	1	1	1	
5	93106-30044	OIL SEAL	1	1	1	1	
6	93106-30045	OIL SEAL	1	1	1	1	
7	99009-45500	CIRCLIP	1	1	1	1	
8	94421-19602	RIM (2.15-19)	1	1	1	1	
9	5HD-25304-00	SPOKE SET, REAR	1	1	1	1	
10	94111-19012	TIRE (110/90-19 62M D739)	1			1	DUNLOP
*		TIRE (110/90-19 MT320)		1			LM PIRELLI
	94111-1913A	TIRE (110/90-19 62M D755)		1		1	DUNLOP (FRA,CAN)
	94111-19011	TIRE (110/90-19 62M M602)			1		BRIDGESTONE
11	94211-19273	TUBE (110/90-19 M/C TR4)	1	1		1	DUNLOP FOR FRA
*		TUBE (110/90-19)			1		LM PIRELLI
	94211-19274	TUBE (110/90-19 M/C TR4)				1	BRIDGESTONE
12	94311-19155	BAND, RIM (2.15-19)	1	1		1	DUNLOP FOR FRA
*		BAND, RIM (3.50-18)			1		LM METZELER
	94321-19157	BAND, RIM (2.15-19)				1	BRIDGESTONE
13	3JE-25394-00	SPACER, BEAD	1	1	1	1	
14	4XM-25364-00	DAMPÉR	1	1	1	1	
15	1C3-25451-00	SPROCKET, DRIVEN (51T)	1	1	1	1	STD
	1C3-25447-00	SPROCKET, DRIVEN (47T)	1	1	1	1	AP
	1C3-25448-00	SPROCKET, DRIVEN (48T)	1	1	1	1	AP
	1C3-25449-00	SPROCKET, DRIVEN (49T)	1	1	1	1	AP
	1C3-25450-00	SPROCKET, DRIVEN (50T)	1	1	1	1	AP
	1C3-25452-00	SPROCKET, DRIVEN (52T)	1	1	1	1	AP

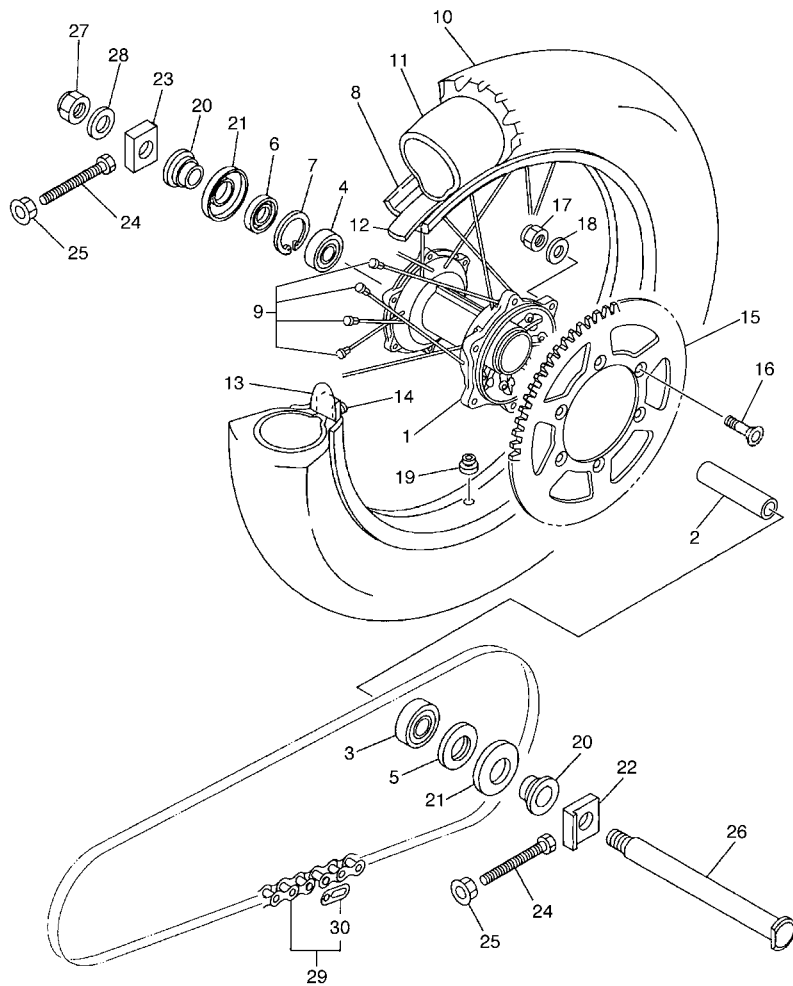

5XD5100-D300

FIG. 30 REAR WHEEL

REF. NO.	PART NO.	DESCRIPTION	5XD5	5XD6	5XD7	5XD8	REMARKS
16	90109-081G1	BOLT	6	6	6	6	
17	90185-08169	NUT, SELF-LOCKING	6	6	6	6	
18	90201-08326	WASHER, PLATE	6	6	6	6	
19	90480-08608	GROMMET	1	1	1	1	
20	5UN-25383-00	COLLAR, WHEEL	2	2	2	2	
21	5ET-25367-00	COVER, HUB DUST	2	2	2	2	
22	1C3-25388-00	PULLER, CHAIN 1	1	1	1	1	
23	1C3-25389-00	PULLER, CHAIN 2	1	1	1	1	
24	90101-08777	BOLT	2	2	2	2	
25	90179-08299	NUT	2	2	2	2	
26	1C3-25381-00	AXLE, WHEEL	1	1	1	1	
27	90185-20168	NUT, SELF-LOCKING	1	1	1	1	
28	90201-203U1	WASHER, PLATE	1	1	1	1	
29	94581-92115	CHAIN	1	1	1	1	
30	94681-68001	.JOINT,CHAIN (DID 520DM-RJ)	1	1	1	1	

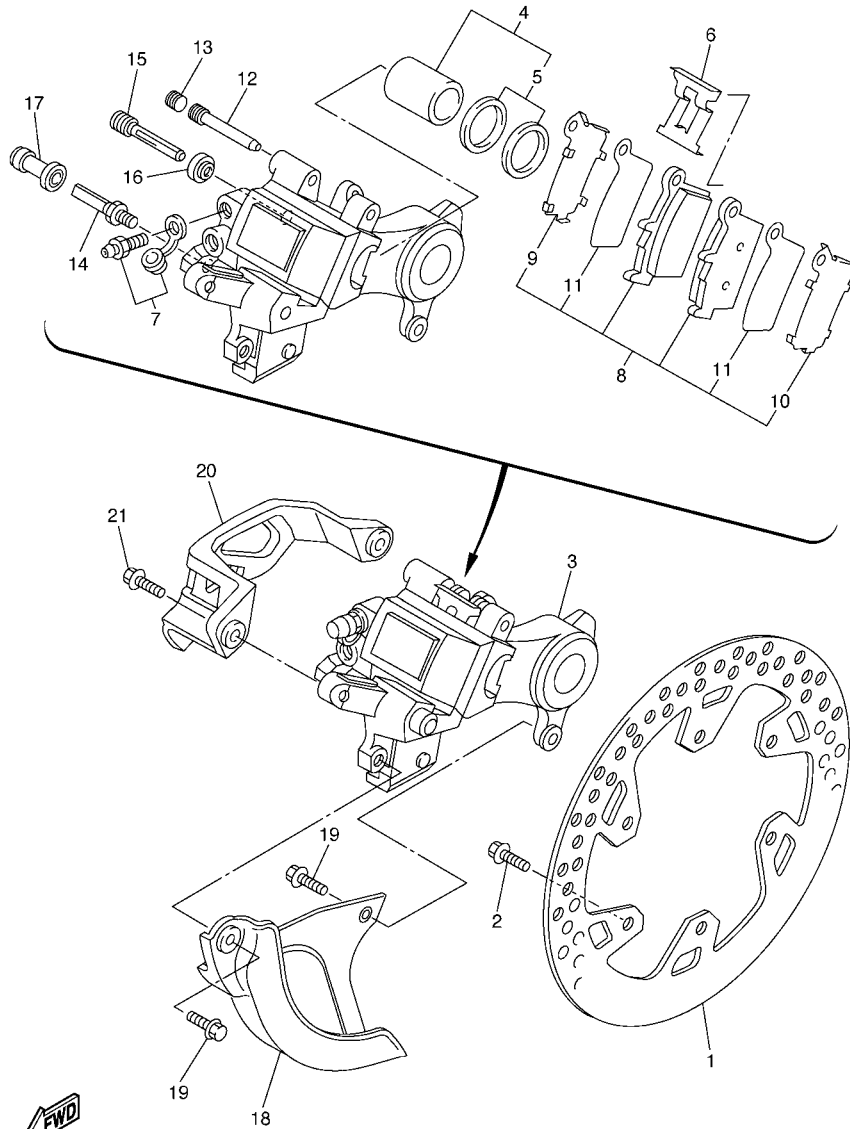

5XD5100-D310

FIG. 31 REAR BRAKE CALIPER

REF. NO.	PART NO.	DESCRIPTION	5XD5	5XD6	5XD7	5XD8	REMARKS
1	5NY-2582W-00	DISK, REAR BRAKE 2	1	1	1	1	
2	90109-065G4	BOLT	6	6	6	6	
3	1C3-2580W-00	CALIPER ASSY, REAR 2	1	1	1	1	
4	5UN-W0057-50	.PISTON ASSY, CALIPER	1	1	1	1	
5	5UN-W0047-50	..CALIPER SEAL KIT	1	1	1	1	
6	5DH-25919-50	..SUPPORT, PAD	1	1	1	1	
7	1UY-W0048-50	.BLEED SCREW KIT	1	1	1	1	
8	1C3-W0046-00	.BRAKE PAD KIT 2	1	1	1	1	
9	5UN-25828-60	..SHIM, CALIPER	1	1	1	1	
10	5UN-25827-60	..SHIM, CALIPER	1	1	1	1	
11	5UN-22898-60	..INSULATOR, HEAT	2	2	2	2	
12	8CR-25924-00	.PIN, PAD	1	1	1	1	
13	5DH-25916-00	.PLUG	1	1	1	1	
14	5UN-25914-00	.PIN, SLIDE	1	1	1	1	
15	5DH-25914-50	.PIN, SLIDE	1	1	1	1	
16	3JD-25917-00	.BOOT, CALIPER	1	1	1	1	
17	1UY-25937-51	.BOOT 2	1	1	1	1	
18	5DH-25718-01	PROTECTOR, DISK BRAKE	1	1	1	1	
19	95027-06012	BOLT, FLANGE	2	2	2	2	
20	5TA-27491-00	PROTECTOR	1	1	1	1	
21	95027-06016	BOLT, FLANGE	2	2	2	2	

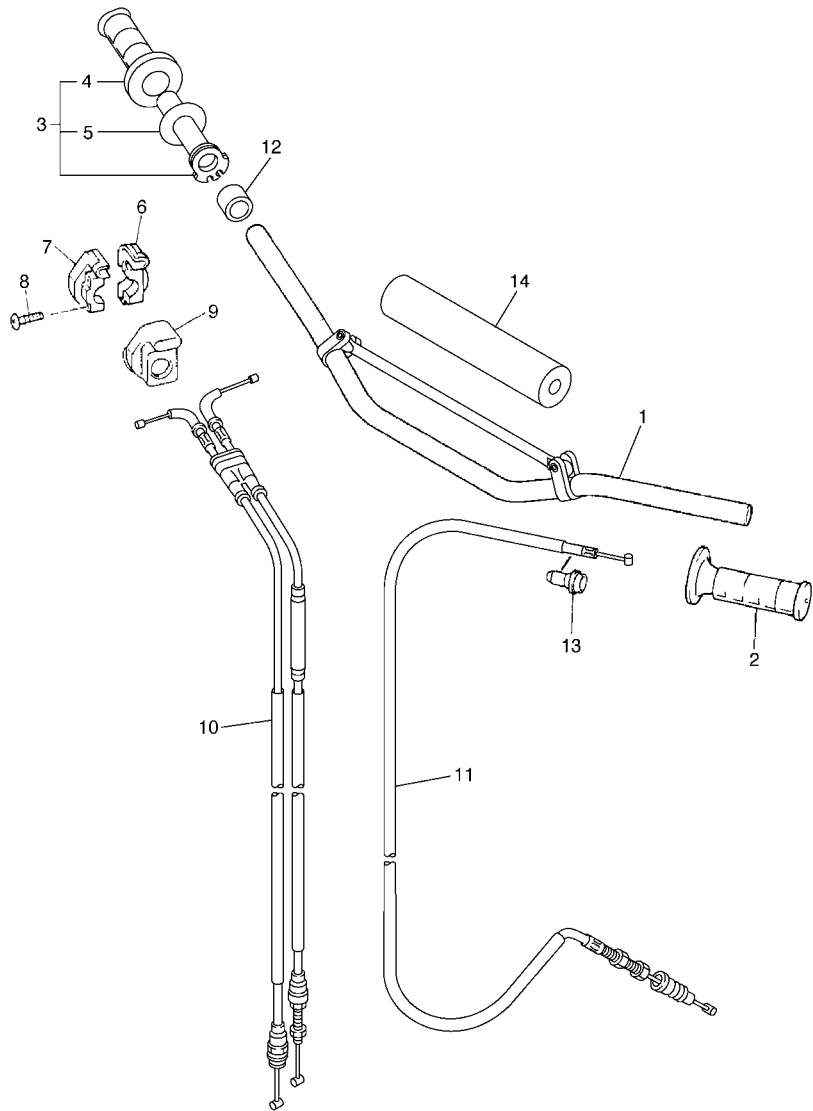

FIG. 32 STEERING HANDLE & CABLE

REF. NO.	PART NO.	DESCRIPTION	5XD5	5XD6	5XD7	5XD8	REMARKS
1	1C3-26111-00	HANDLEBAR	1	1	1	1	
2	4GY-26241-00	GRIP	1	1	1	1	
3	5BE-26240-00	GRIP ASSY	1	1	1	1	
4	4GY-26242-00	.GRIP (RIGHT)	1	1	1	1	
5	3Y1-26249-00	.RING, LEAF	1	1	1	1	
6	5BE-26281-00	CAP, GRIP UPPER	1	1	1	1	
7	5BE-26282-00	CAP, GRIP LOWER	1	1	1	1	
8	98507-05020	SCREW, PAN HEAD	2	2	2	2	
9	5SF-26287-00	COVER, CAP GRIP	1	1	1	1	
10	5XD-26302-00	THROTTLE CABLE ASSY	1	1	1	1	
11	5UL-26335-00	CABLE, CLUTCH	1	1	1	1	
12	90387-225N2	COLLAR	1	1	1	1	
13	5HD-26342-00	BOOT, CABLE	1	1	1	1	
14	1C3-26124-00	PROTECTOR, HANDLEBAR	1	1	1	1	

FWD
5XD5100-D320

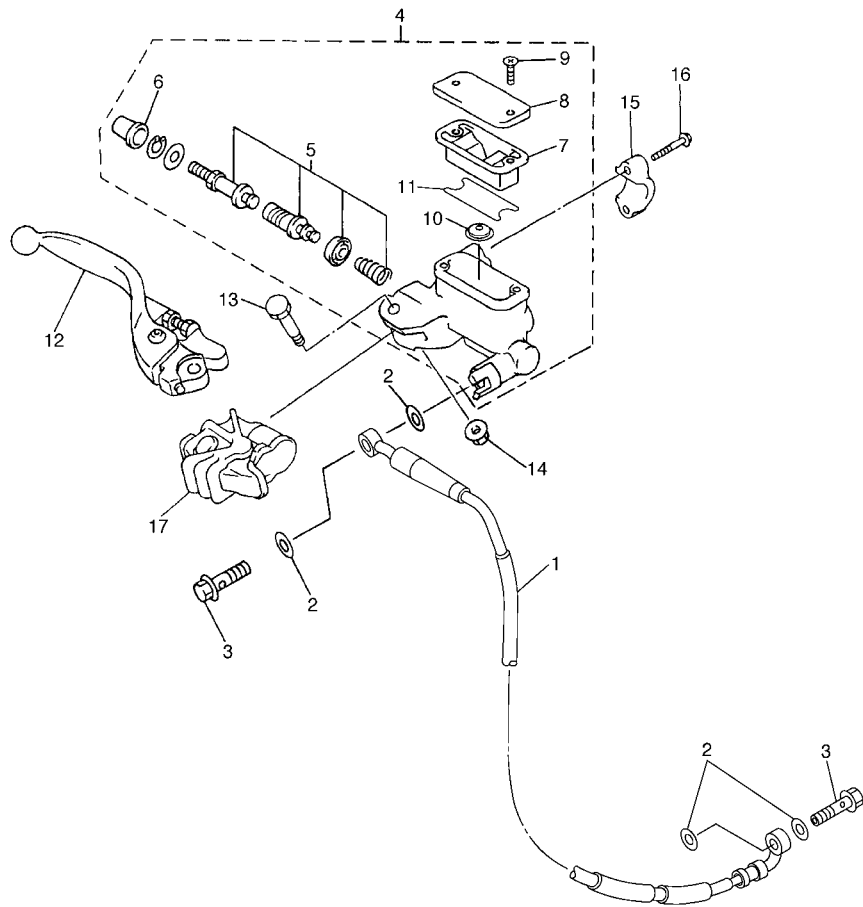

FIG. 33 FRONT MASTER CYLINDER

REF. NO.	PART NO.	DESCRIPTION	5XD5	5XD6	5XD7	5XD8	REMARKS
1	1C3-25872-00	HOSE, BRAKE 1	1	1	1	1	
2	90201-10118	WASHER, PLATE	4	4	4	4	
3	90401-10172	BOLT, UNION	2	2	2	2	
4	5XE-W2587-00	MASTER CYLINDER SUB ASSY	1	1	1	1	
5	5NY-W0041-00	.CYLINDER KIT, MASTER	1	1	1	1	
6	5NY-25868-00	.BOOT, MASTER CYLINDER	1	1	1	1	
7	5XE-25854-00	.DIAPHRAGM, RESERVOIR	1	1	1	1	
8	5MV-25852-01	.CAP, RESERVOIR	1	1	1	1	
9	98706-04012	.SCREW, FLAT HEAD	2	2	2	2	
10	5CG-25715-00	.SEPARATOR ASSY	1	1	1	1	
11	5XE-25853-00	.FLOAT, RESERVOIR	1	1	1	1	
12	5MV-83922-00	LEVER 2	1	1	1	1	
13	5MV-2589F-00	BOLT, LEVER	1	1	1	1	
14	95701-06500	NUT, FLANGE	1	1	1	1	
15	5MV-25867-00	BRACKET, MASTER CYLINDER	1	1	1	1	
16	5MV-25833-00	BOLT, FITTING	2	2	2	2	
17	5NY-26372-00	COVER, HANDLE LEVER 1	1	1	1	1	



5XD5100-D330

FIG. 34 STAND & FOOTREST

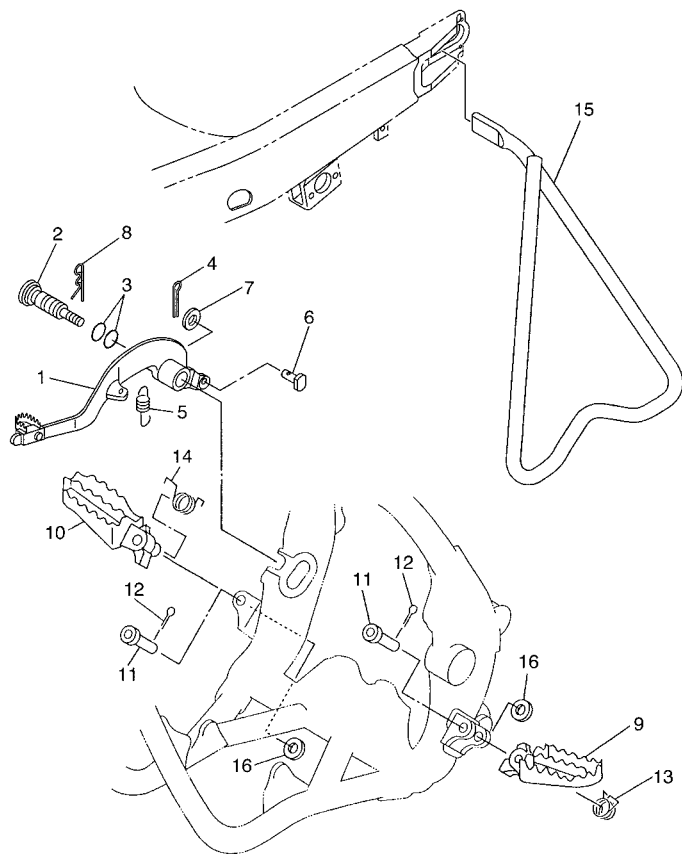

REF. NO.	PART NO.	DESCRIPTION	5XD5	5XD6	5XD7	5XD8	REMARKS
1	5TA-27200-00	PEDAL, BRAKE	1	1	1	1	
2	1C3-27217-00	BOLT	1	1	1	1	
3	93210-11073	O-RING	2	2	2	2	
4	91401-20012	PIN, COTTER	1	1	1	1	
5	90506-16500	SPRING, TENSION	1	1	1	1	
6	90240-08120	PIN, CLEVIS	1	1	1	1	
7	90201-08089	WASHER, PLATE	1	1	1	1	
8	90468-16099	CLIP	1	1	1	1	
9	5XE-27411-01	FOOTREST 1	1	1	1	1	
10	5XE-27421-01	FOOTREST 2	1	1	1	1	
11	90240-10142	PIN, CLEVIS	2	2	2	2	
12	91401-25015	PIN, COTTER	2	2	2	2	
13	90508-282B8	SPRING, TORSION	1	1	1	1	
14	90508-282B9	SPRING, TORSION	1	1	1	1	
15	1C3-27311-00	STAND, SIDE	1	1	1	1	
16	90201-10119	WASHER, PLATE	2	2	2	2	

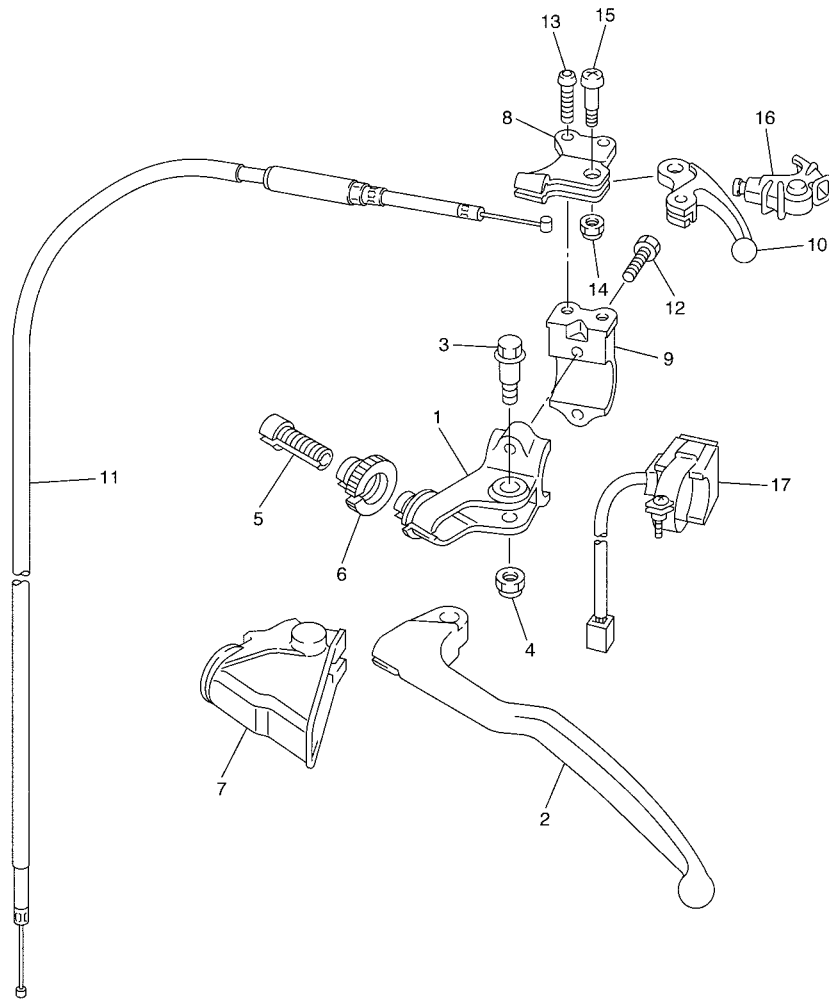

5XD5100-D340



5TA1100-B370

FIG. 37 HANDLE SWITCH & LEVER

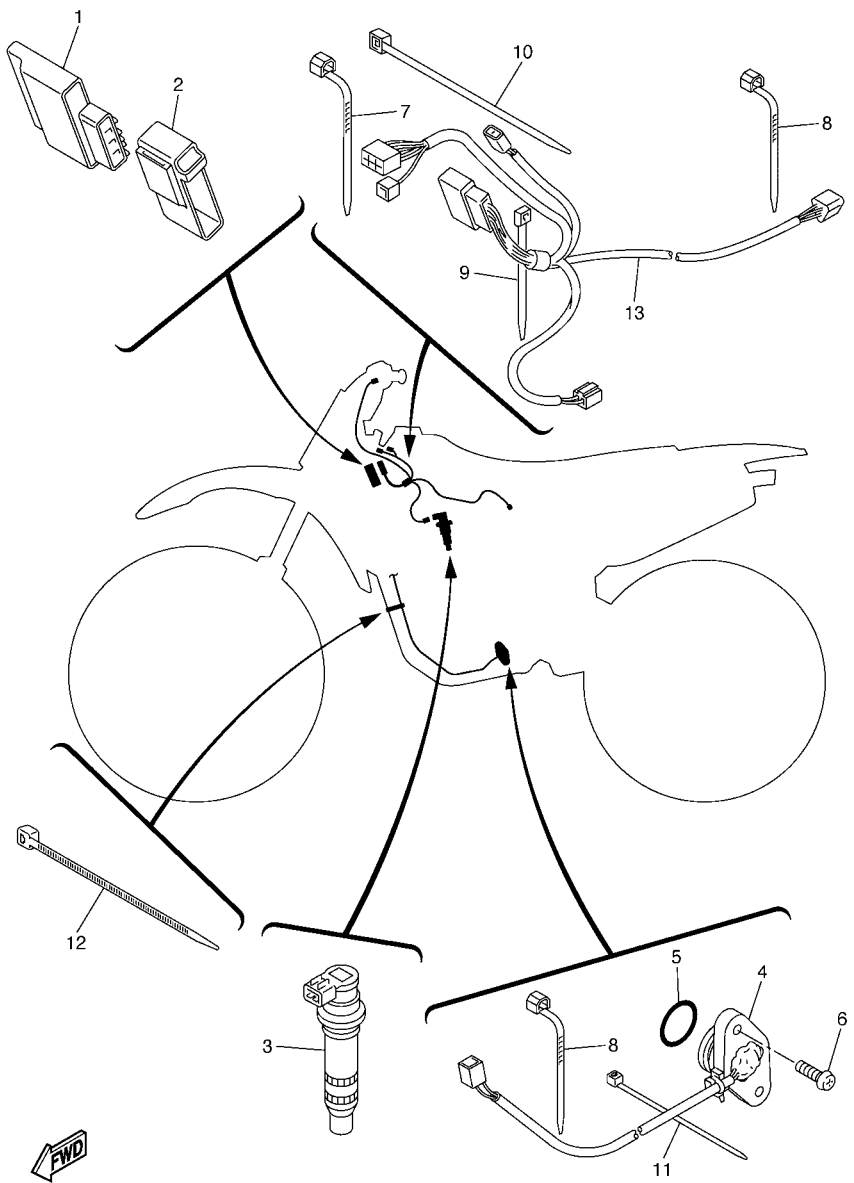
REF. NO.	PART NO.	DESCRIPTION	5XD5	5XD6	5XD7	5XD8	REMARKS
1	5XE-82911-00	HOLDER, LEVER 1	1	1	1	1	
2	5MV-83912-00	LEVER 1	1	1	1	1	
3	90109-06034	BOLT	1	1	1	1	
4	5LP-84126-10	NUT, LENS FITTING	1	1	1	1	
5	5TA-26337-00	BOLT, ADJUSTING	1	1	1	1	
6	5HD-83951-00	BOLT, CABLE ADJUSTING	1	1	1	1	
7	5HD-26372-00	COVER, HANDLE LEVER 1	1	1	1	1	
8	5XD-82946-00	HOLDER, STARTER LEVER	1	1	1	1	
9	5XD-82913-00	HOLDER, LEVER LOWER 1	1	1	1	1	
10	5TA-83941-00	LEVER, STARTER	1	1	1	1	
11	5TA-26334-00	CABLE, STARTER 2	1	1	1	1	
12	90101-05033	BOLT	2	2	2	2	
13	92014-05012	BOLT, BUTTON HEAD	2	2	2	2	
14	95607-05100	NUT, U	1	1	1	1	
15	90149-05162	SCREW	1	1	1	1	
16	5TA-26339-00	BOOT	1	1	1	1	
17	1C3-83976-00	SWITCH, HANDLE 1	1	1	1	1	



FWD
5XD1100-C380

FIG. 38 ELECTRICAL 1

REF. NO.	PART NO.	DESCRIPTION	5XD5	5XD6	5XD7	5XD8	REMARKS
1	5XD-85540-50	C.D.I. UNIT ASSY	1				
	5XD-85540-60	C.D.I. UNIT ASSY		1	1	1	
2	5XD-85546-00	BAND	1	1	1	1	
3	5TA-82310-10	IGNITION COIL ASSY	1	1	1	1	
4	5TA-82540-00	NEUTRAL SWITCH ASSY	1	1	1	1	
5	93210-21276	O-RING	1	1	1	1	
6	90154-05026	SCREW, BINDING	2	2	2	2	
7	90464-13077	CLAMP	2	2	2	2	
8	90464-13073	CLAMP	3	3	3	3	
9	90465-13152	CLAMP	1	1	1	1	
10	90465-13275	CLAMP	4	4	4	4	
11	5Y9-12491-00	CLAMP 1	3	3	3	3	
12	3MA-82591-00	BAND	1	1	1	1	
13	5XD-82509-01	WIRE, SUB LEAD	1	1	1	1	

FIG. 39 ALTERNATE FOR CHASSIS

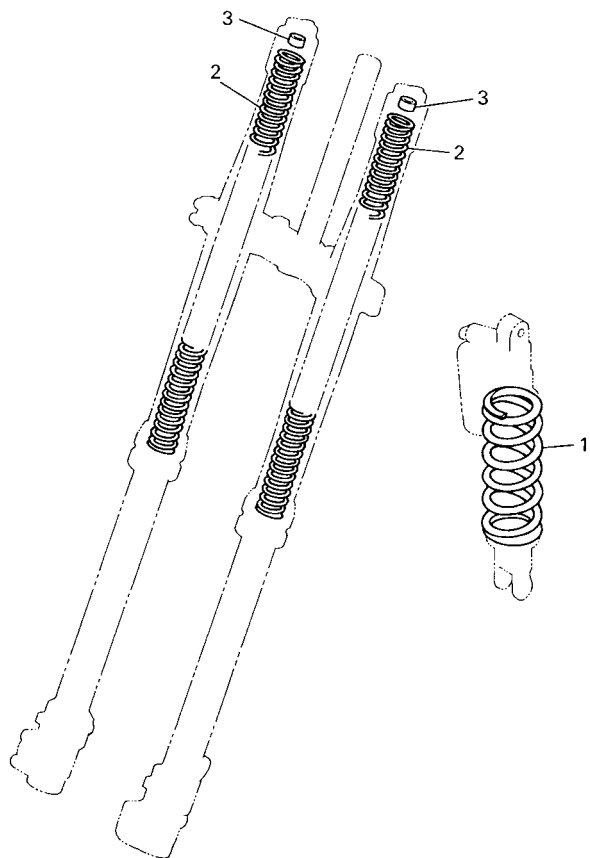

REF. NO.	PART NO.	DESCRIPTION	5XD5	5XD6	5XD7	5XD8	REMARKS
1	5UN-22212-00	SPRING (K=42N/MM)	1	1	1	1	AP
	5UN-22212-10	SPRING (K=44N/MM)	1	1	1	1	AP
	5UN-22212-20	SPRING (K=46N/MM)	1	1	1	1	AP
	5UN-22212-30	SPRING (K=48N/MM)	1	1	1	1	AP
	5UN-22212-40	SPRING (K=50N/MM)	1	1	1	1	AP
	5UN-22212-50	SPRING (K=52N/MM)	1	1	1	1	AP
	5UN-22212-60	SPRING (K=54N/MM)	1	1	1	1	AP
	5UN-22212-70	SPRING (K=56N/MM)	1	1	1	1	AP
	5UN-22212-A0	SPRING (K=APPROX.44N/MM)	1	1	1	1	AP
	5UN-22212-B0	SPRING (K=APPROX.46N/MM)	1	1	1	1	AP
	5UN-22212-C0	SPRING (K=APPROX.48N/MM)	1	1	1	1	AP
	5UN-22212-D0	SPRING (K=APPROX.50N/MM)	1	1	1	1	AP
	5UN-22212-E0	SPRING (K=APPROX.52N/MM)	1	1	1	1	AP
	5UN-22212-F0	SPRING (K=APPROX.54N/MM)	1	1	1	1	AP
5UN-22212-G0	SPRING (K=APPROX.56N/MM)	1	1	1	1	AP	
2	1C3-23141-00	SPRING (K=3.9N/MM)	2	2	2	2	AP
	1C3-23141-10	SPRING (K=4.0N/MM)	2	2	2	2	AP
	1C3-23141-20	SPRING (K=4.1N/MM)	2	2	2	2	AP
	1C3-23141-30	SPRING (K=4.2N/MM)	2	2	2	2	AP
	1C3-23141-40	SPRING (K=4.3N/MM)	2	2	2	2	AP
	1C3-23141-50	SPRING (K=4.4N/MM)	2	2	2	2	AP
	1C3-23141-60	SPRING (K=4.5N/MM)	2	2	2	2	AP
	1C3-23141-70	SPRING (K=4.6N/MM)	2	2	2	2	AP
1C3-23141-80	SPRING (K=4.7N/MM)	2	2	2	2	AP	
3	1C3-23364-00	COLLAR 2	2	2	2	2	UN



5BE100-8390

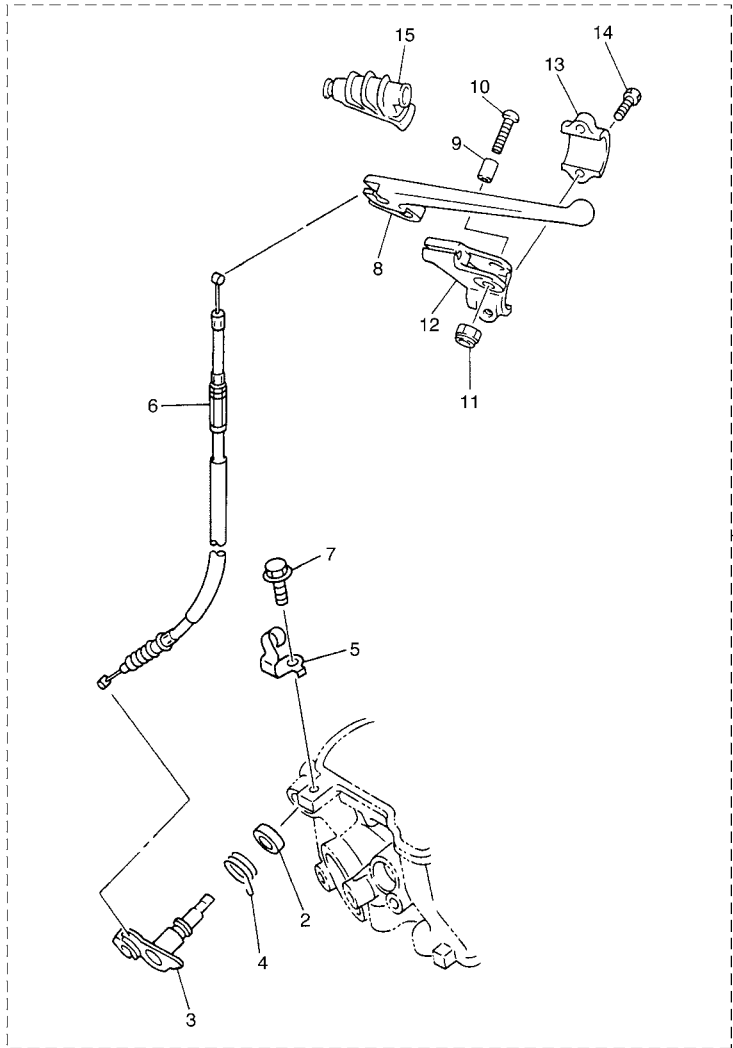

5TA1100-B400

FIG. 40 ALTERNATE DECOMPRESSION KIT

REF. NO.	PART NO.	DESCRIPTION	5XD5	5XD6	5XD7	5XD8	REMARKS
1	5TA-W1228-00	DECOMPRESSION KIT	1	1	1	1	AP
2	93102-12224	.OIL SEAL	1	1	1	1	
3	5BE-12280-10	.DECOMPRESSION ASSY	1	1	1	1	
4	90508-162B2	.SPRING, TORSION	1	1	1	1	
5	5NL-12283-00	.BRACKET, DECOMPRESSION	1	1	1	1	
6	5BE-12292-10	.CABLE, DECOMPRESSION	1	1	1	1	
7	95827-06014	.BOLT, FLANGE	1	1	1	1	
8	583-83981-00	.LEVER, DECOMPRESSION	1	1	1	1	
9	5BE-83913-00	.COLLAR, LEVER 1	1	1	1	1	
10	98507-05020	.SCREW, PAN HEAD	1	1	1	1	
11	95607-05100	.NUT, U	1	1	1	1	
12	5BE-82912-00	.HOLDER, LEVER UPPER 1	1	1	1	1	
13	38V-82913-00	.HOLDER, LEVER LOWER 1	1	1	1	1	
14	97007-05016	.BOLT	2	2	2	2	
15	583-26352-00	.COVER, DECOMPRESSION CABLE	1	1	1	1	

NUMERICAL INDEX

PART NO.	GRID NO.	PART NO.	GRID NO.	PART NO.	GRID NO.	PART NO.	GRID NO.	PART NO.	GRID NO.	PART NO.	GRID NO.
5XD-11102-00	B - 2	3LD-12168-R1	B - 5	5TA-13412-00	B - 10	5JG-14531-00	C - 2	4MX-14943-91	B - 14	5GR-15664-00	C - 7
4KG-1111G-00	B - 2	3LD-12168-U1	B - 5	5TA-13440-00	B - 11	3TJ-14536-40	B - 15	4MX-14943-92	B - 14	5SG-15668-00	C - 7
5TA-11133-10	B - 2	3LD-12168-W1	B - 5	5BE-13447-10	B - 11	5JG-14546-01	B - 13	4MX-14943-93	B - 14	4GY-15671-00	C - 7
5TA-11134-10	B - 2	3LD-12168-Y1	B - 5	5TA-13464-00	B - 10	676-14548-00	B - 15	5XD-14947-00	B - 14	214-15686-00	C - 7
5TA-11166-00	B - 2	3LD-12169-11	B - 5	5TA-13465-00	B - 10	4MX-14561-00	C - 2	4MX-14948-02	B - 14	5XD-16111-00	C - 8
5BE-11167-00	B - 2	3LD-12169-31	B - 6	5XD-13597-10	B - 12	6H4-14561-00	B - 15	4MX-14948-03	B - 14	5XD-16150-50	C - 8
371-11167-01	B - 2	3LD-12169-50	B - 6	5XD-14101-50	B - 13	5NX-14562-00	C - 2	4MX-14948-04	B - 14	5XD-16154-00	C - 8
5TA-11181-00	B - 2	3LD-12169-70	B - 6	5NL-14105-00	B - 15	5JG-14565-00	C - 2	4MX-14948-05	B - 14	5TA-16321-00	C - 8
5TG-11190-10	B - 2	3LD-12169-90	B - 6	4MX-14115-00	C - 2	5JG-14591-00	C - 2	4MX-14948-06	B - 14	5JG-16325-00	C - 8
5TA-11193-00	B - 3	3LD-12169-E0	B - 6	3TJ-14137-40	B - 12	688-14592-00	B - 13	4MX-14948-07	B - 14	5JG-16351-00	C - 8
5TA-11311-01	B - 3	3LD-12169-G0	B - 6			5TA-14611-00	C - 3	4MX-14948-08	B - 14	5JG-16356-00	C - 8
5TA-11351-00	B - 3	3LD-12169-J0	B - 6	5BE-14146-00	C - 2	3VD-14613-01	C - 3	4TJ-1494F-01	B - 15	5TA-16357-10	C - 8
5JG-11387-00	B - 3	3LD-12169-L0	B - 6	5PA-14146-00	C - 2	5TA-14628-00	C - 3	4TJ-1494F-03	B - 15	5TA-16371-10	C - 8
5XD-11400-00	B - 4	3LD-12169-N0	B - 6	5TA-14155-00	B - 15	5TA-1469A-00	C - 3	4TJ-1494F-05	B - 15	5XD-16381-00	C - 8
5TA-11412-00	B - 4	3LD-12169-T0	B - 6	633-14159-00	B - 15	5TA-1469E-00	C - 3	4TJ-1494F-07	B - 15	5TA-16384-01	C - 8
5TA-11422-00	B - 4	5TA-12170-00	B - 7	3TJ-14159-40	B - 13	5XD-14714-00	C - 3	4TJ-1494F-09	B - 15	5TA-17121-10	C - 9
5BE-11454-00	B - 4	5TA-12180-00	B - 7	5TA-14171-00	B - 15	5BE-14747-00	C - 3	3TJ-1494F-14	B - 14	5TA-17131-20	C - 9
5TA-11455-11	B - 4	5TA-12210-00	B - 7	3TJ-14191-40	B - 15	4BD-14766-00	C - 3	3TJ-1494F-15	B - 14	5TA-17141-20	C - 9
5TA-11531-01	B - 4	4FM-12213-00	B - 7	5TA-14196-00	C - 2	5BE-14788-00	C - 3	3TJ-1494F-16	B - 14	5TA-17211-10	C - 9
5TA-11536-00	B - 4	5BE-12241-00	B - 2	5TA-14197-00	C - 2	5TA-14916-L1	B - 13	3TJ-1494F-17	B - 14	5TA-17221-10	C - 9
5JG-11603-00	B - 4	5TA-12251-01	B - 7	5NX-14216-00	C - 2	5TA-14916-LN	B - 13	3TJ-1494F-18	B - 14	5TA-17231-10	C - 9
5TJ-11631-00	B - 4	5TA-12252-00	B - 7	5TA-14227-00	B - 12	5TA-14916-LP	B - 13	5JG-14951-00	B - 13	5TA-17241-10	C - 9
5TA-11633-00	B - 4	5BE-12280-10	E - 12	5TA-14239-00	B - 12	5TA-14916-LR	B - 13	5JG-14959-00	B - 13	5TA-17402-10	C - 9
5XD-11651-00	B - 4	5NL-12283-00	E - 12	5TA-14261-00	C - 2	5TA-14916-LS	B - 13	5JG-14984-00	B - 15	5TA-17411-20	C - 9
5TA-11681-00	B - 4	5BE-12292-10	E - 12	5JG-14264-00	B - 14	5TA-14916-LT	B - 13	4SR-14985-00	B - 15	5TA-17466-00	C - 4
5TA-12111-00	B - 5	5TA-1240A-00	B - 9	3TJ-14267-40	B - 13	5TA-14916-LU	B - 13	5TA-14987-00	B - 12	4L0-17471-00	C - 4
5TA-12112-00	B - 5	5BE-12422-20	B - 8	5JG-14275-00	B - 14	5TA-14916-P1	B - 13	5TJ-14987-00	C - 2	5GR-17471-00	C - 10
5TA-12113-00	B - 5	5BE-12439-00	B - 8	5TA-14293-00	B - 12	5TA-14916-PN	B - 13	5TA-14991-00	B - 15	5TJ-18101-00	C - 12
5TA-12114-00	B - 5	5DJ-12451-00	B - 8	3TJ-14293-40	B - 15	5TA-14916-PP	B - 13	4FN-14997-00	B - 13	5TA-18110-00	C - 12
4GY-12117-00	B - 5	5GR-12458-00	B - 8	5XD-14325-00	C - 2	5TA-14916-PR	B - 13	5TA-14997-00	B - 15	5MW-18122-01	C - 12
5BE-12117-00	B - 5	5TA-12461-00	B - 9	5TA-14335-00	B - 15	5TA-14916-PS	B - 13	5TA-15150-11	C - 4	3XK-18140-00	C - 11
1AA-12118-00	B - 5	5HD-12462-00	B - 9	5JG-14346-00	C - 2	5TA-14916-PT	B - 13	5TA-15362-01	C - 14	5TJ-18172-00	C - 12
1WG-12118-00	B - 5	5TA-12481-00	B - 9	5TA-14371-00	B - 15	5TA-14916-PU	B - 13	3Y1-15363-00	C - 5	3XJ-18173-10	C - 12
33M-12119-00	B - 5	5TA-12482-00	B - 9	5TA-14374-00	B - 15	5JG-14922-00	C - 2	5XD-15378-00	C - 5	3XJ-18178-00	C - 12
4SV-12119-00	B - 5	5Y9-12491-00	E - 10	5JG-14379-00	C - 2	3TJ-14933-40	B - 15	4JT-15381-01	C - 4	3XJ-18182-00	C - 12
5TA-12121-00	B - 5	5BE-12564-00	B - 8	5JG-14388-00	B - 13	5TA-14934-00	C - 2	5BE-15383-01	C - 4	3XJ-18184-00	C - 12
3GM-12126-00	B - 5	5TA-12576-00	B - 9	4MX-14392-00	B - 15	5JG-14940-16	B - 15	5TA-15411-10	C - 5	4EW-18185-00	C - 12
3FV-12153-10	B - 6	5TA-12578-00	B - 9	5TA-14401-01	B - 12	5JG-14940-17	B - 15	5TA-15415-10	C - 5	5TA-18501-00	C - 11
3LD-12168-00	B - 5	5SG-12579-00	B - 9	5XD-14417-00	B - 12	5JG-14940-18	B - 15	5TA-15421-00	C - 4	5TA-18502-00	C - 11
3LD-12168-20	B - 5	5TA-12579-00	B - 9	5TA-14428-00	B - 12	5TA-14943-27	B - 15	5XD-15431-00	C - 5	5TA-18541-00	C - 11
3LD-12168-40	B - 5	583-13113-00	C - 5	5NY-14442-00	B - 12	4MX-14943-38	B - 14	5XD-15441-00	C - 4	278-18542-00	C - 11
3LD-12168-60	B - 5	5TG-13161-00	B - 11	4XM-14451-00	B - 12	4MX-14943-39	B - 14	5TA-15451-00	C - 5	5DH-18562-00	C - 4
3LD-12168-80	B - 5	5TA-13171-00	B - 11	5XD-14453-00	B - 12	4MX-14943-40	B - 14	5TA-15453-00	C - 5	5XD-21101-50	C - 13
3LD-12168-A0	B - 5	5TA-13300-00	B - 10	5NY-14455-10	B - 12	4MX-14943-41	B - 14	5TA-15462-00	C - 5	5XD-21190-50	C - 13
3LD-12168-F0	B - 5	5TA-13320-00	B - 10	5BE-14458-00	B - 12	4MX-14943-42	B - 14	5XD-15601-00	C - 7	5XD-21274-00	C - 14
3LD-12168-H1	B - 5	5TA-13341-00	B - 10	5NY-14459-00	B - 12	4MX-14943-88	B - 14	5XD-15620-00	C - 7	1C3-2135F-00	D - 4
3LD-12168-K1	B - 5	5BE-13342-00	B - 10	5JG-14521-00	B - 14	4MX-14943-89	B - 14	5XD-15621-00	C - 7	1C3-2139R-00	D - 4
3LD-12168-M1	B - 5	5BE-13411-00	B - 10	5JG-14522-00	B - 13	4MX-14943-90	B - 14	5TA-15651-00	C - 7	5XD-21417-50	C - 14

NUMERICAL INDEX

PART NO.	GRID NO.	PART NO.	GRID NO.	PART NO.	GRID NO.	PART NO.	GRID NO.	PART NO.	GRID NO.	PART NO.	GRID NO.
5XD-21425-00	C - 13	5UN-22212-00	E - 11	1C3-23141-10	E - 11	5NY-24186-00	D - 10	5UN-25854-00	E - 7	1C3-27311-00	E - 6
5XD-21425-10	C - 13	5UN-22212-10	E - 11	1C3-23141-20	E - 11	5XD-24240-10	D - 11	5XE-25854-00	E - 5	5XE-27411-01	E - 6
5XD-21455-60	C - 13	5UN-22212-20	E - 11	1C3-23141-30	E - 11	3XJ-24380-00	D - 10	5UN-2585B-00	E - 7	5XE-27421-01	E - 6
5TA-21471-00	C - 14	5UN-22212-30	E - 11	1C3-23141-40	E - 11	4DP-24500-01	D - 10	5MV-25867-00	E - 5	5TA-27491-00	E - 3
5TA-2147A-00	C - 14	5UN-22212-40	D - 6	1C3-23141-50	E - 11	4X8-24512-00	D - 10	5NY-25868-00	E - 5	5TA-2814F-00	C - 14
5TA-2147E-00	C - 14		E - 11	1C3-23141-60	E - 11	3AC-24523-00	D - 10	1C3-25872-00	E - 5	5ET-28166-00	C - 14
5HD-21511-00	C - 15	5UN-22212-50	D - 6	1C3-23141-70	E - 11	3AJ-24534-01	D - 10	5UN-25873-00	E - 7	5TA-82310-10	E - 10
5UN-2153A-00	D - 4		E - 11	1C3-23141-80	E - 11	5NY-24610-00	D - 10	1C3-25875-00	D - 14	5XD-82509-01	E - 10
4XL-2153A-10	D - 9	5UN-22212-60	E - 11	5XD-23141-N0	D - 8	5XD-2470F-00	D - 12	1C3-25876-00	E - 7	5TA-82540-00	E - 10
4ES-2153E-01	C - 15	5UN-22212-70	E - 11	5XD-23141-P0	D - 8	5XD-24710-00	D - 12	2VM-25876-00	E - 7	3MA-82591-00	E - 10
5XD-21610-00	C - 15	5UN-22212-A0	E - 11	5XE-23144-L0	D - 8	5NY-25104-00	D - 13	5MV-2589F-00	E - 5	5XE-82911-00	E - 9
5XD-21635-00	C - 15	5UN-22212-B0	E - 11	1C3-23145-L0	D - 8	5NY-25111-00	D - 13	5UN-25914-00	E - 3	5BE-82912-00	E - 12
5XD-2163G-00	C - 15	5UN-22212-C0	E - 11	5XE-23146-L0	D - 8	5NY-25117-00	D - 13	5DH-25914-50	E - 3	38V-82913-00	E - 12
5TA-21642-00	C - 15	5UN-22212-D0	E - 11	1C3-2314F-L0	D - 8	1C3-25181-00	D - 13	3SP-25914-51	D - 14	5XD-82913-00	E - 9
5TA-21711-00	D - 2	5UN-22212-E0	E - 11	5XE-23153-L0	D - 8	5NY-25183-00	D - 13	5DH-25916-00	D - 14	5XD-82946-00	E - 9
5TA-21721-00	D - 2	5UN-22212-F0	E - 11	2HH-23158-L0	D - 8	5NY-25186-00	D - 13		E - 3	5MV-83912-00	E - 9
5TA-2172A-00	D - 2	5UN-22212-G0	E - 11	1C3-2315H-00	D - 9	5HD-25304-00	D - 15	3JD-25917-00	D - 14	5BE-83913-00	E - 12
5TA-21730-00	D - 2	3SP-22213-00	D - 5	1C3-2315J-00	D - 9	5ET-25311-00	D - 15		E - 3	5MV-83922-00	E - 5
5XD-2173-10	D - 2	5XE-22214-00	D - 6	5XD-2316A-N0	D - 8	5ET-25317-00	D - 15	5DH-25919-00	D - 14	5TA-83941-00	E - 9
5XD-2173F-10	D - 2	5MV-22224-00	D - 5	5XD-2316A-P0	D - 8	4XM-25364-00	D - 15	5DH-25919-50	E - 3	5HD-83951-00	E - 9
5TA-21740-00	D - 2	4JX-22226-00	D - 5	1C3-2316E-L0	D - 8	5ET-25367-00	E - 2	8CR-25924-00	E - 3	1C3-83976-00	E - 9
5TA-2174A-00	D - 2	3SP-22234-00	D - 5	5XD-23170-N0	D - 8	1C3-25381-00	E - 2	3SP-25926-51	D - 14	583-83981-00	E - 12
5TA-2174T-00	C - 15	5NY-22241-00	D - 6	5XD-23170-P0	D - 8	5UN-25383-00	E - 2	5DH-25933-00	D - 14	5LP-84126-10	E - 9
5TA-21756-00	C - 13	5XE-22242-00	D - 6	5XE-23171-L0	D - 8	1C3-25388-00	E - 2	1UY-25937-51	D - 14	5XD-85540-50	E - 10
5MV-2175C-00	D - 2	1C3-22253-00	D - 5	5DH-23183-00	D - 5	1C3-25389-00	E - 2		E - 3	5XD-85540-60	E - 10
1C3-22110-00	D - 3	5MV-22253-00	D - 5	509-23184-L0	D - 5	3JE-25394-00	D - 15	1C3-26111-00	E - 4	5XD-85546-00	E - 10
5XD-22121-50	D - 4	4AA-22259-40	D - 5	5TJ-2319U-00	D - 7	5SF-25394-00	D - 13	1C3-26124-00	E - 4	5TA-85550-00	E - 8
1C3-22122-00	D - 4	4AA-22259-50	D - 5	5XD-23340-M0	D - 9	1C3-25447-00	D - 15	5BE-26240-00	E - 4	5XD-85560-00	E - 8
1C3-22128-00	D - 3	4AA-22259-60	D - 5	5NY-23346-L0	D - 9	1C3-25448-00	D - 15	4GY-26241-00	E - 4	5TA-85885-00	C - 2
5XD-22141-50	D - 3	4AA-22259-80	D - 5	3SP-23356-L0	D - 9	1C3-25449-00	D - 15	4GY-26242-00	E - 4	5NY-W0041-00	E - 5
1C3-22151-00	D - 3	1P8-22355-00	D - 3	5TA-23357-00	D - 7	1C3-25450-00	D - 15	3Y1-26249-00	E - 4	5UN-W0042-50	E - 7
5UN-22176-00	D - 5	4EW-22474-00	D - 5	1C3-23364-00	E - 11	1C3-25451-00	D - 15	5BE-26281-00	E - 4	5MV-W0045-01	D - 14
4EW-22178-01	C - 13	3JE-22475-00	D - 5	5XE-23389-00	D - 7	1C3-25452-00	D - 15	5BE-26282-00	E - 4	1C3-W0046-00	E - 3
3JD-22178-20	C - 13	5NY-22475-00	D - 6	4EW-23416-00	D - 7	5CG-25715-00	E - 5	5SF-26287-00	E - 4	3JD-W0047-00	D - 14
1C3-2217A-00	D - 3	5UN-22898-60	E - 3	5XE-23435-20	D - 7		E - 7	5XD-26302-00	E - 4	5UN-W0047-50	E - 3
1C3-2217F-00	D - 3	1C3-22969-00	D - 3	5XE-23441-00	D - 7	5DH-25718-01	E - 3	5TA-26334-00	E - 9	1UY-W0048-50	D - 14
5MV-22184-00	D - 5	5XD-23102-50	D - 8	1C3-23466-00	D - 9	1C3-2580T-00	D - 14	5UL-26335-00	E - 4		E - 3
1C3-22199-00	D - 3	5XD-23102-60	D - 8	1C3-23467-00	D - 9	1C3-2580W-00	E - 3	5TA-26337-00	E - 9	5UN-W0057-00	D - 14
5XD-22201-50	D - 5	5XD-23103-50	D - 8	1C3-23485-00	D - 7	5MV-2581T-00	D - 14	5TA-26339-00	E - 9	5UN-W0057-50	E - 3
5XD-22201-60	D - 5	5XD-23103-60	D - 8	5XD-24110-01	D - 10	5UN-25827-60	E - 3	5HD-26342-00	E - 4	5TA-W1228-00	E - 12
5XD-22201-70	D - 5	1P8-23110-L0	D - 8	4EW-2412F-00	D - 10	5UN-25828-60	E - 3	583-26352-00	E - 12	5XE-W2587-00	E - 5
5XD-22201-80	D - 5	1C3-23111-L0	D - 8	5XE-24144-00	D - 10	5NY-2582W-00	E - 3	5HD-26372-00	E - 9	5XD-Y1475-00	C - 3
5XD-22201-90	D - 5	5XE-23113-00	D - 7	5SF-24173-00	D - 10	5MV-25833-00	E - 5	5NY-26372-00	E - 5	5XD-Y1475-10	C - 3
5XD-22210-50	D - 5	1C3-23118-L0	D - 8	5XE-24176-00	D - 10	5UN-2583V-00	E - 7	5TA-27200-00	E - 6	90101-05033	E - 9
5XD-22210-60	D - 5	1P8-23120-L0	D - 8	22W-24181-00	C - 3	5DH-25849-00	D - 14	1C3-27217-00	E - 6	90101-06001	C - 7
5XD-22210-70	D - 5	5XE-23125-L0	D - 8	4SS-24181-00	D - 10	5MV-25852-01	E - 5	5UN-27217-00	E - 7	90101-06034	C - 12
5XD-22210-80	D - 5	1C3-23136-L0	D - 8	5BE-24182-00	D - 10	5UN-25852-50	E - 7	5UN-27218-00	E - 7	90101-08777	E - 2
5XD-22210-90	D - 5	1C3-23141-00	E - 11	5NY-24183-00	D - 10	5XE-25853-00	E - 5	5UN-27222-00	E - 7	90105-06027	B - 2

NUMERICAL INDEX

PART NO.	GRID NO.	PART NO.	GRID NO.	PART NO.	GRID NO.	PART NO.	GRID NO.	PART NO.	GRID NO.	PART NO.	GRID NO.
90105-06055	D - 2	90179-16002	D - 13	90209-21332	C - 9	90450-28014	B - 9	91A20-05065	B - 9	93306-90403	D - 13
90105-06553	C - 4	90179-20001	C - 10	90215-14287	B - 4	90450-57009	B - 12	92014-05012	E - 9	93306-90501	C - 11
	C - 10	90179-20009	C - 8	90215-20005	C - 8	90450-59002	B - 12	92017-10060	C - 13	93310-63417	B - 4
90105-08057	C - 3	90179-28003	D - 7	90215-21003	C - 10	90450-61001	B - 12	92907-06600	B - 7	93311-62574	B - 4
	C - 13	90183-06023	B - 12	90240-08120	E - 6	90461-10136	C - 4		C - 14	93315-32165	D - 3
90105-08120	C - 13	90185-08169	E - 2	90240-10142	E - 6	90462-10241	C - 5	93101-14164	C - 5	93315-32166	D - 3
90105-08659	C - 3	90185-10060	D - 6	90267-32070	B - 12	90464-13073	E - 10	93102-12106	B - 8	93317-11287	C - 8
	D - 14	90185-14007	D - 4	90267-48084	C - 3	90464-13077	E - 10	93102-12224	C - 8	93317-22262	D - 3
90105-10099	C - 13	90185-16127	D - 3	90280-03001	B - 4	90465-13152	D - 10		C - 12	93332-00068	D - 7
90105-104A7	B - 2	90185-20168	E - 2	90338-18004	B - 7		E - 10		E - 12	93332-00081	D - 9
90105-106A3	B - 2	90201-03313	B - 12	90338-18176	C - 14	90465-13275	E - 10	93102-20108	C - 7	93340-21505	C - 8
90105-10733	C - 13	90201-06557	C - 15	90340-12112	B - 2	90467-09006	B - 9	93102-26468	D - 13	93342-22217	D - 3
90109-06034	E - 9	90201-06571	B - 9	90340-14128	C - 5	90467-10008	D - 10	93102-32480	C - 9	93410-20038	C - 7
90109-063F8	C - 11	90201-08008	C - 3	90340-32123	C - 5	90467-11106	B - 3	93106-22019	D - 3	93420-18082	B - 4
90109-06418	B - 7	90201-08089	E - 6	90387-06009	C - 15	90467-14015	B - 3	93106-30044	D - 15	93440-10085	C - 8
90109-065G2	B - 11	90201-08326	E - 2	90387-06065	B - 9	90468-16099	E - 6	93106-30045	D - 15	93440-10153	B - 2
90109-065G4	E - 3	90201-08410	C - 2	90387-06090	C - 15	90480-08608	E - 2	93109-11073	B - 8		B - 10
90109-066F0	B - 2	90201-08512	B - 8	90387-0814J	C - 3	90480-15528	B - 9	93109-21001	D - 4	93440-25084	C - 9
90109-067F4	B - 12	90201-086P8	C - 13	90387-086N4	C - 13	90480-18549	D - 10	93109-25001	D - 3	93440-30077	C - 9
90109-081G1	E - 2	90201-087A9	C - 7	90387-124F4	C - 12	90501-043E0	C - 6	93109-28043	D - 3	93440-41178	B - 7
90110-06058	B - 10	90201-10025	B - 2	90387-14006	D - 4	90501-052G5	C - 12	93210-04122	C - 11	93503-08007	C - 6
90110-08035	C - 7	90201-10118	E - 5	90387-16010	D - 3	90501-06022	C - 11	93210-07003	B - 11	93507-32009	C - 7
90111-06029	E - 7		E - 7	90387-18004	D - 3	90501-147A5	C - 7	93210-07135	B - 11	93511-32027	C - 8
90119-06001	C - 14	90201-10119	E - 6	90387-18007	C - 4	90501-16016	C - 7	93210-08001	C - 14	93603-16219	B - 10
90119-06096	C - 15	90201-104R2	C - 13	90387-18009	D - 3	90501-231E9	C - 8	93210-09008	B - 11	93604-10011	B - 8
90119-06192	C - 15	90201-12166	B - 10	90387-225N2	E - 4	90506-16500	E - 6	93210-10197	B - 10	93608-33002	C - 12
90119-06225	C - 15	90201-125L6	C - 8	90387-25008	C - 9	90508-12007	C - 8		C - 4	93612-16254	B - 3
90119-08238	D - 2	90201-127E1	E - 8	90387-25013	C - 9	90508-162B2	E - 12	93210-11073	E - 6	9383E-14215	C - 9
90122-06035	B - 12	90201-145M4	C - 13	90387-2513F	C - 9	90508-26561	C - 11	93210-12759	B - 11	94108-21012	D - 13
90149-05162	E - 9	90201-14740	D - 4	90401-08038	B - 11	90508-282B8	E - 6	93210-14369	C - 5	94108-21015	D - 13
90149-06011	D - 10	90201-15701	C - 5	90401-10159	B - 11	90508-282B9	E - 6	93210-16500	B - 9	94108-2112Y	D - 13
90149-06126	C - 4	90201-160F6	D - 3	90401-10172	E - 5	90508-291A8	C - 12	93210-17570	C - 7	94111-19011	D - 15
90149-06250	B - 4	90201-162H4	C - 7		E - 7	90508-305B0	C - 7	93210-19123	C - 5	94111-19012	D - 15
90149-06324	E - 8	90201-167P7	C - 7	90430-06014	B - 2	91314-06030	B - 10	93210-19758	B - 8	94111-1913A	D - 15
90149-06326	C - 4	90201-20276	C - 7		B - 7	91314-06065	C - 4	93210-21276	E - 10	94209-21229	D - 13
90149-06327	D - 14	90201-203U1	E - 2		B - 8	91314-06080	C - 4	93210-22164	C - 9	94211-19273	D - 15
90151-04001	D - 3	90201-20685	C - 7		C - 4	91316-04012	B - 13	93210-32172	C - 5	94211-19274	D - 15
90152-06010	C - 7	90201-206L6	C - 9	90430-08119	B - 11	91317-06012	B - 9	93210-47675	B - 11	94227-21101	D - 13
90154-05026	E - 10	90201-21013	D - 3		C - 13	91317-06020	B - 11	93300-60804	C - 13	94309-21161	D - 13
90159-06078	D - 2	90201-247L2	D - 7	90430-10188	B - 11	91317-06050	C - 4	93306-00105	B - 8	94311-19155	D - 15
90159-06092	C - 8	90201-253G3	C - 9		C - 4	91317-06060	C - 4	93306-00426	C - 9	94321-19157	D - 15
90170-14171	B - 4	90201-286K9	D - 7	90445-09095	D - 10	91317-06065	B - 11	93306-00431	C - 9	94330-21084	D - 13
90170-20327	C - 8	90202-05193	D - 10	90445-09220	D - 10	91317-06075	C - 4	93306-07202	D - 15	94416-21003	D - 13
90179-06500	B - 3	90202-08045	B - 13	90445-11185	D - 10	91317-08020	C - 3	93306-20335	B - 4	94421-19602	D - 15
90179-06568	D - 3	90206-06090	C - 3	90445-112K0	B - 3	91401-20012	E - 6	93306-20532	C - 9	94581-92115	E - 2
90179-08299	E - 2	90208-25045	C - 8	90450-22017	B - 9	91401-25015	E - 6	93306-20593	C - 9	94591-57118	B - 7
90179-10658	C - 13	90209-06096	B - 12		B - 10	91808-16023	B - 2	93306-27205	D - 15	94681-68001	E - 2
90179-12657	E - 8	90209-16008	D - 3	90450-25037	B - 9	91812-16001	C - 5	93306-30633	B - 4	94701-00410	B - 2

NUMERICAL INDEX

PART NO.	GRID NO.	PART NO.	GRID NO.	PART NO.	GRID NO.	PART NO.	GRID NO.	PART NO.	GRID NO.	PART NO.	GRID NO.
94701-00411	B - 2	97027-06012	C - 14								
94703-00410	B - 2	97027-06016	B - 7								
94703-00411	B - 2	97707-60016	C - 15								
95024-06010	C - 4	98502-04012	B - 13								
95027-06010	B - 2	98507-03008	D - 10								
	D - 3	98507-05010	E - 7								
	D - 14	98507-05020	E - 4								
95027-06012	B - 9		E - 12								
	B - 11	98507-06025	C - 4								
	C - 8	98706-04012	E - 5								
	C - 14	98707-06025	D - 10								
	E - 3	98907-06025	D - 10								
95027-06014	D - 7	98980-06008	C - 3								
95027-06016	D - 10	99001-08600	B - 10								
	E - 3	99009-12400	B - 10								
95027-06020	C - 12	99009-16400	C - 7								
	D - 7	99009-20400	C - 7								
95027-06025	B - 7		C - 9								
	B - 9	99009-22500	C - 5								
	B - 10	99009-45500	D - 15								
95027-06030	B - 8	99530-08012	B - 10								
	C - 5	99530-08016	C - 5								
95027-06035	B - 3	99530-10114	B - 10								
95027-06040	C - 5		C - 4								
95027-06050	D - 3	99530-10116	C - 4								
95027-06080	C - 5	99530-14016	C - 4								
95027-08035	D - 7										
95027-08040	C - 13										
	D - 7										
95027-08065	C - 13										
95027-10016	C - 4										
95607-05100	E - 9										
	E - 12										
95607-10200	D - 6										
95617-06635	B - 2										
95617-08620	B - 2										
95701-06500	E - 5										
95707-06500	D - 9										
95707-08500	B - 2										
	C - 13										
95817-08012	C - 14										
95817-08016	C - 14										
95817-10055	C - 13										
95827-06010	B - 9										
95827-06014	E - 12										
95827-06016	D - 2										
95827-08012	C - 13										
97007-05016	E - 12										