



PARTS CATALOGUE

YZ450FD (33DD) CANADA

YZ450F (33DE) EUROPE

YZ450F (33DF) JAPAN

YZ450FD (33DG) OCEANIA,SOUTH AFRICA

YZ450FD/YZ450F
PARTS CATALOGUE
©2012 by Yamaha Motor Co., Ltd.
1st edition, June 2012
All rights reserved.
Any reprinting or unauthorized use
without the written permission of
Yamaha Motor Co., Ltd.
is expressly prohibited.
Printed in Japan.

FOREWORD

This Parts Catalogue is related to the parts for the model(s) on the cover page. When you are ordering replacement parts, please refer to this Parts Catalogue and quote both part numbers and part names correctly.

1. Modifications or additions which have been made after the issue of the Parts Catalogue will be announced in the Parts News.

It is advisable that you make the necessary corrections to the Parts Catalogue according to the Parts News.

2. Abbreviations

The following abbreviations are used in this Parts Catalogue.

“UR” Use specified parts number.

“UN” Use as many as needed.

“AP” Alternate Parts

“LM” Locally Made (Parts need to be ordered locally)

“F#” Frame No. (Applicable machine No.)

“O/S” Over Size

3. The number of components for assembly

- Parts, which are to be supplied in an assembly, are listed with a dot (.) in front of the part name as shown below.
- The numeral appearing to the right of each component part indicates the quantity of parts for each assembly unit.

PART NO.	DESCRIPTION	Q'TY	REMARKS
2F5-83310-60	FRONT FLASHER LIGHT ASSY	2	
115-83311-60	.BULB (6V-18W)	1	

4. Applicable colours of graphics are represented in the “REMARKS” as shown below.

PART NO.	DESCRIPTION	Q'TY	REMARKS
2N4-24110-00-X5	FUEL TANK COMP.	2	MXR
3J1-24240-10	.GRAPHIC, FUEL TANK	1	FOR MXR

5. Note that the illustrations for reference in finding parts numbers are not to be used for assembling. When assembling, please use the applicable service manual.

6. The asterisk (*) before a reference number indicates modified items after the first edition.

MODEL LABEL

(1) A label called "Model Label" is affixed in the location as indicated in (3) below. When using this parts catalogue, please be sure to cross-reference the "model code – production code No." in the catalogue with the "model code – production code No." indicated on the Model Label affixed onto the product concerned.

(2) "Model Label" Indication

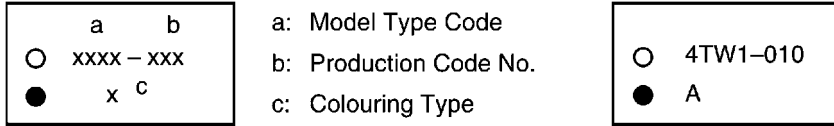

(3) Model Label Affixing Location

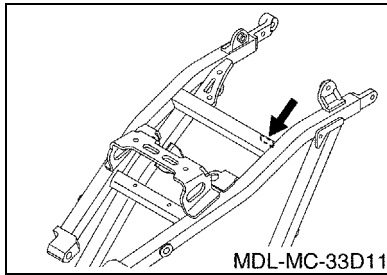

(4) Colouring Information

Model Code	Colouring Type Code	Colour Code	Colour Name	Abbreviation
33DD	A	0583	DEEP PURPLISH BLUE SOLID E	DPBSE
	B	0206	PURPLISH WHITE SOLID 1	PWS1
33DE	A	0583	DEEP PURPLISH BLUE SOLID E	DPBSE
	B	0206	PURPLISH WHITE SOLID 1	PWS1
33DF	A	0583	DEEP PURPLISH BLUE SOLID E	DPBSE
	B	0206	PURPLISH WHITE SOLID 1	PWS1
33DG	A	0583	DEEP PURPLISH BLUE SOLID E	DPBSE
	B	0206	PURPLISH WHITE SOLID 1	PWS1

(5) Model Code – Production Code Number of Model Listed in This Parts Catalogue

Model Code	Production Code No.	Country (destination)	Model Code	Production Code No.	Country (destination)
33DD	020	CANADA	33DG	010	SOUTH AFRICA
33DE	010	AUSTRIA			
		BELGIUM			
		CZECHO			
		DENMARK			
		FINLAND			
		FRANCE			
		GERMANY			
		GREECE			
		HUNGARY			
		IRELAND			
		ITALY			
		NETHERLANDS			
		NORWAY			
		POLAND			
		PORTUGAL			
		SLOVAKIA			
		SLOVENIA			
SPAIN					
SWEDEN					
SWITZERLAND					
UNITED KINGDOM					
33DF	010	JAPAN			
33DG	010	AUSTRALIA			
		NEW ZEALAND			

CONTENTS

ENGINE

CYLINDER	1
CRANKSHAFT & PISTON	3
VALVE	4
CAMSHAFT & CHAIN	6
WATER PUMP	7
RADIATOR & HOSE	8
OIL PUMP	9
OIL CLEANER	10
INTAKE	11
INTAKE 2	13
EXHAUST	14
CRANKCASE	15
CRANKCASE COVER 1	17
STARTER	19
CLUTCH	20
TRANSMISSION	21
SHIFT CAM & FORK	23
SHIFT SHAFT	24

CHASSIS

FRAME	25
FENDER	28
SIDE COVER	29
REAR ARM	31
REAR SUSPENSION	33
STEERING	35
FRONT FORK	36
FUEL TANK	39
SEAT	41
FRONT WHEEL	42
FRONT BRAKE CALIPER	43
REAR WHEEL	44
REAR BRAKE CALIPER	46
STEERING HANDLE & CABLE	47
FRONT MASTER CYLINDER	48
STAND & FOOTREST	49
REAR MASTER CYLINDER	50
GENERATOR	51
HANDLE SWITCH & LEVER	52
ELECTRICAL 1	53
ALTERNATE FOR CHASSIS	55

INDEX

NUMERICAL INDEX	56
-----------------------	----

FIG. 1 CYLINDER

REF. NO.	PART NO.	DESCRIPTION	33DD	33DE	33DF	33DG	REMARKS
1	33D-11102-00	CYLINDER HEAD ASSY	1	1	1	1	
2	5PS-11133-10	.GUIDE, VALVE 1	2	2	2	2	
3	5PS-11134-10	.GUIDE, VALVE 2	2	2	2	2	
4	90105-06027	.BOLT, FLANGE	8	8	8	8	
5	90340-12007	.PLUG, STRAIGHT SCREW	2	2	2	2	
6	91808-16023	.PIN, DOWEL	2	2	2	2	
7	91808-16023	.PIN, DOWEL	2	2	2	2	
8	95022-08012	BOLT, FLANGE	1	1	1	1	
9	90430-08119	GASKET	1	1	1	1	
10	95022-06010	BOLT, FLANGE	2	2	2	2	
11	90430-06014	GASKET	2	2	2	2	
12	90116-06037	BOLT, STUD	3	3	3	3	
13	94701-00411	PLUG, SPARK (NGK R CR8E)	1	1		1	STD
	94703-00411	PLUG, SPARK (NGK R CR8E)			1		STD
	94701-00410	PLUG, SPARK (NGK R CR9E)	1	1		1	AP
	94703-00410	PLUG, SPARK (NGK R CR9E)			1		AP
14	33D-11181-00	GASKET, CYLINDER HEAD 1	1	1	1	1	
15	93612-16254	PIN, DOWEL	2	2	2	2	
16	90105-10367	BOLT, FLANGE	4	4	4	4	
17	90201-10025	WASHER, PLATE	4	4	4	4	
18	95022-06035	BOLT, FLANGE	2	2	2	2	
19	33D-11191-10	COVER, CYLINDER HEAD 1	1	1	1	1	
20	5BE-12241-00	GUIDE, STOPPER 2	1	1	1	1	
21	33D-11193-01	GASKET, HEAD COVER 1	1	1	1	1	
22	371-11167-01	PIPE, BREATHER 2	1	1	1	1	
23	33D-11166-00	PIPE, BREATHER 1	1	1	1	1	
24	90467-140A4	CLIP	1	1	1	1	

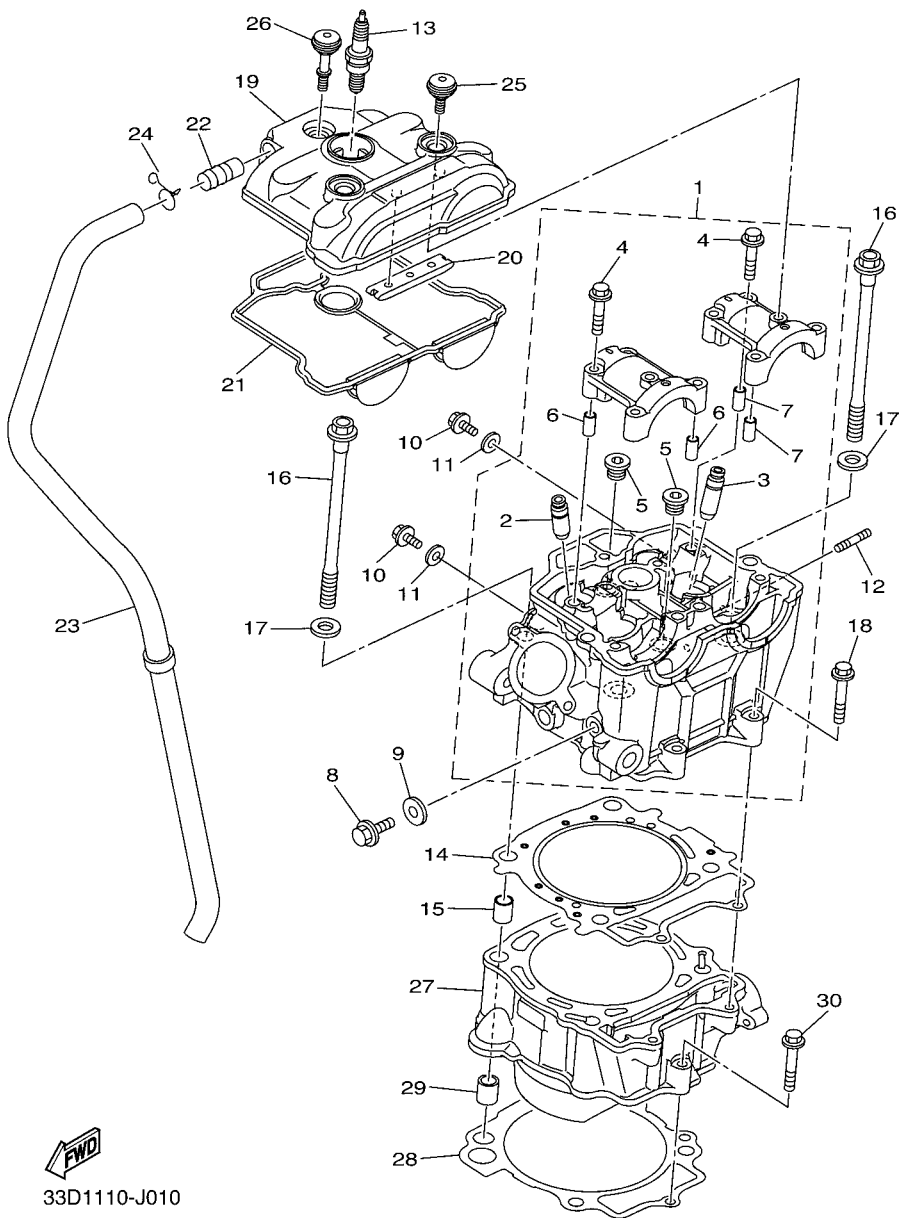

33D1110-J010

FIG. 1 CYLINDER

REF. NO.	PART NO.	DESCRIPTION	33DD	33DE	33DF	33DG	REMARKS
25	5UM-1119E-00	BOLT, COVER HEAD	2	2	2	2	
26	33D-1119E-00	BOLT, COVER HEAD	1	1	1	1	
27	33D-11311-10	CYLINDER 1	1	1	1	1	
28	33D-11351-00	GASKET, CYLINDER	1	1	1	1	
29	99530-14016	PIN, DOWEL	2	2	2	2	
30	95022-06035	BOLT, FLANGE	1	1	1	1	

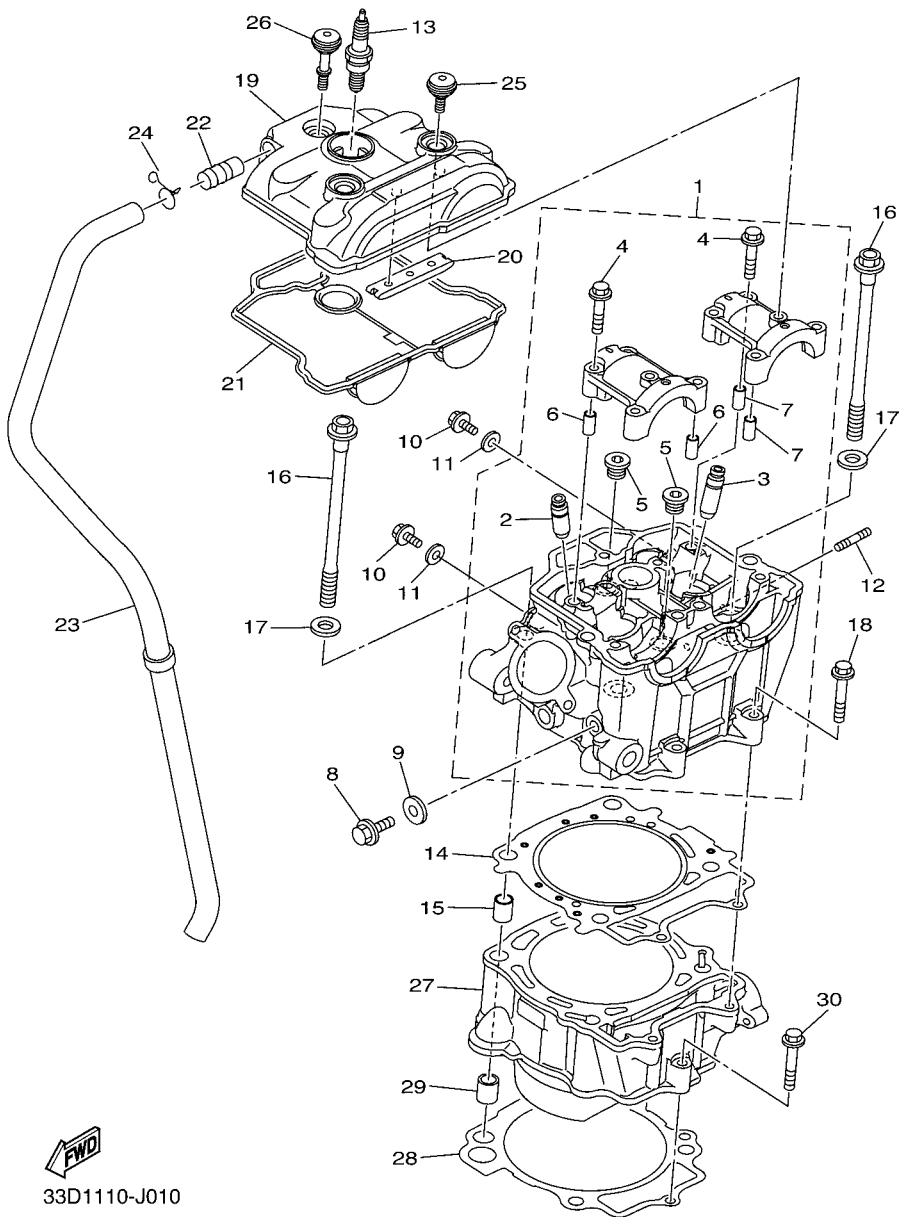

33D1110-J010

FIG. 2 CRANKSHAFT & PISTON

REF. NO.	PART NO.	DESCRIPTION	33DD	33DE	33DF	33DG	REMARKS
1	33D-11400-01	CRANKSHAFT ASSY	1	1	1	1	
2	33D-11412-00	.CRANK 1	1	1	1	1	
3	33D-11422-00	.CRANK 2	1	1	1	1	
4	5TG-11681-01	.PIN, CRANK 1	1	1	1	1	
5	93310-63458	.BEARING	1	1	1	1	
6	33D-11651-00	.ROD, CONNECTING	1	1	1	1	
7	93306-30633	BEARING	2	2	2	2	
8	33D-11536-00	GEAR, DRIVE	1	1	1	1	
9	33D-11455-00	SHAFT 1	1	1	1	1	
10	93304-20310	BEARING	2	2	2	2	
11	2S2-11531-00	GEAR, BALANCE WEIGHT	1	1	1	1	
12	90170-14171	NUT	1	1	1	1	
13	90215-14287	WASHER, LOCK	1	1	1	1	
14	33D-11454-00	WEIGHT 1	1	1	1	1	
15	90149-06083	SCREW	3	3	3	3	
16	33D-11464-00	WEIGHT 2	1	1	1	1	
17	90282-05034	KEY, STRAIGHT	1	1	1	1	
18	90170-10405	NUT	1	1	1	1	
19	90215-10009	WASHER, LOCK	1	1	1	1	
20	90280-03006	KEY, WOODRUFF	1	1	1	1	
21	33D-116A0-00	PISTON ASSY	1	1	1	1	
22	33D-11631-00	.PISTON (STD)	1	1	1	1	
23	33D-11603-00	.PISTON RING SET (STD)	1	1	1	1	
24	33D-11633-00	.PIN, PISTON	1	1	1	1	
25	93450-19052	.CIRCLIP	2	2	2	2	

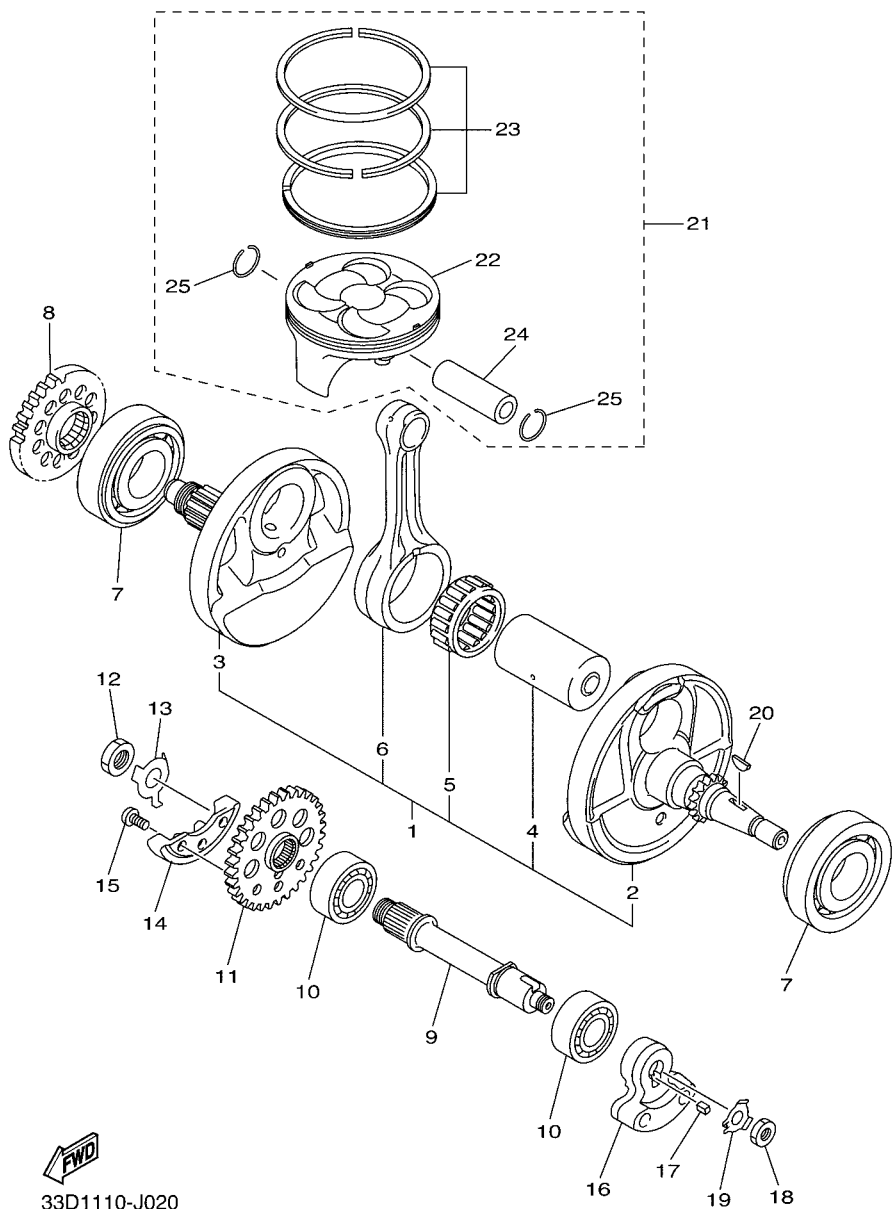

33D1110-J020

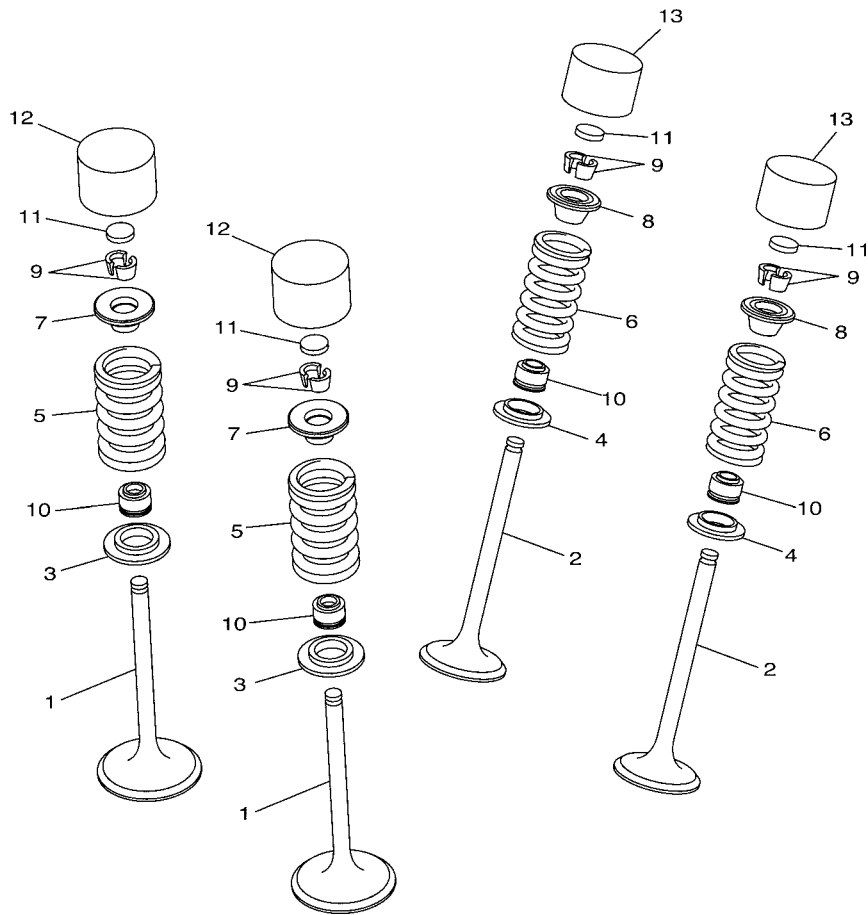

33D1110-J030

FIG. 3 VALVE

REF. NO.	PART NO.	DESCRIPTION	33DD	33DE	33DF	33DG	REMARKS
1	33D-12111-00	VALVE, INTAKE	2	2	2	2	
2	33D-12121-00	VALVE, EXHAUST	2	2	2	2	
3	33D-12116-00	SEAT, VALVE SPRING	2	2	2	2	
4	33D-12126-00	SEAT, VALVE SPRING 2	2	2	2	2	
5	33D-12113-00	SPRING, VALVE INNER	2	2	2	2	
6	33D-12114-00	SPRING, VALVE OUTER	2	2	2	2	
7	33D-12117-00	RETAINER, VALVE SPRING	2	2	2	2	
8	3LD-12117-00	RETAINER, VALVE SPRING	2	2	2	2	
9	3LD-12118-00	COTTER, VALVE	8	8	8	8	
10	51Y-12119-00	SEAL, VALVE STEM	4	4	4	4	
11	3LD-12168-00	PAD, ADJUSTING (1.20)	4	4	4	4	UR
	3LD-12168-20	PAD, ADJUSTING (1.25)	4	4	4	4	UR
	3LD-12168-40	PAD, ADJUSTING (1.30)	4	4	4	4	UR
	3LD-12168-60	PAD, ADJUSTING (1.35)	4	4	4	4	UR
	3LD-12168-80	PAD, ADJUSTING (1.40)	4	4	4	4	UR
	3LD-12168-A0	PAD, ADJUSTING (1.45)	4	4	4	4	UR
	3LD-12168-F0	PAD, ADJUSTING (1.50)	4	4	4	4	UR
	3LD-12168-H1	PAD, ADJUSTING (1.55)	4	4	4	4	UR
	3LD-12168-K1	PAD, ADJUSTING (1.60)	4	4	4	4	UR
	3LD-12168-M1	PAD, ADJUSTING (1.65)	4	4	4	4	UR
	3LD-12168-R1	PAD, ADJUSTING (1.70)	4	4	4	4	UR
	3LD-12168-U1	PAD, ADJUSTING (1.75)	4	4	4	4	UR
	3LD-12168-W1	PAD, ADJUSTING (1.80)	4	4	4	4	UR
	3LD-12168-Y1	PAD, ADJUSTING (1.85)	4	4	4	4	UR
	3LD-12169-11	PAD, ADJUSTING (1.90)	4	4	4	4	UR
	3LD-12169-31	PAD, ADJUSTING (1.95)	4	4	4	4	UR
	3LD-12169-50	PAD, ADJUSTING (2.00)	4	4	4	4	UR

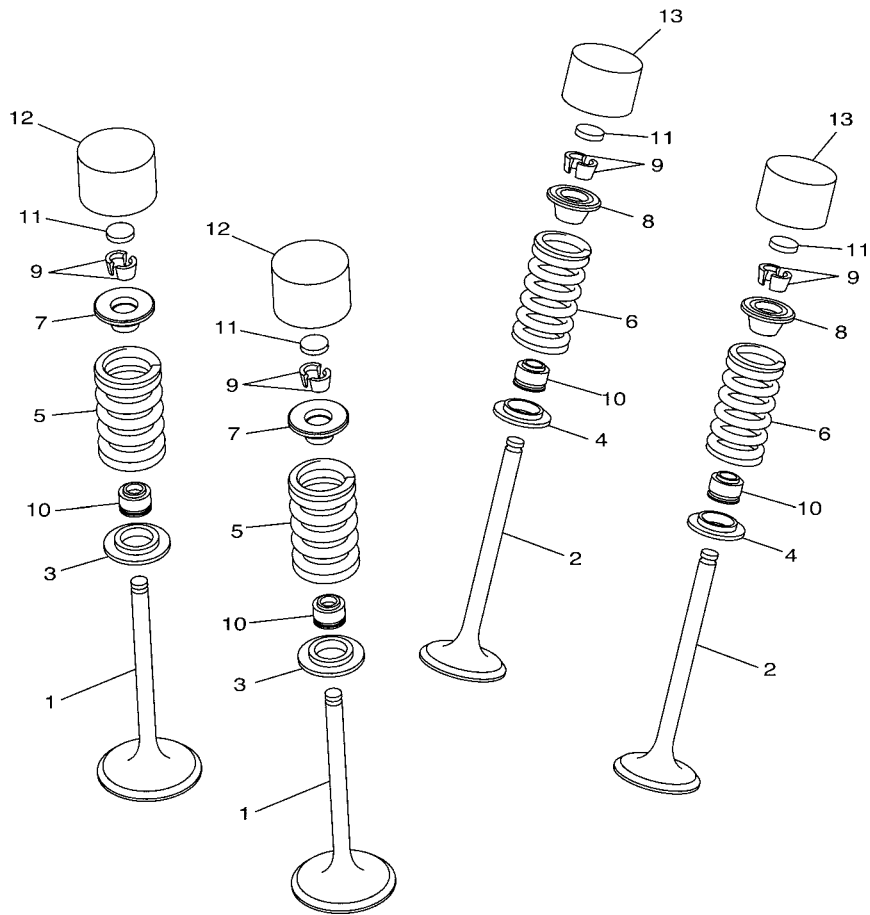

33D1110-J030

FIG. 3 VALVE

REF. NO.	PART NO.	DESCRIPTION	33DD	33DE	33DF	33DG	REMARKS
11	3LD-12169-70	PAD, ADJUSTING (2.05)	4	4	4	4	UR
	3LD-12169-90	PAD, ADJUSTING (2.10)	4	4	4	4	UR
	3LD-12169-E0	PAD, ADJUSTING (2.15)	4	4	4	4	UR
	3LD-12169-G0	PAD, ADJUSTING (2.20)	4	4	4	4	UR
	3LD-12169-J0	PAD, ADJUSTING (2.25)	4	4	4	4	UR
	3LD-12169-L0	PAD, ADJUSTING (2.30)	4	4	4	4	UR
	3LD-12169-N0	PAD, ADJUSTING (2.35)	4	4	4	4	UR
	3LD-12169-T0	PAD, ADJUSTING (2.40)	4	4	4	4	UR
12	4C8-12153-10	LIFTER, VALVE	2	2	2	2	YELLOW
13	5EB-12153-10	LIFTER, VALVE	2	2	2	2	YELLOW

FIG. 4 CAMSHAFT & CHAIN

REF. NO.	PART NO.	DESCRIPTION	33DD	33DE	33DF	33DG	REMARKS
1	33D-12170-00	CAMSHAFT ASSY 1	1	1	1	1	
2	33D-12180-00	CAMSHAFT ASSY 2	1	1	1	1	
3	93440-41178	CIRCLIP	2	2	2	2	
4	94591-57122	CHAIN	1	1	1	1	
5	5TA-12210-30	TENSIONER ASSY, CAM CHAIN	1	1	1	1	
6	5EL-12228-00	.BOLT	1	1	1	1	
7	5EL-12214-00	.GASKET	1	1	1	1	
8	4FM-12213-00	GASKET, TENSIONER CASE	1	1	1	1	
9	95022-06025	BOLT, FLANGE	2	2	2	2	
10	90430-06014	GASKET	1	1	1	1	
11	33D-12251-00	DAMPER, CHAIN 1	1	1	1	1	
12	33D-12252-00	DAMPER, CHAIN 2	1	1	1	1	
13	33D-12233-00	PLATE, GUIDE STOPPER 1	1	1	1	1	
14	90105-06099	BOLT, FLANGE	2	2	2	2	

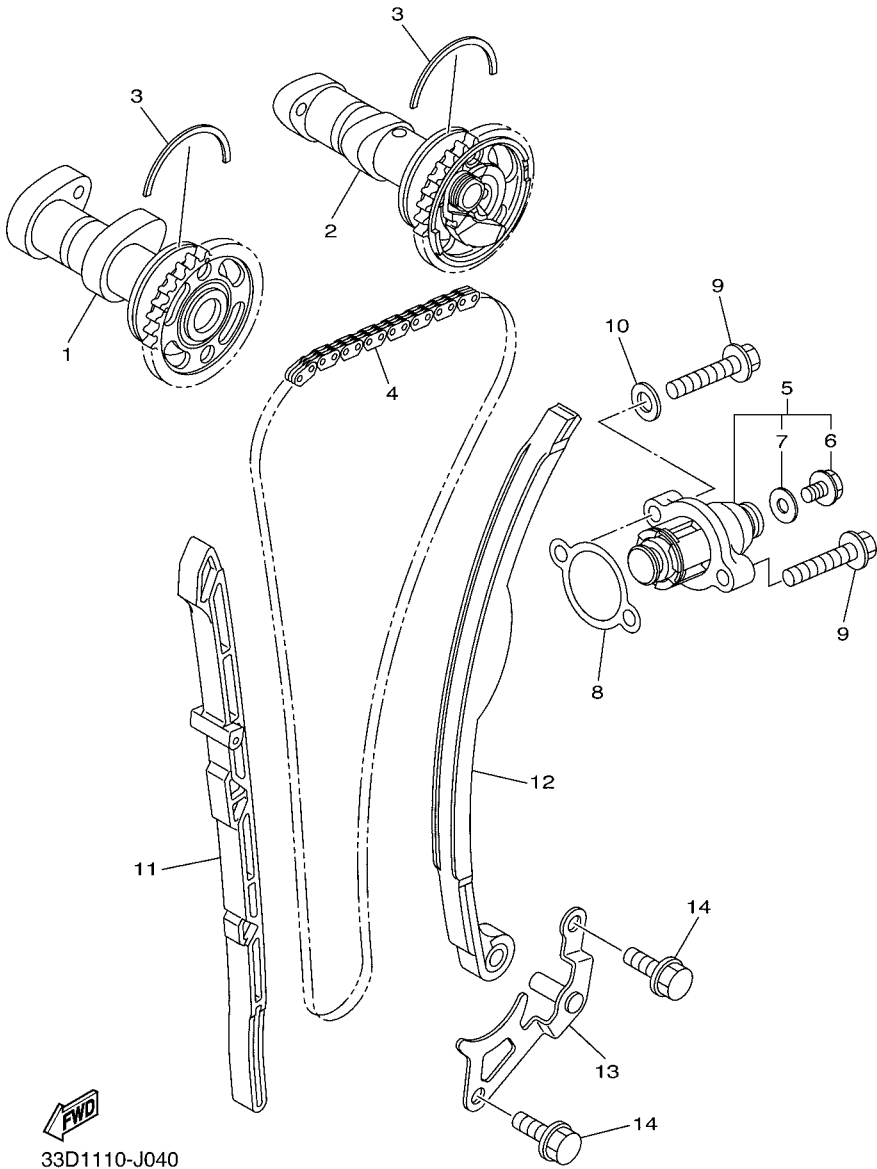

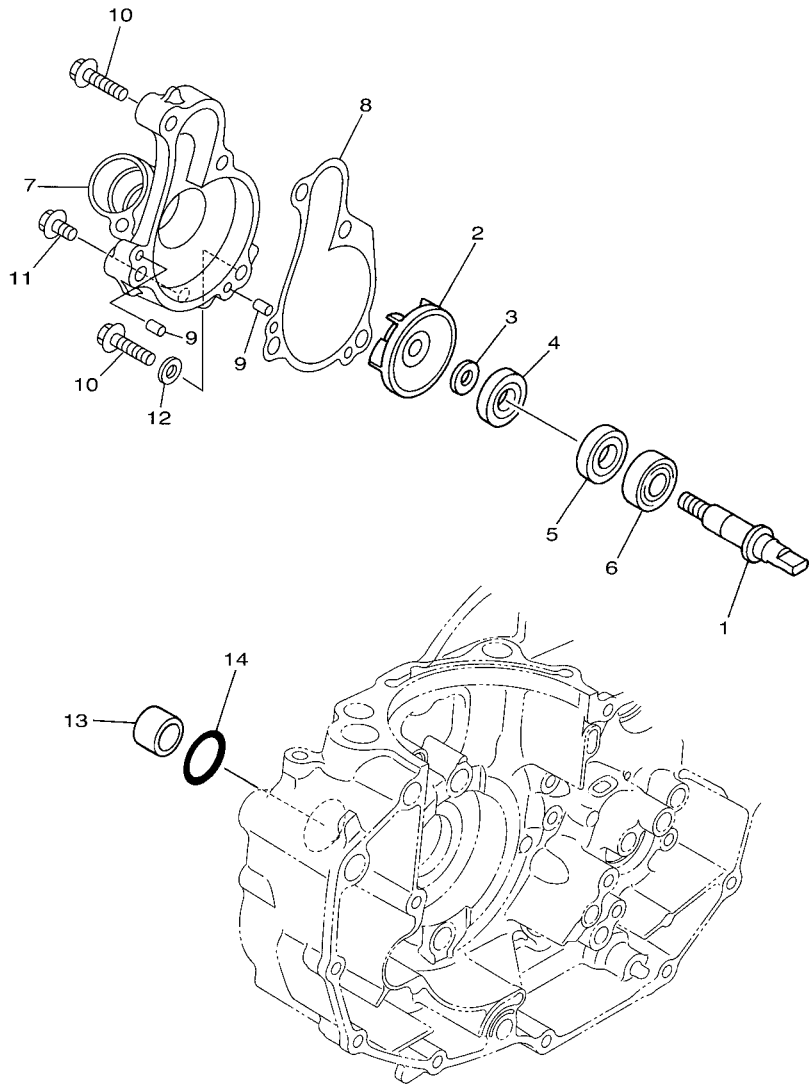

33D1110-J050

FIG. 5 WATER PUMP

REF. NO.	PART NO.	DESCRIPTION	33DD	33DE	33DF	33DG	REMARKS
1	5GR-12458-00	SHAFT, IMPELLER	1	1	1	1	
2	5DJ-12451-00	IMPELLER, WATER PUMP	1	1	1	1	
3	90201-08512	WASHER, PLATE	1	1	1	1	
4	93109-11073	OIL SEAL	1	1	1	1	
5	93102-12106	OIL SEAL (SD 12-22-5 HS)	1	1	1	1	
6	93306-00105	BEARING	1	1	1	1	
7	33D-12422-00	COVER, HOUSING	1	1	1	1	
8	33D-12427-00	GASKET, HOUSING COVER 1	1	1	1	1	
9	93604-10011	PIN, DOWEL	2	2	2	2	
10	95022-06025	BOLT, FLANGE	4	4	4	4	
11	95022-06010	BOLT, FLANGE	1	1	1	1	
12	90430-06014	GASKET	1	1	1	1	
13	5BE-12564-00	PIPE, WATER	1	1	1	1	
14	93210-19758	O-RING	1	1	1	1	

FIG. 6 RADIATOR & HOSE

REF. NO.	PART NO.	DESCRIPTION					REMARKS
			33DD	33DE	33DF	33DG	
1	33D-12446-00	JOINT	1	1	1	1	
2	93210-24253	O-RING	1	1	1	1	
3	95022-06020	BOLT, FLANGE	1	1	1	1	
4	33D-12482-00	PIPE 2	1	1	1	1	
5	95022-06012	BOLT, FLANGE	1	1	1	1	
6	93210-16500	O-RING	1	1	1	1	
7	33D-1240A-00	RADIATOR ASSY	1	1	1	1	
8	33D-12461-00	RADIATOR COMP	1	1	1	1	
9	5SL-12462-00	CAP, RADIATOR	1	1	1	1	
10	33D-12465-00	DAMPER, RADIATOR	3	3	3	3	
11	91A20-05065	TUBE, FLEXIBLE VINYL	1	1	1	1	
12	90467-090A2	CLIP	1	1	1	1	
13	33D-12576-00	HOSE 1	1	1	1	1	
14	33D-12577-00	HOSE 2	1	1	1	1	
15	33D-12578-00	HOSE 3	1	1	1	1	
16	33D-12579-00	HOSE 4	1	1	1	1	
17	90450-28001	HOSE CLAMP ASSY	2	2	2	2	
18	90450-25001	HOSE CLAMP ASSY	3	3	3	3	
19	90450-22001	HOSE CLAMP ASSY	2	2	2	2	
20	90450-32003	HOSE CLAMP ASSY	1	1	1	1	
21	90480-15012	GROMMET	4	4	4	4	
22	90387-06065	COLLAR	4	4	4	4	
23	90105-06111	BOLT, FLANGE	4	4	4	4	
24	90201-06571	WASHER, PLATE	4	4	4	4	
25	90119-06239	BOLT, WITH WASHER	2	2	2	2	

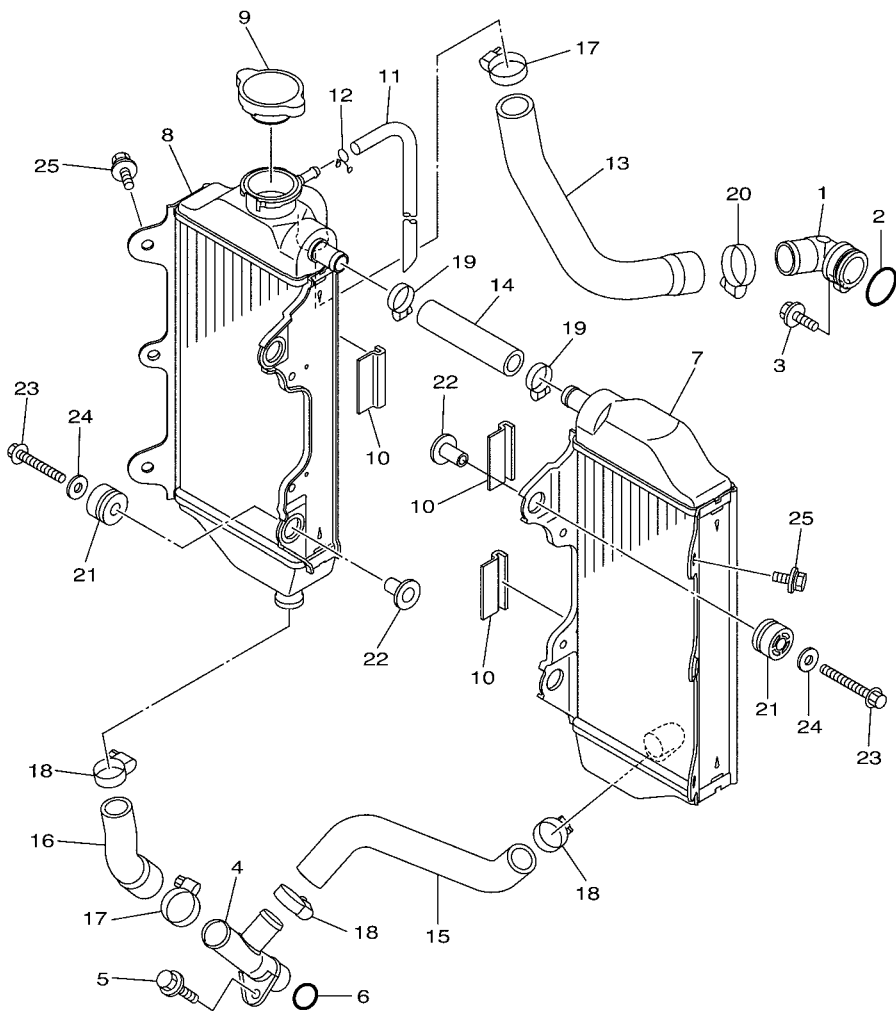

33D1110-J060

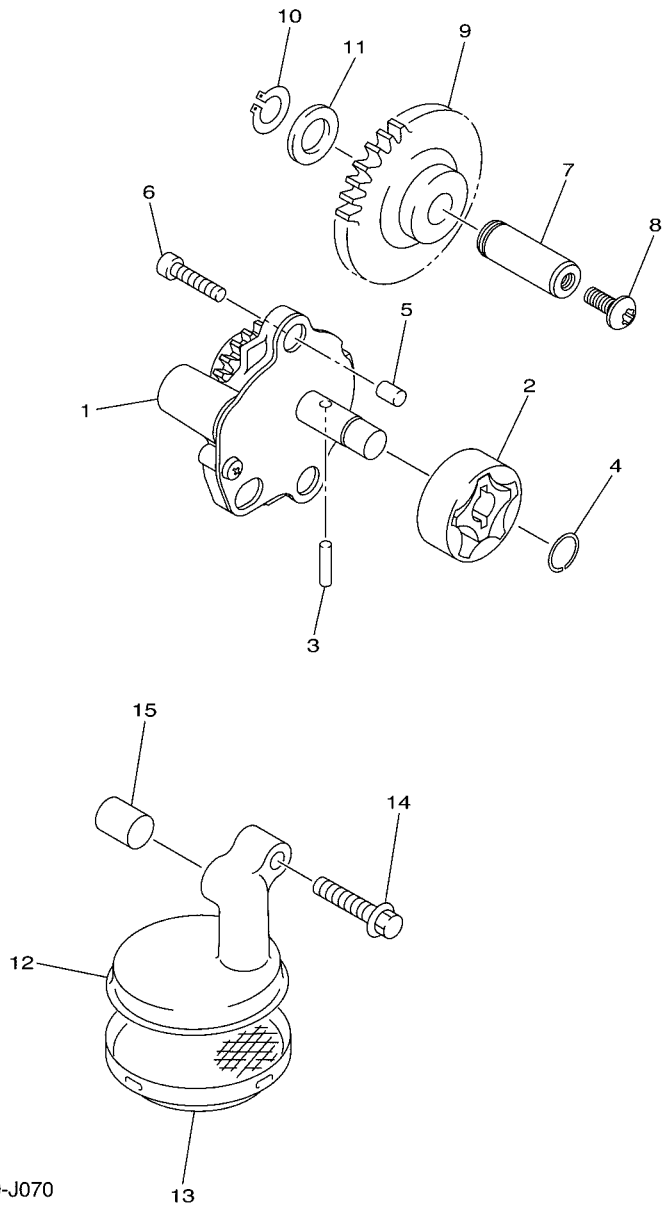
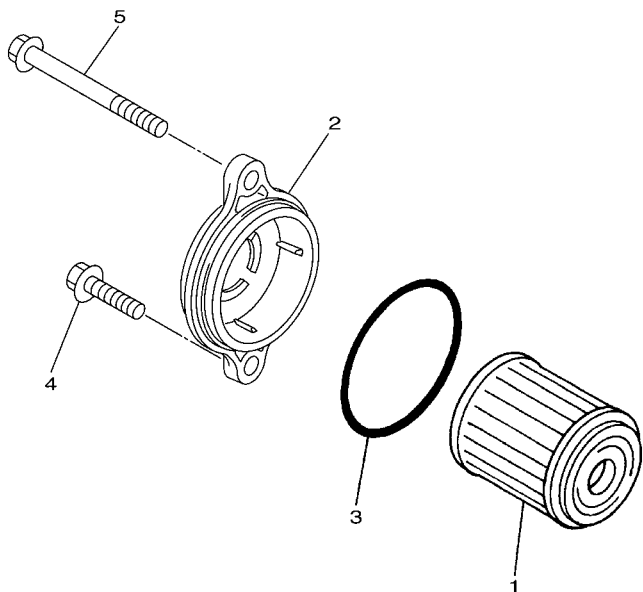

FIG. 7 OIL PUMP

REF. NO.	PART NO.	DESCRIPTION	33DD	33DE	33DF	33DG	REMARKS
1	2S2-13300-10	OIL PUMP ASSY	1	1	1	1	
2	5TA-13320-00	ROTOR ASSY 2	1	1	1	1	
3	93603-16219	PIN, DOWEL	1	1	1	1	
4	93440-10153	CIRCLIP	1	1	1	1	
5	99530-08012	PIN, DOWEL	2	2	2	2	
6	91312-06030	BOLT	2	2	2	2	
7	2S2-13342-00	SHAFT, IDLE GEAR	1	1	1	1	
8	90149-06069	SCREW	1	1	1	1	
9	2S2-13341-00	GEAR, OIL PUMP IDLE	1	1	1	1	
10	99009-12400	CIRCLIP	1	1	1	1	
11	90201-12166	WASHER, PLATE	1	1	1	1	
12	2S2-13412-00	HOUSING, STRAINER	1	1	1	1	
13	5BE-13411-00	STRAINER, OIL	1	1	1	1	
14	90105-06091	BOLT, FLANGE	1	1	1	1	
15	99530-10114	PIN, DOWEL	1	1	1	1	

FIG. 8 OIL CLEANER



REF. NO.	PART NO.	DESCRIPTION	33DD	33DE	33DF	33DG	REMARKS
1	5D3-13440-01	ELEMENT ASSY, OIL CLEANER	1	1	1	1	
2	33D-13447-00	COVER, OIL ELEMENT	1	1	1	1	
3	93210-45708	O-RING	1	1	1	1	
4	95022-06016	BOLT, FLANGE	1	1	1	1	
5	95022-06070	BOLT, FLANGE	1	1	1	1	
<hr style="border-top: 1px dashed black;"/>							
<hr style="border-top: 1px dashed black;"/>							
<hr style="border-top: 1px dashed black;"/>							
<hr style="border-top: 1px dashed black;"/>							
<hr style="border-top: 1px dashed black;"/>							
<hr style="border-top: 1px dashed black;"/>							
<hr style="border-top: 1px dashed black;"/>							
<hr style="border-top: 1px dashed black;"/>							



33D1110-J080

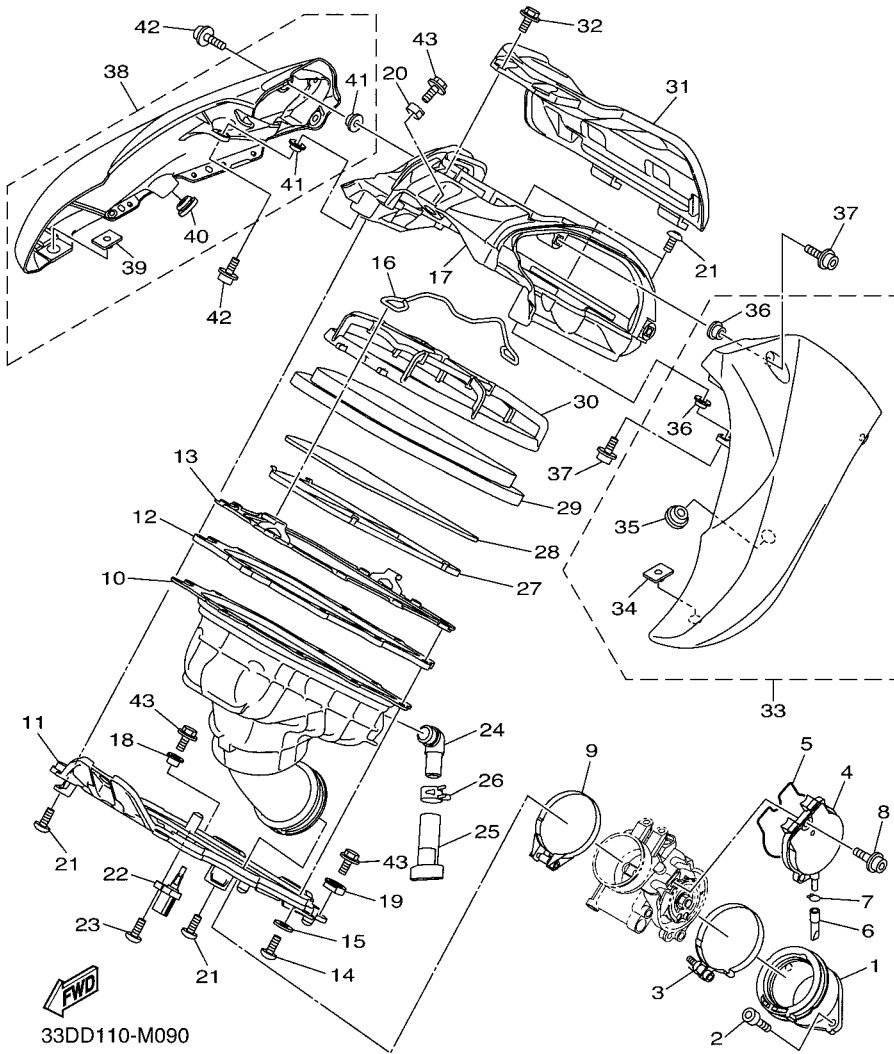
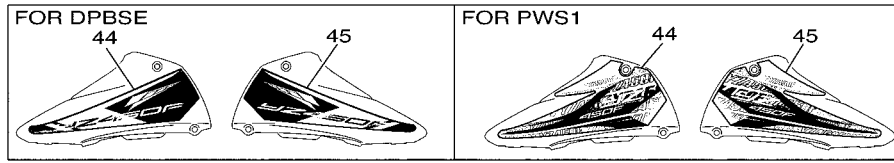

33DD110-M090

FIG. 9 INTAKE

REF. NO.	PART NO.	DESCRIPTION	33DD	33DE	33DF	33DG	REMARKS
1	33D-13597-00	JOINT, CARBURETOR 3	1	1	1	1	
2	91312-06020	BOLT	2	2	2	2	
3	90450-60004	HOSE CLAMP ASSY	1	1	1	1	
4	33D-14293-00	COVER 1	1	1	1	1	
5	33D-14227-00	WASHER	1	1	1	1	
6	33D-14987-00	HOSE	1	1	1	1	
7	3TJ-14137-40	CLIP	1	1	1	1	
8	33D-14428-00	BOLT	2	2	2	2	
9	90450-58007	HOSE CLAMP ASSY	1	1	1	1	
10	33D-14454-00	JOINT	1	1	1	1	
11	33D-14477-00	PLATE	1	1	1	1	
12	33D-14462-00	SEAL	1	1	1	1	
13	33D-14459-00	HOLDER, GUIDE	1	1	1	1	
14	90111-04008	BOLT, HEX. SOCKET BUTTON	9	9	9	9	
15	90201-04030	WASHER, PLATE	9	9	9	9	
16	33D-1441G-00	BINDER 1	1	1	1	1	
17	33D-14417-00	COVER 1	1	1	1	1	
18	90387-06009	COLLAR	1	1	1	1	
19	33D-14495-00	COLLAR	1	1	1	1	
20	33D-14449-00	COLLAR	1	1	1	1	
21	97702-50516	SCREW, TAPPING	9	9	9	9	
22	8FP-85886-00	SENSOR, AIR TEMPERATURE	1	1	1	1	
23	97702-50516	SCREW, TAPPING	1	1	1	1	
24	5TJ-14419-00	PIPE	1	1	1	1	
25	33D-1443E-00	PIPE, DRAIN	1	1	1	1	
26	90467-16098	CLIP	1	1	1	1	
27	33D-1441B-00	NET 1	1	1	1	1	

FIG. 9 INTAKE

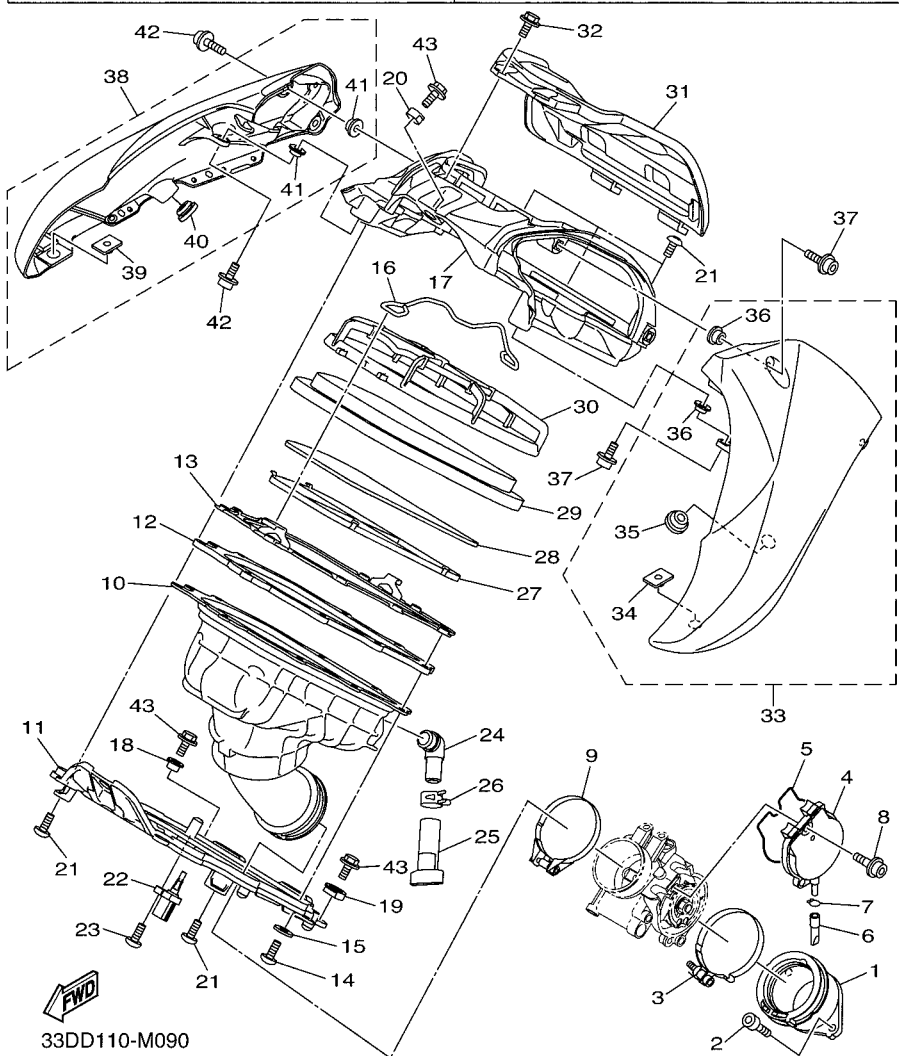
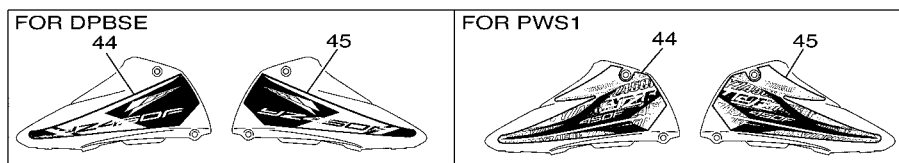

REF. NO.	PART NO.	DESCRIPTION	33DD	33DE	33DF	33DG	REMARKS
28	33D-14461-00	ELEMENT, AIR CLEANER 2	1	1	1	1	
29	33D-14451-00	ELEMENT, AIR CLEANER	1	1	1	1	
30	33D-14458-00	GUIDE	1	1	1	1	
31	33D-14480-00	COVER SUB ASSY	1	1	1	1	
32	90105-05028	BOLT, FLANGE	2	2	2	2	
33	33D-14437-00	DUCT	1	1	1	1	UR FOR DPBSE
	33D-14437-10	DUCT	1	1	1	1	UR FOR PWS1
34	90179-06055	.NUT	1	1	1	1	
35	33D-14425-00	.DAMPER 1	1	1	1	1	
36	90387-06009	.COLLAR	3	3	3	3	
37	90110-06245	BOLT, HEXAGON SOCKET HEAD	3	3	3	3	
38	33D-1443A-00	DUCT	1	1	1	1	UR FOR DPBSE
	33D-1443A-10	DUCT	1	1	1	1	UR FOR PWS1
39	90179-06055	.NUT	1	1	1	1	
40	33D-14425-00	.DAMPER 1	1	1	1	1	
41	90387-06009	.COLLAR	3	3	3	3	
42	90110-06245	BOLT, HEXAGON SOCKET HEAD	3	3	3	3	
43	90105-06170	BOLT, FLANGE	3	3	3	3	
44	33D-2173E-50	GRAPHIC 1	1	1	1	1	UR FOR DPBSE
	33D-2173E-60	GRAPHIC 1	1	1	1	1	UR FOR PWS1
45	33D-2173F-50	GRAPHIC 2	1	1	1	1	UR FOR DPBSE
	33D-2173F-60	GRAPHIC 2	1	1	1	1	UR FOR PWS1

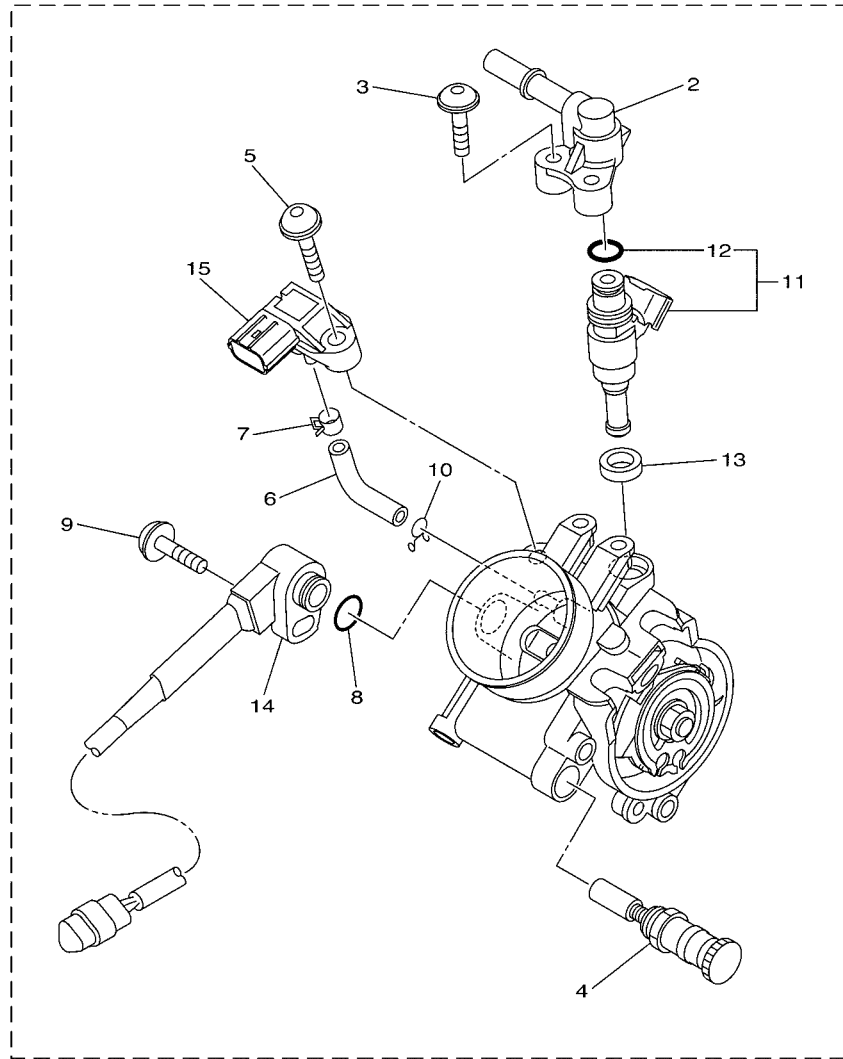

33D1110-J100

FIG. 10 INTAKE 2

REF. NO.	PART NO.	DESCRIPTION	33DD	33DE	33DF	33DG	REMARKS
1	33D-13750-00	THROTTLE BODY ASSY	1	1	1	1	
2	33D-13938-00	.PIPE	1	1	1	1	
3	33D-14486-00	.SCREW, ROD	2	2	2	2	
4	33D-14171-00	.PLUNGER, STARTER	1	1	1	1	
5	33D-14325-00	.SCREW, PAN HEAD	1	1	1	1	
6	33D-14348-00	.PIPE 1	1	1	1	1	
7	33D-13577-00	.CLIP	1	1	1	1	
8	33D-14562-00	.O-RING	1	1	1	1	
9	33D-14216-00	.SCREW	1	1	1	1	
10	3TJ-14137-40	.CLIP	1	1	1	1	
11	3B4-13761-00	.INJECTOR	1	1	1	1	
12	5PS-14147-00	.O-RING	1	1	1	1	
13	90430-09002	.GASKET	1	1	1	1	
14	33D-85885-00	.THROTTLE SENSOR ASSY	1	1	1	1	
15	2C0-82380-00	.SENSOR, PRESSURE	1	1	1	1	

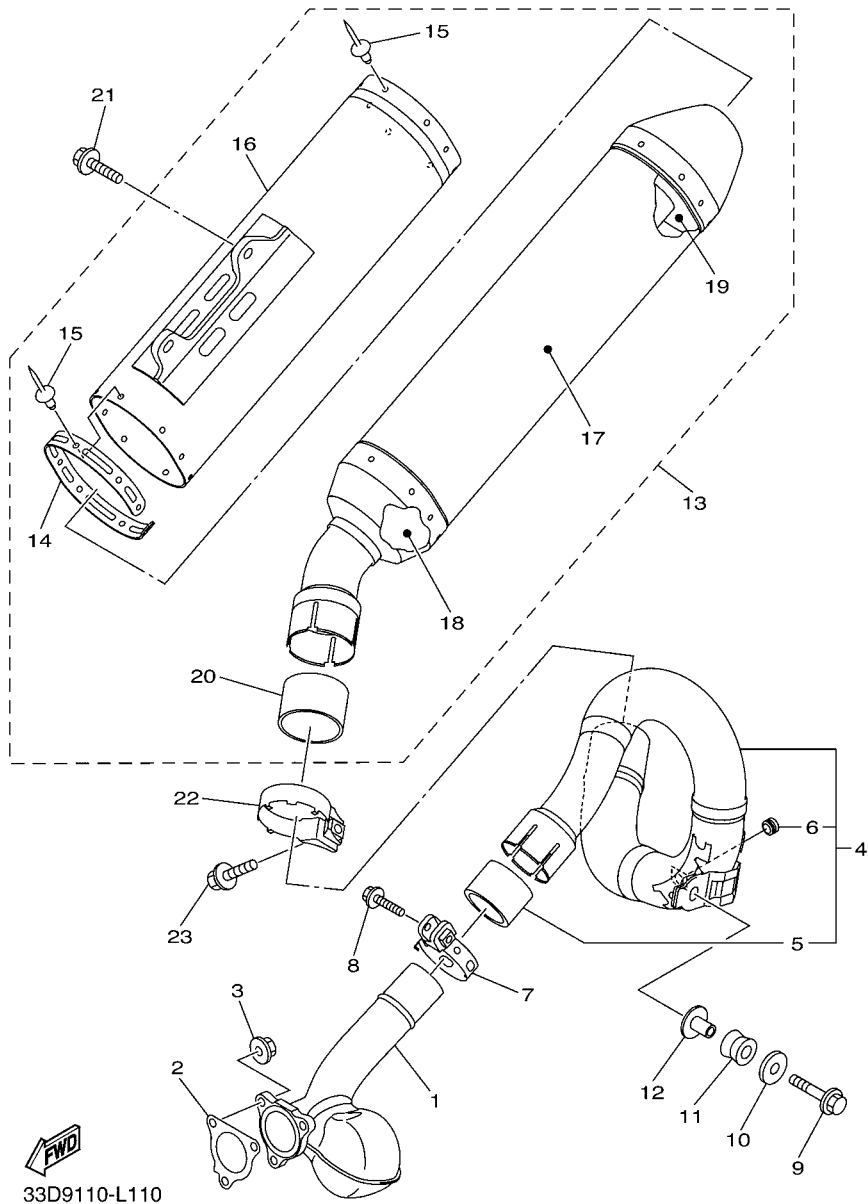

33D9110-L110

FIG. 11 EXHAUST

REF. NO.	PART NO.	DESCRIPTION	33DD	33DE	33DF	33DG	REMARKS
1	33D-14611-00	PIPE, EXHAUST 1	1	1	1	1	
2	33D-14613-00	GASKET, EXHAUST PIPE	1	1	1	1	
3	95704-06500	NUT, FLANGE	3	3	3	3	
4	33D-14620-00	EXHAUST PIPE ASSY 2	1	1	1	1	
5	5PH-14714-00	.GASKET, MUFFLER	1	1	1	1	
6	2D1-14737-00	.DAMPER, MUFFLER	1	1	1	1	
7	33D-14788-00	BAND, SILENCER	1	1	1	1	
8	95024-08035	BOLT, FLG.(SMALL HEAD)	1	1	1	1	
9	90105-08137	BOLT, FLANGE	1	1	1	1	
10	90201-08061	WASHER, PLATE	1	1	1	1	
11	5VY-14747-00	DAMPER, MUFFLER	1	1	1	1	
12	90387-08081	COLLAR	1	1	1	1	
13	33D-14750-10	SILENCER ASSY	1				
	33D-14750-E0	SILENCER ASSY		1	1	1	
14	33D-1476F-10	.REINF. ,3	1	1	1	1	
15	90267-48084	.RIVET, BLIND	16	16	16	16	
16	33D-1466G-10	.BODY, SILENCER	1	1	1	1	
17	2S2-1469A-10	.FIBER	1	1	1	1	
18	2S2-1469E-00	.FIBER	1	1	1	1	
19	2S2-1469F-00	.FIBER	1	1	1	1	
20	8GL-14714-00	.GASKET, MUFFLER	1	1	1	1	
21	90119-08133	BOLT, WITH WASHER	2	2	2	2	
22	8GL-14789-00	BAND, SILENCER	1	1	1	1	
23	95024-08025	BOLT, FLG.(SMALL HEAD)	1	1	1	1	

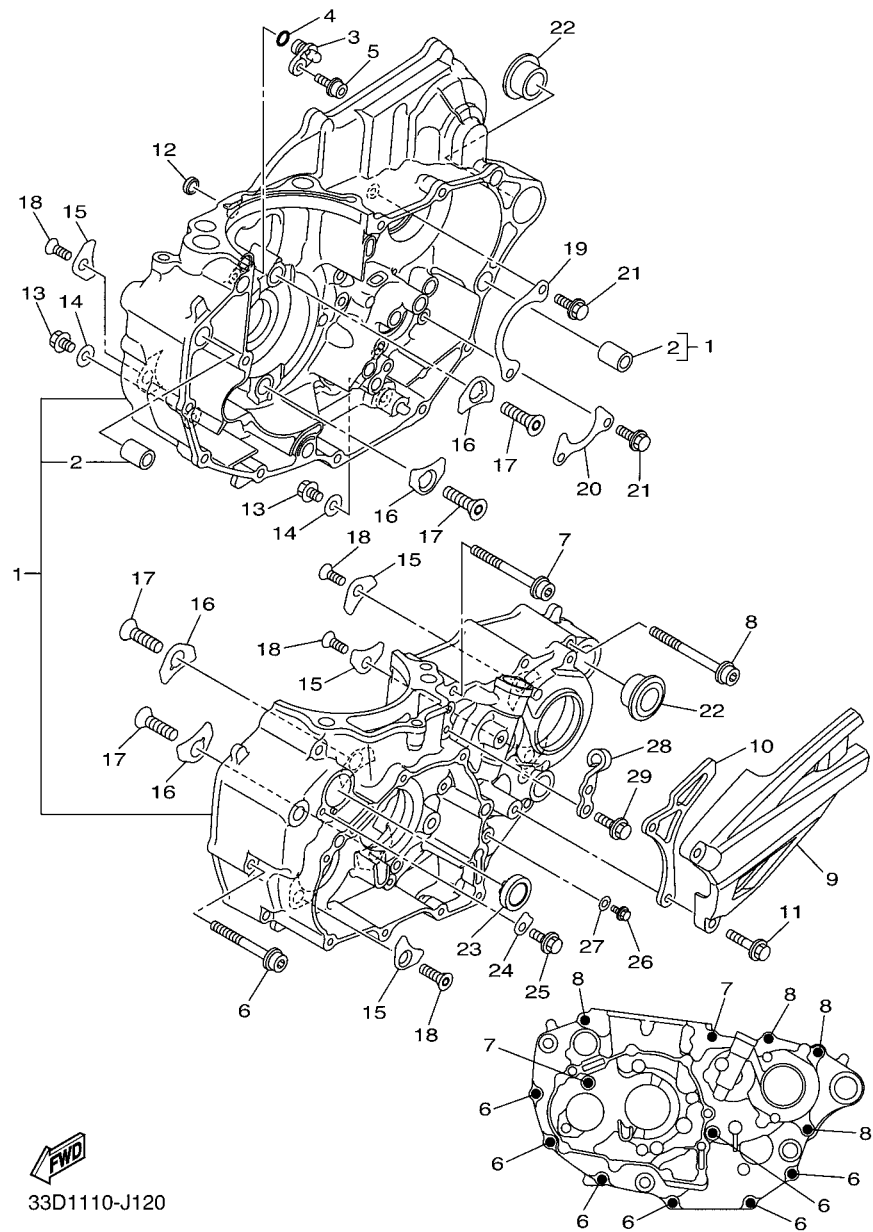

33D1110-J120

FIG. 12 CRANKCASE

REF. NO.	PART NO.	DESCRIPTION	33DD	33DE	33DF	33DG	REMARKS
1	33D-15100-09	CRANKCASE ASSY	1	1	1	1	
2	99530-14016	.PIN, DOWEL	2	2	2	2	
3	17D-15155-00	NOZZLE 3	1	1	1	1	
4	93210-07001	O-RING	1	1	1	1	
5	90110-05062	BOLT, HEXAGON SOCKET HEAD	1	1	1	1	
6	90110-06362	BOLT, HEXAGON SOCKET HEAD	7	7	7	7	
7	90110-06363	BOLT, HEXAGON SOCKET HEAD	2	2	2	2	
8	90110-06364	BOLT, HEXAGON SOCKET HEAD	4	4	4	4	
9	33D-15421-00	COVER, CRANKCASE 2	1	1	1	1	
10	2S2-17466-00	GUIDE, CHAIN	1	1	1	1	
11	90105-06189	BOLT, FLANGE	2	2	2	2	
12	90430-08002	GASKET	1	1	1	1	
13	95822-08016	BOLT, FLANGE	2	2	2	2	
14	90430-08119	GASKET	2	2	2	2	
15	4JT-15381-01	PLATE, BEARING COVER	4	4	4	4	
16	18P-15383-00	PLATE, BEARING COVER	4	4	4	4	
17	90151-08003	SCREW, COUNTERSUNK	4	4	4	4	
18	90149-06074	SCREW	4	4	4	4	
19	2S2-15388-00	PLATE, BEARING COVER	1	1	1	1	
20	33D-18562-00	PLATE, STOPPER 2	1	1	1	1	
21	90105-06081	BOLT, FLANGE	4	4	4	4	
22	90387-17015	COLLAR	2	2	2	2	
23	3Y1-15361-00	GAUGE, LEVEL	1	1	1	1	
24	5XC-15118-00	HOLDER	1	1	1	1	
25	95022-06012	BOLT, FLANGE	1	1	1	1	
26	95022-06012	BOLT, FLANGE	1	1	1	1	
27	90430-06014	GASKET	1	1	1	1	

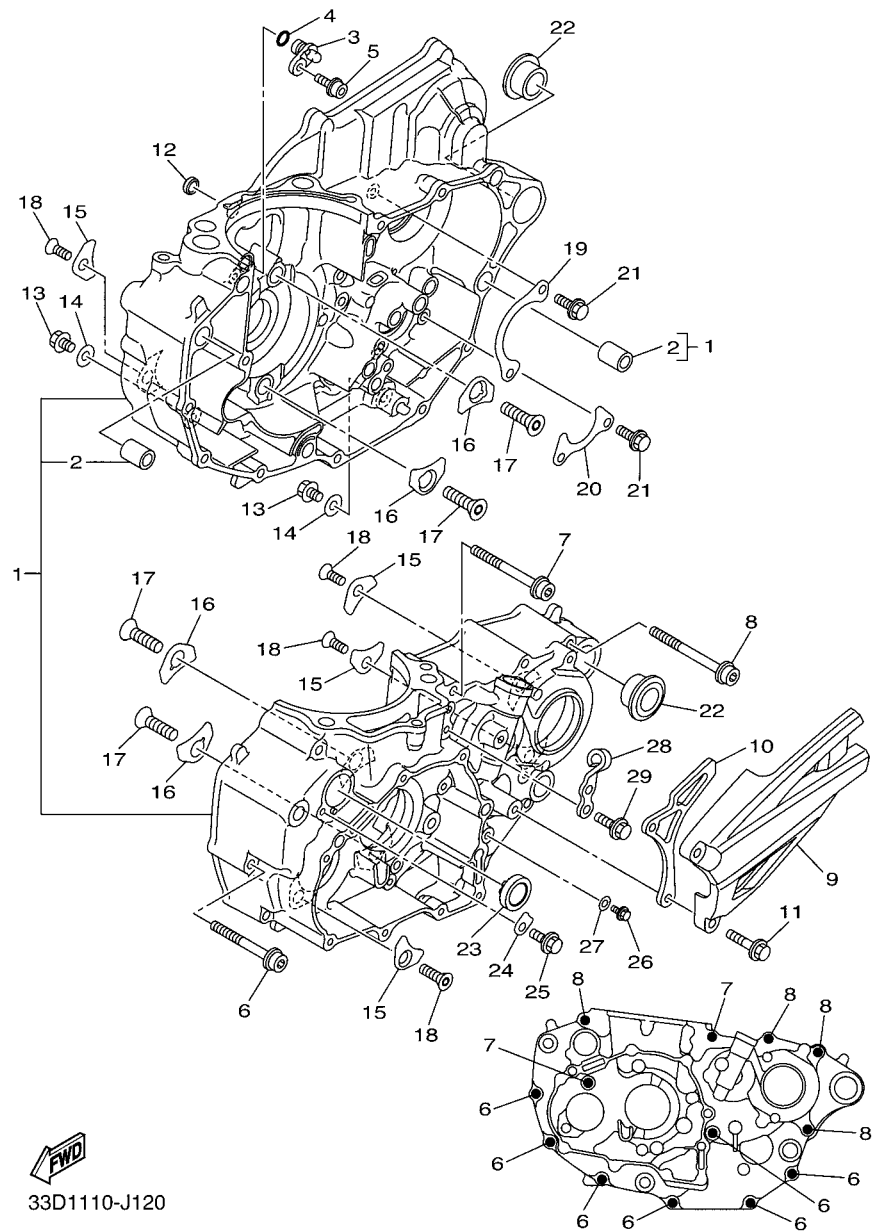

33D1110-J120

FIG. 12 CRANKCASE

REF. NO.	PART NO.	DESCRIPTION	33DD	33DE	33DF	33DG	REMARKS
28	33D-15441-10	HOLDER, CLUTCH CABLE	1	1	1	1	
29	90105-06099	BOLT, FLANGE	2	2	2	2	

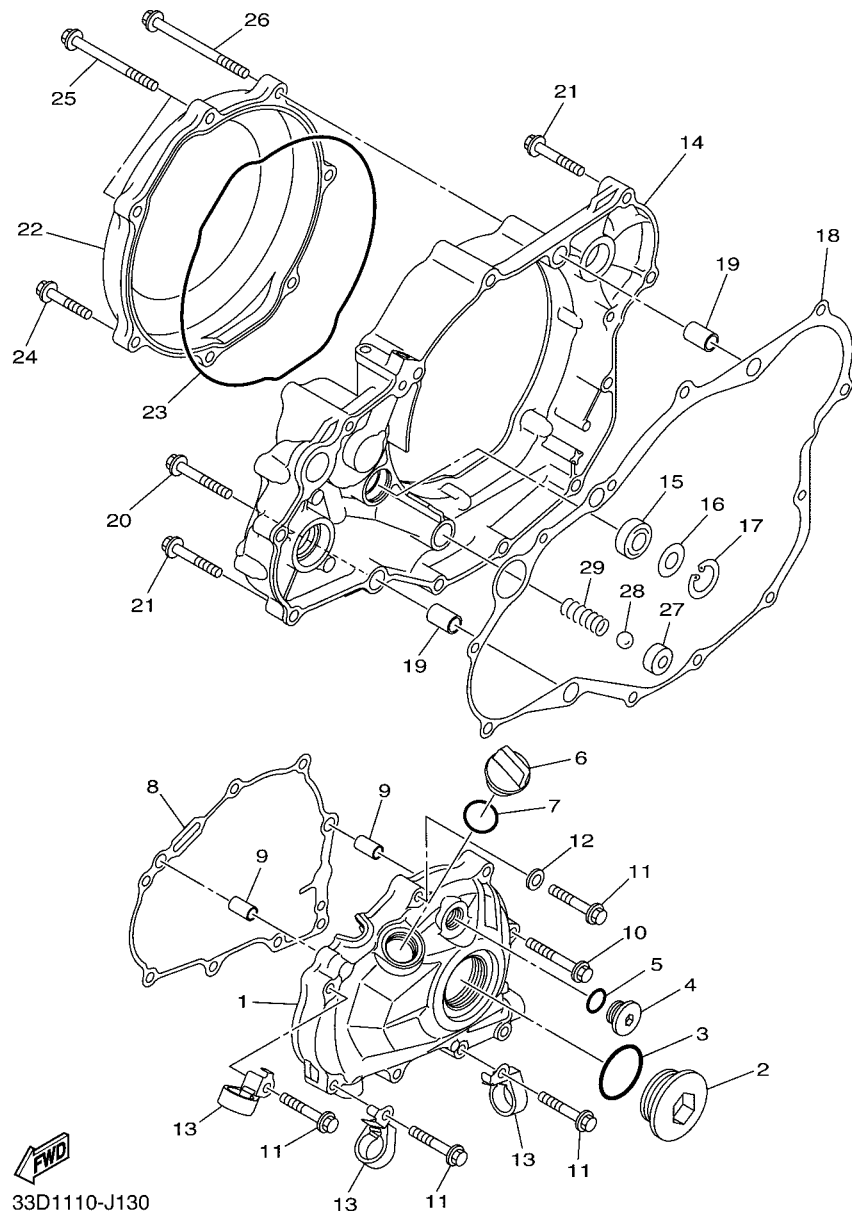

33D1110-J130

FIG. 13 CRANKCASE COVER 1

REF. NO.	PART NO.	DESCRIPTION	33DD	33DE	33DF	33DG	REMARKS
1	33D-15411-00	COVER, CRANKCASE 1	1	1	1	1	
2	90340-36002	PLUG, STRAIGHT SCREW	1	1	1	1	
3	93210-357A3	O-RING	1	1	1	1	
4	90340-14011	PLUG, STRAIGHT SCREW	1	1	1	1	
5	93210-14369	O-RING	1	1	1	1	
6	3Y1-15363-10	PLUG, OIL	1	1	1	1	
7	93210-19123	O-RING	1	1	1	1	
8	33D-15451-00	GASKET, CRANKCASE COVER 1	1	1	1	1	
9	99530-08016	PIN, DOWEL	2	2	2	2	
10	95022-06040	BOLT, FLANGE	1	1	1	1	
11	95022-06030	BOLT, FLANGE	7	7	7	7	
12	90430-06014	GASKET	1	1	1	1	
13	2S2-15378-00	HOLDER	3	3	3	3	
14	33D-15431-00	COVER, CRANKCASE 3	1	1	1	1	
15	93101-14164	OIL SEAL	1	1	1	1	
16	90201-15701	WASHER, PLATE (T=1.0)	1	1	1	1	
17	99009-22500	CIRCLIP	1	1	1	1	
18	33D-15462-00	GASKET, CRANKCASE COVER 3	1	1	1	1	
19	91812-16001	PIN, DOWEL	2	2	2	2	
20	95022-06040	BOLT, FLANGE	1	1	1	1	
21	95022-06030	BOLT, FLANGE	8	8	8	8	
22	33D-15415-10	COVER, GENERATOR	1	1	1	1	
23	33D-15453-00	GASKET	1	1	1	1	
24	95022-06025	BOLT, FLANGE	4	4	4	4	
25	95022-06070	BOLT, FLANGE	2	2	2	2	
26	95022-06080	BOLT, FLANGE	1	1	1	1	
27	583-13113-00	SEAT, CHECK BALL	1	1	1	1	

FIG. 14 STARTER

REF. NO.	PART NO.	DESCRIPTION	33DD	33DE	33DF	33DG	REMARKS
1	2S2-15601-00	KICK SHAFT ASSY	1	1	1	1	
2	90201-20685	.WASHER, PLATE (T=0.5)	1	1	1	1	
3	93410-20038	.CIRCLIP	1	1	1	1	
4	2S2-15671-00	.WHEEL, RATCHET	1	1	1	1	
5	90501-160A2	.SPRING, COMPRESSION	1	1	1	1	
6	90201-167P7	.WASHER, PLATE	1	1	1	1	
7	99009-16400	.CIRCLIP	1	1	1	1	
8	5GR-15664-00	.GUIDE, SPRING	1	1	1	1	
9	90508-305B0	.SPRING, TORSION	1	1	1	1	
10	90201-162H4	WASHER, PLATE	1	1	1	1	
11	3Y6-15674-00	GUIDE, RATCHET WHEEL	1	1	1	1	
12	2NX-15668-00	STOPPER	1	1	1	1	
13	90101-06044	BOLT	2	2	2	2	
14	93102-20108	OIL SEAL	1	1	1	1	
15	5TA-15651-00	GEAR, KICK IDLE	1	1	1	1	
16	90201-20685	WASHER, PLATE (T=0.5)	1	1	1	1	
17	99009-20400	CIRCLIP	1	1	1	1	
18	33D-15620-01	KICK CRANK ASSY	1	1	1	1	
19	33D-15621-01	.BOSS, KICK CRANK	1	1	1	1	
20	90501-147A5	.SPRING, COMPRESSION	1	1	1	1	
21	93507-32009	.BALL	1	1	1	1	
22	90151-06045	.SCREW, COUNTERSUNK	1	1	1	1	
23	93210-17570	.O-RING	1	1	1	1	
24	90110-08087	BOLT, HEXAGON SOCKET HEAD	1	1	1	1	
25	90201-08047	WASHER, PLATE	1	1	1	1	

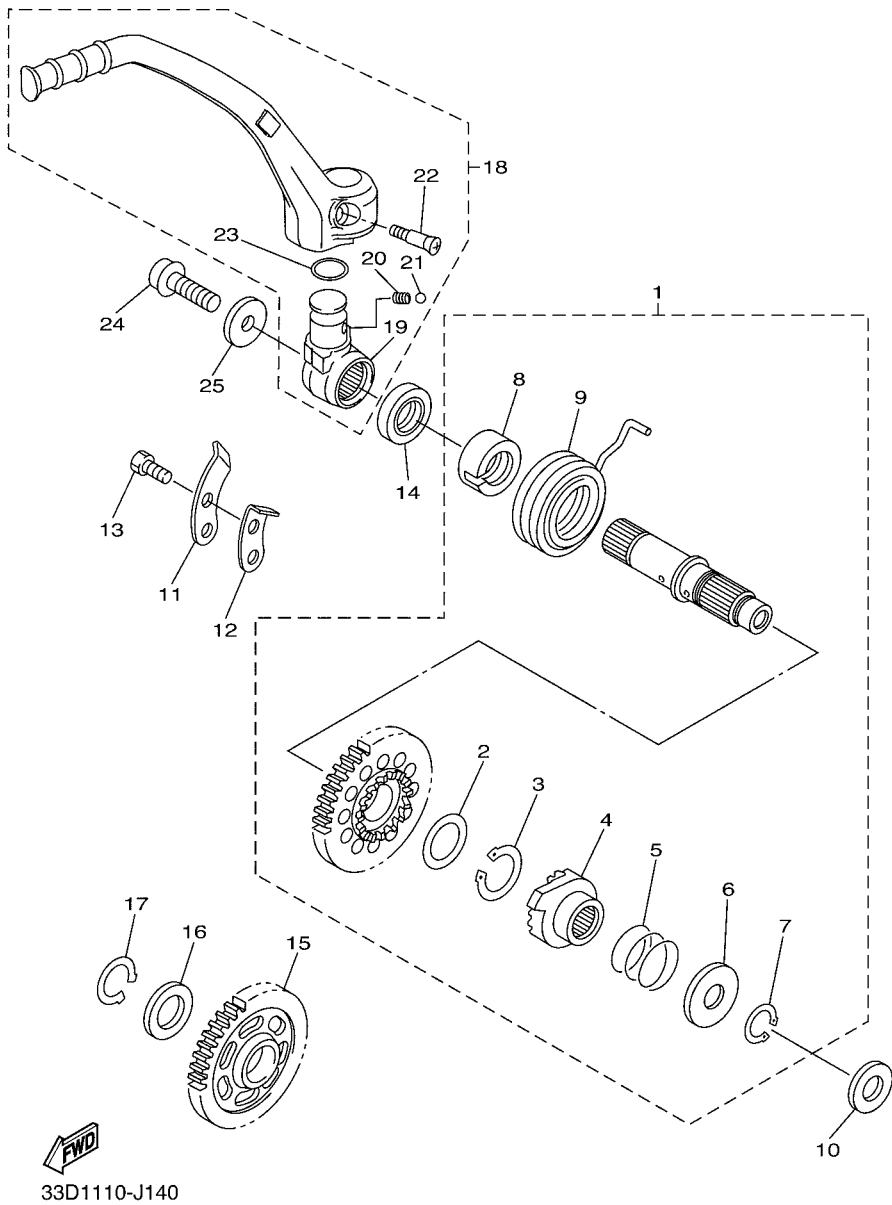

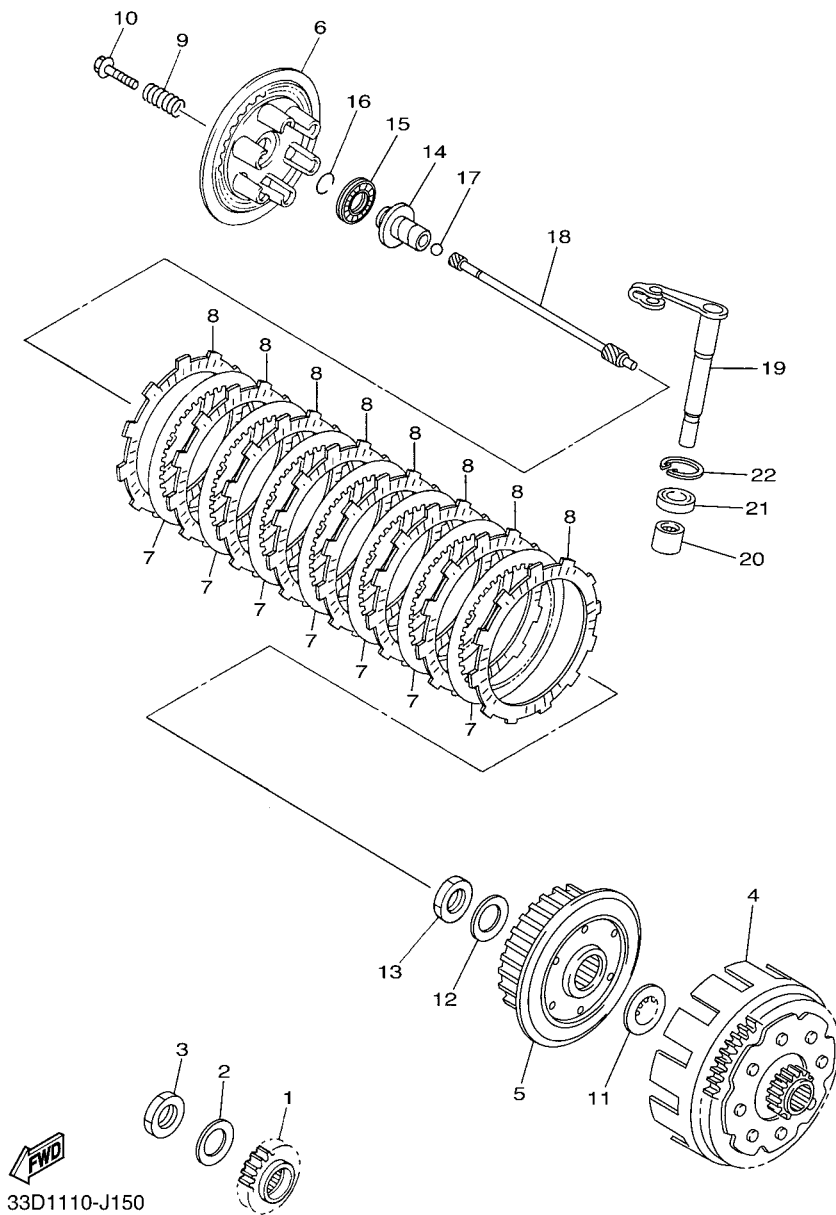
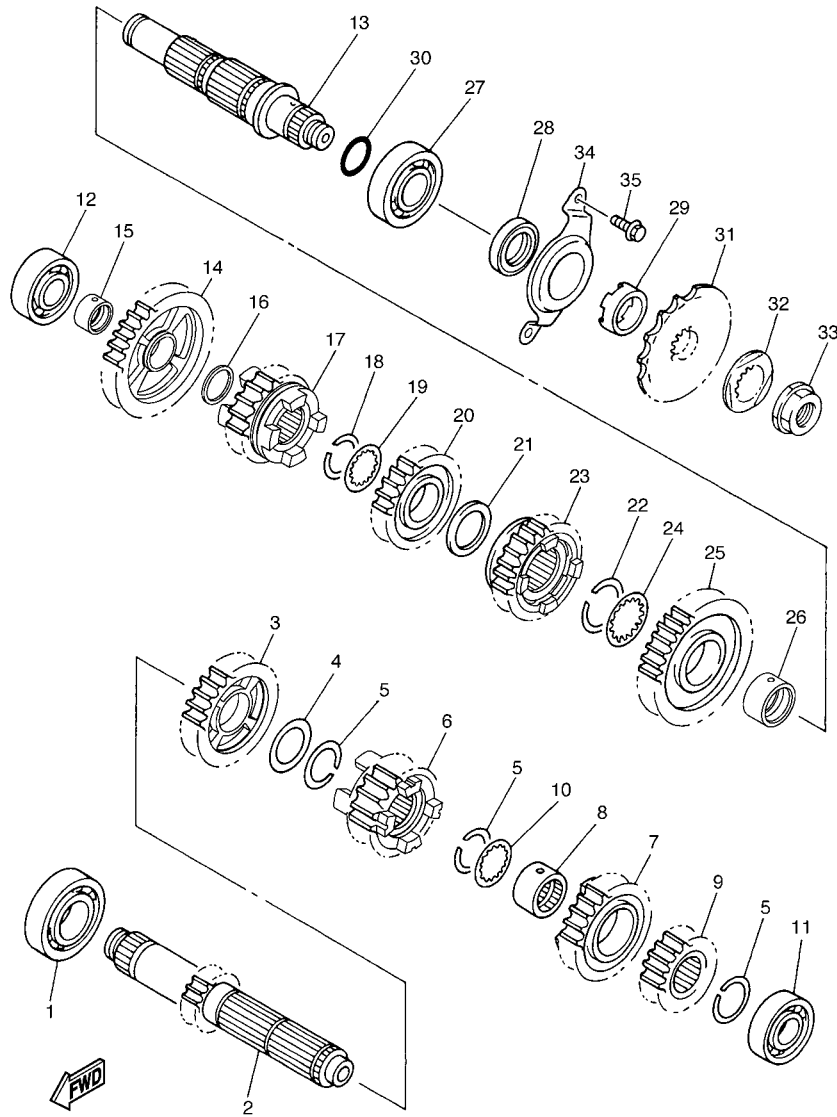

FIG. 15 CLUTCH

REF. NO.	PART NO.	DESCRIPTION	33DD	33DE	33DF	33DG	REMARKS
1	2S2-16111-60	GEAR, PRIMARY DRIVE	1	1	1	1	
2	90208-20008	WASHER, CONICAL SPRING	1	1	1	1	
3	90170-20255	NUT	1	1	1	1	
4	5XD-16150-60	PRIMARY DRIVEN GEAR COMP.	1	1	1	1	
5	5TA-16371-10	BOSS, CLUTCH	1	1	1	1	
6	2S2-16351-00	PLATE, PRESSURE 1	1	1	1	1	
7	4B1-16324-00	PLATE, CLUTCH 1	7	7	7	7	
8	5TA-16321-00	PLATE, FRICTION	8	8	8	8	
9	90501-230E4	SPRING, COMPRESSION	6	6	6	6	
10	90159-06010	SCREW, WITH WASHER	6	6	6	6	
11	5XD-16154-00	PLATE, THRUST 1	1	1	1	1	
12	90208-20008	WASHER, CONICAL SPRING	1	1	1	1	
13	90170-20255	NUT	1	1	1	1	
14	33D-16356-00	ROD, PUSH 1	1	1	1	1	
15	93340-21209	BEARING	1	1	1	1	
16	93440-10085	CIRCLIP	1	1	1	1	
17	93511-32027	BALL	1	1	1	1	
18	2S2-16357-00	ROD, PUSH 2	1	1	1	1	
19	33D-16381-10	PUSH LEVER COMP.	1	1	1	1	
20	93317-11287	BEARING	1	1	1	1	
21	93102-12224	OIL SEAL	1	1	1	1	
22	99009-20500	CIRCLIP	1	1	1	1	



2S21100-E160

FIG. 16 TRANSMISSION

REF. NO.	PART NO.	DESCRIPTION	33DD	33DE	33DF	33DG	REMARKS
1	93306-20532	BEARING	1	1	1	1	
2	2S2-17411-00	AXLE,MAIN(14T)	1	1	1	1	
3	2S2-17151-00	GEAR, 5TH PINION(21T)	1	1	1	1	
4	90201-253K0	WASHER, PLATE (T=1.0)	1	1	1	1	
5	93440-25084	CIRCLIP	3	3	3	3	
6	33D-17131-00	GEAR, 3RD PINION (18T)	1	1	1	1	
7	2S2-17141-00	GEAR, 4TH PINION (22T)	1	1	1	1	
8	90387-21005	COLLAR	1	1	1	1	
9	2S2-17121-00	GEAR, 2ND PINION(15T)	1	1	1	1	
10	90209-21332	WASHER	1	1	1	1	
11	93306-00447	BEARING	1	1	1	1	
12	93306-00426	BEARING	1	1	1	1	
13	33D-17402-00	DRIVE AXLE ASSY	1	1	1	1	
14	2S2-17211-00	GEAR, 1ST WHEEL(27T)	1	1	1	1	
15	90387-20028	COLLAR	1	1	1	1	
16	90201-203E7	WASHER, PLATE	1	1	1	1	
17	33D-17251-00	GEAR, 5TH WHEEL (20T)	1	1	1	1	
18	93440-25084	CIRCLIP	1	1	1	1	
19	90209-22008	WASHER	1	1	1	1	
20	2S2-17231-00	GEAR, 3RD WHEEL(23T)	1	1	1	1	
21	90201-253K0	WASHER, PLATE (T=1.0)	1	1	1	1	
22	93440-28062	CIRCLIP	1	1	1	1	
23	2S2-17241-00	GEAR, 4TH WHEEL(24T)	1	1	1	1	
24	90209-26348	WASHER	1	1	1	1	
25	2S2-17221-00	GEAR, 2ND WHEEL(23T)	1	1	1	1	
26	90387-28012	COLLAR	1	1	1	1	
27	93306-205A5	BEARING	1	1	1	1	

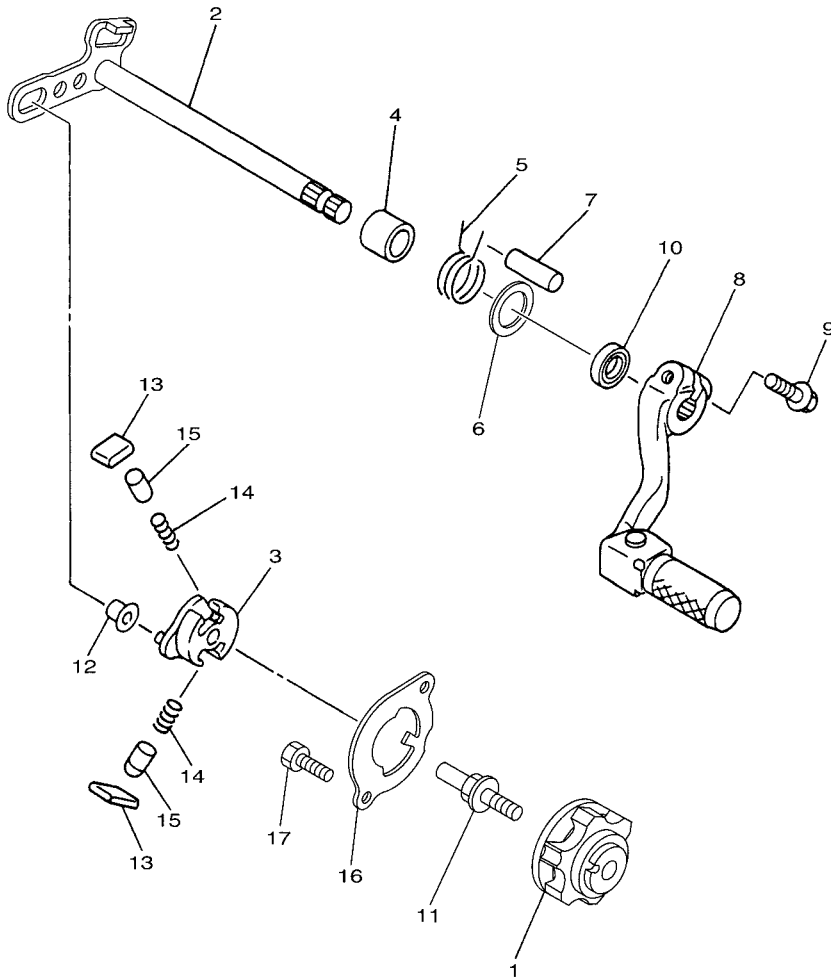

33D1110-J180

FIG. 18 SHIFT SHAFT

REF. NO.	PART NO.	DESCRIPTION	33DD	33DE	33DF	33DG	REMARKS
1	1C3-18185-00	SEGMENT	1	1	1	1	
2	33D-18101-00	SHIFT SHAFT ASSY	1	1	1	1	
3	18P-18122-00	LEVER, SHIFT 2	1	1	1	1	
4	90387-124F4	COLLAR	1	1	1	1	
5	90508-29021	SPRING, TORSION	1	1	1	1	
6	90201-127E1	WASHER, PLATE	1	1	1	1	
7	93608-33002	PIN, DOWEL	1	1	1	1	
8	2S2-18110-00	SHIFT PEDAL ASSY	1	1	1	1	
9	90105-06127	BOLT, FLANGE	1	1	1	1	
10	93102-12224	OIL SEAL	1	1	1	1	
11	3XJ-18173-10	PIN, SHIFT	1	1	1	1	
12	3XJ-18178-00	ROLLER, SHIFT LEVER	1	1	1	1	
13	3XJ-18182-00	PAWL, SHIFTER	2	2	2	2	
14	90501-052G5	SPRING, COMPRESSION	2	2	2	2	
15	3XJ-18184-00	PIN, PAWL	2	2	2	2	
16	5TJ-18172-00	GUIDE, SHIFT	1	1	1	1	
17	90101-06041	BOLT	2	2	2	2	

FIG. 19 FRAME

REF. NO.	PART NO.	DESCRIPTION	33DD	33DE	33DF	33DG	REMARKS
1	33D-21101-90	FRONT FRAME COMP.	1	1	1	1	
2	17D-21447-00	.BRACKET, FOOTREST	1	1	1	1	
3	17D-21448-00	.BRACKET, FOOTREST	1	1	1	1	
4	90149-10031	.SCREW	4	4	4	4	
5	33D-21190-00	REAR FRAME COMP.	1	1	1	1	
6	90105-08231	BOLT, FLANGE	2	2	2	2	
7	90105-08230	BOLT, FLANGE	2	2	2	2	
8	30X-22178-00	TENSIONER	1	1	1	1	
9	4V4-22184-00	BUSH	1	1	1	1	
10	90201-08045	WASHER, PLATE	2	2	2	2	
11	90387-08041	COLLAR	1	1	1	1	
12	95022-08040	BOLT, FLANGE	1	1	1	1	
13	33D-2117F-00	COVER	1	1	1	1	
14	98502-05016	SCREW, PAN HEAD	2	2	2	2	
15	90201-05N15	WASHER, PLATE	2	2	2	2	
16	90387-05003	COLLAR	2	2	2	2	
17	90480-12025	GROMMET	2	2	2	2	
18	3JD-22178-20	TENSIONER	1	1	1	1	
19	93300-60839	BEARING	1	1	1	1	
20	90387-086N4	COLLAR	1	1	1	1	
21	90105-08232	BOLT, FLANGE	1	1	1	1	
22	90185-08009	NUT, SELF-LOCKING	1	1	1	1	
23	90201-08043	WASHER, PLATE	1	1	1	1	
24	90105-10193	BOLT, FLANGE	1	1	1	1	
25	90179-10658	NUT	1	1	1	1	
26	90201-10045	WASHER, PLATE	1	1	1	1	
27	33D-21417-00	BRACKET, FRONT LOWER 1	2	2	2	2	

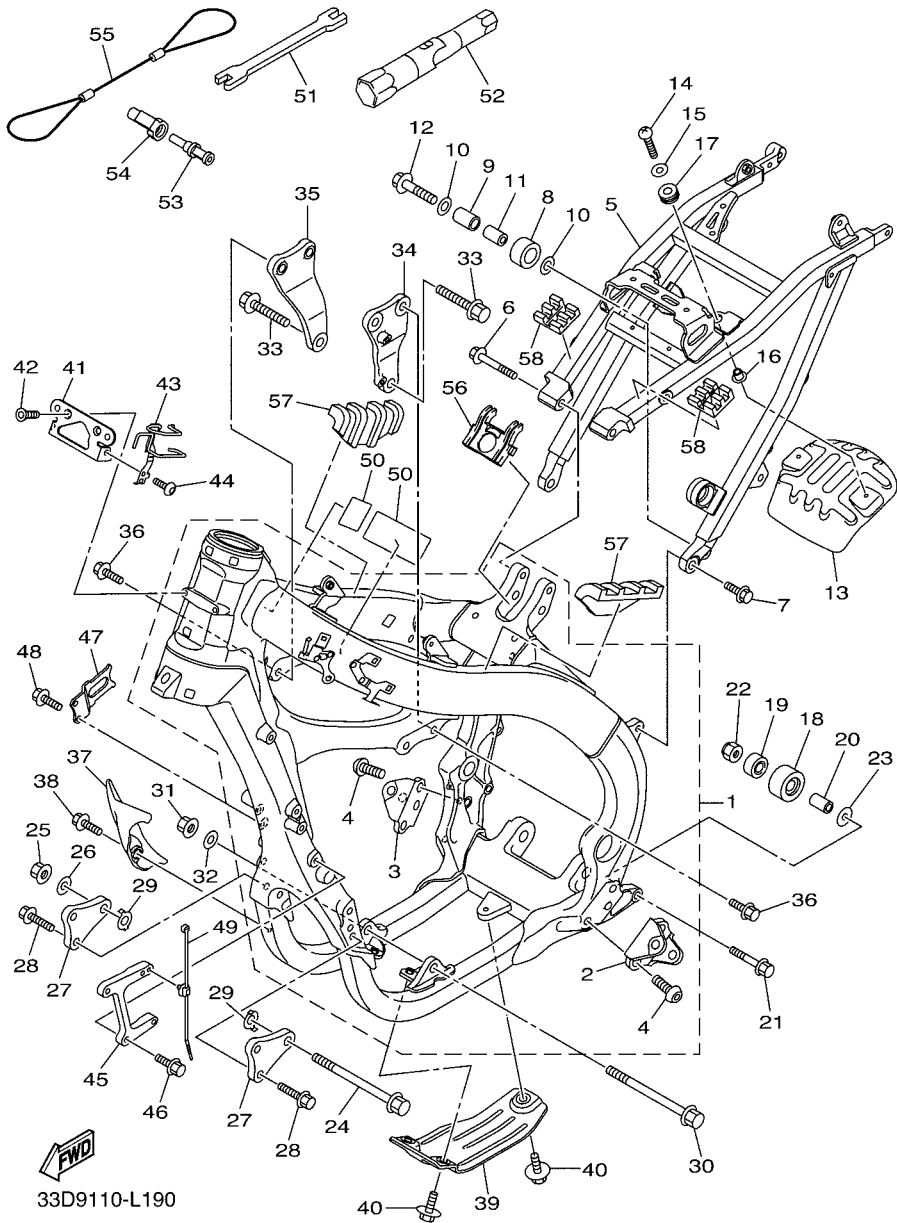
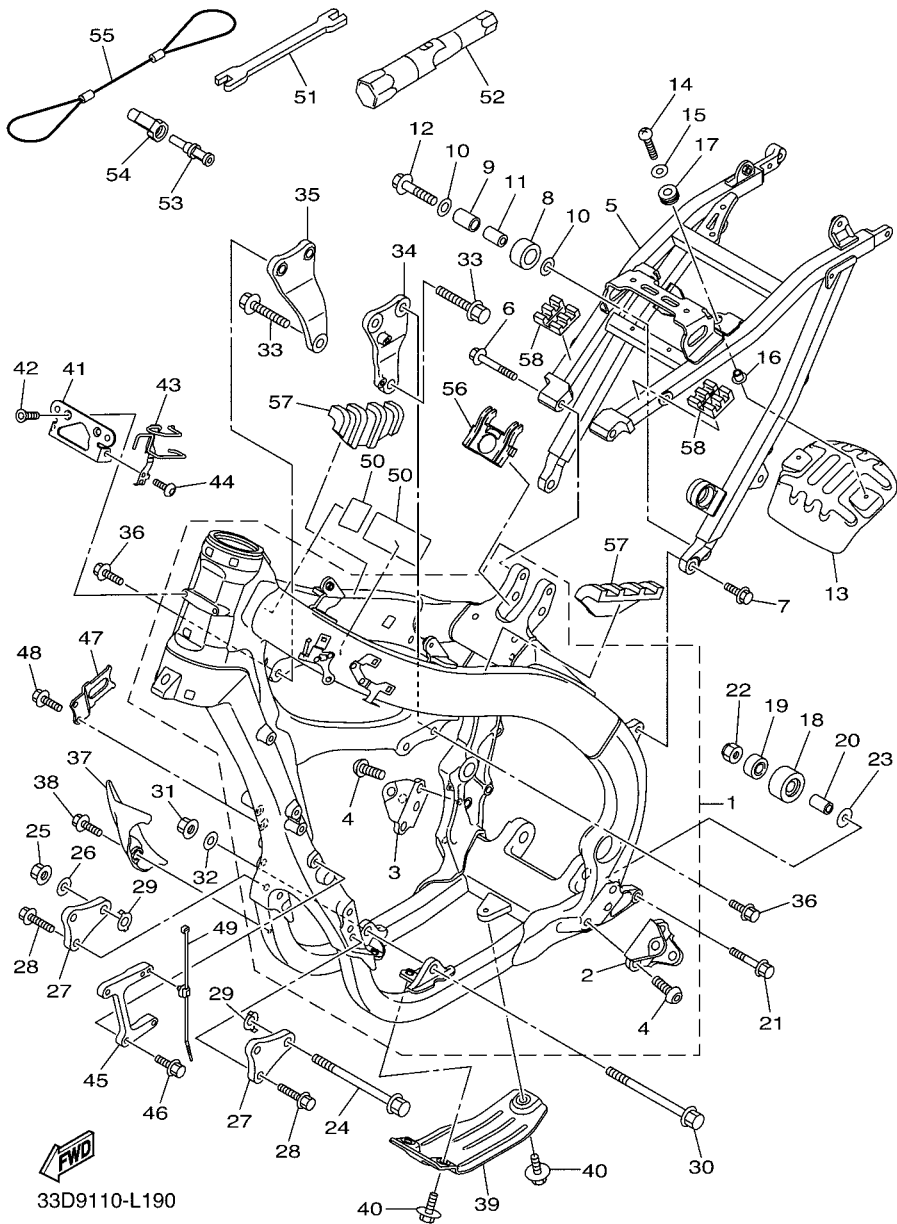

FIG. 19 FRAME

REF. NO.	PART NO.	DESCRIPTION	33DD	33DE	33DF	33DG	REMARKS
28	90105-08143	BOLT, FLANGE	4	4	4	4	
29	5XC-21456-90	PLATE, PATCH	2	2	2	2	
30	90105-10176	BOLT, FLANGE	1	1	1	1	
31	90179-10658	NUT	1	1	1	1	
32	90201-10045	WASHER, PLATE	1	1	1	1	
33	90105-10189	BOLT, FLANGE	2	2	2	2	
34	33D-21425-00	BRACKET, REAR UPPER 1	1	1	1	1	
35	33D-21426-00	BRACKET, REAR UPPER 2	1	1	1	1	
36	90105-08226	BOLT, FLANGE	4	4	4	4	
37	33D-21471-00	PROTECTOR, ENGINE	1	1	1	1	
38	90119-06149	BOLT, WITH WASHER	1	1	1	1	
39	33D-2147E-00	GUARD, ENGINE 2	1	1	1	1	
40	90119-06146	BOLT, WITH WASHER	3	3	3	3	
41	33D-2116M-00	BRACKET 10	1	1	1	1	
42	90151-06032	SCREW, COUNTERSUNK	2	2	2	2	
43	33D-21163-00	HOLDER, CLUTCH CABLE	1	1	1	1	
44	92012-05010	BOLT, BUTTON HEAD	1	1	1	1	
45	33D-2194U-00	STAY, IGNITION COIL	1	1	1	1	
46	90105-06170	BOLT, FLANGE	2	2	2	2	
47	33D-2116J-00	BRACKET 7	1	1	1	1	
48	95022-06010	BOLT, FLANGE	2	2	2	2	
49	90464-31002	CLAMP	1	1	1	1	
50	33D-21268-00	SEAL	2	2	2	2	
51	5ET-28166-10	WRENCH, HEXAGON	1	1	1	1	
52	5TA-2814F-00	BOX, SPARK PLUG	1	1	1	1	
53	18P-2467E-00	CAP	1	1	1	1	
54	18P-2464V-00	CASE, CAP	1	1	1	1	



33D9110-L190

FIG. 19 FRAME

REF. NO.	PART NO.	DESCRIPTION	33DD	33DE	33DF	33DG	REMARKS
55	33D-2814A-00	WIRE, HOOK	1	1	1	1	
56	33D-24181-00	DAMPER, LOCATING 1	1	1	1	1	
57	33D-24182-00	DAMPER, LOCATING 2	2	2	2	2	
58	33D-24183-00	DAMPER, LOCATING 3	2	2	2	2	

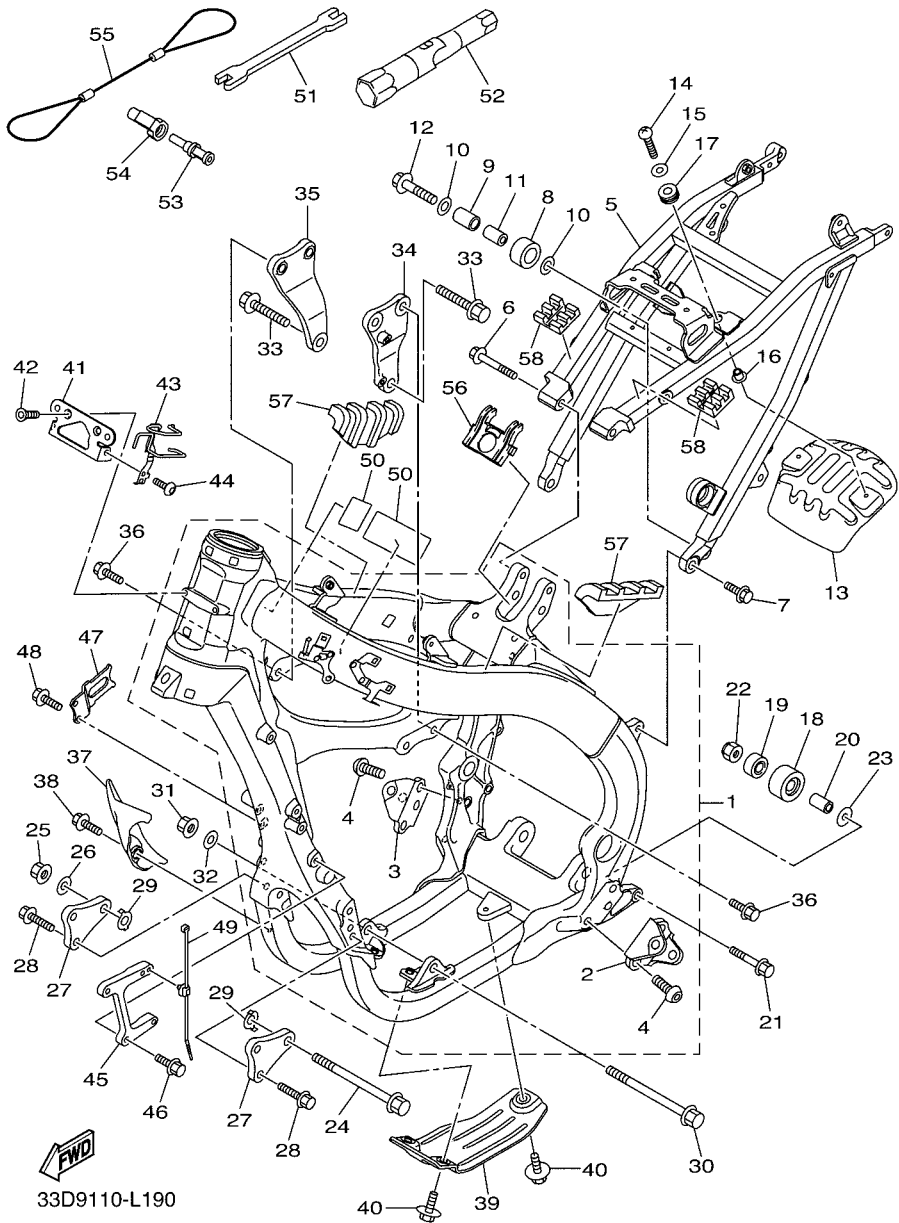
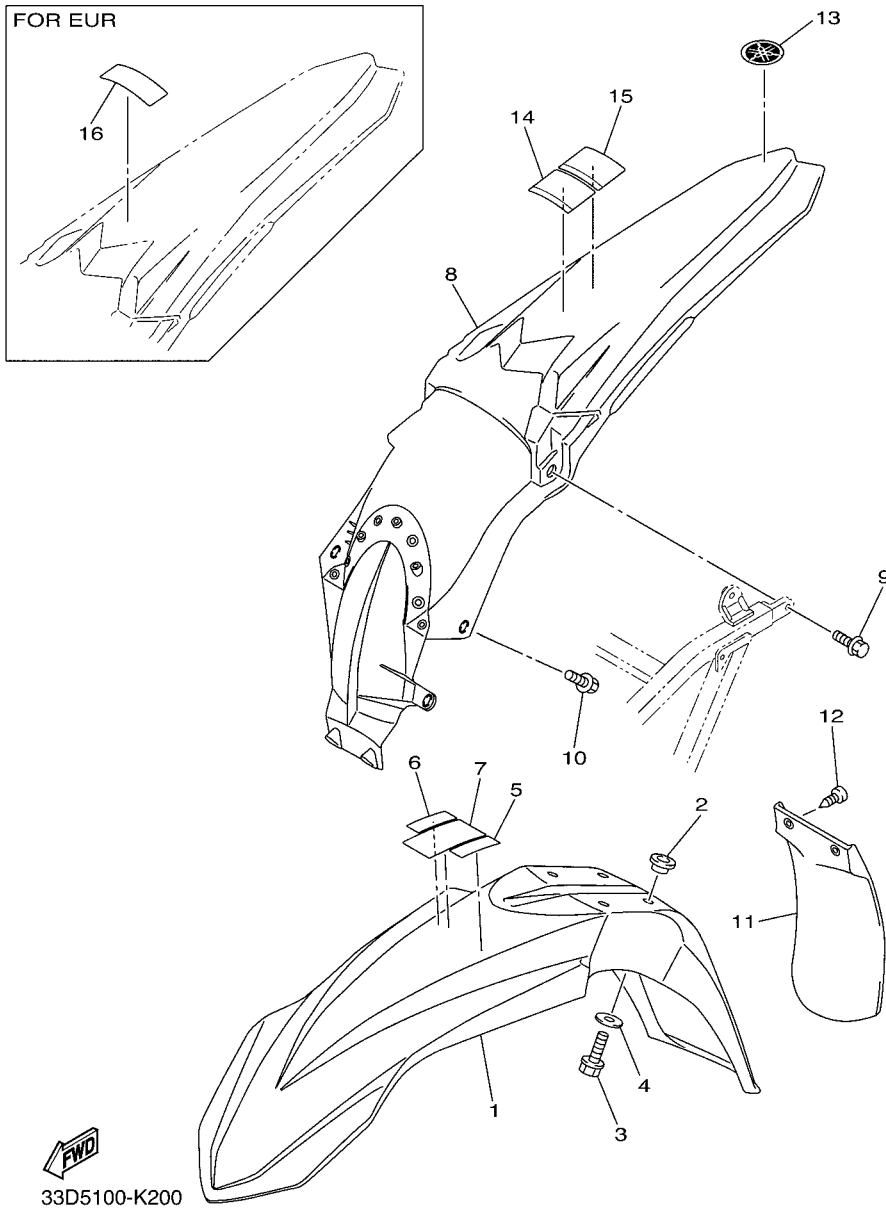
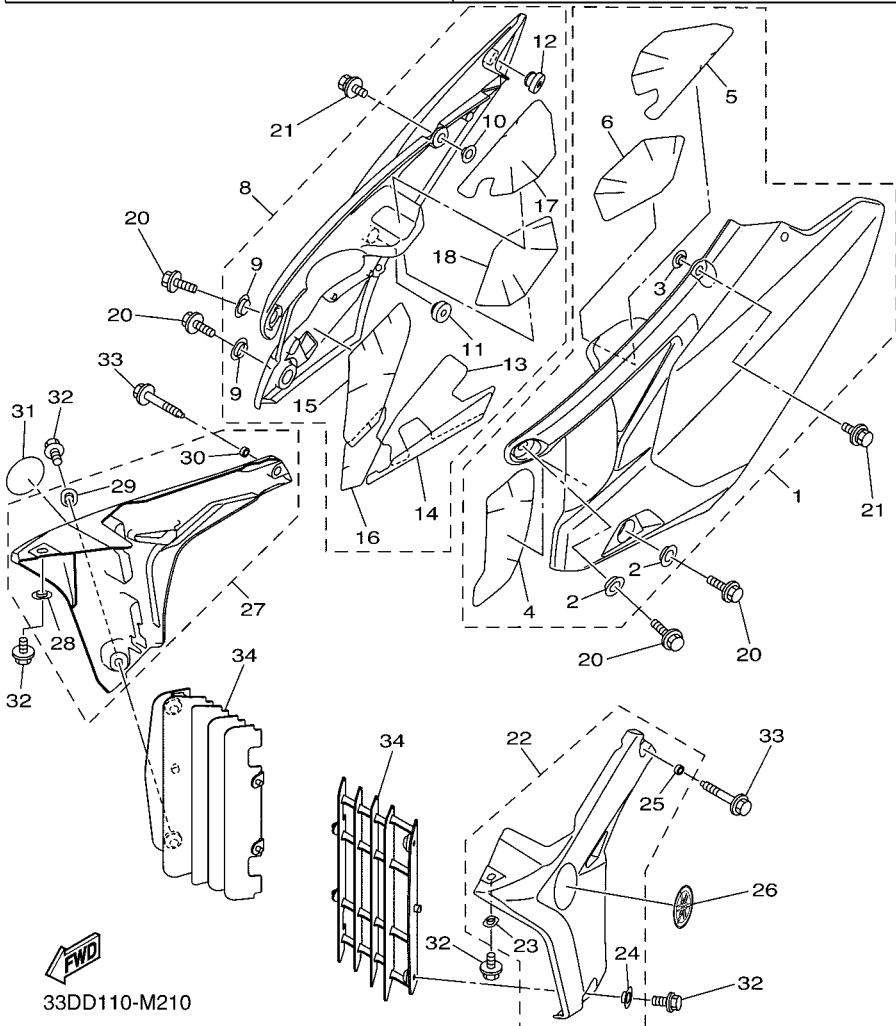
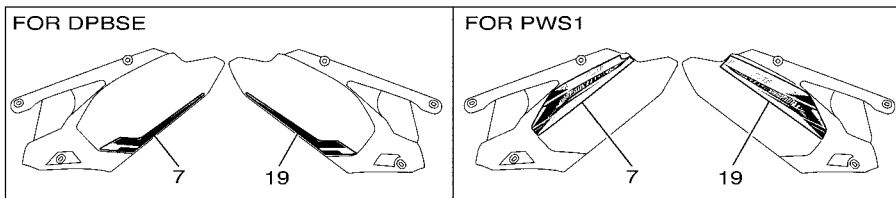

FIG. 20 FENDER



REF. NO.	PART NO.	DESCRIPTION	33DD	33DE	33DF	33DG	REMARKS
1	17D-21511-50	FENDER, FRONT	1	1	1	1	UR FOR DPBSE
	17D-21511-60	FENDER, FRONT	1	1	1	1	UR FOR PWS1
2	90387-06259	COLLAR	4	4	4	4	
3	90105-06127	BOLT, FLANGE	4	4	4	4	
4	90201-06108	WASHER, PLATE	4	4	4	4	
5	3FB-2415E-02	LABEL, CAUTION	1				
	3FB-2415E-C1	LABEL, CAUTION			1		JAPANESE
6	3FB-2415E-12	LABEL, CAUTION	1				
7	4SR-2416E-00	LABEL, CAUTION CANADA	1				
8	33D-21610-10	REAR FENDER COMP.	1	1	1	1	
9	90105-06100	BOLT, FLANGE	2	2	2	2	
10	90105-06170	BOLT, FLANGE	3	3	3	3	
11	33D-21642-00	GUARD, FLAP	1	1	1	1	
12	97702-60016	SCREW, TAPPING	2	2	2	2	
13	3C5-2411B-20	EMBLEM	1	1	1	1	
14	5PA-2118K-00	LABEL, CAUTION	1			1	
	5PA-2118K-20	LABEL, CAUTION			1		
15	5PA-2118K-10	LABEL, CAUTION	1				
16	5PG-2816R-00	LABEL, WARNING GENERAL INFO.		1			

FIG. 21 SIDE COVER



REF. NO.	PART NO.	DESCRIPTION	33DD	33DE	33DF	33DG	REMARKS
1	33D-21710-01	SIDE COVER ASSY 1	1	1	1	1	
2	17D-21749-00	.COLLAR	2	2	2	2	
3	5BE-21749-00	.COLLAR	1	1	1	1	
4	33D-2172S-00	.INSULATOR 3	1	1	1	1	
5	33D-2172P-00	.SEAT	1	1	1	1	
6	33D-2174P-00	.SEAT 3	1	1	1	1	
7	33D-2174G-40	GRAPHIC 3	1	1	1	1	UR FOR DPBSE
	33D-2174G-50	GRAPHIC 3	1	1	1	1	UR FOR PWS1
8	33D-21720-01	SIDE COVER ASSY 2	1	1	1	1	
9	17D-21749-00	.COLLAR	2	2	2	2	
10	5BE-21749-00	.COLLAR	1	1	1	1	
11	5XC-21719-90	.GROMMET	1	1	1	1	
12	33D-21719-00	.GROMMET	1	1	1	1	
13	33D-2174A-00	.INSULATOR, SIDE COVER	1	1	1	1	
14	33D-2174T-00	.INSULATOR, SIDE COVER 2	1	1	1	1	
15	33D-2173S-00	.INSULATOR 4	1	1	1	1	
16	33D-2174S-00	.INSULATOR 5	1	1	1	1	
17	33D-2173P-00	.SEAT 2	1	1	1	1	
18	33D-2175P-00	.SEAT 4	1	1	1	1	
19	33D-2174H-40	GRAPHIC 4	1	1	1	1	UR FOR DPBSE
	33D-2174H-50	GRAPHIC 4	1	1	1	1	UR FOR PWS1
20	90105-06170	BOLT, FLANGE	4	4	4	4	
21	90119-08095	BOLT, WITH WASHER	2	2	2	2	
22	33D-21730-51	SIDE COVER ASSY 3	1	1	1	1	UR FOR DPBSE
	33D-21730-01	SIDE COVER ASSY 3	1	1	1	1	UR FOR PWS1
23	5PA-21748-00	.COLLAR	1	1	1	1	
24	17D-21749-00	.COLLAR	1	1	1	1	

FIG. 21 SIDE COVER

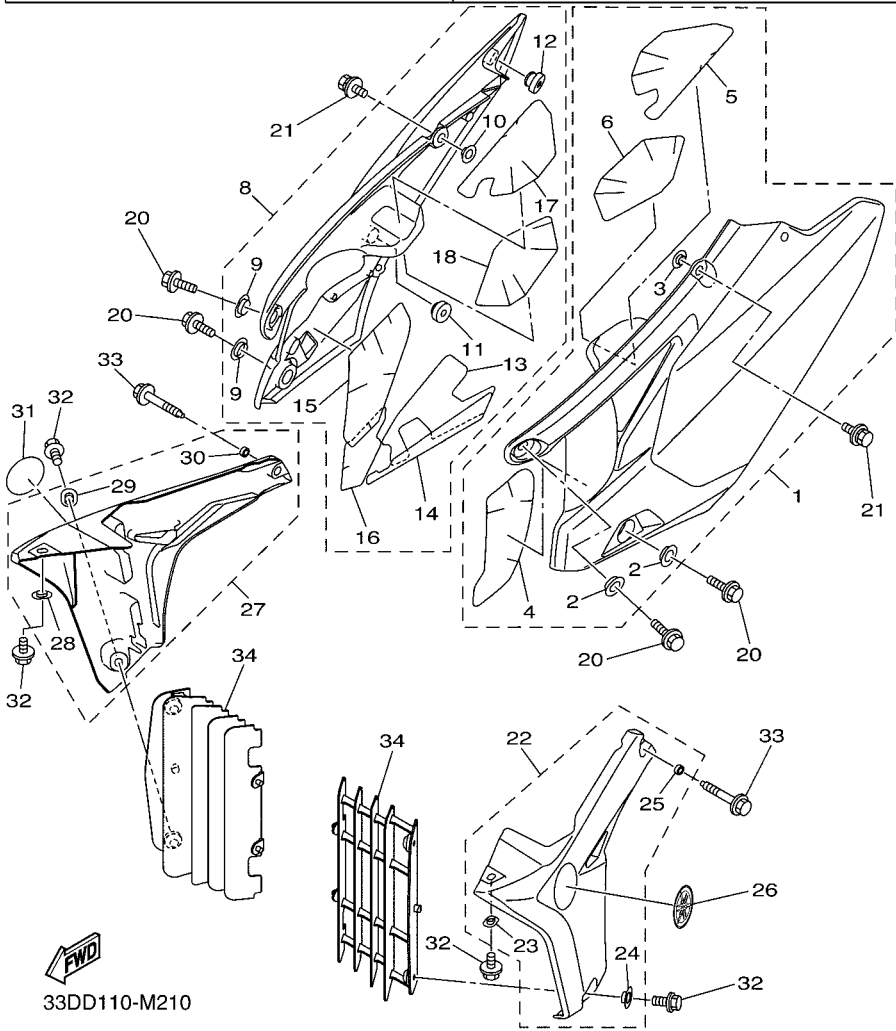
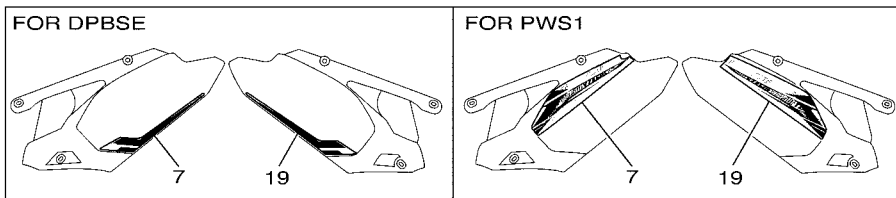

REF. NO.	PART NO.	DESCRIPTION	33DD	33DE	33DF	33DG	REMARKS
25	90387-06133	.COLLAR	1	1	1	1	
26	5PW-2413B-00	EMBLEM	1	1	1	1	
27	33D-21740-51	SIDE COVER ASSY 4	1	1	1	1	UR FOR DPBSE
	33D-21740-01	SIDE COVER ASSY 4	1	1	1	1	UR FOR PWS1
28	5PA-21748-00	.COLLAR	1	1	1	1	
29	17D-21749-00	.COLLAR	1	1	1	1	
30	90387-06133	.COLLAR	1	1	1	1	
31	5PW-2413B-00	EMBLEM	1	1	1	1	
32	90105-06064	BOLT, FLANGE	4	4	4	4	
33	90105-06179	BOLT, FLANGE	2	2	2	2	
34	33D-2172A-00	PANEL 1	2	2	2	2	

FIG. 22 REAR ARM

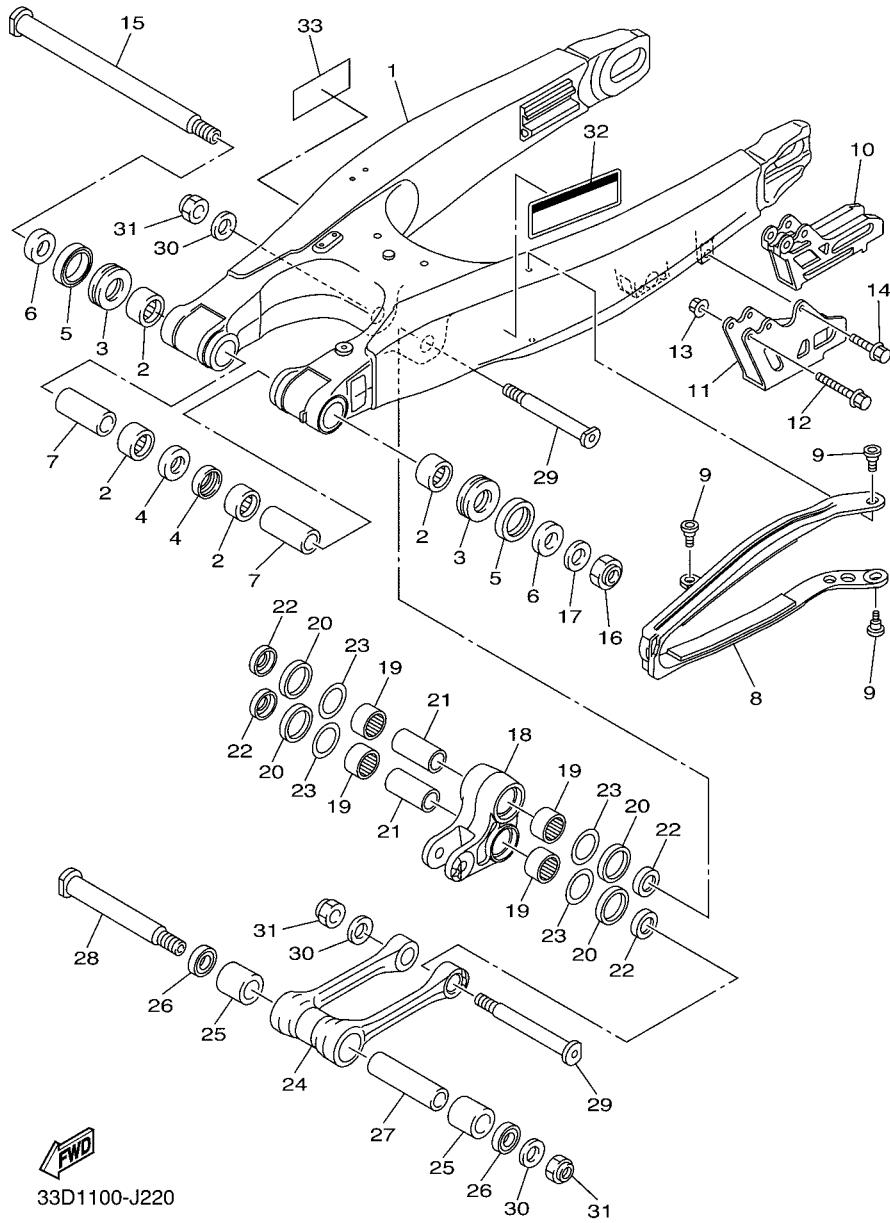

33D1100-J220

REF. NO.	PART NO.	DESCRIPTION	33DD	33DE	33DF	33DG	REMARKS
1	33D-22110-00	REAR ARM COMP.	1	1	1	1	
2	93317-22262	BEARING	4	4	4	4	
3	93342-22217	BEARING	2	2	2	2	
4	93106-22002	OIL SEAL	2	2	2	2	
5	93109-28043	OIL SEAL	2	2	2	2	
6	90387-17016	COLLAR	2	2	2	2	
7	90387-1714S	COLLAR	2	2	2	2	
8	34P-22151-01	SEAL, GUARD	1	1	1	1	
9	1C3-22969-90	SCREW, 1	3	3	3	3	
10	2S2-22199-70	SUPPORT, CHAIN	1	1	1	1	
11	2S2-22128-70	COVER, THRUST 1	1	1	1	1	
12	90105-06104	BOLT, FLANGE	2	2	2	2	
13	95702-06500	NUT, FLANGE	2	2	2	2	
14	90105-06105	BOLT, FLANGE	1	1	1	1	
15	33D-22141-00	SHAFT, PIVOT	1	1	1	1	
16	90185-16002	NUT, SELF-LOCKING	1	1	1	1	
17	90201-16018	WASHER, PLATE	1	1	1	1	
18	17D-2217A-00	ARM, RELAY	1	1	1	1	
19	93315-32166	BEARING	4	4	4	4	
20	93109-25001	OIL SEAL	4	4	4	4	
21	90387-16026	COLLAR	2	2	2	2	
22	90209-16011	WASHER	4	4	4	4	
23	90201-21014	WASHER, PLATE	4	4	4	4	
24	33D-2217F-00	ROD, CONNECTING 1	1	1	1	1	
25	93315-32166	BEARING	2	2	2	2	
26	93109-21001	OIL SEAL	2	2	2	2	
27	90387-14016	COLLAR	1	1	1	1	

FIG. 22 REAR ARM

REF. NO.	PART NO.	DESCRIPTION	33DD	33DE	33DF	33DG	REMARKS
28	5XC-22121-91	SHAFT 1	1	1	1	1	
29	34P-22122-00	SHAFT 2	2	2	2	2	
30	90201-14020	WASHER, PLATE	3	3	3	3	
31	90185-14010	NUT, SELF-LOCKING	3	3	3	3	
32	3RV-21668-A0	LABEL, TIRE	1			1	
33	3RV-21668-B0	LABEL, TIRE	1				

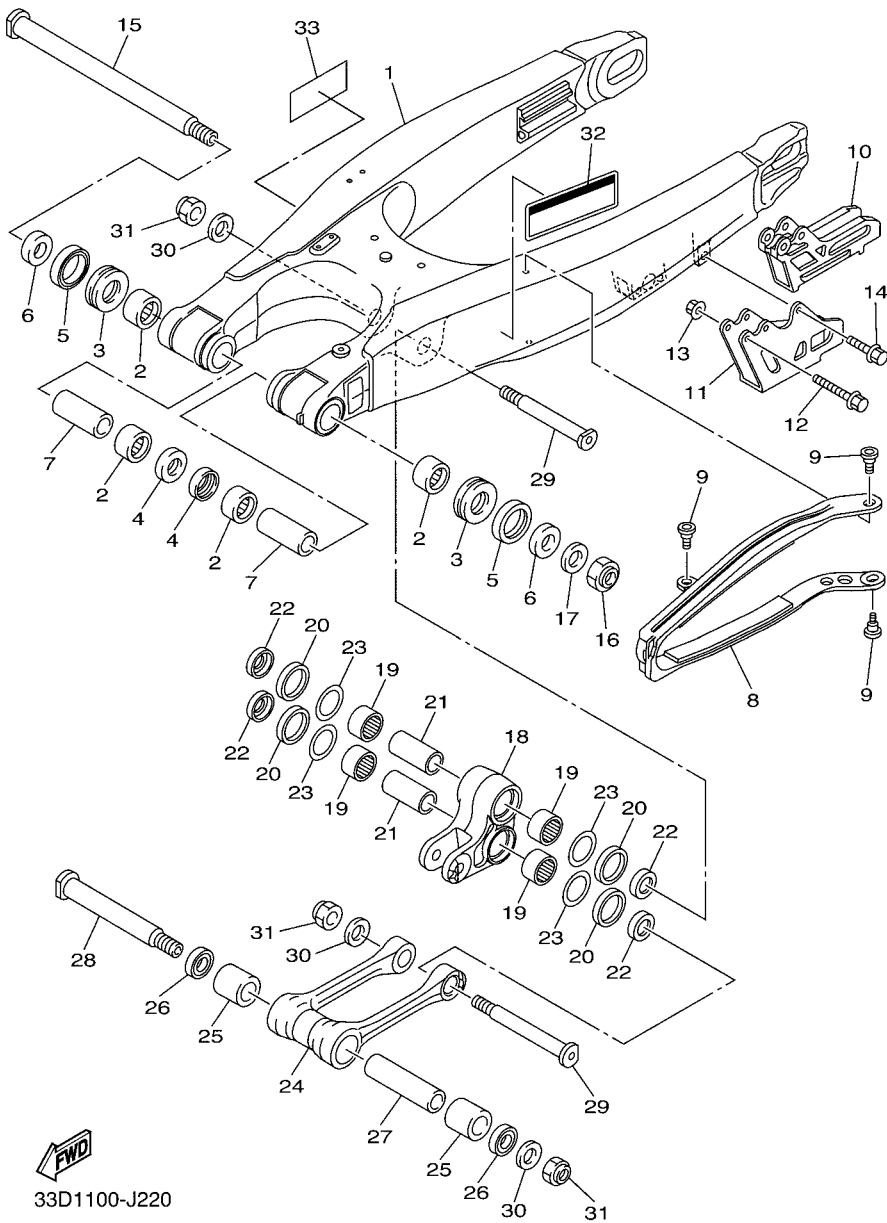

33D1100-J220

FIG. 23 REAR SUSPENSION

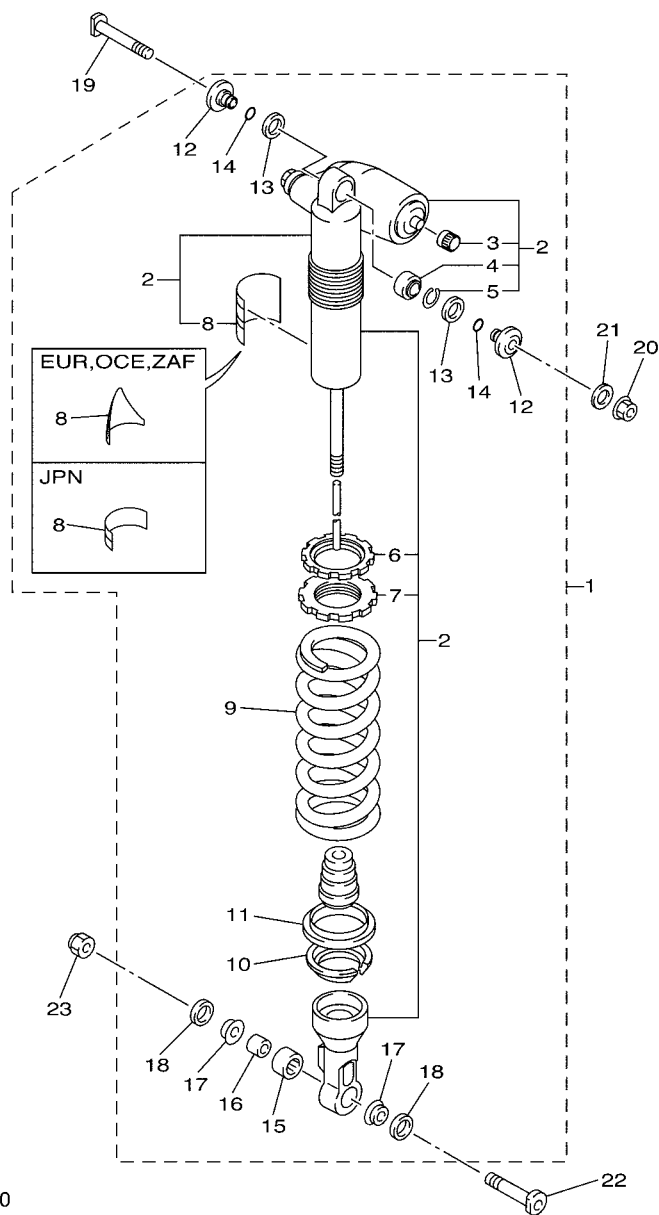

33D1100-J230

REF. NO.	PART NO.	DESCRIPTION	33DD	33DE	33DF	33DG	REMARKS
1	33D-22200-B0	SHOCK ABSORBER ASSY, REAR	1				UR FOR DPBSE
	33D-22200-F0	SHOCK ABSORBER ASSY, REAR	1				UR FOR PWS1
	33D-22200-90	SHOCK ABSORBER ASSY, REAR		1	1		UR FOR DPBSE
	33D-22200-D0	SHOCK ABSORBER ASSY, REAR		1	1		UR FOR PWS1
	33D-22200-A0	SHOCK ABSORBER ASSY, REAR			1		UR FOR DPBSE
	33D-22200-E0	SHOCK ABSORBER ASSY, REAR			1		UR FOR PWS1
2	33D-22201-70	.DAMPER SUB ASSY	1				
	33D-22201-50	.DAMPER SUB ASSY		1	1		
	33D-22201-60	.DAMPER SUB ASSY			1		
3	509-23184-L0	..CAP, AIR VALVE	1	1	1	1	
4	4JX-22226-00	..BUSH, SHOCK ABSORBER LOWER	1	1	1	1	
5	5DH-23183-00	..CIRCLIP	1	1	1	1	
6	33D-22234-00	..GUIDE, SPRING 3	1	1	1	1	
7	33D-22213-00	..SEAT, SPRING UPPER	1	1	1	1	
8	4AA-22259-70	..LABEL, WARNING	1				
	4AA-22259-40	..LABEL, WARNING		1		1	
	4AA-22259-50	..LABEL, WARNING			1		
9	33D-22212-30	.SPRING (K=56N/MM)	1				UR FOR DPBSE
	33D-22212-D0	.SPRING (K=56N/MM)	1				UR FOR PWS1
	33D-22212-20	.SPRING (K=54N/MM)		1	1	1	UR FOR DPBSE
	33D-22212-C0	.SPRING (K=54N/MM)		1	1	1	UR FOR PWS1
10	33D-22214-00	.GUIDE, SPRING 1	1	1	1	1	
11	33D-22224-00	.GUIDE, SPRING 2	1	1	1	1	
12	1C3-22253-50	.COLLAR, DISTANCE	2	2	2	2	
13	3JE-22475-00	.SEAL, DUST	2	2	2	2	
14	4EW-22474-00	.SEAL, RING	2	2	2	2	
15	5UN-22176-00	.BEARING	1	1	1	1	

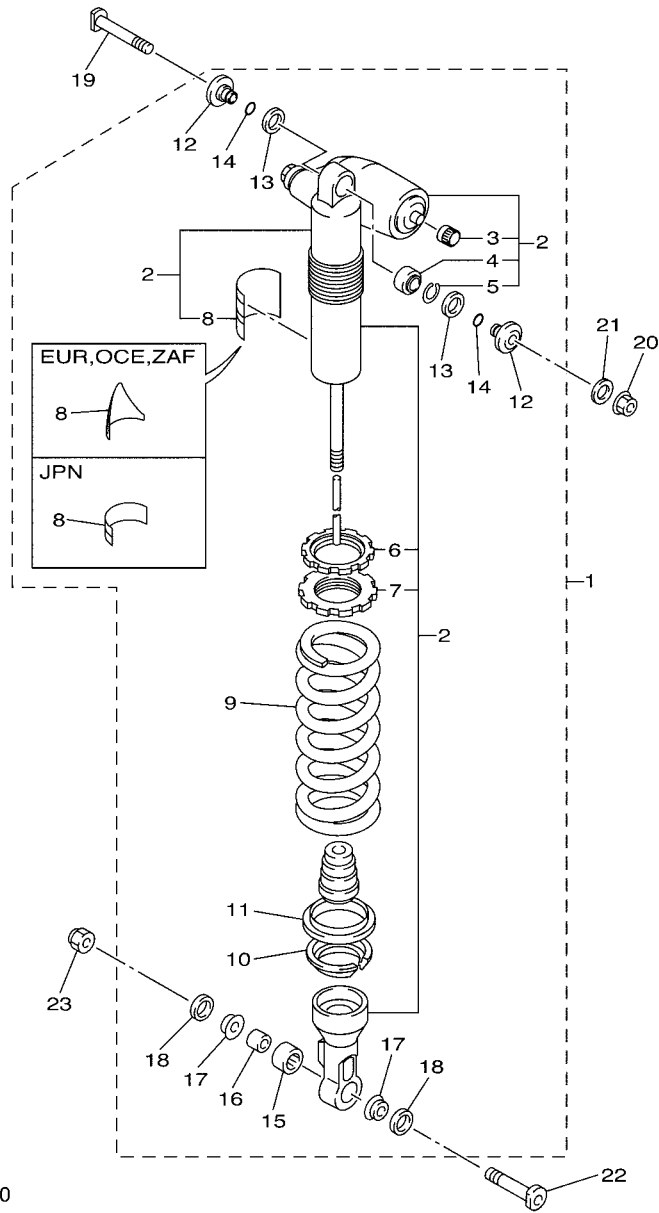

FWD
33D1100-J230

FIG. 23 REAR SUSPENSION

REF. NO.	PART NO.	DESCRIPTION	33DD	33DE	33DF	33DG	REMARKS
16	5MV-22184-00	.BUSH	1	1	1	1	
17	1C3-22253-L1	.COLLAR, DISTANCE	2	2	2	2	
18	5NY-22475-00	.SEAL, DUST	2	2	2	2	
19	5XE-22242-00	BOLT 2	1	1	1	1	
20	95602-10200	NUT, U FLANGE	1	1	1	1	
21	92902-10200	WASHER	1	1	1	1	
22	5NY-22241-00	BOLT 1	1	1	1	1	
23	90185-10012	NUT, SELF-LOCKING	1	1	1	1	

FIG. 24 STEERING

REF. NO.	PART NO.	DESCRIPTION					REMARKS
			33DD	33DE	33DF	33DG	
1	93332-00081	BEARING	1	1	1	1	
2	17D-23389-50	GUIDE, CABLE	1	1	1	1	
3	90105-06170	BOLT, FLANGE	1	1	1	1	
4	90387-06105	COLLAR	1	1	1	1	
5	93332-00068	BEARING	1	1	1	1	
6	17D-23416-50	COVER, BALL RACE 2	1	1	1	1	
7	90179-28015	NUT	1	1	1	1	
8	90201-286K9	WASHER, PLATE (T1.0)	1	1	1	1	
9	33D-23435-00	CROWN, HANDLE	1	1	1	1	
10	90179-24004	NUT	1	1	1	1	
11	18P-23441-00	HOLDER, HANDLE UPPER	2	2	2	2	
12	33D-23442-00	HOLDER, HANDLE LOWER	2	2	2	2	
13	92902-10200	WASHER	2	2	2	2	
14	95602-10200	NUT, U FLANGE	2	2	2	2	
15	5YU-2143A-00	CAP	1	1	1	1	
16	90105-08154	BOLT, FLANGE	8	8	8	8	
17	17D-23485-50	PLATE, NUMBER	1	1	1	1	
18	90105-06064	BOLT, FLANGE	1	1	1	1	
19	33D-23472-00	PROTECTOR	1	1	1	1	
20	17D-2339R-00	GRAPHIC SET, 1	1	1	1	1	FOR PWS1

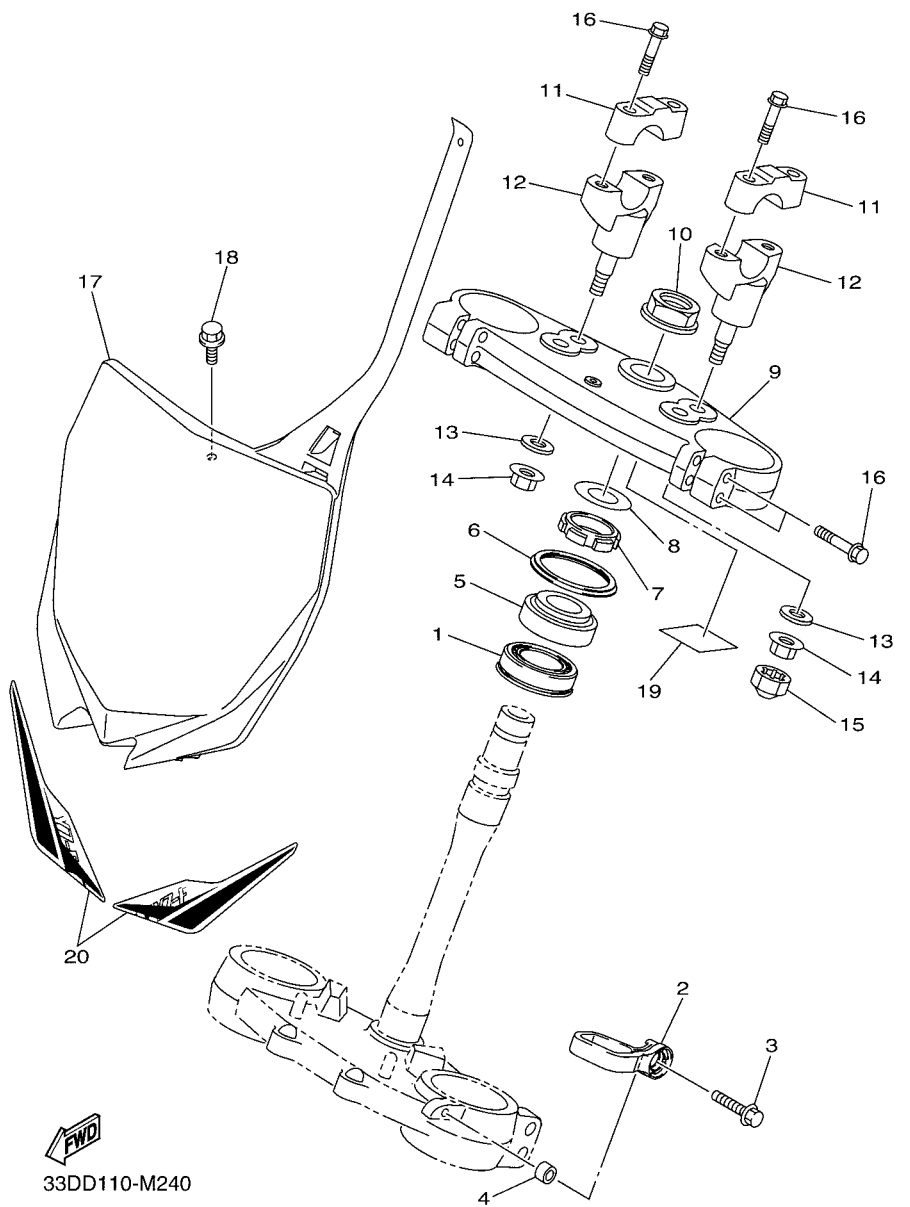

33DD110-M240

FIG. 25 FRONT FORK

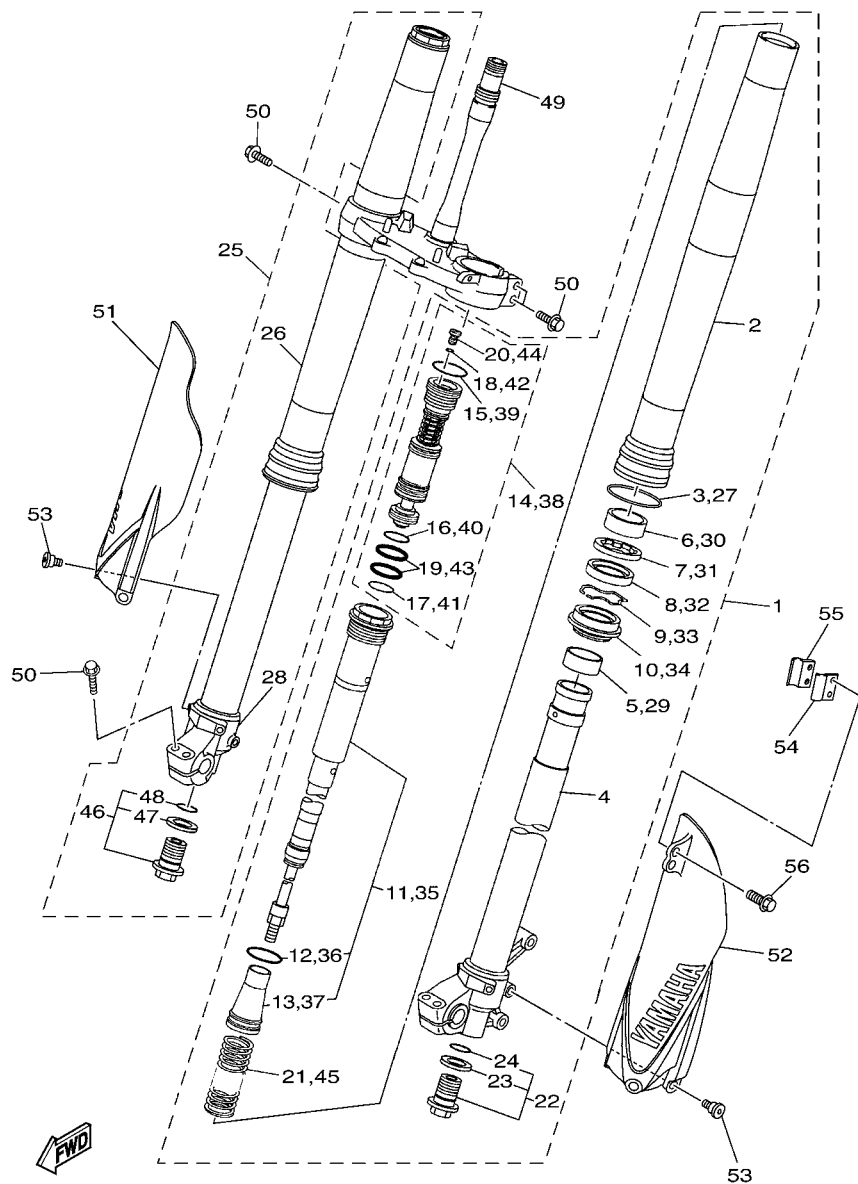

33D9110-L250

REF. NO.	PART NO.	DESCRIPTION	33DD	33DE	33DF	33DG	REMARKS
1	33D-23102-20	FRONT FORK ASSY (L.H)	1				
	33D-23102-30	FRONT FORK ASSY (L.H)		1	1	1	
2	33D-23136-00	.TUBE, OUTER (RIGHT)	1	1	1	1	
3	17D-23153-00	.RING, SNAP	1	1	1	1	
4	33D-23120-10	.INNER TUBE COMP.2	1	1	1	1	
5	5XE-23171-L0	.PISTON, FRONT FORK	1	1	1	1	
6	5XE-23125-L0	.METAL, SLIDE 1	1	1	1	1	
7	5XC-23146-10	.WASHER, OIL SEAL	1	1	1	1	
8	17D-23145-00	.OIL SEAL	1	1	1	1	
9	5XE-23153-L0	.RING, SNAP	1	1	1	1	
10	5XE-23144-L0	.SEAL, DUST	1	1	1	1	
11	33D-23170-20	.CYLINDER COMP., FRONT FORK	1				
	33D-23170-30	.CYLINDER COMP., FRONT FORK		1	1	1	
12	1C3-23147-L0	..O-RING	1	1	1	1	
13	1C3-23142-L0	..SEAT, SPRING UPPER	1				
	17D-23142-00	..SEAT, SPRING UPPER		1	1	1	
14	33D-2316A-20	.VALVE COMP.	1				
	33D-2316A-30	.VALVE COMP.		1	1	1	
15	1C3-23188-L0	..O-RING	1	1	1	1	
16	1C3-23188-N0	..O-RING	1	1	1	1	
17	1C3-23188-P0	..O-RING	1	1	1	1	
18	1C3-23188-R0	..O-RING	1	1	1	1	
19	1AE-23147-00	..O-RING	2	2	2	2	
20	1C3-23190-L0	..AIR VALVE COMP.	1	1	1	1	
21	33D-23141-D0	.SPRING, FRONT FORK(K=4.6N/MM)	1	1	1	1	
22	5XC-23111-00	.BOLT, CAP	1	1	1	1	
23	2HH-23158-L0	..GASKET	1	1	1	1	

FIG. 25 FRONT FORK

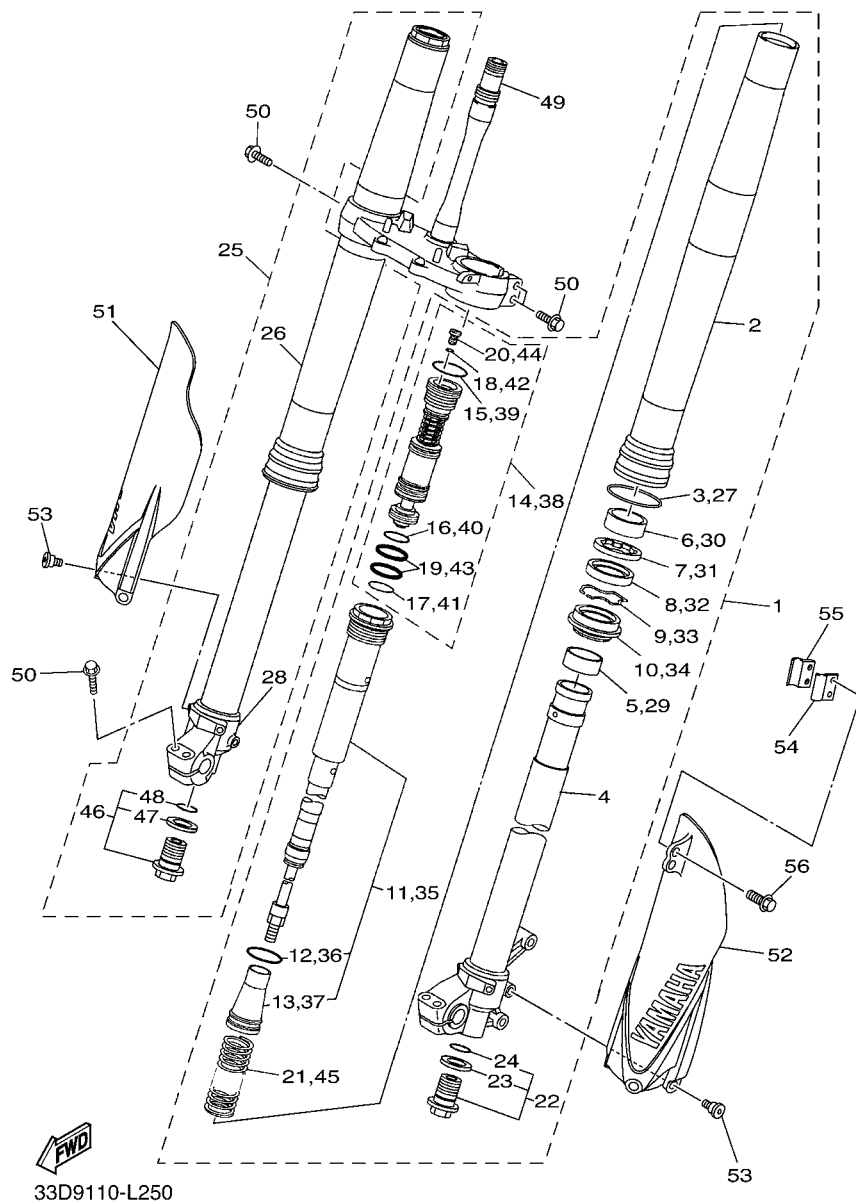

33D9110-L250

REF. NO.	PART NO.	DESCRIPTION	33DD	33DE	33DF	33DG	REMARKS
24	276-23114-00	..GASKET	1	1	1	1	
25	33D-23103-20	FRONT FORK ASSY (R.H)	1				
	33D-23103-30	FRONT FORK ASSY (R.H)		1	1	1	
26	33D-23136-00	.TUBE, OUTER (RIGHT)	1	1	1	1	
27	17D-23153-00	.RING, SNAP	1	1	1	1	
28	33D-23110-10	..INNER TUBE COMP.1	1	1	1	1	
29	5XE-23171-L0	.PISTON, FRONT FORK	1	1	1	1	
30	5XE-23125-L0	.METAL, SLIDE 1	1	1	1	1	
31	5XC-23146-10	.WASHER, OIL SEAL	1	1	1	1	
32	17D-23145-00	.OIL SEAL	1	1	1	1	
33	5XE-23153-L0	.RING, SNAP	1	1	1	1	
34	5XE-23144-L0	.SEAL, DUST	1	1	1	1	
35	33D-23170-20	.CYLINDER COMP., FRONT FORK	1				
	33D-23170-30	.CYLINDER COMP., FRONT FORK		1	1	1	
36	1C3-23147-L0	..O-RING	1	1	1	1	
37	1C3-23142-L0	..SEAT, SPRING UPPER	1				
	17D-23142-00	..SEAT, SPRING UPPER		1	1	1	
38	33D-2316A-20	.VALVE COMP.	1				
	33D-2316A-30	.VALVE COMP.		1	1	1	
39	1C3-23188-L0	..O-RING	1	1	1	1	
40	1C3-23188-N0	..O-RING	1	1	1	1	
41	1C3-23188-P0	..O-RING	1	1	1	1	
42	1C3-23188-R0	..O-RING	1	1	1	1	
43	1AE-23147-00	..O-RING	2	2	2	2	
44	1C3-23190-L0	..AIR VALVE COMP.	1	1	1	1	
45	33D-23141-D0	.SPRING, FRONT FORK(K=4.6N/MM)	1	1	1	1	
46	5XC-23111-00	.BOLT, CAP	1	1	1	1	

FIG. 26 FUEL TANK

REF. NO.	PART NO.	DESCRIPTION	33DD	33DE	33DF	33DG	REMARKS
1	33D-24110-50	FUEL TANK COMP.	1	1	1	1	
2	5NY-24610-10	CAP ASSY	1	1	1	1	
3	90445-09003	HOSE (L30)	1	1	1	1	
4	3XJ-24380-00	PIPE JOINT ASSY	1	1	1	1	
5	90445-09005	HOSE	1	1	1	1	
6	33D-24144-00	HOLDER, DAMPER	2	2	2	2	
7	90387-06091	COLLAR	2	2	2	2	
8	90480-18549	GROMMET	2	2	2	2	
9	90111-06007	BOLT,HEX. SOCKET BUTTON	4	4	4	4	
10	33D-2419A-00	HOLDER	1	1	1	1	
11	90111-06007	BOLT,HEX. SOCKET BUTTON	2	2	2	2	
12	95022-06025	BOLT, FLANGE	2	2	2	2	
13	90387-06236	COLLAR	2	2	2	2	
14	90480-01023	GROMMET	2	2	2	2	
15	33D-13907-00	FUEL PUMP COMP.	1	1	1	1	
16	33D-24486-00	O-RING	1	1	1	1	
17	33D-24491-00	BRACKET, FUEL PUMP	1	1	1	1	
18	33D-24192-00	BRACKET, FUEL TANK 2	1	1	1	1	
19	90154-05012	SCREW, BINDING	2	2	2	2	
20	90110-05058	BOLT, HEXAGON SOCKET HEAD	6	6	6	6	
21	33D-13971-00	PIPE, FUEL 1	1	1	1	1	
22	33D-24135-00	CLAMP 1	1	1	1	1	
23	4EW-2412F-00	BRACKET, SEAT	1	1	1	1	
24	98702-06025	SCREW, FLAT HEAD	1	1	1	1	
25	33D-24217-00	COVER	1	1	1	1	
26	33D-24665-00	.DAMPER	1	1	1	1	
27	90269-07001	RIVET	2	2	2	2	

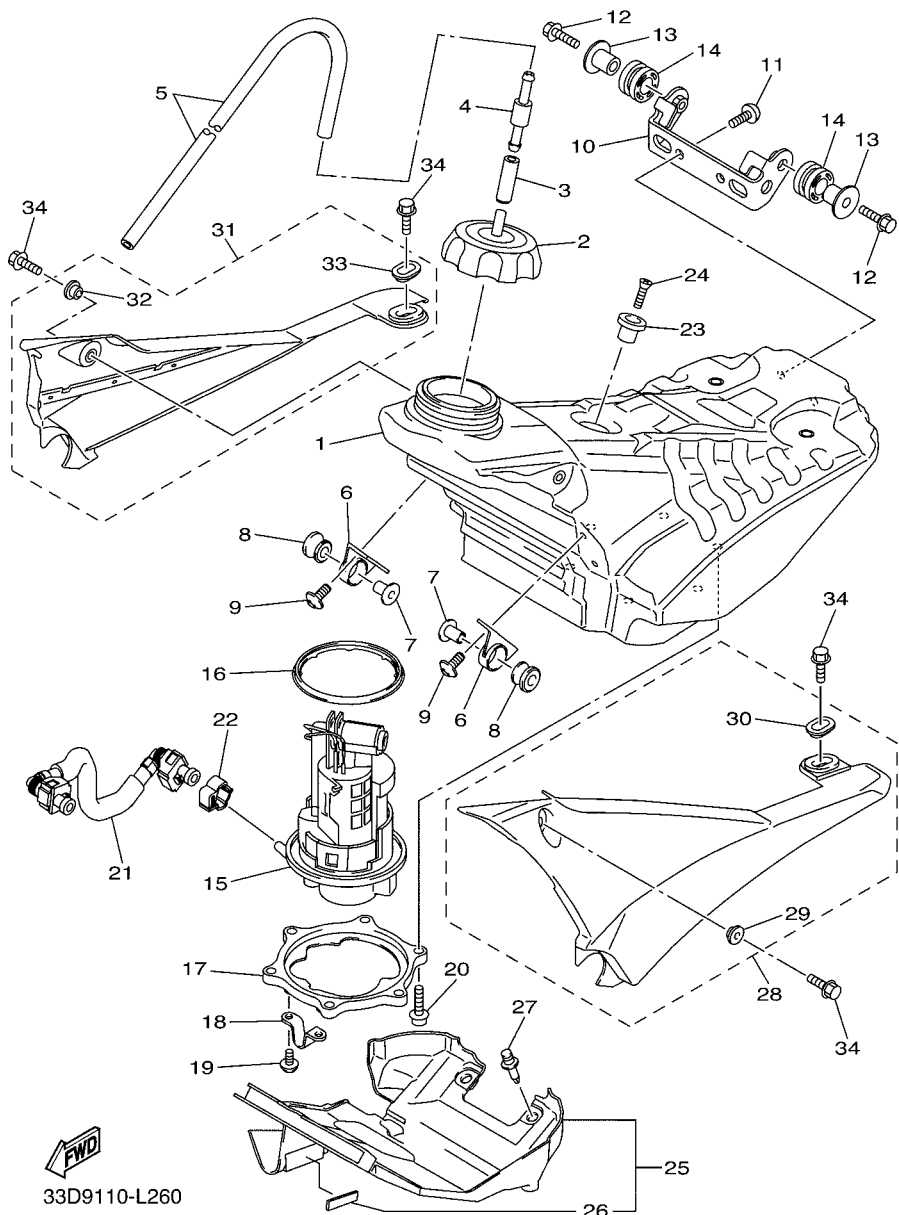

33D9110-L260

FIG. 26 FUEL TANK

REF. NO.	PART NO.	DESCRIPTION	33DD	33DE	33DF	33DG	REMARKS
28	33D-24106-50	TANK SIDE COVER ASSY 1	1	1	1	1	UR FOR DPBSE
	33D-24106-10	TANK SIDE COVER ASSY 1	1	1	1	1	UR FOR PWS1
29	90387-06009	.COLLAR	1	1	1	1	
30	5XC-21749-90	.COLLAR	1	1	1	1	
31	33D-24108-50	TANK SIDE COVER ASSY 2	1	1	1	1	UR FOR DPBSE
	33D-24108-10	TANK SIDE COVER ASSY 2	1	1	1	1	UR FOR PWS1
32	90387-06009	.COLLAR	1	1	1	1	
33	5XC-21749-90	.COLLAR	1	1	1	1	
34	90105-06064	BOLT, FLANGE	4	4	4	4	

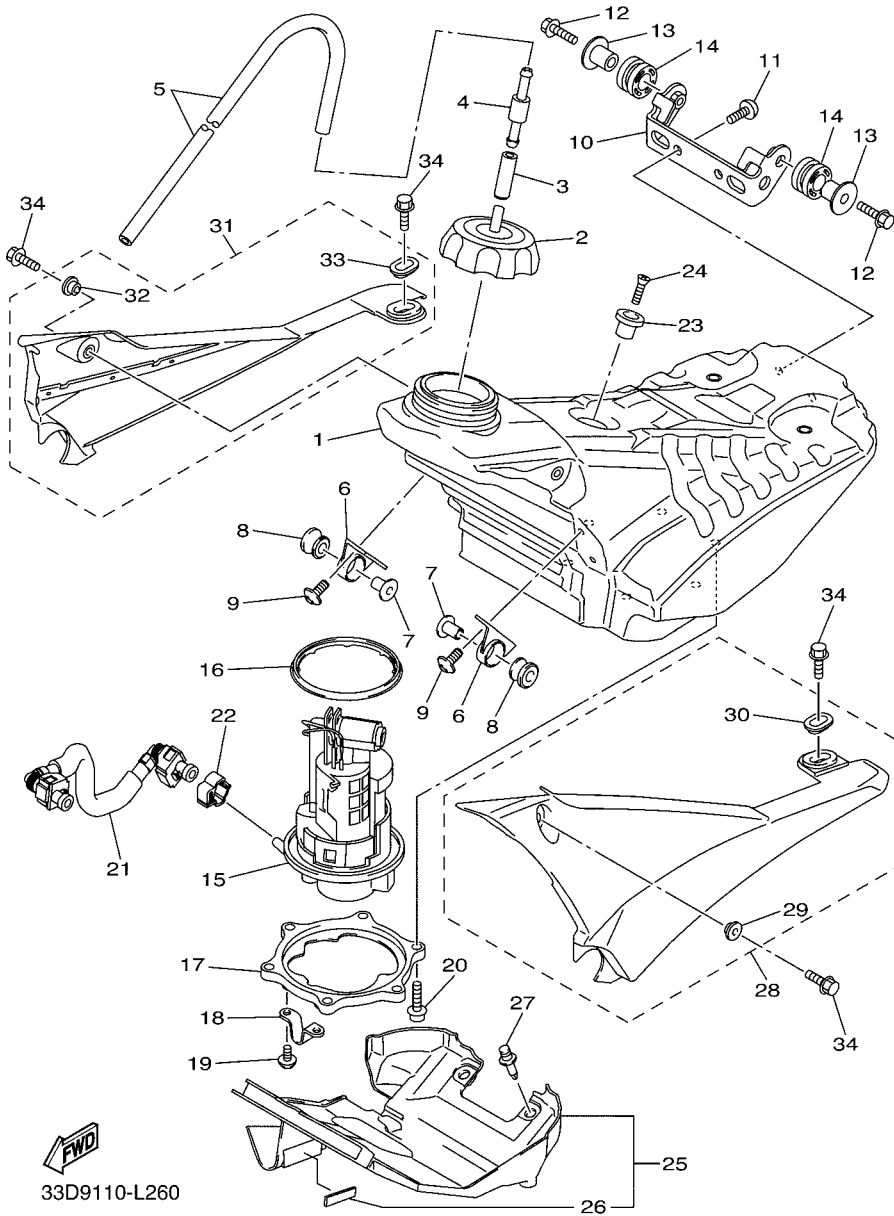

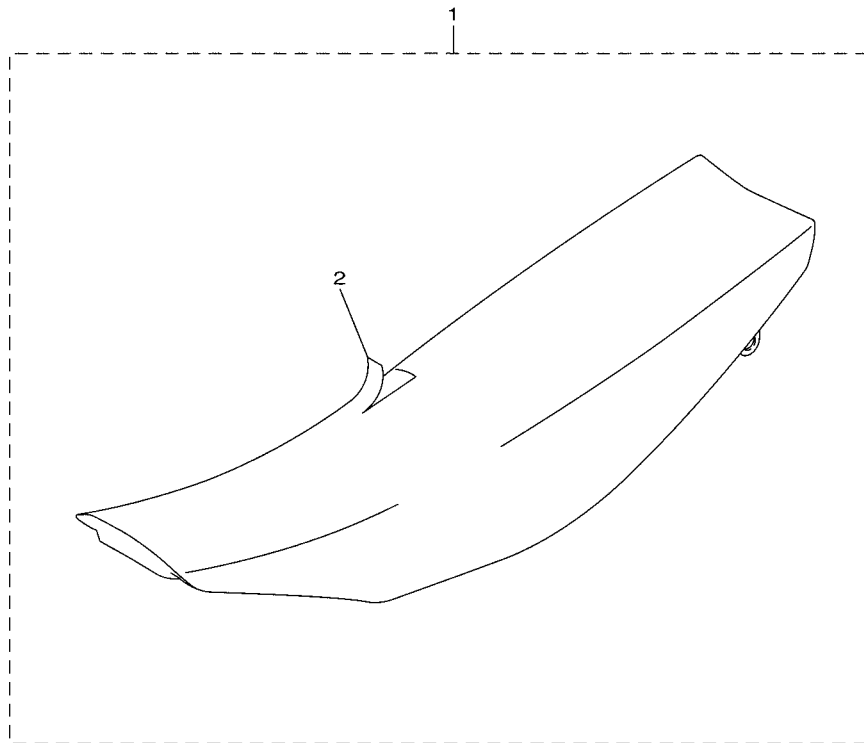

FIG. 27 SEAT

REF. NO.	PART NO.	DESCRIPTION	33DD	33DE	33DF	33DG	REMARKS
1	33D-24710-90	SINGLE SEAT ASSY	1	1	1	1	UR FOR DPBSE
	33D-24710-A0	SINGLE SEAT ASSY	1	1	1	1	UR FOR PWS1
2	33D-2470F-50	.SEAT COVER COMP.	1	1	1	1	UR FOR DPBSE
	33D-2470F-A0	.SEAT COVER COMP.	1	1	1	1	UR FOR PWS1



33D1110-J270

FIG. 28 FRONT WHEEL

REF. NO.	PART NO.	DESCRIPTION	33DD	33DE	33DF	33DG	REMARKS
1	5NY-25111-00	HUB, FRONT	1	1	1	1	
2	93306-90409	BEARING	2	2	2	2	
3	5NY-25117-00	SPACER, BEARING	1	1	1	1	
4	93102-26468	OIL SEAL	2	2	2	2	
5	94416-21045	RIM (1.60-21)	1	1	1	1	
6	17D-2531B-00	.EMBLEM, WHEEL	2	2	2	2	
7	5NY-25104-00	SPOKE SET, FRONT	1	1	1	1	
8	5NY-25196-00	.SPOKE, INNER 1			36		
9	56A-25195-00	.NIPPLE, SPOKE			36		
10	94108-21028	TIRE (80/100-21 51M MX51FG)	1			1	DUNLOP
*		TIRE (80/100-21 51R MST)		1			LM PIRELLI
*		TIRE(80/100-21 51M M601)			1		LM BRIDGESTONE
11	94227-21101	TUBE (80/100-21 M/C TR4)	1			1	DUNLOP
*		TUBE (80/100-21)		1			LM PIRELLI
*		TUBE (80/100-21 M/C TR4)			1		LM BRIDGESTONE
12	94309-21161	BAND, RIM (22-21)	1			1	DUNLOP
*		BAND, RIM (80/100-21)		1			LM PIRELLI
*		BAND,RIM (1.60-21)			1		LM BRIDGESTONE
13	5SF-25394-00	SPACER, BEAD	1	1	1	1	
14	5XC-25181-G0	AXLE, WHEEL	1	1	1	1	
15	5XC-25183-G0	COLLAR, WHEEL	1	1	1	1	
16	5XC-25186-G0	COLLAR, WHEEL	1	1	1	1	
17	90179-16011	NUT	1	1	1	1	

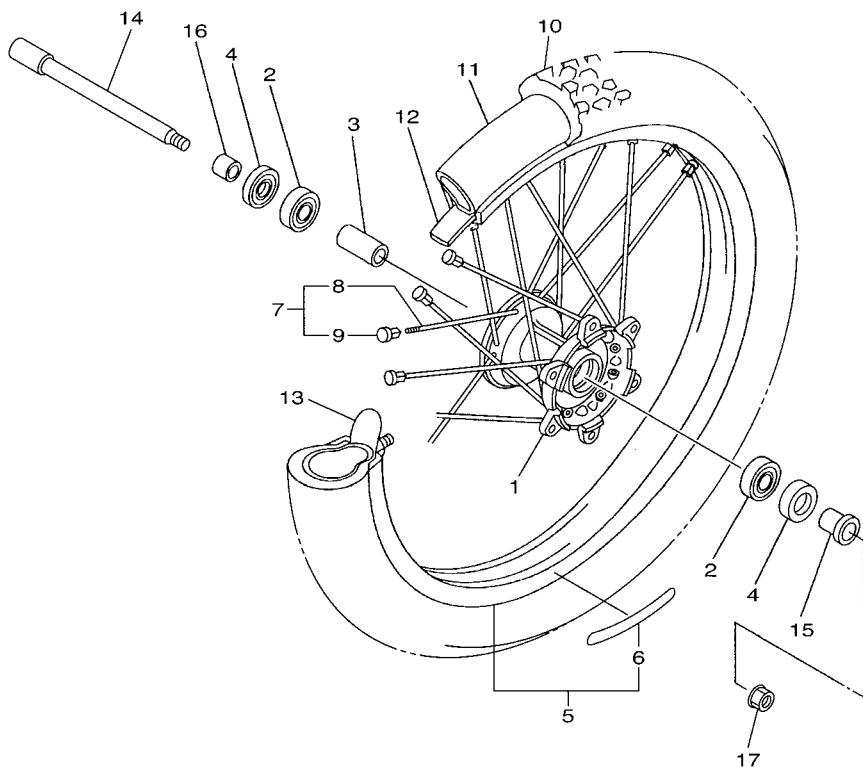

17DD100-K280

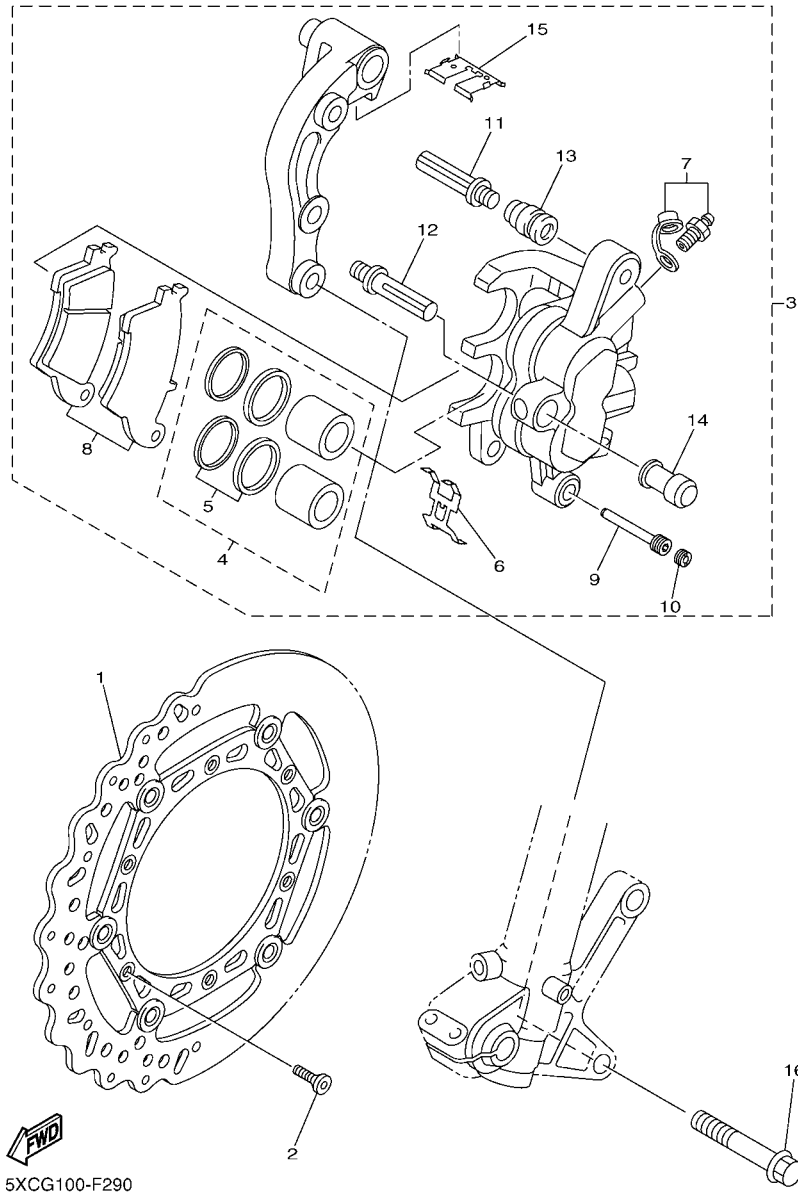

5XCG100-F290

FIG. 29 FRONT BRAKE CALIPER

REF. NO.	PART NO.	DESCRIPTION	33DD	33DE	33DF	33DG	REMARKS
1	5XC-2581T-G0	DISK BRAKE ASSY	1	1	1	1	
2	90151-06051	SCREW, COUNTERSUNK	6	6	6	6	
3	5XC-2580T-G0	CALIPER ASSY (LEFT)	1	1	1	1	
4	5XC-W0057-00	.PISTON ASSY, CALIPER	1	1	1	1	
5	5KM-W0047-10	..CALIPER SEAL KIT	1	1	1	1	
6	5DH-25919-00	.SUPPORT, PAD	1	1	1	1	
7	1UY-W0048-50	.BLEED SCREW KIT	1	1	1	1	
8	5XC-W0045-00	.BRAKE PAD KIT	1	1	1	1	
9	5DH-25933-00	.PIN, PAD	1	1	1	1	
10	5DH-25916-00	.PLUG	1	1	1	1	
11	3SP-25926-51	.BOLT	1	1	1	1	
12	3SP-25914-51	.PIN, SLIDE	1	1	1	1	
13	3JD-25917-00	.BOOT, CALIPER	1	1	1	1	
14	1UY-25937-51	.BOOT 2	1	1	1	1	
15	5XC-25849-G0	.RETAINER, CALIPER	1	1	1	1	
16	90105-08137	BOLT, FLANGE	2	2	2	2	

FIG. 30 REAR WHEEL

REF. NO.	PART NO.	DESCRIPTION	33DD	33DE	33DF	33DG	REMARKS
1	17D-25311-00	HUB, REAR	1	1	1	1	
2	17D-25317-00	SPACER, BEARING	1	1	1	1	
3	93306-90510	BEARING	3	3	3	3	
4	93102-32337	OIL SEAL	2	2	2	2	
5	99009-42700	CIRCLIP	1	1	1	1	
6	17D-25448-50	SPROCKET, DRIVEN (48T)	1				STD
	17D-25449-50	SPROCKET, DRIVEN (49T)		1	1	1	STD
	17D-25447-50	SPROCKET, DRIVEN (47T)	1	1	1	1	AP
	17D-25450-50	SPROCKET, DRIVEN (50T)	1	1	1	1	AP
	17D-25451-50	SPROCKET, DRIVEN (51T)	1	1	1	1	AP
	17D-25452-50	SPROCKET, DRIVEN (52T)	1	1	1	1	AP
	17D-25449-50	SPROCKET, DRIVEN (49T)	1				AP
	17D-25448-50	SPROCKET, DRIVEN (48T)		1	1	1	AP
7	90109-08078	BOLT	6	6	6	6	
8	90185-08008	NUT, SELF-LOCKING	6	6	6	6	
9	90201-08048	WASHER, PLATE	6	6	6	6	
10	34P-25304-00	SPOKE SET, REAR	1	1	1	1	
11	34P-25396-00	.SPOKE, INNER 2			18		
12	34P-25397-00	.SPOKE, OUTER 2			18		
13	5ET-25395-00	.NIPPLE, SPOKE			36		
14	94421-19013	RIM (2.15-19)	1	1	1	1	
15	17D-2531B-00	.EMBLEM, WHEEL	2	2	2	2	
16	94112-19009	TIRE (120/80-19 63M MX51)	1			1	DUNLOP
	*	TIRE (110/90-19 62M NHS)		1			LM PIRELLI
	*	TIRE (110/90-19 62M M602)			1		LM BRIDGESTONE
17	94211-19273	TUBE (110/90-19 M/C TR4)	1			1	DUNLOP
	*	TUBE (110/90-19)		1			LM PIRELLI

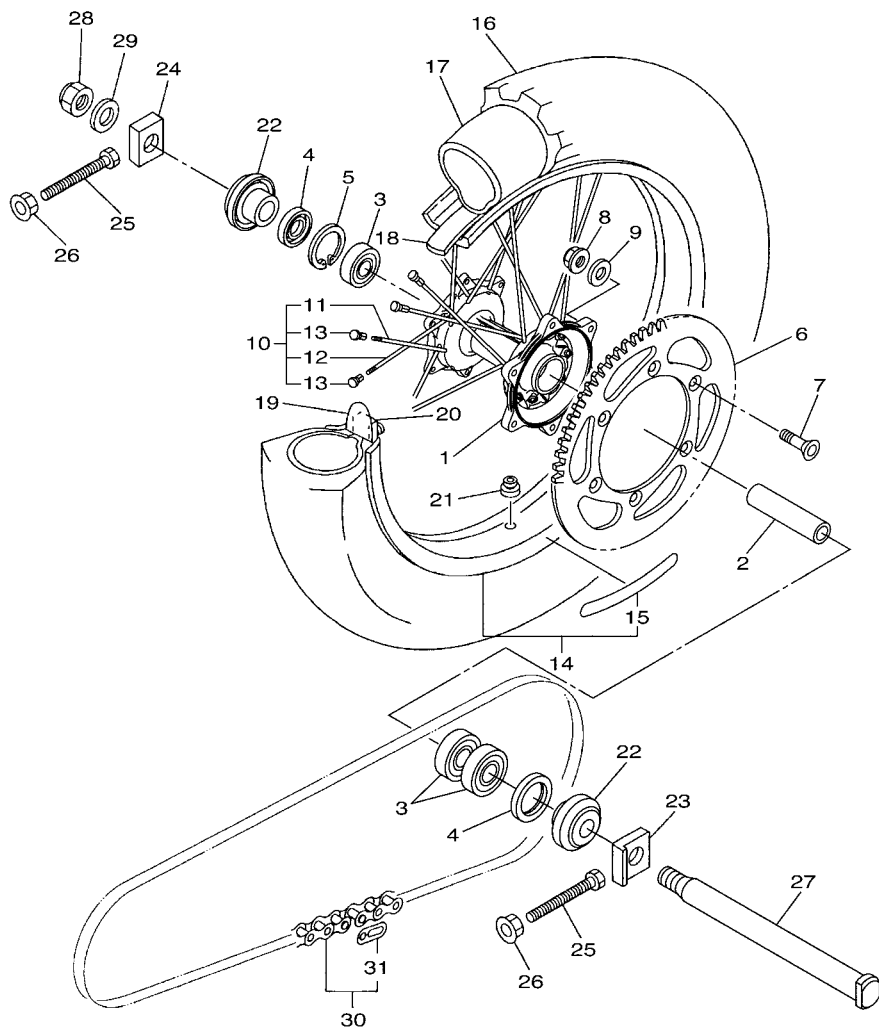

17DD100-K300

FIG. 30 REAR WHEEL

REF. NO.	PART NO.	DESCRIPTION	33DD	33DE	33DF	33DG	REMARKS
17	*	TUBE (110/90-19 M/C TR4)			1		LM BRIDGESTONE
18	94311-19155	BAND, RIM (2.5-19)	1			1	DUNLOP
	*	BAND, RIM (3.50-18)		1			LM METZELER
	*	BAND, RIM (2.15-19)			1		LM BRIDGESTONE
19	3JE-25394-00	SPACER, BEAD	1	1	1	1	
20	4XM-25364-00	DAMPER	1	1	1	1	
21	90480-08608	GROMMET	1	1	1	1	
22	17D-2530S-00	COLLAR ASSY	2	2	2	2	
23	17D-25388-00	PULLER, CHAIN 1	1	1	1	1	
24	33D-25389-00	PULLER, CHAIN 2	1	1	1	1	
25	90101-08006	BOLT	2	2	2	2	
26	90179-08019	NUT	2	2	2	2	
27	17D-25381-00	AXLE, WHEEL	1	1	1	1	
28	90185-22011	NUT, SELF-LOCKING	1	1	1	1	
29	90201-22023	WASHER, PLATE	1	1	1	1	
30	9Y582-28113	CHAIN (DID520DMA2-114LL)	1	1			
	9Y581-92113	CHAIN (DID520DMA2 SDH 114LL)			1	1	UR FOR DPBSE
	9Y582-28113	CHAIN (DID520DMA2-114LL)			1	1	UR FOR PWS1
31	94682-28001	.JOINT, CHAIN(DID520DM G&B-RJ)	1	1			
	94681-68001	.JOINT,CHAIN (DID 520DM-RJ)			1	1	UR FOR DPBSE
	94682-28001	.JOINT, CHAIN(DID520DM G&B-RJ)			1	1	UR FOR PWS1

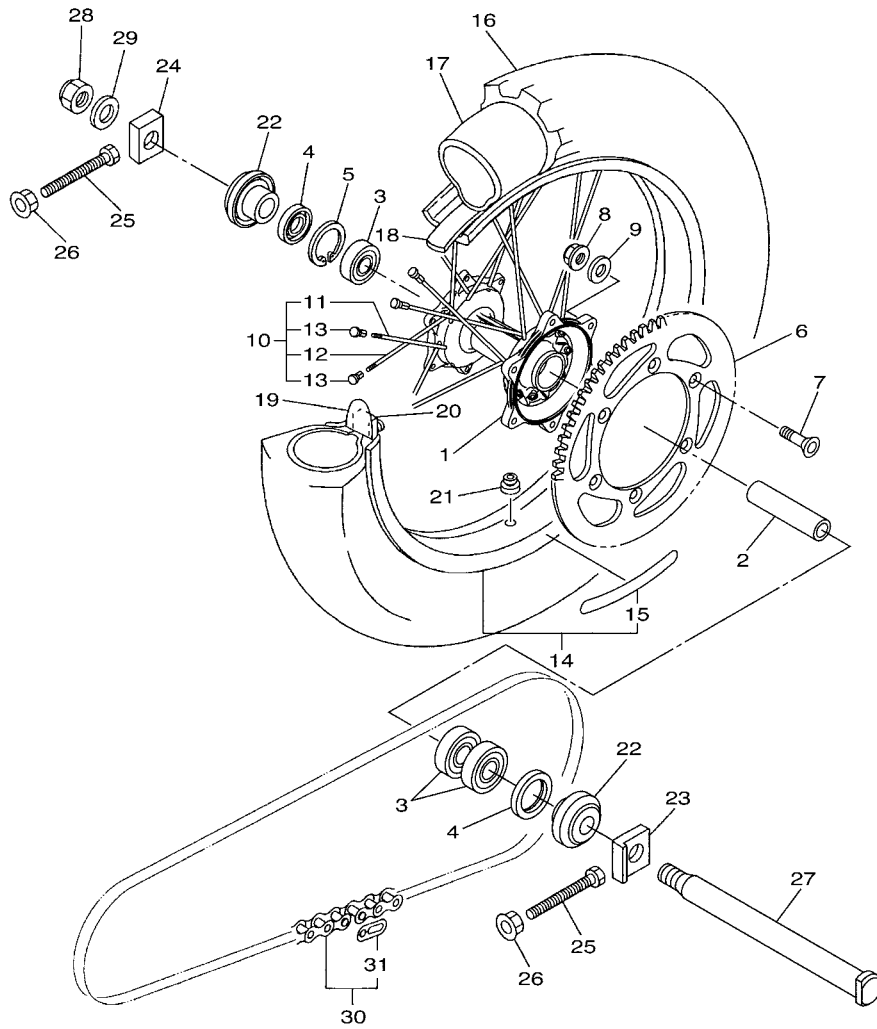

17DD100-K300

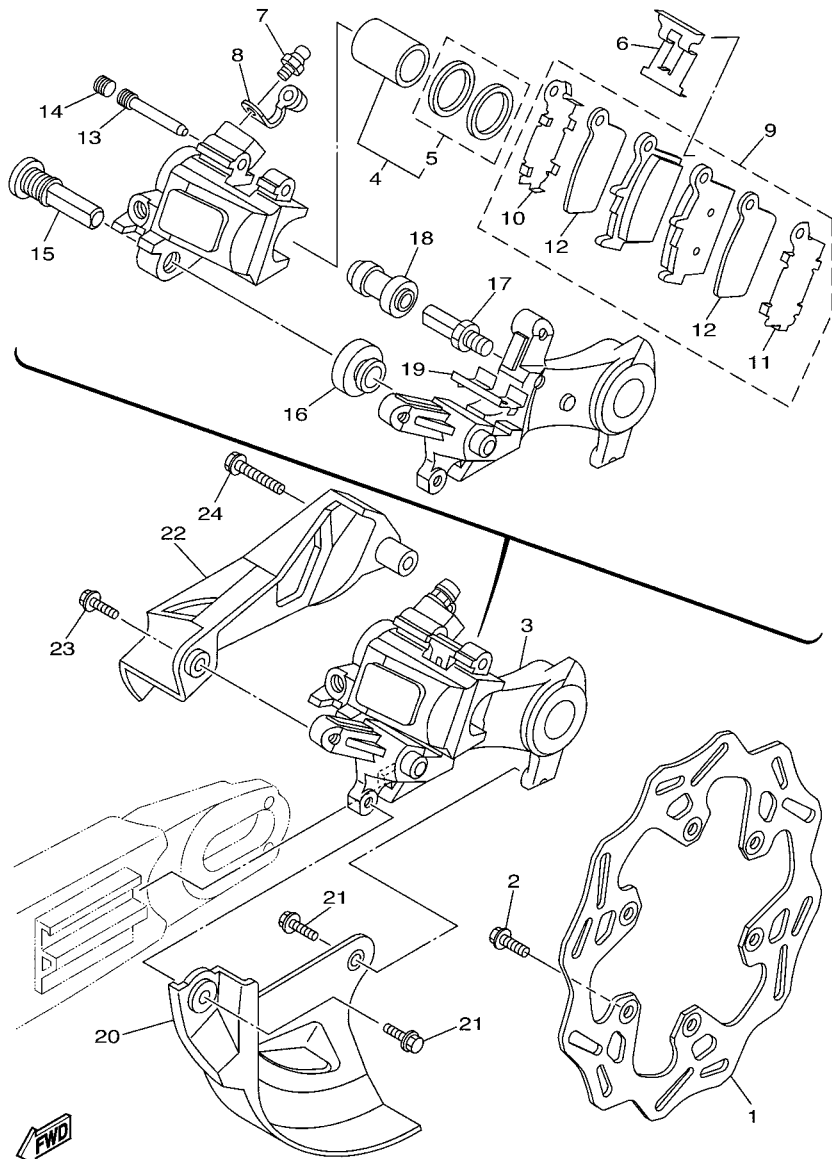

33DD110-M310

FIG. 31 REAR BRAKE CALIPER

REF. NO.	PART NO.	DESCRIPTION	33DD	33DE	33DF	33DG	REMARKS
1	2S2-2582W-70	DISK, REAR BRAKE 2	1	1	1	1	
2	90105-06156	BOLT, FLANGE	6	6	6	6	
3	17D-2580W-01	CALIPER ASSY, REAR 2	1		1	1	
	17D-2580W-11	CALIPER ASSY, REAR 2		1			
4	5UN-W0057-50	.PISTON ASSY, CALIPER	1	1	1	1	
5	5UN-W0047-50	..CALIPER SEAL KIT	1	1	1	1	
6	5DH-25919-50	.SUPPORT, PAD	1	1	1	1	
7	1UY-25824-51	.SCREW, BLEED	1	1	1	1	
8	1UY-25825-51	.CAP	1	1	1	1	
9	1C3-W0046-50	.BRAKE PAD KIT 2	1		1	1	
	1C3-W0046-B0	.BRAKE PAD KIT 2		1			
10	5UN-25828-60	..SHIM, CALIPER	1	1	1	1	
11	5UN-25827-60	..SHIM, CALIPER	1	1	1	1	
12	5UN-22898-60	..INSULATOR, HEAT	2	2	2	2	
13	8CR-25924-00	.PIN, PAD	1	1	1	1	
14	5DH-25916-00	.PLUG	1	1	1	1	
15	5DH-25914-50	.PIN, SLIDE	1	1	1	1	
16	3JD-25917-00	.BOOT, CALIPER	1	1	1	1	
17	5UN-25914-00	.PIN, SLIDE	1	1	1	1	
18	1UY-25937-51	.BOOT 2	1	1	1	1	
19	5UN-25913-00	.RETAINER	1	1	1	1	
20	17D-25718-50	PROTECTOR, DISK BRAKE	1	1	1	1	
21	90105-06110	BOLT, FLANGE	2	2	2	2	
22	17D-27491-50	PROTECTOR	1	1	1	1	
23	90105-06107	BOLT, FLANGE	1	1	1	1	
24	90105-06111	BOLT, FLANGE	1	1	1	1	

FIG. 32 STEERING HANDLE & CABLE

REF. NO.	PART NO.	DESCRIPTION	33DD	33DE	33DF	33DG	REMARKS
1	17D-26111-H0	HANDLEBAR	1	1	1	1	
2	4GY-26241-00	GRIP	1	1	1	1	
3	5TJ-26240-C0	GRIP ASSY	1	1	1	1	
4	4GY-26242-00	.GRIP (RIGHT)	1	1	1	1	
5	3Y1-26249-00	.RING, LEAF	1	1	1	1	
6	5BE-26281-01	CAP, GRIP UPPER	1	1	1	1	
7	5BE-26282-00	CAP, GRIP UNDER	1	1	1	1	
8	98507-05020	SCREW, PAN HEAD	2	2	2	2	
9	5SF-26287-11	COVER, CAP GRIP	1	1	1	1	
10	33D-26302-00	THROTTLE CABLE ASSY	1	1	1	1	
11	33D-26335-00	CABLE, CLUTCH	1	1	1	1	
12	34P-26342-00	BOOT, CABLE	1	1	1	1	
13	90387-225N2	COLLAR	1	1	1	1	
14	17D-26124-00	PROTECTOR, HANDLEBAR	1	1	1	1	
15	17D-26143-H0	COVER, HAND UPPER 1	1	1	1	1	

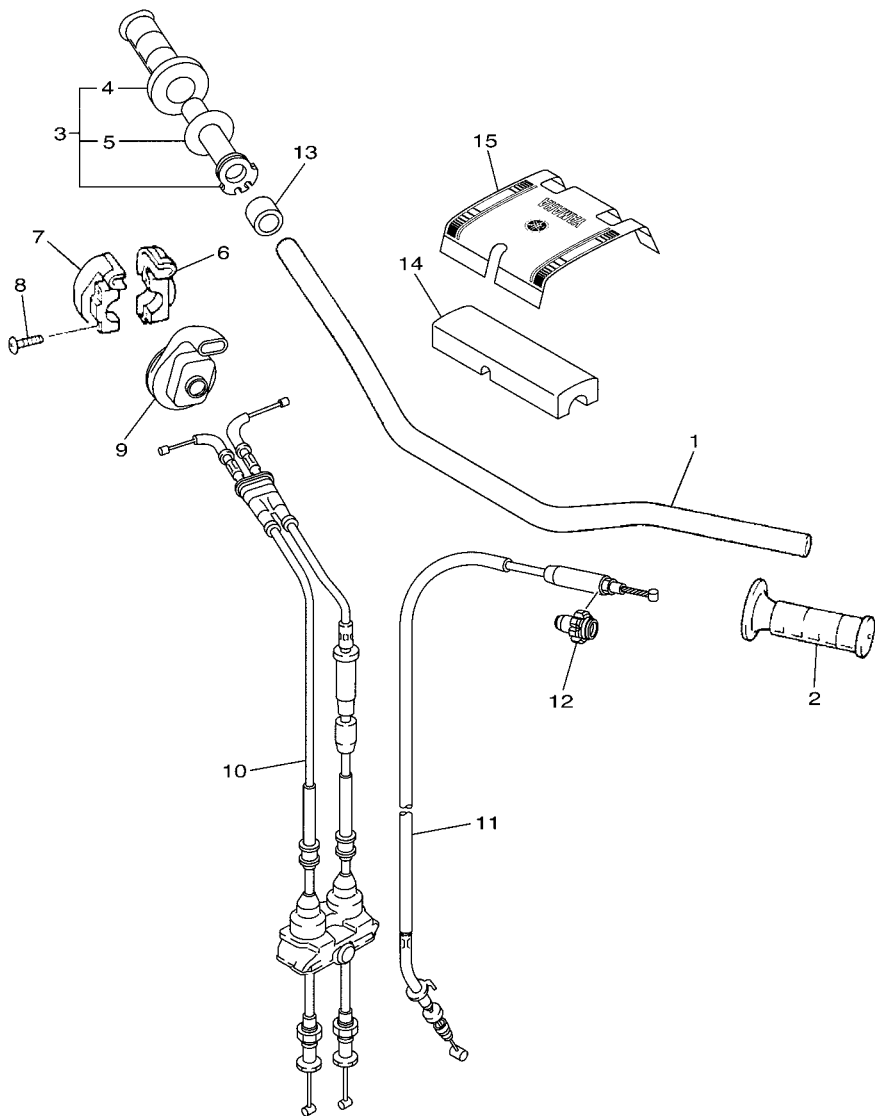

33DD110-M320

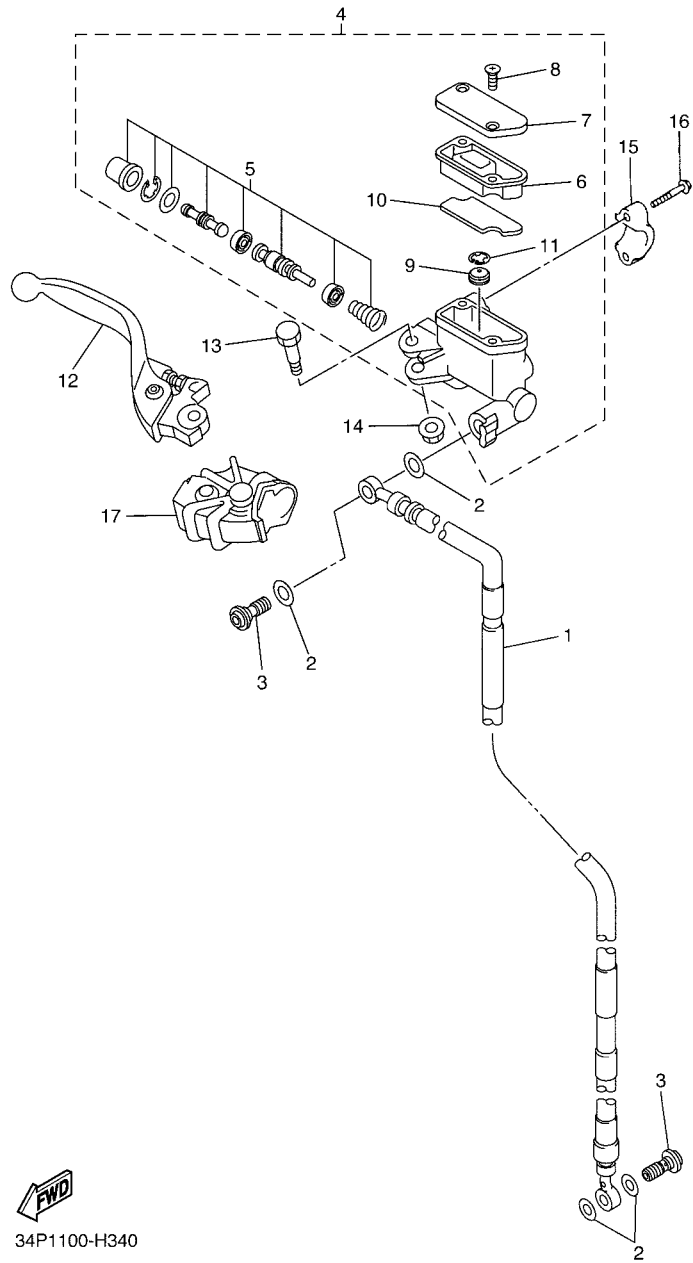

FWD
34P1100-H340

FIG. 33 FRONT MASTER CYLINDER

REF. NO.	PART NO.	DESCRIPTION	33DD	33DE	33DF	33DG	REMARKS
1	17D-25872-50	HOSE, BRAKE 1	1	1	1	1	
2	90430-10005	GASKET	4	4	4	4	
3	90401-10172	BOLT, UNION	2	2	2	2	
4	5XC-W2587-00	MASTER CYLINDER SUB ASSY	1	1	1	1	
5	5XC-W0041-00	.CYLINDER KIT, MASTER	1	1	1	1	
6	5XC-25854-G0	.DIAPHRAGM, RESERVOIR	1	1	1	1	
7	5XC-25852-G0	.CAP, RESERVOIR	1	1	1	1	
8	98706-04012	.SCREW, FLAT HEAD	2	2	2	2	
9	5CG-25715-00	.SEPARATOR ASSY	1	1	1	1	
10	5XC-25853-G0	.FLOAT, RESERVOIR	1	1	1	1	
11	5CG-2585G-00	.CIRCLIP	1	1	1	1	
12	5XC-83922-L0	LEVER 2	1	1	1	1	
13	5MV-2589F-00	BOLT, LEVER	1	1	1	1	
14	95701-06500	NUT, WITH WASHER	1	1	1	1	
15	5MV-25867-00	BRACKET, MASTER CYLINDER	1	1	1	1	
16	5MV-25833-00	BOLT, FITTING	2	2	2	2	
17	5XC-26372-G0	COVER, HANDLE LEVER 1	1	1	1	1	

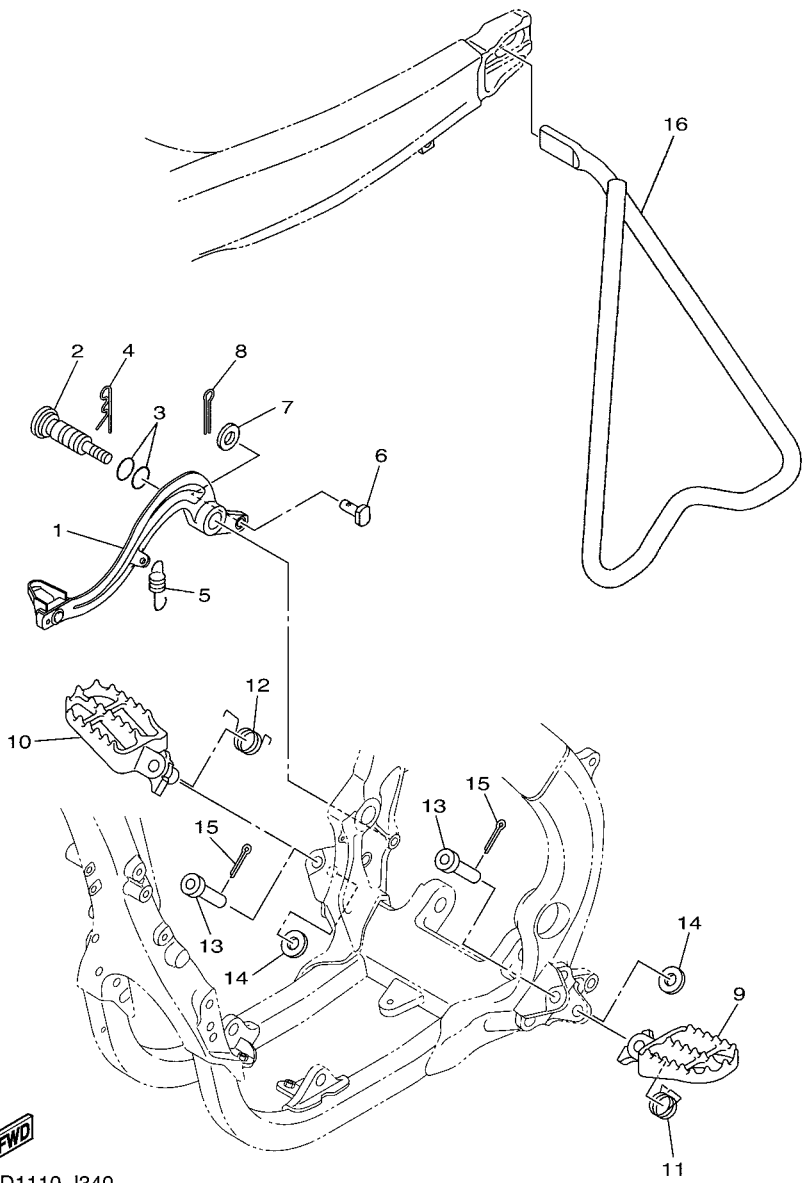

33D1110-J340

FIG. 34 STAND & FOOTREST

REF. NO.	PART NO.	DESCRIPTION	33DD	33DE	33DF	33DG	REMARKS
1	33D-27200-01	PEDAL, BRAKE	1	1	1	1	
2	17D-27217-00	BOLT	1	1	1	1	
3	93210-11073	O-RING	2	2	2	2	
4	90468-16001	CLIP	1	1	1	1	
5	90506-18019	SPRING, TENSION	1	1	1	1	
6	90240-08120	PIN, CLEVIS	1	1	1	1	
7	90201-08044	WASHER, PLATE	1	1	1	1	
8	91402-20012	PIN, COTTER	1	1	1	1	
9	17D-27411-00	FOOTREST 1	1	1	1	1	
10	17D-27421-00	FOOTREST 2	1	1	1	1	
11	90508-28015	SPRING, TORSION	1	1	1	1	
12	90508-28018	SPRING, TORSION	1	1	1	1	
13	90240-10004	PIN, CLEVIS	2	2	2	2	
14	90201-10032	WASHER, PLATE	2	2	2	2	
15	91402-25015	PIN, COTTER	2	2	2	2	
16	34P-27311-00	STAND, SIDE	1	1	1	1	

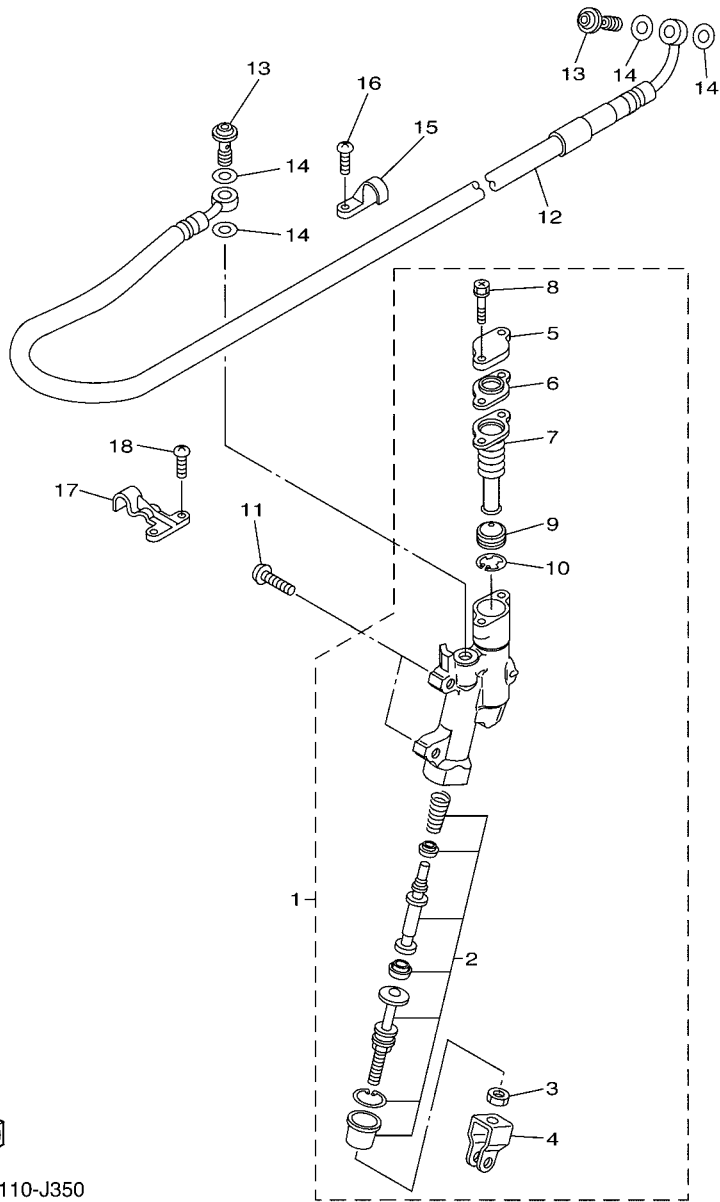

33D1110-J350

FIG. 35 REAR MASTER CYLINDER

REF. NO.	PART NO.	DESCRIPTION	33DD	33DE	33DF	33DG	REMARKS
1	33D-2583V-00	RR. MASTER CYLINDER ASSY.	1	1	1	1	
2	5UN-W0042-50	.CYLINDER KIT, MASTER	1	1	1	1	
3	5UN-27218-00	.NUT	1	1	1	1	
4	5UN-27222-00	.JOINT	1	1	1	1	
5	5UN-25852-50	.CAP, RESERVOIR	1	1	1	1	
6	5UN-2585B-00	.PLATE, DIAPHRAGM	1	1	1	1	
7	5UN-25854-00	.DIAPHRAGM, RESERVOIR	1	1	1	1	
8	5UN-27217-00	.BOLT	2	2	2	2	
9	5CG-25715-00	.SEPARATOR ASSY	1	1	1	1	
10	5CG-2585G-00	.CIRCLIP	1	1	1	1	
11	90111-06116	BOLT,HEX. SOCKET BUTTON	2	2	2	2	
12	5XC-25873-L0	HOSE, BRAKE 2	1	1	1	1	
13	90401-10172	BOLT, UNION	2	2	2	2	
14	90430-10005	GASKET	4	4	4	4	
15	1C3-25886-50	HOLDER, BRAKE HOSE	1	1	1	1	
16	98502-05010	SCREW, PAN HEAD	2	2	2	2	
17	1C3-25876-50	HOLDER, BRAKE HOSE 2	1	1	1	1	
18	98502-05010	SCREW, PAN HEAD	2	2	2	2	

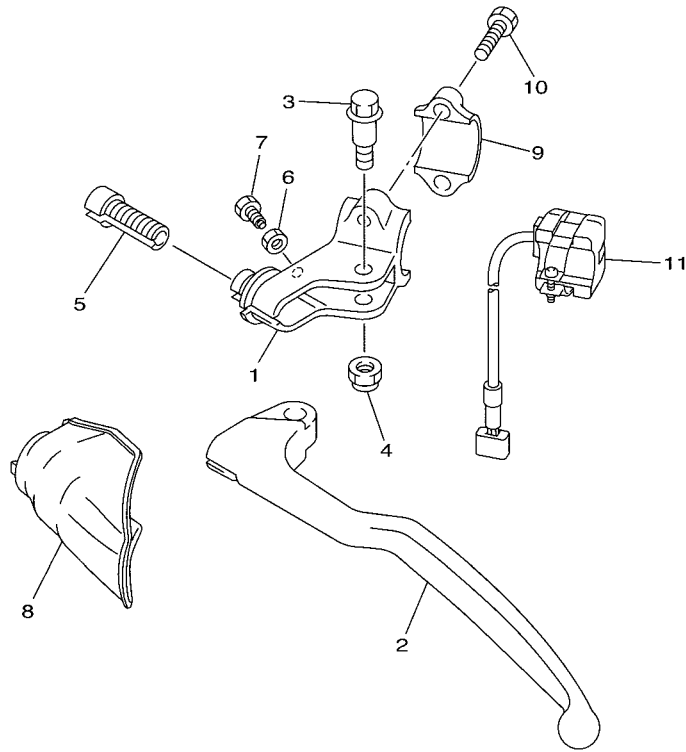

FIG. 37 HANDLE SWITCH & LEVER

REF. NO.	PART NO.	DESCRIPTION	33DD	33DE	33DF	33DG	REMARKS
1	17D-82911-00	HOLDER, LEVER 1	1	1	1	1	
2	17D-83912-00	LEVER 1	1	1	1	1	
3	90109-06034	BOLT	1	1	1	1	
4	5LP-84126-10	NUT, LENS FITTING	1	1	1	1	
5	17D-26337-00	BOLT, ADJUSTING	1	1	1	1	
6	95302-05600	NUT	1	1	1	1	
7	90101-05005	BOLT	1	1	1	1	
8	34P-26372-00	COVER, HANDLE LEVER 1	1	1	1	1	
9	33D-82913-00	HOLDER, LEVER LOWER 1	1	1	1	1	
10	95022-06020	BOLT, FLANGE	2	2	2	2	
11	33D-83976-01	SWITCH, HANDLE 1	1	1	1	1	



33D1110-J370

FIG. 38 ELECTRICAL 1

REF. NO.	PART NO.	DESCRIPTION	33DD	33DE	33DF	33DG	REMARKS
1	33D-8591A-70	ENGINE CONTROL UNIT ASSY	1				
	33D-8591A-40	ENGINE CONTROL UNIT ASSY		1			
	33D-8591A-50	ENGINE CONTROL UNIT ASSY			1		
	33D-8591A-60	ENGINE CONTROL UNIT ASSY				1	
2	92012-05025	BOLT, BUTTON HEAD	2	2	2	2	
3	90387-05048	COLLAR	2	2	2	2	
4	90480-13029	GROMMET	2	2	2	2	
5	90201-05043	WASHER, PLATE	2	2	2	2	
6	33D-82310-00	IGNITION COIL ASSY	1	1	1	1	
7	33D-82351-00	TUBE, CORD	1	1	1	1	
8	90480-11015	GROMMET	1	1	1	1	
9	33D-82370-00	PLUG CAP ASSY	1	1	1	1	
10	92012-05016	BOLT, BUTTON HEAD	2	2	2	2	
11	33D-13542-00	HOSE, VACUUM SENSING 1	1	1	1	1	
12	90467-07138	CLIP	1	1	1	1	
13	92012-05016	BOLT, BUTTON HEAD	1	1	1	1	
14	4P9-83591-00	THERMO UNIT	1	1	1	1	
15	90430-10004	GASKET	1	1	1	1	
16	2C0-82380-00	SENSOR, PRESSURE	1	1	1	1	
17	33D-82388-00	PLATE	1	1	1	1	
18	90105-06110	BOLT, FLANGE	1	1	1	1	
19	33D-81960-00	RECTIFIER & REGULATOR ASSY	1	1	1	1	
20	90105-06110	BOLT, FLANGE	2	2	2	2	
21	33D-81965-00	CONDENSER, SMOOTHING	1	1	1	1	
22	33D-82590-00	WIRE HARNESS ASSY	1	1	1	1	
23	33D-82378-00	CONNECTOR	1	1	1	1	
24	90464-13077	CLAMP	1	1	1	1	

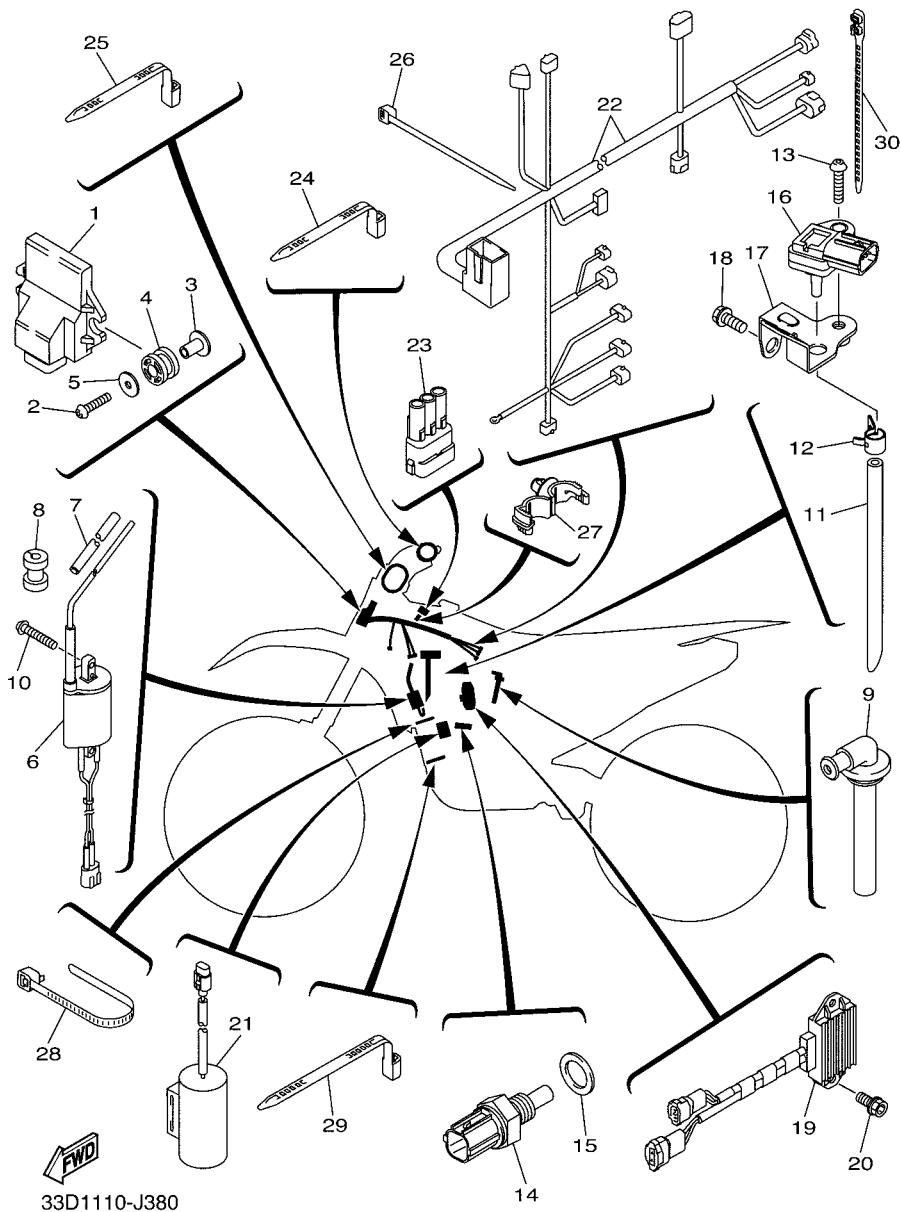

33D1110-J380

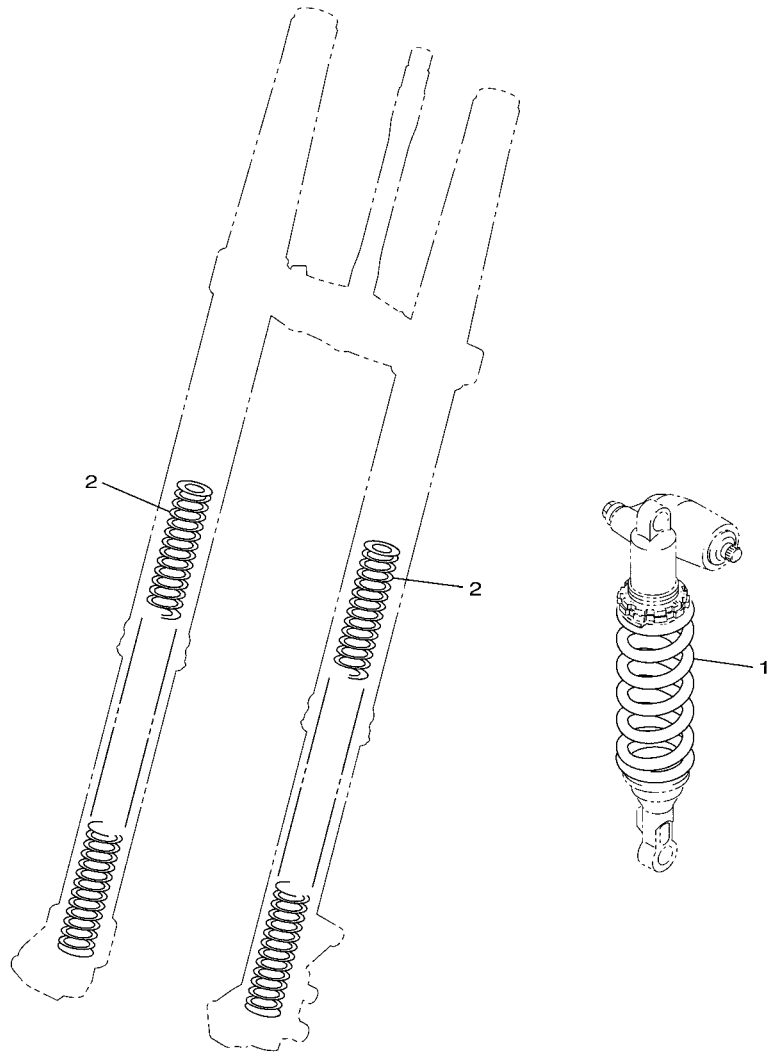

33D1110-J390

FIG. 39 ALTERNATE FOR CHASSIS

REF. NO.	PART NO.	DESCRIPTION	33DD	33DE	33DF	33DG	REMARKS
1	33D-22212-10	SPRING (K=52N/MM)	1	1	1	1	AP BLUE
	33D-22212-20	SPRING (K=54N/MM)	1				AP BLUE
	33D-22212-30	SPRING (K=56N/MM)		1	1	1	AP BLUE
	33D-22212-40	SPRING (K=58N/MM)	1	1	1	1	AP BLUE
	33D-22212-B0	SPRING (K=52N/MM)	1	1	1	1	AP RED
	33D-22212-C0	SPRING (K=54N/MM)	1				AP RED
	33D-22212-D0	SPRING (K=56N/MM)		1	1	1	AP RED
	33D-22212-E0	SPRING (K=58N/MM)	1	1	1	1	AP RED
2	33D-23141-20	SPRING, FRONT FORK(K=4.5N/MM)	2	2	2	2	AP
	33D-23141-30	SPRING, FRONT FORK(K=4.6N/MM)	2	2	2	2	AP
	33D-23141-40	SPRING, FRONT FORK(K=4.7N/MM)	2	2	2	2	AP

NUMERICAL INDEX

PART NO.	REF. NO.	PART NO.	REF. NO.	PART NO.	REF. NO.	PART NO.	REF. NO.	PART NO.	REF. NO.	PART NO.	REF. NO.
33D-11102-00	1 - 1	3LD-12168-R1	3 - 11	5D3-13440-01	8 - 1	2S2-1469E-00	11 - 18	33D-17131-00	16 - 6	17D-21511-60	20 - 1
5PS-11133-10	1 - 2	3LD-12168-U1	3 - 11	33D-13447-00	8 - 2	2S2-1469F-00	11 - 19	2S2-17141-00	16 - 7	33D-21610-10	20 - 8
5PS-11134-10	1 - 3	3LD-12168-W1	3 - 11	33D-13542-00	38 - 11	5PH-14714-00	11 - 5	2S2-17151-00	16 - 3	33D-21642-00	20 - 11
33D-11166-00	1 - 23	3LD-12168-Y1	3 - 11	33D-13577-00	10 - 7	8GL-14714-00	11 - 20	2S2-17211-00	16 - 14	3RV-21668-A0	22 - 32
371-11167-01	1 - 22	3LD-12169-11	3 - 11	33D-13597-00	9 - 1	2D1-14737-00	11 - 6	2S2-17221-00	16 - 25	3RV-21668-B0	22 - 33
33D-11181-00	1 - 14	3LD-12169-31	3 - 11	33D-13750-00	10 - 1	5VY-14747-00	11 - 11	2S2-17231-00	16 - 20	33D-21710-01	21 - 1
33D-11191-10	1 - 19	3LD-12169-50	3 - 11	3B4-13761-00	10 - 11	33D-14750-10	11 - 13	2S2-17241-00	16 - 23	33D-21719-00	21 - 12
33D-11193-01	1 - 21	3LD-12169-70	3 - 11	33D-13907-00	26 - 15	33D-14750-E0	11 - 13	33D-17251-00	16 - 17	5XC-21719-90	21 - 11
33D-1119E-00	1 - 26	3LD-12169-90	3 - 11	33D-13938-00	10 - 2	33D-1476F-10	11 - 14	33D-17402-00	16 - 13	33D-21720-01	21 - 8
5UM-1119E-00	1 - 25	3LD-12169-E0	3 - 11	33D-13971-00	26 - 21	33D-14788-00	11 - 7	2S2-17411-00	16 - 2	33D-2172A-00	21 - 34
33D-11311-10	1 - 27	3LD-12169-G0	3 - 11	3TJ-14137-40	9 - 7	8GL-14789-00	11 - 22	2S2-17466-00	12 - 10	33D-2172P-00	21 - 5
33D-11351-00	1 - 28	3LD-12169-J0	3 - 11		10 - 10	33D-14987-00	9 - 6	2S2-17471-00	16 - 34	33D-2172S-00	21 - 4
33D-11400-01	2 - 1	3LD-12169-L0	3 - 11	5PS-14147-00	10 - 12	33D-15100-09	12 - 1	33D-18101-00	18 - 2	33D-21730-01	21 - 22
33D-11412-00	2 - 2	3LD-12169-N0	3 - 11	33D-14171-00	10 - 4	5XC-15118-00	12 - 24	2S2-18110-00	18 - 8	33D-21730-51	21 - 22
33D-11422-00	2 - 3	3LD-12169-T0	3 - 11	33D-14216-00	10 - 9	17D-15155-00	12 - 3	18P-18122-00	18 - 3	33D-2173E-50	9 - 44
33D-11454-00	2 - 14	33D-12170-00	4 - 1	33D-14227-00	9 - 5	3Y1-15361-00	12 - 23	33D-18140-00	17 - 4	33D-2173E-60	9 - 44
33D-11455-00	2 - 9	33D-12180-00	4 - 2	33D-14293-00	9 - 4	3Y1-15363-10	13 - 6	5TJ-18172-00	18 - 16	33D-2173F-50	9 - 45
33D-11464-00	2 - 16	5TA-12210-30	4 - 5	33D-14325-00	10 - 5	2S2-15378-00	13 - 13	3XJ-18173-10	18 - 11	33D-2173F-60	9 - 45
2S2-11531-00	2 - 11	4FM-12213-00	4 - 8	33D-14348-00	10 - 6	4JT-15381-01	12 - 15	33D-18175-00	17 - 7	33D-2173P-00	21 - 17
33D-11536-00	2 - 8	5EL-12214-00	4 - 7	33D-14417-00	9 - 17	18P-15383-00	12 - 16	3XJ-18178-00	18 - 12	33D-2173S-00	21 - 15
33D-11603-00	2 - 23	5EL-12228-00	4 - 6	5TJ-14419-00	9 - 24	2S2-15388-00	12 - 19	3XJ-18182-00	18 - 13	33D-21740-01	21 - 27
33D-11631-00	2 - 22	33D-12233-00	4 - 13	33D-1441B-00	9 - 27	33D-15411-00	13 - 1	3XJ-18184-00	18 - 15	33D-21740-51	21 - 27
33D-11633-00	2 - 24	5BE-12241-00	1 - 20	33D-1441G-00	9 - 16	33D-15415-10	13 - 22	1C3-18185-00	18 - 1	5PA-21748-00	21 - 23
33D-11651-00	2 - 6	33D-12251-00	4 - 11	33D-14425-00	9 - 35	33D-15421-00	12 - 9	33D-18501-10	17 - 8		21 - 28
5TG-11681-01	2 - 4	33D-12252-00	4 - 12		9 - 40	33D-15431-00	13 - 14	33D-18502-10	17 - 9	17D-21749-00	21 - 2
33D-116A0-00	2 - 21	33D-1240A-00	6 - 7	33D-14428-00	9 - 8	33D-15441-10	12 - 28	5TG-18503-00	17 - 10		21 - 9
33D-12111-00	3 - 1	33D-12422-00	5 - 7	33D-14437-00	9 - 33	33D-15451-00	13 - 8	33D-18541-10	17 - 1		21 - 24
33D-12113-00	3 - 5	33D-12427-00	5 - 8	33D-14437-10	9 - 33	33D-15453-00	13 - 23	33D-18562-00	12 - 20		21 - 29
33D-12114-00	3 - 6	33D-12446-00	6 - 1	33D-1443A-00	9 - 38	33D-15462-00	13 - 18	33D-21101-90	19 - 1	5BE-21749-00	21 - 3
33D-12116-00	3 - 3	5DJ-12451-00	5 - 2	33D-1443A-10	9 - 38	2S2-15601-00	14 - 1	33D-21163-00	19 - 43		21 - 10
33D-12117-00	3 - 7	5GR-12458-00	5 - 1	33D-1443E-00	9 - 25	33D-15620-01	14 - 18	33D-2116J-00	19 - 47	5XC-21749-90	26 - 30
3LD-12117-00	3 - 8	33D-12461-00	6 - 8	33D-14449-00	9 - 20	33D-15621-01	14 - 19	33D-2116M-00	19 - 41		26 - 33
3LD-12118-00	3 - 9	5SL-12462-00	6 - 9	33D-14451-00	9 - 29	5TA-15651-00	14 - 15	33D-2117F-00	19 - 13	33D-2174A-00	21 - 13
51Y-12119-00	3 - 10	33D-12465-00	6 - 10	33D-14454-00	9 - 10	5GR-15664-00	14 - 8	5PA-2118K-00	20 - 14	33D-2174G-40	21 - 7
33D-12121-00	3 - 2	33D-12482-00	6 - 4	33D-14458-00	9 - 30	2NX-15668-00	14 - 12	5PA-2118K-10	20 - 15	33D-2174G-50	21 - 7
33D-12126-00	3 - 4	5Y9-12491-00	38 - 26	33D-14459-00	9 - 13	2S2-15671-00	14 - 4	5PA-2118K-20	20 - 14	33D-2174H-40	21 - 19
4C8-12153-10	3 - 12	5BE-12564-00	5 - 13	33D-14461-00	9 - 28	3Y6-15674-00	14 - 11	33D-21190-00	19 - 5	33D-2174H-50	21 - 19
5EB-12153-10	3 - 13	33D-12576-00	6 - 13	33D-14462-00	9 - 12	2S2-16111-60	15 - 1	33D-21268-00	19 - 50	33D-2174P-00	21 - 6
3LD-12168-00	3 - 11	33D-12577-00	6 - 14	33D-14477-00	9 - 11	5XD-16150-60	15 - 4	33D-21417-00	19 - 27	33D-2174S-00	21 - 16
3LD-12168-20	3 - 11	33D-12578-00	6 - 15	33D-14480-00	9 - 31	5XD-16154-00	15 - 11	33D-21425-00	19 - 34	33D-2174T-00	21 - 14
3LD-12168-40	3 - 11	33D-12579-00	6 - 16	33D-14486-00	10 - 3	5TA-16321-00	15 - 8	33D-21426-00	19 - 35	33D-2175P-00	21 - 18
3LD-12168-60	3 - 11	5B3-13113-00	13 - 27	33D-14495-00	9 - 19	4B1-16324-00	15 - 7	5YU-2143A-00	24 - 15	33D-2194U-00	19 - 45
3LD-12168-80	3 - 11	2S2-13300-10	7 - 1	33D-14562-00	10 - 8	2S2-16351-00	15 - 6	17D-21447-00	19 - 2	33D-22110-00	22 - 1
3LD-12168-A0	3 - 11	5TA-13320-00	7 - 2	33D-14611-00	11 - 1	33D-16356-00	15 - 14	17D-21448-00	19 - 3	5XC-22121-91	22 - 28
3LD-12168-F0	3 - 11	2S2-13341-00	7 - 9	33D-14613-00	11 - 2	2S2-16357-00	15 - 18	5XC-21456-90	19 - 29	34P-22122-00	22 - 29
3LD-12168-H1	3 - 11	2S2-13342-00	7 - 7	33D-14620-00	11 - 4	5TA-16371-10	15 - 5	33D-21471-00	19 - 37	2S2-22128-70	22 - 11
3LD-12168-K1	3 - 11	5BE-13411-00	7 - 13	33D-1466G-10	11 - 16	33D-16381-10	15 - 19	33D-2147E-00	19 - 39	33D-22141-00	22 - 15
3LD-12168-M1	3 - 11	2S2-13412-00	7 - 12	2S2-1469A-10	11 - 17	2S2-17121-00	16 - 9	17D-21511-50	20 - 1	34P-22151-01	22 - 8

NUMERICAL INDEX

PART NO.	REF. NO.	PART NO.	REF. NO.	PART NO.	REF. NO.	PART NO.	REF. NO.	PART NO.	REF. NO.	PART NO.	REF. NO.
5UN-22176-00	23 - 15	33D-23103-20	25 - 25	33D-23170-30	25 - 35	33D-24486-00	26 - 16	1UY-25824-51	31 - 7	33D-26335-00	32 - 11
30X-22178-00	19 - 8	33D-23103-30	25 - 25	5XE-23171-L0	25 - 5	33D-24491-00	26 - 17	1UY-25825-51	31 - 8	17D-26337-00	37 - 5
3JD-22178-20	19 - 18	33D-23110-10	25 - 28		25 - 29	5NY-24610-10	26 - 2	5UN-25827-60	31 - 11	34P-26342-00	32 - 12
17D-2217A-00	22 - 18	5XC-23111-00	25 - 22	5DH-23183-00	23 - 5	18P-2464V-00	19 - 54	5UN-25828-60	31 - 10	34P-26372-00	37 - 8
33D-2217F-00	22 - 24		25 - 46	509-23184-L0	23 - 3	33D-24665-00	26 - 26	2S2-2582W-70	31 - 1	5XC-26372-G0	33 - 17
4V4-22184-00	19 - 9	276-23114-00	25 - 24	1C3-23188-L0	25 - 15	18P-2467E-00	19 - 53	5MV-25833-00	33 - 16	33D-27200-01	34 - 1
5MV-22184-00	23 - 16		25 - 48		25 - 39	33D-2470F-50	27 - 2	33D-2583V-00	35 - 1	17D-27217-00	34 - 2
2S2-22199-70	22 - 10	33D-23120-10	25 - 4	1C3-23188-N0	25 - 16	33D-2470F-A0	27 - 2	5XC-25849-G0	29 - 15	5UN-27217-00	35 - 8
33D-22200-90	23 - 1	5XE-23125-L0	25 - 6		25 - 40	33D-24710-90	27 - 1	5UN-25852-50	35 - 5	5UN-27218-00	35 - 3
33D-22200-A0	23 - 1		25 - 30	1C3-23188-P0	25 - 17	33D-24710-A0	27 - 1	5XC-25852-G0	33 - 7	5UN-27222-00	35 - 4
33D-22200-B0	23 - 1	33D-23136-00	25 - 2		25 - 41	5NY-25104-00	28 - 7	5XC-25853-G0	33 - 10	34P-27311-00	34 - 16
33D-22200-D0	23 - 1		25 - 26	1C3-23188-R0	25 - 18	5NY-25111-00	28 - 1	5UN-25854-00	35 - 7	17D-27411-00	34 - 9
33D-22200-E0	23 - 1	33D-23141-20	39 - 2		25 - 42	5NY-25117-00	28 - 3	5XC-25854-G0	33 - 6	17D-27421-00	34 - 10
33D-22200-F0	23 - 1	33D-23141-30	39 - 2	1C3-23190-L0	25 - 20	5XC-25181-G0	28 - 14	5UN-25855B-00	35 - 6	17D-27491-50	31 - 22
33D-22201-50	23 - 2	33D-23141-40	39 - 2		25 - 44	5XC-25183-G0	28 - 15	5CG-2585G-00	33 - 11	33D-2814A-00	19 - 55
33D-22201-60	23 - 2	33D-23141-D0	25 - 21	33D-23340-00	25 - 49	5XC-25186-G0	28 - 16		35 - 10	5TA-2814F-00	19 - 52
33D-22201-70	23 - 2		25 - 45	17D-23389-50	24 - 2	56A-25195-00	28 - 9	5MV-25867-00	33 - 15	5ET-28166-10	19 - 51
33D-22212-10	39 - 1	17D-23142-00	25 - 13	17D-2339R-00	24 - 20	5NY-25196-00	28 - 8	17D-25872-50	33 - 1	5PG-2816R-00	20 - 16
33D-22212-20	23 - 9		25 - 37	17D-23416-50	24 - 6	34P-25304-00	30 - 10	5XC-25873-L0	35 - 12	33D-81410-00	36 - 1
	39 - 1	1C3-23142-L0	25 - 13	33D-23435-00	24 - 9	17D-2530S-00	30 - 22	1C3-25876-50	35 - 17	33D-81450-00	36 - 2
33D-22212-30	23 - 9		25 - 37	18P-23441-00	24 - 11	17D-25311-00	30 - 1	1C3-81528-50	35 - 15	33D-81528-00	36 - 3
	39 - 1	5XE-23144-L0	25 - 10	33D-23442-00	24 - 12	17D-25317-00	30 - 2	5MV-2589F-00	33 - 13	33D-81960-00	38 - 19
33D-22212-40	39 - 1		25 - 34	17D-23466-00	25 - 54	17D-2531B-00	28 - 6	5UN-25913-00	31 - 19	33D-81965-00	38 - 21
33D-22212-B0	39 - 1	17D-23145-00	25 - 8	17D-23467-00	25 - 55		30 - 15	5UN-25914-00	31 - 17	33D-82310-00	38 - 6
33D-22212-C0	23 - 9		25 - 32	33D-23472-00	24 - 19	4XM-25364-00	30 - 20	5DH-25914-50	31 - 15	33D-82351-00	38 - 7
	39 - 1	5XC-23146-10	25 - 7	17D-23485-50	24 - 17	17D-25381-00	30 - 27	3SP-25914-51	29 - 12	33D-82370-00	38 - 9
33D-22212-D0	23 - 9		25 - 31	33D-24106-10	26 - 28	17D-25388-00	30 - 23	5DH-25916-00	29 - 10	33D-82378-00	38 - 23
	39 - 1	1AE-23147-00	25 - 19	33D-24106-50	26 - 28	33D-25389-00	30 - 24		31 - 14	2C0-82380-00	10 - 15
33D-22212-E0	39 - 1		25 - 43	33D-24108-10	26 - 31	3JE-25394-00	30 - 19	3JD-25917-00	29 - 13		38 - 16
33D-22213-00	23 - 7	1C3-23147-L0	25 - 12	33D-24108-50	26 - 31	5SF-25394-00	28 - 13		31 - 16	33D-82388-00	38 - 17
33D-22214-00	23 - 10		25 - 36	33D-24110-50	26 - 1	5ET-25395-00	30 - 13	5DH-25919-00	29 - 6	33D-82590-00	38 - 22
33D-22224-00	23 - 11	17D-23153-00	25 - 3	3C5-2411B-20	20 - 13	34P-25396-00	30 - 11	5DH-25919-50	31 - 6	17D-82911-00	37 - 1
4JX-22226-00	23 - 4		25 - 27	4EW-2412F-00	26 - 23	34P-25397-00	30 - 12	8CR-25924-00	31 - 13	33D-82913-00	37 - 9
33D-22234-00	23 - 6	5XE-23153-L0	25 - 9	33D-24135-00	26 - 22	17D-25447-50	30 - 6	3SP-25926-51	29 - 11	4P9-83591-00	38 - 14
5NY-22241-00	23 - 22		25 - 33	5PW-2413B-00	21 - 26	17D-25448-50	30 - 6	5DH-25933-00	29 - 9	17D-83912-00	37 - 2
5XE-22242-00	23 - 19	2HH-23158-L0	25 - 23		21 - 31		30 - 6	1UY-25937-51	29 - 14	5XC-83922-L0	33 - 12
1C3-22253-50	23 - 12		25 - 47	33D-24144-00	26 - 6	17D-25449-50	30 - 6		31 - 18	33D-83976-01	37 - 11
1C3-22253-L1	23 - 17	17D-2315H-50	25 - 52	3FB-2415E-02	20 - 5		30 - 6	17D-26111-H0	32 - 1	5LP-84126-10	37 - 4
4AA-22259-40	23 - 8	17D-2315H-H0	25 - 52	3FB-2415E-12	20 - 6	17D-25450-50	30 - 6	17D-26124-00	32 - 14	33D-85885-00	10 - 14
4AA-22259-50	23 - 8	17D-2315J-50	25 - 51	3FB-2415E-C1	20 - 5	17D-25451-50	30 - 6	17D-26143-H0	32 - 15	8FP-85886-00	9 - 22
4AA-22259-70	23 - 8	17D-2315J-H0	25 - 51	4SR-2416E-00	20 - 7	17D-25452-50	30 - 6	5TJ-26240-C0	32 - 3	33D-8591A-40	38 - 1
4EW-22474-00	23 - 14	33D-2316A-20	25 - 14	33D-24181-00	19 - 56	5CG-25715-00	33 - 9	33D-8591A-00	32 - 2	33D-8591A-50	38 - 1
3JE-22475-00	23 - 13		25 - 38	33D-24182-00	19 - 57		35 - 9	4GY-26242-00	32 - 4	33D-8591A-60	38 - 1
5NY-22475-00	23 - 18	33D-2316A-30	25 - 14	33D-24183-00	19 - 58	17D-25718-50	31 - 20	3Y1-26249-00	32 - 5	33D-8591A-70	38 - 1
5UN-22898-60	31 - 12		25 - 38	33D-24192-00	26 - 18	5XC-2580T-G0	29 - 3	5BE-26281-01	32 - 6	5XC-W0041-00	33 - 5
1C3-22969-90	22 - 9	33D-23170-20	25 - 11	33D-2419A-00	26 - 10	17D-2580W-01	31 - 3	5BE-26282-00	32 - 7	5UN-W0042-50	35 - 2
33D-23102-20	25 - 1		25 - 35	33D-24217-00	26 - 25	17D-2580W-11	31 - 3	5SF-26287-11	32 - 9	5XC-W0045-00	29 - 8
33D-23102-30	25 - 1	33D-23170-30	25 - 11	3XJ-24380-00	26 - 4	5XC-2581T-G0	29 - 1	33D-26302-00	32 - 10	1C3-W0046-50	31 - 9

NUMERICAL INDEX

PART NO.	REF. NO.	PART NO.	REF. NO.	PART NO.	REF. NO.	PART NO.	REF. NO.	PART NO.	REF. NO.	PART NO.	REF. NO.
1C3-W0046-B0	31 - 9	90105-08231	19 - 6	90179-10658	19 - 31	90209-22008	16 - 19	90430-06014	13 - 12	91402-20012	34 - 8
5KM-W0047-10	29 - 5	90105-08232	19 - 21	90179-12657	36 - 6	90209-26348	16 - 24	90430-08002	12 - 12	91402-25015	34 - 15
5UN-W0047-50	31 - 5	90105-10176	19 - 30	90179-16011	28 - 17	90215-10009	2 - 19	90430-08119	1 - 9	91808-16023	1 - 6
1UY-W0048-50	29 - 7	90105-10189	19 - 33	90179-20001	16 - 33	90215-14287	2 - 13		12 - 14		1 - 7
5XC-W0057-00	29 - 4	90105-10193	19 - 24	90179-24004	24 - 10	90215-21003	16 - 32	90430-09002	10 - 13	91812-16001	13 - 19
5UN-W0057-50	31 - 4	90105-10367	1 - 16	90179-28015	24 - 7	90240-08120	34 - 6	90430-10004	38 - 15	91A20-05065	6 - 11
5XC-W2587-00	33 - 4	90109-06034	37 - 3	90185-08008	30 - 8	90240-10004	34 - 13	90430-10005	33 - 2	92012-05010	19 - 44
90101-05005	37 - 7	90109-06232	25 - 53	90185-08009	19 - 22	90267-48084	11 - 15		35 - 14	92012-05016	38 - 10
90101-06041	18 - 17	90109-08078	30 - 7	90185-10012	23 - 23	90269-07001	26 - 27	90445-09003	26 - 3		38 - 13
90101-06044	14 - 13	90110-05058	26 - 20	90185-14010	22 - 31	90280-03006	2 - 20	90445-09005	26 - 5	92012-05025	38 - 2
90101-08006	30 - 25	90110-05062	12 - 5	90185-16002	22 - 16	90282-05034	2 - 17	90450-22001	6 - 19	92902-10200	23 - 21
90105-05028	9 - 32	90110-06161	36 - 5	90185-22011	30 - 28	90340-12007	1 - 5	90450-25001	6 - 18		24 - 13
90105-06027	1 - 4	90110-06245	9 - 37	90201-04030	9 - 15	90340-14011	13 - 4	90450-28001	6 - 17	93101-14164	13 - 15
90105-06064	21 - 32		9 - 42	90201-05043	38 - 5	90340-36002	13 - 2	90450-32003	6 - 20	93102-12106	5 - 5
	24 - 18	90110-06362	12 - 6	90201-05N15	19 - 15	90387-05003	19 - 16	90450-58007	9 - 9	93102-12224	15 - 21
	26 - 34	90110-06363	12 - 7	90201-06108	20 - 4	90387-05048	38 - 3	90450-60004	9 - 3		18 - 10
90105-06081	12 - 21	90110-06364	12 - 8	90201-06571	6 - 24	90387-06009	9 - 18	90464-13073	38 - 25	93102-20108	14 - 14
	16 - 35	90110-08087	14 - 24	90201-08043	19 - 23		9 - 36	90464-13077	38 - 24	93102-26468	28 - 4
90105-06091	7 - 14	90111-04008	9 - 14	90201-08044	34 - 7		9 - 41	90464-15195	38 - 29	93102-32337	30 - 4
90105-06099	4 - 14	90111-06007	26 - 9	90201-08045	19 - 10		26 - 29	90464-18002	38 - 27	93102-32480	16 - 28
	12 - 29		26 - 11	90201-08047	14 - 25		26 - 32	90464-22058	38 - 28	93106-22002	22 - 4
90105-06100	20 - 9	90111-06116	35 - 11	90201-08048	30 - 9	90387-06065	6 - 22	90464-31002	19 - 49	93109-11073	5 - 4
90105-06104	22 - 12	90116-06037	1 - 12	90201-08061	11 - 10	90387-06091	26 - 7	90464-45001	38 - 30	93109-21001	22 - 26
90105-06105	22 - 14	90119-06146	19 - 40	90201-08512	5 - 3	90387-06105	24 - 4	90467-07138	38 - 12	93109-25001	22 - 20
90105-06107	31 - 23	90119-06149	19 - 38	90201-10025	1 - 17	90387-06133	21 - 25	90467-090A2	6 - 12	93109-28043	22 - 5
90105-06110	31 - 21	90119-06239	6 - 25	90201-10032	34 - 14		21 - 30	90467-140A4	1 - 24	93210-07001	12 - 4
	38 - 18	90119-08095	21 - 21	90201-10045	19 - 26	90387-06236	26 - 13	90467-16098	9 - 26	93210-11073	34 - 3
	38 - 20	90119-08133	11 - 21		19 - 32	90387-06259	20 - 2	90468-16001	34 - 4	93210-14369	13 - 5
90105-06111	6 - 23	90149-05031	36 - 4	90201-12166	7 - 11	90387-08041	19 - 11	90480-01023	26 - 14	93210-16500	6 - 6
	31 - 24	90149-06069	7 - 8	90201-127E1	18 - 6	90387-08081	11 - 12	90480-08608	30 - 21	93210-17570	14 - 23
90105-06127	18 - 9	90149-06074	12 - 18		36 - 7	90387-086N4	19 - 20	90480-11015	38 - 8	93210-19123	13 - 7
	20 - 3	90149-06083	2 - 15	90201-14020	22 - 30	90387-124F4	18 - 4	90480-12025	19 - 17	93210-19758	5 - 14
90105-06156	31 - 2	90149-10031	19 - 4	90201-15701	13 - 16	90387-14016	22 - 27	90480-13029	38 - 4	93210-22164	16 - 30
90105-06170	9 - 43	90151-06032	19 - 42	90201-16018	22 - 17	90387-16026	22 - 21	90480-15012	6 - 21	93210-24253	6 - 2
	19 - 46	90151-06045	14 - 22	90201-162H4	14 - 10	90387-17015	12 - 22	90480-18549	26 - 8	93210-357A3	13 - 3
	20 - 10	90151-06051	29 - 2	90201-167P7	14 - 6	90387-17016	22 - 6	90501-043E0	13 - 29	93210-45708	8 - 3
	21 - 20	90151-08003	12 - 17	90201-203E7	16 - 16	90387-1714S	22 - 7	90501-052G5	18 - 14	93300-60839	19 - 19
	24 - 3	90154-05012	26 - 19	90201-20685	14 - 2	90387-20028	16 - 15	90501-147A5	14 - 20	93304-20310	2 - 10
	25 - 56	90159-06010	15 - 10		14 - 16	90387-21005	16 - 8	90501-160A2	14 - 5	93306-00105	5 - 6
90105-06179	21 - 33	90159-06027	17 - 6	90201-21014	22 - 23	90387-225N2	32 - 13	90501-230E4	15 - 9	93306-00426	16 - 12
90105-06189	12 - 11	90170-10405	2 - 18	90201-22023	30 - 29	90387-2513F	16 - 29	90506-18019	34 - 5	93306-00447	16 - 11
90105-08137	11 - 9	90170-14171	2 - 12	90201-253K0	16 - 4	90387-28012	16 - 26	90508-26021	17 - 5	93306-20532	16 - 1
	29 - 16	90170-20255	15 - 3		16 - 21	90401-10172	33 - 3	90508-28015	34 - 11	93306-205A5	16 - 27
90105-08143	19 - 28		15 - 13	90201-286K9	24 - 8		35 - 13	90508-28018	34 - 12	93306-30633	2 - 7
90105-08154	24 - 16	90179-06055	9 - 34	90208-20008	15 - 2	90430-06014	1 - 11	90508-29021	18 - 5	93306-80502	17 - 3
	25 - 50		9 - 39		15 - 12		4 - 10	90508-305B0	14 - 9	93306-90409	17 - 2
90105-08226	19 - 36	90179-08019	30 - 26	90209-16011	22 - 22		5 - 12	91312-06020	9 - 2		28 - 2
90105-08230	19 - 7	90179-10658	19 - 25	90209-21332	16 - 10		12 - 27	91312-06030	7 - 6	93306-90510	30 - 3

NUMERICAL INDEX

PART NO.	REF. NO.	PART NO.	REF. NO.	PART NO.	REF. NO.	PART NO.	REF. NO.	PART NO.	REF. NO.	PART NO.	REF. NO.
93310-63458	2 - 5	95022-06020	6 - 3	9Y582-28113	30 - 30						
93315-32166	22 - 19		37 - 10								
	22 - 25	95022-06025	4 - 9								
93317-11287	15 - 20		5 - 10								
93317-22262	22 - 2		13 - 24								
93332-00068	24 - 5		26 - 12								
93332-00081	24 - 1	95022-06030	13 - 11								
93340-21209	15 - 15		13 - 21								
93342-22217	22 - 3	95022-06035	1 - 18								
93410-20038	14 - 3		1 - 30								
93440-10085	15 - 16	95022-06040	13 - 10								
93440-10153	7 - 4		13 - 20								
93440-25084	16 - 5	95022-06070	8 - 5								
	16 - 18		13 - 25								
93440-28062	16 - 22	95022-06080	13 - 26								
93440-41178	4 - 3	95022-08012	1 - 8								
93450-19052	2 - 25	95022-08040	19 - 12								
93503-08007	13 - 28	95024-08025	11 - 23								
93507-32009	14 - 21	95024-08035	11 - 8								
93511-32027	15 - 17	95302-05600	37 - 6								
93603-16219	7 - 3	95602-10200	23 - 20								
93604-10011	5 - 9		24 - 14								
93608-33002	18 - 7	95701-06500	33 - 14								
93612-16254	1 - 15	95702-06500	22 - 13								
9383E-13233	16 - 31	95704-06500	11 - 3								
94108-21028	28 - 10	95822-08016	12 - 13								
94112-19009	30 - 16	97702-50516	9 - 21								
94211-19273	30 - 17		9 - 23								
94227-21101	28 - 11	97702-60016	20 - 12								
94309-21161	28 - 12	98502-05010	35 - 16								
94311-19155	30 - 18		35 - 18								
94416-21045	28 - 5	98502-05016	19 - 14								
94421-19013	30 - 14	98507-05020	32 - 8								
94591-57122	4 - 4	98702-06025	26 - 24								
94681-68001	30 - 31	98706-04012	33 - 8								
94682-28001	30 - 31	99009-12400	7 - 10								
	30 - 31	99009-16400	14 - 7								
94701-00410	1 - 13	99009-20400	14 - 17								
94701-00411	1 - 13	99009-20500	15 - 22								
94703-00410	1 - 13	99009-22500	13 - 17								
94703-00411	1 - 13	99009-42700	30 - 5								
95022-06010	1 - 10	99530-08012	7 - 5								
	5 - 11	99530-08016	13 - 9								
	19 - 48	99530-10114	7 - 15								
95022-06012	6 - 5	99530-14016	1 - 29								
	12 - 25		12 - 2								
	12 - 26	9Y581-92113	30 - 30								
95022-06016	8 - 4	9Y582-28113	30 - 30								