

# **PARTS CATALOGUE**

***WaveRunner FX140***

**FX1000-B/C-B** (F1B4/60ED/60E1)

**FX1000-B** (F1B5/60EE/60E1)

**MJ-FX1000'03** (F1B6/60EF/60E1)

FX1000-B  
FX1000C-B/MJ-FX1000'03  
PARTS CATALOGUE  
©2003 by Yamaha Motor Co., Ltd.  
1st edition, January 2003  
All rights reserved.  
Any reprinting or unauthorized use  
without the written permission of  
Yamaha Motor Co., Ltd.  
is expressly prohibited.  
Printed in Japan.

**A3**



**A4**

# FOREWORD

This Parts Catalogue is related to the parts for the model(s) on the cover page. When you are ordering replacement parts, please refer to this Parts Catalogue and quote both part numbers and part names correctly.

1. Modifications or additions which have been made after the issue of the Parts Catalogue will be announced in the Yamaha Parts News.  
It is advisable that you make the necessary corrections to the Parts Catalogue according to the Yamaha Parts News.

2. Abbreviations

The following abbreviations are used in this Parts Catalogue.

“UR” Use specified parts number.

“UN” Use as many as needed.

“AP” Alternate Parts

“LM” Locally Made (Parts need to be ordered locally)

“F#” Frame No. (Applicable machine No.)

“O/S” Over Size

3. The number of components for assembly

- Parts, which are to be supplied in an assembly, are listed with a dot (.) in front of the part name as shown below.
- The numeral appearing to the right of each component part indicates the quantity of parts for each assembly unit.

PART NO.	DESCRIPTION	Q'TY	REMARKS
2F5-83310-60	FRONT FLASHER LIGHT ASSY	2	
115-83311-60	.BULB (6V-18W)	1	

4. Applicable colours of graphics are represented in the “REMARKS” as shown below.

PART NO.	DESCRIPTION	Q'TY	REMARKS
2N4-24110-00-X5	FUEL TANK COMP.	2	MXR
3J1-24240-10	.GRAPHIC, FUEL TANK	1	FOR MXR

5. Note that the illustrations for reference in finding parts numbers are not to be used for assembling. When assembling, please use the applicable service manual.

6. The asterisk (\*) before a reference number indicates modified items after the first edition.
7. A part with “YMUS” in the remarks column can be obtained from YMUS (USA) and not from YAMAHA MOTOR CO.,LTD (JAPAN).

PART NO.	DESCRIPTION	Q'TY	REMARKS
EW2-U5160-00	ENGINE HATCH COMP	2	YMUS
90601-168U7	BAND,HOSE	1	YMUS

ADDRESS:

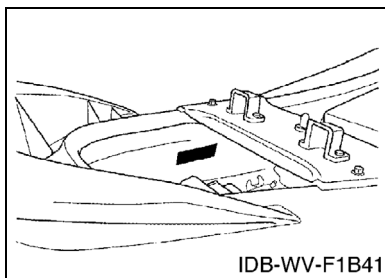
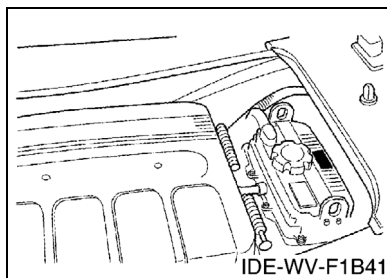
YAMAHA MOTOR CORPORATION U.S.A.  
PARTS & ACCESSORY DIV.  
6555 KATELLA AVENUE  
CYPRESS, CALIFORNIA 90630 U.S.A.

# FOREWORD

## 8. Applicable Serial No.

Engine Serial No.

Hull Serial No.



## 9. Applicable Colour Code

Abbreviation	Colour Name	Colour Code
SS4	BLACK SOLID 4	008P
DPBMF	DARK PUPLISH BLUE METALLIC F	0770
SMF	BLACK METALLIC F	0878
PURW	PURE WHITE	0240

## 10. Quantity Column Information

Column No.	Name Of Q'ty Column	Destination
1	U49	EXCEPT CALIFORNIA FOR USA
2	CAL	CALIFORNIA
3	CAN	CANADA
4	GENE	EXCEPT USA, CANADA, JAPAN
5	JPN	JAPAN

## 11. Applicable Starting Serial No.

Hull Serial No.

Serial No.	Name Of Q'ty Column	Model Code
F1B-807601	U49	F1B4
F1B-809401	CAL	F1B4
F1B-807601	CAN	F1B4
F1B-807501	GENE	F1B5
F1B-100601	JPN	F1B6

Engine Serial No.

Serial No.	Name Of Q'ty Column	Model Code
60E-1001701	U49	60ED
60E-1001701	CAL	60ED
60E-1001701	CAN	60ED
60E-1001701	GENE	60EE
60E-1001701	JPN	60EF

# CONTENTS

CYLINDER .....	B2
CRANKCASE .....	B4
CRANKSHAFT. PISTON .....	B6
VALVE .....	B8
INTAKE .....	B10
INJECTION PUMP .....	B12
OIL PUMP .....	B13
OIL COOLER .....	B15
EXHAUST 1 .....	C3
EXHAUST 2 .....	C5
JET UNIT 1 .....	C8
JET UNIT 2 .....	C11
JET UNIT 3 .....	C12
GENERATOR .....	C13
STARTING MOTOR .....	C14
ELECTRICAL 1 .....	C15
ELECTRICAL 2 .....	D3
ELECTRICAL 3 .....	D5
ENGINE HATCH 1 .....	D6
ENGINE HATCH 2 .....	D8
HULL. DECK .....	D10
GUNWALE. MAT .....	D12
VENTILATION .....	D13
SEAT. UNDER LOCKER .....	D14
FUEL TANK .....	E2
BILGE PUMP .....	E4
EXHAUST 3 .....	E6
CONTROL CABLE .....	E7
STEERING 1 .....	E9
STEERING 2 .....	E11
GRAPHICS .....	E12
IMPORTANT LABELS .....	E13
IMPORTANT LABELS 2 .....	E14
IMPORTANT LABELS 3 .....	E15
REPAIR KIT 1 .....	F2

## INDEX

NUMERICAL INDEX .....	M1
-----------------------	----

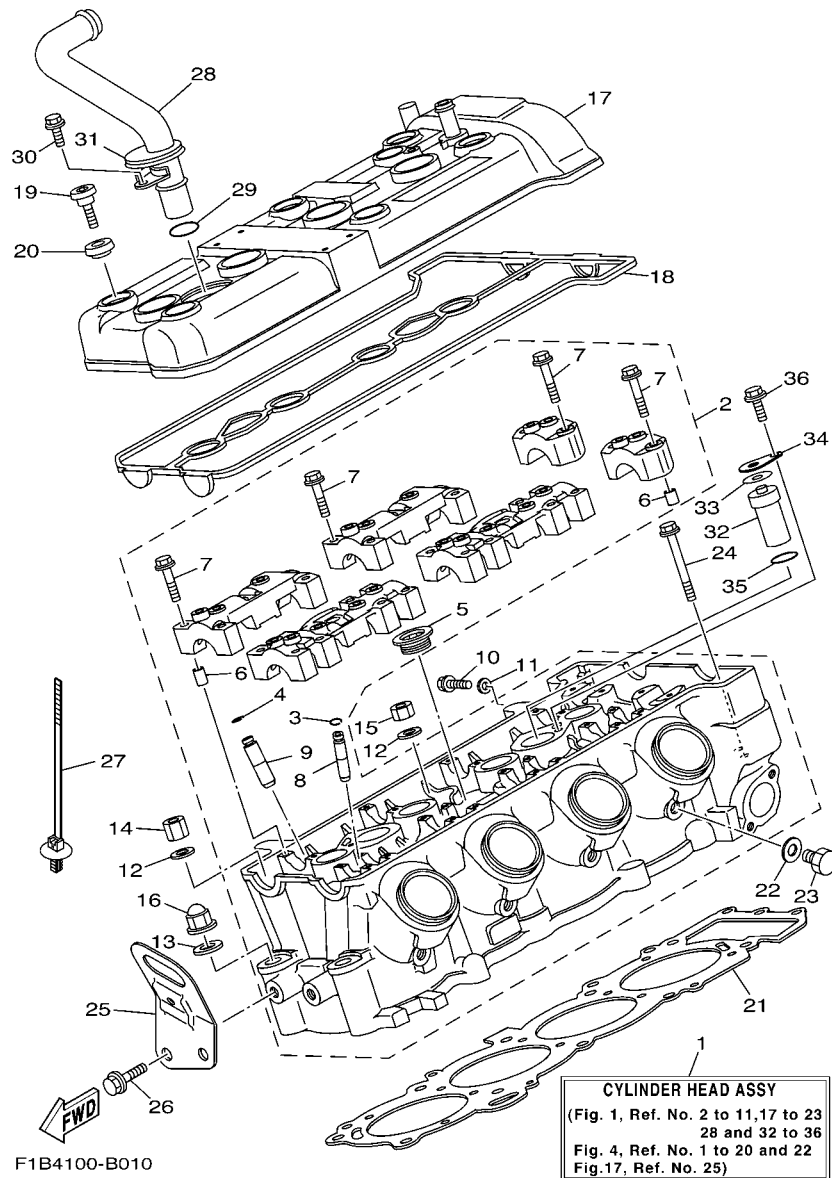
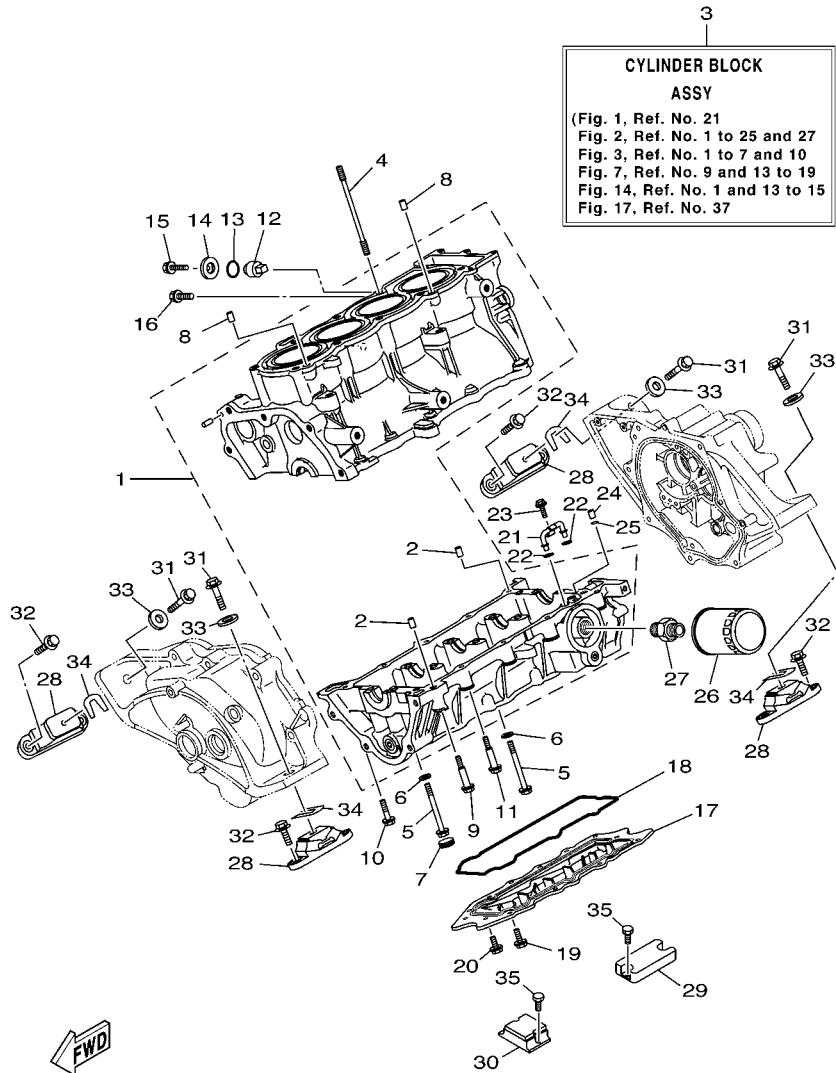


FIG. 1 CYLINDER

REF. NO.	PART NO.	DESCRIPTION	U49	CAL	CAN	GENE	JPN	REMARKS
1	60E-W009A-10-8P	CYLINDER HEAD ASSY	1	1	1	1	1	
2	60E-11102-00-94	CYLINDER HEAD ASSY	1	1	1	1	1	
3	93440-07149	.CIRCLIP	12	12	12	12	12	
4	93440-10153	.CIRCLIP	8	8	8	8	8	
5	90340-27001	.PLUG, STRAIGHT SCREW	1	1	1	1	1	
6	91808-16023	.PIN, DOWEL	12	12	12	12	12	
7	90105-06026	.BOLT, FLANGE	28	28	28	28	28	
8	3TJ-11133-10	.GUIDE, VALVE	12	12	12	12	12	
9	1WG-11133-11	.GUIDE, VALVE	8	8	8	8	8	
10	95023-06012	BOLT	1	1	1	1	1	
11	90430-06014	GASKET	1	1	1	1	1	
12	90201-10013	WASHER, PLATE	8	8	8	8	8	
13	90201-10019	WASHER, PLATE	2	2	2	2	2	
14	90179-10006	NUT	3	3	3	3	3	
15	90179-10414	NUT	5	5	5	5	5	
16	90176-10001	NUT, CROWN	2	2	2	2	2	
17	60E-11191-00-94	COVER, CYLINDER HEAD 1	1	1	1	1	1	
18	60E-11193-00	GASKET, HEAD COVER 1	1	1	1	1	1	
19	90109-066F0	BOLT	6	6	6	6	6	
20	4KG-1111G-00	RUBBER, MOUNT 1	6	6	6	6	6	
21	60E-11181-00	GASKET, CYLINDER HEAD 1	1	1	1	1	1	
22	90430-06014	GASKET	4	4	4	4	4	
23	91380-06012	BOLT	4	4	4	4	4	
24	97513-06555	BOLT, WITH WASHER	3	3	3	3	3	
25	60E-1111E-00	HANGER, ENGINE 2	1	1	1	1	1	
26	97513-08520	BOLT, WITH WASHER	2	2	2	2	2	
27	90464-20005	CLAMP	1	1	1	1	1	



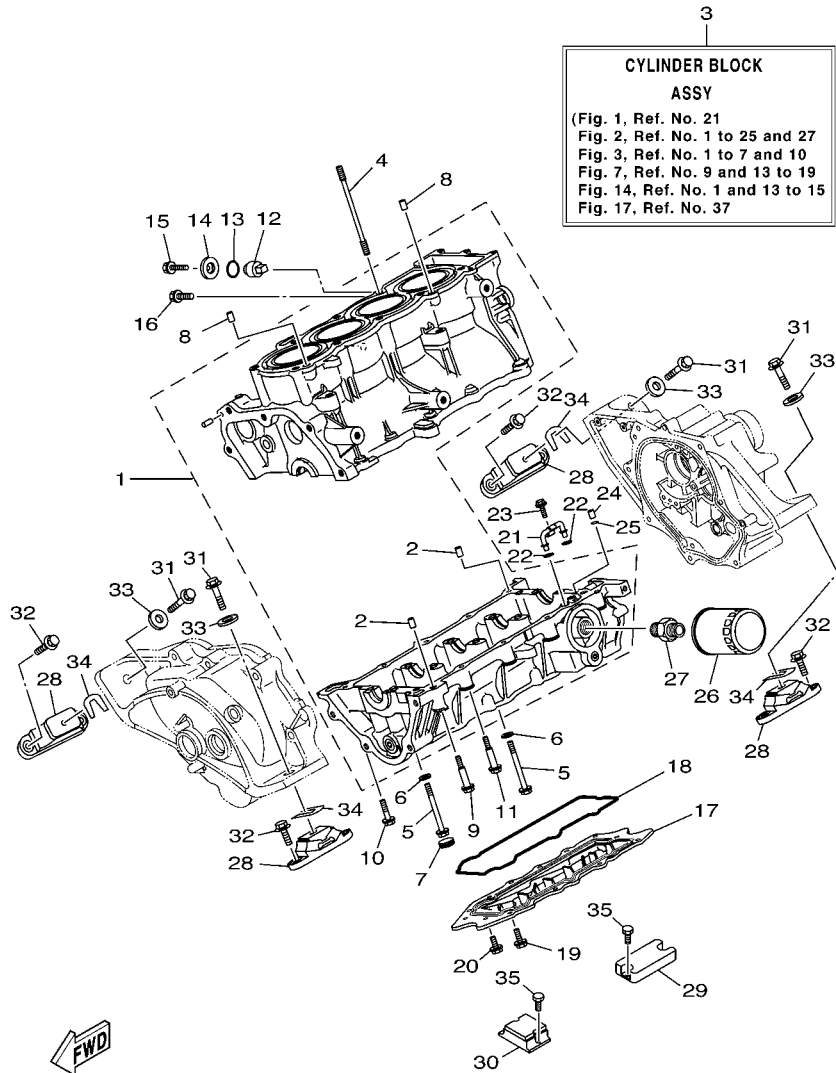




F1B4100-B020

FIG. 2 CRANKCASE

REF. NO.	PART NO.	DESCRIPTION	U49	CAL	CAN	GENE	JPN	REMARKS
1	60E-15100-01-8P	CRANKCASE ASSY	1	1	1	1	1	
2	99530-10014	.PIN, DOWEL	2	2	2	2	2	
3	60E-W009B-01-8P	CYLINDER BLOCK ASSY	1	1	1	1	1	
4	90116-10619	BOLT, STUD	10	10	10	10	10	
5	90105-093A5	BOLT, FLANGE	10	10	10	10	10	
6	90201-096J9	WASHER, PLATE	10	10	10	10	10	
7	60E-11328-00	GROMMET, ANODE	4	4	4	4	4	
8	99530-10014	PIN, DOWEL	2	2	2	2	2	
9	90109-06051	BOLT	2	2	2	2	2	
10	90105-06033	BOLT, FLANGE	1	1	1	1	1	
11	90105-06M17	BOLT, FLANGE	7	7	7	7	7	
12	67F-11325-00	ANODE	1	1	1	1	1	
13	67F-11328-00	GROMMET, ANODE	1	1	1	1	1	
14	69J-11327-00-94	COVER, ANODE	1	1	1	1	1	
15	97595-06520	BOLT, WITH WASHER	1	1	1	1	1	
16	97595-08540	BOLT, WITH WASHER	1	1	1	1	1	
17	60E-1310A-00-94	PAN, OIL	1	1	1	1	1	
18	60E-13557-00	GASKET	1	1	1	1	1	
19	97513-06520	BOLT, WITH WASHER	9	9	9	9	9	
20	97513-06525	BOLT, WITH WASHER	4	4	4	4	4	
21	60E-13161-00	PIPE, DELIVERY 1	1	1	1	1	1	
22	93210-06667	O-RING	2	2	2	2	2	
23	95027-06010	BOLT, FLANGE	1	1	1	1	1	
24	99530-08012	PIN, DOWEL	1	1	1	1	1	
25	93210-08001	O-RING	1	1	1	1	1	
26	5GH-13440-00	ELEMENT ASSY, OIL CLEANER	1	1	1	1	1	
27	90401-20145	BOLT, UNION	1	1	1	1	1	



**FWD**  
F1B4100-B020

**FIG. 2 CRANKCASE**

REF. NO.	PART NO.	DESCRIPTION	U49	CAL	CAN	GENE	JPN	REMARKS
28	67X-44517-10-94	MOUNT RUBBER	4	4	4	4	4	
29	60E-44574-00-94	STOPPER LWR MOUNT RUBBER	1	1	1	1	1	
30	66V-44532-00-94	STOPPER, UPPER MOUNT	1	1	1	1	1	
31	90119-08812	BOLT, WITH WASHER	4	4	4	4	4	
32	90119-089U6	BOLT, WITH WASHER	8	8	8	8	8	YMUS
33	90201-099U3	WASHER, PLATE	4	4	4	4	4	YMUS
34	EU0-U7354-00-01	SHIM (T=0.1)	10	10	10	10	10	UR, YMUS
	EU0-U7354-00-03	SHIM (T=0.3)	10	10	10	10	10	UR, YMUS
	EU0-U7354-00-05	SHIM (T=0.5)	10	10	10	10	10	UR, YMUS
	EU0-U7354-00-10	SHIM (T=1.0)	10	10	10	10	10	UR, YMUS
	EU0-U7354-00-20	SHIM (T=2.0)	10	10	10	10	10	UR, YMUS
35	90101-06917	BOLT	4	4	4	4	4	

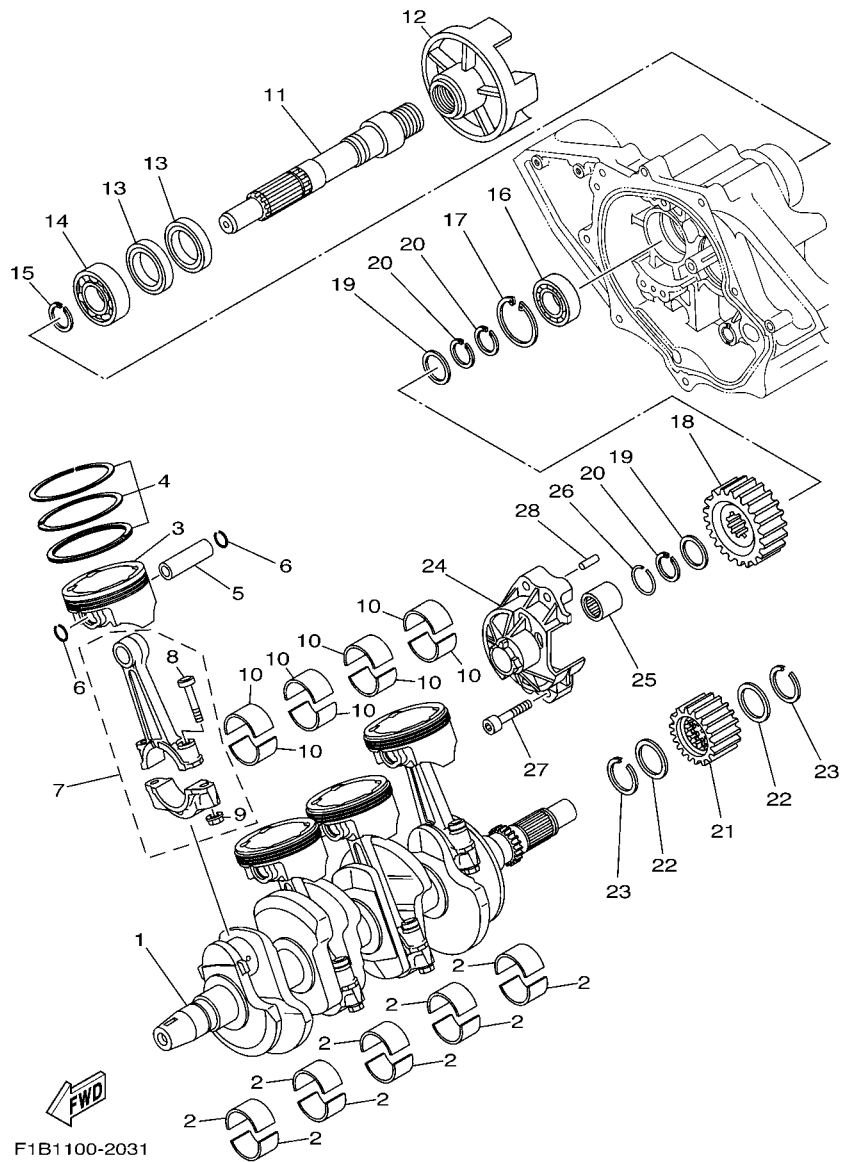
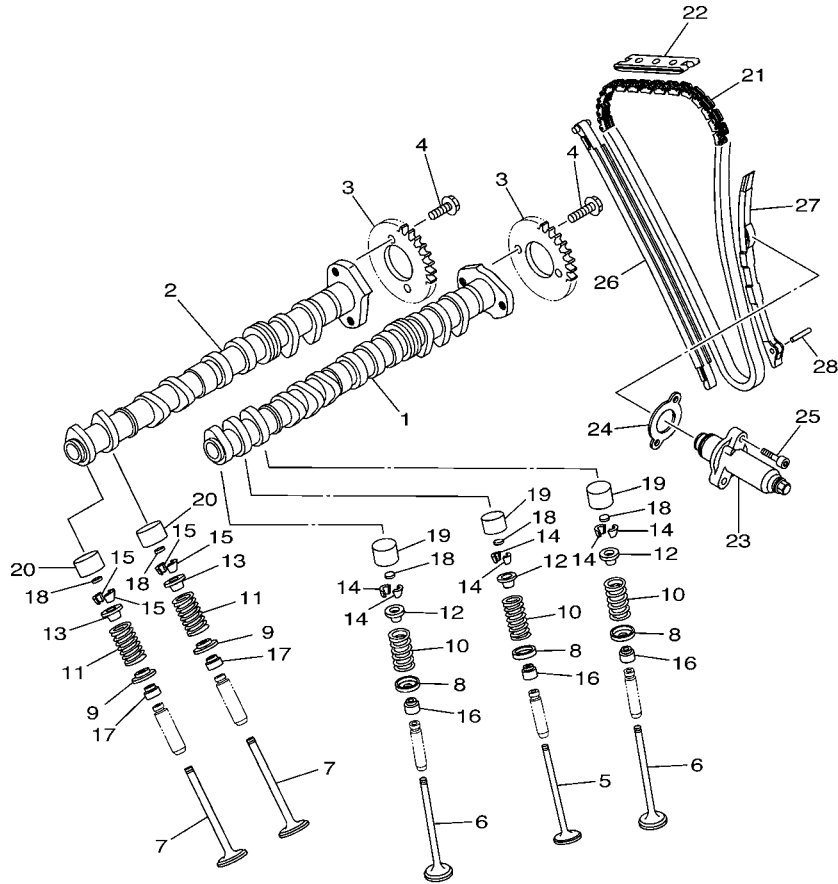


FIG. 3 CRANKSHAFT. PISTON

REF. NO.	PART NO.	DESCRIPTION	U49	CAL	CAN	GENE	JPN	REMARKS
1	60E-11411-11	CRANKSHAFT	1	1	1	1	1	
2	60E-11416-00	PLANE BEARING, CRANKSHAFT 1	10	10	10	10	10	UR BROWN
	60E-11416-10	PLANE BEARING, CRANKSHAFT 1	10	10	10	10	10	UR BLACK
	60E-11416-20	PLANE BEARING, CRANKSHAFT 1	10	10	10	10	10	UR BLUE
	60E-11416-30	PLANE BEARING, CRANKSHAFT 1	10	10	10	10	10	UR GREEN
	60E-11416-40	PLANE BEARING, CRANKSHAFT 1	10	10	10	10	10	UR YELLOW
3	60E-11631-00-B0	PISTON (STD)	4	4	4	4	4	
	60E-11636-00	PISTON (0.50MM O/S)	4	4	4	4	4	AP
4	4XV-11603-00	PISTON RING SET (STD)	4	4	4	4	4	
	60E-11605-00	PISTON RING SET (0.50MM O/S)	4	4	4	4	4	AP
5	4XV-11633-00	PIN, PISTON	4	4	4	4	4	
6	90468-12069	CLIP	8	8	8	8	8	
7	5PW-11650-00	CONNECTING ROD ASSY	4	4	4	4	4	
8	5JW-11654-10	.BOLT, CONNECTING ROD	2	2	2	2	2	
9	90179-08327	.NUT	2	2	2	2	2	
10	60E-11656-00	PLANE BEARING, CONNECTING ROD	8	8	8	8	8	UR BROWN
	60E-11656-10	PLANE BEARING, CONNECTING ROD	8	8	8	8	8	UR BLACK
	60E-11656-20	PLANE BEARING, CONNECTING ROD	8	8	8	8	8	UR BLUE
	60E-11656-30	PLANE BEARING, CONNECTING ROD	8	8	8	8	8	UR GREEN
11	60E-17572-00	SHAFT, TRANSFER	1	1	1	1	1	
12	66E-45813-10-94	FLANGE, COUPLING	1	1	1	1	1	
13	93101-35004	OIL SEAL	2	2	2	2	2	
14	93306-20511	BEARING	1	1	1	1	1	
15	93440-25084	CIRCLIP	1	1	1	1	1	
16	93306-00501	BEARING (B6005)	1	1	1	1	1	
17	99009-47500	CIRCLIP	1	1	1	1	1	
18	60E-17588-00	GEAR, TRANSFER DRIVEN	1	1	1	1	1	

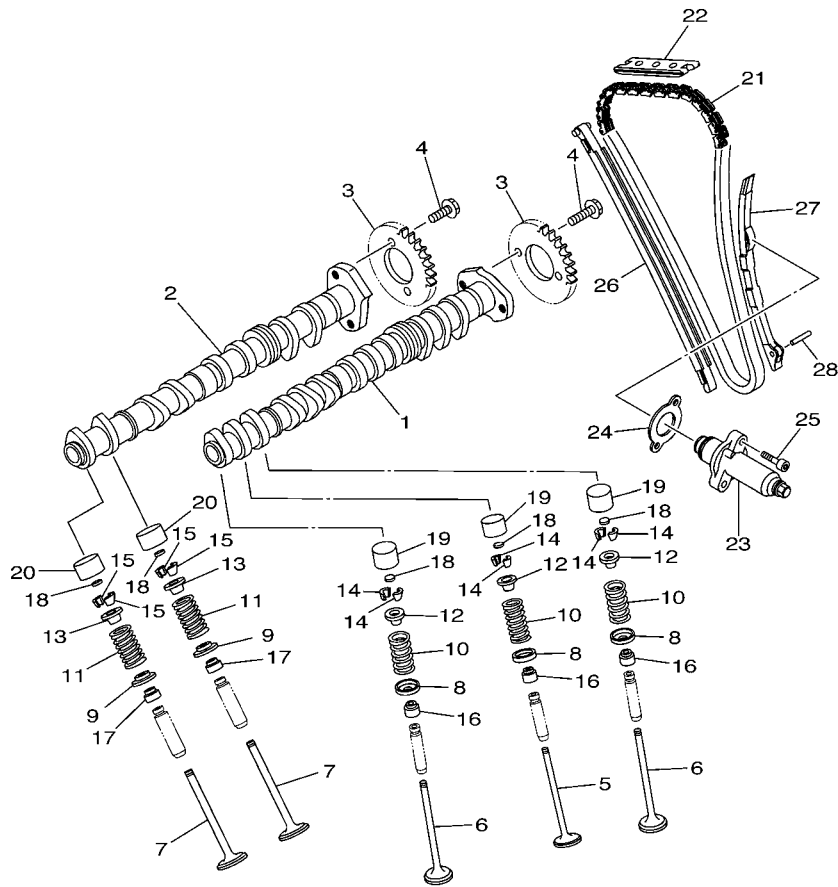


FIG. 4 VALVE



F1B1100-2040

REF. NO.	PART NO.	DESCRIPTION	U49	CAL	CAN	GENE	JPN	REMARKS
1	60E-12171-00	CAMSHAFT 1	1	1	1	1	1	
2	60E-12181-00	CAMSHAFT 2	1	1	1	1	1	
3	4XV-12176-00	SPROCKET, CAM CHAIN	2	2	2	2	2	
4	90105-07342	BOLT, FLANGE	4	4	4	4	4	
5	4XV-12111-00	VALVE, INTAKE	4	4	4	4	4	
6	4XV-12112-00	VALVE, INTAKE 2	8	8	8	8	8	
7	5LV-12121-00	VALVE, EXHAUST	8	8	8	8	8	
8	1HX-12116-01	SEAT, VALVE SPRING	12	12	12	12	12	
9	3GM-12126-00	SEAT, VALVE SPRING 2	8	8	8	8	8	
10	4XV-12113-00	SPRING, VALVE INNER	12	12	12	12	12	
11	4XV-12114-00	SPRING, VALVE OUTER	8	8	8	8	8	
12	1HX-12117-00	RETAINER, VALVE SPRING	12	12	12	12	12	
13	1WG-12117-00	RETAINER, VALVE SPRING	8	8	8	8	8	
14	1HX-12118-00	COTTER, VALVE	24	24	24	24	24	
15	1WG-12118-00	COTTER, VALVE	16	16	16	16	16	
16	4TV-12119-00	SEAL, VALVE STEM	12	12	12	12	12	
17	4SV-12119-00	SEAL, VALVE STEM	8	8	8	8	8	
18	1HX-12168-00	PAD, ADJUSTING 2 (1.20)	20	20	20	20	20	UR
	1HX-12168-20	PAD, ADJUSTING 2 (1.25)	20	20	20	20	20	UR
	1HX-12168-40	PAD, ADJUSTING 2 (1.30)	20	20	20	20	20	UR
	1HX-12168-60	PAD, ADJUSTING 2 (1.35)	20	20	20	20	20	UR
	1HX-12168-80	PAD, ADJUSTING 2 (1.40)	20	20	20	20	20	UR
	1HX-12168-A0	PAD, ADJUSTING 2 (1.45)	20	20	20	20	20	UR
	1HX-12168-F0	PAD, ADJUSTING 2 (1.50)	20	20	20	20	20	UR
	1HX-12168-H1	PAD, ADJUSTING 2 (1.55)	20	20	20	20	20	UR
	1HX-12168-K1	PAD, ADJUSTING 2 (1.60)	20	20	20	20	20	UR
	1HX-12168-M1	PAD, ADJUSTING 2 (1.65)	20	20	20	20	20	UR



F1B1100-2040

FIG. 4 VALVE

REF. NO.	PART NO.	DESCRIPTION	U49	CAL	CAN	GENE	JPN	REMARKS
18	1HX-12168-R1	PAD, ADJUSTING 2 (1.70)	20	20	20	20	20	UR
	1HX-12168-U1	PAD, ADJUSTING 2 (1.75)	20	20	20	20	20	UR
	1HX-12168-W1	PAD, ADJUSTING 2 (1.80)	20	20	20	20	20	UR
	1HX-12168-Y1	PAD, ADJUSTING 2 (1.85)	20	20	20	20	20	UR
	1HX-12169-11	PAD, ADJUSTING 2 (1.90)	20	20	20	20	20	UR
	1HX-12169-31	PAD, ADJUSTING 2 (1.95)	20	20	20	20	20	UR
	1HX-12169-50	PAD, ADJUSTING 2 (2.00)	20	20	20	20	20	UR
	1HX-12169-70	PAD, ADJUSTING 2 (2.05)	20	20	20	20	20	UR
	1HX-12169-90	PAD, ADJUSTING 2 (2.10)	20	20	20	20	20	UR
	1HX-12169-E0	PAD, ADJUSTING 2 (2.15)	20	20	20	20	20	UR
	1HX-12169-G0	PAD, ADJUSTING 2 (2.20)	20	20	20	20	20	UR
	1HX-12169-J0	PAD, ADJUSTING 2 (2.25)	20	20	20	20	20	UR
	1HX-12169-L0	PAD, ADJUSTING 2 (2.30)	20	20	20	20	20	UR
	1HX-12169-N0	PAD, ADJUSTING 2 (2.35)	20	20	20	20	20	UR
	1HX-12169-T0	PAD, ADJUSTING 2 (2.40)	20	20	20	20	20	UR
19	60E-12153-20	LIFTER, VALVE	12	12	12	12	12	UR BLUE
	60E-12153-30	LIFTER, VALVE	12	12	12	12	12	UR RED
20	3FV-12153-20	LIFTER, VALVE	8	8	8	8	8	UR BLUE
	3FV-12153-30	LIFTER, VALVE	8	8	8	8	8	UR RED
21	94582-12130	CHAIN	1	1	1	1	1	
22	5BE-12241-00	GUIDE, STOPPER 2	1	1	1	1	1	
23	60E-12210-00	TENSIONER ASSY, CAM CHAIN	1	1	1	1	1	
24	4FM-12213-00	GASKET, TENSIONER CASE	1	1	1	1	1	
25	91380-06025	BOLT	2	2	2	2	2	
26	4XV-12251-00	DAMPER, CHAIN 1	1	1	1	1	1	
27	4XV-12252-00	DAMPER, CHAIN 2	1	1	1	1	1	
28	93607-44190	PIN, DOWEL	1	1	1	1	1	

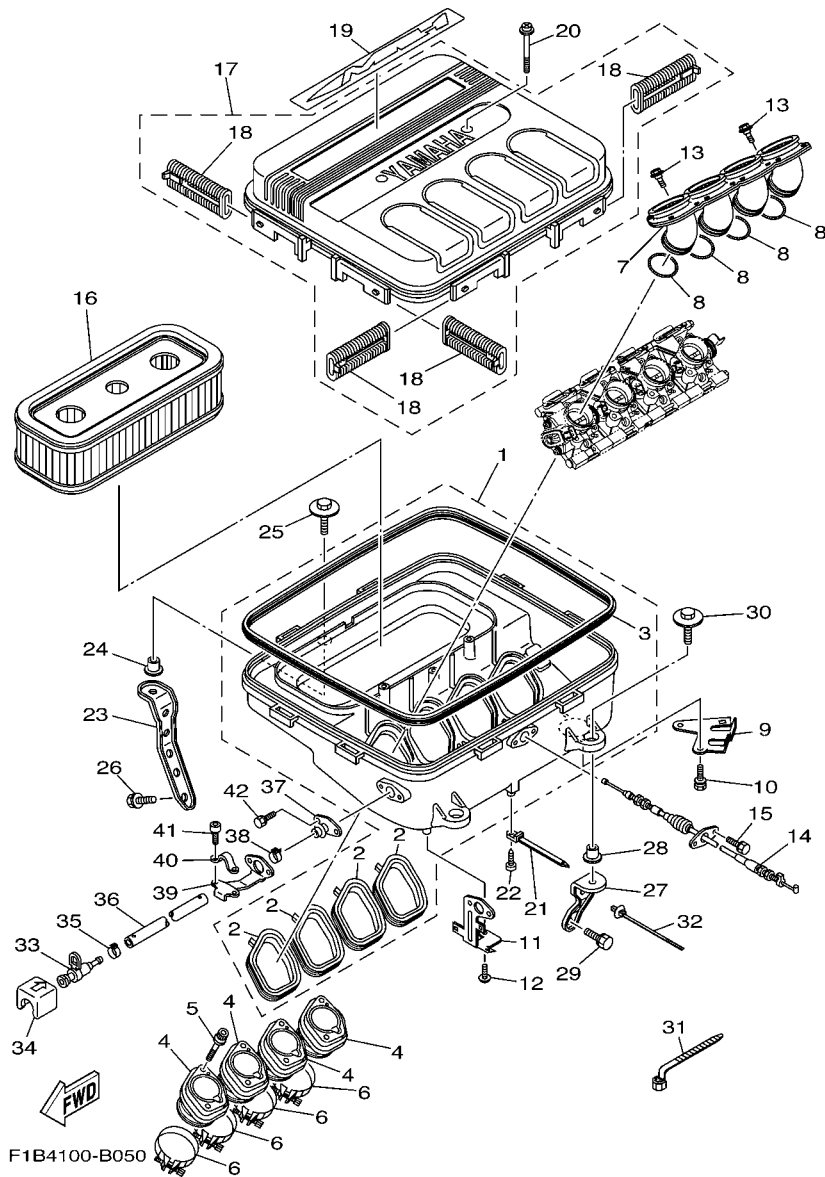


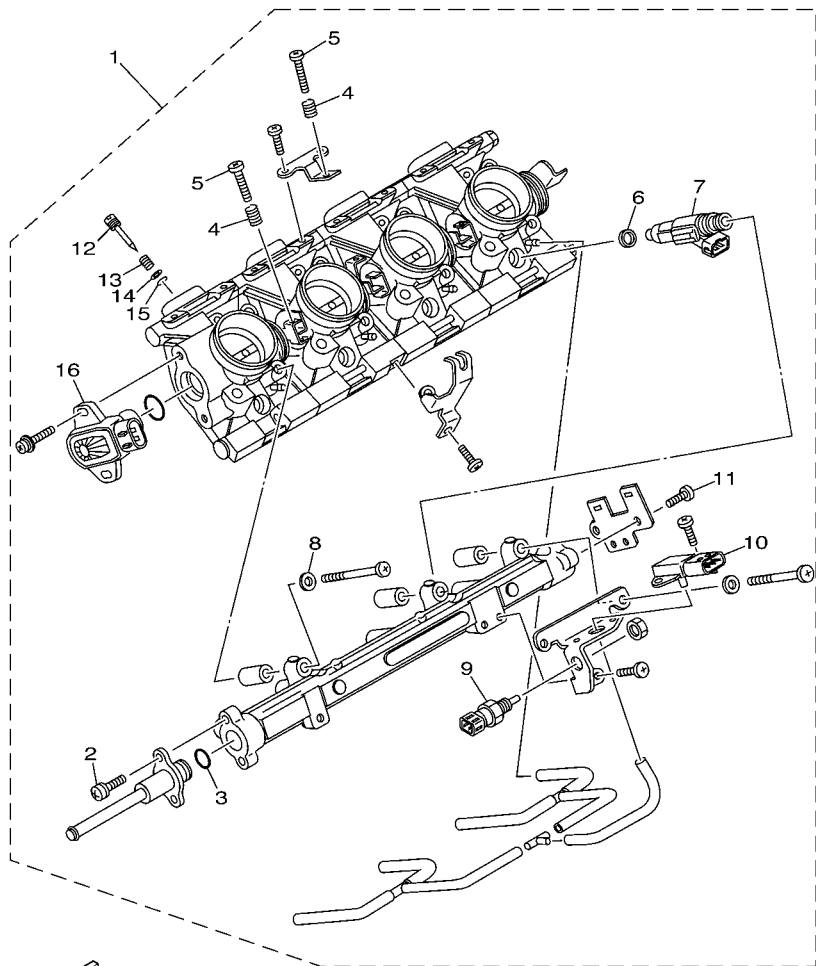
FIG. 5 INTAKE

REF. NO.	PART NO.	DESCRIPTION	U49	CAL	CAN	GENE	JPN	REMARKS
1	60E-14410-00	AIR FILTER ASSY.	1	1	1	1	1	
2	60E-14239-00	.SEAL	4	4	4	4	4	
3	60E-14457-00	.SEAL	1	1	1	1	1	
4	60E-13795-00	JOINTT, THROTTLE BODY 1	4	4	4	4	4	
5	90110-08020	BOLT, HEXAGON SOCKET HEAD	8	8	8	8	8	
6	90450-57002	HOSE CLAMP ASSY	4	4	4	4	4	
7	60E-1440A-01	RIBON, SUB ASSY	1	1	1	1	1	
8	4XV-14275-00	SPRING	4	4	4	4	4	
9	60E-14869-00	BRACKET 3	1	1	1	1	1	
10	97513-06516	BOLT, WITH WASHER	2	2	2	2	2	
11	60E-14867-00	BRACKET	1	1	1	1	1	
12	90160-05003	SCREW, ROUND TAPPING	1	1	1	1	1	
13	90109-06053	BOLT	4	4	4	4	4	
14	60E-26311-00	CABLE, THROTTLE 1	1	1	1	1	1	
15	97513-06514	BOLT, WITH WASHER	2	2	2	2	2	
16	60E-14451-00	ELEMENT, AIR CLEANER	1	1	1	1	1	
17	60E-14420-00	AIR CLEANER ASSY 2	1	1	1	1	1	
18	66V-13898-00	.HOLDER	8	8	8	8	8	
19	60E-2339E-20	GRAPHIC 1	1	1	1		1	EXCEPT GENE
	60E-2339E-A0	GRAPHIC 1				1		FOR GENE
20	90159-05006	SCREW, WITH WASHER	2	2	2	2	2	
21	90465-12M53	CLAMP	1	1	1	1	1	
22	90160-05003	SCREW, ROUND TAPPING	1	1	1	1	1	
23	60E-14413-00	STAY	1	1	1	1	1	
24	60E-14449-00	COLLAR	1	1	1	1	1	
25	90119-08050	BOLT, WITH WASHER	1	1	1	1	1	
26	90119-08032	BOLT, WITH WASHER	1	1	1	1	1	





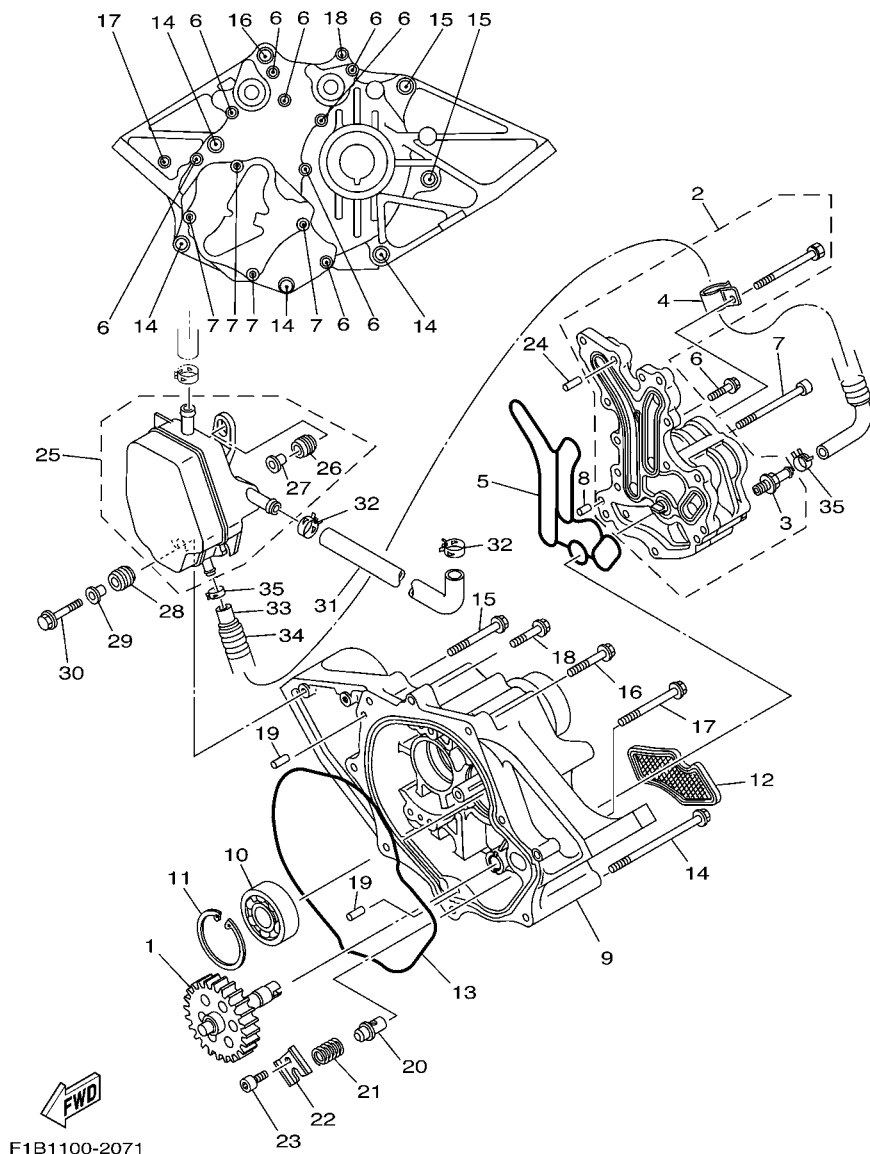
FIG. 6 INJECTION PUMP



F1B1100-2060

REF. NO.	PART NO.	DESCRIPTION	U49	CAL	CAN	GENE	JPN	REMARKS
1	60E-13750-10	THROTTLE BODY ASSY	1	1	1	1	1	
2	68V-81147-00	.SCREW 3	4	4	4	4	4	
3	68V-14397-00	.O-RING	1	1	1	1	1	
4	3KW-14932-00	.SPRING, THROTTLE 2	7	7	7	7	7	
5	69J-14321-00	.SCREW, THROTTLE	4	4	4	4	4	
6	90430-09002	.GASKET	4	4	4	4	4	
7	60E-13761-00	.INJECTOR ASSY	4	4	4	4	4	
8	4XY-14951-00	.WASHER	1	1	1	1	1	
9	65L-85886-00	.THERMOSENSOR	1	1	1	1	1	
10	60E-82380-00	.SENSOR, PRESSURE	1	1	1	1	1	
11	97890-05008	.SCREW, PAN HEAD	2	2	2	2	2	
12	4BH-14923-00	.SCREW, PILOT	4	4	4	4	4	
13	4BH-14134-00	.SPRING, AIR ADJUSTING	4	4	4	4	4	
14	3L5-14962-00	.WASHER	4	4	4	4	4	
15	3H1-14147-00	.O-RING	4	4	4	4	4	
16	60E-85885-10	.THROTTLE SENSOR ASSY	1	1	1	1	1	

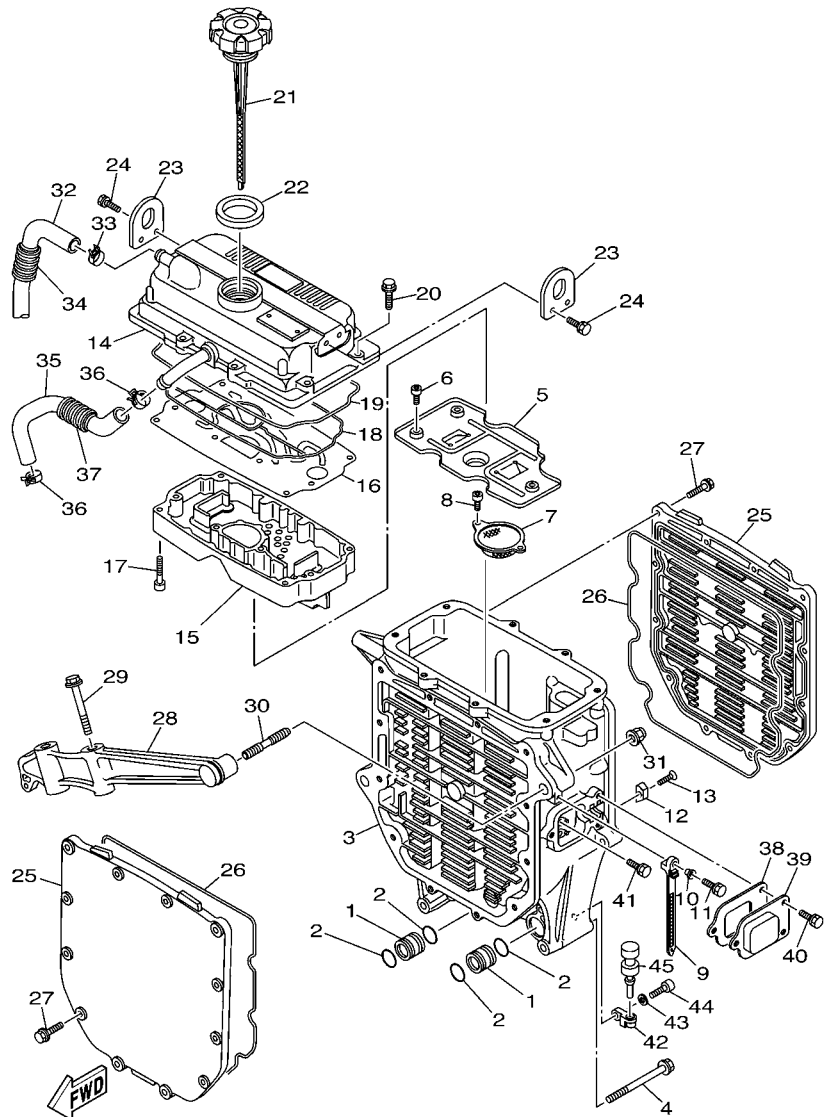
FIG. 7 OIL PUMP



F1B1100-2071

REF. NO.	PART NO.	DESCRIPTION	U49	CAL	CAN	GENE	JPN	REMARKS
1	60E-13360-00	DRIVEN GEAR ASSY	1	1	1	1	1	
2	60E-13300-01	OIL PUMP ASSY	1	1	1	1	1	
3	60E-13185-00	.BOLT, BREATHER	1	1	1	1	1	
4	90462-08019	.CLAMP	1	1	1	1	1	
5	60E-13563-00	GASKET	1	1	1	1	1	
6	97513-06525	BOLT, WITH WASHER	8	8	8	8	8	
7	90119-08067	BOLT, WITH WASHER	4	4	4	4	4	
8	93606-12019	PIN, DOWEL	2	2	2	2	2	
9	60E-13327-10-94	COVER, PUMP GEAR	1	1	1	1	1	
10	93306-30441	BEARING	1	1	1	1	1	
11	99009-52500	CIRCLIP	1	1	1	1	1	
12	60E-13411-01	STRAINER, OIL	1	1	1	1	1	
13	93211-95001	O-RING	1	1	1	1	1	
14	90119-08045	BOLT, WITH WASHER	4	4	4	4	4	
15	90119-08034	BOLT, WITH WASHER	2	2	2	2	2	
16	90119-08043	BOLT, WITH WASHER	1	1	1	1	1	
17	97513-06555	BOLT, WITH WASHER	1	1	1	1	1	
18	97513-06535	BOLT, WITH WASHER	1	1	1	1	1	
19	93608-16M16	PIN, DOWEL	2	2	2	2	2	
20	60E-13483-00	PLUNGER, RELIEF	1	1	1	1	1	
21	4WM-13484-00	SPRING, RELIEF	1	1	1	1	1	
22	90214-06029	WASHER, CLAW	1	1	1	1	1	
23	91317-06016	BOLT	1	1	1	1	1	
24	93606-25M00	PIN, DOWEL	2	2	2	2	2	
25	60E-11164-00	SEPERATOR, OIL	1	1	1	1	1	
26	6A0-82317-00	.DAMPER, IGNITION COIL	1	1	1	1	1	
27	624-42542-00	.PIPE	1	1	1	1	1	



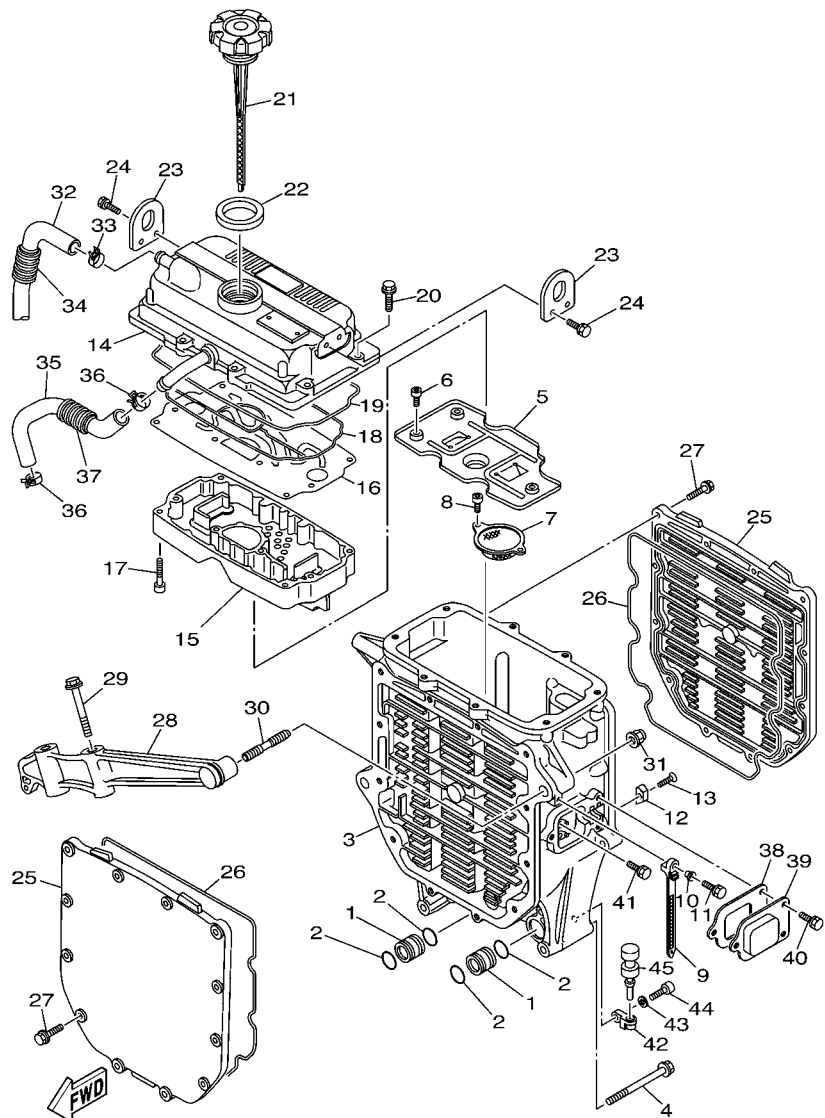


F1B1100-2081

FIG. 8 OIL COOLER

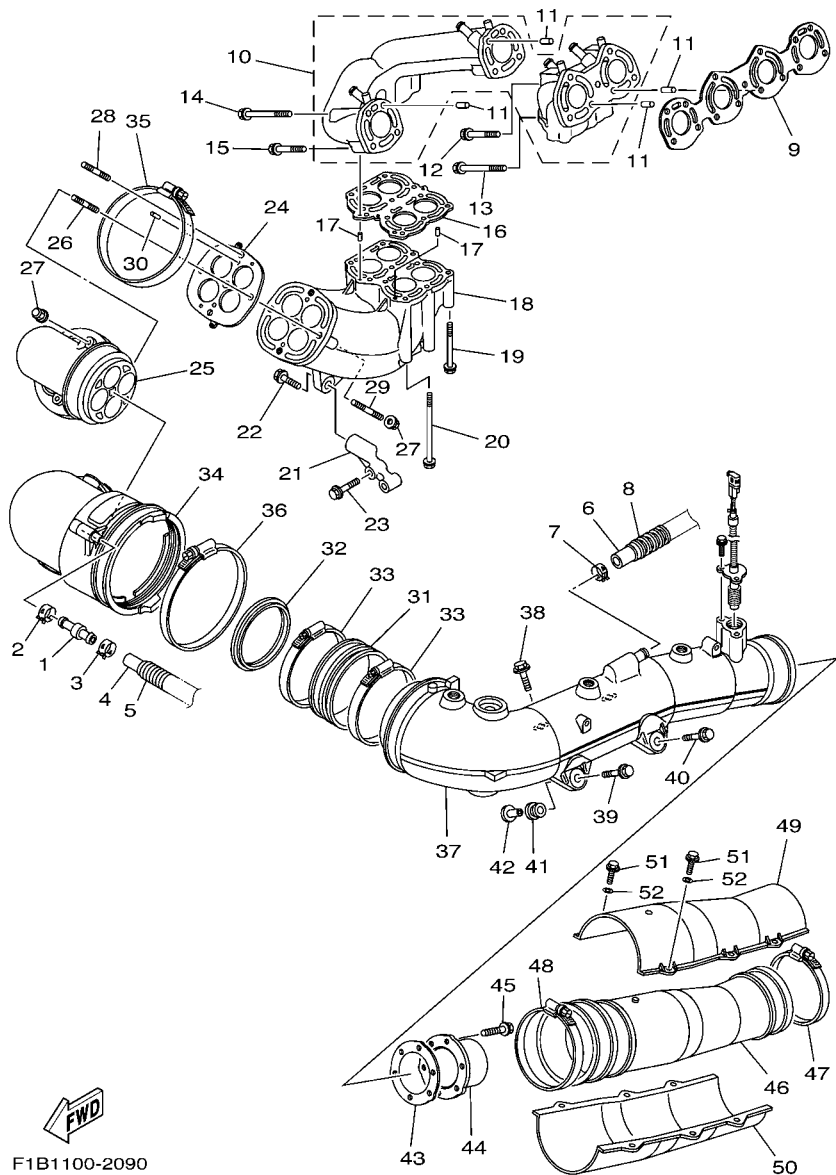
REF. NO.	PART NO.	DESCRIPTION	U49	CAL	CAN	GENE	JPN	REMARKS
1	60E-13446-00	CONNECTOR	2	2	2	2	2	
2	93210-18322	O-RING	4	4	4	4	4	
3	60E-13462-00-94	CASE, OIL COOLER	1	1	1	1	1	
4	90119-08M67	BOLT, WITH WASHER	4	4	4	4	4	
5	60E-13317-00	PLATE, BAFFLE	1	1	1	1	1	
6	91317-05014	BOLT	3	3	3	3	3	
7	60E-13421-00	STRAINER 2	1	1	1	1	1	
8	91317-06014	BOLT	2	2	2	2	2	
9	90465-12M53	CLAMP	1	1	1	1	1	
10	90387-06M05	COLLAR	1	1	1	1	1	
11	97595-06520	BOLT, WITH WASHER	1	1	1	1	1	
12	6E5-11325-00	ANODE	1	1	1	1	1	
13	98780-04015	SCREW, FLAT HEAD	1	1	1	1	1	
14	60E-13463-00-94	COVER, OIL COOLER	1	1	1	1	1	
15	60E-11165-00	PLATE, BREATHER	1	1	1	1	1	
16	60E-11145-00	PLATE, BREATHER 2	1	1	1	1	1	
17	91317-05035	BOLT	10	10	10	10	10	
18	60E-13475-00	GASKET	1	1	1	1	1	
19	60E-13477-00	GASKET	1	1	1	1	1	
20	90105-06036	BOLT, FLANGE	8	8	8	8	8	
21	60E-15362-00	PLUG, OIL LEVEL	1	1	1	1	1	
22	60E-13473-00	O-RING	1	1	1	1	1	
23	68F-11119-00	HANGER, ENGINE	2	2	2	2	2	
24	90119-06MA2	BOLT, WITH WASHER	4	4	4	4	4	
25	60E-13443-00-94	COVER, OIL COOLER	2	2	2	2	2	
26	60E-13476-00	GASKET	2	2	2	2	2	
27	90105-06M07	BOLT, FLANGE	24	24	24	24	24	

FIG. 8 OIL COOLER



F1B1100-2081

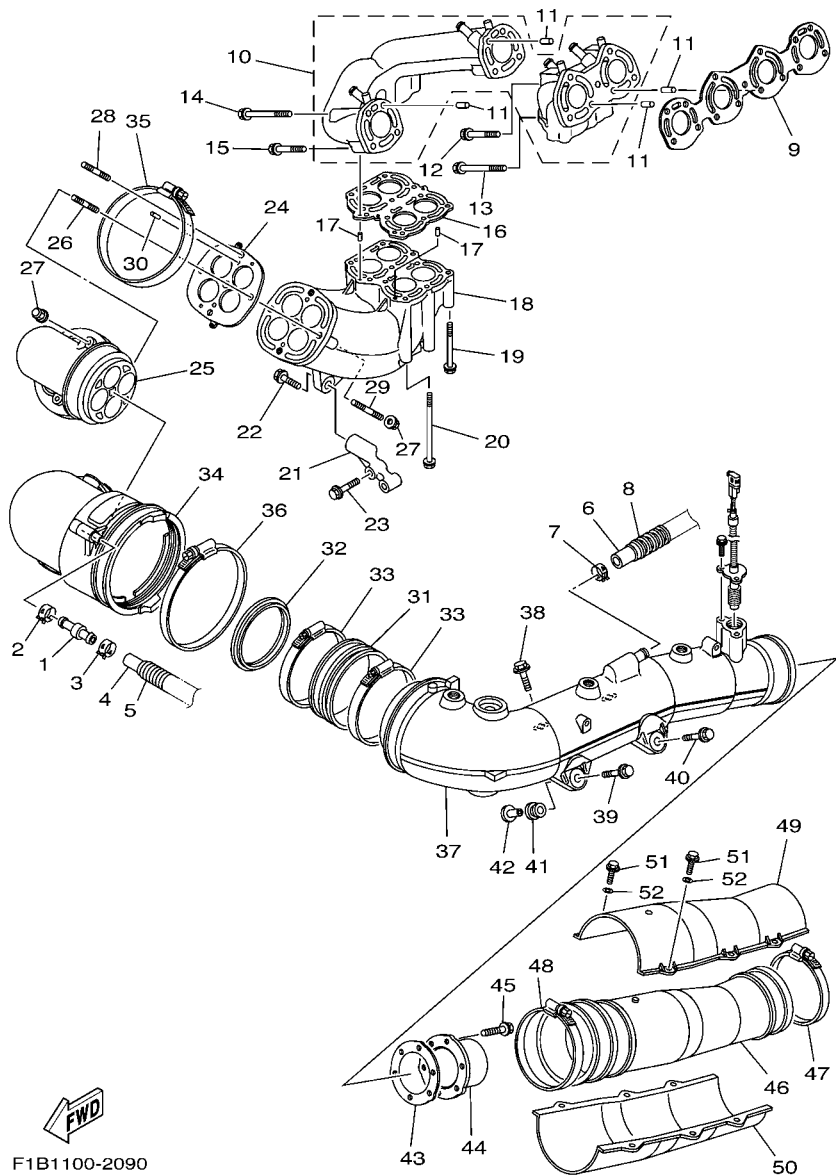
REF. NO.	PART NO.	DESCRIPTION	U49	CAL	CAN	GENE	JPN	REMARKS
28	60E-13151-00-94	STAY	1	1	1	1	1	
29	90119-10M02	BOLT, WITH WASHER	2	2	2	2	2	
30	90116-10016	BOLT, STUD	2	2	2	2	2	
31	90176-10001	NUT, CROWN	2	2	2	2	2	
32	60E-11166-01	PIPE, BREATHER 1	1	1	1	1	1	
33	90467-170A0	CLIP	2	2	2	2	2	
34	90447-19005	HOSE, WITH SPRING	2	2	2	2	2	
35	60E-11167-01	PIPE, BREATHER 2	1	1	1	1	1	
36	90467-170A0	CLIP	2	2	2	2	2	
37	90447-19004	HOSE, WITH SPRING	1	1	1	1	1	
38	60E-13567-00	GASKET	1	1	1	1	1	
39	60E-13882-00	COVER 2	1	1	1	1	1	
40	97580-06516	BOLT, WITH WASHER	3	3	3	3	3	
41	97507-06512	BOLT, WITH WASHER	2	2	2	2	2	
42	60E-51341-00	BRACKET 1	2	2	2	2	2	
43	92995-06600	WASHER	2	2	2	2	2	
44	91380-06020	BOLT	2	2	2	2	2	
45	90480-06M46	GROMMET	2	2	2	2	2	



F1B1100-2090

FIG. 9 EXHAUST 1

REF. NO.	PART NO.	DESCRIPTION	U49	CAL	CAN	GENE	JPN	REMARKS
1	60E-12594-00	JOINT, HOSE 4	1	1	1	1	1	
2	90467-120A0	CLIP	1	1	1	1	1	
3	90467-130A0	CLIP	1	1	1	1	1	
4	90445-14M06	HOSE (L630)	1	1	1	1	1	
5	90446-20M65	HOSE	1	1	1	1	1	
6	90445-20002	HOSE	1	1	1	1	1	
7	90467-200A0	CLIP	1	1	1	1	1	
8	90447-22002	TUBE (L1150)	1	1	1	1	1	
9	60E-14613-00	GASKET, EXHAUST PIPE	1	1	1	1	1	
10	60E-14610-00-94	EXHAUST PIPE ASSY 1	1	1	1	1	1	
11	93608-16M16	PIN, DOWEL	4	4	4	4	4	
12	90119-08029	BOLT, WITH WASHER	1	1	1	1	1	
13	90119-08034	BOLT, WITH WASHER	4	4	4	4	4	
14	90119-08029	BOLT, WITH WASHER	4	4	4	4	4	
15	90119-08M62	BOLT, WITH WASHER	2	2	2	2	2	
16	60E-14739-01	GASKET, MUFFLER DAMPER 1	1	1	1	1	1	
17	93606-12019	PIN, DOWEL	2	2	2	2	2	
18	60E-14631-00-94	PIPE, EXHAUST 3	1	1	1	1	1	
19	90119-08036	BOLT, WITH WASHER	4	4	4	4	4	
20	90119-08031	BOLT, WITH WASHER	6	6	6	6	6	
21	60E-14771-00-94	STAY, MUFFLER 1	1	1	1	1	1	
22	90119-10013	BOLT, WITH WASHER	1	1	1	1	1	
23	90119-08043	BOLT, WITH WASHER	2	2	2	2	2	
24	60E-14749-01	GASKET, MUFFLER DAMPER 2	1	1	1	1	1	
25	60E-14712-00-94	RING, JOINT	1	1	1	1	1	
26	90116-10016	BOLT, STUD	1	1	1	1	1	
27	90179-10M35	NUT	5	5	5	5	5	



F1B1100-2090

FIG. 9 EXHAUST 1

REF. NO.	PART NO.	DESCRIPTION	U49	CAL	CAN	GENE	JPN	REMARKS
28	90116-10017	BOLT, STUD	3	3	3	3	3	
29	90116-10018	BOLT, STUD	1	1	1	1	1	
30	93606-12019	PIN, DOWEL	2	2	2	2	2	
31	60E-14625-00	JOINT, EXHAUST 2	1	1	1	1	1	
32	60E-14642-00	SEAL, EXHAUST	1	1	1	1	1	
33	90450-99M06	HOSE CLAMP ASSY	2	2	2	2	2	
34	60E-14615-00	JOINT, EXHAUST 1	1	1	1	1	1	
35	90450-99M16	HOSE CLAMP ASSY	1	1	1	1	1	
36	90450-99M18	HOSE CLAMP ASSY	1	1	1	1	1	
37	60E-14721-00-94	MUFFLER 2	1	1	1	1	1	
38	90119-10013	BOLT, WITH WASHER	2	2	2	2	2	
39	90119-10011	BOLT, WITH WASHER	1	1	1	1	1	
40	90119-10017	BOLT, WITH WASHER	1	1	1	1	1	
41	90480-21M63	GROMMET	1	1	1	1	1	
42	90387-11002	COLLAR	1	1	1	1	1	
43	60E-14623-00	GASKET, EXHAUST PIPE	1	1	1	1	1	
44	60E-14784-00-94	PIPE, TAIL	1	1	1	1	1	
45	95023-06016	BOLT	3	3	3	3	3	
46	60E-14752-A0	PIPE, OUTLET	1	1	1	1	1	
47	90460-90M11	CLAMP, HOSE	1	1	1	1	1	
48	90450-99M06	HOSE CLAMP ASSY	1	1	1	1	1	
49	60E-14718-00-94	PROTECTOR, MUFFLER 1	1	1	1	1	1	
50	60E-14728-00-94	PROTECTOR, MUFFLER 2	1	1	1	1	1	
51	97013-06025	BOLT	6	6	6	6	6	
52	92903-06600	WASHER, PLATE	6	6	6	6	6	

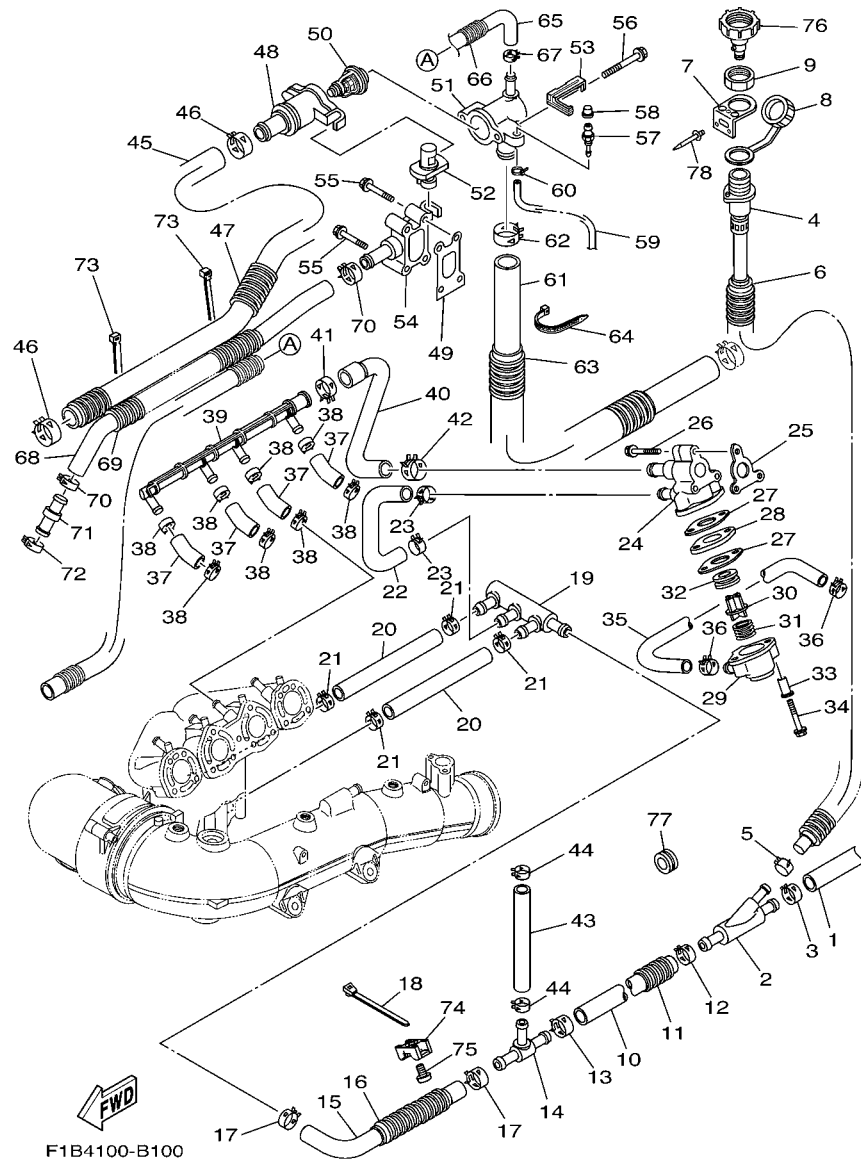
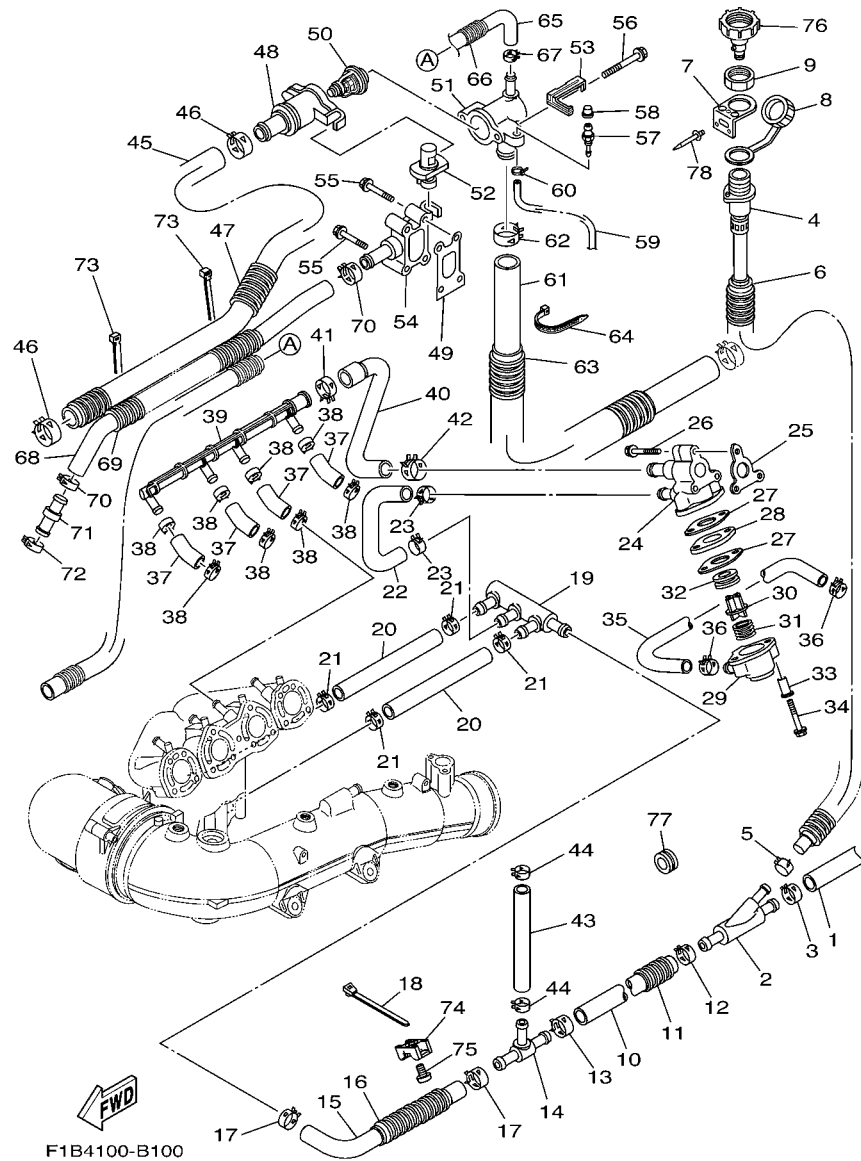


FIG. 10 EXHAUST 2

REF. NO.	PART NO.	DESCRIPTION	U49	CAL	CAN	GENE	JPN	REMARKS
1	60E-1243A-00	HOSE 1	1	1	1	1	1	
2	60E-12581-00	JOINT, HOSE 1	1	1	1	1	1	
3	90467-200A0	CLIP	1	1	1	1	1	
4	60E-12580-00	JOINT ASSY	1	1	1	1	1	
5	90467-150A0	CLIP	1	1	1	1	1	
6	90446-24M79	HOSE	1	1	1	1	1	
7	60E-12443-00	STAY	1	1	1	1	1	
8	682-84385-01	CAP,1	1	1	1	1	1	
9	EU0-61652-00	NUT	1	1	1	1	1	
10	90445-21003	HOSE	1	1	1	1	1	
11	90447-22003	HOSE, WITH SPRING	1	1	1	1	1	
12	90467-200A0	CLIP	1	1	1	1	1	
13	90467-200A0	CLIP	1	1	1	1	1	
14	60E-12584-00	JOINT, HOSE 3	1	1	1	1	1	
15	60E-1243E-00	HOSE 2	1	1	1	1	1	
16	90447-22001	HOSE, WITH SPRING	1	1	1	1	1	
17	90467-200A0	CLIP	2	2	2	2	2	
18	90464-55001	CLAMP	1	1	1	1	1	
19	60E-12582-00	JOINT, HOSE 2	1	1	1	1	1	
20	90445-18003	HOSE	2	2	2	2	2	
21	90467-160A0	CLIP	4	4	4	4	4	
22	60E-1243F-00	HOSE,3	1	1	1	1	1	
23	90467-160A0	CLIP	2	2	2	2	2	
24	60E-12479-00-94	JOINT	1	1	1	1	1	
25	60E-12434-00	GASKET	1	1	1	1	1	
26	97595-06545	BOLT, WITH WASHER	3	3	3	3	3	
27	60E-12414-00	GASKET, COVER	2	2	2	2	2	





F1B4100-B100

FIG. 10 EXHAUST 2

REF. NO.	PART NO.	DESCRIPTION	U49	CAL	CAN	GENE	JPN	REMARKS
28	60E-12535-00	PLATE	1	1	1	1	1	
29	60E-12422-00	COVER, HOUSING	1	1	1	1	1	
30	6G5-12416-00	VALVE, PRESSURE CONTROL	1	1	1	1	1	
31	90501-16M11	SPRING, COMPRESSION	1	1	1	1	1	
32	90480-20M05	GROMMET	1	1	1	1	1	
33	90387-06M65	COLLAR	2	2	2	2	2	
34	97595-06540	BOLT, WITH WASHER	2	2	2	2	2	
35	90445-18M13	HOSE (L350)	1	1	1	1	1	
36	90467-160A0	CLIP	2	2	2	2	2	
37	60E-12576-00	HOSE 1	4	4	4	4	4	
38	90467-150A1	CLIP	8	8	8	8	8	
39	60E-12469-00	JOINT 1	1	1	1	1	1	
40	60E-12577-00	HOSE 2	1	1	1	1	1	
41	90467-22002	CLIP	1	1	1	1	1	
42	90467-200A0	CLIP	1	1	1	1	1	
43	90445-18004	HOSE (L130)	1	1	1	1	1	
44	90467-160A0	CLIP	2	2	2	2	2	
45	60E-12578-00	HOSE 3	1	1	1	1	1	
46	90467-240A0	CLIP	2	2	2	2	2	
47	90447-28003	HOSE, WITH SPRING	1	1	1	1	1	
48	60E-12417-00-94	HOUSING, THERMOSTAT	1	1	1	1	1	
49	60E-12435-00	GASKET	1	1	1	1	1	
50	60E-12411-00	THERMOSTAT	1	1	1	1	1	
51	60E-12413-00-94	COVER, THERMOSTAT	1	1	1	1	1	
52	60E-12499-00	JOINT	1	1	1	1	1	
53	60E-1244F-00	BRACKET 1	1	1	1	1	1	
54	60E-12446-00-94	JOINT	1	1	1	1	1	

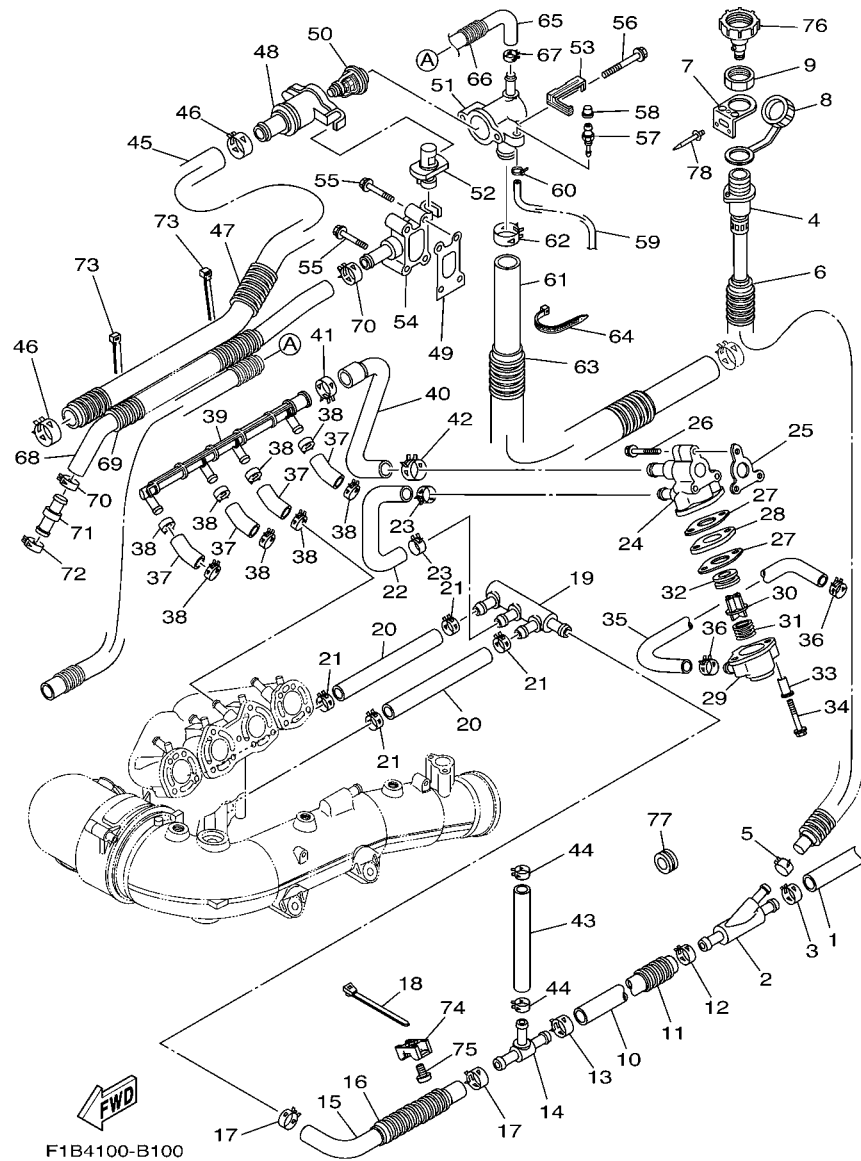
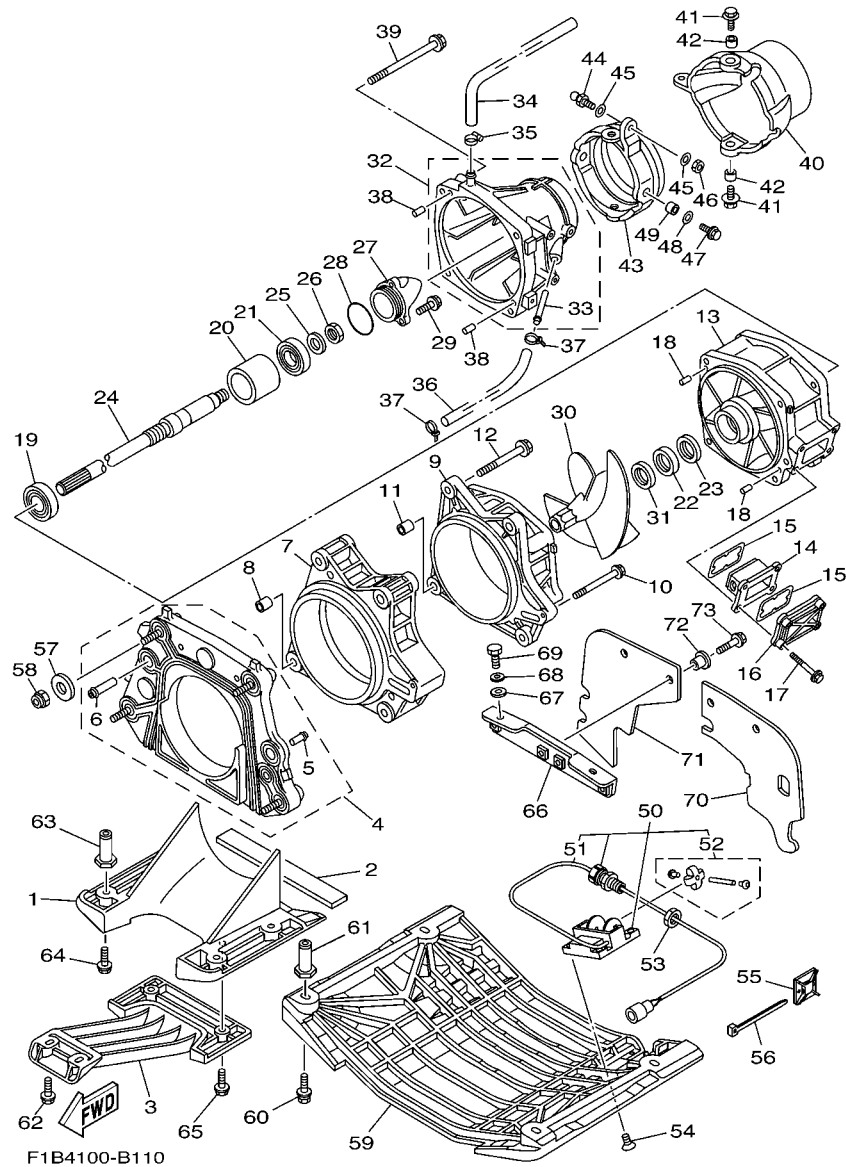


FIG. 10 EXHAUST 2

REF. NO.	PART NO.	DESCRIPTION	U49	CAL	CAN	GENE	JPN	REMARKS
55	90105-06035	BOLT, FLANGE	4	4	4	4	4	
56	90105-06035	BOLT, FLANGE	2	2	2	2	2	
57	61L-5169A-00	NIPPLE, GREASE	1	1	1	1	1	
58	663-45119-00	CAP, GREASE NIPPLE	1	1	1	1	1	
59	90445-09M33	HOSE (L580)	1	1	1	1	1	
60	90465-11M10	CLAMP	1	1	1	1	1	
61	90445-25003	HOSE (L900)	1	1	1	1	1	
62	90467-240A0	CLIP	1	1	1	1	1	
63	90447-28002	TUBE (L800)	1	1	1	1	1	
64	90465-13M18	CLAMP	1	1	1	1	1	
65	60E-12552-00	HOSE 8	1	1	1	1	1	
66	90447-22002	TUBE (L1150)	1	1	1	1	1	
67	90467-120A0	CLIP	1	1	1	1	1	
68	90445-21004	HOSE (L530)	1	1	1	1	1	
69	90446-27M55	TUBE (L400)	1	1	1	1	1	
70	90467-200A0	CLIP	2	2	2	2	2	
71	60E-51142-00	CONNECTION	1	1	1	1	1	
72	90467-200A0	CLIP	1	1	1	1	1	
73	90465-14M66	CLAMP	2	2	2	2	2	
74	60E-1244E-00	BRACKET 1	1	1	1	1	1	
75	97980-05210	SCREW, WITH WASHER	1	1	1	1	1	
76	67X-12590-00	CONDUCTION ASSY	1	1				FOR U49,CAL
	67X-12590-20	CONDUCTION ASSY			1	1		FOR CAN,GENE
	67X-12590-10	CONDUCTION ASSY					1	FOR JPN
77	90480-38800	GROMMET	1	1	1	1	1	YMUS
78	90267-48802	RIVET, BLIND	2	2	2	2	2	YMUS



F1B4100-B110

FIG. 11 JET UNIT 1

REF. NO.	PART NO.	DESCRIPTION	U49	CAL	CAN	GENE	JPN	REMARKS
1	60E-R1311-00-94	DUCT, INTAKE	1	1	1	1	1	YMUS
2	66V-51367-00	FELT, PACKING	1	1	1	1	1	
3	60E-R1333-00-94	SCREEN, INTAKE	1	1	1	1	1	YMUS
4	60E-G5831-00	PLATE, TRANSOM	1	1	1	1	1	YMUS
5	65A-R1129-00	.NIPPLE	1	1	1	1	1	YMUS
6	66V-51129-10	.NIPPLE	3	3	3	3	3	
7	60E-51317-00-94	HOUSING, IMPELLER 2	1	1	1	1	1	
8	99590-14016	PIN, DOWEL	2	2	2	2	2	
9	66V-51312-01-94	HOUSING, IMPELLER	1	1	1	1	1	
10	90119-06842	BOLT, WITH WASHER	1	1	1	1	1	YMUS
11	99590-14016	PIN, DOWEL	2	2	2	2	2	
12	90119-10800	BOLT, WITH WASHER	4	4	4	4	4	YMUS
13	66V-51315-00-94	DUCT, IMPELLER	1	1	1	1	1	
14	66V-46882-00	FILTER	1	1	1	1	1	
15	66V-42414-00	O-RING	2	2	2	2	2	
16	66V-45214-00-94	COVER, WATER INLET	1	1	1	1	1	
17	90119-06800	BOLT, WITH WASHER	4	4	4	4	4	YMUS
18	93606-12019	PIN, DOWEL	2	2	2	2	2	
19	93306-205U0	BEARING	1	1	1	1	1	
20	65V-45538-00	SPACER 1	1	1	1	1	1	
21	93306-304U1	BEARING	1	1	1	1	1	
22	93101-28M66	OIL SEAL	1	1	1	1	1	
23	93101-28M65	OIL SEAL	1	1	1	1	1	
24	68Y-45511-00	SHAFT, DRIVE	1	1	1	1	1	
25	9299R-16600	WASHER	1	1	1	1	1	YMUS
26	9531P-16700	NUT	1	1	1	1	1	YMUS
27	65A-R1326-00	CAP	1	1	1	1	1	YMUS

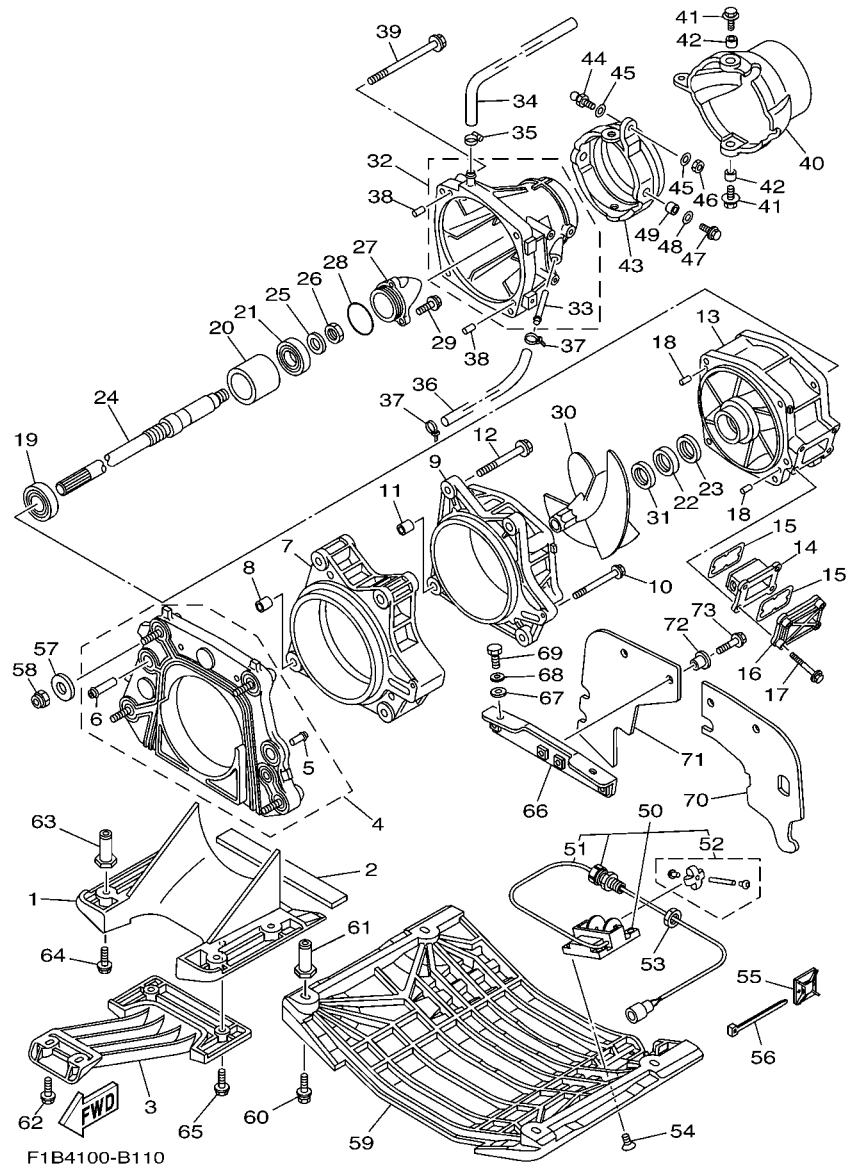


FIG. 11 JET UNIT 1

REF. NO.	PART NO.	DESCRIPTION	U49	CAL	CAN	GENE	JPN	REMARKS
28	93210-46M16	O-RING	1	1	1	1	1	
29	90119-069UB	BOLT, WITH WASHER	3	3	3	3	3	YMUS
30	68N-R1321-00	IMPELLER	1	1	1	1	1	YMUS
31	66V-R1348-10	SPACER	1	1	1	1	1	YMUS
32	60E-51318-00-94	NOZZLE	1	1	1	1	1	
33	63M-51334-00	.NIPPLE,HOSE	1	1	1	1	1	
34	90445-16M09	HOSE (L310)	1	1	1	1	1	
35	90601-118UF	BAND, HOSE 18	1	1	1	1	1	YMUS
36	90445-14804	HOSE (L330)	1	1	1	1	1	YMUS
37	90465-11829	CLAMP	2	2	2	2	2	YMUS
38	93606-12019	PIN, DOWEL	2	2	2	2	2	
39	90119-10837	BOLT, WITH WASHER	4	4	4	4	4	YMUS
40	60E-51313-00	NOZZLE,DEFLECTOR	1	1	1	1	1	
41	90119-089UE	BOLT, WITH WASHER	2	2	2	2	2	YMUS
42	90387-08M06	COLLAR	2	2	2	2	2	
43	60E-51190-00-94	RING,TRIM	1	1	1	1	1	
44	GH3-U146E-00	STUD, JOINT BALL	1	1	1	1	1	YMUS
45	90201-068M4	WASHER, PLATE	2	2	2	2	2	YMUS
46	9538R-06700	NUT	1	1	1	1	1	YMUS
47	90105-08829	BOLT, FLANGE	2	2	2	2	2	YMUS
48	90202-10M56	WASHER, PLATE	2	2	2	2	2	
49	90387-08M19	COLLAR	2	2	2	2	2	
50	GJ1-U8K31-02	SENSOR SPEED	1	1	1	1	1	YMUS
51	EU0-67267-20	.CONNECTOR, CABLE	1	1	1	1	1	
52	GJ1-U835D-00	.SERVIS KIT (SPEED SENSOR)	1	1	1	1	1	YMUS
53	EU0-62241-30	NUT, DRAIN 1	1	1	1	1	1	
54	9878R-05512	SCREW, FLAT HEAD	4	4	4	4	4	YMUS

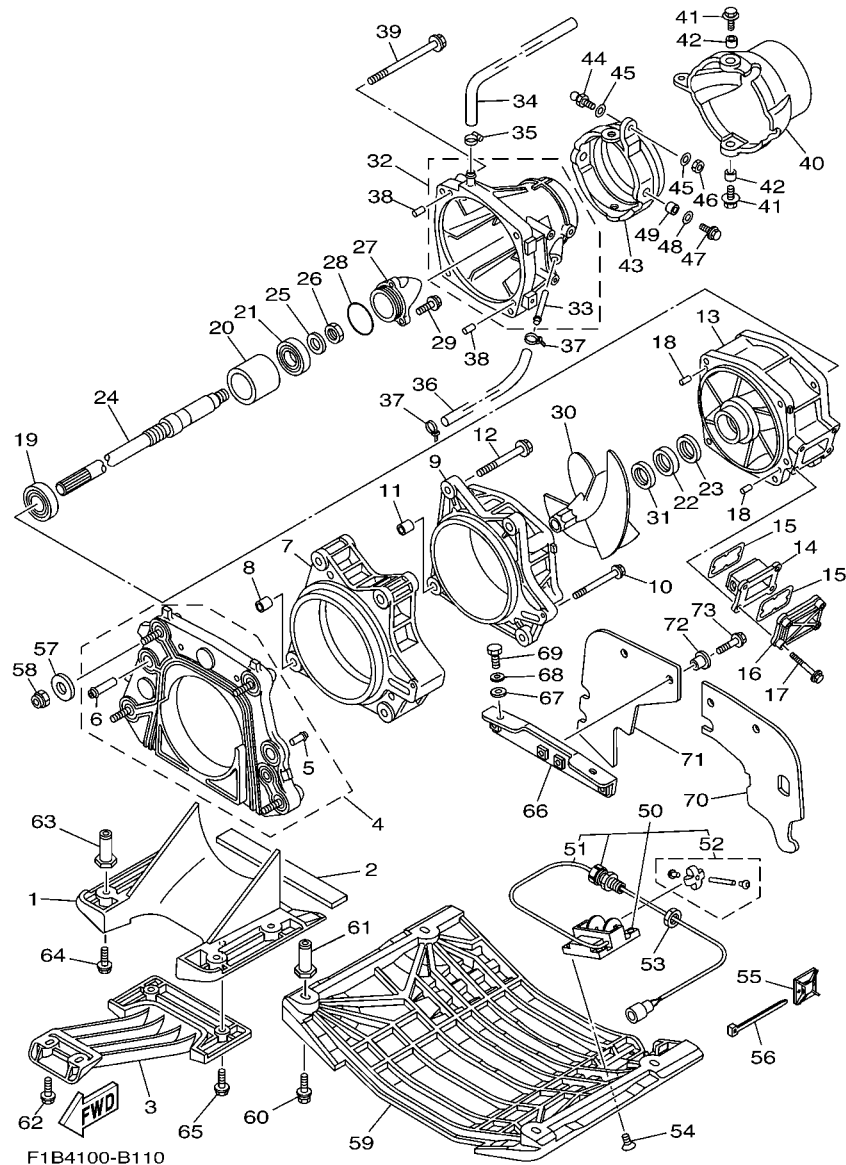
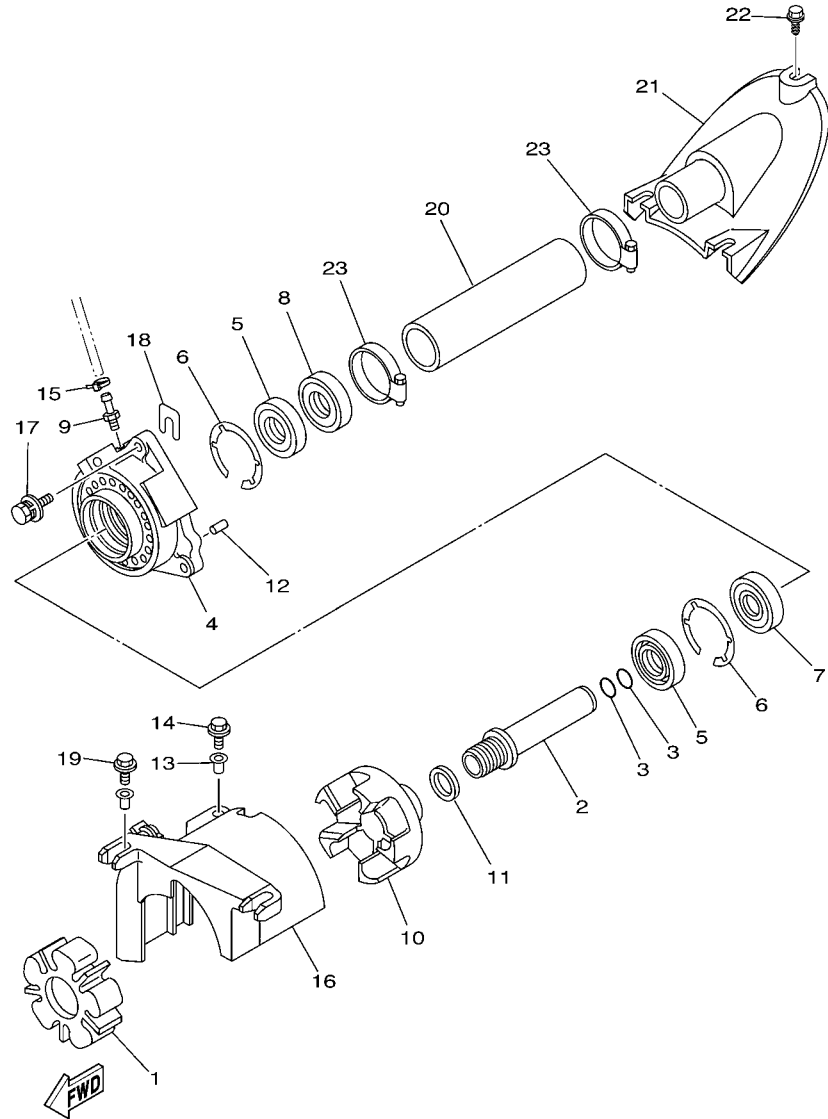


FIG. 11 JET UNIT 1

REF. NO.	PART NO.	DESCRIPTION	U49	CAL	CAN	GENE	JPN	REMARKS
55	90600-900U6	BASE, CLAMP	4	4	4	4	4	YMUS
56	90464-40825	CLAMP	4	4	4	4	4	YMUS
57	F1B-U725E-00	WASHER	4	4	4	4	4	YMUS
58	9572R-10300	NUT, FLANGE	4	4	4	4	4	YMUS
59	F1B-U273B-02	PLATE 2	1	1	1	1	1	YMUS
60	90119-089U6	BOLT, WITH WASHER	4	4	4	4	4	YMUS
61	90179-08812	NUT	4	4	4	4	4	YMUS
62	90119-069UK	BOLT, WITH WASHER	2	2	2	2	2	YMUS
63	90179-08812	NUT	4	4	4	4	4	YMUS
64	90119-089U6	BOLT, WITH WASHER	4	4	4	4	4	YMUS
65	90119-069UB	BOLT, WITH WASHER	2	2	2	2	2	YMUS
66	F1B-67557-00	BRACKET	1	1	1	1	1	
67	90430-12002	GASKET	2	2	2	2	2	
68	90201-12017	WASHER, PLATE	2	2	2	2	2	
69	90109-08041	BOLT	2	2	2	2	2	
70	F1B-6757E-00	PLATE, RUBBER 1	1	1	1	1	1	
71	F1B-6757F-00	PLATE, RUBBER 2	1	1	1	1	1	
72	90387-06051	COLLAR	4	4	4	4	4	
73	90119-06827	BOLT, WITH WASHER	4	4	4	4	4	YMUS

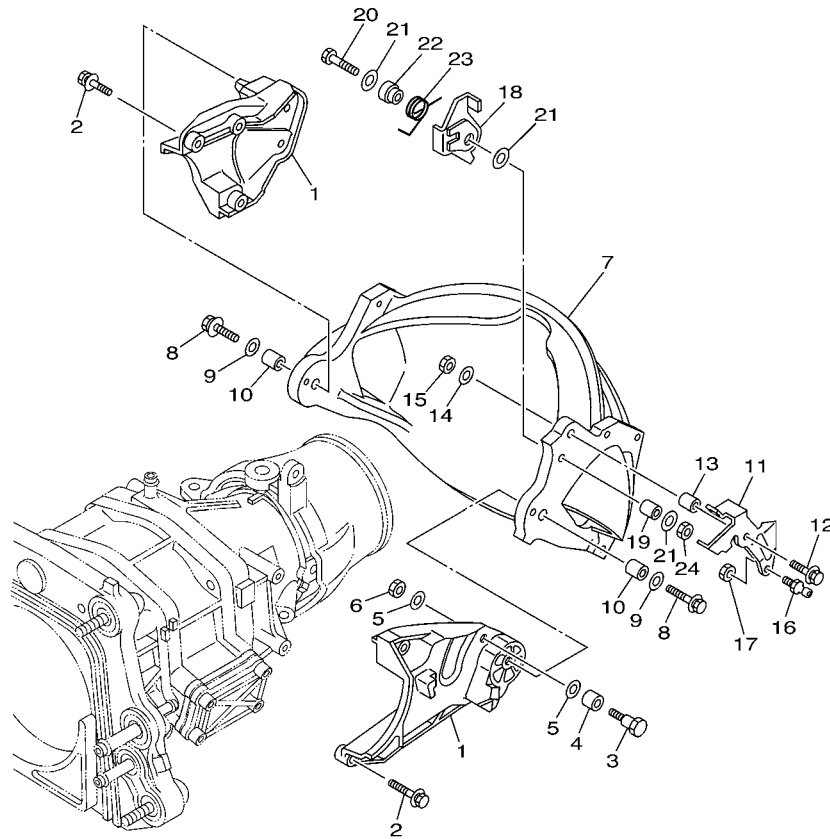
FIG. 12 JET UNIT 2



F1B1100-2120

REF. NO.	PART NO.	DESCRIPTION	U49	CAL	CAN	GENE	JPN	REMARKS
1	66E-4581J-00	RUBBER SHAFT COUPLING	1	1	1	1	1	
2	60E-51323-00	SHAFT, COUPLOR	1	1	1	1	1	
3	93210-19MJ4	O-RING	2	2	2	2	2	
4	61X-45332-03-94	HOUSING, BEARING	1	1	1	1	1	
5	93101-25M55	OIL SEAL	2	2	2	2	2	
<hr/>								
6	93430-47M04	CIRCLIP	2	2	2	2	2	
7	93306-205U6	BEARING	1	1	1	1	1	
8	93102-25009	OIL SEAL	1	1	1	1	1	
9	61L-45378-00	NIPPLE, HOSE	1	1	1	1	1	
10	66E-45813-10-94	FLANGE, COUPLING	1	1	1	1	1	
<hr/>								
11	90201-278T0	WASHER, PLATE	1	1	1	1	1	YMUS
12	93606-12019	PIN, DOWEL	2	2	2	2	2	
13	90387-06M60	COLLAR	1	1	1	1	1	
14	90119-069UD	BOLT, WITH WASHER	1	1	1	1	1	YMUS
15	90465-11829	CLAMP	1	1	1	1	1	YMUS
<hr/>								
16	60E-R1381-00	COVER	1	1	1	1	1	
17	90119-089UL	BOLT, WITH WASHER	3	3	3	3	3	YMUS
18	GD0-U7249-00-05	SHIM (T=0.5)	2	2	2	2	2	UR, YMUS
	GD0-U7249-00-10	SHIM (T=1.0)	2	2	2	2	2	UR, YMUS
19	90119-069UD	BOLT, WITH WASHER	1	1	1	1	1	YMUS
<hr/>								
20	F0D-U883B-01	PIPE, 1	1	1	1	1	1	YMUS
21	F1B-U883E-00	JOINT, PIPE	1	1	1	1	1	YMUS
22	90149-069UA	SCREW	3	3	3	3	3	YMUS
23	90601-152U3	BAND, HOSE 52	2	2	2	2	2	YMUS
<hr/>								

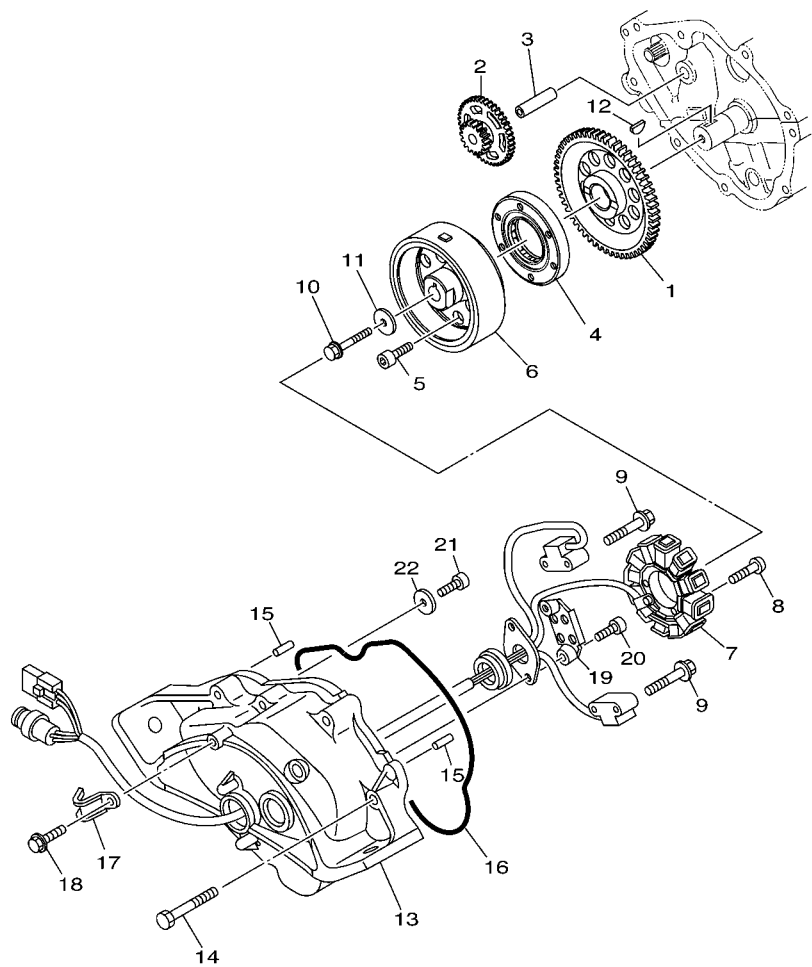
FIG. 13 JET UNIT 3



F1F4100-B110

REF. NO.	PART NO.	DESCRIPTION	U49	CAL	CAN	GENE	JPN	REMARKS
1	66V-51341-00-94	BRACKET 1	2	2	2	2	2	
2	90119-069UD	BOLT, WITH WASHER	6	6	6	6	6	YMUS
3	90109-08879	BOLT	1	1	1	1	1	YMUS
4	90387-10M09	COLLAR	1	1	1	1	1	
5	9299R-08600	WASHER	2	2	2	2	2	YMUS
6	9538R-08600	NUT	1	1	1	1	1	YMUS
7	66V-51314-00	GATE, REVERSE	1	1	1	1	1	
8	90119-089UF	BOLT, WITH WASHER	2	2	2	2	2	YMUS
9	90201-088T2	WASHER, PLATE	2	2	2	2	2	YMUS
10	90387-08M30	COLLAR	2	2	2	2	2	
11	66V-44121-00	LEVER, SHIFT ROD	1	1	1	1	1	
12	90119-069UB	BOLT, WITH WASHER	1	1	1	1	1	YMUS
13	90387-06M74	COLLAR	1	1	1	1	1	
14	90201-068T1	WASHER, PLATE	1	1	1	1	1	YMUS
15	9538R-06600	NUT	1	1	1	1	1	YMUS
16	66V-U146E-00	STUD, JOINT BALL	1	1	1	1	1	YMUS
17	9538R-06600	NUT	1	1	1	1	1	YMUS
18	66V-44125-00	LEVER, SHIFT ROD	1	1	1	1	1	
19	90387-06M74	COLLAR	1	1	1	1	1	
20	90101-06806	BOLT	1	1	1	1	1	YMUS
21	90201-068T1	WASHER, PLATE	3	3	3	3	3	YMUS
22	90387-06M84	COLLAR	1	1	1	1	1	
23	90508-14M43	SPRING, TORSION	1	1	1	1	1	
24	9538R-06600	NUT	1	1	1	1	1	YMUS

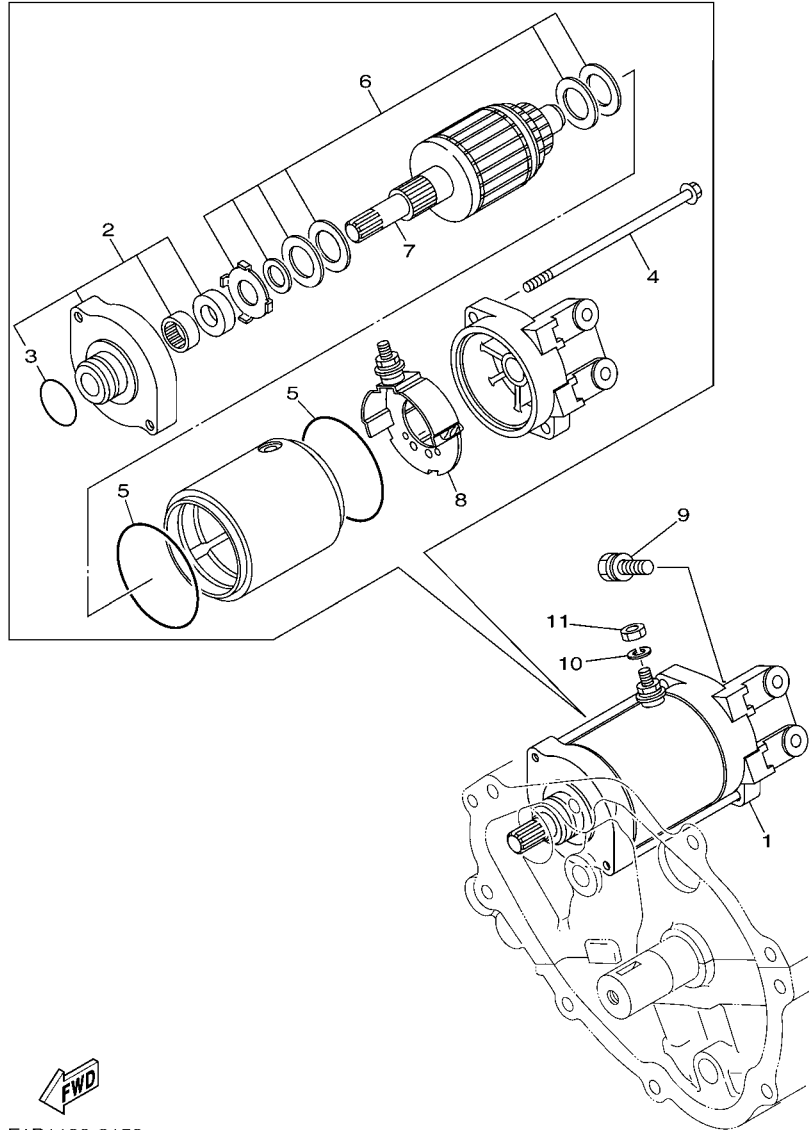
FIG. 14 GENERATOR



F1B1100-2140

REF. NO.	PART NO.	DESCRIPTION	U49	CAL	CAN	GENE	JPN	REMARKS
1	60E-15515-01	GEAR 3	1	1	1	1	1	
2	60E-15517-00	GEAR, IDLER 2	1	1	1	1	1	
3	60E-15521-00	SHAFT 1	1	1	1	1	1	
4	4WM-15590-00	STARTER ONE-WAY ASSY	1	1	1	1	1	
5	90110-08212	BOLT, HEXAGON SOCKET HEAD	6	6	6	6	6	
6	60E-81450-00	ROTOR ASSY	1	1	1	1	1	
7	60E-81410-00	STATOR ASSY	1	1	1	1	1	
8	90149-06013	SCREW	3	3	3	3	3	
9	97513-05514	BOLT, WITH WASHER	4	4	4	4	4	
10	90105-105A6	BOLT, FLANGE	1	1	1	1	1	
11	90201-103U7	WASHER, PLATE	1	1	1	1	1	YMUS
12	90280-03047	KEY, WOODRUFF	1	1	1	1	1	
13	60E-81337-00-94	COVER, FLYWHEEL	1	1	1	1	1	
14	90119-10016	BOLT, WITH WASHER	8	8	8	8	8	
15	93608-16M16	PIN, DOWEL	2	2	2	2	2	
16	93212-04001	O-RING	1	1	1	1	1	
17	90462-10016	CLAMP	1	1	1	1	1	
18	91380-05010	BOLT	1	1	1	1	1	
19	60E-81328-00	CLAMP	1	1	1	1	1	
20	91317-06014	BOLT	2	2	2	2	2	
21	91317-05010	BOLT	3	3	3	3	3	
22	90201-05014	WASHER, PLATE	3	3	3	3	3	

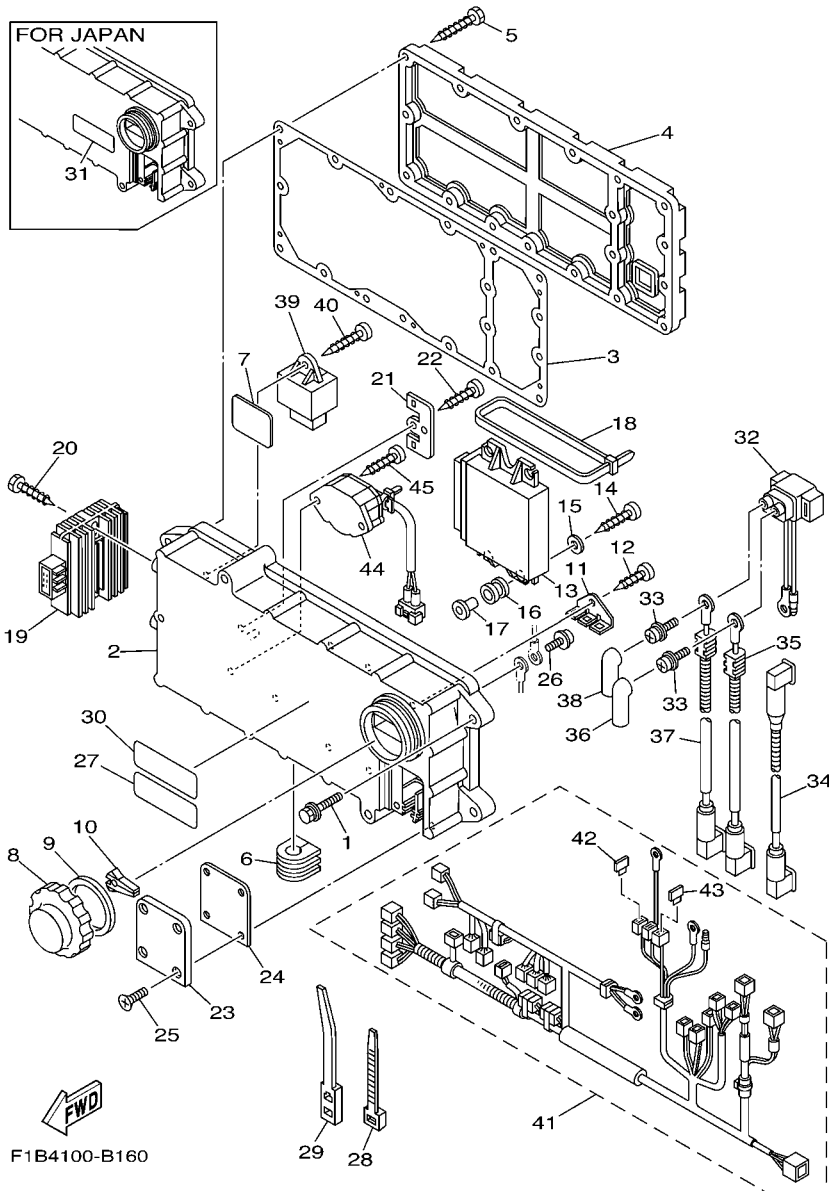




F1B1100-2150

FIG. 15 STARTING MOTOR

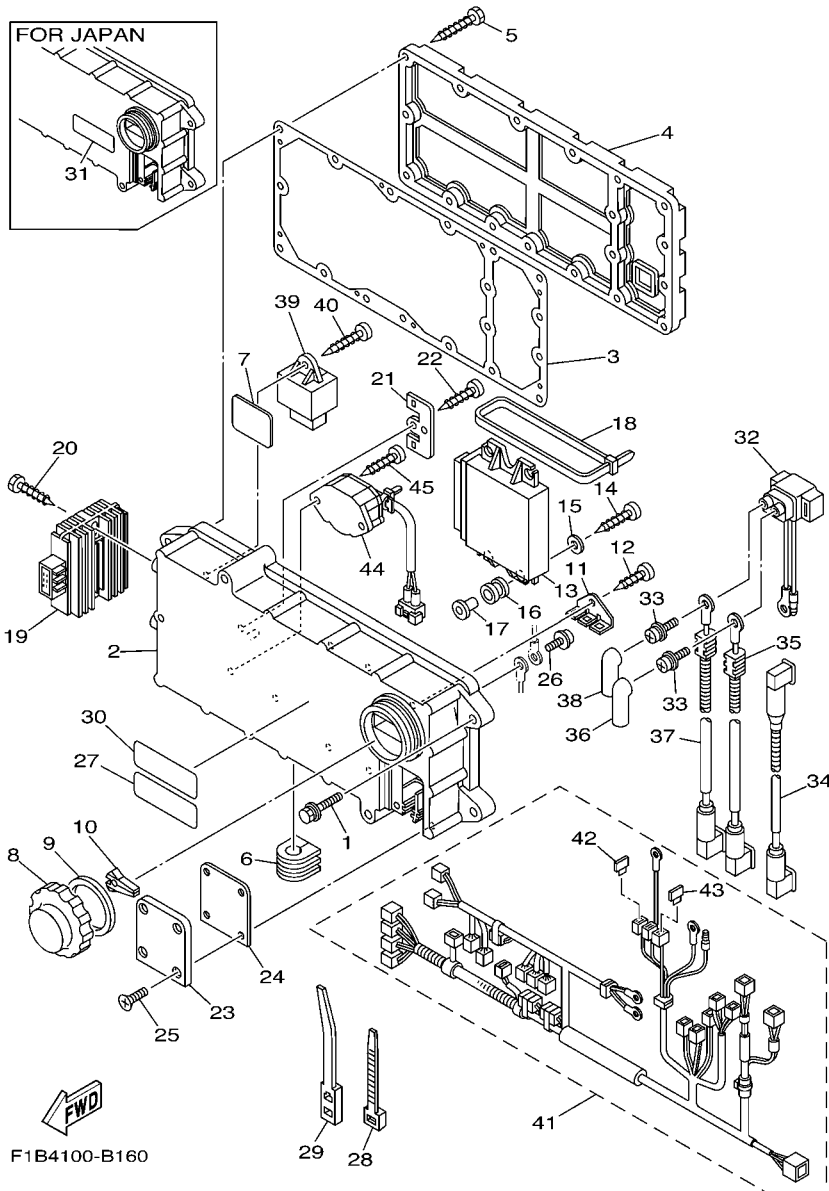
REF. NO.	PART NO.	DESCRIPTION	U49	CAL	CAN	GENE	JPN	REMARKS
1	60E-81800-00	STARTING MOTOR ASSY	1	1	1	1	1	
2	6M6-81830-00	.FRONT BRACKET ASSY	1	1	1	1	1	
3	1FK-81847-00	..O-RING	1	1	1	1	1	
4	6M6-81826-00	.BOLT	2	2	2	2	2	
5	11H-81844-00	.GASKET	2	2	2	2	2	
6	3AJ-81809-00	.WASHER KIT	1	1	1	1	1	
7	6M6-81850-00	.ARMATURE ASSY	1	1	1	1	1	
8	6M6-81840-10	.BRUSH HOLDER ASSY	1	1	1	1	1	
9	97513-08530	BOLT, WITH WASHER	2	2	2	2	2	
10	92990-06100	WASHER, SPRING	1	1	1	1	1	
11	95380-06700	NUT	1	1	1	1	1	



F1B4100-B160

FIG. 16 ELECTRICAL 1

REF. NO.	PART NO.	DESCRIPTION	U49	CAL	CAN	GENE	JPN	REMARKS
1	90119-08817	BOLT, WITH WASHER	4	4	4	4	4	YMUS
2	60E-8552A-00	HOUSING	1	1	1	1	1	
3	60E-81921-00	GASKET, TERMINAL	1	1	1	1	1	
4	60E-8552E-00	COVER, CASE	1	1	1	1	1	
5	97780-60430	SCREW, TAPPING	18	18	18	18	18	
6	90480-01012	GROMMET	1	1	1	1	1	
7	60E-84742-00	SEAT, BASE	1	1	1	1	1	
8	66V-8132W-00	CAP	1	1	1	1	1	
9	66V-81844-00	GASKET	1	1	1	1	1	
10	67F-2812A-00	PULLER, FUSE	1	1	1	1	1	
11	60E-82153-00	STAY, FUSE HOLDER	1	1	1	1	1	
12	97780-60516	SCREW, TAPPING	1	1	1	1	1	
13	60E-8591A-10	ENGINE CONTROL UNIT ASSY	1	1	1	1	1	
14	97780-60530	SCREW, TAPPING	4	4	4	4	4	
15	90201-06M05	WASHER, PLATE	4	4	4	4	4	
16	6A0-82317-00	DAMPER, IGNITION COIL	4	4	4	4	4	
17	624-42542-00	PIPE	4	4	4	4	4	
18	90464-90001	CLAMP	2	2	2	2	2	
19	68V-81960-00	RECTIFIER & REGULATOR ASSY	1	1	1	1	1	
20	97780-60430	SCREW, TAPPING	2	2	2	2	2	
21	60E-87179-00	PLATE, COUPLER	1	1	1	1	1	
22	97780-60516	SCREW, TAPPING	1	1	1	1	1	
23	60E-81916-00	COVER, TERMINAL	1	1	1	1	1	
24	60E-82533-00	GASKET	1	1	1	1	1	
25	98680-05520	SCREW, OVAL HEAD	4	4	4	4	4	
26	97980-06212	SCREW, WITH WASHER	1	1	1	1	1	
27	6R7-83623-40	MARK 3	1	1	1	1	1	EXCEPT JPN

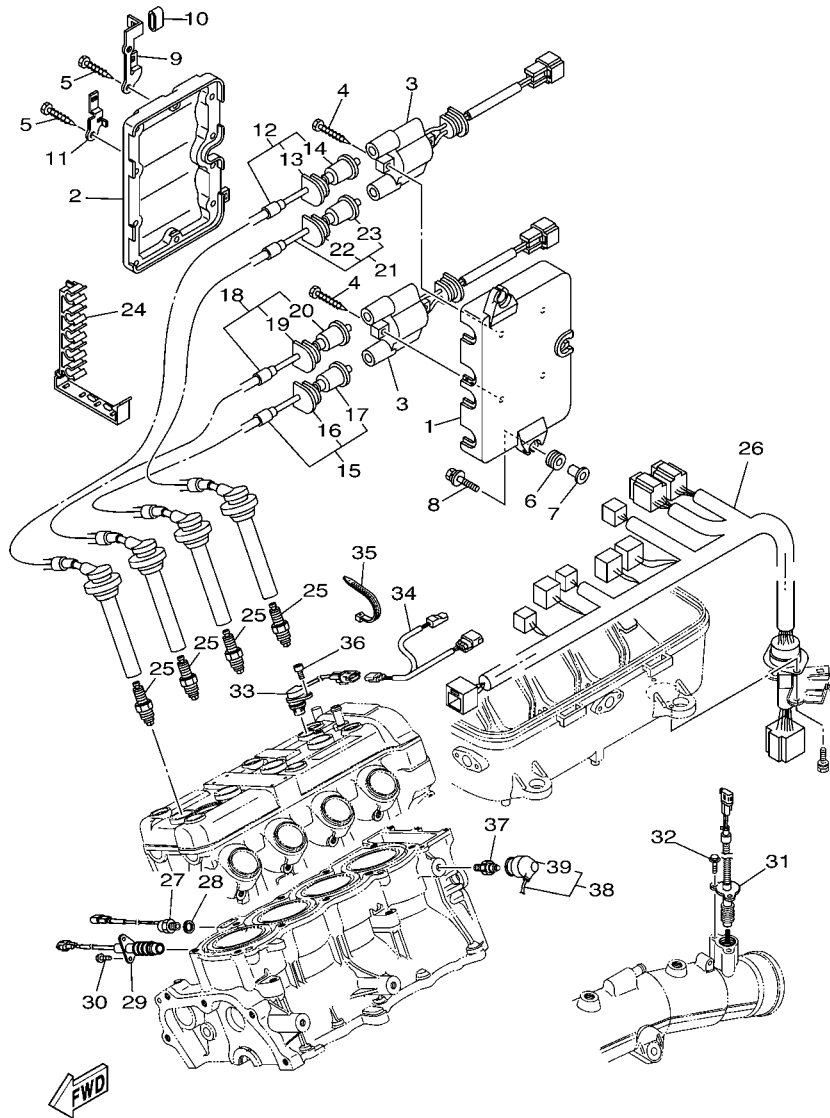


F1B4100-B160

FIG. 16 ELECTRICAL 1

REF. NO.	PART NO.	DESCRIPTION	U49	CAL	CAN	GENE	JPN	REMARKS
28	90465-13M97	CLAMP	1	1	1	1	1	
29	90464-50002	CLAMP	2	2	2	2	2	
30	6R7-83623-50	MARK 3			1	1		FOR CAN,GENE
31	63N-83623-00	MARK 3					1	FOR JPN
32	68N-81940-00	STARTER RELAY ASSY	1	1	1	1	1	
33	90159-06008	SCREW, WITH WASHER	2	2	2	2	2	
34	60E-82117-00	WIRE, LEAD	1	1	1	1	1	
35	60E-82117-10	WIRE, LEAD	1	1	1	1	1	
36	66V-82119-00	COVER, LEAD WIRE	1	1	1	1	1	
37	60E-82117-20	WIRE, LEAD	1	1	1	1	1	
38	66V-82119-00	COVER, LEAD WIRE	1	1	1	1	1	
39	60E-81950-00	RELAY ASSY	1	1	1	1	1	
40	97780-60520	SCREW, TAPPING	1	1	1	1	1	
41	60E-8259L-10	WIRE HARNESS ASSY 1	1	1	1	1	1	
42	67F-82151-30	.FUSE	4	4	4	4	4	
43	67F-82151-00	.FUSE (20A)	2	2	2	2	2	
44	60E-8259E-00	SWITCH ASSY	1	1	1	1	1	
45	97780-60520	SCREW, TAPPING	2	2	2	2	2	

FIG. 17 ELECTRICAL 2



F1B4100-B170

REF. NO.	PART NO.	DESCRIPTION	U49	CAL	CAN	GENE	JPN	REMARKS
1	60E-8235A-00	CASE 1	1	1	1	1	1	
2	60E-82314-00	COVER, IGNITION COIL	1	1	1	1	1	
3	60E-82310-00	IGNITION COIL ASSY	2	2	2	2	2	
4	97780-60525	SCREW, TAPPING	4	4	4	4	4	
5	97780-60520	SCREW, TAPPING	10	10	10	10	10	
6	6A0-82317-00	DAMPER, IGNITION COIL	4	4	4	4	4	
7	624-42542-00	PIPE	4	4	4	4	4	
8	90119-06M59	BOLT, WITH WASHER	3	3	3	3	3	
9	60E-85112-00	BRACKET, REFLECTOR 1	1	1	1	1	1	
10	60E-82353-00	HOSE	1	1	1	1	1	
11	60E-85122-00	BRACKET, REFLECTOR 2	1	1	1	1	1	
12	60E-82341-00	CORD, HIGH TENSION 1	1	1	1	1	1	
13	90480-06M43	.GROMMET	1	1	1	1	1	
14	66V-82355-00	.GROMMET	1	1	1	1	1	
15	60E-82342-00	CORD, HIGH TENSION 2	1	1	1	1	1	
16	90480-06M43	.GROMMET	1	1	1	1	1	
17	66V-82355-00	.GROMMET	1	1	1	1	1	
18	60E-82343-00	CORD, HIGH TENSION 3	1	1	1	1	1	
19	90480-06M43	.GROMMET	1	1	1	1	1	
20	66V-82355-00	.GROMMET	1	1	1	1	1	
21	60E-82344-00	CORD, HIGH TENSION 4	1	1	1	1	1	
22	90480-06M43	.GROMMET	1	1	1	1	1	
23	66V-82355-00	.GROMMET	1	1	1	1	1	
24	60E-81317-00	CLAMP, CORD	1	1	1	1	1	
25	94702-00409	PLUG, SPARK (NGK CR9EB)	4	4	4	4	4	EXCEPT JPN
	94709-00409	PLUG, SPARK (NGK CR9EB)					4	FOR JPN
26	60E-8259M-10	WIRE HARNESS ASSY 2	1	1	1	1	1	



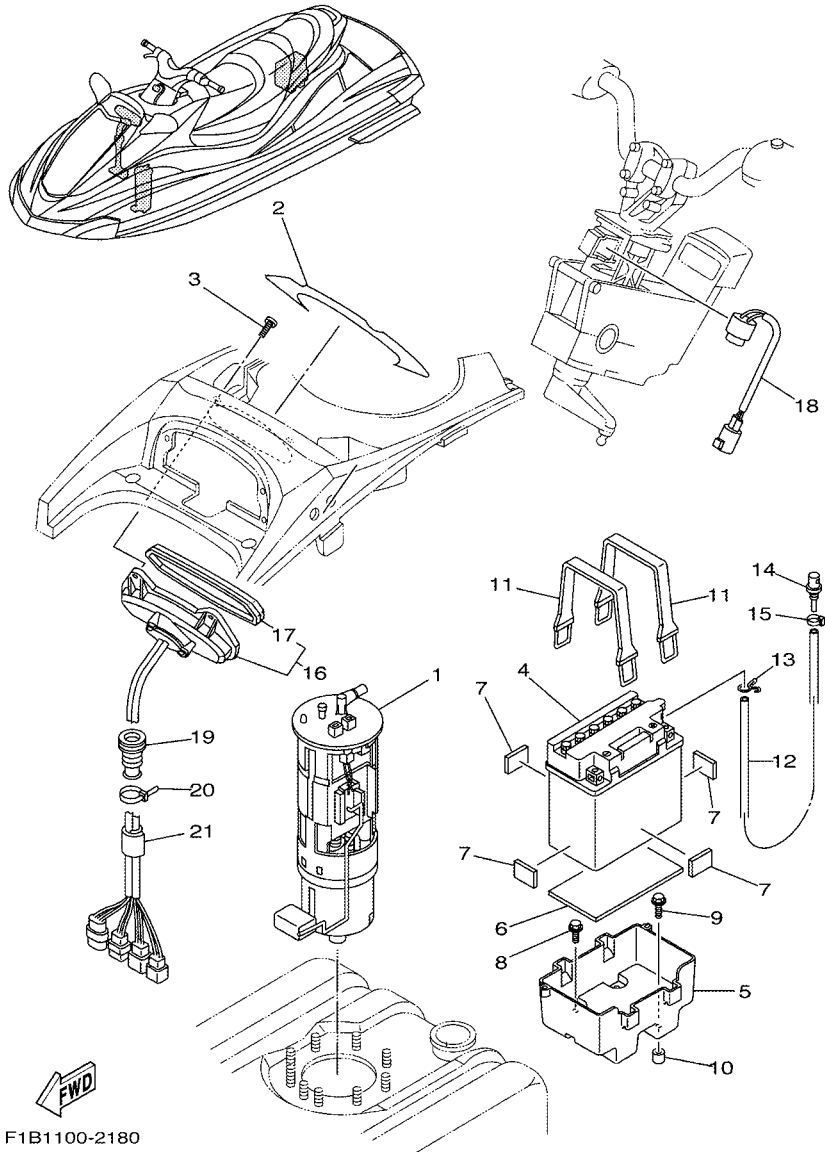


FIG. 18 ELECTRICAL 3

REF. NO.	PART NO.	DESCRIPTION	U49	CAL	CAN	GENE	JPN	REMARKS
1	60E-13907-00	FUEL PUMP COMP.	1	1	1	1	1	
2	F1B-64174-00	GRAPHIC B	1	1	1	1	1	
3	90111-05008	BOLT	4	4	4	4	4	
4	EU0-82110-09	BATTERY ASSY (YB16CL-B)	1	1	1	1	1	YUASA
5	GP7-U8211-00	CASE, BATTERY	1	1	1	1	1	YMUS
6	F0X-U8221-00	PAD, BATTERY	1	1	1	1	1	YMUS
7	EU0-U8221-30	PAD, BATTERY 2	4	4	4	4	4	YMUS
8	90119-06854	BOLT, WITH WASHER	2	2	2	2	2	EXCEPT JPN, YMUS
	90119-069US	BOLT, WITH WASHER					2	FOR JPN, YMUS
9	90119-06832	BOLT, WITH WASHER	2	2	2	2	2	YMUS
10	F1B-6821G-00	PLATE, BATTERY	2	2	2	2	2	EXCEPT JPN
	F1B-6821G-01	PLATE, BATTERY					2	FOR JPN
11	EU0-U821D-00	BAND, BATTERY 2	2	2	2	2	2	YMUS
12	F0D-U785G-10	HOSE, AIR VENT	1	1	1	1	1	YMUS
13	90467-089U1	CLIP	1	1	1	1	1	YMUS
14	GJ3-6215F-00	NIPPLE	1	1	1	1	1	
15	90465-11829	CLAMP	1	1	1	1	1	YMUS
16	F1B-6820A-00	METER ASSY	1	1	1	1	1	
17	F1B-6821K-00	.PANEL, METER	1	1	1	1	1	
18	F0D-U8341-00	BUZZER	1	1	1	1	1	YMUS
19	GU2-6822E-01	GROMMET	1	1	1	1	1	
20	90601-200U1	BAND	1	1	1	1	1	YMUS
21	GJ1-U7578-11	PACKING, HOSE 2	2	2	2	2	2	YMUS

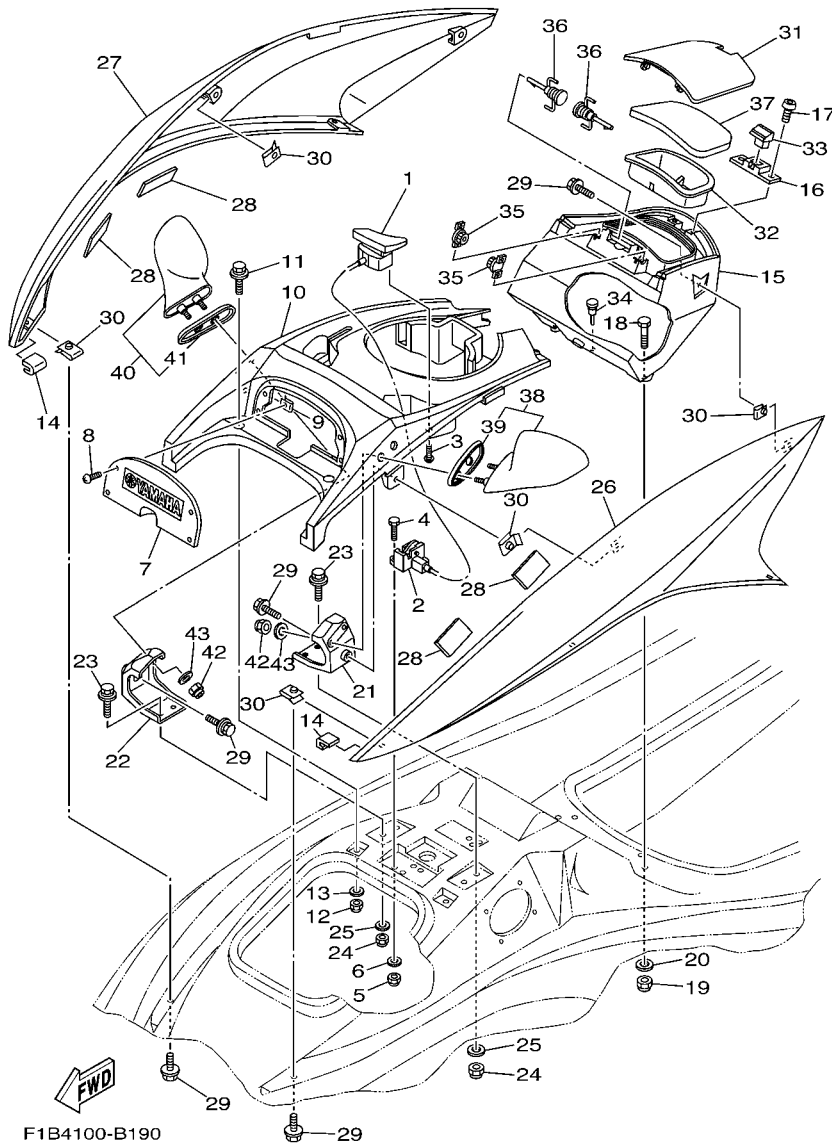


FIG. 19 ENGINE HATCH 1

REF. NO.	PART NO.	DESCRIPTION	U49	CAL	CAN	GENE	JPN	REMARKS
1	F1B-651A1-00	LEVER, LID LOCK	1	1	1	1	1	
2	F1B-6517C-00	LOCK, LID	1	1	1	1	1	
3	90149-05946	SCREW	4	4	4	4	4	
4	90119-06824	BOLT, WITH WASHER	2	2	2	2	2	YMUS
5	9572R-06300	NUT, NYLON	2	2	2	2	2	YMUS
6	9299R-06200	WASHER	2	2	2	2	2	YMUS
7	F1B-U555B-00	SEAL, COVER CENTER	1	1	1	1	1	YMUS
8	90149-05981	SCREW	4	4	4	4	4	
9	FJ0-61432-00	NUT	4	4	4	4	4	
10	F1B-U5554-00	COVER, CENTER	1	1	1	1	1	YB, YMUS
11	90119-06934	BOLT, WITH WASHER	2	2	2	2	2	
12	9572R-06300	NUT, NYLON	2	2	2	2	2	YMUS
13	9299R-06200	WASHER	2	2	2	2	2	YMUS
14	F1B-U5115-00	TRIM, HATCH 1	2	2	2	2	2	YMUS
15	F1B-U516P-00	BOX GLOVE	1	1	1	1	1	YB, YMUS
16	F1B-65193-00	PLATE	1	1	1	1	1	
17	90111-06036	BOLT	4	4	4	4	4	
18	97080-08030	BOLT	2	2	2	2	2	
19	9572R-08300	NUT, FLANGE	2	2	2	2	2	YMUS
20	9299R-08200	WASHER	2	2	2	2	2	YMUS
21	F1B-U377M-00	BRKT., COVER SIDE 1	1	1	1	1	1	YMUS
22	F1B-U377N-00	BRKT, COVER SIDE 2	1	1	1	1	1	YMUS
23	90119-06934	BOLT, WITH WASHER	4	4	4	4	4	
24	9572R-06300	NUT, NYLON	4	4	4	4	4	YMUS
25	9299R-06200	WASHER	4	4	4	4	4	YMUS
26	F1B-U377B-10-P0	COVER, SIDE 1	1	1	1	1	1	UR DPBMF, YMUS
	F1B-U377B-20-P0	COVER, SIDE 1	1	1	1	1	1	UR SMF, YMUS

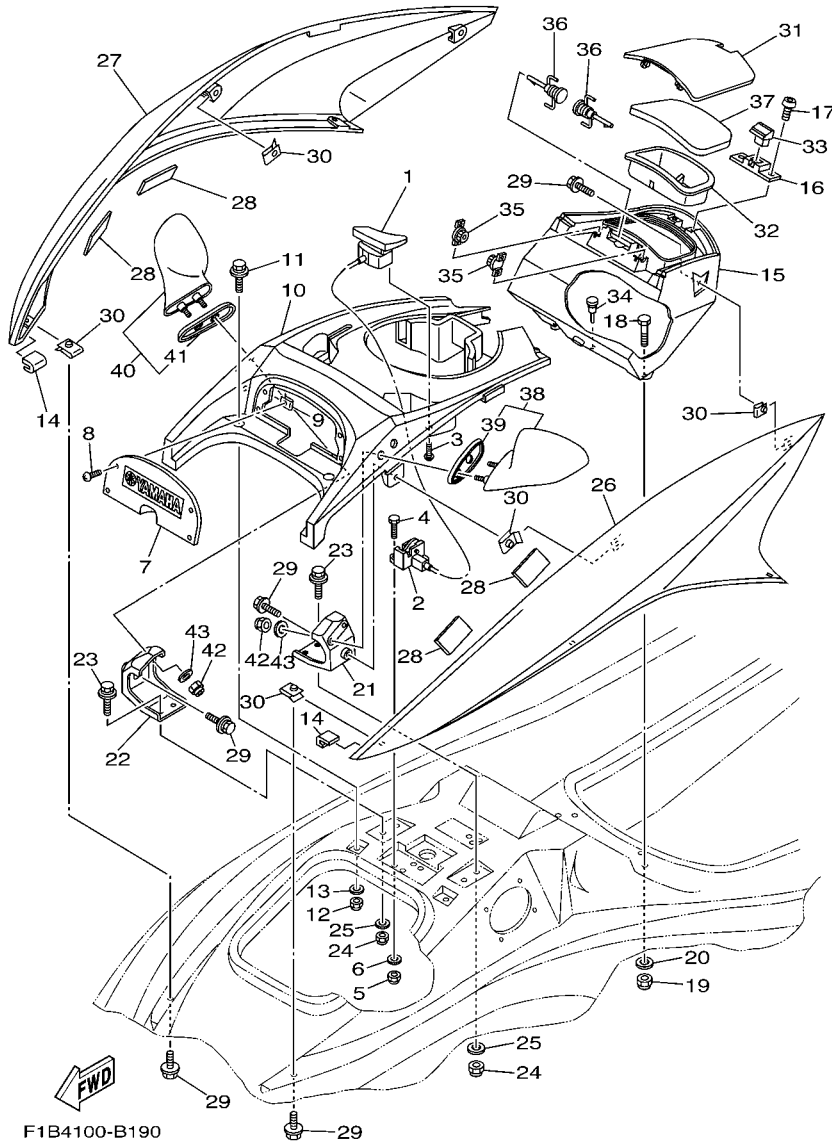
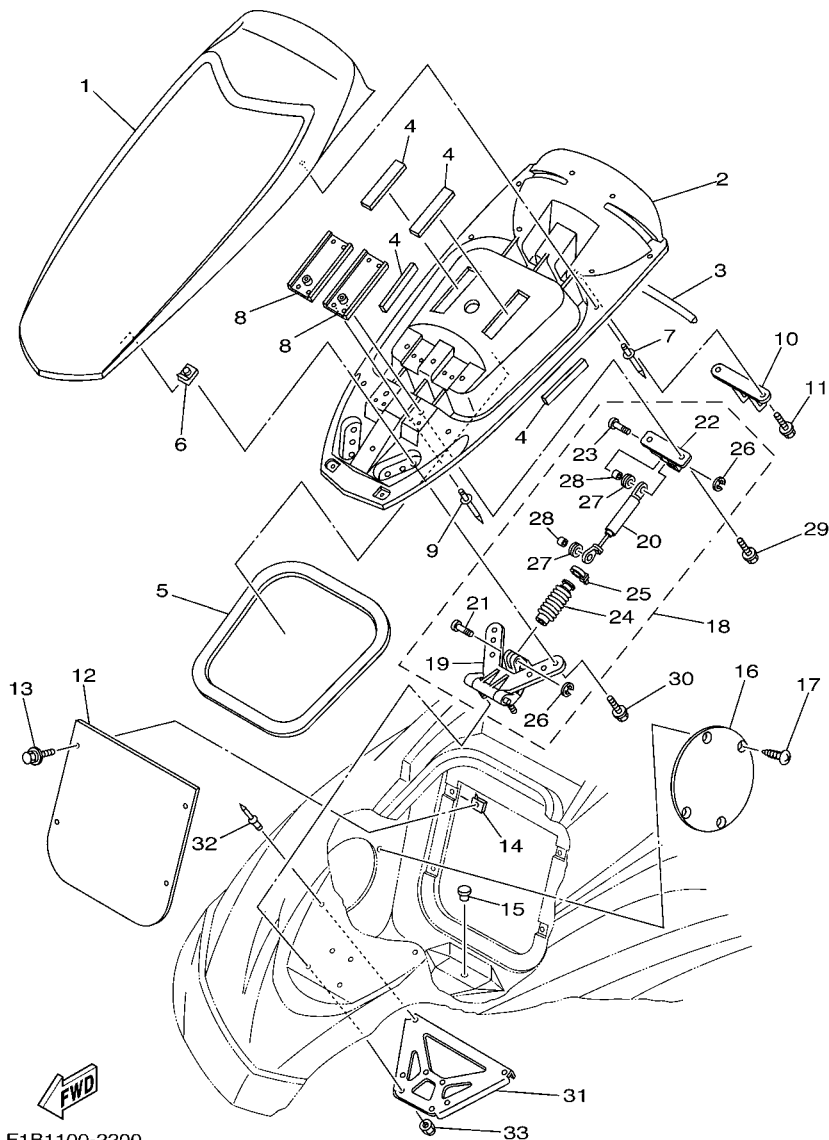


FIG. 19 ENGINE HATCH 1

REF. NO.	PART NO.	DESCRIPTION	U49	CAL	CAN	GENE	JPN	REMARKS
27	F1B-U377C-10-P0	COVER, SIDE 2	1	1	1	1	1	UR DPBMF, YMUS
	F1B-U377C-20-P1	COVER, SIDE 2	1	1	1	1	1	UR SMF, YMUS
28	GJ1-U759C-00	MAT 2	4	4	4	4	4	YMUS
29	90119-06858	BOLT, WITH WASHER	8	8	8	8	8	YMUS
30	90183-06902	NUT, SPRING	8	8	8	8	8	
31	F1B-U517H-00	LID HATCH	1	1	1	1	1	YMUS
32	F1B-U5633-00	HOLDER, DRINK	1	1	1	1	1	YMUS
33	F0D-62875-00	LOCK	1	1	1	1	1	
34	90605-502U2	PLUG	1	1	1	1	1	YMUS
35	F1B-60210-00	GEAR ASSY	2	2	2	2	2	
36	F1B-6517R-00	PIN, HINGE	2	2	2	2	2	
37	F1B-U519D-00	PACKING CASE	1	1	1	1	1	YMUS
38	F1B-6596B-00	MIRROR LH	1	1	1	1	1	BL
39	F1B-6596F-00	.GASKET, MIRROR LH	1	1	1	1	1	BL
40	F1B-6596C-00	MIRROR RH	1	1	1	1	1	BL
41	F1B-6596G-00	.GASKET, MIRROR RH	1	1	1	1	1	BL
42	9572R-08300	NUT, FLANGE	4	4	4	4	4	YMUS
43	9299R-08200	WASHER	4	4	4	4	4	YMUS



FIG. 20 ENGINE HATCH 2

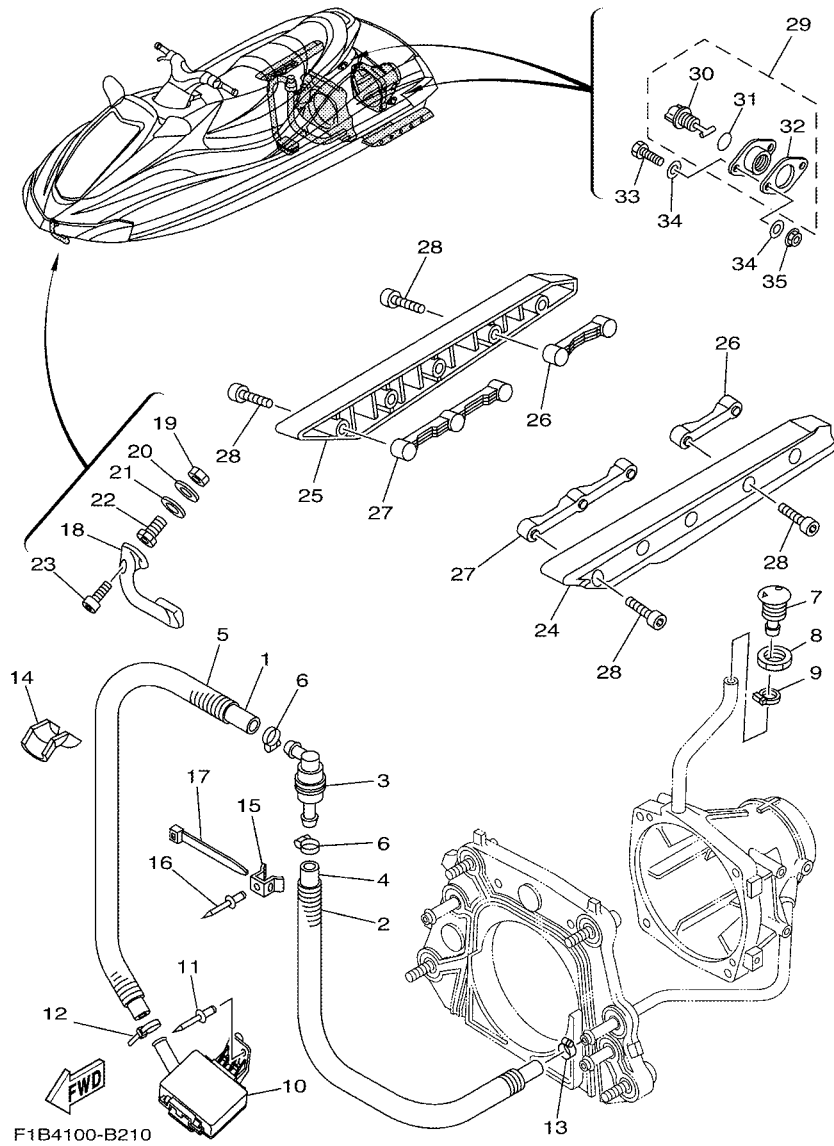


F1B1100-2200

REF. NO.	PART NO.	DESCRIPTION	U49	CAL	CAN	GENE	JPN	REMARKS
1	F1B-U517B-10-P0	LID, ENGINE ROOM	1	1	1	1	1	UR DPBMF, YMUS
	F1B-U517B-20-P0	LID, ENGINE ROOM	1	1	1	1	1	UR SMF, YMUS
2	F1B-U2103-00	VENTILATOR COVER COMP., 2	1	1	1	1	1	YMUS
3	F1B-U266B-00	PACKING 3	1	1	1	1	1	YMUS
4	F0V-U3635-00	TAPE, FITTING	4	4	4	4	4	YMUS
5	F1B-U2663-00	PACKING 1	1	1	1	1	1	YMUS
6	90183-06902	NUT, SPRING	4	4	4	4	4	
7	90267-48807	RIVET, BLIND	13	13	13	13	13	YMUS
8	F1B-65148-00	PLATE, HATCH	2	2	2	2	2	
9	90267-489U9	RIVET, BLIND	8	8	8	8	8	YMUS
10	F0X-6517F-01	HOOK, LID LOCK	1	1	1	1	1	
11	90119-069UH	BOLT, WITH WASHER	2	2	2	2	2	YMUS
12	F1B-U475F-00	PLATE, LOKER BOW	1	1	1	1	1	YMUS
13	90119-069UH	BOLT, WITH WASHER	4	4	4	4	4	YMUS
14	90183-06902	NUT, SPRING	4	4	4	4	4	
15	90605-502U1	PLUG, BLIND	1	1	1	1	1	YMUS
16	GP1-U7228-00	COVER, INSPECTION 2	1	1	1	1	1	YMUS
17	9778R-40712	SCREW, TAPPING	4	4	4	4	4	YMUS
18	F1B-6515A-00	HINGE ASSY.	1	1	1	1	1	
19	F1B-6517D-00	.HINGE, LID	1	1	1	1	1	
20	F1B-6515D-00	.DAMPER 1	1	1	1	1	1	
21	F1B-6515H-00	.SHAFT A	1	1	1	1	1	
22	F1B-6514U-00	.STAY, DAMPER	1	1	1	1	1	
23	F1B-6515J-00	.SHAFT B	1	1	1	1	1	
24	F1B-6518F-00	.COVER, SPRING	1	1	1	1	1	
25	90464-44001	.CLAMP	1	1	1	1	1	
26	99080-06600	.CIRCLIP	2	2	2	2	2	



FIG. 21 HULL. DECK



REF. NO.	PART NO.	DESCRIPTION	U49	CAL	CAN	GENE	JPN	REMARKS
1	90445-198B6	HOSE (L860)	1	1	1	1	1	YMUS
2	90446-27M73	HOSE	1	1	1	1	1	
3	68N-5112T-00	JOINT, HOSE	1	1	1	1	1	
4	90445-19896	HOSE (L500)	1	1	1	1	1	YMUS
5	90446-27M55	TUBE (L400)	1	1	1	1	1	
6	90601-118UF	BAND, HOSE 18	2	2	2	2	2	YMUS
7	FN8-6269B-00	SPOUT	1	1	1	1	1	
8	EU0-61652-00	NUT	1	1	1	1	1	
9	90601-118UF	BAND, HOSE 18	1	1	1	1	1	YMUS
10	F1B-U761D-00	STRAINER, BILGE	1	1	1	1	1	YMUS
11	90267-48802	RIVET, BLIND	1	1	1	1	1	YMUS
12	90601-200U1	BAND	2	2	2	2	2	YMUS
13	90467-200A0	CLIP	2	2	2	2	2	
14	F1B-U7578-20	PACKING, HOSE 2	1	1	1	1	1	YMUS
15	90600-917U4	CLAMP COMP.	3	3	3	3	3	YMUS
16	90267-48802	RIVET, BLIND	3	3	3	3	3	YMUS
17	90464-32801	CLAMP	3	3	3	3	3	YMUS
18	F0X-61624-00	BOWEYE 1 (S)	1	1	1	1	1	
19	99780-12600	NUT.HEX.(COARS)	2	2	2	2	2	
20	92990-12200	WASHER, PLAIN	2	2	2	2	2	
21	F0X-61637-00	WASHER	2	2	2	2	2	
22	F0X-61652-00	NUT	2	2	2	2	2	
23	90110-06040	BOLT, HEXAGON SOCKET HEAD	2	2	2	2	2	
24	F1B-U883N-00	STABILIZER LH	1	1	1	1	1	YB, YMUS
25	F1B-U883P-00	STABILIZER RH	1	1	1	1	1	YB, YMUS
26	F1F-U883T-01	BRACKET,STABILIZER	2	2	2	2	2	YMUS
27	F1B-U883T-01	BRACKET,STABILIZER	2	2	2	2	2	YMUS



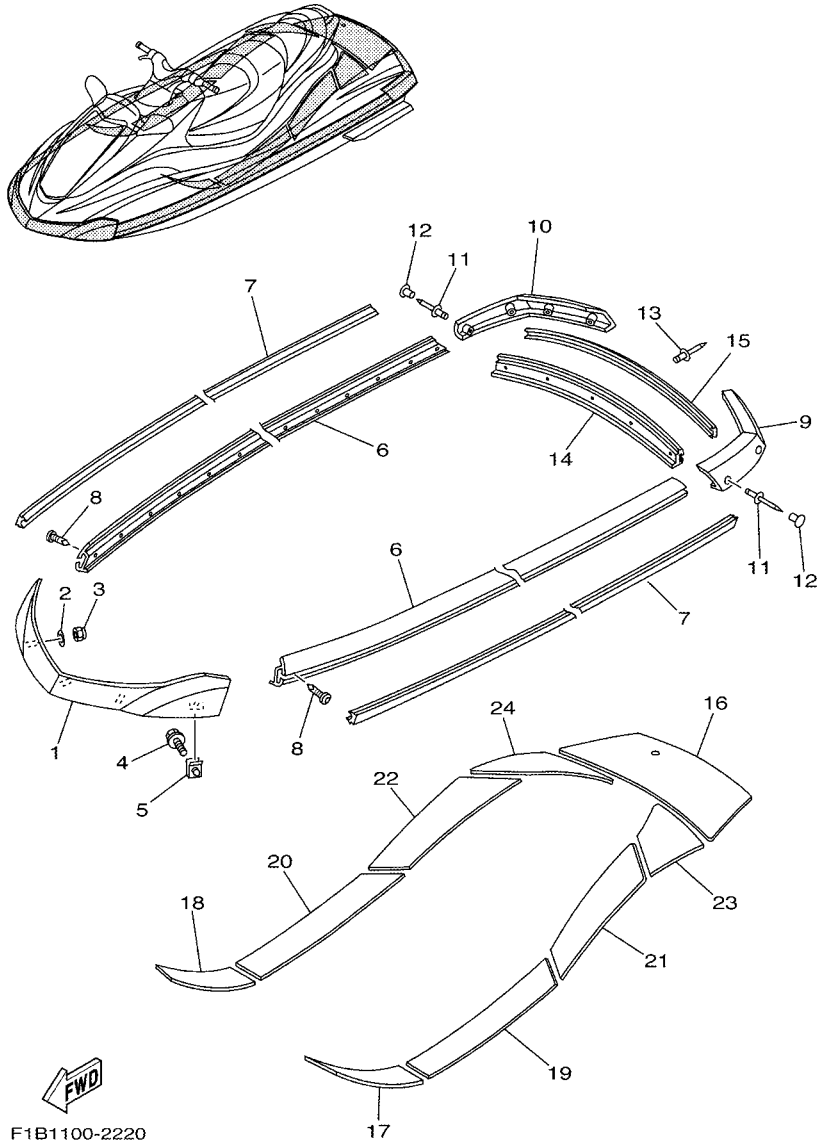
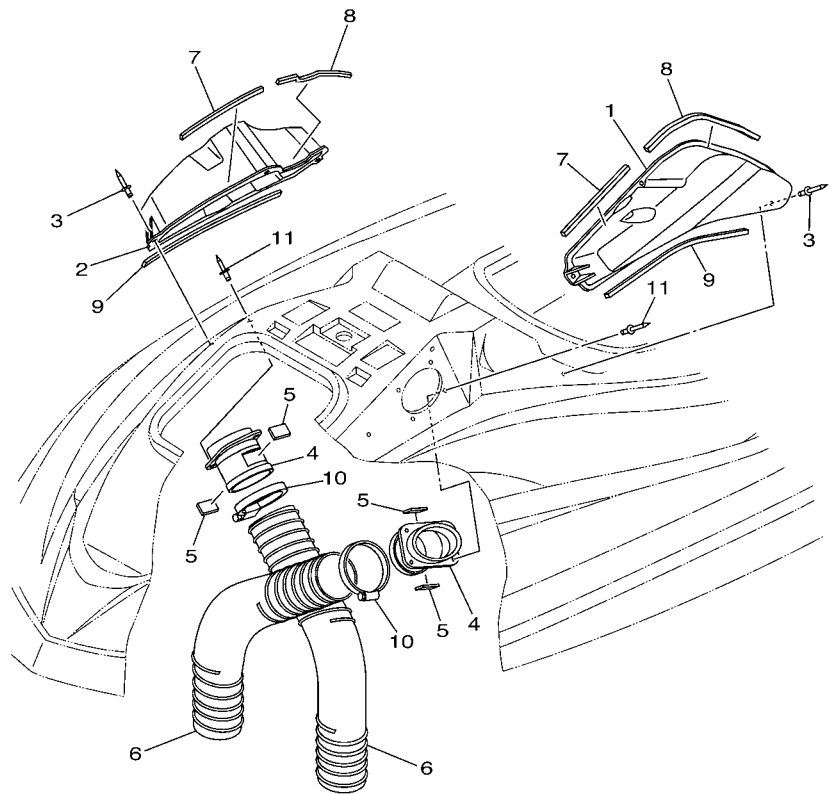


FIG. 22 GUNWALE. MAT

REF. NO.	PART NO.	DESCRIPTION	U49	CAL	CAN	GENE	JPN	REMARKS
1	F1B-62501-10	BOW GUNWALE COMP.	1	1	1	1	1	BL
2	9299R-06200	WASHER	3	3	3	3	3	YMUS
3	9572R-06300	NUT, NYLON	3	3	3	3	3	YMUS
4	90119-069UD	BOLT, WITH WASHER	4	4	4	4	4	YMUS
5	90183-06902	NUT, SPRING	4	4	4	4	4	
6	F1B-U2512-10	GUNWALE, SIDE	2	2	2	2	2	YB, YMUS
7	F1B-U2519-10	INNER, GUNWALE	2	2	2	2	2	YB, YMUS
8	90169-059U1	SCREW, TAPPING	36	36	36	36	36	YMUS
9	F1B-U251D-10	GUNWALE, STERN 1	1	1	1	1	1	YB, YMUS
10	F1B-U251E-10	GUNWALE, STERN 2	1	1	1	1	1	YB, YMUS
11	90267-489UT	RIVET, BLIND	8	8	8	8	8	YMUS
12	F0D-U352E-00	MAT, BOW	8	8	8	8	8	GRY, YMUS
13	90267-489US	RIVET, BLIND	5	5	5	5	5	YMUS
14	F1B-U252C-10	COVER, GUNWALE 1	1	1	1	1	1	YB, YMUS
15	F1B-U252D-10	COVER, GUNWALE 2	1	1	1	1	1	YB, YMUS
16	F1B-U3581-01	MAT, UPPER	1	1	1	1	1	BL, YMUS
17	F1B-U351H-01	MAT, STEP 1	1	1	1	1	1	BL, YMUS
18	F1B-U351J-01	MAT, STEP 2	1	1	1	1	1	BL, YMUS
19	F1B-U351K-01	MAT, STEP 3	1	1	1	1	1	BL, YMUS
20	F1B-U351M-01	MAT, STEP 4	1	1	1	1	1	BL, YMUS
21	F1B-U351N-02	MAT, STEP 5	1	1	1	1	1	BL, YMUS
22	F1B-U351P-02	MAT, STEP 6	1	1	1	1	1	BL, YMUS
23	F1B-U351R-01	MAT, STEP 7	1	1	1	1	1	BL, YMUS
24	F1B-U351S-01	MAT, STEP 8	1	1	1	1	1	BL, YMUS

FIG. 23 VENTILATION



REF. NO.	PART NO.	DESCRIPTION	U49	CAL	CAN	GENE	JPN	REMARKS
1	F1B-U2187-01	BOX, INDUCATION 1	1	1	1	1	1	YMUS
2	F1B-U2188-00	BOX, INDUCATION 2	1	1	1	1	1	YMUS
3	90267-48806	RIVET, BLIND	8	8	8	8	8	YMUS
4	F1B-62127-00	BASE, AIR INTAKE	2	2	2	2	2	
5	F1B-62157-00	PACKING	4	4	4	4	4	
6	F0X-U213G-01	HOSE, VENTILATOR 2	2	2	2	2	2	YMUS
7	F1B-6266E-00	PACKING,6	2	2	2	2	2	
8	F1B-6266F-00	PACKING 7	2	2	2	2	2	
9	F1B-6266G-00	PACKING 8	2	2	2	2	2	
10	90601-200U7	BAND	2	2	2	2	2	YMUS
11	90267-48806	RIVET, BLIND	8	8	8	8	8	YMUS

  
F1B1100-2230

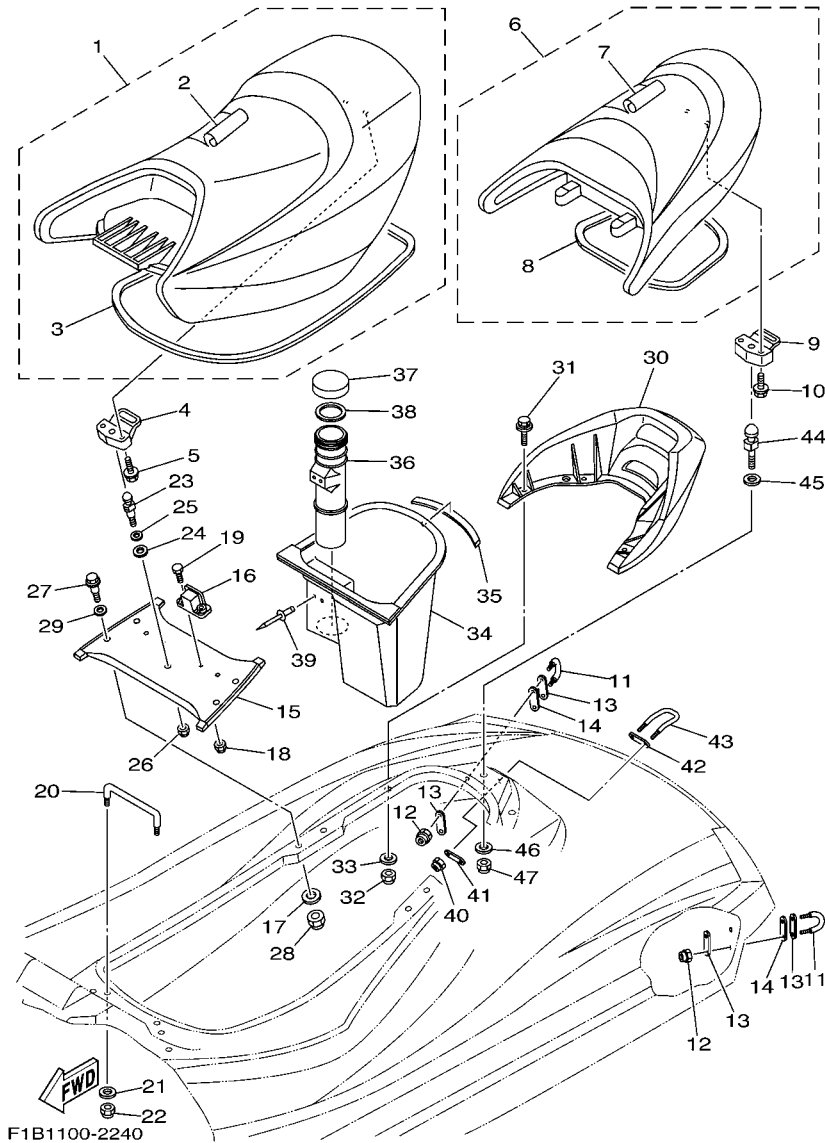


FIG. 24 SEAT. UNDER LOCKER

REF. NO.	PART NO.	DESCRIPTION	U49	CAL	CAN	GENE	JPN	REMARKS
1	F1B-U371A-11	DOUBLE SEAT ASSY	1	1	1	1	1	FOR DPBMF, YMUS
	F1B-U371A-21	DOUBLE SEAT ASSY	1	1	1	1	1	FOR SMF, YMUS
2	F1B-U371B-10	.COVER, SEAT 1	1	1	1	1	1	FOR DPBMF, YMUS
	F1B-U371B-20	.COVER, SEAT 1	1	1	1	1	1	FOR SMF, YMUS
3	F1B-U266C-00	.PACKING 4	1	1	1	1	1	YMUS
4	F0D-63850-01	SEAT LOCK ASSY	1	1	1	1	1	
5	90119-06853	BOLT, WITH WASHER	2	2	2	2	2	YMUS
6	F1B-U372A-11	SINGLE SEAT ASSY	1	1	1	1	1	FOR DPBMF, YMUS
	F1B-U372A-21	SINGLE SEAT ASSY	1	1	1	1	1	FOR SMF, YMUS
7	F1B-U372B-10	.COVER, SEAT	1	1	1	1	1	FOR DPBMF, YMUS
	F1B-U372B-20	.COVER, SEAT	1	1	1	1	1	FOR SMF, YMUS
8	F1B-U266D-00	.PACKING 5	1	1	1	1	1	YMUS
9	F0D-63850-01	SEAT LOCK ASSY	1	1	1	1	1	
10	90119-06853	BOLT, WITH WASHER	2	2	2	2	2	YMUS
11	GP7-61628-00	STERN EYE	2	2	2	2	2	
12	9572R-08300	NUT, FLANGE	4	4	4	4	4	YMUS
13	GP7-U4953-00	PLATE A	4	4	4	4	4	YMUS
14	F1B-U1653-01	PACKING	2	2	2	2	2	YMUS
15	F1B-U8952-01	BEAM, DECK 1	1	1	1	1	1	YMUS
16	GU2-6378D-01	STAY, SEAT 2	2	2	2	2	2	
17	9299R-08200	WASHER	4	4	4	4	4	YMUS
18	9572R-06300	NUT, NYLON	4	4	4	4	4	YMUS
19	90101-069U0	BOLT	4	4	4	4	4	YMUS
20	F0X-6378C-00	STAY, SEAT 1	1	1	1	1	1	
21	90201-099U3	WASHER, PLATE	2	2	2	2	2	YMUS
22	9572R-08300	NUT, FLANGE	2	2	2	2	2	YMUS
23	F1B-U3774-00	PIN	1	1	1	1	1	YMUS

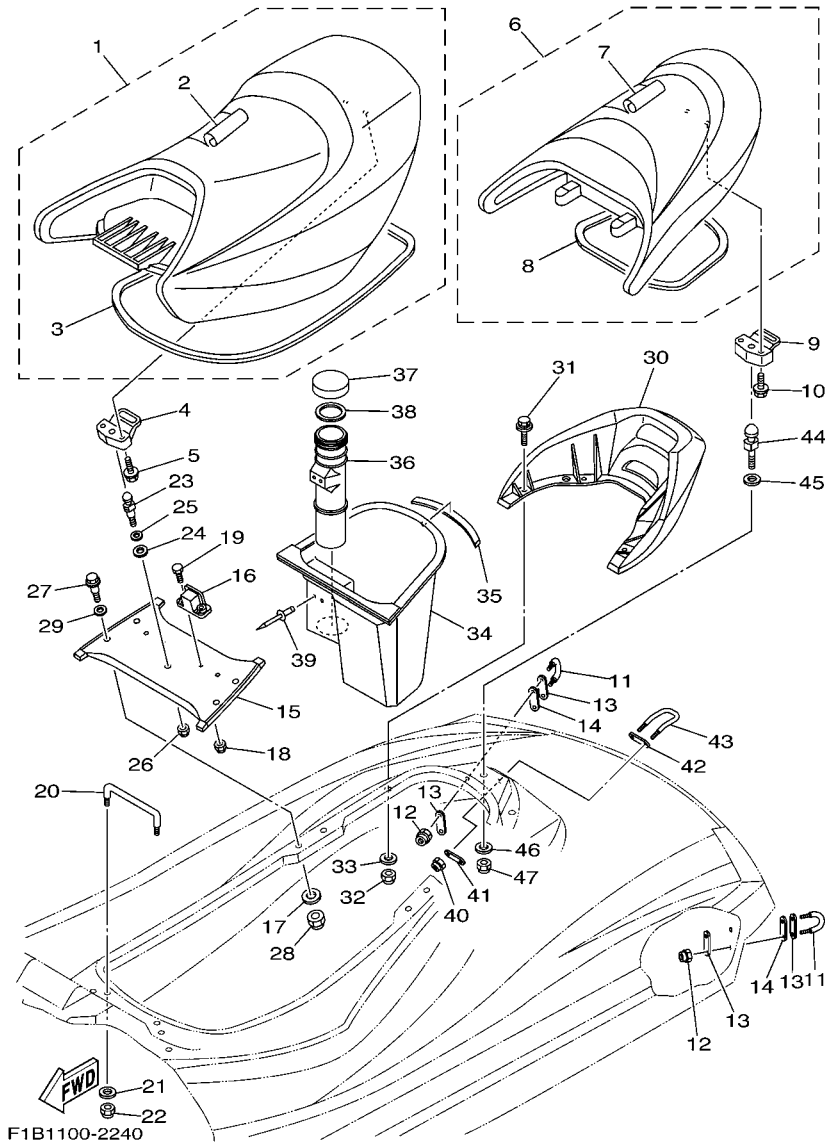
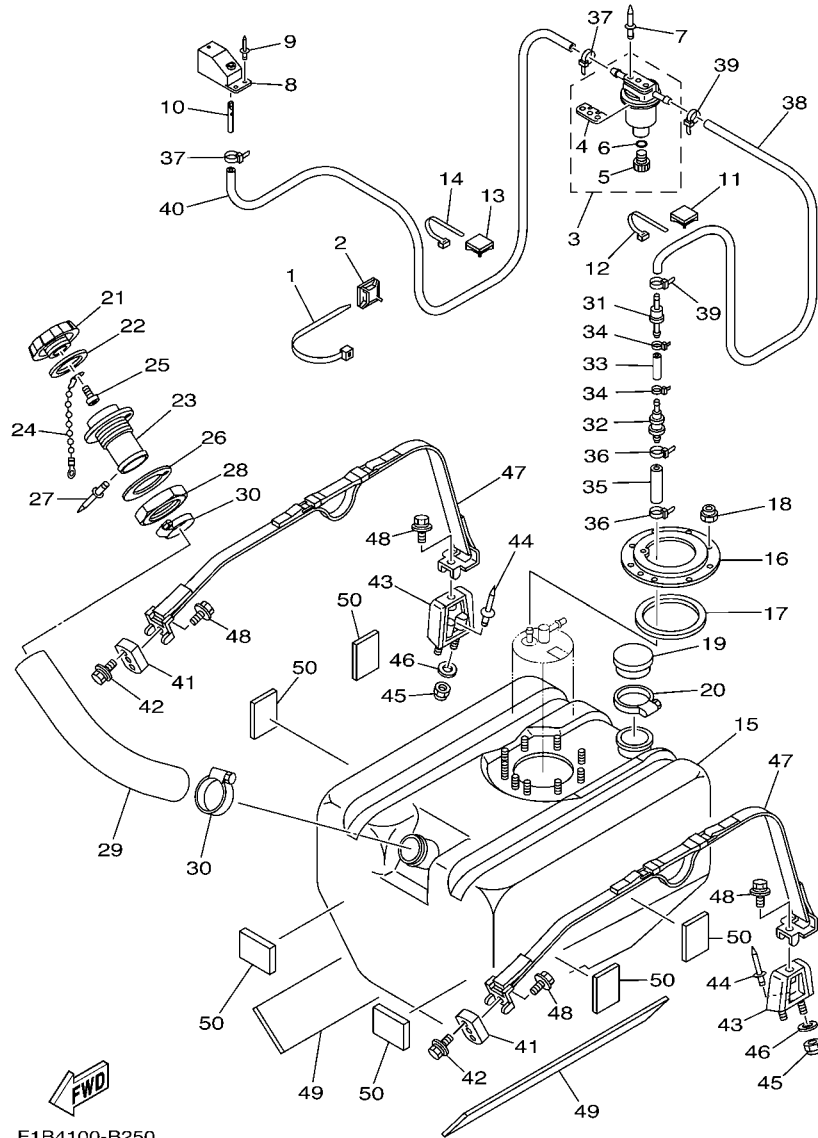


FIG. 24 SEAT. UNDER LOCKER

REF. NO.	PART NO.	DESCRIPTION	U49	CAL	CAN	GENE	JPN	REMARKS
24	F0X-6375E-00	PACKING 1	1	1	1	1	1	
25	92990-12200	WASHER, PLAIN	1	1	1	1	1	
26	9572R-10300	NUT, FLANGE	1	1	1	1	1	YMUS
27	F1B-U2624-00	BOLT	4	4	4	4	4	YMUS
28	9572R-08300	NUT, FLANGE	4	4	4	4	4	YMUS
29	9299R-10200	WASHER	4	4	4	4	4	YMUS
30	F1B-U271B-00	GRIP, HAND	1	1	1	1	1	YB, YMUS
31	90119-08942	BOLT, WITH WASHER	4	4	4	4	4	
32	9572R-08300	NUT, FLANGE	4	4	4	4	4	YMUS
33	9299R-08200	WASHER	4	4	4	4	4	YMUS
34	F1B-U4742-01	LOCKER, UNDER 2	1	1	1	1	1	YMUS
35	F0X-U266E-01	PACKING,6	1	1	1	1	1	YMUS
36	F0X-U5983-01	BOX, FIRE EXTINGUISHER	1	1	1	1	1	YMUS
37	EW2-U5912-01	CAP, CASE	1	1	1	1	1	YMUS
38	EW2-U5913-01	PACKING, CASE	1	1	1	1	1	YMUS
39	90267-489UP	RIVET, BLIND	4	4	4	4	4	YMUS
40	9572R-08300	NUT, FLANGE	2	2	2	2	2	YMUS
41	GP7-U4953-00	PLATE A	1	1	1	1	1	YMUS
42	GP7-U4953-00	PLATE A	1	1	1	1	1	YMUS
43	F1B-U1629-00	SKI TOWS	1	1	1	1	1	YMUS
44	GH1-U3774-00	PIN	1	1	1	1	1	YMUS
45	90201-109U6	WASHER, PLATE	1	1	1	1	1	YMUS
46	9299R-10200	WASHER	1	1	1	1	1	YMUS
47	9572R-10300	NUT, FLANGE	1	1	1	1	1	YMUS



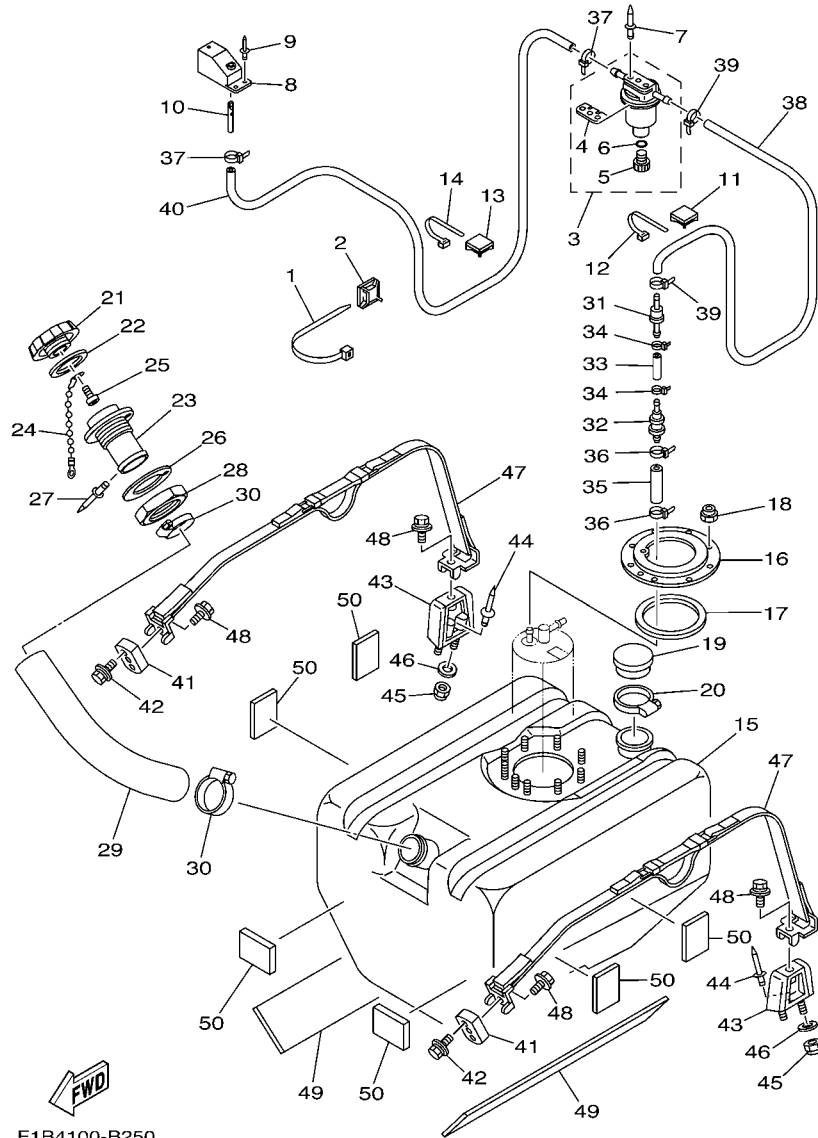
FIG. 25 FUEL TANK



F1B4100-B250

REF. NO.	PART NO.	DESCRIPTION	U49	CAL	CAN	GENE	JPN	REMARKS
1	90464-99804	CLAMP	2	2	2	2	2	YMUS
2	90600-900U6	BASE, CLAMP	2	2	2	2	2	YMUS
3	EW2-62140-00	FILTER, VENT ASSY	1	1	1	1	1	
4	EW2-62142-00	.PLATE, FILTER	1	1	1	1	1	
5	70R-24543-00	.PLUG, DRAIN	1	1	1	1	1	
6	70R-24489-00	.O-RING	1	1	1	1	1	
7	90267-489U2	RIVET, BLIND	2	2	2	2	2	YMUS
8	GP7-62159-01	SOCKET, VENTILATION	1	1	1	1	1	
9	90267-489U6	RIVET, BLIND	2	2	2	2	2	YMUS
10	EW2-62149-00	PIPE, VENTILATION 1	1	1	1	1	1	
11	90600-900U6	BASE, CLAMP	1	1	1	1	1	YMUS
12	90464-40825	CLAMP	1	1	1	1	1	YMUS
13	90600-900U6	BASE, CLAMP	1	1	1	1	1	YMUS
14	90464-40825	CLAMP	1	1	1	1	1	YMUS
15	F1B-U7711-01	TANK, FUEL	1	1	1	1	1	YMUS
16	F1B-U7773-00	RING	1	1	1	1	1	YMUS
17	F1B-67747-00	PACKING, SEAL	1	1	1	1	1	
18	9572R-06300	NUT, NYLON	9	9	9	9	9	YMUS
19	FN8-6771K-00	COVER	1	1	1	1	1	
20	90601-162U5	BAND, HOSE 62	1	1	1	1	1	YMUS
21	GP7-U7831-01	CAP, FUEL FILLER	1	1	1	1	1	PURW, YMUS
22	GP7-U7832-01	PACKING	1	1	1	1	1	YMUS
23	GP7-U7833-00	SOCKET	1	1	1	1	1	YMUS
24	GP7-U7835-00	CHAIN BALL	1	1	1	1	1	YMUS
25	90169-049U1	TAPPING SCREW	1	1	1	1	1	YMUS
26	GP7-U7834-00	PACKING FUEL FILLER	1	1	1	1	1	YMUS
27	90267-329UR	RIVET, BLIND	1	1	1	1	1	YMUS

FIG. 25 FUEL TANK



F1B4100-B250

REF. NO.	PART NO.	DESCRIPTION	U49	CAL	CAN	GENE	JPN	REMARKS
28	GP7-U783F-00	NUT, FUEL FILLER	1	1	1	1	1	YMUS
29	F1B-U7844-00	HOSE	1	1	1	1	1	YMUS
30	90601-155U4	BAND, HOSE 55	2	2	2	2	2	YMUS
31	F1B-67767-00	CHECK VALVE	1	1	1	1	1	
32	FJ0-67766-00	ROLL OVER VALVE	1	1	1	1	1	
<hr/>								
33	90699-50004	HOSE	1	1	1	1	1	
34	90465-11M10	CLAMP	2	2	2	2	2	
35	GP7-U785H-00	HOSE, AIR VENT 3	1	1	1	1	1	YMUS
36	90465-11829	CLAMP	2	2	2	2	2	YMUS
37	90465-11829	CLAMP	2	2	2	2	2	YMUS
<hr/>								
38	F0D-U785G-10	HOSE, AIR VENT	1	1	1	1	1	YMUS
39	90465-11829	CLAMP	2	2	2	2	2	YMUS
40	F0D-U7856-10	HOSE, AIR VENT 3	1	1	1	1	1	YMUS
41	F1B-U2873-00	NUT, SPECIAL	2	2	2	2	2	YMUS
42	90119-089U7	BOLT, WITH WASHER	4	4	4	4	4	YMUS
<hr/>								
43	F1B-6774J-00	BRKT, BAND	2	2	2	2	2	
44	90267-489U2	RIVET, BLIND	2	2	2	2	2	YMUS
45	9572R-06300	NUT, NYLON	4	4	4	4	4	YMUS
46	9299R-06200	WASHER	4	4	4	4	4	YMUS
47	F1B-67743-01	BELT, TANK 1	2	2	2	2	2	
<hr/>								
48	90119-089U7	BOLT, WITH WASHER	4	4	4	4	4	YMUS
49	F1B-U759B-00	MAT 1	2	2	2	2	2	YMUS
50	F1B-U759C-00	MAT 2	6	6	6	6	6	YMUS
<hr/>								

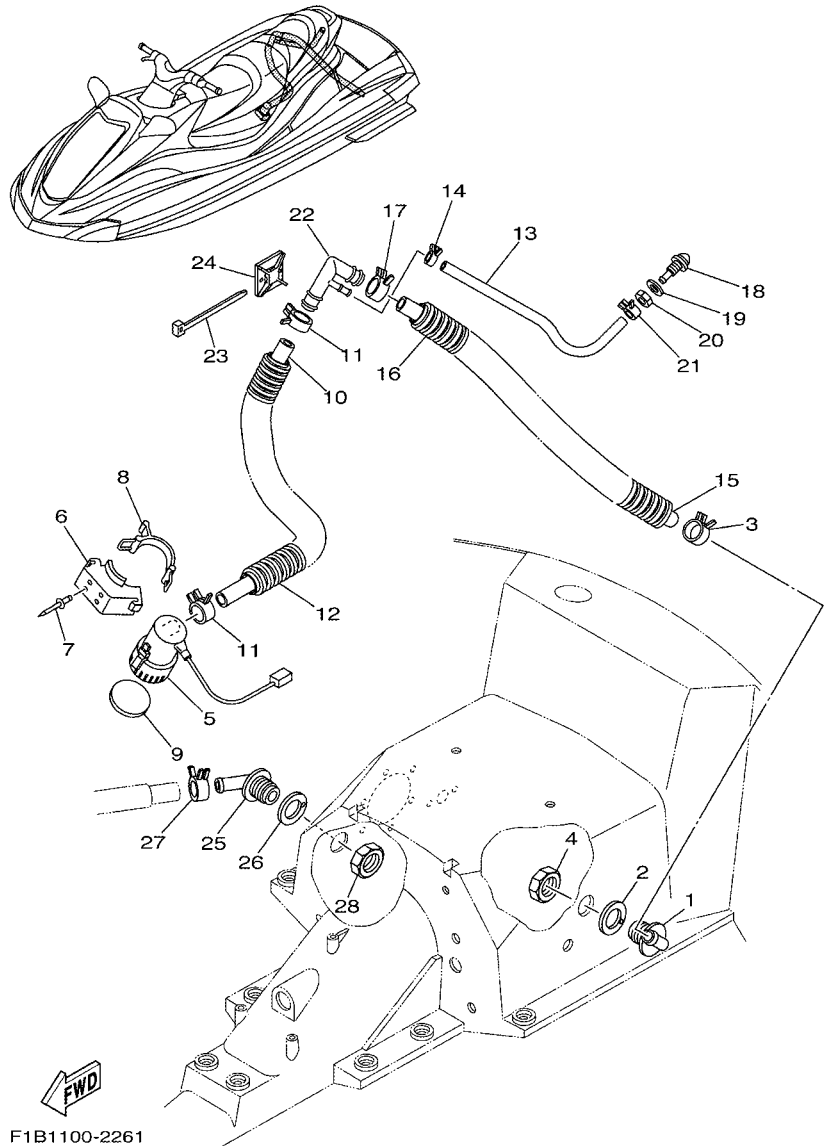
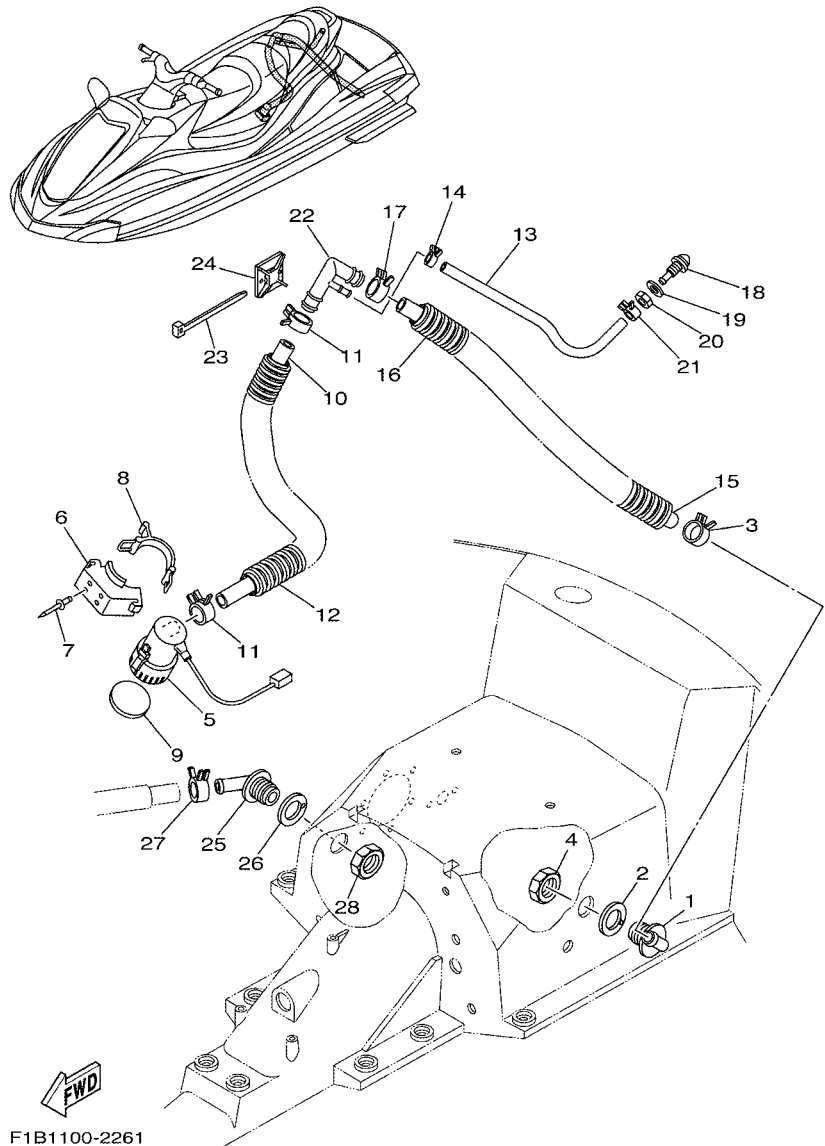


FIG. 26 BILGE PUMP

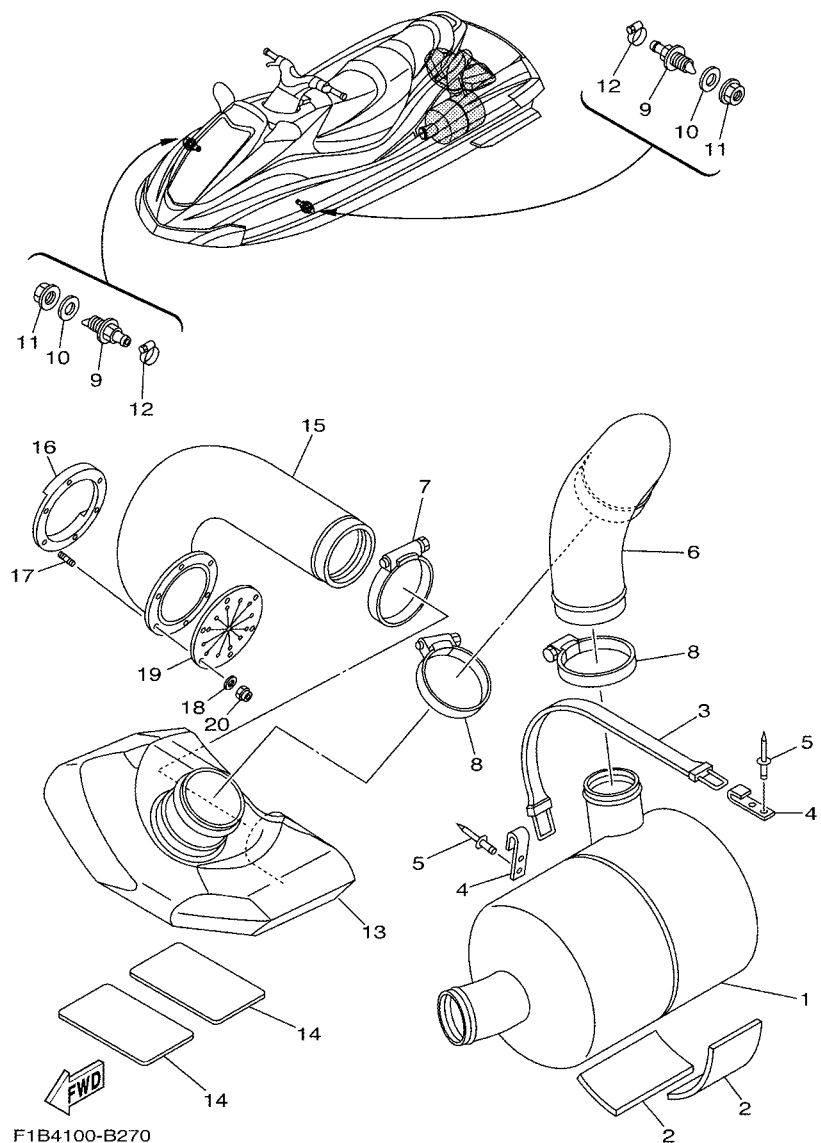
REF. NO.	PART NO.	DESCRIPTION	U49	CAL	CAN	GENE	JPN	REMARKS
1	F1B-6224E-00	BODY, DRAIN 3	1	1	1	1	1	
2	F1B-67525-00	PACKING	1	1	1	1	1	
3	90467-250A0	CLIP	1	1	1	1	1	
4	F1B-62241-00	DRAIN, COCKPIT	1	1	1	1	1	
5	F1B-U8360-01	BILGE PUMP ASSY (12V)	1	1	1	1	1	YMUS
6	F1B-U7698-00	BRACKET	1	1	1	1	1	YMUS
7	90267-489UP	RIVET, BLIND	2	2	2	2	2	YMUS
8	GA7-68218-00	BAND, BATTERY	1	1	1	1	1	
9	F1B-U7656-00	PACKING, BILGE	1	1	1	1	1	YMUS
10	F1B-U7626-00	HOSE 1	1	1	1	1	1	YMUS
11	90467-210A0	CLIP	2	2	2	2	2	
12	90447-28004	HOSE, WITH SPRING	1	1	1	1	1	
13	F1B-U7629-00	HOSE, DRAIN 2	1	1	1	1	1	YMUS
14	90467-140A1	CLIP	1	1	1	1	1	
15	F1B-U7628-00	HOSE, DRAIN 3	1	1	1	1	1	YMUS
16	90447-28004	HOSE, WITH SPRING	1	1	1	1	1	
17	90467-250A0	CLIP	1	1	1	1	1	
18	GH7-6753B-00	PILOT, WATER	1	1	1	1	1	
19	90430-16910	GASKET	1	1	1	1	1	
20	GP7-61652-00	NUT	1	1	1	1	1	
21	90467-140A1	CLIP	1	1	1	1	1	
22	F1B-67617-00	JOINT, DRAIN	1	1	1	1	1	
23	90464-40825	CLAMP	1	1	1	1	1	YMUS
24	F1B-U828M-00	BASE, CLAMP	1	1	1	1	1	YMUS
25	F1B-6224E-00	BODY, DRAIN 3	1	1	1	1	1	
26	F1B-67525-00	PACKING	1	1	1	1	1	
27	90467-250A0	CLIP	1	1	1	1	1	

FIG. 26 BILGE PUMP



REF. NO.	PART NO.	DESCRIPTION	U49	CAL	CAN	GENE	JPN	REMARKS
28	F1B-62241-00	DRAIN, COCKPIT	1	1	1	1	1	

FIG. 27 EXHAUST 3



REF. NO.	PART NO.	DESCRIPTION	U49	CAL	CAN	GENE	JPN	REMARKS
1	F1B-U7550-01	WATER LOCK COMP.	1	1	1	1	1	YMUS
2	F1B-U755J-01	MAT,WATER LOCK	2	2	2	2	2	YMUS
3	EW2-67821-00	BAND, FUEL TANK	1	1	1	1	1	
4	GA7-65772-00	HOOK A	2	2	2	2	2	
5	90267-489U1	RIVET,BLIND	4	4	4	4	4	YMUS
6	F1B-U7555-00	HOSE, EXHAUST	1	1	1	1	1	YMUS
7	90601-195UD	BAND, HOSE 95	1	1	1	1	1	YMUS
8	90450-99801	HOSE CLAMP ASSY	2	2	2	2	2	YMUS
9	F0P-6753B-00	PILOT, WATER	2	2	2	2	2	
10	90430-16910	GASKET	2	2	2	2	2	
11	F0X-62733-00	NUT	2	2	2	2	2	
12	90601-118UF	BAND, HOSE 18	2	2	2	2	2	YMUS
13	F0X-U4261-12	TANK, WATER	1	1	1	1	1	YMUS
14	F0X-U8221-00	PAD, BATTERY	2	2	2	2	2	YMUS
15	F1B-U758D-00	HOSE,EXHAUST 3	1	1	1	1	1	YMUS
16	F0V-U757B-00	PLATE	1	1	1	1	1	YMUS
17	90116-06802	BOLT, STUD	6	6	6	6	6	YMUS
18	9299R-06200	WASHER	6	6	6	6	6	YMUS
19	F1B-U751G-00	VALVE, EXHAUST	1	1	1	1	1	YMUS
20	9572R-06300	NUT, NYLON	6	6	6	6	6	YMUS

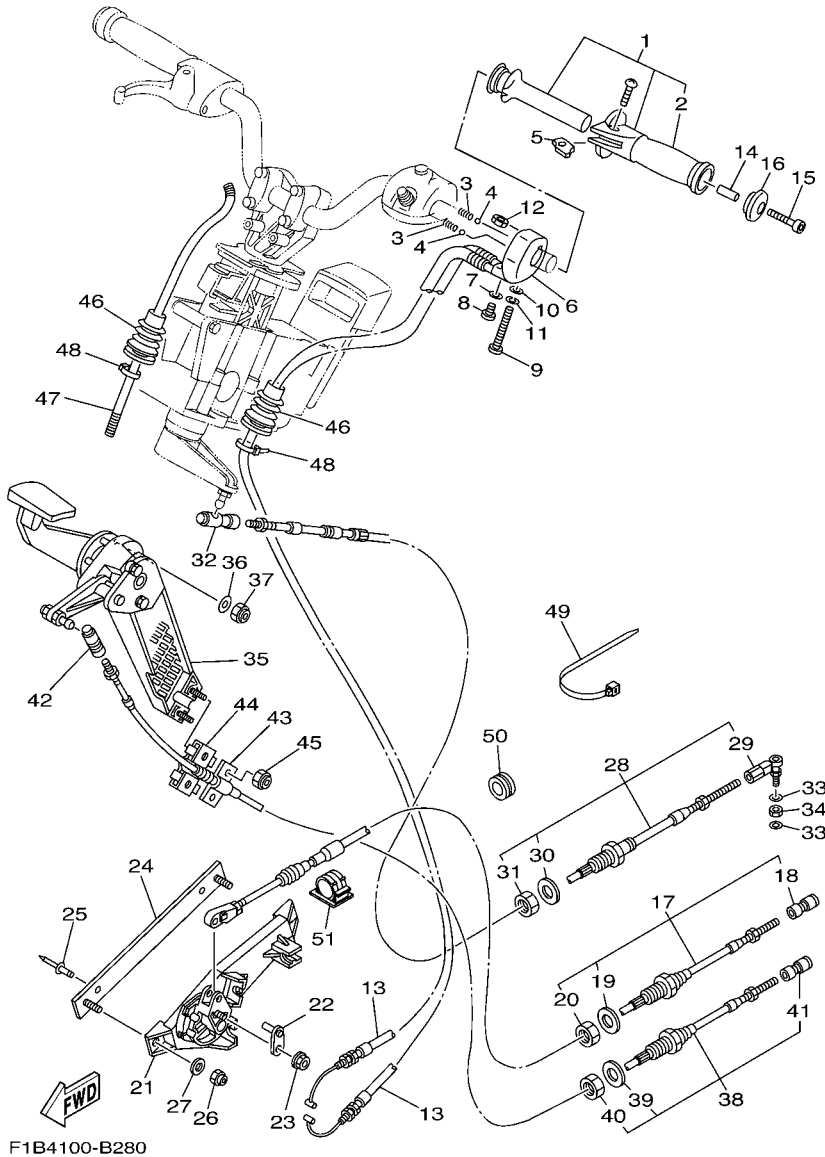
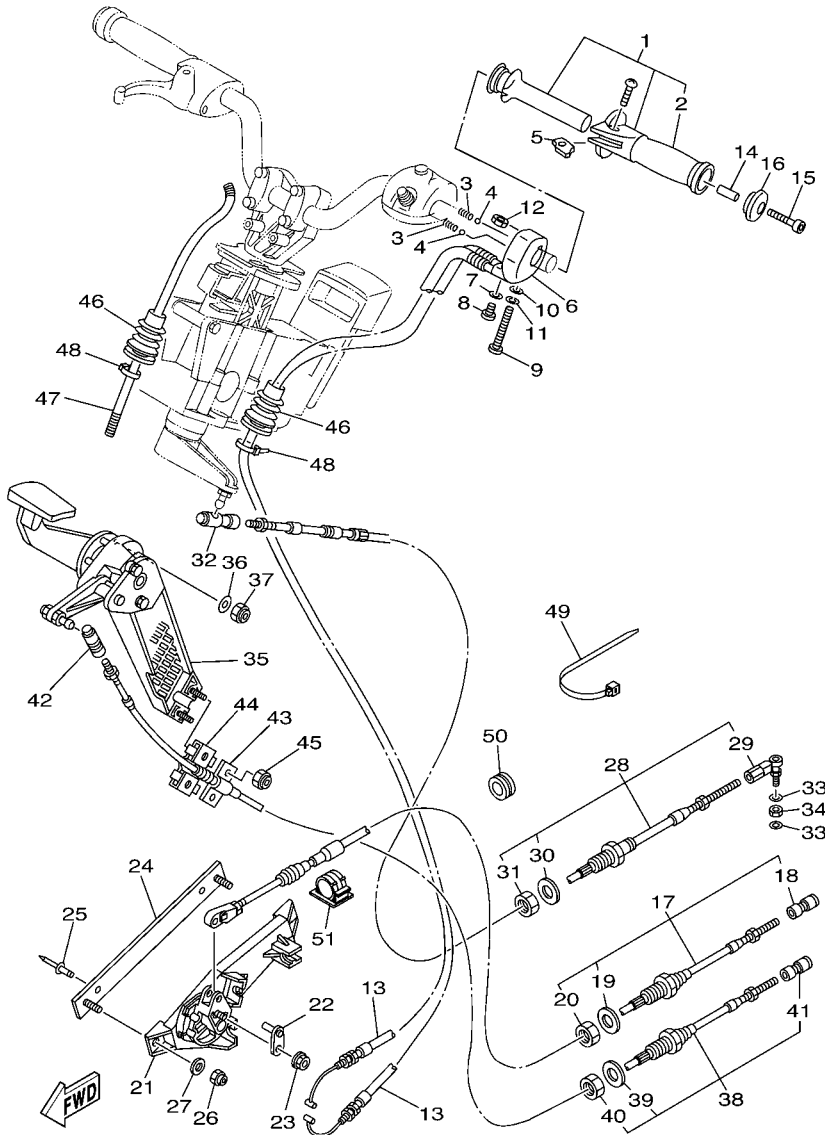


FIG. 28 CONTROL CABLE

REF. NO.	PART NO.	DESCRIPTION	U49	CAL	CAN	GENE	JPN	REMARKS
1	GP7-U157A-00	GRIP HANDLE ASSY.	1	1	1	1	1	YMUS
2	GP7-U155C-00	.GRIP,HANDLE	1	1	1	1	1	YMUS
3	GP7-U152P-00	SPRING	2	2	2	2	2	YMUS
4	GP7-U152R-00	BALL	2	2	2	2	2	YMUS
5	GP7-U151M-00	LEVER ASSY	1	1	1	1	1	YMUS
6	GP7-U152M-00	HOUSING ASSY	1	1	1	1	1	YMUS
7	92990-04600	WASHER, PLATE	1	1	1	1	1	
8	98980-04010	SCREW, BIND	1	1	1	1	1	
9	97880-06065	SCREW, PAN HEAD	1	1	1	1	1	
10	92990-06600	WASHER, PLATE	1	1	1	1	1	
11	9299R-06100	WASHER	1	1	1	1	1	YMUS
12	GH1-U143B-00	NUT,SPECIAL	1	1	1	1	1	YMUS
13	F1B-U153D-01	CABLE,NOZZLE CONTROL 2	2	2	2	2	2	YMUS
14	90387-05800	COLLAR	1	1	1	1	1	YMUS
15	90110-05015	BOLT, HEXAGON SOCKET HEAD	1	1	1	1	1	
16	GP7-U155F-00	GRIP, END	1	1	1	1	1	YMUS
17	F1B-6153E-01	CABLE,NOZZLE CONTROL 3	1	1	1	1	1	
18	F1B-61460-00	.BALL JOINT ASSY	1	1	1	1	1	
19	F1B-61438-00	.PACKING	1	1	1	1	1	
20	F1B-6151S-00	.NUT	1	1	1	1	1	
21	F0D-U153J-10	REMOCON,NOZZLE 2	1	1	1	1	1	YMUS
22	F0D-U152C-10	PIN	1	1	1	1	1	YMUS
23	9572R-06300	NUT, NYLON	1	1	1	1	1	YMUS
24	F0X-U4958-00	BASE, REMOCON.	1	1	1	1	1	YMUS
25	90267-489U6	RIVET, BLIND	2	2	2	2	2	YMUS
26	9572R-06300	NUT, NYLON	2	2	2	2	2	YMUS
27	9299R-06200	WASHER	2	2	2	2	2	YMUS

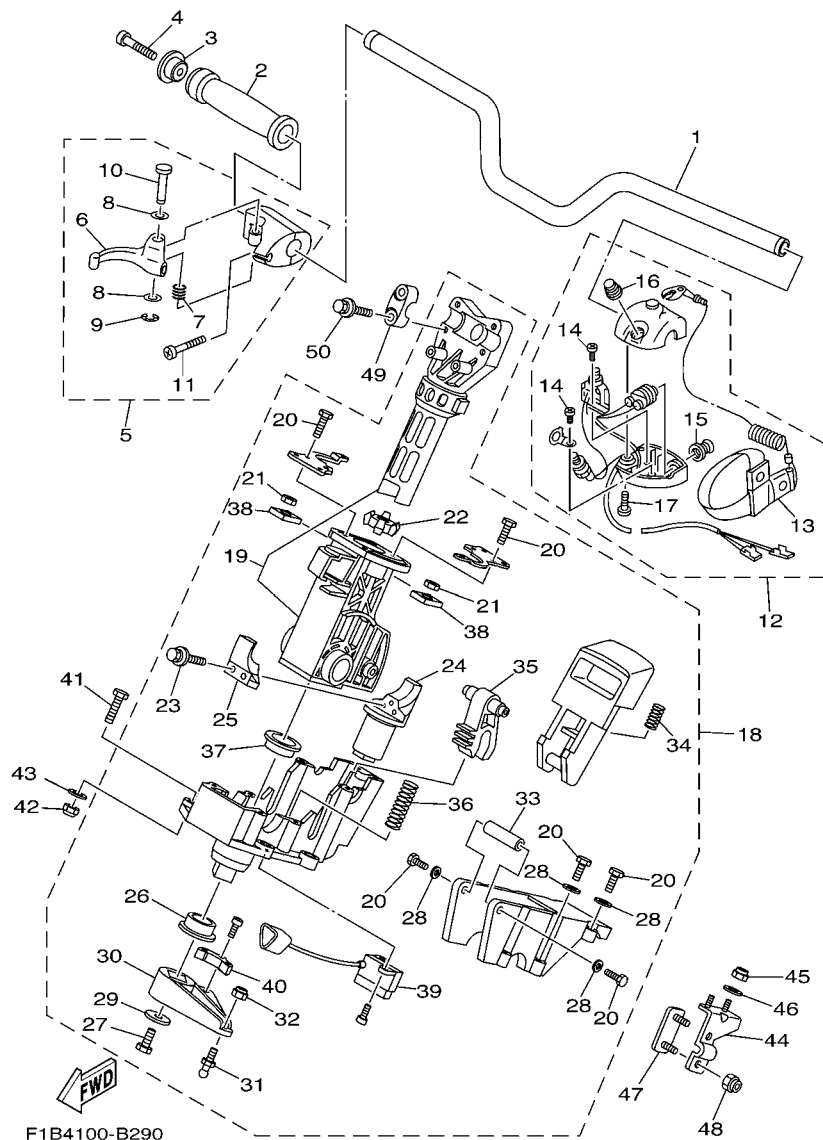


F1B4100-B280

FIG. 28 CONTROL CABLE

REF. NO.	PART NO.	DESCRIPTION	U49	CAL	CAN	GENE	JPN	REMARKS
28	F1B-61481-01	CABLE, STEERING	1	1	1	1	1	
29	F1B-61461-01	.STUD, JOINT BALL	1	1	1	1	1	
30	F1B-61438-00	.PACKING	1	1	1	1	1	
31	F1B-6151S-00	.NUT	1	1	1	1	1	
32	F1B-61460-10	BALL JOINT ASSY	1	1	1	1	1	
33	90201-06906	WASHER, PLATE	2	2	2	2	2	
34	9538R-06700	NUT	1	1	1	1	1	YMUS
35	F1B-6134A-00	REMOCON. LEVER ASSY.	1	1	1	1	1	
36	9299R-06200	WASHER	3	3	3	3	3	YMUS
37	9572R-06300	NUT, NYLON	3	3	3	3	3	YMUS
38	F1B-6149C-01	CABLE, REVERSE	1	1	1	1	1	
39	F1B-61438-00	.PACKING	1	1	1	1	1	
40	F1B-6151S-00	.NUT	1	1	1	1	1	
41	F1B-61460-00	.BALL JOINT ASSY	1	1	1	1	1	
42	F1B-61460-00	BALL JOINT ASSY	1	1	1	1	1	
43	GH1-61468-01	STOPPER, CABLE	1	1	1	1	1	
44	GU5-6146K-10	HOLDER, STOPPER	1	1	1	1	1	
45	9572R-06300	NUT, NYLON	2	2	2	2	2	YMUS
46	F0D-6822E-00	GROMMET	2	2	2	2	2	
47	F0D-6773E-00	TUBE, 2	1	1	1	1	1	
48	90601-200U1	BAND	2	2	2	2	2	YMUS
49	90464-32801	CLAMP	1	1	1	1	1	YMUS
50	90480-279U1	GROMMET	2	2	2	2	2	YMUS
51	90600-925U9	CLAMP	1	1	1	1	1	YMUS

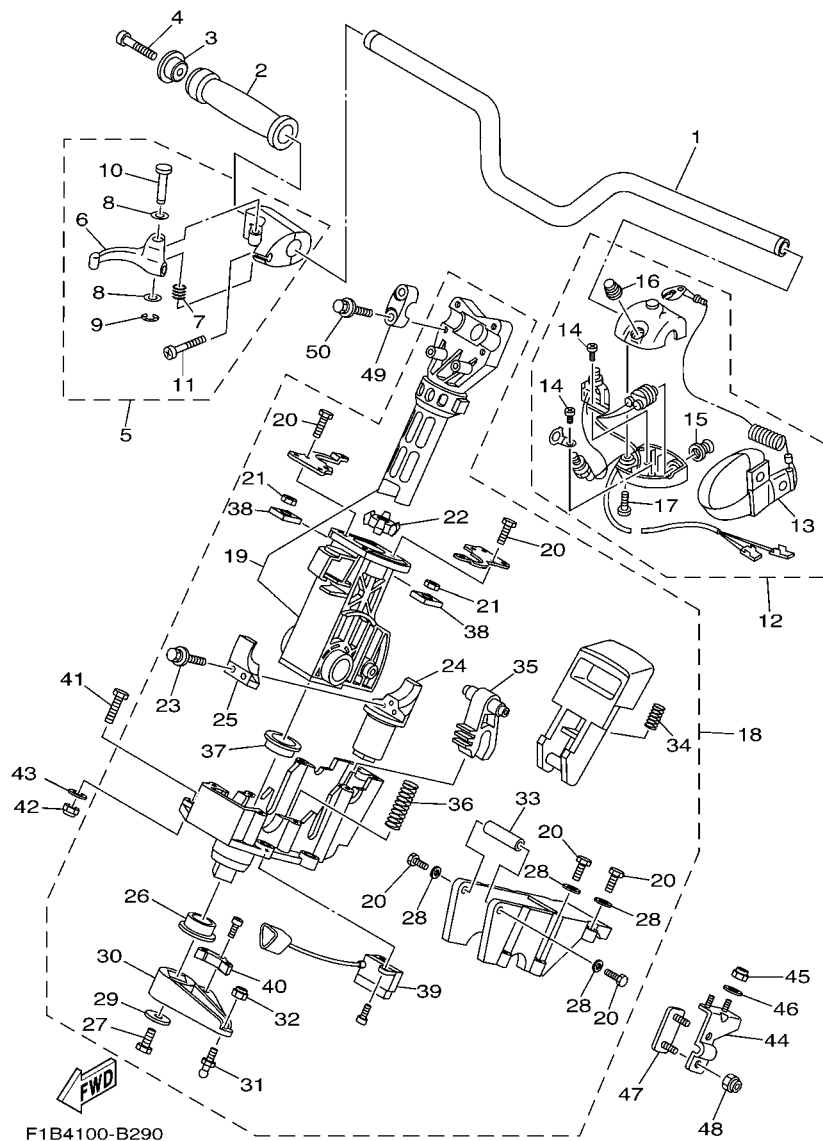
FIG. 29 STEERING 1



REF. NO.	PART NO.	DESCRIPTION	U49	CAL	CAN	GENE	JPN	REMARKS
1	F1B-61552-00	HANDLE	1	1	1	1	1	
2	GP7-U155D-00	GRIP, HANDLE	1	1	1	1	1	YMUS
3	GP7-U155F-00	GRIP, END	1	1	1	1	1	YMUS
4	90110-05015	BOLT, HEXAGON SOCKET HEAD	1	1	1	1	1	
5	F0D-67250-03	THROTTLE LEVER ASSY	1	1	1	1	1	
6	F0D-67255-01	.LEVER, THROTTLE	1	1	1	1	1	
7	EW2-67256-00	.SPRING	1	1	1	1	1	
8	EW2-67258-01	.WASHER	2	2	2	2	2	
9	EW2-67259-01	.E-RING	1	1	1	1	1	
10	F0D-67257-00	.SHAFT	1	1	1	1	1	
11	98580-05025	.SCREW, PAN HEAD	2	2	2	2	2	
12	FK7-68310-07	SWITCH BOX ASSY	1	1	1	1	1	
13	EW2-68348-00	.LANYARD, STOP SWITCH	1	1	1	1	1	
14	97880-03008	.SCREW, PAN HEAD	2	2	2	2	2	
15	FK7-68312-02	.STOP BUTTON COMP	1	1	1	1	1	
16	FK7-68313-02	.START BUTTON COMP.	1	1	1	1	1	
17	97880-05025	.SCREW, PAN HEAD	2	2	2	2	2	
18	F1B-61400-10	STEERING MASTER ASSY	1	1	1	1	1	
19	F0D-67410-00	.SHAFT ASSY. (D=45)	1	1	1	1	1	
20	F0D-61355-00	.BOLT	12	12	12	12	12	
21	F0D-6151S-00	.NUT	4	4	4	4	4	
22	F0D-6152R-00	.BALL	1	1	1	1	1	
23	F0D-62624-00	.BOLT	2	2	2	2	2	
24	F0D-6152D-00	.SHAFT	1	1	1	1	1	
25	F0D-52543-00	.JOINT, UNIVERSAL	1	1	1	1	1	
26	F0D-6134M-00	.BUSH	1	1	1	1	1	
27	F0D-6491K-00	.BOLT, SPECIAL	1	1	1	1	1	

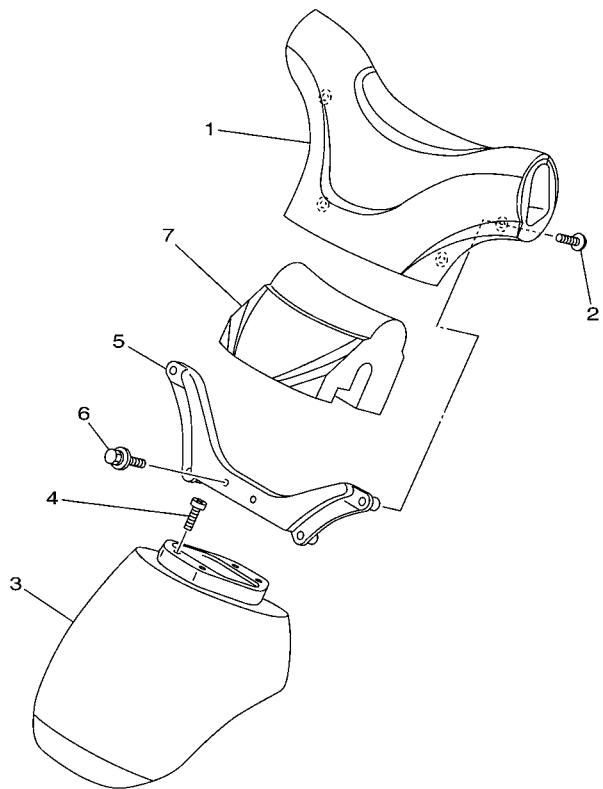


FIG. 29 STEERING 1



REF. NO.	PART NO.	DESCRIPTION	U49	CAL	CAN	GENE	JPN	REMARKS
28	F0D-6134E-00	.WASHER	8	8	8	8	8	
29	92990-08200	.WASHER, PLAIN	1	1	1	1	1	
30	F1B-6151B-10	.ARM, STEERING	1	1	1	1	1	
31	EU0-61461-02	.STUD, JOINT BALL	1	1	1	1	1	
32	95720-06300	.NUT, SELF-LOCKING	1	1	1	1	1	
33	F0D-61574-00	.CONNECTOR	1	1	1	1	1	
34	F0D-61349-00	.SPRING	1	1	1	1	1	
35	F0D-61782-00	.LOCK 1	1	1	1	1	1	
36	F0D-6134K-00	.SPRING	1	1	1	1	1	
37	F0D-62814-00	.BUSH	1	1	1	1	1	
38	F0D-6724H-00	.HOLDER	4	4	4	4	4	
39	F1B-6838B-00	.SANSOR MAGNET	1	1	1	1	1	
40	F1B-6838C-00	.MAGNET	1	1	1	1	1	
41	97080-08035	BOLT	4	4	4	4	4	
42	9572R-08300	NUT, FLANGE	4	4	4	4	4	YMUS
43	90201-099U3	WASHER, PLATE	4	4	4	4	4	YMUS
44	F1B-61467-00	BRACKET, STOPPER CABLE	1	1	1	1	1	
45	9572R-06300	NUT, NYLON	2	2	2	2	2	YMUS
46	9299R-06200	WASHER	2	2	2	2	2	YMUS
47	F1B-61468-00	STOPPER, CABLE	1	1	1	1	1	
48	9572R-06300	NUT, NYLON	2	2	2	2	2	YMUS
49	EU0-23814-30	HOLDER, HANDLE UPPER	2	2	2	2	2	
50	90119-089UU	BOLT, WITH WASHER	4	4	4	4	4	YMUS

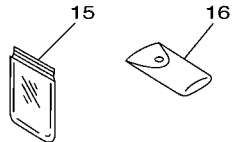
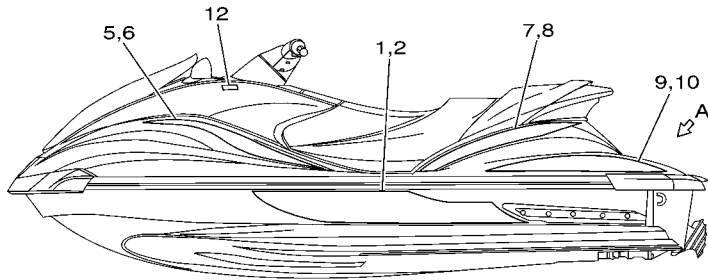
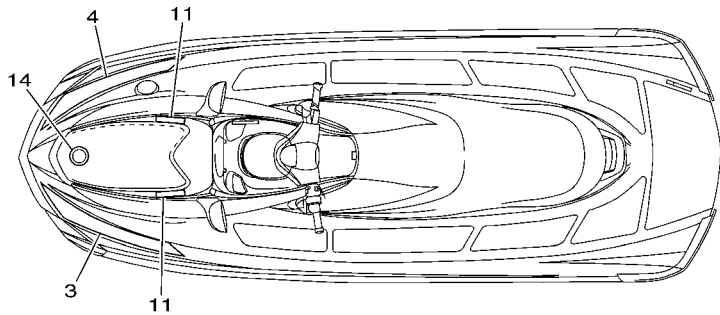
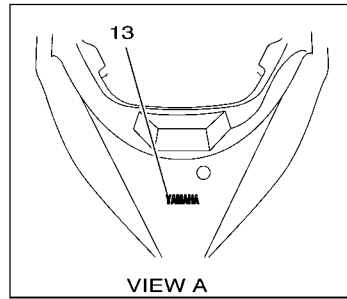
FIG. 30 STEERING 2



REF. NO.	PART NO.	DESCRIPTION	U49	CAL	CAN	GENE	JPN	REMARKS
1	F1B-U143D-00	PAD, STEERING 1	1	1	1	1	1	BL, YMUS
2	90150-06008	SCREW, ROUND HEAD	4	4	4	4	4	
3	F0D-U143E-00	PAD, STEERING 2	1	1	1	1	1	BL, YMUS
4	90154-06006	SCREW, BINDING	4	4	4	4	4	
5	F1B-U142K-00	FIX, STEERING PAD	1	1	1	1	1	YMUS
6	90119-06854	BOLT, WITH WASHER	2	2	2	2	2	YMUS
7	F1B-U156E-00	PAD 1	1	1	1	1	1	YMUS

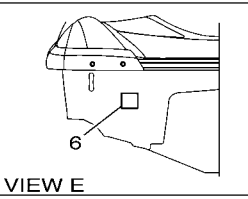
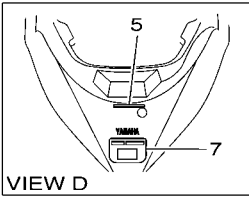
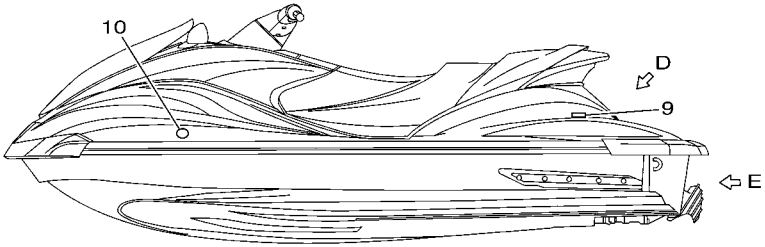
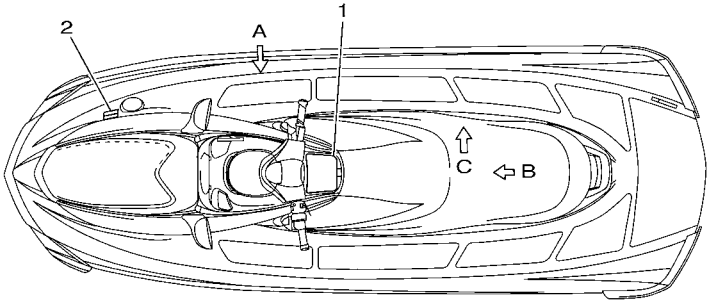
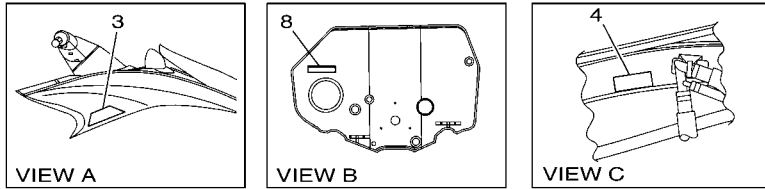
  
F1B1100-2300

FIG. 31 GRAPHICS



F1B4100-B310

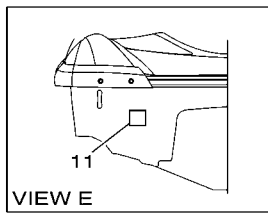
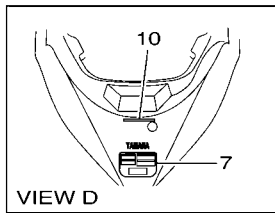
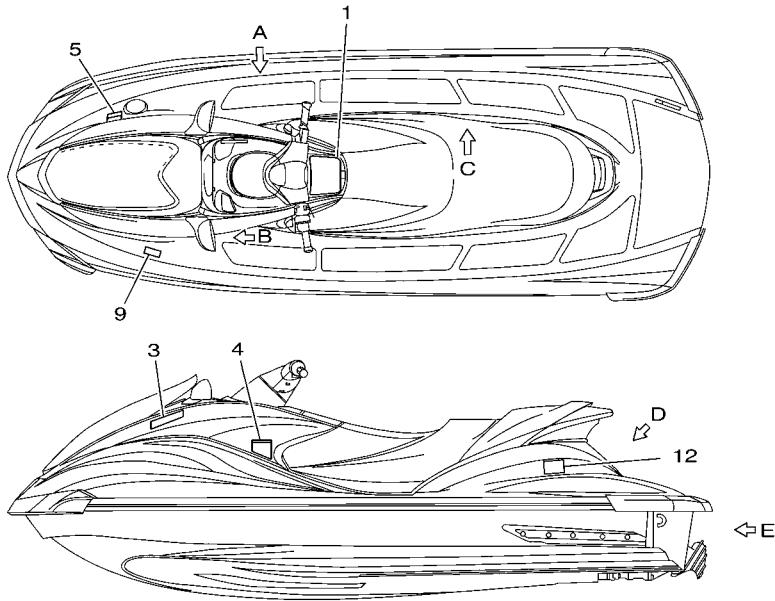
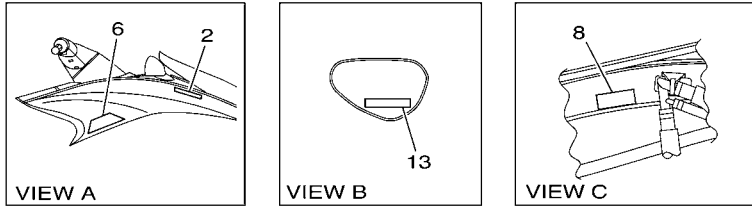
REF. NO.	PART NO.	DESCRIPTION	U49	CAL	CAN	GENE	JPN	REMARKS
1	F1B-U417B-10	GRAPHIC 1 LH	1	1	1	1	1	FOR DPBMF, YMUS
	F1B-U417B-20	GRAPHIC 1 LH	1	1	1	1	1	FOR SMF, YMUS
2	F1B-U417C-10	GRAPHIC 2 RH	1	1	1	1	1	FOR DPBMF, YMUS
	F1B-U417C-20	GRAPHIC 2 RH	1	1	1	1	1	FOR SMF, YMUS
3	F1B-U417D-10	GRAPHIC 3	1	1	1	1	1	FOR DPBMF, YMUS
	F1B-U417D-20	GRAPHIC 3	1	1	1	1	1	FOR SMF, YMUS
4	F1B-U417E-10	GRAPHIC 4	1	1	1	1	1	FOR DPBMF, YMUS
	F1B-U417E-20	GRAPHIC 4	1	1	1	1	1	FOR SMF, YMUS
5	F1B-U417F-10	GRAPHIC 5 LH	1	1	1	1	1	FOR DPBMF, YMUS
	F1B-U417F-20	GRAPHIC 5 LH	1	1	1	1	1	FOR SMF, YMUS
6	F1B-U417G-10	GRAPHIC 6 RH	1	1	1	1	1	FOR DPBMF, YMUS
	F1B-U417G-20	GRAPHIC 6 RH	1	1	1	1	1	FOR SMF, YMUS
7	F1B-U417H-10	GRAPHIC 7 LH	1	1	1	1	1	FOR DPBMF, YMUS
	F1B-U417H-20	GRAPHIC 7 LH	1	1	1	1	1	FOR SMF, YMUS
8	F1B-U417J-10	GRAPHIC 8 RH	1	1	1	1	1	FOR DPBMF, YMUS
	F1B-U417J-20	GRAPHIC 8 RH	1	1	1	1	1	FOR SMF, YMUS
9	F1B-U417K-10	GRAPHIC 9 LH	1	1	1	1	1	FOR DPBMF, YMUS
	F1B-U417K-20	GRAPHIC 9 LH	1	1	1	1	1	FOR SMF, YMUS
10	F1B-U417L-10	GRAPHIC B RH	1	1	1	1	1	FOR DPBMF, YMUS
	F1B-U417L-20	GRAPHIC B RH	1	1	1	1	1	FOR SMF, YMUS
11	F1B-U417M-10	GRAPHIC C	2	2	2		2	FOR DPBMF, YMUS
	F1B-U417M-20	GRAPHIC C	2	2	2		2	FOR SMF, YMUS
12	F1B-U4122-00	EMBLEM 2	2	2	2	2	2	YMUS
13	F1B-U411C-01	EMBLEM, YAMAHA	1	1	1	1	1	YMUS
14	F1B-U411H-00	EMBLEM, TUNING FORK	1	1	1	1	1	YMUS
15	F1B-65986-00	TOOL SET	1	1	1	1	1	
16	EU0-65901-01	TOOL BAG	1	1	1	1	1	



F1B4100-B320

FIG. 32 IMPORTANT LABELS

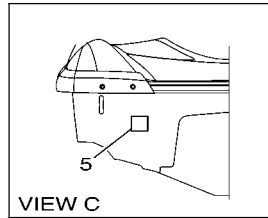
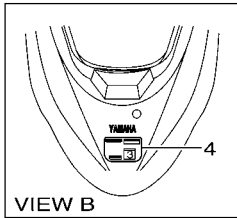
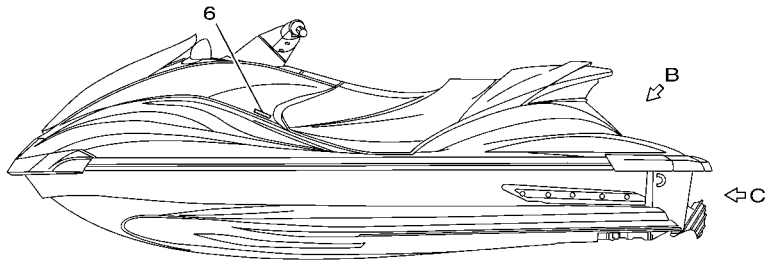
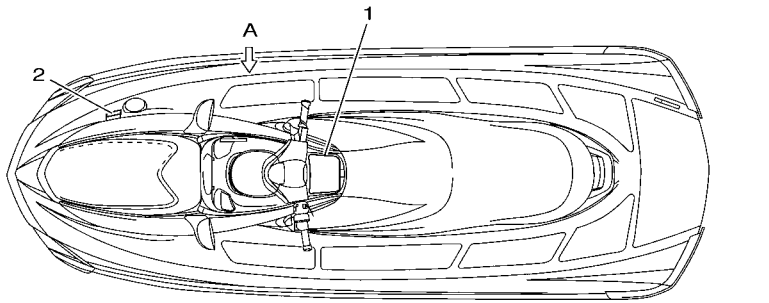
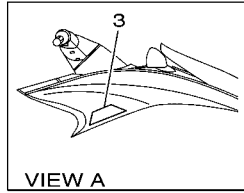
REF. NO.	PART NO.	DESCRIPTION	U49	CAL	CAN	GENE	JPN	REMARKS
1	F1B-U41B1-00	LABEL, WARNING JDC 1	1	1				YMUS
2	F1B-U415B-01	LABEL, WARNING(FUEL)	1	1				YMUS
3	F0V-U41D5-20	LABEL, WARNING SHIFT LEVER	1	1				YMUS
4	F0V-U41DB-01	LABEL, WARNING BATTERY	1	1				YMUS
5	F1B-U41F5-00	LABEL, FIRE EXTINGUISHER 1	1	1				YMUS
6	GA9-U418F-00	LABEL, RIGHTING	1	1				YMUS
7	F1B-U41E1-20	LABEL, SET 1	1	1				YMUS
8	F1B-U413N-10	LABEL, CARB		1				FOR CAL, YMUS
9	F0P-U41G1-00	LABEL, CAPACITY	1	1				YMUS
10	F1B-U413L-10	RABEL, STARMARK		1				FOR CAL, YMUS



F1B4100-B330

FIG. 33 IMPORTANT LABELS 2

REF. NO.	PART NO.	DESCRIPTION	U49	CAL	CAN	GENE	JPN	REMARKS
1	F1B-U41B1-10	LABEL, WARNING JDC 1				1	1	YMUS
2	F1B-U41B1-20	LABEL, WARNING JDC 1				1	1	YMUS
3	F1B-U41B1-30	LABEL, WARNING JDC 1				1	1	YMUS
4	F1B-U41B2-00	LABEL, WARNING JDC 2				1	1	YMUS
5	F1B-U415B-10	LABEL, WARNING(FUEL)				1	1	YMUS
6	F0V-U41D5-30	LABEL, WARNING SHIFT LEVER				1	1	YMUS
7	F0V-U41E1-40	LABEL, SET 1				1	1	YMUS
8	F0V-U41DB-11	LABEL, WARNING BATTERY				1		FOR GENE, YMUS
9	GJ3-U416H-00	LABEL,WARNING(FRANCE)				1		FOR GENE, YMUS
10	F1B-U41F5-10	LABEL, FIRE EXTINGUISHER 1				1	1	YMUS
11	GA9-U418F-00	LABEL, RIGHTING				1	1	YMUS
12	GJ3-U419E-00	LABEL 4				1		FOR CAN, YMUS
13	GJ1-U419F-21	LABEL,5				2	2	YMUS



F1B4100-B340

FIG. 34 IMPORTANT LABELS 3

REF. NO.	PART NO.	DESCRIPTION	U49	CAL	CAN	GENE	JPN	REMARKS
1	F1B-641B1-20	LABEL, WARNING JDC 1					1	
2	F1B-6415B-20	LABEL, WARNING(FUEL)					1	
3	F0V-641D5-40	LABEL, WARNING SHIFT LEVER					1	
4	F1F-641E2-20	LABEL, SET 2					1	
5	GA9-U418F-00	LABEL, RIGHTING					1	YMUS
6	GA9-U411B-00	PLATE,ASSY					1	YMUS

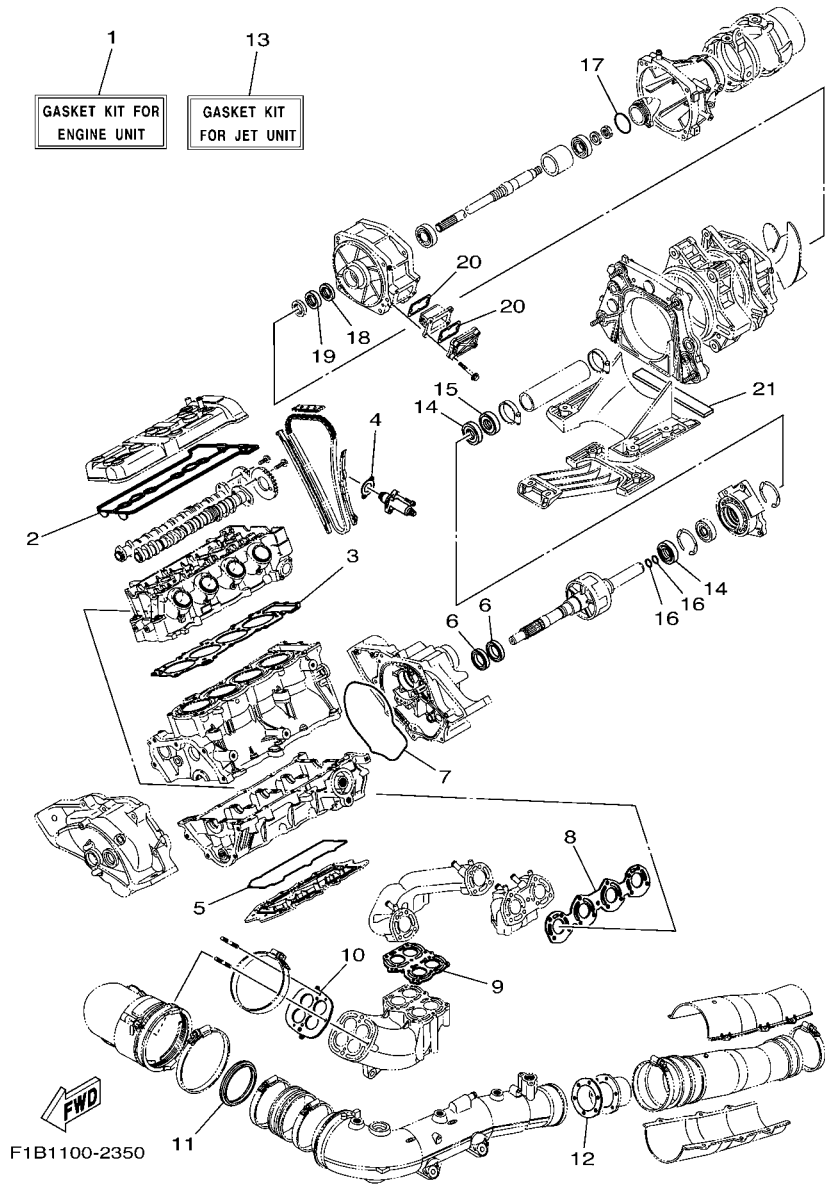


FIG. 35 REPAIR KIT 1

REF. NO.	PART NO.	DESCRIPTION	U49	CAL	CAN	GENE	JPN	REMARKS
1	60E-W0001-01	GASKET KIT FOR ENGINE UNIT	1	1	1	1	1	
2	60E-11193-00	.GASKET, HEAD COVER 1	1	1	1	1	1	
3	60E-11181-00	.GASKET, CYLINDER HEAD 1	1	1	1	1	1	
4	4FM-12213-00	.GASKET, TENSIONER CASE	1	1	1	1	1	
5	60E-13557-00	.GASKET	1	1	1	1	1	
6	93101-35004	.OIL SEAL	2	2	2	2	2	
7	93211-95001	.O-RING	1	1	1	1	1	
8	60E-14613-00	.GASKET, EXHAUST PIPE	1	1	1	1	1	
9	60E-14739-00	.GASKET, MUFFLER DAMPER 1	1	1	1	1	1	
10	60E-14749-00	.GASKET, MUFFLER DAMPER 2	1	1	1	1	1	
11	60E-14642-00	.SEAL, EXHAUST	1	1	1	1	1	
12	60E-14623-00	.GASKET, EXHAUST PIPE	1	1	1	1	1	
13	60E-W0001-20	GASKET KIT FOR JET UNIT	1	1	1	1	1	
14	93101-25M55	.OIL SEAL	2	2	2	2	2	
15	93102-25009	.OIL SEAL	1	1	1	1	1	
16	93210-19MJ4	.O-RING	2	2	2	2	2	
17	93210-46M16	.O-RING	1	1	1	1	1	
18	93101-28M65	.OIL SEAL	1	1	1	1	1	
19	93101-28M66	.OIL SEAL	1	1	1	1	1	
20	66V-42414-00	.O-RING	2	2	2	2	2	
21	66V-51367-00	.FELT, PACKING	1	1	1	1	1	

NUMERICAL INDEX

PART NO.	GRID NO.	PART NO.	GRID NO.	PART NO.	GRID NO.	PART NO.	GRID NO.	PART NO.	GRID NO.	PART NO.	GRID NO.
60E-11102-00-94	B - 2	1WG-12118-00	B - 8	60E-12422-00	C - 6	60E-13476-00	B - 15	60E-14771-00-94	C - 3	66E-4581J-00	C - 11
68F-11119-00	B - 15	4SV-12119-00	B - 8	60E-12434-00	C - 5	60E-13477-00	B - 15	60E-14784-00-94	C - 4	66V-46882-00	C - 8
60E-1111E-00	B - 2	4TV-12119-00	B - 8	60E-12435-00	C - 6	60E-13483-00	B - 13	60E-14867-00	B - 10	66V-51129-10	C - 8
4KG-1111G-00	B - 2	5LV-12121-00	B - 8	60E-1243A-00	C - 5	60E-13484-00	B - 13	60E-14869-00	B - 10	68N-5112T-00	D - 10
60E-11125-02	B - 14	3GM-12126-00	B - 8	60E-1243E-00	C - 5	4WM-13484-00	B - 4	4BH-14923-00	B - 12	60E-51142-00	C - 7
60E-11126-01	B - 14	3FV-12153-20	B - 9	60E-1243F-00	C - 5	60E-13557-00	F - 2	3KW-14932-00	B - 12	60E-51190-00-94	C - 9
3TJ-11133-10	B - 2	60E-12153-20	B - 9	60E-12443-00	C - 5	60E-13563-00	B - 13	4XY-14951-00	B - 12	66V-51312-01-94	C - 8
1WG-11133-11	B - 2	3FV-12153-30	B - 9	60E-12446-00-94	C - 6	60E-13567-00	C - 2	3L5-14962-00	B - 12	60E-51313-00	C - 9
60E-11145-00	B - 15	60E-12153-30	B - 9	60E-1244E-00	C - 7	60E-13750-10	B - 12	60E-15100-01-8P	B - 4	66V-51314-00	C - 12
60E-11164-00	B - 13	1HX-12168-00	B - 8	60E-1244F-00	C - 6	60E-13761-00	B - 12	60E-15362-00	B - 15	66V-51315-00-94	C - 8
60E-11165-00	B - 15	1HX-12168-20	B - 8	60E-12469-00	C - 6	60E-13795-00	B - 10	60E-15515-01	C - 13	60E-51317-00-94	C - 8
60E-11166-01	C - 2	1HX-12168-40	B - 8	60E-12474-00	B - 3	60E-13882-00	C - 2	60E-15517-00	C - 13	60E-51318-00-94	C - 9
60E-11167-01	C - 2	1HX-12168-60	B - 8	60E-12479-00-94	C - 5	66V-13898-00	B - 10	60E-15521-00	C - 13	60E-51323-00	C - 11
60E-11181-00	B - 2	1HX-12168-80	B - 8	60E-12482-00	B - 3	60E-13907-00	D - 5	4WM-15590-00	C - 13	63M-51334-00	C - 9
	F - 2	1HX-12168-A0	B - 8	60E-12483-10	B - 3	4BH-14134-00	B - 12	60E-17521-00	B - 7	60E-51341-00	C - 2
60E-11191-00-94	B - 2	1HX-12168-F0	B - 8	60E-12494-00	B - 3	3H1-14147-00	B - 12	60E-17572-00	B - 6	66V-51341-00-94	C - 12
60E-11193-00	B - 2	1HX-12168-H1	B - 8	60E-12499-00	C - 6	60E-14239-00	B - 10	60E-17586-00	B - 7	66V-51367-00	C - 8
	F - 2	1HX-12168-K1	B - 8	60E-12535-00	C - 6	4XV-14275-00	B - 10	60E-17588-00	B - 6		F - 2
67F-11325-00	B - 4	1HX-12168-M1	B - 8	60E-12537-00	B - 3	60E-14294-00	B - 11	60E-2339E-20	B - 10	61L-5169A-00	C - 7
6E5-11325-00	B - 15	1HX-12168-R1	B - 9	60E-12552-00	C - 7	69J-14321-00	B - 12	60E-2339E-A0	B - 10	F0D-52543-00	E - 9
69J-11327-00-94	B - 4	1HX-12168-U1	B - 9	60E-12576-00	C - 6	68V-14397-00	B - 12	EU0-23814-30	E - 10	F1B-60210-00	D - 7
60E-11328-00	B - 4	1HX-12168-W1	B - 9	60E-12577-00	C - 6	60E-1440A-01	B - 10	60E-24300-00	B - 11	F0D-61349-00	E - 10
67F-11328-00	B - 4	1HX-12168-Y1	B - 9	60E-12578-00	C - 6	60E-14410-00	B - 10	60E-24329-00	B - 11	F1B-6134A-00	E - 8
60E-11411-11	B - 6	1HX-12169-11	B - 9	60E-12580-00	C - 5	60E-14413-00	B - 10	60E-24364-00	B - 11	F0D-6134E-00	E - 10
60E-11416-00	B - 6	1HX-12169-31	B - 9	60E-12581-00	C - 5	60E-14414-00	B - 11	60E-24366-00	B - 11	F0D-6134K-00	E - 10
60E-11416-10	B - 6	1HX-12169-50	B - 9	60E-12582-00	C - 5	60E-14420-00	B - 10	60E-24474-00	B - 11	F0D-6134M-00	E - 9
60E-11416-20	B - 6	1HX-12169-70	B - 9	60E-12584-00	C - 5	60E-14449-00	B - 10	70R-24489-00	E - 2	F0D-61355-00	E - 9
60E-11416-30	B - 6	1HX-12169-90	B - 9	67X-12590-00	C - 7	60E-14451-00	B - 10	70R-24543-00	E - 2	F1B-61400-10	E - 9
60E-11416-40	B - 6	1HX-12169-E0	B - 9	67X-12590-10	C - 7	60E-14457-00	B - 10	60E-26311-00	B - 10	FJ0-61432-00	D - 6
4XV-11603-00	B - 6	1HX-12169-G0	B - 9	67X-12590-20	C - 7	60E-14610-00-94	C - 3	67F-2812A-00	C - 15	F1B-61438-00	E - 7
60E-11605-00	B - 6	1HX-12169-J0	B - 9	60E-12594-00	C - 3	60E-14613-00	C - 3	66V-42414-00	C - 8	F1B-61460-00	E - 7
60E-11631-00-B0	B - 6	1HX-12169-L0	B - 9	60E-1310A-00-94	B - 4		F - 2		F - 2	F1B-61460-10	E - 8
4XV-11633-00	B - 6	1HX-12169-N0	B - 9	60E-13151-00-94	C - 2	60E-14615-00	C - 4	624-42542-00	B - 13	F1B-61461-01	E - 8
60E-11636-00	B - 6	1HX-12169-T0	B - 9	60E-13161-00	B - 4	60E-14623-00	C - 4		C - 15	EU0-61461-02	E - 10
5PW-11650-00	B - 6	60E-12171-00	B - 8	60E-13185-00	B - 13		F - 2		D - 3	F1B-61467-00	E - 10
5JW-11654-10	B - 6	4XV-12176-00	B - 8	60E-13300-01	B - 13	60E-14625-00	C - 4	66V-44121-00	C - 12	F1B-61468-00	E - 10
60E-11656-00	B - 6	60E-12181-00	B - 8	60E-13317-00	B - 15	60E-14631-00-94	C - 3	66V-44125-00	C - 12	GH1-61468-01	E - 8
60E-11656-10	B - 6	60E-12210-00	B - 9	60E-13327-10-94	B - 13	60E-14642-00	C - 4	67X-44517-10-94	B - 5	GU5-6146K-10	E - 8
60E-11656-20	B - 6	4FM-12213-00	B - 9	60E-13360-00	B - 13		F - 2	66V-44532-00-94	B - 5	F1B-61481-01	E - 8
60E-11656-30	B - 6		F - 2	60E-13411-01	B - 13	60E-14712-00-94	C - 3	60E-44574-00-94	B - 5	F1B-6149C-01	E - 8
4XV-12111-00	B - 8	5BE-12241-00	B - 9	60E-13421-00	B - 15	60E-14718-00-94	C - 4	663-45119-00	C - 7	F0D-6151B-10	E - 10
4XV-12112-00	B - 8	4XV-12251-00	B - 9	5GH-13440-00	B - 4	60E-14721-00-94	C - 4	66V-45214-00-94	C - 8	F0D-6151S-00	E - 9
4XV-12113-00	B - 8	4XV-12252-00	B - 9	60E-13443-00-94	B - 15	60E-14728-00-94	C - 4	61X-45332-03-94	C - 11	F1B-6151S-00	E - 7
4XV-12114-00	B - 8	60E-12411-00	C - 6	60E-13446-00	B - 15	60E-14739-00	F - 2	61L-45378-00	C - 11	F0D-6152D-00	E - 9
1HX-12116-01	B - 8	60E-12413-00-94	C - 6	60E-13462-00-94	B - 15	60E-14739-01	C - 3	68Y-45511-00	C - 8	F0D-6152R-00	E - 9
1HX-12117-00	B - 8	60E-12414-00	C - 5	60E-13463-00-94	B - 15	60E-14749-00	F - 2	65V-45538-00	C - 8	F1B-6153E-01	E - 7
1WG-12117-00	B - 8	6G5-12416-00	C - 6	60E-13473-00	B - 15	60E-14749-01	C - 3	66E-45813-10-94	B - 6	F1B-61552-00	E - 9
1HX-12118-00	B - 8	60E-12417-00-94	C - 6	60E-13475-00	B - 15	60E-14752-A0	C - 4		C - 11	F0D-61574-00	E - 10



NUMERICAL INDEX

PART NO.	GRID NO.	PART NO.	GRID NO.	PART NO.	GRID NO.	PART NO.	GRID NO.	PART NO.	GRID NO.	PART NO.	GRID NO.
FOX-61624-00	D - 10	F1B-6517D-00	D - 8	EW2-68348-00	E - 9	60E-82532-00	D - 4	F1B-U156E-00	E - 11	F1B-U377M-00	D - 6
GP7-61628-00	D - 14	FOX-6517F-01	D - 8	F1B-6838B-00	E - 10	60E-82533-00	C - 15	GP7-U157A-00	E - 7	F1B-U377N-00	D - 6
FOX-61637-00	D - 10	F1B-6517R-00	D - 7	F1B-6838C-00	E - 10	60E-82560-00	D - 4	F1B-U1629-00	D - 15	GA9-U411B-00	E - 15
EU0-61652-00	C - 5	F1B-6518E-00	D - 9	68V-81147-00	B - 12	60E-82560-A0	D - 4	F1B-U1653-01	D - 14	F1B-U411C-01	E - 12
	D - 10	F1B-6518F-00	D - 8	60E-81315-00	D - 4	60E-8259E-00	D - 2	F1B-U2103-00	D - 8	F1B-U411H-00	E - 12
FOX-61652-00	D - 10	F1B-65193-00	D - 6	60E-81317-00	D - 3	60E-8259L-10	D - 2	FOX-U213G-01	D - 13	F1B-U4122-00	E - 12
GP7-61652-00	E - 4	F1B-651A1-00	D - 6	60E-81325-00	D - 4	60E-8259M-10	D - 3	F1B-U2187-01	D - 13	F1B-U413L-10	E - 13
F0D-61782-00	E - 10	GA7-65772-00	E - 6	60E-81328-00	C - 13	63N-83623-00	D - 2	F1B-U2188-00	D - 13	F1B-U413N-10	E - 13
F1B-62127-00	D - 13	EU0-65901-01	E - 12	66V-8132W-00	C - 15	6R7-83623-40	C - 15	F1B-U2512-10	D - 12	F1B-U415B-01	E - 13
EW2-62140-00	E - 2	F1B-6596B-00	D - 7	60E-81337-00-94	C - 13	6R7-83623-50	D - 2	F1B-U2519-10	D - 12	F1B-U415B-10	E - 14
EW2-62142-00	E - 2	F1B-6596C-00	D - 7	60E-81410-00	C - 13	682-84385-01	C - 5	F1B-U251D-10	D - 12	GJ3-U416H-00	E - 14
EW2-62149-00	E - 2	F1B-6596F-00	D - 7	60E-81450-00	C - 13	60E-84742-00	C - 15	F1B-U251E-10	D - 12	F1B-U417B-10	E - 12
F1B-62157-00	D - 13	F1B-6596G-00	D - 7	60E-81800-00	C - 14	60E-85112-00	D - 3	F1B-U252C-10	D - 12	F1B-U417B-20	E - 12
GP7-62159-01	E - 2	F1B-65986-00	E - 12	3AJ-81809-00	C - 14	60E-85122-00	D - 3	F1B-U252D-10	D - 12	F1B-U417C-10	E - 12
GJ3-6215F-00	D - 5	F0D-6724H-00	E - 10	6M6-81826-00	C - 14	60E-8552A-00	C - 15	F1B-U2624-00	D - 15	F1B-U417C-20	E - 12
F1B-62241-00	E - 4	F0D-67250-03	E - 9	6M6-81830-00	C - 14	60E-8552E-00	C - 15	F1B-U2663-00	D - 8	F1B-U417D-10	E - 12
EU0-62241-30	C - 9	F0D-67255-01	E - 9	6M6-81840-10	C - 14	60E-85790-01	D - 4	F1B-U266B-00	D - 8	F1B-U417D-20	E - 12
F1B-6224E-00	E - 4	EW2-67256-00	E - 9	11H-81844-00	C - 14	60E-85885-10	B - 12	F1B-U266C-00	D - 14	F1B-U417E-10	E - 12
EU0-62280-00	D - 11	F0D-67257-00	E - 9	66V-81844-00	C - 15	65L-85886-00	B - 12	F1B-U266D-00	D - 14	F1B-U417E-20	E - 12
EU0-62282-00	D - 11	EW2-67258-01	E - 9	60E-81847-00	C - 14	60E-85896-00	D - 4	FOX-U266E-01	D - 15	F1B-U417F-10	E - 12
EU0-62283-00	D - 11	EW2-67259-01	E - 9	6M6-81850-00	C - 14	60E-8591A-10	C - 15	F1B-U271B-00	D - 15	F1B-U417F-20	E - 12
EU0-62285-01	D - 11	EU0-67267-20	C - 9	60E-81916-00	C - 15	60E-87179-00	C - 15	F1B-U273B-02	C - 10	F1B-U417G-10	E - 12
F1B-62501-10	D - 12	F0D-67410-00	E - 9	60E-81921-00	C - 15	60E-G5831-00	C - 8	F1B-U2873-00	E - 3	F1B-U417G-20	E - 12
F0D-62624-00	E - 9	F1B-67525-00	E - 4	68N-81940-00	D - 2	65A-R1129-00	C - 8	F1B-U351H-01	D - 12	F1B-U417H-10	E - 12
F1B-6266E-00	D - 13	F0P-6753B-00	E - 6	60E-81950-00	D - 2	60E-R1311-00-94	C - 8	F1B-U351J-01	D - 12	F1B-U417H-20	E - 12
F1B-6266F-00	D - 13	GH7-6753B-00	E - 4	68V-81960-00	C - 15	68N-R1321-00	C - 9	F1B-U351K-01	D - 12	F1B-U417J-10	E - 12
F1B-6266G-00	D - 13	F1B-67557-00	C - 10	EU0-82110-09	D - 5	65A-R1326-00	C - 8	F1B-U351M-01	D - 12	F1B-U417J-20	E - 12
FN8-6269B-00	D - 10	F1B-6757E-00	C - 10	60E-82117-00	D - 2	60E-R1333-00-94	C - 8	F1B-U351N-02	D - 12	F1B-U417K-10	E - 12
FOX-62733-00	E - 6	F1B-6757F-00	C - 10	60E-82117-10	D - 2	66V-R1348-10	C - 9	F1B-U351P-02	D - 12	F1B-U417K-20	E - 12
F0D-62814-00	E - 10	F1B-67617-00	E - 4	60E-82117-20	D - 2	60E-R1381-00	C - 11	F1B-U351R-01	D - 12	F1B-U417L-10	E - 12
F0D-62875-00	D - 7	FN8-6771K-00	E - 2	66V-82119-00	D - 2	F1B-U1355-00	D - 11	F1B-U351S-01	D - 12	F1B-U417L-20	E - 12
FOX-6375E-00	D - 15	F0D-6773E-00	E - 8	67F-82151-00	D - 2	F1B-U142K-00	E - 11	F0D-U352E-00	D - 12	F1B-U417M-10	E - 12
FOX-6378C-00	D - 14	F1B-67743-01	E - 3	67F-82151-30	D - 2	GH1-U143B-00	E - 7	F1B-U3581-01	D - 12	F1B-U417M-20	E - 12
GU2-6378D-01	D - 14	F1B-67747-00	E - 2	60E-82153-00	C - 15	F1B-U143D-00	E - 11	F0V-U3635-00	D - 8	GA9-U418F-00	E - 13
F0D-63850-01	D - 14	F1B-6774J-00	E - 3	60E-82310-00	D - 3	F0D-U143E-00	E - 11	F1B-U371A-11	D - 14		E - 14
F1B-6415B-20	E - 15	FJ0-67766-00	E - 3	60E-82314-00	D - 3	66V-U146E-00	C - 12	F1B-U371A-21	D - 14		E - 15
F1B-64174-00	D - 5	F1B-67767-00	E - 3	6A0-82317-00	B - 13	GH3-U146E-00	C - 9	F1B-U371B-10	D - 14	GJ3-U419E-00	E - 14
F1B-641B1-20	E - 15	EW2-67821-00	E - 6		C - 15	GP7-U151M-00	E - 7	F1B-U371B-20	D - 14	GJ1-U419F-21	E - 14
F0V-641D5-40	E - 15	F1B-6820A-00	D - 5	60E-82341-00	D - 3	F0D-U152C-10	E - 7	F1B-U372A-11	D - 14	F1B-U41B1-00	E - 13
F1F-641E2-20	E - 15	GA7-68218-00	E - 4	60E-82342-00	D - 3	GP7-U152M-00	E - 7	F1B-U372A-21	D - 14	F1B-U41B1-10	E - 14
F0D-6491K-00	E - 9	F1B-6821G-00	D - 5	60E-82343-00	D - 3	GP7-U152P-00	E - 7	F1B-U372B-10	D - 14	F1B-U41B1-20	E - 14
F1B-65148-00	D - 8	F1B-6821G-01	D - 5	60E-82344-00	D - 3	GP7-U152R-00	E - 7	F1B-U372B-20	D - 14	F1B-U41B1-30	E - 14
F1B-6514U-00	D - 8	F1B-6821K-00	D - 5	60E-82344-00	D - 3	F1B-U153D-01	E - 7	F1B-U3774-00	D - 14	F1B-U41B2-00	E - 14
F1B-6515A-00	D - 8	F0D-6822E-00	E - 8	60E-82353-00	D - 3	F0D-U153J-10	E - 7	GH1-U3774-00	D - 15	F0V-U41D5-20	E - 13
F1B-6515D-00	D - 8	GU2-6822E-01	D - 5	66V-82355-00	D - 3	GP7-U155C-00	E - 7	F1B-U377B-10-P0	D - 6	F0V-U41D5-30	E - 14
F1B-6515H-00	D - 8	FK7-68310-07	E - 9	60E-8235A-00	D - 3	GP7-U155D-00	E - 9	F1B-U377B-20-P0	D - 6	F0V-U41DB-01	E - 13
F1B-6515J-00	D - 8	FK7-68312-02	E - 9	60E-82380-00	B - 12	GP7-U155F-00	E - 7	F1B-U377C-10-P0	D - 7	F0V-U41DB-11	E - 14
F1B-6517C-00	D - 6	FK7-68313-02	E - 9	68V-82504-00	D - 4		E - 9	F1B-U377C-20-P1	D - 7	F1B-U41E1-20	E - 13

NUMERICAL INDEX

PART NO.	GRID NO.	PART NO.	GRID NO.	PART NO.	GRID NO.	PART NO.	GRID NO.	PART NO.	GRID NO.	PART NO.	GRID NO.
F0V-U41E1-40	E - 14	F1B-U7773-00	E - 2	90109-066F0	B - 2	90119-08067	B - 13	90201-099U3	B - 5	90430-16910	E - 6
F1B-U41F5-00	E - 13	GP7-U7831-01	E - 2	90109-08041	C - 10	90119-08812	B - 5		D - 14	90445-09M33	C - 7
F1B-U41F5-10	E - 14	GP7-U7832-01	E - 2	90109-08879	C - 12	90119-08817	C - 15		E - 10	90445-14804	C - 9
F0P-U41G1-00	E - 13	GP7-U7833-00	E - 2	90110-05015	E - 7	90119-08942	D - 15	90201-10013	B - 2	90445-14M06	C - 9
F0X-U4261-12	E - 6	GP7-U7834-00	E - 2		E - 9	90119-089U6	B - 5	90201-10019	B - 2	90445-16M09	C - 3
F1B-U4742-01	D - 15	GP7-U7835-00	E - 2	90110-06040	D - 10		C - 10	90201-103U7	C - 13	90445-18003	C - 5
F1B-U475F-00	D - 8	GP7-U783F-00	E - 3	90110-08020	B - 10	90119-089U7	E - 3	90201-109U6	D - 15	90445-18004	C - 6
GP7-U4953-00	D - 14	F1B-U7844-00	E - 3	90110-08212	C - 13	90119-089UE	C - 9	90201-12017	C - 10	90445-18M13	C - 6
F0X-U4958-00	E - 7	F0D-U7856-10	E - 3	90111-05008	D - 5	90119-089UF	C - 12	90201-278T0	C - 11	90445-19896	D - 10
F1B-U5115-00	D - 6	F0D-U785G-10	D - 5	90111-06036	D - 6	90119-089UL	C - 11	90202-10M56	C - 9	90445-198B6	D - 10
F1B-U516P-00	D - 6		E - 3	90116-06802	E - 6	90119-089UU	E - 10	90209-21011	B - 7	90445-20002	C - 3
F1B-U517B-10-P0	D - 8	GP7-U785H-00	E - 3	90116-10016	C - 2	90119-08M62	C - 3	90209-25008	B - 7	90445-21003	C - 5
F1B-U517B-20-P0	D - 8	GP7-U8211-00	D - 5		C - 3	90119-08M67	B - 15	90214-06029	B - 13	90445-21004	C - 7
F1B-U517H-00	D - 7	EU0-U821D-00	D - 5	90116-10017	C - 4	90119-10011	C - 4	90267-329UR	E - 2	90445-25003	C - 7
F1B-U519D-00	D - 7	F0X-U8221-00	D - 5	90116-10018	C - 4	90119-10013	C - 3	90267-48020	D - 9	90446-17M75	B - 14
F1B-U5554-00	D - 6		E - 6	90116-10619	B - 4	90119-10016	C - 13	90267-48802	C - 7	90446-20M65	C - 3
F1B-U555B-00	D - 6	EU0-U8221-30	D - 5	90119-06800	C - 8	90119-10017	C - 4		D - 10	90446-24M79	C - 5
F1B-U5633-00	D - 7	F1B-U828M-00	E - 4	90119-06824	D - 6	90119-10800	C - 8	90267-48806	D - 13	90446-27M55	C - 7
EW2-U5912-01	D - 15	F0D-U8341-00	D - 5	90119-06827	C - 10	90119-10837	C - 9	90267-48807	D - 8		D - 10
EW2-U5913-01	D - 15	GJ1-U835D-00	C - 9	90119-06832	D - 5	90119-10M02	C - 2	90267-489U1	E - 6	90446-27M73	D - 10
F0X-U5983-01	D - 15	F1B-U8360-01	E - 4	90119-06842	C - 8	90119-05946	D - 6	90267-489U2	E - 2	90447-19004	C - 2
GP1-U7228-00	D - 8	F0D-U883B-01	C - 11	90119-06853	D - 14	90149-05981	D - 6	90267-489U6	E - 2	90447-19005	C - 2
GD0-U7249-00-05	C - 11	F1B-U883E-00	C - 11	90119-06854	D - 5	90149-06013	C - 13		E - 7	90447-22001	C - 5
GD0-U7249-00-10	C - 11	F1B-U883N-00	D - 10		E - 11	90149-069UA	C - 11	90267-489U9	D - 8	90447-22002	C - 3
F1B-U725E-00	C - 10	F1B-U883P-00	D - 10	90119-06858	D - 7	90150-06008	E - 11	90267-489UP	D - 15		C - 7
EU0-U7354-00-01	B - 5	F1B-U883T-01	D - 10	90119-06934	D - 6	90154-06006	E - 11		E - 4	90447-22003	C - 5
EU0-U7354-00-03	B - 5	F1F-U883T-01	D - 10	90119-06934	C - 9	90159-05006	B - 10	90267-489US	D - 12	90447-28002	C - 7
EU0-U7354-00-05	B - 5	F1B-U8952-01	D - 14	90119-069UB	C - 12	90159-06008	D - 2	90267-489UT	D - 12	90447-28003	C - 6
EU0-U7354-00-10	B - 5	GJ1-U8K31-02	C - 9	90119-069UD	C - 11	90160-05003	B - 10	90280-03047	C - 13	90447-28004	E - 4
EU0-U7354-00-20	B - 5	60E-W0001-01	F - 2		C - 12	90169-049U1	E - 2	90340-27001	B - 2	90450-17M17	B - 11
F1B-U751G-00	E - 6	60E-W0001-20	F - 2		D - 12	90169-059U1	D - 12	90387-05800	E - 7	90450-57002	B - 10
F1B-U7550-01	E - 6	60E-W009A-10-8P	B - 2	90119-069UH	D - 8	90176-10001	B - 2	90387-06051	C - 10	90450-99801	E - 6
F1B-U7555-00	E - 6	60E-W009B-01-8P	B - 4	90119-069UK	C - 10		C - 2	90387-06M05	B - 15	90450-99M06	C - 4
F1B-U755J-01	E - 6	90101-06806	C - 12		D - 9	90179-08327	B - 6	90387-06M60	C - 11	90450-99M16	C - 4
GJ1-U7578-11	D - 5	90101-06917	B - 5	90119-069US	D - 5	90179-08812	C - 10	90387-06M65	C - 6	90450-99M18	C - 4
F1B-U7578-20	D - 10	90101-069U0	D - 14	90119-06M59	D - 3	90179-10006	B - 2	90387-06M74	C - 12	90460-90M11	C - 4
F0V-U757B-00	E - 6	90105-06026	B - 2	90119-06M65	B - 14	90179-10414	B - 2	90387-06M84	C - 12	90462-08019	B - 13
F1B-U758D-00	E - 6	90105-06033	B - 4	90119-06MA2	B - 15	90179-10M35	C - 3	90387-07008	D - 9	90462-10016	C - 13
F1B-U759B-00	E - 3	90105-06035	C - 7	90119-08029	C - 3	90183-06902	D - 7	90387-08M06	C - 9	90464-20005	B - 2
F1B-U759C-00	E - 3	90105-06036	B - 15	90119-08031	C - 3		D - 8	90387-08M19	C - 9		B - 11
GJ1-U759C-00	D - 7	90105-06M07	B - 15	90119-08032	B - 10		D - 12	90387-08M30	C - 12	90464-28002	B - 11
F1B-U761D-00	D - 10	90105-06M17	B - 4	90119-08034	B - 13	90201-05014	C - 13	90387-10M09	C - 12	90464-32801	D - 10
F1B-U7626-00	E - 4	90105-07342	B - 8		C - 3	90201-068M4	C - 9	90387-11002	C - 4		E - 8
F1B-U7628-00	E - 4	90105-08829	C - 9	90119-08036	C - 3	90201-068T1	C - 12	90401-20145	B - 4	90464-40825	C - 10
F1B-U7629-00	E - 4	90105-093A5	B - 4	90119-08043	B - 13	90201-06906	E - 8	90430-06014	B - 2		E - 2
F1B-U7656-00	E - 4	90105-105A6	C - 13		C - 3	90201-06M05	C - 15	90430-09002	B - 12		E - 4
F1B-U7698-00	E - 4	90109-06051	B - 4	90119-08045	B - 13	90201-088T2	C - 12	90430-12002	C - 10	90464-44001	D - 8
F1B-U7711-01	E - 2	90109-06053	B - 10	90119-08050	B - 10	90201-096J9	B - 4	90430-16910	E - 4	90464-50002	D - 2

NUMERICAL INDEX

PART NO.	GRID NO.	PART NO.	GRID NO.	PART NO.	GRID NO.	PART NO.	GRID NO.	PART NO.	GRID NO.	PART NO.	GRID NO.
90464-55001	C - 5	90600-925U9	E - 8	9299R-08200	D - 14	94582-12130	B - 9	97595-08540	B - 4		
90464-90001	C - 15	90601-118UF	C - 9	9299R-08600	C - 12	94702-00409	D - 3	97780-60430	C - 15		
90464-99804	E - 2		D - 10	9299R-10200	D - 15	94709-00409	D - 3	97780-60516	C - 15		
90465-11829	C - 9		E - 6	9299R-16600	C - 8	95023-06012	B - 2	97780-60520	D - 2		
	C - 11	90601-152U3	C - 11	93101-25M55	C - 11	95023-06016	C - 4		D - 3		
	D - 5	90601-155U4	E - 3		F - 2	95027-06010	B - 4	97780-60525	D - 3		
	E - 3	90601-162U5	E - 2	93101-28M65	C - 8	9531P-16700	C - 8	97780-60530	C - 15		
90465-11M10	C - 7	90601-195UD	E - 6		F - 2	95380-06700	C - 14	9778R-40712	D - 8		
	E - 3	90601-200U1	D - 5	93101-28M66	C - 8	9538R-06600	C - 12	97880-03008	E - 9		
90465-12M53	B - 10		D - 10		F - 2	9538R-06700	C - 9	97880-05025	E - 9		
	B - 15		E - 8	93101-35004	B - 6		E - 8	97880-06065	E - 7		
90465-13M11	D - 4	90601-200U7	D - 13		F - 2	9538R-08600	C - 12	9788R-05025	D - 11		
90465-13M18	C - 7	90605-502U1	D - 8	93102-25009	C - 11	95720-06300	E - 10	97890-05008	B - 12		
90465-13M97	D - 2	90605-502U2	D - 7		F - 2	9572R-05300	D - 11	97980-05210	C - 7		
90465-14M66	C - 7	90699-50004	E - 3	93210-06667	B - 4	9572R-06300	D - 6	97980-06212	C - 15		
90467-089U1	D - 5	91317-05010	C - 13	93210-08001	B - 4		D - 9	98580-05025	E - 9		
90467-09120	B - 11	91317-05014	B - 15	93210-18322	B - 15		D - 12	98680-05520	C - 15		
90467-110A1	B - 14	91317-05035	B - 15	93210-18417	B - 3		D - 14	98780-04015	B - 15		
90467-120A0	C - 3	91317-06014	B - 15	93210-19MJ4	C - 11		E - 2	9878R-05512	C - 9		
	C - 7		C - 13		F - 2		E - 6	98980-04010	E - 7		
90467-130A0	C - 3	91317-06016	B - 3	93210-46M16	C - 9		E - 7	99009-47500	B - 6		
90467-140A1	E - 4		B - 13		F - 2		E - 10	99009-52500	B - 13		
90467-150A0	C - 5	91318-08040	B - 7	93211-95001	B - 13	9572R-08300	D - 6	99080-06600	D - 8		
90467-150A1	C - 6	91380-04008	B - 11		F - 2		D - 14	99530-08012	B - 4		
90467-160A0	C - 5	91380-05010	C - 13	93212-04001	C - 13		E - 10	99530-10014	B - 4		
90467-170A0	B - 14	91380-06012	B - 2	93306-00501	B - 6	9572R-10300	C - 10	99590-14016	C - 8		
	C - 2	91380-06016	D - 4	93306-20511	B - 6		D - 15	99780-12600	D - 10		
90467-200A0	C - 3	91380-06020	C - 2	93306-205U0	C - 8	97013-06025	C - 4				
	C - 5	91380-06025	B - 9	93306-205U6	C - 11	97080-08030	D - 6				
	D - 10	91808-16023	B - 2	93306-30441	B - 13	97080-08035	E - 10				
90467-210A0	E - 4	92903-06600	C - 4	93306-304U1	C - 8	97507-06512	C - 2				
90467-22002	C - 6	92990-04600	E - 7	93311-32079	B - 7	97513-05514	C - 13				
90467-240A0	C - 6	92990-06100	C - 14	93430-47M04	C - 11	97513-06514	B - 10				
90467-250A0	E - 4	92990-06600	E - 7	93440-07149	B - 2	97513-06516	B - 10				
90468-12069	B - 6	92990-08200	E - 10	93440-10153	B - 2	97513-06520	B - 4				
90480-01012	C - 15	92990-10600	D - 4	93440-25084	B - 6	97513-06525	B - 4				
90480-06M43	D - 3	92990-12200	D - 10	93440-28062	B - 7		B - 13				
90480-06M46	C - 2		D - 15	93450-30150	B - 7	97513-06535	B - 13				
90480-10006	D - 9	92995-06600	C - 2	93606-12019	B - 7	97513-06555	B - 2				
90480-20M05	C - 6	9299R-05200	D - 11		B - 13		B - 13				
90480-21M63	C - 4	9299R-06100	E - 7		C - 3	97513-08520	B - 2				
90480-279U1	E - 8	9299R-06200	D - 6		C - 8	97513-08530	C - 14				
90480-38800	C - 7		D - 12		C - 11	97580-06516	C - 2				
90501-16M11	C - 6		E - 3	93606-25M00	B - 13	97595-06416	D - 4				
90508-14M43	C - 12		E - 6	93607-44190	B - 9	97595-06520	B - 4				
90600-900U6	C - 10		E - 7	93608-16M16	B - 13		B - 15				
	E - 2		E - 10		C - 3	97595-06540	C - 6				
90600-917U4	D - 10	9299R-08200	D - 6		C - 13	97595-06545	C - 5				