

# **PARTS CATALOGUE**

## ***WaveRunner FX(Cruiser)HighOutput***

**FX1100(A)-E** (F1X1,F1X4/6B6G/6B62)

**FX1100(A)-E** (F1X2,F1X5/6B6H/6B62)

**MJ-FX1100(A)'06** (F1X3,F1X6/6B6G/6B62)

FX1100(A)-E/MJ-FX1100(A)'06  
PARTS CATALOGUE  
©2005 by Yamaha Motor Co., Ltd.  
1st edition, October 2005  
All rights reserved.  
Any reprinting or unauthorized use  
without the written permission of  
Yamaha Motor Co., Ltd.  
is expressly prohibited.  
Printed in Japan.

**A3**

**FX-1100A Cruiser (NYM4)**



**FX-1100A Cruiser (LNMP)**



**FX-1100 (YM3)**



**FX-1100 (DPBMT)**



# FOREWORD

This Parts Catalogue is related to the parts for the model(s) on the cover page. When you are ordering replacement parts, please refer to this Parts Catalogue and quote both part numbers and part names correctly.

1. Modifications or additions which have been made after the issue of the Parts Catalogue will be announced in the Parts News.

It is advisable that you make the necessary corrections to the Parts Catalogue according to the Parts News.

2. Abbreviations

The following abbreviations are used in this Parts Catalogue.

“UR” Use specified parts number.

“UN” Use as many as needed.

“AP” Alternate Parts

“LM” Locally Made (Parts need to be ordered locally)

“F#” Frame No. (Applicable machine No.)

“O/S” Over Size

3. The number of components for assembly

- Parts, which are to be supplied in an assembly, are listed with a dot (.) in front of the part name as shown below.
- The numeral appearing to the right of each component part indicates the quantity of parts for each assembly unit.

PART NO.	DESCRIPTION	Q'TY	REMARKS
2F5-83310-60	FRONT FLASHER LIGHT ASSY	2	
115-83311-60	.BULB (6V-18W)	1	

4. Applicable colours of graphics are represented in the “REMARKS” as shown below.

PART NO.	DESCRIPTION	Q'TY	REMARKS
2N4-24110-00-X5	FUEL TANK COMP.	2	MXR
3J1-24240-10	.GRAPHIC, FUEL TANK	1	FOR MXR

5. Note that the illustrations for reference in finding parts numbers are not to be used for assembling. When assembling, please use the applicable service manual.

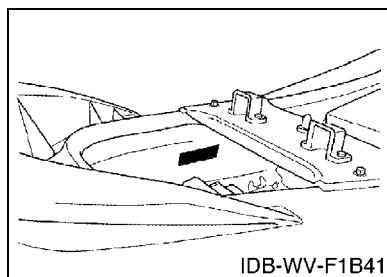
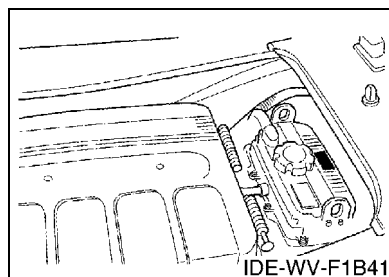
6. The asterisk (\*) before a reference number indicates modified items after the first edition.

# FOREWORD

## 7. Applicable Serial No.

Engine Serial No.

Hull Serial No.



## 8. Applicable Colour Code (The (\*) mark shows Model colour.)

Abbreviation	Colour Name	Colour Code
DNMC	DARK GRAY METALLIC C	0922
DPBMT	DEEP PURPLISH BLUE METALLIC T	0978
LNMP	LIGHT GRAY METALLIC P	0925
NYM4	GRAYISH YELLOW METALLIC 4	1004
PURW(*)	PURE WHITE	0240
SMF	BLACK METALLIC F	0878
SS4(*)	BLACK SOLID 4	008P
SSA(*)	BLACK SOLID A	1000
YM3	YELLOW METALLIC 3	1003

## 9. Quantity Column Information

Column No.	Name Of Q'ty Column	Destination
1	USA	U.S.A.
2	CAN	CANADA
3	GENE	EXCEPT U.S.A., CANADA, JAPAN
4	JPN	JAPAN

## 10. Applicable Starting Serial No.

Engine Serial No.

Serial No.	Name Of Q'ty Column	Model Code
6B6-1018901	USA	6B6G
6B6-1018901	CAN	6B6G
6B6-1018901	GENE	6B6H
6B6-1018901	JPN	6B6G

Hull Serial No.

Serial No.	Name Of Q'ty Column	Model Code
F1X-800101	USA	F1X1
F1X-800141		F1X4
F1X-800101	CAN	F1X1
F1X-800141		F1X4
F1X-800121	GENE	F1X2
F1X-800501		F1X5
F1X-800121	JPN	F1X3
F1X-800501		F1X6

# CONTENTS

CYLINDER .....	B2
CRANKCASE .....	B4
CRANKSHAFT & PISTON .....	B6
VALVE .....	B8
INTAKE .....	B10
INJECTION PUMP .....	B12
OIL PUMP .....	B14
OIL COOLER .....	C2
EXHAUST 1 .....	C4
EXHAUST 2 .....	C6
JET UNIT 1 .....	C9
JET UNIT 2 .....	C12
JET UNIT 3 .....	C13
GENERATOR .....	C14
STARTING MOTOR .....	C15
ELECTRICAL 1 .....	D2
ELECTRICAL 2 .....	D4
ELECTRICAL 3 .....	D5
ENGINE HATCH 1 .....	D6
ENGINE HATCH 2 .....	D9
HULL & DECK .....	D11
GUNWALE & MAT .....	D13
VENTILATION .....	D15
SEAT & UNDER LOCKER .....	E2
FUEL TANK .....	E5
BILGE PUMP .....	E7
EXHAUST 3 .....	E9
CONTROL CABLE .....	E10
STEERING 1 .....	E13
STEERING 2 .....	E15
GRAPHICS .....	F2
IMPORTANT LABELS .....	F4
IMPORTANT LABELS 2 .....	F5
IMPORTANT LABELS 3 .....	F6
REPAIR KIT 1 .....	F7

## INDEX

NUMERICAL INDEX .....	M1
-----------------------	----

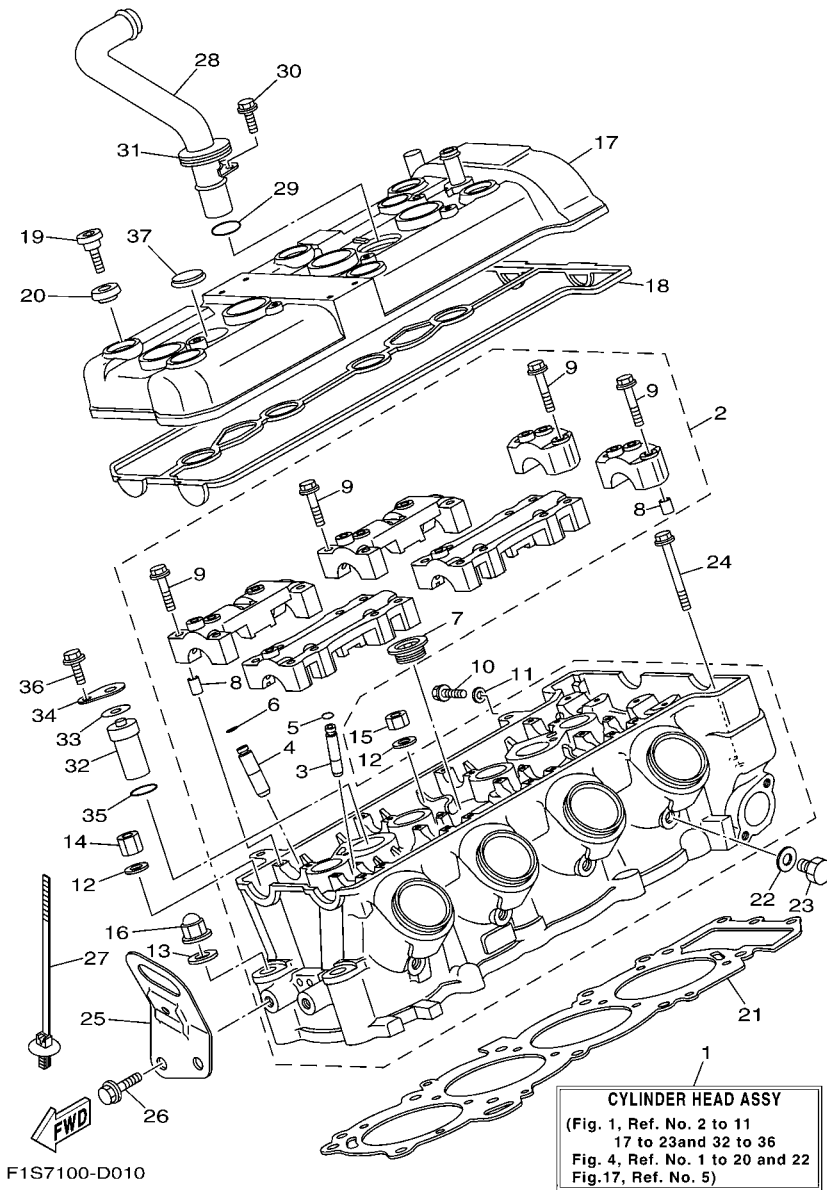
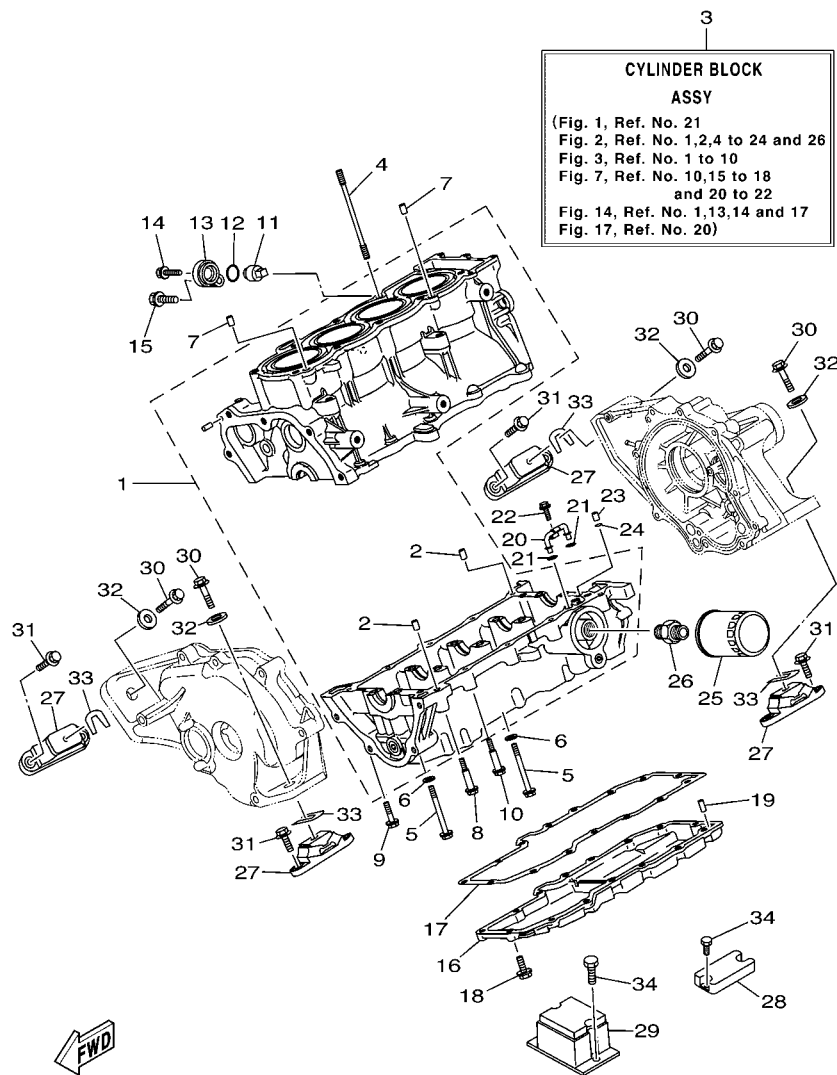


FIG. 1 CYLINDER

REF. NO.	PART NO.	DESCRIPTION	USA	CAN	GENE	JPN	REMARKS
1	6B6-W009A-00-94	CYLINDER HEAD ASSY	1	1	1	1	
2	6B6-11102-00-94	CYLINDER HEAD ASSY	1	1	1	1	
3	3TJ-11133-10	.GUIDE, VALVE	12	12	12	12	
4	1WG-11133-11	.GUIDE, VALVE	8	8	8	8	
5	93440-07149	.CIRCLIP	12	12	12	12	
6	93440-10153	.CIRCLIP	8	8	8	8	
7	90340-27001	.PLUG, STRAIGHT SCREW	1	1	1	1	
8	91808-16023	.PIN, DOWEL	12	12	12	12	
9	90105-06026	.BOLT, FLANGE	28	28	28	28	
10	95023-06012	BOLT	1	1	1	1	
11	90430-06014	GASKET	1	1	1	1	
12	90201-10013	WASHER, PLATE	8	8	8	8	
13	90201-10019	WASHER, PLATE	2	2	2	2	
14	90179-10006	NUT	3	3	3	3	
15	90179-10414	NUT	5	5	5	5	
16	90176-10001	NUT, CROWN	2	2	2	2	
17	6B6-11191-01-94	COVER, CYLINDER HEAD 1	1	1	1	1	
18	60E-11193-01	GASKET, HEAD COVER 1	1	1	1	1	
19	90109-066F0	BOLT	6	6	6	6	
20	4KG-1111G-00	RUBBER, MOUNT 1	6	6	6	6	
21	6B6-11181-00	GASKET, CYLINDER HEAD 1	1	1	1	1	
22	90430-06014	GASKET	4	4	4	4	
23	91380-06012	BOLT	4	4	4	4	
24	97513-06555	BOLT, WITH WASHER	3	3	3	3	
25	60E-1111E-00	HANGER, ENGINE 2	1	1	1	1	
26	97513-08520	BOLT, WITH WASHER	2	2	2	2	
27	90464-20005	CLAMP	1	1	1	1	



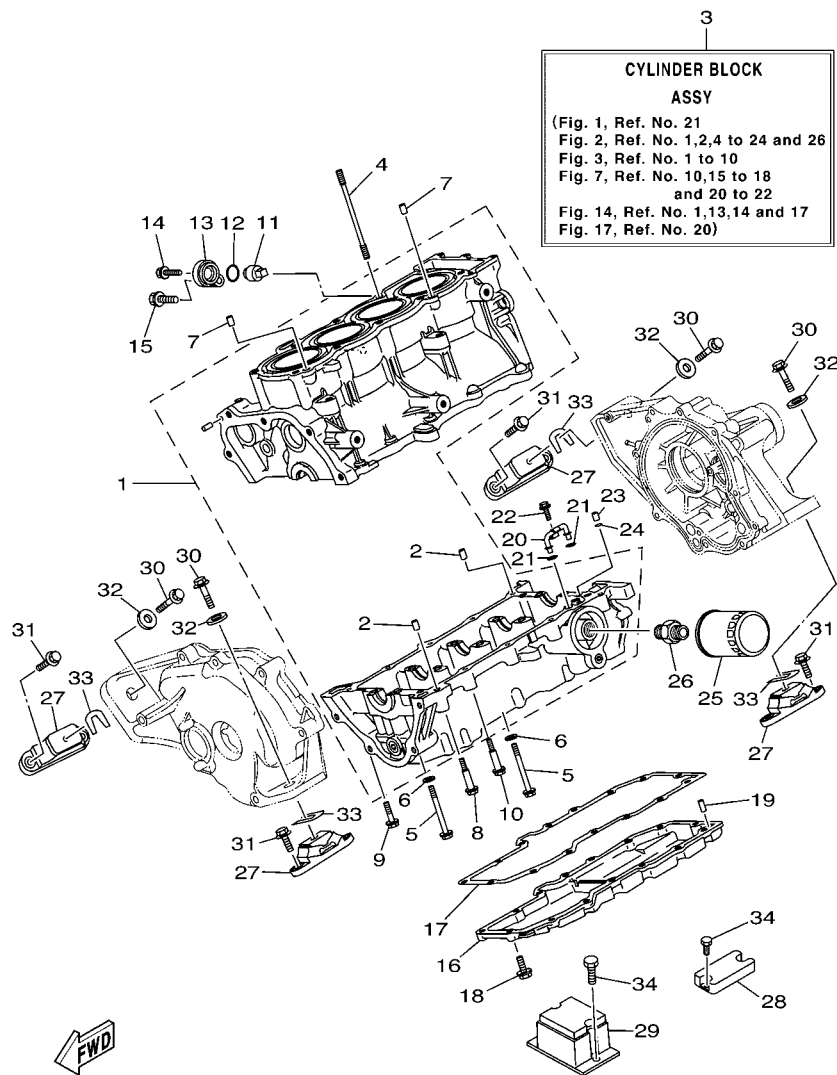




**FIG. 2 CRANKCASE**

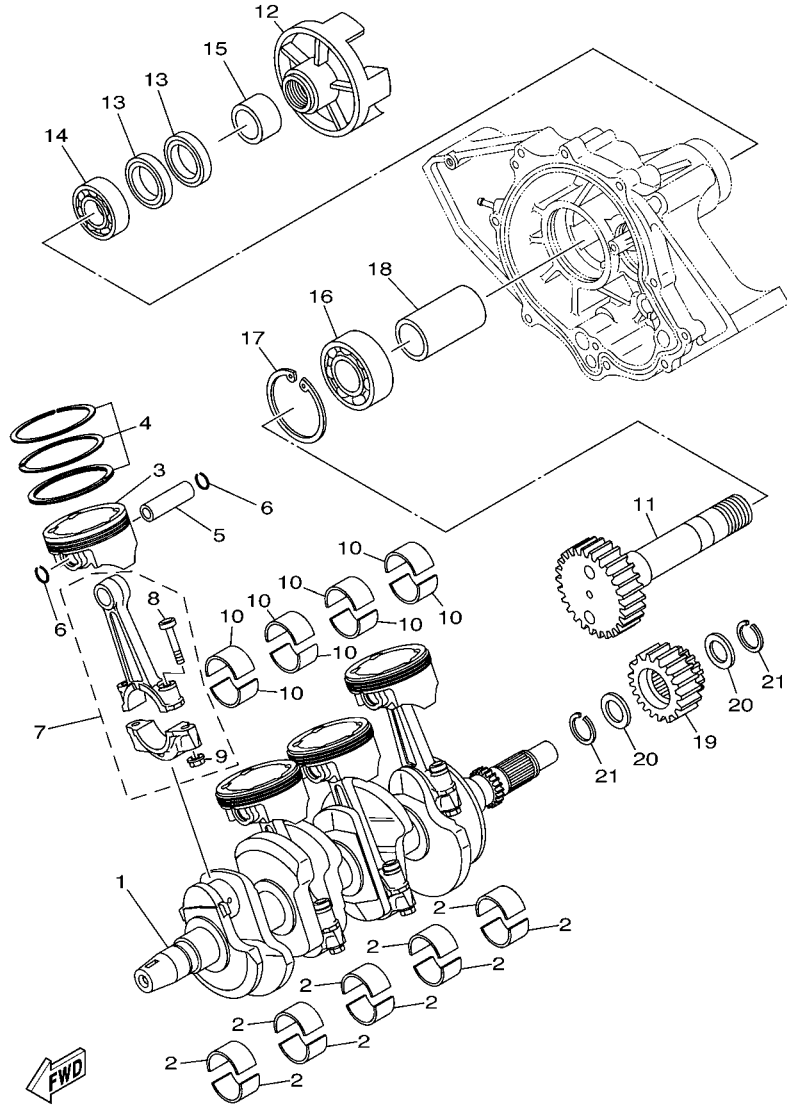
REF. NO.	PART NO.	DESCRIPTION	USA	CAN	GENE	JPN	REMARKS
1	6B6-15100-00-8P	CRANKCASE ASSY	1	1	1	1	
2	99530-10014	.PIN, DOWEL	2	2	2	2	
3	6B6-W009B-00-8P	CYLINDER BLOCK ASSY	1	1	1	1	
4	90116-10619	BOLT, STUD	10	10	10	10	
5	90105-093A5	BOLT, FLANGE	10	10	10	10	
6	90201-096J9	WASHER, PLATE	10	10	10	10	
7	99530-10014	PIN, DOWEL	2	2	2	2	
8	90109-06051	BOLT	2	2	2	2	
9	90105-06033	BOLT, FLANGE	1	1	1	1	
10	90105-06M17	BOLT, FLANGE	7	7	7	7	
11	67F-11325-01	ANODE	1	1	1	1	
12	67F-11328-00	GROMMET, ANODE	1	1	1	1	
13	69J-11327-01-94	COVER, ANODE	1	1	1	1	
14	97595-06520	BOLT, WITH WASHER	1	1	1	1	
15	97595-08540	BOLT, WITH WASHER	1	1	1	1	
16	6B6-1310A-00-94	PAN, OIL	1	1	1	1	
17	6B6-13557-01	GASKET	1	1	1	1	
18	97513-06520	BOLT, WITH WASHER	15	15	15	15	
19	93603-14M15	PIN, DOWEL	2	2	2	2	
20	60E-13161-00	PIPE, DELIVERY 1	1	1	1	1	
21	93210-06667	O-RING	2	2	2	2	
22	95027-06010	BOLT, FLANGE	1	1	1	1	
23	99530-08012	PIN, DOWEL	1	1	1	1	
24	93210-08001	O-RING	1	1	1	1	
25	5GH-13440-00	ELEMENT ASSY, OIL CLEANER	1	1	1	1	
26	90401-20145	BOLT, UNION	1	1	1	1	
27	67X-44517-10-94	MOUNT RUBBER	4	4	4	4	

**FIG. 2 CRANKCASE**



F1X1100-E020

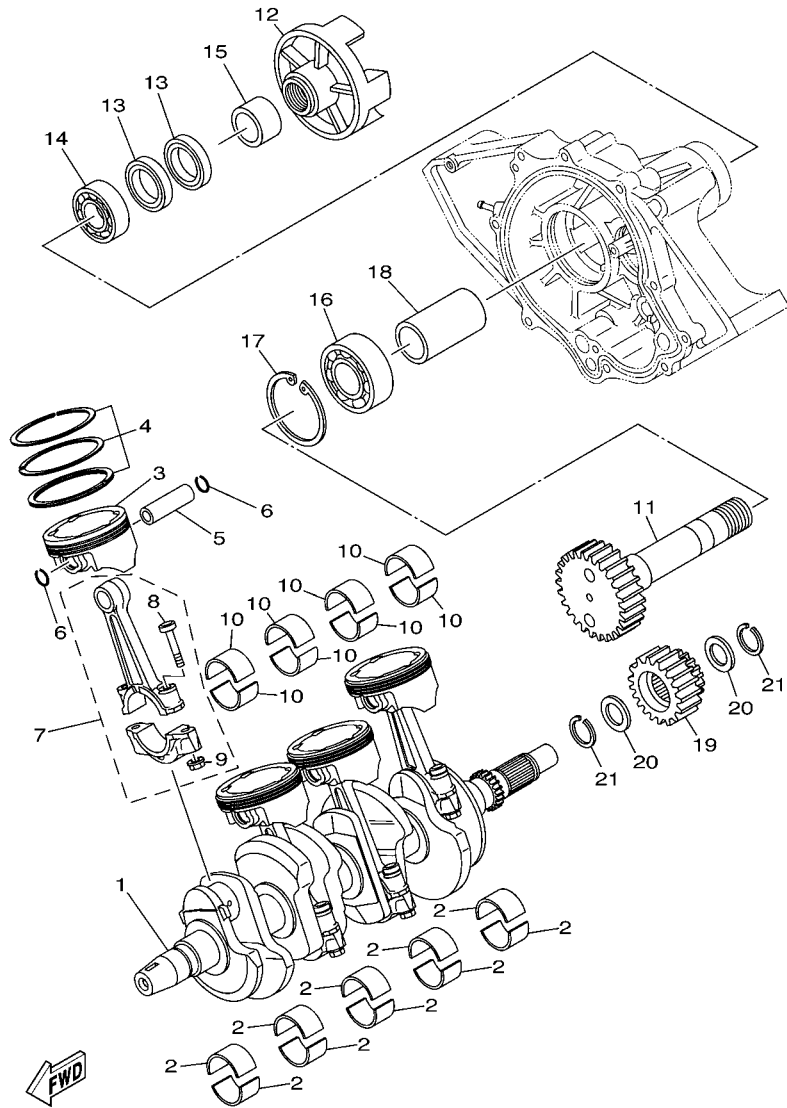
REF. NO.	PART NO.	DESCRIPTION	USA	CAN	GENE	JPN	REMARKS
28	60E-44574-00-94	STOPPER LWR MOUNT RUBBER	1	1	1	1	
29	6B6-44532-00-94	STOPPER, UPPER MOUNT	1	1	1	1	
30	90119-08835	BOLT, WITH WASHER	4	4	4	4	
31	90119-08823	BOLT, WITH WASHER	8	8	8	8	
32	90201-099U3	WASHER, PLATE	4	4	4	4	
33	EU0-U7354-00-01	SHIM (T=0.1)	10	10	10	10	UR
	EU0-U7354-00-03	SHIM (T=0.3)	10	10	10	10	UR
	EU0-U7354-00-05	SHIM (T=0.5)	10	10	10	10	UR
	EU0-U7354-00-10	SHIM (T=1.0)	10	10	10	10	UR
	EU0-U7354-00-20	SHIM (T=2.0)	10	10	10	10	UR
34	90101-06917	BOLT	4	4	4	4	



F1S1100-C030

FIG. 3 CRANKSHAFT & PISTON

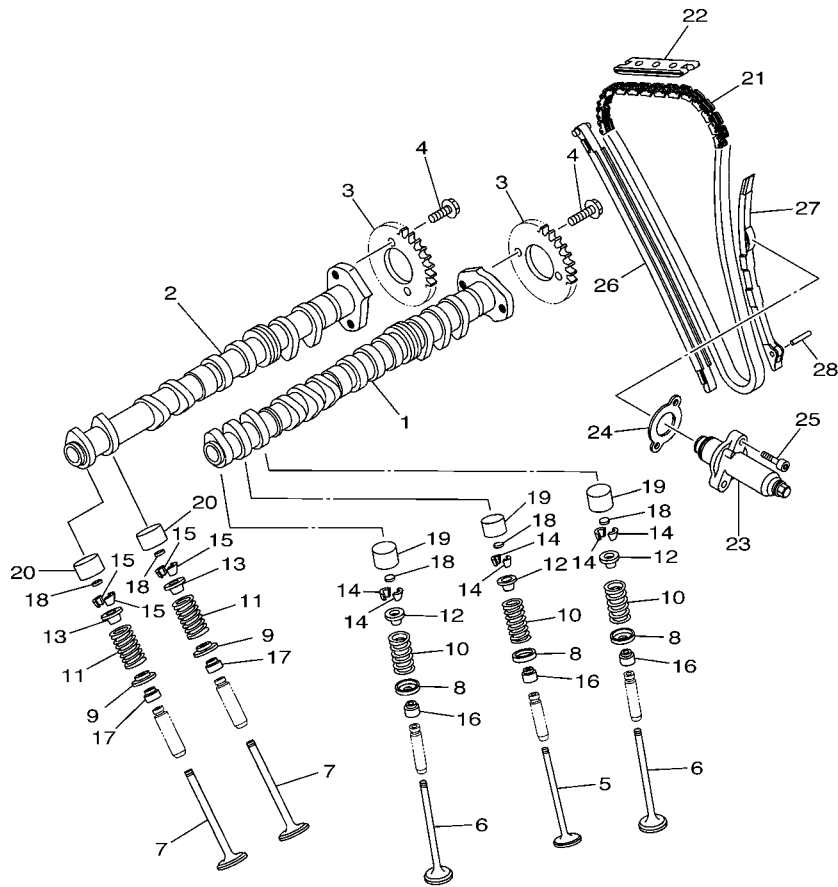
REF. NO.	PART NO.	DESCRIPTION	USA	CAN	GENE	JPN	REMARKS
1	60E-11411-11	CRANKSHAFT	1	1	1	1	
2	60E-11416-00	PLANE BEARING, CRANKSHAFT 1	10	10	10	10	UR BROWN
	60E-11416-10	PLANE BEARING, CRANKSHAFT 1	10	10	10	10	UR BLACK
	60E-11416-20	PLANE BEARING, CRANKSHAFT 1	10	10	10	10	UR BLUE
	60E-11416-30	PLANE BEARING, CRANKSHAFT 1	10	10	10	10	UR GREEN
	60E-11416-40	PLANE BEARING, CRANKSHAFT 1	10	10	10	10	UR YELLOW
3	6B6-11631-00-B0	PISTON (STD)	4	4	4	4	
4	6B6-11603-00	PISTON RING SET (STD)	4	4	4	4	
5	4XV-11633-00	PIN, PISTON	4	4	4	4	
6	90468-12069	CLIP	8	8	8	8	
7	5PW-11650-00	CONNECTING ROD ASSY	4	4	4	4	
8	5JW-11654-00	.BOLT, CONNECTING ROD	2	2	2	2	
9	90179-08327	.NUT	2	2	2	2	
10	60E-11656-00	PLANE BEARING, CONNECTING ROD	8	8	8	8	UR BROWN
	60E-11656-10	PLANE BEARING, CONNECTING ROD	8	8	8	8	UR BLACK
	60E-11656-20	PLANE BEARING, CONNECTING ROD	8	8	8	8	UR BLUE
	60E-11656-30	PLANE BEARING, CONNECTING ROD	8	8	8	8	UR GREEN
11	6B6-17572-00	SHAFT, TRANSFER	1	1	1	1	
12	66E-45813-10-94	FLANGE, COUPLING	1	1	1	1	
13	93101-35004	OIL SEAL	2	2	2	2	
14	93306-07801	BEARING	1	1	1	1	
15	6B6-11478-00	COLLAR	1	1	1	1	
16	93306-30610	BEARING	1	1	1	1	
17	99009-72500	CIRCLIP	1	1	1	1	
18	6B6-17585-00	COLLAR, GEAR	1	1	1	1	
19	6B6-17586-00	GEAR, TRANSFER DRIVE	1	1	1	1	
20	90209-25008	WASHER	2	2	2	2	



F1S1100-C030

FIG. 3 CRANKSHAFT & PISTON

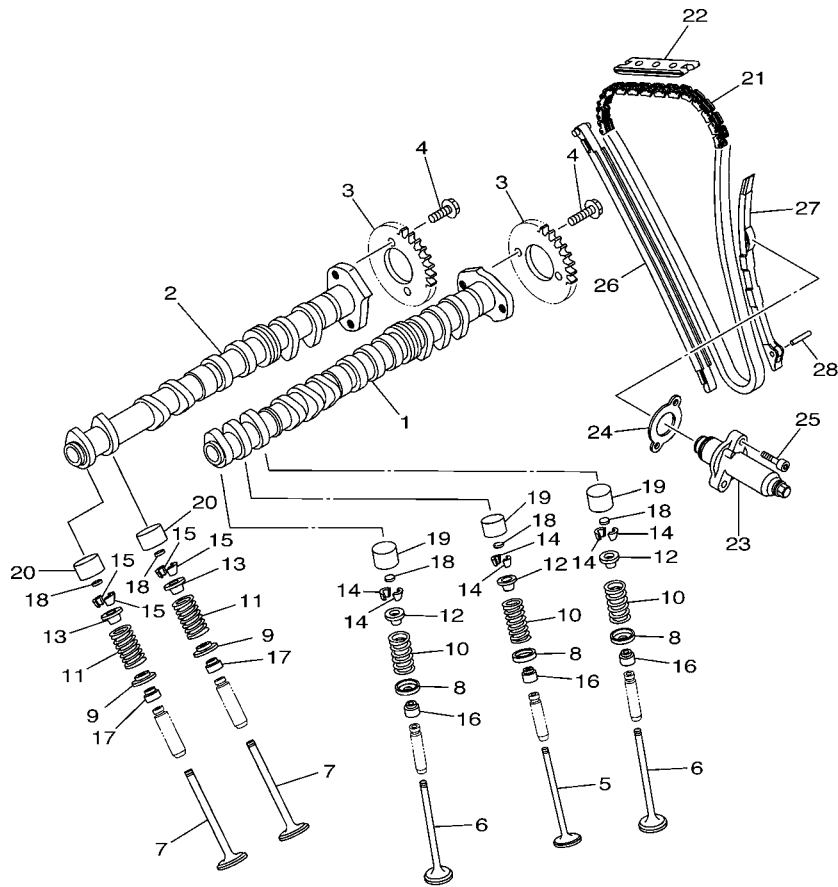
REF. NO.	PART NO.	DESCRIPTION	USA	CAN	GENE	JPN	REMARKS
21	93440-28062	CIRCLIP	2	2	2	2	



F1S1100-C040

FIG. 4 VALVE

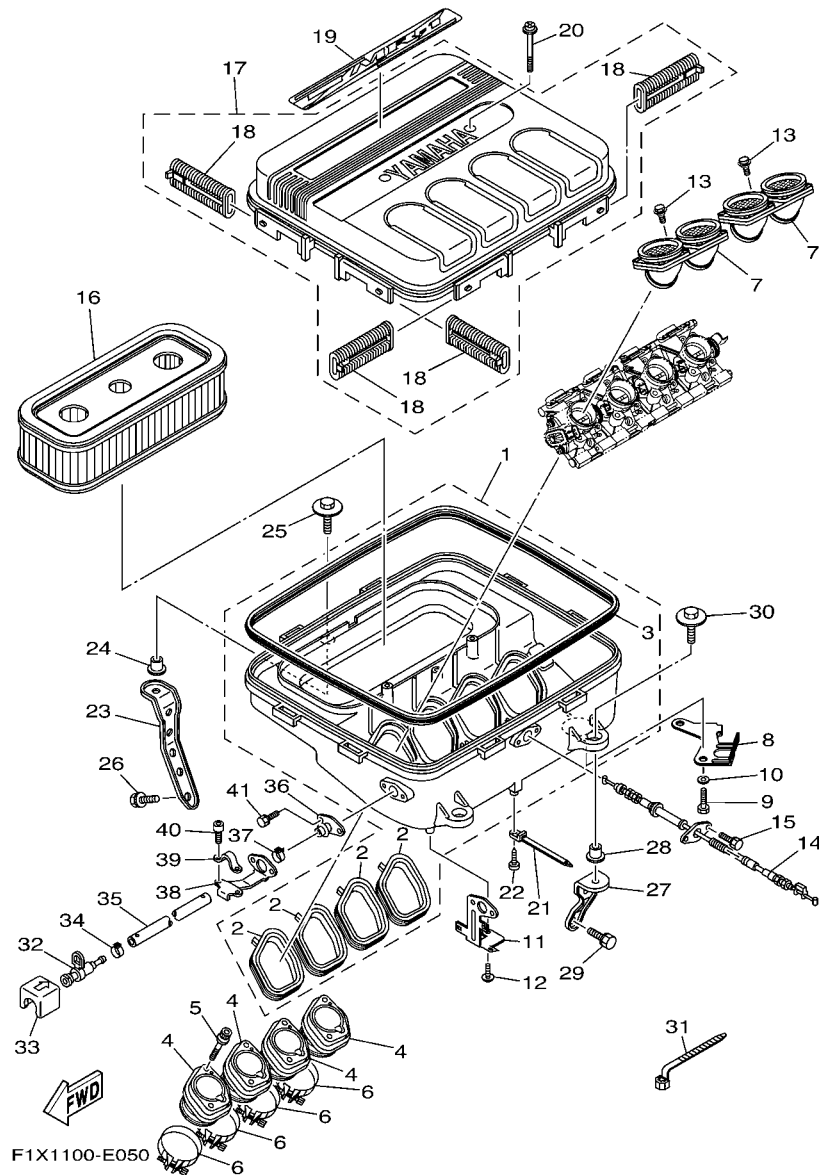
REF. NO.	PART NO.	DESCRIPTION	USA	CAN	GENE	JPN	REMARKS
1	6B6-12171-00	CAMSHAFT 1	1	1	1	1	
2	5JJ-12181-00	CAMSHAFT 2	1	1	1	1	
3	6D3-12176-00	SPROCKET, CAM CHAIN	2	2	2	2	
4	90105-07004	BOLT, FLANGE	4	4	4	4	
5	4XV-12111-00	VALVE, INTAKE	4	4	4	4	
6	4XV-12112-00	VALVE, INTAKE 2	8	8	8	8	
7	5LV-12121-00	VALVE, EXHAUST	8	8	8	8	
8	1HX-12116-01	SEAT, VALVE SPRING	12	12	12	12	
9	3GM-12126-00	SEAT, VALVE SPRING 2	8	8	8	8	
10	4XV-12113-00	SPRING, VALVE INNER	12	12	12	12	
11	4XV-12114-00	SPRING, VALVE OUTER	8	8	8	8	
12	1HX-12117-00	RETAINER, VALVE SPRING	12	12	12	12	
13	1WG-12117-00	RETAINER, VALVE SPRING	8	8	8	8	
14	1HX-12118-00	COTTER, VALVE	24	24	24	24	
15	1WG-12118-00	COTTER, VALVE	16	16	16	16	
16	4TV-12119-00	SEAL, VALVE STEM	12	12	12	12	
17	4SV-12119-00	SEAL, VALVE STEM	8	8	8	8	
18	1HX-12168-00	PAD, ADJUSTING 2 (1.20)	20	20	20	20	UR
	1HX-12168-20	PAD, ADJUSTING 2 (1.25)	20	20	20	20	UR
	1HX-12168-40	PAD, ADJUSTING 2 (1.30)	20	20	20	20	UR
	1HX-12168-60	PAD, ADJUSTING 2 (1.35)	20	20	20	20	UR
	1HX-12168-80	PAD, ADJUSTING 2 (1.40)	20	20	20	20	UR
	1HX-12168-A0	PAD, ADJUSTING 2 (1.45)	20	20	20	20	UR
	1HX-12168-F0	PAD, ADJUSTING 2 (1.50)	20	20	20	20	UR
	1HX-12168-H1	PAD, ADJUSTING 2 (1.55)	20	20	20	20	UR
	1HX-12168-K1	PAD, ADJUSTING 2 (1.60)	20	20	20	20	UR
	1HX-12168-M1	PAD, ADJUSTING 2 (1.65)	20	20	20	20	UR



F1S1100-C040

FIG. 4 VALVE

REF. NO.	PART NO.	DESCRIPTION	USA	CAN	GENE	JPN	REMARKS
18	1HX-12168-R1	PAD, ADJUSTING 2 (1.70)	20	20	20	20	UR
	1HX-12168-U1	PAD, ADJUSTING 2 (1.75)	20	20	20	20	UR
	1HX-12168-W1	PAD, ADJUSTING 2 (1.80)	20	20	20	20	UR
	1HX-12168-Y1	PAD, ADJUSTING 2 (1.85)	20	20	20	20	UR
	1HX-12169-11	PAD, ADJUSTING 2 (1.90)	20	20	20	20	UR
	1HX-12169-31	PAD, ADJUSTING 2 (1.95)	20	20	20	20	UR
	1HX-12169-50	PAD, ADJUSTING 2 (2.00)	20	20	20	20	UR
	1HX-12169-70	PAD, ADJUSTING 2 (2.05)	20	20	20	20	UR
	1HX-12169-90	PAD, ADJUSTING 2 (2.10)	20	20	20	20	UR
	1HX-12169-E0	PAD, ADJUSTING 2 (2.15)	20	20	20	20	UR
	1HX-12169-G0	PAD, ADJUSTING 2 (2.20)	20	20	20	20	UR
	1HX-12169-J0	PAD, ADJUSTING 2 (2.25)	20	20	20	20	UR
	1HX-12169-L0	PAD, ADJUSTING 2 (2.30)	20	20	20	20	UR
	1HX-12169-N0	PAD, ADJUSTING 2 (2.35)	20	20	20	20	UR
	1HX-12169-T0	PAD, ADJUSTING 2 (2.40)	20	20	20	20	UR
19	3LN-12153-10	LIFTER, VALVE	12	12	12	12	YELLOW
20	3FV-12153-10	LIFTER, VALVE	8	8	8	8	YELLOW
21	94591-49130	CHAIN	1	1	1	1	
22	5BE-12241-00	GUIDE, STOPPER 2	1	1	1	1	
23	60E-12210-00	TENSIONER ASSY, CAM CHAIN	1	1	1	1	
24	4FM-12213-00	GASKET, TENSIONER CASE	1	1	1	1	
25	91380-06025	BOLT	2	2	2	2	
26	6D3-12251-00	DAMPER, CHAIN 1	1	1	1	1	
27	4XV-12252-00	DAMPER, CHAIN 2	1	1	1	1	
28	93607-54002	PIN, DOWEL	1	1	1	1	



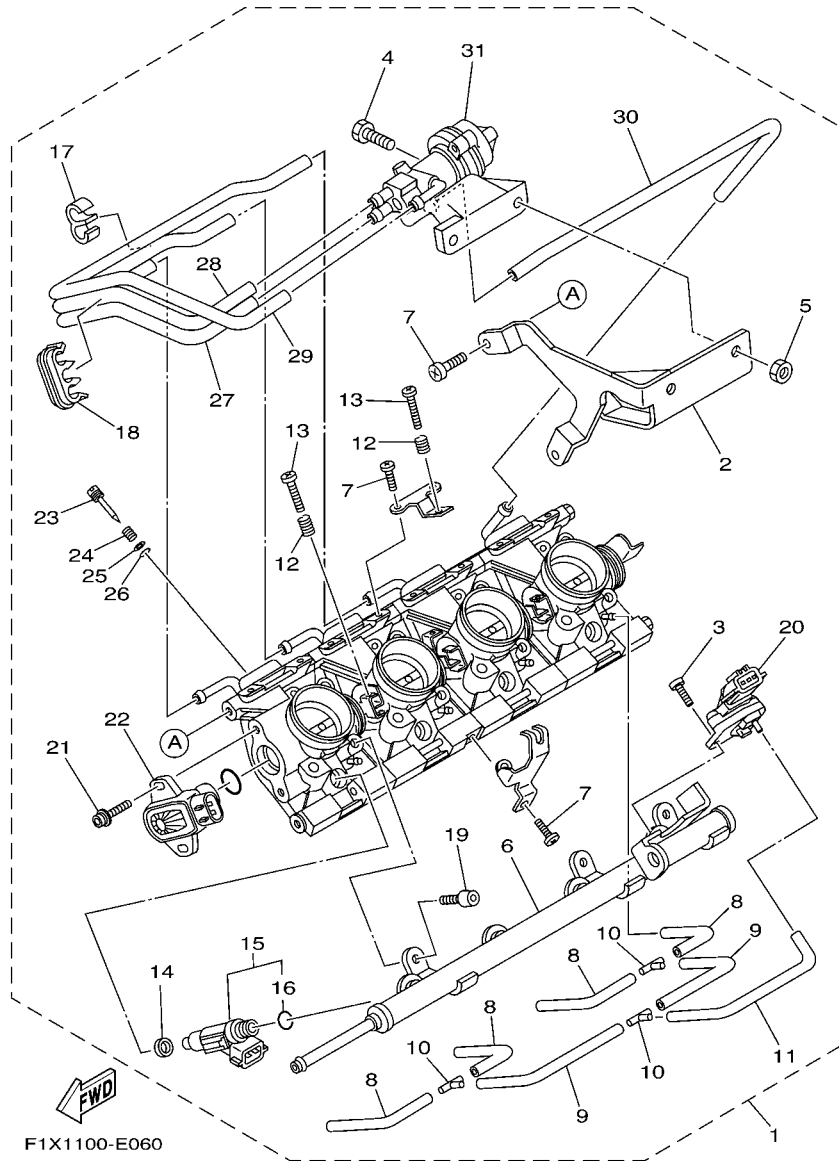
F1X1100-E050

FIG. 5 INTAKE

REF. NO.	PART NO.	DESCRIPTION	USA	CAN	GENE	JPN	REMARKS
1	6B6-14410-01	AIR CLEANER ASSY.	1	1	1	1	
2	6B6-14239-00	.SEAL	4	4	4	4	
3	60E-14457-00	.SEAL	1	1	1	1	
4	6B6-13795-00	JOINT, THROTTLE BODY 1	4	4	4	4	
5	90110-08020	BOLT, HEXAGON SOCKET HEAD	8	8	8	8	
6	90450-57002	HOSE CLAMP ASSY	4	4	4	4	
7	6B6-1440A-00	RIBBON, SUB ASSY	2	2	2	2	
8	6B6-14869-00	BRACKET 3	1	1	1	1	
9	97013-06016	BOLT	2	2	2	2	
10	92903-06600	WASHER, PLATE	2	2	2	2	
11	60E-14867-00	BRACKET	1	1	1	1	
12	90160-05003	SCREW, ROUND TAPPING	1	1	1	1	
13	90109-06053	BOLT	4	4	4	4	
14	6B6-26311-11	CABLE, THROTTLE 1	1	1	1	1	
15	90119-06078	BOLT, WITH WASHER	2	2	2	2	
16	6B6-14451-01	ELEMENT, AIR CLEANER	1	1	1	1	
17	6B6-14420-00	AIR CLEANER ASSY 2	1	1	1	1	
18	66V-13898-00	.HOLDER	8	8	8	8	
19	6B6-2339F-00	GRAPHIC 2	1	1	1	1	
20	90159-05006	SCREW, WITH WASHER	2	2	2	2	
21	90465-12M53	CLAMP	1	1	1	1	
22	90160-05003	SCREW, ROUND TAPPING	1	1	1	1	
23	60E-14413-00	STAY	1	1	1	1	
24	60E-14449-00	COLLAR	1	1	1	1	
25	90119-08050	BOLT, WITH WASHER	1	1	1	1	
26	90119-08032	BOLT, WITH WASHER	1	1	1	1	
27	60E-14414-00	STAY 2	2	2	2	2	



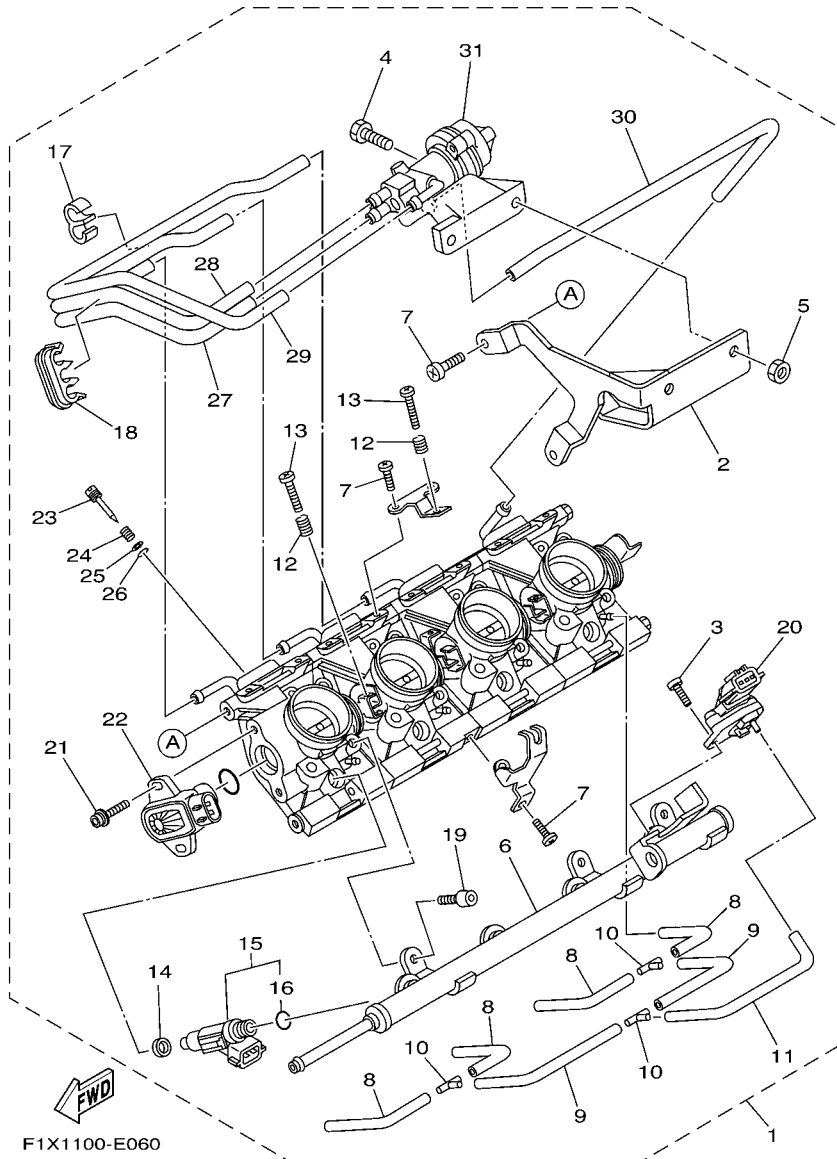




F1X1100-E060

FIG. 6 INJECTION PUMP

REF. NO.	PART NO.	DESCRIPTION	USA	CAN	GENE	JPN	REMARKS
1	6B6-13750-01	THROTTLE BODY ASSY	1	1	1	1	
2	6B6-14291-00	.BRACKET 1	1	1	1	1	
3	68V-81147-00	.SCREW 3	2	2	2	2	
4	63P-14446-00	.BOLT	2	2	2	2	
5	6B6-14358-00	.NUT	2	2	2	2	
6	60E-12880-11	.DELIVERY PIPE	1	1	1	1	
7	60E-14216-00	.SCREW	7	7	7	7	
8	5FL-14987-10	.HOSE	4	4	4	4	
9	5FL-14349-10	.PIPE	2	2	2	2	
10	4N0-14251-00	.NIPPLE	3	3	3	3	
11	5PW-14396-00	.PIPE	1	1	1	1	
12	3KW-14932-00	.SPRING, THROTTLE 2	7	7	7	7	
13	69J-14321-00	.SCREW, THROTTLE	4	4	4	4	
14	90430-09002	.GASKET	4	4	4	4	
15	60E-13761-10	.INJECTOR ASSY	4	4	4	4	
16	60E-14147-00	.O-RING	1	1	1	1	
17	6B6-12486-00	.CLIP	1	1	1	1	
18	6B6-12487-00	.CLIP 2	1	1	1	1	
19	6B6-14446-00	.BOLT	3	3	3	3	
20	6B6-83688-00	.SENSOR ASSY	1	1	1	1	
21	68V-81145-01	.SCREW 1	2	2	2	2	
22	60E-85885-10	.THROTTLE SENSOR ASSY	1	1	1	1	
23	4BH-14923-00	.SCREW, PILOT	4	4	4	4	
24	4BH-14134-00	.SPRING, AIR ADJUSTING	4	4	4	4	
25	3L5-14962-00	.WASHER	4	4	4	4	
26	3H1-14147-00	.O-RING	4	4	4	4	
27	6B6-13545-00	.HOSE 1	1	1	1	1	

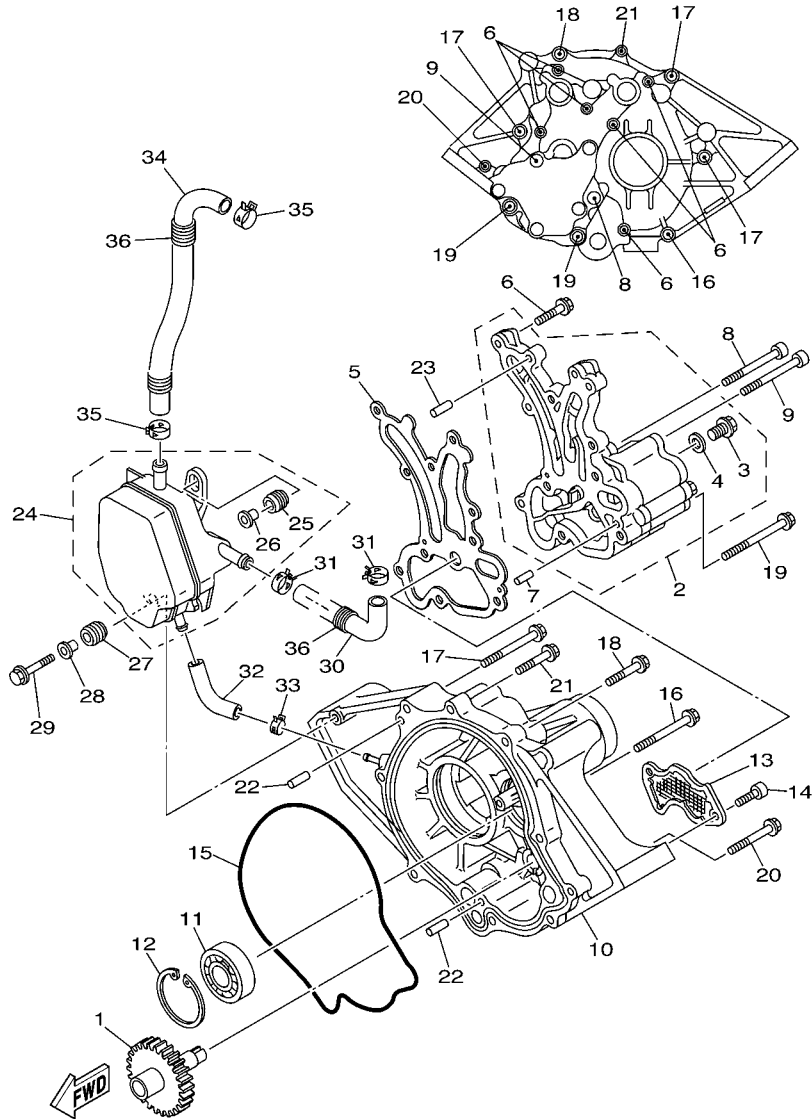


F1X1100-E060

FIG. 6 INJECTION PUMP

REF. NO.	PART NO.	DESCRIPTION	USA	CAN	GENE	JPN	REMARKS
28	6B6-13546-00	.HOSE 2	1	1	1	1	
29	6B6-13547-00	.HOSE 3	1	1	1	1	
30	6B6-13548-00	.HOSE, AIR 4	1	1	1	1	
31	6B6-13660-00	.INTAKE VALVE ASSY	1	1	1	1	

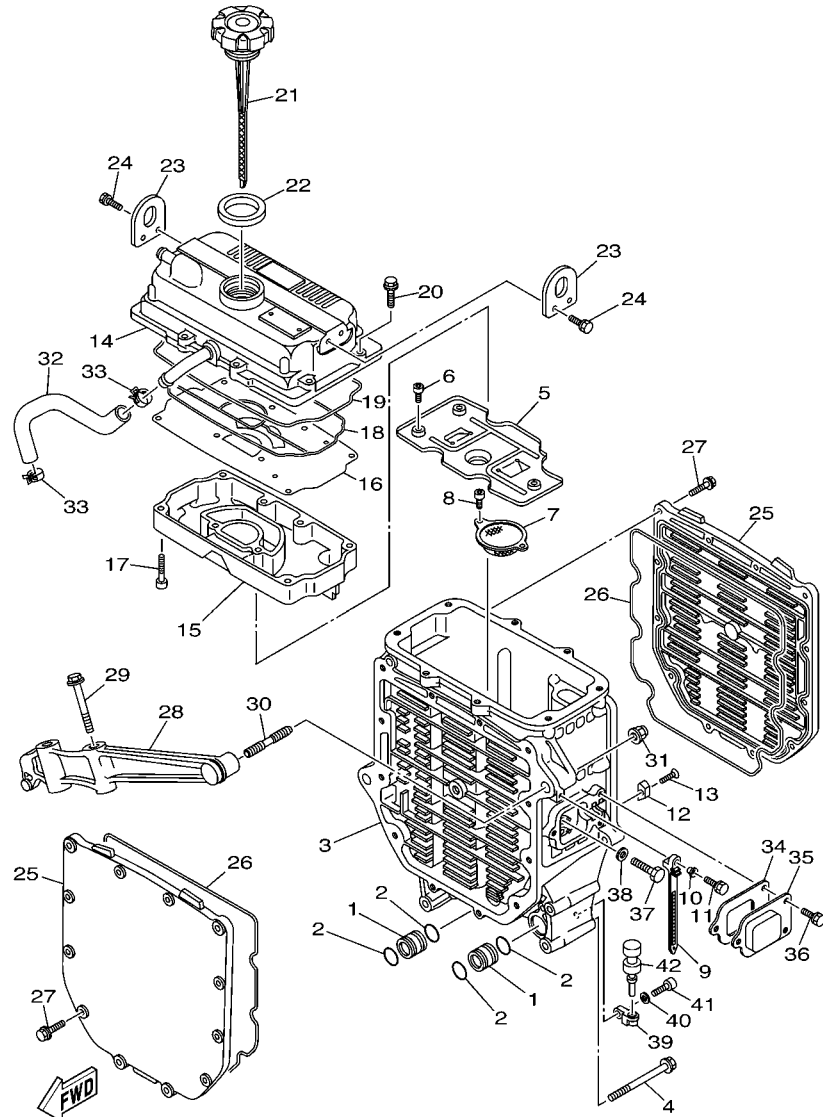
FIG. 7 OIL PUMP



F1S1100-C070

REF. NO.	PART NO.	DESCRIPTION	USA	CAN	GENE	JPN	REMARKS
1	6B6-13360-00	DRIVEN GEAR ASSY	1	1	1	1	
2	6B6-13300-01	OIL PUMP ASSY	1	1	1	1	
3	95817-08012	.BOLT, FLANGE	1	1	1	1	
4	90430-08119	.GASKET	1	1	1	1	
5	6B6-13563-01	GASKET	1	1	1	1	
6	97513-06525	BOLT, WITH WASHER	6	6	6	6	
7	93603-12221	PIN, DOWEL	2	2	2	2	
8	90110-08039	BOLT, HEXAGON SOCKET HEAD	1	1	1	1	
9	90110-08040	BOLT, HEXAGON SOCKET HEAD	1	1	1	1	
10	6B6-13327-01-94	COVER, PUMP GEAR	1	1	1	1	
11	93306-30441	BEARING	1	1	1	1	
12	99009-52500	CIRCLIP	1	1	1	1	
13	6B6-13411-00	STRAINER, OIL	1	1	1	1	
14	91317-06016	BOLT	2	2	2	2	
15	6B6-13475-00	GASKET	1	1	1	1	
16	90119-08045	BOLT, WITH WASHER	1	1	1	1	
17	90119-08034	BOLT, WITH WASHER	3	3	3	3	
18	90119-08043	BOLT, WITH WASHER	1	1	1	1	
19	90119-08073	BOLT, WITH WASHER	2	2	2	2	
20	97513-06555	BOLT, WITH WASHER	1	1	1	1	
21	97513-06535	BOLT, WITH WASHER	1	1	1	1	
22	93608-16M16	PIN, DOWEL	2	2	2	2	
23	93606-25M00	PIN, DOWEL	2	2	2	2	
24	60E-11164-00	SEPERATOR, OIL	1	1	1	1	
25	6A0-82317-00	.DAMPER, IGNITION COIL	1	1	1	1	
26	90387-06119	.COLLAR	1	1	1	1	
27	6A0-82317-00	DAMPER, IGNITION COIL	2	2	2	2	

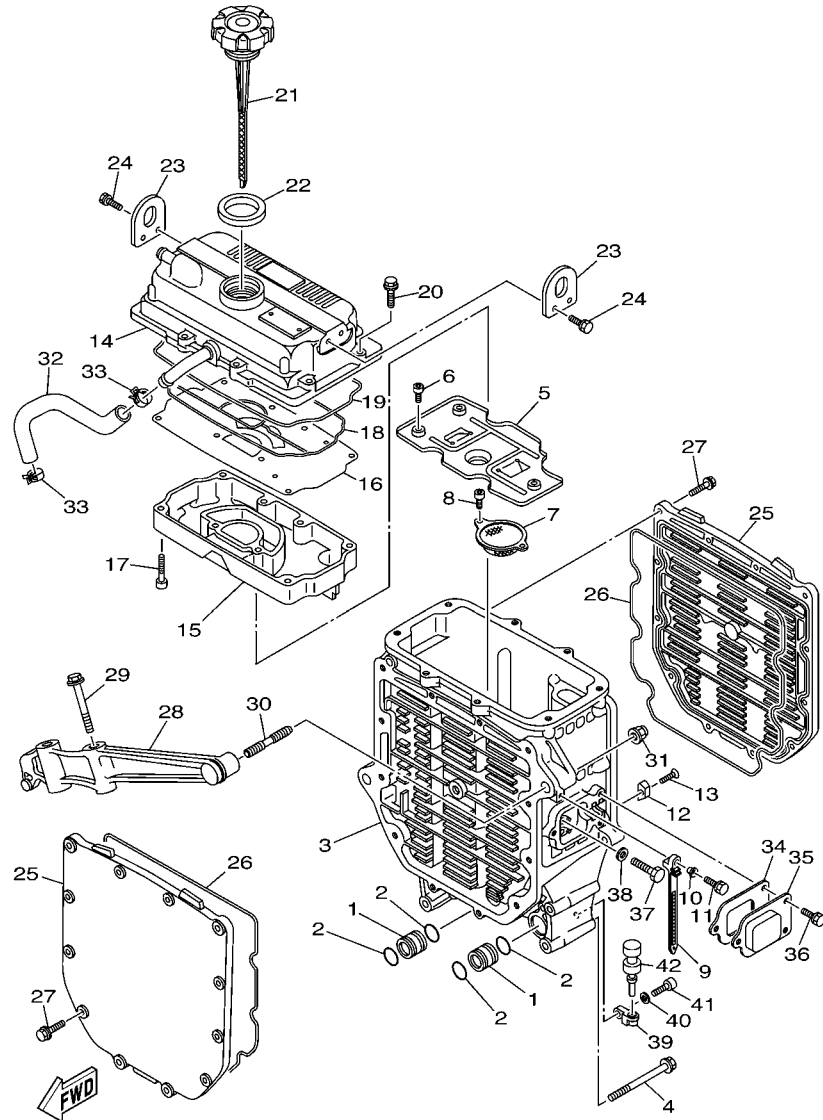




F1S1100-C080

FIG. 8 OIL COOLER

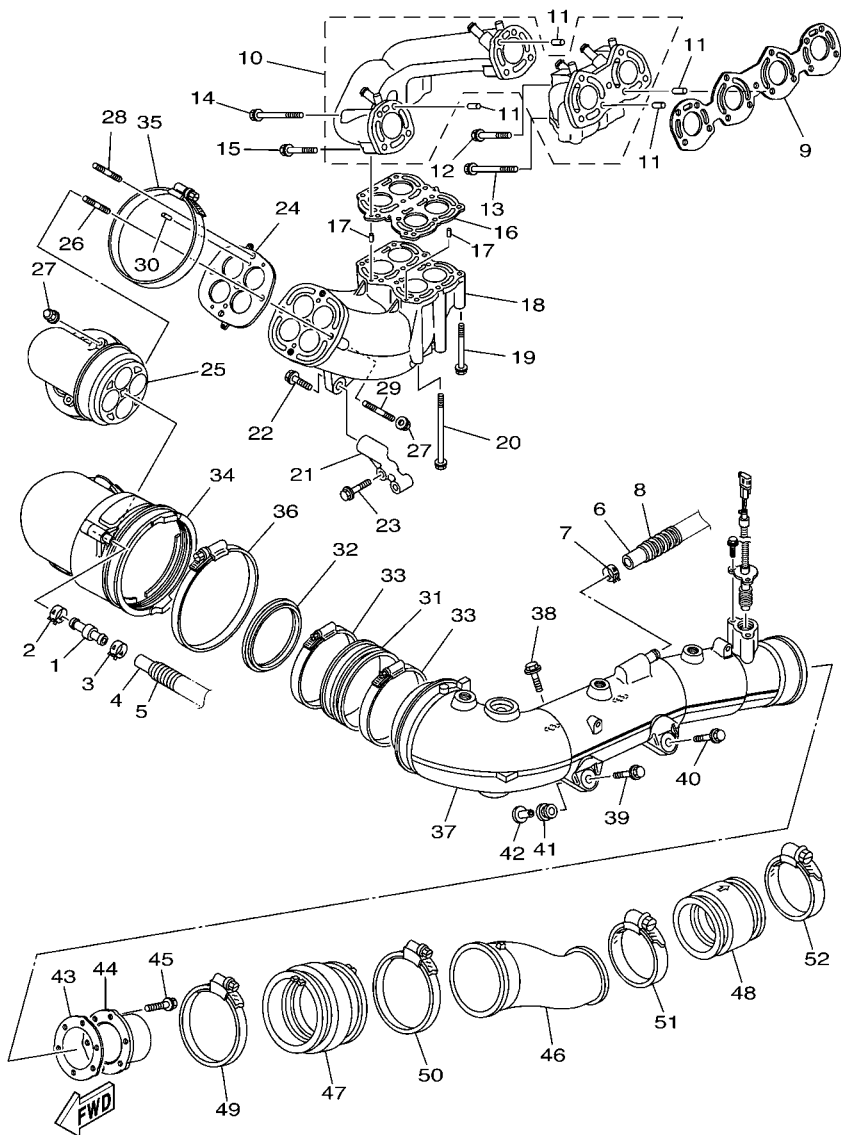
REF. NO.	PART NO.	DESCRIPTION	USA	CAN	GENE	JPN	REMARKS
1	60E-13446-00	CONNECTOR	2	2	2	2	
2	93210-18322	O-RING	4	4	4	4	
3	6B6-13462-00-94	CASE, OIL COOLER	1	1	1	1	
4	90119-10020	BOLT, WITH WASHER	5	5	5	5	
5	6B6-13317-00	PLATE, BAFFLE	1	1	1	1	
6	91317-05014	BOLT	3	3	3	3	
7	60E-13421-00	STRAINER 2	1	1	1	1	
8	91317-06014	BOLT	2	2	2	2	
9	90465-12M53	CLAMP	1	1	1	1	
10	90387-06M05	COLLAR	1	1	1	1	
11	97595-06520	BOLT, WITH WASHER	1	1	1	1	
12	6E5-11325-00	ANODE	1	1	1	1	
13	98780-04015	SCREW, FLAT HEAD	1	1	1	1	
14	60E-13463-10-94	COVER, OIL COOLER	1	1	1	1	
15	6B6-11165-00	PLATE, BREATHER	1	1	1	1	
16	6B6-11145-00	PLATE, BREATHER 2	1	1	1	1	
17	91317-05035	BOLT	8	8	8	8	
18	60E-13475-00	GASKET	1	1	1	1	
19	60E-13477-00	GASKET	1	1	1	1	
20	90105-06036	BOLT, FLANGE	8	8	8	8	
21	60E-15362-00	PLUG, OIL LEVEL	1	1	1	1	
22	60E-13473-00	O-RING	1	1	1	1	
23	6B6-11119-00	HANGER, ENGINE	2	2	2	2	
24	90119-06023	BOLT, WITH WASHER	4	4	4	4	
25	6D3-13443-00-94	COVER, OIL COOLER	2	2	2	2	
26	60E-13476-10	GASKET	2	2	2	2	
27	90105-06M07	BOLT, FLANGE	24	24	24	24	



F1S1100-C080

FIG. 8 OIL COOLER

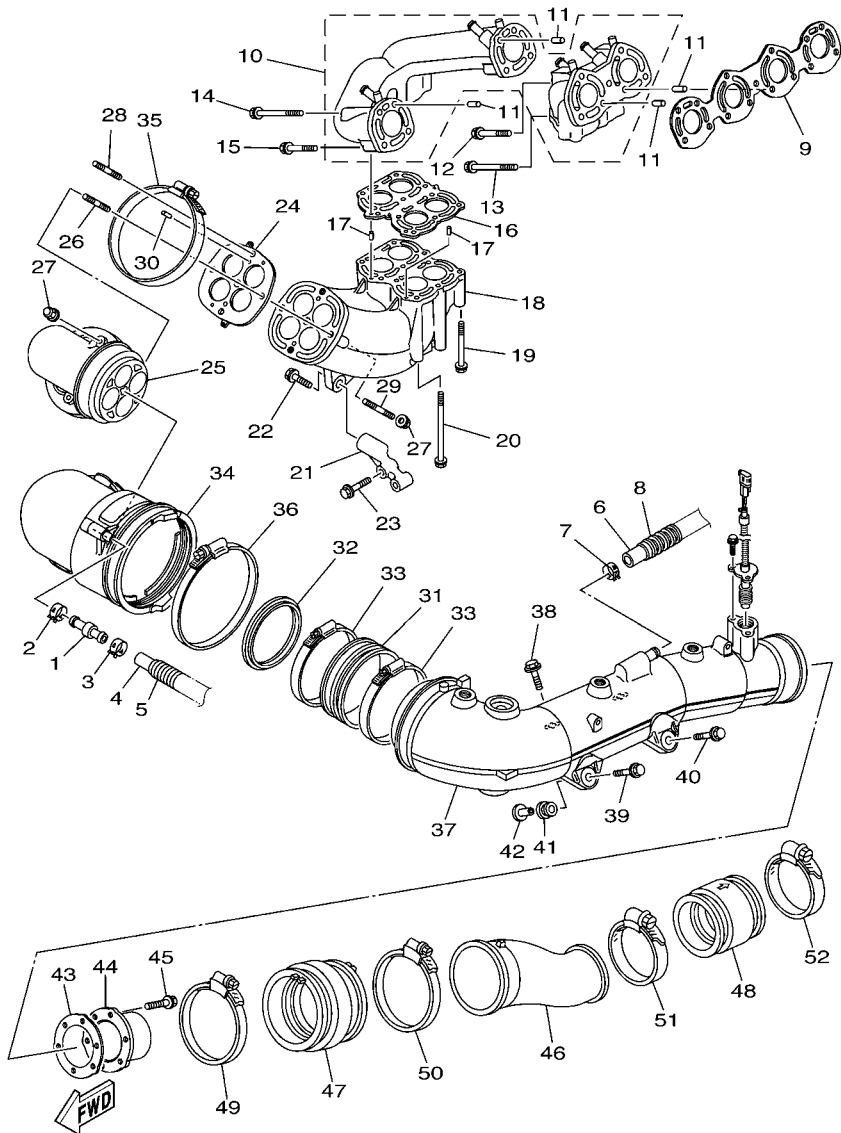
REF. NO.	PART NO.	DESCRIPTION	USA	CAN	GENE	JPN	REMARKS
28	6B6-13151-00-94	STAY	1	1	1	1	
29	90119-10M02	BOLT, WITH WASHER	2	2	2	2	
30	90116-10016	BOLT, STUD	2	2	2	2	
31	90176-10001	NUT, CROWN	2	2	2	2	
32	6B6-11167-00	PIPE, BREATHER 2	1	1	1	1	
33	90467-170A0	CLIP	2	2	2	2	
34	60E-13567-00	GASKET	1	1	1	1	
35	60E-13882-00	COVER 2	1	1	1	1	
36	97580-06516	BOLT, WITH WASHER	3	3	3	3	
37	97013-06012	BOLT	2	2	2	2	
38	92903-06600	WASHER, PLATE	2	2	2	2	
39	60E-51341-00-94	BRACKET 1	2	2	2	2	
40	92995-06600	WASHER	2	2	2	2	
41	91380-06020	BOLT	2	2	2	2	
42	90480-06M46	GROMMET	2	2	2	2	



F1S1100-C090

FIG. 9 EXHAUST 1

REF. NO.	PART NO.	DESCRIPTION	USA	CAN	GENE	JPN	REMARKS
1	60E-12594-00	JOINT, HOSE 4	1	1	1	1	
2	90467-120A0	CLIP	1	1	1	1	
3	90467-130A0	CLIP	1	1	1	1	
4	90445-14M06	HOSE (L630)	1	1	1	1	
5	90446-20M65	HOSE (L445)	1	1	1	1	
6	90445-20002	HOSE (L=1250)	1	1	1	1	
7	90467-200A0	CLIP	1	1	1	1	
8	90447-22002	TUBE (L1150)	1	1	1	1	
9	60E-14613-01	GASKET, EXHAUST PIPE	1	1	1	1	
10	60E-14610-00-94	EXHAUST PIPE ASSY 1	1	1	1	1	
11	93608-16M16	PIN, DOWEL	4	4	4	4	
12	90119-08029	BOLT, WITH WASHER	1	1	1	1	
13	90119-08034	BOLT, WITH WASHER	4	4	4	4	
14	90119-08029	BOLT, WITH WASHER	4	4	4	4	
15	90119-08M62	BOLT, WITH WASHER	2	2	2	2	
16	60E-14739-02	GASKET, MUFFLER DAMPER 1	1	1	1	1	
17	93606-12019	PIN, DOWEL	2	2	2	2	
18	60E-14631-00-94	PIPE, EXHAUST 3	1	1	1	1	
19	90119-08036	BOLT, WITH WASHER	4	4	4	4	
20	90119-08031	BOLT, WITH WASHER	6	6	6	6	
21	60E-14771-00-94	STAY, MUFFLER 1	1	1	1	1	
22	90119-10013	BOLT, WITH WASHER	1	1	1	1	
23	90119-08043	BOLT, WITH WASHER	2	2	2	2	
24	60E-14749-02	GASKET, MUFFLER DAMPER 2	1	1	1	1	
25	60E-14712-01-94	RING, JOINT	1	1	1	1	
26	90116-10016	BOLT, STUD	1	1	1	1	
27	90179-10M35	NUT	5	5	5	5	



F1S1100-C090

FIG. 9 EXHAUST 1

REF. NO.	PART NO.	DESCRIPTION	USA	CAN	GENE	JPN	REMARKS
28	90116-10017	BOLT, STUD	3	3	3	3	
29	90116-10018	BOLT, STUD	1	1	1	1	
30	93606-12019	PIN, DOWEL	2	2	2	2	
31	60E-14625-00	JOINT, EXHAUST 2	1	1	1	1	
32	60E-14642-00	SEAL, EXHAUST	1	1	1	1	
33	90450-99M06	HOSE CLAMP ASSY	2	2	2	2	
34	60E-14615-00	JOINT, EXHAUST 1	1	1	1	1	
35	90450-99M16	HOSE CLAMP ASSY	1	1	1	1	
36	90450-99M18	HOSE CLAMP ASSY	1	1	1	1	
37	60E-14721-00-94	MUFFLER 2	1	1	1	1	
38	90119-10013	BOLT, WITH WASHER	2	2	2	2	
39	90119-10011	BOLT, WITH WASHER	1	1	1	1	
40	90119-10017	BOLT, WITH WASHER	1	1	1	1	
41	90480-21M63	GROMMET	1	1	1	1	
42	90387-11002	COLLAR	1	1	1	1	
43	60E-14623-00	GASKET, EXHAUST PIPE	1	1	1	1	
44	60E-14784-00-94	PIPE, TAIL	1	1	1	1	
45	95023-06016	BOLT	3	3	3	3	
46	6B6-14752-00-94	PIPE, OUTLET	1	1	1	1	
47	6B6-1475E-00	PIPE 2	1	1	1	1	
48	6B6-1475F-00	PIPE 3	1	1	1	1	
49	90450-99M06	HOSE CLAMP ASSY	1	1	1	1	
50	90450-99M06	HOSE CLAMP ASSY	1	1	1	1	
51	90460-90M11	CLAMP, HOSE	1	1	1	1	
52	90460-90M11	CLAMP, HOSE	1	1	1	1	



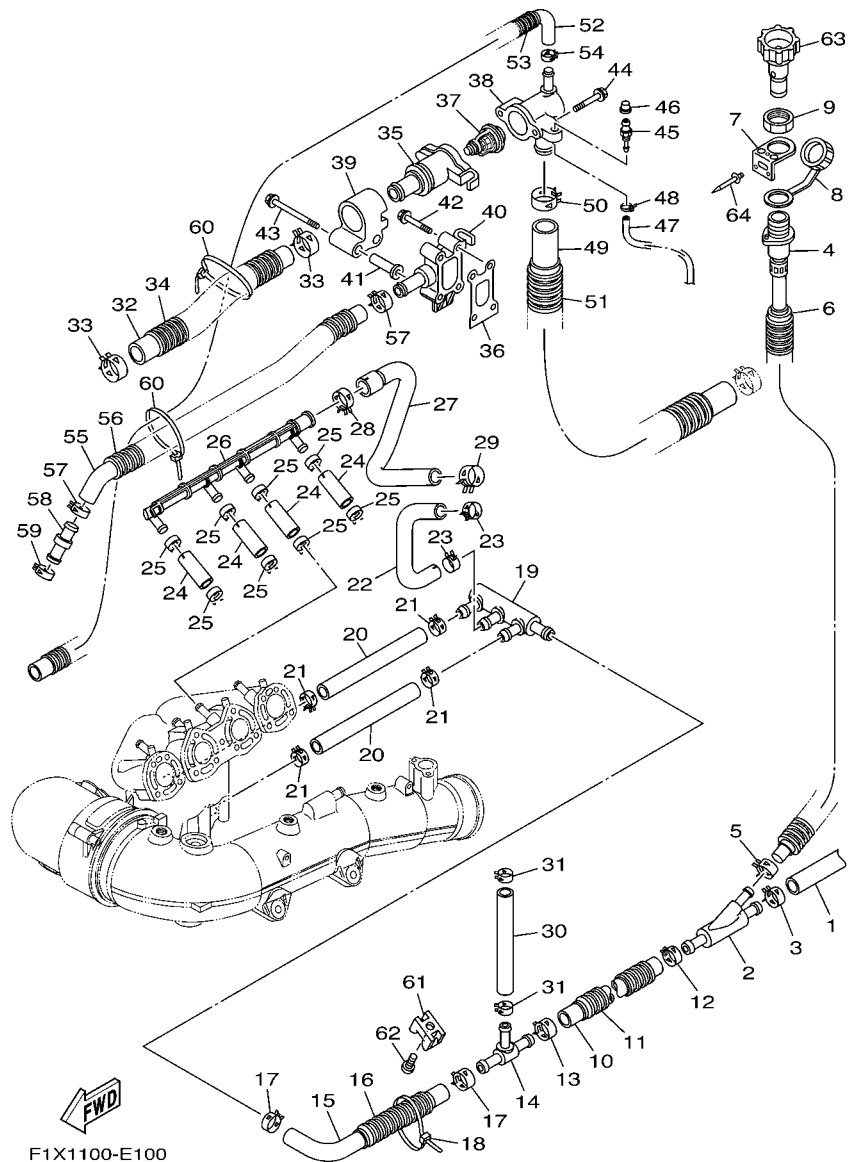


FIG. 10 EXHAUST 2

REF. NO.	PART NO.	DESCRIPTION	USA	CAN	GENE	JPN	REMARKS
1	60E-E243A-00	HOSE 1	1	1	1	1	
2	60E-12581-00	JOINT, HOSE 1	1	1	1	1	
3	90467-200A0	CLIP	1	1	1	1	
4	60E-12580-00	JOINT ASSY	1	1	1	1	
5	90467-150A0	CLIP	1	1	1	1	
6	90446-24M79	HOSE (L230)	1	1	1	1	
7	60E-12443-00	STAY	1	1	1	1	
8	682-84385-01	CAP,1	1	1	1	1	
9	EU0-61652-00	NUT	1	1	1	1	
10	90445-21804	HOSE (L370)	1	1	1	1	
11	90447-22003	HOSE, WITH SPRING	1	1	1	1	
12	90467-200A0	CLIP	1	1	1	1	
13	90467-200A0	CLIP	1	1	1	1	
14	60E-12584-00	JOINT, HOSE 3	1	1	1	1	
15	60E-1243E-00	HOSE 2	1	1	1	1	
16	90447-22001	HOSE, WITH SPRING (L100)	1	1	1	1	
17	90467-200A0	CLIP	2	2	2	2	
18	90465-13M24	CLAMP	1	1	1	1	
19	60E-12582-00	JOINT, HOSE 2	1	1	1	1	
20	90445-18003	HOSE (L150)	2	2	2	2	
21	90467-160A0	CLIP	4	4	4	4	
22	6B6-1243F-00	HOSE,3	1	1	1	1	
23	90467-160A0	CLIP	2	2	2	2	
24	6B6-12576-10	HOSE 1	4	4	4	4	
25	90467-170A0	CLIP	8	8	8	8	
26	60E-12469-00	JOINT 1	1	1	1	1	
27	6B6-12577-10	HOSE 2	1	1	1	1	

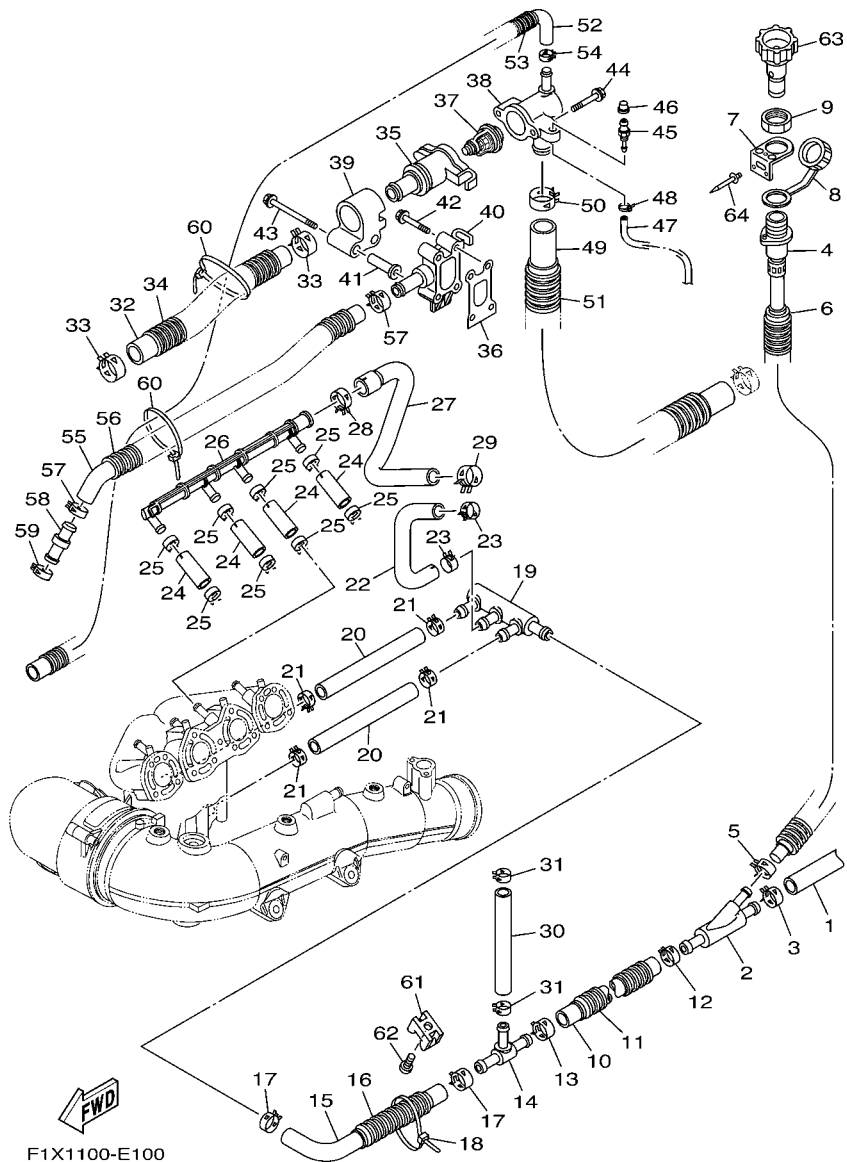


FIG. 10 EXHAUST 2

REF. NO.	PART NO.	DESCRIPTION	USA	CAN	GENE	JPN	REMARKS
28	90467-240A1	CLIP	1	1	1	1	
29	90467-210A0	CLIP	1	1	1	1	
30	90445-18003	HOSE (L150)	1	1	1	1	
31	90467-160A0	CLIP	2	2	2	2	
32	90445-26002	HOSE (L205)	1	1	1	1	
33	90467-240A0	CLIP	2	2	2	2	
34	90447-28005	HOSE (L100)	1	1	1	1	
35	60E-12417-10-94	HOUSING, THERMOSTAT	1	1	1	1	
36	60E-12435-00	GASKET	1	1	1	1	
37	60E-12411-01	THERMOSTAT	1	1	1	1	
38	60E-12413-10-94	COVER, THERMOSTAT	1	1	1	1	
39	6B6-12499-00	JOINT	1	1	1	1	
40	6D3-12446-00	JOINT	1	1	1	1	
41	90387-06083	COLLAR	2	2	2	2	
42	90105-06035	BOLT, FLANGE	2	2	2	2	
43	90105-06054	BOLT, FLANGE	2	2	2	2	
44	90105-06035	BOLT, FLANGE	2	2	2	2	
45	61L-5169A-00	NIPPLE, GREASE	1	1	1	1	
46	663-45119-00	CAP, GREASE NIPPLE	1	1	1	1	
47	90445-09M33	HOSE (L580)	1	1	1	1	
48	90465-11M10	CLAMP	1	1	1	1	
49	90445-25003	HOSE (L900)	1	1	1	1	
50	90467-240A0	CLIP	1	1	1	1	
51	90447-28002	TUBE (L800)	1	1	1	1	
52	60E-12552-00	HOSE 8	1	1	1	1	
53	90447-22002	TUBE (L1150)	1	1	1	1	
54	90467-120A0	CLIP	1	1	1	1	



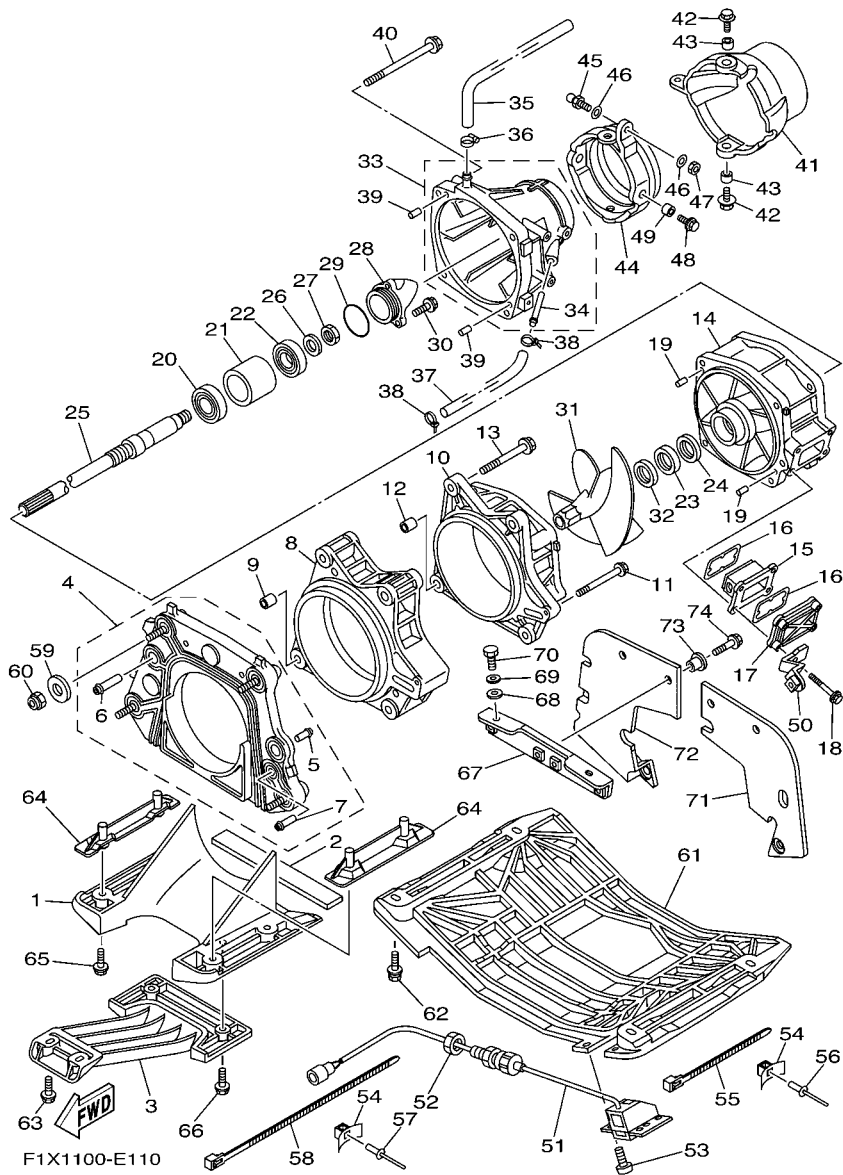
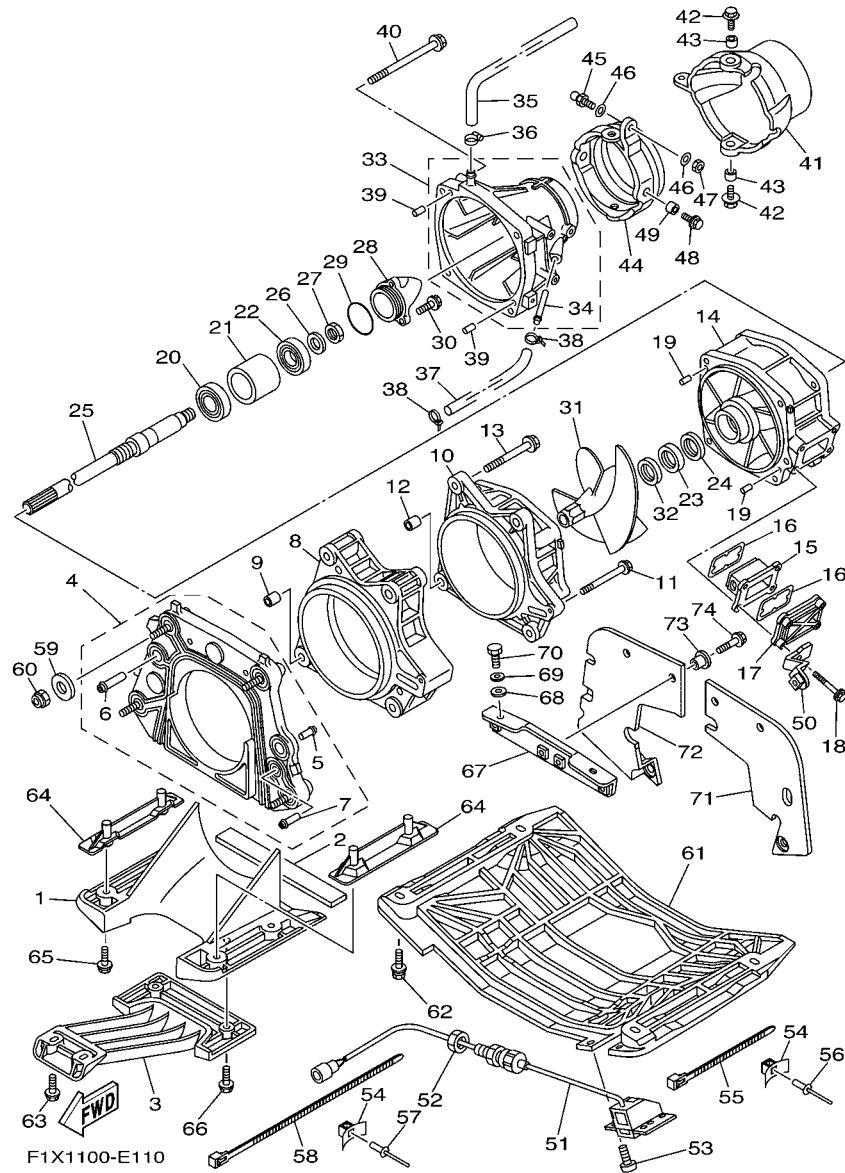


FIG. 11 JET UNIT 1

REF. NO.	PART NO.	DESCRIPTION	USA	CAN	GENE	JPN	REMARKS
1	60E-R1311-00-94	DUCT, INTAKE	1	1	1	1	
2	66V-R1367-00	FELT, PACKING	1	1	1	1	
3	60E-R1333-00-94	SCREEN, INTAKE	1	1	1	1	
4	60E-G5831-01	PLATE, TRANSOM	1	1	1	1	
5	65A-R1129-00	.NIPPLE	1	1	1	1	
6	66V-51129-10	.NIPPLE	2	2	2	2	
7	60E-51129-30	.NIPPLE	1	1	1	1	
8	60E-51317-00-94	HOUSING, IMPELLER 2	1	1	1	1	
9	99590-14016	PIN, DOWEL	2	2	2	2	
10	66V-51312-01-94	HOUSING, IMPELLER	1	1	1	1	
11	90119-06859	BOLT, WITH WASHER	1	1	1	1	
12	99590-14016	PIN, DOWEL	2	2	2	2	
13	90119-10803	BOLT, WITH WASHER	4	4	4	4	
14	6B6-51315-01-94	DUCT, IMPELLER	1	1	1	1	
15	66V-46882-00	FILTER	1	1	1	1	
16	66V-42414-00	O-RING	2	2	2	2	
17	66V-45214-00-94	COVER, WATER INLET 1	1	1	1	1	
18	90119-06800	BOLT, WITH WASHER	4	4	4	4	
19	93606-12019	PIN, DOWEL	2	2	2	2	
20	93306-205U0	BEARING	1	1	1	1	
21	65V-45538-00	SPACER 1	1	1	1	1	
22	93306-304U1	BEARING	1	1	1	1	
23	93101-28M66	OIL SEAL	1	1	1	1	
24	93101-28002	OIL SEAL	1	1	1	1	
25	68Y-45511-00	SHAFT, DRIVE	1	1	1	1	
26	9299R-16600	WASHER	1	1	1	1	
27	9531P-16700	NUT	1	1	1	1	

FIG. 11 JET UNIT 1



REF. NO.	PART NO.	DESCRIPTION	USA	CAN	GENE	JPN	REMARKS
28	6B6-51326-10	CAP	1	1	1	1	
29	93210-464A3	O-RING	1	1	1	1	
30	90110-06822	BOLT, HEXAGON SOCKET HEAD	3	3	3	3	
31	6B6-R1321-00	IMPELLER	1	1	1	1	
32	66V-R1348-10	SPACER	1	1	1	1	
-----							
33	6B6-51318-00-94	NOZZLE	1	1	1	1	
34	63M-51334-00	.NIPPLE,HOSE	1	1	1	1	
35	90445-16M09	HOSE (L310)	1	1	1	1	
36	90601-118UF	BAND, HOSE 18	1	1	1	1	
37	90445-14804	HOSE (L330)	1	1	1	1	
-----							
38	90465-11829	CLAMP	2	2	2	2	
39	93606-12019	PIN, DOWEL	2	2	2	2	
40	90119-10837	BOLT, WITH WASHER	4	4	4	4	
41	66V-R1313-01	NOZZLE, DEFLECTOR	1	1	1	1	
42	90119-089UE	BOLT, WITH WASHER	2	2	2	2	
-----							
43	90387-08M06	COLLAR	2	2	2	2	
44	60T-51190-00-94	RING,TRIM	1	1	1	1	
45	GH3-U146E-00	STUD, JOINT BALL	1	1	1	1	
46	90201-068M4	WASHER, PLATE	2	2	2	2	
47	9538R-06700	NUT	1	1	1	1	
-----							
48	90119-089UE	BOLT, WITH WASHER	2	2	2	2	
49	90387-08M06	COLLAR	2	2	2	2	
50	6B6-51342-00	BRACKET 2	1	1	1	1	
51	F1S-U8K31-02	SENSOR SPEED	1	1	1	1	
	F1X-U8K31-02	SENSOR SPEED	1	1	1	1	
-----							
52	EU0-62241-30	NUT, DRAIN 1	1	1	1	1	
53	90150-05807	SCREW, ROUND HEAD	4	4	4	4	

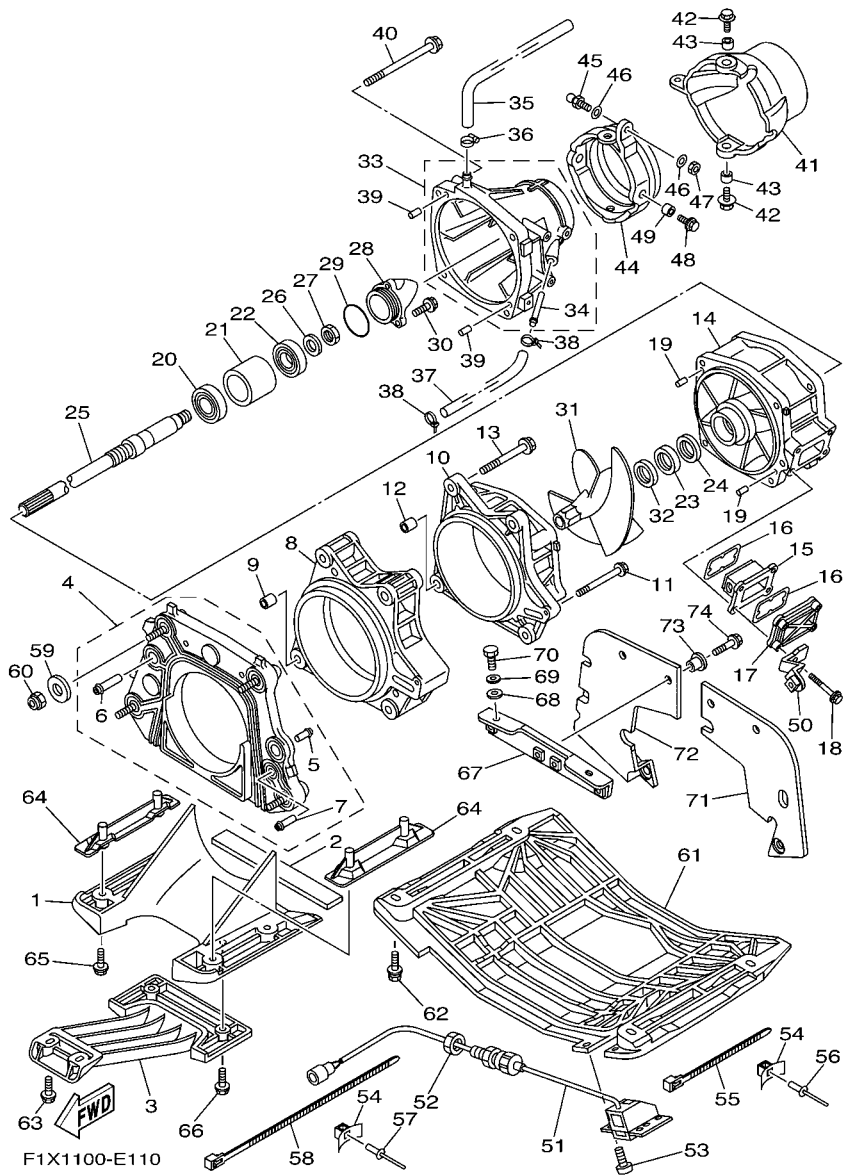


FIG. 11 JET UNIT 1

REF. NO.	PART NO.	DESCRIPTION	USA	CAN	GENE	JPN	REMARKS
54	90600-917U4	CLAMP COMP.	4	4	4	4	
55	90464-32801	CLAMP	3	3	3	3	
56	90267-48802	RIVET, BLIND	3	3	3	3	
57	90267-489U6	RIVET, BLIND	1	1	1	1	
58	90464-99801	CLAMP	1	1	1	1	
59	F1S-U725E-00	WASHER	4	4	4	4	
60	9572R-10300	NUT, FLANGE	4	4	4	4	
61	F1S-U273B-01	PLATE 2	1	1	1	1	
62	90119-08823	BOLT, WITH WASHER	4	4	4	4	
63	90119-069UK	BOLT, WITH WASHER	2	2	2	2	
64	F1G-U8571-00	BRACKET 1	2	2	2	2	
65	90119-08823	BOLT, WITH WASHER	4	4	4	4	
66	90119-069UB	BOLT, WITH WASHER	2	2	2	2	
67	F1B-67557-00	BRACKET	1	1	1	1	
68	90430-12002	GASKET	2	2	2	2	
69	92990-12200	WASHER, PLAIN	2	2	2	2	
70	90109-08041	BOLT	2	2	2	2	
71	F1S-U757E-02	PLATE, RUBBER 1	1	1	1	1	
72	F1S-U757F-02	PLATE, RUBBER 2	1	1	1	1	
73	90387-06080	COLLAR	6	6	6	6	
74	90119-06827	BOLT, WITH WASHER	6	6	6	6	

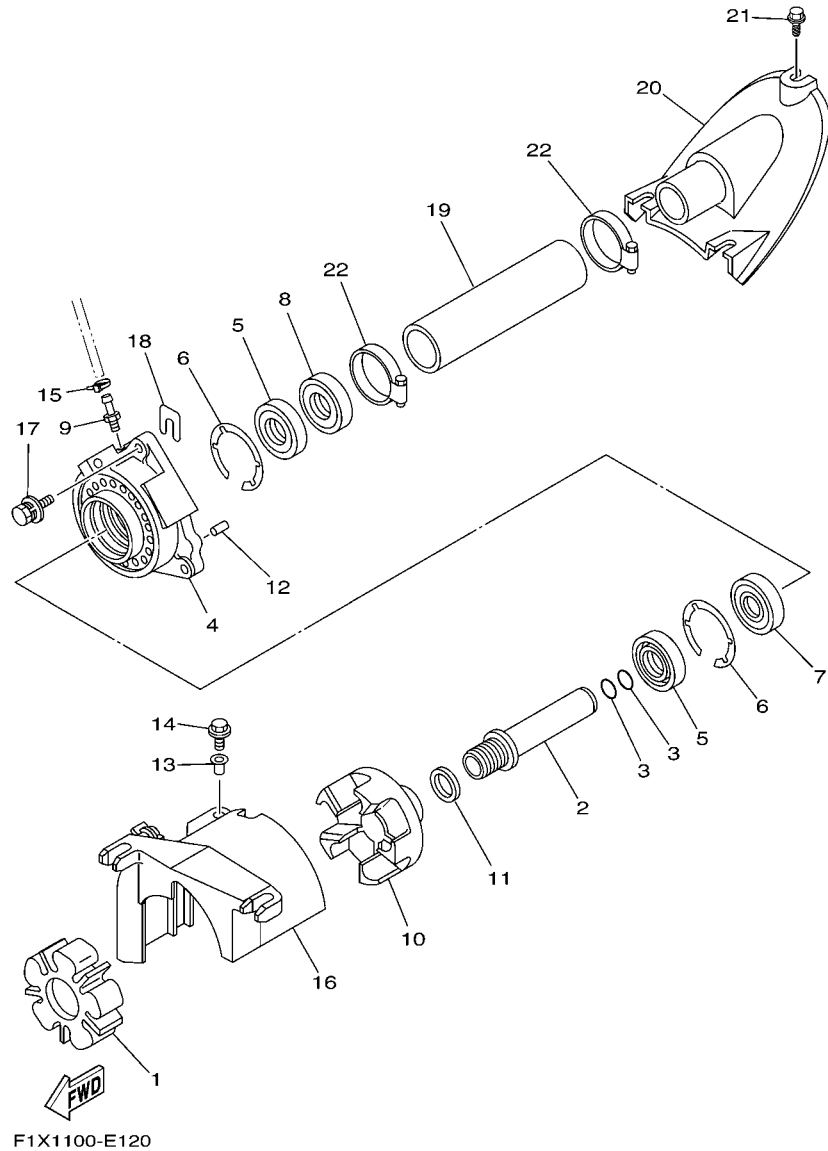
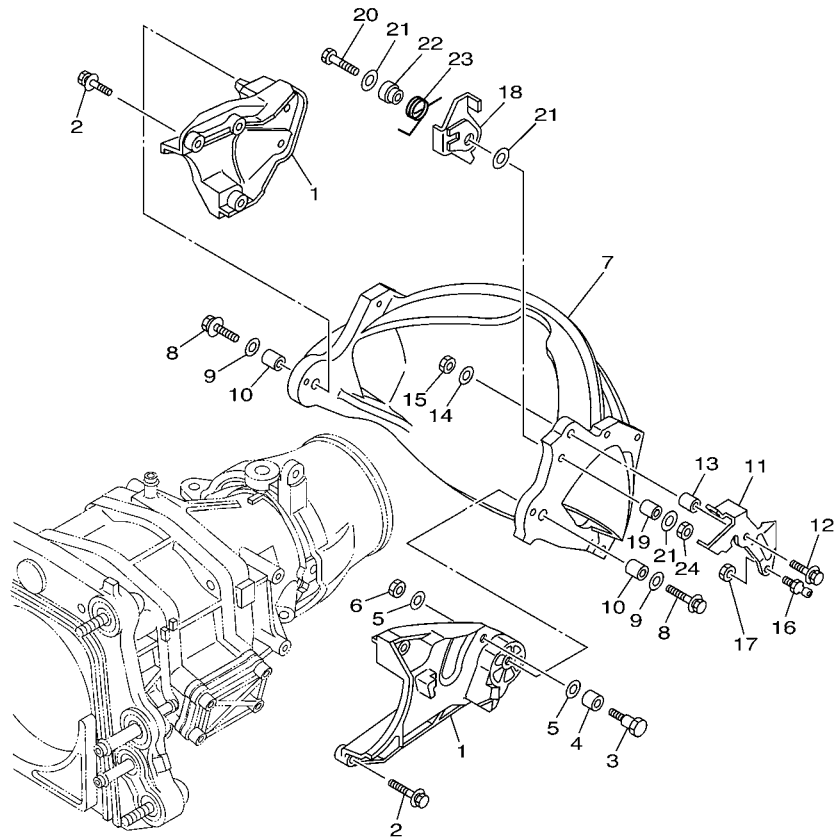


FIG. 12 JET UNIT 2

REF. NO.	PART NO.	DESCRIPTION	USA	CAN	GENE	JPN	REMARKS
1	6D3-4581J-00	RUBBER SHAFT COUPLING	1	1	1	1	
2	60E-51323-00	SHAFT, COUPLOR	1	1	1	1	
3	93210-19001	O-RING	2	2	2	2	
4	61X-45332-03-94	HOUSING, BEARING	1	1	1	1	
5	93101-25M55	OIL SEAL	2	2	2	2	
6	93430-47M04	CIRCLIP	2	2	2	2	
7	93306-205U6	BEARING	1	1	1	1	
8	93102-25009	OIL SEAL	1	1	1	1	
9	61L-45378-00	NIPPLE, HOSE	1	1	1	1	
10	66E-45813-10-94	FLANGE, COUPLING	1	1	1	1	
11	90201-278T0	WASHER, PLATE	1	1	1	1	
12	93606-12019	PIN, DOWEL	2	2	2	2	
13	90387-06M60	COLLAR	1	1	1	1	
14	90119-069UD	BOLT, WITH WASHER	1	1	1	1	
15	90465-11829	CLAMP	1	1	1	1	
16	60E-R1381-01	COVER	1	1	1	1	
17	90119-089UL	BOLT, WITH WASHER	3	3	3	3	
18	GD0-U7249-00-05	SHIM (T=0.5)	2	2	2	2	
19	F0D-U883B-01	PIPE, 1	1	1	1	1	
20	F1B-U883E-00	JOINT, PIPE	1	1	1	1	
21	90149-069UA	SCREW	3	3	3	3	
22	90601-152U3	BAND, HOSE 52	2	2	2	2	

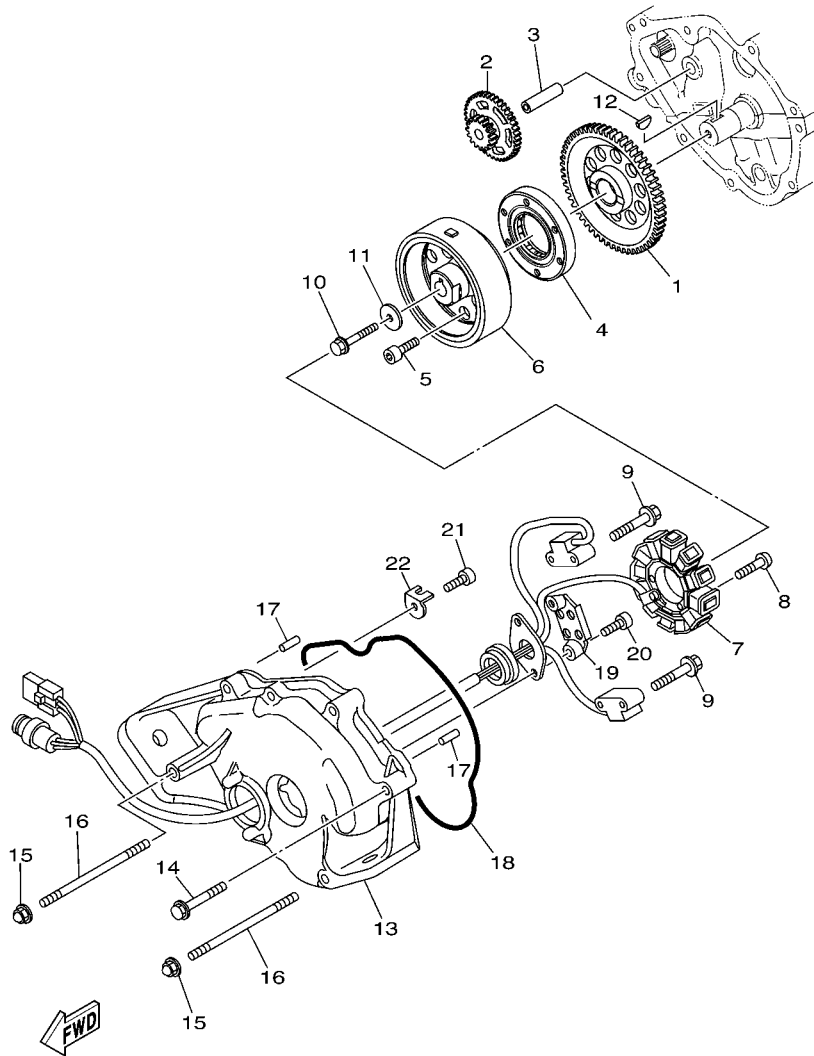
FIG. 13 JET UNIT 3



F1F4100-B110

REF. NO.	PART NO.	DESCRIPTION	USA	CAN	GENE	JPN	REMARKS
1	66V-51341-00-94	BRACKET 1	2	2	2	2	
2	90119-069UD	BOLT, WITH WASHER	6	6	6	6	
3	90109-08879	BOLT	1	1	1	1	
4	90387-10M09	COLLAR	1	1	1	1	
5	9299R-08600	WASHER	2	2	2	2	
6	9538R-08600	NUT	1	1	1	1	
7	66V-51314-01	GATE, REVERSE	1	1	1	1	
8	90119-089UF	BOLT, WITH WASHER	2	2	2	2	
9	90201-088T2	WASHER, PLATE	2	2	2	2	
10	90387-08M30	COLLAR	2	2	2	2	
11	66V-44121-00	LEVER, SHIFT ROD	1	1	1	1	
12	90119-069UB	BOLT, WITH WASHER	1	1	1	1	
13	90387-06M74	COLLAR	1	1	1	1	
14	90201-068T1	WASHER, PLATE	1	1	1	1	
15	9538R-06600	NUT	1	1	1	1	
16	66V-U146E-00	STUD, JOINT BALL	1	1	1	1	
17	9538R-06600	NUT	1	1	1	1	
18	66V-44125-00	LEVER, SHIFT ROD	1	1	1	1	
19	90387-06M74	COLLAR	1	1	1	1	
20	90101-06806	BOLT	1	1	1	1	
21	90201-068T1	WASHER, PLATE	3	3	3	3	
22	90387-06M84	COLLAR	1	1	1	1	
23	90508-14M43	SPRING, TORSION	1	1	1	1	
24	9538R-06600	NUT	1	1	1	1	





F1X1100-E140

FIG. 14 GENERATOR

REF. NO.	PART NO.	DESCRIPTION	USA	CAN	GENE	JPN	REMARKS
1	6D3-15515-00	GEAR 3	1	1	1	1	
2	60E-15517-00	GEAR, IDLER 2	1	1	1	1	
3	60E-15521-00	SHAFT 1	1	1	1	1	
4	4WM-15590-00	STARTER ONE-WAY ASSY	1	1	1	1	
5	90110-08212	BOLT, HEXAGON SOCKET HEAD	6	6	6	6	
6	60E-81450-00	ROTOR ASSY	1	1	1	1	
7	60E-81410-00	STATOR ASSY	1	1	1	1	
8	90149-06013	SCREW	3	3	3	3	
9	97513-05514	BOLT, WITH WASHER	4	4	4	4	
10	90105-105A6	BOLT, FLANGE	1	1	1	1	
11	90201-103U7	WASHER, PLATE	1	1	1	1	
12	90280-03047	KEY, WOODRUFF	1	1	1	1	
13	6B6-81337-00-94	COVER, FLYWHEEL	1	1	1	1	
14	90119-10016	BOLT, WITH WASHER	6	6	6	6	
15	90176-10001	NUT, CROWN	2	2	2	2	
16	90116-10024	BOLT, STUD	2	2	2	2	
17	93608-16M16	PIN, DOWEL	2	2	2	2	
18	93212-04001	O-RING	1	1	1	1	
19	60E-81328-00	CLAMP	1	1	1	1	
20	91317-06014	BOLT	2	2	2	2	
21	91317-05010	BOLT	3	3	3	3	
22	6D3-81845-00	PLATE	3	3	3	3	

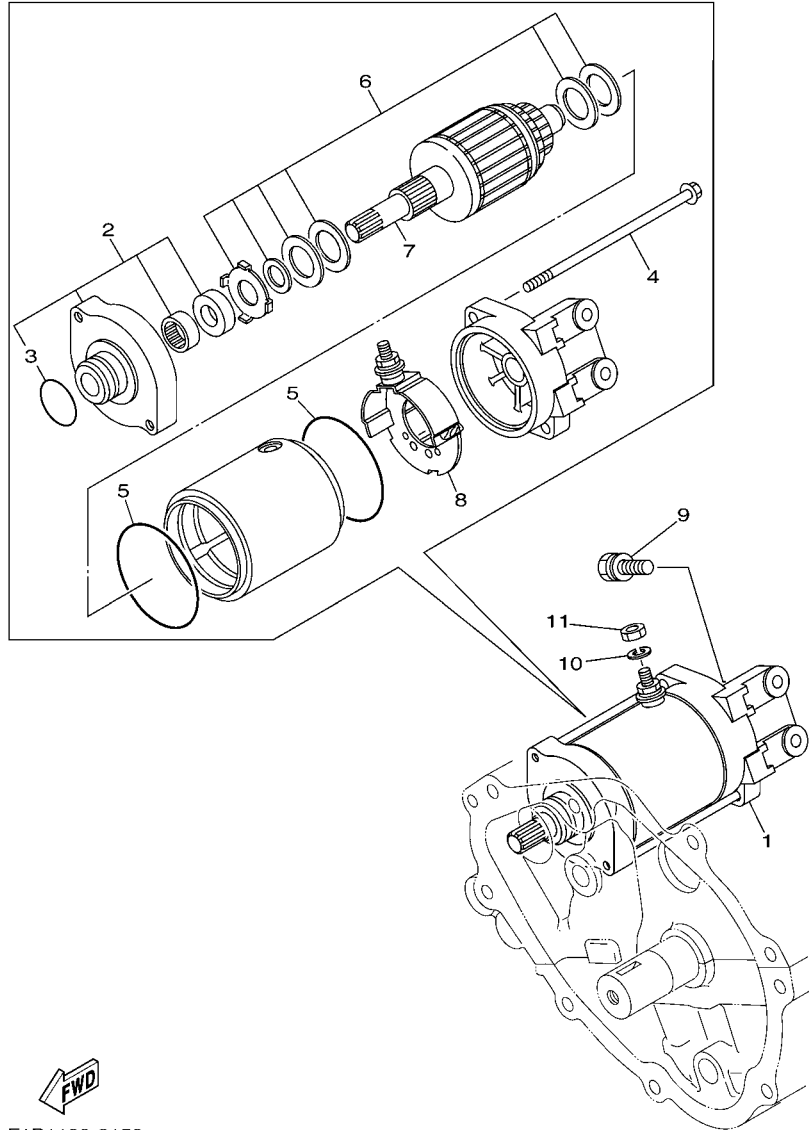


FIG. 15 STARTING MOTOR

REF. NO.	PART NO.	DESCRIPTION	USA	CAN	GENE	JPN	REMARKS
1	60E-81800-00	STARTING MOTOR ASSY	1	1	1	1	
2	6M6-81830-00	.FRONT BRACKET ASSY	1	1	1	1	
3	1FK-81847-00	..O-RING	1	1	1	1	
4	6M6-81826-00	.BOLT	2	2	2	2	
5	11H-81844-00	.GASKET	2	2	2	2	
6	3AJ-81809-00	.WASHER KIT	1	1	1	1	
7	6M6-81850-00	.ARMATURE ASSY	1	1	1	1	
8	6M6-81840-10	.BRUSH HOLDER ASSY	1	1	1	1	
9	97513-08530	BOLT, WITH WASHER	2	2	2	2	
10	92990-06100	WASHER, SPRING	1	1	1	1	
11	95380-06700	NUT	1	1	1	1	



F1B1100-2150

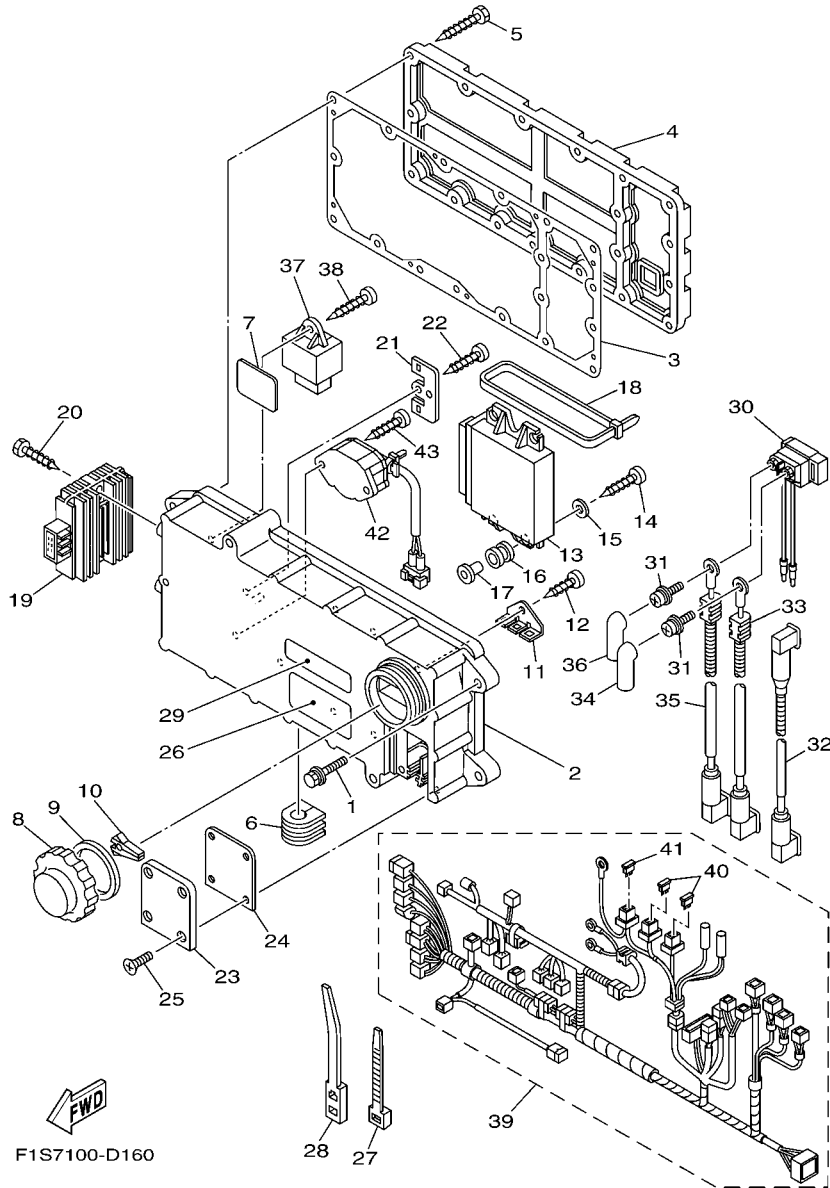
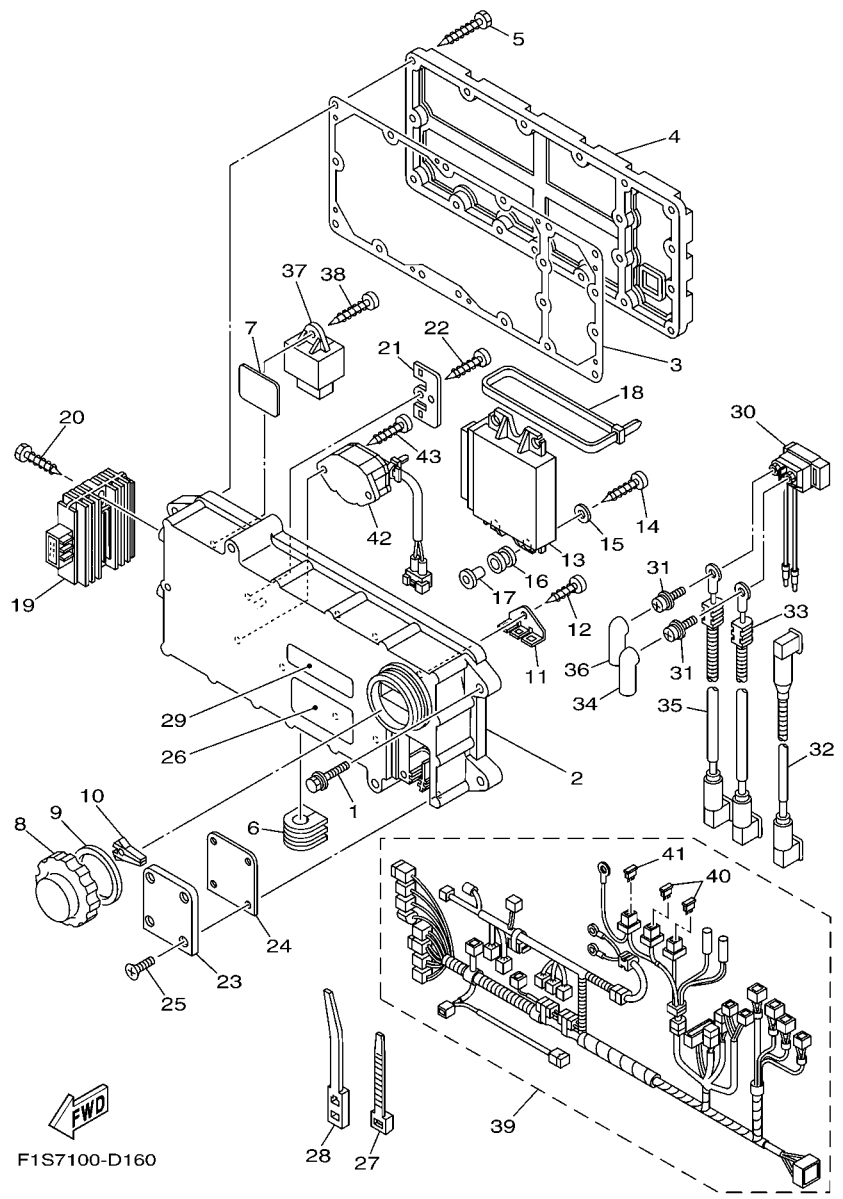


FIG. 16 ELECTRICAL 1

REF. NO.	PART NO.	DESCRIPTION	USA	CAN	GENE	JPN	REMARKS
1	90119-089UT	BOLT, WITH WASHER	4	4	4	4	
2	6B6-8552A-00	HOUSING	1	1	1	1	
3	60E-81921-00	GASKET, TERMINAL	1	1	1	1	
4	60E-8552E-00	COVER, CASE	1	1	1	1	
5	97780-60430	SCREW, TAPPING	18	18	18	18	
6	90480-01012	GROMMET	1	1	1	1	
7	60E-84742-00	SEAT, BASE	1	1	1	1	
8	66V-8132W-00	CAP	1	1	1	1	
9	66V-81844-00	GASKET	1	1	1	1	
10	67F-2812A-00	PULLER, FUSE	1	1	1	1	
11	60E-82153-00	STAY, FUSE HOLDER	1	1	1	1	
12	97780-60516	SCREW, TAPPING	1	1	1	1	
13	6B6-8591A-20	ENGINE CONTROL UNIT ASSY	1	1	1	1	
14	97780-60530	SCREW, TAPPING	4	4	4	4	
15	90201-06M05	WASHER, PLATE	4	4	4	4	
16	6A0-82317-00	DAMPER, IGNITION COIL	4	4	4	4	
17	90387-06119	COLLAR	4	4	4	4	
18	90464-99003	CLAMP	1	1	1	1	
19	68V-81960-00	RECTIFIER & REGULATOR ASSY	1	1	1	1	
20	97780-60430	SCREW, TAPPING	2	2	2	2	
21	60E-87179-00	PLATE, COUPLER	1	1	1	1	
22	97780-60516	SCREW, TAPPING	1	1	1	1	
23	60E-81916-00	COVER, TERMINAL	1	1	1	1	
24	60E-82533-00	GASKET	1	1	1	1	
25	98680-05520	SCREW, OVAL HEAD	4	4	4	4	
26	6B6-83623-00	MARK 3	1	1	1	1	
27	90465-13M97	CLAMP	1	1	1	1	

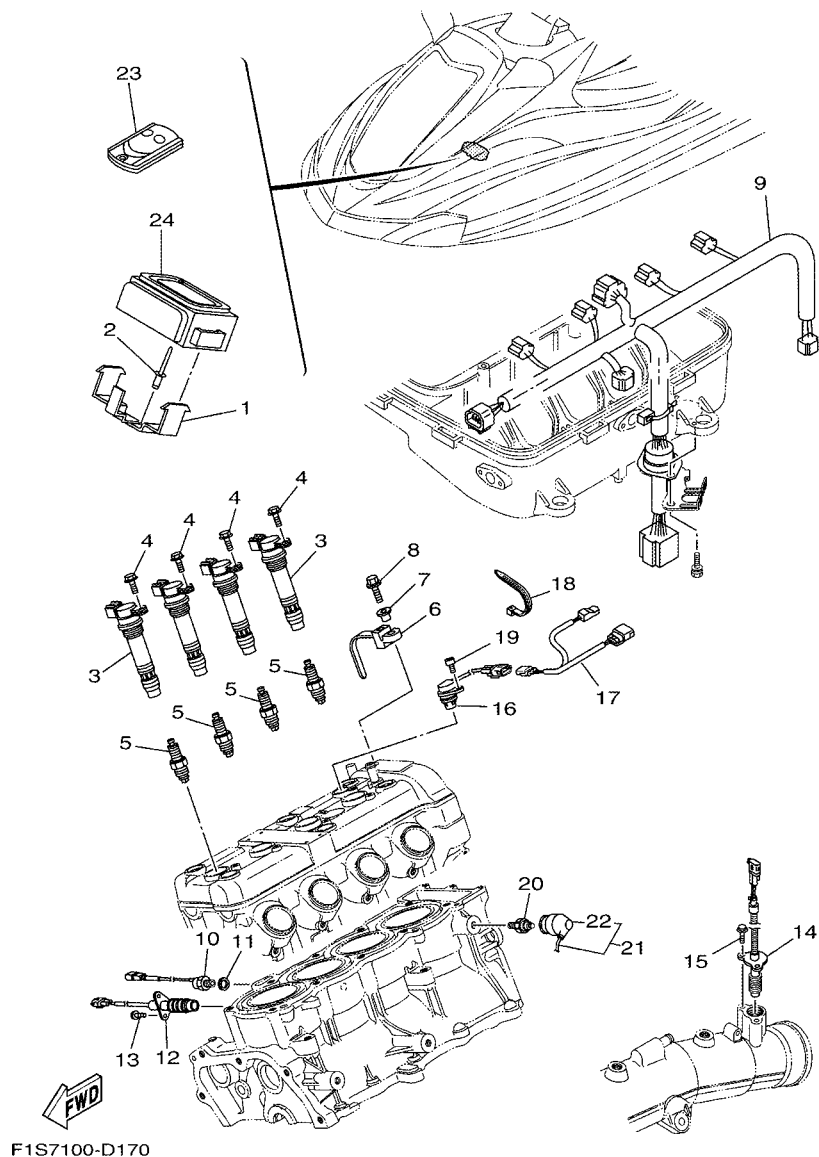


F1S7100-D160

FIG. 16 ELECTRICAL 1

REF. NO.	PART NO.	DESCRIPTION	USA	CAN	GENE	JPN	REMARKS
28	90464-50002	CLAMP	2	2	2	2	
29	60E-83627-00	LABEL, CAUTION 7	1	1	1	1	
30	6B6-81940-00	STARTER RELAY ASSY	1	1	1	1	
31	90159-06008	SCREW, WITH WASHER	2	2	2	2	
32	6D3-82116-00	WIRE, MINUS LEAD	1	1	1	1	
33	60E-82117-10	WIRE, LEAD	1	1	1	1	
34	66V-82119-00	COVER, LEAD WIRE	1	1	1	1	
35	60E-82117-20	WIRE, LEAD	1	1	1	1	
36	66V-82119-00	COVER, LEAD WIRE	1	1	1	1	
37	60E-81950-00	RELAY ASSY	1	1	1	1	
38	97780-60520	SCREW, TAPPING	1	1	1	1	
39	6B6-8259L-11	WIRE HARNESS ASSY 1	1	1	1	1	
40	67F-82151-30	.FUSE (3A)	4	4	4	4	
41	67F-82151-00	.FUSE (20A)	2	2	2	2	
42	60E-8259E-00	SWITCH ASSY	1	1	1	1	
43	97780-60520	SCREW, TAPPING	2	2	2	2	

FIG. 17 ELECTRICAL 2



REF. NO.	PART NO.	DESCRIPTION	USA	CAN	GENE	JPN	REMARKS
1	F1S-U826C-00	BRACKET	1	1	1	1	
2	90267-489U9	RIVET, BLIND	2	2	2	2	
3	6B6-82310-00	IGNITION COIL ASSY	4	4	4	4	
4	95814-06016	BOLT, FLANGE	4	4	4	4	
5	94702-00409	PLUG, SPARK (NGK CR9EB)	4	4	4	4	
6	90465-12M53	CLAMP	1	1	1	1	
7	90387-06M05	COLLAR	1	1	1	1	
8	95814-06016	BOLT, FLANGE	1	1	1	1	
9	6B6-8259M-00	WIRE HARNESS ASSY 2	1	1	1	1	
10	60E-85790-01	THERMOSENSOR ASSY	1	1	1	1	
11	92990-10600	WASHER, PLATE	1	1	1	1	
12	60E-82560-A1	THERMO SWITCH ASSY	1	1	1	1	
13	97595-06416	BOLT, WITH WASHER	2	2	2	2	
14	60E-82560-01	THERMO SWITCH ASSY	1	1	1	1	
15	97595-06416	BOLT, WITH WASHER	2	2	2	2	
16	60E-85896-00	SENSOR, CAM POSITION	1	1	1	1	
17	60E-81325-10	CONDENSER 1	1	1	1	1	
18	90465-13M11	CLAMP	1	1	1	1	
19	91380-06016	BOLT	1	1	1	1	
20	68V-82504-00	OIL PRESSURE SWITCH ASSY	1	1	1	1	
21	60E-81315-00	LEAD WIRE ASSY	1	1	1	1	
22	60E-82532-00	.CAP	1	1	1	1	
23	6B6-86261-00	TRANSMITTER COMP	2	2		2	EXCEPT GENE
	6B6-86261-10	TRANSMITTER COMP			2		GENE
24	6B6-86265-00	RECIVER COMP	1	1		1	EXCEPT GENE
	6B6-86265-10	RECIVER COMP			1		GENE

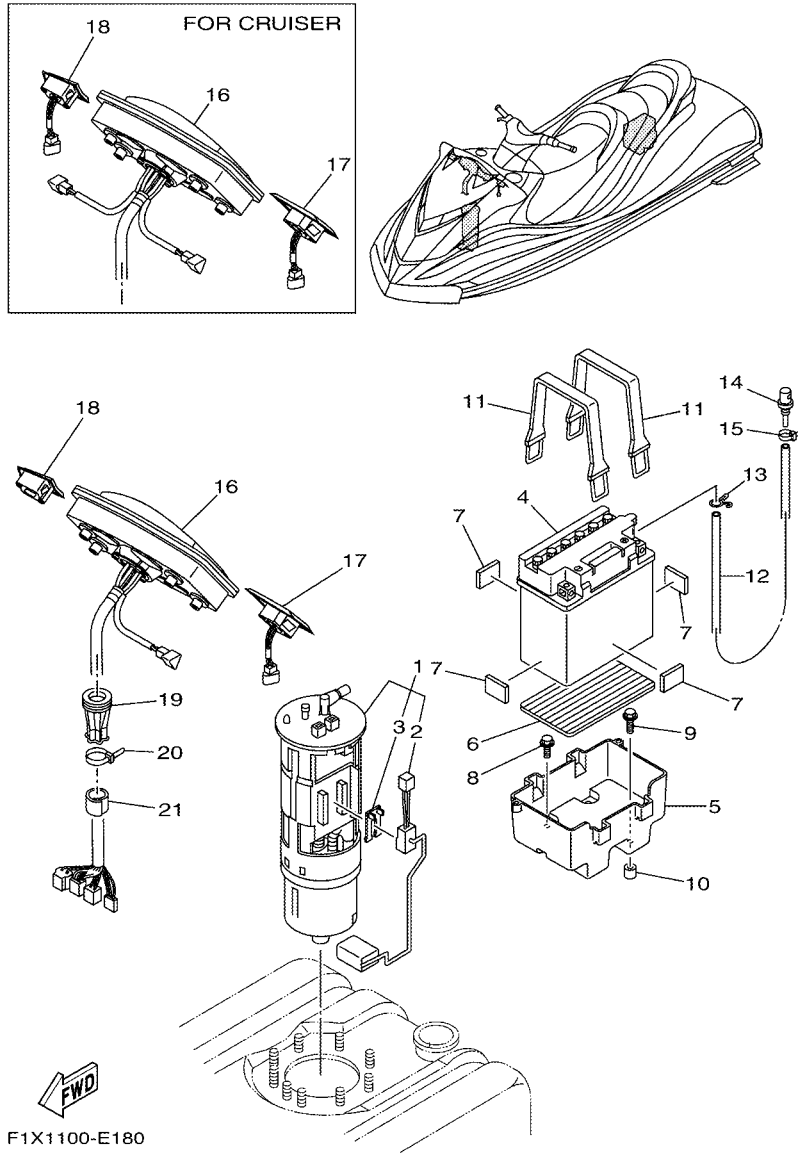


FIG. 18 ELECTRICAL 3

REF. NO.	PART NO.	DESCRIPTION	USA	CAN	GENE	JPN	REMARKS
1	60E-13907-01	FUEL PUMP COMP.	1	1	1	1	
2	60E-682E0-00	.FUEL SENDER ASSY	1	1	1	1	
3	60E-82556-00	.DAMPER, STOPPER	1	1	1	1	
4	EU0-82110-09	BATTERY ASSY (YB16CL-B)	1	1	1	1	YUASA
5	GP7-U8211-00	CASE, BATTERY	1	1	1	1	
6	F1S-U8221-00	PAD, BATTERY	1	1	1	1	
7	EU0-U8221-30	PAD, BATTERY 2	4	4	4	4	
8	90119-069US	BOLT, WITH WASHER	2	2	2	2	
9	90119-06832	BOLT, WITH WASHER	2	2	2	2	
10	F1B-6821G-01	PLATE, BATTERY	2	2	2	2	
11	EU0-U821D-00	BAND,BATTERY 1	2	2	2	2	
12	F0D-U785G-10	HOSE, AIR VENT	1	1	1	1	
13	90467-089U1	CLIP	1	1	1	1	
14	GJ3-6215F-00	NIPPLE	1	1	1	1	
15	90465-11829	CLAMP	1	1	1	1	
16	F1X-6820A-00	METER ASSY	1	1	1	1	FOR CRUISER
	F1X-6820A-10	METER ASSY	1	1	1	1	
17	F1X-68090-00	SWITCH ASSY.	1	1	1	1	
18	F1X-68090-10	SWITCH ASSY.	1	1	1	1	FOR CRUISER
	F1Y-68322-00	PANEL	1	1	1	1	
19	F1X-U822E-00	GROMMET	1	1	1	1	
20	90601-200U1	BAND	1	1	1	1	
21	GJ1-U7578-11	PACKING, HOSE 2	1	1	1	1	

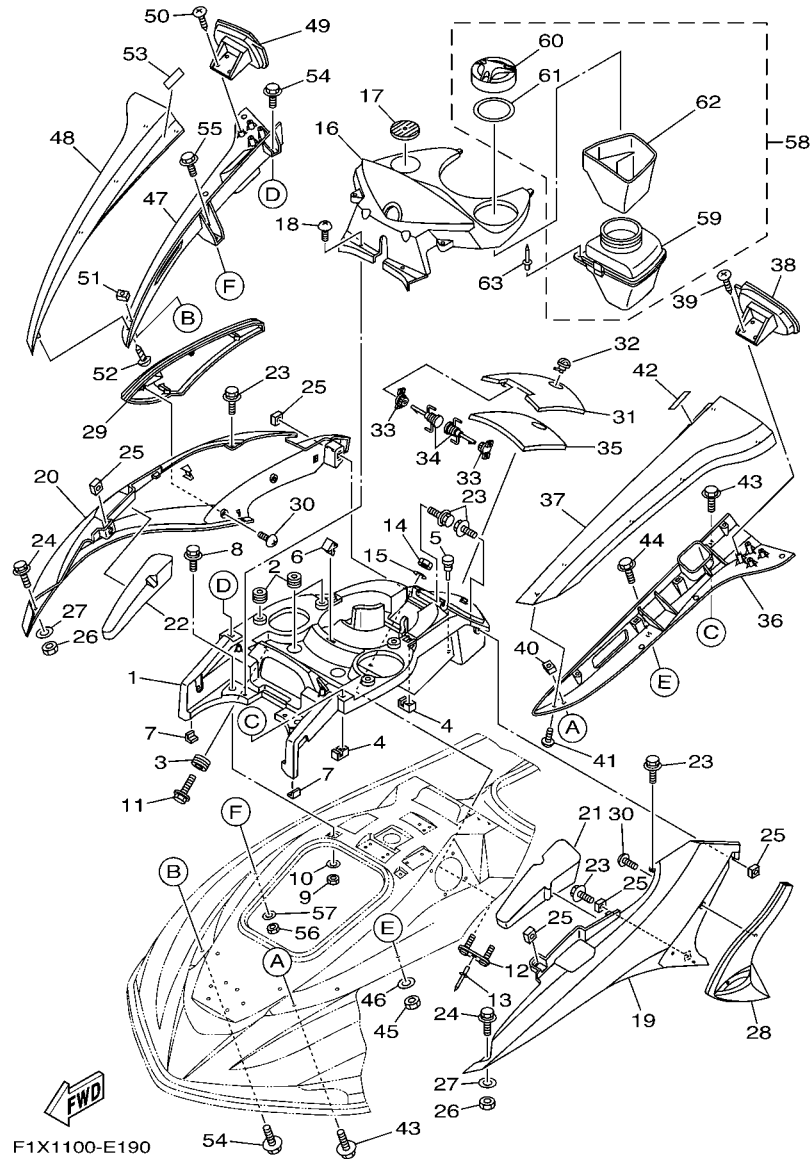
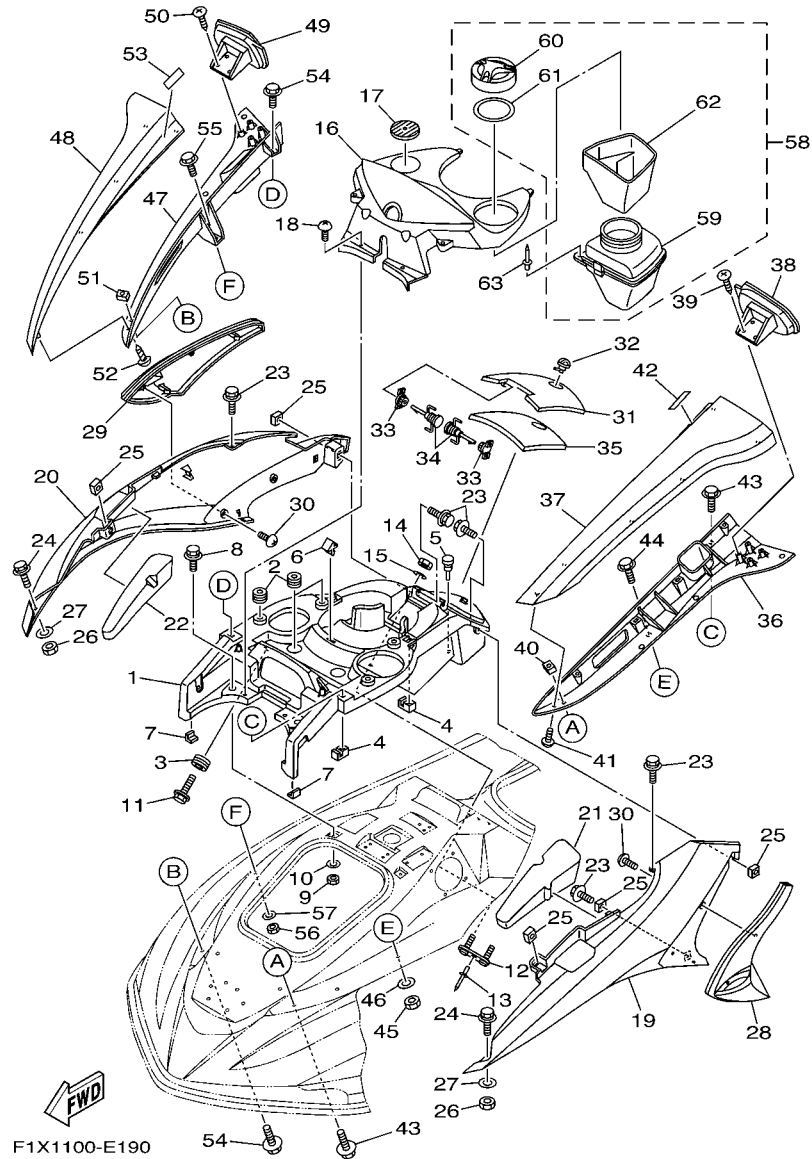


FIG. 19 ENGINE HATCH 1

REF. NO.	PART NO.	DESCRIPTION	USA	CAN	GENE	JPN	REMARKS
1	F1X-U550A-00	CENTER COVER COMP.	1	1	1	1	
2	F1X-U828E-01	DAMPER 1	6	6	6	6	
3	90480-19800	GROMMET	4	4	4	4	
4	F1X-U517E-10	NUT	4	4	4	4	
5	90605-502U2	PLUG	1	1	1	1	
6	F1K-U266C-00	PACKING 4	1	1	1	1	
7	F1B-U5115-00	TRIM,HATCH 1	2	2	2	2	
8	90119-06803	BOLT, WITH WASHER	1	1	1	1	
9	9572R-06300	NUT, NYLON	2	2	2	2	
10	9299R-06200	WASHER	2	2	2	2	
11	90119-05803	BOLT, WITH WASHER	4	4	4	4	
12	F1X-U5372-00	BRACKET	1	1	1	1	
13	90267-489U1	RIVET,BLIND	1	1	1	1	
14	9572R-06300	NUT, NYLON	2	2	2	2	
15	9299R-06200	WASHER	2	2	2	2	
16	F1X-U8262-01-P0	COVER METER	1	1	1	1	SMF
	F1X-U8262-10-P0	COVER METER	1	1	1	1	DNMC
	F1X-U8262-20-P1	COVER METER	1	1	1	1	LNMP
17	F1X-U3844-00	MAT	1	1	1	1	
18	90149-05903	SCREW	4	4	4	4	
19	F1X-U377B-02-P0	COVER,SIDE 1	1	1	1	1	NYM4
	F1X-U377B-10-P0	COVER,SIDE 1	1	1	1	1	DNMC
	F1X-U377B-20-P0	COVER,SIDE 1	1	1	1	1	YM3
	F1X-U377B-30-P0	COVER,SIDE 1	1	1	1	1	DPBMT
20	F1X-U377C-02-P0	COVER,SIDE 2	1	1	1	1	NYM4
	F1X-U377C-10-P0	COVER,SIDE 2	1	1	1	1	DNMC
	F1X-U377C-20-P0	COVER,SIDE 2	1	1	1	1	YM3



F1X1100-E190

FIG. 19 ENGINE HATCH 1

REF. NO.	PART NO.	DESCRIPTION	USA	CAN	GENE	JPN	REMARKS
20	F1X-U377C-30-P0	COVER, SIDE 2	1	1	1	1	DPBMT
21	F1X-U377H-01	INNER, COVER SIDE 1	1	1	1	1	
22	F1X-U377J-01	INNER, COVER SIDE 2	1	1	1	1	
23	90119-06858	BOLT, WITH WASHER	8	8	8	8	
24	90119-06803	BOLT, WITH WASHER	2	2	2	2	
25	F1X-U517E-10	NUT	6	6	6	6	
26	9572R-06300	NUT, NYLON	2	2	2	2	
27	9299R-06200	WASHER	2	2	2	2	
28	F1X-U377F-00	ORNAMENT, SIDE LH	1	1	1	1	
29	F1X-U377G-00	ORNAMENT, SIDE RH	1	1	1	1	
30	90149-05903	SCREW	4	4	4	4	
31	F1X-U517H-00	LID HATCH	1	1	1	1	
32	F1X-62875-00	LOCK	1	1	1	1	
33	F1B-60210-00	GEAR ASSY	2	2	2	2	
34	F1B-6517R-00	PIN, HINGE	2	2	2	2	
35	F1X-U519D-01	PACKING CASE	1	1	1	1	
36	F1X-U596K-03-P0	COVER, MIRROR LOWER	1	1	1	1	SMF
	F1X-U596K-10-P0	COVER, MIRROR LOWER	1	1	1	1	DNMC
	F1X-U596K-20-P0	COVER, MIRROR LOWER	1	1	1	1	LNMP
37	F1X-U596H-02-P0	COVER, MIRROR UPPER	1	1	1	1	SMF
	F1X-U596H-10-P0	COVER, MIRROR UPPER	1	1	1	1	DNMC
	F1X-U596H-20-P0	COVER, MIRROR UPPER	1	1	1	1	LNMP
38	F1X-U596B-01	MIRROR LH	1	1	1	1	FOR SMF
	F1X-U596B-10	MIRROR LH	1	1	1	1	FOR DNMC, LNMP
39	90149-05903	SCREW	4	4	4	4	
40	F1X-U517E-10	NUT	1	1	1	1	
41	90149-05903	SCREW	6	6	6	6	



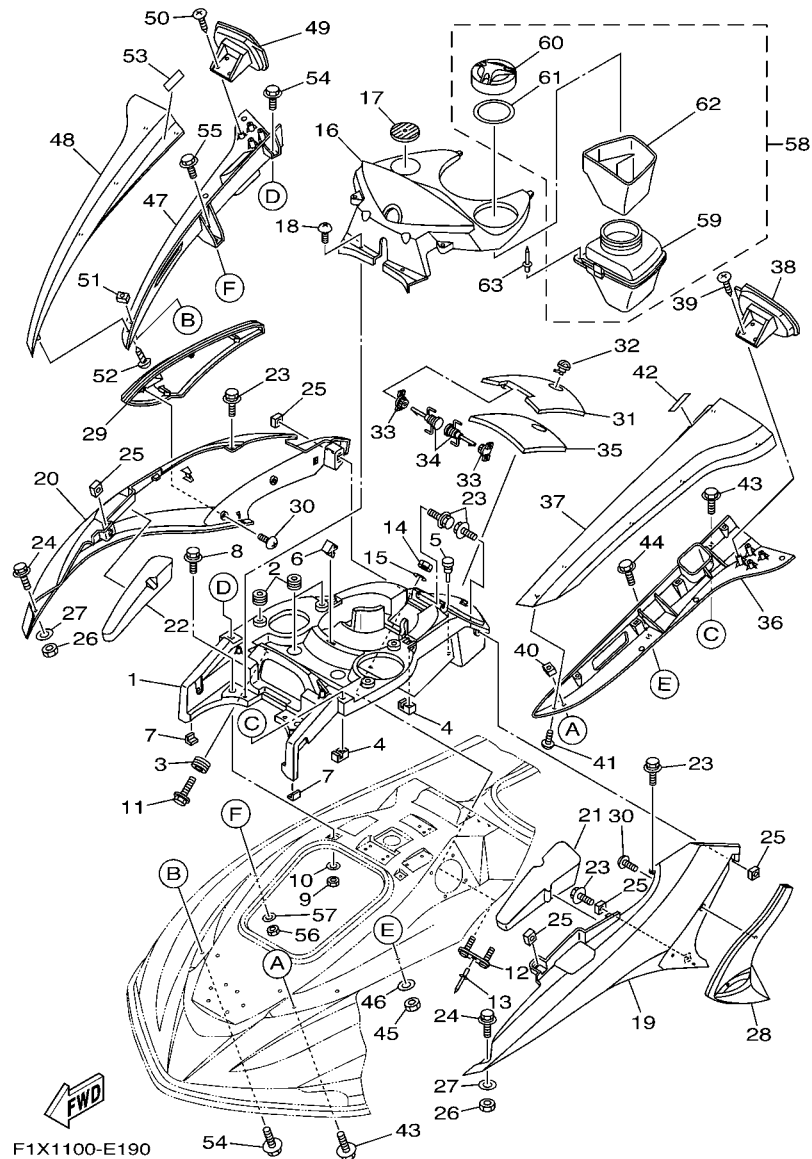
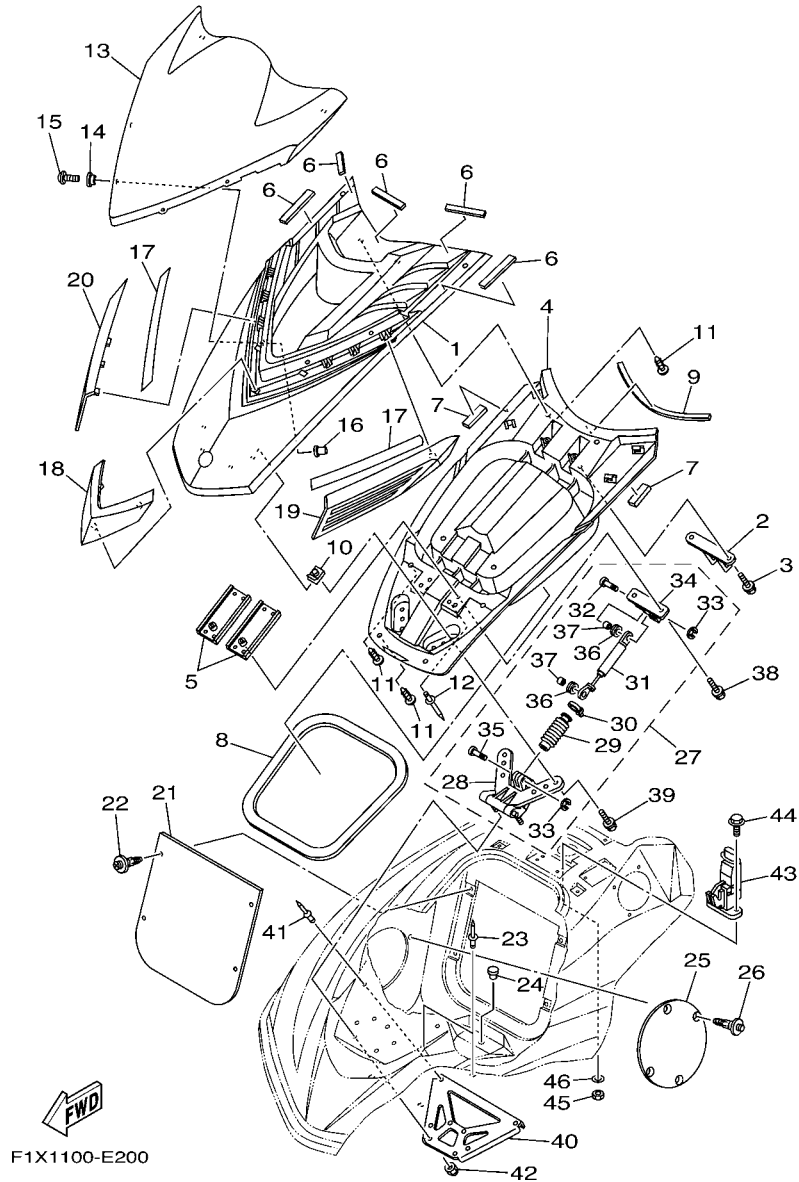


FIG. 19 ENGINE HATCH 1

REF. NO.	PART NO.	DESCRIPTION	USA	CAN	GENE	JPN	REMARKS
42	F1K-U266B-00	PACKING 3	1	1	1	1	
43	90119-06858	BOLT, WITH WASHER	2	2	2	2	
44	90119-06803	BOLT, WITH WASHER	1	1	1	1	
45	9572R-06300	NUT, NYLON	1	1	1	1	
46	9299R-06200	WASHER	1	1	1	1	
47	F1X-U596L-03-P0	COVER, MIRROR LOWER	1	1	1	1	SMF
	F1X-U596L-10-P0	COVER, MIRROR LOWER	1	1	1	1	DNMC
	F1X-U596L-20-P0	COVER, MIRROR LOWER	1	1	1	1	LNMP
48	F1X-U596J-02-P0	COVER, MIRROR UPPER	1	1	1	1	SMF
	F1X-U596J-10-P0	COVER, MIRROR UPPER	1	1	1	1	DNMC
	F1X-U596J-20-P0	COVER, MIRROR UPPER	1	1	1	1	LNMP
49	F1X-U596C-01	MIRROR RH	1	1	1	1	FOR SMF
	F1X-U596C-10	MIRROR RH	1	1	1	1	FOR DNMC, LNMP
50	90149-05903	SCREW	4	4	4	4	
51	F1X-U517E-10	NUT	1	1	1	1	
52	90149-05903	SCREW	6	6	6	6	
53	F1K-U266B-00	PACKING 3	1	1	1	1	
54	90119-06858	BOLT, WITH WASHER	2	2	2	2	
55	90119-06803	BOLT, WITH WASHER	1	1	1	1	
56	9572R-06300	NUT, NYLON	1	1	1	1	
57	9299R-06200	WASHER	1	1	1	1	
58	F1X-U591A-01	CASE, ASSY 1	1	1	1	1	
59	F1X-U591B-01	.BODY, CASE 1	1	1	1	1	
60	F1X-U591C-01	.CAP, CASE	1	1	1	1	
61	F1X-U591D-01	.PACKING, CASE	1	1	1	1	
62	F1X-U591L-00	.INNER, CASE	1	1	1	1	
63	90267-489UP	RIVET, BLIND	2	2	2	2	

FIG. 20 ENGINE HATCH 2



F1X1100-E200

REF. NO.	PART NO.	DESCRIPTION	USA	CAN	GENE	JPN	REMARKS
1	F1X-U517B-02-P0	LID, ENGINE ROOM	1	1	1	1	NYM4
	F1X-U517B-10-P0	LID, ENGINE ROOM	1	1	1	1	LNMP
	F1X-U517B-20-P0	LID, ENGINE ROOM	1	1	1	1	YM3
	F1X-U517B-30-P0	LID, ENGINE ROOM	1	1	1	1	DPBMT
2	F0X-6517F-01	HOOK,LID LOCK	1	1	1	1	
3	90119-069UH	BOLT, WITH WASHER	2	2	2	2	
4	F1X-U2103-01	VENTILATOR COVER COMP., 2	1	1	1	1	
5	F1B-65148-00	PLATE, HATCH	2	2	2	2	
6	F0X-U515E-01	DAMPER 2	5	5	5	5	
7	F1X-U266B-00	PACKING 3	2	2	2	2	
8	F1B-U2663-00	PACKING 1	1	1	1	1	
9	F1B-U266B-00	PACKING 3	1	1	1	1	
10	90183-06902	NUT, SPRING	4	4	4	4	
11	90149-05903	SCREW	8	8	8	8	
12	90267-489U9	RIVET, BLIND	8	8	8	8	
13	F1X-U515N-01	VISOR	1	1	1	1	
14	90381-05041	BUSH, SOLID	6	6	6	6	
15	90111-05017	BOLT,HEX. SOCKET BUTTON	6	6	6	6	
16	90179-05800	NUT	6	6	6	6	
17	F0V-U3635-11	TAPE, FITTING	2	2	2	2	
18	F1X-U517V-00	ORNAMENT, CENTER	1	1	1	1	
19	F1X-U517W-01	ORNAMENT, LH	1	1	1	1	
20	F1X-U517X-01	ORNAMENT, RH	1	1	1	1	
21	F1S-U475F-00	PLATE, LOKER BOW	1	1	1	1	
22	90269-08801	RIVET	4	4	4	4	
23	90267-489UP	RIVET, BLIND	4	4	4	4	
24	90605-502U1	PLUG, BLIND	1	1	1	1	

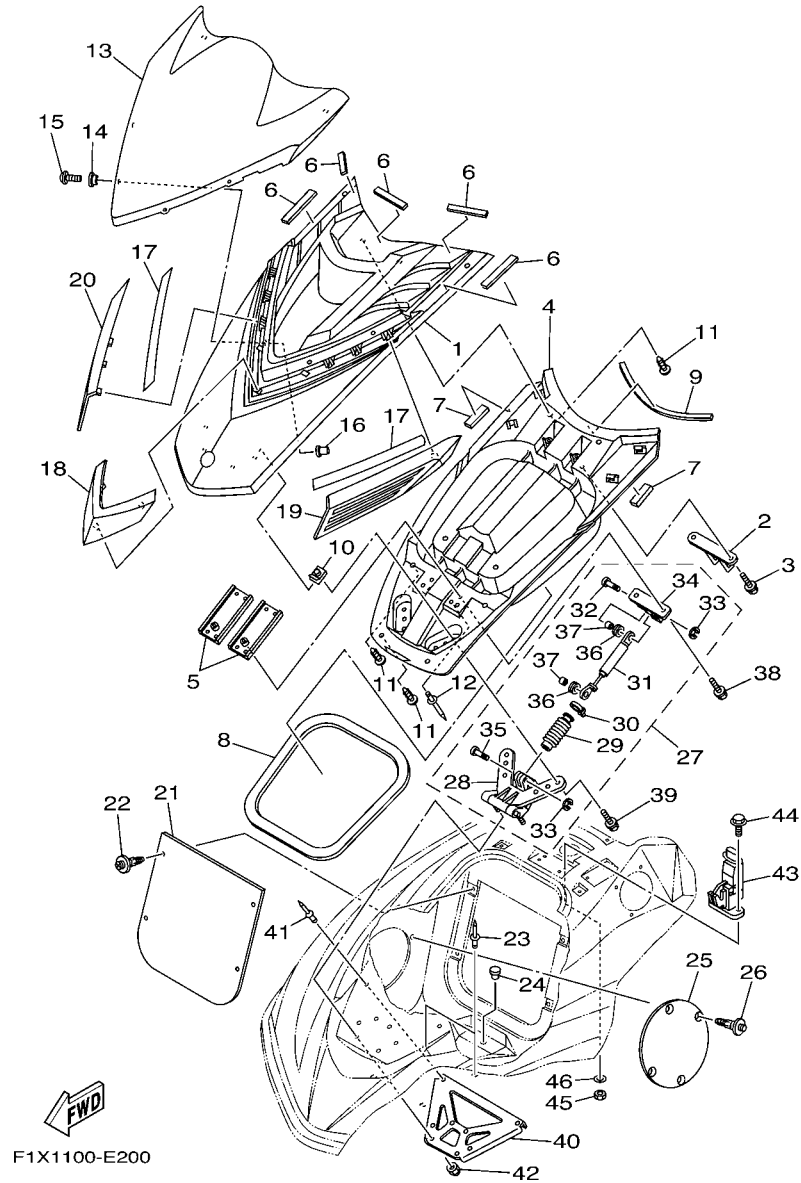
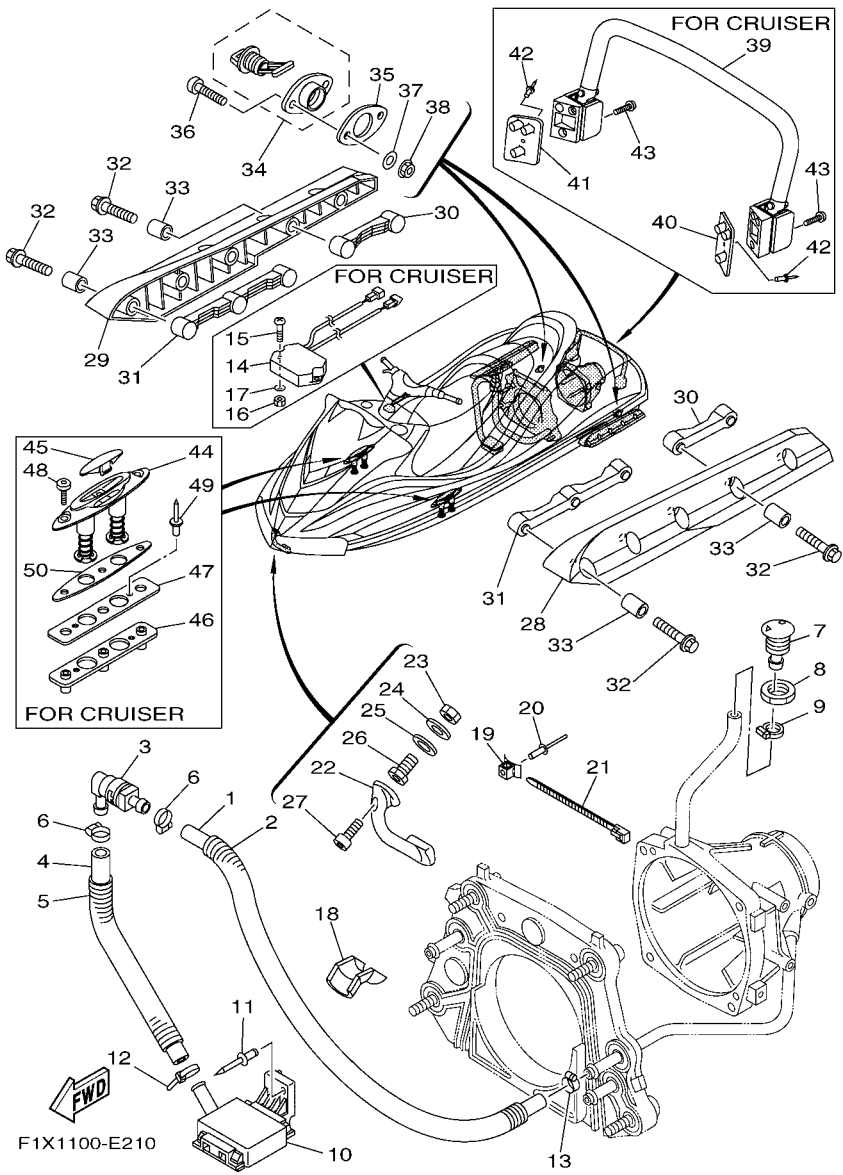


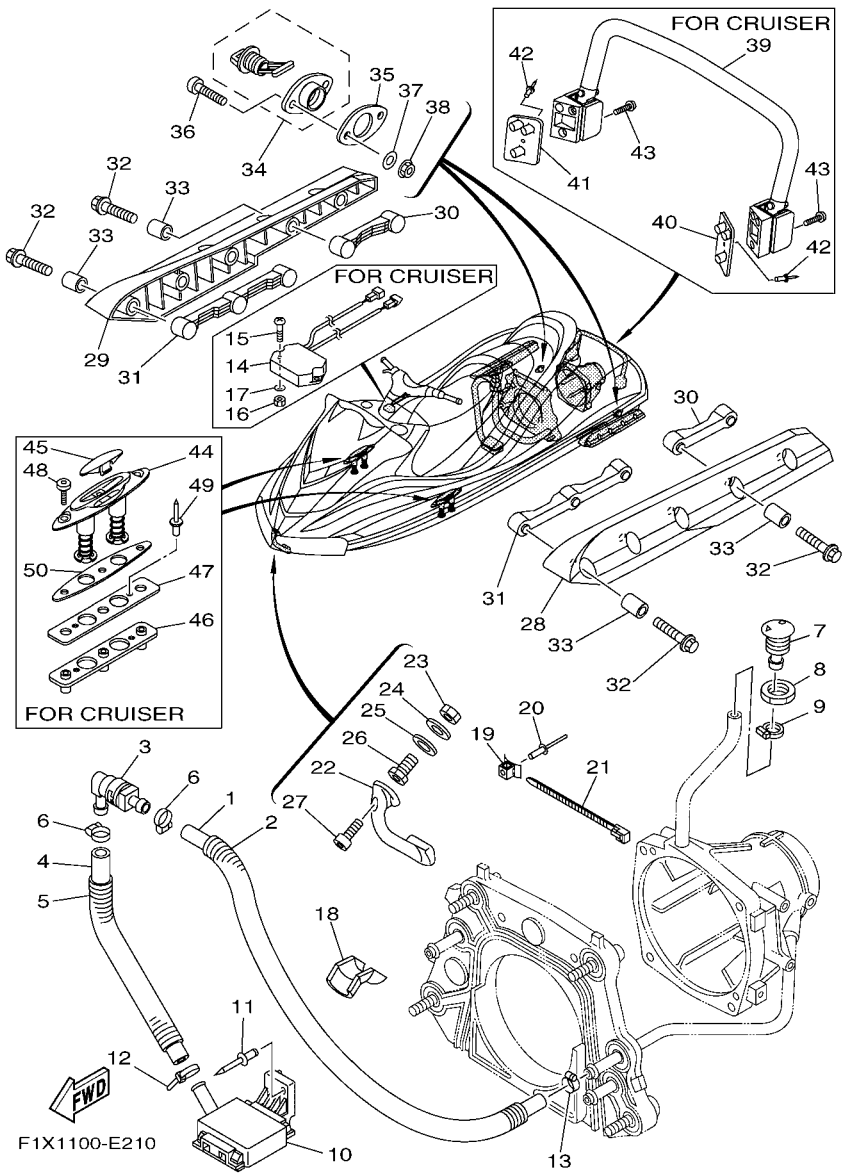
FIG. 20 ENGINE HATCH 2

REF. NO.	PART NO.	DESCRIPTION	USA	CAN	GENE	JPN	REMARKS
25	F1S-U7228-00	COVER, INSPECTION 2	1	1	1	1	
26	90269-08801	RIVET	4	4	4	4	
27	F1B-6515A-01	HINGE ASSY.	1	1	1	1	
28	F1B-6517D-00	.HINGE, LID	1	1	1	1	
29	F1B-6518F-00	.COVER , SPRING	1	1	1	1	
30	90464-44001	.CLAMP	1	1	1	1	
31	F1B-6515D-01	.DAMPER 1	1	1	1	1	
32	F1B-6515J-00	.SHAFT B	1	1	1	1	
33	99080-06600	.CIRCLIP	2	2	2	2	
34	F1B-6514U-00	.STAY, DAMPER	1	1	1	1	
35	F1B-6515H-00	.SHAFT A	1	1	1	1	
36	90480-10006	.GROMMET	2	2	2	2	
37	90387-07008	.COLLAR	2	2	2	2	
38	90119-069UH	BOLT, WITH WASHER	2	2	2	2	
39	90119-069UK	BOLT, WITH WASHER	4	4	4	4	
40	F1B-6518E-00	PRATE, HINGE LID	1	1	1	1	
41	90267-48020	RIVET, BLIND	4	4	4	4	
42	9572R-06300	NUT, NYLON	4	4	4	4	
43	F1X-6517C-00	LOCK, LID	1	1	1	1	
44	90119-06837	BOLT, WITH WASHER	2	2	2	2	
45	9572R-06300	NUT, NYLON	2	2	2	2	
46	9299R-06200	WASHER	2	2	2	2	



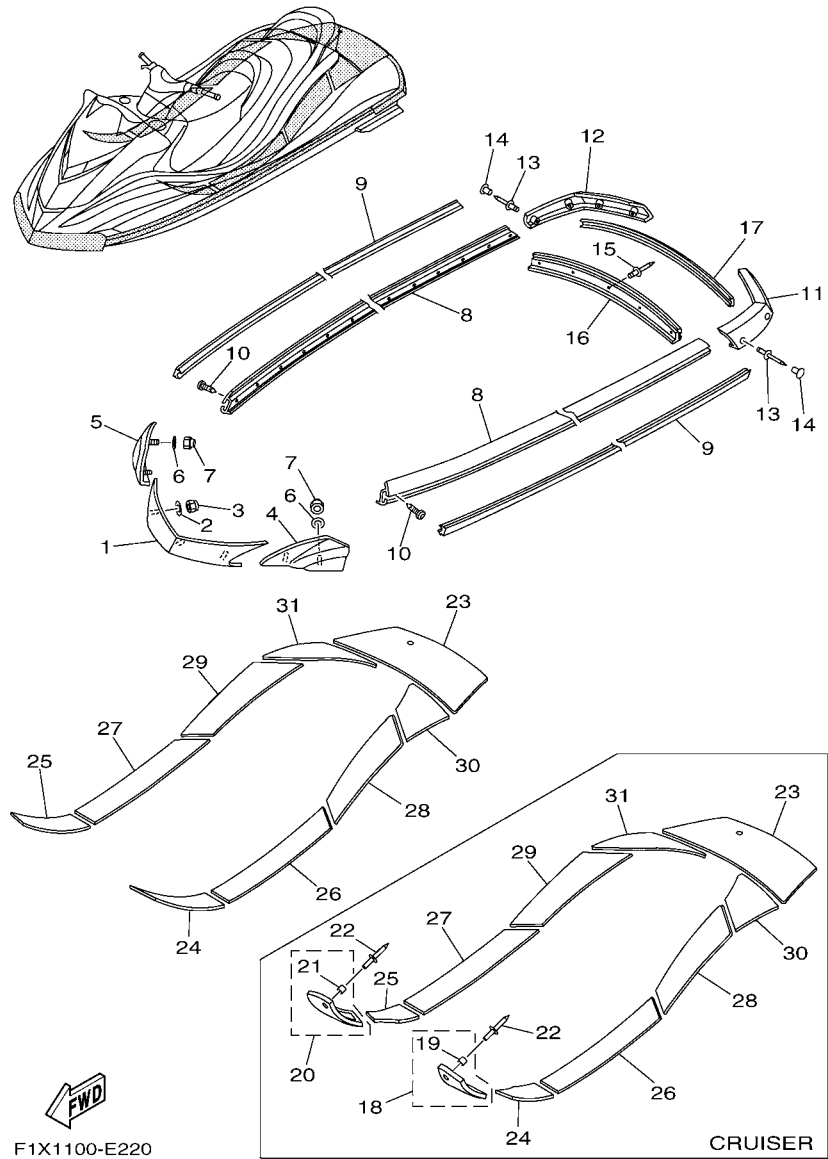
**FIG. 21 HULL & DECK**

REF. NO.	PART NO.	DESCRIPTION	USA	CAN	GENE	JPN	REMARKS
1	90445-20804	HOSE (L860)	1	1	1	1	
2	90446-27M73	HOSE (L700)	1	1	1	1	
3	68N-5112T-00	JOINT, HOSE	1	1	1	1	
4	90445-20800	HOSE (L500)	1	1	1	1	
5	90446-27M55	TUBE (L400)	1	1	1	1	
6	90601-118UF	BAND, HOSE 18	2	2	2	2	
7	FN8-6269B-00	SPOUT	1	1	1	1	
8	EU0-61652-00	NUT	1	1	1	1	
9	90601-118UF	BAND, HOSE 18	1	1	1	1	
10	F1B-U761D-02	STRAINER, BILGE	1	1	1	1	
11	90267-489U8	RIVET, BLIND	1	1	1	1	
12	90601-200U1	BAND	2	2	2	2	
13	90467-200A0	CLIP	2	2	2	2	
14	F1X-U8K22-01	SENSOR, COMPASS	1	1	1	1	FOR CRUISER
15	9788R-05025	SCREW, PAN HEAD	2	2	2	2	FOR CRUISER
16	9572R-05300	NUT, FLANGE	2	2	2	2	FOR CRUISER
17	9299R-05200	WASHER	2	2	2	2	FOR CRUISER
18	F1S-U828H-01	TRIM, 1	1	1	1	1	
19	90600-917U4	CLAMP COMP.	3	3	3	3	
20	90267-48802	RIVET, BLIND	3	3	3	3	
21	90464-32801	CLAMP	3	3	3	3	
22	F1K-61624-00	BOWEYE 1	1	1	1	1	
23	99780-12600	NUT.HEX.(COARS)	2	2	2	2	
24	92990-12200	WASHER, PLAIN	2	2	2	2	
25	F0X-61637-00	WASHER	2	2	2	2	
26	F0X-61652-00	NUT (BOLT/NUT)	2	2	2	2	
27	90110-06040	BOLT, HEXAGON SOCKET HEAD	2	2	2	2	



**FIG. 21 HULL & DECK**

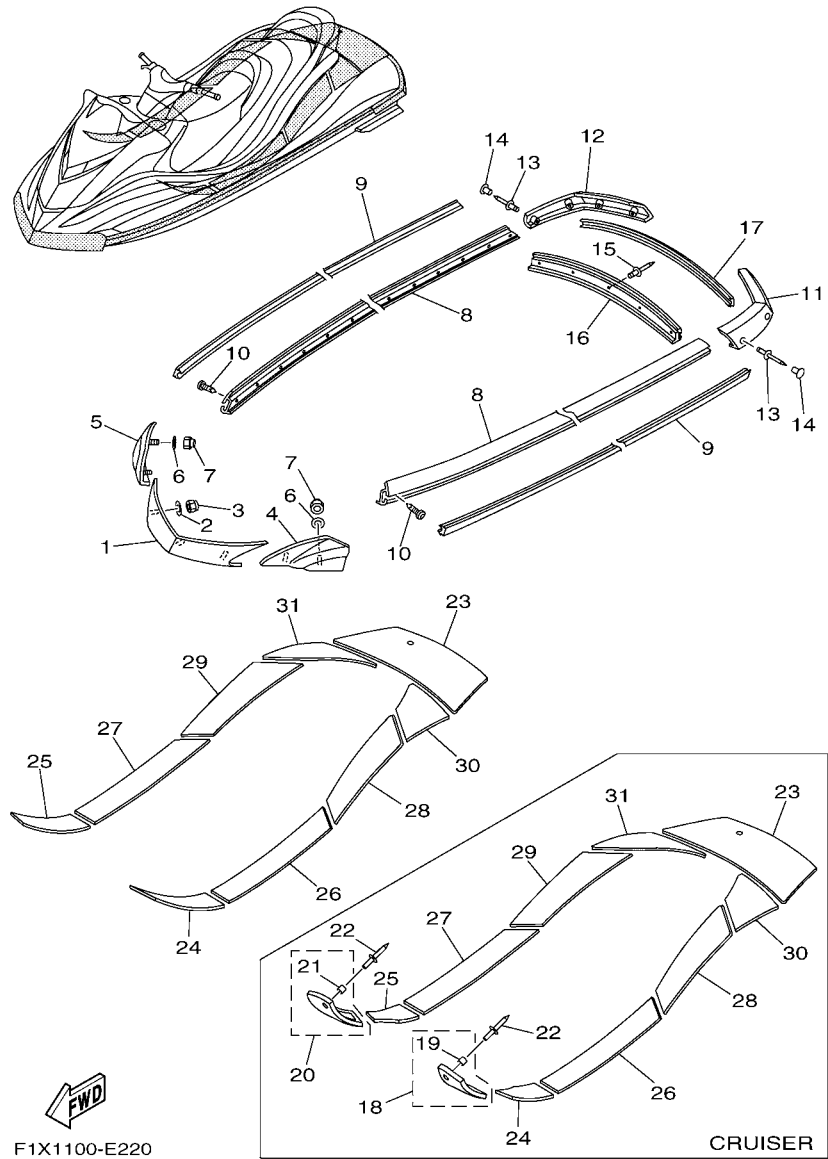
REF. NO.	PART NO.	DESCRIPTION	USA	CAN	GENE	JPN	REMARKS
28	F1S-U883N-01	STABILIZER LH	1	1	1	1	BL
29	F1S-U883P-01	STABILIZER RH	1	1	1	1	BL
30	F1F-U883T-02	BRACKET,STABILIZER	2	2	2	2	
31	F1B-U883T-02	BRACKET,STABILIZER	2	2	2	2	
32	90105-08860	BOLT, FLANGE	10	10	10	10	
33	F1K-U8169-00	SPACER	10	10	10	10	
34	F1S-U2280-00	DRAIN PLUG ASSY.	2	2	2	2	
35	F1S-U2285-00	PACKING, DRAIN	2	2	2	2	
36	9788R-05025	SCREW, PAN HEAD	4	4	4	4	
37	9299R-05200	WASHER	4	4	4	4	
38	9572R-05300	NUT, FLANGE	4	4	4	4	
39	F1X-U278A-00	LADDER, STEP ASSY	1	1	1	1	FOR CRUISER
40	F1X-U278F-00	BRACKET, LADDER LH	1	1	1	1	FOR CRUISER
41	F1X-U278G-00	BRACKET, LADDER RH	1	1	1	1	FOR CRUISER
42	90267-489U8	RIVET, BLIND	2	2	2	2	FOR CRUISER
43	90111-08803	BOLT,HEX. SOCKET BUTTON	6	6	6	6	FOR CRUISER
44	F1X-U163A-01	CLEAT ASSY.	2	2	2	2	FOR CRUISER
45	F1X-U826D-00	COVER	2	2	2	2	FOR CRUISER
46	F1X-U826C-00	BRACKET	2	2	2	2	FOR CRUISER
47	F1X-U2157-00	PACKING	2	2	2	2	FOR CRUISER
48	90111-06805	BOLT,HEX. SOCKET BUTTON	6	6	6	6	FOR CRUISER
49	90267-489U6	RIVET, BLIND	4	4	4	4	FOR CRUISER
50	F1X-U2284-00	PACKING	2	2	2	2	FOR CRUISER



F1X1100-E220

FIG. 22 GUNWALE & MAT

REF. NO.	PART NO.	DESCRIPTION	USA	CAN	GENE	JPN	REMARKS
1	F1S-U2501-10	BOW GUNWALE COMP.	1	1	1	1	FOR CRUISER GRAY
	F1S-U2501-02	BOW GUNWALE COMP.	1	1	1	1	BL
2	9299R-06200	WASHER	3	3	3	3	
3	9572R-06300	NUT, NYLON	3	3	3	3	
4	F1S-U252E-10	JOINT, GUNWALE LH	1	1	1	1	FOR CRUISER GRAY
	F1S-U252E-01	JOINT, GUNWALE LH	1	1	1	1	BL
5	F1S-U252F-10	JOINT, GUNWALE RH	1	1	1	1	FOR CRUISER GRAY
	F1S-U252F-01	JOINT, GUNWALE RH	1	1	1	1	BL
6	9299R-06200	WASHER	4	4	4	4	
7	9572R-06300	NUT, NYLON	4	4	4	4	
8	F1B-U2512-00	GUNWALE, SIDE	2	2	2	2	FOR CRUISER LS 1
	F1B-U2512-10	GUNWALE, SIDE	2	2	2	2	YB
9	F1B-U2519-00	INNER,GUNWALE	2	2	2	2	LS 1
	F1B-U2519-10	INNER,GUNWALE	2	2	2	2	YB
10	90169-059U1	SCREW,TAPPING	36	36	36	36	
11	F1B-U251D-02	GUNWALE, STERN 1	1	1	1	1	FOR CRUISER GRAY
	F1B-U251D-10	GUNWALE, STERN 1	1	1	1	1	YB
12	F1B-U251E-02	GUNWALE, STERN 2	1	1	1	1	FOR CRUISER GRAY
	F1B-U251E-10	GUNWALE, STERN 2	1	1	1	1	YB
13	90267-489UT	RIVET, BLIND	8	8	8	8	
14	F0D-U352E-10	PLUG, MUSHROOM	8	8	8	8	YB
15	90267-489US	RIVET, BLIND	5	5	5	5	
16	F1B-U252C-00	COVER, GUNWALE 1	1	1	1	1	FOR CRUISER SG C
	F1B-U252C-10	COVER, GUNWALE 1	1	1	1	1	YB
17	F1B-U252D-01	COVER, GUNWALE 2	1	1	1	1	SG C
	F1B-U252D-10	COVER, GUNWALE 2	1	1	1	1	YB
18	F1S-U350V-00	FOOT STEP ASSY., LH	1	1	1	1	FOR CRUISER BL



F1X1100-E220

FIG. 22 GUNWALE & MAT

REF. NO.	PART NO.	DESCRIPTION	USA	CAN	GENE	JPN	REMARKS
19	90387-06867	.COLLAR	2	2	2	2	
20	F1S-U350W-00	FOOT STEP ASSY., RH	1	1	1	1	FOR CRUISER BL
21	90387-06867	.COLLAR	2	2	2	2	
22	90267-48819	RIVET, BLIND	4	4	4	4	
23	F1S-U3581-10	MAT, UPPER	1	1	1	1	GRAY
24	F1S-U351H-01	MAT, STEP 1	1	1	1	1	FOR CRUISER GRAY
	F1S-U351H-20	MAT, STEP 1	1	1	1	1	DARK GRAY
25	F1S-U351J-01	MAT, STEP 2	1	1	1	1	FOR CRUISER GRAY
	F1S-U351J-20	MAT, STEP 2	1	1	1	1	DARK GRAY
26	F1S-U351K-10	MAT, STEP 3	1	1	1	1	GRAY
27	F1S-U351M-10	MAT, STEP 4	1	1	1	1	GRAY
28	F1S-U351N-10	MAT, STEP 5	1	1	1	1	GRAY
29	F1S-U351P-10	MAT, STEP 6	1	1	1	1	GRAY
30	F1S-U351R-10	MAT, STEP 7	1	1	1	1	GRAY
31	F1S-U351S-10	MAT, STEP 8	1	1	1	1	GRAY





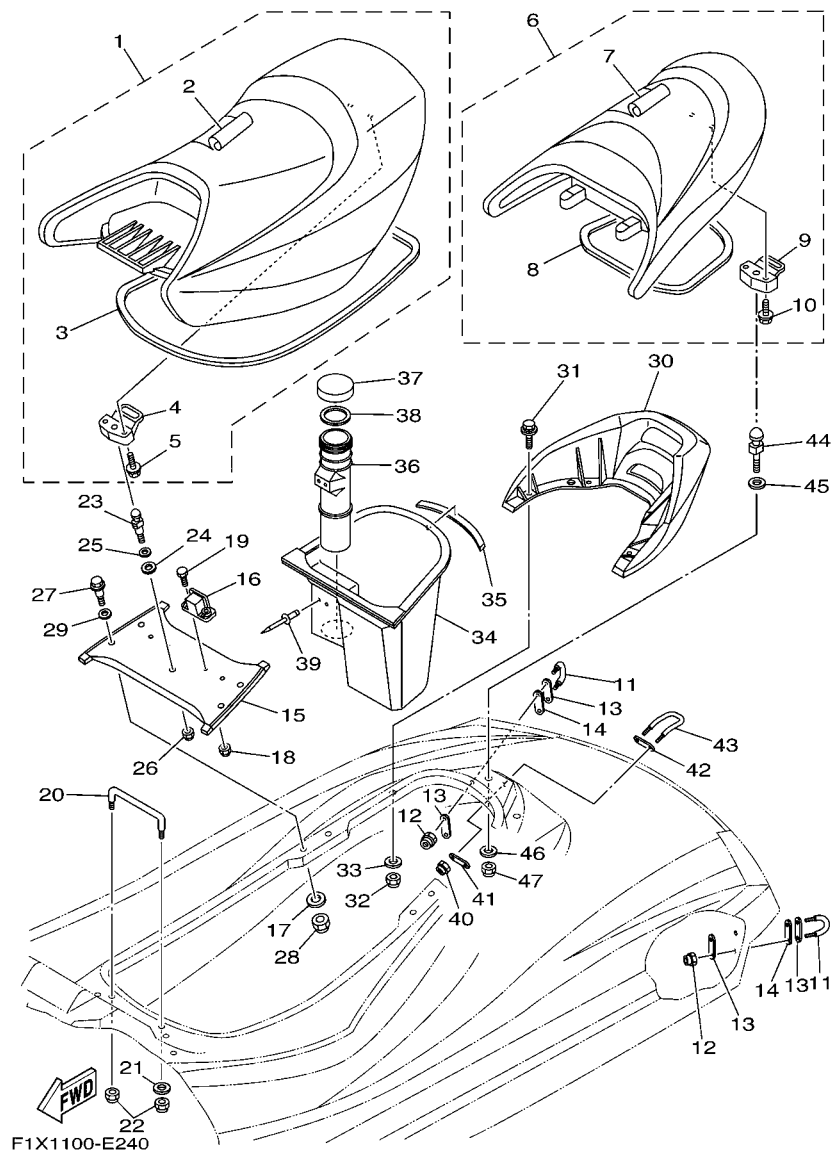


FIG. 24 SEAT & UNDER LOCKER

REF. NO.	PART NO.	DESCRIPTION	USA	CAN	GENE	JPN	REMARKS
1	F1S-U371A-60	DOUBLE SEAT ASSY	1	1	1	1	CRUISER GOLD
	F1S-U371A-70	DOUBLE SEAT ASSY	1	1	1	1	CRUISER SILVER
	F1S-U371A-90	DOUBLE SEAT ASSY	1	1	1	1	SILVER
	F1S-U371A-A0	DOUBLE SEAT ASSY	1	1	1	1	BLUE
2	F1S-U371B-60	.COVER, SEAT 1	1	1	1	1	CRUISER GOLD
	F1S-U371B-70	.COVER, SEAT 1	1	1	1	1	CRUISER SILVER
	F1S-U371B-90	.COVER, SEAT 1	1	1	1	1	SILVER
3	F1S-U371B-A0	.COVER, SEAT 1	1	1	1	1	BLUE
	F1B-U2664-00	.PACKING	1	1	1	1	
	F1B-U3850-01	.SEAT LOCK ASSY	1	1	1	1	
5	90119-069UP	.BOLT, WITH WASHER	2	2	2	2	
6	F1S-U372A-20	SINGLE SEAT ASSY	1	1	1	1	CRUISER GOLD
	F1S-U372A-30	SINGLE SEAT ASSY	1	1	1	1	CRUISER SILVER
	F1B-U372A-90	SINGLE SEAT ASSY	1	1	1	1	SILVER
	F1B-U372A-A0	SINGLE SEAT ASSY	1	1	1	1	BLUE
7	F1S-U372B-20	.COVER, SEAT	1	1	1	1	CRUISER GOLD
	F1S-U372B-30	.COVER, SEAT	1	1	1	1	CRUISER SILVER
	F1B-U372B-90	.COVER, SEAT	1	1	1	1	SILVER
	F1B-U372B-A0	.COVER, SEAT	1	1	1	1	BLUE
8	F1B-U266D-00	.PACKING 5	1	1	1	1	
	F1B-U3850-01	.SEAT LOCK ASSY	1	1	1	1	
	9	90119-069UP	.BOLT, WITH WASHER	2	2	2	2
11	F1K-61628-00	STERN EYE	2	2	2	2	
12	9572R-08300	NUT, FLANGE	4	4	4	4	
13	GP7-U4953-10	PLATE A	4	4	4	4	
14	F1B-U1653-01	PACKING	2	2	2	2	
15	F1B-U8952-01	BEAM, DECK 1	1	1	1	1	

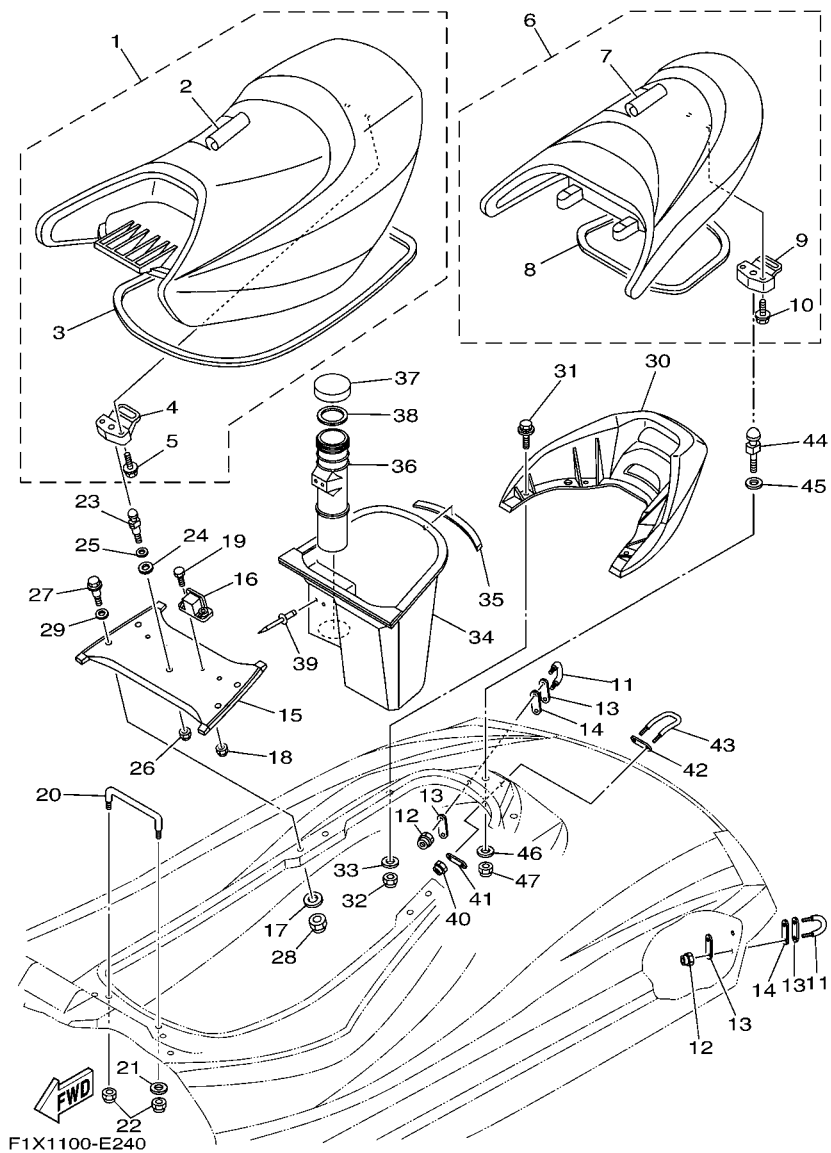
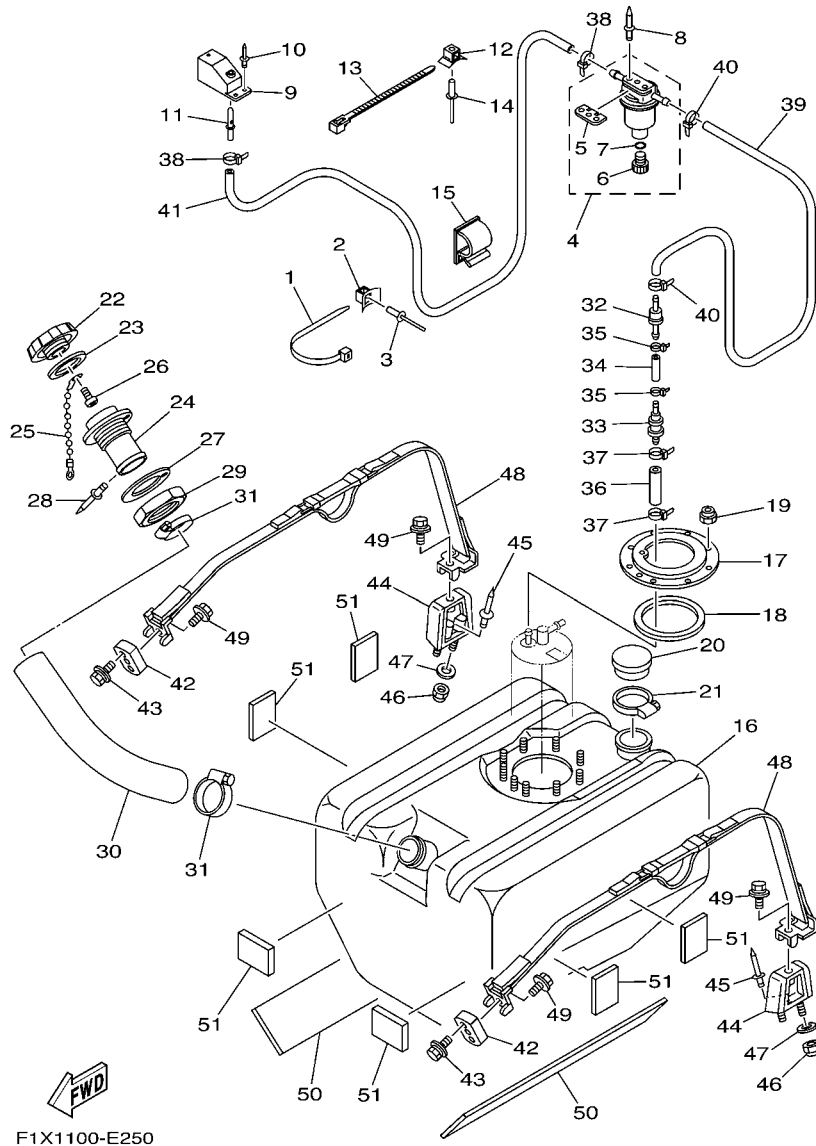


FIG. 24 SEAT & UNDER LOCKER

REF. NO.	PART NO.	DESCRIPTION	USA	CAN	GENE	JPN	REMARKS
16	GU2-6378D-02	STAY, SEAT 2	2	2	2	2	
17	9299R-08200	WASHER	4	4	4	4	
18	9572R-06300	NUT, NYLON	4	4	4	4	
19	90101-069U0	BOLT	4	4	4	4	
20	F0X-6378C-00	STAY, SEAT 1	1	1	1	1	
21	90201-099U3	WASHER, PLATE	1	1	1	1	
22	9572R-08300	NUT, FLANGE	2	2	2	2	
23	F1B-U3774-00	PIN	1	1	1	1	
24	F0X-6375E-00	PACKING 1	1	1	1	1	
25	92990-12200	WASHER, PLAIN	1	1	1	1	
26	9572R-10300	NUT, FLANGE	1	1	1	1	
27	F1B-U2624-00	BOLT	4	4	4	4	
28	9572R-08300	NUT, FLANGE	4	4	4	4	
29	9299R-10200	WASHER	4	4	4	4	
30	F1S-U271B-01	GRIP, HAND	1	1	1	1	CRUISER YB
	F1B-U271B-00	GRIP, HAND	1	1	1	1	YB
31	90119-08942	BOLT, WITH WASHER	4	4	4	4	
32	9572R-08300	NUT, FLANGE	4	4	4	4	
33	9299R-08200	WASHER	4	4	4	4	
34	F1B-U4742-01	LOCKER, UNDER 2	1	1	1	1	
35	F0X-U266E-01	PACKING, 6	1	1	1	1	
36	F0X-U5983-01	BOX, FIRE EXTINGUISHER	1	1	1	1	
37	EW2-U5912-01	CAP, CASE	1	1	1	1	
38	EW2-U5913-01	PACKING, CASE	1	1	1	1	
39	90267-489UP	RIVET, BLIND	4	4	4	4	
40	9572R-08300	NUT, FLANGE	2	2	2	2	
41	GP7-U4953-10	PLATE A	1	1	1	1	



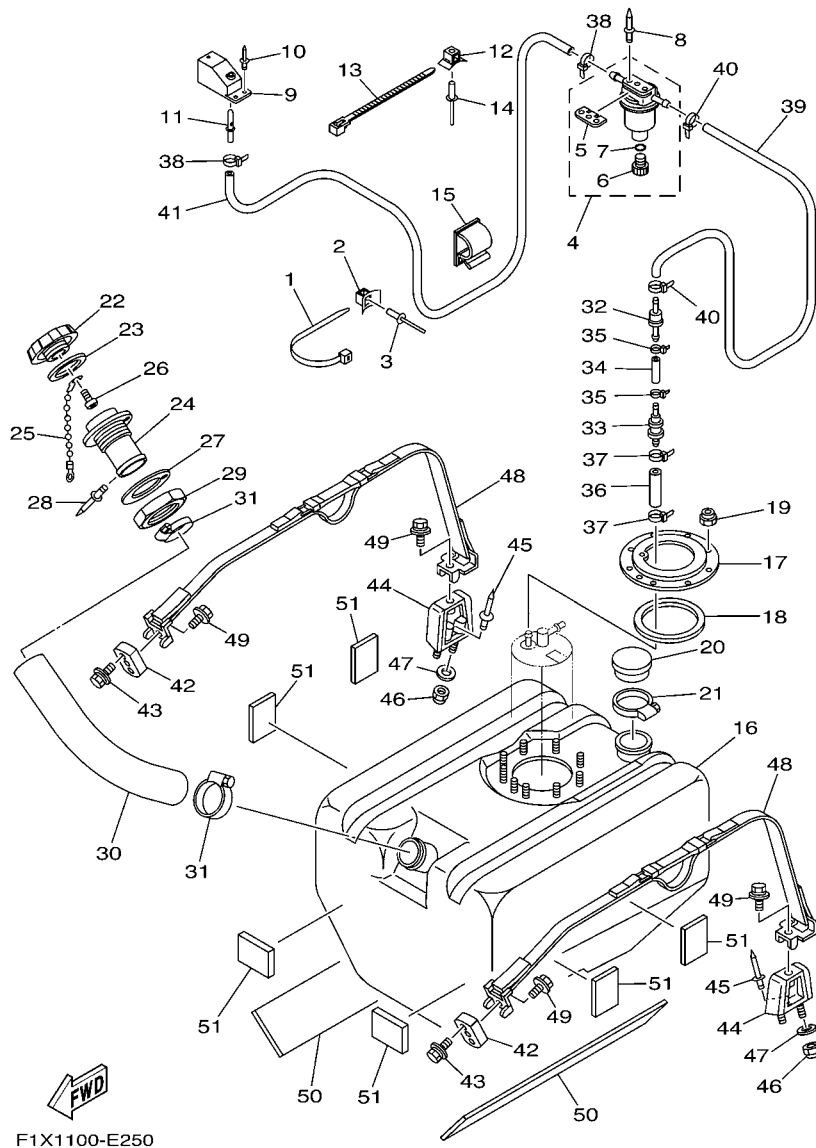


F1X1100-E250

FIG. 25 FUEL TANK

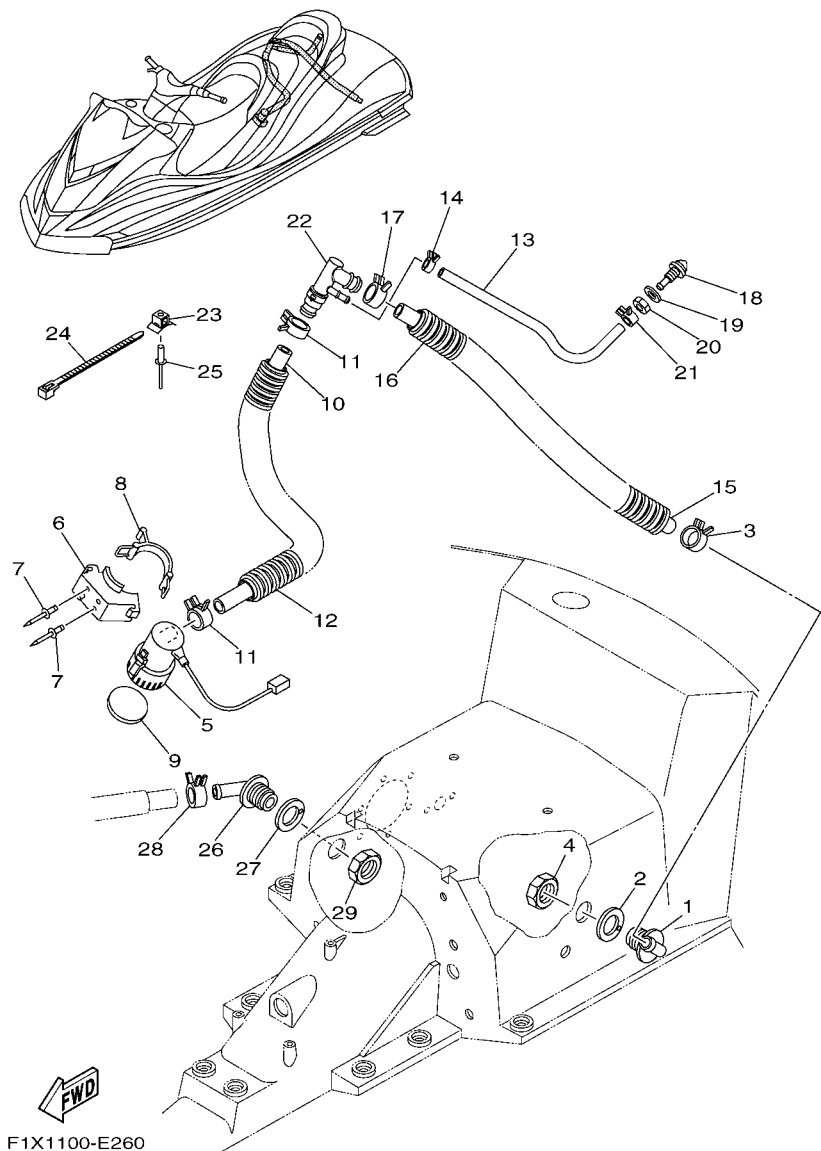
REF. NO.	PART NO.	DESCRIPTION	USA	CAN	GENE	JPN	REMARKS
1	90464-99804	CLAMP	2	2	2	2	
2	90600-917U4	CLAMP COMP.	2	2	2	2	
3	90267-48802	RIVET, BLIND	2	2	2	2	
4	EW2-62140-00	FILTER, VENT ASSY	1	1	1	1	
5	EW2-62142-00	.PLATE, FILTER	1	1	1	1	
6	70R-24543-00	.PLUG, DRAIN	1	1	1	1	
7	70R-24489-00	.O-RING	1	1	1	1	
8	90267-489U2	RIVET, BLIND	2	2	2	2	
9	GP7-62159-02	SOCKET, VENTILATION	1	1	1	1	
10	90267-489U6	RIVET, BLIND	2	2	2	2	
11	F1G-62149-00	PIPE, VENTILATION	1	1	1	1	
12	90600-917U4	CLAMP COMP.	3	3	3	3	
13	90464-32801	CLAMP	3	3	3	3	
14	90267-489U6	RIVET, BLIND	3	3	3	3	
15	90464-17800	CLAMP	1	1	1	1	
16	F1B-U7711-01	TANK, FUEL	1	1	1	1	
17	F1B-U7773-00	RING	1	1	1	1	
18	F1B-67747-00	PACKING, SEAL	1	1	1	1	
19	9572R-06300	NUT, NYLON	9	9	9	9	
20	FN8-6771K-00	COVER	1	1	1	1	
21	90601-162U5	BAND, HOSE 62	1	1	1	1	
22	GP7-U7831-01	CAP, FUEL FILLER	1	1	1	1	UR PURW
	GP7-U7831-11	CAP, FUEL FILLER	1	1	1	1	UR BL
23	GP7-U7832-01	PACKING	1	1	1	1	
24	GP7-U7833-00	SOCKET	1	1	1	1	UR PURW
	GP7-U7833-10	SOCKET	1	1	1	1	UR BL
25	GP7-U7835-00	CHAIN BALL	1	1	1	1	

FIG. 25 FUEL TANK



F1X1100-E250

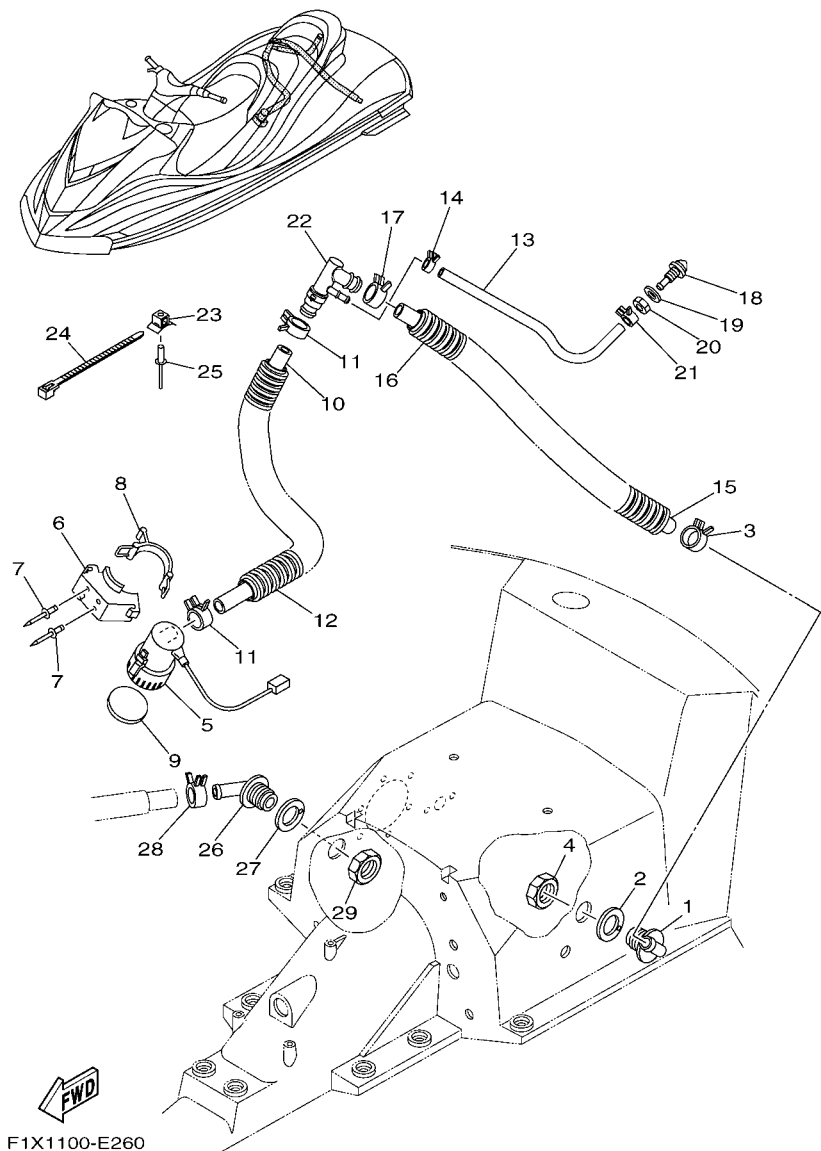
REF. NO.	PART NO.	DESCRIPTION	USA	CAN	GENE	JPN	REMARKS
26	90169-049U1	TAPPING SCREW	1	1	1	1	
27	GP7-U7834-00	PACKING FUEL FILLER	1	1	1	1	
28	90267-329UR	RIVET, BLIND	1	1	1	1	
29	GP7-U783F-00	NUT, FUEL FILLER	1	1	1	1	
30	F1B-U7844-01	HOSE	1	1	1	1	
31	90601-155U4	BAND, HOSE 55	2	2	2	2	
32	F1B-67767-00	CHECK VALVE	1	1	1	1	
33	FJ0-67766-00	ROLL OVER VALVE	1	1	1	1	
34	90699-50004	HOSE	1	1	1	1	
35	90465-11M10	CLAMP	2	2	2	2	
36	GP7-U785H-00	HOSE, AIR VENT 3	1	1	1	1	
37	90465-11829	CLAMP	2	2	2	2	
38	90465-11829	CLAMP	2	2	2	2	
39	F0D-U785G-10	HOSE, AIR VENT	1	1	1	1	
40	90465-11829	CLAMP	2	2	2	2	
41	F0D-U7856-10	HOSE, AIR VENT 3	1	1	1	1	
42	F1B-U2873-00	NUT, SPECIAL	2	2	2	2	
43	90119-089U7	BOLT, WITH WASHER	4	4	4	4	
44	F1B-6774J-00	BRKT, BAND	2	2	2	2	
45	90267-489UE	RIVET, BLIND	2	2	2	2	
46	9572R-06300	NUT, NYLON	4	4	4	4	
47	9299R-06200	WASHER	4	4	4	4	
48	F1B-67743-02	BELT, TANK 1	2	2	2	2	
49	90119-089U7	BOLT, WITH WASHER	4	4	4	4	
50	F1B-U759B-00	MAT 1	2	2	2	2	
51	F1B-U759C-00	MAT 2	6	6	6	6	



F1X1100-E260

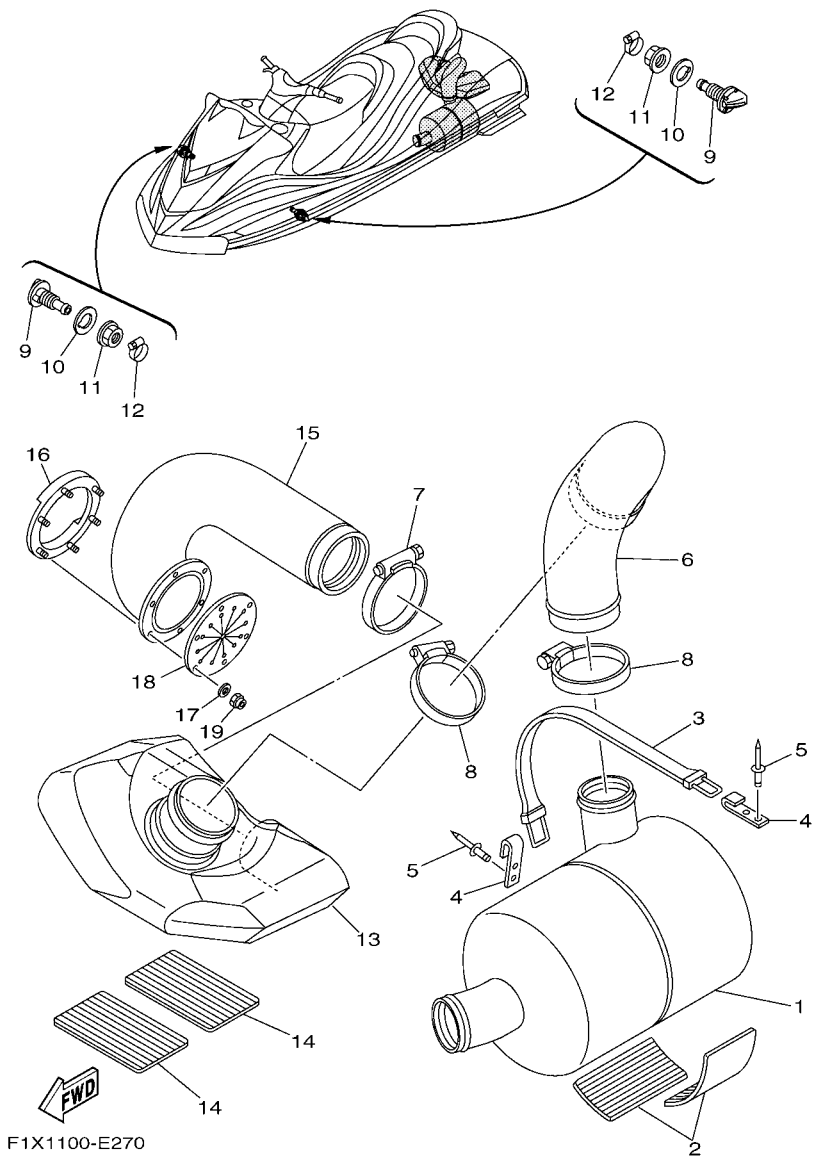
FIG. 26 BILGE PUMP

REF. NO.	PART NO.	DESCRIPTION	USA	CAN	GENE	JPN	REMARKS
1	F1B-6224E-00	BODY, DRAIN 3	1	1	1	1	
2	F1S-U7525-01	PACKING	1	1	1	1	
3	90467-250A0	CLIP	1	1	1	1	
4	F1B-62241-00	DRAIN, COCKPIT	1	1	1	1	
5	F1B-U8360-01	BILGE PUMP ASSY	1	1	1	1	
6	F1B-U7698-01	BRACKET	1	1	1	1	
7	90267-489UP	RIVET, BLIND	2	2	2	2	
8	GA7-68218-00	BAND, BATTERY	1	1	1	1	
9	F1B-U7656-00	PACKING, BILGE	1	1	1	1	
10	F1B-U7626-00	HOSE 1	1	1	1	1	
11	90467-210A0	CLIP	2	2	2	2	
12	90447-28004	HOSE, WITH SPRING (L800)	1	1	1	1	
13	F1B-U7629-00	HOSE, DRAIN 2	1	1	1	1	
14	90467-140A1	CLIP	1	1	1	1	
15	F1B-U7628-00	HOSE, DRAIN 3	1	1	1	1	
16	90447-28004	HOSE, WITH SPRING (L800)	1	1	1	1	
17	90467-250A0	CLIP	1	1	1	1	
18	GH7-6753B-00	PILOT,WATER	1	1	1	1	
19	90430-16910	GASKET	1	1	1	1	
20	GP7-61652-00	NUT	1	1	1	1	
21	90467-140A1	CLIP	1	1	1	1	
22	F1S-67620-00	HOSE JOINT	1	1	1	1	
23	90600-917U4	CLAMP COMP.	1	1	1	1	
24	90464-32801	CLAMP	1	1	1	1	
25	90267-489U6	RIVET, BLIND	1	1	1	1	
26	F1B-6224E-00	BODY, DRAIN 3	1	1	1	1	
27	F1S-U7525-01	PACKING	1	1	1	1	



**FIG. 26 BILGE PUMP**

REF. NO.	PART NO.	DESCRIPTION	USA	CAN	GENE	JPN	REMARKS
28	90467-250A0	CLIP	1	1	1	1	
29	F1B-62241-00	DRAIN, COCKPIT	1	1	1	1	
-----							
-----							
-----							
-----							
-----							
-----							
-----							
-----							



**FIG. 27 EXHAUST 3**

REF. NO.	PART NO.	DESCRIPTION	USA	CAN	GENE	JPN	REMARKS
1	F1S-67550-00	WATER LOCK COMP.	1	1	1	1	
2	F1S-U8221-00	PAD, BATTERY	2	2	2	2	
3	EW2-67821-00	BAND, FUEL TANK	1	1	1	1	
4	GA7-65772-00	HOOK A	2	2	2	2	
5	90267-489U1	RIVET,BLIND	4	4	4	4	
6	F1B-U7555-02	HOSE, EXHAUST	1	1	1	1	
7	90601-195UD	BAND, HOSE 95	1	1	1	1	
8	90450-99801	HOSE CLAMP ASSY	2	2	2	2	
9	F1B-6753B-00	PILOT, WATER	2	2	2	2	
10	F1B-67564-00	GASKET	2	2	2	2	
11	F0X-62733-00	NUT	2	2	2	2	
12	90601-118UF	BAND, HOSE 18	2	2	2	2	
13	F0X-U4261-13	TANK, WATER	1	1	1	1	
14	F1S-U8221-00	PAD, BATTERY	2	2	2	2	
15	F1B-U758D-02	HOSE,EXHAUST 3	1	1	1	1	
16	F1S-U757B-00	PLATE	1	1	1	1	
17	9299R-06200	WASHER	6	6	6	6	
18	F1B-U751G-00	VALVE, EXHAUST	1	1	1	1	
19	9572R-06300	NUT, NYLON	6	6	6	6	



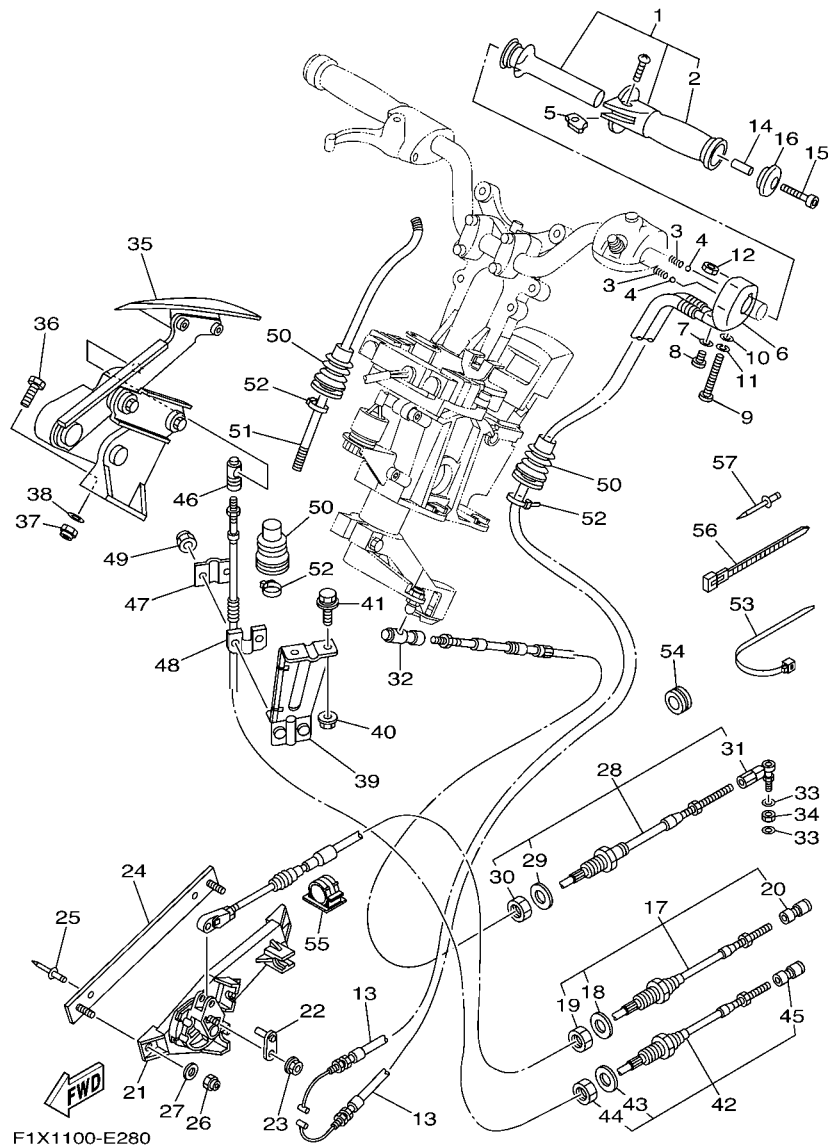


FIG. 28 CONTROL CABLE

REF. NO.	PART NO.	DESCRIPTION	USA	CAN	GENE	JPN	REMARKS
1	GP7-U157A-00	GRIP HANDLE ASSY.	1	1	1	1	
2	GP7-U155C-00	.GRIP,HANDLE	1	1	1	1	
3	GP7-U152P-00	SPRING	2	2	2	2	
4	GP7-U152R-00	BALL	2	2	2	2	
5	GP7-U151M-00	LEVER ASSY	1	1	1	1	
6	GP7-U152M-00	HOUSING ASSY	1	1	1	1	
7	92990-04600	WASHER, PLATE	1	1	1	1	
8	98980-04010	SCREW, BIND	1	1	1	1	
9	97880-06065	SCREW, PAN HEAD	1	1	1	1	
10	92990-06600	WASHER, PLATE	1	1	1	1	
11	9299R-06100	WASHER	1	1	1	1	
12	GH1-U143B-00	NUT,SPECIAL	1	1	1	1	
13	F1B-U153D-01	CABLE,NOZZLE CONTROL 2	2	2	2	2	
14	90387-05800	COLLAR	1	1	1	1	
15	90110-05908	BOLT, HEXAGON SOCKET HEAD	1	1	1	1	
16	F1S-U155F-00	GRIP, END	1	1	1	1	FOR CRUISER
	GP7-U155F-00	GRIP, END	1	1	1	1	
17	F1S-6153E-00	CABLE,NOZZLE CONTROL 3	1	1	1	1	
18	F1B-61438-00	.PACKING	1	1	1	1	
19	F1B-6151S-00	.NUT	1	1	1	1	
20	F1B-61460-00	.BALL JOINT ASSY	1	1	1	1	
21	F0D-U153J-10	REMOCON,NOZZLE 2	1	1	1	1	
22	F0D-U152C-10	PIN	1	1	1	1	
23	9572R-06300	NUT, NYLON	1	1	1	1	
24	F0X-U4958-00	BASE, REMOCON.	1	1	1	1	
25	90267-489U6	RIVET, BLIND	2	2	2	2	
26	9572R-06300	NUT, NYLON	2	2	2	2	

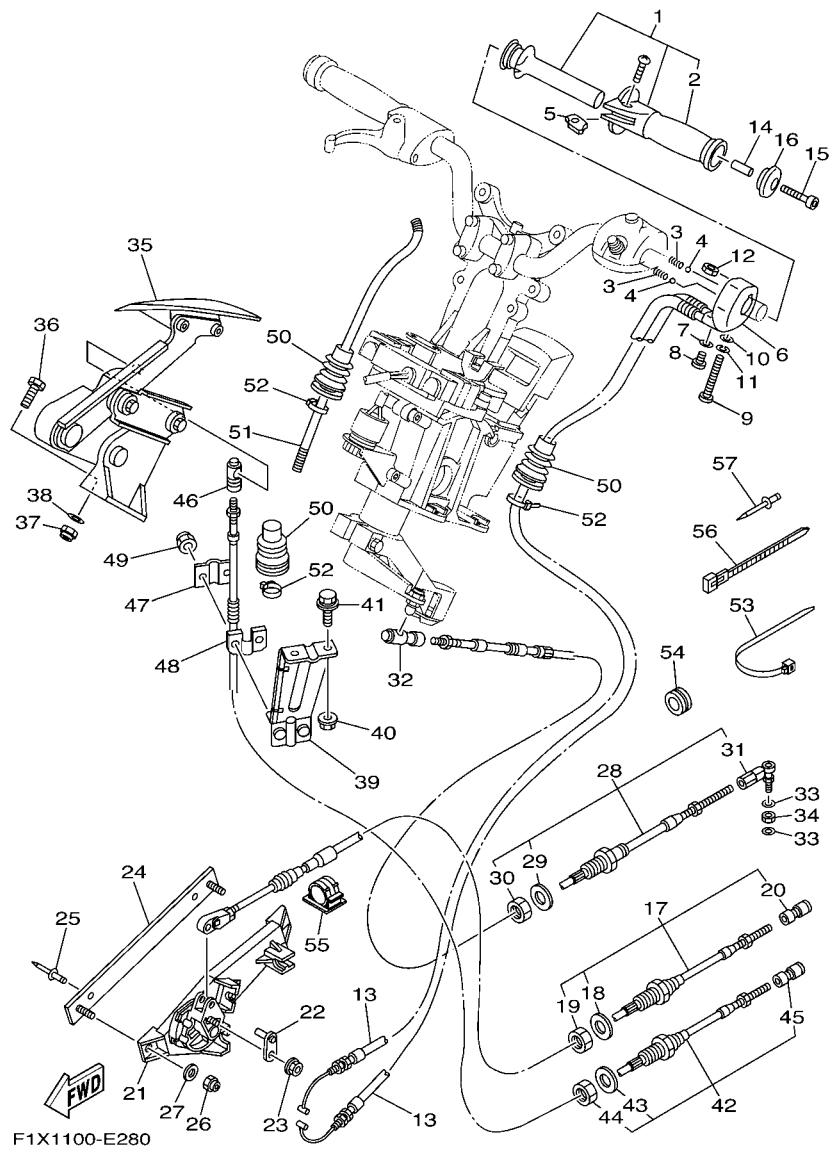


FIG. 28 CONTROL CABLE

REF. NO.	PART NO.	DESCRIPTION	USA	CAN	GENE	JPN	REMARKS
27	9299R-06200	WASHER	2	2	2	2	
28	F1S-61481-00	CABLE, STEERING	1	1	1	1	
29	F1B-61438-00	.PACKING	1	1	1	1	
30	F1B-6151S-00	.NUT	1	1	1	1	
31	F1B-61461-02	.STUD, JOINT BALL	1	1	1	1	
32	GK5-U146F-00	SHAFT, JOINT BALL	1	1	1	1	
33	90201-06906	WASHER, PLATE	2	2	2	2	
34	9538R-06700	NUT	1	1	1	1	
35	F1X-6134A-01	REMOCON. LEVER ASSY.	1	1	1	1	
36	97080-06030	BOLT	3	3	3	3	
37	9572R-06300	NUT, NYLON	3	3	3	3	
38	90201-06802	WASHER, PLATE	3	3	3	3	
39	F1X-61467-01	BRACKET, STOPPER CABLE	1	1	1	1	
40	9572R-08300	NUT, FLANGE	1	1	1	1	
41	90119-08832	BOLT, WITH WASHER	1	1	1	1	
42	F1B-6149C-02	CABLE, REVERSE	1	1	1	1	
43	F1B-61438-00	.PACKING	1	1	1	1	
44	F1B-6151S-00	.NUT	1	1	1	1	
45	F1B-61460-00	.BALL JOINT ASSY	1	1	1	1	
46	F1B-61460-00	BALL JOINT ASSY	1	1	1	1	
47	GH1-61468-01	STOPPER, CABLE	1	1	1	1	
48	GU5-6146K-10	HOLDER, STOPPER	1	1	1	1	
49	9572R-06300	NUT, NYLON	2	2	2	2	
50	F0D-6822E-00	GROMMET	3	3	3	3	
51	F0D-6773E-00	TUBE, 2	1	1	1	1	
52	90601-200U1	BAND	3	3	3	3	
53	90464-32801	CLAMP	1	1	1	1	



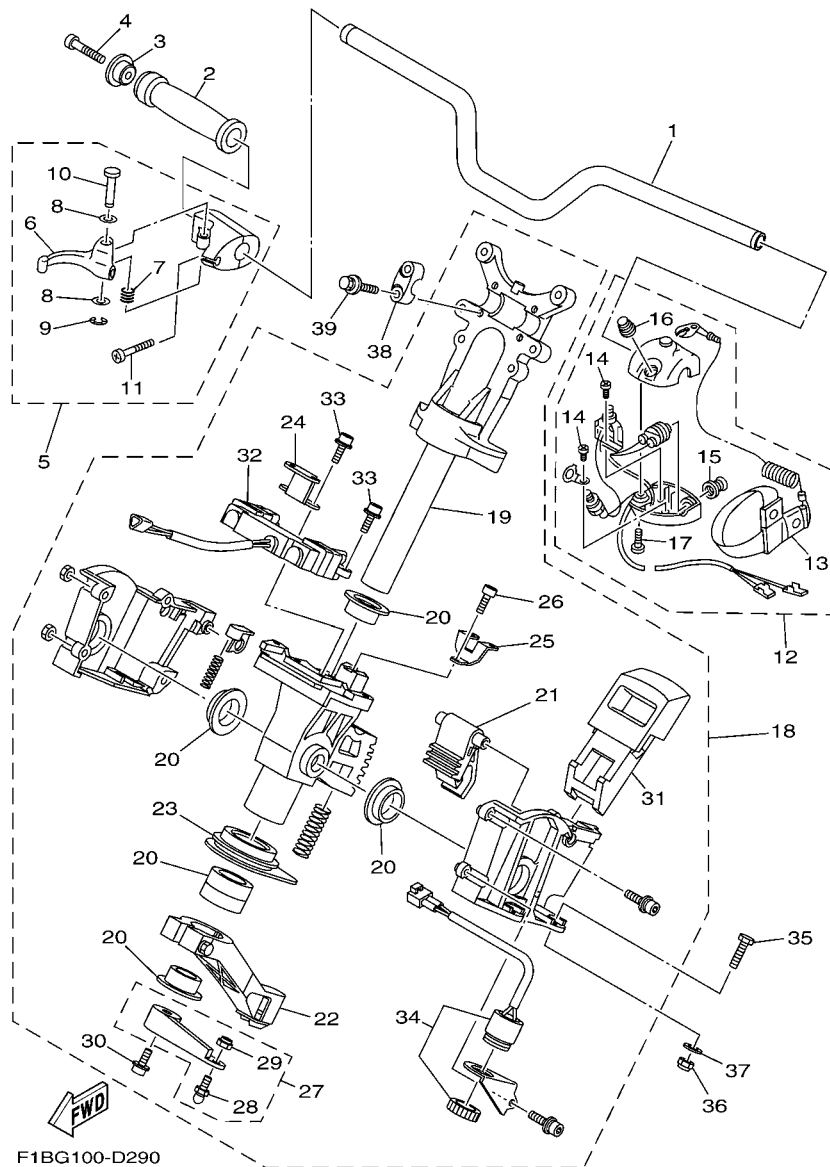
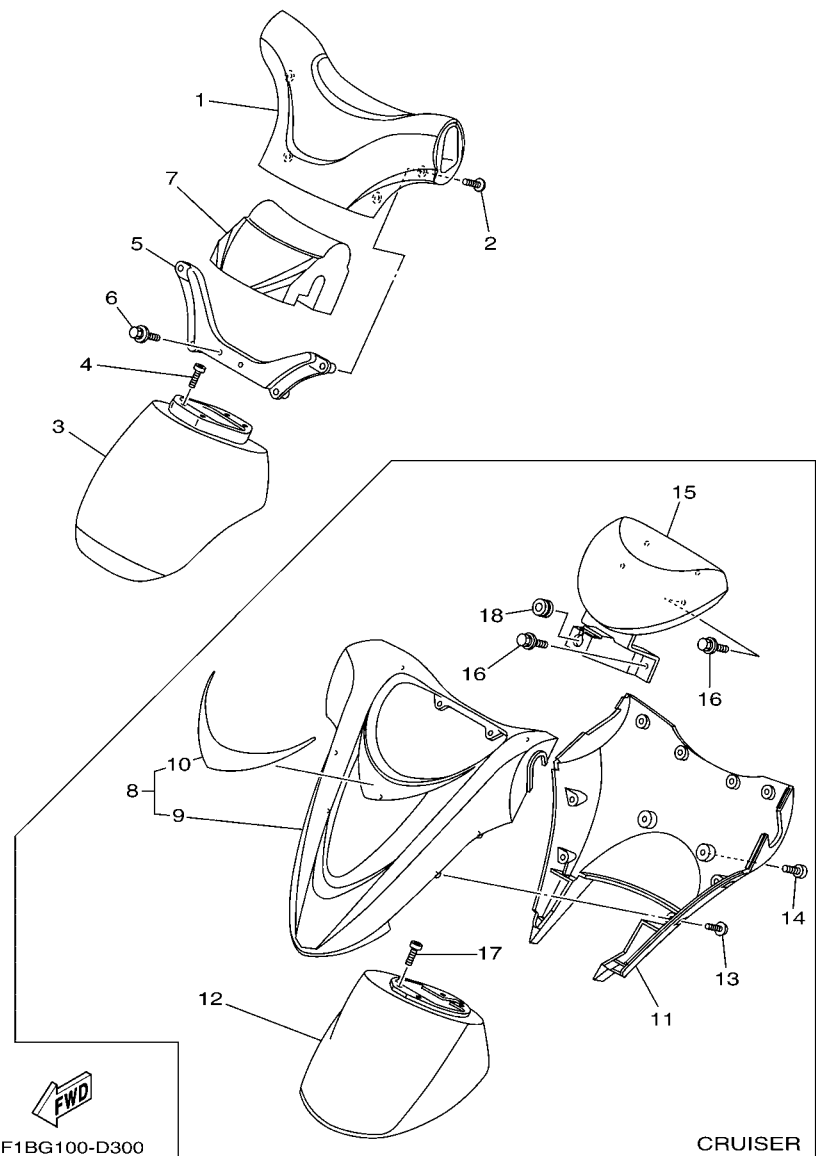


FIG. 29 STEERING 1

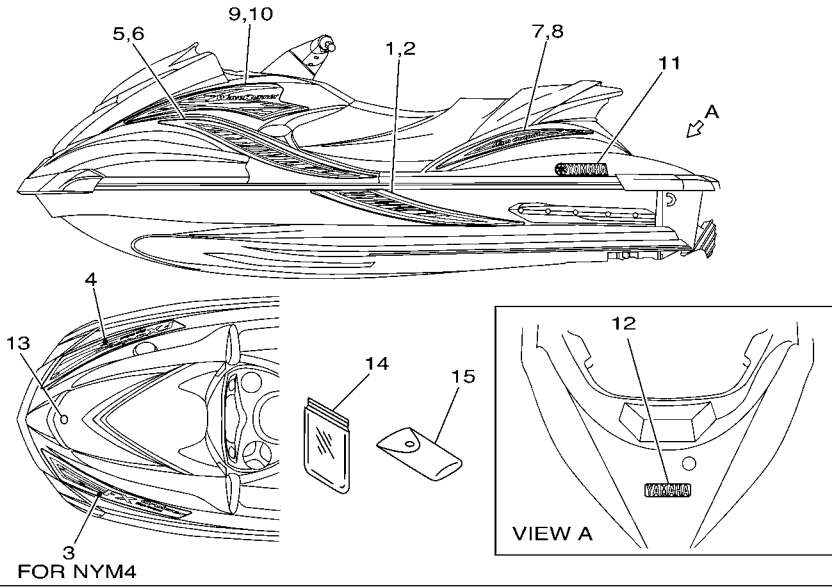
REF. NO.	PART NO.	DESCRIPTION	USA	CAN	GENE	JPN	REMARKS
1	F1S-61552-00	HANDLE	1	1	1	1	FOR CRUISER
	F1B-61552-00	HANDLE	1	1	1	1	
2	GP7-U155D-00	GRIP, HANDLE	1	1	1	1	
3	F1S-U155F-00	GRIP, END	1	1	1	1	FOR CRUISER
	GP7-U155F-00	GRIP, END	1	1	1	1	
4	90110-05908	BOLT, HEXAGON SOCKET HEAD	1	1	1	1	
5	F0D-67250-03	THROTTLE LEVER ASSY	1	1	1	1	
6	F0D-67255-01	.LEVER, THROTTLE	1	1	1	1	
7	EW2-67256-00	.SPRING	1	1	1	1	
8	EW2-67258-01	.WASHER	2	2	2	2	
9	EW2-67259-01	.E-RING	1	1	1	1	
10	F0D-67257-00	.SHAFT	1	1	1	1	
11	98580-05025	.SCREW, PAN HEAD	2	2	2	2	
12	F1S-68310-01	SWITCH BOX ASSY	1	1	1	1	
13	EW2-68348-00	.LANYARD, STOP SWITCH	1	1	1	1	
14	97880-03008	.SCREW, PAN HEAD	2	2	2	2	
15	FK7-68312-02	.STOP BUTTON COMP	1	1	1	1	
16	FK7-68313-02	.START BUTTON COMP.	1	1	1	1	
17	97880-05025	.SCREW, PAN HEAD	2	2	2	2	
18	F1S-61400-14	STEERING MASTER ASSY	1	1	1	1	FOR CRUISER
	F1S-61400-03	STEERING MASTER ASSY	1	1	1	1	
19	F1S-67410-10	.SHAFT ASSY	1	1	1	1	FOR CRUISER
	F1S-67410-00	.SHAFT ASSY	1	1	1	1	
20	F1S-6773D-00	.TUBE	1	1	1	1	
21	F1S-61782-00	.LOCK 1	1	1	1	1	
22	F1S-6146A-00	.CABLE STOPPER ASSY.	1	1	1	1	
23	F1S-6143C-00	.SEAL, RUBBER	1	1	1	1	



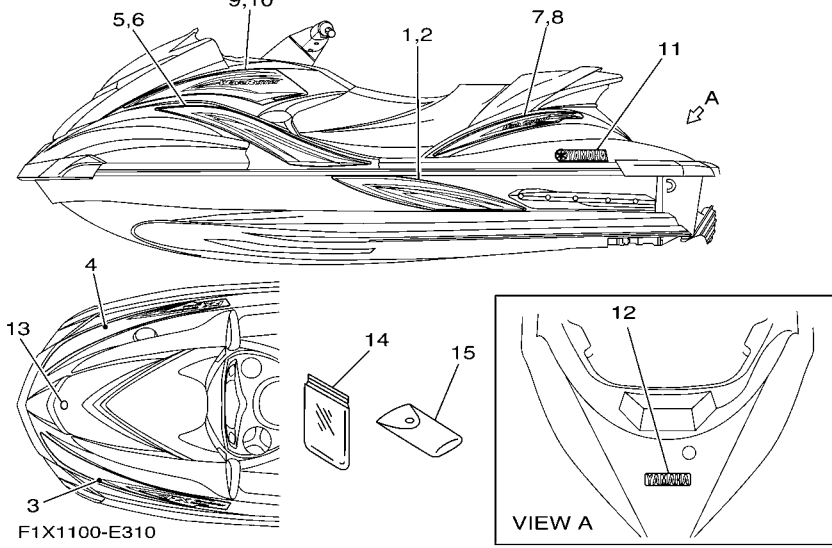
FIG. 30 STEERING 2



REF. NO.	PART NO.	DESCRIPTION	USA	CAN	GENE	JPN	REMARKS
1	F1B-U143D-00	PAD, STEERING 1	1	1	1	1	BL
2	90149-06910	SCREW	4	4	4	4	
3	F0D-U143E-01	PAD, STEERING 2	1	1	1	1	BL
4	90154-06010	SCREW, BINDING	4	4	4	4	
5	F1B-U142K-00	FIX, STEERING PAD	1	1	1	1	
6	90119-069US	BOLT, WITH WASHER	2	2	2	2	
7	F1B-U156E-00	PAD 1	1	1	1	1	
8	F1S-U142A-00	STEERING PAD COMP	1	1	1	1	FOR CRUISER GRAY
9	F1S-U143D-01	.PAD, STEERING 1	1	1	1	1	FOR CRUISER GRAY
10	F1B-U4124-01	.EMBLEM, 4	1	1	1	1	FOR CRUISER GRAY
11	F1S-U143E-00	PAD, STEERING 2	1	1	1	1	FOR CRUISER
12	F1S-U143L-01	PAD, STEERING 3	1	1	1	1	FOR CRUISER YB
13	90149-05903	SCREW	8	8	8	8	FOR CRUISER
14	90154-06017	SCREW, BINDING	2	2	2	2	FOR CRUISER
15	F1S-U142G-01	PAD ASSY.	1	1	1	1	FOR CRUISER
16	90119-069UJ	BOLT, WITH WASHER	4	4	4	4	FOR CRUISER
17	90154-06010	SCREW, BINDING	4	4	4	4	FOR CRUISER
18	90480-18802	GROMMET	1	1	1	1	FOR CRUISER



FOR NYM4

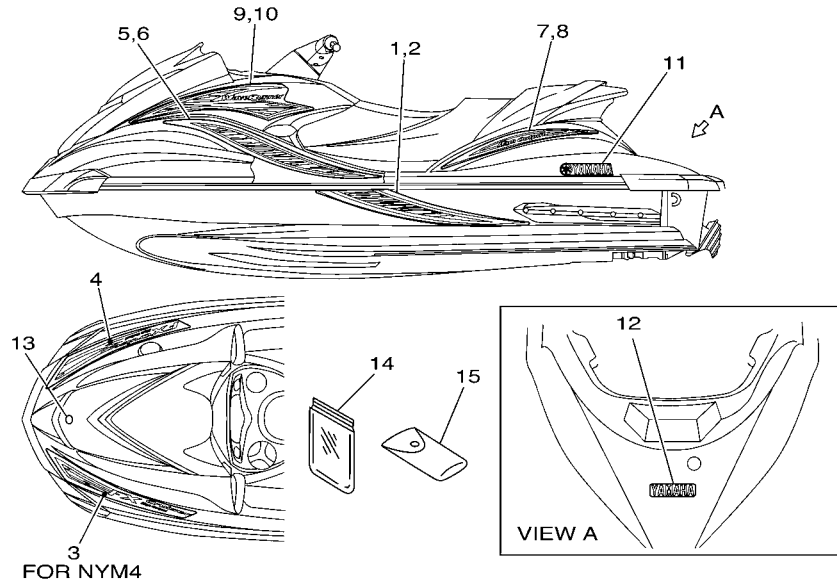


F1X1100-E310

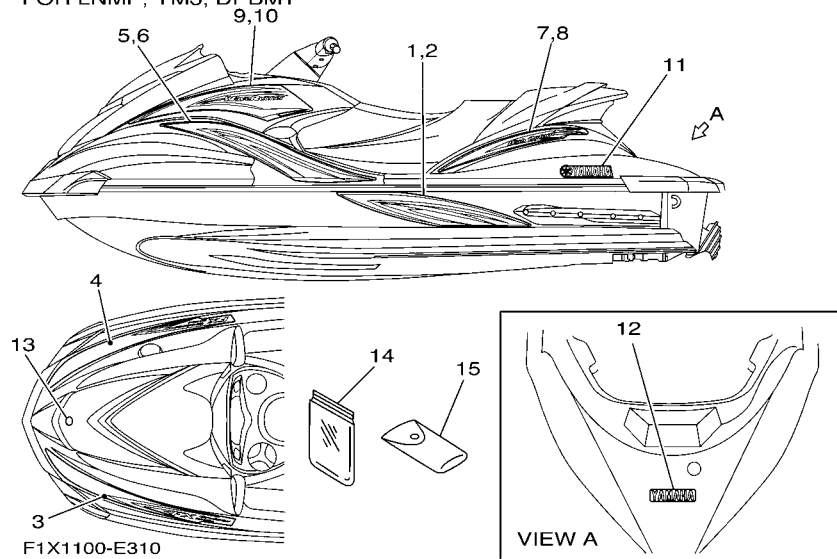
FIG. 31 GRAPHICS

REF. NO.	PART NO.	DESCRIPTION	USA	CAN	GENE	JPN	REMARKS
1	F1X-U417B-00	GRAPHIC 1 (LH)	1	1	1	1	FOR CRUISER, NYM4
	F1X-U417B-10	GRAPHIC 1 (LH)	1	1	1	1	FOR CRUISER, LNMP
	F1X-U417B-20	GRAPHIC 1 (LH)	1	1	1	1	FOR YM3
	F1X-U417B-30	GRAPHIC 1 (LH)	1	1	1	1	FOR DPBMT
2	F1X-U417C-00	GRAPHIC 2 (RH)	1	1	1	1	FOR CRUISER, NYM4
	F1X-U417C-10	GRAPHIC 2 (RH)	1	1	1	1	FOR CRUISER, LNMP
	F1X-U417C-20	GRAPHIC 2 (RH)	1	1	1	1	FOR YM3
	F1X-U417C-30	GRAPHIC 2 (RH)	1	1	1	1	FOR DPBMT
3	F1X-U417D-00	GRAPHIC 3 (LH)	1	1	1	1	FOR CRUISER, NYM4
	F1X-U417D-10	GRAPHIC 3 (LH)	1	1	1	1	FOR CRUISER, LNMP
	F1X-U417D-20	GRAPHIC 3 (LH)	1	1	1	1	FOR YM3
	F1X-U417D-30	GRAPHIC 3 (LH)	1	1	1	1	FOR DPBMT
4	F1X-U417E-00	GRAPHIC 4 (RH)	1	1	1	1	FOR CRUISER, NYM4
	F1X-U417E-10	GRAPHIC 4 (RH)	1	1	1	1	FOR CRUISER, LNMP
	F1X-U417E-20	GRAPHIC 4 (RH)	1	1	1	1	FOR YM3
	F1X-U417E-30	GRAPHIC 4 (RH)	1	1	1	1	FOR DPBMT
5	F1X-U417F-00	GRAPHIC 5 (LH)	1	1	1	1	FOR CRUISER, NYM4
	F1X-U417F-10	GRAPHIC 5 (LH)	1	1	1	1	FOR CRUISER, LNMP
	F1X-U417F-20	GRAPHIC 5 (LH)	1	1	1	1	FOR YM3
	F1X-U417F-30	GRAPHIC 5 (LH)	1	1	1	1	FOR DPBMT
6	F1X-U417G-00	GRAPHIC 6 (RH)	1	1	1	1	FOR CRUISER, NYM4
	F1X-U417G-10	GRAPHIC 6 (RH)	1	1	1	1	FOR CRUISER, LNMP
	F1X-U417G-20	GRAPHIC 6 (RH)	1	1	1	1	FOR YM3
	F1X-U417G-30	GRAPHIC 6 (RH)	1	1	1	1	FOR DPBMT
7	F1X-U417H-00	GRAPHIC 7 (LH)	1	1	1	1	FOR CRUISER, NYM4
	F1X-U417H-10	GRAPHIC 7 (LH)	1	1	1	1	FOR CRUISER, LNMP
	F1X-U417H-20	GRAPHIC 7 (LH)	1	1	1	1	FOR YM3

FIG. 31 GRAPHICS



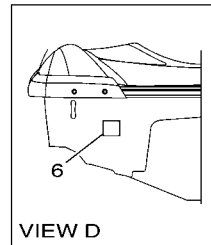
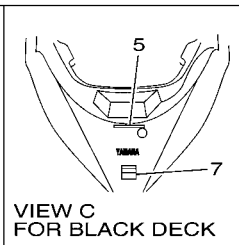
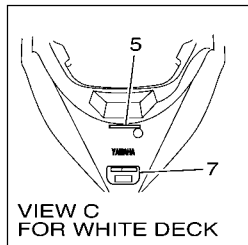
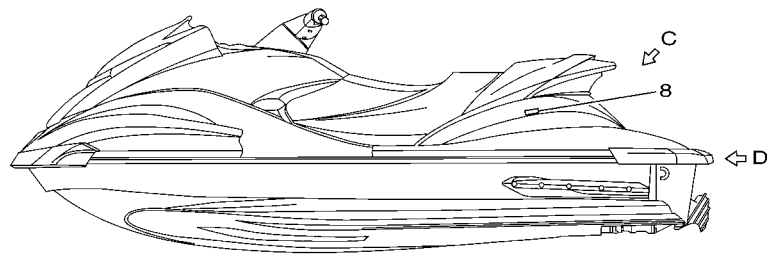
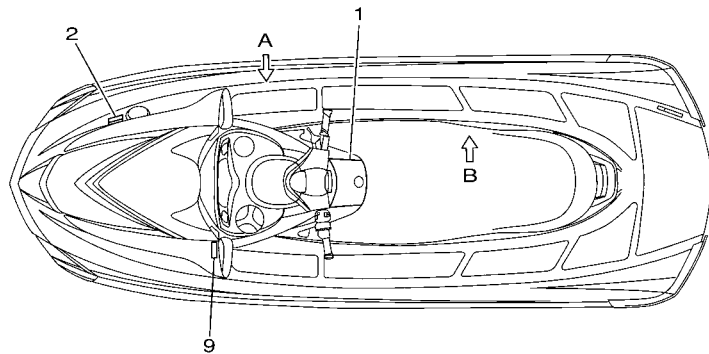
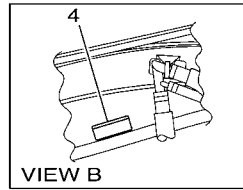
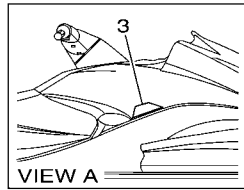
FOR NYM4  
FOR LNMP, YM3, DPBMT



F1X1100-E310

REF. NO.	PART NO.	DESCRIPTION	USA	CAN	GENE	JPN	REMARKS
7	F1X-U417H-30	GRAPHIC 7 (LH)	1	1	1	1	FOR DPBMT
8	F1X-U417J-00	GRAPHIC 8 (RH)	1	1	1	1	FOR CRUISER, NYM4
	F1X-U417J-10	GRAPHIC 8 (RH)	1	1	1	1	FOR CRUISER, LNMP
	F1X-U417J-20	GRAPHIC 8 (RH)	1	1	1	1	FOR YM3
	F1X-U417J-30	GRAPHIC 8 (RH)	1	1	1	1	FOR DPBMT
9	F1X-U417K-00	GRAPHIC 9 (LH)	1	1	1	1	FOR CRUISER, NYM4
	F1X-U417K-10	GRAPHIC 9 (LH)	1	1	1	1	FOR CRUISER, LNMP
	F1X-U417K-20	GRAPHIC 9 (LH)	1	1	1	1	FOR YM3
	F1X-U417K-30	GRAPHIC 9 (LH)	1	1	1	1	FOR DPBMT
10	F1X-U417L-00	GRAPHIC B (RH)	1	1	1	1	FOR CRUISER, NYM4
	F1X-U417L-10	GRAPHIC B (RH)	1	1	1	1	FOR CRUISER, LNMP
	F1X-U417L-20	GRAPHIC B (RH)	1	1	1	1	FOR YM3
	F1X-U417L-30	GRAPHIC B (RH)	1	1	1	1	FOR DPBMT
11	F0V-U411C-10	EMBLEM, YAMAHA	2	2	2	2	FOR NYM4
	F1X-U411C-10	EMBLEM, YAMAHA	2	2	2	2	FOR LNMP, DPBMT
	F1G-U411C-30	EMBLEM, YAMAHA	2	2	2	2	FOR YM3
12	F1B-U411C-02	EMBLEM, YAMAHA	1	1	1	1	FOR NYM4
	F1X-U411C-20	EMBLEM, YAMAHA	1	1	1	1	FOR LNMP, DPBMT
	F1G-U4114-30	MARK, YAMAHA A	1	1	1	1	FOR YM3
13	F1K-U411H-00	EMBLEM, TUNING FORK	1	1	1	1	
14	F1B-65986-00	TOOL SET	1	1	1	1	
15	EU0-65901-01	TOOL BAG	1	1	1	1	

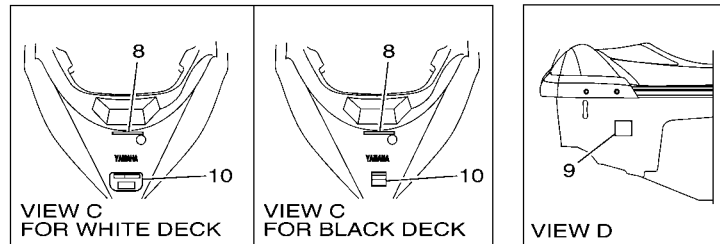
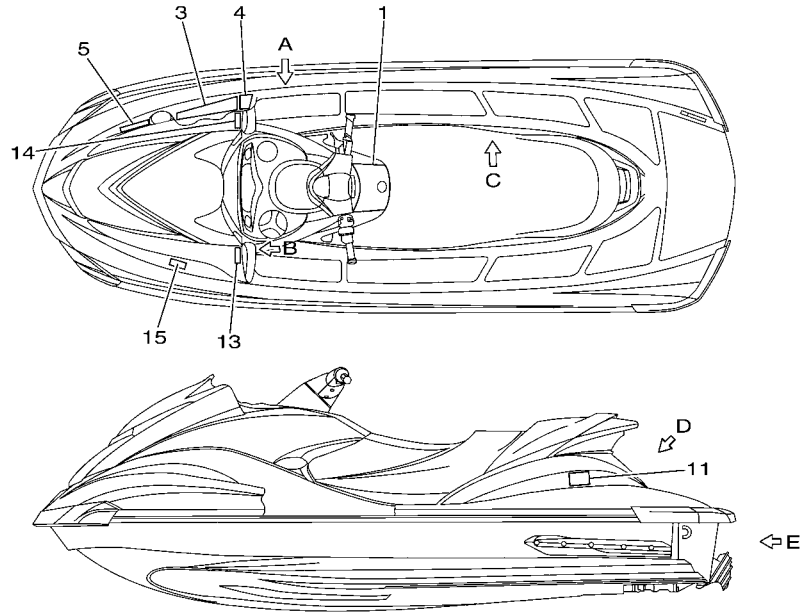
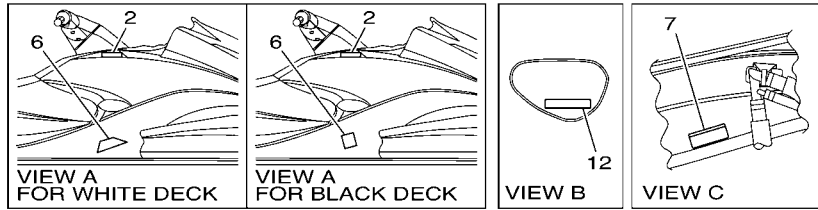




**FIG. 32 IMPORTANT LABELS**

REF. NO.	PART NO.	DESCRIPTION	USA	CAN	GENE	JPN	REMARKS
1	F1X-U41B1-00	LABEL, WARNING JDC 1	1				
2	F1B-U415B-02	LABEL, WARNING(FUEL)	1				FOR WIHTE DECK
	F1S-U415B-01	LABEL, WARNING(FUEL)	1				FOR BLACK DECK
3	F0V-U41D5-21	LABEL, WARNING SHIFT LEVER	1				
4	F0V-U41DB-02	LABEL, WARNING BATTERY	1				
5	F1B-U41F5-01	LABEL, FIRE EXTINGUISHER 1	1				FOR WIHTE DECK
	F0V-U41F5-01	LABEL, FIRE EXTINGUISHER 1	1				FOR BLACK DECK
6	F1G-U418F-00	LABEL, RIGHTING	1				
7	F1B-U41E1-21	LABEL, SET 1	1				FOR WIHTE DECK
	F1S-U41E1-01	LABEL, SET 1	1				FOR BLACK DECK
8	F0P-U41G1-01	LABEL, CAPACITY	1				FOR WIHTE DECK
	F1S-U41G1-01	LABEL, CAPACITY	1				FOR BLACK DECK
9	F0X-U41FD-01	LABEL, VISOR	1				

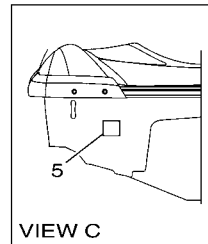
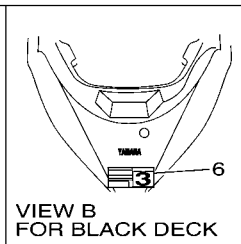
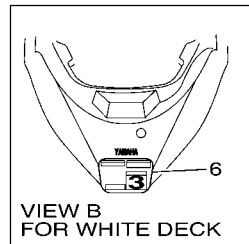
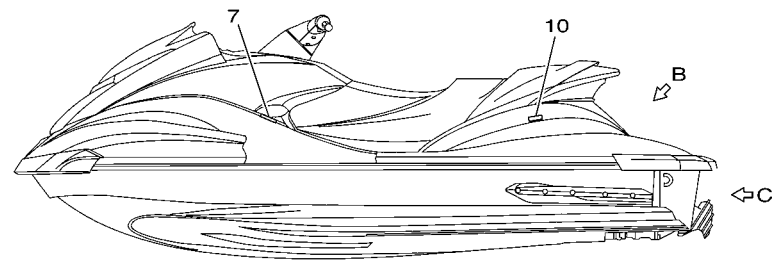
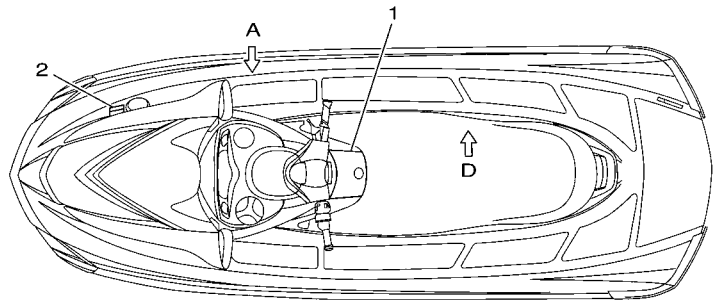
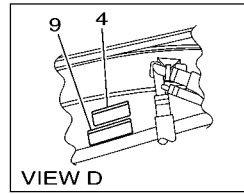
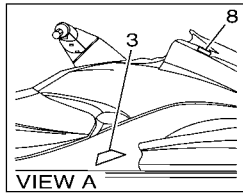
F1X1100-E320



F1X7100-E330

FIG. 33 IMPORTANT LABELS 2

REF. NO.	PART NO.	DESCRIPTION	USA	CAN	GENE	JPN	REMARKS
1	F1X-U41B1-10	LABEL, WARNING JDC 1		1	1		
2	F1B-U41B1-21	LABEL, WARNING JDC 1		1	1		
3	F0V-U41B1-31	LABEL, WARNING JDC 1		1	1		FOR WHITE DECK
	F1B-U41B1-31	LABEL, WARNING JDC 1		1	1		FOR BLACK DECK
4	F0M-U41B2-11	LABEL, WARNING JDC 2		1	1		FOR WHITE DECK
	F1B-U41B2-01	LABEL, WARNING JDC 2		1	1		FOR BLACK DECK
5	F1B-U415B-11	LABEL, WARNING(FUEL)		1	1		FOR WHITE DECK
	F1S-U415B-11	LABEL, WARNING(FUEL)		1	1		FOR BLACK DECK
6	F0P-U41D5-10	LABEL, WARNING SHIFT LEVER		1	1		FOR WHITE DECK
	F0V-U41D5-31	LABEL, WARNING SHIFT LEVER		1	1		FOR BLACK DECK
7	F0V-U41DB-12	LABEL, WARNING BATTERY		1	1		
8	F1B-U41F5-11	LABEL, FIRE EXTINGUISHER 1		1	1		FOR WHITE DECK
	F1B-U41F5-21	LABEL, FIRE EXTINGUISHER 1		1	1		FOR BLACK DECK
9	F1G-U418F-00	LABEL, RIGHTING		1	1		
10	F0V-U41E1-41	LABEL, SET 1		1	1		FOR WHITE DECK
	F1S-U41E1-11	LABEL, SET 1		1	1		FOR BLACK DECK
11	GJ3-U419E-00	LABEL 4		1			FOR WHITE DECK
	F1S-U419E-01	LABEL 4		1			FOR BLACK DECK
12	GJ1-U419F-21	LABEL,5		2	2		
13	F0X-U41FD-01	LABEL, VISOR		1	1		
14	F0X-U41FD-11	LABEL, VISOR		1	1		
15	GJ3-U416H-01	LABEL,WARNING(FRANCE)			1		FOR WHITE DECK
	GP8-U416H-01	LABEL,WARNING(FRANCE)			1		FOR BLACK DECK



F1X1100-E340

FIG. 34 IMPORTANT LABELS 3

REF. NO.	PART NO.	DESCRIPTION	USA	CAN	GENE	JPN	REMARKS
1	F1X-641B1-20	LABEL, WARNING JDC 1				1	
2	F1B-6415B-20	LABEL, WARNING(FUEL)				1	FOR WHITE DECK
	F1S-6415B-20	LABEL, WARNING(FUEL)				1	FOR BLACK DECK
3	F0V-641D5-40	LABEL, WARNING SHIFT LEVER				1	
4	F0V-641DB-20	LABEL, WARNING BATTERY				1	
5	F1G-U418F-00	LABEL, RIGHTING				1	
6	F1F-641E2-20	LABEL, SET 2				1	FOR WHITE DECK
	F1S-641E2-20	LABEL, SET 2				1	FOR BLACK DECK
7	FN8-U411B-00	PLATE,ASSY				1	FOR WHITE DECK
	GA9-U411B-00	PLATE,ASSY				1	FOR BLACK DECK
8	F1G-641FD-00	LABEL, VISOR				1	
9	F0V-U41DB-02	LABEL, WARNING BATTERY				1	
10	F0P-U41G1-01	LABEL, CAPACITY				1	FOR WHITE DECK
	F1S-U41G1-01	LABEL, CAPACITY				1	FOR BLACK DECK

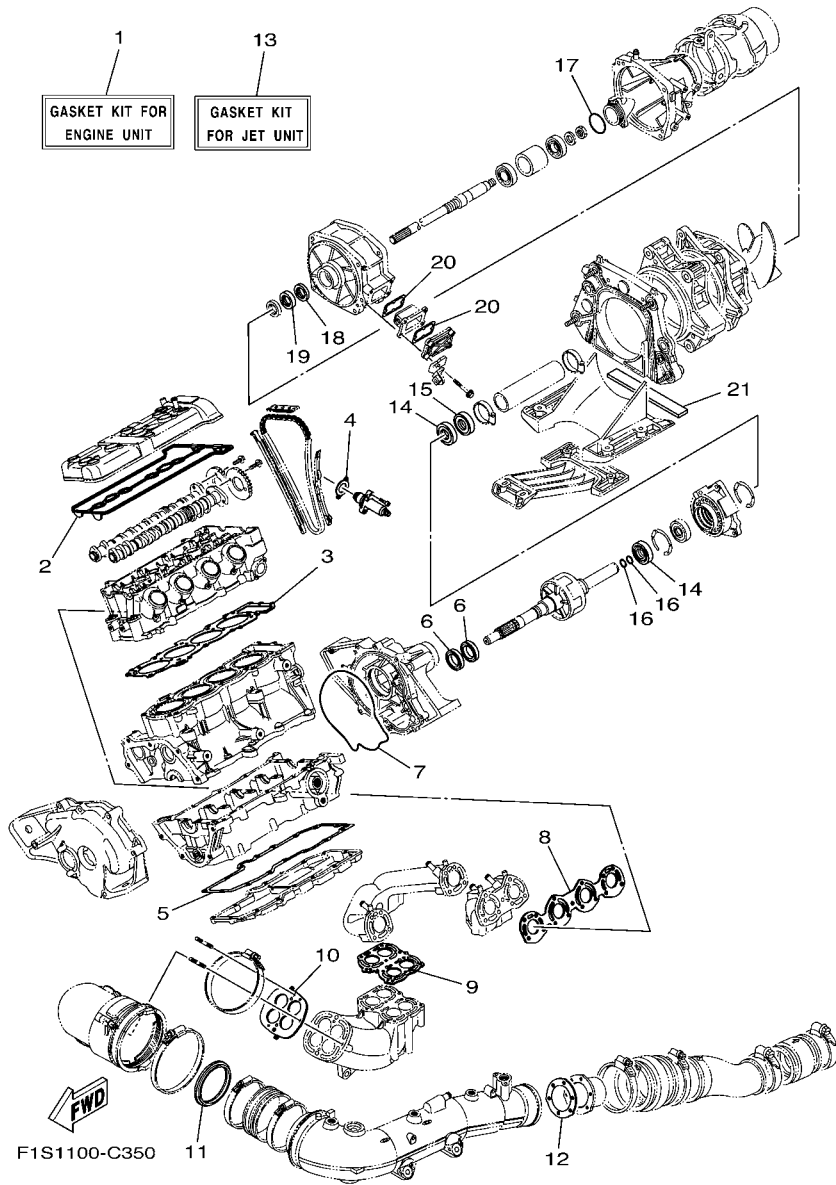


FIG. 35 REPAIR KIT 1

REF. NO.	PART NO.	DESCRIPTION	USA	CAN	GENE	JPN	REMARKS
1	6B6-W0001-01	GASKET KIT FOR ENGINE UNIT	1	1	1	1	
2	60E-11193-01	.GASKET, HEAD COVER 1	1	1	1	1	
3	6B6-11181-00	.GASKET, CYLINDER HEAD 1	1	1	1	1	
4	4FM-12213-00	.GASKET, TENSIONER CASE	1	1	1	1	
5	6B6-13557-01	.GASKET	1	1	1	1	
6	93101-35004	.OIL SEAL	2	2	2	2	
7	6B6-13475-00	.GASKET	1	1	1	1	
8	60E-14613-01	.GASKET, EXHAUST PIPE	1	1	1	1	
9	60E-14739-02	.GASKET, MUFFLER DAMPER 1	1	1	1	1	
10	60E-14749-02	.GASKET, MUFFLER DAMPER 2	1	1	1	1	
11	60E-14642-00	.SEAL, EXHAUST	1	1	1	1	
12	60E-14623-00	.GASKET, EXHAUST PIPE	1	1	1	1	
13	6B6-W0001-20	GASKET KIT FOR JET UNIT	1	1	1	1	
14	93101-25M55	.OIL SEAL	2	2	2	2	
15	93102-25009	.OIL SEAL	1	1	1	1	
16	93210-19MJ4	.O-RING	2	2	2	2	
17	93210-464A3	.O-RING	1	1	1	1	
18	93101-28M65	.OIL SEAL	1	1	1	1	
19	93101-28M66	.OIL SEAL	1	1	1	1	
20	66V-42414-00	.O-RING	2	2	2	2	
21	66V-51367-00	.FELT, PACKING	1	1	1	1	

NUMERICAL INDEX

PART NO.	GRID NO.	PART NO.	GRID NO.	PART NO.	GRID NO.	PART NO.	GRID NO.	PART NO.	GRID NO.	PART NO.	GRID NO.
6B6-11102-00-94	B - 2	4TV-12119-00	B - 8	60E-12469-00	C - 6	6B6-13750-01	B - 12	60E-14784-00-94	C - 5	60T-51190-00-94	C - 10
6B6-11119-00	C - 2	5LV-12121-00	B - 8	60E-12474-00	B - 3	60E-13761-10	B - 12	60E-14867-00	B - 10	66V-51312-01-94	C - 9
60E-1111E-00	B - 2	3GM-12126-00	B - 8	6B6-12482-00	B - 3	6B6-13795-00	B - 10	6B6-14869-00	B - 10	66V-51314-01	C - 13
4KG-1111G-00	B - 2	3FV-12153-10	B - 9	60E-12483-10	B - 3	60E-13882-00	C - 3	4BH-14923-00	B - 12	6B6-51315-01-94	C - 9
6B6-11125-00	B - 15	3LN-12153-10	B - 9	6B6-12486-00	B - 12	66V-13898-00	B - 10	3KW-14932-00	B - 12	60E-51317-00-94	C - 9
60E-11126-01	B - 15	1HX-12168-00	B - 8	6B6-12487-00	B - 12	60E-13907-01	D - 5	3L5-14962-00	B - 12	6B6-51318-00-94	C - 10
3TJ-11133-10	B - 2	1HX-12168-20	B - 8	60E-12494-00	B - 3	4BH-14134-00	B - 12	5FL-14987-10	B - 12	60E-51323-00	C - 12
1WG-11133-11	B - 2	1HX-12168-40	B - 8	60E-12495-00	B - 3	3H1-14147-00	B - 12	6B6-15100-00-8P	B - 4	6B6-51326-10	C - 10
6B6-11145-00	C - 2	1HX-12168-60	B - 8	6B6-12499-00	C - 7	60E-14147-00	B - 12	60E-15362-00	C - 2	63M-51334-00	C - 10
60E-11164-00	B - 14	1HX-12168-80	B - 8	60E-12537-00	B - 3	60E-14216-00	B - 12	6D3-15515-00	C - 14	60E-51341-00-94	C - 3
6B6-11165-00	C - 2	1HX-12168-A0	B - 8	60E-12552-00	C - 7	6B6-14239-00	B - 10	60E-15517-00	C - 14	66V-51341-00-94	C - 13
60E-11166-01	B - 15	1HX-12168-F0	B - 8	6B6-12576-10	C - 6	4N0-14251-00	B - 12	60E-15521-00	C - 14	6B6-51342-00	C - 10
6B6-11167-00	C - 3	1HX-12168-H1	B - 8	6B6-12577-10	C - 6	6B6-14291-00	B - 12	4WM-15590-00	C - 14	66V-51367-00	F - 7
6B6-11181-00	B - 2	1HX-12168-K1	B - 8	60E-12580-00	C - 6	60E-14294-00	B - 11	6B6-17572-00	B - 6	61L-5169A-00	C - 7
	F - 7	1HX-12168-M1	B - 8	60E-12581-00	C - 6	69J-14321-00	B - 12	6B6-17585-00	B - 6	F1B-60210-00	D - 7
6B6-11191-01-94	B - 2	1HX-12168-R1	B - 9	60E-12582-00	C - 6	5FL-14349-10	B - 12	6B6-17586-00	B - 6	F1X-6134A-01	E - 11
60E-11193-01	F - 7	1HX-12168-U1	B - 9	60E-12584-00	C - 6	6B6-14358-00	B - 12	6B6-2339F-00	B - 10	F1S-61355-00	E - 14
		1HX-12168-W1	B - 9	60E-12594-00	C - 4	5PW-14396-00	B - 12	EU0-23814-30	E - 14	F1B-613C1-00	E - 14
6E5-11325-00	C - 2	1HX-12168-Y1	B - 9	60E-12880-11	B - 12	6B6-1440A-00	B - 10	60E-24300-01	B - 11	F1S-61400-03	E - 13
67F-11325-01	B - 4	1HX-12169-11	B - 9	6B6-1310A-00-94	B - 4	6B6-14410-01	B - 10	60E-24329-00	B - 11	F1S-61400-14	E - 13
69J-11327-01-94	B - 4	1HX-12169-31	B - 9	6B6-13151-00-94	C - 3	60E-14413-00	B - 10	60E-24364-00	B - 11	F1B-61438-00	E - 10
67F-11328-00	B - 4	1HX-12169-50	B - 9	60E-13161-00	B - 4	60E-14414-00	B - 10	60E-24366-00	B - 11	F1S-6143C-00	E - 13
60E-11411-11	B - 6	1HX-12169-70	B - 9	6B6-13300-01	B - 14	6B6-14420-00	B - 10	60E-24474-00	B - 11	F1B-61460-00	E - 10
60E-11416-00	B - 6	1HX-12169-90	B - 9	6B6-13317-00	C - 2	63P-14446-00	B - 12	70R-24489-00	E - 5	EU0-61461-02	E - 14
60E-11416-10	B - 6	1HX-12169-E0	B - 9	6B6-13327-01-94	B - 14	6B6-14446-00	B - 12	70R-24543-00	E - 5	F1B-61461-02	E - 11
60E-11416-20	B - 6	1HX-12169-G0	B - 9	6B6-13360-00	B - 14	60E-14449-00	B - 10	6B6-26311-11	B - 10	F1X-61467-01	E - 11
60E-11416-30	B - 6	1HX-12169-J0	B - 9	6B6-13411-00	B - 14	6B6-14451-01	B - 10	67F-2812A-00	D - 2	GH1-61468-01	E - 11
60E-11416-40	B - 6	1HX-12169-L0	B - 9	60E-13421-00	C - 2	60E-14457-00	B - 10	66V-42414-00	C - 9	F1S-6146A-00	E - 13
6B6-11478-00	B - 6	1HX-12169-N0	B - 9	5GH-13440-00	B - 4	60E-14610-00-94	C - 4		F - 7	GU5-6146K-10	E - 11
6B6-11603-00	B - 6	1HX-12169-T0	B - 9	6D3-13443-00-94	C - 2	60E-14613-01	C - 4	66V-44121-00	C - 13	F1S-61481-00	E - 11
6B6-11631-00-B0	B - 6	6B6-12171-00	B - 8	60E-13446-00	C - 2		F - 7	66V-44125-00	C - 13	F1B-6149C-02	E - 11
4XV-11633-00	B - 6	6D3-12176-00	B - 8	6B6-13462-00-94	C - 2	60E-14615-00	C - 5	67X-44517-10-94	B - 4	F1B-6151M-03	E - 14
5PW-11650-00	B - 6	5JJ-12181-00	B - 8	60E-13463-10-94	C - 2	60E-14623-00	C - 5	6B6-44532-00-94	B - 5	F1B-6151S-00	E - 10
5JW-11654-00	B - 6	60E-12210-00	B - 9	60E-13473-00	C - 2		F - 7	60E-44574-00-94	B - 5	F1S-6153E-00	E - 10
60E-11656-00	B - 6	4FM-12213-00	B - 9	60E-13475-00	C - 2	60E-14625-00	C - 5	663-45119-00	C - 7	F1S-6153R-00	E - 14
60E-11656-10	B - 6		F - 7	6B6-13475-00	B - 14	60E-14631-00-94	C - 4	66V-45214-00-94	C - 9	F1B-61552-00	E - 13
60E-11656-20	B - 6	5BE-12241-00	B - 9		F - 7	60E-14642-00	C - 5	61X-45332-03-94	C - 12	F1S-61552-00	E - 13
60E-11656-30	B - 6	6D3-12251-00	B - 9	60E-13476-10	C - 2		F - 7	61L-45378-00	C - 12	F1K-61624-00	D - 11
4XV-12111-00	B - 8	4XV-12252-00	B - 9	60E-13477-00	C - 2	60E-14712-01-94	C - 4	68Y-45511-00	C - 9	F1K-61628-00	E - 2
4XV-12112-00	B - 8	60E-12411-01	C - 7	6B6-13545-00	B - 12	60E-14721-00-94	C - 5	65V-45538-00	C - 9	F0X-61637-00	D - 11
4XV-12113-00	B - 8	60E-12413-10-94	C - 7	6B6-13546-00	B - 13	60E-14739-02	C - 4	66E-45813-10-94	B - 6	EU0-61652-00	C - 6
4XV-12114-00	B - 8	6B6-12417-10-94	C - 7	6B6-13547-00	B - 13		F - 7		C - 12		D - 11
1HX-12116-01	B - 8	60E-12435-00	C - 7	6B6-13548-00	B - 13	60E-14749-02	C - 4	6D3-4581J-00	C - 12	F0X-61652-00	D - 11
1HX-12117-00	B - 8	60E-1243E-00	C - 6	6B6-13557-01	B - 4		F - 7	66V-46882-00	C - 9	GP7-61652-00	E - 7
1WG-12117-00	B - 8	6B6-1243F-00	C - 6		F - 7	6B6-14752-00-94	C - 5	66V-51129-10	C - 9	F1S-61782-00	E - 13
1HX-12118-00	B - 8	60E-12443-00	C - 6	6B6-13563-01	B - 14	6B6-1475E-00	C - 5	60E-51129-30	C - 9	F1X-62127-00	D - 15
1WG-12118-00	B - 8	6D3-12446-00	C - 7	60E-13567-00	C - 3	6B6-1475F-00	C - 5	68N-5112T-00	D - 11	EW2-62140-00	E - 5
4SV-12119-00	B - 8	60E-1244E-00	C - 8	6B6-13660-00	B - 13	60E-14771-00-94	C - 4	60E-51142-00	C - 8	EW2-62142-00	E - 5

NUMERICAL INDEX

PART NO.	GRID NO.	PART NO.	GRID NO.	PART NO.	GRID NO.	PART NO.	GRID NO.	PART NO.	GRID NO.	PART NO.	GRID NO.
F1G-62149-00	E - 5	F1B-67557-00	C - 11	6B6-81940-00	D - 3	66V-R1348-10	C - 10	F1B-U251D-10	D - 13	F1S-U371B-90	E - 2
GP7-62159-02	E - 5	F1B-67564-00	E - 9	60E-81950-00	D - 3	66V-R1367-00	C - 9	F1B-U251E-02	D - 13	F1S-U371B-A0	E - 2
GJ3-6215F-00	D - 5	F1S-67620-00	E - 7	68V-81960-00	D - 2	60E-R1381-01	C - 12	F1B-U251E-10	D - 13	F1S-U372A-20	E - 2
F1B-62241-00	E - 7	FN8-6771K-00	E - 5	EU0-82110-09	D - 5	F1S-U142A-00	E - 15	F1B-U252C-00	D - 13	F1S-U372A-30	E - 2
EU0-62241-30	C - 10	F1S-6773D-00	E - 13	6D3-82116-00	D - 3	F1S-U142G-01	E - 15	F1B-U252C-10	D - 13	F1B-U372A-90	E - 2
F1B-6224E-00	E - 7	F0D-6773E-00	E - 11	60E-82117-10	D - 3	F1B-U142K-00	E - 15	F1B-U252D-01	D - 13	F1B-U372A-A0	E - 2
FN8-6269B-00	D - 11	F1B-67743-02	E - 6	60E-82117-20	D - 3	GH1-U143B-00	E - 10	F1B-U252D-10	D - 13	F1S-U372B-20	E - 2
FOX-62733-00	E - 9	F1B-67747-00	E - 5	66V-82119-00	D - 3	F1B-U143D-00	E - 15	F1S-U252E-01	D - 13	F1S-U372B-30	E - 2
F1X-62875-00	D - 7	F1B-6774J-00	E - 6	67F-82151-00	D - 3	F1S-U143D-01	E - 15	F1S-U252E-10	D - 13	F1B-U372B-90	E - 2
FOX-6375E-00	E - 3	FJ0-67766-00	E - 6	67F-82151-30	D - 3	F1S-U143E-00	E - 15	F1S-U252F-01	D - 13	F1B-U372B-A0	E - 2
FOX-6378C-00	E - 3	F1B-67767-00	E - 6	60E-82153-00	D - 2	F0D-U143E-01	E - 15	F1S-U252F-10	D - 13	F1B-U3774-00	E - 3
GU2-6378D-02	E - 3	EW2-67821-00	E - 9	6B6-82310-00	D - 4	F1S-U143L-01	E - 15	F1B-U2624-00	E - 3	GH1-U3774-00	E - 4
F1B-6415B-20	F - 6	F1X-68090-00	D - 5	6A0-82317-00	B - 14	66V-U146E-00	C - 13	F1B-U2663-00	D - 9	F1X-U377B-02-P0	D - 6
F1S-6415B-20	F - 6	F1X-68090-10	D - 5			GH3-U146E-00	C - 10	F1B-U2664-00	E - 2	F1X-U377B-10-P0	D - 6
F1X-641B1-20	F - 6	F1X-6820A-00	D - 5	68V-82504-00	D - 4	GK5-U146F-00	E - 11	F1B-U266B-00	D - 9	F1X-U377B-20-P0	D - 6
F0V-641D5-40	F - 6	F1X-6820A-10	D - 5	60E-82532-00	D - 4	GP7-U151M-00	E - 10	F1K-U266B-00	D - 8	F1X-U377B-30-P0	D - 6
F0V-641DB-20	F - 6	GA7-68218-00	E - 7	60E-82533-00	D - 2	F0D-U152C-10	E - 10	F1X-U266B-00	D - 9	F1X-U377C-02-P0	D - 6
F1F-641E2-20	F - 6	F1B-6821G-01	D - 5	60E-82556-00	D - 5	GP7-U152M-00	E - 10	F1K-U266C-00	D - 6	F1X-U377C-10-P0	D - 6
F1S-641E2-20	F - 6	F0D-6822E-00	E - 11	60E-82560-01	D - 4	GP7-U152P-00	E - 10	F1B-U266D-00	E - 2	F1X-U377C-20-P0	D - 6
F1G-641FD-00	F - 6	60E-682E0-00	D - 5	60E-82560-A1	D - 4	GP7-U152R-00	E - 10	F0X-U266E-01	E - 3	F1X-U377C-30-P0	D - 7
F1B-65148-00	D - 9	F1B-68303-10	E - 14	60E-8259E-00	D - 3	F1B-U153D-01	E - 10	F1B-U271B-00	E - 3	F1X-U377F-00	D - 7
F1B-6514U-00	D - 10	F1S-68310-01	E - 13	6B6-8259L-11	D - 3	F0D-U153J-10	E - 10	F1S-U271B-01	E - 3	F1X-U377G-00	D - 7
F1B-6515A-01	D - 10	FK7-68312-02	E - 13	6B6-8259M-00	D - 4	GP7-U155C-00	E - 10	F1S-U273B-01	C - 11	F1X-U377H-01	D - 7
F1B-6515D-01	D - 10	FK7-68313-02	E - 13	6B6-83623-00	D - 2	GP7-U155D-00	E - 13	F1X-U278A-00	D - 12	F1X-U377J-01	D - 7
F1B-6515H-00	D - 10	F1Y-68322-00	D - 5	60E-83627-00	D - 3	F1S-U155F-00	E - 10	F1X-U278F-00	D - 12	F1X-U3844-00	D - 6
F1B-6515J-00	D - 10	F1S-68341-00	E - 14	6B6-83688-00	B - 12			F1X-U278G-00	D - 12	F1B-U3850-01	E - 2
F1X-6517C-00	D - 10	EW2-68348-00	E - 13	682-84385-01	C - 6	GP7-U155F-00	E - 10	F1B-U2873-00	E - 6	F1G-U4114-30	F - 3
F1B-6517D-00	D - 10	68V-81145-01	B - 12	60E-84742-00	D - 2			F1S-U350V-00	D - 13	FN8-U411B-00	F - 6
FOX-6517F-01	D - 9	68V-81147-00	B - 12	6B6-8552A-00	D - 2	F1B-U156E-00	E - 15	F1S-U350W-00	D - 14	GA9-U411B-00	F - 6
F1B-6517R-00	D - 7	60E-81315-00	D - 4	60E-8552E-00	D - 2	GP7-U157A-00	E - 10	F1S-U351H-01	D - 14	F1B-U411C-02	F - 3
F1B-6518E-00	D - 10	60E-81325-10	D - 4	60E-85790-01	D - 4	F1B-U1629-00	E - 4	F1S-U351H-20	D - 14	F0V-U411C-10	F - 3
F1B-6518F-00	D - 10	60E-81328-00	C - 14	60E-85885-10	B - 12	F1X-U163A-01	D - 12	F1S-U351J-01	D - 14	F1X-U411C-10	F - 3
GA7-65772-00	E - 9	66V-8132W-00	D - 2	60E-85896-00	D - 4	F1B-U1653-01	E - 2	F1S-U351J-20	D - 14	F1X-U411C-20	F - 3
EU0-65901-01	F - 3	6B6-81337-00-94	C - 14	6B6-8591A-20	D - 2	F1X-U2103-01	D - 9	F1S-U351K-10	D - 14	F1G-U411C-30	F - 3
F1S-65938-00	E - 14	60E-81410-00	C - 14	6B6-86261-00	D - 4	FOX-U213G-01	D - 15	F1S-U351M-10	D - 14	F1K-U411H-00	F - 3
F1S-65939-00	E - 14	60E-81450-00	C - 14	6B6-86261-10	D - 4	F1X-U2157-00	D - 12	F1S-U351N-10	D - 14	F1B-U4124-01	E - 15
F1B-65986-00	F - 3	60E-81800-00	C - 15	6B6-86265-00	D - 4	F1X-U2187-02	D - 15	F1S-U351P-10	D - 14	F1S-U415B-01	F - 4
F0D-67250-03	E - 13	3AJ-81809-00	C - 15	6B6-86265-10	D - 4	F1X-U2188-02	D - 15	F1S-U351R-10	D - 14	F1B-U415B-02	F - 4
F0D-67255-01	E - 13	6M6-81826-00	C - 15	60E-87179-00	D - 2	F1S-U2280-00	D - 12	F1S-U351S-10	D - 14	F1B-U415B-11	F - 5
EW2-67256-00	E - 13	6M6-81830-00	C - 15	60E-E243A-00	C - 6	F1X-U2284-00	D - 12	F0D-U352E-10	D - 13	F1S-U415B-11	F - 5
F0D-67257-00	E - 13	6M6-81840-10	C - 15	67X-E2590-00	C - 8	F1S-U2285-00	D - 12	F1S-U3581-10	D - 14	GJ3-U416H-01	F - 5
EW2-67258-01	E - 13	11H-81844-00	C - 15	67X-E2590-10	C - 8	F1S-U2501-02	D - 13	F0V-U3635-11	D - 9	GP8-U416H-01	F - 5
EW2-67259-01	E - 13	66V-81844-00	D - 2	60E-G5831-01	C - 9	F1S-U2501-10	D - 13	F1S-U371A-60	E - 2	F1X-U417B-00	F - 2
F1S-67410-00	E - 13	6D3-81845-00	C - 14	65A-R1129-00	C - 9	F1B-U2512-00	D - 13	F1S-U371A-70	E - 2	F1X-U417B-10	F - 2
F1S-67410-10	E - 13	1FK-81847-00	C - 15	60E-R1311-00-94	C - 9	F1B-U2512-10	D - 13	F1S-U371A-90	E - 2	F1X-U417B-20	F - 2
F1B-6753B-00	E - 9	6M6-81850-00	C - 15	66V-R1313-01	C - 10	F1B-U2519-00	D - 13	F1S-U371A-A0	E - 2	F1X-U417B-30	F - 2
GH7-6753B-00	E - 7	60E-81916-00	D - 2	6B6-R1321-00	C - 10	F1B-U2519-10	D - 13	F1S-U371B-60	E - 2	F1X-U417C-00	F - 2
F1S-67550-00	E - 9	60E-81921-00	D - 2	60E-R1333-00-94	C - 9	F1B-U251D-02	D - 13	F1S-U371B-70	E - 2	F1X-U417C-10	F - 2

NUMERICAL INDEX

PART NO.	GRID NO.	PART NO.	GRID NO.	PART NO.	GRID NO.	PART NO.	GRID NO.	PART NO.	GRID NO.	PART NO.	GRID NO.
F1X-U417C-20	F - 2	F0V-U41D5-21	F - 4	F1X-U596B-10	D - 7	GP7-U7835-00	E - 5	90105-07004	B - 8	90119-08029	C - 4
F1X-U417C-30	F - 2	F0V-U41D5-31	F - 5	F1X-U596C-01	D - 8	GP7-U783F-00	E - 6	90105-08860	D - 12	90119-08031	C - 4
F1X-U417D-00	F - 2	F0V-U41DB-02	F - 4	F1X-U596C-10	D - 8	F1B-U7844-01	E - 6	90105-093A5	B - 4	90119-08032	B - 10
F1X-U417D-10	F - 2		F - 6	F1X-U596H-02-P0	D - 7	F0D-U7856-10	E - 6	90105-105A6	C - 14	90119-08034	B - 14
F1X-U417D-20	F - 2	F0V-U41DB-12	F - 5	F1X-U596H-10-P0	D - 7	F0D-U785G-10	D - 5	90109-06051	B - 4		C - 4
F1X-U417D-30	F - 2	F1S-U41E1-01	F - 4	F1X-U596H-20-P0	D - 7		E - 6	90109-06053	B - 10	90119-08036	C - 4
F1X-U417E-00	F - 2	F1S-U41E1-11	F - 5	F1X-U596J-02-P0	D - 8	GP7-U785H-00	E - 6	90109-066F0	B - 2	90119-08043	B - 14
F1X-U417E-10	F - 2	F1B-U41E1-21	F - 4	F1X-U596J-10-P0	D - 8	F1K-U8169-00	D - 12	90109-08041	C - 11		C - 4
F1X-U417E-20	F - 2	F0V-U41E1-41	F - 5	F1X-U596J-20-P0	D - 8	GP7-U8211-00	D - 5	90109-08879	C - 13	90119-08045	B - 14
F1X-U417E-30	F - 2	F0V-U41F5-01	F - 4	F1X-U596K-03-P0	D - 7	EU0-U821D-00	D - 5	90110-05908	E - 10	90119-08050	B - 10
F1X-U417F-00	F - 2	F1B-U41F5-01	F - 4	F1X-U596K-10-P0	D - 7	F1S-U8221-00	D - 5		E - 13	90119-08073	B - 14
F1X-U417F-10	F - 2	F1B-U41F5-11	F - 5	F1X-U596K-20-P0	D - 7		E - 9	90110-06040	D - 11	90119-08823	B - 5
F1X-U417F-20	F - 2	F1B-U41F5-21	F - 5	F1X-U596L-03-P0	D - 8	EU0-U8221-30	D - 5	90110-06822	C - 10		C - 11
F1X-U417F-30	F - 2	F0X-U41FD-01	F - 4	F1X-U596L-10-P0	D - 8	F1X-U822E-00	D - 5	90110-08020	B - 10	90119-08832	E - 11
F1X-U417G-00	F - 2		F - 5	F1X-U596L-20-P0	D - 8	F1X-U8262-01-P0	D - 6	90110-08039	B - 14	90119-08835	B - 5
F1X-U417G-10	F - 2	F0X-U41FD-11	F - 5	F0X-U5983-01	E - 3	F1X-U8262-10-P0	D - 6	90110-08040	B - 14	90119-08942	E - 3
F1X-U417G-20	F - 2	F0P-U41G1-01	F - 4	F1X-U7228-00	D - 10	F1X-U8262-20-P1	D - 6	90110-08212	C - 14	90119-089U7	E - 6
F1X-U417G-30	F - 2		F - 6	GD0-U7249-00-05	C - 12	F1S-U826C-00	D - 4	90111-05017	D - 9	90119-089UE	C - 10
F1X-U417H-00	F - 2	F1S-U41G1-01	F - 4	F1S-U725E-00	C - 11	F1X-U826C-00	D - 12	90111-06805	D - 12	90119-089UF	C - 13
F1X-U417H-10	F - 2		F - 6	EU0-U7354-00-01	B - 5	F1X-U826D-00	D - 12	90111-08803	D - 12	90119-089UL	C - 12
F1X-U417H-20	F - 2	F0X-U4261-13	E - 9	EU0-U7354-00-03	B - 5	F1X-U828E-01	D - 6	90119-089UT	C - 3	90119-089U7	D - 2
F1X-U417H-30	F - 3	F1B-U4742-01	E - 3	EU0-U7354-00-05	B - 5	F1S-U828H-01	D - 11		C - 4	90119-089UU	E - 14
F1X-U417J-00	F - 3	F1S-U475F-00	D - 9	EU0-U7354-00-10	B - 5	F1B-U8360-01	E - 7	90116-10017	C - 5	90119-08M62	C - 4
F1X-U417J-10	F - 3	GP7-U4953-10	E - 2	EU0-U7354-00-20	B - 5	F1G-U8571-00	C - 11	90116-10018	C - 5	90119-10011	C - 5
F1X-U417J-20	F - 3	F0X-U4958-00	E - 10	F1B-U751G-00	E - 9	F0D-U883B-01	C - 12	90116-10024	C - 14	90119-10013	C - 4
F1X-U417J-30	F - 3	F1B-U5115-00	D - 6	F1S-U7525-01	E - 7	F1B-U883E-00	C - 12	90116-10619	B - 4	90119-10016	C - 14
F1X-U417K-00	F - 3	F0X-U515E-01	D - 9	F1B-U7555-02	E - 9	F1S-U883N-01	D - 12	90119-05803	D - 6	90119-10017	C - 5
F1X-U417K-10	F - 3	F1X-U515N-01	D - 9	GJ1-U7578-11	D - 5	F1S-U883P-01	D - 12	90119-06023	C - 2	90119-10020	C - 2
F1X-U417K-20	F - 3	F1X-U517B-02-P0	D - 9	F1S-U757B-00	E - 9	F1B-U883T-02	D - 12	90119-06078	B - 10	90119-10803	C - 9
F1X-U417K-30	F - 3	F1X-U517B-10-P0	D - 9	F1S-U757E-02	C - 11	F1F-U883T-02	D - 12	90119-06800	C - 9	90119-10837	C - 10
F1X-U417L-00	F - 3	F1X-U517B-20-P0	D - 9	F1S-U757F-02	C - 11	F1B-U8952-01	E - 2	90119-06803	D - 6	90119-10M02	C - 3
F1X-U417L-10	F - 3	F1X-U517B-30-P0	D - 9	F1B-U758D-02	E - 9	F1X-U8K22-01	D - 11	90119-06827	C - 11	90149-05903	D - 6
F1X-U417L-20	F - 3	F1X-U517E-10	D - 6	F1B-U759B-00	E - 6	F1S-U8K31-02	C - 10	90119-06832	D - 5		D - 9
F1X-U417L-30	F - 3	F1X-U517H-00	D - 7	F1B-U759C-00	E - 6	F1X-U8K31-02	C - 10	90119-06837	D - 10		E - 15
F1G-U418F-00	F - 4	F1X-U517V-00	D - 9	F1B-U761D-02	D - 11	6B6-W0001-01	F - 7	90119-06858	D - 7	90149-06013	C - 14
	F - 5	F1X-U517W-01	D - 9	F1B-U7626-00	E - 7	6B6-W0001-20	F - 7	90119-06859	C - 9	90149-06910	E - 15
	F - 6	F1X-U517X-01	D - 9	F1B-U7628-00	E - 7	6B6-W009A-00-94	B - 2	90119-069UB	C - 11	90149-069UA	C - 12
	F - 5	F1X-U519D-01	D - 7	F1B-U7629-00	E - 7	6B6-W009B-00-8P	B - 4		C - 13	90150-05807	C - 10
GJ3-U419E-00	F - 5	F1X-U5372-00	D - 6	F1B-U7656-00	E - 7	90101-06806	C - 13	90119-069UD	C - 12	90154-06010	E - 15
F1S-U419E-01	F - 5	F1X-U550A-00	D - 6	F1B-U7698-01	E - 7	90101-06917	B - 5		C - 13	90154-06017	E - 15
GJ1-U419F-21	F - 5	EW2-U5912-01	E - 3	F1B-U7711-01	E - 5	90101-069U0	E - 3	90119-069UH	D - 9	90159-05006	B - 10
F1X-U41B1-00	F - 4	F1X-U5913-01	E - 3	F1B-U7773-00	E - 5	90105-06026	B - 2	90119-069UJ	E - 15	90159-06008	D - 3
F1X-U41B1-10	F - 5	F1X-U591A-01	D - 8	GP7-U7831-01	E - 5	90105-06033	B - 4	90119-069UK	C - 11	90160-05003	B - 10
F1B-U41B1-21	F - 5	F1X-U591B-01	D - 8	GP7-U7831-11	E - 5	90105-06035	C - 7		D - 10	90169-049U1	E - 6
F0V-U41B1-31	F - 5	F1X-U591C-01	D - 8	GP7-U7832-01	E - 5	90105-06036	C - 2	90119-069UP	E - 2	90169-059U1	D - 13
F1B-U41B1-31	F - 5	F1X-U591D-01	D - 8	GP7-U7833-00	E - 5	90105-06054	C - 7	90119-069US	D - 5	90176-10001	B - 2
F1B-U41B2-01	F - 5	F1X-U591L-00	D - 8	GP7-U7833-10	E - 5	90105-06M07	C - 2		E - 15		C - 3
F0M-U41B2-11	F - 5	F1X-U596B-01	D - 7	GP7-U7834-00	E - 6	90105-06M17	B - 4	90119-06M65	B - 15		C - 14
F0P-U41D5-10	F - 5										

NUMERICAL INDEX

PART NO.	GRID NO.	PART NO.	GRID NO.	PART NO.	GRID NO.	PART NO.	GRID NO.	PART NO.	GRID NO.	PART NO.	GRID NO.
90179-05800	D - 9	90267-489UT	D - 13	90447-22003	C - 6	90467-170A0	C - 6	91380-06025	B - 9	93306-30610	B - 6
90179-08327	B - 6	90269-08801	D - 9	90447-28002	C - 7	90467-200A0	C - 4	91808-16023	B - 2	93430-47M04	C - 12
90179-10006	B - 2	90280-03047	C - 14	90447-28004	E - 7		C - 6	92903-06600	B - 10	93440-07149	B - 2
90179-10414	B - 2	90340-27001	B - 2	90447-28005	C - 7		D - 11		C - 3	93440-10153	B - 2
90179-10M35	C - 4	90381-05041	D - 9	90450-17M17	B - 11	90467-210A0	C - 7	92990-04600	E - 10	93440-28062	B - 7
90183-06902	D - 9	90387-05800	E - 10	90450-57002	B - 10		E - 7	92990-06100	C - 15	93603-12221	B - 14
90201-06802	E - 11	90387-06080	C - 11	90450-99801	E - 9	90467-240A0	C - 7	92990-06600	E - 10	93603-14M15	B - 4
90201-068M4	C - 10	90387-06083	C - 7	90450-99M06	C - 5	90467-240A1	C - 7	92990-10600	D - 4	93606-12019	C - 4
90201-068T1	C - 13	90387-06119	B - 14	90450-99M16	C - 5	90467-250A0	E - 7	92990-12200	C - 11		C - 9
90201-06906	E - 11		D - 2	90450-99M18	C - 5	90468-12069	B - 6		D - 11		C - 12
90201-06M05	D - 2	90387-06867	D - 14	90460-90M11	C - 5	90480-01012	D - 2		E - 3	93606-25M00	B - 14
90201-088T2	C - 13	90387-06M05	C - 2	90464-17800	E - 5	90480-06M46	C - 3	92995-06600	C - 3	93607-54002	B - 9
90201-096J9	B - 4		D - 4	90464-20005	B - 2	90480-10006	D - 10	9299R-05200	D - 11	93608-16M16	B - 14
90201-099U3	B - 5	90387-06M60	C - 12		B - 11	90480-18802	E - 15	9299R-06100	E - 10		C - 4
	E - 3	90387-06M74	C - 13	90464-32801	C - 11	90480-19800	D - 6	9299R-06200	D - 6		C - 14
	E - 14	90387-06M84	C - 13		D - 11	90480-21M63	C - 5		D - 10	94591-49130	B - 9
90201-10013	B - 2	90387-07008	D - 10		E - 5	90480-279U1	E - 12		D - 13	94702-00409	D - 4
90201-10019	B - 2	90387-08M06	C - 10		E - 7	90508-14M43	C - 13		E - 6	95023-06012	B - 2
90201-103U7	C - 14	90387-08M30	C - 13		E - 11	90600-917U4	C - 11		E - 9	95023-06016	C - 5
90201-109U6	E - 4	90387-10M09	C - 13	90464-44001	D - 10		D - 11		E - 11	95027-06010	B - 4
90201-278T0	C - 12	90387-11002	C - 5	90464-50002	D - 3		E - 5	9299R-08200	E - 3	9531P-16700	C - 9
90209-25008	B - 6	90401-20145	B - 4	90464-99003	D - 2		E - 7	9299R-08600	C - 13	95380-06700	C - 15
90267-329UR	E - 6	90430-06014	B - 2	90464-99801	C - 11		E - 12	9299R-10200	E - 3	9538R-06600	C - 13
90267-48020	D - 10	90430-08119	B - 14	90464-99804	E - 5	90601-118UF	C - 10	9299R-16600	C - 9	9538R-06700	C - 10
90267-48802	C - 8	90430-09002	B - 12	90465-11829	C - 10		D - 11	93101-25M55	C - 12		E - 11
	C - 11	90430-12002	C - 11		C - 12		E - 9		F - 7	9538R-08600	C - 14
	D - 11	90430-16910	E - 7		D - 5	90601-152U3	C - 12	93101-28002	C - 9	95720-06300	E - 13
	E - 5	90445-09M33	C - 7		E - 6	90601-155U4	E - 6	93101-28M65	F - 7	9572R-05300	D - 11
	E - 12	90445-14804	C - 10	90465-11M10	C - 7	90601-162U5	E - 5	93101-28M66	C - 9	9572R-06300	D - 6
90267-48806	D - 15	90445-14M06	C - 4		E - 6	90601-195UD	E - 9		F - 7		D - 10
90267-48819	D - 14	90445-16M09	C - 10	90465-12M53	B - 10	90601-200U1	D - 5	93101-35004	B - 6		D - 13
90267-489U1	D - 6	90445-18003	C - 6		C - 2		D - 11		F - 7		E - 3
	E - 9	90445-20002	C - 4		D - 4		E - 11	93102-25009	C - 12		E - 5
90267-489U2	E - 5	90445-20800	D - 11	90465-13M11	D - 4	90601-200U7	D - 15		F - 7		E - 9
90267-489U6	C - 11	90445-20804	D - 11	90465-13M24	C - 6	90605-502U1	D - 9	93210-06667	B - 4		E - 10
	D - 12	90445-21004	C - 8	90465-13M97	D - 2	90605-502U2	D - 6	93210-08001	B - 4	9572R-08300	E - 2
	E - 5	90445-21804	C - 6	90465-14M66	C - 8	90699-50004	E - 6	93210-18322	C - 2		E - 11
	E - 7	90445-25003	C - 7	90467-089U1	D - 5	91317-05010	C - 14	93210-18417	B - 3		E - 14
	E - 10	90445-26002	C - 7	90467-09120	B - 11	91317-05014	C - 2	93210-19001	C - 12	9572R-10300	C - 11
90267-489U8	D - 11	90446-20M65	C - 4	90467-110A1	B - 15	91317-05035	C - 2	93210-19MJ4	F - 7		E - 3
90267-489U9	D - 4	90446-24M79	C - 6	90467-120A0	C - 4	91317-06014	C - 2	93210-464A3	C - 10	95814-06016	D - 4
	D - 9	90446-27M55	C - 8		C - 7		C - 14		F - 7	95817-08012	B - 14
90267-489UE	E - 6		D - 11	90467-130A0	C - 4	91317-06016	B - 3	93212-04001	C - 14	97013-06012	C - 3
90267-489UP	D - 8	90446-27M73	D - 11	90467-140A1	E - 7		B - 14	93306-07801	B - 6	97013-06016	B - 10
	D - 9	90447-19005	B - 15	90467-150A0	C - 6	91380-04008	B - 11	93306-205U0	C - 9	97080-06030	E - 11
	E - 3	90447-22001	C - 6	90467-160A0	C - 6	91380-06012	B - 2	93306-205U6	C - 12	97080-08035	E - 14
	E - 7	90447-22002	C - 4	90467-170A0	B - 15	91380-06016	D - 4	93306-30441	B - 14	97513-05514	C - 14
90267-489US	D - 13		C - 7		C - 3	91380-06020	C - 3	93306-304U1	C - 9	97513-06516	B - 11



NUMERICAL INDEX

PART NO.	GRID NO.	PART NO.	GRID NO.	PART NO.	GRID NO.	PART NO.	GRID NO.	PART NO.	GRID NO.	PART NO.	GRID NO.
97513-06520	B - 4										
97513-06525	B - 14										
97513-06535	B - 14										
97513-06555	B - 2										
	B - 14										
97513-08520	B - 2										
97513-08530	C - 15										
97580-06516	C - 3										
97595-06416	D - 4										
97595-06520	B - 4										
	C - 2										
97595-08540	B - 4										
97780-60430	D - 2										
97780-60516	D - 2										
97780-60520	D - 3										
97780-60530	D - 2										
97880-03008	E - 13										
97880-05025	E - 13										
97880-06065	E - 10										
9788R-05025	D - 11										
97980-05210	C - 8										
98580-05025	E - 13										
98680-05520	D - 2										
98780-04015	C - 2										
98980-04010	E - 10										
99009-52500	B - 14										
99009-72500	B - 6										
99080-06600	D - 10										
99530-08012	B - 4										
99530-10014	B - 4										
99590-14016	C - 9										
99780-12600	D - 11										