

PARTS CATALOGUE

Wave Runner FX Cruiser SHO

FX1800A-G (F1W1/6S5A/6S51)

FX1800A-G (F1W2/6S5B/6S51)

FX1800A-G (F1W3/6S5C/6S51)

1GF1W-100E1

()



2009/4/15

NEWS NO.	DATE	COMMENT
PE0-WV-080006	Aug., 4,2008	MOD: FX1800 FIG.4, 6, 8, 19, 26 LIST/ILLUSTRATION REVISION
PE0-WV-090001	Jan., 8,2009	MOD: FIG.6, 7, 27, 34 LIST/ILLUSTRATION REVISION
PE0-WV-090004	Feb., 18,2009	IMPORTANT LABELS LIST CORRECTION
PE0-WV-090006	Feb., 18,2009	IMPORTANT LABELS LIST CORRECTION
PE0-WV-090007	Apr., 8,2009	MOD: FIG.25 ENGINE HATCH 1 LIST/ILLUSTRATION REVISION

FX1800A-G
PARTS CATALOGUE
©2008 by Yamaha Motor Co., Ltd.
1st edition, January 2008
All rights reserved.
Any reprinting or unauthorized use
without the written permission of
Yamaha Motor Co., Ltd.
is expressly prohibited.
Printed in Japan.

FOREWORD

This Parts Catalogue is related to the parts for the model(s) on the cover page. When you are ordering replacement parts, please refer to this Parts Catalogue and quote both part numbers and part names correctly.

1. Modifications or additions which have been made after the issue of the Parts Catalogue will be announced in the Parts News.

It is advisable that you make the necessary corrections to the Parts Catalogue according to the Parts News.

2. Abbreviations

The following abbreviations are used in this Parts Catalogue.

“UR” Use specified parts number.

“UN” Use as many as needed.

“AP” Alternate Parts

“LM” Locally Made (Parts need to be ordered locally)

“F#” Frame No. (Applicable machine No.)

“O/S” Over Size

3. The number of components for assembly

- Parts, which are to be supplied in an assembly, are listed with a dot (.) in front of the part name as shown below.
- The numeral appearing to the right of each component part indicates the quantity of parts for each assembly unit.

PART NO.	DESCRIPTION	Q'TY	REMARKS
2F5-83310-60	FRONT FLASHER LIGHT ASSY	2	
115-83311-60	.BULB (6V-18W)	1	

4. Applicable colours of graphics are represented in the “REMARKS” as shown below.

PART NO.	DESCRIPTION	Q'TY	REMARKS
2N4-24110-00-X5	FUEL TANK COMP.	2	MXR
3J1-24240-10	.GRAPHIC, FUEL TANK	1	FOR MXR

5. Note that the illustrations for reference in finding parts numbers are not to be used for assembling. When assembling, please use the applicable service manual.

6. The asterisk (*) before a reference number indicates modified items after the first edition.

FOREWORD

7. Applicable Serial No.

Engine Serial No.

Hull Serial No.

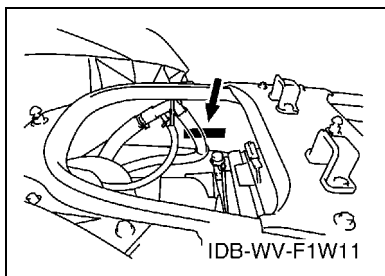
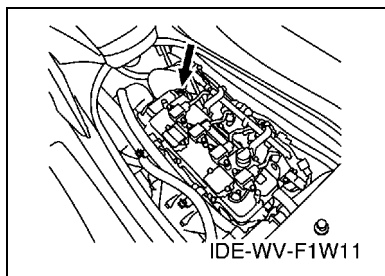

8. Applicable Colour Code (The (*) mark shows Model colour.)

Abbreviation	Colour Name	Colour Code
DRMR(*)	DEEP RED METALLIC R	1080
LNMP(*)	LIGHT GRAY METALLIC P	0925
SSA(*)	BLACK SOLID A	1000
LYNM	LIGHT YELLOWISH GRAY MET C	1079
NME	GRAY METALLIC E	1049
BMG	BLACK METALLIC G	1050

9. Quantity Column Information

Column No.	Name Of Q'ty Column	Destination
1	USA	U.S.A.
2	CAN	CANADA
3	EUR	EUROPE
4	GENE	EXCEPT USA, CAN, EUR

10. Applicable Starting Serial No.

Engine Serial No.

Serial No.	Name Of Q'ty Column	Model Code
6S5-1000001	USA	6S5A
6S5-1000001	CAN	6S5A
6S5-1000001	EUR	6S5C
6S5-1000001	GENE	6S5B

Hull Serial No.

Serial No.	Name Of Q'ty Column	Model Code
F1W-800426	USA	F1W1
F1W-800401	CAN	F1W1
F1W-800201	EUR	F1W3
F1W-800101	GENE	F1W2

CONTENTS

CYLINDER 1	1
CYLINDER 2	2
CRANKCASE	3
CRANKSHAFT & PISTON	5
VALVE	7
INTAKE 1	9
INTAKE 2	11
INTAKE 3	13
OIL PUMP	14
OIL PAN	15
OIL COOLER	16
BREATHING OIL	17
EXHAUST 1	18
EXHAUST 2	19
JET UNIT 1	22
JET UNIT 2	24
JET UNIT 3	25
JET UNIT 4	26
GENERATOR	28
STARTING MOTOR	29
ELECTRICAL 1	30
ELECTRICAL 2	32
ELECTRICAL 3	34
ENGINE MOUNT	36
ENGINE HATCH 1	37
ENGINE HATCH 2	39
HULL & DECK	42
GUNWALE & MAT	45
VENTILATION	47
SEAT & UNDER LOCKER	48
FUEL TANK	50
BILGE PUMP	52
EXHAUST 3	54
CONTROL CABLE	55
STEERING 1	57
STEERING 2	59
GRAPHICS	60
IMPORTANT LABELS	61
IMPORTANT LABELS 2	62
REPAIR KIT 1	63

INDEX

NUMERICAL INDEX	64
-----------------------	----

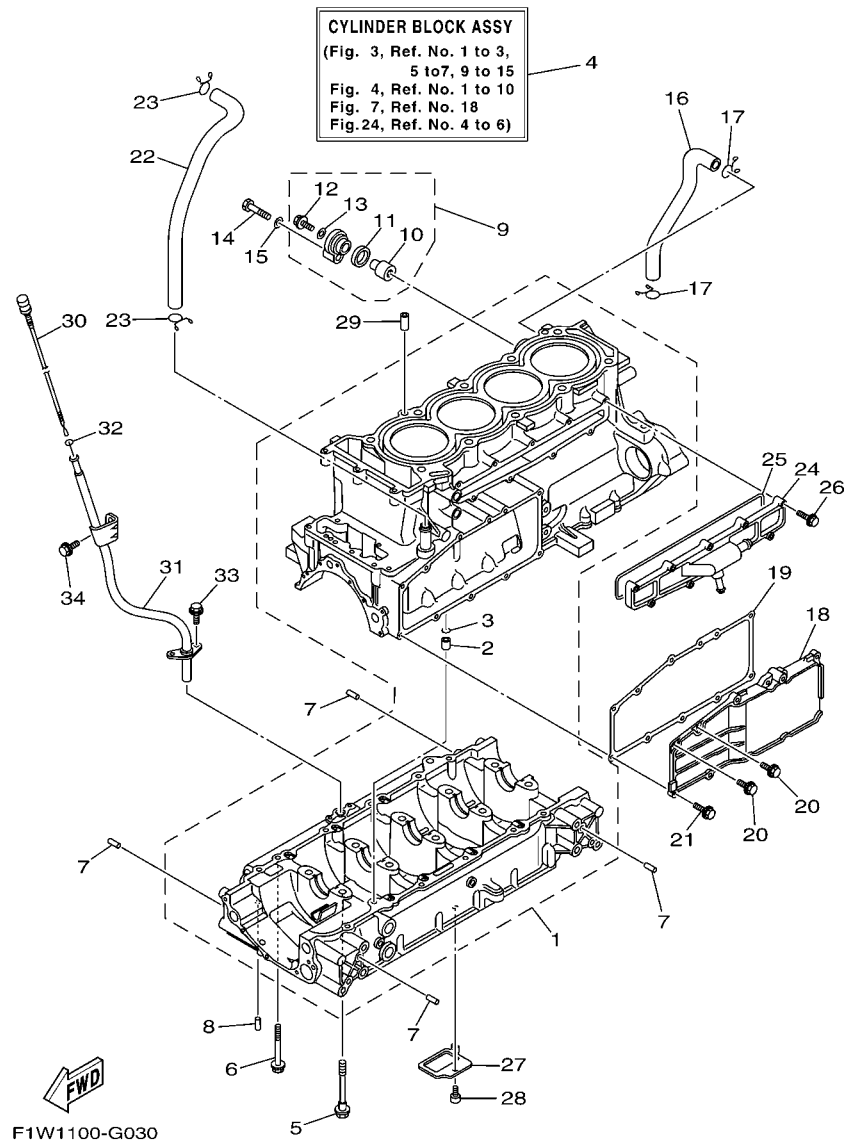

FIG. 3 CRANKCASE

REF. NO.	PART NO.	DESCRIPTION	USA	CAN	EUR	GENE	REMARKS
1	6S5-15100-00-94	CRANKCASE ASSY	1	1	1	1	
2	99530-10114	.PIN, DOWEL	1	1	1	1	
3	93210-11453	.O-RING	1	1	1	1	
4	6S5-W009B-00-94	CYLINDER BLOCK ASSY	1	1	1	1	
5	90105-10071	BOLT, FLANGE	10	10	10	10	
6	95814-06070	BOLT, FLANGE	12	12	12	12	
7	93606-12019	PIN, DOWEL	8	8	8	8	
8	93604-10M03	PIN, DOWEL	2	2	2	2	
9	69J-11301-10	ANODE COVER ASSY	1	1	1	1	
10	68V-11325-02	.ANODE	1	1	1	1	
11	67F-11328-00	.GROMMET, ANODE	1	1	1	1	
12	90105-06M07	.BOLT, FLANGE	1	1	1	1	
13	90430-06M03	.GASKET	1	1	1	1	
14	97095-08040	BOLT	1	1	1	1	
15	92995-08600	WASHER	1	1	1	1	
16	6S5-11377-00	HOSE	1	1	1	1	
17	90467-190A0	CLIP	2	2	2	2	
18	6S5-1131M-00-94	COVER	1	1	1	1	
19	6S5-13557-00	GASKET	1	1	1	1	
20	95024-06014	BOLT, FLANGE	2	2	2	2	
21	95024-06020	BOLT, FLANGE	9	9	9	9	
22	6S5-11126-00	PIPE, BREATHER 3	1	1	1	1	
23	90467-190A0	CLIP	2	2	2	2	
24	6S5-12469-00-94	JOINT 1	1	1	1	1	
25	6S5-12517-00	GASKET, WATER INLET	1	1	1	1	
26	95023-06025	BOLT	9	9	9	9	
27	6S5-13337-00	PLATE, BAFFLE LOWER	1	1	1	1	

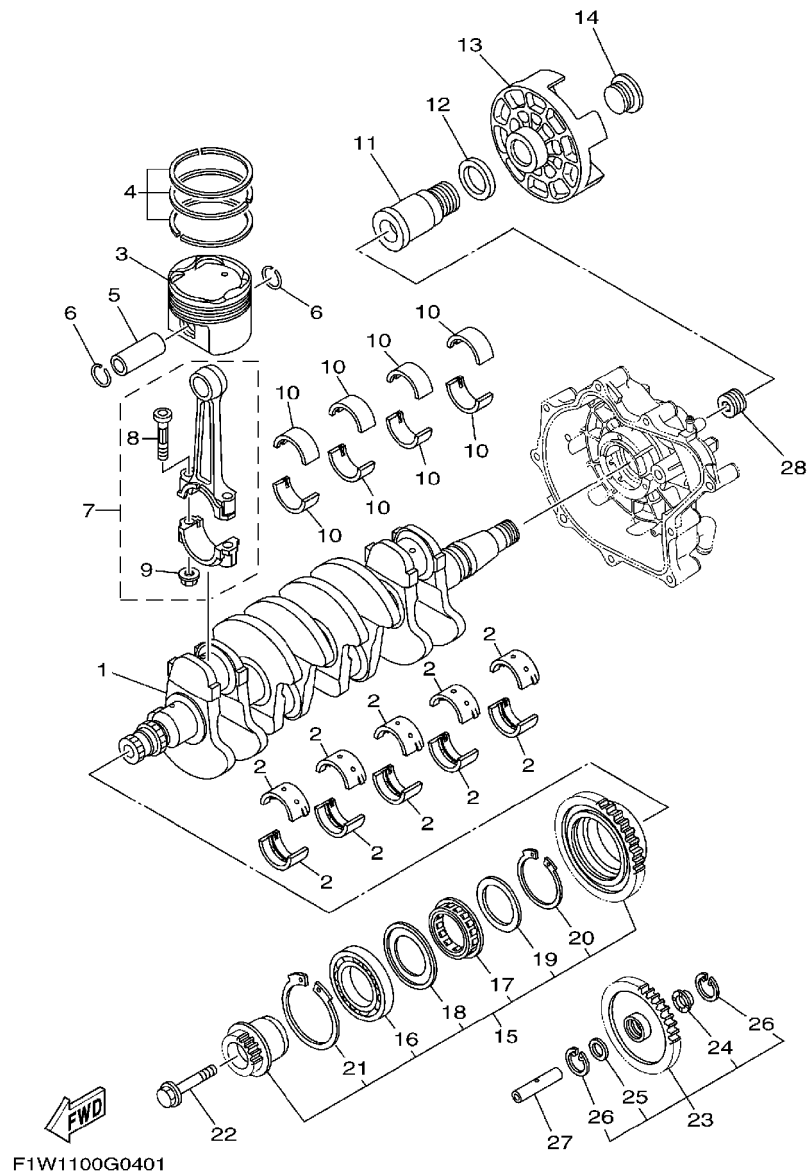
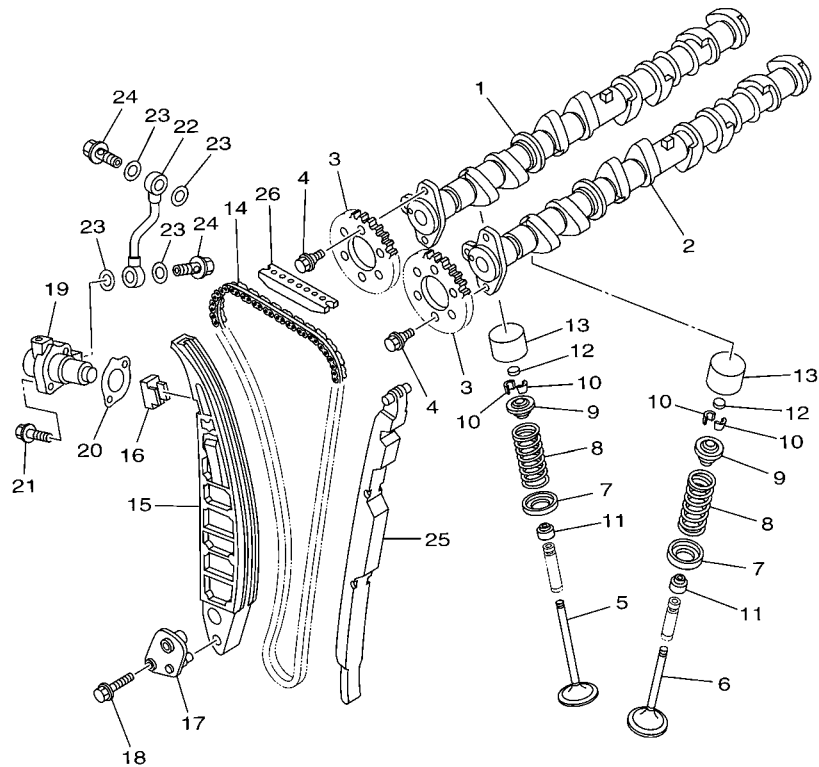

FIG. 4 CRANKSHAFT & PISTON

REF. NO.	PART NO.	DESCRIPTION	USA	CAN	EUR	GENE	REMARKS
1	6S5-11411-00	CRANKSHAFT	1	1	1	1	
2	6S5-11416-00	PLANE BEARING, CRANKSHAFT 1	10	10	10	10	UR BROWN
	6S5-11416-10	PLANE BEARING, CRANKSHAFT 1	10	10	10	10	UR BLACK
	6S5-11416-20	PLANE BEARING, CRANKSHAFT 1	10	10	10	10	UR BLUE
	6S5-11416-30	PLANE BEARING, CRANKSHAFT 1	10	10	10	10	UR GREEN
	6S5-11416-40	PLANE BEARING, CRANKSHAFT 1	10	10	10	10	UR YELLOW
3	6S5-11631-10-B0	PISTON (STD)	4	4	4	4	
4	6S5-11603-00	PISTON RING SET (STD)	4	4	4	4	
5	6S5-11633-00	PIN, PISTON	4	4	4	4	
6	93450-24028	CIRCLIP	8	8	8	8	
7	6S5-11650-00	CONNECTING ROD ASSY	4	4	4	4	
8	6S5-11654-00	.BOLT, CONNECTING ROD	2	2	2	2	
9	90179-09379	.NUT	2	2	2	2	
10	6S5-11656-00	PLANE BEARING, CONNECTING ROD	8	8	8	8	UR BROWN
	6S5-11656-10	PLANE BEARING, CONNECTING ROD	8	8	8	8	UR BLACK
	6S5-11656-20	PLANE BEARING, CONNECTING ROD	8	8	8	8	UR BLUE
	6S5-11656-30	PLANE BEARING, CONNECTING ROD	8	8	8	8	UR GREEN
11	6S5-17572-01	SHAFT, TRANSFER	1	1	1	1	
12	6S5-12289-00	WASHER	1	1	1	1	
13	6S5-45813-01-94	FLANGE, COUPLING	1	1	1	1	
14	6S5-17525-00	HOLDER 2	1	1	1	1	
15	6S5-17800-00	GEAR UNIT ASSY, TACHO. DRIVE	1	1	1	1	
16	93316-00901	.BEARING	1	1	1	1	
17	6S5-15657-00	.CLUTCH, ONEWAY	1	1	1	1	
18	6S5-17648-00	.WASHER	1	1	1	1	
19	6S5-17658-00	.WASHER	1	1	1	1	
20	93450-63160	.CIRCLIP	1	1	1	1	



FIW1100-G050

FIG. 5 VALVE

REF. NO.	PART NO.	DESCRIPTION	USA	CAN	EUR	GENE	REMARKS
1	6S5-12171-00	CAMSHAFT 1	1	1	1	1	
2	6S5-12181-00	CAMSHAFT 2	1	1	1	1	
3	6D3-12176-00	SPROCKET, CAM CHAIN	2	2	2	2	
4	90105-07004	BOLT, FLANGE	4	4	4	4	
5	6S5-12111-00	VALVE, INTAKE	8	8	8	8	
6	6S5-12121-00	VALVE, EXHAUST	8	8	8	8	
7	6S5-12116-00	SEAT, VALVE SPRING	16	16	16	16	
8	6S5-12113-00	SPRING, VALVE INNER	16	16	16	16	
9	6S5-12117-00	RETAINER, VALVE SPRING	16	16	16	16	
10	3LD-12118-00	COTTER, VALVE	32	32	32	32	
11	51Y-12119-00	SEAL, VALVE STEM	16	16	16	16	
12	3LD-12168-00	PAD, ADJUSTING (1.20)	16	16	16	16	UR
	3LD-12168-20	PAD, ADJUSTING (1.25)	16	16	16	16	UR
	3LD-12168-40	PAD, ADJUSTING (1.30)	16	16	16	16	UR
	3LD-12168-60	PAD, ADJUSTING (1.35)	16	16	16	16	UR
	3LD-12168-80	PAD, ADJUSTING (1.40)	16	16	16	16	UR
	3LD-12168-A0	PAD, ADJUSTING (1.45)	16	16	16	16	UR
	3LD-12168-F0	PAD, ADJUSTING (1.50)	16	16	16	16	UR
	3LD-12168-H1	PAD, ADJUSTING (1.55)	16	16	16	16	UR
	3LD-12168-K1	PAD, ADJUSTING (1.60)	16	16	16	16	UR
	3LD-12168-M1	PAD, ADJUSTING (1.65)	16	16	16	16	UR
	3LD-12168-R1	PAD, ADJUSTING (1.70)	16	16	16	16	UR
	3LD-12168-U1	PAD, ADJUSTING (1.75)	16	16	16	16	UR
	3LD-12168-W1	PAD, ADJUSTING (1.80)	16	16	16	16	UR
	3LD-12168-Y1	PAD, ADJUSTING (1.85)	16	16	16	16	UR
	3LD-12169-11	PAD, ADJUSTING (1.90)	16	16	16	16	UR
	3LD-12169-31	PAD, ADJUSTING (1.95)	16	16	16	16	UR

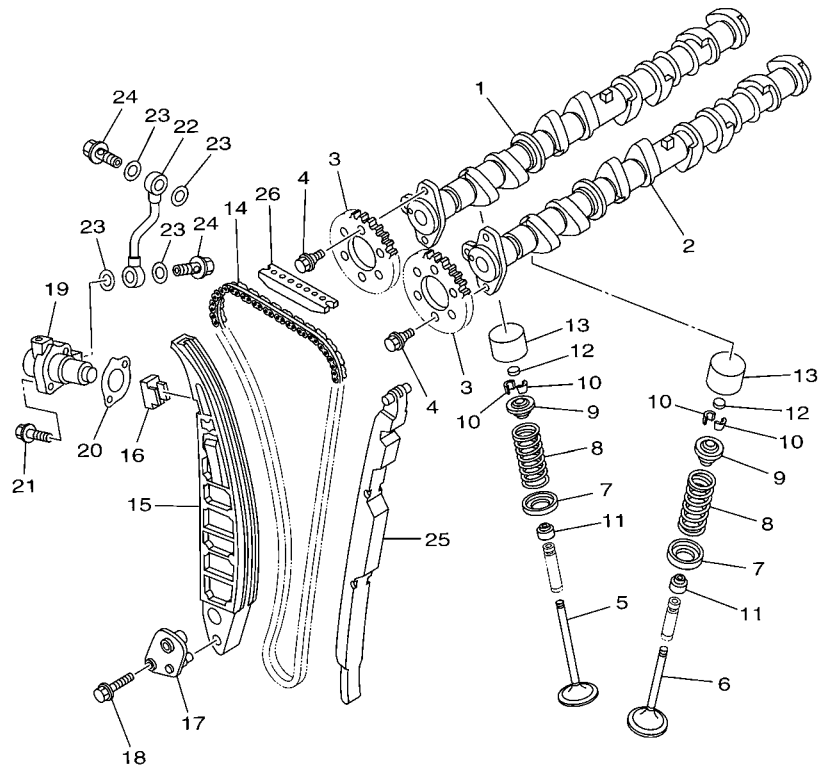

FWD
FIW1100-G050

FIG. 5 VALVE

REF. NO.	PART NO.	DESCRIPTION	USA	CAN	EUR	GENE	REMARKS
12	3LD-12169-50	PAD, ADJUSTING (2.00)	16	16	16	16	UR
	3LD-12169-70	PAD, ADJUSTING (2.05)	16	16	16	16	UR
	3LD-12169-90	PAD, ADJUSTING (2.10)	16	16	16	16	UR
	3LD-12169-E0	PAD, ADJUSTING (2.15)	16	16	16	16	UR
	3LD-12169-G0	PAD, ADJUSTING (2.20)	16	16	16	16	UR
	3LD-12169-J0	PAD, ADJUSTING (2.25)	16	16	16	16	UR
	3LD-12169-L0	PAD, ADJUSTING (2.30)	16	16	16	16	UR
13	6S5-12153-00	LIFTER, VALVE	16	16	16	16	
14	94591-66152	CHAIN	1	1	1	1	
15	6S5-12252-00	DAMPER, CHAIN 2	1	1	1	1	
16	6S5-12215-00	CAP, TENSIONER CASE	1	1	1	1	
17	6S5-12279-00	PLATE	1	1	1	1	
18	95814-06030	BOLT, FLANGE	2	2	2	2	
19	6S5-12210-00	TENSIONER ASSY, CAM CHAIN	1	1	1	1	
20	6S5-121E2-00	GASKET	1	1	1	1	
21	91380-06025	BOLT	2	2	2	2	
22	6S5-13418-00	PIPE, OIL 2	1	1	1	1	
23	90430-10007	GASKET	4	4	4	4	
24	90401-10040	BOLT, UNION	2	2	2	2	
25	6S5-12251-00	DAMPER, CHAIN 1	1	1	1	1	
26	6S5-12241-00	GUIDE, STOPPER 2	1	1	1	1	

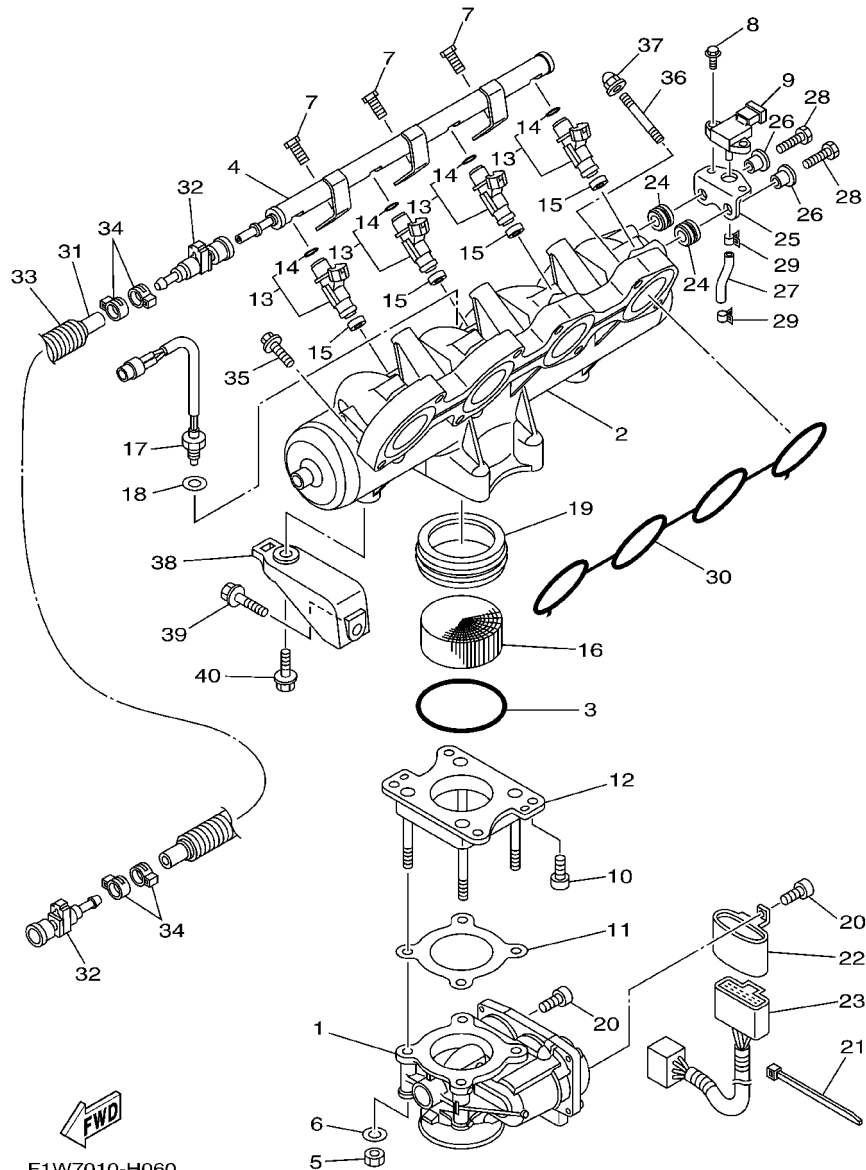

F1W7010-H060

FIG. 6 INTAKE 1

REF. NO.	PART NO.	DESCRIPTION	USA	CAN	EUR	GENE	REMARKS
1	6S5-13750-00	THROTTLE BODY ASSY	1	1	1	1	
2	6S5-13641-00	MANIFOLD 1	1	1	1	1	
3	6S5-14147-00	O-RING	1	1	1	1	
4	6S5-12880-00	DELIVERY PIPE	1	1	1	1	
5	6P2-13588-00	NUT	4	4	4	4	
6	6P2-13578-00	WASHER	4	4	4	4	
7	63P-14446-00	BOLT	3	3	3	3	
8	6S5-13573-00	BOLT 1	2	2	2	2	
9	6S5-82380-00	SENSOR, PRESSURE	1	1	1	1	
10	6S5-14496-00	BOLT	4	4	4	4	
11	6S5-14536-00	GASKET	1	1	1	1	
12	6S5-14360-00	THROTTLE DAMPER ASSY	1	1	1	1	
13	6S5-13761-00	INJECTOR	4	4	4	4	
14	60E-14147-00	.O-RING	1	1	1	1	
15	8FP-13556-00	GASKET, MANIFOLD	4	4	4	4	
16	6D3-1444B-00	RIBBON	1	1	1	1	
17	6S5-85886-00	SENSOR, AIR TEMPERATURE	1	1	1	1	
18	6S5-14285-00	WASHER	1	1	1	1	
19	6D3-14457-00	SEAL	1	1	1	1	
20	6S5-14216-00	SCREW	2	2	2	2	
21	6S5-81128-00	CLAMP	1	1	1	1	
22	6S5-13881-00	COVER 1	1	1	1	1	
23	6S5-82509-00	WIRE, SUB LEAD	1	1	1	1	
24	6S5-14445-00	GROMMET	2	2	2	2	
25	6S5-14291-00	BRACKET 1	1	1	1	1	
26	6S5-14534-00	COLLAR	2	2	2	2	
27	69J-13532-00	HOSE, VACUUM SENSING 3	1	1	1	1	

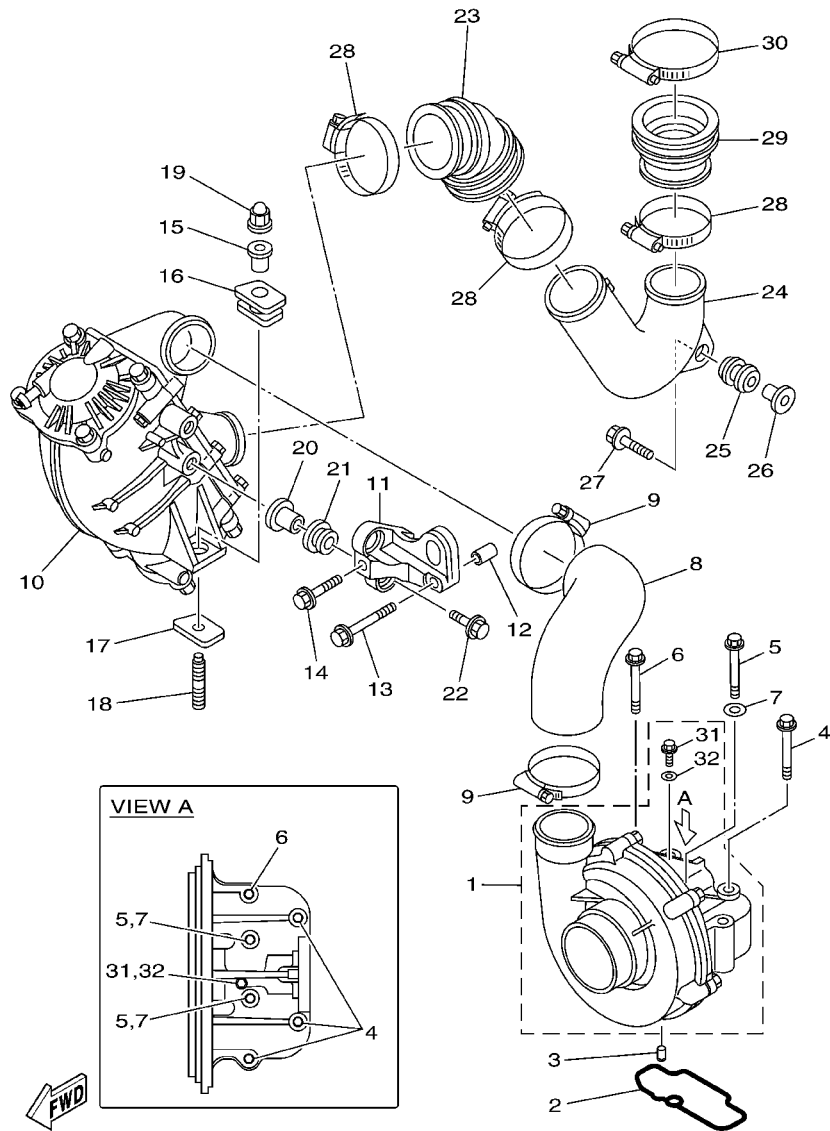

F1W1100G0701

FIG. 7 INTAKE 2

REF. NO.	PART NO.	DESCRIPTION	USA	CAN	EUR	GENE	REMARKS
1	6S5-141A0-00	SUPER CHARGER ASSY	1	1	1	1	
2	6S5-1416A-00	O-RING	1	1	1	1	
3	93604-10M03	PIN, DOWEL	2	2	2	2	
4	95814-08065	BOLT, FLANGE	3	3	3	3	
5	95814-06065	BOLT, FLANGE	2	2	2	2	
6	90105-08188	BOLT, FLANGE	1	1	1	1	
7	90201-06028	WASHER, PLATE	2	2	2	2	
8	6S5-14349-00	PIPE	1	1	1	1	
9	90450-75003	HOSE CLAMP ASSY	2	2	2	2	
10	6S5-13670-00	AIR COOLER ASSY.	1	1	1	1	
11	6S5-13691-00-94	BRACKET, AIR COOLER	1	1	1	1	
12	99590-14016	PIN, DOWEL	2	2	2	2	
13	90119-10047	BOLT, WITH WASHER	1	1	1	1	
14	90119-10046	BOLT, WITH WASHER	1	1	1	1	
15	6S5-14495-00	COLLAR	1	1	1	1	
16	6S5-14435-00	GROMMET	1	1	1	1	
17	6S5-14243-00	PLATE	1	1	1	1	
18	90116-10044	BOLT, STUD	1	1	1	1	
19	90176-10001	NUT, CROWN	1	1	1	1	
20	90387-11002	COLLAR	2	2	2	2	
21	90480-21M63	GROMMET	2	2	2	2	
22	90119-10011	BOLT, WITH WASHER	2	2	2	2	
23	6S5-14148-00	PIPE	1	1	1	1	
24	6S5-13651-00	PIPE, BOOST	1	1	1	1	
25	90480-22M15	GROMMET	1	1	1	1	
26	6D3-14495-00	COLLAR	1	1	1	1	
27	90119-08M22	BOLT, WITH WASHER	1	1	1	1	

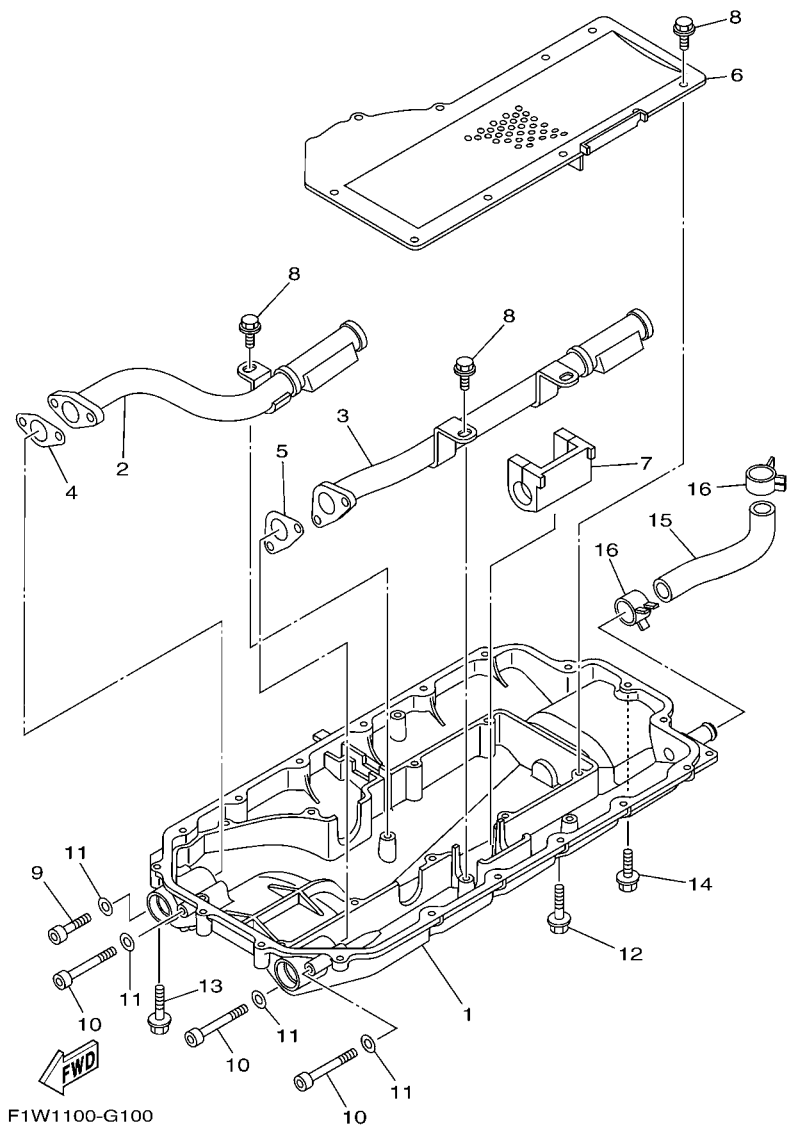
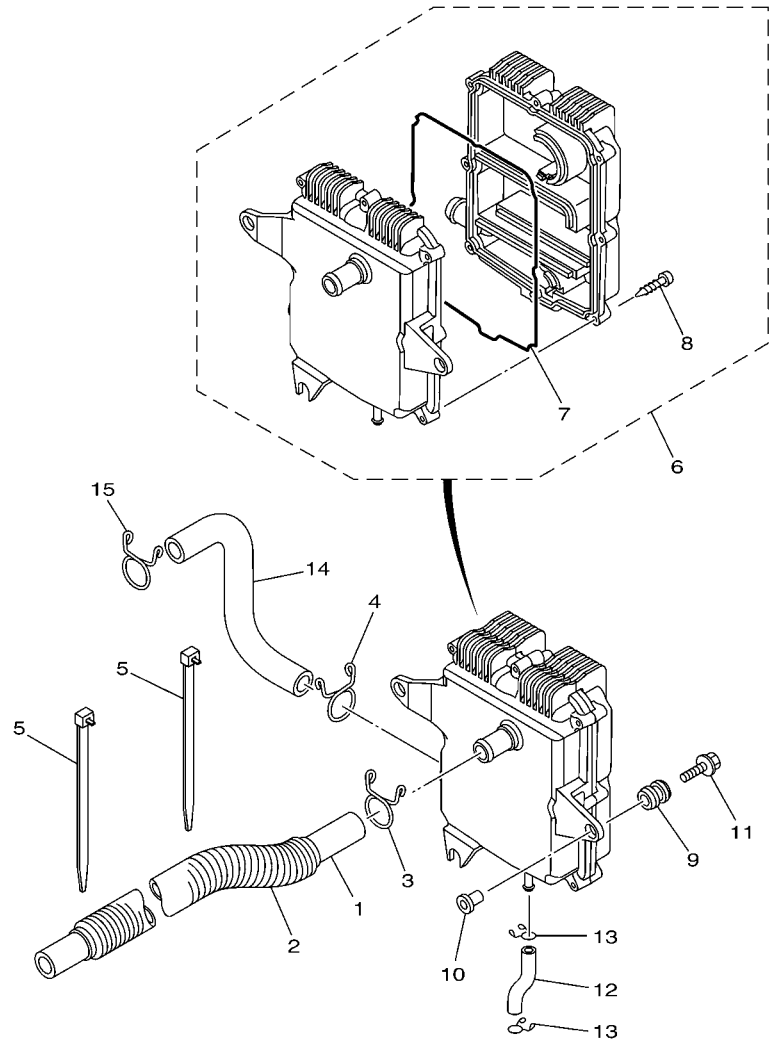

FIG. 10 OIL PAN

REF. NO.	PART NO.	DESCRIPTION	USA	CAN	EUR	GENE	REMARKS
1	6S5-1310A-00-94	PAN, OIL	1	1	1	1	
2	6S5-13405-00	OIL PIPE COMP. 1	1	1	1	1	
3	6S5-13406-00	OIL PIPE COMP. 2	1	1	1	1	
4	6S5-13476-00	GASKET	1	1	1	1	
5	6S5-13477-00	GASKET	1	1	1	1	
6	6S5-13317-00	PLATE, BAFFLE	1	1	1	1	
7	6S5-15486-00	GROMMET	1	1	1	1	
8	95817-06014	BOLT, FLANGE	13	13	13	13	
9	91314-06035	BOLT	1	1	1	1	
10	91314-06060	BOLT	3	3	3	3	
11	90201-06028	WASHER, PLATE	4	4	4	4	
12	95024-06035	BOLT, FLANGE	16	16	16	16	
13	95024-06030	BOLT, FLANGE	1	1	1	1	
14	95024-06020	BOLT, FLANGE	1	1	1	1	
15	6S5-11378-00	HOSE 2	1	1	1	1	
16	90467-200A0	CLIP	2	2	2	2	



 F1W1100-G120

FIG. 12 BREATHER OIL

REF. NO.	PART NO.	DESCRIPTION	USA	CAN	EUR	GENE	REMARKS
1	6S5-11166-00	PIPE, BREATHER 1	1	1	1	1	
2	90446-30MF1	HOSE (L600)	1	1	1	1	
3	90467-240A2	CLIP	1	1	1	1	
4	90467-240A2	CLIP	1	1	1	1	
5	90465-14M66	CLAMP	2	2	2	2	
6	6S5-11160-00	BREATHER ASSY	1	1	1	1	
7	93212-02001	.O-RING	1	1	1	1	
8	97780-60530	.SCREW, TAPPING	8	8	8	8	
9	61N-82317-00	DAMPER, IGNITION COIL	3	3	3	3	
10	90387-06119	COLLAR	3	3	3	3	
11	95824-06030	BOLT, FLANGE	3	3	3	3	
12	6S5-11125-00	PIPE, BREATHER 4	1	1	1	1	
13	90467-11019	CLIP	2	2	2	2	
14	6S5-11167-00	PIPE, BREATHER 2	1	1	1	1	
15	90467-240A2	CLIP	1	1	1	1	

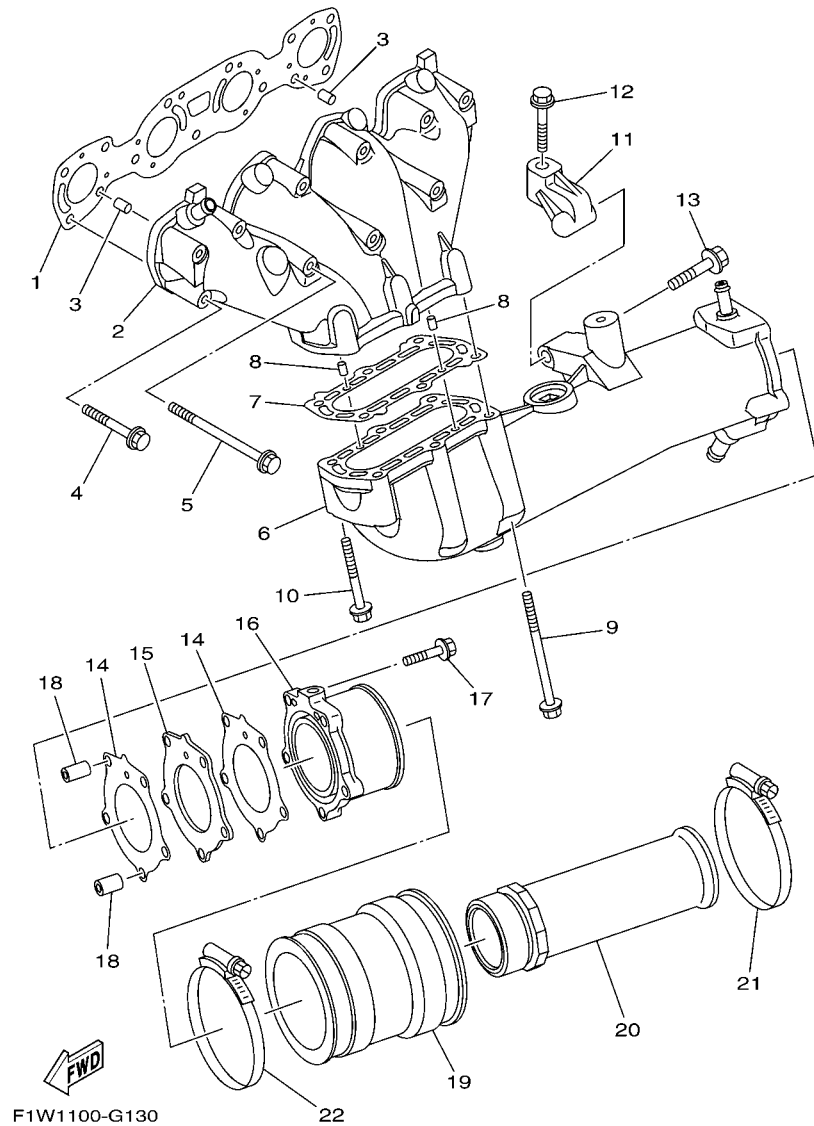

F1W1100-G130

FIG. 13 EXHAUST 1

REF. NO.	PART NO.	DESCRIPTION	USA	CAN	EUR	GENE	REMARKS
1	6S5-14613-00	GASKET, EXHAUST PIPE	1	1	1	1	
2	6S5-14711-00-94	MUFFLER 1	1	1	1	1	
3	93608-16M16	PIN, DOWEL	2	2	2	2	
4	90119-08034	BOLT, WITH WASHER	8	8	8	8	
5	90119-08097	BOLT, WITH WASHER	3	3	3	3	
6	6S5-14721-00-94	MUFFLER 2	1	1	1	1	
7	6S5-14739-00	GASKET, MUFFLER DAMPER 1	1	1	1	1	
8	93606-12019	PIN, DOWEL	2	2	2	2	
9	90119-08097	BOLT, WITH WASHER	4	4	4	4	
10	90119-08034	BOLT, WITH WASHER	2	2	2	2	
11	6S5-14771-00-94	STAY, MUFFLER 1	1	1	1	1	
12	90119-08096	BOLT, WITH WASHER	1	1	1	1	
13	90119-10029	BOLT, WITH WASHER	1	1	1	1	
14	6S5-14749-00	GASKET, MUFFLER DAMPER 2	2	2	2	2	
15	6S5-1469W-00	PLATE, SILENCER 6	1	1	1	1	
16	6S5-14784-00-94	PIPE, TAIL	1	1	1	1	
17	95024-08035	BOLT, FLANGE	5	5	5	5	
18	99590-10114	PIN, DOWEL	2	2	2	2	
19	6S5-14752-00	PIPE, OUTLET	1	1	1	1	
20	6S5-1475A-00	PIPE 1	1	1	1	1	
21	90450-99M06	HOSE CLAMP ASSY	1	1	1	1	
22	90450-90M10	HOSE CLAMP ASSY	1	1	1	1	

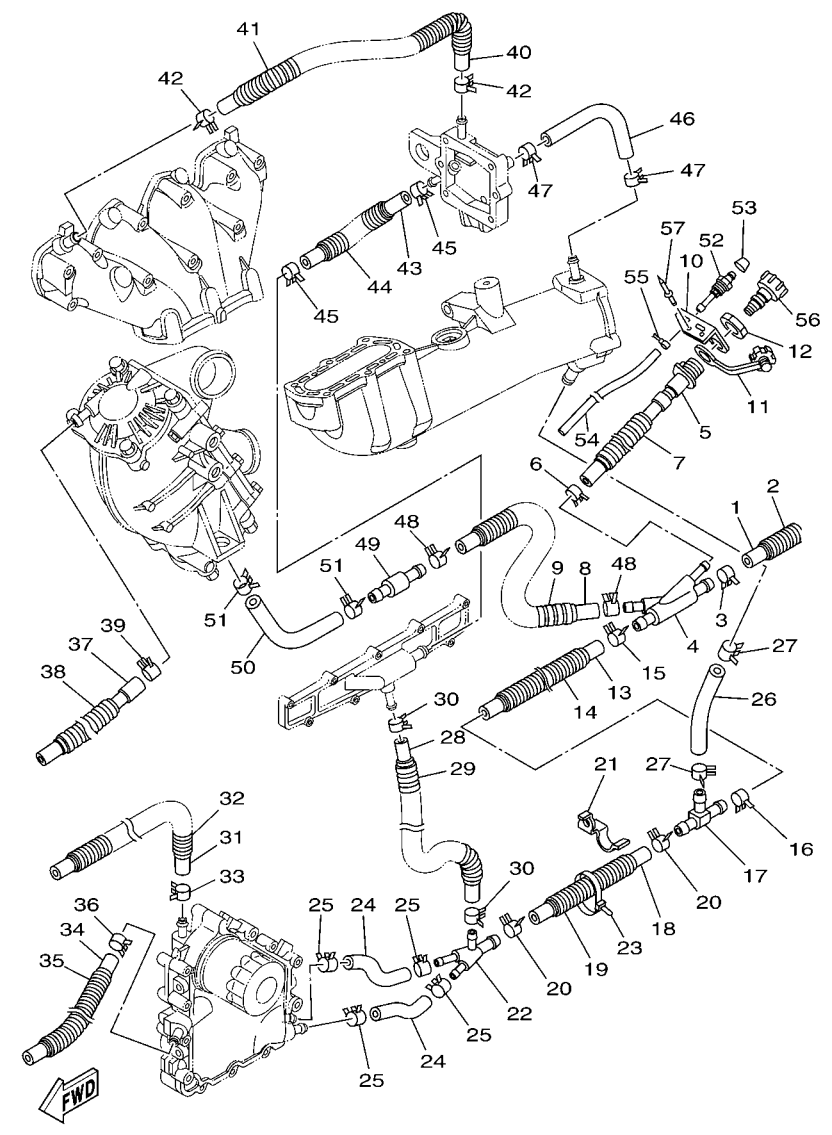

F1W1100-G140

FIG. 14 EXHAUST 2

REF. NO.	PART NO.	DESCRIPTION	USA	CAN	EUR	GENE	REMARKS
1	90445-21806	HOSE	1	1	1	1	
2	90447-22801	TUBE	1	1	1	1	
3	90467-200A0	CLIP	1	1	1	1	
4	6S5-12581-00	JOINT, HOSE 1	1	1	1	1	
5	63M-12580-00	JOINT ASSY	1	1	1	1	
6	90467-150A0	CLIP	1	1	1	1	
7	90447-19800	TUBE	1	1	1	1	
8	90445-21807	HOSE	1	1	1	1	
9	90447-22802	TUBE	1	1	1	1	
10	6S5-12443-00	STAY	1	1	1	1	
11	682-84385-01	CAP,1	1	1	1	1	
12	EU0-61652-00	NUT	1	1	1	1	
13	6S5-1243E-00	HOSE 2	1	1	1	1	
14	90447-22011	TUBE (L170)	1	1	1	1	
15	90467-200A0	CLIP	1	1	1	1	
16	90467-200A0	CLIP	1	1	1	1	
17	6S5-12584-00	JOINT, HOSE 3	1	1	1	1	
18	6S5-1243F-00	HOSE,3	1	1	1	1	
19	90447-22013	TUBE	1	1	1	1	
20	90467-200A0	CLIP	2	2	2	2	
21	90462-10044	CLAMP	1	1	1	1	
22	6S5-12582-00	JOINT, HOSE 2	1	1	1	1	
23	90464-35132	CLAMP	1	1	1	1	
24	6S5-1244J-00	HOSE 6	2	2	2	2	
25	90467-160A0	CLIP	4	4	4	4	
26	6S5-12589-00	HOSE 6	1	1	1	1	
27	90467-200A0	CLIP	2	2	2	2	

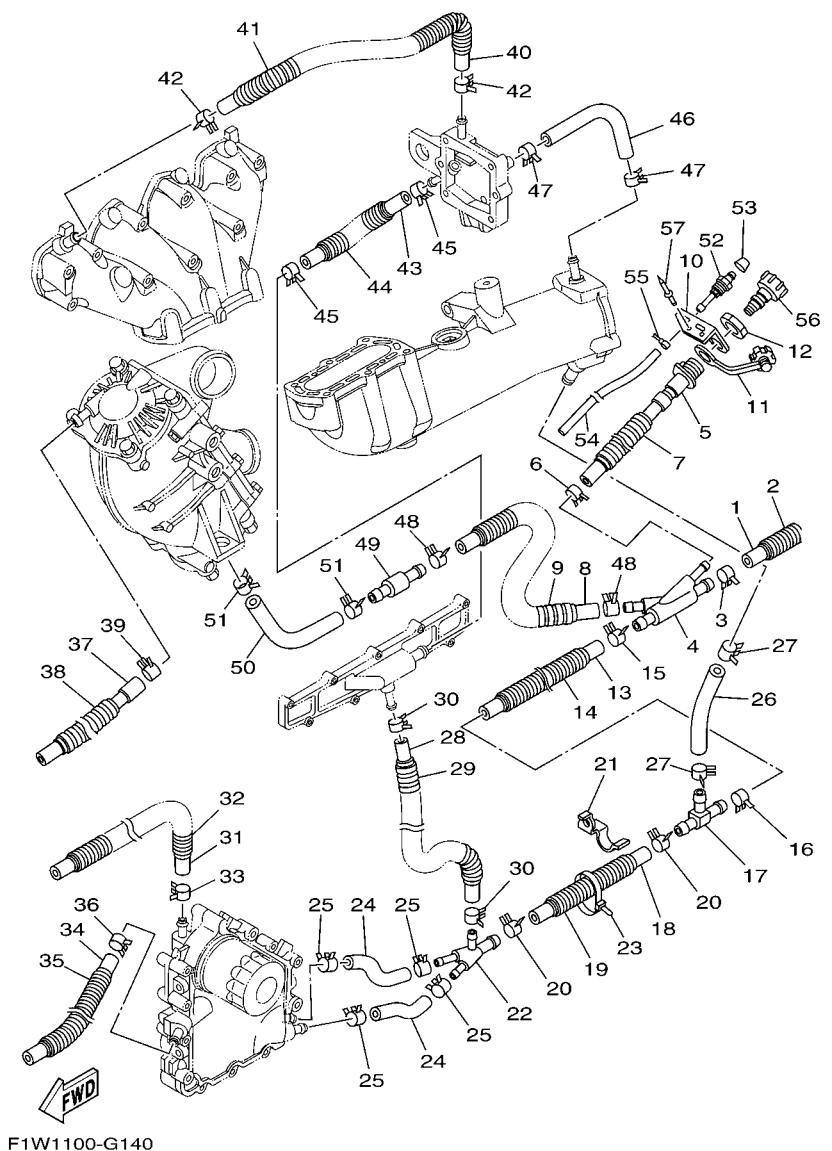

FIG. 14 EXHAUST 2

REF. NO.	PART NO.	DESCRIPTION	USA	CAN	EUR	GENE	REMARKS
28	6S5-1244H-00	HOSE 5	1	1	1	1	
29	90447-19011	TUBE	1	1	1	1	
30	90467-150A1	CLIP	2	2	2	2	
31	6S5-12588-00	HOSE 5	1	1	1	1	
32	90447-19006	HOSE, WITH SPRING (L=630)	1	1	1	1	
33	90467-160A0	CLIP	1	1	1	1	
34	6S5-14987-00	HOSE	1	1	1	1	
35	90447-19006	HOSE, WITH SPRING (L=630)	1	1	1	1	
36	90467-160A0	CLIP	1	1	1	1	
37	6S5-12552-00	HOSE 8	1	1	1	1	
38	90446-24M89	HOSE (L420)	1	1	1	1	
39	90467-170A0	CLIP	1	1	1	1	
40	6S5-12577-00	HOSE 2	1	1	1	1	
41	90446-27M55	TUBE (L400)	1	1	1	1	
42	90467-160A0	CLIP	2	2	2	2	
43	6S5-12579-00	HOSE 4	1	1	1	1	
44	90447-19011	TUBE	1	1	1	1	
45	90467-160A0	CLIP	2	2	2	2	
46	6S5-1244G-00	HOSE, 4	1	1	1	1	
47	90467-160A0	CLIP	2	2	2	2	
48	90467-200A0	CLIP	2	2	2	2	
49	6S5-12594-00	JOINT, HOSE 4	1	1	1	1	
50	6S5-12576-00	HOSE 1	1	1	1	1	
51	90467-200A0	CLIP	2	2	2	2	
52	61L-5169A-00	NIPPLE, GREASE	1	1	1	1	
53	663-45119-00	CAP, GREASE NIPPLE	1	1	1	1	
54	90445-09M21	HOSE (L445)	1	1	1	1	

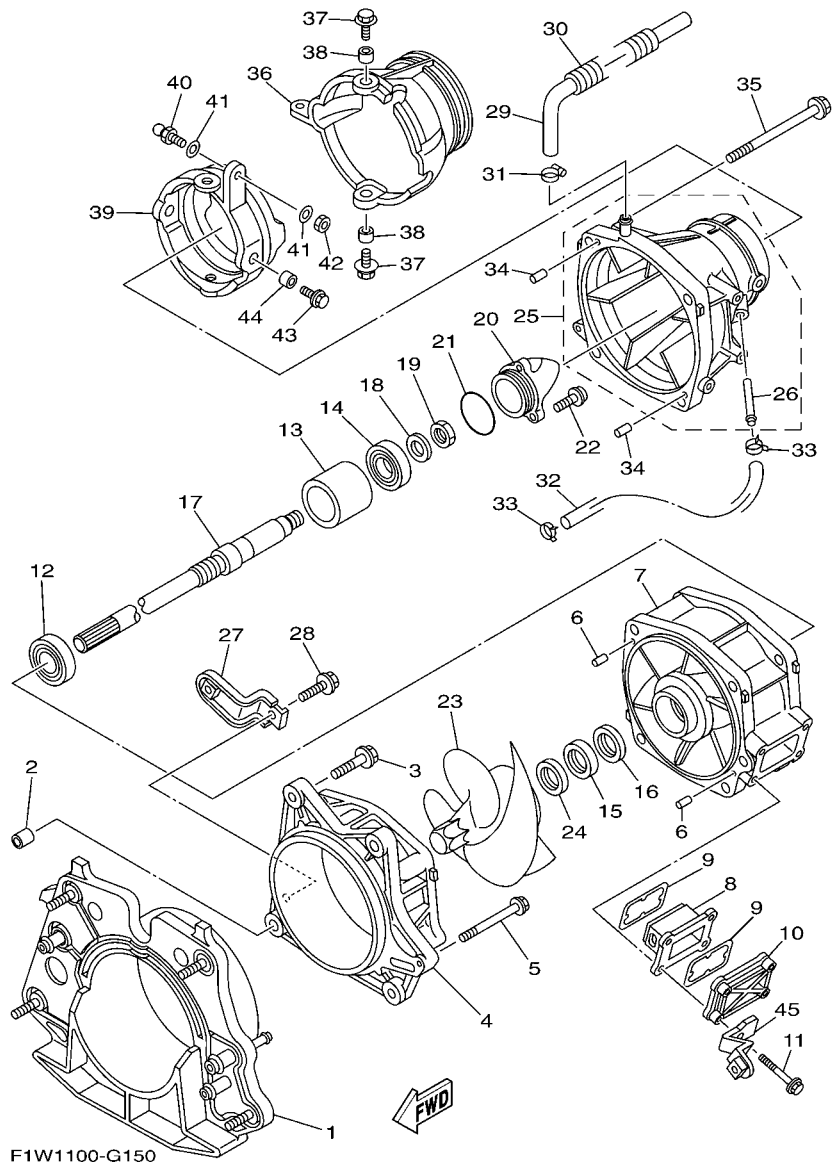

FIG. 15 JET UNIT 1

REF. NO.	PART NO.	DESCRIPTION	USA	CAN	EUR	GENE	REMARKS
1	6S5-G5831-01	PLATE, TRANSOM	1	1	1	1	
2	99590-14016	PIN, DOWEL	2	2	2	2	
3	90119-10836	BOLT, WITH WASHER	4	4	4	4	
4	66V-51312-01-94	HOUSING, IMPELLER	1	1	1	1	
5	90119-06835	BOLT, WITH WASHER	1	1	1	1	
6	93606-12019	PIN, DOWEL	2	2	2	2	
7	6S5-51315-00-94	DUCT, IMPELLER	1	1	1	1	
8	66V-46882-00	FILTER	1	1	1	1	
9	66V-42414-00	O-RING	2	2	2	2	
10	66V-45214-00-94	COVER, WATER INLET 1	1	1	1	1	
11	90119-06800	BOLT, WITH WASHER	4	4	4	4	
12	93306-20654	BEARING	1	1	1	1	
13	6S5-45538-00	SPACER 1	1	1	1	1	
14	93306-30582	BEARING	1	1	1	1	
15	93102-31008	OIL SEAL	1	1	1	1	
16	93102-31004	OIL SEAL	1	1	1	1	
17	6S5-45511-00	SHAFT, DRIVE	1	1	1	1	
18	9290P-20600	WASHER	1	1	1	1	
19	90170-20802	NUT	1	1	1	1	
20	6S5-51326-00-94	CAP	1	1	1	1	
21	6S5-5111K-00	O-RING 1	1	1	1	1	
22	90110-06822	BOLT, HEXAGON SOCKET HEAD	3	3	3	3	
23	6S5-R1321-03	IMPELLER	1	1	1	1	
24	6S5-R1348-00	SPACER	1	1	1	1	
25	6S5-51318-00-94	NOZZLE	1	1	1	1	
26	63M-51334-00	.NIPPLE,HOSE	1	1	1	1	
27	6B6-R1343-00	BRACKET	1	1	1	1	

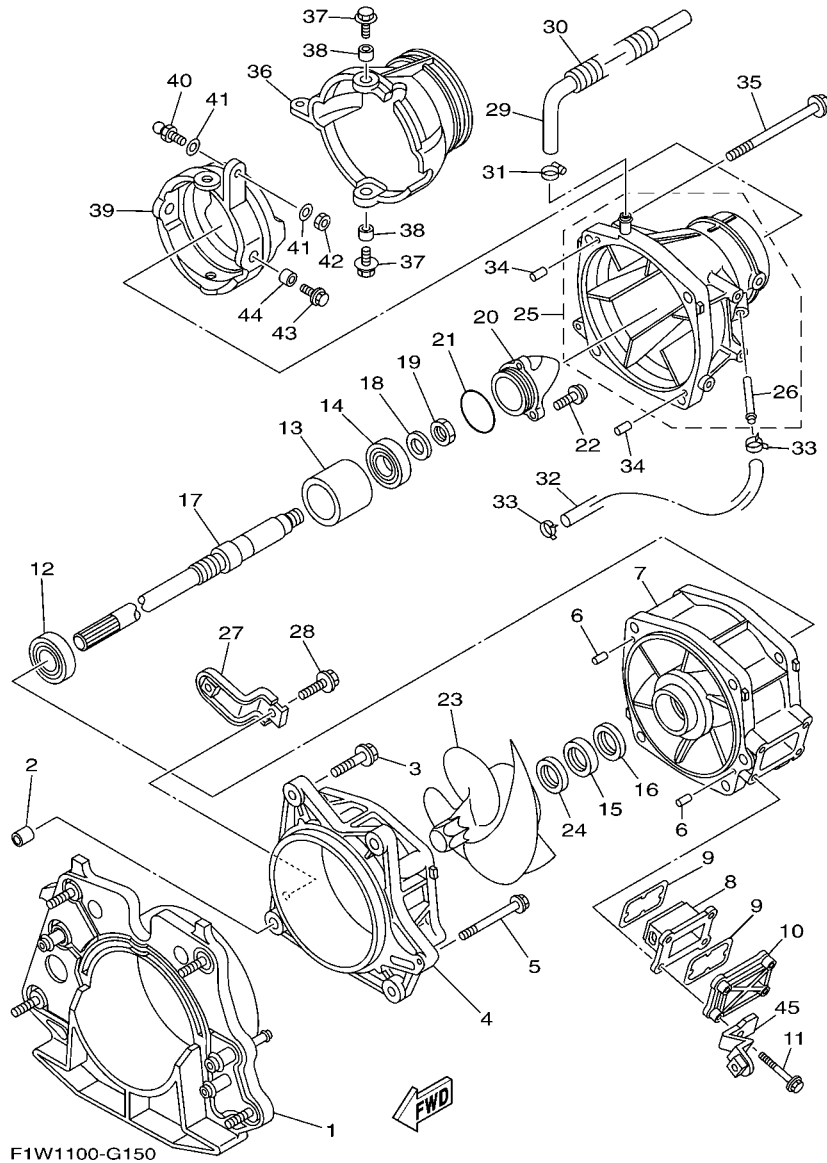

FIG. 15 JET UNIT 1

REF. NO.	PART NO.	DESCRIPTION	USA	CAN	EUR	GENE	REMARKS
28	90119-069UB	BOLT, WITH WASHER	1	1	1	1	
29	90445-16806	HOSE (L310)	1	1	1	1	
30	90447-19015	TUBE (L230)	1	1	1	1	
31	90601-118UF	BAND, HOSE 18	1	1	1	1	
32	90445-14804	HOSE (L330)	1	1	1	1	
33	90467-14803	CLIP	2	2	2	2	
34	93606-12019	PIN, DOWEL	2	2	2	2	
35	90119-10837	BOLT, WITH WASHER	4	4	4	4	
36	6S5-R1313-00	NOZZLE, DEFLECTOR	1	1	1	1	
37	90119-089UE	BOLT, WITH WASHER	2	2	2	2	
38	90387-08M06	COLLAR	2	2	2	2	
39	60T-51190-00-94	RING, TRIM	1	1	1	1	
40	GH3-U146E-00	STUD, JOINT BALL	1	1	1	1	
41	90201-068M4	WASHER, PLATE	2	2	2	2	
42	9538R-06700	NUT	1	1	1	1	
43	90119-089UE	BOLT, WITH WASHER	2	2	2	2	
44	90387-08M06	COLLAR	2	2	2	2	
45	6B6-51342-00	BRACKET 2	1	1	1	1	

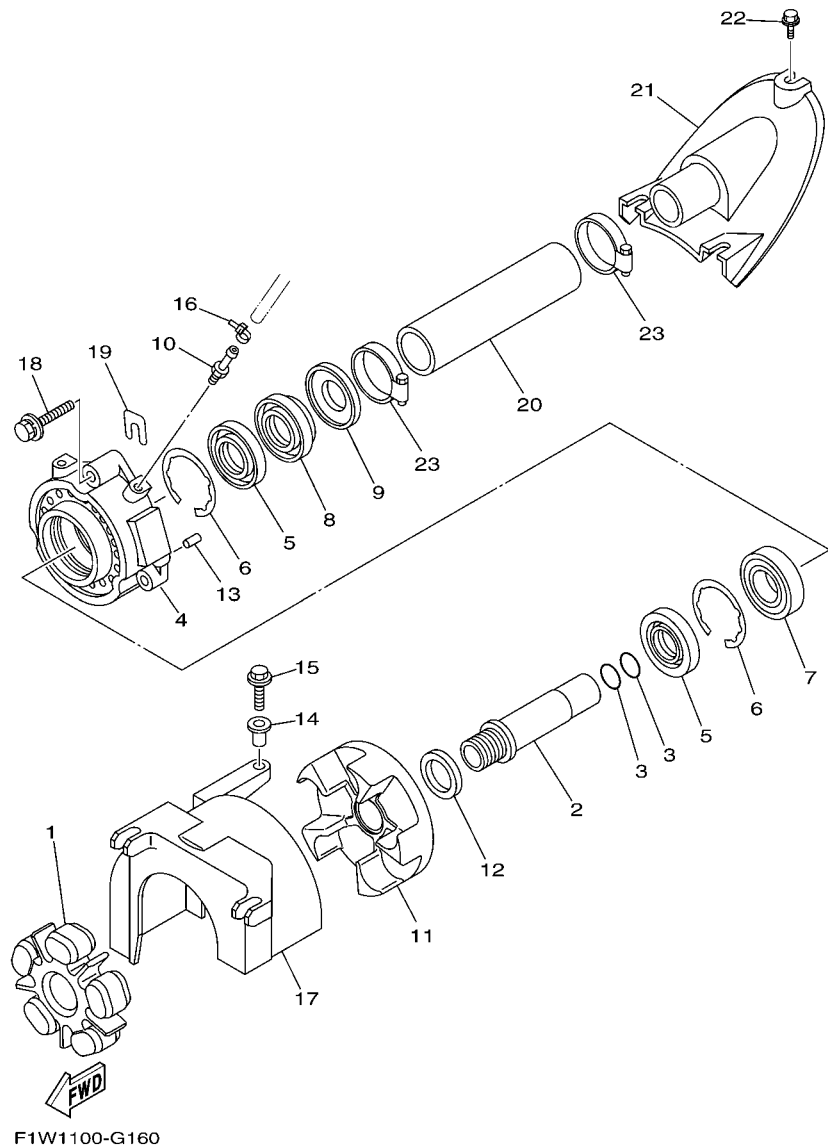
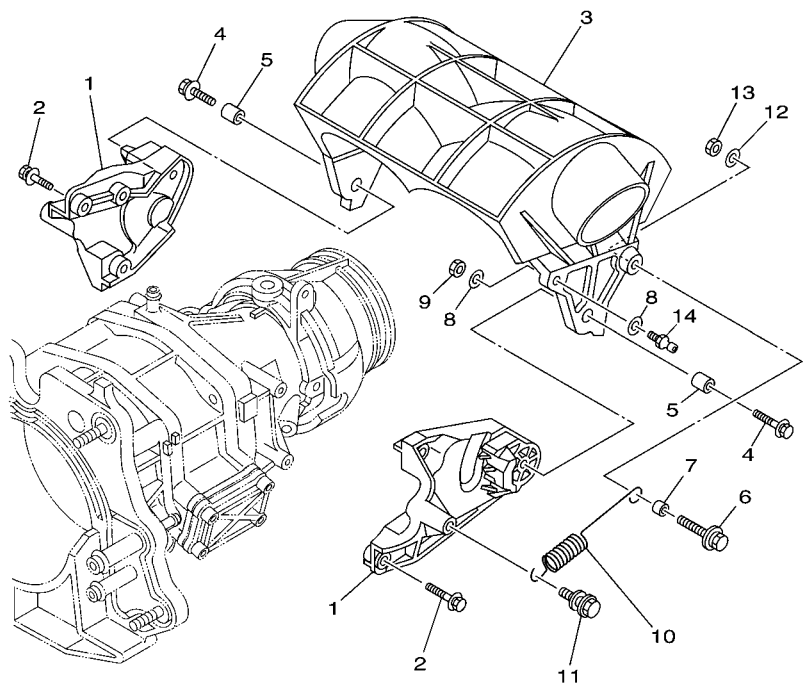

FIG. 16 JET UNIT 2

REF. NO.	PART NO.	DESCRIPTION	USA	CAN	EUR	GENE	REMARKS
1	6S5-4581J-01	RUBBER SHAFT COUPLING	1	1	1	1	
2	6S5-51323-00	SHAFT, COUPLER	1	1	1	1	
3	93210-22MF1	O-RING	2	2	2	2	
4	6S5-45332-00-94	HOUSING, BEARING	1	1	1	1	
5	93102-29008	OIL SEAL	2	2	2	2	
6	93450-66156	CIRCLIP	2	2	2	2	
7	93306-20655	BEARING	1	1	1	1	
8	93102-29004	OIL SEAL	1	1	1	1	
9	6S5-45613-10	WASHER, THRUST	1	1	1	1	
10	61L-45378-00	NIPPLE, HOSE	1	1	1	1	
11	6S5-45593-00-94	FLANGE, COUPLING 1	1	1	1	1	
12	6S5-12289-00	WASHER	1	1	1	1	
13	93606-12019	PIN, DOWEL	2	2	2	2	
14	90387-06M60	COLLAR	1	1	1	1	
15	90119-069UD	BOLT, WITH WASHER	1	1	1	1	
16	90465-11829	CLAMP	1	1	1	1	
17	6S5-R1381-00	COVER	1	1	1	1	
18	90119-089UU	BOLT, WITH WASHER	3	3	3	3	
19	GD0-U7249-00-05	SHIM (T=0.5)	2	2	2	2	UR
20	F1W-U883B-01	PIPE, 1	1	1	1	1	
21	F1W-U883E-00	JOINT, PIPE	1	1	1	1	
22	90149-069UA	SCREW	3	3	3	3	
23	90601-152U3	BAND, HOSE 52	2	2	2	2	

FIG. 17 JET UNIT 3



F1W1100-G170

REF. NO.	PART NO.	DESCRIPTION	USA	CAN	EUR	GENE	REMARKS
1	6S5-51341-00-94	BRACKET 1	2	2	2	2	
2	90119-069UD	BOLT, WITH WASHER	6	6	6	6	
3	6S5-R1314-00	GATE, REVERSE	1	1	1	1	
4	90119-089UF	BOLT, WITH WASHER	2	2	2	2	
5	90387-08M30	COLLAR	2	2	2	2	
6	90119-069UX	BOLT, WITH WASHER	1	1	1	1	
7	90387-06M30	COLLAR	1	1	1	1	
8	90201-06801	WASHER, PLATE	1	1	1	1	
9	9538R-06600	NUT	1	1	1	1	
10	6S5-52358-00	SPRING, RETAINER	1	1	1	1	
11	6S5-45241-00	BOLT, FLANGE WWASHER	1	1	1	1	
12	90201-06801	WASHER, PLATE	2	2	2	2	
13	9538R-06600	NUT	1	1	1	1	
14	EU0-U1461-02	STUD, JOINT BALL	1	1	1	1	

FIG. 18 JET UNIT 4

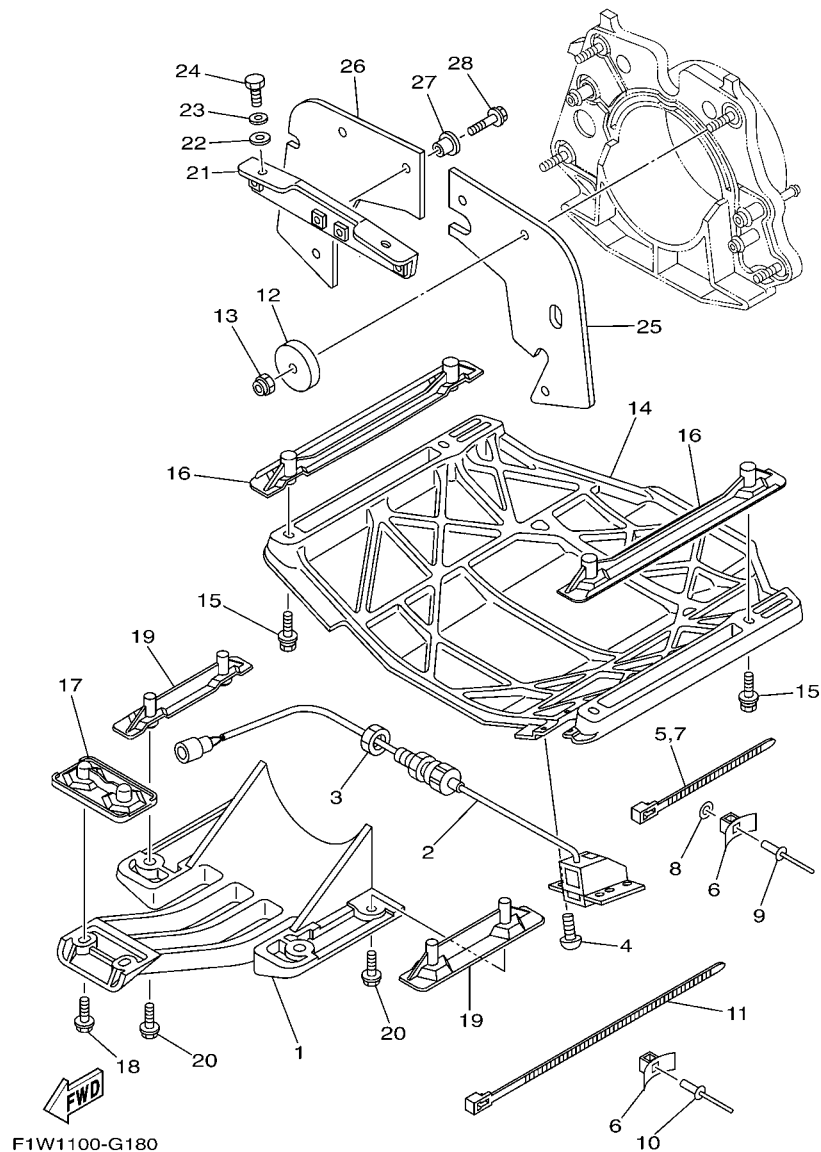

F1W1100-G180

REF. NO.	PART NO.	DESCRIPTION	USA	CAN	EUR	GENE	REMARKS
1	6S5-R1333-01	SCREEN, INTAKE	1	1	1	1	
2	F1X-U8K31-02	SENSOR SPEED	1	1	1	1	
3	EU0-62241-30	NUT, DRAIN 1	1	1	1	1	
4	90150-05807	SCREW, ROUND HEAD	4	4	4	4	
5	90464-32801	CLAMP	1	1	1	1	
6	90600-91736	CLAMP COMP.	8	8	8	8	
7	90464-32801	CLAMP	7	7	7	7	
8	9299R-05200	WASHER	2	2	2	2	
9	90267-48802	RIVET, BLIND	6	6	6	6	
10	90267-489U6	RIVET, BLIND	2	2	2	2	
11	90464-99801	CLAMP	1	1	1	1	
12	F1S-U725E-00	WASHER	4	4	4	4	
13	9572R-10300	NUT, FLANGE	4	4	4	4	
14	F1W-6273B-02	PLATE 2	1	1	1	1	
15	90119-08823	BOLT, WITH WASHER	4	4	4	4	
16	F1B-U8572-00	BRACKET 2	2	2	2	2	
17	F1K-U8577-00	BRACKET, 3	1	1	1	1	
18	90119-069UK	BOLT, WITH WASHER	2	2	2	2	
19	F1G-U8571-00	BRACKET 1	2	2	2	2	
20	90119-08823	BOLT, WITH WASHER	4	4	4	4	
21	F1B-67557-00	BRACKET	1	1	1	1	
22	90430-12002	GASKET	2	2	2	2	
23	92990-12200	WASHER, PLAIN	2	2	2	2	
24	90109-08041	BOLT	2	2	2	2	
25	F1X-U757E-00	PLATE, RUBBER 1	1	1	1	1	
26	F1X-U757F-00	PLATE, RUBBER 2	1	1	1	1	
27	90387-06080	COLLAR	6	6	6	6	

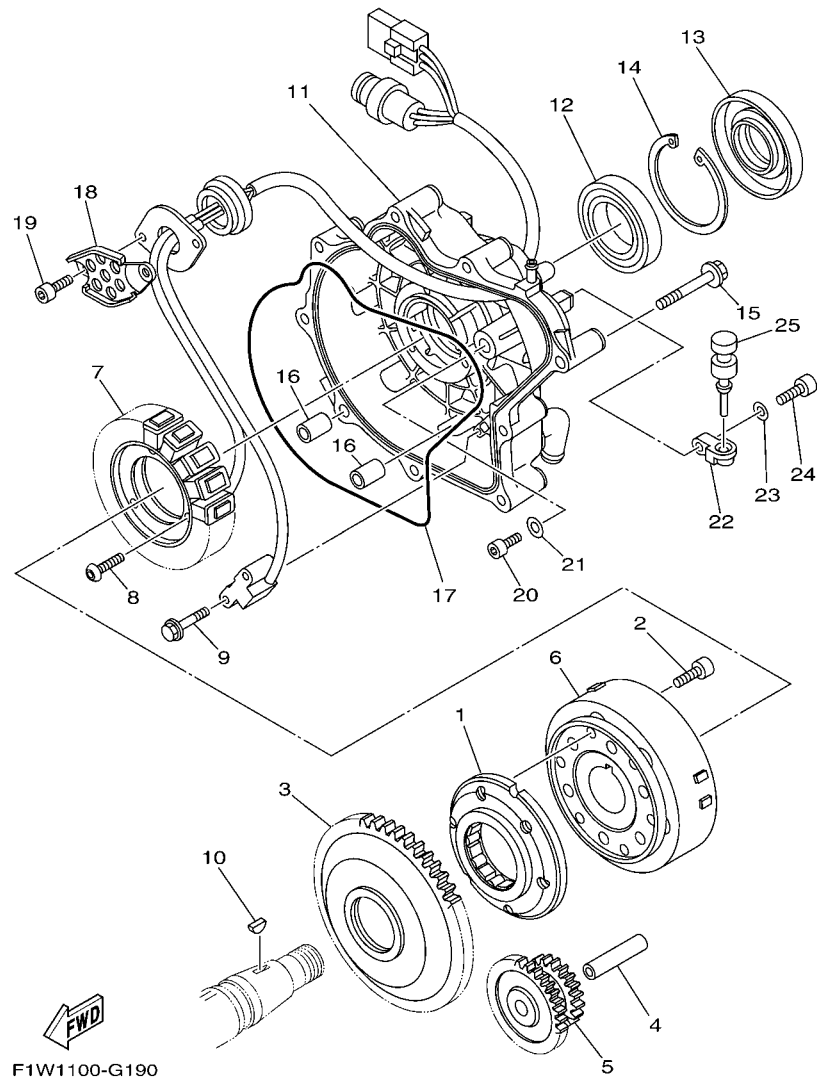
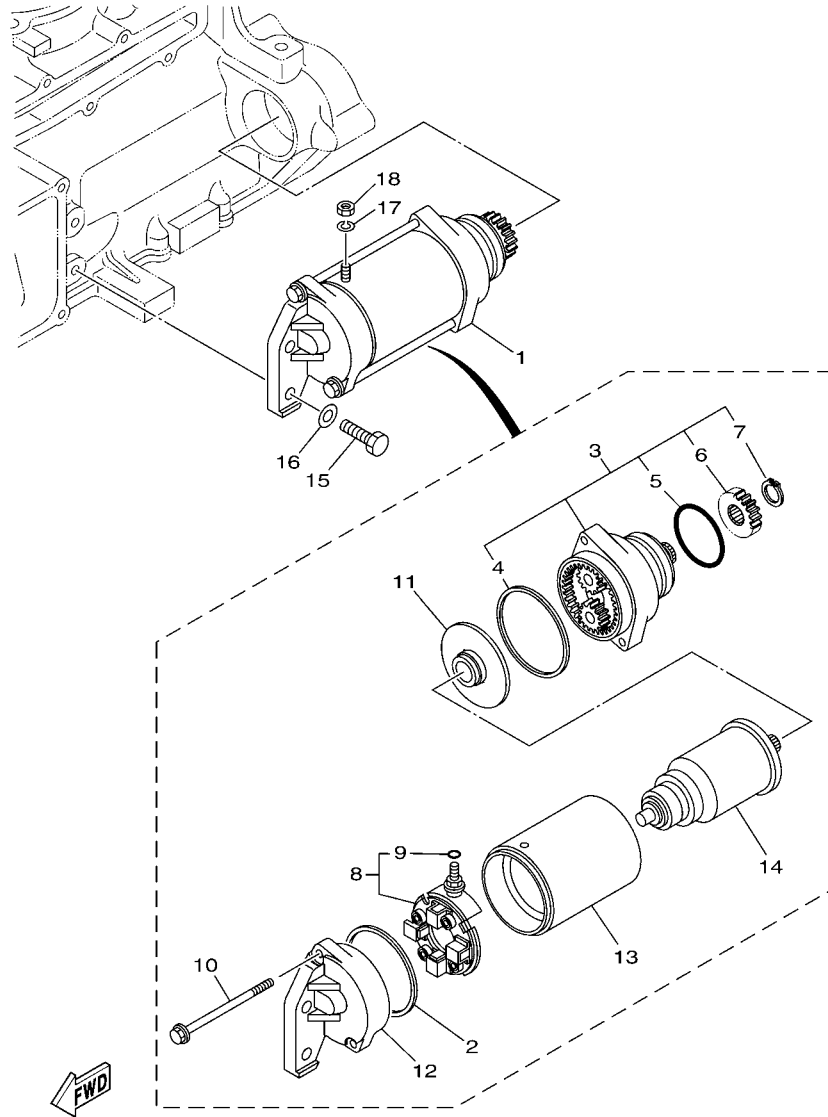

FIG. 19 GENERATOR

REF. NO.	PART NO.	DESCRIPTION	USA	CAN	EUR	GENE	REMARKS
1	6S5-15590-01	STARTER ONE-WAY ASSY	1	1	1	1	
2	90110-08212	BOLT, HEXAGON SOCKET HEAD	6	6	6	6	
3	6S5-15515-00	GEAR 3	1	1	1	1	
4	6S5-15521-00	SHAFT 1	1	1	1	1	
5	6S5-15517-00	GEAR, IDLER 2	1	1	1	1	
6	6S5-81450-01	ROTOR ASSY	1	1	1	1	
7	6S5-81410-00	STATOR ASSY	1	1	1	1	
8	90149-06229	SCREW	3	3	3	3	
9	97513-05514	BOLT, WITH WASHER	2	2	2	2	
10	90280-03047	KEY, WOODRUFF	1	1	1	1	
11	6S5-81337-00-94	COVER, FLYWHEEL	1	1	1	1	
12	93306-00805	BEARING	1	1	1	1	
13	6S5-81167-00	OIL SEAL	1	1	1	1	
14	99009-72500	CIRCLIP	1	1	1	1	
15	95024-08050	BOLT, FLANGE	9	9	9	9	
16	99530-10114	PIN, DOWEL	2	2	2	2	
17	6S5-81168-00	O-RING	1	1	1	1	
18	6S5-81328-00	CLAMP	1	1	1	1	
19	91317-06014	BOLT	2	2	2	2	
20	91317-05010	BOLT	1	1	1	1	
21	90201-052E8	WASHER, PLATE	1	1	1	1	
22	60E-51341-00-94	BRACKET 1	2	2	2	2	
23	92995-06600	WASHER	2	2	2	2	
24	91380-06020	BOLT	2	2	2	2	
25	90480-06M46	GROMMET	2	2	2	2	



F1W1100-G200

FIG. 20 STARTING MOTOR

REF. NO.	PART NO.	DESCRIPTION	USA	CAN	EUR	GENE	REMARKS
1	6S5-81800-00	STARTING MOTOR ASSY	1	1	1	1	
2	11H-81844-00	.GASKET	1	1	1	1	
3	6S5-81830-00	.FRONT BRACKET ASSY	1	1	1	1	
4	4G0-81844-00	..GASKET	1	1	1	1	
5	1J7-81847-60	..O-RING	1	1	1	1	
6	5EL-15511-00	..GEAR, STARTING MOTOR	1	1	1	1	
7	93410-12003	..CIRCLIP	1	1	1	1	
8	6S5-81840-00	.BRUSH HOLDER ASSY	1	1	1	1	
9	3TB-81847-00	..O-RING	1	1	1	1	
10	6S5-81826-00	.BOLT	2	2	2	2	
11	5EL-81845-00	.PLATE	1	1	1	1	
12	6S5-81820-00	.REAR BRACKET ASSY	1	1	1	1	
13	6S5-81810-00	.STATOR ASSY	1	1	1	1	
14	5A8-81850-10	.ARMATURE ASSY	1	1	1	1	
15	97013-08030	BOLT	2	2	2	2	
16	92903-08600	WASHER, PLATE	2	2	2	2	
17	92990-06100	WASHER, SPRING	1	1	1	1	
18	95380-06700	NUT	1	1	1	1	

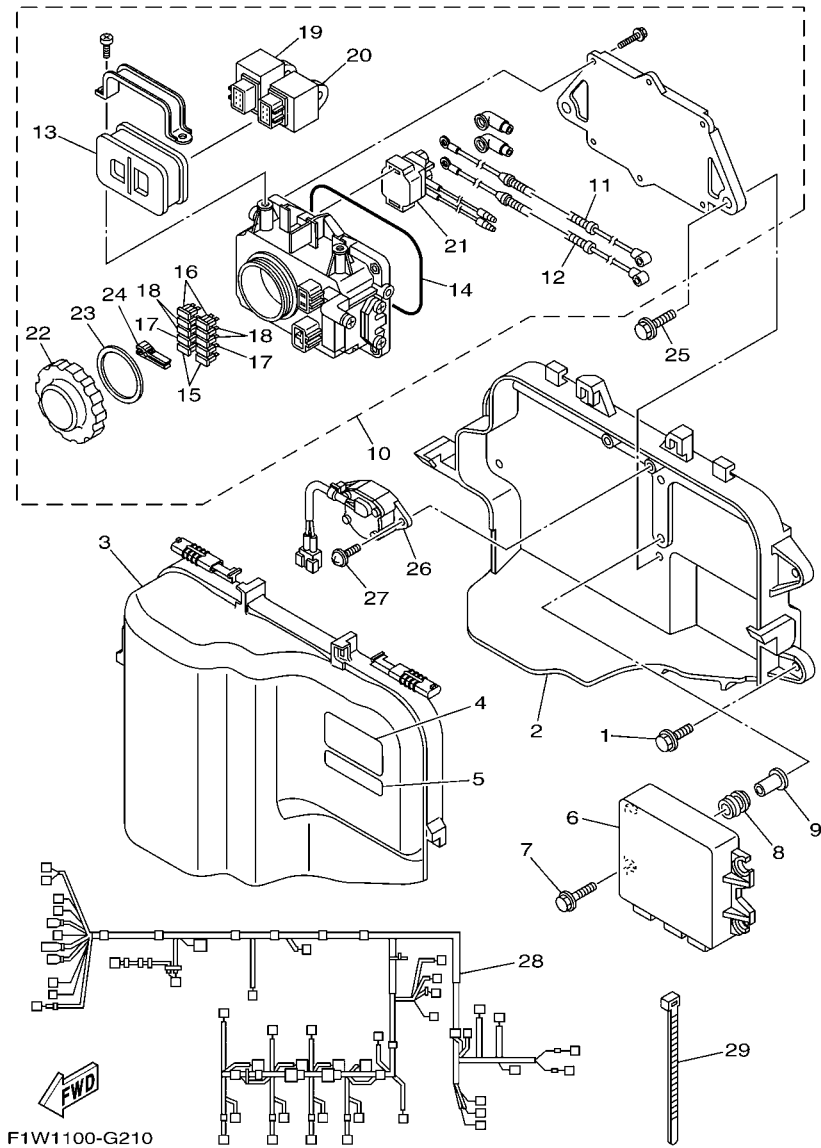

FIG. 21 ELECTRICAL 1

REF. NO.	PART NO.	DESCRIPTION	USA	CAN	EUR	GENE	REMARKS
1	90119-089UT	BOLT, WITH WASHER	4	4	4	4	
2	6S5-81845-00	PLATE	1	1	1	1	
3	6S5-81942-00	COVER	1	1	1	1	
4	6B6-83623-00	MARK 3	1	1	1	1	
5	60E-83627-00	LABEL, CAUTION 7	1	1	1	1	
6	6S5-8591A-01	ENGINE CONTROL UNIT ASSY	1	1		1	FOR USA,CAN,GENE
	6S5-8591A-11	ENGINE CONTROL UNIT ASSY			1		FOR EUR
7	90119-06M35	BOLT, WITH WASHER	4	4	4	4	
8	6A0-82317-00	DAMPER, IGNITION COIL	4	4	4	4	
9	90387-06119	COLLAR	4	4	4	4	
10	6S5-82170-00	FUSE BOX ASSY	1	1	1	1	
11	6S5-82115-00	.WIRE, PLUS LEAD	1	1	1	1	
12	6S5-82117-00	.WIRE, LEAD	1	1	1	1	
13	6D3-82157-00	.DAMPER	1	1	1	1	
14	6D3-81921-00	.GASKET, TERMINAL	1	1	1	1	
15	67F-82151-00	.FUSE (20A)	2	2	2	2	
16	67F-82151-10	.FUSE (30A)	2	2	2	2	
17	67F-82151-30	.FUSE (3A)	2	2	2	2	
18	67F-82151-40	.FUSE (10A)	4	4	4	4	
19	60E-81950-00	.RELAY ASSY	1	1	1	1	
20	68V-81950-00	.RELAY ASSY	1	1	1	1	
21	6B6-81940-00	.STARTER RELAY ASSY	1	1	1	1	
22	66V-8132W-00	.CAP	1	1	1	1	
23	66V-81844-00	.GASKET	1	1	1	1	
24	67F-2812A-00	.PULLER, FUSE	1	1	1	1	
25	90119-08123	BOLT, WITH WASHER	2	2	2	2	
26	6S5-8259E-00	SWITCH ASSY	1	1	1	1	

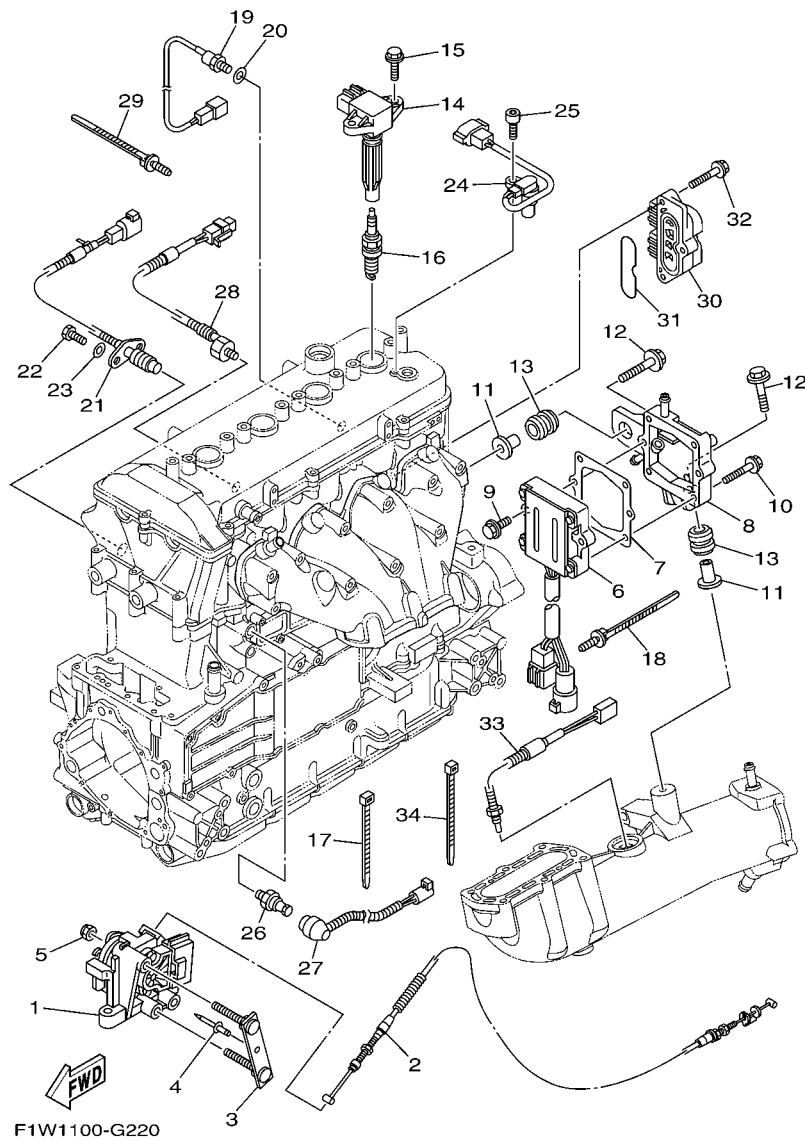

FIG. 22 ELECTRICAL 2

REF. NO.	PART NO.	DESCRIPTION	USA	CAN	EUR	GENE	REMARKS
1	6D3-14305-21	ACCEL. POSITON SENSOR ASSY	1	1	1	1	
2	6S5-26311-10	CABLE, THROTTLE 1	1	1	1	1	
3	F1W-U7254-00	BRACKET, THROTTLE	1	1	1	1	
4	90267-489U1	RIVET,BLIND	1	1	1	1	
5	95780-08300	NUT, FLANGE	2	2	2	2	
6	6S5-81960-00	RECTIFIER & REGULATOR ASSY	1	1	1	1	
7	6S5-81975-00	PLATE, RECTIFIER FITTING	1	1	1	1	
8	6S5-81972-00-94	COVER, RECTIFIER	1	1	1	1	
9	90119-06MA3	BOLT, WITH WASHER	2	2	2	2	
10	90119-06MA5	BOLT, WITH WASHER	4	4	4	4	
11	6D3-14495-00	COLLAR	2	2	2	2	
12	90119-08M22	BOLT, WITH WASHER	2	2	2	2	
13	90480-22M15	GROMMET	2	2	2	2	
14	6S5-82310-00	IGNITION COIL ASSY	4	4	4	4	
15	90105-06903	BOLT, FLANGE	8	8	8	8	
16	94702-00427	PLUG, SPARK (NGK LFR6A)	4	4	4	4	
17	90465-13M18	CLAMP	5	5	5	5	
18	90464-31001	CLAMP	2	2	2	2	
19	61A-85790-00	THERMOSENSOR ASSY	1	1	1	1	
20	92990-10600	WASHER, PLATE	1	1	1	1	
21	60E-82560-01	THERMO SWITCH ASSY	1	1	1	1	
22	97095-06016	BOLT	2	2	2	2	
23	92995-06600	WASHER	2	2	2	2	
24	6D3-85896-00	SENSOR, CAM POSITION	1	1	1	1	
25	91380-06016	BOLT	1	1	1	1	
26	68V-82504-00	OIL PRESSURE SWITCH ASSY	1	1	1	1	
27	6S5-81315-00	LEAD WIRE ASSY	1	1	1	1	

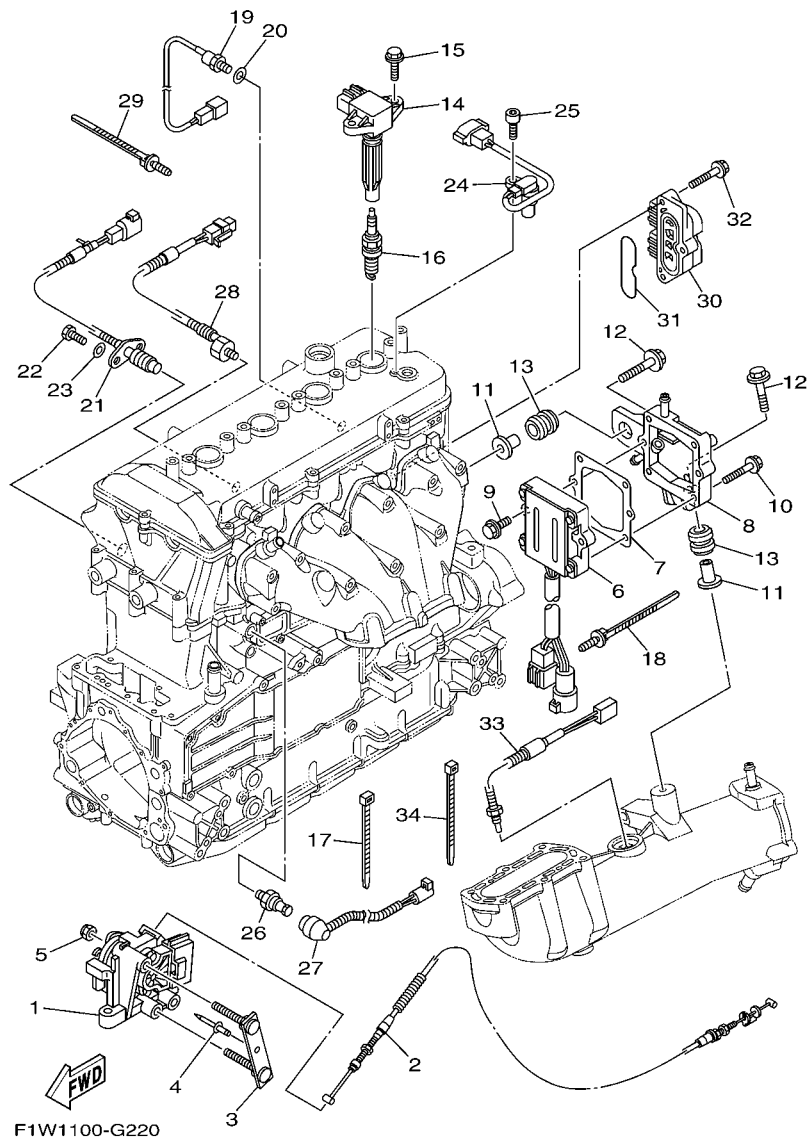

FIG. 22 ELECTRICAL 2

REF. NO.	PART NO.	DESCRIPTION	USA	CAN	EUR	GENE	REMARKS
28	6P2-85780-00	SENSOR, KNOCK	1	1	1	1	
29	90464-31001	CLAMP	1	1	1	1	
30	6D3-8273J-01	EARTH PLATE COMP.	1	1	1	1	
31	93210-60ME8	O-RING	1	1	1	1	
32	90119-06048	BOLT, WITH WASHER	3	3	3	3	
33	6AA-85790-00	THERMOSENSOR ASSY	1	1	1	1	
34	90464-31001	CLAMP	1	1	1	1	

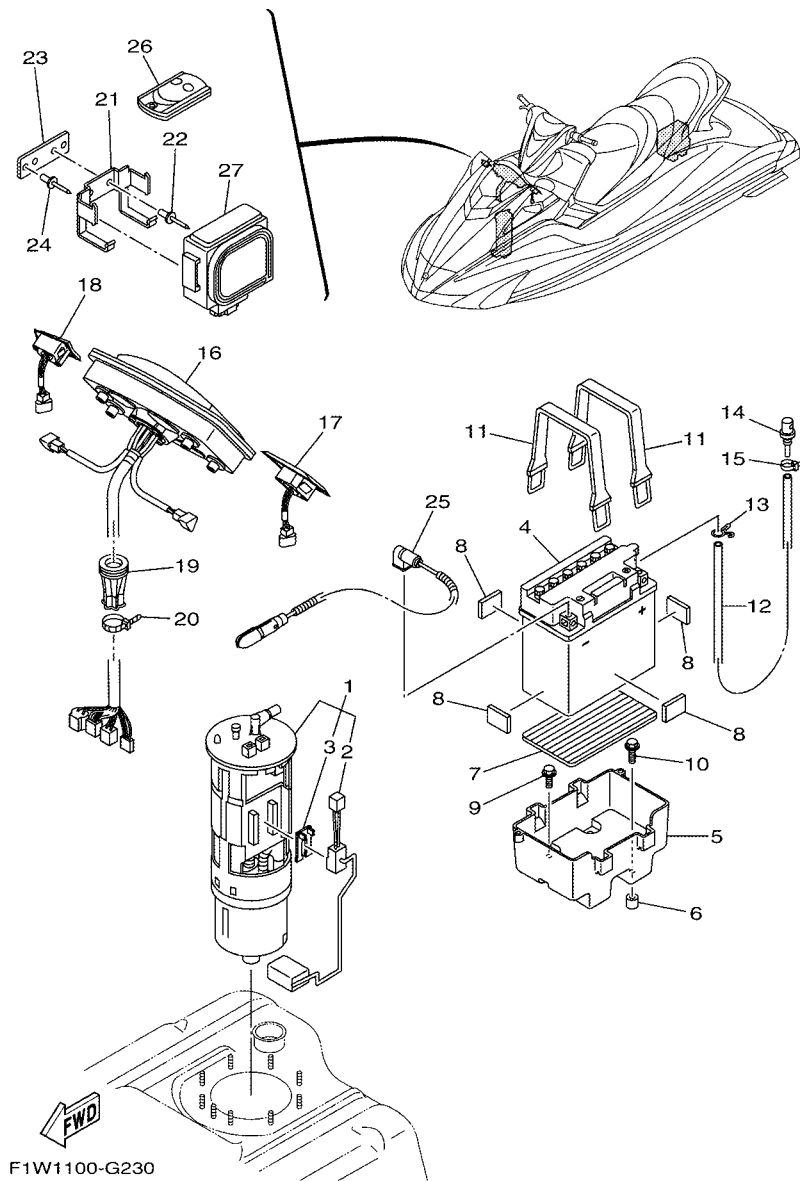
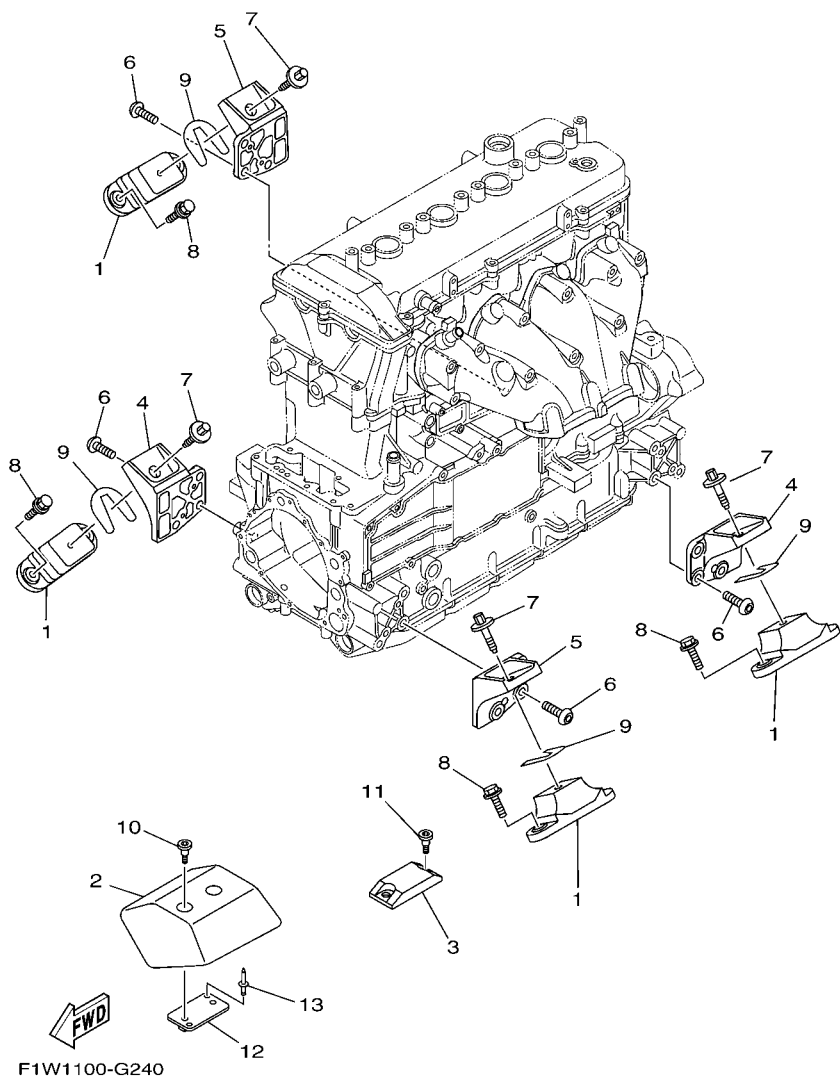

FIG. 23 ELECTRICAL 3

REF. NO.	PART NO.	DESCRIPTION	USA	CAN	EUR	GENE	REMARKS
1	6S5-13907-00	FUEL PUMP COMP.	1	1	1	1	
2	6S5-682E0-00	.FUEL SENDER ASSY	1	1	1	1	
3	60E-82556-00	.DAMPER, STOPPER	1	1	1	1	
4	EU0-82110-09	BATTERY ASSY (YB16CL-B)	1	1	1	1	YUASA
5	GP7-U8211-00	CASE, BATTERY	1	1	1	1	
6	F1B-6821G-01	PLATE, BATTERY	2	2	2	2	
7	F1S-U8221-00	PAD, BATTERY	1	1	1	1	
8	EU0-U8221-30	PAD, BATTERY 2	4	4	4	4	
9	90119-069US	BOLT, WITH WASHER	2	2	2	2	
10	90119-06832	BOLT, WITH WASHER	2	2	2	2	
11	EU0-U821D-00	BAND,BATTERY 1	2	2	2	2	
12	F0D-U785G-10	HOSE, AIR VENT	1	1	1	1	
13	90467-089U1	CLIP	1	1	1	1	
14	GJ3-6215F-00	NIPPLE	1	1	1	1	
15	90465-11829	CLAMP	1	1	1	1	
16	F1W-6820A-00	METER ASSY	1	1	1	1	
17	F1X-68090-00	SWITCH ASSY.	1	1	1	1	
18	F1X-68090-10	SWITCH ASSY.	1	1	1	1	
19	F1X-U822E-00	GROMMET	1	1	1	1	
20	90464-32801	CLAMP	1	1	1	1	
21	F1W-U826C-00	BRACKET	1	1	1	1	
22	90267-489U1	RIVET,BLIND	2	2	2	2	
23	F1W-U8376-00	PLATE	1	1	1	1	
24	90267-489U1	RIVET,BLIND	2	2	2	2	
25	6S5-82116-00	WIRE, MINUS LEAD	1	1	1	1	
26	6B6-86261-00	TRANSMITTER COMP	2	2			FOR USA,CAN
	6B6-86261-10	TRANSMITTER COMP			2	2	FOR EUR,GENE

FIG. 24 ENGINE MOUNT



REF. NO.	PART NO.	DESCRIPTION	USA	CAN	EUR	GENE	REMARKS
1	67X-44517-10-94	MOUNT RUBBER	4	4	4	4	
2	6S5-G4532-00	STOPPER, UPPER MOUNT	1	1	1	1	
3	60E-G4574-00	STOPPER, LOWER MOUNT RUBBER	1	1	1	1	
4	6S5-41661-00-94	BRACKET 1	2	2	2	2	
5	6S5-41662-00-94	BRACKET 2	2	2	2	2	
6	90149-10052	SCREW	12	12	12	12	
7	90119-08842	BOLT, WITH WASHER	4	4	4	4	
8	90119-08823	BOLT, WITH WASHER	8	8	8	8	
9	EU0-U7354-00-01	SHIM (T=0.1)	10	10	10	10	UR
	EU0-U7354-00-03	SHIM (T=0.3)	10	10	10	10	UR
	EU0-U7354-00-05	SHIM (T=0.5)	10	10	10	10	UR
	EU0-U7354-00-10	SHIM (T=1.0)	10	10	10	10	UR
	EU0-U7354-00-20	SHIM (T=2.0)	10	10	10	10	UR
10	90109-06857	BOLT	2	2	2	2	
11	90109-06864	BOLT	2	2	2	2	
12	F1W-U732B-00	PLATE	1	1	1	1	
13	90267-489U2	RIVET, BLIND	2	2	2	2	

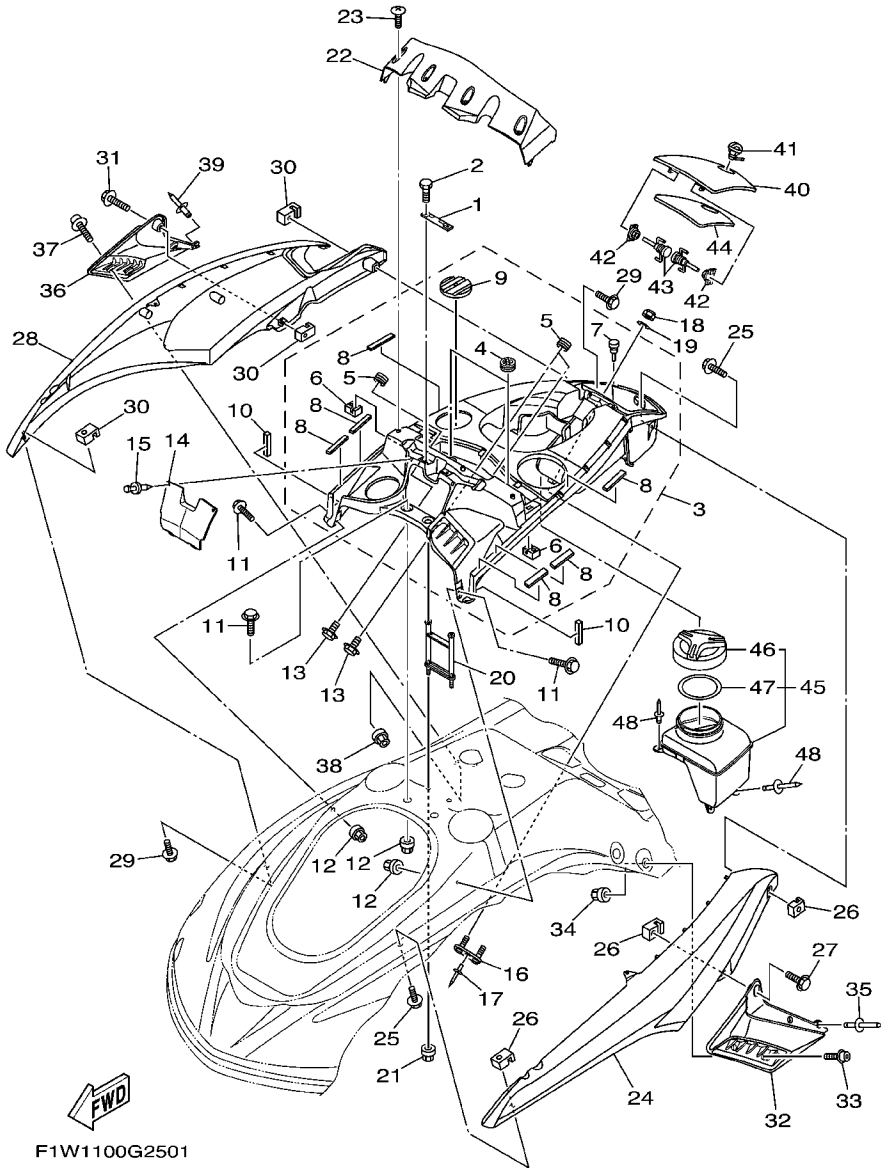

F1W1100G2501

FIG. 25 ENGINE HATCH 1

REF. NO.	PART NO.	DESCRIPTION	USA	CAN	EUR	GENE	REMARKS
1	F1W-U517F-00	HOOK,LID LOCK	1	1	1	1	
2	90101-05800	BOLT	2	2	2	2	
3	F1W-U5508-00	CENTER COVER ASSY.	1	1	1	1	BLACK FOR RED
	F1W-U5508-20	CENTER COVER ASSY.	1	1	1	1	SILVER FOR GRAY
4	F1X-U828E-01	.DAMPER 1	2	2	2	2	
5	90480-19800	.GROMMET	4	4	4	4	
6	F1X-U517E-01	.NUT	2	2	2	2	
7	90605-502U2	.PLUG	1	1	1	1	
8	F0X-U515E-01	.DAMPER 2	6	6	6	6	
9	F1X-U3844-01	.MAT	1	1	1	1	
10	F1W-U518D-00	PACKING	2	2	2	2	
11	90119-06880	BOLT, WITH WASHER	4	4	4	4	
12	90185-06014	NUT, SELF-LOCKING	4	4	4	4	
13	90119-05803	BOLT, WITH WASHER	4	4	4	4	
14	F1W-U555B-00	SEAL, COVER CENTER	1	1	1	1	
15	F1W-U2698-00	RIVET	2	2	2	2	
16	F1X-U5372-00	BRACKET	1	1	1	1	
17	90267-489U1	RIVET,BLIND	1	1	1	1	
18	9572R-06300	NUT, NYLON	2	2	2	2	
19	9299R-06200	WASHER	2	2	2	2	
20	F1W-U555D-01	BRKT., COVER CENTER 1	1	1	1	1	
21	90185-06014	NUT, SELF-LOCKING	2	2	2	2	
22	F1W-U8262-02-P0	COVER METER	1	1	1	1	BMG FOR RED
	F1W-U8262-10-P0	COVER METER	1	1	1	1	NME FOR GRAY
23	90149-05903	SCREW	4	4	4	4	
24	F1W-U377B-01-P0	COVER,SIDE 1	1	1	1	1	DRMR FOR RED
	F1W-U377B-10-P0	COVER,SIDE 1	1	1	1	1	LNMP FOR GRAY

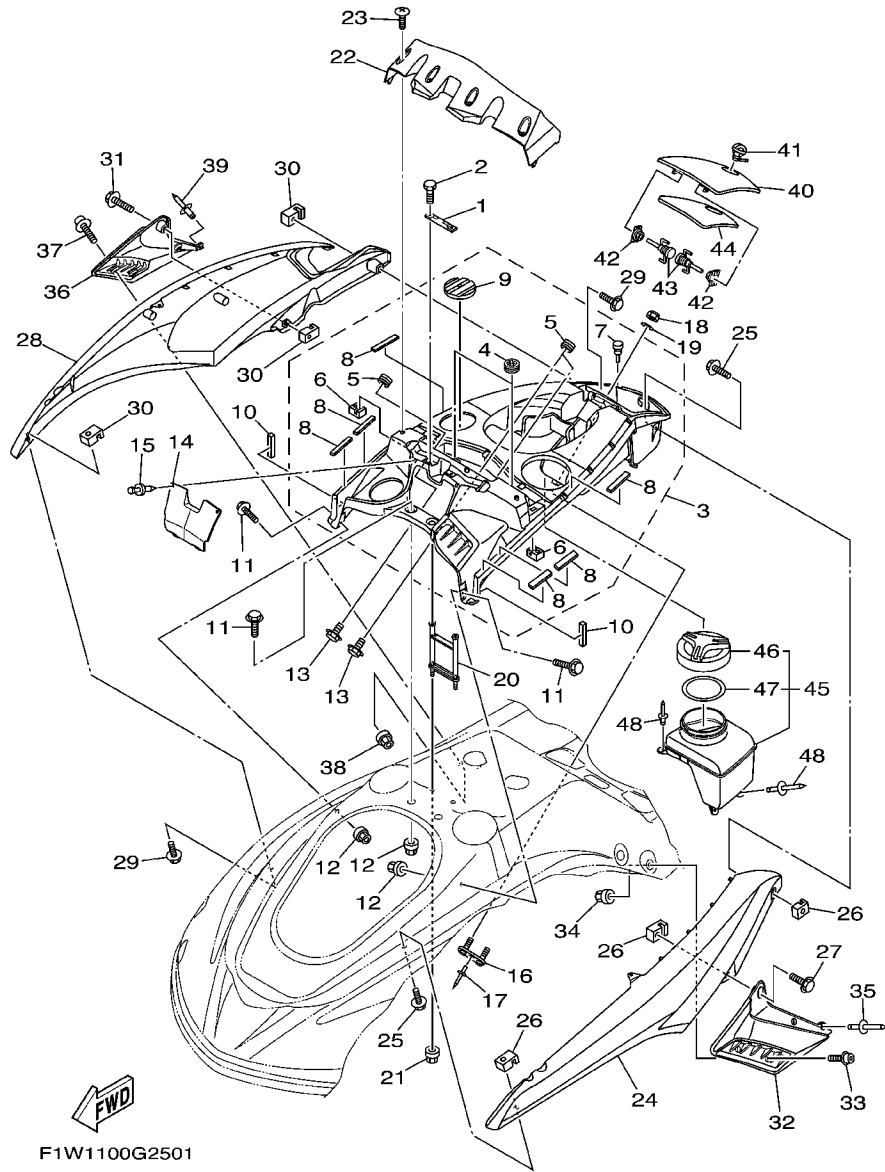

FIG. 25 ENGINE HATCH 1

REF. NO.	PART NO.	DESCRIPTION	USA	CAN	EUR	GENE	REMARKS
25	90119-06880	BOLT, WITH WASHER	3	3	3	3	
26	F1X-U517E-01	NUT	3	3	3	3	
27	90119-06880	BOLT, WITH WASHER	1	1	1	1	
28	F1W-U377C-01-P0	COVER, SIDE 2	1	1	1	1	DRMR FOR RED
	F1W-U377C-10-P0	COVER, SIDE 2	1	1	1	1	LNMP FOR GRAY
29	90119-06880	BOLT, WITH WASHER	3	3	3	3	
30	F1X-U517E-01	NUT	3	3	3	3	
31	90119-06880	BOLT, WITH WASHER	1	1	1	1	
32	F1W-U377F-01	ORNAMENT, SIDE LH	1	1	1	1	
33	90110-06823	BOLT, HEXAGON SOCKET HEAD	3	3	3	3	
34	90185-06014	NUT, SELF-LOCKING	3	3	3	3	
35	90267-48807	RIVET, BLIND	1	1	1	1	
36	F1W-U377G-01	ORNAMENT, SIDE RH	1	1	1	1	
37	90110-06823	BOLT, HEXAGON SOCKET HEAD	3	3	3	3	
38	90185-06014	NUT, SELF-LOCKING	3	3	3	3	
39	90267-48807	RIVET, BLIND	1	1	1	1	
40	F1W-U517H-01	LID HATCH	1	1	1	1	
41	F1X-62875-00	LOCK	1	1	1	1	
42	F1B-60210-00	GEAR ASSY	2	2	2	2	
43	F1B-6517R-00	PIN, HINGE	2	2	2	2	
44	F1W-U519D-01	PACKING CASE	1	1	1	1	
45	F1W-U591A-00	CASE, ASSY 1	1	1	1	1	
46	F1W-U591C-00	.CAPCASE	1	1	1	1	
47	F1W-U591D-00	.PACKING, CASE	1	1	1	1	
48	90267-489U6	RIVET, BLIND	3	3	3	3	

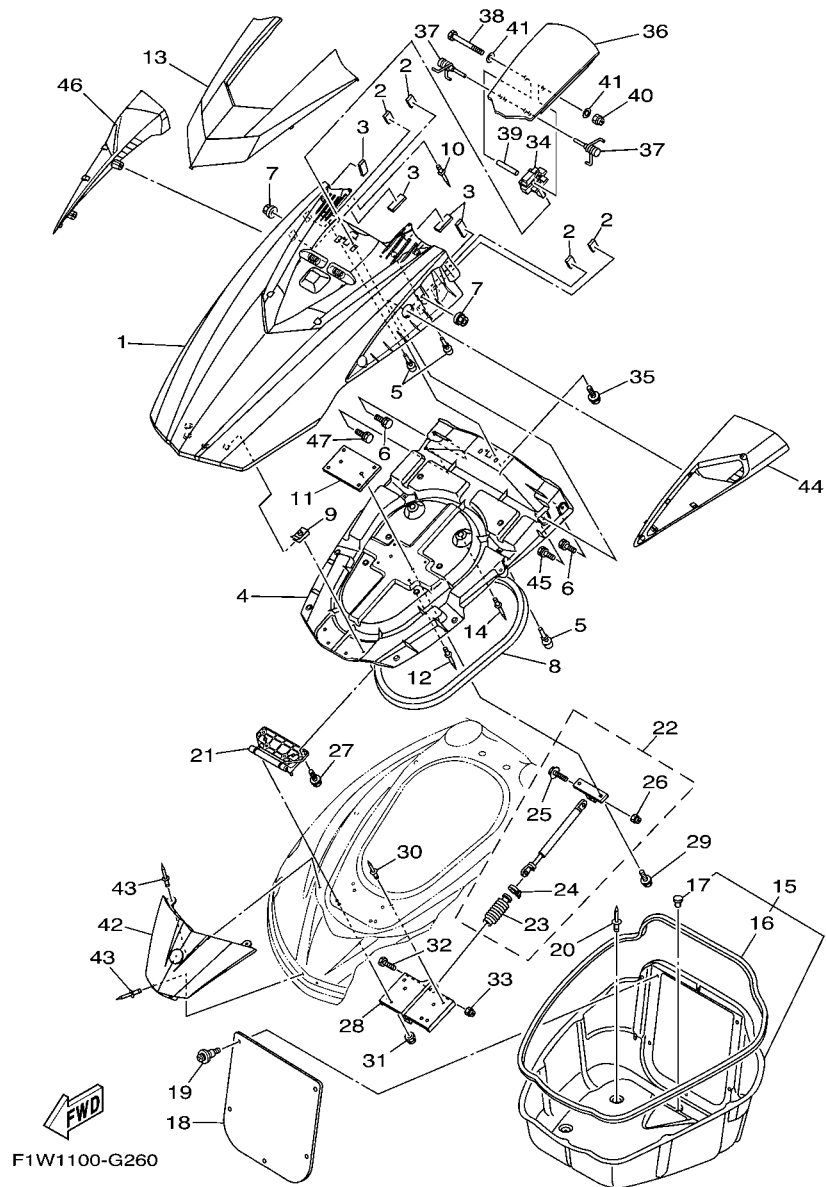
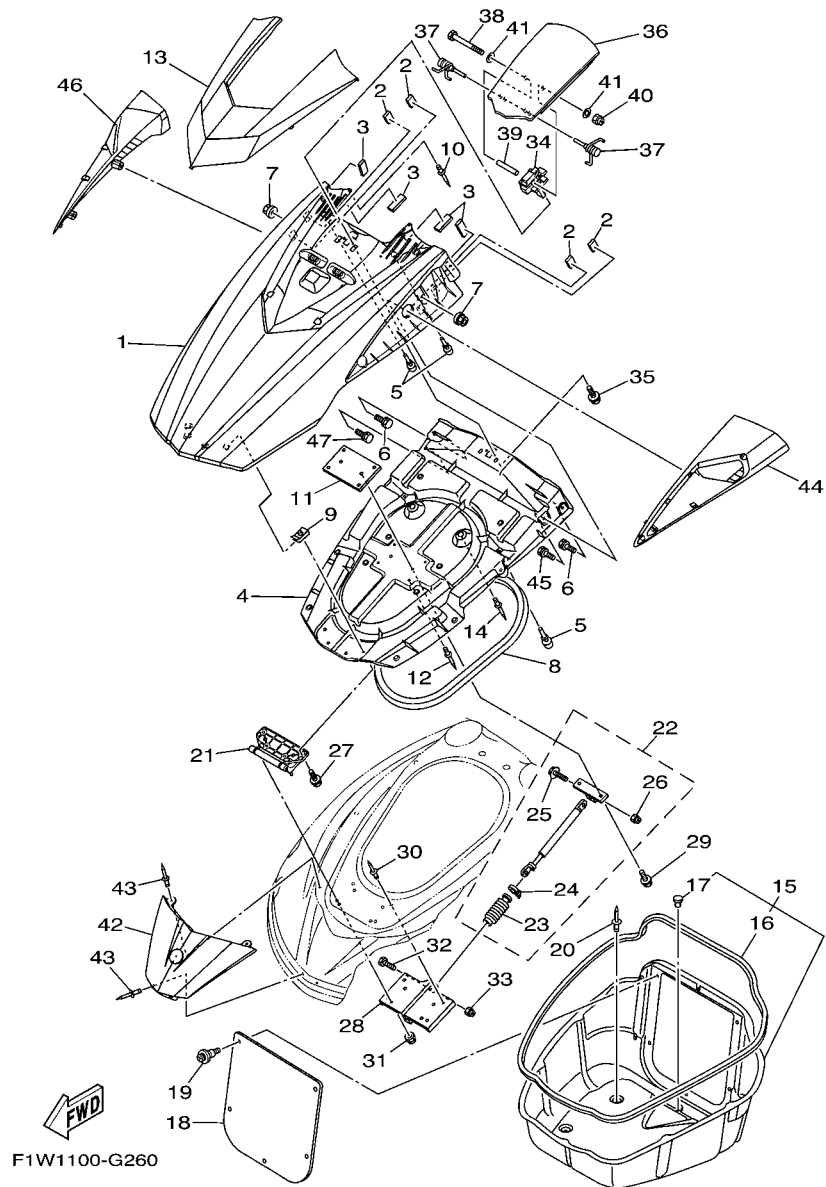

FIG. 26 ENGINE HATCH 2

REF. NO.	PART NO.	DESCRIPTION	USA	CAN	EUR	GENE	REMARKS
1	F1W-U517B-01-P0	LID, ENGINE ROOM	1	1	1	1	DRMR FOR RED
	F1W-U517B-10-P0	LID, ENGINE ROOM	1	1	1	1	LNMP FOR GRAY
2	F1W-U5136-00	STOPPER, HATCH 2	4	4	4	4	
3	F1K-U266B-00	PACKING 3	4	4	4	4	
4	F1W-U213B-01	COVER, VENTILATOR 1	1	1	1	1	
5	F1W-U3768-01	CUSHION, RUBBER	4	4	4	4	
6	90119-06880	BOLT, WITH WASHER	2	2	2	2	
7	90185-06014	NUT, SELF-LOCKING	2	2	2	2	
8	F1K-U2663-00	PACKING 1	1	1	1	1	
9	90183-06902	NUT, SPRING	4	4	4	4	
10	90267-48807	RIVET, BLIND	12	12	12	12	
11	F1W-U5148-00	PLATE, HATCH	1	1	1	1	
12	90267-48807	RIVET, BLIND	4	4	4	4	
13	F1W-U515N-00-P0	VISOR	1	1	1	1	LYNM FOR RED
	F1W-U515N-10-P0	VISOR	1	1	1	1	NME FOR GRAY
14	90267-48807	RIVET, BLIND	6	6	6	6	
15	F1W-U475B-04	LOCKER, BOW	1	1	1	1	
16	F1W-U266C-00	.PACKING 4	1	1	1	1	
17	90605-502U1	.PLUG, BLIND	1	1	1	1	
18	F1W-U475F-01	PLATE, LOKER BOW	1	1	1	1	
19	90269-08801	RIVET	5	5	5	5	
20	90267-489UP	RIVET, BLIND	4	4	4	4	
21	F1W-U517D-01	HINGE, LID	1	1	1	1	
22	F1W-6514S-00	DAMPER ASSY	1	1	1	1	
23	F1W-6514T-00	.COVER, DAMPER	1	1	1	1	
24	90601-20005	.BAND	1	1	1	1	
25	90109-06218	.BOLT	1	1	1	1	



F1W1100-G260

FIG. 26 ENGINE HATCH 2

REF. NO.	PART NO.	DESCRIPTION	USA	CAN	EUR	GENE	REMARKS
26	95720-06300	.NUT, SELF-LOCKING	1	1	1	1	
27	90119-069UK	BOLT, WITH WASHER	4	4	4	4	
28	F1W-U518E-02	PLATE, HINGE LID	1	1	1	1	
29	90119-069UH	BOLT, WITH WASHER	2	2	2	2	
30	90267-48020	RIVET, BLIND	4	4	4	4	
31	9572R-06300	NUT, NYLON	4	4	4	4	
32	90109-06218	BOLT	1	1	1	1	
33	9572R-06300	NUT, NYLON	1	1	1	1	
34	F1W-6517C-02	LOCK, LID	1	1	1	1	
35	90119-059U4	BOLT, WITH WASHER	2	2	2	2	
36	F1W-U515P-01	VISOR, 2	1	1	1	1	UR FOR RED
	F1W-U515P-30	VISOR, 2	1	1	1	1	UR FOR GRAY
37	F1W-6517R-00	PIN, HINGE	2	2	2	2	
38	F1W-U515H-00	SHAFT A	1	1	1	1	
39	F1W-U2693-00	PIPE	1	1	1	1	
40	9572R-05300	NUT, FLANGE	1	1	1	1	
41	9299R-05200	WASHER	2	2	2	2	
42	F1W-U513M-01-P0	COVER, FRONT	1	1	1	1	DRMR FOR RED
	F1W-U513M-10-P0	COVER, FRONT	1	1	1	1	LNMP FOR GRAY
43	90267-489U6	RIVET, BLIND	4	4	4	4	
44	F1W-U590D-02	MIRROR ASSY. 1	1				LYNM FOR RED
	F1W-U590D-11	MIRROR ASSY. 1	1				NME FOR GRAY
	F1W-U590D-41	MIRROR ASSY. 1		1	1	1	LYNM FOR RED
	F1W-U590D-51	MIRROR ASSY. 1		1	1	1	NME FOR GRAY
45	90119-089UL	BOLT, WITH WASHER	2	2	2	2	
46	F1W-U590E-02	MIRROR ASSY. 2	1				LYNM FOR RED
	F1W-U590E-11	MIRROR ASSY. 2	1				NME FOR GRAY

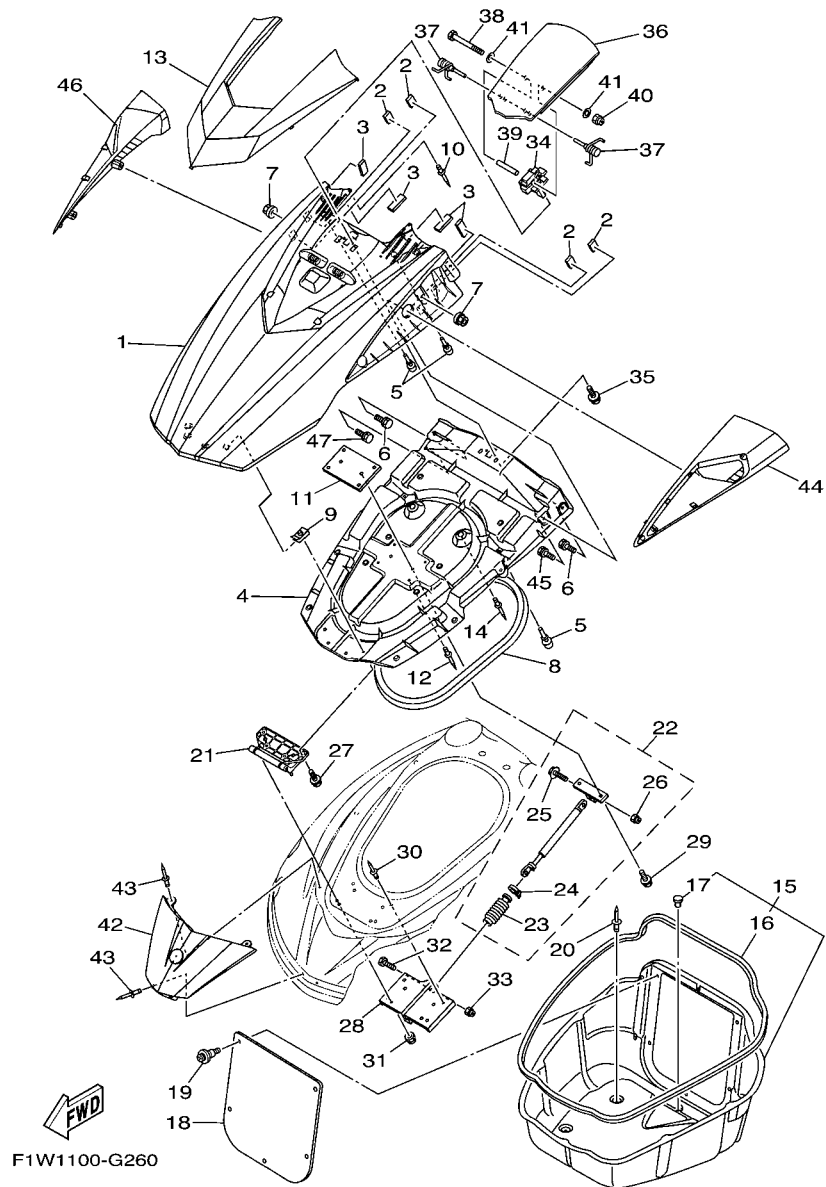

FIG. 26 ENGINE HATCH 2

REF. NO.	PART NO.	DESCRIPTION	USA	CAN	EUR	GENE	REMARKS
46	F1W-U590E-41	MIRROR ASSY. 2		1	1	1	LYNM FOR RED
	F1W-U590E-51	MIRROR ASSY. 2			1	1	NME FOR GRAY
47	90119-089UL	BOLT, WITH WASHER	2	2	2	2	

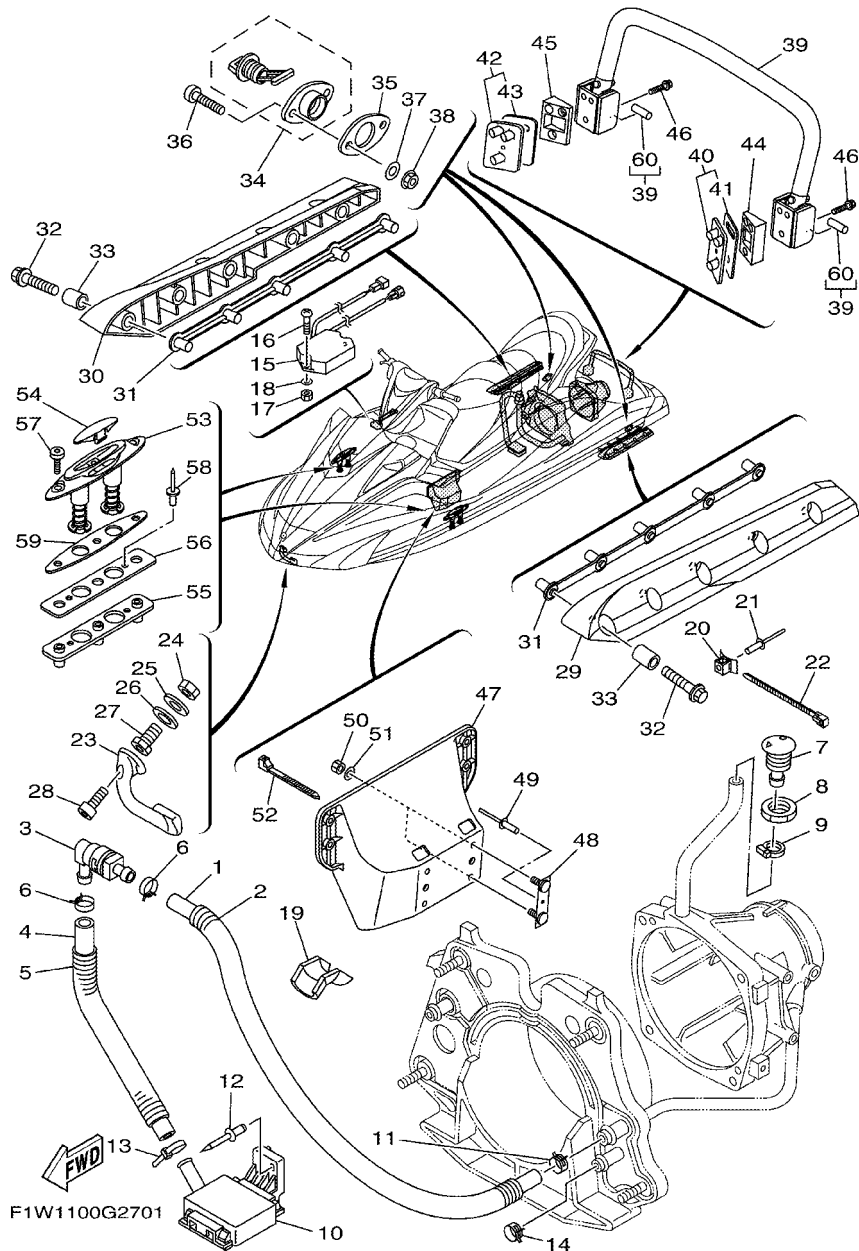

FIG. 27 HULL & DECK

REF. NO.	PART NO.	DESCRIPTION	USA	CAN	EUR	GENE	REMARKS
1	90445-20804	HOSE (L860)	1	1	1	1	
2	90446-27M73	HOSE (L700)	1	1	1	1	
3	68N-5112T-00	JOINT, HOSE	1	1	1	1	
4	90445-20800	HOSE (L500)	1	1	1	1	
5	90446-27M55	TUBE (L400)	1	1	1	1	
6	90467-18804	CLIP	2	2	2	2	
7	F1W-U269B-00	SPOUT	1	1	1	1	
8	EU0-61652-00	NUT	1	1	1	1	
9	90601-118UF	BAND, HOSE 18	1	1	1	1	
10	F1B-U761D-02	STRAINER, BILGE	1	1	1	1	
11	90467-21800	CLIP	1	1	1	1	
12	90267-489U8	RIVET, BLIND	1	1	1	1	
13	90601-200U1	BAND	1	1	1	1	
14	90467-200A0	CLIP	1	1	1	1	
15	F1X-U8K22-01	SENSOR, COMPASS	1	1	1	1	
16	9788R-05025	SCREW, PAN HEAD	2	2	2	2	
17	9572R-05300	NUT, FLANGE	2	2	2	2	
18	9299R-05200	WASHER	2	2	2	2	
19	F1S-U828H-01	TRIM, 1	1	1	1	1	
20	90600-91736	CLAMP COMP.	1	1	1	1	
21	90267-48802	RIVET, BLIND	2	2	2	2	
22	90464-32801	CLAMP	2	2	2	2	
23	F1K-61624-00	BOWEYE 1	1	1	1	1	
24	99780-12600	NUT.HEX.(COARS)	2	2	2	2	
25	92990-12200	WASHER, PLAIN	2	2	2	2	
26	F0X-61637-00	WASHER	2	2	2	2	
27	F0X-61652-00	NUT (BOLT/NUT)	2	2	2	2	

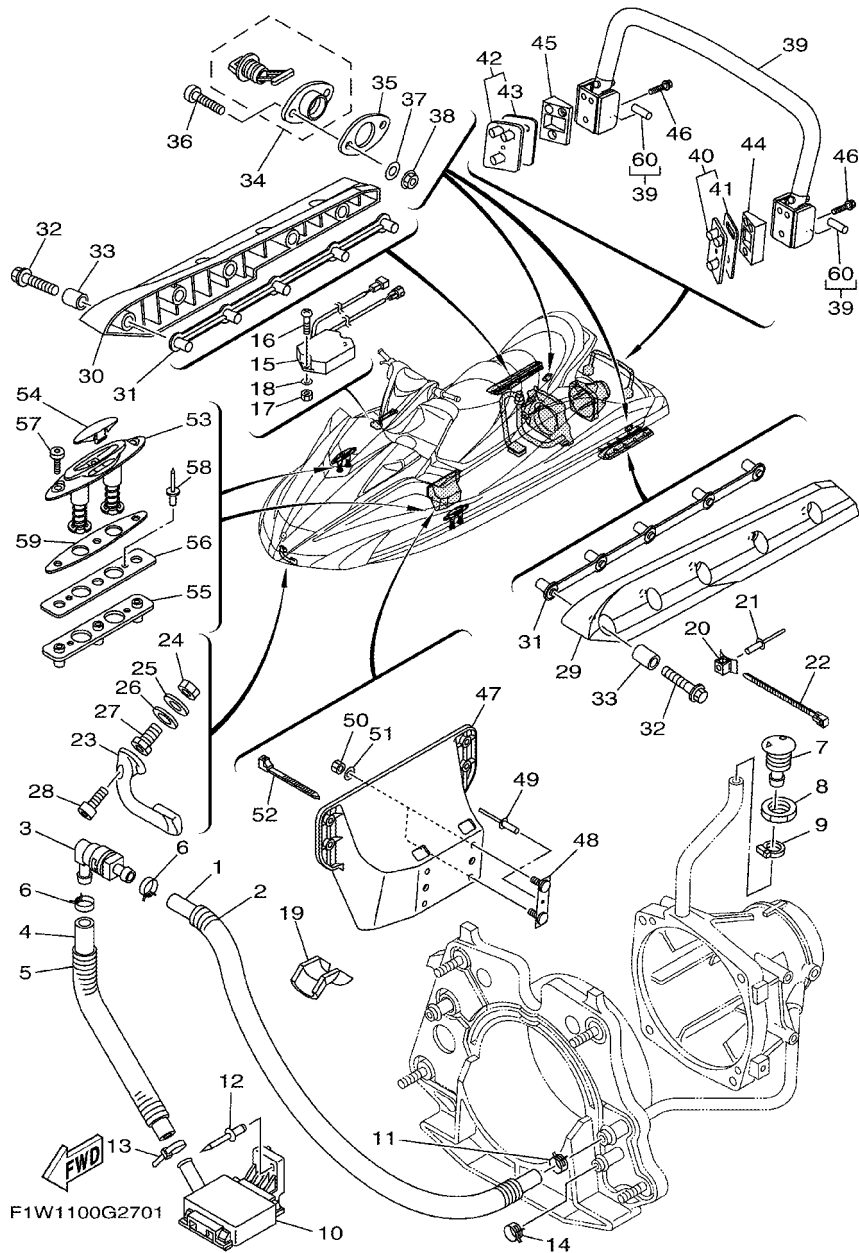

FIG. 27 HULL & DECK

REF. NO.	PART NO.	DESCRIPTION	USA	CAN	EUR	GENE	REMARKS
28	90110-06040	BOLT, HEXAGON SOCKET HEAD	2	2	2	2	
29	F1S-U883N-01	STABILIZER LH	1	1	1	1	BLACK
30	F1S-U883P-01	STABILIZER RH	1	1	1	1	BLACK
31	F1X-U883T-00	BRACKET,STABILIZER	2	2	2	2	
32	90105-08860	BOLT, FLANGE	10	10	10	10	
33	F1K-U8169-00	SPACER	10	10	10	10	
34	F1S-U2280-00	DRAIN PLUG ASSY.	2	2	2	2	
35	F1S-U2285-00	PACKING, DRAIN	2	2	2	2	
36	9788R-05025	SCREW, PAN HEAD	4	4	4	4	
37	9299R-05200	WASHER	4	4	4	4	
38	9572R-05300	NUT, FLANGE	4	4	4	4	
39	F1W-U278A-01	LADDER, STEP ASSY	1	1	1	1	
40	F1X-U278F-01	BRACKET, LADDER LH	1	1	1	1	
41	F1X-U278H-10	.PACKING, BRKT. 1	1	1	1	1	
42	F1X-U278G-01	BRACKET, LADDER RH	1	1	1	1	
43	F1X-U278H-10	.PACKING, BRKT. 1	1	1	1	1	
44	F1X-U278K-00	BRACKET 1	1	1	1	1	
45	F1X-U278L-00	BRACKET 2	1	1	1	1	
46	90119-08844	BOLT, WITH WASHER	6	6	6	6	
47	F1W-U8572-01	BRACKET 2	1	1	1	1	
48	F1K-U826C-02	BRACKET	2	2	2	2	
49	90267-489U1	RIVET,BLIND	2	2	2	2	
50	9572R-08300	NUT, FLANGE	4	4	4	4	
51	9299R-08200	WASHER	4	4	4	4	
52	90464-32801	CLAMP	1	1	1	1	
53	F1X-U163A-01	CLEAT ASSY.	2	2	2	2	
54	F1X-U826D-00	COVER	2	2	2	2	

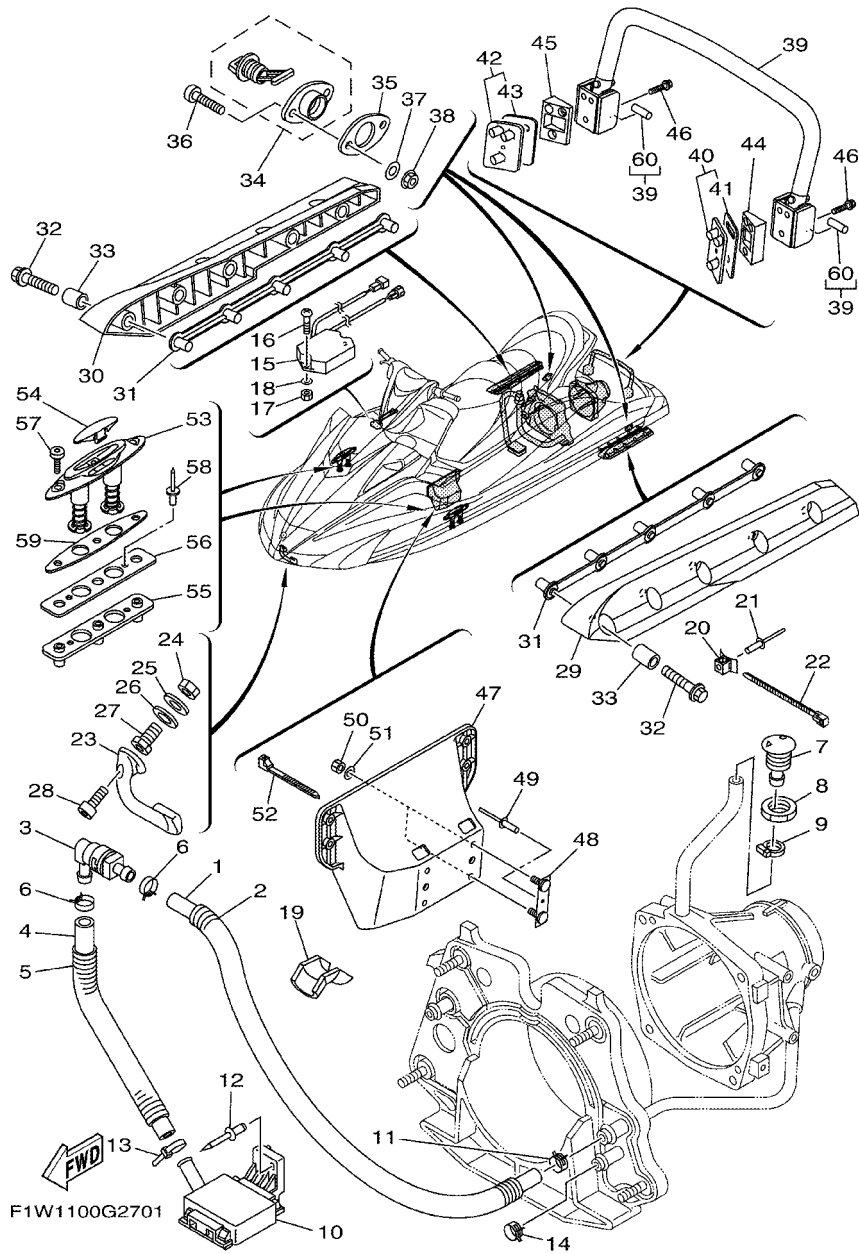
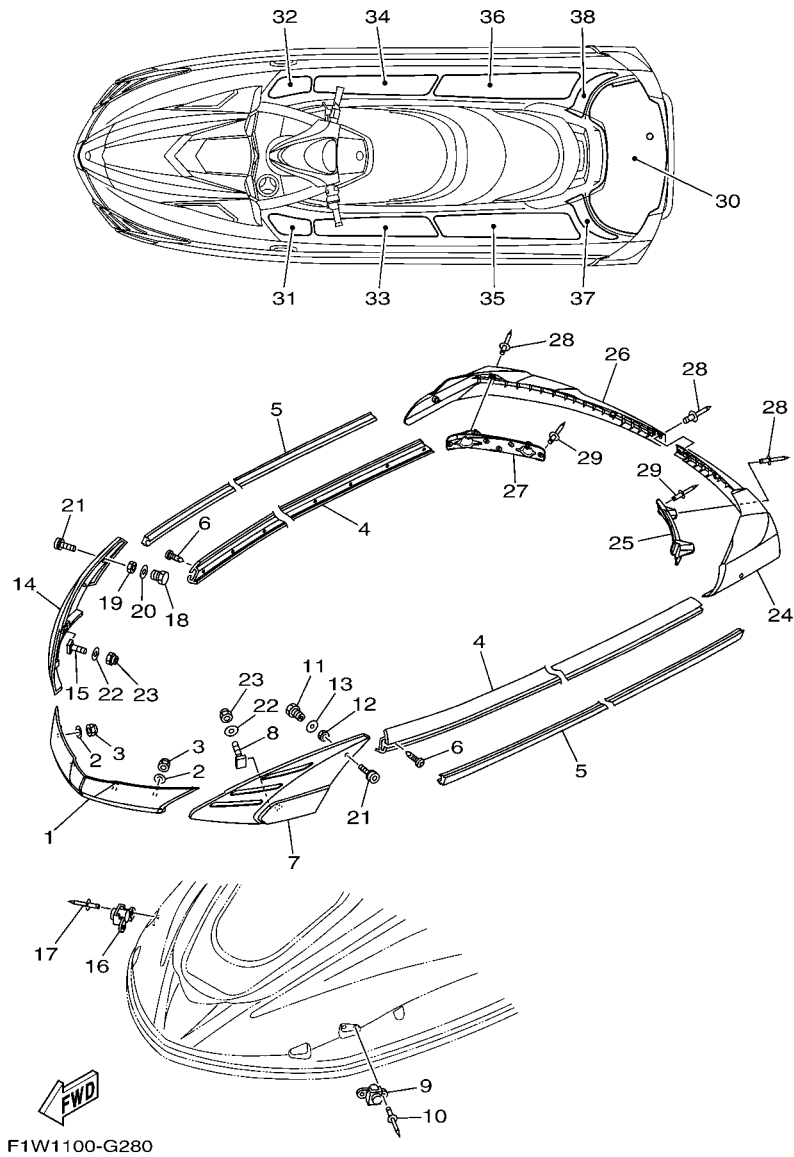

FIG. 27 HULL & DECK

REF. NO.	PART NO.	DESCRIPTION	USA	CAN	EUR	GENE	REMARKS
55	F1X-U826C-00	BRACKET	2	2	2	2	
56	F1X-U2157-00	PACKING	2	2	2	2	
57	90111-06805	BOLT,HEX. SOCKET BUTTON	6	6	6	6	
58	90267-489U6	RIVET, BLIND	4	4	4	4	
59	F1X-U2284-00	PACKING	2	2	2	2	
60	F1W-U771H-00	.SLEEVE 1	4	4	4	4	
<hr/>							
<hr/>							
<hr/>							
<hr/>							
<hr/>							
<hr/>							
<hr/>							
<hr/>							
<hr/>							



F1W1100-G280

FIG. 28 GUNWALE & MAT

REF. NO.	PART NO.	DESCRIPTION	USA	CAN	EUR	GENE	REMARKS
1	F1W-U2501-00	BOW GUNWALE COMP.	1	1	1	1	UR FOR RED
	F1W-U2501-10	BOW GUNWALE COMP.	1	1	1	1	UR FOR GRAY
2	9299R-06200	WASHER	4	4	4	4	
3	9572R-06300	NUT, NYLON	4	4	4	4	
4	F1B-U2512-20	GUNWALE, SIDE	2	2	2	2	UR FOR RED
	F1B-U2512-00	GUNWALE, SIDE	2	2	2	2	UR FOR GRAY
5	F1B-U2519-10	INNER,GUNWALE	2	2	2	2	YAMAHA BLACK
6	90169-059U1	SCREW,TAPPING	36	36	36	36	
7	F1W-U252E-01	JOINT, GUNWALE LH	1	1	1	1	UR FOR RED
	F1W-U252E-10	JOINT, GUNWALE LH	1	1	1	1	UR FOR GRAY
8	F1W-U491K-00	BOLT, SPECIAL	2	2	2	2	
9	F1W-U250B-00	GROMMET ASSY	2	2	2	2	
10	90267-489U6	RIVET, BLIND	4	4	4	4	
11	F1W-62873-00	NUT, SPECIAL	1	1	1	1	
12	95380-14700	NUT	1	1	1	1	
13	F1W-62157-00	PACKING	1	1	1	1	
14	F1W-U252F-01	JOINT, GUNWALE RH	1	1	1	1	UR FOR RED
	F1W-U252F-10	JOINT, GUNWALE RH	1	1	1	1	UR FOR GRAY
15	F1W-U491K-00	BOLT, SPECIAL	2	2	2	2	
16	F1W-U250B-00	GROMMET ASSY	2	2	2	2	
17	90267-489U6	RIVET, BLIND	4	4	4	4	
18	F1W-62873-00	NUT, SPECIAL	1	1	1	1	
19	95380-14700	NUT	1	1	1	1	
20	F1W-62157-00	PACKING	1	1	1	1	
21	90111-06114	BOLT,HEX. SOCKET BUTTON	2	2	2	2	
22	9299R-06200	WASHER	4	4	4	4	
23	9572R-06300	NUT, NYLON	4	4	4	4	

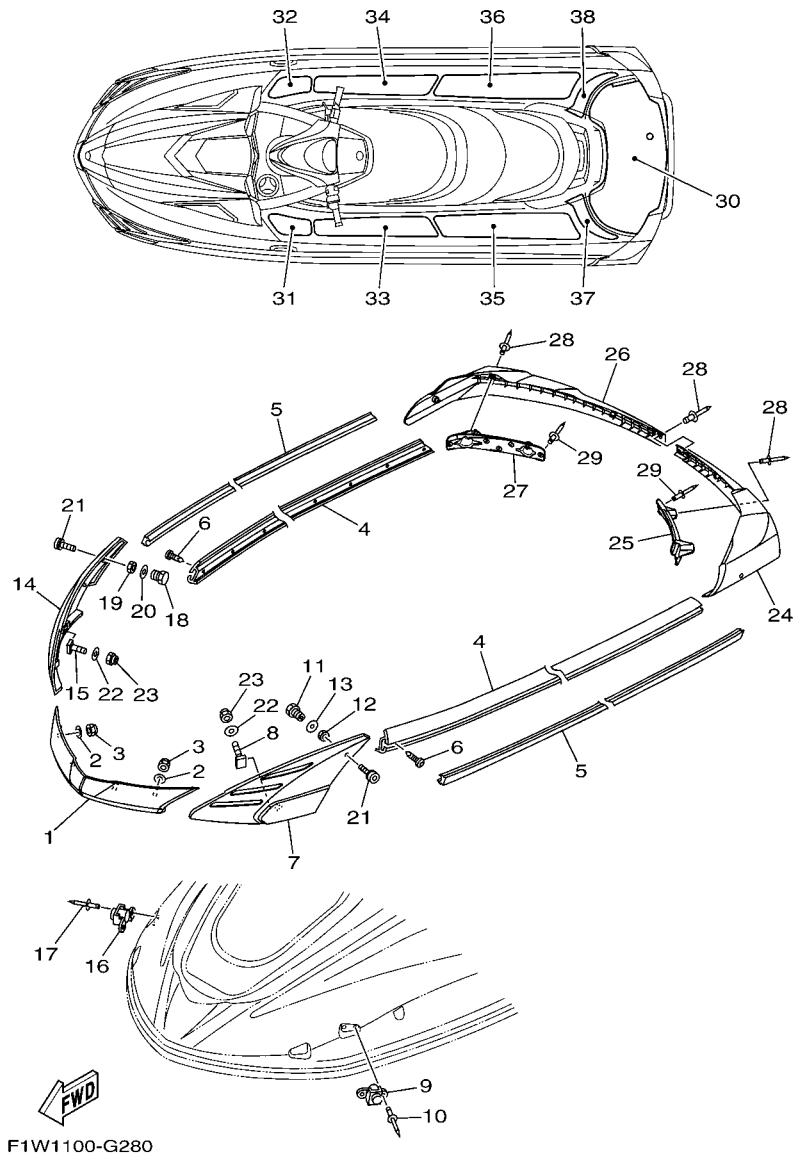

FIG. 28 GUNWALE & MAT

REF. NO.	PART NO.	DESCRIPTION	USA	CAN	EUR	GENE	REMARKS
24	F1W-U251D-01	GUNWALE, STERN 1	1	1	1	1	UR FOR RED
	F1W-U251D-10	GUNWALE, STERN 1	1	1	1	1	UR FOR GRAY
25	F1W-U251L-01	BRACKET, GUNWALE 1	1	1	1	1	
26	F1W-U251E-01	GUNWALE, STERN 2	1	1	1	1	UR FOR RED
	F1W-U251E-10	GUNWALE, STERN 2	1	1	1	1	UR FOR GRAY
27	F1W-U251M-01	BRACKET, GUNWALE 2	1	1	1	1	
28	90267-48825	RIVET, BLIND	9	9	9	9	
29	90267-489U8	RIVET, BLIND	10	10	10	10	
30	F1W-U3581-10	MAT, UPPER	1	1	1	1	UR FOR RED
	F1W-U3581-00	MAT, UPPER	1	1	1	1	UR FOR GRAY
31	F1W-U351H-10	MAT, STEP 1	1	1	1	1	UR FOR RED
	F1W-U351H-00	MAT, STEP 1	1	1	1	1	UR FOR GRAY
32	F1W-U351J-10	MAT, STEP 2	1	1	1	1	UR FOR RED
	F1W-U351J-00	MAT, STEP 2	1	1	1	1	UR FOR GRAY
33	F1W-U351K-10	MAT, STEP 3	1	1	1	1	UR FOR RED
	F1W-U351K-00	MAT, STEP 3	1	1	1	1	UR FOR GRAY
34	F1W-U351M-10	MAT, STEP 4	1	1	1	1	UR FOR RED
	F1W-U351M-00	MAT, STEP 4	1	1	1	1	UR FOR GRAY
35	F1W-U351N-10	MAT, STEP 5	1	1	1	1	UR FOR RED
	F1W-U351N-00	MAT, STEP 5	1	1	1	1	UR FOR GRAY
36	F1W-U351P-10	MAT, STEP 6	1	1	1	1	UR FOR RED
	F1W-U351P-00	MAT, STEP 6	1	1	1	1	UR FOR GRAY
37	F1W-U351R-10	MAT, STEP 7	1	1	1	1	UR FOR RED
	F1W-U351R-00	MAT, STEP 7	1	1	1	1	UR FOR GRAY
38	F1W-U351S-10	MAT, STEP 8	1	1	1	1	UR FOR RED
	F1W-U351S-00	MAT, STEP 8	1	1	1	1	UR FOR GRAY

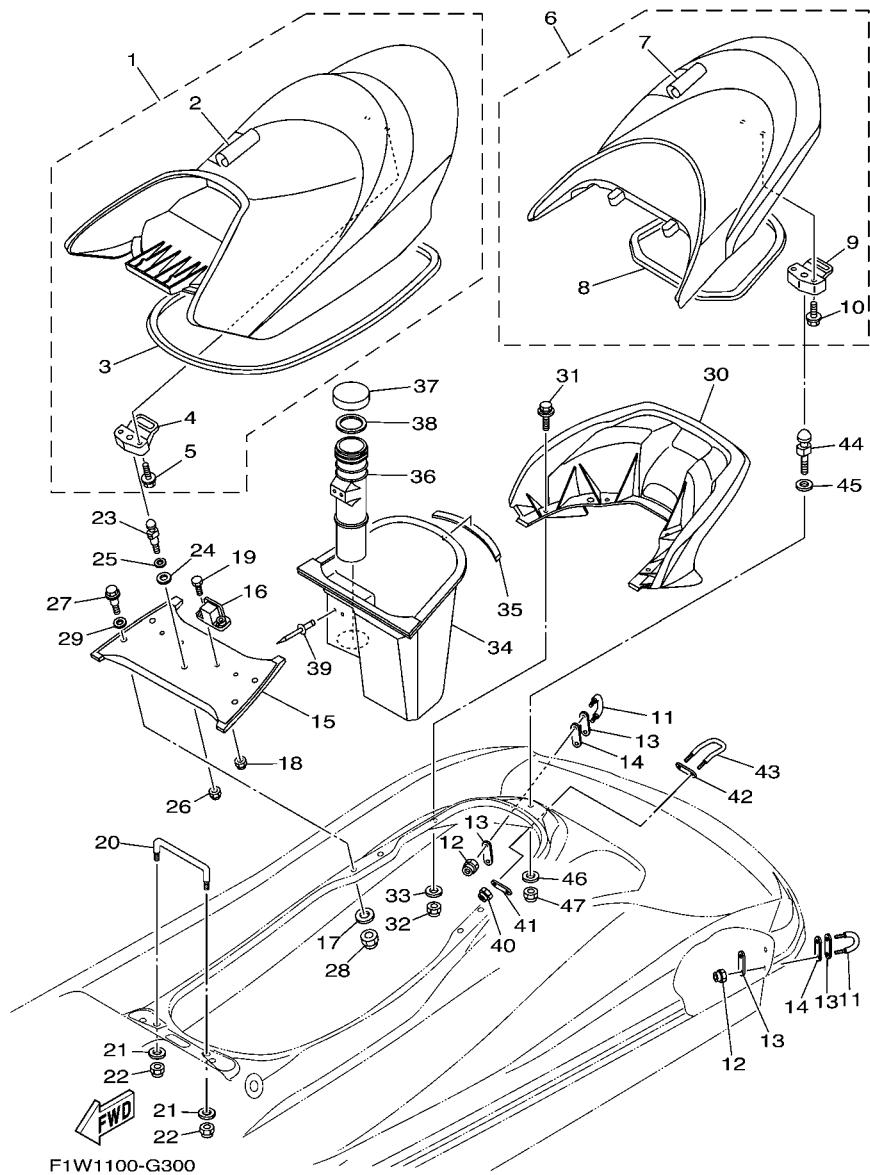

FIG. 30 SEAT & UNDER LOCKER

REF. NO.	PART NO.	DESCRIPTION	USA	CAN	EUR	GENE	REMARKS
1	F1W-U371A-11	DOUBLE SEAT ASSY	1	1	1	1	UR FOR RED
	F1W-U371A-20	DOUBLE SEAT ASSY	1	1	1	1	UR FOR GRAY
2	F1W-U371B-11	.COVER, SEAT 1	1	1	1	1	UR FOR RED
	F1W-U371B-20	.COVER, SEAT 1	1	1	1	1	UR FOR GRAY
3	F1W-U2664-01	.PACKING	1	1	1	1	
4	F1B-U3850-02	.SEAT LOCK ASSY	1	1	1	1	
5	90119-069UP	.BOLT, WITH WASHER	2	2	2	2	
6	F1W-U372A-11	SINGLE SEAT ASSY	1	1	1	1	UR FOR RED
	F1W-U372A-20	SINGLE SEAT ASSY	1	1	1	1	UR FOR GRAY
7	F1W-U372B-10	.COVER, SEAT	1	1	1	1	UR FOR RED
	F1W-U372B-20	.COVER, SEAT	1	1	1	1	UR FOR GRAY
8	F1W-U266D-00	.PACKING 5	1	1	1	1	
9	F1B-U3850-02	.SEAT LOCK ASSY	1	1	1	1	
10	90119-069UP	.BOLT, WITH WASHER	2	2	2	2	
11	F1K-61628-00	STERN EYE	2	2	2	2	
12	9572R-08300	NUT, FLANGE	4	4	4	4	
13	GP7-U4953-10	PLATE A	4	4	4	4	
14	F1B-U1653-01	PACKING	2	2	2	2	
15	F1W-U8952-00	BEAM, DECK 1	1	1	1	1	
16	GU2-6378D-02	STAY, SEAT 2	2	2	2	2	
17	9299R-08200	WASHER	4	4	4	4	
18	9572R-06300	NUT, NYLON	4	4	4	4	
19	90101-069U0	BOLT	4	4	4	4	
20	F0X-6378C-00	STAY, SEAT 1	1	1	1	1	
21	90201-099U3	WASHER, PLATE	2	2	2	2	
22	9572R-08300	NUT, FLANGE	2	2	2	2	
23	F1B-U3774-00	PIN	1	1	1	1	

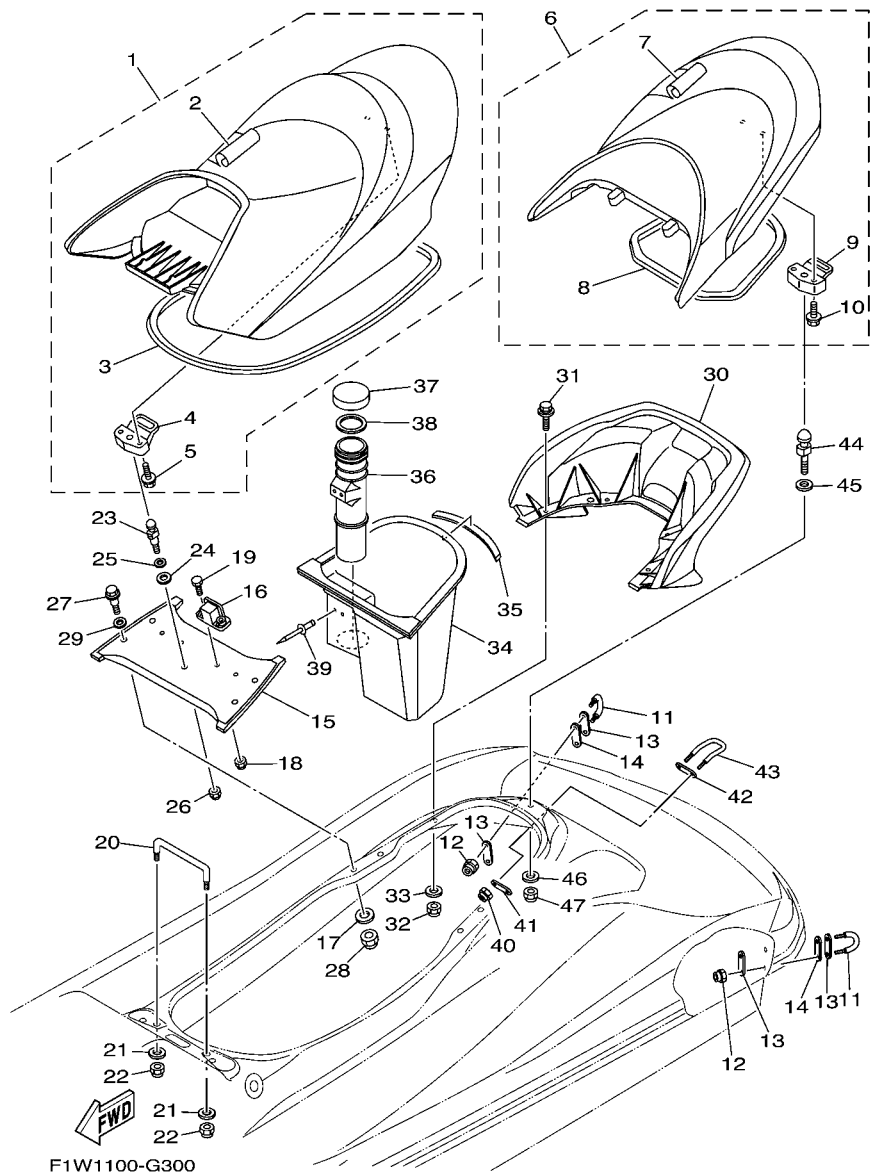

FIG. 30 SEAT & UNDER LOCKER

REF. NO.	PART NO.	DESCRIPTION	USA	CAN	EUR	GENE	REMARKS
24	F0X-6375E-00	PACKING 1	1	1	1	1	
25	92990-12200	WASHER, PLAIN	1	1	1	1	
26	9572R-10300	NUT, FLANGE	1	1	1	1	
27	F1B-U2624-00	BOLT	4	4	4	4	
28	9572R-08300	NUT, FLANGE	4	4	4	4	
29	9299R-10200	WASHER	4	4	4	4	
30	F1W-U271B-00	GRIP, HAND	1	1	1	1	
31	90119-08942	BOLT, WITH WASHER	4	4	4	4	
32	9572R-08300	NUT, FLANGE	4	4	4	4	
33	9299R-08200	WASHER	4	4	4	4	
34	F1B-U4742-01	LOCKER, UNDER 2	1	1	1	1	
35	F0X-U266E-01	PACKING,6	1	1	1	1	
36	F0X-U5983-01	BOX, FIRE EXTINGUISHER	1	1	1	1	
37	EW2-U5912-01	CAP, CASE	1	1	1	1	
38	EW2-U5913-01	PACKING, CASE	1	1	1	1	
39	90267-489UP	RIVET, BLIND	4	4	4	4	
40	9572R-08300	NUT, FLANGE	2	2	2	2	
41	GP7-U4953-10	PLATE A	1	1	1	1	
42	GP7-U4953-10	PLATE A	1	1	1	1	
43	F1B-U1629-00	SKI TOWS	1	1	1	1	
44	GH1-U3774-00	PIN	1	1	1	1	
45	90201-109U6	WASHER, PLATE	1	1	1	1	
46	9299R-10200	WASHER	1	1	1	1	
47	9572R-10300	NUT, FLANGE	1	1	1	1	

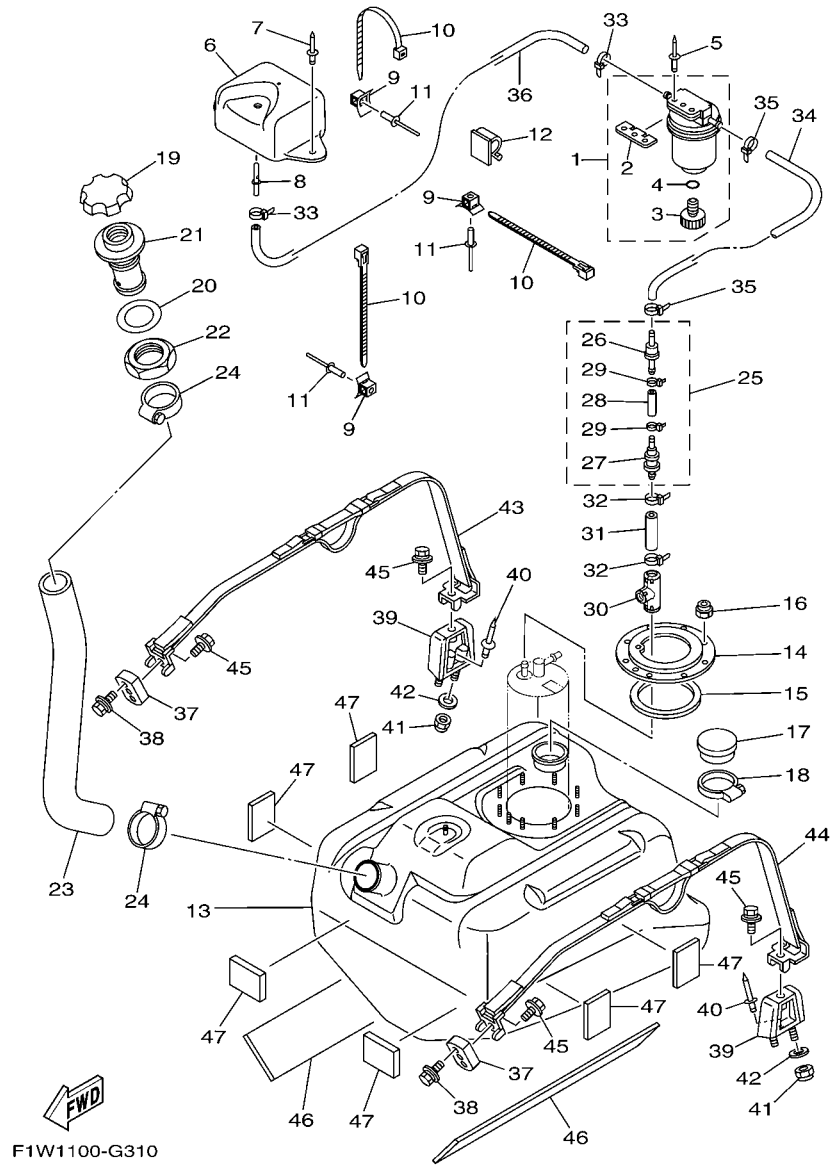

FIG. 31 FUEL TANK

REF. NO.	PART NO.	DESCRIPTION	USA	CAN	EUR	GENE	REMARKS
1	F2F-6214A-00	FILTER, VENT ASSY	1	1	1	1	
2	EW2-62142-00	.PLATE, FILTER	1	1	1	1	
3	70R-24543-00	.PLUG, DRAIN	1	1	1	1	
4	70R-24489-00	.O-RING	1	1	1	1	
5	90267-489U2	RIVET, BLIND	2	2	2	2	
6	F1W-U2159-00	SOCKET, VENTILATION	1	1	1	1	
7	90267-489U6	RIVET, BLIND	2	2	2	2	
8	F1G-62149-00	PIPE, VENTILATION	1	1	1	1	
9	90600-91736	CLAMP COMP.	3	3	3	3	
10	90464-32801	CLAMP	3	3	3	3	
11	90267-489U6	RIVET, BLIND	3	3	3	3	
12	90464-17800	CLAMP	1	1	1	1	
13	F1W-U7711-01	TANK, FUEL	1	1	1	1	
14	F1B-U7773-00	RING	1	1	1	1	
15	F1B-67747-00	PACKING, SEAL	1	1	1	1	
16	9572R-06300	NUT, NYLON	9	9	9	9	
17	FN8-6771K-00	COVER	1	1	1	1	
18	90601-162U5	BAND, HOSE 62	1	1	1	1	
19	GP7-U7831-11	CAP, FUEL FILLER	1	1	1	1	BLACK
20	GP7-U7834-10	PACKING FUEL FILLER	1	1	1	1	
21	GP7-U7833-11	SOCKET	1	1	1	1	BLACK
22	GP7-U783F-00	NUT, FUEL FILLER	1	1	1	1	
23	F1W-U7844-00	HOSE	1	1	1	1	
24	90601-155U4	BAND, HOSE 55	2	2	2	2	
25	F1B-62150-00	AIR, VENT ASSY	1	1	1	1	
26	F1B-67767-00	.CHECK VALVE	1	1	1	1	
27	FJ0-67766-00	.ROLL OVER VALVE	1	1	1	1	

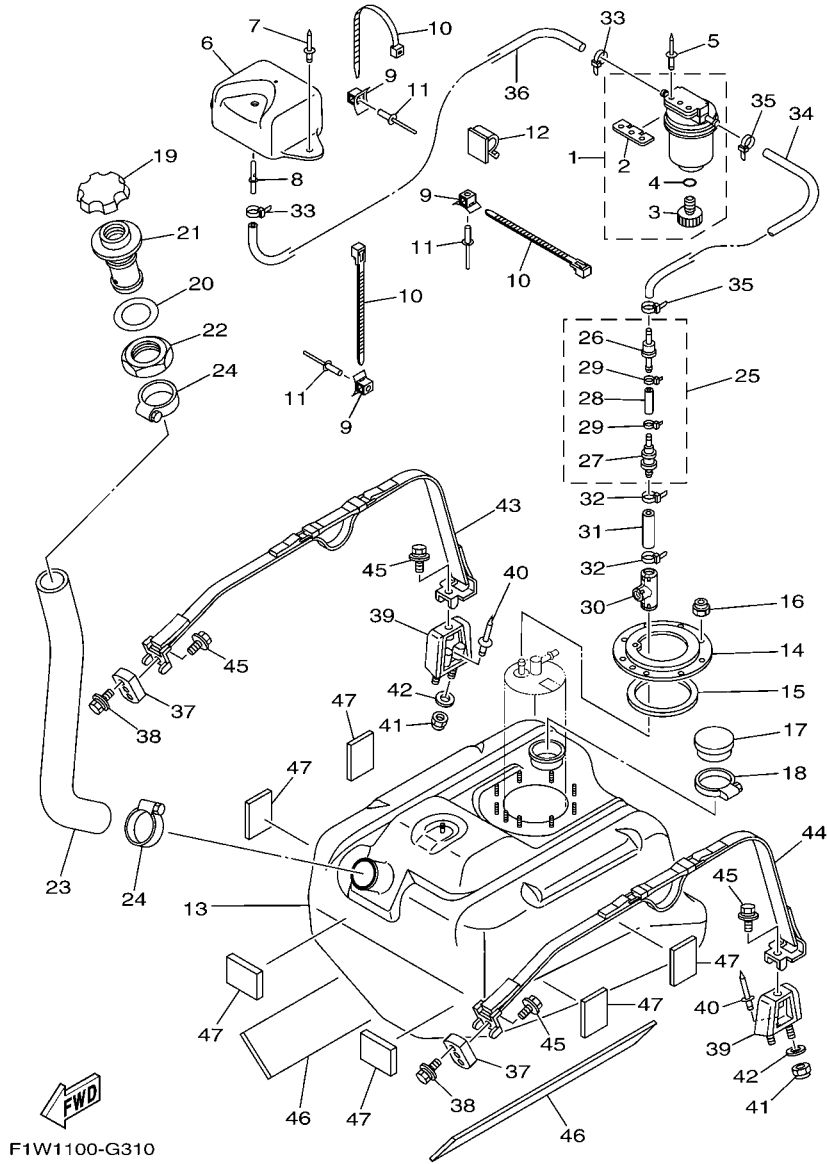

FIG. 31 FUEL TANK

REF. NO.	PART NO.	DESCRIPTION	USA	CAN	EUR	GENE	REMARKS
28	90699-50004	.HOSE (L40)	1	1	1	1	
29	90465-11M10	.CLAMP	2	2	2	2	
30	F1W-U771K-00	COVER	1	1	1	1	
31	F1W-U785H-00	HOSE, AIR VENT 3	1	1	1	1	
32	90465-11829	CLAMP	2	2	2	2	
33	90465-11829	CLAMP	2	2	2	2	
34	F0D-U785G-10	HOSE, AIR VENT	1	1	1	1	
35	90465-11829	CLAMP	2	2	2	2	
36	F0D-U7856-10	HOSE, AIR VENT 3	1	1	1	1	
37	F1X-U2873-00	NUT, SPECIAL	2	2	2	2	
38	90119-069UH	BOLT, WITH WASHER	4	4	4	4	
39	F1B-6774J-00	BRKT, BAND	2	2	2	2	
40	90267-489UE	RIVET, BLIND	2	2	2	2	
41	9572R-06300	NUT, NYLON	4	4	4	4	
42	9299R-06200	WASHER	4	4	4	4	
43	F1B-67743-02	BELT, TANK 1	1	1	1	1	
44	F1W-67743-00	BELT, TANK 1	1	1	1	1	
45	90119-089U7	BOLT, WITH WASHER	4	4	4	4	
46	F1B-U759B-00	MAT 1	2	2	2	2	
47	F1W-U759C-01	MAT 2	6	6	6	6	

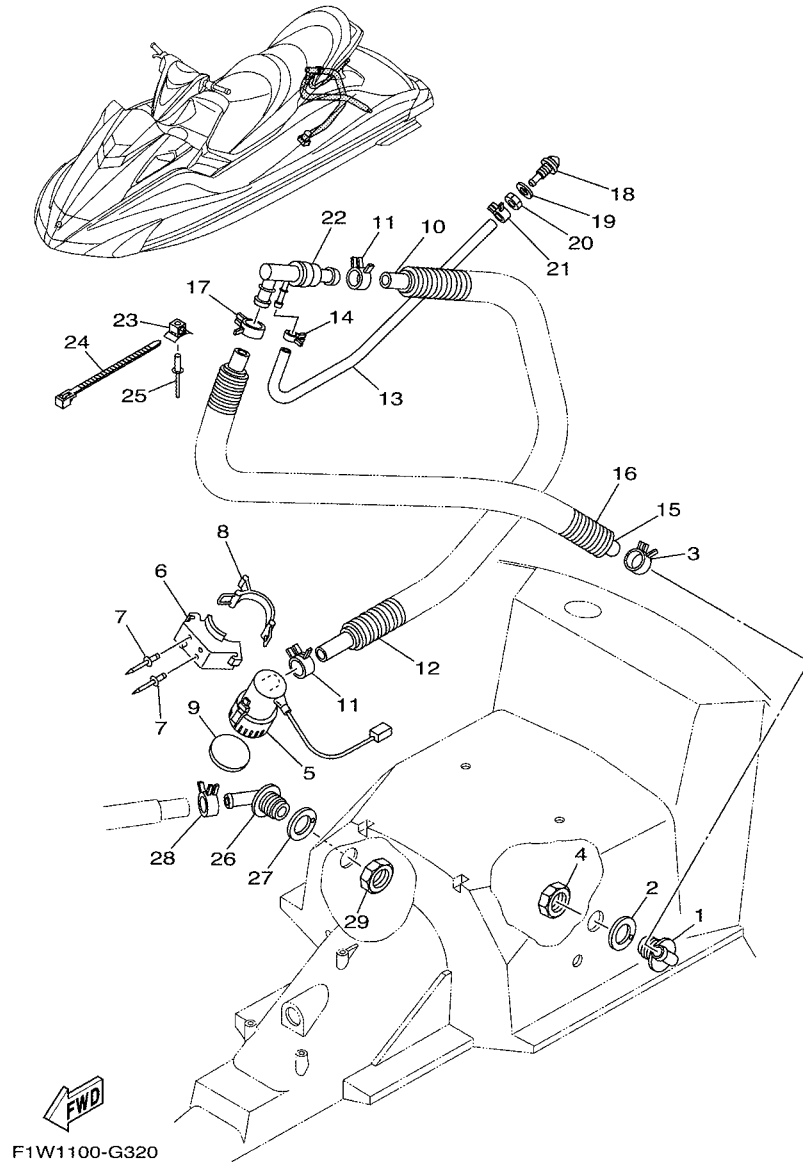

FIG. 32 BILGE PUMP

REF. NO.	PART NO.	DESCRIPTION	USA	CAN	EUR	GENE	REMARKS
1	F1B-6224E-00	BODY, DRAIN 3	1	1	1	1	
2	F1S-U7525-01	PACKING	1	1	1	1	
3	90467-26800	CLIP	1	1	1	1	
4	F1B-62241-00	DRAIN, COCKPIT	1	1	1	1	
5	F1B-U8360-01	BILGE PUMP ASSY	1	1	1	1	
6	F1B-U7698-01	BRACKET	1	1	1	1	
7	90267-489UP	RIVET, BLIND	2	2	2	2	
8	GA7-68218-00	BAND, BATTERY	1	1	1	1	
9	F1B-U7656-00	PACKING, BILGE	1	1	1	1	
10	F1B-U7626-00	HOSE 1	1	1	1	1	
11	90467-25801	CLIP	2	2	2	2	
12	90447-28004	HOSE, WITH SPRING (L800)	1	1	1	1	
13	F1W-U7629-00	HOSE, DRAIN 2	1	1	1	1	
14	90467-14803	CLIP	1	1	1	1	
15	F1B-U7628-00	HOSE, DRAIN 3	1	1	1	1	
16	90447-28004	HOSE, WITH SPRING (L800)	1	1	1	1	
17	90467-26800	CLIP	1	1	1	1	
18	GH7-6753B-00	PILOT, WATER	1	1	1	1	
19	90430-16910	GASKET	1	1	1	1	
20	GP7-61652-00	NUT	1	1	1	1	
21	90467-14803	CLIP	1	1	1	1	
22	F1S-67620-00	HOSE JOINT	1	1	1	1	
23	90600-91736	CLAMP COMP.	1	1	1	1	
24	90464-51800	CLAMP	1	1	1	1	
25	90267-489U6	RIVET, BLIND	1	1	1	1	
26	F1B-6224E-00	BODY, DRAIN 3	1	1	1	1	
27	F1S-U7525-01	PACKING	1	1	1	1	

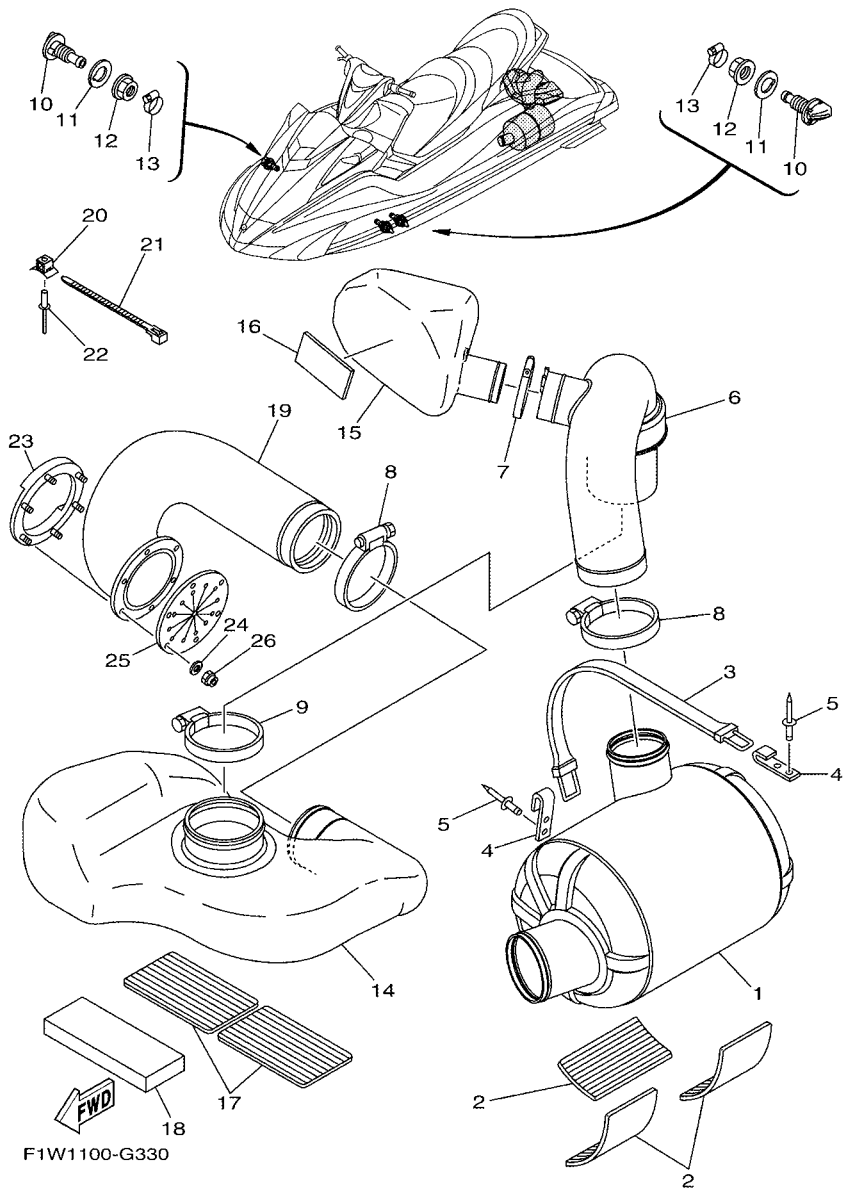

FIG. 33 EXHAUST 3

REF. NO.	PART NO.	DESCRIPTION	USA	CAN	EUR	GENE	REMARKS
1	F1W-U7550-00	WATER LOCK COMP.	1	1	1	1	
2	F1S-U8221-00	PAD, BATTERY	3	3	3	3	
3	EW2-67821-00	BAND, FUEL TANK	1	1	1	1	
4	GA7-65772-00	HOOK A	2	2	2	2	
5	90267-489U1	RIVET,BLIND	4	4	4	4	
6	F1W-U7555-00	HOSE, EXHAUST	1	1	1	1	
7	90601-170UG	BAND, HOSE 70	1	1	1	1	
8	90450-99801	HOSE CLAMP ASSY	2	2	2	2	
9	90450-99804	HOSE CLAMP ASSY	1	1	1	1	
10	F1K-6753B-00	PILOT, WATER	3	3	3	3	
11	F1B-67564-00	GASKET	3	3	3	3	
12	F0X-62733-00	NUT	3	3	3	3	
13	90467-17802	CLIP	3	3	3	3	
14	F1W-U4261-00	TANK, WATER	1	1	1	1	
15	F1W-U753C-01	RESONATOR 1	1	1	1	1	
16	F1K-U759C-00	MAT 2	2	2	2	2	
17	F1S-U8221-00	PAD, BATTERY	2	2	2	2	
18	F1W-U8831-01	BED,TANK 1	1	1	1	1	
19	F1B-U758D-02	HOSE,EXHAUST 3	1	1	1	1	
20	90600-91736	CLAMP COMP.	1	1	1	1	
21	90464-32801	CLAMP	1	1	1	1	
22	90267-48802	RIVET, BLIND	1	1	1	1	
23	F1S-U757B-00	PLATE	1	1	1	1	
24	9299R-06200	WASHER	6	6	6	6	
25	F1B-U751G-00	VALVE, EXHAUST	1	1	1	1	
26	9572R-06300	NUT, NYLON	6	6	6	6	

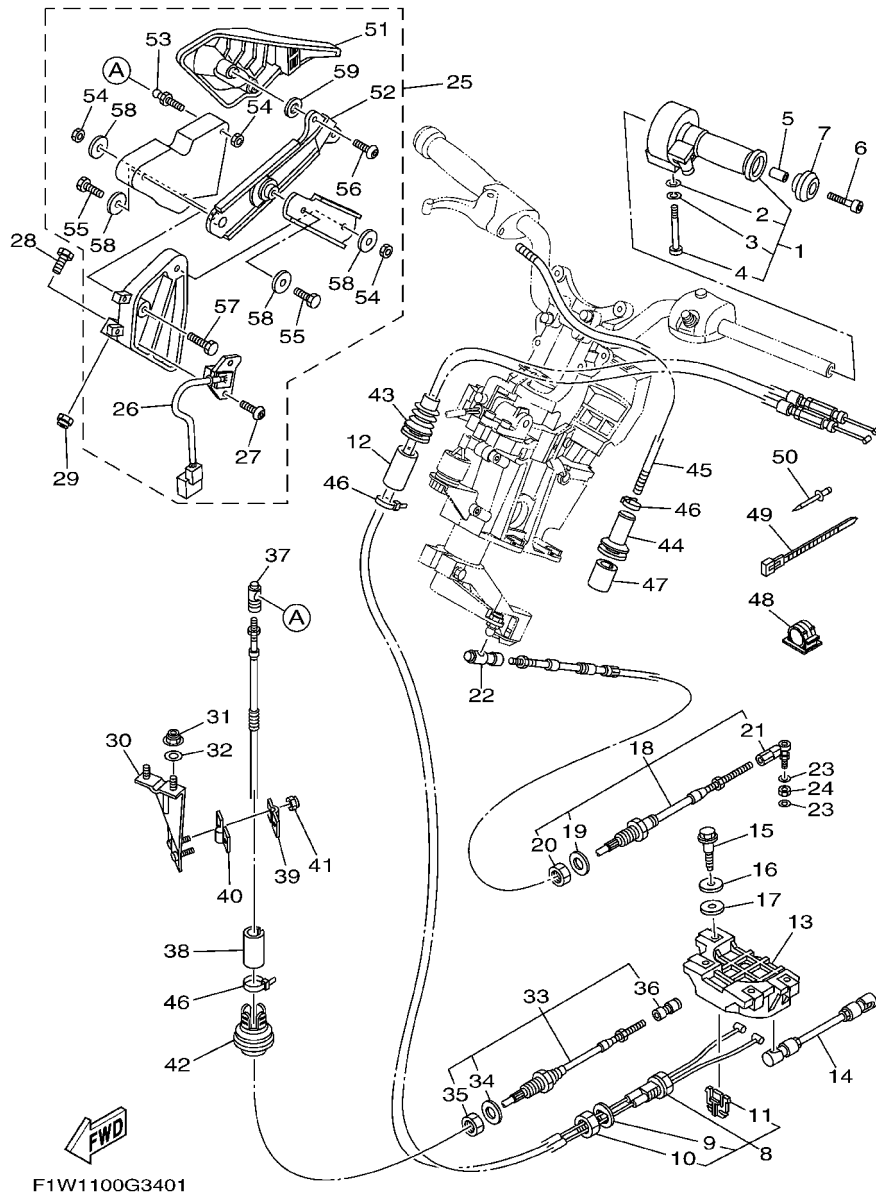

FIG. 34 CONTROL CABLE

REF. NO.	PART NO.	DESCRIPTION	USA	CAN	EUR	GENE	REMARKS
1	F1W-6153A-00	NOZZLE, CONTROL ASSY	1	1	1	1	
2	92990-06200	.WASHER, PLAIN	1	1	1	1	
3	92990-06100	.WASHER, SPRING	1	1	1	1	
4	F1W-613C1-00	.SCREW	1	1	1	1	
5	90387-05800	COLLAR	1	1	1	1	
6	90110-05908	BOLT, HEXAGON SOCKET HEAD	1	1	1	1	
7	F1S-U155F-00	GRIP, END	1	1	1	1	
8	F1W-6153E-01	CABLE, NOZZLE CONTROL 3	1	1	1	1	
9	F1W-61438-00	.PACKING	1	1	1	1	
10	F1B-6151S-00	.NUT	1	1	1	1	
11	F1W-61557-00	.GUIDE, CABLE	1	1	1	1	
12	GJ1-U7578-11	PACKING, HOSE 2	1	1	1	1	
13	F1W-6153J-00	REMOCON, NOZZLE 2	1	1	1	1	
14	F1W-6150A-00	ROD ASSY	1	1	1	1	
15	90109-06233	BOLT	4	4	4	4	
16	90201-099U3	WASHER, PLATE	4	4	4	4	
17	90202-08002	WASHER, PLATE	4	4	4	4	
18	F1S-61481-00	CABLE, STEERING	1	1	1	1	
19	F1B-61438-00	.PACKING	1	1	1	1	
20	F1B-6151S-00	.NUT	1	1	1	1	
21	F1B-61461-02	.STUD, JOINT BALL	1	1	1	1	
22	GK5-U146F-00	SHAFT, JOINT BALL	1	1	1	1	
23	90201-06906	WASHER, PLATE	2	2	2	2	
24	9538R-06700	NUT	1	1	1	1	
25	F1W-6134A-00	REMOCON. LEVER ASSY.	1	1	1	1	
26	F1W-6830K-00	.REVERSE SENSOR ASSY	1	1	1	1	Go to P/N : PE0-WV-090001
27	F1B-613C1-00	.SCREW	2	2	2	2	

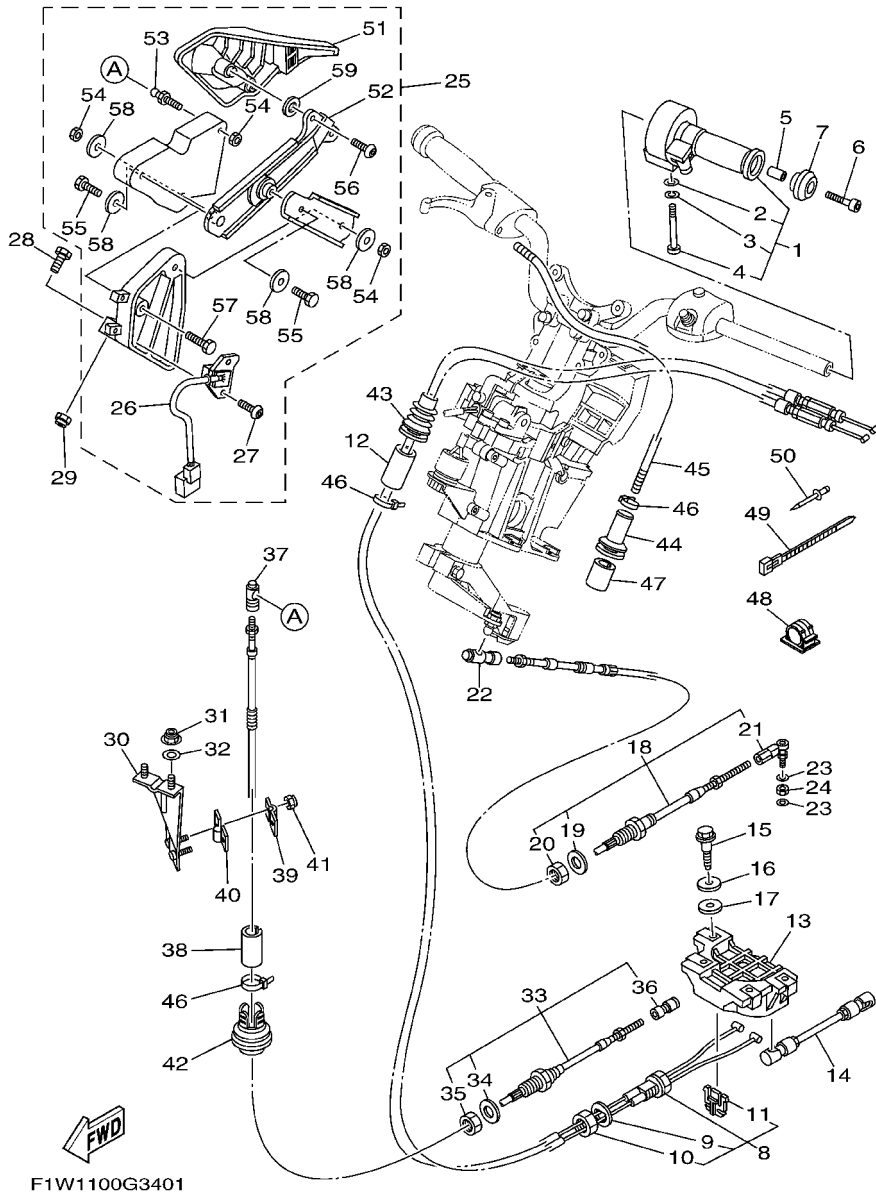

FIG. 34 CONTROL CABLE

REF. NO.	PART NO.	DESCRIPTION	USA	CAN	EUR	GENE	REMARKS
28	97080-06030	BOLT	3	3	3	3	
29	90185-06014	NUT, SELF-LOCKING	3	3	3	3	
30	F1W-U1467-02	BRACKET, STOPPER CABLE	1	1	1	1	
31	9572R-08300	NUT, FLANGE	2	2	2	2	
32	9299R-08200	WASHER	2	2	2	2	
33	F1W-6149C-01	CABLE, REVERSE	1	1	1	1	
34	F1B-61438-00	.PACKING	1	1	1	1	
35	F1B-6151S-00	.NUT	1	1	1	1	
36	F1B-61460-00	.BALL JOINT ASSY	1	1	1	1	
37	F1B-61460-00	BALL JOINT ASSY	1	1	1	1	
38	F1W-U146G-00	PACKING, CABLE	1	1	1	1	
39	GH1-61468-01	STOPPER, CABLE	1	1	1	1	
40	GU5-6146K-10	HOLDER, STOPPER	1	1	1	1	
41	9572R-06300	NUT, NYLON	2	2	2	2	
42	F1W-U1519-00	GROMMET	1	1	1	1	
43	F0D-6822E-00	GROMMET	1	1	1	1	
44	GU2-6822E-01	GROMMET	1	1	1	1	
45	90447-07001	HOSE, WITH SPRING (L400)	1	1	1	1	
46	90601-200U1	BAND	3	3	3	3	
47	GJ1-U7578-11	PACKING, HOSE 2	1	1	1	1	
48	90600-91736	CLAMP COMP.	1	1	1	1	
49	90464-32801	CLAMP	1	1	1	1	
50	90267-48802	RIVET, BLIND	1	1	1	1	

PARTS NEWS

Date:2009/1/8

News No.PE0-WV-090001

Signature: K . Otsuka

 Cause Revision Notice Correction Sales Unit Change Others

Model	See the"List of Models and CATALOGUE No's below."	
Subject	PARTS CATALOGUE CORRECTIONS	
CATALOGUE NO.	See the"List of Models and CATALOGUE No's below."	
Time of YPEC Revision	Text, Illustration --> Jan./30/2009	PDF Replace --> Jan./30/2009
(YPEC = Yamaha Parts Electrical Catalogue = Website parts catalogue)		

FIG.34 CONTROL CABLE SECTION

1. ILLUSTRATION CORRECTION

(INCORRECT)

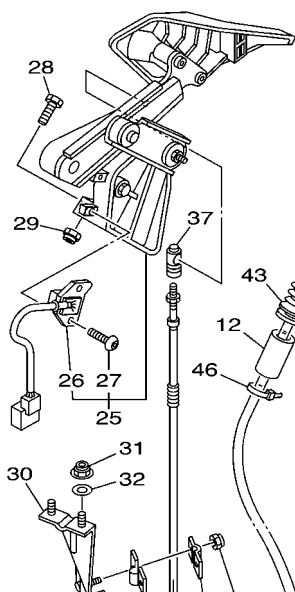

(CORRECT)

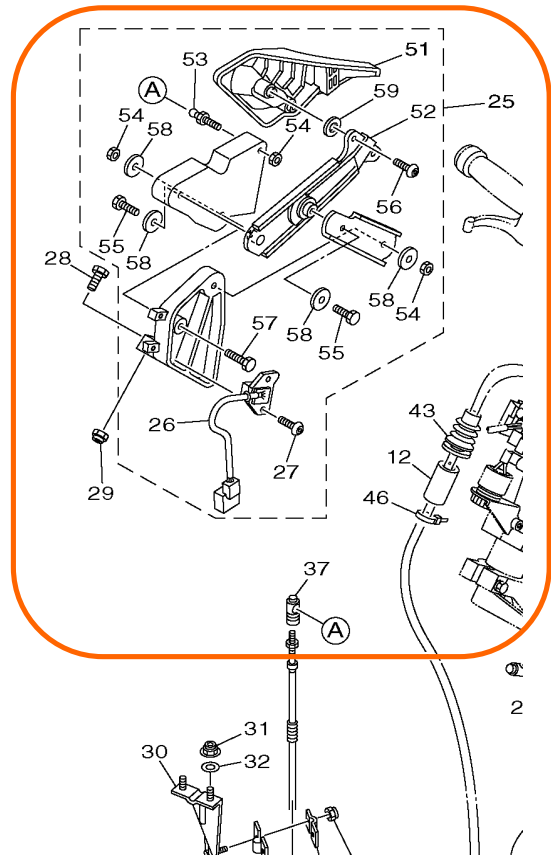

2. LIST CORRECTION

Ref.No.	PART No.	PART NAME	Q'TY	REMARKS	MEMO
25	F1W-6134A-00	REMOCON. LEVER ASSY	1	FOR 2008 MODEL	Complete parts added
	F1W-6134A-01	REMOCON. LEVER ASSY	1	FOR 2009 MODEL	
26	F1W-6830K-00	.REVERSE SENSOR ASSY	1		Illustration correction
27	F1B-613C1-00	.SCREW	2		
51	F1W-62714-00	.GRIP	1		List & Illustration added
52	F1W-62289-00	.LEVER	1		
53	F1X-61461-00	.STUD, JOINT BALL	1		
54	95720-06300	.NUT, SELF-LOCKING	3		
55	F0D-61516-00	.BOLT	2		
56	F1X-613C1-00	.SCREW	2		
57	F0D-61355-00	.BOLT	2		
58	FJ0-61353-00	.WASHER	4		
59	F1W-6134E-00	.WASHER	1		

* These changes are applied from initial production.

Thank you very much for your cooperation.

 Parts
 Manager
 Check

 Service
 Manager
 Check

 Parts
 Manager
 File

 YAMAHA MOTOR CO.,LTD
 2500 Shingai Iwata Shizuoka 438-8501.Japan
 Technical Publication Dept.

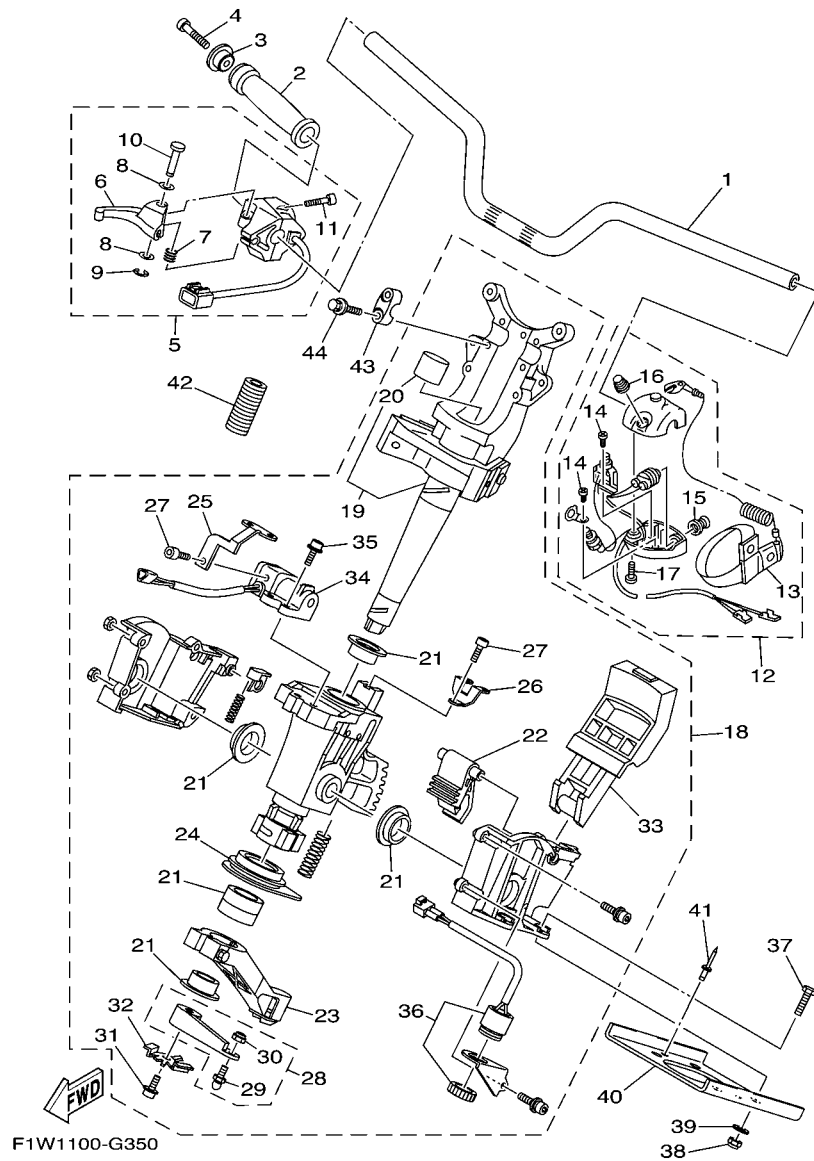

FIG. 35 STEERING 1

REF. NO.	PART NO.	DESCRIPTION	USA	CAN	EUR	GENE	REMARKS
1	F1S-61552-00	HANDLE	1	1	1	1	
2	GP7-U155D-01	GRIP, HANDLE	1	1	1	1	
3	F1S-U155F-00	GRIP, END	1	1	1	1	
4	90110-05908	BOLT, HEXAGON SOCKET HEAD	1	1	1	1	
5	F1W-67250-00	THROTTLE LEVER ASSY	1	1	1	1	
6	F0D-67255-02	.LEVER, THROTTLE	1	1	1	1	
7	EW2-67256-00	.SPRING	1	1	1	1	
8	EW2-67258-01	.WASHER	2	2	2	2	
9	EW2-67259-01	.E-RING	1	1	1	1	
10	F0D-67257-00	.SHAFT	1	1	1	1	
11	F1X-6725F-01	.BOLT, THROTTLE	2	2	2	2	
12	F1S-68310-01	SWITCH BOX ASSY	1	1	1	1	
13	EW2-68348-00	.LANYARD, STOP SWITCH	1	1	1	1	
14	97880-03008	.SCREW, PAN HEAD	2	2	2	2	
15	FK7-68312-02	.STOP BUTTON COMP	1	1	1	1	
16	FK7-68313-02	.START BUTTON COMP.	1	1	1	1	
17	97880-05025	.SCREW, PAN HEAD	2	2	2	2	
18	F1W-61400-10	STEERING MASTER ASSY	1	1	1	1	
19	F1W-67410-10	.SHAFT ASSY	1	1	1	1	
20	F1W-61435-00	..SEAL, PIPE 30	1	1	1	1	
21	F1W-6773D-00	.TUBE & BUSHING SET	1	1	1	1	
22	F1S-61782-00	.LOCK 1	1	1	1	1	
23	F1S-6146A-00	.CABLE STOPPER ASSY.	1	1	1	1	
24	F1S-6143C-00	.SEAL, RUBBER	1	1	1	1	
25	F1W-65938-00	.STAY 1	1	1	1	1	
26	F1S-65939-00	.STAY 2	1	1	1	1	
27	F1B-613C1-00	.SCREW	2	2	2	2	

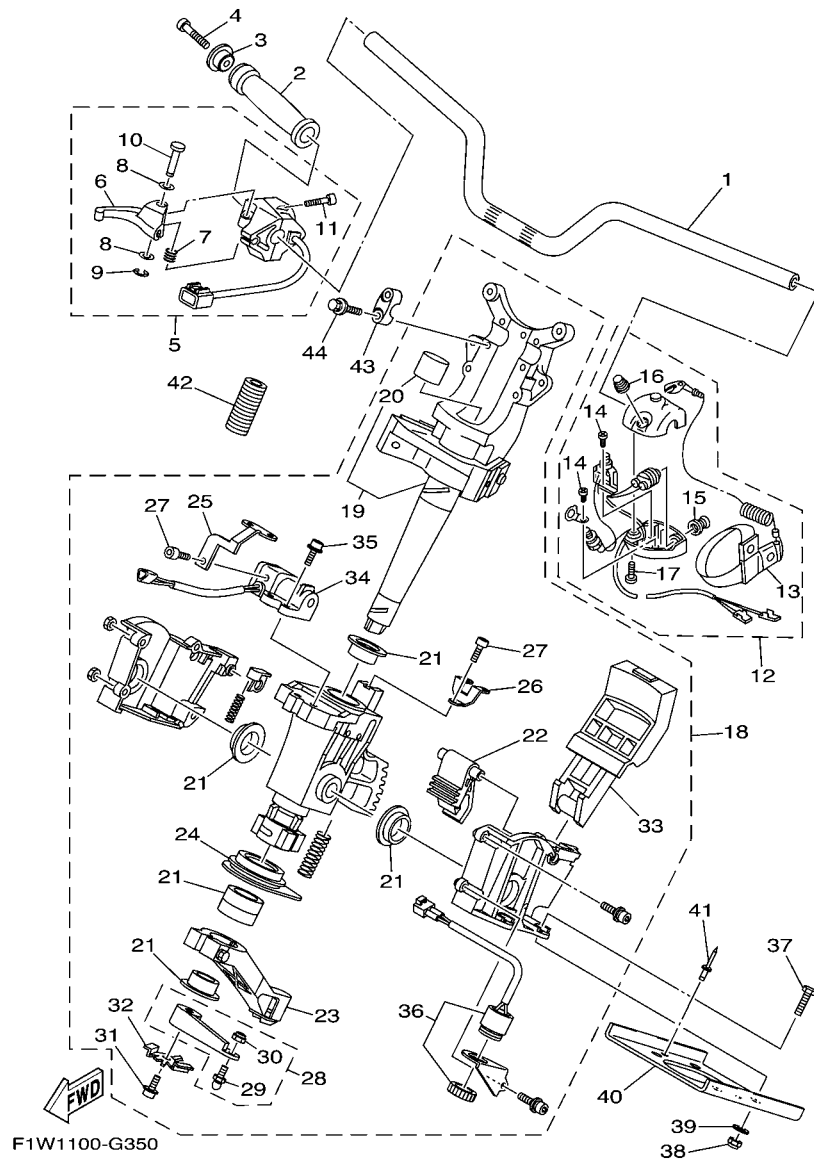
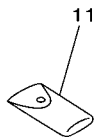
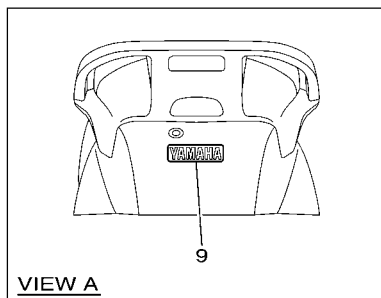
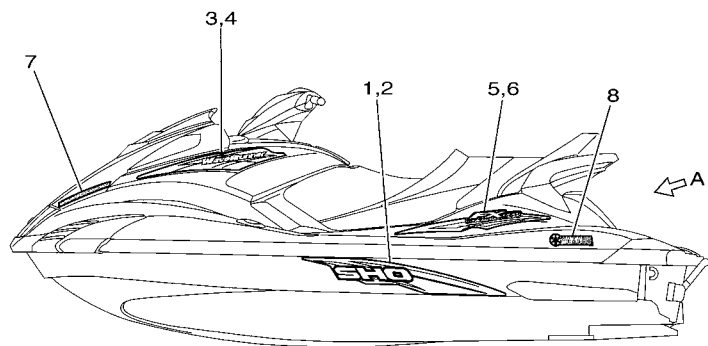
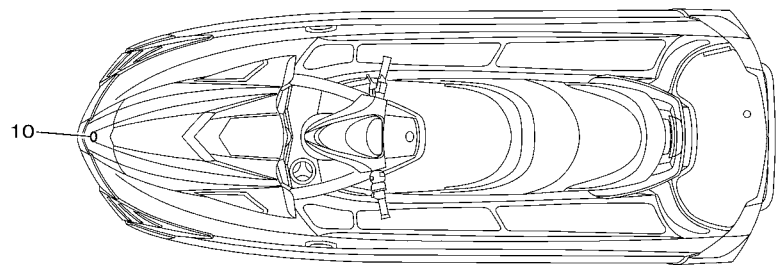

FIG. 35 STEERING 1

REF. NO.	PART NO.	DESCRIPTION	USA	CAN	EUR	GENE	REMARKS
28	F1S-6153R-01	.ARM ASSY.	1	1	1	1	
29	EU0-61461-02	..STUD, JOINT BALL	1	1	1	1	
30	95720-06300	..NUT, SELF-LOCKING	1	1	1	1	
31	F1W-61355-00	.BOLT	1	1	1	1	
32	F1W-6142B-00	.PLATE, RETAINING	1	1	1	1	
33	F1W-6151M-00	..LEVER ASSY	1	1	1	1	
34	F1W-68303-00	.SENSOR ASSY	1	1	1	1	
35	F1S-61355-00	.BOLT	4	4	4	4	
36	F1S-68341-00	.BUZZER	1	1	1	1	
37	97080-08035	BOLT	4	4	4	4	
38	9572R-08300	NUT, FLANGE	4	4	4	4	
39	F1W-U725E-00	WASHER	4	4	4	4	
40	F1X-U1554-00	PLATE, RETAINING	1	1	1	1	
41	90267-489U6	RIVET, BLIND	2	2	2	2	
42	90447-22803	TUBE	1	1	1	1	
43	EU0-23814-30	HOLDER, HANDLE UPPER	2	2	2	2	
44	90119-089UU	BOLT, WITH WASHER	4	4	4	4	



F1W1100-G370

FIG. 37 GRAPHICS

REF. NO.	PART NO.	DESCRIPTION	USA	CAN	EUR	GENE	REMARKS
1	F1W-U417B-00	GRAPHIC 1 (LH)	1	1	1	1	UR FOR RED
	F1W-U417B-10	GRAPHIC 1 (LH)	1	1	1	1	UR FOR GRAY
2	F1W-U417C-00	GRAPHIC 2 (RH)	1	1	1	1	UR FOR RED
	F1W-U417C-10	GRAPHIC 2 (RH)	1	1	1	1	UR FOR GRAY
3	F1W-U417D-00	GRAPHIC 3 (LH)	1	1	1	1	UR FOR RED
	F1W-U417D-10	GRAPHIC 3 (LH)	1	1	1	1	UR FOR GRAY
4	F1W-U417E-00	GRAPHIC 4 (RH)	1	1	1	1	UR FOR RED
	F1W-U417E-10	GRAPHIC 4 (RH)	1	1	1	1	UR FOR GRAY
5	F1W-U417H-00	GRAPHIC 7 (LH)	1	1	1	1	UR FOR RED
	F1W-U417H-10	GRAPHIC 7 (LH)	1	1	1	1	UR FOR GRAY
6	F1W-U417J-00	GRAPHIC 8 (RH)	1	1	1	1	UR FOR RED
	F1W-U417J-10	GRAPHIC 8 (RH)	1	1	1	1	UR FOR GRAY
7	F1W-U417M-00	GRAPHIC C	2	2	2	2	UR FOR RED
	F1W-U417M-10	GRAPHIC C	2	2	2	2	UR FOR GRAY
8	F1W-U411C-00	EMBLEM, YAMAHA	2	2	2	2	UR FOR RED
	F1X-U411C-60	EMBLEM, YAMAHA	2	2	2	2	UR FOR GRAY
9	F1W-U4114-00	MARK, YAMAHA A	1	1	1	1	UR FOR RED
	F1X-U4114-60	MARK, YAMAHA A	1	1	1	1	UR FOR GRAY
10	F1K-U411H-00	EMBLEM, TUNING FORK	1	1	1	1	
11	F1B-65986-00	TOOL SET	1	1	1	1	
12	EU0-65901-01	TOOL BAG	1	1	1	1	

FIG. 39 IMPORTANT LABELS 2

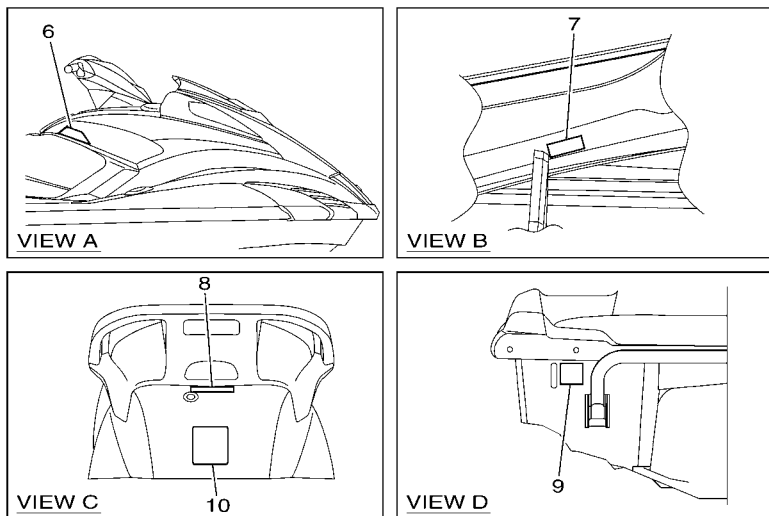
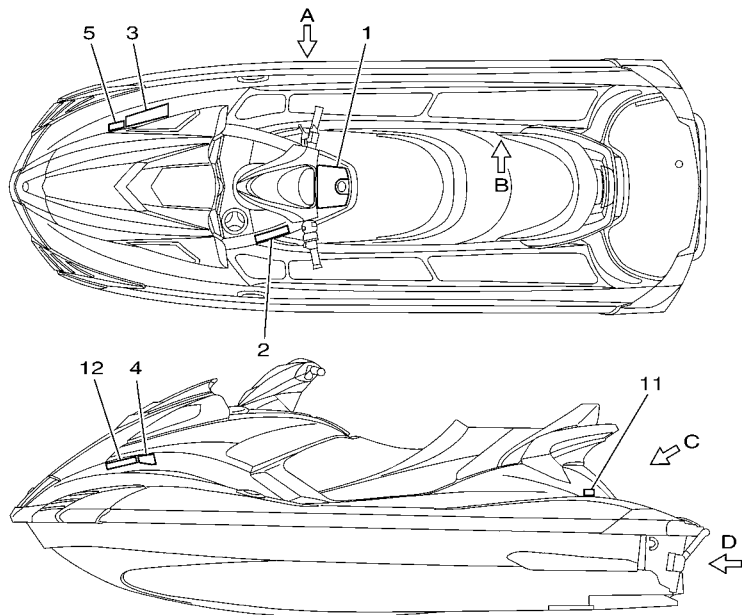

F1W1100-G390

REF. NO.	PART NO.	DESCRIPTION	USA	CAN	EUR	GENE	REMARKS
1	F1W-U41B1-10	LABEL, WARNING UNIFORM 1		1	1	1	
2	F1B-U41B1-21	LABEL, WARNING UNIFORM 1		1	1	1	
3	F1B-U41B1-31	LABEL, WARNING UNIFORM 1		1	1	1	
4	F1B-U41B2-01	LABEL, WARNING UNIFORM 2		1	1	1	
5	F1S-U415B-11	LABEL, WARNING(FUEL)		1	1	1	
6	F0V-U41D5-31	LABEL, WARNING SHIFT LEVER		1	1	1	
7	F0V-U41DB-12	LABEL, WARNING BATTERY		1	1	1	
8	F1B-U41F5-21	LABEL, FIRE EXTINGUISHER 1		1	1	1	
9	F1G-U418F-00	LABEL, RIGHTING		1	1	1	
10	F1S-U41E1-11	LABEL, SET 1		1	1	1	
11	F1S-U419E-01	LABEL 4		1			FOR CAN
12	GP8-U416H-01	LABEL,WARNING(FRANCE)			1		FOR EUR

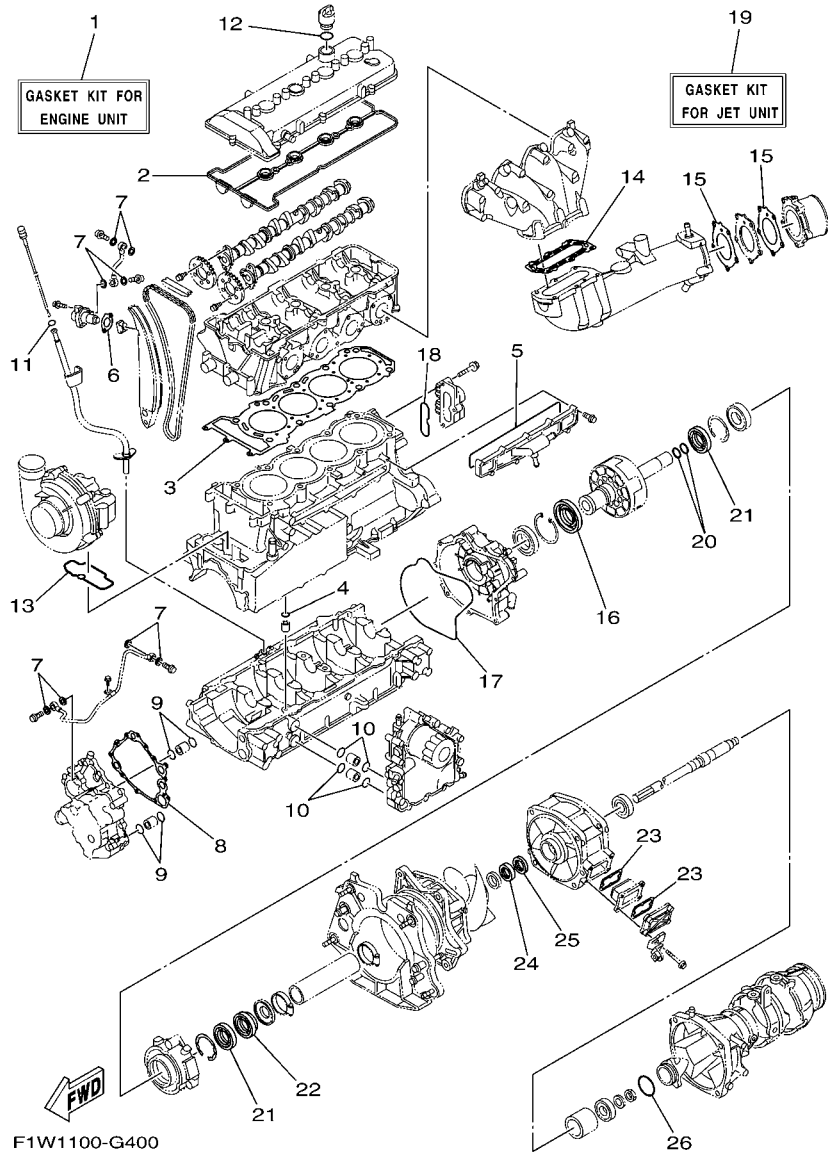

FIG. 40 REPAIR KIT 1

REF. NO.	PART NO.	DESCRIPTION	USA	CAN	EUR	GENE	REMARKS
1	6S5-W0001-00	GASKET KIT FOR ENGINE UNIT	1	1	1	1	
2	6S5-11193-00	.GASKET, HEAD COVER 1	1	1	1	1	
3	6S5-11181-00	.GASKET, CYLINDER HEAD 1	1	1	1	1	
4	93210-11453	.O-RING	1	1	1	1	
5	6S5-12517-00	.GASKET, WATER INLET	1	1	1	1	
6	6S5-121E2-00	.GASKET	1	1	1	1	
7	90430-10007	.GASKET	8	8	8	8	
8	6S5-13563-00	.GASKET	1	1	1	1	
9	93210-21631	.O-RING	4	4	4	4	
10	93210-18322	.O-RING	4	4	4	4	
11	93210-12790	.O-RING	1	1	1	1	
12	93210-24M79	.O-RING	1	1	1	1	
13	6S5-1416A-00	.O-RING	1	1	1	1	
14	6S5-14739-00	.GASKET, MUFFLER DAMPER 1	1	1	1	1	
15	6S5-14749-00	.GASKET, MUFFLER DAMPER 2	2	2	2	2	
16	6S5-81167-00	.OIL SEAL	1	1	1	1	
17	6S5-81168-00	.O-RING	1	1	1	1	
18	93210-60ME8	.O-RING	1	1	1	1	
19	6S5-W0001-20	GASKET KIT FOR JET UNIT	1	1	1	1	
20	93210-22MF1	.O-RING	2	2	2	2	
21	93102-29008	.OIL SEAL	2	2	2	2	
22	93102-29004	.OIL SEAL	1	1	1	1	
23	66V-42414-00	.O-RING	2	2	2	2	
24	93102-31008	.OIL SEAL	1	1	1	1	
25	93102-31004	.OIL SEAL	1	1	1	1	
26	6S5-5111K-00	.O-RING 1	1	1	1	1	

NUMERICAL INDEX

PART NO.	REF. NO.	PART NO.	REF. NO.	PART NO.	REF. NO.	PART NO.	REF. NO.	PART NO.	REF. NO.	PART NO.	REF. NO.
6S5-11026-00	1 - 9	3LD-12168-40	5 - 12	6S5-12577-00	14 - 40	6S5-14159-00	6 - 29	6S5-15657-00	4 - 17	F1S-61355-00	35 - 35
6S5-11102-00-94	2 - 2	3LD-12168-60	5 - 12	6S5-12578-00	2 - 17	6S5-1416A-00	7 - 2	6S5-17031-00	4 - 22	F1W-61355-00	35 - 31
6S5-11119-00	2 - 12	3LD-12168-80	5 - 12	6S5-12579-00	14 - 43		40 - 13	6S5-17529-00	4 - 24	F1B-613C1-00	34 - 27
6S5-1111G-00	1 - 10	3LD-12168-A0	5 - 12	63M-12580-00	14 - 5	6S5-141A0-00	7 - 1	6S5-17553-00	4 - 27		35 - 27
6S5-11125-00	12 - 12	3LD-12168-F0	5 - 12	6S5-12581-00	5 - 12	6S5-14216-00	6 - 20	6S5-17572-00	4 - 11	F1W-613C1-00	34 - 4
6S5-11126-00	3 - 22	3LD-12168-H1	5 - 12	6S5-12582-00	14 - 22	6S5-14243-00	7 - 17	6S5-17648-00	4 - 18	F1W-61400-10	35 - 18
6S5-11133-10	2 - 3	3LD-12168-K1	5 - 12	6S5-12584-00	14 - 17	6S5-14285-00	6 - 18	6S5-17658-00	4 - 19	F1W-6142B-00	35 - 32
6S5-11160-00	12 - 6	3LD-12168-M1	5 - 12	6S5-12588-00	14 - 31	6S5-14291-00	6 - 25	6S5-17800-00	4 - 15	F1W-61435-00	35 - 20
6S5-11166-00	12 - 1	3LD-12168-R1	5 - 12	6S5-12589-00	14 - 26	6S5-14294-00	6 - 31	EU0-23814-30	35 - 43	F1B-61438-00	34 - 19
6S5-11167-00	12 - 14	3LD-12168-U1	5 - 12	6S5-12594-00	14 - 49	6D3-14305-21	22 - 1	6S5-24300-00	6 - 32		34 - 34
6S5-11181-00	2 - 11	3LD-12168-W1	5 - 12	6S5-12858-00	11 - 2	6S5-14349-00	7 - 8	70R-24489-00	31 - 4	F1W-61438-00	34 - 9
	40 - 3	3LD-12168-Y1	5 - 12	6S5-12880-00	6 - 4	6S5-14360-00	6 - 12	70R-24543-00	31 - 3	F1S-6143C-00	35 - 24
6S5-11191-00-94	1 - 1	3LD-12169-11	5 - 12	6S5-1310A-00-94	10 - 1	6S5-14413-00-94	6 - 38	6S5-26311-10	22 - 2	F1B-61460-00	34 - 36
6S5-11193-00	1 - 3	3LD-12169-31	5 - 12	6S5-13300-00	9 - 1	6S5-14435-00	7 - 16	67F-2812A-00	21 - 24		34 - 37
	40 - 2	3LD-12169-50	5 - 12	6S5-13317-00	10 - 6	6S5-14445-00	6 - 24	6S5-41661-00-94	24 - 4	EU0-61461-02	35 - 29
69J-11301-10	3 - 9	3LD-12169-70	5 - 12	6S5-13337-00	3 - 27	63P-14446-00	6 - 7	6S5-41662-00-94	24 - 5	F1B-61461-02	34 - 21
6S5-1131M-00-94	3 - 18	3LD-12169-90	5 - 12	6S5-13405-00	10 - 2	6S5-14446-00	6 - 28	66V-42414-00	15 - 9	GH1-61468-01	34 - 39
68V-11325-02	3 - 10	3LD-12169-E0	5 - 12	6S5-13406-00	10 - 3	6D3-1444B-00	6 - 16		40 - 23	F1S-6146A-00	35 - 23
67F-11328-00	3 - 11	3LD-12169-G0	5 - 12	6S5-13416-00	9 - 7	6D3-14457-00	6 - 19	67X-44517-10-94	24 - 1	GU5-6146K-10	34 - 40
6S5-11377-00	3 - 16	3LD-12169-J0	5 - 12	6S5-13418-00	5 - 22	6D3-14495-00	7 - 26	663-45119-00	14 - 53	F1S-61481-00	34 - 18
6S5-11378-00	10 - 15	3LD-12169-L0	5 - 12	69J-13440-01	11 - 1		8 - 2	66V-45214-00-94	15 - 10	F1W-6149C-01	34 - 33
6S5-11411-00	4 - 1	6S5-12171-00	5 - 1	60E-13446-00	9 - 6		22 - 11	6S5-45241-00	17 - 11	F1W-6150A-00	34 - 14
6S5-11416-00	4 - 2	6D3-12176-00	5 - 3	6S5-13446-00	11 - 3	6S5-14495-00	7 - 15	6S5-45332-00-94	16 - 4	F1W-6151M-00	35 - 33
6S5-11416-10	4 - 2	6S5-12181-00	5 - 2	6S5-13470-00	11 - 4	6S5-14496-00	6 - 10	61L-45378-00	16 - 10	F1B-6151S-00	34 - 10
6S5-11416-20	4 - 2	6S5-121E2-00	5 - 20	6S5-13476-00	10 - 4	6S5-14534-00	6 - 26	6S5-45511-00	15 - 17		34 - 20
6S5-11416-30	4 - 2		40 - 6	6S5-13477-00	10 - 5	6S5-14536-00	6 - 11	6S5-45538-00	15 - 13		34 - 35
6S5-11416-40	4 - 2	6S5-12210-00	5 - 19	69J-13532-00	6 - 27	6S5-14613-00	13 - 1	6S5-45593-00-94	16 - 11	F1W-6153A-00	34 - 1
6S5-11469-00	4 - 14	6S5-12215-00	5 - 16	6S5-13556-00	11 - 5	6S5-1469W-00	13 - 15	6S5-45613-10	16 - 9	F1W-6153E-01	34 - 8
6S5-11603-00	4 - 4	6S5-12228-00	2 - 7	8FP-13556-00	6 - 15	6S5-14711-00-94	13 - 2	6S5-45813-00-94	4 - 13	F1W-6153J-00	34 - 13
6S5-11631-10-B0	4 - 3	6S5-12241-00	5 - 26	6S5-13557-00	3 - 19	6S5-14721-00-94	13 - 6	6S5-4581J-01	16 - 1	F1S-6153R-01	35 - 28
6S5-11633-00	4 - 5	6S5-12251-00	5 - 25	6S5-13563-00	9 - 2	6S5-14739-00	13 - 7	66V-46882-00	15 - 8	F1S-61552-00	35 - 1
6S5-11650-00	4 - 7	6S5-12252-00	5 - 15		40 - 8		40 - 14	6S5-5111K-00	15 - 21	F1W-61557-00	34 - 11
6S5-11654-00	4 - 8	6S5-12279-00	5 - 17	6S5-13573-00	6 - 8	6S5-14749-00	13 - 14		40 - 26	F1K-61624-00	27 - 23
6S5-11656-00	4 - 10	6S5-12289-00	4 - 12	6P2-13578-00	6 - 6		40 - 15	68N-5112T-00	27 - 3	F1K-61628-00	30 - 11
6S5-11656-10	4 - 10		16 - 12	6P2-13588-00	6 - 5	6S5-14752-00	13 - 19	60T-51190-00-94	15 - 39	F0X-61637-00	27 - 26
6S5-11656-20	4 - 10	60E-12411-01	2 - 14	6S5-13641-00	6 - 2	6S5-1475A-00	13 - 20	66V-51312-01-94	15 - 4	EU0-61652-00	14 - 12
6S5-11656-30	4 - 10	6S5-12413-00-94	2 - 15	6S5-13645-00	6 - 30	6S5-14771-00-94	13 - 11	6S5-51315-00-94	15 - 7		27 - 8
6S5-11941-00	1 - 8	6S5-1243E-00	14 - 13	6S5-13651-00	7 - 24	6S5-14784-00-94	13 - 16	6S5-51318-00-94	15 - 25	F0X-61652-00	27 - 27
6S5-12111-00	5 - 5	6S5-1243F-00	14 - 18	6S5-13652-00	7 - 29	6S5-14987-00	14 - 34	6S5-51323-00	16 - 2	GP7-61652-00	32 - 20
6S5-12113-00	5 - 8	6S5-12443-00	14 - 10	6S5-13670-00	7 - 10	6S5-15100-00-94	3 - 1	6S5-51326-00-94	15 - 20	F1S-61782-00	35 - 22
6S5-12116-00	5 - 7	6S5-1244G-00	14 - 46	6S5-13691-00-94	7 - 11	6S5-15362-00	3 - 30	63M-51334-00	15 - 26	EW2-62142-00	31 - 2
6S5-12117-00	5 - 9	6S5-1244H-00	14 - 28	6S5-13750-00	6 - 1	6S5-15363-00	1 - 11	60E-51341-00-94	19 - 22	F1G-62149-00	31 - 8
3LD-12118-00	5 - 10	6S5-1244J-00	14 - 24	6S5-13761-00	6 - 13	6S5-15486-00	10 - 7	6S5-51341-00-94	17 - 1	F2F-6214A-00	31 - 1
51Y-12119-00	5 - 11	6S5-12469-00-94	3 - 24	6S5-13881-00	6 - 22	5EL-15511-00	20 - 6	6B6-51342-00	15 - 45	F1B-62150-00	31 - 25
6S5-12121-00	5 - 6	6S5-12517-00	3 - 25	6S5-13907-00	23 - 1	6S5-15515-00	19 - 3	61L-5169A-00	14 - 52	F1W-62157-00	28 - 13
6S5-12153-00	5 - 13		40 - 5	60E-14147-00	6 - 14	6S5-15517-00	19 - 5	6S5-52358-00	17 - 10		28 - 20
3LD-12168-00	5 - 12	6S5-12552-00	14 - 37	6S5-14147-00	6 - 3	6S5-15521-00	19 - 4	F1B-60210-00	25 - 42	GJ3-6215F-00	23 - 14
3LD-12168-20	5 - 12	6S5-12576-00	14 - 50	6S5-14148-00	7 - 23	6S5-15590-00	19 - 1	F1W-6134A-00	34 - 25	F1B-62241-00	32 - 4

NUMERICAL INDEX

PART NO.	REF. NO.	PART NO.	REF. NO.	PART NO.	REF. NO.	PART NO.	REF. NO.	PART NO.	REF. NO.	PART NO.	REF. NO.
F1B-62241-00	32 - 29	F1B-6821G-01	23 - 6	67F-82151-00	21 - 15	6S5-R1314-00	17 - 3	F1W-U251M-01	28 - 27	F1W-U372B-10	30 - 7
EU0-62241-30	18 - 3	F0D-6822E-00	34 - 43	67F-82151-10	21 - 16	6S5-R1321-03	15 - 23	F1W-U252E-01	28 - 7	F1W-U372B-20	30 - 7
F1B-6224E-00	32 - 1	GU2-6822E-01	34 - 44	67F-82151-30	21 - 17	6S5-R1333-01	18 - 1	F1W-U252E-10	28 - 7	F1W-U3768-01	26 - 5
	32 - 26	6S5-682E0-00	23 - 2	67F-82151-40	21 - 18	6B6-R1343-00	15 - 27	F1W-U252F-01	28 - 14	F1B-U3774-00	30 - 23
F0X-62733-00	33 - 12	F1W-68303-00	35 - 34	F1W-68303-00	21 - 13	6S5-R1348-00	15 - 24	F1W-U252F-10	28 - 14	GH1-U3774-00	30 - 44
F1W-6273B-02	18 - 14	F1W-6830K-00	34 - 26	6S5-82170-00	21 - 10	6S5-R1381-00	16 - 17	F1B-U2624-00	30 - 27	F1W-U377B-01-P0	25 - 24
F1W-62873-00	28 - 11	F1S-68310-01	35 - 12	6S5-82310-00	22 - 14	F1S-U142A-01	36 - 1	F1K-U2663-00	26 - 8	F1W-U377B-10-P0	25 - 24
	28 - 18	FK7-68312-02	35 - 15	61N-82317-00	12 - 9	F1S-U142A-10	36 - 1	F1W-U2664-01	30 - 3	F1W-U377C-01-P0	25 - 28
F1X-62875-00	25 - 41	FK7-68313-02	35 - 16	6A0-82317-00	21 - 8	F1S-U142G-01	36 - 6	F1K-U266B-00	26 - 3	F1W-U377C-10-P0	25 - 28
F0X-6375E-00	30 - 24	F1S-68341-00	35 - 36	6S5-82380-00	6 - 9	F1S-U142G-10	36 - 6	F1W-U266C-00	26 - 16	F1W-U377F-01	25 - 32
F0X-6378C-00	30 - 20	EW2-68348-00	35 - 13	68V-82504-00	22 - 26	F1S-U143E-00	36 - 2	F1W-U266D-00	30 - 8	F1W-U377G-01	25 - 36
GU2-6378D-02	30 - 16	6S5-81128-00	6 - 21	6S5-82509-00	6 - 23	F1S-U143E-10	36 - 2	F0X-U266E-01	30 - 35	F1X-U3844-01	25 - 10
F1W-6514S-00	26 - 22	6S5-81167-00	19 - 13	60E-82556-00	23 - 3	F1S-U143L-02	36 - 3	F1W-U2693-00	26 - 39	F1B-U3850-02	30 - 4
F1W-6514T-00	26 - 23		40 - 16	60E-82560-01	22 - 21	EU0-U1461-02	17 - 14	F1W-U2698-00	25 - 15		30 - 9
F1W-6517C-02	26 - 34	6S5-81168-00	19 - 17	6S5-8259E-00	21 - 26	F1W-U1467-02	34 - 30	F1W-U269B-00	27 - 7	F1W-U4114-00	37 - 9
F1B-6517R-00	25 - 43		40 - 17	6S5-8259L-00	21 - 28	GH3-U146E-00	15 - 40	F1W-U271B-00	30 - 30	F1X-U4114-60	37 - 9
F1W-6517R-00	26 - 37	6S5-81315-00	22 - 27	6D3-8273J-01	22 - 30	GK5-U146F-00	34 - 22	F1W-U266A-01	27 - 39	F1W-U411C-00	37 - 8
GA7-65772-00	33 - 4	6S5-81328-00	19 - 18	6B6-83623-00	21 - 4	F1W-U146G-00	34 - 38	F1X-U278F-01	27 - 40	F1X-U411C-60	37 - 8
EU0-65901-01	37 - 12	66V-8132W-00	21 - 22	60E-83627-00	21 - 5	F1W-U1519-00	34 - 42	F1X-U278G-01	27 - 42	F1K-U411H-00	37 - 10
F1W-65938-00	35 - 25	6S5-81337-00-94	19 - 11	682-84385-01	14 - 11	F1X-U1554-00	35 - 40	F1X-U278H-10	27 - 41	F1S-U415B-01	38 - 2
F1S-65939-00	35 - 26	6S5-81410-00	19 - 7	6S5-8572F-00	3 - 31	GP7-U155D-01	35 - 2		27 - 43	F1S-U415B-11	39 - 5
F1B-65986-00	37 - 11	6S5-81450-00	19 - 6	6P2-85780-00	22 - 28	F1S-U155F-00	34 - 7	F1X-U278K-00	27 - 44	GP8-U416H-01	39 - 12
F1W-67250-00	35 - 5	6S5-81800-00	20 - 1	61A-85790-00	22 - 19		35 - 3	F1X-U278L-00	27 - 45	F1W-U417B-00	37 - 1
F0D-67255-02	35 - 6	6S5-81810-00	20 - 13	6AA-85790-00	22 - 33	F1B-U1629-00	30 - 43	F1X-U2873-00	31 - 37	F1W-U417B-10	37 - 1
EW2-67256-00	35 - 7	6S5-81820-00	20 - 12	6S5-85886-00	6 - 17	F1X-U163A-01	27 - 53	F1W-U351H-00	28 - 31	F1W-U417C-00	37 - 2
F0D-67257-00	35 - 10	6S5-81826-00	20 - 10	6D3-85896-00	22 - 24	F1B-U1653-01	30 - 14	F1W-U351H-10	28 - 31	F1W-U417C-10	37 - 2
EW2-67258-01	35 - 8	6S5-81830-00	20 - 3	6S5-8591A-01	21 - 6	F1W-U2127-00	29 - 3	F1W-U351J-00	28 - 32	F1W-U417D-00	37 - 3
EW2-67259-01	35 - 9	6S5-81840-00	20 - 8	6S5-8591A-11	21 - 6	F1W-U213B-01	26 - 4	F1W-U351J-10	28 - 32	F1W-U417D-10	37 - 3
F1X-6725F-01	35 - 11	11H-81844-00	20 - 2	6B6-86261-00	23 - 26	F0X-U213G-01	29 - 5	F1W-U351K-00	28 - 33	F1W-U417E-00	37 - 4
F1W-67410-10	35 - 19	4G0-81844-00	20 - 4	6B6-86261-10	23 - 26	F1X-U2157-00	27 - 56	F1W-U351K-10	28 - 33	F1W-U417E-10	37 - 4
F1K-6753B-00	33 - 10	66V-81844-00	21 - 23	6B6-86265-00	23 - 27	F1W-U2159-00	31 - 6	F1W-U351M-00	28 - 34	F1W-U417H-00	37 - 5
GH7-6753B-00	32 - 18	5EL-81845-00	20 - 11	6B6-86265-10	23 - 27	F1W-U2187-00	29 - 1	F1W-U351M-10	28 - 34	F1W-U417H-10	37 - 5
F1B-67557-00	18 - 21	6S5-81845-00	21 - 2	6S5-E110M-00	1 - 4	F1W-U2188-00	29 - 2	F1W-U351N-00	28 - 35	F1W-U417J-00	37 - 6
F1B-67564-00	33 - 11	3TB-81847-00	20 - 9	6S5-E118E-00	1 - 6	F1S-U2280-00	27 - 34	F1W-U351N-10	28 - 35	F1W-U417J-10	37 - 6
F1S-67620-00	32 - 22	1J7-81847-60	20 - 5	6S5-E1328-00	1 - 5	F1X-U2284-00	27 - 59	F1W-U351P-00	28 - 36	F1W-U417M-00	37 - 7
FN8-6771K-00	31 - 17	5A8-81850-10	20 - 14	67X-E2590-00	14 - 56	F1S-U2285-00	27 - 35	F1W-U351P-10	28 - 36	F1W-U417M-10	37 - 7
F1W-6773D-00	35 - 21	6D3-81921-00	21 - 14	67X-E2590-10	14 - 56	F1W-U2501-00	28 - 1	F1W-U351R-00	28 - 37	F1G-U418F-00	38 - 6
F1W-67743-00	31 - 44	6B6-81940-00	21 - 21	6S5-E4410-00	8 - 5	F1W-U2501-10	28 - 1	F1W-U351R-10	28 - 37		39 - 9
F1B-67743-02	31 - 43	6S5-81942-00	21 - 3	6S5-E4419-00	8 - 12	F1W-U250B-00	28 - 9	F1W-U351S-00	28 - 38	F1S-U419E-01	39 - 11
F1B-67747-00	31 - 15	60E-81950-00	21 - 19	6S5-E4436-00	8 - 7		28 - 16	F1W-U351S-10	28 - 38	F1W-U41B1-00	38 - 1
F1B-6774J-00	31 - 39	68V-81950-00	21 - 20	6S5-E4451-00	8 - 6	F1B-U2512-00	28 - 4	F1W-U3581-00	28 - 30	F1W-U41B1-10	39 - 1
FJ0-67766-00	31 - 27	6S5-81960-00	22 - 6	6S5-E4462-00	8 - 9	F1B-U2512-20	28 - 4	F1W-U3581-10	28 - 30	F1B-U41B1-21	39 - 2
F1B-67767-00	31 - 26	6S5-81972-00-94	22 - 8	6S5-G2717-00	8 - 8	F1B-U2519-10	28 - 5	F1W-U371A-11	30 - 1	F1B-U41B1-31	39 - 3
EW2-67821-00	33 - 3	6S5-81975-00	22 - 7	6S5-G4532-00	24 - 2	F1W-U251D-01	28 - 24	F1W-U371A-20	30 - 1	F1B-U41B2-01	39 - 4
F1X-68090-00	23 - 17	EU0-82110-09	23 - 4	60E-G4574-00	24 - 3	F1W-U251D-10	28 - 24	F1W-U371B-11	30 - 2	F0V-U41D5-21	38 - 3
F1X-68090-10	23 - 18	6S5-82115-00	21 - 11	6S5-G5831-01	15 - 1	F1W-U251E-01	28 - 26	F1W-U371B-20	30 - 2	F0V-U41D5-31	39 - 6
F1W-6820A-00	23 - 16	6S5-82116-00	23 - 25	6S5-R1142-00	8 - 13	F1W-U251E-10	28 - 26	F1W-U372A-11	30 - 6	F0V-U41DB-02	38 - 4
GA7-68218-00	32 - 8	6S5-82117-00	21 - 12	6S5-R1313-00	15 - 36	F1W-U251L-01	28 - 25	F1W-U372A-20	30 - 6	F0V-U41DB-12	39 - 7

NUMERICAL INDEX

PART NO.	REF. NO.	PART NO.	REF. NO.	PART NO.	REF. NO.	PART NO.	REF. NO.	PART NO.	REF. NO.	PART NO.	REF. NO.
F1S-U41E1-01	38 - 7	EW2-U5912-01	30 - 37	F1W-U785H-00	31 - 31	90105-08169	11 - 9	90119-06M35	21 - 7	90179-09379	4 - 9
F1S-U41E1-11	39 - 10	EW2-U5913-01	30 - 38	F1K-U8169-00	27 - 33	90105-08170	11 - 10	90119-06MA3	22 - 9	90183-06902	26 - 9
F0V-U41F5-01	38 - 5	F1W-U591A-00	25 - 45	GP7-U8211-00	23 - 5	90105-08188	7 - 6	90119-06MA5	22 - 10	90185-06014	25 - 12
F1B-U41F5-21	39 - 8	F1W-U591C-00	25 - 46	EU0-U821D-00	23 - 11	90105-08860	27 - 32	90119-08022	6 - 35		25 - 21
F1S-U41G1-01	38 - 8	F1W-U591D-00	25 - 47	F1S-U8221-00	23 - 7	90105-10071	3 - 5	90119-08034	13 - 4		25 - 34
F1W-U4261-00	33 - 14	FOX-U5983-01	30 - 36		33 - 2	90109-06218	26 - 25		13 - 10		25 - 38
F1B-U4742-01	30 - 34	GD0-U7249-00-05	16 - 19		33 - 17		26 - 32	90119-08043	6 - 39		26 - 7
F1W-U475B-04	26 - 15	F1W-U7254-00	22 - 3	EU0-U8221-30	23 - 8	90109-06233	34 - 15	90119-08096	13 - 12		34 - 29
F1W-U475F-01	26 - 18	F1S-U725E-00	18 - 12	F1X-U822E-00	23 - 19	90109-06857	24 - 10	90119-08097	13 - 5	90201-052E8	19 - 21
F1W-U491K-00	28 - 8	F1W-U725E-00	35 - 39	F1W-U8262-02-P0	25 - 22	90109-06864	24 - 11		13 - 9	90201-06028	7 - 7
	28 - 15	F1W-U732B-00	24 - 12	F1W-U8262-10-P0	25 - 22	90109-08041	18 - 24	90119-08099	6 - 40		10 - 11
GP7-U4953-10	30 - 13	EU0-U7354-00-01	24 - 9	F1W-U826C-00	23 - 21	90110-05908	34 - 6	90119-08123	21 - 25	90201-06801	17 - 8
	30 - 41	EU0-U7354-00-03	24 - 9	F1X-U826C-00	27 - 55		35 - 4	90119-08823	18 - 15		17 - 12
	30 - 42	EU0-U7354-00-05	24 - 9	F1K-U826C-02	27 - 48	90110-06040	27 - 28		18 - 20	90201-068M4	15 - 41
F1W-U5136-00	26 - 2	EU0-U7354-00-10	24 - 9	F1X-U826D-00	27 - 54	90110-06182	3 - 28		24 - 8	90201-06906	34 - 23
F1W-U513M-01-P0	26 - 42	EU0-U7354-00-20	24 - 9	F1X-U828E-01	25 - 4	90110-06822	15 - 22	90119-08842	24 - 7	90201-099U3	30 - 21
F1W-U513M-10-P0	26 - 42	F1B-U751G-00	33 - 25	F1S-U828H-01	27 - 19	90110-06823	25 - 33	90119-08844	27 - 46		34 - 16
F1W-U5148-00	26 - 11	F1S-U7525-01	32 - 2	F1B-U8360-01	32 - 5		25 - 37	90119-08942	30 - 31	90201-109U6	30 - 45
FOX-U515E-01	25 - 8		32 - 27	F1W-U8376-00	23 - 23	90110-08212	19 - 2	90119-089U7	31 - 45	90201-12039	2 - 8
F1W-U515H-00	26 - 38	F1W-U753C-01	33 - 15	F1G-U8571-00	18 - 19	90111-06114	28 - 21	90119-089UE	15 - 37	90201-132G5	4 - 25
F1W-U515N-00-P0	26 - 13	F1W-U7550-00	33 - 1	F1B-U8572-00	18 - 16	90111-06805	27 - 57		15 - 43	90202-08002	34 - 17
F1W-U515N-10-P0	26 - 13	F1W-U7555-00	33 - 6	F1W-U8572-01	27 - 47	90116-08032	6 - 36	90119-089UF	17 - 4	90267-48020	26 - 30
F1W-U515P-01	26 - 36	GJ1-U7578-11	34 - 12	F1K-U8577-00	18 - 17	90116-10044	7 - 18	90119-089UL	26 - 45	90267-48802	18 - 9
F1W-U515P-30	26 - 36		34 - 47	F1W-U8831-01	33 - 18	90119-05803	25 - 13		26 - 47		27 - 21
F1W-U517B-01-P0	26 - 1	F1S-U757B-00	33 - 23	F1W-U883B-01	16 - 20	90119-059U4	26 - 35	90119-089UT	21 - 1		29 - 9
F1W-U517B-10-P0	26 - 1	F1X-U757E-00	18 - 25	F1W-U883E-00	16 - 21	90119-06048	22 - 32	90119-089UU	16 - 18		33 - 22
F1W-U517D-01	26 - 21	F1X-U757F-00	18 - 26	F1S-U883N-01	27 - 29	90119-06800	15 - 11		35 - 44		34 - 50
F1X-U517E-01	25 - 6	F1B-U758D-02	33 - 19	F1S-U883P-01	27 - 30	90119-06827	18 - 28	90119-08M22	7 - 27	90267-48806	29 - 4
	25 - 26	F1B-U759B-00	31 - 46	F1X-U883T-00	27 - 31	90119-06832	23 - 10		8 - 3	90267-48807	25 - 35
	25 - 30	F1K-U759C-00	33 - 16	F1W-U8952-00	30 - 15	90119-06835	15 - 5		22 - 12		25 - 39
F1W-U517F-00	25 - 1	F1W-U759C-01	31 - 47	F1X-U8K22-01	27 - 15	90119-06880	25 - 11	90119-10011	7 - 22		26 - 10
F1W-U517H-01	25 - 40	F1B-U761D-02	27 - 10	F1X-U8K31-02	18 - 2		25 - 25	90119-10029	13 - 13		26 - 12
F1W-U518D-00	25 - 9	F1B-U7626-00	32 - 10	6S5-W0001-00	40 - 1		25 - 27	90119-10046	7 - 14		26 - 14
F1W-U518E-02	26 - 28	F1B-U7628-00	32 - 15	6S5-W0001-20	40 - 19		25 - 29	90119-10047	7 - 13	90267-48825	28 - 28
F1W-U519D-01	25 - 44	F1W-U7629-00	32 - 13	6S5-W0009A-00-94	2 - 1		25 - 31	90119-10836	15 - 3	90267-489U1	14 - 57
F1X-U5372-00	25 - 16	F1B-U7656-00	32 - 9	6S5-W0009B-00-94	3 - 4		26 - 6	90119-10837	15 - 35		22 - 4
F1W-U5508-00	25 - 3	F1B-U7698-01	32 - 6	6S5-W1783-10	4 - 23	90119-069UB	15 - 28	90149-05903	25 - 23		23 - 22
F1W-U5508-20	25 - 3	F1W-U7711-01	31 - 13	90101-05800	25 - 2	90119-069UD	16 - 15		36 - 4		23 - 24
F1W-U555B-00	25 - 14	F1W-U771K-00	31 - 30	90101-069U0	30 - 19		17 - 2	90149-06229	19 - 8		25 - 17
F1W-U555D-01	25 - 20	F1B-U7773-00	31 - 14	90105-06007	1 - 7	90119-069UH	26 - 29	90149-069UA	16 - 22		27 - 49
F1W-U590D-01-P0	26 - 44	GP7-U7831-11	31 - 19	90105-06028	1 - 2		31 - 38	90149-10052	24 - 6		33 - 5
F1W-U590D-10-P0	26 - 44	GP7-U7833-11	31 - 21	90105-06035	2 - 16	90119-069UJ	36 - 7	90150-05807	18 - 4	90267-489U2	24 - 13
F1W-U590D-40-P0	26 - 44	GP7-U7834-10	31 - 20	90105-06903	22 - 15	90119-069UK	18 - 18	90154-06017	36 - 5		31 - 5
F1W-U590D-50-P0	26 - 44	GP7-U783F-00	31 - 22	90105-06M07	3 - 12		26 - 27	90154-06030	36 - 8	90267-489U6	18 - 10
F1W-U590E-01-P0	26 - 46	F1W-U7844-00	31 - 23	90105-06M16	11 - 8	90119-069UP	30 - 5	90169-059U1	28 - 6		25 - 48
F1W-U590E-10-P0	26 - 46	F0D-U7856-10	31 - 36	90105-06M24	11 - 7		30 - 10	90170-20802	15 - 19		26 - 43
F1W-U590E-40-P0	26 - 46	F0D-U785G-10	23 - 12	90105-07004	5 - 4	90119-069US	23 - 9	90176-08080	6 - 37		27 - 58
F1W-U590E-50-P0	26 - 46		31 - 34	90105-07009	2 - 6	90119-069UX	17 - 6	90176-10001	7 - 19		28 - 10

NUMERICAL INDEX

PART NO.	REF. NO.	PART NO.	REF. NO.	PART NO.	REF. NO.	PART NO.	REF. NO.	PART NO.	REF. NO.	PART NO.	REF. NO.
90267-489U6	28 - 17	90447-19013	6 - 33	90467-14803	15 - 33	90600-91736	33 - 20	9299R-08200	27 - 51	93608-16M16	13 - 3
	31 - 7	90447-19015	15 - 30		32 - 14		34 - 48		30 - 17	94591-66152	5 - 14
	31 - 11	90447-19800	14 - 7		32 - 21	90601-118UF	15 - 31		30 - 33	94702-00427	22 - 16
	32 - 25	90447-22011	14 - 14	90467-150A0	14 - 6		27 - 9		34 - 32	95023-06012	3 - 34
	35 - 41	90447-22013	14 - 19	90467-150A1	14 - 30	90601-152U3	16 - 23	9299R-10200	30 - 29		9 - 10
90267-489U8	27 - 12	90447-22801	14 - 2	90467-150A3	6 - 34	90601-155U4	31 - 24		30 - 46	95023-06025	3 - 26
	28 - 29	90447-22802	14 - 9	90467-160A0	14 - 25	90601-162U5	31 - 18	93102-29004	16 - 8	95024-06014	3 - 20
90267-489UE	31 - 40	90447-22803	35 - 42		14 - 33	90601-170UG	33 - 7		40 - 22	95024-06020	3 - 21
90267-489UP	26 - 20	90447-28004	32 - 12		14 - 36	90601-20005	26 - 24	93102-29008	16 - 5		10 - 14
	30 - 39		32 - 16		14 - 42	90601-200U1	27 - 13		40 - 21	95024-06030	10 - 13
	32 - 7	90447-28008	2 - 18		14 - 45		34 - 46	93102-31004	15 - 16	95024-06035	10 - 12
90269-08801	26 - 19	90450-70005	7 - 28		14 - 47	90601-200U7	29 - 6		40 - 25	95024-08035	13 - 17
90280-03047	19 - 10	90450-70M13	7 - 30	90467-170A0	14 - 39	90605-502U1	26 - 17	93102-31008	15 - 15	95024-08050	19 - 15
90387-05800	34 - 5	90450-75003	7 - 9	90467-17802	33 - 13	90605-502U2	25 - 7		40 - 24	95380-06700	20 - 18
90387-06080	18 - 27	90450-90M10	13 - 22	90467-18804	27 - 6	90699-50004	31 - 28	93210-11453	3 - 3	95380-14700	28 - 12
90387-06119	12 - 10	90450-99801	33 - 8	90467-190A0	3 - 17	91314-06020	9 - 4		40 - 4		28 - 19
	21 - 9	90450-99804	33 - 9		3 - 23	91314-06035	10 - 9	93210-12790	3 - 32	9538R-06600	17 - 9
90387-06M30	17 - 7	90450-99M06	13 - 21	90467-200A0	10 - 16	91314-06060	10 - 10		40 - 11		17 - 13
90387-06M60	16 - 14	90460-90M11	8 - 4		14 - 3	91317-05010	19 - 20	93210-18322	11 - 11	9538R-06700	15 - 42
90387-08M06	15 - 38	90462-10044	14 - 21		14 - 15	91317-06014	19 - 19		40 - 10		34 - 24
	15 - 44	90464-17800	31 - 12		14 - 16	91380-06016	22 - 25	93210-21631	9 - 5	95720-06300	26 - 26
	17 - 5	90464-31001	22 - 18		14 - 20	91380-06020	19 - 24		40 - 9		35 - 30
90387-08M30	7 - 20		22 - 29		14 - 27	91380-06025	5 - 21	93210-22MF1	16 - 3	9572R-05300	26 - 40
90387-11002	5 - 24		22 - 34		14 - 48	91809-16001	2 - 4		40 - 20		27 - 17
90401-10040	9 - 8	90464-32801	18 - 5		14 - 51		2 - 5	93210-24M79	1 - 12		27 - 38
	3 - 13		18 - 7		27 - 14	92014-06012	2 - 13		40 - 12	9572R-06300	25 - 18
90430-06M03	5 - 23		23 - 20	90467-21800	27 - 11	92903-06600	2 - 10	93210-60ME8	22 - 31		26 - 31
90430-10007	9 - 9		27 - 22	90467-240A0	2 - 19	92903-08600	20 - 16		40 - 18		26 - 33
	40 - 7		27 - 52	90467-240A2	12 - 3	9290P-20600	15 - 18	93212-02001	12 - 7		28 - 3
90430-12002	18 - 22		31 - 10		12 - 4	92990-06100	20 - 17	93306-00805	19 - 12		28 - 23
90430-16910	32 - 19		33 - 21		12 - 15		34 - 3	93306-20654	15 - 12		30 - 18
90445-09M21	14 - 54		34 - 49	90467-25801	32 - 11	92990-06200	34 - 2	93306-20655	16 - 7		31 - 16
90445-14804	15 - 32	90464-35132	14 - 23	90467-26800	32 - 3	92990-10600	22 - 20	93306-30582	15 - 14		31 - 41
90445-16806	15 - 29	90464-51800	32 - 24		32 - 17	92990-12200	18 - 23	93316-00901	4 - 16		33 - 26
90445-20800	27 - 4	90464-99801	18 - 11		32 - 28		27 - 25	93410-12003	20 - 7		34 - 41
90445-20804	27 - 1	90464-99804	29 - 7	90480-06M46	19 - 25		30 - 25	93450-24028	4 - 6	9572R-08300	27 - 50
90445-21806	14 - 1	90465-11829	14 - 55	90480-18802	36 - 9	92995-06600	19 - 23	93450-63160	4 - 20		30 - 12
90445-21807	14 - 8		16 - 16	90480-19800	25 - 5		22 - 23	93450-66156	16 - 6		30 - 22
90446-24M89	14 - 38		23 - 15	90480-21M63	7 - 21	92995-08600	3 - 15	93450-75161	4 - 21		30 - 28
90446-27M55	14 - 41		31 - 32	90480-22801	8 - 11	9299R-05200	18 - 8	93604-10M03	3 - 8		30 - 32
	27 - 5		31 - 33	90480-22M15	7 - 25		26 - 41		7 - 3		30 - 40
90446-27M73	27 - 2		31 - 35		8 - 1		27 - 18		11 - 6		34 - 31
90446-30MF1	12 - 2	90465-11M10	31 - 29		22 - 13		27 - 37	93606-12019	3 - 7		35 - 38
90447-07001	34 - 45	90465-13M18	22 - 17	90600-91736	18 - 6	9299R-06200	25 - 19		9 - 3	9572R-10300	18 - 13
90447-19006	14 - 32	90465-14M66	12 - 5		27 - 20		28 - 2		13 - 8		30 - 26
	14 - 35		21 - 29		29 - 8		28 - 22		15 - 6		30 - 47
90447-19011	14 - 29	90467-089U1	23 - 13		31 - 9		31 - 42		15 - 34	95780-08300	22 - 5
	14 - 44	90467-11019	12 - 13		32 - 23		33 - 24		16 - 13	95814-06030	5 - 18

NUMERICAL INDEX

PART NO.	REF. NO.	PART NO.	REF. NO.	PART NO.	REF. NO.	PART NO.	REF. NO.	PART NO.	REF. NO.
95814-06065	7 - 5								
95814-06070	3 - 6								
95814-08065	7 - 4								
95817-06014	10 - 8								
95824-06030	12 - 11								
95880-06014	3 - 33								
97013-06055	2 - 9								
97013-08030	20 - 15								
97080-06030	34 - 28								
97080-08035	35 - 37								
97095-06016	22 - 22								
97095-08040	3 - 14								
97513-05514	19 - 9								
97780-60516	8 - 10								
97780-60520	21 - 27								
97780-60530	12 - 8								
97880-03008	35 - 14								
97880-05025	35 - 17								
9788R-05025	27 - 16								
	27 - 36								
99009-24700	4 - 26								
99009-72500	19 - 14								
99530-10114	3 - 2								
	3 - 29								
	19 - 16								
99590-10114	13 - 18								
99590-14016	7 - 12								
	15 - 2								
99780-12600	27 - 24								