



# PARTS CATALOGUE

## *WaveRunner FZR*

**GX1800-P** (F3L4/6EVD/6EV1)

**GX1800-P** (F3L5/6EVE/6EV1)

**GX1800-P** (F3L6/6EVF/6EV1)

GX1800-P  
PARTS CATALOGUE  
©2014 by Yamaha Motor Co., Ltd.  
1st edition, August 2014  
All rights reserved.  
Any reprinting or unauthorized use  
without the written permission of  
Yamaha Motor Co., Ltd.  
is expressly prohibited.  
Printed in Japan.

# FOREWORD

This Parts Catalogue is related to the parts for the model(s) on the cover page. When you are ordering replacement parts, please refer to this Parts Catalogue and quote both part numbers and part names correctly.

1. Modifications or additions which have been made after the issue of the Parts Catalogue will be announced in the Parts News.

It is advisable that you make the necessary corrections to the Parts Catalogue according to the Parts News.

2. Abbreviations

The following abbreviations are used in this Parts Catalogue.

“UR” Use specified parts number.

“UN” Use as many as needed.

“AP” Alternate Parts

“LM” Locally Made (Parts need to be ordered locally)

“F#” Frame No. (Applicable machine No.)

“O/S” Over Size

3. The number of components for assembly

- Parts, which are to be supplied in an assembly, are listed with a dot (.) in front of the part name as shown below.
- The numeral appearing to the right of each component part indicates the quantity of parts for each assembly unit.

PART NO.	DESCRIPTION	Q'TY	REMARKS
2F5-83310-60	FRONT FLASHER LIGHT ASSY	2	
115-83311-60	.BULB (6V-18W)	1	

4. Applicable colours of graphics are represented in the “REMARKS” as shown below.

PART NO.	DESCRIPTION	Q'TY	REMARKS
2N4-24110-00-X5	FUEL TANK COMP.	2	MXR
3J1-24240-10	.GRAPHIC, FUEL TANK	1	FOR MXR

5. Note that the illustrations for reference in finding parts numbers are not to be used for assembling. When assembling, please use the applicable service manual.

6. The asterisk (\*) before a reference number indicates modified items after the first edition.

# FOREWORD

7. Applicable Serial No.

Engine Serial No.

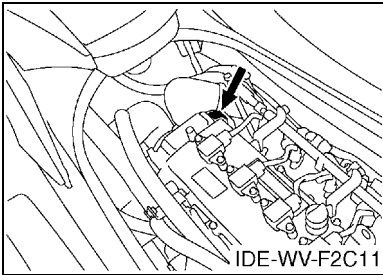

Primary Identification No.

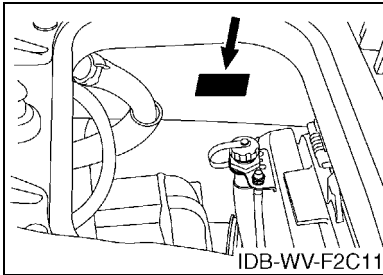

8. Applicable Colour Code (The (\*) mark shows Model colour.)

Abbreviation	Colour Name	Colour Code
RM9(*)	RED METALLIC 9	1485

9. Quantity Column Information

Column No.	Name Of Q'ty Column	Destination
1	CAN	CANADA
2	EUR	EUROPE
3	GENE	EXCEPT CANADA, EUROPE

10. Applicable Starting Serial No.

Engine Serial No.

Serial No.	Name Of Q'ty Column	Model Code
6EV-1003801	CAN	6EVD
6EV-1003801	EUR	6EVF
6EV-1003801	GENE	6EVE

Primary Identification No.

Serial No.	Name Of Q'ty Column	Model Code
F3L-801601	CAN	F3L4
F3L-801601	EUR	F3L6
F3L-801601	GENE	F3L5

# CONTENTS

CYLINDER 1 .....	1
CYLINDER 2 .....	2
CRANKCASE .....	3
CRANKSHAFT & PISTON .....	5
VALVE .....	7
INTAKE 1 .....	9
INTAKE 2 .....	11
INTAKE 3 .....	12
OIL PUMP .....	13
OIL PAN .....	14
OIL COOLER .....	15
BREATHING OIL .....	16
EXHAUST 1 .....	17
EXHAUST 2 .....	18
JET UNIT 1 .....	20
JET UNIT 2 .....	22
JET UNIT 3 .....	23
JET UNIT 4 .....	24
GENERATOR .....	26
STARTING MOTOR .....	27
ELECTRICAL 1 .....	28
ELECTRICAL 2 .....	30
ELECTRICAL 3 .....	32
ENGINE MOUNT .....	33
ENGINE HATCH 1 .....	34
ENGINE HATCH 2 .....	36
HULL & DECK .....	38
GUNWALE & MAT .....	40
VENTILATION .....	42
SEAT & UNDER LOCKER .....	43
FUEL TANK .....	45
BILGE PUMP .....	47
EXHAUST 3 .....	48
CONTROL CABLE .....	49
STEERING 1 .....	51
STEERING 2 .....	53
GRAPHICS .....	54
IMPORTANT LABELS .....	55
REPAIR KIT 1 .....	56

## INDEX

NUMERICAL INDEX .....	58
-----------------------	----

FIG. 1 CYLINDER 1

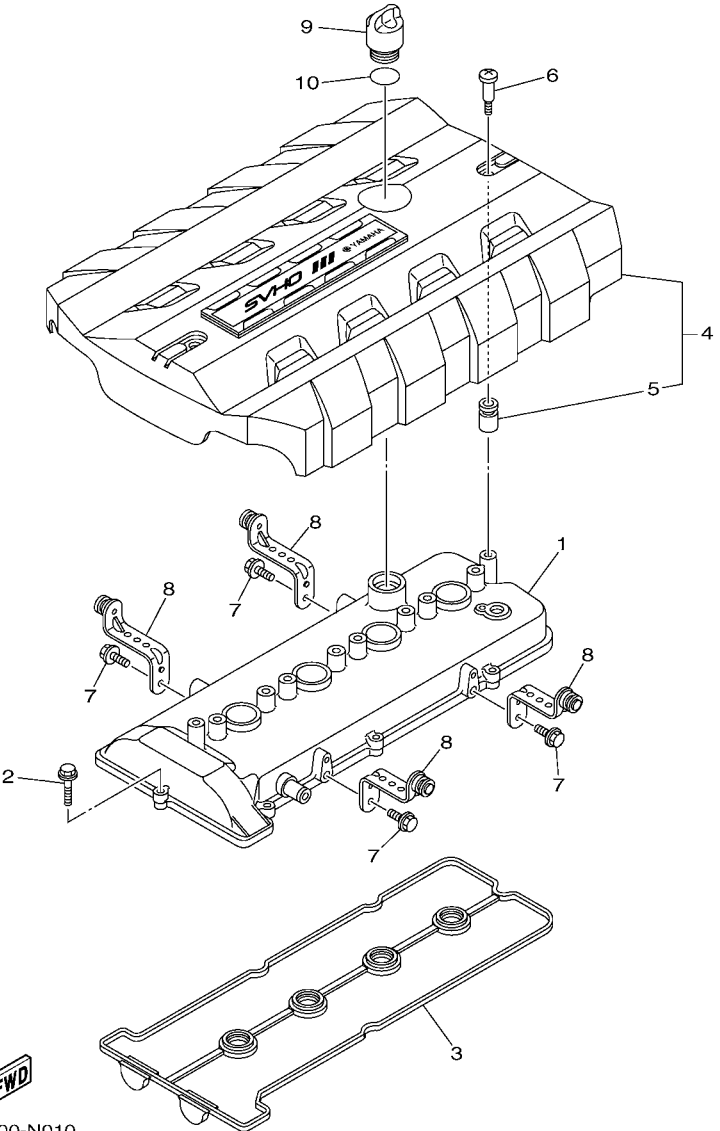

REF. NO.	PART NO.	DESCRIPTION	CAN	EUR	GENE	REMARKS
1	6S5-11191-20	COVER, CYLINDER HEAD 1	1	1	1	
2	90105-06028	BOLT, FLANGE	8	8	8	
3	6BH-11193-00	GASKET, HEAD COVER 1	1	1	1	
4	6ET-E110M-00	COVER ASSY 1	1	1	1	
5	6S5-E1328-00	.GROMMET, ANODE	2	2	2	
6	6S5-E118E-00	BOLT, COVER MOUNTING	2	2	2	
7	95814-06012	BOLT, FLANGE	4	4	4	
8	6S5-11941-10	STAY	4	4	4	
9	6S5-15363-00	PLUG, OIL	1	1	1	
10	93210-24M79	O-RING	1	1	1	

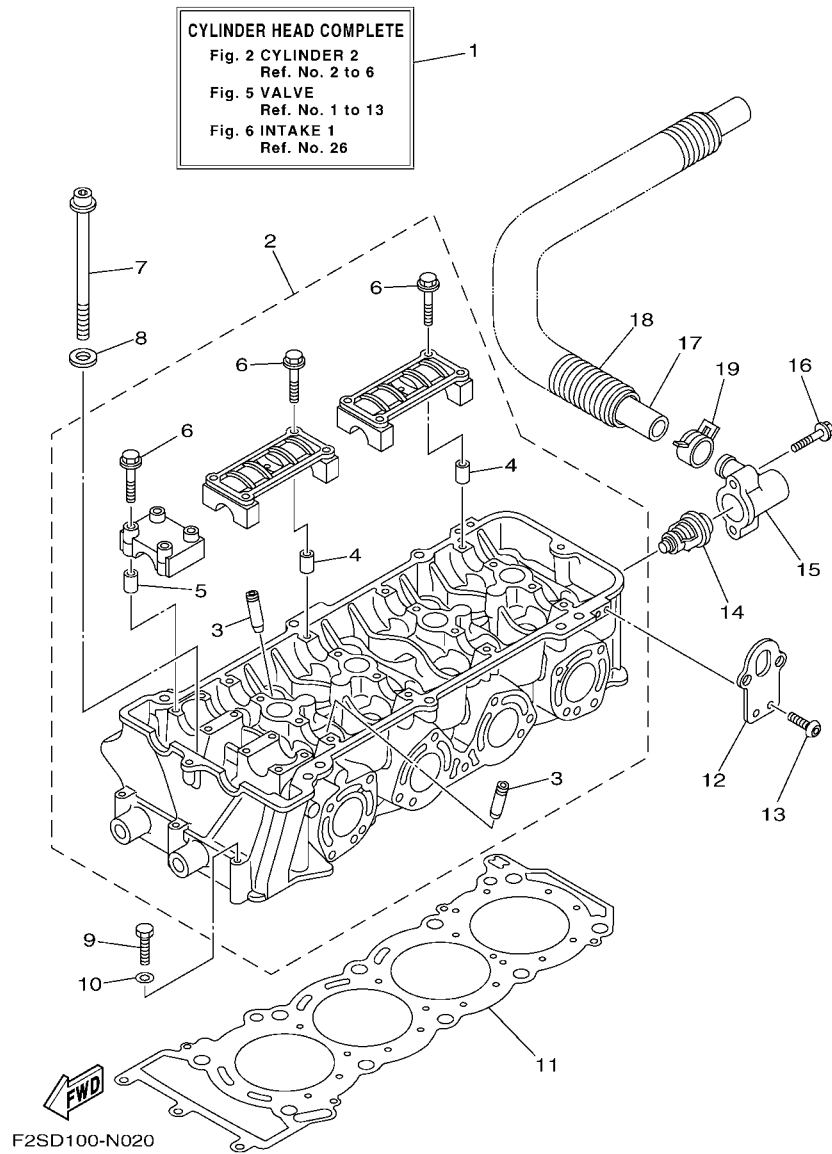

**FIG. 2 CYLINDER 2**

REF. NO.	PART NO.	DESCRIPTION	CAN	EUR	GENE	REMARKS
1	6ET-W009A-00-94	CYLINDER HEAD COMPLETE	1	1	1	
2	6S5-11102-11	CYLINDER HEAD ASSY	1	1	1	
3	6S5-11133-10	.GUIDE, VALVE 1	16	16	16	
4	91809-16002	.PIN, DOWEL	8	8	8	
5	91809-16002	.PIN, DOWEL	4	4	4	
6	90105-07009	.BOLT, FLANGE	24	24	24	
7	6S5-12228-01	BOLT	10	10	10	
8	90201-12039	WASHER, PLATE	10	10	10	
9	97013-06055	BOLT	3	3	3	
10	92903-06600	WASHER, PLATE	3	3	3	
11	6BH-11181-00	GASKET, CYLINDER HEAD 1	1	1	1	
12	6BH-1111E-00	HANGER, ENGINE 2	2	2	2	
13	90119-06078	BOLT, WITH WASHER	4	4	4	
14	6D3-12411-00	THERMOSTAT	1	1	1	
15	6BH-12413-00	COVER, THERMOSTAT	1	1	1	
16	90105-06035	BOLT, FLANGE	2	2	2	
17	6S5-12578-00	HOSE 3	1	1	1	
18	90447-28008	TUBE (L850)	1	1	1	
19	90467-240A0	CLIP	1	1	1	

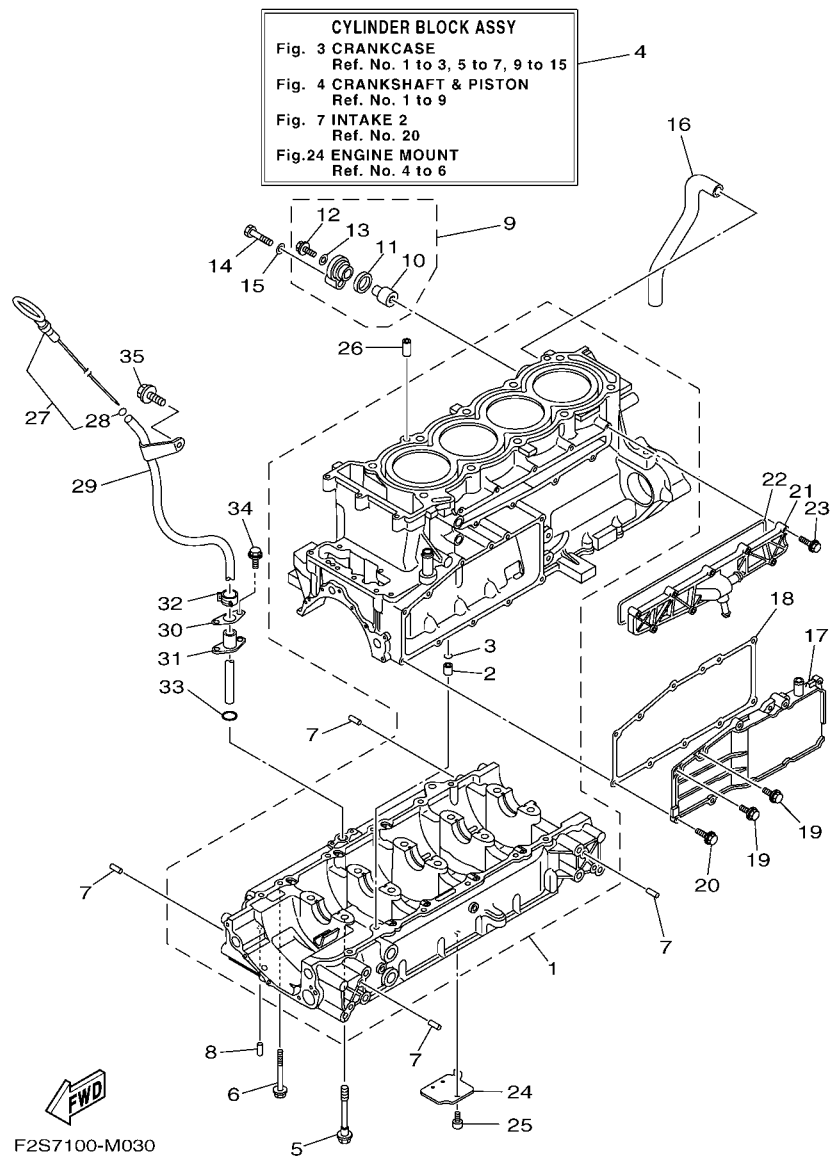

F2S7100-M030

FIG. 3 CRANKCASE

REF. NO.	PART NO.	DESCRIPTION	CAN	EUR	GENE	REMARKS
1	6CS-15100-11	CRANKCASE ASSY	1	1	1	
2	99530-10114	.PIN, DOWEL	1	1	1	
3	93210-11453	.O-RING	1	1	1	
4	6ET-W009B-00-94	CYLINDER BLOCK ASSY	1	1	1	
5	90105-10071	BOLT, FLANGE	10	10	10	
6	95814-06070	BOLT, FLANGE	12	12	12	
7	93606-12019	PIN, DOWEL	8	8	8	
8	93604-10M03	PIN, DOWEL	2	2	2	
9	69J-11301-10	ANODE COVER ASSY	1	1	1	
10	68V-11325-02	.ANODE	1	1	1	
11	67F-11328-00	.GROMMET, ANODE	1	1	1	
12	90105-06M07	.BOLT, FLANGE	1	1	1	
13	90430-06M03	.GASKET	1	1	1	
14	97095-08040	BOLT	1	1	1	
15	92995-08600	WASHER	1	1	1	
16	6S5-11377-00	HOSE	1	1	1	
17	6S5-1131M-10-8P	COVER	1	1	1	
18	6BH-13557-00	GASKET	1	1	1	
19	95024-06014	BOLT, FLG.(SMALL HEAD)	2	2	2	
20	95024-06020	BOLT, FLG.(SMALL HEAD)	9	9	9	
21	6CS-12469-A0	JOINT 1	1	1	1	
22	6CS-12517-00	GASKET, WATER INLET	1	1	1	
23	95814-06035	BOLT, FLANGE	9	9	9	
24	6S5-13337-10	PLATE, BAFFLE LOWER	1	1	1	
25	90110-06182	BOLT, HEXAGON SOCKET HEAD	1	1	1	
26	99530-10114	PIN, DOWEL	2	2	2	
27	6ET-15362-00	PLUG, OIL LEVEL	1	1	1	



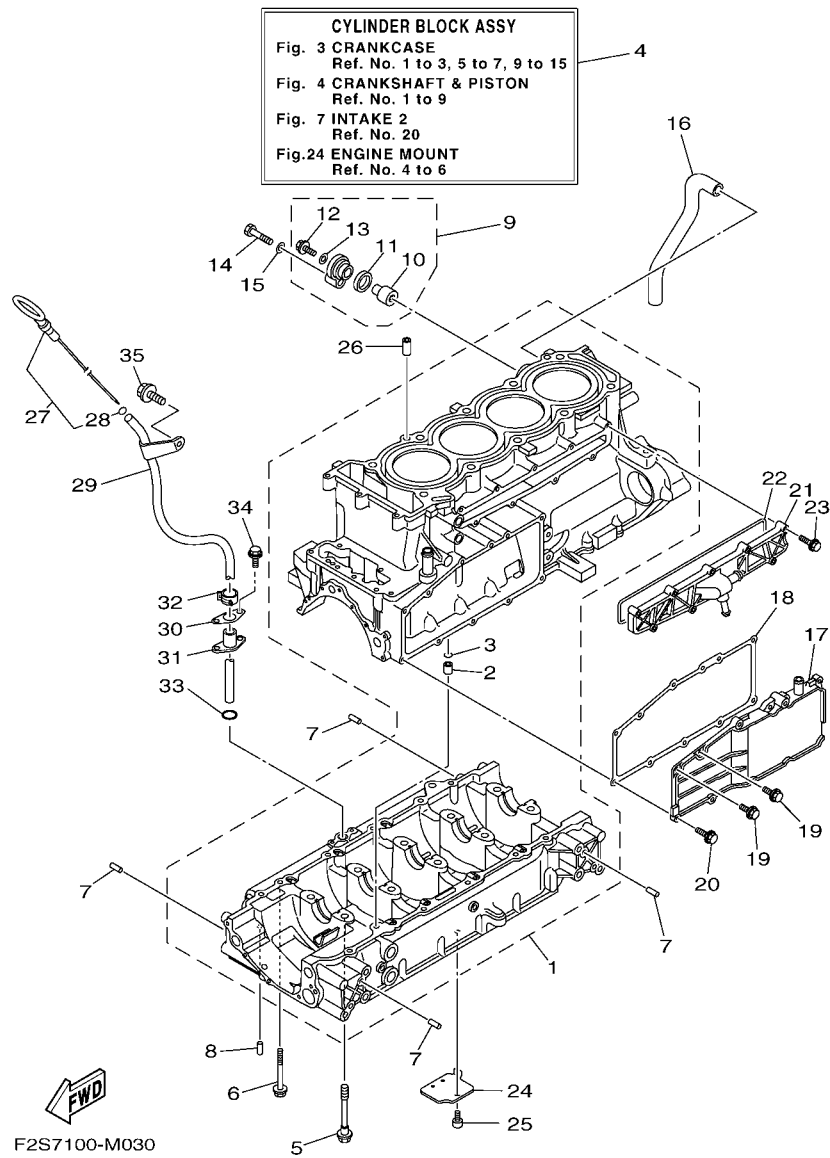
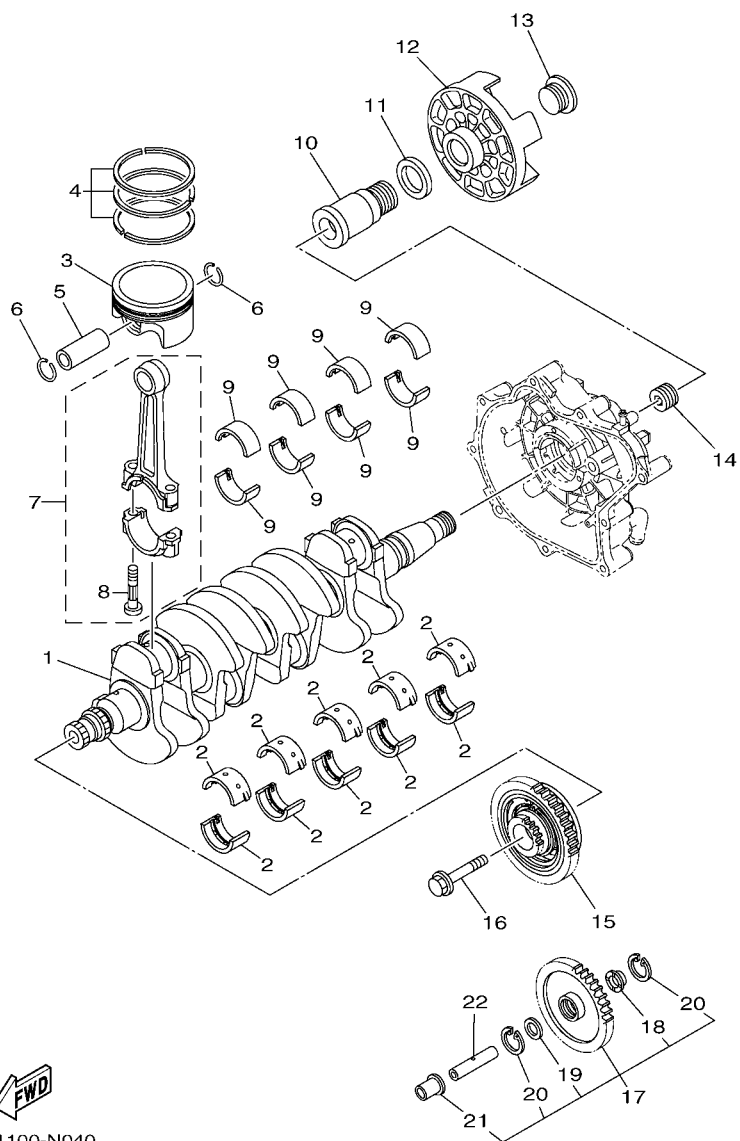

FIG. 3 CRANKCASE

REF. NO.	PART NO.	DESCRIPTION	CAN	EUR	GENE	REMARKS
28	93210-06632	.O-RING	1	1	1	
29	6CS-8572F-00	PIPE, OIL LEVEL	1	1	1	
30	6BH-1319K-00	PLATE	1	1	1	
31	6CS-85516-00	SPACER	1	1	1	
32	90467-150A1	CLIP	1	1	1	
33	93210-12016	O-RING	1	1	1	
34	90109-06268	BOLT	2	2	2	
35	90105-08021	BOLT, FLANGE	1	1	1	

**FIG. 4 CRANKSHAFT & PISTON**



F3J1100-N040

REF. NO.	PART NO.	DESCRIPTION	CAN	EUR	GENE	REMARKS
1	6S5-11411-00	CRANKSHAFT	1	1	1	
2	6S5-11416-00	PLANE BEARING, CRANKSHAFT 1	10	10	10	UR BROWN
	6S5-11416-10	PLANE BEARING, CRANKSHAFT 1	10	10	10	UR BLACK
	6S5-11416-20	PLANE BEARING, CRANKSHAFT 1	10	10	10	UR BLUE
	6S5-11416-30	PLANE BEARING, CRANKSHAFT 1	10	10	10	UR GREEN
	6S5-11416-40	PLANE BEARING, CRANKSHAFT 1	10	10	10	UR YELLOW
3	6ET-11631-00-B0	PISTON (STD)	4	4	4	
4	6S5-11603-00	PISTON RING SET (STD)	4	4	4	
5	6ET-11633-00	PIN, PISTON	4	4	4	
6	93450-24028	CIRCLIP	8	8	8	
7	6S5-11650-10	CONNECTING ROD ASSY	4	4	4	
8	6S5-11654-10	.BOLT, CONNECTING ROD	2	2	2	
9	6S5-11656-40	PLANE BEARING, CONNECTING ROD	8	8	8	UR BLUE
	6S5-11656-50	PLANE BEARING, CONNECTING ROD	8	8	8	UR BLACK
	6S5-11656-60	PLANE BEARING, CONNECTING ROD	8	8	8	UR BROWN
	6S5-11656-70	PLANE BEARING, CONNECTING ROD	8	8	8	UR GREEN
10	6S5-17572-01	SHAFT, TRANSFER	1	1	1	
11	6S5-12289-00	WASHER	1	1	1	
12	6S5-45813-01-94	FLANGE, COUPLING	1	1	1	
13	6S5-17525-01	HOLDER 2	1	1	1	
14	6S5-11459-01	NUT, SPECIAL	1	1	1	
15	6ET-17800-00	GEAR UNIT ASSY	1	1	1	
16	6S5-17031-00	BOLT	1	1	1	
17	6S5-W1783-20	DRIVE GEAR & COLLAR SET (18T)	1	1	1	
18	6S5-17529-00	.WASHER, THRUST	1	1	1	
19	90201-132G5	.WASHER, PLATE	1	1	1	
20	99009-24700	.CIRCLIP	2	2	2	



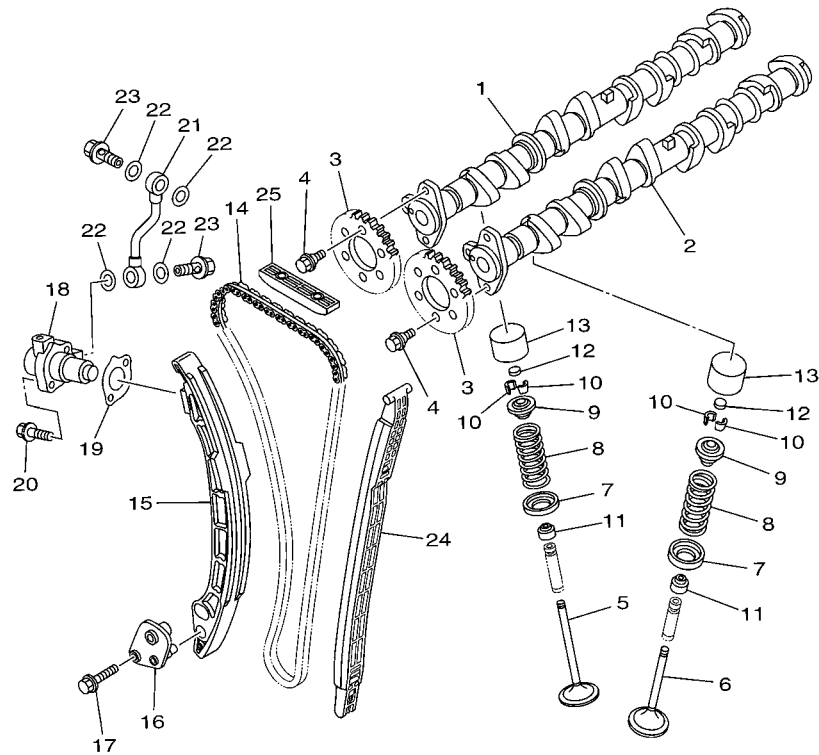

F2CD100-L050

FIG. 5 VALVE

REF. NO.	PART NO.	DESCRIPTION	CAN	EUR	GENE	REMARKS
1	6S5-12171-10	CAMSHAFT 1	1	1	1	
2	6ET-12181-00	CAMSHAFT 2	1	1	1	
3	6D3-12176-10	SPROCKET, CAM CHAIN	2	2	2	
4	90105-07004	BOLT, FLANGE	4	4	4	
5	6S5-12111-00	VALVE, INTAKE	8	8	8	
6	6S5-12121-00	VALVE, EXHAUST	8	8	8	
7	6S5-12116-00	SEAT, VALVE SPRING	16	16	16	
8	6S5-12113-00	SPRING, VALVE INNER	16	16	16	
9	6S5-12117-00	RETAINER, VALVE SPRING	16	16	16	
10	3LD-12118-00	LOCK, VALVE SPRING RETAINER	32	32	32	
11	51Y-12119-00	SEAL, VALVE STEM	16	16	16	
12	3LD-12168-00	PAD, ADJUSTING (1.20)	16	16	16	UR
	3LD-12168-20	PAD, ADJUSTING (1.25)	16	16	16	UR
	3LD-12168-40	PAD, ADJUSTING (1.30)	16	16	16	UR
	3LD-12168-60	PAD, ADJUSTING (1.35)	16	16	16	UR
	3LD-12168-80	PAD, ADJUSTING (1.40)	16	16	16	UR
	3LD-12168-A0	PAD, ADJUSTING (1.45)	16	16	16	UR
	3LD-12168-F0	PAD, ADJUSTING (1.50)	16	16	16	UR
	3LD-12168-H1	PAD, ADJUSTING (1.55)	16	16	16	UR
	3LD-12168-K1	PAD, ADJUSTING (1.60)	16	16	16	UR
	3LD-12168-M1	PAD, ADJUSTING (1.65)	16	16	16	UR
	3LD-12168-R1	PAD, ADJUSTING (1.70)	16	16	16	UR
	3LD-12168-U1	PAD, ADJUSTING (1.75)	16	16	16	UR
	3LD-12168-W1	PAD, ADJUSTING (1.80)	16	16	16	UR
	3LD-12168-Y1	PAD, ADJUSTING (1.85)	16	16	16	UR
	3LD-12169-11	PAD, ADJUSTING (1.90)	16	16	16	UR
	3LD-12169-31	PAD, ADJUSTING (1.95)	16	16	16	UR

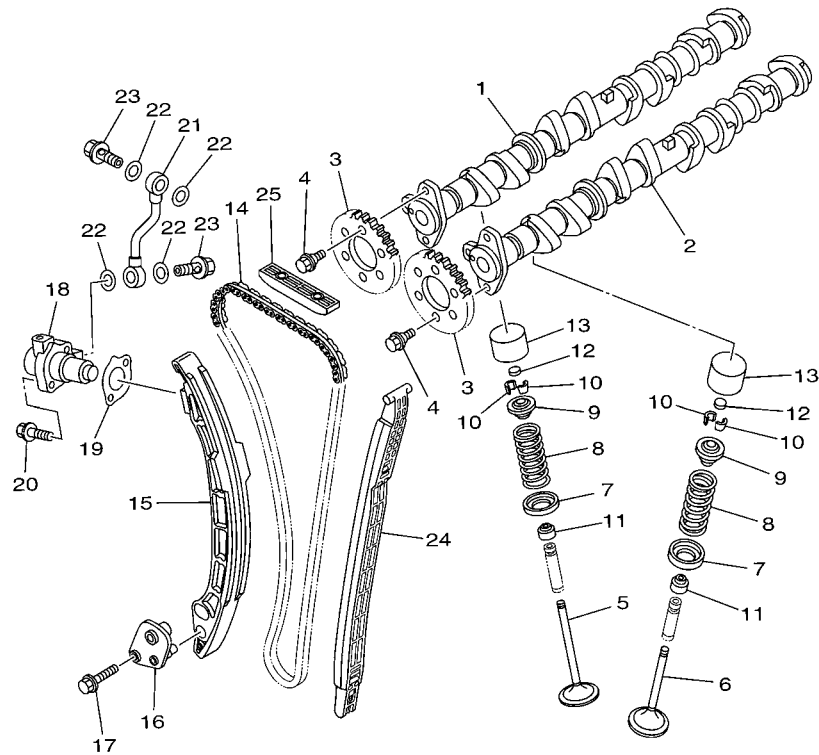

  
F2CD100-L050

**FIG. 5 VALVE**

REF. NO.	PART NO.	DESCRIPTION	CAN	EUR	GENE	REMARKS
12	3LD-12169-50	PAD, ADJUSTING (2.00)	16	16	16	UR
	3LD-12169-70	PAD, ADJUSTING (2.05)	16	16	16	UR
	3LD-12169-90	PAD, ADJUSTING (2.10)	16	16	16	UR
	3LD-12169-E0	PAD, ADJUSTING (2.15)	16	16	16	UR
	3LD-12169-G0	PAD, ADJUSTING (2.20)	16	16	16	UR
	3LD-12169-J0	PAD, ADJUSTING (2.25)	16	16	16	UR
	3LD-12169-L0	PAD, ADJUSTING (2.30)	16	16	16	UR
13	6S5-12153-00	LIFTER, VALVE	16	16	16	
14	94591-66152	CHAIN	1	1	1	
15	6BH-12252-00	DAMPER, CHAIN 2	1	1	1	
16	6BH-12279-00	PLATE	1	1	1	
17	95814-06030	BOLT, FLANGE	2	2	2	
18	6S5-12210-00	TENSIONER ASSY, CAM CHAIN	1	1	1	
19	6S5-121E2-00	GASKET	1	1	1	
20	91380-06025	BOLT	2	2	2	
21	6S5-13418-00	PIPE, OIL 2	1	1	1	
22	90430-10007	GASKET	4	4	4	
23	90401-10040	BOLT, UNION	2	2	2	
24	6BH-12251-00	DAMPER, CHAIN 1	1	1	1	
25	6BH-12241-00	GUIDE, STOPPER 2	1	1	1	

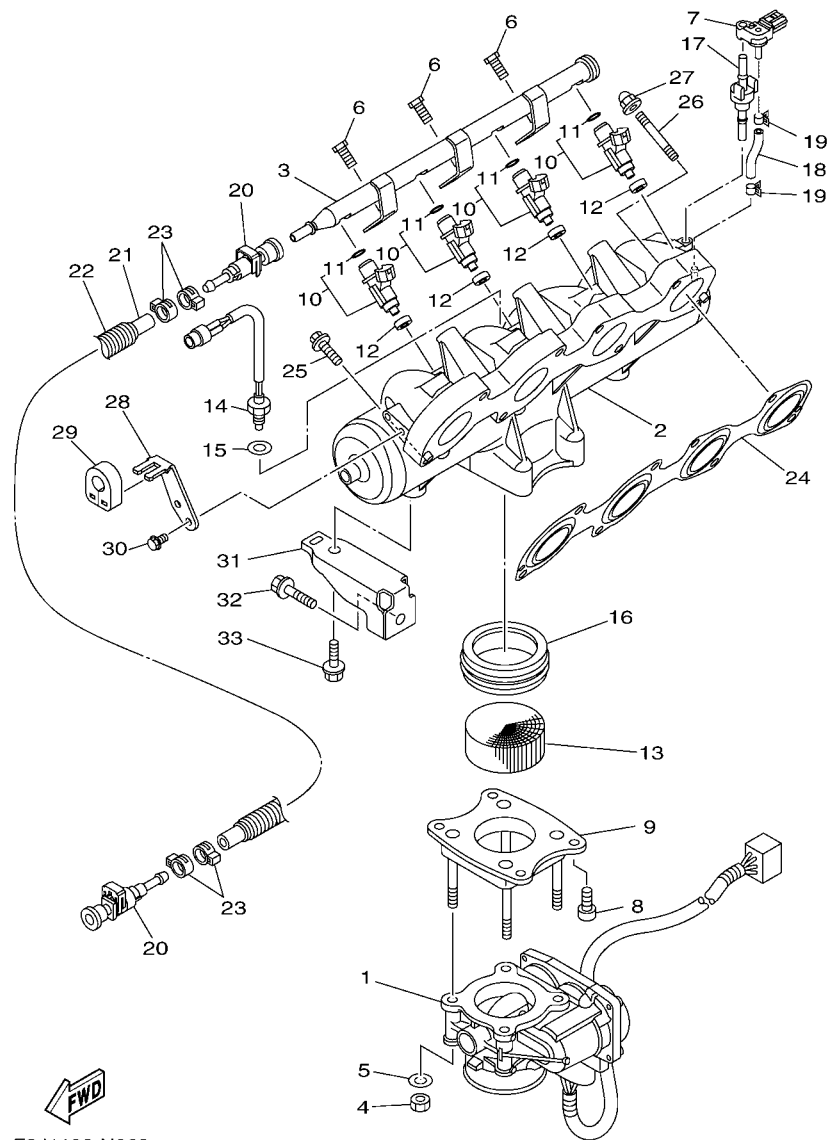

F3J1100-N060

FIG. 6 INTAKE 1

REF. NO.	PART NO.	DESCRIPTION	CAN	EUR	GENE	REMARKS
1	6S5-13750-10	THROTTLE BODY ASSY	1	1	1	
2	6S5-13641-A2	MANIFOLD, INTAKE 1	1	1	1	
3	6CS-12880-00	DELIVERY PIPE	1	1	1	
4	6P2-13588-00	NUT	4	4	4	
5	6P2-13578-00	WASHER	4	4	4	
6	6CS-14446-00	BOLT	3	3	3	
7	6BH-82380-00	SENSOR, PRESSURE	1	1	1	
8	6S5-14496-00	BOLT	4	4	4	
9	6S5-14360-11	THROTTLE DAMPER ASSY	1	1	1	
10	6ET-13761-00	INJECTOR	4	4	4	
11	68V-1416A-00	.O-RING	1	1	1	
12	8FP-13556-10	GASKET, MANIFOLD	4	4	4	
13	6D3-1444B-00	RIBBON	1	1	1	
14	6S5-85886-00	SENSOR, AIR TEMPERATURE	1	1	1	
15	6S5-14285-00	WASHER	1	1	1	
16	6S5-14457-00	HOLDER	1	1	1	
17	6BH-14445-00	GROMMET	1	1	1	
18	6S5-13532-00	HOSE, VACUUM SENSING 3	1	1	1	
19	6S5-14159-00	CLIP	2	2	2	
20	6S5-24300-01	FUEL PIPE JOINT	2	2	2	
21	6AN-14294-10	HOSE	1	1	1	
22	90447-19017	TUBE (L495)	1	1	1	
23	90450-17M17	HOSE CLAMP ASSY	4	4	4	
24	6BH-13645-00	GASKET, MANIFOLD 1	1	1	1	
25	97513-08535	BOLT, WITH WASHER	6	6	6	
26	90116-08032	BOLT, STUD	2	2	2	
27	90176-08080	NUT, CROWN	2	2	2	

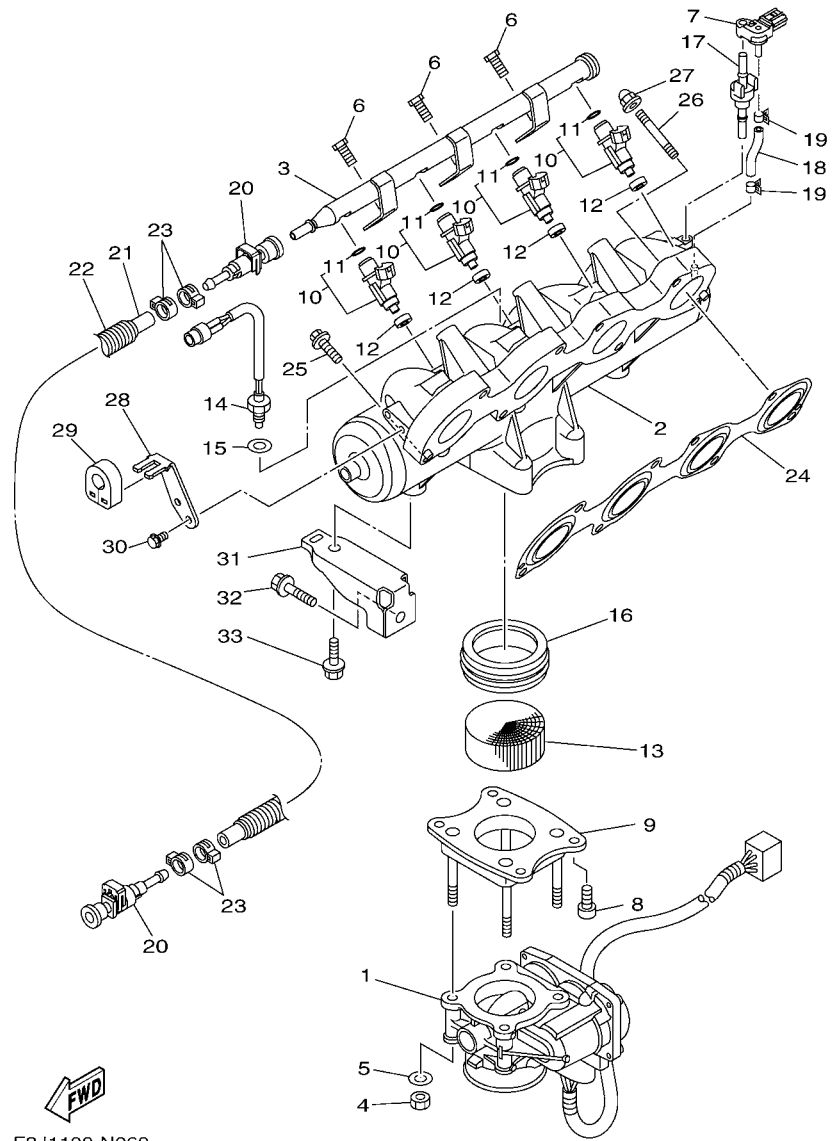

F3J1100-N060

FIG. 6 INTAKE 1

REF. NO.	PART NO.	DESCRIPTION	CAN	EUR	GENE	REMARKS
28	6CS-14572-00	PLATE, STAY	1	1	1	
29	6CS-14445-00	GROMMET	1	1	1	
30	95023-06012	BOLT	2	2	2	
31	6CS-14413-00	STAY	2	2	2	
32	90119-08099	BOLT, WITH WASHER	2	2	2	
33	90119-08074	BOLT, WITH WASHER	2	2	2	
<hr/>						
<hr/>						
<hr/>						
<hr/>						
<hr/>						
<hr/>						
<hr/>						
<hr/>						
<hr/>						

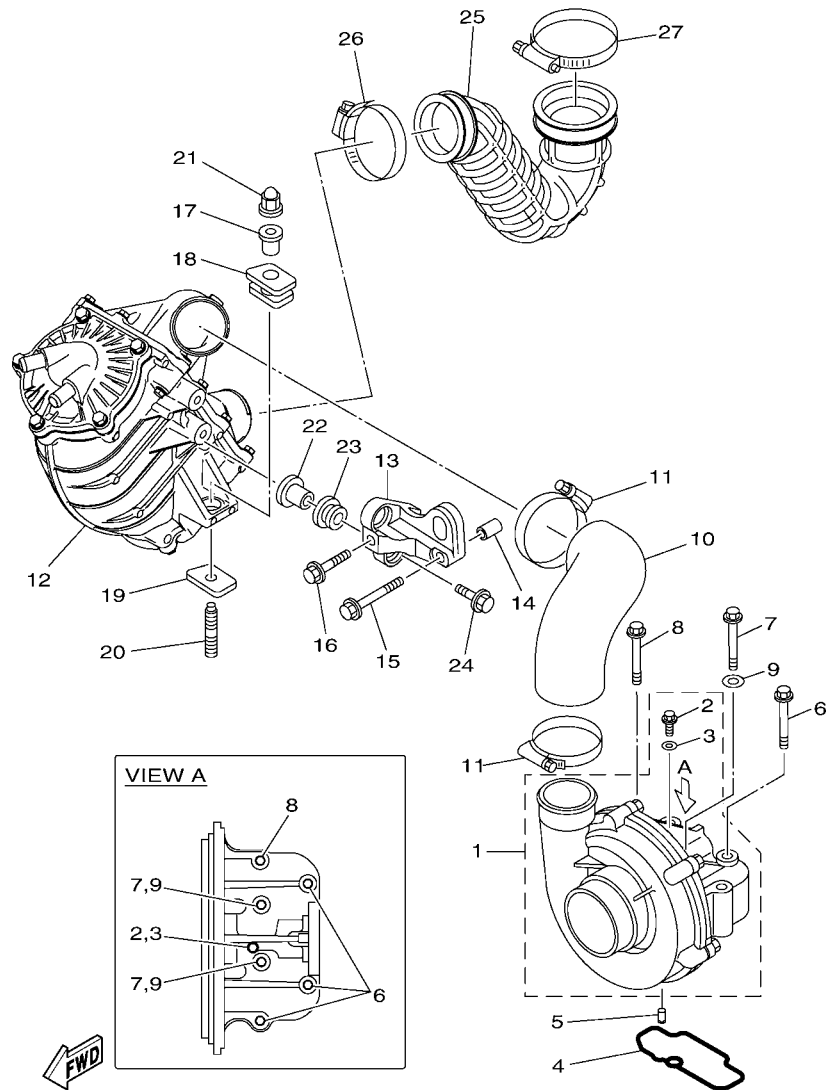

F3J1100-N070

FIG. 7 INTAKE 2

REF. NO.	PART NO.	DESCRIPTION	CAN	EUR	GENE	REMARKS
1	6ET-141A0-01	SUPER CHARGER ASSY	1	1	1	
2	90105-05020	.BOLT, FLANGE	1	1	1	
3	6S5-14199-00	.GASKET	1	1	1	
4	6S5-1416A-00	O-RING	1	1	1	
5	93604-10M03	PIN, DOWEL	2	2	2	
6	95814-08065	BOLT, FLANGE	3	3	3	
7	95814-06065	BOLT, FLANGE	2	2	2	
8	90105-08188	BOLT, FLANGE	1	1	1	
9	90201-06028	WASHER, PLATE	2	2	2	
10	6S5-14349-00	PIPE	1	1	1	
11	90450-75003	HOSE CLAMP ASSY	2	2	2	
12	6ET-13670-00	AIR COOLER ASSY.	1	1	1	
13	6S5-13691-12	BRACKET, AIR COOLER	1	1	1	
14	99590-14016	PIN, DOWEL	2	2	2	
15	90119-10047	BOLT, WITH WASHER	1	1	1	
16	90119-10046	BOLT, WITH WASHER	1	1	1	
17	90387-11007	COLLAR	1	1	1	
18	6S5-14435-00	GROMMET	1	1	1	
19	6S5-14243-01	PLATE	1	1	1	
20	90116-10044	BOLT, STUD	1	1	1	
21	90176-10001	NUT, CROWN	1	1	1	
22	90387-11008	COLLAR	2	2	2	
23	90480-21M63	GROMMET	2	2	2	
24	90119-10011	BOLT, WITH WASHER	2	2	2	
25	6CS-13651-00	PIPE, BOOST	1	1	1	
26	90450-70006	HOSE CLAMP ASSY	1	1	1	
27	90450-90002	HOSE CLAMP ASSY	1	1	1	



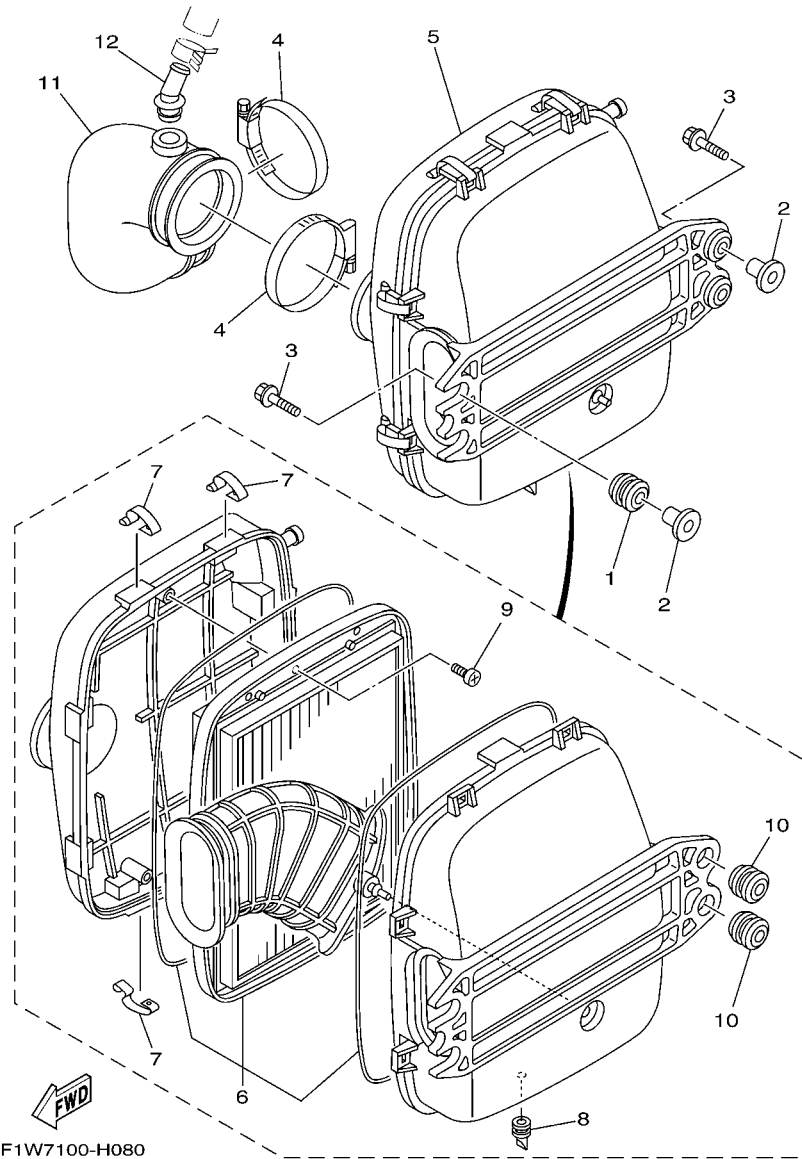
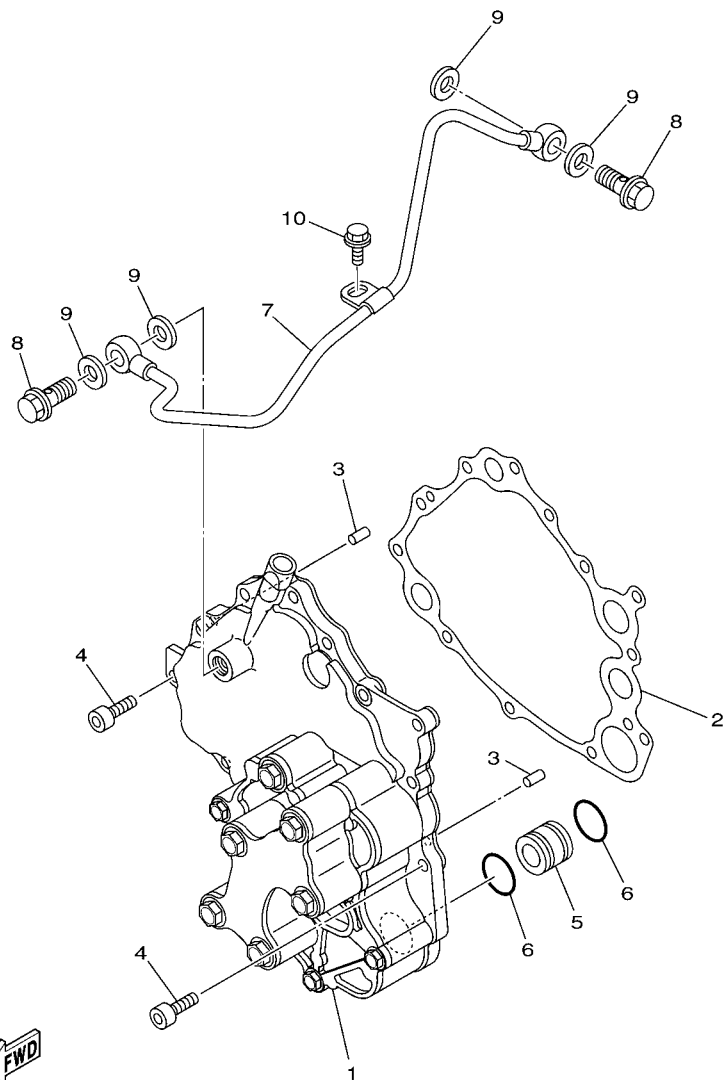

FIG. 8 INTAKE 3

REF. NO.	PART NO.	DESCRIPTION	CAN	EUR	GENE	REMARKS
1	90480-22M15	GROMMET	2	2	2	
2	90387-08M37	COLLAR	4	4	4	
3	90119-08M22	BOLT, WITH WASHER	4	4	4	
4	90450-90002	HOSE CLAMP ASSY	2	2	2	
5	6S5-E4410-01	AIR CLEANER ASSY.	1	1	1	
6	6S5-E4451-00	.ELEMENT, AIR CLEANER	1	1	1	
7	6S5-E4436-00	.HOOK	8	8	8	
8	6S5-G2717-00	.RUBBER, SEAL 2	1	1	1	
9	97780-60516	.SCREW, TAPPING	3	3	3	
10	90480-22801	.GROMMET	2	2	2	
11	6S5-E4419-00	PIPE	1	1	1	
12	6S5-R1142-10	CONNECTION	1	1	1	

**FIG. 9 OIL PUMP**



F2CD100-L090

REF. NO.	PART NO.	DESCRIPTION	CAN	EUR	GENE	REMARKS
1	6S5-13300-22	OIL PUMP ASSY	1	1	1	
2	6S5-13563-00	GASKET	1	1	1	
3	93606-12019	PIN, DOWEL	2	2	2	
4	91314-06020	BOLT, HEXAGON SOCKET HEAD	12	12	12	
5	6S5-13446-10	CONNECTOR	1	1	1	
6	93210-21631	O-RING	2	2	2	
7	6S5-13416-00	PIPE, OIL 1	1	1	1	
8	90401-10040	BOLT, UNION	2	2	2	
9	90430-10007	GASKET	4	4	4	
10	95023-06012	BOLT	1	1	1	

**FIG. 10 OIL PAN**

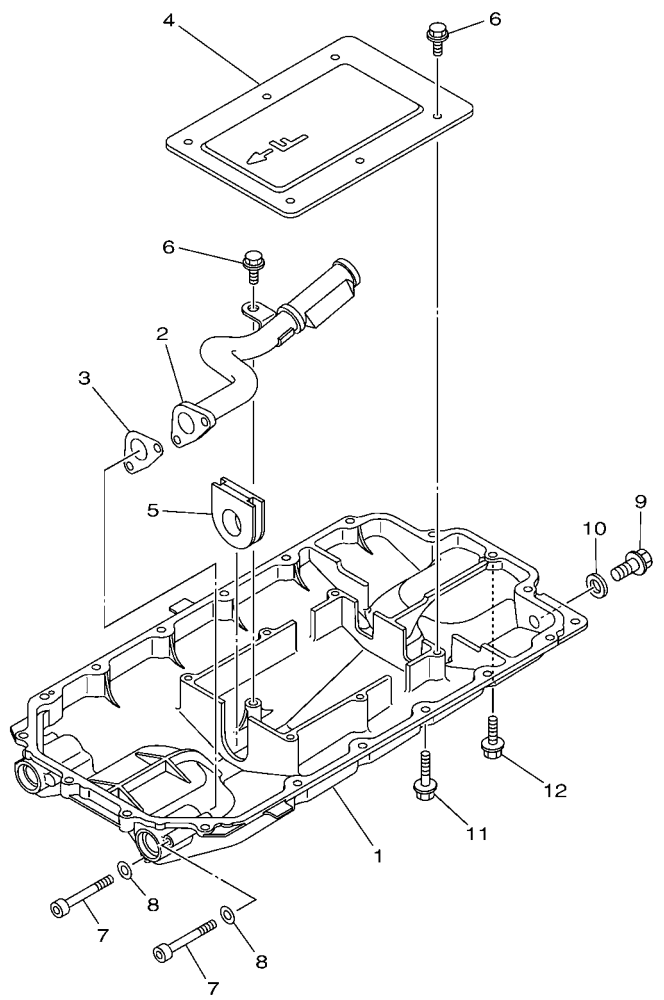

**FWD**  
F3K4100-P100

REF. NO.	PART NO.	DESCRIPTION	CAN	EUR	GENE	REMARKS
1	6S5-1310A-23	PAN, OIL	1	1	1	
2	6S5-13405-11	OIL PIPE COMP. 1	1	1	1	
3	6S5-13477-00	GASKET	1	1	1	
4	6S5-13317-10	PLATE, BAFFLE	1	1	1	
5	6S5-15486-10	GROMMET	1	1	1	
6	95817-06014	BOLT, FLANGE	7	7	7	
7	91314-06060	BOLT, HEXAGON SOCKET HEAD	2	2	2	
8	90201-06028	WASHER, PLATE	2	2	2	
9	95814-08020	BOLT, FLANGE	1	1	1	
10	90430-08209	GASKET	1	1	1	
11	95024-06035	BOLT, FLG.(SMALL HEAD)	17	17	17	
12	95024-06020	BOLT, FLG.(SMALL HEAD)	1	1	1	

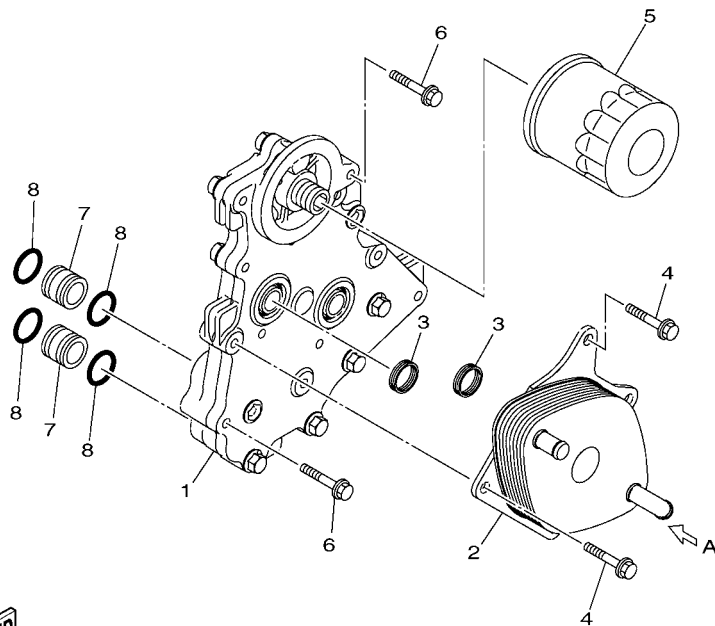
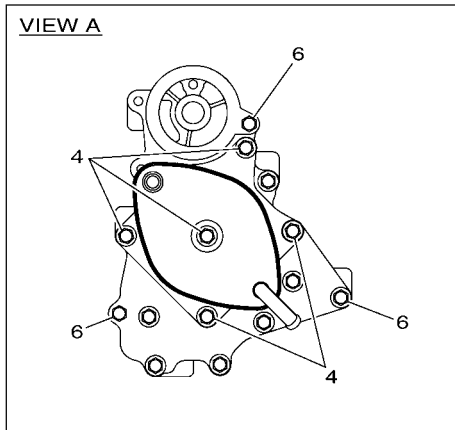

F3J1100-N110

**FIG. 11 OIL COOLER**

REF. NO.	PART NO.	DESCRIPTION	CAN	EUR	GENE	REMARKS
1	6ET-13460-00	ADAPTER PLATE ASSY	1	1	1	
2	6ET-13470-01	OIL COOLER ASSY	1	1	1	
3	6ET-13557-00	GASKET	2	2	2	
4	95814-08030	BOLT, FLANGE	5	5	5	
5	69J-13440-03	ELEMENT ASSY, OIL CLEANER	1	1	1	
6	95814-08050	BOLT, FLANGE	3	3	3	
7	60E-13446-00	CONNECTOR	2	2	2	
8	93210-18322	O-RING	4	4	4	
<hr/>						
<hr/>						
<hr/>						
<hr/>						
<hr/>						
<hr/>						
<hr/>						
<hr/>						
<hr/>						
<hr/>						

**FIG. 12 BREATHER OIL**

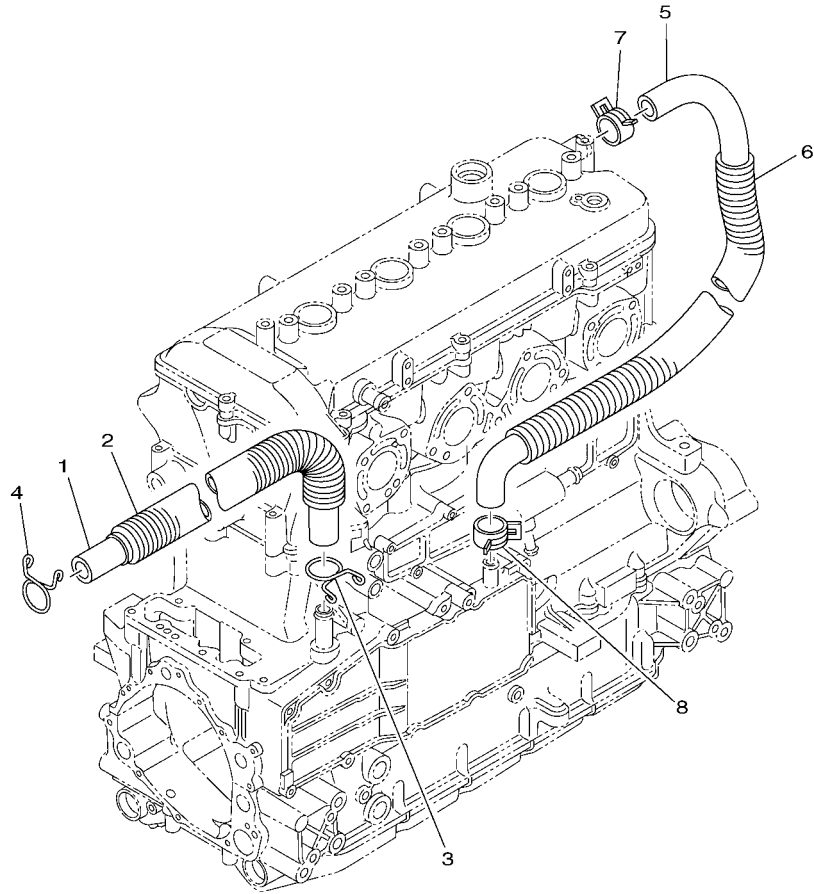

 F3J1100-N120

REF. NO.	PART NO.	DESCRIPTION	CAN	EUR	GENE	REMARKS
1	6S5-11166-10	PIPE, BREATHER 1	1	1	1	
2	90447-22015	TUBE (L410)	1	1	1	
3	90467-190A0	CLIP	1	1	1	
4	90467-190A0	CLIP	1	1	1	
5	6S5-11167-10	PIPE, BREATHER 2	1	1	1	
6	90447-22016	TUBE (L490)	1	1	1	
7	90467-240A0	CLIP	1	1	1	
8	90467-200A3	CLIP	1	1	1	
-----						
-----						
-----						
-----						
-----						
-----						
-----						

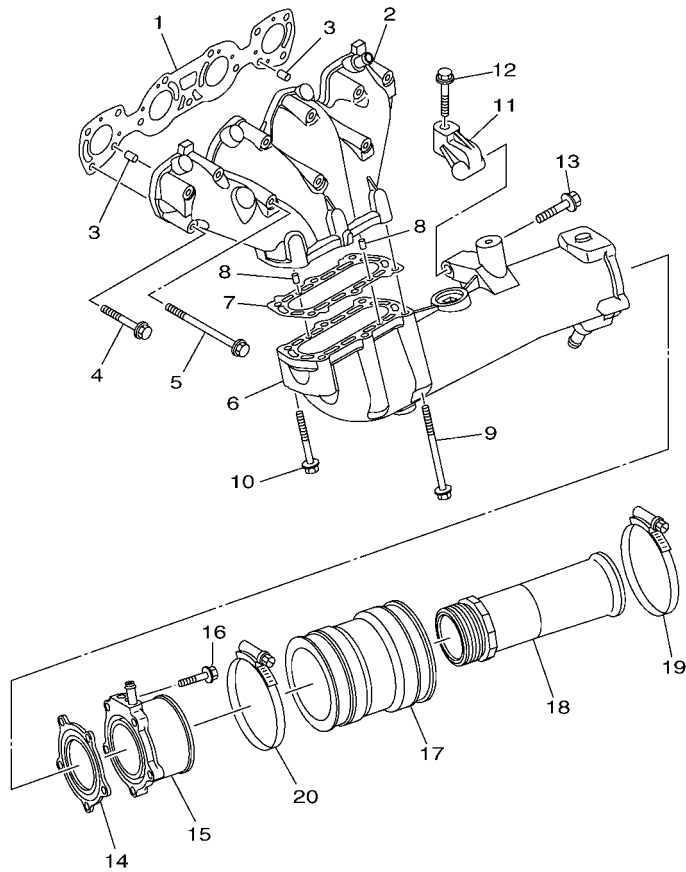

F3J1100-N130

FIG. 13 EXHAUST 1

REF. NO.	PART NO.	DESCRIPTION	CAN	EUR	GENE	REMARKS
1	6ET-14613-00	GASKET, EXHAUST PIPE	1	1	1	
2	6BH-14711-10	MUFFLER 1	1	1	1	
3	93608-16M16	PIN, DOWEL	2	2	2	
4	90119-08034	BOLT, WITH WASHER	8	8	8	
5	90119-08097	BOLT, WITH WASHER	3	3	3	
6	6BH-14721-10	MUFFLER 2	1	1	1	
7	6S5-14739-00	GASKET, MUFFLER DAMPER 1	1	1	1	
8	93606-12019	PIN, DOWEL	2	2	2	
9	90119-08097	BOLT, WITH WASHER	4	4	4	
10	90119-08034	BOLT, WITH WASHER	2	2	2	
11	6S5-14771-00-94	STAY, MUFFLER 1	1	1	1	
12	90119-08096	BOLT, WITH WASHER	1	1	1	
13	90119-10029	BOLT, WITH WASHER	1	1	1	
14	6BH-14749-00	GASKET, MUFFLER DAMPER 2	1	1	1	
15	6BH-14784-01-94	PIPE, TAIL	1	1	1	
16	95024-08035	BOLT, FLG.(SMALL HEAD)	5	5	5	
17	6S5-E4752-00	PIPE, OUTLET	1	1	1	
18	6CS-1475A-00	PIPE 1	1	1	1	
19	90450-99016	HOSE CLAMP ASSY	1	1	1	
20	90450-99015	HOSE CLAMP ASSY	1	1	1	

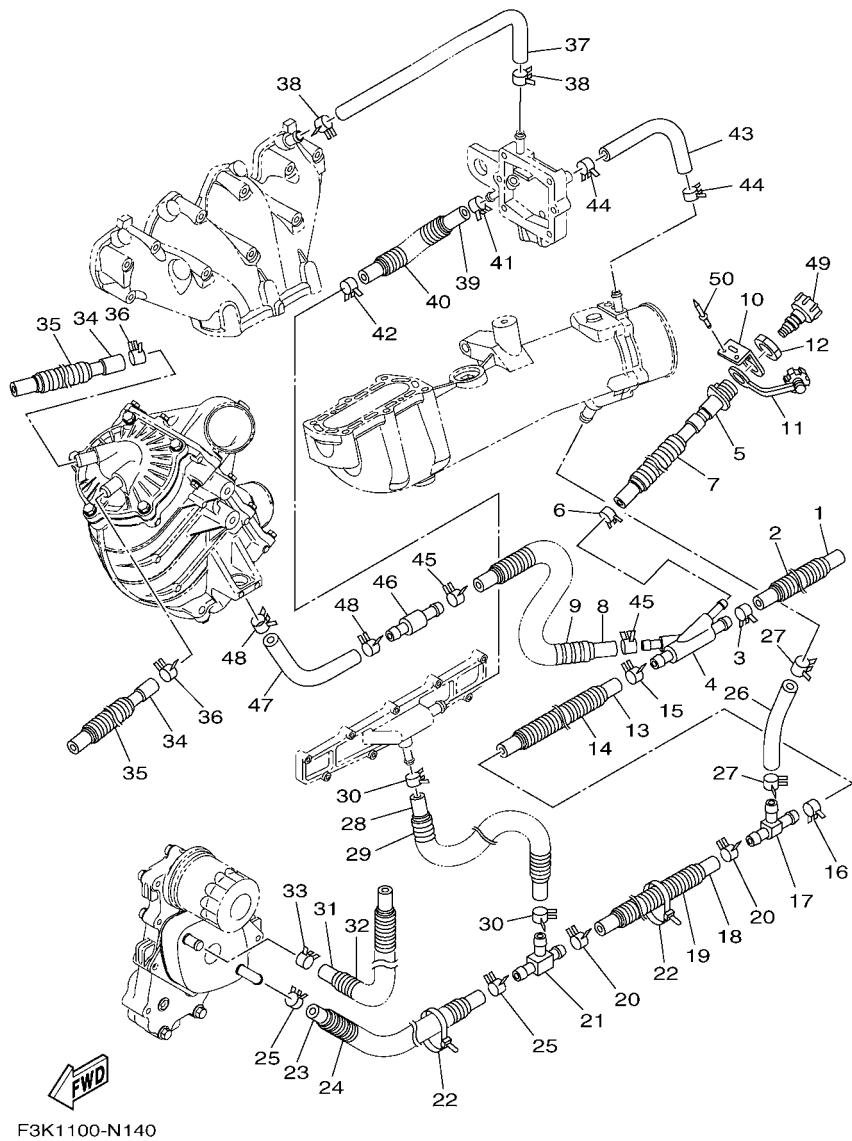
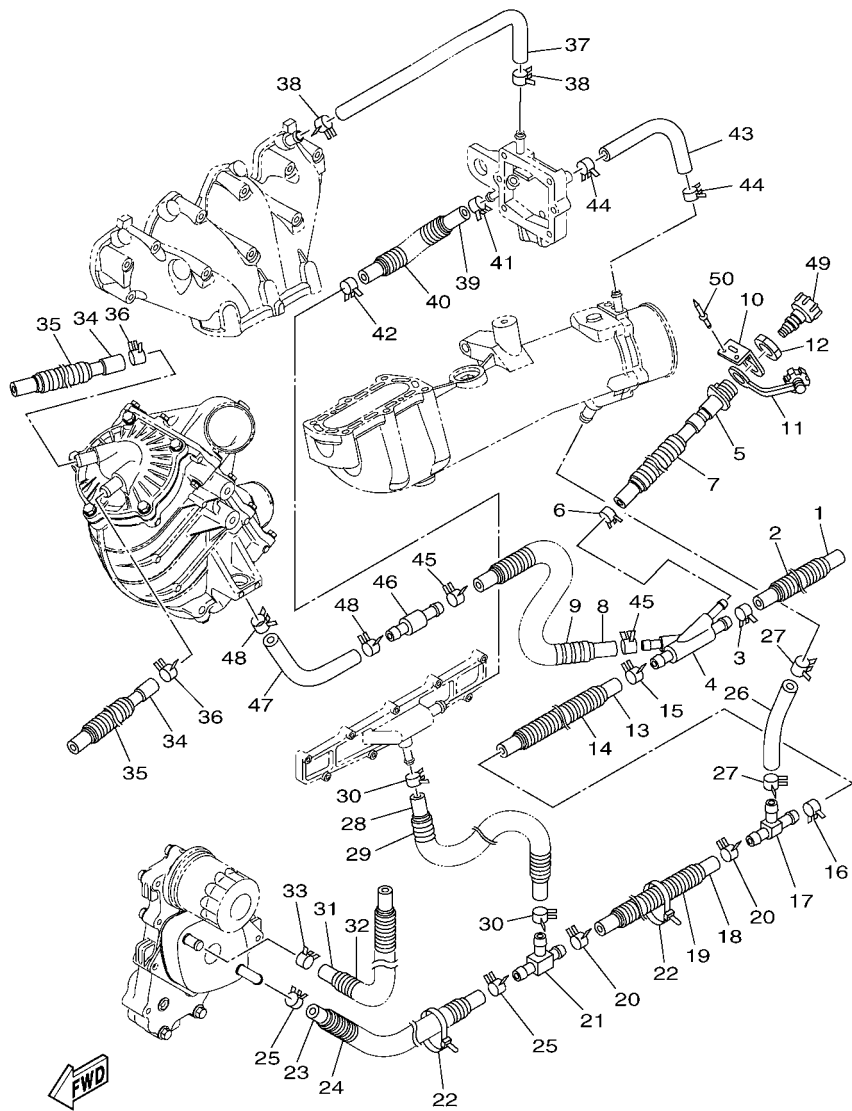

FIG. 14 EXHAUST 2

REF. NO.	PART NO.	DESCRIPTION	CAN	EUR	GENE	REMARKS
1	90445-21813	HOSE (L285)	1	1	1	
2	90447-22801	TUBE (L200)	1	1	1	
3	90467-200A3	CLIP	1	1	1	
4	6ET-12581-10	JOINT, HOSE 1	1	1	1	
5	63M-12580-00	JOINT ASSY	1	1	1	
6	90467-150A5	CLIP	1	1	1	
7	90447-19801	TUBE (L485)	1	1	1	
8	90445-21807	HOSE (L970)	1	1	1	
9	90447-22802	TUBE (L850)	1	1	1	
10	60E-12443-00	STAY	1	1	1	
11	682-84385-01	CAP,1	1	1	1	
12	EU0-61652-00	NUT	1	1	1	
13	6S5-1243E-01	HOSE 2	1	1	1	
14	90447-22011	TUBE (L170)	1	1	1	
15	90467-200A3	CLIP	1	1	1	
16	90467-200A3	CLIP	1	1	1	
17	6BH-12584-00	JOINT, HOSE 3	1	1	1	
18	90445-18017	HOSE (L220)	1	1	1	
19	90447-19004	HOSE, WITH SPRING (L=130)	1	1	1	
20	90467-160A0	CLIP	2	2	2	
21	6ET-12582-00	JOINT, HOSE 2	1	1	1	
22	90464-35132	CLAMP	2	2	2	
23	90445-18017	HOSE (L220)	1	1	1	
24	90447-19004	HOSE, WITH SPRING (L=130)	1	1	1	
25	90467-160A0	CLIP	2	2	2	
26	6S5-12589-01	HOSE 6	1	1	1	
27	90467-200A3	CLIP	2	2	2	



F3K1100-N140

FIG. 14 EXHAUST 2

REF. NO.	PART NO.	DESCRIPTION	CAN	EUR	GENE	REMARKS
28	6S5-1244H-00	HOSE 5	1	1	1	
29	90447-19011	TUBE (L150)	1	1	1	
30	90467-150A1	CLIP	2	2	2	
31	6S5-12588-00	HOSE 5	1	1	1	
32	90447-19006	HOSE, WITH SPRING (L=630)	1	1	1	
33	90467-160A0	CLIP	1	1	1	
34	6S5-12552-00	HOSE 8	2	2	2	
35	90446-24M89	HOSE (L420)	2	2	2	
36	90467-170A4	CLIP	2	2	2	
37	6BH-12577-00	HOSE 2	1	1	1	
38	90467-160A0	CLIP	2	2	2	
39	6S5-12579-00	HOSE 4	1	1	1	
40	90447-19011	TUBE (L150)	1	1	1	
41	90467-160A0	CLIP	1	1	1	
42	90467-170A5	CLIP	1	1	1	
43	90445-16013	HOSE (L220)	1	1	1	
44	90467-160A0	CLIP	2	2	2	
45	90467-200A3	CLIP	2	2	2	
46	6S5-12594-00	JOINT, HOSE 4	1	1	1	
47	6S5-12576-01	HOSE 1	1	1	1	
48	90467-200A3	CLIP	2	2	2	
49	67X-E2590-10	CONDUCTION ASSY	1	1	1	
50	90267-489U1	RIVET,BLIND	2	2	2	



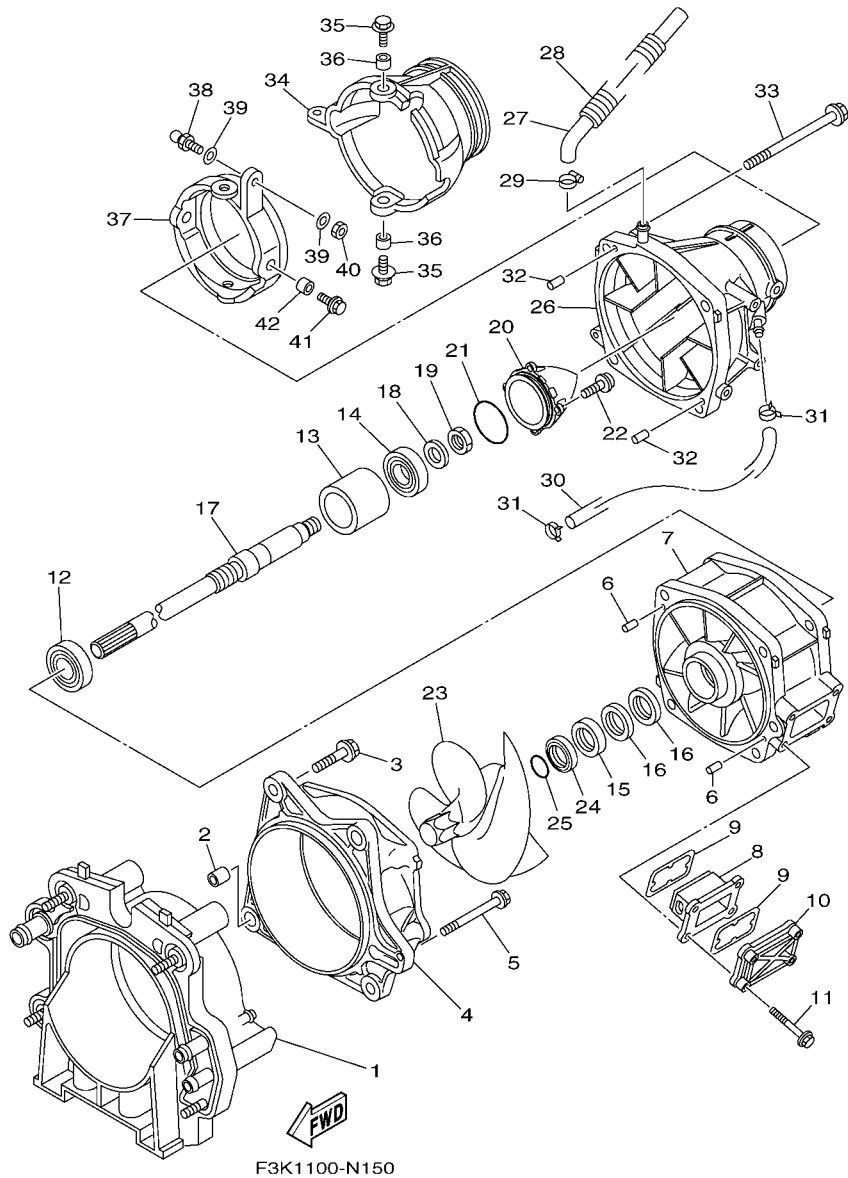

F3K1100-N150

FIG. 15 JET UNIT 1

REF. NO.	PART NO.	DESCRIPTION	CAN	EUR	GENE	REMARKS
1	6EV-G5831-00	PLATE, TRANSOM	1	1	1	
2	99590-14016	PIN, DOWEL	2	2	2	
3	90119-10810	BOLT, WITH WASHER	4	4	4	
4	6ET-51312-00	HOUSING, IMPELLER	1	1	1	
5	90119-06893	BOLT, WITH WASHER	1	1	1	
6	93606-12019	PIN, DOWEL	2	2	2	
7	6ET-51315-00	DUCT, IMPELLER	1	1	1	
8	6ET-G6882-00	FILTER	1	1	1	
9	66V-42414-00	O-RING	2	2	2	
10	6AN-G5214-00	COVER, WATER INLET 1	1	1	1	
11	90119-06897	BOLT, WITH WASHER	4	4	4	
12	93306-20654	BEARING	1	1	1	
13	6CS-G5538-00	SPACER 1	1	1	1	
14	93306-30537	BEARING	1	1	1	
15	93102-31009	OIL SEAL	1	1	1	
16	93101-31001	OIL SEAL	2	2	2	
17	6EV-45511-00	SHAFT, DRIVE	1	1	1	
18	9290P-20600	WASHER	1	1	1	
19	90170-20802	NUT	1	1	1	
20	6ET-R1326-00	CAP	1	1	1	
21	6S5-5111K-00	O-RING 1	1	1	1	
22	90110-06822	BOLT, HEXAGON SOCKET HEAD	4	4	4	
23	6EV-R1321-00	IMPELLER	1	1	1	
24	6BH-51348-01	SPACER	1	1	1	
25	93210-30611	O-RING	1	1	1	
26	6EV-R1318-00	NOZZLE	1	1	1	
27	6AN-U72M2-00	HOSE 1	1	1	1	

FIG. 15 JET UNIT 1

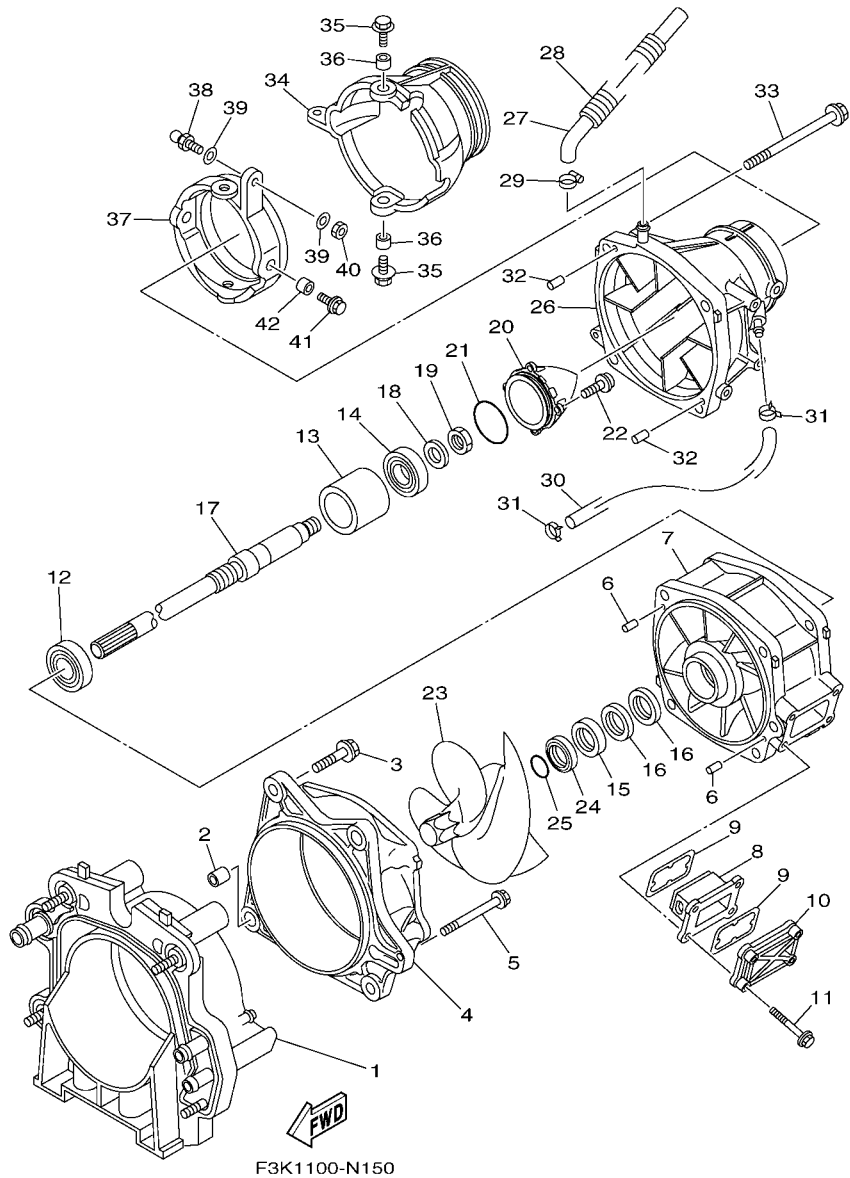

REF. NO.	PART NO.	DESCRIPTION	CAN	EUR	GENE	REMARKS
28	6CN-U773D-00	TUBE	1	1	1	
29	90601-118UF	BAND, HOSE 18	1	1	1	
30	90445-14804	HOSE (L330)	1	1	1	
31	90467-14803	CLIP	2	2	2	
32	93606-12019	PIN, DOWEL	2	2	2	
33	90119-10806	BOLT, WITH WASHER	4	4	4	
34	6S5-R1313-01	NOZZLE, DEFLECTOR	1	1	1	
35	90119-08851	BOLT, WITH WASHER	2	2	2	
36	90387-08M06	COLLAR	2	2	2	
37	6AN-R1190-00	RING, TRIM	1	1	1	
38	GH3-U146E-00	STUD, JOINT BALL	1	1	1	
39	90201-068M4	WASHER, PLATE	2	2	2	
40	9538R-06700	NUT	1	1	1	
41	90119-08851	BOLT, WITH WASHER	2	2	2	
42	90387-08M06	COLLAR	2	2	2	

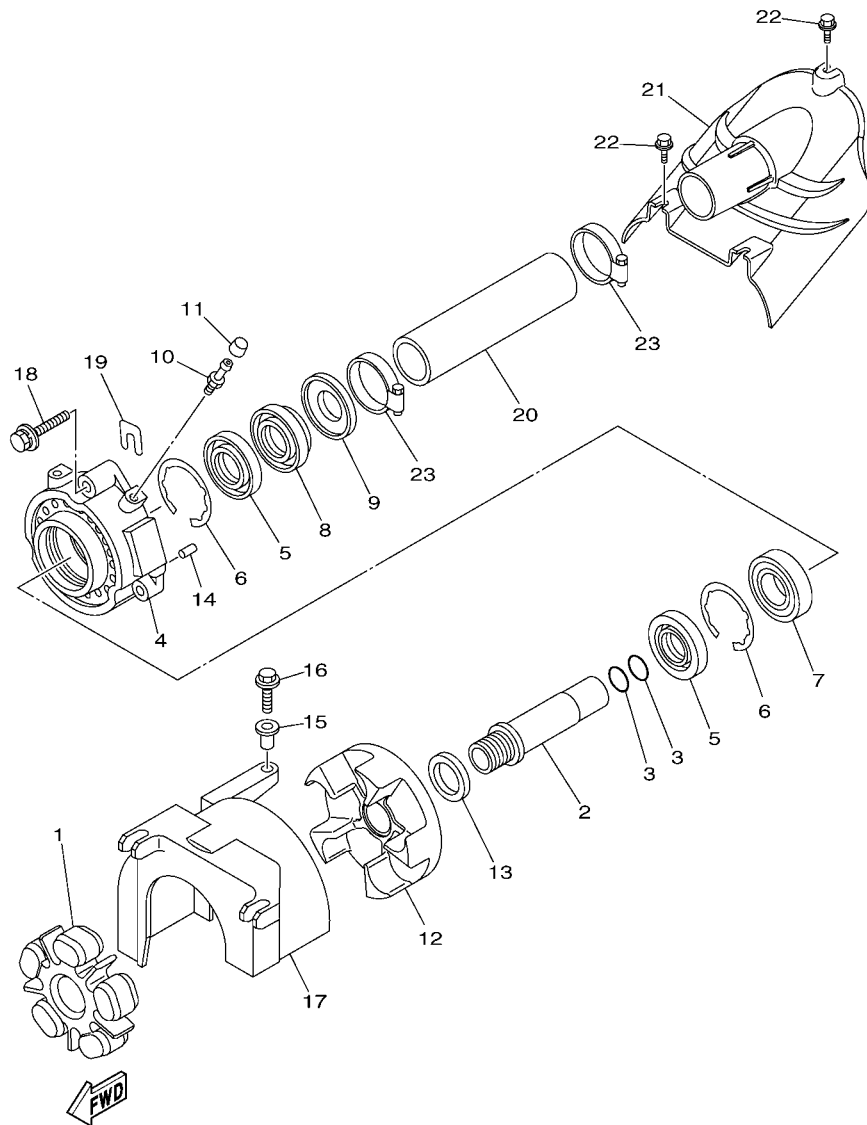

F3K1100-N160

FIG. 16 JET UNIT 2

REF. NO.	PART NO.	DESCRIPTION	CAN	EUR	GENE	REMARKS
1	6BH-4581J-00	RUBBER SHAFT COUPLING	1	1	1	
2	6S5-51323-00	SHAFT, COUPLER	1	1	1	
3	93210-22MF1	O-RING	2	2	2	
4	6S5-45332-00-94	HOUSING, BEARING	1	1	1	
5	93102-29008	OIL SEAL	2	2	2	
6	93450-66156	CIRCLIP	2	2	2	
7	93306-20655	BEARING	1	1	1	
8	93102-29009	OIL SEAL	1	1	1	
9	6ET-45613-00	WASHER, THRUST	1	1	1	
10	93700-06M03	NIPPLE, GREASE	1	1	1	
11	663-45119-00	CAP, GREASE NIPPLE	1	1	1	
12	6S5-45593-00-94	FLANGE, COUPLING 1	1	1	1	
13	6ET-E2289-00	WASHER	1	1	1	
14	93606-12019	PIN, DOWEL	2	2	2	
15	90387-06289	COLLAR	1	1	1	
16	90119-06891	BOLT, WITH WASHER	1	1	1	
17	6S5-R1381-01	COVER	1	1	1	
18	90119-089UU	BOLT, WITH WASHER	3	3	3	
19	GD0-U7249-00-05	SHIM (T=0.5)	2	2	2	UN
20	F2C-U883B-00	PIPE, 1	1	1	1	
21	F3K-U883E-00	JOINT, PIPE	1	1	1	
22	90109-06832	BOLT	3	3	3	
23	90601-152U3	BAND, HOSE 52	2	2	2	

FIG. 17 JET UNIT 3

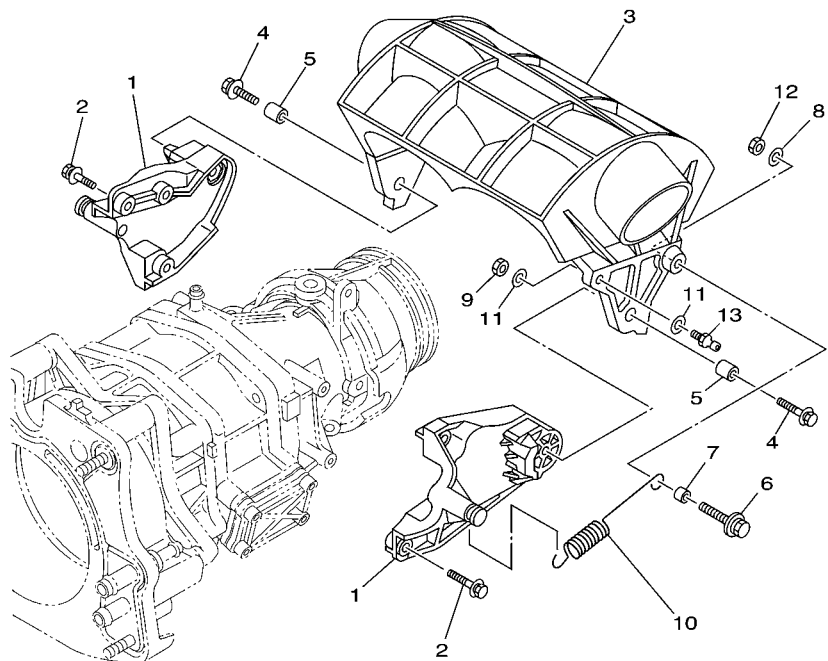

REF. NO.	PART NO.	DESCRIPTION	CAN	EUR	GENE	REMARKS
1	6CS-R1341-00	BRACKET 1	2	2	2	
2	90119-06891	BOLT, WITH WASHER	6	6	6	
3	6S5-R1314-02	GATE, REVERSE	1	1	1	
4	90119-08840	BOLT, WITH WASHER	2	2	2	
5	90387-08M30	COLLAR	2	2	2	
6	90119-069UX	BOLT, WITH WASHER	1	1	1	
7	90387-06M30	COLLAR	1	1	1	
8	90201-06801	WASHER, PLATE	1	1	1	
9	9538R-06600	NUT	1	1	1	
10	6S5-52358-00	SPRING, RETAINER	1	1	1	
11	90201-06801	WASHER, PLATE	2	2	2	
12	9538R-06600	NUT	1	1	1	
13	EU0-U1461-02	STUD, JOINT BALL	1	1	1	

 F2S1100-L170

FIG. 18 JET UNIT 4

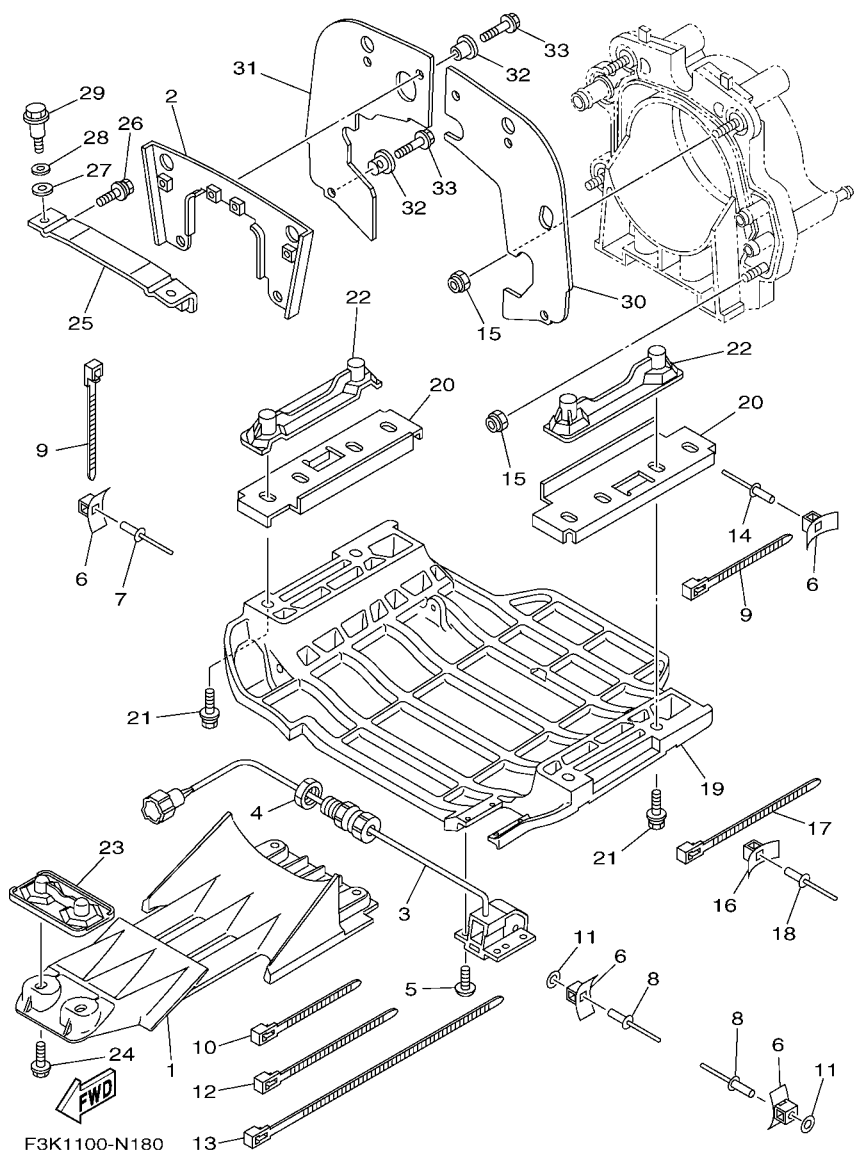

F3K1100-N180

REF. NO.	PART NO.	DESCRIPTION	CAN	EUR	GENE	REMARKS
1	6EV-R1333-00	SCREEN, INTAKE	1	1	1	
2	6AN-R1341-01	BRACKET 1	1	1	1	
3	F1S-U8K31-02	SENSOR SPEED	1	1	1	
4	F2C-U151S-00	NUT	1	1	1	
5	90150-05807	SCREW, ROUND HEAD	4	4	4	
6	F1W-U828M-00	BASE, CLAMP	11	11	11	
7	90267-48802	RIVET, BLIND	4	4	4	
8	90267-489U2	RIVET, BLIND	2	2	2	
9	90464-32801	CLAMP	8	8	8	
10	90601-200U1	BAND	2	2	2	
11	9299R-05200	WASHER	2	2	2	
12	90464-32801	CLAMP	1	1	1	
13	90464-99801	CLAMP	1	1	1	
14	90267-489U6	RIVET, BLIND	5	5	5	
15	9572R-10300	NUT, NYLON	4	4	4	
16	F1W-U828M-00	BASE, CLAMP	2	2	2	
17	90464-32801	CLAMP	2	2	2	
18	90267-48802	RIVET, BLIND	2	2	2	
19	F3K-6273B-00	PLATE 2	1	1	1	
20	F2C-U143G-00	SPACER	2	2	2	
21	90119-08823	BOLT, WITH WASHER	4	4	4	
22	F1G-U8572-02	BRACKET 2	2	2	2	
23	F2C-U8577-03	BRACKET, 3	1	1	1	
24	90119-10808	BOLT, WITH WASHER	6	6	6	
25	F2C-U7557-01	BRACKET	1	1	1	
26	90119-089U7	BOLT, WITH WASHER	2	2	2	
27	90430-12002	GASKET	2	2	2	



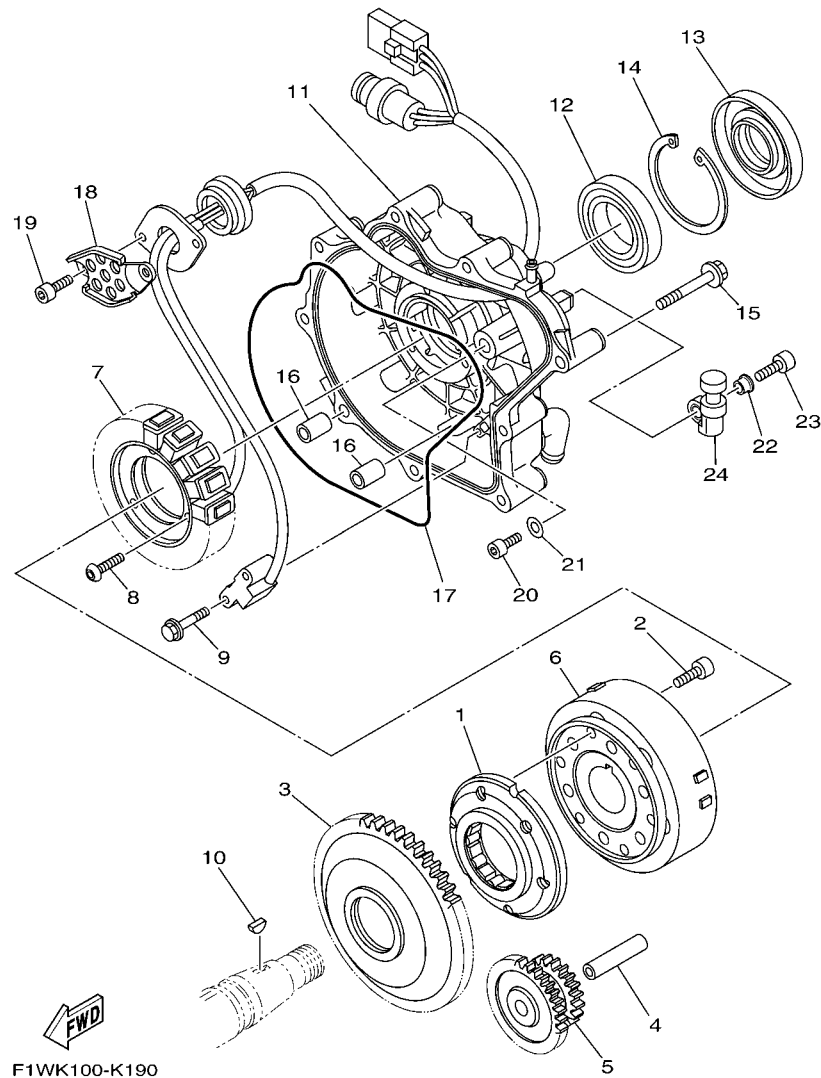

**FIG. 19 GENERATOR**

REF. NO.	PART NO.	DESCRIPTION	CAN	EUR	GENE	REMARKS
1	6S5-15590-00	STARTER ONE-WAY ASSY	1	1	1	
2	90110-08212	BOLT, HEXAGON SOCKET HEAD	6	6	6	
3	6S5-15515-00	GEAR 3	1	1	1	
4	6S5-15521-00	SHAFT 1	1	1	1	
5	6S5-15517-00	GEAR, IDLER 2	1	1	1	
6	6S5-81450-01	ROTOR ASSY	1	1	1	
7	6S5-81410-11	STATOR ASSY	1	1	1	
8	90149-06229	SCREW	3	3	3	
9	97513-05514	BOLT, WITH WASHER	2	2	2	
10	90280-03047	KEY, WOODRUFF	1	1	1	
11	6S5-81337-20	COVER, FLYWHEEL	1	1	1	
12	93306-00805	BEARING	1	1	1	
13	6S5-81167-10	OIL SEAL	1	1	1	
14	99009-72500	CIRCLIP	1	1	1	
15	90105-08249	BOLT, FLANGE	9	9	9	
16	99530-10114	PIN, DOWEL	2	2	2	
17	6S5-81168-00	O-RING	1	1	1	
18	6S5-81328-00	CLAMP	1	1	1	
19	91317-06014	BOLT	2	2	2	
20	91317-05010	BOLT	1	1	1	
21	90201-052E8	WASHER, PLATE	1	1	1	
22	90387-06M05	COLLAR	2	2	2	
23	91380-06020	BOLT	2	2	2	
24	6S5-81364-10	GROMMET	2	2	2	

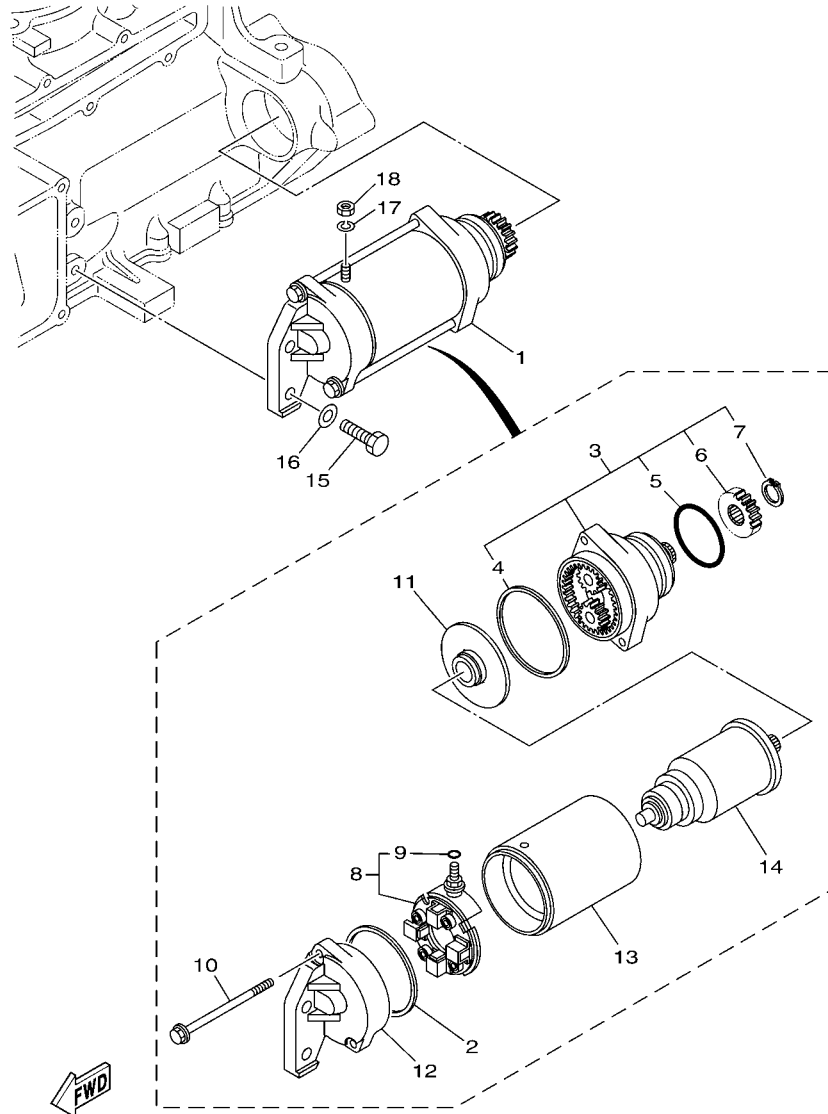

F1W1100-G200

FIG. 20 STARTING MOTOR

REF. NO.	PART NO.	DESCRIPTION	CAN	EUR	GENE	REMARKS
1	6S5-81800-00	STARTING MOTOR ASSY	1	1	1	
2	11H-81844-00	.GASKET	1	1	1	
3	6S5-81830-00	.FRONT BRACKET ASSY	1	1	1	
4	4G0-81844-00	..GASKET	1	1	1	
5	1J7-81847-60	..O-RING	1	1	1	
6	5EL-15511-00	..GEAR, STARTING MOTOR	1	1	1	
7	93410-12003	..CIRCLIP	1	1	1	
8	6S5-81840-00	.BRUSH HOLDER ASSY	1	1	1	
9	3TB-81847-00	..O-RING	1	1	1	
10	6S5-81826-00	.BOLT	2	2	2	
11	5EL-81845-00	.PLATE	1	1	1	
12	6S5-81820-00	.REAR BRACKET ASSY	1	1	1	
13	6S5-81810-00	.STATOR ASSY	1	1	1	
14	5A8-81850-10	.ARMATURE ASSY	1	1	1	
15	97013-08030	BOLT	2	2	2	
16	92903-08600	WASHER, PLATE	2	2	2	
17	92990-06100	WASHER, SPRING	1	1	1	
18	95380-06700	NUT	1	1	1	



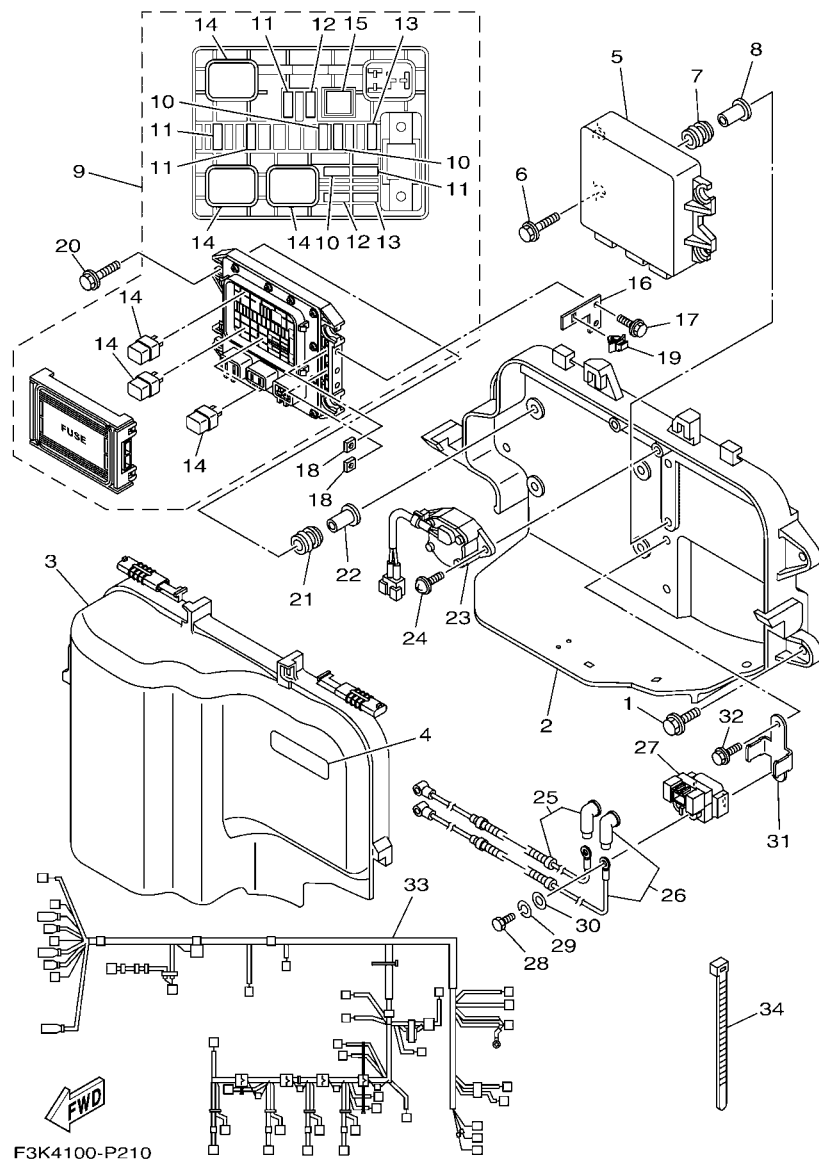

F3K4100-P210

FIG. 21 ELECTRICAL 1

REF. NO.	PART NO.	DESCRIPTION	CAN	EUR	GENE	REMARKS
1	90119-089UT	BOLT, WITH WASHER	4	4	4	
2	6CS-81845-00	PLATE	1	1	1	
3	6S5-81942-11	COVER	1	1	1	
4	60E-83627-00	LABEL, CAUTION 7	1	1	1	
5	6EV-8591A-20	ENGINE CONTROL UNIT ASSY	1			FOR CAN
6	6EV-8591A-40	ENGINE CONTROL UNIT ASSY		1		FOR EUR
7	6EV-8591A-30	ENGINE CONTROL UNIT ASSY			1	FOR GENE
6	90119-06M35	BOLT, WITH WASHER	4	4	4	
7	6A0-82317-00	DAMPER, IGNITION COIL	4	4	4	
8	90387-06119	COLLAR	4	4	4	
9	6EX-82170-10	FUSE BOX ASSY	1	1	1	
10	67F-82151-30	.FUSE (3A)	3	3	3	
11	67F-82151-40	.FUSE (10A)	4	4	4	
12	67F-82151-00	.FUSE (20A)	2	2	2	
13	67F-82151-10	.FUSE (30A)	2	2	2	
14	6EX-8195A-00	.RELAY ASSY	3	3	3	
15	6EX-2812A-00	.PULLER, FUSE	1	1	1	
16	6CS-82588-00	PLATE	1	1	1	
17	97595-06514	BOLT, WITH WASHER	2	2	2	
18	90173-06015	NUT, SQUARE	2	2	2	
19	90464-09M47	CLAMP	1	1	1	
20	90119-06M35	BOLT, WITH WASHER	4	4	4	
21	6A0-82317-00	DAMPER, IGNITION COIL	4	4	4	
22	90387-06119	COLLAR	4	4	4	
23	6S5-8259E-00	SWITCH ASSY	1	1	1	
24	97780-60520	SCREW, TAPPING	2	2	2	
25	6CS-82115-00	WIRE, PLUS LEAD	1	1	1	

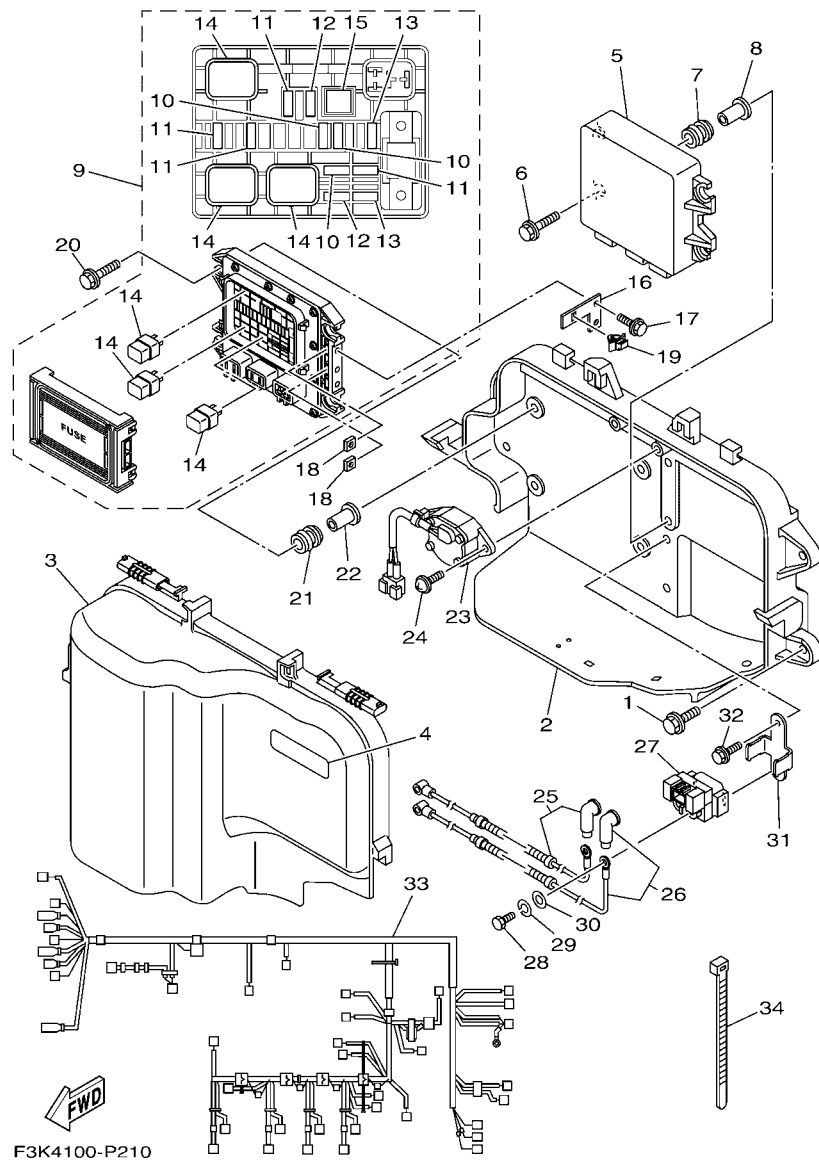
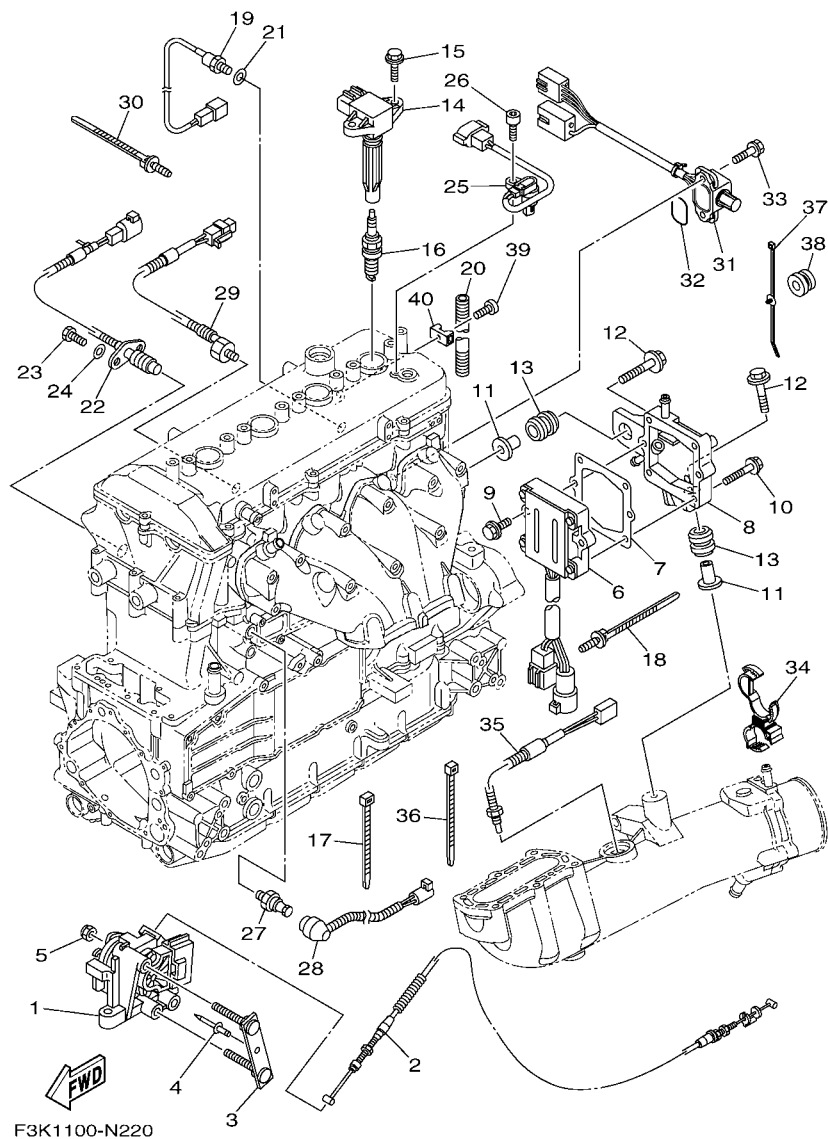

FIG. 21 ELECTRICAL 1

REF. NO.	PART NO.	DESCRIPTION	CAN	EUR	GENE	REMARKS
26	6CS-82117-00	WIRE, LEAD	1	1	1	
27	1B7-81940-00	STARTER RELAY ASSY (2768102-A)	1	1	1	
28	97095-06012	BOLT	2	2	2	
29	92995-06100	WASHER, SPRING	2	2	2	
30	92995-06600	WASHER	2	2	2	
31	6CS-81953-00	STAY, RELAY	1	1	1	
32	95814-06012	BOLT, FLANGE	2	2	2	
33	6EV-8259L-10	WIRE HARNESS ASSY 1	1	1	1	
34	90465-14M66	CLAMP	2	2	2	



F3K1100-N220

FIG. 22 ELECTRICAL 2

REF. NO.	PART NO.	DESCRIPTION	CAN	EUR	GENE	REMARKS
1	6D3-14305-21	ACCEL. POSITON SENSOR ASSY	1	1	1	
2	6AN-26311-00	CABLE, THROTTLE 1	1	1	1	
3	F2N-U7254-00	BRACKET, THROTTLE	1	1	1	
4	90267-489U1	RIVET,BLIND	1	1	1	
5	95780-08300	NUT, FLANGE	2	2	2	
6	6S5-81960-10	RECTIFIER & REGULATOR ASSY	1	1	1	
7	6S5-81975-00	PLATE, RECTIFIER FITTING	1	1	1	
8	6S5-81972-01-94	COVER, RECTIFIER	1	1	1	
9	90119-06MA3	BOLT, WITH WASHER	2	2	2	
10	90119-06048	BOLT, WITH WASHER	4	4	4	
11	90387-08M37	COLLAR	2	2	2	
12	90119-08M22	BOLT, WITH WASHER	2	2	2	
13	90480-22M15	GROMMET	2	2	2	
14	6S5-82310-00	IGNITION COIL ASSY	4	4	4	
15	90105-06903	BOLT, FLANGE	8	8	8	
16	94702-00435	PLUG, SPARK (NGK LFR7A)	4	4	4	
17	90465-13M18	CLAMP	8	8	8	
18	90464-31001	CLAMP	1	1	1	
19	61A-85790-00	THERMOSENSOR ASSY	1	1	1	
20	90446-10MH3	HOSE (L350)	1	1	1	
21	92990-10600	WASHER, PLATE	1	1	1	
22	60E-82560-01	THERMO SWITCH ASSY	1	1	1	
23	97095-06016	BOLT	2	2	2	
24	92995-06600	WASHER	2	2	2	
25	60E-85896-01	SENSOR, CAM POSITION	1	1	1	
26	91380-06016	BOLT	1	1	1	
27	68V-82504-00	OIL PRESSURE SWITCH ASSY	1	1	1	

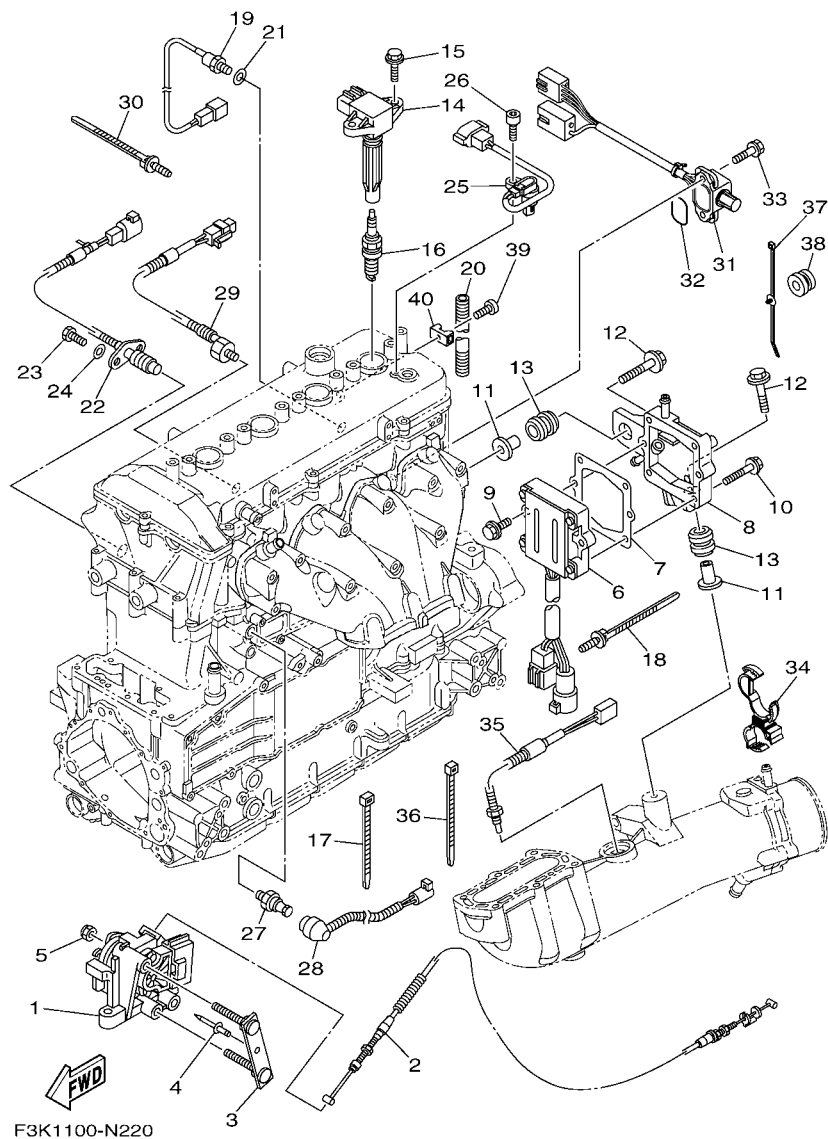

FIG. 22 ELECTRICAL 2

REF. NO.	PART NO.	DESCRIPTION	CAN	EUR	GENE	REMARKS
28	6S5-81315-00	LEAD WIRE ASSY	1	1	1	
29	6AN-85780-00	SENSOR, KNOCK	1	1	1	
30	90464-31001	CLAMP	1	1	1	
31	6CS-8273J-10	EARTH PLATE COMP.	1	1	1	
32	93210-32172	O-RING	1	1	1	
33	90119-06MA3	BOLT, WITH WASHER	2	2	2	
34	90464-20008	CLAMP	1	1	1	
35	6AA-85790-00	THERMOSENSOR ASSY	1	1	1	
36	90464-31001	CLAMP	1	1	1	
37	90464-31002	CLAMP	1	1	1	
38	90480-20132	GROMMET	1	1	1	
39	92014-06012	BOLT, BUTTON HEAD	1	1	1	
40	60E-1244E-00	BRACKET 1	1	1	1	

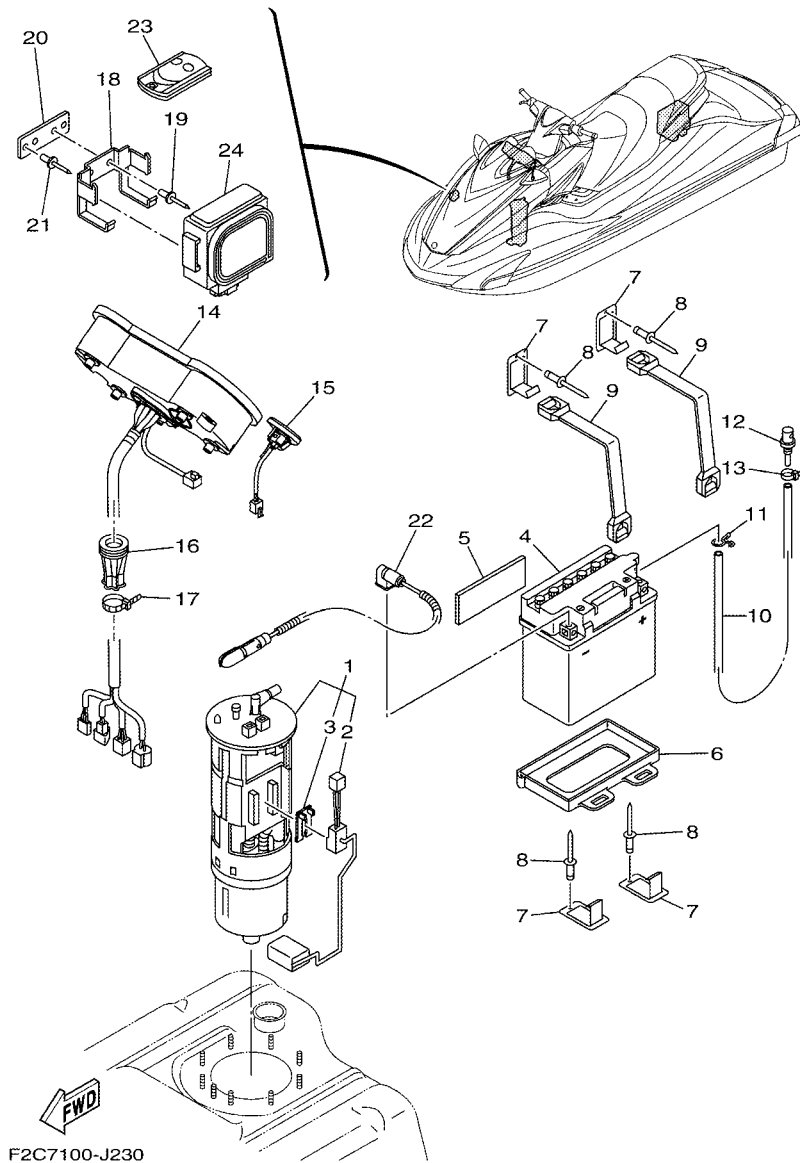
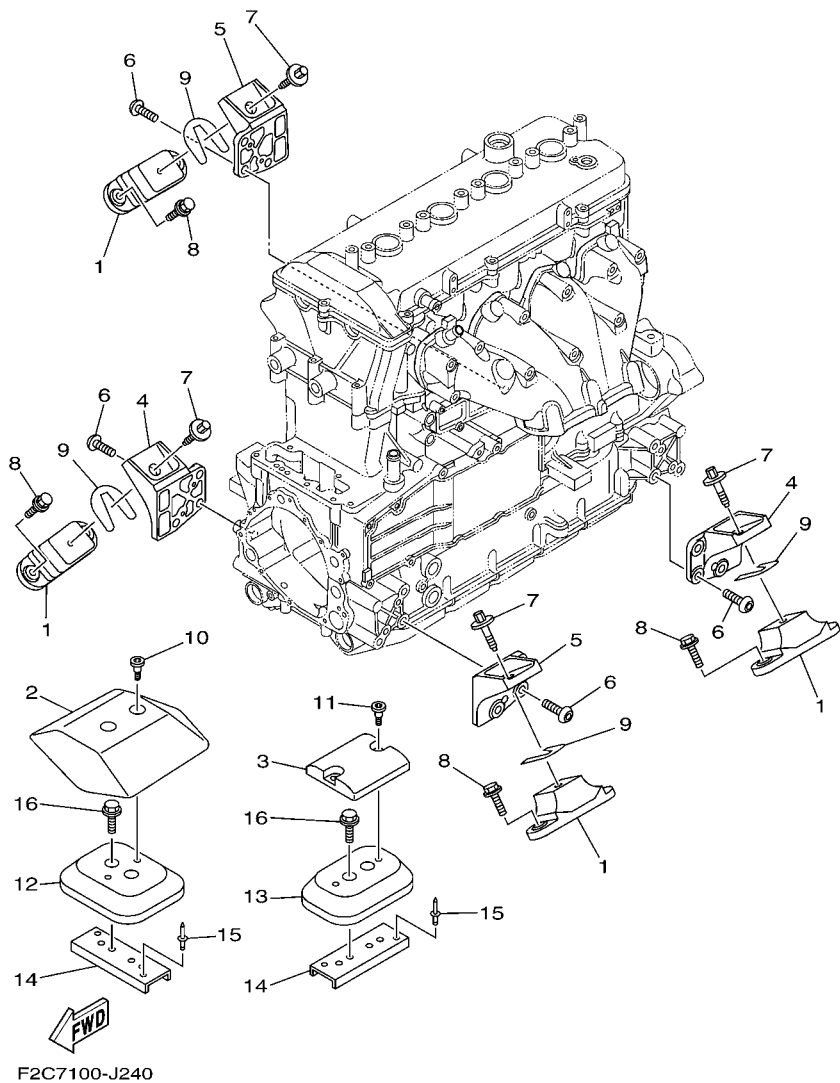

FIG. 23 ELECTRICAL 3

REF. NO.	PART NO.	DESCRIPTION	CAN	EUR	GENE	REMARKS
1	6S5-13907-01	FUEL PUMP COMP.	1	1	1	
2	6S5-682E0-00	.FUEL SENDER ASSY	1	1	1	
3	60E-82556-00	.DAMPER, STOPPER	1	1	1	
4	EU0-82110-09	BATTERY ASSY (YB16CL-B)	1	1	1	YUASA
5	F1K-U8221-00	PAD, BATTERY	1	1	1	
6	F1K-U8211-01	CASE, BATTERY	1	1	1	
7	F1K-U5772-04	HOOK A	4	4	4	
8	90267-489U1	RIVET,BLIND	4	4	4	
9	F1K-U821D-01	BAND, BATTERY 1	2	2	2	
10	F0D-U785G-10	HOSE, AIR VENT	1	1	1	
11	90467-089U1	CLIP	1	1	1	
12	GJ3-6215F-00	NIPPLE	1	1	1	
13	90465-11829	CLAMP	1	1	1	
14	F2C-6820A-10	METER ASSY	1	1	1	
15	F2C-68090-00	SWITCH ASSY.	1	1	1	
16	F1X-U822E-00	GROMMET	1	1	1	
17	90601-200U1	BAND	1	1	1	
18	F1W-U826C-00	BRACKET	1	1	1	
19	90267-489U1	RIVET,BLIND	2	2	2	
20	F1W-U8376-00	PLATE	1	1	1	
21	90267-489U1	RIVET,BLIND	2	2	2	
22	6S5-82116-00	WIRE, MINUS LEAD	1	1	1	
23	6B6-86261-00	XMTR. COMP.	2			FOR CAN
	6B6-86261-10	XMTR. COMP.		2	2	FOR EUR, GENE
24	6B6-86265-00	RECEIVER COMPLETE	1			FOR CAN
	6B6-86265-10	RECEIVER COMPLETE		1	1	FOR EUR, GENE

FIG. 24 ENGINE MOUNT



REF. NO.	PART NO.	DESCRIPTION	CAN	EUR	GENE	REMARKS
1	67X-44517-10	MOUNT RUBBER	4	4	4	
2	6BH-G4532-00	STOPPER, UPPER MOUNT	1	1	1	
3	6BH-G4574-00	STOPPER, LOWER MOUNT RUBBER	1	1	1	
4	6BH-41661-00-94	BRACKET 1	2	2	2	
5	6BH-41662-00-94	BRACKET 2	2	2	2	
6	90149-10052	SCREW	12	12	12	
7	90119-08859	BOLT, WITH WASHER	4	4	4	
8	90119-08823	BOLT, WITH WASHER	8	8	8	
9	EU0-U7354-00-01	SHIM (T=0.1)	10	10	10	UN
	EU0-U7354-00-03	SHIM (T=0.3)	10	10	10	UN
	EU0-U7354-00-05	SHIM (T=0.5)	10	10	10	UN
	EU0-U7354-00-10	SHIM (T=1.0)	10	10	10	UN
	EU0-U7354-00-20	SHIM (T=2.0)	10	10	10	UN
10	90109-06874	BOLT	2	2	2	
11	90109-06875	BOLT	2	2	2	
12	F2C-U721B-00	SPACER,ENGINE MOUNT	1	1	1	
13	F2C-U721B-10	SPACER,ENGINE MOUNT	1	1	1	
14	F2N-U732B-10	PLATE	2	2	2	
15	90267-489U2	RIVET, BLIND	4	4	4	
16	90119-06891	BOLT, WITH WASHER	4	4	4	

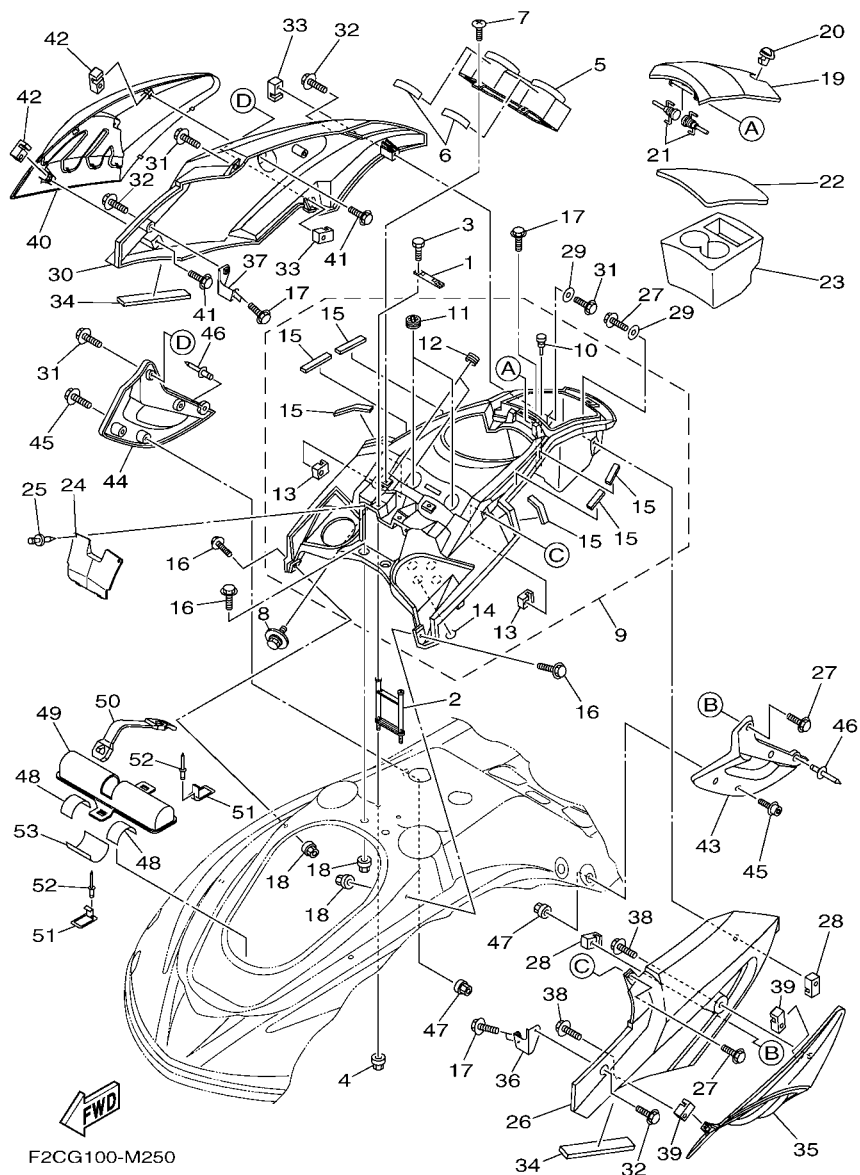

F2CG100-M250

FIG. 25 ENGINE HATCH 1

REF. NO.	PART NO.	DESCRIPTION	CAN	EUR	GENE	REMARKS
1	F1W-U517F-00	HOOK,LID LOCK	1	1	1	
2	F1W-U555D-02	BRKT., COVER CENTER 1	1	1	1	
3	90101-05800	BOLT	2	2	2	
4	F2N-U142L-00	NUT, LOCK	2	2	2	
5	F2C-U82AA-00	METER COVER ASSY.	1	1	1	
6	F0X-U515E-01	DAMPER 2	2	2	2	
7	90149-05903	SCREW	2	2	2	
8	90119-05803	BOLT, WITH WASHER	4	4	4	
9	F2C-U5508-02	CENTER COVER ASSY.	1	1	1	
10	90605-502U2	.PLUG	1	1	1	
11	F1X-U828E-01	.DAMPER 1	2	2	2	
12	90480-19800	.GROMMET	4	4	4	
13	F1X-U517E-01	.NUT	2	2	2	
14	F2R-U884B-00	.SEAL 1	4	4	4	
15	F0X-U515E-01	.DAMPER 2	6	6	6	
16	90119-06880	BOLT, WITH WASHER	4	4	4	
17	90119-06882	BOLT, WITH WASHER	5	5	5	
18	F2N-U142L-00	NUT, LOCK	4	4	4	
19	F2C-U517H-01	LID HATCH	1	1	1	
20	GU2-62875-02	LOCK	1	1	1	
21	F1B-6517R-00	PIN, HINGE	2	2	2	
22	F2C-U519D-01	PACKING CASE	1	1	1	
23	F2C-U5633-00	HOLDER, DRINK	1	1	1	
24	F1W-U555B-00	SEAL, COVER CENTER	1	1	1	
25	F1W-U2698-00	RIVET	2	2	2	
26	F2C-U377B-02-P9	COVER, SIDE 1 (RM9)	1	1	1	FOR RED
27	90119-06880	BOLT, WITH WASHER	3	3	3	

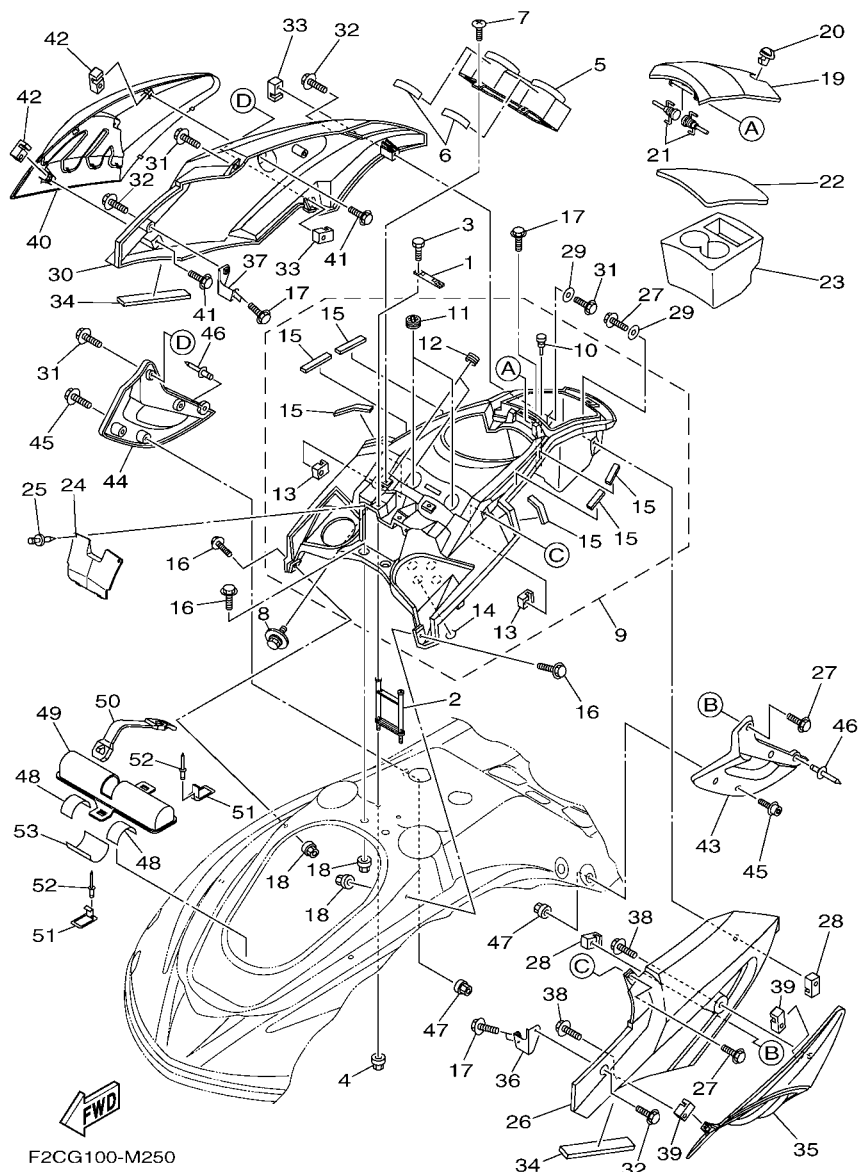

F2CG100-M250

FIG. 25 ENGINE HATCH 1

REF. NO.	PART NO.	DESCRIPTION	CAN	EUR	GENE	REMARKS
28	F1X-U517E-01	NUT	2	2	2	
29	90201-068G7	WASHER, PLATE	2	2	2	
30	F2C-U377C-02-P9	COVER, SIDE 2 (RM9)	1	1	1	FOR RED
31	90119-06880	BOLT, WITH WASHER	3	3	3	
32	90119-06882	BOLT, WITH WASHER	3	3	3	
33	F1X-U517E-01	NUT	2	2	2	
34	F2C-U515D-00	DAMPER 1	2	2	2	
35	F2C-U517W-00	ORNAMENT, LH	1	1	1	
36	F2C-U377M-00	BRKT., COVER SIDE 1	1	1	1	
37	F2C-U377N-00	BRKT., COVER SIDE 2	1	1	1	
38	90119-06880	BOLT, WITH WASHER	2	2	2	
39	F1X-U517E-01	NUT	2	2	2	
40	F2C-U517X-00	ORNAMENT, RH	1	1	1	
41	90119-06880	BOLT, WITH WASHER	2	2	2	
42	F1X-U517E-01	NUT	2	2	2	
43	F2C-U353B-20	PAD, KNEE	1	1	1	
44	F2C-U353B-30	PAD, KNEE	1	1	1	
45	90110-06823	BOLT, HEXAGON SOCKET HEAD	6	6	6	
46	90267-48807	RIVET, BLIND	2	2	2	
47	F2N-U142L-00	NUT, LOCK	6	6	6	
48	F1K-U759C-00	MAT 2	2	2	2	
49	F1K-U5983-01	BOX, FIRE EXTINGUISHER	1	1	1	
50	F2P-U828K-00	BAND 1	1	1	1	
51	F1K-U5772-04	HOOK A	2	2	2	
52	90267-489U1	RIVET, BLIND	2	2	2	
53	F1S-U8221-00	PAD, BATTERY	1	1	1	



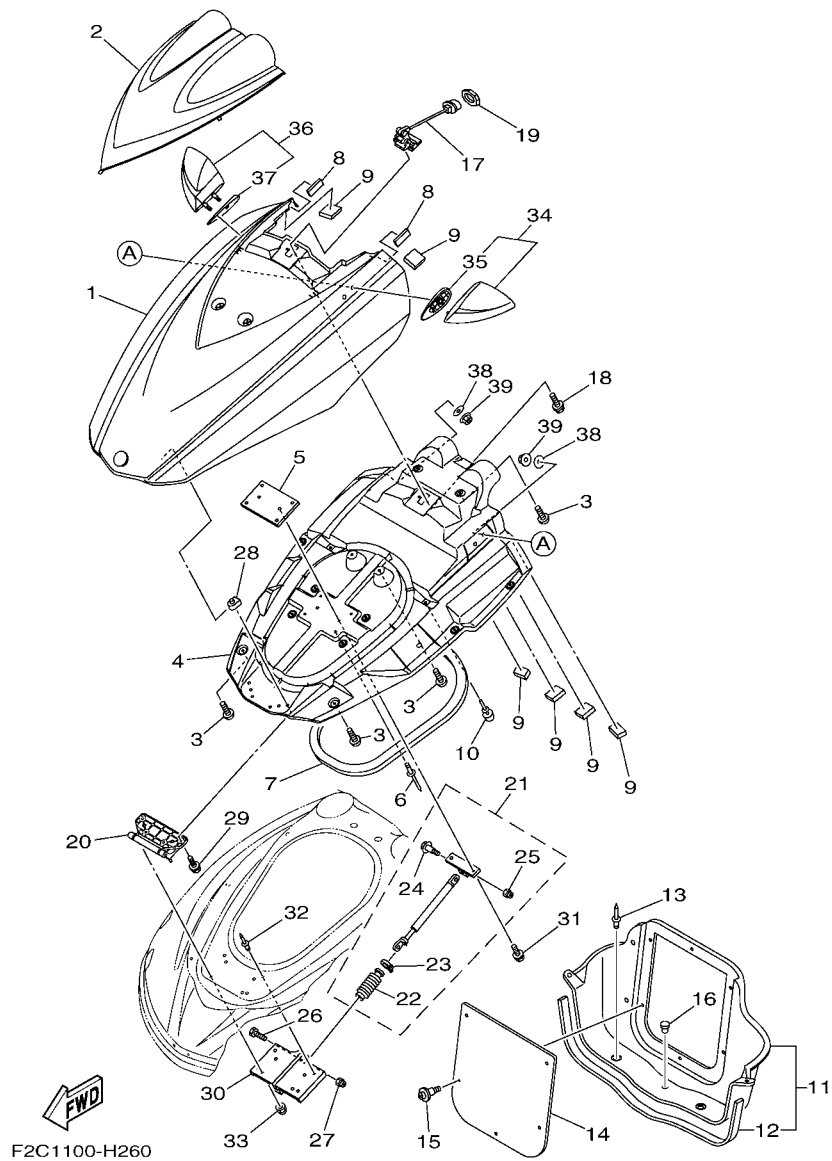

FIG. 26 ENGINE HATCH 2

REF. NO.	PART NO.	DESCRIPTION	CAN	EUR	GENE	REMARKS
1	F2C-U517B-02-P9	LID, ENGINE ROOM (RM9)	1	1	1	FOR RED
2	F2C-U515N-20	VISOR	1	1	1	
3	90149-05903	SCREW	14	14	14	
4	F2C-U213B-01	COVER, VENTILATOR 1	1	1	1	
5	F1W-U5148-00	PLATE, HATCH	1	1	1	
6	90267-48807	RIVET, BLIND	4	4	4	
7	F1K-U2663-01	PACKING 1	1	1	1	
8	F1K-U266B-00	PACKING 3	2	2	2	
9	F2C-U1743-00	PACKING	6	6	6	
10	F1W-U3768-01	CUSHION, RUBBER	2	2	2	
11	F2C-U475B-00	LOCKER, BOW	1	1	1	
12	F2C-U266C-00	.PACKING 4	1	1	1	
13	F3J-U516R-00	RIVET 1	4	4	4	
14	F1W-U475F-01	PLATE, LOKER BOW	1	1	1	
15	90269-08801	RIVET	5	5	5	
16	90605-502U1	PLUG, BLIND	1	1	1	
17	F2C-U517C-01	LOCK, LID	1	1	1	
18	90119-059U4	BOLT, WITH WASHER	2	2	2	
19	F2C-U518D-00	PACKING	1	1	1	
20	F2C-U517D-00	HINGE, LID	1	1	1	
21	F2C-6514S-00	DAMPER ASSY	1	1	1	
22	F1W-6514T-00	.COVER, DAMPER	1	1	1	
23	1UA-82591-00	.BAND	1	1	1	
24	90109-06218	.BOLT	1	1	1	
25	95720-06300	.NUT, SELF-LOCKING	1	1	1	
26	90109-06218	BOLT	1	1	1	
27	9572R-06300	NUT, NYLON	1	1	1	



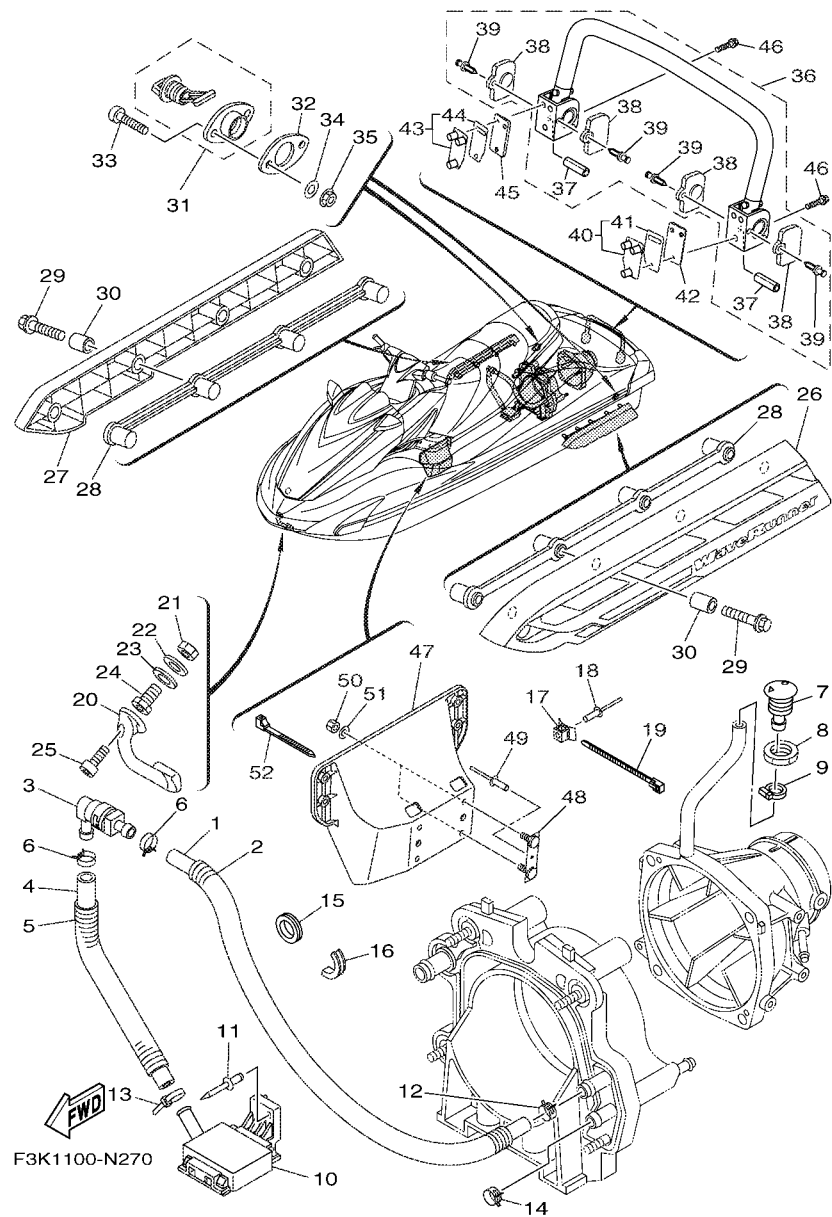

FIG. 27 HULL & DECK

REF. NO.	PART NO.	DESCRIPTION	CAN	EUR	GENE	REMARKS
1	90445-20804	HOSE (L860)	1	1	1	
2	90446-27M73	HOSE (L700)	1	1	1	
3	68N-5112T-00	JOINT, HOSE	1	1	1	
4	90445-20800	HOSE (L500)	1	1	1	
5	90446-27M55	TUBE (L400)	1	1	1	
6	90467-18804	CLIP	2	2	2	
7	F1W-U269B-00	SPOUT	1	1	1	
8	EU0-61652-00	NUT	1	1	1	
9	90601-118UF	BAND, HOSE 18	1	1	1	
10	F1B-U761D-02	STRAINER, BILGE	1	1	1	
11	90267-489U8	RIVET, BLIND	1	1	1	
12	90467-21800	CLIP	1	1	1	
13	90601-200U1	BAND	1	1	1	
14	90467-200A0	CLIP	1	1	1	
15	90480-38800	GROMMET	1	1	1	
16	F1S-U828H-01	TRIM, 1	1	1	1	
17	F1W-U828M-00	BASE, CLAMP	2	2	2	
18	90267-48802	RIVET, BLIND	2	2	2	
19	90464-32801	CLAMP	2	2	2	
20	F1K-61624-00	BOWEYE 1	1	1	1	
21	99780-12600	NUT, HEX. (COARS)	2	2	2	
22	92990-12200	WASHER, PLAIN	2	2	2	
23	F0X-61637-00	WASHER	2	2	2	
24	F0X-61652-00	NUT (BOLT/NUT)	2	2	2	
25	90110-06040	BOLT, HEXAGON SOCKET HEAD	2	2	2	
26	F2S-U883N-01	STABILIZER LH	1	1	1	
27	F2S-U883P-01	STABILIZER RH	1	1	1	

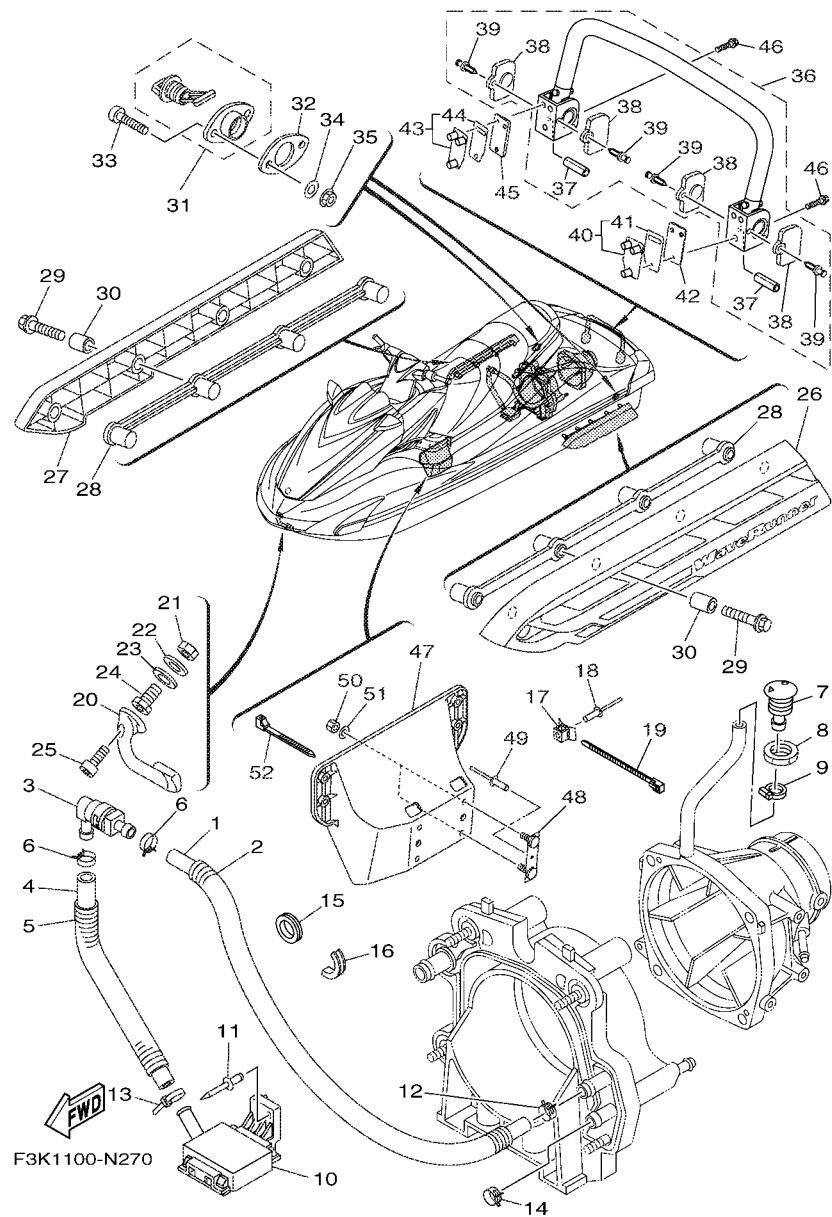
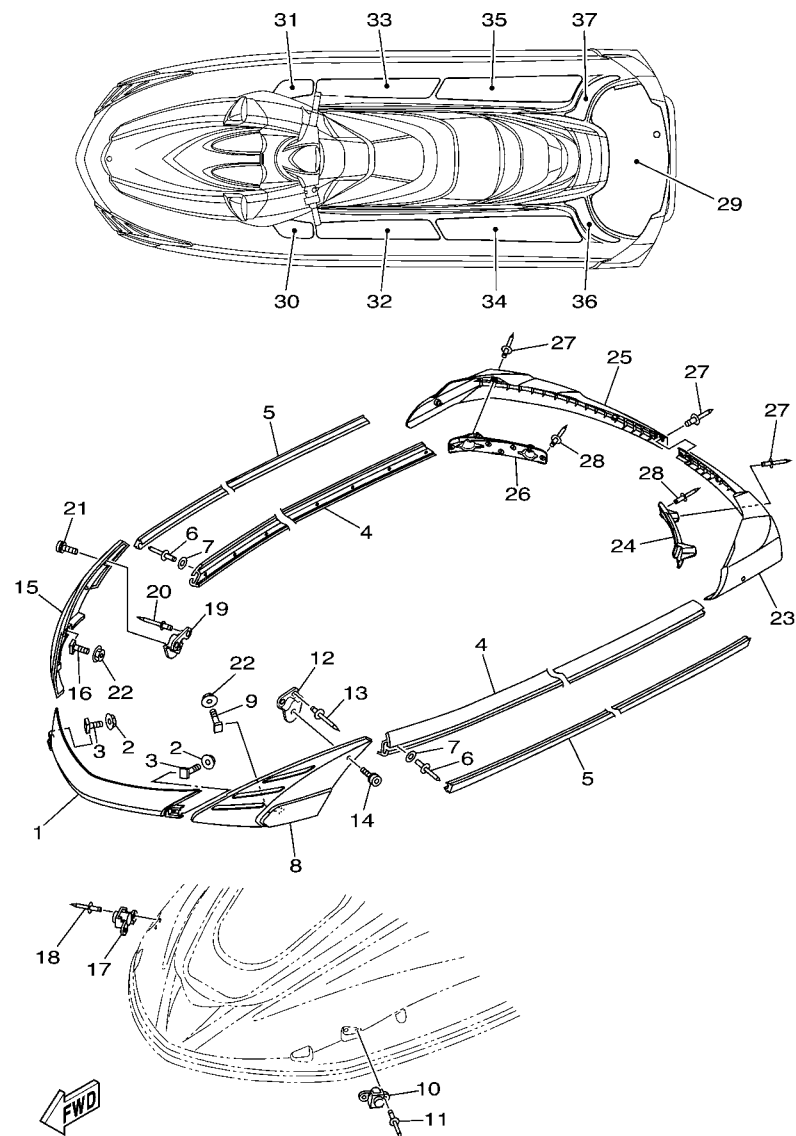

FIG. 27 HULL & DECK

REF. NO.	PART NO.	DESCRIPTION	CAN	EUR	GENE	REMARKS
28	F2S-U883T-00	BRACKET,STABILIZER	2	2	2	
29	90105-08860	BOLT, FLANGE	8	8	8	
30	F2N-U8169-00	SPACER	8	8	8	
31	F1S-U2280-02	DRAIN PLUG ASSY.	2	2	2	
32	F1S-U2285-00	PACKING, DRAIN	2	2	2	
33	9788R-05025	SCREW, PAN HEAD	4	4	4	
34	9299R-05200	WASHER	4	4	4	
35	9572R-05300	NUT, FLANGE	4	4	4	
36	F2C-U278A-00	LADDER, STEP ASSY	1	1	1	
37	F1W-U771H-00	.SLEEVE 1	2	2	2	
38	F2C-U377H-00	.INNER, COVER SIDE 1	4	4	4	
39	F2C-U1314-00	.PIN	4	4	4	
40	F2C-U278F-00	BRACKET, LADDER LH	1	1	1	
41	F2C-U278H-00	.PACKING, BRKT. 1	1	1	1	
42	F2C-U278L-00	BRACKET 2	1	1	1	
43	F2C-U278G-00	BRACKET, LADDER RH	1	1	1	
44	F2C-U278H-00	.PACKING, BRKT. 1	1	1	1	
45	F2C-U278K-00	BRACKET 1	1	1	1	
46	90119-08844	BOLT, WITH WASHER	6	6	6	
47	F1W-U8572-01	BRACKET 2	1	1	1	
48	F1K-U826C-03	BRACKET	2	2	2	
49	90267-489U1	RIVET,BLIND	2	2	2	
50	9572R-08300	NUT, FLANGE	4	4	4	
51	9299R-08200	WASHER	4	4	4	
52	90464-32801	CLAMP	1	1	1	

FIG. 28 GUNWALE & MAT



F2CA100-K280

REF. NO.	PART NO.	DESCRIPTION	CAN	EUR	GENE	REMARKS
1	F2C-U2511-11	GUNWALE, BOW	1	1	1	YAMAHA BLACK
2	F2N-U142L-00	NUT, LOCK	4	4	4	
3	F1W-U491K-00	BOLT, SPECIAL	4	4	4	
4	F1B-U2512-10	GUNWALE, SIDE	2	2	2	YB
5	F1B-U2519-10	INNER, GUNWALE	2	2	2	YAMAHA BLACK
6	90267-489U8	RIVET, BLIND	36	36	36	
7	9299R-05200	WASHER	36	36	36	
8	F1W-U252E-21	JOINT, GUNWALE LH	1	1	1	YAMAHA BLACK
9	F1W-U491K-00	BOLT, SPECIAL	2	2	2	
10	F1W-U250B-00	GROMMET ASSY	1	1	1	
11	90267-489U6	RIVET, BLIND	2	2	2	
12	F1W-U4949-00	BRACKET	1	1	1	
13	90267-489U6	RIVET, BLIND	2	2	2	
14	90111-06114	BOLT, HEX. SOCKET BUTTON	1	1	1	
15	F1W-U252F-21	JOINT, GUNWALE RH	1	1	1	YAMAHA BLACK
16	F1W-U491K-00	BOLT, SPECIAL	2	2	2	
17	F1W-U250B-00	GROMMET ASSY	1	1	1	
18	90267-489U6	RIVET, BLIND	2	2	2	
19	F1W-U4949-00	BRACKET	1	1	1	
20	90267-489U6	RIVET, BLIND	2	2	2	
21	90111-06114	BOLT, HEX. SOCKET BUTTON	1	1	1	
22	F2N-U142L-00	NUT, LOCK	4	4	4	
23	F1W-U251D-20	GUNWALE, STERN 1	1	1	1	YB
24	F1W-U251L-01	BRACKET, GUNWALE 1	1	1	1	
25	F1W-U251E-20	GUNWALE, STERN 2	1	1	1	YB
26	F1W-U251M-01	BRACKET, GUNWALE 2	1	1	1	
27	90267-48825	RIVET, BLIND	9	9	9	





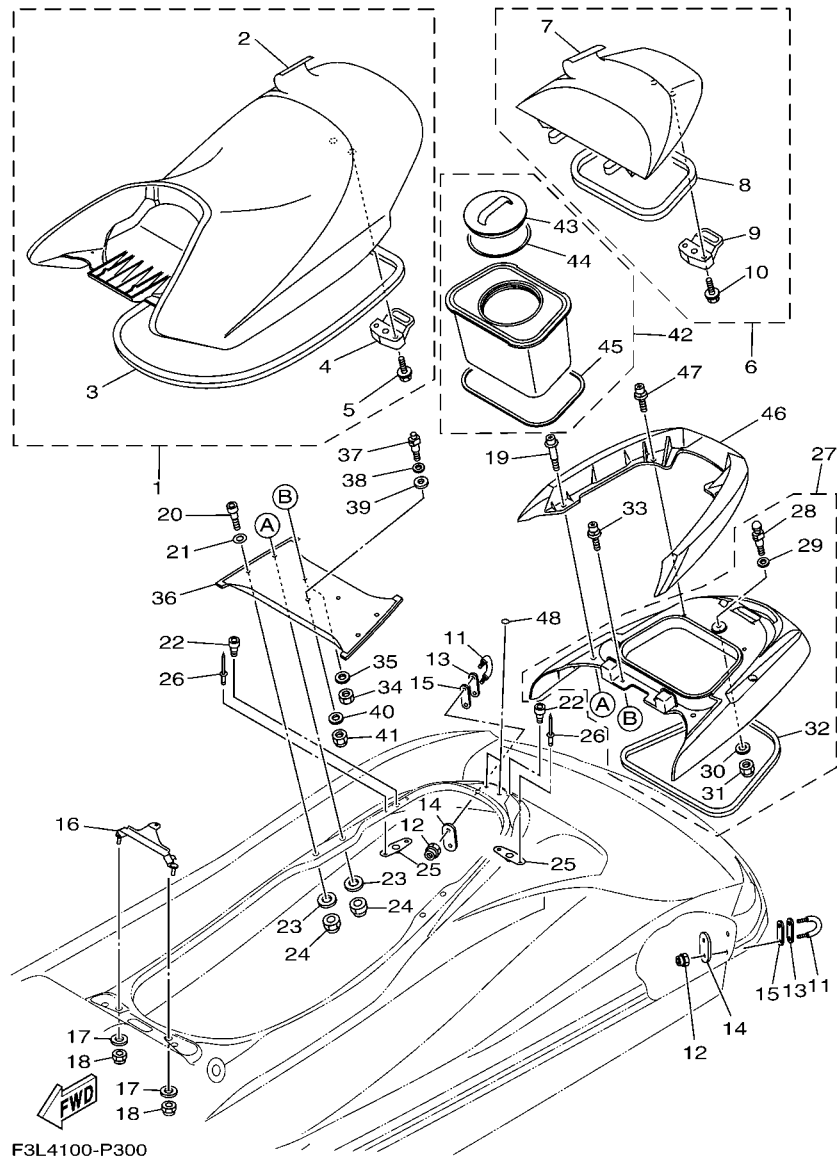

F3L4100-P300

FIG. 30 SEAT & UNDER LOCKER

REF. NO.	PART NO.	DESCRIPTION	CAN	EUR	GENE	REMARKS
1	F2R-U371A-40	DOUBLE SEAT ASSY	1	1	1	
2	F2R-U371B-40	.COVER, SEAT 1	1	1	1	
3	F1W-U2664-01	.PACKING	1	1	1	
4	F1B-U3850-02	.SEAT LOCK ASSY	1	1	1	
5	90119-069UP	.BOLT, WITH WASHER	2	2	2	
6	F2R-U372A-40	SINGLE SEAT ASSY	1	1	1	
7	F2R-U372B-40	.COVER, SEAT	1	1	1	
8	F2C-U266D-01	.PACKING 5	1	1	1	
9	F2C-U3850-00	.SEAT LOCK ASSY	1	1	1	
10	90119-069UP	.BOLT, WITH WASHER	2	2	2	
11	F2N-U1628-02	STERN EYE	2	2	2	
12	9572R-08300	NUT, FLANGE	4	4	4	
13	GP7-U4953-10	PLATE A	2	2	2	
14	F2C-U4953-10	PLATE A	2	2	2	
15	F1B-U1653-02	PACKING	2	2	2	
16	F2C-U378C-00	STAY, SEAT 1	1	1	1	
17	90201-099U3	WASHER, PLATE	2	2	2	
18	9572R-08300	NUT, FLANGE	2	2	2	
19	F2C-U2624-01	BOLT	2	2	2	
20	F2C-U2624-20	BOLT	2	2	2	
21	9299R-10200	WASHER	2	2	2	
22	F2C-U2624-10	BOLT	3	3	3	
23	9299R-08200	WASHER	4	4	4	
24	9572R-08300	NUT, FLANGE	4	4	4	
25	F2C-U826C-00	BRACKET	3	3	3	
26	90267-489U1	RIVET,BLIND	6	6	6	
27	F2C-U890L-10	DECK BEAM ASSY	1	1	1	



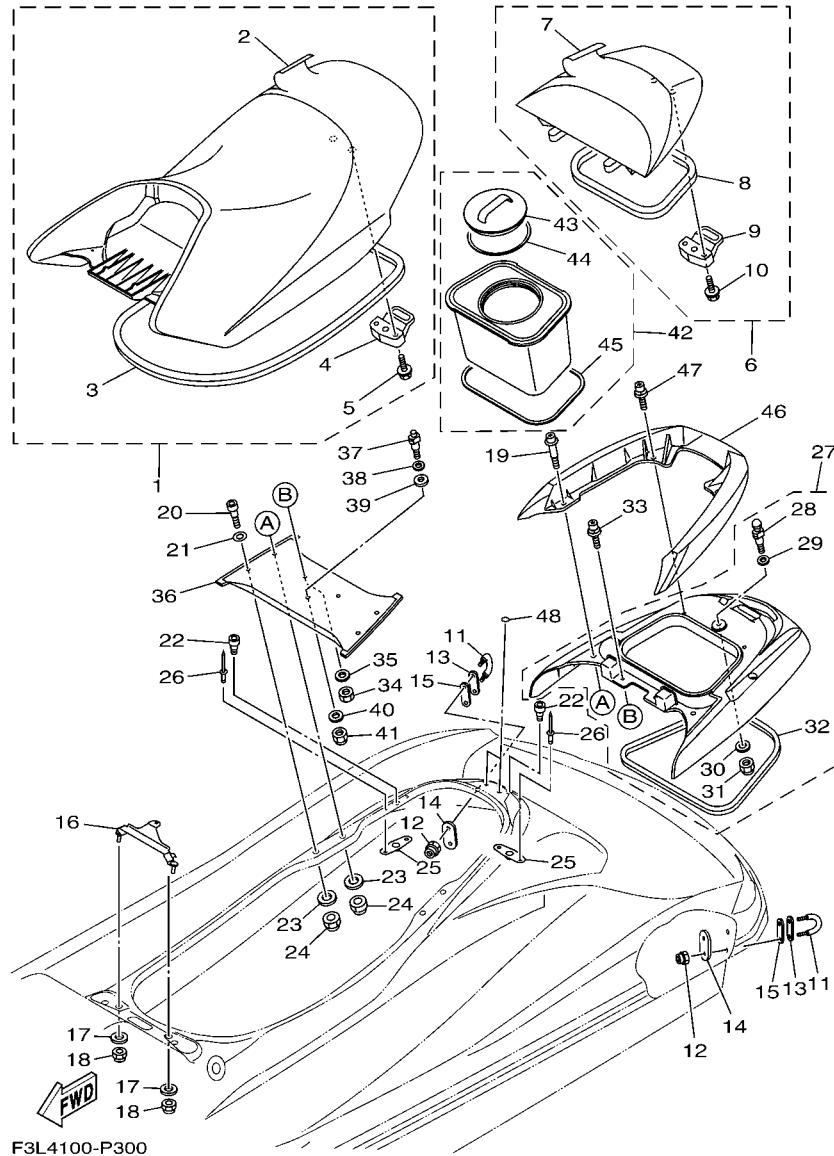

F3L4100-P300

FIG. 30 SEAT & UNDER LOCKER

REF. NO.	PART NO.	DESCRIPTION	CAN	EUR	GENE	REMARKS
28	GH1-U3774-00	.PIN	1	1	1	
29	90201-109U6	.WASHER, PLATE	1	1	1	
30	9299R-10200	.WASHER	1	1	1	
31	9572R-10300	.NUT, NYLON	1	1	1	
32	F2C-U375E-00	.PACKING 1	1	1	1	
33	F2C-U2624-30	BOLT	2	2	2	
34	9538R-08600	NUT	2	2	2	
35	9299R-08200	WASHER	2	2	2	
36	F2C-U8952-11	BEAM, DECK 1	1	1	1	
37	F1B-U3774-00	PIN	1	1	1	
38	92990-12200	WASHER, PLAIN	1	1	1	
39	F0X-6375E-00	PACKING 1	1	1	1	
40	9299R-10200	WASHER	1	1	1	
41	9572R-10300	NUT, NYLON	1	1	1	
42	F2C-U591A-02	CASE, ASSY 1	1	1	1	
43	F2C-U591C-00	.CAP, CASE	1	1	1	
44	F2C-U591D-01	.PACKING, CASE	1	1	1	
45	F2C-U266E-00	.PACKING, 6	1	1	1	
46	F2R-U271B-10	GRIP, HAND	1	1	1	
47	F2C-U2624-30	BOLT	2	2	2	
48	F2R-U884B-00	SEAL 1	2	2	2	

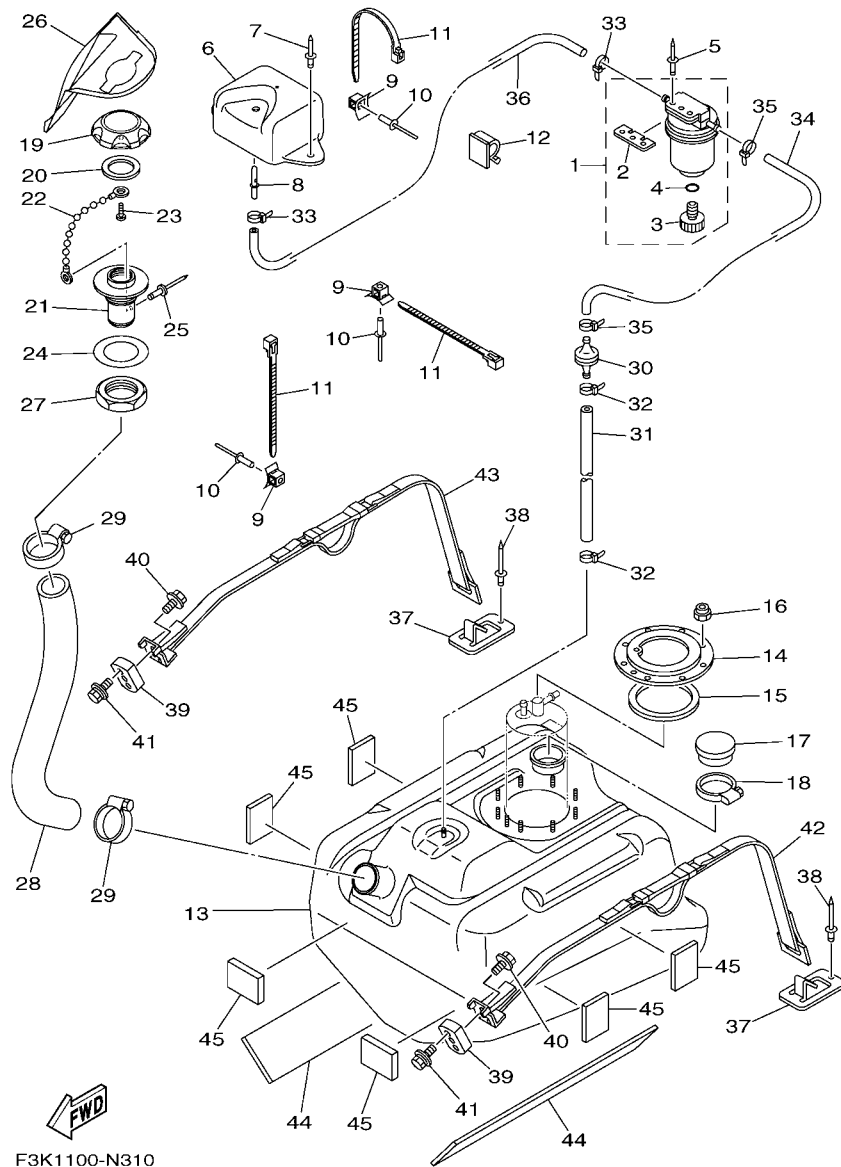

F3K1100-N310

FIG. 31 FUEL TANK

REF. NO.	PART NO.	DESCRIPTION	CAN	EUR	GENE	REMARKS
1	F2F-6214A-00	FILTER, VENT ASSY	1	1	1	
2	EW2-62142-00	.PLATE, FILTER	1	1	1	
3	70R-24543-00	.PLUG, DRAIN	1	1	1	
4	70R-24489-00	.O-RING	1	1	1	
5	90267-489U2	RIVET, BLIND	2	2	2	
6	F1W-U2159-00	SOCKET, VENTILATION	1	1	1	
7	90267-489U6	RIVET, BLIND	2	2	2	
8	F1G-62149-00	PIPE, VENTILATION	1	1	1	
9	F1W-U828M-00	BASE, CLAMP	3	3	3	
10	90267-489U6	RIVET, BLIND	3	3	3	
11	90464-32801	CLAMP	3	3	3	
12	90464-17800	CLAMP	1	1	1	
13	F1W-U7711-12	TANK, FUEL	1			FOR CAN
	F1W-U7711-03	TANK, FUEL		1	1	FOR EUR, GENE
14	F1B-U7773-00	RING	1	1	1	
15	F1B-67747-00	PACKING, SEAL	1	1	1	
16	9572R-06300	NUT, NYLON	9	9	9	
17	FN8-6771K-00	COVER	1	1	1	
18	90601-162U5	BAND, HOSE 62	1	1	1	
19	F2N-U7831-10	CAP, FUEL FILLER	1	1	1	BLACK
20	GP7-U7832-01	PACKING	1	1	1	
21	GP7-U7833-11	SOCKET	1	1	1	BLACK
22	GP7-U7835-00	CHAIN BALL	1	1	1	
23	90169-049U1	TAPPING SCREW	1	1	1	
24	GP7-U7834-10	PACKING FUEL FILLER	1	1	1	
25	90267-329UR	RIVET, BLIND	1	1	1	
26	F3K-U895D-00	PROTECTOR	1	1	1	

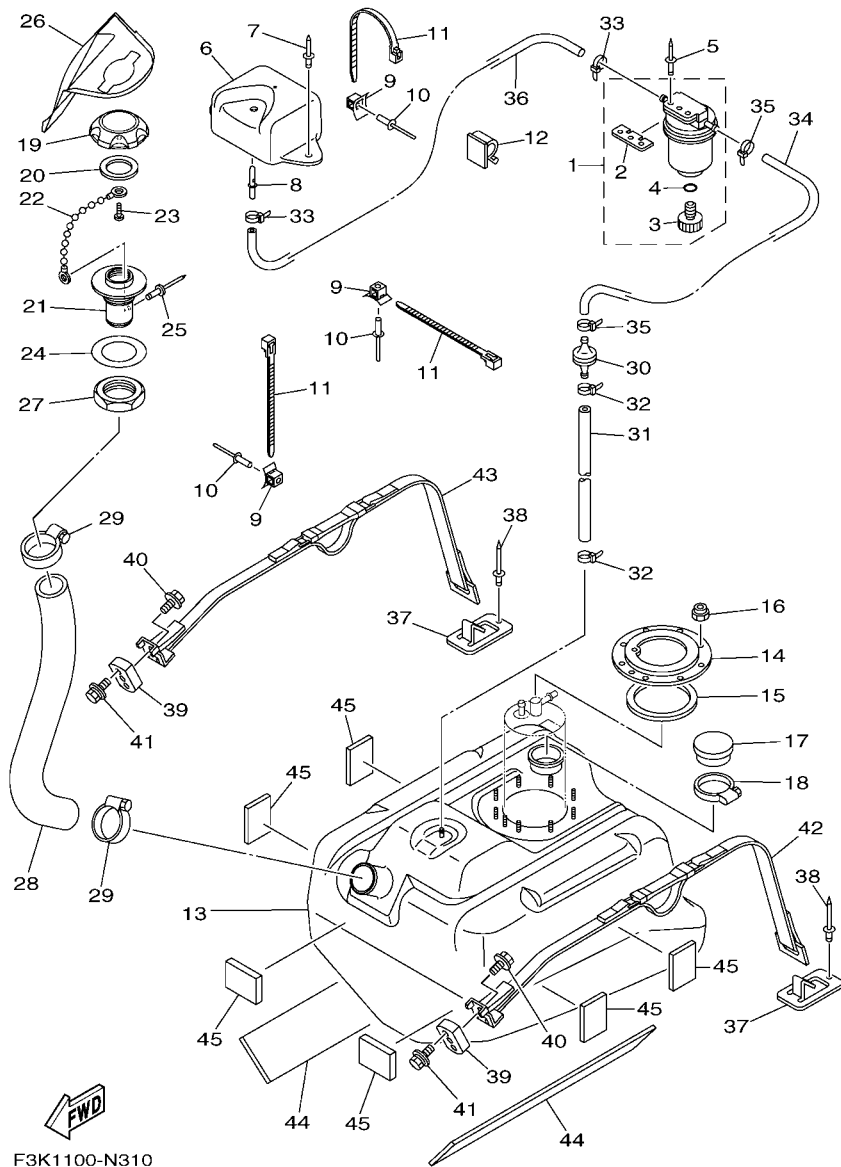

F3K1100-N310

FIG. 31 FUEL TANK

REF. NO.	PART NO.	DESCRIPTION	CAN	EUR	GENE	REMARKS
27	GP7-U783F-00	NUT, FUEL FILLER	1	1	1	
28	F2C-U7844-00	HOSE	1	1	1	
29	90601-155U4	BAND, HOSE 55	2	2	2	
30	EU0-67767-31	CHECK VALVE	1	1	1	
31	F2H-U785H-00	HOSE, AIR VENT 3	1	1	1	
32	90465-11829	CLAMP	2	2	2	
33	90465-11829	CLAMP	2	2	2	
34	F2C-U785G-00	HOSE, AIR VENT	1	1	1	
35	90465-11829	CLAMP	2	2	2	
36	F0D-U7856-10	HOSE, AIR VENT 3	1	1	1	
37	F1K-U5772-04	HOOK A	2	2	2	
38	90267-489U1	RIVET,BLIND	2	2	2	
39	F1X-U2873-00	NUT, SPECIAL	2	2	2	
40	90119-089U7	BOLT, WITH WASHER	2	2	2	
41	90119-069UH	BOLT, WITH WASHER	4	4	4	
42	F2C-67743-00	BELT, TANK 1	1	1	1	
43	F2C-67743-10	BELT, TANK 1	1	1	1	
44	F1W-U759B-00	MAT 1	2	2	2	
45	F1W-U759C-01	MAT 2	6	6	6	

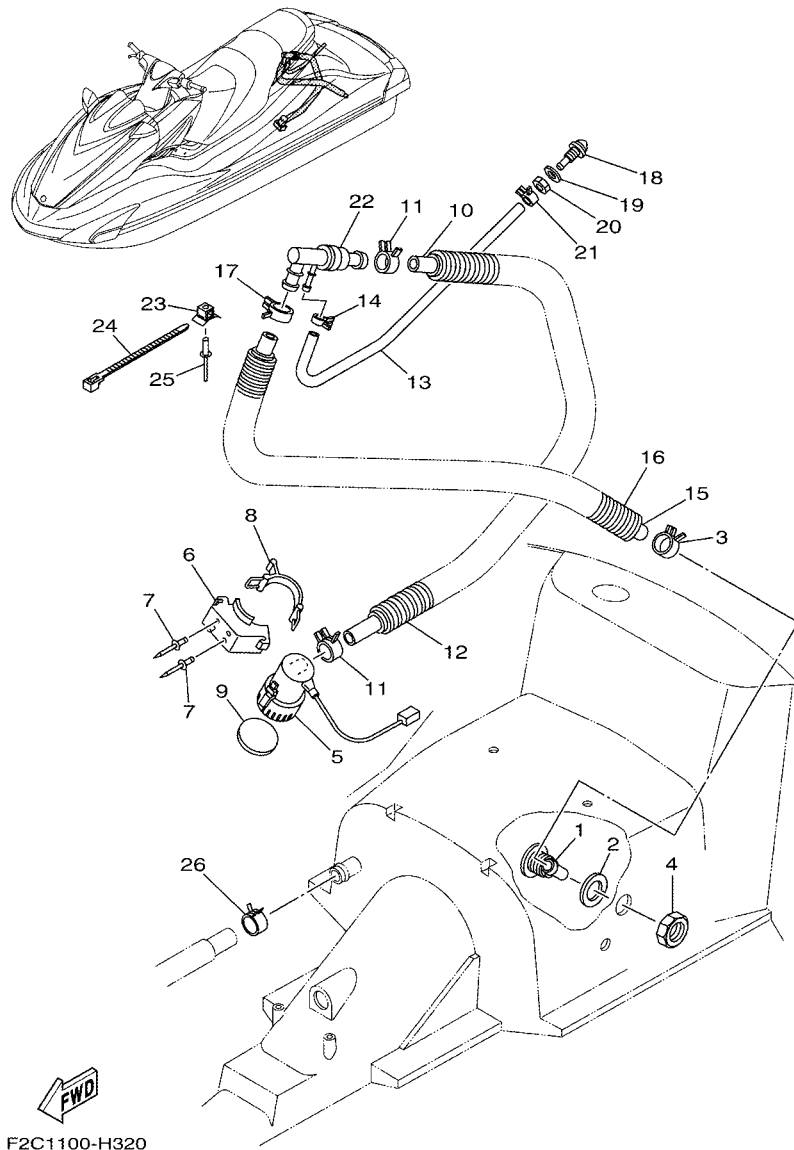

**FIG. 32 BILGE PUMP**

REF. NO.	PART NO.	DESCRIPTION	CAN	EUR	GENE	REMARKS
1	F1W-U224E-00	BODY, DRAIN 3	1	1	1	
2	F1S-U7525-01	PACKING	1	1	1	
3	90467-26800	CLIP	1	1	1	
4	F1B-62241-00	DRAIN, COCKPIT	1	1	1	
5	F1B-U8360-01	BILGE PUMP ASSY	1	1	1	
6	F1B-U7698-01	BRACKET	1	1	1	
7	F3J-U516R-00	RIVET 1	2	2	2	
8	GA7-68218-00	BAND, BATTERY	1	1	1	
9	F1B-U7656-00	PACKING, BILGE	1	1	1	
10	F1B-U7626-00	HOSE 1	1	1	1	
11	90467-25801	CLIP	2	2	2	
12	90447-28004	HOSE, WITH SPRING (L800)	1	1	1	
13	F1W-U7629-00	HOSE, DRAIN 2	1	1	1	
14	90467-14803	CLIP	1	1	1	
15	F1B-U7628-00	HOSE, DRAIN 3	1	1	1	
16	90447-28004	HOSE, WITH SPRING (L800)	1	1	1	
17	90467-26800	CLIP	1	1	1	
18	GH7-6753B-00	PILOT,WATER	1	1	1	
19	90430-16910	GASKET	1	1	1	
20	GP7-61652-00	NUT	1	1	1	
21	90467-14803	CLIP	1	1	1	
22	F1S-67620-00	HOSE JOINT	1	1	1	
23	F1W-U828M-00	BASE, CLAMP	1	1	1	
24	F2C-U4256-00	CLAMP	1	1	1	
25	90267-489U6	RIVET, BLIND	1	1	1	
26	90467-26800	CLIP	1	1	1	

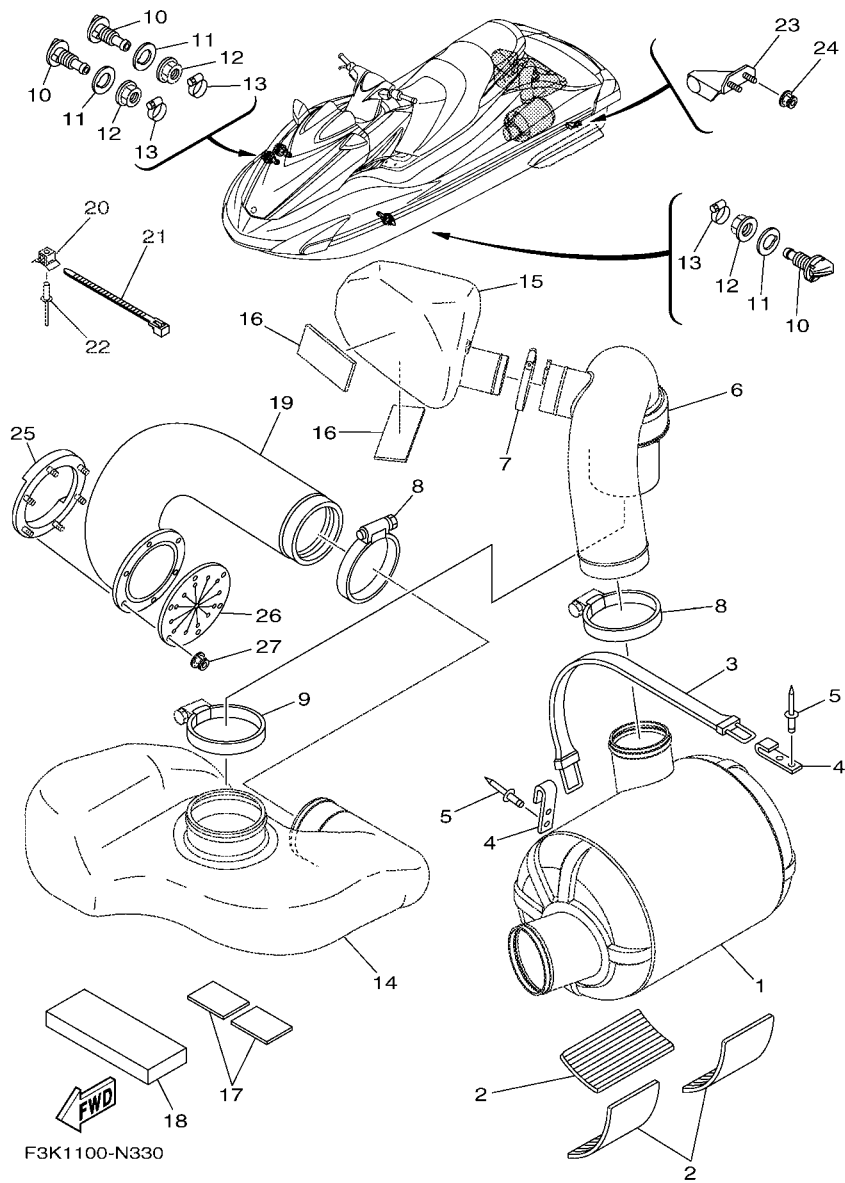
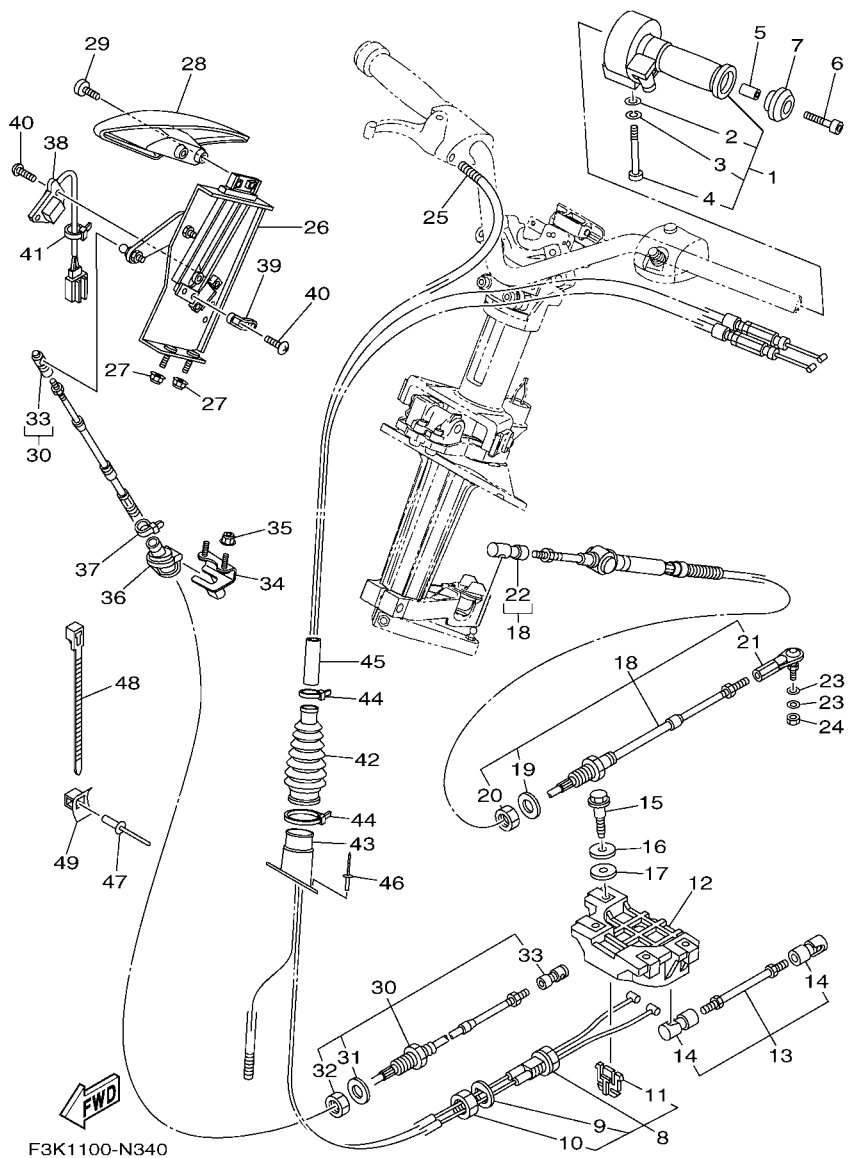

FIG. 33 EXHAUST 3

REF. NO.	PART NO.	DESCRIPTION	CAN	EUR	GENE	REMARKS
1	F1W-U7550-02	WATER LOCK COMP.	1	1	1	
2	F1S-U8221-00	PAD, BATTERY	3	3	3	
3	EW2-67821-00	BAND, FUEL TANK	1	1	1	
4	GA7-65772-00	HOOK A	2	2	2	
5	90267-489U1	RIVET,BLIND	4	4	4	
6	F1W-U7555-01	HOSE, EXHAUST	1	1	1	
7	90601-170UG	BAND, HOSE 70	1	1	1	
8	90450-99801	HOSE CLAMP ASSY	2	2	2	
9	90450-99804	HOSE CLAMP ASSY	1	1	1	
10	F2C-U753B-01	PILOT, WATER	3	3	3	
11	F2C-U7564-00	GASKET	3	3	3	
12	F2C-U2733-00	NUT	3	3	3	
13	90467-17802	CLIP	3	3	3	
14	F1W-U4261-00	TANK, WATER	1	1	1	
15	F1W-U753C-01	RESONATOR 1	1	1	1	
16	F1K-U759C-00	MAT 2	2	2	2	
17	F1W-U759C-01	MAT 2	2	2	2	
18	F1W-U8831-01	BED,TANK 1	1	1	1	
19	F1B-U758D-03	HOSE,EXHAUST 3	1	1	1	
20	F1W-U828M-00	BASE, CLAMP	1	1	1	
21	90464-32801	CLAMP	1	1	1	
22	90267-48802	RIVET, BLIND	1	1	1	
23	F2C-U755G-00	BRKT., WATER LOCK	1	1	1	
24	F2N-U142L-00	NUT, LOCK	2	2	2	
25	F1S-U757B-01	PLATE	1	1	1	
26	F1B-U751G-00	VALVE, EXHAUST	1	1	1	
27	F2N-U142L-00	NUT, LOCK	6	6	6	

FIG. 34 CONTROL CABLE



F3K1100-N340

REF. NO.	PART NO.	DESCRIPTION	CAN	EUR	GENE	REMARKS
1	F1W-6153A-00	NOZZLE,CONTROL ASSY	1	1	1	
2	92990-06200	.WASHER, PLAIN	1	1	1	
3	92990-06100	.WASHER, SPRING	1	1	1	
4	F1W-613C1-00	.SCREW	1	1	1	
5	90387-05800	COLLAR	1	1	1	
6	90110-05908	BOLT, HEXAGON SOCKET HEAD	1	1	1	
7	GP7-U155F-00	GRIP, END	1	1	1	
8	F2C-6153E-00	CABLE,NOZZLE CONTROL 3	1	1	1	
9	F1W-61438-00	.PACKING C	1	1	1	
10	F1B-6151S-00	.NUT	1	1	1	
11	F1W-61557-00	.GUIDE, CABLE	1	1	1	
12	F1W-6153J-00	REMOCON,NOZZLE 2	1	1	1	
13	F3K-6150A-00	ROD ASSY	1	1	1	
14	F1B-61460-00	.BALL JOINT ASSY	2	2	2	
15	90109-06233	BOLT	4	4	4	
16	90201-099U3	WASHER, PLATE	4	4	4	
17	90202-08002	WASHER, PLATE	4	4	4	
18	F2C-61481-10	CABLE, STEERING	1	1	1	
19	F1B-61438-00	.PACKING C	1	1	1	
20	F1B-6151S-00	.NUT	1	1	1	
21	F1B-61461-02	.STUD, JOINT BALL	1	1	1	
22	F2N-61460-00	.BALL JOINT ASSY	1	1	1	
23	90201-06906	WASHER, PLATE	2	2	2	
24	9538R-06700	NUT	1	1	1	
25	90447-07001	HOSE, WITH SPRING (L400)	1	1	1	
26	F2C-U134A-03	REMOCON. LEVER ASSY.	1	1	1	
27	F2N-U142L-00	NUT, LOCK	2	2	2	

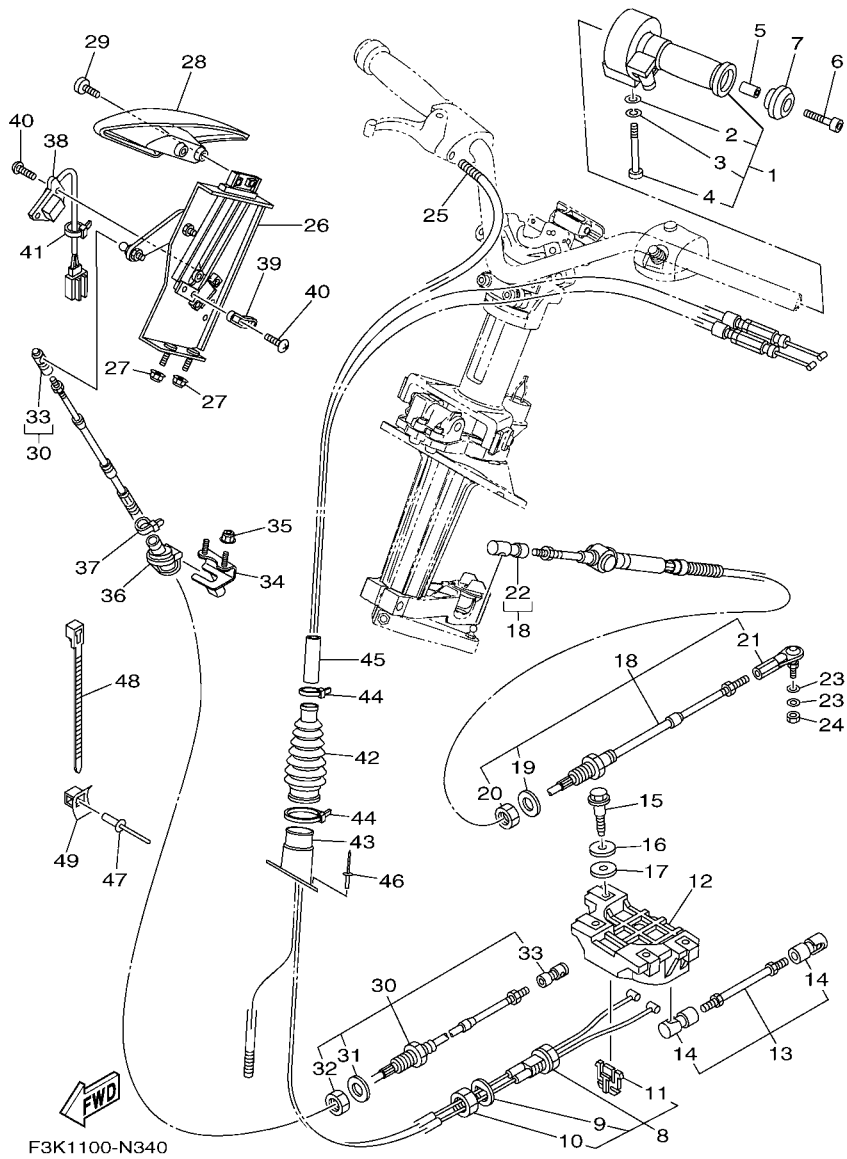

FIG. 34 CONTROL CABLE

REF. NO.	PART NO.	DESCRIPTION	CAN	EUR	GENE	REMARKS
28	F2C-U2714-00	GRIP	1	1	1	
29	90154-06017	SCREW, BINDING	2	2	2	
30	F3K-6149C-00	CABLE, REVERSE	1	1	1	
31	F1B-61438-00	.PACKING C	1	1	1	
32	F1B-6151S-00	.NUT	1	1	1	
33	F2C-61460-00	.BALL JOINT ASSY	2	2	2	
34	F2C-U1467-01	BRACKET, STOPPER CABLE	1	1	1	
35	F2N-U142L-00	NUT, LOCK	2	2	2	
36	F2C-U146G-01	PACKING, CABLE	1	1	1	
37	90465-11829	CLAMP	1	1	1	
38	F1W-6830K-00	REVERSE SENSOR ASSY	1	1	1	
39	F2C-6838C-00	MAGNET	1	1	1	
40	90150-05807	SCREW, ROUND HEAD	4	4	4	
41	90465-11829	CLAMP	1	1	1	
42	F2C-U822E-01	GROMMET	1	1	1	
43	F2C-U1465-00	COLLAR, PLASTIC	1	1	1	
44	90464-40825	CLAMP	2	2	2	
45	GJ1-U7578-11	PACKING, HOSE 2	1	1	1	
46	90267-48806	RIVET, BLIND	3	3	3	
47	90267-489U6	RIVET, BLIND	1	1	1	
48	90464-32801	CLAMP	1	1	1	
49	F1W-U828M-00	BASE, CLAMP	1	1	1	

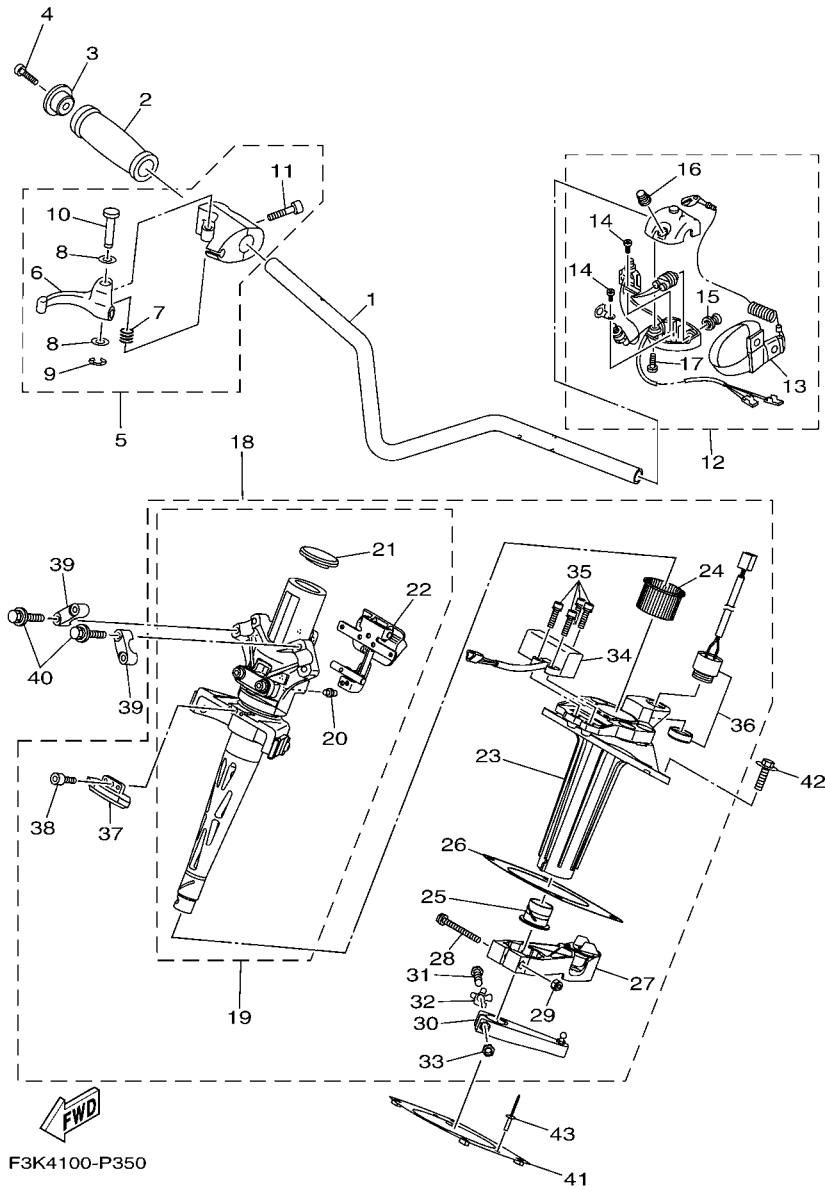

FIG. 35 STEERING 1

REF. NO.	PART NO.	DESCRIPTION	CAN	EUR	GENE	REMARKS
1	F2C-U1552-00	HANDLE	1	1	1	
2	GP7-U155D-01	GRIP, HANDLE	1	1	1	
3	GP7-U155F-00	GRIP, END	1	1	1	
4	90110-05908	BOLT, HEXAGON SOCKET HEAD	1	1	1	
5	F0D-67250-10	THROTTLE LEVER ASSY	1	1	1	
6	F0D-67255-02	.LEVER, THROTTLE	1	1	1	
7	EW2-67256-00	.SPRING	1	1	1	
8	EW2-67258-01	.WASHER	2	2	2	
9	EW2-67259-01	.E-RING	1	1	1	
10	F0D-67257-00	.SHAFT	1	1	1	
11	F1X-6725F-01	.BOLT, THROTTLE	2	2	2	
12	F2C-68310-00	SWITCH BOX ASSY	1	1	1	
13	EW2-68348-00	.LANYARD, STOP SWITCH	1	1	1	
14	97880-03008	.SCREW, PAN HEAD	2	2	2	
15	FK7-68312-02	.STOP BUTTON COMP	1	1	1	
16	FK7-68313-02	.START BUTTON COMP.	1	1	1	
17	97880-05025	.SCREW, PAN HEAD	2	2	2	
18	F3K-61400-00	STEERING MASTER ASSY	1	1	1	
19	F3K-67410-00	.SHAFT ASSY	1	1	1	
20	F2C-6151T-00	..NIPPLE, GREASE	1	1	1	
21	F2C-613B0-00	..CAP	1	1	1	
22	F2C-6287A-00	..LOCK ASSY	1	1	1	
23	F2C-6152M-00	.HOUSING ASSY	1	1	1	
24	F1K-6134M-00	.BUSH	1	1	1	
25	F2C-6134M-00	.BUSH	1	1	1	
26	F2C-6143C-00	.SEAL, RUBBER	1	1	1	
27	F2C-6146A-00	.CABLE STOPPER ASSY.	1	1	1	



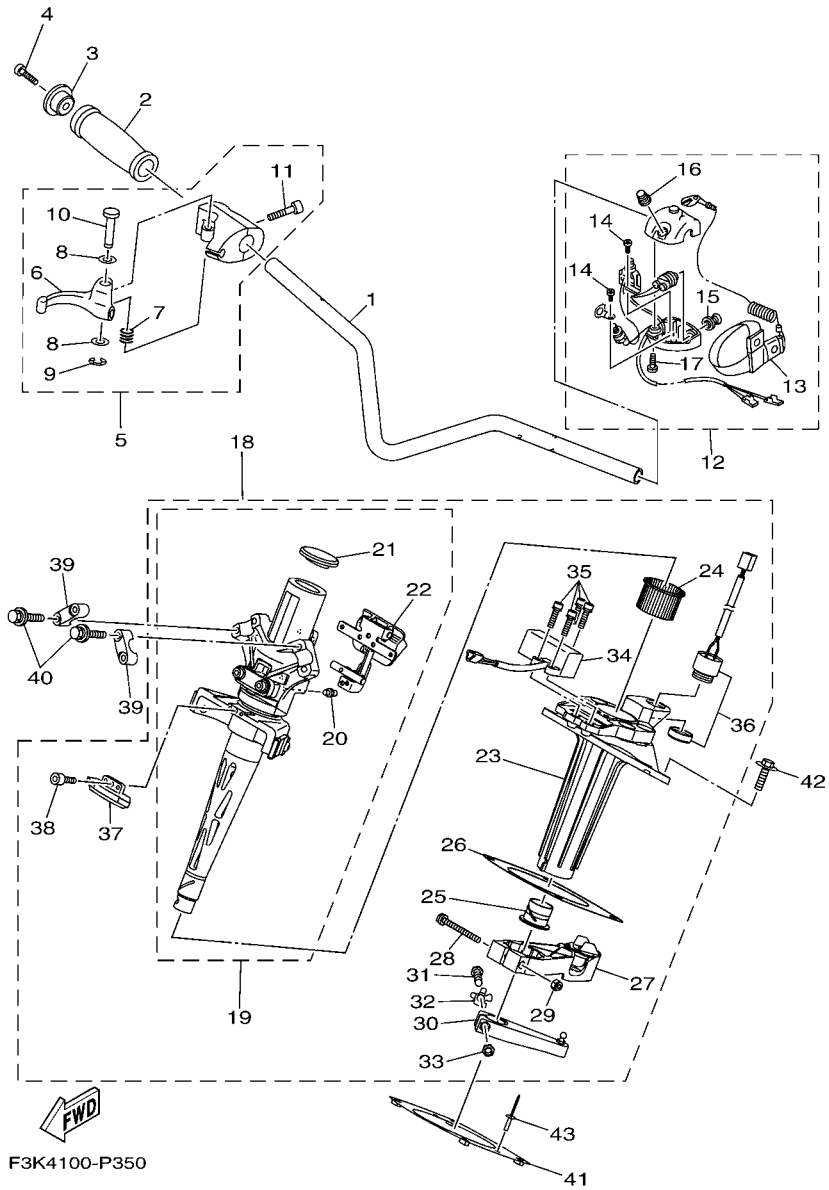
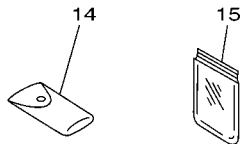
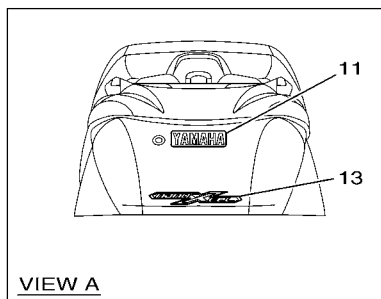
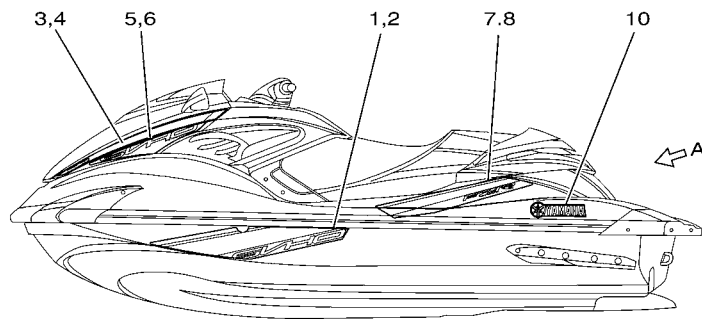
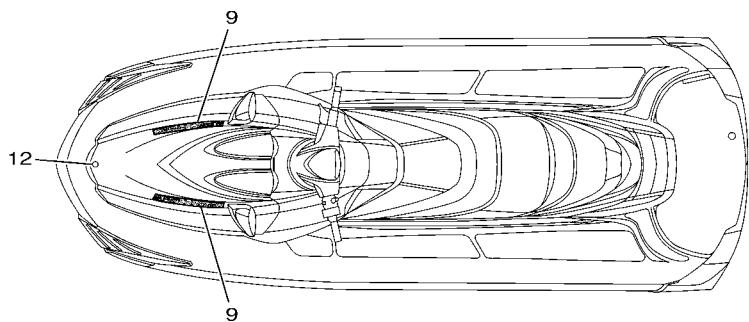

FIG. 35 STEERING 1

REF. NO.	PART NO.	DESCRIPTION	CAN	EUR	GENE	REMARKS
28	F2C-61369-00	.BOLT	1	1	1	
29	95720-06300	.NUT, SELF-LOCKING	1	1	1	
30	F2C-6153R-00	.ARM ASSY.	1	1	1	
31	F1K-61355-00	.BOLT	1	1	1	
32	F1K-6142B-00	.PLATE, RETAINING	1	1	1	
33	95720-08300	.NUT, SELF-LOCKING	1	1	1	
34	F3J-6838B-00	.SENSOR, MAGNET	1	1	1	
35	F1W-61516-00	.BOLT	4	4	4	
36	F1S-68341-00	.BUZZER	1	1	1	
37	F3J-6838C-00	.MAGNET	1	1	1	
38	F1B-613C1-00	.SCREW	1	1	1	
39	EU0-23814-31	HOLDER, HANDLE UPPER	2	2	2	
40	90119-089UU	BOLT, WITH WASHER	4	4	4	
41	F2C-U1554-00	PLATE, RETAINING	1	1	1	
42	90119-08836	BOLT, WITH WASHER	4	4	4	
43	90267-48806	RIVET, BLIND	2	2	2	





F3L4100-P370

FIG. 37 GRAPHICS

REF. NO.	PART NO.	DESCRIPTION	CAN	EUR	GENE	REMARKS
1	F3L-U417B-10	GRAPHIC 1 (LH)	1	1	1	
2	F3L-U417C-10	GRAPHIC 2 (RH)	1	1	1	
3	F3L-U417D-10	GRAPHIC 3 (LH)	1	1	1	
4	F3L-U417E-10	GRAPHIC 4 (RH)	1	1	1	
5	F3L-U417F-10	GRAPHIC 5 (LH)	1	1	1	
6	F3L-U417G-10	GRAPHIC 6 (RH)	1	1	1	
7	F3L-U417H-10	GRAPHIC 7 (LH)	1	1	1	
8	F3L-U417J-10	GRAPHIC 8 (RH)	1	1	1	
9	F3L-U417M-10	GRAPHIC C	2	2	2	
10	F3L-U411C-10	EMBLEM, YAMAHA	2	2	2	
11	F3L-U4114-10	MARK, YAMAHA A	1	1	1	
12	F1K-U411H-00	EMBLEM, TUNING FORK	1	1	1	
13	F3J-U4121-00	EMBLEM A	1	1	1	
14	F1B-65986-13	TOOL SET	1	1	1	
15	EU0-65901-02	TOOL BAG	1	1	1	

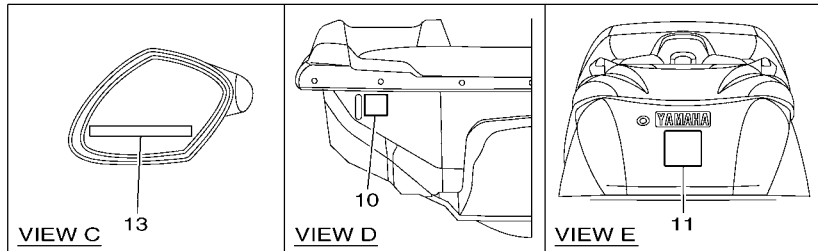
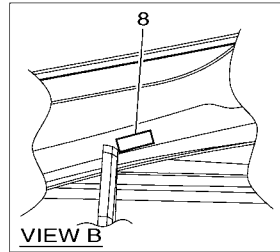
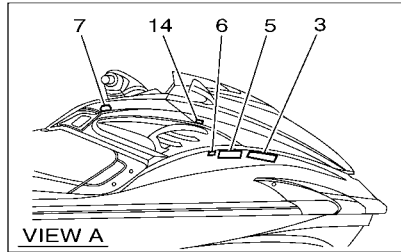
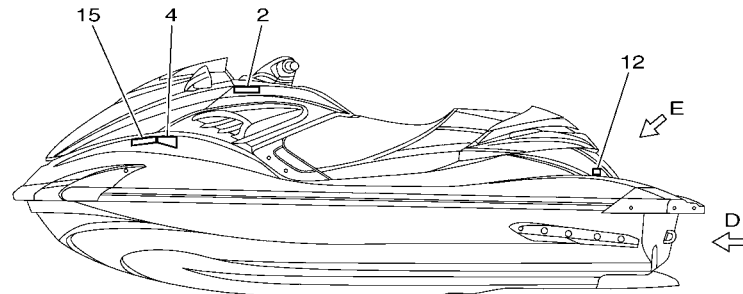
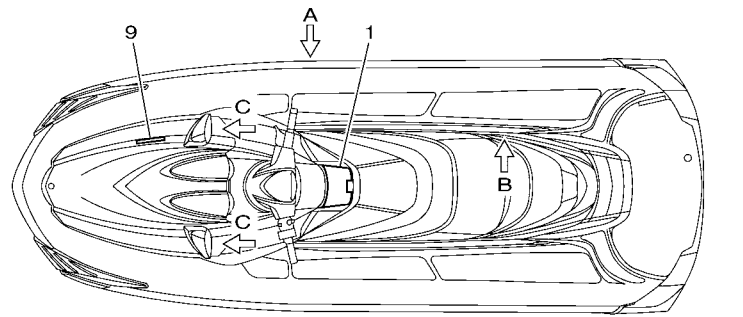

F3L1100-N380

FIG. 38 IMPORTANT LABELS

REF. NO.	PART NO.	DESCRIPTION	CAN	EUR	GENE	REMARKS
1	F2C-U41B1-10	LABEL, WARNING UNIFORM 1	1	1	1	
2	F1B-U41B1-21	LABEL, WARNING UNIFORM 1	1	1	1	
3	F1B-U41B1-31	LABEL, WARNING UNIFORM 1	1	1	1	
4	F1B-U41B2-01	LABEL, WARNING UNIFORM 2	1	1	1	
5	F3J-U415B-10	LABEL, WARNING(FUEL)	1	1	1	
6	F3J-U419B-10	LABEL 1	1	1	1	
7	F3K-U41D5-30	LABEL, WARNING SHIFT LEVER	1	1	1	
8	F0V-U41DB-12	LABEL, WARNING BATTERY	1	1	1	
9	F1B-U41F5-21	LABEL, FIRE EXTINGUISHER 1	1	1	1	
10	F1G-U418F-00	LABEL, RIGHTING	1	1	1	
11	F2R-U41E1-00	LABEL, SET 1	1	1	1	
12	F1S-U419E-01	LABEL 4	1			FOR CAN
13	GJ1-U419F-21	LABEL,5	2	2	2	
14	F1G-U413P-02	LABEL, BUILDERS PLATE		1		FOR EUR
15	GP8-U416H-01	LABEL,WARNING(FRANCE)		1		FOR EUR

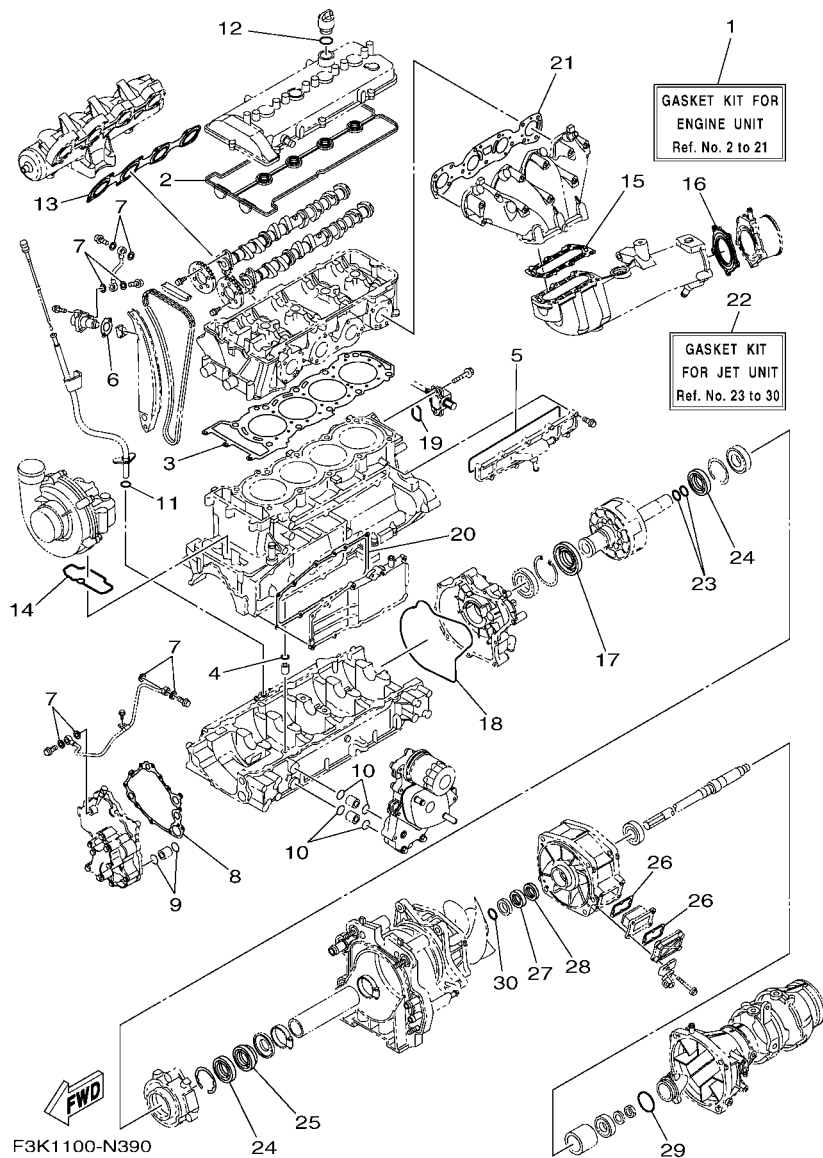

FIG. 39 REPAIR KIT 1

REF. NO.	PART NO.	DESCRIPTION	CAN	EUR	GENE	REMARKS
1	6ET-W0001-00	GASKET KIT FOR ENGINE UNIT	1	1	1	
2	6BH-11193-00	.GASKET, HEAD COVER 1	1	1	1	
3	6BH-11181-00	.GASKET, CYLINDER HEAD 1	1	1	1	
4	93210-11453	.O-RING	1	1	1	
5	6CS-12517-00	.GASKET, WATER INLET	1	1	1	
6	6S5-121E2-00	.GASKET	1	1	1	
7	90430-10007	.GASKET	8	8	8	
8	6S5-13563-00	.GASKET	1	1	1	
9	93210-21631	.O-RING	2	2	2	
10	93210-18322	.O-RING	4	4	4	
11	93210-12016	.O-RING	1	1	1	
12	93210-24M79	.O-RING	1	1	1	
13	6BH-13645-00	.GASKET, MANIFOLD 1	1	1	1	
14	6S5-1416A-00	.O-RING	1	1	1	
15	6S5-14739-00	.GASKET, MUFFLER DAMPER 1	1	1	1	
16	6BH-14749-00	.GASKET, MUFFLER DAMPER 2	1	1	1	
17	6S5-81167-10	.OIL SEAL	1	1	1	
18	6S5-81168-00	.O-RING	1	1	1	
19	93210-32172	.O-RING	1	1	1	
20	6BH-13557-00	.GASKET	1	1	1	
21	6ET-14613-00	.GASKET, EXHAUST PIPE	1	1	1	
22	6S5-W0001-22	GASKET KIT FOR JET UNIT	1	1	1	
23	93210-22MF1	.O-RING	2	2	2	
24	93102-29008	.OIL SEAL	2	2	2	
25	93102-29009	.OIL SEAL	1	1	1	
26	66V-42414-00	.O-RING	2	2	2	
27	93102-31009	.OIL SEAL	1	1	1	

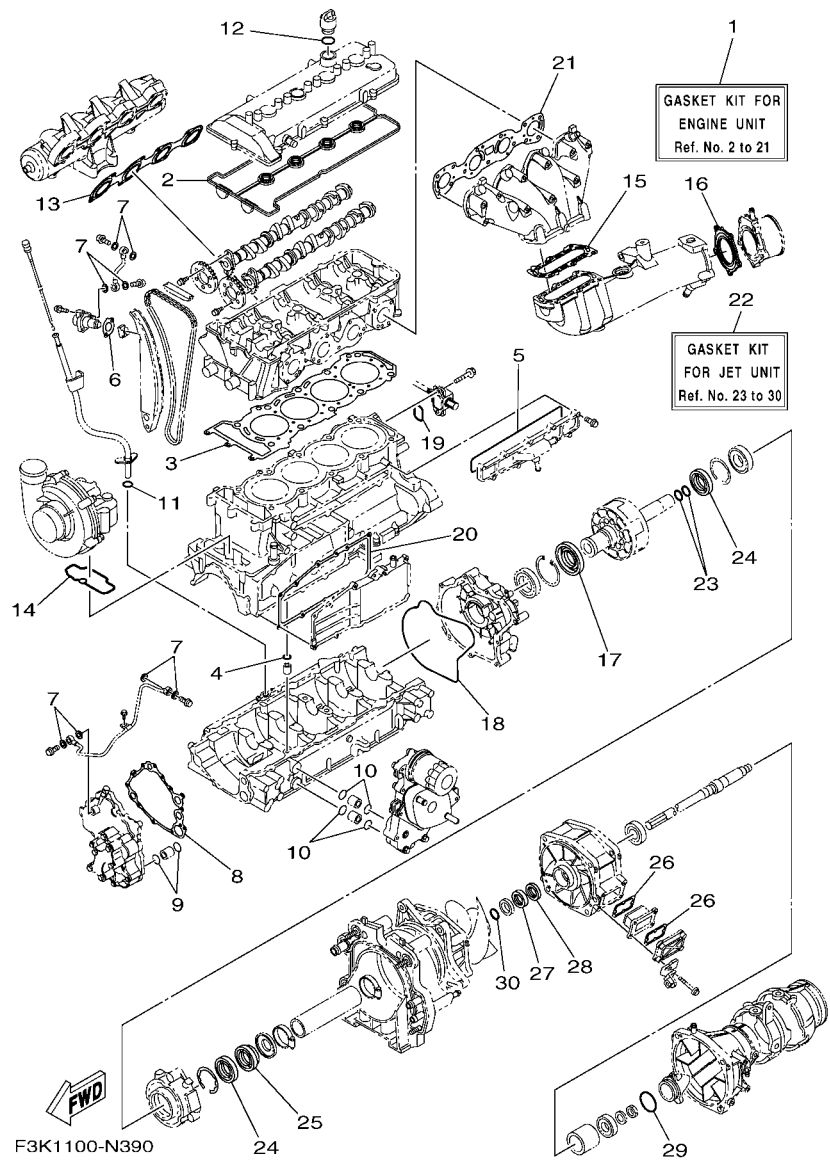

FIG. 39 REPAIR KIT 1

REF. NO.	PART NO.	DESCRIPTION	CAN	EUR	GENE	REMARKS
28	93101-31001	.OIL SEAL	1	1	1	
29	6S5-5111K-00	.O-RING 1	1	1	1	
30	93210-30611	.O-RING	1	1	1	
-----						
-----						
-----						
-----						
-----						
-----						
-----						
-----						
-----						

NUMERICAL INDEX

PART NO.	REF. NO.	PART NO.	REF. NO.	PART NO.	REF. NO.	PART NO.	REF. NO.	PART NO.	REF. NO.	PART NO.	REF. NO.
6S5-11102-11	2 - 2	3LD-12168-K1	5 - 12	6CS-12880-00	6 - 3	6CS-14445-00	6 - 29	6ET-45613-00	16 - 9	GP7-61652-00	32 - 20
6BH-11111E-00	2 - 12	3LD-12168-M1	5 - 12	6S5-1310A-23	10 - 1	6CS-14446-00	6 - 6	6S5-45813-01-94	4 - 12	EW2-62142-00	31 - 2
6S5-11133-10	2 - 3	3LD-12168-R1	5 - 12	6BH-1319K-00	3 - 30	6D3-1444B-00	6 - 13	6BH-4581J-00	16 - 1	F1G-62149-00	31 - 8
6S5-11166-10	12 - 1	3LD-12168-U1	5 - 12	6S5-13300-22	9 - 1	6S5-14457-00	6 - 16	6S5-5111K-00	15 - 21	F2F-6214A-00	31 - 1
6S5-11167-10	12 - 5	3LD-12168-W1	5 - 12	6S5-13317-10	10 - 4	6S5-14496-00	6 - 8		39 - 29	GJ3-6215F-00	23 - 12
6BH-11181-00	2 - 11	3LD-12168-Y1	5 - 12	6S5-13337-10	3 - 24	6CS-14572-00	6 - 28	68N-5112T-00	27 - 3	F1B-62241-00	32 - 4
	39 - 3	3LD-12169-11	5 - 12	6S5-13405-11	10 - 2	6ET-14613-00	13 - 1	6ET-51312-00	15 - 4	F3K-6273B-00	18 - 19
6S5-11191-20	1 - 1	3LD-12169-31	5 - 12	6S5-13416-00	9 - 7		39 - 21	6ET-51315-00	15 - 7	GU2-62875-02	25 - 20
6BH-11193-00	1 - 3	3LD-12169-50	5 - 12	6S5-13418-00	5 - 21	6BH-14711-10	13 - 2	6S5-51323-00	16 - 2	F2C-6287A-00	35 - 22
	39 - 2	3LD-12169-70	5 - 12	69J-13440-03	11 - 5	6BH-14721-10	13 - 6	6BH-51348-01	15 - 24	FOX-6375E-00	30 - 39
69J-11301-10	3 - 9	3LD-12169-90	5 - 12	60E-13446-00	11 - 7	6S5-14739-00	13 - 7	6S5-52358-00	17 - 10	F2C-6514S-00	26 - 21
6S5-1131M-10-8P	3 - 17	3LD-12169-E0	5 - 12	6S5-13446-10	9 - 5		39 - 15	F1K-6134M-00	35 - 24	F1W-6514T-00	26 - 22
68V-11325-02	3 - 10	3LD-12169-G0	5 - 12	6ET-13460-00	11 - 1	6BH-14749-00	13 - 14	F2C-6134M-00	35 - 25	F1B-6517R-00	25 - 21
67F-11328-00	3 - 11	3LD-12169-J0	5 - 12	6ET-13470-01	11 - 2		39 - 16	F1K-61355-00	35 - 31	GA7-65172-00	33 - 4
6S5-11377-00	3 - 16	3LD-12169-L0	5 - 12	6S5-13477-00	10 - 3	6CS-1475A-00	13 - 18	F2C-61369-00	35 - 28	EU0-65901-02	37 - 15
6S5-11411-00	4 - 1	6S5-12171-10	5 - 1	6S5-13532-00	6 - 18	6S5-14771-00-94	13 - 11	F2C-613B0-00	35 - 21	F1B-65986-13	37 - 14
6S5-11416-00	4 - 2	6D3-12176-10	5 - 3	8FP-13556-10	6 - 12	6BH-14784-01-94	13 - 15	F1B-613C1-00	35 - 38	F0D-67250-10	35 - 5
6S5-11416-10	4 - 2	6ET-12181-00	5 - 2	6BH-13557-00	3 - 18	6CS-15100-11	3 - 1	F1W-613C1-00	34 - 4	F0D-67255-02	35 - 6
6S5-11416-20	4 - 2	6S5-121E2-00	5 - 19		39 - 20	6ET-15362-00	3 - 27	F3K-61400-00	35 - 18	EW2-67256-00	35 - 7
6S5-11416-30	4 - 2		39 - 6	6ET-13557-00	11 - 3	6S5-15363-00	1 - 9	F1K-6142B-00	35 - 32	F0D-67257-00	35 - 10
6S5-11416-40	4 - 2	6S5-12210-00	5 - 18	6S5-13563-00	9 - 2	6S5-15486-10	10 - 5	F1B-61438-00	34 - 19	EW2-67258-01	35 - 8
6S5-11459-01	4 - 14	6S5-12228-01	2 - 7		39 - 8	5EL-15511-00	20 - 6		34 - 31	EW2-67259-01	35 - 9
6S5-11603-00	4 - 4	6BH-12241-00	5 - 25	6P2-13578-00	6 - 5	6S5-15515-00	19 - 3	F1W-61438-00	34 - 9	F1X-6725F-01	35 - 11
6ET-11631-00-B0	4 - 3	6BH-12251-00	5 - 24	6P2-13588-00	6 - 4	6S5-15517-00	19 - 5	F2C-6143C-00	35 - 26	F3K-67410-00	35 - 19
6ET-11633-00	4 - 5	6BH-12252-00	5 - 15	6S5-13641-A2	6 - 2	6S5-15521-00	19 - 4	F1B-61460-00	34 - 14	GH7-6753B-00	32 - 18
6S5-11650-10	4 - 7	6BH-12279-00	5 - 16	6BH-13645-00	6 - 24	6S5-15590-00	19 - 1	F2C-61460-00	34 - 33	F1S-67620-00	32 - 22
6S5-11654-10	4 - 8	6S5-12289-00	4 - 11		39 - 13	6S5-17031-00	4 - 16	F2N-61460-00	34 - 22	FN8-6771K-00	31 - 17
6S5-11656-40	4 - 9	6D3-12411-00	2 - 14	6CS-13651-00	7 - 25	6S5-17525-01	4 - 13	F1B-61461-02	34 - 21	F2C-67743-00	31 - 42
6S5-11656-50	4 - 9	6BH-12413-00	2 - 15	6ET-13670-00	7 - 12	6S5-17529-00	4 - 18	F2C-6146A-00	35 - 27	F2C-67743-10	31 - 43
6S5-11656-60	4 - 9	6S5-1243E-01	14 - 13	6S5-13691-12	7 - 13	6S5-17553-00	4 - 22	F2C-61481-10	34 - 18	F1B-67747-00	31 - 15
6S5-11656-70	4 - 9	60E-12443-00	14 - 10	6S5-13750-10	6 - 1	6S5-17572-01	4 - 10	F3K-6149C-00	34 - 30	EU0-67767-31	31 - 30
6S5-11941-10	1 - 8	60E-1244E-00	22 - 40	6ET-13761-00	6 - 10	6S5-17585-10	4 - 21	F3K-6150A-00	34 - 13	EW2-67821-00	33 - 3
6S5-12111-00	5 - 5	6S5-1244H-00	14 - 28	6S5-13907-01	23 - 1	6ET-17800-00	4 - 15	F1W-61516-00	35 - 35	F2C-68090-00	23 - 15
6S5-12113-00	5 - 8	6CS-12469-A0	3 - 21	6S5-14159-00	6 - 19	EU0-23814-31	35 - 39	F1B-6151S-00	34 - 10	F2C-6820A-10	23 - 14
6S5-12116-00	5 - 7	6CS-12517-00	3 - 22	68V-1416A-00	6 - 11	6S5-24300-01	6 - 20		34 - 20	GA7-68218-00	32 - 8
6S5-12117-00	5 - 9		39 - 5	6S5-1416A-00	7 - 4	70R-24489-00	31 - 4		34 - 32	6S5-682E0-00	23 - 2
3LD-12118-00	5 - 10	6S5-12552-00	14 - 34		39 - 14	70R-24543-00	31 - 3	F2C-6151T-00	35 - 20	F1W-6830K-00	34 - 38
51Y-12119-00	5 - 11	6S5-12576-01	14 - 47	6S5-14199-00	7 - 3	6AN-26311-00	22 - 2	F2C-6152M-00	35 - 23	F2C-68310-00	35 - 12
6S5-12121-00	5 - 6	6BH-12577-00	14 - 37	6ET-141A0-01	7 - 1	6EX-2812A-00	21 - 15	F1W-6153A-00	34 - 1	FK7-68312-02	35 - 15
6S5-12153-00	5 - 13	6S5-12578-00	2 - 17	6S5-14243-01	7 - 19	6BH-41661-00-94	24 - 4	F2C-6153E-00	34 - 8	FK7-68313-02	35 - 16
3LD-12168-00	5 - 12	6S5-12579-00	14 - 39	6S5-14285-00	6 - 15	6BH-41662-00-94	24 - 5	F1W-6153J-00	34 - 12	F1S-68341-00	35 - 36
3LD-12168-20	5 - 12	63M-12580-00	14 - 5	6AN-14294-10	6 - 21	66V-42414-00	15 - 9	F2C-6153R-00	35 - 30	EW2-68348-00	35 - 13
3LD-12168-40	5 - 12	6ET-12581-10	14 - 4	6D3-14305-21	22 - 1		39 - 26	F1W-61557-00	34 - 11	F3J-6838B-00	35 - 34
3LD-12168-60	5 - 12	6ET-12582-00	14 - 21	6S5-14349-00	7 - 10	67X-44517-10	24 - 1	F1K-61624-00	27 - 20	F2C-6838C-00	34 - 39
3LD-12168-80	5 - 12	6BH-12584-00	14 - 17	6S5-14360-11	6 - 9	663-45119-00	16 - 11	FOX-61637-00	27 - 23	F3J-6838C-00	35 - 37
3LD-12168-A0	5 - 12	6S5-12588-00	14 - 31	6CS-14413-00	6 - 31	6S5-45332-00-94	16 - 4	EU0-61652-00	14 - 12	6S5-81167-10	19 - 13
3LD-12168-F0	5 - 12	6S5-12589-01	14 - 26	6S5-14435-00	7 - 18	6EV-45511-00	15 - 17		27 - 8		39 - 17
3LD-12168-H1	5 - 12	6S5-12594-00	14 - 46	6BH-14445-00	6 - 17	6S5-45593-00-94	16 - 12	FOX-61652-00	27 - 24	6S5-81168-00	19 - 17

NUMERICAL INDEX

PART NO.	REF. NO.	PART NO.	REF. NO.	PART NO.	REF. NO.	PART NO.	REF. NO.	PART NO.	REF. NO.	PART NO.	REF. NO.
6S5-81168-00	39 - 18	60E-83627-00	21 - 4	F2N-U142L-00	25 - 18	F2C-U2624-20	30 - 20	F1B-U3850-02	30 - 4	F3J-U516R-00	32 - 7
6S5-81315-00	22 - 28	682-84385-01	14 - 11		25 - 47	F2C-U2624-30	30 - 33	F3L-U4114-10	37 - 11	F2C-U517B-02-P9	26 - 1
6S5-81328-00	19 - 18	6CS-85516-00	3 - 31		28 - 2		30 - 47	F3L-U411C-10	37 - 10	F2C-U517C-01	26 - 17
6S5-81337-20	19 - 11	6CS-8572F-00	3 - 29		28 - 22	F1K-U2663-01	26 - 7	F1K-U411H-00	37 - 12	F2C-U517D-00	26 - 20
6S5-81364-10	19 - 24	6AN-85780-00	22 - 29		33 - 24	F1W-U2664-01	30 - 3	F3J-U4121-00	37 - 13	F1X-U517E-01	25 - 13
6S5-81410-11	19 - 7	61A-85790-00	22 - 19		33 - 27	F1K-U266B-00	26 - 8	F1G-U413P-02	38 - 14		25 - 28
6S5-81450-01	19 - 6	6AA-85790-00	22 - 35		34 - 27	F2C-U266C-00	26 - 12	F3J-U415B-10	38 - 5		25 - 33
6S5-81800-00	20 - 1	6S5-85886-00	6 - 14		34 - 35	F2C-U266D-01	30 - 8	GP8-U416H-01	38 - 15		25 - 39
6S5-81810-00	20 - 13	60E-85896-01	22 - 25	F2C-U143D-10	36 - 2	F2C-U266E-00	30 - 45	F3L-U417B-10	37 - 1		25 - 42
6S5-81820-00	20 - 12	6EV-8591A-20	21 - 5	F2C-U143E-10	36 - 3	F1W-U2698-00	25 - 25	F3L-U417C-10	37 - 2	F1W-U517F-00	25 - 1
6S5-81826-00	20 - 10	6EV-8591A-30	21 - 5	F2C-U143G-00	18 - 20	F1W-U269B-00	27 - 7	F3L-U417D-10	37 - 3	F2C-U517H-01	25 - 19
6S5-81830-00	20 - 3	6EV-8591A-40	21 - 5	EU0-U1461-02	17 - 13	F2C-U2714-00	34 - 28	F3L-U417E-10	37 - 4	F2C-U517W-00	25 - 35
6S5-81840-00	20 - 8	6B6-86261-00	23 - 23	F2C-U1465-00	34 - 43	F2R-U271B-10	30 - 46	F3L-U417F-10	37 - 5	F2C-U517X-00	25 - 40
11H-81844-00	20 - 2	6B6-86261-10	23 - 23	F2C-U1467-01	34 - 34	F2C-U2733-00	33 - 12	F3L-U417G-10	37 - 6	F2C-U518D-00	26 - 19
4G0-81844-00	20 - 4	6B6-86265-00	23 - 24	GH3-U146E-00	15 - 38	F2C-U278A-00	27 - 36	F3L-U417H-10	37 - 7	F1W-U518E-02	26 - 30
5EL-81845-00	20 - 11	6B6-86265-10	23 - 24	F2C-U146G-01	34 - 36	F2C-U278F-00	27 - 40	F3L-U417J-10	37 - 8	F2C-U519D-01	25 - 22
6CS-81845-00	21 - 2	6ET-E110M-00	1 - 4	F2C-U151S-00	18 - 4	F2C-U278G-00	27 - 43	F3L-U417M-10	37 - 9	F2C-U5508-02	25 - 9
3TB-81847-00	20 - 9	6S5-E118E-00	1 - 6	F2C-U1552-00	35 - 1	F2C-U278H-00	27 - 41	F1G-U418F-00	38 - 10	F1W-U555B-00	25 - 24
1J7-81847-60	20 - 5	6S5-E1328-00	1 - 5	F2C-U1554-00	35 - 41		27 - 44	F3J-U419B-10	38 - 6	F1W-U555D-02	25 - 2
5A8-81850-10	20 - 14	6ET-E2289-00	16 - 13	GP7-U155D-01	35 - 2	F2C-U278K-00	27 - 45	F1S-U419E-01	38 - 12	F2C-U5633-00	25 - 23
1B7-81940-00	21 - 27	67X-E2590-10	14 - 49	GP7-U155F-00	34 - 7	F2C-U278L-00	27 - 42	GJ1-U419F-21	38 - 13	F1K-U5772-04	23 - 7
6S5-81942-11	21 - 3	6S5-E4410-01	8 - 5		35 - 3	F1X-U2873-00	31 - 39	F2C-U41B1-10	38 - 1		25 - 51
6CS-81953-00	21 - 31	6S5-E4419-00	8 - 11	F2C-U156E-00	36 - 1	F2C-U351H-10	28 - 30	F1B-U41B1-21	38 - 2		31 - 37
6EX-8195A-00	21 - 14	6S5-E4436-00	8 - 7	F2N-U1628-02	30 - 11	F2C-U351J-10	28 - 31	F1B-U41B1-31	38 - 3	F2C-U591A-02	30 - 42
6S5-81960-10	22 - 6	6S5-E4451-00	8 - 6	F1B-U1653-02	30 - 15	F2C-U351K-10	28 - 32	F1B-U41B2-01	38 - 4	F2C-U591C-00	30 - 43
6S5-81972-01-94	22 - 8	6S5-E4752-00	13 - 17	F2C-U1743-00	26 - 9	F2C-U351M-10	28 - 33	F3K-U41D5-30	38 - 7	F2C-U591D-01	30 - 44
6S5-81975-00	22 - 7	6S5-G2717-00	8 - 8	F1W-U2127-01	29 - 1	F2C-U351N-10	28 - 34	F0V-U41DB-12	38 - 8	F2C-U596B-00	26 - 34
EU0-82110-09	23 - 4	6BH-G4532-00	24 - 2	F2C-U213B-01	26 - 4	F2C-U351P-10	28 - 35	F2R-U41E1-00	38 - 11	F2C-U596C-00	26 - 36
6CS-82115-00	21 - 25	6BH-G4574-00	24 - 3	F0X-U213G-01	29 - 3	F2C-U351R-10	28 - 36	F1B-U41F5-21	38 - 9	F1K-U5983-01	25 - 49
6S5-82116-00	23 - 22	6AN-G5214-00	15 - 10	F1W-U2159-00	31 - 6	F2C-U351S-10	28 - 37	F2C-U4256-00	32 - 24	F2C-U721B-00	24 - 12
6CS-82117-00	21 - 26	6CS-G5538-00	15 - 13	F2C-U2187-01	29 - 8	F2C-U353B-20	25 - 43	F1W-U4261-00	33 - 14	F2C-U721B-10	24 - 13
67F-82151-00	21 - 12	6EV-G5831-00	15 - 1	F2C-U2188-01	29 - 9	F2C-U353B-30	25 - 44	F2C-U471E-00	26 - 35	GD0-U7249-00-05	16 - 19
67F-82151-10	21 - 13	6ET-G6882-00	15 - 8	F1W-U224E-00	32 - 1	F2C-U3581-10	28 - 29	F2C-U471F-00	26 - 37	F2N-U7254-00	22 - 3
67F-82151-30	21 - 10	6S5-R1142-10	8 - 12	F1S-U2280-02	27 - 31	F2R-U371A-40	30 - 1	F2C-U475B-00	26 - 11	6AN-U72M2-00	15 - 27
67F-82151-40	21 - 11	6AN-R1190-00	15 - 37	F1S-U2285-00	27 - 32	F2R-U371B-40	30 - 2	F1W-U475F-01	26 - 14	F2N-U732B-10	24 - 14
6EX-82170-10	21 - 9	6S5-R1313-01	15 - 34	F1W-U250B-00	28 - 10	F2R-U372A-40	30 - 6	F1W-U491K-00	28 - 3	EU0-U7354-00-01	24 - 9
6S5-82310-00	22 - 14	6S5-R1314-02	17 - 3		28 - 17	F2R-U372B-40	30 - 7		28 - 9	EU0-U7354-00-03	24 - 9
6A0-82317-00	21 - 7	6EV-R1318-00	15 - 26	F2C-U2511-11	28 - 1	F2C-U375E-00	30 - 32		28 - 16	EU0-U7354-00-05	24 - 9
	21 - 21	6EV-R1321-00	15 - 23	F1B-U2512-10	28 - 4	F1W-U3768-01	26 - 10	F1W-U4949-00	28 - 12	EU0-U7354-00-10	24 - 9
	6 - 7	6ET-R1326-00	15 - 20	F1B-U2519-10	28 - 5	F1B-U3774-00	30 - 37		28 - 19	EU0-U7354-00-20	24 - 9
68V-82504-00	22 - 27	6EV-R1333-00	18 - 1	F1W-U251D-20	28 - 23	GH1-U3774-00	30 - 28	F2C-U4953-10	30 - 14	F1B-U751G-00	33 - 26
60E-82556-00	23 - 3	6CS-R1341-00	17 - 1	F1W-U251E-20	28 - 25	F2C-U377B-02-P9	25 - 26	GP7-U4953-10	30 - 13	F1S-U7525-01	32 - 2
60E-82560-01	22 - 22	6AN-R1341-01	18 - 2	F1W-U251L-01	28 - 24	F2C-U377C-02-P9	25 - 30	F1W-U5148-00	26 - 5	F2C-U753B-01	33 - 10
6CS-82588-00	21 - 16	6S5-R1381-01	16 - 17	F1W-U251M-01	28 - 26	F2C-U377H-00	27 - 38	F2C-U515D-00	25 - 34	F1W-U753C-01	33 - 15
1UA-82591-00	26 - 23	F2C-U1314-00	27 - 39	F1W-U252E-21	28 - 8	F2C-U377M-00	25 - 36	F0X-U515E-01	25 - 6	F1W-U7550-02	33 - 1
6S5-8259E-00	21 - 23	F2C-U134A-03	34 - 26	F1W-U252F-21	28 - 15	F2C-U377N-00	25 - 37		25 - 15	F1W-U7555-01	33 - 6
6EV-8259L-10	21 - 33	F1K-U142D-30	36 - 4	F2C-U2624-01	30 - 19	F2C-U378C-00	30 - 16	F2C-U515N-20	26 - 2	F2C-U7557-01	18 - 25
6CS-8273J-10	22 - 31	F2N-U142L-00	25 - 4	F2C-U2624-10	30 - 22	F2C-U3850-00	30 - 9	F3J-U516R-00	26 - 13	F2C-U755G-00	33 - 23



NUMERICAL INDEX

PART NO.	REF. NO.	PART NO.	REF. NO.	PART NO.	REF. NO.	PART NO.	REF. NO.	PART NO.	REF. NO.	PART NO.	REF. NO.
F2C-U7564-00	33 - 11	F1W-U828M-00	18 - 16	90109-06874	24 - 10	90119-08823	18 - 21	90201-12039	2 - 8	90387-06M05	19 - 22
GJ1-U7578-11	34 - 45		27 - 17	90109-06875	24 - 11		24 - 8	90201-132G5	4 - 19	90387-06M30	17 - 7
F1S-U757B-01	33 - 25		29 - 4	90109-08041	18 - 29	90119-08836	35 - 42	90202-08002	34 - 17	90387-08M06	15 - 36
F3K-U757E-00	18 - 30		31 - 9	90110-05908	34 - 6	90119-08840	17 - 4	90267-329UR	31 - 25		15 - 42
F3K-U757F-00	18 - 31		32 - 23		35 - 4	90119-08844	27 - 46	90267-48020	26 - 32	90387-08M30	17 - 5
F1B-U758D-03	33 - 19		33 - 20	90110-06040	27 - 25	90119-08851	15 - 35	90267-48802	18 - 7	90387-08M37	8 - 2
F1W-U759B-00	31 - 44		34 - 49	90110-06182	3 - 25		15 - 41		18 - 18		22 - 11
F1K-U759C-00	25 - 48	F2C-U82AA-00	25 - 5	90110-06822	15 - 22	90119-08859	24 - 7		27 - 18	90387-11007	7 - 17
	33 - 16	F1B-U8360-01	32 - 5	90110-06823	25 - 45	90119-089U7	18 - 26		33 - 22	90387-11008	7 - 22
F1W-U759C-01	31 - 45	F1W-U8376-00	23 - 20	90110-08212	19 - 2		31 - 40	90267-48806	29 - 2	90401-10040	5 - 23
	33 - 17	F1W-U8572-01	27 - 47	90111-06114	28 - 14	90119-089UT	21 - 1		34 - 46		9 - 8
F1B-U761D-02	27 - 10	F1G-U8572-02	18 - 22		28 - 21	90119-089UU	16 - 18		35 - 43	90430-06M03	3 - 13
F1B-U7626-00	32 - 10	F2C-U8577-03	18 - 23	90116-08032	6 - 26		35 - 40	90267-48807	25 - 46	90430-08209	10 - 10
F1B-U7628-00	32 - 15	F1W-U8831-01	33 - 18	90116-10044	7 - 20	90119-08M22	8 - 3		26 - 6	90430-10007	5 - 22
F1W-U7629-00	32 - 13	F2C-U883B-00	16 - 20	90119-05803	25 - 8		22 - 12	90267-48825	28 - 27		9 - 9
F1B-U7656-00	32 - 9	F3K-U883E-00	16 - 21	90119-059U4	26 - 18	90119-10011	7 - 24	90267-489U1	14 - 50		39 - 7
F1B-U7698-01	32 - 6	F2S-U883N-01	27 - 26	90119-06048	22 - 10	90119-10029	13 - 13		22 - 4	90430-12002	18 - 27
F1W-U7711-03	31 - 13	F2S-U883P-01	27 - 27	90119-06078	2 - 13	90119-10046	7 - 16		23 - 8	90430-16910	32 - 19
F1W-U7711-12	31 - 13	F2S-U883T-00	27 - 28	90119-06827	18 - 33	90119-10047	7 - 15		23 - 19	90445-14804	15 - 30
F1W-U771H-00	27 - 37	F2R-U884B-00	25 - 14	90119-06880	25 - 16	90119-10806	15 - 33		23 - 21	90445-16013	14 - 43
6CN-U773D-00	15 - 28		30 - 48		25 - 27	90119-10808	18 - 24		25 - 52	90445-18017	14 - 18
F1B-U7773-00	31 - 14	F2C-U890L-10	30 - 27		25 - 31	90119-10810	15 - 3		27 - 49		14 - 23
F2N-U7831-10	31 - 19	F2C-U8952-11	30 - 36		25 - 38	90149-05903	25 - 7		30 - 26	90445-20800	27 - 4
GP7-U7832-01	31 - 20	F3K-U895D-00	31 - 26		25 - 41		26 - 3		31 - 38	90445-20804	27 - 1
GP7-U7833-11	31 - 21	F1S-U8K31-02	18 - 3	90119-06882	25 - 17		36 - 6		33 - 5	90445-21807	14 - 8
GP7-U7834-10	31 - 24	6ET-W0001-00	39 - 1		25 - 32	90149-06229	19 - 8	90267-489U2	18 - 8	90445-21813	14 - 1
GP7-U7835-00	31 - 22	6S5-W0001-22	39 - 22	90119-06891	16 - 16	90149-10052	24 - 6		24 - 15	90446-10MH3	22 - 20
GP7-U783F-00	31 - 27	6ET-W009A-00-94	2 - 1		17 - 2	90150-05807	18 - 5		31 - 5	90446-24M89	14 - 35
F2C-U7844-00	31 - 28	6ET-W009B-00-94	3 - 4		24 - 16		34 - 40	90267-489U6	18 - 14	90446-27M55	27 - 5
F0D-U7856-10	31 - 36	6S5-W1783-20	4 - 17	90119-06893	15 - 5	90154-06017	34 - 29		28 - 11	90446-27M73	27 - 2
F2C-U785G-00	31 - 34	90101-05800	25 - 3	90119-06895	26 - 29		36 - 5		28 - 13	90447-07001	34 - 25
F0D-U785G-10	23 - 10	90105-05020	7 - 2	90119-06897	15 - 11	90169-049U1	31 - 23		28 - 18	90447-19004	14 - 19
F2H-U785H-00	31 - 31	90105-06028	1 - 2	90119-069UH	26 - 31	90170-20802	15 - 19		28 - 20		14 - 24
F2N-U8169-00	27 - 30	90105-06035	2 - 16		31 - 41	90173-06015	21 - 18		29 - 5	90447-19006	14 - 32
F1K-U8211-01	23 - 6	90105-06903	22 - 15	90119-069UP	30 - 5	90176-08080	6 - 27		31 - 7	90447-19011	14 - 29
F1K-U821D-01	23 - 9	90105-06M07	3 - 12		30 - 10	90176-10001	7 - 21		31 - 10		14 - 40
F1K-U8221-00	23 - 5	90105-07004	5 - 4	90119-069UX	17 - 6	90183-06902	26 - 28		32 - 25	90447-19017	6 - 22
F1S-U8221-00	25 - 53	90105-07009	2 - 6	90119-06M35	21 - 6	90201-052E8	19 - 21		34 - 47	90447-19801	14 - 7
	33 - 2	90105-08021	3 - 35		21 - 20	90201-06028	7 - 9	90267-489U8	27 - 11	90447-22011	14 - 14
F1X-U822E-00	23 - 16	90105-08188	7 - 8	90119-06MA3	22 - 9		10 - 8		28 - 6	90447-22015	12 - 2
F2C-U822E-01	34 - 42	90105-08249	19 - 15		22 - 33	90201-06801	17 - 8		28 - 28	90447-22016	12 - 6
F1W-U826C-00	23 - 18	90105-08860	27 - 29	90119-08034	13 - 4		17 - 11	90269-08801	26 - 15	90447-22801	14 - 2
F2C-U826C-00	30 - 25	90105-10071	3 - 5		13 - 10	90201-068G7	25 - 29	90280-03047	19 - 10	90447-22802	14 - 9
F1K-U826C-03	27 - 48	90109-06218	26 - 24	90119-08074	6 - 33	90201-068M4	15 - 39	90387-05800	34 - 5	90447-28004	32 - 12
F1X-U828E-01	25 - 11		26 - 26	90119-08096	13 - 12	90201-06906	34 - 23	90387-06080	18 - 32		32 - 16
F1S-U828H-01	27 - 16	90109-06233	34 - 15	90119-08097	13 - 5	90201-099U3	30 - 17	90387-06119	21 - 8	90447-28008	2 - 18
F2P-U828K-00	25 - 50	90109-06268	3 - 34		13 - 9		34 - 16		21 - 22	90450-17M17	6 - 23
F1W-U828M-00	18 - 6	90109-06832	16 - 22	90119-08099	6 - 32	90201-109U6	30 - 29	90387-06289	16 - 15	90450-70006	7 - 26

NUMERICAL INDEX

PART NO.	REF. NO.	PART NO.	REF. NO.	PART NO.	REF. NO.	PART NO.	REF. NO.	PART NO.	REF. NO.	PART NO.	REF. NO.
90450-75003	7 - 11	90467-170A5	14 - 42	92014-06012	22 - 39	93210-32172	22 - 32	9572R-10300	30 - 41		
90450-90002	7 - 27	90467-17802	33 - 13	92903-06600	2 - 10		39 - 19	95780-08300	22 - 5		
	8 - 4	90467-18804	27 - 6	92903-08600	20 - 16	93306-00805	19 - 12	95814-06012	1 - 7		
90450-99015	13 - 20	90467-190A0	12 - 3	9290P-20600	15 - 18	93306-20654	15 - 12		21 - 32		
90450-99016	13 - 19		12 - 4	92990-06100	20 - 17	93306-20655	16 - 7	95814-06030	5 - 17		
90450-99801	33 - 8	90467-200A0	27 - 14		34 - 3	93306-30537	15 - 14	95814-06035	3 - 23		
90450-99804	33 - 9	90467-200A3	12 - 8	92990-06200	34 - 2	93410-12003	20 - 7	95814-06065	7 - 7		
90464-09M47	21 - 19		14 - 3	92990-10600	22 - 21	93450-24028	4 - 6	95814-06070	3 - 6		
90464-17800	31 - 12		14 - 15	92990-12200	18 - 28	93450-66156	16 - 6	95814-08020	10 - 9		
90464-20008	22 - 34		14 - 16		27 - 22	93604-10M03	3 - 8	95814-08030	11 - 4		
90464-31001	22 - 18		14 - 27		30 - 38		7 - 5	95814-08050	11 - 6		
	22 - 30		14 - 45	92995-06100	21 - 29	93606-12019	3 - 7	95814-08065	7 - 6		
	22 - 36		14 - 48	92995-06600	21 - 30		9 - 3	95817-06014	10 - 6		
90464-31002	22 - 37	90467-21800	27 - 12		22 - 24		13 - 8	97013-06055	2 - 9		
90464-32801	18 - 9	90467-240A0	2 - 19	92995-08600	3 - 15		15 - 6	97013-08030	20 - 15		
	18 - 12		12 - 7	9299R-05200	18 - 11		15 - 32	97095-06012	21 - 28		
	18 - 17	90467-25801	32 - 11		27 - 34		16 - 14	97095-06016	22 - 23		
	27 - 19	90467-26800	32 - 3		28 - 7	93608-16M16	13 - 3	97095-08040	3 - 14		
	27 - 52		32 - 17	9299R-08200	26 - 38	93700-06M03	16 - 10	97513-05514	19 - 9		
	31 - 11		32 - 26		27 - 51	94591-66152	5 - 14	97513-08535	6 - 25		
	33 - 21	90480-19800	25 - 12		30 - 23	94702-00435	22 - 16	97595-06514	21 - 17		
	34 - 48	90480-20132	22 - 28		30 - 35	95023-06012	6 - 30	97780-60516	8 - 9		
90464-35132	14 - 22	90480-21M63	7 - 23	9299R-10200	30 - 21		9 - 10	97780-60520	21 - 24		
90464-40825	34 - 44	90480-22801	8 - 10		30 - 30	95024-06014	3 - 19	97880-03008	35 - 14		
90464-99801	18 - 13	90480-22M15	8 - 1		30 - 40	95024-06020	3 - 20	97880-05025	35 - 17		
90464-99804	29 - 6		22 - 13	93101-31001	15 - 16		10 - 12	9788R-05025	27 - 33		
90465-11829	23 - 13	90480-38800	27 - 15		39 - 28	95024-06035	10 - 11	99009-24700	4 - 20		
	31 - 32	90601-118UF	15 - 29	93102-29008	16 - 5	95024-08035	13 - 16	99009-72500	19 - 14		
	31 - 33		27 - 9		39 - 24	95380-06700	20 - 18	99530-10114	3 - 2		
	31 - 35	90601-152U3	16 - 23	93102-29009	16 - 8	9538R-06600	17 - 9		3 - 26		
	34 - 37	90601-155U4	31 - 29		39 - 25		17 - 12		19 - 16		
	34 - 41	90601-162U5	31 - 18	93102-31009	15 - 15	9538R-06700	15 - 40	99590-14016	7 - 14		
90465-13M18	22 - 17	90601-170UG	33 - 7		39 - 27		34 - 24		15 - 2		
90465-14M66	21 - 34	90601-200U1	18 - 10	93210-06632	3 - 28	9538R-08600	30 - 34	99780-12600	27 - 21		
90467-089U1	23 - 11		23 - 17	93210-11453	3 - 3	95720-06300	26 - 25				
90467-14803	15 - 31		27 - 13		39 - 4		35 - 29				
	32 - 14	90601-200U7	29 - 7	93210-12016	3 - 33	95720-08300	35 - 33				
	32 - 21	90605-502U1	26 - 16		39 - 11	9572R-05300	27 - 35				
90467-150A1	3 - 32	90605-502U2	25 - 10	93210-18322	11 - 8	9572R-06300	26 - 27				
	14 - 30	91314-06020	9 - 4		39 - 10		26 - 33				
90467-150A5	14 - 6	91314-06060	10 - 7	93210-21631	9 - 6		31 - 16				
90467-160A0	14 - 20	91317-05010	19 - 20		39 - 9	9572R-08300	26 - 39				
	14 - 25	91317-06014	19 - 19	93210-22MF1	16 - 3		27 - 50				
	14 - 33	91380-06016	22 - 26		39 - 23		30 - 12				
	14 - 38	91380-06020	19 - 23	93210-24M79	1 - 10		30 - 18				
	14 - 41	91380-06025	5 - 20		39 - 12		30 - 24				
	14 - 44	91809-16002	2 - 4	93210-30611	15 - 25	9572R-10300	18 - 15				
90467-170A4	14 - 36		2 - 5		39 - 30		30 - 31				