

YAMAHA

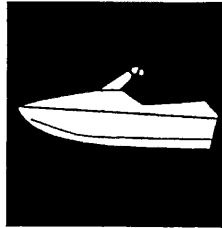

**PARTS
CATALOGUE**

WAVE RAIDER

RA700BU (GJ81,GJ82)

RA700B (GJ82,GJ83)

YAMAHA
GENUINE
Parts & Accessories

16GJ8-100E1

A2

FOREWORD

This Parts Catalogue is related to the parts for the model(s) in the below frame. When you are ordering replacement parts, please refer to this Parts Catalogue and quote both part numbers and part names correctly.

RA700BU (GJ81,GJ82) RA700B(GJ82,GJ83)

1. Modifications or additions which have been made after issue of the Parts Catalogue will be announced in the Yamaha Parts News. It is advisable that you make necessary corrections to the Parts Catalogue according to the Yamaha Parts News.

2. Abbreviations

The following abbreviations are used in this Parts Catalogue.

- "UR" Use specified parts number.
- "UN" Use as many as needed.
- "AP" Alternate Parts
- "LM" Local Made (Parts need to be ordered locally)
- "F#" Frame No. (Applicable machine No.)

3. Parts, which are to be supplied in an assembly, are listed with a dot (.) in front of the part name as shown below. The numeral appearing to the right of each component part indicates the quantity of parts for each assembly unit.

EXAMPLE

PART NO.	DESCRIPTION	Q'TY	REMARKS
EU0-62280-00	DRAIN PLUG ASSY	2	
EU0-62282-00	. PLUG, DRAIN	1	

4. Applicable Serial No. and Color Code

① Hull Serial No.	(GJ81,GJ82) GJ8-800101 ~
	(GJ83) GJ8-600101 ~
② Engine Serial No.	64R-000101 ~

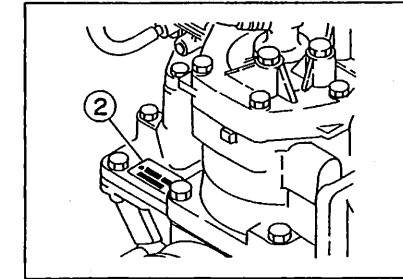
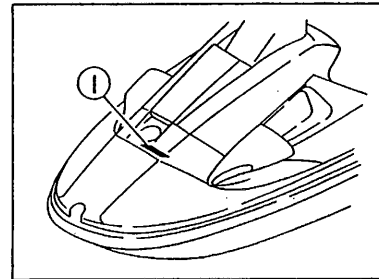

Color Code	Color Name	Abbreviation
4D	DARK BLUISH GRAY METALLIC 2	DBNM2

5. Note that the illustrations are for reference in finding parts numbers, not to be used for assembling. When assembling, please use the applicable service manual.
6. A part with "YMUS" in the remarks column can be obtained from YMUS(USA) and not from YAMAHA MOTOR CO.,LTD (JAPAN).

EXAMPLE

PART NO.	DESCRIPTION	QTY	REMARKS
EW2-U5160-00	ENGINE HATCH COMP.	1	YMUS
90601-168U7	BAND, HOSE	1	YMUS

ADDRESS:

YAMAHA MOTOR CORPORATION U.S.A. PARTS & ACCESSORY DIV. 6555 KATELLA AVENUE CYPRESS, CALIFORNIA 90630, U.S.A.

CONTENTS

Cylinder. Crankcase	B2~B3
Crankshaft. Piston	B4
Intake	B5~B6
Carburetor	B7~B8
Oil Pump	B9
Exhaust 1	B10~B11
Fuel	B12
Jet Unit 1	B13~B14
Jet Unit 2	B15~C2
Generator	C3
Starting Motor	C4
Electrical 1	C5~C6
Electrical 2	C7
Engine Hatch	C8~C9
Hull. Deck	C10~C11
Gunwale. Mat	C12
Seat · Under Locker 1	C13~C14
Seat · Under Locker 2	C15
Oil Tank	D2
Fuel Tank	D3~D4

Exhaust 2	D5
Control Cable	D6
Steering 1	D7~D8
Steering 2	D9
Graphic 1. Tool (For USA)	D10
Graphic 2. Tool (For CAN, GUM, AUS, FRA)	D11
Repair Kit 1	D12~D13
Repair Kit 2	D14

INDEX

Numerical Index	M1~M3
-----------------------	-------

FIG. 1 CYLINDER. CRANKCASE

REF. NO.	PART NO.	DESCRIPTION	Q'TY	REMARKS
1	61X-W0090-03-4D	CRANK CYLINDER ASSY	1	OIL INJECTION
2	61X-15100-00-94	CRANKCASE ASSY	1	
3	90380-12M29	.BUSH, SOLID	1	
4	90119-08M55	BOLT, WITH WASHER	4	
5	62T-44532-10	STOPPER, UPPER MOUNT	1	
6	90109-08M56	BOLT	4	
7	93606-12019	PIN, DOWEL	4	
8	93603-10049	PIN, DOWEL	4	
9	93604-07141	PIN, DOWEL	1	
10	61X-11311-00-94	CYLINDER 1	1	
11	6E5-11325-00	ANODE	1	
12	98780-04015	SCREW, FLAT HEAD	1	
13	6M6-11351-A2	GASKET, CYLINDER	1	
14	90119-10M56	BOLT, WITH WASHER	4	
15	90119-10M07	BOLT, WITH WASHER	2	
16	61X-11111-00-94	HEAD, CYLINDER 1	1	
17	6K8-51129-00	.NIPPLE	1	
18	6R7-14485-00	.PIPE, JOINT	1	
19	61X-11181-A0	GASKET, CYLINDER HEAD 1	1	
20	90119-08M19	BOLT, WITH WASHER	10	
21	90445-07M19	HOSE	1	
22	90467-06016	CLIP	2	
23	6R7-21415-00-94	BRACKET, FRONT UPPER 1	1	
24	6R7-21425-00-94	BRACKET, REAR UPPER 1	1	
25	90119-10M02	BOLT, WITH WASHER	5	
26	90119-10M00	BOLT, WITH WASHER	1	
27	90119-10M03	BOLT, WITH WASHER	1	
28	6M6-44517-A1-5B	MOUNT RUBBER	4	

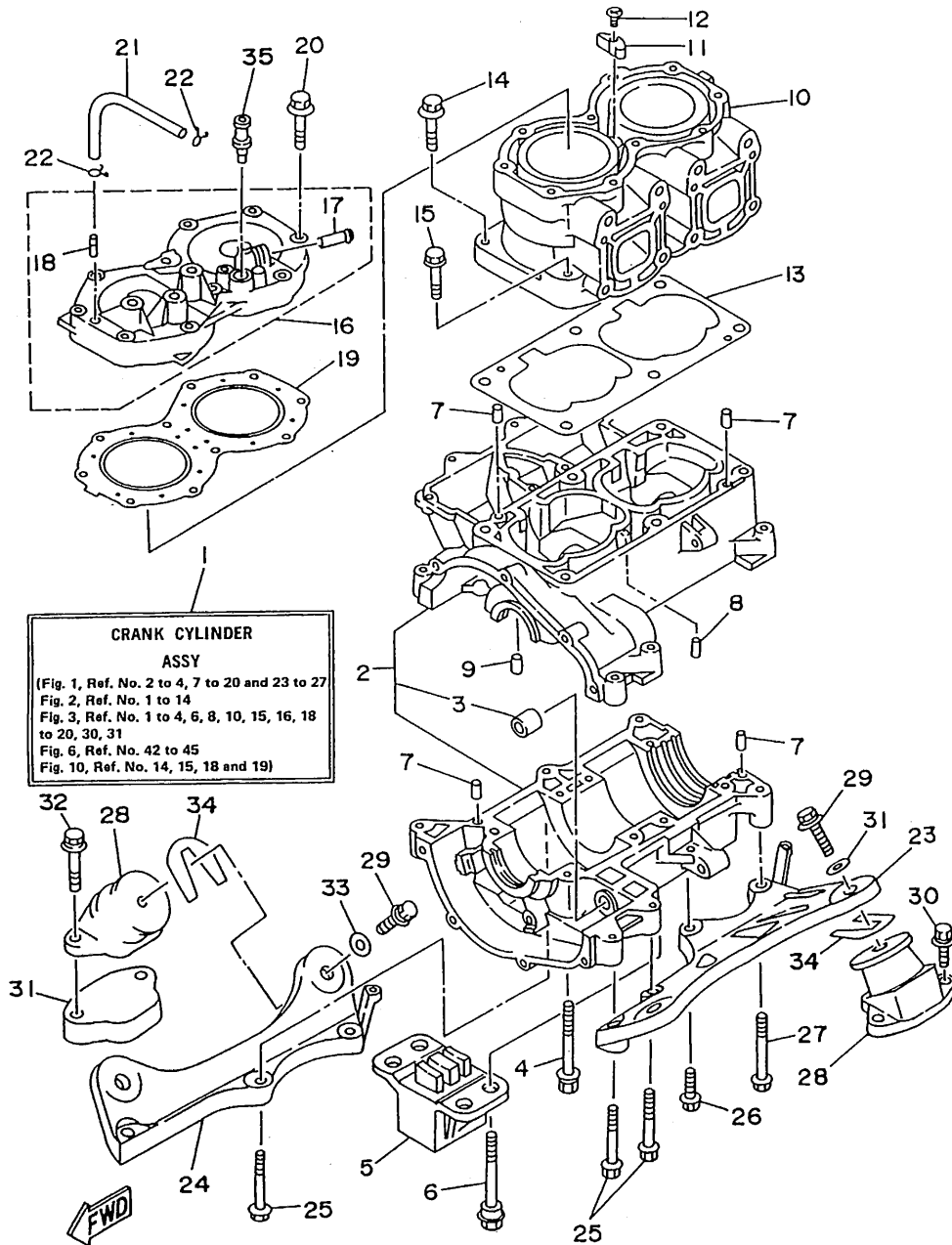

GJ81100-6010

FIG. 1 CYLINDER. CRANKCASE

REF. NO.	PART NO.	DESCRIPTION	Q'TY	REMARKS
29	90119-08904	BOLT, WITH WASHER	4	
30	90119-08038	BOLT, WITH WASHER	2	
31	GJ1-6721B-00	SPACER, ENGINE MOUNT	3	
32	90119-089U1	BOLT, WITH WASHER	6	YMUS
33	EU0-67324-00	PLATE	4	
34	EU0-U7354-00-01	SHIM (T=0.1)	10	UR YMUS
	EU0-67354-00-01	SHIM (T=0.1)	10	UR
	EU0-U7354-00-03	SHIM (T=0.3)	10	UR YMUS
	EU0-67354-00-03	SHIM (T=0.3)	10	UR
	EU0-U7354-00-05	SHIM (T=0.5)	10	UR YMUS
	EU0-67354-00-05	SHIM (T=0.5)	10	UR
	EU0-U7354-00-10	SHIM (T=1.0)	10	UR YMUS
	EU0-67354-00-10	SHIM (T=1.0)	10	UR
	EU0-U7354-00-20	SHIM (T=2.0)	10	UR YMUS
	EU0-67354-00-20	SHIM (T=2.0)	10	UR
35	6E0-28193-00-94	PLUG, WATER CHEAK	1	UR FOR EXEPT USA
	626-28193-01-94	PLUG, WATER CHEAK	1	UR FOR JAPAN

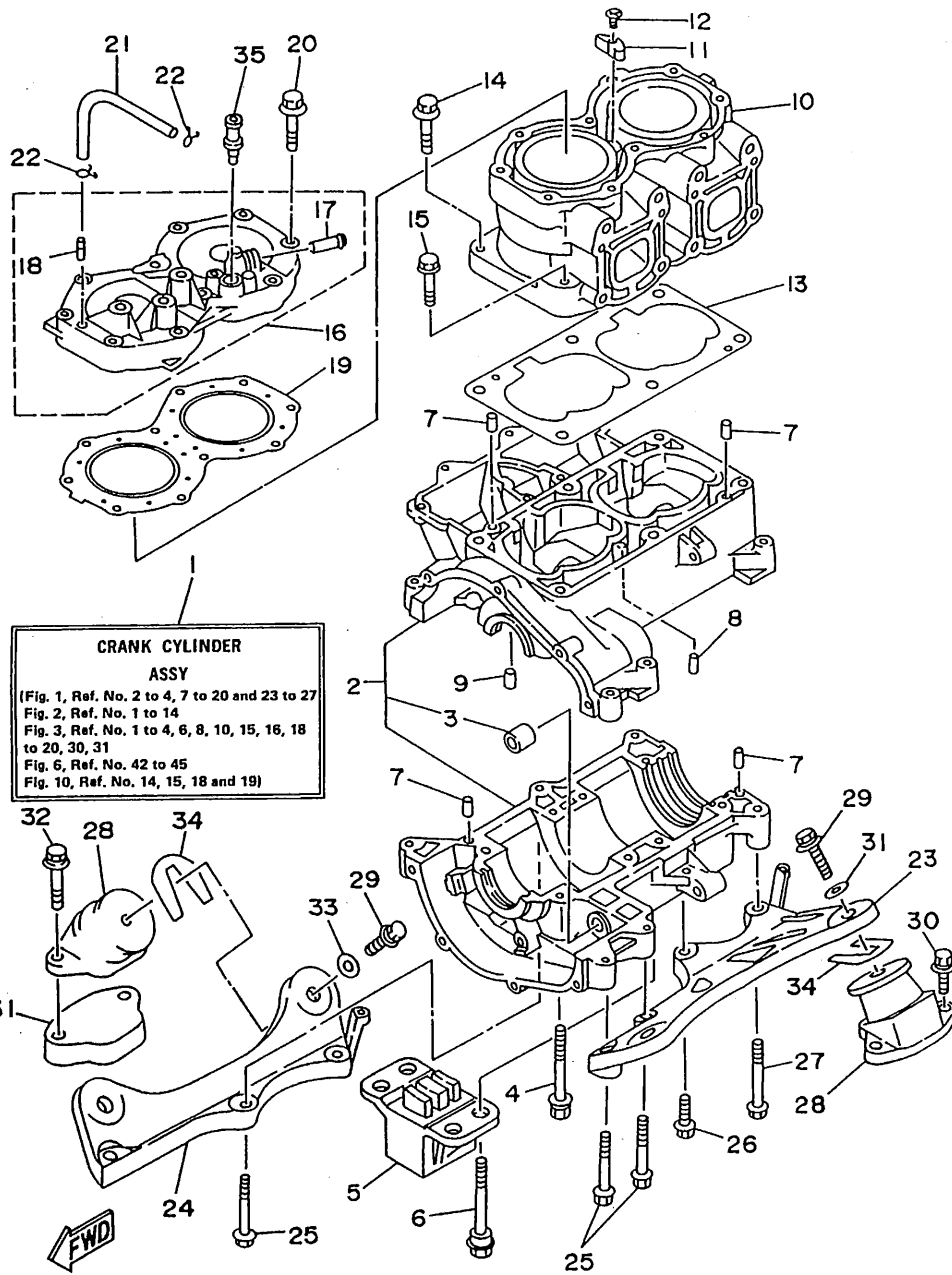

GJ81100-6010

B3

FIG. 2 CRANKSHAFT. PISTON

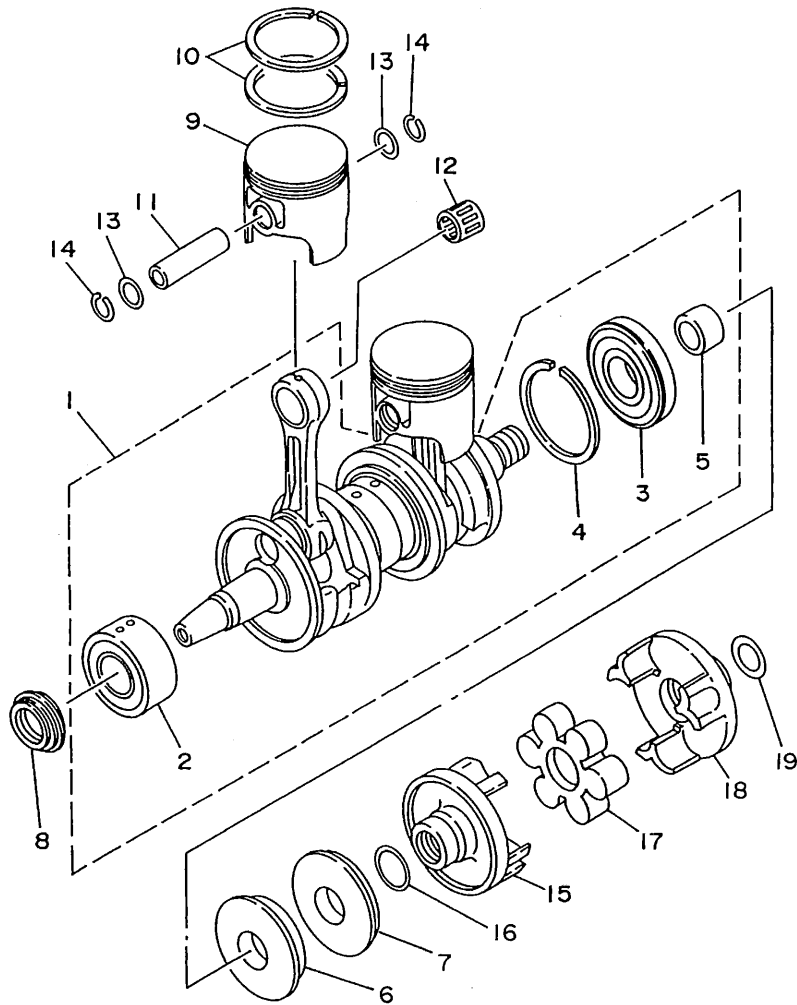

REF. NO.	PART NO.	DESCRIPTION	Q'TY	REMARKS
1	6M6-11400-02	CRANKSHAFT ASSY	1	
2	93305-30601	.BEARING	1	
3	93306-307U3	.BEARING	1	
4	93440-80023	.CIRCLIP	1	
5	62T-45526-00	.COLLAR, DRIVE SHAFT	1	
6	93102-36M33	OIL SEAL	1	
7	93101-36M46	OIL SEAL	1	
8	93103-32M01	OIL SEAL	1	
9	61X-11631-00-93	PISTON (STD)	2	
	61X-11635-00	PISTON (0.25MM O/S)	2	AP
	61X-11636-00	PISTON (0.50MM O/S)	2	AP
10	61X-11603-00	PISTON RING SET (STD)	4	
	61X-11604-00	PISTON RING SET (0.25MM O/S)	2	AP
	61X-11605-00	PISTON RING SET (0.50MM O/S)	2	AP
11	61X-11633-00	PIN, PISTON	2	
12	90201-20M04	WASHER, PLATE	4	
13	93310-320U2	BEARING, CYLINDRICAL	2	
14	93450-21053	CIRCLIP	4	
15	6M6-45813-31-9M	FLANGE, COUPLING	1	
16	62T-45127-00	SEAL	1	
17	61X-4581J-00	RUBBER SHAFT COUPLING	1	
18	6M6-45813-21-9M	FLANGE, COUPLING	1	
19	90201-24M02	WASHER, PLATE	1	



GH1D200-6020

B4

FIG. 3 INTAKE

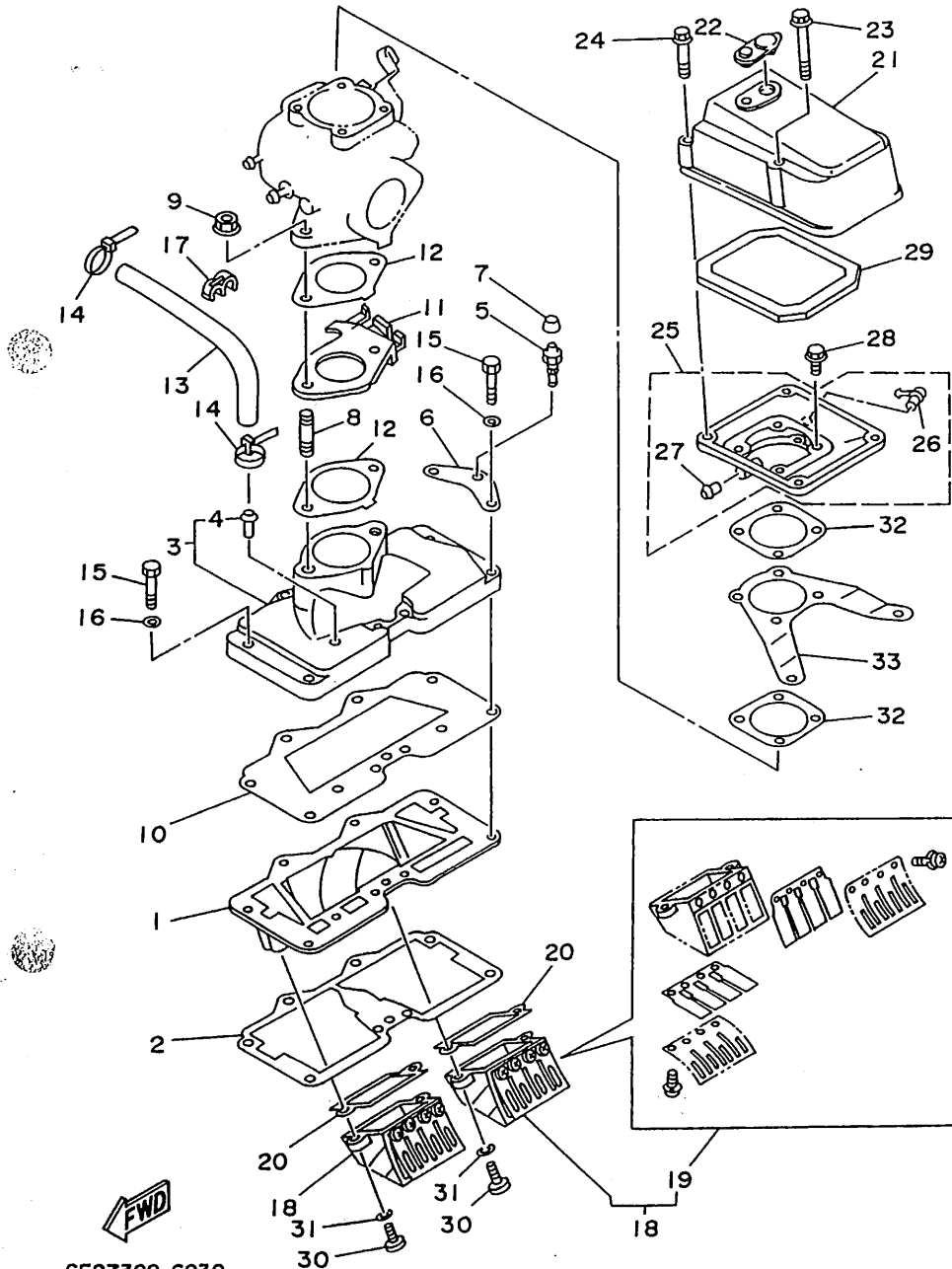

REF. NO.	PART NO.	DESCRIPTION	Q'TY	REMARKS
1	61X-13641-01-94	MANIFOLD 1	1	
2	61X-13566-A1	GASKET	1	
3	61X-13555-01-94	MANIFOLD, INTAKE	1	
4	650-24378-00	.PIPE, JOINT	1	
5	61L-5169A-00	NIPPLE, GREASE	1	
6	61L-14243-00	PLATE	1	
7	663-45119-00	CAP, GREASE NIPPLE	1	
8	90116-08M14	BOLT, STUD	2	
9	90179-08M15	NUT	2	
10	61X-13563-A1	GASKET	1	
11	6M6-14527-02-4D	PLATE	1	
12	6M6-13556-A1	GASKET, MANIFOLD	2	
13	90445-10M48	HOSE	1	
14	90465-11M10	CLAMP	2	
15	97014-06035	BOLT	8	
16	92990-06600	WASHER, PLATE	8	
17	90464-10M38	CLAMP	2	
18	61X-13610-01	REED VALVE ASSY	2	
19	61X-W0004-00	.REED SET	1	
20	61X-13621-A0	GASKET, VALVE SEAT	2	
21	61X-14283-01	COVER, CARBURETOR 1	1	
22	6K8-14435-00	GROMMET	1	
23	90105-05M46	BOLT, WASHER BASED	2	
24	90105-05M53	BOLT, WASHER BASED	2	
25	6R8-14284-00-98	COVER, CARBURETOR 2	1	
26	6E5-11372-00	.NIPPLE, HOSE	1	
27	6H1-14485-00	.PIPE, JOINT	1	
28	97595-06520	BOLT, WITH WASHER	4	

FIG. 3 INTAKE

REF. NO.	PART NO.	DESCRIPTION	Q'TY	REMARKS
29	6M6-14451-00	ELEMENT, AIR CLEANER	1	
30	98580-05016	SCREW, PAN HEAD	4	
31	92990-05600	WASHER, PLATE	4	
32	6M6-13674-A1	GASKET, AIR COOLER COVER 1	2	
33	6R7-14255-00	PLATE	1	

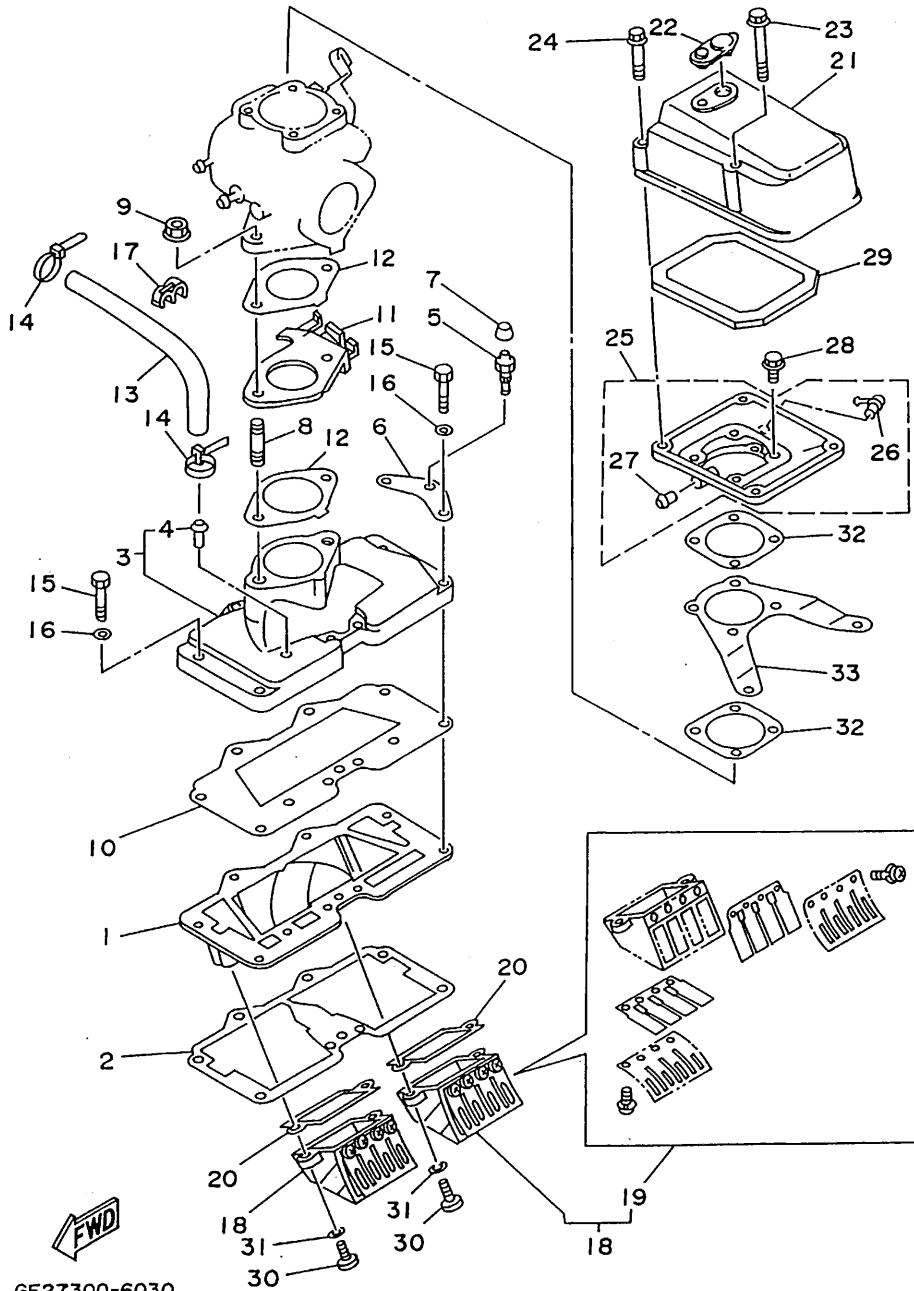

GE27300-6030

B6

FIG. 4 CARBURETOR

REF. NO.	PART NO.	DESCRIPTION	Q'TY	REMARKS
1	61X-14301-01	CARBURETOR ASSY 1	1	
2	6R7-14596-01	.WASHER	2	
3	6K8-14534-10	.COLLAR	1	
4	6K8-14556-10	.SPRING	1	
5	6K8-14926-10	.BRACKET, THROTTLE 1	1	
6	6K8-14930-00	.THROTTLE SHAFT ASSY	1	
7	92990-08100	.WASHER, SPRING	1	
8	95380-08700	.NUT	1	
9	97980-05330	.SCREW, WITH WASHER	4	
10	6K8-14559-00	.WASHER	2	
11	6M6-14521-00	.SCREW, ADJUST	1	
12	6K8-14562-00	.O-RING	1	
13	6K8-14946-10	.METERING NEEDLE	1	
14	6K8-14471-00	.CAP, CARBURETOR	1	
15	6M6-14503-00	.SCREW	1	
16	3G2-14231-27	.JET, MAIN (#135)	1	
17	6K8-14503-02	.SCREW	2	
18	6K8-14521-10	.SCREW	2	
19	830-14231-23	.JET, PILOT (#115)	1	
20	6K8-14591-10	.SCREW	4	
21	6K8-14523-11	.SCREW, STOP	1	
22	6K8-14527-11	.PLATE	1	
23	6K8-14579-00	.PIN, FLOAT	1	
24	6R7-24412-01	.BODY 1	1	
25	6K8-14536-11	.GASKET	1	
26	6R7-14569-00	.STRAINER	1	
27	61X-14916-15	.NEEDLE	1	
28	6K8-14547-01	.ARM, FLOAT	1	

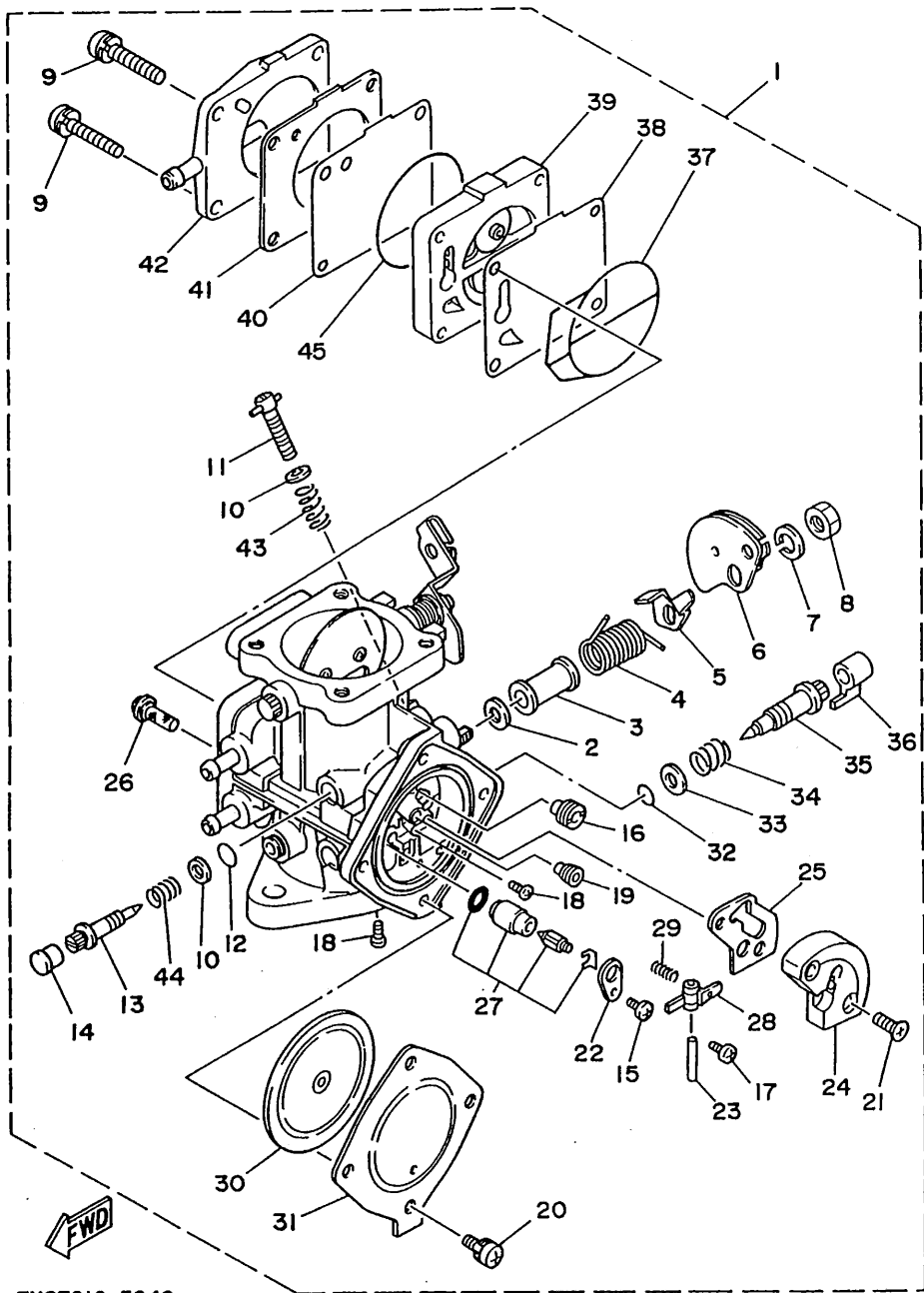

FN8F010-3040

B7

FIG. 4 CARBURETOR

REF. NO.	PART NO.	DESCRIPTION	Q'TY	REMARKS
29	6R7-14253-00	.SPRING	1	
30	6R7-14541-00	.DIAPHRAGM, PUMP	1	
31	6R7-14542-00	.BODY, PUMP 1	1	
32	583-14561-00	.O-RING	1	
33	6K8-14537-00	.GASKET	1	
34	6K8-14589-00	.SPRING	1	
35	6M6-14923-10	.SCREW, PILOT	1	
36	6K8-14481-10	.CAP, CARBURETOR	1	
37	6K8-14564-00	.O-RING	1	
38	6K8-24411-20	.DIAPHRAGM	1	
39	6M6-24413-00	.BODY 2	1	
40	6K8-24421-10	.VALVE, CHECK	1	
41	6K8-24431-20	.GASKET, FUEL PUMP 1	1	
42	6K8-24452-10	.COVER	1	
43	6K8-14531-00	.SPRING, ADJUST SCREW	1	
44	6K8-14533-00	.SPRING, ADJUST SCREW	1	
45	6K8-14563-00	.O-RING	1	

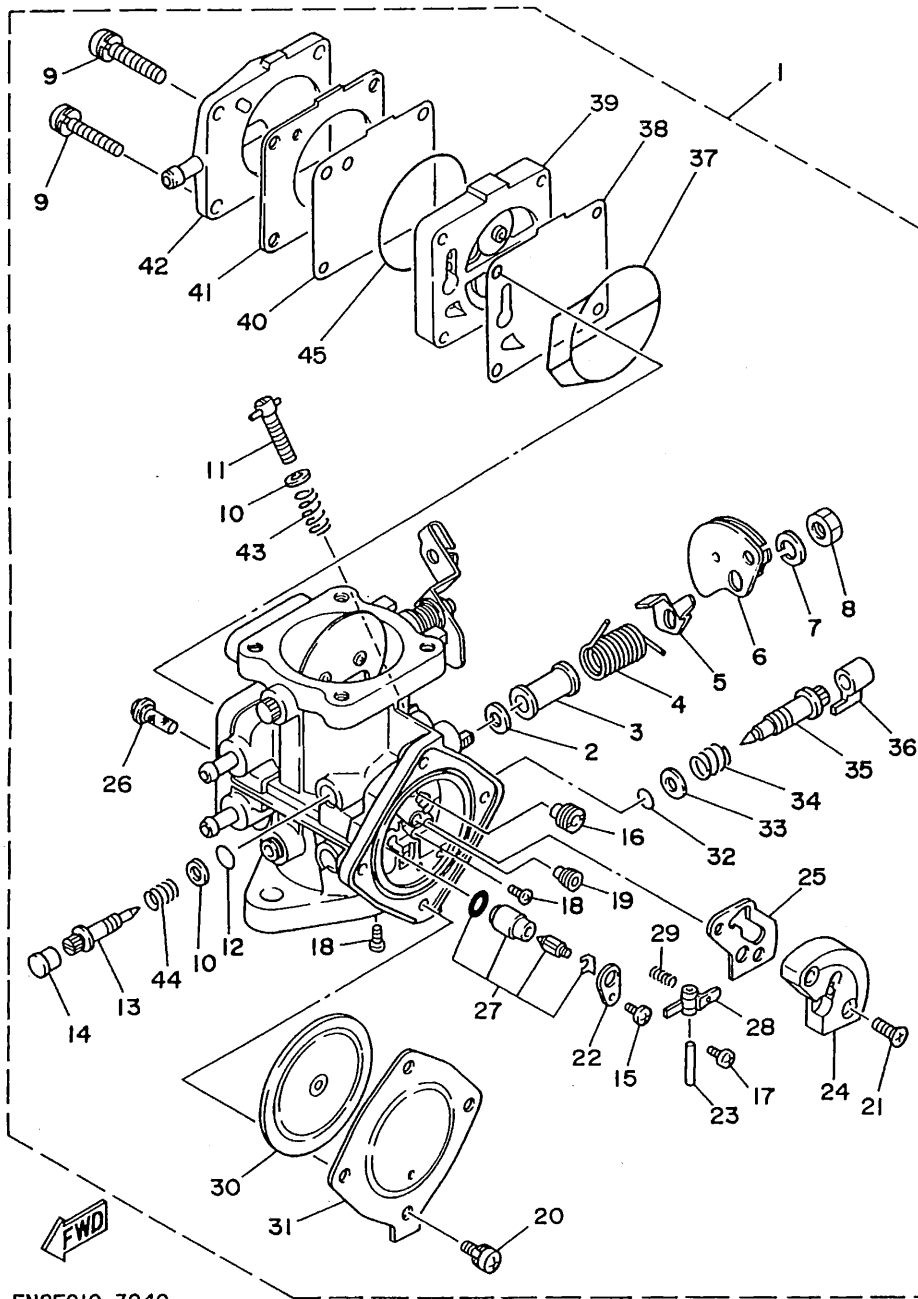

FN8F010-3040

B8

FIG. 5 OIL PUMP

REF. NO.	PART NO.	DESCRIPTION	Q'TY	REMARKS
1	61X-13200-10	OIL INJECTION PUMP ASSY	1	
2	6R8-13116-A0	GASKET, PUMP CASE	1	
3	97095-06035	BOLT	2	
4	92990-06600	WASHER, PLATE	2	
5	90445-07M87	HOSE	1	
6	90446-07M35	HOSE	1	
7	90445-07M87	HOSE	1	
8	90446-07M36	HOSE	1	
9	6R3-13183-00	VALVE, CHECK	2	
10	90465-11M10	CLAMP	8	
11	90465-08M37	CLAMP	1	
12	90445-11M34	HOSE	1	
13	90465-11M10	CLAMP	2	

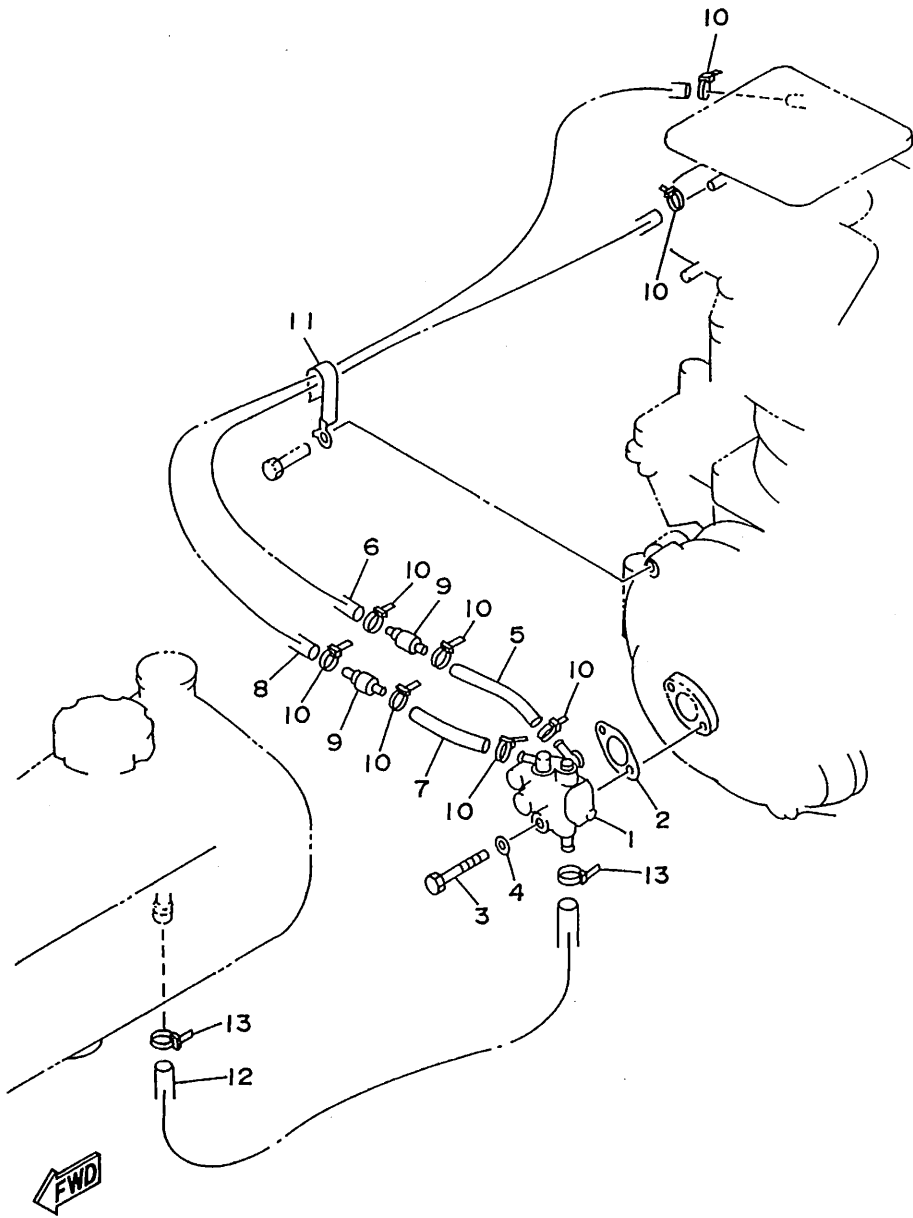

GJ81100-6050

B9

FIG. 6 EXHAUST 1

REF. NO.	PART NO.	DESCRIPTION	Q'TY	REMARKS
1	61X-14711-01-9M	MUFFLER 1	1	
2	6K8-51129-00	.NIPPLE	1	
3	6M6-14718-01-9M	PROTECTOR, MUFFLER 1	1	
4	6M6-14739-A1	GASKET, MUFFLER DAMPER 1	1	
5	61X-14613-A0	GASKET, EXHAUST PIPE	1	
6	97013-08035	BOLT	8	
7	92990-08600	WASHER, PLATE	8	
8	61L-14712-00-9M	RING, JOINT	1	
9	6K8-51129-00	.NIPPLE	1	
10	90340-08M04	PLUG, STRAIGHT SCREW	1	
11	90430-08020	GASKET	1	
12	90119-08M73	BOLT, WITH WASHER	2	
13	97013-06025	BOLT	4	
14	92990-06600	WASHER, PLATE	4	
15	97013-08025	BOLT	2	
16	92990-08600	WASHER, PLATE	2	
17	6R7-14749-A0	GASKET, MUFFLER DAMPER 2	1	
18	90445-14M29	HOSE	2	
19	6E5-24378-00	PIPE, JOINT 4	1	
20	90445-14M33	HOSE	1	
21	90465-11M10	CLAMP	5	
22	90445-14M25	HOSE	1	
23	90450-14M05	HOSE CLAMP ASSY	1	
24	90446-20M31	HOSE	1	
25	6R7-14721-00-9M	MUFFLER 2	1	
26	6R7-14485-00	.PIPE, JOINT	1	
27	6R7-14753-00-9M	SILENCER, EXHAUST	1	
28	6R7-15761-00	SEAL, RUBBER 1	1	

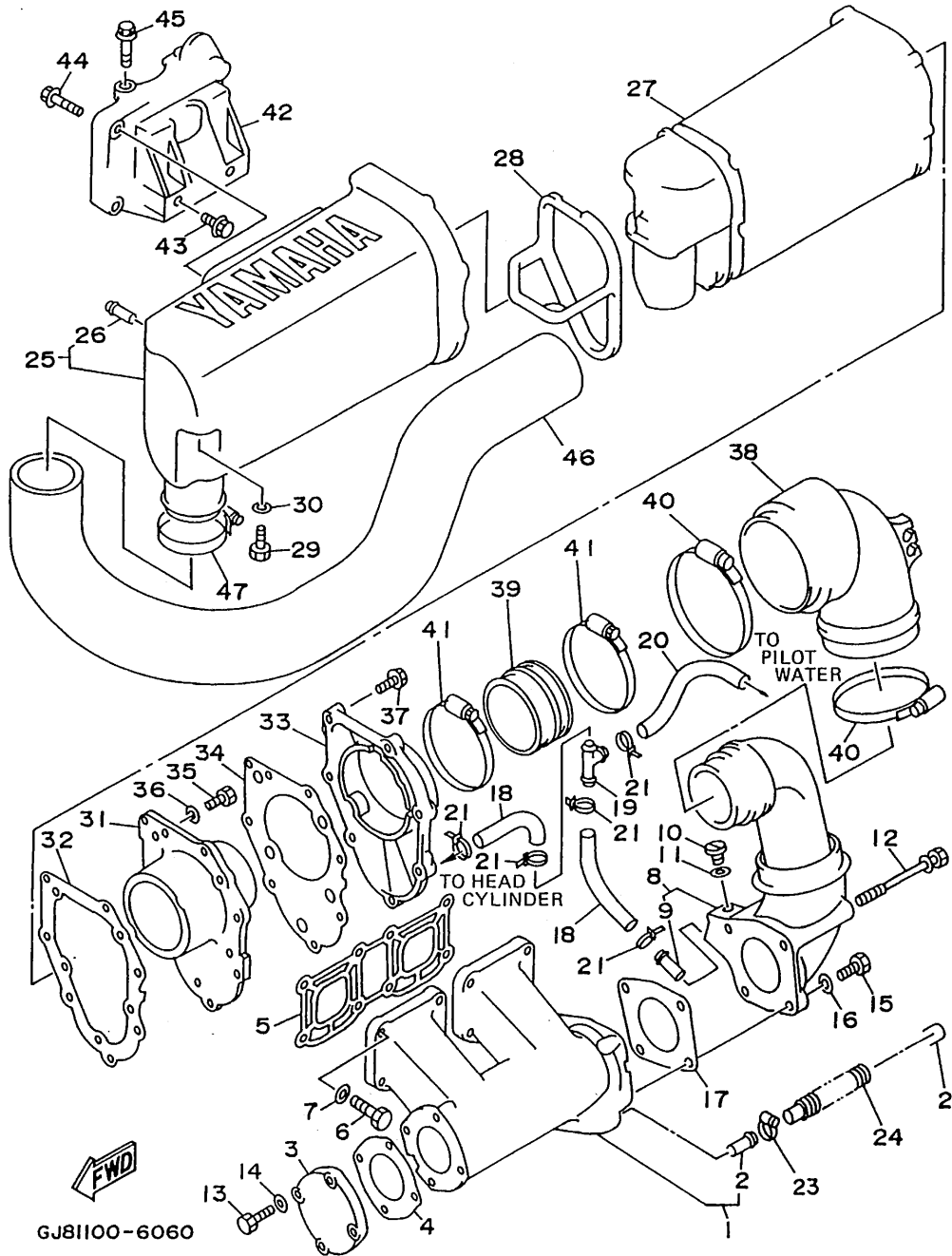

GJ81100-6060

B10

FIG. 6 EXHAUST 1

REF. NO.	PART NO.	DESCRIPTION	Q'TY	REMARKS
29	97013-06020	BOLT	1	
30	92990-06600	WASHER, PLATE	1	
31	6R7-14785-00-9M	DIFFUSER	1	
32	6R7-14755-A0	GASKET, SILENCER	1	
33	6R7-41113-00-9M	OUTER COVER, EXHAUST	1	
34	6R7-41114-A0	GASKET, EXHAUST OUTER COVER	1	
35	97095-06016	BOLT	5	
36	92990-06600	WASHER, PLATE	5	
37	90119-06MA1	BOLT, WITH WASHER	7	
38	61L-14615-00	JOINT, EXHAUST 1	1	
39	61L-14625-00	JOINT, EXHAUST 2	1	
40	90460-90M11	CLAMP, HOSE	2	
41	90460-70M16	CLAMP, HOSE	2	
42	6M6-14771-00-94	STAY, MUFFLER 1	1	
43	90105-10M49	BOLT, WASHER BASED	2	
44	90105-10M45	BOLT, WASHER BASED	3	
45	90119-10M72	BOLT, WITH WASHER	3	
46	64R-14752-00	PIPE, OUTLET	1	
47	90460-64M15	CLAMP, HOSE	1	

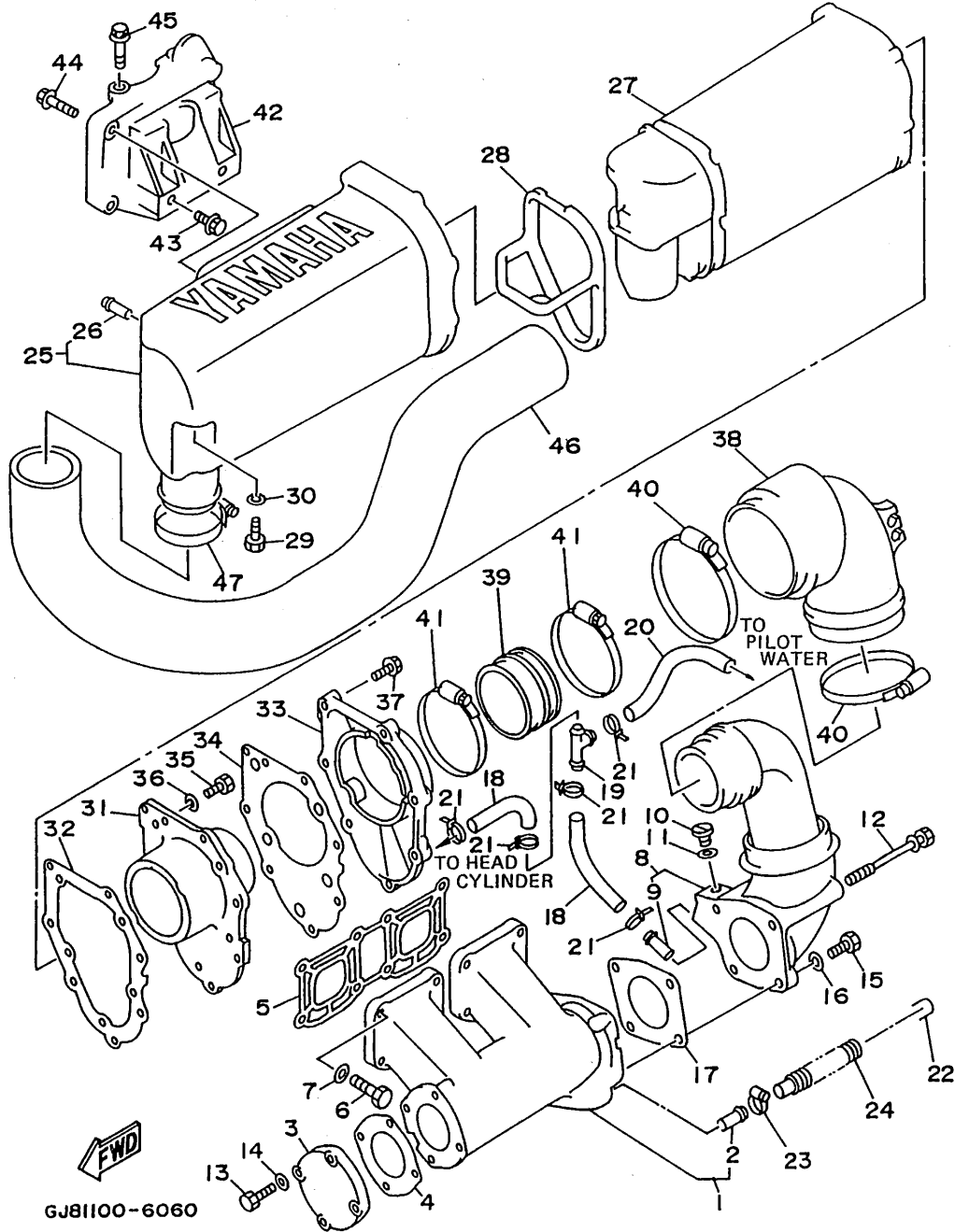

B11

FIG. 7 FUEL

REF. NO.	PART NO.	DESCRIPTION	Q'TY	REMARKS
1	90445-10M30	HOSE	1	
2	90445-10M92	HOSE	1	
3	90465-11M10	CLAMP	2	
4	6K8-24560-10	FILTER ASSY	1	
5	6K8-24500-02	FUEL COCK ASSY 1	1	
6	90445-10M71	HOSE	1	RES
7	90465-11M10	CLAMP	3	
8	90445-10M70	HOSE	1	ON
9	90465-11M10	CLAMP	3	
10	90445-10M72	HOSE	1	OUT
11	90465-11M10	CLAMP	2	
12	6K8-24524-10	LEVER, COCK	1	
13	90170-22M11	NUT	1	
14	98580-04010	SCREW, PAN HEAD	1	
15	92990-04600	WASHER, PLATE	1	
16	GJ1-U773J-00	PROTECTOR, HOSE	1	YMUS
17	90601-20015	NYLON CLIP 1	1	
18	EU0-67817-00	HOLDER	1	
19	FN8-67816-00	BRACKET, FUEL FILTER	1	
20	90601-200U1	NYLON CLIP 1	1	YMUS
21	90267-489U1	RIVET, BLIND	2	YMUS
22	90600-91736	CLAMP	2	
23	90201-05925	WASHER, PLATE	1	
24	90267-48925	RIVET, BLIND	2	
25	90601-20006	NYLON CLIP 1	2	

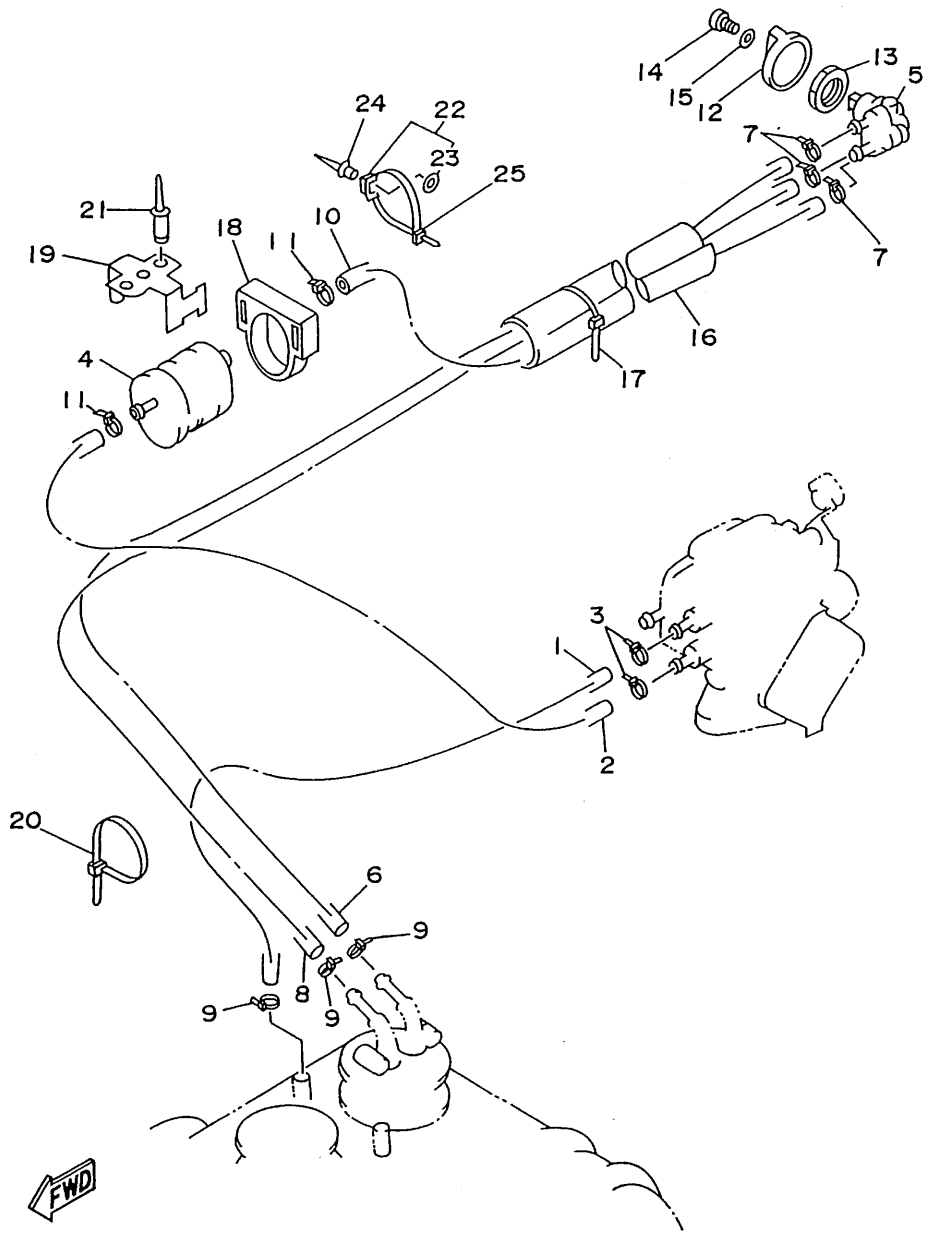

GJ81100-6070

B12

FIG. 8 JET UNIT 1

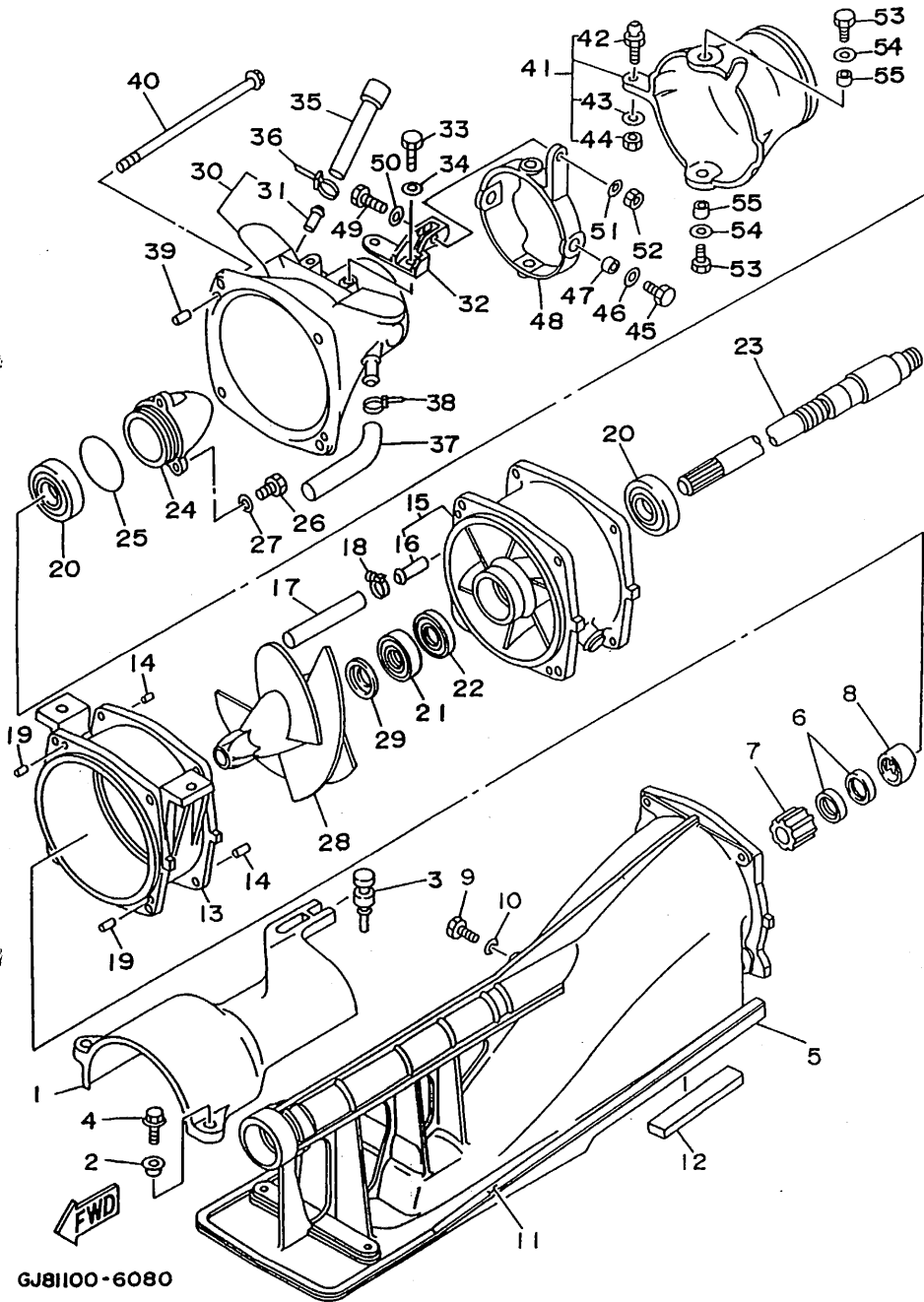

REF. NO.	PART NO.	DESCRIPTION	Q'TY	REMARKS
1	62T-51381-00	COVER	1	
2	90387-06M60	COLLAR	2	
3	90480-06M46	GROMMET	1	
4	97595-06525	BOLT, WITH WASHER	2	
5	62T-51311-00-94	DUCT, INTAKE	1	
6	93102-18M35	OIL SEAL	2	
7	6R8-45318-00	BUSHING, DRIVE SHAFT	1	
8	6R8-51348-00-5B	SPACER	1	
9	97095-06025	BOLT	1	
10	92990-06600	WASHER, PLATE	1	
11	6R8-51367-01	FELT, PACKING	2	
12	63N-51368-00	FELT, PACKING	2	
13	6R8-51312-00-94	HOUSING, IMPELLER	1	
14	93606-12019	PIN, DOWEL	2	
15	62T-51315-00-94	DUCT, IMPELLER	1	
16	6K8-51129-00	.NIPPLE	1	
17	90445-14M17	HOSE	1	
18	90450-14M05	HOSE CLAMP ASSY	1	
19	93606-12019	PIN, DOWEL	2	
20	93306-205U0	BEARING	2	
21	93102-25M34	OIL SEAL	1	
22	93101-25M50	OIL SEAL	1	
23	6R8-45511-00	SHAFT, DRIVE	1	
24	62T-51326-00	CAP	1	
25	93210-46M16	O-RING	1	
26	97095-06016	BOLT	3	
27	92990-06600	WASHER, PLATE	3	
28	6R7-51321-00-94	IMPELLER	1	

GJ81100-6080

B13

FIG. 8 JET UNIT 1

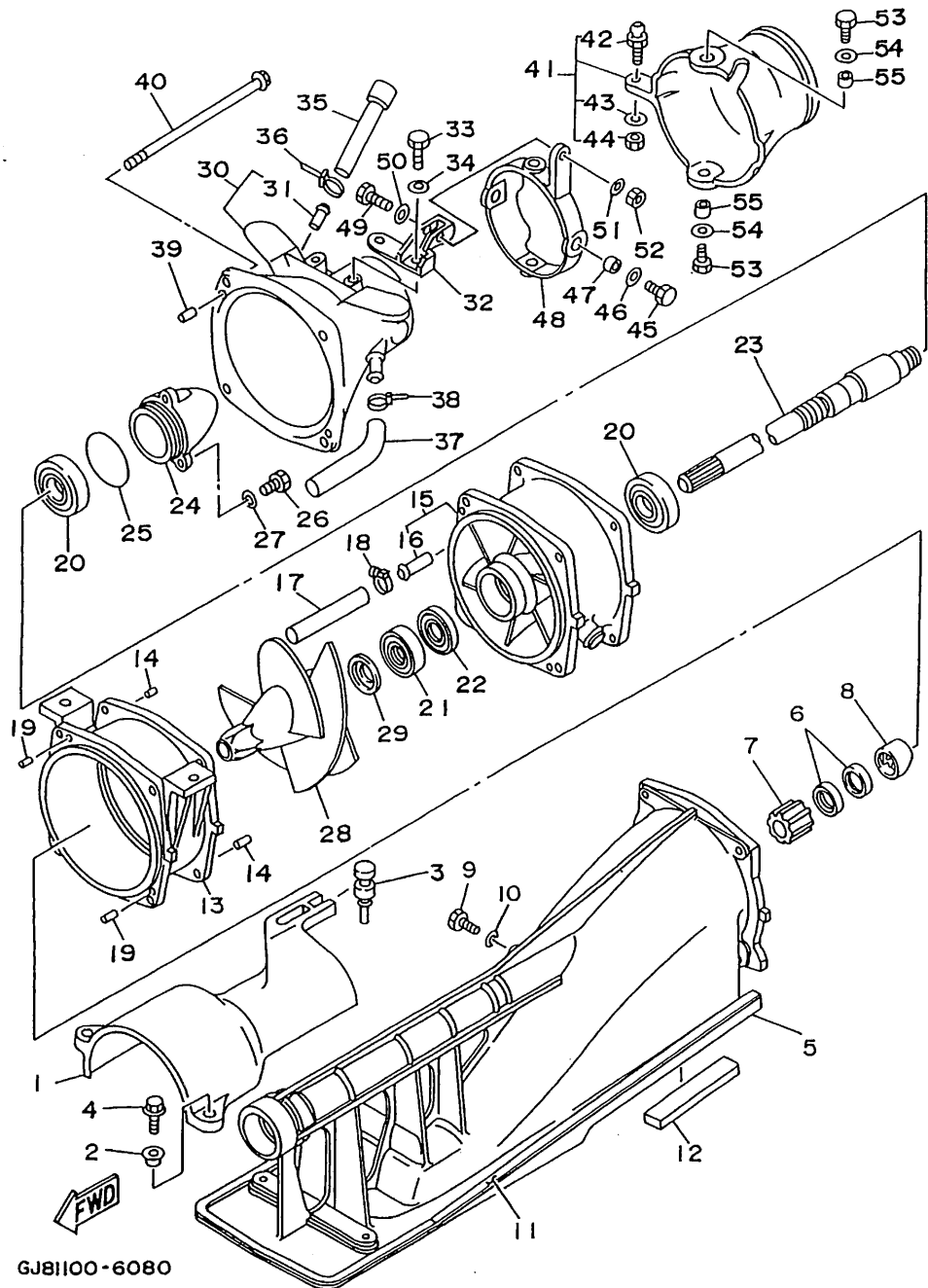

REF. NO.	PART NO.	DESCRIPTION	Q'TY	REMARKS
29	90209-20M20	WASHER	1	
30	64R-51318-00-5B	NOZZLE	1	
31	6K8-51129-00	.NIPPLE	1	
32	64R-51387-00-5B	STAY	1	
33	97095-06020	BOLT	2	
34	92990-06600	WASHER, PLATE	2	
35	62T-51673-00	PIPE 1	1	
36	90465-11M10	CLAMP	1	
37	90445-14M24	HOSE	1	
38	90465-11M10	CLAMP	1	
39	93606-12019	PIN, DOWEL	2	
40	90101-06M04	BOLT	4	
41	62T-51313-00	NOZZLE, DEFLECTOR	1	
42	6R7-42316-00	.BOLT, JOINT	1	
43	90201-06M02	.WASHER, PLATE	1	
44	95380-06700	.NUT	1	
45	97095-08018	BOLT	2	
46	92995-08600	WASHER	2	
47	90387-08M08	COLLAR	2	
48	62T-51190-00-5B	RING, TRIM	1	
49	97095-06035	BOLT	1	
50	92990-06600	WASHER, PLATE	1	
51	90201-06M31	WASHER, PLATE	1	
52	95380-06700	NUT	1	
53	97095-08020	BOLT	2	
54	92995-08600	WASHER	2	
55	90387-08M06	COLLAR	2	

GJ81100-6080

B14

FIG. 9 JET UNIT 2

REF. NO.	PART NO.	DESCRIPTION	Q'TY	REMARKS
1	63N-51333-00-5B	SCREEN, INTAKE	1	
2	97095-06018	BOLT	6	
3	92990-06600	WASHER, PLATE	6	
4	6R8-51323-03	SHAFT, COUPLOR	1	
5	93210-17MA4	O-RING	2	
6	62G-45331-00-94	HOUSING, BEARING	1	
7	93210-35M72	O-RING	1	
8	61X-45332-01-9M	HOUSING, BEARING	1	
9	97095-08025	BOLT	3	
10	92995-08600	WASHER	3	
11	93606-12019	PIN, DOWEL	2	
12	93101-25M55	OIL SEAL	1	
13	93430-47M04	CIRCLIP	2	
14	93306-205U6	BEARING	1	
15	63M-51348-00	SPACER	1	
16	93101-25M56	OIL SEAL	1	
17	61L-45378-00	NIPPLE, HOSE	1	
18	90465-11M10	CLAMP	1	
19	90445-09M21	HOSE	1	
20	6K8-45127-00	SEAL	1	
21	GJ1-U273B-00	PLATE 2	1	YMUS
22	GJ8-6273C-00	COVER, PLATE	1	
23	98780-05512	SCREW, FLAT HEAD	4	
24	95720-05300	NUT, FLANGE	4	
25	90119-089U6	BOLT, WITH WASHER	6	YMUS
26	GJ1-62733-00	PACKING	6	
27	90119-089U5	BOLT, WITH WASHER	12	YMUS
28	GHI-62663-01	PACKING 1	6	

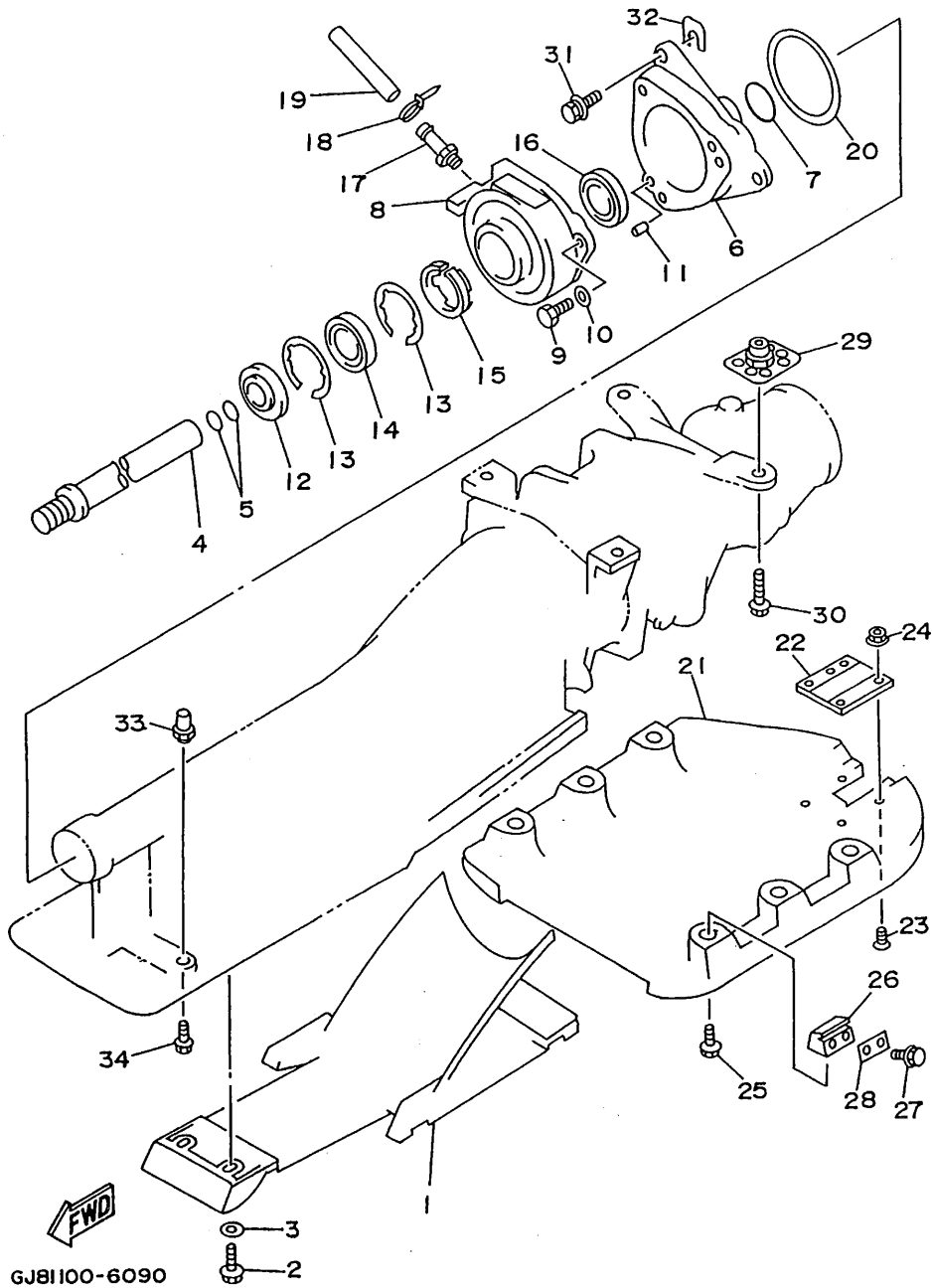

GJ81100-6090

FIG. 9 JET UNIT 2

REF. NO.	PART NO.	DESCRIPTION	Q'TY	REMARKS
29	90179-10925	NUT	4	
30	90119-109U8	BOLT, WITH WASHER	4	
31	90119-08907	BOLT, WITH WASHER	3	
32	G00-U7249-00-05	SHIM (T=0.5)	2	UR YMUS
	G00-67249-00-05	SHIM (T=0.5)	2	UR
	G00-U7249-00-10	SHIM (T=1.0)	2	UR YMUS
	G00-67249-00-10	SHIM (T=1.0)	2	UR
33	90179-06947	NUT	2	
34	90119-06929	BOLT, WITH WASHER	2	

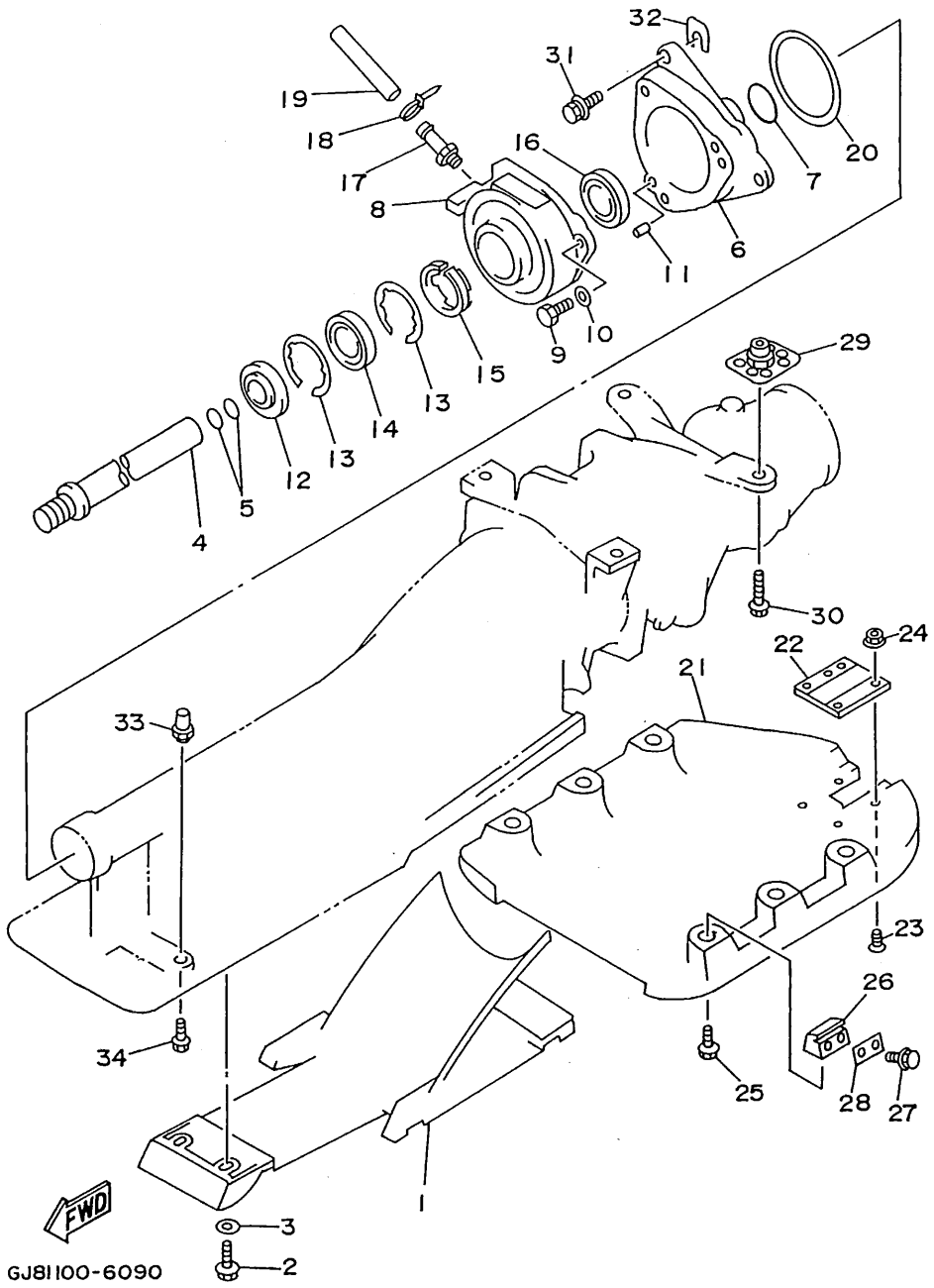

C2

FIG. 10 GENERATOR

REF. NO.	PART NO.	DESCRIPTION	Q'TY	REMARKS
1	62T-85550-00	ROTOR ASSY	1	
2	62T-85560-00	BASE ASSY	1	
3	62T-85520-00	.COIL, CHARGE	1	
4	62T-85533-00	.COIL, LIGHTING	1	
5	6M6-85580-00	.COIL, PULSER	1	
6	62T-85515-00	.LEAD WIRE ASSY	1	
7	97902-05125	.SCREW, WITH WASHER	4	
8	97902-04122	.SCREW, WITH WASHER	2	
9	98580-04008	.SCREW, PAN HEAD	1	
10	98580-06016	SCREW, PAN HEAD	2	
11	92990-06600	WASHER, PLATE	2	
12	90280-16053	KEY, WOODRUFF	1	
13	90109-10M47	BOLT	1	
14	6R8-81337-00-9M	COVER, FLYWHEEL	1	
15	90380-12M29	.BUSH, SOLID	1	
16	6M6-81365-A0	GASKET, HOLE COVER	1	
17	93606-12019	PIN, DOWEL	2	
18	97095-06025	BOLT	7	
19	92990-06600	WASHER, PLATE	7	

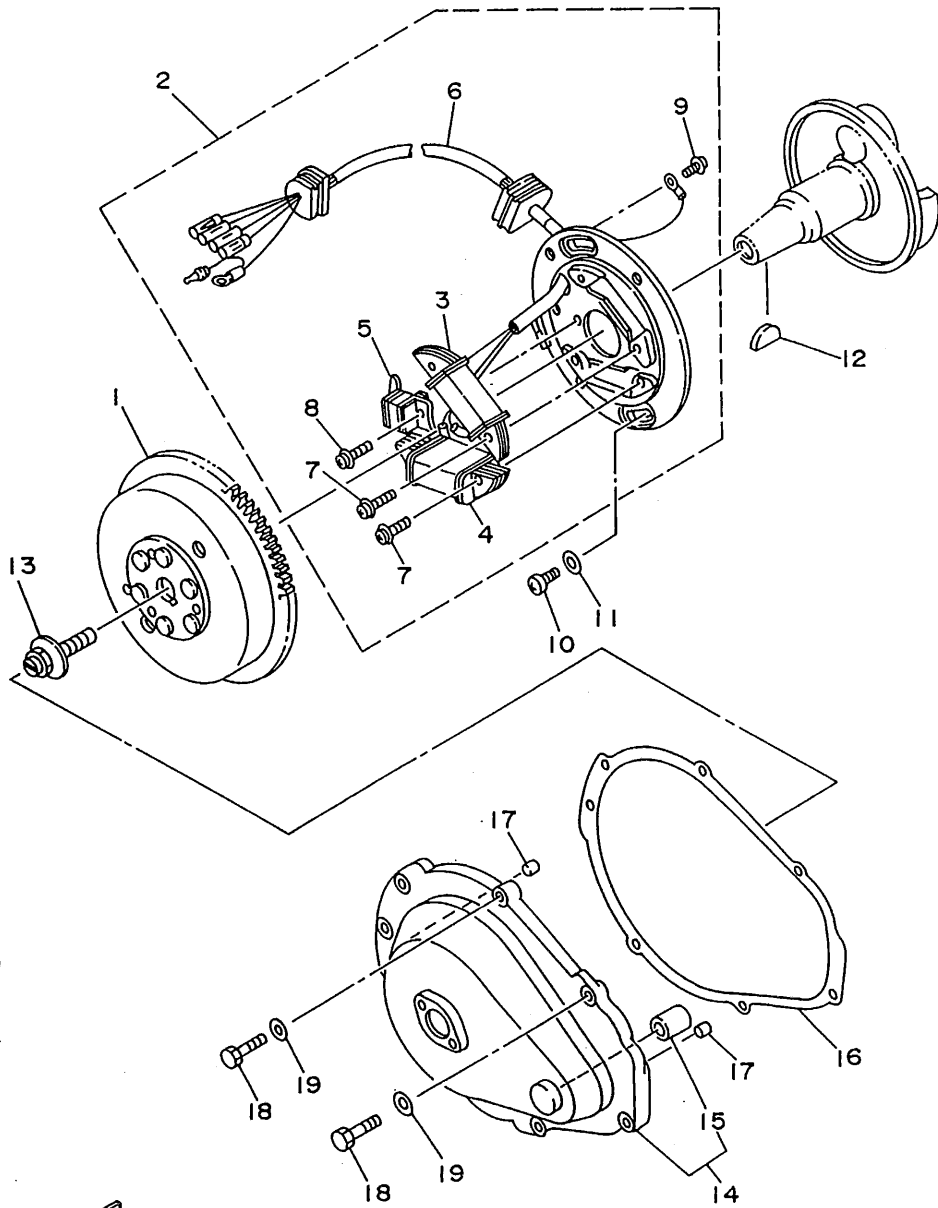

GHI4010-4100

C3

FIG. 11 STARTING MOTOR

REF. NO.	PART NO.	DESCRIPTION	Q'TY	REMARKS
1	6M6-81800-10	STARTING MOTOR ASSY	1	
2	3AJ-81809-00	.WASHER KIT	1	
3	6M6-81840-10	.BRUSH HOLDER ASSY	1	
4	11H-81844-00	.GASKET	2	
5	6M6-81826-00	.BOLT	2	
6	6M6-81850-00	.ARMATURE ASSY	1	
7	6M6-81820-00	.REAR BRACKET ASSY	1	
8	6M6-81830-00	.FRONT BRACKET ASSY	1	
9	26H-81847-00	.O-RING	1	
10	97013-08040	BOLT	1	
11	92990-08600	WASHER, PLATE	1	
12	97013-08035	BOLT	1	
13	92990-08600	WASHER, PLATE	1	
14	92995-06100	WASHER, SPRING	1	
15	95380-06700	NUT	1	
16	6M6-8183E-00	IDLE GEAR COMP.	1	
17	6M6-81866-00	.WEIGHT SPRING	1	
18	6M6-81865-00	.WEIGHT HOLDER	1	
19	93440-25M08	.CIRCLIP	1	
20	93450-18M06	.CIRCLIP	1	
21	90501-14M73	SPRING, COMPRESSION	1	
22	92990-06600	WASHER, PLATE	2	

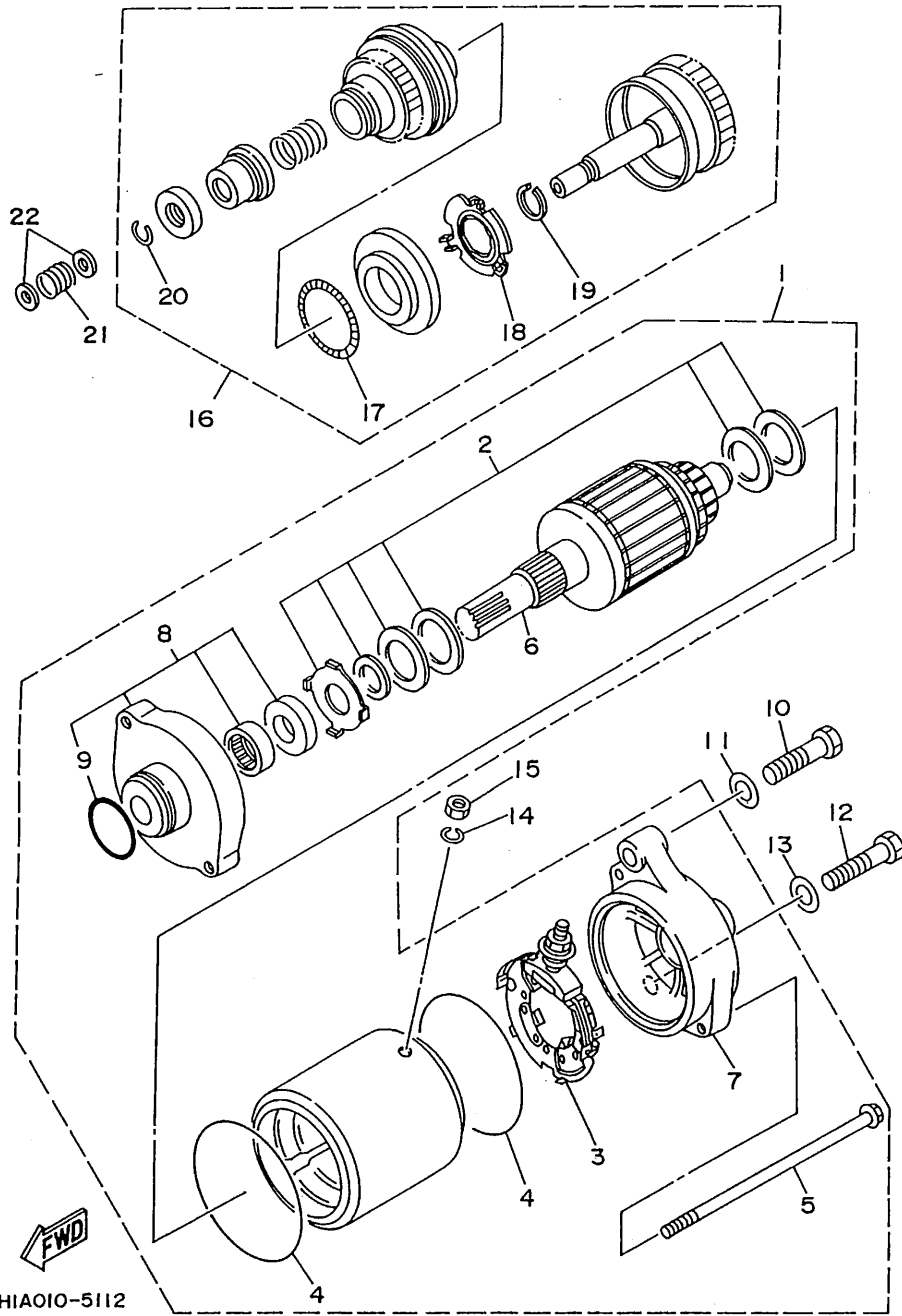

FWD
GHIAOIO-5112

C4

FIG. 12 ELECTRICAL 1

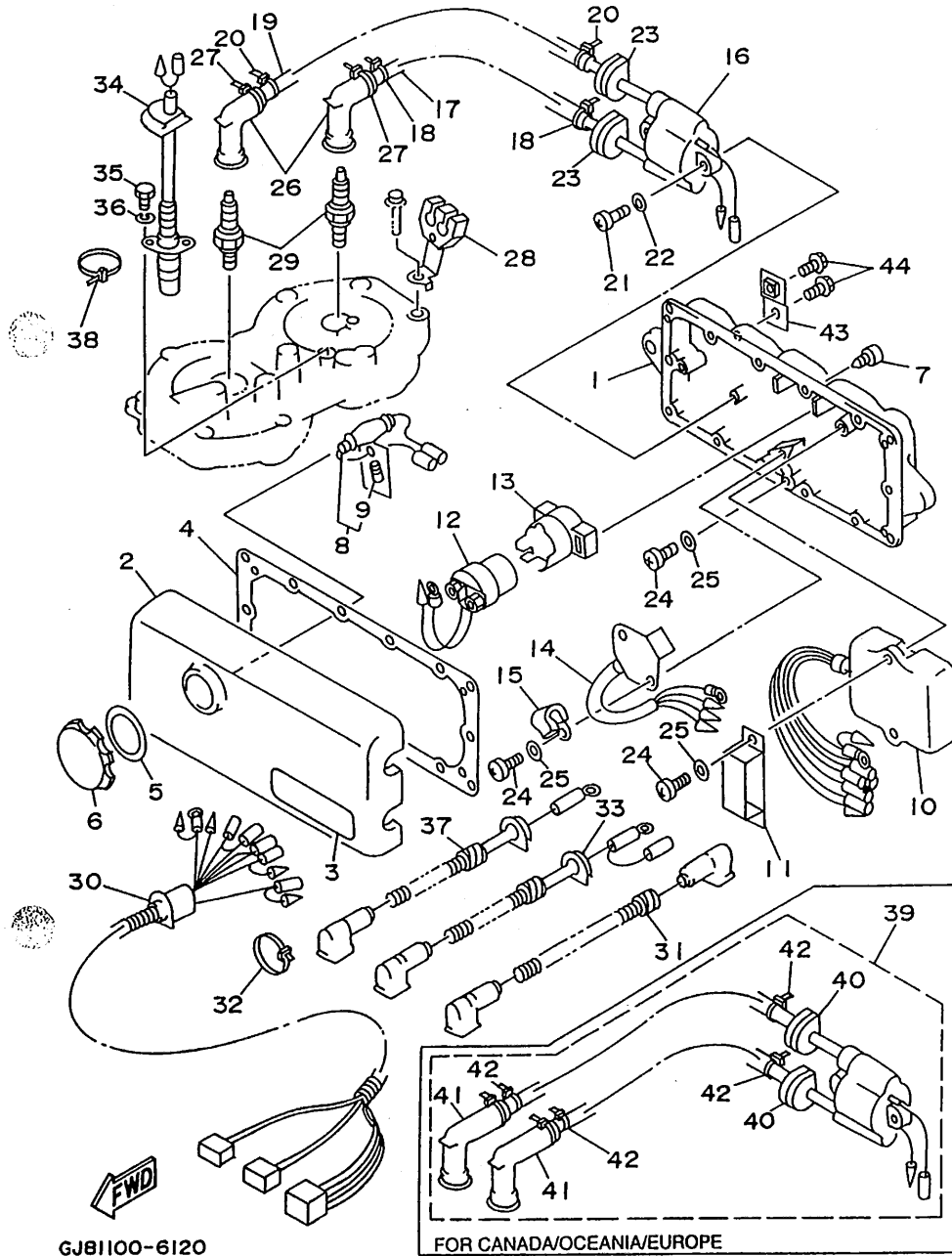

GJ81100-6120

REF. NO.	PART NO.	DESCRIPTION	Q'TY	REMARKS
1	62L-8552A-00-98	HOUSING	1	
2	6M6-8552E-00	COVER, CASE	1	
3	6R7-83623-40	MARK 3	1	UR ENGLISH
	6R7-83623-50	MARK 3	1	UR FRENCH
	63N-83623-00	MARK 3	1	UR JAPAN
4	6M6-81921-00	GASKET, TERMINAL	1	
5	6M6-81844-00	GASKET	1	
6	6M6-8132W-00	CAP	1	
7	97780-60525	SCREW, TAPPING	14	
8	6K8-82150-01	FUSE HOLDER ASSY	1	
9	6G1-82151-00	.FUSE	1	
10	62T-85540-00	C.D.I. UNIT ASSY	1	
11	90464-06M29	CLAMP	1	
12	6G1-81941-10	STARTER RELAY ASSY	1	
13	6M6-81952-01	HOLDER, RELAY	1	
14	6M6-81960-A0	RECTIFIER & REGULATOR ASSY	1	
15	90465-08028	CLAMP	1	
16	62E-85570-00	IGNITION COIL ASSY	1	UR FOR USA/GUAM/JAPAN
17	62E-82351-00	TUBE, CORD	1	UR FOR USA/GUAM/JAPAN
18	90465-11M10	CLAMP	2	UR FOR USA/GUAM/JAPAN
19	62E-82352-00	TUBE, CORD 2	1	UR FOR USA/GUAM/JAPAN
20	90465-11M10	CLAMP	2	UR FOR USA/GUAM/JAPAN
21	97880-06030	SCREW, PAN HEAD	2	
22	92990-06600	WASHER, PLATE	2	
23	90480-06M43	GROMMET	2	UR FOR USA/GUAM/JAPAN
24	98580-06016	SCREW, PAN HEAD	6	
25	92990-06600	WASHER, PLATE	6	
26	6K8-82370-00	PLUG CAP ASSY	2	UR FOR USA/GUAM/JAPAN

C5

FIG. 12 ELECTRICAL 1

REF. NO.	PART NO.	DESCRIPTION	Q'TY	REMARKS
27	90465-11M10	CLAMP	2	UR FOR USA/GUAM/JAPAN
28	6R8-82361-00	CLAMP, CORD	1	
29	94701-00041	PLUG, SPARK (NGK B8HS)	2	UR FOR USA/GUAM/JAPAN
	94702-00195	PLUG, SPARK (NGK BR8HS)	2	UR FOR CANADA/OCEANIA /EUROPE
30	62T-82553-01	EXTENSION, WIRE LEAD	1	
31	62T-82117-00	WIRE, LEAD	1	
32	90465-13M11	CLAMP	1	
33	62T-82117-10	WIRE, LEAD	1	
34	6R7-82560-00	THERMO SWITCH ASSY	1	
35	97095-06016	BOLT	2	
36	92995-06100	WASHER, SPRING	2	
37	62L-82117-20	WIRE, LEAD	1	
38	90465-13M11	CLAMP	1	
39	62E-85570-10	IGNITION COIL ASSY	1	UR FOR CANADA/OCEANIA /EUROPE
40	90480-06M43	.GROMMET	2	
41	62E-82371-10	.PLUG, CAP	2	
42	90465-11M10	.CLAMP	4	
43	GH6-6815D-00	BRACKET, ELECTRIC BOX	1	
44	90119-089U7	BOLT, WITH WASHER	4	YMUS

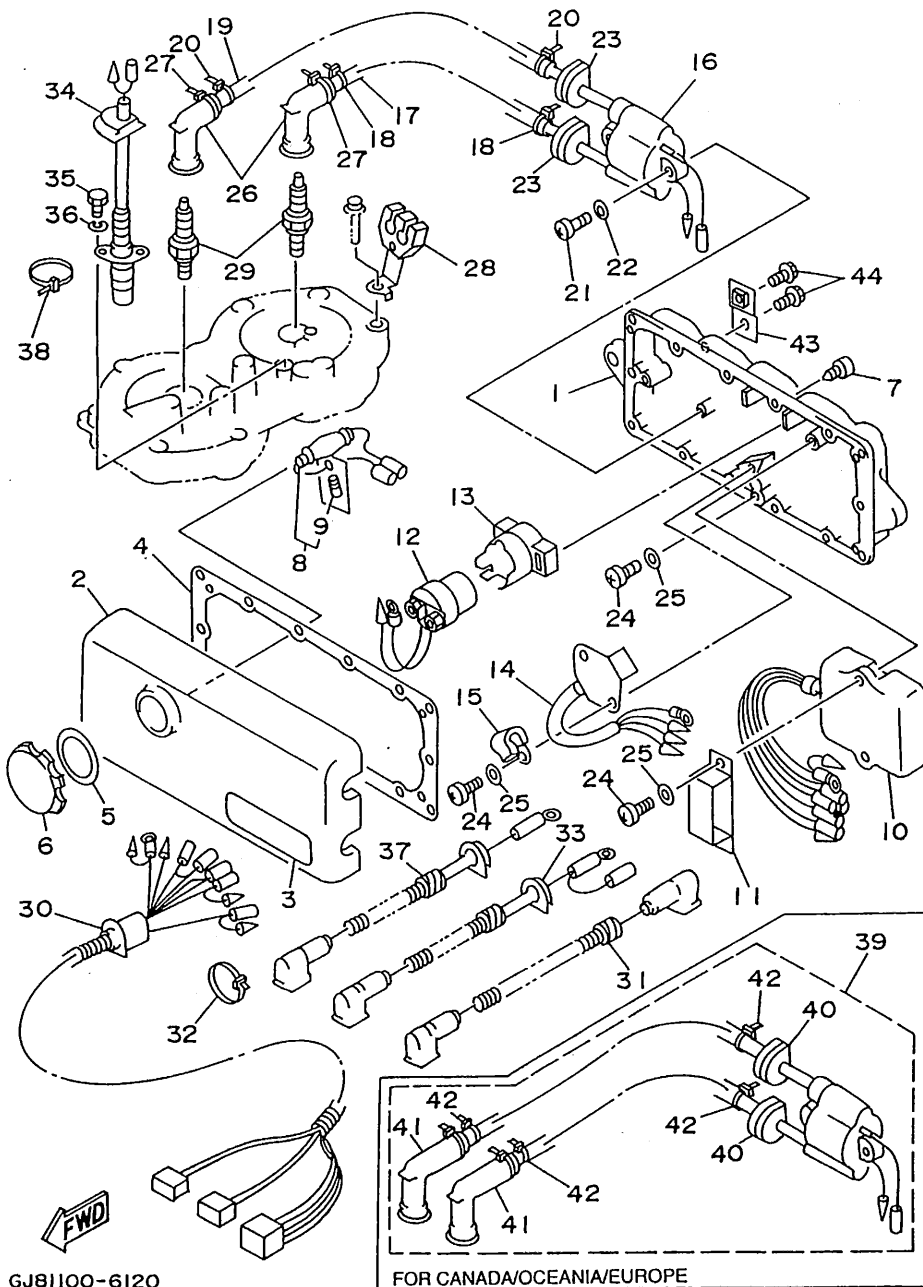

GJ81100-6120

C6

FIG. 13 ELECTRICAL 2

REF. NO.	PART NO.	DESCRIPTION	Q'TY	REMARKS
1	EU0-82110-77	BATTERY (FB16CL-B)	1	
2	90467-08M10	CLIP	1	
3	GE1-U7856-30	HOSE, AIRVENT 3	1	YMUS
4	90600-91736	CLAMP	4	
5	90201-05925	.WASHER, PLATE	1	
6	90267-48925	RIVET, BLIND	4	
7	90601-20006	NYLON CLIP 1	4	
8	GJ8-6820A-00	METER, ASSY	1	
9	GJ8-68238-00	BRACKET, METER	2	
10	97780-50520	SCREW, TAPPING	4	
11	90601-20006	NYLON CLIP 1	1	
12	GJ8-6824C-00	SENDER, OIL	1	
13	GH6-U8211-00	BATTERY CASE COMP.	1	YMUS
14	GJ1-6266B-00	PACKING 3	1	
15	GH6-6822E-00	GROMMET	2	
16	FJ0-68221-00	PAD, BATTERY 1	2	
17	FJ0-68221-30	PAD, BATTERY 2	1	
18	GJ1-U8221-00	PAD, BATTERY	2	YMUS
19	90149-05984	SCREW	6	
20	90600-913U2	CLIP, NYLON 13	1	YMUS
21	97780-40116	SCREW, TAPPING	1	
22	GA7-65772-00	HOOK A	1	
23	90267-489U7	RIVET, BLIND	2	YMUS
24	GJ1-66607-00	HOOK COMP.	1	
25	90267-489U7	RIVET, BLIND	2	YMUS
26	EU0-67593-40	MAT 3	3	

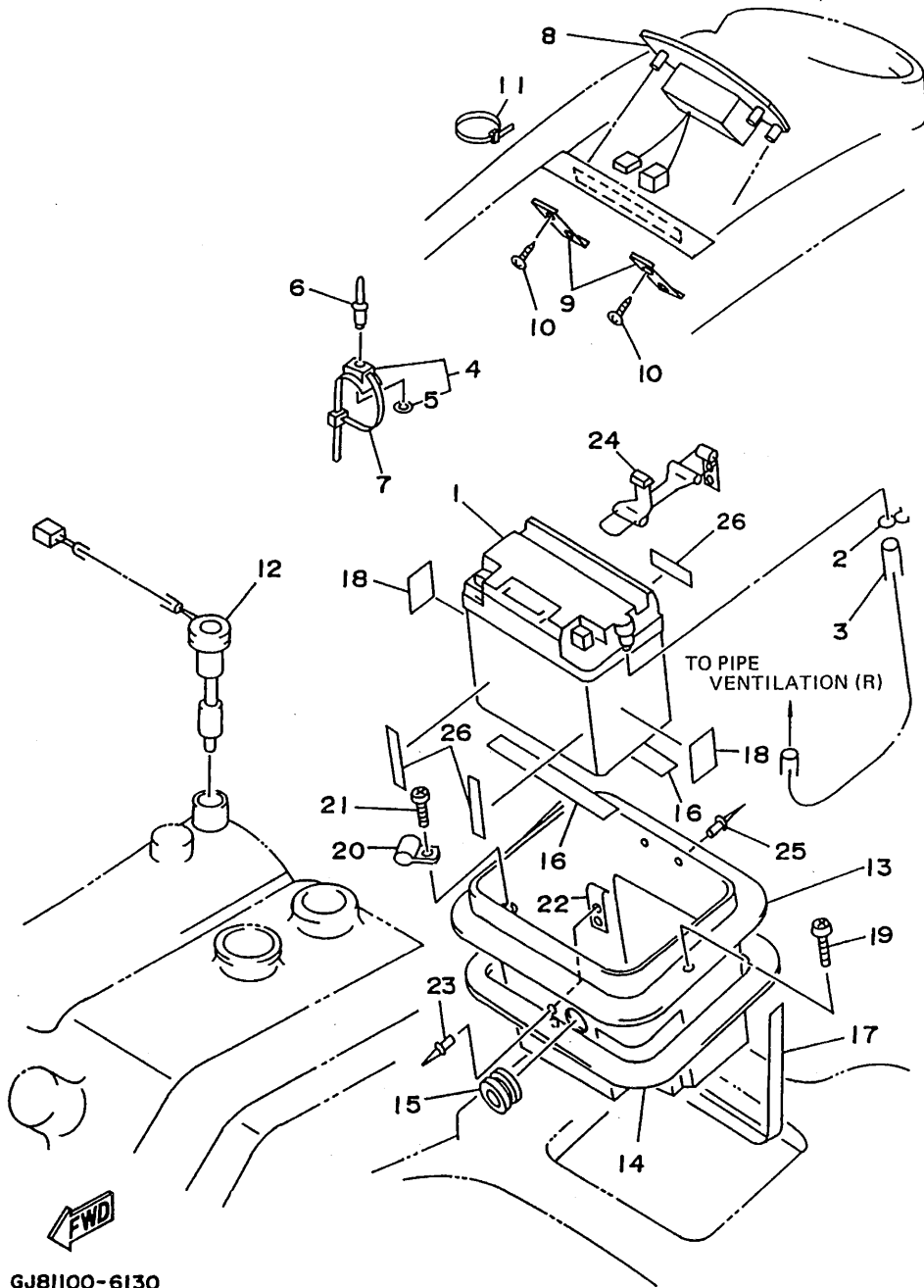

GJB1100-6130

FIG. 14 ENGINE HATCH

REF. NO.	PART NO.	DESCRIPTION	Q'TY	REMARKS
1	GJ8-U516A-00-PO	ENGINE HATCH COMP.	1	YMUS
2	90179-06926	.NUT	4	
3	90179-08927	.NUT	4	
4	GH1-6516N-20	COVER, ENGINE HATCH	1	VIOLET SOLID 6
5	90149-05903	SCREW	2	
6	90149-05984	SCREW	4	
7	FN8-62884-00	BRACKET, HATCH SUPPORT	1	
8	90267-489U2	RIVET, BLIND	2	YMUS
9	GJ1-U2664-00	PACKING	1	YMUS
10	GJ1-62840-00	HATCH LOCK ASSY	2	
11	92990-05600	WASHER, PLATE	8	
12	95720-05300	NUT, FLANGE	8	
13	90119-05935	BOLT, WITH WASHER	6	
14	90119-06940	BOLT, WITH WASHER	4	
15	GH1-61557-00	GUIDE, CABLE	1	
16	90267-489U2	RIVET, BLIND	2	YMUS
17	GH1-62891-01	SUPPORT, HATCH	1	
18	90159-06901	SCREW, WITH WASHER	2	
19	FN8-62892-00	FIX, PLATE	1	
20	90159-06901	SCREW, WITH WASHER	2	
21	GH1-62128-20	UNIVERSAL, AIRINTAKE	1	VIOLET SOLID 6
22	90149-04902	SCREW	2	
23	GH1-6517G-04	HINGE, HATCH	2	
24	90119-06940	BOLT, WITH WASHER	6	
25	GH1-6517J-01	PLATE, HATCH HINGE (LH)	1	
26	GH1-6517K-01	PLATE, HATCH HINGE (RH)	1	
27	90267-489U1	RIVET, BLIND	6	YMUS
28	GH1-6378C-00	STAY, SEAT 1	1	

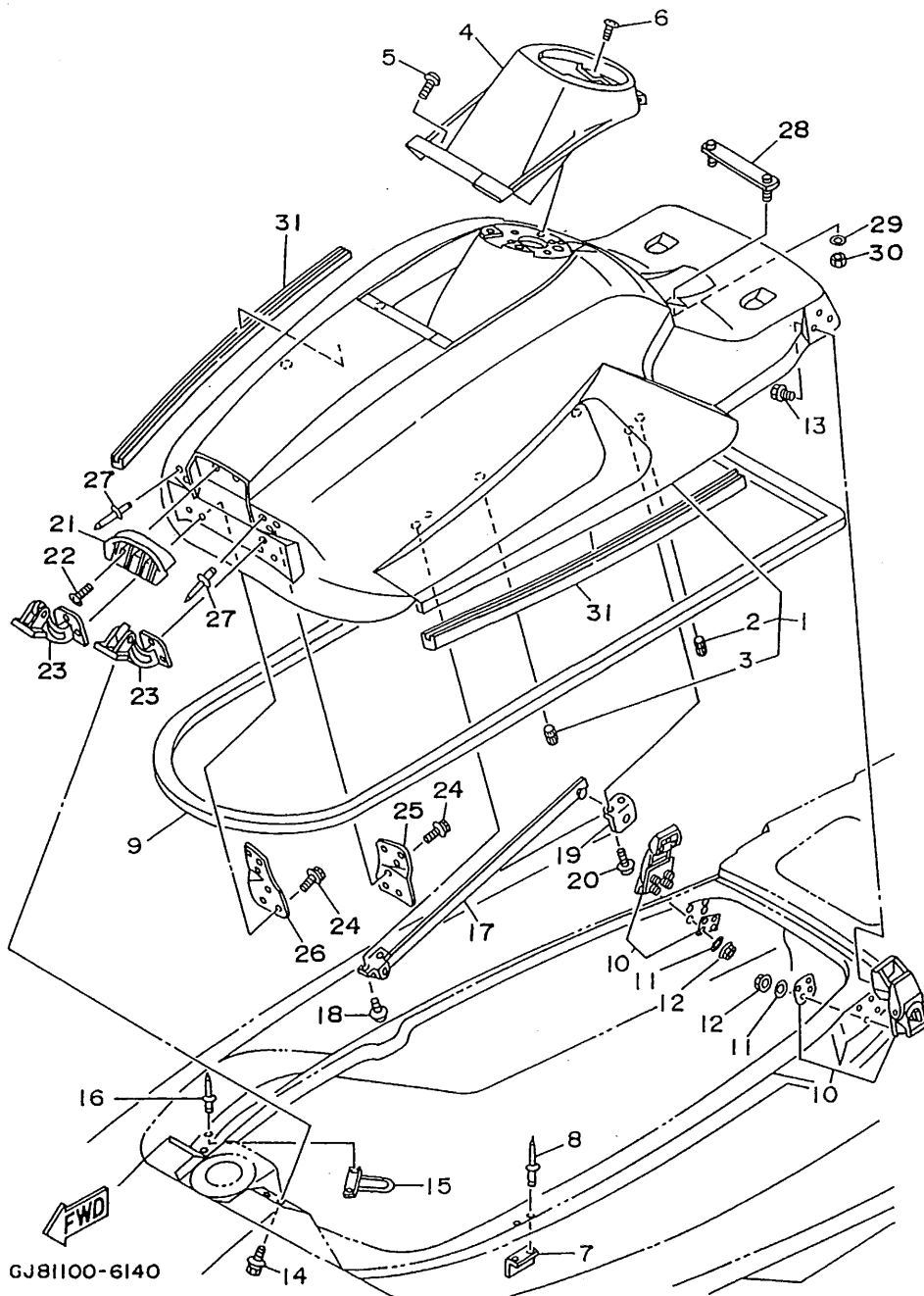

C8

FIG. 14 ENGINE HATCH

REF. NO.	PART NO.	DESCRIPTION	Q'TY	REMARKS
29	92990-06200	WASHER, PLAIN	2	
30	95720-06300	NUT, SELF-LOCKING	2	
31	GH1-65162-01	TRIM	2	

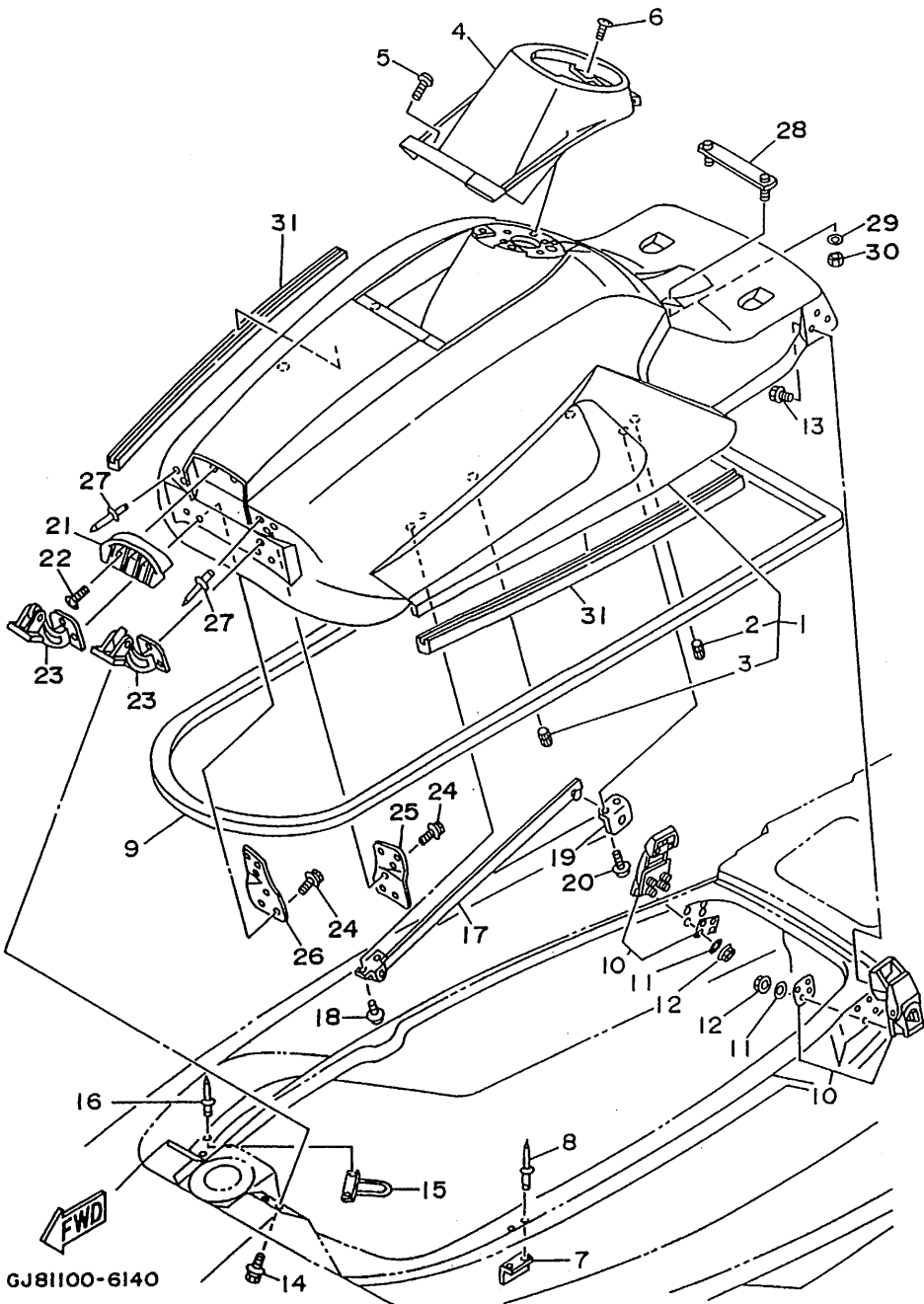
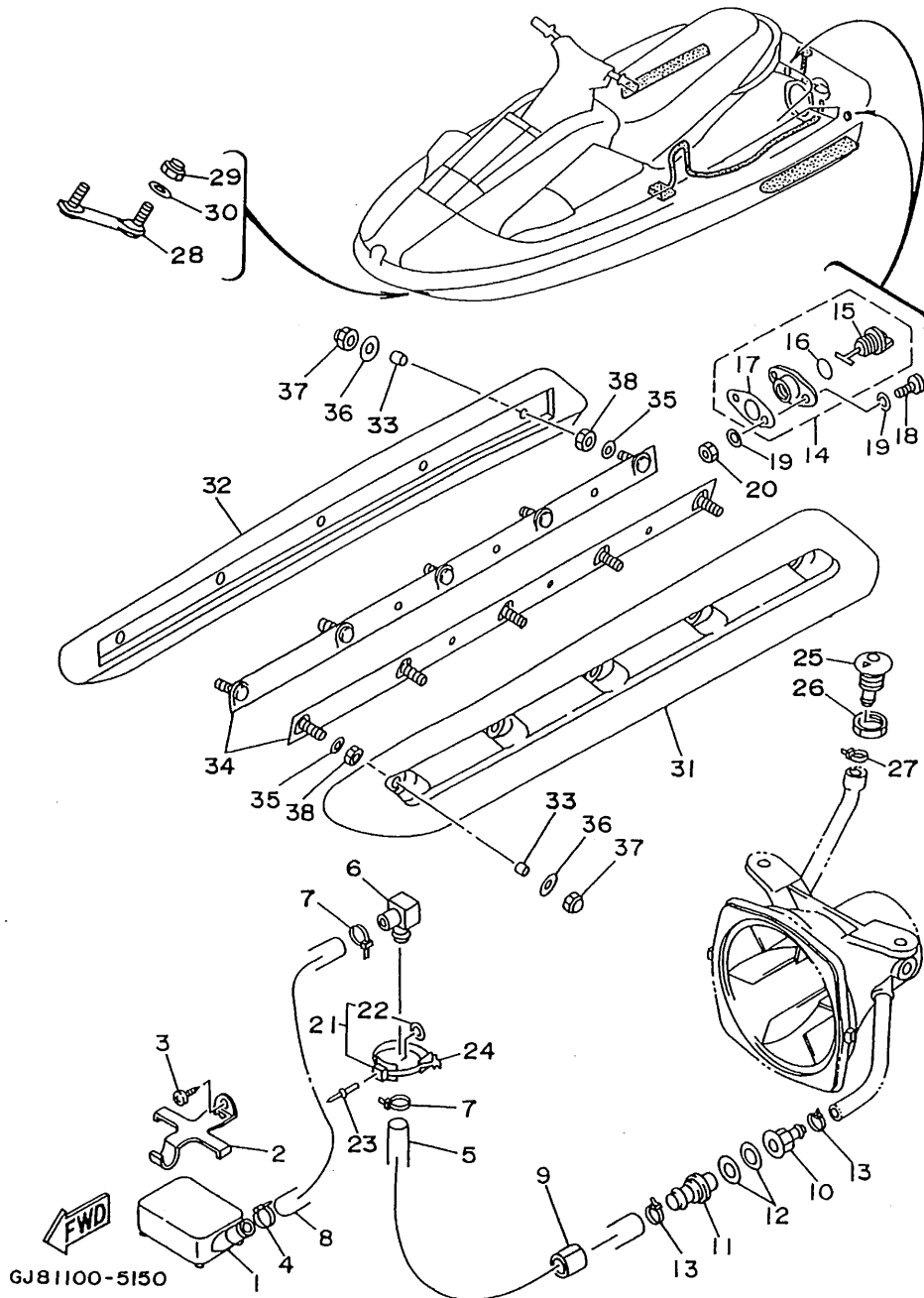

FIG. 15 HULL. DECK

REF. NO.	PART NO.	DESCRIPTION	QTY	REMARKS
1	GDO-6761D-00	STRAINER, BILGE	1	
2	EW2-67618-00	BASE, STRAINER BLIGE	1	
3	97780-50612	SCREW, TAPPING	1	
4	90601-200U1	NYLON CLIP 1	1	YMUS
5	90445-19M07	HOSE	1	
6	61X-51162-00	JOINT, HOSE	1	
7	90465-13M11	CLAMP	2	
8	90445-19M06	HOSE	1	
9	GJ1-67578-10	PACKING, HOSE 2	1	
10	90604-80759	CONNECTION, THRU-HULL 1/4	1	
11	90604-80775	THROUGH, HULL CONNECTION	1	
12	90430-13909	GASKET	2	
13	90601-200U1	NYLON CLIP 1	2	YMUS
14	EU0-62280-00	DRAIN PLUG ASSY	2	
15	EU0-62282-00	.PLUG, DRAIN	1	
16	EU0-62283-00	.O-RING	1	
17	EU0-62285-01	.PACKING, DRAIN	1	
18	97880-05020	SCREW, PAN HEAD	4	
19	92990-05200	WASHER, PLAIN	8	
20	95720-05300	NUT, FLANGE	4	
21	90600-91736	CLAMP	1	
22	90201-05925	.WASHER, PLATE	1	
23	90267-48925	RIVET, BLIND	1	
24	90601-20006	NYLON CLIP 1	1	
25	FN8-6269B-00	SPOUT	1	
26	EU0-61652-00	NUT	1	
27	90465-11M10	CLAMP	1	
28	FN8-U1624-00	BOWEYE 1 (S)	1	YMUS



C10

FIG. 15 HULL. DECK

REF. NO.	PART NO.	DESCRIPTION	Q'TY	REMARKS
29	95720-08300	NUT, SELF-LOCKING	2	
30	92990-08200	WASHER, PLAIN	2	
31	GH1-6883N-50	STABILIZER LH	1	GREENISH YELLOW SOLID 2
32	GH1-6883P-50	STABILIZER RH	1	GREENISH YELLOW SOLID 2
33	90387-06916	COLLAR	10	
34	GH1-6883T-00	BRACKET, STABILIZER	2	
35	92990-06200	WASHER, PLAIN	10	
36	90201-065F3	WASHER, PLATE	10	
37	90179-06959	NUT	10	
38	95380-06700	NUT	10	

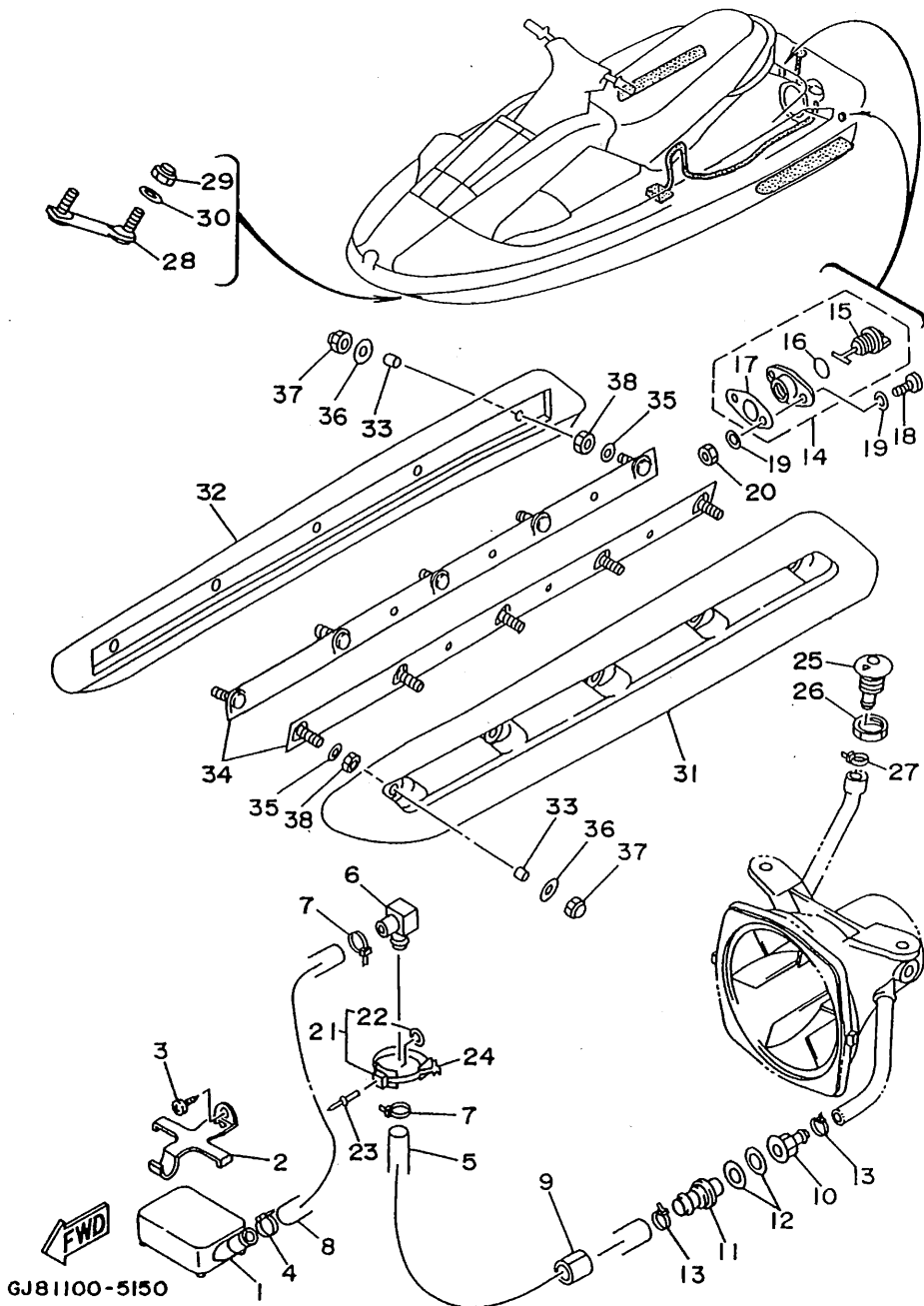

C11

FIG. 16 GUNWALE. MAT

REF. NO.	PART NO.	DESCRIPTION	Q'TY	REMARKS
1	GJ1-U2501-10	BOW GUNWALE COMP.	1	YMUS VIOLET SOLID 6
2	GJ1-6252A-20	JOINT, GUNWALE	2	
3	92990-06200	WASHER, PLAIN	6	
4	95720-06300	NUT, SELF-LOCKING	6	
5	GJ1-U2552-10	GUNWALE, SIDE 1	2	YMUS VIOLET SOLID 6
6	GJ1-U2519-10	INNER GUNWALE	2	YMUS GREENISH YELLOW SOLID 2
7	90169-059U1	SCREW, TAPPING	22	YMUS
8	GH1-6251D-20	GUNWALE, STERN 1	1	VIOLET SOLID 6
9	GH1-6251E-20	GUNWALE, STERN 2	1	VIOLET SOLID 6
10	90267-489U8	RIVET, BLIND	10	YMUS
11	90267-48835	RIVET, BLIND	2	
12	GH1-6354D-30	CAP, HEAD	12	
13	GJ1-U252C-10	COVER, GUNWALE 1	1	YMUS VIOLET SOLID 6
14	GJ1-U252D-10	COVER, GUNWALE 2	1	YMUS GREENISH YELLOW SOLID 2
15	90267-489U8	RIVET, BLIND	4	YMUS
16	FN8-61651-00	ROPE HOLE	2	
17	EU0-61652-00	NUT	2	
18	GH1-61651-00	ROPE HOLE	1	
19	EU0-61652-00	NUT	1	
20	GJ1-63581-10	MAT, UPPER	1	VIOLET SOLID 6
21	GJ1-U351H-10	MAT, STEP 1	2	YMUS VIOLET SOLID 6
22	GJ1-U351K-10	MAT, STEP 3	1	YMUS VIOLET SOLID 6
23	GJ1-U351M-10	MAT, STEP 4	1	YMUS VIOLET SOLID 6
24	GJ1-U351N-10	MAT, STEP 5	1	YMUS VIOLET SOLID 6
25	GJ1-U351P-10	MAT, STEP 6	1	YMUS VIOLET SOLID 6
26	GH1-6351R-20	MAT, STEP 7	1	YMUS VIOLET SOLID 6
27	GH1-6351S-20	MAT, STEP 8	1	YMUS VIOLET SOLID 6

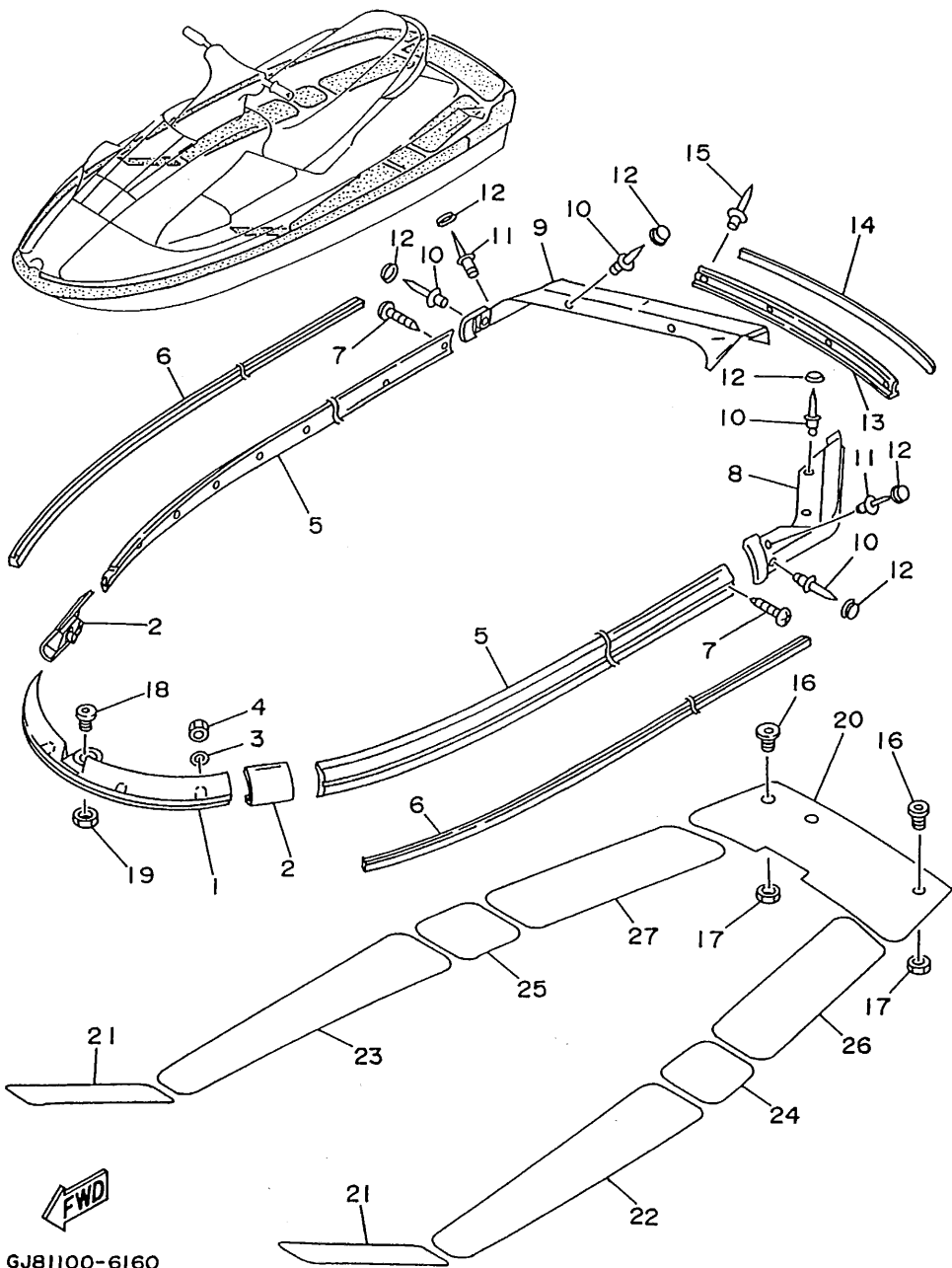

GJ81100-6160

FIG. 17 SEAT - UNDER LOCKER 1

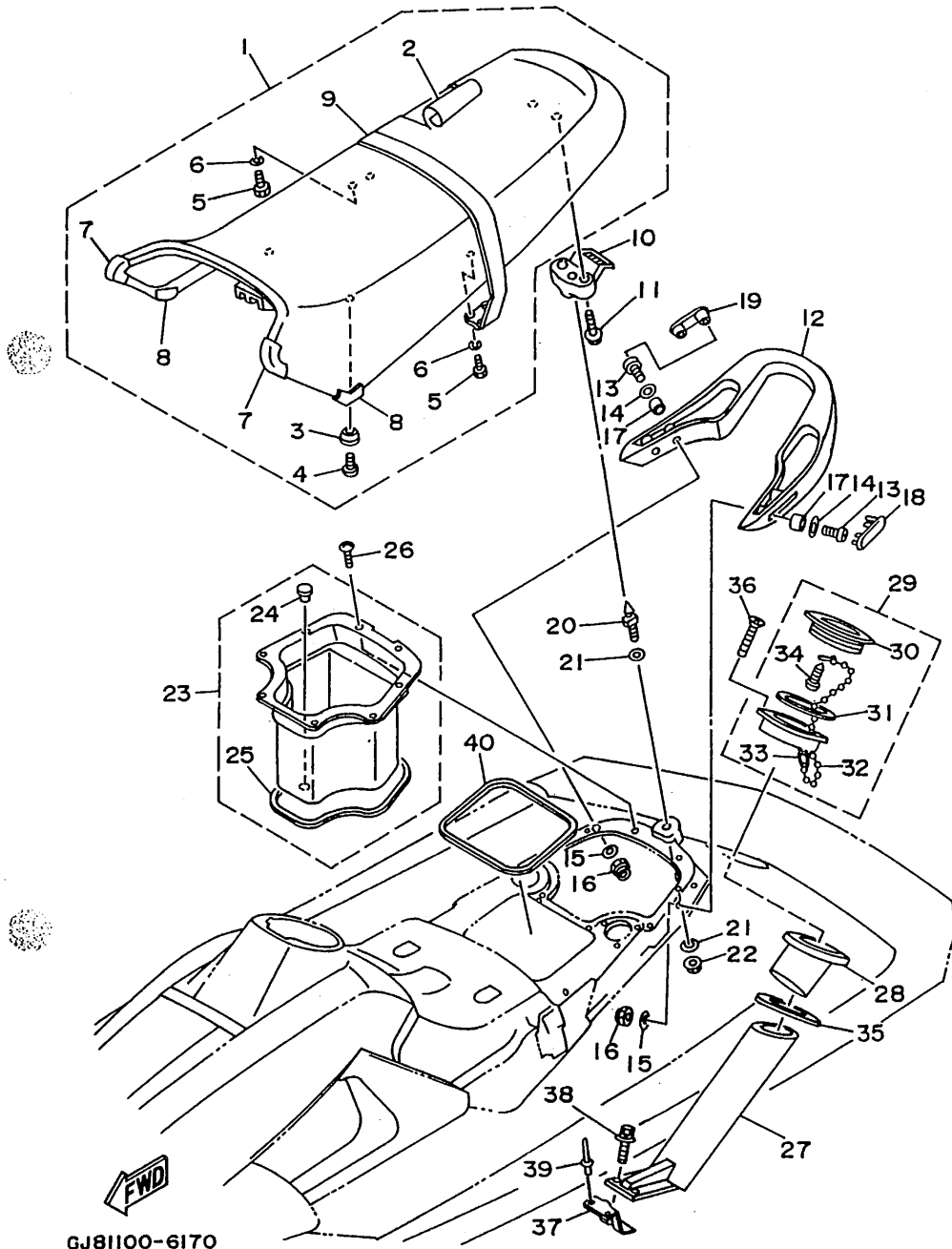

REF. NO.	PART NO.	DESCRIPTION	Q'TY	REMARKS
1	GJ1-U371A-10	DOUBLE SEAT ASSY	1	YMUS GREENISH YELLOW SOLID 2
2	GJ1-U371B-10	.COVER, SEAT 1	1	YMUS
3	GH1-63729-00	.STOPPER, SEAT	2	
4	97980-06116	.SCREW, WITH WASHER	2	
5	97090-06016	.BOLT	4	
6	92995-06100	.WASHER, SPRING	4	
7	GJ1-U375A-10	.PAD, SEAT 1	2	YMUS
8	GJ1-U375B-20	.PAD, SEAT 2	2	YMUS
9	GJ1-U373D-10	.BAND, SEAT COMP.	1	YMUS
10	GH1-63850-00	SEAT LOCK ASSY	1	
11	90119-06914	BOLT, WITH WASHER	2	
12	GH1-6271B-20	GRIP, HAND	1	
13	98980-06025	SCREW, BIND	4	
14	92990-06200	WASHER, PLAIN	4	
15	90201-065F3	WASHER, PLATE	4	
16	95720-06300	NUT, SELF-LOCKING	4	
17	90387-06914	COLLAR	4	
18	GH1-6271C-20	CAP, GRIP HAND LH	1	
19	GH1-6271D-20	CAP, GRIP HAND RH	1	
20	GH1-63774-01	PIN	1	
21	92990-10200	WASHER, PLAIN	2	
22	95720-10300	NUT	1	
23	GJ1-U474A-00	UNDER LOCKER ASSY	1	YMUS
24	90338-12081	.PLUG	1	
25	GH1-6266B-00	.PACKING 3	1	
26	90149-04943	SCREW	8	
27	GA7-65983-00	BOX, FIRE EXTINGUISHER	1	
28	GA7-65984-00	GROMMET	1	

GJ81100-6170

C13

FIG. 17 SEAT - UNDER LOCKER 1

REF. NO.	PART NO.	DESCRIPTION	Q'TY	REMARKS
29	EU0-62720-31	INSPECTION COVER ASSY	1	
30	EU0-62721-31	.COVER, INSPECTION	1	
31	93211-03902	.RING	1	
32	EU0-67835-30	.CHAIN BALL	1	
33	EU0-67839-00	.COUPLING	1	
34	97780-04110	.SCREW, TAPPING	1	
35	GA7-6593J-00	PLATE, FIRE EXTINGUISHER	1	
36	98780-04535	SCREW, FLAT HEAD	6	
37	GJ1-6593H-00	BRKT, FIRE EXTINGUISHER	1	
38	90119-06908	BOLT, WITH WASHER	2	
39	90267-489U1	RIVET, BLIND	2	YMUS
40	GJ1-U266D-00	PACKING 5	1	YMUS

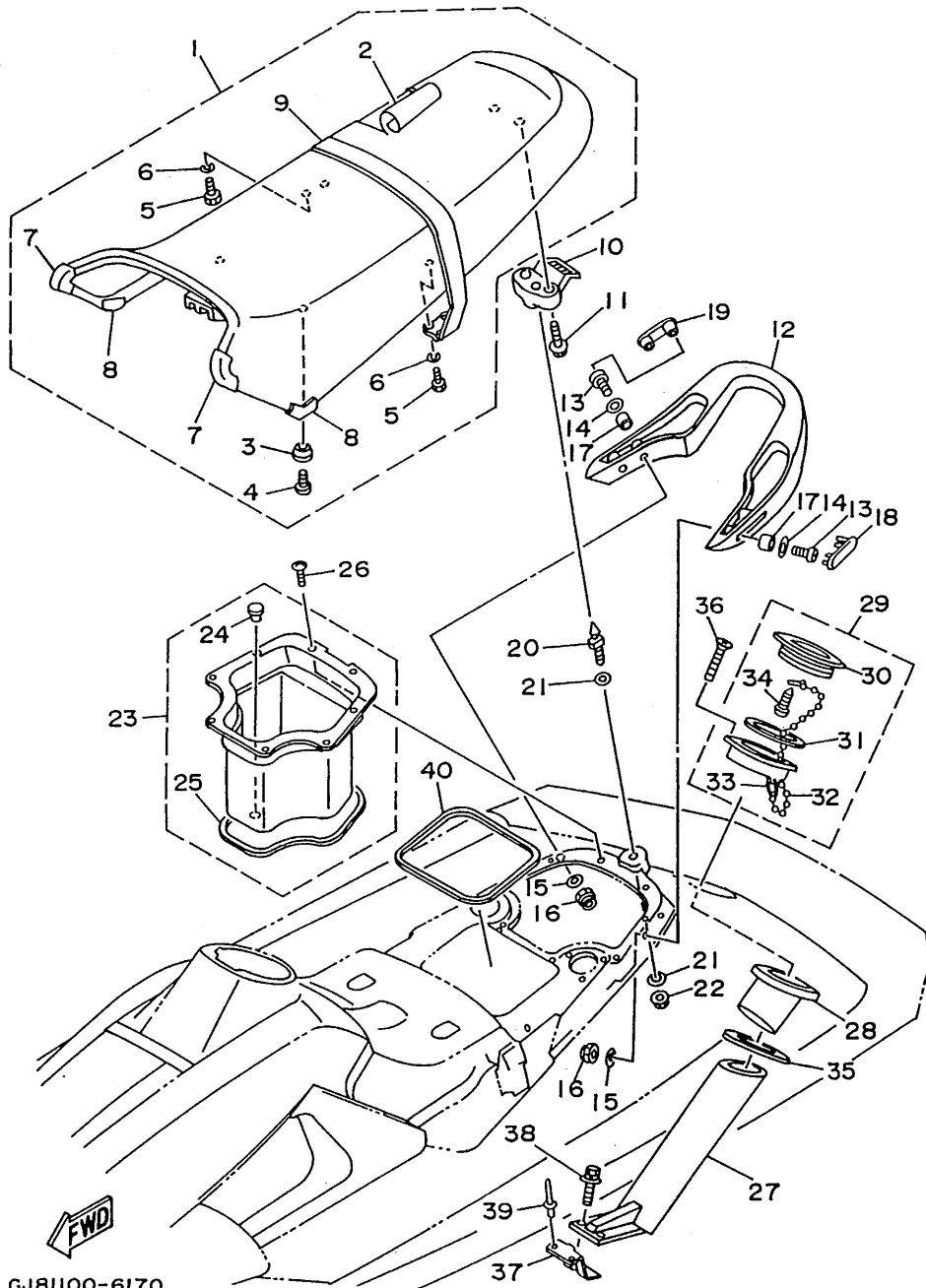

GJ81100-6170

FIG. 18 SEAT - UNDER LOCKER 2

REF. NO.	PART NO.	DESCRIPTION	Q'TY	REMARKS
1	EW2-62150-00	PIPE, VENTILATION 3	2	
2	90465-11M10	CLAMP	2	
3	GH1-6215G-00	PLATE, GUIDE	1	
4	90267-489U1	RIVET, BLIND	1	YMUS
5	GJ8-6521B-00	COVER, BOW	1	
6	90267-48951	RIVET, BLIND	6	
7	GH1-62139-00	VENTILATOR, OUTLET	2	
8	90267-409U5	RIVET, BLIND	6	
9	GH1-62127-00	BASE, AIR INTAKE	2	
10	90267-48925	RIVET, BLIND	8	
11	GH1-6213F-01	HOSE, VENTILATOR 1	2	
12	GH1-6213G-00	HOSE, VENTILATOR 2	2	
13	90601-20007	NYLON CLIP 1	2	

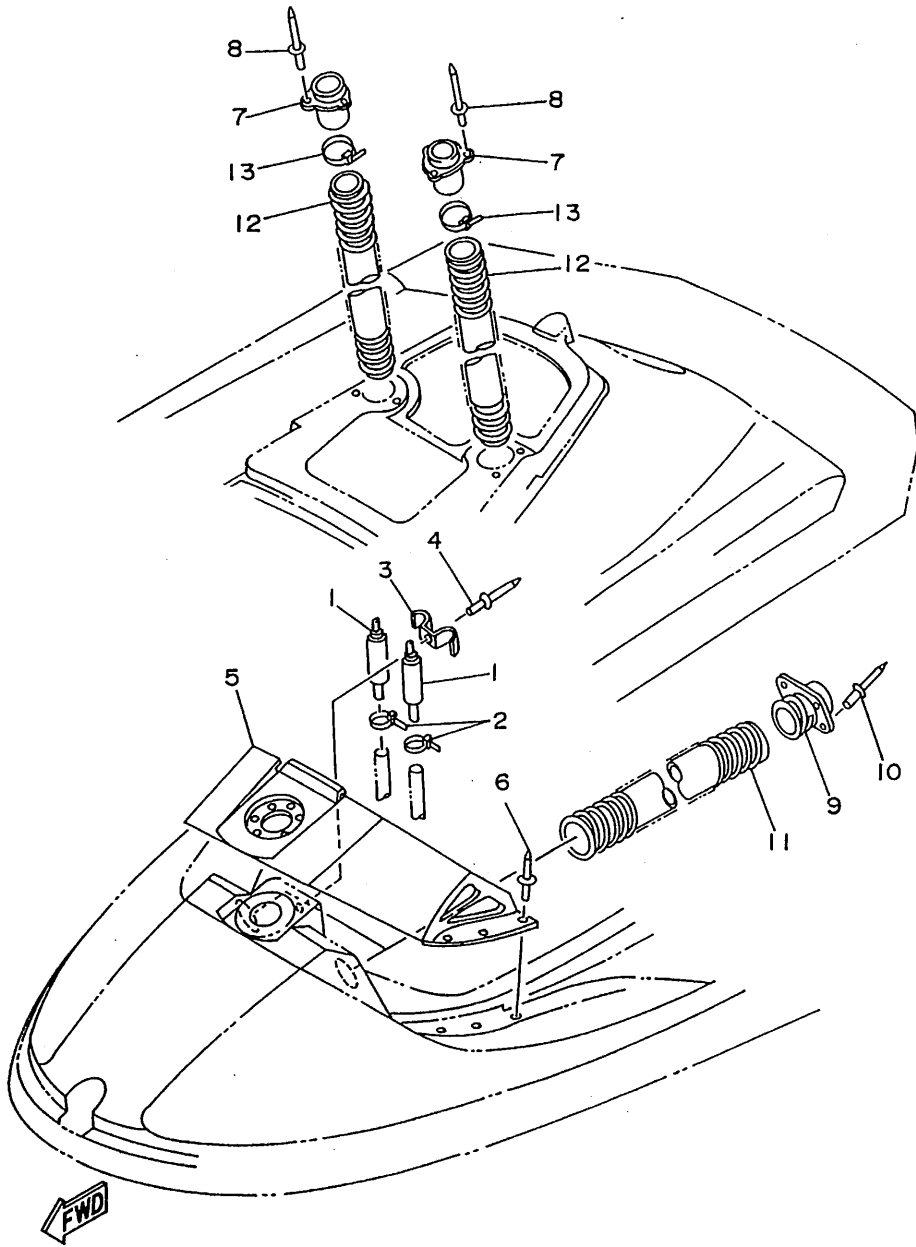

GJ11100-5180

FIG. 19 OIL TANK

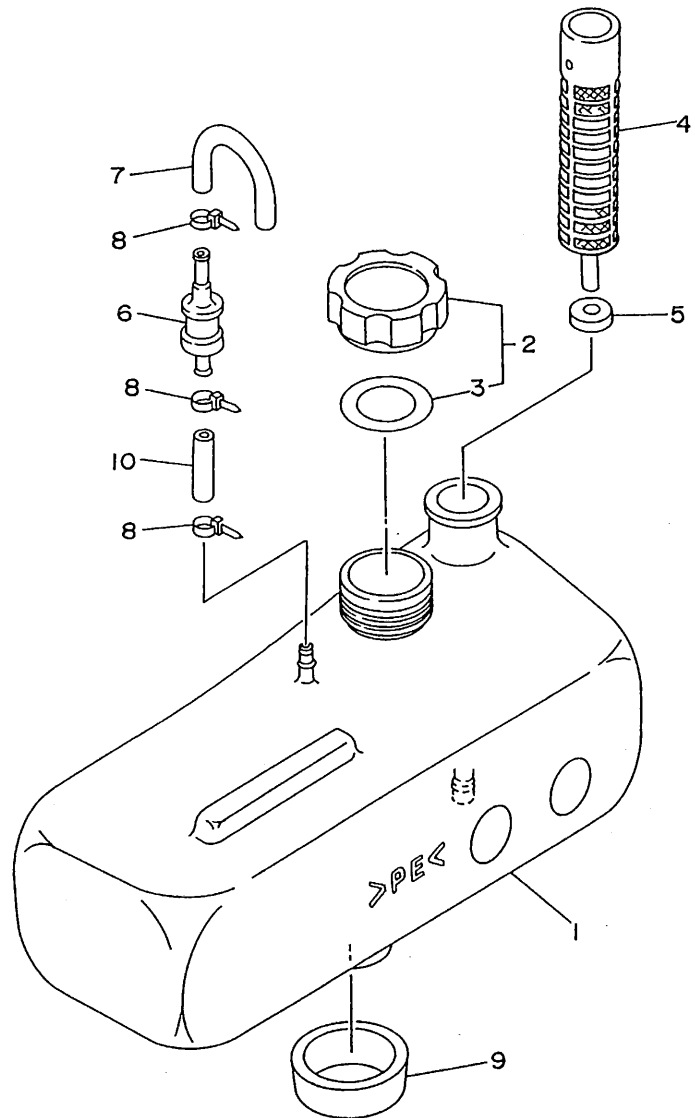

REF. NO.	PART NO.	DESCRIPTION	Q'TY	REMARKS
1	GJ1-U775B-00	TANK, OIL	1	YMUS
2	FJ0-67840-00	OIL TANK CAP ASSY	1	
3	FJ0-67841-01	.PACKING, OIL CAP	1	
4	6J8-13411-00	STRAINER, OIL	1	
5	6J8-13414-00	GASKET, STRAINER COVER	1	
6	FJ0-67766-00	ROLL OVER VALVE	1	
7	FJ0-62158-00	HOSE	1	
8	90465-11M10	CLAMP	3	
9	GH1-6759D-00	MAT 3	1	
10	90445-09901	HOSE	1	



GH61100-5190

D2

FIG. 20 FUEL TANK

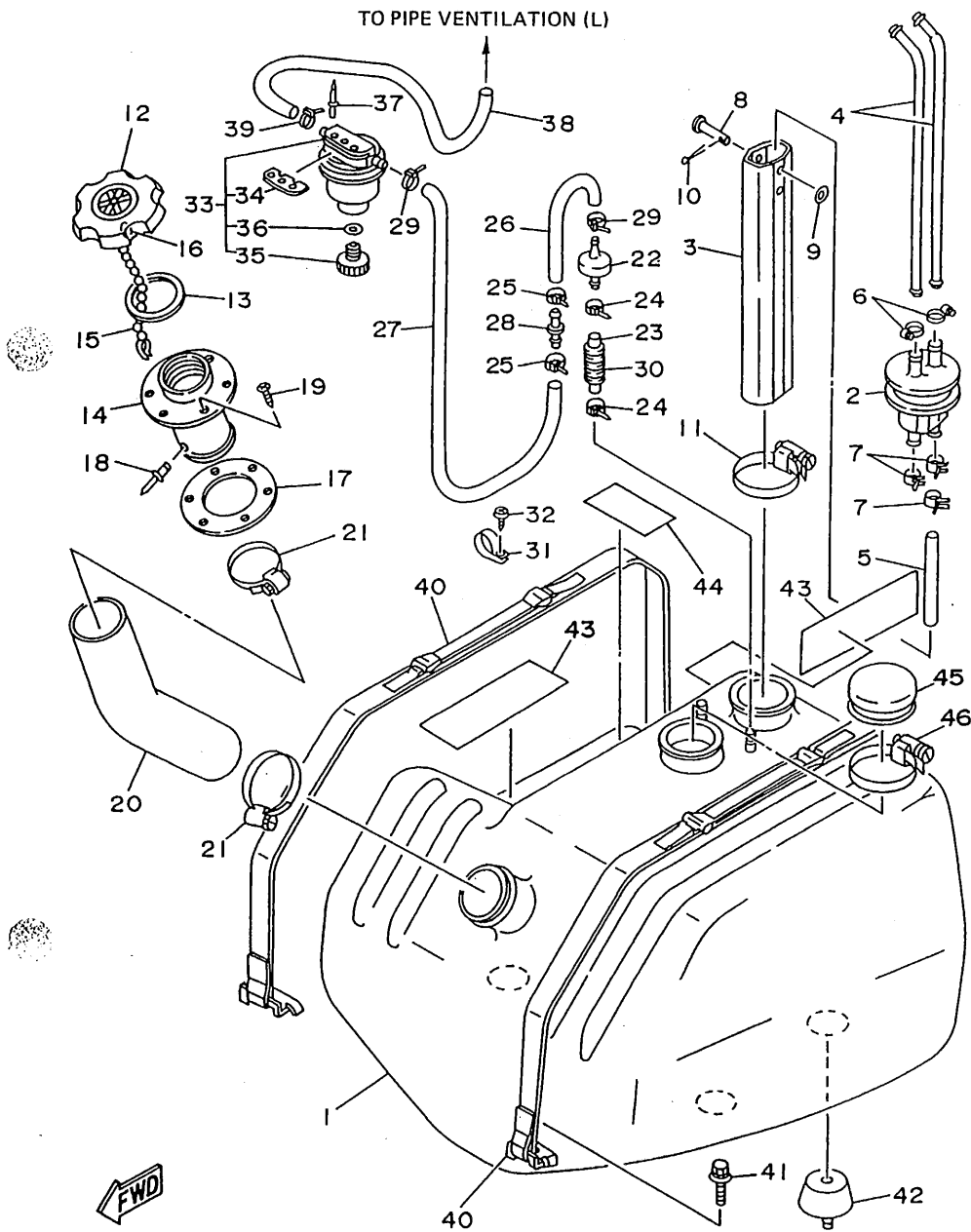

REF. NO.	PART NO.	DESCRIPTION	Q'TY	REMARKS
1	GJ1-U7711-00	TANK, FUEL	1	YMUS
2	FJ0-67713-00	PIPE, JOINT	1	
3	FJ0-67716-00	SLEEVE 1	1	
4	FJ0-67714-00	PIPE, SUCTION 3	2	
5	90445-11903	HOSE	1	
6	90601-11062	BAND, HOSE 11	2	
7	90467-11044	CLIP	3	
8	91790-05040	PIN, CLEVIS	1	
9	92990-05600	WASHER, PLATE	1	
10	91490-16010	PIN, COTTER	1	
11	90601-162U5	BAND, HOSE 62	1	YMUS
12	GA7-67831-01	CAP, FUEL FILLER	1	
13	EU0-67832-00	PACKING 1	1	
14	GA7-67833-00	SOCKET	1	
15	EU0-67835-00	CHAIN BALL	1	
16	EU0-67839-00	COUPLING	1	
17	EU0-67834-00	PACKING, FUEL FILLER	1	
18	90267-40935	RIVET, BLIND	1	
19	EU0-67869-00	SCREW, FLAT HEAD	6	
20	GJ1-U7844-00	HOSE	1	YMUS
21	90601-155U4	BAND, HOSE 55	2	YMUS
22	EU0-67767-31	CHECK VALVE	1	
23	GA7-6785G-00	HOSE, AIRVENT	1	
24	90465-11M10	CLAMP	2	
25	90465-11M10	CLAMP	2	
26	EU0-67856-50	HOSE, AIRVENT 3	1	
27	GJ1-67856-00	HOSE, AIRVENT 3	1	
28	6G8-24376-00	PIPE, JOINT 1	1	

GJ81100-6200

D3

FIG. 20 FUEL TANK

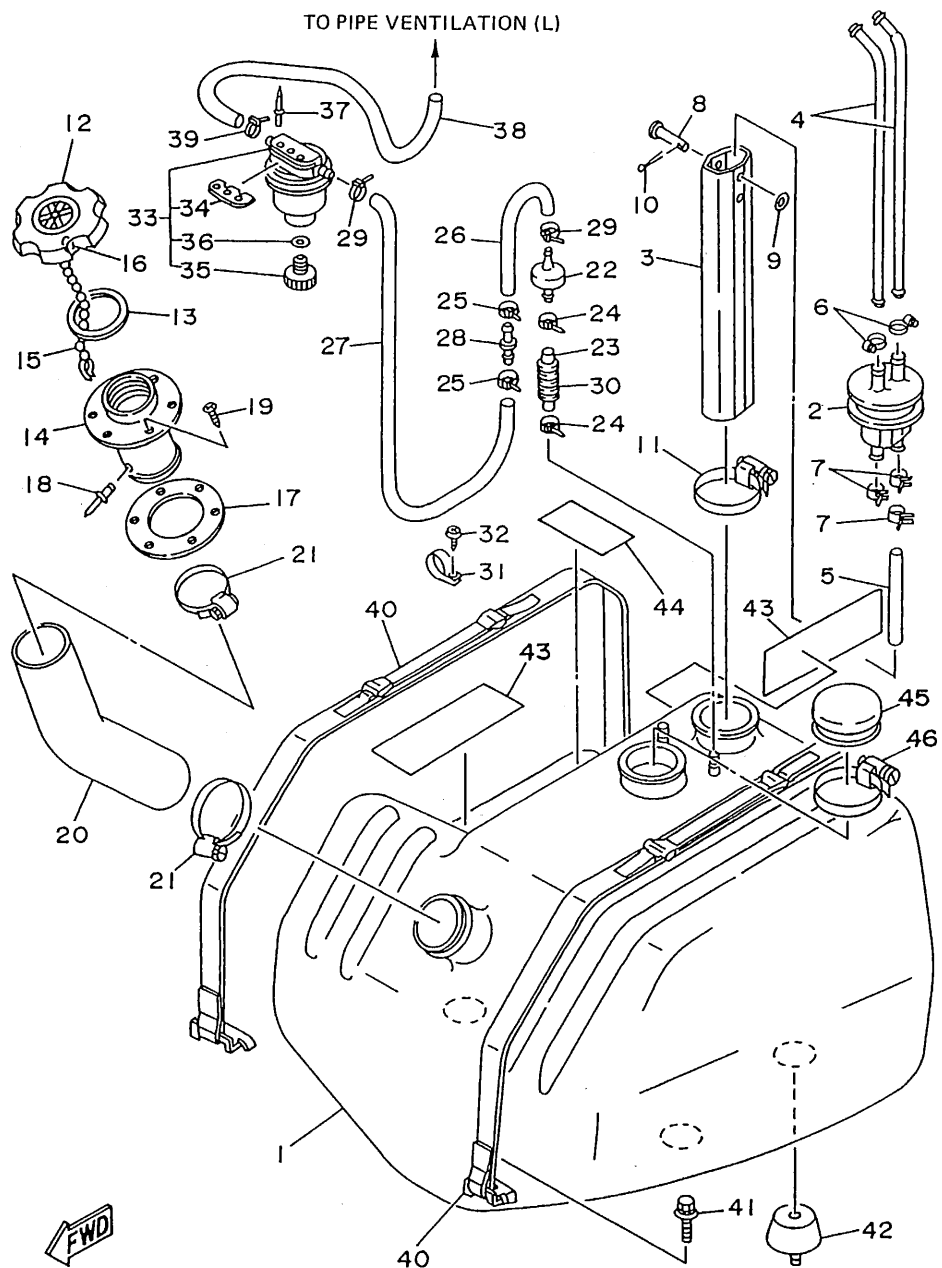

GJ81100-6200

REF. NO.	PART NO.	DESCRIPTION	Q'TY	REMARKS
29	90465-11M10	CLAMP	2	
30	GJ1-6773D-00	TUBE	1	
31	90600-918U3	CLIP, NYLON 16	1	YMUS
32	97780-60116	SCREW, TAPPING	1	
33	EW2-62140-00	FILTER, VENT ASSY	1	
34	EW2-62142-00	.PLATE, FILTER	1	
35	70R-24543-00	.PLUG, DRAIN	1	
36	70R-24489-00	.O-RING, SEPARATER 2	1	
37	90267-489U2	RIVET, BLIND	2	YMUS
38	90445-09905	HOSE	1	
39	90465-11M10	CLAMP	1	
40	GJ1-67743-00	BELT, TANK 1	2	
41	90119-089U7	BOLT, WITH WASHER	4	YMUS
42	GH1-6782B-01	DAMPER, FUEL TANK	4	
43	GJ1-6759B-00	MAT 1	2	
44	GJ1-6759C-00	MAT 2	1	
45	FN8-6771K-00	COVER	1	
46	90601-162U5	BAND, HOSE 62	1	YMUS

D4

FIG. 21 EXHAUST 2

REF. NO.	PART NO.	DESCRIPTION	Q'TY	REMARKS
1	GH1-U7550-00	WATER LOCK	1	YMUS
2	GH6-U7555-00	HOSE	1	YMUS
3	GH6-67577-01	PACKING, HOSE 1	2	
4	90601-168U7	BAND, HOSE 68	3	YMUS
5	90601-110UC	BAND, HOSE 17	1	YMUS
6	90604-80757	CONNECTION, THRU-HULL 1/4	1	
7	90604-80758	CONNECTION, THRU-HULL 1/4	1	
8	90430-13909	GASKET	2	
9	90601-118UF	BAND, HOSE 18	2	YMUS
10	GJ1-6753B-02	PILOT, WATER	1	
11	95380-14700	NUT	1	
12	92990-14200	WASHER, PLAIN	1	
13	90465-11M10	CLAMP	1	
14	GA9-67565-00	THRU-HULL, EXHAUST	1	
15	GA9-U7525-00	PACKING	1	YMUS
16	90119-059U4	BOLT, WITH WASHER	3	YMUS
17	GJ1-U7570-00	HOOK C	2	YMUS
18	EW2-65772-00	HOOK A	2	
19	90105-06900	BOLT, WASHER BASED	4	
20	90445-14M26	HOSE	1	
21	6M6-51142-00	CONNECTION	1	
22	90450-14M05	HOSE CLAMP ASSY	1	

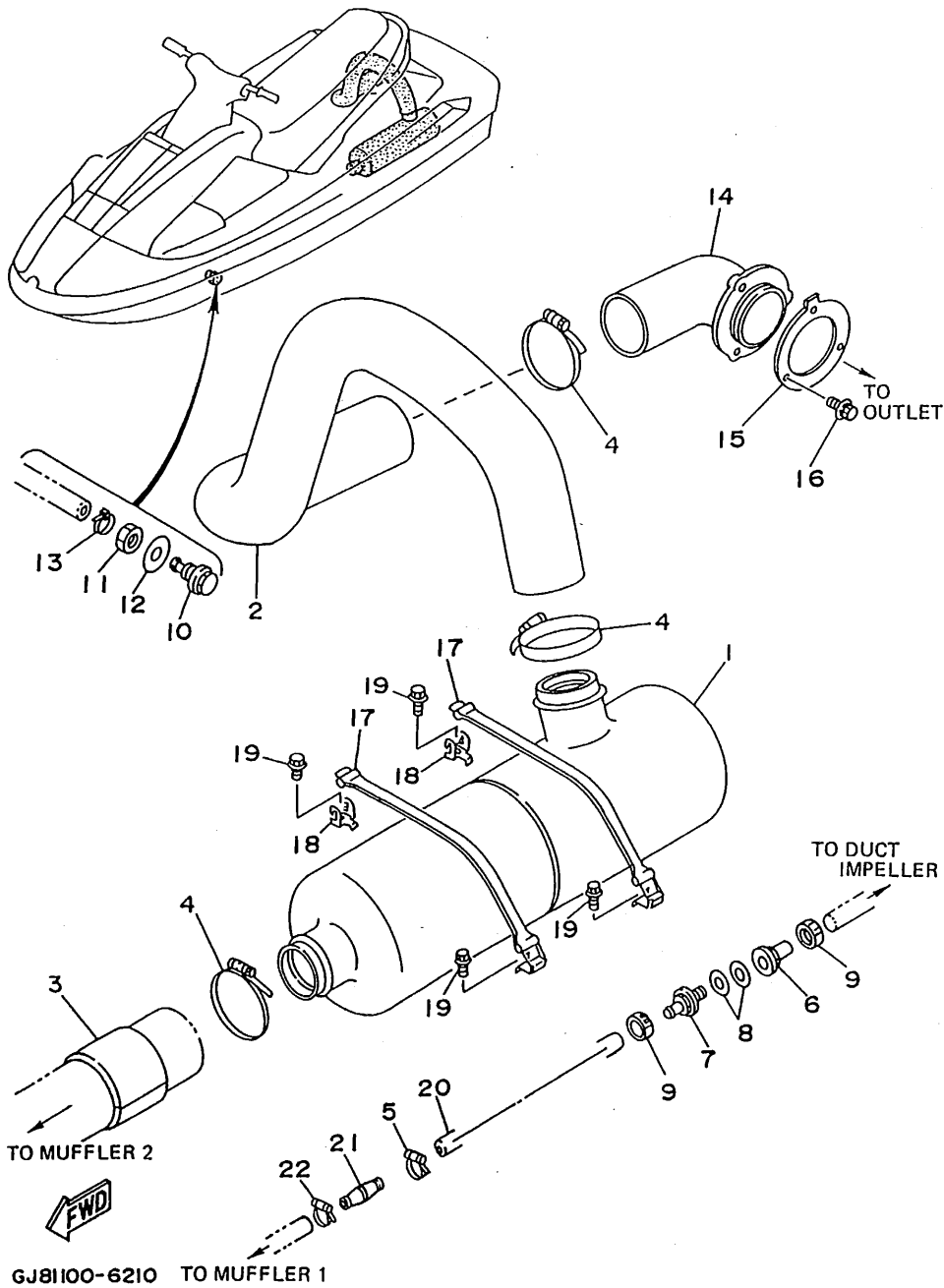
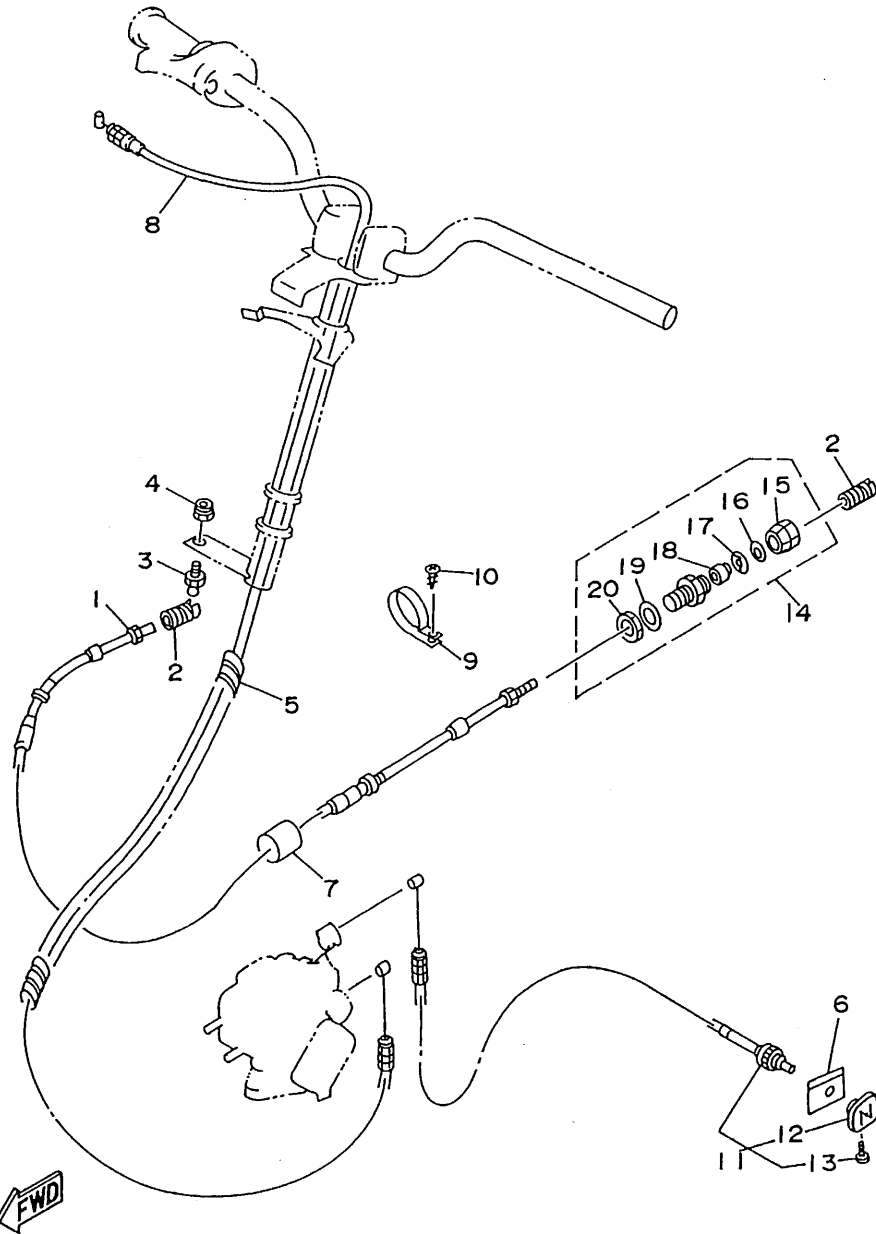

FIG. 22 CONTROL CABLE



REF. NO.	PART NO.	DESCRIPTION	Q'TY	REMARKS
1	GH6-U1481-00	CABLE, STEERING	1	YMUS
2	EU0-U1461-30	SHAFT, JOINT BALL	2	YMUS
3	EU0-U1461-01	STUD, JOINT BALL	1	YMUS
4	95720-06300	NUT, SELF-LOCKING	1	
5	90699-36U01	SPIRAP 11	1	YMUS
6	GJ1-6824D-00	PLATE, CHOKE	1	
7	GJ1-67578-20	PACKING, HOSE 2	1	
8	EU0-67252-02	CABLE, THROTTLE 1	1	
9	90600-918U3	CLIP, NYLON 16	1	YMUS
10	97780-60116	SCREW, TAPPING	1	
11	FN8-U7242-00	CABLE, CHOKE	1	YMUS
12	GA9-U724C-00	.KNOB	1	YMUS
13	GA9-U724D-00	.SCREW	1	YMUS
14	EU0-67267-00	CONNECTOR, CABLE	1	
15	EU0-62694-00	.CAP	1	
16	EU0-61446-00	.WASHER 30	1	
17	EU0-61486-00	.STOPPER	1	
18	EU0-61435-00	.SEAL, PIPE 30	1	
19	EU0-61438-00	.PACKING (C)	1	
20	EU0-62241-30	.NUT, DRAIN 1	1	

GJ81100-6220

D6

FIG. 23 STEERING 1

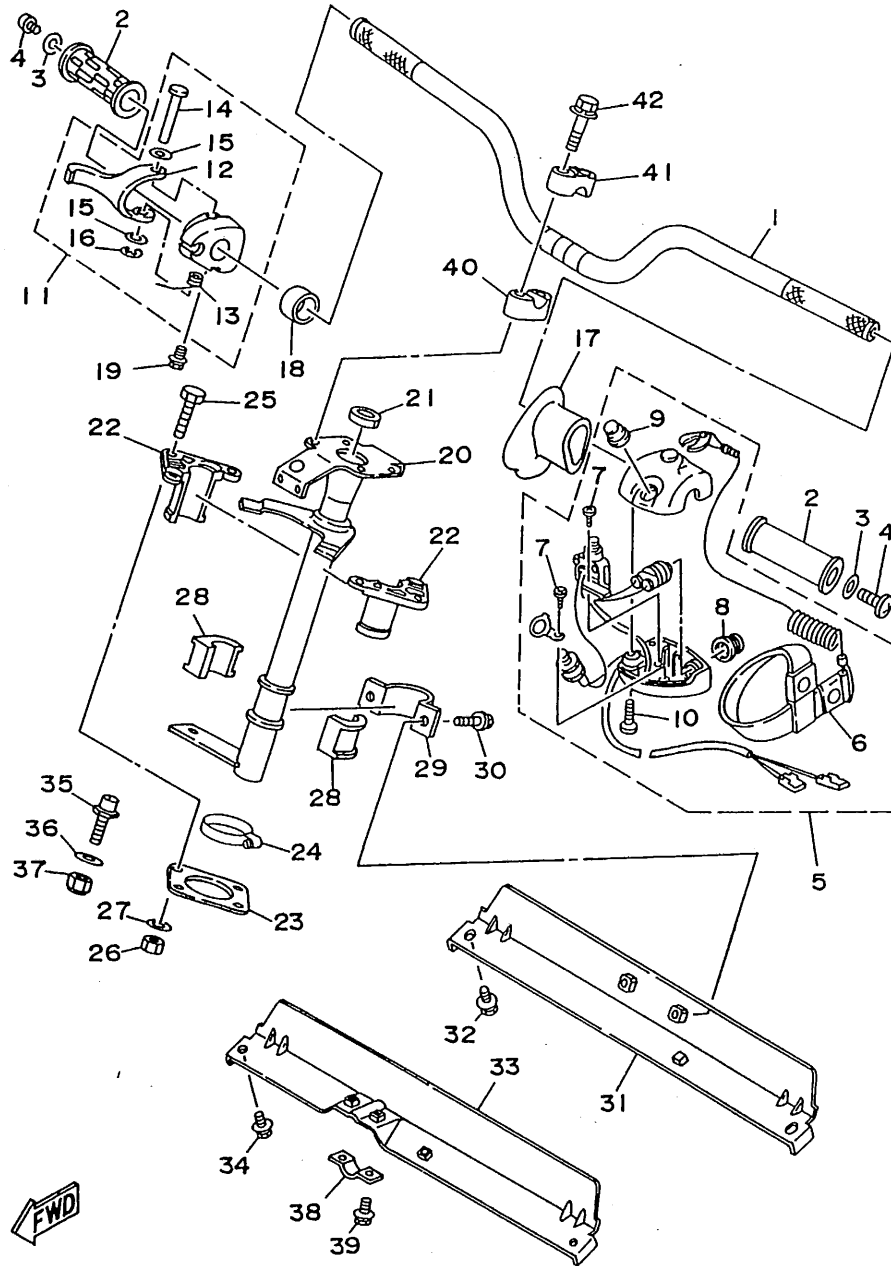

REF. NO.	PART NO.	DESCRIPTION	Q'TY	REMARKS
1	GJ1-U1552-02	HANDLE	1	YMUS
2	EW2-61553-00	GRIP, HANDLE 1	2	
3	90201-05928	WASHER, PLATE	2	
4	90149-05959	SCREW	2	
5	FK7-68310-06	SWITCH BOX ASSY	1	
6	EW2-68348-00	.LANYARD, STOP SWITCH	1	
7	98580-03008	.SCREW, PAN HEAD	2	
8	FK7-68312-02	.STOP BUTTON COMP.	1	
9	FK7-68313-01	.START BUTTON COMP.	1	
10	98580-05525	.SCREW, PAN HEAD	2	
11	EW2-67250-01	THROTTLE LEVER ASSY	1	
12	EW2-67255-00	.LEVER, THROTTLE	1	
13	EW2-67256-00	.SPRING	1	
14	EW2-67257-00	.SHAFT	1	
15	EW2-67258-01	.WASHER	2	
16	EW2-67259-01	.E-RING	1	
17	GJ3-6143G-00	SPACER	1	
18	90560-22281	SPACER	1	
19	90159-05900	SCREW, WITH WASHER	1	
20	GH1-61541-02	COLUMN, STEERING	1	
21	GH1-61469-00	PACKING, STEERING COLUMN	1	
22	GH1-6141B-00	BEARING, COLUMN	2	
23	GH1-6143C-30	SEAL, RUBBER	1	
24	90601-142U6	NYLON CLIP 1	1	YMUS
25	97080-06030	BOLT	4	
26	95720-06300	NUT, SELF-LOCKING	4	
27	92990-06200	WASHER, PLAIN	4	
28	GH1-6141D-01	BEARING, STEERING	2	

GJ81100-6230

D7

FIG. 23 STEERING 1

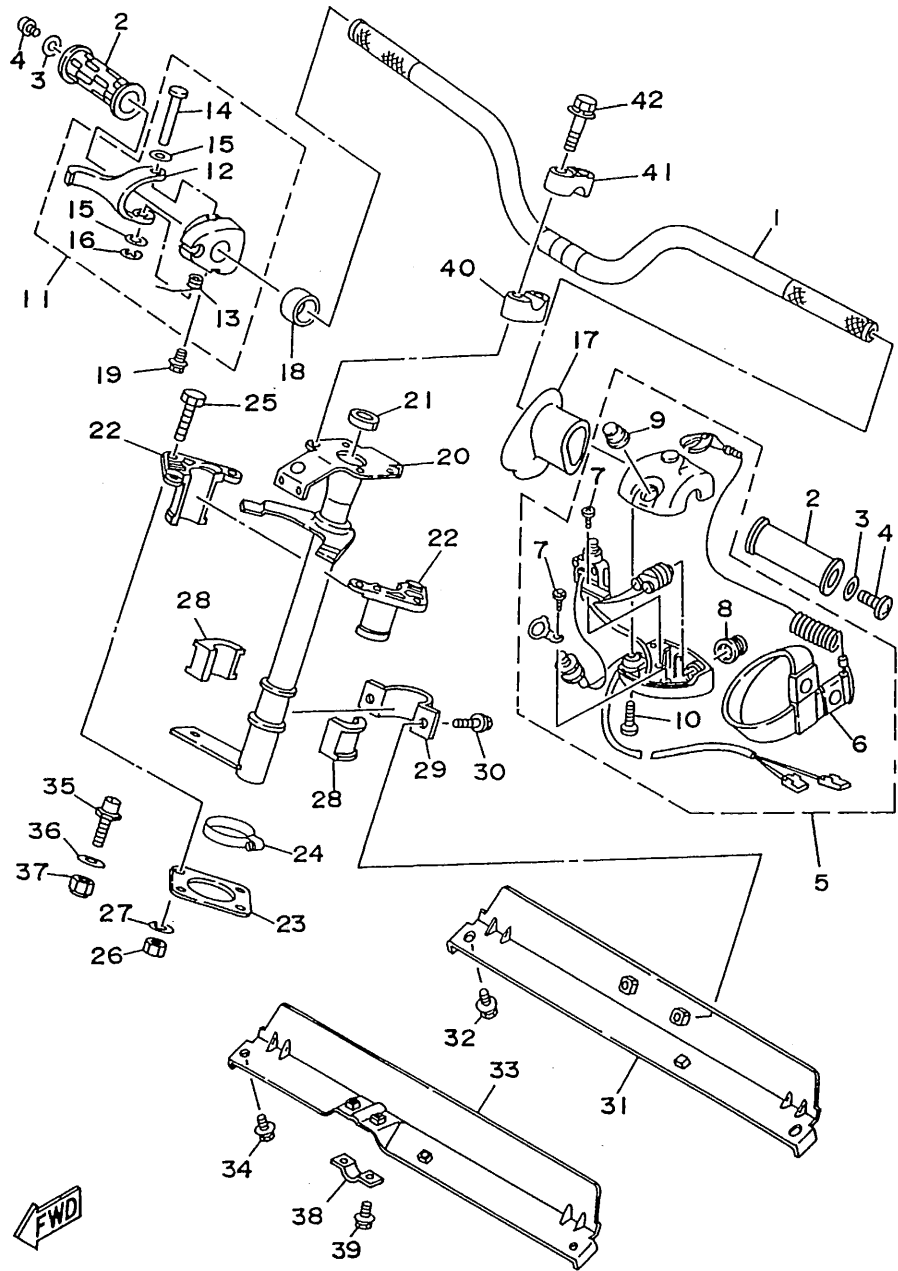

REF. NO.	PART NO.	DESCRIPTION	Q'TY	REMARKS
29	EU0-61588-00	JOINT, BEARING	1	
30	90119-08903	BOLT, WITH WASHER	2	
31	GH1-61433-00	BRACKET, BEARING	1	
32	90119-08903	BOLT, WITH WASHER	2	
33	GH1-61467-01	BRACKET, STOPPER CABLE	1	
34	90119-08903	BOLT, WITH WASHER	2	
35	FN8-6131B-00	PIN, STOPPER	1	
36	92990-10200	WASHER, PLAIN	1	
37	95720-10300	NUT	1	
38	GH1-61468-01	STOPPER, CABLE	1	
39	90119-06908	BOLT, WITH WASHER	2	
40	EU0-23814-01	HOLDER, HANDLE LOWER	2	
41	EU0-23814-30	HOLDER, HANDLE UPPER	2	
42	90119-08925	BOLT, WITH WASHER	4	

FWD

GJ81100-6230

D8

FIG. 24 STEERING 2

REF. NO.	PART NO.	DESCRIPTION	Q'TY	REMARKS
1	GH1-6142A-30	STEERING PAD COMP.	1	VIOLET SOLID 6
2	GA7-6144D-00	.PLATE	4	
3	90267-48951	.RIVET, BLIND	4	
4	90149-05959	SCREW	4	
5	90149-04903	SCREW	4	

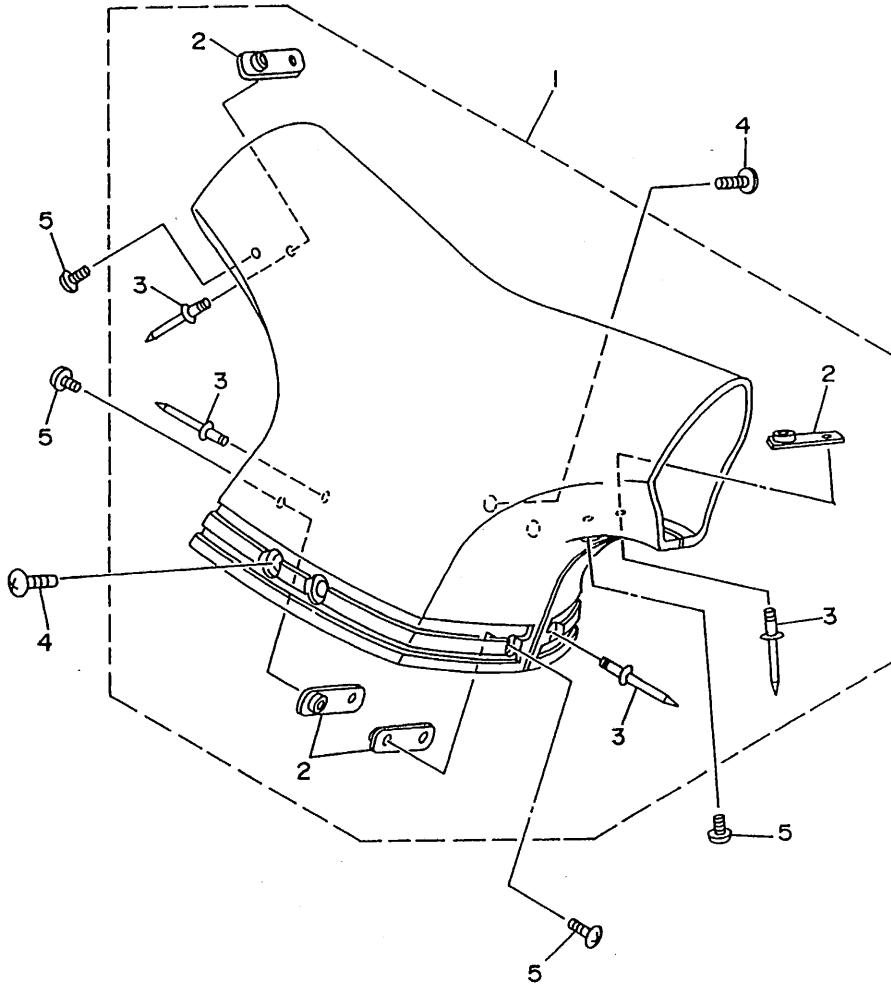

GH14010-4240

D9

FIG. 25 GRAPHIC 1. TOOL (FOR USA)

REF. NO.	PART NO.	DESCRIPTION	Q'TY	REMARKS
1	GJ8-U417B-00	GRAPHIC 1	1	YMUS
2	GJ8-U417C-00	GRAPHIC 2	1	YMUS
3	GJ8-U417F-00	GRAPHIC 5	1	YMUS
4	GJ8-U417G-00	GRAPHIC 6	1	YMUS
5	GJ8-U417H-00	GRAPHIC 7	2	YMUS
6	GJ3-U4114-10	MARK, YAMAHA A	1	YMUS
7	GJ1-U4122-10	EMBLEM 2	1	YMUS
8	GE1-U4125-00	EMBLEM	1	YMUS
9	GA9-U416B-00	LABEL, WARNING	1	YMUS
10	GJ1-U416C-01	LABEL, WARNING 1	1	YMUS
11	GA9-U416F-00	LABEL, WARNING 4	1	YMUS
12	GJ1-U418C-30	LABEL, CAUTION	1	YMUS
13	GJ1-U419C-00	LABEL 2	1	YMUS
14	GA9-U418C-00	LABEL, CAUTION	1	YMUS
15	GA9-U418G-00	LABEL, CAUTION	1	YMUS
16	EU0-U418B-00	LABEL, CAUTION	1	YMUS
17	GA9-U418E-00	LABEL, USCG.	1	YMUS
18	GA9-U418C-41	LABEL, CAUTION	1	YMUS
19	GA9-U418F-00	LABEL, UP RIGHTING	1	YMUS
20	GA9-U416G-00	LABEL, WARNING	1	YMUS
21	GJ1-U418C-00	LABEL, CAUTION	1	YMUS
22	EU0-28100-03	TOOL KIT	1	
23	EU0-65901-01	BAG, VINYL	1	

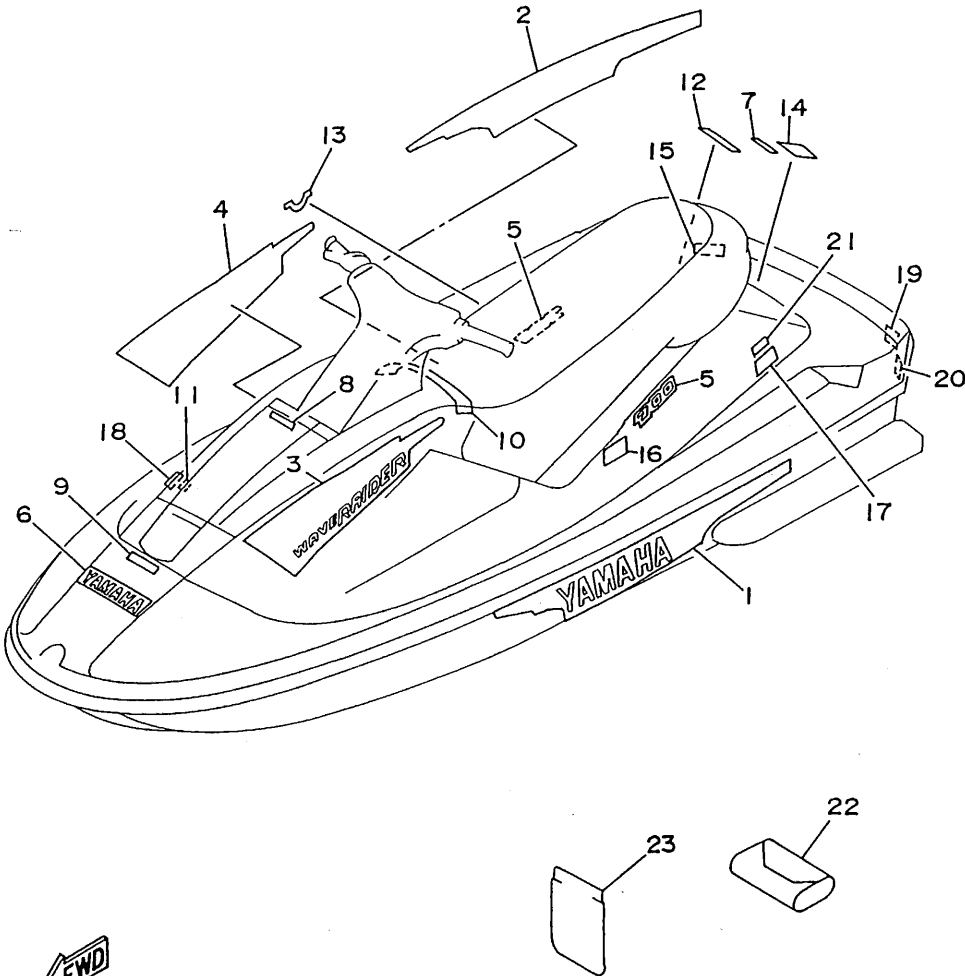

GJ8100-6250

D10

FIG. 26 GRAPHIC 2. TOOL (FOR CAN, GUM, AUS, FRA)

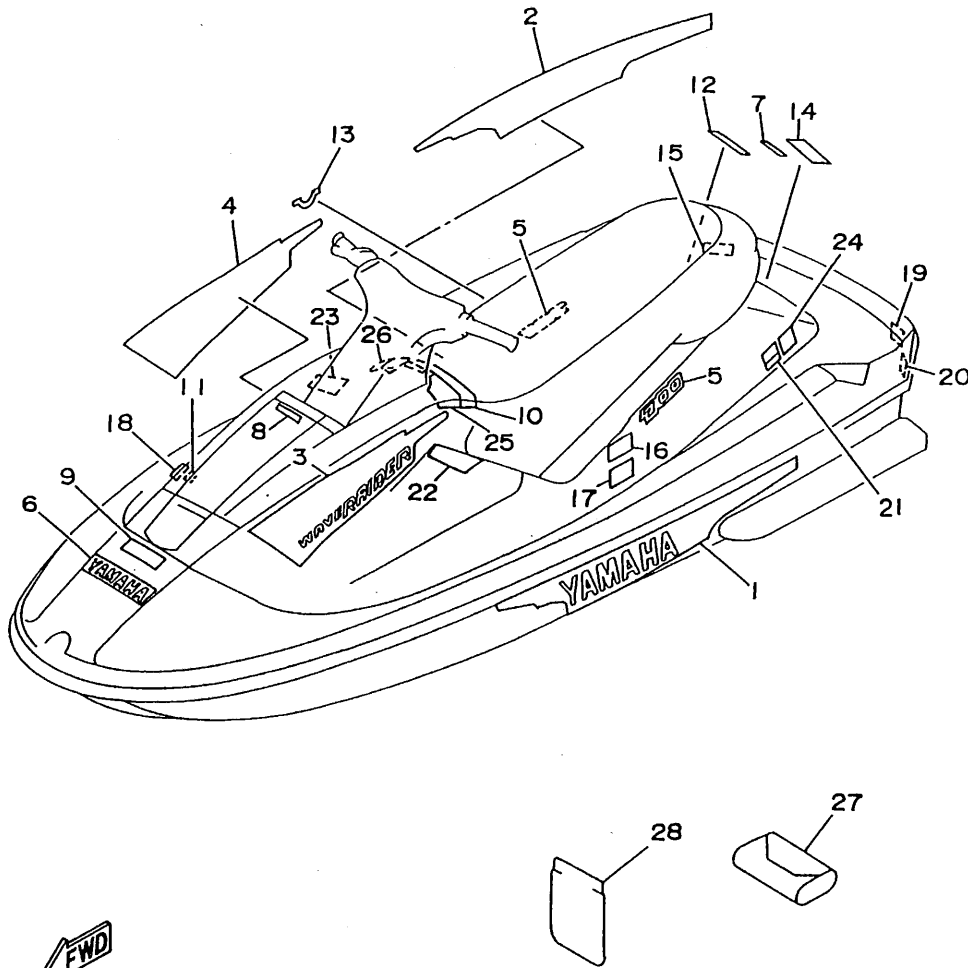

REF. NO.	PART NO.	DESCRIPTION	Q'TY	REMARKS
1	GJ8-U417B-00	GRAPHIC 1	1	YMUS
2	GJ8-U417C-00	GRAPHIC 2	1	YMUS
3	GJ8-U417F-00	GRAPHIC 5	1	YMUS
4	GJ8-U417G-00	GRAPHIC 6	1	YMUS
5	GJ8-U417H-00	GRAPHIC 7	2	YMUS
6	GJ3-U4114-10	MARK, YAMAHA	1	YMUS
7	GJ1-U4122-10	EMBLEM 2	1	YMUS
8	GE1-U4125-00	EMBLEM	1	YMUS USA/CAN ONLY
9	GA9-U416B-10	LABEL, WARNING (FUEL)	1	YMUS
10	GJ1-U416C-20	LABEL, WARNING 1	1	YMUS
11	GA9-U416F-10	LABEL, WARNING 4	1	YMUS
12	GJ1-U418C-40	LABEL, CAUTION	1	YMUS
13	GJ1-U419C-00	LABEL 2	1	YMUS
14	GA9-U418C-10	LABEL, CAUTION	1	YMUS
15	GA9-U418G-10	LABEL, CAUTION (DRAIN)	1	YMUS
16	EU0-U418B-00	LABEL, CAUTION (BATTERY)	1	YMUS
17	EU0-U418B-10	LABEL, CAUTION (BATTERY)	1	YMUS
18	GA9-U418C-50	LABEL, CAUTION (OIL)	1	YMUS
19	GA9-U418F-00	LABEL, UP RIGHTING	1	YMUS
20	GA9-U416G-10	LABEL, WARNING 5	1	YMUS
21	GJ1-U418C-10	LABEL, CAUTION	1	YMUS
22	GJ1-U416C-10	LABEL, WARNING 1 (LH)	1	YMUS
23	GJ1-U416D-11	LABEL, WARNING 1 (RH)	1	YMUS
24	GA9-U418E-00	LABEL, USCG.	1	YMUS GUAM ONLY
25	GJ1-U416H-10	LABEL, WARNING (FRANCE)	1	YMUS FRANCE ONLY
26	GJ1-U416H-20	LABEL, WARNING (FRANCE)	1	YMUS FRANCE ONLY
27	EU0-28100-03	TOOL KIT	1	
28	EU0-65901-01	BAG, VINYL	1	

FWD
GJ81100-6260

D11

FIG. 27 REPAIR KIT 1

REF. NO.	PART NO.	DESCRIPTION	Q'TY	REMARKS
1	61X-W0001-02	GASKET KIT	1	
2	6M6-11351-A2	.GASKET, CYLINDER	1	
3	61X-11181-A0	.GASKET, CYLINDER HEAD 1	1	
4	93102-36M33	.OIL SEAL	1	
5	93101-36M46	.OIL SEAL	1	
6	93103-32M01	.OIL SEAL	1	
7	62T-45127-00	.SEAL	1	'96MODEL
8	61X-13566-A1	.GASKET	1	
9	61X-13563-A1	.GASKET	1	
10	6M6-13556-A1	.GASKET, MANIFOLD	2	
11	61X-13621-A0	.GASKET, VALVE SEAT	2	
12	6M6-13674-A1	.GASKET, AIR COOLER COVER 1	2	
13	6R8-13116-A0	.GASKET, PUMP CASE	1	
14	6M6-14739-A1	.GASKET, MUFFLER DAMPER 1	2	
15	61X-14613-A0	.GASKET, EXHAUST PIPE	1	
16	90430-08020	.GASKET	1	
17	6R7-14749-A0	.GASKET, MUFFLER DAMPER 2	1	
18	6R7-14755-A0	.GASKET, SILENCER	1	
19	6R7-41114-A0	.GASKET, EXHAUST OUTER COVER	1	
20	6M6-81365-A0	.GASKET, HOLE COVER	1	
21	63N-W0001-20	GASKET KIT	1	
22	93102-18M35	.OIL SEAL	2	
23	6R8-51367-01	.FELT, PACKING	2	
24	63N-51368-00	.FELT, PACKING	2	
25	93210-17MA4	.O-RING	2	
26	93210-35M72	.O-RING	1	
27	93101-25M55	.OIL SEAL	1	
28	93101-25M56	.OIL SEAL	1	

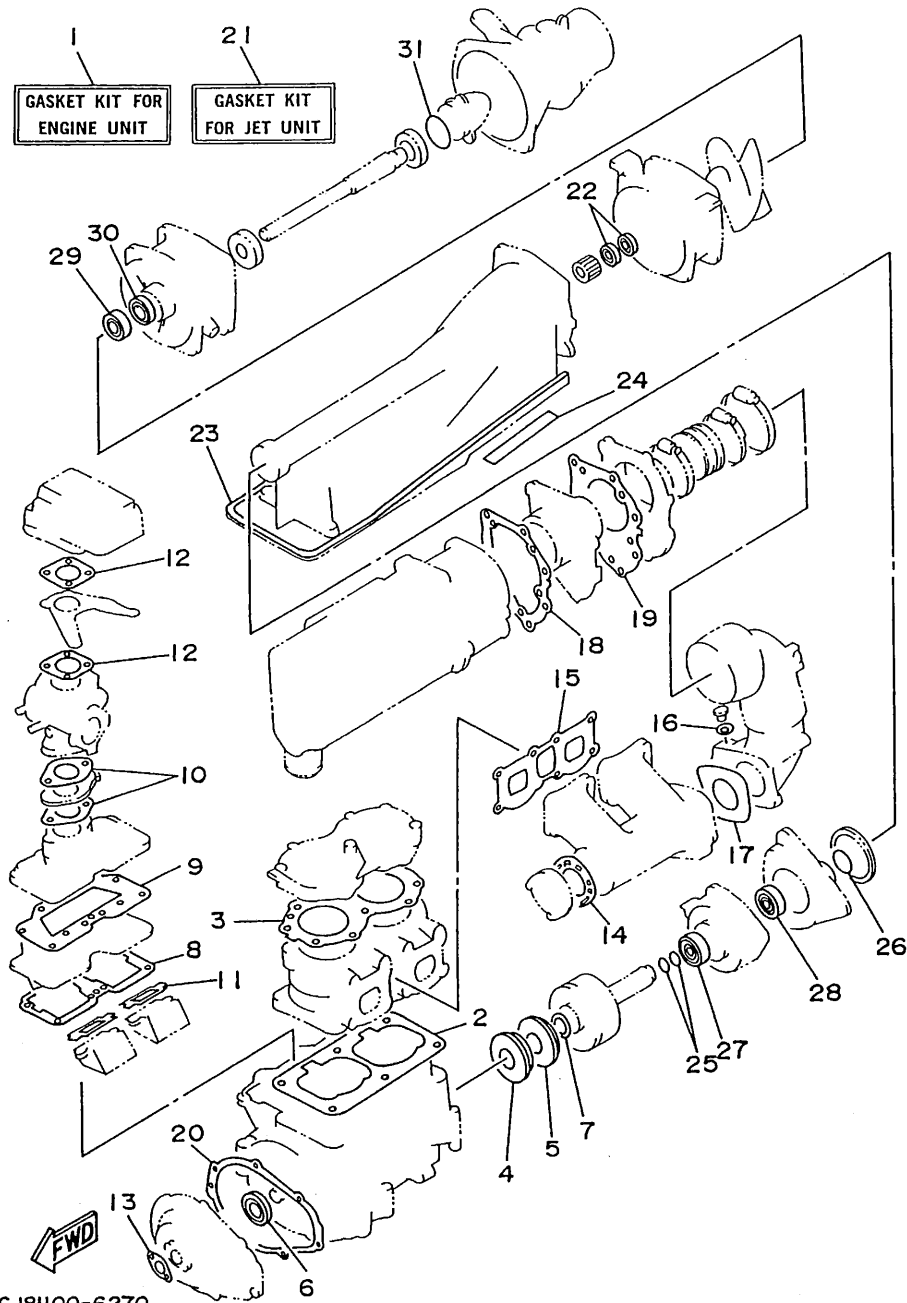

GJ81100-6270

D12

FIG. 27 REPAIR KIT I

REF. NO.	PART NO.	DESCRIPTION	Q'TY	REMARKS
29	93102-25M34	.OIL SEAL	1	
30	93101-25M50	.OIL SEAL	1	
31	93210-46M16	.O-RING	1	

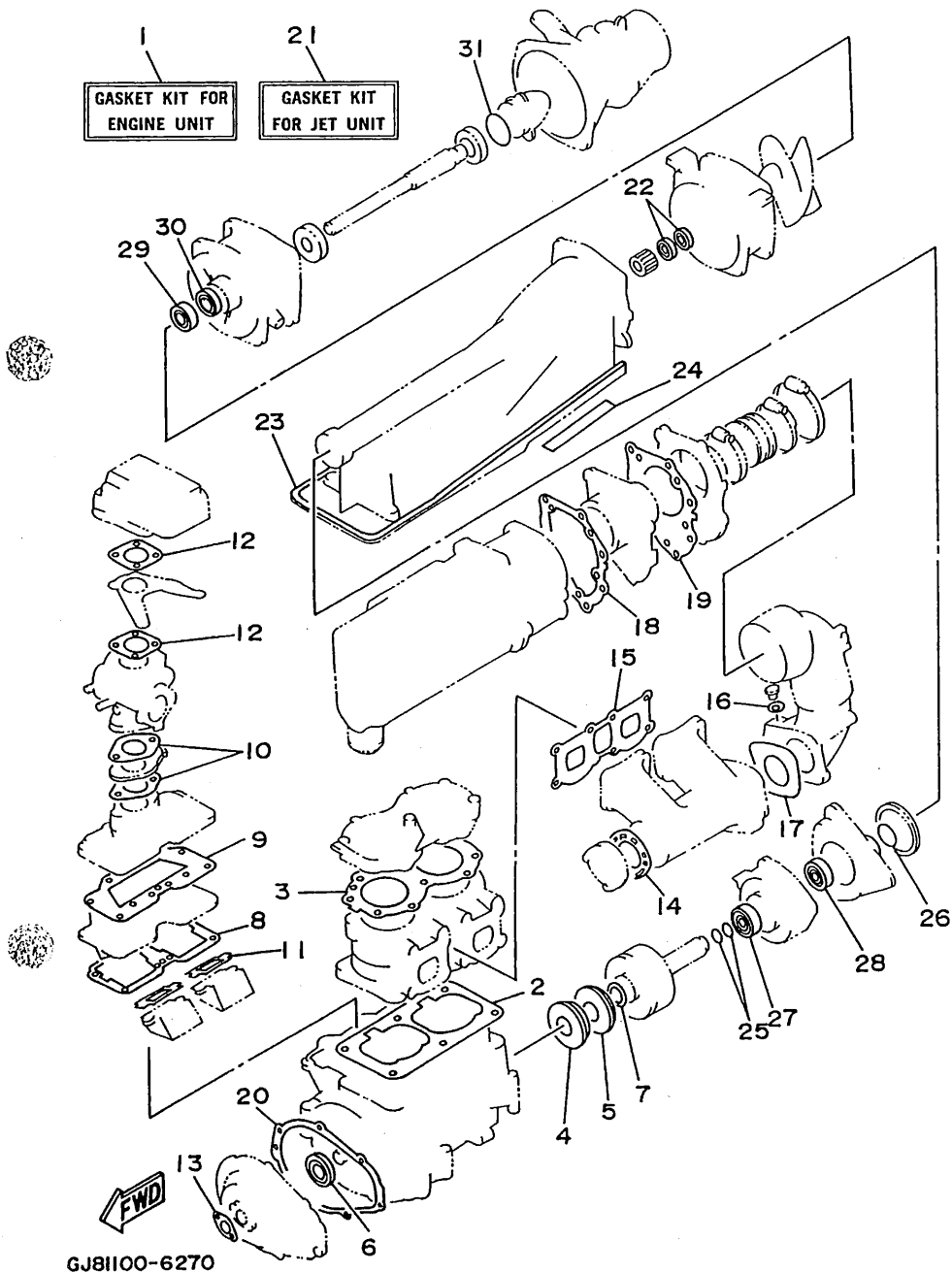
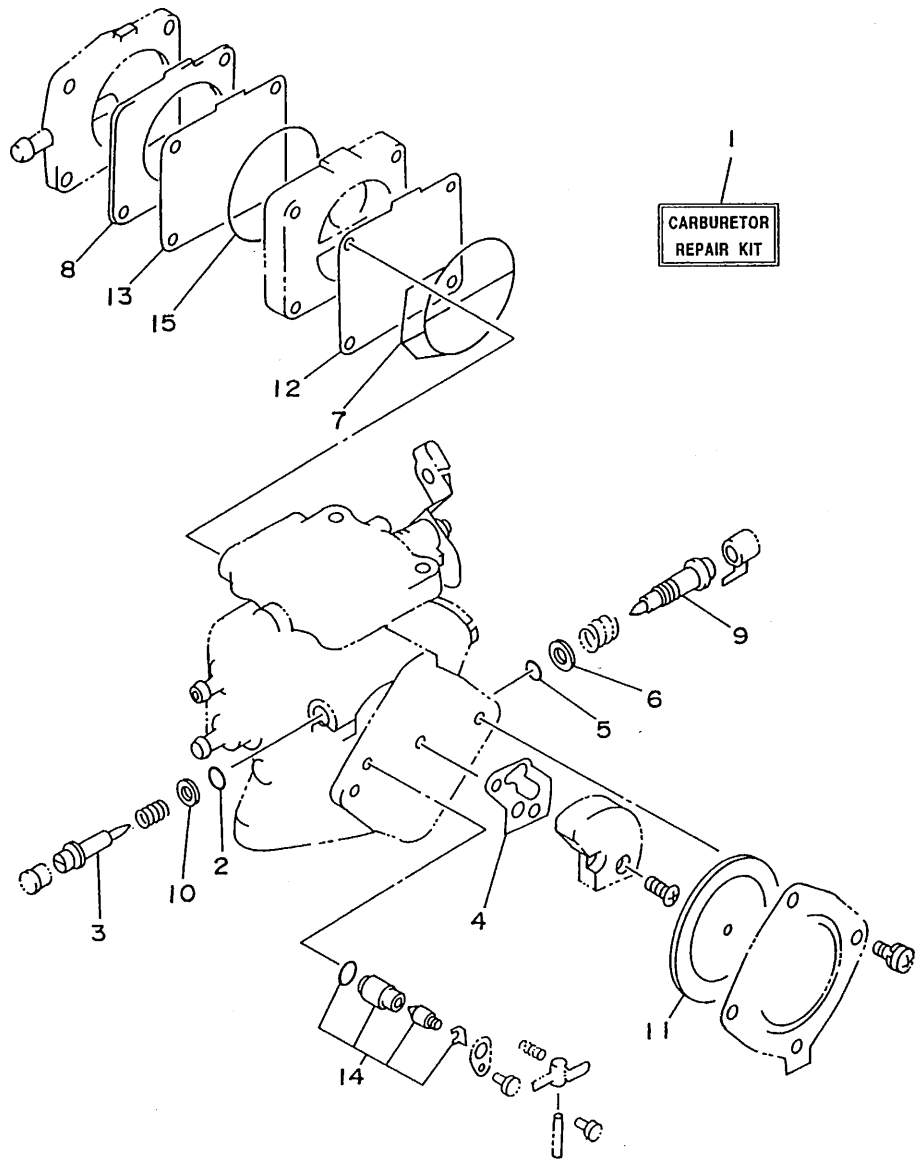

FIG. 28 REPAIR KIT 2

REF. NO.	PART NO.	DESCRIPTION	Q'TY	REMARKS
1	6M6-W0093-12	CARBURETOR REPAIR KIT	1	
2	6K8-14562-00	.O-RING	1	
3	6K8-14946-10	.METERING NEEDLE	1	
4	6K8-14536-11	.GASKET	1	
5	583-14561-00	.O-RING	1	
6	6K8-14537-00	.GASKET	1	
7	6K8-14564-00	.O-RING	1	
8	6K8-24431-20	.GASKET, FUEL PUMP 1	1	
9	6M6-14923-10	.SCREW, PILOT	1	
10	6K8-14559-00	.WASHER	2	
11	6R7-14541-00	.DIAPHRAGM, PUMP	1	
12	6K8-24411-20	.DIAPHRAGM	1	
13	6K8-24421-10	.VALVE, CHECK	1	
14	61X-14916-15	.NEEDLE	1	
15	6K8-14563-00	.O-RING	1	



GJ81100-6280

D14

NUMERICAL INDEX

PART NO.	REF. NO.	PART NO.	REF. NO.	PART NO.	REF. NO.	PART NO.	REF. NO.	PART NO.	REF. NO.	PART NO.	REF. NO.
EUO-U1461-01	22- 3	GJ8-U417G-00	26- 4	61X-W0090-03-4D	1- 1	6K8-14481-10	4-36	6R7-14749-A0	6-17	62T-44532-10	1- 5
EUO-U1461-30	22- 2	GJ8-U417H-00	25- 5	6M6-W0093-12	28- 1	6H1-14485-00	3-27		27-17	663-45119-00	3- 7
GH6-U1481-00	22- 1		26- 5	61X-11111-00-94	1-16	6R7-14485-00	1-18	64R-14752-00	6-46	6K8-45127-00	9-20
GJ1-U1552-02	23- 1	EUO-U418B-00	25-16	61X-11181-A0	1-19		6-26	6R7-14753-00-9M	6-27	62T-45127-00	2-16
FN8-U1624-00	15-28		26-16		27- 3	6K8-14503-02	4-17	6R7-14755-A0	6-32		27- 7
GJ1-U2501-10	16- 1	EUO-U418B-10	26-17	61X-11311-00-94	1-10	6M6-14503-00	4-15		27-18	6R8-45318-00	8- 7
GJ1-U2519-10	16- 6	GA9-U418C-00	25-14	6E5-11325-00	1-11	6K8-14521-10	4-18	6M6-14771-00-94	6-42	62G-45331-00-94	9- 6
GJ1-U252C-10	16-13	GA9-U418C-10	26-14	6M6-11351-A2	1-13	6M6-14521-00	4-11	6R7-14785-00-9M	6-31	61X-45332-01-9M	9- 8
GJ1-U252D-10	16-14	GA9-U418C-41	25-18		27- 2	6K8-14523-11	4-21	61X-14916-15	4-27	61L-45378-00	9-17
GJ1-U2552-10	16- 5	GA9-U418C-50	26-18	6E5-11372-00	3-26	6K8-14527-11	4-22		28-14	6R8-45511-00	8-23
GJ1-U266D-00	17-40	GJ1-U418C-00	25-21	6M6-11400-02	2- 1	6M6-14527-02-4D	3-11	6M6-14923-10	4-35	62T-45526-00	2- 5
GJ1-U2664-00	14- 9	GJ1-U418C-10	26-21	61X-11603-00	2-10	6K8-14531-00	4-43		28- 9	61X-4581J-00	2-17
GJ1-U273B-00	9-21	GJ1-U418C-30	25-12	61X-11604-00	2-10	6K8-14533-00	4-44	6K8-14926-10	4- 5	6M6-45813-21-9M	2-18
GJ1-U351H-10	16-21	GJ1-U418C-40	26-12	61X-11605-00	2-10	6K8-14534-10	4- 3	6K8-14930-00	4- 6	6M6-45813-31-9M	2-15
GJ1-U351K-10	16-22	GA9-U418E-00	25-17	61X-11631-00-93	2- 9	6K8-14536-11	4-25	6K8-14946-10	4-13	6K8-51129-00	1-17
GJ1-U351M-10	16-23		26-24	61X-11633-00	2-11		28- 4		28- 3		6- 2
GJ1-U351N-10	16-24	GA9-U418F-00	25-19	61X-11635-00	2- 9	6K8-14537-00	4-33	61X-15100-00-94	1- 2		6- 9
GJ1-U351P-10	16-25		26-19	61X-11636-00	2- 9		28- 6	6R7-15761-00	6-28		8-16
GJ1-U371A-10	17- 1	GA9-U418G-00	25-15	6R8-13116-A0	5- 2	6R7-14541-00	4-30	6R7-21415-00-94	1-23		8-31
GJ1-U371B-10	17- 2	GA9-U418G-10	26-15		27-13		28-11	6R7-21425-00-94	1-24	6M6-51142-00	21-21
GJ1-U373D-10	17- 9	GJ1-U419C-00	25-13	6R3-13183-00	5- 9	6R7-14542-00	4-31	EUO-23814-01	23-40	61X-51162-00	15- 6
GJ1-U375A-10	17- 7		26-13	61X-13200-10	5- 1	6K8-14547-01	4-28	EUO-23814-30	23-41	62T-51190-00-5B	8-48
GJ1-U375B-20	17- 8	GJ1-U474A-00	17-23	6J8-13411-00	19- 4	6K8-14556-10	4- 4	6G8-24376-00	20-28	62T-51311-00-94	8- 5
GJ3-U4114-10	25- 6	GJ8-U516A-00-PO	14- 1	6J8-13414-00	19- 5	6K8-14559-00	4-10	6E5-24378-00	6-19	6R8-51312-00-94	8-13
	26- 6	GA9-U724C-00	22-12	61X-13555-01-94	3- 3		28-10	650-24378-00	3- 4	62T-51313-00	8-41
GJ1-U4122-10	25- 7	GA9-U724D-00	22-13	6M6-13556-A1	3-12	583-14561-00	4-32	6K8-24411-20	4-38	62T-51315-00-94	8-15
	26- 7	FN8-U7242-00	22-11		27-10		28- 5		28-12	64R-51318-00-5B	8-30
GE1-U4125-00	25- 8	GDO-U7249-00-05	9-32	61X-13563-A1	3-10	6K8-14562-00	4-12	6R7-24412-01	4-24	6R7-51321-00-94	8-28
	26- 8	GDO-U7249-00-10	9-32		27- 9		28- 2	6M6-24413-00	4-39	6R8-51323-03	9- 4
GA9-U416B-00	25- 9	EUO-U7354-00-01	1-34	61X-13566-A1	3- 2	6K8-14563-00	4-45	6K8-24421-10	4-40	62T-51326-00	8-24
GA9-U416B-10	26- 9	EUO-U7354-00-03	1-34		27- 8		28-15		28-13	63N-51333-00-5B	9- 1
GJ1-U416C-01	25-10	EUO-U7354-00-05	1-34	61X-13610-01	3-18	6K8-14564-00	4-37	6K8-24431-20	4-41	6R8-51348-00-5B	8- 8
GJ1-U416C-10	26-22	EUO-U7354-00-10	1-34	61X-13621-A0	3-20		28- 7		28- 8	63M-51348-00	9-15
GJ1-U416C-20	26-10	EUO-U7354-00-20	1-34		27-11	6R7-14569-00	4-26	6K8-24452-10	4-42	6R8-51367-01	8-11
GJ1-U416D-11	26-23	GA9-U7525-00	21-15	61X-13641-01-94	3- 1	6K8-14579-00	4-23	70R-24489-00	20-36		27-23
GA9-U416F-00	25-11	GH1-U7550-00	21- 1	6M6-13674-A1	3-32	6K8-14589-00	4-34	6K8-24500-02	7- 5	63N-51368-00	8-12
GA9-U416F-10	26-11	GH6-U7555-00	21- 2		27-12	6K8-14591-10	4-20	6K8-24524-10	7-12		27-24
GA9-U416G-00	25-20	GJ1-U7570-00	21-17	3G2-14231-27	4-16	6R7-14596-01	4- 2	70R-24543-00	20-35	62T-51381-00	8- 1
GA9-U416G-10	26-20	GJ1-U7711-00	20- 1	830-14231-23	4-19	61X-14613-A0	6- 5	6K8-24560-10	7- 4	64R-51387-00-5B	8-32
GJ1-U416H-10	26-25	GJ1-U773J-00	7-16	61L-14243-00	3- 6		27-15	EUO-28100-03	25-22	62T-51673-00	8-35
GJ1-U416H-20	26-26	GJ1-U775B-00	19- 1	6R7-14253-00	4-29	61L-14615-00	6-38		26-27	61L-5169A-00	3- 5
GJ8-U417B-00	25- 1	GJ1-U7844-00	20-20	6R7-14255-00	3-33	61L-14625-00	6-39	6E0-28193-00-94	1-35	FN8-6131B-00	23-35
	26- 1	GE1-U7856-30	13- 3	61X-14283-01	3-21	61X-14711-01-9M	6- 1	626-28193-01-94	1-35	GH1-6141B-00	23-22
GJ8-U417C-00	25- 2	GH6-U8211-00	13-13	6R8-14284-00-98	3-25	61L-14712-00-9M	6- 8	6R7-41113-00-9M	6-33	GH1-6141D-01	23-28
	26- 2	GJ1-U8221-00	13-18	61X-14301-01	4- 1	6M6-14718-01-9M	6- 3	6R7-41114-A0	6-34	GH1-6142A-30	24- 1
GJ8-U417F-00	25- 3	61X-W0001-02	27- 1	6K8-14435-00	3-22	6R7-14721-00-9M	6-25		27-19	GH1-6143C-30	23-23
	26- 3	63N-W0001-20	27-21	6M6-14451-00	3-29	6M6-14739-A1	6- 4	6R7-42316-00	8-42	GJ3-6143G-00	23-17
GJ8-U417G-00	25- 4	61X-W0004-00	3-19	6K8-14471-00	4-14		27-14	6M6-44517-A1-5B	1-28	GH1-61433-00	23-31

NUMERICAL INDEX

PART NO.	REF. NO.	PART NO.	REF. NO.	PART NO.	REF. NO.	PART NO.	REF. NO.	PART NO.	REF. NO.	PART NO.	REF. NO.
EU0-61435-00	22-18	FN8-62884-00	14- 7	GJ1-6759B-00	20-43	6M6-81365-A0	10-16	90105-05M53	3-24	90159-06901	14-20
EU0-61438-00	22-19	GH1-62891-01	14-17	GJ1-6759C-00	20-44		27-20	90105-06900	21-19	90169-059U1	16- 7
GA7-6144D-00	24- 2	FN8-62892-00	14-19	GH1-6759D-00	19- 9	6M6-81800-10	11- 1	90105-10M45	6-44	90170-22M11	7-13
EU0-61446-00	22-16	GH1-6351R-20	16-26	EU0-67593-40	13-26	3AJ-81809-00	11- 2	90105-10M49	6-43	90179-06926	14- 2
GH1-61467-01	23-33	GH1-6351S-20	16-27	GDO-6761D-00	15- 1	6M6-81820-00	11- 7	90109-08M56	1- 6	90179-06947	9-33
GH1-61468-01	23-38	GH1-6354D-30	16-12	EW2-67618-00	15- 2	6M6-81826-00	11- 5	90109-10M47	10-13	90179-06959	15-37
GH1-61469-00	23-21	GJ1-63581-10	16-20	FN8-6771K-00	20-45	6M6-8183E-00	11-16	90116-08M14	3- 8	90179-08M15	3- 9
EU0-61486-00	22-17	GH1-63729-00	17- 3	FJ0-67713-00	20- 2	6M6-81830-00	11- 8	90119-059U4	21-16	90179-08927	14- 3
GH1-61541-02	23-20	GH1-63774-01	17-20	FJ0-67714-00	20- 4	6M6-81840-10	11- 3	90119-05935	14-13	90179-10925	9-29
EW2-61553-00	23- 2	GH1-6378C-00	14-28	FJ0-67716-00	20- 3	11H-81844-00	11- 4	90119-06MA1	6-37	90201-05925	7-23
GH1-61557-00	14-15	GH1-63850-00	17-10	GJ1-6773D-00	20-30	6M6-81844-00	12- 5	90119-06908	17-38		13- 5
EU0-61588-00	23-29	GH1-6516N-20	14- 4	GJ1-67743-00	20-40	26H-81847-00	11- 9		23-39		15-22
FN8-61651-00	16-16	GH1-65162-01	14-31	FJ0-67766-00	19- 6	6M6-81850-00	11- 6	90119-06914	17-11	90201-05928	23- 3
GH1-61651-00	16-18	GH1-6517G-04	14-23	EU0-67767-31	20-22	6M6-81865-00	11-18	90119-06929	9-34	90201-06M02	8-43
EU0-61652-00	15-26	GH1-6517J-01	14-25	FN8-67816-00	7-19	6M6-81866-00	11-17	90119-06940	14-14	90201-06M31	8-51
	16-17	GH1-6517K-01	14-26	EU0-67817-00	7-18	6M6-81921-00	12- 4		14-24	90201-065F3	15-36
	16-19	GJ8-6521B-00	18- 5	GH1-6782B-01	20-42	6G1-81941-10	12-12	90119-08M19	1-20		17-15
GH1-62127-00	18- 9	EW2-65772-00	21-18	GA7-67831-01	20-12	6M6-81952-01	12-13	90119-08M55	1- 4	90201-20M04	2-12
GH1-62128-20	14-21	GA7-65772-00	13-22	EU0-67832-00	20-13	6M6-81960-A0	12-14	90119-08M73	6-12	90201-24M02	2-19
GH1-6213F-01	18-11	EU0-65901-01	25-23	GA7-67833-00	20-14	EU0-82110-77	13- 1	90119-08038	1-30	90209-20M20	8-29
GH1-6213G-00	18-12		26-28	EU0-67834-00	20-17	62L-82117-20	12-37	90119-089U1	1-32	90267-409U5	18- 8
GH1-62139-00	18- 7	GJ1-6593H-00	17-37	EU0-67835-00	20-15	62T-82117-00	12-31	90119-089U5	9-27	90267-40935	20-18
EW2-62140-00	20-33	GA7-6593J-00	17-35	EU0-67835-30	17-32	62T-82117-10	12-33	90119-089U6	9-25	90267-48835	16-11
EW2-62142-00	20-34	GA7-65983-00	17-27	EU0-67839-00	17-33	6K8-82150-01	12- 8	90119-089U7	12-44	90267-489U1	7-21
GH1-62156-00	18- 3	GA7-65984-00	17-28		20-16	6G1-82151-00	12- 9		20-41		14-27
EW2-62150-00	18- 1	GJ1-66607-00	13-24	FJ0-67840-00	19- 2	62E-82351-00	12-17	90119-08903	23-30		17-39
FJ0-62158-00	19- 7	GJ1-6721B-00	1-31	FJ0-67841-01	19- 3	62E-82352-00	12-19		23-32		18- 4
EU0-62241-30	22-20	GDO-67249-00-05	9-32	GA7-67856-00	20-23	6R8-82361-00	12-28		23-34	90267-489U2	14- 8
EU0-62280-00	15-14	GDO-67249-00-10	9-32	EU0-67856-50	20-26	6K8-82370-00	12-26	90119-08904	1-29		14-16
EU0-62282-00	15-15	EW2-67250-01	23-11	GJ1-67856-00	20-27	62E-82371-10	12-41	90119-08907	9-31		20-37
EU0-62283-00	15-16	EU0-67252-02	22- 8	EU0-67869-00	20-19	62T-82553-01	12-30	90119-08925	23-42	90267-489U7	13-23
EU0-62285-01	15-17	EW2-67255-00	23-12	GH6-6815D-00	12-43	6R7-82560-00	12-34	90119-10M00	1-26		13-25
GH1-6251D-20	16- 8	EW2-67256-00	23-13	GJ8-6820A-00	13- 8	6R7-83623-40	12- 3	90119-10M02	1-25	90267-489U8	16-10
GH1-6251E-20	16- 9	EW2-67257-00	23-14	GH6-6822E-00	13-15	6R7-83623-50	12- 3	90119-10M03	1-27		16-15
GJ1-6252A-20	16- 2	EW2-67258-01	23-15	FJ0-68221-00	13-16	63N-83623-00	12- 3	90119-10M07	1-15	90267-48925	7-24
GH1-6266B-00	17-25	EW2-67259-01	23-16	FJ0-68221-30	13-17	62T-85515-00	10- 6	90119-10M56	1-14		13- 6
GJ1-6266B-00	13-14	EU0-67267-00	22-14	GJ8-68223-00	13- 9	62L-8552A-00-98	12- 1	90119-10M72	6-45		15-23
GH1-62663-01	9-28	EU0-67324-00	1-33	GJ8-6824C-00	13-12	6M6-8552E-00	12- 2	90119-109U8	9-30		18-10
FN8-6269B-00	15-25	EU0-67354-00-01	1-34	GJ1-6824D-00	22- 6	62T-85520-00	10- 3	90149-04902	14-22	90267-48951	18- 6
EU0-62694-00	22-15	EU0-67354-00-03	1-34	FK7-68310-06	23- 5	62T-85533-00	10- 4	90149-04903	24- 5		24- 3
GH1-6271B-20	17-12	EU0-67354-00-05	1-34	FK7-68312-02	23- 8	62T-85540-00	12-10	90149-04943	17-26	90280-16053	10-12
GH1-6271C-20	17-18	EU0-67354-00-10	1-34	FK7-68313-01	23- 9	62T-85550-00	10- 1	90149-05903	14- 5	90338-12081	17-24
GH1-6271D-20	17-19	EU0-67354-00-20	1-34	EW2-68348-00	23- 6	62T-85560-00	10- 2	90149-05959	23- 4	90340-08M04	6-10
EU0-62720-31	17-29	GJ1-6753B-02	21-10	GH1-6883N-50	15-31	62E-85570-00	12-16		24- 4	90380-12M29	1- 3
EU0-62721-31	17-30	GA9-67565-00	21-14	GH1-6883P-50	15-32	62E-85570-10	12-39	90149-05984	13-19		10-15
GJ8-6273C-00	9-22	GH6-67577-01	21- 3	GH1-6883T-00	15-34	6M6-85580-00	10- 5		14- 6	90387-06M60	8- 2
GJ1-62733-00	9-26	GJ1-67578-10	15- 9	6M6-8132W-00	12- 6	90101-06M04	8-40	90159-05900	23-19	90387-06914	17-17
GJ1-62840-00	14-10	GJ1-67578-20	22- 7	6R8-81337-00-9M	10-14	90105-05M46	3-23	90159-06901	14-18	90387-06916	15-33

NUMERICAL INDEX

PART NO.	REF. NO.	PART NO.	REF. NO.	PART NO.	REF. NO.	PART NO.	REF. NO.	PART NO.	REF. NO.	PART NO.	REF. NO.
90387-08M06	8-55	90465-11M10	7-11	90601-20007	18-13	92995-08600	9-10	95380-08700	4- 8	97980-06116	17- 4
90387-08M08	8-47		8-36	90601-20015	7-17	93101-25M50	8-22	95380-14700	21-11	98580-03008	23- 7
90430-08020	6-11		8-38	90604-80757	21- 6		27-30	95720-05300	9-24	98580-04008	10- 9
	27-16		9-18	90604-80758	21- 7	93101-25M55	9-12		14-12	98580-04010	7-14
90430-13909	15-12		12-18	90604-80759	15-10		27-27		15-20	98580-05016	3-30
	21- 8		12-20	90604-80775	15-11	93101-25M56	9-16	95720-06300	14-30	98580-05525	23-10
90445-07M19	1-21		12-27	90699-36U01	22- 5		27-28		16- 4	98580-06016	10-10
90445-07M87	5- 5		12-42	91490-16010	20-10	93101-36M46	2- 7		17-16		12-24
	5- 7		15-27	91790-05040	20- 8		27- 5		22- 4	98780-04015	1-12
90445-09M21	9-19		18- 2	92990-04600	7-15	93102-18M35	8- 6		23-26	98780-04535	17-36
90445-09901	19-10		19- 8	92990-05200	15-19		27-22	95720-08300	15-29	98780-05512	9-23
90445-09905	20-38		20-24	92990-05600	3-31	93102-25M34	8-21	95720-10300	17-22	98980-06025	17-13
90445-10M30	7- 1		20-25		14-11		27-29		23-37		
90445-10M48	3-13		20-29		20- 9	93102-36M33	2- 6	97013-06020	6-29		
90445-10M70	7- 8		20-39	92990-06200	14-29		27- 4	97013-06025	6-13		
90445-10M71	7- 6		21-13		15-35	93103-32M01	2- 8	97013-08025	6-15		
90445-10M72	7-10	90465-13M11	12-32		16- 3		27- 6	97013-08035	6- 6		
90445-10M92	7- 2		12-38		17-14	93210-17MA4	9- 5		11-12		
90445-11M34	5-12		15- 7		23-27		27-25	97013-08040	11-10		
90445-11903	20- 5	90467-06016	1-22	92990-06600	3-16	93210-35M72	9- 7	97014-06035	3-15		
90445-14M17	8-17	90467-08M10	13- 2		5- 4		27-26	97080-06030	23-25		
90445-14M24	8-37	90467-11044	20- 7		6-14	93210-46M16	8-25	97090-06016	17- 5		
90445-14M25	6-22	90480-06M43	12-23		6-30		27-31	97095-06016	6-35		
90445-14M26	21-20		12-40		6-36	93211-03902	17-31		8-26		
90445-14M29	6-18	90480-06M46	8- 3		8-10	93305-30601	2- 2		12-35		
90445-14M33	6-20	90501-14M73	11-21		8-27	93306-205U0	8-20	97095-06018	9- 2		
90445-19M06	15- 8	90560-22281	23-18		8-34	93306-205U6	9-14	97095-06020	8-33		
90445-19M07	15- 5	90600-913U2	13-20		8-50	93306-307U3	2- 3	97095-06025	8- 9		
90446-07M35	5- 6	90600-91736	7-22		9- 3	93310-320U2	2-13		10-18		
90446-07M36	5- 8		13- 4		10-11	93430-47M04	9-13	97095-06035	5- 3		
90446-20M31	6-24		15-21		10-19	93440-25M08	11-19		8-49		
90450-14M05	6-23	90600-918U3	20-31		11-22	93440-80023	2- 4	97095-08018	8-45		
	8-18		22- 9		12-22	93450-18M06	11-20	97095-08020	8-53		
	21-22	90601-110UC	21- 5		12-25	93450-21053	2-14	97095-08025	9- 9		
90460-64M15	6-47	90601-11062	20- 6	92990-08100	4- 7	93603-10049	1- 8	97595-06520	3-28		
90460-70M16	6-41	90601-118UF	21- 9	92990-08200	15-30	93604-07141	1- 9	97595-06525	8- 4		
90460-90M11	6-40	90601-142U6	23-24	92990-08600	6- 7	93606-12019	1- 7	97780-04110	17-34		
90464-06M29	12-11	90601-155U4	20-21		6-16		8-14	97780-40116	13-21		
90464-10M38	3-17	90601-162U5	20-11		11-11		8-19	97780-50520	13-10		
90465-08M37	5-11		20-46		11-13		8-39	97780-50612	15- 3		
90465-08028	12-15	90601-168U7	21- 4	92990-10200	17-21		9-11	97780-60116	20-32		
90465-11M10	3-14	90601-200U1	7-20		23-36		10-17		22-10		
	5-10		15- 4	92990-14200	21-12	94701-00041	12-29	97780-60525	12- 7		
	5-13		15-13	92995-06100	11-14	94702-00195	12-29	97880-05020	15-18		
	6-21	90601-20006	7-25		12-36	95380-06700	8-44	97880-06030	12-21		
	7- 3		13- 7		17- 6		8-52	97902-04122	10- 8		
	7- 7		13-11	92995-08600	8-46		11-15	97902-05125	10- 7		
	7- 9		15-24		8-54		15-38	97980-05330	4- 9		

