

YAMAHA

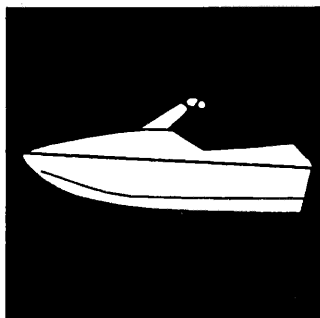

**PARTS
CATALOGUE**

SUPERJET

SJ700AW

(GM69, GM6A, GM6C)

MJ-700SJ'98

(GM6B)

YAMAHA
GENUINE
Parts & Accessories

18GM6-100E1

FOREWORD

This Parts Catalogue is related to the parts for the model(s) in the below frame. When you are ordering replacement parts, please refer to this Parts Catalogue and quote both part numbers and part names correctly.

SJ700AW(GM69, GM6A, GM6C), MJ-700SJ'98(GM6B)

1. Modifications or additions which have been made after issue of the Parts Catalogue will be announced in the Yamaha Parts News. It is advisable that you make necessary corrections to the Parts Catalogue according to the Yamaha Parts News.

2. Abbreviations

The following abbreviations are used in this Parts Catalogue.

- "UR" Use specified parts number.
- "UN" Use as many as needed.
- "AP" Alternate Parts
- "LM" Local Made (Parts need to be ordered locally)
- "F#" Frame No. (Applicable machine No.)

3. Parts, which are to be supplied in an assembly, are listed with a dot (.) in front of the part name as shown below.

The numeral appearing to the right of each component part indicates the quantity of parts for each assembly unit.

EXAMPLE

PART NO.	DESCRIPTION	Q'TY	REMARKS
EU0-62280-00	DRAIN PLUG ASSY	2	
EU0-62282-00	. PLUG, DRAIN	1	

4. Applicable Serial No. and Color Code

① Hull Serial No.	(GM69)	GM6-902684	~
	(GM6A)	GM6-911831	~
	(GM6B)	GM6-0301701	~
	(GM6C)	GM6-900934	~
② Engine Serial No.		64V-006294	~

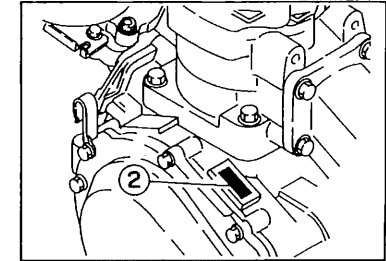
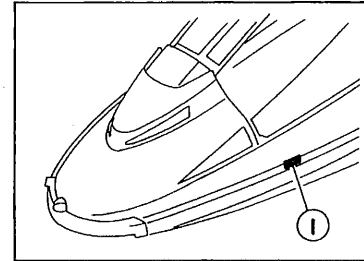

Color Code	Color Name	Abbreviation
0240	PURE WHITE	PURW

5. Note that the illustrations are for reference in finding parts numbers, not to be used for assembling. When assembling, please use the applicable service manual.

6. A part with "YMUS" in the remarks column can be obtained from YMUS(USA) and not from YAMAHA MOTOR CO.,LTD (JAPAN).

EXAMPLE

PART NO.	DESCRIPTION	QTY	REMARKS
EW2-U5160-00	ENGINE HATCH COMP.	1	YMUS
90601-168U7	BAND, HOSE	1	YMUS

ADDRESS:

YAMAHA MOTOR CORPORATION U.S.A.
 PARTS & ACCESSORY DIV.
 6555 KATELLA AVENUE
 CYPRESS, CALIFORNIA 90630, U.S.A.

CONTENTS

Cylinder. Crankcase	B2 ~ B3
Crankshaft. Piston	B4
Intake	B5 ~ B6
Carburetor	B7 ~ B8
Exhaust 1	B9 ~ B10
Fuel	B11
Jet Unit 1	B12 ~ B13
Jet Unit 2	B14
Generator	B15
Starting Motor	C2
Electrical 1	C3 ~ C4
Electrical 2	C5
Engine Hatch	C6 ~ C7
Hull. Deck	C8
Gunwale. Mat	C9
Fuel Tank	C10 ~ C11
Exhaust 2	C12
Control Cable	C13
Steering 1	C14 ~ C15
Steering 2	D2 ~ D3

Graphic. Tool	D4
Imprtant Labels	D5
Repair Kit 1	D6
Repair Kit 2	D7

INDEX

Numerical Index	M1 ~ M3
-----------------------	---------

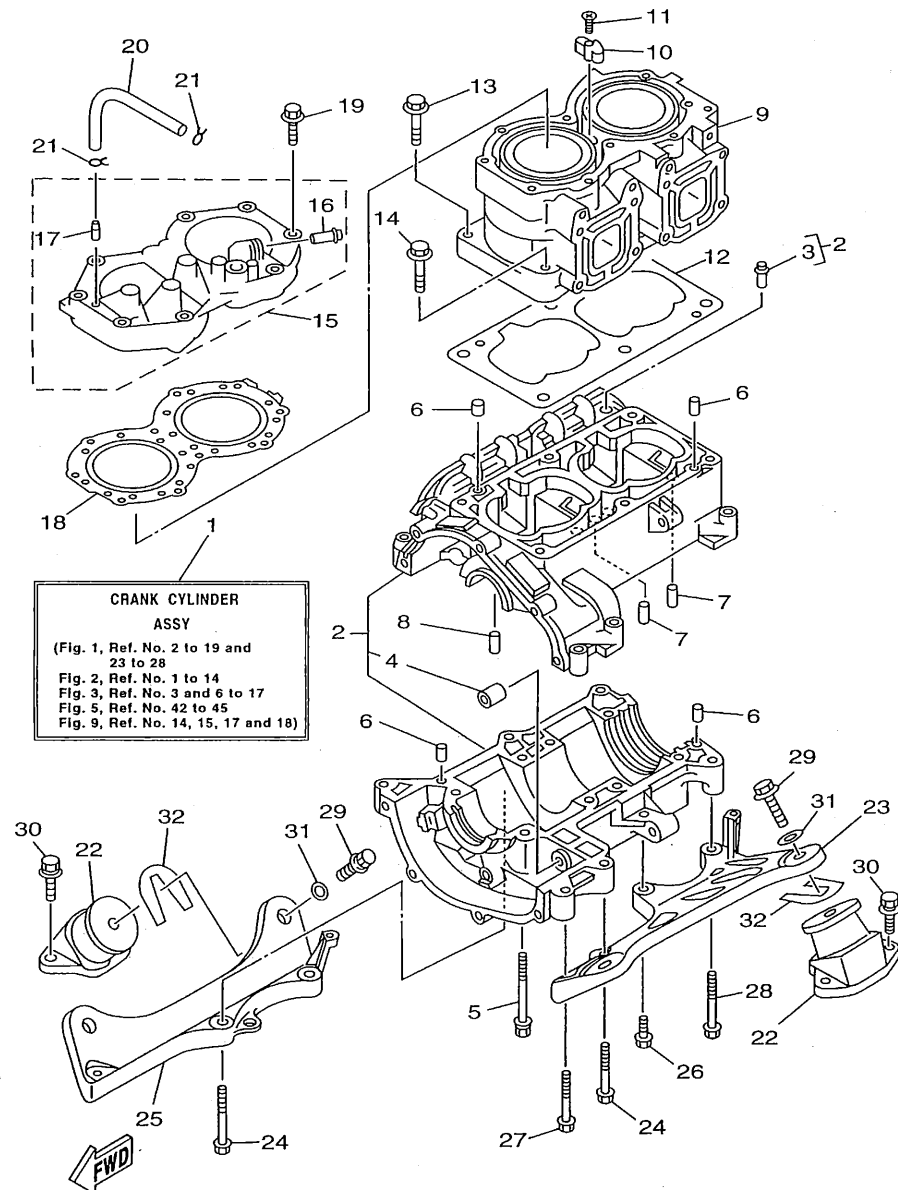

CRANK CYLINDER ASSY
 (Fig. 1, Ref. No. 2 to 19 and 23 to 28)
 Fig. 2, Ref. No. 1 to 14
 Fig. 3, Ref. No. 3 and 6 to 17
 Fig. 5, Ref. No. 42 to 45
 Fig. 9, Ref. No. 14, 15, 17 and 18)

GM69100-8010

FIG. 1 CYLINDER. CRANKCASE

REF. NO.	PART NO.	DESCRIPTION	Q'TY	REMARKS
1	64V-W0090-00-8P	CRANK CYLINDER ASSY	1	
2	62T-15100-00-94	CRANKCASE ASSY	1	
3	62T-14251-00	.NIPPLE	1	
4	90380-12M29	.BUSH, SOLID	1	
5	90119-08M55	BOLT, WITH WASHER	8	
6	93606-12019	PIN, DOWEL	4	
7	93603-10049	PIN, DOWEL	4	
8	93604-07141	PIN, DOWEL	1	
9	61X-11311-00-94	CYLINDER 1	1	
10	6E5-11325-00	ANODE	1	
11	98780-04015	SCREW, FLAT HEAD	1	
12	6M6-11351-A2	GASKET, CYLINDER	1	
13	90119-10M56	BOLT, WITH WASHER	4	
14	90119-10M07	BOLT, WITH WASHER	2	
15	64U-11111-00-94	HEAD, CYLINDER 1	1	
16	6K8-51129-00	.NIPPLE	1	
17	6R7-14485-00	.PIPE, JOINT	1	
18	62T-11181-00	GASKET, CYLINDER HEAD 1	1	
19	90119-08M19	BOLT, WITH WASHER	10	
20	90445-07M19	HOSE	1	
21	90467-06016	CLIP	2	
22	6R7-44517-00-9M	MOUNT RUBBER	4	
23	6R7-21415-01-94	BRACKET, FRONT UPPER 1	1	
24	90119-10M02	BOLT, WITH WASHER	4	
25	6R7-21425-01-94	BRACKET, REAR UPPER 1	1	
26	90119-10M00	BOLT, WITH WASHER	1	
27	90119-10M01	BOLT, WITH WASHER	1	
28	90119-10M03	BOLT, WITH WASHER	1	

FIG. 1 CYLINDER. CRANKCASE

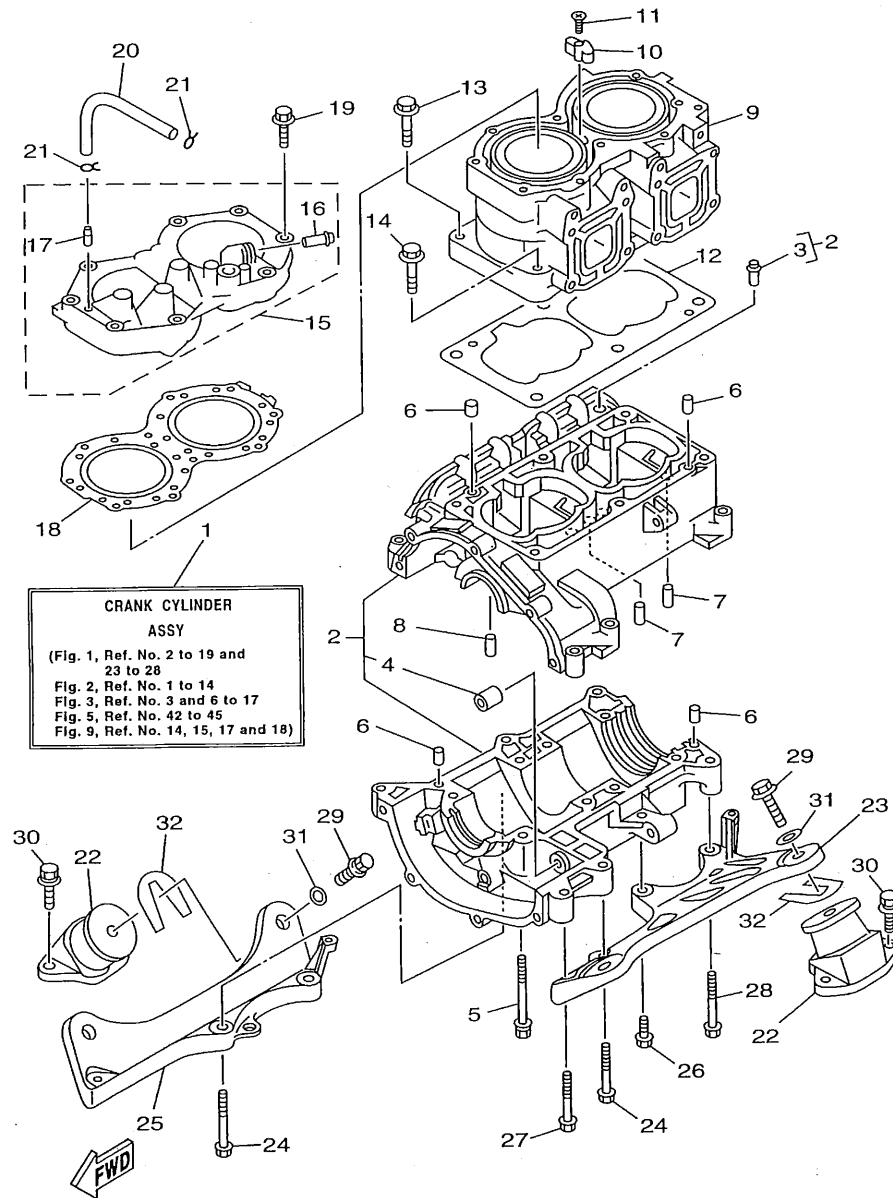

REF. NO.	PART NO.	DESCRIPTION	Q'TY	REMARKS
29	90119-08904	BOLT, WITH WASHER	4	
30	90119-08038	BOLT, WITH WASHER	8	
31	EU0-67324-00	PLATE	4	
32	EU0-67354-00-01	SHIM (T=0.1)	10	UR
	EU0-67354-00-02	SHIM (T=0.2)	10	UR
	EU0-67354-00-03	SHIM (T=0.3)	10	UR
	EU0-67354-00-05	SHIM (T=0.5)	10	UR
	EU0-67354-00-10	SHIM (T=1.0)	10	UR
	EU0-67354-00-20	SHIM (T=2.0)	10	UR

GM69100-8010

B3

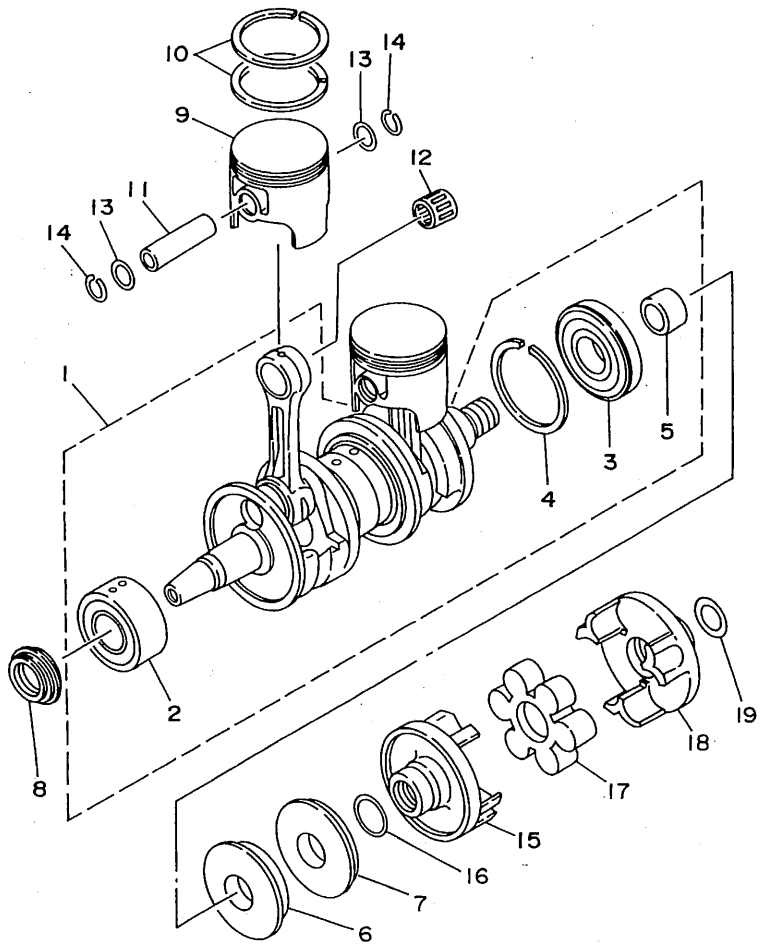

FIG. 2 CRANKSHAFT. PISTON

REF. NO.	PART NO.	DESCRIPTION	Q'TY	REMARKS
1	61X-11400-03	CRANKSHAFT ASSY	1	
2	93305-30601	.BEARING	1	
3	93306-307U3	.BEARING	1	
4	93440-80023	.CIRCLIP	1	
5	62T-45526-00	.COLLAR, DRIVE SHAFT	1	
6	93102-36M33	OIL SEAL	1	
7	93101-36M46	OIL SEAL	1	
8	93103-32M01	OIL SEAL	1	
9	61X-11631-00-93	PISTON (STD)	2	
	61X-11635-00	PISTON (0.25MM O/S)	2	AP
	61X-11636-00	PISTON (0.50MM O/S)	2	AP
10	61X-11603-00	PISTON RING SET (STD)	4	
	61X-11604-00	PISTON RING SET (0.25MM O/S)	2	AP
	61X-11605-00	PISTON RING SET (0.50MM O/S)	2	AP
11	61X-11633-00	PIN, PISTON	2	
12	93310-320U2	BEARING, CYLINDRICAL	2	
13	90201-20M04	WASHER, PLATE	4	
14	93450-21053	CIRCLIP	4	
15	6M6-45813-31-8P	FLANGE, COUPLING	1	
16	62T-45127-00	SEAL	1	
17	61X-4581J-00	RUBBER SHAFT COUPLING	1	
18	6M6-45813-21-9M	FLANGE, COUPLING	1	
19	90201-24M02	WASHER, PLATE	1	



GHID200-6020

B4

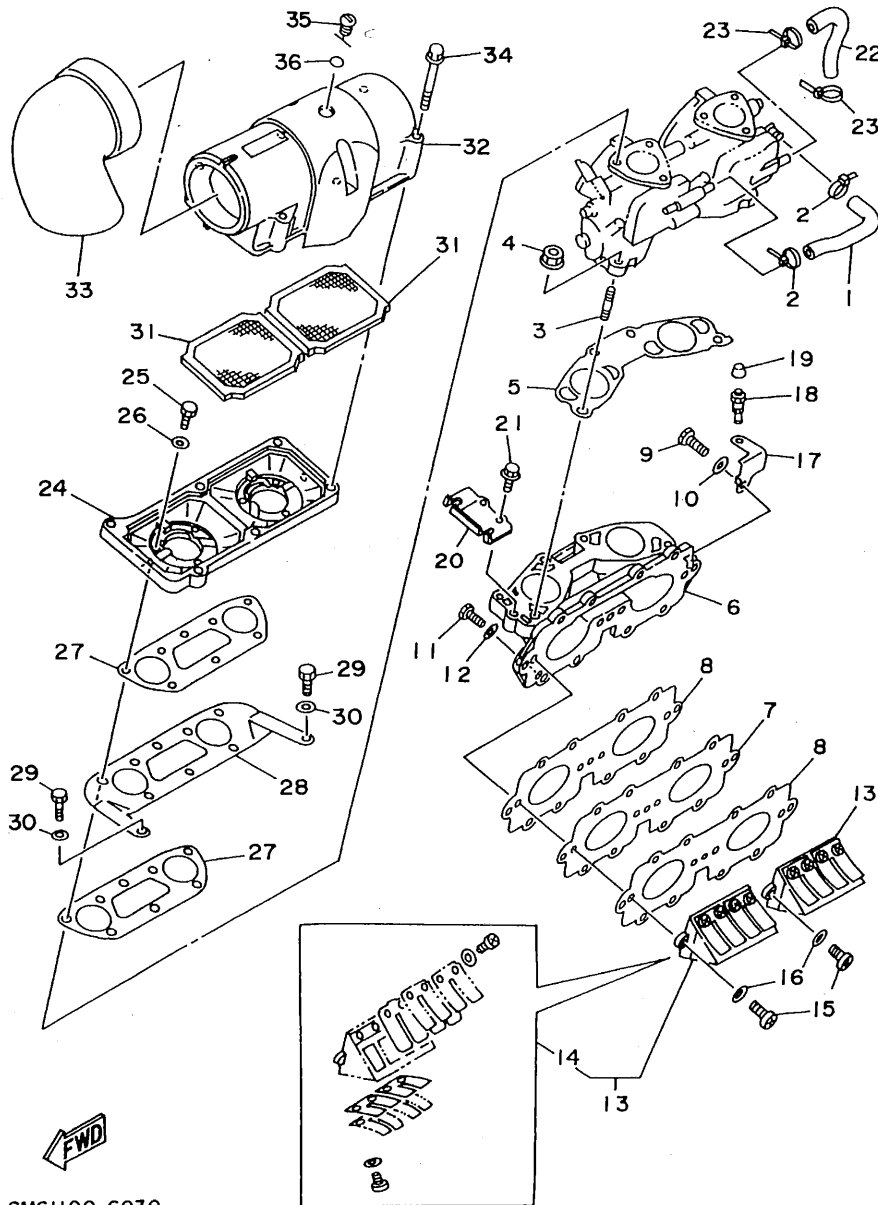

GM61100-6030

FIG. 3 INTAKE

REF. NO.	PART NO.	DESCRIPTION	Q'TY	REMARKS
1	62T-24313-01	PIPE 3	1	
2	90465-11M10	CLAMP	2	
3	90116-08M60	BOLT, STUD	4	
4	90179-08M15	NUT	4	
5	62T-13556-00	GASKET, MANIFOLD	1	
6	62T-13555-00-8P	MANIFOLD, INTAKE	1	
7	62T-13624-00	PLATE, REED VALVE	1	
8	62T-13566-00	GASKET	2	
9	97013-06035	BOLT	3	
10	92903-06600	WASHER, PLATE	3	
11	97013-06025	BOLT	8	
12	92903-06600	WASHER, PLATE	8	
13	62T-13610-00	REED VALVE ASSY	2	
14	62T-W0004-00	.REED SET	1	
15	97880-05016	SCREW, PAN HEAD	4	
16	92990-05600	WASHER, PLATE	4	
17	62T-14243-01	PLATE	1	
18	61L-5169A-00	NIPPLE, GREASE	1	
19	663-45119-00	CAP, GREASE NIPPLE	1	
20	62T-14527-02	PLATE	1	
21	97513-06516	BOLT, WITH WASHER	2	
22	62T-24314-01	PIPE 4	1	
23	90465-11M10	CLAMP	2	
24	62T-14284-10-98	COVER, CARBURETOR 2	1	
25	97013-06020	BOLT	6	
26	92903-06600	WASHER, PLATE	6	
27	62T-13674-00	GASKET, AIR COOLER COVER 1	2	
28	62T-14255-00	PLATE	1	

B5

FIG. 3 INTAKE

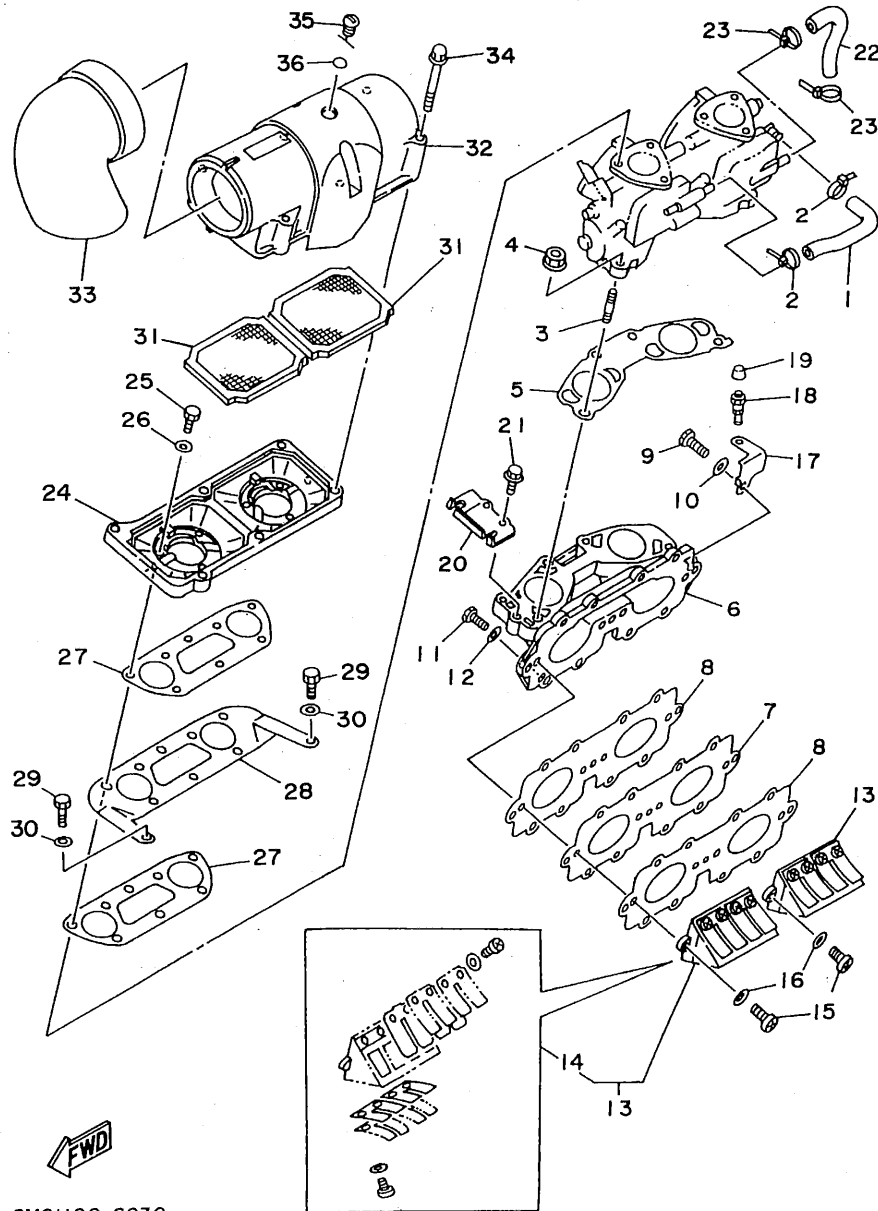

GM61100-6030

REF. NO.	PART NO.	DESCRIPTION	Q'TY	REMARKS
29	97013-06012	BOLT	2	
30	92903-06600	WASHER, PLATE	2	
31	62T-14451-00	ELEMENT, AIR CLEANER	2	
32	62T-14283-00	COVER, CARBURETOR 1	1	
33	62T-14419-00	PIPE	1	
34	90119-05M02	BOLT, WASHER BASED	6	
35	62T-14435-00	GROMMET	1	
36	93210-13M63	O-RING	1	

B6

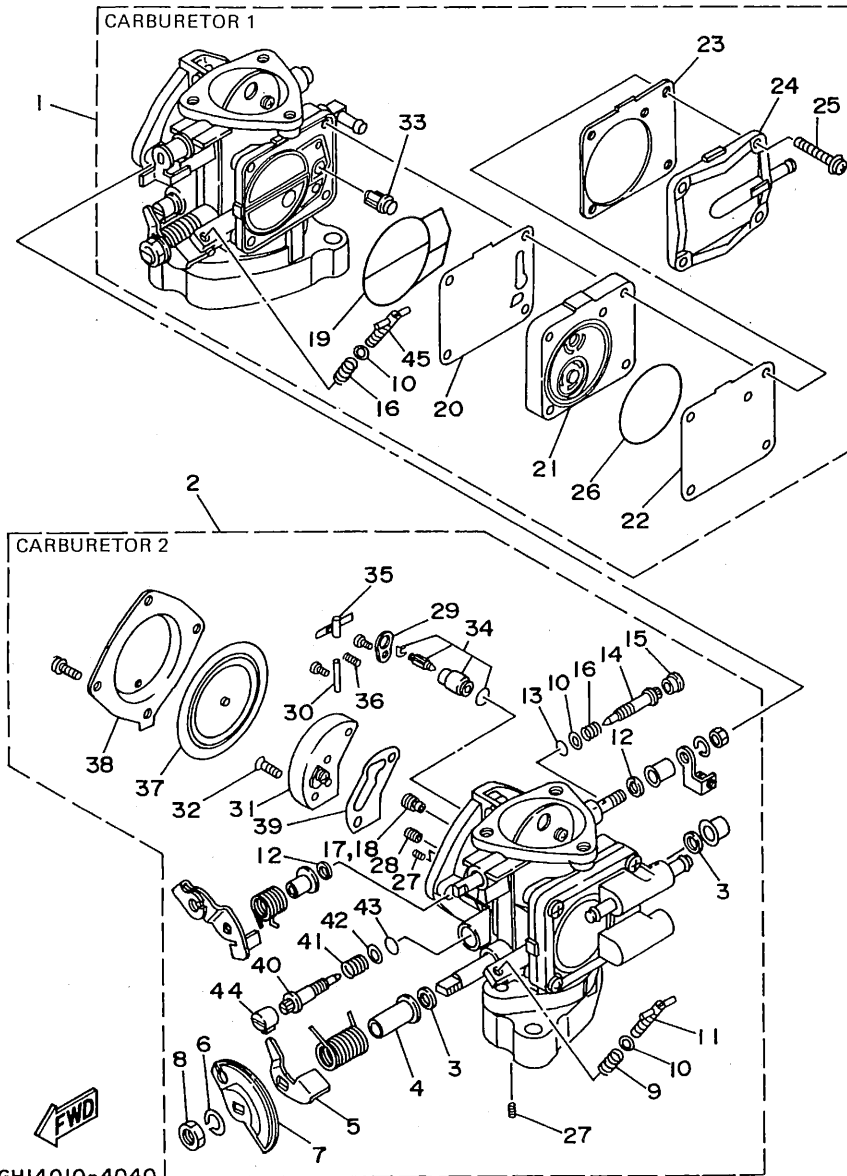
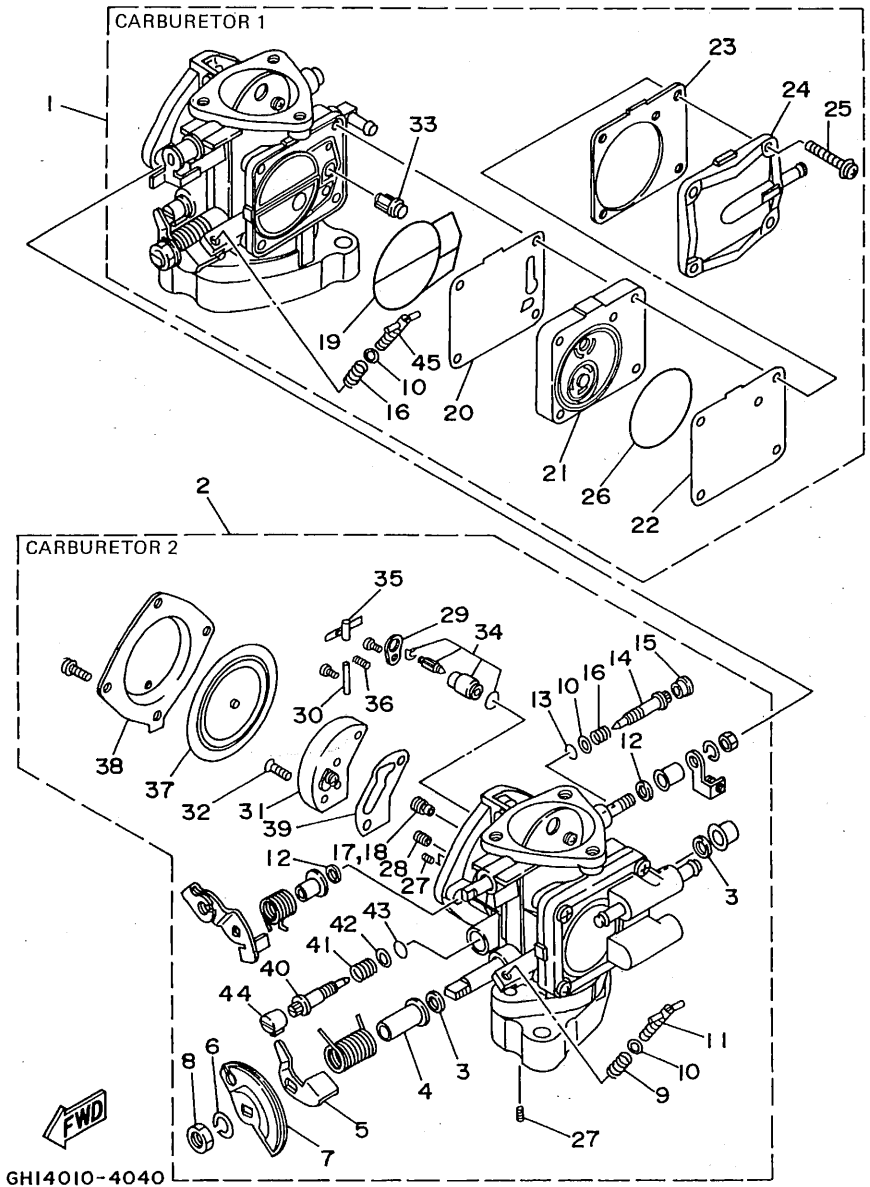

FIG. 4 CARBURETOR

REF. NO.	PART NO.	DESCRIPTION	Q'TY	REMARKS
1	64U-14301-00	CARBURETOR ASSY 1	1	
2	64U-14302-00	CARBURETOR ASSY 2	1	
3	6R7-14596-01	.WASHER	4	
4	6K8-14534-10	.COLLAR	2	
5	6K8-14926-10	.BRACKET, THROTTLE 1	1	CARBURETOR 2
6	92990-08100	.WASHER, SPRING	2	
7	6K8-14930-00	.THROTTLE SHAFT ASSY	1	CARBURETOR 2
8	95380-08700	.NUT	2	
9	6K8-14531-00	.SPRING, ADJUST SCREW	1	CARBURETOR 2
10	6K8-14559-00	.WASHER	4	
11	6M6-14521-00	.SCREW, ADJUST	1	CARBURETOR 2
12	6K8-14597-11	.WASHER	4	
13	6K8-14562-00	.O-RING	2	
14	63M-14946-00	.PLATE, NEEDLE FITTING	2	
15	6K8-14471-10	.CAP, CARBURETOR	2	
16	6K8-14533-00	.SPRING, ADJUST SCREW	3	
17	3G2-14231-26-A0	.JET, MAIN (#130)	1	CARBURETOR 1
18	3G2-14231-26-A0	.JET, MAIN (#130)	1	CARBURETOR 2
19	6K8-14564-00	.O-RING	2	CARBURETOR 1
20	6K8-24411-20	.DIAPHRAGM	1	CARBURETOR 1
21	6M6-24413-00	.BODY 2	1	CARBURETOR 1
22	6K8-24421-10	.VALVE, CHECK	1	CARBURETOR 1
23	6K8-24431-20	.GASKET, FUEL PUMP 1	1	CARBURETOR 1
24	6K8-24452-10	.COVER	1	CARBURETOR 1
25	97980-05330	.SCREW, WITH WASHER	4	CARBURETOR 1
26	6K8-14563-00	.O-RING	1	CARBURETOR 1
27	6K8-14521-10	.SCREW	4	
28	830-14231-14	.JET, MAIN (# 70)	2	

B7



GHI4010-4040

FIG. 4 CARBURETOR

REF. NO.	PART NO.	DESCRIPTION	Q'TY	REMARKS
29	6K8-14527-11	.PLATE	2	
30	6K8-14579-00	.PIN, FLOAT	2	
31	6R7-24412-01	.BODY 1	2	
32	6K8-14523-11	.SCREW, STOP	4	
33	6R7-14569-00	.STRAINER	2	
34	61X-14916-15	.NEEDLE	2	
35	6K8-14547-01	.ARM, FLOAT	2	
36	6R7-14253-00	.SPRING	2	
37	6R7-14541-00	.DIAPHRAGM, PUMP	2	
38	6R7-14542-00	.BODY, PUMP 1	2	
39	6K8-14536-11	.GASKET	2	
40	63M-14923-00	.SCREW, PILOT	2	
41	6K8-14589-00	.SPRING	2	
42	6K8-14537-00	.GASKET	2	
43	583-14561-00	.O-RING	2	
44	6K8-14481-10	.CAP, CARBURETOR	2	
45	6K8-14521-00	.SCREW, ADJUST	1	CARBURETOR 1

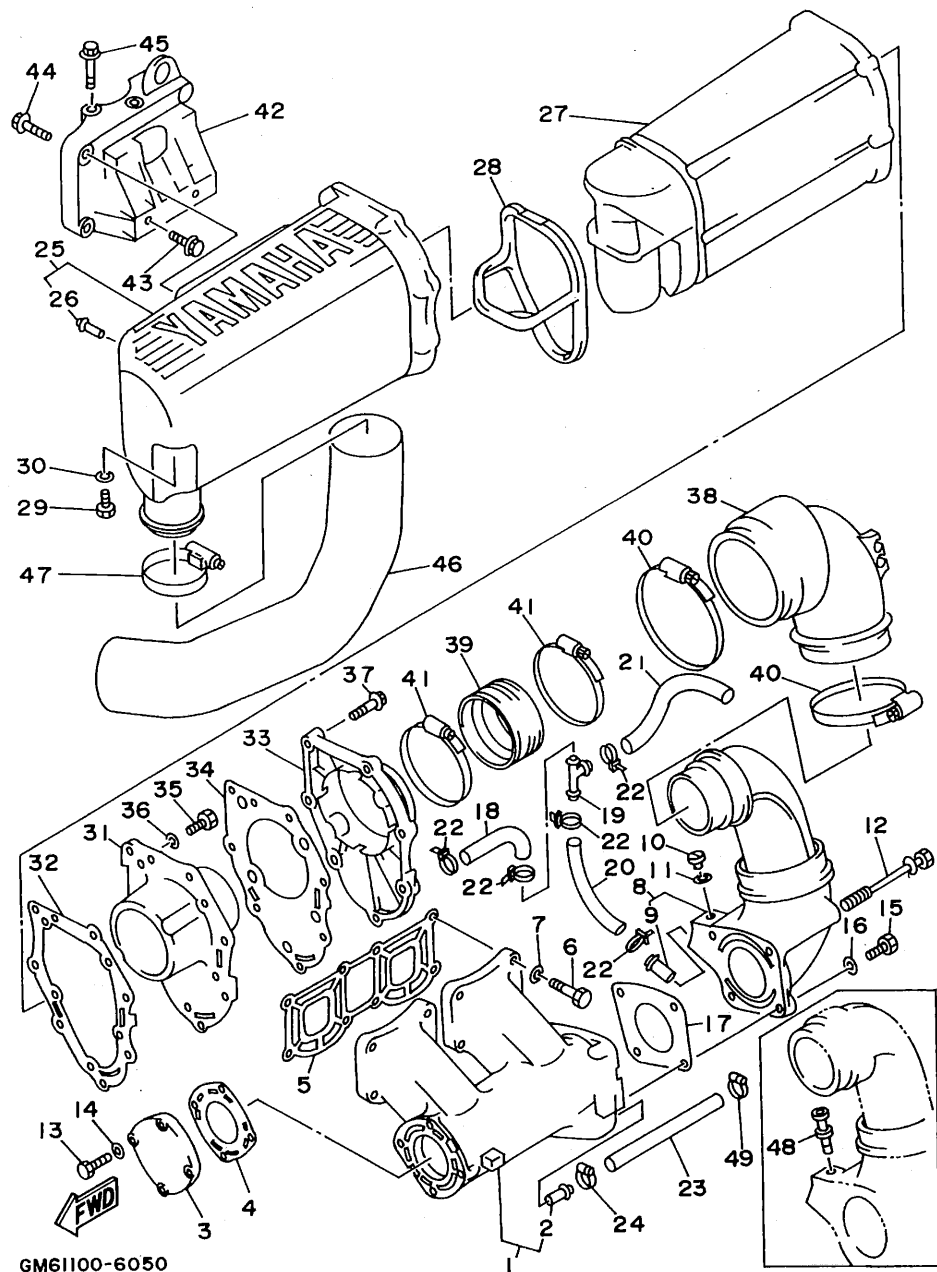

GM61100-6050

FIG. 5 EXHAUST 1

REF. NO.	PART NO.	DESCRIPTION	Q'TY	REMARKS
1	61X-14711-01-9P	MUFFLER 1	1	
2	6K8-51129-00	.NIPPLE	1	
3	6M6-14718-01-9P	PROTECTOR, MUFFLER 1	1	
4	6M6-14739-A1	GASKET, MUFFLER DAMPER 1	1	
5	61X-14613-A0	GASKET, EXHAUST PIPE	1	
6	97013-08035	BOLT	8	
7	92903-08600	WASHER, PLATE	8	
8	61L-14712-00-9P	RING, JOINT	1	
9	6K8-51129-00	.NIPPLE	1	
10	90340-08M04	PLUG, STRAIGHT SCREW	1	
11	90430-08020	GASKET	1	
12	90119-08M73	BOLT, WITH WASHER	2	
13	97013-06025	BOLT	4	
14	92903-06600	WASHER, PLATE	4	
15	97013-08025	BOLT	2	
16	92903-08600	WASHER, PLATE	2	
17	6R7-14749-A0	GASKET, MUFFLER DAMPER 2	1	
18	90445-14M29	HOSE	1	
19	6E5-24378-00	PIPE, JOINT 4	1	
20	90445-14M29	HOSE	1	
21	90445-14M33	HOSE	1	
22	90465-11M10	CLAMP	5	
23	90445-14M06	HOSE	1	
24	90450-14M05	HOSE CLAMP ASSY	1	
25	6R7-14721-00-9M	MUFFLER 2	1	
26	6R7-14485-00	.PIPE, JOINT	1	
27	6R7-14753-00-9M	SILENCER, EXHAUST	1	
28	6R7-15761-00	SEAL, RUBBER 1	1	

B9

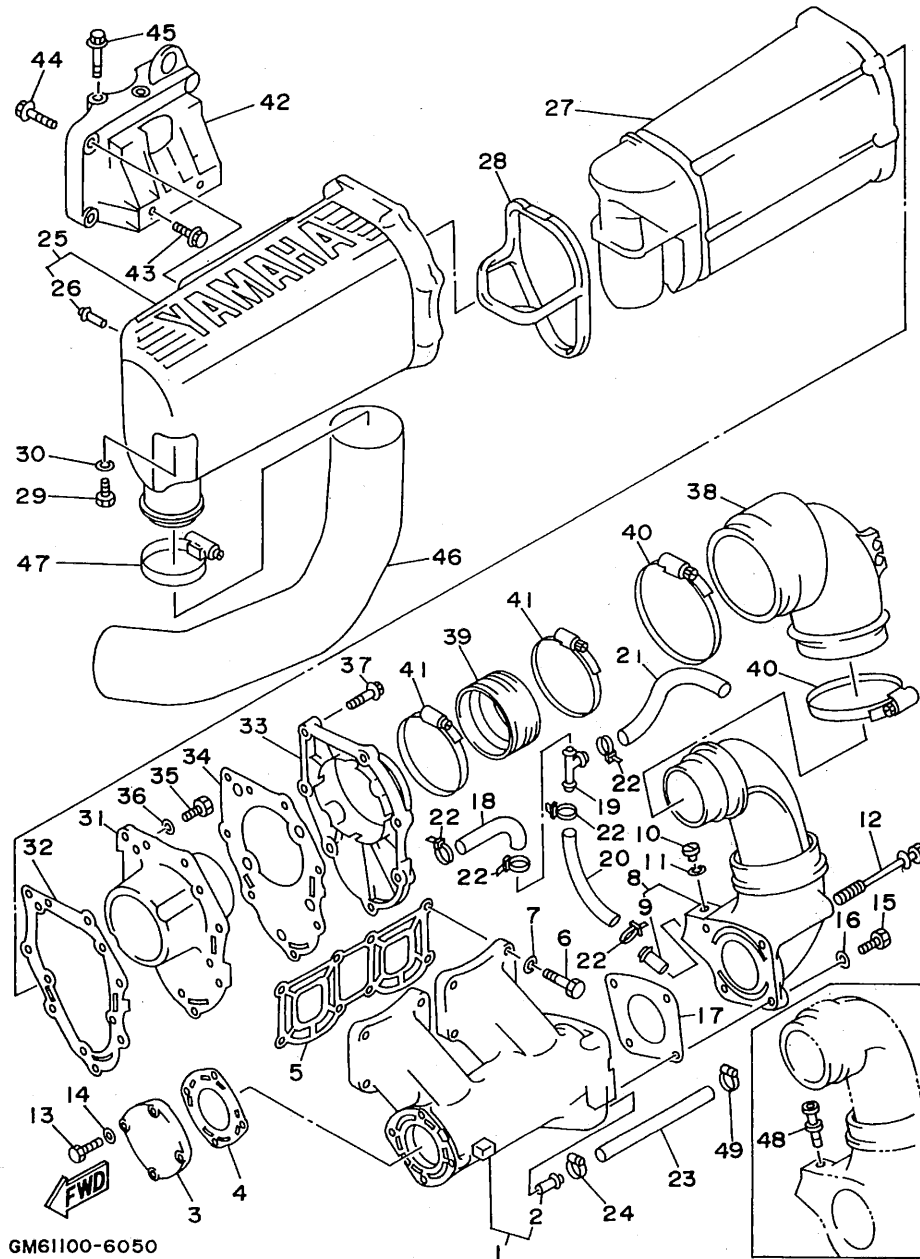

GM61100-6050

FIG. 5 EXHAUST 1

REF. NO.	PART NO.	DESCRIPTION	Q'TY	REMARKS
29	97013-06020	BOLT	1	
30	92903-06600	WASHER, PLATE	1	
31	6R7-14785-00-9M	DIFFUSER	1	
32	6R7-14755-A0	GASKET, SILENCER	1	
33	6R7-41113-00-9M	OUTER COVER, EXHAUST	1	
34	6R7-41114-A0	GASKET, EXHAUST OUTER COVER	1	
35	97095-06016	BOLT	5	
36	92995-06600	WASHER, PLATE	5	
37	90119-06MA1	BOLT, WITH WASHER	7	
38	61L-14615-A0	JOINT, EXHAUST 1	1	
39	61L-14625-A0	JOINT, EXHAUST 2	1	
40	90460-90M11	CLAMP, HOSE	2	
41	90460-70M16	CLAMP, HOSE	2	
42	6M6-14771-00-94	STAY, MUFFLER 1	1	
43	90105-10M49	BOLT, WASHER BASED	2	
44	90105-10M45	BOLT, WASHER BASED	3	
45	90119-10M72	BOLT, WITH WASHER	3	
46	64V-14752-00	PIPE, OUTLET	1	
47	90460-64M15	CLAMP, HOSE	1	
48	6E0-28193-00-94	PLUG, WATER CHECK	1	UR EXCEPT USA, JAPAN
	626-28193-01-94	PLUG, WATER CHECK	1	UR JAPAN
49	90601-11062	BAND, HOSE 11	1	

B10

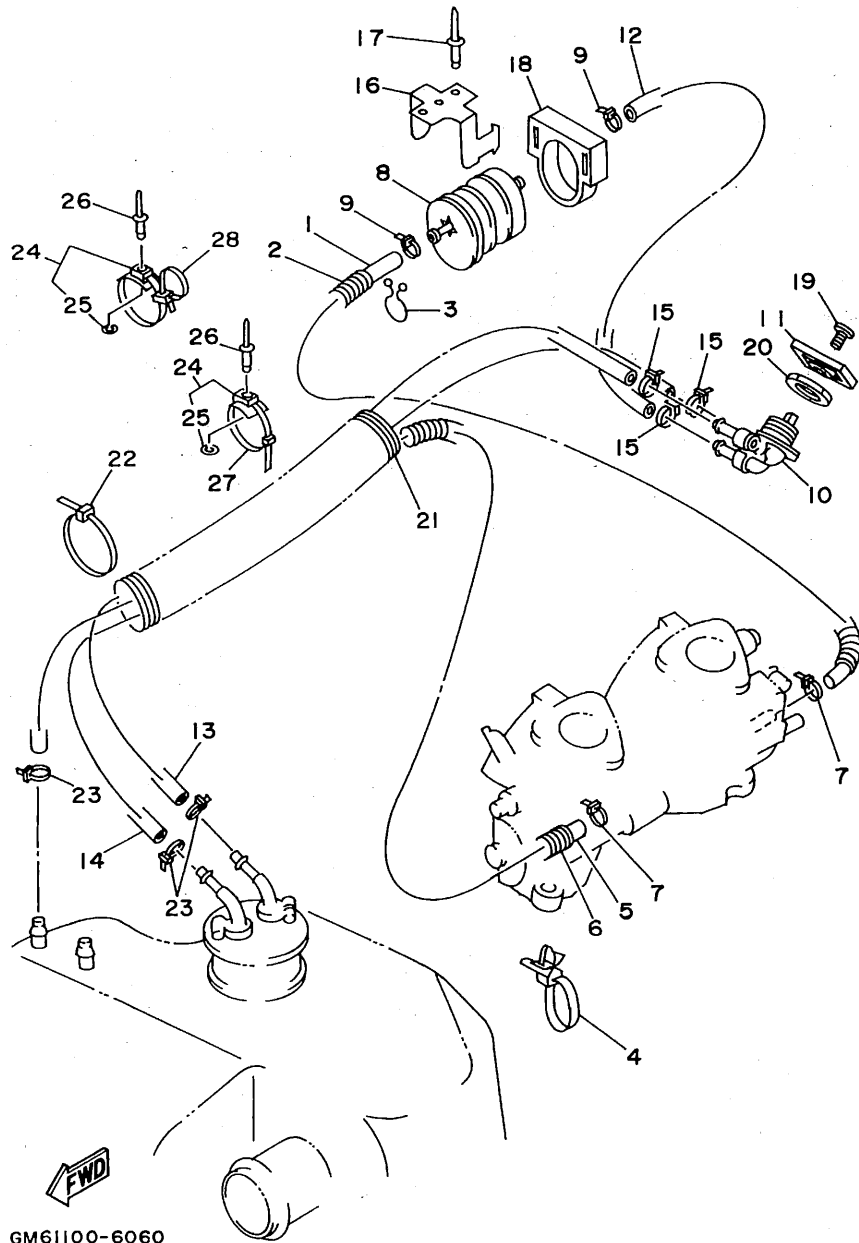

GM61100-6060

FIG. 6 FUEL

REF. NO.	PART NO.	DESCRIPTION	Q'TY	REMARKS
1	90445-10ME8	HOSE	1	
2	90446-14M23	HOSE	1	
3	90465-08M07	CLAMP	1	
4	90465-12M56	CLAMP	1	
5	90445-10MF1	HOSE	1	
6	90446-14M64	HOSE	1	
7	90465-11M10	CLAMP	2	
8	6K8-24560-10	FILTER ASSY	1	
9	90465-11M10	CLAMP	2	
10	6K8-24500-02	FUEL COCK ASSY 1	1	
11	6R7-24524-00	LEVER, COCK	1	
12	90445-10ME3	HOSE	1	
13	90445-10M98	HOSE	1	
14	90445-10ME4	HOSE	1	
15	90465-11M10	CLAMP	3	
16	EU0-67816-30	BRACKET, FUEL FILTER	1	
17	90267-48925	RIVET, BLIND	2	
18	EU0-67817-00	HOLDER	1	
19	98980-04008	SCREW, BIND	1	
20	90170-22187	NUT	1	
21	GM6-6773E-00	TUBE 2	1	
22	90601-20006	NYLON CLIP 1	1	
23	90465-11M10	CLAMP	3	
24	90600-91736	CLAMP	7	
25	90201-05925	WASHER, PLATE	1	
26	90267-48925	RIVET, BLIND	7	
27	90601-20006	NYLON CLIP 1	5	
28	90601-20016	NYLON CLIP 1	2	

B11

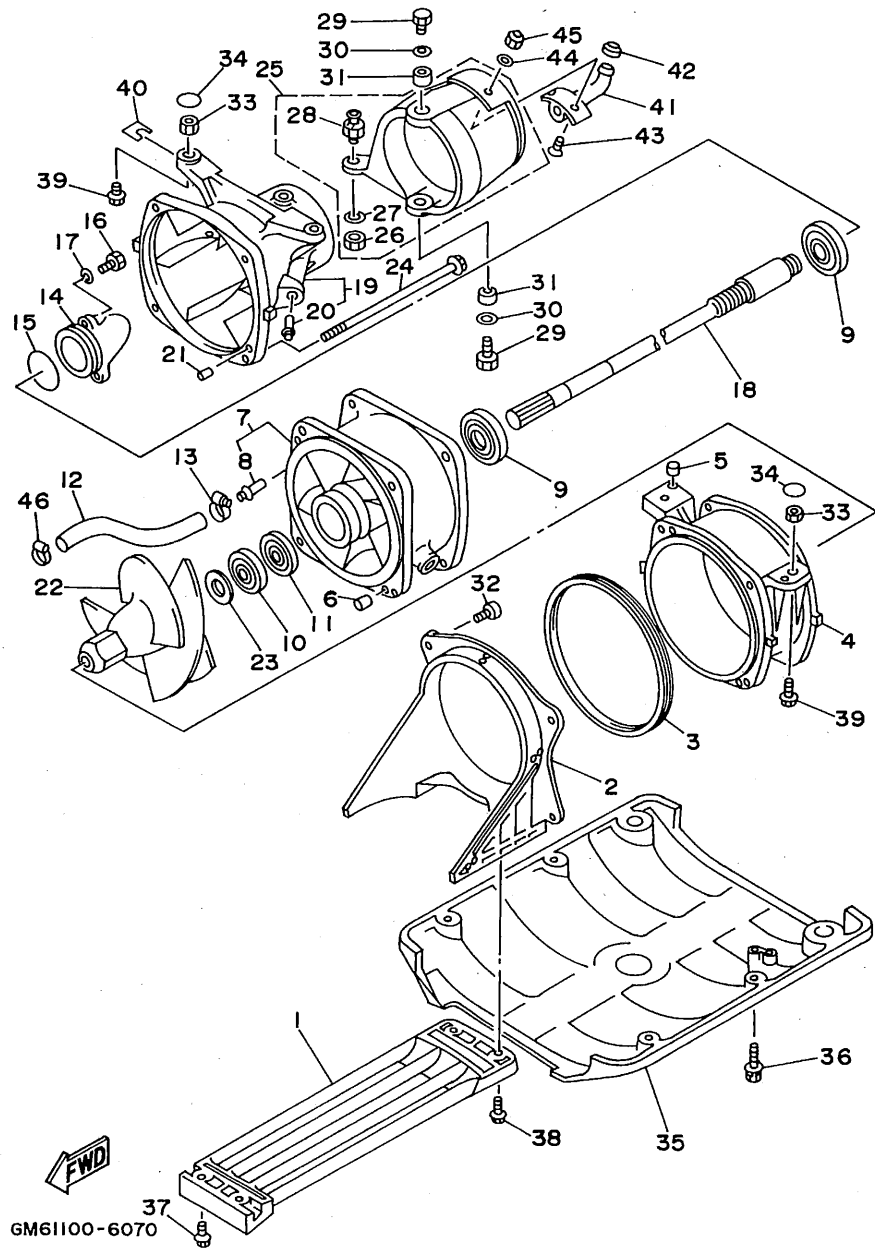

FIG. 7 JET UNIT 1

REF. NO.	PART NO.	DESCRIPTION	Q'TY	REMARKS
1	6R7-51333-00	SCREEN, INTAKE	1	
2	6R7-51311-00	DUCT, INTAKE	1	
3	6R7-51117-01	PACKING	1	
4	6R7-51312-00-94	HOUSING, IMPELLER	1	
5	93606-07M17	PIN, DOWEL	2	
6	93606-12019	PIN, DOWEL	2	
7	62T-51315-01-94	DUCT, IMPELLER	1	
8	6K8-51129-00	.NIPPLE	1	
9	93306-205U0	BEARING	2	
10	93102-25M34	OIL SEAL	1	
11	93101-25M50	OIL SEAL	1	
12	90445-14M12	HOSE	1	
13	90450-14M05	HOSE CLAMP ASSY	1	
14	62T-51326-00	CAP	1	
15	93210-46M16	O-RING	1	
16	97095-06020	BOLT	3	
17	92990-06600	WASHER, PLATE	3	
18	6R7-45511-01	SHAFT, DRIVE	1	
19	6R7-51318-05-94	NOZZLE	1	
20	6K8-51129-00	.NIPPLE	1	
21	93606-12019	PIN, DOWEL	1	
22	6R7-51321-00-94	IMPELLER	1	
23	62T-51348-00	SPACER	1	
24	90119-06M70	BOLT, WITH WASHER	4	
25	61L-51313-00	NOZZLE, DEFLECTOR	1	
26	95380-06700	.NUT	1	
27	90201-06M02	.WASHER, PLATE	1	
28	6R7-42316-00	.BOLT, JOINT	1	

B12

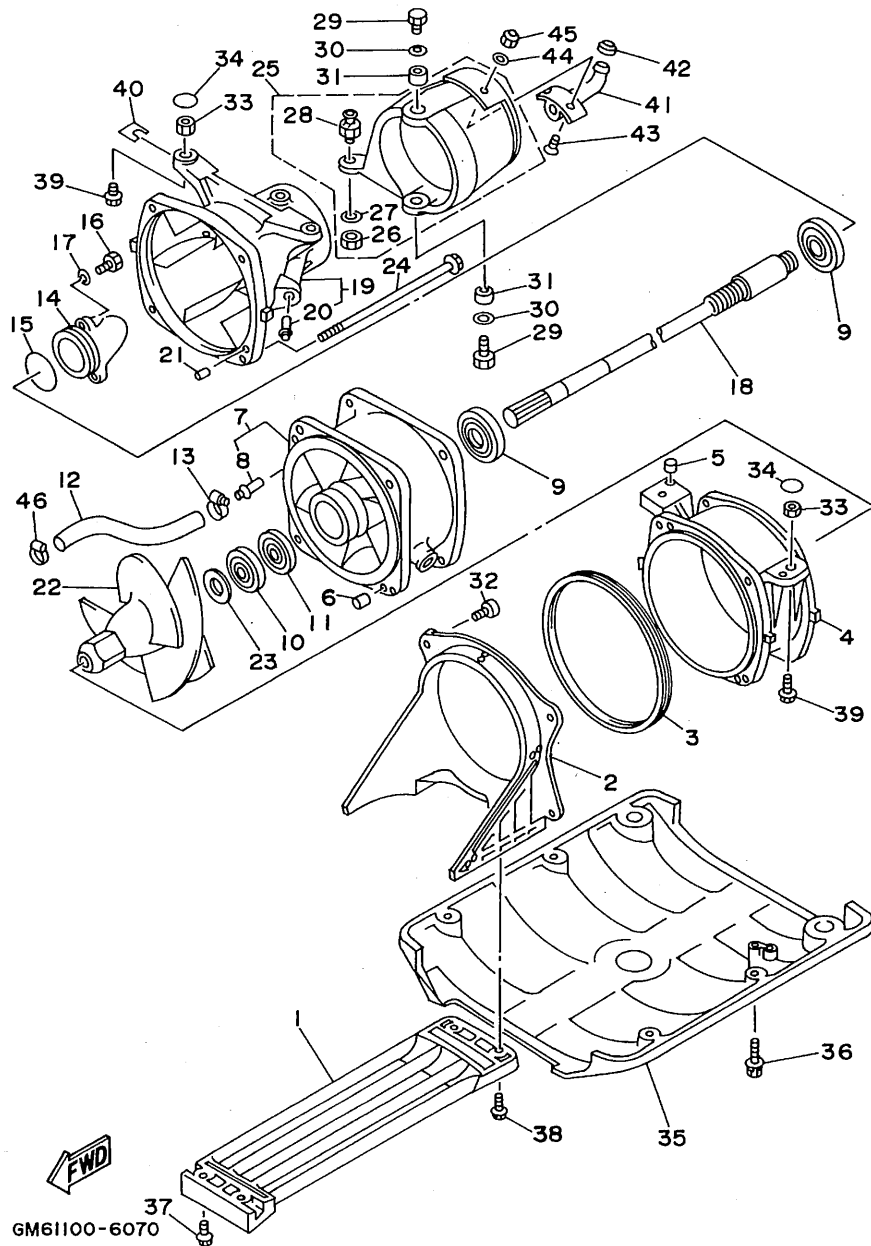
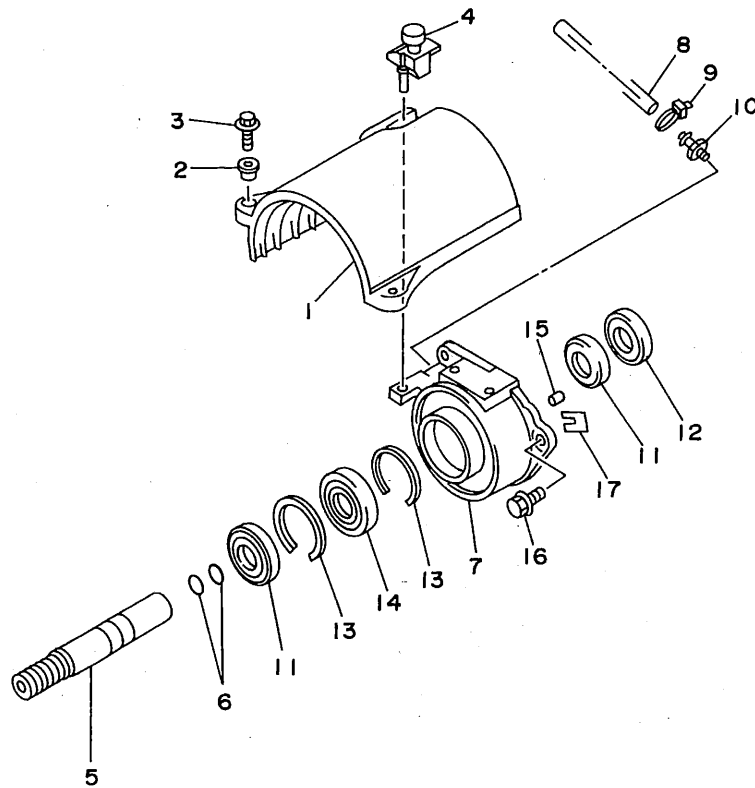

FIG. 7 JET UNIT 1

REF. NO.	PART NO.	DESCRIPTION	Q'TY	REMARKS
29	97095-08018	BOLT	2	
30	92995-08600	WASHER	2	
31	90387-08M06	COLLAR	2	
32	97780-60120	SCREW, TAPPING	4	
33	90179-10925	NUT	4	
34	EW2-62723-30	SEAL	4	
35	EW2-62731-01	PLATE 2	1	
36	90119-08943	BOLT, WITH WASHER	4	
37	90119-06915	BOLT, WITH WASHER	2	
38	90119-06908	BOLT, WITH WASHER	2	
39	90119-10948	BOLT, WITH WASHER	4	
40	EW2-67354-00-01	SHIM (T=0.1)	10	UR
	EW2-67354-00-03	SHIM (T=0.3)	10	UR
	EW2-67354-00-05	SHIM (T=0.5)	10	UR
	EW2-67354-00-10	SHIM (T=1.0)	10	UR
41	EU0-62693-02	SPOUT	1	
42	EU0-62695-00	CAP, SPOUT	1	
43	98780-05016	SCREW, FLAT HEAD	2	
44	92990-05200	WASHER, PLAIN	2	
45	95720-05300	NUT, FLANGE	2	
46	90601-11062	BAND, HOSE 11	1	

B13

FIG. 8 JET UNIT 2



REF. NO.	PART NO.	DESCRIPTION	Q'TY	REMARKS
1	61X-51381-00	COVER	1	
2	90387-06M60	COLLAR	2	
3	97595-06525	BOLT, WITH WASHER	2	
4	90480-06M69	GROMMET	1	
5	6R7-51323-02	SHAFT, COUPLOR	1	
6	93210-17MA4	O-RING	2	
7	61X-45332-02-94	HOUSING, BEARING	1	
8	90445-09M17	HOSE	1	
9	90465-11M10	CLAMP	1	
10	61L-45378-00	NIPPLE, HOSE	1	
11	93101-25M55	OIL SEAL	2	
12	93101-25M56	OIL SEAL	1	
13	93430-47M04	CIRCLIP	2	
14	93306-205U6	BEARING	1	
15	93606-12019	PIN, DOWEL	2	
16	90119-08907	BOLT, WITH WASHER	3	
17	GDO-67249-00-05	SHIM (T=0.5)	1	UR
	GDO-67249-00-10	SHIM (T=1.0)	1	UR



GM61100-6080

B14

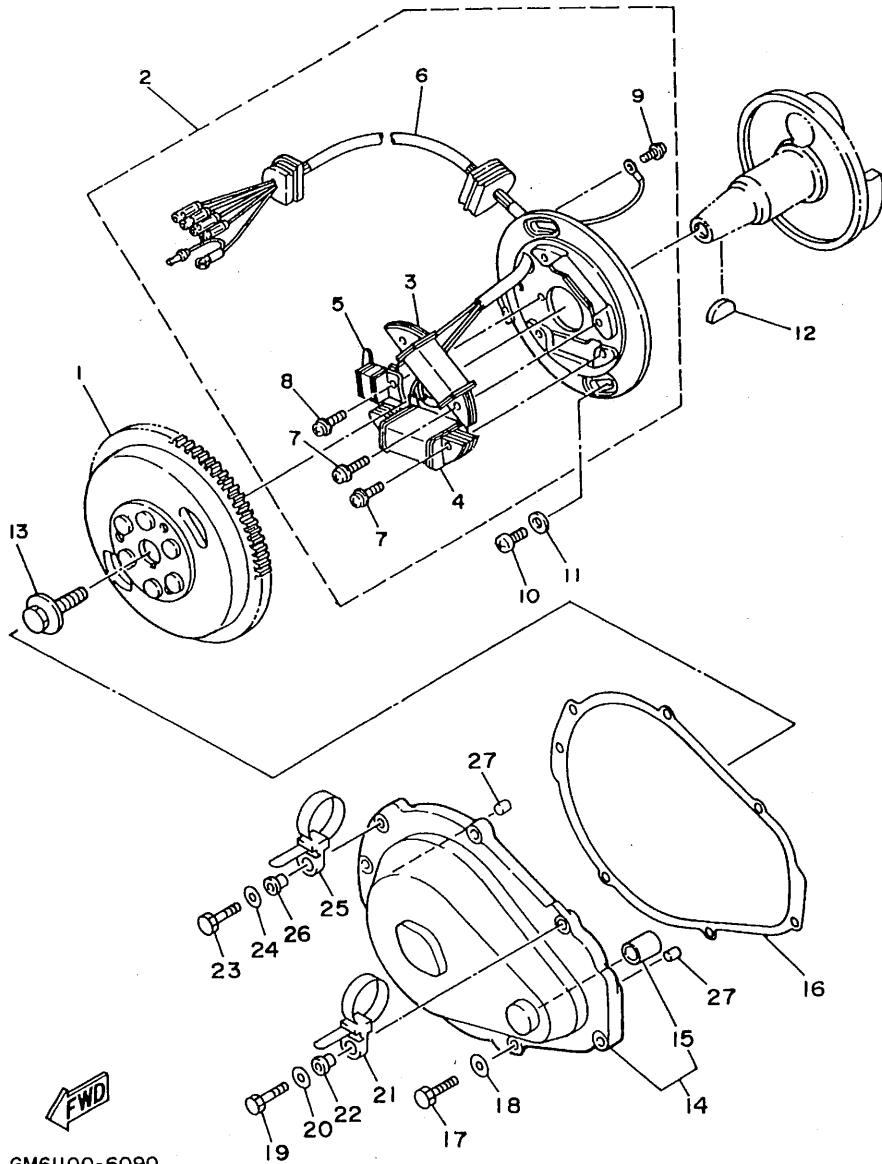

GM61100-6090



FIG. 9 GENERATOR

REF. NO.	PART NO.	DESCRIPTION	Q'TY	REMARKS
1	62T-85550-00	ROTOR ASSY	1	
2	6R7-85560-10	BASE ASSY	1	
3	62T-85520-00	.COIL, CHARGE	1	
4	62T-85533-00	.COIL, LIGHTING	1	
5	6M6-85580-00	.COIL, PULSER	1	
6	62T-85515-00	.LEAD WIRE ASSY	1	
7	97902-05125	.SCREW, WITH WASHER	4	
8	97902-04122	.SCREW, WITH WASHER	2	
9	98580-04008	.SCREW, PAN HEAD	1	
10	98580-06016	SCREW, PAN HEAD	2	
11	92990-06600	WASHER, PLATE	2	
12	90280-05013	KEY, WOODRUFF	1	
13	90109-10M44	BOLT	1	
14	6M6-81337-00-8P	COVER, FLYWHEEL	1	
15	90380-12M29	.BUSH, SOLID	1	
16	6M6-81365-A0	GASKET, HOLE COVER	1	
17	97095-06025	BOLT	5	
18	92995-06600	WASHER, PLATE	5	
19	97095-06035	BOLT	1	
20	92990-06600	WASHER, PLATE	1	
21	90465-12M53	CLAMP	1	
22	90387-06M05	COLLAR	1	
23	97095-06035	BOLT	1	
24	92990-06600	WASHER, PLATE	1	
25	90465-12M53	CLAMP	1	
26	90387-06M05	COLLAR	1	
27	93606-12019	PIN, DOWEL	2	

B15

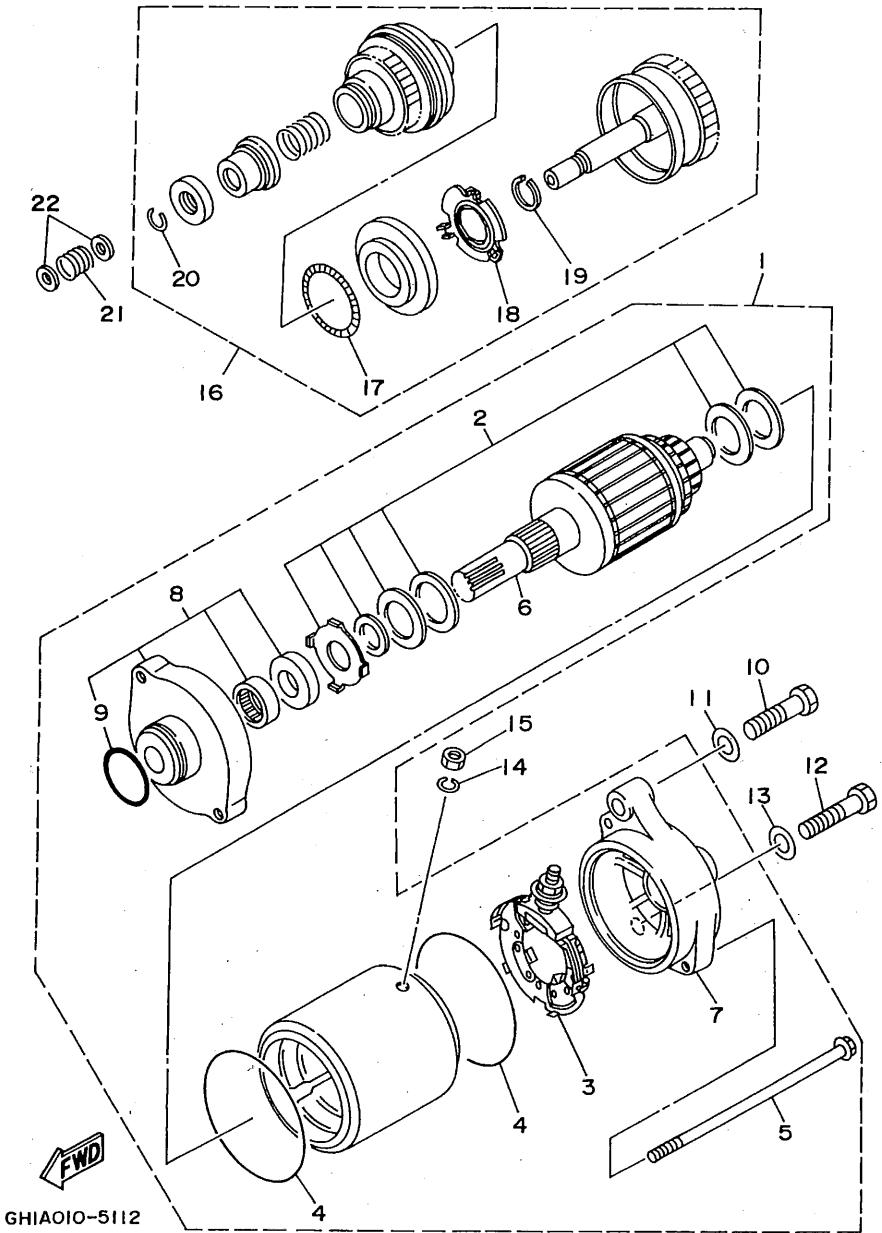

GHIAOIO-5112

FIG. 10 STARTING MOTOR

REF. NO.	PART NO.	DESCRIPTION	Q'TY	REMARKS
1	6M6-81800-10	STARTING MOTOR ASSY	1	
2	3AJ-81809-00	.WASHER KIT	1	
3	6M6-81840-10	.BRUSH HOLDER ASSY	1	
4	11H-81844-00	.GASKET	2	
5	6M6-81826-00	.BOLT	2	
6	6M6-81850-00	.ARMATURE ASSY	1	
7	6M6-81820-00	.REAR BRACKET ASSY	1	
8	6M6-81830-00	.FRONT BRACKET ASSY	1	
9	26H-81847-00	.O-RING	1	
10	97013-08040	BOLT	1	
11	92903-08600	WASHER, PLATE	1	
12	97013-08035	BOLT	1	
13	92903-08600	WASHER, PLATE	1	
14	92990-06100	WASHER, SPRING	1	
15	95380-06700	NUT	1	
16	6M6-8183E-00	IDLE GEAR COMP	1	
17	6M6-81866-00	.WEIGHT SPRING	1	
18	6M6-81865-00	.WEIGHT HOLDER	1	
19	93440-25M08	.CIRCLIP	1	
20	93450-18M06	.CIRCLIP	1	
21	90501-14M73	SPRING, COMPRESSION	1	
22	92990-06600	WASHER, PLATE	2	

C2

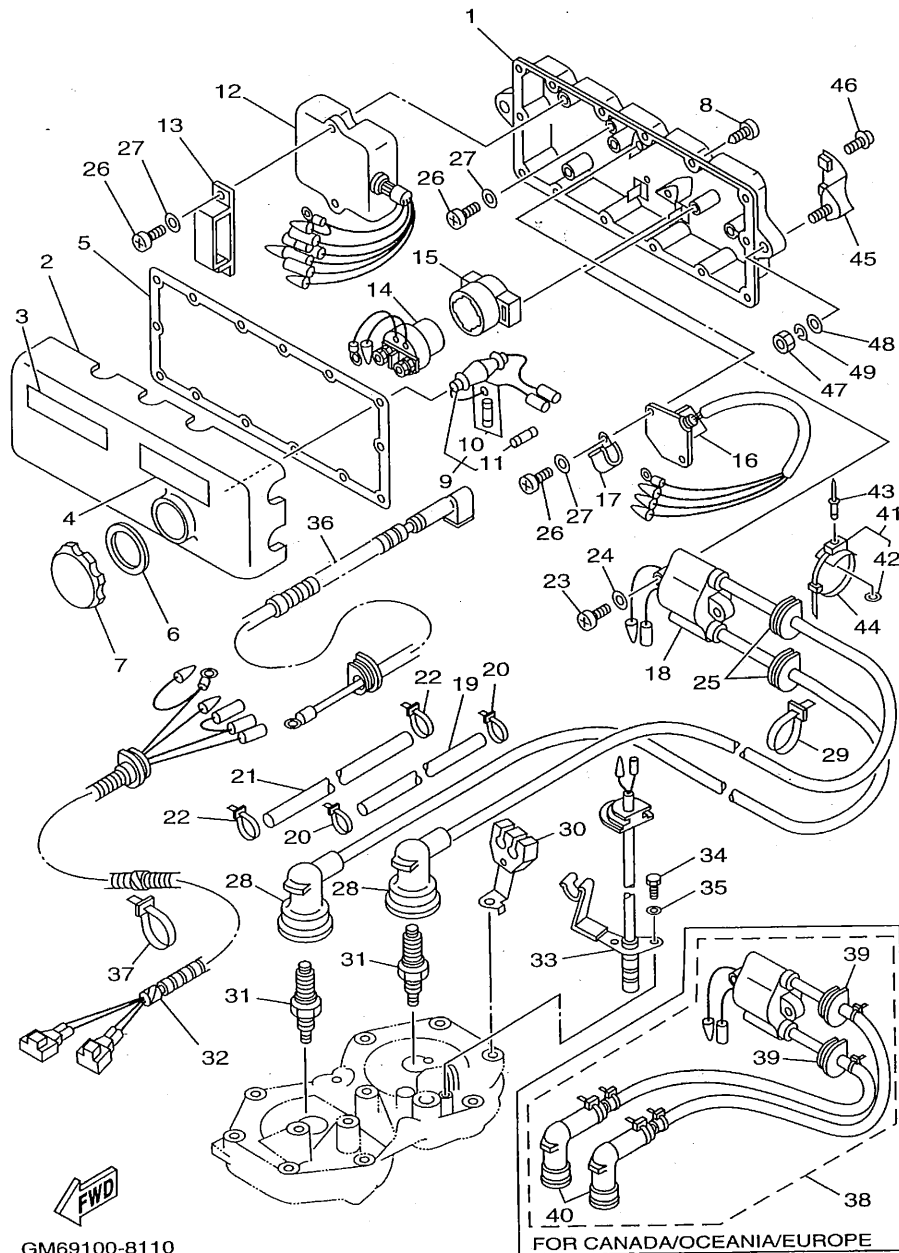

GM69100-8110

FIG. 11 ELECTRICAL 1

REF. NO.	PART NO.	DESCRIPTION	Q'TY	REMARKS
1	6M6-8552A-01-98	HOUSING	1	
2	6M6-8552E-01	COVER, CASE	1	
3	6R7-83623-40	MARK 3	1	UR ENGLISH
	63N-83623-00	MARK 3	1	UR JAPAN
4	6R7-83623-50	MARK 3	1	FRENCH
5	6M6-81921-00	GASKET, TERMINAL	1	
6	6M6-81844-00	GASKET	1	
7	6M6-8132W-00	CAP	1	
8	97780-60525	SCREW, TAPPING	14	
9	6K8-82150-01	FUSE HOLDER ASSY	1	
10	6K8-82159-00	.FUSE SPEAR	1	
11	6G1-82151-00	.FUSE	1	
12	62T-85540-01	C.D.I. UNIT ASSY	1	
13	90464-06M29	CLAMP	1	
14	6G1-81941-10	STARTER RELAY ASSY	1	
15	6M6-81952-01	HOLDER, RELAY	1	
16	6M6-81960-A0	RECTIFIER & REGULATOR ASSY	1	
17	90465-08M07	CLAMP	1	
18	62E-85570-00	IGNITION COIL ASSY	1	UR USA, GUAM, JAPAN
19	6R7-82351-00	TUBE, CORD	1	UR USA, GUAM, JAPAN
20	90465-11M10	CLAMP	2	UR USA, GUAM, JAPAN
21	6R7-82352-00	TUBE, CORD 2	1	UR USA, GUAM, JAPAN
22	90465-11M10	CLAMP	2	UR USA, GUAM, JAPAN
23	97880-06030	SCREW, PAN HEAD	2	
24	92990-06600	WASHER, PLATE	2	
25	90480-06M43	GROMMET	2	UR USA, GUAM, JAPAN
26	97880-06016	SCREW, PAN HEAD	6	
27	92990-06600	WASHER, PLATE	6	

C3

FIG. 11 ELECTRICAL 1

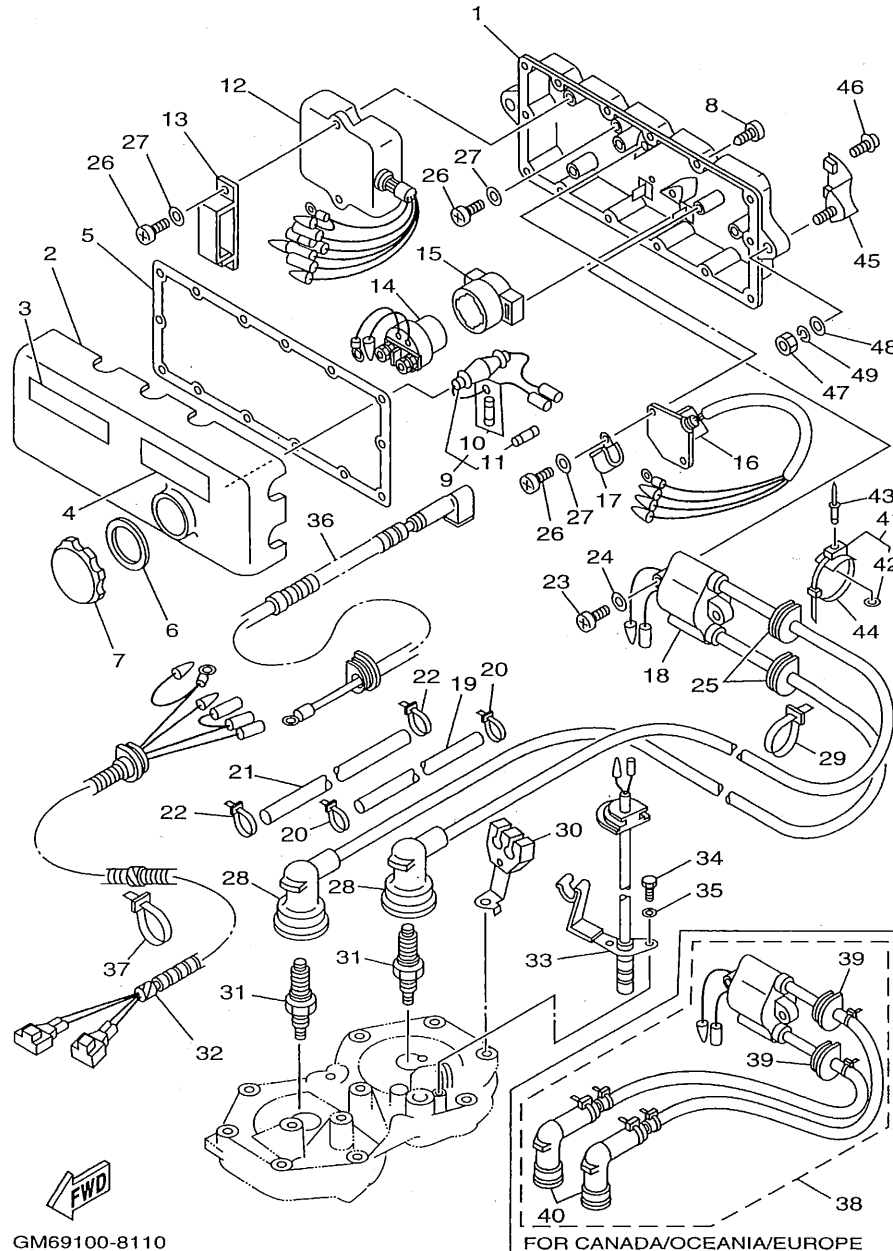

GM69100-8110

REF. NO.	PART NO.	DESCRIPTION	Q'TY	REMARKS
28	6R7-82370-00	PLUG CAP ASSY	2	UR USA, GUAM, JAPAN
29	90465-11M10	CLAMP	2	
30	6R7-82361-01	CLAMP, CORD	1	
31	94702-00040	PLUG, SPARK (NGK B8HS)	2	UR USA, GUAM
	94709-00040	PLUG, SPARK (NGK B8HS)	2	UR JAPAN
	94702-00272	PLUG, SPARK (NGK BR7HS)	2	UR CANADA, OCEANIA, EUROPE
32	6R7-82553-01	EXTENSION, WIRE LEAD	1	
33	6R7-82560-00	THERMO SWITCH ASSY	1	
34	97095-06016	BOLT	2	
35	92995-06100	WASHER, SPRING	2	
36	62E-82117-20	WIRE, LEAD	1	
37	90465-13M11	CLAMP	1	
38	62E-85570-11	IGNITION COIL ASSY	1	UR CANADA, OCEANIA, EUROPE
39	90480-06M43	.GROMMET	2	
40	62E-82371-11	.PLUG, CAP	2	
41	90600-91736	CLAMP	2	
42	90201-05925	.WASHER, PLATE	1	
43	90267-48925	RIVET, BLIND	2	
44	90601-20006	NYLON CLIP 1	2	
45	EW2-68156-00	BRACKET, ELECTRIC BOX	2	
46	90119-06908	BOLT, WITH WASHER	4	
47	95380-08600	NUT	2	
48	92990-08200	WASHER, PLAIN	2	
49	92990-08100	WASHER, SPRING	2	

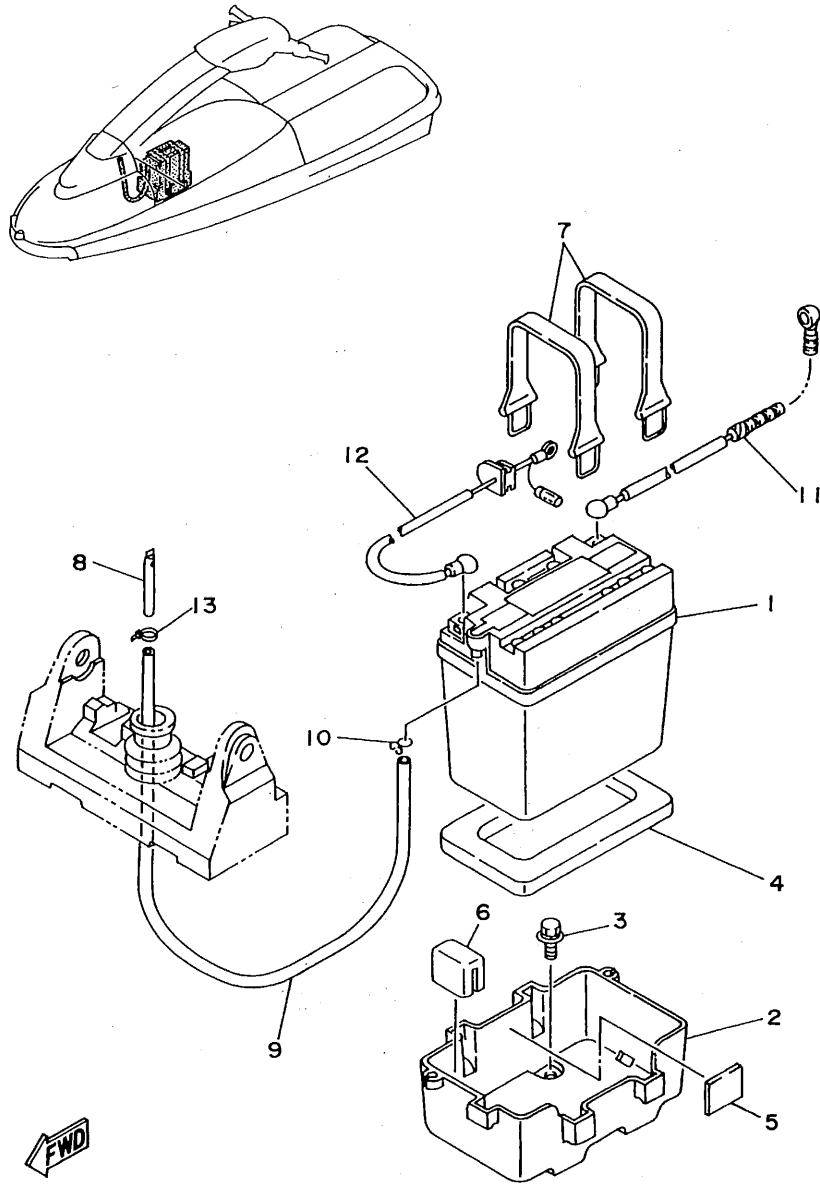

FIG. 12 ELECTRICAL 2

REF. NO.	PART NO.	DESCRIPTION	Q'TY	REMARKS
1	EU0-82110-09	BATTERY ASSY	1	
2	EW2-68211-00	CASE, BATTERY	1	
3	90119-06920	BOLT, WITH WASHER	4	
4	EU0-68221-00	PAD, BATTERY 1	1	
5	EU0-68221-30	PAD, BATTERY 2	3	
6	EW2-68221-00	PAD, BATTERY	1	
7	EU0-68218-04	BAND, BATTERY	2	
8	EW2-62149-00	PIPE, VENTILATION 1	1	
9	EU0-67856-40	HOSE, AIR VENT 3	1	
10	90467-08M10	CLIP	1	
11	64V-82117-00	WIRE, LEAD	1	
12	6R7-82117-11	WIRE, LEAD	1	
13	90465-11M10	CLAMP	1	



GM65100-7120

C5

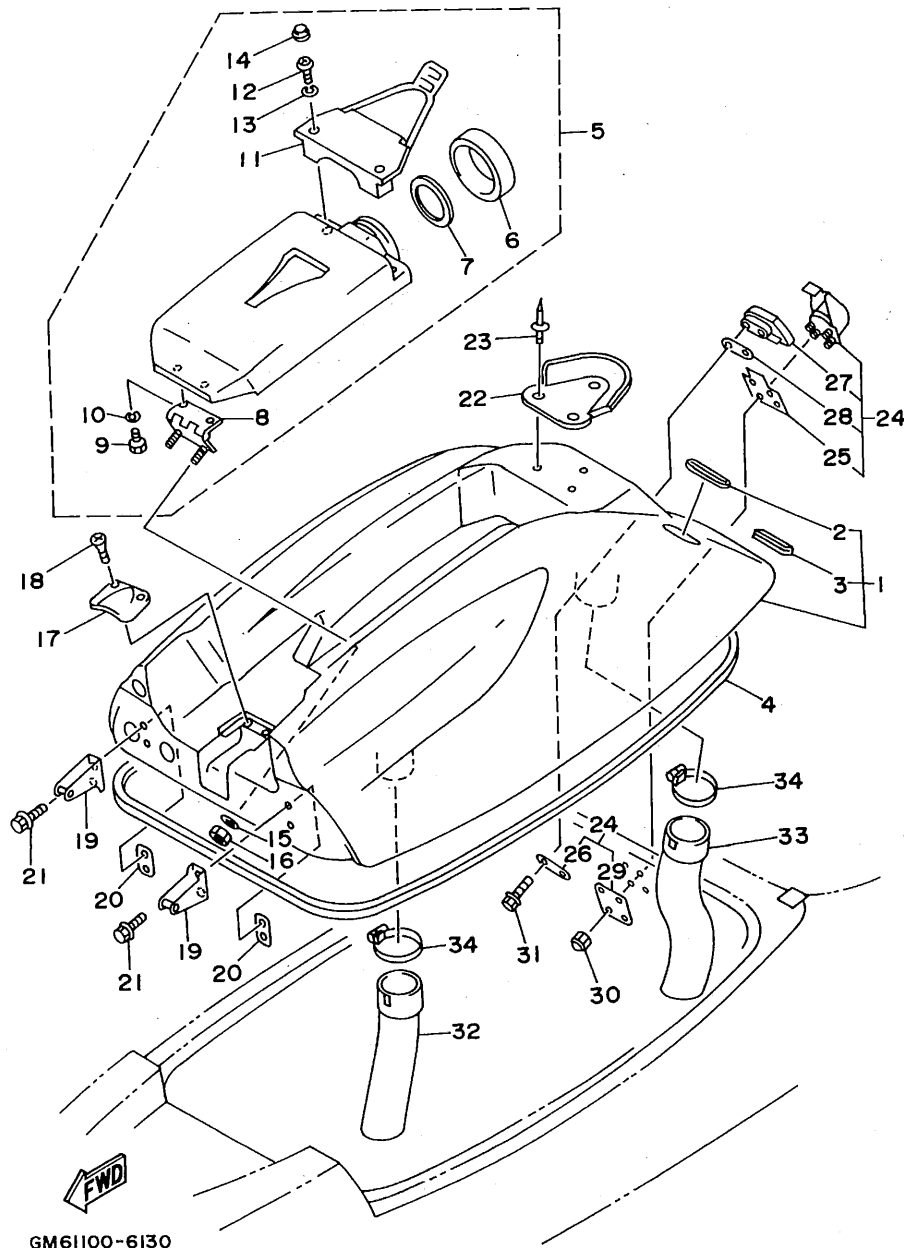
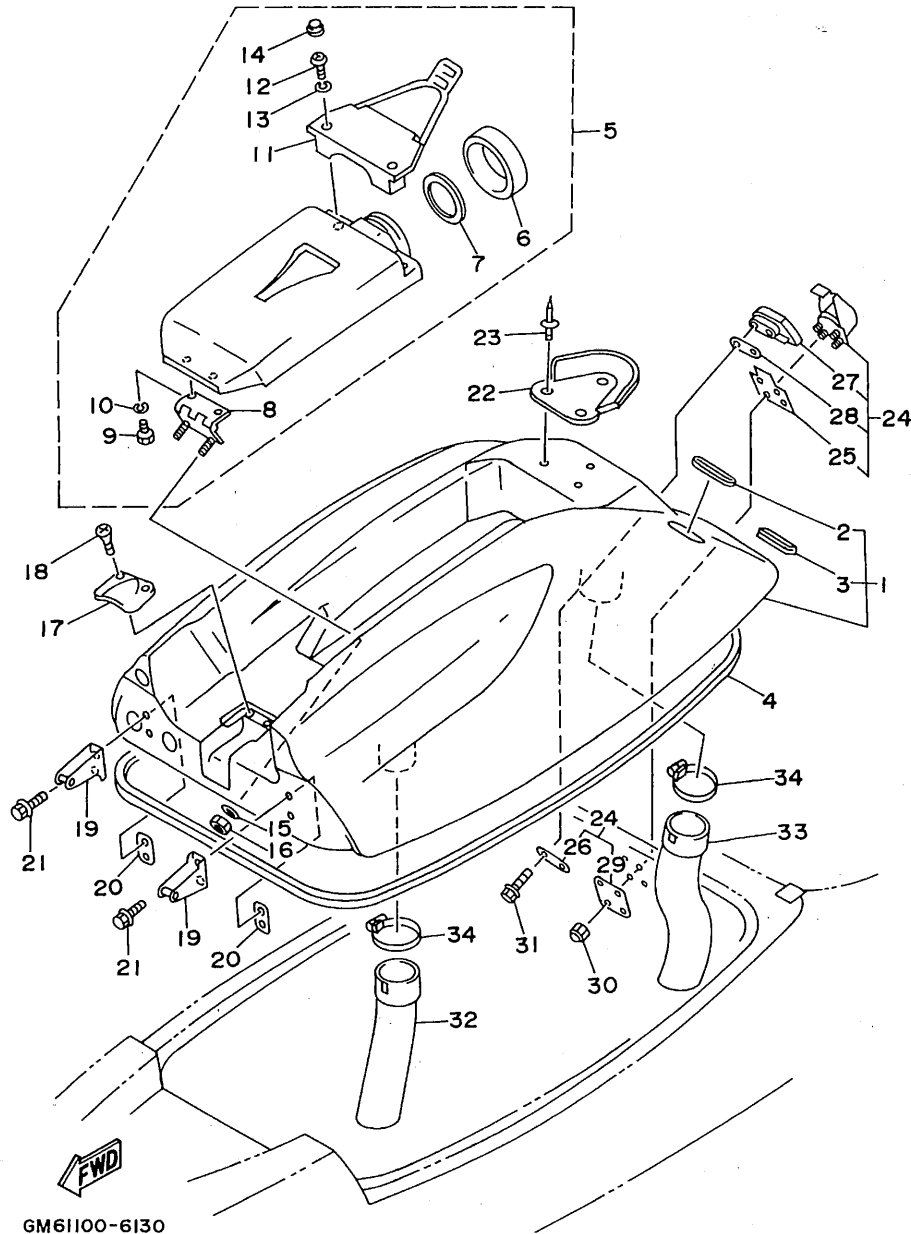

FIG. 13 ENGINE HATCH

REF. NO.	PART NO.	DESCRIPTION	Q'TY	REMARKS
1	GM6-6516A-10-PO	ENGINE HATCH COMP.	1	
2	FX1-65116-10	.TRIM, HATCH 2	2	
3	GM6-6516C-00	.TRIM 1	1	
4	GM6-62664-00	PACKING	1	
5	FX1-6591A-10	CASE ASSY 1	1	
6	EW2-65912-00	.CAP, CASE	1	
7	EW2-65913-00	.PACKING, CASE	1	
8	FX1-6517D-00	.HINGE, LID	1	
9	97090-06014	.BOLT	2	
10	92990-06100	.WASHER, SPRING	2	
11	FX1-6591K-00	.BAND, CASE	1	
12	92580-06016	.SCREW, PAN HEAD	2	
13	92990-06100	.WASHER, SPRING	2	
14	FX1-6514F-00	.CAP	2	
15	92990-06200	WASHER, PLAIN	2	
16	95720-06300	NUT, SELF-LOCKING	2	
17	A00-62858-02	PLATE, HATCH (FL1)	1	
18	97780-50316	SCREW, TAPPING	2	
19	GM6-65136-00	STOPPER HATCH 2	2	
20	EW2-65137-00	PLATE, STOPPER HATCH 2	2	
21	90119-06900	BOLT, WITH WASHER	4	
22	FX1-6514B-00	DAMPER, POLE	1	
23	90267-48938	RIVET, BLIND	3	
24	EW2-62840-10	HATCH LOCK ASSY	1	
25	EW2-62845-10	.PACKING, HATCH LOCK	1	
26	EW2-62846-00	.PLATE, HATCH LOCK	1	
27	EW2-62843-00	.HOOK, HATCH LOCK	1	
28	EW2-62847-00	.PACKING, HOOK	1	

FIG. 13 ENGINE HATCH



GM61100-6130

REF. NO.	PART NO.	DESCRIPTION	Q'TY	REMARKS
29	EW2-62848-00	.PLATE, HOOK	1	
30	95720-05300	NUT, FLANGE	4	
31	90119-05923	BOLT, WITH WASHER	2	
32	GM6-6213F-00	HOSE, VENTILATOR 1	1	
33	EW2-62137-00	HOSE, VENTILATOR 2	1	
34	90601-16875	BAND, HOSE	2	

C7

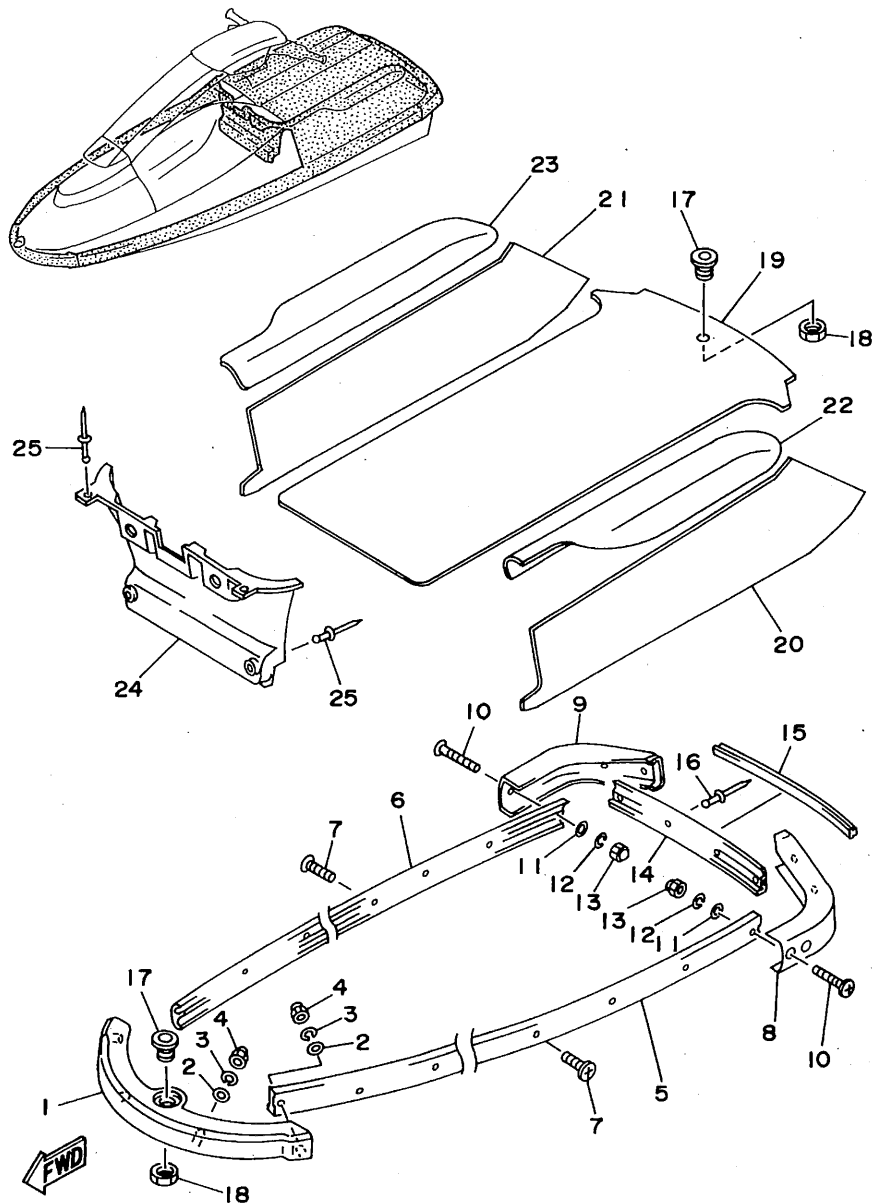

GM65100-7150

FIG. 15 GUNWALE. MAT

REF. NO.	PART NO.	DESCRIPTION	Q'TY	REMARKS
1	GM6-62501-10	BOW GUNWALE COMP.	1	
2	92990-06200	WASHER, PLAIN	4	
3	92995-06100	WASHER, SPRING	4	
4	95380-06800	NUT	4	
5	GM6-62552-10	GUNWALE, SIDE 1	1	
6	GM6-62553-10	GUNWALE, SIDE 2	1	
7	90149-05962	SCREW	22	
8	GM6-6251D-00	GUNWALE, STERN 1	1	
9	GM6-6251E-00	GUNWALE, STERN 2	1	
10	90149-05960	SCREW	8	
11	92990-05200	WASHER, PLAIN	8	
12	92990-05100	WASHER, SPRING	8	
13	90179-05964	NUT	8	
14	GM6-6252C-10	COVER, GUNWALE 1	1	
15	GM6-6252D-10	COVER, GUNWALE 2	1	
16	90267-48932	RIVET, BLIND	4	
17	FN8-61651-00	ROPE HOLE	2	
18	EU0-61652-00	NUT	2	
19	GM6-6351B-00	MAT, LOWER	1	
20	GM6-6351C-00	MAT, SIDE 1	1	
21	GM6-6351D-00	MAT, SIDE 2	1	
22	GM6-6521C-00	PAD 1	1	
23	GM6-6521D-00	PAD 2	1	
24	GM6-6351E-00	MAT, BOW	1	
25	90267-48963	RIVET, BLINDD	4	

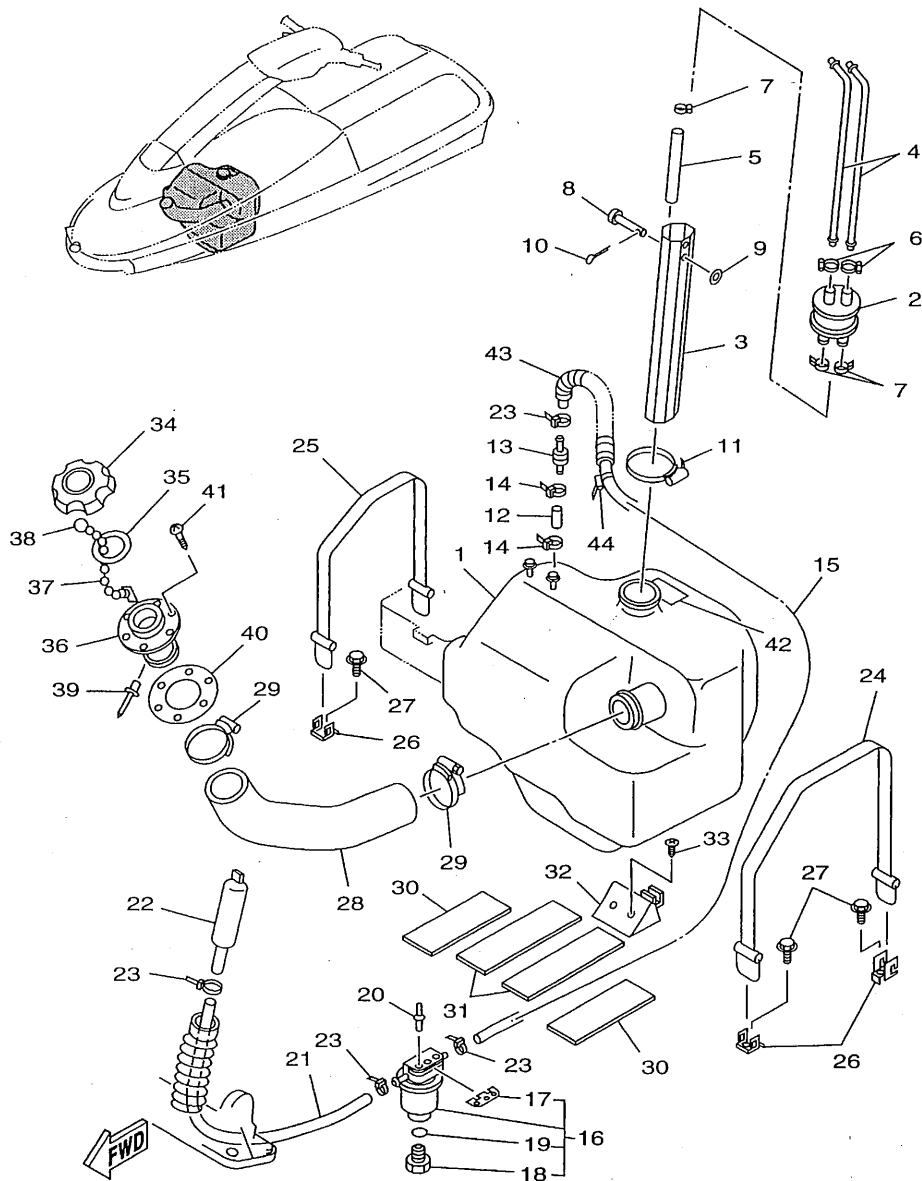

GM69100-8160

FIG. 16 FUEL TANK

REF. NO.	PART NO.	DESCRIPTION	Q'TY	REMARKS
1	EW2-67711-01	TANK, FUEL	1	
2	FJ0-67713-00	PIPE, JOINT	1	
3	EW2-67716-01	SLEEVE 1	1	
4	EW2-67714-02	PIPE, SUCTION 3	2	
5	90445-11903	HOSE	1	
6	90601-11062	BAND, HOSE 11	2	
7	90467-11032	CLIP	3	
8	91790-05040	PIN, CLEVIS	1	
9	92990-05600	WASHER, PLATE	1	
10	91490-16010	PIN, COTTER	1	
11	90601-16274	BAND, HOSE 62	1	
12	90699-50003	HOSE	1	
13	EU0-67767-31	CHECK VALVE	1	
14	90465-11M10	CLAMP	2	
15	90699-50120	HOSE	1	
16	EW2-62140-00	FILTER, VENT ASSY	1	
17	EW2-62142-00	.PLATE, FILTER	1	
18	70R-24543-00	.PLUG, DRAIN	1	
19	70R-24489-00	.O-RING, SEPARATER 2	1	
20	90267-48925	RIVET, BLIND	2	
21	90699-50045	HOSE	1	
22	EW2-62150-00	PIPE, VENTILATION 3	1	
23	90465-11M10	CLAMP	4	
24	EW2-67821-00	BAND, FUEL TANK	1	
25	EW2-67821-30	BAND, FUEL TANK	1	
26	EW2-65772-00	HOOK A	3	
27	90105-06900	BOLT, WASHER BASED	3	
28	GM6-67844-10	HOSE	1	

C10

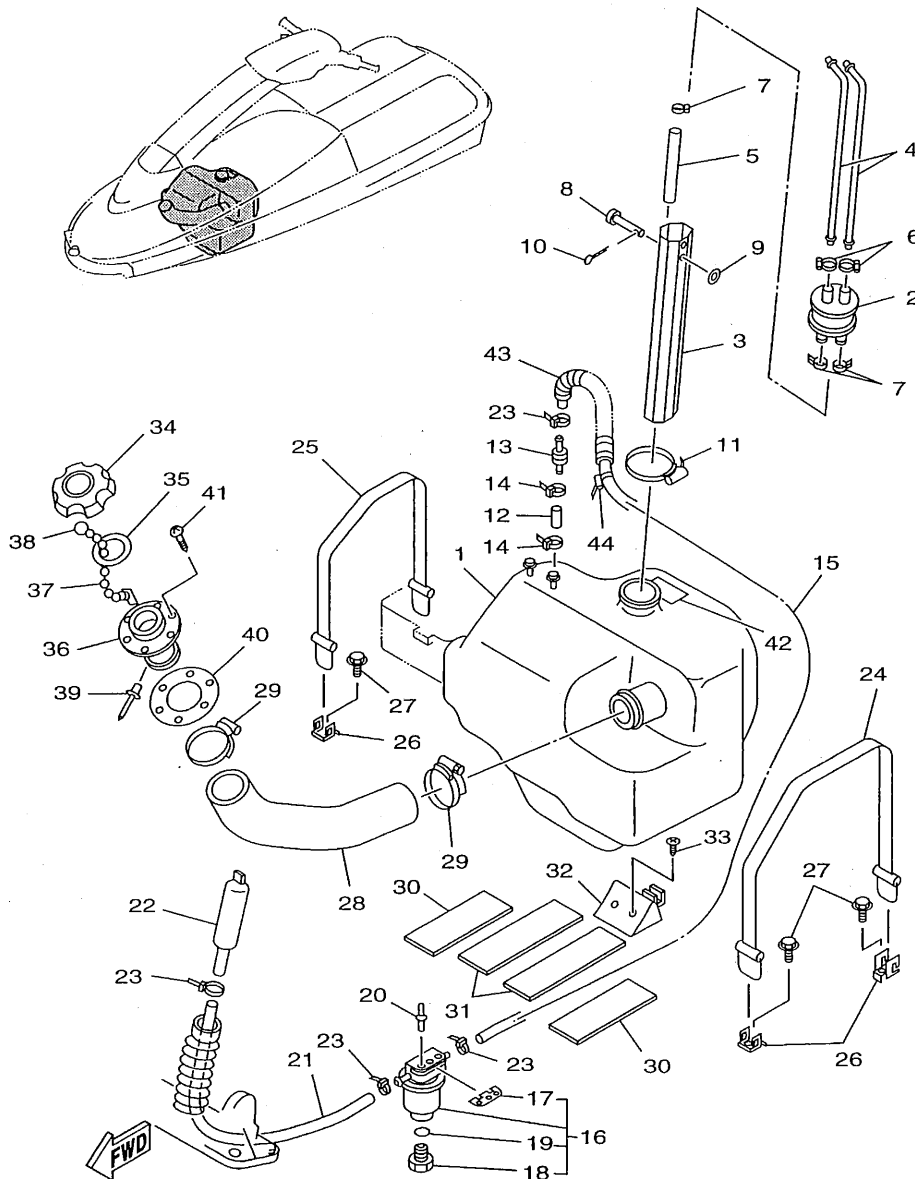

GM69100-8160

FIG. 16 FUEL TANK

REF. NO.	PART NO.	DESCRIPTION	Q'TY	REMARKS
29	90601-15573	BAND, HOSE	2	
30	GM6-67593-00	MAT	2	
31	GM6-67594-00	MAT	2	
32	EW2-67822-01	DAMPER FUEL TANK	1	
33	97780-50114	SCREW, PAN HEAD TAPPING	2	
34	FN8-67831-01	CAP, FUEL FILLER	1	
35	EU0-67832-00	PACKING 1	1	
36	FN8-67833-00	SOCKET	1	
37	EU0-67835-00	CHAIN BALL	1	
38	EU0-67839-00	COUPLING	1	
39	90267-40935	RIVET, BLIND	1	
40	EU0-67834-00	PACKING, FUEL FILLER	1	
41	EU0-67869-00	SCREW, FLAT HEAD	6	
42	GM6-6418D-00	LABEL, FUEL TANK	1	
43	90446-14M30	TUBE	1	
44	90465-11M10	CLAMP	1	

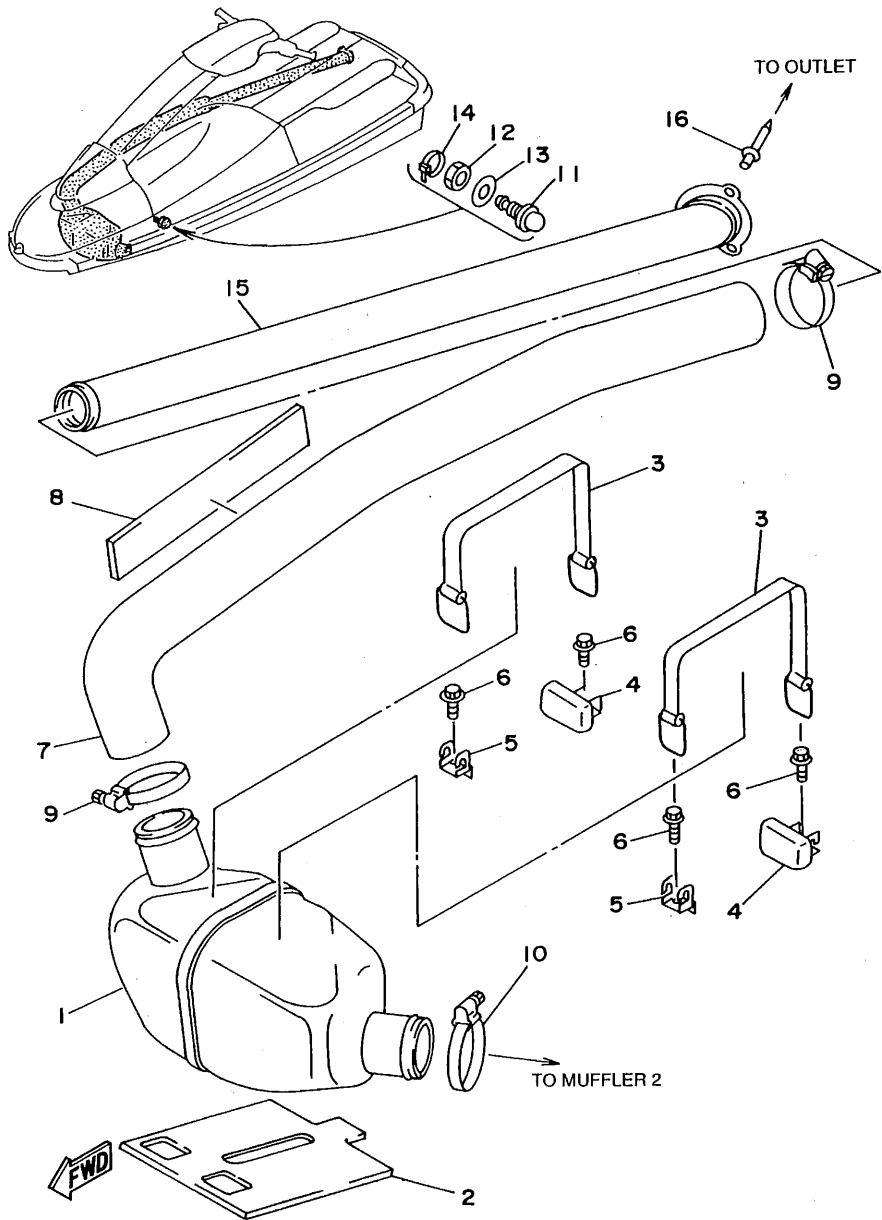

GM65100-7170

FIG. 17 EXHAUST 2

REF. NO.	PART NO.	DESCRIPTION	Q'TY	REMARKS
1	GM6-67550-00	WATER LOCK	1	
2	GM6-6755J-00	MAT, WATER LOCK	1	
3	EU0-68218-04	BAND, BATTERY	2	
4	FX1-65760-00	HOOK B ASSY	2	
5	EW2-65772-00	HOOK A	2	
6	90105-06900	BOLT, WASHER BASED	4	
7	GM6-67555-00	HOSE	1	
8	GM6-63844-00	MAT	1	
9	90601-16875	BAND, HOSE	2	
10	90601-16875	BAND, HOSE	1	
11	GH7-6753B-00	PILOT, WATER	1	
12	GP7-61652-00	NUT	1	
13	92990-14200	WASHER, PLAIN	1	
14	90465-11M10	CLAMP	1	
15	GM6-67565-00	THRU-HULL, EXHAUST	1	
16	90267-48930	RIVET, SEALD	3	

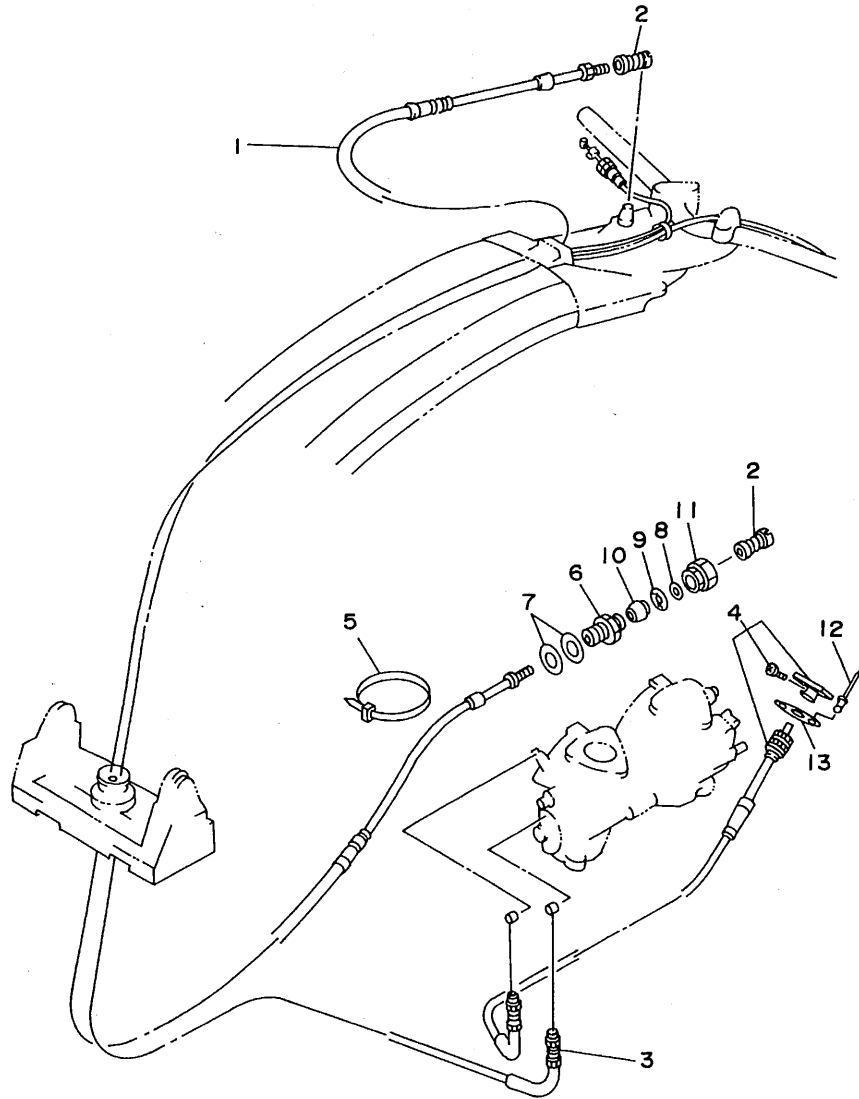

FIG. 18 CONTROL CABLE

REF. NO.	PART NO.	DESCRIPTION	Q'TY	REMARKS
1	GM6-61481-00	CABLE, STEERING	1	
2	EU0-61461-30	SHAFT, JOINT BALL	2	
3	GM6-67252-00	CABLE, THROTTLE	1	
4	GM6-67242-00	CABLE, CHOKE	1	
5	90465-13M11	CLAMP	1	
6	EU0-61436-00	BODY, CABLE CONNECTOR	1	
7	EU0-61438-00	PACKING (C)	2	
8	EU0-61446-00	WASHER 30	1	
9	EU0-61486-00	STOPPER	1	
10	EU0-61435-00	SEAL, PIPE 30	1	
11	EU0-62694-00	CAP	1	
12	90267-40945	RIVET, BLIND	2	
13	90209-12920	WASHER	1	



GM61100-6180

C13

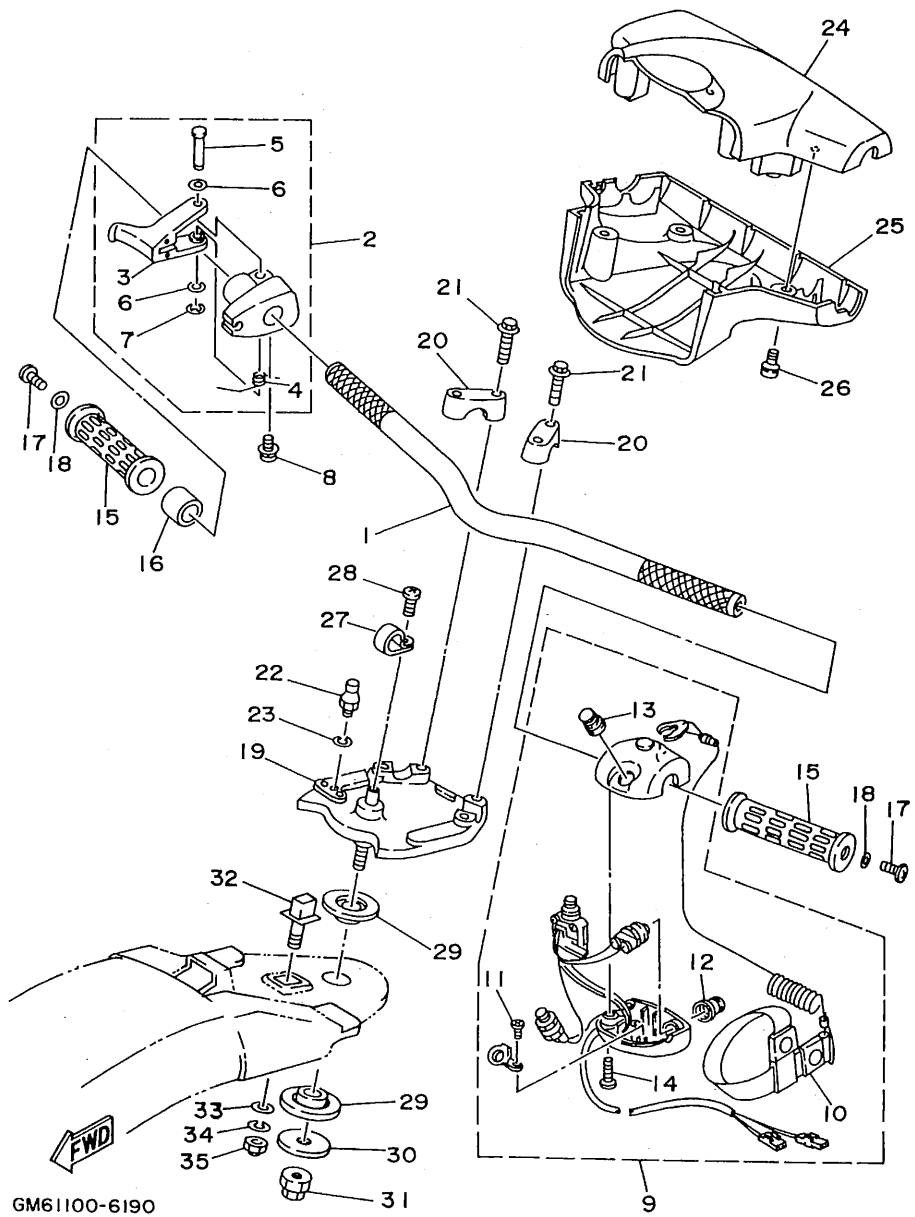

GM61100-6190

FIG. 19 STEERING 1

REF. NO.	PART NO.	DESCRIPTION	Q'TY	REMARKS
1	FX1-61552-00	HANDLE	1	
2	EW2-67250-02	THROTTLE LEVER ASSY	1	
3	EW2-67255-00	.LEVER, THROTTLE	1	
4	EW2-67256-00	.SPRING	1	
5	EW2-67257-01	.SHAFT	1	
6	EW2-67258-01	.WASHER	2	
7	EW2-67259-01	.E-RING	1	
8	90159-05900	SCREW, WITH WASHER	1	
9	EW2-68310-03	SWITCH BOX ASSY	1	
10	EW2-68348-00	.LANYARD, STOP SWITCH	1	
11	97880-03008	.SCREW, PAN HEAD	2	
12	FK7-68312-02	.STOP BUTTON COMP.	1	
13	FK7-68313-01	.START BUTTON COMP.	1	
14	97880-05025	.SCREW, PAN HEAD	2	
15	EW2-61553-00	GRIP, HANDLE 1	2	
16	90560-22281	SPACER	1	
17	90149-05959	SCREW	2	
18	90201-05928	WASHER, PLATE	2	
19	EW2-61540-10	COLUMN, STEERING	1	
20	EU0-23814-01	HOLDER, HANDLE LOWER	2	
21	90105-08902	BOLT, WASHER BASED	4	
22	EU0-61461-01	STUD, JOINT BALL	1	
23	92990-06100	WASHER, SPRING	1	
24	FX1-6143D-20	PAD, STEERING 1	1	
25	FX1-6143E-20	PAD, STEERING 2	1	
26	90149-05937	SCREW	4	
27	90600-91728	CLIP, NYLON 17	1	
28	98980-04010	SCREW, BIND	1	

C14

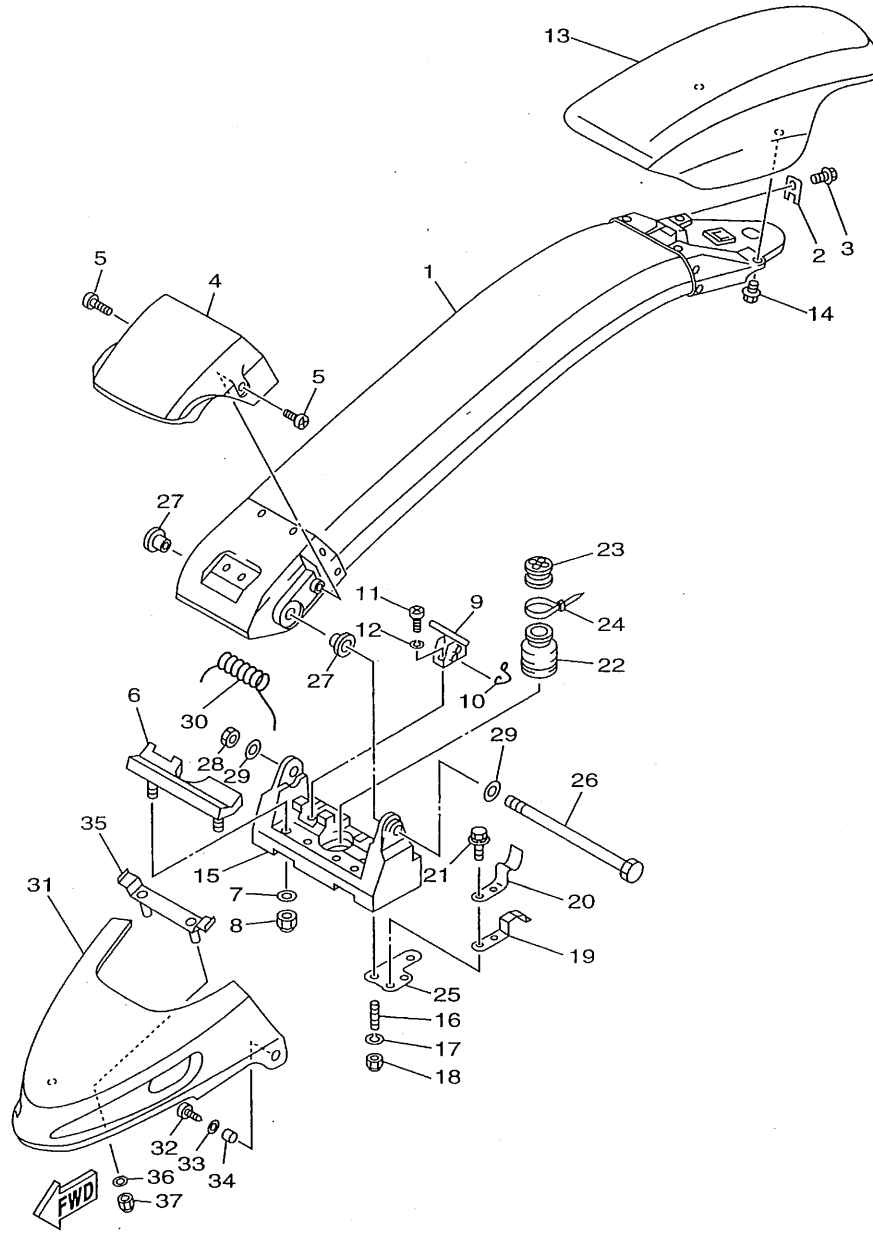

GM69100-8200

FIG. 20 STEERING 2

REF. NO.	PART NO.	DESCRIPTION	Q'TY	REMARKS
1	GM6-6491A-00-3S	STEERING POLE COMP.	1	
2	FX1-61468-00	STOPPER, CABLE	1	
3	90119-06913	BOLT, WITH WASHER	1	
4	FX1-6492E-10	COVER, POLE	1	
5	90149-06997	SCREW	2	
6	FX1-61337-00	STOPPER, POLE	1	
7	92990-06200	WASHER, PLAIN	2	
8	95720-06300	NUT, SELF-LOCKING	2	
9	FX1-61105-00	STOPPER PIN ASSY	1	
10	EW2-61395-30	SPRING, TORSION	1	
11	98580-05012	SCREW, PAN HEAD	2	
12	92990-05100	WASHER, SPRING	2	
13	GM6-6142A-10	STEERING PAD COMP.	1	
14	90119-06918	BOLT, WITH WASHER	2	
15	FX1-6133C-11	BRACKET, PIVOT	1	
16	95680-08630	BOLT, STUD	4	
17	92990-08100	WASHER, SPRING	4	
18	95720-08300	NUT, SELF-LOCKING	4	
19	GM6-6215G-00	PLATE, GUIDE	2	
20	GM6-65135-00	STOPPER, HATCH 1	2	
21	90119-06900	BOLT, WITH WASHER	4	
22	FX1-61338-00	GROMMET	1	
23	EW2-61465-00	PACKING, CABLE	1	
24	90601-20006	NYLON CLIP 1	1	
25	GM6-6133B-00	PLATE, BRACKET	2	
26	FX1-6134L-00	SHAFT, PIVOT	1	
27	EW2-61344-01	BUSH	2	
28	90170-14913	NUT	1	

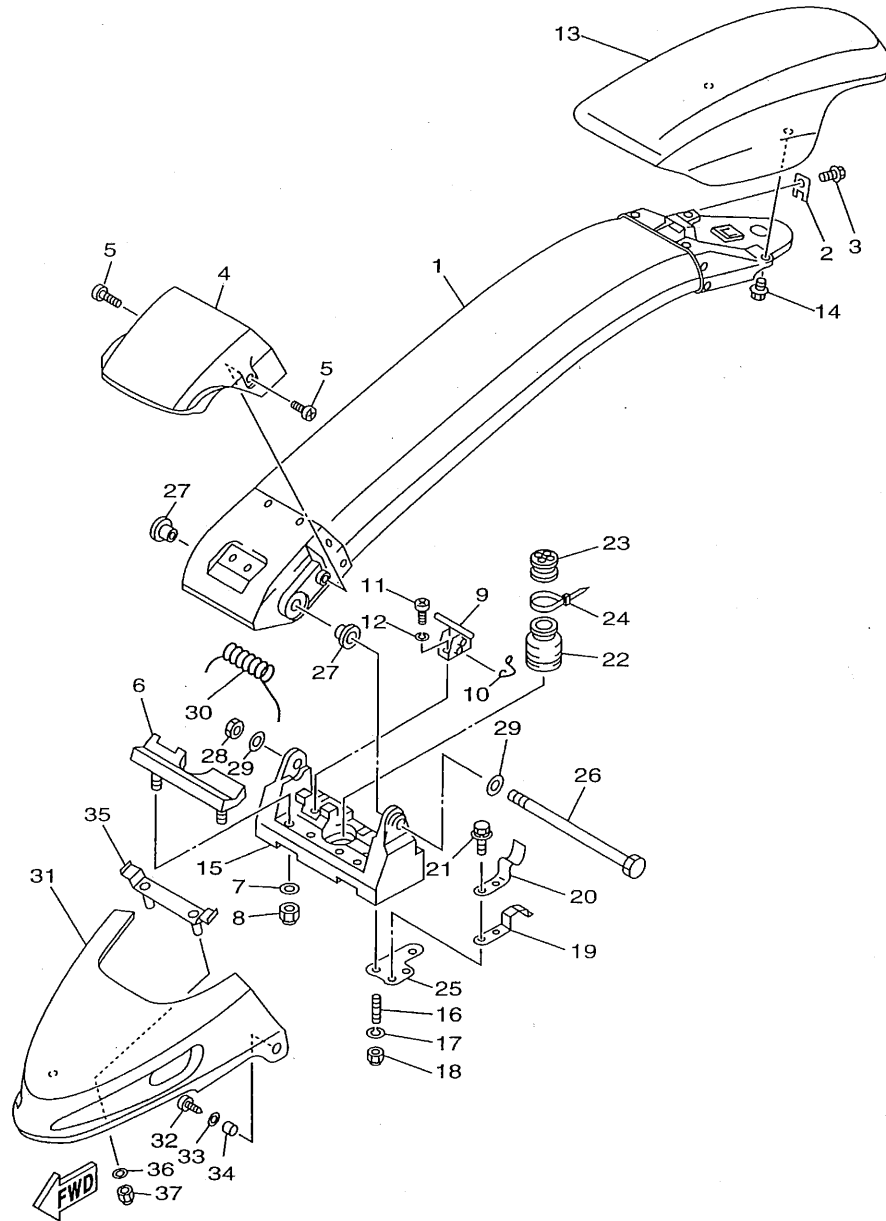

GM69100-8200

FIG. 20 STEERING 2

REF. NO.	PART NO.	DESCRIPTION	Q'TY	REMARKS
29	92990-14200	WASHER, PLAIN	2	
30	FX1-61391-00	SPRING, PIVOT	1	
31	GM6-6492J-10	COVER, PIVOT 1	1	
32	97780-60520	SCREW, TAPPING	2	
33	92990-06200	WASHER, PLAIN	2	
34	90387-06916	COLLAR	2	
35	GM6-64949-00	BRACKET	1	
36	92990-06200	WASHER, PLAIN	2	
37	95720-06300	NUT, SELF-LOCKING	2	

FIG. 21 GRAPHIC. TOOL

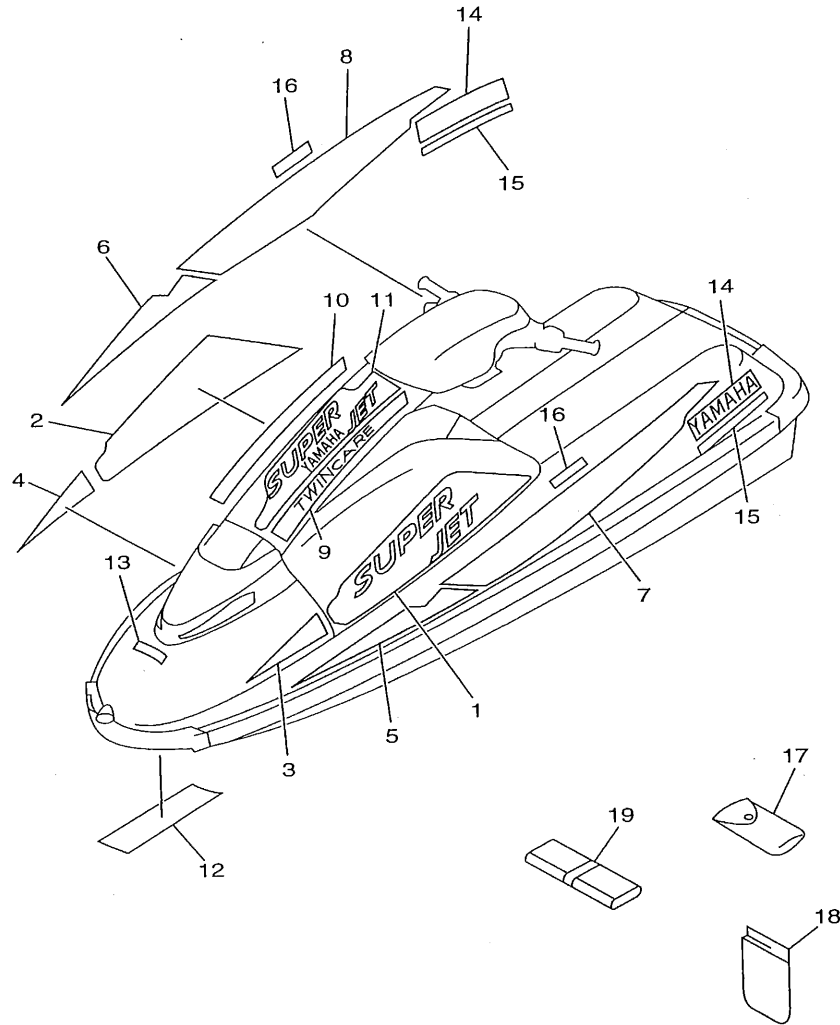

REF. NO.	PART NO.	DESCRIPTION	Q'TY	REMARKS
1	GM6-6417B-30	GRAPHIC 1	1	
2	GM6-6417B-40	GRAPHIC 1	1	
3	GM6-6417C-30	GRAPHIC 2	1	
4	GM6-6417C-40	GRAPHIC 2	1	
5	GM6-6417D-30	GRAPHIC 3	1	
6	GM6-6417D-40	GRAPHIC 3	1	
7	GM6-6417E-30	GRAPHIC 4	1	
8	GM6-6417E-40	GRAPHIC 4	1	
9	GM6-6417F-30	GRAPHIC 5	1	
10	GM6-6417F-40	GRAPHIC 5	1	
11	GM6-6417G-10	GRAPHIC 6	1	
12	GM6-64114-10	MARK, YAMAHA A	1	
13	GM6-64115-10	MARK, YAMAHA B	1	
14	GM6-64116-10	MARK, YAMAHA	2	
15	GM6-64175-00	MARK	2	EXCEPT EUROPE
16	GH7-64121-10	EMBLEM	2	FOR JAPAN
17	EU0-65986-00	TOOL SET	1	UR EXCEPT JAPAN
	EU0-65986-10	TOOL SET	1	UR FOR JAPAN
18	EU0-65901-01	BAG, VINYL	1	
19	GM6-65987-00	BAG	1	

GM69100-8210

D4

FIG. 22 IMPORTANT LABELS

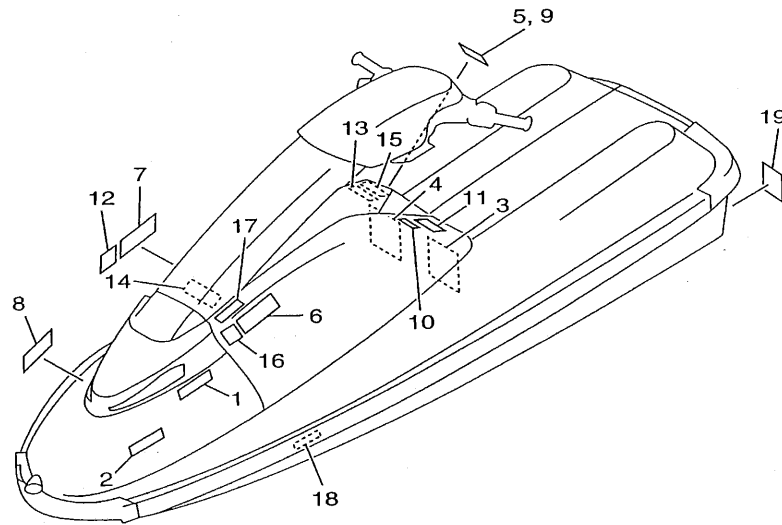

REF. NO.	PART NO.	DESCRIPTION	Q'TY	REMARKS
1	GM6-6415B-00	LABEL, WARNING (FUEL)	1	UR JPN
	GM6-6416B-00	LABEL, WARNING	1	UR USA
2	GM6-6416B-10	LABEL, WARNING	1	FOR EUR/CAN
3	GH7-6416C-20	LABEL, WARNING 1	1	UR USA
	GM6-6415C-00	LABEL, WARNING 1	1	UR JPN
	GM6-6416C-20	LABEL, WARNING 1	1	UR EUR/CAN
4	GH7-6416D-20	LABEL, WARNING 2	1	UR EXCEPT JPN
	GM6-6415D-00	LABEL, WARNING	1	UR JPN
5	GM6-6415E-30	LABEL, WARNING	1	UR EUR/CAN
	GM6-6415E-40	LABEL, WARNING	1	UR JPN
6	GM6-6416E-20	LABEL, WARNING 3	1	FOR EUR/CAN
7	GM6-6416F-20	LABEL, WARNING 4	1	FOR EUR/CAN
8	GA7-6416H-20	LABEL, WARNING (FRANCE)	1	FOR EUR
9	GM6-6415E-30	LABEL, WARNING	1	FOR USA
10	GM6-6415E-50	LABEL, WARNING	1	FOR EUR/CAN
11	GM6-6419D-20	LABEL 3	1	EXCEPT JPN
12	GM6-6419D-30	LABEL 3	1	FOR JPN
13	GM6-6419D-10	LABEL 3	1	UR EUR/CAN
	GM6-6418E-00	LABEL, USCG.	1	UR USA
14	GL3-6418B-10	LABEL, CAUTION	1	UR USA
	GM6-6418B-00	LABEL, CAUTION	1	UR JPN
	GM6-6418B-30	LABEL, CAUTION	1	UR EUR/CAN
15	GK5-6411B-00	PLATE, ASSY	1	FOR USA
16	EW3-64197-00	PLATE CAPACITY	1	FOR JPN
17	GR7-6419E-10	LABEL 4	1	FOR CAN
18	EW2-64184-00	LABEL, PATENT	1	
19	EU0-64188-00	LABEL, UP RIGHTING	1	



GM69100-8220

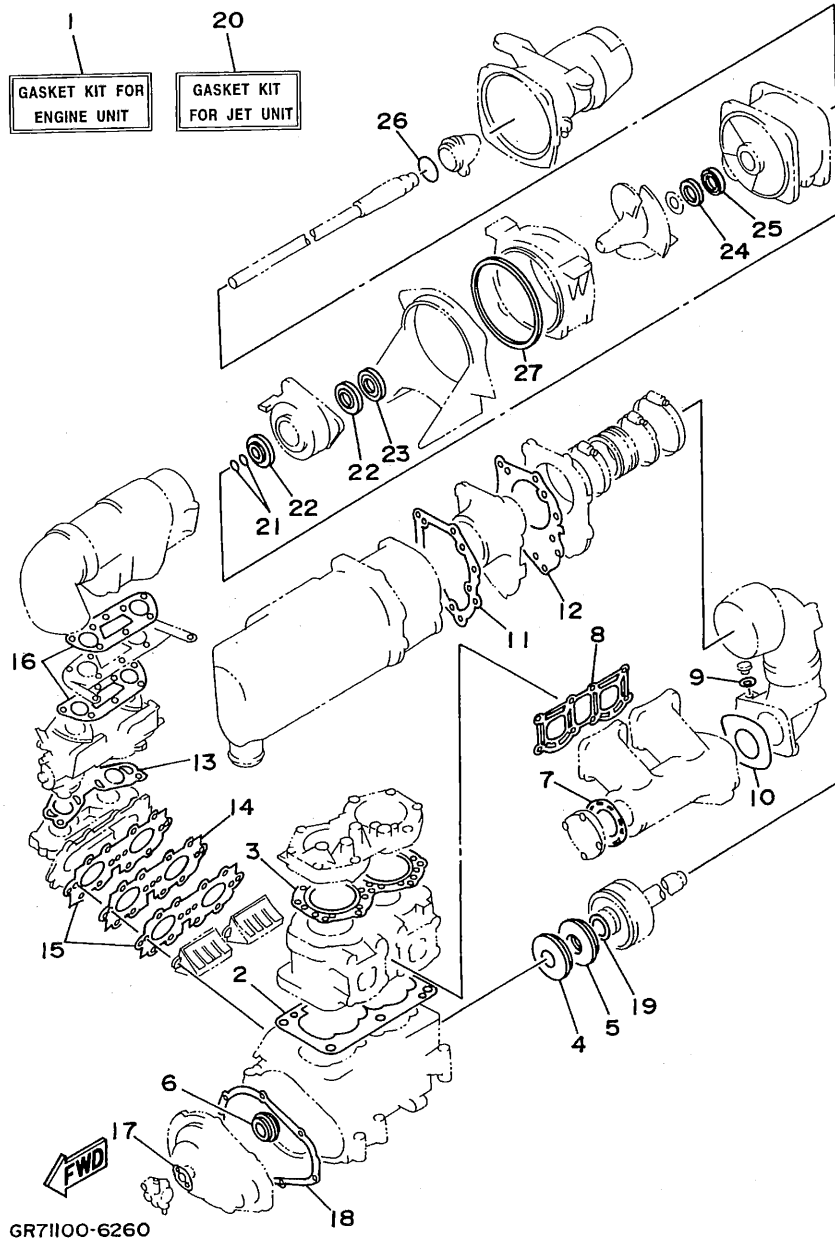
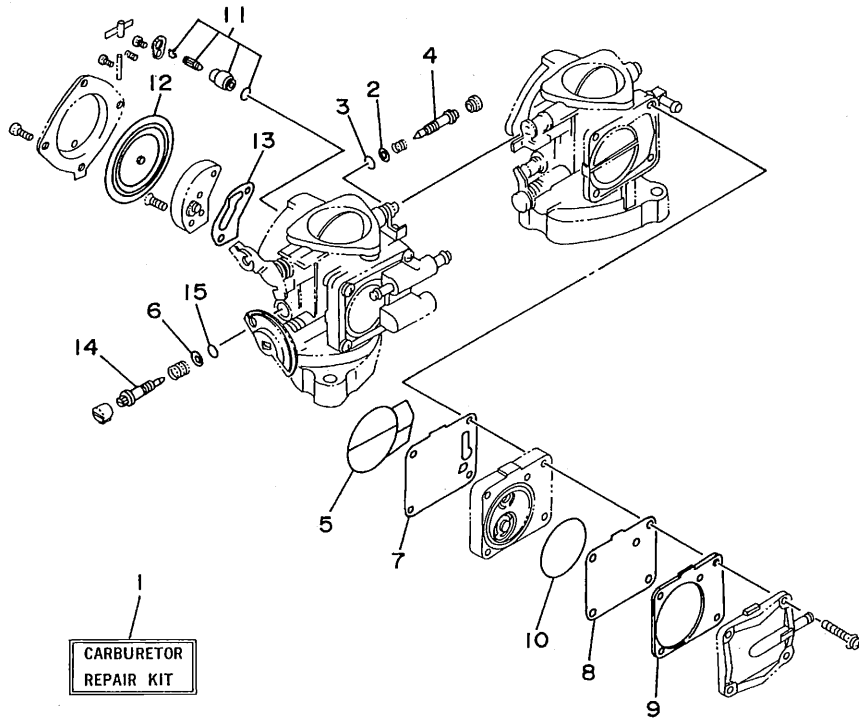

FIG. 23 REPAIR KIT 1

REF. NO.	PART NO.	DESCRIPTION	Q'TY	REMARKS
1	64U-W0001-00	GASKET KIT FOR ENGINE UNIT	1	
2	6M6-11351-A2	.GASKET, CYLINDER	1	
3	62T-11181-00	.GASKET, CYLINDER HEAD 1	1	
4	93102-36M33	.OIL SEAL	1	
5	93101-36M46	.OIL SEAL	1	
6	93103-32M01	.OIL SEAL	1	
7	6M6-14739-A1	.GASKET, MUFFLER DAMPER 1	1	
8	61X-14613-A0	.GASKET, EXHAUST PIPE	1	
9	90430-08020	.GASKET	1	
10	6R7-14749-A0	.GASKET, MUFFLER DAMPER 2	1	
11	6R7-14755-A0	.GASKET, SILENCER	1	
12	6R7-41114-A0	.GASKET, EXHAUST OUTER COVER	1	
13	62T-13556-00	.GASKET, MANIFOLD	1	
14	62T-13624-00	.PLATE, REED VALVE	1	
15	62T-13566-00	.GASKET	2	
16	62T-13674-00	.GASKET, AIR COOLER COVER 1	2	
17	6R8-13116-A0	.GASKET, PUMP CASE	1	
18	6M6-81365-A0	.GASKET, HOLE COVER	1	
19	62T-45127-00	.SEAL	1	
20	61X-W0001-22	GASKETKIT FOR JET UNIT	1	
21	93210-17MA4	.O-RING	2	
22	93101-25M55	.OIL SEAL	2	
23	93101-25M56	.OIL SEAL	1	
24	93102-25M34	.OIL SEAL	1	
25	93101-25M50	.OIL SEAL	1	
26	93210-46M16	.O-RING	1	
27	6R7-51117-01	.PACKING	1	

FIG. 24 REPAIR KIT 2

REF. NO.	PART NO.	DESCRIPTION	Q'TY	REMARKS
1	64U-W0093-00	CARBURETOR REPAIR KIT	1	
2	6K8-14559-00	.WASHER	4	
3	6K8-14562-00	.O-RING	2	
4	63M-14946-00	.PLATE, NEEDLE FITTING	2	
5	6K8-14564-00	.O-RING	2	
6	6K8-14537-00	.GASKET	2	
7	6K8-24411-20	.DIAPHRAGM	1	
8	6K8-24421-10	.VALVE, CHECK	1	
9	6K8-24431-20	.GASKET, FUEL PUMP 1	1	
10	6K8-14563-00	.O-RING	1	
11	61X-14916-15	.NEEDLE	2	
12	6R7-14541-00	.DIAPHRAGM, PUMP	2	
13	6K8-14536-11	.GASKET	2	
14	63M-14923-00	.SCREW, PILOT	2	
15	583-14561-00	.O-RING	2	



GHI4010-4271

D7

NUMERICAL INDEX

PART NO.	GRID NO.	PART NO.	GRID NO.	PART NO.	GRID NO.	PART NO.	GRID NO.	PART NO.	GRID NO.	PART NO.	GRID NO.
61X-W0001-22	D- 6	6R7-14485-00	B- 9	6R7-14755-A0	D- 6	6M6-45813-21-9M	B- 4	FX1-61552-00	C-14	GM6-6415E-50	D- 5
64U-W0001-00	D- 6	6K8-14521-00	B- 8	6M6-14771-00-94	B-10	6M6-45813-31-8P	B- 4	EW2-61553-00	C-14	GM6-6416B-00	D- 5
62T-W0004-00	B- 5	6K8-14521-10	B- 7	6R7-14785-00-9M	B-10	6R7-51117-01	B-12	FN8-61651-00	C- 9	GM6-6416B-10	D- 5
64V-W0090-00-8P	B- 2	6M6-14521-00	B- 7	61X-14916-15	B- 8		D- 6	EU0-61652-00	C- 9	GH7-6416C-20	D- 5
64U-W0093-00	D- 7	6K8-14523-11	B- 8		D- 7	6K8-51129-00	B- 2	GP7-61652-00	C-12	GM6-6416C-20	D- 5
64U-11111-01-94	B- 2	6K8-14527-11	B- 8	63M-14923-00	B- 8		B- 9	GM6-6213F-00	C- 7	GH7-6416D-20	D- 5
62T-11181-00	B- 2	62T-14527-02	B- 5		D- 7		B- 9	EW2-62137-00	C- 7	GM6-6416E-20	D- 5
	D- 6	6K8-14531-00	B- 7	6K8-14926-10	B- 7		B-12	EW2-62140-00	C-10	GM6-6416F-20	D- 5
61X-11311-00-94	B- 2	6K8-14533-00	B- 7	6K8-14930-00	B- 7		B-12	EW2-62142-00	C-10	GA7-6416H-20	D- 5
6E5-11325-00	B- 2	6K8-14534-10	B- 7	63M-14946-00	B- 7	6K8-51162-00	C- 8	EW2-62149-00	C- 5	GM6-6417B-30	D- 4
6M6-11351-A2	B- 2	6K8-14536-11	B- 8		D- 7	6R7-51311-00	B-12	GM6-6215G-00	D- 2	GM6-6417B-40	D- 4
	D- 6		B- 8	62T-15100-00-94	B- 2	6R7-51312-00-94	B-12	EW2-62150-00	C-10	GM6-6417C-30	D- 4
61X-11400-03	B- 4	6K8-14537-00	B- 8	6R7-15761-00	B- 9	61L-51313-00	B-12	GM6-62501-10	C- 9	GM6-6417C-40	D- 4
61X-11603-00	B- 4		D- 7	6R7-21415-01-94	B- 2	62T-51315-01-94	B-12	GM6-6251D-00	C- 9	GM6-6417D-30	D- 4
61X-11604-00	B- 4	6R7-14541-00	B- 8	6R7-21425-01-94	B- 2	6R7-51318-05-94	B-12	GM6-6251E-00	C- 9	GM6-6417D-40	D- 4
61X-11605-00	B- 4		D- 7	EU0-23814-01	C-14	6R7-51321-00-94	B-12	GM6-6252C-10	C- 9	GM6-6417E-30	D- 4
61X-11631-00-93	B- 4	6R7-14542-00	B- 8	62T-24313-01	B- 5	6R7-51323-02	B-14	GM6-6252D-10	C- 9	GM6-6417E-40	D- 4
61X-11633-00	B- 4	6K8-14547-01	B- 8	62T-24314-01	B- 5	62T-51326-00	B-12	GM6-62552-10	C- 9	GM6-6417F-30	D- 4
61X-11635-00	B- 4	6K8-14559-00	B- 7	6E5-24378-00	B- 9	6R7-51333-00	B-12	GM6-62553-10	C- 9	GM6-6417F-40	D- 4
61X-11636-00	B- 4		D- 7	6K8-24411-20	B- 7	62T-51348-00	B-12	GM6-62664-00	C- 6	GM6-6417G-10	D- 4
6R8-13116-A0	D- 6	583-14561-00	B- 8		D- 7	61X-51381-00	B-14	EU0-62693-02	B-13	GM6-64175-00	D- 4
62T-13555-00-8P	B- 5		D- 7	6R7-24412-01	B- 8	61L-5169A-00	B- 5	EU0-62694-00	C-13	GL3-6418B-10	D- 5
62T-13556-00	B- 5	6K8-14562-00	B- 7	6M6-24413-00	B- 7	FX1-61105-00	D- 2	EU0-62695-00	B-13	GM6-6418B-00	D- 5
	D- 6		D- 7	6K8-24421-10	B- 7	EW2-61314-00	C-15	EW2-62723-30	B-13	GM6-6418B-30	D- 5
62T-13566-00	B- 5	6K8-14563-00	B- 7		D- 7	GM6-61338-00	D- 2	EW2-62731-01	B-13	GM6-6418D-00	C-11
	D- 6		D- 7	6K8-24431-20	B- 7	FX1-6133C-11	D- 2	EW2-62840-10	C- 6	GM6-6418E-00	D- 5
62T-13610-00	B- 5	6K8-14564-00	B- 7		D- 7	FX1-61337-00	D- 2	EW2-62843-00	C- 6	EW2-64184-00	D- 5
62T-13624-00	B- 5		D- 7	6K8-24452-10	B- 7	FX1-61338-00	D- 2	EW2-62845-10	C- 6	EU0-64188-00	D- 5
	D- 6	6R7-14569-00	B- 8	70R-24489-00	C-10	FX1-6134L-00	D- 2	EW2-62846-00	C- 6	GM6-6419D-30	D- 5
62T-13674-00	B- 5	6K8-14579-00	B- 8	6K8-24500-02	B-11	EW2-61344-01	D- 2	EW2-62847-00	C- 6	GM6-6419D-20	D- 5
	D- 6	6K8-14589-00	B- 8	6R7-24524-00	B-11	FX1-61391-00	D- 3	EW2-62848-00	C- 7	GM6-6419D-30	D- 5
3G2-14231-26-A0	B- 7	6R7-14596-01	B- 7	70R-24543-00	C-10	EW2-61395-30	D- 2	A00-62858-02	C- 6	GR7-6419E-10	D- 5
	B- 7	6K8-14597-11	B- 7	6K8-24560-10	B-11	EW2-61417-00	C-15	GM6-6351B-00	C- 9	EW3-64197-00	D- 5
830-14231-14	B- 7	61X-14613-A0	B- 9	6E0-28193-00-94	B-10	EW2-61419-00	C-15	GM6-6351C-00	C- 9	GM6-6491A-00-3S	D- 2
62T-14243-01	B- 5		D- 6	626-28193-01-94	B-10	GM6-6142A-10	D- 2	GM6-6351D-00	C- 9	FX1-6492E-10	D- 2
62T-14251-00	B- 2	61L-14615-A0	B-10	6R7-41113-00-9M	B-10	FX1-6143D-20	C-14	GM6-6351E-00	C- 9	GM6-6492J-10	D- 3
6R7-14253-00	B- 8	61L-14625-A0	B-10	6R7-41114-A0	B-10	FX1-6143E-20	C-14	GM6-63844-00	C-12	GM6-64949-00	D- 3
62T-14255-00	B- 5	61X-14711-01-9P	B- 9		D- 6	EU0-61435-00	C-13	GK5-6411B-00	D- 5	FX1-65116-10	C- 6
62T-14283-00	B- 6	61L-14712-00-9P	B- 9	6R7-42316-00	B-12	EU0-61436-00	C-13	GM6-64114-10	D- 4	GM6-65135-00	D- 2
62T-14284-10-98	B- 5	6M6-14718-01-9P	B- 9	6R7-44517-00-9M	B- 2	EU0-61438-00	C-13	GM6-64115-10	D- 4	GM6-65136-00	C- 6
64U-14301-00	B- 7	6R7-14721-00-9M	B- 9	663-45119-00	B- 5	EU0-61446-00	C-13	GM6-64116-10	D- 4	EW2-65137-00	C- 6
64U-14302-00	B- 7	6M6-14739-A1	B- 9	62T-45127-00	B- 4	EU0-61461-01	C-14	GH7-64121-10	D- 4	FX1-6514B-00	C- 6
62T-14419-00	B- 6		D- 6		D- 6	EU0-61461-30	C-13	GM6-6415B-00	D- 5	FX1-6514F-00	C- 6
62T-14435-00	B- 6	6R7-14749-A0	B- 9	61X-45332-02-94	B-14	EW2-61465-00	D- 2	GM6-6415C-00	D- 5	GM6-6516A-10-PO	C- 6
62T-14451-00	B- 6		D- 6	61L-45378-00	B-14	FX1-61468-00	D- 2	GM6-6415D-00	D- 5	GM6-6516C-00	C- 6
6K8-14471-10	B- 7	64V-14752-00	B-10	6R7-45511-01	B-12	GM6-61481-00	C-13	GM6-6415E-30	D- 5	FX1-6517D-00	C- 6
6K8-14481-10	B- 8	6R7-14753-00-9M	B- 9	62T-45526-00	B- 4	EU0-61486-00	C-13		D- 5	GM6-6521C-00	C- 9
6R7-14485-00	B- 2	6R7-14755-A0	B-10	61X-4581J-00	B- 4	EW2-61540-10	C-14	GM6-6415E-40	D- 5	GM6-6521D-00	C- 9

NUMERICAL INDEX

PART NO.	GRID NO.	PART NO.	GRID NO.	PART NO.	GRID NO.	PART NO.	GRID NO.	PART NO.	GRID NO.	PART NO.	GRID NO.
FX1-65760-00	C-12	EU0-67817-00	B-11	64V-82117-00	C- 5	90119-08904	B- 3	90387-06M05	B-15	90465-11M10	C-12
EW2-65772-00	C-10	EW2-67821-00	C-10	6K8-82150-01	C- 3	90119-08907	B-14	90387-06M60	B-14	90465-12M53	B-15
	C-12	EW2-67821-30	C-10	6G1-82151-00	C- 3	90119-08943	B-13	90387-06916	D- 3		B-15
EU0-65901-01	D- 4	EW2-67822-01	C-11	6K8-82159-00	C- 3	90119-10M00	B- 2	90387-08M06	B-13	90465-12M56	B-11
FX1-6591A-10	C- 6	FN8-67831-01	C-11	6R7-82351-00	C- 3	90119-10M01	B- 2	90430-08020	B- 9	90465-13M11	C- 4
FX1-6591K-00	C- 6	EU0-67832-00	C-11	6R7-82352-00	C- 3	90119-10M02	B- 2		D- 6		C- 8
EW2-65912-00	C- 6	FN8-67833-00	C-11	6R7-82361-01	C- 4	90119-10M03	B- 2	90445-07M19	B- 2		C- 8
EW2-65913-00	C- 6	EU0-67834-00	C-11	6R7-82370-00	C- 4	90119-10M07	B- 2	90445-09M17	B-14		C-13
EU0-65986-00	D- 4	EU0-67835-00	C-11	62E-82371-11	C- 4	90119-10M56	B- 2	90445-10ME3	B-11	90467-06016	B- 2
EU0-65986-10	D- 4	EU0-67839-00	C-11	6R7-82553-01	C- 4	90119-10M72	B-10	90445-10ME4	B-11	90467-08M10	C- 5
GM6-65987-00	D- 4	GM6-67844-10	C-10	6R7-82560-00	C- 4	90119-10948	B-13	90445-10ME8	B-11	90467-11032	C-10
GM6-67242-00	C-13	EU0-67856-40	C- 5	6R7-83623-40	C- 3	90149-05937	C-14	90445-10MF1	B-11	90480-06M43	C- 3
GDO-67249-00-05	B-14	EU0-67869-00	C-11	6R7-83623-50	C- 3	90149-05959	C-14	90445-10M98	B-11		C- 4
GDO-67249-00-10	B-14	EW2-68156-00	C- 4	63N-83623-00	C- 3	90149-05960	C- 9	90445-11903	C-10	90480-06M69	B-14
EW2-67250-02	C-14	EW2-68211-00	C- 5	62T-85515-00	B-15	90149-05962	C- 9	90445-14M04	C- 8	90501-14M73	C- 2
GM6-67252-00	C-13	EU0-68218-04	C- 5	6M6-8552A-01-98	C- 3	90149-06997	D- 2	90445-14M06	B- 9	90560-22281	C-14
EW2-67255-00	C-14		C-12	6M6-8552E-01	C- 3	90159-05900	C-14	90445-14M12	B-12	90600-91728	C-14
EW2-67256-00	C-14	EU0-68221-00	C- 5	62T-85520-00	B-15	90170-14913	D- 2	90445-14M19	C- 8	90600-91736	B-11
EW2-67257-01	C-14	EU0-68221-30	C- 5	62T-85533-00	B-15	90170-22187	B-11	90445-14M29	B- 9		C- 4
EW2-67258-01	C-14	EW2-68221-00	C- 5	62T-85540-01	C- 3	90176-10915	C-15		B- 9		C- 8
EW2-67259-01	C-14	EW2-68310-03	C-14	62T-85550-00	B-15	90179-05964	C- 9	90445-14M33	B- 9	90601-11062	B-10
EU0-67324-00	B- 3	FK7-68312-02	C-14	6R7-85560-10	B-15	90179-08M15	B- 5	90446-14M23	B-11		B-13
EU0-67354-00-01	B- 3	FK7-68313-01	C-14	62E-85570-00	C- 3	90179-10925	B-13	90446-14M30	C-11		C-10
EU0-67354-00-02	B- 3	EW2-68348-00	C-14	62E-85570-11	C- 4	90179-12933	C-15	90446-14M64	B-11	90601-15573	C-11
EU0-67354-00-03	B- 3	6M6-8132W-00	C- 3	6M6-85580-00	B-15	90201-05925	B-11	90450-14M05	B- 9	90601-16274	C-10
EU0-67354-00-05	B- 3	6M6-81337-00-8P	B-15	90105-06900	C-10		C- 4		B-12	90601-16875	C- 7
EU0-67354-00-10	B- 3	6M6-81365-A0	B-15		C-12		C- 8	90460-64M15	B-10		C-12
EU0-67354-00-20	B- 3		D- 6	90105-08902	C-14	90201-05928	C-14	90460-70M16	B-10		C-12
EW2-67354-00-01	B-13	6M6-81800-10	C- 2	90105-10M45	B-10	90201-06M02	B-12	90460-90M11	B-10	90601-20006	B-11
EW2-67354-00-03	B-13	3AJ-81809-00	C- 2	90105-10M49	B-10	90201-20M04	B- 4	90464-06M29	C- 3		B-11
EW2-67354-00-05	B-13	6M6-81820-00	C- 2	90109-10M44	B-15	90201-24M02	B- 4	90465-08M07	B-11		C- 4
EW2-67354-00-10	B-13	6M6-81826-00	C- 2	90116-08M60	B- 5	90209-12920	C-13		C- 3		C- 8
GH7-6753B-00	C-12	6M6-8183E-00	C- 2	90119-05M02	B- 6	90267-40935	C-11	90465-11M10	B- 5		D- 2
GM6-6755J-00	C-12	6M6-81830-00	C- 2	90119-05923	C- 7	90267-40945	C-13		B- 5	90601-20016	B-11
GM6-67550-00	C-12	6M6-81840-10	C- 2	90119-06MA1	B-10	90267-48925	B-11		B- 9	90699-50003	C-10
GM6-67555-00	C-12	11H-81844-00	C- 2	90119-06M70	B-12		B-11		B-11	90699-50045	C-10
GM6-67565-00	C-12	6M6-81844-00	C- 3	90119-06900	C- 6		C- 4		B-11	90699-50120	C-10
GM6-67593-00	C-11	26H-81847-00	C- 2		D- 2		C- 8		B-11	91490-16010	C-10
GM6-67594-00	C-11	6M6-81850-00	C- 2	90119-06908	B-13		C-10		B-11	91790-05040	C-10
EU0-67613-00	C- 8	6M6-81865-00	C- 2		C- 4	90267-48930	C-12		B-14	92580-06016	C- 6
EW2-67618-00	C- 8	6M6-81866-00	C- 2	90119-06913	D- 2	90267-48932	C- 9		C- 3	92903-06600	B- 5
EW2-67711-01	C-10	6M6-81921-00	C- 3	90119-06915	B-13	90267-48938	C- 6		C- 3		B- 5
FJO-67713-00	C-10	6G1-81941-10	C- 3	90119-06918	D- 2	90267-48963	C- 9		C- 4		B- 5
EW2-67714-02	C-10	6M6-81952-01	C- 3	90119-06920	C- 5	90280-05013	B-15		C- 5		B- 6
EW2-67716-01	C-10	6M6-81960-A0	C- 3	90119-08M19	B- 2	90340-08M04	B- 9		C- 8		B- 9
GM6-6773E-00	B-11	EU0-82110-09	C- 5	90119-08M55	B- 2	90380-12M29	B- 2		C-10		B-10
EU0-67767-31	C-10	6R7-82117-11	C- 5	90119-08M73	B- 9		B-15		C-10	92903-08600	B- 9
EU0-67816-30	B-11	62E-82117-20	C- 4	90119-08038	B- 3	90387-06M05	B-15		C-11		B- 9

NUMERICAL INDEX

PART NO.	GRID NO.	PART NO.	GRID NO.	PART NO.	GRID NO.	PART NO.	GRID NO.	PART NO.	GRID NO.	PART NO.	GRID NO.
92903-08600	C- 2	93102-36M33	D- 6	97013-08035	B- 9						
	C- 2	93103-32M01	B- 4		C- 2						
92990-05100	C- 9		D- 6	97013-08040	C- 2						
	D- 2	93210-13M63	B- 6	97090-06014	C- 6						
92990-05200	B-13	93210-17MA4	B-14	97095-06016	B-10						
	C- 9		D- 6		C- 4						
92990-05600	B- 5	93210-46M16	B-12	97095-06020	B-12						
	C-10		D- 6	97095-06025	B-15						
92990-06100	C- 2	93305-30601	B- 4	97095-06035	B-15						
	C- 6	93306-205U0	B-12		B-15						
	C- 6	93306-205U6	B-14	97095-08018	B-13						
	C-14	93306-307U3	B- 4	97513-06516	B- 5						
92990-06200	C- 6	93310-320U2	B- 4	97595-06525	B-14						
	C- 9	93430-47M04	B-14	97780-50114	C- 8						
	D- 2	93440-25M08	C- 2		C-11						
	D- 3	93440-80023	B- 4	97780-50316	C- 6						
	D- 3	93450-18M06	C- 2	97780-60120	B-13						
92990-06600	B-12	93450-21053	B- 4	97780-60520	D- 3						
	B-15	93603-10049	B- 2	97780-60525	C- 3						
	B-15	93604-07141	B- 2	97880-03008	C-14						
	B-15	93606-07M17	B-12	97880-05016	B- 5						
	C- 2	93606-12019	B- 2	97880-05025	C-14						
	C- 3		B-12	97880-06016	C- 3						
	C- 3		B-12	97880-06030	C- 3						
92990-08100	B- 7		B-14	97902-04122	B-15						
	C- 4		B-15	97902-05125	B-15						
	D- 2	94702-00040	C- 4	97980-05330	B- 7						
92990-08200	C- 4	94702-00272	C- 4	98580-04008	B-15						
92990-10100	C-15	94709-00040	C- 4	98580-05012	D- 2						
92990-10200	C-15	95380-06700	B-12	98580-06016	B-15						
92990-14200	C-12		C- 2	98780-04015	B- 2						
	D- 3	95380-06800	C- 9	98780-05016	B-13						
92995-06100	C- 4	95380-08600	C- 4	98980-04008	B-11						
	C- 9	95380-08700	B- 7	98980-04010	C-14						
92995-06600	B-10	95680-08630	D- 2								
	B-15	95720-05300	B-13								
92995-08600	B-13		C- 7								
93101-25M50	B-12	95720-06300	C- 6								
	D- 6		D- 2								
93101-25M55	B-14		D- 3								
	D- 6	95720-08300	D- 2								
93101-25M56	B-14	97013-06012	B- 6								
	D- 6	97013-06020	B- 5								
93101-36M46	B- 4		B-10								
	D- 6	97013-06025	B- 5								
93102-25M34	B-12		B- 9								
	D- 6	97013-06035	B- 5								
93102-36M33	B- 4	97013-08025	B- 9								

*COPYRIGHT: All rights reserved. No part of this publication
may be reproduced without permission.*

YAMAHA

YAMAHA MOTOR CO., LTD.
2500 SHINGA I IWATA SHIZUOKA JAPAN
SERVICE INFORMATION DIV.

PRINTED ON RECYCLED PAPER

Printed in Japan
First edition SEP., 1997