

PARTS CATALOGUE

SuperJet 700

SJ700B-E (F1ND/64VT/64V2)

SJ700B-E (F1NE/64VU/64V2)

MJ-SJ700 '06 (F1NF/64VV/64V2)

SJ700B-E/MJ-SJ700
PARTS CATALOGUE
©2005 by Yamaha Motor Co., Ltd.
1st edition, July 2005
All rights reserved.
Any reprinting or unauthorized use
without the written permission of
Yamaha Motor Co., Ltd.
is expressly prohibited.
Printed in Japan.

A3



A4

FOREWORD

This Parts Catalogue is related to the parts for the model(s) on the cover page. When you are ordering replacement parts, please refer to this Parts Catalogue and quote both part numbers and part names correctly.

1. Modifications or additions which have been made after the issue of the Parts Catalogue will be announced in the Parts News.

It is advisable that you make the necessary corrections to the Parts Catalogue according to the Parts News.

2. Abbreviations

The following abbreviations are used in this Parts Catalogue.

“UR” Use specified parts number.

“UN” Use as many as needed.

“AP” Alternate Parts

“LM” Locally Made (Parts need to be ordered locally)

“F#” Frame No. (Applicable machine No.)

“O/S” Over Size

3. The number of components for assembly

- Parts, which are to be supplied in an assembly, are listed with a dot (.) in front of the part name as shown below.
- The numeral appearing to the right of each component part indicates the quantity of parts for each assembly unit.

PART NO.	DESCRIPTION	Q'TY	REMARKS
2F5-83310-60	FRONT FLASHER LIGHT ASSY	2	
115-83311-60	.BULB (6V-18W)	1	

4. Applicable colours of graphics are represented in the “REMARKS” as shown below.

PART NO.	DESCRIPTION	Q'TY	REMARKS
2N4-24110-00-X5	FUEL TANK COMP.	2	MXR
3J1-24240-10	.GRAPHIC, FUEL TANK	1	FOR MXR

5. Note that the illustrations for reference in finding parts numbers are not to be used for assembling. When assembling, please use the applicable service manual.

6. The asterisk (*) before a reference number indicates modified items after the first edition.

FOREWORD

7. Applicable Serial No.

Engine Serial No.

Hull Serial No.

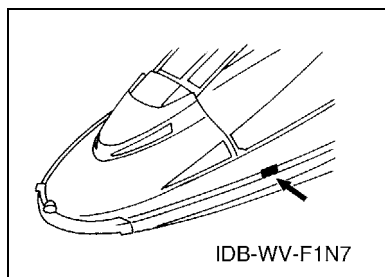
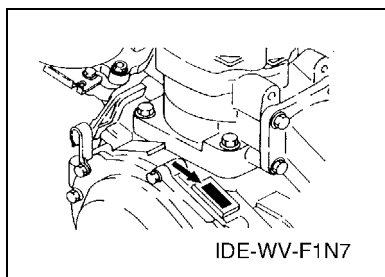

8. Applicable Colour Code (The (*) mark shows Model colour.)

Abbreviation	Colour Name	Colour Code
NMC(*)	GRAY METALLIC C	008S
SC1(*)	BLACK COAT 1	GA5W
SS4	BLACK SOLID 4	008P
PURW	PURE WHITE	0240
YB	YAMAHA BLACK	0033

9. Quantity Column Information

Column No.	Name Of Q'ty Column	Destination
1	USA	U.S.A.
2	GENE	EXCEPT USA, JPN
3	JPN	JAPAN

10. Applicable Starting Serial No.

Engine Serial No.

Serial No.	Name Of Q'ty Column	Model Code
64V-1009895	USA	64VT
64V-1009895	GENE	64VU
64V-1009895	JPN	64VV

Hull Serial No.

Serial No.	Name Of Q'ty Column	Model Code
F1N-505965	USA	F1ND
F1N-505965	GENE	F1NE
F1N-1800916	JPN	F1NF

CONTENTS

CYLINDER & CRANKCASE	B2
CRANKSHAFT & PISTON	B4
INTAKE	B6
CARBURETOR	B8
CARBURETOR 2	B10
EXHAUST 1	B12
FUEL	B15
JET UNIT 1	C3
JET UNIT 2	C5
GENERATOR	C6
STARTING MOTOR	C7
ELECTRICAL 1	C8
ELECTRICAL 2	C10
ENGINE HATCH	C11
HULL & DECK	C13
GUNWALE & MAT	C14
FUEL TANK	C15
EXHAUST 2	D3
CONTROL CABLE	D4
STEERING 1	D5
STEERING 2	D7
GRAPHICS	D9
IMPORTANT LABELS	D10
IMPORTANT LABELS 2	D11
IMPORTANT LABELS 3	D12
REPAIR KIT 1	D13
REPAIR KIT 2	D14

INDEX

NUMERICAL INDEX	M1
-----------------------	----

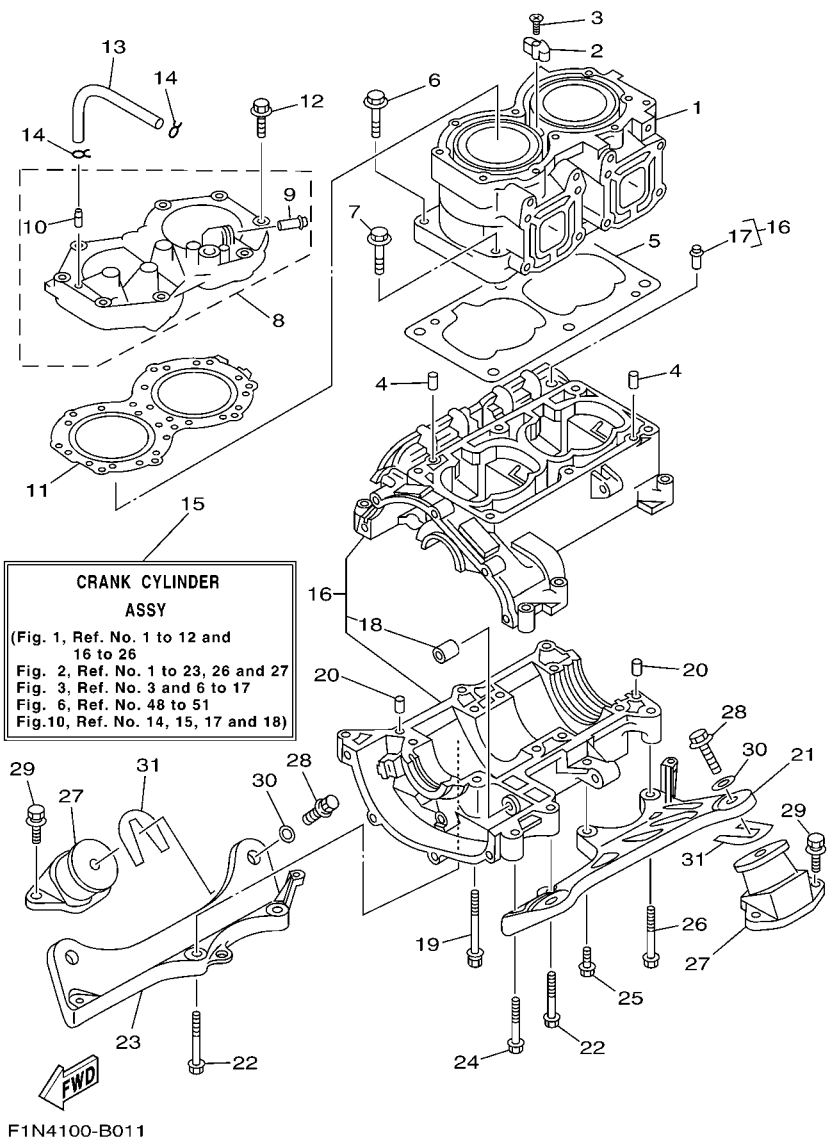
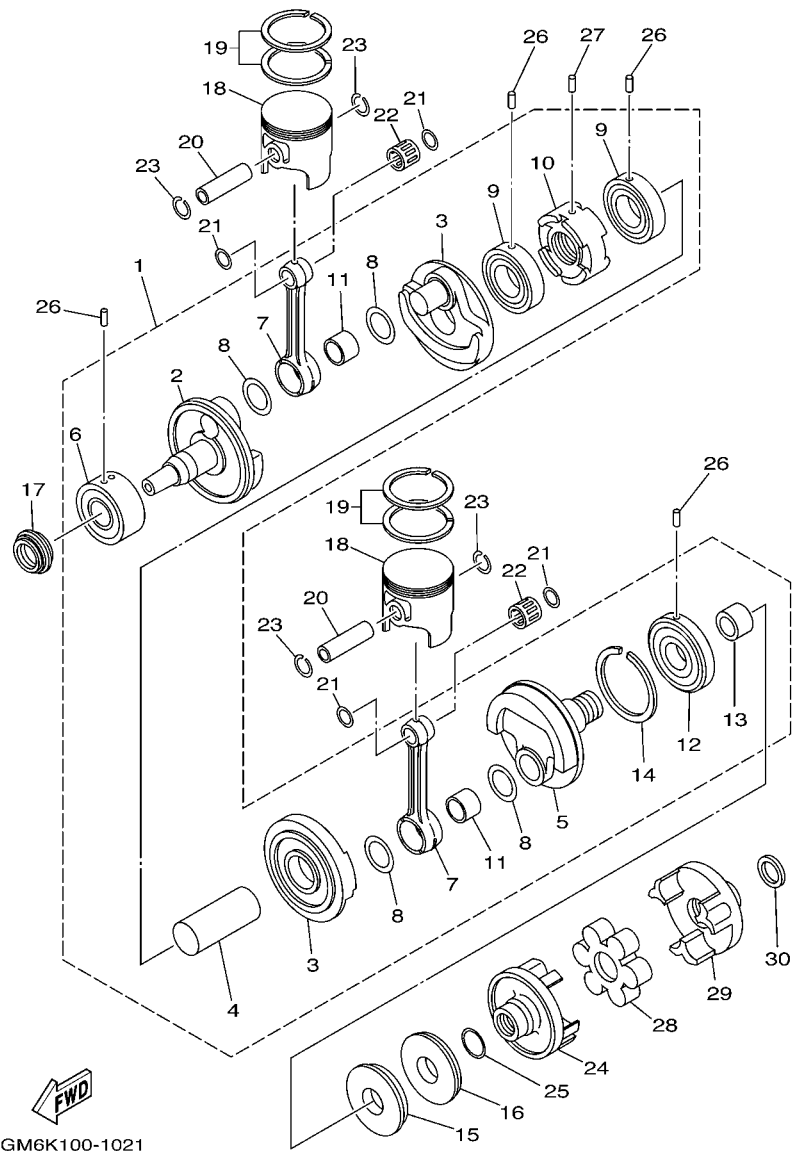

FIG. 1 CYLINDER & CRANKCASE

REF. NO.	PART NO.	DESCRIPTION	USA	GENE	JPN	REMARKS
1	61X-11311-01-8S	CYLINDER 1	1	1	1	
2	6E5-11325-00	ANODE	1	1	1	
3	98780-04015	SCREW, FLAT HEAD	1	1	1	
4	93606-12019	PIN, DOWEL	2	2	2	
5	6M6-11351-A2	GASKET, CYLINDER	1	1	1	
6	90119-10M56	BOLT, WITH WASHER	4	4	4	
7	90119-10M07	BOLT, WITH WASHER	2	2	2	
8	64U-11111-00-8S	HEAD, CYLINDER 1	1	1	1	
9	6K8-51129-00	.NIPPLE	1	1	1	
10	6R7-14485-00	.PIPE, JOINT	1	1	1	
11	62T-11181-00	GASKET, CYLINDER HEAD 1	1	1	1	
12	90119-08M96	BOLT, WITH WASHER	10	10	10	
13	90445-07M19	HOSE (L200)	1	1	1	
14	90467-06016	CLIP	2	2	2	
15	64V-W0090-02-8S	CRANK CYLINDER ASSY	1	1	1	
16	62T-15100-00-8S	CRANKCASE ASSY	1	1	1	
17	62T-14251-10	.NIPPLE	1	1	1	
18	90380-12M29	.BUSH, SOLID	1	1	1	
19	90119-08M55	BOLT, WITH WASHER	8	8	8	
20	93606-12019	PIN, DOWEL	2	2	2	
21	6R7-21415-01-94	BRACKET, FRONT UPPER 1	1	1	1	
22	90119-10M02	BOLT, WITH WASHER	4	4	4	
23	6R7-21425-01-94	BRACKET, REAR UPPER 1	1	1	1	
24	90119-10M01	BOLT, WITH WASHER	1	1	1	
25	90119-10M00	BOLT, WITH WASHER	1	1	1	
26	90119-10M03	BOLT, WITH WASHER	1	1	1	
27	6R7-44517-00-8S	MOUNT RUBBER	4	4	4	



GM6K100-1021

FIG. 2 CRANKSHAFT & PISTON

REF. NO.	PART NO.	DESCRIPTION	USA	GENE	JPN	REMARKS
1	61X-11400-03	CRANKSHAFT ASSY	1	1	1	
2	6M6-11412-00	.CRANK 1	1	1	1	
3	6M6-11422-00	.CRANK 2	2	2	2	
4	6M6-11431-00	.CRANK 3	1	1	1	
5	6M6-11442-01	.CRANK 4	1	1	1	
6	93305-30601	.BEARING	1	1	1	
7	62T-11651-00	.ROD, CONNECTING	2	2	2	
8	82M-11685-00	.WASHER, CRANK PIN	4	4	4	
9	93306-207U2	.BEARING	2	2	2	
10	82M-11515-00	.SEAL, LABYRINTH 1	1	1	1	
11	93310-525U0	.BEARING	2	2	2	
12	93306-307U3	.BEARING	1	1	1	
13	62T-45526-00	.COLLAR, DRIVE SHAFT	1	1	1	
14	93440-80023	.CIRCLIP	1	1	1	
15	93102-36M33	OIL SEAL	1	1	1	
16	93101-36M46	OIL SEAL	1	1	1	
17	93103-32M01	OIL SEAL	1	1	1	
18	61X-11631-02-93	PISTON (STD)	2	2	2	
	61X-11635-02	PISTON (0.25MM O/S)	2	2	2	AP
	61X-11636-02	PISTON (0.50MM O/S)	2	2	2	AP
19	61X-11603-01	PISTON RING SET (STD)	2	2	2	
	61X-11604-01	PISTON RING SET (0.25MM O/S)	2	2	2	AP
	61X-11605-01	PISTON RING SET (0.50MM O/S)	2	2	2	AP
20	61X-11633-00	PIN, PISTON	2	2	2	
21	90201-20M04	WASHER, PLATE	4	4	4	
22	93310-320U2	BEARING	2	2	2	
23	93450-21053	CIRCLIP	4	4	4	

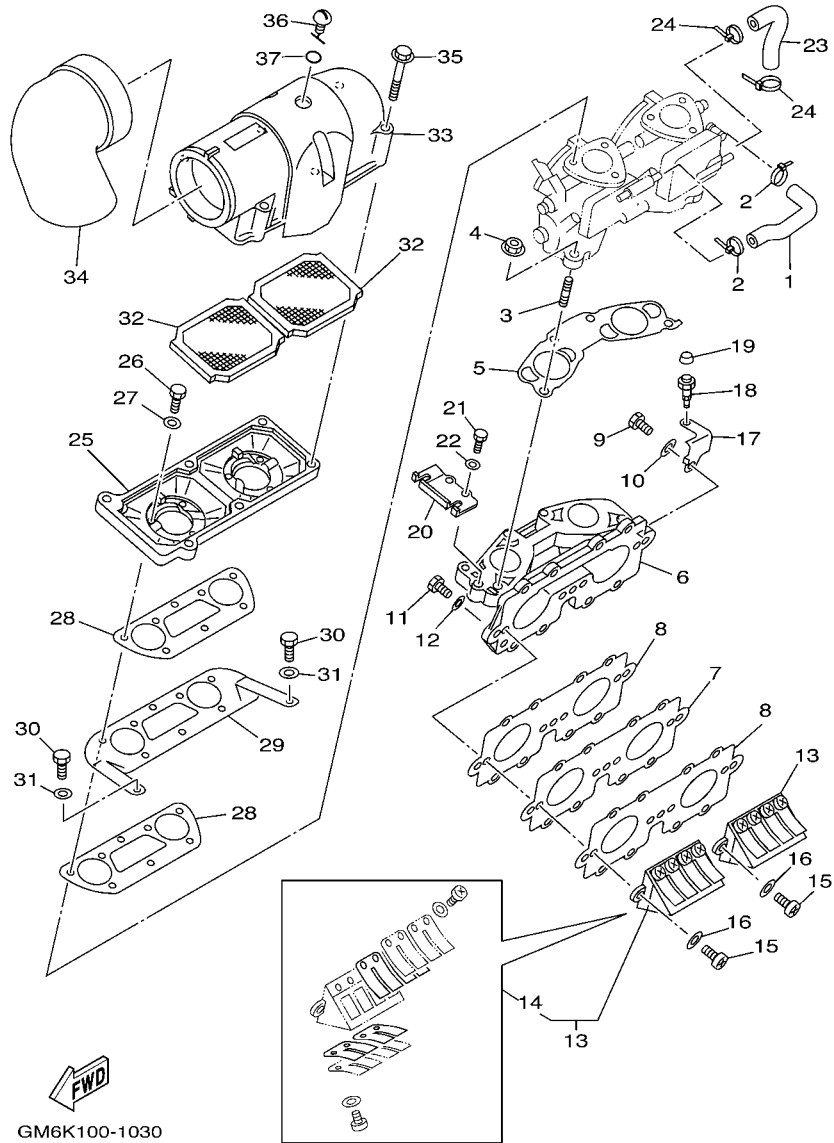

GM6K100-1030

FIG. 3 INTAKE

REF. NO.	PART NO.	DESCRIPTION	USA	GENE	JPN	REMARKS
1	62T-24313-01	PIPE 3	1	1	1	
2	90465-11M10	CLAMP	2	2	2	
3	90116-08M60	BOLT, STUD	4	4	4	
4	90179-08M15	NUT	4	4	4	
5	62T-13556-00	GASKET, MANIFOLD	1	1	1	
6	62T-13555-00-94	MANIFOLD, INTAKE	1	1	1	
7	62T-13624-00	PLATE, REED VALVE	1	1	1	
8	62T-13566-00	GASKET	2	2	2	
9	97013-06035	BOLT	3	3	3	
10	92903-06600	WASHER, PLATE	3	3	3	
11	97013-06025	BOLT	8	8	8	
12	92903-06600	WASHER, PLATE	8	8	8	
13	62T-13610-00	REED VALVE ASSY	2	2	2	
14	62T-W0004-00	.REED SET	1	1	1	
15	97880-05016	SCREW, PAN HEAD	4	4	4	
16	92990-05600	WASHER, PLATE	4	4	4	
17	62T-14243-01	PLATE	1	1	1	
18	61L-5169A-00	NIPPLE, GREASE	1	1	1	
19	663-45119-00	CAP, GREASE NIPPLE	1	1	1	
20	62T-14527-02	PLATE	1	1	1	
21	97013-06016	BOLT	2	2	2	
22	92903-06600	WASHER, PLATE	2	2	2	
23	62T-24314-01	PIPE 4	1	1	1	
24	90465-11M10	CLAMP	2	2	2	
25	62T-14284-10-8S	COVER, CARBURETOR 2	1	1	1	
26	97013-06020	BOLT	6	6	6	
27	92903-06600	WASHER, PLATE	6	6	6	

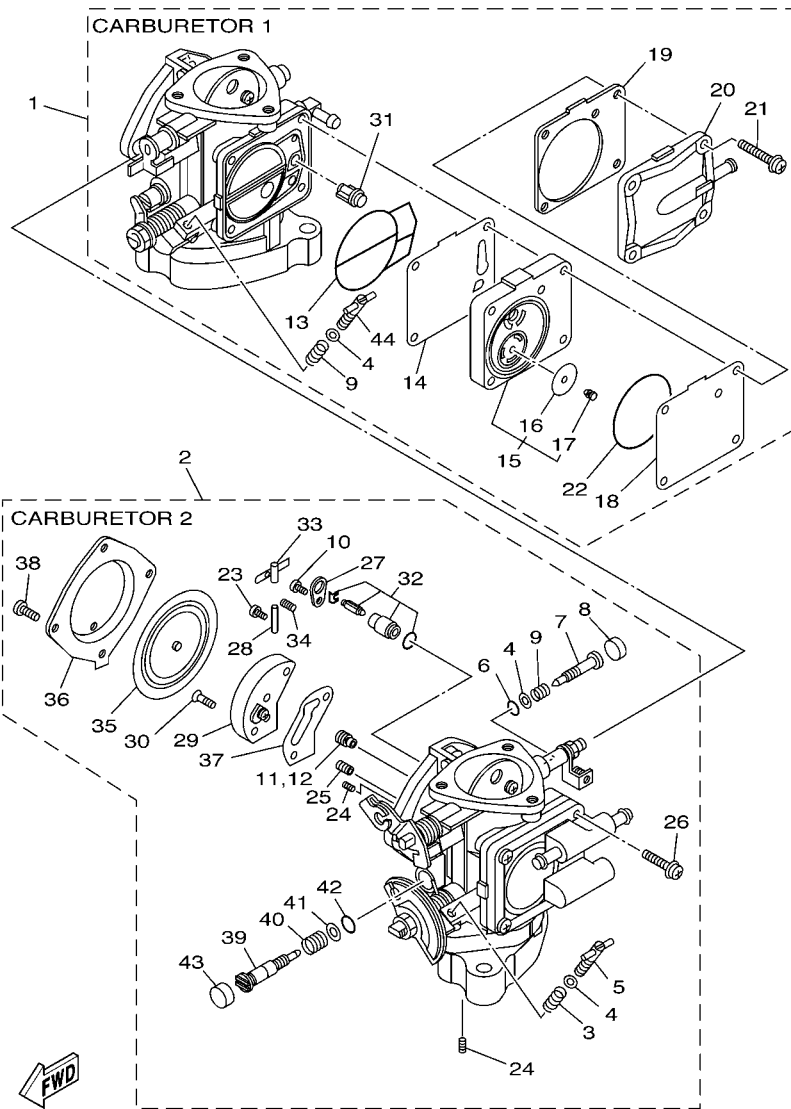

F1N7100-C040

FIG. 4 CARBURETOR

REF. NO.	PART NO.	DESCRIPTION	USA	GENE	JPN	REMARKS
1	64U-14301-10	CARBURETOR ASSY 1	1			
2	64U-14302-10	CARBURETOR ASSY 2	1			
3	47X-14133-00	.SPRING, THROTTLE STOP	1			CARBURETOR 2
4	812-14235-00	.WASHER, NEEDLE	4			
5	6M6-14521-01	.SCREW, ADJUST	1			CARBURETOR 2
6	812-14147-00	.O-RING	2			
7	64U-14946-00	.PLATE, NEEDLE FITTING	2			
8	64U-1432A-00	.PLUG	2			
9	3KW-14932-00	.SPRING, THROTTLE 2	3			
10	6M6-14503-00	.SCREW	2			
11	3G2-14231-26	.JET, MAIN (#130)	1			CARBURETOR 1
12	3G2-14231-26	.JET, MAIN (#130)	1			CARBURETOR 2
13	6K8-14564-00	.O-RING	2			
14	6K8-24411-20	.DIAPHRAGM	1			CARBURETOR 1
15	6M6-24413-02	.BODY 2	1			CARBURETOR 1
16	65U-24421-00	..VALVE, CHECK	2			CARBURETOR 1
17	65U-24492-00	..BUSH, FULEL PUMP	2			CARBURETOR 1
18	6K8-24421-10	.VALVE, CHECK	1			CARBURETOR 1
19	6K8-24431-20	.GASKET, FUEL PUMP 1	1			CARBURETOR 1
20	6K8-24452-10	.COVER	1			CARBURETOR 1
21	97980-05330	.SCREW, WITH WASHER	4			CARBURETOR 1
22	6K8-14563-00	.O-RING	1			CARBURETOR 1
23	6K8-14503-02	.SCREW	2			
24	6K8-14521-10	.SCREW	4			
25	830-14231-14	.JET, MAIN (# 70)	2			
26	98580-05018	.SCREW, PAN HEAD	4			CARBURETOR 2
27	6K8-14527-11	.PLATE	2			

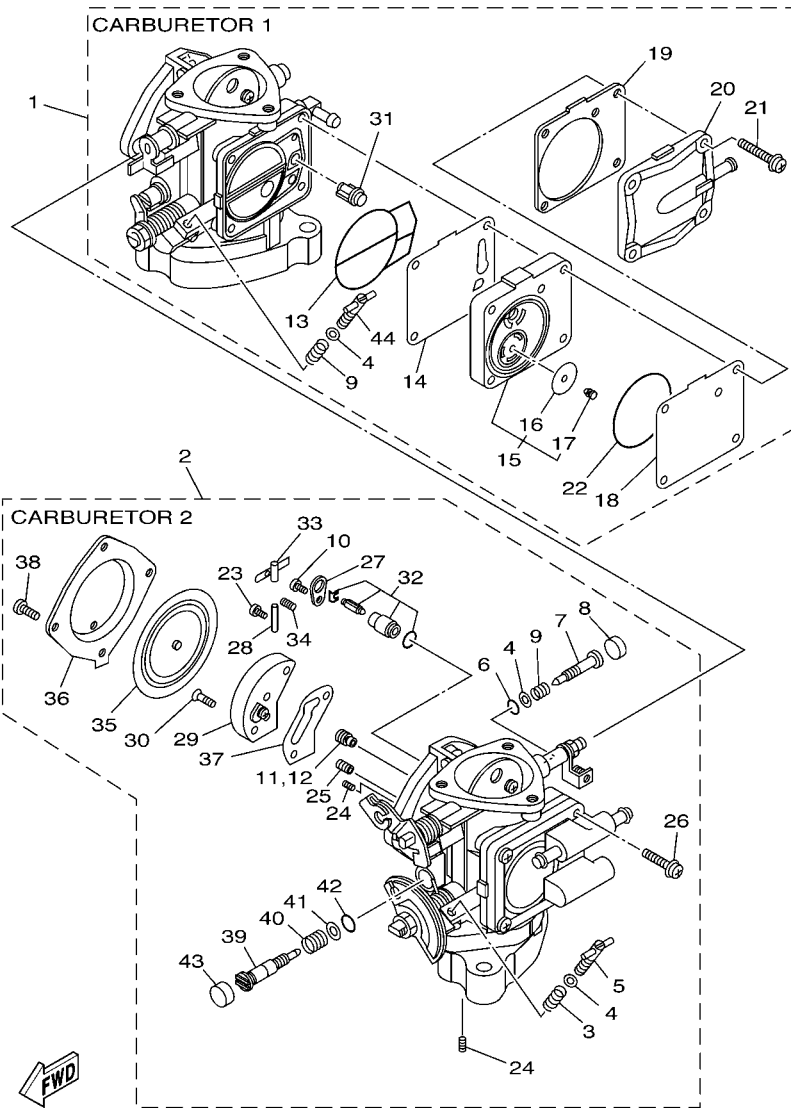

F1N7100-C040

FIG. 4 CARBURETOR

REF. NO.	PART NO.	DESCRIPTION	USA	GENE	JPN	REMARKS
28	439-14186-00	.PIN, FLOAT	2			
29	6R7-24412-02	.BODY 1	2			
30	6K8-14523-11	.SCREW, STOP	4			
31	6R7-14569-00	.STRAINER	2			
32	61X-14916-16	.NEEDLE	2			
33	6K8-14547-01	.ARM, FLOAT	2			
34	6R7-14253-00	.SPRING	2			
35	6R7-14541-00	.DIAPHRAGM, PUMP	2			
36	6R7-14542-00	.BODY, PUMP 1	2			
37	6K8-14536-11	.GASKET	2			
38	97880-05012	.SCREW, PAN HEAD	8			
39	64U-14923-10	.SCREW, PILOT	2			
40	6K8-14589-00	.SPRING	2			
41	822-14235-00	.WASHER, NEEDLE	2			
42	583-14561-00	.O-RING	2			
43	64U-1432A-10	.PLUG	2			
44	6K8-14521-01	.SCREW, ADJUST	1			CARBURETOR 1

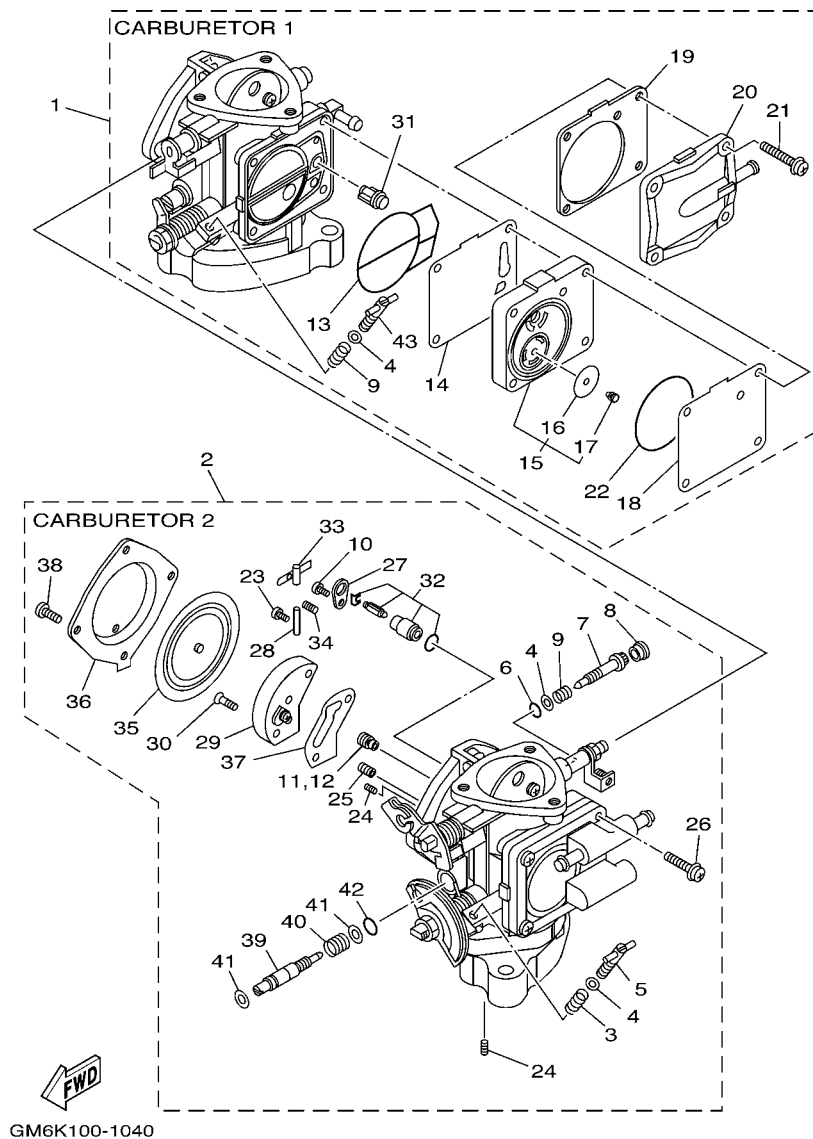
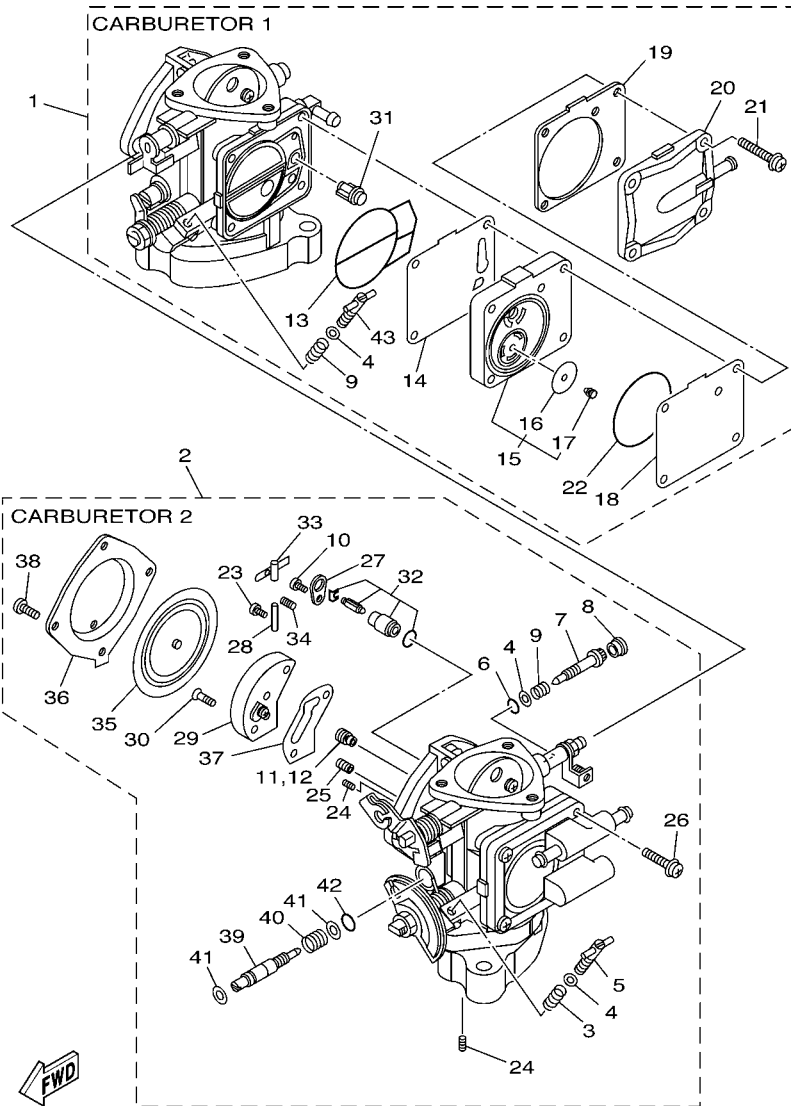

FIG. 5 CARBURETOR 2

REF. NO.	PART NO.	DESCRIPTION	USA	GENE	JPN	REMARKS
1	64U-14301-03	CARBURETOR ASSY 1		1	1	
2	64U-14302-03	CARBURETOR ASSY 2		1	1	
3	47X-14133-00	.SPRING, THROTTLE STOP		1	1	CARBURETOR 2
4	812-14235-00	.WASHER, NEEDLE		4	4	
5	6M6-14521-01	.SCREW, ADJUST		1	1	CARBURETOR 2
6	812-14147-00	.O-RING		2	2	
7	63M-14946-00	.PLATE, NEEDLE FITTING		2	2	
8	6K8-14471-10	.CAP, CARBURETOR		2	2	
9	3KW-14932-00	.SPRING, THROTTLE 2		3	3	
10	6M6-14503-00	.SCREW		2	2	
11	3G2-14231-26	.JET, MAIN (#130)		1	1	CARBURETOR 1
12	3G2-14231-26	.JET, MAIN (#130)		1	1	CARBURETOR 2
13	6K8-14564-00	.O-RING		2	2	
14	6K8-24411-20	.DIAPHRAGM		1	1	CARBURETOR 1
15	6M6-24413-01	.BODY 2		1	1	CARBURETOR 1
16	65U-24421-00	..VALVE, CHECK		2	2	CARBURETOR 1
17	65U-24492-00	..BUSH, FULEL PUMP		2	2	CARBURETOR 1
18	6K8-24421-10	.VALVE, CHECK		1	1	CARBURETOR 1
19	6K8-24431-20	.GASKET, FUEL PUMP 1		1	1	CARBURETOR 1
20	6K8-24452-10	.COVER		1	1	CARBURETOR 1
21	97980-05330	.SCREW, WITH WASHER		4	4	CARBURETOR 1
22	6K8-14563-00	.O-RING		1	1	CARBURETOR 1
23	6K8-14503-02	.SCREW		2	2	
24	6K8-14521-10	.SCREW		4	4	
25	830-14231-14	.JET, MAIN (# 70)		2	2	
26	98580-05018	.SCREW, PAN HEAD		4	4	CARBURETOR 2
27	6K8-14527-11	.PLATE		2	2	



GM6K100-1040

FIG. 5 CARBURETOR 2

REF. NO.	PART NO.	DESCRIPTION	USA	GENE	JPN	REMARKS
28	439-14186-00	.PIN, FLOAT		2	2	
29	6R7-24412-01	.BODY 1		2	2	
30	6K8-14523-11	.SCREW, STOP		4	4	
31	6R7-14569-00	.STRAINER		2	2	
32	61X-14916-16	.NEEDLE		2	2	
33	6K8-14547-01	.ARM, FLOAT		2	2	
34	6R7-14253-00	.SPRING		2	2	
35	6R7-14541-00	.DIAPHRAGM, PUMP		2	2	
36	6R7-14542-00	.BODY, PUMP 1		2	2	
37	6K8-14536-11	.GASKET		2	2	
38	97880-05012	.SCREW, PAN HEAD		8	8	
39	64U-14923-00	.SCREW, PILOT		2	2	
40	6K8-14589-00	.SPRING		2	2	
41	822-14235-00	.WASHER, NEEDLE		4	4	
42	583-14561-00	.O-RING		2	2	
43	6K8-14521-01	.SCREW, ADJUST		1	1	CARBURETOR 1

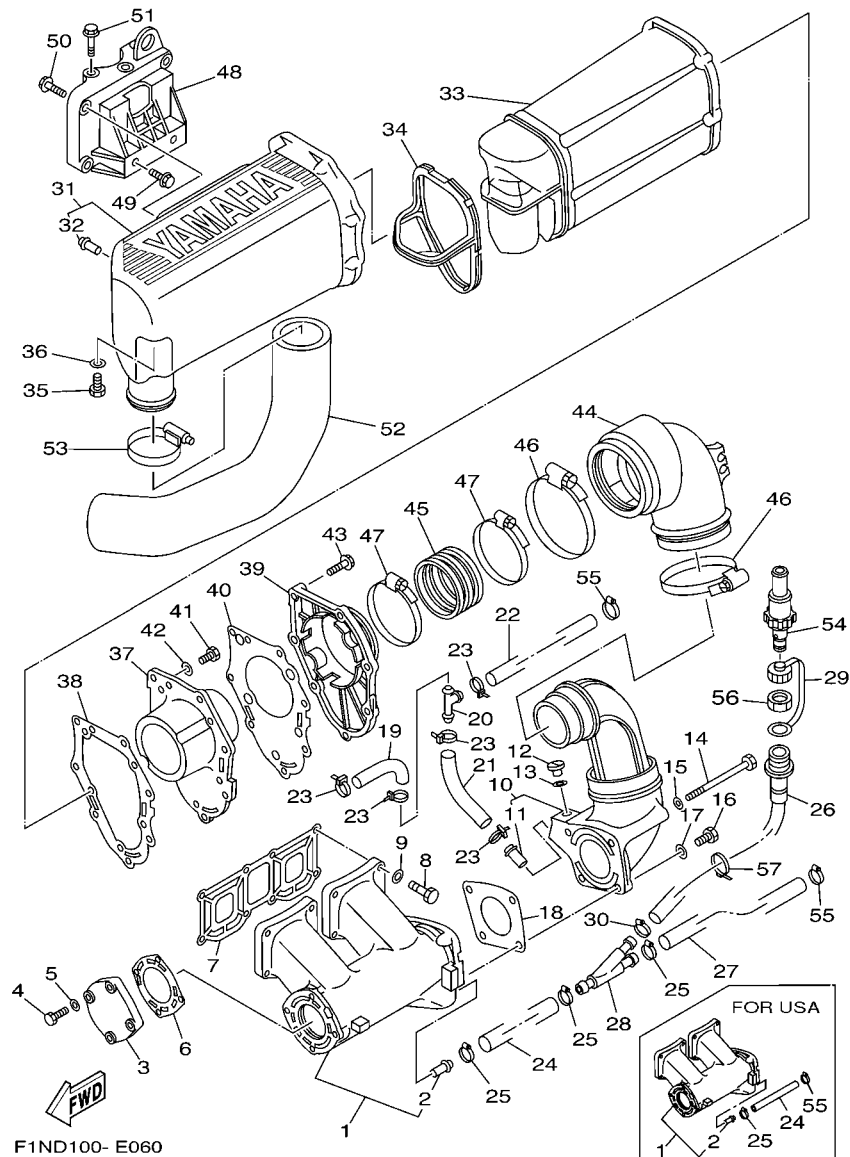

F1ND100- E060

FIG. 6 EXHAUST 1

REF. NO.	PART NO.	DESCRIPTION	USA	GENE	JPN	REMARKS
1	61X-14711-01-94	MUFFLER 1	1	1	1	
2	6K8-51129-00	.NIPPLE	1	1	1	
3	6M6-14718-01-8S	PROTECTOR, MUFFLER 1	1	1	1	
4	97013-06025	BOLT	4	4	4	
5	92903-06600	WASHER, PLATE	4	4	4	
6	6M6-14739-A1	GASKET, MUFFLER DAMPER 1	1	1	1	
7	61X-14613-A0	GASKET, EXHAUST PIPE	1	1	1	
8	97013-08035	BOLT	8	8	8	
9	92903-08600	WASHER, PLATE	8	8	8	
10	61L-14712-00-94	RING, JOINT	1	1	1	
11	6K8-51129-00	.NIPPLE	1	1	1	
12	90340-08M04	PLUG, STRAIGHT SCREW	1	1	1	
13	90430-08020	GASKET	1	1	1	
14	97013-08090	BOLT	2	2	2	
15	92903-08600	WASHER, PLATE	2	2	2	
16	97013-08025	BOLT	2	2	2	
17	92903-08600	WASHER, PLATE	2	2	2	
18	6R7-14749-A0	GASKET, MUFFLER DAMPER 2	1	1	1	
19	90445-14M29	HOSE (L125)	1	1	1	
20	6E5-24378-00	PIPE, JOINT 3	1	1	1	
21	90445-14M29	HOSE (L125)	1	1	1	
22	90445-14M33	HOSE (L1150)	1	1	1	
23	90465-11M10	CLAMP	5	5	5	
24	90445-14M06	HOSE (L630)	1			FOR USA
	90445-14M14	HOSE (L330)		1	1	FOR GENE,JPN
25	90450-14M05	HOSE CLAMP ASSY	1	3	3	
26	63M-12580-00	JOINT ASSY		1	1	FOR GENE,JPN

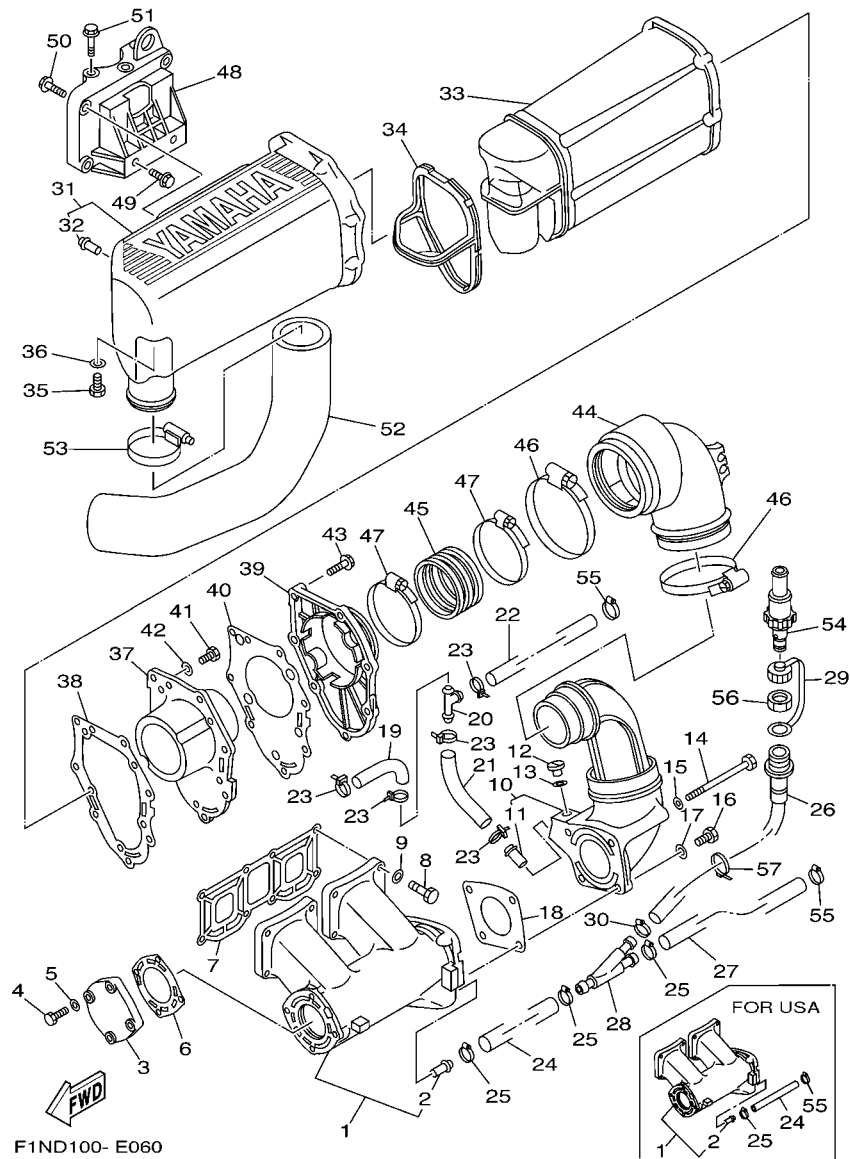

FIG. 6 EXHAUST 1

REF. NO.	PART NO.	DESCRIPTION	USA	GENE	JPN	REMARKS
27	90445-14M05	HOSE (L240)		1	1	FOR GENE,JPN
28	64X-12581-00	JOINT, HOSE 1		1	1	FOR GENE,JPN
29	682-84385-01	CAP,1		1	1	FOR GENE,JPN
30	90450-18M09	HOSE CLAMP ASSY		1	1	FOR GENE,JPN
31	6R7-14721-00-8S	MUFFLER 2	1	1	1	
32	6R7-14485-00	PIPE, JOINT	1	1	1	
33	6R7-14753-00-9M	SILENCER, EXHAUST	1	1	1	
34	6R7-15761-00	SEAL, RUBBER 1	1	1	1	
35	97013-06020	BOLT	1	1	1	
36	92903-06600	WASHER, PLATE	1	1	1	
37	6R7-14785-00-8S	DIFFUSER	1	1	1	
38	6R7-14755-A0	GASKET, SILENCER	1	1	1	
39	6R7-41113-00-8S	OUTER COVER, EXHAUST	1	1	1	
40	6R7-41114-A0	GASKET, EXHAUST OUTER COVER	1	1	1	
41	97095-06016	BOLT	5	5	5	
42	92995-06600	WASHER	5	5	5	
43	90119-06MA1	BOLT, WITH WASHER	7	7	7	
44	61L-14615-A0	JOINT, EXHAUST 1	1	1	1	
45	61L-14625-A0	JOINT, EXHAUST 2	1	1	1	
46	90460-90M11	CLAMP, HOSE	2	2	2	
47	90460-70M16	CLAMP, HOSE	2	2	2	
48	6M6-14771-00	STAY, MUFFLER 1	1	1	1	
49	90105-10M49	BOLT, FLANGE	2	2	2	
50	90105-10M88	BOLT, FLANGE	3	3	3	
51	90119-10M17	BOLT, WITH WASHER	3	3	3	
52	64V-14752-00	PIPE, OUTLET	1	1	1	
53	90460-64M15	CLAMP, HOSE	1	1	1	

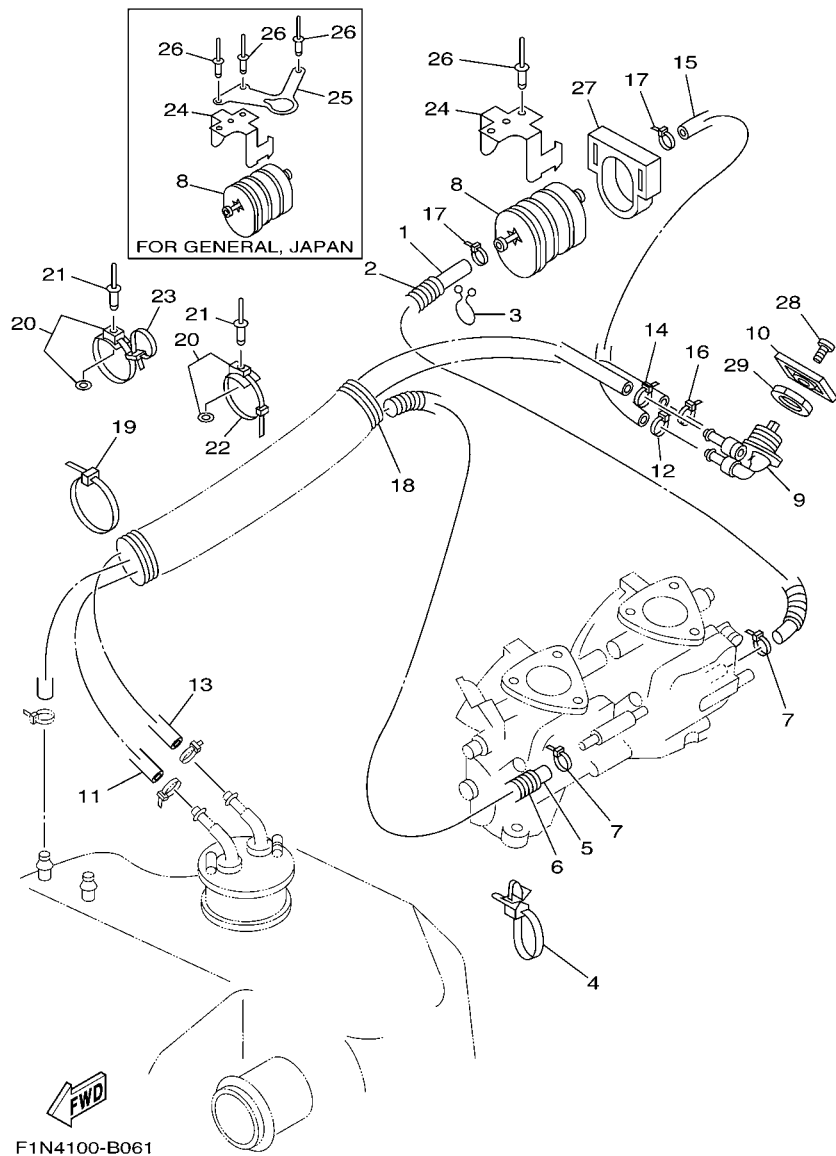

FIG. 7 FUEL

REF. NO.	PART NO.	DESCRIPTION	USA	GENE	JPN	REMARKS
1	90445-10ME8	HOSE (L230)	1	1	1	
2	90446-14M23	HOSE	1	1	1	
3	90464-08M07	CLAMP	1	1	1	
4	90465-12M56	CLAMP	1	1	1	
5	90445-10MF1	HOSE (L1220)	1	1	1	
6	90446-14M64	HOSE	1	1	1	
7	90465-11M10	CLAMP	2	2	2	
8	6K8-24560-10	FILTER ASSY	1	1	1	
9	6K8-24500-02	FUEL COCK ASSY 1	1	1	1	
10	6R7-24524-00	LEVER, COCK	1	1	1	
11	90445-10ME3	HOSE (L1010)	1	1	1	
12	90465-11M10	CLAMP	1	1	1	
13	90445-10M98	HOSE (L1010)	1	1	1	
14	90465-11M10	CLAMP	1	1	1	
15	90445-10ME4	HOSE (L140)	1	1	1	
16	90465-11M10	CLAMP	1	1	1	
17	90465-11M10	CLAMP	2	2	2	
18	GM6-6773E-00	TUBE,2	1	1	1	
19	90601-20006	BAND	1	1	1	
20	90600-91736	CLAMP COMP.	7	7	7	
21	90267-48925	RIVET, BLIND	7	7	7	
22	90601-20006	BAND	6	6	6	
23	90601-20016	BAND	2	2	2	
24	EU0-67816-30	BRACKET, FUEL FILTER	1	1	1	
25	F1N-65938-00	STAY 1		1	1	FOR GENE,JPN
26	90267-48925	RIVET, BLIND	2			FOR USA
	90267-48940	RIVET, BLIND		3	3	FOR GENE,JPN

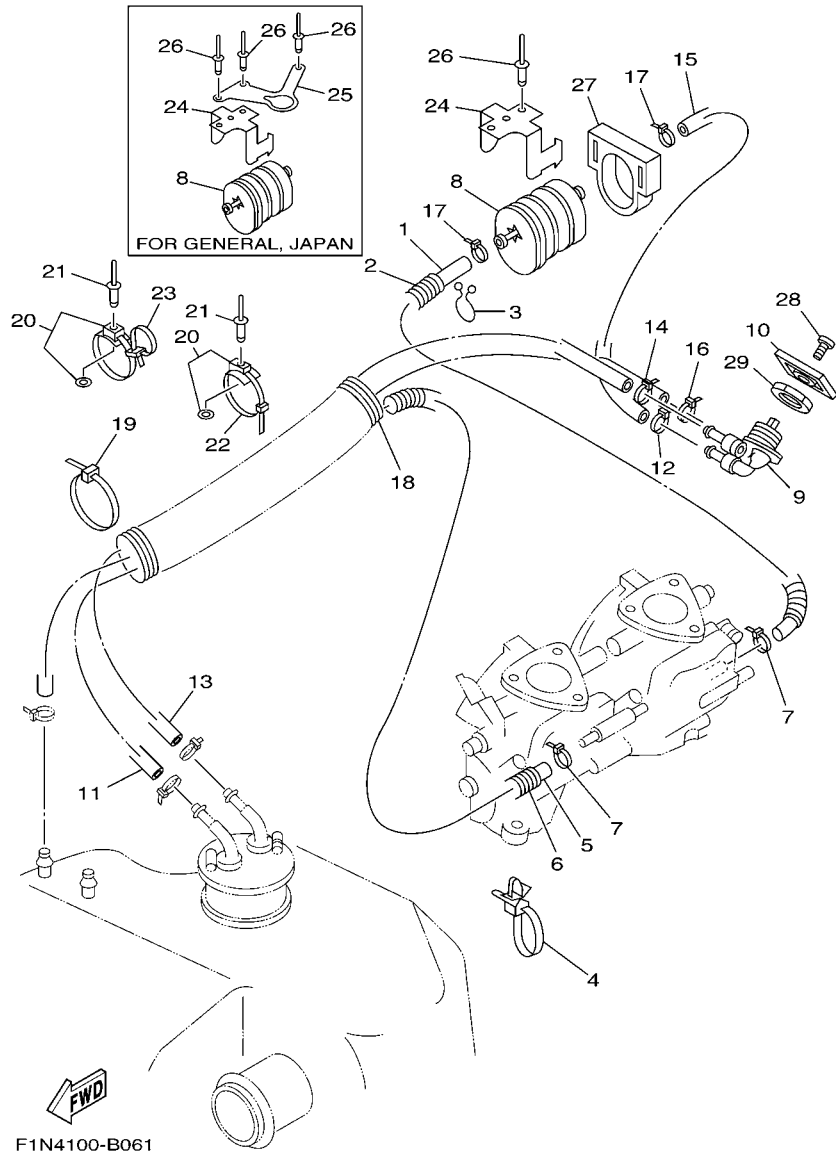
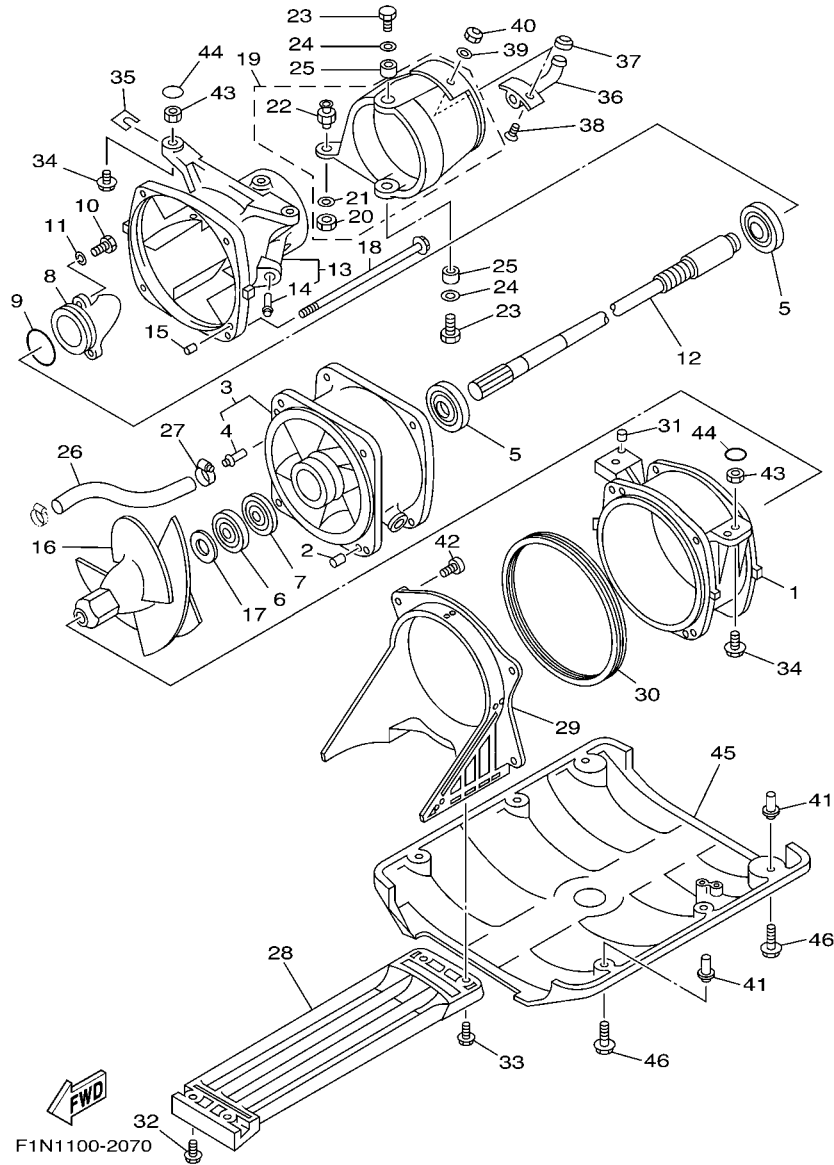

FIG. 7 FUEL

REF. NO.	PART NO.	DESCRIPTION	USA	GENE	JPN	REMARKS
27	EU0-67817-00	HOLDER	1	1	1	
28	98980-04008	SCREW, BIND	1	1	1	
29	90170-22187	NUT	1	1	1	

FIG. 8 JET UNIT 1



REF. NO.	PART NO.	DESCRIPTION	USA	GENE	JPN	REMARKS
1	6R7-51312-03-94	HOUSING, IMPELLER	1	1	1	
2	93606-12019	PIN, DOWEL	2	2	2	
3	62T-51315-01-94	DUCT, IMPELLER	1	1	1	
4	6K8-51129-00	.NIPPLE	1	1	1	
5	93306-205U0	BEARING	2	2	2	
6	93102-25M34	OIL SEAL	1	1	1	
7	93101-25M50	OIL SEAL	1	1	1	
8	62T-51326-00	CAP	1	1	1	
9	93210-46M16	O-RING	1	1	1	
10	97095-06020	BOLT	3	3	3	
11	92995-06600	WASHER	3	3	3	
12	6R7-45511-01	SHAFT, DRIVE	1	1	1	
13	6R7-51318-05-94	NOZZLE	1	1	1	
14	6K8-51129-00	.NIPPLE	1	1	1	
15	93606-12019	PIN, DOWEL	1	1	1	
16	6R7-51321-00-8S	IMPELLER	1	1	1	
17	62T-51348-00	SPACER	1	1	1	
18	90119-06M70	BOLT, WITH WASHER	4	4	4	
19	61L-51313-00	NOZZLE, DEFLECTOR	1	1	1	
20	95380-06700	.NUT	1	1	1	
21	90201-06M02	.WASHER, PLATE	1	1	1	
22	6R7-42316-00	.BOLT, JOINT	1	1	1	
23	97095-08018	BOLT	2	2	2	
24	92995-08600	WASHER	2	2	2	
25	90387-08M06	COLLAR	2	2	2	
26	90445-14M12	HOSE (L110)	1	1	1	
27	90450-14M05	HOSE CLAMP ASSY	1	1	1	

FIG. 8 JET UNIT 1

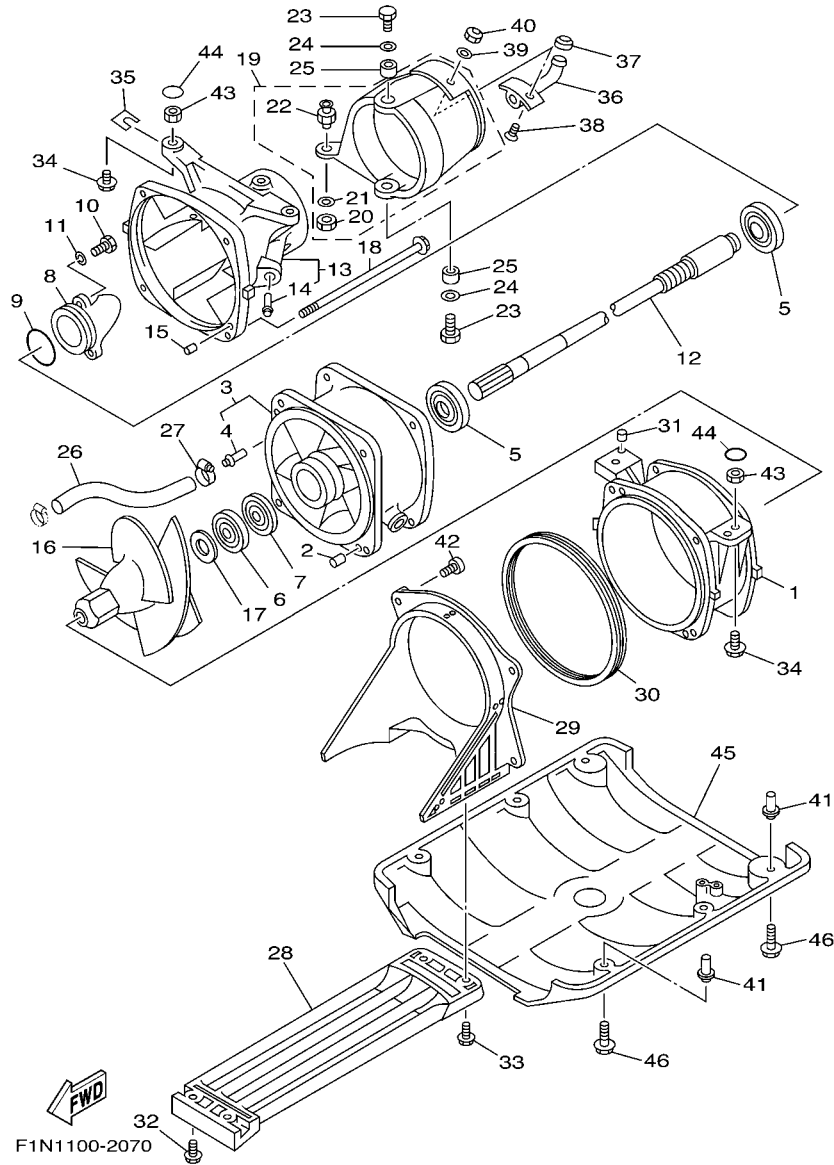

REF. NO.	PART NO.	DESCRIPTION	USA	GENE	JPN	REMARKS
28	6R7-51333-00	SCREEN, INTAKE	1	1	1	
29	6R7-51311-00	DUCT, INTAKE	1	1	1	
30	6R7-51117-01	PACKING	1	1	1	
31	93606-07M17	PIN, DOWEL	2	2	2	
32	90119-06915	BOLT, WITH WASHER	2	2	2	
33	90119-06908	BOLT, WITH WASHER	2	2	2	
34	90119-10948	BOLT, WITH WASHER	4	4	4	
35	EW2-67354-00-01	SHIM (T=0.1)	10	10	10	UR
	EW2-67354-00-03	SHIM (T=0.3)	10	10	10	UR
	EW2-67354-00-05	SHIM (T=0.5)	10	10	10	UR
	EW2-67354-00-10	SHIM (T=1.0)	10	10	10	UR
36	EU0-62693-02	SPOUT	1	1	1	
37	EU0-62695-00	CAP, SPOUT	1	1	1	
38	98780-05016	SCREW, FLAT HEAD	2	2	2	
39	92990-05200	WASHER, PLAIN	2	2	2	
40	95720-05300	NUT, FLANGE	2	2	2	
41	90179-08962	NUT	4	4	4	
42	97780-60120	SCREW, TAPPING	4	4	4	
43	90179-10925	NUT	4	4	4	
44	EW2-62723-30	SEAL	4	4	4	
45	F1N-6273B-00	PLATE 2	1	1	1	
46	90119-08943	BOLT, WITH WASHER	4	4	4	

FIG. 9 JET UNIT 2

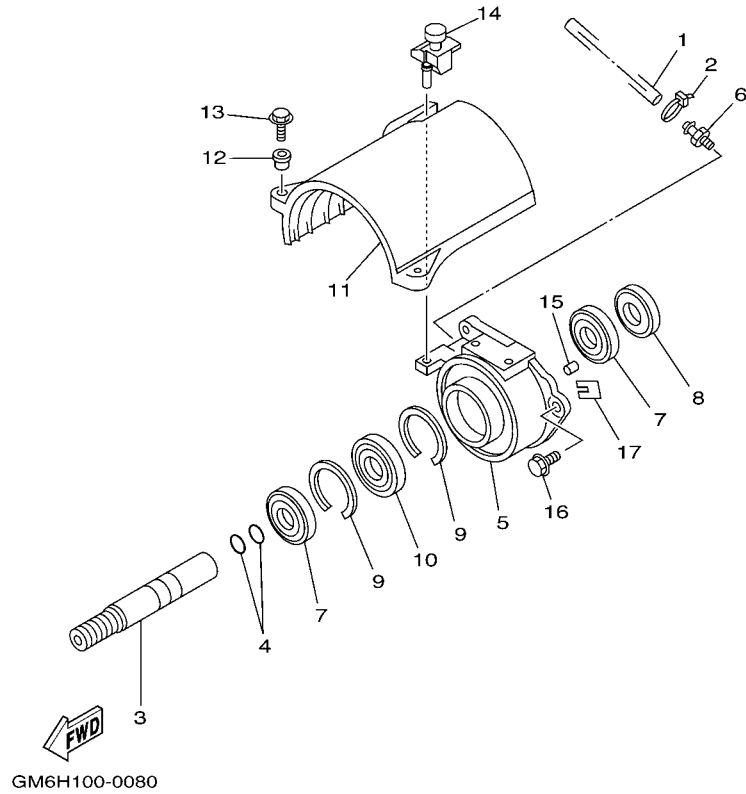

REF. NO.	PART NO.	DESCRIPTION	USA	GENE	JPN	REMARKS
1	90445-09M17	HOSE (L320)	1	1	1	
2	90465-11M10	CLAMP	1	1	1	
3	6R7-51323-02	SHAFT, COUPLOR	1	1	1	
4	93210-17MA4	O-RING	2	2	2	
5	61X-45332-03-94	HOUSING, BEARING	1	1	1	
6	61L-45378-00	NIPPLE, HOSE	1	1	1	
7	93101-25M55	OIL SEAL	2	2	2	
8	93101-25M56	OIL SEAL	1	1	1	
9	93430-47M04	CIRCLIP	2	2	2	
10	93306-205U6	BEARING	1	1	1	
11	61X-51381-00	COVER	1	1	1	
12	90387-06M60	COLLAR	2	2	2	
13	97595-06525	BOLT, WITH WASHER	2	2	2	
14	90480-06M69	GROMMET	1	1	1	
15	93606-12019	PIN, DOWEL	2	2	2	
16	90119-08907	BOLT, WITH WASHER	3	3	3	
17	GD0-67249-00-05	SHIM (T=0.5)	1	1	1	UR
	GD0-67249-00-10	SHIM (T=1.0)	1	1	1	UR

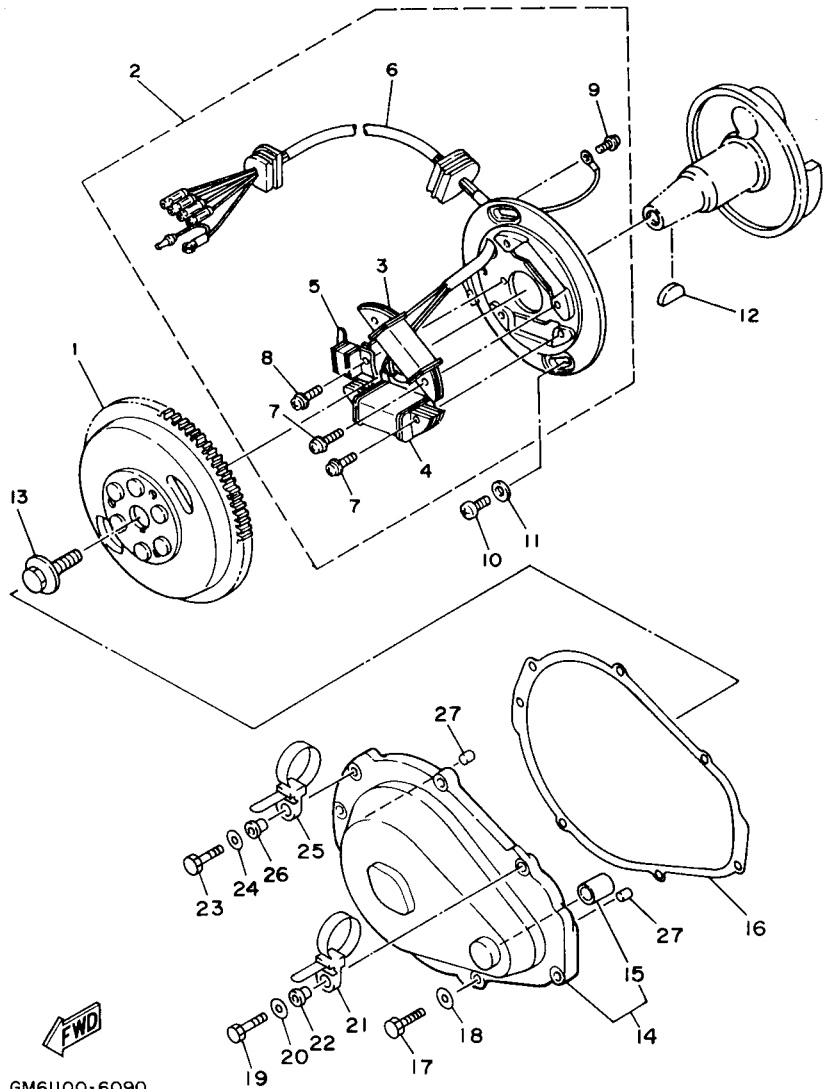

GM61100-6090

FIG. 10 GENERATOR

REF. NO.	PART NO.	DESCRIPTION	USA	GENE	JPN	REMARKS
1	62T-85550-00	ROTOR ASSY	1	1	1	
2	62T-85560-00	BASE ASSY	1	1	1	
3	62T-85520-00	.COIL, CHARGE	1	1	1	
4	62T-85533-00	.COIL, LIGHTING	1	1	1	
5	6M6-85580-00	.COIL, PULSER	1	1	1	
6	62T-85515-00	.LEAD WIRE ASSY	1	1	1	
7	97902-05125	.SCREW, WITH WASHER	4	4	4	
8	97902-04122	.SCREW, WITH WASHER	2	2	2	
9	97802-04008	.SCREW, PAN HEAD	1	1	1	
10	97880-06016	SCREW, PAN HEAD	2	2	2	
11	92990-06600	WASHER, PLATE	2	2	2	
12	90280-05013	KEY, WOODRUFF	1	1	1	
13	90109-10M44	BOLT	1	1	1	
14	6M6-81337-00-8S	COVER, FLYWHEEL	1	1	1	
15	90380-12M29	.BUSH, SOLID	1	1	1	
16	6M6-81365-A0	GASKET, HOLE COVER	1	1	1	
17	97095-06025	BOLT	5	5	5	
18	92995-06600	WASHER	5	5	5	
19	97095-06035	BOLT	1	1	1	
20	92995-06600	WASHER	1	1	1	
21	90465-12M53	CLAMP	1	1	1	
22	90387-06M05	COLLAR	1	1	1	
23	97095-06035	BOLT	1	1	1	
24	92995-06600	WASHER	1	1	1	
25	90465-12M53	CLAMP	1	1	1	
26	90387-06M05	COLLAR	1	1	1	
27	93606-12019	PIN, DOWEL	2	2	2	

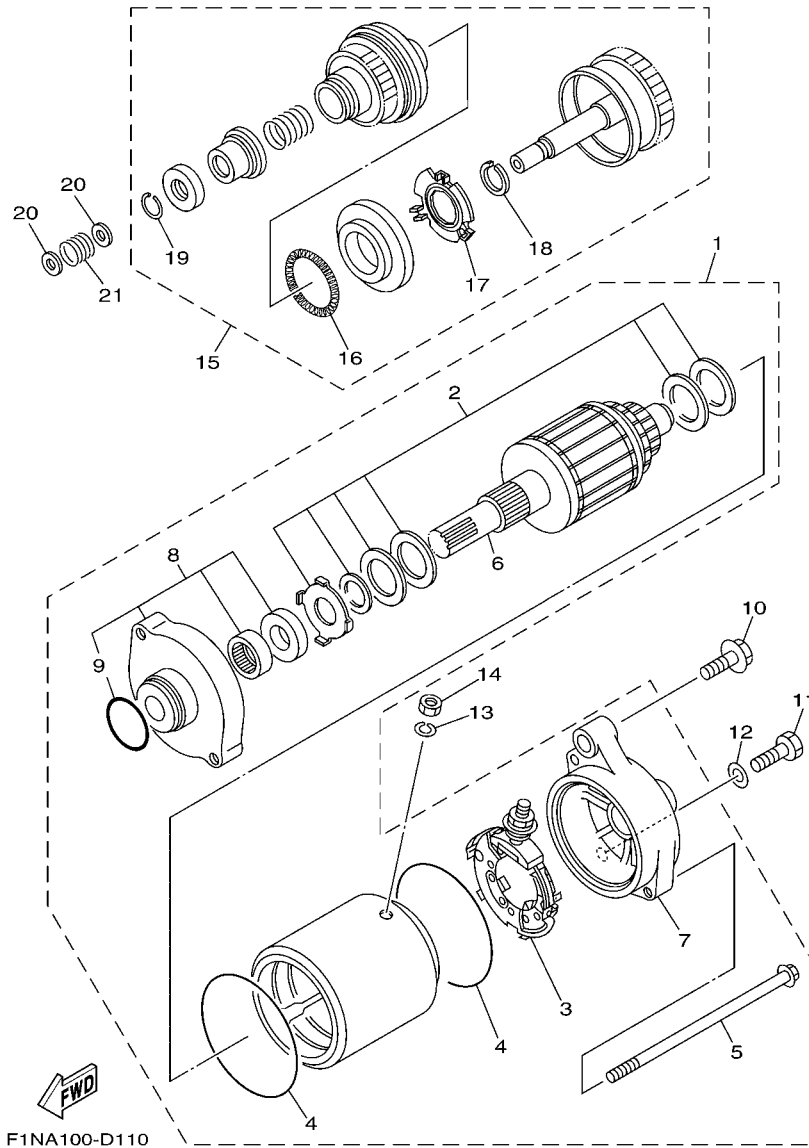

F1NA100-D110

FIG. 11 STARTING MOTOR

REF. NO.	PART NO.	DESCRIPTION	USA	GENE	JPN	REMARKS
1	6M6-81800-10	STARTING MOTOR ASSY	1	1	1	
2	3AJ-81809-00	.WASHER KIT	1	1	1	
3	6M6-81840-10	.BRUSH HOLDER ASSY	1	1	1	
4	11H-81844-00	.GASKET	2	2	2	
5	6M6-81826-00	.BOLT	2	2	2	
6	6M6-81850-00	.ARMATURE ASSY	1	1	1	
7	6M6-81820-00	.REAR BRACKET ASSY	1	1	1	
8	6M6-81830-00	.FRONT BRACKET ASSY	1	1	1	
9	26H-81847-00	..O-RING	1	1	1	
10	97513-08540	BOLT, WITH WASHER	1	1	1	
11	97013-08035	BOLT	1	1	1	
12	92903-08600	WASHER, PLATE	1	1	1	
13	92990-06100	WASHER, SPRING	1	1	1	
14	95380-06700	NUT	1	1	1	
15	6M6-8183E-01	IDLE GEAR COMP.	1	1	1	
16	6M6-81866-00	.WEIGHT SPRING	1	1	1	
17	6M6-81865-00	.WEIGHT HOLDER	1	1	1	
18	93440-25M08	.CIRCLIP	1	1	1	
19	93450-18M06	.CIRCLIP	1	1	1	
20	92903-06600	WASHER, PLATE	2	2	2	
21	90501-14M73	SPRING, COMPRESSION	1	1	1	

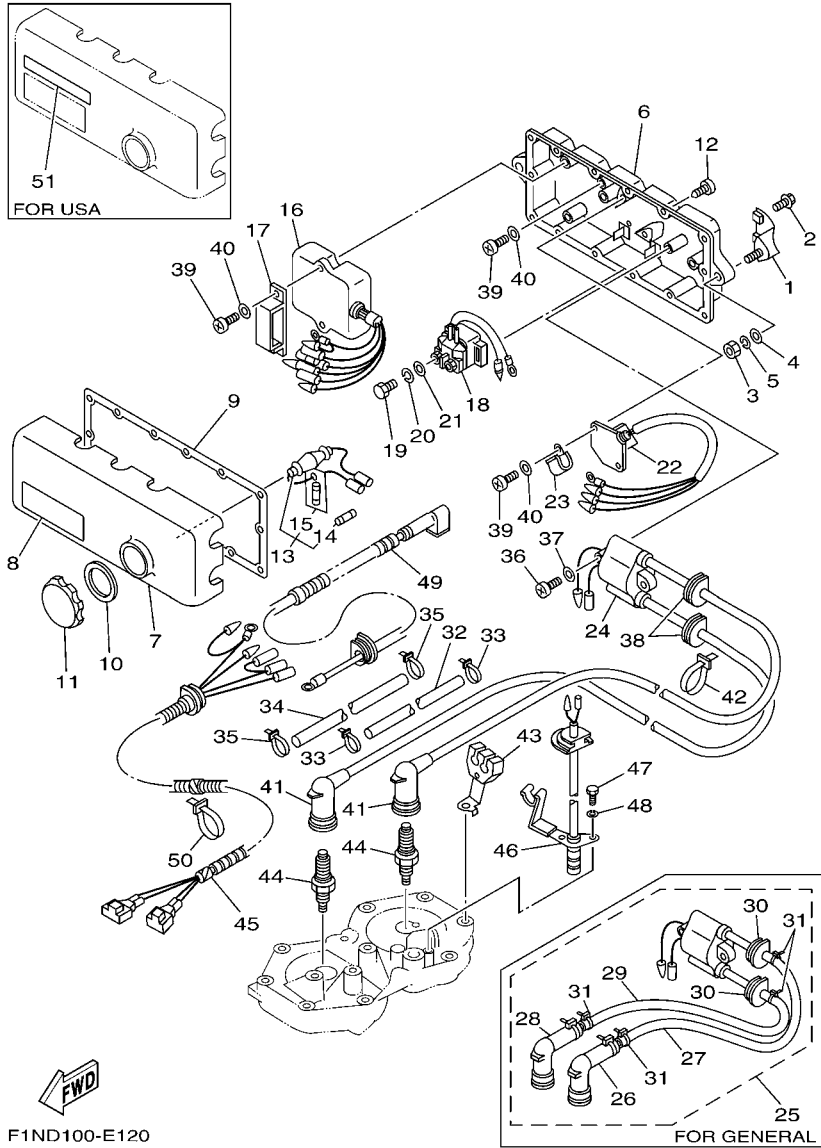

F1ND100-E120

FIG. 12 ELECTRICAL 1

REF. NO.	PART NO.	DESCRIPTION	USA	GENE	JPN	REMARKS
1	EW2-68156-00	BRACKET, ELECTRIC BOX	2	2	2	
2	90119-06908	BOLT, WITH WASHER	4	4	4	
3	95380-08600	NUT	2	2	2	
4	92990-08200	WASHER, PLAIN	2	2	2	
5	92990-08100	WASHER, SPRING	2	2	2	
6	6M6-8552A-01-8P	HOUSING	1	1	1	
7	6M6-8552E-01	COVER, CASE	1	1	1	
8	6B6-83623-00	MARK 3	1	1	1	
9	6M6-81921-00	GASKET, TERMINAL	1	1	1	
10	6M6-81844-00	GASKET	1	1	1	
11	6M6-8132W-00	CAP	1	1	1	
12	97780-60525	SCREW, TAPPING	14	14	14	
13	6K8-82150-01	FUSE HOLDER ASSY	1	1	1	
14	6G1-82151-00	.FUSE (10A)	1	1	1	
15	6K8-82159-00	.FUSE SPEAR (10A)	1	1	1	
16	62T-85540-01	C.D.I. UNIT ASSY	1	1	1	
17	90464-06M29	CLAMP	1	1	1	
18	68N-81940-00	STARTER RELAY ASSY	1	1	1	
19	97095-06010	BOLT	2	2	2	
20	92995-06100	WASHER, SPRING	2	2	2	
21	92995-06600	WASHER	2	2	2	
22	6M6-81960-A0	RECTIFIER & REGULATOR ASSY	1	1	1	
23	90465-06M86	CLAMP	1	1	1	
24	62E-85570-00	IGNITION COIL ASSY	1		1	FOR USA, JPN
25	62E-85570-11	IGNITION COIL ASSY		1		FOR GENE
26	62E-82371-11	.CAP, PLUG		1		FOR GENE
27	62E-82351-01	.TUBE, CORD		1		FOR GENE

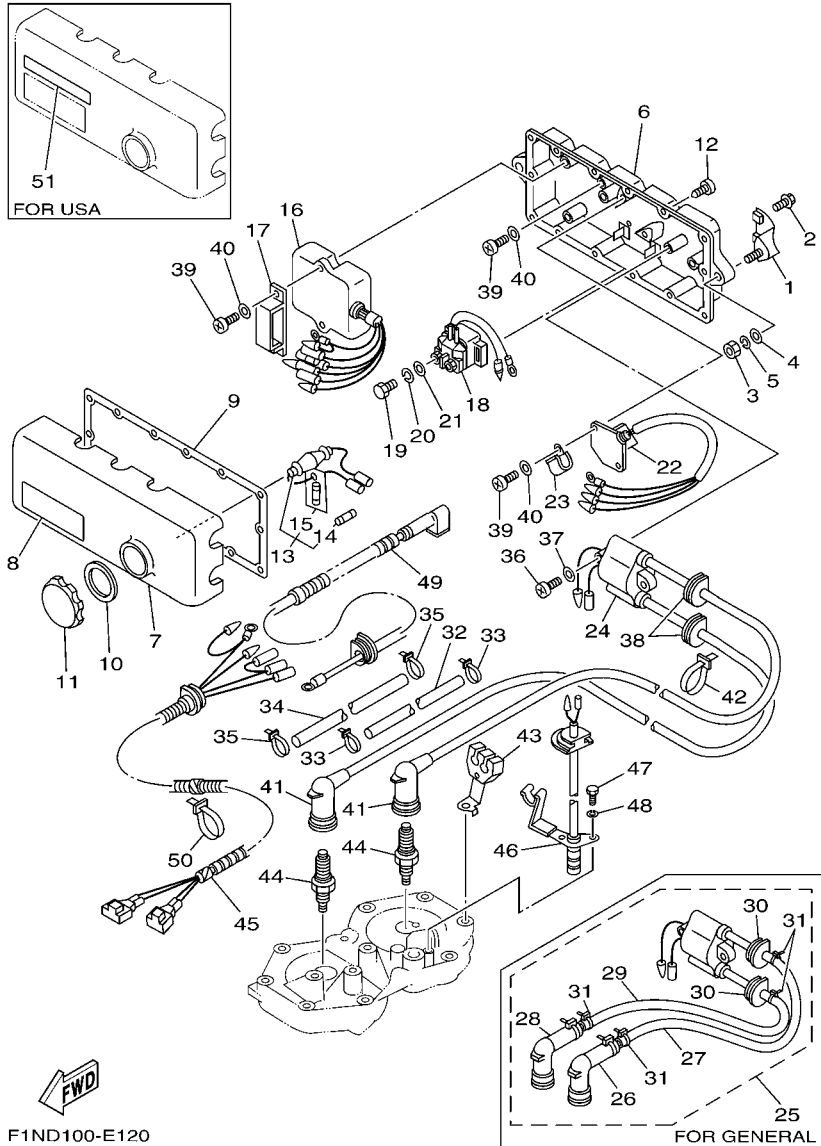

FWD
 F1ND100-E120

FIG. 12 ELECTRICAL 1

REF. NO.	PART NO.	DESCRIPTION	USA	GENE	JPN	REMARKS
28	62E-82371-11	.CAP, PLUG		1		FOR GENE
29	62E-82352-01	.TUBE, CORD 2		1		FOR GENE
30	90480-06M43	.GROMMET		2		FOR GENE
31	90465-11M10	.CLAMP		4		FOR GENE
32	6R7-82351-00	TUBE, CORD	1		1	FOR USA,JPN
33	90465-11M10	CLAMP	2		2	FOR USA,JPN
34	6R7-82352-00	TUBE, CORD 2	1		1	FOR USA,JPN
35	90465-11M10	CLAMP	2		2	FOR USA,JPN
36	97880-06030	SCREW, PAN HEAD	2	2	2	
37	92990-06600	WASHER, PLATE	2	2	2	
38	90480-06M43	GROMMET	2		2	FOR USA,JPN
39	97880-06016	SCREW, PAN HEAD	6	6	6	
40	92990-06600	WASHER, PLATE	6	6	6	
41	66T-82370-00	PLUG CAP ASSY	2		2	FOR USA,JPN
42	90465-11M10	CLAMP	2		2	FOR USA,JPN
43	6R7-82361-01	CLAMP, CORD	1	1	1	
44	94702-00040	PLUG, SPARK (NGK B7HS)	2			FOR USA
	94702-00272	PLUG, SPARK (NGK BR7HS)		2		FOR GENE
	94709-00040	PLUG, SPARK (NGK B7HS)			2	FOR JPN
45	6R7-82553-01	EXTENSION, WIRE LEAD	1	1	1	
46	6R7-82560-11	THERMO SWITCH ASSY	1	1	1	
47	97095-06016	BOLT	2	2	2	
48	92995-06100	WASHER, SPRING	2	2	2	
49	62E-82117-20	WIRE, LEAD	1	1	1	
50	90465-13M11	CLAMP	1	1	1	
51	60E-83627-00	LABEL, CAUTION 7	1			FOR USA

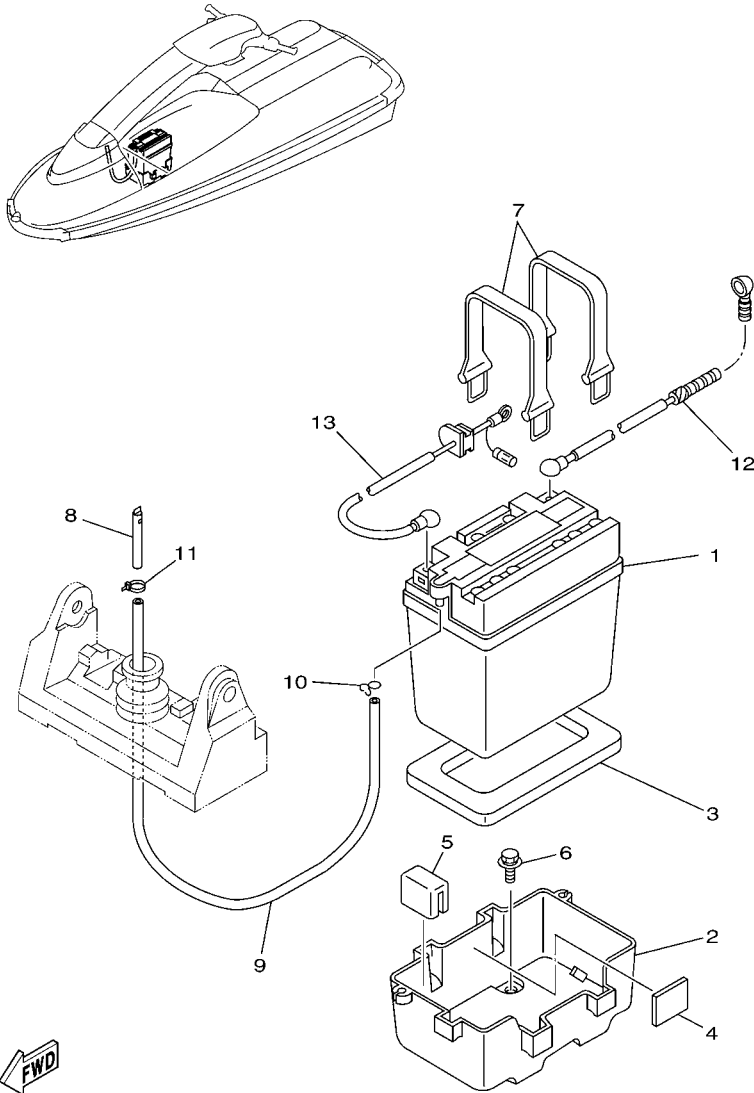

F1NA100-D130

FIG. 13 ELECTRICAL 2

REF. NO.	PART NO.	DESCRIPTION	USA	GENE	JPN	REMARKS
1	EU0-82110-09	BATTERY ASSY (YB16CL-B)	1	1	1	YUASA
2	EW2-68211-00	CASE, BATTERY	1	1	1	
3	EU0-68221-00	PAD, BATTERY 1	1	1	1	
4	EU0-68221-30	PAD, BATTERY 2	3	3	3	
5	EW2-68221-00	PAD, BATTERY	1	1	1	
6	90119-06920	BOLT, WITH WASHER	4	4	4	
7	EU0-68218-04	BAND, BATTERY	2	2	2	
8	EW2-62149-00	PIPE, VENTILATION 1	1	1	1	
9	EU0-67856-40	HOSE, AIRVENT 3	1	1	1	
10	90467-08M10	CLIP	1	1	1	
11	90465-11M10	CLAMP	1	1	1	
12	64V-82117-00	WIRE, LEAD	1	1	1	
13	6R7-82117-11	WIRE, LEAD	1	1	1	

FIG. 14 ENGINE HATCH

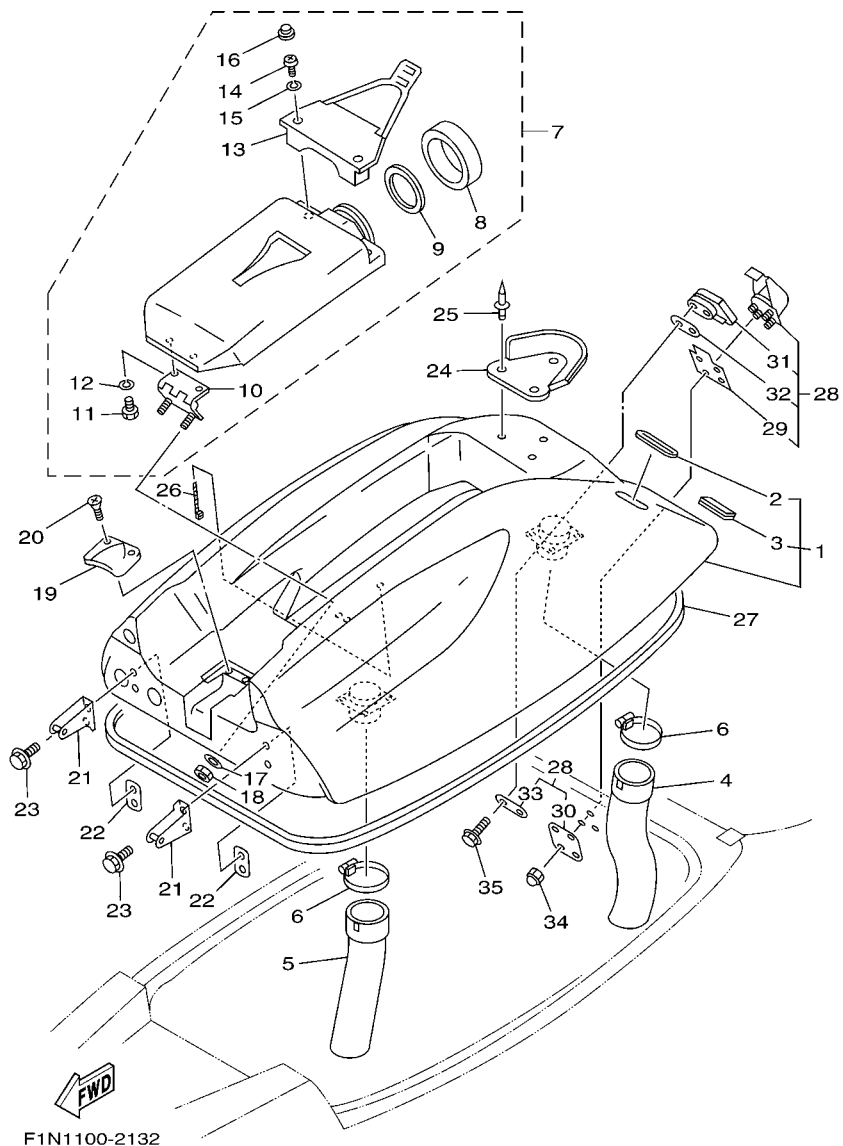

REF. NO.	PART NO.	DESCRIPTION	USA	GENE	JPN	REMARKS
1	GM6-6516A-10-33	ENGINE HATCH COMP.	1	1	1	YB
2	FX1-65116-10	.TRIM,HATCH 2	2	2	2	
3	GM6-6516C-00	.TRIM 1	1	1	1	
4	GM6-6213F-00	HOSE,VENTILATOR 1	1	1	1	
5	EW2-62137-00	HOSE, VENTILATOR 2	1	1	1	
6	90601-16875	BAND, HOSE 68	2	2	2	
7	FX1-6591A-10	CASE,ASSY 1	1	1	1	
8	EW2-65912-00	.CAP, CASE	1	1	1	
9	EW2-65913-00	.PACKING, CASE	1	1	1	
10	FX1-6517D-00	.HINGE, LID	1	1	1	
11	97090-06014	.BOLT	2	2	2	
12	92990-06100	.WASHER, SPRING	2	2	2	
13	FX1-6591K-00	.BAND,CASE	1	1	1	
14	92580-06016	.SCREW	2	2	2	
15	92990-06100	.WASHER, SPRING	2	2	2	
16	FX1-6514F-00	.CAP	2	2	2	
17	92990-06200	WASHER, PLAIN	2	2	2	
18	95720-06300	NUT, SELF-LOCKING	2	2	2	
19	A00-62858-02	PLATE, HATCH (FL1)	1	1	1	
20	97780-50316	SCREW, TAPPING	2	2	2	
21	GM6-65136-00	STOPPER HATCH 2	2	2	2	
22	EW2-65137-00	PLATE, STOPPER HATCH 2	2	2	2	
23	90119-06900	BOLT, WITH WASHER	4	4	4	
24	FX1-6514B-00	DAMPER, POLE	1	1	1	
25	90267-48938	RIVET, BLIND	3	3	3	
26	90464-20258	CLAMP	2	2	2	
27	GM6-62664-00	PACKING	1	1	1	

FIG. 16 GUNWALE & MAT

REF. NO.	PART NO.	DESCRIPTION	USA	GENE	JPN	REMARKS
1	GM6-62501-10	BOW GUNWALE COMP.	1	1	1	BL
2	92990-06200	WASHER, PLAIN	4	4	4	
3	92990-06100	WASHER, SPRING	4	4	4	
4	95380-06800	NUT	4	4	4	
5	GM6-62552-10	GUNWALE, SIDE 1	1	1	1	BL
6	GM6-62553-10	GUNWALE, SIDE 2	1	1	1	BL
7	90149-05962	SCREW	22	22	22	
8	GM6-6251D-10	GUNWALE, STERN 1	1	1	1	YB
9	GM6-6251E-10	GUNWALE, STERN 2	1	1	1	YB
10	90149-05960	SCREW	8	8	8	
11	92990-05200	WASHER, PLAIN	8	8	8	
12	92990-05100	WASHER, SPRING	8	8	8	
13	90179-05964	NUT	8	8	8	
14	GM6-6252C-10	COVER, GUNWALE 1	1	1	1	BL
15	GM6-6252D-10	COVER, GUNWALE 2	1	1	1	BL
16	90267-48932	RIVET, BLIND	4	4	4	
17	FN8-61651-01	ROPE HOLE	2	2	2	
18	EU0-61652-00	NUT	2	2	2	
19	GM6-6351B-00	MAT, LOWER	1	1	1	BL
20	GM6-6351C-00	MAT, SIDE 1	1	1	1	BL
21	GM6-6351D-00	MAT, SIDE 2	1	1	1	BL
22	GM6-6521C-10	PAD 1	1	1	1	BL
23	GM6-6521D-10	PAD 2	1	1	1	BL
24	GM6-6351E-10	MAT, BOW	1	1	1	YB
25	90267-48963	RIVET, BLIND	4	4	4	

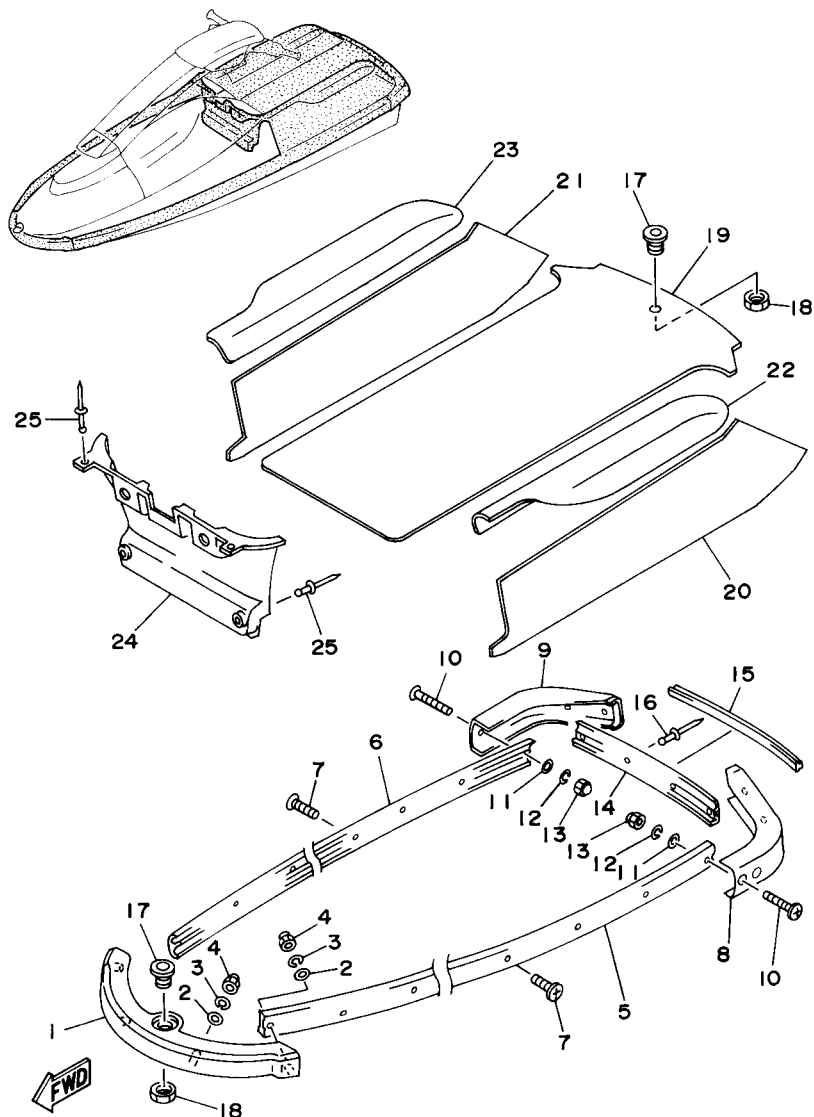

GM65100-7150

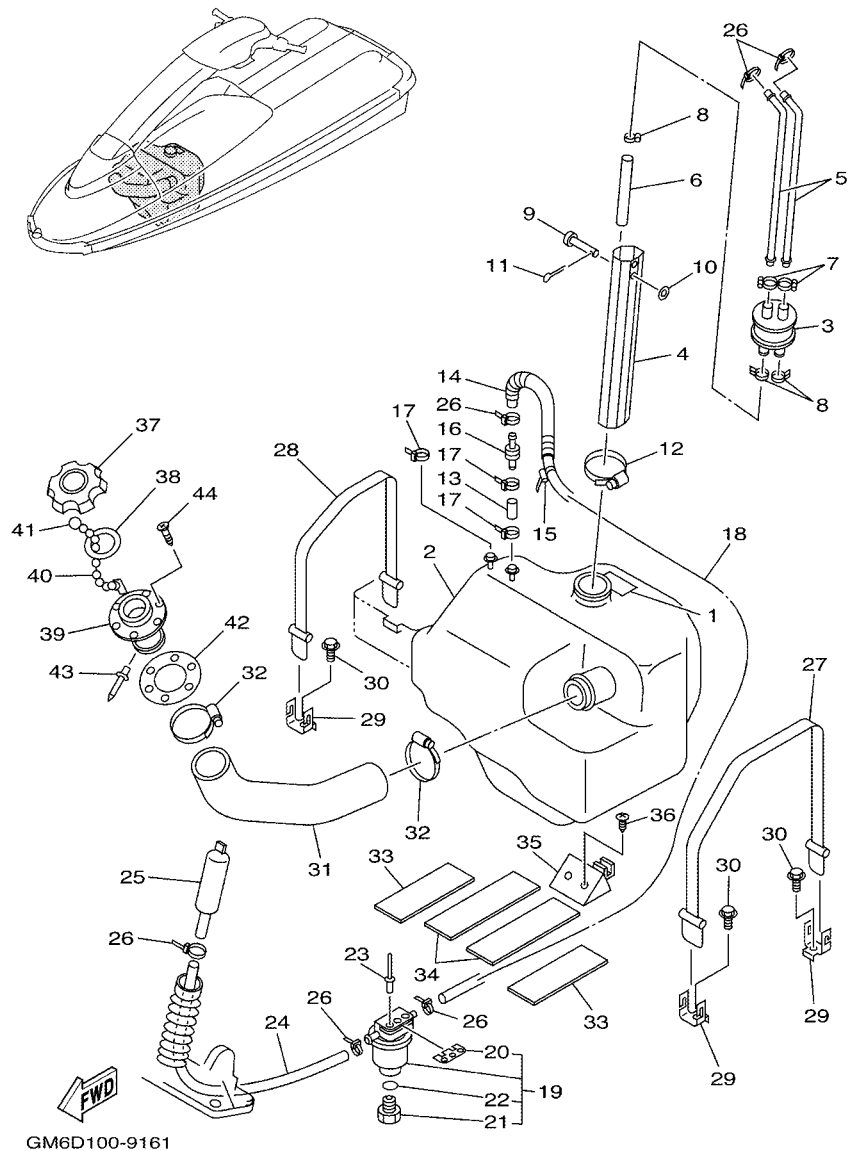

GM6D100-9161

FIG. 17 FUEL TANK

REF. NO.	PART NO.	DESCRIPTION	USA	GENE	JPN	REMARKS
1	GM6-6418D-00	LABEL,FUEL TANK	1	1		FOR USA,GENE
2	EW2-67711-01	TANK, FUEL	1	1	1	
3	FJ0-67713-00	PIPE, JOINT	1	1	1	
4	EW2-67716-01	PIPE, FILLER	1	1	1	
5	EW2-67714-02	PIPE, SUCTION 3	2	2	2	
6	90445-11903	HOSE (L105)	1	1	1	
7	90601-11062	BAND, HOSE 11	2	2	2	
8	90467-11032	CLIP	3	3	3	
9	91790-05040	PIN, CLEVIS	1	1	1	
10	92990-05600	WASHER, PLATE	1	1	1	
11	91490-16010	PIN, COTTER	1	1	1	
12	90601-16274	BAND, HOSE 62	1	1	1	
13	90699-50003	HOSE	1	1	1	
14	90446-14M30	TUBE	1	1	1	
15	90465-13M11	CLAMP	1	1	1	
16	EU0-67767-31	CHECK VALVE	1	1	1	
17	90465-11M10	CLAMP	3	3	3	
18	90699-50120	HOSE	1	1	1	
19	EW2-62140-00	FILTER, VENT ASSY	1	1	1	
20	EW2-62142-00	.PLATE, FILTER	1	1	1	
21	70R-24543-00	.PLUG, DRAIN	1	1	1	
22	70R-24489-00	.O-RING	1	1	1	
23	90267-48925	RIVET, BLIND	2	2	2	
24	90699-50045	HOSE	1	1	1	
25	EW2-62150-00	PIPE,VENTILATION 3	1	1	1	
26	90465-11M10	CLAMP	6	6	6	
27	EW2-67821-00	BAND, FUEL TANK	1	1	1	

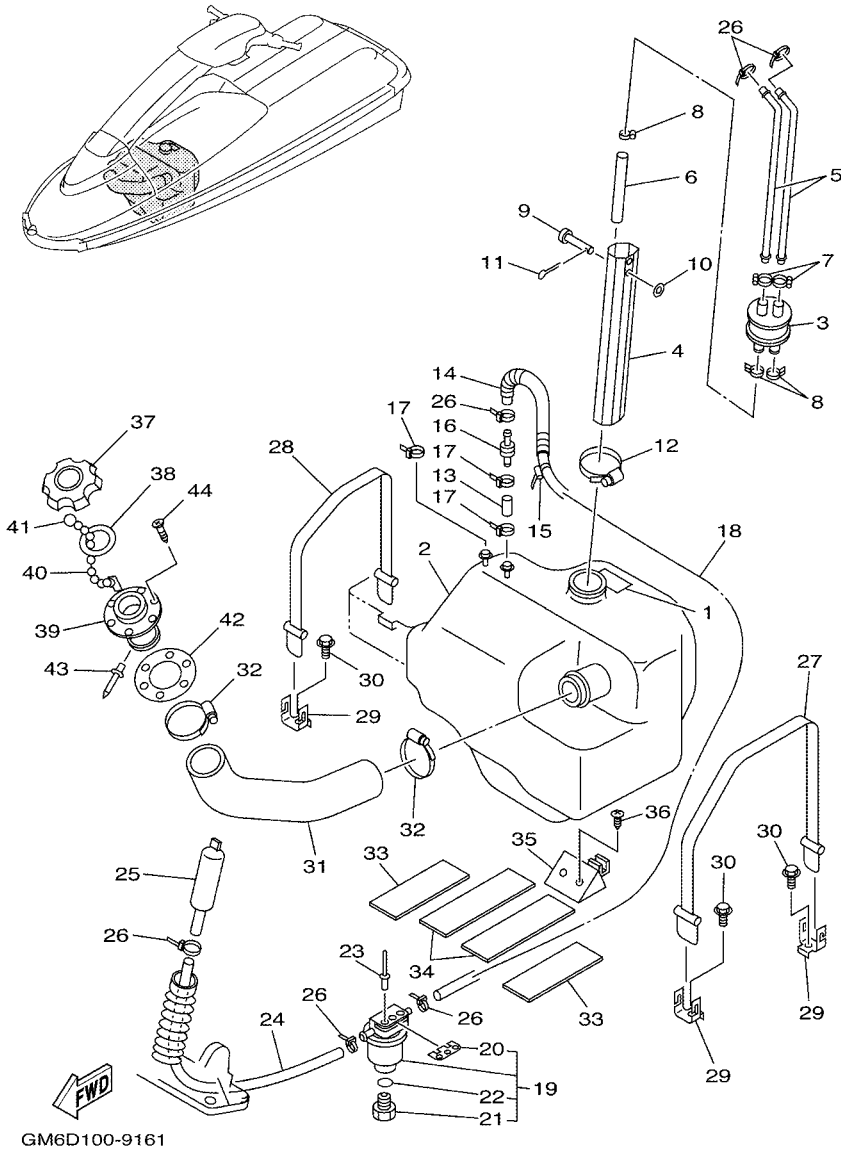

FIG. 17 FUEL TANK

REF. NO.	PART NO.	DESCRIPTION	USA	GENE	JPN	REMARKS
28	EW2-67821-30	BAND, FUEL TANK	1	1	1	
29	EW2-65772-00	HOOK A	3	3	3	
30	90105-06900	BOLT, FLANGE	3	3	3	
31	GM6-67844-10	HOSE	1	1	1	
32	90601-15573	BAND, HOSE 55	2	2	2	
33	GM6-67593-00	MAT	2	2	2	
34	GM6-67594-00	MAT	2	2	2	
35	EW2-67822-01	DAMPER FUEL TANK	1	1	1	
36	97780-50114	SCREW, PAN HEAD TAPPING	2	2	2	
37	FN8-67831-01	CAP, FUEL FILLER	1	1	1	YB
38	EU0-67832-00	PACKING 1	1	1	1	
39	FN8-67833-00	SOCKET	1	1	1	
40	EU0-67835-00	CHAIN BALL	1	1	1	
41	EU0-67839-00	COUPLING	1	1	1	
42	EU0-67834-00	PACKING, FUEL FILLER	1	1	1	
43	90267-40935	RIVET, BLIND	1	1	1	
44	EU0-67869-00	SCREW, FLAT HEAD	6	6	6	

FIG. 18 EXHAUST 2

REF. NO.	PART NO.	DESCRIPTION	USA	GENE	JPN	REMARKS
1	GM6-67550-00	WATER LOCK	1	1	1	
2	GM6-6755J-00	MAT,WATER LOCK	1	1	1	
3	EU0-68218-04	BAND, BATTERY	2	2	2	
4	FX1-65760-00	HOOK B ASSY	2	2	2	
5	EW2-65772-00	HOOK A	2	2	2	
6	90105-06900	BOLT, FLANGE	4	4	4	
7	GM6-67555-00	HOSE	1	1	1	
8	GM6-63844-00	MAT	1	1	1	
9	90601-16875	BAND, HOSE 68	2	2	2	
10	90601-16875	BAND, HOSE 68	1	1	1	
11	GH7-6753B-00	PILOT,WATER	1	1	1	
12	GP7-61652-00	NUT	1	1	1	
13	92990-14200	WASHER, PLAIN	1	1	1	
14	90465-11M10	CLAMP	1	1	1	
15	GM6-67565-00	THRU-HULL,EXHAUST	1	1	1	
16	90267-48930	RIVET, SEALD	3	3	3	

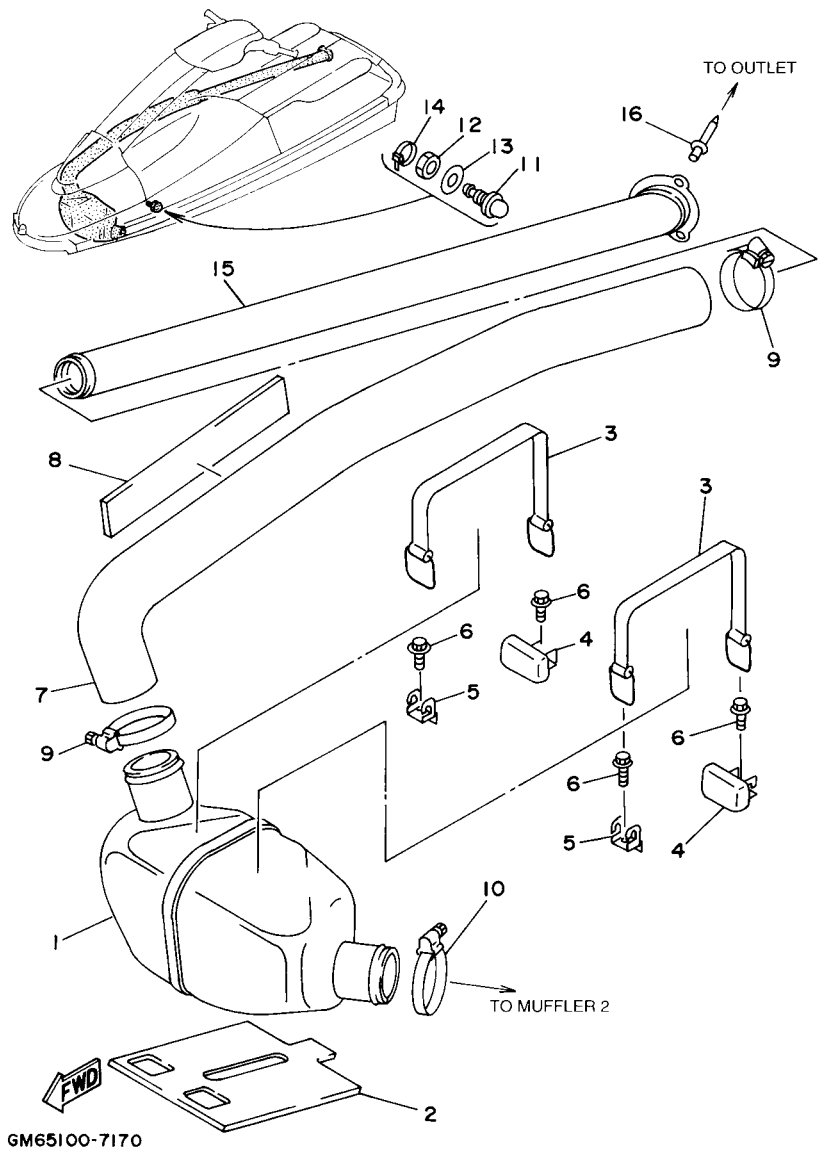
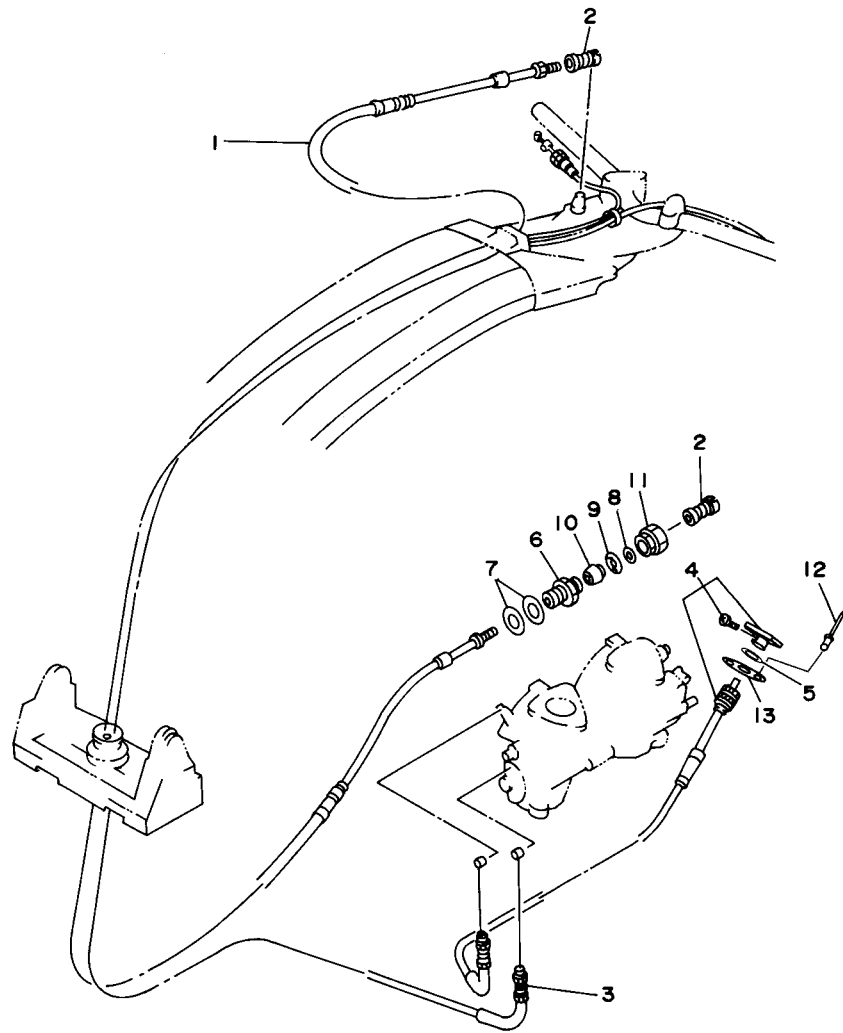

FIG. 19 CONTROL CABLE



REF. NO.	PART NO.	DESCRIPTION	USA	GENE	JPN	REMARKS
1	GM6-61481-10	CABLE, STEERING	1	1	1	
2	EU0-61461-30	SHAFT, JOINT BALL	2	2	2	
3	GM6-67252-00	CABLE, THROTTLE	1	1	1	
4	GM6-67242-00	CABLE, CHOKE	1	1	1	
5	90201-11008	WASHER, PLATE	1	1	1	
6	EU0-61436-00	BODY, CABLE CONNECTOR	1	1	1	
7	EU0-61438-00	PACKING (C)	2	2	2	
8	EU0-61446-00	WASHER 30	1	1	1	
9	EU0-61486-00	STOPPER	1	1	1	
10	EU0-61435-00	SEAL, PIPE 30	1	1	1	
11	EU0-62694-00	CAP	1	1	1	
12	90267-40945	RIVET, BLIND	2	2	2	
13	90209-12920	WASHER	1	1	1	

FWD
F1N7100-C190

FIG. 20 STEERING 1

REF. NO.	PART NO.	DESCRIPTION	USA	GENE	JPN	REMARKS
1	FX1-61552-00	HANDLE	1	1	1	
2	EW2-67250-02	THROTTLE LEVER ASSY	1	1	1	
3	EW2-67255-00	.LEVER, THROTTLE	1	1	1	
4	EW2-67256-00	.SPRING	1	1	1	
5	EW2-67257-01	.SHAFT	1	1	1	
6	EW2-67258-01	.WASHER	2	2	2	
7	EW2-67259-01	.E-RING	1	1	1	
8	90159-05900	SCREW, WITH WASHER	1	1	1	
9	EW2-68310-04	SWITCH BOX ASSY	1	1	1	
10	EW2-68348-00	.LANYARD, STOP SWITCH	1	1	1	
11	97880-03008	.SCREW, PAN HEAD	2	2	2	
12	FK7-68312-02	.STOP BUTTON COMP	1	1	1	
13	FK7-68313-02	.START BUTTON COMP.	1	1	1	
14	97880-05025	.SCREW, PAN HEAD	1	1	1	
15	EW2-61553-00	GRIP, HANDLE 1	2	2	2	
16	90560-22281	SPACER	1	1	1	
17	90149-05959	SCREW	2	2	2	
18	90201-05928	WASHER, PLATE	2	2	2	
19	EW2-61540-11	BRAKE, ASSY.	1	1	1	
20	EU0-23814-01	HOLDER, HANDLE LOWER	2	2	2	
21	90105-08902	BOLT, FLANGE	4	4	4	
22	EU0-61461-02	STUD, JOINT BALL	1	1	1	
23	92990-06100	WASHER, SPRING	1	1	1	
24	FX1-6143D-20	PAD, STEERING 1	1	1	1	YB
25	FX1-6143E-20	PAD, STEERING 2	1	1	1	YB
26	90149-05937	SCREW	4	4	4	
27	90600-91728	CLIP, NYLON 17	1	1	1	

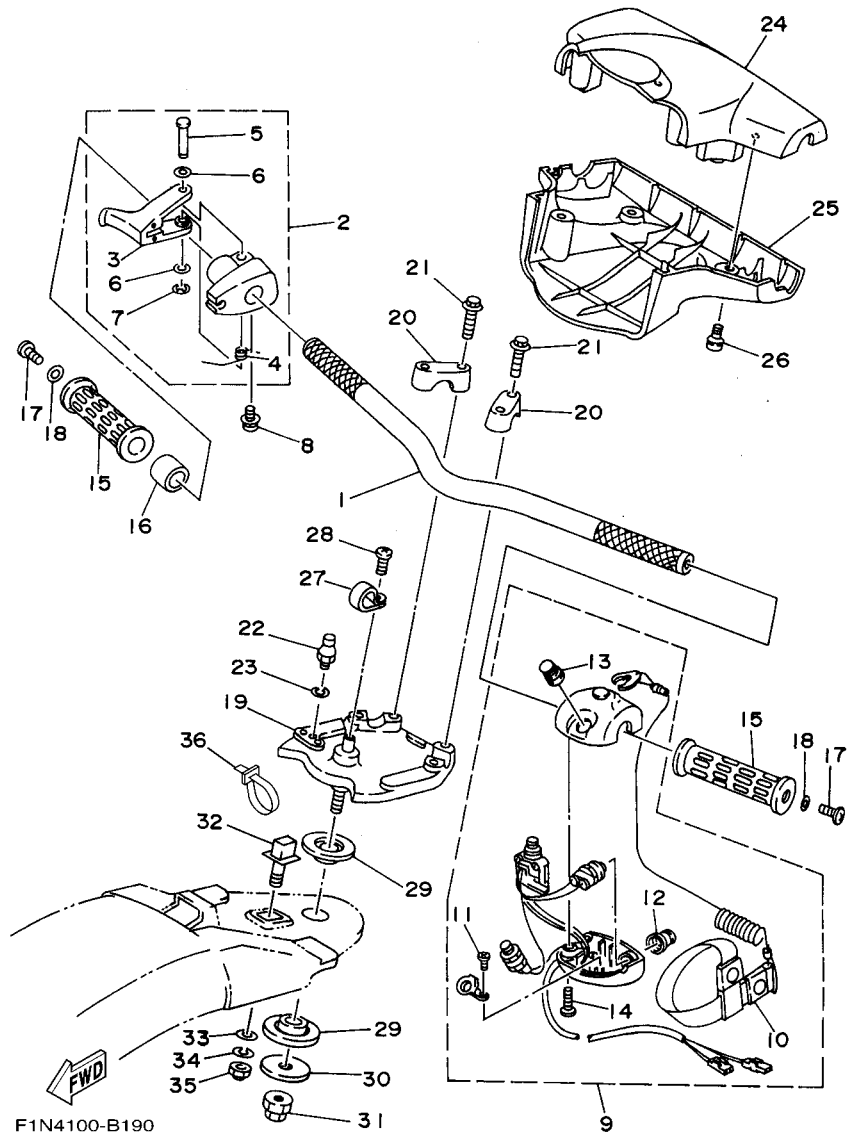

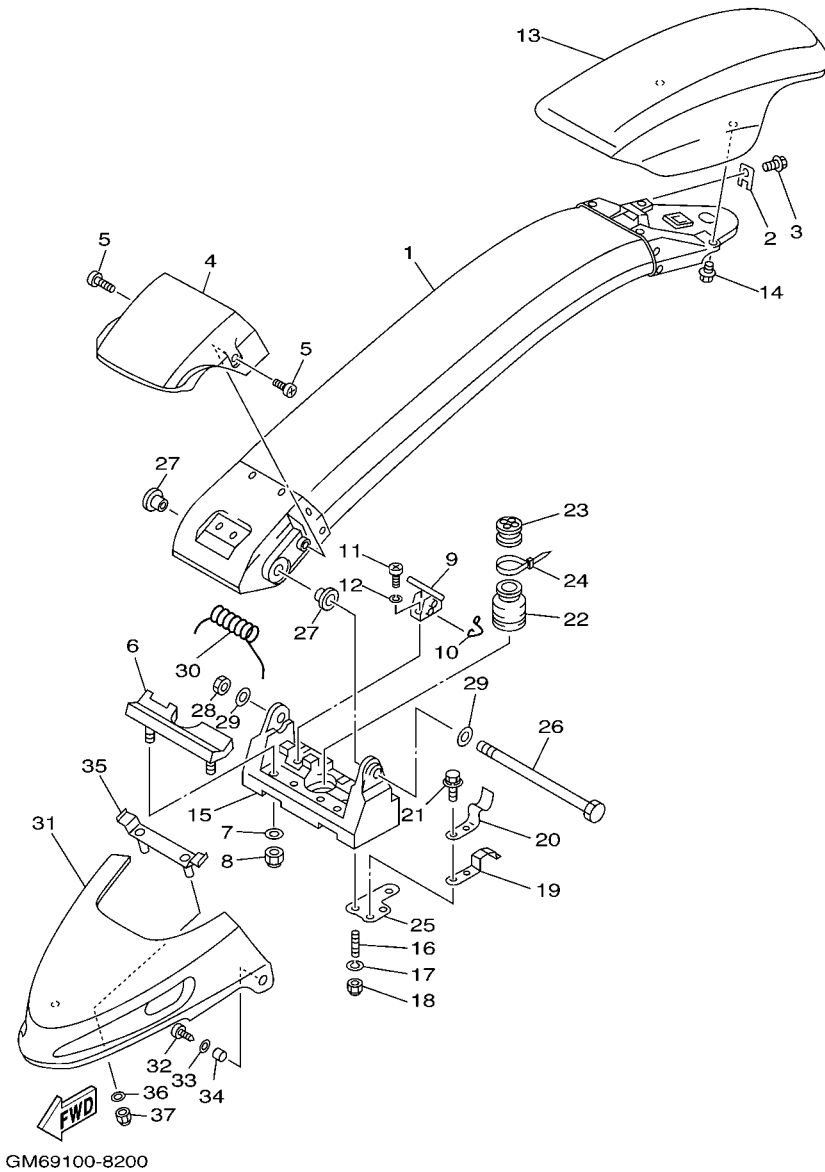
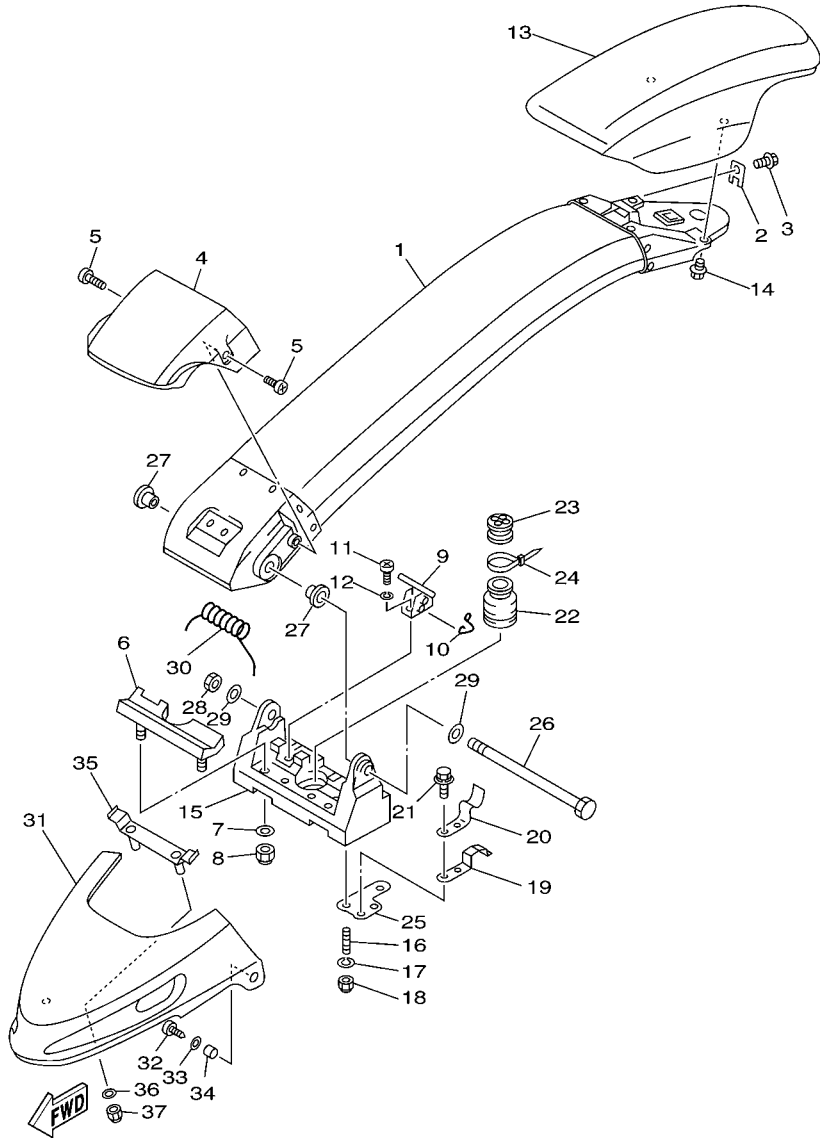

FIG. 21 STEERING 2

REF. NO.	PART NO.	DESCRIPTION	USA	GENE	JPN	REMARKS
1	GM6-6491A-03-P2	STEERING POLE COMP.	1	1	1	SC1
2	FX1-61468-00	STOPPER, CABLE	1	1	1	
3	90119-06913	BOLT, WITH WASHER	1	1	1	
4	FX1-6492E-10	COVER,POLE	1	1	1	BL
5	90149-06997	SCREW	2	2	2	
6	FX1-61337-00	STOPPER, POLE	1	1	1	
7	92990-06200	WASHER, PLAIN	2	2	2	
8	95720-06300	NUT, SELF-LOCKING	2	2	2	
9	FX1-61105-00	STOPPER PIN ASSY	1	1	1	
10	EW2-61395-30	SPRING, TORSION	1	1	1	
11	97880-05012	SCREW, PAN HEAD	2	2	2	
12	92990-05100	WASHER, SPRING	2	2	2	
13	GM6-6142A-30	STEERING PAD COMP	1	1	1	LNS6
14	90119-06918	BOLT, WITH WASHER	2	2	2	
15	FX1-6133C-13	BRACKET,PIVOT	1	1	1	
16	95680-08630	BOLT, STUD	4	4	4	
17	92990-08100	WASHER, SPRING	4	4	4	
18	95720-08300	NUT, SELF-LOCKING	4	4	4	
19	GM6-6215G-00	PLATE,GUIDE	2	2	2	
20	GM6-65135-00	STOPPER, HATCH 1	2	2	2	
21	90119-06900	BOLT, WITH WASHER	4	4	4	
22	FX1-61338-00	GROMMET	1	1	1	
23	EW2-61465-00	PACKING, CABLE	1	1	1	
24	90601-20006	BAND	1	1	1	
25	GM6-6133B-00	PLATE, BRACKET	2	2	2	
26	FX1-6134L-00	SHAFT,PIVOT	1	1	1	
27	EW2-61344-01	BUSH	2	2	2	



GM69100-8200

FIG. 21 STEERING 2

REF. NO.	PART NO.	DESCRIPTION	USA	GENE	JPN	REMARKS
28	90170-14913	NUT	1	1	1	
29	92990-14200	WASHER, PLAIN	2	2	2	
30	FX1-61391-00	SPRING, PIVOT	1	1	1	
31	GM6-6492J-30	COVER, PIVOT 1	1	1	1	YB
32	97780-60520	SCREW, TAPPING	2	2	2	
33	92990-06200	WASHER, PLAIN	2	2	2	
34	90387-06916	COLLAR	2	2	2	
35	GM6-64949-00	BRACKET	1	1	1	
36	92990-06200	WASHER, PLAIN	2	2	2	
37	95720-06300	NUT, SELF-LOCKING	2	2	2	

FIG. 22 GRAPHICS

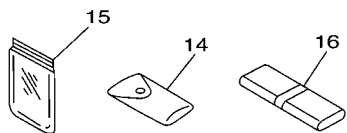
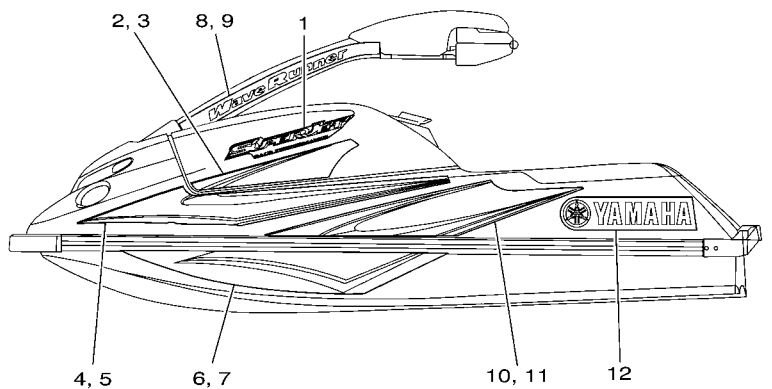
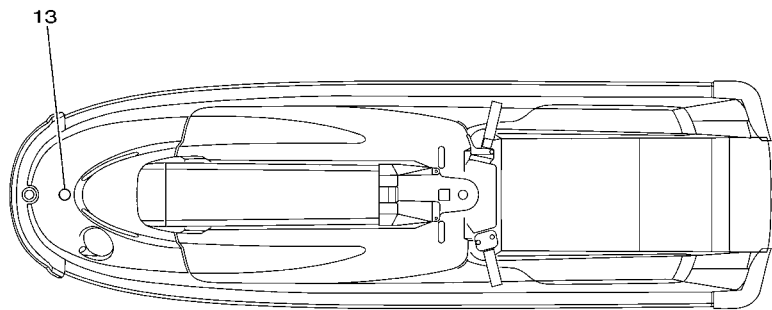

F1N7100-C220

REF. NO.	PART NO.	DESCRIPTION	USA	GENE	JPN	REMARKS
1	F1N-6417B-10	GRAPHIC 1	2	2	2	
2	F1N-6417C-30	GRAPHIC 2	1	1	1	LH
3	F1N-6417C-40	GRAPHIC 2	1	1	1	RH
4	F1N-6417D-30	GRAPHIC 3	1	1	1	LH
5	F1N-6417D-40	GRAPHIC 3	1	1	1	RH
6	F1N-6417E-30	GRAPHIC 4	1	1	1	LH
7	F1N-6417E-40	GRAPHIC 4	1	1	1	RH
8	F1N-6417F-30	GRAPHIC 5	1	1	1	LH
9	F1N-6417F-40	GRAPHIC 5	1	1	1	RH
10	F1N-6417G-30	GRAPHIC 6	1	1	1	LH
11	F1N-6417G-40	GRAPHIC 6	1	1	1	RH
12	F1N-64114-00	MARK, YAMAHA A	2	2	2	
13	GM6-6411H-00	EMBLEM, TUNING FORK	1	1	1	
14	EU0-65986-00	TOOL SET	1	1		FOR USA,GENE
	EU0-65986-10	TOOL SET			1	FOR JPN
15	EU0-65901-01	TOOL BAG	1	1	1	
16	GM6-65987-00	BAG	1	1	1	

FIG. 26 REPAIR KIT 1

REF. NO.	PART NO.	DESCRIPTION	USA	GENE	JPN	REMARKS
1	64U-W0001-00	GASKET KIT FOR ENGINE UNIT	1	1	1	
2	6M6-11351-A2	.GASKET, CYLINDER	1	1	1	
3	62T-11181-00	.GASKET, CYLINDER HEAD 1	1	1	1	
4	93102-36M33	.OIL SEAL	1	1	1	
5	93101-36M46	.OIL SEAL	1	1	1	
6	93103-32M01	.OIL SEAL	1	1	1	
7	6M6-14739-A1	.GASKET, MUFFLER DAMPER 1	1	1	1	
8	61X-14613-A0	.GASKET, EXHAUST PIPE	1	1	1	
9	90430-08020	.GASKET	1	1	1	
10	6R7-14749-A0	.GASKET, MUFFLER DAMPER 2	1	1	1	
11	6R7-14755-A0	.GASKET, SILENCER	1	1	1	
12	6R7-41114-A0	.GASKET, EXHAUST OUTER COVER	1	1	1	
13	62T-13556-00	.GASKET, MANIFOLD	1	1	1	
14	62T-13624-00	.PLATE, REED VALVE	1	1	1	
15	62T-13566-00	.GASKET	2	2	2	
16	62T-13674-00	.GASKET, AIR COOLER COVER 1	2	2	2	
17	6R8-13116-A0	.GASKET, PUMP CASE	1	1	1	
18	6M6-81365-A0	.GASKET, HOLE COVER	1	1	1	
19	62T-45127-00	.SEAL	1	1	1	
20	61X-W0001-22	GASKETKIT FOR JET UNIT	1	1	1	
21	93210-17MA4	.O-RING	2	2	2	
22	93101-25M55	.OIL SEAL	2	2	2	
23	93101-25M56	.OIL SEAL	1	1	1	
24	93102-25M34	.OIL SEAL	1	1	1	
25	93101-25M50	.OIL SEAL	1	1	1	
26	93210-46M16	.O-RING	1	1	1	
27	6R7-51117-01	.PACKING	1	1	1	

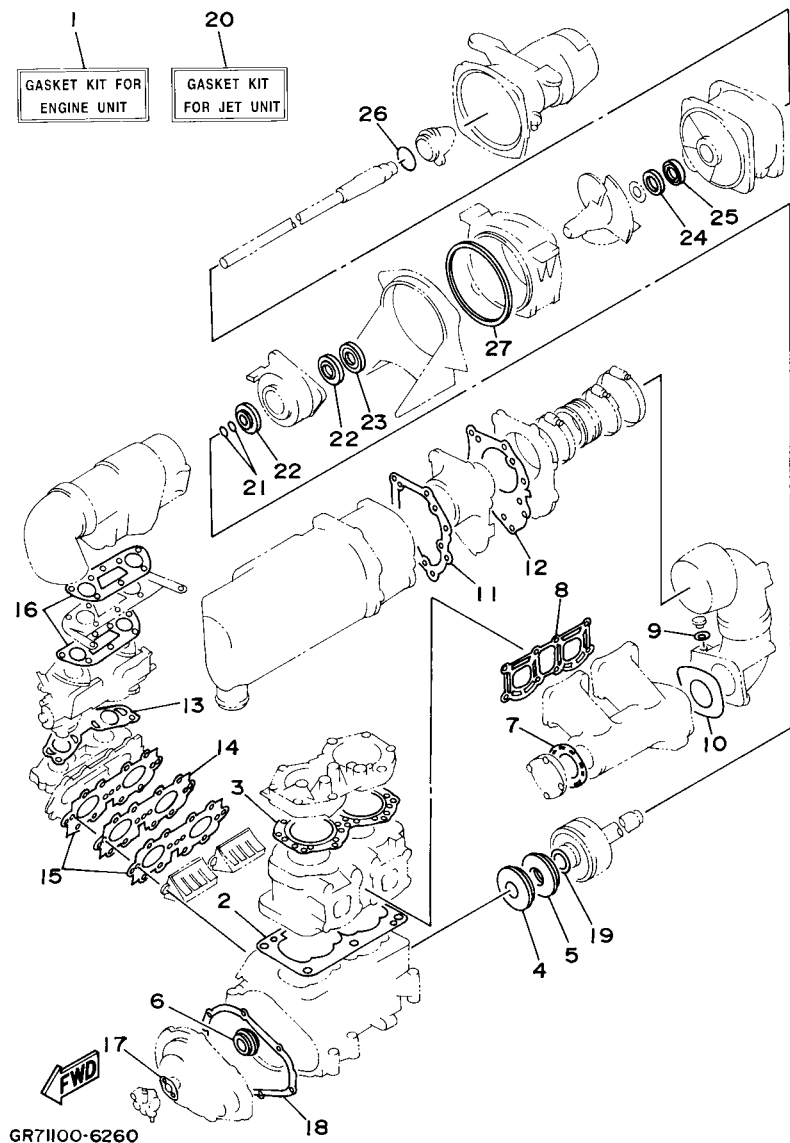
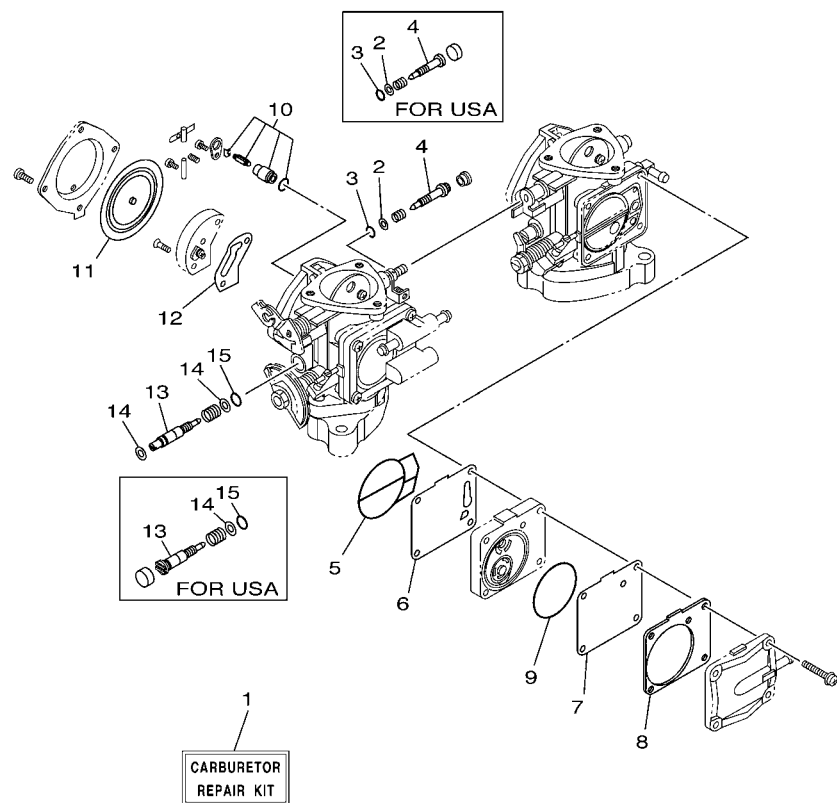

FIG. 27 REPAIR KIT 2



REF. NO.	PART NO.	DESCRIPTION	USA	GENE	JPN	REMARKS
1	64U-W0093-10	CARBURETOR REPAIR KIT	1			FOR USA
	64U-W0093-02	CARBURETOR REPAIR KIT		1	1	FOR GENE,JPN
2	812-14235-00	.WASHER, NEEDLE	4	4	4	
3	812-14147-00	.O-RING	2	2	2	
4	64U-14946-00	.PLATE, NEEDLE FITTING	2			FOR USA
	63M-14946-00	.PLATE, NEEDLE FITTING		2	2	FOR GENE,JPN
5	6K8-14564-00	.O-RING	2	2	2	
6	6K8-24411-20	.DIAPHRAGM	1	1	1	
7	6K8-24421-10	.VALVE, CHECK	1	1	1	
8	6K8-24431-20	.GASKET, FUEL PUMP 1	1	1	1	
9	6K8-14563-00	.O-RING	1	1	1	
10	61X-14916-16	.NEEDLE	2	2	2	
11	6R7-14541-00	.DIAPHRAGM, PUMP	2	2	2	
12	6K8-14536-11	.GASKET	2	2	2	
13	64U-14923-10	.SCREW, PILOT	2			FOR USA
	64U-14923-00	.SCREW, PILOT		2	2	FOR GENE,JPN
14	822-14235-00	.WASHER, NEEDLE	2			FOR USA
	822-14235-00	.WASHER, NEEDLE		4	4	FOR GENE,JPN
15	583-14561-00	.O-RING	2	2	2	

FWD
F1N7100-C270

NUMERICAL INDEX

PART NO.	GRID NO.	PART NO.	GRID NO.	PART NO.	GRID NO.	PART NO.	GRID NO.	PART NO.	GRID NO.	PART NO.	GRID NO.
64U-11111-00-8S	B - 2	812-14235-00	D - 14	583-14561-00	B - 9	EU0-23814-01	D - 5	6K8-51162-00	C - 13	EW2-62142-00	C - 15
62T-11181-00	B - 2	822-14235-00	B - 9		B - 11	62T-24313-01	B - 6	6R7-51311-00	C - 4	EW2-62149-00	C - 10
	D - 13		B - 11		D - 14	62T-24314-01	B - 6	6R7-51312-03-94	C - 3	EW2-62150-00	C - 15
61X-11311-01-8S	B - 2		D - 14	6K8-14563-00	B - 8	6E5-24378-00	B - 12	61L-51313-00	C - 3	GM6-6215G-00	D - 7
6E5-11325-00	B - 2	62T-14243-01	B - 6		B - 10	6K8-24411-20	B - 8	62T-51315-01-94	C - 3	GM6-62501-10	C - 14
6M6-11351-A2	B - 2	62T-14251-10	B - 2		D - 14		B - 10	6R7-51318-05-94	C - 3	GM6-6251D-10	C - 14
	D - 13	6R7-14253-00	B - 9	6K8-14564-00	B - 8		D - 14	6R7-51321-00-8S	C - 3	GM6-6251E-10	C - 14
61X-11400-03	B - 4		B - 11		B - 10	6R7-24412-01	B - 11	6R7-51323-02	C - 5	GM6-6252C-10	C - 14
6M6-11412-00	B - 4	62T-14255-00	B - 7		D - 14	6R7-24412-02	B - 9	62T-51326-00	C - 3	GM6-6252D-10	C - 14
6M6-11422-00	B - 4	62T-14283-00	B - 7	6R7-14569-00	B - 9	6M6-24413-01	B - 10	6R7-51333-00	C - 4	GM6-62552-10	C - 14
6M6-11431-00	B - 4	62T-14284-10-8S	B - 6		B - 11	6M6-24413-02	B - 8	62T-51348-00	C - 3	GM6-62553-10	C - 14
6M6-11442-01	B - 4	64U-14301-03	B - 10	6K8-14589-00	B - 9	65U-24421-00	B - 8	61X-51381-00	C - 5	GM6-62664-00	C - 11
82M-11515-00	B - 4	64U-14301-10	B - 8		B - 11		B - 10	61L-5169A-00	B - 6	EU0-62693-02	C - 4
61X-11603-01	B - 4	64U-14302-03	B - 10	61X-14613-A0	B - 12		B - 8	FX1-61105-00	D - 7	EU0-62694-00	D - 4
61X-11604-01	B - 4	64U-14302-10	B - 8		D - 13		B - 10	EW2-61314-00	D - 6	EU0-62695-00	C - 4
61X-11605-01	B - 4	64U-1432A-00	B - 8	61L-14615-A0	B - 13		D - 14	FX1-61337-00	D - 7	EW2-62723-30	C - 4
61X-11631-02-93	B - 4	64U-1432A-10	B - 9	61L-14625-A0	B - 13	6K8-24431-20	B - 8	FX1-61338-00	D - 7	F1N-6273B-00	C - 4
61X-11633-00	B - 4	62T-14419-00	B - 7	61X-14711-01-94	B - 12		B - 10	GM6-6133B-00	D - 7	EW2-62840-10	C - 12
61X-11635-02	B - 4	62T-14435-00	B - 7	61L-14712-00-94	B - 12		D - 14	FX1-6133C-13	D - 7	EW2-62843-00	C - 12
61X-11636-02	B - 4	62T-14451-00	B - 7	6M6-14718-01-8S	B - 12	6K8-24452-10	B - 8	EW2-61344-01	D - 7	EW2-62845-10	C - 12
62T-11651-00	B - 4	6K8-14471-10	B - 10	6R7-14721-00-8S	B - 13		B - 10	FX1-6134L-00	D - 7	EW2-62846-00	C - 12
82M-11685-00	B - 4	6R7-14485-00	B - 2	6M6-14739-A1	B - 12	70R-24489-00	C - 15	FX1-61391-00	D - 8	EW2-62847-00	C - 12
63M-12580-00	B - 12		B - 13		D - 13	65U-24492-00	B - 8	EW2-61395-30	D - 7	EW2-62848-00	C - 12
64X-12581-00	B - 13	6M6-14503-00	B - 8	6R7-14749-A0	B - 12		B - 10	EW2-61417-00	D - 6	A00-62858-02	C - 11
6R8-13116-A0	D - 13		B - 10		D - 13	6K8-24500-02	B - 15	EW2-61419-00	D - 6	GM6-6351B-00	C - 14
62T-13555-00-94	B - 6	6K8-14503-02	B - 8	64V-14752-00	B - 13	6R7-24524-00	B - 15	GM6-6142A-30	D - 7	GM6-6351C-00	C - 14
62T-13556-00	B - 6		B - 10	6R7-14753-00-9M	B - 13	70R-24543-00	C - 15	EU0-61435-00	D - 4	GM6-6351D-00	C - 14
	D - 13	6K8-14521-01	B - 9	6R7-14755-A0	B - 13	6K8-24560-10	B - 15	EU0-61436-00	D - 4	GM6-6351E-10	C - 14
62T-13566-00	B - 6		B - 11		D - 13	6R7-41113-00-8S	B - 13	EU0-61438-00	D - 4	GM6-63844-00	D - 3
	D - 13	6M6-14521-01	B - 8	6M6-14771-00	B - 13	6R7-41114-A0	B - 13	FX1-6143D-20	D - 5	F1N-64114-00	D - 9
62T-13610-00	B - 6		B - 10	6R7-14785-00-8S	B - 13		D - 13	FX1-6143E-20	D - 5	GM6-6411H-00	D - 9
62T-13624-00	B - 6	6K8-14521-10	B - 8	61X-14916-16	B - 9	6R7-42316-00	C - 3	EU0-61446-00	D - 4	F1N-6415B-00	D - 10
	D - 13		B - 10		B - 11	6R7-44517-00-8S	B - 2	EU0-61461-02	D - 5	F1N-6415B-10	D - 11
62T-13674-00	B - 7	6K8-14523-11	B - 9		D - 14	663-45119-00	B - 6	EU0-61461-30	D - 4	F1N-6415B-20	D - 12
	D - 13		B - 11	64U-14923-00	B - 11	62T-45127-00	B - 5	EW2-61465-00	D - 7	GA7-6416H-20	D - 11
47X-14133-00	B - 8	62T-14527-02	B - 6		D - 14		D - 13	FX1-61468-00	D - 7	F1N-6417B-10	D - 9
	B - 10	6K8-14527-11	B - 8	64U-14923-10	B - 9	61X-45332-03-94	C - 5	GM6-61481-10	D - 4	F1N-6417C-30	D - 9
812-14147-00	B - 8		B - 10		D - 14	61L-45378-00	C - 5	EU0-61486-00	D - 4	F1N-6417C-40	D - 9
	B - 10	6K8-14536-11	B - 9	3KW-14932-00	B - 8	6R7-45511-01	C - 3	EW2-61540-11	D - 5	F1N-6417D-30	D - 9
	D - 14		B - 11		B - 10	62T-45526-00	B - 4	FX1-61552-00	D - 5	F1N-6417D-40	D - 9
439-14186-00	B - 9		D - 14	63M-14946-00	B - 10	6M6-45813-22-8P	B - 5	EW2-61553-00	D - 5	F1N-6417E-30	D - 9
	B - 11	6R7-14541-00	B - 9		D - 14	6M6-45813-32-8P	B - 5	FN8-61651-01	C - 14	F1N-6417E-40	D - 9
830-14231-14	B - 8		B - 11	64U-14946-00	B - 8	61X-4581J-00	B - 5	EU0-61652-00	B - 14	F1N-6417F-30	D - 9
	B - 10		D - 14		D - 14	6R7-51117-01	C - 4		C - 14	F1N-6417F-40	D - 9
3G2-14231-26	B - 8	6R7-14542-00	B - 9	62T-15100-00-8S	B - 2		D - 13	GP7-61652-00	D - 3	F1N-6417G-30	D - 9
	B - 10		B - 11	6R7-15761-00	B - 13	6K8-51129-00	B - 2	EW2-62137-00	C - 11	F1N-6417G-40	D - 9
812-14235-00	B - 8	6K8-14547-01	B - 9	6R7-21415-01-94	B - 2		B - 12	GM6-6213F-00	C - 11	EU0-64188-00	D - 10
	B - 10		B - 11	6R7-21425-01-94	B - 2		C - 3	EW2-62140-00	C - 15		D - 11

NUMERICAL INDEX

PART NO.	GRID NO.	PART NO.	GRID NO.	PART NO.	GRID NO.	PART NO.	GRID NO.	PART NO.	GRID NO.	PART NO.	GRID NO.
EU0-64188-00	D - 12	GM6-65987-00	D - 9	EU0-67856-40	C - 10	6R7-82560-11	C - 9	90119-10M00	B - 2	90445-10M98	B - 15
GM6-6418D-00	C - 15	GM6-67242-00	D - 4	EU0-67869-00	D - 2	6B6-83623-00	C - 8	90119-10M01	B - 2	90445-10ME3	B - 15
EW3-64197-00	D - 12	GD0-67249-00-05	C - 5	EW2-68156-00	C - 8	60E-83627-00	C - 9	90119-10M02	B - 2	90445-10ME4	B - 15
GM6-641B1-01	D - 10	GD0-67249-00-10	C - 5	EW2-68211-00	C - 10	682-84385-01	B - 13	90119-10M03	B - 2	90445-10ME8	B - 15
GM6-641B1-10	D - 10	EW2-67250-02	D - 5	EU0-68218-04	C - 10	62T-85515-00	C - 6	90119-10M07	B - 2	90445-10MF1	B - 15
	D - 11	GM6-67252-00	D - 4		D - 3	62T-85520-00	C - 6	90119-10M17	B - 13	90445-11903	C - 15
GM6-641B1-21	D - 11	EW2-67255-00	D - 5	EU0-68221-00	C - 10	6M6-8552A-01-8P	C - 8	90119-10M56	B - 2	90445-14M04	C - 13
GM6-641B1-41	D - 11	EW2-67256-00	D - 5	EW2-68221-00	C - 10	6M6-8552E-01	C - 8	90149-05937	D - 5	90445-14M05	B - 13
GM6-641B1-50	D - 11	EW2-67257-01	D - 5	EU0-68221-30	C - 10	62T-85533-00	C - 6	90149-05959	D - 5	90445-14M06	B - 12
GM6-641B1-60	D - 12	EW2-67258-01	D - 5	EW2-68310-04	D - 5	62T-85540-01	C - 8	90149-05960	C - 14	90445-14M12	C - 3
GM6-641B1-70	D - 12	EW2-67259-01	D - 5	FK7-68312-02	D - 5	62T-85550-00	C - 6	90149-05962	C - 14	90445-14M14	B - 12
GM6-641B2-00	D - 10	EU0-67324-00	B - 3	FK7-68313-02	D - 5	62T-85560-00	C - 6	90149-06997	D - 7	90445-14M19	C - 13
	D - 11	EU0-67354-00-01	B - 3	EW2-68348-00	D - 5	62E-85570-00	C - 8	90159-05900	D - 5	90445-14M29	B - 12
GM6-641B2-10	D - 10	EW2-67354-00-01	C - 4	6M6-8132W-00	C - 8	62E-85570-11	C - 8	90170-14913	D - 8	90445-14M33	B - 12
	D - 11	EU0-67354-00-03	B - 3	6M6-81337-00-8S	C - 6	6M6-85580-00	C - 6	90170-22187	C - 2	90446-14M23	B - 15
GM6-641B2-40	D - 11	EW2-67354-00-03	C - 4	6M6-81365-A0	C - 6	67X-E2590-10	B - 14	90176-10915	D - 6	90446-14M30	C - 15
GM6-641B2-50	D - 11	EU0-67354-00-05	B - 3		D - 13	64U-W0001-00	D - 13	90179-05964	C - 14	90446-14M64	B - 15
GM6-641B2-60	D - 12	EW2-67354-00-05	C - 4	6M6-81800-10	C - 7	61X-W0001-22	D - 13	90179-08962	C - 4	90450-14M05	B - 12
GM6-641B2-70	D - 12	EU0-67354-00-10	B - 3	3AJ-81809-00	C - 7	62T-W0004-00	B - 6	90179-08M15	B - 6		C - 3
F1N-641DB-00	D - 10	EW2-67354-00-10	C - 4	6M6-81820-00	C - 7	64V-W0090-02-8S	B - 2	90179-10925	C - 4	90450-18M09	B - 13
F1N-641DB-10	D - 11	EU0-67354-00-20	B - 3	6M6-81826-00	C - 7	64U-W0093-02	D - 14	90179-12933	D - 6	90460-64M15	B - 13
F1N-641DB-20	D - 12	GH7-6753B-00	D - 3	6M6-81830-00	C - 7	64U-W0093-10	D - 14	90201-05928	D - 5	90460-70M16	B - 13
GM6-6491A-03-P2	D - 7	GM6-67550-00	D - 3	6M6-8183E-01	C - 7	90105-06900	D - 2	90201-06M02	C - 3	90460-90M11	B - 13
FX1-6492E-10	D - 7	GM6-67555-00	D - 3	6M6-81840-10	C - 7		D - 3	90201-11008	D - 4	90464-06M29	C - 8
GM6-6492J-30	D - 8	GM6-6755J-00	D - 3	11H-81844-00	C - 7	90105-08902	D - 5	90201-20M04	B - 4	90464-08M07	B - 15
GM6-64949-00	D - 8	GM6-67565-00	D - 3	6M6-81844-00	C - 8	90105-10M49	B - 13	90201-24M02	B - 5	90464-20258	C - 11
FX1-65116-10	C - 11	GM6-67593-00	D - 2	26H-81847-00	C - 7	90105-10M88	B - 13	90209-12920	D - 4	90465-06M86	C - 8
GM6-65135-00	D - 7	GM6-67594-00	D - 2	6M6-81850-00	C - 7	90109-10M44	C - 6	90267-40935	D - 2	90465-11M10	B - 6
GM6-65136-00	C - 11	EU0-67613-00	C - 13	6M6-81865-00	C - 7	90116-08M60	B - 6	90267-40945	D - 4		B - 12
EW2-65137-00	C - 11	EW2-67618-00	C - 13	6M6-81866-00	C - 7	90119-05923	C - 12	90267-48925	B - 15		B - 15
FX1-6514B-00	C - 11	EW2-67711-01	C - 15	6M6-81921-00	C - 8	90119-05M02	B - 7		C - 15		C - 5
FX1-6514F-00	C - 11	FJ0-67713-00	C - 15	68N-81940-00	C - 8	90119-06900	C - 11	90267-48930	D - 3		C - 9
GM6-6516A-10-33	C - 11	EW2-67714-02	C - 15	6M6-81960-A0	C - 8		D - 7	90267-48932	C - 14		C - 10
GM6-6516C-00	C - 11	EW2-67716-01	C - 15	EU0-82110-09	C - 10	90119-06908	C - 4	90267-48938	C - 11		C - 13
FX1-6517D-00	C - 11	GM6-6773E-00	B - 15	64V-82117-00	C - 10		C - 8	90267-48940	B - 15		C - 15
GM6-6521C-10	C - 14	EU0-67767-31	C - 15	6R7-82117-11	C - 10	90119-06913	D - 7	90267-48963	C - 14		D - 3
GM6-6521D-10	C - 14	EU0-67816-30	B - 15	62E-82117-20	C - 9	90119-06915	C - 4	90280-05013	C - 6	90465-12M53	C - 6
FX1-65760-00	D - 3	EU0-67817-00	C - 2	6K8-82150-01	C - 8	90119-06918	D - 7	90340-08M04	B - 12	90465-12M56	B - 15
EW2-65772-00	D - 2	EW2-67821-00	C - 15	6G1-82151-00	C - 8	90119-06920	C - 10	90380-12M29	B - 2	90465-13M11	C - 9
	D - 3	EW2-67821-30	D - 2	6K8-82159-00	C - 8	90119-06M70	C - 3		C - 6		C - 13
EU0-65901-01	D - 9	EW2-67822-01	D - 2	6R7-82351-00	C - 9	90119-06MA1	B - 13	90387-06916	D - 8		C - 15
EW2-65912-00	C - 11	FN8-67831-01	D - 2	62E-82351-01	C - 8	90119-08038	B - 3	90387-06M05	C - 6		D - 6
EW2-65913-00	C - 11	EU0-67832-00	D - 2	6R7-82352-00	C - 9	90119-08904	B - 3	90387-06M60	C - 5	90467-06016	B - 2
FX1-6591A-10	C - 11	FN8-67833-00	D - 2	62E-82352-01	C - 9	90119-08907	C - 5	90387-08M06	C - 3	90467-08M10	C - 10
FX1-6591K-00	C - 11	EU0-67834-00	D - 2	6R7-82361-01	C - 9	90119-08943	C - 4	90430-08020	B - 12	90467-11032	C - 15
F1N-65938-00	B - 15	EU0-67835-00	D - 2	66T-82370-00	C - 9	90119-08M55	B - 2		D - 13	90480-06M43	C - 9
EU0-65986-00	D - 9	EU0-67839-00	D - 2	62E-82371-11	C - 8	90119-08M96	B - 2	90445-07M19	B - 2	90480-06M69	C - 5
EU0-65986-10	D - 9	GM6-67844-10	D - 2	6R7-82553-01	C - 9	90119-10948	C - 4	90445-09M17	C - 5	90501-14M73	C - 7

NUMERICAL INDEX

PART NO.	GRID NO.	PART NO.	GRID NO.	PART NO.	GRID NO.	PART NO.	GRID NO.	PART NO.	GRID NO.	PART NO.	GRID NO.
90560-22281	D - 5	92995-06600	C - 6	95680-08630	D - 7	98580-05018	B - 10				
90600-91728	D - 5		C - 8	95720-05300	C - 4	98780-04015	B - 2				
90600-91736	B - 15	92995-08600	C - 3		C - 12	98780-05016	C - 4				
90601-11062	C - 15	93101-25M50	C - 3	95720-06300	C - 11	98980-04008	C - 2				
90601-15573	D - 2		D - 13		D - 7	98980-04010	D - 6				
90601-16274	C - 15	93101-25M55	C - 5	95720-08300	D - 7						
90601-16875	C - 11		D - 13	97013-06012	B - 7						
	D - 3	93101-25M56	C - 5	97013-06016	B - 6						
90601-20006	B - 15		D - 13	97013-06020	B - 6						
	D - 7	93101-36M46	B - 4		B - 13						
90601-20016	B - 15		D - 13	97013-06025	B - 6						
90601-20024	B - 14	93102-25M34	C - 3		B - 12						
90699-50003	C - 15		D - 13	97013-06035	B - 6						
90699-50045	C - 15	93102-36M33	B - 4	97013-08025	B - 12						
90699-50120	C - 15		D - 13	97013-08035	B - 12						
91490-16010	C - 15	93103-32M01	B - 4		C - 7						
91790-05040	C - 15		D - 13	97013-08090	B - 12						
92580-06016	C - 11	93210-13M63	B - 7	97090-06014	C - 11						
92903-06600	B - 6	93210-17MA4	C - 5	97095-06010	C - 8						
	B - 12		D - 13	97095-06016	B - 13						
	C - 7	93210-46M16	C - 3		C - 9						
92903-08600	B - 12		D - 13	97095-06020	C - 3						
	C - 7	93305-30601	B - 4	97095-06025	C - 6						
92990-05100	C - 14	93306-205U0	C - 3	97095-06035	C - 6						
	D - 7	93306-205U6	C - 5	97095-08018	C - 3						
92990-05200	C - 4	93306-207U2	B - 4	97513-08540	C - 7						
	C - 14	93306-307U3	B - 4	97595-06525	C - 5						
92990-05600	B - 6	93310-320U2	B - 4	97780-50114	C - 13						
	C - 15	93310-525U0	B - 4		D - 2						
92990-06100	C - 7	93430-47M04	C - 5	97780-50316	C - 11						
	C - 11	93440-25M08	C - 7	97780-60120	C - 4						
	C - 14	93440-80023	B - 4	97780-60520	D - 8						
	D - 5	93450-18M06	C - 7	97780-60525	C - 8						
92990-06200	C - 11	93450-21053	B - 4	97802-04008	C - 6						
	C - 14	93603-10049	B - 5	97880-03008	D - 5						
	D - 7	93604-07141	B - 5	97880-05012	B - 9						
92990-06600	C - 6	93606-07M17	C - 4		B - 11						
	C - 9	93606-12019	B - 2		D - 7						
92990-08100	C - 8		C - 3	97880-05016	B - 6						
	D - 7		C - 5	97880-05025	D - 5						
92990-08200	C - 8		C - 6	97880-06016	C - 6						
92990-10100	D - 6	94702-00040	C - 9		C - 9						
92990-10200	D - 6	94702-00272	C - 9	97880-06030	C - 9						
92990-14200	D - 3	94709-00040	C - 9	97902-04122	C - 6						
	D - 8	95380-06700	C - 3	97902-05125	C - 6						
92995-06100	C - 8		C - 7	97980-05330	B - 8						
92995-06600	B - 13	95380-06800	C - 14		B - 10						
	C - 3	95380-08600	C - 8	98580-05018	B - 8						