

PARTS CATALOGUE

SUPERJET 700

SJ700A-Z (GM6K/64VC/64V1)

MJ-SJ700'01 (GM6L/64VD/64V1)

FOREWORD

This Parts Catalogue is related to the parts for the model(s) in the below frame. When you are ordering replacement parts, please refer to this Parts Catalogue and quote both part numbers and part names correctly.

SJ700A-Z(GM6K/64VC/64V1), MJ-SJ700'01(GM6L/64VD/64V1)

1. Modifications or additions which have been made after issue of the Parts Catalogue will be announced in the Yamaha Parts News.
It is advisable that you make necessary corrections to the Parts Catalogue according to the Yamaha Parts News.

2. Abbreviations

The following abbreviations are used in this Parts Catalogue.

"UR" Use specified parts number.

"UN" Use as many as needed.

"AP" Alternate Parts

"LM" Local Made (Parts need to be ordered locally)

"F#" Frame No. (Applicable machine No.)

3. Parts, which are to be supplied in an assembly, are listed with a dot(.) in front of the part name as shown below.
The numeral appearing to the right of each component part indicates the quantity of parts for each assembly unit.

EXAMPLE

PART NO.	DESCRIPTION	Q'TY	REMARKS
EU0-62280-00	DRAIN PLUG ASSY	2	
EU0-62282-00	.PLUG,DRAIN	1	

4. Quantity Column Information

NAME for Q'TY COLUMN	COUNTRY (destination)
USA	USA
CAN	CANADA
GENE	EXCEPT USA, CANADA, JAPAN
JPN	JAPAN

5. Applicable Starting Serial No. and Color Code

Hull Serial No.	(GM6K) FOR USA,CAN	GM6-915240
	(GM6K) FOR GENE	GM6-915340
	(GM6L) FOR JPN	
Engine Serial No.	(64VC) FOR USA,CAN	64V-012593
	(64VC) FOR GENE	64V-012693
	(64VD) FOR JPN	64V-013313

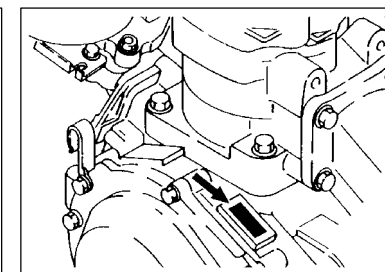
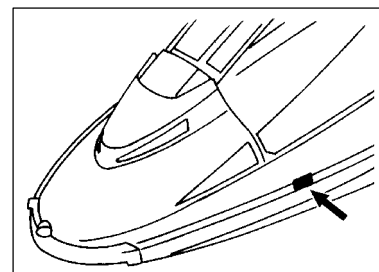

Color Code	Color Name	Abbreviation
GA5D	DARK VIOLET COAT 2	DVC2

6. Note that the illustration for reference in finding parts numbers, not to be used for assembling. When assembling, please use the applicable service manual.
7. A part with "YMUS" in the remarks column can be obtained from YMUS (USA) and not from YAMAHA MOTOR CO.,LTD (JAPAN).

EXAMPLE

PART NO.	DESCRIPTION	Q'TY	REMARKS
EW2-U5160-00	ENGINE HATCH COMP.	2	.. YMUS
90601-168U7	BAND, HOSE	1	.. YMUS

ADDRESS:

YAMAHA MOTOR CORPORATION U.S.A.
PARTS & ACCESSORY DIV.
6555 KATELLA AVENUE
CYPRESS, CALIFORNIA 90630 U.S.A.

FIG. 1 CYLINDER, CRANKCASE

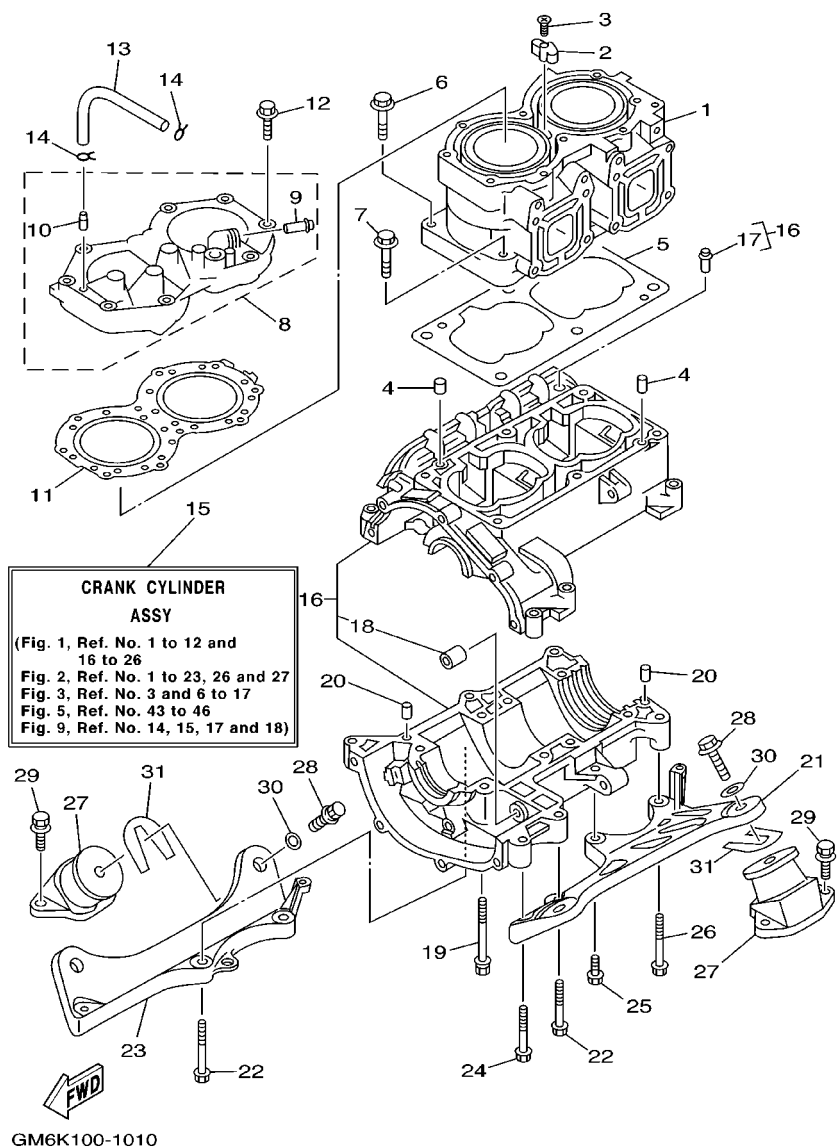

REF. NO.	PART NO.	DESCRIPTION	USA	CAN	GENE	JPN	REMARKS
1	61X-11311-01-94	CYLINDER 1	1	1	1	1	
2	6E5-11325-00	ANODE	1	1	1	1	
3	98780-04015	SCREW, FLAT HEAD	1	1	1	1	
4	93606-12019	PIN, DOWEL	2	2	2	2	
5	6M6-11351-A2	GASKET, CYLINDER	1	1	1	1	
6	90119-10M56	BOLT, WITH WASHER	4	4	4	4	
7	90119-10M07	BOLT, WITH WASHER	2	2	2	2	
8	64U-11111-00-94	HEAD, CYLINDER 1	1	1	1	1	
9	6K8-51129-00	.NIPPLE	1	1	1	1	
10	6R7-14485-00	.PIPE, JOINT	1	1	1	1	
11	62T-11181-00	GASKET, CYLINDER HEAD 1	1	1	1	1	
12	90119-08M96	BOLT, WITH WASHER	10	10	10	10	
13	90445-07M19	HOSE (L200)	1	1	1	1	
14	90467-06016	CLIP	2	2	2	2	
15	64V-W0090-01-8P	CRANK CYLINDER ASSY	1	1	1	1	
16	62T-15100-00-94	CRANKCASE ASSY	1	1	1	1	
17	62T-14251-10	.NIPPLE	1	1	1	1	
18	90380-12M29	.BUSH, SOLID	1	1	1	1	
19	90119-08M55	BOLT, WITH WASHER	8	8	8	8	
20	93606-12019	PIN, DOWEL	2	2	2	2	
21	6R7-21415-01-94	BRACKET, FRONT UPPER 1	1	1	1	1	
22	90119-10M02	BOLT, WITH WASHER	4	4	4	4	
23	6R7-21425-01-94	BRACKET, REAR UPPER 1	1	1	1	1	
24	90119-10M01	BOLT, WITH WASHER	1	1	1	1	
25	90119-10M00	BOLT, WITH WASHER	1	1	1	1	
26	90119-10M03	BOLT, WITH WASHER	1	1	1	1	
27	6R7-44517-00-9M	MOUNT RUBBER	4	4	4	4	

FIG. 1 CYLINDER, CRANKCASE

REF. NO.	PART NO.	DESCRIPTION	USA	CAN	GENE	JPN	REMARKS
28	90119-08904	BOLT, WITH WASHER	4	4	4	4	
29	90119-08038	BOLT, WITH WASHER	8	8	8	8	
30	EU0-67324-00	PLATE	4	4	4	4	
31	EU0-67354-00-01	SHIM (T=0.1)	10	10	10	10	UR
	EU0-67354-00-03	SHIM (T=0.3)	10	10	10	10	UR
	EU0-67354-00-05	SHIM (T=0.5)	10	10	10	10	UR
	EU0-67354-00-10	SHIM (T=1.0)	10	10	10	10	UR
	EU0-67354-00-20	SHIM (T=2.0)	10	10	10	10	UR

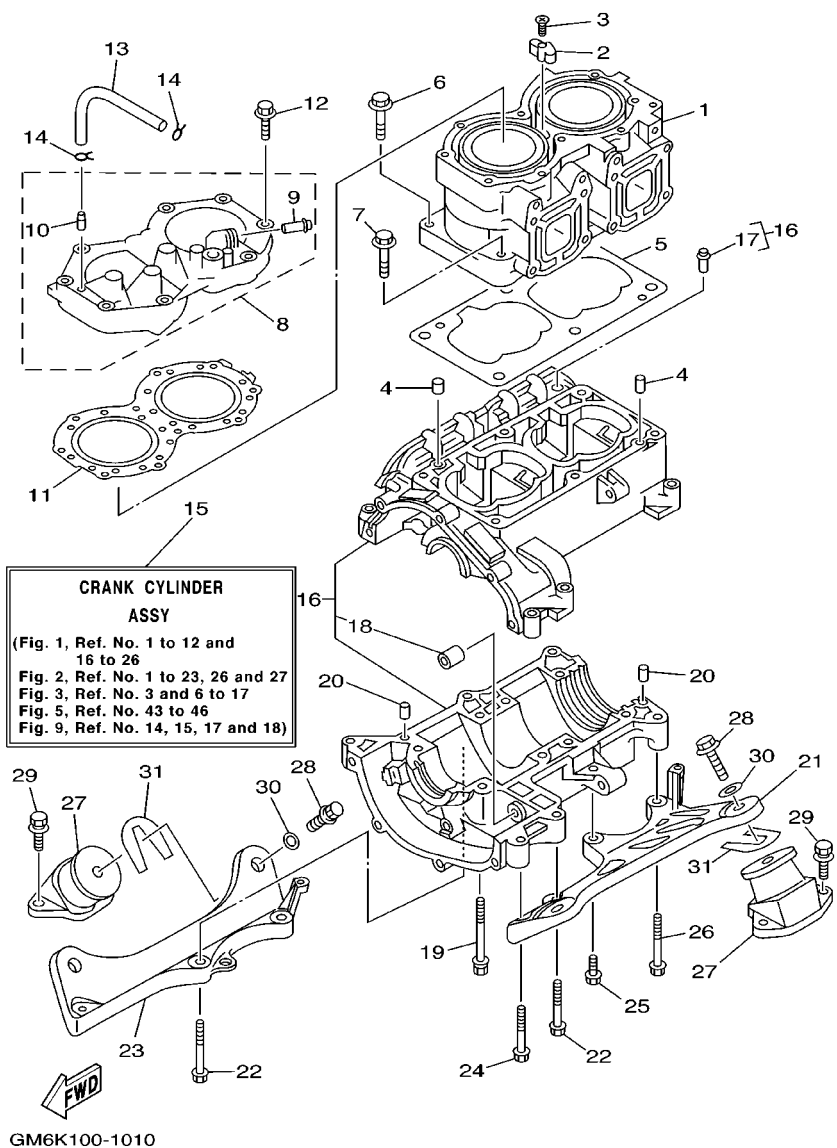
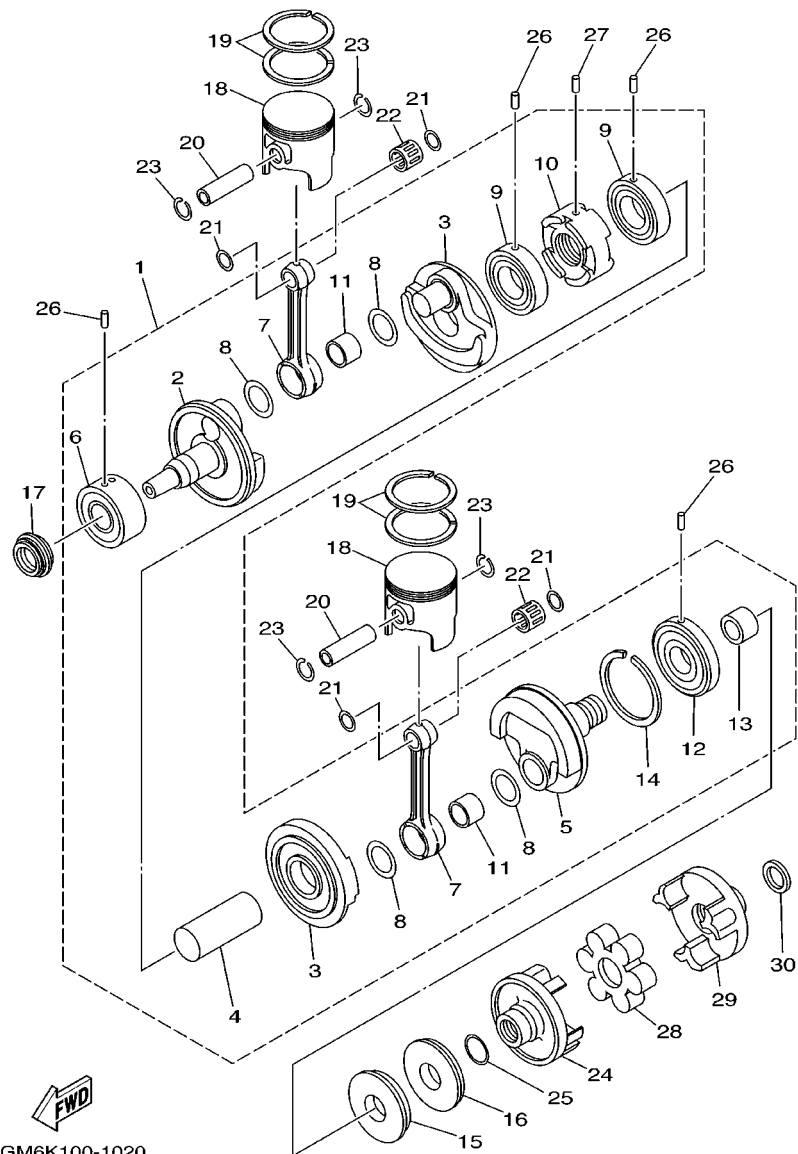

FIG. 2 CRANKSHAFT, PISTON



GM6K100-1020

REF. NO.	PART NO.	DESCRIPTION	USA	CAN	GENE	JPN	REMARKS
1	61X-11400-03	CRANKSHAFT ASSY	1	1	1	1	
2	6M6-11412-00	.CRANK 1	1	1	1	1	
3	6M6-11422-00	.CRANK 2	2	2	2	2	
4	6M6-11431-00	.CRANK 3	1	1	1	1	
5	6M6-11442-01	.CRANK 4	1	1	1	1	
6	93305-30601	.BEARING	1	1	1	1	
7	62T-11651-00	.ROD, CONNECTING	2	2	2	2	
8	82M-11685-00	.WASHER, CRANK PIN	4	4	4	4	
9	93306-207U2	.BEARING	2	2	2	2	
10	82M-11515-00	.SEAL, LABYRINTH 1	1	1	1	1	
11	93310-525U0	.BEARING	2	2	2	2	
12	93306-307U3	.BEARING	1	1	1	1	
13	62T-45526-00	.COLLAR, DRIVE SHAFT	1	1	1	1	
14	93440-80023	.CIRCLIP	1	1	1	1	
15	93102-36M33	OIL SEAL	1	1	1	1	
16	93101-36M46	OIL SEAL	1	1	1	1	
17	93103-32M01	OIL SEAL	1	1	1	1	
18	61X-11631-01-93	PISTON (STD)	2	2	2	2	
	61X-11635-01	PISTON (0.25MM O/S)	2	2	2	2	AP
	61X-11636-01	PISTON (0.50MM O/S)	2	2	2	2	AP
19	61X-11603-00	PISTON RING SET (STD)	2	2	2	2	
	61X-11604-00	PISTON RING SET (0.25MM O/S)	2	2	2	2	AP
	61X-11605-00	PISTON RING SET (0.50MM O/S)	2	2	2	2	AP
20	61X-11633-00	PIN, PISTON	2	2	2	2	
21	90201-20M04	WASHER, PLATE	4	4	4	4	
22	93310-320U2	.BEARING	2	2	2	2	
23	93450-21053	CIRCLIP	4	4	4	4	

FIG. 2 CRANKSHAFT. PISTON

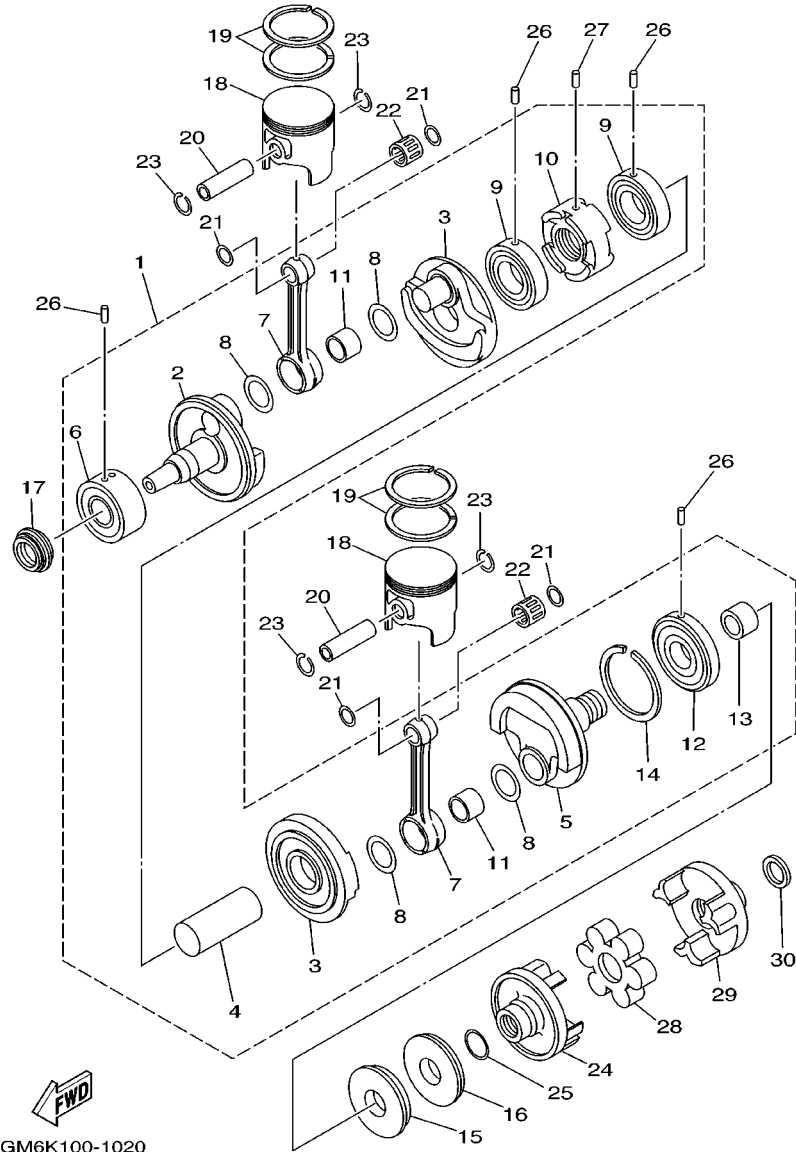

GM6K100-1020

REF. NO.	PART NO.	DESCRIPTION	USA	CAN	GENE	JPN	REMARKS
24	6M6-45813-32-8P	FLANGE, COUPLING	1	1	1	1	
25	62T-45127-00	SEAL	1	1	1	1	
26	93603-10049	PIN, DOWEL	4	4	4	4	
27	93604-07141	PIN, DOWEL	1	1	1	1	
28	61X-4581J-00	RUBBER SHAFT COUPLING	1	1	1	1	
29	6M6-45813-22-8P	FLANGE, COUPLING	1	1	1	1	
30	90201-24M02	WASHER, PLATE	1	1	1	1	

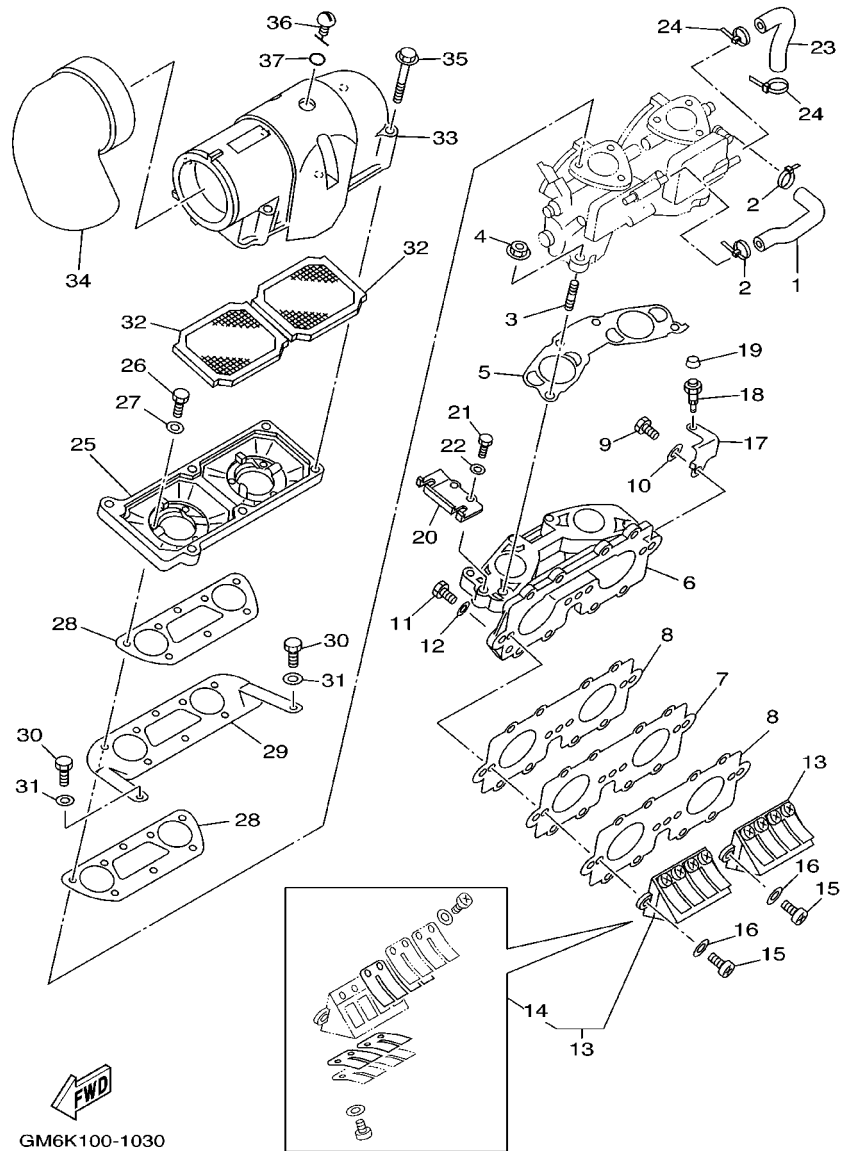

GM6K100-1030

FIG. 3 INTAKE

REF. NO.	PART NO.	DESCRIPTION	USA	CAN	GENE	JPN	REMARKS
1	62T-24313-01	PIPE 3	1	1	1	1	
2	90465-11M10	CLAMP	2	2	2	2	
3	90116-08M60	BOLT, STUD	4	4	4	4	
4	90179-08M15	NUT	4	4	4	4	
5	62T-13556-00	GASKET, MANIFOLD	1	1	1	1	
6	62T-13555-00-8P	MANIFOLD, INTAKE	1	1	1	1	
7	62T-13624-00	PLATE, REED VALVE	1	1	1	1	
8	62T-13566-00	GASKET	2	2	2	2	
9	97013-06035	BOLT	3	3	3	3	
10	92903-06600	WASHER, PLATE	3	3	3	3	
11	97013-06025	BOLT	8	8	8	8	
12	92903-06600	WASHER, PLATE	8	8	8	8	
13	62T-13610-00	REED VALVE ASSY	2	2	2	2	
14	62T-W0004-00	.REED SET	1	1	1	1	
15	97880-05016	SCREW, PAN HEAD	4	4	4	4	
16	92990-05600	WASHER, PLATE	4	4	4	4	
17	62T-14243-01	PLATE	1	1	1	1	
18	61L-5169A-00	NIPPLE, GREASE	1	1	1	1	
19	663-45119-00	CAP, GREASE NIPPLE	1	1	1	1	
20	62T-14527-02	PLATE	1	1	1	1	
21	97013-06016	BOLT	2	2	2	2	
22	92903-06600	WASHER, PLATE	2	2	2	2	
23	62T-24314-01	PIPE 4	1	1	1	1	
24	90465-11M10	CLAMP	2	2	2	2	
25	62T-14284-10-8P	COVER, CARBURETOR 2	1	1	1	1	
26	97013-06020	BOLT	6	6	6	6	
27	92903-06600	WASHER, PLATE	6	6	6	6	

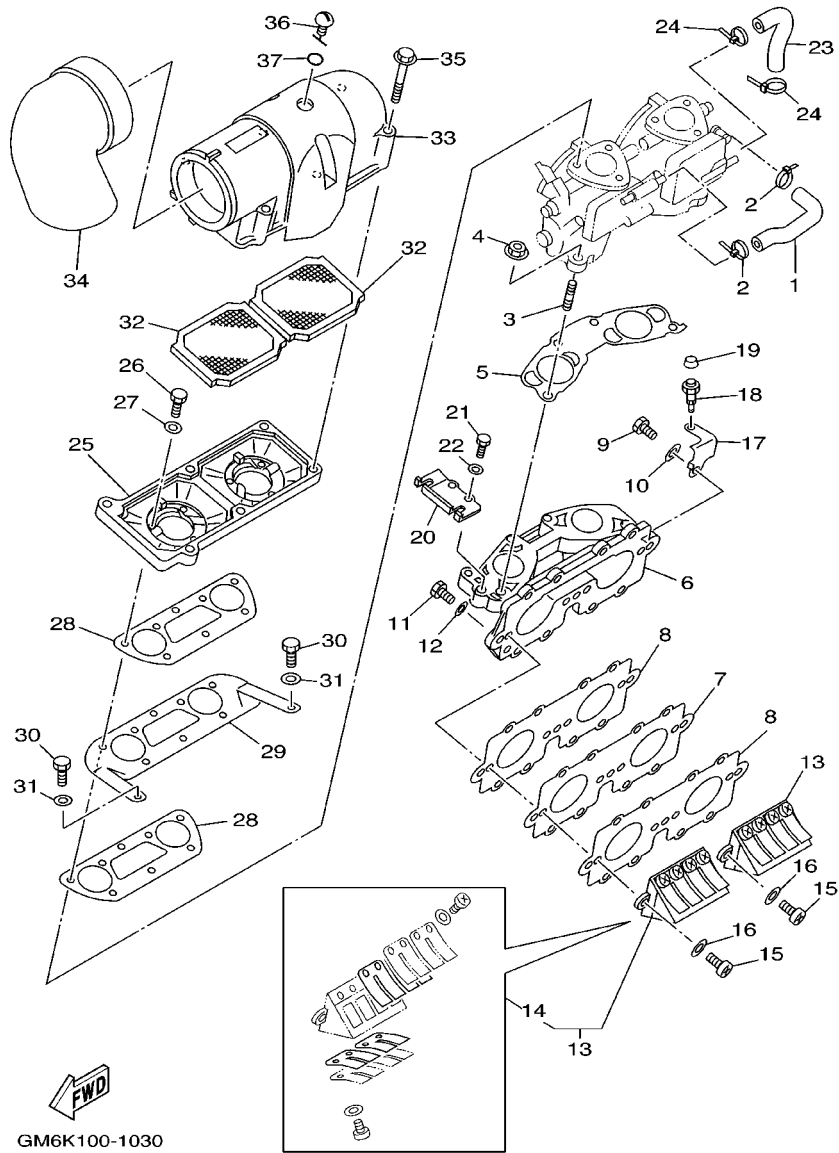
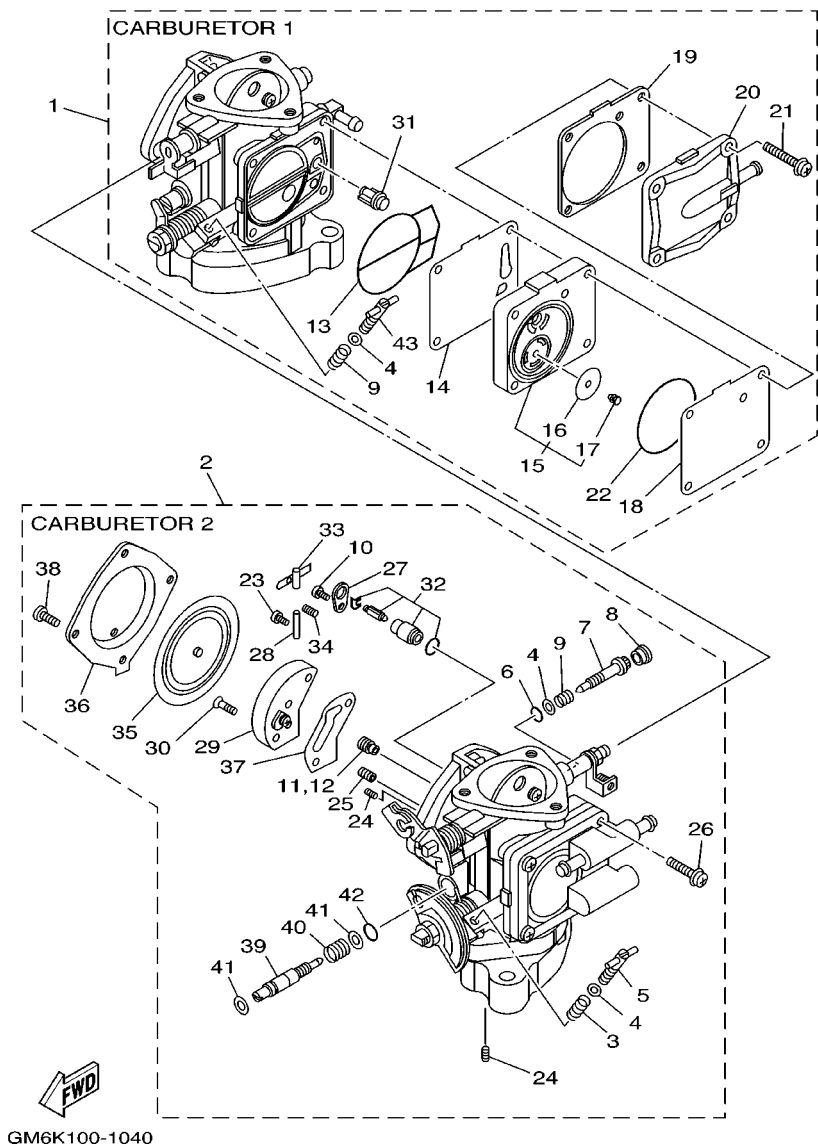

FIG. 3 INTAKE

REF. NO.	PART NO.	DESCRIPTION	USA	CAN	GENE	JPN	REMARKS
28	62T-13674-00	GASKET, AIR COOLER COVER 1	2	2	2	2	
29	62T-14255-00	PLATE	1	1	1	1	
30	97013-06012	BOLT	2	2	2	2	
31	92903-06600	WASHER, PLATE	2	2	2	2	
32	62T-14451-00	ELEMENT, AIR CLEANER	2	2	2	2	
33	62T-14283-00	COVER, CARBURETOR 1	1	1	1	1	
34	62T-14419-00	PIPE	1	1	1	1	
35	90119-05M02	BOLT, WITH WASHER	6	6	6	6	
36	62T-14435-00	GROMMET	1	1	1	1	
37	93210-13M63	O-RING	1	1	1	1	

FIG. 4 CARBURETOR



REF. NO.	PART NO.	DESCRIPTION	USA	CAN	GENE	JPN	REMARKS
1	64U-14301-02	CARBURETOR ASSY 1	1	1	1	1	
2	64U-14302-02	CARBURETOR ASSY 2	1	1	1	1	
3	47X-14133-00	.SPRING, THROTTLE STOP	1	1	1	1	CARBURETOR 2
4	812-14235-00	.WASHER, NEEDLE	4	4	4	4	
5	6M6-14521-01	.SCREW, ADJUST	1	1	1	1	CARBURETOR 2
6	812-14147-00	.O-RING	2	2	2	2	
7	63M-14946-00	.PLATE, NEEDLE FITTING	2	2	2	2	
8	6K8-14471-10	.CAP, CARBURETOR	2	2	2	2	
9	3KW-14932-00	.SPRING, THROTTLE 2	3	3	3	3	
10	6M6-14503-00	.SCREW	2	2	2	2	
11	3G2-14231-26	.JET, MAIN (#130)	1	1	1	1	CARBURETOR 1
12	3G2-14231-26	.JET, MAIN (#130)	1	1	1	1	CARBURETOR 2
13	6K8-14564-00	.O-RING	2	2	2	2	
14	6K8-24411-20	.DIAPHRAGM	1	1	1	1	CARBURETOR 1
15	6M6-24413-01	.BODY 2	1	1	1	1	CARBURETOR 1
16	65U-24421-00	.VALVE, CHECK	2	2	2	2	CARBURETOR 1
17	65U-24492-00	.BUSH, FULEL PUMP	2	2	2	2	CARBURETOR 1
18	6K8-24421-10	.VALVE, CHECK	1	1	1	1	CARBURETOR 1
19	6K8-24431-20	.GASKET, FUEL PUMP 1	1	1	1	1	CARBURETOR 1
20	6K8-24452-10	.COVER	1	1	1	1	CARBURETOR 1
21	97980-05330	.SCREW, WITH WASHER	4	4	4	4	CARBURETOR 1
22	6K8-14563-00	.O-RING	1	1	1	1	CARBURETOR 1
23	6K8-14503-02	.SCREW	2	2	2	2	
24	6K8-14521-10	.SCREW	4	4	4	4	
25	830-14231-14	.JET, MAIN (# 70)	2	2	2	2	
26	98580-05018	.SCREW, PAN HEAD	1	1	1	1	CARBURETOR 1
27	6K8-14527-11	.PLATE	2	2	2	2	

FIG. 4 CARBURETOR

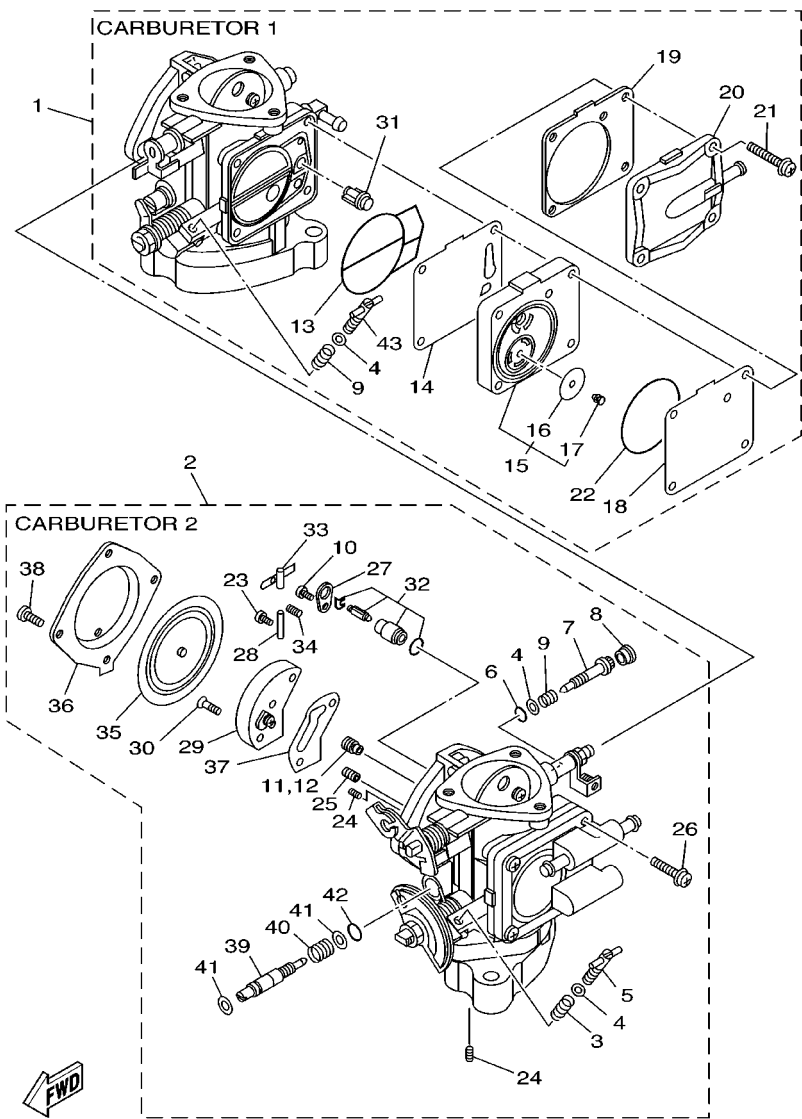

GM6K100-1040

REF. NO.	PART NO.	DESCRIPTION	USA	CAN	GENE	JPN	REMARKS
28	439-14186-00	.PIN, FLOAT	2	2	2	2	
29	6R7-24412-01	.BODY 1	2	2	2	2	
30	6K8-14523-11	.SCREW, STOP	4	4	4	4	
31	6R7-14569-00	.STRAINER	2	2	2	2	
32	61X-14916-15	.NEEDLE	2	2	2	2	
33	6K8-14547-01	.ARM, FLOAT	2	2	2	2	
34	6R7-14253-00	.SPRING	2	2	2	2	
35	6R7-14541-00	.DIAPHRAGM, PUMP	2	2	2	2	
36	6R7-14542-00	.BODY, PUMP 1	2	2	2	2	
37	6K8-14536-11	.GASKET	2	2	2	2	
38	97880-05012	.SCREW, PAN HEAD	8	8	8	8	
39	64U-14923-00	.SCREW, PILOT	2	2	2	2	
40	6K8-14589-00	.SPRING	2	2	2	2	
41	822-14235-00	.WASHER, NEEDLE	4	4	4	4	
42	583-14561-00	.O-RING	2	2	2	2	
43	6K8-14521-01	.SCREW, ADJUST	1	1	1	1	CARBURETOR 1

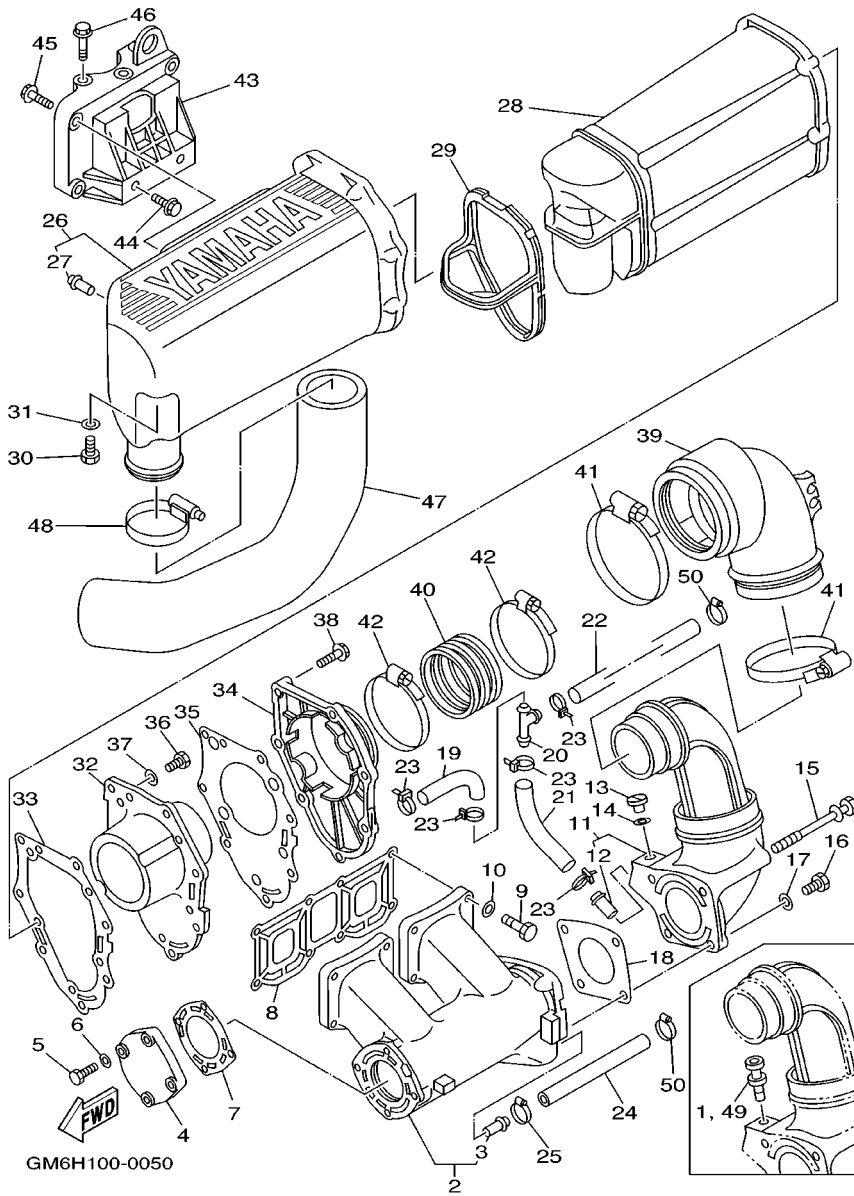

FIG. 5 EXHAUST 1

REF. NO.	PART NO.	DESCRIPTION	USA	CAN	GENE	JPN	REMARKS
1	626-28193-01-94	PLUG, WATER CHECK				1	FOR JPN, D:15MM
2	61X-14711-01-9P	MUFFLER 1	1	1	1	1	
3	6K8-51129-00	.NIPPLE	1	1	1	1	
4	6M6-14718-01-9P	PROTECTOR, MUFFLER 1	1	1	1	1	
5	97013-06025	BOLT	4	4	4	4	
6	92903-06600	WASHER, PLATE	4	4	4	4	
7	6M6-14739-A1	GASKET, MUFFLER DAMPER 1	1	1	1	1	
8	61X-14613-A0	GASKET, EXHAUST PIPE	1	1	1	1	
9	97013-08035	BOLT	8	8	8	8	
10	92903-08600	WASHER, PLATE	8	8	8	8	
11	61L-14712-00-9P	RING, JOINT	1	1	1	1	
12	6K8-51129-00	.NIPPLE	1	1	1	1	
13	90340-08M04	PLUG, STRAIGHT SCREW	1	1	1	1	
14	90430-08020	GASKET	1	1	1	1	
15	90119-08M73	BOLT, WITH WASHER	2	2	2	2	
16	97013-08025	BOLT	2	2	2	2	
17	92903-08600	WASHER, PLATE	2	2	2	2	
18	6R7-14749-A0	GASKET, MUFFLER DAMPER 2	1	1	1	1	
19	90445-14M29	HOSE (L125)	1	1	1	1	
20	6E5-24378-00	PIPE, JOINT 4	1	1	1	1	
21	90445-14M29	HOSE (L125)	1	1	1	1	
22	90445-14M33	HOSE (L1150)	1	1	1	1	
23	90465-11M10	CLAMP	5	5	5	5	
24	90445-14M06	HOSE (L630)	1	1	1	1	
25	90450-14M05	HOSE CLAMP ASSY	1	1	1	1	
26	6R7-14721-00-9M	MUFFLER 2	1	1	1	1	
27	6R7-14485-00	.PIPE, JOINT	1	1	1	1	

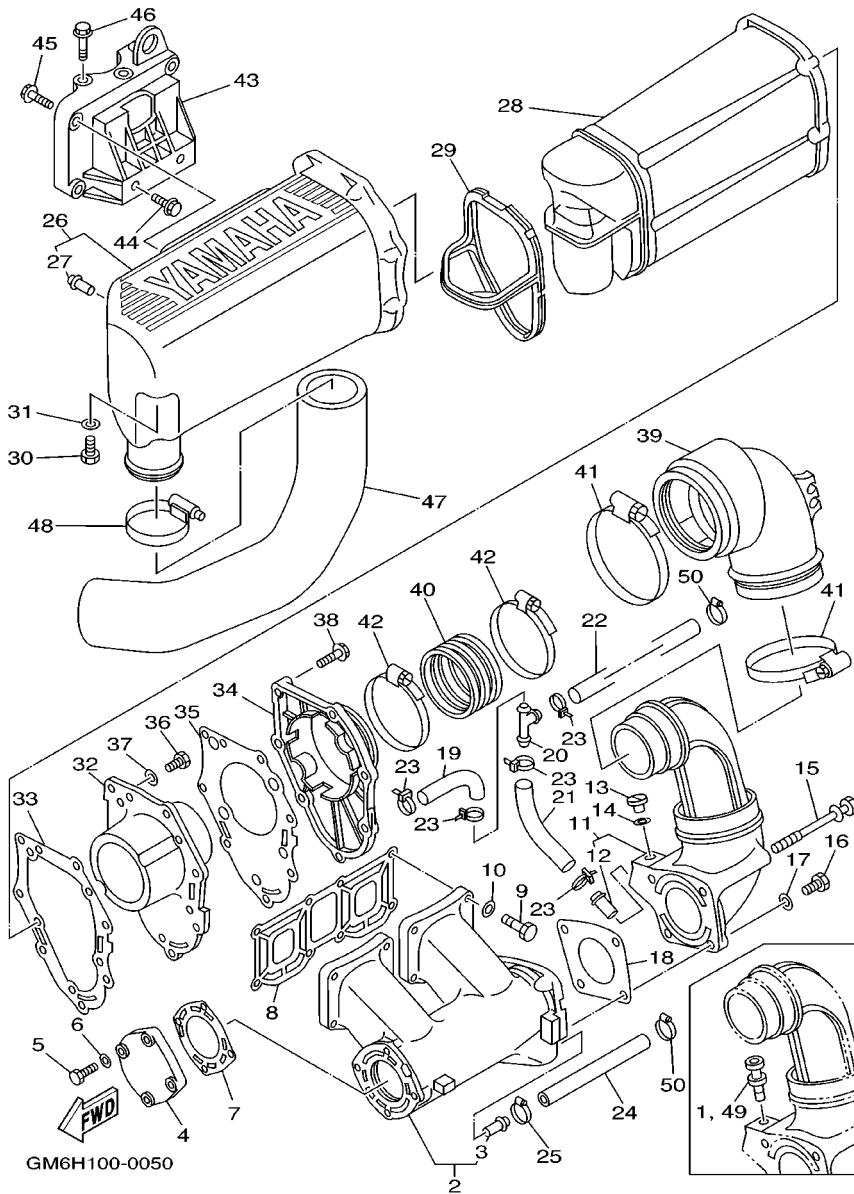

FIG. 5 EXHAUST 1

REF. NO.	PART NO.	DESCRIPTION	USA	CAN	GENE	JPN	REMARKS
28	6R7-14753-00-9M	SILENCER, EXHAUST	1	1	1	1	
29	6R7-15761-00	SEAL, RUBBER 1	1	1	1	1	
30	97013-06020	BOLT	1	1	1	1	
31	92903-06600	WASHER, PLATE	1	1	1	1	
32	6R7-14785-00-9M	DIFFUSER	1	1	1	1	
33	6R7-14755-A0	GASKET, SILENCER	1	1	1	1	
34	6R7-41113-00-9M	OUTER COVER, EXHAUST	1	1	1	1	
35	6R7-41114-A0	GASKET, EXHAUST OUTER COVER	1	1	1	1	
36	97095-06016	BOLT	5	5	5	5	
37	92995-06600	WASHER	5	5	5	5	
38	90119-06MA1	BOLT, WITH WASHER	7	7	7	7	
39	61L-14615-A0	JOINT, EXHAUST 1	1	1	1	1	
40	61L-14625-A0	JOINT, EXHAUST 2	1	1	1	1	
41	90460-90M11	CLAMP, HOSE	2	2	2	2	
42	90460-70M16	CLAMP, HOSE	2	2	2	2	
43	6M6-14771-00-94	STAY, MUFFLER 1	1	1	1	1	
44	90105-10M49	BOLT, WASHER BASED	2	2	2	2	
45	90105-10M88	BOLT, WASHER BASED	3	3	3	3	
46	90119-10M17	BOLT, WITH WASHER	3	3	3	3	
47	64V-14752-00	PIPE, OUTLET	1	1	1	1	
48	90460-64M15	CLAMP, HOSE	1	1	1	1	
49	6E0-28193-00-94	PLUG, WATER CHECK	1	1			FOR CAN, GENE, D:12.5MM
50	90601-11062	BAND, HOSE 11	2	2	2	2	

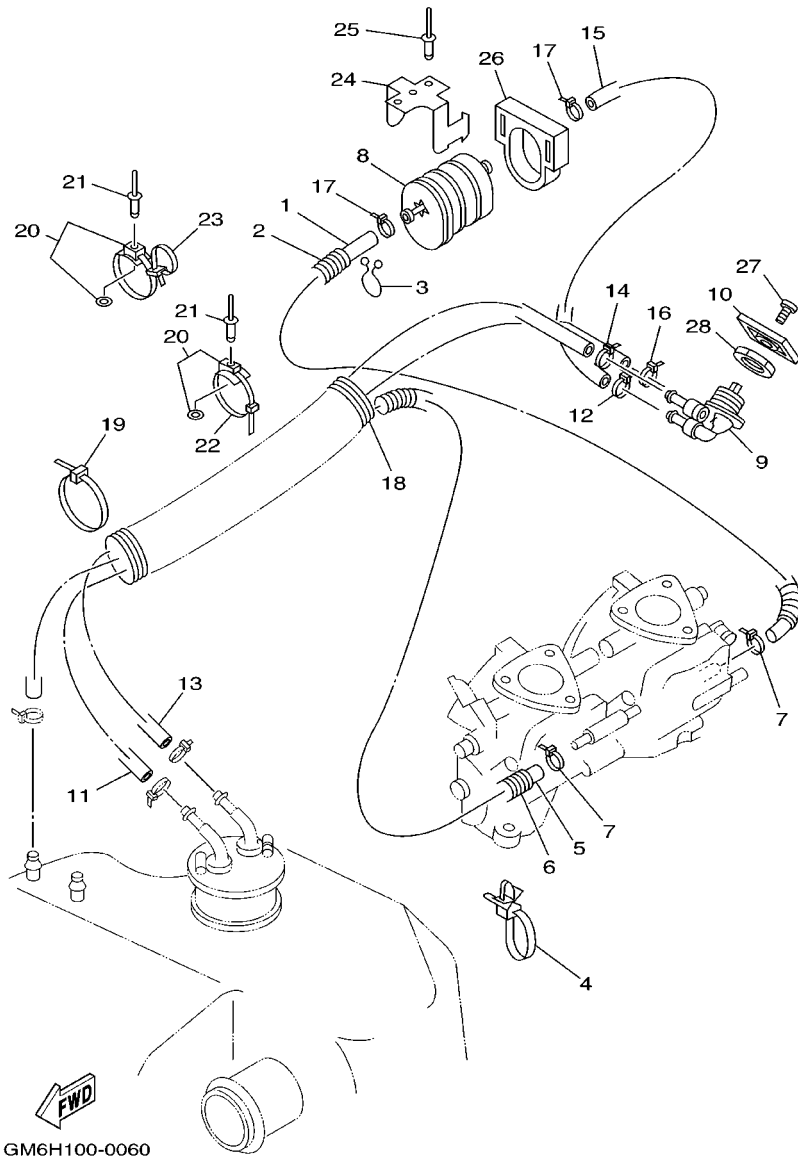

FIG. 6 FUEL

REF. NO.	PART NO.	DESCRIPTION	USA	CAN	GENE	JPN	REMARKS
1	90445-10ME8	HOSE (L230)	1	1	1	1	
2	90446-14M23	HOSE	1	1	1	1	
3	90464-08M07	CLAMP	1	1	1	1	
4	90465-12M56	CLAMP	1	1	1	1	
5	90445-10MF1	HOSE (L1220)	1	1	1	1	
6	90446-14M64	HOSE	1	1	1	1	
7	90465-11M10	CLAMP	2	2	2	2	
8	6K8-24560-10	FILTER ASSY	1	1	1	1	
9	6K8-24500-02	FUEL COCK ASSY 1	1	1	1	1	
10	6R7-24524-00	LEVER, COCK	1	1	1	1	
11	90445-10ME3	HOSE (L1010)	1	1	1	1	
12	90465-11M10	CLAMP	1	1	1	1	
13	90445-10M98	HOSE (L1010)	1	1	1	1	
14	90465-11M10	CLAMP	1	1	1	1	
15	90445-10ME4	HOSE (L140)	1	1	1	1	
16	90465-11M10	CLAMP	1	1	1	1	
17	90465-11M10	CLAMP	2	2	2	2	
18	GM6-6773E-00	TUBE,2	1	1	1	1	
19	90601-20006	BAND	1	1	1	1	
20	90600-91736	CLAMP COMP.	7	7	7	7	
21	90267-48925	RIVET, BLIND	7	7	7	7	
22	90601-20006	BAND	6	6	6	6	
23	90601-20016	BAND	2	2	2	2	
24	EU0-67816-30	BRACKET, FUEL FILTER	1	1	1	1	
25	90267-48925	RIVET, BLIND	2	2	2	2	
26	EU0-67817-00	HOLDER	1	1	1	1	
27	98980-04008	SCREW, BIND	1	1	1	1	

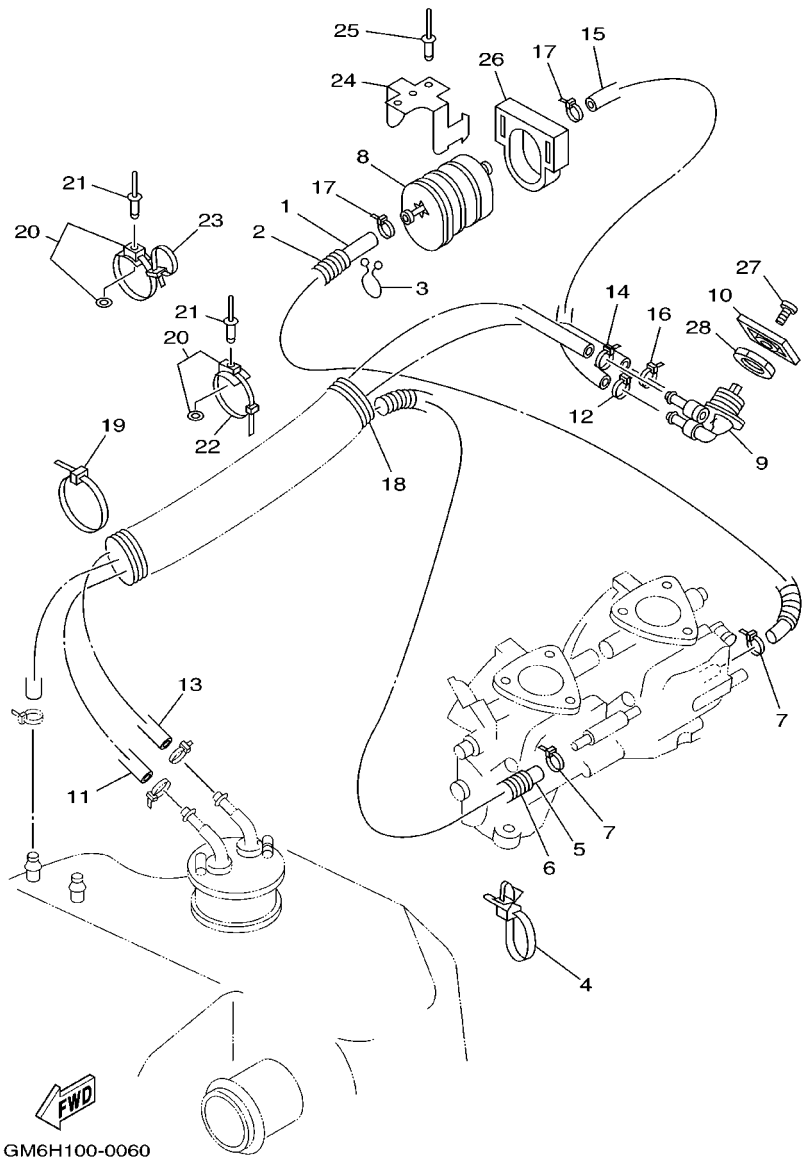
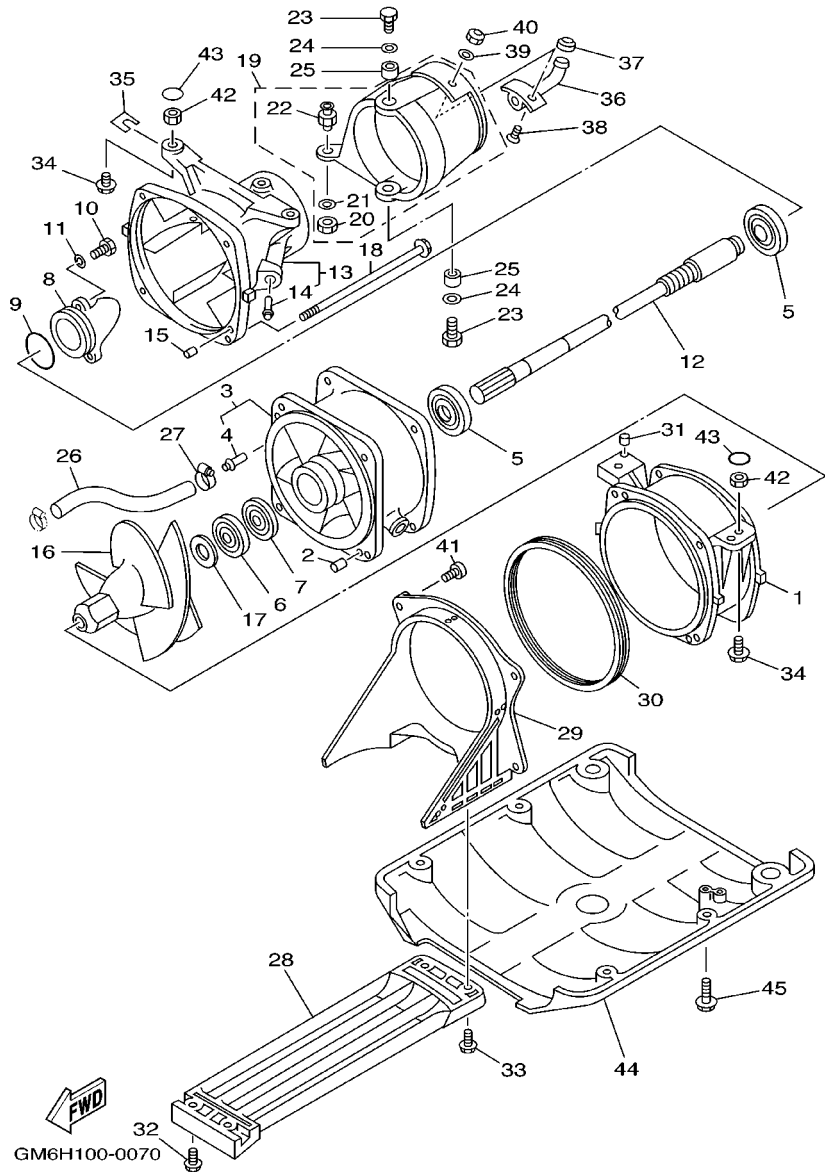

FIG. 6 FUEL

REF. NO.	PART NO.	DESCRIPTION	USA	CAN	GENE	JPN	REMARKS
28	90170-22187	NUT	1	1	1	1	

FIG. 7 JET UNIT 1



REF. NO.	PART NO.	DESCRIPTION	USA	CAN	GENE	JPN	REMARKS
1	6R7-51312-03-94	HOUSING, IMPELLER	1	1	1	1	
2	93606-12019	PIN, DOWEL	2	2	2	2	
3	62T-51315-01-94	DUCT, IMPELLER	1	1	1	1	
4	6K8-51129-00	.NIPPLE	1	1	1	1	
5	93306-205U0	BEARING	2	2	2	2	
6	93102-25M34	OIL SEAL	1	1	1	1	
7	93101-25M50	OIL SEAL	1	1	1	1	
8	62T-51326-00	CAP	1	1	1	1	
9	93210-46M16	O-RING	1	1	1	1	
10	97095-06020	BOLT	3	3	3	3	
11	92995-06600	WASHER	3	3	3	3	
12	6R7-45511-01	SHAFT, DRIVE	1	1	1	1	
13	6R7-51318-05-94	NOZZLE	1	1	1	1	
14	6K8-51129-00	.NIPPLE	1	1	1	1	
15	93606-12019	PIN, DOWEL	1	1	1	1	
16	6R7-51321-00-94	IMPELLER	1	1	1	1	
17	62T-51348-00	SPACER	1	1	1	1	
18	90119-06M70	BOLT, WITH WASHER	4	4	4	4	
19	61L-51313-00	NOZZLE, DEFLECTOR	1	1	1	1	
20	95380-06700	.NUT	1	1	1	1	
21	90201-06M02	.WASHER, PLATE	1	1	1	1	
22	6R7-42316-00	.BOLT, JOINT	1	1	1	1	
23	97095-08018	BOLT	2	2	2	2	
24	92995-08600	WASHER	2	2	2	2	
25	90387-08M06	COLLAR	2	2	2	2	
26	90445-14M12	HOSE (L110)	1	1	1	1	
27	90450-14M05	HOSE CLAMP ASSY	1	1	1	1	

FIG. 7 JET UNIT 1

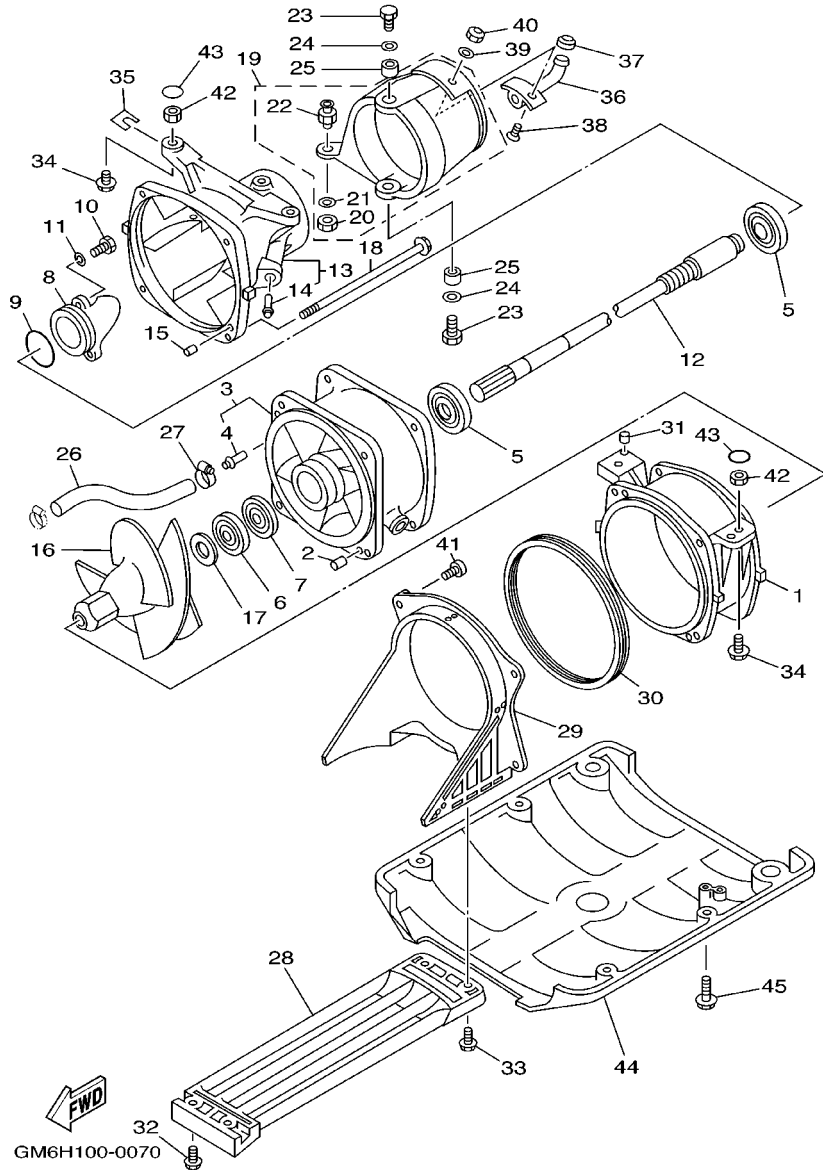

REF. NO.	PART NO.	DESCRIPTION	USA	CAN	GENE	JPN	REMARKS
28	6R7-51333-00	SCREEN, INTAKE	1	1	1	1	
29	6R7-51311-00	DUCT, INTAKE	1	1	1	1	
30	6R7-51117-01	PACKING	1	1	1	1	
31	93606-07M17	PIN, DOWEL	2	2	2	2	
32	90119-06915	BOLT, WITH WASHER	2	2	2	2	
33	90119-06908	BOLT, WITH WASHER	2	2	2	2	
34	90119-10948	BOLT, WITH WASHER	4	4	4	4	
35	EW2-67354-00-01	SHIM (T=0.1)	10	10	10	10	UR
	EW2-67354-00-03	SHIM (T=0.3)	10	10	10	10	UR
	EW2-67354-00-05	SHIM (T=0.5)	10	10	10	10	UR
	EW2-67354-00-10	SHIM (T=1.0)	10	10	10	10	UR
36	EU0-62693-02	SPOUT	1	1	1	1	
37	EU0-62695-00	CAP, SPOUT	1	1	1	1	
38	98780-05016	SCREW, FLAT HEAD	2	2	2	2	
39	92990-05200	WASHER, PLAIN	2	2	2	2	
40	95720-05300	NUT, FLANGE	2	2	2	2	
41	97780-60120	SCREW, TAPPING	4	4	4	4	
42	90179-10925	NUT	4	4	4	4	
43	EW2-62723-30	SEAL	4	4	4	4	
44	EW2-62731-01	PLATE 2	1	1	1	1	
45	90119-08943	BOLT, WITH WASHER	4	4	4	4	

FIG. 8 JET UNIT 2

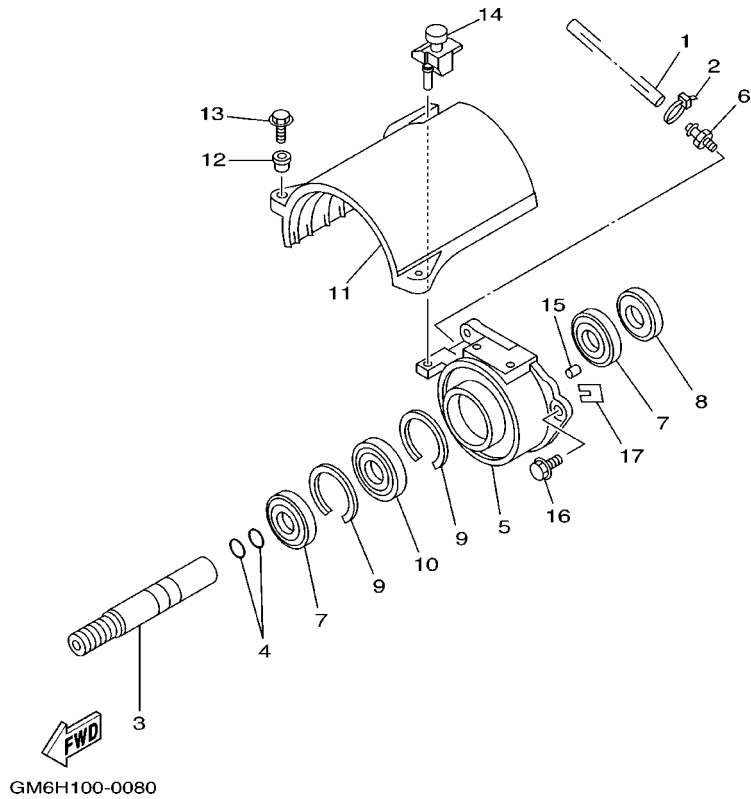

REF. NO.	PART NO.	DESCRIPTION	USA	CAN	GENE	JPN	REMARKS
1	90445-09M17	HOSE (L320)	1	1	1	1	
2	90465-11M10	CLAMP	1	1	1	1	
3	6R7-51323-02	SHAFT, COUPLOR	1	1	1	1	
4	93210-17MA4	O-RING	2	2	2	2	
5	61X-45332-03-94	HOUSING, BEARING	1	1	1	1	
6	61L-45378-00	NIPPLE, HOSE	1	1	1	1	
7	93101-25M55	OIL SEAL	2	2	2	2	
8	93101-25M56	OIL SEAL	1	1	1	1	
9	93430-47M04	CIRCLIP	2	2	2	2	
10	93306-205U6	BEARING	1	1	1	1	
11	61X-51381-00	COVER	1	1	1	1	
12	90387-06M60	COLLAR	2	2	2	2	
13	97595-06525	BOLT, WITH WASHER	2	2	2	2	
14	90480-06M69	GROMMET	1	1	1	1	
15	93606-12019	PIN, DOWEL	2	2	2	2	
16	90119-08907	BOLT, WITH WASHER	3	3	3	3	
17	GD0-67249-00-05	SHIM (T=0.5)	1	1	1	1	UR
	GD0-67249-00-10	SHIM (T=1.0)	1	1	1	1	UR

FIG. 9 GENERATOR

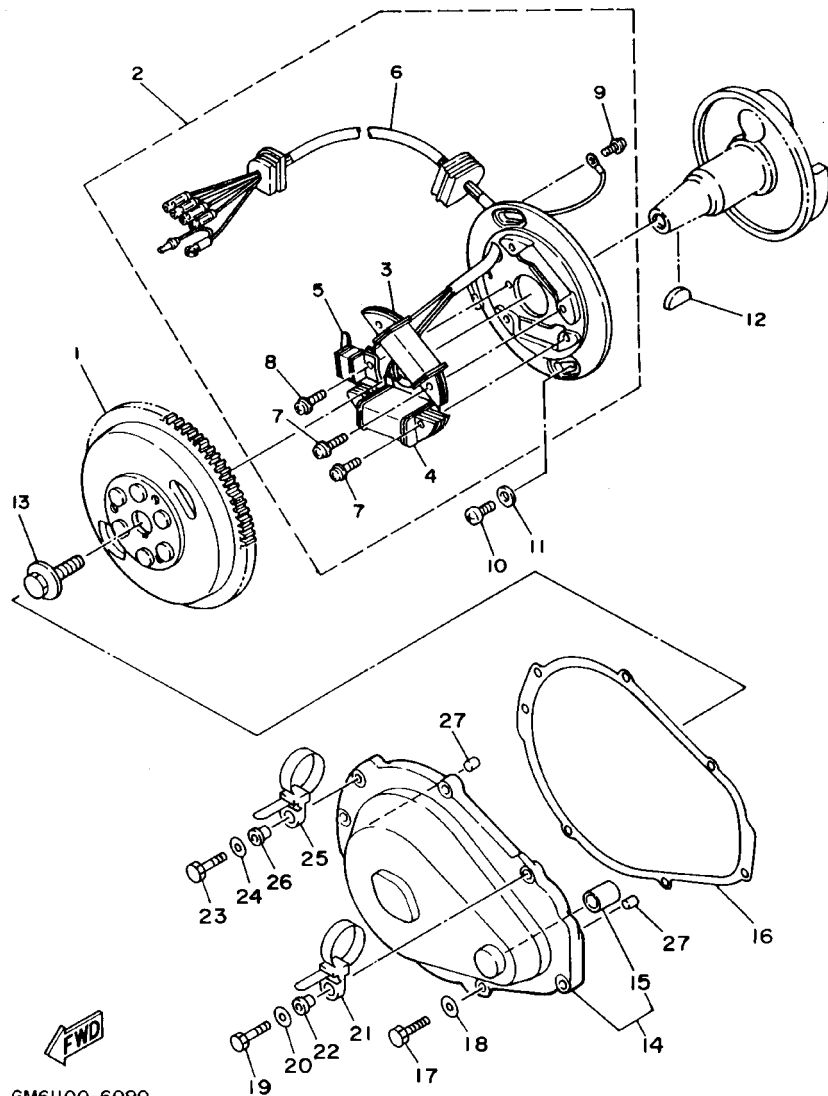

REF. NO.	PART NO.	DESCRIPTION	USA	CAN	GENE	JPN	REMARKS
1	62T-85550-00	ROTOR ASSY	1	1	1	1	
2	62T-85560-00	BASE ASSY	1	1	1	1	
3	62T-85520-00	.COIL, CHARGE	1	1	1	1	
4	62T-85533-00	.COIL, LIGHTING	1	1	1	1	
5	6M6-85580-00	.COIL, PULSER	1	1	1	1	
6	62T-85515-00	.LEAD WIRE ASSY	1	1	1	1	
7	97902-05125	.SCREW, WITH WASHER	4	4	4	4	
8	97902-04122	.SCREW, WITH WASHER	2	2	2	2	
9	97802-04008	.SCREW, PAN HEAD	1	1	1	1	
10	97880-06016	SCREW, PAN HEAD	2	2	2	2	
11	92990-06600	WASHER, PLATE	2	2	2	2	
12	90280-05013	KEY, WOODRUFF	1	1	1	1	
13	90109-10M44	BOLT	1	1	1	1	
14	6M6-81337-00-8P	COVER, FLYWHEEL	1	1	1	1	
15	90380-12M29	.BUSH, SOLID	1	1	1	1	
16	6M6-81365-A0	GASKET, HOLE COVER	1	1	1	1	
17	97095-06025	BOLT	5	5	5	5	
18	92995-06600	WASHER	5	5	5	5	
19	97095-06035	BOLT	1	1	1	1	
20	92995-06600	WASHER	1	1	1	1	
21	90465-12M53	CLAMP	1	1	1	1	
22	90387-06M05	COLLAR	1	1	1	1	
23	97095-06035	BOLT	1	1	1	1	
24	92995-06600	WASHER	1	1	1	1	
25	90465-12M53	CLAMP	1	1	1	1	
26	90387-06M05	COLLAR	1	1	1	1	
27	93606-12019	PIN, DOWEL	2	2	2	2	

FIG. 10 STARTING MOTOR

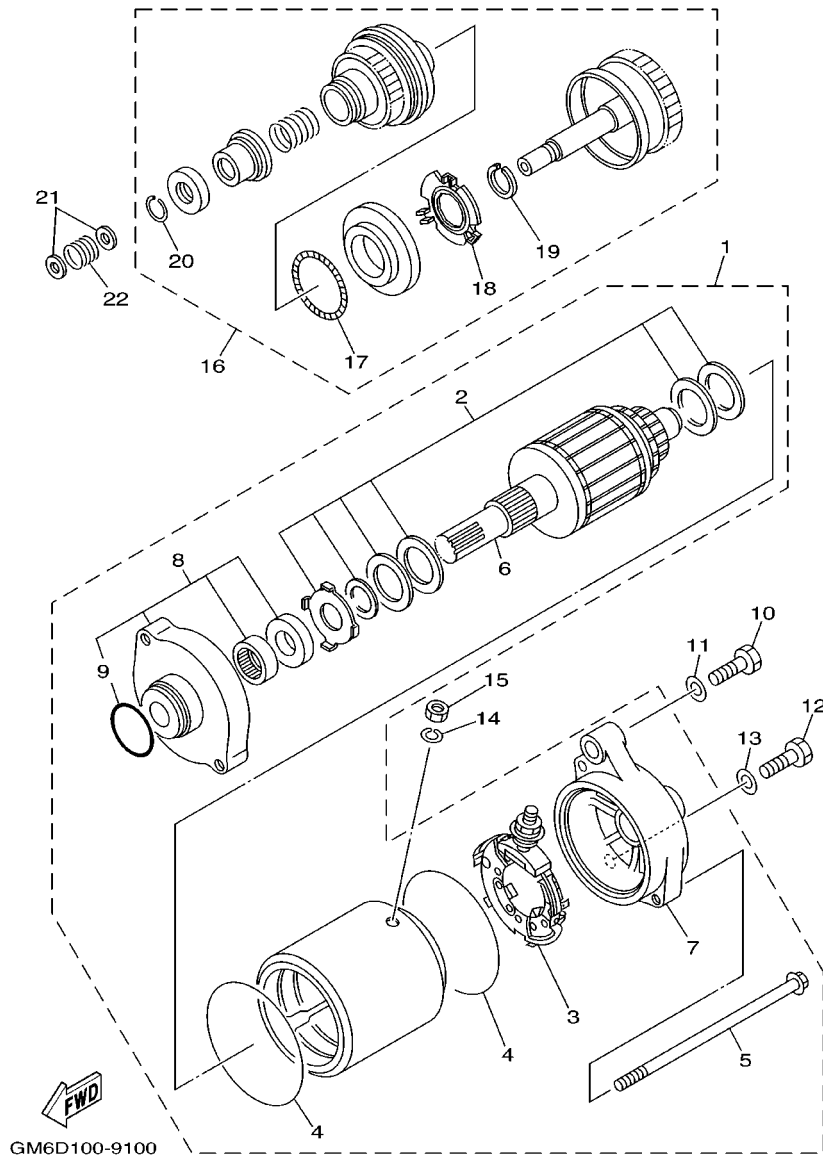

REF. NO.	PART NO.	DESCRIPTION	USA	CAN	GENE	JPN	REMARKS
1	6M6-81800-10	STARTING MOTOR ASSY	1	1	1	1	
2	3AJ-81809-00	.WASHER KIT	1	1	1	1	
3	6M6-81840-10	.BRUSH HOLDER ASSY	1	1	1	1	
4	11H-81844-00	.GASKET	2	2	2	2	
5	6M6-81826-00	.BOLT	2	2	2	2	
6	6M6-81850-00	.ARMATURE ASSY	1	1	1	1	
7	6M6-81820-00	.REAR BRACKET ASSY	1	1	1	1	
8	6M6-81830-00	.FRONT BRACKET ASSY	1	1	1	1	
9	26H-81847-00	.O-RING	1	1	1	1	
10	97013-08040	BOLT	1	1	1	1	
11	92903-08600	WASHER, PLATE	1	1	1	1	
12	97013-08035	BOLT	1	1	1	1	
13	92903-08600	WASHER, PLATE	1	1	1	1	
14	92990-06100	WASHER, SPRING	1	1	1	1	
15	95380-06700	NUT	1	1	1	1	
16	6M6-8183E-00	IDLE GEAR COMP	1	1	1	1	
17	6M6-81866-00	.WEIGHT SPRING	1	1	1	1	
18	6M6-81865-00	.WEIGHT HOLDER	1	1	1	1	
19	93440-25M08	.CIRCLIP	1	1	1	1	
20	93450-18M06	.CIRCLIP	1	1	1	1	
21	92903-06600	WASHER, PLATE	2	2	2	2	
22	90501-14M73	SPRING, COMPRESSION	1	1	1	1	

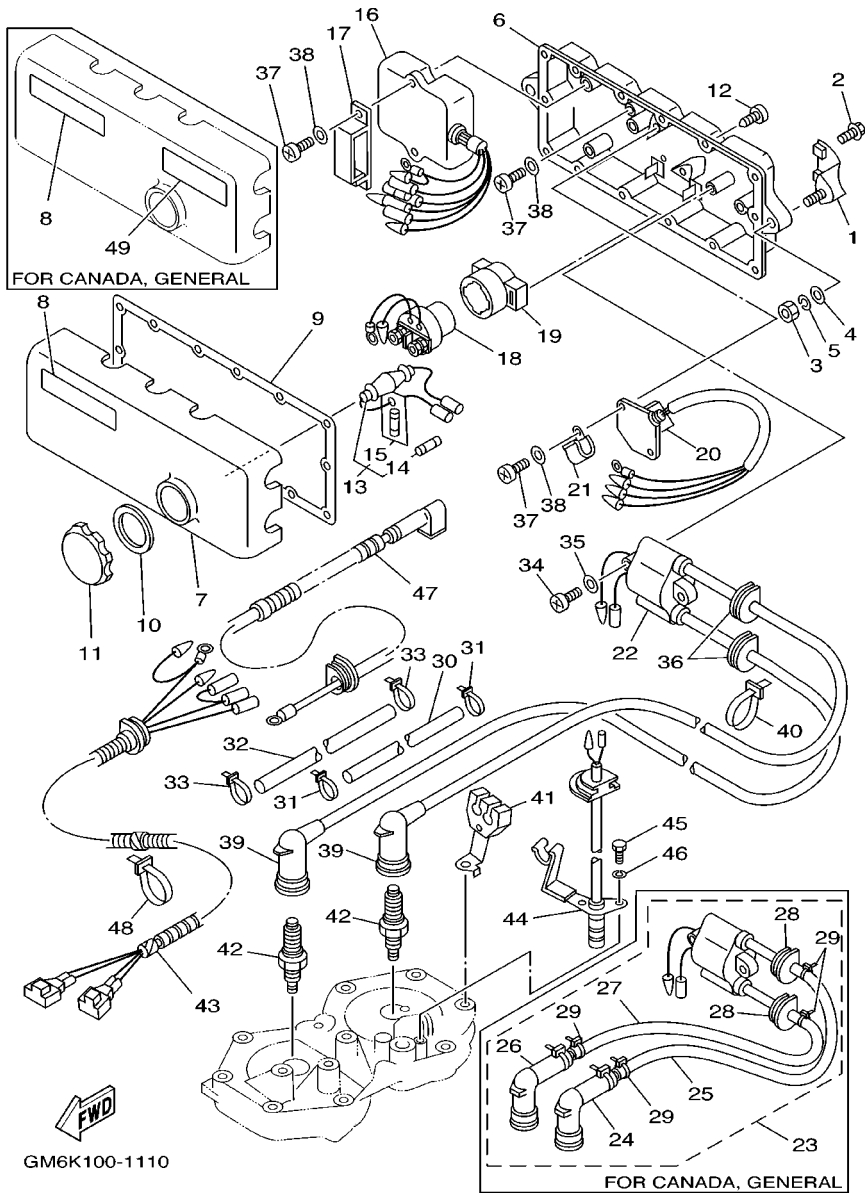

FIG. 11 ELECTRICAL 1

REF. NO.	PART NO.	DESCRIPTION	USA	CAN	GENE	JPN	REMARKS
1	EW2-68156-00	BRACKET, ELECTRIC BOX	2	2	2	2	
2	90119-06908	BOLT, WITH WASHER	4	4	4	4	
3	95380-08600	NUT	2	2	2	2	
4	92990-08200	WASHER, PLAIN	2	2	2	2	
5	92990-08100	WASHER, SPRING	2	2	2	2	
6	6M6-8552A-01-8P	HOUSING	1	1	1	1	
7	6M6-8552E-01	COVER, CASE	1	1	1	1	
8	63N-83623-00	MARK 3				1	FOR JPN
	6R7-83623-40	MARK 3	1	1	1		FOR USA,CAN,GENE
9	6M6-81921-00	GASKET, TERMINAL	1	1	1	1	
10	6M6-81844-00	GASKET	1	1	1	1	
11	6M6-8132W-00	CAP	1	1	1	1	
12	97780-60525	SCREW, TAPPING	14	14	14	14	
13	6K8-82150-01	FUSE HOLDER ASSY	1	1	1	1	
14	6G1-82151-00	.FUSE	1	1	1	1	
15	6K8-82159-00	.FUSE SPEAR	1	1	1	1	
16	62T-85540-01	C.D.I. UNIT ASSY	1	1	1	1	
17	90464-06M29	CLAMP	1	1	1	1	
18	6G1-81941-10	STARTER RELAY ASSY	1	1	1	1	
19	6M6-81952-01	HOLDER, RELAY	1	1	1	1	
20	6M6-81960-A0	RECTIFIER & REGULATOR ASSY	1	1	1	1	
21	90465-06M86	CLAMP	1	1	1	1	
22	62E-85570-00	IGNITION COIL ASSY	1			1	FOR USA,JPN
23	62E-85570-11	IGNITION COIL ASSY	1	1			FOR CAN,GENE
24	62E-82371-11	.CAP, PLUG	1	1			FOR CAN,GENE
25	62E-82351-01	.TUBE, CORD	1	1			FOR CAN,GENE
26	62E-82371-11	.CAP, PLUG	1	1			FOR CAN,GENE

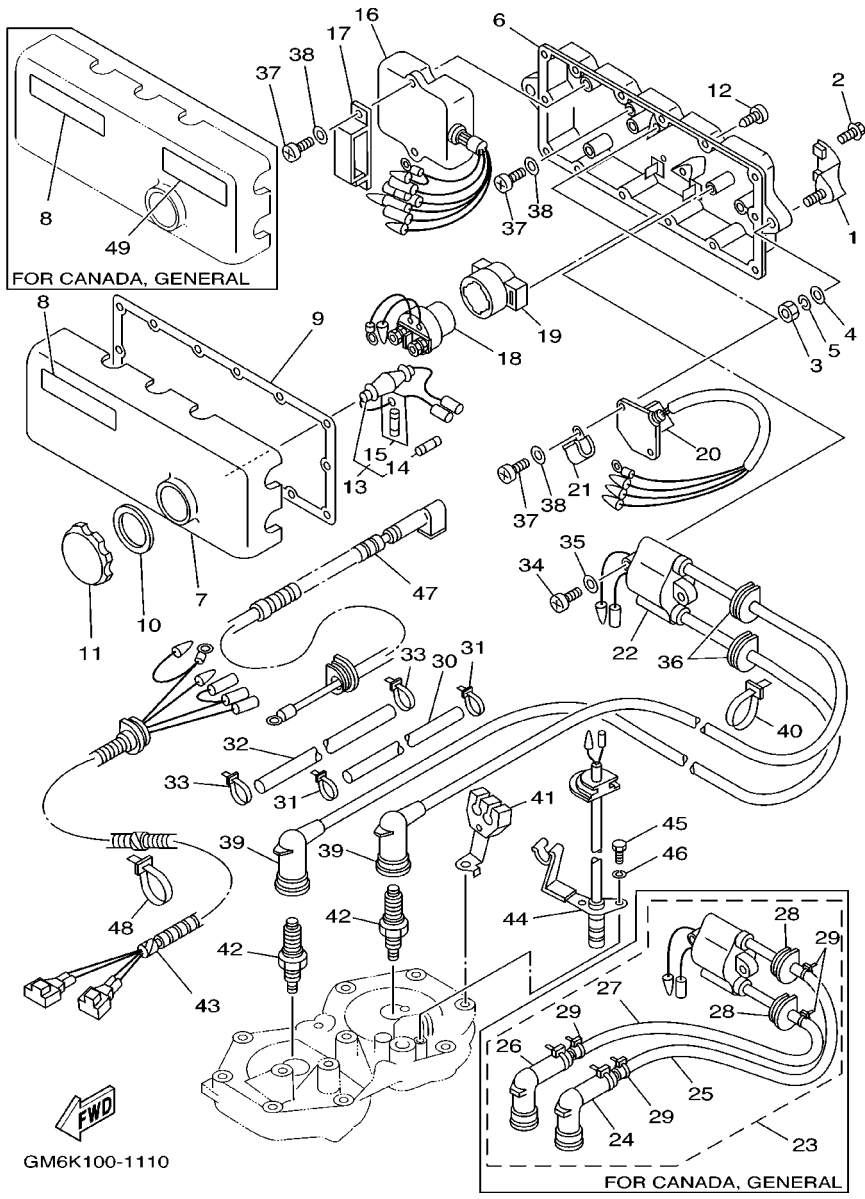
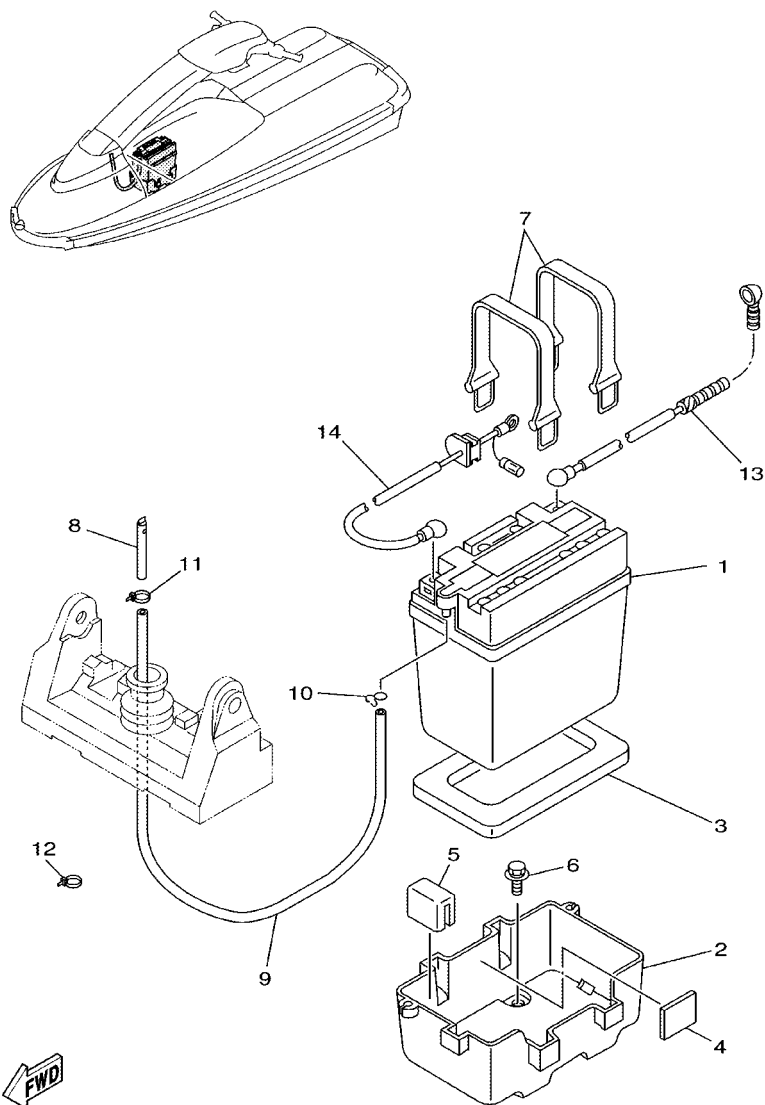

FIG. 11 ELECTRICAL 1

REF. NO.	PART NO.	DESCRIPTION	USA	CAN	GENE	JPN	REMARKS
27	62E-82352-01	.TUBE, CORD 2		1	1		FOR CAN,GENE
28	90480-06M43	.GROMMET		2	2		FOR CAN,GENE
29	90465-11M10	.CLAMP		4	4		FOR CAN,GENE
30	6R7-82351-00	TUBE, CORD	1			1	FOR USA,JPN
31	90465-11M10	CLAMP	2			2	FOR USA,JPN
32	6R7-82352-00	TUBE, CORD 2	1			1	FOR USA,JPN
33	90465-11M10	CLAMP	2			2	FOR USA,JPN
34	97880-06030	SCREW, PAN HEAD	2	2	2	2	
35	92990-06600	WASHER, PLATE	2	2	2	2	
36	90480-06M43	GROMMET		2		2	FOR USA,JPN
37	97880-06016	SCREW, PAN HEAD	6	6	6	6	
38	92990-06600	WASHER, PLATE	6	6	6	6	
39	66T-82370-00	PLUG CAP ASSY	2			2	FOR USA,JPN
40	90465-11M10	CLAMP	2			2	FOR USA,JPN
41	6R7-82361-01	CLAMP, CORD	1	1	1	1	
42	94702-00040	PLUG, SPARK (NGK B7HS)	2				FOR USA
	94702-00272	PLUG, SPARK (NGK BR7HS)		2	2		FOR CAN,GENE
	94709-00040	PLUG, SPARK				2	FOR JPN
43	6R7-82553-01	EXTENSION, WIRE LEAD	1	1	1	1	
44	6R7-82560-00	THERMO SWITCH ASSY	1	1	1	1	
45	97095-06016	BOLT	2	2	2	2	
46	92995-06100	WASHER, SPRING	2	2	2	2	
47	62E-82117-20	WIRE, LEAD	1	1	1	1	
48	90465-13M11	CLAMP	1	1	1	1	
49	6R7-83623-50	MARK 3		1	1		FOR CAN,GENE

FIG. 12 ELECTRICAL 2



GM6D100-9120

REF. NO.	PART NO.	DESCRIPTION	USA	CAN	GENE	JPN	REMARKS
1	EU0-82110-09	BATTERY ASSY	1	1	1	1	
2	EW2-68211-00	CASE, BATTERY	1	1	1	1	
3	EU0-68221-00	PAD, BATTERY 1	1	1	1	1	
4	EU0-68221-30	PAD, BATTERY 2	3	3	3	3	
5	EW2-68221-00	PAD, BATTERY	1	1	1	1	
6	90119-06920	BOLT, WITH WASHER	4	4	4	4	
7	EU0-68218-04	BAND, BATTERY	2	2	2	2	
8	EW2-62149-00	PIPE, VENTILATION 1	1	1	1	1	
9	EU0-67856-40	HOSE, AIRVENT 3	1	1	1	1	
10	90467-08M10	CLIP	1	1	1	1	
11	90465-11M10	CLAMP	1	1	1	1	
12	90465-13M11	CLAMP	1	1	1	1	
13	64V-82117-00	WIRE, LEAD	1	1	1	1	
14	6R7-82117-11	WIRE, LEAD	1	1	1	1	

FIG. 13 ENGINE HATCH

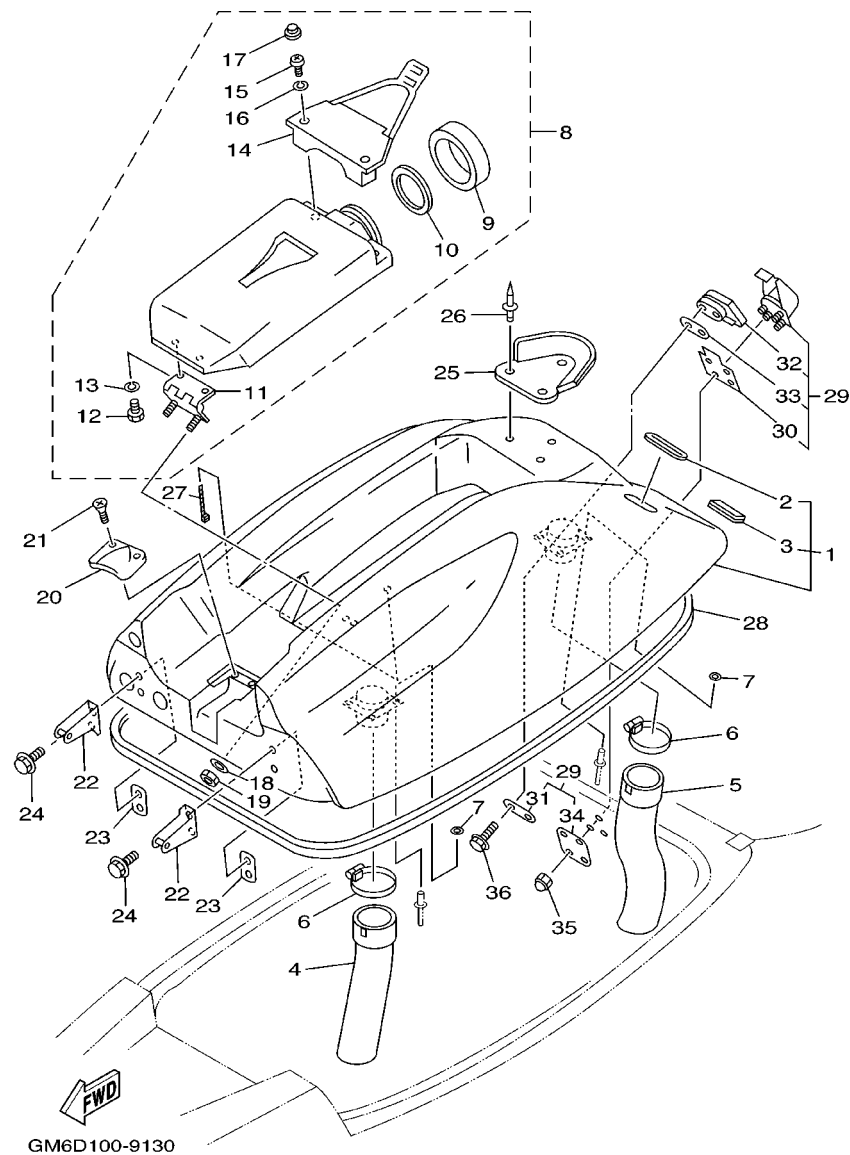

REF. NO.	PART NO.	DESCRIPTION	USA	CAN	GENE	JPN	REMARKS
1	GM6-6516A-10-P1	ENGINE HATCH COMP.	1	1	1	1	DPBSM
2	FX1-65116-10	.TRIM,HATCH 2	2	2	2	2	
3	GM6-6516C-00	.TRIM 1	1	1	1	1	
4	GM6-6213F-00	HOSE,VENTILATOR 1	1	1	1	1	
5	EW2-62137-00	HOSE, VENTILATOR 2	1	1	1	1	
6	90601-16875	BAND, HOSE 68	2	2	2	2	
7	92990-05200	WASHER, PLAIN	8	8	8	8	
8	FX1-6591A-10	CASE,ASSY 1	1	1	1	1	
9	EW2-65912-00	.CAP, CASE	1	1	1	1	
10	EW2-65913-00	.PACKING, CASE	1	1	1	1	
11	FX1-6517D-00	.HINGE, LID	1	1	1	1	
12	97090-06014	.BOLT	2	2	2	2	
13	92990-06100	.WASHER, SPRING	2	2	2	2	
14	FX1-6591K-00	.BAND,CASE	1	1	1	1	
15	92580-06016	.SCREW	2	2	2	2	
16	92990-06100	.WASHER, SPRING	2	2	2	2	
17	FX1-6514F-00	.CAP	2	2	2	2	
18	92990-06200	WASHER, PLAIN	2	2	2	2	
19	95720-06300	NUT, SELF-LOCKING	2	2	2	2	
20	A00-62858-02	PLATE, HATCH (FL1)	1	1	1	1	
21	97780-50316	SCREW, TAPPING	2	2	2	2	
22	GM6-65136-00	STOPPER HATCH 2	2	2	2	2	
23	EW2-65137-00	PLATE, STOPPER HATCH 2	2	2	2	2	
24	90119-06900	BOLT, WITH WASHER	4	4	4	4	
25	FX1-6514B-00	DAMPER, POLE	1	1	1	1	
26	90267-48938	RIVET, BLIND	3	3	3	3	
27	90464-20258	CLAMP	1	1	1	1	

FIG. 13 ENGINE HATCH

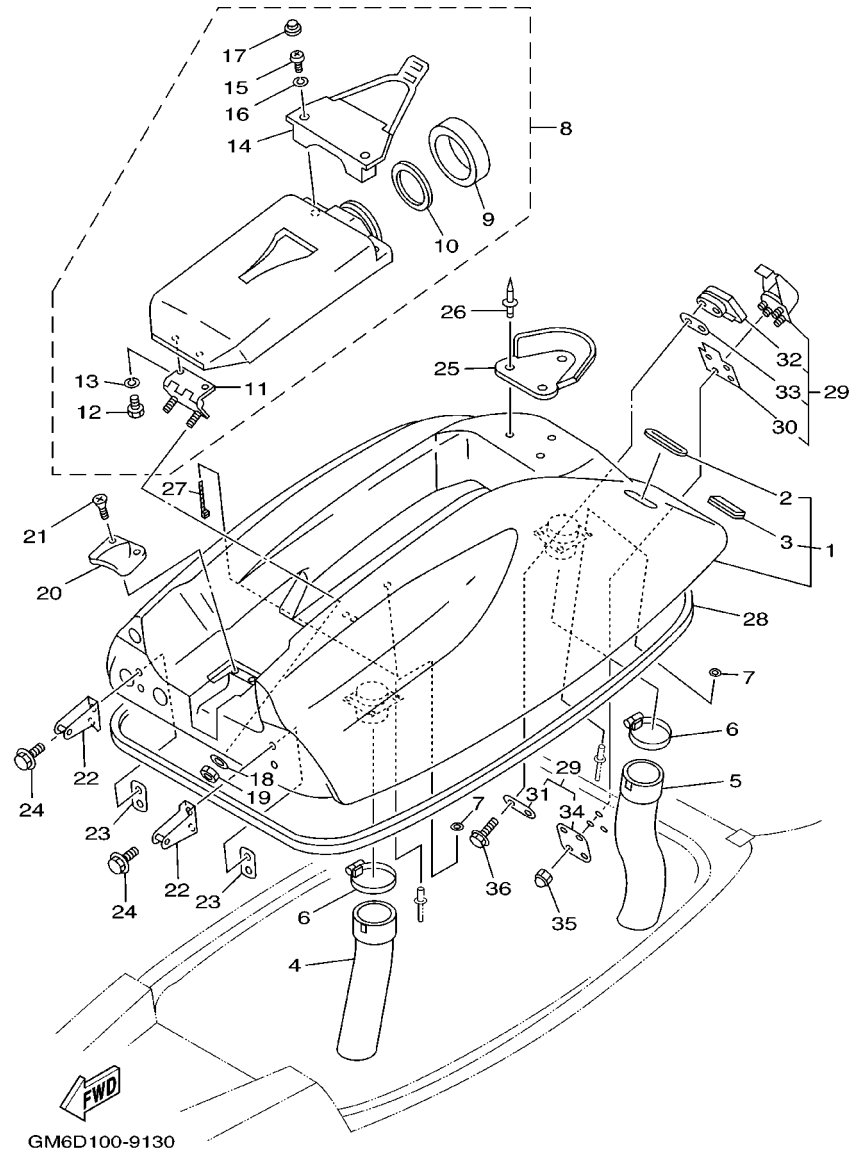

REF. NO.	PART NO.	DESCRIPTION	USA	CAN	GENE	JPN	REMARKS
28	GM6-62664-00	PACKING	1	1	1	1	
29	EW2-62840-10	HATCH LOCK ASSY	1	1	1	1	
30	EW2-62845-10	.PACKING, HATCH LOCK	1	1	1	1	
31	EW2-62846-00	.PLATE, HATCH LOCK	1	1	1	1	
32	EW2-62843-00	.HOOK, HATCH LOCK	1	1	1	1	
33	EW2-62847-00	.PACKING, HOOK	1	1	1	1	
34	EW2-62848-00	.PLATE, HOOK	1	1	1	1	
35	95720-05300	NUT, FLANGE	4	4	4	4	
36	90119-05923	BOLT, WITH WASHER	2	2	2	2	

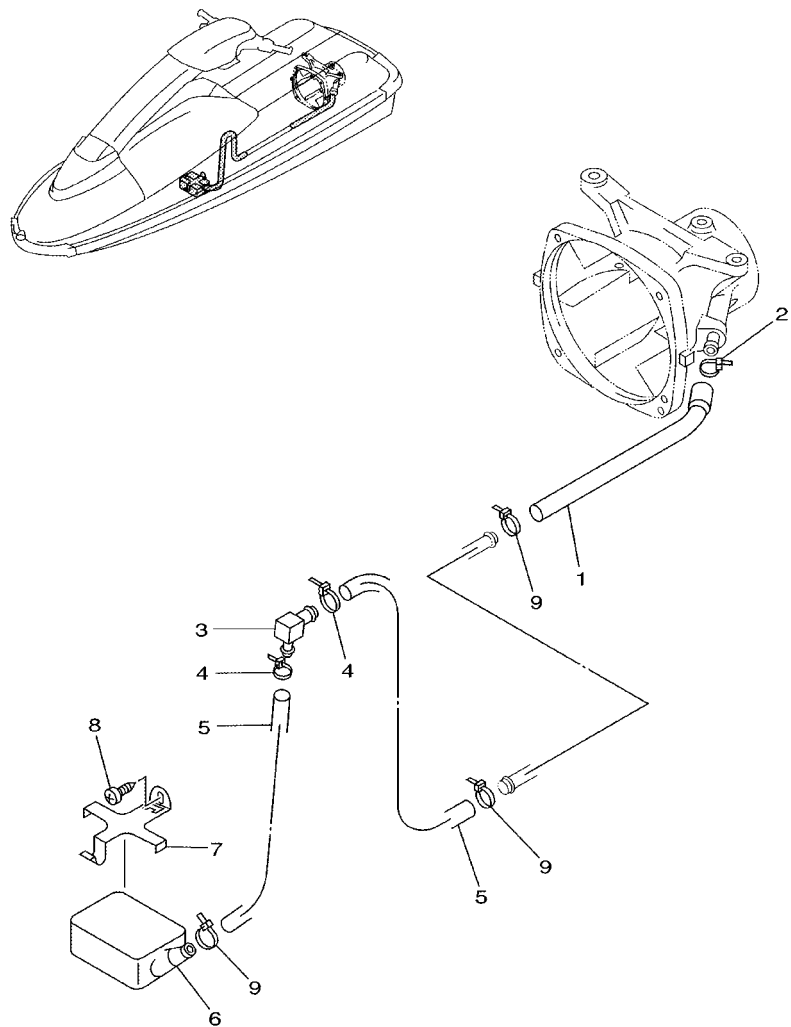

GM6H100-0140

FIG. 14 HULL DECK

REF. NO.	PART NO.	DESCRIPTION	USA	CAN	GENE	JPN	REMARKS
1	90445-14M19	HOSE (L202)	1	1	1	1	
2	90465-11M10	CLAMP	1	1	1	1	
3	6K8-51162-00	JOINT, HOSE	1	1	1	1	
4	90465-13M11	CLAMP	2	2	2	2	
5	90445-14M04	HOSE (L450)	2	2	2	2	
6	EU0-67613-00	STRAINER	1	1	1	1	
7	EW2-67618-00	BASE, STRAINER BLIGE	1	1	1	1	
8	97780-50114	SCREW, PAN HEAD TAPPING	1	1	1	1	
9	90465-13M11	CLAMP	3	3	3	3	

FIG. 15 GUNWALE. MAT

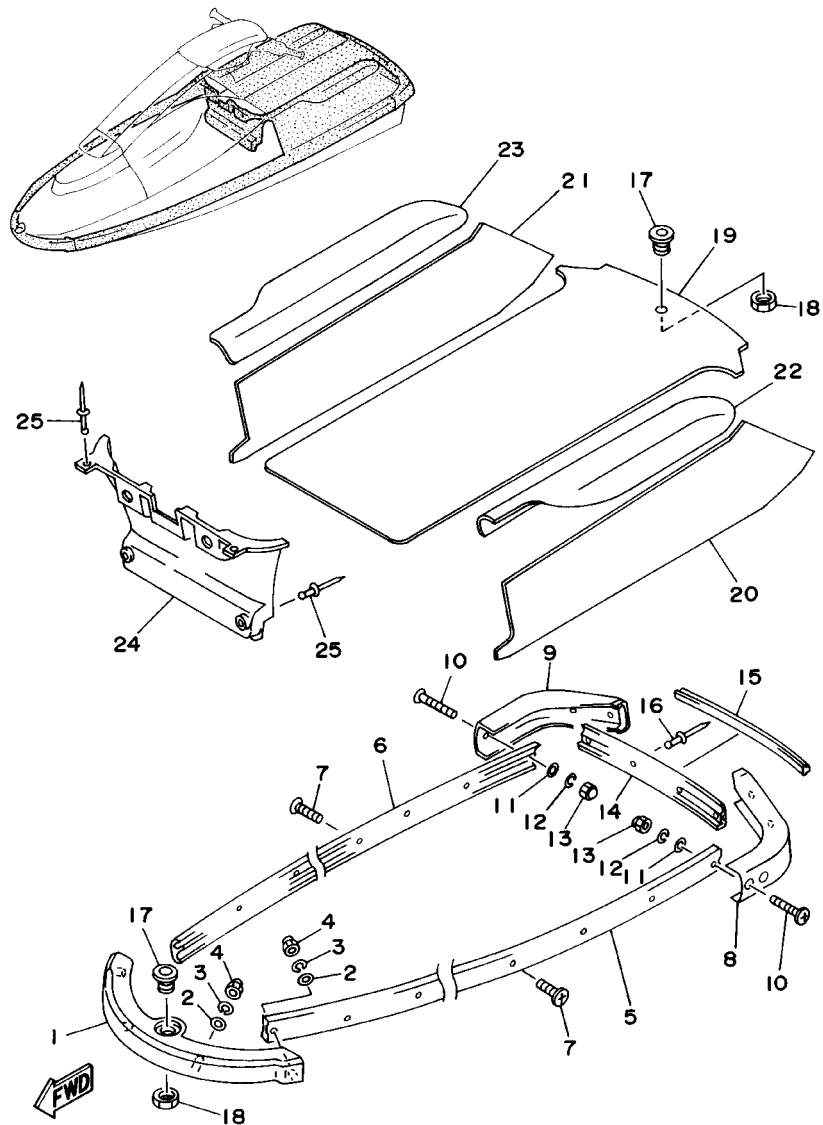

GM65100-7150

REF. NO.	PART NO.	DESCRIPTION	USA	CAN	GENE	JPN	REMARKS
1	GM6-62501-10	BOW GUNWALE COMP.	1	1	1	1	BL
2	92990-06200	WASHER, PLAIN	4	4	4	4	
3	92990-06100	WASHER, SPRING	4	4	4	4	
4	95380-06800	NUT	4	4	4	4	
5	GM6-62552-10	GUNWALE, SIDE 1	1	1	1	1	BL
6	GM6-62553-10	GUNWALE, SIDE 2	1	1	1	1	BL
7	90149-05962	SCREW	22	22	22	22	
8	GM6-6251D-10	GUNWALE, STERN 1	1	1	1	1	YB
9	GM6-6251E-10	GUNWALE, STERN 2	1	1	1	1	YB
10	90149-05960	SCREW	8	8	8	8	
11	92990-05200	WASHER, PLAIN	8	8	8	8	
12	92990-05100	WASHER, SPRING	8	8	8	8	
13	90179-05964	NUT	8	8	8	8	
14	GM6-6252C-10	COVER, GUNWALE 1	1	1	1	1	BL
15	GM6-6252D-10	COVER, GUNWALE 2	1	1	1	1	BL
16	90267-48932	RIVET, BLIND	4	4	4	4	
17	FN8-61651-00	ROPE HOLE	2	2	2	2	
18	EU0-61652-00	NUT	2	2	2	2	
19	GM6-6351B-00	MAT, LOWER	1	1	1	1	BL
20	GM6-6351C-00	MAT, SIDE 1	1	1	1	1	BL
21	GM6-6351D-00	MAT, SIDE 2	1	1	1	1	BL
22	GM6-6521C-10	PAD, 1	1	1	1	1	BL
23	GM6-6521D-10	PAD, 2	1	1	1	1	BL
24	GM6-6351E-10	MAT, BOW	1	1	1	1	YB
25	90267-48963	RIVET, BLIND	4	4	4	4	

FIG. 16 FUEL TANK

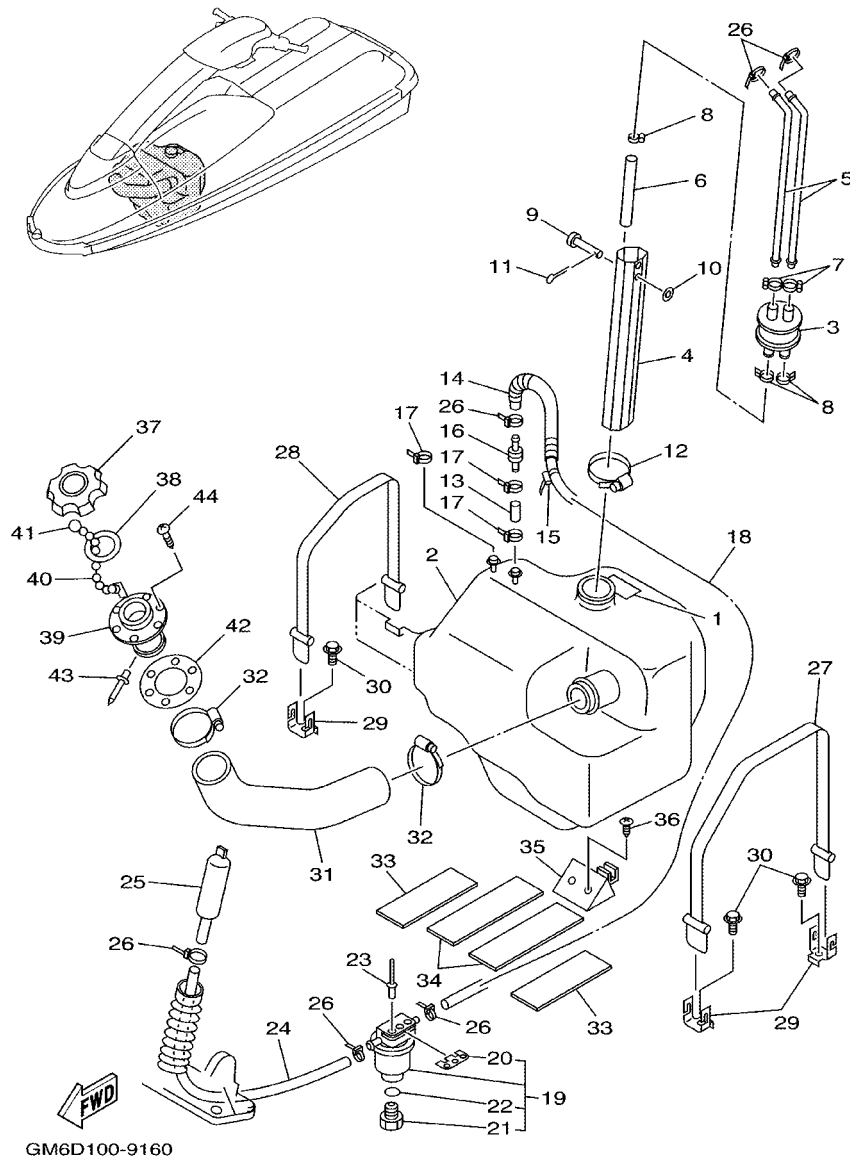

REF. NO.	PART NO.	DESCRIPTION	USA	CAN	GENE	JPN	REMARKS
1	GM6-6418D-00	LABEL,FUEL TANK	1	1	1		FOR USA,CAN,GENE
2	EW2-67711-01	TANK, FUEL	1	1	1	1	
3	FJ0-67713-00	PIPE, JOINT	1	1	1	1	
4	EW2-67716-01	PIPE, FILLER	1	1	1	1	
5	EW2-67714-02	PIPE, SUCTION 3	2	2	2	2	
6	90445-11903	HOSE (L105)	1	1	1	1	
7	90601-11062	BAND, HOSE 11	2	2	2	2	
8	90467-11032	CLIP	3	3	3	3	
9	91790-05040	PIN, CLEVIS	1	1	1	1	
10	92990-05600	WASHER, PLATE	1	1	1	1	
11	91490-16010	PIN, COTTER	1	1	1	1	
12	90601-16274	BAND, HOSE 62	1	1	1	1	
13	90699-50003	HOSE	1	1	1	1	
14	90446-14M30	TUBE	1	1	1	1	
15	90465-11M10	CLAMP	1	1	1	1	
16	EU0-67767-31	CHECK VALVE	1	1	1	1	
17	90465-11M10	CLAMP	3	3	3	3	
18	90699-50120	HOSE	1	1	1	1	
19	EW2-62140-00	FILTER, VENT ASSY	1	1	1	1	
20	EW2-62142-00	.PLATE, FILTER	1	1	1	1	
21	70R-24543-00	.PLUG, DRAIN	1	1	1	1	
22	70R-24489-00	.O-RING	1	1	1	1	
23	90267-48925	RIVET, BLIND	2	2	2	2	
24	90699-50045	HOSE	1	1	1	1	
25	EW2-62150-00	PIPE, VENTILATION 3	1	1	1	1	
26	90465-11M10	CLAMP	6	6	6	6	
27	EW2-67821-00	BAND, FUEL TANK	1	1	1	1	

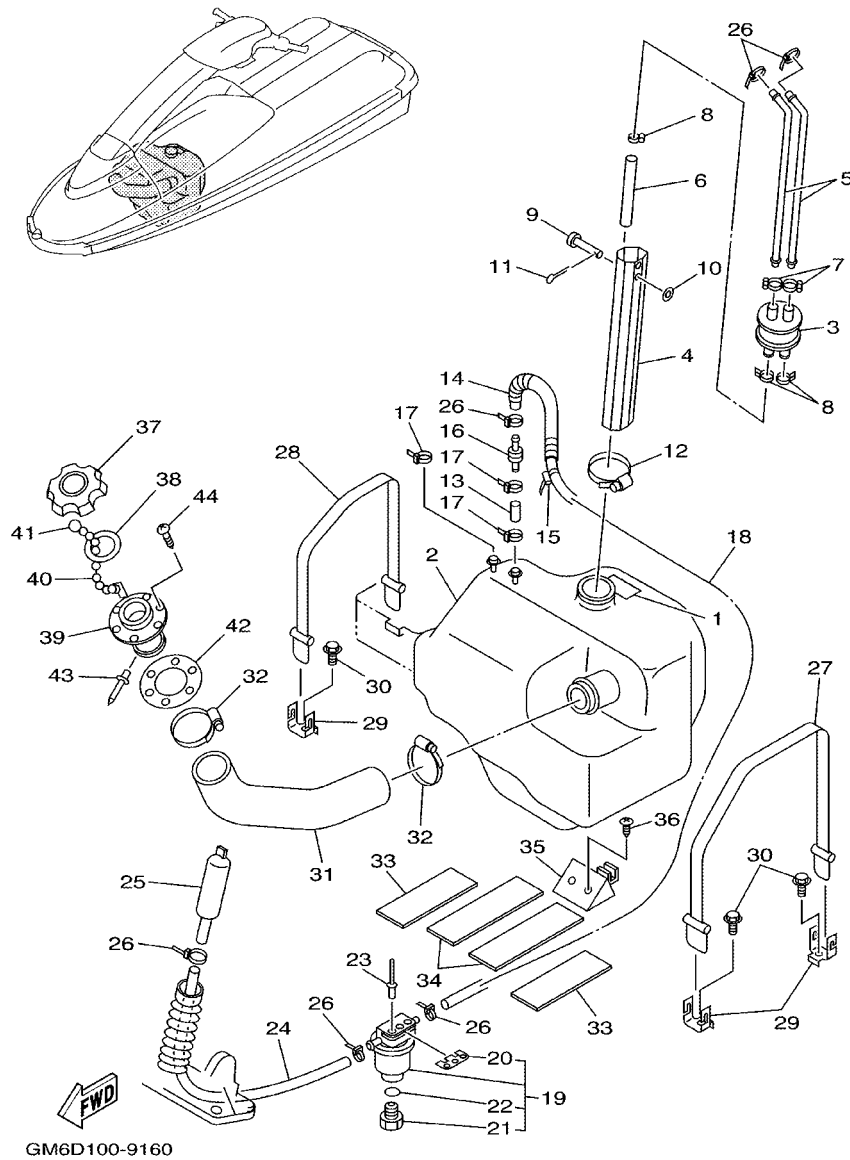
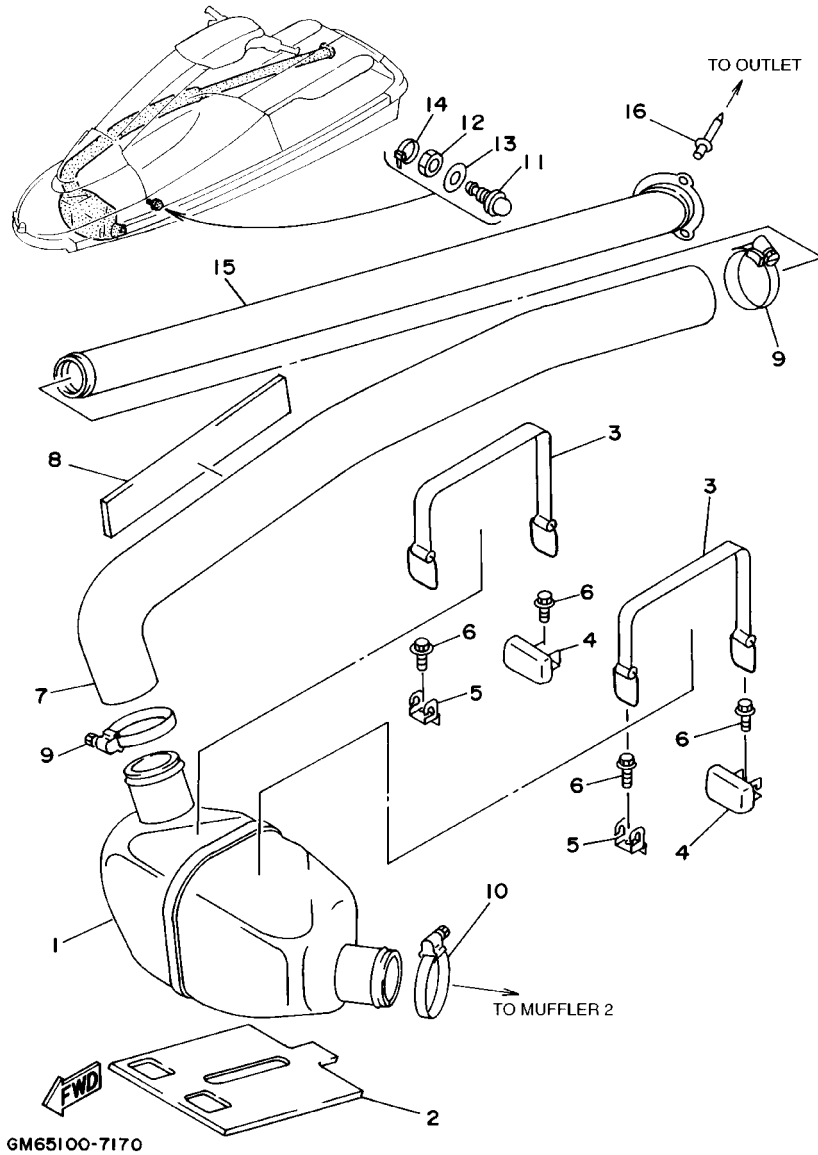

FIG. 16 FUEL TANK

REF. NO.	PART NO.	DESCRIPTION	USA	CAN	GENE	JPN	REMARKS
28	EW2-67821-30	BAND, FUEL TANK	1	1	1	1	
29	EW2-65772-00	HOOK A	3	3	3	3	
30	90105-06900	BOLT, WASHER BASED	3	3	3	3	
31	GM6-67844-10	HOSE	1	1	1	1	
32	90601-15573	BAND, HOSE 55	2	2	2	2	
33	GM6-67593-00	MAT	2	2	2	2	
34	GM6-67594-00	MAT	2	2	2	2	
35	EW2-67822-01	DAMPER FUEL TANK	1	1	1	1	
36	97780-50114	SCREW, PAN HEAD TAPPING	2	2	2	2	
37	FN8-67831-01	CAP, FUEL FILLER	1	1	1	1	YB
38	EU0-67832-00	PACKING 1	1	1	1	1	
39	FN8-67833-00	SOCKET	1	1	1	1	
40	EU0-67835-00	CHAIN BALL	1	1	1	1	
41	EU0-67839-00	COUPLING	1	1	1	1	
42	EU0-67834-00	PACKING, FUEL FILLER	1	1	1	1	
43	90267-40935	RIVET, BLIND	1	1	1	1	
44	EU0-67869-00	SCREW, FLAT HEAD	6	6	6	6	

FIG. 17 EXHAUST 2



REF. NO.	PART NO.	DESCRIPTION	USA	CAN	GENE	JPN	REMARKS
1	GM6-67550-00	WATER LOCK	1	1	1	1	
2	GM6-6755J-00	MAT,WATER LOCK	1	1	1	1	
3	EU0-68218-04	BAND, BATTERY	2	2	2	2	
4	FX1-65760-00	HOOK B ASSY	2	2	2	2	
5	EW2-65772-00	HOOK A	2	2	2	2	
6	90105-06900	BOLT, WASHER BASED	4	4	4	4	
7	GM6-67555-00	HOSE	1	1	1	1	
8	GM6-63844-00	MAT	1	1	1	1	
9	90601-16875	BAND, HOSE 68	2	2	2	2	
10	90601-16875	BAND, HOSE 68	1	1	1	1	
11	GH7-6753B-00	PILOT,WATER	1	1	1	1	
12	GP7-61652-00	NUT	1	1	1	1	
13	92990-14200	WASHER, PLAIN	1	1	1	1	
14	90465-11M10	CLAMP	1	1	1	1	
15	GM6-67565-00	THRU-HULL,EXHAUST	1	1	1	1	
16	90267-48930	RIVET, SEALD	3	3	3	3	

FIG. 18 CONTROL CABLE

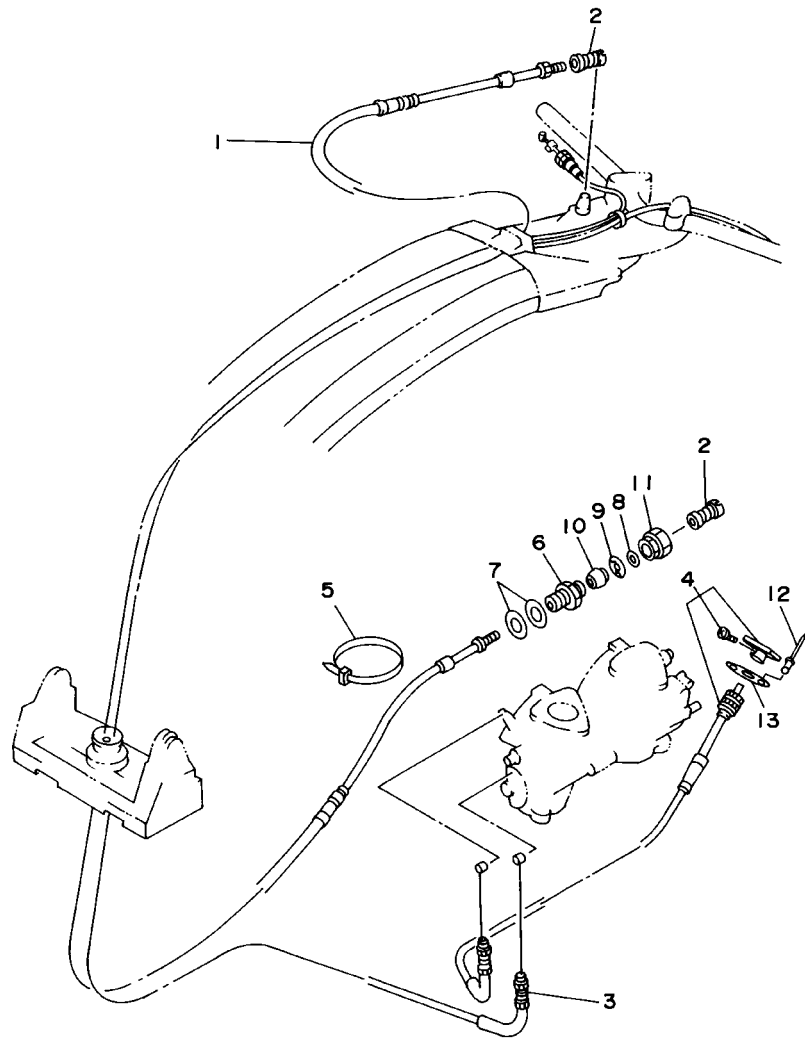

REF. NO.	PART NO.	DESCRIPTION	USA	CAN	GENE	JPN	REMARKS
1	GM6-61481-00	CABLE, STEERING	1	1	1	1	
2	EU0-61461-30	SHAFT, JOINT BALL	2	2	2	2	
3	GM6-67252-00	CABLE, THROTTLE	1	1	1	1	
4	GM6-67242-00	CABLE, CHOKE	1	1	1	1	
5	90465-13M11	CLAMP	1	1	1	1	
6	EU0-61436-00	BODY,CABLE CONNECTOR	1	1	1	1	
7	EU0-61438-00	PACKING (C)	2	2	2	2	
8	EU0-61446-00	WASHER 30	1	1	1	1	
9	EU0-61486-00	STOPPER	1	1	1	1	
10	EU0-61435-00	SEAL, PIPE 30	1	1	1	1	
11	EU0-62694-00	CAP	1	1	1	1	
12	90267-40945	RIVET, BLIND	2	2	2	2	
13	90209-12920	WASHER	1	1	1	1	



GM61100-6180

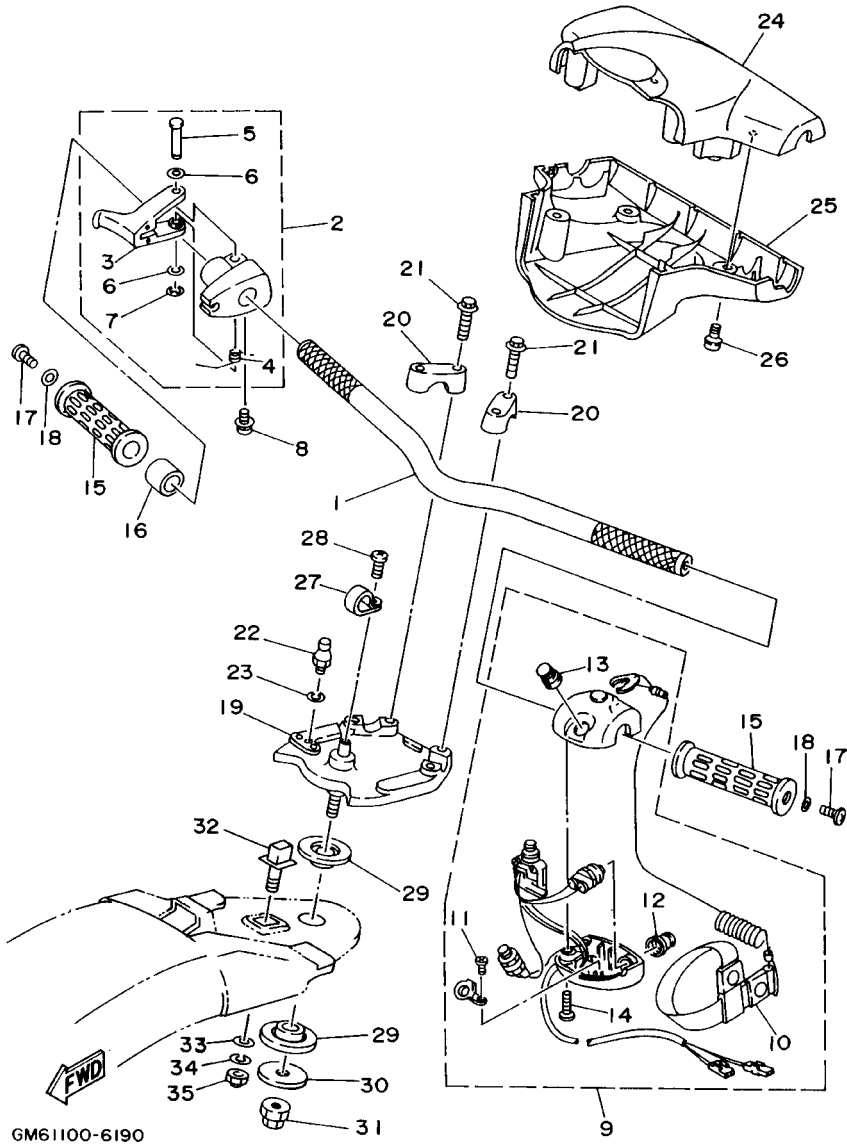

FIG. 19 STEERING 1

REF. NO.	PART NO.	DESCRIPTION	USA	CAN	GENE	JPN	REMARKS
1	FX1-61552-00	HANDLE	1	1	1	1	
2	EW2-67250-02	THROTTLE LEVER ASSY	1	1	1	1	
3	EW2-67255-00	.LEVER, THROTTLE	1	1	1	1	
4	EW2-67256-00	.SPRING	1	1	1	1	
5	EW2-67257-01	.SHAFT	1	1	1	1	
6	EW2-67258-01	.WASHER	2	2	2	2	
7	EW2-67259-01	.E-RING	1	1	1	1	
8	90159-05900	SCREW, WITH WASHER	1	1	1	1	
9	EW2-68310-04	SWITCH BOX ASSY	1	1	1	1	
10	EW2-68348-00	.LANYARD, STOP SWITCH	1	1	1	1	
11	97880-03008	.SCREW, PAN HEAD	2	2	2	2	
12	FK7-68312-02	.STOP BUTTON COMP	1	1	1	1	
13	FK7-68313-02	.START BUTTON COMP.	1	1	1	1	
14	97880-05025	.SCREW, PAN HEAD	1	1	1	1	
15	EW2-61553-00	GRIP, HANDLE 1	2	2	2	2	
16	90560-22281	SPACER	1	1	1	1	
17	90149-05959	SCREW	2	2	2	2	
18	90201-05928	WASHER, PLATE	2	2	2	2	
19	EW2-61540-11	BRAKE, ASSY.	1	1	1	1	
20	EU0-23814-01	HOLDER, HANDLE LOWER	2	2	2	2	
21	90105-08902	BOLT, WASHER BASED	4	4	4	4	
22	EU0-61461-02	STUD, JOINT BALL	1	1	1	1	
23	92990-06100	WASHER, SPRING	1	1	1	1	
24	FX1-6143D-20	PAD, STEERING 1	1	1	1	1	YB
25	FX1-6143E-20	PAD, STEERING 2	1	1	1	1	YB
26	90149-05937	SCREW	4	4	4	4	
27	90600-91728	CLIP, NYLON 17	1	1	1	1	

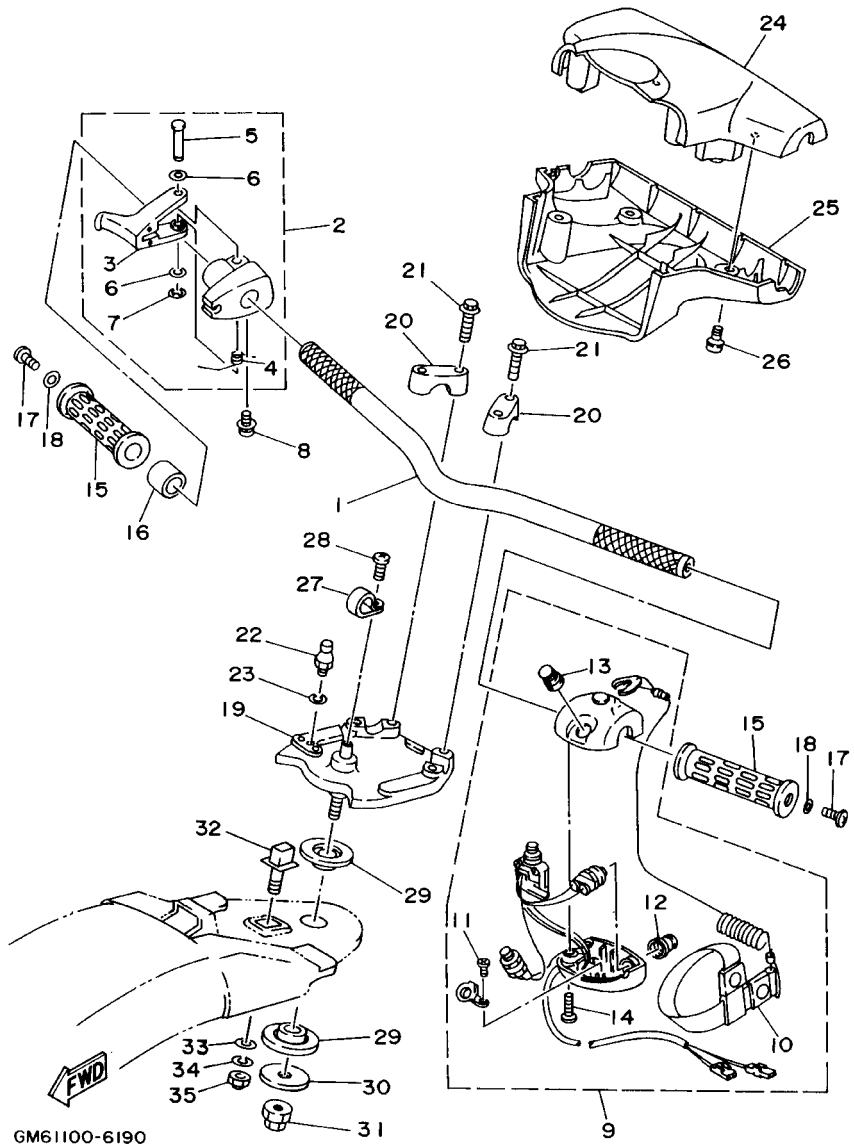
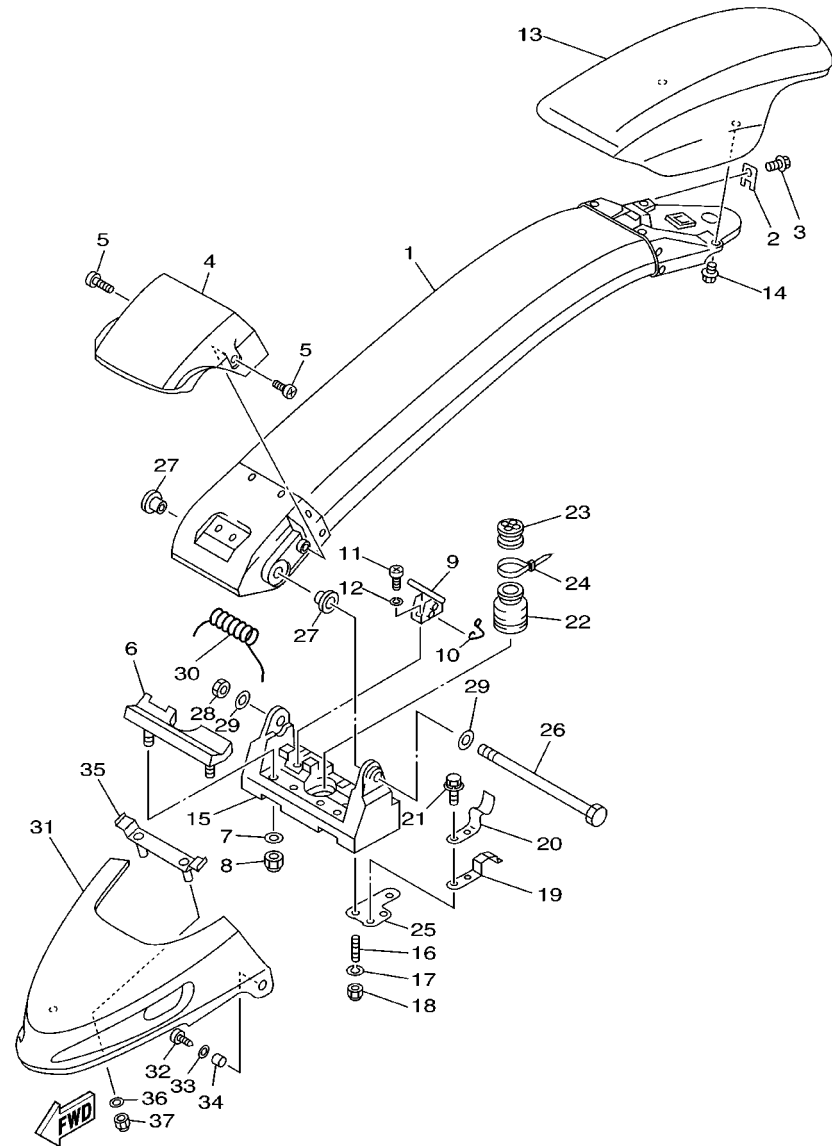

FIG. 19 STEERING 1

REF. NO.	PART NO.	DESCRIPTION	USA	CAN	GENE	JPN	REMARKS
28	98980-04010	SCREW, BIND	1	1	1	1	
29	EW2-61417-00	BEARING, COLUMN	2	2	2	2	
30	EW2-61419-00	WASHER, STEERING	1	1	1	1	
31	90179-12933	NUT	1	1	1	1	
32	EW2-61314-00	PIN, STOPPER 1	1	1	1	1	
33	92990-10200	WASHER, PLAIN	1	1	1	1	
34	92990-10100	WASHER, SPRING	1	1	1	1	
35	90176-10915	NUT, CROWN	1	1	1	1	



GM69100-8200

FIG. 20 STEERING 2

REF. NO.	PART NO.	DESCRIPTION	USA	CAN	GENE	JPN	REMARKS
1	GM6-6491A-02-P1	STEERING POLE COMP.	1	1	1	1	DVC2
2	FX1-61468-00	STOPPER, CABLE	1	1	1	1	
3	90119-06913	BOLT, WITH WASHER	1	1	1	1	
4	FX1-6492E-10	COVER,POLE	1	1	1	1	BL
5	90149-06997	SCREW	2	2	2	2	
6	FX1-61337-00	STOPPER, POLE	1	1	1	1	
7	92990-06200	WASHER, PLAIN	2	2	2	2	
8	95720-06300	NUT, SELF-LOCKING	2	2	2	2	
9	FX1-61105-00	STOPPER PIN ASSY	1	1	1	1	
10	EW2-61395-30	SPRING, TORSION	1	1	1	1	
11	97880-05012	SCREW, PAN HEAD	2	2	2	2	
12	92990-05100	WASHER, SPRING	2	2	2	2	
13	GM6-6142A-20	STEERING PAD COMP	1	1	1	1	YB
14	90119-06918	BOLT, WITH WASHER	2	2	2	2	
15	FX1-6133C-12	BRACKET,PIVOT	1	1	1	1	
16	95680-08630	BOLT, STUD	4	4	4	4	
17	92990-08100	WASHER, SPRING	4	4	4	4	
18	95720-08300	NUT, SELF-LOCKING	4	4	4	4	
19	GM6-6215G-00	PLATE,GUIDE	2	2	2	2	
20	GM6-65135-00	STOPPER, HATCH 1	2	2	2	2	
21	90119-06900	BOLT, WITH WASHER	4	4	4	4	
22	FX1-61338-00	GROMMET	1	1	1	1	
23	EW2-61465-00	PACKING, CABLE	1	1	1	1	
24	90601-20006	BAND	1	1	1	1	
25	GM6-6133B-00	PLATE, BRACKET	2	2	2	2	
26	FX1-6134L-00	SHAFT,PIVOT	1	1	1	1	
27	EW2-61344-01	BUSH	2	2	2	2	

FIG. 20 STEERING 2

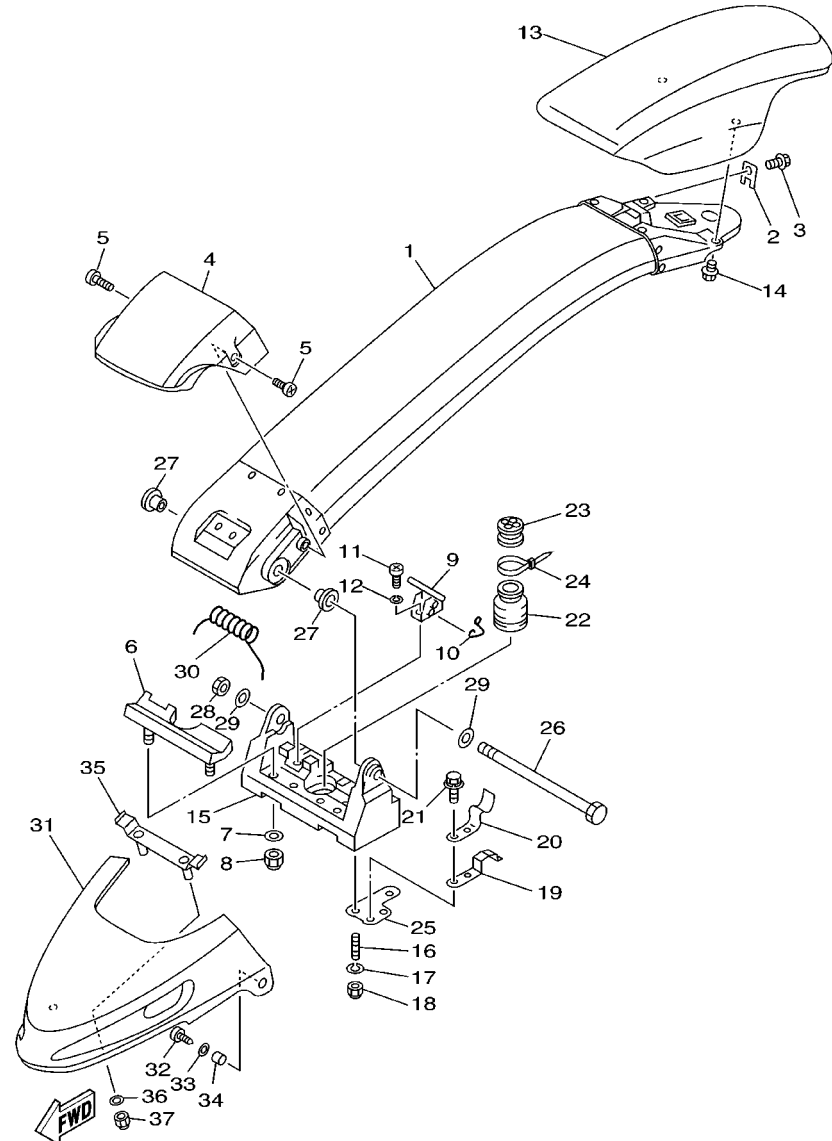

GM69100-8200

REF. NO.	PART NO.	DESCRIPTION	USA	CAN	GENE	JPN	REMARKS
28	90170-14913	NUT	1	1	1	1	DVC2
29	92990-14200	WASHER, PLAIN	2	2	2	2	
30	FX1-61391-00	SPRING, PIVOT	1	1	1	1	
31	GM6-6492J-20	COVER,PIVOT 1	1	1	1	1	
32	97780-60520	SCREW, TAPPING	2	2	2	2	
33	92990-06200	WASHER, PLAIN	1	1	1	1	
34	90387-06916	COLLAR	2	2	2	2	
35	GM6-64949-00	BRACKET	1	1	1	1	
36	92990-06200	WASHER, PLAIN	2	2	2	2	
37	95720-06300	NUT, SELF-LOCKING	2	2	2	2	

FIG. 21 GRAPHICS

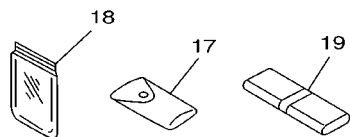
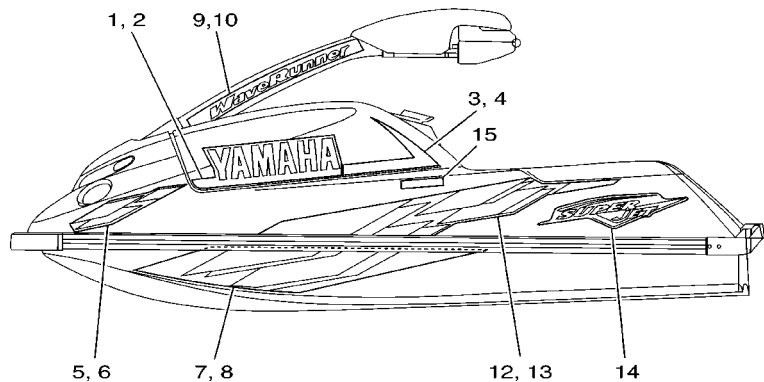
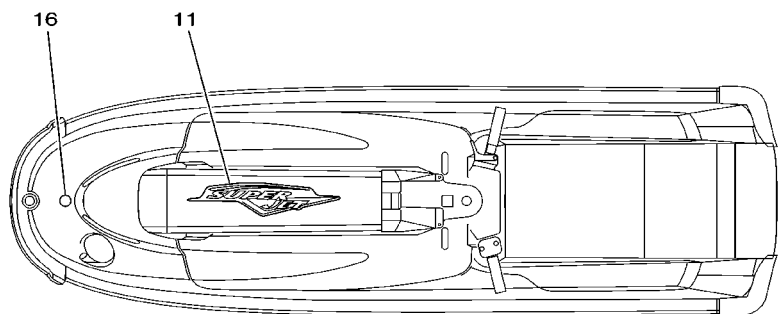

GM6H100-0210

REF. NO.	PART NO.	DESCRIPTION	USA	CAN	GENE	JPN	REMARKS
1	GM6-6417B-50	GRAPHIC 1	1	1	1	1	LH
2	GM6-6417B-60	GRAPHIC 1	1	1	1	1	RH
3	GM6-6417C-50	GRAPHIC 2	1	1	1	1	LH
4	GM6-6417C-60	GRAPHIC 2	1	1	1	1	RH
5	GM6-6417D-50	GRAPHIC 3	1	1	1	1	LH
6	GM6-6417D-60	GRAPHIC 3	1	1	1	1	RH
7	GM6-6417E-50	GRAPHIC 4	1	1	1	1	LH
8	GM6-6417E-60	GRAPHIC 4	1	1	1	1	RH
9	GM6-6417F-70	GRAPHIC 5	1	1	1	1	LH
10	GM6-6417F-80	GRAPHIC 5	1	1	1	1	RH
11	GM6-6417G-20	GRAPHIC 6	1	1	1	1	
12	GM6-6417H-10	GRAPHIC 7	1	1	1	1	LH
13	GM6-6417H-20	GRAPHIC 7	1	1	1	1	RH
14	GM6-6417J-00	GRAPHIC 8	2	2	2	2	
15	GM6-64121-00	EMBLEM A				2	FOR JPN
16	GM6-6411H-00	EMBLEM, TUNING FORK	1	1	1	1	
17	EU0-65986-00	TOOL SET	1	1	1		FOR USA,CAN,GENE
	EU0-65986-10	TOOL SET				1	FOR JPN
18	EU0-65901-01	TOOL BAG	1	1	1	1	
19	GM6-65987-00	GAG	1	1	1	1	

FIG. 22 IMPORTANT LABELS

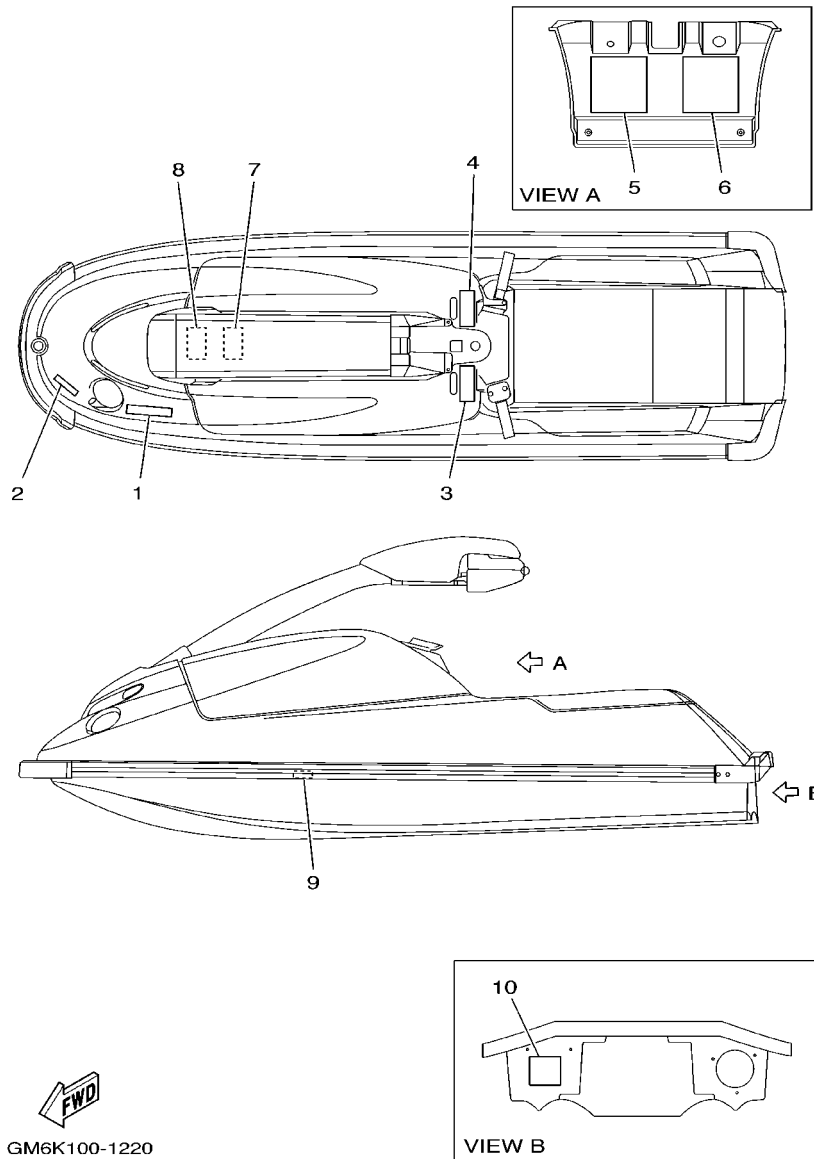

REF. NO.	PART NO.	DESCRIPTION	USA	CAN	GENE	JPN	REMARKS
1	GM6-6415B-30	LABEL, WARNING(FUEL)	1				
2	GM6-6418R-00	LABEL, WARNING VENTILATION	1				
3	GM6-641B1-00	LABEL, WARNING JDC 1	1				
4	GM6-641B1-10	LABEL, WARNING JDC 1	1				
5	GM6-641B2-00	LABEL, WARNING JDC 2	1				
6	GM6-641B2-10	LABEL, WARNING JDC 2	1				
7	GM6-641F1-00	LABEL, AFTER OPERATION	1				
8	GM6-6418B-40	LABEL, CAUTION	1				
9	EW2-64184-00	LABEL,PATENT	1				LH INSIDE
10	EU0-64188-00	LABEL, RIGHTING	1				

FIG. 23 IMPORTANT LABELS 2

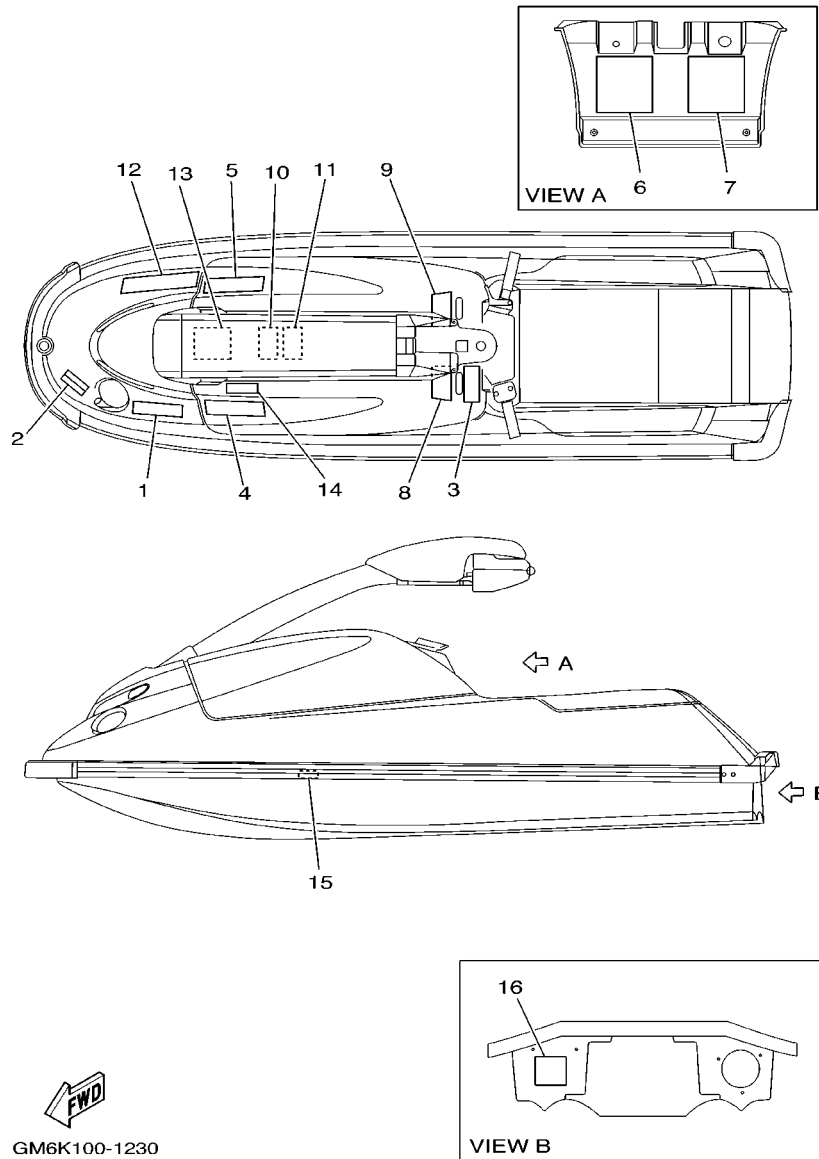

FWD
GM6K100-1230

REF. NO.	PART NO.	DESCRIPTION	USA	CAN	GENE	JPN	REMARKS
1	GM6-6415B-40	LABEL, WARNING(FUEL)		1	1		
2	GM6-6418R-10	LABEL, WARNING VENTILATION		1	1		
3	GM6-641B1-20	LABEL, WARNING JDC 1		1	1		
4	GM6-641B1-40	LABEL, WARNING JDC 1		1	1		
5	GM6-641B1-50	LABEL, WARNING JDC 1		1	1		
6	GM6-641B2-00	LABEL, WARNING JDC 2		1	1		
7	GM6-641B2-10	LABEL, WARNING JDC 2		1	1		
8	GM6-641B2-40	LABEL, WARNING JDC 2		1	1		
9	GM6-641B2-50	LABEL, WARNING JDC 2		1	1		
10	GM6-641F1-00	LABEL, AFTER OPERATION		1	1		
11	GM6-641F1-10	LABEL, AFTER OPERATION		1	1		
12	GA7-6416H-20	LABEL,WARNING(FRANCE)			1		FOR EUR
13	GM6-6418B-50	LABEL, CAUTION		1	1		
14	GR7-6419E-10	LABEL 4		1			FOR CAN
15	EW2-64184-00	LABEL,PATENT		1	1		LH INSIDE
16	EU0-64188-00	LABEL, RIGHTING		1	1		

FIG. 24 IMPORTANT LABELS 3

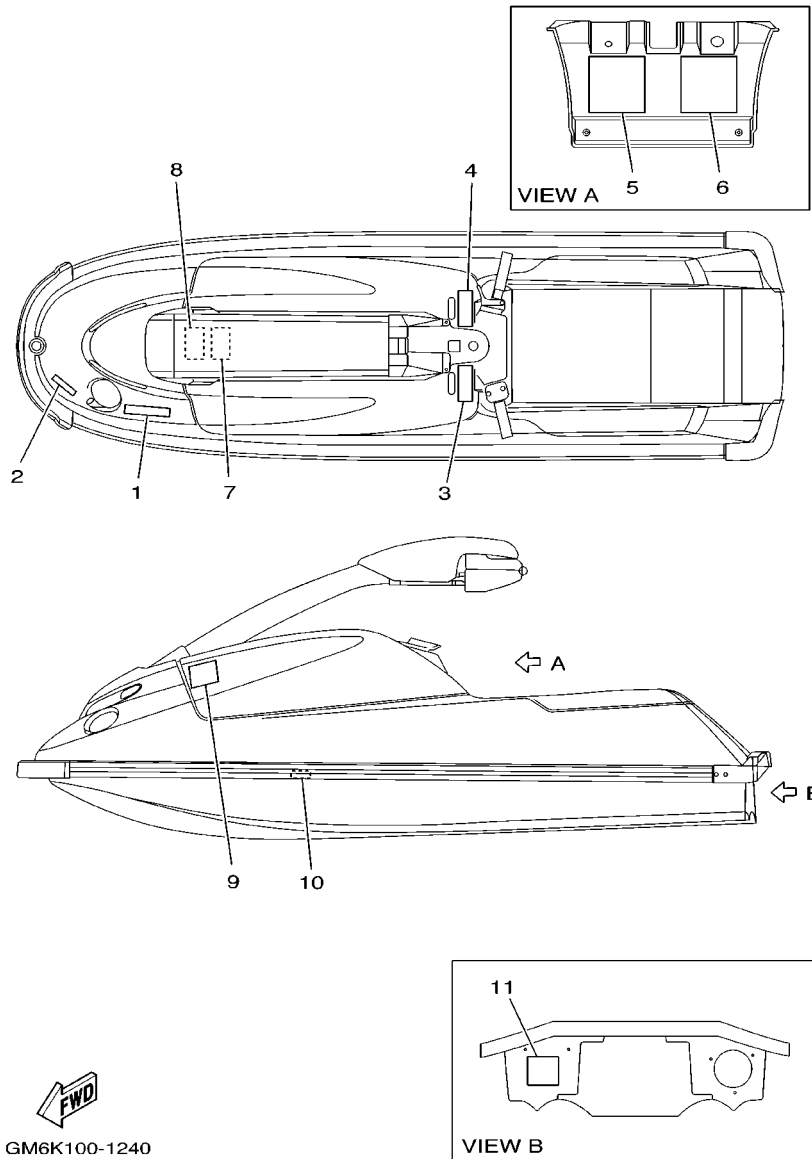

GM6K100-1240

REF. NO.	PART NO.	DESCRIPTION	USA	CAN	GENE	JPN	REMARKS
1	GM6-6415B-50	LABEL, WARNING(FUEL)				1	
2	GM6-6418R-20	LABEL, WARNING VENTILATION				1	
3	GM6-641B1-60	LABEL, WARNING JDC 1				1	
4	GM6-641B1-70	LABEL, WARNING JDC 1				1	
5	GM6-641B2-60	LABEL, WARNING JDC 2				1	
6	GM6-641B2-70	LABEL, WARNING JDC 2				1	
7	GM6-641F1-20	LABEL, AFTER OPERATION				1	
8	GM6-6418B-60	LABEL, CAUTION				1	
9	EW3-64197-00	PLATE CAPACITY				1	
10	EW2-64184-00	LABEL,PATENT				1	LH INSIDE
11	EU0-64188-00	LABEL, RIGHTING				1	

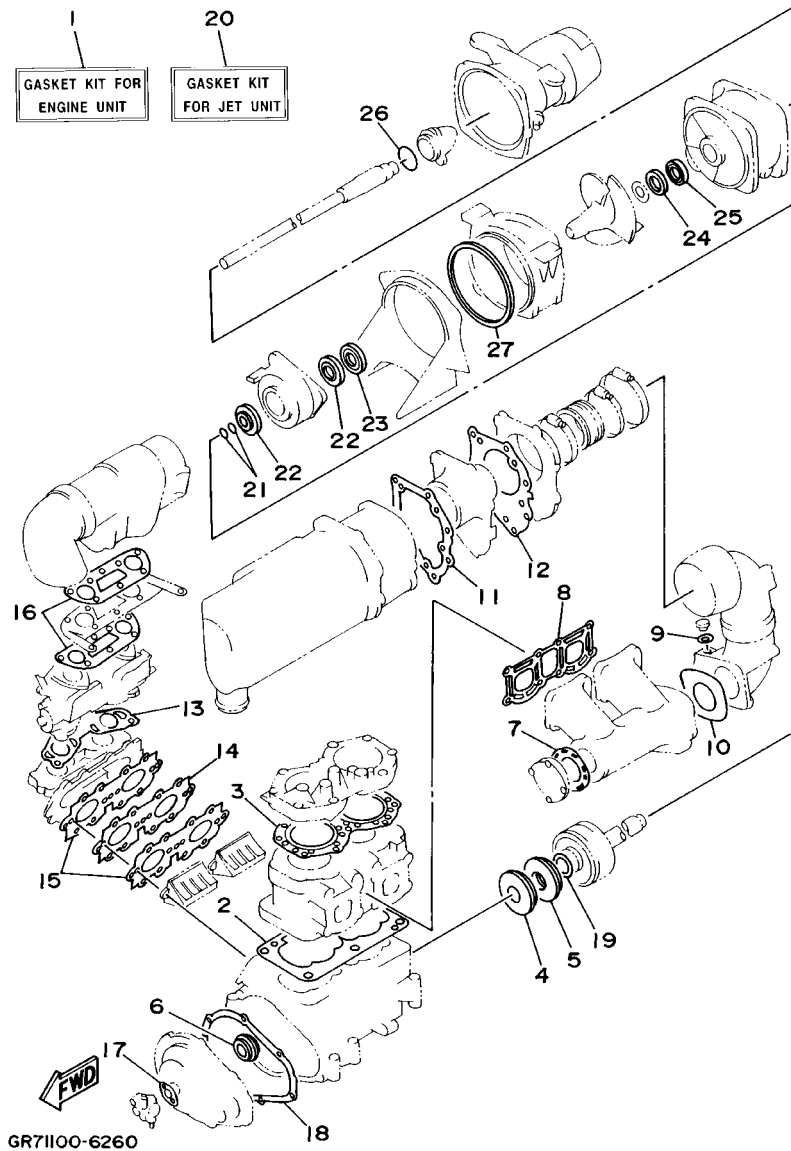
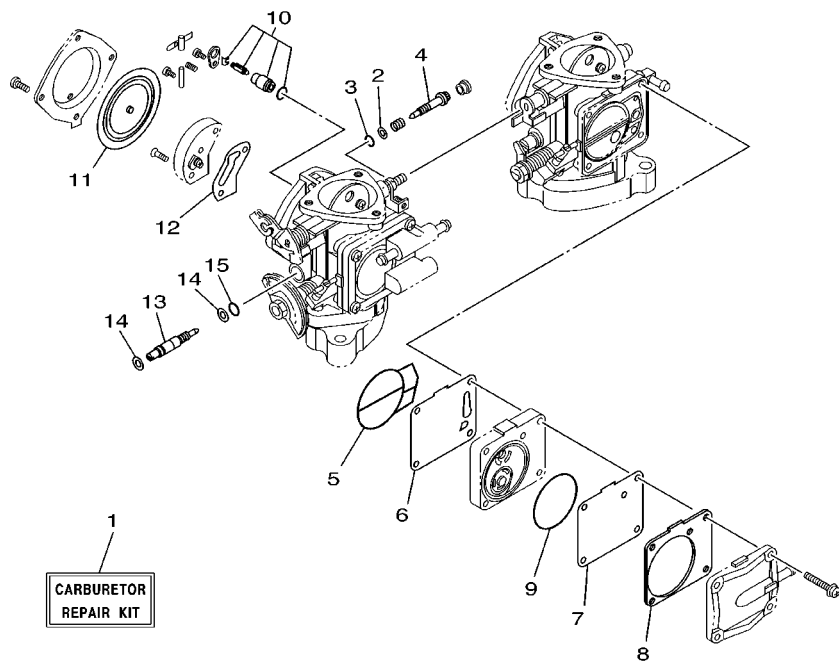

FIG. 25 REPAIR KIT 1

REF. NO.	PART NO.	DESCRIPTION	USA	CAN	GENE	JPN	REMARKS
1	64U-W0001-00	GASKET KIT FOR ENGINE UNIT	1	1	1	1	
2	6M6-11351-A2	.GASKET, CYLINDER	1	1	1	1	
3	62T-11181-00	.GASKET, CYLINDER HEAD 1	1	1	1	1	
4	93102-36M33	.OIL SEAL	1	1	1	1	
5	93101-36M46	.OIL SEAL	1	1	1	1	
6	93103-32M01	.OIL SEAL	1	1	1	1	
7	6M6-14739-A1	.GASKET, MUFFLER DAMPER 1	1	1	1	1	
8	61X-14613-A0	.GASKET, EXHAUST PIPE	1	1	1	1	
9	90430-08020	.GASKET	1	1	1	1	
10	6R7-14749-A0	.GASKET, MUFFLER DAMPER 2	1	1	1	1	
11	6R7-14755-A0	.GASKET, SILENCER	1	1	1	1	
12	6R7-41114-A0	.GASKET, EXHAUST OUTER COVER	1	1	1	1	
13	62T-13556-00	.GASKET, MANIFOLD	1	1	1	1	
14	62T-13624-00	.PLATE, REED VALVE	1	1	1	1	
15	62T-13566-00	.GASKET	2	2	2	2	
16	62T-13674-00	.GASKET, AIR COOLER COVER 1	2	2	2	2	
17	6R8-13116-A0	.GASKET, PUMP CASE	1	1	1	1	
18	6M6-81365-A0	.GASKET, HOLE COVER	1	1	1	1	
19	62T-45127-00	.SEAL	1	1	1	1	
20	61X-W0001-22	GASKETKIT FOR JET UNIT	1	1	1	1	
21	93210-17MA4	.O-RING	2	2	2	2	
22	93101-25M55	.OIL SEAL	2	2	2	2	
23	93101-25M56	.OIL SEAL	1	1	1	1	
24	93102-25M34	.OIL SEAL	1	1	1	1	
25	93101-25M50	.OIL SEAL	1	1	1	1	
26	93210-46M16	.O-RING	1	1	1	1	
27	6R7-51117-01	.PACKING	1	1	1	1	

FIG. 26 REPAIR KIT 2



REF. NO.	PART NO.	DESCRIPTION	USA	CAN	GENE	JPN	REMARKS
1	64U-W0093-02	CARBURETOR REPAIR KIT	1	1	1	1	
2	812-14235-00	.WASHER, NEEDLE	4	4	4	4	
3	812-14147-00	.O-RING	2	2	2	2	
4	63M-14946-00	.PLATE, NEEDLE FITTING	2	2	2	2	
5	6K8-14564-00	.O-RING	2	2	2	2	
6	6K8-24411-20	.DIAPHRAGM	1	1	1	1	
7	6K8-24421-10	.VALVE, CHECK	1	1	1	1	
8	6K8-24431-20	.GASKET, FUEL PUMP 1	1	1	1	1	
9	6K8-14563-00	.O-RING	1	1	1	1	
10	61X-14916-15	.NEEDLE	2	2	2	2	
11	6R7-14541-00	.DIAPHRAGM, PUMP	2	2	2	2	
12	6K8-14536-11	.GASKET	2	2	2	2	
13	64U-14923-00	.SCREW, PILOT	2	2	2	2	
14	822-14235-00	.WASHER, NEEDLE	4	4	4	4	
15	583-14561-00	.O-RING	2	2	2	2	

NUMERICAL INDEX

PARTNO.	GRID NO.	PARTNO.	GRID NO.	PARTNO.	GRID NO.	PARTNO.	GRID NO.	PARTNO.	GRID NO.	PARTNO.	GRID NO.
61X-W0001-22	D - 10	62T-14243-01	B - 6	64V-14752-00	B - 11	61L-45378-00	C - 2	EU0-61486-00	C - 15	GM6-641B2-10	D - 7
64U-W0001-00	D - 10	62T-14251-10	B - 2	6R7-14753-00-9M	B - 11	6R7-45511-01	B - 14	EW2-61540-11	D - 2		
62T-W0004-00	B - 6	6R7-14253-00	B - 9	6R7-14755-A0	B - 11	62T-45526-00	B - 4	FX1-61552-00	D - 2	GM6-641B2-40	D - 8
64V-W0090-01-8P	B - 2	62T-14255-00	B - 7			61X-4581J-00	B - 5	EW2-61553-00	D - 2	GM6-641B2-50	D - 8
64U-W0093-02	D - 11	62T-14283-00	B - 7	6M6-14771-00-94	B - 11	6M6-45813-22-8P	B - 5	FN8-61651-00	C - 11	GM6-641B2-60	D - 9
64U-111111-00-94	B - 2	62T-14284-10-8P	B - 6	6R7-14785-00-9M	B - 11	6M6-45813-32-8P	B - 5	EU0-61652-00	C - 11	GM6-641B2-70	D - 9
62T-11181-00	B - 2	64U-14301-02	B - 8	61X-14916-15	B - 9	6R7-51117-01	B - 15	GP7-61652-00	C - 14	GM6-641F1-00	D - 7
	D - 10	64U-14302-02	B - 8					GM6-6213F-00	C - 8		
61X-11311-01-94	B - 2	62T-14419-00	B - 7	64U-14923-00	B - 9	6K8-51129-00	B - 2	EW2-62137-00	C - 8	GM6-641F1-10	D - 8
6E5-11325-00	B - 2	62T-14435-00	B - 7					EW2-62140-00	C - 12	GM6-641F1-20	D - 9
6M6-11351-A2	B - 2	62T-14451-00	B - 7	3KW-14932-00	B - 8			EW2-62142-00	C - 12	GM6-6411H-00	D - 9
	D - 10	6K8-14471-10	B - 8	63M-14946-00	B - 8	6K8-51162-00	C - 10	EW2-62149-00	C - 7	GM6-64121-00	D - 6
61X-11400-03	B - 4	6R7-14485-00	B - 2			6R7-51311-00	B - 15	GM6-6215G-00	D - 4	GM6-6415B-30	D - 7
6M6-11412-00	B - 4			62T-15100-00-94	B - 2	6R7-51312-03-94	B - 14	EW2-62150-00	C - 12	GM6-6415B-40	D - 8
6M6-11422-00	B - 4	6K8-14503-02	B - 8	6R7-15761-00	B - 11	61L-51313-00	B - 14	GM6-62501-10	C - 11	GM6-6415B-50	D - 9
6M6-11431-00	B - 4	6M6-14503-00	B - 8	6R7-21415-01-94	B - 2	62T-51315-01-94	B - 14	GM6-6251D-10	C - 11	GA7-6416H-20	D - 8
6M6-11442-01	B - 4	6K8-14521-01	B - 9	6R7-21425-01-94	B - 2	6R7-51318-05-94	B - 14	GM6-6251E-10	C - 11	GM6-6417B-50	D - 6
82M-11515-00	B - 4	6K8-14521-10	B - 8	EU0-23814-01	D - 2	6R7-51321-00-94	B - 14	GM6-6252C-10	C - 11	GM6-6417B-60	D - 6
61X-11603-00	B - 4	6M6-14521-01	B - 8	62T-24313-01	B - 6	6R7-51323-02	C - 2	GM6-6252D-10	C - 11	GM6-6417C-50	D - 6
61X-11604-00	B - 4	6K8-14523-11	B - 9	62T-24314-01	B - 6	62T-51326-00	B - 14	GM6-62552-10	C - 11	GM6-6417C-60	D - 6
61X-11605-00	B - 4	6K8-14527-11	B - 8	6E5-24378-00	B - 10	6R7-51333-00	B - 15	GM6-62553-10	C - 11	GM6-6417D-50	D - 6
61X-11631-01-93	B - 4	62T-14527-02	B - 6	6K8-24411-20	B - 8	62T-51348-00	B - 14	GM6-62664-00	C - 9	GM6-6417D-60	D - 6
61X-11633-00	B - 4	6K8-14536-11	B - 9			61X-51381-00	C - 2	EU0-62693-02	B - 15	GM6-6417E-50	D - 6
61X-11635-01	B - 4			6R7-24412-01	B - 9	61L-5169A-00	B - 6	EU0-62694-00	C - 15	GM6-6417E-60	D - 6
61X-11636-01	B - 4	6R7-14541-00	B - 9	6M6-24413-01	B - 8	FX1-61105-00	D - 4	EU0-62695-00	B - 15	GM6-6417F-70	D - 6
62T-11651-00	B - 4			6K8-24421-10	B - 8	EW2-61314-00	D - 3	EW2-62723-30	B - 15	GM6-6417F-80	D - 6
82M-11685-00	B - 4	6R7-14542-00	B - 9			GM6-6133B-00	D - 4	EW2-62731-01	B - 15	GM6-6417G-20	D - 6
6R8-13116-A0	D - 10	6K8-14547-01	B - 9	65U-24421-00	B - 8	FX1-6133C-12	D - 4	EW2-62840-10	C - 9	GM6-6417H-10	D - 6
62T-13555-00-8P	B - 6	583-14561-00	B - 9	6K8-24431-20	B - 8	FX1-61337-00	D - 4	EW2-62843-00	C - 9	GM6-6417H-20	D - 6
62T-13556-00	B - 6					FX1-61338-00	D - 4	EW2-62845-10	C - 9	GM6-6417J-00	D - 6
	D - 10	6K8-14563-00	B - 8	6K8-24452-10	B - 8	FX1-6134L-00	D - 4	EW2-62846-00	C - 9	GM6-6418B-40	D - 7
62T-13566-00	B - 6			70R-24489-00	C - 12	EW2-61344-01	D - 4	EW2-62847-00	C - 9	GM6-6418B-50	D - 8
	D - 10	6K8-14564-00	B - 8	65U-24492-00	B - 8	FX1-61391-00	D - 5	EW2-62848-00	C - 9	GM6-6418B-60	D - 9
62T-13610-00	B - 6			6K8-24500-02	B - 12	EW2-61395-30	D - 4	A00-62858-02	C - 8	GM6-6418D-00	C - 12
62T-13624-00	B - 6	6R7-14569-00	B - 9	6R7-24524-00	B - 12	EW2-61417-00	D - 3	GM6-6351B-00	C - 11	GM6-6418R-00	D - 7
	D - 10	6K8-14589-00	B - 9	70R-24543-00	C - 12	EW2-61419-00	D - 3	GM6-6351C-00	C - 11	GM6-6418R-10	D - 8
62T-13674-00	B - 7	61X-14613-A0	B - 10	6K8-24560-10	B - 12	GM6-6142A-20	D - 4	GM6-6351D-00	C - 11	GM6-6418R-20	D - 9
	D - 10			6E0-28193-00-94	B - 11	FX1-6143D-20	D - 2	GM6-6351E-10	C - 11	EW2-64184-00	D - 7
47X-14133-00	B - 8	61L-14615-A0	B - 11	626-28193-01-94	B - 10	FX1-6143E-20	D - 2	GM6-63844-00	C - 14		
812-14147-00	B - 8	61L-14625-A0	B - 11	6R7-41113-00-9M	B - 11	EU0-61435-00	C - 15	GM6-641B1-00	D - 7		
	D - 11	61X-14711-01-9P	B - 10	6R7-41114-A0	B - 11	EU0-61436-00	C - 15	GM6-641B1-10	D - 7	EU0-64188-00	D - 7
439-14186-00	B - 9	61L-14712-00-9P	B - 10			EU0-61438-00	C - 15	GM6-641B1-20	D - 8		
3G2-14231-26	B - 8	6M6-14718-01-9P	B - 10	6R7-42316-00	B - 14	EU0-61446-00	C - 15	GM6-641B1-40	D - 8		
830-14231-14	B - 8	6R7-14721-00-9M	B - 10	6R7-44517-00-9M	B - 2	EU0-61461-02	D - 2	GM6-641B1-50	D - 8	GR7-6419E-10	D - 8
812-14235-00	B - 8	6M6-14739-A1	B - 10	663-45119-00	B - 6	EU0-61461-30	C - 15	GM6-641B1-60	D - 9	EW3-64197-00	D - 9
	D - 11			62T-45127-00	B - 5	EW2-61465-00	D - 4	GM6-641B1-70	D - 9	GM6-6491A-02-P1	D - 4
822-14235-00	B - 9	6R7-14749-A0	B - 10			FX1-61468-00	D - 4	GM6-641B2-00	D - 7	FX1-6492E-10	D - 4
	D - 11			61X-45332-03-94	C - 2	GM6-61481-00	C - 15			GM6-6492J-20	D - 5

NUMERICAL INDEX

PARTNO.	GRID NO.	PARTNO.	GRID NO.	PARTNO.	GRID NO.	PARTNO.	GRID NO.	PARTNO.	GRID NO.	PARTNO.	GRID NO.
GM6-64949-00	D - 5	GM6-67593-00	C - 13	26H-81847-00	C - 4	90119-06M70	B - 14	90267-48938	C - 8	90465-12M56	B - 12
FX1-65116-10	C - 8	GM6-67594-00	C - 13	6M6-81850-00	C - 4	90119-06900	C - 8	90267-48963	C - 11	90465-13M11	C - 6
GM6-65135-00	D - 4	EU0-67613-00	C - 10	6M6-81865-00	C - 4		D - 4	90280-05013	C - 3		C - 7
GM6-65136-00	C - 8	EW2-67618-00	C - 10	6M6-81866-00	C - 4	90119-06908	B - 15	90340-08M04	B - 10		C - 10
EW2-65137-00	C - 8	EW2-67711-01	C - 12	6M6-81921-00	C - 5		C - 5	90380-12M29	B - 2		C - 15
FX1-6514B-00	C - 8	FJ0-67713-00	C - 12	6G1-81941-10	C - 5	90119-06913	D - 4		C - 3	90467-06016	B - 2
FX1-6514F-00	C - 8	EW2-67714-02	C - 12	6M6-81952-01	C - 5	90119-06915	B - 15	90387-06M05	C - 3	90467-08M10	C - 7
GM6-6516A-10-P1	C - 8	EW2-67716-01	C - 12	6M6-81960-A0	C - 5	90119-06918	D - 4	90387-06M60	C - 2	90467-11032	C - 12
GM6-6516C-00	C - 8	GM6-6773E-00	B - 12	EU0-82110-09	C - 7	90119-06920	C - 7	90387-06916	D - 5	90480-06M43	C - 6
FX1-6517D-00	C - 8	EU0-67767-31	C - 12	6R7-82117-11	C - 7	90119-08M55	B - 2	90387-08M06	B - 14	90480-06M69	C - 2
GM6-6521C-10	C - 11	EU0-67816-30	B - 12	62E-82117-20	C - 6	90119-08M73	B - 10	90430-08020	B - 10	90501-14M73	C - 4
GM6-6521D-10	C - 11	EU0-67817-00	B - 12	64V-82117-00	C - 7	90119-08M96	B - 2		D - 10	90560-22281	D - 2
FX1-65760-00	C - 14	EW2-67821-00	C - 12	6K8-82150-01	C - 5	90119-08038	B - 3	90445-07M19	B - 2	90600-91728	D - 2
EW2-65772-00	C - 13	EW2-67821-30	C - 13	6G1-82151-00	C - 5	90119-08904	B - 3	90445-09M17	C - 2	90600-91736	B - 12
	C - 14	EW2-67822-01	C - 13	6K8-82159-00	C - 5	90119-08907	C - 2	90445-10ME3	B - 12	90601-11062	B - 11
EU0-65901-01	D - 6	FN8-67831-01	C - 13	6R7-82351-00	C - 6	90119-08943	B - 15	90445-10ME4	B - 12		C - 12
FX1-6591A-10	C - 8	EU0-67832-00	C - 13	62E-82351-01	C - 5	90119-10M00	B - 2	90445-10ME8	B - 12	90601-15573	C - 13
FX1-6591K-00	C - 8	FN8-67833-00	C - 13	6R7-82352-00	C - 6	90119-10M01	B - 2	90445-10MF1	B - 12	90601-16274	C - 12
EW2-65912-00	C - 8	EU0-67834-00	C - 13	62E-82352-01	C - 6	90119-10M02	B - 2	90445-10M98	B - 12	90601-16875	C - 8
EW2-65913-00	C - 8	EU0-67835-00	C - 13	6R7-82361-01	C - 6	90119-10M03	B - 2	90445-11903	C - 12		C - 14
EU0-65986-00	D - 6	EU0-67839-00	C - 13	66T-82370-00	C - 6	90119-10M07	B - 2	90445-14M04	C - 10	90601-20006	B - 12
EU0-65986-10	D - 6	GM6-67844-10	C - 13	62E-82371-11	C - 5	90119-10M17	B - 11	90445-14M06	B - 10		D - 4
GM6-65987-00	D - 6	EU0-67856-40	C - 7	6R7-82553-01	C - 6	90119-10M56	B - 2	90445-14M12	B - 14	90601-20016	B - 12
GM6-67242-00	C - 15	EU0-67869-00	C - 13	6R7-82560-00	C - 6	90119-10948	B - 15	90445-14M19	C - 10	90699-50003	C - 12
GD0-67249-00-05	C - 2	EW2-68156-00	C - 5	6R7-83623-40	C - 5	90149-05937	D - 2	90445-14M29	B - 10	90699-50045	C - 12
GD0-67249-00-10	C - 2	EW2-68211-00	C - 7	6R7-83623-50	C - 6	90149-05959	D - 2	90445-14M33	B - 10	90699-50120	C - 12
EW2-67250-02	D - 2	EU0-68218-04	C - 7	63N-83623-00	C - 5	90149-05960	C - 11	90446-14M23	B - 12	91490-16010	C - 12
GM6-67252-00	C - 15		C - 14	62T-85515-00	C - 3	90149-05962	C - 11	90446-14M30	C - 12	91790-05040	C - 12
EW2-67255-00	D - 2	EU0-68221-00	C - 7	6M6-8552A-01-8P	C - 5	90149-06997	D - 4	90446-14M64	B - 12	92580-06016	C - 8
EW2-67256-00	D - 2	EU0-68221-30	C - 7	6M6-8552E-01	C - 5	90159-05900	D - 2	90450-14M05	B - 10	92903-06600	B - 6
EW2-67257-01	D - 2	EW2-68221-00	C - 7	62T-85520-00	C - 3	90170-14913	D - 5		B - 14		B - 7
EW2-67258-01	D - 2	EW2-68310-04	D - 2	62T-85533-00	C - 3	90170-22187	B - 13	90460-64M15	B - 11		B - 10
EW2-67259-01	D - 2	FK7-68312-02	D - 2	62T-85540-01	C - 5	90176-10915	D - 3	90460-70M16	B - 11		B - 11
EU0-67324-00	B - 3	FK7-68313-02	D - 2	62T-85550-00	C - 3	90179-05964	C - 11	90460-90M11	B - 11		C - 4
EU0-67354-00-01	B - 3	EW2-68348-00	D - 2	62T-85560-00	C - 3	90179-08M15	B - 6	90464-06M29	C - 5	92903-08600	B - 10
EU0-67354-00-03	B - 3	6M6-8132W-00	C - 5	62E-85570-00	C - 5	90179-10925	B - 15	90464-08M07	B - 12		C - 4
EU0-67354-00-05	B - 3	6M6-81337-00-8P	C - 3	62E-85570-11	C - 5	90179-12933	D - 3	90464-20258	C - 8	92990-05100	C - 11
EU0-67354-00-10	B - 3	6M6-81365-A0	C - 3	6M6-85580-00	C - 3	90201-05928	D - 2	90465-06M86	C - 5		D - 4
EU0-67354-00-20	B - 3		D - 10	90105-06900	C - 13	90201-06M02	B - 14	90465-11M10	B - 6	92990-05200	B - 15
EW2-67354-00-01	B - 15	6M6-81800-10	C - 4		C - 14	90201-20M04	B - 4		B - 10		C - 8
EW2-67354-00-03	B - 15	3AJ-81809-00	C - 4	90105-08902	D - 2	90201-24M02	B - 5		B - 12		C - 11
EW2-67354-00-05	B - 15	6M6-81820-00	C - 4	90105-10M49	B - 11	90209-12920	C - 15		C - 2	92990-05600	B - 6
EW2-67354-00-10	B - 15	6M6-81826-00	C - 4	90105-10M88	B - 11	90267-40935	C - 13		C - 6		C - 12
GH7-6753B-00	C - 14	6M6-8183E-00	C - 4	90109-10M44	C - 3	90267-40945	C - 15		C - 7	92990-06100	C - 4
GM6-6755J-00	C - 14	6M6-81830-00	C - 4	90116-08M60	B - 6	90267-48925	B - 12		C - 10		C - 8
GM6-67550-00	C - 14	6M6-81840-10	C - 4	90119-05M02	B - 7		C - 12		C - 12		C - 11
GM6-67555-00	C - 14	11H-81844-00	C - 4	90119-05923	C - 9	90267-48930	C - 14		C - 14		D - 2
GM6-67565-00	C - 14	6M6-81844-00	C - 5	90119-06MA1	B - 11	90267-48932	C - 11	90465-12M53	C - 3	92990-06200	C - 8

NUMERICAL INDEX

PARTNO.	GRID NO.	PARTNO.	GRID NO.	PARTNO.	GRID NO.	PARTNO.	GRID NO.	PARTNO.	GRID NO.	PARTNO.	GRID NO.
92990-06200	C - 11	93603-10049	B - 5	97880-05012	B - 9						
	D - 4	93604-07141	B - 5		D - 4						
	D - 5	93606-07M17	B - 15	97880-05016	B - 6						
92990-06600	C - 3	93606-12019	B - 2	97880-05025	D - 2						
	C - 6		B - 14	97880-06016	C - 3						
92990-08100	C - 5		C - 2		C - 6						
	D - 4		C - 3	97880-06030	C - 6						
92990-08200	C - 5	94702-00040	C - 6	97902-04122	C - 3						
92990-10100	D - 3	94702-00272	C - 6	97902-05125	C - 3						
92990-10200	D - 3	94709-00040	C - 6	97980-05330	B - 8						
92990-14200	C - 14	95380-06700	B - 14	98580-05018	B - 8						
	D - 5		C - 4	98780-04015	B - 2						
92995-06100	C - 6	95380-06800	C - 11	98780-05016	B - 15						
92995-06600	B - 11	95380-08600	C - 5	98980-04008	B - 12						
	B - 14	95680-08630	D - 4	98980-04010	D - 3						
	C - 3	95720-05300	B - 15								
92995-08600	B - 14		C - 9								
93101-25M50	B - 14	95720-06300	C - 8								
	D - 10		D - 4								
93101-25M55	C - 2		D - 5								
	D - 10	95720-08300	D - 4								
93101-25M56	C - 2	97013-06012	B - 7								
	D - 10	97013-06016	B - 6								
93101-36M46	B - 4	97013-06020	B - 6								
	D - 10		B - 11								
93102-25M34	B - 14	97013-06025	B - 6								
	D - 10		B - 10								
93102-36M33	B - 4	97013-06035	B - 6								
	D - 10	97013-08025	B - 10								
93103-32M01	B - 4	97013-08035	B - 10								
	D - 10		C - 4								
93210-13M63	B - 7	97013-08040	C - 4								
93210-17MA4	C - 2	97090-06014	C - 8								
	D - 10	97095-06016	B - 11								
93210-46M16	B - 14		C - 6								
	D - 10	97095-06020	B - 14								
93305-30601	B - 4	97095-06025	C - 3								
93306-205U0	B - 14	97095-06035	C - 3								
93306-205U6	C - 2	97095-08018	B - 14								
93306-207U2	B - 4	97595-06525	C - 2								
93306-307U3	B - 4	97780-50114	C - 10								
93310-320U2	B - 4		C - 13								
93310-525U0	B - 4	97780-50316	C - 8								
93430-47M04	C - 2	97780-60120	B - 15								
93440-25M08	C - 4	97780-60520	D - 5								
93440-80023	B - 4	97780-60525	C - 5								
93450-18M06	C - 4	97802-04008	C - 3								
93450-21053	B - 4	97880-03008	D - 2								

CONTENTS

CYLINDER. CRANKCASE	B2
CRANKSHAFT. PISTON	B4
INTAKE	B6
CARBURETOR	B8
EXHAUST 1	B10
FUEL	B12
JET UNIT 1	B14
JET UNIT 2	C2
GENERATOR	C3
STARTING MOTOR	C4
ELECTRICAL 1	C5
ELECTRICAL 2	C7
ENGINE HATCH	C8
HULL. DECK	C10
GUNWALE. MAT	C11
FUEL TANK	C12
EXHAUST 2	C14
CONTROL CABLE	C15
STEERING 1	D2
STEERING 2	D4

GRAPHICS	D6
IMPORTANT LABELS	D7
IMPORTANT LABELS 2	D8
IMPORTANT LABELS 3	D9
REPAIR KIT 1	D10
REPAIR KIT 2	D11

INDEX

NUMERICAL INDEX	M1
-----------------------	----