

PARTS CATALOGUE

WaveRunner SUV1200

SV1200-B (GU57/66GF/66G3)

SV1200-B (GU58/66GG/66G3)

MJ-SUV1200'03 (GU59/66GH/66G3)

SV1200-B/MJ-SUV1200
PARTS CATALOGUE
©2002 by Yamaha Motor Co., Ltd.
1st Edition, Sep. 2002
All rights reserved.
Any reprinting or unauthorized use
without the written permission of
Yamaha Motor Co., Ltd.
is expressly prohibited.
Printed in Japan

A3



A4

FOREWORD

This Parts Catalogue is related to the parts for the model(s) in the below frame. When you are ordering replacement parts, please refer to this Parts Catalogue and quote both part numbers and part names correctly.

SV1200-B(GU57/66GF/66G3), SV1200-B(GU58/66GG/66G3),
MJ-SUV1200'03(GU59/66GH/66G3)

1. Modifications or additions which have been made after issue of the Parts Catalogue will be announced in the Yamaha Parts News.

It is advisable that you make necessary corrections to the Parts Catalogue according to the Yamaha Parts News.

2. Abbreviations

The following abbreviations are used in this Parts Catalogue.

“UR” Use specified parts number.

“UN” Use as many as needed.

“AP” Alternate Parts

“LM” Local Made (Parts need to be ordered locally)

“F#” Frame No. (Applicable machine No.)

3. Parts, which are to be supplied in an assembly, are listed with a dot(.) in front of the part name as shown below.

The numeral appearing to the right of each component part indicates the quantity of parts for each assembly unit.

EXAMPLE

PART NO.	DESCRIPTION	Q'TY	REMARKS
EU0-62280-00	DRAIN PLUG ASSY	2	
EU0-62282-00	.PLUG,DRAIN	1	

4. Quantity Column Information

NAME for Q'TY COLUMN	COUNTRY (destination)
USA	USA
CAN	CANADA
GENE	EXCEPT USA, CANADA, JAPAN
JPN	JAPAN

5. Note that the illustration for reference in finding parts numbers, not to be used for assembling. When assembling, please use the applicable service manual.

6. A part with “YMUS” in the remarks column can be obtained from YMUS (USA) and not from YAMAHA MOTOR CO.,LTD (JAPAN).

EXAMPLE

PART NO.	DESCRIPTION	Q'TY	REMARKS
EW2-U5160-00	ENGINE HATCH COMP.	2	.. YMUS
90601-168U7	BAND, HOSE	1	.. YMUS

ADDRESS:

YAMAHA MOTOR CORPORATION U.S.A.
PARTS & ACCESSORY DIV.
6555 KATELLA AVENUE
CYPRESS, CALIFORNIA 90630 U.S.A.

FOREWORD

7. Applicable Starting Serial No. and Color Code

Starting Serial No.

Hull Serial No.	GU5-704111
Engine Serial No.	66G-1000001

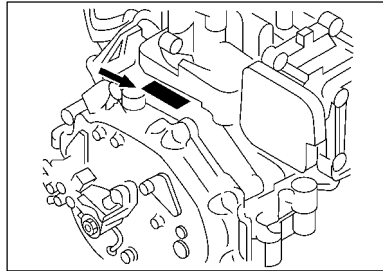
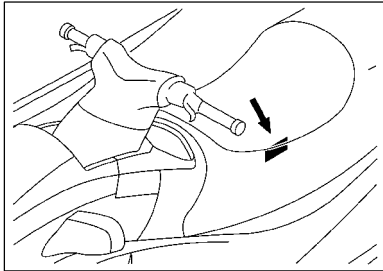

Color Code

Parts No./Part Name	Color Code	Color Name	Abbreviation
F0D-U516N-50-P0 COVER, ENGINE HATCH	0882	PURPLISH BLUE METALLIC D	PBMD
F0D-U517B-10-P7 LID, ENGINE ROOM	0882	PURPLISH BLUE METALLIC D	PBMD
F0D-U517H-50-P1 LID, HATCH	0882	PURPLISH BLUE METALLIC D	PBMD
GU5-U518P-10-5E LOCKER STERN LID COMP.	GA5E	WHITE COAT 5	WC5
GU5-U518P-20-5E LOCKER STERN LID COMP.	GA5E	WHITE COAT 5	WC5
ENGINE	008P	BLACK SOLID 4	SS4

CONTENTS

CYLINDER. CRANKCASE	B2
CRANKSHAFT. PISTON	B4
INTAKE	B6
CARBURETOR	B8
OIL PUMP	B11
EXHAUST 1	B13
FUEL	C2
JET UNIT 1	C3
JET UNIT 2	C6
JET UNIT 3	C7
GENERATOR	C8
STARTING MOTOR	C9
ELECTRICAL 1	C10
ELECTRICAL 2	C13
ENGINE HATCH 1	C15
ENGINE HATCH 2	D2
HULL. DECK	D4
GUNWALE. MAT	D6
VENTILATION	D7
SEAT. UNDER LOCKER	D8

OIL TANK	D10
FUEL TANK	D11
EXHAUST 2	D13
CONTROL CABLE	D14
STEERING 1	E3
STEERING 2	E5
STERN HATCH	E6
STERN LOCKER	E7
GRAPHICS	E8
IMPORTANT LABELS	E9
IMPORTANT LABELS 2	E10
IMPORTANT LABELS 3	E11
REPAIR KIT 1	E12
REPAIR KIT 2	E14

INDEX

NUMERICAL INDEX	M1
-----------------------	----

FIG. 1 CYLINDER. CRANKCASE

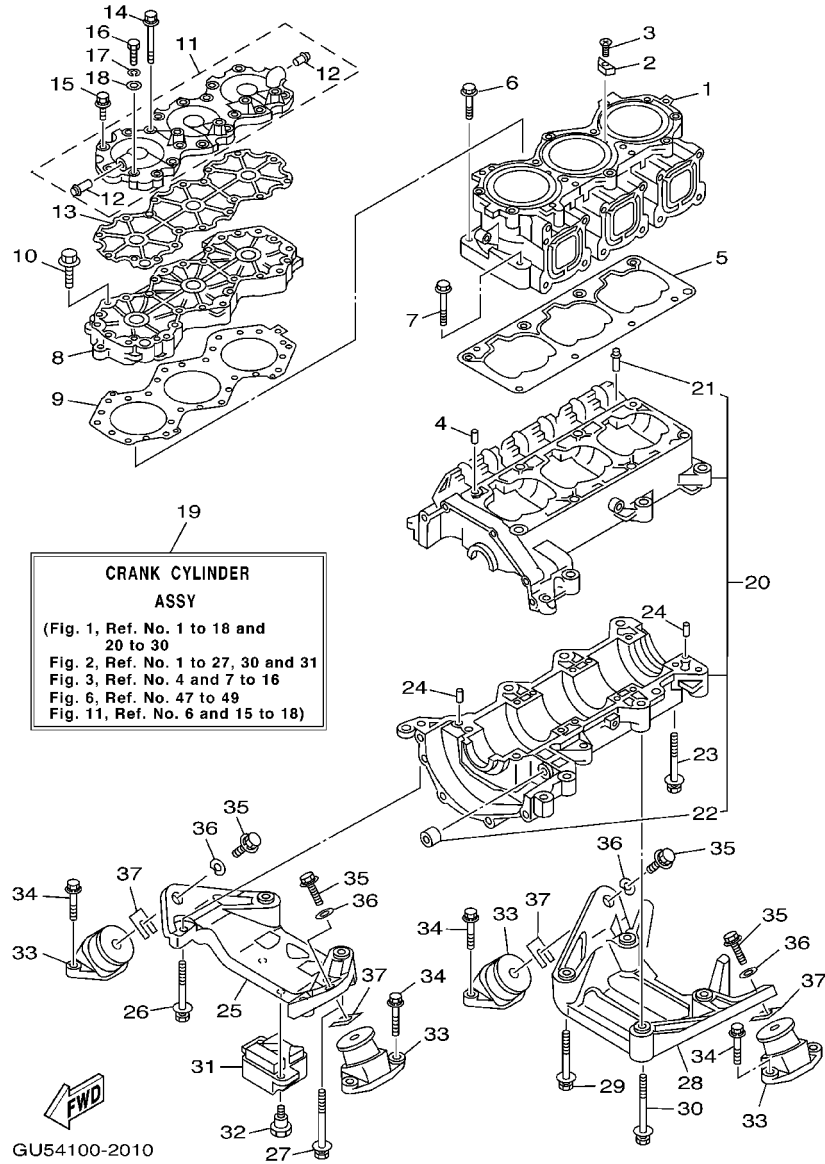

REF. NO.	PART NO.	DESCRIPTION	USA	CAN	GENE	JPN	REMARKS
1	65U-11311-00-94	CYLINDER 1	1	1	1	1	
2	6E5-11325-00	ANODE	2	2	2	2	
3	98780-04015	SCREW, FLAT HEAD	2	2	2	2	
4	93606-12019	PIN, DOWEL	2	2	2	2	
5	63M-11351-01	GASKET, CYLINDER	1	1	1	1	
6	90119-10M56	BOLT, WITH WASHER	6	6	6	6	
7	90119-10M07	BOLT, WITH WASHER	2	2	2	2	
8	65U-11111-00-94	HEAD, CYLINDER 1	1	1	1	1	
9	65U-11181-00	GASKET, CYLINDER HEAD 1	1	1	1	1	
10	90119-08M96	BOLT, WITH WASHER	10	10	10	10	
11	63M-11191-00-94	COVER, CYLINDER HEAD 1	1	1	1	1	
12	6K8-51129-00	.NIPPLE	2	2	2	2	
13	63M-11193-00	GASKET, HEAD COVER 1	1	1	1	1	
14	90119-08M95	BOLT, WITH WASHER	4	4	4	4	
15	90119-08M97	BOLT, WITH WASHER	13	13	13	13	
16	97013-06030	BOLT	2	2	2	2	
17	92903-06100	WASHER, SPRING	2	2	2	2	
18	92903-06600	WASHER, PLATE	2	2	2	2	
19	65U-W0090-03-8P	CRANK CYLINDER ASSY	1	1	1	1	
20	65U-15100-00-8P	CRANKCASE ASSY	1	1	1	1	
21	62T-14251-10	.NIPPLE	3	3	3	3	
22	90380-12M29	.BUSH, SOLID	1	1	1	1	
23	90119-08M55	BOLT, WITH WASHER	12	12	12	12	
24	93606-12019	PIN, DOWEL	2	2	2	2	
25	63M-21415-03-94	BRACKET, FRONT UPPER 1	1	1	1	1	
26	90119-10M02	BOLT, WITH WASHER	4	4	4	4	
27	90119-10M17	BOLT, WITH WASHER	1	1	1	1	

FIG. 1 CYLINDER. CRANKCASE

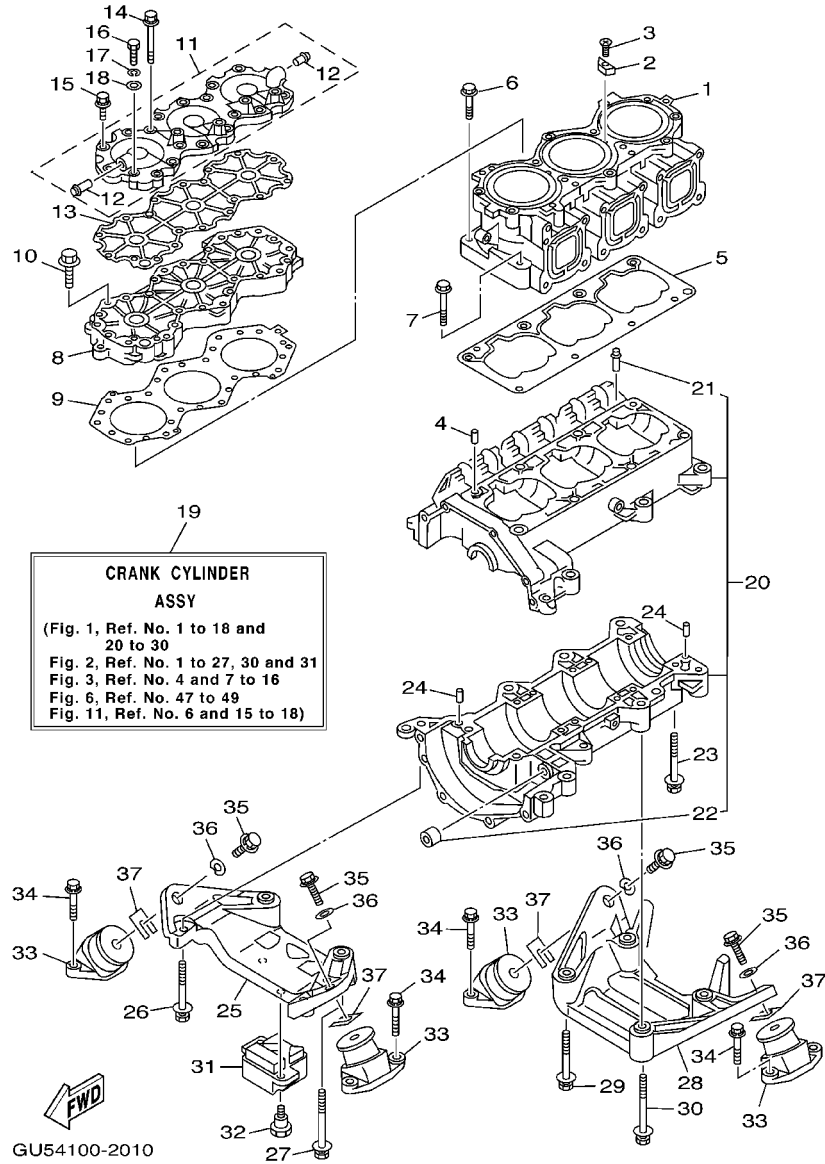

REF. NO.	PART NO.	DESCRIPTION	USA	CAN	GENE	JPN	REMARKS
28	63M-21425-01-94	BRACKET, REAR UPPER 1	1	1	1	1	
29	90119-10M02	BOLT, WITH WASHER	2	2	2	2	
30	90119-10M03	BOLT, WITH WASHER	2	2	2	2	
31	66G-44532-00	STOPPER, UPPER MOUNT	1	1	1	1	
32	90109-06M98	BOLT	2	2	2	2	
33	63M-44517-01-5B	MOUNT RUBBER	4	4	4	4	
34	90119-089U5	BOLT, WITH WASHER	8	8	8	8	YMUS
35	90119-089UR	BOLT, WITH WASHER	4	4	4	4	YMUS
36	90201-099U3	WASHER, PLATE	4	4	4	4	YMUS
37	EU0-U7354-00-01	SHIM (T=0.1)	10	10	10	10	UR, YMUS
	EU0-U7354-00-03	SHIM (T=0.3)	10	10	10	10	UR, YMUS
	EU0-U7354-00-05	SHIM (T=0.5)	10	10	10	10	UR, YMUS
	EU0-U7354-00-10	SHIM (T=1.0)	10	10	10	10	UR, YMUS
	EU0-U7354-00-20	SHIM (T=2.0)	10	10	10	10	UR, YMUS

FIG. 2 CRANKSHAFT. PISTON

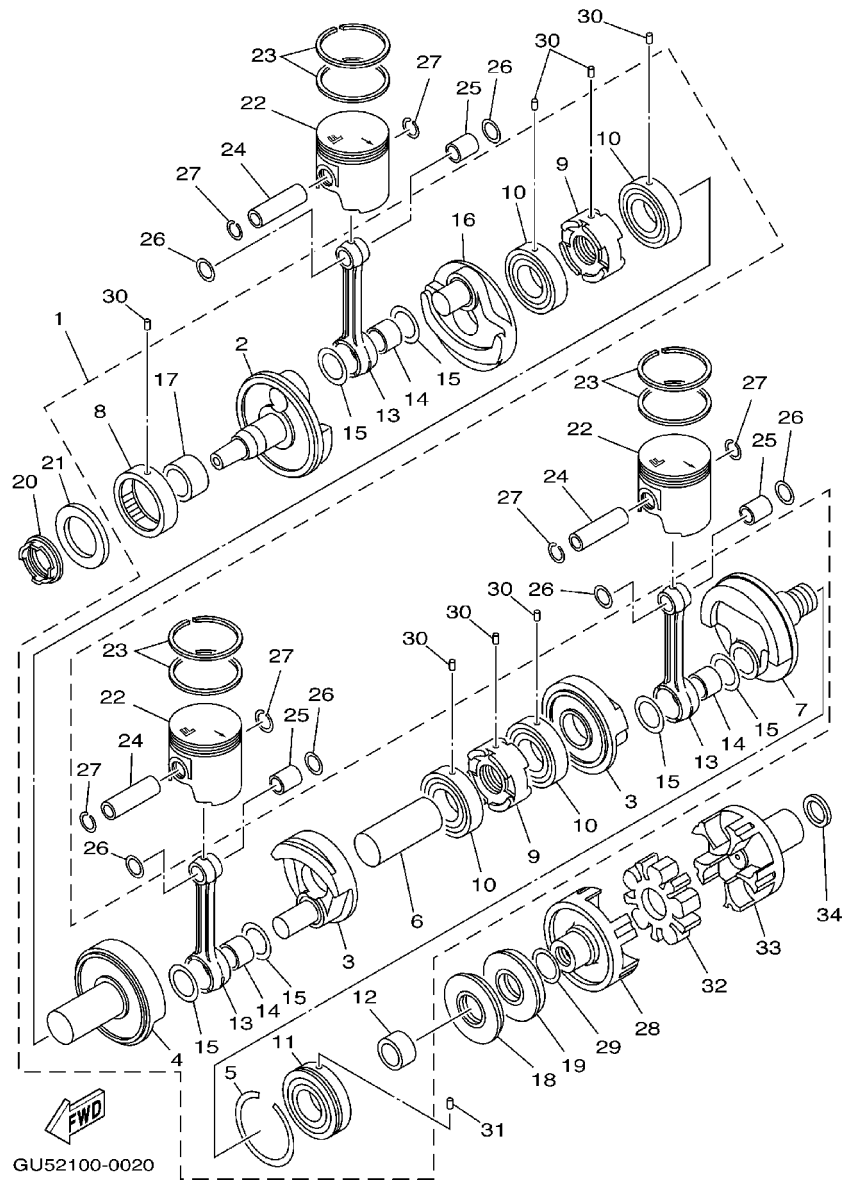

GU52100-0020

REF. NO.	PART NO.	DESCRIPTION	USA	CAN	GENE	JPN	REMARKS
1	65U-11400-00	CRANKSHAFT ASSY	1	1	1	1	
2	6M6-11412-00	.CRANK 1	1	1	1	1	
3	6M6-11422-00	.CRANK 2	2	2	2	2	
4	63M-11452-00	.CRANK 5	1	1	1	1	
5	93440-80023	.CIRCLIP	1	1	1	1	
6	6M6-11431-10	.CRANK 3	1	1	1	1	
7	6M6-11442-01	.CRANK 4	1	1	1	1	
8	93390-000U4	.BEARING	1	1	1	1	
9	65U-11515-00	.SEAL, LABYRINTH 1	2	2	2	2	
10	93306-207U2	.BEARING	4	4	4	4	
11	93306-307U3	.BEARING	1	1	1	1	
12	62T-45526-00	.COLLAR, DRIVE SHAFT	1	1	1	1	
13	64X-11651-01	.ROD, CONNECTING	3	3	3	3	
14	93310-525U4	.BEARING	3	3	3	3	
15	82M-11685-00	.WASHER, CRANK PIN	6	6	6	6	
16	65U-11422-00	.CRANK 2	1	1	1	1	
17	90387-32M02	.COLLAR	1	1	1	1	
18	93102-36M33	OIL SEAL	1	1	1	1	
19	93101-36M46	OIL SEAL	1	1	1	1	
20	93103-32M01	OIL SEAL	1	1	1	1	
21	65U-11445-00	SPACER	1	1	1	1	
22	65U-11631-02-90	PISTON (STD)	3	3	3	3	
	65U-11635-02	PISTON (0.25MM O/S)	3	3	3	3	AP
	65U-11636-02	PISTON (0.50MM O/S)	3	3	3	3	AP
23	65U-11603-01	PISTON RING SET (STD)	3	3	3	3	
	65U-11604-01	PISTON RING SET (0.25MM O/S)	3	3	3	3	AP
	65U-11605-01	PISTON RING SET (0.50MM O/S)	3	3	3	3	AP

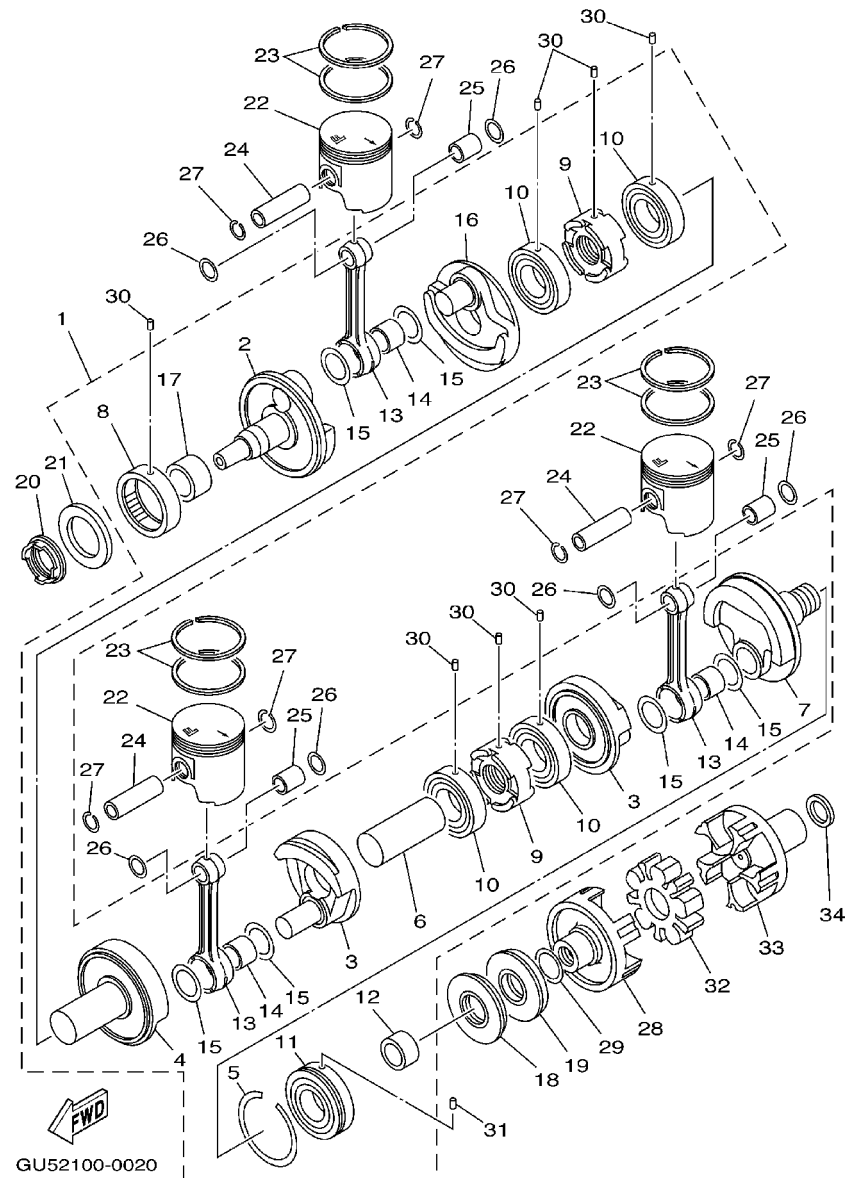

GU52100-0020

FIG. 2 CRANKSHAFT. PISTON

REF. NO.	PART NO.	DESCRIPTION	USA	CAN	GENE	JPN	REMARKS
24	62T-11633-00	PIN, PISTON	3	3	3	3	
25	93310-320U2	BEARING	3	3	3	3	
26	90201-20M04	WASHER, PLATE	6	6	6	6	
27	93450-21053	CIRCLIP	6	6	6	6	
28	63M-45813-01-8P	FLANGE, COUPLING	1	1	1	1	
29	62T-45127-00	SEAL	1	1	1	1	
30	93603-10049	PIN, DOWEL	7	7	7	7	
31	93604-07141	PIN, DOWEL	1	1	1	1	
32	63M-4581J-00	RUBBER SHAFT COUPLING	1	1	1	1	
33	64X-45813-00-8P	FLANGE, COUPLING	1	1	1	1	
34	90201-248M5	WASHER, PLATE	1	1	1	1	

FIG. 3 INTAKE

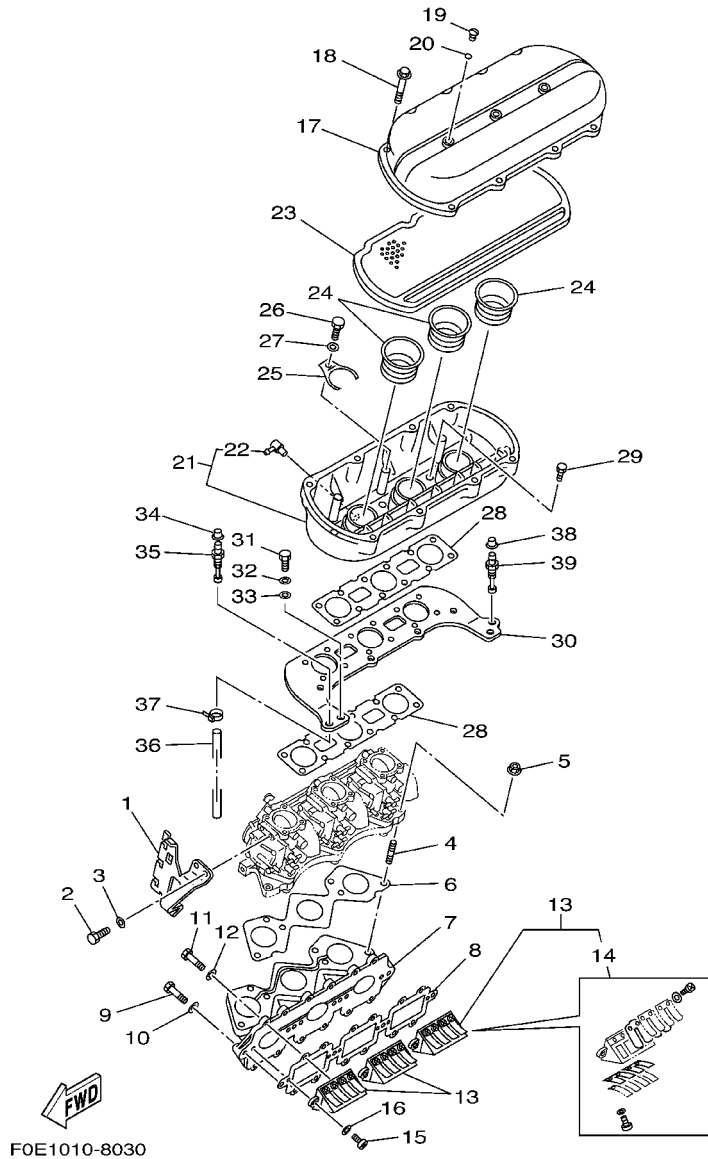

REF. NO.	PART NO.	DESCRIPTION	USA	CAN	GENE	JPN	REMARKS
1	65U-14527-01	PLATE	1	1	1	1	
2	97013-06016	BOLT	3	3	3	3	
3	92903-06600	WASHER, PLATE	3	3	3	3	
4	90116-08M60	BOLT, STUD	6	6	6	6	
5	90179-08M15	NUT	6	6	6	6	
6	65U-13556-00	GASKET, MANIFOLD	1	1	1	1	
7	65U-13555-00-8P	MANIFOLD, INTAKE	1	1	1	1	
8	65U-13566-00	GASKET	1	1	1	1	
9	97013-06035	BOLT	4	4	4	4	
10	92903-06600	WASHER, PLATE	4	4	4	4	
11	97013-06025	BOLT	12	12	12	12	
12	92903-06600	WASHER, PLATE	12	12	12	12	
13	65U-13610-00	REED VALVE ASSY	3	3	3	3	
14	65U-W0004-00	.REED SET	1	1	1	1	
15	97880-05016	SCREW, PAN HEAD	6	6	6	6	
16	92990-05600	WASHER, PLATE	6	6	6	6	
17	65U-14283-00	COVER, CARBURETOR 1	1	1	1	1	
18	90109-05MA0	BOLT	8	8	8	8	
19	62T-14435-00	GROMMET	3	3	3	3	
20	93210-13M63	O-RING	3	3	3	3	
21	65U-14284-02-8P	COVER, CARBURETOR 2	1	1	1	1	
22	6E5-13552-00	.NOZZLE	3	3	3	3	
23	65U-14451-00	ELEMENT, AIR CLEANER	1	1	1	1	
24	65U-14469-00	FUNNEL, AIR	3	3	3	3	
25	65U-14477-00	PLATE	3	3	3	3	
26	97095-05010	BOLT	3	3	3	3	
27	92995-05600	WASHER	3	3	3	3	

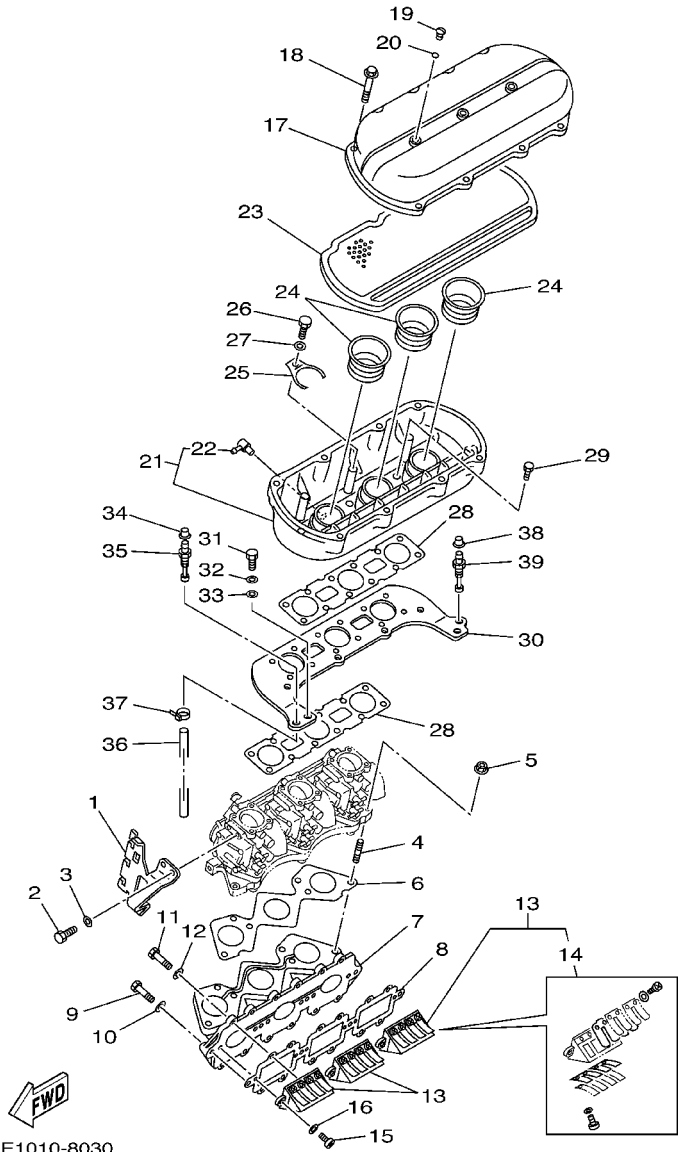

FOE1010-8030

FIG. 3 INTAKE

REF. NO.	PART NO.	DESCRIPTION	USA	CAN	GENE	JPN	REMARKS
28	65U-13674-00	GASKET, AIR COOLER COVER 1	2	2	2	2	
29	90109-06M76	BOLT	12	12	12	12	
30	65U-14255-00	PLATE	1	1	1	1	
31	97013-06014	BOLT	2	2	2	2	
32	92903-06600	WASHER, PLATE	2	2	2	2	
33	90201-06M31	WASHER, PLATE	2	2	2	2	
34	663-45119-00	CAP, GREASE NIPPLE	1	1	1	1	
35	61L-5169A-00	NIPPLE, GREASE	1	1	1	1	
36	90445-09M31	HOSE (L250)	1	1	1	1	
37	90465-11M10	CLAMP	2	2	2	2	
38	663-45119-00	CAP, GREASE NIPPLE	1	1	1	1	
39	61L-5169A-00	NIPPLE, GREASE	1	1	1	1	

FIG. 4 CARBURETOR

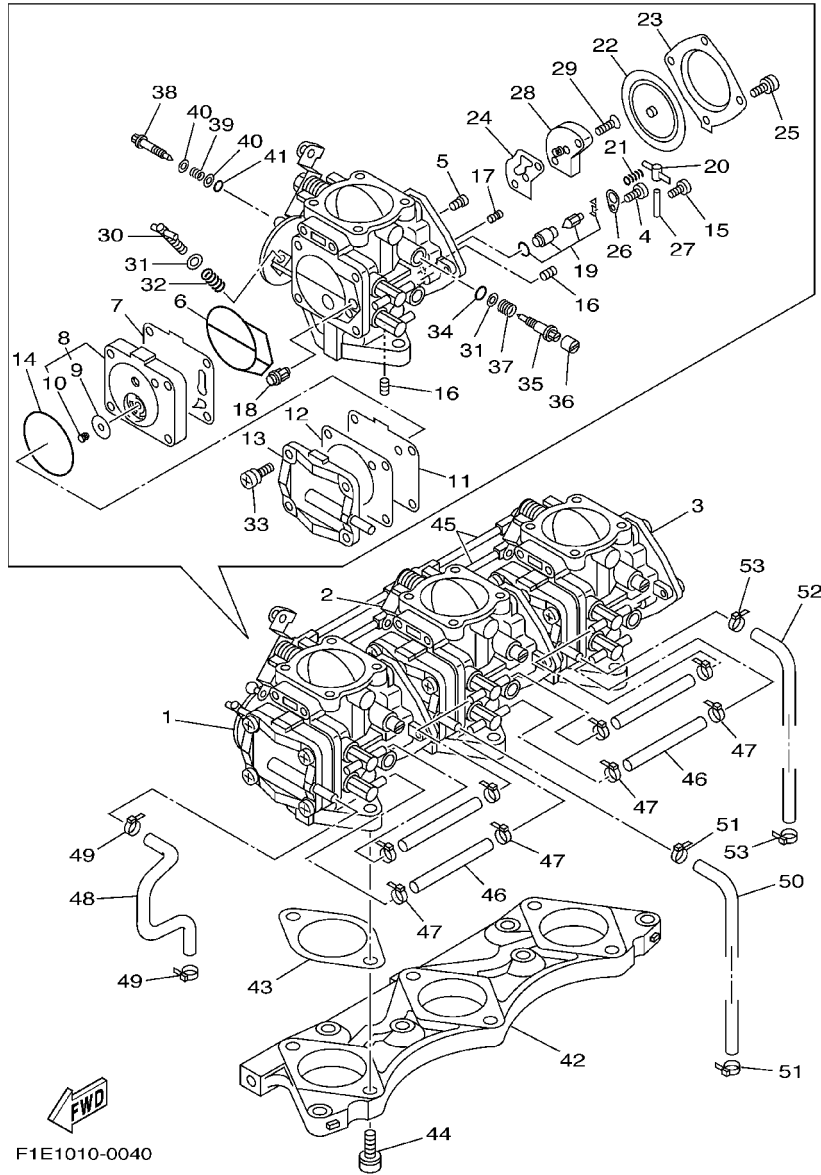

F1E1010-0040

REF. NO.	PART NO.	DESCRIPTION	USA	CAN	GENE	JPN	REMARKS
1	66G-14301-02	CARBURETOR ASSY 1	1	1	1	1	
2	66G-14302-02	CARBURETOR ASSY 2	1	1	1	1	
3	66G-14303-02	CARBURETOR ASSY 3	1	1	1	1	
4	6M6-14503-00	.SCREW	3	3	3	3	
5	3G2-14231-27	.JET, MAIN (#135)	3	3	3	3	
6	6K8-14564-00	.O-RING	3	3	3	3	
7	6K8-24411-20	.DIAPHRAGM	3	3	3	3	
8	6M6-24413-01	.BODY 2	3	3	3	3	
9	65U-24421-00	..VALVE, CHECK	2	2	2	2	
10	65U-24492-00	..BUSH, FULEL PUMP	2	2	2	2	
11	6K8-24421-10	.VALVE, CHECK	3	3	3	3	
12	6K8-24431-20	.GASKET, FUEL PUMP 1	3	3	3	3	
13	6K8-24452-10	.COVER	3	3	3	3	
14	6K8-14563-00	.O-RING	3	3	3	3	
15	6K8-14503-02	.SCREW	3	3	3	3	
16	6K8-14521-10	.SCREW	6	6	6	6	
17	830-14231-20	.JET, MAIN (#100)	1	1	1	1	UR CARBURETOR 1
	830-14231-19	.JET, MAIN (# 95)	1	1	1	1	UR CARBURETOR 2
	830-1423A-70	.JET, MAIN (#97.5)	1	1	1	1	UR CARBURETOR 3
18	6R7-14569-00	.STRAINER	3	3	3	3	
19	64T-14916-01	.NEEDLE	3	3	3	3	
20	6K8-14547-01	.ARM, FLOAT	3	3	3	3	
21	63M-14253-00	.SPRING	3	3	3	3	
22	6R7-14541-00	.DIAPHRAGM, PUMP	3	3	3	3	
23	6R7-14542-00	.BODY, PUMP 1	3	3	3	3	
24	6K8-14536-11	.GASKET	3	3	3	3	
25	6K8-14591-10	.SCREW	12	12	12	12	

FIG. 4 CARBURETOR

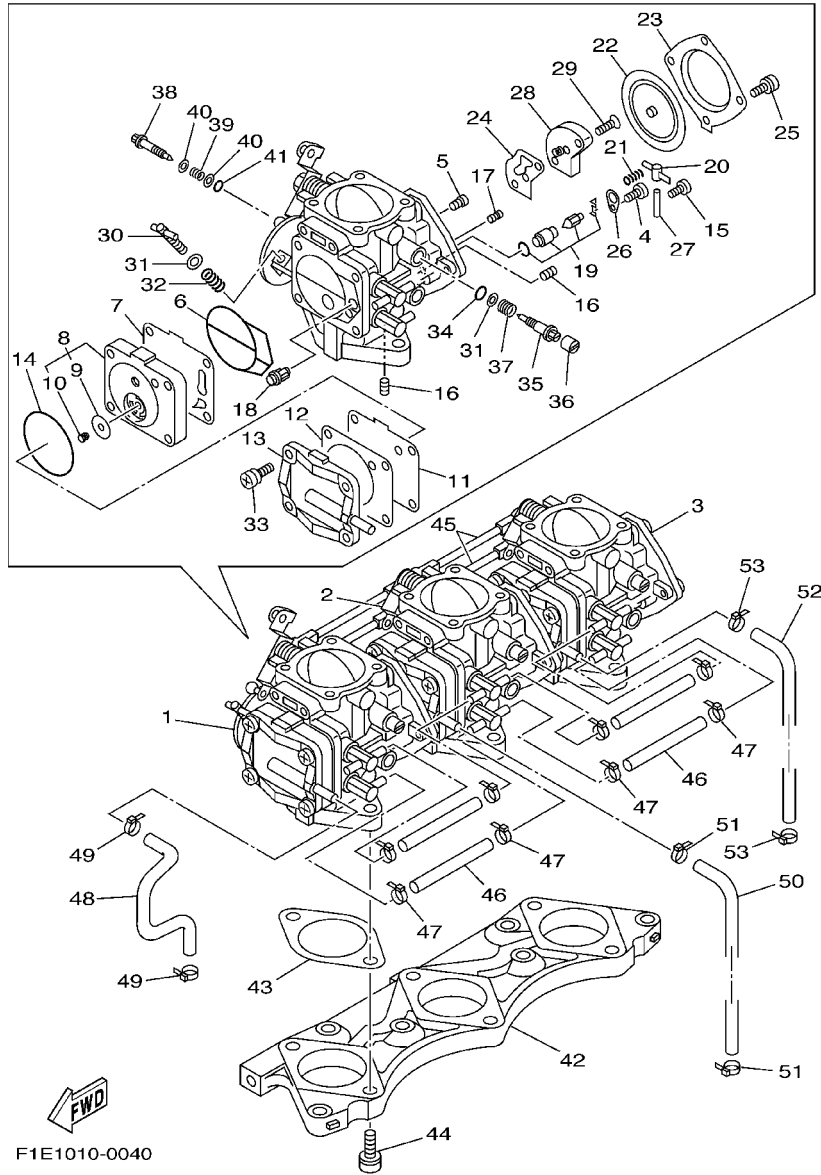

F1E1010-0040

REF. NO.	PART NO.	DESCRIPTION	USA	CAN	GENE	JPN	REMARKS
26	6K8-14527-11	.PLATE	3	3	3	3	
27	439-14186-00	.PIN, FLOAT	3	3	3	3	
28	6R7-24412-01	.BODY 1	3	3	3	3	
29	6K8-14523-11	.SCREW, STOP	6	6	6	6	
30	6M6-14521-01	.SCREW, ADJUST	1	1	1	1	CARBURETOR 1
31	812-14235-00	.WASHER, NEEDLE	4	4	4	4	
32	47X-14133-00	.SPRING, THROTTLE STOP	1	1	1	1	CARBURETOR 1
33	97980-05330	.SCREW, WITH WASHER	12	12	12	12	
34	812-14147-00	.O-RING	3	3	3	3	
35	6K8-14946-10	.METERING NEEDLE	3	3	3	3	
36	6K8-14471-10	.CAP, CARBURETOR	3	3	3	3	
37	3KW-14932-00	.SPRING, THROTTLE 2	3	3	3	3	
38	65U-14923-10	.SCREW, PILOT	3	3	3	3	
39	6K8-14589-00	.SPRING	3	3	3	3	
40	822-14235-00	.WASHER, NEEDLE	6	6	6	6	
41	583-14561-00	.O-RING	3	3	3	3	
42	65U-14243-00	PLATE	1	1	1	1	
43	64X-14398-00	GASKET	3	3	3	3	
44	64X-14162-00	BOLT, HOLDING	6	6	6	6	
45	65U-41217-00	ROD, ACCEL LEVER	1	1	1	1	
46	90445-11M64	HOSE (L105)	4	4	4	4	
47	90465-11M10	CLAMP	8	8	8	8	
48	65U-24315-01	PIPE 5	1	1	1	1	
49	90465-11M10	CLAMP	2	2	2	2	
50	65U-24314-01	PIPE 4	1	1	1	1	
51	90465-11M10	CLAMP	2	2	2	2	
52	65U-24314-01	PIPE 4	1	1	1	1	

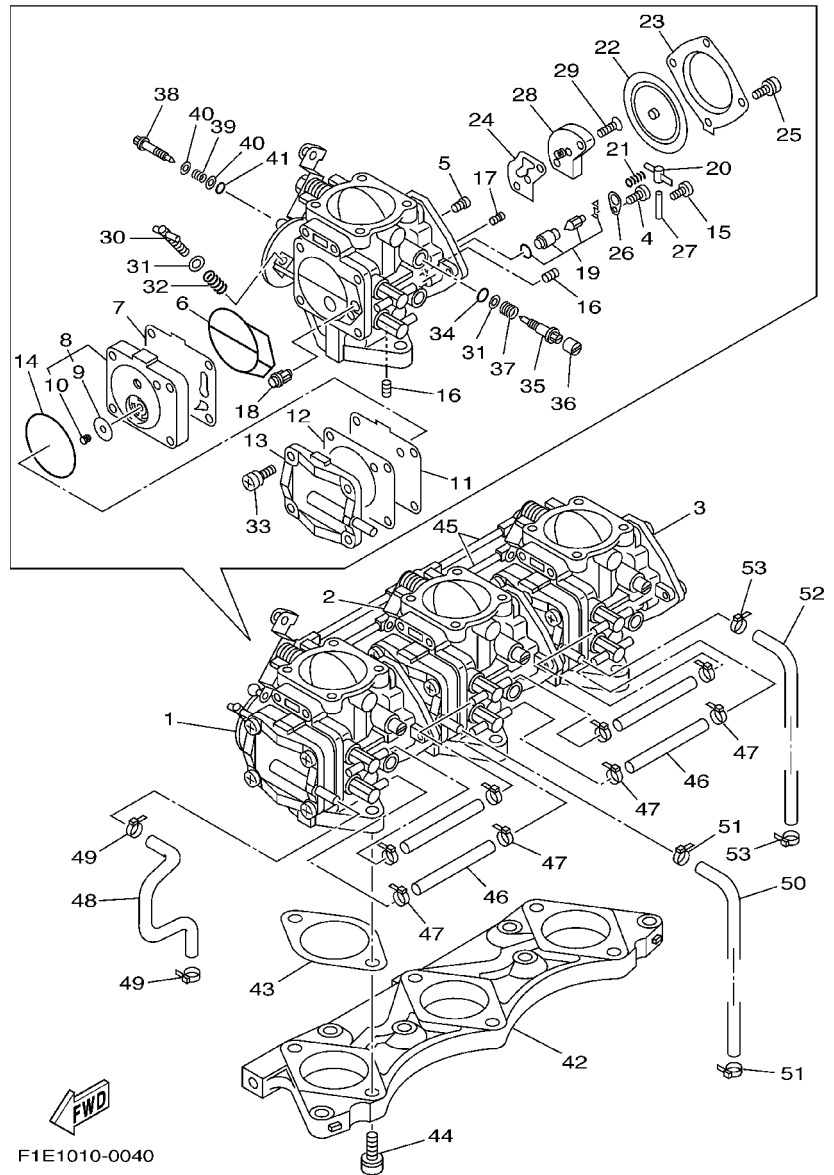
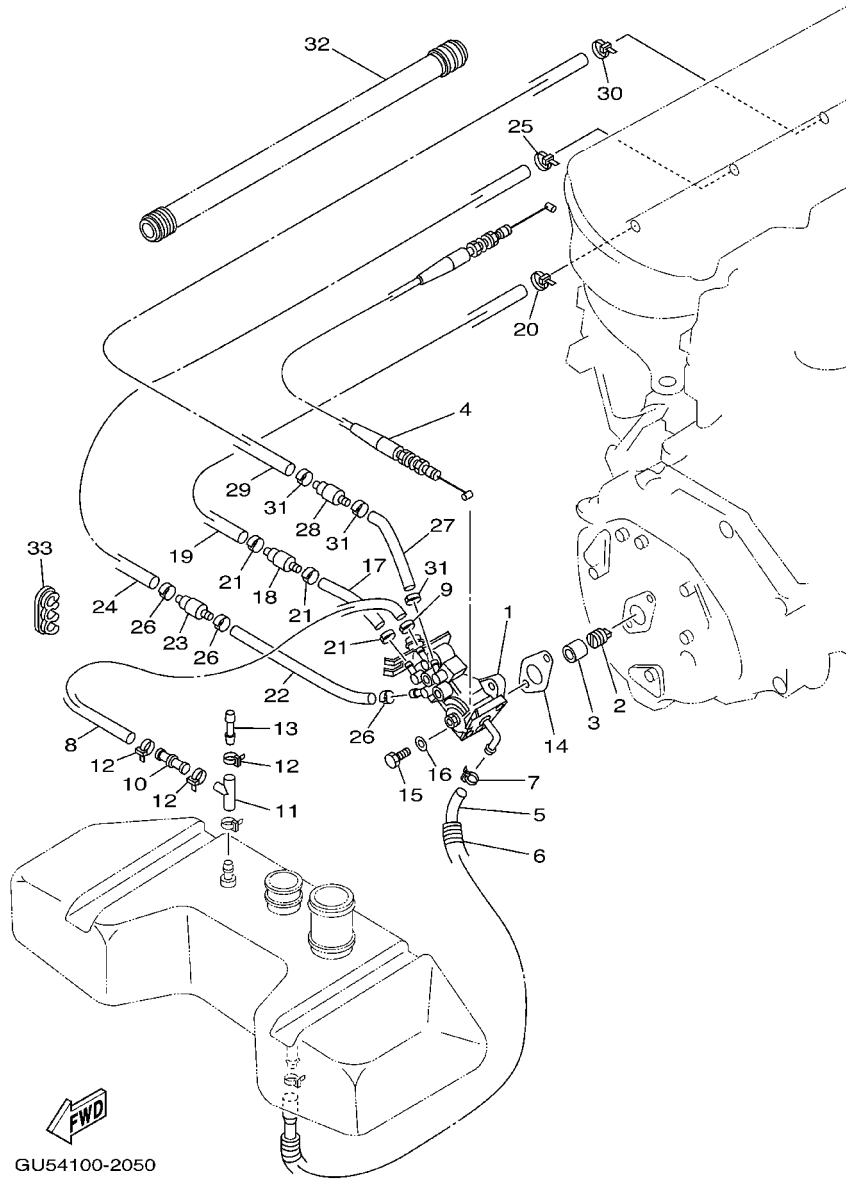

FIG. 4 CARBURETOR

REF. NO.	PART NO.	DESCRIPTION	USA	CAN	GENE	JPN	REMARKS
53	90465-11M10	CLAMP	2	2	2	2	

FIG. 5 OIL PUMP



GU54100-2050

REF. NO.	PART NO.	DESCRIPTION	USA	CAN	GENE	JPN	REMARKS
1	66G-13200-01	OIL INJECTION PUMP ASSY	1	1	1	1	
2	65U-13132-00	JOINT	1	1	1	1	
3	65U-13554-00	RING, RUBBER	1	1	1	1	
4	66H-26320-00	PUMP CABLE ASSY	1	1	1	1	
5	66G-13416-00	PIPE, OIL 1	1	1	1	1	
6	90446-17M72	HOSE	1	1	1	1	
7	90465-11M10	CLAMP	1	1	1	1	
8	90445-07M11	HOSE (L610)	1	1	1	1	
9	90468-02001	CLIP	1	1	1	1	
10	63M-13132-00	JOINT	1	1	1	1	
11	63M-24378-00	PIPE, JOINT 4	1	1	1	1	
12	90465-11M10	CLAMP	2	2	2	2	
13	6G8-24376-00	PIPE, JOINT 1	1	1	1	1	
14	63M-13116-00	GASKET, PUMP CASE	1	1	1	1	
15	97095-06020	BOLT	2	2	2	2	
16	92995-06600	WASHER	2	2	2	2	
17	90445-07007	HOSE	1	1	1	1	
18	67X-13183-00	VALVE, CHECK	1	1	1	1	
19	90446-07M35	HOSE	1	1	1	1	
20	90465-11M10	CLAMP	1	1	1	1	
21	90468-02001	CLIP	3	3	3	3	
22	90445-07007	HOSE	1	1	1	1	
23	67X-13183-00	VALVE, CHECK	1	1	1	1	
24	90446-07M36	HOSE	1	1	1	1	
25	90465-11M10	CLAMP	1	1	1	1	
26	90468-02001	CLIP	3	3	3	3	
27	90445-07007	HOSE	1	1	1	1	

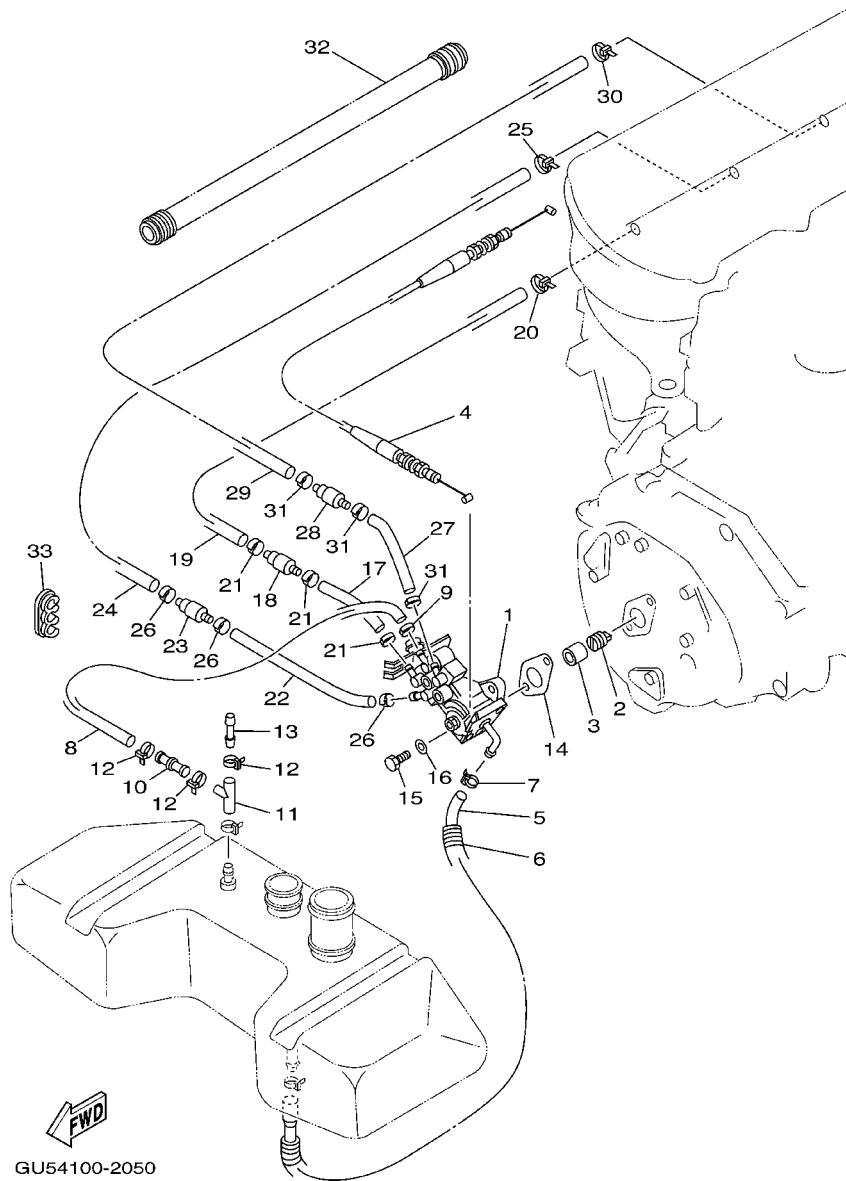

GU54100-2050

FIG. 5 OIL PUMP

REF. NO.	PART NO.	DESCRIPTION	USA	CAN	GENE	JPN	REMARKS
28	67X-13183-00	VALVE, CHECK	1	1	1	1	
29	90446-07M74	HOSE	1	1	1	1	
30	90465-11M10	CLAMP	1	1	1	1	
31	90468-02001	CLIP	3	3	3	3	
32	90446-24M79	HOSE	1	1	1	1	
33	90464-07M05	CLAMP	1	1	1	1	

FIG. 6 EXHAUST 1

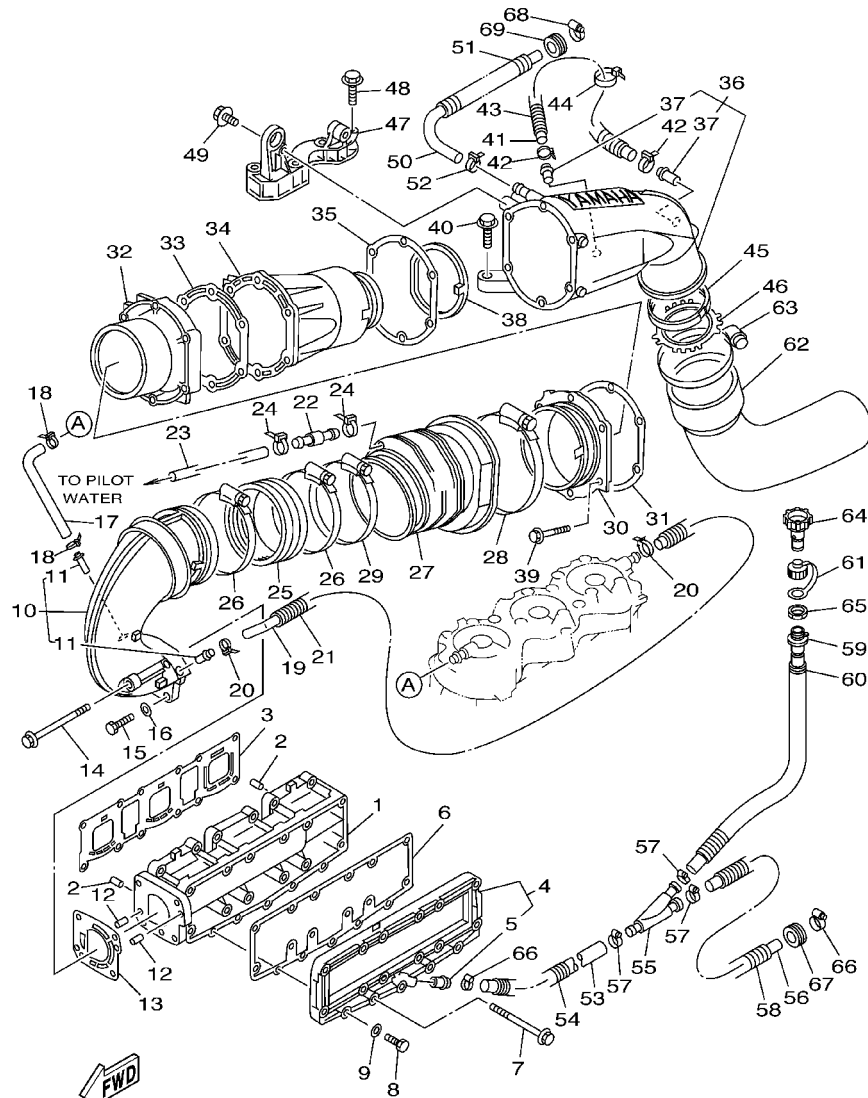

GU53100-1060

REF. NO.	PART NO.	DESCRIPTION	USA	CAN	GENE	JPN	REMARKS
1	63M-14711-00-94	MUFFLER 1	1	1	1	1	
2	93605-12M21	PIN, DOWEL	2	2	2	2	
3	65U-14613-00	GASKET, EXHAUST PIPE	1	1	1	1	
4	63M-14718-00-9P	PROTECTOR, MUFFLER 1	1	1	1	1	
5	63M-51129-00	.NIPPLE	1	1	1	1	
6	63M-14739-00	GASKET, MUFFLER DAMPER 1	1	1	1	1	
7	90119-08M98	BOLT, WITH WASHER	12	12	12	12	
8	97095-06030	BOLT	5	5	5	5	
9	92995-06600	WASHER	5	5	5	5	
10	63M-14712-00-9P	RING, JOINT	1	1	1	1	
11	6K8-51129-00	.NIPPLE	2	2	2	2	
12	93605-12M21	PIN, DOWEL	2	2	2	2	
13	63M-14749-00	GASKET, MUFFLER DAMPER 2	1	1	1	1	
14	90119-08M02	BOLT, WITH WASHER	2	2	2	2	
15	97013-08030	BOLT	2	2	2	2	
16	92903-08600	WASHER, PLATE	2	2	2	2	
17	63M-12576-00	HOSE 1	1	1	1	1	
18	90450-14M05	HOSE CLAMP ASSY	2	2	2	2	
19	63M-12577-00	HOSE 2	1	1	1	1	
20	90450-14M05	HOSE CLAMP ASSY	2	2	2	2	
21	90446-20M53	HOSE	1	1	1	1	
22	6R3-24377-00	PIPE, JOINT 3	1	1	1	1	
23	90445-14M22	HOSE (L1300)	1	1	1	1	
24	90465-11M10	CLAMP	2	2	2	2	
25	62T-14625-00	JOINT, EXHAUST 2	1	1	1	1	
26	90450-99M06	HOSE CLAMP ASSY	2	2	2	2	
27	63M-14615-00	JOINT, EXHAUST 1	1	1	1	1	

FIG. 6 EXHAUST 1

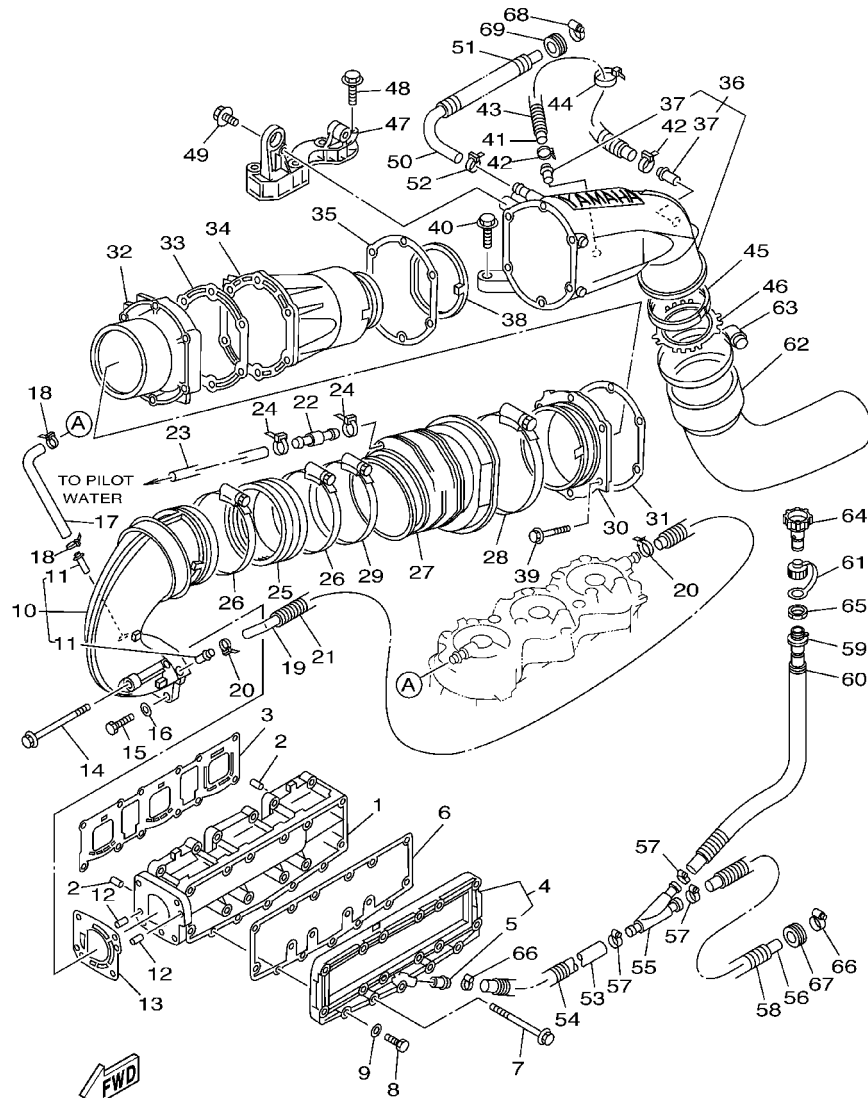

GU53100-1060

REF. NO.	PART NO.	DESCRIPTION	USA	CAN	GENE	JPN	REMARKS
28	90450-99M16	HOSE CLAMP ASSY	1	1	1	1	
29	90450-99M02	HOSE CLAMP ASSY	1	1	1	1	
30	63M-41113-00-94	OUTER COVER, EXHAUST	1	1	1	1	
31	63M-41114-00	GASKET, EXHAUST OUTER COVER	1	1	1	1	
32	63M-14721-00-94	MUFFLER 2	1	1	1	1	
33	63M-41122-00	GASKET, EXHAUST INNER COVER	1	1	1	1	
34	63M-41121-00-94	INNER COVER, EXHAUST	1	1	1	1	
35	63M-41114-00	GASKET, EXHAUST OUTER COVER	1	1	1	1	
36	63M-41123-00-94	OUTER COVER, EXHAUST	1	1	1	1	
37	6K8-51129-00	.NIPPLE	2	2	2	2	
38	63M-15761-00	SEAL, RUBBER 1	1	1	1	1	
39	90105-08M66	BOLT, FLANGE	6	6	6	6	
40	90105-10M60	BOLT, FLANGE	2	2	2	2	
41	90445-14M05	HOSE (L240)	1	1	1	1	
42	90465-11M10	CLAMP	2	2	2	2	
43	90446-20M39	HOSE	1	1	1	1	
44	90465-13M24	CLAMP	1	1	1	1	
45	63M-41138-00	SEAL, EXT. 1	1	1	1	1	
46	63M-14680-00	STOPPER	1	1	1	1	
47	63M-14771-00-94	STAY, MUFFLER 1	1	1	1	1	
48	90119-10M17	BOLT, WITH WASHER	4	4	4	4	
49	90105-10M88	BOLT, FLANGE	2	2	2	2	
50	66G-12578-00	HOSE 3	1	1	1	1	
51	90446-30MF1	HOSE	1	1	1	1	
52	90450-22M14	HOSE CLAMP ASSY	1	1	1	1	
53	90445-18M13	HOSE (L350)	1	1	1	1	
54	90446-24M54	HOSE	1	1	1	1	

FIG. 6 EXHAUST 1

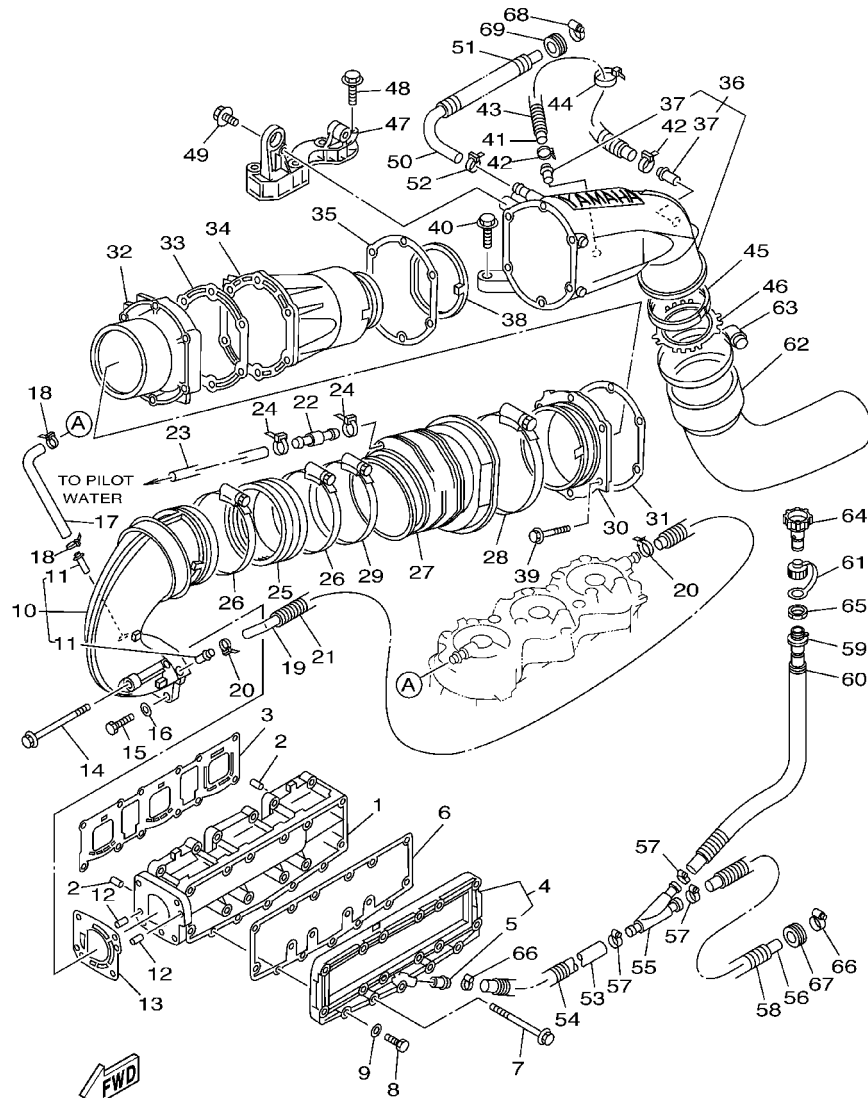

GU53100-1060

REF. NO.	PART NO.	DESCRIPTION	USA	CAN	GENE	JPN	REMARKS
55	63M-12581-00	JOINT, HOSE 1	1	1	1	1	
56	90445-18M14	HOSE (L600)	1	1	1	1	
57	90450-18M09	HOSE CLAMP ASSY	3	3	3	3	
58	90446-24M89	HOSE	1	1	1	1	
59	64T-12580-00	JOINT ASSY	1	1	1	1	
60	90446-24M89	HOSE	1	1	1	1	
61	682-84385-01	CAP,1	1	1	1	1	
62	66G-14752-00	PIPE, OUTLET	1	1	1	1	
63	90450-99M02	HOSE CLAMP ASSY	1	1	1	1	
64	67X-12590-00	CONDUCTION ASSY	1				FOR USA
	67X-12590-20	CONDUCTION ASSY		1	1		FOR CAN,GENE
	67X-12590-10	CONDUCTION ASSY				1	FOR JPN
65	EU0-61652-00	NUT	1	1	1	1	
66	90601-118UF	BAND, HOSE 18	2	2	2	2	YMUS
67	90480-329U2	GROMMET	1	1	1	1	YMUS
68	90601-118UF	BAND, HOSE 18	1	1	1	1	YMUS
69	90480-329U2	GROMMET	1	1	1	1	YMUS

FIG. 7 FUEL

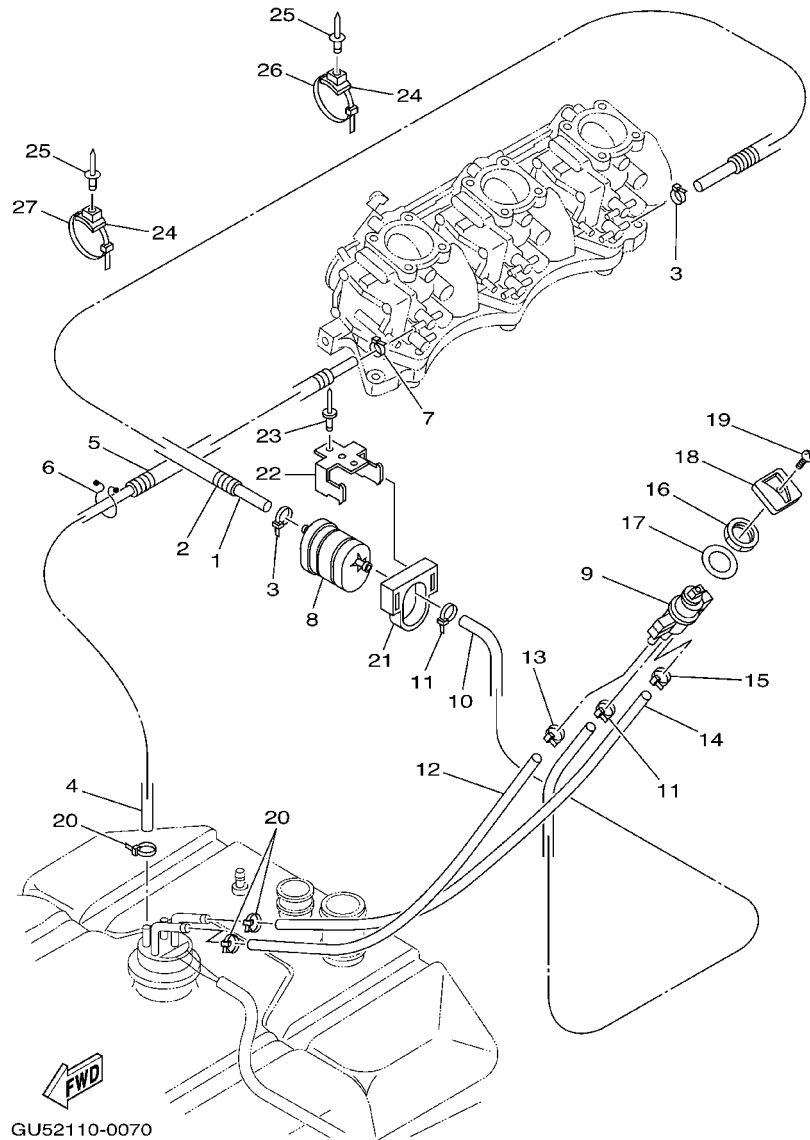

GU52110-0070

REF. NO.	PART NO.	DESCRIPTION	USA	CAN	GENE	JPN	REMARKS
1	90445-11M59	HOSE (L1400)	1	1	1	1	
2	90446-17MA7	HOSE	1	1	1	1	
3	90465-11M10	CLAMP	2	2	2	2	
4	90445-11M60	HOSE (L910)	1	1	1	1	
5	90446-17MA8	HOSE	1	1	1	1	
6	90464-13M54	CLAMP	1	1	1	1	
7	90465-11M10	CLAMP	1	1	1	1	
8	66V-24560-00	FILTER ASSY	1	1	1	1	
9	66V-24500-02	FUEL COCK ASSY 1	1	1	1	1	
10	90445-11M63	HOSE (L740)	1	1	1	1	
11	90465-11M10	CLAMP	2	2	2	2	
12	90445-11M61	HOSE (L600)	1	1	1	1	
13	90465-11M10	CLAMP	1	1	1	1	
14	90445-11M62	HOSE (L600)	1	1	1	1	
15	90465-11M10	CLAMP	1	1	1	1	
16	90170-22187	NUT	1	1	1	1	
17	90202-229U1	WASHER, PLATE	1	1	1	1	YMUS
18	F0D-6777C-00	LEVER, COCK	1	1	1	1	
19	98980-04008	SCREW, BIND	1	1	1	1	
20	90465-11829	CLAMP	3	3	3	3	YMUS
21	EU0-67817-00	HOLDER	1	1	1	1	
22	EU0-67816-30	BRACKET, FUEL FILTER	1	1	1	1	
23	90267-489U2	RIVET, BLIND	2	2	2	2	YMUS
24	90600-917U4	CLAMP COMP.	6	6	6	6	YMUS
25	90267-48802	RIVET, BLIND	6	6	6	6	YMUS
26	90464-32801	CLAMP	5	5	5	5	YMUS
27	90601-200U2	BAND	1	1	1	1	YMUS

FIG. 8 JET UNIT 1

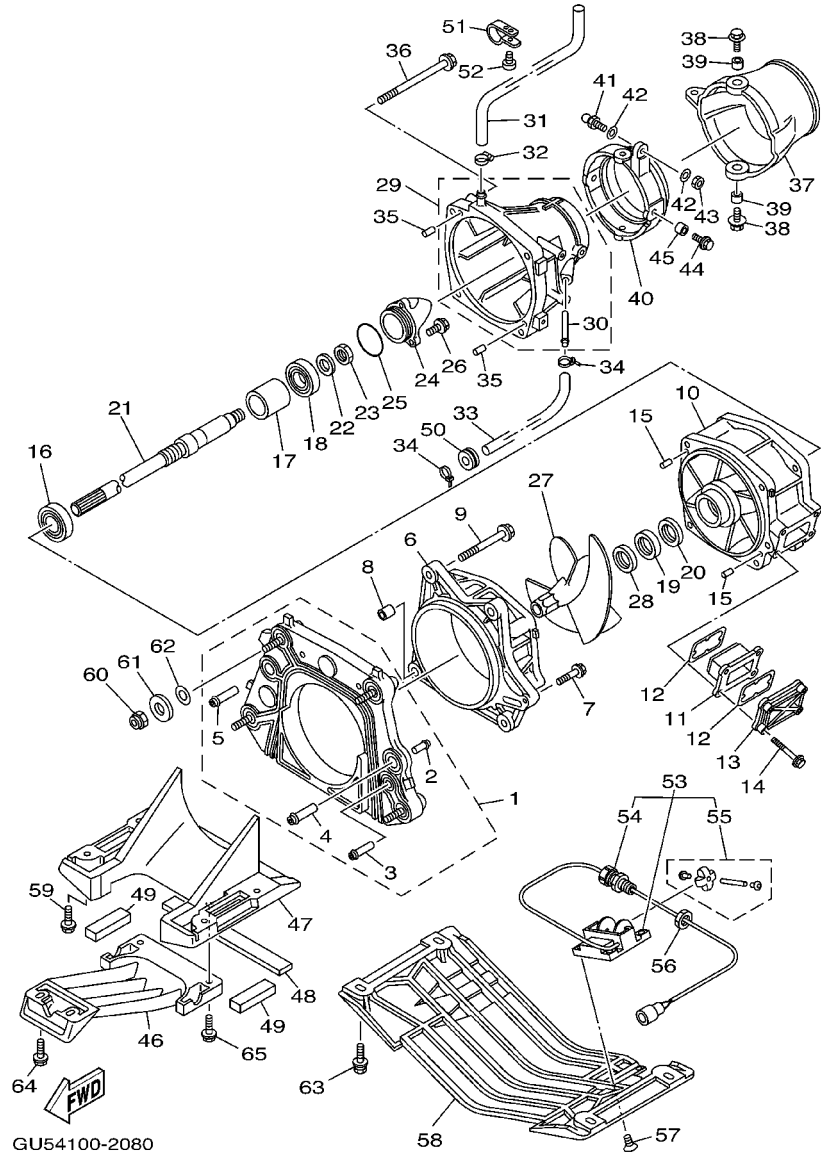

REF. NO.	PART NO.	DESCRIPTION	USA	CAN	GENE	JPN	REMARKS
1	66G-G5831-02	PLATE, TRANSOM	1	1	1	1	
2	65A-R1129-00	.NIPPLE	1	1	1	1	YMUS
3	66G-51129-00	.NIPPLE	1	1	1	1	
4	66V-51129-10	.NIPPLE	1	1	1	1	
5	66G-51129-10	.NIPPLE	1	1	1	1	
6	66V-51312-01-94	HOUSING, IMPELLER	1	1	1	1	
7	90119-06835	BOLT, WITH WASHER	1	1	1	1	YMUS
8	99590-14016	PIN, DOWEL	2	2	2	2	
9	90119-10836	BOLT, WITH WASHER	4	4	4	4	YMUS
10	66V-51315-00-94	DUCT, IMPELLER	1	1	1	1	
11	66V-46882-00	FILTER	1	1	1	1	
12	66V-42414-00	O-RING	2	2	2	2	
13	66V-45214-00-94	COVER, WATER INLET	1	1	1	1	
14	90119-06800	BOLT, WITH WASHER	4	4	4	4	YMUS
15	93606-12019	PIN, DOWEL	2	2	2	2	
16	93306-205U0	BEARING	1	1	1	1	
17	65V-45538-00	SPACER 1	1	1	1	1	
18	93306-304U1	BEARING	1	1	1	1	
19	93101-28M66	OIL SEAL	1	1	1	1	
20	93101-28M65	OIL SEAL	1	1	1	1	
21	68Y-45511-00	SHAFT, DRIVE	1	1	1	1	
22	9299R-16600	WASHER	1	1	1	1	YMUS
23	9531P-16700	NUT	1	1	1	1	YMUS
24	65A-R1326-00	CAP	1	1	1	1	YMUS
25	93210-46M16	O-RING	1	1	1	1	
26	90119-069UB	BOLT, WITH WASHER	3	3	3	3	YMUS
27	66G-R1321-00	IMPELLER	1	1	1	1	YMUS

FIG. 8 JET UNIT 1

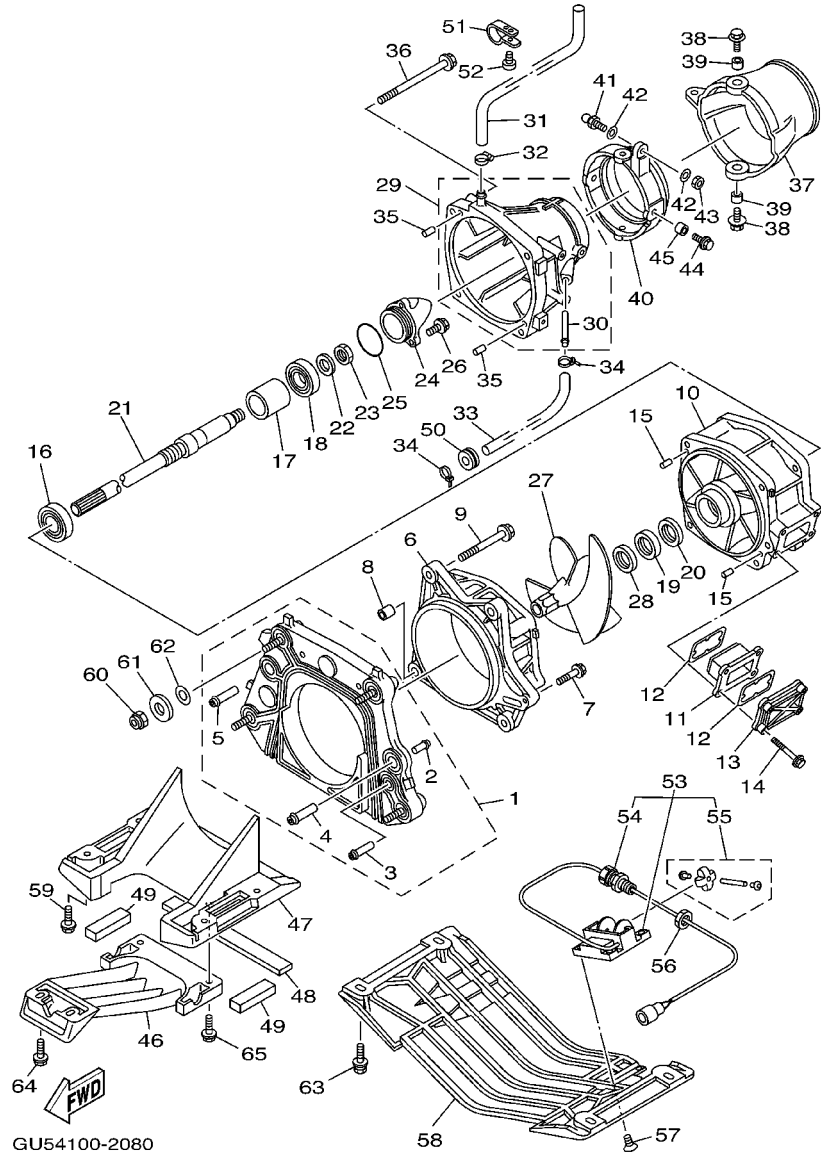

REF. NO.	PART NO.	DESCRIPTION	USA	CAN	GENE	JPN	REMARKS
28	66V-R1348-10	SPACER	1	1	1	1	YMUS
29	66V-51318-00-94	NOZZLE	1	1	1	1	
30	63M-51334-00	.NIPPLE,HOSE	1	1	1	1	
31	90445-16M08	HOSE (L450)	1	1	1	1	
32	90601-118UF	BAND, HOSE 18	1	1	1	1	YMUS
33	90445-14898	HOSE (L270)	1	1	1	1	YMUS
34	90465-11829	CLAMP	2	2	2	2	YMUS
35	93606-12019	PIN, DOWEL	2	2	2	2	
36	90119-10837	BOLT, WITH WASHER	4	4	4	4	YMUS
37	66V-R1313-01	NOZZLE,DEFLECTOR	1	1	1	1	YMUS
38	90119-089UE	BOLT, WITH WASHER	2	2	2	2	YMUS
39	90387-08M06	COLLAR	2	2	2	2	
40	66G-51190-00-94	RING,TRIM	1	1	1	1	
41	GH3-U146E-00	STUD, JOINT BALL	1	1	1	1	YMUS
42	90201-068M4	WASHER, PLATE	2	2	2	2	YMUS
43	9538R-06700	NUT	1	1	1	1	YMUS
44	90119-089UE	BOLT, WITH WASHER	2	2	2	2	YMUS
45	90387-08M06	COLLAR	2	2	2	2	
46	66V-51333-00-94	SCREEN, INTAKE	1	1	1	1	
47	66V-51311-00-94	DUCT, INTAKE	1	1	1	1	
48	66V-51367-00	FELT, PACKING	1	1	1	1	
49	66V-51368-00	FELT, PACKING	1	1	1	1	
50	90480-279U1	GROMMET	1	1	1	1	YMUS
51	90600-918U3	CLIP, NYLON 18	1	1	1	1	YMUS
52	97780-50520	SCREW, TAPPING	1	1	1	1	
53	GJ1-U8K31-02	SENSOR SPEED	1	1	1	1	YMUS
54	EU0-67267-20	.CONNECTOR, CABLE	1	1	1	1	

FIG. 8 JET UNIT 1

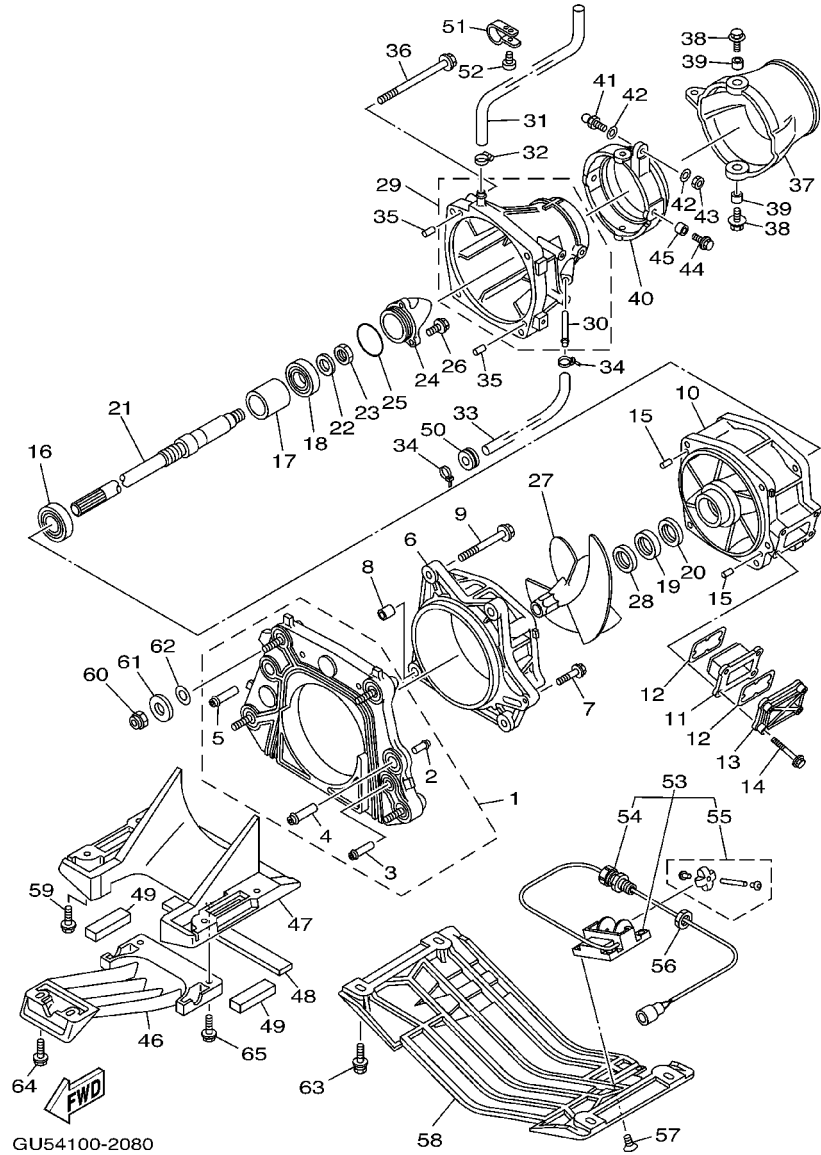

REF. NO.	PART NO.	DESCRIPTION	USA	CAN	GENE	JPN	REMARKS
55	GJ1-U835D-00	.SERVIS KIT (SPEED SENSOR)	1	1	1	1	YMUS
56	EU0-62241-30	NUT, DRAIN 1	1	1	1	1	
57	9878R-05512	SCREW, FLAT HEAD	4	4	4	4	YMUS
58	F0D-U273B-00	PLATE 2	1	1	1	1	YMUS
59	90119-089U6	BOLT, WITH WASHER	4	4	4	4	YMUS
60	9572R-10300	NUT, FLANGE	4	4	4	4	YMUS
61	90201-10940	WASHER, PLATE	4	4	4	4	
62	GU5-67354-00	SHIM	2	2	2	2	
63	90119-089U6	BOLT, WITH WASHER	4	4	4	4	YMUS
64	90119-069UK	BOLT, WITH WASHER	2	2	2	2	YMUS
65	90119-069UC	BOLT, WITH WASHER	2	2	2	2	YMUS

FIG. 9 JET UNIT 2

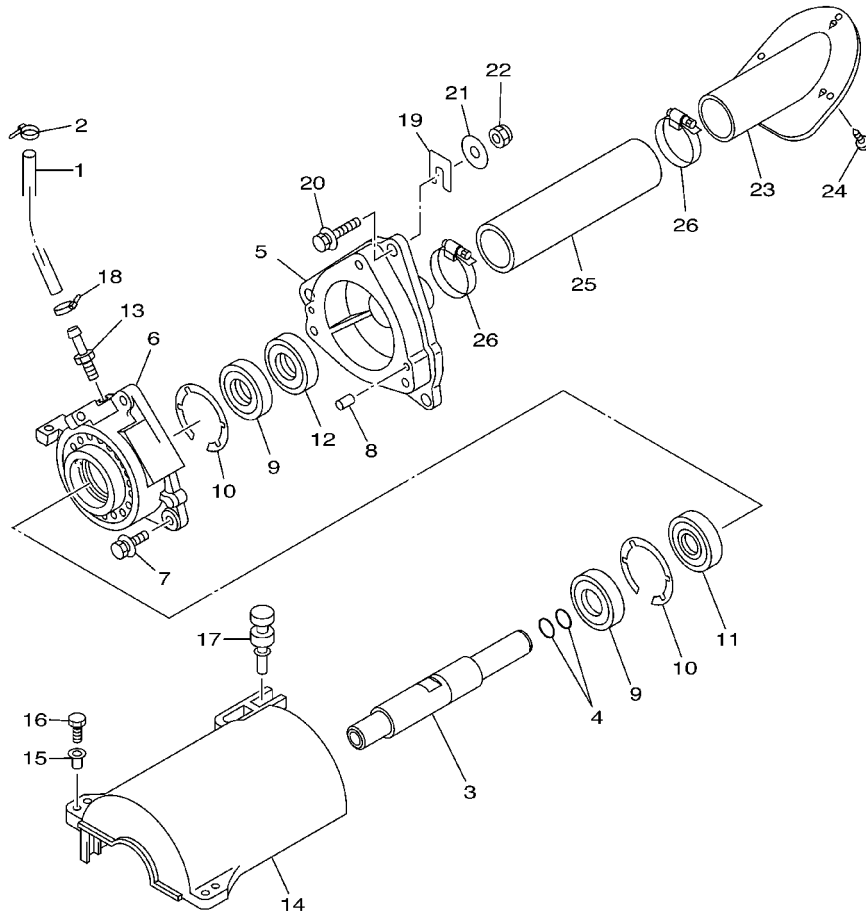

FWD
GU54100-2090

REF. NO.	PART NO.	DESCRIPTION	USA	CAN	GENE	JPN	REMARKS
1	90445-09M21	HOSE (L445)	1	1	1	1	
2	90465-11M10	CLAMP	1	1	1	1	
3	68N-51323-00	SHAFT, COUPLOR	1	1	1	1	
4	93210-19MJ4	O-RING	2	2	2	2	
5	66G-45331-00-94	HOUSING, BEARING	1	1	1	1	
6	66G-45332-00-94	HOUSING, BEARING	1	1	1	1	
7	90119-089UF	BOLT, WITH WASHER	3	3	3	3	YMUS
8	93606-12019	PIN, DOWEL	2	2	2	2	
9	93101-25M55	OIL SEAL	2	2	2	2	
10	93430-47M04	CIRCLIP	2	2	2	2	
11	93306-205U6	BEARING	1	1	1	1	
12	93101-25M56	OIL SEAL	1	1	1	1	
13	61L-45378-00	NIPPLE, HOSE	1	1	1	1	
14	64Y-51381-00	COVER	1	1	1	1	
15	90387-06M60	COLLAR	2	2	2	2	
16	90119-069UD	BOLT, WITH WASHER	2	2	2	2	YMUS
17	90480-06M46	GROMMET	1	1	1	1	
18	90465-11829	CLAMP	1	1	1	1	YMUS
19	GD0-U7249-00-05	SHIM (T=0.5)	2	2	2	2	UR, YMUS
	GD0-U7249-00-10	SHIM (T=1.0)	2	2	2	2	UR, YMUS
20	90119-08801	BOLT, WITH WASHER	3	3	3	3	YMUS
21	90201-099U1	WASHER, PLATE	3	3	3	3	YMUS
22	9572R-08300	NUT, FLANGE	3	3	3	3	YMUS
23	GK5-6883E-00	JOINT, PIPE	1	1	1	1	
24	97780-40712	SCREW, TAPPING	4	4	4	4	
25	GU5-U883B-00	PIPE, 1	1	1	1	1	YMUS
26	90601-152U3	BAND, HOSE 52	2	2	2	2	YMUS

FIG. 10 JET UNIT 3

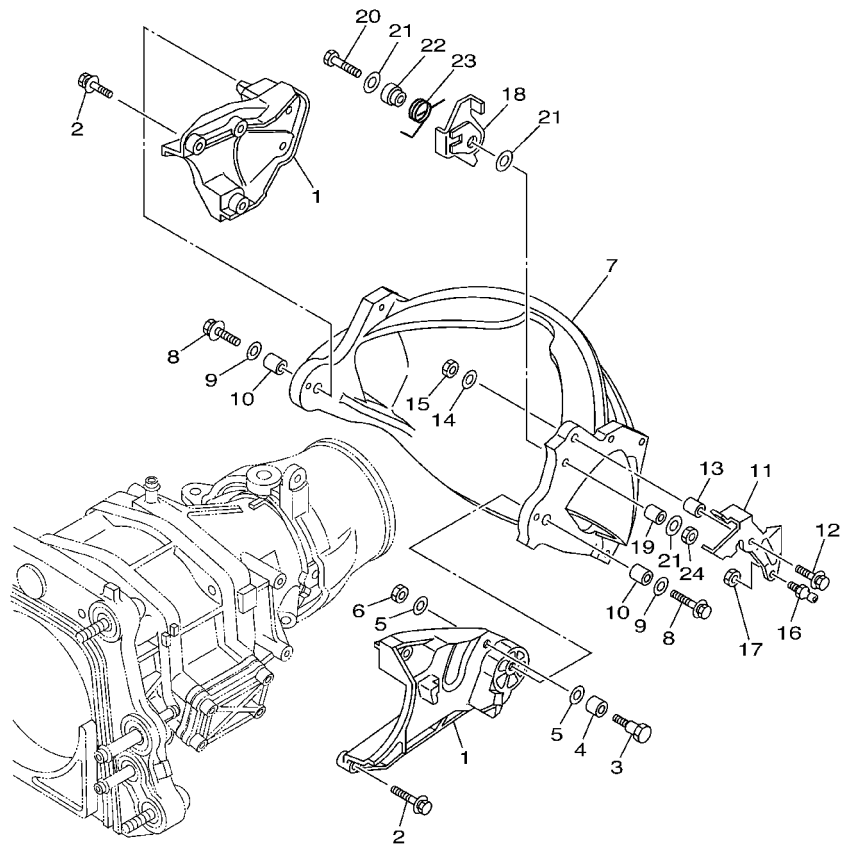

REF. NO.	PART NO.	DESCRIPTION	USA	CAN	GENE	JPN	REMARKS
1	66V-51341-00-94	BRACKET 1	2	2	2	2	
2	90119-069UD	BOLT, WITH WASHER	6	6	6	6	YMUS
3	90109-08879	BOLT	1	1	1	1	YMUS
4	90387-10M09	COLLAR	1	1	1	1	
5	9299R-08600	WASHER	2	2	2	2	YMUS
6	9538R-08600	NUT	1	1	1	1	YMUS
7	66V-51314-00	GATE, REVERSE	1	1	1	1	
8	90119-089UF	BOLT, WITH WASHER	2	2	2	2	YMUS
9	90201-088T2	WASHER, PLATE	2	2	2	2	YMUS
10	90387-08M30	COLLAR	2	2	2	2	
11	66V-44121-00	LEVER, SHIFT ROD	1	1	1	1	
12	90119-069UB	BOLT, WITH WASHER	1	1	1	1	YMUS
13	90387-06M74	COLLAR	1	1	1	1	
14	90201-068T1	WASHER, PLATE	1	1	1	1	YMUS
15	9538R-06600	NUT	1	1	1	1	YMUS
16	66V-U146E-00	STUD, JOINT BALL	1	1	1	1	YMUS
17	9538R-06600	NUT	1	1	1	1	YMUS
18	66V-44125-00	LEVER, SHIFT ROD	1	1	1	1	
19	90387-06M74	COLLAR	1	1	1	1	
20	90101-06806	BOLT	1	1	1	1	YMUS
21	90201-068T1	WASHER, PLATE	3	3	3	3	YMUS
22	90387-06M84	COLLAR	1	1	1	1	
23	90508-14M43	SPRING, TORSION	1	1	1	1	
24	9538R-06600	NUT	1	1	1	1	YMUS



F1F4100-B110

FIG. 11 GENERATOR

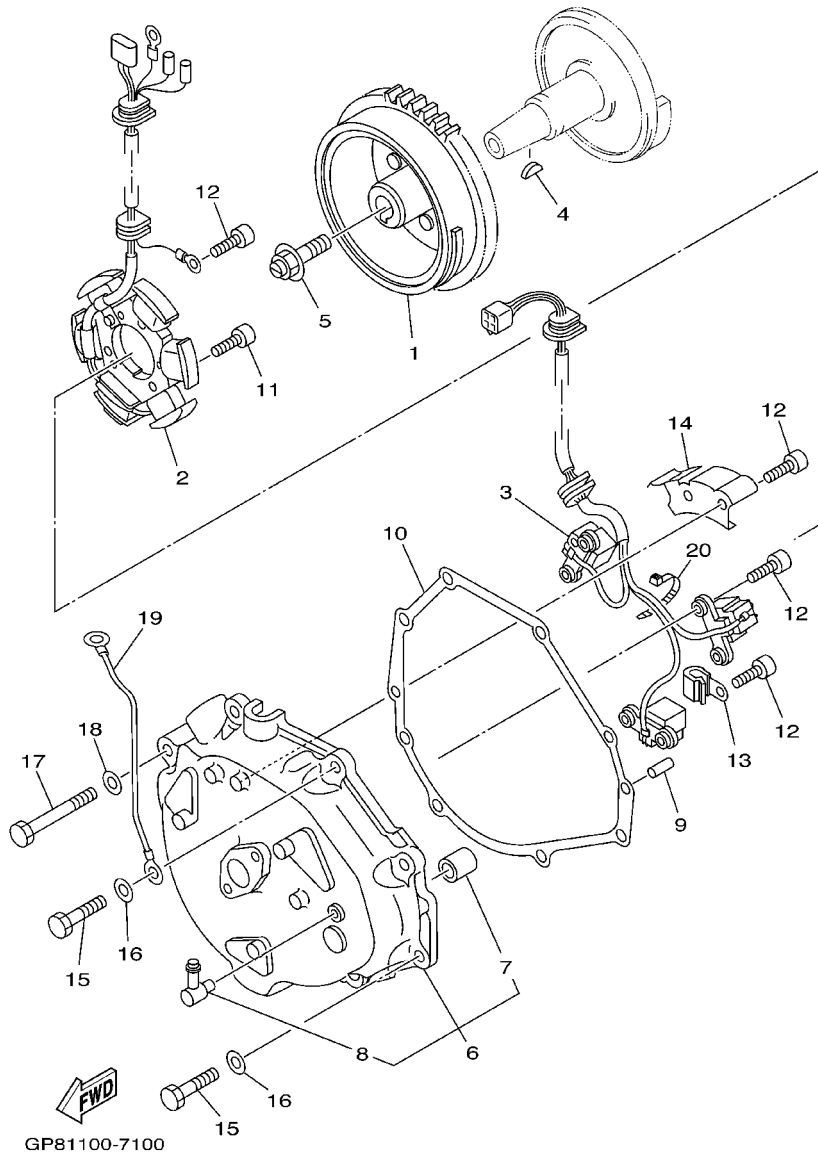

REF. NO.	PART NO.	DESCRIPTION	USA	CAN	GENE	JPN	REMARKS
1	65U-85550-00	ROTOR ASSY	1	1	1	1	
2	65U-85510-01	STATOR ASSY	1	1	1	1	
3	65U-85580-00	COIL, PULSER	1	1	1	1	
4	90280-05013	KEY, WOODRUFF	1	1	1	1	
5	90109-10M72	BOLT	1	1	1	1	
6	65U-81337-00-8P	COVER, FLYWHEEL	1	1	1	1	
7	90380-12M29	.BUSH, SOLID	1	1	1	1	
8	676-11372-00	.NIPPLE, HOSE	1	1	1	1	
9	93606-12019	PIN, DOWEL	2	2	2	2	
10	63M-81365-00	GASKET, HOLE COVER	1	1	1	1	
11	91318-06025	BOLT	3	3	3	3	
12	91318-06014	BOLT	13	13	13	13	
13	90465-06M67	CLAMP	4	4	4	4	
14	65U-81328-00	CLAMP	1	1	1	1	
15	97095-08030	BOLT	7	7	7	7	
16	92995-08600	WASHER	7	7	7	7	
17	97095-08055	BOLT	1	1	1	1	
18	92995-08600	WASHER	1	1	1	1	
19	6H5-82127-00	WIRE, LEAD 2	1	1	1	1	
20	90465-11M10	CLAMP	1	1	1	1	

FIG. 12 STARTING MOTOR

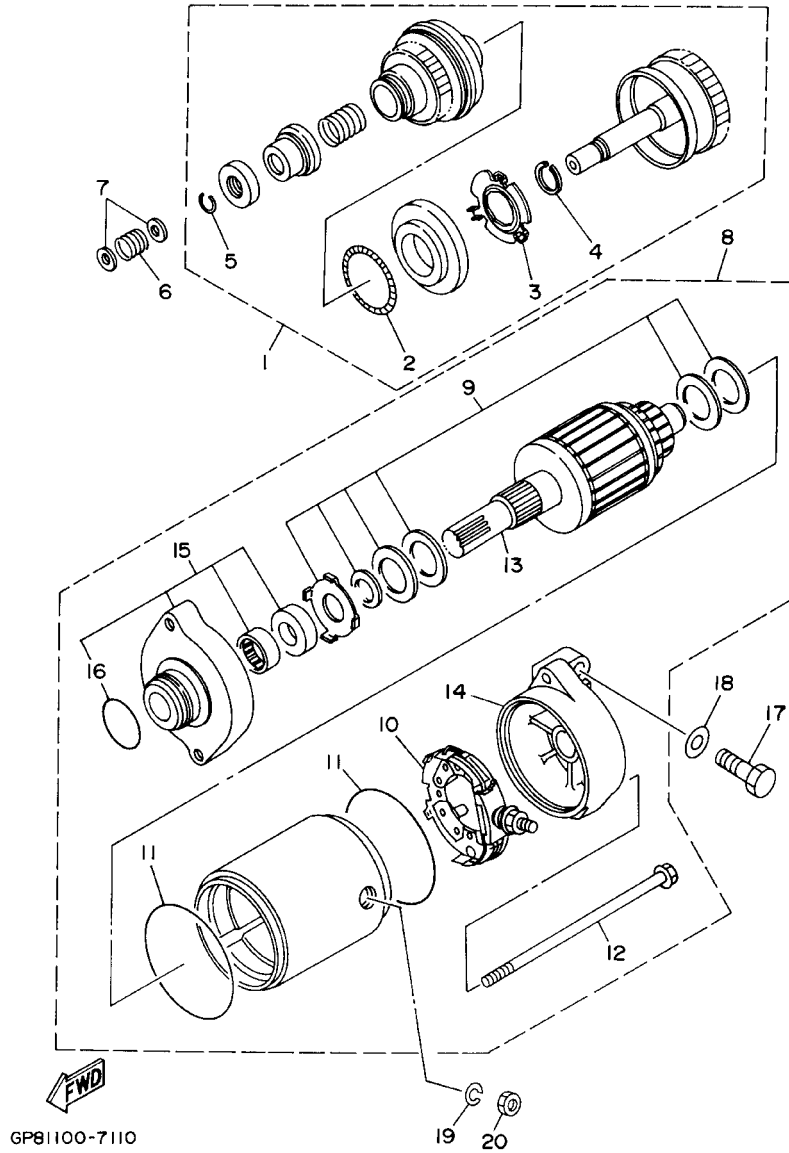

REF. NO.	PART NO.	DESCRIPTION	USA	CAN	GENE	JPN	REMARKS
1	6M6-8183E-01	IDLE GEAR COMP.	1	1	1	1	
2	6M6-81866-00	.WEIGHT SPRING	1	1	1	1	
3	6M6-81865-00	.WEIGHT HOLDER	1	1	1	1	
4	93440-25M08	.CIRCLIP	1	1	1	1	
5	93450-18M06	.CIRCLIP	1	1	1	1	
6	90501-14M73	SPRING, COMPRESSION	1	1	1	1	
7	92903-06600	WASHER, PLATE	2	2	2	2	
8	63M-81800-00	STARTING MOTOR ASSY	1	1	1	1	
9	3AJ-81809-00	.WASHER KIT	1	1	1	1	
10	6M6-81840-10	.BRUSH HOLDER ASSY	1	1	1	1	
11	11H-81844-00	.GASKET	2	2	2	2	
12	6M6-81826-00	.BOLT	2	2	2	2	
13	6M6-81850-00	.ARMATURE ASSY	1	1	1	1	
14	63M-81830-00	.REAR BRACKET ASSY	1	1	1	1	
15	6M6-81830-00	.FRONT BRACKET ASSY	1	1	1	1	
16	1FK-81847-00	.O-RING	1	1	1	1	
17	97013-08025	BOLT	2	2	2	2	
18	92903-08600	WASHER, PLATE	2	2	2	2	
19	92990-06100	WASHER, SPRING	1	1	1	1	
20	95380-06700	NUT	1	1	1	1	

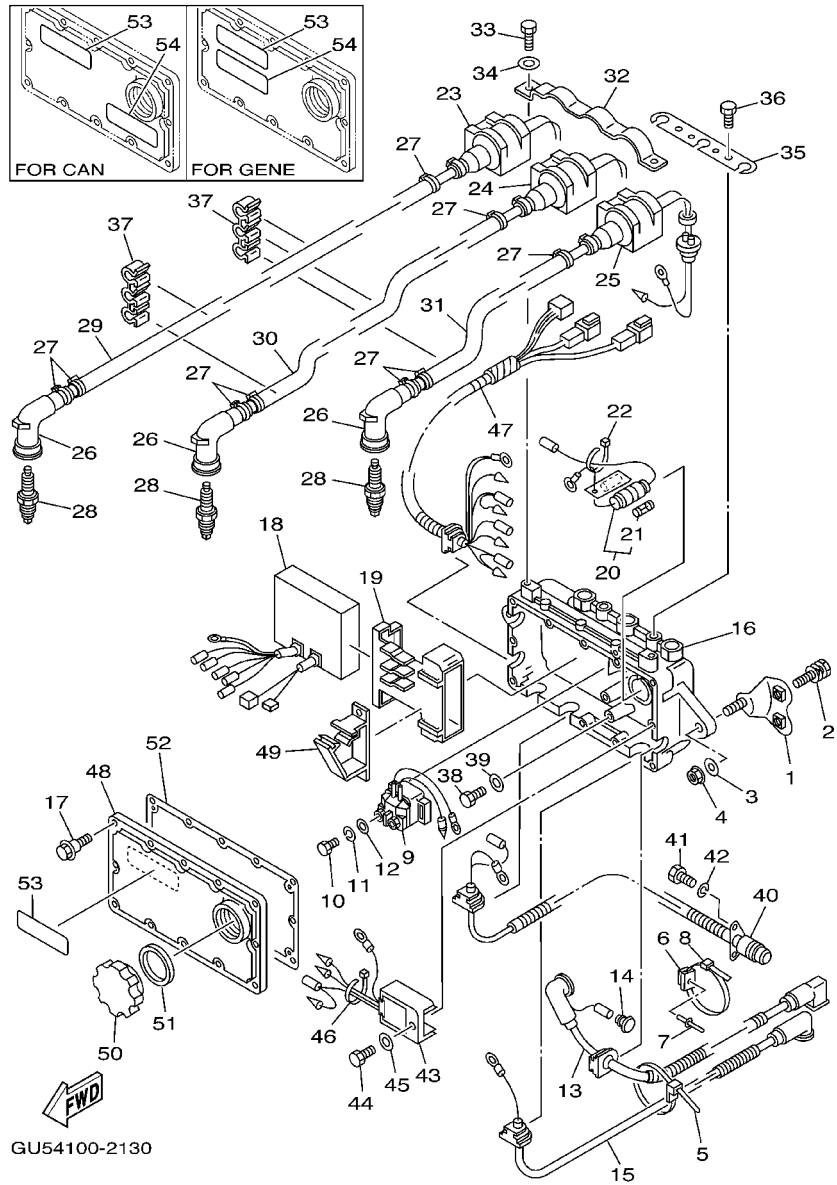

FIG. 13 ELECTRICAL 1

REF. NO.	PART NO.	DESCRIPTION	USA	CAN	GENE	JPN	REMARKS
1	F0E-6815D-00	BRACKET, ELECTRIC BOX	2	2	2	2	
2	90119-06959	BOLT, WITH WASHER	4	4	4	4	
3	9299R-08200	WASHER	2	2	2	2	YMUS
4	9572R-08300	NUT, FLANGE	2	2	2	2	YMUS
5	90464-32801	CLAMP	1	1	1	1	YMUS
6	90600-917U4	CLAMP COMP.	1	1	1	1	YMUS
7	90267-48802	RIVET, BLIND	1	1	1	1	YMUS
8	90464-32801	CLAMP	1	1	1	1	YMUS
9	68N-81940-00	STARTER RELAY ASSY	1	1	1	1	
10	97095-06010	BOLT	2	2	2	2	
11	92995-06100	WASHER, SPRING	2	2	2	2	
12	92995-06600	WASHER	2	2	2	2	
13	61L-82117-10	WIRE, LEAD	1	1	1	1	
14	703-82119-00	COVER, LEAD WIRE	1	1	1	1	
15	62E-82117-20	WIRE, LEAD	1	1	1	1	
16	65U-8552A-00-5B	HOUSING	1	1	1	1	
17	90109-05MA0	BOLT	12	12	12	12	
18	65U-85540-00	C.D.I. UNIT ASSY	1	1	1	1	
19	65U-85546-00	BAND	1	1	1	1	
20	65U-82150-00	FUSE HOLDER ASSY	1	1	1	1	
21	6G1-82151-00	.FUSE (10A)	1	1	1	1	
22	90465-11M10	CLAMP	1	1	1	1	
23	65U-85570-00	IGNITION COIL ASSY	1	1	1	1	
24	66G-85570-10	IGNITION COIL ASSY	1	1	1	1	
25	66G-85570-20	IGNITION COIL ASSY	1	1	1	1	
26	63M-82370-01	PLUG CAP ASSY	3	3	3	3	
27	90465-11M10	CLAMP	9	9	9	9	

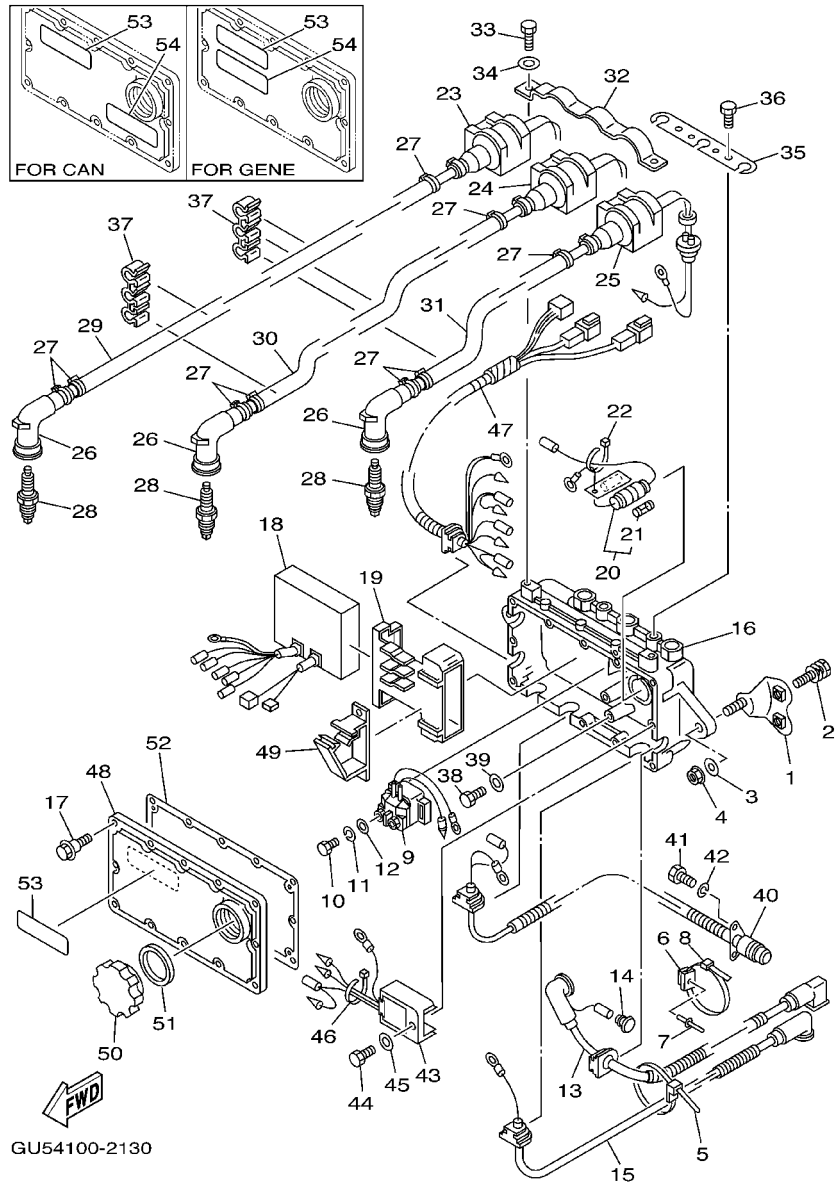

FIG. 13 ELECTRICAL 1

REF. NO.	PART NO.	DESCRIPTION	USA	CAN	GENE	JPN	REMARKS
28	94702-00195	PLUG, SPARK (NGK BR8HS)	3	3	3		FOR USA,CAN,GENE
	94709-00195	PLUG, SPARK(51X) NGK BR8HS				3	FOR JPN
29	6R7-82352-00	TUBE, CORD 2	1	1	1	1	
30	6R7-82351-00	TUBE, CORD	1	1	1	1	
31	66G-82351-00	TUBE, CORD	1	1	1	1	
32	65U-85542-00	BRACKET	1	1	1	1	
33	97095-08016	BOLT	2	2	2	2	
34	92995-08600	WASHER	2	2	2	2	
35	65U-85525-00	COVER	1	1	1	1	
36	97095-06012	BOLT	2	2	2	2	
37	65U-81317-10	CLAMP, CORD	2	2	2	2	
38	97095-06012	BOLT	3	3	3	3	
39	92995-06600	WASHER	3	3	3	3	
40	65U-82560-10	THERMO SWITCH ASSY	1	1	1	1	
41	97095-06016	BOLT	2	2	2	2	
42	92995-06100	WASHER, SPRING	2	2	2	2	
43	6H2-81960-00	RECTIFIER & REGULATOR ASSY	1	1	1	1	
44	97095-06020	BOLT	1	1	1	1	
45	92995-06600	WASHER	1	1	1	1	
46	90465-11M10	CLAMP	1	1	1	1	
47	66G-82553-00	EXTENSION, WIRE LEAD	1	1	1	1	
48	65U-8552E-00	COVER, CASE	1	1	1	1	
49	90464-06M29	CLAMP	1	1	1	1	
50	6M6-8132W-00	CAP	1	1	1	1	
51	6M6-81844-00	GASKET	1	1	1	1	
52	65U-81921-00	GASKET, TERMINAL	1	1	1	1	
53	6R7-83623-40	MARK 3	1	1	1		FOR USA,CAN,GENE

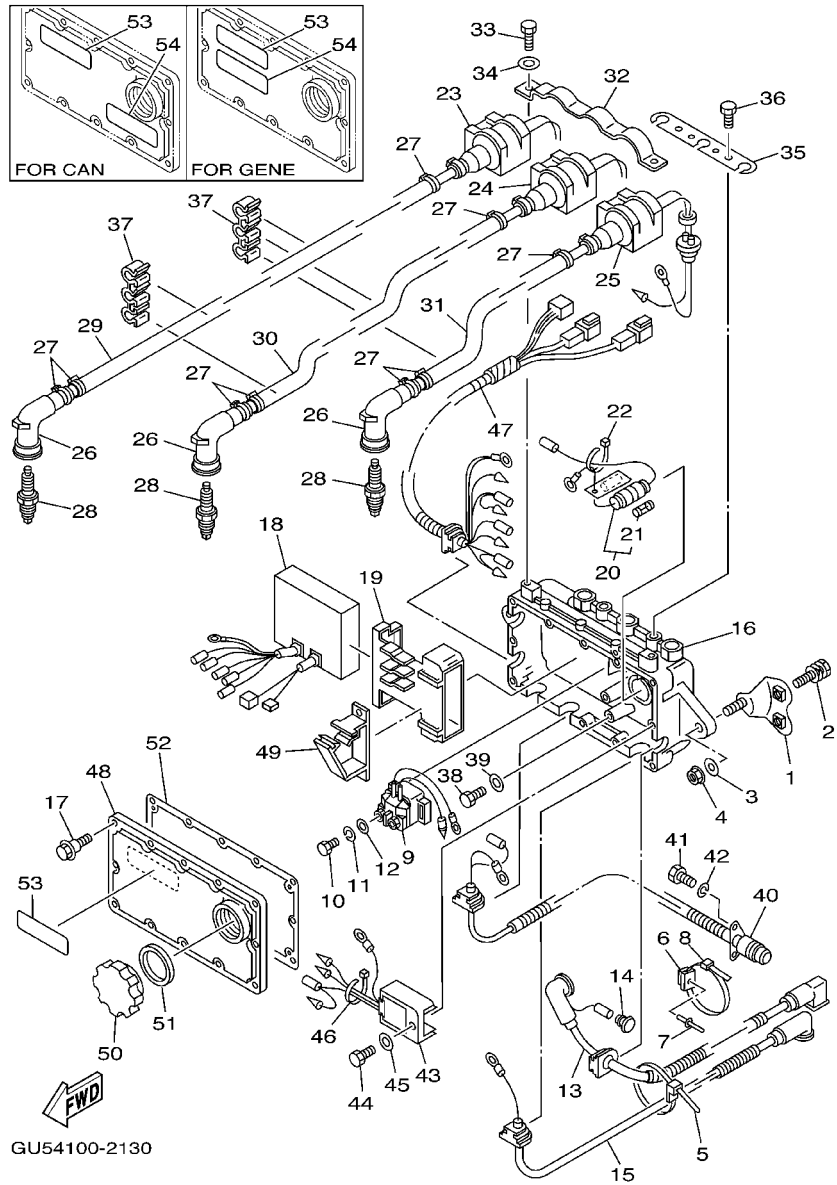

FIG. 13 ELECTRICAL 1

REF. NO.	PART NO.	DESCRIPTION	USA	CAN	GENE	JPN	REMARKS
53	63N-83623-00	MARK 3				1	FOR JPN
54	6R7-83623-50	MARK 3		1	1		FOR CAN,GENE

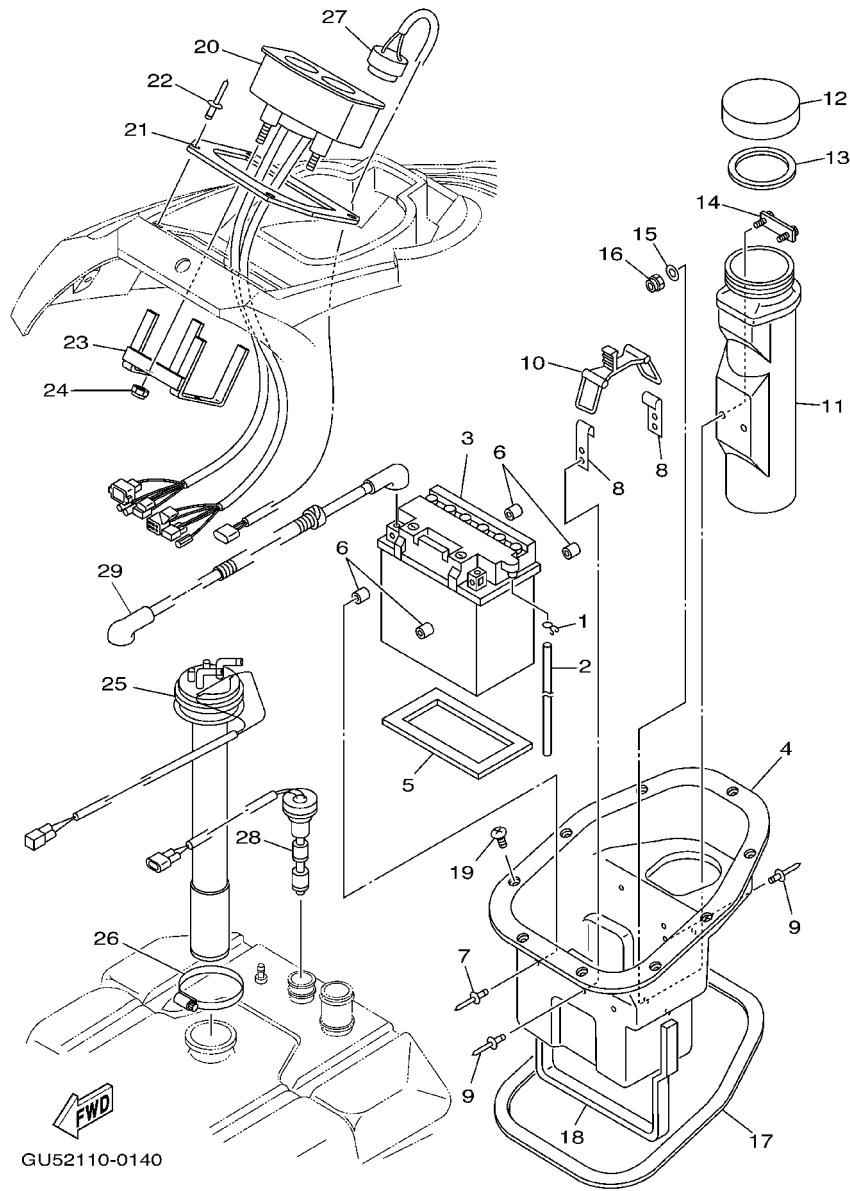

FIG. 14 ELECTRICAL 2

REF. NO.	PART NO.	DESCRIPTION	USA	CAN	GENE	JPN	REMARKS
1	90467-089U1	CLIP	1	1	1	1	YMUS
2	GU2-U785H-00	HOSE, AIR VENT 3	1	1	1	1	YMUS
3	EU0-82110-09	BATTERY ASSY (YB16CL-B)	1	1	1	1	YUASA
4	GK5-68211-00	BATTERY CASE COMP.	1	1	1	1	
5	EU0-U8221-00	PAD, BATTERY 1	1	1	1	1	YMUS
6	GK5-63768-00	CUSHION, RUBBER	4	4	4	4	
7	90267-48802	RIVET, BLIND	4	4	4	4	YMUS
8	GA7-65772-00	HOOK A	2	2	2	2	
9	90267-489U9	RIVET, BLIND	4	4	4	4	YMUS
10	GA7-68218-00	BAND, BATTERY	1	1	1	1	
11	GK5-65983-00	BOX, FIRE EXTINGUISHER	1	1	1	1	
12	EW2-65912-00	CAP, CASE	1	1	1	1	
13	EW2-65913-00	PACKING, CASE	1	1	1	1	
14	GK5-6593H-00	BRKT. FIRE EXTINGUISHER	1	1	1	1	
15	9299R-05200	WASHER	2	2	2	2	YMUS
16	9572R-05300	NUT, FLANGE	2	2	2	2	YMUS
17	90656-67100	PACKING, 48	1	1	1	1	
18	GK5-6266J-00	PACKING 10	1	1	1	1	
19	97780-50014	SCREW, TAPPING	9	9	9	9	
20	F0D-6820A-31	METER ASSY	1				FOR USA
	F0D-6820A-41	METER ASSY		1	1	1	FOR CAN, GENE, JPN
21	GU5-68376-00	PLATE	1	1	1	1	
22	90267-489UE	RIVET, BLIND	4	4	4	4	YMUS
23	F0D-68238-10	BRACKET, METER	1	1	1	1	
24	9572R-05300	NUT, FLANGE	2	2	2	2	YMUS
25	F0V-U824B-01	SENDER, FUEL	1	1	1	1	YMUS
26	90601-162U5	BAND, HOSE 62	1	1	1	1	YMUS

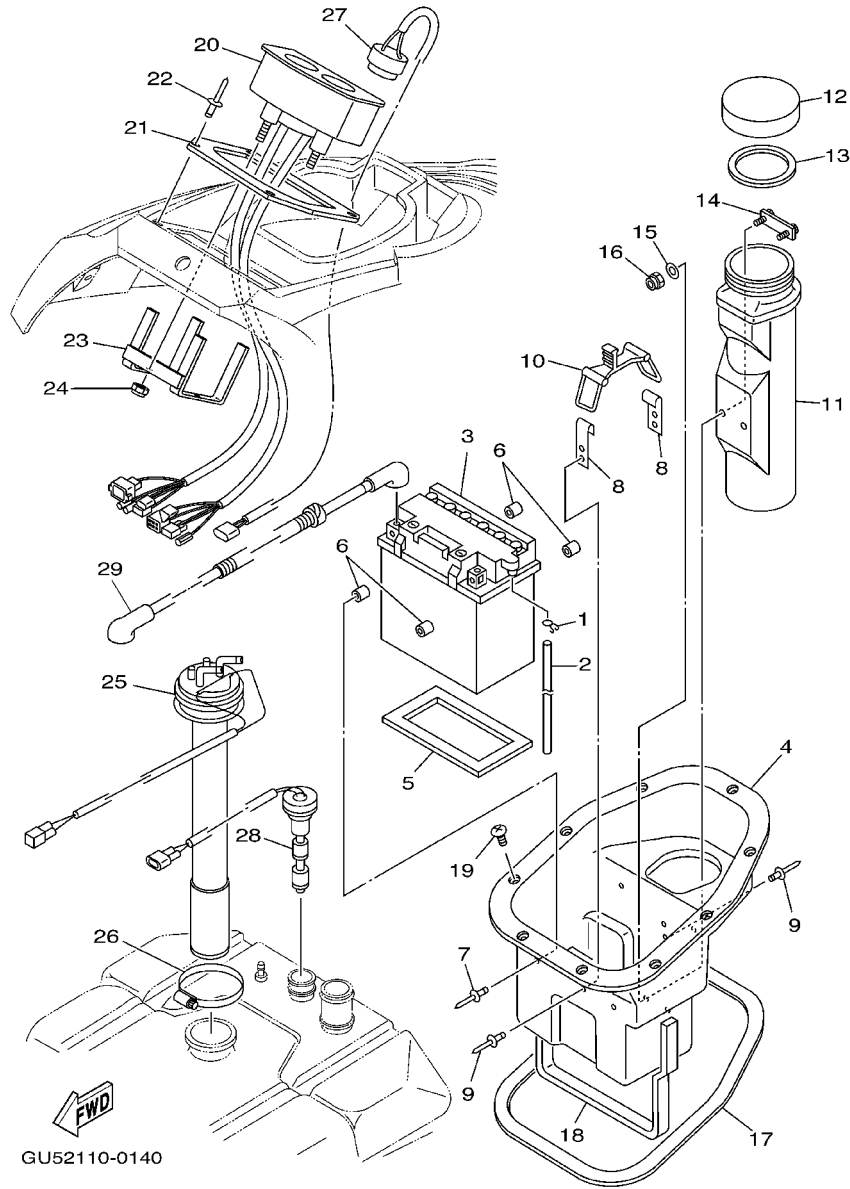
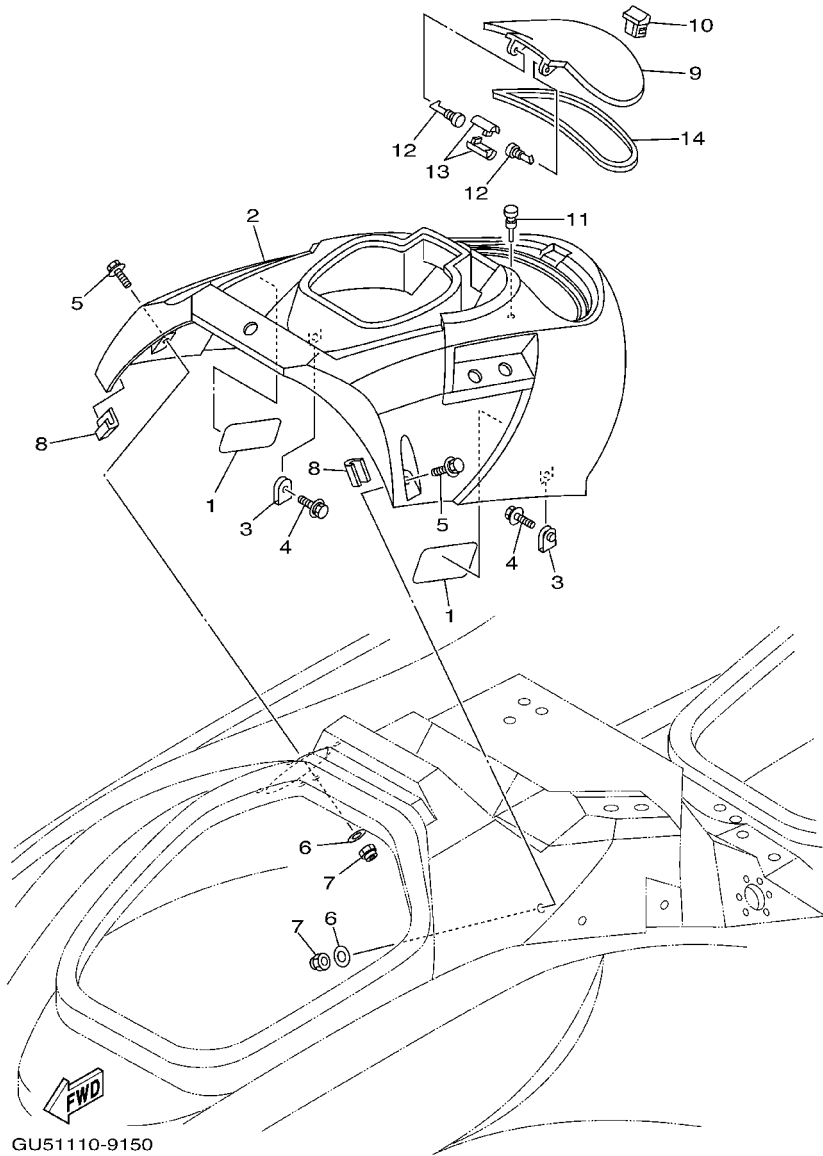

FIG. 14 ELECTRICAL 2

REF. NO.	PART NO.	DESCRIPTION	USA	CAN	GENE	JPN	REMARKS
27	F0D-U8341-00	BUZZER	1	1	1	1	YMUS
28	F0D-U824C-10	SENDER, OIL	1	1	1	1	YMUS
29	64T-82117-00	WIRE, LEAD	1	1	1	1	

FIG. 15 ENGINE HATCH 1



REF. NO.	PART NO.	DESCRIPTION	USA	CAN	GENE	JPN	REMARKS
1	F0D-65116-00	TRIM,HATCH 2	2	2	2	2	
2	F0D-U516N-50-P0	COVER, ENGINE HATCH	1	1	1	1	PBMD, YMUS
3	90183-06902	NUT, SPRING	2	2	2	2	
4	90119-069UH	BOLT, WITH WASHER	2	2	2	2	YMUS
5	90119-06803	BOLT, WITH WASHER	2	2	2	2	YMUS
6	9299R-06200	WASHER	2	2	2	2	YMUS
7	9572R-06300	NUT, FLANGE	2	2	2	2	YMUS
8	GP7-U5114-00	RUBBER, WATER PROOF	2	2	2	2	YMUS
9	F0D-U517H-50-P1	LID HATCH	1	1	1	1	PBMD, YMUS
10	F0D-62875-00	LOCK	1	1	1	1	
11	90605-502U2	PLUG	1	1	1	1	YMUS
12	F0D-6517R-00	PIN, HINGE	2	2	2	2	
13	F0D-6517T-00	JOINT, HINGE	2	2	2	2	
14	F0D-U519D-00	PACKING CASE	1	1	1	1	YMUS

FIG. 16 ENGINE HATCH 2

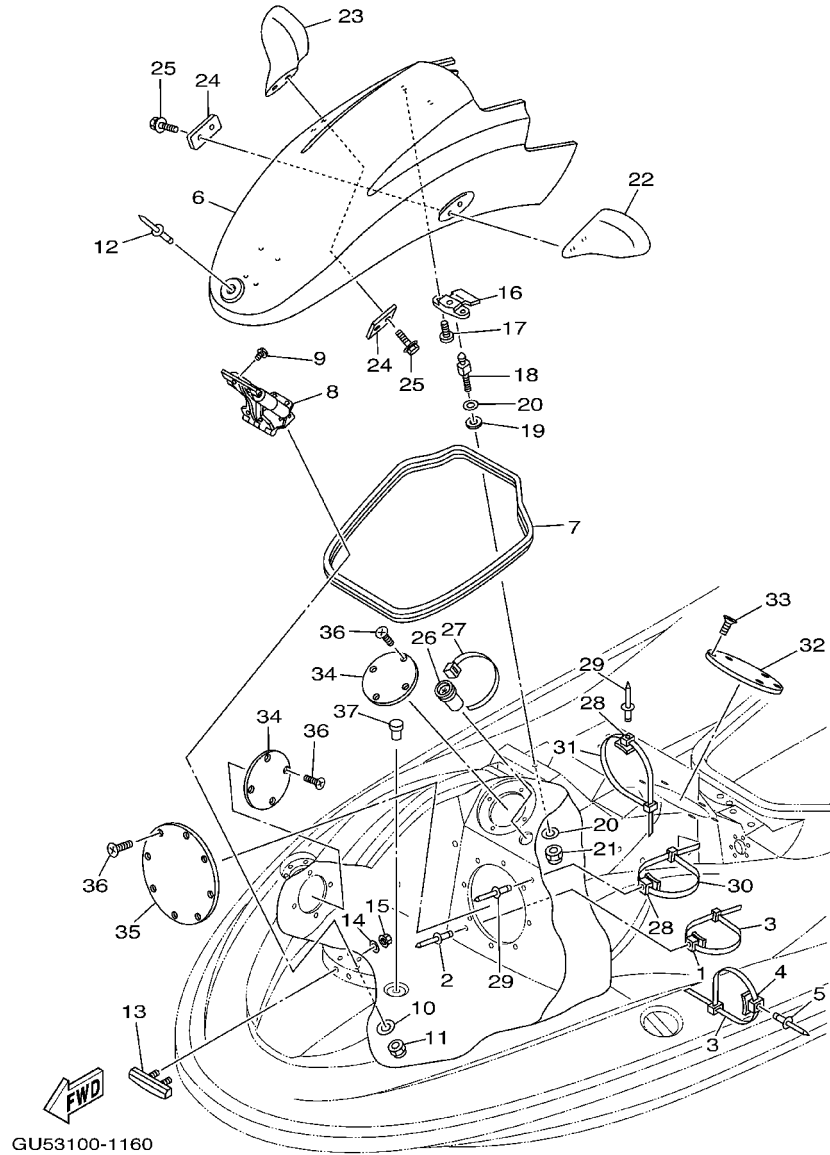

REF. NO.	PART NO.	DESCRIPTION	USA	CAN	GENE	JPN	REMARKS
1	90600-917U4	CLAMP COMP.	1	1	1	1	YMUS
2	90267-48802	RIVET, BLIND	1	1	1	1	YMUS
3	90464-99800	CLAMP	2	2	2	2	YMUS
4	90600-917U4	CLAMP COMP.	1	1	1	1	YMUS
5	90267-48802	RIVET, BLIND	1	1	1	1	YMUS
6	F0D-U517B-10-P7	LID, ENGINE ROOM	1	1	1	1	PBMD, YMUS
7	GU5-U2663-00	PACKING 1	1	1	1	1	YMUS
8	F0D-6515A-04	HINGE ASSY.	1	1	1	1	
9	90119-06966	BOLT, WITH WASHER	4	4	4	4	YMUS
10	90201-06802	WASHER, PLATE	4	4	4	4	YMUS
11	9572R-06300	NUT, FLANGE	4	4	4	4	YMUS
12	90267-489U8	RIVET, BLIND	1	1	1	1	YMUS
13	F0D-6518E-01	PRATE, HINGE LID	1	1	1	1	
14	9299R-06200	WASHER	2	2	2	2	YMUS
15	9572R-06300	NUT, FLANGE	2	2	2	2	YMUS
16	F0D-6517C-04	LOCK, LID	1	1	1	1	
17	90149-06906	SCREW	2	2	2	2	
18	GU5-63774-00	PIN	1	1	1	1	
19	F0D-6515E-00	DAMPER 2	1	1	1	1	
20	9299R-08200	WASHER	2	2	2	2	YMUS
21	9572R-08300	NUT, FLANGE	1	1	1	1	YMUS
22	F0D-U596B-00	MIRROR LH	1	1	1	1	YB, YMUS
23	F0D-U596C-00	MIRROR RH	1	1	1	1	YB, YMUS
24	F0D-U5646-00	PLATE	2	2	2	2	YMUS
25	90119-089UN	BOLT, WITH WASHER	4	4	4	4	YMUS
26	GU2-6822E-01	GROMMÉT	1	1	1	1	
27	90464-32801	CLAMP	1	1	1	1	YMUS

FIG. 16 ENGINE HATCH 2

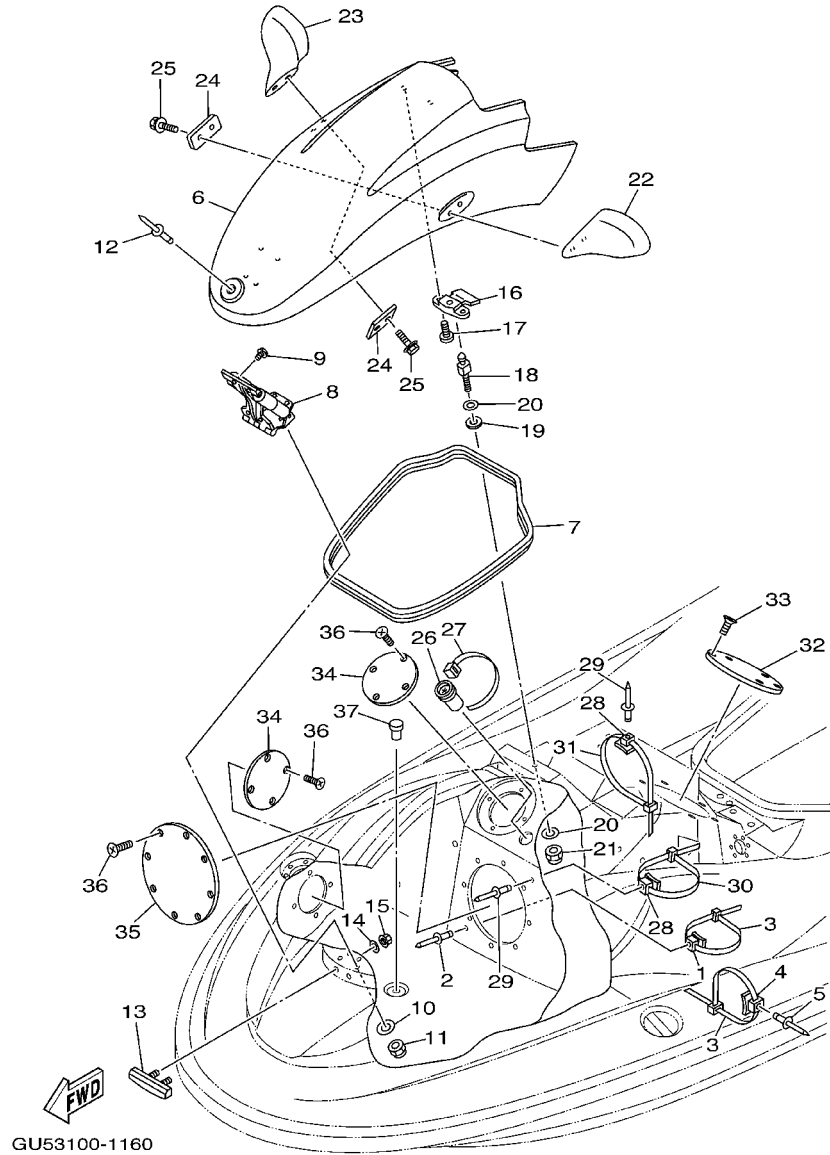

REF. NO.	PART NO.	DESCRIPTION	USA	CAN	GENE	JPN	REMARKS
28	90600-917U4	CLAMP COMP.	3	3	3	3	YMUS
29	90267-48802	RIVET, BLIND	3	3	3	3	YMUS
30	90601-200U2	BAND	2	2	2	2	YMUS
31	90464-32801	CLAMP	1	1	1	1	YMUS
32	GP1-U7228-00	COVER, INSPECTION 2	1	1	1	1	YMUS
33	97780-40712	SCREW, TAPPING	5	5	5	5	
34	GP1-U7227-00	COVER, INSPECTION 1	2	2	2	2	YMUS
35	GU5-U7861-00	COVER INSPECTION	1	1	1	1	YMUS
36	97780-40712	SCREW, TAPPING	16	16	16	16	
37	90605-502U1	PLUG, BLIND	1	1	1	1	YMUS

FIG. 17 HULL. DECK

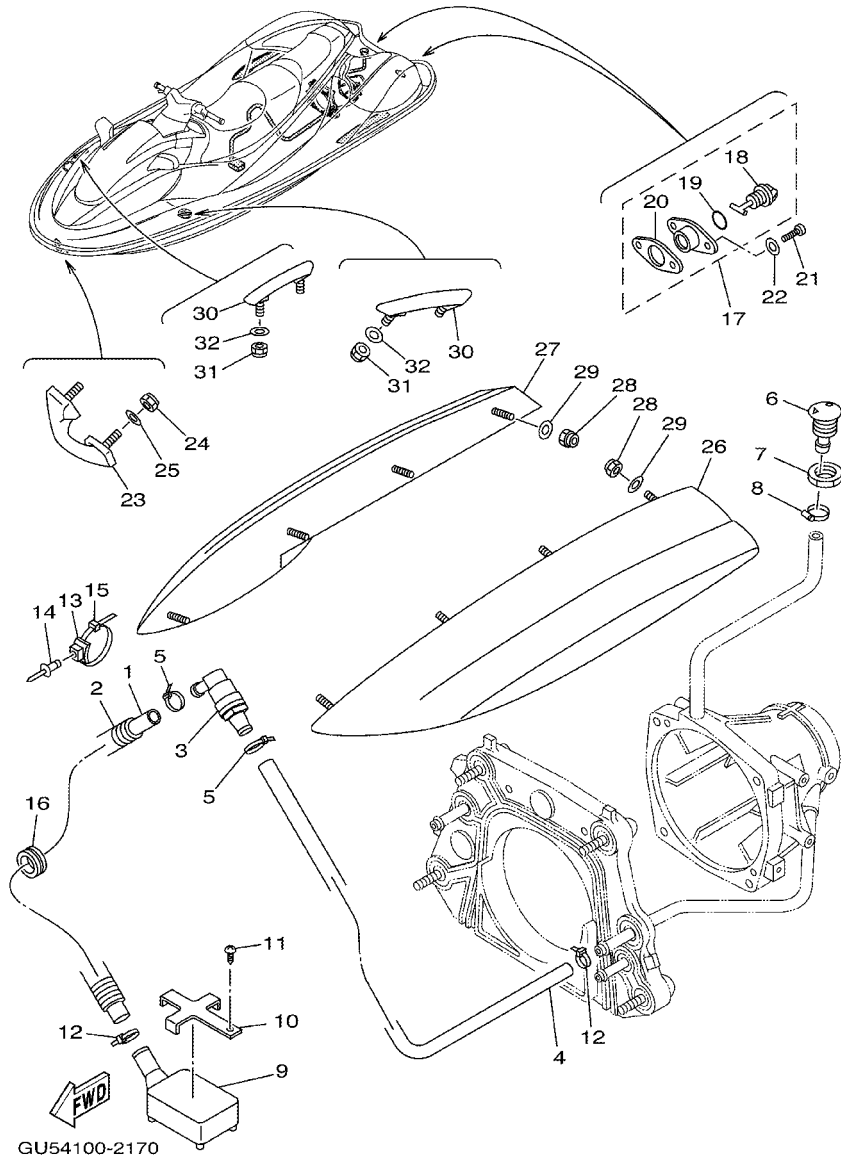

REF. NO.	PART NO.	DESCRIPTION	USA	CAN	GENE	JPN	REMARKS
1	90445-19M12	HOSE (L720)	1	1	1	1	
2	90446-27MA4	HOSE	1	1	1	1	
3	68N-5112T-00	JOINT, HOSE	1	1	1	1	
4	90445-19M09	HOSE (L550)	1	1	1	1	
5	90465-13M11	CLAMP	2	2	2	2	
6	FN8-6269B-00	SPOUT	1	1	1	1	
7	EU0-61652-00	NUT	1	1	1	1	
8	90600-91755	CLIP	1	1	1	1	
9	GD0-U761D-00	STRAINER, BILGE	1	1	1	1	YMUS
10	FJ0-67618-00	BASE	1	1	1	1	
11	9778R-50112	SCREW, TAPPING	1	1	1	1	YMUS
12	90601-200U1	BAND	2	2	2	2	YMUS
13	90600-917U4	CLAMP COMP.	1	1	1	1	YMUS
14	90267-489UE	RIVET, BLIND	1	1	1	1	YMUS
15	90464-32801	CLAMP	1	1	1	1	YMUS
16	90480-329U2	GROMMET	1	1	1	1	YMUS
17	EU0-62280-00	DRAIN PLUG ASSY	2	2	2	2	
18	EU0-62282-00	.PLUG, DRAIN	1	1	1	1	
19	EU0-62283-00	.O-RING	1	1	1	1	
20	EU0-62285-01	.PACKING DRAIN (EU0)	1	1	1	1	
21	97780-50520	SCREW, TAPPING	4	4	4	4	
22	9299R-05200	WASHER	4	4	4	4	YMUS
23	GU5-61624-00	BOWEYE 1 (S)	1	1	1	1	
24	9572R-08300	NUT, FLANGE	2	2	2	2	YMUS
25	90201-08800	WASHER, PLATE	2	2	2	2	YMUS
26	GU5-6883N-00	STABILIZER LH	1	1	1	1	YB
27	GU5-6883P-00	STABILIZER RH	1	1	1	1	YB

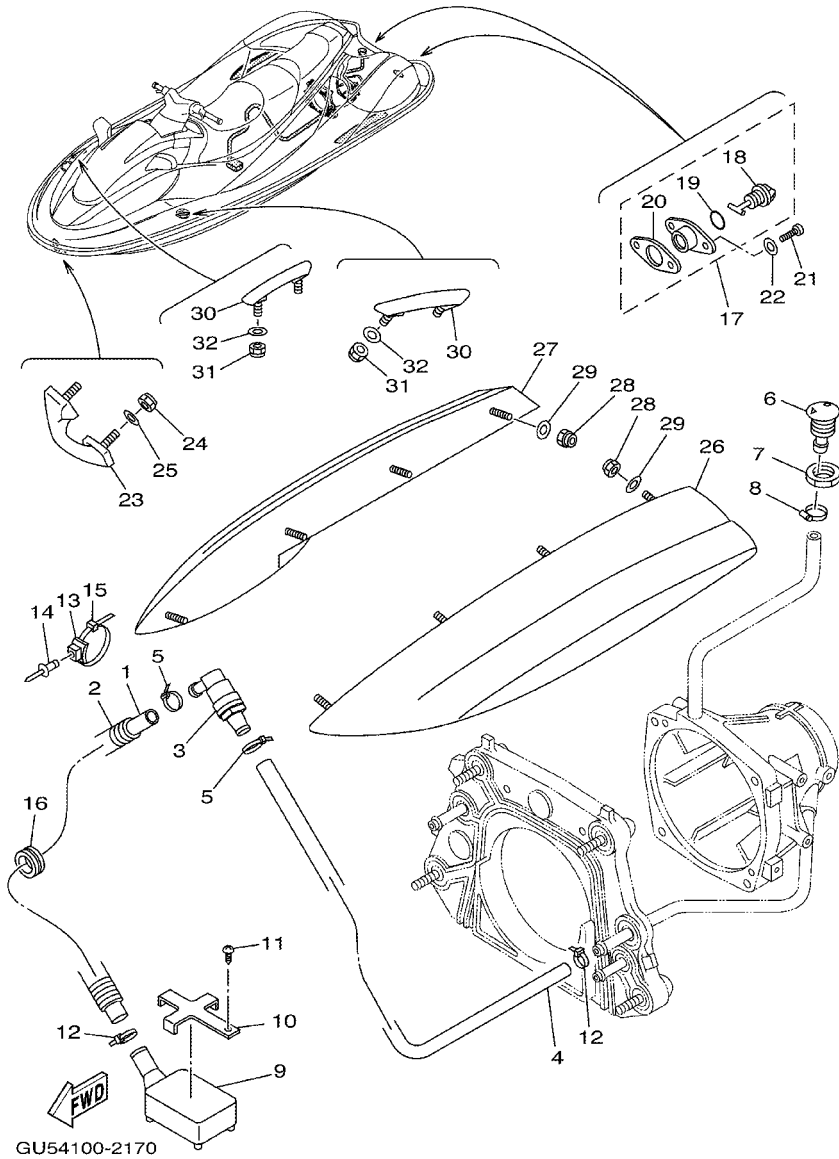
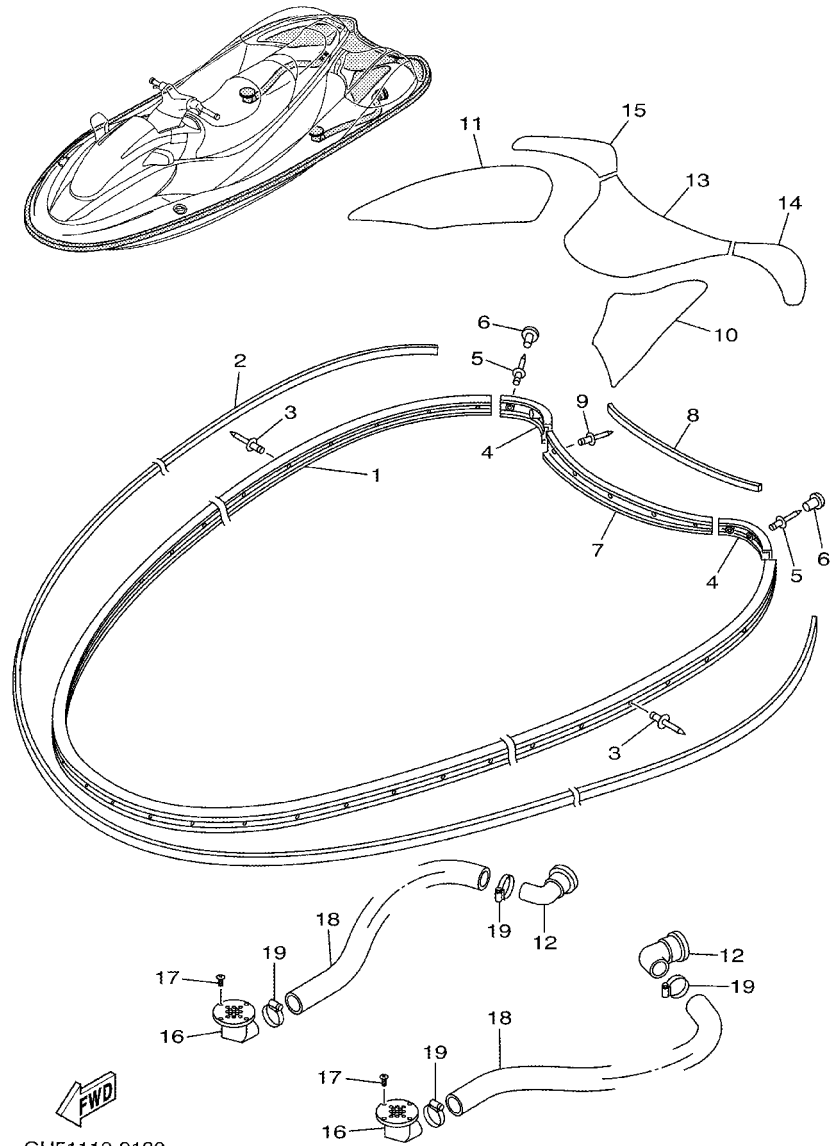

FIG. 17 HULL. DECK

REF. NO.	PART NO.	DESCRIPTION	USA	CAN	GENE	JPN	REMARKS
28	9572R-06300	NUT, FLANGE	8	8	8	8	YMUS
29	90201-06808	WASHER, PLATE	8	8	8	8	
30	GU5-61685-01	DECK EYE	2	2	2	2	
31	9572R-08300	NUT, FLANGE	4	4	4	4	YMUS
32	9299R-08200	WASHER	4	4	4	4	YMUS
<hr/>							
<hr/>							
<hr/>							
<hr/>							
<hr/>							
<hr/>							
<hr/>							
<hr/>							

FIG. 18 GUNWALE. MAT



REF. NO.	PART NO.	DESCRIPTION	USA	CAN	GENE	JPN	REMARKS
1	GU5-U2512-00	GUNWALE, SIDE	1	1	1	1	YB, YMUS
2	GU5-U2519-00	INNER,GUNWALE	1	1	1	1	YB, YMUS
3	90267-489US	RIVET, BLIND	60	60	60	60	YMUS
4	GU5-U251D-00	GUNWALE, STERN 1	2	2	2	2	YB, YMUS
5	90267-48835	RIVET, BLIND	4	4	4	4	YMUS
6	GJ3-U352E-40	MAT, BOW	4	4	4	4	DBGS8, YMUS
7	GU5-U252C-00	COVER, GUNWALE 1	1	1	1	1	YB, YMUS
8	GU5-U252D-00	COVER, GUNWALE 2	1	1	1	1	YB, YMUS
9	90267-489US	RIVET, BLIND	5	5	5	5	YMUS
10	GU5-U351H-00	MAT, STEP 1	1	1	1	1	BL, YMUS
11	GU5-U351J-00	MAT, STEP 2	1	1	1	1	BL, YMUS
12	GP1-U7617-00	THRU-HULL FITTING	2	2	2	2	YMUS
13	GU5-U3581-10	MAT, UPPER	1	1	1	1	BL, YMUS
14	GU5-U351C-10	MAT, SIDE 1	1	1	1	1	BL, YMUS
15	GU5-U351D-10	MAT,SIDE 2	1	1	1	1	BL, YMUS
16	GU5-U2287-00	SCUPPER, DRAIN	2	2	2	2	YMUS
17	90162-08S12	SCREW, TAPPING	8	8	8	8	YMUS
18	GU5-U8532-00	HOSE, DRAIN	2	2	2	2	YMUS
19	90601-152U3	BAND, HOSE 52	4	4	4	4	YMUS

FIG. 19 VENTILATION

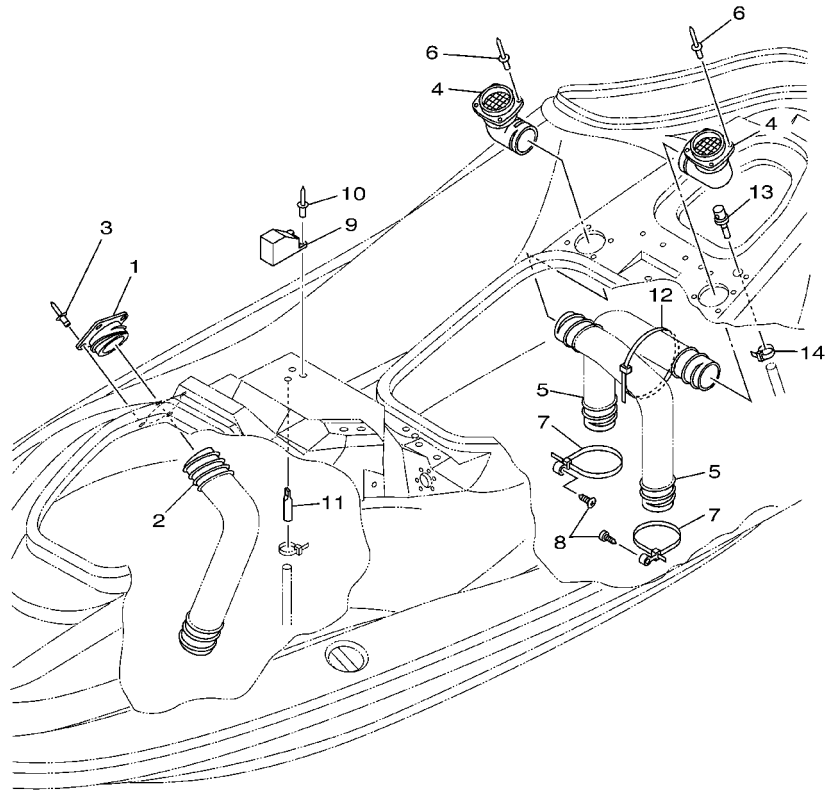

REF. NO.	PART NO.	DESCRIPTION	USA	CAN	GENE	JPN	REMARKS
1	F0D-62127-00	BASE, AIR INTAKE	1	1	1	1	
2	GU5-U213F-00	HOSE, VENTILATOR 1	1	1	1	1	YMUS
3	90267-489UE	RIVET, BLIND	4	4	4	4	YMUS
4	F0D-62139-00	VENTILATOR, OUTLET	2	2	2	2	
5	GU5-U213G-00	HOSE, VENTILATOR 2	2	2	2	2	YMUS
6	90267-489UE	RIVET, BLIND	8	8	8	8	YMUS
7	90601-200U8	BAND	2	2	2	2	YMUS
8	9778R-50116	SCREW, TAPPING	2	2	2	2	YMUS
9	GP7-62159-01	SOCKET, VENTILATION	1	1	1	1	
10	90267-489UE	RIVET, BLIND	2	2	2	2	YMUS
11	GK5-62149-00	PIPE, VENTILATION	1	1	1	1	
12	90601-200U7	BAND	1	1	1	1	YMUS
13	GJ3-6215F-00	NIPPLE	1	1	1	1	
14	90465-11829	CLAMP	1	1	1	1	YMUS



GU51110-9190

FIG. 20 SEAT. UNDER LOCKER

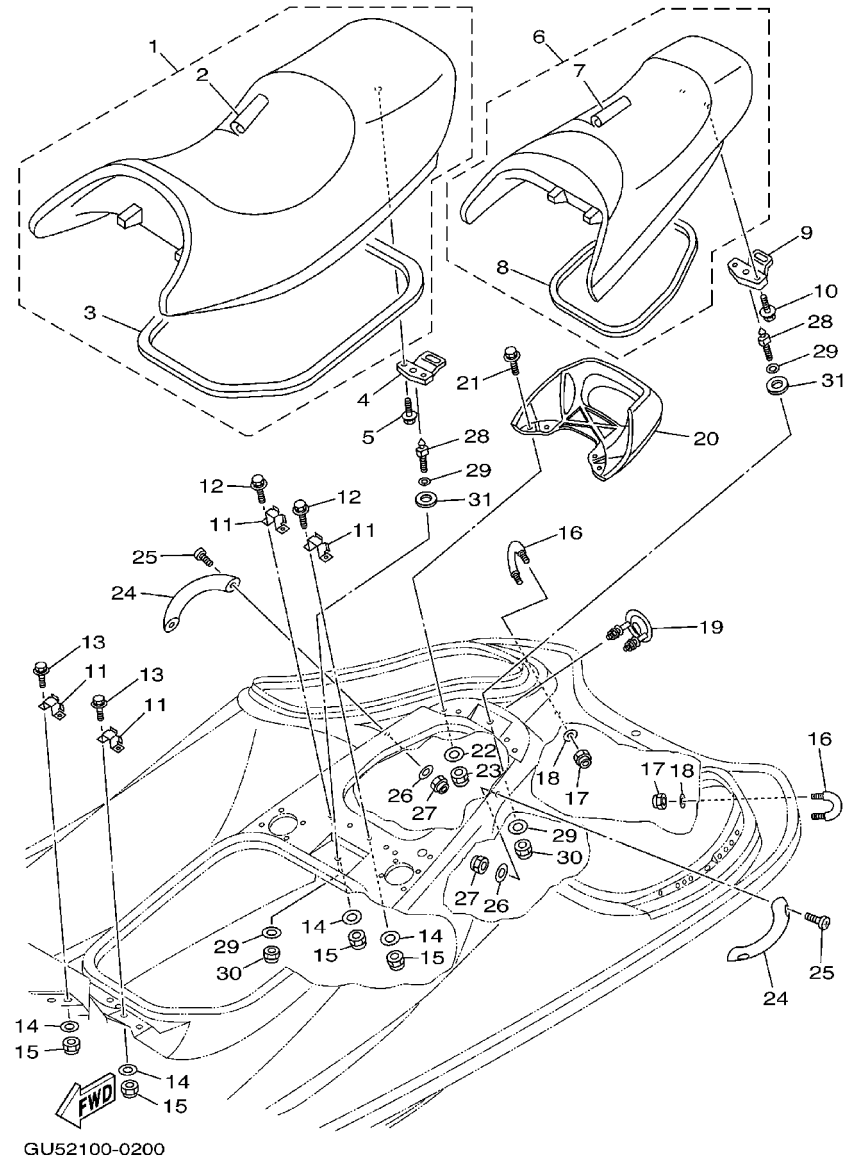

REF. NO.	PART NO.	DESCRIPTION	USA	CAN	GENE	JPN	REMARKS
1	GU5-U371A-40	DOUBLE SEAT ASSY	1	1	1	1	YMUS
2	GU5-U371B-40	.COVER, SEAT 1	1	1	1	1	YMUS
3	GU5-U2664-00	.PACKING	1	1	1	1	YMUS
4	F0D-63850-01	SEAT LOCK ASSY	1	1	1	1	
5	90119-06853	BOLT, WITH WASHER	2	2	2	2	YMUS
6	GU5-U372A-40	SINGLE SEAT ASSY	1	1	1	1	YMUS
7	GU5-U372B-40	.COVER, SEAT	1	1	1	1	YMUS
8	GU5-U266B-00	.PACKING 3	1	1	1	1	YMUS
9	F0D-63850-01	SEAT LOCK ASSY	1	1	1	1	
10	90119-06853	BOLT, WITH WASHER	2	2	2	2	YMUS
11	GU5-6378D-00	STAY, SEAT 2	4	4	4	4	
12	90119-06803	BOLT, WITH WASHER	4	4	4	4	YMUS
13	90119-06824	BOLT, WITH WASHER	4	4	4	4	YMUS
14	9299R-06200	WASHER	8	8	8	8	YMUS
15	9572R-06300	NUT, FLANGE	8	8	8	8	YMUS
16	GU5-61628-00	STERN EYE	2	2	2	2	
17	9572R-08300	NUT, FLANGE	4	4	4	4	YMUS
18	90201-08800	WASHER, PLATE	4	4	4	4	YMUS
19	GP1-U1629-00	SKI TOWS	1	1	1	1	YMUS
20	F0D-U271B-00	GRIP, HAND	1	1	1	1	YB, YMUS
21	90119-06820	BOLT, WITH WASHER	4	4	4	4	YMUS
22	9299R-06200	WASHER	4	4	4	4	YMUS
23	9572R-06300	NUT, FLANGE	4	4	4	4	YMUS
24	F0R-U271B-00	GRIP, HAND	2	2	2	2	YMUS
25	9898R-06030	SCREW, BIND	4	4	4	4	YMUS
26	90201-06802	WASHER, PLATE	4	4	4	4	YMUS
27	9572R-06300	NUT, FLANGE	4	4	4	4	YMUS

FIG. 20 SEAT. UNDER LOCKER

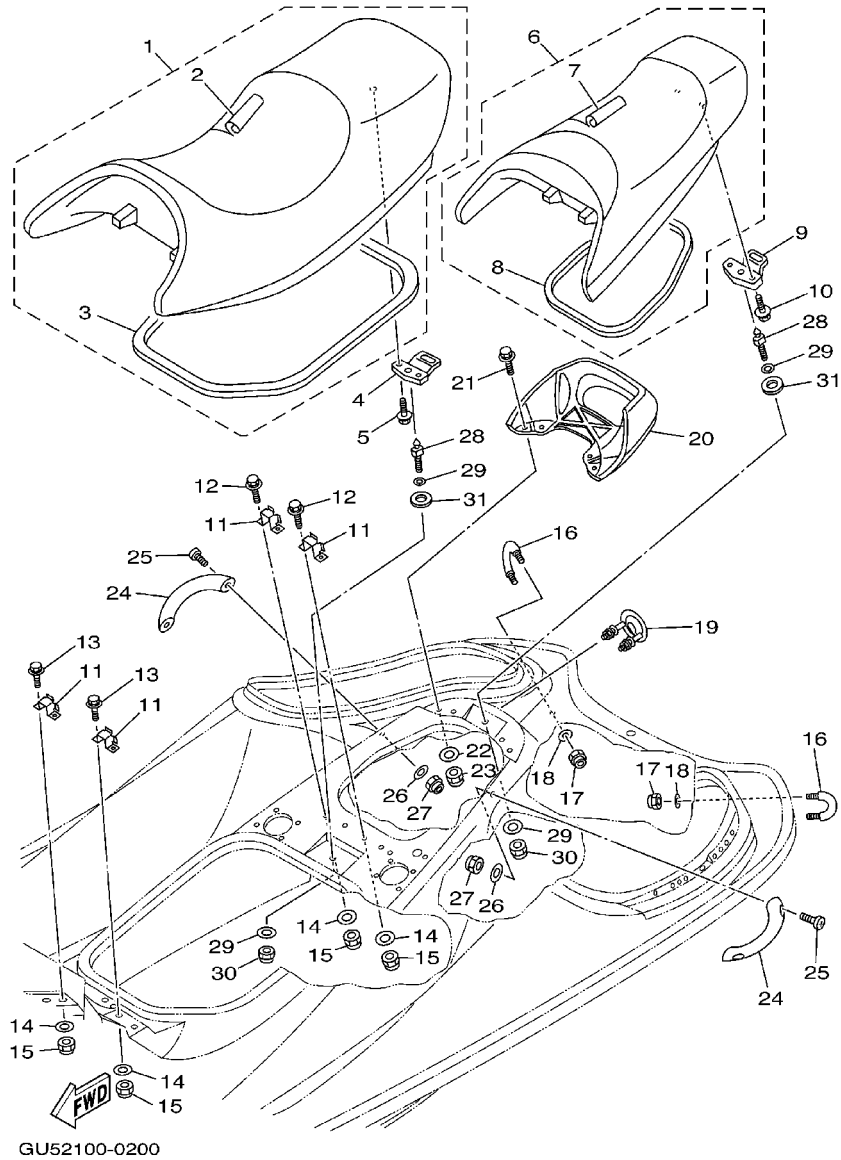

REF. NO.	PART NO.	DESCRIPTION	USA	CAN	GENE	JPN	REMARKS
28	GH1-U3774-00	PIN	2	2	2	2	YMUS
29	9299R-10200	WASHER	4	4	4	4	YMUS
30	9572R-10300	NUT, FLANGE	2	2	2	2	YMUS
31	GJ3-U5578-00	TAPE	2	2	2	2	YMUS

FIG. 21 OIL TANK

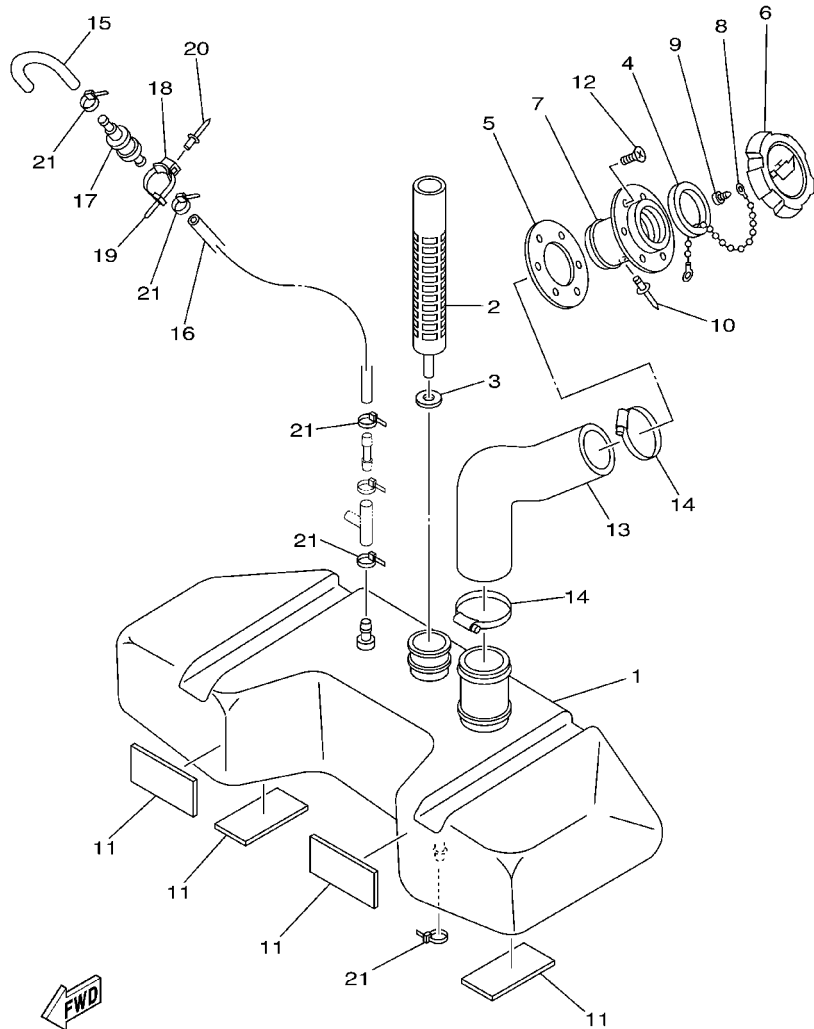

GU51110-9210

REF. NO.	PART NO.	DESCRIPTION	USA	CAN	GENE	JPN	REMARKS
1	GU5-U775B-01	TANK, OIL	1	1	1	1	YMUS
2	F0D-6775C-01	FILTER	1	1	1	1	
3	F0D-6775E-01	PACKING	1	1	1	1	
4	GJ3-U778C-00	PACKING,OIL CAP	1	1	1	1	YMUS
5	GJ3-U778E-00	PACKING,OIL FILLER	1	1	1	1	YMUS
6	GJ3-U778B-00	CAP,OIL FILLER	1	1	1	1	YMUS
7	GJ3-U778D-00	SOCKET,OIL FILLER	1	1	1	1	YMUS
8	EU0-U7835-00	CHAIN BALL	1	1	1	1	YMUS
9	97780-04110	SCREW, TAPPING	1	1	1	1	
10	90267-40935	RIVET, BLIND	1	1	1	1	
11	GJ1-U759C-00	MAT 2	4	4	4	4	YMUS
12	FX1-67869-00	SCREW, FLAT HEAD TAPPING	6	6	6	6	
13	GU5-U776C-00	HOSE,OIL FILLER	1	1	1	1	YMUS
14	90601-152U3	BAND, HOSE 52	2	2	2	2	YMUS
15	FJ0-U2158-00	HOSE	1	1	1	1	YMUS
16	GP7-U7856-00	HOSE, AIR VENT 3	1	1	1	1	YMUS
17	FJ0-67766-00	ROLL OVER VALVE	1	1	1	1	
18	90600-917U4	CLAMP COMP.	1	1	1	1	YMUS
19	90464-32801	CLAMP	1	1	1	1	YMUS
20	90267-48802	RIVET, BLIND	1	1	1	1	YMUS
21	90465-11829	CLAMP	5	5	5	5	YMUS

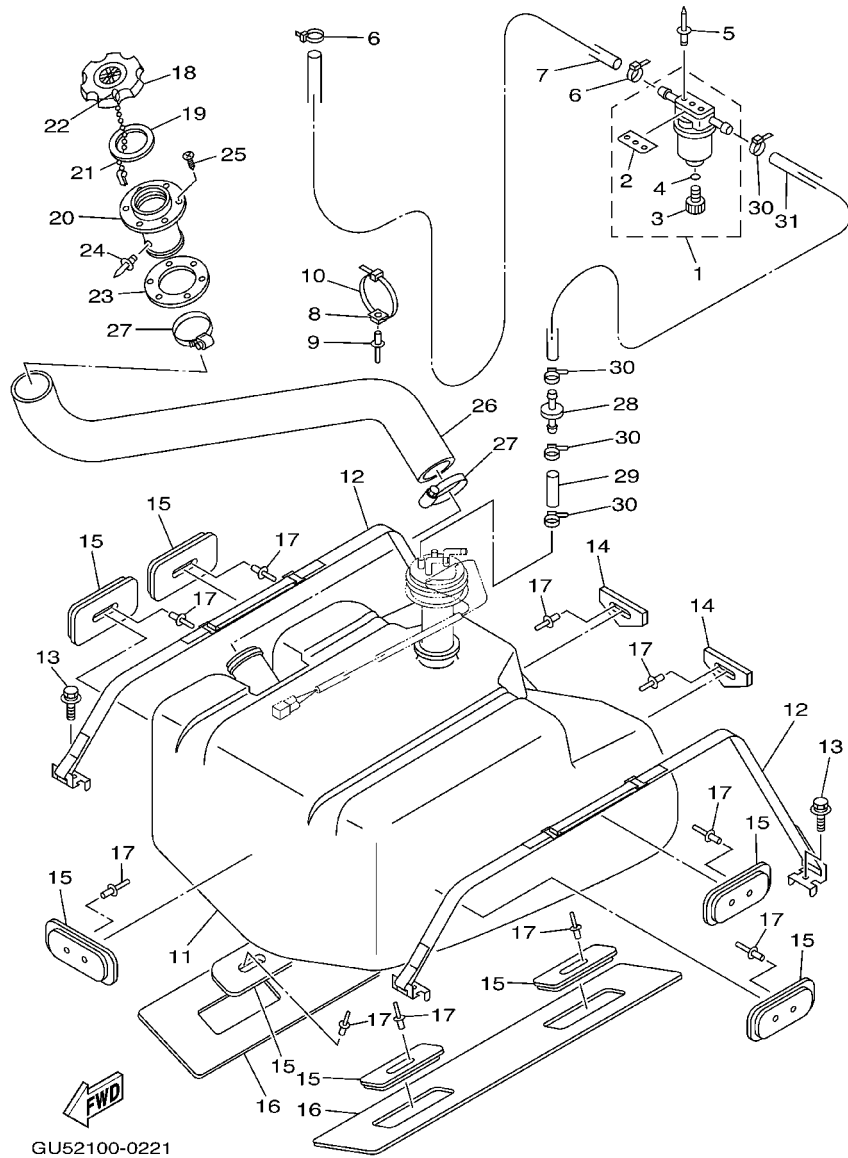

FIG. 22 FUEL TANK

REF. NO.	PART NO.	DESCRIPTION	USA	CAN	GENE	JPN	REMARKS
1	EW2-62140-00	FILTER, VENT ASSY	1	1	1	1	
2	EW2-62142-00	.PLATE, FILTER	1	1	1	1	
3	70R-24543-00	.PLUG, DRAIN	1	1	1	1	
4	70R-24489-00	.O-RING	1	1	1	1	
5	90267-489U2	RIVET, BLIND	2	2	2	2	YMUS
6	90465-11829	CLAMP	2	2	2	2	YMUS
7	GP7-U785G-10	HOSE, AIR VENT	1	1	1	1	YMUS
8	90600-917U4	CLAMP COMP.	1	1	1	1	YMUS
9	90267-48802	RIVET, BLIND	1	1	1	1	YMUS
10	90464-32801	CLAMP	1	1	1	1	YMUS
11	GU5-U7711-00	TANK, FUEL	1	1	1	1	YMUS
12	GH3-67743-01	BELT, TANK 1	2	2	2	2	
13	90119-089UN	BOLT, WITH WASHER	4	4	4	4	YMUS
14	GU5-U759B-00	MAT 1	2	2	2	2	YMUS
15	GU5-U759C-00	MAT 2	9	9	9	9	YMUS
16	GU5-U759D-00	MAT 3	2	2	2	2	YMUS
17	90267-489UK	RIVET, BLIND	22	22	22	22	YMUS
18	FN8-67831-01	CAP, FUEL FILLER	1	1	1	1	YB
19	EU0-67832-00	PACKING 1	1	1	1	1	
20	FN8-67833-00	SOCKET	1	1	1	1	
21	EU0-67835-00	CHAIN BALL	1	1	1	1	
22	EU0-67839-00	COUPLING	1	1	1	1	
23	EU0-67834-00	PACKING, FUEL FILLER	1	1	1	1	
24	90267-40935	RIVET, BLIND	1	1	1	1	
25	FX1-67869-00	SCREW, FLAT HEAD TAPPING	6	6	6	6	
26	GU5-U7844-00	HOSE	1	1	1	1	YMUS
27	90601-155U4	BAND, HOSE 55	2	2	2	2	YMUS

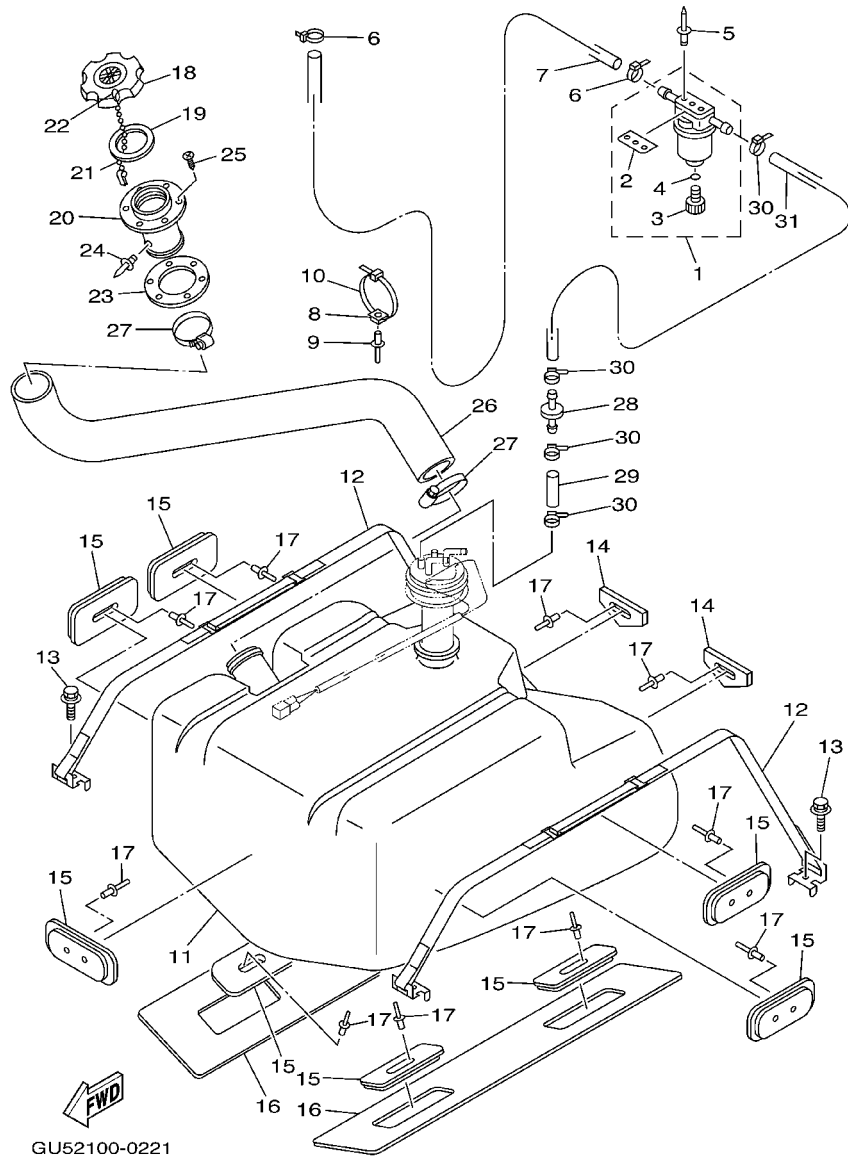
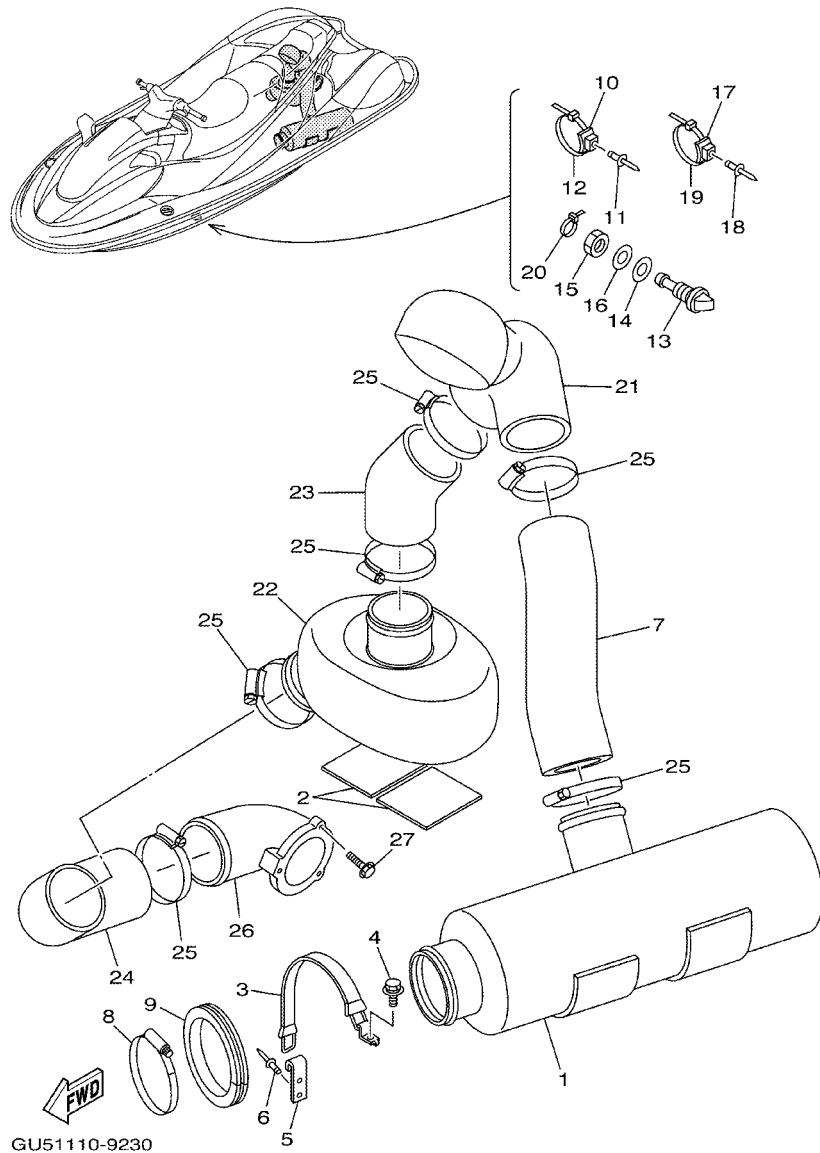

FIG. 22 FUEL TANK

REF. NO.	PART NO.	DESCRIPTION	USA	CAN	GENE	JPN	REMARKS
28	EU0-67767-31	CHECK VALVE	1	1	1	1	
29	GA7-U785G-00	HOSE, AIR VENT	1	1	1	1	YMUS
30	90465-11829	CLAMP	4	4	4	4	YMUS
31	GJ3-U7856-10	HOSE, AIR VENT 3	1	1	1	1	YMUS

FIG. 23 EXHAUST 2



REF. NO.	PART NO.	DESCRIPTION	USA	CAN	GENE	JPN	REMARKS
1	F0D-67550-03	WATER LOCK COMP.	1	1	1	1	
2	GJ3-U755J-00	MAT,WATER LOCK	2	2	2	2	YMUS
3	GU5-U7570-00	C HOOK COMP.	1	1	1	1	YMUS
4	90119-069UH	BOLT, WITH WASHER	1	1	1	1	YMUS
5	GA7-65772-00	HOOK A	1	1	1	1	
6	90267-48802	RIVET, BLIND	2	2	2	2	YMUS
7	F0D-6758B-00	HOSE,EXHAUST 1	1	1	1	1	
8	90601-B12U2	BAND, HOSE 120	1	1	1	1	YMUS
9	GU5-U5162-00	TRIM	1	1	1	1	YMUS
10	90600-917U4	CLAMP COMP.	1	1	1	1	YMUS
11	90267-48802	RIVET, BLIND	1	1	1	1	YMUS
12	90464-32801	CLAMP	1	1	1	1	YMUS
13	GJ1-6753B-02	PILOT,WATER	1	1	1	1	
14	GP3-U1438-00	PACKING	1	1	1	1	YMUS
15	GP7-61652-00	NUT	1	1	1	1	
16	9299R-14200	WASHER	1	1	1	1	YMUS
17	90600-917U4	CLAMP COMP.	1	1	1	1	YMUS
18	90267-48802	RIVET, BLIND	1	1	1	1	YMUS
19	90464-32801	CLAMP	1	1	1	1	YMUS
20	90465-11829	CLAMP	1	1	1	1	YMUS
21	F0D-6753D-01	RESONATOR, 2	1	1	1	1	
22	F0D-64261-02	TANK, WATER	1	1	1	1	
23	F0D-6758C-01	HOSE,EXHAUST2	1	1	1	1	
24	F0D-6758D-01	HOSE,EXHAUST 3	1	1	1	1	
25	90601-195UD	BAND, HOSE 95	6	6	6	6	YMUS
26	F0D-67565-01	THRU-HULL,EXHAUST	1	1	1	1	
27	90119-069UK	BOLT, WITH WASHER	3	3	3	3	YMUS

FIG. 24 CONTROL CABLE

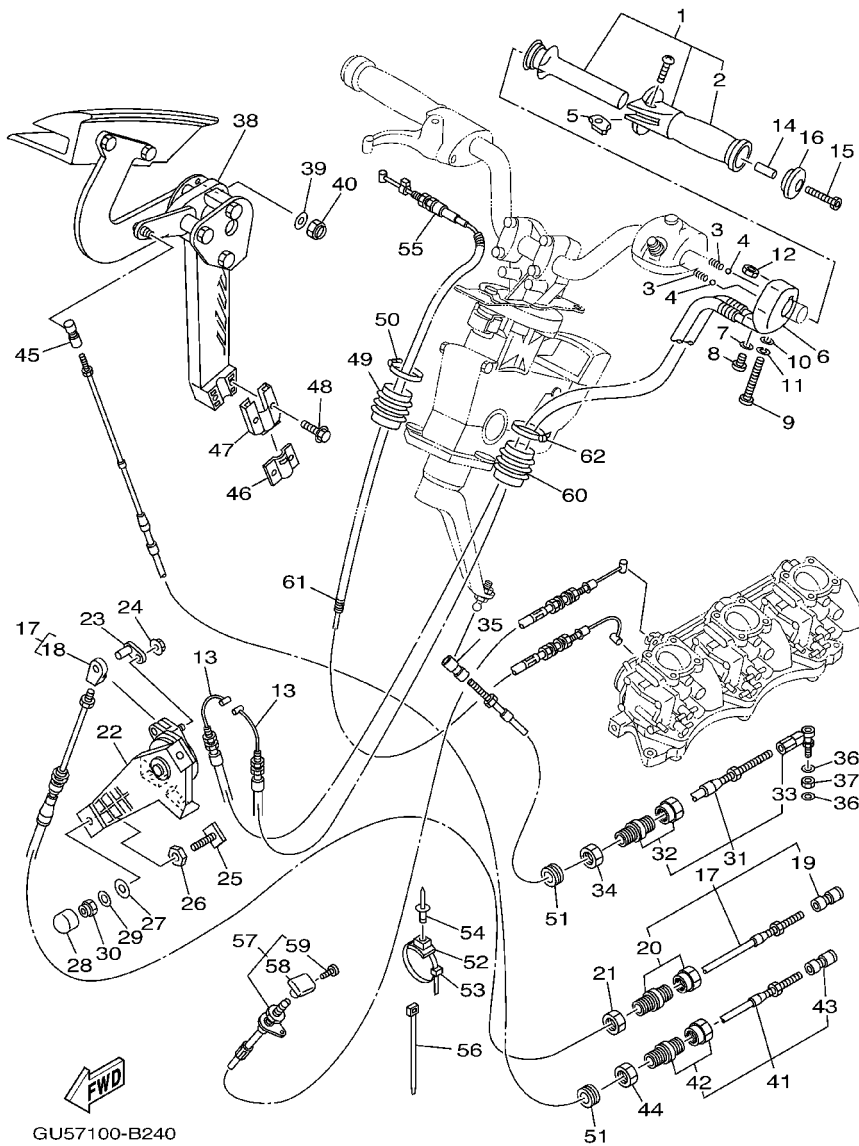

GU57100-B240

REF. NO.	PART NO.	DESCRIPTION	USA	CAN	GENE	JPN	REMARKS
1	GP7-U157A-00	GRIP HANDLE ASSY.	1	1	1	1	YMUS
2	GP7-U155C-00	.GRIP,HANDLE	1	1	1	1	YMUS
3	GP7-U152P-00	SPRING	2	2	2	2	YMUS
4	GP7-U152R-00	BALL	2	2	2	2	YMUS
5	GP7-U151M-00	LEVER ASSY	1	1	1	1	YMUS
6	GP7-U152M-00	HOUSING ASSY	1	1	1	1	YMUS
7	92990-04600	WASHER, PLATE	1	1	1	1	
8	98980-04010	SCREW, BIND	1	1	1	1	
9	97880-06065	SCREW, PAN HEAD	1	1	1	1	
10	92990-06600	WASHER, PLATE	1	1	1	1	
11	9299R-06100	WASHER	1	1	1	1	YMUS
12	GH1-U143B-00	NUT,SPECIAL	1	1	1	1	YMUS
13	F0D-U153D-01	CABLE,NOZZLE CONTROL 2	2	2	2	2	YMUS
14	90387-05800	COLLAR	1	1	1	1	YMUS
15	90110-05908	BOLT, HEXAGON SOCKET HEAD	1	1	1	1	
16	GP7-U155F-00	GRIP, END	1	1	1	1	YMUS
17	GU5-U153E-00	CABLE,NOZZLE CONTROL 3	1	1	1	1	YMUS
18	GH1-U046C-00	.END,CABLE	1	1	1	1	YMUS
19	EU0-U1461-30	.SHAFT, JOINT BALL	1	1	1	1	YMUS
20	EU0-67267-10	.CONNECTOR, CABLE	1	1	1	1	
21	EU0-62241-30	NUT, DRAIN 1	1	1	1	1	
22	F0D-U153J-10	REMOCON,NOZZLE 2	1	1	1	1	YMUS
23	F0D-U152C-10	PIN	1	1	1	1	YMUS
24	9572R-06300	NUT, FLANGE	1	1	1	1	YMUS
25	90109-06907	BOLT	2	2	2	2	
26	90179-06977	NUT	2	2	2	2	
27	90201-06906	WASHER, PLATE	2	2	2	2	

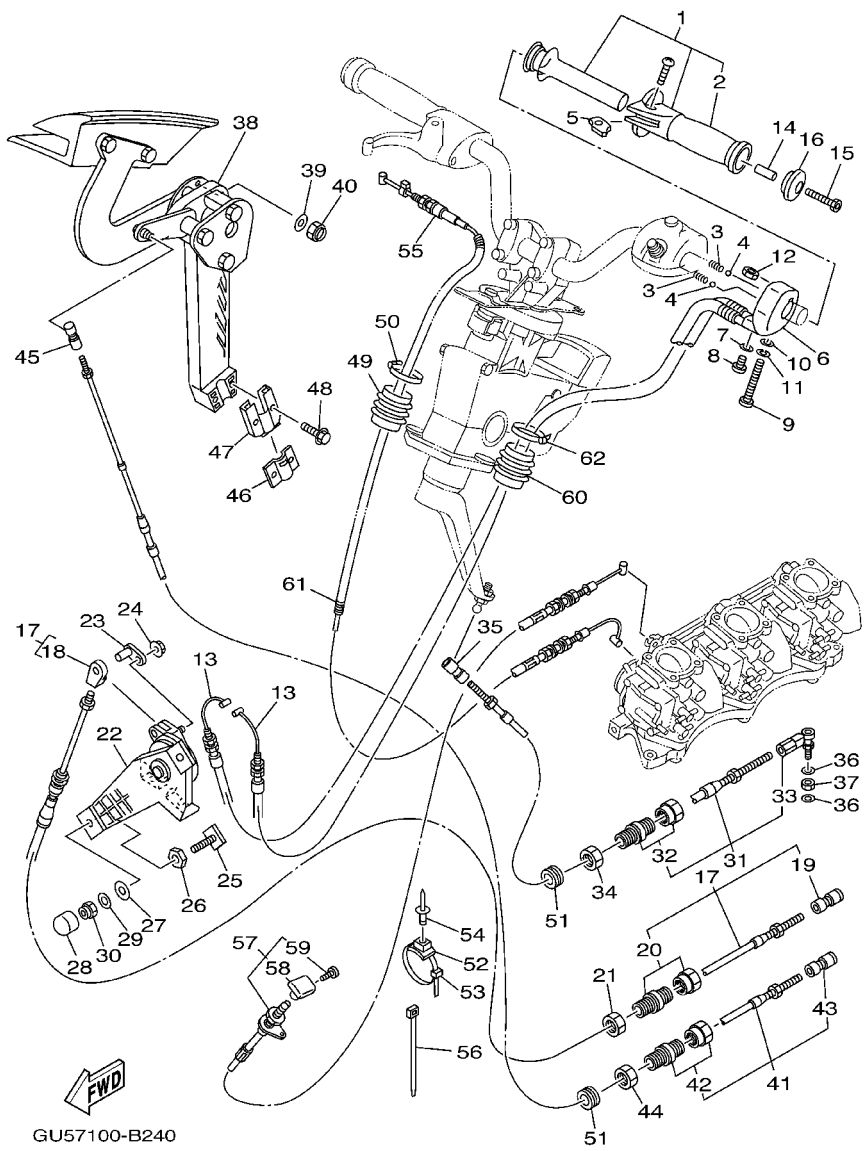

GU57100-B240

FIG. 24 CONTROL CABLE

REF. NO.	PART NO.	DESCRIPTION	USA	CAN	GENE	JPN	REMARKS
28	90190-06010	CLING	2	2	2	2	
29	9299R-06200	WASHER	2	2	2	2	YMUS
30	9572R-06300	NUT, FLANGE	2	2	2	2	YMUS
31	GU5-U1481-00	CABLE, STEERING	1	1	1	1	YMUS
32	GK5-67267-10	.CONNECTOR, CABLE	1	1	1	1	
33	GP8-U1461-T0	.STUD, JOINT BALL	1	1	1	1	YMUS
34	EU0-62241-30	NUT, DRAIN 1	1	1	1	1	
35	GK5-U146F-00	SHAFT, JOINT BALL	1	1	1	1	YMUS
36	90201-06906	WASHER, PLATE	2	2	2	2	
37	9538R-06700	NUT	1	1	1	1	YMUS
38	F0D-6134A-04	REMOCON. LEVER ASSY.	1	1	1	1	
39	9299R-06200	WASHER	3	3	3	3	YMUS
40	9572R-06300	NUT, FLANGE	3	3	3	3	YMUS
41	GU5-U149C-00	CABLE, REVERSE	1	1	1	1	YMUS
42	EU0-67267-10	.CONNECTOR, CABLE	1	1	1	1	
43	EU0-U1461-30	.SHAFT, JOINT BALL	1	1	1	1	YMUS
44	EU0-62241-30	NUT, DRAIN 1	1	1	1	1	
45	EU0-U1461-30	SHAFT, JOINT BALL	1	1	1	1	YMUS
46	GH1-61468-01	STOPPER, CABLE	1	1	1	1	
47	GU5-6146K-10	HOLDER, STOPPER	1	1	1	1	
48	90119-069UJ	BOLT, WITH WASHER	2	2	2	2	YMUS
49	GU5-6822E-00	GROMMET	1	1	1	1	
50	90601-200U1	BAND	1	1	1	1	YMUS
51	90480-279U1	GROMMET	2	2	2	2	YMUS
52	90600-917U4	CLAMP COMP.	1	1	1	1	YMUS
53	90464-32801	CLAMP	1	1	1	1	YMUS
54	90267-48802	RIVET, BLIND	1	1	1	1	YMUS

FIG. 24 CONTROL CABLE

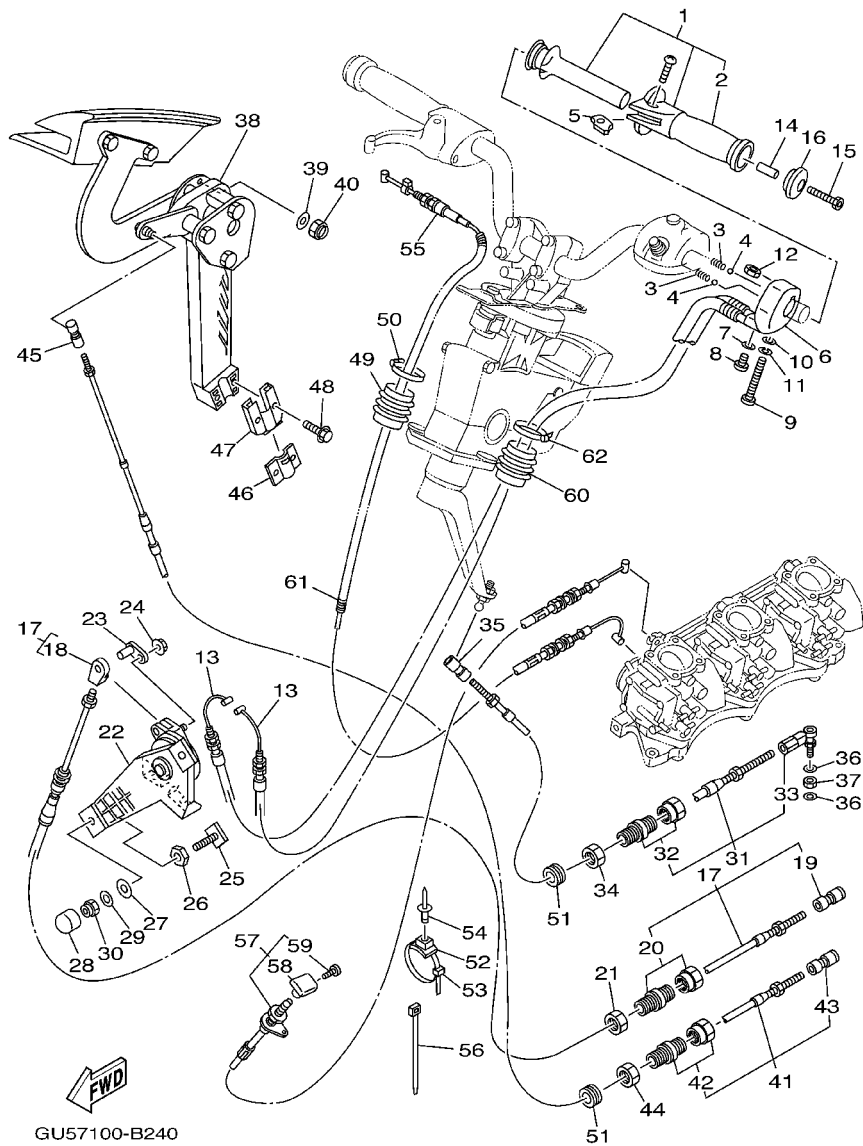

REF. NO.	PART NO.	DESCRIPTION	USA	CAN	GENE	JPN	REMARKS
55	GU5-U7252-00	CABLE, THROTTLE	1	1	1	1	YMUS
56	90464-32801	CLAMP	3	3	3	3	YMUS
57	F1D-67242-00	CABLE, CHOKE	1	1	1	1	
58	EW2-67243-00	.KNOB	1	1	1	1	
59	90149-03930	.SCREW	1	1	1	1	
60	GU5-6822E-00	GROMMET	1	1	1	1	
61	F0D-6773E-00	TUBE,2	1	1	1	1	
62	90601-200U1	BAND	1	1	1	1	YMUS

FIG. 25 STEERING 1

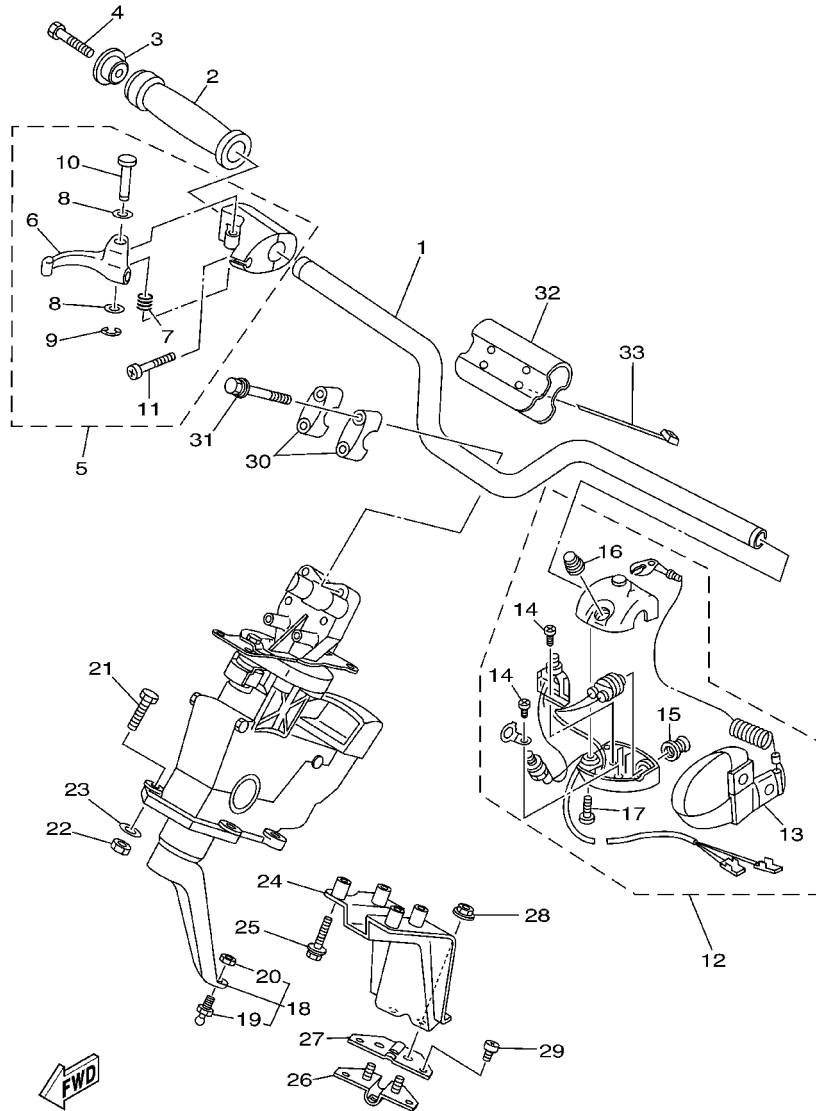

GU54100-2250

REF. NO.	PART NO.	DESCRIPTION	USA	CAN	GENE	JPN	REMARKS
1	F0D-U1552-00	HANDLE	1	1	1	1	YMUS
2	GP7-U155D-00	GRIP, HANDLE	1	1	1	1	YMUS
3	GP7-U155F-00	GRIP, END	1	1	1	1	YMUS
4	90110-05908	BOLT, HEXAGON SOCKET HEAD	1	1	1	1	
5	F0D-67250-03	THROTTLE LEVER ASSY	1	1	1	1	
6	F0D-67255-01	.LEVER, THROTTLE	1	1	1	1	
7	EW2-67256-00	.SPRING	1	1	1	1	
8	EW2-67258-01	.WASHER	2	2	2	2	
9	EW2-67259-01	.E-RING	1	1	1	1	
10	F0D-67257-00	.SHAFT	1	1	1	1	
11	98580-05025	.SCREW, PAN HEAD	2	2	2	2	
12	GP7-68310-01	SWITCH BOX ASSY	1	1	1	1	
13	EW2-68348-00	.LANYARD, STOP SWITCH	1	1	1	1	
14	97880-03008	.SCREW, PAN HEAD	2	2	2	2	
15	FK7-68312-02	.STOP BUTTON COMP	1	1	1	1	
16	FK7-68313-02	.START BUTTON COMP.	1	1	1	1	
17	97880-05025	.SCREW, PAN HEAD	2	2	2	2	
18	GU5-61400-03	STEERING MASTER ASSY	1	1	1	1	
19	EU0-61461-02	.STUD, JOINT BALL	1	1	1	1	
20	95720-06300	.NUT, SELF-LOCKING	1	1	1	1	
21	97080-08035	BOLT	4	4	4	4	
22	9572R-08300	NUT, FLANGE	4	4	4	4	YMUS
23	9299R-08200	WASHER	4	4	4	4	YMUS
24	GU5-61467-01	BRACKET,STOPPER CABLE	1	1	1	1	
25	90119-06964	BOLT, WITH WASHER	4	4	4	4	
26	GU5-61468-00	STOPPER, CABLE	1	1	1	1	
27	GU5-6146K-00	HOLDER, STOPPER	1	1	1	1	

FIG. 25 STEERING 1

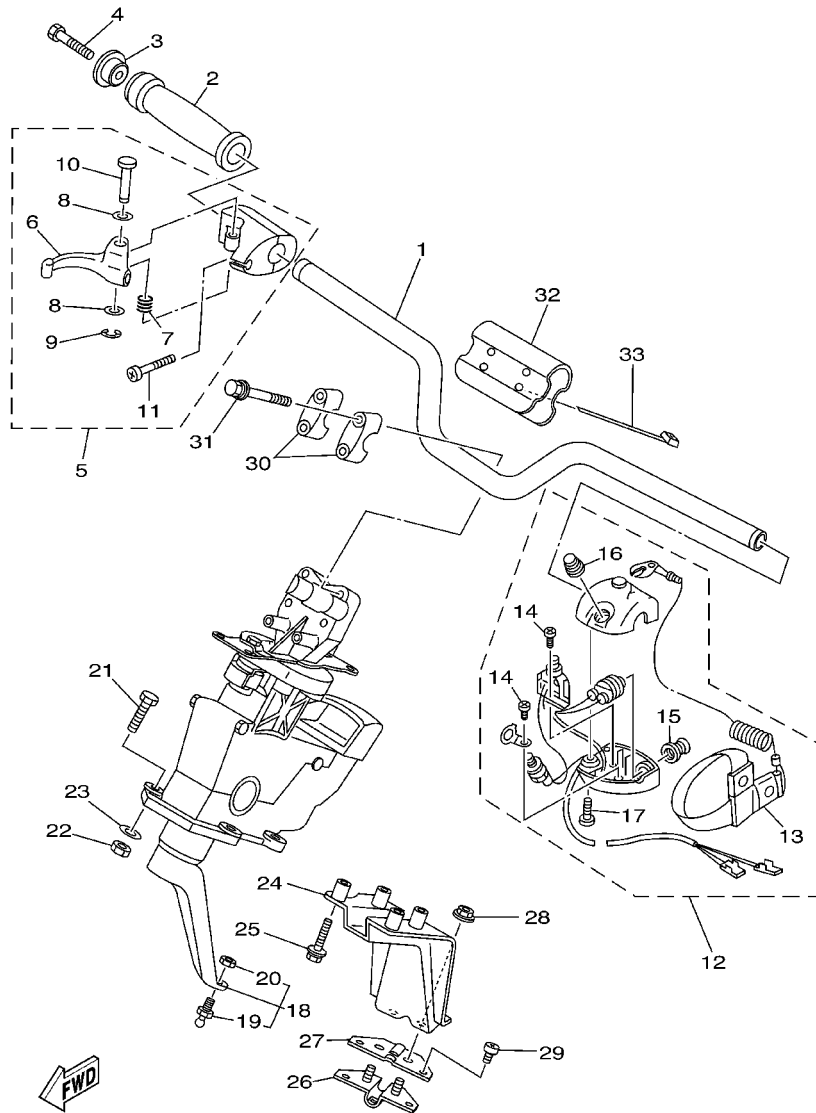

GU54100-2250

REF. NO.	PART NO.	DESCRIPTION	USA	CAN	GENE	JPN	REMARKS
28	9572R-06300	NUT, FLANGE	2	2	2	2	YMUS
29	98580-04506	SCREW, PAN HEAD	2	2	2	2	
30	EU0-23814-30	HOLDER, HANDLE UPPER	2	2	2	2	
31	90119-089UU	BOLT, WITH WASHER	4	4	4	4	YMUS
32	F0D-U156E-00	PAD 1	1	1	1	1	YMUS
33	90601-200U2	BAND	2	2	2	2	YMUS

FIG. 26 STEERING 2

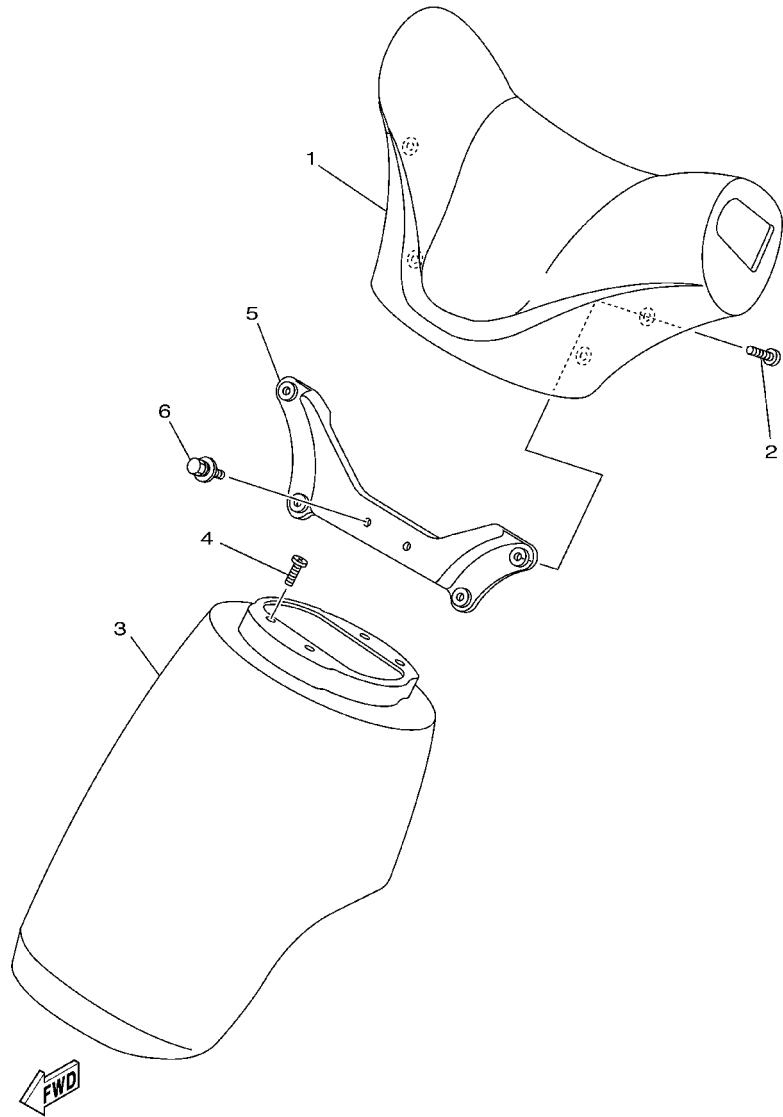

F0D1110-9280

REF. NO.	PART NO.	DESCRIPTION	USA	CAN	GENE	JPN	REMARKS
1	F0D-U143D-00	PAD, STEERING 1	1	1	1	1	BL, YMUS
2	90149-06910	SCREW	4	4	4	4	
3	F0D-U143E-00	PAD, STEERING 2	1	1	1	1	BL, YMUS
4	90149-06906	SCREW	4	4	4	4	
5	F0D-U142K-00	FIX, STEERING PAD	1	1	1	1	YMUS
6	90119-06854	BOLT, WITH WASHER	2	2	2	2	YMUS
<hr/>							
<hr/>							
<hr/>							
<hr/>							
<hr/>							
<hr/>							
<hr/>							
<hr/>							
<hr/>							
<hr/>							

FIG. 27 STERN HATCH

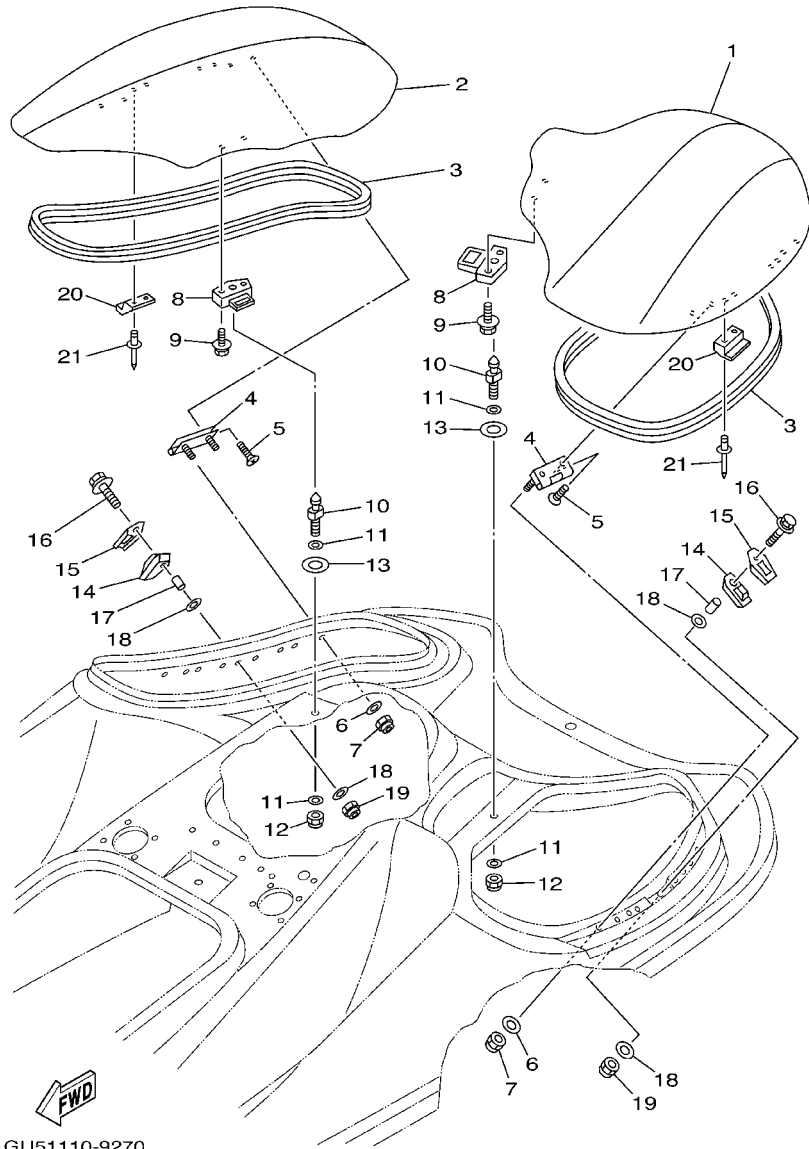

GU51110-9270

REF. NO.	PART NO.	DESCRIPTION	USA	CAN	GENE	JPN	REMARKS
1	GU5-U518P-10-5E	LOCKER STERN LID COMP.	1	1	1	1	WC5, YMUS
2	GU5-U518P-20-5E	LOCKER STERN LID COMP.	1	1	1	1	WC5, YMUS
3	GU5-U266C-00	PACKING 4	2	2	2	2	YMUS
4	GK5-6517D-00	HINGE, LID	4	4	4	4	
5	98780-05016	SCREW, FLAT HEAD	8	8	8	8	
6	90201-05800	WASHER, PLATE	8	8	8	8	YMUS
7	9572R-05300	NUT, FLANGE	8	8	8	8	YMUS
8	GJ3-63850-03	SEAT LOCK ASSY	2	2	2	2	
9	90119-06853	BOLT, WITH WASHER	4	4	4	4	YMUS
10	GH1-U3774-00	PIN	2	2	2	2	YMUS
11	9299R-10200	WASHER	4	4	4	4	YMUS
12	9572R-10300	NUT, FLANGE	2	2	2	2	YMUS
13	GJ3-U5578-00	TAPE	2	2	2	2	YMUS
14	GU5-6517P-00	SUPPORT, LID	2	2	2	2	
15	GU5-65175-00	PLATE, FIX	2	2	2	2	
16	90119-06808	BOLT, WITH WASHER	2	2	2	2	YMUS
17	90387-06900	COLLAR	2	2	2	2	
18	9299R-06200	WASHER	4	4	4	4	YMUS
19	9572R-06300	NUT, FLANGE	2	2	2	2	YMUS
20	GU5-U515D-00	DAMPER 1	2	2	2	2	GY, YMUS
21	90267-489UE	RIVET, BLIND	4	4	4	4	YMUS

FIG. 28 STERN LOCKER

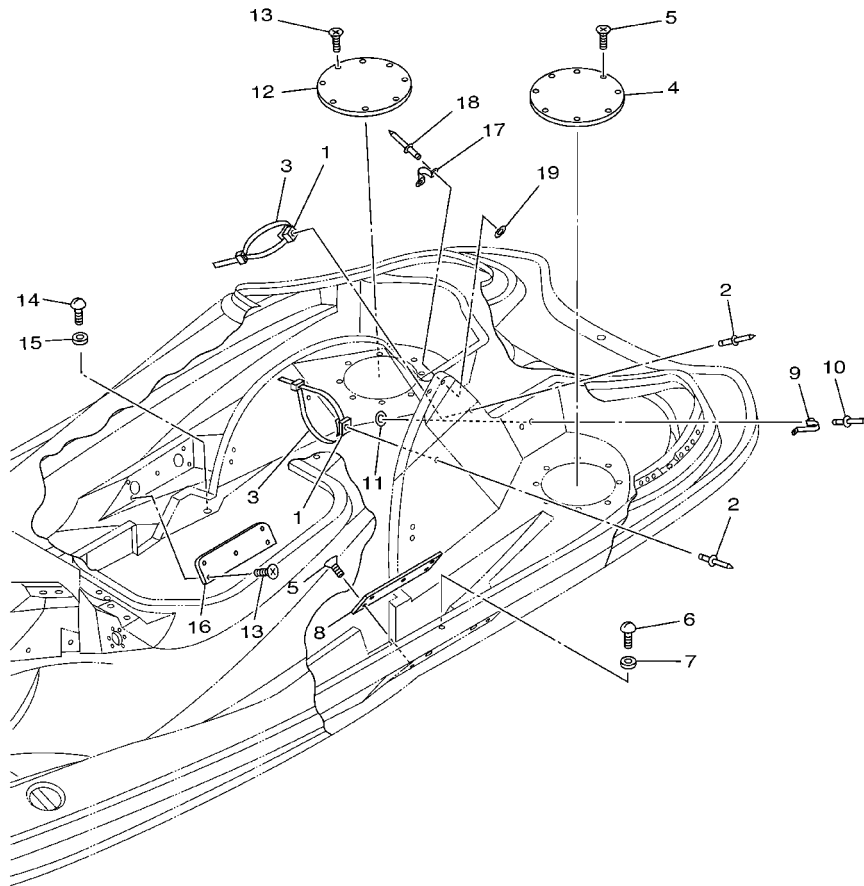

REF. NO.	PART NO.	DESCRIPTION	USA	CAN	GENE	JPN	REMARKS
1	90600-917U4	CLAMP COMP.	2	2	2	2	YMUS
2	90267-48802	RIVET, BLIND	2	2	2	2	YMUS
3	90464-32801	CLAMP	2	2	2	2	YMUS
4	GU5-U7861-00	COVER INSPECTION	1	1	1	1	YMUS
5	97780-40712	SCREW, TAPPING	13	13	13	13	
6	90149-10900	SCREW	1	1	1	1	
7	F0D-6515E-00	DAMPER 2	1	1	1	1	
8	GU5-65784-00	COVER INSPECTION	1	1	1	1	
9	GU5-U6319-00	EYE STRAP	4	4	4	4	YMUS
10	90267-40803	RIVET, BLIND	8	8	8	8	YMUS
11	92990-04200	WASHER, PLAIN	4	4	4	4	
12	GU5-U7861-00	COVER INSPECTION	1	1	1	1	YMUS
13	97780-40712	SCREW, TAPPING	13	13	13	13	
14	90149-10900	SCREW	1	1	1	1	
15	F0D-6515E-00	DAMPER 2	1	1	1	1	
16	GU5-65784-00	COVER INSPECTION	1	1	1	1	
17	GU5-U6319-00	EYE STRAP	4	4	4	4	YMUS
18	90267-40803	RIVET, BLIND	8	8	8	8	YMUS
19	92990-04200	WASHER, PLAIN	4	4	4	4	



GU53100-1280

FIG. 29 GRAPHICS

REF. NO.	PART NO.	DESCRIPTION	USA	CAN	GENE	JPN	REMARKS
1	GU5-U417D-40	GRAPHIC 3	1	1	1	1	LH, YMUS
2	GU5-U417E-40	GRAPHIC 4	1	1	1	1	RH, YMUS
3	GU5-U417F-40	GRAPHIC 5	1	1	1	1	LH, YMUS
4	GU5-U417G-40	GRAPHIC 6	1	1	1	1	RH, YMUS
5	GU5-U417H-40	GRAPHIC 7	1	1	1	1	LH, YMUS
6	GU5-U417J-40	GRAPHIC 8	1	1	1	1	RH, YMUS
7	GU5-U417K-40	GRAPHIC 9	1	1	1	1	LH, YMUS
8	GU5-U417L-40	GRAPHIC B	1	1	1	1	RH, YMUS
9	GU5-U4123-10	EMBLEM,3	2	2	2	2	YMUS
10	F1B-U411H-00	EMBLEM, TUNING FORK	1	1	1	1	YMUS
11	F1F-U4122-00	EMBLEM 2	2	2	2	2	RH,LH, YMUS
12	GU5-U411C-00	EMBLEM, YAMAHA	1	1	1	1	YMUS
13	EU0-65986-00	TOOL SET	1	1	1	1	
14	EU0-65901-01	TOOL BAG	1	1	1	1	

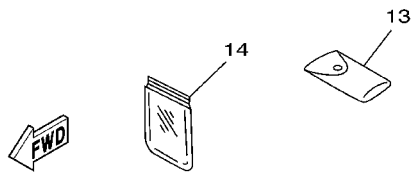
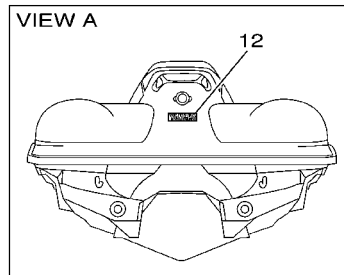
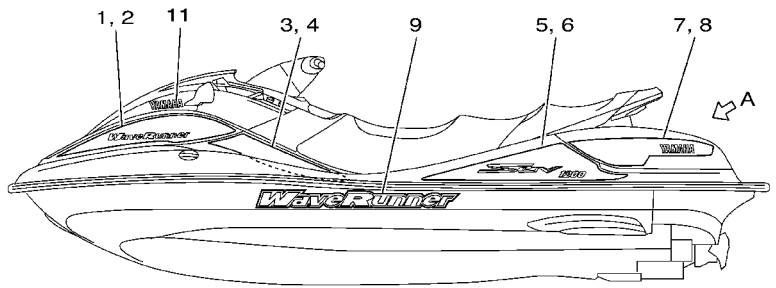
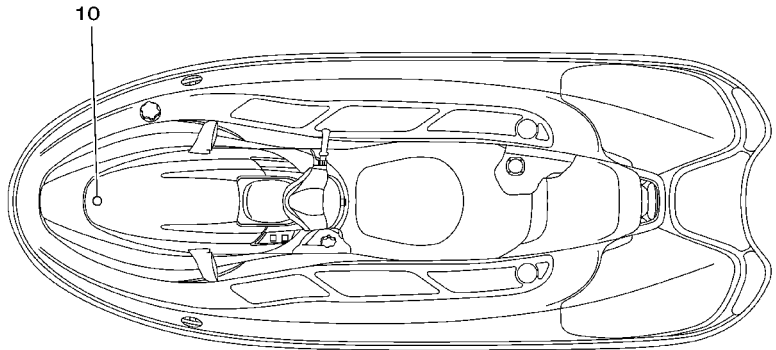

GU57100-B290

FIG. 30 IMPORTANT LABELS

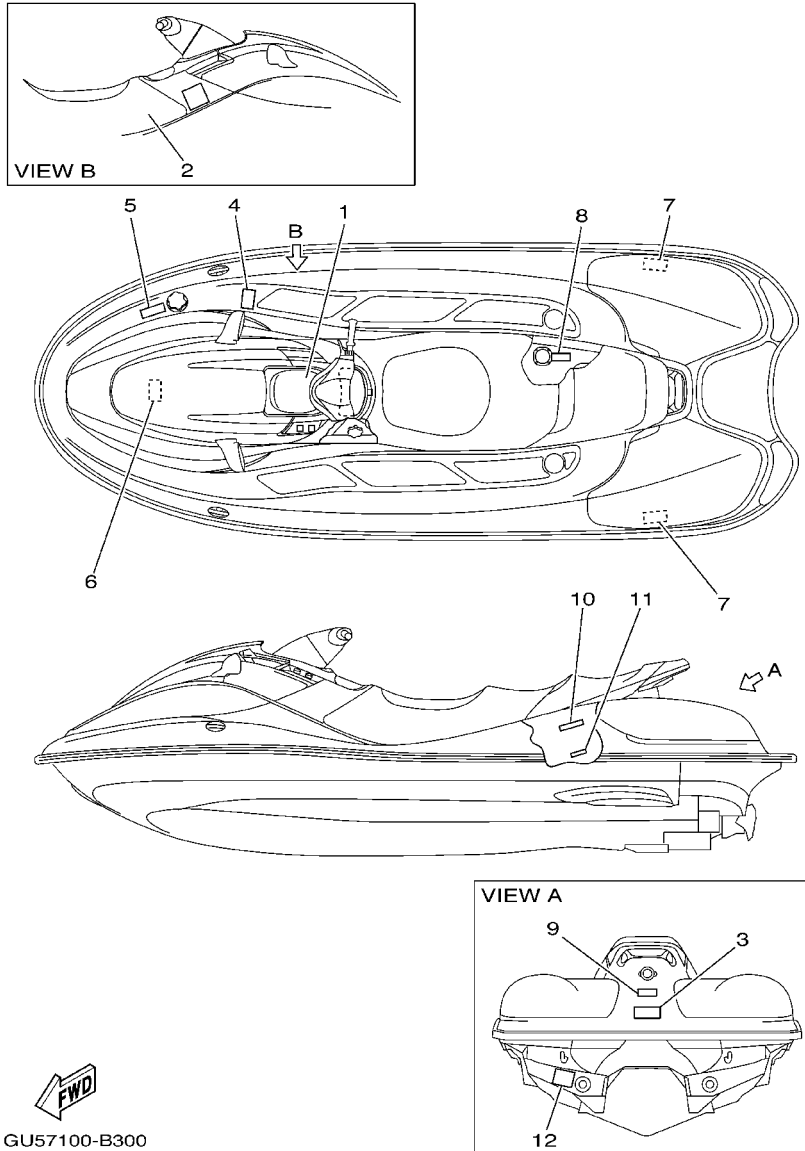

GU57100-B300

REF. NO.	PART NO.	DESCRIPTION	USA	CAN	GENE	JPN	REMARKS
1	GU5-U41B1-01	LABEL, WARNING JDC 1	1				YMUS
2	GU5-U41B2-00	LABEL, WARNING JDC 2	1				YMUS
3	F0P-U41D1-00	LABEL, WARNING BODY CAVITIES	1				YMUS
4	F0P-U41D5-00	LABEL, WARNING SHIFT LEVER	1				YMUS
5	GU5-U415B-20	LABEL, WARNING(FUEL)	1				YMUS
6	GU5-U416T-00	LABEL, WARNING COMPARTMENT 1	1				YMUS
7	GU5-U416U-00	LABEL, WARNING COMPARTMENT 2	2				YMUS
8	GU5-U41DB-00	LABEL, WARNING BATTERY	1				YMUS
9	GU5-U41D9-00	LABEL, WARNING CLEAT GRIP	1				YMUS
10	F0M-U41F6-00	LABEL, FIRE EXTINGUISHER 2	1				YMUS
11	GU5-U41G1-00	LABEL, CAPACITY	1				YMUS
12	GU5-U419B-00	LABEL 1	1				YMUS

FIG. 31 IMPORTANT LABELS 2

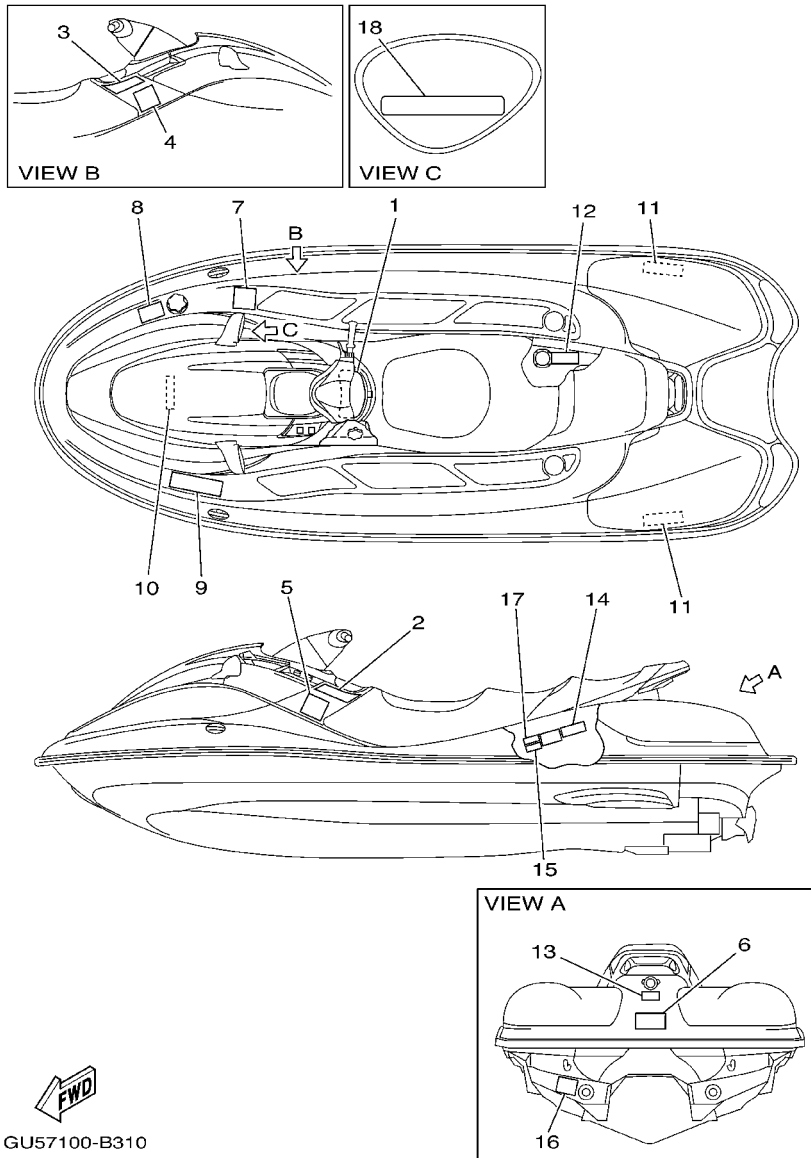

REF. NO.	PART NO.	DESCRIPTION	USA	CAN	GENE	JPN	REMARKS
1	GU5-U41B1-11	LABEL, WARNING JDC 1		1	1		YMUS
2	GU5-U41B1-21	LABEL, WARNING JDC 1		1	1		YMUS
3	GU5-U41B1-30	LABEL, WARNING JDC 1		1	1		YMUS
4	GU5-U41B2-00	LABEL, WARNING JDC 2		1	1		YMUS
5	GU5-U41B2-10	LABEL, WARNING JDC 2		1	1		YMUS
6	F0P-U41D1-10	LABEL, WARNING BODY CAVITIES		1	1		YMUS
7	F0P-U41D5-10	LABEL, WARNING SHIFT LEVER		1	1		YMUS
8	GU5-U415B-10	LABEL, WARNING(FUEL)		1	1		YMUS
9	GJ3-U416H-00	LABEL,WARNING(FRANCE)			1		YMUS
10	GU5-U416T-10	LABEL, WARNING COMPARTMENT 1		1	1		YMUS
11	GU5-U416U-10	LABEL, WARNING COMPARTMENT 2		2	2		YMUS
12	GU5-U41DB-10	LABEL, WARNING BATTERY		1	1		YMUS
13	GU5-U41D9-10	LABEL, WARNING CLEAT GRIP		1	1		YMUS
14	F0M-U41F6-11	LABEL, FIRE EXTINGUISHER 2		1	1		YMUS
15	GU5-U41G1-10	LABEL, CAPACITY		1	1		YMUS
16	GU5-U419B-00	LABEL 1		1	1		YMUS
17	GJ3-U419E-00	LABEL 4		1			YMUS
18	GJ1-U419F-21	LABEL,5		2	2		YMUS

FIG. 32 IMPORTANT LABELS 3

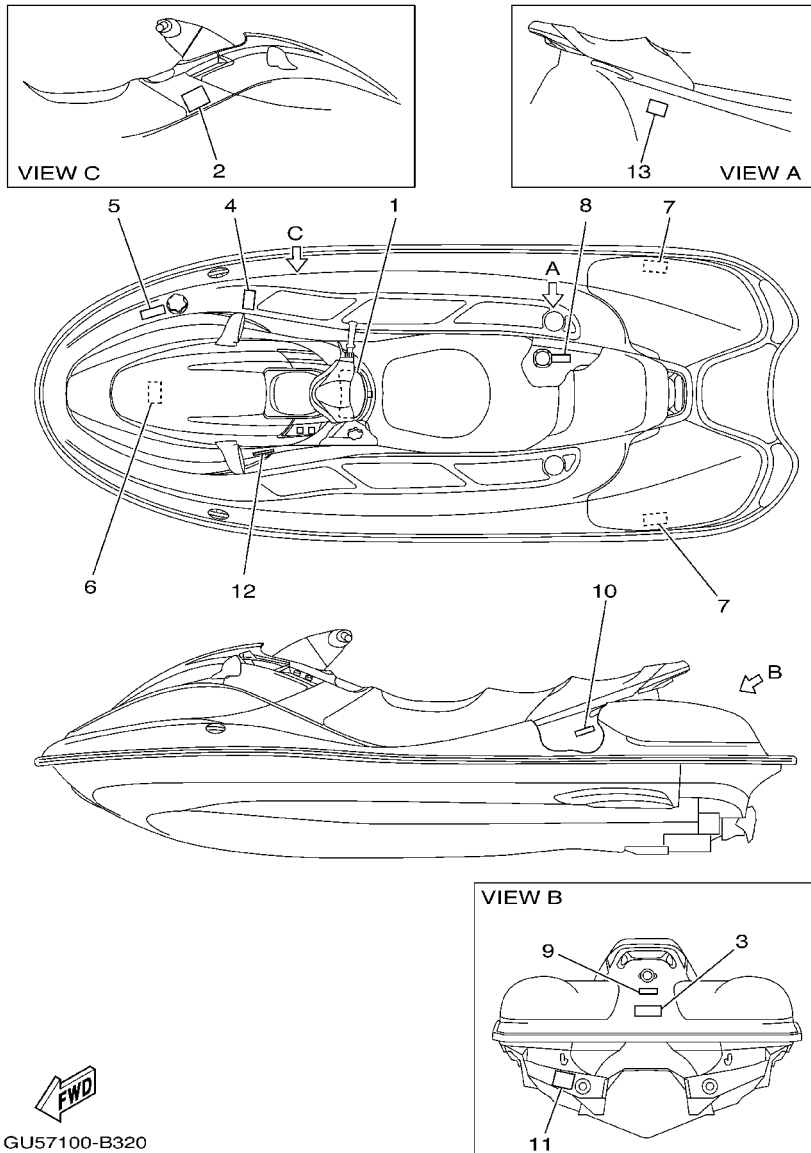

REF. NO.	PART NO.	DESCRIPTION	USA	CAN	GENE	JPN	REMARKS
1	GU5-U41B1-40	LABEL, WARNING JDC 1				1	YMUS
2	GU5-U41B2-20	LABEL, WARNING JDC 2				1	YMUS
3	GU5-U41D1-00	LABEL, WARNING BODY CAVITIES				1	YMUS
4	GU5-U41D5-00	LABEL, WARNING SHIFT LEVER				1	YMUS
5	GU5-U415B-30	LABEL, WARNING(FUEL)				1	YMUS
6	GU5-U416T-20	LABEL, WARNING COMPARTMENT 1				1	YMUS
7	GU5-U416U-20	LABEL, WARNING COMPARTMENT 2				2	YMUS
8	GU5-U41DB-20	LABEL, WARNING BATTERY				1	YMUS
9	GU5-U41D9-20	LABEL, WARNING CLEAT GRIP				1	YMUS
10	GU5-U41G1-20	LABEL, CAPACITY				1	YMUS
11	GU5-U419B-00	LABEL 1				1	YMUS
12	FN8-U411B-00	PLATE,ASSY				1	YMUS
13	A00-64197-20	PLATE, CAPACITY (4P)				1	

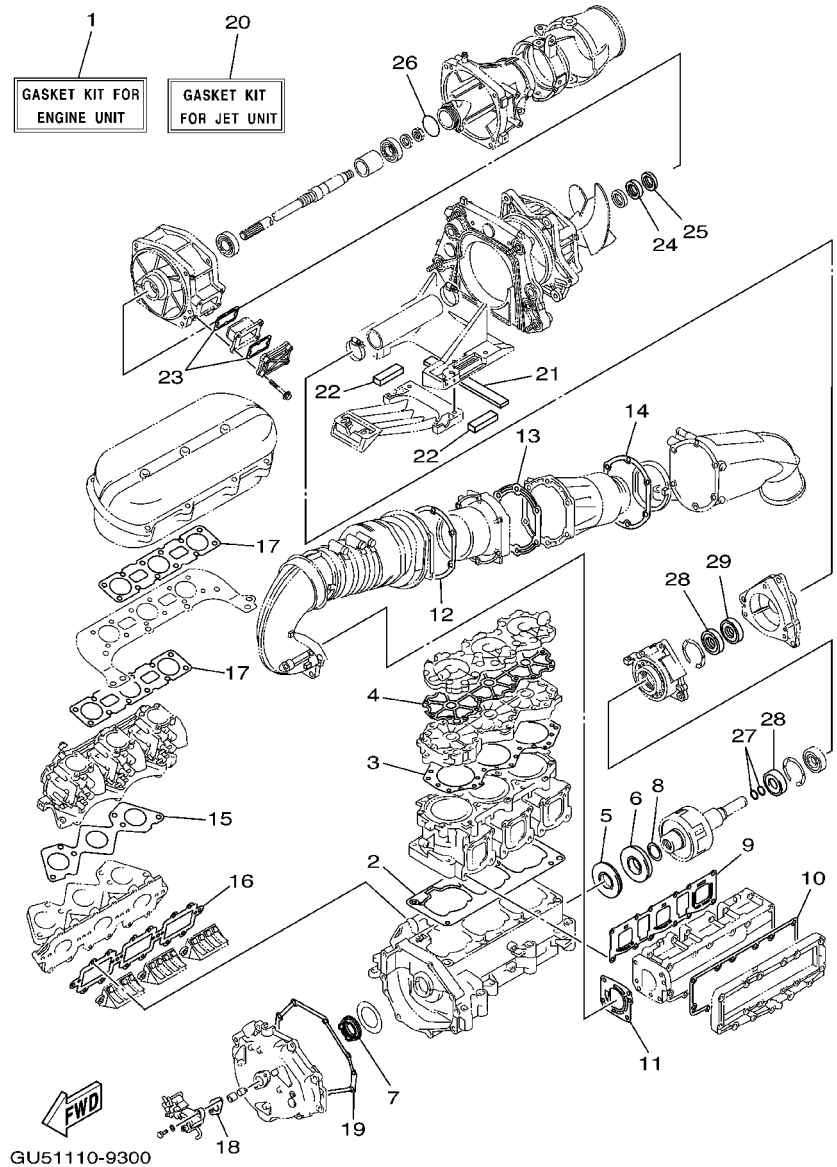

FIG. 33 REPAIR KIT 1

REF. NO.	PART NO.	DESCRIPTION	USA	CAN	GENE	JPN	REMARKS
1	65U-W0001-00	GASKET KIT FOR ENGINE UNIT	1	1	1	1	
2	63M-11351-01	.GASKET, CYLINDER	1	1	1	1	
3	65U-11181-00	.GASKET, CYLINDER HEAD 1	1	1	1	1	
4	63M-11193-00	.GASKET, HEAD COVER 1	1	1	1	1	
5	93102-36M33	.OIL SEAL	1	1	1	1	
6	93101-36M46	.OIL SEAL	1	1	1	1	
7	93103-32M01	.OIL SEAL	1	1	1	1	
8	62T-45127-00	.SEAL	1	1	1	1	
9	65U-14613-00	.GASKET, EXHAUST PIPE	1	1	1	1	
10	63M-14739-00	.GASKET, MUFFLER DAMPER 1	1	1	1	1	
11	63M-14749-00	.GASKET, MUFFLER DAMPER 2	1	1	1	1	
12	63M-41114-00	.GASKET, EXHAUST OUTER COVER	1	1	1	1	
13	63M-41122-00	.GASKET, EXHAUST INNER COVER	1	1	1	1	
14	63M-41114-00	.GASKET, EXHAUST OUTER COVER	1	1	1	1	
15	65U-13556-00	.GASKET, MANIFOLD	1	1	1	1	
16	65U-13566-00	.GASKET	1	1	1	1	
17	65U-13674-00	.GASKET, AIR COOLER COVER 1	2	2	2	2	
18	63M-13116-00	.GASKET, PUMP CASE	1	1	1	1	
19	63M-81365-00	.GASKET, HOLE COVER	1	1	1	1	
20	66V-W0001-20	GASKET KIT FOR JET UNIT	1	1	1	1	
21	66V-51367-00	.FELT, PACKING	1	1	1	1	
22	66V-51368-00	.FELT, PACKING	1	1	1	1	
23	66V-42414-00	.O-RING	2	2	2	2	
24	93101-28M66	.OIL SEAL	1	1	1	1	
25	93101-28M65	.OIL SEAL	1	1	1	1	
26	93210-46M16	.O-RING	1	1	1	1	
27	93210-19MJ4	.O-RING	2	2	2	2	

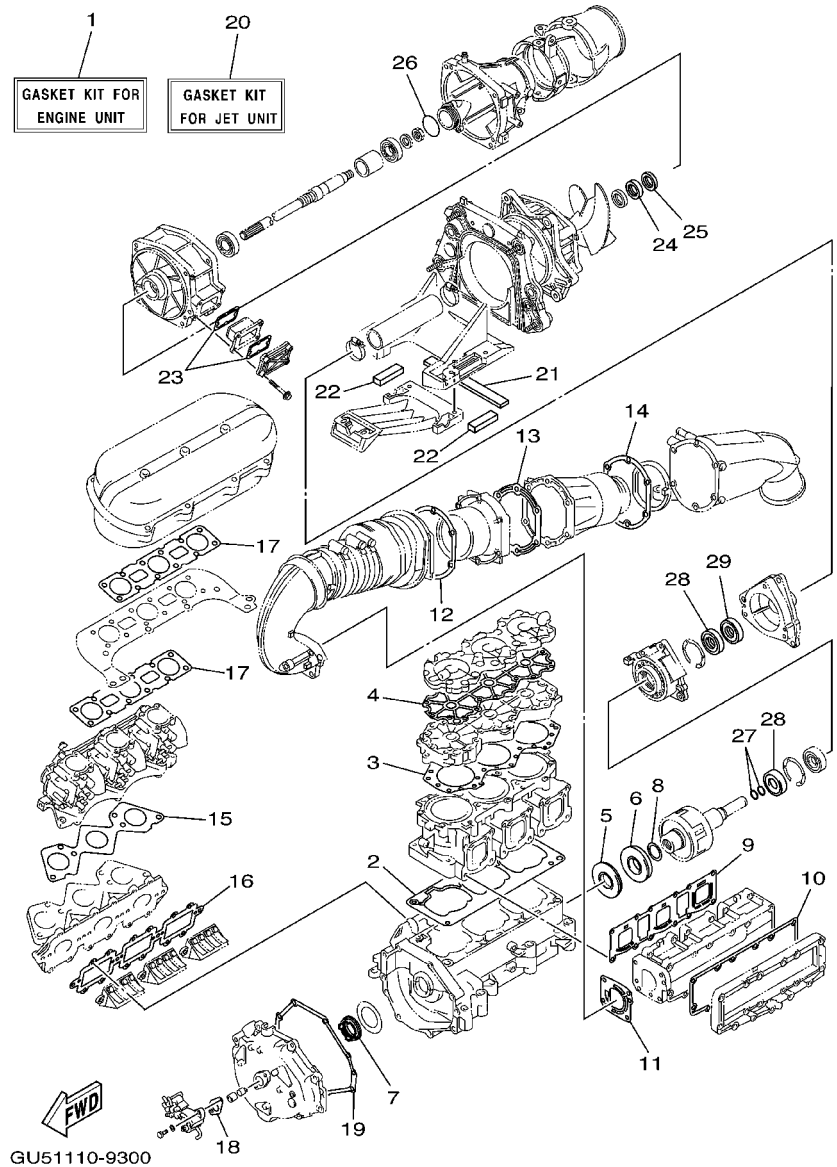
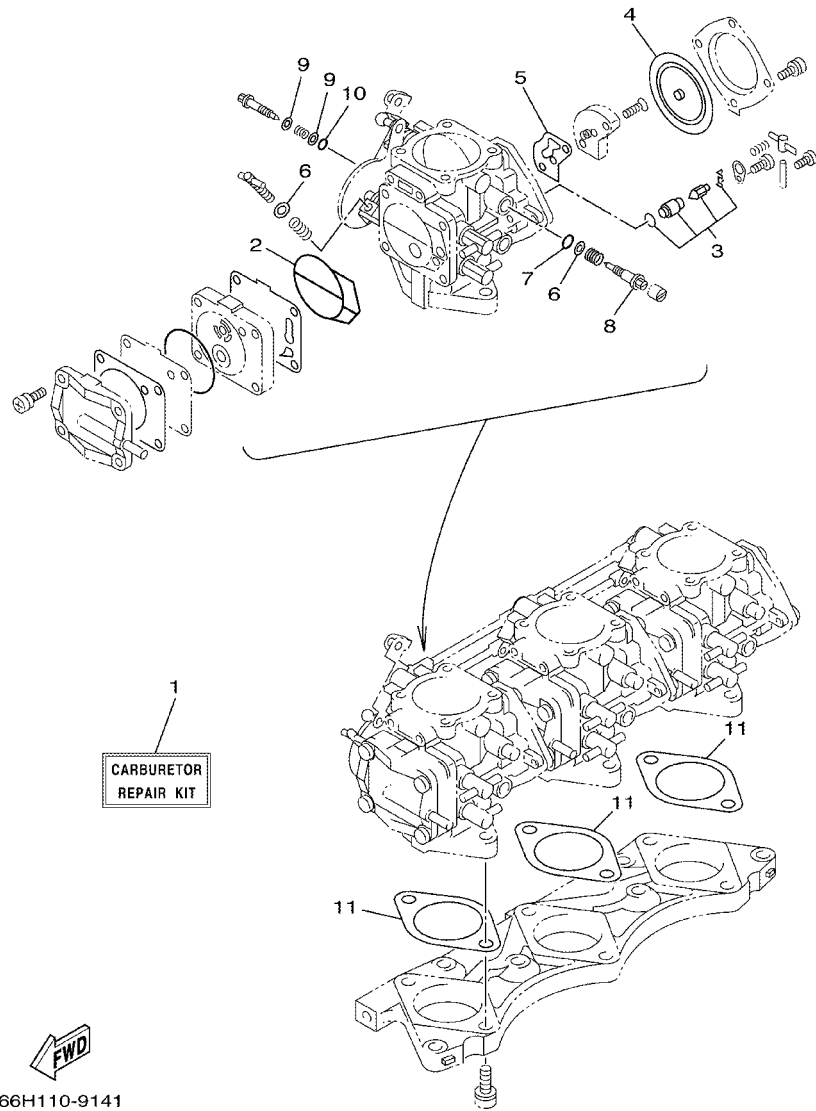

FIG. 33 REPAIR KIT 1

REF. NO.	PART NO.	DESCRIPTION	USA	CAN	GENE	JPN	REMARKS
28	93101-25M55	.OIL SEAL	2	2	2	2	
29	93101-25M56	.OIL SEAL	1	1	1	1	

FIG. 34 REPAIR KIT 2



REF. NO.	PART NO.	DESCRIPTION	USA	CAN	GENE	JPN	REMARKS
1	65U-W0093-00	CARBURETOR REPAIR KIT	1	1	1	1	
2	6K8-14564-00	.O-RING	3	3	3	3	
3	64T-14916-00	.NEEDLE	3	3	3	3	
4	6R7-14541-00	.DIAPHRAGM, PUMP	3	3	3	3	
5	6K8-14536-11	.GASKET	3	3	3	3	
6	812-14235-00	.WASHER, NEEDLE	4	4	4	4	
7	812-14147-00	.O-RING	3	3	3	3	
8	6K8-14946-10	.METERING NEEDLE	3	3	3	3	
9	822-14235-00	.WASHER, NEEDLE	3	3	3	3	
10	583-14561-00	.O-RING	3	3	3	3	
11	64X-14398-00	.GASKET	3	3	3	3	

66H110-9141

NUMERICAL INDEX

PART NO.	GRID NO.	PART NO.	GRID NO.	PART NO.	GRID NO.	PART NO.	GRID NO.	PART NO.	GRID NO.	PART NO.	GRID NO.
66G-G5831-02	C-3	GU5-U2664-00	D-8	GU5-U415B-20	E-9	GU5-U7570-00	D-13	6M6-11412-00	B-4	830-1423A-70	B-8
65A-R1129-00	C-3	F0D-U271B-00	D-8	GU5-U415B-30	E-11	GU5-U759B-00	D-11	6M6-11422-00	B-4	3G2-14231-27	B-8
66V-R1313-01	C-4	F0R-U271B-00	D-8	GJ3-U416H-00	E-10	GJ1-U759C-00	D-10	65U-11422-00	B-4	830-14231-19	B-8
66G-R1321-00	C-3	F0D-U273B-00	C-5	GU5-U416T-00	E-9	GU5-U759C-00	D-11	6M6-11431-10	B-4	830-14231-20	B-8
65A-R1326-00	C-3	GU5-U351C-10	D-6	GU5-U416T-10	E-10	GU5-U759D-00	D-11	6M6-11442-01	B-4	812-14235-00	B-9
66V-R1348-10	C-4	GU5-U351D-10	D-6	GU5-U416T-20	E-11	GD0-U761D-00	D-4	65U-11445-00	B-4		E-14
GH1-U046C-00	D-14	GU5-U351H-00	D-6	GU5-U416U-00	E-9	GP1-U7617-00	D-6	63M-11452-00	B-4	822-14235-00	B-9
F0D-U142K-00	E-5	GU5-U351J-00	D-6	GU5-U416U-10	E-10	GU5-U7711-00	D-11	65U-11515-00	B-4		E-14
GH1-U143B-00	D-14	GJ3-U352E-40	D-6	GU5-U416U-20	E-11	GU5-U775B-01	D-10	65U-11603-01	B-4	65U-14243-00	B-9
F0D-U143D-00	E-5	GU5-U3581-10	D-6	GU5-U417D-40	E-8	GU5-U776C-00	D-10	65U-11604-01	B-4	62T-14251-10	B-2
F0D-U143E-00	E-5	GU5-U371A-40	D-8	GU5-U417E-40	E-8	GJ3-U778B-00	D-10	65U-11605-01	B-4	63M-14253-00	B-8
GP3-U1438-00	D-13	GU5-U371B-40	D-8	GU5-U417F-40	E-8	GJ3-U778C-00	D-10	65U-11605-01	B-4	65U-14255-00	B-7
GH3-U146E-00	C-4	GU5-U372A-40	D-8	GU5-U417G-40	E-8	GJ3-U778D-00	D-10	62T-11633-00	B-5	65U-14283-00	B-6
66V-U146E-00	C-7	GU5-U372B-40	D-8	GU5-U417H-40	E-8	GJ3-U778E-00	D-10	65U-11635-02	B-4	65U-14284-02-8P	B-8
GK5-U146F-00	D-15	GH1-U3774-00	D-9	GU5-U417J-40	E-8	EU0-U7835-00	D-10	65U-11636-02	B-4	66G-14301-02	B-8
EU0-U1461-30	D-14		E-6	GU5-U417K-40	E-8	GU5-U7844-00	D-11	64X-11651-01	B-4	66G-14302-02	B-8
	D-15	GU5-U41B1-01	E-9	GU5-U417L-40	E-8	GA7-U785G-00	D-12	82M-11685-00	B-4	66G-14303-02	B-8
GP8-U1461-T0	D-15	GU5-U41B1-11	E-10	GU5-U419B-00	E-9	GP7-U785G-10	D-11	63M-12576-00	B-13	64X-14398-00	B-9
GU5-U1481-00	D-15	GU5-U41B1-21	E-10		E-10	GU2-U785H-00	C-13	63M-12577-00	B-13		E-14
GU5-U149C-00	D-15	GU5-U41B1-30	E-10	GJ3-U419E-00	E-11	GJ3-U7856-10	D-12	66G-12578-00	B-14	62T-14435-00	B-6
GP7-U151M-00	D-14	GU5-U41B1-40	E-11	GJ1-U419F-21	E-10	GP7-U7856-00	D-10	64T-12580-00	B-15	65U-14451-00	B-6
F0D-U152C-10	D-14	GU5-U41B2-00	E-9	GP7-U5114-00	C-15	GU5-U7861-00	D-3	63M-12581-00	B-15	65U-14469-00	B-6
GP7-U152M-00	D-14		E-10	GU5-U515D-00	E-6		E-7	67X-12590-00	B-15	6K8-14471-10	B-9
GP7-U152P-00	D-14	GU5-U41B2-10	E-10	F0D-U516N-50-P0	C-15	GJ1-U8K31-02	C-4	67X-12590-10	B-15	65U-14477-00	B-6
GP7-U152R-00	D-14	GU5-U41B2-20	E-11	GU5-U5162-00	D-13	EU0-U8221-00	C-13	67X-12590-20	B-15	6K8-14503-02	B-8
F0D-U153D-01	D-14	GU5-U41DB-00	E-9	F0D-U517B-10-P7	D-2	F0V-U824B-01	C-13	63M-13116-00	B-11	6M6-14503-00	B-8
GU5-U153E-00	D-14	GU5-U41DB-10	E-10	F0D-U517H-50-P1	C-15	F0D-U824C-10	C-14		E-12	6K8-14521-10	B-8
F0D-U153J-10	D-14	GU5-U41DB-20	E-11	GU5-U518P-10-5E	E-6	F0D-U8341-00	C-14	63M-13132-00	B-11	6M6-14521-01	B-9
GP7-U155C-00	D-14	F0P-U41D1-00	E-9	GU5-U518P-20-5E	E-6	GJ1-U835D-00	C-5	65U-13132-00	B-11	6K8-14523-11	B-9
GP7-U155D-00	E-3	F0P-U41D1-10	E-10	F0D-U519D-00	C-15	GU5-U8532-00	D-6	67X-13183-00	B-11	6K8-14527-11	B-9
GP7-U155F-00	D-14	GU5-U41D1-00	E-11	GJ3-U5578-00	D-9	GU5-U883B-00	C-6		B-12	65U-14527-01	B-6
	E-3	F0P-U41D5-00	E-9		E-6	65U-W0001-00	E-12	66G-13200-01	B-11	6K8-14536-11	B-8
F0D-U1552-00	E-3	F0P-U41D5-10	E-10	F0D-U5646-00	D-2	66V-W0001-20	E-12	66G-13416-00	B-11		E-14
F0D-U156E-00	E-4	GU5-U41D5-00	E-11	F0D-U596B-00	D-2	65U-W0004-00	B-6	6E5-13552-00	B-6	6R7-14541-00	B-8
GP7-U157A-00	D-14	GU5-U41D9-00	E-9	F0D-U596C-00	D-2	65U-W0090-03-8P	B-2	65U-13554-00	B-11		E-14
GP1-U1629-00	D-8	GU5-U41D9-10	E-10	GU5-U6319-00	E-7	65U-W0093-00	E-14	65U-13555-00-8P	B-6	6R7-14542-00	B-8
GU5-U213F-00	D-7	GU5-U41D9-20	E-11	GP1-U7227-00	D-3	65U-11111-00-94	B-2	65U-13556-00	B-6	6K8-14547-01	B-8
GU5-U213G-00	D-7	F0M-U41F6-00	E-9	GP1-U7228-00	D-3	65U-11181-00	B-2		E-12	583-14561-00	B-9
FJ0-U2158-00	D-10	F0M-U41F6-11	E-10	GD0-U7249-00-05	C-6		E-12	65U-13566-00	B-6		E-14
GU5-U2287-00	D-6	GU5-U41G1-00	E-9	GD0-U7249-00-10	C-6	63M-11191-00-94	B-2		E-12	6K8-14563-00	B-8
GU5-U251D-00	D-6	GU5-U41G1-10	E-10	GU5-U7252-00	E-2	63M-11193-00	B-2	65U-13610-00	B-6	6K8-14564-00	B-8
GU5-U2512-00	D-6	GU5-U41G1-20	E-11	EU0-U7354-00-01	B-3		B-2	65U-13674-00	B-7		E-14
GU5-U2519-00	D-6	FN8-U411B-00	E-11	EU0-U7354-00-03	B-3	65U-11311-00-94	B-2		E-12	6R7-14569-00	B-8
GU5-U252C-00	D-6	GU5-U411C-00	E-8	EU0-U7354-00-05	B-3	6E5-11325-00	B-2	47X-14133-00	B-9	6K8-14589-00	B-9
GU5-U252D-00	D-6	F1B-U411H-00	E-8	EU0-U7354-00-10	B-3	63M-11351-01	B-2	812-14147-00	B-9	6K8-14591-10	B-8
GU5-U266B-00	D-8	F1F-U4122-00	E-8	EU0-U7354-00-20	B-3		E-12		E-14	65U-14613-00	B-13
GU5-U266C-00	E-6	GU5-U4123-10	E-8	GJ3-U755J-00	D-13	676-11372-00	C-8	64X-14162-00	B-9		E-12
GU5-U2663-00	D-2	GU5-U415B-10	E-10			65U-11400-00	B-4	439-14186-00	B-9	63M-14615-00	B-13

NUMERICAL INDEX

PART NO.	GRID NO.	PART NO.	GRID NO.	PART NO.	GRID NO.	PART NO.	GRID NO.	PART NO.	GRID NO.	PART NO.	GRID NO.
62T-14625-00	B-13	63M-41138-00	B-14	GU5-6146K-00	E-3	GA7-65772-00	D-13	F0D-6820A-41	C-13	63M-82370-01	C-10
63M-14680-00	B-14	65U-41217-00	B-9	GU5-6146K-10	D-15	GU5-65784-00	E-7	GK5-68211-00	C-13	66G-82553-00	C-11
63M-14711-00-94	B-13	66V-42414-00	C-3	EU0-61461-02	E-3	EU0-65901-01	E-8	GA7-68218-00	C-13	65U-82560-10	C-11
63M-14712-00-9P	B-13		E-12	GU5-61467-01	E-3	EW2-65912-00	C-13	GU2-6822E-01	D-2	6R7-83623-40	C-11
63M-14718-00-9P	B-13	66V-44121-00	C-7	GH1-61468-01	D-15	DW2-65913-00	C-13	GU5-6822E-00	D-15	6R7-83623-50	C-12
63M-14721-00-94	B-14	66V-44125-00	C-7	GU5-61468-00	E-3	GK5-6593H-00	C-13		E-2	63N-83623-00	C-12
63M-14739-00	B-13	63M-44517-01-5B	B-3	GU5-61624-00	D-4	GK5-65983-00	C-13	F0D-68238-10	C-13	682-84385-01	B-15
	E-12	66G-44532-00	B-3	GU5-61628-00	D-8	EU0-65986-00	E-8	GP7-68310-01	E-3	65U-85510-01	C-8
63M-14749-00	B-13	663-45119-00	B-7	EU0-61652-00	B-15	F1D-67242-00	E-2	FK7-68312-02	E-3	65U-8552A-00-5B	C-10
	E-12	62T-45127-00	B-5		D-4	EW2-67243-00	E-2	FK7-68313-02	E-3	65U-8552E-00	C-11
66G-14752-00	B-15		E-12	GP7-61652-00	D-13	F0D-67250-03	E-3	EW2-68348-00	E-3	65U-85525-00	C-11
63M-14771-00-94	B-14	66V-45214-00-94	C-3	GU5-61685-01	D-5	F0D-67255-01	E-3	GU5-68376-00	C-13	65U-85540-00	C-10
64T-14916-00	E-14	66G-45331-00-94	C-6	F0D-62127-00	D-7	EW2-67256-00	E-3	GK5-6883E-00	C-6	65U-85542-00	C-11
64T-14916-01	B-8	66G-45332-00-94	C-6	F0D-62139-00	D-7	F0D-67257-00	E-3	GU5-6883N-00	D-4	65U-85546-00	C-10
65U-14923-10	B-9	61L-45378-00	C-6	61L-45378-00	D-11	EW2-67258-01	E-3	GU5-6883P-00	D-4	65U-85550-00	C-8
3KW-14932-00	B-9	68Y-45511-00	C-3	EW2-62142-00	D-11	EW2-67259-01	E-3	65U-81317-10	C-11	65U-85570-00	C-10
6K8-14946-10	B-9	62T-45526-00	B-4	GK5-62149-00	D-7	EU0-67267-10	D-14	6M6-8132W-00	C-11	66G-85570-10	C-10
	E-14	65V-45538-00	C-3	GJ3-6215F-00	D-7		D-15	65U-81328-00	C-8	66G-85570-20	C-10
65U-15100-00-8P	B-2	63M-4581J-00	B-5	GP7-62159-01	D-7	EU0-67267-20	C-4	65U-81337-00-8P	C-8	65U-85580-00	C-8
63M-15761-00	B-14	63M-45813-01-8P	B-5	EU0-62241-30	C-5	GK5-67267-10	D-15	63M-81365-00	C-8	90101-06806	C-7
63M-21415-03-94	B-2	64X-45813-00-8P	B-5		D-14	GU5-67354-00	C-5		E-12	90105-08M66	B-14
63M-21425-01-94	B-3	66V-46882-00	C-3	EU0-62280-00	D-4	GJ1-6753B-02	D-13	63M-81800-00	C-9	90105-10M60	B-14
EU0-23814-30	E-4	68N-5112T-00	D-4	EU0-62282-00	D-4	F0D-6753D-01	D-13	3AJ-81809-00	C-9	90105-10M88	B-14
65U-24314-01	B-9	6K8-51129-00	B-2	EU0-62283-00	D-4	F0D-67550-03	D-13	6M6-81826-00	C-9	90109-05MA0	B-6
65U-24315-01	B-9		B-13	EU0-62285-01	D-4	F0D-67565-01	D-13	6M6-8183E-01	C-9		C-10
6G8-24376-00	B-11		B-14	EU0-62285-01	D-4	F0D-6758B-00	D-13	6M6-81830-00	C-9	90109-06M76	B-7
6R3-24377-00	B-13	63M-51129-00	B-13	GK5-6266J-00	C-13	F0D-6758C-01	D-13	63M-81830-00	C-9	90109-06M98	B-3
63M-24378-00	B-11	66G-51129-00	C-3	FN8-6269B-00	D-4	F0D-6758D-01	D-13	6M6-81840-10	C-9	90109-06907	D-14
6K8-24411-20	B-8	66G-51129-10	C-3	F0D-62875-00	C-15	FJ0-67618-00	D-4	11H-81844-00	C-9	90109-08879	C-7
6R7-24412-01	B-9	66V-51129-10	C-3	GK5-63768-00	C-13	F0D-6773E-00	E-2	6M6-81844-00	C-11	90109-10M72	C-8
6M6-24413-01	B-8	66G-51190-00-94	C-4	GU5-63774-00	D-2	GH3-67743-01	D-11	1FK-81847-00	C-9	90110-05908	D-14
6K8-24421-10	B-8	66V-51311-00-94	C-4	GU5-6378D-00	D-8	F0D-6775C-01	D-10	6M6-81850-00	C-9		E-3
65U-24421-00	B-8	66V-51312-01-94	C-3	F0D-63850-01	D-8	F0D-6775E-01	D-10	6M6-81865-00	C-9	90116-08M60	B-6
6K8-24431-20	B-8	66V-51314-00	C-7	GJ3-63850-03	E-6	FJ0-67766-00	D-10	6M6-81866-00	C-9	90119-06800	C-3
6K8-24452-10	B-8	66V-51315-00-94	C-3	A00-64197-20	E-11	EU0-67767-31	D-12	65U-81921-00	C-11	90119-06803	C-15
70R-24489-00	D-11	66V-51318-00-94	C-4	F0D-64261-02	D-13	F0D-6777C-00	C-2	68N-81940-00	C-10		D-8
65U-24492-00	B-8	68N-51323-00	C-6	F0D-65116-00	C-15	EU0-67816-30	C-2	6H2-81960-00	C-11	90119-06808	E-6
66V-24500-02	C-2	66V-51333-00-94	C-4	F0D-6515A-04	D-2	EU0-67817-00	C-2	EU0-82110-09	C-13	90119-06820	D-8
70R-24543-00	D-11	63M-51334-00	C-4	F0D-6515E-00	D-2	FN8-67831-01	D-11	61L-82117-10	C-10	90119-06824	D-8
66V-24560-00	C-2	66V-51341-00-94	C-7		E-7	EU0-67832-00	D-11	62E-82117-20	C-10	90119-06835	C-3
66H-26320-00	B-11	66V-51367-00	C-4	F0D-6517C-04	D-2	FN8-67833-00	D-11	64T-82117-00	C-14	90119-06853	D-8
63M-41113-00-94	B-14		E-12	GK5-6517D-00	E-6	EU0-67834-00	D-11	703-82119-00	C-10		E-6
63M-41114-00	B-14	66V-51368-00	C-4	GU5-6517P-00	E-6	EU0-67835-00	D-11	6H5-82127-00	C-8	90119-06854	E-5
	E-12		E-12	F0D-6517R-00	C-15	EU0-67839-00	D-11	65U-82150-00	C-10	90119-069UB	C-3
63M-41121-00-94	B-14	64Y-51381-00	C-6	F0D-6517T-00	C-15	FX1-67869-00	D-10	6G1-82151-00	C-10		C-7
63M-41122-00	B-14	61L-5169A-00	B-7	GU5-65175-00	E-6		D-11	6R7-82351-00	C-11	90119-069UC	C-5
	E-12	F0D-6134A-04	D-15	F0D-6518E-01	D-2	F0E-6815D-00	C-10	66G-82351-00	C-11	90119-069UD	C-6
63M-41123-00-94	B-14	GU5-61400-03	E-3	GA7-65772-00	C-13	F0D-6820A-31	C-13	6R7-82352-00	C-11		C-7

NUMERICAL INDEX

PART NO.	GRID NO.	PART NO.	GRID NO.	PART NO.	GRID NO.	PART NO.	GRID NO.	PART NO.	GRID NO.	PART NO.	GRID NO.
90119-069UH	C - 15	90201-06802	D - 2	90387-10M09	C - 7	90464-32801	D - 10	90600-917U4	D - 15	9299R-14200	D - 13
	D - 13		D - 8	90387-32M02	B - 4		D - 11		E - 7	9299R-16600	C - 3
90119-069UJ	D - 15	90201-06808	D - 5	90445-07M11	B - 11		D - 13	90600-91755	D - 4	92990-04200	E - 7
90119-069UK	C - 5	90201-06906	D - 14	90445-07007	B - 11		D - 15	90600-918U3	C - 4	92990-04600	D - 14
	D - 13		D - 15	90445-09M21	C - 6		E - 2	90601-B12U2	D - 13	92990-05600	B - 6
90119-06959	C - 10	90201-088T2	C - 7	90445-09M31	B - 7		E - 7	90601-118UF	B - 15	92990-06100	C - 9
90119-06964	E - 3	90201-08800	D - 4	90445-11M59	C - 2	90464-99800	D - 2		C - 4	92990-06600	D - 14
90119-06966	D - 2		D - 8	90445-11M60	C - 2	90465-06M67	C - 8	90601-152U3	C - 6	92995-05600	B - 6
90119-08M02	B - 13	90201-099U1	C - 6	90445-11M61	C - 2	90465-11M10	B - 7		D - 6	92995-06100	C - 10
90119-08M55	B - 2	90201-099U3	B - 3	90445-11M62	C - 2		B - 9		D - 10		C - 11
90119-08M95	B - 2	90201-10940	C - 5	90445-11M63	C - 2		B - 10	90601-155U4	D - 11	92995-06600	B - 11
90119-08M96	B - 2	90201-20M04	B - 5	90445-11M64	B - 9		B - 11	90601-162U5	C - 13		B - 13
90119-08M97	B - 2	90201-248M5	B - 5	90445-14M05	B - 14		B - 12	90601-195UD	D - 13		C - 10
90119-08M98	B - 13	90202-229U1	C - 2	90445-14M22	B - 13		B - 13	90601-200U1	D - 4		C - 11
90119-08801	C - 6	90267-40803	E - 7	90445-14898	C - 4		B - 14		D - 15	92995-08600	C - 8
90119-089UE	C - 4	90267-40935	D - 10	90445-16M08	C - 4		C - 2		E - 2		C - 11
90119-089UF	C - 6		D - 11	90445-18M13	B - 14		C - 6	90601-200U2	C - 2	93101-25M55	C - 6
	C - 7	90267-48802	C - 2	90445-18M14	B - 15		C - 8		D - 3		E - 13
90119-089UN	D - 2		C - 10	90445-19M09	D - 4		C - 10		E - 4	93101-25M56	C - 6
	D - 11		C - 13	90445-19M12	D - 4		C - 11	90601-200U7	D - 7		E - 13
90119-089UR	B - 3		D - 2	90446-07M35	B - 11	90465-11829	C - 2	90601-200U8	D - 7	93101-28M65	C - 3
90119-089UU	E - 4		D - 3	90446-07M36	B - 11		C - 4	90605-502U1	D - 3		E - 12
90119-089U5	B - 3		D - 10	90446-07M74	B - 12		C - 6	90605-502U2	C - 15	93101-28M66	C - 3
90119-089U6	C - 5		D - 11	90446-17MA7	C - 2		D - 7	90656-67100	C - 13		E - 12
90119-10M02	B - 2		D - 13	90446-17MA8	C - 2		D - 10	91318-06014	C - 8	93101-36M46	B - 4
	B - 3		D - 15	90446-17M72	B - 11		D - 11	91318-06025	C - 8		E - 12
90119-10M03	B - 3		E - 7	90446-20M39	B - 14		D - 12	92903-06100	B - 2	93102-36M33	B - 4
90119-10M07	B - 2	90267-48835	D - 6	90446-20M53	B - 13		D - 13	92903-06600	B - 2		E - 12
90119-10M17	B - 2	90267-489UE	C - 13	90446-24M54	B - 14	90465-13M11	D - 4		B - 6	93103-32M01	B - 4
	B - 14		D - 4	90446-24M79	B - 12	90465-13M24	B - 14		B - 7		E - 12
90119-10M56	B - 2		D - 7	90446-24M89	B - 15	90467-089U1	C - 13		C - 9	93210-13M63	B - 6
90119-10836	C - 3		E - 6	90446-27MA4	D - 4	90468-02001	B - 11	92903-08600	B - 13	93210-19MJ4	C - 6
90119-10837	C - 4	90267-489UK	D - 11	90446-30MF1	B - 14		B - 12		C - 9		E - 12
90149-03930	E - 2	90267-489US	D - 6	90450-14M05	B - 13	90480-06M46	C - 6	9299R-05200	C - 13	93210-46M16	C - 3
90149-06906	D - 2	90267-489U2	C - 2	90450-18M09	B - 15	90480-279U1	C - 4		D - 4		E - 12
	E - 5		D - 11	90450-22M14	B - 14		D - 15	9299R-06100	D - 14	93306-205U0	C - 3
90149-06910	E - 5	90267-489U8	D - 2	90450-99M02	B - 14	90480-329U2	B - 15	9299R-06200	C - 15	93306-205U6	C - 6
90149-10900	E - 7	90267-489U9	C - 13		B - 15		D - 4		D - 2	93306-207U2	B - 4
90162-08S12	D - 6	90280-05013	C - 8	90450-99M06	B - 13	90501-14M73	C - 9		D - 8	93306-304U1	C - 3
90170-22187	C - 2	90380-12M29	B - 2	90450-99M16	B - 14	90508-14M43	C - 7		D - 15	93306-307U3	B - 4
90179-06977	D - 14		C - 8	90464-06M29	C - 11	90600-917U4	C - 2		E - 6	93310-320U2	B - 5
90179-08M15	B - 6	90387-05800	D - 14	90464-07M05	B - 12		C - 10	9299R-08200	C - 10	93310-525U4	B - 4
90183-06902	C - 15	90387-06M60	C - 6	90464-13M54	C - 2		D - 2		D - 2	93390-000U4	B - 4
90190-06010	D - 15	90387-06M74	C - 7	90464-32801	C - 2		D - 3		D - 5	93430-47M04	C - 6
90201-05800	E - 6	90387-06M84	C - 7		C - 10		D - 4		E - 3	93440-25M08	C - 9
90201-06M31	B - 7	90387-06900	E - 6		D - 2		D - 10	9299R-08600	C - 7	93440-80023	B - 4
90201-068M4	C - 4	90387-08M06	C - 4		D - 3		D - 11	9299R-10200	D - 9	93450-18M06	C - 9
90201-068T1	C - 7	90387-08M30	C - 7		D - 4		D - 13		E - 6	93450-21053	B - 5

NUMERICAL INDEX

PART NO.	GRID NO.	PART NO.	GRID NO.	PART NO.	GRID NO.	PART NO.	GRID NO.	PART NO.	GRID NO.
93603-10049	B- 5	97095-06016	C- 11						
93604-07141	B- 5	97095-06020	B- 11						
93605-12M21	B- 13		C- 11						
93606-12019	B- 2	97095-06030	B- 13						
	C- 3	97095-08016	C- 11						
	C- 4	97095-08030	C- 8						
	C- 6	97095-08055	C- 8						
	C- 8	9778R-50112	D- 4						
94702-00195	C- 11	9778R-50116	D- 7						
94709-00195	C- 11	97780-04110	D- 10						
9531P-16700	C- 3	97780-40712	C- 6						
9538R-06600	C- 7		D- 3						
9538R-06700	C- 4		E- 7						
	D- 15	97780-50014	C- 13						
9538R-08600	C- 7	97780-50520	C- 4						
95380-06700	C- 9		D- 4						
9572R-05300	C- 13	97880-03008	E- 3						
	E- 6	97880-05016	B- 6						
9572R-06300	C- 15	97880-05025	E- 3						
	D- 2	97880-06065	D- 14						
	D- 5	97980-05330	B- 9						
	D- 8	98580-04506	E- 4						
	D- 14	98580-05025	E- 3						
	D- 15	9878R-05512	C- 5						
	E- 4	98780-04015	B- 2						
	E- 6	98780-05016	E- 6						
9572R-08300	C- 6	9898R-06030	D- 8						
	C- 10	98980-04008	C- 2						
	D- 2	98980-04010	D- 14						
	D- 4	99590-14016	C- 3						
	D- 5								
	D- 8								
	E- 3								
9572R-10300	C- 5								
	D- 9								
	E- 6								
95720-06300	E- 3								
97013-06014	B- 7								
97013-06016	B- 6								
97013-06025	B- 6								
97013-06030	B- 2								
97013-06035	B- 6								
97013-08025	C- 9								
97013-08030	B- 13								
97080-08035	E- 3								
97095-05010	B- 6								
97095-06010	C- 10								
97095-06012	C- 11								