



# **PARTS CATALOGUE**

## ***WaveRunner V1 Sport***

**VX1100D-P** (F2PK/6ENL/6EN1)

**VX1100D-P** (F2PL/6ENL/6EN1)

**VX1100D-P** (F2PM/6ENM/6EN1)

VX1100D-P  
PARTS CATALOGUE  
©2014 by Yamaha Motor Co., Ltd.  
1st edition, October 2014  
All rights reserved.  
Any reprinting or unauthorized use  
without the written permission of  
Yamaha Motor Co., Ltd.  
is expressly prohibited.  
Printed in Japan.

# FOREWORD

This Parts Catalogue is related to the parts for the model(s) on the cover page. When you are ordering replacement parts, please refer to this Parts Catalogue and quote both part numbers and part names correctly.

1. Modifications or additions which have been made after the issue of the Parts Catalogue will be announced in the Parts News.

It is advisable that you make the necessary corrections to the Parts Catalogue according to the Parts News.

2. Abbreviations

The following abbreviations are used in this Parts Catalogue.

“UR” Use specified parts number.

“UN” Use as many as needed.

“AP” Alternate Parts

“LM” Locally Made (Parts need to be ordered locally)

“F#” Frame No. (Applicable machine No.)

“O/S” Over Size

3. The number of components for assembly

- Parts, which are to be supplied in an assembly, are listed with a dot (.) in front of the part name as shown below.
- The numeral appearing to the right of each component part indicates the quantity of parts for each assembly unit.

PART NO.	DESCRIPTION	Q'TY	REMARKS
2F5-83310-60	FRONT FLASHER LIGHT ASSY	2	
115-83311-60	.BULB (6V-18W)	1	

4. Applicable colours of graphics are represented in the “REMARKS” as shown below.

PART NO.	DESCRIPTION	Q'TY	REMARKS
2N4-24110-00-X5	FUEL TANK COMP.	2	MXR
3J1-24240-10	.GRAPHIC, FUEL TANK	1	FOR MXR

5. Note that the illustrations for reference in finding parts numbers are not to be used for assembling. When assembling, please use the applicable service manual.

6. The asterisk (\*) before a reference number indicates modified items after the first edition.

# FOREWORD

7. Applicable Serial No.

Engine Serial No.

Primary Identification No.

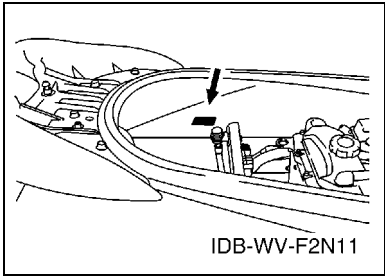
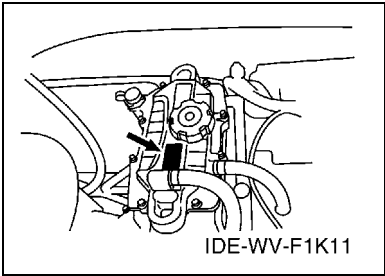

8. Applicable Colour Code (The (\*) mark shows Model colour.)

Abbreviation	Colour Name	Colour Code
PURW(*)	PURE WHITE	0240

9. Quantity Column Information

Column No.	Name Of Q'ty Column	Destination
1	CAN	CANADA
2	EUR	EUROPE
3	GENE	EXCEPT CANADA, EUROPE

10. Applicable Starting Serial No.

Engine Serial No.

Serial No.	Name Of Q'ty Column	Model Code
6EN-1024801	CAN	6ENL
6EN-1024801	EUR	6ENM
6EN-1024801	GENE	6ENL

Primary Identification No.

Serial No.	Name Of Q'ty Column	Model Code
F2P-824901	CAN	F2PK
F2P-824901	EUR	F2PM
F2P-824901	GENE	F2PL

# CONTENTS

CYLINDER .....	1
CRANKCASE .....	3
CRANKSHAFT & PISTON .....	4
VALVE .....	6
INTAKE .....	8
INTAKE 2 .....	9
OIL PUMP .....	10
OIL COOLER .....	12
EXHAUST 1 .....	14
EXHAUST 2 .....	16
EXHAUST 3 .....	18
JET UNIT 1 .....	20
JET UNIT 2 .....	22
JET UNIT 3 .....	23
GENERATOR .....	24
STARTING MOTOR .....	25
ELECTRICAL 1 .....	26
ELECTRICAL 2 .....	28
ELECTRICAL 3 .....	30
ENGINE MOUNT .....	32
ENGINE HATCH 1 .....	33
ENGINE HATCH 2 .....	34
HULL & DECK .....	36
GUNWALE & MAT .....	38
VENTILATION .....	39
SEAT & UNDER LOCKER .....	40
FUEL TANK .....	41
EXHAUST 4 .....	43
CONTROL CABLE .....	44
STEERING 1 .....	45
STEERING 2 .....	47
GRAPHICS .....	48
IMPORTANT LABELS .....	49
IMPORTANT LABELS 2 .....	50
REPAIR KIT 1 .....	51
<b>INDEX</b>	
NUMERICAL INDEX .....	52

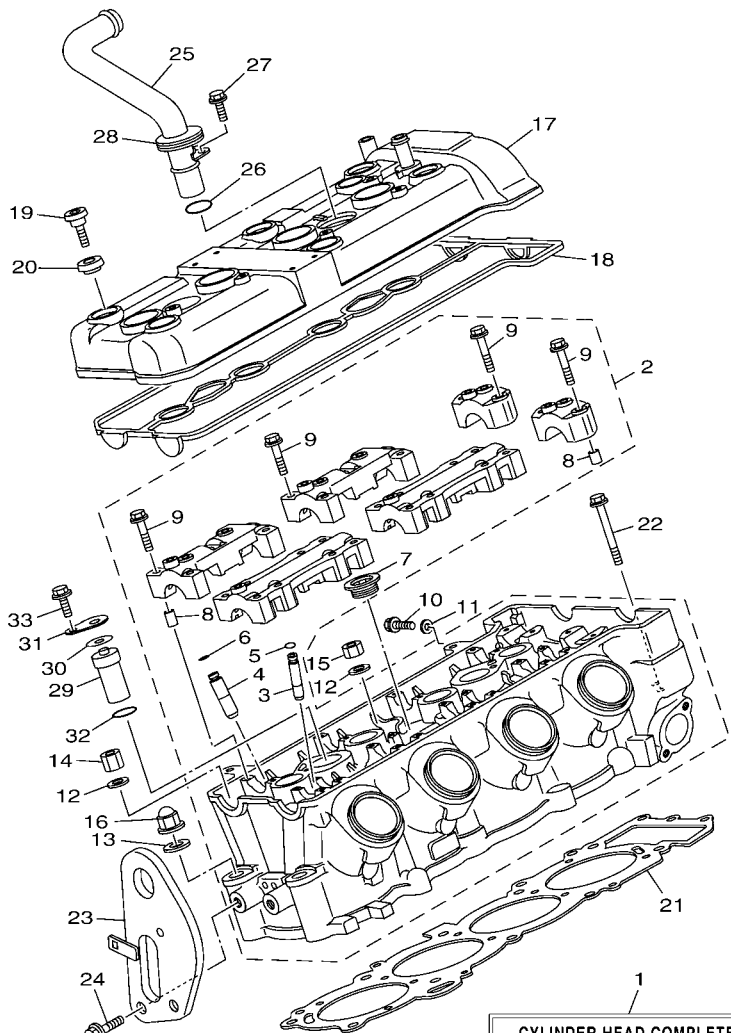

**CYLINDER HEAD COMPLETE**  
 Fig. 1 CYLINDER  
 Ref. No. 2 to 11  
 17 to 21 and 29 to 33  
 Fig. 4 VALVE  
 Ref. No. 1 to 20 and 22  
 Fig.18 ELECTRICAL 2  
 Ref. No. 8

F2PK100-P010

**FIG. 1 CYLINDER**

REF. NO.	PART NO.	DESCRIPTION	CAN	EUR	GENE	REMARKS
1	6D3-W009A-11-94	CYLINDER HEAD COMPLETE	1	1	1	
2	6D3-11102-00	CYLINDER HEAD ASSY	1	1	1	
3	3TJ-11133-10	.GUIDE, VALVE	12	12	12	
4	1WG-11133-11	.GUIDE, VALVE	8	8	8	
5	93440-07149	.CIRCLIP	12	12	12	
6	93440-10153	.CIRCLIP	8	8	8	
7	90340-27001	.PLUG, STRAIGHT SCREW	1	1	1	
8	91808-16023	.PIN, DOWEL	12	12	12	
9	90105-06026	.BOLT, FLANGE	28	28	28	
10	95023-06012	BOLT	1	1	1	
11	90430-06014	GASKET	1	1	1	
12	90201-10013	WASHER, PLATE	8	8	8	
13	90201-10019	WASHER, PLATE	2	2	2	
14	90179-10006	NUT	3	3	3	
15	90179-10414	NUT	5	5	5	
16	90176-10001	NUT, CROWN	2	2	2	
17	6D3-11191-10	COVER, CYLINDER HEAD 1	1	1	1	
18	60E-11193-01	GASKET, HEAD COVER 1	1	1	1	
19	90109-066F0	BOLT	6	6	6	
20	4KG-1111G-00	RUBBER, MOUNT 1	6	6	6	
21	6D3-11181-00	GASKET, CYLINDER HEAD 1	1	1	1	
22	97513-06555	BOLT, WITH WASHER	3	3	3	
23	6D3-85132-00	BRACKET, REFLECTOR 1	1	1	1	
24	97513-08520	BOLT, WITH WASHER	2	2	2	
25	6D3-12482-00	PIPE 2	1	1	1	
26	93210-18417	O-RING	1	1	1	
27	91317-06016	BOLT	1	1	1	



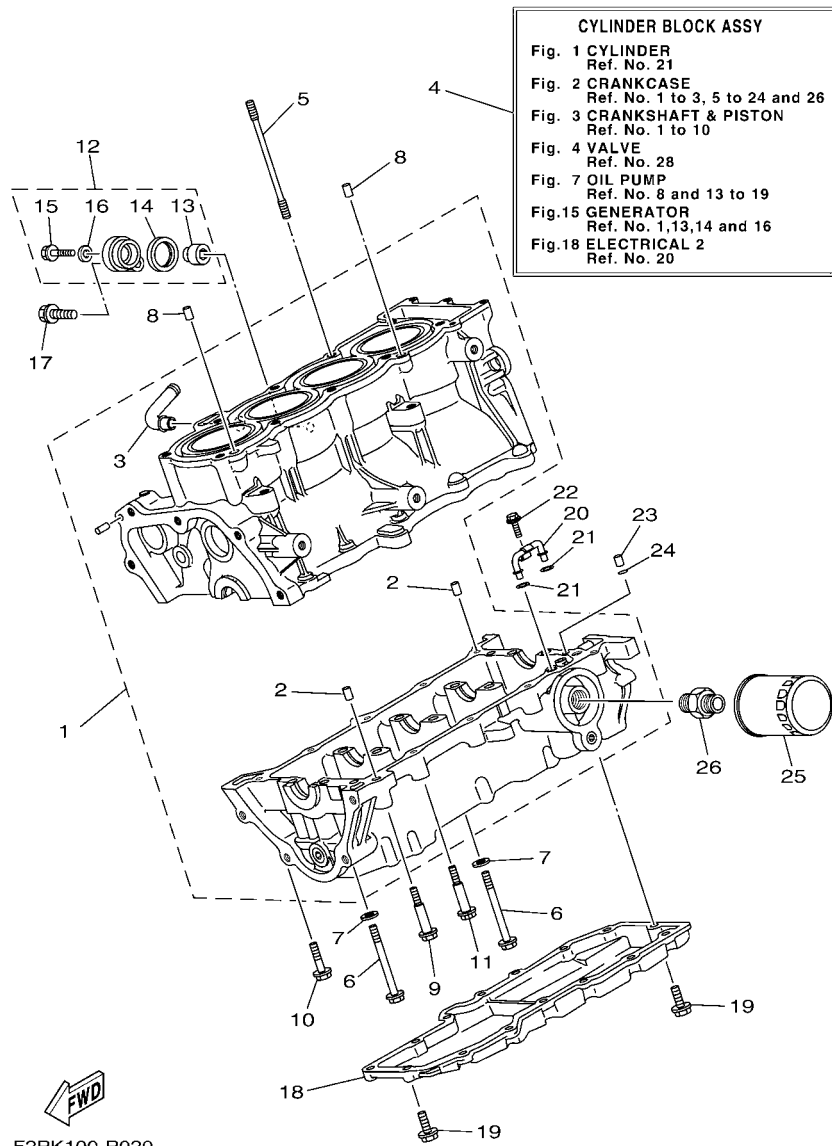

F2PK100-P020

FIG. 2 CRANKCASE

REF. NO.	PART NO.	DESCRIPTION	CAN	EUR	GENE	REMARKS
1	6BU-15100-00	CRANKCASE ASSY	1	1	1	
2	99530-10014	.PIN, DOWEL	2	2	2	
3	6D3-51129-00	.NIPPLE	1	1	1	
4	6BU-W009B-00-94	CYLINDER BLOCK ASSY	1	1	1	
5	90116-10058	BOLT, STUD	10	10	10	
6	90105-093A5	BOLT, FLANGE	10	10	10	
7	90201-096J9	WASHER, PLATE	10	10	10	
8	99530-10014	PIN, DOWEL	2	2	2	
9	90109-06051	BOLT	2	2	2	
10	95814-06070	BOLT, FLANGE	1	1	1	
11	90105-06M17	BOLT, FLANGE	7	7	7	
12	69J-11301-10	ANODE COVER ASSY	1	1	1	
13	68V-11325-02	.ANODE	1	1	1	
14	67F-11328-00	.GROMMET, ANODE	1	1	1	
15	90105-06M07	.BOLT, FLANGE	1	1	1	
16	90430-06M03	.GASKET	1	1	1	
17	97595-08540	BOLT, WITH WASHER	1	1	1	
18	6B6-1310A-01-94	PAN, OIL	1	1	1	
19	97513-06520	BOLT, WITH WASHER	15	15	15	
20	60E-13161-00	PIPE, DELIVERY 1	1	1	1	
21	93210-06667	O-RING	2	2	2	
22	95027-06010	BOLT, FLANGE	1	1	1	
23	99530-08012	PIN, DOWEL	1	1	1	
24	93210-08001	O-RING	1	1	1	
25	5GH-13440-50	ELEMENT ASSY, OIL CLEANER	1	1	1	
26	90401-20007	BOLT, UNION	1	1	1	



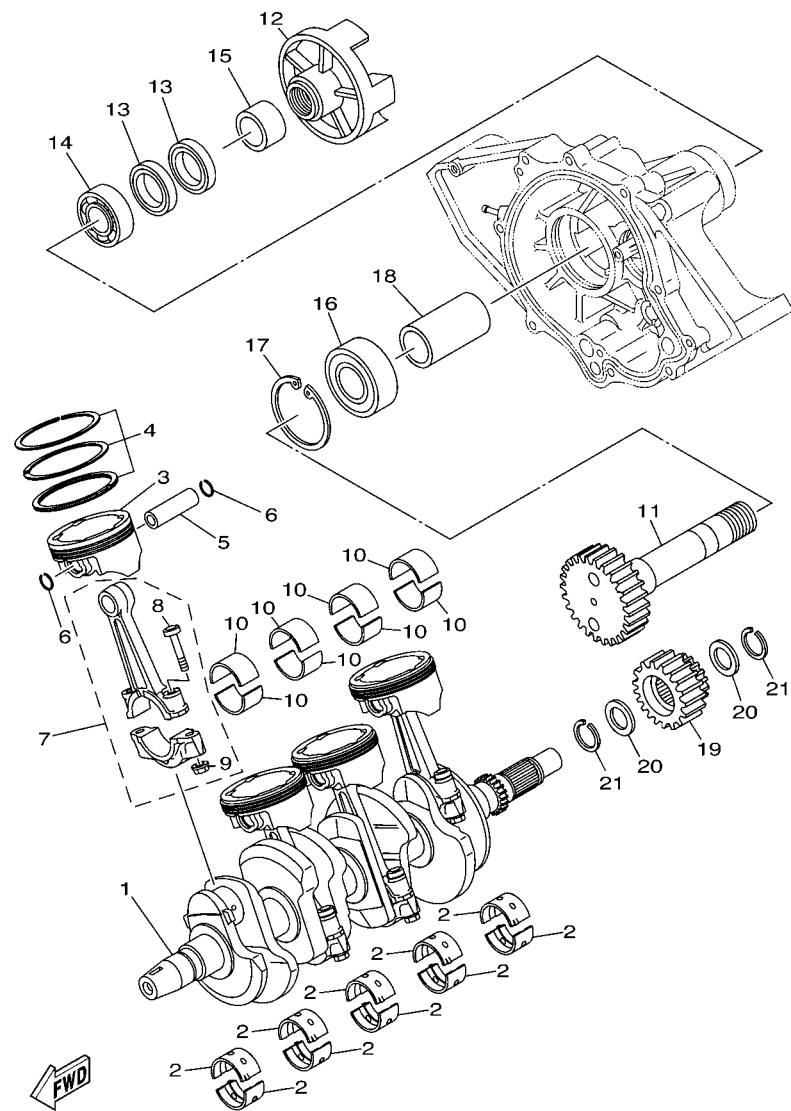

F1K1100-D030

FIG. 3 CRANKSHAFT & PISTON

REF. NO.	PART NO.	DESCRIPTION	CAN	EUR	GENE	REMARKS
1	60E-11411-11	CRANKSHAFT	1	1	1	
2	6D3-11416-A0	PLANE BEARING, CRANKSHAFT 1	10	10	10	UR RED/RED
	6D3-11416-00	PLANE BEARING, CRANKSHAFT 1	10	10	10	UR RED/BROWN
	6D3-11416-10	PLANE BEARING, CRANKSHAFT 1	10	10	10	UR RED/BLACK
	6D3-11416-20	PLANE BEARING, CRANKSHAFT 1	10	10	10	UR RED/BLUE
	6D3-11416-30	PLANE BEARING, CRANKSHAFT 1	10	10	10	UR RED/GREEN
3	6D3-11631-01-B0	PISTON (STD)	4	4	4	
4	6D3-11603-00	PISTON RING SET (STD)	4	4	4	
5	6D3-11633-00	PIN, PISTON	4	4	4	
6	90468-12069	CLIP	8	8	8	
7	6D3-11650-00	CONNECTING ROD ASSY	4	4	4	
8	5JW-11654-00	.BOLT, CONNECTING ROD	2	2	2	
9	90179-08327	.NUT	2	2	2	
10	60E-11656-00	PLANE BEARING, CONNECTING ROD	8	8	8	UR BROWN
	60E-11656-10	PLANE BEARING, CONNECTING ROD	8	8	8	UR BLACK
	60E-11656-20	PLANE BEARING, CONNECTING ROD	8	8	8	UR BLUE
	60E-11656-30	PLANE BEARING, CONNECTING ROD	8	8	8	UR GREEN
11	6D3-17572-00	SHAFT, TRANSFER	1	1	1	
12	6D3-45813-00-94	FLANGE, COUPLING	1	1	1	
13	93101-35004	OIL SEAL	2	2	2	
14	93306-07801	BEARING	1	1	1	
15	6B6-11478-00	COLLAR	1	1	1	
16	93306-30610	BEARING	1	1	1	
17	99009-72500	CIRCLIP	1	1	1	
18	6B6-17585-00	COLLAR, GEAR	1	1	1	
19	6B6-17586-00	GEAR, TRANSFER DRIVE	1	1	1	
20	90209-25008	WASHER	2	2	2	



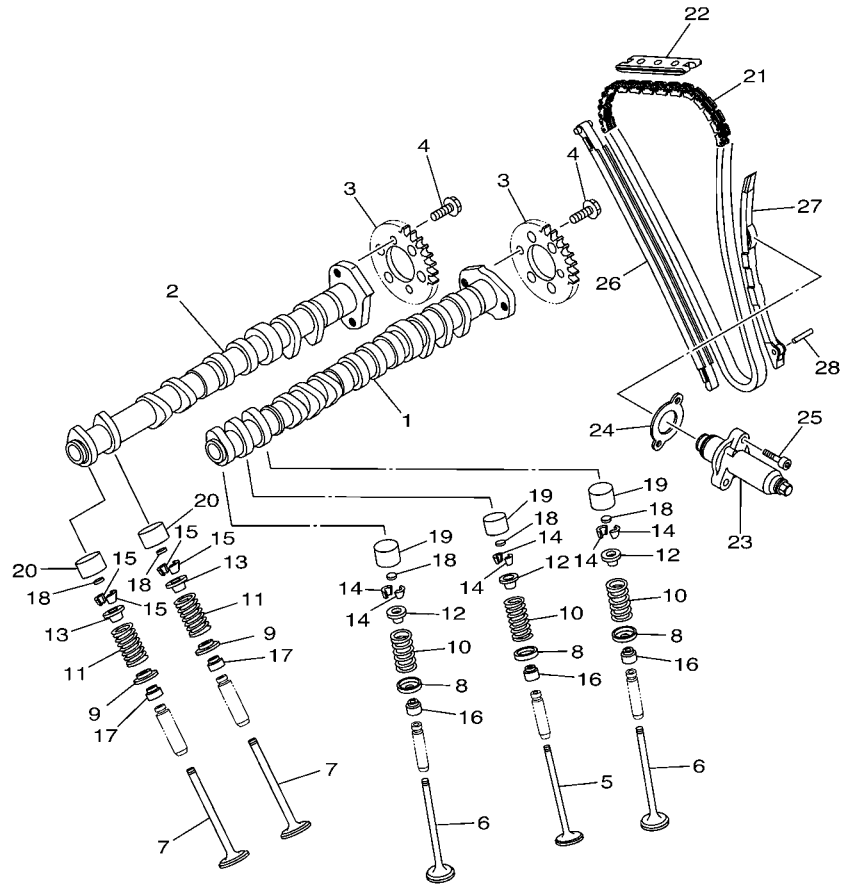

**FWD**  
F1K1100-D040

**FIG. 4 VALVE**

REF. NO.	PART NO.	DESCRIPTION	CAN	EUR	GENE	REMARKS
1	6D3-12171-11	CAMSHAFT 1	1	1	1	
2	6D3-12181-00	CAMSHAFT 2	1	1	1	
3	6D3-12176-00	SPROCKET, CAM CHAIN	2	2	2	
4	90105-07004	BOLT, FLANGE	4	4	4	
5	4XV-12111-00	VALVE, INTAKE	4	4	4	
6	4XV-12112-00	VALVE, INTAKE 2	8	8	8	
7	5LV-12121-00	VALVE, EXHAUST	8	8	8	
8	1HX-12116-01	SEAT, VALVE SPRING	12	12	12	
9	3GM-12126-00	SEAT, VALVE SPRING 2	8	8	8	
10	4XV-12113-00	SPRING, VALVE INNER	12	12	12	
11	4XV-12114-00	SPRING, VALVE OUTER	8	8	8	
12	1HX-12117-00	RETAINER, VALVE SPRING	12	12	12	
13	1WG-12117-00	RETAINER, VALVE SPRING	8	8	8	
14	1HX-12118-00	LOCK, VALVE SPRING RETAINER	24	24	24	
15	1WG-12118-00	LOCK, VALVE SPRING RETAINER	16	16	16	
16	4TV-12119-00	SEAL, VALVE STEM	12	12	12	
17	4SV-12119-00	SEAL, VALVE STEM	8	8	8	
18	1HX-12168-00	PAD, ADJUSTING 2 (1.20)	20	20	20	UR
	1HX-12168-20	PAD, ADJUSTING 2 (1.25)	20	20	20	UR
	1HX-12168-40	PAD, ADJUSTING 2 (1.30)	20	20	20	UR
	1HX-12168-60	PAD, ADJUSTING 2 (1.35)	20	20	20	UR
	1HX-12168-80	PAD, ADJUSTING 2 (1.40)	20	20	20	UR
	1HX-12168-A0	PAD, ADJUSTING 2 (1.45)	20	20	20	UR
	1HX-12168-F0	PAD, ADJUSTING 2 (1.50)	20	20	20	UR
	1HX-12168-H1	PAD, ADJUSTING 2 (1.55)	20	20	20	UR
	1HX-12168-K1	PAD, ADJUSTING 2 (1.60)	20	20	20	UR
	1HX-12168-M1	PAD, ADJUSTING 2 (1.65)	20	20	20	UR

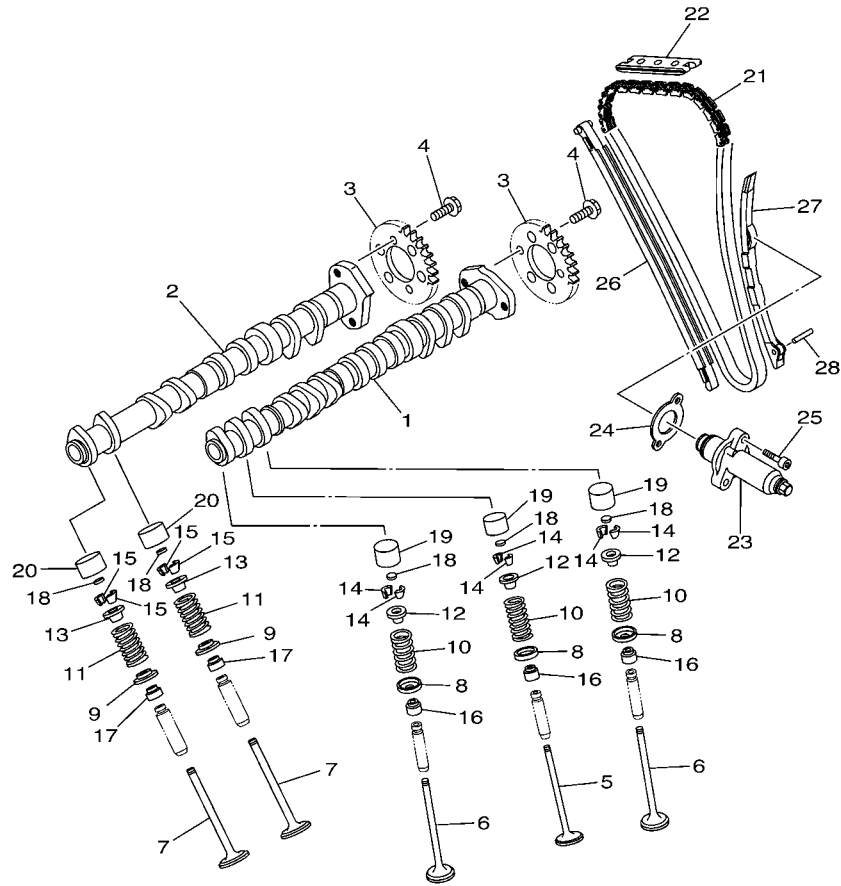

**FWD**  
F1K1100-D040

**FIG. 4 VALVE**

REF. NO.	PART NO.	DESCRIPTION	CAN	EUR	GENE	REMARKS
18	1HX-12168-R1	PAD, ADJUSTING 2 (1.70)	20	20	20	UR
	1HX-12168-U1	PAD, ADJUSTING 2 (1.75)	20	20	20	UR
	1HX-12168-W1	PAD, ADJUSTING 2 (1.80)	20	20	20	UR
	1HX-12168-Y1	PAD, ADJUSTING 2 (1.85)	20	20	20	UR
	1HX-12169-11	PAD, ADJUSTING 2 (1.90)	20	20	20	UR
	1HX-12169-31	PAD, ADJUSTING 2 (1.95)	20	20	20	UR
	1HX-12169-50	PAD, ADJUSTING 2 (2.00)	20	20	20	UR
	1HX-12169-70	PAD, ADJUSTING 2 (2.05)	20	20	20	UR
	1HX-12169-90	PAD, ADJUSTING 2 (2.10)	20	20	20	UR
	1HX-12169-E0	PAD, ADJUSTING 2 (2.15)	20	20	20	UR
	1HX-12169-G0	PAD, ADJUSTING 2 (2.20)	20	20	20	UR
	1HX-12169-J0	PAD, ADJUSTING 2 (2.25)	20	20	20	UR
	1HX-12169-L0	PAD, ADJUSTING 2 (2.30)	20	20	20	UR
	1HX-12169-N0	PAD, ADJUSTING 2 (2.35)	20	20	20	UR
	1HX-12169-T0	PAD, ADJUSTING 2 (2.40)	20	20	20	UR
19	3LN-12153-10	LIFTER, VALVE	12	12	12	YELLOW
20	3FV-12153-10	LIFTER, VALVE	8	8	8	YELLOW
21	94591-49130	CHAIN	1	1	1	
22	5BE-12241-00	GUIDE, STOPPER 2	1	1	1	
23	6D3-12210-00	TENSIONER ASSY, CAM CHAIN	1	1	1	
24	4FM-12213-00	GASKET, TENSIONER CASE	1	1	1	
25	91380-06025	BOLT	2	2	2	
26	6D3-12251-00	DAMPER, CHAIN 1	1	1	1	
27	4XV-12252-00	DAMPER, CHAIN 2	1	1	1	
28	93607-44002	PIN, DOWEL	1	1	1	

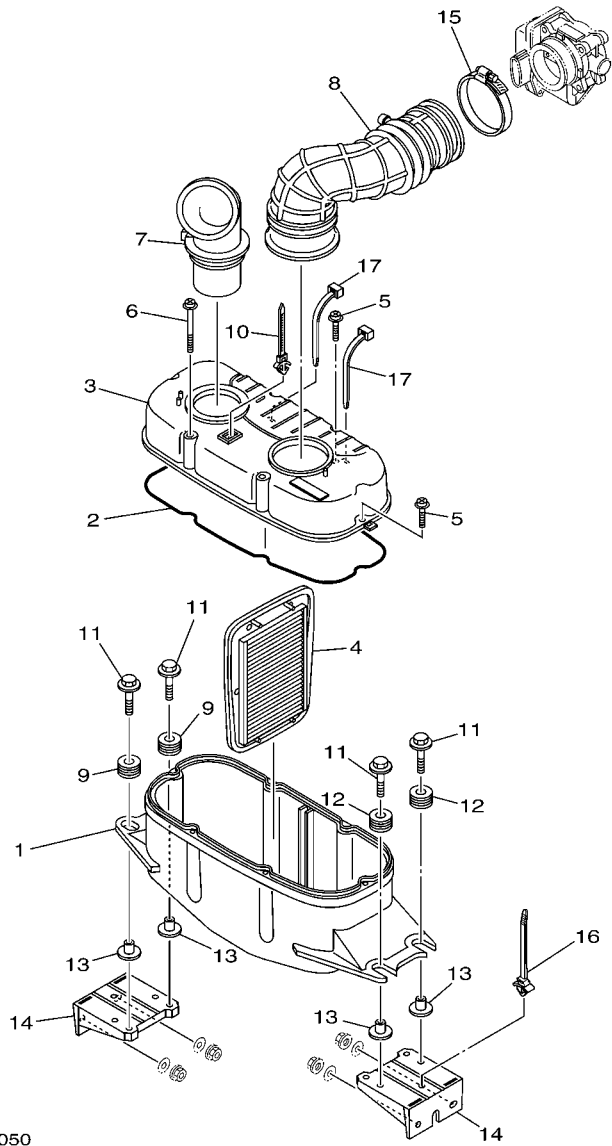

F2NG100-K050

FIG. 5 INTAKE

REF. NO.	PART NO.	DESCRIPTION	CAN	EUR	GENE	REMARKS
1	6D3-14411-00	CASE, AIR CLEANER 1	1	1	1	
2	4XV-14452-00	SEAL	1	1	1	
3	6D3-14421-02	CASE, AIR CLEANER 2	1	1	1	
4	6D3-14451-00	ELEMENT, AIR CLEANER	1	1	1	
5	90159-05013	SCREW, WITH WASHER	4	4	4	
6	90159-05014	SCREW, WITH WASHER	2	2	2	
7	6D3-14437-00	DUCT	1	1	1	
8	6D3-14419-01	PIPE	1	1	1	
9	90480-22M15	GROMMET	2	2	2	
10	90464-12089	CLAMP	1	1	1	
11	90119-08M22	BOLT, WITH WASHER	4	4	4	
12	90480-22M15	GROMMET	2	2	2	
13	90387-08M37	COLLAR	4	4	4	
14	F2N-U8572-00	BRACKET 2	2	2	2	
15	90601-175UR	BAND, HOSE 75	1	1	1	
16	90464-38800	CLAMP	1	1	1	
17	90464-40825	CLAMP	2	2	2	

FIG. 6 INTAKE 2

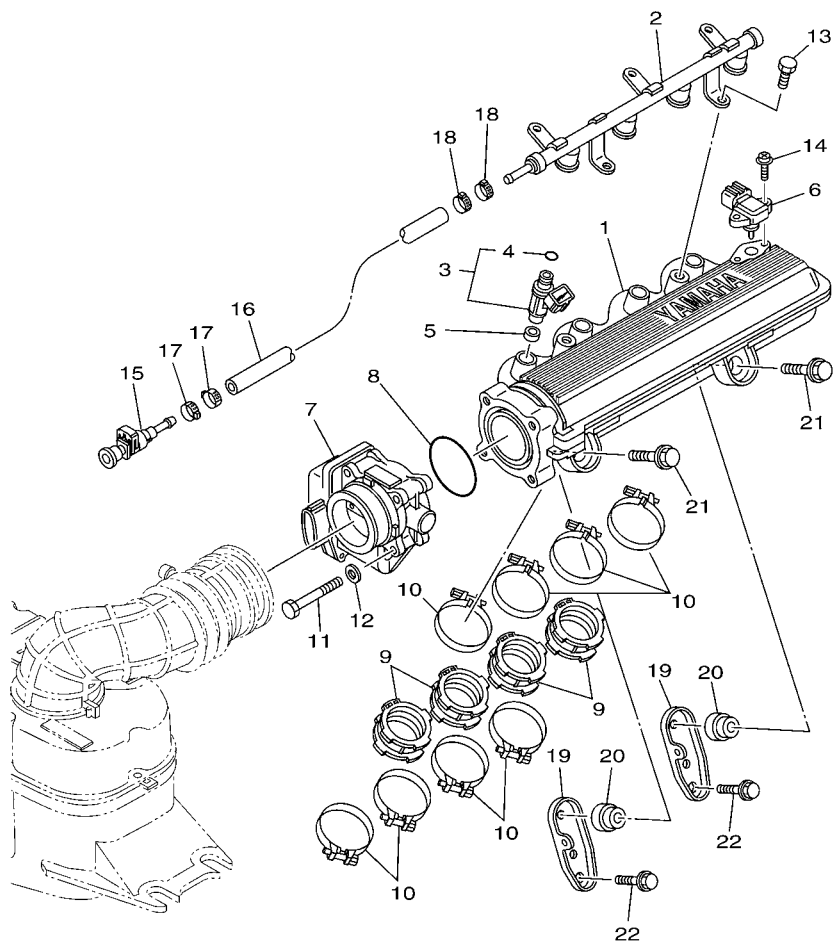

F2NK100-L060

REF. NO.	PART NO.	DESCRIPTION	CAN	EUR	GENE	REMARKS
1	6D3-13641-00	MANIFOLD, INTAKE 1	1	1	1	
2	6BU-12880-11	DELIVERY PIPE	1	1	1	
3	60E-13761-20	INJECTOR	4	4	4	
4	68V-1416A-00	.O-RING	1	1	1	
5	8FP-13556-10	GASKET, MANIFOLD	4	4	4	
6	68F-83688-10	SENSOR ASSY	1	1	1	
7	6BU-13750-00	THROTTLE BODY ASSY	1	1	1	
8	6D3-14457-00	SEAL	1	1	1	
9	6D3-13795-01	JOINT, THROTTLE BODY 1	4	4	4	
10	90450-57006	HOSE CLAMP ASSY	8	8	8	
11	68V-13573-00	BOLT 1	4	4	4	
12	68V-14475-00	WASHER	4	4	4	
13	63P-14446-00	BOLT	2	2	2	
14	6D3-81147-00	SCREW 3	2	2	2	
15	6S5-24300-01	FUEL PIPE JOINT	1	1	1	
16	6D3-14294-10	HOSE	1	1	1	
17	90450-17M17	HOSE CLAMP ASSY	2	2	2	
18	90450-17M17	HOSE CLAMP ASSY	2	2	2	
19	6D3-14414-10	STAY 2	2	2	2	
20	60E-14449-00-94	COLLAR	2	2	2	
21	90119-08050	BOLT, WITH WASHER	2	2	2	
22	90119-08074	BOLT, WITH WASHER	2	2	2	

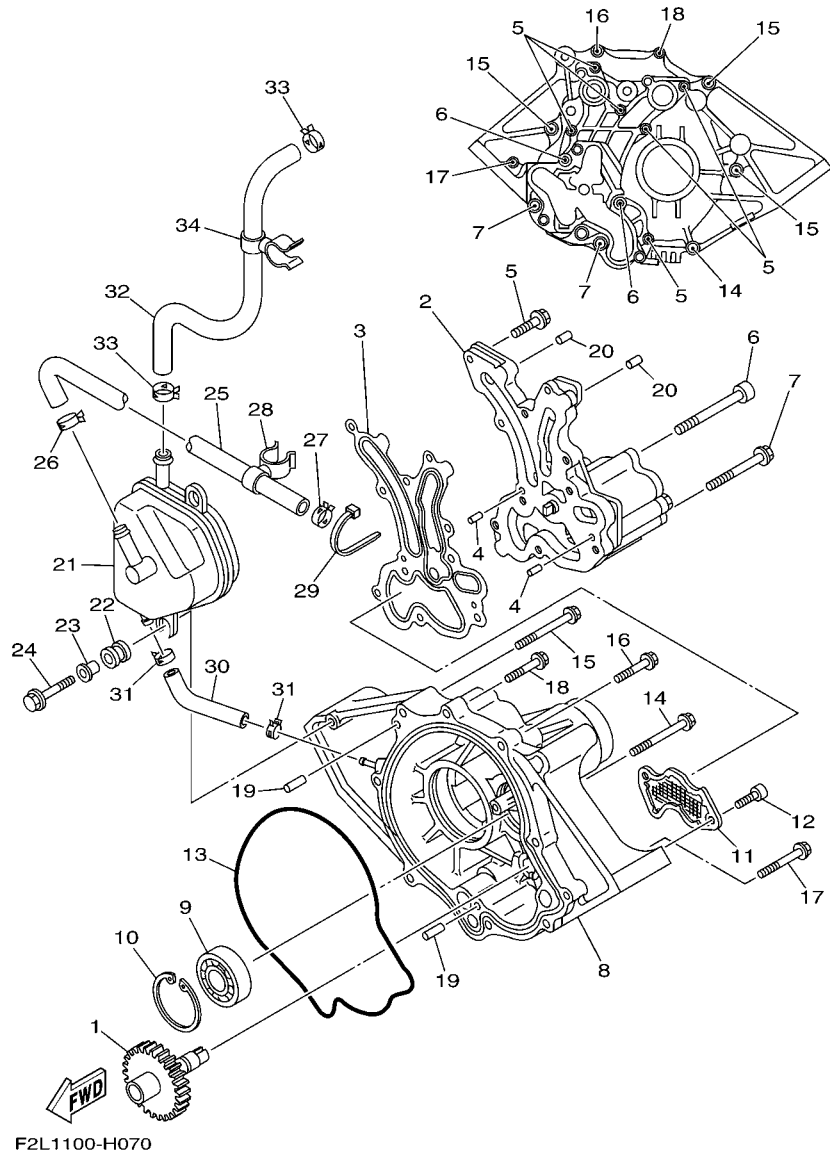
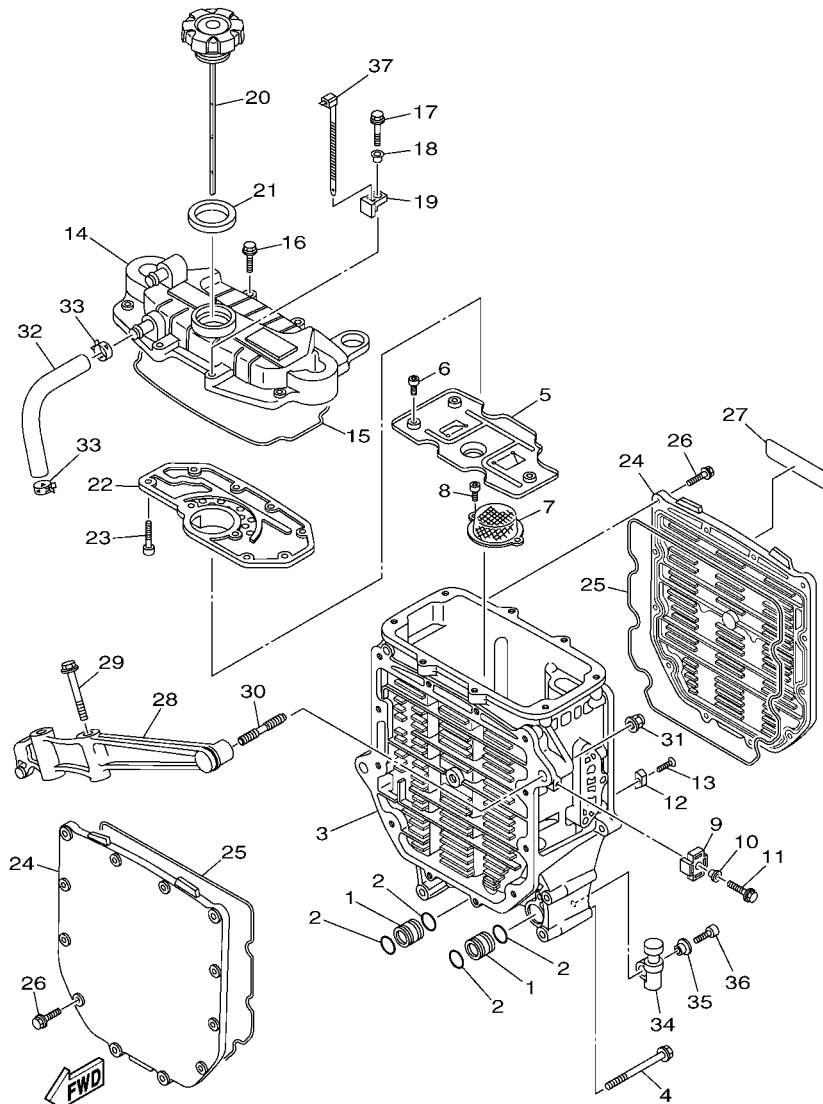

FIG. 7 OIL PUMP

REF. NO.	PART NO.	DESCRIPTION	CAN	EUR	GENE	REMARKS
1	6B6-13360-00	DRIVEN GEAR ASSY	1	1	1	
2	6D3-13300-10	OIL PUMP ASSY	1	1	1	
3	6B6-13563-01	GASKET	1	1	1	
4	93603-12221	PIN, DOWEL	2	2	2	
5	97513-06525	BOLT, WITH WASHER	6	6	6	
6	90110-08041	BOLT, HEXAGON SOCKET HEAD	2	2	2	
7	90119-08085	BOLT, WITH WASHER	2	2	2	
8	6B6-13327-02-94	COVER, PUMP GEAR	1	1	1	
9	93306-30441	BEARING	1	1	1	
10	99009-52500	CIRCLIP	1	1	1	
11	6B6-13411-00	STRAINER, OIL	1	1	1	
12	91317-06016	BOLT	2	2	2	
13	6B6-13475-01	GASKET	1	1	1	
14	90119-08045	BOLT, WITH WASHER	1	1	1	
15	90119-08034	BOLT, WITH WASHER	3	3	3	
16	90119-08043	BOLT, WITH WASHER	1	1	1	
17	97513-06555	BOLT, WITH WASHER	1	1	1	
18	97513-06535	BOLT, WITH WASHER	1	1	1	
19	93608-16M16	PIN, DOWEL	2	2	2	
20	93606-25M00	PIN, DOWEL	2	2	2	
21	6D3-11164-00	SEPERATOR, OIL	1	1	1	
22	6A0-82317-00	DAMPER, IGNITION COIL	2	2	2	
23	90387-06119	COLLAR	2	2	2	
24	90119-06M65	BOLT, WITH WASHER	2	2	2	
25	6D3-11126-00	PIPE, BREATHER 3	1	1	1	
26	90467-170A4	CLIP	1	1	1	
27	90467-170A4	CLIP	1	1	1	







F2P1100-M080

FIG. 8 OIL COOLER

REF. NO.	PART NO.	DESCRIPTION	CAN	EUR	GENE	REMARKS
1	60E-13446-00	CONNECTOR	2	2	2	
2	93210-18322	O-RING	4	4	4	
3	6D3-13462-00-94	CASE, OIL COOLER	1	1	1	
4	90119-10020	BOLT, WITH WASHER	5	5	5	
5	6B6-13317-00	PLATE, BAFFLE	1	1	1	
6	91317-05014	BOLT	3	3	3	
7	60E-13421-00	STRAINER 2	1	1	1	
8	91317-06014	BOLT	2	2	2	
9	6BU-85542-00	BRACKET	1	1	1	
10	90387-06M05	COLLAR	1	1	1	
11	97595-06520	BOLT, WITH WASHER	1	1	1	
12	6E5-11325-00	ANODE	1	1	1	
13	98780-04015	SCREW, FLAT HEAD	1	1	1	
14	6D3-13463-00-94	COVER, OIL COOLER	1	1	1	
15	60E-13475-00	GASKET	1	1	1	
16	90105-06036	BOLT, FLANGE	7	7	7	
17	90105-06035	BOLT, FLANGE	1	1	1	
18	90387-06M05	COLLAR	1	1	1	
19	6AA-85542-00	BRACKET	1	1	1	
20	6BU-15362-A0	PLUG, OIL LEVEL	1	1	1	
21	60E-13473-00	O-RING	1	1	1	
22	6D3-11165-00	PLATE, BREATHER	1	1	1	
23	91317-05016	BOLT	9	9	9	
24	6D3-13443-00-94	COVER, OIL COOLER	2	2	2	
25	60E-13476-10	GASKET	2	2	2	
26	90105-06M07	BOLT, FLANGE	24	24	24	
27	60E-83627-00	LABEL, CAUTION 7	1	1	1	

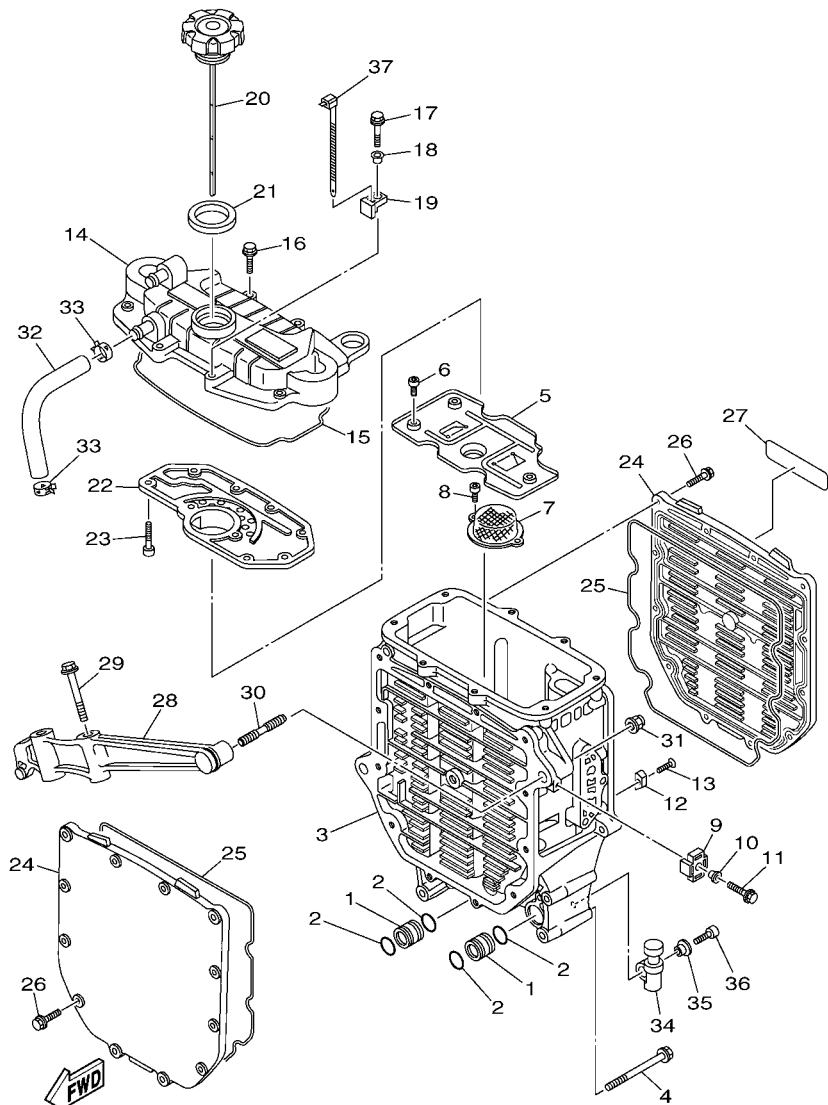

F2P1100-M080

FIG. 8 OIL COOLER

REF. NO.	PART NO.	DESCRIPTION	CAN	EUR	GENE	REMARKS
28	6B6-13151-00-94	STAY	1	1	1	
29	90119-10M02	BOLT, WITH WASHER	2	2	2	
30	90116-10016	BOLT, STUD	2	2	2	
31	90176-10001	NUT, CROWN	2	2	2	
32	6D3-11167-00	PIPE, BREATHER 2	1	1	1	
33	90467-170A4	CLIP	2	2	2	
34	6S5-81364-10	GROMMET	2	2	2	
35	90387-06M05	COLLAR	2	2	2	
36	91380-06020	BOLT	2	2	2	
37	90465-13M39	CLAMP	1	1	1	

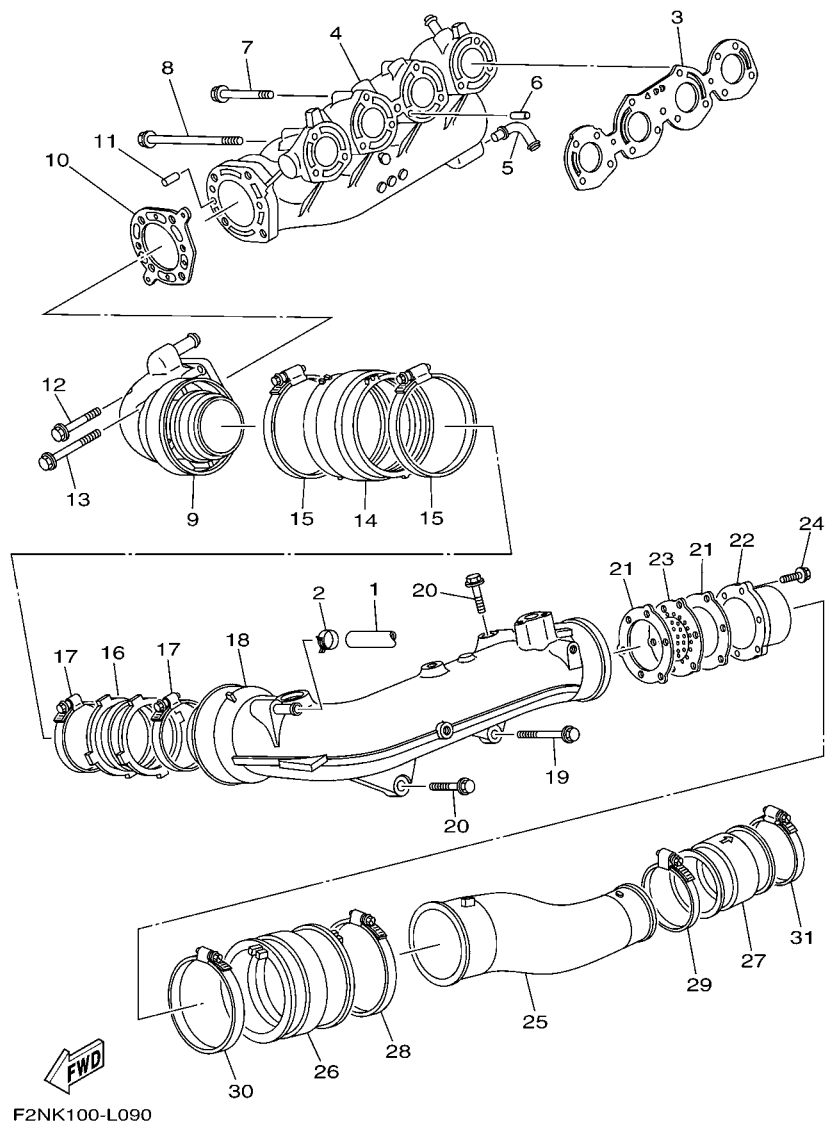
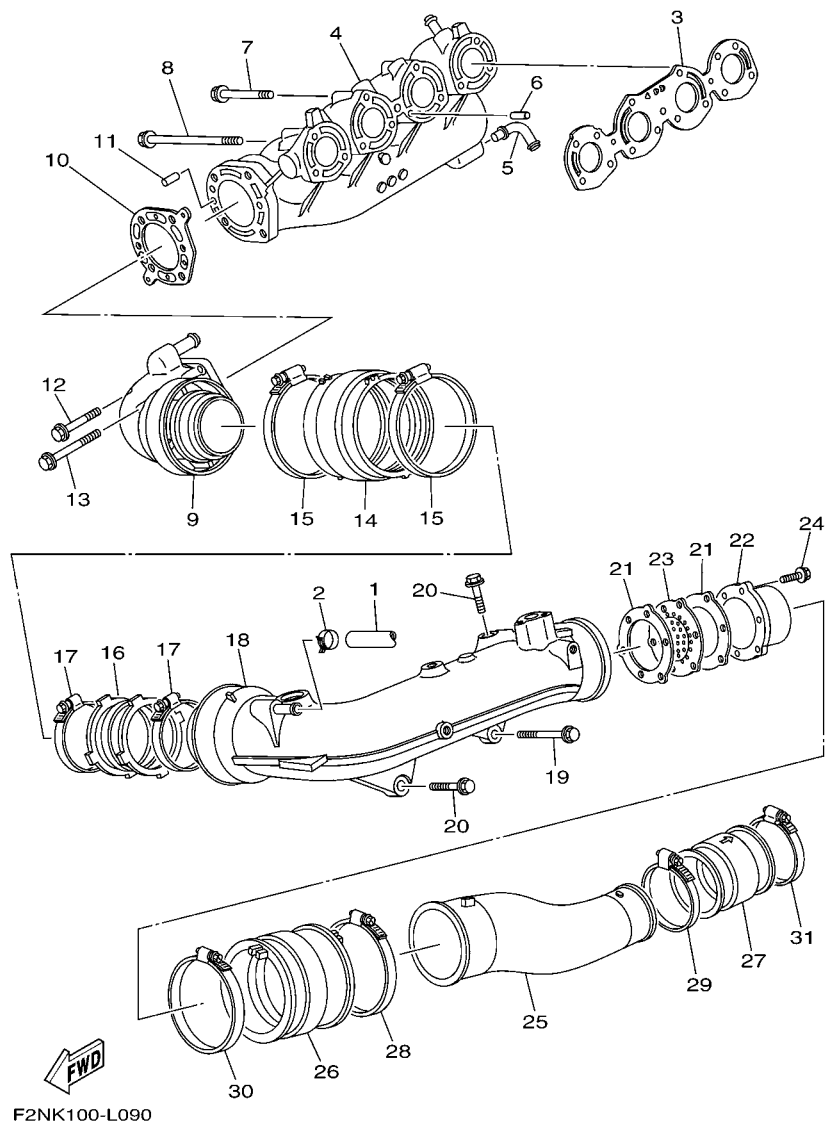

FIG. 9 EXHAUST 1

REF. NO.	PART NO.	DESCRIPTION	CAN	EUR	GENE	REMARKS
1	6BU-1244G-10	HOSE, 4	1	1	1	
2	90467-160A0	CLIP	1	1	1	
3	6D3-14613-10	GASKET, EXHAUST PIPE	1	1	1	
4	6D3-14711-10	MUFFLER 1	1	1	1	
5	60E-11372-10	NIPPLE, HOSE	1	1	1	
6	93608-16M16	PIN, DOWEL	2	2	2	
7	90119-08036	BOLT, WITH WASHER	5	5	5	
8	90119-08075	BOLT, WITH WASHER	6	6	6	
9	6D3-14712-00-94	RING, JOINT	1	1	1	
10	6D3-14739-10	GASKET, MUFFLER DAMPER 1	1	1	1	
11	93606-12019	PIN, DOWEL	2	2	2	
12	90119-08036	BOLT, WITH WASHER	2	2	2	
13	90119-08031	BOLT, WITH WASHER	2	2	2	
14	6D3-14615-00	JOINT, EXHAUST 1	1	1	1	
15	90450-99005	HOSE CLAMP ASSY	2	2	2	
16	6D3-14625-00	JOINT, EXHAUST 2	1	1	1	
17	90450-90001	HOSE CLAMP ASSY	2	2	2	
18	6D3-14721-10	MUFFLER 2	1	1	1	
19	90119-10017	BOLT, WITH WASHER	1	1	1	
20	90119-10013	BOLT, WITH WASHER	3	3	3	
21	60E-14623-00	GASKET, EXHAUST PIPE	2	2	2	
22	60E-14784-00-94	PIPE, TAIL	1	1	1	
23	6D3-1469W-10	PLATE, SILENCER 6	1	1	1	
24	90105-06790	BOLT, FLANGE	3	3	3	
25	6BU-14752-00-94	PIPE, OUTLET	1	1	1	
26	6BU-1475E-00	PIPE 2	1	1	1	
27	6BU-1475F-00	PIPE 3	1	1	1	



**FIG. 9 EXHAUST 1**

REF. NO.	PART NO.	DESCRIPTION	CAN	EUR	GENE	REMARKS
28	90450-99004	HOSE CLAMP ASSY	1	1	1	
29	90450-94001	HOSE CLAMP ASSY	1	1	1	
30	90450-99004	HOSE CLAMP ASSY	1	1	1	
31	90450-94001	HOSE CLAMP ASSY	1	1	1	
-----						
-----						
-----						
-----						
-----						
-----						
-----						
-----						
-----						
-----						
-----						

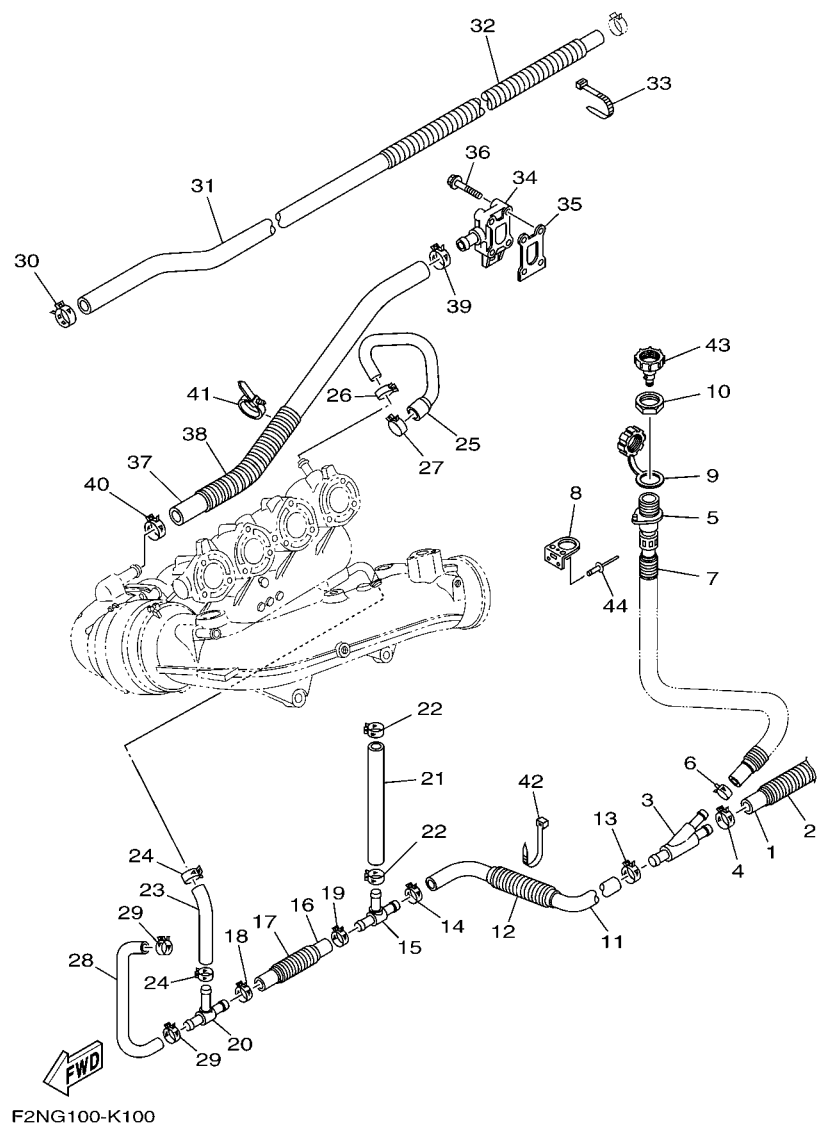

F2NG100-K100

FIG. 10 EXHAUST 2

REF. NO.	PART NO.	DESCRIPTION	CAN	EUR	GENE	REMARKS
1	90445-21805	HOSE (L300)	1		1	
2	90447-22004	HOSE, WITH SPRING (L200)	1		1	
3	60E-12581-00	JOINT, HOSE 1	1		1	
4	90467-200A3	CLIP	1		1	
5	63M-12580-00	JOINT ASSY	1		1	
6	90467-150A5	CLIP	1		1	
7	90447-19801	TUBE (L485)	1		1	
8	60E-12443-00	STAY	1		1	
9	682-84385-01	CAP,1	1		1	
10	EU0-61652-00	NUT	1		1	
11	6BU-1243A-00	HOSE 1	1		1	
12	90447-22003	HOSE, WITH SPRING (L300)	1		1	
13	90467-200A3	CLIP	1		1	
14	90467-200A3	CLIP	1		1	
15	60E-12584-00	JOINT, HOSE 3	1		1	
16	6S5-12589-01	HOSE 6	1		1	
17	90447-22001	HOSE, WITH SPRING (L100)	1		1	
18	90467-200A3	CLIP	1		1	
19	90467-200A3	CLIP	1		1	
20	6D3-12584-00	JOINT, HOSE 3	1		1	
21	6D3-1244H-10	HOSE 5	1		1	
22	90467-160A0	CLIP	2		2	
23	90445-18M03	HOSE (L108)	1		1	
24	90467-160A0	CLIP	2		2	
25	6D3-12577-10	HOSE 2	1		1	
26	90467-170A4	CLIP	1		1	
27	90467-200A3	CLIP	1		1	

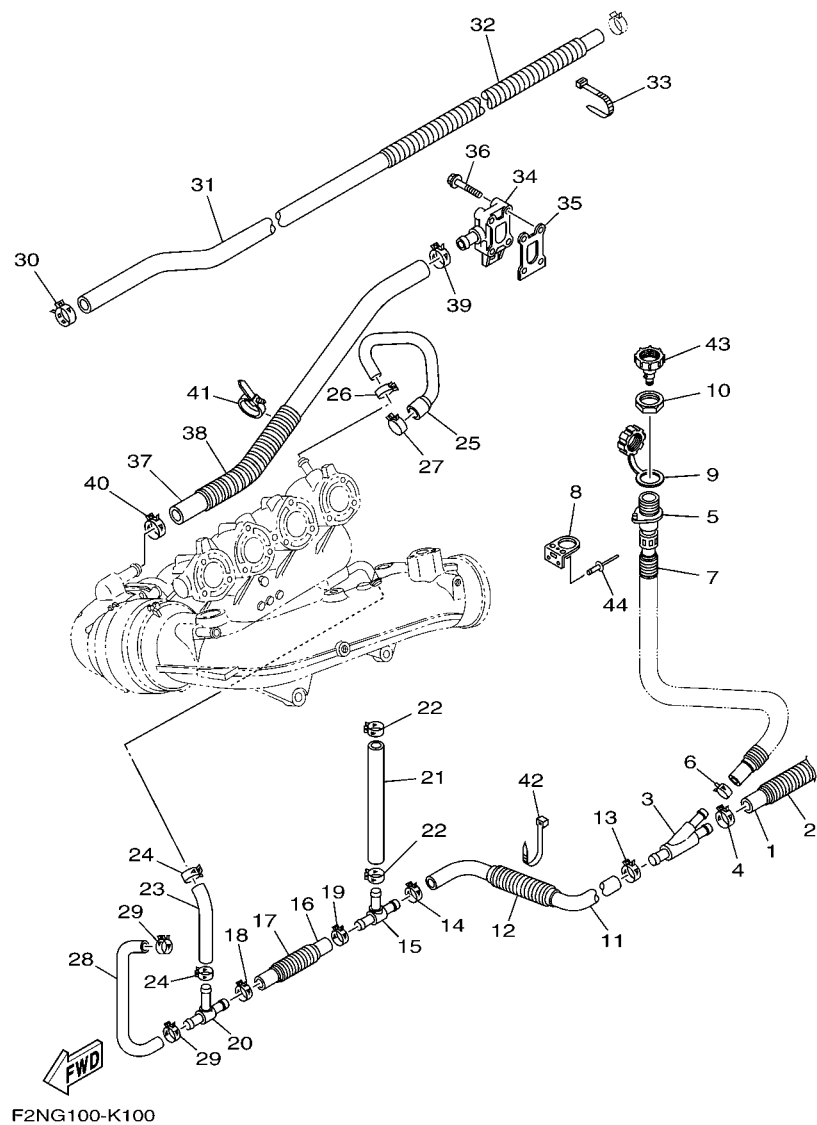

FIG. 10 EXHAUST 2

REF. NO.	PART NO.	DESCRIPTION	CAN	EUR	GENE	REMARKS
28	6D3-1244G-10	HOSE, 4	1		1	
29	90467-160A0	CLIP	2		2	
30	90467-210A0	CLIP	1		1	
31	90445-22007	HOSE (L1165)	1		1	
32	90447-25002	TUBE (L800)	1		1	
33	90464-35132	CLAMP	1		1	
34	6D3-12446-00	JOINT	1		1	
35	60E-12435-00	GASKET	1		1	
36	90105-06035	BOLT, FLANGE	4		4	
37	6BU-1243F-10	HOSE,3	1		1	
38	90447-22005	HOSE, WITH SPRING (L200)	1		1	
39	90467-200A3	CLIP	1		1	
40	90467-200A3	CLIP	1		1	
41	90464-31001	CLAMP	1		1	
42	90464-35132	CLAMP	1		1	
43	67X-E2590-10	CONDUCTION ASSY	1		1	
44	90267-489U1	RIVET,BLIND	2		2	

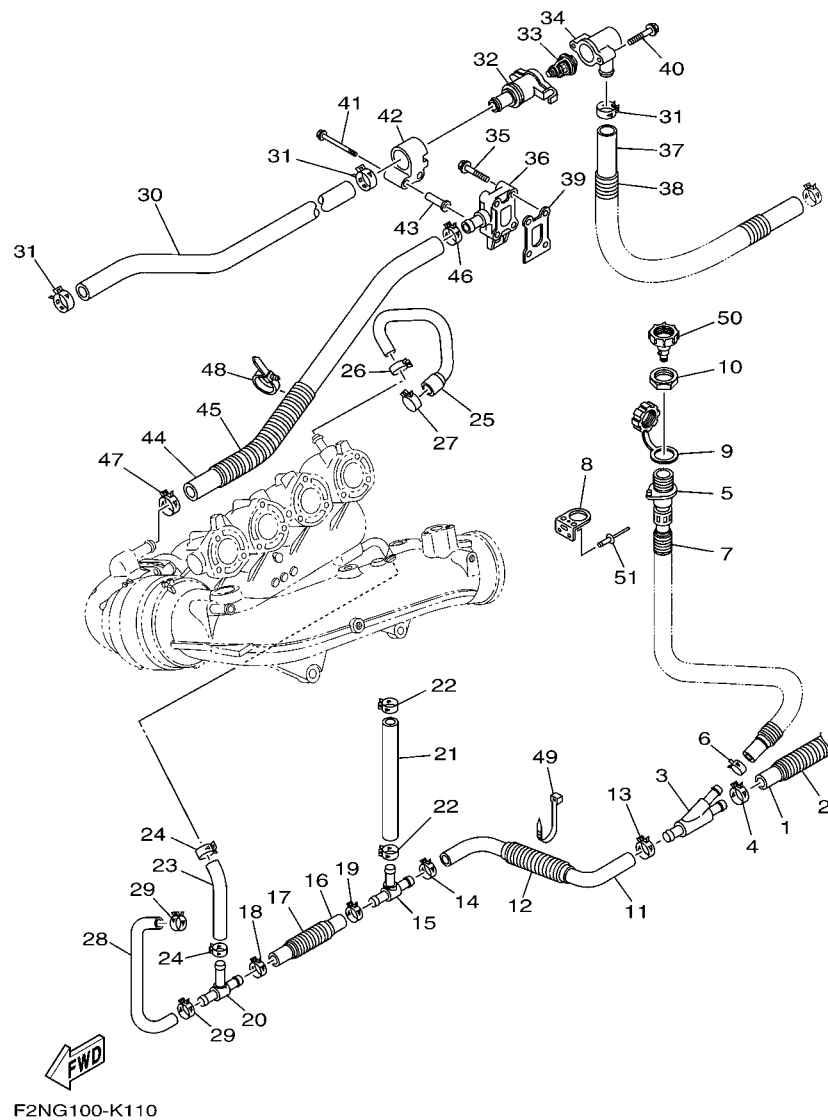

FIG. 11 EXHAUST 3

REF. NO.	PART NO.	DESCRIPTION	CAN	EUR	GENE	REMARKS
1	90445-21805	HOSE (L300)		1		
2	90447-22004	HOSE, WITH SPRING (L200)		1		
3	60E-12581-00	JOINT, HOSE 1		1		
4	90467-200A3	CLIP		1		
5	63M-12580-00	JOINT ASSY		1		
6	90467-150A5	CLIP		1		
7	90447-19801	TUBE (L485)		1		
8	60E-12443-00	STAY		1		
9	682-84385-01	CAP,1		1		
10	EU0-61652-00	NUT		1		
11	6BU-1243A-00	HOSE 1		1		
12	90447-22003	HOSE, WITH SPRING (L300)		1		
13	90467-200A3	CLIP		1		
14	90467-200A3	CLIP		1		
15	60E-12584-00	JOINT, HOSE 3		1		
16	6S5-12589-01	HOSE 6		1		
17	90447-22001	HOSE, WITH SPRING (L100)		1		
18	90467-200A3	CLIP		1		
19	90467-200A3	CLIP		1		
20	6D3-12584-00	JOINT, HOSE 3		1		
21	6D3-1244H-10	HOSE 5		1		
22	90467-160A0	CLIP		2		
23	90445-18M03	HOSE (L108)		1		
24	90467-160A0	CLIP		2		
25	6D3-12577-10	HOSE 2		1		
26	90467-170A4	CLIP		1		
27	90467-200A3	CLIP		1		

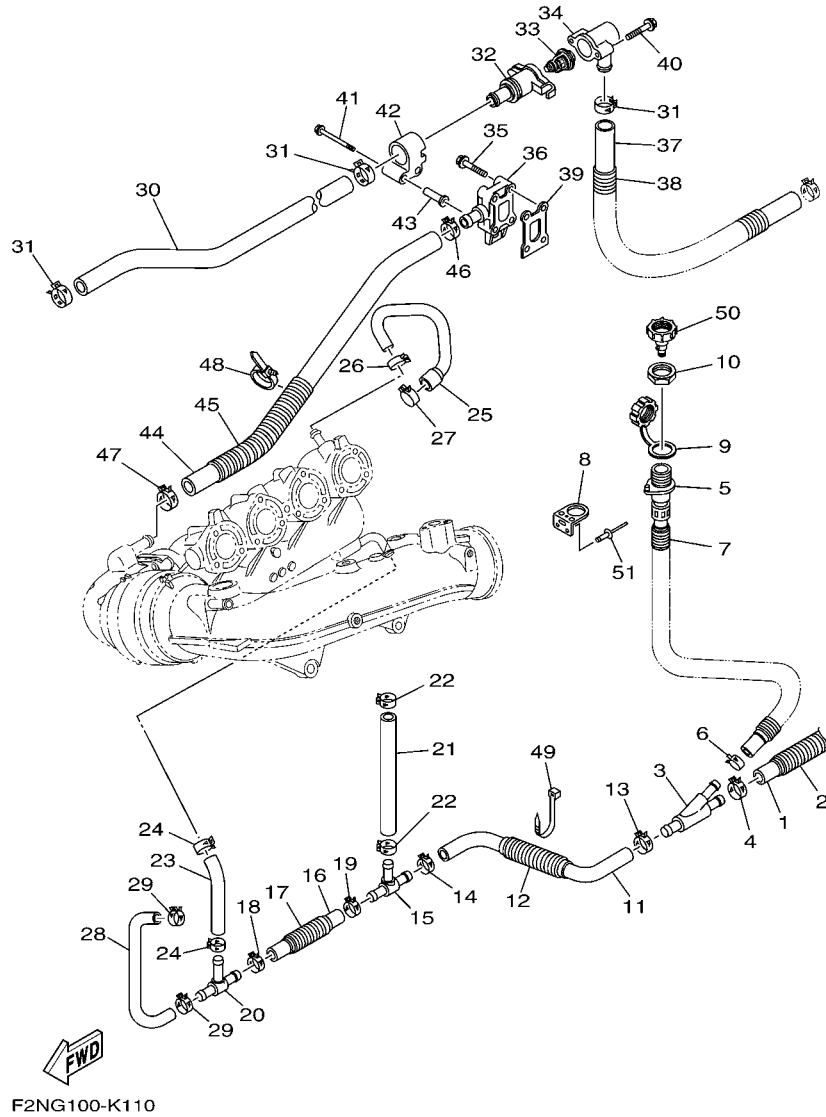
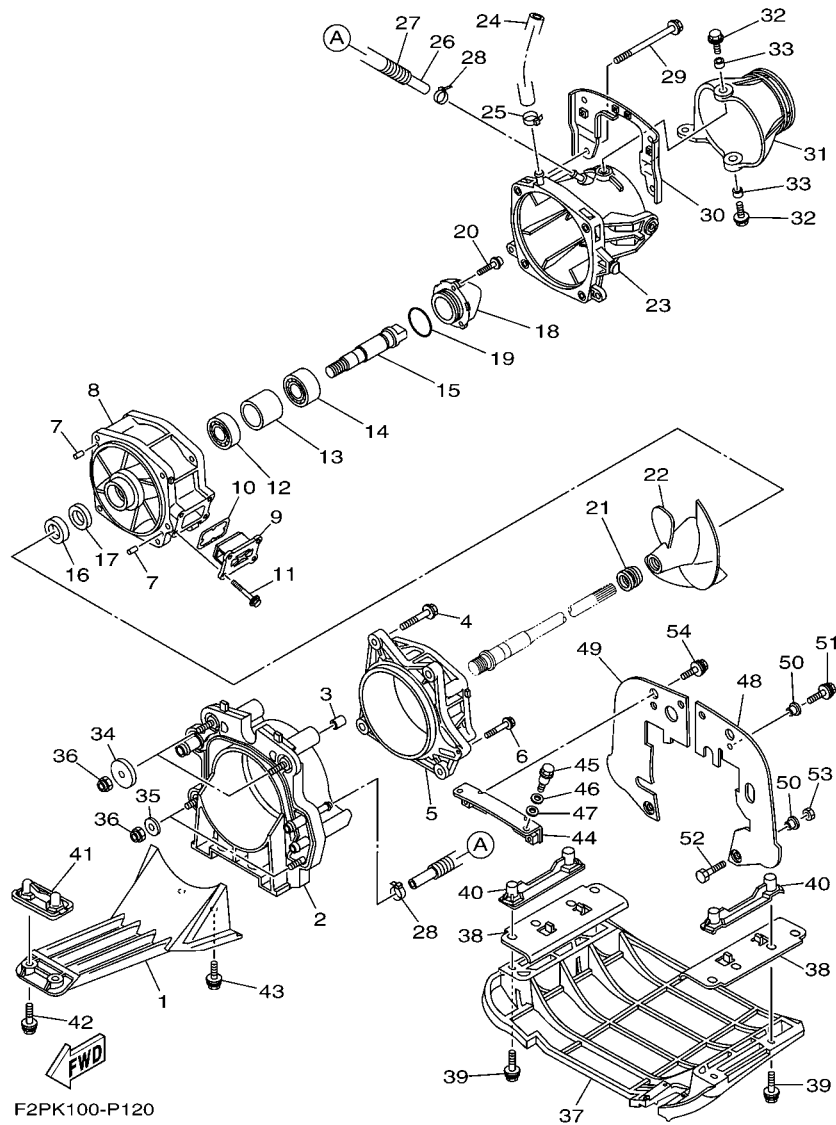

FIG. 11 EXHAUST 3

REF. NO.	PART NO.	DESCRIPTION	CAN	EUR	GENE	REMARKS
28	6D3-1244G-10	HOSE, 4		1		
29	90467-160A0	CLIP		2		
30	90445-26004	HOSE (L375)		1		
31	90467-240A0	CLIP		3		
32	60E-12417-10	HOUSING, THERMOSTAT		1		
33	6D3-12411-00	THERMOSTAT		1		
34	6BH-12413-00	COVER, THERMOSTAT		1		
35	90105-06035	BOLT, FLANGE		2		
36	6D3-12446-00	JOINT		1		
37	90445-25006	HOSE (L760)		1		
38	90447-28010	TUBE (L650)		1		
39	60E-12435-00	GASKET		1		
40	90105-06035	BOLT, FLANGE		2		
41	90105-06054	BOLT, FLANGE		2		
42	6B6-12499-00	JOINT		1		
43	90387-06083	COLLAR		2		
44	6BU-1243F-10	HOSE,3		1		
45	90447-22005	HOSE, WITH SPRING (L200)		1		
46	90467-200A3	CLIP		1		
47	90467-200A3	CLIP		1		
48	90464-31001	CLAMP		1		
49	90464-35132	CLAMP		1		
50	67X-E2590-10	CONDUCTION ASSY		1		
51	90267-489U1	RIVET,BLIND		2		





F2PK100-P120

FIG. 12 JET UNIT 1

REF. NO.	PART NO.	DESCRIPTION	CAN	EUR	GENE	REMARKS
1	6D3-R1333-01-94	SCREEN, INTAKE	1	1	1	
2	6AN-G5831-00	PLATE, TRANSOM	1	1	1	
3	99590-14016	PIN, DOWEL	2	2	2	
4	90119-10810	BOLT, WITH WASHER	4	4	4	
5	66V-51312-01-94	HOUSING, IMPELLER	1	1	1	
6	90119-06893	BOLT, WITH WASHER	1	1	1	
7	93606-12019	PIN, DOWEL	2	2	2	
8	6B6-51315-01-94	DUCT, IMPELLER	1	1	1	
9	6EX-G6882-00	FILTER	1	1	1	
10	66V-42414-00	O-RING	1	1	1	
11	90119-06889	BOLT, WITH WASHER	4	4	4	
12	93306-27211	BEARING	1	1	1	
13	6EX-G5538-00	SPACER 1	1	1	1	
14	93306-205U0	BEARING	1	1	1	
15	6EX-45514-00	SHAFT, DRIVE 4	1	1	1	
16	93101-21001	OIL SEAL	1	1	1	
17	93101-21002	OIL SEAL	1	1	1	
18	6EX-R1326-00	CAP	1	1	1	
19	93210-464A3	O-RING	2	2	2	
20	90110-06822	BOLT, HEXAGON SOCKET HEAD	3	3	3	
21	6D3-R1319-00	CAP, IMPELLER	1	1	1	
22	6D3-R1321-02	IMPELLER	1	1	1	
23	6BU-R1318-01	NOZZLE	1	1	1	
24	90445-16006	HOSE (L260)	1	1	1	
25	90601-118UF	BAND, HOSE 18	1	1	1	
26	90445-14807	HOSE (L355)	1	1	1	
27	90446-20MF5	HOSE (L320)	1	1	1	

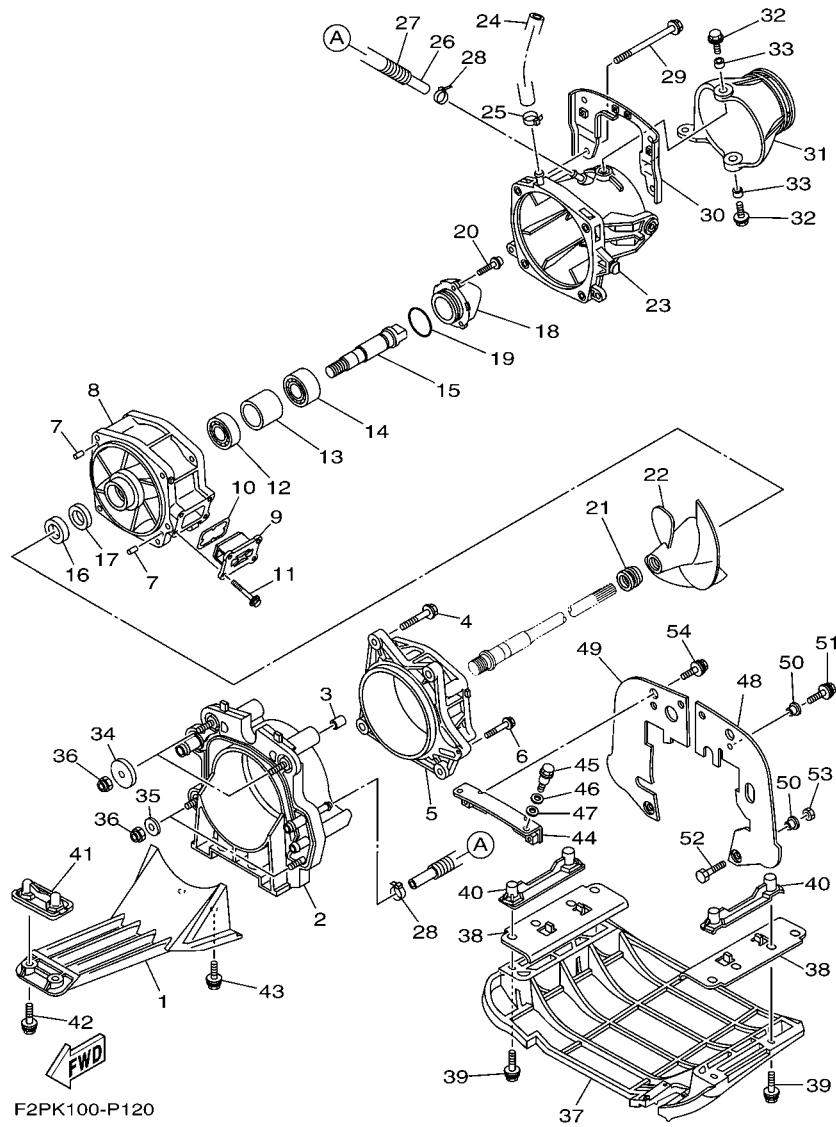

FIG. 12 JET UNIT 1

REF. NO.	PART NO.	DESCRIPTION	CAN	EUR	GENE	REMARKS
28	90465-11829	CLAMP	2	2	2	
29	90119-10806	BOLT, WITH WASHER	4	4	4	
30	6D3-R1341-00	BRACKET 1	1	1	1	
31	6BU-R1313-00-94	NOZZLE, DEFLECTOR	1	1	1	
32	90119-08840	BOLT, WITH WASHER	2	2	2	
33	90387-08M06	COLLAR	2	2	2	
34	F1S-U725E-01	WASHER	2	2	2	
35	90201-10801	WASHER, PLATE	2	2	2	
36	9572R-10300	NUT, NYLON	4	4	4	
37	F2N-U273B-10	PLATE 2	1	1	1	
38	F2M-U143G-00	SPACER	2	2	2	
39	90119-08823	BOLT, WITH WASHER	4	4	4	
40	F1G-U8572-02	BRACKET 2	2	2	2	
41	F1K-U8577-01	BRACKET, 3	1	1	1	
42	90119-06895	BOLT, WITH WASHER	2	2	2	
43	90119-10808	BOLT, WITH WASHER	2	2	2	
44	F1K-U7557-01	BRACKET	1	1	1	
45	90109-08041	BOLT	2	2	2	
46	92990-12200	WASHER, PLAIN	2	2	2	
47	90430-12002	GASKET	2	2	2	
48	F1K-U757E-01	PLATE, RUBBER 1	1	1	1	
49	F1K-U757F-01	PLATE, RUBBER 2	1	1	1	
50	90387-06080	COLLAR	6	6	6	
51	90119-06882	BOLT, WITH WASHER	4	4	4	
52	90101-069U0	BOLT	2	2	2	
53	9572R-06300	NUT, NYLON	2	2	2	
54	90119-089U7	BOLT, WITH WASHER	2	2	2	

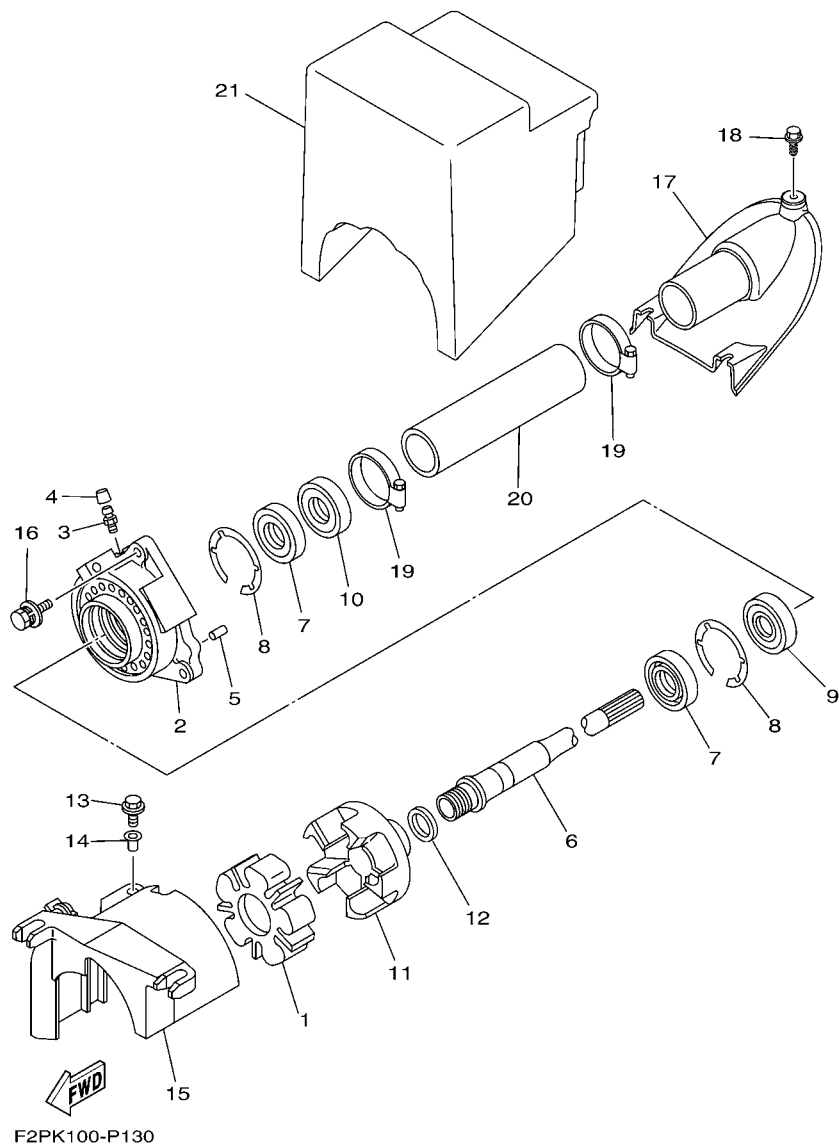
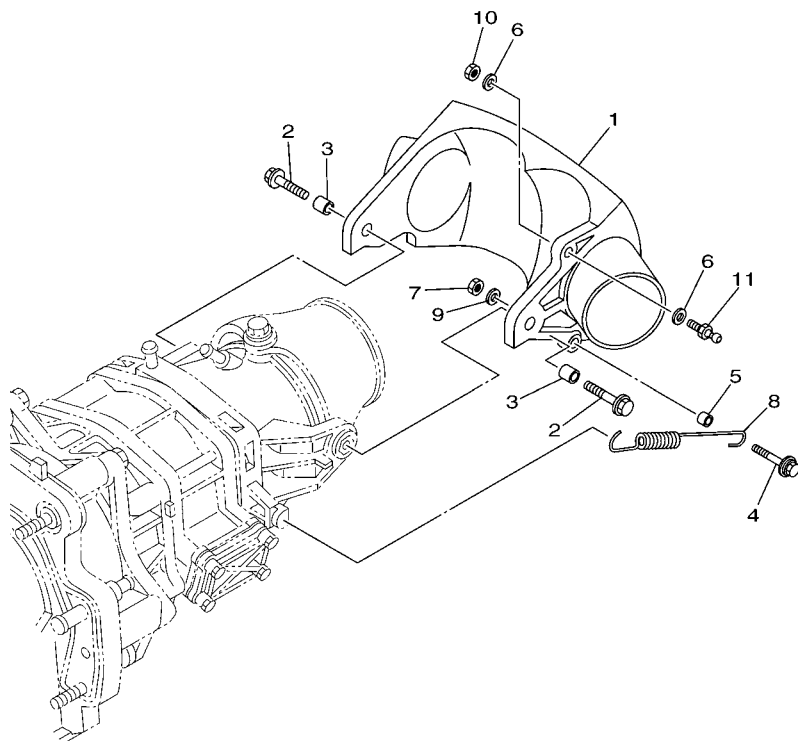

FIG. 13 JET UNIT 2

REF. NO.	PART NO.	DESCRIPTION	CAN	EUR	GENE	REMARKS
1	6D3-4581J-00	RUBBER SHAFT COUPLING	1	1	1	
2	61X-45332-03-94	HOUSING, BEARING	1	1	1	
3	93700-06M03	NIPPLE, GREASE	1	1	1	
4	663-45119-00	CAP, GREASE NIPPLE	1	1	1	
5	93606-12019	PIN, DOWEL	2	2	2	
6	6BU-45511-00	SHAFT, DRIVE	1	1	1	
7	93101-25M55	OIL SEAL	2	2	2	
8	93430-47M04	CIRCLIP	2	2	2	
9	93306-205A3	BEARING	1	1	1	
10	93102-25009	OIL SEAL	1	1	1	
11	6D3-45593-00-94	FLANGE, COUPLING 1	1	1	1	
12	90201-24800	WASHER, PLATE	1	1	1	
13	90119-06891	BOLT, WITH WASHER	1	1	1	
14	90387-06289	COLLAR	1	1	1	
15	60E-R1381-01	COVER	1	1	1	
16	90119-089UL	BOLT, WITH WASHER	3	3	3	
17	F2N-U883E-00	JOINT, PIPE	1	1	1	
18	90109-06832	BOLT	3	3	3	
19	90601-155U4	BAND, HOSE 55	2	2	2	
20	F2N-U883B-00	PIPE, 1	1	1	1	
21	F1K-U892D-00	FLOTATION, STERN	1	1	1	

FIG. 14 JET UNIT 3



  
F2NA100-K140

REF. NO.	PART NO.	DESCRIPTION	CAN	EUR	GENE	REMARKS
1	6D3-R1314-00	GATE, REVERSE	1	1	1	
2	90119-08840	BOLT, WITH WASHER	2	2	2	
3	90387-08M30	COLLAR	2	2	2	
4	90119-069UX	BOLT, WITH WASHER	1	1	1	
5	90387-06M30	COLLAR	1	1	1	
6	90201-06801	WASHER, PLATE	2	2	2	
7	9538R-06600	NUT	1	1	1	
8	6D3-52358-00	SPRING, RETAINER	1	1	1	
9	90201-06801	WASHER, PLATE	1	1	1	
10	9538R-06600	NUT	1	1	1	
11	EU0-U1461-03	STUD, JOINT BALL	1	1	1	

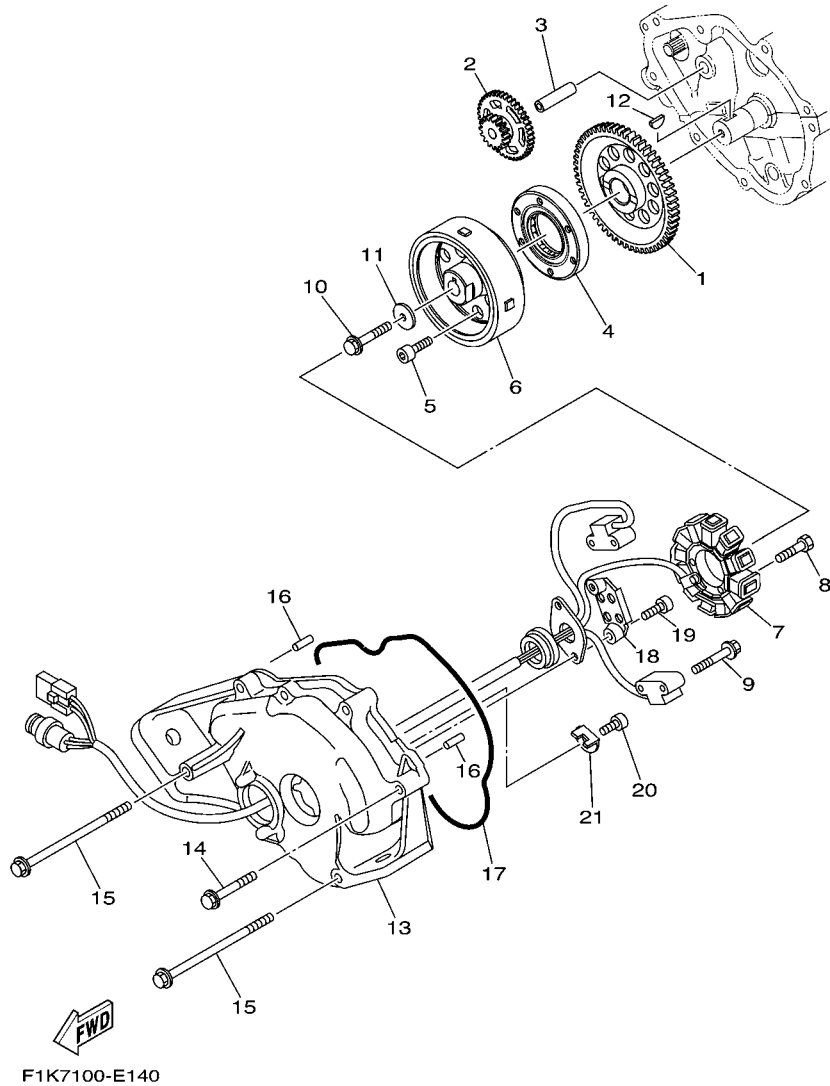
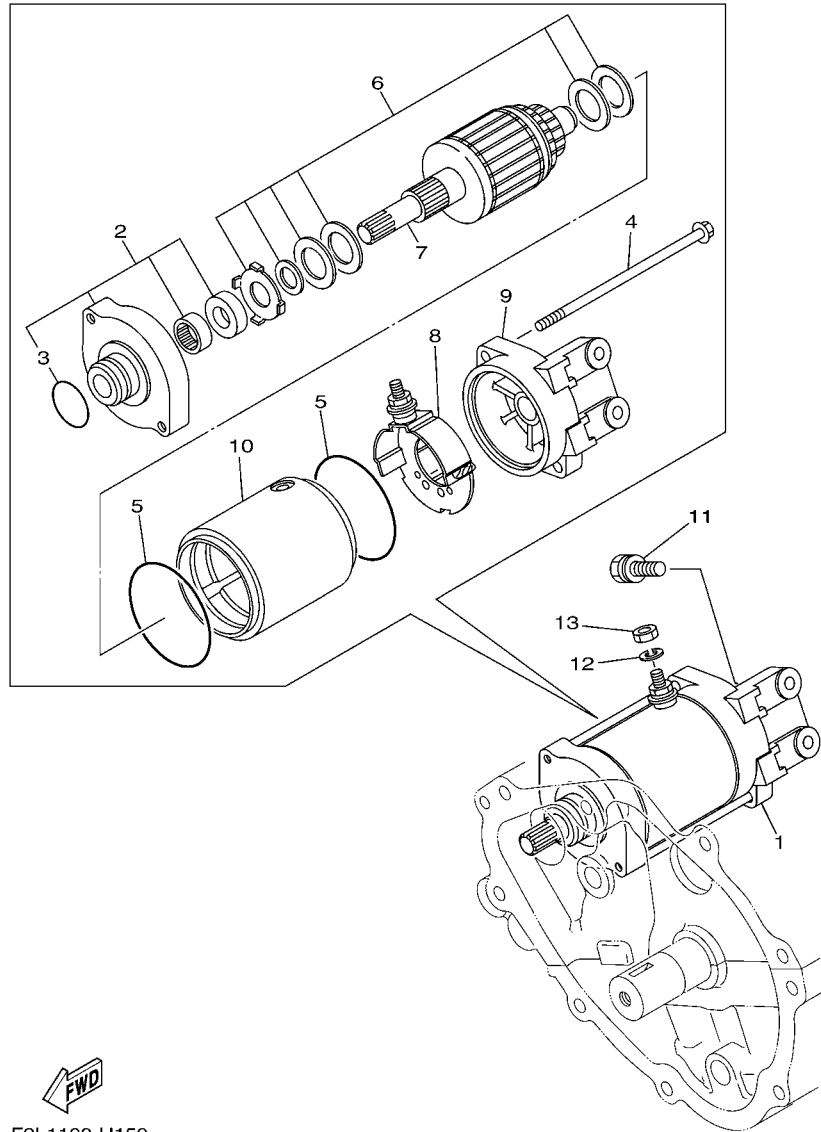

FIG. 15 GENERATOR

REF. NO.	PART NO.	DESCRIPTION	CAN	EUR	GENE	REMARKS
1	6D3-15515-00	GEAR 3	1	1	1	
2	60E-15517-00	GEAR, IDLER 2	1	1	1	
3	60E-15521-00	SHAFT 1	1	1	1	
4	4WM-15590-00	STARTER ONE-WAY ASSY	1	1	1	
5	90110-08212	BOLT, HEXAGON SOCKET HEAD	6	6	6	
6	6D3-81450-00	ROTOR ASSY	1	1	1	
7	6D3-81410-02	STATOR ASSY	1	1	1	
8	91317-06035	BOLT	3	3	3	
9	97513-05514	BOLT, WITH WASHER	2	2	2	
10	90105-105A6	BOLT, FLANGE	1	1	1	
11	90201-103U7	WASHER, PLATE	1	1	1	
12	90280-03047	KEY, WOODRUFF	1	1	1	
13	6D3-81337-00-94	COVER, FLYWHEEL	1	1	1	
14	90119-10016	BOLT, WITH WASHER	6	6	6	
15	90119-10M19	BOLT, WITH WASHER	2	2	2	
16	93608-16M16	PIN, DOWEL	2	2	2	
17	93212-04001	O-RING	1	1	1	
18	60E-81328-00	CLAMP	1	1	1	
19	91317-06014	BOLT	2	2	2	
20	91317-05010	BOLT	1	1	1	
21	6D3-81845-00	PLATE	1	1	1	



F2L1100-H150

FIG. 16 STARTING MOTOR

REF. NO.	PART NO.	DESCRIPTION	CAN	EUR	GENE	REMARKS
1	6D3-81800-00	STARTING MOTOR ASSY	1	1	1	
2	6M6-81830-00	.FRONT BRACKET ASSY	1	1	1	
3	1FK-81847-00	..O-RING	1	1	1	
4	6M6-81826-00	.BOLT	2	2	2	
5	11H-81844-00	.GASKET	2	2	2	
6	3AJ-81809-00	.WASHER KIT	1	1	1	
7	6M6-81850-00	.ARMATURE ASSY	1	1	1	
8	6M6-81840-10	.BRUSH HOLDER ASSY	1	1	1	
9	6D3-81820-00	.REAR BRACKET ASSY	1	1	1	
10	60E-81810-00	.STATOR ASSY	1	1	1	
11	97513-08530	BOLT, WITH WASHER	2	2	2	
12	92990-06100	WASHER, SPRING	1	1	1	
13	95380-06700	NUT	1	1	1	

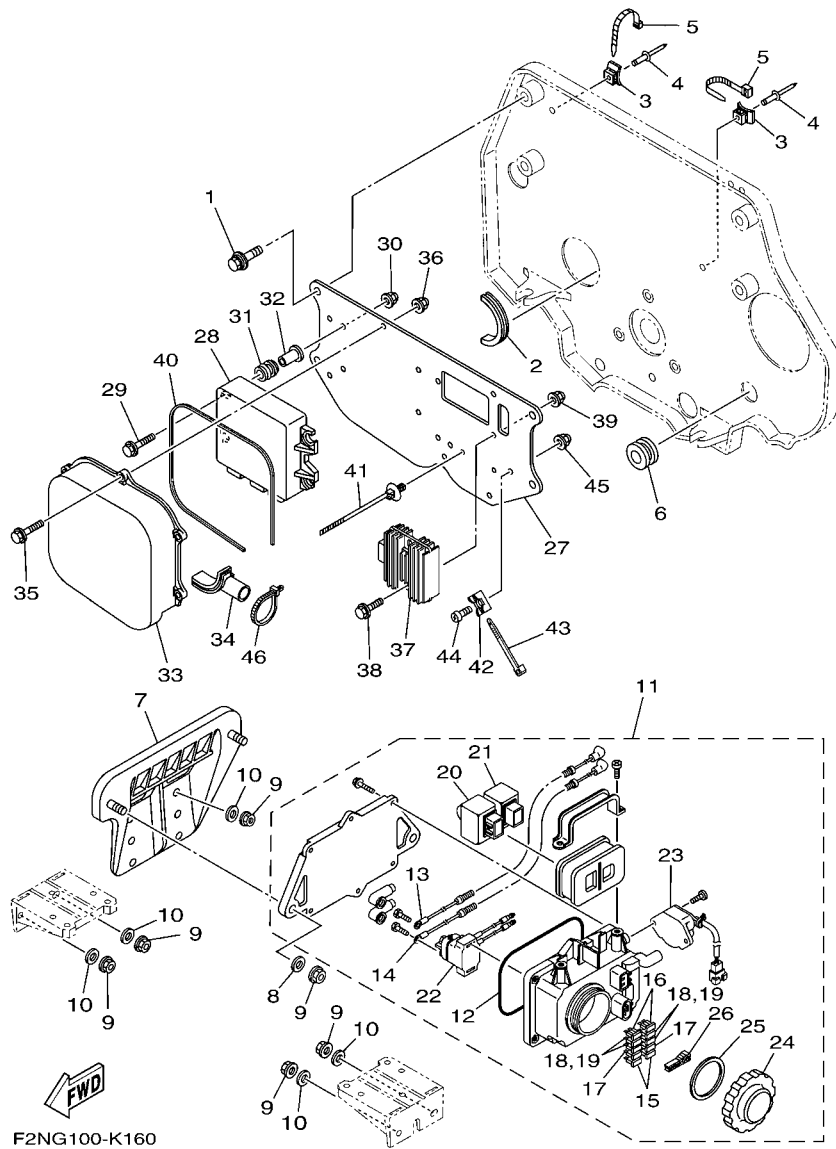

FIG. 17 ELECTRICAL 1

REF. NO.	PART NO.	DESCRIPTION	CAN	EUR	GENE	REMARKS
1	90119-089U7	BOLT, WITH WASHER	4	4	4	
2	F1S-U828H-01	TRIM, 1	1	1	1	
3	F1W-U828M-00	BASE, CLAMP	2	2	2	
4	90267-48802	RIVET, BLIND	2	2	2	
5	90464-32801	CLAMP	2	2	2	
6	90480-279U1	GROMMET	1	1	1	
7	F2N-U815D-01	BRACKET, ELECTRIC BOX	1	1	1	
8	90201-099U3	WASHER, PLATE	2	2	2	
9	9572R-08300	NUT, FLANGE	10	10	10	
10	9299R-08200	WASHER	8	8	8	
11	6BU-82170-00	FUSE BOX ASSY	1	1	1	
12	6D3-81921-00	.GASKET, TERMINAL	1	1	1	
13	6BU-82115-00	.WIRE, PLUS LEAD	1	1	1	
14	6D3-82117-00	.WIRE, LEAD	1	1	1	
15	67F-82151-00	.FUSE (20A)	2	2	2	
16	67F-82151-10	.FUSE (30A)	2	2	2	
17	67F-82151-30	.FUSE (3A)	2	2	2	
18	67F-82151-40	.FUSE (10A)	2	2	2	
19	67F-82151-40	.FUSE (10A)	2	2	2	
20	60E-81950-00	.RELAY ASSY	1	1	1	
21	68V-81950-00	.RELAY ASSY	1	1	1	
22	6B6-81940-00	.STARTER RELAY ASSY	1	1	1	
23	60E-8259E-00	.SWITCH ASSY	1	1	1	
24	66V-8132W-00	.CAP	1	1	1	
25	66V-81844-00	.GASKET	1	1	1	
26	67F-2812A-00	.PULLER, FUSE	1	1	1	
27	6BU-81845-00	PLATE	1	1	1	

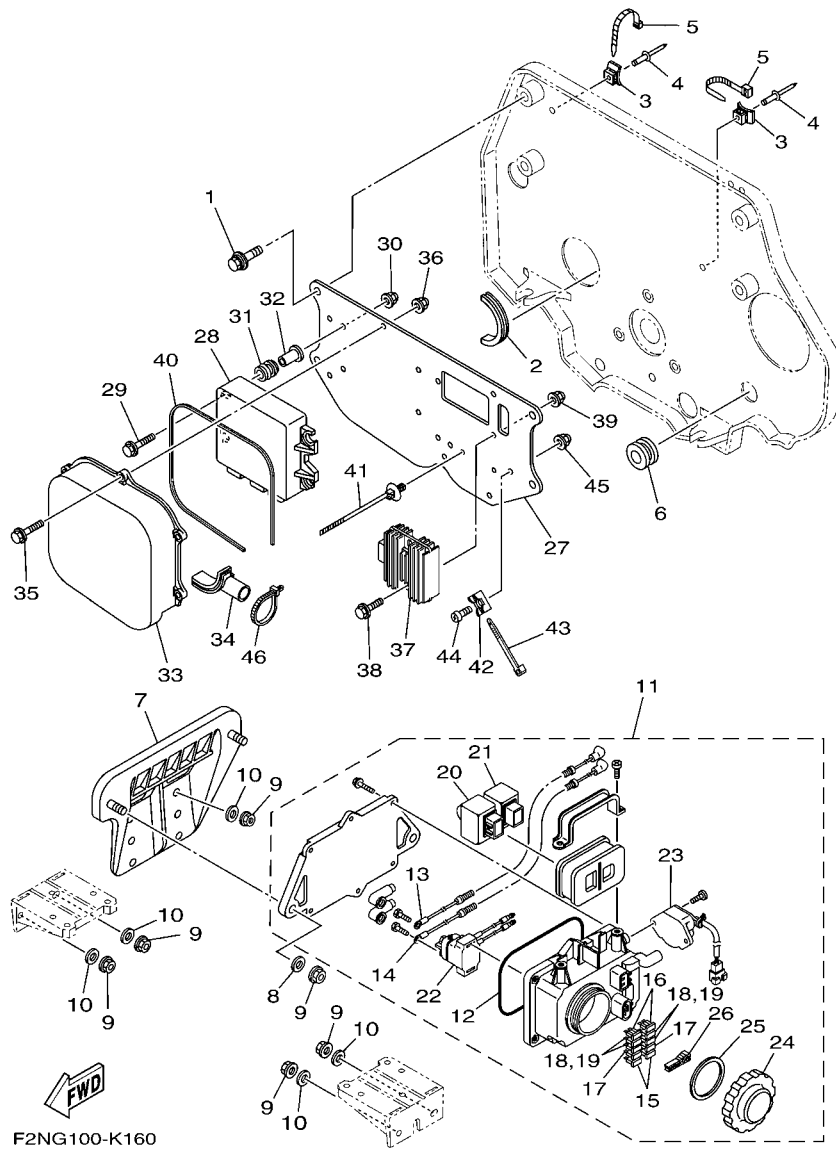

FIG. 17 ELECTRICAL 1

REF. NO.	PART NO.	DESCRIPTION	CAN	EUR	GENE	REMARKS
28	6EN-8591A-00	ENGINE CONTROL UNIT ASSY	1		1	FOR CAN, GENE
	6EN-8591A-10	ENGINE CONTROL UNIT ASSY		1		FOR EUR
29	95814-06025	BOLT, FLANGE	4	4	4	
30	90176-06047	NUT,CAP	4	4	4	
31	6A0-82317-00	DAMPER, IGNITION COIL	4	4	4	
32	90387-06119	COLLAR	4	4	4	
33	6BU-81639-00	COVER	1	1	1	
34	6BU-81336-00	GROMMET	1	1	1	
35	95814-06020	BOLT, FLANGE	5	5	5	
36	90176-06047	NUT,CAP	5	5	5	
37	6S8-81960-00	RECTIFIER & REGULATOR ASSY	1	1	1	
38	95814-06020	BOLT, FLANGE	2	2	2	
39	90176-06047	NUT,CAP	2	2	2	
40	6BU-81861-00	GASKET	1	1	1	
41	90464-31001	CLAMP	1	1	1	
42	60E-1244E-00	BRACKET 1	1	1	1	
43	90465-13M24	CLAMP	1	1	1	
44	92014-06012	BOLT, BUTTON HEAD	1	1	1	
45	90176-06047	NUT,CAP	1	1	1	
46	90465-13M18	CLAMP	1	1	1	



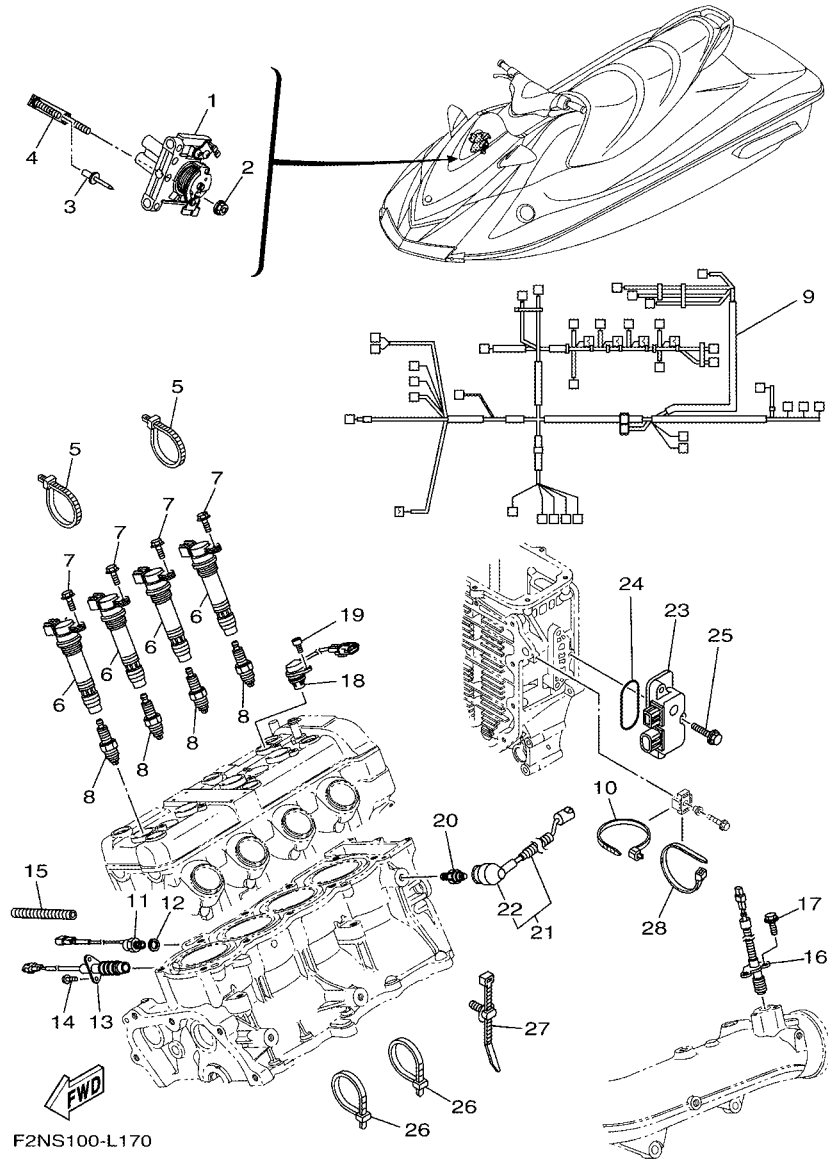

FIG. 18 ELECTRICAL 2

REF. NO.	PART NO.	DESCRIPTION	CAN	EUR	GENE	REMARKS
1	6D3-14305-21	ACCEL. POSITON SENSOR ASSY	1	1	1	
2	95780-08300	NUT, FLANGE	2	2	2	
3	90267-489U1	RIVET,BLIND	1	1	1	
4	F2N-U7254-00	BRACKET, THROTTLE	1	1	1	
5	90464-35132	CLAMP	2	2	2	
6	6D3-82310-01	IGNITION COIL ASSY	4	4	4	
7	95880-06016	BOLT, FLANGE	4	4	4	
8	94702-00409	PLUG, SPARK (NGK CR9EB)	4	4	4	
9	6BU-8259L-20	WIRE HARNESS ASSY 1	1	1	1	
10	90465-13M24	CLAMP	1	1	1	
11	61A-85790-00	THERMOSENSOR ASSY	1	1	1	
12	92990-10600	WASHER, PLATE	1	1	1	
13	60E-82560-A1	THERMO SWITCH ASSY	1	1	1	
14	97595-06416	BOLT, WITH WASHER	2	2	2	
15	90446-14M23	HOSE (L180)	1	1	1	
16	6D3-82560-01	THERMO SWITCH ASSY	1	1	1	
17	97595-06416	BOLT, WITH WASHER	2	2	2	
18	6D3-85896-00	SENSOR, CAM POSITION	1	1	1	
19	91380-06016	BOLT	1	1	1	
20	68V-82504-00	OIL PRESSURE SWITCH ASSY	1	1	1	
21	60E-81315-00	LEAD WIRE ASSY	1	1	1	
22	60E-82532-00	.CAP	1	1	1	
23	6D3-8273J-01	EARTH PLATE COMP.	1	1	1	
24	93210-60ME8	O-RING	1	1	1	
25	90119-06048	BOLT, WITH WASHER	3	3	3	
26	90465-13M18	CLAMP	2	2	2	
27	90464-45002	CLAMP	1	1	1	



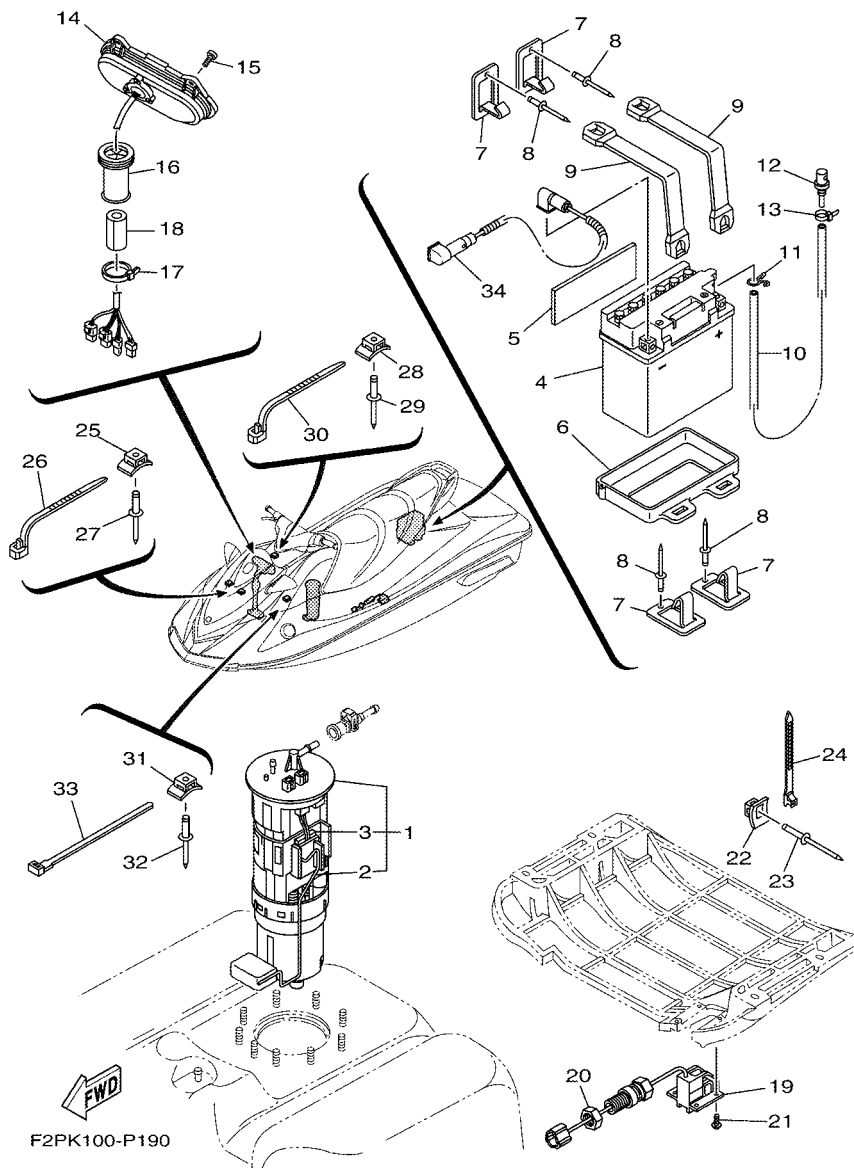
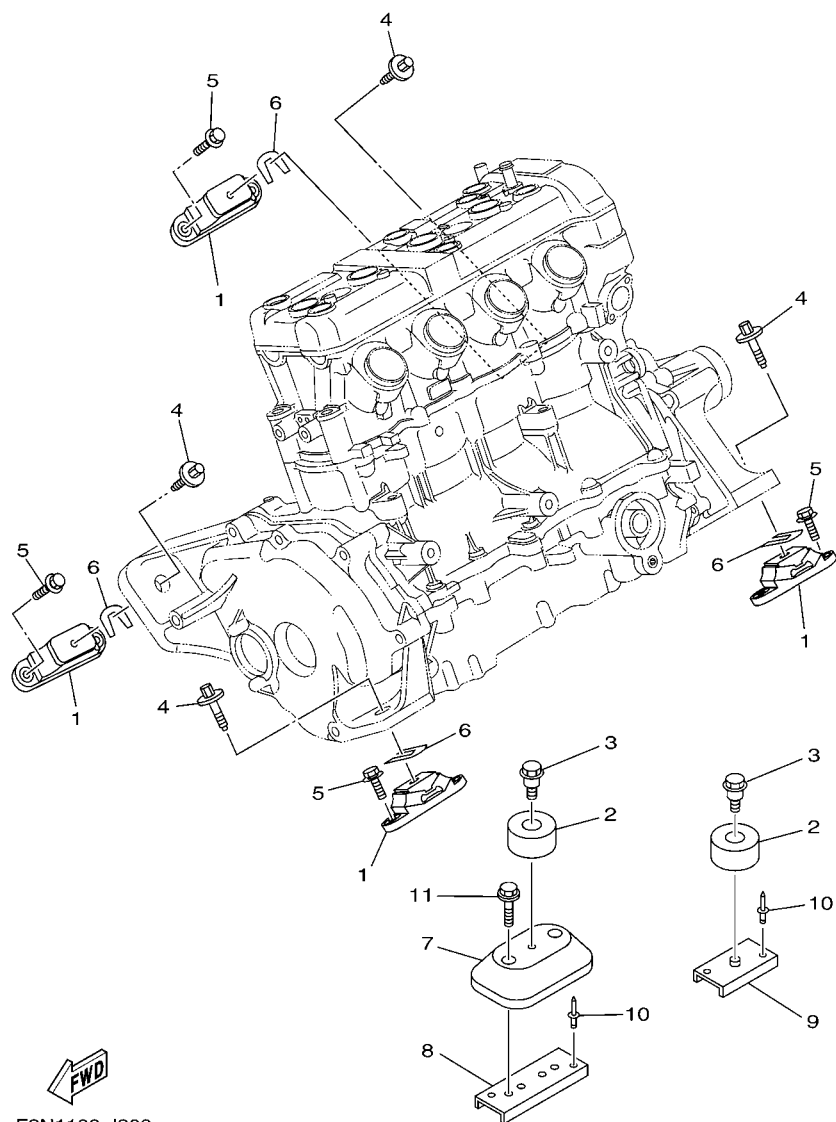

FIG. 19 ELECTRICAL 3

REF. NO.	PART NO.	DESCRIPTION	CAN	EUR	GENE	REMARKS
1	60E-13907-03	FUEL PUMP COMP.	1	1	1	
2	60E-682E0-00	.FUEL SENDER ASSY	1	1	1	
3	60E-82556-00	.DAMPER, STOPPER	1	1	1	
4	EU0-U8217-H2	BATTERY (YB16CL-B)	1	1	1	
5	F1K-U8221-00	PAD, BATTERY	1	1	1	
6	F1K-U8211-01	CASE, BATTERY	1	1	1	
7	F1K-U5772-04	HOOK A	4	4	4	
8	90267-489U1	RIVET,BLIND	4	4	4	
9	F1K-U821D-01	BAND, BATTERY 1	2	2	2	
10	F0D-U785G-10	HOSE, AIR VENT	1	1	1	
11	90467-089U1	CLIP	1	1	1	
12	GJ3-6215F-00	NIPPLE	1	1	1	
13	90465-11829	CLAMP	1	1	1	
14	F2N-U820A-10	METER ASSY	1	1	1	
15	90111-05008	BOLT,HEX. SOCKET BUTTON	4	4	4	
16	GU2-6822E-01	GROMMET	1	1	1	
17	90464-32801	CLAMP	1	1	1	
18	GJ1-U7578-21	PACKING, HOSE 2	1	1	1	
19	F1S-U8K31-02	SENSOR SPEED	1	1	1	
20	F2C-U151S-00	NUT	1	1	1	
21	90150-05807	SCREW, ROUND HEAD	4	4	4	
22	F1W-U828M-00	BASE, CLAMP	6	6	6	
23	90267-489U6	RIVET, BLIND	6	6	6	
24	90464-32801	CLAMP	6	6	6	
25	F1W-U828M-00	BASE, CLAMP	2	2	2	
26	90464-32801	CLAMP	2	2	2	
27	90267-489U6	RIVET, BLIND	2	2	2	



FIG. 20 ENGINE MOUNT



F2N1100-J200

REF. NO.	PART NO.	DESCRIPTION	CAN	EUR	GENE	REMARKS
1	67X-44517-10-94	MOUNT RUBBER	4	4	4	
2	6D3-44574-00	STOPPER, LOWER MOUNT RUBBER	2	2	2	
3	90109-06M92	BOLT	2	2	2	
4	90119-08859	BOLT, WITH WASHER	4	4	4	
5	90119-08823	BOLT, WITH WASHER	8	8	8	
6	EU0-U7354-00-01	SHIM (T=0.1)	4	4	4	UN
	EU0-U7354-00-03	SHIM (T=0.3)	4	4	4	UN
	EU0-U7354-00-05	SHIM (T=0.5)	4	4	4	UN
	EU0-U7354-00-10	SHIM (T=1.0)	4	4	4	UN
	EU0-U7354-00-20	SHIM (T=2.0)	4	4	4	UN
7	F2N-U721B-00	SPACER,ENGINE MOUNT	1	1	1	
8	F2N-U732B-10	PLATE	1	1	1	
9	F2N-U732B-01	PLATE	1	1	1	
10	90267-489U2	RIVET, BLIND	4	4	4	
11	90119-06891	BOLT, WITH WASHER	2	2	2	



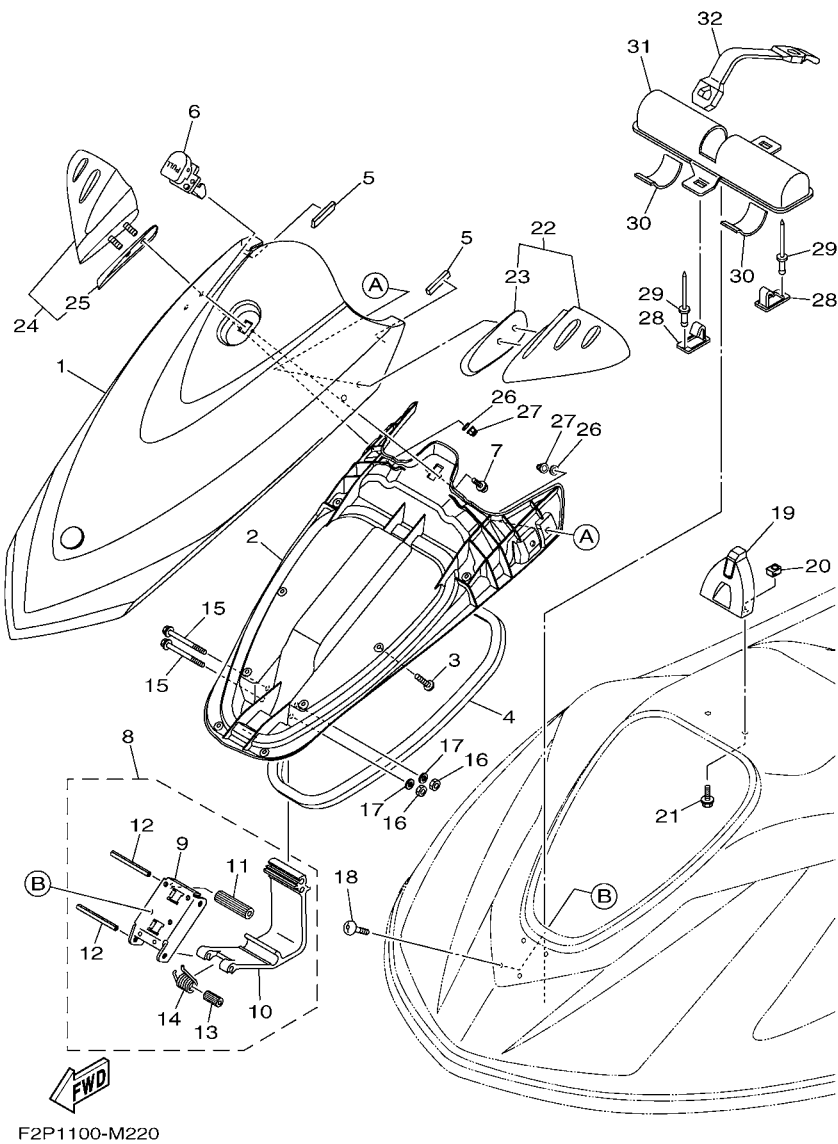

FIG. 22 ENGINE HATCH 2

REF. NO.	PART NO.	DESCRIPTION	CAN	EUR	GENE	REMARKS
1	F2N-U517B-10-PC	LID, ENGINE ROOM (YRM2)	1	1	1	
2	F2N-U213B-01	COVER, VENTILATOR 1	1	1	1	
3	90149-05903	SCREW	8	8	8	
4	F2N-U2663-01	PACKING 1	1	1	1	
5	F1K-U266B-00	PACKING 3	2	2	2	
6	F1K-6517C-00	LOCK, LID	1	1	1	
7	90119-059U4	BOLT, WITH WASHER	2	2	2	
8	F1K-U515A-00	HINGE ASSY.	1	1	1	
9	F1K-U518E-04	.PLATE, HINGE LID	1	1	1	
10	F1K-U517D-05	.HINGE, LID	1	1	1	
11	F1K-U135C-01	.ROLLER, DETENT	1	1	1	
12	F1K-U517R-00	.PIN, HINGE	2	2	2	
13	F1K-U471E-03	.SPACER 1	1	1	1	
14	F1K-U283B-02	.SPRING, TORSION	1	1	1	
15	90105-06826	BOLT, FLANGE	2	2	2	
16	9572R-06300	NUT, NYLON	2	2	2	
17	9299R-06200	WASHER	2	2	2	
18	F2N-67823-00	SCREW	4	4	4	
19	F2N-U517F-00	HOOK, LID LOCK	1	1	1	
20	F1X-U517E-01	NUT	2	2	2	
21	90119-06880	BOLT, WITH WASHER	2	2	2	
22	F2N-U596B-00	MIRROR LH	1	1	1	
23	F2N-U471E-00	.SPACER 1	1	1	1	
24	F2N-U596C-00	MIRROR RH	1	1	1	
25	F2N-U471F-00	.SPACER 2	1	1	1	
26	9299R-08200	WASHER	4	4	4	
27	9572R-08300	NUT, FLANGE	4	4	4	





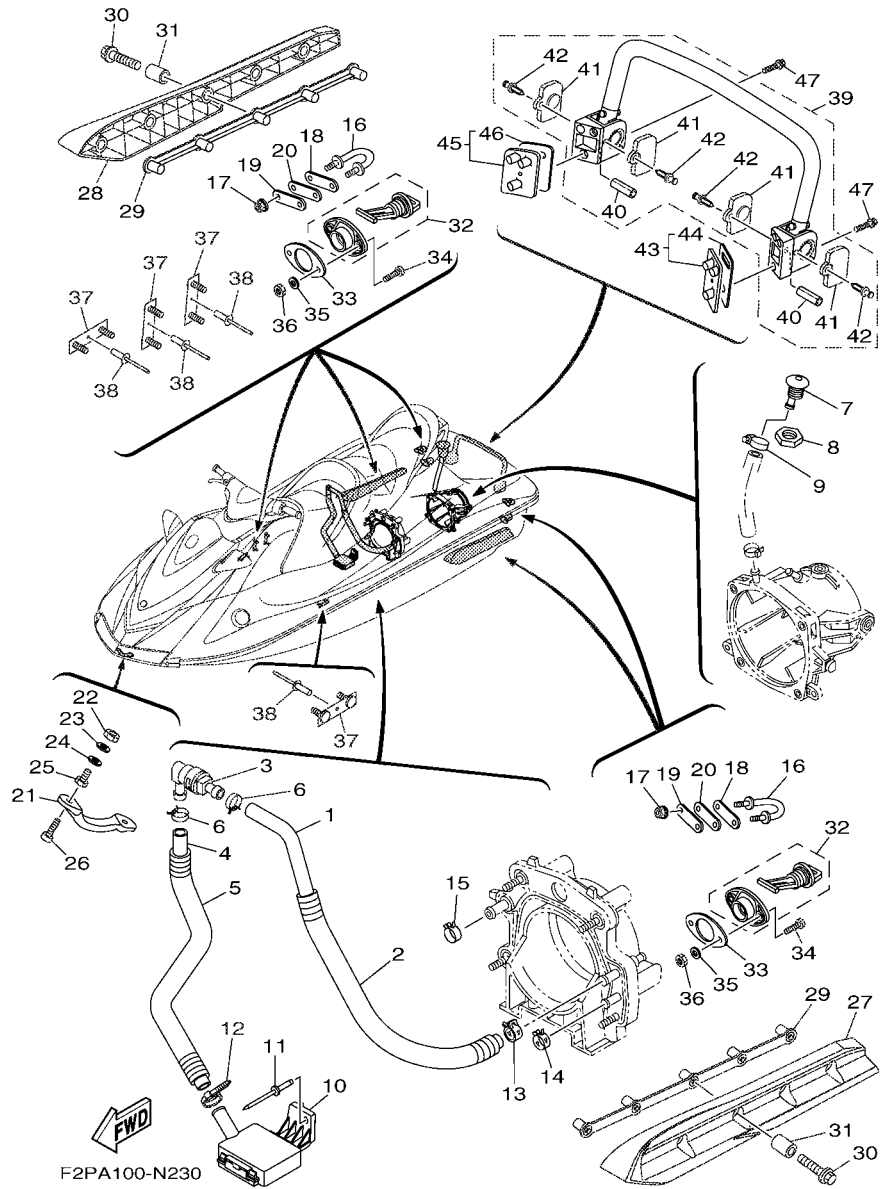

FIG. 23 HULL & DECK

REF. NO.	PART NO.	DESCRIPTION	CAN	EUR	GENE	REMARKS
1	90445-20804	HOSE (L860)	1	1	1	
2	6EX-U773E-00	TUBE,2	1	1	1	
3	68N-5112T-00	JOINT, HOSE	1	1	1	
4	90445-20800	HOSE (L500)	1	1	1	
5	6EX-U773D-00	TUBE	1	1	1	
6	90467-18804	CLIP	2	2	2	
7	F1W-U269B-00	SPOUT	1	1	1	
8	EU0-61652-00	NUT	1	1	1	
9	90601-118UF	BAND, HOSE 18	1	1	1	
10	F1B-U761D-02	STRAINER, BILGE	1	1	1	
11	90267-489U8	RIVET, BLIND	1	1	1	
12	90465-11829	CLAMP	1	1	1	
13	90467-21800	CLIP	1	1	1	
14	90467-200A0	CLIP	1	1	1	
15	90467-210A0	CLIP	1	1		FOR CAN, GENE
	90467-26800	CLIP		1		FOR EUR
16	F2N-U1628-02	STERN EYE	2	2	2	
17	9572R-08300	NUT, FLANGE	4	4	4	
18	GP7-U4953-10	PLATE A	2	2	2	
19	F2C-U4953-10	PLATE A	2	2	2	
20	F1B-U1653-02	PACKING	2	2	2	
21	F1K-61624-00	BOWEYE 1	1	1	1	
22	99780-12600	NUT.HEX.(COARS)	2	2	2	
23	92990-12200	WASHER, PLAIN	2	2	2	
24	F0X-61637-00	WASHER	2	2	2	
25	F0X-61652-00	NUT (BOLT/NUT)	2	2	2	
26	90110-06040	BOLT, HEXAGON SOCKET HEAD	2	2	2	

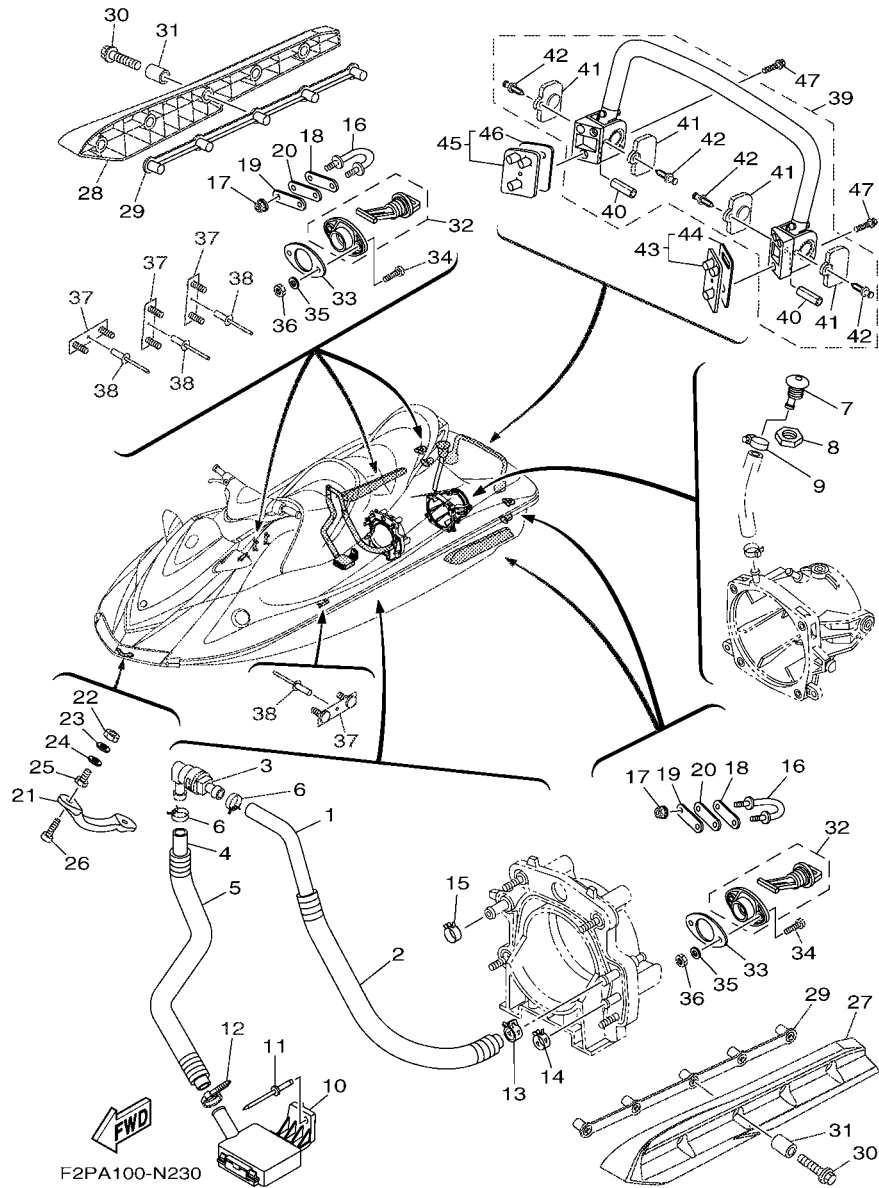
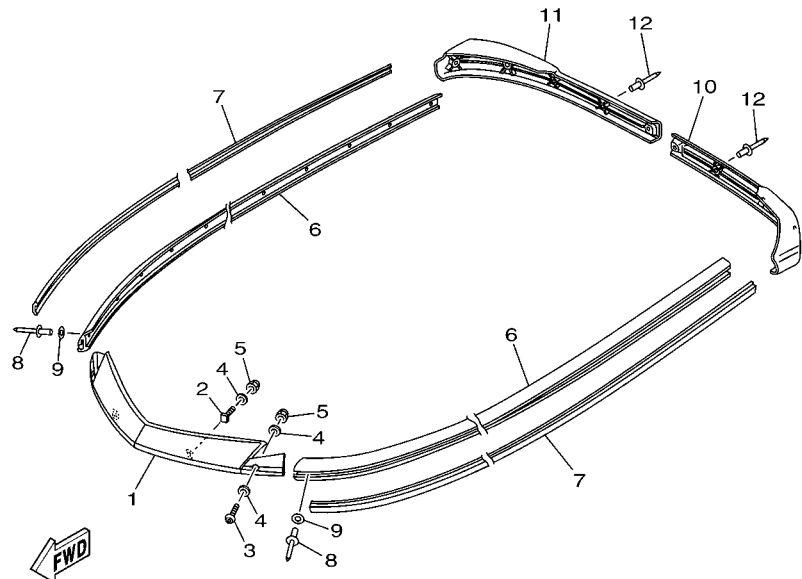
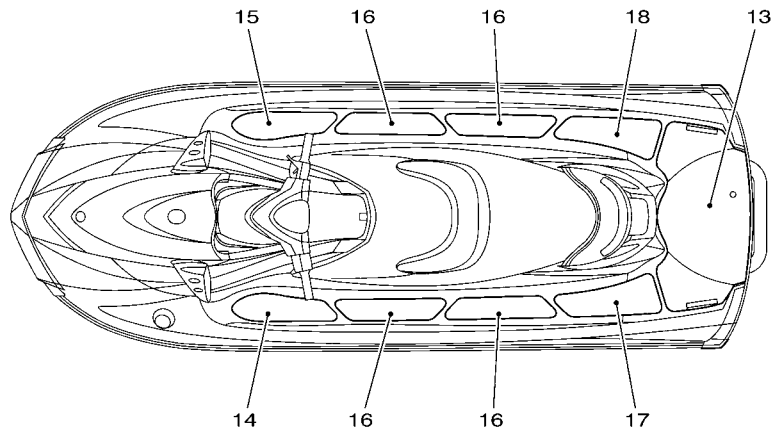

FIG. 23 HULL & DECK

REF. NO.	PART NO.	DESCRIPTION	CAN	EUR	GENE	REMARKS
27	F2N-U883N-00	STABILIZER LH	1	1	1	
28	F2N-U883P-00	STABILIZER RH	1	1	1	
29	F1X-U883T-01	BRACKET,STABILIZER	2	2	2	
30	90105-08860	BOLT, FLANGE	10	10	10	
31	F2N-U8169-00	SPACER	10	10	10	
32	F1S-U2280-02	DRAIN PLUG ASSY.	2	2	2	
33	F1S-U2285-00	PACKING, DRAIN	2	2	2	
34	9788R-05025	SCREW, PAN HEAD	4	4	4	
35	9299R-05200	WASHER	4	4	4	
36	9572R-05300	NUT, FLANGE	4	4	4	
37	F1K-U826C-03	BRACKET	4	4	4	
38	90267-489U1	RIVET,BLIND	4	4	4	
39	F2N-U278A-00	LADDER, STEP ASSY	1	1	1	
40	F1W-U771H-00	.SLEEVE 1	2	2	2	
41	F2C-U377H-00	.INNER, COVER SIDE 1	4	4	4	
42	F2C-U1314-00	.PIN	4	4	4	
43	F2L-U278F-01	BRACKET, LADDER LH	1	1	1	
44	F2L-U278H-00	.PACKING, BRKT. 1	1	1	1	
45	F2L-U278G-01	BRACKET, LADDER RH	1	1	1	
46	F2L-U278H-00	.PACKING, BRKT. 1	1	1	1	
47	90119-08861	BOLT, WITH WASHER	6	6	6	



F2V1100-K170

FIG. 24 GUNWALE & MAT

REF. NO.	PART NO.	DESCRIPTION	CAN	EUR	GENE	REMARKS
1	F2N-U2511-30	GUNWALE, BOW	1	1	1	DARK GRAY
2	F1W-U491K-00	BOLT, SPECIAL	2	2	2	
3	90111-06803	BOLT,HEX. SOCKET BUTTON	2	2	2	
4	9299R-06200	WASHER	6	6	6	
5	9572R-06300	NUT, NYLON	4	4	4	
6	F1K-U2512-30	GUNWALE, SIDE	2	2	2	DARK GRAY
7	F1K-U2519-20	INNER,GUNWALE	2	2	2	YAMAHA BLACK
8	90267-489U8	RIVET, BLIND	30	30	30	
9	9299R-05200	WASHER	30	30	30	
10	F1K-U251D-30	GUNWALE, STERN 1	1	1	1	DARK GRAY
11	F1K-U251E-30	GUNWALE, STERN 2	1	1	1	DARK GRAY
12	90267-48963	RIVET, BLIND	9	9	9	
13	F2P-U3581-00	MAT, UPPER	1	1	1	DARK GREY
14	F2P-U351H-00	MAT, STEP 1	1	1	1	DARK GREY
15	F2P-U351J-00	MAT, STEP 2	1	1	1	DARK GREY
16	F2P-U351K-00	MAT, STEP 3	4	4	4	DARK GREY
17	F2P-U351M-00	MAT, STEP 4	1	1	1	DARK GREY
18	F2P-U351N-00	MAT, STEP 5	1	1	1	DARK GREY



**FIG. 26 SEAT & UNDER LOCKER**

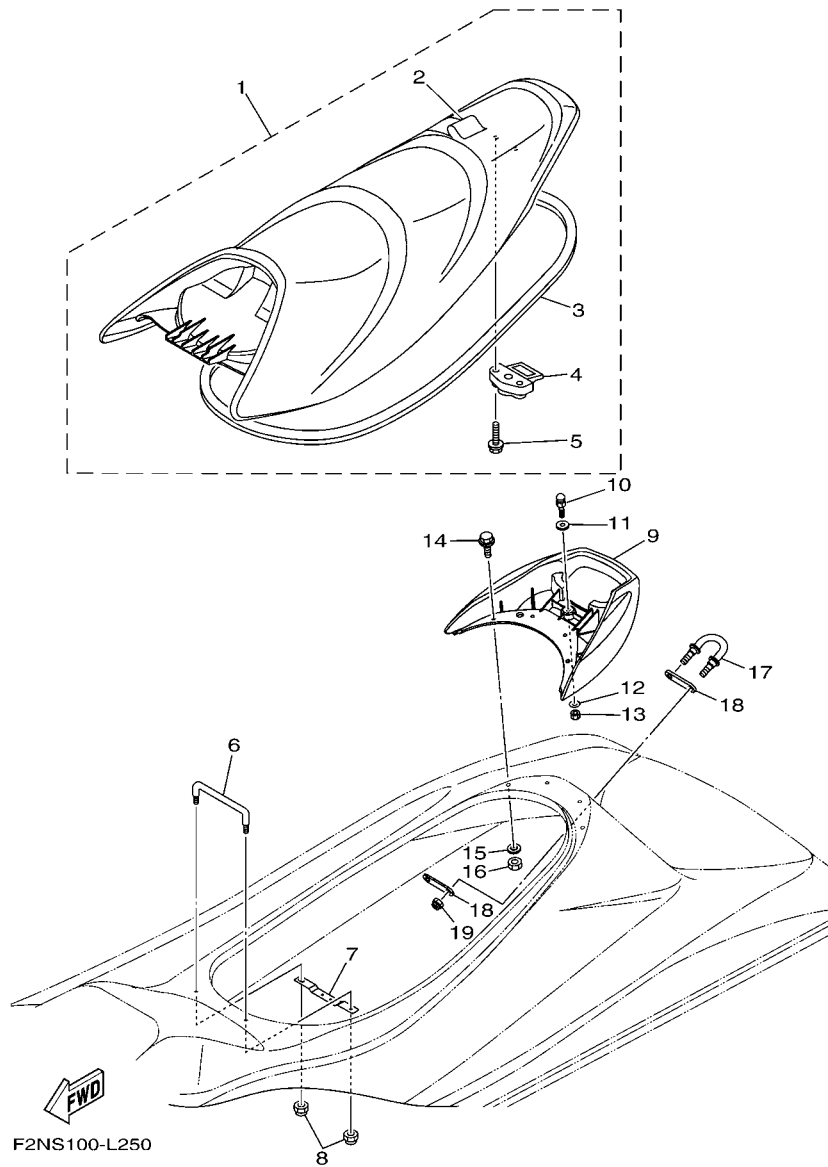

REF. NO.	PART NO.	DESCRIPTION	CAN	EUR	GENE	REMARKS
1	F2N-U371A-04	DOUBLE SEAT ASSY	1	1	1	
2	F2N-U371B-00	.COVER, SEAT 1	1	1	1	
3	F2N-U2664-00	.PACKING	1	1	1	
4	F2C-U3850-00	.SEAT LOCK ASSY	1	1	1	
5	90119-069UP	.BOLT, WITH WASHER	2	2	2	
6	F0X-6378C-00	STAY, SEAT 1	1	1	1	
7	F2N-U781E-00	BRACKET, FILTER	1	1	1	
8	9572R-08300	NUT, FLANGE	2	2	2	
9	F2N-U271B-20	GRIP, HAND	1	1	1	
10	GH1-U3774-00	PIN	1	1	1	
11	90201-109U6	WASHER, PLATE	1	1	1	
12	9299R-10200	WASHER	1	1	1	
13	9572R-10300	NUT, NYLON	1	1	1	
14	90119-089U2	BOLT, WITH WASHER	4	4	4	
15	9299R-08200	WASHER	4	4	4	
16	9572R-08300	NUT, FLANGE	4	4	4	
17	F2N-U1628-02	STERN EYE	1	1	1	
18	GP7-U4953-10	PLATE A	2	2	2	
19	9572R-08300	NUT, FLANGE	2	2	2	

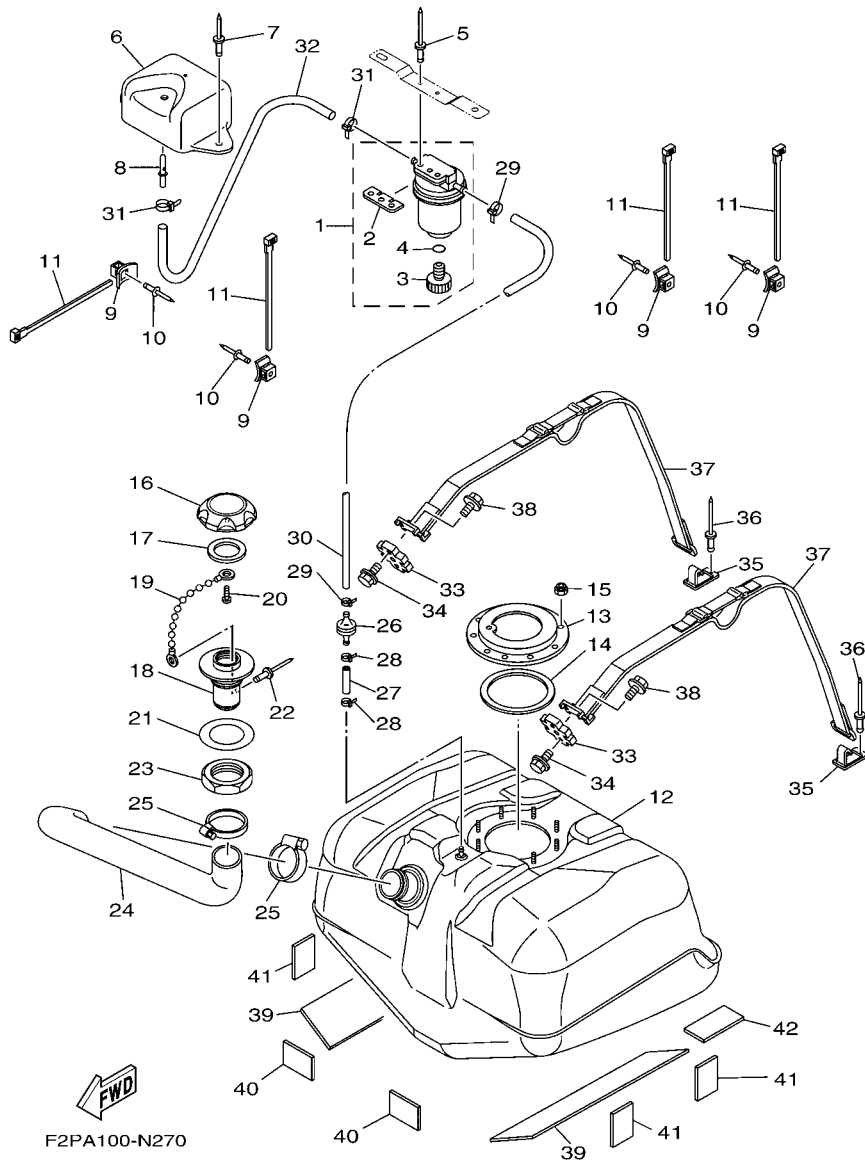

FIG. 27 FUEL TANK

REF. NO.	PART NO.	DESCRIPTION	CAN	EUR	GENE	REMARKS
1	F2F-6214A-00	FILTER, VENT ASSY	1	1	1	
2	EW2-62142-00	.PLATE, FILTER	1	1	1	
3	70R-24543-00	.PLUG, DRAIN	1	1	1	
4	70R-24489-00	.O-RING	1	1	1	
5	90267-489U1	RIVET,BLIND	2	2	2	
6	F1W-U2159-00	SOCKET, VENTILATION	1	1	1	
7	90267-489U6	RIVET, BLIND	2	2	2	
8	F1G-62149-00	PIPE, VENTILATION	1	1	1	
9	F1W-U828M-00	BASE, CLAMP	4	4	4	
10	90267-489U6	RIVET, BLIND	4	4	4	
11	90464-32801	CLAMP	4	4	4	
12	F2S-U7711-02	TANK, FUEL	1	1	1	
13	F1B-U7773-00	RING	1	1	1	
14	F1B-67747-00	PACKING, SEAL	1	1	1	
15	9572R-06300	NUT, NYLON	9	9	9	
16	F2N-U7831-10	CAP, FUEL FILLER	1	1	1	BLACK
17	GP7-U7832-01	PACKING	1	1	1	
18	GP7-U7833-11	SOCKET	1	1	1	BLACK
19	GP7-U7835-00	CHAIN BALL	1	1	1	
20	90169-049U1	TAPPING SCREW	1	1	1	
21	GP7-U7834-00	PACKING FUEL FILLER	1	1	1	
22	90267-329UR	RIVET, BLIND	1	1	1	
23	GP7-U783F-00	NUT, FUEL FILLER	1	1	1	
24	F2P-U7844-00	HOSE	1	1	1	
25	90601-155U4	BAND, HOSE 55	2	2	2	
26	EU0-67767-31	CHECK VALVE	1	1	1	
27	GP7-U785H-00	HOSE, AIR VENT 3	1	1	1	

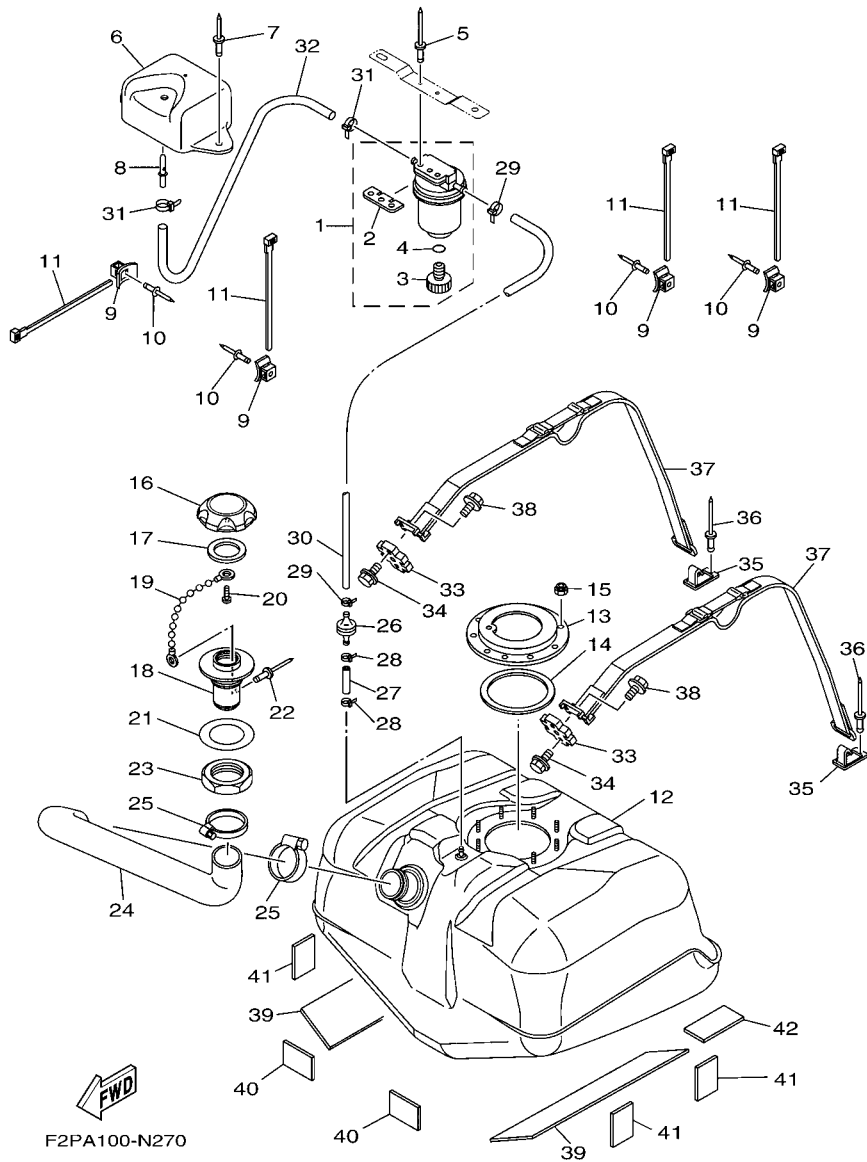
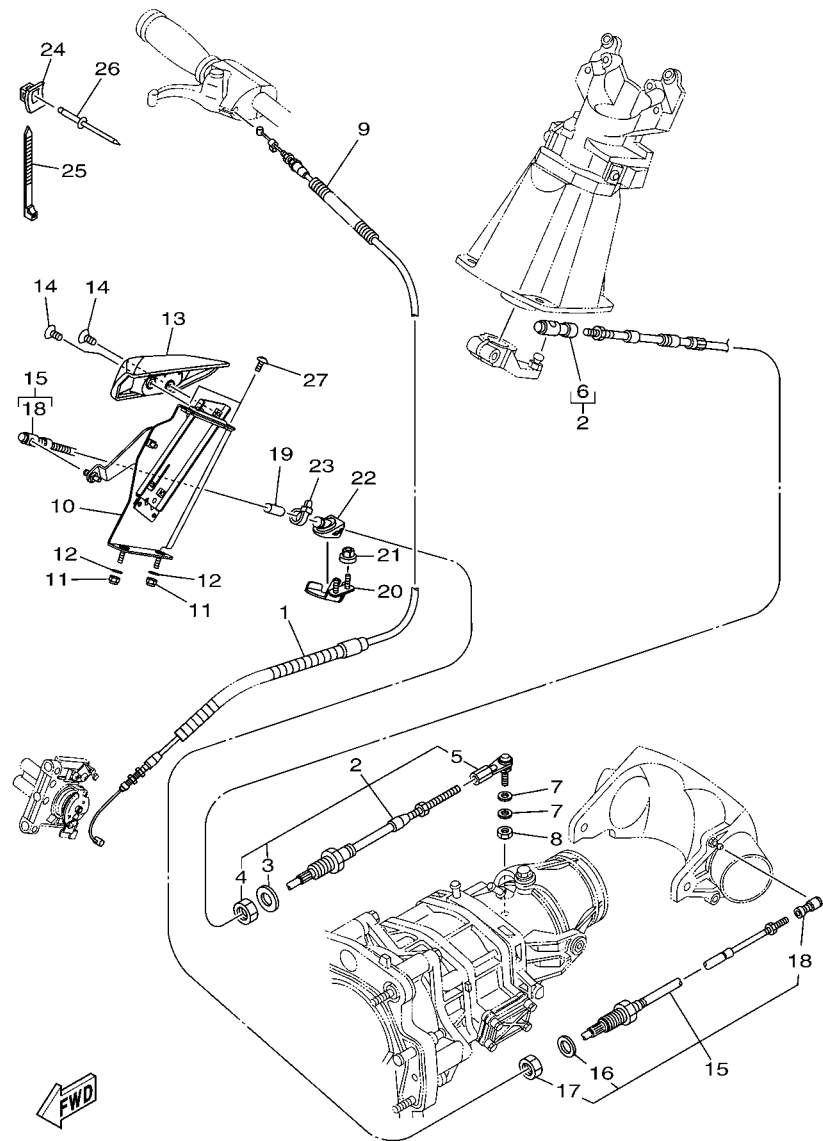

FIG. 27 FUEL TANK

REF. NO.	PART NO.	DESCRIPTION	CAN	EUR	GENE	REMARKS
28	90465-11829	CLAMP	2	2	2	
29	90465-11829	CLAMP	2	2	2	
30	F1K-U785G-00	HOSE, AIR VENT	1	1	1	
31	90465-11829	CLAMP	2	2	2	
32	F0D-U7856-10	HOSE, AIR VENT 3	1	1	1	
33	F1X-U2873-00	NUT, SPÉCIAL	2	2	2	
34	90119-069UH	BOLT, WITH WASHER	4	4	4	
35	F1K-U5772-04	HOOK A	2	2	2	
36	90267-489U1	RIVET,BLIND	2	2	2	
37	F2P-67743-00	BELT, TANK 1	2	2	2	
38	90119-089U7	BOLT, WITH WASHER	2	2	2	
39	F2S-U759B-00	MAT 1	2	2	2	
40	F2P-U759C-00	MAT 2	2	2	2	
41	F1W-U759C-01	MAT 2	4	4	4	
42	F1K-U759C-00	MAT 2	2	2	2	







F2N1100-J290

FIG. 29 CONTROL CABLE

REF. NO.	PART NO.	DESCRIPTION	CAN	EUR	GENE	REMARKS
1	6BU-26311-00	CABLE, THROTTLE 1	1	1	1	
2	F2N-61481-00	CABLE, STEERING	1	1	1	
3	F1B-61438-00	.PACKING C	1	1	1	
4	F1B-6151S-00	.NUT	1	1	1	
5	F1B-61461-02	.STUD, JOINT BALL	1	1	1	
6	F2N-61460-00	.BALL JOINT ASSY	1	1	1	
7	90201-06906	WASHER, PLATE	2	2	2	
8	9538R-06700	NUT	1	1	1	
9	90447-06803	TUBE	1	1	1	
10	F2N-U134A-00	REMOCON. LEVER ASSY.	1	1	1	
11	9572R-06300	NUT, NYLON	2	2	2	
12	9299R-06200	WASHER	2	2	2	
13	F2N-U2714-01	GRIP	1	1	1	
14	90151-06815	SCREW, COUNTERSUNK	2	2	2	
15	F2N-U149C-00	CABLE, REVERSE	1	1	1	
16	F2S-U1438-00	.PACKING C	1	1	1	
17	F2S-U151S-00	.NUT	2	2	2	
18	F0V-U1461-00	.STUD, JOINT BALL	2	2	2	
19	F1W-U146G-00	PACKING, CABLE	1	1	1	
20	F2N-U1467-00	BRACKET, STOPPER CABLE	1	1	1	
21	F2N-U142L-00	NUT, LOCK	2	2	2	
22	F2N-U146G-00	PACKING, CABLE	1	1	1	
23	90465-11829	CLAMP	1	1	1	
24	F1W-U828M-00	BASE, CLAMP	1	1	1	
25	90464-32801	CLAMP	1	1	1	
26	90267-489U6	RIVET, BLIND	1	1	1	
27	F2N-67823-00	SCREW	2	2	2	

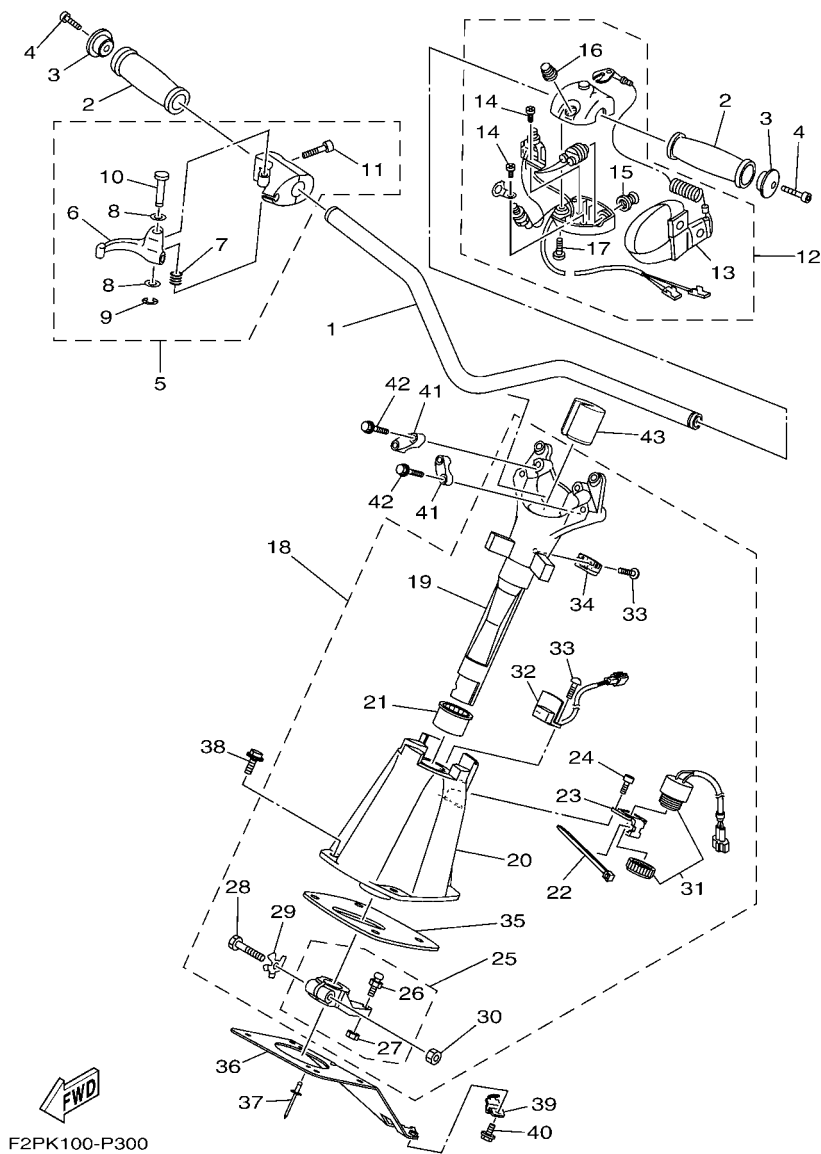

F2PK100-P300

FIG. 30 STEERING 1

REF. NO.	PART NO.	DESCRIPTION	CAN	EUR	GENE	REMARKS
1	F2N-U1552-00	HANDLE	1	1	1	
2	GP7-U155D-01	GRIP, HANDLE	2	2	2	
3	GP7-U155F-00	GRIP, END	2	2	2	
4	90110-05908	BOLT, HEXAGON SOCKET HEAD	2	2	2	
5	F0D-67250-10	THROTTLE LEVER ASSY	1	1	1	
6	F0D-67255-02	.LEVER, THROTTLE	1	1	1	
7	EW2-67256-00	.SPRING	1	1	1	
8	EW2-67258-01	.WASHER	2	2	2	
9	EW2-67259-01	.E-RING	1	1	1	
10	F0D-67257-00	.SHAFT	1	1	1	
11	F1X-6725F-01	.BOLT, THROTTLE	2	2	2	
12	FK7-68310-07	SWITCH BOX ASSY	1	1	1	
13	EW2-68348-00	.LANYARD, STOP SWITCH	1	1	1	
14	97880-03008	.SCREW, PAN HEAD	2	2	2	
15	FK7-68312-02	.STOP BUTTON COMP	1	1	1	
16	FK7-68313-02	.START BUTTON COMP.	1	1	1	
17	97880-05025	.SCREW, PAN HEAD	2	2	2	
18	F2X-61400-10	STEERING MASTER ASSY	1	1	1	
19	F2X-6152D-00	.SHAFT	1	1	1	
20	F2X-6152M-00	.HOUSING ASSY	1	1	1	
21	F1K-6134M-00	.BUSH	1	1	1	
22	703-82591-00	.BAND	1	1	1	
23	F2P-6146H-00	.SPACER, BRKT.	1	1	1	
24	F1B-613C1-00	.SCREW	2	2	2	
25	F1K-6153R-00	.ARM ASSY.	1	1	1	
26	EU0-61461-02	..STUD, JOINT BALL	1	1	1	
27	95720-06300	..NUT, SELF-LOCKING	1	1	1	

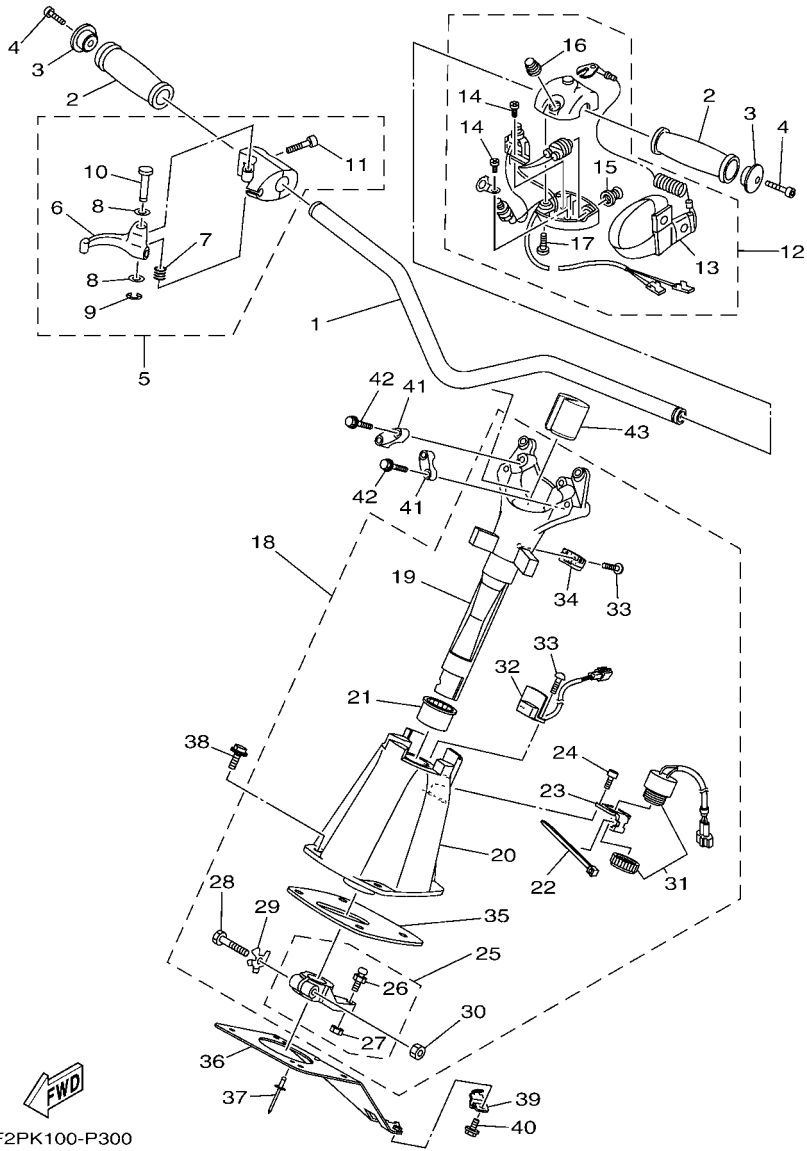
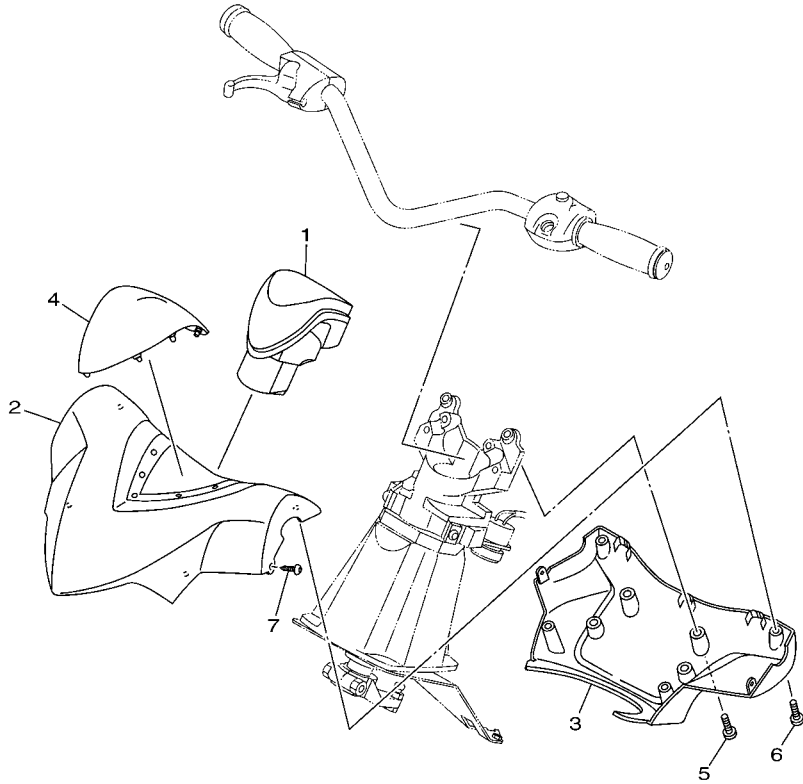

FIG. 30 STEERING 1

REF. NO.	PART NO.	DESCRIPTION	CAN	EUR	GENE	REMARKS
28	F1K-61355-00	.BOLT	1	1	1	
29	F1K-6142B-00	.PLATE, RETAINING	1	1	1	
30	95720-08300	.NUT, SELF-LOCKING	1	1	1	
31	F1S-68341-00	.BUZZER	1	1	1	
32	F2X-6838B-00	.SENSOR, MAGNET	1	1	1	
33	F2X-613C1-00	.SCREW	3	3	3	
34	F2X-6838C-00	.MAGNET	1	1	1	
35	F1K-6143C-00	.SEAL, RUBBER	1	1	1	
36	F1K-U1467-01	BRACKET, STOPPER CABLE	1	1	1	
37	90267-489U2	RIVET, BLIND	2	2	2	
38	90119-08836	BOLT, WITH WASHER	4	4	4	
39	F1K-U1468-03	STOPPER, CABLE	1	1	1	
40	90119-069UH	BOLT, WITH WASHER	1	1	1	
41	EU0-23814-31	HOLDER, HANDLE UPPER	2	2	2	
42	90119-08827	BOLT, WITH WASHER	4	4	4	
43	F1K-U1949-00	PLUG	1	1	1	

**FIG. 31 STEERING 2**



REF. NO.	PART NO.	DESCRIPTION	CAN	EUR	GENE	REMARKS
1	F1K-U156E-01	PAD 1	1	1	1	
2	F1K-U143D-10	PAD, STEERING 1	1	1	1	
3	F1K-U143E-10	PAD, STEERING 2	1	1	1	
4	F1K-U142D-10	COVER, PAD	1	1	1	
5	90154-06017	SCREW, BINDING	4	4	4	
6	90149-05903	SCREW	4	4	4	
7	90167-04003	SCREW, TAPPING	2	2	2	

  
 F2L1100-H290

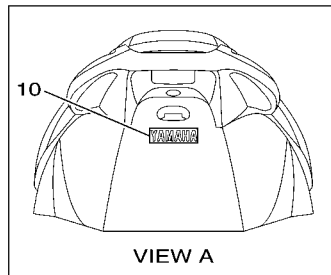
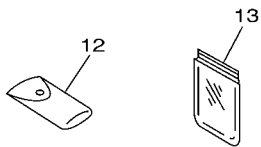
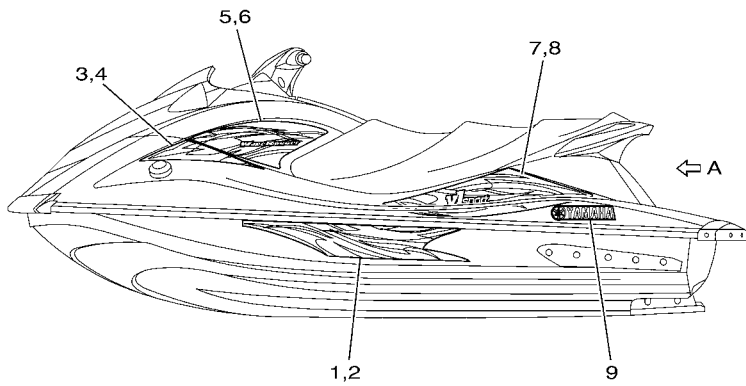
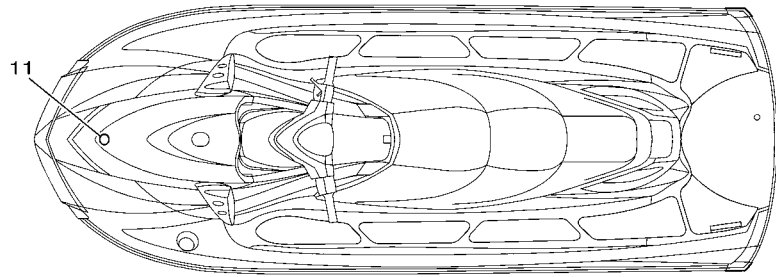

**FWD**  
F2PK100-P320

**FIG. 32 GRAPHICS**

REF. NO.	PART NO.	DESCRIPTION	CAN	EUR	GENE	REMARKS
1	F2P-U417B-90	GRAPHIC 1 (LH)	1	1	1	
2	F2P-U417C-90	GRAPHIC 2 (RH)	1	1	1	
3	F2P-U417D-90	GRAPHIC 3 (LH)	1	1	1	
4	F2P-U417E-90	GRAPHIC 4 (RH)	1	1	1	
5	F2P-U417F-90	GRAPHIC 5 (LH)	1	1	1	
6	F2P-U417G-90	GRAPHIC 6 (RH)	1	1	1	
7	F2P-U417H-90	GRAPHIC 7 (LH)	1	1	1	
8	F2P-U417J-90	GRAPHIC 8 (RH)	1	1	1	
9	F2N-U411C-00	EMBLEM, YAMAHA	2	2	2	
10	F1B-U411C-02	EMBLEM, YAMAHA	1	1	1	
11	F1K-U411H-00	EMBLEM, TUNING FORK	1	1	1	
12	F1B-65986-13	TOOL SET	1	1	1	
13	EU0-65901-02	TOOL BAG	1	1	1	

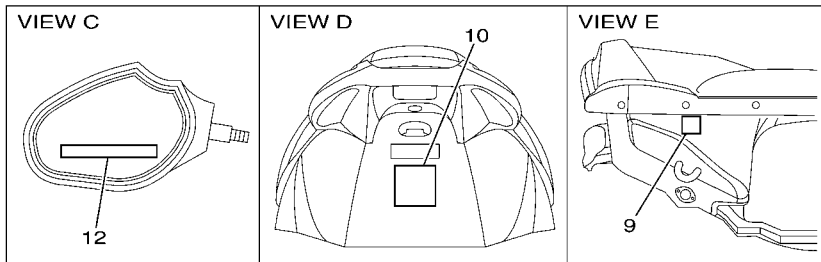
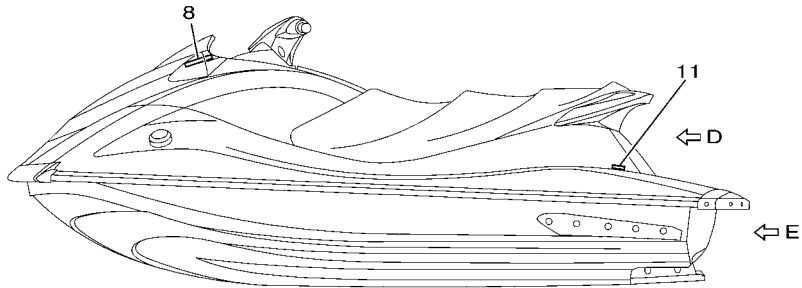
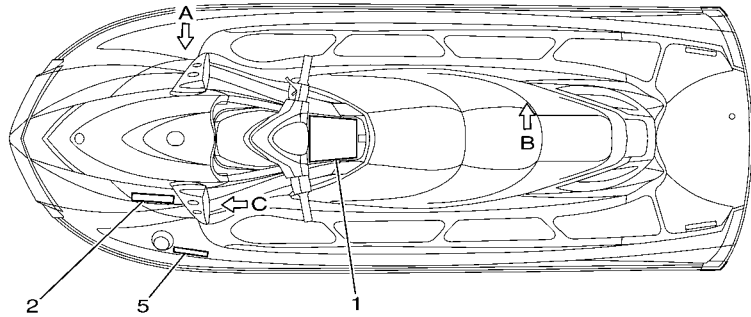
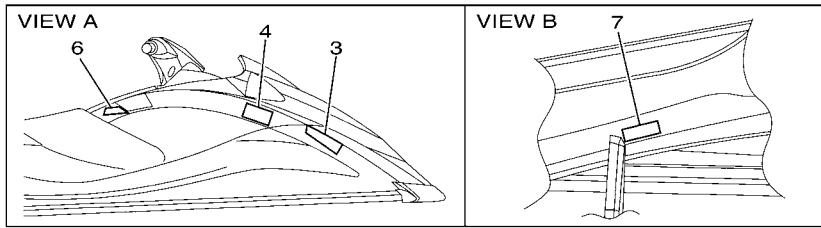

F2PK100-P330

FIG. 33 IMPORTANT LABELS

REF. NO.	PART NO.	DESCRIPTION	CAN	EUR	GENE	REMARKS
1	F2N-U41B1-10	LABEL, WARNING UNIFORM 1	1			
2	F1B-U41B1-21	LABEL, WARNING UNIFORM 1	1			
3	F0V-U41B1-31	LABEL, WARNING UNIFORM 1	1			
4	F1B-U41B2-01	LABEL, WARNING UNIFORM 2	1			
5	F1B-U415B-11	LABEL, WARNING(FUEL)	1			
6	F3K-U41D5-30	LABEL, WARNING SHIFT LEVER	1			
7	F0V-U41DB-12	LABEL, WARNING BATTERY	1			
8	F1B-U41F5-21	LABEL, FIRE EXTINGUISHER 1	1			
9	F1G-U418F-00	LABEL, RIGHTING	1			
10	F0V-U41E1-41	LABEL, SET 1	1			
11	GJ3-U419E-00	LABEL 4	1			
12	GJ1-U419F-21	LABEL,5	2			

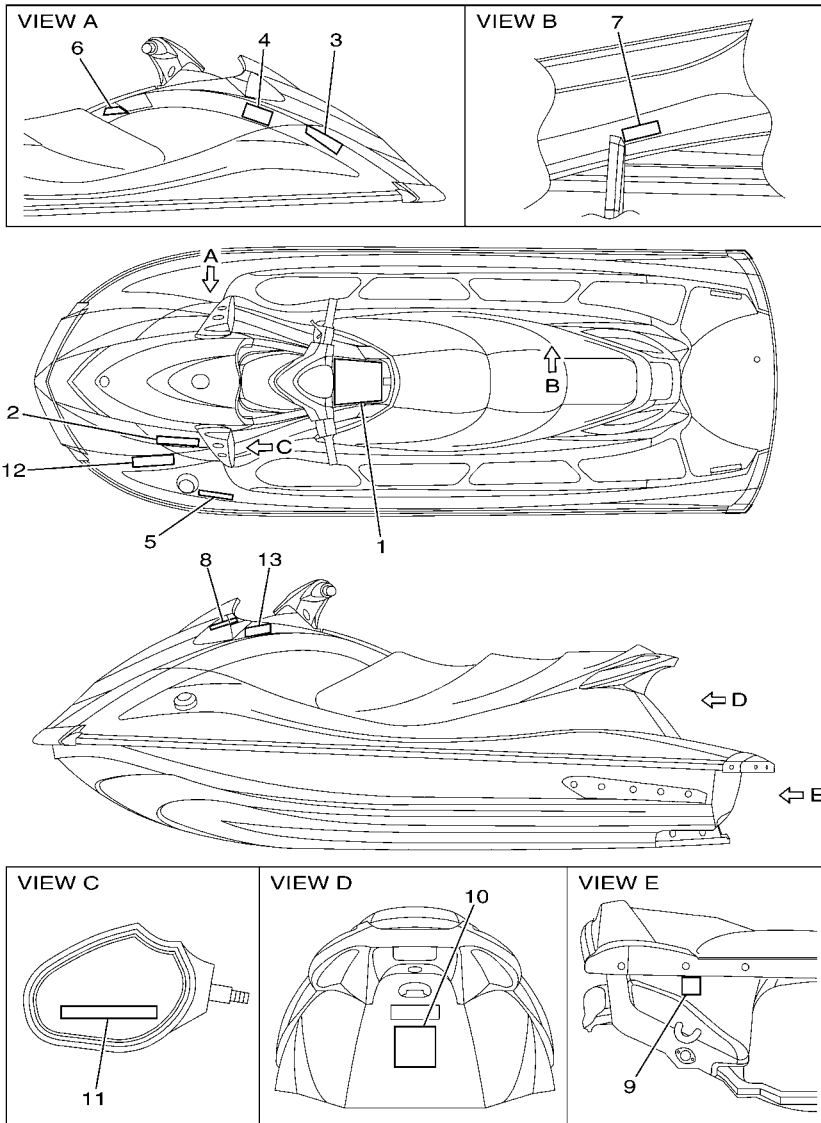

**FIG. 34 IMPORTANT LABELS 2**

REF. NO.	PART NO.	DESCRIPTION	CAN	EUR	GENE	REMARKS
1	F2N-U41B1-10	LABEL, WARNING UNIFORM 1		1	1	
2	F1B-U41B1-21	LABEL, WARNING UNIFORM 1		1	1	
3	F0V-U41B1-31	LABEL, WARNING UNIFORM 1		1	1	
4	F1B-U41B2-01	LABEL, WARNING UNIFORM 2		1	1	
5	F1B-U415B-11	LABEL, WARNING(FUEL)		1	1	
6	F3K-U41D5-30	LABEL, WARNING SHIFT LEVER		1	1	
7	F0V-U41DB-12	LABEL, WARNING BATTERY		1	1	
8	F1B-U41F5-21	LABEL, FIRE EXTINGUISHER 1		1	1	
9	F1G-U418F-00	LABEL, RIGHTING		1	1	
10	F0V-U41E1-41	LABEL, SET 1		1	1	
11	GJ1-U419F-21	LABEL,5		2	2	
12	GJ3-U416H-01	LABEL,WARNING(FRANCE)		1		FOR EUR
13	F1X-U413P-02	LABEL, BUILDERS PLATE		1		FOR EUR
<hr/>						
<hr/>						
<hr/>						
<hr/>						
<hr/>						
<hr/>						

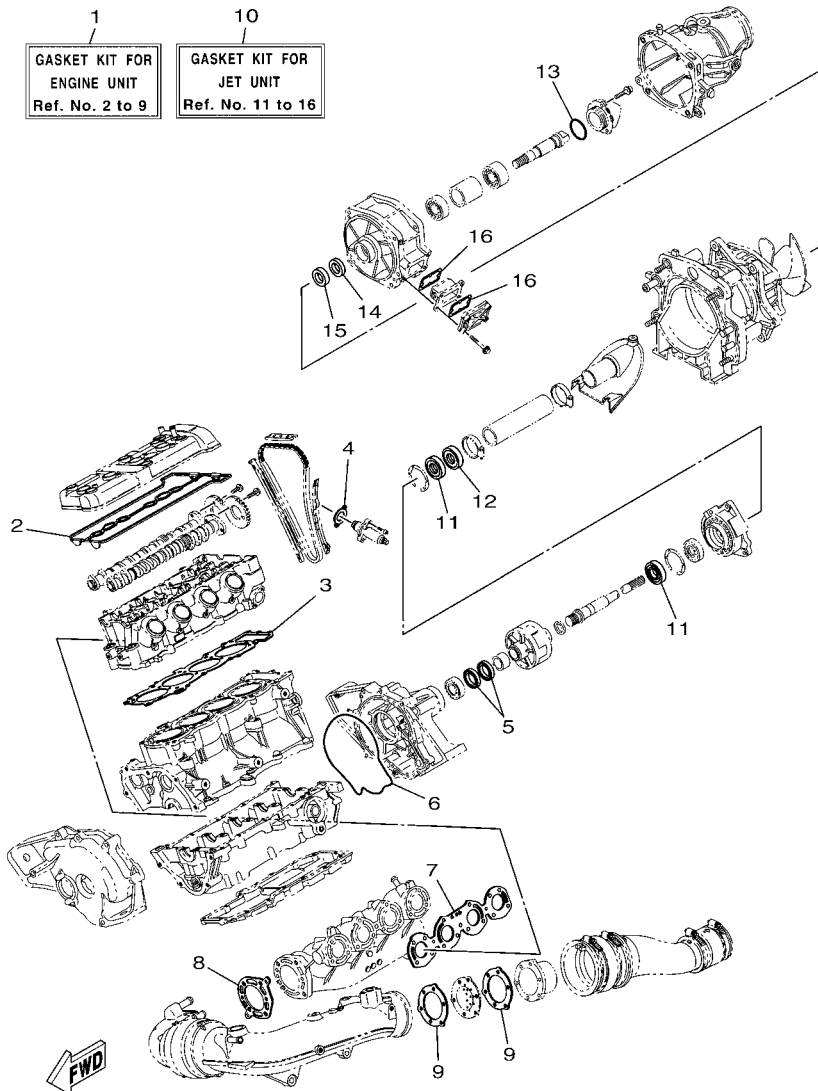

F2PA100-N350

FIG. 35 REPAIR KIT 1

REF. NO.	PART NO.	DESCRIPTION	CAN	EUR	GENE	REMARKS
1	6D3-W0001-01	GASKET KIT FOR ENGINE UNIT	1	1	1	
2	60E-11193-01	.GASKET, HEAD COVER 1	1	1	1	
3	6D3-11181-00	.GASKET, CYLINDER HEAD 1	1	1	1	
4	4FM-12213-00	.GASKET, TENSIONER CASE	1	1	1	
5	93101-35004	.OIL SEAL	2	2	2	
6	6B6-13475-01	.GASKET	1	1	1	
7	6D3-14613-10	.GASKET, EXHAUST PIPE	1	1	1	
8	6D3-14739-10	.GASKET, MUFFLER DAMPER 1	1	1	1	
9	60E-14623-00	.GASKET, EXHAUST PIPE	2	2	2	
10	6BU-W0001-20	GASKET KIT FOR JET UNIT	1	1	1	
11	93101-25M55	.OIL SEAL	2	2	2	
12	93102-25009	.OIL SEAL	1	1	1	
13	93210-464A3	.O-RING	1	1	1	
14	93101-21002	.OIL SEAL	1	1	1	
15	93101-21001	.OIL SEAL	1	1	1	
16	66V-42414-00	.O-RING	2	2	2	



NUMERICAL INDEX

PART NO.	REF. NO.	PART NO.	REF. NO.	PART NO.	REF. NO.	PART NO.	REF. NO.	PART NO.	REF. NO.	PART NO.	REF. NO.
6D3-11102-00	1 - 2	3GM-12126-00	4 - 9	6D3-12446-00	10 - 34	68V-13573-00	6 - 11	70R-24543-00	27 - 3	F1K-6517C-00	22 - 6
4KG-1111G-00	1 - 20	3FV-12153-10	4 - 20		11 - 36	6D3-13641-00	6 - 1	6BU-26311-00	29 - 1	FOX-6517R-01	21 - 19
6D3-11125-00	7 - 30	3LN-12153-10	4 - 19	60E-1244E-00	17 - 42	6BU-13750-00	6 - 7	67F-2812A-00	17 - 26	GA7-65772-00	28 - 4
6D3-11126-00	7 - 25	1HX-12168-00	4 - 18	6BU-1244G-10	9 - 1	60E-13761-20	6 - 3	66V-42414-00	12 - 10	EU0-65901-02	32 - 13
3TJ-11133-10	1 - 3	1HX-12168-20	4 - 18	6D3-1244G-10	10 - 28	6D3-13795-01	6 - 9		35 - 16	F1B-65986-13	32 - 12
1WG-11133-11	1 - 4	1HX-12168-40	4 - 18		11 - 28	60E-13907-03	19 - 1	67X-44517-10-94	20 - 1	F0D-67250-10	30 - 5
6D3-11164-00	7 - 21	1HX-12168-60	4 - 18	6D3-1244H-10	10 - 21	68V-1416A-00	6 - 4	6D3-44574-00	20 - 2	F0D-67255-02	30 - 6
6D3-11165-00	8 - 22	1HX-12168-80	4 - 18		11 - 21	6D3-14294-10	6 - 16	663-45119-00	13 - 4	EW2-67256-00	30 - 7
6D3-11166-00	7 - 32	1HX-12168-A0	4 - 18	60E-12474-00	1 - 30	6D3-14305-21	18 - 1	61X-45332-03-94	13 - 2	F0D-67257-00	30 - 10
6D3-11167-00	8 - 32	1HX-12168-F0	4 - 18	6D3-12482-00	1 - 25	6D3-14411-00	5 - 1	6BU-45511-00	13 - 6	EW2-67258-01	30 - 8
6D3-11181-00	1 - 21	1HX-12168-H1	4 - 18	60E-12483-10	1 - 29	6D3-14414-10	6 - 19	6EX-45514-00	12 - 15	EW2-67259-01	30 - 9
	35 - 3	1HX-12168-K1	4 - 18	60E-12494-00	1 - 28	6D3-14419-01	5 - 8	6D3-45593-00-94	13 - 11	F1X-6725F-01	30 - 11
6D3-11191-10	1 - 17	1HX-12168-M1	4 - 18	6B6-12499-00	11 - 42	6D3-14421-02	5 - 3	6D3-45813-00-94	3 - 12	F2P-67743-00	27 - 37
60E-11193-01	1 - 18	1HX-12168-R1	4 - 18	60E-12537-01	1 - 31	6D3-14437-00	5 - 7	6D3-4581J-00	13 - 1	F1B-67747-00	27 - 14
	35 - 2	1HX-12168-U1	4 - 18	6D3-12577-10	10 - 25	63P-14446-00	6 - 13	6D3-51129-00	2 - 3	EU0-67767-31	27 - 26
69J-11301-10	2 - 12	1HX-12168-W1	4 - 18		11 - 25	60E-14449-00-94	6 - 20	68N-5112T-00	23 - 3	EW2-67821-00	28 - 3
6E5-11325-00	8 - 12	1HX-12168-Y1	4 - 18	63M-12580-00	10 - 5	6D3-14451-00	5 - 4	6D3-51312-01-94	12 - 5	F2N-67823-00	22 - 18
68V-11325-02	2 - 13	1HX-12169-11	4 - 18		11 - 5	4XV-14452-00	5 - 2	6B6-51315-01-94	12 - 8		29 - 27
67F-11328-00	2 - 14	1HX-12169-31	4 - 18	60E-12581-00	10 - 3	6D3-14457-00	6 - 8	6D3-52358-00	14 - 8	F2N-67823-10	21 - 16
60E-11372-10	9 - 5	1HX-12169-50	4 - 18		11 - 3	68V-14475-00	6 - 12	F1K-6134M-00	30 - 21	GU2-6822E-01	19 - 16
60E-11411-11	3 - 1	1HX-12169-70	4 - 18	60E-12584-00	10 - 15	6D3-14613-10	9 - 3	F1K-61355-00	30 - 28	60E-682E0-00	19 - 2
6D3-11416-00	3 - 2	1HX-12169-90	4 - 18		11 - 15		35 - 7	F1B-613C1-00	30 - 24	FK7-68310-07	30 - 12
6D3-11416-10	3 - 2	1HX-12169-E0	4 - 18	6D3-12584-00	10 - 20	6D3-14615-00	9 - 14	F2X-613C1-00	30 - 33	FK7-68312-02	30 - 15
6D3-11416-20	3 - 2	1HX-12169-G0	4 - 18		11 - 20	60E-14623-00	9 - 21	F2X-61400-10	30 - 18	FK7-68313-02	30 - 16
6D3-11416-30	3 - 2	1HX-12169-J0	4 - 18	6S5-12589-01	10 - 16		35 - 9	F1K-6142B-00	30 - 29	F1S-68341-00	30 - 31
6D3-11416-A0	3 - 2	1HX-12169-L0	4 - 18		11 - 16	6D3-14625-00	9 - 16	F1B-61438-00	29 - 3	EW2-68348-00	30 - 13
6B6-11478-00	3 - 15	1HX-12169-N0	4 - 18	6BU-12880-11	6 - 2	6D3-1469W-10	9 - 23	F1K-6143C-00	30 - 35	F2X-6838B-00	30 - 32
6D3-11603-00	3 - 4	1HX-12169-T0	4 - 18	6B6-1310A-01-94	2 - 18	6D3-14711-10	9 - 4	F2N-61460-00	29 - 6	F2X-6838C-00	30 - 34
6D3-11631-01-B0	3 - 3	6D3-12171-11	4 - 1	6B6-13151-00-94	8 - 28	6D3-14712-00-94	9 - 9	EU0-61461-02	30 - 26	6D3-81147-00	6 - 14
6D3-11633-00	3 - 5	6D3-12176-00	4 - 3	60E-13161-00	2 - 20	6D3-14721-10	9 - 18	F1B-61461-02	29 - 5	60E-81315-00	18 - 21
6D3-11650-00	3 - 7	6D3-12181-00	4 - 2	6D3-13300-10	7 - 2	6D3-14739-10	9 - 10	F2P-6146H-00	30 - 23	60E-81328-00	15 - 18
5JW-11654-00	3 - 8	6D3-12210-00	4 - 23	6B6-13317-00	8 - 5		35 - 8	F2N-61481-00	29 - 2	66V-8132W-00	17 - 24
60E-11656-00	3 - 10	4FM-12213-00	4 - 24	6B6-13327-02-94	7 - 8	6BU-14752-00-94	9 - 25	F1B-6151S-00	29 - 4	6BU-81336-00	17 - 34
60E-11656-10	3 - 10		35 - 4	6B6-13360-00	7 - 1	6BU-1475E-00	9 - 26	F2X-6152D-00	30 - 19	6D3-81337-00-94	15 - 13
60E-11656-20	3 - 10	5BE-12241-00	4 - 22	6B6-13411-00	7 - 11	6BU-1475F-00	9 - 27	F2X-6152M-00	30 - 20	6S5-81364-10	8 - 34
60E-11656-30	3 - 10	6D3-12251-00	4 - 26	60E-13421-00	8 - 7	60E-14784-00-94	9 - 22	F1K-6153R-00	30 - 25	6D3-81410-02	15 - 7
4XV-12111-00	4 - 5	4XV-12252-00	4 - 27	5GH-13440-50	2 - 25	6BU-15100-00	2 - 1	F1K-61624-00	23 - 21	6D3-81450-00	15 - 6
4XV-12112-00	4 - 6	6D3-12411-00	11 - 33	6D3-13443-00-94	8 - 24	6BU-15362-A0	8 - 20	FOX-61637-00	23 - 24	6BU-81639-00	17 - 33
4XV-12113-00	4 - 10	6BH-12413-00	11 - 34	60E-13446-00	8 - 1	6D3-15515-00	15 - 1	EU0-61652-00	10 - 10	6D3-81800-00	16 - 1
4XV-12114-00	4 - 11	60E-12417-10	11 - 32	6D3-13462-00-94	8 - 3	60E-15517-00	15 - 2		11 - 10	3AJ-81809-00	16 - 6
1HX-12116-01	4 - 8	60E-12435-00	10 - 35	6D3-13463-00-94	8 - 14	60E-15521-00	15 - 3		23 - 8	60E-81810-00	16 - 10
1HX-12117-00	4 - 12		11 - 39	60E-13473-00	8 - 21	4WM-15590-00	15 - 4	FOX-61652-00	23 - 25	6D3-81820-00	16 - 9
1WG-12117-00	4 - 13	6BU-1243A-00	10 - 11	60E-13475-00	8 - 15	6D3-17572-00	3 - 11	EW2-62142-00	27 - 2	6M6-81826-00	16 - 4
1HX-12118-00	4 - 14		11 - 11	6B6-13475-01	7 - 13	6B6-17585-00	3 - 18	F1G-62149-00	27 - 8	6M6-81830-00	16 - 2
1WG-12118-00	4 - 15	6BU-1243F-10	10 - 37		35 - 6	6B6-17586-00	3 - 19	F2F-6214A-00	27 - 1	6M6-81840-10	16 - 8
4SV-12119-00	4 - 17		11 - 44	60E-13476-10	8 - 25	EU0-23814-31	30 - 41	GU3-6215F-00	19 - 12	11H-81844-00	16 - 5
4TV-12119-00	4 - 16	60E-12443-00	10 - 8	8FP-13556-10	6 - 5	6S5-24300-01	6 - 15	GU2-62875-02	21 - 20	66V-81844-00	17 - 25
5LV-12121-00	4 - 7		11 - 8	6B6-13563-01	7 - 3	70R-24489-00	27 - 4	FOX-6378C-00	26 - 6	6BU-81845-00	17 - 27

NUMERICAL INDEX

PART NO.	REF. NO.	PART NO.	REF. NO.	PART NO.	REF. NO.	PART NO.	REF. NO.	PART NO.	REF. NO.	PART NO.	REF. NO.
6D3-81845-00	15 - 21	6BU-R1318-01	12 - 23	F1K-U251E-30	24 - 11	GJ1-U419F-21	34 - 11	F1S-U725E-01	12 - 34	F1K-U8221-00	19 - 5
1FK-81847-00	16 - 3	6D3-R1319-00	12 - 21	F2N-U2663-01	22 - 4	F2N-U41B1-10	33 - 1	F2N-U732B-01	20 - 9	F1S-U8221-00	28 - 2
6M6-81850-00	16 - 7	6D3-R1321-02	12 - 22	F2N-U2664-00	26 - 3		34 - 1	F2N-U732B-10	20 - 8		28 - 12
6BU-81861-00	17 - 40	6EX-R1326-00	12 - 18	F1K-U2666B-00	22 - 5	F1B-U41B1-21	33 - 2	EU0-U7354-00-01	20 - 6	F1K-U826C-03	23 - 37
6D3-81921-00	17 - 12	6D3-R1333-01-94	12 - 1	F1K-U266C-00	21 - 12		34 - 2	EU0-U7354-00-03	20 - 6	F1S-U828H-01	17 - 2
6B6-81940-00	17 - 22	6D3-R1341-00	12 - 30	F2N-U266C-01	21 - 2	F0V-U41B1-31	33 - 3	EU0-U7354-00-05	20 - 6	F2P-U828K-00	22 - 32
60E-81950-00	17 - 20	60E-R1381-01	13 - 15	F1W-U269B-00	23 - 7		34 - 3	EU0-U7354-00-10	20 - 6	F1W-U828M-00	17 - 3
68V-81950-00	17 - 21	F2C-U1314-00	23 - 42	F2N-U2714-01	29 - 13	F1B-U41B2-01	33 - 4	EU0-U7354-00-20	20 - 6		19 - 22
6S8-81960-00	17 - 37	F2N-U134A-00	29 - 10	F2N-U271B-20	26 - 9		34 - 4	F1B-U751G-00	28 - 15		19 - 25
6BU-82115-00	17 - 13	F1K-U135C-01	22 - 11	F2C-U2733-00	28 - 20	F3K-U41D5-30	33 - 6	F2C-U753B-01	28 - 18		19 - 28
6BU-82116-00	19 - 34	F1K-U142D-10	31 - 4	F2N-U273B-10	12 - 37		34 - 6	F2X-U7550-00	28 - 1		19 - 31
6D3-82117-00	17 - 14	F2N-U142L-00	21 - 17	F2N-U278A-00	23 - 39	F0V-U41DB-12	33 - 7	F2N-U7555-01	28 - 8		21 - 4
67F-82151-00	17 - 15		28 - 17	F2L-U278F-01	23 - 43		34 - 7	F1K-U7557-01	12 - 44		25 - 3
67F-82151-10	17 - 16		29 - 21	F2L-U278G-01	23 - 45	F0V-U41E1-41	33 - 10	F2C-U7564-00	28 - 19		27 - 9
67F-82151-30	17 - 17	F2S-U1438-00	29 - 16	F2L-U278H-00	23 - 44		34 - 10	GJ1-U7578-21	19 - 18		28 - 21
67F-82151-40	17 - 18	F1K-U143D-10	31 - 2		23 - 46	F1B-U41F5-21	33 - 8	F1S-U757B-01	28 - 16		29 - 24
	17 - 19	F1K-U143E-10	31 - 3	F1K-U283B-02	22 - 14		34 - 8	EU0-U757E-01	12 - 48	F2N-U8572-00	5 - 14
6BU-82170-00	17 - 11	F2M-U143G-00	12 - 38	F1X-U2873-00	27 - 33	F2N-U4261-00	28 - 11	F1K-U757F-01	12 - 49	F1G-U8572-02	12 - 40
6D3-82310-01	18 - 6	F0V-U1461-00	29 - 18	F2P-U351H-00	24 - 14	F2N-U471E-00	22 - 23	F2N-U758D-00	28 - 13	F1K-U8577-01	12 - 41
6A0-82317-00	7 - 22	EU0-U1461-03	14 - 11	F2P-U351J-00	24 - 15	F1K-U471E-03	22 - 13	F2S-U759B-00	27 - 39	F2N-U883B-00	13 - 20
	17 - 31	F2N-U1467-00	29 - 20	F2P-U351K-00	24 - 16	F2N-U471F-00	22 - 25	F1K-U759C-00	22 - 30	F2N-U883E-00	13 - 17
68V-82504-00	18 - 20	F1K-U1467-01	30 - 36	F2P-U351M-00	24 - 17	F2N-U475B-04	21 - 1		27 - 42	F2N-U883N-00	23 - 27
60E-82532-00	18 - 22	F1K-U1468-03	30 - 39	F2P-U351N-00	24 - 18	F1W-U475F-01	21 - 8	F2P-U759C-00	27 - 40	F2N-U883P-00	23 - 28
60E-82556-00	19 - 3	F1W-U146G-00	29 - 19	F2P-U3581-00	24 - 13	F1W-U491K-00	24 - 2	F1W-U759C-01	27 - 41	F1X-U883T-01	23 - 29
6D3-82560-01	18 - 16	F2N-U146G-00	29 - 22	F2N-U371A-04	26 - 1	F2C-U4953-10	23 - 19	F1B-U761D-02	23 - 10	F1K-U892D-00	13 - 21
60E-82560-A1	18 - 13	F2N-U149C-00	29 - 15	F2N-U371B-00	26 - 2	GP7-U4953-10	23 - 18	F2S-U7711-02	27 - 12	F1S-U8K31-02	19 - 19
703-82591-00	30 - 22	F2C-U151S-00	19 - 20	GH1-U3774-00	26 - 10		26 - 18	F1W-U771H-00	23 - 40	6D3-W0001-01	35 - 1
60E-8259E-00	17 - 23	F2S-U151S-00	29 - 17	F2C-U377H-00	23 - 41	F1K-U515A-00	22 - 8	6EX-U773D-00	23 - 5	6BU-W0001-20	35 - 10
6BU-8259L-20	18 - 9	F2N-U1552-00	30 - 1	F2C-U3850-00	26 - 4	F2N-U516N-00-PC	21 - 10	6EX-U773E-00	23 - 2	6D3-W009A-11-94	1 - 1
6D3-8273J-01	18 - 23	GP7-U155D-01	30 - 2	F2N-U411C-00	32 - 9	F2N-U516P-00	21 - 11	F1B-U7773-00	27 - 13	6BU-W009B-00-94	2 - 4
60E-83627-00	8 - 27	GP7-U155F-00	30 - 3	F1B-U411C-02	32 - 10	F2N-U517B-10-PC	22 - 1	F2N-U781E-00	26 - 7	90101-069U0	12 - 52
68F-83688-10	6 - 6	F1K-U156E-01	31 - 1	F1K-U411H-00	32 - 11	F1K-U517D-05	22 - 10	F2N-U7831-10	27 - 16	90105-06026	1 - 9
682-84385-01	10 - 9	F2N-U1628-02	23 - 16	F1X-U413P-02	34 - 13	F1X-U517E-01	22 - 20	GP7-U7832-01	27 - 17	90105-06035	8 - 17
	11 - 9		26 - 17	F1B-U415B-11	33 - 5	F2N-U517F-00	22 - 19	GP7-U7833-11	27 - 18		10 - 36
6D3-85132-00	1 - 23	F1B-U1653-02	23 - 20		34 - 5	F2N-U517H-01	21 - 18	GP7-U7834-00	27 - 21		11 - 35
6AA-85542-00	8 - 19	F1K-U1949-00	30 - 43	GJ3-U416H-01	34 - 12	F1K-U517R-00	22 - 12	GP7-U7835-00	27 - 19		11 - 40
6BU-85542-00	8 - 9	F2N-U2127-00	25 - 1	F2P-U417B-90	32 - 1	F1K-U518E-04	22 - 9	GP7-U783F-00	27 - 23	90105-06036	8 - 16
61A-85790-00	18 - 11	F2N-U213B-01	22 - 2	F2P-U417C-90	32 - 2	F2P-U519D-00	21 - 21	F2P-U7844-00	27 - 24	90105-06054	11 - 41
6D3-85896-00	18 - 18	F2N-U213G-01	25 - 2	F2P-U417D-90	32 - 3	F2N-U5633-00	21 - 22	F0D-U7856-10	27 - 32	90105-06790	9 - 24
6EN-8591A-00	17 - 28	F1W-U2159-00	27 - 6	F2P-U417E-90	32 - 4	F1K-U5772-04	19 - 7	F1K-U785G-00	27 - 30	90105-06826	22 - 15
6EN-8591A-10	17 - 28	F2N-U2187-00	25 - 6	F2P-U417F-90	32 - 5		22 - 28	F0D-U785G-10	19 - 10	90105-06M07	2 - 15
67X-E2590-10	10 - 43	F2N-U2188-00	25 - 7	F2P-U417G-90	32 - 6		27 - 35	GP7-U785H-00	27 - 27		8 - 26
	11 - 50	F1S-U2280-02	23 - 32	F2P-U417H-90	32 - 7		28 - 6	F2N-U815D-01	17 - 7	90105-06M17	2 - 11
6EX-G5538-00	12 - 13	F1S-U2285-00	23 - 33	F2P-U417J-90	32 - 8	F2N-U596B-00	22 - 22	F2N-U8169-00	23 - 31	90105-07004	4 - 4
6AN-G5831-00	12 - 2	F2N-U2511-30	24 - 1	F1G-U418F-00	33 - 9	F2N-U596C-00	22 - 24	F2N-U820A-10	19 - 14	90105-08860	23 - 30
6EX-G6882-00	12 - 9	F1K-U2512-30	24 - 6		34 - 9	F1K-U5983-01	22 - 31	F1K-U8211-01	19 - 6	90105-093A5	2 - 6
6BU-R1313-00-94	12 - 31	F1K-U2519-20	24 - 7	GJ3-U419E-00	33 - 11	F2N-U721B-00	20 - 7	EU0-U8217-H2	19 - 4	90105-105A6	15 - 10
6D3-R1314-00	14 - 1	F1K-U251D-30	24 - 10	GJ1-U419F-21	33 - 12	F2N-U7254-00	18 - 4	F1K-U821D-01	19 - 9	90109-06051	2 - 9

NUMERICAL INDEX

PART NO.	REF. NO.	PART NO.	REF. NO.	PART NO.	REF. NO.	PART NO.	REF. NO.	PART NO.	REF. NO.	PART NO.	REF. NO.
90109-066F0	1 - 19	90119-089U7	12 - 54	90267-48806	25 - 8	90445-18M03	11 - 23	90464-32801	28 - 23	90467-200A3	10 - 27
90109-06832	13 - 18		17 - 1	90267-48963	24 - 12	90445-20800	23 - 4		29 - 25		10 - 39
90109-06M92	20 - 3		27 - 38	90267-489U1	10 - 44	90445-20804	23 - 1	90464-35132	10 - 33		10 - 40
90109-08041	12 - 45	90119-089UL	13 - 16		11 - 51	90445-21805	10 - 1		10 - 42		11 - 4
90110-05908	30 - 4	90119-08M22	5 - 11		18 - 3		11 - 1		11 - 49		11 - 13
90110-06040	23 - 26	90119-10013	9 - 20		19 - 8	90445-22007	10 - 31		18 - 5		11 - 14
90110-06822	12 - 20	90119-10016	15 - 14		22 - 29	90445-25006	11 - 37	90464-38800	5 - 16		11 - 18
90110-08041	7 - 6	90119-10017	9 - 19		23 - 38	90445-26004	11 - 30	90464-40825	5 - 17		11 - 19
90110-08212	15 - 5	90119-10020	8 - 4		27 - 5	90446-14M23	18 - 15	90464-45002	18 - 27		11 - 27
90111-05008	19 - 15	90119-10806	12 - 29		27 - 36	90446-20MF5	12 - 27	90464-99804	25 - 5		11 - 46
90111-06803	24 - 3	90119-10808	12 - 43		28 - 5	90447-06803	29 - 9	90465-11829	12 - 28		11 - 47
90116-10016	8 - 30	90119-10810	12 - 4		28 - 7	90447-19801	10 - 7		19 - 13	90467-210A0	10 - 30
90116-10058	2 - 5	90119-10M02	8 - 29	90267-489U2	20 - 10		11 - 7		23 - 12		23 - 15
90119-059U4	22 - 7	90119-10M19	15 - 15		30 - 37	90447-22001	10 - 17		27 - 28	90467-21800	23 - 13
90119-06048	18 - 25	90149-05903	22 - 3	90267-489U6	19 - 23		11 - 17		27 - 29	90467-240A0	11 - 31
90119-06880	21 - 14		31 - 6		19 - 27	90447-22003	10 - 12		27 - 31	90467-26800	23 - 15
	22 - 21	90150-05807	19 - 21		19 - 29		11 - 12		29 - 23	90468-12069	3 - 6
90119-06882	12 - 51	90151-06815	29 - 14		19 - 32	90447-22004	10 - 2	90465-13152	18 - 28	90480-22M15	5 - 9
	21 - 15	90154-06017	31 - 5		25 - 4		11 - 2	90465-13M18	17 - 46		5 - 12
90119-06889	12 - 11	90159-05013	5 - 5		27 - 7	90447-22005	10 - 38		18 - 26	90480-279U1	17 - 6
90119-06891	13 - 13	90159-05014	5 - 6		27 - 10		11 - 45	90465-13M24	17 - 43	90601-118UF	12 - 25
	20 - 11	90167-04003	31 - 7		28 - 22	90447-25002	10 - 32		18 - 10		23 - 9
90119-06893	12 - 6	90169-049U1	27 - 20		29 - 26	90447-28010	11 - 38	90465-13M39	8 - 37	90601-155U4	13 - 19
90119-06895	12 - 42	90176-06047	17 - 30	90267-489U8	23 - 11	90450-17M17	6 - 17	90467-089U1	19 - 11		27 - 25
90119-069UH	27 - 34		17 - 36		24 - 8		6 - 18	90467-110A1	7 - 31	90601-175UR	5 - 15
	30 - 40		17 - 39	90269-08801	21 - 7	90450-57006	6 - 10	90467-150A5	10 - 6	90601-179U8	28 - 9
90119-069UP	26 - 5		17 - 45		21 - 9	90450-90001	9 - 17		11 - 6	90601-200U2	19 - 33
90119-069UX	14 - 4	90176-10001	1 - 16	90280-03047	15 - 12	90450-94001	9 - 29	90467-160A0	9 - 2	90605-502U1	21 - 3
90119-06M65	7 - 24		8 - 31	90340-27001	1 - 7		9 - 31		10 - 22	91317-05010	15 - 20
90119-08031	9 - 13	90179-08327	3 - 9	90387-06080	12 - 50	90450-99004	9 - 28		10 - 24	91317-05014	8 - 6
90119-08034	7 - 15	90179-10006	1 - 14	90387-06083	11 - 43		9 - 30		10 - 29	91317-05016	8 - 23
90119-08036	9 - 7	90179-10414	1 - 15	90387-06119	7 - 23	90450-99005	9 - 15		11 - 22	91317-06014	8 - 8
	9 - 12	90183-06902	21 - 13		17 - 32	90450-99801	28 - 14		11 - 24		15 - 19
90119-08043	7 - 16	90201-06801	14 - 6	90387-06289	13 - 14	90450-99804	28 - 10		11 - 29	91317-06016	1 - 27
90119-08045	7 - 14		14 - 9	90387-06M05	8 - 10	90464-12089	5 - 10	90467-170A4	7 - 26		1 - 33
90119-08050	6 - 21	90201-06906	29 - 7		8 - 18	90464-21001	7 - 28		7 - 27		7 - 12
90119-08074	6 - 22	90201-096J9	2 - 7		8 - 35		7 - 29		7 - 33	91317-06035	15 - 8
90119-08075	9 - 8	90201-099U3	17 - 8	90387-06M30	14 - 5		7 - 34		8 - 33	91380-06016	18 - 19
90119-08085	7 - 7	90201-10013	1 - 12	90387-08M06	12 - 33	90464-31001	10 - 41		10 - 26	91380-06020	8 - 36
90119-08823	12 - 39	90201-10019	1 - 13	90387-08M30	14 - 3		11 - 48		11 - 26	91380-06025	4 - 25
	20 - 5	90201-103U7	15 - 11	90387-08M37	5 - 13		17 - 41	90467-17802	28 - 24	91808-16023	1 - 8
90119-08827	30 - 42	90201-10801	12 - 35	90401-20007	2 - 26	90464-32801	17 - 5	90467-18804	23 - 6	92014-06012	17 - 44
90119-08836	30 - 38	90201-109U6	26 - 11	90430-06014	1 - 11		19 - 17	90467-200A0	23 - 14	92990-06100	16 - 12
90119-08840	12 - 32	90201-24800	13 - 12	90430-06M03	2 - 16		19 - 24	90467-200A3	10 - 4	92990-10600	18 - 12
	14 - 2	90209-25008	3 - 20	90430-12002	12 - 47		19 - 26		10 - 13	92990-12200	12 - 46
90119-08859	20 - 4	90267-329UR	27 - 22	90445-14807	12 - 26		19 - 30		10 - 14		23 - 23
90119-08861	23 - 47	90267-48802	17 - 4	90445-16006	12 - 24		21 - 6		10 - 18	9299R-05200	23 - 35
90119-089U2	26 - 14	90267-48803	21 - 5	90445-18M03	10 - 23		27 - 11		10 - 19		24 - 9

NUMERICAL INDEX

PART NO.	REF. NO.	PART NO.	REF. NO.	PART NO.	REF. NO.	PART NO.	REF. NO.	PART NO.	REF. NO.	PART NO.	REF. NO.
9299R-06200	22 - 17	95023-06012	1 - 10	99530-10014	2 - 8						
	24 - 4	95027-06010	2 - 22	99590-14016	12 - 3						
	29 - 12	95380-06700	16 - 13	99780-12600	23 - 22						
9299R-08200	17 - 10	9538R-06600	14 - 7								
	22 - 26		14 - 10								
	26 - 15	9538R-06700	29 - 8								
9299R-10200	26 - 12	95720-06300	30 - 27								
93101-21001	12 - 16	95720-08300	30 - 30								
	35 - 15	9572R-05300	23 - 36								
93101-21002	12 - 17	9572R-06300	12 - 53								
	35 - 14		22 - 16								
93101-25M55	13 - 7		24 - 5								
	35 - 11		27 - 15								
93101-35004	3 - 13		29 - 11								
	35 - 5	9572R-08300	17 - 9								
93102-25009	13 - 10		22 - 27								
	35 - 12		23 - 17								
93210-06667	2 - 21		26 - 8								
93210-08001	2 - 24		26 - 16								
93210-18322	8 - 2		26 - 19								
93210-18417	1 - 26	9572R-10300	12 - 36								
	1 - 32		26 - 13								
93210-464A3	12 - 19	95780-08300	18 - 2								
	35 - 13	95814-06020	17 - 35								
93210-60ME8	18 - 24		17 - 38								
93212-04001	15 - 17	95814-06025	17 - 29								
93306-07801	3 - 14	95814-06070	2 - 10								
93306-205A3	13 - 9	95880-06016	18 - 7								
93306-205U0	12 - 14	97513-05514	15 - 9								
93306-27211	12 - 12	97513-06520	2 - 19								
93306-30441	7 - 9	97513-06525	7 - 5								
93306-30610	3 - 16	97513-06535	7 - 18								
93430-47M04	13 - 8	97513-06555	1 - 22								
93440-07149	1 - 5		7 - 17								
93440-10153	1 - 6	97513-08520	1 - 24								
93440-28062	3 - 21	97513-08530	16 - 11								
93603-12221	7 - 4	97595-06416	18 - 14								
93606-12019	9 - 11		18 - 17								
	12 - 7	97595-06520	8 - 11								
	13 - 5	97595-08540	2 - 17								
93606-25M00	7 - 20	97880-03008	30 - 14								
93607-44002	4 - 28	97880-05025	30 - 17								
93608-16M16	7 - 19	9788R-05025	23 - 34								
	9 - 6	98780-04015	8 - 13								
	15 - 16	99009-52500	7 - 10								
93700-06M03	13 - 3	99009-72500	3 - 17								
94591-49130	4 - 21	99530-08012	2 - 23								
94702-00409	18 - 8	99530-10014	2 - 2								