

PARTS CATALOGUE

WaveRunner VX Cruiser/Deluxe

VX1100A-P (F2X1,F2X2,F2X3/6EXA,6EXB,6EXC/6EX1)

VX1100B-P (F2X4,F2X5,F2X6/6EXA,6EXB,6EXC/6EX1)



1PF2X-100E1



VX1100A-P/VX1100B-P
PARTS CATALOGUE
©2014 by Yamaha Motor Co., Ltd.
1st edition, November 2014
All rights reserved.
Any reprinting or unauthorized use
without the written permission of
Yamaha Motor Co., Ltd.
is expressly prohibited.
Printed in Japan.

FOREWORD

This Parts Catalogue is related to the parts for the model(s) on the cover page. When you are ordering replacement parts, please refer to this Parts Catalogue and quote both part numbers and part names correctly.

1. Modifications or additions which have been made after the issue of the Parts Catalogue will be announced in the Parts News.

It is advisable that you make the necessary corrections to the Parts Catalogue according to the Parts News.

2. Abbreviations

The following abbreviations are used in this Parts Catalogue.

“UR” Use specified parts number.

“UN” Use as many as needed.

“AP” Alternate Parts

“LM” Locally Made (Parts need to be ordered locally)

“F#” Frame No. (Applicable machine No.)

“O/S” Over Size

3. The number of components for assembly

- Parts, which are to be supplied in an assembly, are listed with a dot (.) in front of the part name as shown below.
- The numeral appearing to the right of each component part indicates the quantity of parts for each assembly unit.

PART NO.	DESCRIPTION	Q'TY	REMARKS
2F5-83310-60	FRONT FLASHER LIGHT ASSY	2	
115-83311-60	.BULB (6V-18W)	1	

4. Applicable colours of graphics are represented in the “REMARKS” as shown below.

PART NO.	DESCRIPTION	Q'TY	REMARKS
2N4-24110-00-X5	FUEL TANK COMP.	2	MXR
3J1-24240-10	.GRAPHIC, FUEL TANK	1	FOR MXR

5. Note that the illustrations for reference in finding parts numbers are not to be used for assembling. When assembling, please use the applicable service manual.

6. The asterisk (*) before a reference number indicates modified items after the first edition.

FOREWORD

7. Applicable Serial No.

Engine Serial No.

Primary Identification No.

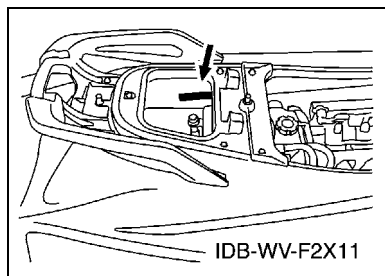
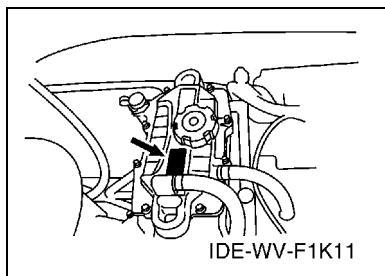

8. Applicable Colour Code (The (*) mark shows Model colour.)

Abbreviation	Colour Name	Colour Code
BMG(*)	BLACK METALLIC G	1050
DPBM11(*)	DARK PURPLISH BLUE METALLIC 11	1187
LGM3(*)	LIGHT GRAY METALLIC 3	0137
PURW(*)	PURE WHITE	0240

9. Quantity Column Information

Column No.	Name Of Q'ty Column	Destination
1	CAN	CANADA
2	EUR	EUROPE
3	GENE	EXCEPT CANADA, EUROPE

10. Applicable Starting Serial No.

Engine Serial No.

Serial No.	Name Of Q'ty Column	Model Code
6EX-1000001	CAN	6EXA
6EX-1000001	EUR	6EXC
6EX-1000001	GENE	6EXB

Primary Identification No.

Serial No.	Name Of Q'ty Column	Model Code
F2X-800101	CAN	F2X1
F2X-800101		F2X4
F2X-800101	EUR	F2X3
F2X-800101		F2X6
F2X-800101	GENE	F2X2
F2X-800101		F2X5

CONTENTS

CYLINDER	1
CRANKCASE	3
CRANKSHAFT & PISTON	4
VALVE	6
INTAKE	8
INTAKE 2	9
OIL PUMP	10
OIL COOLER	12
EXHAUST 1	14
EXHAUST 2	16
EXHAUST 3	18
JET UNIT 1	20
JET UNIT 2	22
JET UNIT 3	23
GENERATOR	24
STARTING MOTOR	25
ELECTRICAL 1	26
ELECTRICAL 2	29
ELECTRICAL 3	31
ENGINE MOUNT	33
ENGINE HATCH 1	34
ENGINE HATCH 2	36
HULL & DECK	38
GUNWALE & MAT	40
VENTILATION	43
SEAT & UNDER LOCKER	44
FUEL TANK	46
EXHAUST 4	48
CONTROL CABLE	49
STEERING 1	50
STEERING 2	51
STEERING 3	52
GRAPHICS	53
IMPORTANT LABELS	55
REPAIR KIT 1	57
INDEX	
NUMERICAL INDEX	58

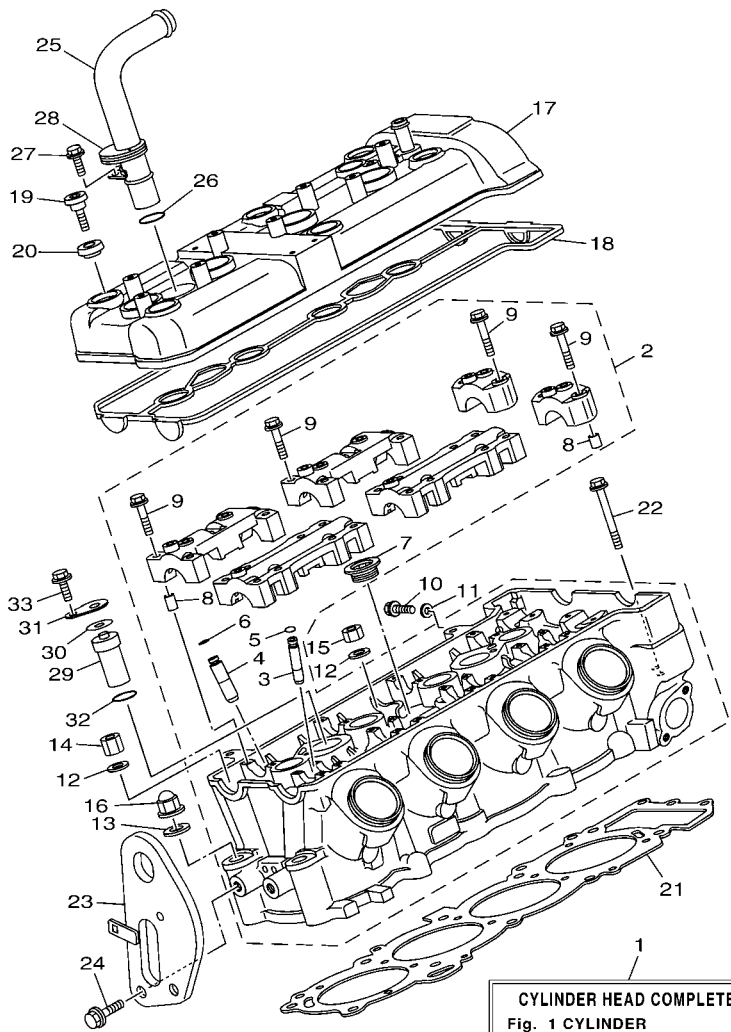

CYLINDER HEAD COMPLETE
 Fig. 1 CYLINDER
 Ref. No. 2 to 11
 17, 19, 20, 21, 26, 27,
 29, 30 and 31
 Fig. 4 VALVE
 Ref. No. 1 to 20 and 22
 Fig.18 ELECTRICAL 2
 Ref. No. 8

FWD
 F2X1100-P010

FIG. 1 CYLINDER

REF. NO.	PART NO.	DESCRIPTION	CAN	EUR	GENE	REMARKS
1	6EX-W009A-00-94	CYLINDER HEAD COMPLETE	1	1	1	
2	6D3-11102-00	CYLINDER HEAD ASSY	1	1	1	
3	3TJ-11133-10	.GUIDE, VALVE	12	12	12	
4	1WG-11133-11	.GUIDE, VALVE	8	8	8	
5	93440-07149	.CIRCLIP	12	12	12	
6	93440-10153	.CIRCLIP	8	8	8	
7	90340-27001	.PLUG, STRAIGHT SCREW	1	1	1	
8	91808-16023	.PIN, DOWEL	12	12	12	
9	90105-06026	.BOLT, FLANGE	28	28	28	
10	95023-06012	BOLT	1	1	1	
11	90430-06014	GASKET	1	1	1	
12	90201-10013	WASHER, PLATE	8	8	8	
13	90201-10019	WASHER, PLATE	2	2	2	
14	90179-10006	NUT	3	3	3	
15	90179-10414	NUT	5	5	5	
16	90176-10001	NUT, CROWN	2	2	2	
17	6EX-11191-00	COVER, CYLINDER HEAD 1	1	1	1	
18	60E-11193-01	GASKET, HEAD COVER 1	1	1	1	
19	90109-066F0	BOLT	6	6	6	
20	4KG-1111G-00	RUBBER, MOUNT 1	6	6	6	
21	6D3-11181-00	GASKET, CYLINDER HEAD 1	1	1	1	
22	97513-06555	BOLT, WITH WASHER	3	3	3	
23	6D3-85132-00	BRACKET, REFLECTOR 1	1	1	1	
24	97513-08520	BOLT, WITH WASHER	2	2	2	
25	6EX-12482-00	PIPE 2	1	1	1	
26	93210-18417	O-RING	1	1	1	
27	91317-06016	BOLT	1	1	1	

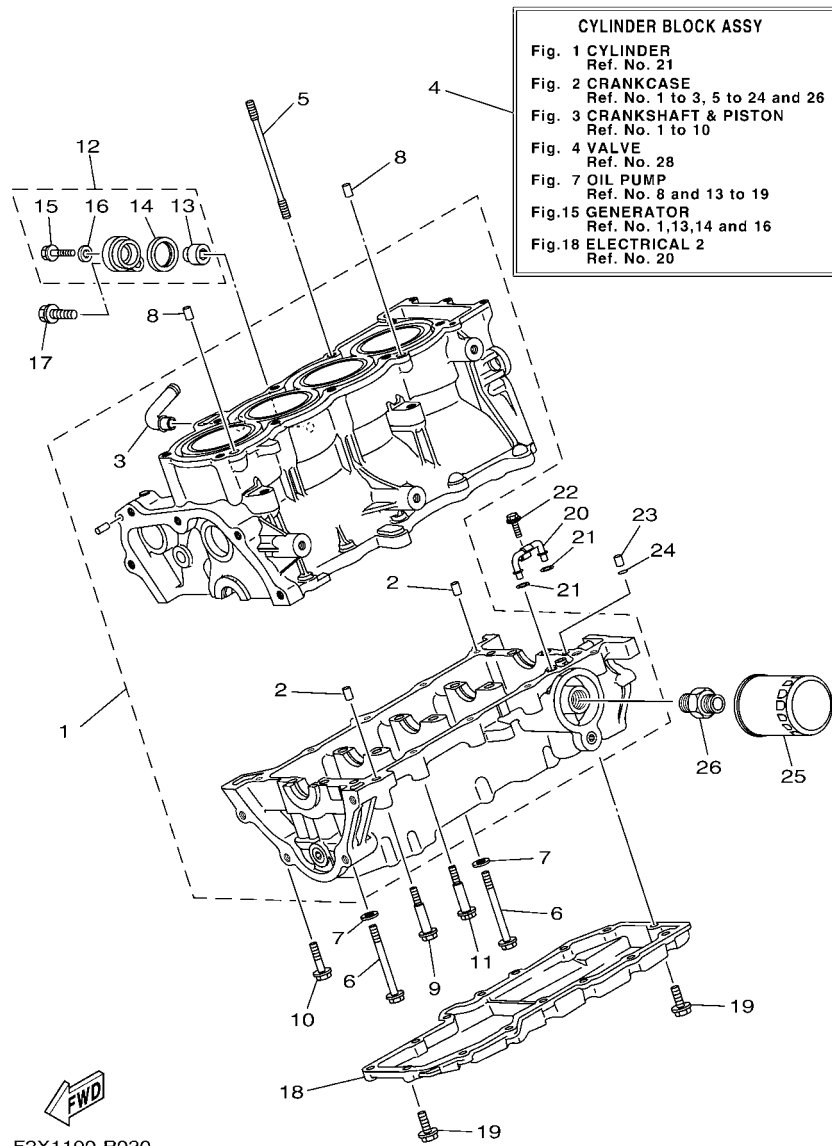

F2X1100-P020

FIG. 2 CRANKCASE

REF. NO.	PART NO.	DESCRIPTION	CAN	EUR	GENE	REMARKS
1	6BU-15100-00	CRANKCASE ASSY	1	1	1	
2	99530-10014	.PIN, DOWEL	2	2	2	
3	6D3-51129-00	.NIPPLE	1	1	1	
4	6BU-W009B-00-94	CYLINDER BLOCK ASSY	1	1	1	
5	90116-10058	BOLT, STUD	10	10	10	
6	90105-093A5	BOLT, FLANGE	10	10	10	
7	90201-096J9	WASHER, PLATE	10	10	10	
8	99530-10014	PIN, DOWEL	2	2	2	
9	90109-06051	BOLT	2	2	2	
10	95814-06070	BOLT, FLANGE	1	1	1	
11	90105-06M17	BOLT, FLANGE	7	7	7	
12	69J-11301-10	ANODE COVER ASSY	1	1	1	
13	68V-11325-02	.ANODE	1	1	1	
14	67F-11328-00	.GROMMET, ANODE	1	1	1	
15	90105-06M07	.BOLT, FLANGE	1	1	1	
16	90430-06M03	.GASKET	1	1	1	
17	97595-08540	BOLT, WITH WASHER	1	1	1	
18	6B6-1310A-01-94	PAN, OIL	1	1	1	
19	97513-06520	BOLT, WITH WASHER	15	15	15	
20	60E-13161-00	PIPE, DELIVERY 1	1	1	1	
21	93210-06667	O-RING	2	2	2	
22	95027-06010	BOLT, FLANGE	1	1	1	
23	99530-08012	PIN, DOWEL	1	1	1	
24	93210-08001	O-RING	1	1	1	
25	5GH-13440-50	ELEMENT ASSY, OIL CLEANER	1	1	1	
26	90401-20007	BOLT, UNION	1	1	1	

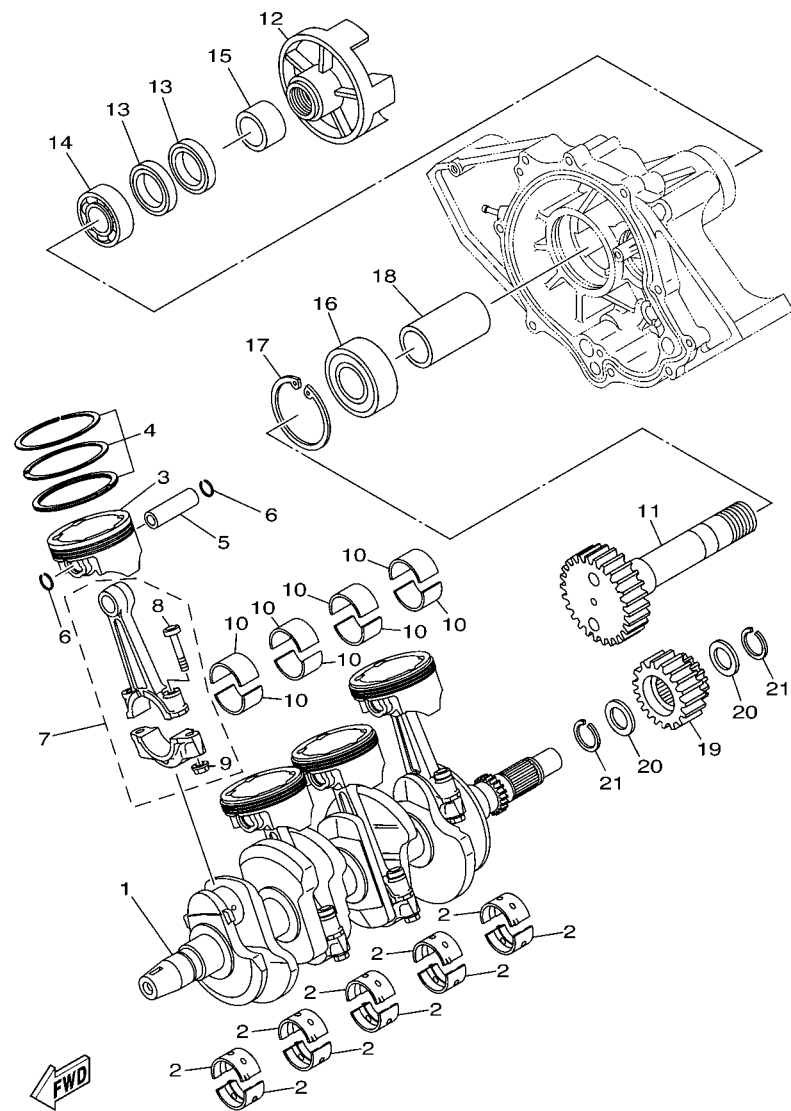

F1K1100-D030

FIG. 3 CRANKSHAFT & PISTON

REF. NO.	PART NO.	DESCRIPTION	CAN	EUR	GENE	REMARKS
1	60E-11411-11	CRANKSHAFT	1	1	1	
2	6D3-11416-A0	PLANE BEARING, CRANKSHAFT 1	10	10	10	UR RED/RED
	6D3-11416-00	PLANE BEARING, CRANKSHAFT 1	10	10	10	UR RED/BROWN
	6D3-11416-10	PLANE BEARING, CRANKSHAFT 1	10	10	10	UR RED/BLACK
	6D3-11416-20	PLANE BEARING, CRANKSHAFT 1	10	10	10	UR RED/BLUE
	6D3-11416-30	PLANE BEARING, CRANKSHAFT 1	10	10	10	UR RED/GREEN
3	6D3-11631-01-B0	PISTON (STD)	4	4	4	
4	6D3-11603-00	PISTON RING SET (STD)	4	4	4	
5	6D3-11633-00	PIN, PISTON	4	4	4	
6	90468-12069	CLIP	8	8	8	
7	6D3-11650-00	CONNECTING ROD ASSY	4	4	4	
8	5JW-11654-00	.BOLT, CONNECTING ROD	2	2	2	
9	90179-08327	.NUT	2	2	2	
10	60E-11656-00	PLANE BEARING, CONNECTING ROD	8	8	8	UR BROWN
	60E-11656-10	PLANE BEARING, CONNECTING ROD	8	8	8	UR BLACK
	60E-11656-20	PLANE BEARING, CONNECTING ROD	8	8	8	UR BLUE
	60E-11656-30	PLANE BEARING, CONNECTING ROD	8	8	8	UR GREEN
11	6D3-17572-00	SHAFT, TRANSFER	1	1	1	
12	6D3-45813-00-94	FLANGE, COUPLING	1	1	1	
13	93101-35004	OIL SEAL	2	2	2	
14	93306-07801	BEARING	1	1	1	
15	6B6-11478-00	COLLAR	1	1	1	
16	93306-30610	BEARING	1	1	1	
17	99009-72500	CIRCLIP	1	1	1	
18	6B6-17585-00	COLLAR, GEAR	1	1	1	
19	6B6-17586-00	GEAR, TRANSFER DRIVE	1	1	1	
20	90209-25008	WASHER	2	2	2	

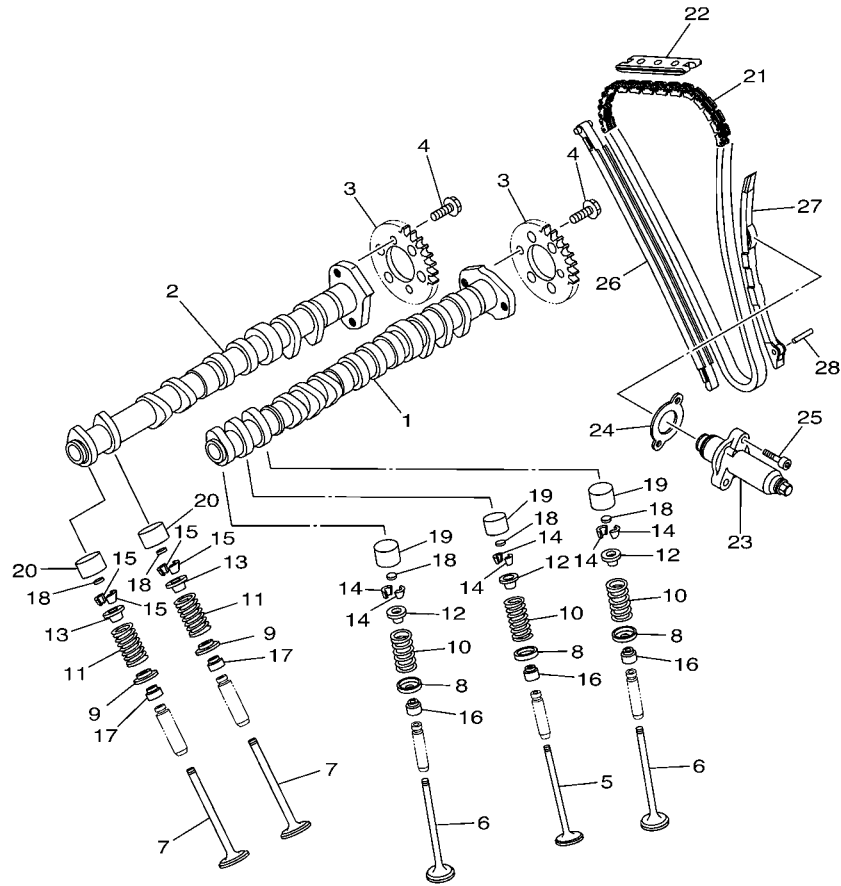

FWD
F1K1100-D040

FIG. 4 VALVE

REF. NO.	PART NO.	DESCRIPTION	CAN	EUR	GENE	REMARKS
1	6D3-12171-11	CAMSHAFT 1	1	1	1	
2	6D3-12181-00	CAMSHAFT 2	1	1	1	
3	6D3-12176-00	SPROCKET, CAM CHAIN	2	2	2	
4	90105-07004	BOLT, FLANGE	4	4	4	
5	4XV-12111-00	VALVE, INTAKE	4	4	4	
6	4XV-12112-00	VALVE, INTAKE 2	8	8	8	
7	5LV-12121-00	VALVE, EXHAUST	8	8	8	
8	1HX-12116-01	SEAT, VALVE SPRING	12	12	12	
9	3GM-12126-00	SEAT, VALVE SPRING 2	8	8	8	
10	4XV-12113-00	SPRING, VALVE INNER	12	12	12	
11	4XV-12114-00	SPRING, VALVE OUTER	8	8	8	
12	1HX-12117-00	RETAINER, VALVE SPRING	12	12	12	
13	1WG-12117-00	RETAINER, VALVE SPRING	8	8	8	
14	1HX-12118-00	LOCK, VALVE SPRING RETAINER	24	24	24	
15	1WG-12118-00	LOCK, VALVE SPRING RETAINER	16	16	16	
16	4TV-12119-00	SEAL, VALVE STEM	12	12	12	
17	4SV-12119-00	SEAL, VALVE STEM	8	8	8	
18	1HX-12168-00	PAD, ADJUSTING 2 (1.20)	20	20	20	UR
	1HX-12168-20	PAD, ADJUSTING 2 (1.25)	20	20	20	UR
	1HX-12168-40	PAD, ADJUSTING 2 (1.30)	20	20	20	UR
	1HX-12168-60	PAD, ADJUSTING 2 (1.35)	20	20	20	UR
	1HX-12168-80	PAD, ADJUSTING 2 (1.40)	20	20	20	UR
	1HX-12168-A0	PAD, ADJUSTING 2 (1.45)	20	20	20	UR
	1HX-12168-F0	PAD, ADJUSTING 2 (1.50)	20	20	20	UR
	1HX-12168-H1	PAD, ADJUSTING 2 (1.55)	20	20	20	UR
	1HX-12168-K1	PAD, ADJUSTING 2 (1.60)	20	20	20	UR
	1HX-12168-M1	PAD, ADJUSTING 2 (1.65)	20	20	20	UR

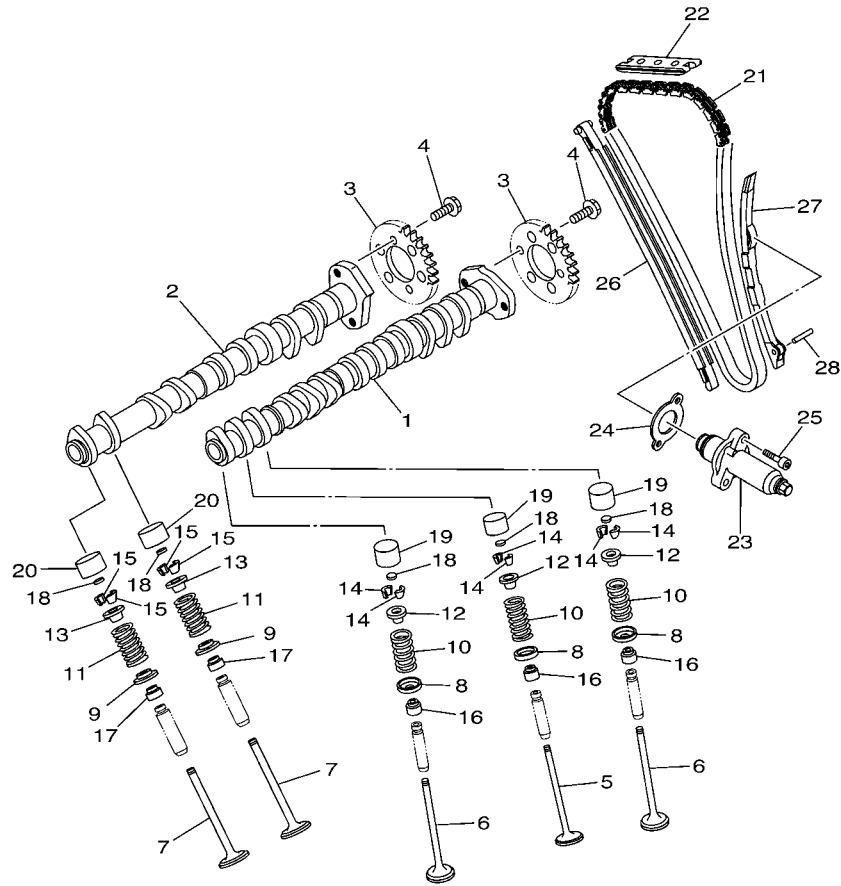

FWD
F1K1100-D040

FIG. 4 VALVE

REF. NO.	PART NO.	DESCRIPTION	CAN	EUR	GENE	REMARKS
18	1HX-12168-R1	PAD, ADJUSTING 2 (1.70)	20	20	20	UR
	1HX-12168-U1	PAD, ADJUSTING 2 (1.75)	20	20	20	UR
	1HX-12168-W1	PAD, ADJUSTING 2 (1.80)	20	20	20	UR
	1HX-12168-Y1	PAD, ADJUSTING 2 (1.85)	20	20	20	UR
	1HX-12169-11	PAD, ADJUSTING 2 (1.90)	20	20	20	UR
	1HX-12169-31	PAD, ADJUSTING 2 (1.95)	20	20	20	UR
	1HX-12169-50	PAD, ADJUSTING 2 (2.00)	20	20	20	UR
	1HX-12169-70	PAD, ADJUSTING 2 (2.05)	20	20	20	UR
	1HX-12169-90	PAD, ADJUSTING 2 (2.10)	20	20	20	UR
	1HX-12169-E0	PAD, ADJUSTING 2 (2.15)	20	20	20	UR
	1HX-12169-G0	PAD, ADJUSTING 2 (2.20)	20	20	20	UR
	1HX-12169-J0	PAD, ADJUSTING 2 (2.25)	20	20	20	UR
	1HX-12169-L0	PAD, ADJUSTING 2 (2.30)	20	20	20	UR
	1HX-12169-N0	PAD, ADJUSTING 2 (2.35)	20	20	20	UR
	1HX-12169-T0	PAD, ADJUSTING 2 (2.40)	20	20	20	UR
19	3LN-12153-10	LIFTER, VALVE	12	12	12	YELLOW
20	3FV-12153-10	LIFTER, VALVE	8	8	8	YELLOW
21	94591-49130	CHAIN	1	1	1	
22	5BE-12241-00	GUIDE, STOPPER 2	1	1	1	
23	6D3-12210-00	TENSIONER ASSY, CAM CHAIN	1	1	1	
24	4FM-12213-00	GASKET, TENSIONER CASE	1	1	1	
25	91380-06025	BOLT	2	2	2	
26	6D3-12251-00	DAMPER, CHAIN 1	1	1	1	
27	4XV-12252-00	DAMPER, CHAIN 2	1	1	1	
28	93607-44002	PIN, DOWEL	1	1	1	

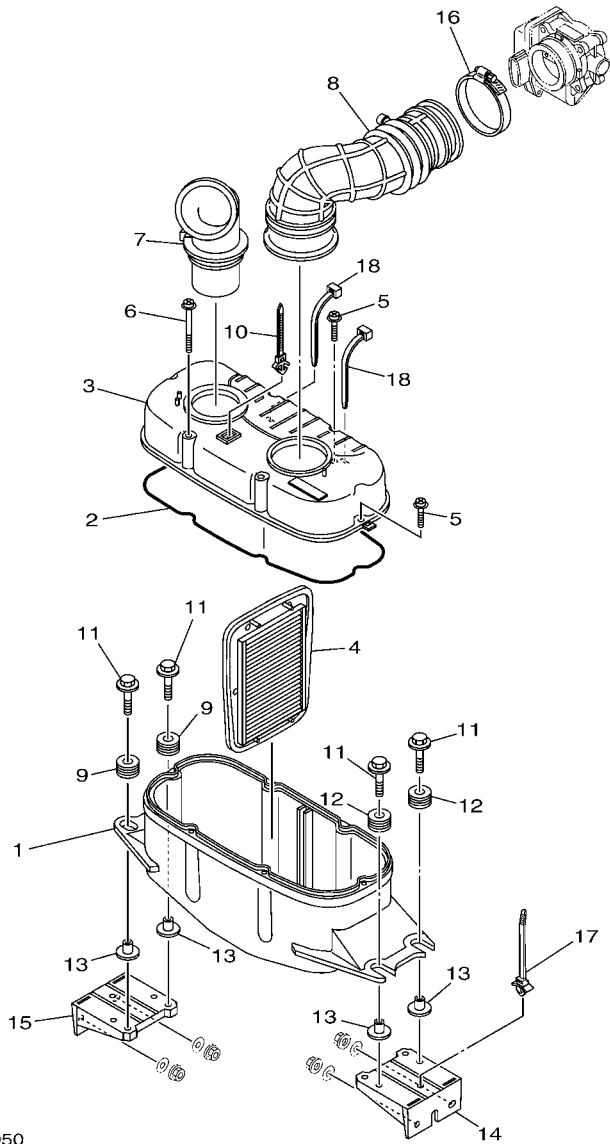

F2X1100-P050

FIG. 5 INTAKE

REF. NO.	PART NO.	DESCRIPTION	CAN	EUR	GENE	REMARKS
1	6D3-14411-00	CASE, AIR CLEANER 1	1	1	1	
2	4XV-14452-00	SEAL	1	1	1	
3	6D3-14421-02	CASE, AIR CLEANER 2	1	1	1	
4	6D3-14451-00	ELEMENT, AIR CLEANER	1	1	1	
5	90159-05013	SCREW, WITH WASHER	4	4	4	
6	90159-05014	SCREW, WITH WASHER	2	2	2	
7	6D3-14437-00	DUCT	1	1	1	
8	6D3-14419-01	PIPE	1	1	1	
9	90480-22M15	GROMMET	2	2	2	
10	90464-12089	CLAMP	1	1	1	
11	90119-08M22	BOLT, WITH WASHER	4	4	4	
12	90480-22M15	GROMMET	2	2	2	
13	90387-08M37	COLLAR	4	4	4	
14	F2N-U8572-00	BRACKET 2	1	1	1	
15	F2N-U8572-00	BRACKET 2	1	1	1	
16	90601-175UR	BAND, HOSE 75	1	1	1	
17	90464-38800	CLAMP	1	1	1	
18	90464-40825	CLAMP	2	2	2	

FIG. 6 INTAKE 2

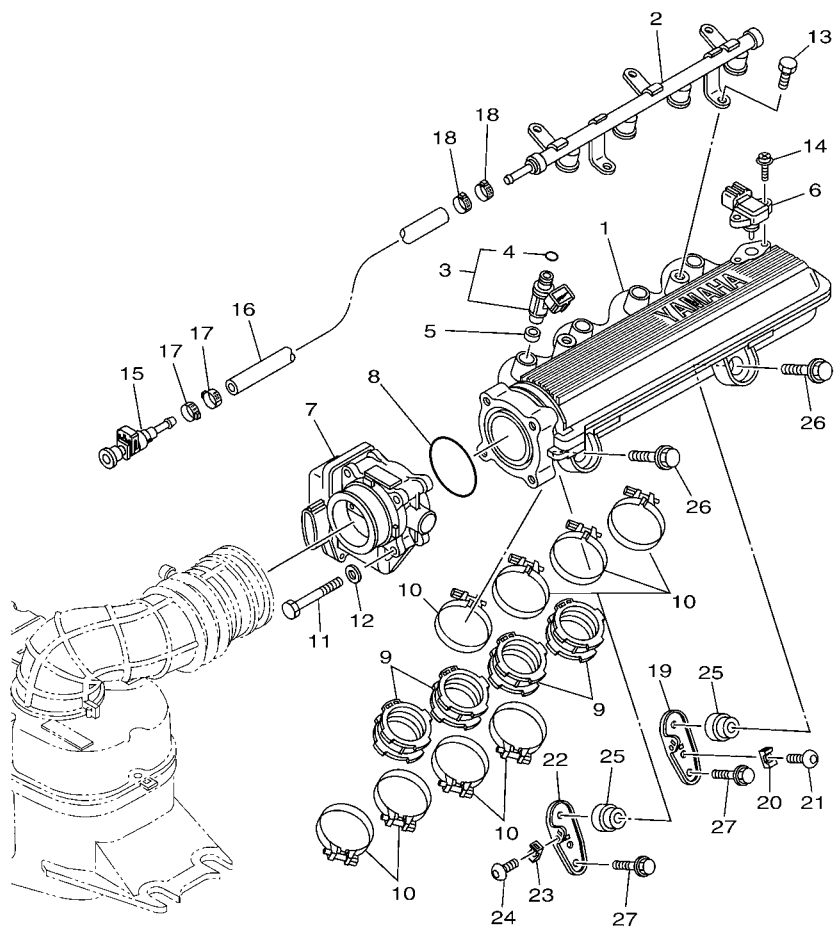

F2X1100-P060

REF. NO.	PART NO.	DESCRIPTION	CAN	EUR	GENE	REMARKS
1	6D3-13641-00	MANIFOLD, INTAKE 1	1	1	1	
2	6BU-12880-11	DELIVERY PIPE	1	1	1	
3	60E-13761-20	INJECTOR	4	4	4	
4	68V-1416A-00	.O-RING	1	1	1	
5	8FP-13556-10	GASKET, MANIFOLD	4	4	4	
6	68F-83688-10	SENSOR ASSY	1	1	1	
7	6BU-13750-00	THROTTLE BODY ASSY	1	1	1	
8	6D3-14457-00	SEAL	1	1	1	
9	6D3-13795-01	JOINT, THROTTLE BODY 1	4	4	4	
10	90450-57006	HOSE CLAMP ASSY	8	8	8	
11	68V-13573-00	BOLT 1	4	4	4	
12	68V-14475-00	WASHER	4	4	4	
13	63P-14446-00	BOLT	2	2	2	
14	6D3-81147-00	SCREW 3	2	2	2	
15	6S5-24300-01	FUEL PIPE JOINT	1	1	1	
16	6D3-14294-10	HOSE	1	1	1	
17	90450-17M17	HOSE CLAMP ASSY	2	2	2	
18	90450-17M17	HOSE CLAMP ASSY	2	2	2	
19	6EX-14414-00	STAY 2	1	1	1	
20	60E-1244E-00	BRACKET 1	1	1	1	
21	92014-06012	BOLT, BUTTON HEAD	1	1	1	
22	6EX-14414-10	STAY 2	1	1	1	
23	60E-1244E-00	BRACKET 1	1	1	1	
24	92014-06012	BOLT, BUTTON HEAD	1	1	1	
25	60E-14449-00-94	COLLAR	2	2	2	
26	90119-08050	BOLT, WITH WASHER	2	2	2	
27	90119-08074	BOLT, WITH WASHER	2	2	2	

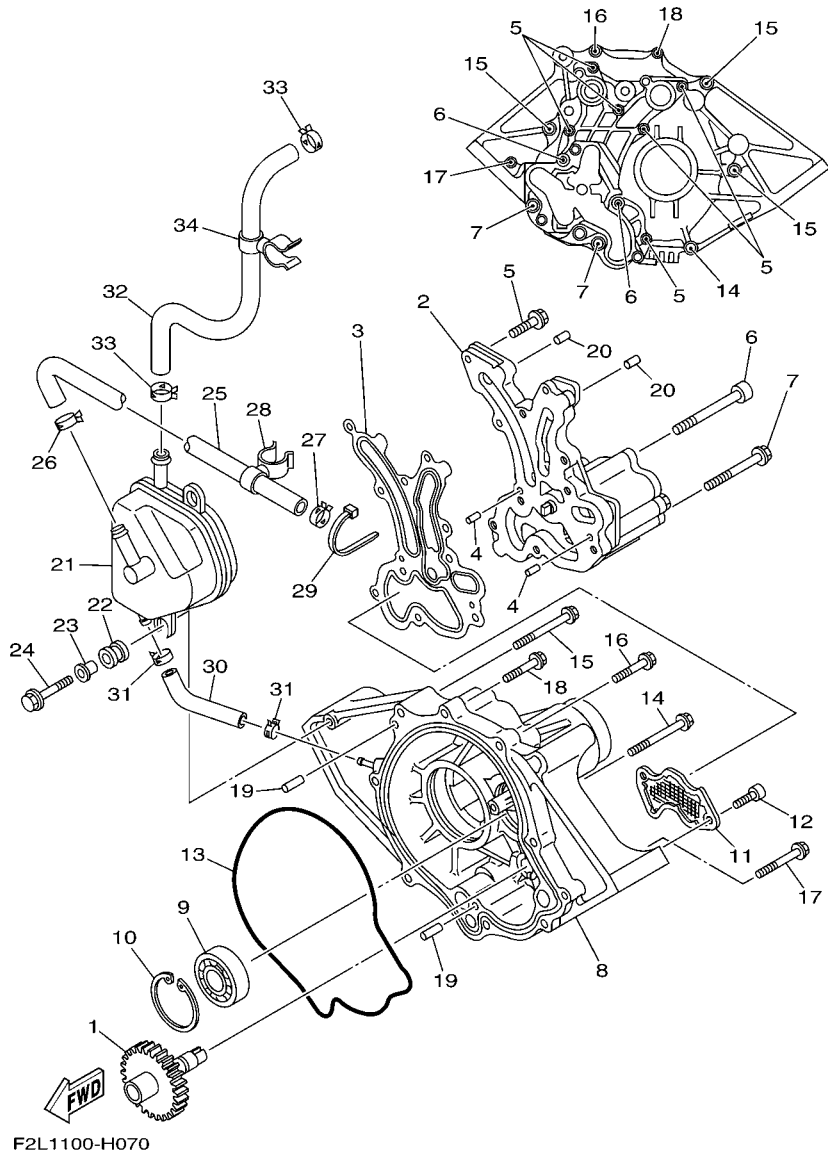
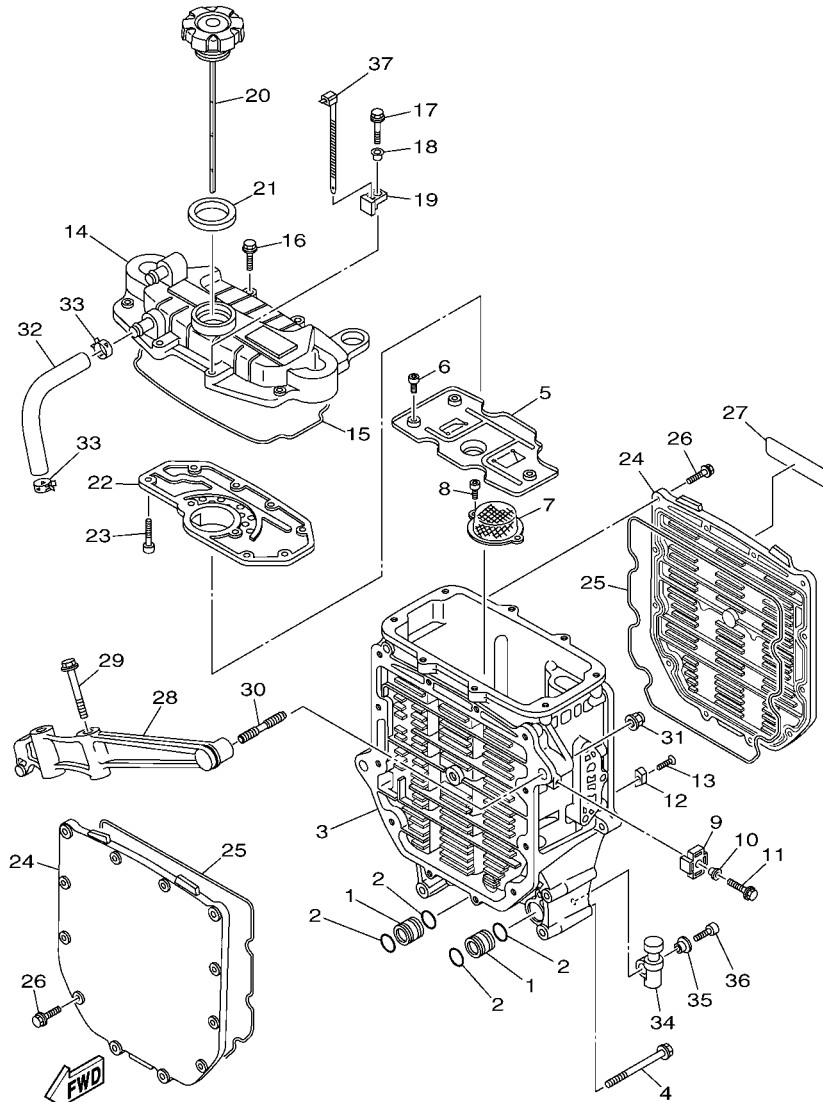

FIG. 7 OIL PUMP

REF. NO.	PART NO.	DESCRIPTION	CAN	EUR	GENE	REMARKS
1	6B6-13360-00	DRIVEN GEAR ASSY	1	1	1	
2	6D3-13300-10	OIL PUMP ASSY	1	1	1	
3	6B6-13563-01	GASKET	1	1	1	
4	93603-12221	PIN, DOWEL	2	2	2	
5	97513-06525	BOLT, WITH WASHER	6	6	6	
6	90110-08041	BOLT, HEXAGON SOCKET HEAD	2	2	2	
7	90119-08085	BOLT, WITH WASHER	2	2	2	
8	6B6-13327-02-94	COVER, PUMP GEAR	1	1	1	
9	93306-30441	BEARING	1	1	1	
10	99009-52500	CIRCLIP	1	1	1	
11	6B6-13411-00	STRAINER, OIL	1	1	1	
12	91317-06016	BOLT	2	2	2	
13	6B6-13475-01	GASKET	1	1	1	
14	90119-08045	BOLT, WITH WASHER	1	1	1	
15	90119-08034	BOLT, WITH WASHER	3	3	3	
16	90119-08043	BOLT, WITH WASHER	1	1	1	
17	97513-06555	BOLT, WITH WASHER	1	1	1	
18	97513-06535	BOLT, WITH WASHER	1	1	1	
19	93608-16M16	PIN, DOWEL	2	2	2	
20	93606-25M00	PIN, DOWEL	2	2	2	
21	6D3-11164-00	SEPERATOR, OIL	1	1	1	
22	6A0-82317-00	DAMPER, IGNITION COIL	2	2	2	
23	90387-06119	COLLAR	2	2	2	
24	90119-06M65	BOLT, WITH WASHER	2	2	2	
25	6D3-11126-00	PIPE, BREATHER 3	1	1	1	
26	90467-170A4	CLIP	1	1	1	
27	90467-170A4	CLIP	1	1	1	



F2P1100-M080

FIG. 8 OIL COOLER

REF. NO.	PART NO.	DESCRIPTION	CAN	EUR	GENE	REMARKS
1	60E-13446-00	CONNECTOR	2	2	2	
2	93210-18322	O-RING	4	4	4	
3	6D3-13462-00-94	CASE, OIL COOLER	1	1	1	
4	90119-10020	BOLT, WITH WASHER	5	5	5	
5	6B6-13317-00	PLATE, BAFFLE	1	1	1	
6	91317-05014	BOLT	3	3	3	
7	60E-13421-00	STRAINER 2	1	1	1	
8	91317-06014	BOLT	2	2	2	
9	6BU-85542-00	BRACKET	1	1	1	
10	90387-06M05	COLLAR	1	1	1	
11	97595-06520	BOLT, WITH WASHER	1	1	1	
12	6E5-11325-00	ANODE	1	1	1	
13	98780-04015	SCREW, FLAT HEAD	1	1	1	
14	6D3-13463-00-94	COVER, OIL COOLER	1	1	1	
15	60E-13475-00	GASKET	1	1	1	
16	90105-06036	BOLT, FLANGE	7	7	7	
17	90105-06035	BOLT, FLANGE	1	1	1	
18	90387-06M05	COLLAR	1	1	1	
19	6AA-85542-00	BRACKET	1	1	1	
20	6BU-15362-A0	PLUG, OIL LEVEL	1	1	1	
21	60E-13473-00	O-RING	1	1	1	
22	6D3-11165-00	PLATE, BREATHER	1	1	1	
23	91317-05016	BOLT	9	9	9	
24	6D3-13443-00-94	COVER, OIL COOLER	2	2	2	
25	60E-13476-10	GASKET	2	2	2	
26	90105-06M07	BOLT, FLANGE	24	24	24	
27	60E-83627-00	LABEL, CAUTION 7	1	1	1	

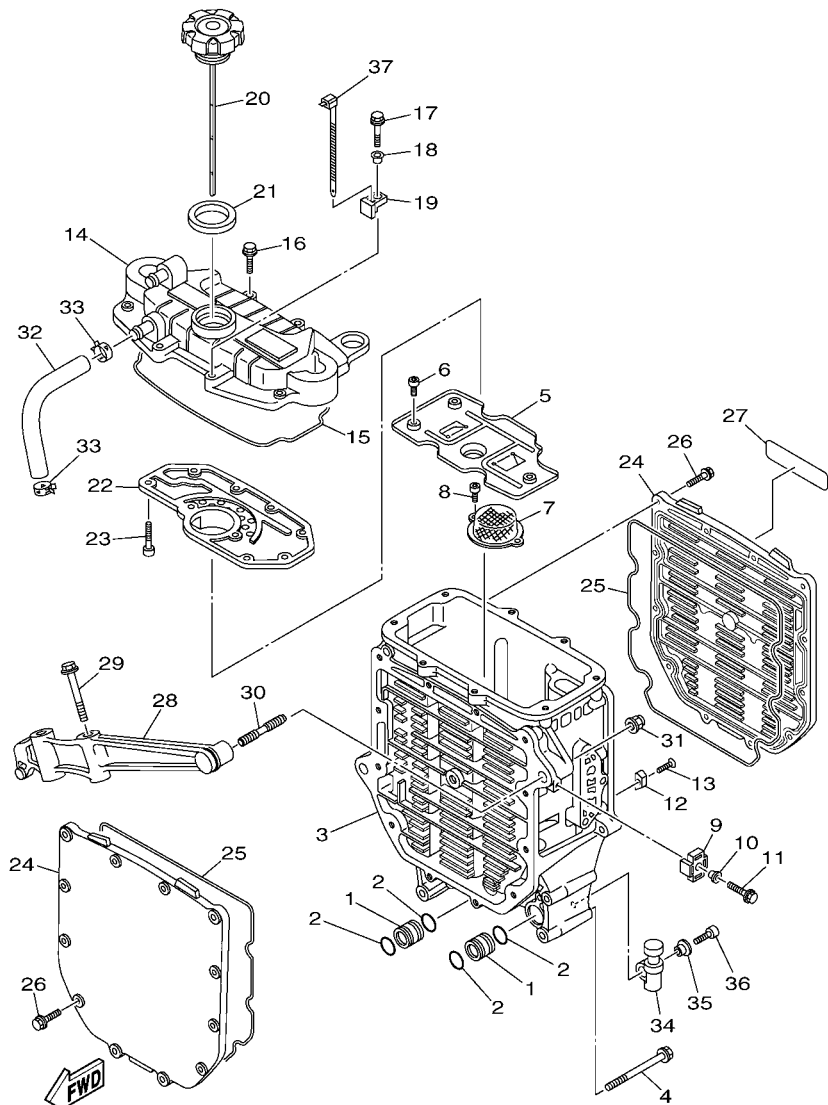

F2P1100-M080

FIG. 8 OIL COOLER

REF. NO.	PART NO.	DESCRIPTION	CAN	EUR	GENE	REMARKS
28	6B6-13151-00-94	STAY	1	1	1	
29	90119-10M02	BOLT, WITH WASHER	2	2	2	
30	90116-10016	BOLT, STUD	2	2	2	
31	90176-10001	NUT, CROWN	2	2	2	
32	6D3-11167-00	PIPE, BREATHER 2	1	1	1	
33	90467-170A4	CLIP	2	2	2	
34	6S5-81364-10	GROMMET	2	2	2	
35	90387-06M05	COLLAR	2	2	2	
36	91380-06020	BOLT	2	2	2	
37	90465-13M39	CLAMP	1	1	1	

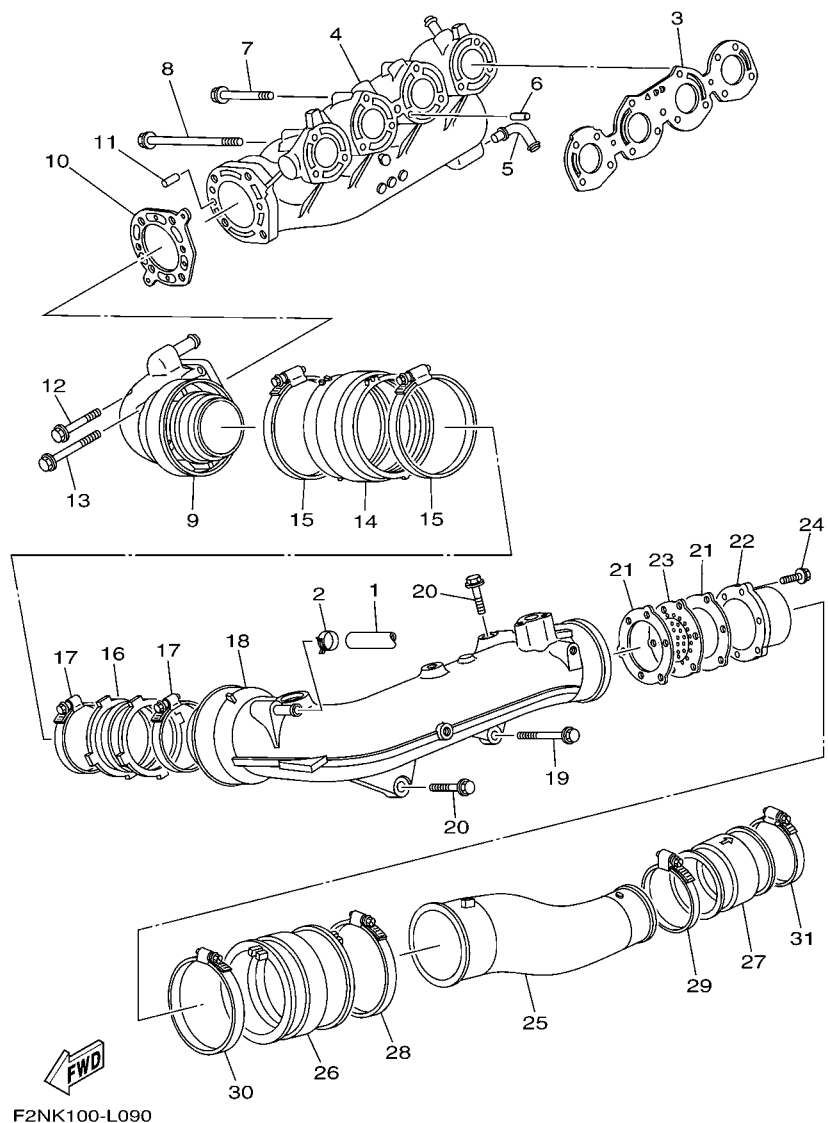

FIG. 9 EXHAUST 1

REF. NO.	PART NO.	DESCRIPTION	CAN	EUR	GENE	REMARKS
1	6BU-1244G-10	HOSE, 4	1	1	1	
2	90467-160A0	CLIP	1	1	1	
3	6D3-14613-10	GASKET, EXHAUST PIPE	1	1	1	
4	6D3-14711-10	MUFFLER 1	1	1	1	
5	60E-11372-10	NIPPLE, HOSE	1	1	1	
6	93608-16M16	PIN, DOWEL	2	2	2	
7	90119-08036	BOLT, WITH WASHER	5	5	5	
8	90119-08075	BOLT, WITH WASHER	6	6	6	
9	6D3-14712-00-94	RING, JOINT	1	1	1	
10	6D3-14739-10	GASKET, MUFFLER DAMPER 1	1	1	1	
11	93606-12019	PIN, DOWEL	2	2	2	
12	90119-08036	BOLT, WITH WASHER	2	2	2	
13	90119-08031	BOLT, WITH WASHER	2	2	2	
14	6D3-14615-00	JOINT, EXHAUST 1	1	1	1	
15	90450-99005	HOSE CLAMP ASSY	2	2	2	
16	6D3-14625-00	JOINT, EXHAUST 2	1	1	1	
17	90450-90001	HOSE CLAMP ASSY	2	2	2	
18	6D3-14721-10	MUFFLER 2	1	1	1	
19	90119-10017	BOLT, WITH WASHER	1	1	1	
20	90119-10013	BOLT, WITH WASHER	3	3	3	
21	60E-14623-00	GASKET, EXHAUST PIPE	2	2	2	
22	60E-14784-00-94	PIPE, TAIL	1	1	1	
23	6D3-1469W-10	PLATE, SILENCER 6	1	1	1	
24	90105-06790	BOLT, FLANGE	3	3	3	
25	6BU-14752-00-94	PIPE, OUTLET	1	1	1	
26	6BU-1475E-00	PIPE 2	1	1	1	
27	6BU-1475F-00	PIPE 3	1	1	1	

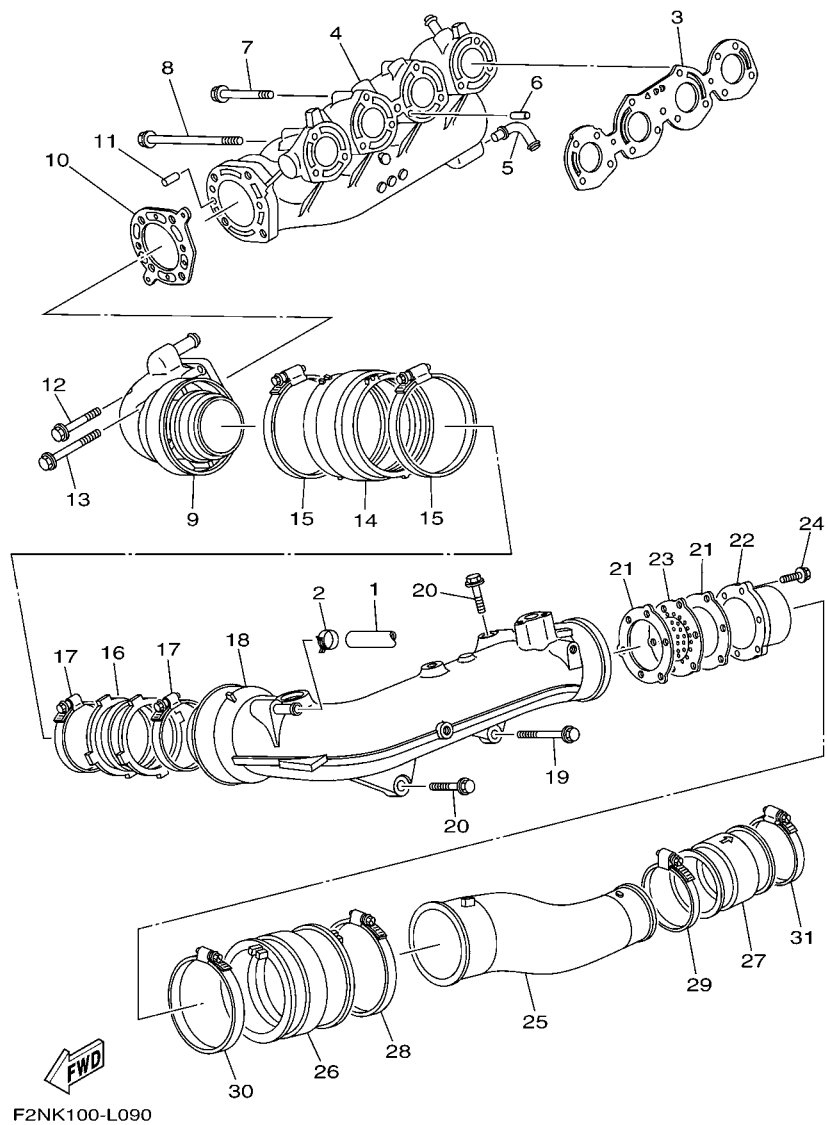

FIG. 9 EXHAUST 1

REF. NO.	PART NO.	DESCRIPTION	CAN	EUR	GENE	REMARKS
28	90450-99004	HOSE CLAMP ASSY	1	1	1	
29	90450-94001	HOSE CLAMP ASSY	1	1	1	
30	90450-99004	HOSE CLAMP ASSY	1	1	1	
31	90450-94001	HOSE CLAMP ASSY	1	1	1	

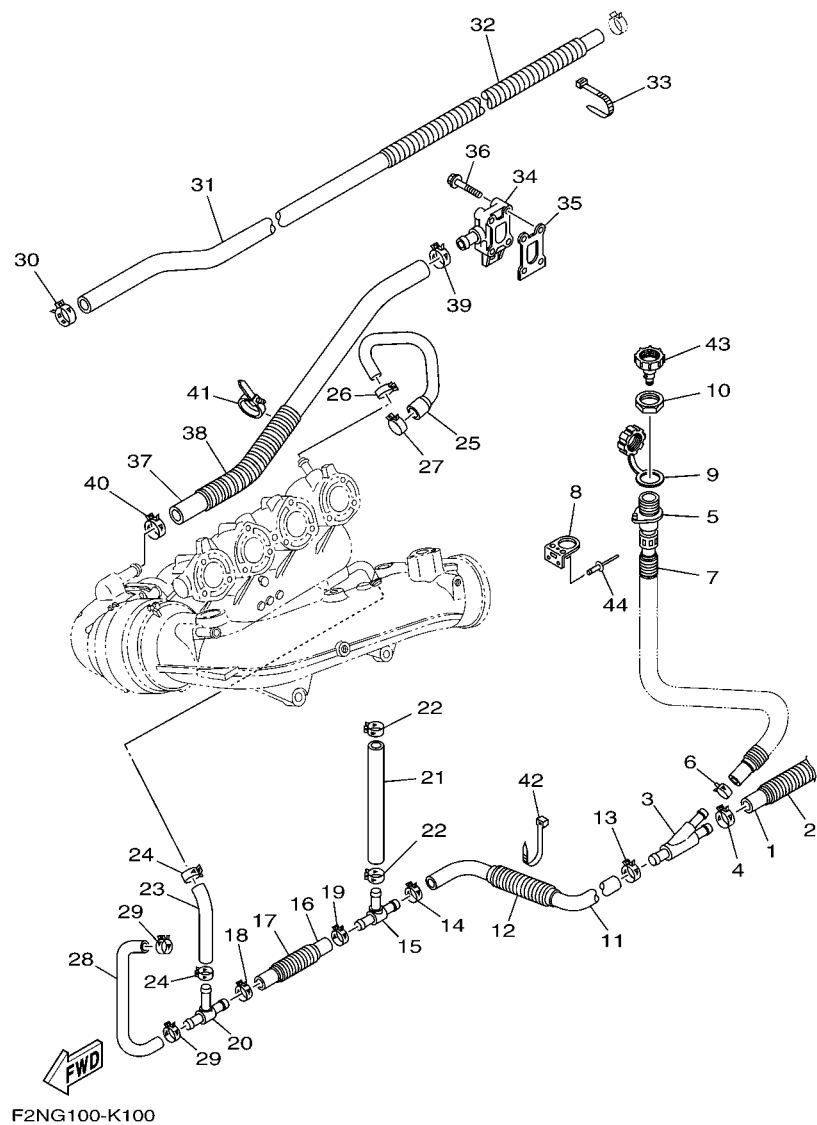

FIG. 10 EXHAUST 2

REF. NO.	PART NO.	DESCRIPTION	CAN	EUR	GENE	REMARKS
1	90445-21805	HOSE (L300)	1		1	
2	90447-22004	HOSE, WITH SPRING (L200)	1		1	
3	60E-12581-00	JOINT, HOSE 1	1		1	
4	90467-200A3	CLIP	1		1	
5	63M-12580-00	JOINT ASSY	1		1	
6	90467-150A5	CLIP	1		1	
7	90447-19801	TUBE (L485)	1		1	
8	60E-12443-00	STAY	1		1	
9	682-84385-01	CAP,1	1		1	
10	EU0-61652-00	NUT	1		1	
11	6BU-1243A-00	HOSE 1	1		1	
12	90447-22003	HOSE, WITH SPRING (L300)	1		1	
13	90467-200A3	CLIP	1		1	
14	90467-200A3	CLIP	1		1	
15	60E-12584-00	JOINT, HOSE 3	1		1	
16	6S5-12589-01	HOSE 6	1		1	
17	90447-22001	HOSE, WITH SPRING (L100)	1		1	
18	90467-200A3	CLIP	1		1	
19	90467-200A3	CLIP	1		1	
20	6D3-12584-00	JOINT, HOSE 3	1		1	
21	6D3-1244H-10	HOSE 5	1		1	
22	90467-160A0	CLIP	2		2	
23	90445-18M03	HOSE (L108)	1		1	
24	90467-160A0	CLIP	2		2	
25	6D3-12577-10	HOSE 2	1		1	
26	90467-170A4	CLIP	1		1	
27	90467-200A3	CLIP	1		1	

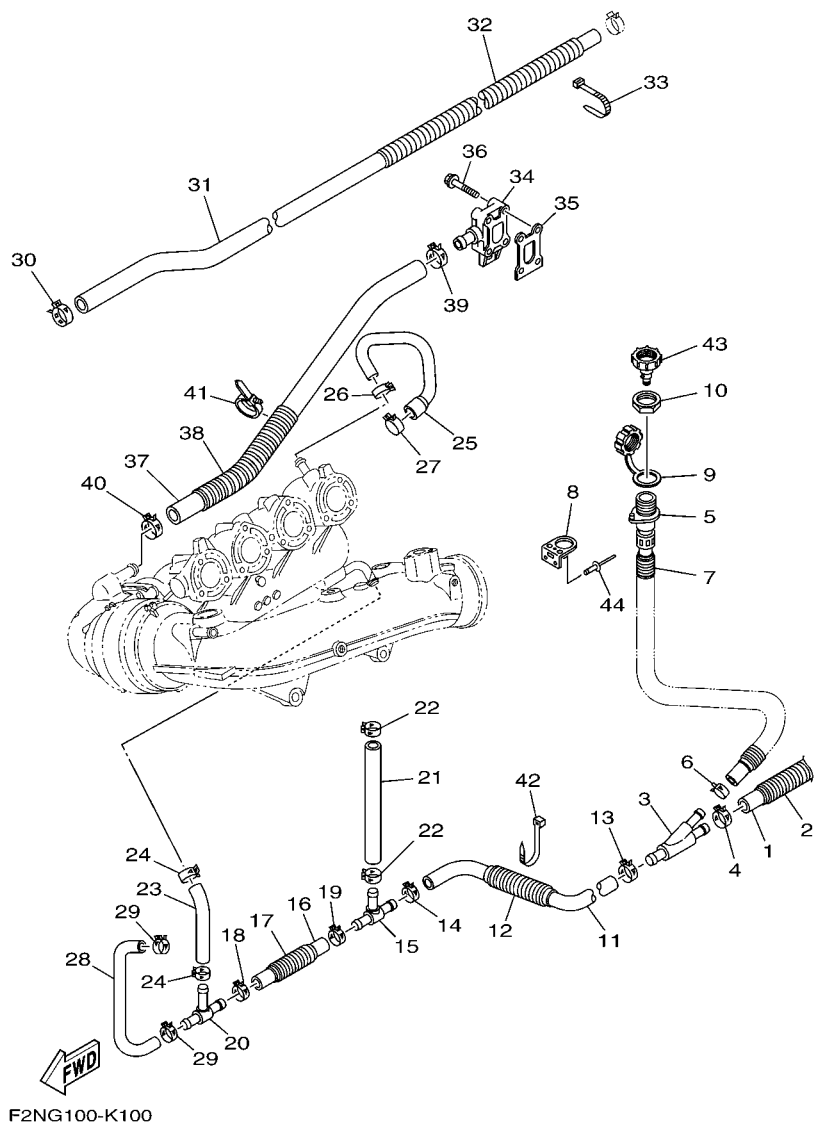

FIG. 10 EXHAUST 2

REF. NO.	PART NO.	DESCRIPTION	CAN	EUR	GENE	REMARKS
28	6D3-1244G-10	HOSE, 4	1		1	
29	90467-160A0	CLIP	2		2	
30	90467-210A0	CLIP	1		1	
31	90445-22007	HOSE (L1165)	1		1	
32	90447-25002	TUBE (L800)	1		1	
33	90464-35132	CLAMP	1		1	
34	6D3-12446-00	JOINT	1		1	
35	60E-12435-00	GASKET	1		1	
36	90105-06035	BOLT, FLANGE	4		4	
37	6BU-1243F-10	HOSE,3	1		1	
38	90447-22005	HOSE, WITH SPRING (L200)	1		1	
39	90467-200A3	CLIP	1		1	
40	90467-200A3	CLIP	1		1	
41	90464-31001	CLAMP	1		1	
42	90464-35132	CLAMP	1		1	
43	67X-E2590-10	CONDUCTION ASSY	1		1	
44	90267-489U1	RIVET,BLIND	2		2	

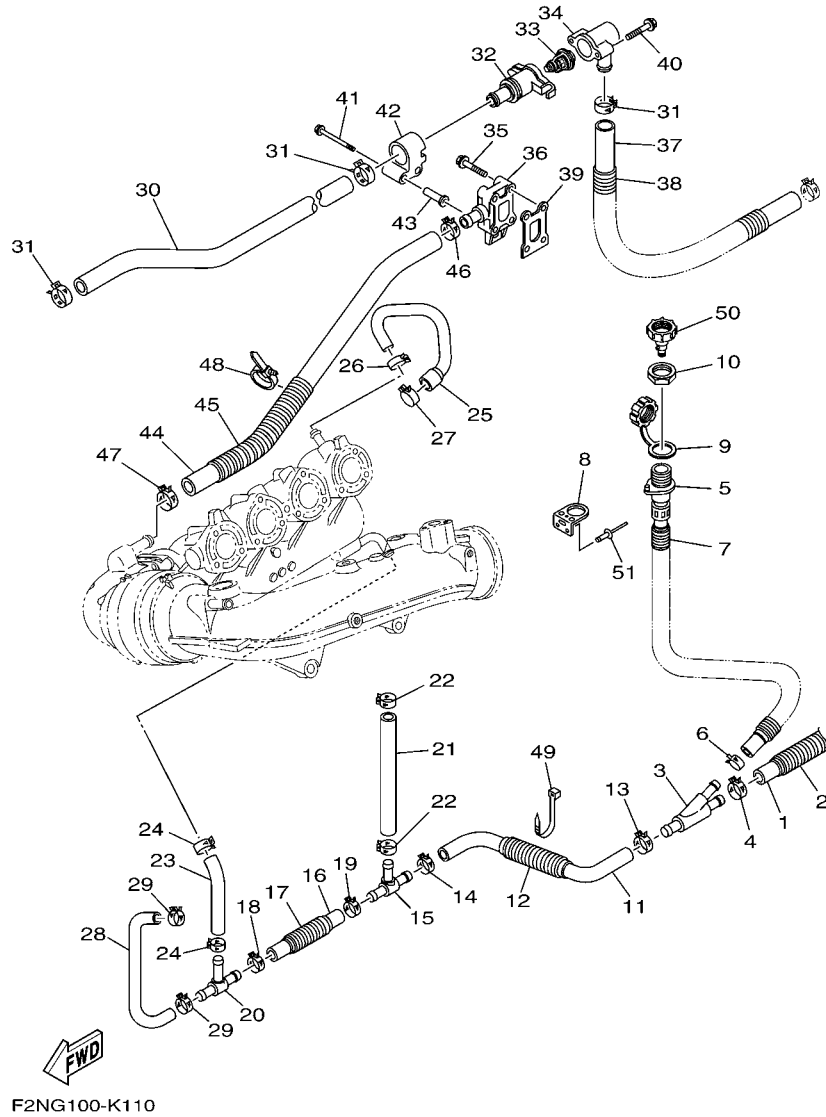

FIG. 11 EXHAUST 3

REF. NO.	PART NO.	DESCRIPTION	CAN	EUR	GENE	REMARKS
1	90445-21805	HOSE (L300)		1		
2	90447-22004	HOSE, WITH SPRING (L200)		1		
3	60E-12581-00	JOINT, HOSE 1		1		
4	90467-200A3	CLIP		1		
5	63M-12580-00	JOINT ASSY		1		
6	90467-150A5	CLIP		1		
7	90447-19801	TUBE (L485)		1		
8	60E-12443-00	STAY		1		
9	682-84385-01	CAP,1		1		
10	EU0-61652-00	NUT		1		
11	6BU-1243A-00	HOSE 1		1		
12	90447-22003	HOSE, WITH SPRING (L300)		1		
13	90467-200A3	CLIP		1		
14	90467-200A3	CLIP		1		
15	60E-12584-00	JOINT, HOSE 3		1		
16	6S5-12589-01	HOSE 6		1		
17	90447-22001	HOSE, WITH SPRING (L100)		1		
18	90467-200A3	CLIP		1		
19	90467-200A3	CLIP		1		
20	6D3-12584-00	JOINT, HOSE 3		1		
21	6D3-1244H-10	HOSE 5		1		
22	90467-160A0	CLIP		2		
23	90445-18M03	HOSE (L108)		1		
24	90467-160A0	CLIP		2		
25	6D3-12577-10	HOSE 2		1		
26	90467-170A4	CLIP		1		
27	90467-200A3	CLIP		1		

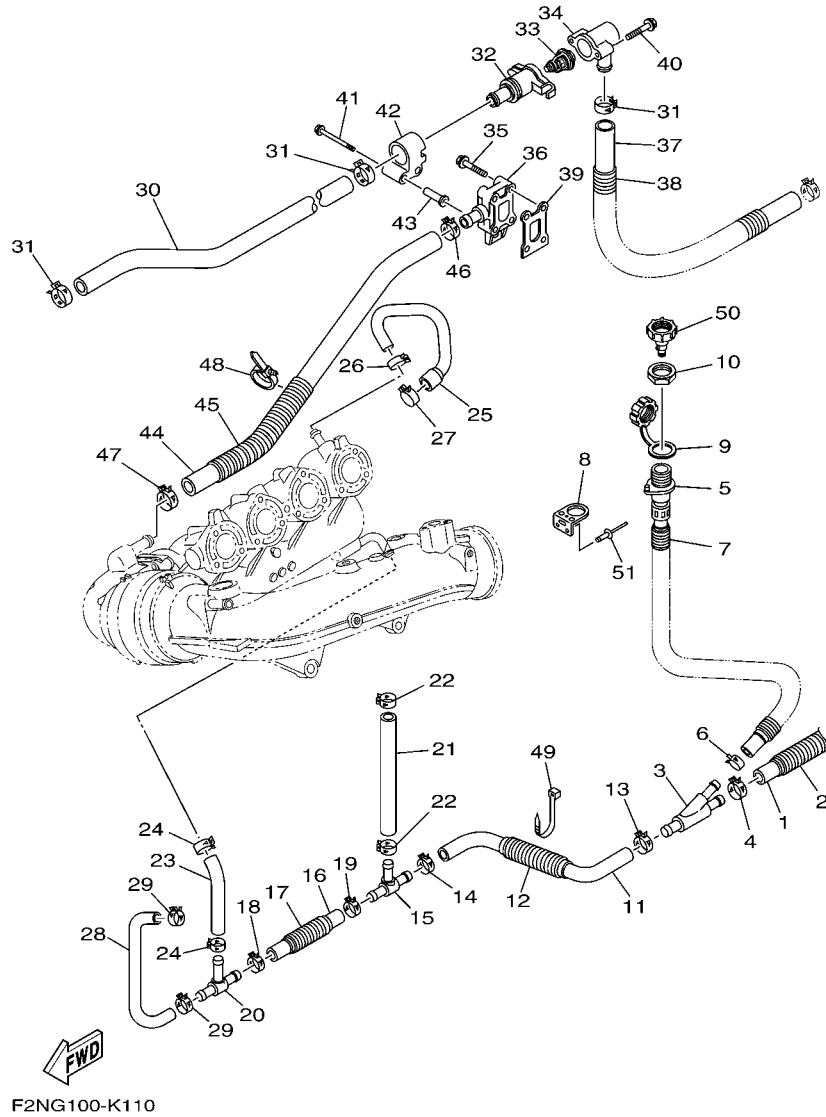

FIG. 11 EXHAUST 3

REF. NO.	PART NO.	DESCRIPTION	CAN	EUR	GENE	REMARKS
28	6D3-1244G-10	HOSE, 4		1		
29	90467-160A0	CLIP		2		
30	90445-26004	HOSE (L375)		1		
31	90467-240A0	CLIP		3		
32	60E-12417-10	HOUSING, THERMOSTAT		1		
33	6D3-12411-00	THERMOSTAT		1		
34	6BH-12413-00	COVER, THERMOSTAT		1		
35	90105-06035	BOLT, FLANGE		2		
36	6D3-12446-00	JOINT		1		
37	90445-25006	HOSE (L760)		1		
38	90447-28010	TUBE (L650)		1		
39	60E-12435-00	GASKET		1		
40	90105-06035	BOLT, FLANGE		2		
41	90105-06054	BOLT, FLANGE		2		
42	6B6-12499-00	JOINT		1		
43	90387-06083	COLLAR		2		
44	6BU-1243F-10	HOSE,3		1		
45	90447-22005	HOSE, WITH SPRING (L200)		1		
46	90467-200A3	CLIP		1		
47	90467-200A3	CLIP		1		
48	90464-31001	CLAMP		1		
49	90464-35132	CLAMP		1		
50	67X-E2590-10	CONDUCTION ASSY		1		
51	90267-489U1	RIVET,BLIND		2		

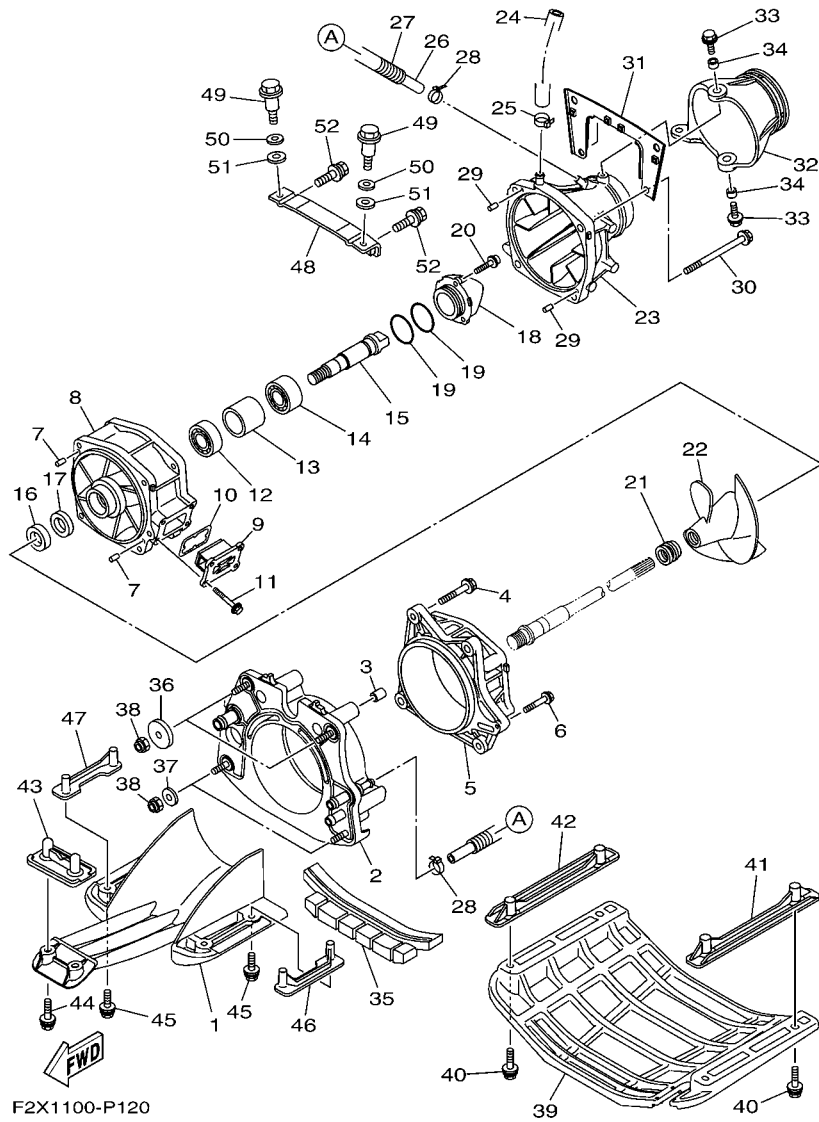
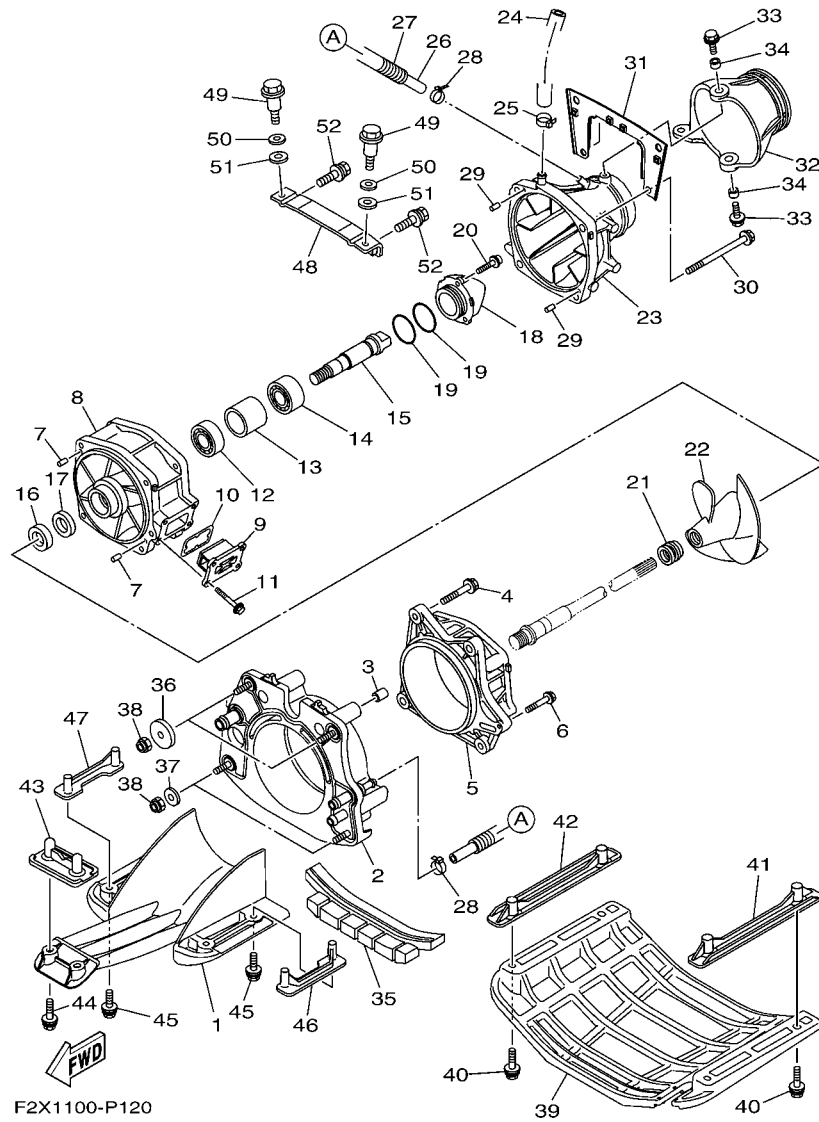

FIG. 12 JET UNIT 1

REF. NO.	PART NO.	DESCRIPTION	CAN	EUR	GENE	REMARKS
1	6EX-R1333-00	SCREEN, INTAKE	1	1	1	
2	6CS-G5831-00	PLATE, TRANSOM	1	1	1	
3	99590-14016	PIN, DOWEL	2	2	2	
4	90119-10810	BOLT, WITH WASHER	4	4	4	
5	66V-51312-01-94	HOUSING, IMPELLER	1	1	1	
6	90119-06893	BOLT, WITH WASHER	1	1	1	
7	93606-12019	PIN, DOWEL	2	2	2	
8	6B6-51315-01-94	DUCT, IMPELLER	1	1	1	
9	6EX-G6882-00	FILTER	1	1	1	
10	66V-42414-00	O-RING	1	1	1	
11	90119-06889	BOLT, WITH WASHER	4	4	4	
12	93306-27211	BEARING	1	1	1	
13	6EX-G5538-00	SPACER 1	1	1	1	
14	93306-205U0	BEARING	1	1	1	
15	6EX-45514-00	SHAFT, DRIVE 4	1	1	1	
16	93101-21001	OIL SEAL	1	1	1	
17	93101-21002	OIL SEAL	1	1	1	
18	6EX-R1326-00	CAP	1	1	1	
19	93210-464A3	O-RING	2	2	2	
20	90110-06822	BOLT, HEXAGON SOCKET HEAD	3	3	3	
21	6D3-R1319-00	CAP, IMPELLER	1	1	1	
22	6D3-R1321-02	IMPELLER	1	1	1	
23	6EX-R1318-00	NOZZLE	1	1	1	
24	6CN-U72M2-00	HOSE 1	1	1	1	
25	90601-118UF	BAND, HOSE 18	1	1	1	
26	90445-14807	HOSE (L355)	1	1	1	
27	90446-20MF5	HOSE (L320)	1	1	1	



F2X1100-P120

FIG. 12 JET UNIT 1

REF. NO.	PART NO.	DESCRIPTION	CAN	EUR	GENE	REMARKS
28	90465-11829	CLAMP	2	2	2	
29	93606-12019	PIN, DOWEL	2	2	2	
30	90119-10806	BOLT, WITH WASHER	4	4	4	
31	6EX-R1341-00	BRACKET 1	1	1	1	
32	6EX-R1313-00	NOZZLE, DEFLECTOR	1	1	1	
33	90119-08840	BOLT, WITH WASHER	2	2	2	
34	90387-08M06	COLLAR	2	2	2	
35	F2X-U72C0-00	SPACER	1	1	1	
36	F1S-U725E-01	WASHER	2	2	2	
37	90201-10801	WASHER, PLATE	2	2	2	
38	9572R-10300	NUT, NYLON	4	4	4	
39	F2X-U273B-00	PLATE 2	1	1	1	
40	90119-08823	BOLT, WITH WASHER	4	4	4	
41	F2X-U8572-00	BRACKET 2	1	1	1	
42	F2X-U8572-00	BRACKET 2	1	1	1	
43	F2S-U8577-00	BRACKET, 3	1	1	1	
44	90119-08823	BOLT, WITH WASHER	2	2	2	
45	90119-08823	BOLT, WITH WASHER	4	4	4	
46	F2X-U8571-00	BRACKET 1	1	1	1	
47	F2X-U8571-00	BRACKET 1	1	1	1	
48	F2C-U7557-01	BRACKET	1	1	1	
49	90109-08041	BOLT	2	2	2	
50	92990-12200	WASHER, PLAIN	2	2	2	
51	90430-12002	GASKET	2	2	2	
52	90119-089U7	BOLT, WITH WASHER	2	2	2	

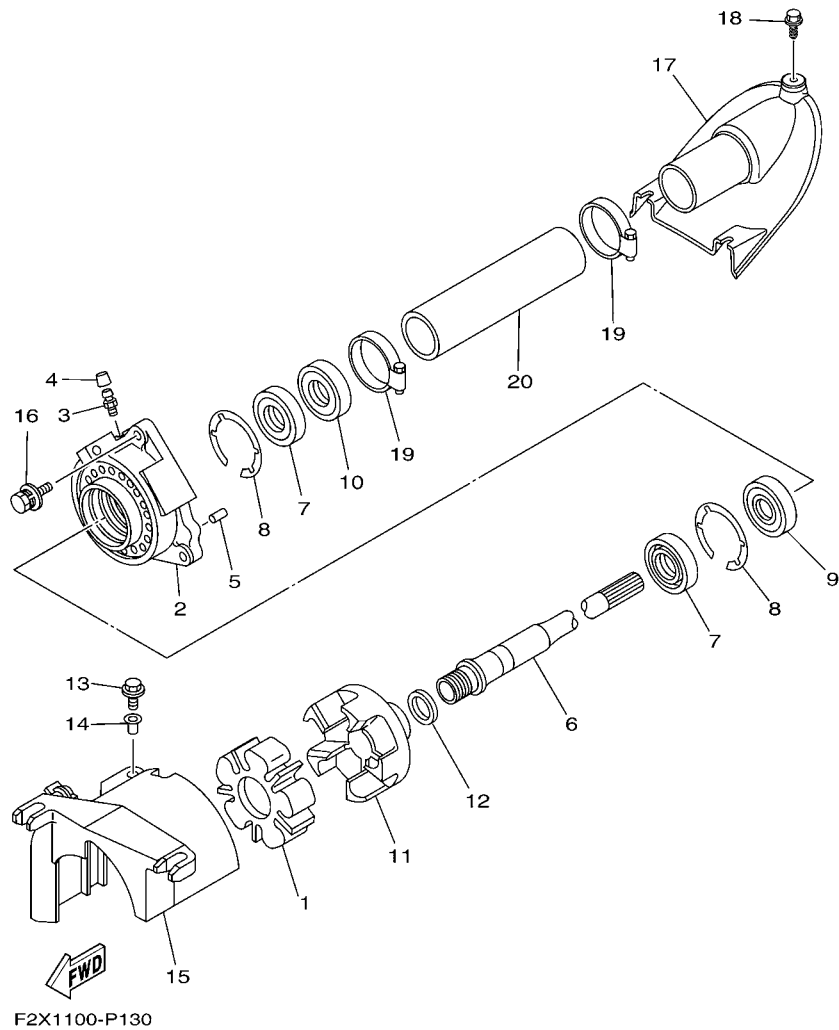
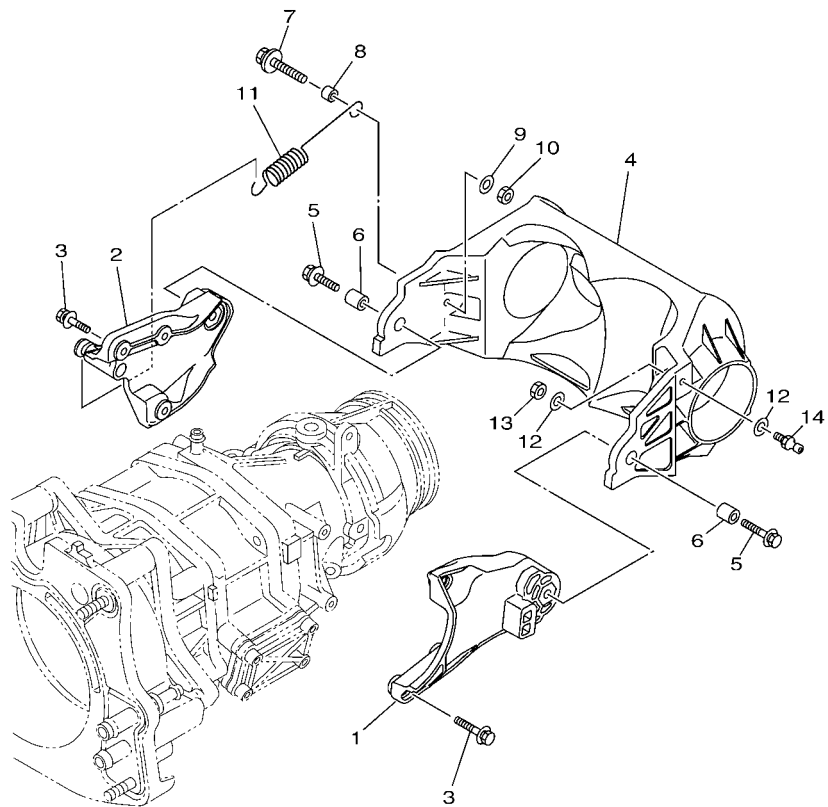

FIG. 13 JET UNIT 2

REF. NO.	PART NO.	DESCRIPTION	CAN	EUR	GENE	REMARKS
1	6D3-4581J-00	RUBBER SHAFT COUPLING	1	1	1	
2	61X-45332-03-94	HOUSING, BEARING	1	1	1	
3	93700-06M03	NIPPLE, GREASE	1	1	1	
4	663-45119-00	CAP, GREASE NIPPLE	1	1	1	
5	93606-12019	PIN, DOWEL	2	2	2	
6	6BU-45511-00	SHAFT, DRIVE	1	1	1	
7	93101-25M55	OIL SEAL	2	2	2	
8	93430-47M04	CIRCLIP	2	2	2	
9	93306-205A3	BEARING	1	1	1	
10	93102-25009	OIL SEAL	1	1	1	
11	6D3-45593-00-94	FLANGE, COUPLING 1	1	1	1	
12	90201-24800	WASHER, PLATE	1	1	1	
13	90119-06891	BOLT, WITH WASHER	1	1	1	
14	90387-06289	COLLAR	1	1	1	
15	60E-R1381-01	COVER	1	1	1	
16	90119-089UL	BOLT, WITH WASHER	3	3	3	
17	F2N-U883E-00	JOINT, PIPE	1	1	1	
18	90109-06832	BOLT	3	3	3	
19	90601-155U4	BAND, HOSE 55	2	2	2	
20	F2N-U883B-00	PIPE, 1	1	1	1	

FIG. 14 JET UNIT 3



 F3J7100-P170

REF. NO.	PART NO.	DESCRIPTION	CAN	EUR	GENE	REMARKS
1	6ET-R1341-00	BRACKET 1	1	1	1	
2	6ET-R1342-00	BRACKET 2	1	1	1	
3	90119-06891	BOLT, WITH WASHER	6	6	6	
4	6ET-R1314-01	GATE, REVERSE	1	1	1	
5	90119-08840	BOLT, WITH WASHER	2	2	2	
6	90387-08M30	COLLAR	2	2	2	
7	90119-069UX	BOLT, WITH WASHER	1	1	1	
8	90387-06M30	COLLAR	1	1	1	
9	90201-06801	WASHER, PLATE	1	1	1	
10	9538R-06600	NUT	1	1	1	
11	6S5-52358-00	SPRING, RETAINER	1	1	1	
12	90201-06801	WASHER, PLATE	2	2	2	
13	9538R-06600	NUT	1	1	1	
14	EU0-U1461-03	STUD, JOINT BALL	1	1	1	

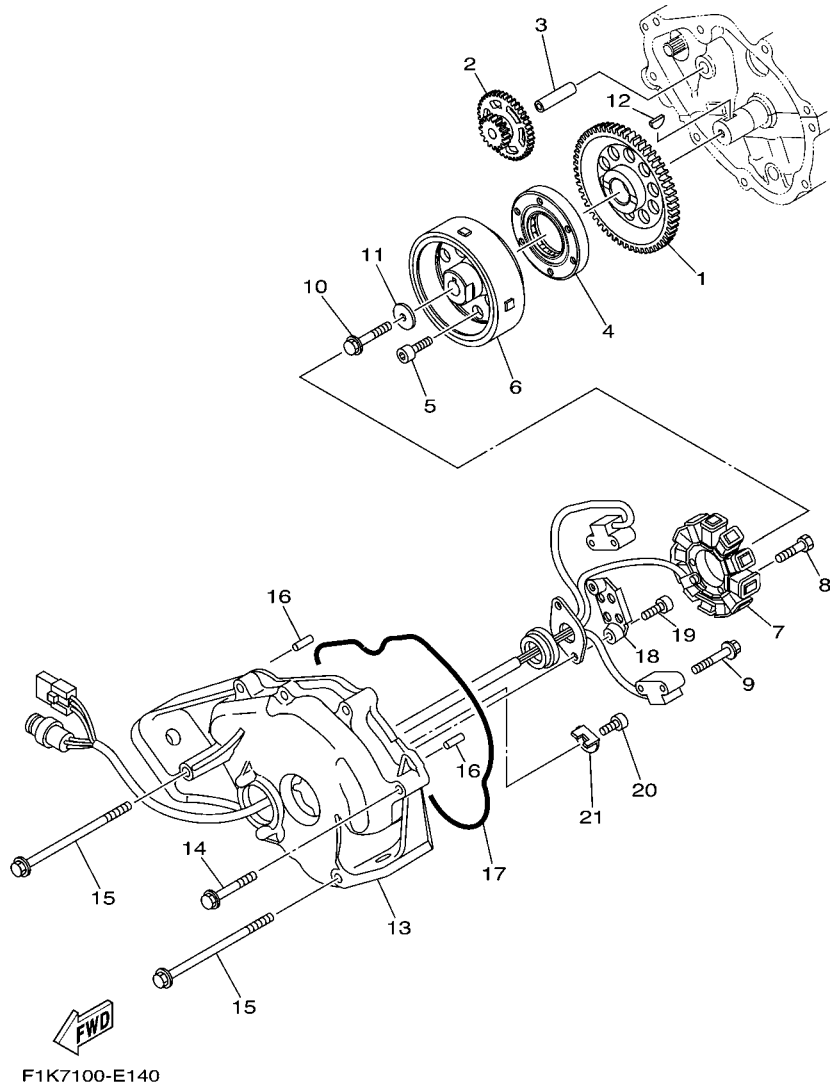
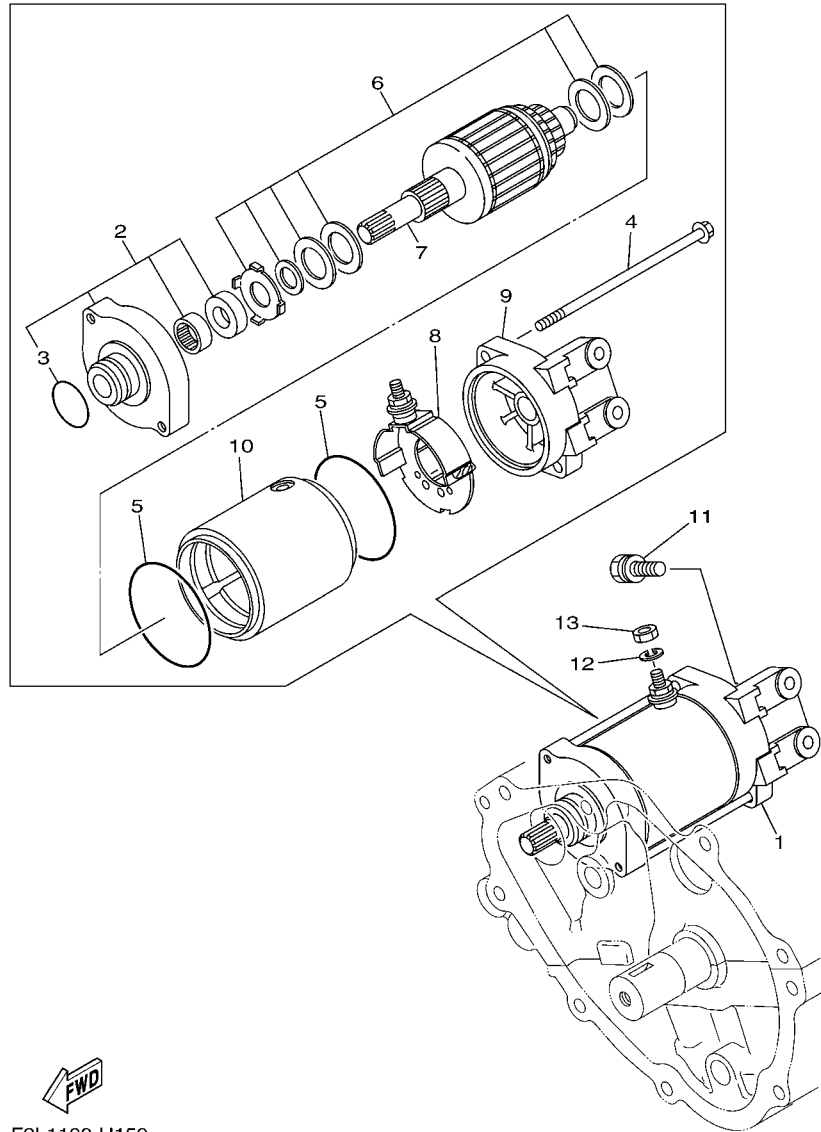

FIG. 15 GENERATOR

REF. NO.	PART NO.	DESCRIPTION	CAN	EUR	GENE	REMARKS
1	6D3-15515-00	GEAR 3	1	1	1	
2	60E-15517-00	GEAR, IDLER 2	1	1	1	
3	60E-15521-00	SHAFT 1	1	1	1	
4	4WM-15590-00	STARTER ONE-WAY ASSY	1	1	1	
5	90110-08212	BOLT, HEXAGON SOCKET HEAD	6	6	6	
6	6D3-81450-00	ROTOR ASSY	1	1	1	
7	6D3-81410-02	STATOR ASSY	1	1	1	
8	91317-06035	BOLT	3	3	3	
9	97513-05514	BOLT, WITH WASHER	2	2	2	
10	90105-105A6	BOLT, FLANGE	1	1	1	
11	90201-103U7	WASHER, PLATE	1	1	1	
12	90280-03047	KEY, WOODRUFF	1	1	1	
13	6D3-81337-00-94	COVER, FLYWHEEL	1	1	1	
14	90119-10016	BOLT, WITH WASHER	6	6	6	
15	90119-10M19	BOLT, WITH WASHER	2	2	2	
16	93608-16M16	PIN, DOWEL	2	2	2	
17	93212-04001	O-RING	1	1	1	
18	60E-81328-00	CLAMP	1	1	1	
19	91317-06014	BOLT	2	2	2	
20	91317-05010	BOLT	1	1	1	
21	6D3-81845-00	PLATE	1	1	1	



F2L1100-H150

FIG. 16 STARTING MOTOR

REF. NO.	PART NO.	DESCRIPTION	CAN	EUR	GENE	REMARKS
1	6D3-81800-00	STARTING MOTOR ASSY	1	1	1	
2	6M6-81830-00	.FRONT BRACKET ASSY	1	1	1	
3	1FK-81847-00	..O-RING	1	1	1	
4	6M6-81826-00	.BOLT	2	2	2	
5	11H-81844-00	.GASKET	2	2	2	
6	3AJ-81809-00	.WASHER KIT	1	1	1	
7	6M6-81850-00	.ARMATURE ASSY	1	1	1	
8	6M6-81840-10	.BRUSH HOLDER ASSY	1	1	1	
9	6D3-81820-00	.REAR BRACKET ASSY	1	1	1	
10	60E-81810-00	.STATOR ASSY	1	1	1	
11	97513-08530	BOLT, WITH WASHER	2	2	2	
12	92990-06100	WASHER, SPRING	1	1	1	
13	95380-06700	NUT	1	1	1	

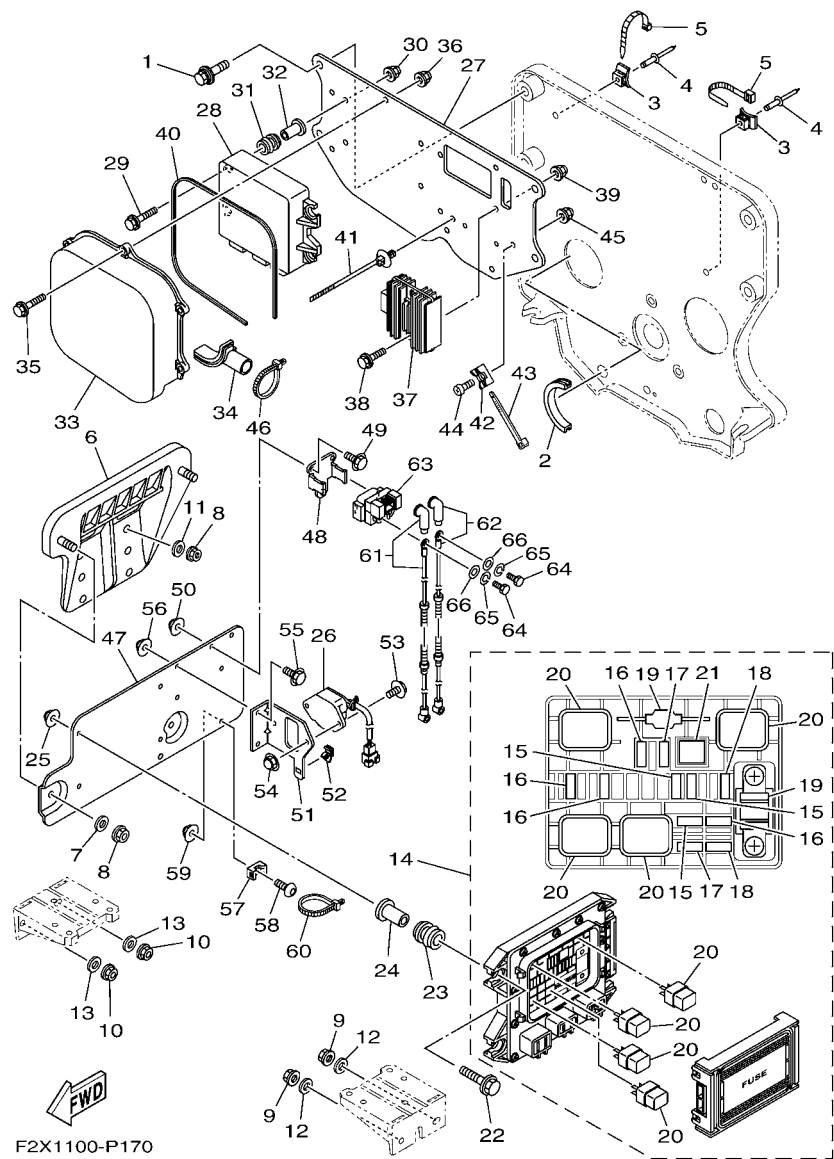

FIG. 17 ELECTRICAL 1

REF. NO.	PART NO.	DESCRIPTION	CAN	EUR	GENE	REMARKS
1	90119-089U7	BOLT, WITH WASHER	4	4	4	
2	F1S-U828H-01	TRIM, 1	1	1	1	
3	F1W-U828M-00	BASE, CLAMP	2	2	2	
4	90267-48802	RIVET, BLIND	2	2	2	
5	90464-32801	CLAMP	2	2	2	
6	F2N-U815D-01	BRACKET, ELECTRIC BOX	1	1	1	
7	90201-099U3	WASHER, PLATE	2	2	2	
8	9572R-08300	NUT, FLANGE	6	6	6	
9	9572R-08300	NUT, FLANGE	2	2	2	
10	9572R-08300	NUT, FLANGE	2	2	2	
11	9299R-08200	WASHER	4	4	4	
12	9299R-08200	WASHER	2	2	2	
13	9299R-08200	WASHER	2	2	2	
14	6EX-82170-00	FUSE BOX ASSY	1	1	1	
15	67F-82151-30	.FUSE (3A)	3	3	3	
16	67F-82151-40	.FUSE (10A)	4	4	4	
17	67F-82151-00	.FUSE (20A)	2	2	2	
18	67F-82151-10	.FUSE (30A)	2	2	2	
19	6EX-82151-00	.FUSE (50A)	2	2	2	
20	6EX-8195A-00	.RELAY ASSY	4	4	4	
21	6EX-2812A-00	.PULLER, FUSE	1	1	1	
22	95814-06025	BOLT, FLANGE	4	4	4	
23	6A0-82317-00	DAMPER, IGNITION COIL	4	4	4	
24	90387-06119	COLLAR	4	4	4	
25	90176-06047	NUT,CAP	4	4	4	
26	60E-8259E-00	SWITCH ASSY	1	1	1	
27	6BU-81845-00	PLATE	1	1	1	

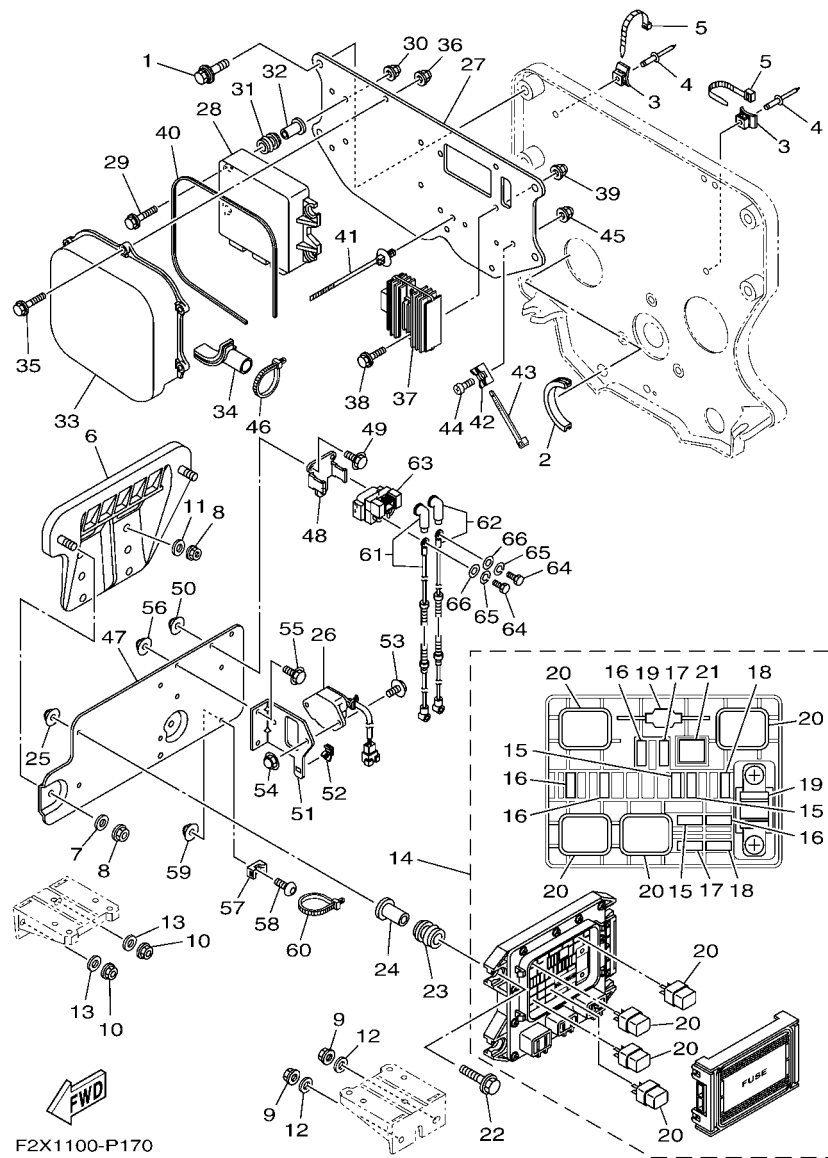
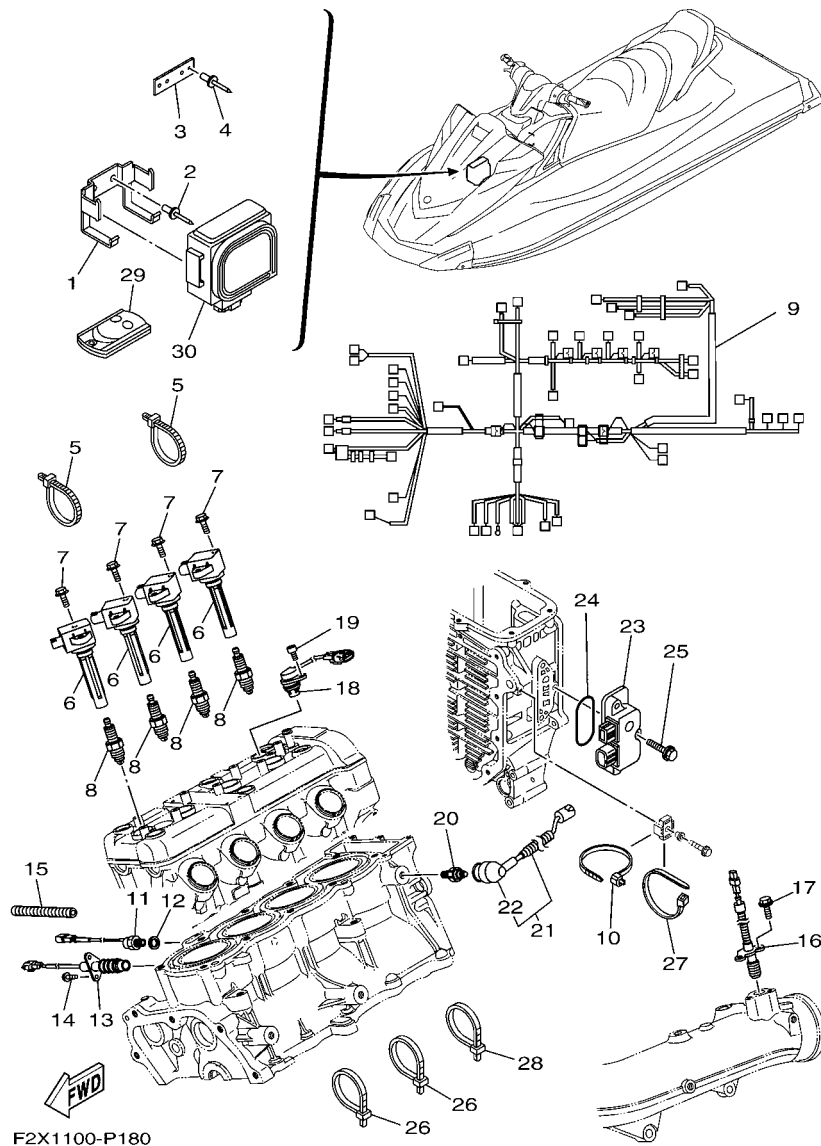

FIG. 17 ELECTRICAL 1

REF. NO.	PART NO.	DESCRIPTION	CAN	EUR	GENE	REMARKS
28	6EX-8591A-A0	ENGINE CONTROL UNIT ASSY	1		1	FOR CAN, GENE
	6EX-8591A-B0	ENGINE CONTROL UNIT ASSY		1		FOR EUR
29	95814-06025	BOLT, FLANGE	4	4	4	
30	90176-06047	NUT,CAP	4	4	4	
31	6A0-82317-00	DAMPER, IGNITION COIL	4	4	4	
32	90387-06119	COLLAR	4	4	4	
33	6BU-81639-00	COVER	1	1	1	
34	6BU-81336-00	GROMMET	1	1	1	
35	95814-06020	BOLT, FLANGE	5	5	5	
36	90176-06047	NUT,CAP	5	5	5	
37	6S8-81960-00	RECTIFIER & REGULATOR ASSY	1	1	1	
38	95814-06020	BOLT, FLANGE	2	2	2	
39	90176-06047	NUT,CAP	2	2	2	
40	6BU-81861-00	GASKET	1	1	1	
41	90464-31001	CLAMP	1	1	1	
42	60E-1244E-00	BRACKET 1	1	1	1	
43	90465-13M24	CLAMP	1	1	1	
44	92014-06012	BOLT, BUTTON HEAD	1	1	1	
45	90176-06047	NUT,CAP	1	1	1	
46	90465-13M18	CLAMP	1	1	1	
47	6EX-81845-00	PLATE	1	1	1	
48	6EX-81953-00	STAY, RELAY	1	1	1	
49	95814-06012	BOLT, FLANGE	3	3	3	
50	90176-06047	NUT,CAP	3	3	3	
51	6EX-82588-00	PLATE	1	1	1	
52	90464-09M47	CLAMP	1	1	1	
53	95814-06012	BOLT, FLANGE	2	2	2	



F2X1100-P180

FIG. 18 ELECTRICAL 2

REF. NO.	PART NO.	DESCRIPTION	CAN	EUR	GENE	REMARKS
1	F1W-U826C-00	BRACKET	1	1	1	
2	90267-489U1	RIVET,BLIND	2	2	2	
3	F1W-U8376-00	PLATE	1	1	1	
4	90267-489U1	RIVET,BLIND	2	2	2	
5	90464-35132	CLAMP	2	2	2	
6	6EX-82310-00	IGNITION COIL ASSY	4	4	4	
7	95880-06016	BOLT, FLANGE	8	8	8	
8	94702-00409	PLUG, SPARK (NGK CR9EB)	4	4	4	
9	6EX-8259L-A0	WIRE HARNESS ASSY 1	1	1	1	
10	90465-13M24	CLAMP	1	1	1	
11	61A-85790-00	THERMOSENSOR ASSY	1	1	1	
12	92990-10600	WASHER, PLATE	1	1	1	
13	60E-82560-A1	THERMO SWITCH ASSY	1	1	1	
14	97595-06416	BOLT, WITH WASHER	2	2	2	
15	90446-14M23	HOSE (L180)	1	1	1	
16	6D3-82560-01	THERMO SWITCH ASSY	1	1	1	
17	97595-06416	BOLT, WITH WASHER	2	2	2	
18	60E-85896-01	SENSOR, CAM POSITION	1	1	1	
19	91380-06016	BOLT	1	1	1	
20	68V-82504-00	OIL PRESSURE SWITCH ASSY	1	1	1	
21	60E-81315-00	LEAD WIRE ASSY	1	1	1	
22	60E-82532-00	.CAP	1	1	1	
23	6D3-8273J-01	EARTH PLATE COMP.	1	1	1	
24	93210-60ME8	O-RING	1	1	1	
25	90119-06048	BOLT, WITH WASHER	3	3	3	
26	90465-13M18	CLAMP	2	2	2	
27	90465-13152	CLAMP	1	1	1	

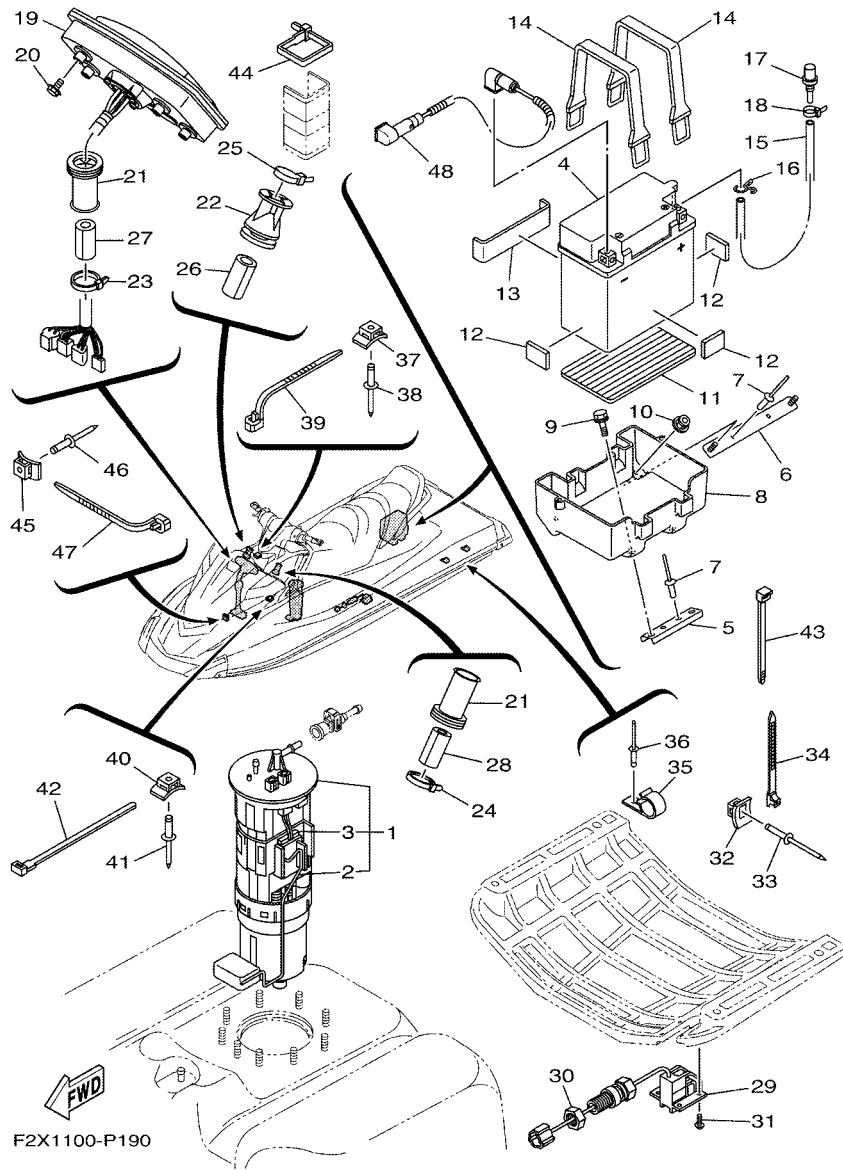

FIG. 19 ELECTRICAL 3

REF. NO.	PART NO.	DESCRIPTION	CAN	EUR	GENE	REMARKS
1	60E-13907-03	FUEL PUMP COMP.	1	1	1	
2	60E-682E0-00	.FUEL SENDER ASSY	1	1	1	
3	60E-82556-00	.DAMPER, STOPPER	1	1	1	
4	EU0-U8217-H2	BATTERY (YB16CL-B)	1	1	1	
5	F2S-U8592-00	PLATE, BASE 2	1	1	1	
6	F2S-U8593-00	PLATE, BASE 3	1	1	1	
7	90267-489U1	RIVET,BLIND	4	4	4	
8	F2S-U8211-00	CASE, BATTERY	1	1	1	
9	90119-06832	BOLT, WITH WASHER	2	2	2	
10	F2N-U142L-00	NUT, LOCK	2	2	2	
11	F1S-U8221-00	PAD, BATTERY	1	1	1	
12	EU0-U8221-30	PAD, BATTERY 2	3	3	3	
13	F1K-U8221-00	PAD, BATTERY	1	1	1	
14	EU0-U821D-00	BAND,BATTERY 1	2	2	2	
15	F0D-U785G-10	HOSE, AIR VENT	1	1	1	
16	90467-089U1	CLIP	1	1	1	
17	GJ3-6215F-00	NIPPLE	1	1	1	
18	90465-11829	CLAMP	1	1	1	
19	F2X-6820A-00	METER ASSY	1	1	1	
20	90119-05803	BOLT, WITH WASHER	4	4	4	
21	GU2-6822E-01	GROMMET	2	2	2	
22	F3J-U822E-00	GROMMET	1	1	1	
23	90464-32801	CLAMP	1	1	1	
24	90464-32801	CLAMP	1	1	1	
25	90464-32801	CLAMP	1	1	1	
26	GJ1-U7578-21	PACKING, HOSE 2	1	1	1	
27	GJ1-U7578-11	PACKING, HOSE 2	1	1	1	

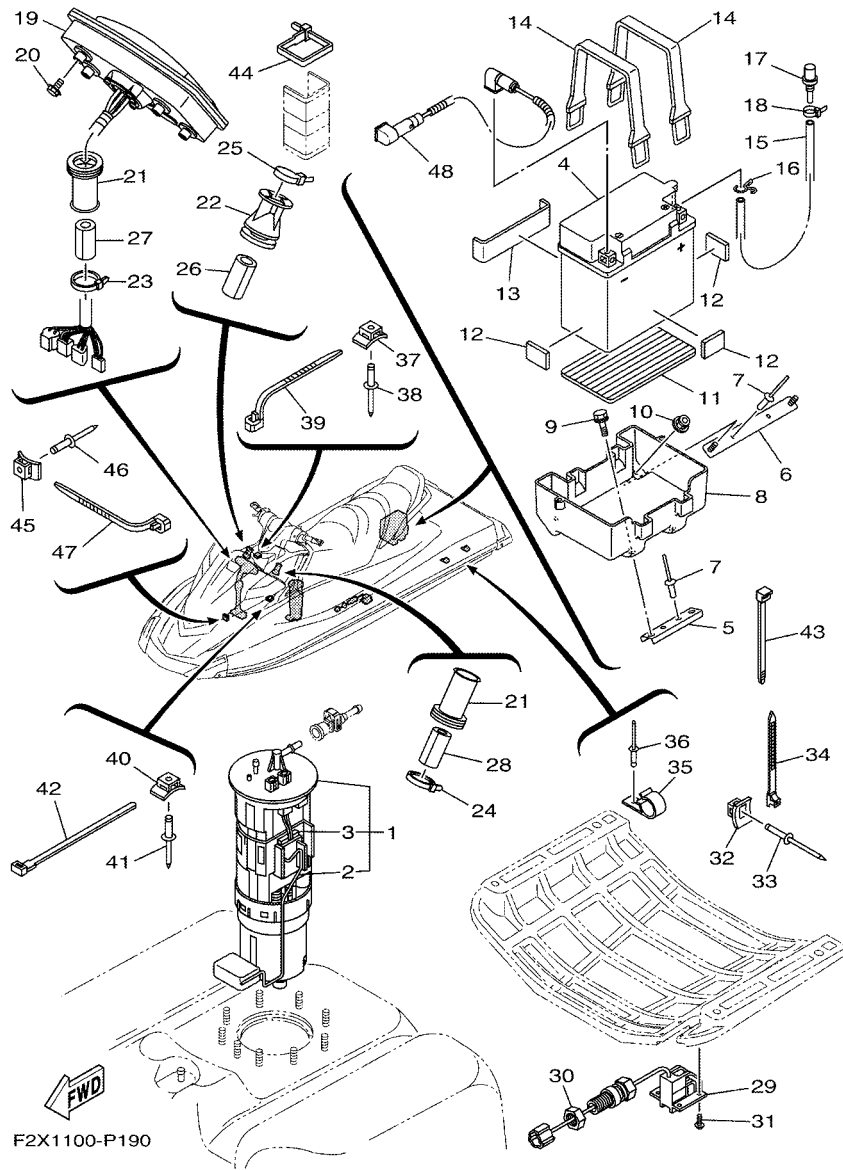
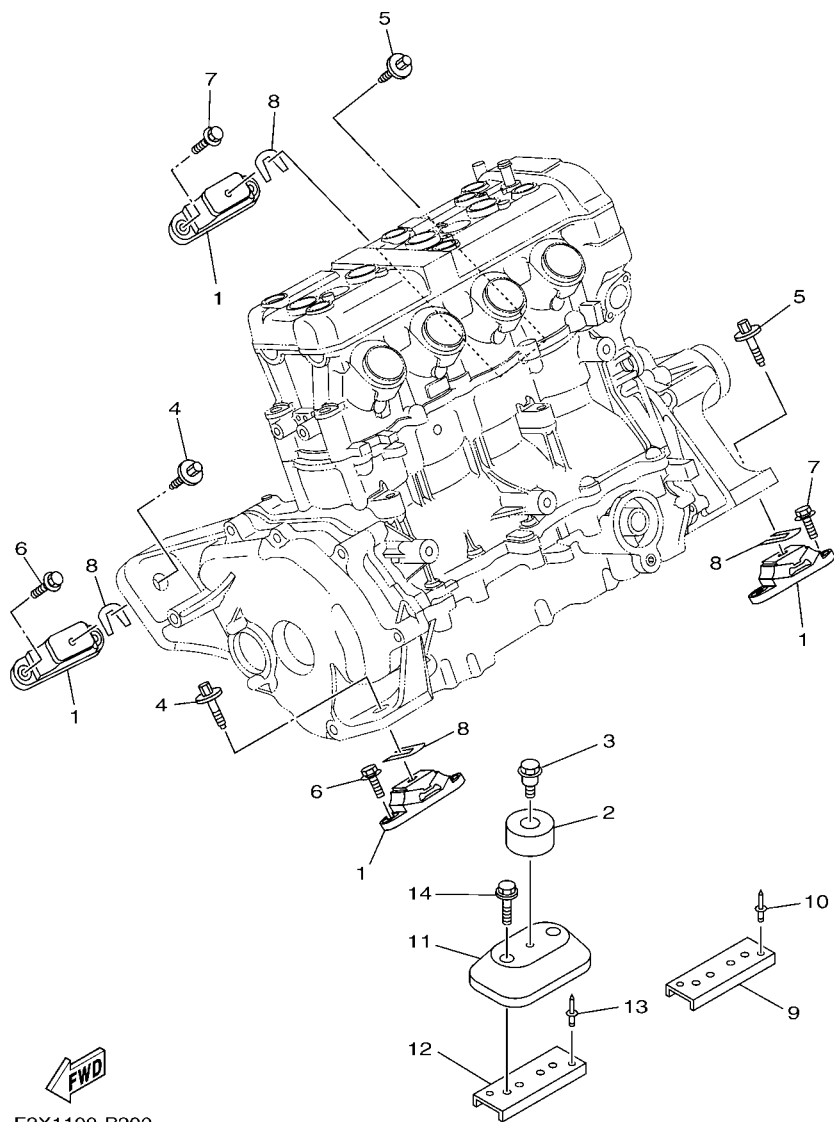

FIG. 19 ELECTRICAL 3

REF. NO.	PART NO.	DESCRIPTION	CAN	EUR	GENE	REMARKS
28	GJ1-U7578-11	PACKING, HOSE 2	1	1	1	
29	F1S-U8K31-02	SENSOR SPEED	1	1	1	
30	F2C-U151S-00	NUT	1	1	1	
31	90150-05807	SCREW, ROUND HEAD	4	4	4	
32	F1W-U828M-00	BASE, CLAMP	8	8	8	
33	90267-489U6	RIVET, BLIND	8	8	8	
34	90464-32801	CLAMP	8	8	8	
35	F3J-U8368-01	CLAMP	2	2	2	
36	90267-409U5	RIVET, BLIND	2	2	2	
37	F1W-U828M-00	BASE, CLAMP	3	3	3	
38	90267-489U6	RIVET, BLIND	3	3	3	
39	90464-32801	CLAMP	3	3	3	
40	F1W-U828M-00	BASE, CLAMP	1	1	1	
41	90267-489U6	RIVET, BLIND	1	1	1	
42	90601-200U2	BAND	1	1	1	
43	F2C-U4256-00	CLAMP	1	1	1	
44	90601-200U2	BAND	1	1	1	
45	F1W-U828M-00	BASE, CLAMP	1	1	1	
46	90267-48803	RIVET, BLIND	1	1	1	
47	90464-32801	CLAMP	1	1	1	
48	6BU-82116-00	WIRE, MINUS LEAD	1	1	1	

FIG. 20 ENGINE MOUNT



F2X1100-P200

REF. NO.	PART NO.	DESCRIPTION	CAN	EUR	GENE	REMARKS
1	67X-44517-10	MOUNT RUBBER	4	4	4	
2	6D3-44574-00	STOPPER, LOWER MOUNT RUBBER	1	1	1	
3	90109-06M92	BOLT	1	1	1	
4	90119-08859	BOLT, WITH WASHER	2	2	2	
5	90119-08859	BOLT, WITH WASHER	2	2	2	
6	90119-08823	BOLT, WITH WASHER	4	4	4	
7	90119-08823	BOLT, WITH WASHER	4	4	4	
8	EU0-U7354-00-01	SHIM (T=0.1)	4	4	4	UN
	EU0-U7354-00-03	SHIM (T=0.3)	4	4	4	UN
	EU0-U7354-00-05	SHIM (T=0.5)	4	4	4	UN
	EU0-U7354-00-10	SHIM (T=1.0)	4	4	4	UN
	EU0-U7354-00-20	SHIM (T=2.0)	4	4	4	UN
9	F2S-U732B-00	PLATE	2	2	2	
10	90267-489U2	RIVET, BLIND	4	4	4	
11	F2N-U721B-00	SPACER, ENGINE MOUNT	1	1	1	
12	F2N-U732B-10	PLATE	1	1	1	
13	90267-489U2	RIVET, BLIND	2	2	2	
14	90119-06891	BOLT, WITH WASHER	2	2	2	

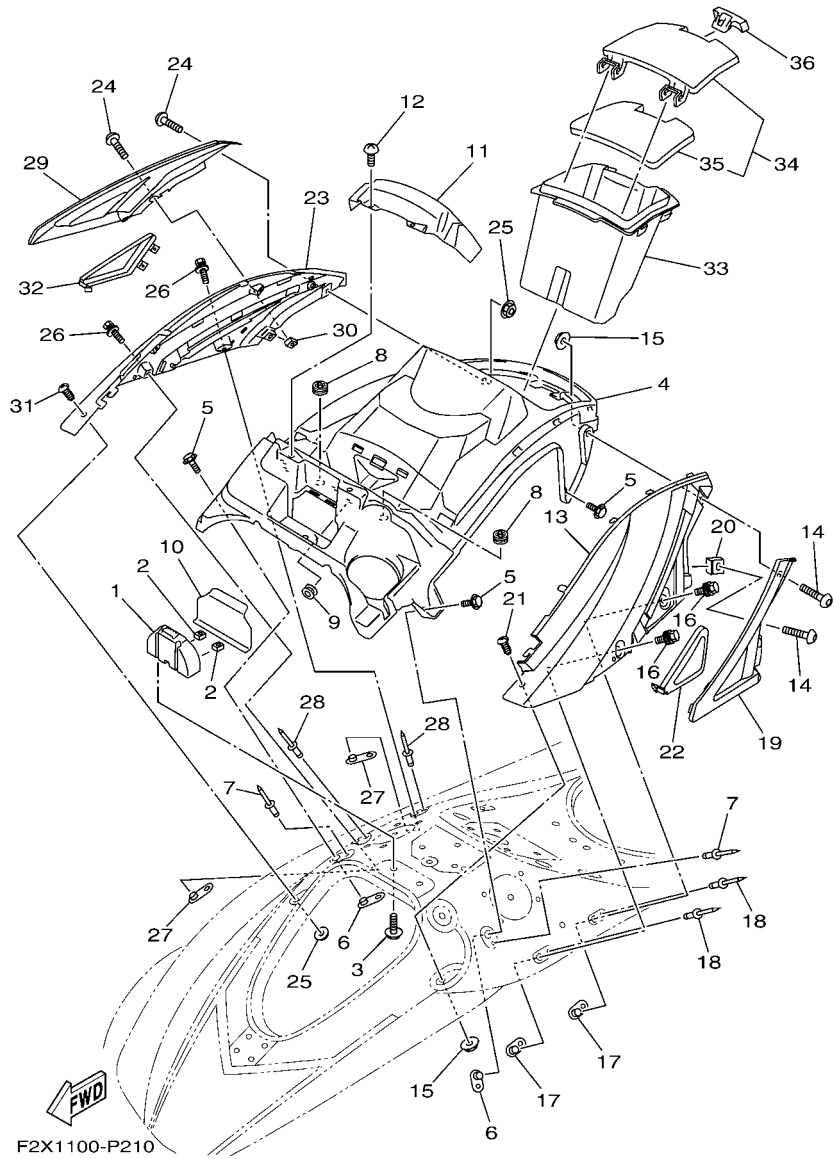

F2X1100-P210

FIG. 21 ENGINE HATCH 1

REF. NO.	PART NO.	DESCRIPTION	CAN	EUR	GENE	REMARKS
1	F2X-U517F-00	HOOK,LID LOCK	1	1	1	
2	F2X-U517E-00	NUT	2	2	2	
3	90119-06880	BOLT, WITH WASHER	2	2	2	
4	F2X-U5554-00	COVER, CENTER	1	1	1	
5	90119-06882	BOLT, WITH WASHER	4	4	4	
6	F2X-U5175-00	PLATE, FIX	2	2	2	
7	90267-48802	RIVET, BLIND	2	2	2	
8	F1X-U828E-01	DAMPER 1	2	2	2	
9	90480-19800	GROMMET	4	4	4	
10	F2X-U555B-00	SEAL, COVER CENTER	1	1	1	
11	F2X-U8262-00	COVER METER	1	1	1	
12	F2S-U13C1-00	SCREW	2	2	2	
13	F2X-U377B-00-P0	COVER,SIDE 1 (DPBM11)	1	1	1	CRUISER BLUE
	F2X-U377B-00-P2	COVER,SIDE 1 (PURW)	1	1	1	CRUISER WHITE
	F2X-U377B-00-P3	COVER,SIDE 1 (LNMP)	1	1	1	DELUXE GRAY
	F2X-U377B-00-P4	COVER,SIDE 1 (BMG)	1	1	1	DELUXE BLACK
14	90111-06803	BOLT,HEX. SOCKET BUTTON	2	2	2	
15	F2N-U142L-00	NUT, LOCK	2	2	2	
16	90119-06882	BOLT, WITH WASHER	2	2	2	
17	F2X-U5175-00	PLATE, FIX	2	2	2	
18	90267-48802	RIVET, BLIND	2	2	2	
19	F2X-U377F-00	ORNAMENT, SIDE LH	1	1	1	
20	F2X-U517E-00	NUT	1	1	1	
21	F2N-67823-10	SCREW	1	1	1	
22	F2X-U377H-00	INNER, COVER SIDE 1	1	1	1	
23	F2X-U377C-00-P0	COVER,SIDE 2 (DPBM11)	1	1	1	CRUISER BLUE
	F2X-U377C-00-P2	COVER,SIDE 2 (PURW)	1	1	1	CRUISER WHITE

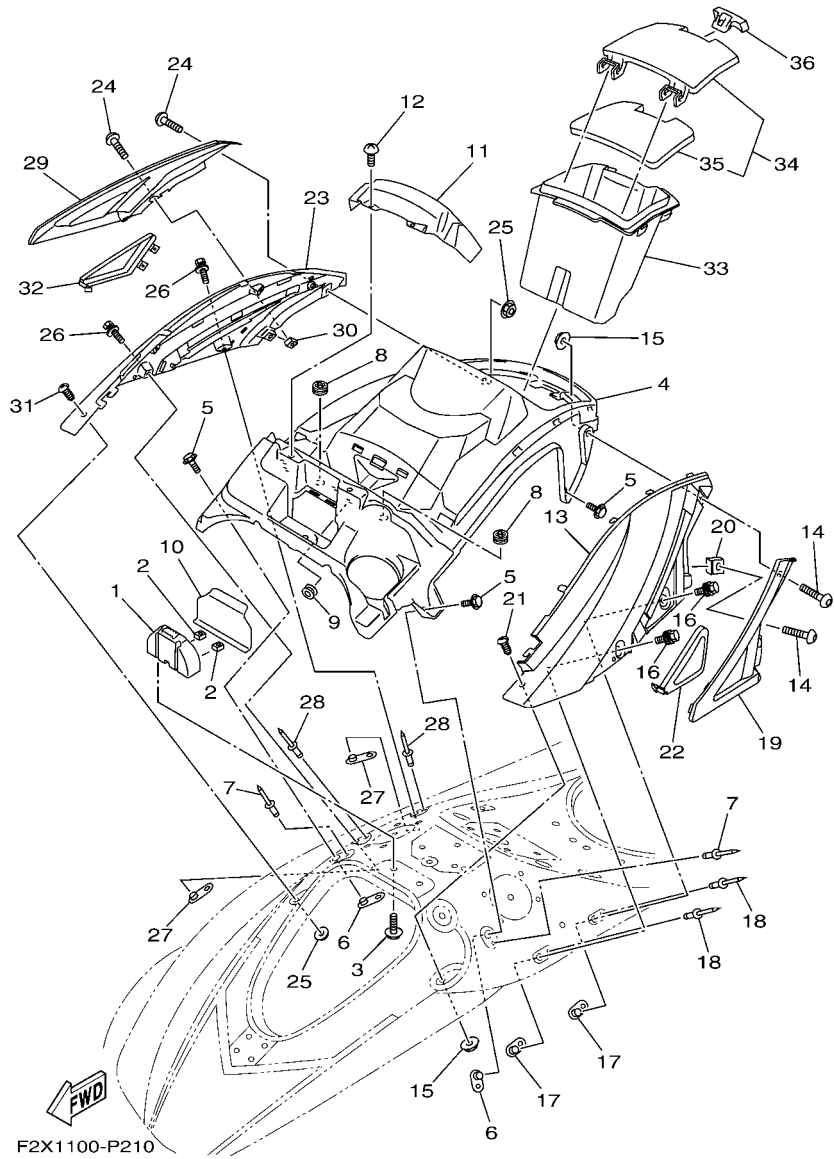

FIG. 21 ENGINE HATCH 1

REF. NO.	PART NO.	DESCRIPTION	CAN	EUR	GENE	REMARKS
23	F2X-U377C-00-P3	COVER,SIDE 2 (LNMP)	1	1	1	DELUXE GRAY
	F2X-U377C-00-P4	COVER,SIDE 2 (BMG)	1	1	1	DELUXE BLACK
24	90111-06803	BOLT,HEX. SOCKET BUTTON	2	2	2	
25	F2N-U142L-00	NUT, LOCK	2	2	2	
26	90119-06882	BOLT, WITH WASHER	2	2	2	
27	F2X-U5175-00	PLATE, FIX	2	2	2	
28	90267-48802	RIVET, BLIND	2	2	2	
29	F2X-U377G-00	ORNAMENT, SIDE RH	1	1	1	
30	F2X-U517E-00	NUT	1	1	1	
31	F2N-67823-10	SCREW	1	1	1	
32	F2X-U377J-00	INNER, COVER SIDE 2	1	1	1	
33	F2X-U516P-00	BOX GLOVE	1	1	1	
34	F2X-U1708-00	GLOVE BOX HATCH ASSY.	1	1	1	
35	F2X-U519D-00	.PACKING CASE	1	1	1	
36	F2X-U2875-00	LOCK	1	1	1	

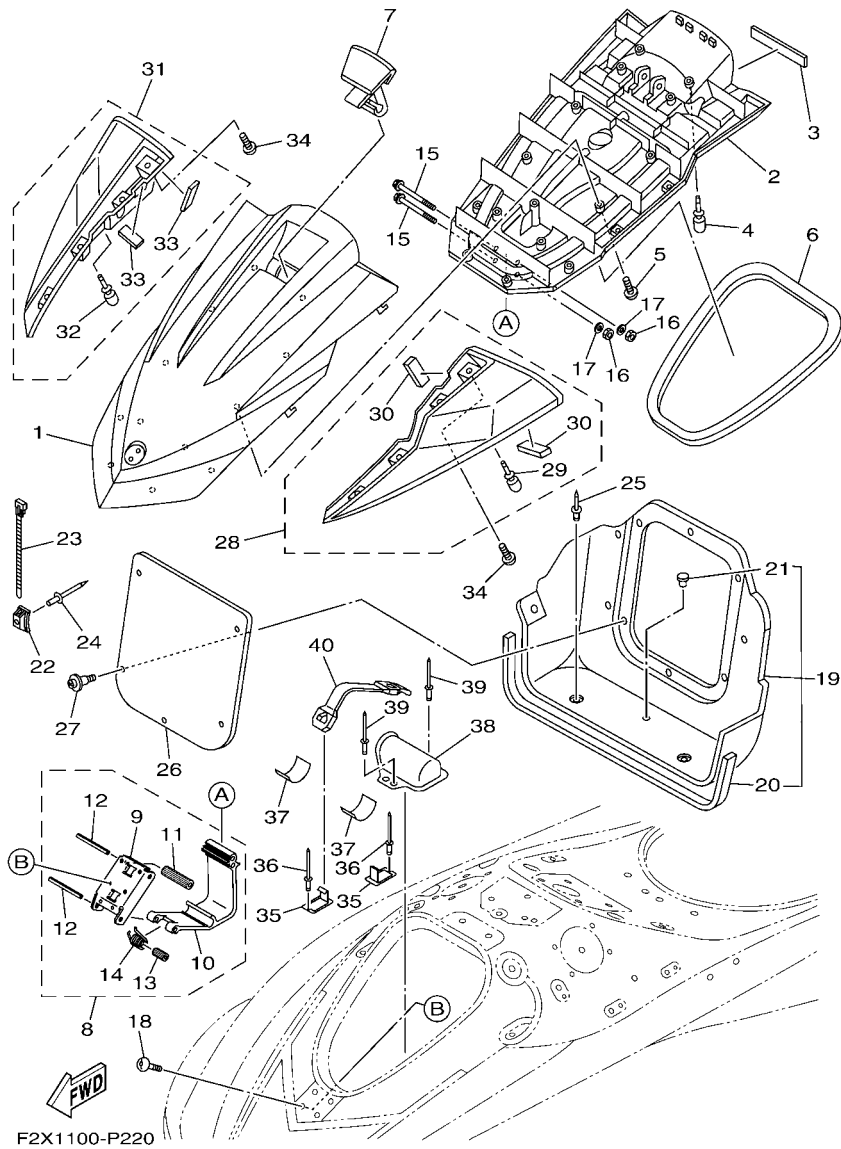

FIG. 22 ENGINE HATCH 2

REF. NO.	PART NO.	DESCRIPTION	CAN	EUR	GENE	REMARKS
1	F2X-U517B-00-P0	LID, ENGINE ROOM (DPBM11)	1	1	1	CRUISER BLUE
	F2X-U517B-00-P2	LID, ENGINE ROOM (PURW)	1	1	1	CRUISER WHITE
	F2X-U517B-00-P3	LID, ENGINE ROOM (LNMP)	1	1	1	DELUXE GRAY
	F2X-U517B-00-P4	LID, ENGINE ROOM (BMG)	1	1	1	DELUXE BLACK
2	F2X-U519G-00	INNER, ENGINE HATCH	1	1	1	
3	F2C-U515D-00	DAMPER 1	1	1	1	
4	F1W-U3768-01	CUSHION, RUBBER	2	2	2	
5	F2S-U13C1-00	SCREW	15	15	15	
6	F2N-U2663-01	PACKING 1	1	1	1	
7	F2X-U517C-01	LOCK, LID	1	1	1	
8	F2X-U515A-00	HINGE ASSY.	1	1	1	
9	F1K-U518E-04	.PLATE, HINGE LID	1	1	1	
10	F1K-U517D-05	.HINGE, LID	1	1	1	
11	F2X-U135C-00	.ROLLER, DETENT	1	1	1	
12	F1K-U517R-00	.PIN, HINGE	2	2	2	
13	F1K-U471E-03	.SPACER 1	1	1	1	
14	F1K-U283B-02	.SPRING, TORSION	1	1	1	
15	90105-06826	BOLT, FLANGE	2	2	2	
16	9572R-06300	NUT, NYLON	2	2	2	
17	9299R-06200	WASHER	2	2	2	
18	F2N-67823-00	SCREW	4	4	4	
19	F2X-U475B-00	LOCKER,BOW	1	1	1	
20	F2N-U266C-01	.PACKING 4	1	1	1	
21	90605-502U1	.PLUG, BLIND	1	1	1	
22	F1W-U828M-00	BASE, CLAMP	1	1	1	
23	90267-48803	RIVET, BLIND	1	1	1	
24	90464-32801	CLAMP	1	1	1	

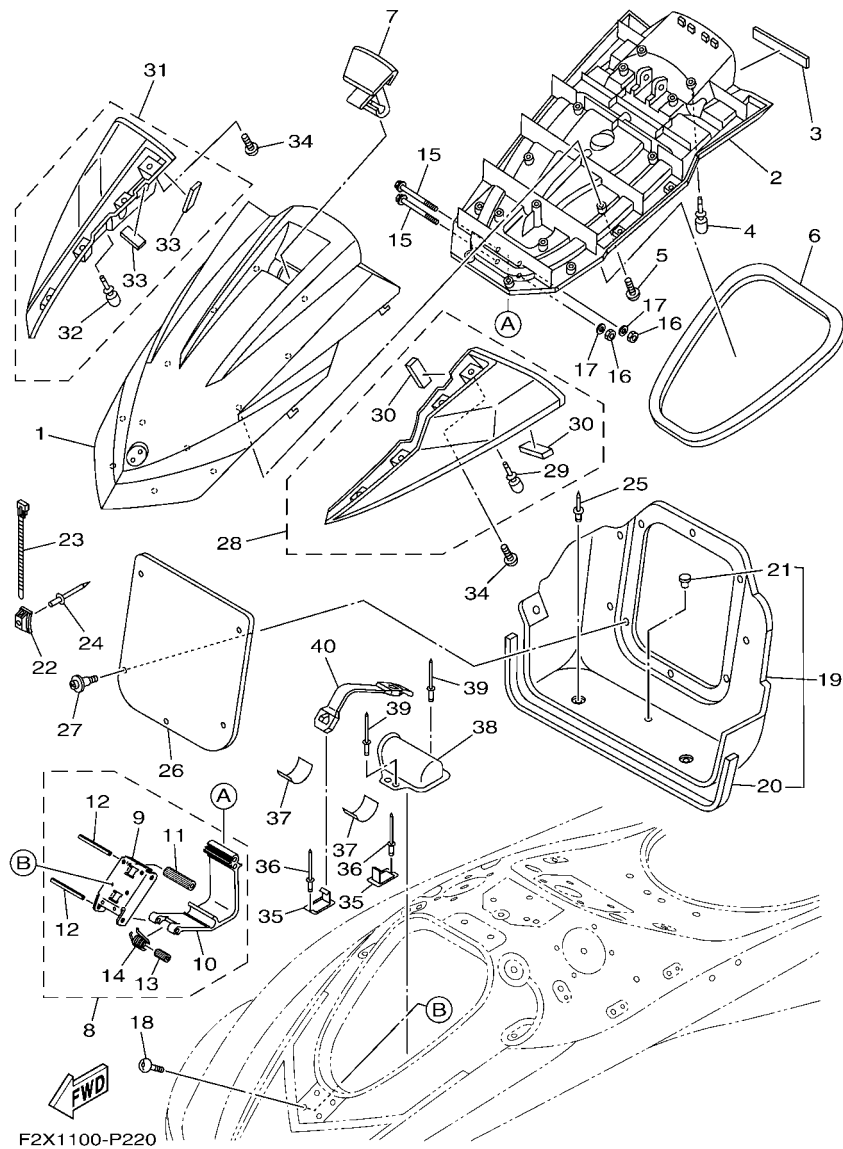

FIG. 22 ENGINE HATCH 2

REF. NO.	PART NO.	DESCRIPTION	CAN	EUR	GENE	REMARKS
25	90269-08801	RIVET	4	4	4	
26	F2S-U475F-00	PLATE, LOKER BOW	1	1	1	
27	90269-08801	RIVET	5	5	5	
28	F2X-U590D-10	MIRROR ASSY. 1	1	1	1	CRUISER BLUE
	F2X-U590D-30	MIRROR ASSY. 1	1	1	1	CRUISER WHITE
	F2X-U590D-50	MIRROR ASSY. 1	1	1	1	DELUXE GRAY
	F2X-U590D-10	MIRROR ASSY. 1	1	1	1	DELUXE BLACK
29	F1W-U3768-01	.CUSHION, RUBBER	1	1	1	
30	F1K-U266B-00	.PACKING 3	2	2	2	
31	F2X-U590E-10	MIRROR ASSY. 2	1	1	1	CRUISER BLUE
	F2X-U590E-30	MIRROR ASSY. 2	1	1	1	CRUISER WHITE
	F2X-U590E-50	MIRROR ASSY. 2	1	1	1	DELUXE GRAY
	F2X-U590E-10	MIRROR ASSY. 2	1	1	1	DELUXE BLACK
32	F1W-U3768-01	.CUSHION, RUBBER	1	1	1	
33	F1K-U266B-00	.PACKING 3	2	2	2	
34	F2X-U13C1-00	SCREW	8	8	8	
35	F1K-U5772-04	HOOK A	2	2	2	
36	90267-489U1	RIVET,BLIND	2	2	2	
37	F1K-U759C-00	MAT 2	2	2	2	
38	F2X-U5983-00	BOX, FIRE EXTINGUISHER	1	1	1	
39	90267-48802	RIVET, BLIND	2	2	2	
40	F2P-U828K-00	BAND 1	1	1	1	

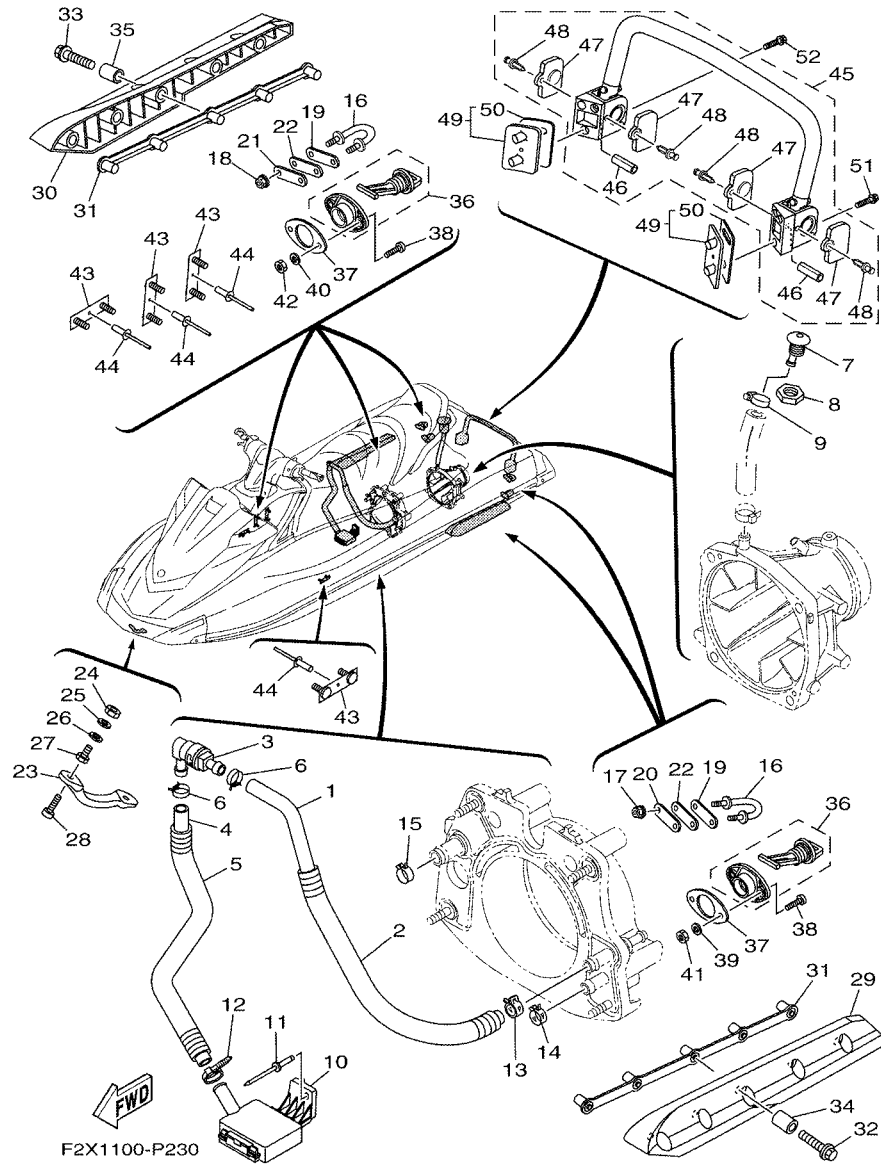

FIG. 23 HULL & DECK

REF. NO.	PART NO.	DESCRIPTION	CAN	EUR	GENE	REMARKS
1	90445-20804	HOSE (L860)	1	1	1	
2	6EX-U773E-00	TUBE,2	1	1	1	
3	68N-5112T-00	JOINT, HOSE	1	1	1	
4	90445-20800	HOSE (L500)	1	1	1	
5	6EX-U773D-00	TUBE	1	1	1	
6	90467-18804	CLIP	2	2	2	
7	F1W-U269B-00	SPOUT	1	1	1	
8	EU0-61652-00	NUT	1	1	1	
9	90601-118UF	BAND, HOSE 18	1	1	1	
10	F1B-U761D-02	STRAINER, BILGE	1	1	1	
11	90267-489U8	RIVET, BLIND	1	1	1	
12	90465-11829	CLAMP	1	1	1	
13	90467-21800	CLIP	1	1	1	
14	90467-200A0	CLIP	1	1	1	
15	90467-210A0	CLIP	1	1		FOR CAN, GENE
	90467-26800	CLIP		1		FOR EUR
16	F2N-U1628-02	STERN EYE	2	2	2	
17	9572R-08300	NUT, FLANGE	2	2	2	
18	9572R-08300	NUT, FLANGE	2	2	2	
19	GP7-U4953-10	PLATE A	2	2	2	
20	GP7-U4953-10	PLATE A	1	1	1	
21	GP7-U4953-10	PLATE A	1	1	1	
22	F1B-U1653-02	PACKING	2	2	2	
23	F1K-61624-00	BOWEYE 1	1	1	1	
24	99780-12600	NUT.HEX.(COARS)	2	2	2	
25	92990-12200	WASHER, PLAIN	2	2	2	
26	F0X-61637-00	WASHER	2	2	2	

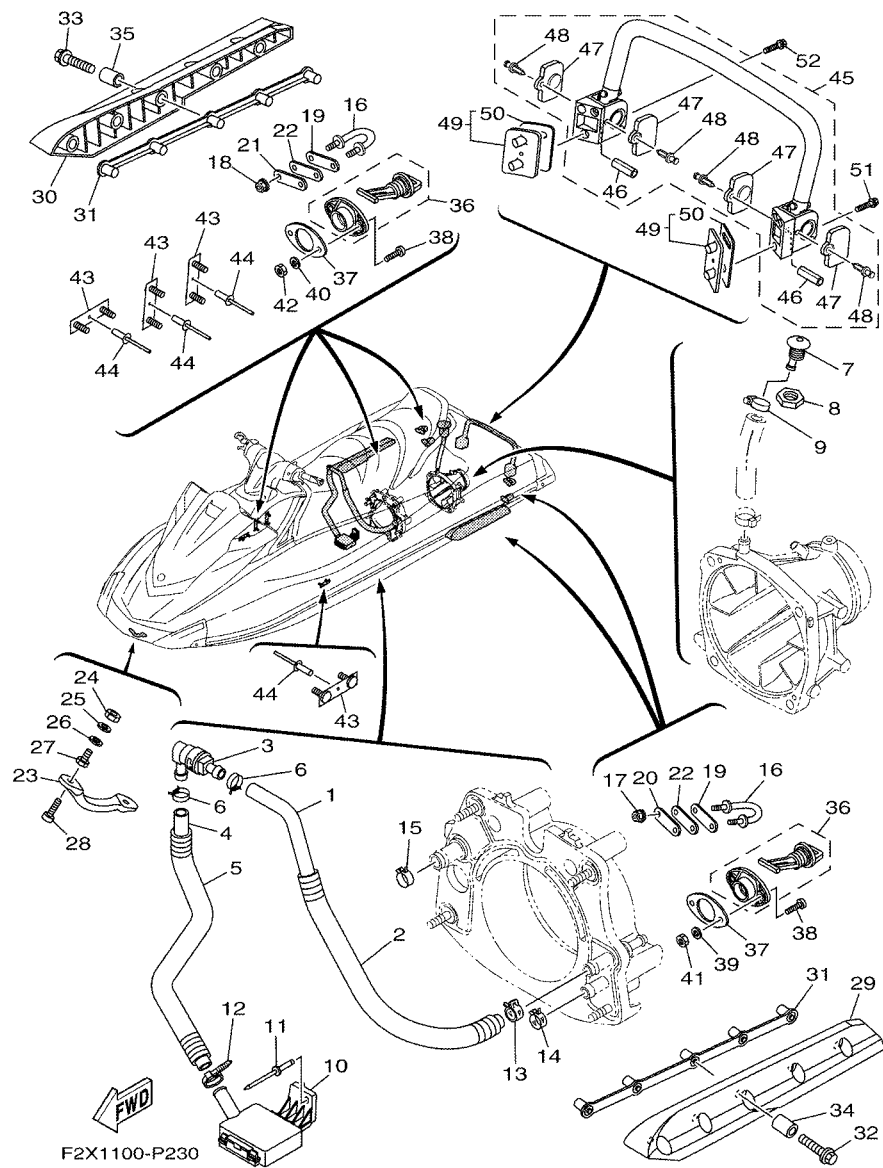
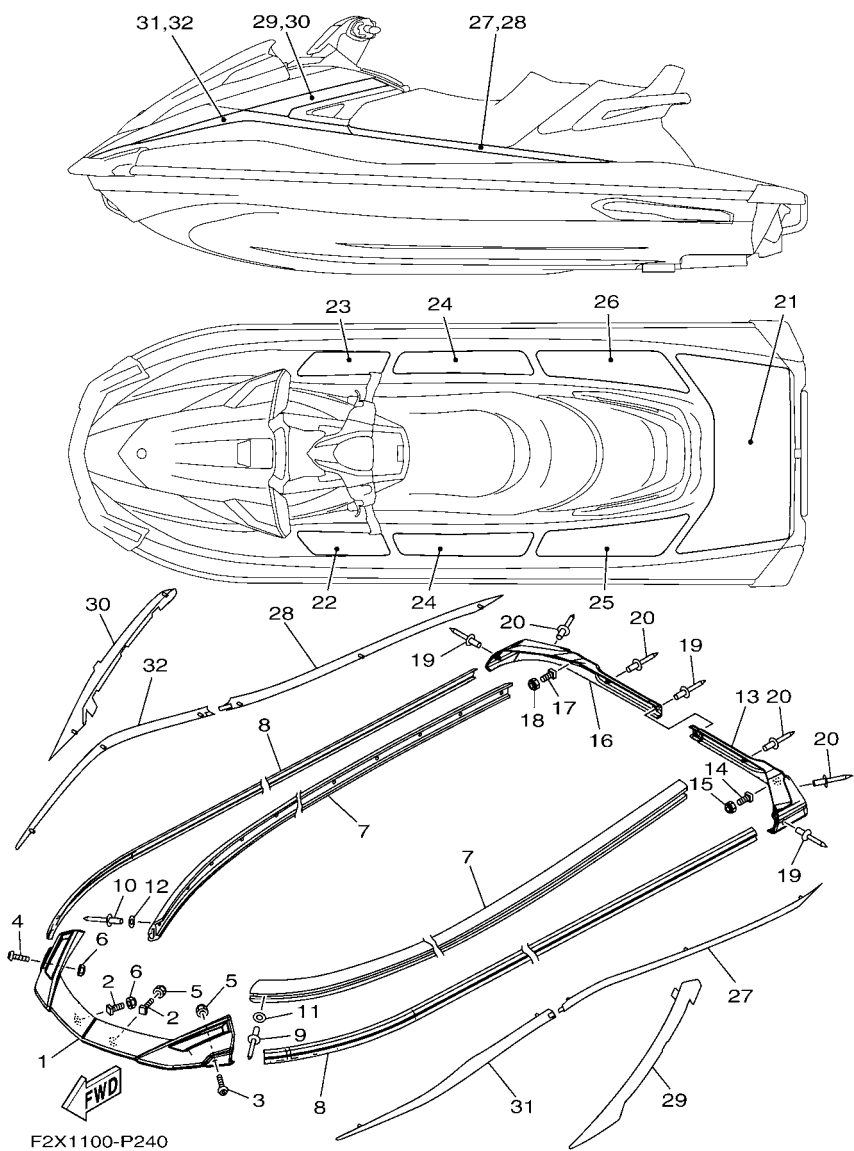

FIG. 23 HULL & DECK

REF. NO.	PART NO.	DESCRIPTION	CAN	EUR	GENE	REMARKS
27	F0X-61652-00	NUT (BOLT/NUT)	2	2	2	
28	90110-06040	BOLT, HEXAGON SOCKET HEAD	2	2	2	
29	F1S-U883N-01	STABILIZER LH	1	1	1	BLACK
30	F1S-U883P-01	STABILIZER RH	1	1	1	BLACK
31	F1X-U883T-01	BRACKET,STABILIZER	2	2	2	
32	90105-08860	BOLT, FLANGE	5	5	5	
33	90105-08860	BOLT, FLANGE	5	5	5	
34	F2N-U8169-00	SPACER	5	5	5	
35	F2N-U8169-00	SPACER	5	5	5	
36	F1S-U2280-02	DRAIN PLUG ASSY.	2	2	2	
37	F1S-U2285-00	PACKING, DRAIN	2	2	2	
38	9788R-05025	SCREW, PAN HEAD	4	4	4	
39	9299R-05200	WASHER	2	2	2	
40	9299R-05200	WASHER	2	2	2	
41	9572R-05300	NUT, FLANGE	2	2	2	
42	9572R-05300	NUT, FLANGE	2	2	2	
43	F1K-U826C-03	BRACKET	4	4	4	
44	90267-489U1	RIVET,BLIND	4	4	4	
45	F2X-U278A-00	LADDER, STEP ASSY	1	1	1	
46	F1W-U771H-00	.SLEEVE 1	2	2	2	
47	F2C-U377H-00	.INNER, COVER SIDE 1	4	4	4	
48	F2C-U1314-00	.PIN	4	4	4	
49	F2S-U278F-00	BRACKET, LADDER LH	2	2	2	
50	F2S-U278H-00	.PACKING, BRKT. 1	1	1	1	
51	90119-08861	BOLT, WITH WASHER	2	2	2	
52	90119-08861	BOLT, WITH WASHER	2	2	2	

FIG. 24 GUNWALE & MAT



F2X1100-P240

REF. NO.	PART NO.	DESCRIPTION	CAN	EUR	GENE	REMARKS
1	F2X-U2511-00	GUNWALE, BOW	1	1	1	CRUISER BLUE
	F2X-U2511-10	GUNWALE, BOW	1	1	1	CRUISER WHITE
	F2X-U2511-00	GUNWALE, BOW	1	1	1	DELUXE
2	F1W-U491K-00	BOLT, SPECIAL	2	2	2	
3	90111-06803	BOLT,HEX. SOCKET BUTTON	1	1	1	
4	90111-06803	BOLT,HEX. SOCKET BUTTON	1	1	1	
5	F2N-U142L-00	NUT, LOCK	2	2	2	
6	F2N-U142L-00	NUT, LOCK	2	2	2	
7	F2X-U2512-00	GUNWALE, SIDE	2	2	2	CRUISER BLUE
	F2X-U2512-10	GUNWALE, SIDE	2	2	2	CRUISER WHITE
	F2X-U2512-00	GUNWALE, SIDE	2	2	2	DELUXE
8	F2X-U2519-10	INNER,GUNWALE	2	2	2	CRUISER BLUE
	F2X-U2519-20	INNER,GUNWALE	2	2	2	CRUISER WHITE
	F2X-U2519-30	INNER,GUNWALE	2	2	2	DELUXE GRAY
	F2X-U2519-10	INNER,GUNWALE	2	2	2	DELUXE BLACK
9	90267-489U8	RIVET, BLIND	15	15	15	
10	90267-489U8	RIVET, BLIND	15	15	15	
11	9299R-05200	WASHER	15	15	15	
12	9299R-05200	WASHER	15	15	15	
13	F2X-U251D-00	GUNWALE, STERN 1	1	1	1	CRUISER BLUE
	F2X-U251D-10	GUNWALE, STERN 1	1	1	1	CRUISER WHITE
	F2X-U251D-00	GUNWALE, STERN 1	1	1	1	DELUXE
14	F1W-U491K-00	BOLT, SPECIAL	1	1	1	
15	F2N-U142L-00	NUT, LOCK	1	1	1	
16	F2X-U251E-00	GUNWALE, STERN 2	1	1	1	CRUISER BLUE
	F2X-U251E-10	GUNWALE, STERN 2	1	1	1	CRUISER WHITE
	F2X-U251E-00	GUNWALE, STERN 2	1	1	1	DELUXE

FIG. 24 GUNWALE & MAT

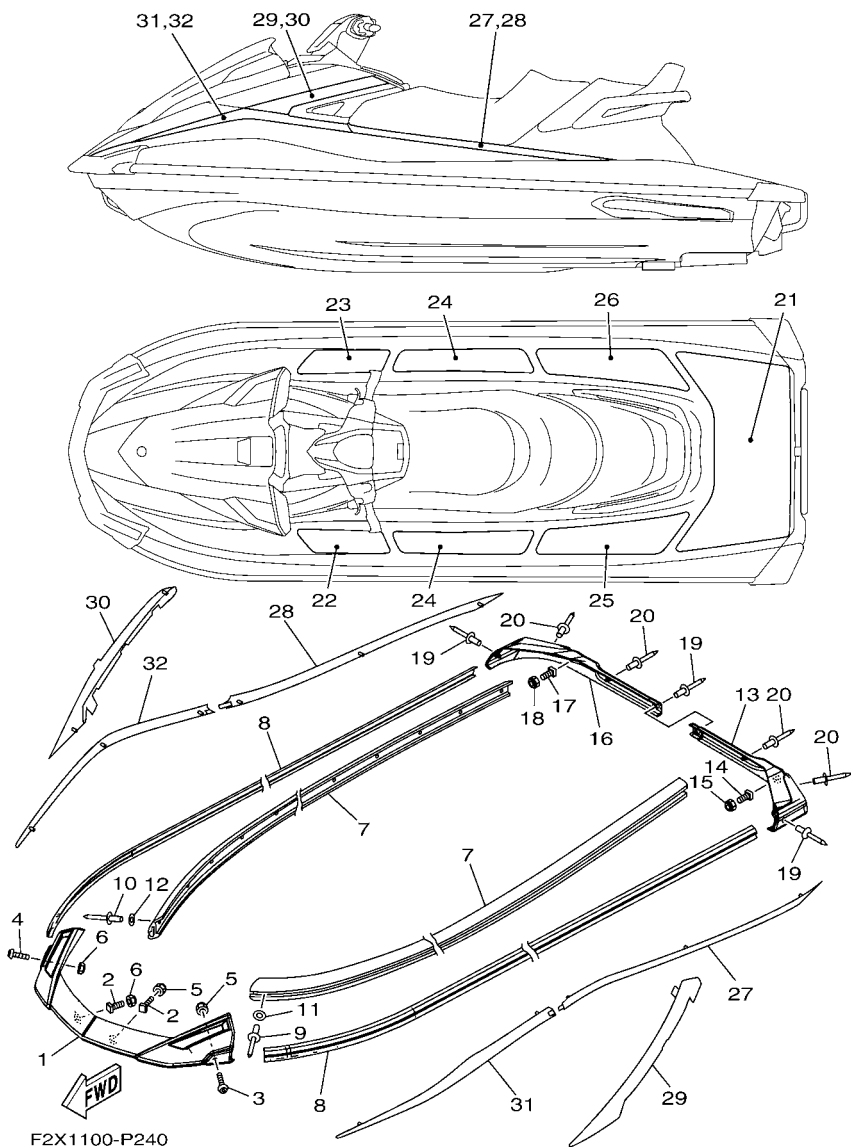

F2X1100-P240

REF. NO.	PART NO.	DESCRIPTION	CAN	EUR	GENE	REMARKS
17	F1W-U491K-00	BOLT, SPECIAL	1	1	1	
18	F2N-U142L-00	NUT, LOCK	1	1	1	
19	90267-48825	RIVET, BLIND	3	3	3	
20	90267-48825	RIVET, BLIND	4	4	4	
21	F2X-U3581-01	MAT, UPPER	1	1	1	CRUISER BLUE
	F2X-U3581-20	MAT, UPPER	1	1	1	CRUISER WHITE
	F2X-U3581-30	MAT, UPPER	1	1	1	DELUXE GRAY
	F2X-U3581-01	MAT, UPPER	1	1	1	DELUXE BLACK
22	F2X-U351H-00	MAT, STEP 1	1	1	1	CRUISER BLUE
	F2X-U351H-20	MAT, STEP 1	1	1	1	CRUISER WHITE
	F2X-U351H-30	MAT, STEP 1	1	1	1	DELUXE GRAY
	F2X-U351H-00	MAT, STEP 1	1	1	1	DELUXE BLACK
23	F2X-U351J-00	MAT, STEP 2	1	1	1	CRUISER BLUE
	F2X-U351J-20	MAT, STEP 2	1	1	1	CRUISER WHITE
	F2X-U351J-30	MAT, STEP 2	1	1	1	DELUXE GRAY
	F2X-U351J-00	MAT, STEP 2	1	1	1	DELUXE BLACK
24	F2X-U351K-00	MAT, STEP 3	2	2	2	CRUISER BLUE
	F2X-U351K-20	MAT, STEP 3	2	2	2	CRUISER WHITE
	F2X-U351K-30	MAT, STEP 3	2	2	2	DELUXE GRAY
	F2X-U351K-00	MAT, STEP 3	2	2	2	DELUXE BLACK
25	F2X-U351M-00	MAT, STEP 4	1	1	1	CRUISER BLUE
	F2X-U351M-20	MAT, STEP 4	1	1	1	CRUISER WHITE
	F2X-U351M-30	MAT, STEP 4	1	1	1	DELUXE GRAY
	F2X-U351M-00	MAT, STEP 4	1	1	1	DELUXE BLACK
26	F2X-U351N-00	MAT, STEP 5	1	1	1	CRUISER BLUE
	F2X-U351N-20	MAT, STEP 5	1	1	1	CRUISER WHITE
	F2X-U351N-30	MAT, STEP 5	1	1	1	DELUXE GRAY

FIG. 24 GUNWALE & MAT

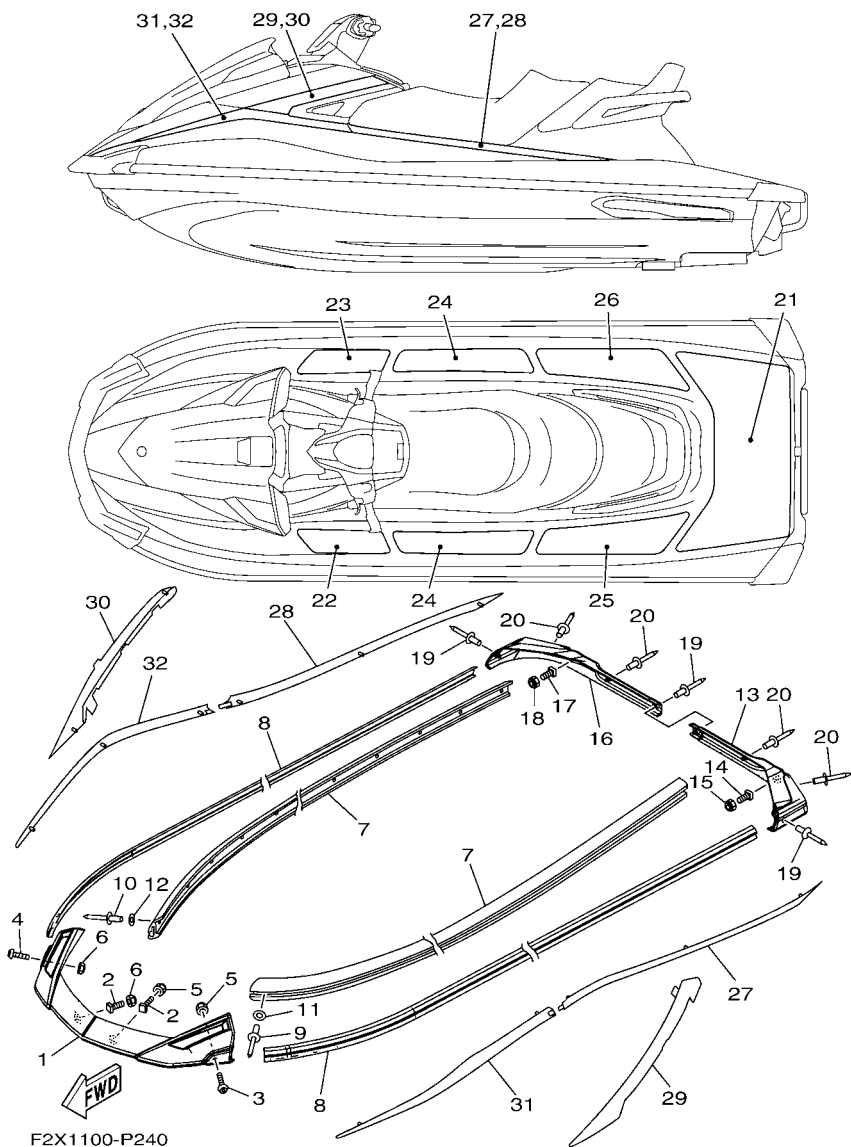

F2X1100-P240

REF. NO.	PART NO.	DESCRIPTION	CAN	EUR	GENE	REMARKS
26	F2X-U351N-00	MAT, STEP 5	1	1	1	DELUXE BLACK
27	F2X-U89A8-10	ORNAMENT, STERN LH	1	1	1	CRUISER BLUE
	F2X-U89A8-00	ORNAMENT, STERN LH	1	1	1	CRUISER WHITE
	F2X-U89A8-20	ORNAMENT, STERN LH	1	1	1	DELUXE GRAY
	F2X-U89A8-10	ORNAMENT, STERN LH	1	1	1	DELUXE BLACK
28	F2X-U89A9-10	ORNAMENT, STERN RH	1	1	1	CRUISER BLUE
	F2X-U89A9-00	ORNAMENT, STERN RH	1	1	1	CRUISER WHITE
	F2X-U89A9-20	ORNAMENT, STERN RH	1	1	1	DELUXE GRAY
	F2X-U89A9-10	ORNAMENT, STERN RH	1	1	1	DELUXE BLACK
29	F2X-U89AA-10	ORNAMENT, MIDDLE LH	1	1	1	CRUISER BLUE
	F2X-U89AA-00	ORNAMENT, MIDDLE LH	1	1	1	CRUISER WHITE
	F2X-U89AA-20	ORNAMENT, MIDDLE LH	1	1	1	DELUXE GRAY
	F2X-U89AA-10	ORNAMENT, MIDDLE LH	1	1	1	DELUXE BLACK
30	F2X-U89AB-10	ORNAMENT, MIDDLE RH	1	1	1	CRUISER BLUE
	F2X-U89AB-00	ORNAMENT, MIDDLE RH	1	1	1	CRUISER WHITE
	F2X-U89AB-20	ORNAMENT, MIDDLE RH	1	1	1	DELUXE GRAY
	F2X-U89AB-10	ORNAMENT, MIDDLE RH	1	1	1	DELUXE BLACK
31	F2X-U89AC-10	ORNAMENT, BOW LH	1	1	1	CRUISER BLUE
	F2X-U89AC-00	ORNAMENT, BOW LH	1	1	1	CRUISER WHITE
	F2X-U89AC-20	ORNAMENT, BOW LH	1	1	1	DELUXE GRAY
	F2X-U89AC-10	ORNAMENT, BOW LH	1	1	1	DELUXE BLACK
32	F2X-U89AD-10	ORNAMENT, BOW RH	1	1	1	CRUISER BLUE
	F2X-U89AD-00	ORNAMENT, BOW RH	1	1	1	CRUISER WHITE
	F2X-U89AD-20	ORNAMENT, BOW RH	1	1	1	DELUXE GRAY
	F2X-U89AD-10	ORNAMENT, BOW RH	1	1	1	DELUXE BLACK

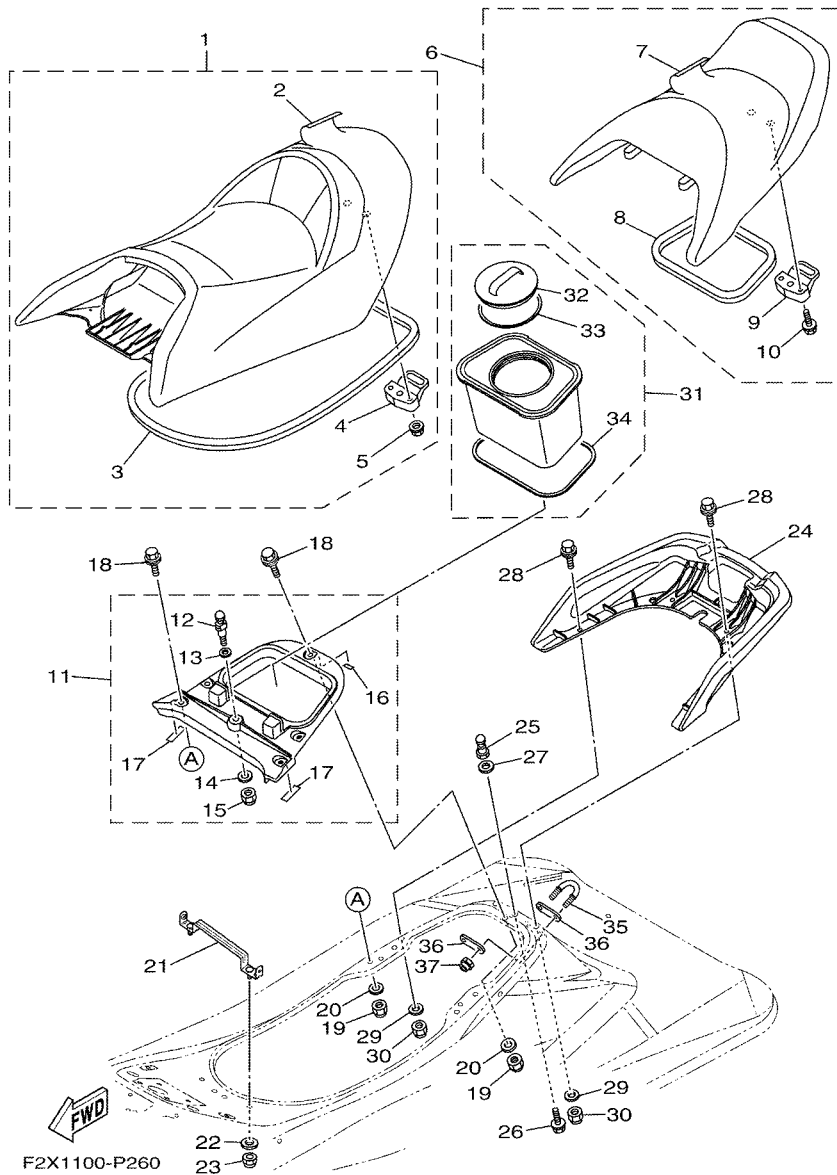
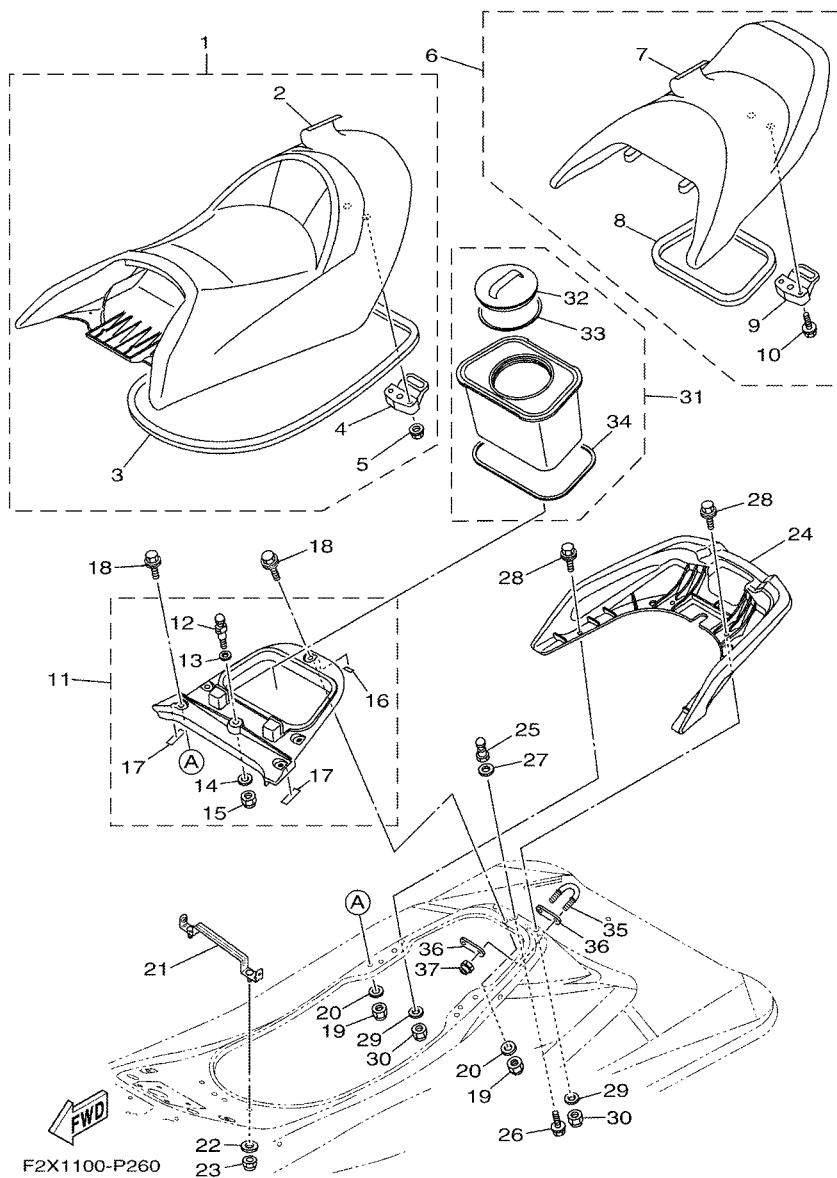

FIG. 26 SEAT & UNDER LOCKER

REF. NO.	PART NO.	DESCRIPTION	CAN	EUR	GENE	REMARKS
1	F2X-U371A-00	DOUBLE SEAT ASSY	1	1	1	CRUISER BLUE
	F2X-U371A-30	DOUBLE SEAT ASSY	1	1	1	CRUISER WHITE
	F2X-U371A-10	DOUBLE SEAT ASSY	1	1	1	DELUXE
2	F2X-U371B-00	.COVER, SEAT 1	1	1	1	CRUISER BLUE
	F2X-U371B-30	.COVER, SEAT 1	1	1	1	CRUISER WHITE
	F2X-U371B-10	.COVER, SEAT 1	1	1	1	DELUXE
3	F1W-U2664-01	.PACKING	1	1	1	
4	F2C-U3850-00	.SEAT LOCK ASSY	1	1	1	
5	90119-069UP	.BOLT, WITH WASHER	2	2	2	
6	F2X-U372A-00	SINGLE SEAT ASSY	1	1	1	CRUISER BLUE
	F2X-U372A-30	SINGLE SEAT ASSY	1	1	1	CRUISER WHITE
	F2X-U372A-10	SINGLE SEAT ASSY	1	1	1	DELUXE
7	F2X-U372B-00	.COVER, SEAT	1	1	1	CRUISER BLUE
	F2X-U372B-30	.COVER, SEAT	1	1	1	CRUISER WHITE
	F2X-U372B-10	.COVER, SEAT	1	1	1	DELUXE
8	F2C-U266D-01	.PACKING 5	1	1	1	
9	F1B-U3850-02	.SEAT LOCK ASSY	1	1	1	
10	90119-069UP	.BOLT, WITH WASHER	2	2	2	
11	F2S-U890L-04	DECK BEAM ASSY	1	1	1	
12	GH1-U3774-00	.PIN	1	1	1	
13	90201-109U6	.WASHER, PLATE	1	1	1	
14	9299R-10200	.WASHER	1	1	1	
15	9572R-10300	.NUT, NYLON	1	1	1	
16	F2S-U375E-00	.PACKING 1	1	1	1	
17	F2S-U8244-00	.PACKING	2	2	2	
18	90119-08828	BOLT, WITH WASHER	5	5	5	
19	9572R-08300	NUT, FLANGE	5	5	5	

FIG. 26 SEAT & UNDER LOCKER



REF. NO.	PART NO.	DESCRIPTION	CAN	EUR	GENE	REMARKS
20	9299R-08200	WASHER	5	5	5	
21	F2X-U378C-00	STAY, SEAT 1	1	1	1	
22	90201-099U3	WASHER, PLATE	2	2	2	
23	9572R-08300	NUT, FLANGE	2	2	2	
24	F2X-U271B-00	GRIP, HAND	1	1	1	CRUISER BLUE
	F2X-U271B-10	GRIP, HAND	1	1	1	CRUISER WHITE
	F2X-U271B-00	GRIP, HAND	1	1	1	DELUXE
25	F1K-U3774-00	PIN	1	1	1	
26	90119-10804	BOLT, WITH WASHER	1	1	1	
27	9299R-10200	WASHER	1	1	1	
28	90119-08828	BOLT, WITH WASHER	4	4	4	
29	9299R-08200	WASHER	4	4	4	
30	9572R-08300	NUT, FLANGE	4	4	4	
31	F2X-U591A-00	CASE, ASSY 1	1	1	1	
32	F2C-U591C-00	.CAP, CASE	1	1	1	
33	F2C-U591D-01	.PACKING, CASE	1	1	1	
34	F2C-U266E-00	.PACKING, 6	1	1	1	
35	F2N-U1628-02	STERN EYE	1	1	1	
36	GP7-U4953-10	PLATE A	2	2	2	
37	9572R-08300	NUT, FLANGE	2	2	2	

FIG. 27 FUEL TANK

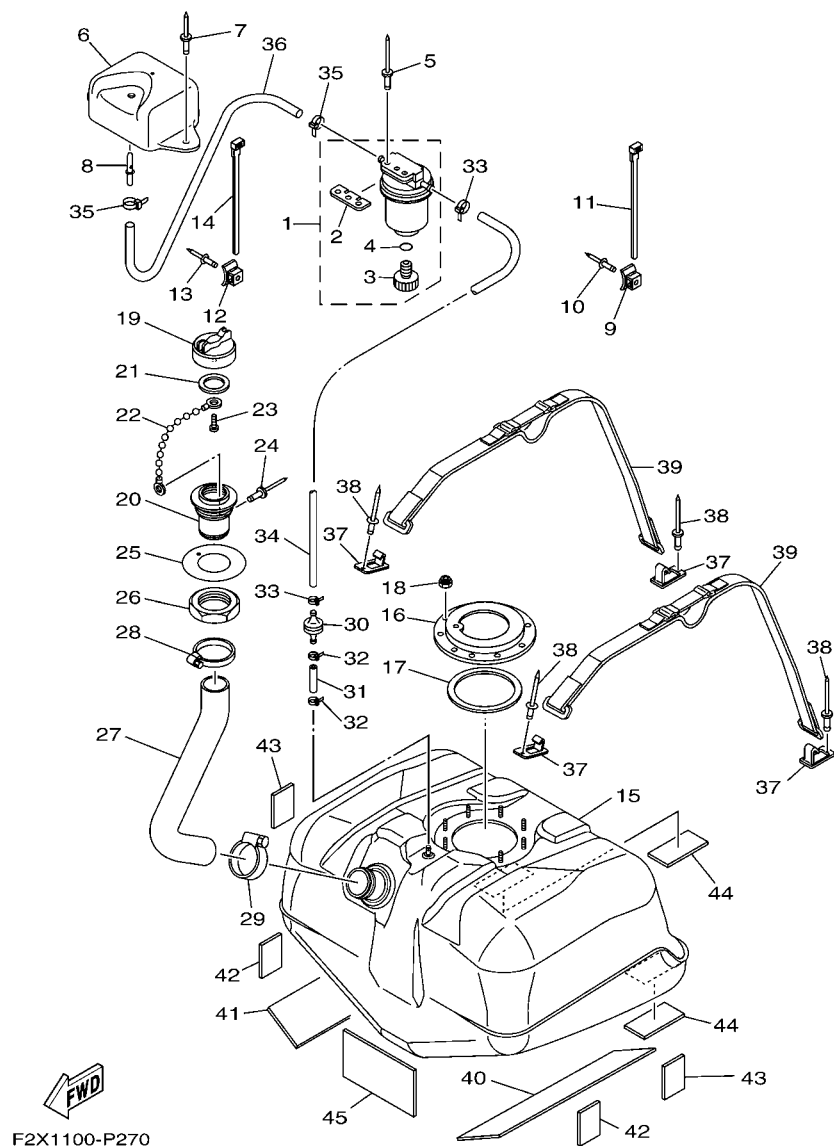

F2X1100-P270

REF. NO.	PART NO.	DESCRIPTION	CAN	EUR	GENE	REMARKS
1	F2F-6214A-00	FILTER, VENT ASSY	1	1	1	
2	EW2-62142-00	.PLATE, FILTER	1	1	1	
3	70R-24543-00	.PLUG, DRAIN	1	1	1	
4	70R-24489-00	.O-RING	1	1	1	
5	90267-489U2	RIVET, BLIND	2	2	2	
6	GP7-62159-02	SOCKET, VENTILATION	1	1	1	
7	90267-489U6	RIVET, BLIND	2	2	2	
8	F1G-62149-00	PIPE, VENTILATION	1	1	1	
9	F1W-U828M-00	BASE, CLAMP	1	1	1	
10	90267-489U6	RIVET, BLIND	1	1	1	
11	90464-32801	CLAMP	1	1	1	
12	F1W-U828M-00	BASE, CLAMP	1	1	1	
13	90267-489U6	RIVET, BLIND	1	1	1	
14	90464-32801	CLAMP	1	1	1	
15	F2S-U7711-02	TANK, FUEL	1	1	1	
16	F1B-U7773-00	RING	1	1	1	
17	F1B-67747-00	PACKING, SEAL	1	1	1	
18	9572R-06300	NUT, NYLON	9	9	9	
19	F2X-U7831-00	CAP, FUEL FILLER	1	1	1	
20	F2X-U7833-00	SOCKET	1	1	1	
21	GP7-U7832-01	PACKING	1	1	1	
22	GP7-U7835-00	CHAIN BALL	1	1	1	
23	90169-049U1	TAPPING SCREW	1	1	1	
24	90267-329UR	RIVET, BLIND	1	1	1	
25	GP7-U7834-10	PACKING FUEL FILLER	1	1	1	
26	GP7-U783F-00	NUT, FUEL FILLER	1	1	1	
27	F2X-U7844-01	HOSE	1	1	1	

FIG. 27 FUEL TANK

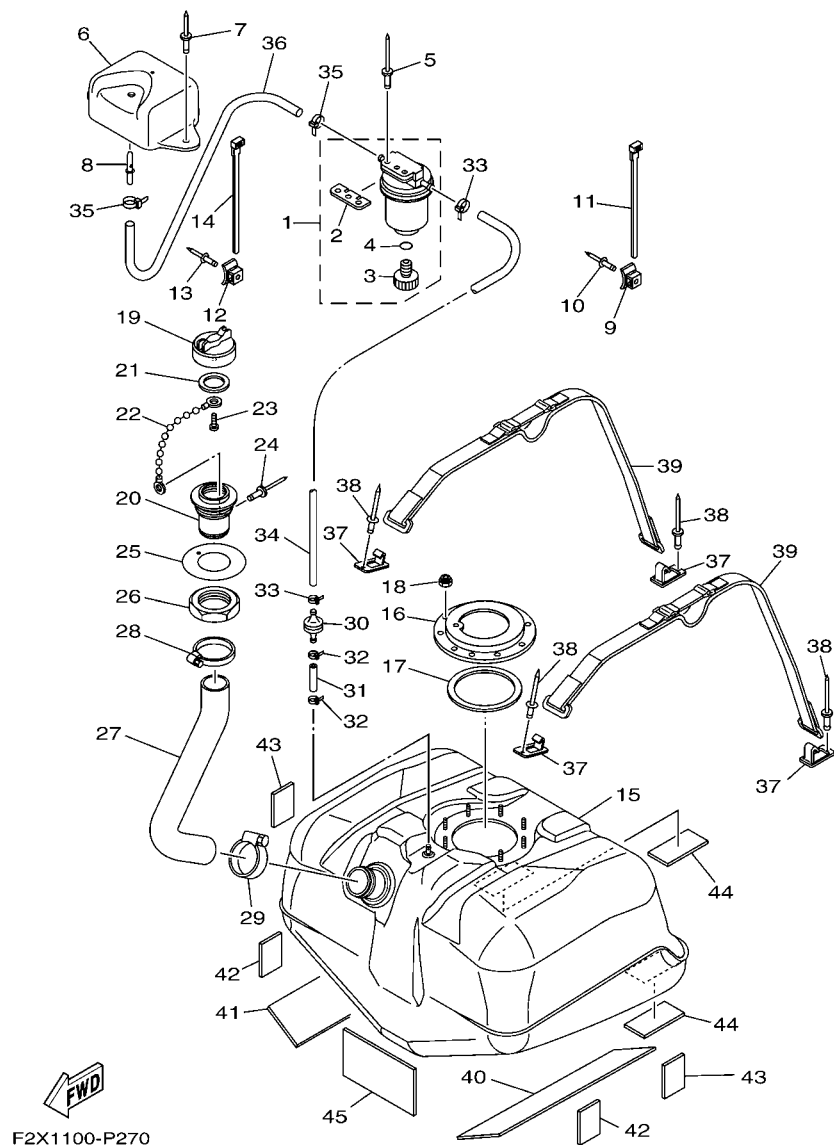

F2X1100-P270

REF. NO.	PART NO.	DESCRIPTION	CAN	EUR	GENE	REMARKS
28	90601-155U4	BAND, HOSE 55	1	1	1	
29	90601-155U4	BAND, HOSE 55	1	1	1	
30	EU0-67767-31	CHECK VALVE	1	1	1	
31	GP7-U785H-00	HOSE, AIR VENT 3	1	1	1	
32	90465-11829	CLAMP	2	2	2	
33	90465-11829	CLAMP	2	2	2	
34	F1K-U785G-00	HOSE, AIR VENT	1	1	1	
35	90465-11829	CLAMP	2	2	2	
36	F0D-U7856-10	HOSE, AIR VENT 3	1	1	1	
37	F1K-U5772-04	HOOK A	4	4	4	
38	90267-489U1	RIVET,BLIND	4	4	4	
39	F2S-67743-00	BELT, TANK 1	2	2	2	
40	F2S-U759B-00	MAT 1	1	1	1	
41	F2S-U759B-00	MAT 1	1	1	1	
42	F1W-U759C-01	MAT 2	2	2	2	
43	F1W-U759C-01	MAT 2	2	2	2	
44	F1K-U759C-00	MAT 2	2	2	2	
45	F1S-U8221-00	PAD, BATTERY	1	1	1	

FIG. 28 EXHAUST 4

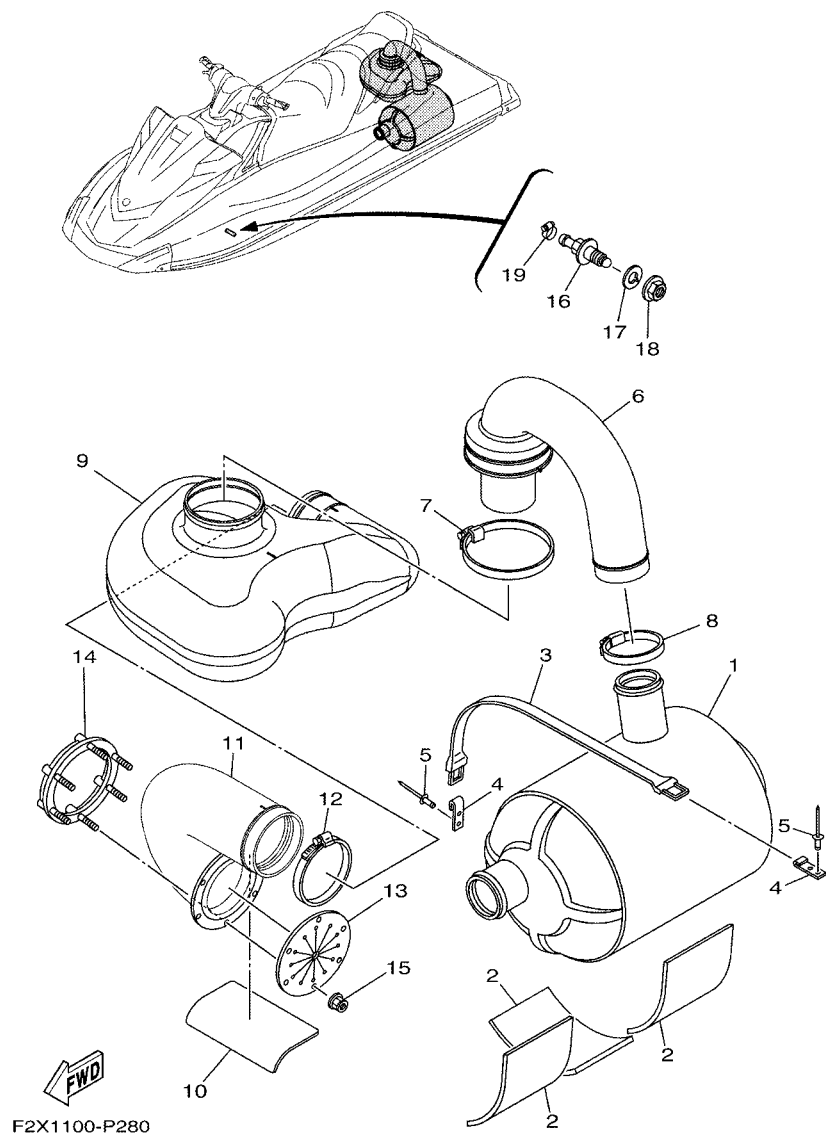

F2X1100-P280

REF. NO.	PART NO.	DESCRIPTION	CAN	EUR	GENE	REMARKS
1	F2X-U7550-00	WATER LOCK COMP.	1	1	1	
2	F1S-U8221-00	PAD, BATTERY	3	3	3	
3	EW2-67821-00	BAND, FUEL TANK	1	1	1	
4	GA7-65772-00	HOOK A	2	2	2	
5	90267-489U1	RIVET,BLIND	4	4	4	
6	F2N-U7555-01	HOSE, EXHAUST	1	1	1	
7	90601-179U8	BAND, HOSE 79	1	1	1	
8	90450-99804	HOSE CLAMP ASSY	1	1	1	
9	F2N-U4261-00	TANK, WATER	1	1	1	
10	F1S-U8221-00	PAD, BATTERY	1	1	1	
11	F2N-U758D-00	HOSE,EXHAUST 3	1	1	1	
12	90450-99801	HOSE CLAMP ASSY	1	1	1	
13	F1B-U751G-00	VALVE, EXHAUST	1	1	1	
14	F1S-U757B-01	PLATE	1	1	1	
15	F2N-U142L-00	NUT, LOCK	6	6	6	
16	F2C-U753B-01	PILOT, WATER	1	1	1	
17	F2C-U7564-00	GASKET	1	1	1	
18	F2C-U2733-00	NUT	1	1	1	
19	90467-17802	CLIP	1	1	1	

FIG. 29 CONTROL CABLE

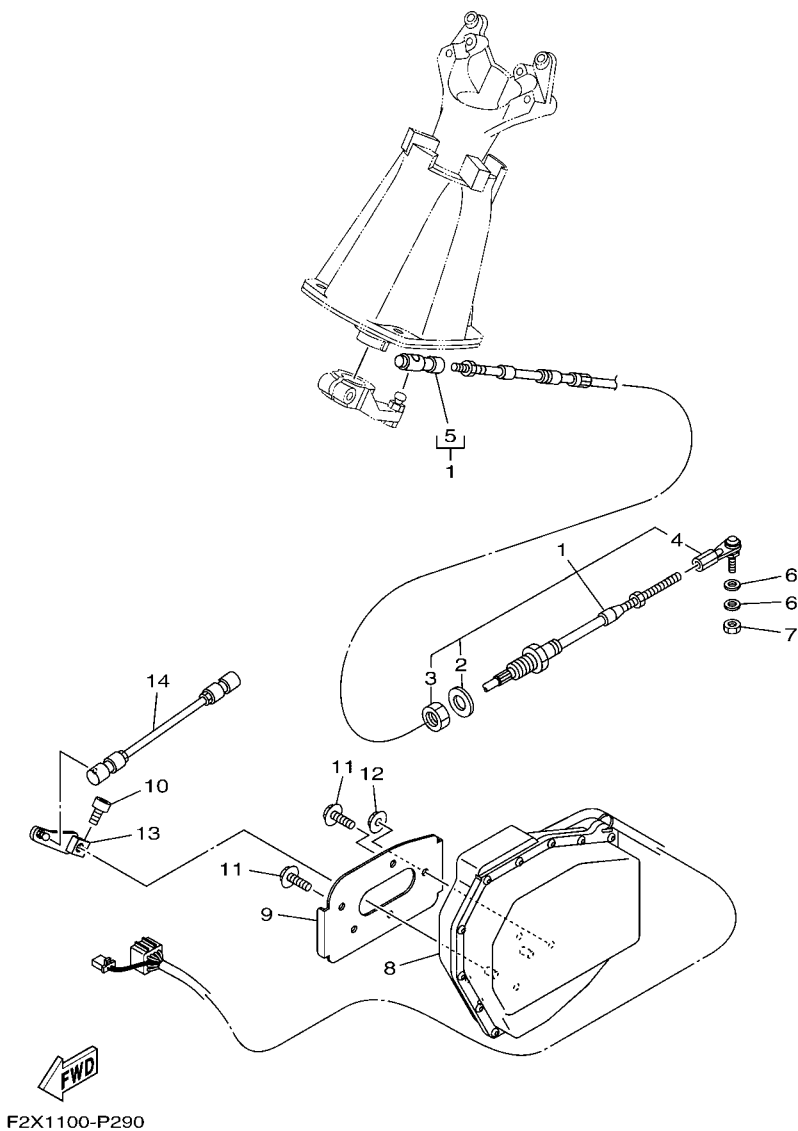

REF. NO.	PART NO.	DESCRIPTION	CAN	EUR	GENE	REMARKS
1	F2N-61481-00	CABLE, STEERING	1	1	1	
2	F1B-61438-00	.PACKING C	1	1	1	
3	F1B-6151S-00	.NUT	1	1	1	
4	F1B-61461-02	.STUD, JOINT BALL	1	1	1	
5	F2N-61460-00	.BALL JOINT ASSY	1	1	1	
6	90201-06906	WASHER, PLATE	2	2	2	
7	9538R-06700	NUT	1	1	1	
8	F2X-6140B-00	MOTOR ASSY.	1	1	1	
9	F3J-U8285-00	PLATE	1	1	1	
10	90110-06040	BOLT, HEXAGON SOCKET HEAD	1	1	1	
11	90119-08851	BOLT, WITH WASHER	2	2	2	
12	9572R-08300	NUT, FLANGE	3	3	3	
13	F3J-6150F-00	SHIFT ARM ASSY	1	1	1	
14	F3J-6150D-00	ROD ASSY 2	1	1	1	

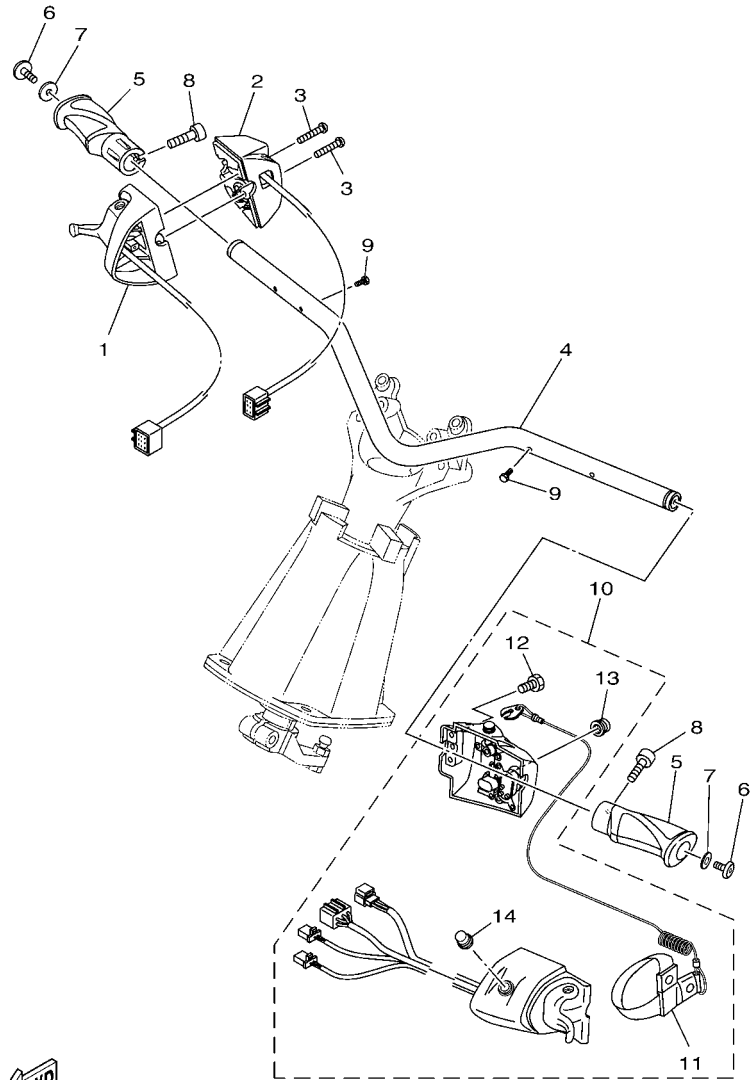

FWD
F2X1100-P300

FIG. 30 STEERING 1

REF. NO.	PART NO.	DESCRIPTION	CAN	EUR	GENE	REMARKS
1	6CS-14305-10	THROTTLE LEVER COMP	1	1	1	
2	6CS-81860-00	SWITCH ASSY	1	1	1	
3	6CS-6725F-00	BOLT, THROTTLE	2	2	2	
4	F2X-U1552-00	HANDLE	1	1	1	
5	F2S-U155D-02	GRIP, HANDLE	2	2	2	
6	90110-06382	BOLT, HEXAGON SOCKET HEAD	2	2	2	
7	90201-068G0	WASHER, PLATE	2	2	2	
8	F2S-U1516-00	BOLT	2	2	2	
9	91380-04030	BOLT	2	2	2	
10	F2X-68310-00	SWITCH BOX ASSY	1	1	1	
11	EW2-68348-00	.LANYARD, STOP SWITCH	1	1	1	
12	6CS-6725F-00	.BOLT, THROTTLE	4	4	4	
13	FK7-68312-02	.STOP BUTTON COMP	1	1	1	
14	FK7-68313-02	.START BUTTON COMP.	1	1	1	

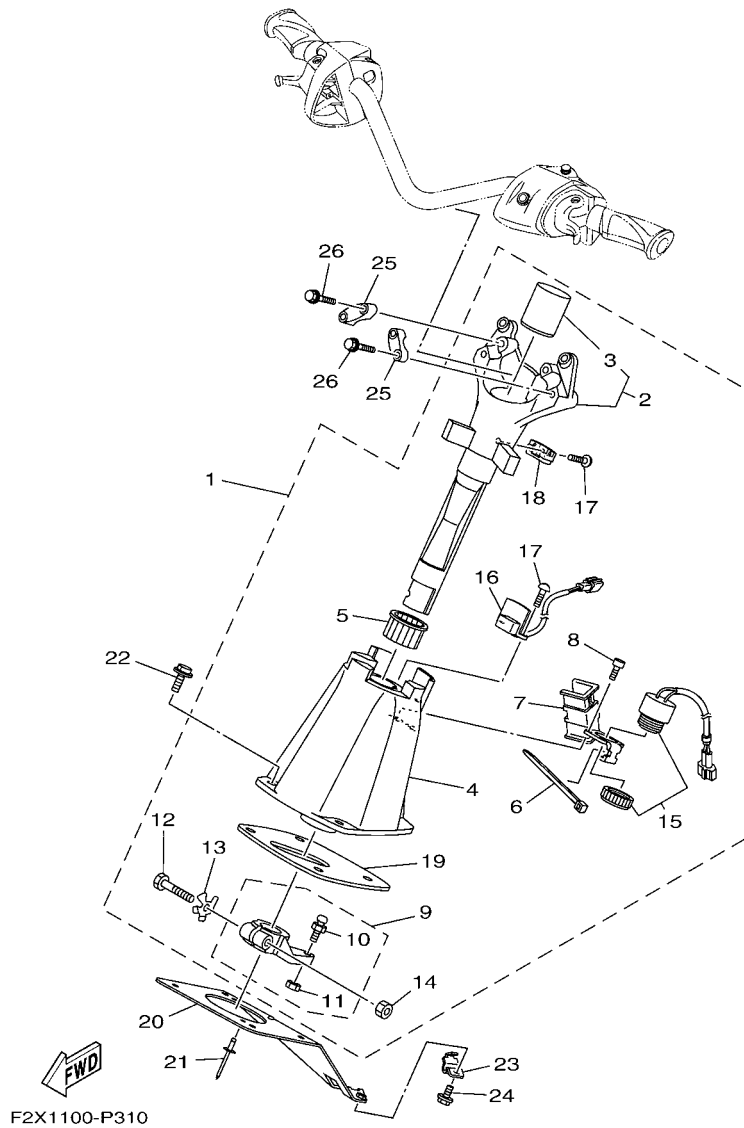
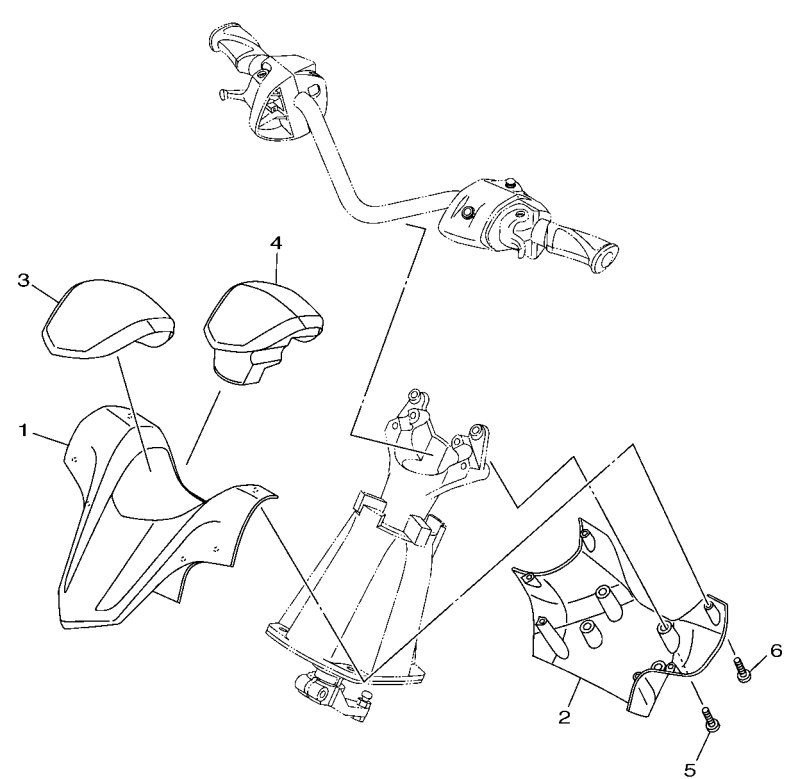

FIG. 31 STEERING 2

REF. NO.	PART NO.	DESCRIPTION	CAN	EUR	GENE	REMARKS
1	F2X-61400-00	STEERING MASTER ASSY	1	1	1	
2	F2X-67410-00	.SHAFT ASSY	1	1	1	
3	F2X-61435-00	..SEAL, PIPE 30	1	1	1	
4	F2X-6152M-00	.HOUSING ASSY	1	1	1	
5	F1K-6134M-00	.BUSH	1	1	1	
6	703-82591-00	.BAND	1	1	1	
7	F2X-6146H-00	.SPACER, BRKT.	1	1	1	
8	F1B-613C1-00	.SCREW	2	2	2	
9	F1K-6153R-00	.ARM ASSY.	1	1	1	
10	EU0-61461-02	..STUD, JOINT BALL	1	1	1	
11	95720-06300	..NUT, SELF-LOCKING	1	1	1	
12	F1K-61355-00	.BOLT	1	1	1	
13	F1K-6142B-00	.PLATE, RETAINING	1	1	1	
14	95720-08300	.NUT, SELF-LOCKING	1	1	1	
15	F1S-68341-00	.BUZZER	1	1	1	
16	F2X-6838B-00	.SENSOR, MAGNET	1	1	1	
17	F2X-613C1-00	.SCREW	3	3	3	
18	F2X-6838C-00	.MAGNET	1	1	1	
19	F1K-6143C-00	.SEAL, RUBBER	1	1	1	
20	F1K-U1467-01	BRACKET,STOPPER CABLE	1	1	1	
21	90267-489U2	RIVET, BLIND	2	2	2	
22	90119-08836	BOLT, WITH WASHER	4	4	4	
23	F1K-U1468-03	STOPPER, CABLE	1	1	1	
24	90119-069UH	BOLT, WITH WASHER	1	1	1	
25	EU0-23814-31	HOLDER, HANDLE UPPER	2	2	2	
26	90119-08827	BOLT, WITH WASHER	4	4	4	

FIG. 32 STEERING 3



REF. NO.	PART NO.	DESCRIPTION	CAN	EUR	GENE	REMARKS
1	F2X-U143D-00	PAD, STEERING 1	1	1	1	CRUISER BLUE
	F2X-U143D-10	PAD, STEERING 1	1	1	1	CRUISER WHITE
	F2X-U143D-00	PAD, STEERING 1	1	1	1	DELUXE
2	F2X-U143E-00	PAD, STEERING 2	1	1	1	CRUISER BLUE
	F2X-U143E-10	PAD, STEERING 2	1	1	1	CRUISER WHITE
	F2X-U143E-00	PAD, STEERING 2	1	1	1	DELUXE
3	F2X-U142D-00	COVER, PAD	1	1	1	CRUISER BLUE
	F2X-U142D-10	COVER, PAD	1	1	1	CRUISER WHITE
	F2X-U142D-00	COVER, PAD	1	1	1	DELUXE
4	F2X-U156E-00	PAD 1	1	1	1	
5	90154-06017	SCREW, BINDING	4	4	4	
6	90149-05903	SCREW	6	6	6	

 F2X1100-P320

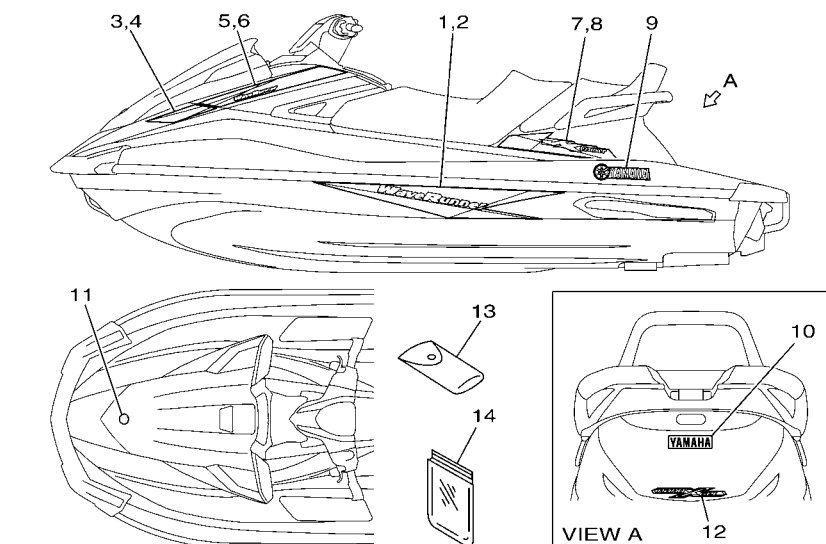

FOR CRUISER

FOR DELUXE

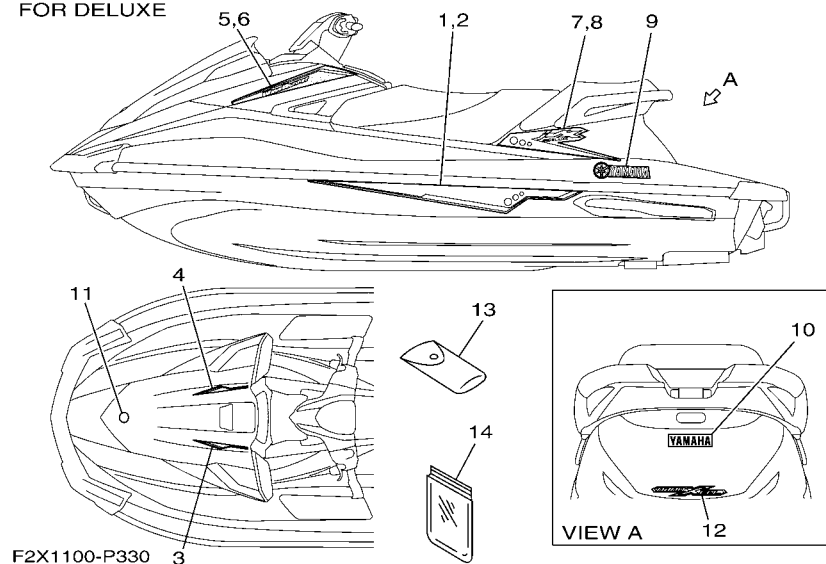

F2X1100-P330 3

FIG. 33 GRAPHICS

REF. NO.	PART NO.	DESCRIPTION	CAN	EUR	GENE	REMARKS
1	F2X-U417B-00	GRAPHIC 1 (LH)	1	1	1	CRUISER BLUE
	F2X-U417B-10	GRAPHIC 1 (LH)	1	1	1	CRUISER WHITE
	F2X-U417B-20	GRAPHIC 1 (LH)	1	1	1	DELUXE GRAY
	F2X-U417B-30	GRAPHIC 1 (LH)	1	1	1	DELUXE BLACK
2	F2X-U417C-00	GRAPHIC 2 (RH)	1	1	1	CRUISER BLUE
	F2X-U417C-10	GRAPHIC 2 (RH)	1	1	1	CRUISER WHITE
	F2X-U417C-20	GRAPHIC 2 (RH)	1	1	1	DELUXE GRAY
	F2X-U417C-30	GRAPHIC 2 (RH)	1	1	1	DELUXE BLACK
3	F2X-U417D-00	GRAPHIC 3 (LH)	1	1	1	CRUISER BLUE
	F2X-U417D-10	GRAPHIC 3 (LH)	1	1	1	CRUISER WHITE
	F2X-U417D-20	GRAPHIC 3 (LH)	1	1	1	DELUXE GRAY
	F2X-U417D-30	GRAPHIC 3 (LH)	1	1	1	DELUXE BLACK
4	F2X-U417E-00	GRAPHIC 4 (RH)	1	1	1	CRUISER BLUE
	F2X-U417E-10	GRAPHIC 4 (RH)	1	1	1	CRUISER WHITE
	F2X-U417E-20	GRAPHIC 4 (RH)	1	1	1	DELUXE GRAY
	F2X-U417E-30	GRAPHIC 4 (RH)	1	1	1	DELUXE BLACK
5	F2X-U417F-00	GRAPHIC 5 (LH)	1	1	1	CRUISER BLUE
	F2X-U417F-10	GRAPHIC 5 (LH)	1	1	1	CRUISER WHITE
	F2X-U417F-20	GRAPHIC 5 (LH)	1	1	1	DELUXE GRAY
	F2X-U417F-30	GRAPHIC 5 (LH)	1	1	1	DELUXE BLACK
6	F2X-U417G-00	GRAPHIC 6 (RH)	1	1	1	CRUISER BLUE
	F2X-U417G-10	GRAPHIC 6 (RH)	1	1	1	CRUISER WHITE
	F2X-U417G-20	GRAPHIC 6 (RH)	1	1	1	DELUXE GRAY
	F2X-U417G-30	GRAPHIC 6 (RH)	1	1	1	DELUXE BLACK
7	F2X-U417H-00	GRAPHIC 7 (LH)	1	1	1	CRUISER BLUE
	F2X-U417H-10	GRAPHIC 7 (LH)	1	1	1	CRUISER WHITE
	F2X-U417H-20	GRAPHIC 7 (LH)	1	1	1	DELUXE GRAY

FIG. 33 GRAPHICS

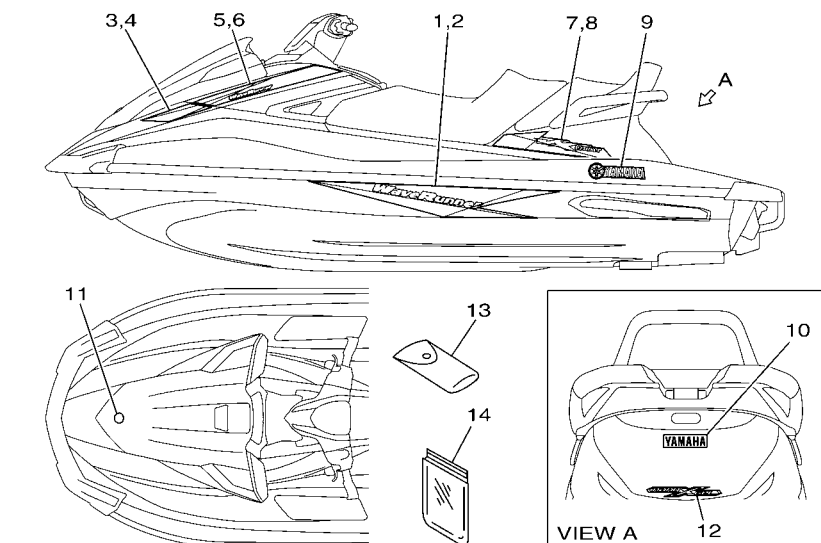

FOR CRUISER
FOR DELUXE

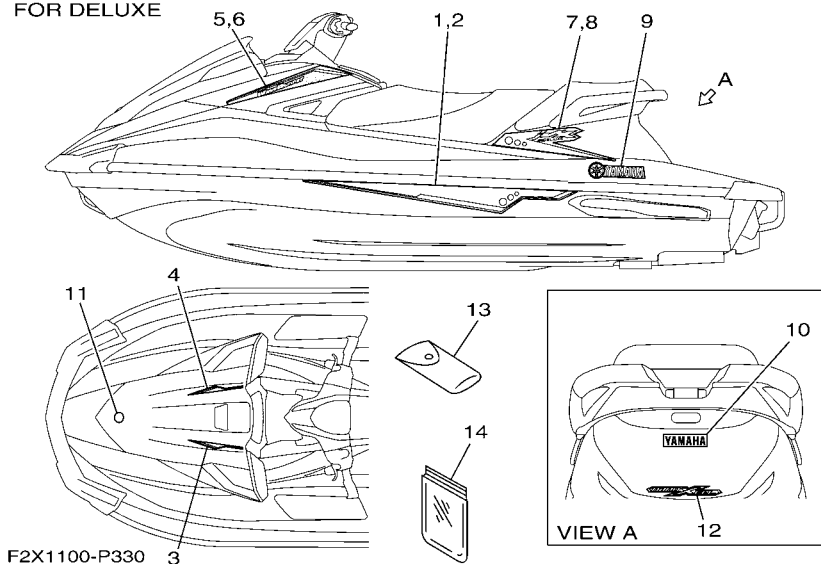

F2X1100-P330

REF. NO.	PART NO.	DESCRIPTION	CAN	EUR	GENE	REMARKS
7	F2X-U417H-30	GRAPHIC 7 (LH)	1	1	1	DELUXE BLACK
8	F2X-U417J-00	GRAPHIC 8 (RH)	1	1	1	CRUISER BLUE
	F2X-U417J-10	GRAPHIC 8 (RH)	1	1	1	CRUISER WHITE
	F2X-U417J-20	GRAPHIC 8 (RH)	1	1	1	DELUXE GRAY
	F2X-U417J-30	GRAPHIC 8 (RH)	1	1	1	DELUXE BLACK
9	F2P-U411C-00	EMBLEM, YAMAHA	2	2	2	CRUISER BLUE
	F2N-U411C-00	EMBLEM, YAMAHA	2	2	2	CRUISER WHITE
	F1X-U411C-60	EMBLEM, YAMAHA	2	2	2	DELUXE GRAY
	F2P-U411C-A0	EMBLEM, YAMAHA	2	2	2	DELUXE BLACK
10	F2P-U4114-00	MARK, YAMAHA A	1	1	1	CRUISER BLUE
	F1B-U411C-02	EMBLEM, YAMAHA	1	1	1	CRUISER WHITE
	F1X-U4114-60	MARK, YAMAHA A	1	1	1	DELUXE GRAY
	F2P-U4114-A0	MARK, YAMAHA A	1	1	1	DELUXE BLACK
11	F2S-6411H-00	EMBLEM, TUNING FORK	1	1	1	
12	F1W-U4121-00	EMBLEM A	1	1	1	
13	F1B-65986-13	TOOL SET	1	1	1	
14	EU0-65901-02	TOOL BAG	1	1	1	

FIG. 34 IMPORTANT LABELS

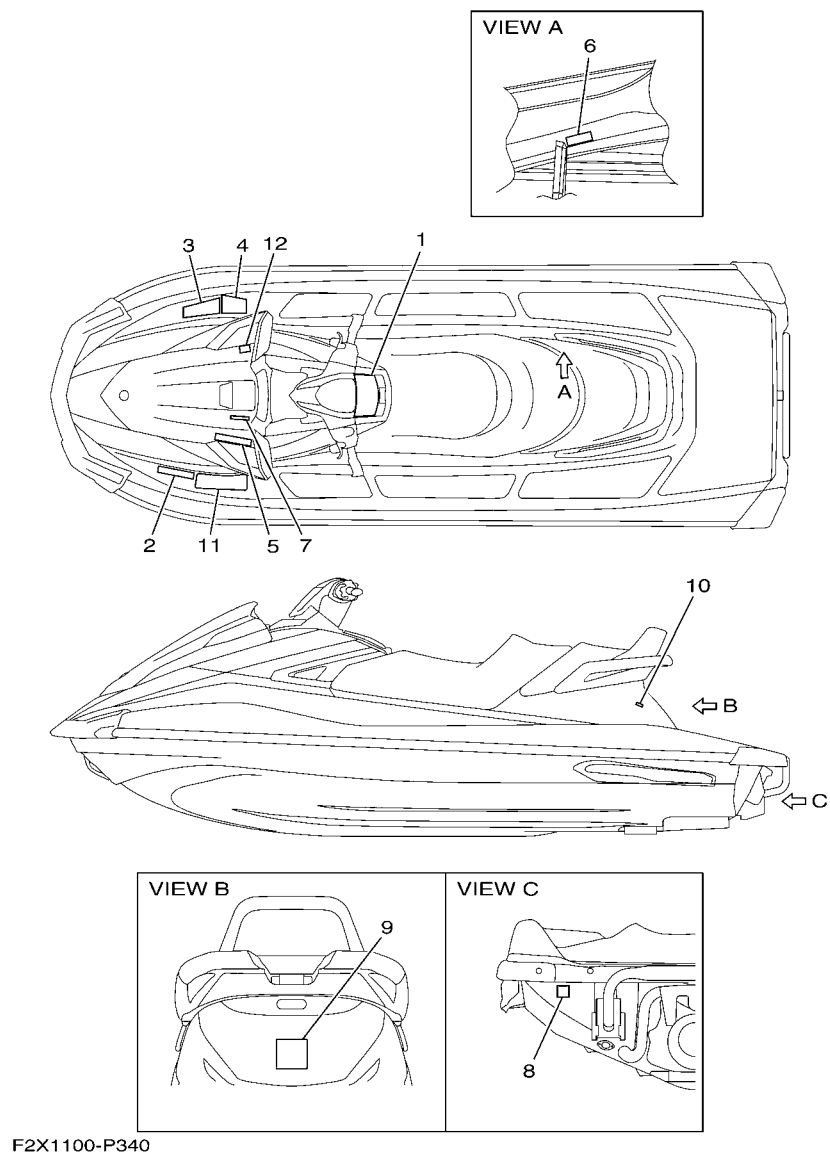

F2X1100-P340

REF. NO.	PART NO.	DESCRIPTION	CAN	EUR	GENE	REMARKS
1	F2X-U41B1-10	LABEL, WARNING UNIFORM 1	1	1	1	
2	F1B-U41B1-21	LABEL, WARNING UNIFORM 1	1	1	1	CRUISER BLUE
	F2S-U41B1-20	LABEL, WARNING UNIFORM 1	1	1	1	CRUISER WHITE
	F1B-U41B1-21	LABEL, WARNING UNIFORM 1	1	1	1	DELUXE
3	F1B-U41B1-31	LABEL, WARNING UNIFORM 1	1	1	1	CRUISER BLUE
	F2S-U41B1-30	LABEL, WARNING UNIFORM 1	1	1	1	CRUISER WHITE
	F1B-U41B1-31	LABEL, WARNING UNIFORM 1	1	1	1	DELUXE
4	F1B-U41B2-01	LABEL, WARNING UNIFORM 2	1	1	1	CRUISER BLUE
	F0M-U41B2-11	LABEL, WARNING UNIFORM 2	1	1	1	CRUISER WHITE
	F1B-U41B2-01	LABEL, WARNING UNIFORM 2	1	1	1	DELUXE
5	F1S-U415B-11	LABEL, WARNING(FUEL)	1	1	1	CRUISER BLUE
	F1B-U415B-11	LABEL, WARNING(FUEL)	1	1	1	CRUISER WHITE
	F1S-U415B-11	LABEL, WARNING(FUEL)	1	1	1	DELUXE
6	F0V-U41DB-12	LABEL, WARNING BATTERY	1	1	1	
7	F1B-U41F5-21	LABEL, FIRE EXTINGUISHER 1	1	1	1	CRUISER BLUE
	F1B-U41F5-11	LABEL, FIRE EXTINGUISHER 1	1	1	1	CRUISER WHITE
	F1B-U41F5-21	LABEL, FIRE EXTINGUISHER 1	1	1	1	DELUXE
8	F1G-U418F-00	LABEL, RIGHTING	1	1	1	
9	F1S-U41E1-11	LABEL, SET 1	1	1	1	CRUISER BLUE
	F2S-U41E1-10	LABEL, SET 1	1	1	1	CRUISER WHITE
	F1S-U41E1-11	LABEL, SET 1	1	1	1	DELUXE
10	F1S-U419E-01	LABEL 4	1			CRUISER BLUE CAN
	GJ3-U419E-00	LABEL 4	1			CRUISER WHITE CAN
	F1S-U419E-01	LABEL 4	1			DELUXE CAN
11	GP8-U416H-01	LABEL,WARNING(FRANCE)		1		CRUISER BLUE EUR
	GJ3-U416H-01	LABEL,WARNING(FRANCE)		1		CRUISER WHITE EUR
	GP8-U416H-01	LABEL,WARNING(FRANCE)		1		DELUXE EUR

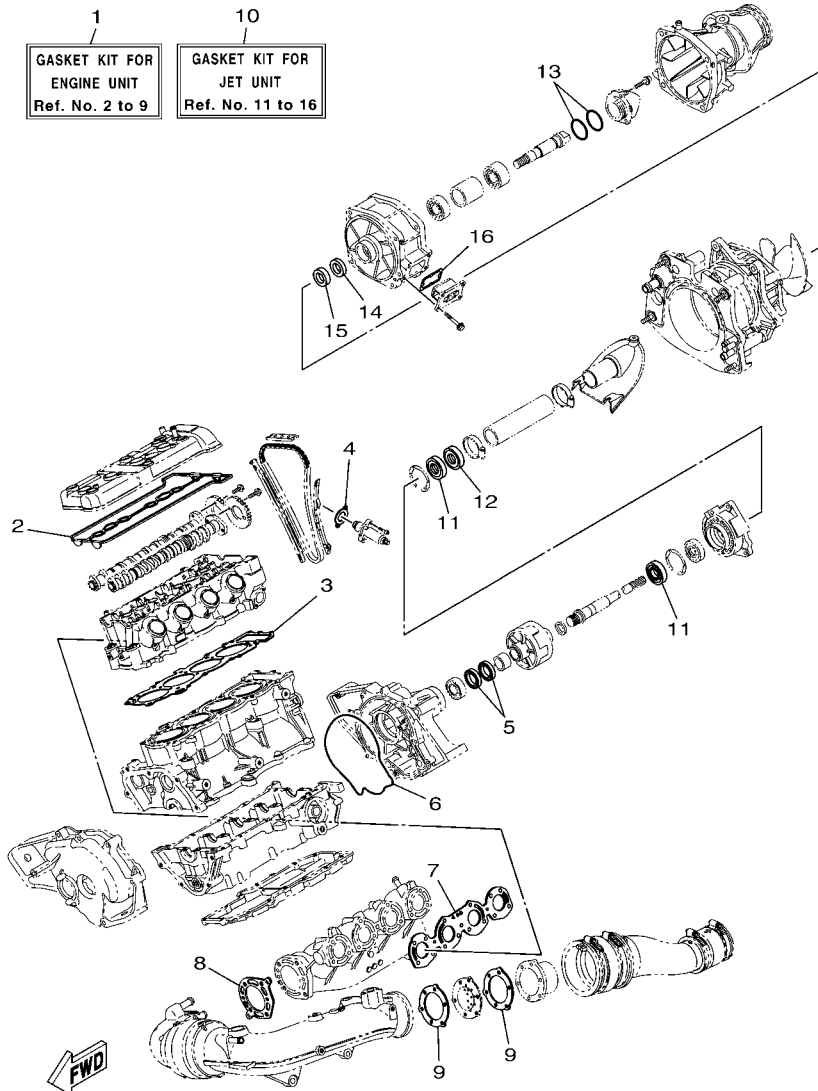

F2X1100-P350

FIG. 35 REPAIR KIT 1

REF. NO.	PART NO.	DESCRIPTION	CAN	EUR	GENE	REMARKS
1	6D3-W0001-01	GASKET KIT FOR ENGINE UNIT	1	1	1	
2	60E-11193-01	.GASKET, HEAD COVER 1	1	1	1	
3	6D3-11181-00	.GASKET, CYLINDER HEAD 1	1	1	1	
4	4FM-12213-00	.GASKET, TENSIONER CASE	1	1	1	
5	93101-35004	.OIL SEAL	2	2	2	
6	6B6-13475-01	.GASKET	1	1	1	
7	6D3-14613-10	.GASKET, EXHAUST PIPE	1	1	1	
8	6D3-14739-10	.GASKET, MUFFLER DAMPER 1	1	1	1	
9	60E-14623-00	.GASKET, EXHAUST PIPE	2	2	2	
10	6EX-W0001-20	GASKET KIT FOR JET UNIT	1	1	1	
11	93101-25M55	.OIL SEAL	2	2	2	
12	93102-25009	.OIL SEAL	1	1	1	
13	93210-464A3	.O-RING	2	2	2	
14	93101-21002	.OIL SEAL	1	1	1	
15	93101-21001	.OIL SEAL	1	1	1	
16	66V-42414-00	.O-RING	1	1	1	

NUMERICAL INDEX

PART NO.	REF. NO.	PART NO.	REF. NO.	PART NO.	REF. NO.	PART NO.	REF. NO.	PART NO.	REF. NO.	PART NO.	REF. NO.
6D3-11102-00	1 - 2	3GM-12126-00	4 - 9	6D3-12446-00	10 - 34	60E-13476-10	8 - 25	6B6-17586-00	3 - 19	EW2-62142-00	27 - 2
4KG-1111G-00	1 - 20	3FV-12153-10	4 - 20		11 - 36	8FP-13556-10	6 - 5	EU0-23814-31	31 - 25	F1G-62149-00	27 - 8
6D3-11125-00	7 - 30	3LN-12153-10	4 - 19	60E-1244E-00	6 - 20	6B6-13563-01	7 - 3	6S5-24300-01	6 - 15	F2F-6214A-00	27 - 1
6D3-11126-00	7 - 25	1HX-12168-00	4 - 18		6 - 23	68V-13573-00	6 - 11	70R-24489-00	27 - 4	GP7-62159-02	27 - 6
3TJ-11133-10	1 - 3	1HX-12168-20	4 - 18		17 - 42	6D3-13641-00	6 - 1	70R-24543-00	27 - 3	GJ3-6215F-00	19 - 17
1WG-11133-11	1 - 4	1HX-12168-40	4 - 18		17 - 57	6BU-13750-00	6 - 7	6EX-2812A-00	17 - 21	F2S-6411H-00	33 - 11
6D3-11164-00	7 - 21	1HX-12168-60	4 - 18	6BU-1244G-10	9 - 1	60E-13761-20	6 - 3	66V-42414-00	12 - 10	GA7-65772-00	28 - 4
6D3-11165-00	8 - 22	1HX-12168-80	4 - 18	6D3-1244G-10	10 - 28	6D3-13795-01	6 - 9		35 - 16	EU0-65901-02	33 - 14
6D3-11166-00	7 - 32	1HX-12168-A0	4 - 18		11 - 28	60E-13907-03	19 - 1	67X-44517-10	20 - 1	F1B-65986-13	33 - 13
6D3-11167-00	8 - 32	1HX-12168-F0	4 - 18	6D3-1244H-10	10 - 21	68V-1416A-00	6 - 4	6D3-44574-00	20 - 2	6CS-6725F-00	30 - 3
6D3-11181-00	1 - 21	1HX-12168-H1	4 - 18		11 - 21	6D3-14294-10	6 - 16	663-45119-00	13 - 4		30 - 12
	35 - 3	1HX-12168-K1	4 - 18	60E-12474-00	1 - 30	6CS-14305-10	30 - 1	61X-45332-03-94	13 - 2	F2X-67410-00	31 - 2
6EX-11191-00	1 - 17	1HX-12168-M1	4 - 18	6EX-12482-00	1 - 25	6D3-14411-00	5 - 1	6BU-45511-00	13 - 6	F2S-67743-00	27 - 39
60E-11193-01	1 - 18	1HX-12168-R1	4 - 18	60E-12483-10	1 - 29	6EX-14414-00	6 - 19	6EX-45514-00	12 - 15	F1B-67747-00	27 - 17
	35 - 2	1HX-12168-U1	4 - 18	6EX-12494-00	1 - 28	6EX-14414-10	6 - 22	6D3-45593-00-94	13 - 11	EU0-67767-31	27 - 30
69J-11301-10	2 - 12	1HX-12168-W1	4 - 18	6B6-12499-00	11 - 42	6D3-14419-01	5 - 8	6D3-45813-00-94	3 - 12	EW2-67821-00	28 - 3
6E5-11325-00	8 - 12	1HX-12168-Y1	4 - 18	60E-12537-01	1 - 31	6D3-14421-02	5 - 3	6D3-4581J-00	13 - 1	F2N-67823-00	22 - 18
68V-11325-02	2 - 13	1HX-12169-11	4 - 18	6D3-12577-10	10 - 25	6D3-14437-00	5 - 7	6D3-51129-00	2 - 3	F2N-67823-10	21 - 21
67F-11328-00	2 - 14	1HX-12169-31	4 - 18		11 - 25	63P-14446-00	6 - 13	68N-5112T-00	23 - 3		21 - 31
60E-11372-10	9 - 5	1HX-12169-50	4 - 18	63M-12580-00	10 - 5	60E-14449-00-94	6 - 25	66V-51312-01-94	12 - 5	F2X-6820A-00	19 - 19
60E-11411-11	3 - 1	1HX-12169-70	4 - 18		11 - 5	6D3-14451-00	5 - 4	6B6-51315-01-94	12 - 8	GU2-6822E-01	19 - 21
6D3-11416-00	3 - 2	1HX-12169-90	4 - 18	60E-12581-00	10 - 3	4XV-14452-00	5 - 2	6S5-52358-00	14 - 11	60E-682E0-00	19 - 2
6D3-11416-10	3 - 2	1HX-12169-E0	4 - 18		11 - 3	6D3-14457-00	6 - 8	F1K-6134M-00	31 - 5	F2X-68310-00	30 - 10
6D3-11416-20	3 - 2	1HX-12169-G0	4 - 18	60E-12584-00	10 - 15	68V-14475-00	6 - 12	F1K-61355-00	31 - 12	FK7-68312-02	30 - 13
6D3-11416-30	3 - 2	1HX-12169-J0	4 - 18		11 - 15	6D3-14613-10	9 - 3	F1B-613C1-00	31 - 8	FK7-68313-02	30 - 14
6D3-11416-A0	3 - 2	1HX-12169-L0	4 - 18	6D3-12584-00	10 - 20		35 - 7	F2X-613C1-00	31 - 17	F1S-68341-00	31 - 15
6B6-11478-00	3 - 15	1HX-12169-N0	4 - 18		11 - 20	6D3-14615-00	9 - 14	F2X-61400-00	31 - 1	EW2-68348-00	30 - 11
6D3-11603-00	3 - 4	1HX-12169-T0	4 - 18	6S5-12589-01	10 - 16	60E-14623-00	9 - 21	F2X-6140B-00	29 - 8	F2X-6838B-00	31 - 16
6D3-11631-01-B0	3 - 3	6D3-12171-11	4 - 1		11 - 16		35 - 9	F1K-6142B-00	31 - 13	F2X-6838C-00	31 - 18
6D3-11633-00	3 - 5	6D3-12176-00	4 - 3	6BU-12880-11	6 - 2	6D3-14625-00	9 - 16	F2X-61435-00	31 - 3	6D3-81147-00	6 - 14
6D3-11650-00	3 - 7	6D3-12181-00	4 - 2	6B6-1310A-01-94	2 - 18	6D3-1469W-10	9 - 23	F1B-61438-00	29 - 2	60E-81315-00	18 - 21
5JW-11654-00	3 - 8	6D3-12210-00	4 - 23	6B6-13151-00-94	8 - 28	6D3-14711-10	9 - 4	F1K-6143C-00	31 - 19	60E-81328-00	15 - 18
60E-11656-00	3 - 10	4FM-12213-00	4 - 24	60E-13161-00	2 - 20	6D3-14712-00-94	9 - 9	F2N-61460-00	29 - 5	6BU-81336-00	17 - 34
60E-11656-10	3 - 10		35 - 4	6D3-13300-10	7 - 2	6D3-14721-10	9 - 18	EU0-61461-02	31 - 10	6D3-81337-00-94	15 - 13
60E-11656-20	3 - 10	5BE-12241-00	4 - 22	6B6-13317-00	8 - 5	6D3-14739-10	9 - 10	F1B-61461-02	29 - 4	6S5-81364-10	8 - 34
60E-11656-30	3 - 10	6D3-12251-00	4 - 26	6B6-13327-02-94	7 - 8		35 - 8	F2X-6146H-00	31 - 7	6D3-81410-02	15 - 7
4XV-12111-00	4 - 5	4XV-12252-00	4 - 27	6B6-13360-00	7 - 1	6BU-14752-00-94	9 - 25	F2N-61481-00	29 - 1	6D3-81450-00	15 - 6
4XV-12112-00	4 - 6	6D3-12411-00	11 - 33	6B6-13411-00	7 - 11	6BU-1475E-00	9 - 26	F3J-6150D-00	29 - 14	6BU-81639-00	17 - 33
4XV-12113-00	4 - 10	6BH-12413-00	11 - 34	60E-13421-00	8 - 7	6BU-1475F-00	9 - 27	F3J-6150F-00	29 - 13	6D3-81800-00	16 - 1
4XV-12114-00	4 - 11	60E-12417-10	11 - 32	5GH-13440-50	2 - 25	60E-14784-00-94	9 - 22	F1B-6151S-00	29 - 3	3AJ-81809-00	16 - 6
1HX-12116-01	4 - 8	60E-12435-00	10 - 35	6D3-13443-00-94	8 - 24	6BU-15100-00	2 - 1	F2X-6152M-00	31 - 4	60E-81810-00	16 - 10
1HX-12117-00	4 - 12		11 - 39	60E-13446-00	8 - 1	6BU-15362-A0	8 - 20	F1K-6153R-00	31 - 9	6D3-81820-00	16 - 9
1WG-12117-00	4 - 13	6BU-1243A-00	10 - 11	6D3-13462-00-94	8 - 3	6D3-15515-00	15 - 1	F1K-61624-00	23 - 23	6M6-81826-00	16 - 4
1HX-12118-00	4 - 14		11 - 11	6D3-13463-00-94	8 - 14	60E-15517-00	15 - 2	FOX-61637-00	23 - 26	6M6-81830-00	16 - 2
1WG-12118-00	4 - 15	6BU-1243F-10	10 - 37	60E-13473-00	8 - 21	60E-15521-00	15 - 3	EU0-61652-00	10 - 10	6M6-81840-10	16 - 8
4SV-12119-00	4 - 17		11 - 44	60E-13475-00	8 - 15	4WM-15590-00	15 - 4		11 - 10	11H-81844-00	16 - 5
4TV-12119-00	4 - 16	60E-12443-00	10 - 8	6B6-13475-01	7 - 13	6D3-17572-00	3 - 11		23 - 8	6BU-81845-00	17 - 27
5LV-12121-00	4 - 7		11 - 8		35 - 6	6B6-17585-00	3 - 18	FOX-61652-00	23 - 27	6D3-81845-00	15 - 21

NUMERICAL INDEX

PART NO.	REF. NO.	PART NO.	REF. NO.	PART NO.	REF. NO.	PART NO.	REF. NO.	PART NO.	REF. NO.	PART NO.	REF. NO.
6EX-81845-00	17 - 47	67X-E2590-10	11 - 50	F2X-U1708-00	21 - 34	F2X-U351K-00	24 - 24	F2C-U3850-00	26 - 4	F2X-U417J-00	33 - 8
1FK-81847-00	16 - 3	6EX-G5538-00	12 - 13	F2X-U2127-00	25 - 1		24 - 24	F1B-U3850-02	26 - 9	F2X-U417J-10	33 - 8
6M6-81850-00	16 - 7	6CS-G5831-00	12 - 2	F2N-U213G-01	25 - 5	F2X-U351K-20	24 - 24	F2P-U4114-00	33 - 10	F2X-U417J-20	33 - 8
6CS-81860-00	30 - 2	6EX-G6882-00	12 - 9	F2X-U2157-00	25 - 2	F2X-U351K-30	24 - 24	F1X-U4114-60	33 - 10	F2X-U417J-30	33 - 8
6BU-81861-00	17 - 40	6EX-R1313-00	12 - 32	F1S-U2280-02	23 - 36	F2X-U351M-00	24 - 25	F2P-U4114-A0	33 - 10	F1G-U418F-00	34 - 8
1B7-81940-00	17 - 63	6ET-R1314-01	14 - 4	F1S-U2285-00	23 - 37		24 - 25	F2N-U411C-00	33 - 9	GJ3-U419E-00	34 - 10
6EX-81953-00	17 - 48	6EX-R1318-00	12 - 23	F2X-U2511-00	24 - 1	F2X-U351M-20	24 - 25	F2P-U411C-00	33 - 9	F1S-U419E-01	34 - 10
6EX-8195A-00	17 - 20	6D3-R1319-00	12 - 21		24 - 1	F2X-U351M-30	24 - 25	F1B-U411C-02	33 - 10		34 - 10
6S8-81960-00	17 - 37	6D3-R1321-02	12 - 22	F2X-U2511-10	24 - 1	F2X-U351N-00	24 - 26	F1X-U411C-60	33 - 9	F2X-U41B1-10	34 - 1
6EX-82115-00	17 - 61	6EX-R1326-00	12 - 18	F2X-U2512-00	24 - 7		24 - 26	F2P-U411C-A0	33 - 9	F2S-U41B1-20	34 - 2
6BU-82116-00	19 - 48	6EX-R1333-00	12 - 1		24 - 7	F2X-U351N-20	24 - 26	F1W-U4121-00	33 - 12	F1B-U41B1-21	34 - 2
6EX-82117-00	17 - 62	6ET-R1341-00	14 - 1	F2X-U2512-10	24 - 7	F2X-U351N-30	24 - 26	F2S-U413P-00	34 - 12		34 - 2
67F-82151-00	17 - 17	6EX-R1341-00	12 - 31	F2X-U2519-10	24 - 8	F2X-U3581-01	24 - 21	F1X-U413P-02	34 - 12	F2S-U41B1-30	34 - 3
6EX-82151-00	17 - 19	6ET-R1342-00	14 - 2		24 - 8		24 - 21		34 - 12	F1B-U41B1-31	34 - 3
67F-82151-10	17 - 18	60E-R1381-01	13 - 15	F2X-U2519-20	24 - 8	F2X-U3581-20	24 - 21	F1B-U415B-11	34 - 5		34 - 3
67F-82151-30	17 - 15	F2C-U1314-00	23 - 48	F2X-U2519-30	24 - 8	F2X-U3581-30	24 - 21	F1S-U415B-11	34 - 5	F1B-U41B2-01	34 - 4
67F-82151-40	17 - 16	F2X-U135C-00	22 - 11	F2X-U251D-00	24 - 13	F2X-U371A-00	26 - 1		34 - 5		34 - 4
6EX-82170-00	17 - 14	F2S-U13C1-00	21 - 12		24 - 13	F2X-U371A-10	26 - 1	GJ3-U416H-01	34 - 11	F0M-U41B2-11	34 - 4
6EX-82310-00	18 - 6		22 - 5	F2X-U251D-10	24 - 13	F2X-U371A-30	26 - 1	GP8-U416H-01	34 - 11	F0V-U41DB-12	34 - 6
6A0-82317-00	7 - 22	F2X-U13C1-00	22 - 34	F2X-U251E-00	24 - 16	F2X-U371B-00	26 - 2		34 - 11	F2S-U41E1-10	34 - 9
	17 - 23	F2X-U142D-00	32 - 3		24 - 16	F2X-U371B-10	26 - 2	F2X-U417B-00	33 - 1	F1S-U41E1-11	34 - 9
	17 - 31		32 - 3	F2X-U251E-10	24 - 16	F2X-U371B-30	26 - 2	F2X-U417B-10	33 - 1		34 - 9
68V-82504-00	18 - 20	F2X-U142D-10	32 - 3	F2N-U2663-01	22 - 6	F2X-U372A-00	26 - 6	F2X-U417B-20	33 - 1	F1B-U41F5-11	34 - 7
60E-82532-00	18 - 22	F2N-U142L-00	19 - 10	F1W-U2664-01	26 - 3	F2X-U372A-10	26 - 6	F2X-U417B-30	33 - 1	F1B-U41F5-21	34 - 7
60E-82556-00	19 - 3		21 - 15	F1K-U266B-00	22 - 30	F2X-U372A-30	26 - 6	F2X-U417C-00	33 - 2		34 - 7
6D3-82560-01	18 - 16		21 - 25		22 - 33	F2X-U372B-00	26 - 7	F2X-U417C-10	33 - 2	F2C-U4256-00	19 - 43
60E-82560-A1	18 - 13		24 - 5	F2N-U266C-01	22 - 20	F2X-U372B-10	26 - 7	F2X-U417C-20	33 - 2	F2N-U4261-00	28 - 9
6EX-82588-00	17 - 51		24 - 6	F2C-U266D-01	26 - 8	F2X-U372B-30	26 - 7	F2X-U417C-30	33 - 2	F1K-U471E-03	22 - 13
703-82591-00	31 - 6		24 - 15	F2C-U266E-00	26 - 34	F2S-U375E-00	26 - 16	F2X-U417D-00	33 - 3	F2X-U475B-00	22 - 19
60E-8259E-00	17 - 26		24 - 18	F1W-U269B-00	23 - 7	F1W-U3768-01	22 - 4	F2X-U417D-10	33 - 3	F2S-U475F-00	22 - 26
6EX-8259L-A0	18 - 9		28 - 15	F2X-U271B-00	26 - 24		22 - 29	F2X-U417D-20	33 - 3	F1W-U491K-00	24 - 2
6D3-8273J-01	18 - 23	F2X-U143D-00	32 - 1		26 - 24		22 - 32	F2X-U417D-30	33 - 3		24 - 14
60E-83627-00	8 - 27		32 - 1	F2X-U271B-10	26 - 24	F1K-U3774-00	26 - 25	F2X-U417E-00	33 - 4		24 - 17
68F-83688-10	6 - 6	F2X-U143D-10	32 - 1	F2C-U2733-00	28 - 18	GH1-U3774-00	26 - 12	F2X-U417E-10	33 - 4	GP7-U4953-10	23 - 19
682-84385-01	10 - 9	F2X-U143E-00	32 - 2	F2X-U273B-00	12 - 39	F2X-U377B-00-P0	21 - 13	F2X-U417E-20	33 - 4		23 - 20
	11 - 9		32 - 2	F2X-U278A-00	23 - 45	F2X-U377B-00-P2	21 - 13	F2X-U417E-30	33 - 4		23 - 21
6D3-85132-00	1 - 23	F2X-U143E-10	32 - 2	F2S-U278F-00	23 - 49	F2X-U377B-00-P3	21 - 13	F2X-U417F-00	33 - 5		26 - 36
6AA-85542-00	8 - 19	EU0-U1461-03	14 - 14	F2S-U278H-00	23 - 50	F2X-U377B-00-P4	21 - 13	F2X-U417F-10	33 - 5	F2X-U515A-00	22 - 8
6BU-85542-00	8 - 9	F1K-U1467-01	31 - 20	F1K-U283B-02	22 - 14	F2X-U377C-00-P0	21 - 23	F2X-U417F-20	33 - 5	F2C-U515D-00	22 - 3
61A-85790-00	18 - 11	F1K-U1468-03	31 - 23	F2X-U2875-00	21 - 36	F2X-U377C-00-P2	21 - 23	F2X-U417F-30	33 - 5	F2X-U516P-00	21 - 33
60E-85896-01	18 - 18	F2S-U1516-00	30 - 8	F2X-U351H-00	24 - 22	F2X-U377C-00-P3	21 - 23	F2X-U417G-00	33 - 6	F2X-U5175-00	21 - 6
6EX-8591A-A0	17 - 28	F2C-U151S-00	19 - 30		24 - 22	F2X-U377C-00-P4	21 - 23	F2X-U417G-10	33 - 6		21 - 17
6EX-8591A-B0	17 - 28	F2X-U1552-00	30 - 4	F2X-U351H-20	24 - 22	F2X-U377F-00	21 - 19	F2X-U417G-20	33 - 6		21 - 27
6B6-86261-00	18 - 29	F2S-U155D-02	30 - 5	F2X-U351H-30	24 - 22	F2X-U377G-00	21 - 29	F2X-U417G-30	33 - 6	F2X-U517B-00-P0	22 - 1
6B6-86261-10	18 - 29	F2X-U156E-00	32 - 4	F2X-U351J-00	24 - 23	F2C-U377H-00	23 - 47	F2X-U417H-00	33 - 7	F2X-U517B-00-P2	22 - 1
6B6-86265-00	18 - 30	F2N-U1628-02	23 - 16		24 - 23	F2X-U377H-00	21 - 22	F2X-U417H-10	33 - 7	F2X-U517B-00-P3	22 - 1
6B6-86265-10	18 - 30		26 - 35	F2X-U351J-20	24 - 23	F2X-U377J-00	21 - 32	F2X-U417H-20	33 - 7	F2X-U517B-00-P4	22 - 1
67X-E2590-10	10 - 43	F1B-U1653-02	23 - 22	F2X-U351J-30	24 - 23	F2X-U378C-00	26 - 21	F2X-U417H-30	33 - 7	F2X-U517C-01	22 - 7

NUMERICAL INDEX

PART NO.	REF. NO.	PART NO.	REF. NO.	PART NO.	REF. NO.	PART NO.	REF. NO.	PART NO.	REF. NO.	PART NO.	REF. NO.
F1K-U517D-05	22 - 10	F2S-U759B-00	27 - 41	F1W-U828M-00	22 - 22	6EX-W009A-00-94	1 - 1	90119-069UH	31 - 24	90159-05014	5 - 6
F2X-U517E-00	21 - 2	F1K-U759C-00	22 - 37		25 - 6	6BU-W009B-00-94	2 - 4	90119-069UP	26 - 5	90169-049U1	27 - 23
	21 - 20		27 - 44		27 - 9	90105-06026	1 - 9		26 - 10	90176-06047	17 - 25
	21 - 30	F1W-U759C-01	27 - 42		27 - 12	90105-06035	8 - 17	90119-069UX	14 - 7		17 - 30
F2X-U517F-00	21 - 1		27 - 43	F3J-U8368-01	19 - 35		10 - 36	90119-06M65	7 - 24		17 - 36
F1K-U517R-00	22 - 12	F1B-U761D-02	23 - 10	F1W-U8376-00	18 - 3		11 - 35	90119-08031	9 - 13		17 - 39
F1K-U518E-04	22 - 9	F2S-U7711-02	27 - 15	F2X-U8571-00	12 - 46		11 - 40	90119-08034	7 - 15		17 - 45
F2X-U519D-00	21 - 35	F1W-U771H-00	23 - 46		12 - 47	90105-06036	8 - 16	90119-08036	9 - 7		17 - 50
F2X-U519G-00	22 - 2	6EX-U773D-00	23 - 5	F2N-U8572-00	5 - 14	90105-06054	11 - 41		9 - 12		17 - 54
F2X-U5554-00	21 - 4	6EX-U773E-00	23 - 2		5 - 15	90105-06790	9 - 24	90119-08043	7 - 16		17 - 56
F2X-U555B-00	21 - 10	F1B-U7773-00	27 - 16	F2X-U8572-00	12 - 41	90105-06826	22 - 15	90119-08045	7 - 14		17 - 59
F1K-U5772-04	22 - 35	F2X-U7831-00	27 - 19		12 - 42	90105-06M07	2 - 15	90119-08050	6 - 26	90176-10001	1 - 16
	27 - 37	GP7-U7832-01	27 - 21	F2S-U8577-00	12 - 43		8 - 26	90119-08074	6 - 27		8 - 31
F2X-U590D-10	22 - 28	F2X-U7833-00	27 - 20	F2S-U8592-00	19 - 5	90105-06M17	2 - 11	90119-08075	9 - 8	90179-08327	3 - 9
	22 - 28	GP7-U7834-10	27 - 25	F2S-U8593-00	19 - 6	90105-07004	4 - 4	90119-08085	7 - 7	90179-10006	1 - 14
F2X-U590D-30	22 - 28	GP7-U7835-00	27 - 22	F2N-U883B-00	13 - 20	90105-08860	23 - 32	90119-08823	12 - 40	90179-10414	1 - 15
F2X-U590D-50	22 - 28	GP7-U783F-00	27 - 26	F2N-U883E-00	13 - 17		23 - 33		12 - 44	90201-06801	14 - 9
F2X-U590E-10	22 - 31	F2X-U7844-01	27 - 27	F1S-U883N-01	23 - 29	90105-093A5	2 - 6		12 - 45		14 - 12
	22 - 31	F0D-U7856-10	27 - 36	F1S-U883P-01	23 - 30	90105-105A6	15 - 10		20 - 6	90201-068G0	30 - 7
F2X-U590E-30	22 - 31	F1K-U785G-00	27 - 34	F1X-U883T-01	23 - 31	90109-06051	2 - 9		20 - 7	90201-06906	29 - 6
F2X-U590E-50	22 - 31	F0D-U785G-10	19 - 15	F2S-U890L-04	26 - 11	90109-066F0	1 - 19	90119-08827	31 - 26	90201-096J9	2 - 7
F2X-U591A-00	26 - 31	GP7-U785H-00	27 - 31	F2X-U89A8-00	24 - 27	90109-06832	13 - 18	90119-08828	26 - 18	90201-099U3	17 - 7
F2C-U591C-00	26 - 32	F2N-U815D-01	17 - 6	F2X-U89A8-10	24 - 27	90109-06M92	20 - 3		26 - 28		26 - 22
F2C-U591D-01	26 - 33	F2N-U8169-00	23 - 34		24 - 27	90109-08041	12 - 49	90119-08836	31 - 22	90201-10013	1 - 12
F2X-U5983-00	22 - 38		23 - 35	F2X-U89A8-20	24 - 27	90110-06040	23 - 28	90119-08840	12 - 33	90201-10019	1 - 13
F2N-U721B-00	20 - 11	F2S-U8211-00	19 - 8	F2X-U89A9-00	24 - 28		29 - 10		14 - 5	90201-103U7	15 - 11
F1S-U725E-01	12 - 36	EU0-U8217-H2	19 - 4	F2X-U89A9-10	24 - 28	90110-06382	30 - 6	90119-08851	29 - 11	90201-10801	12 - 37
F2X-U72C0-00	12 - 35	EU0-U821D-00	19 - 14		24 - 28	90110-06822	12 - 20	90119-08859	20 - 4	90201-109U6	26 - 13
6CN-U72M2-00	12 - 24	F1K-U8221-00	19 - 13	F2X-U89A9-20	24 - 28	90110-08041	7 - 6		20 - 5	90201-24800	13 - 12
F2S-U732B-00	20 - 9	F1S-U8221-00	19 - 11	F2X-U89AA-00	24 - 29	90110-08212	15 - 5	90119-08861	23 - 51	90209-25008	3 - 20
F2N-U732B-10	20 - 12		27 - 45	F2X-U89AA-10	24 - 29	90111-06803	21 - 14		23 - 52	90267-329UR	27 - 24
EU0-U7354-00-01	20 - 8		28 - 2		24 - 29		21 - 24	90119-089U7	12 - 52	90267-409U5	19 - 36
EU0-U7354-00-03	20 - 8		28 - 10	F2X-U89AA-20	24 - 29		24 - 3		17 - 1	90267-48802	17 - 4
EU0-U7354-00-05	20 - 8	EU0-U8221-30	19 - 12	F2X-U89AB-00	24 - 30		24 - 4	90119-089UL	13 - 16		21 - 7
EU0-U7354-00-10	20 - 8	F3J-U822E-00	19 - 22	F2X-U89AB-10	24 - 30	90116-10016	8 - 30	90119-08M22	5 - 11		21 - 18
EU0-U7354-00-20	20 - 8	F2S-U8244-00	26 - 17		24 - 30	90116-10058	2 - 5	90119-10013	9 - 20		21 - 28
F1B-U751G-00	28 - 13	F2X-U8262-00	21 - 11	F2X-U89AB-20	24 - 30	90119-05803	19 - 20	90119-10016	15 - 14		22 - 39
F2C-U753B-01	28 - 16	F1W-U826C-00	18 - 1	F2X-U89AC-00	24 - 31	90119-06048	18 - 25	90119-10017	9 - 19	90267-48803	19 - 46
F2X-U7550-00	28 - 1	F1K-U826C-03	23 - 43	F2X-U89AC-10	24 - 31	90119-06832	19 - 9	90119-10020	8 - 4		22 - 23
F2N-U7555-01	28 - 6	F3J-U8285-00	29 - 9		24 - 31	90119-06880	21 - 3	90119-10804	26 - 26	90267-48806	25 - 3
F2C-U7557-01	12 - 48	F1X-U828E-01	21 - 8	F2X-U89AC-20	24 - 31	90119-06882	21 - 5	90119-10806	12 - 30		25 - 4
F2C-U7564-00	28 - 17	F1S-U828H-01	17 - 2	F2X-U89AD-00	24 - 32		21 - 16	90119-10810	12 - 4	90267-48825	24 - 19
GJ1-U7578-11	19 - 27	F2P-U828K-00	22 - 40	F2X-U89AD-10	24 - 32		21 - 26	90119-10M02	8 - 29		24 - 20
	19 - 28	F1W-U828M-00	17 - 3		24 - 32	90119-06889	12 - 11	90119-10M19	15 - 15	90267-489U1	10 - 44
GJ1-U7578-21	19 - 26		19 - 32	F2X-U89AD-20	24 - 32	90119-06891	13 - 13	90149-05903	32 - 6		11 - 51
F1S-U757B-01	28 - 14		19 - 37	F1S-U8K31-02	19 - 29		14 - 3	90150-05807	19 - 31		18 - 2
F2N-U758D-00	28 - 11		19 - 40	6D3-W0001-01	35 - 1		20 - 14	90154-06017	32 - 5		18 - 4
F2S-U759B-00	27 - 40		19 - 45	6EX-W0001-20	35 - 10	90119-06893	12 - 6	90159-05013	5 - 5		19 - 7

NUMERICAL INDEX

PART NO.	REF. NO.	PART NO.	REF. NO.	PART NO.	REF. NO.	PART NO.	REF. NO.	PART NO.	REF. NO.	PART NO.	REF. NO.
90267-489U1	22 - 36	90446-14M23	18 - 15	90464-40825	5 - 18	90467-200A3	11 - 19	9299R-05200	23 - 40	93608-16M16	9 - 6
	23 - 44	90446-20MF5	12 - 27	90464-99804	25 - 8		11 - 27		24 - 11		15 - 16
	27 - 38	90447-19801	10 - 7	90465-11829	12 - 28		11 - 46		24 - 12	93700-06M03	13 - 3
	28 - 5		11 - 7		19 - 18		11 - 47	9299R-06200	22 - 17	94591-49130	4 - 21
90267-489U2	20 - 10	90447-22001	10 - 17		23 - 12	90467-210A0	10 - 30	9299R-08200	17 - 11	94702-00409	18 - 8
	20 - 13		11 - 17		27 - 32		23 - 15		17 - 12	95023-06012	1 - 10
	27 - 5	90447-22003	10 - 12		27 - 33	90467-21800	23 - 13		17 - 13	95027-06010	2 - 22
	31 - 21		11 - 12		27 - 35	90467-240A0	11 - 31		26 - 20	95380-06700	16 - 13
90267-489U6	19 - 33	90447-22004	10 - 2	90465-13152	18 - 27	90467-26800	23 - 15	9299R-10200	26 - 29	9538R-06600	14 - 10
	19 - 38		11 - 2	90465-13M18	17 - 46	90468-12069	3 - 6		26 - 14		14 - 13
	19 - 41	90447-22005	10 - 38		17 - 60	90480-19800	21 - 9		26 - 27	9538R-06700	29 - 7
	25 - 7		11 - 45		18 - 26	90480-22M15	5 - 9	93101-21001	12 - 16	95720-06300	31 - 11
	27 - 7	90447-25002	10 - 32		18 - 28		5 - 12		35 - 15	95720-08300	31 - 14
	27 - 10	90447-28010	11 - 38	90465-13M24	17 - 43	90601-118UF	12 - 25	93101-21002	12 - 17	9572R-05300	23 - 41
	27 - 13	90450-17M17	6 - 17		18 - 10		23 - 9		35 - 14		23 - 42
90267-489U8	23 - 11		6 - 18	90465-13M39	8 - 37	90601-155U4	13 - 19	93101-25M55	13 - 7	9572R-06300	22 - 16
	24 - 9	90450-57006	6 - 10	90467-089U1	19 - 16		27 - 28		35 - 11		27 - 18
	24 - 10	90450-90001	9 - 17	90467-110A1	7 - 31		27 - 29	93101-35004	3 - 13	9572R-08300	17 - 8
90269-08801	22 - 25	90450-94001	9 - 29	90467-150A5	10 - 6	90601-175UR	5 - 16		35 - 5		17 - 9
	22 - 27		9 - 31		11 - 6	90601-179U8	28 - 7	93102-25009	13 - 10		17 - 10
90280-03047	15 - 12	90450-99004	9 - 28	90467-160A0	9 - 2	90601-200U2	19 - 42		35 - 12		23 - 17
90340-27001	1 - 7		9 - 30		10 - 22		19 - 44	93210-06667	2 - 21		23 - 18
90387-06083	11 - 43	90450-99005	9 - 15		10 - 24	90605-502U1	22 - 21	93210-08001	2 - 24		26 - 19
90387-06119	7 - 23	90450-99801	28 - 12		10 - 29	91317-05010	15 - 20	93210-18322	8 - 2		26 - 23
	17 - 24	90450-99804	28 - 8		11 - 22	91317-05014	8 - 6	93210-18417	1 - 26		26 - 30
	17 - 32	90464-09M47	17 - 52		11 - 24	91317-05016	8 - 23		1 - 32		26 - 37
90387-06289	13 - 14	90464-12089	5 - 10		11 - 29	91317-06014	8 - 8	93210-464A3	12 - 19		29 - 12
90387-06M05	8 - 10	90464-21001	7 - 28	90467-170A4	7 - 26		15 - 19		35 - 13	9572R-10300	12 - 38
	8 - 18		7 - 29		7 - 27	91317-06016	1 - 27	93210-60ME8	18 - 24		26 - 15
	8 - 35		7 - 34		7 - 33		1 - 33	93212-04001	15 - 17	95814-06012	17 - 49
90387-06M30	14 - 8	90464-31001	10 - 41		8 - 33		7 - 12	93306-07801	3 - 14		17 - 53
90387-08M06	12 - 34		11 - 48		10 - 26	91317-06035	15 - 8	93306-205A3	13 - 9		17 - 55
90387-08M30	14 - 6		17 - 41		11 - 26	91380-04030	30 - 9	93306-205U0	12 - 14	95814-06020	17 - 35
90387-08M37	5 - 13	90464-32801	17 - 5	90467-17802	28 - 19	91380-06016	18 - 19	93306-27211	12 - 12		17 - 38
90401-20007	2 - 26		19 - 23	90467-18804	23 - 6	91380-06020	8 - 36	93306-30441	7 - 9	95814-06025	17 - 22
90430-06014	1 - 11		19 - 24	90467-200A0	23 - 14	91380-06025	4 - 25	93306-30610	3 - 16		17 - 29
90430-06M03	2 - 16		19 - 25	90467-200A3	10 - 4	91808-16023	1 - 8	93430-47M04	13 - 8	95814-06070	2 - 10
90430-12002	12 - 51		19 - 34		10 - 13	92014-06012	6 - 21	93440-07149	1 - 5	95880-06016	18 - 7
90445-14807	12 - 26		19 - 39		10 - 14		6 - 24	93440-10153	1 - 6	97095-06012	17 - 64
90445-18M03	10 - 23		19 - 47		10 - 18		17 - 44	93440-28062	3 - 21	97513-05514	15 - 9
	11 - 23		22 - 24		10 - 19		17 - 58	93603-12221	7 - 4	97513-06520	2 - 19
90445-20800	23 - 4		27 - 11		10 - 27	92990-06100	16 - 12	93606-12019	9 - 11	97513-06525	7 - 5
90445-20804	23 - 1		27 - 14		10 - 39	92990-10600	18 - 12		12 - 7	97513-06535	7 - 18
90445-21805	10 - 1	90464-35132	10 - 33		10 - 40	92990-12200	12 - 50		12 - 29	97513-06555	1 - 22
	11 - 1		10 - 42		11 - 4		23 - 25		13 - 5		7 - 17
90445-22007	10 - 31		11 - 49		11 - 13	92995-06100	17 - 65	93606-25M00	7 - 20	97513-08520	1 - 24
90445-25006	11 - 37		18 - 5		11 - 14	92995-06600	17 - 66	93607-44002	4 - 28	97513-08530	16 - 11
90445-26004	11 - 30	90464-38800	5 - 17		11 - 18	9299R-05200	23 - 39	93608-16M16	7 - 19	97595-06416	18 - 14

NUMERICAL INDEX

PART NO.	REF. NO.	PART NO.	REF. NO.	PART NO.	REF. NO.	PART NO.	REF. NO.	PART NO.	REF. NO.
97595-06416	18 - 17								
97595-06520	8 - 11								
97595-08540	2 - 17								
9788R-05025	23 - 38								
98780-04015	8 - 13								
99009-52500	7 - 10								
99009-72500	3 - 17								
99530-08012	2 - 23								
99530-10014	2 - 2								
	2 - 8								
99590-14016	12 - 3								
99780-12600	23 - 24								