

PARTS CATALOGUE

WaveRunner VX Deluxe/Cruiser

VX1100B-F (F1KD,F1KE/6D3H,6D3J/6D32)

VX1100A-F (F1KH,F1KJ/6D3H,6D3J/6D32)

MJ-VX1100A '07 (F1KD,F1KH/6D3H/6D32)

VX1100A-F/VX1100B-F
PARTS CATALOGUE
©2006 by Yamaha Motor Co., Ltd.
1st edition, September 2006
All rights reserved.
Any reprinting or unauthorized use
without the written permission of
Yamaha Motor Co., Ltd.
is expressly prohibited.
Printed in Japan.

A3

FOREWORD

This Parts Catalogue is related to the parts for the model(s) on the cover page. When you are ordering replacement parts, please refer to this Parts Catalogue and quote both part numbers and part names correctly.

1. Modifications or additions which have been made after the issue of the Parts Catalogue will be announced in the Parts News.

It is advisable that you make the necessary corrections to the Parts Catalogue according to the Parts News.

2. Abbreviations

The following abbreviations are used in this Parts Catalogue.

“UR” Use specified parts number.

“UN” Use as many as needed.

“AP” Alternate Parts

“LM” Locally Made (Parts need to be ordered locally)

“F#” Frame No. (Applicable machine No.)

“O/S” Over Size

3. The number of components for assembly

- Parts, which are to be supplied in an assembly, are listed with a dot (.) in front of the part name as shown below.
- The numeral appearing to the right of each component part indicates the quantity of parts for each assembly unit.

PART NO.	DESCRIPTION	Q'TY	REMARKS
2F5-83310-60	FRONT FLASHER LIGHT ASSY	2	
115-83311-60	.BULB (6V-18W)	1	

4. Applicable colours of graphics are represented in the “REMARKS” as shown below.

PART NO.	DESCRIPTION	Q'TY	REMARKS
2N4-24110-00-X5	FUEL TANK COMP.	2	MXR
3J1-24240-10	.GRAPHIC, FUEL TANK	1	FOR MXR

5. Note that the illustrations for reference in finding parts numbers are not to be used for assembling. When assembling, please use the applicable service manual.

6. The asterisk (*) before a reference number indicates modified items after the first edition.

FOREWORD

7. Applicable Serial No.

Engine Serial No.

Hull Serial No.

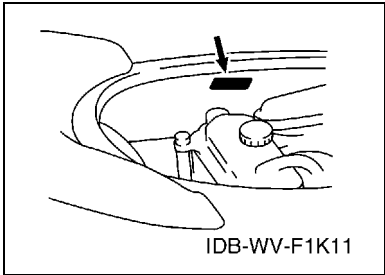
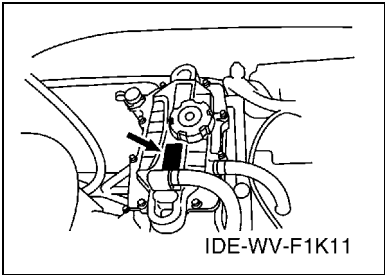

8. Applicable Colour Code (The (*) mark shows Model colour.)

Abbreviation	Colour Name	Colour Code
SS4(*)	BLACK SOLID 4	008P
SSA(*)	BLACK SOLID A	1000
NME	GRAY METALLIC E	1049
DPBMT	DEEP PURPLISH BLUE METALLIC T	0978

9. Quantity Column Information

Column No.	Name Of Q'ty Column	Destination
1	USA	U.S.A.
2	CAN	CANADA
3	GENE	EXCEPT U.S.A., CANADA, JAPAN
4	JPN	JAPAN

10. Applicable Starting Serial No.

Engine Serial No.

Serial No.	Name Of Q'ty Column	Model Code
6D3-1032901	USA	6D3H
6D3-1032901	CAN	6D3H
6D3-1032901	GENE	6D3J
6D3-1032901	JPN	6D3H

Hull Serial No.

Serial No.	Name Of Q'ty Column	Model Code
F1K-834201	USA	F1KD
F1K-833201		F1KH
F1K-838401	CAN	F1KD
F1K-840101		F1KH
F1K-833901	GENE	F1KE
F1K-833101		F1KJ
F1K-838401	JPN	F1KD
F1K-840101		F1KH

CONTENTS

CYLINDER	B2
CRANKCASE	B4
CRANKSHAFT & PISTON	B6
VALVE	B8
INTAKE	B10
INTAKE 2	B11
OIL PUMP	B12
OIL COOLER	B14
EXHAUST 1	C2
EXHAUST 2	C4
JET UNIT 1	C6
JET UNIT 2	C8
JET UNIT 3	C9
GENERATOR	C10
STARTING MOTOR	C11
ELECTRICAL 1	C12
ELECTRICAL 2	C14
ELECTRICAL 3	D2
ENGINE HATCH 1	D4
ENGINE HATCH 2	D5
HULL & DECK	D6
GUNWALE & MAT	D8
VENTILATION	D9
SEAT & UNDER LOCKER	D10
FUEL TANK	D11
EXHAUST 3	D13
CONTROL CABLE	D14
STEERING 1	E2
STEERING 2	E4
GRAPHICS	E5
IMPORTANT LABELS	E6
IMPORTANT LABELS 2	E7
IMPORTANT LABELS 3	E8
IMPORTANT LABELS 4	E9
REPAIR KIT 1	E10

INDEX

NUMERICAL INDEX	M1
-----------------------	----

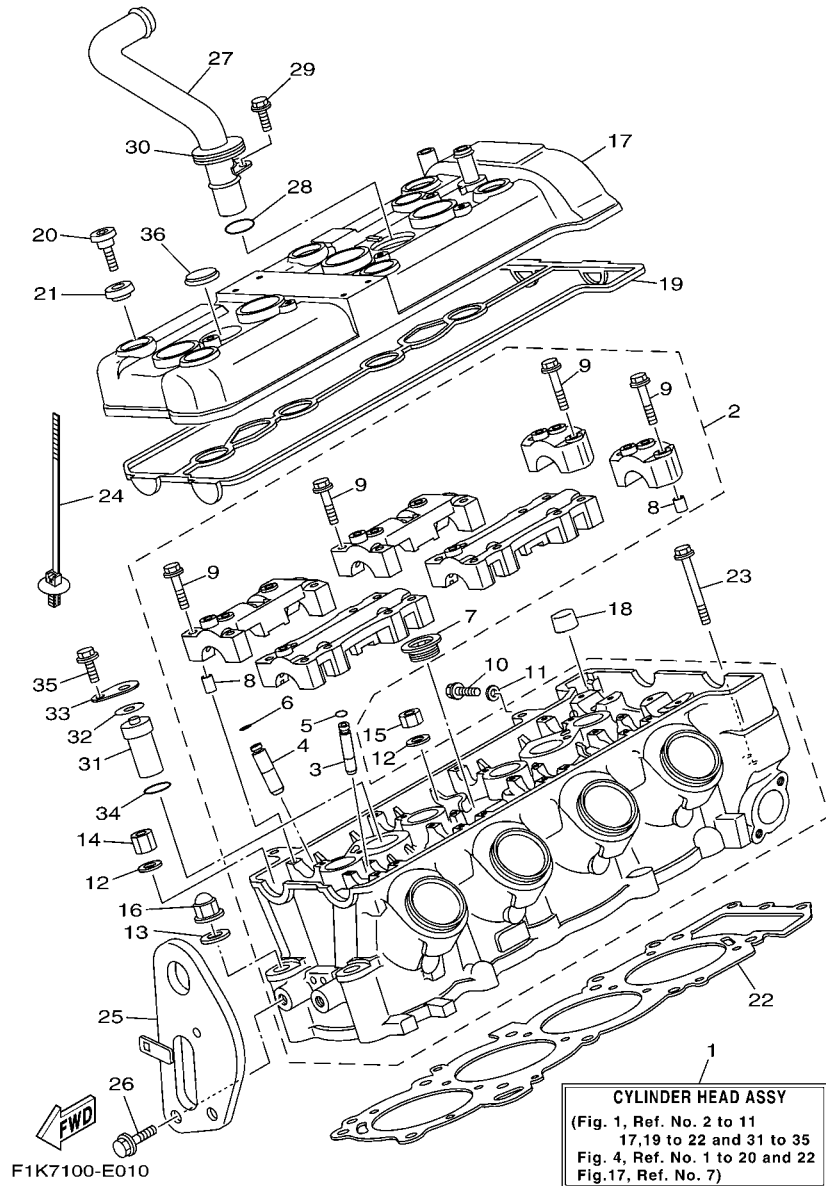
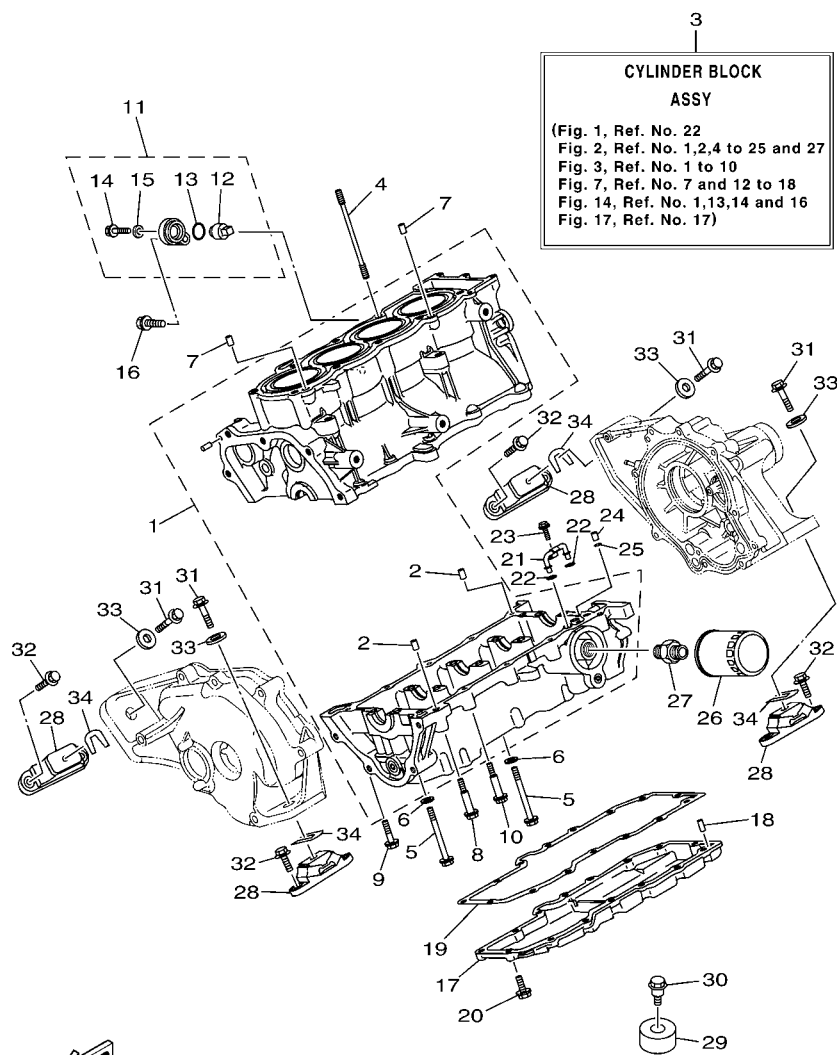

FIG. 1 CYLINDER

REF. NO.	PART NO.	DESCRIPTION	USA	CAN	GENE	JPN	REMARKS
1	6D3-W009A-00-94	CYLINDER HEAD ASSY	1	1		1	EXCEPT GENE
	6D3-W009A-10-94	CYLINDER HEAD ASSY			1		FOR GENE
2	6D3-11102-00-94	CYLINDER HEAD ASSY	1	1	1	1	
3	3TJ-11133-10	.GUIDE, VALVE	12	12	12	12	
4	1WG-11133-11	.GUIDE, VALVE	8	8	8	8	
5	93440-07149	.CIRCLIP	12	12	12	12	
6	93440-10153	.CIRCLIP	8	8	8	8	
7	90340-27001	.PLUG, STRAIGHT SCREW	1	1	1	1	
8	91808-16023	.PIN, DOWEL	12	12	12	12	
9	90105-06026	.BOLT, FLANGE	28	28	28	28	
10	95023-06012	BOLT	1	1	1	1	
11	90430-06014	GASKET	1	1	1	1	
12	90201-10013	WASHER, PLATE	8	8	8	8	
13	90201-10019	WASHER, PLATE	2	2	2	2	
14	90179-10006	NUT	3	3	3	3	
15	90179-10414	NUT	5	5	5	5	
16	90176-10001	NUT, CROWN	2	2	2	2	
17	6D3-11191-01-94	COVER, CYLINDER HEAD 1	1	1	1	1	
18	6D3-1118A-00	COVER	1	1	1	1	
19	60E-11193-01	GASKET, HEAD COVER 1	1	1	1	1	
20	90109-066F0	BOLT	6	6	6	6	
21	4KG-1111G-00	RUBBER, MOUNT 1	6	6	6	6	
22	6D3-11181-00	GASKET, CYLINDER HEAD 1	1	1	1	1	
23	97513-06555	BOLT, WITH WASHER	3	3	3	3	
24	90464-31001	CLAMP	1	1		1	
25	6D3-85132-00	BRACKET, REFLECTOR 1	1	1	1	1	
26	97513-08520	BOLT, WITH WASHER	2	2	2	2	



FWD
F1KD100-F020

FIG. 2 CRANKCASE

REF. NO.	PART NO.	DESCRIPTION	USA	CAN	GENE	JPN	REMARKS
1	6D3-15100-00-94	CRANKCASE ASSY	1	1	1	1	
2	99530-10014	.PIN, DOWEL	2	2	2	2	
3	6D3-W009B-10-94	CYLINDER BLOCK ASSY	1	1	1	1	
4	90116-10619	BOLT, STUD	10	10	10	10	
5	90105-093A5	BOLT, FLANGE	10	10	10	10	
6	90201-096J9	WASHER, PLATE	10	10	10	10	
7	99530-10014	PIN, DOWEL	2	2	2	2	
8	90109-06051	BOLT	2	2	2	2	
9	90105-06033	BOLT, FLANGE	1	1	1	1	
10	90105-06M17	BOLT, FLANGE	7	7	7	7	
11	69J-11301-00	ANODE COVER ASSY	1	1		1	EXCEPT GENE
	69J-11301-10	ANODE COVER ASSY			1		FOR GENE
12	67F-11325-01	.ANODE	1	1		1	EXCEPT GENE
	68V-11325-02	.ANODE			1		FOR GENE
13	67F-11328-00	.GROMMET, ANODE	1	1	1	1	
14	90105-06M07	.BOLT, FLANGE	1	1	1	1	
15	90430-06M03	.GASKET	1	1	1	1	
16	97595-08540	BOLT, WITH WASHER	1	1	1	1	
17	6B6-1310A-00-94	PAN, OIL	1	1	1	1	
18	93603-14M15	PIN, DOWEL	2	2	2	2	
19	6B6-13557-01	GASKET	1	1	1	1	
20	97513-06520	BOLT, WITH WASHER	15	15	15	15	
21	60E-13161-00	PIPE, DELIVERY 1	1	1	1	1	
22	93210-06667	O-RING	2	2	2	2	
23	95027-06010	BOLT, FLANGE	1	1	1	1	
24	99530-08012	PIN, DOWEL	1	1	1	1	
25	93210-08001	O-RING	1	1	1	1	

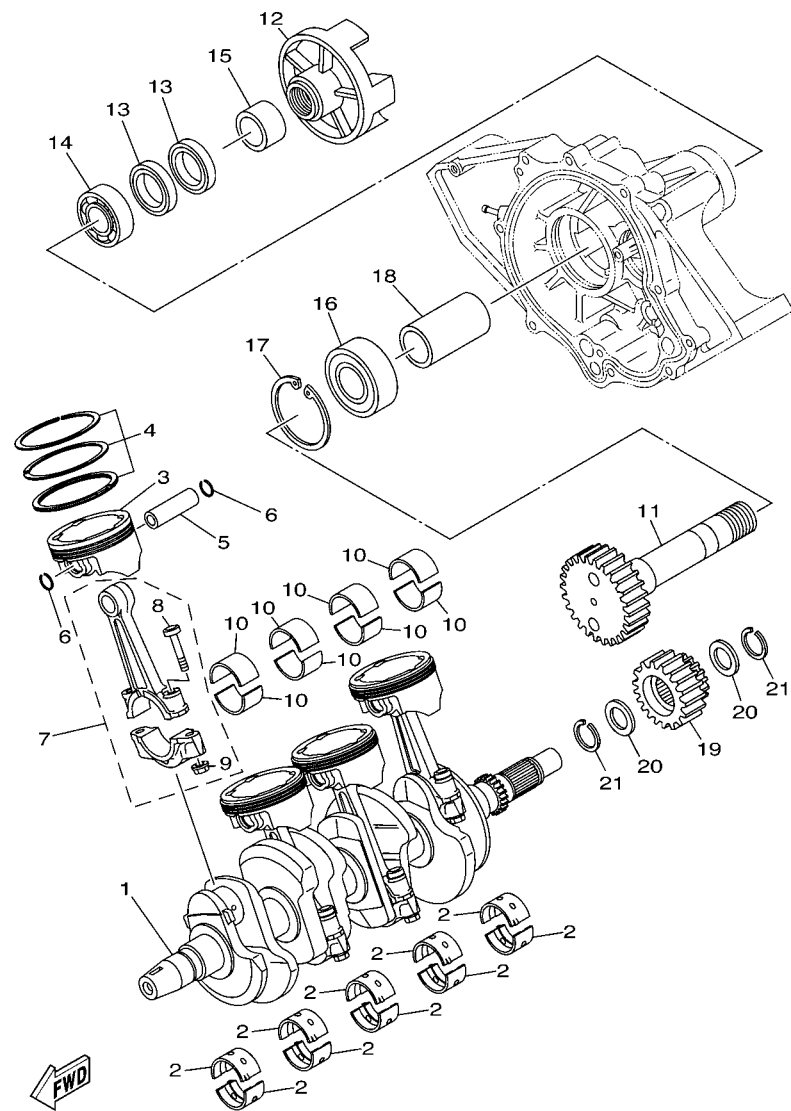

F1K1100-D030

FIG. 3 CRANKSHAFT & PISTON

REF. NO.	PART NO.	DESCRIPTION	USA	CAN	GENE	JPN	REMARKS
1	60E-11411-11	CRANKSHAFT	1	1	1	1	
2	6D3-11416-A0	PLANE BEARING, CRANKSHAFT 1	10	10	10	10	UR RED
	6D3-11416-00	PLANE BEARING, CRANKSHAFT 1	10	10	10	10	UR BROWN
	6D3-11416-10	PLANE BEARING, CRANKSHAFT 1	10	10	10	10	UR BLACK
	6D3-11416-20	PLANE BEARING, CRANKSHAFT 1	10	10	10	10	UR BLUE
	6D3-11416-30	PLANE BEARING, CRANKSHAFT 1	10	10	10	10	UR GREEN
3	6D3-11631-00-B0	PISTON (STD)	4	4	4	4	
4	6D3-11603-00	PISTON RING SET (STD)	4	4	4	4	
5	4XV-11633-00	PIN, PISTON	4	4	4	4	
6	90468-12069	CLIP	8	8	8	8	
7	6D3-11650-00	CONNECTING ROD ASSY	4	4	4	4	
8	5JW-11654-00	.BOLT, CONNECTING ROD	2	2	2	2	
9	90179-08327	.NUT	2	2	2	2	
10	60E-11656-00	PLANE BEARING, CONNECTING ROD	8	8	8	8	UR BROWN
	60E-11656-10	PLANE BEARING, CONNECTING ROD	8	8	8	8	UR BLACK
	60E-11656-20	PLANE BEARING, CONNECTING ROD	8	8	8	8	UR BLUE
	60E-11656-30	PLANE BEARING, CONNECTING ROD	8	8	8	8	UR GREEN
11	6D3-17572-00	SHAFT, TRANSFER	1	1	1	1	
12	6D3-45813-00-94	FLANGE, COUPLING	1	1	1	1	
13	93101-35004	OIL SEAL	2	2	2	2	
14	93306-07801	BEARING	1	1	1	1	
15	6B6-11478-00	COLLAR	1	1	1	1	
16	93306-30610	BEARING	1	1	1	1	
17	99009-72500	CIRCLIP	1	1	1	1	
18	6B6-17585-00	COLLAR, GEAR	1	1	1	1	
19	6B6-17586-00	GEAR, TRANSFER DRIVE	1	1	1	1	
20	90209-25008	WASHER	2	2	2	2	

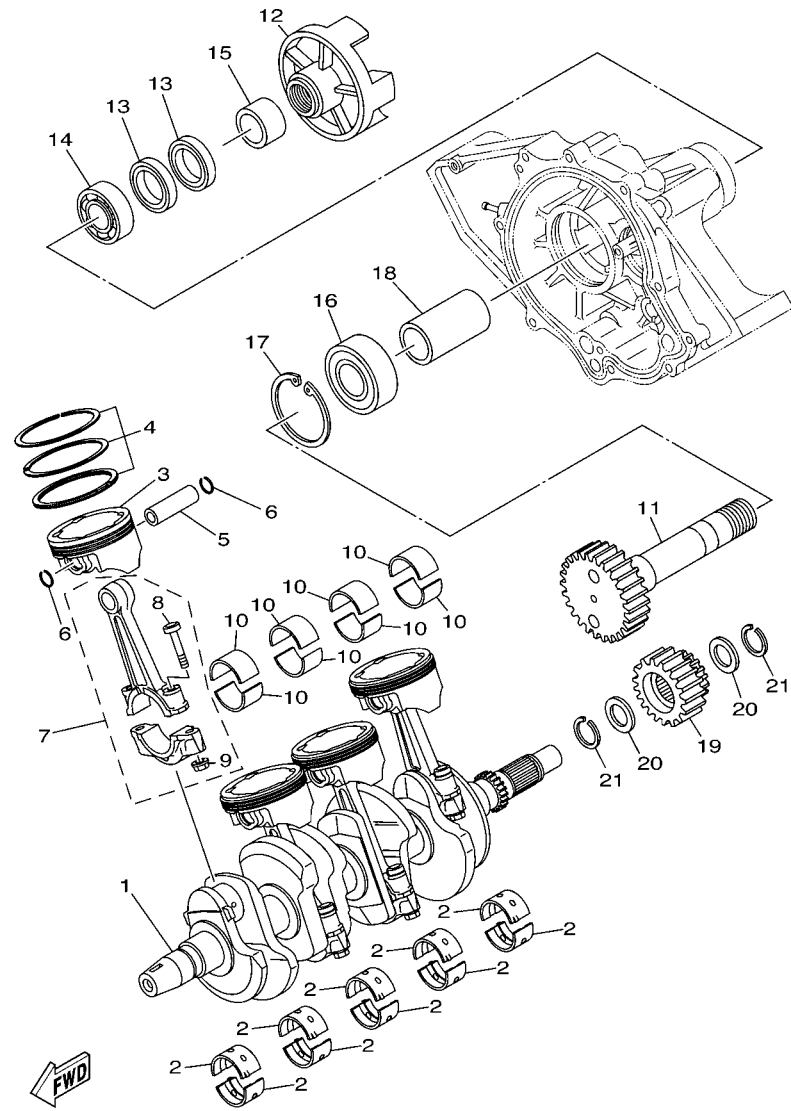

F1K1100-D030

FIG. 3 CRANKSHAFT & PISTON

REF. NO.	PART NO.	DESCRIPTION	USA	CAN	GENE	JPN	REMARKS
21	93440-28062	CIRCLIP	2	2	2	2	

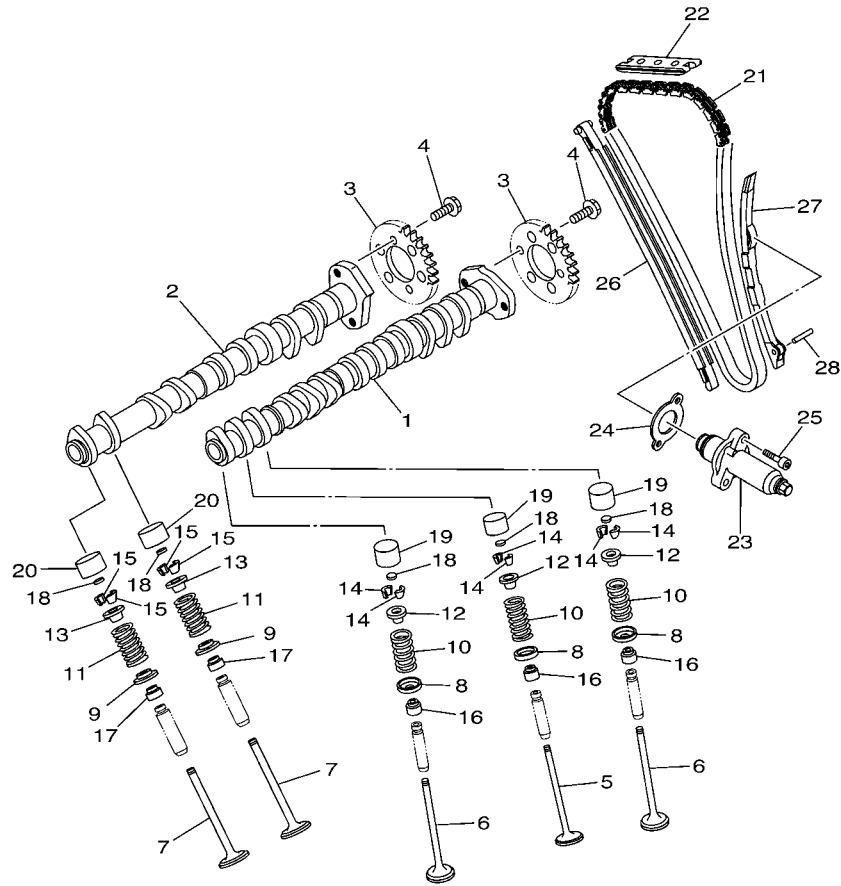

F1K1100-D040

FIG. 4 VALVE

REF. NO.	PART NO.	DESCRIPTION	USA	CAN	GENE	JPN	REMARKS
1	6D3-12171-00	CAMSHAFT 1	1	1		1	EXCEPT GENE
	6D3-12171-10	CAMSHAFT 1			1		FOR GENE
2	6D3-12181-00	CAMSHAFT 2	1	1	1	1	
3	6D3-12176-00	SPROCKET, CAM CHAIN	2	2	2	2	
4	90105-07004	BOLT, FLANGE	4	4	4	4	
5	4XV-12111-00	VALVE, INTAKE	4	4	4	4	
6	4XV-12112-00	VALVE, INTAKE 2	8	8	8	8	
7	5LV-12121-00	VALVE, EXHAUST	8	8	8	8	
8	1HX-12116-01	SEAT, VALVE SPRING	12	12	12	12	
9	3GM-12126-00	SEAT, VALVE SPRING 2	8	8	8	8	
10	4XV-12113-00	SPRING, VALVE INNER	12	12	12	12	
11	4XV-12114-00	SPRING, VALVE OUTER	8	8	8	8	
12	1HX-12117-00	RETAINER, VALVE SPRING	12	12	12	12	
13	1WG-12117-00	RETAINER, VALVE SPRING	8	8	8	8	
14	1HX-12118-00	COTTER, VALVE	24	24	24	24	
15	1WG-12118-00	COTTER, VALVE	16	16	16	16	
16	4TV-12119-00	SEAL, VALVE STEM	12	12	12	12	
17	4SV-12119-00	SEAL, VALVE STEM	8	8	8	8	
18	1HX-12168-00	PAD, ADJUSTING 2 (1.20)	20	20	20	20	UR
	1HX-12168-20	PAD, ADJUSTING 2 (1.25)	20	20	20	20	UR
	1HX-12168-40	PAD, ADJUSTING 2 (1.30)	20	20	20	20	UR
	1HX-12168-60	PAD, ADJUSTING 2 (1.35)	20	20	20	20	UR
	1HX-12168-80	PAD, ADJUSTING 2 (1.40)	20	20	20	20	UR
	1HX-12168-A0	PAD, ADJUSTING 2 (1.45)	20	20	20	20	UR
	1HX-12168-F0	PAD, ADJUSTING 2 (1.50)	20	20	20	20	UR
	1HX-12168-H1	PAD, ADJUSTING 2 (1.55)	20	20	20	20	UR
	1HX-12168-K1	PAD, ADJUSTING 2 (1.60)	20	20	20	20	UR

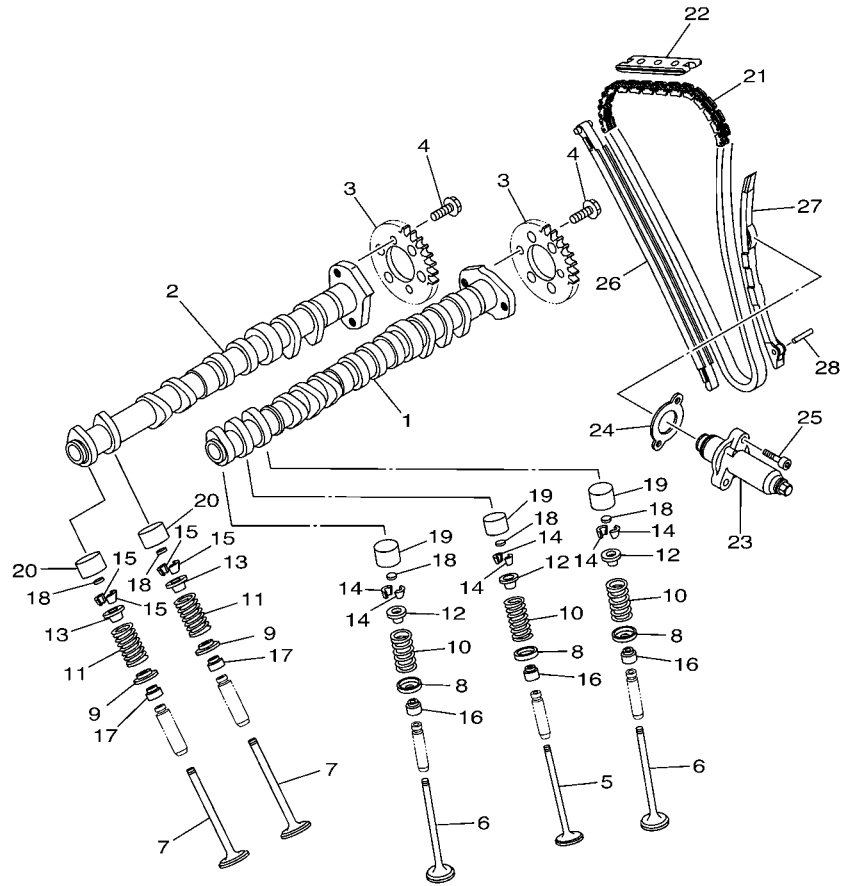

F1K1100-D040

FIG. 4 VALVE

REF. NO.	PART NO.	DESCRIPTION	USA	CAN	GENE	JPN	REMARKS
18	1HX-12168-M1	PAD, ADJUSTING 2 (1.65)	20	20	20	20	UR
	1HX-12168-R1	PAD, ADJUSTING 2 (1.70)	20	20	20	20	UR
	1HX-12168-U1	PAD, ADJUSTING 2 (1.75)	20	20	20	20	UR
	1HX-12168-W1	PAD, ADJUSTING 2 (1.80)	20	20	20	20	UR
	1HX-12168-Y1	PAD, ADJUSTING 2 (1.85)	20	20	20	20	UR
	1HX-12169-11	PAD, ADJUSTING 2 (1.90)	20	20	20	20	UR
	1HX-12169-31	PAD, ADJUSTING 2 (1.95)	20	20	20	20	UR
	1HX-12169-50	PAD, ADJUSTING 2 (2.00)	20	20	20	20	UR
	1HX-12169-70	PAD, ADJUSTING 2 (2.05)	20	20	20	20	UR
	1HX-12169-90	PAD, ADJUSTING 2 (2.10)	20	20	20	20	UR
	1HX-12169-E0	PAD, ADJUSTING 2 (2.15)	20	20	20	20	UR
	1HX-12169-G0	PAD, ADJUSTING 2 (2.20)	20	20	20	20	UR
	1HX-12169-J0	PAD, ADJUSTING 2 (2.25)	20	20	20	20	UR
	1HX-12169-L0	PAD, ADJUSTING 2 (2.30)	20	20	20	20	UR
	1HX-12169-N0	PAD, ADJUSTING 2 (2.35)	20	20	20	20	UR
	1HX-12169-T0	PAD, ADJUSTING 2 (2.40)	20	20	20	20	UR
19	3LN-12153-10	LIFTER, VALVE	12	12	12	12	YELLOW
20	3FV-12153-10	LIFTER, VALVE	8	8	8	8	YELLOW
21	94591-49130	CHAIN	1	1	1	1	
22	5BE-12241-00	GUIDE, STOPPER 2	1	1	1	1	
23	6D3-12210-00	TENSIONER ASSY, CAM CHAIN	1	1	1	1	
24	4FM-12213-00	GASKET, TENSIONER CASE	1	1	1	1	
25	91380-06025	BOLT	2	2	2	2	
26	6D3-12251-00	DAMPER, CHAIN 1	1	1	1	1	
27	4XV-12252-00	DAMPER, CHAIN 2	1	1	1	1	
28	93607-54002	PIN, DOWEL	1	1	1	1	

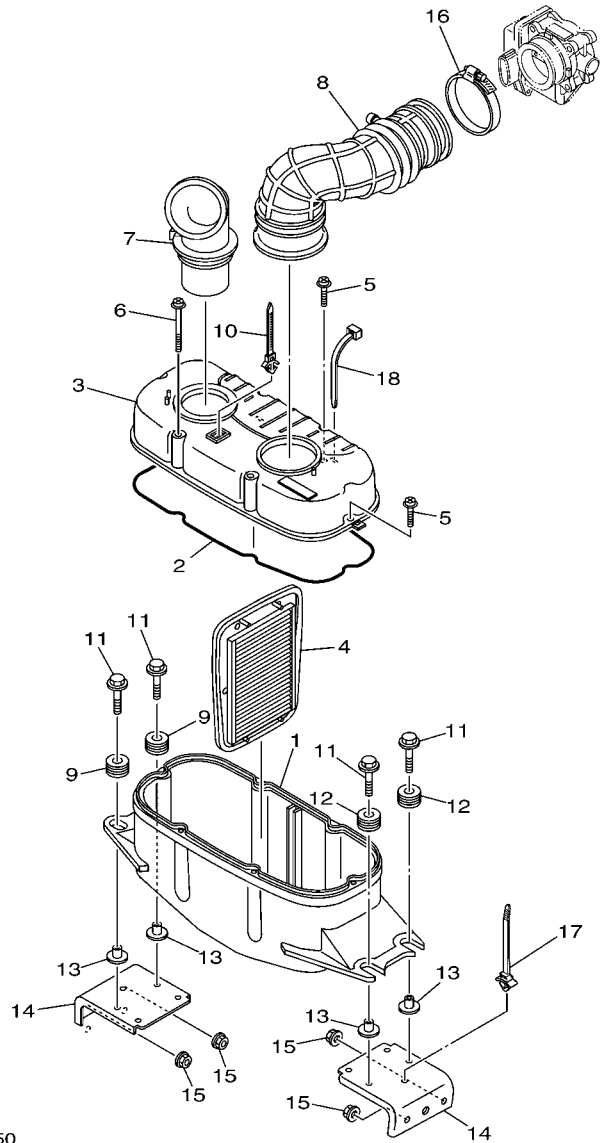

F1KD100-F050

FIG. 5 INTAKE

REF. NO.	PART NO.	DESCRIPTION	USA	CAN	GENE	JPN	REMARKS
1	6D3-14411-00	CASE, AIR CLEANER 1	1	1	1	1	
2	4XV-14452-00	SEAL	1	1	1	1	
3	6D3-14421-01	CASE, AIR CLEANER 2	1	1	1	1	
4	6D3-14451-00	ELEMENT, AIR CLEANER	1	1	1	1	
5	90159-05013	SCREW, WITH WASHER	4	4	4	4	
6	90159-05014	SCREW, WITH WASHER	2	2	2	2	
7	6D3-14437-00	DUCT	1	1	1	1	
8	6D3-14419-00	PIPE	1	1	1	1	
9	90480-22M15	GROMMET	2	2	2	2	
10	90464-12089	CLAMP	1	1	1	1	
11	90119-08M22	BOLT, WITH WASHER	4	4	4	4	
12	90480-22M15	GROMMET	2	2	2	2	
13	6D3-14495-00	COLLAR	4	4	4	4	
14	F1K-U8572-02	BRACKET 2	2	2	2	2	
15	9572R-08300	NUT, FLANGE	4	4	4	4	
16	90601-175UR	BAND, HOSE 75	1	1	1	1	
17	90464-38800	CLAMP	1	1	1	1	
18	90464-40825	CLAMP	2	2	2	2	

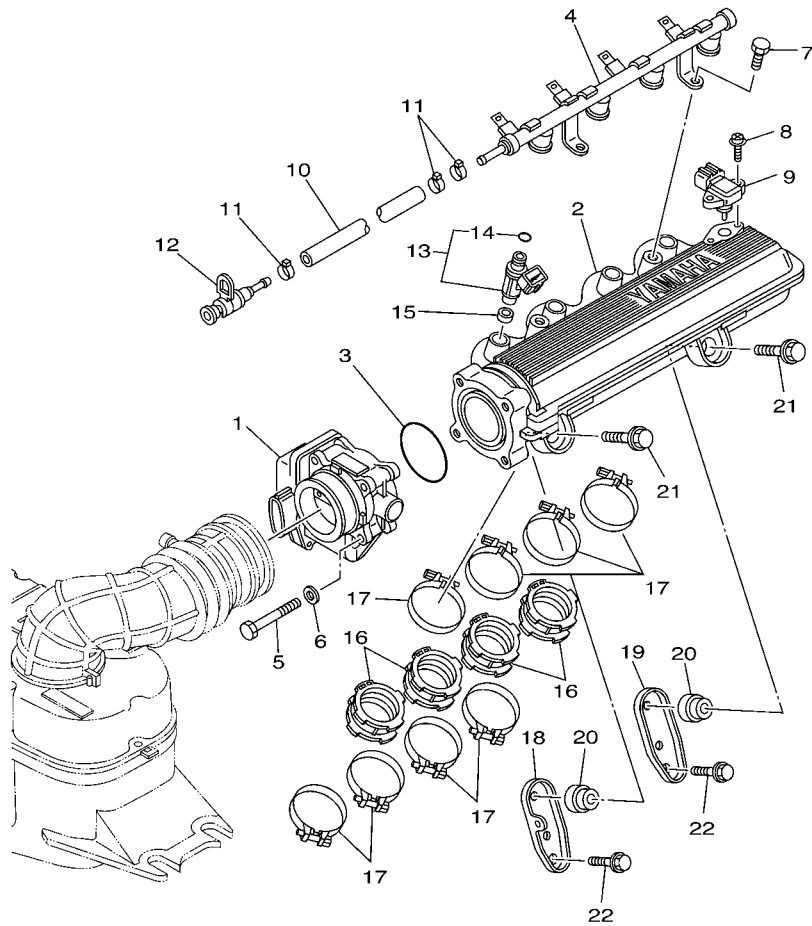

F1K1100-D060

FIG. 6 INTAKE 2

REF. NO.	PART NO.	DESCRIPTION	USA	CAN	GENE	JPN	REMARKS
1	6D3-13750-00	THROTTLE BODY ASSY	1	1	1	1	
2	6D3-13641-00	MANIFOLD 1	1	1	1	1	
3	6D3-14457-00	SEAL	1	1	1	1	
4	6D3-12880-00	DELIVERY PIPE	1	1	1	1	
5	68V-13573-00	BOLT 1	4	4	4	4	
6	68V-14475-00	WASHER	4	4	4	4	
7	63P-14446-00	BOLT	2	2	2	2	
8	6D3-81147-00	SCREW 3	2	2	2	2	
9	68F-83688-00	SENSOR ASSY	1	1	1	1	
10	6D3-14294-00	HOSE (L600)	1	1	1	1	
11	90450-17M17	HOSE CLAMP ASSY	3	3	3	3	
12	60E-24300-01	FUEL PIPE JOINT	1	1	1	1	
13	60E-13761-10	INJECTOR ASSY	4	4	4	4	
14	60E-14147-00	.O-RING	1	1	1	1	
15	90430-09002	GASKET	4	4	4	4	
16	6D3-13795-01	JOINT, THROTTLE BODY 1	4	4	4	4	
17	90450-57006	HOSE CLAMP ASSY	8	8	8	8	
18	6D3-14413-00	STAY	1	1	1	1	
19	6D3-14414-00	STAY 2	1	1	1	1	
20	60E-14449-00	COLLAR	2	2	2	2	
21	90119-08050	BOLT, WITH WASHER	2	2	2	2	
22	90119-08074	BOLT, WITH WASHER	2	2	2	2	

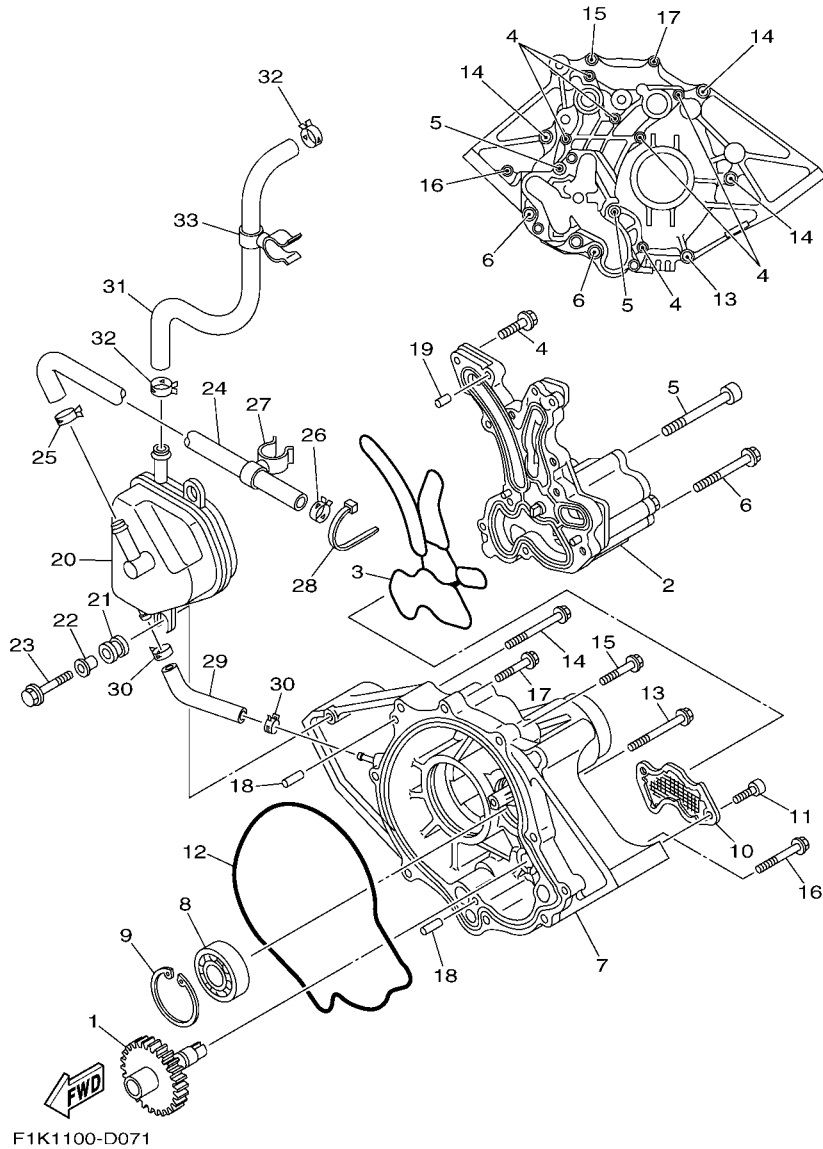

FIG. 7 OIL PUMP

REF. NO.	PART NO.	DESCRIPTION	USA	CAN	GENE	JPN	REMARKS
1	6B6-13360-00	DRIVEN GEAR ASSY	1	1	1	1	
2	6D3-13300-01	OIL PUMP ASSY	1	1	1	1	
3	6D3-13563-00	GASKET	1	1	1	1	
4	97513-06525	BOLT, WITH WASHER	6	6	6	6	
5	90110-08041	BOLT, HEXAGON SOCKET HEAD	2	2	2	2	
6	90119-08085	BOLT, WITH WASHER	2	2	2	2	
7	6B6-13327-01-94	COVER, PUMP GEAR	1	1	1	1	
8	93306-30441	BEARING	1	1	1	1	
9	99009-52500	CIRCLIP	1	1	1	1	
10	6B6-13411-00	STRAINER, OIL	1	1	1	1	
11	91317-06016	BOLT	2	2	2	2	
12	6B6-13475-01	GASKET	1	1	1	1	
13	90119-08045	BOLT, WITH WASHER	1	1	1	1	
14	90119-08034	BOLT, WITH WASHER	3	3	3	3	
15	90119-08043	BOLT, WITH WASHER	1	1	1	1	
16	97513-06555	BOLT, WITH WASHER	1	1	1	1	
17	97513-06535	BOLT, WITH WASHER	1	1	1	1	
18	93608-16M16	PIN, DOWEL	2	2	2	2	
19	93606-25M00	PIN, DOWEL	2	2	2	2	
20	6D3-11164-00	SEPERATOR, OIL	1	1	1	1	
21	6A0-82317-00	DAMPER, IGNITION COIL	2	2	2	2	
22	90387-06119	COLLAR	2	2	2	2	
23	90119-06M65	BOLT, WITH WASHER	2	2	2	2	
24	6D3-11126-00	PIPE, BREATHER 3	1	1	1	1	
25	90467-170A0	CLIP	1	1	1	1	
26	90467-170A0	CLIP	1	1	1	1	
27	90464-21001	CLAMP	1	1	1	1	

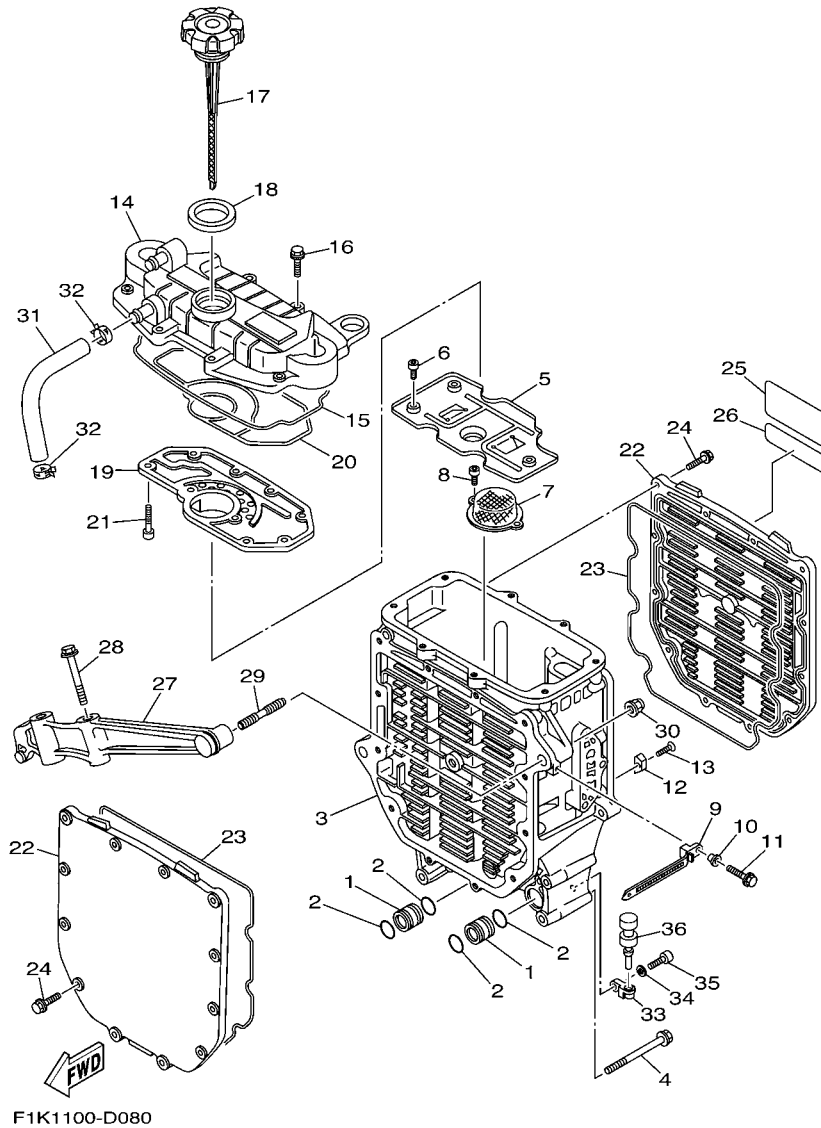
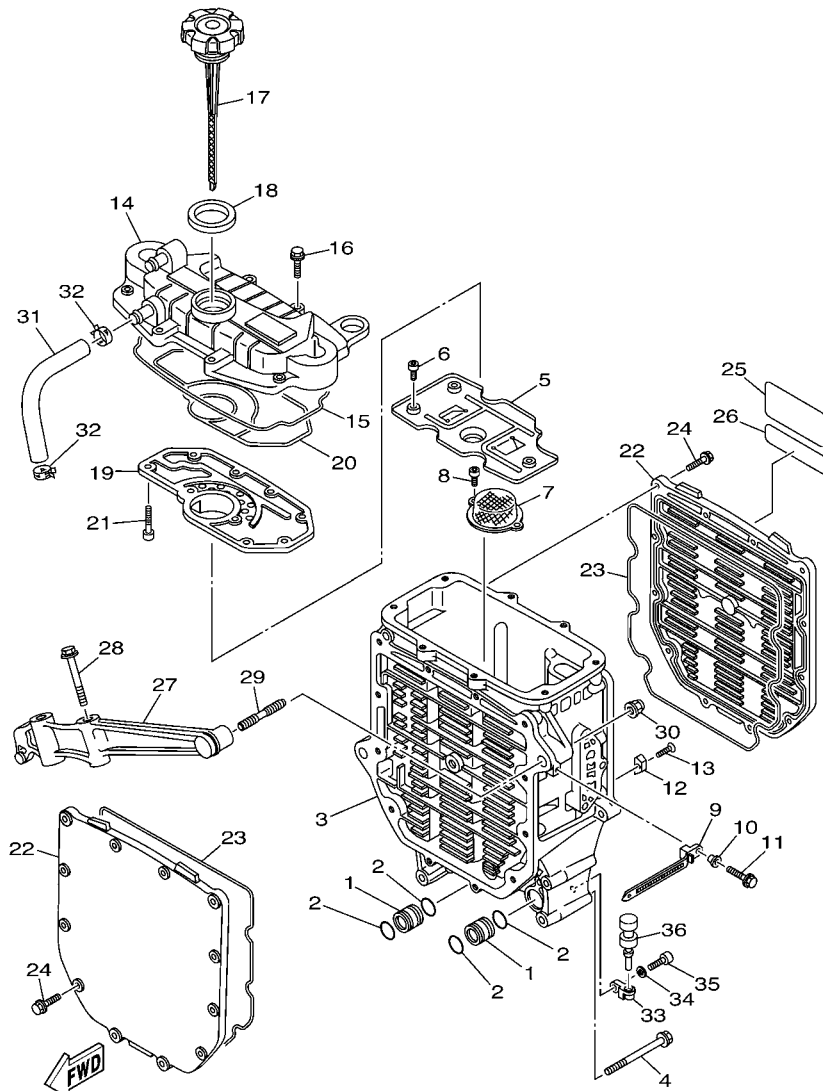

FIG. 8 OIL COOLER

REF. NO.	PART NO.	DESCRIPTION	USA	CAN	GENE	JPN	REMARKS
1	60E-13446-00	CONNECTOR	2	2	2	2	
2	93210-18322	O-RING	4	4	4	4	
3	6D3-13462-00-94	CASE, OIL COOLER	1	1	1	1	
4	90119-10020	BOLT, WITH WASHER	5	5	5	5	
5	6B6-13317-00	PLATE, BAFFLE	1	1	1	1	
6	91317-05014	BOLT	3	3	3	3	
7	60E-13421-00	STRAINER 2	1	1	1	1	
8	91317-06014	BOLT	2	2	2	2	
9	90465-12M53	CLAMP	1	1	1	1	
10	90387-06M05	COLLAR	1	1	1	1	
11	97595-06520	BOLT, WITH WASHER	1	1	1	1	
12	6E5-11325-00	ANODE	1	1	1	1	
13	98780-04015	SCREW, FLAT HEAD	1	1	1	1	
14	6D3-13463-00-94	COVER, OIL COOLER	1	1	1	1	
15	60E-13475-00	GASKET	1	1	1	1	
16	90105-06036	BOLT, FLANGE	8	8	8	8	
17	60E-15362-00	PLUG, OIL LEVEL	1	1	1	1	
18	60E-13473-00	O-RING	1	1	1	1	
19	6D3-11165-00	PLATE, BREATHER	1	1	1	1	
20	6D3-13477-00	GASKET	1	1	1	1	
21	91317-05016	BOLT	9	9	9	9	
22	6D3-13443-00-94	COVER, OIL COOLER	2	2	2	2	
23	60E-13476-10	GASKET	2	2	2	2	
24	90105-06M07	BOLT, FLANGE	24	24	24	24	
25	6B6-83623-00	MARK 3	1	1	1	1	
26	60E-83627-00	LABEL, CAUTION 7	1	1	1	1	
27	6B6-13151-00-94	STAY	1	1	1	1	



F1K1100-D080

FIG. 8 OIL COOLER

REF. NO.	PART NO.	DESCRIPTION	USA	CAN	GENE	JPN	REMARKS
28	90119-10M02	BOLT, WITH WASHER	2	2	2	2	
29	90116-10016	BOLT, STUD	2	2	2	2	
30	90176-10001	NUT, CROWN	2	2	2	2	
31	6D3-11167-00	PIPE, BREATHER 2	1	1	1	1	
32	90467-170A0	CLIP	2	2	2	2	
33	60E-51341-00-94	BRACKET 1	2	2	2	2	
34	92995-06600	WASHER	2	2	2	2	
35	91380-06020	BOLT	2	2	2	2	
36	90480-06M46	GROMMET	2	2	2	2	

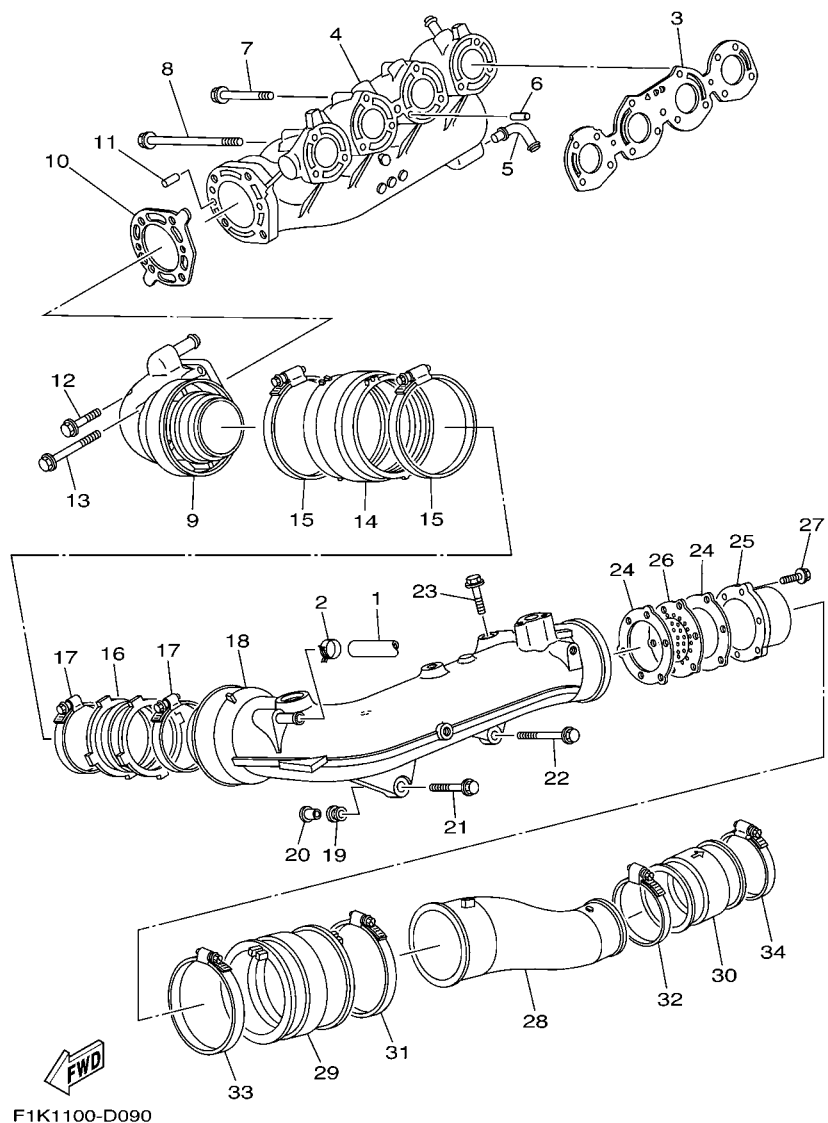
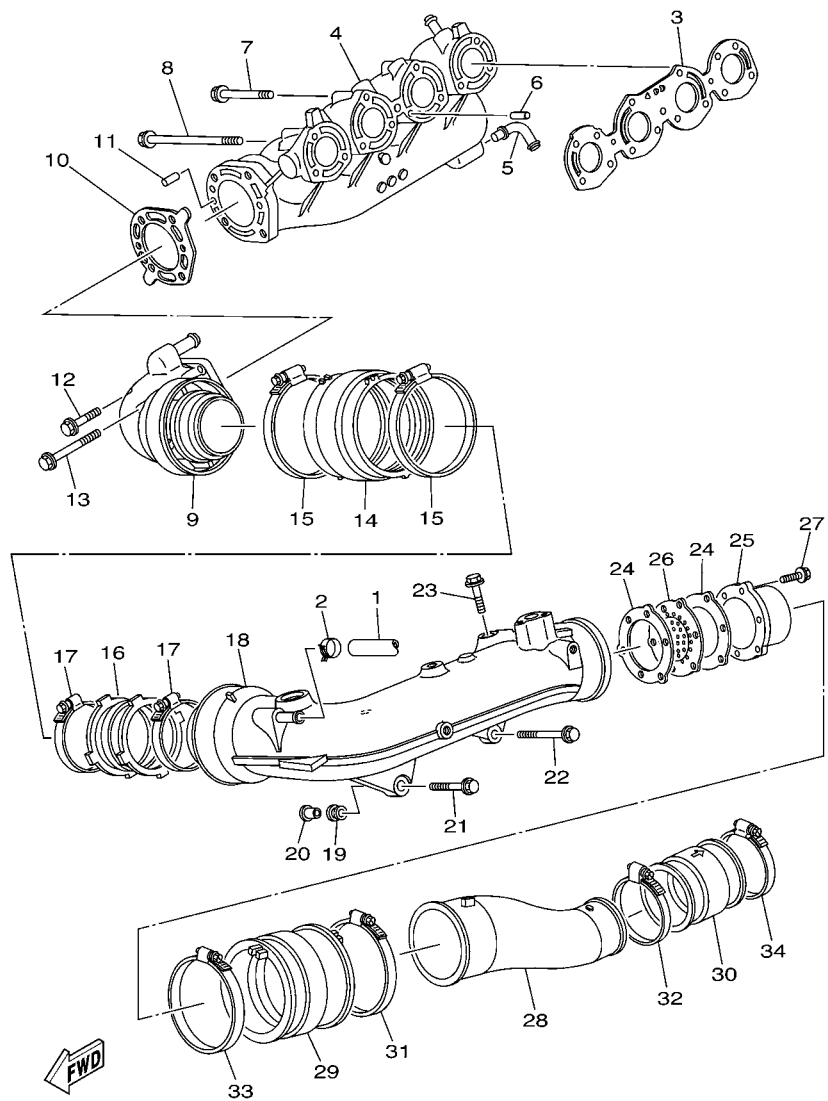

FIG. 9 EXHAUST 1

REF. NO.	PART NO.	DESCRIPTION	USA	CAN	GENE	JPN	REMARKS
1	90445-16005	HOSE (L870)	1	1	1	1	
2	90467-160A0	CLIP	1	1	1	1	
3	6D3-14613-00	GASKET, EXHAUST PIPE	1	1	1	1	
4	6D3-14711-00-94	MUFFLER 1	1	1	1	1	
5	60E-11372-10	NIPPLE, HOSE	1	1	1	1	
6	93608-16M16	PIN, DOWEL	2	2	2	2	
7	90119-08036	BOLT, WITH WASHER	5	5	5	5	
8	90119-08075	BOLT, WITH WASHER	6	6	6	6	
9	6D3-14712-00-94	RING, JOINT	1	1	1	1	
10	6D3-14739-00	GASKET, MUFFLER DAMPER 1	1	1	1	1	
11	93606-12019	PIN, DOWEL	2	2	2	2	
12	90119-08036	BOLT, WITH WASHER	2	2	2	2	
13	90119-08031	BOLT, WITH WASHER	2	2	2	2	
14	6D3-14615-00	JOINT, EXHAUST 1	1	1	1	1	
15	90450-99005	HOSE CLAMP ASSY	2	2	2	2	
16	6D3-14625-00	JOINT, EXHAUST 2	1	1	1	1	
17	90450-88M15	HOSE CLAMP ASSY	2	2	2	2	
18	6D3-14721-00-94	MUFFLER 2	1	1	1	1	
19	90480-21M63	GROMMET	1	1	1	1	
20	90387-11002	COLLAR	1	1	1	1	
21	90119-10011	BOLT, WITH WASHER	1	1	1	1	
22	90119-10017	BOLT, WITH WASHER	1	1	1	1	
23	90119-10013	BOLT, WITH WASHER	2	2	2	2	
24	60E-14623-00	GASKET, EXHAUST PIPE	2	2	2	2	
25	60E-14784-00-94	PIPE, TAIL	1	1	1	1	
26	6D3-1469W-00	PLATE, SILENCER 6	1	1	1	1	
27	90105-06790	BOLT, FLANGE	3	3	3	3	



F1K1100-D090

FIG. 9 EXHAUST 1

REF. NO.	PART NO.	DESCRIPTION	USA	CAN	GENE	JPN	REMARKS
28	6D3-14752-00-94	PIPE, OUTLET	1	1	1	1	
29	6B6-1475E-00	PIPE 2	1	1	1	1	
30	6D3-1475F-00	PIPE 3	1	1	1	1	
31	90450-99004	HOSE CLAMP ASSY	1	1	1	1	
32	90450-94001	HOSE CLAMP ASSY	1	1	1	1	
33	90450-99004	HOSE CLAMP ASSY	1	1	1	1	
34	90450-94001	HOSE CLAMP ASSY	1	1	1	1	

FOR GENERAL

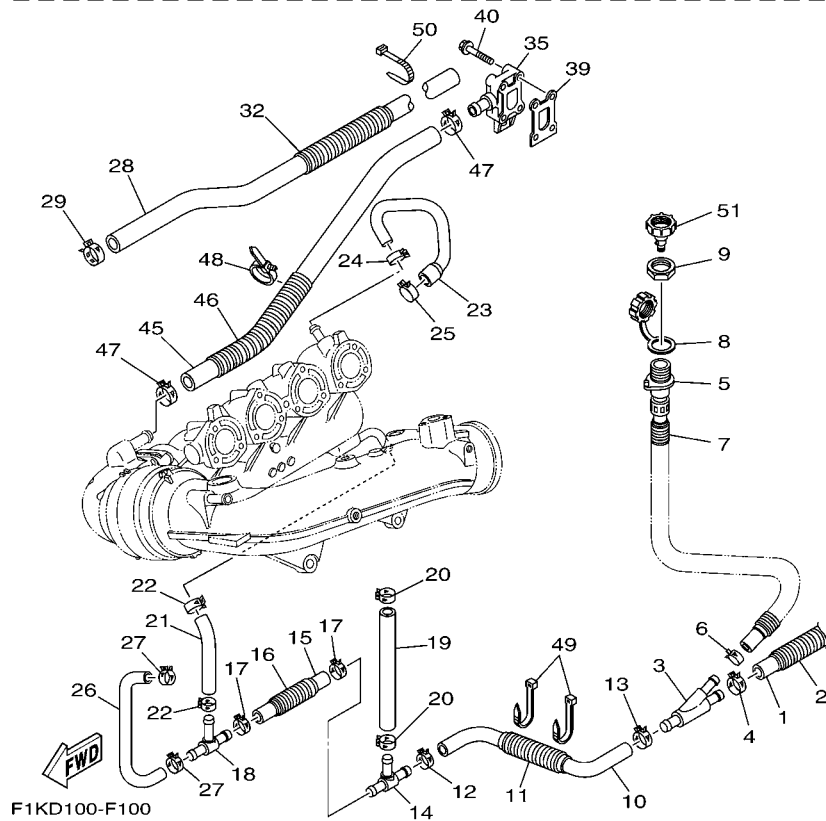
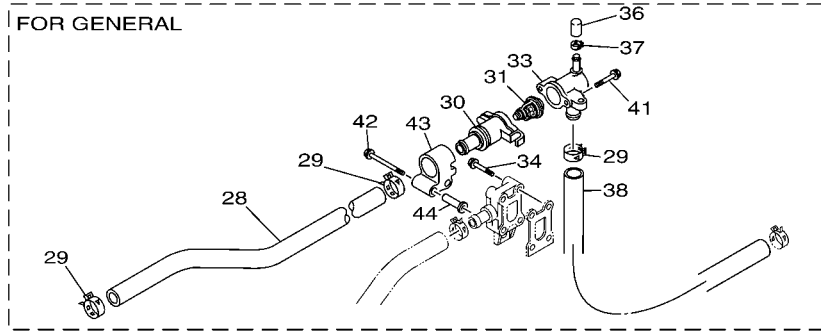

FIG. 10 EXHAUST 2

REF. NO.	PART NO.	DESCRIPTION	USA	CAN	GENE	JPN	REMARKS
1	90445-21805	HOSE (L300)	1	1	1	1	
2	90447-22004	HOSE, WITH SPRING (L200)	1	1	1	1	
3	60E-12581-00	JOINT, HOSE 1	1	1	1	1	
4	90467-200A0	CLIP	1	1	1	1	
5	63M-12580-00	JOINT ASSY	1	1	1	1	
6	90467-150A0	CLIP	1	1	1	1	
7	90446-24M79	HOSE (L230)	1	1	1	1	
8	682-84385-01	CAP,1	1	1	1	1	
9	EU0-61652-00	NUT	1	1	1	1	
10	6D3-1243A-10	HOSE 1	1	1	1	1	
11	90447-22004	HOSE, WITH SPRING (L200)	1	1	1	1	
12	90467-200A0	CLIP	1	1	1	1	
13	90467-200A0	CLIP	1	1	1	1	
14	60E-12584-00	JOINT, HOSE 3	1	1	1	1	
15	6D3-1243E-10	HOSE 2	1	1	1	1	
16	90447-22001	HOSE, WITH SPRING (L100)	1	1	1	1	
17	90467-200A0	CLIP	2	2	2	2	
18	6D3-12584-00	JOINT, HOSE 3	1	1	1	1	
19	90445-18007	HOSE (L180)	1	1	1	1	
20	90467-160A0	CLIP	2	2	2	2	
21	90445-18M03	HOSE (L108)	1	1	1	1	
22	90467-160A0	CLIP	2	2	2	2	
23	6D3-12577-00	HOSE 2	1	1	1	1	
24	90467-160A0	CLIP	1	1	1	1	
25	90467-200A0	CLIP	1	1	1	1	
26	6D3-1244G-00	HOSE, 4	1	1	1	1	
27	90467-160A0	CLIP	2	2	2	2	

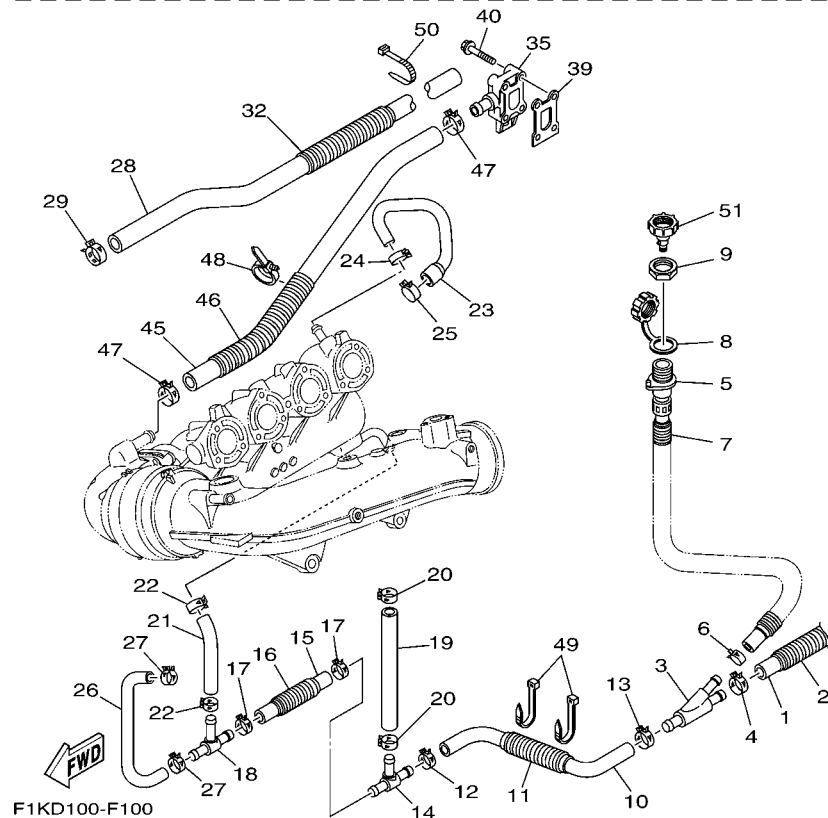
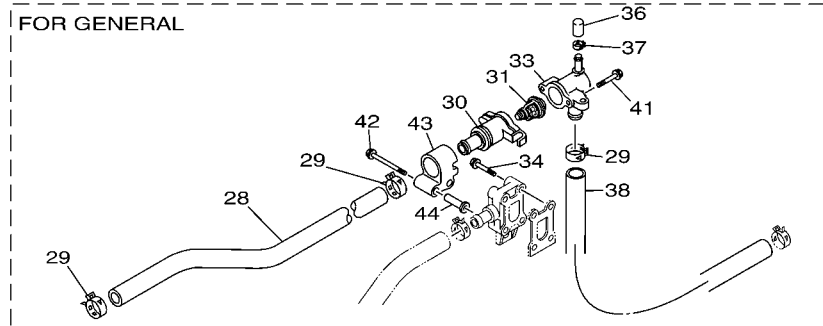
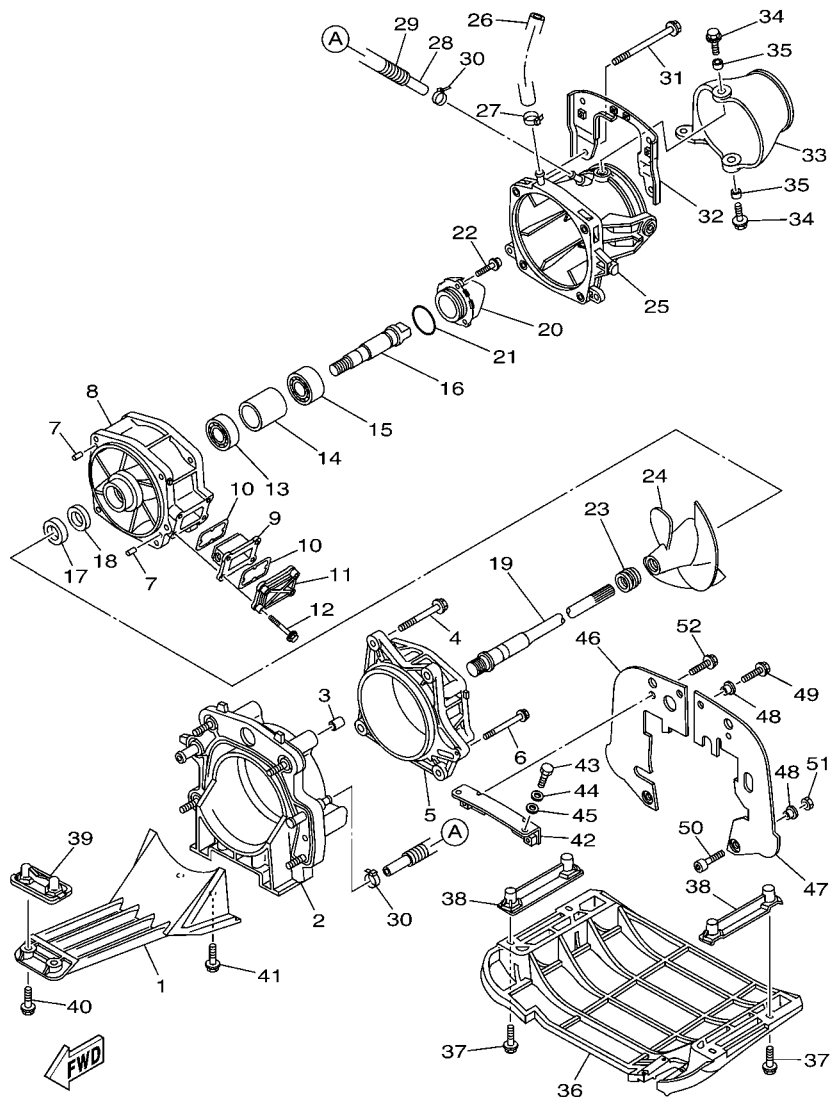

FIG. 10 EXHAUST 2

REF. NO.	PART NO.	DESCRIPTION	USA	CAN	GENE	JPN	REMARKS
28	90445-22003	HOSE (L1010)	1	1		1	EXCEPT GENE
	90445-26004	HOSE (L375)			1		FOR GENE
29	90467-210A0	CLIP	1	1		1	EXCEPT GENE
	90467-240A0	CLIP			3		FOR GENE
30	60E-12417-10-94	HOUSING, THERMOSTAT			1		FOR GENE
31	6D3-12411-00	THERMOSTAT			1		FOR GENE
32	90447-22005	HOSE, WITH SPRING (L200)	1	1		1	EXCEPT GENE
33	60E-12413-10-94	COVER, THERMOSTAT			1		FOR GENE
34	90105-06035	BOLT, FLANGE			2		FOR GENE
35	6D3-12446-00	JOINT	1	1	1	1	
36	6D3-12494-00	SEAL, PIPE 1			1		FOR GENE
37	90467-120A0	CLIP			1		FOR GENE
38	90445-25004	HOSE (L670)			1		FOR GENE
39	60E-12435-00	GASKET	1	1	1	1	
40	90105-06035	BOLT, FLANGE	4	4		4	EXCEPT GENE
41	90105-06035	BOLT, FLANGE			2		FOR GENE
42	90105-06054	BOLT, FLANGE			2		FOR GENE
43	6B6-12499-00	JOINT			1		FOR GENE
44	90387-06083	COLLAR			2		FOR GENE
45	90445-21004	HOSE (L530)	1	1	1	1	
46	90447-22005	HOSE, WITH SPRING (L200)	1	1	1	1	
47	90467-200A0	CLIP	2	2	2	2	
48	90464-31001	CLAMP	1	1	1	1	
49	90464-35132	CLAMP	2	2	2	2	
50	90464-35132	CLAMP	1	1		1	EXCEPT GENE
51	67X-E2590-00	CONDUCTION ASSY	1				FOR USA
	67X-E2590-10	CONDUCTION ASSY		1	1	1	EXCEPT USA



F1K1100-D110

FIG. 11 JET UNIT 1

REF. NO.	PART NO.	DESCRIPTION	USA	CAN	GENE	JPN	REMARKS
1	6D3-R1333-00-94	SCREEN, INTAKE	1	1	1	1	
2	6D3-G5831-00	PLATE, TRANSOM	1	1	1	1	
3	99590-14016	PIN, DOWEL	2	2	2	2	
4	90119-10836	BOLT, WITH WASHER	4	4	4	4	
5	66V-51312-01-94	HOUSING, IMPELLER	1	1	1	1	
6	90119-06835	BOLT, WITH WASHER	1	1	1	1	
7	93606-12019	PIN, DOWEL	2	2	2	2	
8	6B6-51315-01-94	DUCT, IMPELLER	1	1	1	1	
9	66V-46882-00	FILTER	1	1	1	1	
10	66V-42414-00	O-RING	2	2	2	2	
11	66V-45214-00-94	COVER, WATER INLET 1	1	1	1	1	
12	90119-06800	BOLT, WITH WASHER	4	4	4	4	
13	93306-27211	BEARING	1	1	1	1	
14	65V-45538-00	SPACER 1	1	1	1	1	
15	93306-205U0	BEARING	1	1	1	1	
16	6D3-45514-00	SHAFT, DRIVE 4	1	1	1	1	
17	93101-21001	OIL SEAL	1	1	1	1	
18	93101-21002	OIL SEAL	1	1	1	1	
19	6D3-45511-00	SHAFT, DRIVE	1	1	1	1	
20	6B6-51326-10	CAP	1	1	1	1	
21	93210-464A3	O-RING	1	1	1	1	
22	90110-06822	BOLT, HEXAGON SOCKET HEAD	3	3	3	3	
23	6D3-R1319-00	CAP, IMPELLER	1	1	1	1	
24	6D3-R1321-02	IMPELLER	1	1	1	1	
25	6D3-R1318-00	NOZZLE	1	1	1	1	
26	90445-16006	HOSE (L260)	1	1	1	1	
27	90601-118UF	BAND, HOSE 18	1	1	1	1	

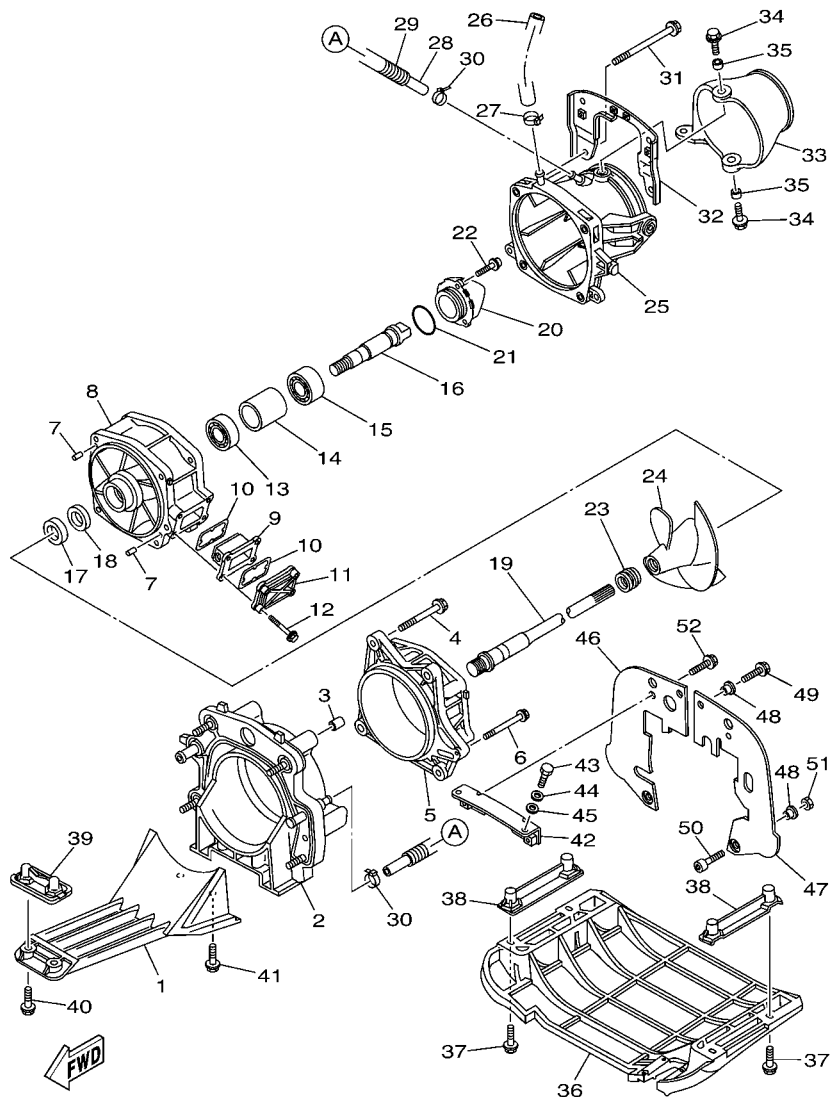

F1K1100-D110

FIG. 11 JET UNIT 1

REF. NO.	PART NO.	DESCRIPTION	USA	CAN	GENE	JPN	REMARKS
28	90445-14008	HOSE (L355)	1	1	1	1	
29	90446-20MF5	HOSE (L320)	1	1	1	1	
30	90465-11829	CLAMP	2	2	2	2	
31	90119-10837	BOLT, WITH WASHER	4	4	4	4	
32	6D3-R1341-00	BRACKET 1	1	1	1	1	
33	6D3-R1313-00	NOZZLE, DEFLECTOR	1	1	1	1	
34	90119-08840	BOLT, WITH WASHER	2	2	2	2	
35	90387-08M06	COLLAR	2	2	2	2	
36	F1K-U273B-03	PLATE 2	1	1	1	1	
37	90119-08823	BOLT, WITH WASHER	4	4	4	4	
38	F1G-U8572-00	BRACKET 2	2	2	2	2	
39	F1K-U8577-00	BRACKET, 3	1	1	1	1	
40	90119-069UK	BOLT, WITH WASHER	2	2	2	2	
41	90119-10805	BOLT, WITH WASHER	2	2	2	2	
42	F1K-U7557-00	BRACKET	1	1	1	1	
43	90109-08041	BOLT	2	2	2	2	
44	92990-12200	WASHER, PLAIN	2	2	2	2	
45	90430-12002	GASKET	2	2	2	2	
46	F1K-U757E-01	PLATE, RUBBER 1	1	1	1	1	
47	F1K-U757F-01	PLATE, RUBBER 2	1	1	1	1	
48	90387-06080	COLLAR	6	6	6	6	
49	90119-06827	BOLT, WITH WASHER	4	4	4	4	
50	90101-069U0	BOLT	2	2	2	2	
51	9572R-06300	NUT, NYLON	2	2	2	2	
52	90119-089U7	BOLT, WITH WASHER	2	2	2	2	

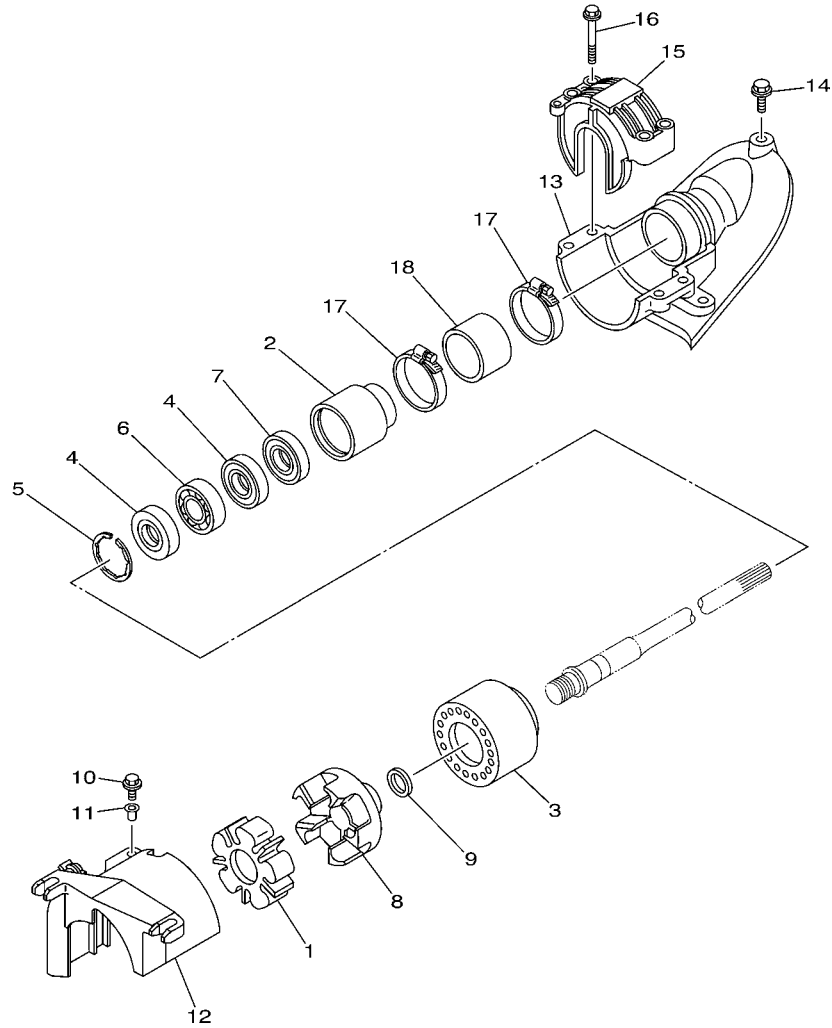

F1K1100-D120

FIG. 12 JET UNIT 2

REF. NO.	PART NO.	DESCRIPTION	USA	CAN	GENE	JPN	REMARKS
1	6D3-4581J-00	RUBBER SHAFT COUPLING	1	1	1	1	
2	6D3-45332-00-94	HOUSING, BEARING	1	1	1	1	
3	6D3-45235-00	DAMPER	1	1	1	1	
4	93101-25M55	OIL SEAL	2	2	2	2	
5	93430-47M04	CIRCLIP	1	1	1	1	
6	93306-205A3	BEARING	1	1	1	1	
7	93101-25M56	OIL SEAL	1	1	1	1	
8	6D3-45593-00-94	FLANGE, COUPLING 1	1	1	1	1	
9	90201-248M5	WASHER, PLATE	1	1	1	1	
10	90119-069UD	BOLT, WITH WASHER	1	1	1	1	
11	90387-06M60	COLLAR	1	1	1	1	
12	60E-R1381-01	COVER	1	1	1	1	
13	F1K-U883E-00	JOINT, PIPE	1	1	1	1	
14	90109-06832	BOLT	3	3	3	3	
15	F1K-U2155-00	CAP	1	1	1	1	
16	90119-089UU	BOLT, WITH WASHER	4	4	4	4	
17	90601-162U5	BAND, HOSE 62	2	2	2	2	
18	F1K-U883B-00	PIPE, 1	1	1	1	1	

FIG. 13 JET UNIT 3

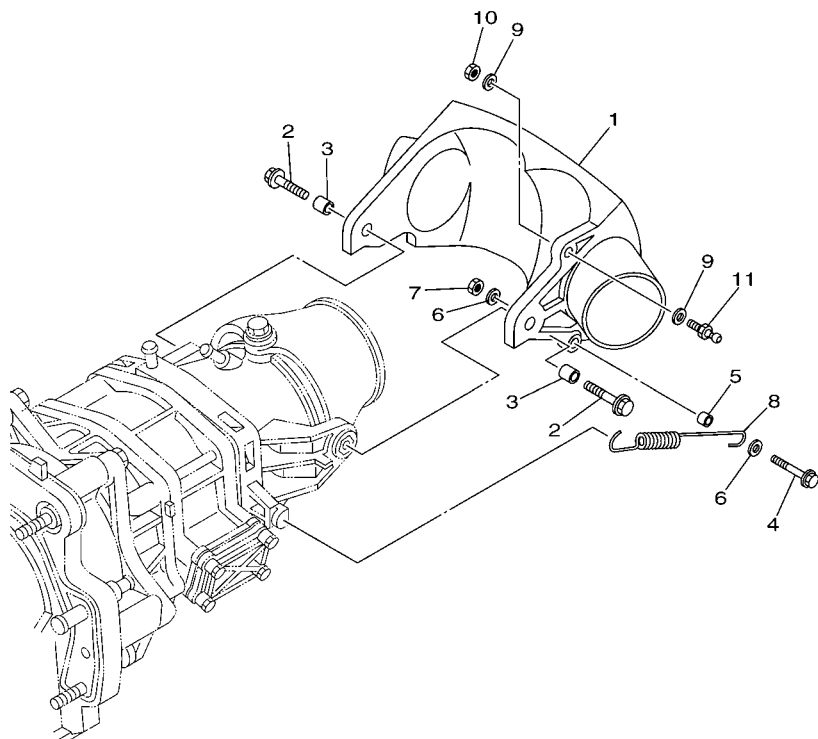

REF. NO.	PART NO.	DESCRIPTION	USA	CAN	GENE	JPN	REMARKS
1	6D3-R1314-00	GATE, REVERSE	1	1	1	1	
2	90119-08840	BOLT, WITH WASHER	2	2	2	2	
3	90387-08M30	COLLAR	2	2	2	2	
4	90119-069UX	BOLT, WITH WASHER	1	1	1	1	
5	90387-06M30	COLLAR	1	1	1	1	
6	90201-06801	WASHER, PLATE	2	2	2	2	
7	9538R-06600	NUT	1	1	1	1	
8	6D3-52358-00	SPRING, RETAINER	1	1	1	1	
9	90201-06801	WASHER, PLATE	2	2	2	2	
10	9538R-06600	NUT	1	1	1	1	
11	EU0-U1461-02	STUD, JOINT BALL	1	1	1	1	

 F1KD100-F130

FIG. 14 GENERATOR

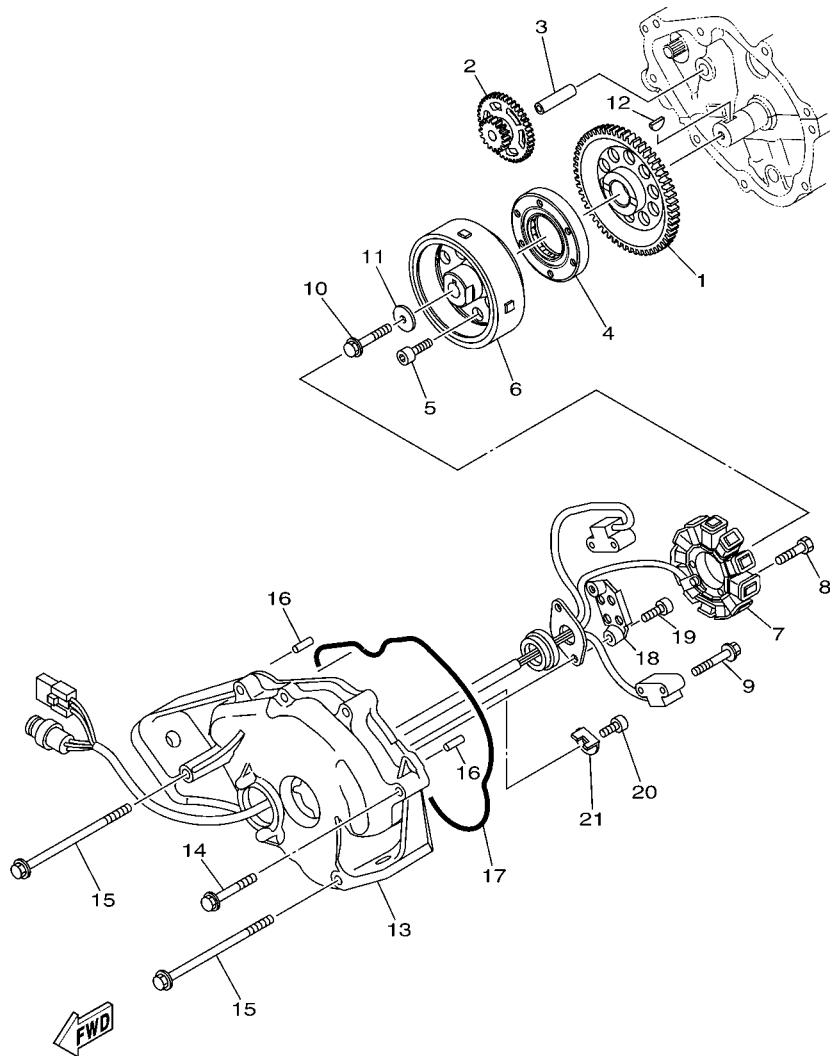

F1K7100-E140

REF. NO.	PART NO.	DESCRIPTION	USA	CAN	GENE	JPN	REMARKS
1	6D3-15515-00	GEAR 3	1	1	1	1	
2	60E-15517-00	GEAR, IDLER 2	1	1	1	1	
3	60E-15521-00	SHAFT 1	1	1	1	1	
4	4WM-15590-00	STARTER ONE-WAY ASSY	1	1	1	1	
5	90110-08212	BOLT, HEXAGON SOCKET HEAD	6	6	6	6	
6	6D3-81450-00	ROTOR ASSY	1	1	1	1	
7	6D3-81410-01	STATOR ASSY	1	1	1	1	
8	91317-06035	BOLT	3	3	3	3	
9	97513-05514	BOLT, WITH WASHER	2	2	2	2	
10	90105-105A6	BOLT, FLANGE	1	1	1	1	
11	90201-103U7	WASHER, PLATE	1	1	1	1	
12	90280-03047	KEY, WOODRUFF	1	1	1	1	
13	6D3-81337-00-94	COVER, FLYWHEEL	1	1	1	1	
14	90119-10016	BOLT, WITH WASHER	6	6	6	6	
15	90119-10M19	BOLT, WITH WASHER	2	2	2	2	
16	93608-16M16	PIN, DOWEL	2	2	2	2	
17	93212-04001	O-RING	1	1	1	1	
18	60E-81328-00	CLAMP	1	1	1	1	
19	91317-06014	BOLT	2	2	2	2	
20	91317-05010	BOLT	1	1	1	1	
21	6D3-81845-00	PLATE	1	1	1	1	

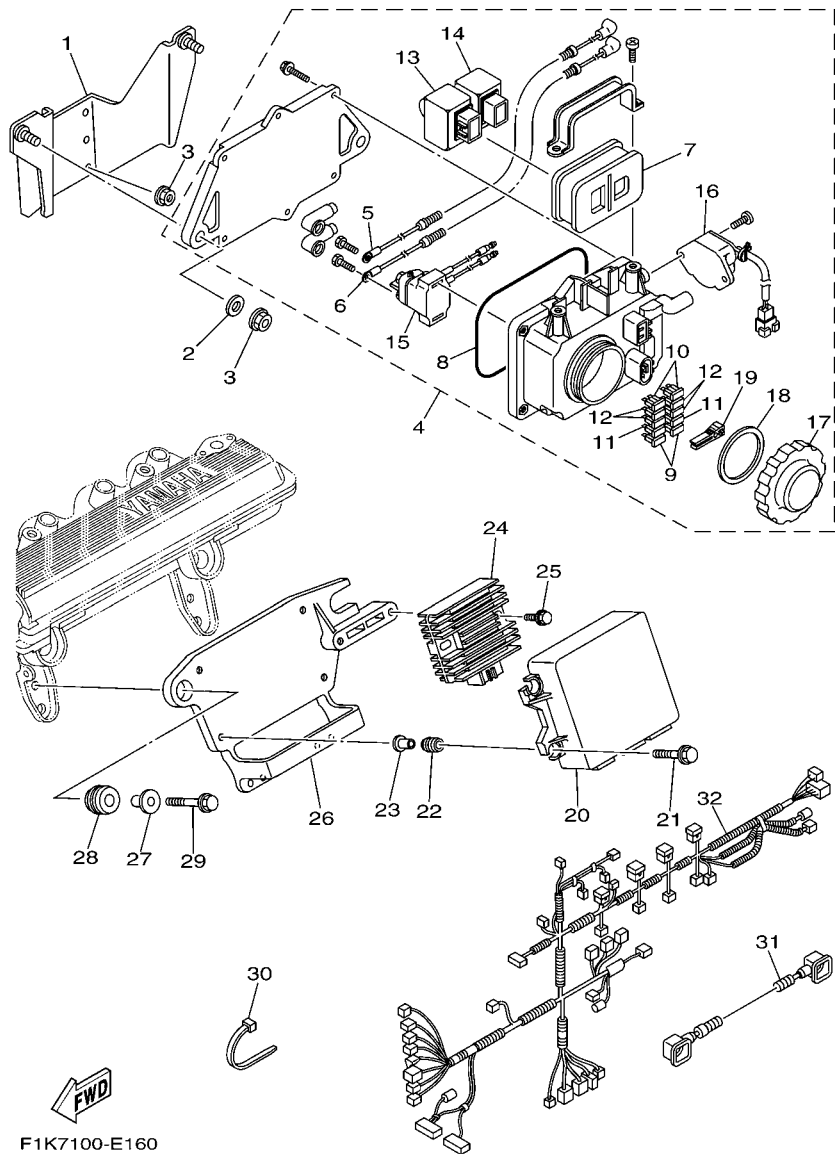

FIG. 16 ELECTRICAL 1

REF. NO.	PART NO.	DESCRIPTION	USA	CAN	GENE	JPN	REMARKS
1	F1K-U815D-00	BRACKET, ELECTRIC BOX	1	1	1	1	
2	90201-099U3	WASHER, PLATE	2	2	2	2	
3	9572R-08300	NUT, FLANGE	6	6	6	6	
4	6D3-82170-00	FUSE BOX ASSY	1	1	1	1	
5	6D3-82115-00	.WIRE, PLUS LEAD	1	1	1	1	
6	6D3-82117-00	.WIRE, LEAD	1	1	1	1	
7	6D3-82157-00	.DAMPER	1	1	1	1	
8	6D3-81921-00	.GASKET, TERMINAL	1	1	1	1	
9	67F-82151-00	.FUSE (20A)	2	2	2	2	
10	67F-82151-10	.FUSE (30A)	2	2	2	2	
11	67F-82151-30	.FUSE (3A)	2	2	2	2	
12	67F-82151-40	.FUSE (10A)	4	4	4	4	
13	60E-81950-00	.RELAY ASSY	1	1	1	1	
14	68V-81950-00	.RELAY ASSY	1	1	1	1	
15	6B6-81940-00	.STARTER RELAY ASSY	1	1	1	1	
16	60E-8259E-00	.SWITCH ASSY	1	1	1	1	
17	66V-8132W-00	.CAP	1	1	1	1	
18	66V-81844-00	.GASKET	1	1	1	1	
19	67F-2812A-00	.PULLER, FUSE	1	1	1	1	
20	6D3-8591A-A0	ENGINE CONTROL UNIT ASSY	1	1		1	EXCEPT GENE
	6D3-8591A-B0	ENGINE CONTROL UNIT ASSY			1		FOR GENE
21	90119-06M35	BOLT, WITH WASHER	4	4	4	4	
22	6A0-82317-00	DAMPER, IGNITION COIL	4	4	4	4	
23	90387-06119	COLLAR	4	4	4	4	
24	6D3-81960-00	RECTIFIER & REGULATOR ASSY	1	1	1	1	
25	90119-06M35	BOLT, WITH WASHER	2	2	2	2	
26	6D3-85991-01	BRACKET, UNIT	1	1	1	1	

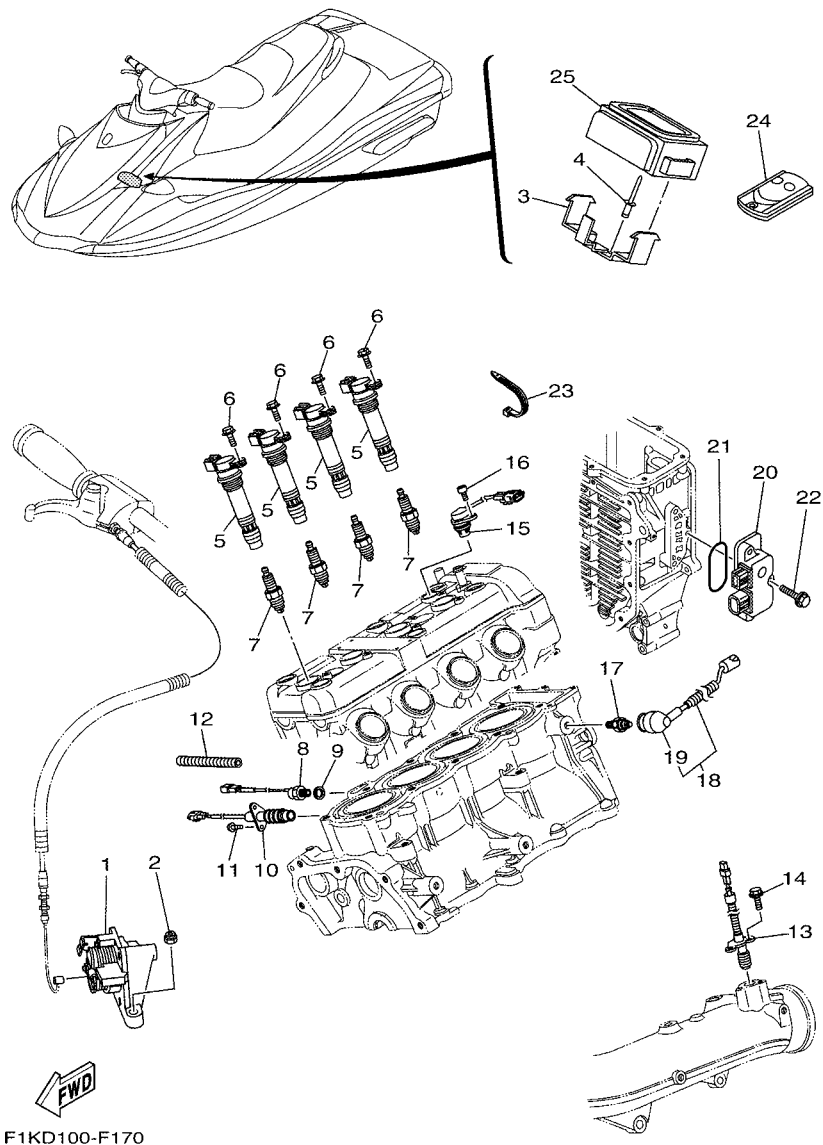
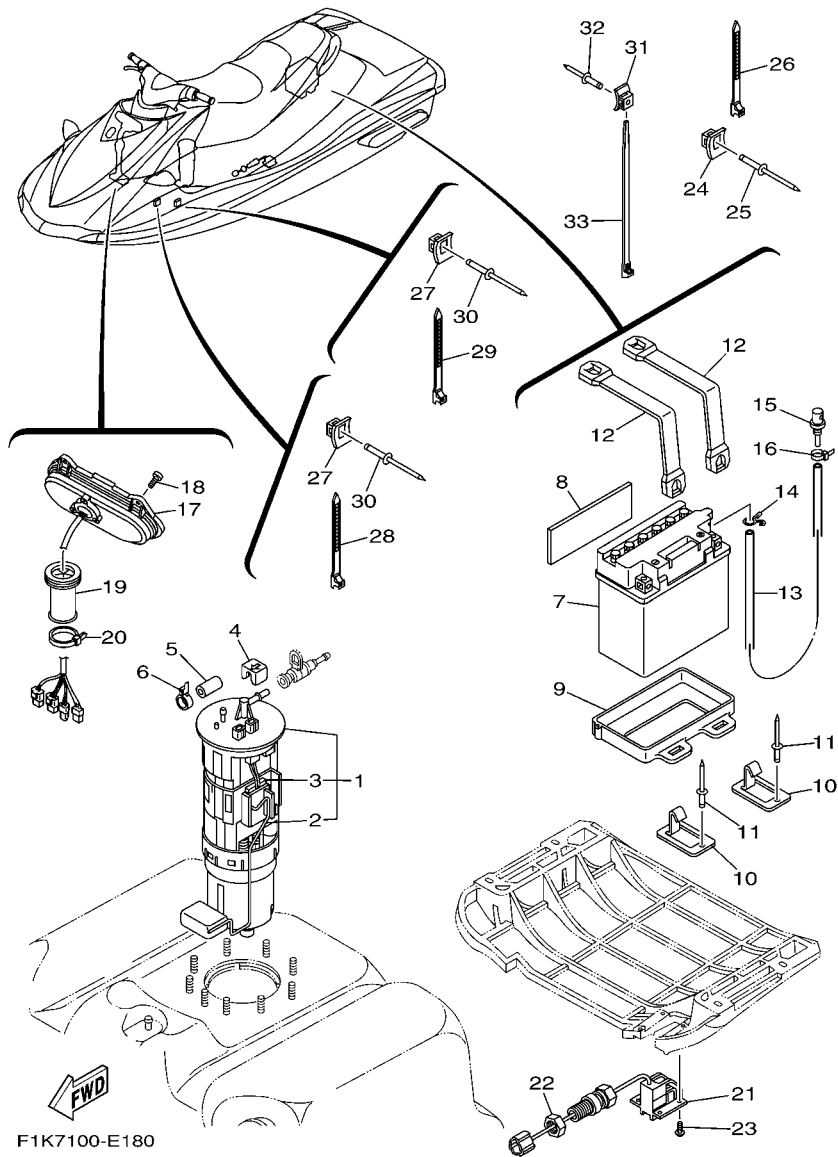

FIG. 17 ELECTRICAL 2

REF. NO.	PART NO.	DESCRIPTION	USA	CAN	GENE	JPN	REMARKS
25	6B6-86265-10	RECIVER COMP			1		FOR GENE



F1K7100-E180

FIG. 18 ELECTRICAL 3

REF. NO.	PART NO.	DESCRIPTION	USA	CAN	GENE	JPN	REMARKS
1	60E-13907-01	FUEL PUMP COMP.	1	1	1	1	
2	60E-682E0-00	.FUEL SENDER ASSY	1	1	1	1	
3	60E-82556-00	.DAMPER, STOPPER	1	1	1	1	
4	60E-24474-00	COVER	1	1	1	1	
5	6D3-24481-00	PLUG	1	1	1	1	
6	6D3-24387-00	CLIP	1	1	1	1	
7	EU0-82110-09	BATTERY ASSY (YB16CL-B)	1	1	1	1	YUASA
8	F1K-U8221-00	PAD, BATTERY	1	1	1	1	
9	F1K-U8211-01	CASE, BATTERY	1	1	1	1	
10	F1K-U5772-02	HOOK A	4	4	4	4	
11	90267-489U1	RIVET,BLIND	4	4	4	4	
12	F1K-U821D-00	BAND, BATTERY 1	2	2	2	2	
13	F0D-U785G-10	HOSE, AIR VENT	1	1	1	1	
14	90467-089U1	CLIP	1	1	1	1	
15	GJ3-6215F-00	NIPPLE	1	1	1	1	
16	90465-11829	CLAMP	1	1	1	1	
17	F1K-6820A-01	METER ASSY	1	1	1	1	
18	90111-05008	BOLT,HEX. SOCKET BUTTON	4	4	4	4	
19	GU2-6822E-01	GROMMET	1	1	1	1	
20	90464-32801	CLAMP	1	1	1	1	
21	F1S-U8K31-02	SENSOR SPEED	1	1	1	1	
22	EU0-62241-30	NUT, DRAIN 1	1	1	1	1	
23	90150-05807	SCREW, ROUND HEAD	4	4	4	4	
24	90600-917U4	CLAMP COMP.	7	7	7	7	
25	90267-489U6	RIVET, BLIND	7	7	7	7	
26	90464-32801	CLAMP	7	7	7	7	
27	90600-917U4	CLAMP COMP.	2	2	2	2	

FIG. 19 ENGINE HATCH 1

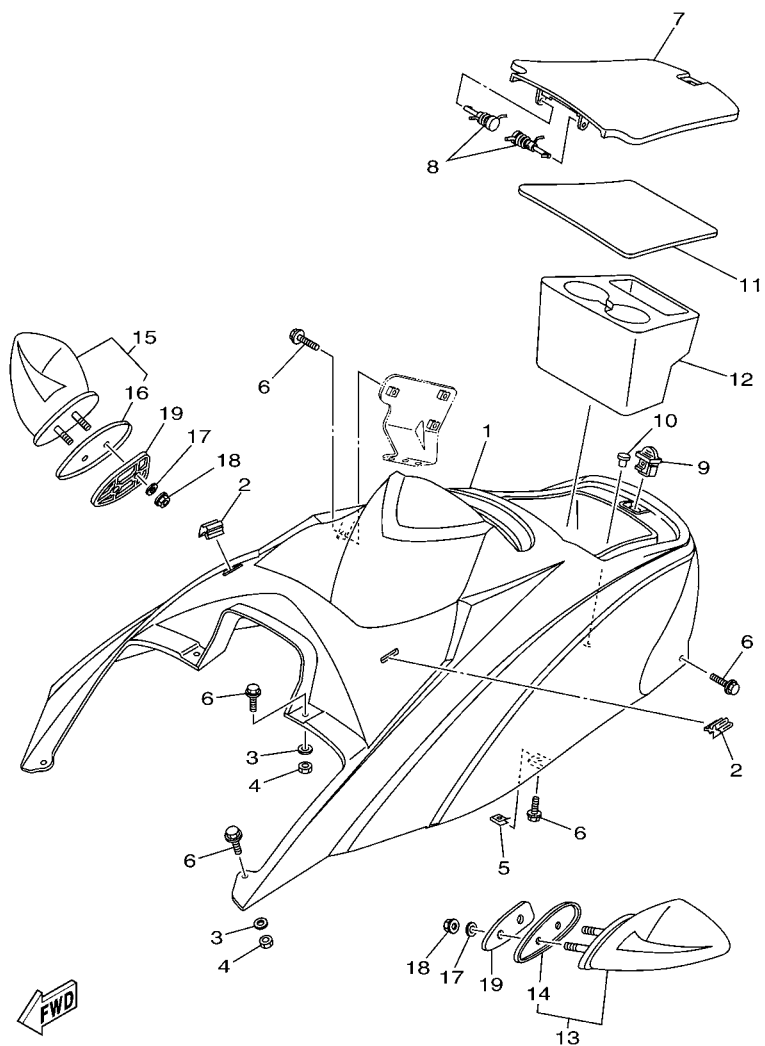

F1KD100-F190

REF. NO.	PART NO.	DESCRIPTION	USA	CAN	GENE	JPN	REMARKS
1	F1K-U516N-11-P0	COVER, ENGINE HATCH	1	1	1	1	DELUXE, DPBMT
	F1K-U516N-41-P0	COVER, ENGINE HATCH	1	1	1	1	CRUISER, NME
2	F1K-U266C-00	PACKING 4	2	2	2	2	
3	9299R-06200	WASHER	4	4	4	4	
4	9572R-06300	NUT, NYLON	4	4	4	4	
5	90183-06902	NUT, SPRING	2	2	2	2	
6	90119-06878	BOLT, WITH WASHER	9	9	9	9	
7	F1K-U517H-01	LID HATCH	1	1	1	1	
8	F0X-6517R-01	PIN, HINGE	2	2	2	2	
9	GU2-62875-01	LOCK	1	1	1	1	
10	90605-502U1	PLUG, BLIND	1	1	1	1	
11	F1K-U519D-00	PACKING CASE	1	1	1	1	
12	F1K-U5633-02	HOLDER, DRINK	1	1	1	1	
13	F1S-U596B-10	MIRROR LH	1	1	1	1	
14	F0V-U471E-00	.SPACER 1	1	1	1	1	
15	F1S-U596C-10	.MIRROR RH	1	1	1	1	
16	F0V-U471F-00	.SPACER 2	1	1	1	1	
17	9299R-08200	WASHER	4	4	4	4	
18	9572R-08300	NUT, FLANGE	4	4	4	4	
19	F1B-U5646-00	PLATE	2	2	2	2	

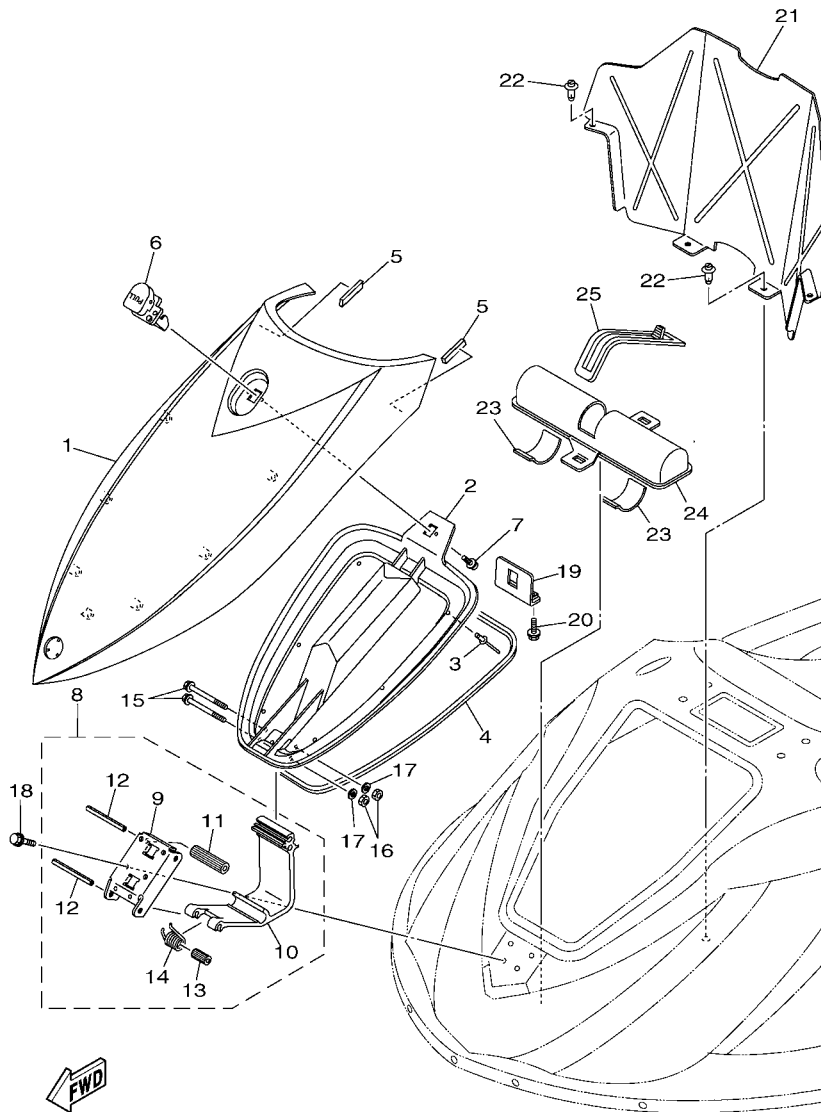

F1K1100-D200

FIG. 20 ENGINE HATCH 2

REF. NO.	PART NO.	DESCRIPTION	USA	CAN	GENE	JPN	REMARKS
1	F1K-U517B-10-P0	LID, ENGINE ROOM	1	1	1	1	DELUXE, DPBMT
	F1K-U517B-40-P0	LID, ENGINE ROOM	1	1	1	1	CRUISER, NME
2	F1K-U2103-00	VENTILATOR COVER COMP., 2	1	1	1	1	
3	90267-48809	RIVET, BLIND	7	7	7	7	
4	F1K-U2663-00	PACKING 1	1	1	1	1	
5	F1K-U266B-00	PACKING 3	2	2	2	2	
6	F1K-6517C-00	LOCK, LID	1	1	1	1	
7	90159-059U2	SCREW, WITH WASHER	2	2	2	2	
8	F1K-U515A-00	HINGE ASSY.	1	1	1	1	
9	F1K-U518E-04	.PLATE, HINGE LID	1	1	1	1	
10	F1K-U517D-05	.HINGE, LID	1	1	1	1	
11	F1K-U135C-00	.ROLLER, DETENT	1	1	1	1	
12	F1K-U517R-00	.PIN, HINGE	2	2	2	2	
13	F1K-U471E-03	.SPACER 1	1	1	1	1	
14	F1K-U283B-02	.SPRING, TORSION	1	1	1	1	
15	90105-06826	BOLT, FLANGE	2	2	2	2	
16	9572R-06300	NUT, NYLON	2	2	2	2	
17	9299R-06200	WASHER	2	2	2	2	
18	90119-069UH	BOLT, WITH WASHER	4	4	4	4	
19	F1K-U517F-01	HOOK, LID LOCK	1	1	1	1	
20	90119-069UH	BOLT, WITH WASHER	2	2	2	2	
21	F1K-U475F-01	PLATE, LOKER BOW	1	1	1	1	
22	90269-08801	RIVET	4	4	4	4	
23	F1K-U759C-00	MAT 2	2	2	2	2	
24	F1K-U5983-01	BOX, FIRE EXTINGUISHER	1	1	1	1	
25	F1K-U828K-00	BAND, 1	1	1	1	1	

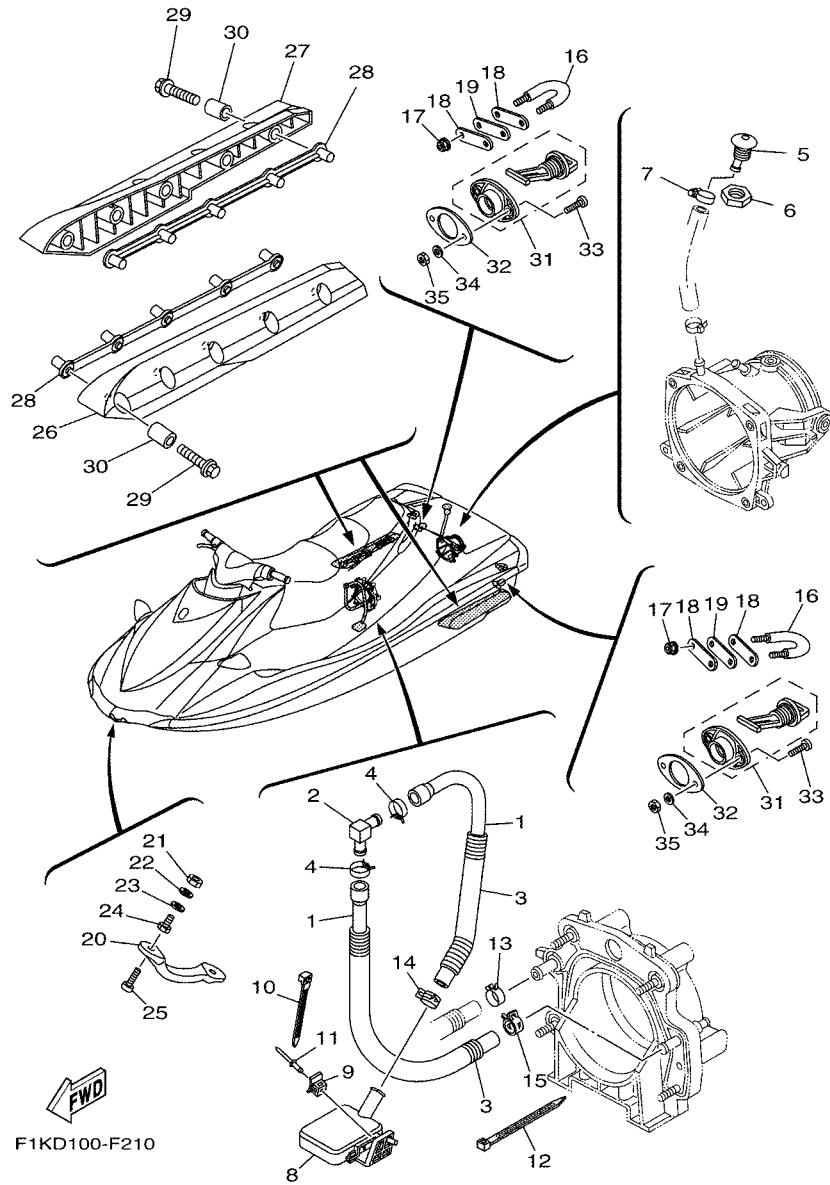

FIG. 21 HULL & DECK

REF. NO.	PART NO.	DESCRIPTION	USA	CAN	GENE	JPN	REMARKS
1	90445-20805	HOSE (L710)	2	2	2	2	
2	61X-51162-00	JOINT, HOSE	1	1	1	1	
3	90446-27M55	TUBE (L400)	2	2	2	2	
4	90467-18804	CLIP	2	2	2	2	
5	FN8-6269B-00	SPOUT	1	1	1	1	
6	EU0-61652-00	NUT	1	1	1	1	
7	90601-118UF	BAND, HOSE 18	1	1	1	1	
8	F1B-U761D-02	STRAINER, BILGE	1	1	1	1	
9	90600-917U4	CLAMP COMP.	1	1	1	1	
10	90464-32801	CLAMP	1	1	1	1	
11	90267-489U8	RIVET, BLIND	1	1	1	1	
12	90601-200U1	BAND	1	1	1	1	
13	90467-21800	CLIP	1	1	1	1	
14	90467-200A0	CLIP	1	1	1	1	
15	90467-210A0	CLIP	1	1	1	1	
16	F1K-61628-00	STERN EYE	2	2	2	2	
17	9572R-08300	NUT, FLANGE	4	4	4	4	
18	GP7-U4953-10	PLATE A	4	4	4	4	
19	F1B-U1653-01	PACKING	2	2	2	2	
20	F1K-61624-00	BOWEYE 1	1	1	1	1	
21	99780-12600	NUT, HEX. (COARS)	2	2	2	2	
22	92990-12200	WASHER, PLAIN	2	2	2	2	
23	F0X-61637-00	WASHER	2	2	2	2	
24	F0X-61652-00	NUT (BOLT/NUT)	2	2	2	2	
25	90110-06040	BOLT, HEXAGON SOCKET HEAD	2	2	2	2	
26	F1S-U883N-01	STABILIZER LH	1	1	1	1	BL
27	F1S-U883P-01	STABILIZER RH	1	1	1	1	BL

D6

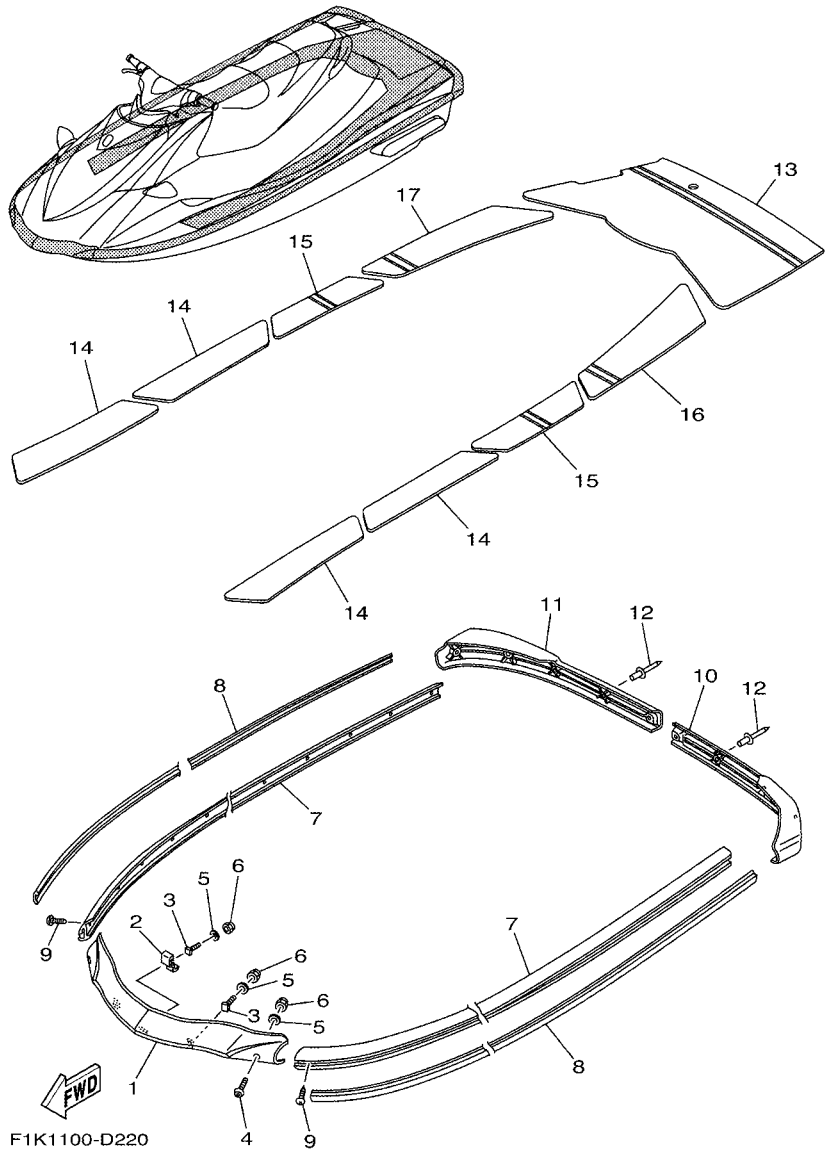
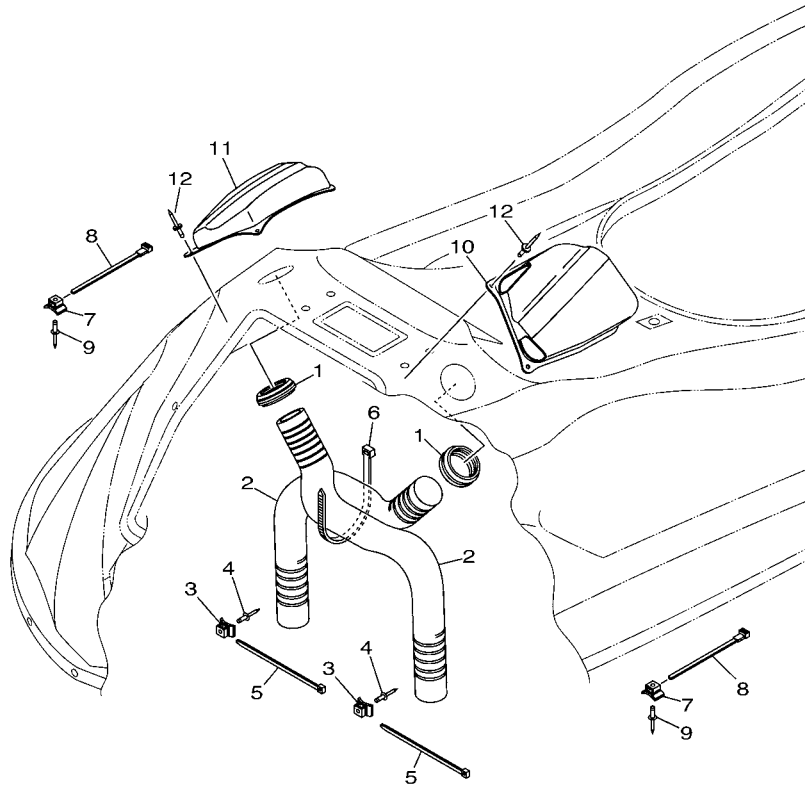

FIG. 22 GUNWALE & MAT

REF. NO.	PART NO.	DESCRIPTION	USA	CAN	GENE	JPN	REMARKS
1	F1K-U2501-01	BOW GUNWALE COMP.	1	1	1	1	GRAY
2	F1K-U2521-02	PLATE	1	1	1	1	
3	F1K-U491K-00	BOLT, SPECIAL	3	3	3	3	
4	90111-06803	BOLT,HEX. SOCKET BUTTON	2	2	2	2	
5	9299R-06200	WASHER	5	5	5	5	
6	9572R-06300	NUT, NYLON	5	5	5	5	
7	F1K-U2512-03	GUNWALE, SIDE	2	2	2	2	GRAY
8	F1K-U2519-20	INNER,GUNWALE	2	2	2	2	
9	90169-059U1	SCREW,TAPPING	30	30	30	30	
10	F1K-U251D-01	GUNWALE, STERN 1	1	1	1	1	GRAY
11	F1K-U251E-01	GUNWALE, STERN 2	1	1	1	1	GRAY
12	90267-47801	RIVET, BLIND	9	9	9	9	
13	F1K-U3581-11	MAT, UPPER	1	1	1	1	GRAY
14	F1K-U351H-11	MAT, STEP 1	4	4	4	4	GRAY
15	F1K-U351J-11	MAT, STEP 2	2	2	2	2	GRAY
16	F1K-U351K-11	MAT, STEP 3	1	1	1	1	GRAY
17	F1K-U351M-11	MAT, STEP 4	1	1	1	1	GRAY

FIG. 23 VENTILATION



REF. NO.	PART NO.	DESCRIPTION	USA	CAN	GENE	JPN	REMARKS
1	F1K-U2127-00	BASE, AIR INTAKE	2	2	2	2	
2	F1K-U213G-00	HOSE, VENTILATOR 2	2	2	2	2	
3	90600-917U4	CLAMP COMP.	2	2	2	2	
4	90267-489U6	RIVET, BLIND	2	2	2	2	
5	90464-99804	CLAMP	2	2	2	2	
6	90601-200U7	BAND	1	1	1	1	
7	90600-917U4	CLAMP COMP.	2	2	2	2	
8	90464-32801	CLAMP	2	2	2	2	
9	90267-489U6	RIVET, BLIND	2	2	2	2	
10	F1K-U2187-00	BOX, INDUCTION 1	1	1	1	1	
11	F1K-U2188-00	BOX, INDUCTION 2	1	1	1	1	
12	90267-48806	RIVET, BLIND	8	8	8	8	

F1K1100-D230

FIG. 24 SEAT & UNDER LOCKER

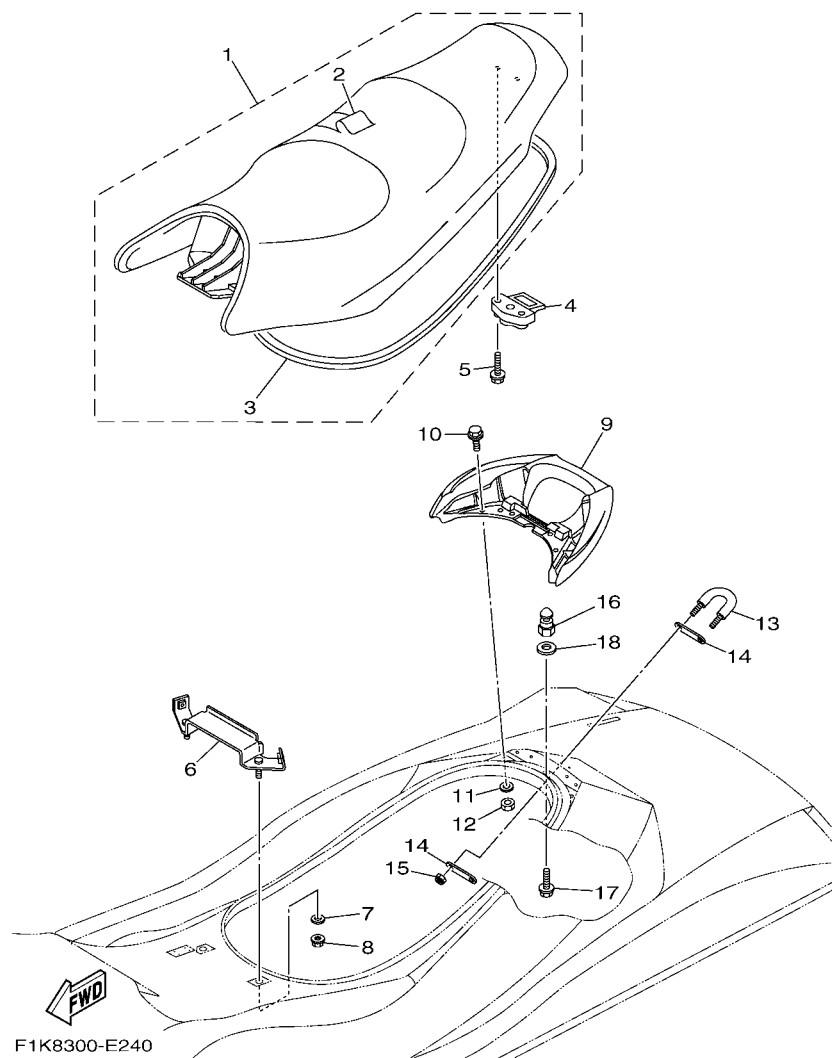

REF. NO.	PART NO.	DESCRIPTION	USA	CAN	GENE	JPN	REMARKS
1	F1K-U371A-11	DOUBLE SEAT ASSY	1	1	1	1	DELUXE
	F1K-U371A-41	DOUBLE SEAT ASSY	1	1	1	1	CRUISER
2	F1K-U371B-10	.COVER, SEAT 1	1	1	1	1	DELUXE
	F1K-U371B-40	.COVER, SEAT 1	1	1	1	1	CRUISER
3	F1K-U2664-01	.PACKING	1	1	1	1	
4	GJ3-63850-03	SEAT LOCK ASSY	1	1	1	1	
5	90119-069UP	BOLT, WITH WASHER	2	2	2	2	
6	F1K-U378C-00	STAY, SEAT 1	1	1	1	1	
7	90201-099U3	WASHER, PLATE	2	2	2	2	
8	9572R-08300	NUT, FLANGE	2	2	2	2	
9	F1K-U271B-04	GRIP, HAND	1	1	1	1	
10	90119-06820	BOLT, WITH WASHER	4	4	4	4	
11	9299R-06200	WASHER	4	4	4	4	
12	9572R-06300	NUT, NYLON	4	4	4	4	
13	F1K-61628-00	STERN EYE	1	1	1	1	
14	GP7-U4953-10	PLATE A	2	2	2	2	
15	9572R-08300	NUT, FLANGE	2	2	2	2	
16	F1K-U3774-00	PIN	1	1	1	1	
17	90119-10804	BOLT, WITH WASHER	1	1	1	1	
18	9299R-10200	WASHER	1	1	1	1	

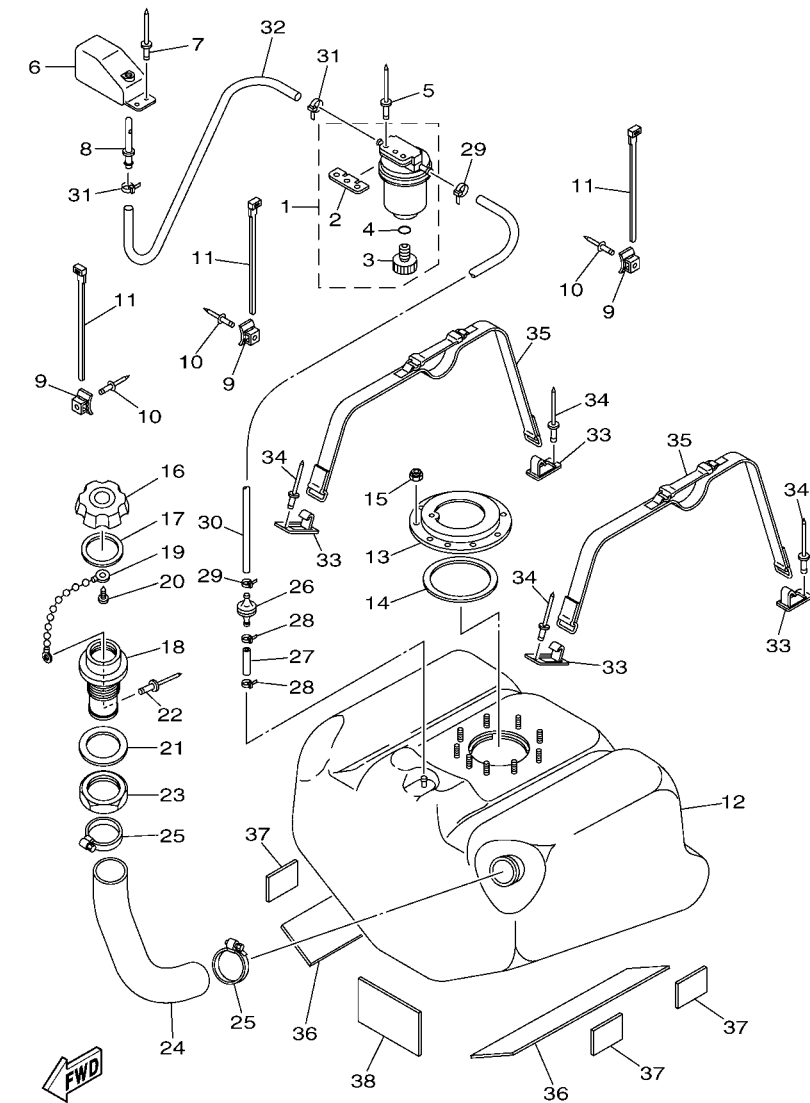

F1K7100-E250

FIG. 25 FUEL TANK

REF. NO.	PART NO.	DESCRIPTION	USA	CAN	GENE	JPN	REMARKS
1	EW2-62140-00	FILTER, VENT ASSY	1	1	1	1	
2	EW2-62142-00	.PLATE, FILTER	1	1	1	1	
3	70R-24543-00	.PLUG, DRAIN	1	1	1	1	
4	70R-24489-00	.O-RING	1	1	1	1	
5	90267-489U2	RIVET, BLIND	2	2	2	2	
6	GP7-62159-02	SOCKET, VENTILATION	1	1	1	1	
7	90267-489U6	RIVET, BLIND	2	2	2	2	
8	F1G-62149-00	PIPE, VENTILATION	1	1	1	1	
9	90600-917U4	CLAMP COMP.	3	3	3	3	
10	90267-489U6	RIVET, BLIND	3	3	3	3	
11	90464-32801	CLAMP	3	3	3	3	
12	F1K-U7711-02	TANK, FUEL	1	1	1	1	
13	F1B-U7773-00	RING	1	1	1	1	
14	F1B-67747-00	PACKING, SEAL	1	1	1	1	
15	9572R-06300	NUT, NYLON	9	9	9	9	
16	GP7-U7831-11	CAP, FUEL FILLER	1	1	1	1	BL
17	GP7-U7832-01	PACKING	1	1	1	1	
18	GP7-U7833-10	SOCKET	1	1	1	1	
19	GP7-U7835-00	CHAIN BALL	1	1	1	1	
20	90169-049U1	TAPPING SCREW	1	1	1	1	
21	GP7-U7834-00	PACKING FUEL FILLER	1	1	1	1	
22	90267-329UR	RIVET, BLIND	1	1	1	1	
23	GP7-U783F-00	NUT, FUEL FILLER	1	1	1	1	
24	F1K-U7844-01	HOSE	1	1	1	1	
25	90601-155U4	BAND, HOSE 55	2	2	2	2	
26	EU0-67767-31	CHECK VALVE	1	1	1	1	
27	GP7-U785H-00	HOSE, AIR VENT 3	1	1	1	1	

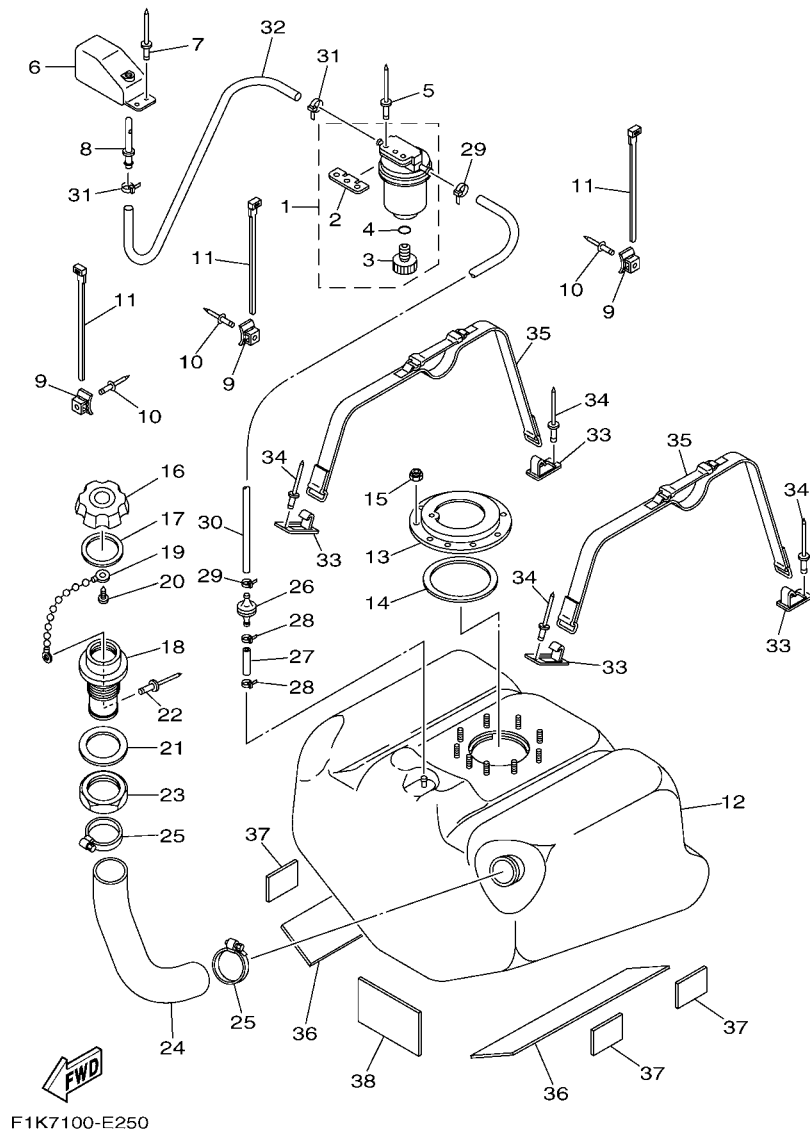
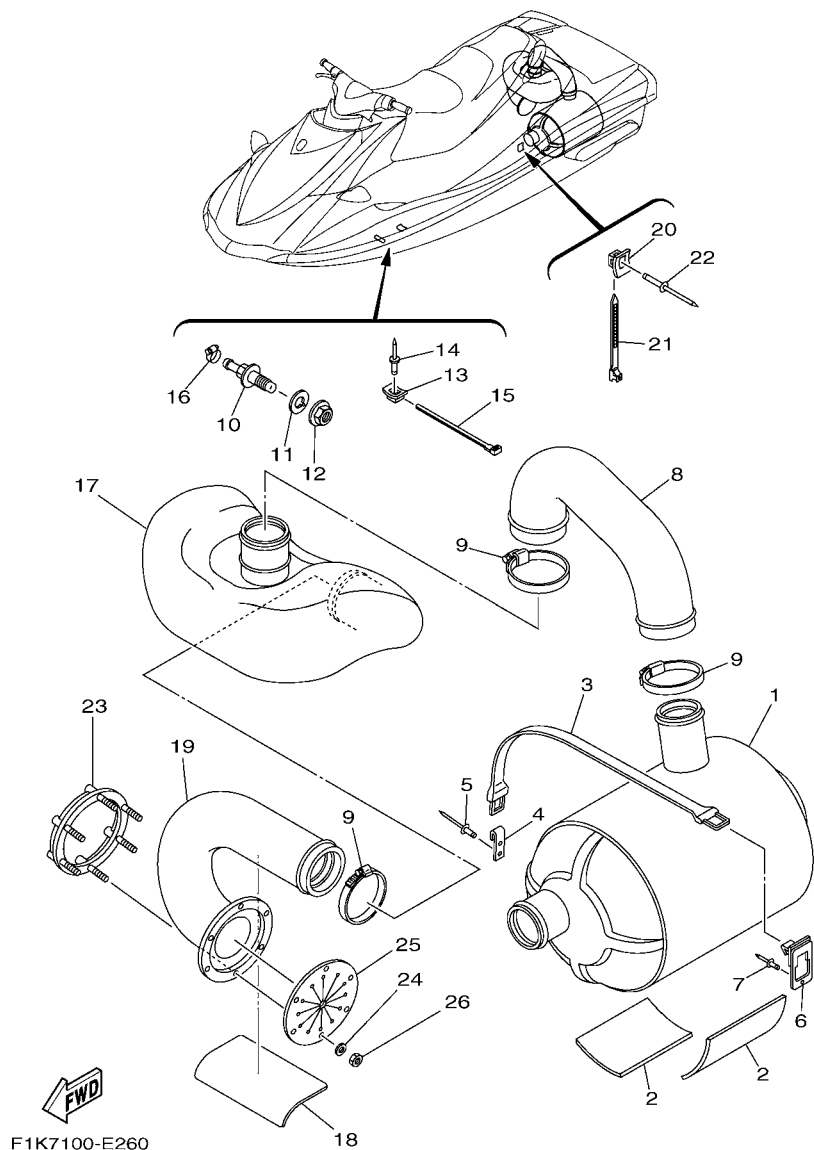

FIG. 25 FUEL TANK

REF. NO.	PART NO.	DESCRIPTION	USA	CAN	GENE	JPN	REMARKS
28	90465-11829	CLAMP	2	2	2	2	
29	90465-11829	CLAMP	2	2	2	2	
30	F1K-U785G-00	HOSE, AIR VENT	1	1	1	1	
31	90465-11829	CLAMP	2	2	2	2	
32	F0D-U7856-10	HOSE, AIR VENT 3	1	1	1	1	
33	F1K-U5772-02	HOOK A	4	4	4	4	
34	90267-489U1	RIVET,BLIND	4	4	4	4	
35	F1K-67743-00	BELT, TANK 1	2	2	2	2	
36	F1K-U759B-00	MAT 1	2	2	2	2	
37	F1B-U759C-00	MAT 2	4	4	4	4	
38	F1S-U8221-00	PAD, BATTERY	1	1	1	1	

FIG. 26 EXHAUST 3



REF. NO.	PART NO.	DESCRIPTION	USA	CAN	GENE	JPN	REMARKS
1	F1K-U7550-01	WATER LOCK COMP.	1	1	1	1	
2	F1S-U8221-00	PAD, BATTERY	2	2	2	2	
3	EW2-67821-00	BAND, FUEL TANK	1	1	1	1	
4	GA7-65772-00	HOOK A	1	1	1	1	
5	90267-489U1	RIVET,BLIND	2	2	2	2	
6	F1K-U5772-02	HOOK A	1	1	1	1	
7	90267-489U1	RIVET,BLIND	1	1	1	1	
8	F1K-U7555-00	HOSE, EXHAUST	1	1	1	1	
9	90601-175UR	BAND, HOSE 75	3	3	3	3	
10	F1K-6753B-00	PILOT, WATER	1	1	1	1	
11	F1B-67564-00	GASKET	1	1	1	1	
12	F0X-62733-00	NUT	1	1	1	1	
13	90600-917U4	CLAMP COMP.	1	1	1	1	
14	90267-489U6	RIVET, BLIND	1	1	1	1	
15	90464-32801	CLAMP	1	1	1	1	
16	90601-118UF	BAND, HOSE 18	1	1	1	1	
17	F1K-U4261-00	TANK, WATER	1	1	1	1	
18	F1S-U8221-00	PAD, BATTERY	1	1	1	1	
19	F1K-U758D-00	HOSE,EXHAUST 3	1	1	1	1	
20	90600-917U4	CLAMP COMP.	1	1	1	1	
21	90464-32801	CLAMP	1	1	1	1	
22	90267-489U6	RIVET, BLIND	1	1	1	1	
23	F1S-U757B-00	PLATE	1	1	1	1	
24	9299R-06200	WASHER	6	6	6	6	
25	F1B-U751G-00	VALVE, EXHAUST	1	1	1	1	
26	9572R-06300	NUT, NYLON	6	6	6	6	

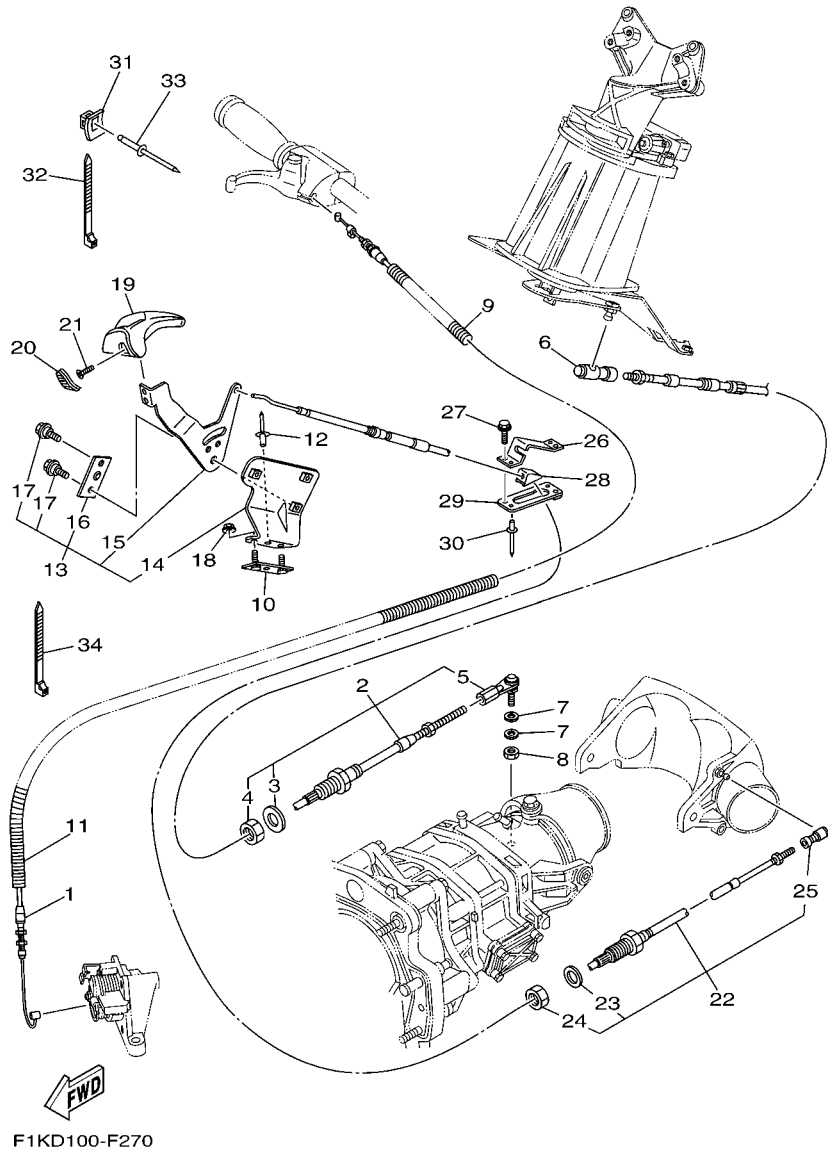

FIG. 27 CONTROL CABLE

REF. NO.	PART NO.	DESCRIPTION	USA	CAN	GENE	JPN	REMARKS
1	6D3-26311-01	CABLE, THROTTLE 1	1	1	1	1	
2	F1K-61481-01	CABLE, STEERING	1	1	1	1	
3	F1B-61438-00	.PACKING	1	1	1	1	
4	F1B-6151S-00	.NUT	1	1	1	1	
5	F1B-61461-02	.STUD, JOINT BALL	1	1	1	1	
6	GK5-U146F-00	SHAFT, JOINT BALL	1	1	1	1	
7	90201-06906	WASHER, PLATE	2	2	2	2	
8	9538R-06700	NUT	1	1	1	1	
9	90447-06802	HOSE, WITH SPRING	1	1	1	1	
10	F1K-U826C-02	BRACKET	1	1	1	1	
11	90447-06800	HOSE, WITH SPRING	1	1	1	1	
12	90267-489U6	RIVET, BLIND	1	1	1	1	
13	F1K-U134A-00	REMOCON. LEVER ASSY.	1	1	1	1	
14	F1K-U1794-02	.BRACKET	1	1	1	1	
15	F1K-U151N-02	.LEVER	1	1	1	1	
16	F1K-U152N-00	.DETENT PLATE	1	1	1	1	
17	F1K-U1355-00	.BOLT	2	2	2	2	
18	9572R-08300	NUT, FLANGE	2	2	2	2	
19	F1K-U2714-02	GRIP	1	1	1	1	
20	F1K-U1336-00	DAMPER, STOPPER	1	1	1	1	
21	90151-05802	SCREW, COUNTERSUNK	2	2	2	2	
22	F1K-6149C-00	CABLE, REVERSE	1	1	1	1	
23	F1B-61438-00	.PACKING	1	1	1	1	
24	F1B-6151S-00	.NUT	1	1	1	1	
25	F1B-61460-00	.BALL JOINT ASSY	1	1	1	1	
26	F1K-U1467-11	BRACKET, STOPPER CABLE	1	1	1	1	
27	90119-06878	BOLT, WITH WASHER	2	2	2	2	

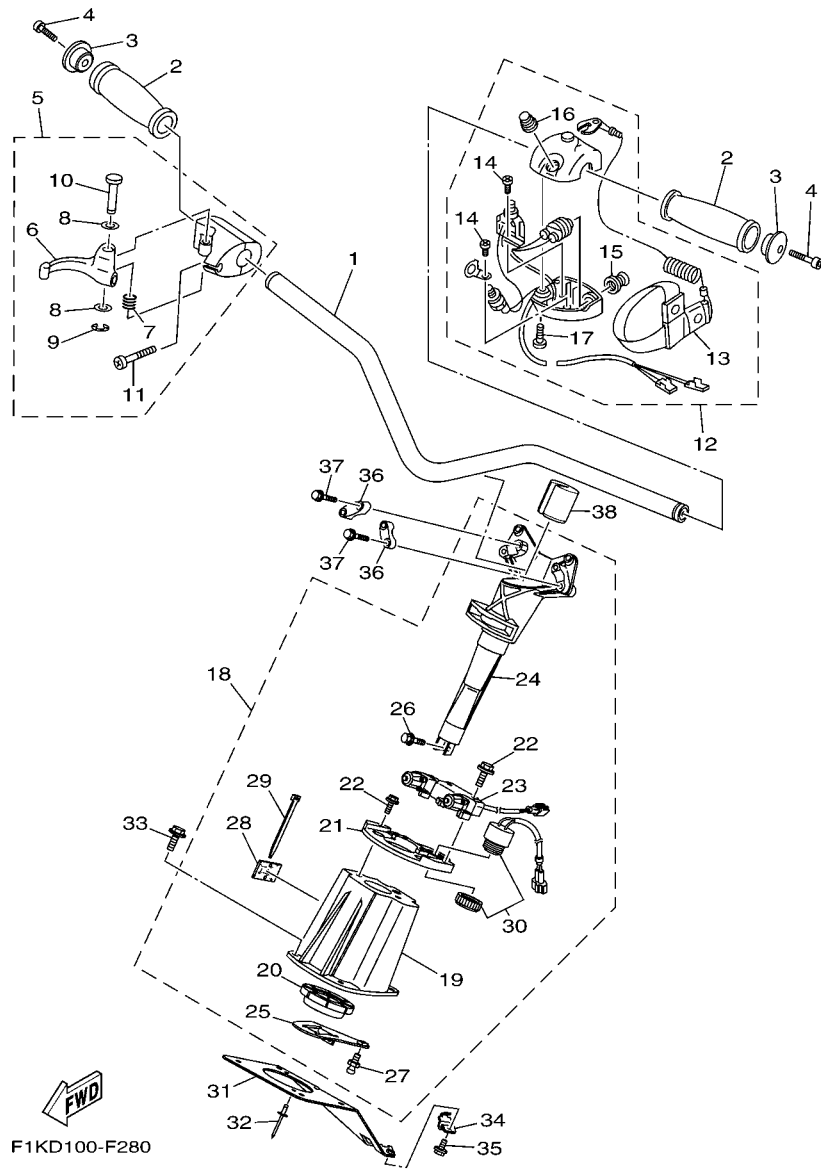
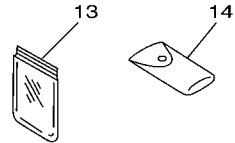
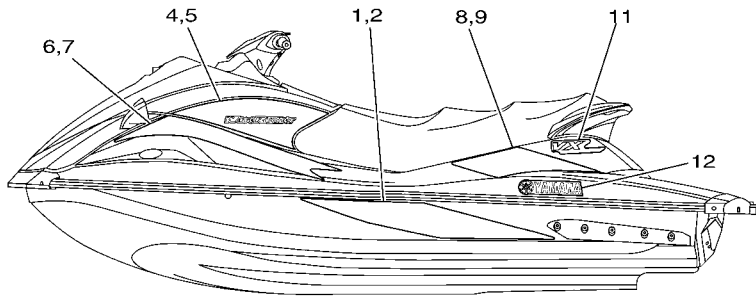
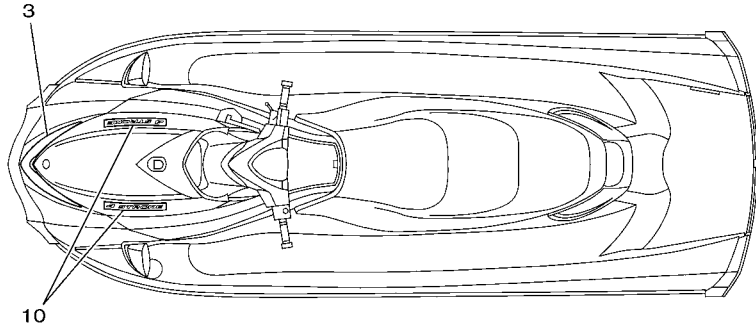

FIG. 28 STEERING 1

REF. NO.	PART NO.	DESCRIPTION	USA	CAN	GENE	JPN	REMARKS
1	F1K-U1552-00	HANDLE	1	1	1	1	
2	GP7-U155D-00	GRIP, HANDLE	2	2	2	2	
3	GP7-U155F-00	GRIP, END	2	2	2	2	
4	90110-05908	BOLT, HEXAGON SOCKET HEAD	2	2	2	2	
5	F0D-67250-03	THROTTLE LEVER ASSY	1	1	1	1	
6	F0D-67255-01	.LEVER, THROTTLE	1	1	1	1	
7	EW2-67256-00	.SPRING	1	1	1	1	
8	EW2-67258-01	.WASHER	2	2	2	2	
9	EW2-67259-01	.E-RING	1	1	1	1	
10	F0D-67257-00	.SHAFT	1	1	1	1	
11	98580-05025	.SCREW, PAN HEAD	2	2	2	2	
12	FK7-68310-07	SWITCH BOX ASSY	1	1	1	1	
13	EW2-68348-00	.LANYARD, STOP SWITCH	1	1	1	1	
14	97880-03008	.SCREW, PAN HEAD	2	2	2	2	
15	FK7-68312-02	.STOP BUTTON COMP	1	1	1	1	
16	FK7-68313-02	.START BUTTON COMP.	1	1	1	1	
17	97880-05025	.SCREW, PAN HEAD	2	2	2	2	
18	F1K-U154A-04	STEERING COLUMN COMP.	1	1	1	1	
19	F1K-U152M-00	.HOUSING ASSY	1	1	1	1	
20	F1K-U143C-00	.SEAL, RUBBER	1	1	1	1	
21	F1K-U146H-01	.SPACER, BRKT.	1	1	1	1	
22	90119-08826	.BOLT, WITH WASHER	7	7	7	7	
23	F1B-68303-10	.SENSOR ASSY	1	1	1	1	
24	F1K-U1541-02	.COLUMN, STEERING	1	1	1	1	
25	F1K-U151B-02	.ARM, STEERING	1	1	1	1	
26	90119-08826	.BOLT, WITH WASHER	1	1	1	1	
27	GH3-U146E-00	.STUD, JOINT BALL	1	1	1	1	



F1KD100-F300

FIG. 30 GRAPHICS

REF. NO.	PART NO.	DESCRIPTION	USA	CAN	GENE	JPN	REMARKS
1	F1K-U417B-70	GRAPHIC 1 (LH)	1	1	1	1	DELUXE
	F1K-U417B-60	GRAPHIC 1 (LH)	1	1	1	1	CRUISER
2	F1K-U417C-70	GRAPHIC 2 (RH)	1	1	1	1	DELUXE
	F1K-U417C-60	GRAPHIC 2 (RH)	1	1	1	1	CRUISER
3	F1K-U417D-70	GRAPHIC 3	1	1	1	1	DELUXE
	F1K-U417D-60	GRAPHIC 3	1	1	1	1	CRUISER
4	F1K-U417F-70	GRAPHIC 5 (LH)	1	1	1	1	DELUXE
	F1K-U417F-60	GRAPHIC 5 (LH)	1	1	1	1	CRUISER
5	F1K-U417G-70	GRAPHIC 6 (RH)	1	1	1	1	DELUXE
	F1K-U417G-60	GRAPHIC 6 (RH)	1	1	1	1	CRUISER
6	F1K-U417H-70	GRAPHIC 7 (LH)	1	1	1	1	DELUXE
	F1K-U417H-60	GRAPHIC 7 (LH)	1	1	1	1	CRUISER
7	F1K-U417J-70	GRAPHIC 8 (RH)	1	1	1	1	DELUXE
	F1K-U417J-60	GRAPHIC 8 (RH)	1	1	1	1	CRUISER
8	F1K-U417K-70	GRAPHIC 9 (LH)	1	1	1	1	DELUXE
	F1K-U417K-60	GRAPHIC 9 (LH)	1	1	1	1	CRUISER
9	F1K-U417L-70	GRAPHIC B (RH)	1	1	1	1	DELUXE
	F1K-U417L-60	GRAPHIC B (RH)	1	1	1	1	CRUISER
10	F1K-U417M-70	GRAPHIC C	2	2	2	2	DELUXE
	F1K-U417M-60	GRAPHIC C	2	2	2	2	CRUISER
11	F1K-U417N-70	GRAPHIC D	2	2	2	2	DELUXE
	F1K-U417N-60	GRAPHIC D	2	2	2	2	CRUISER
12	F1X-U411C-10	EMBLEM, YAMAHA	2	2	2	2	DELUXE
	F1S-U411C-10	EMBLEM, YAMAHA	2	2	2	2	CRUISER
13	F1B-65986-00	TOOL SET	1	1	1	1	
14	EU0-65901-01	TOOL BAG	1	1	1	1	

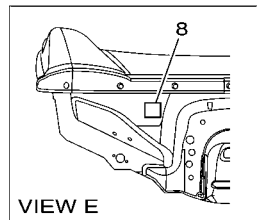
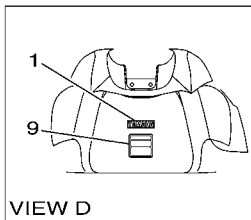
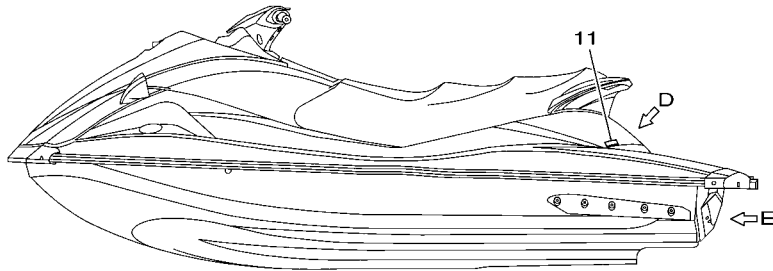
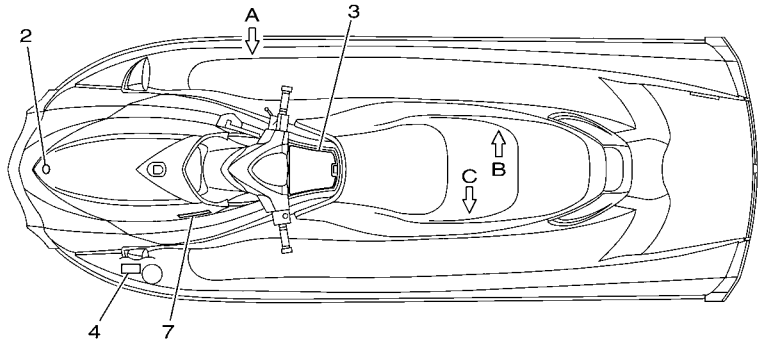
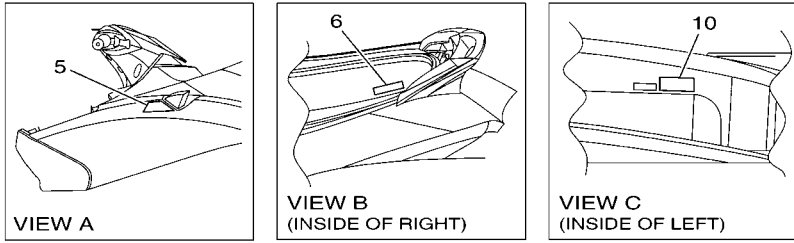

F1KD100-F310

FIG. 31 IMPORTANT LABELS

REF. NO.	PART NO.	DESCRIPTION	USA	CAN	GENE	JPN	REMARKS
1	F1S-U411C-00	EMBLEM, YAMAHA	1				DELUXE
	F1X-U411C-20	EMBLEM, YAMAHA	1				CRUISER
2	F1K-U411H-00	EMBLEM, TUNING FORK	1				
3	F1K-U41B1-01	LABEL, WARNING JDC 1	1				
4	F1S-U415B-01	LABEL, WARNING(FUEL)	1				
5	F0V-U41D5-21	LABEL, WARNING SHIFT LEVER	1				
6	F0V-U41DB-02	LABEL, WARNING BATTERY	1				
7	F0V-U41F5-01	LABEL, FIRE EXTINGUISHER 1	1				
8	F1G-U418F-00	LABEL, RIGHTING	1				
9	F1S-U41E1-01	LABEL, SET 1	1				
10	F1K-U413N-20	LABEL, CARB	1				
11	F1S-U41G1-01	LABEL, CAPACITY	1				

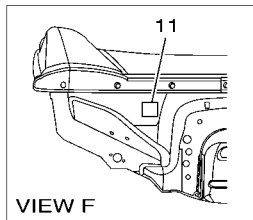
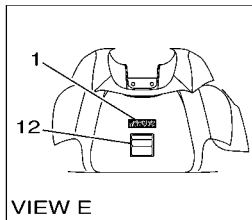
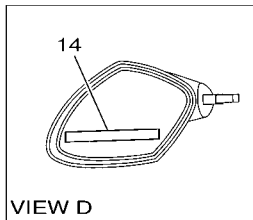
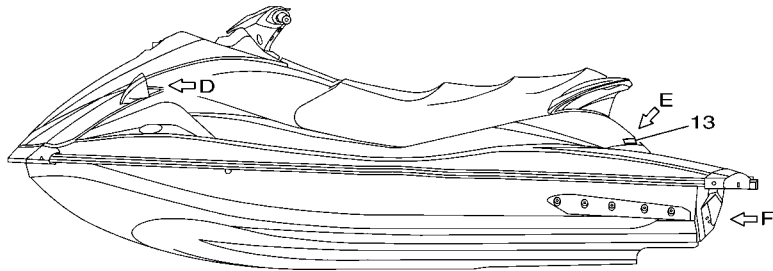
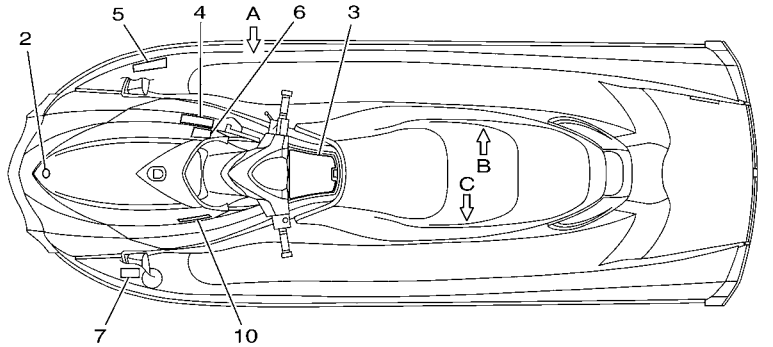
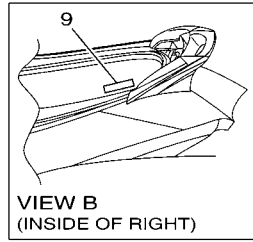
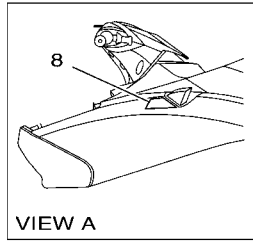

F1KD100-F320

FIG. 32 IMPORTANT LABELS 2

REF. NO.	PART NO.	DESCRIPTION	USA	CAN	GENE	JPN	REMARKS
1	F1S-U411C-00	EMBLEM, YAMAHA		1			DELUXE
	F1X-U411C-20	EMBLEM, YAMAHA		1			CRUISER
2	F1K-U411H-00	EMBLEM, TUNING FORK		1			
3	F1K-U41B1-11	LABEL, WARNING JDC 1		1			
4	F1B-U41B1-21	LABEL, WARNING JDC 1		1			
5	F1B-U41B1-31	LABEL, WARNING JDC 1		1			
6	F1B-U41B2-01	LABEL, WARNING JDC 2		1			
7	F1S-U415B-11	LABEL, WARNING(FUEL)		1			
8	F0V-U41D5-31	LABEL, WARNING SHIFT LEVER		1			
9	F0V-U41DB-12	LABEL, WARNING BATTERY		1			
10	F1B-U41F5-21	LABEL, FIRE EXTINGUISHER 1		1			
11	F1G-U418F-00	LABEL, RIGHTING		1			
12	F1S-U41E1-11	LABEL, SET 1		1			
13	F1S-U419E-01	LABEL 4		1			
14	GJ1-U419F-21	LABEL,5		2			

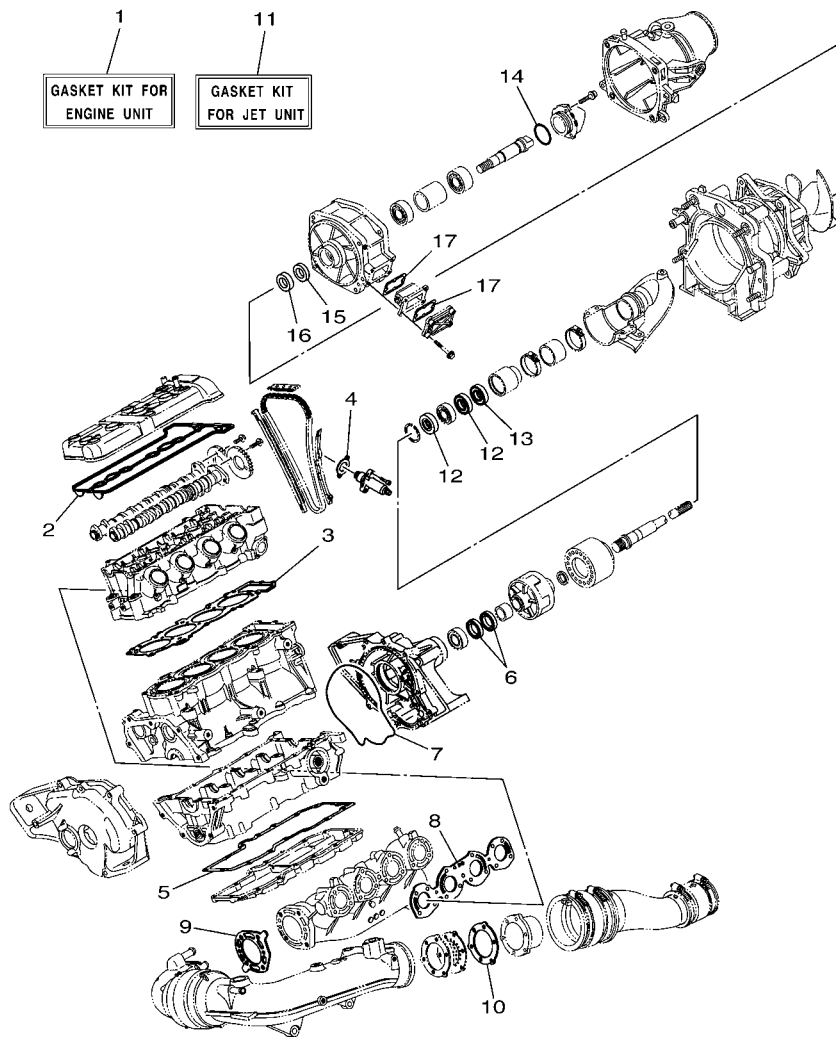

F1K1100-D330

FIG. 35 REPAIR KIT 1

REF. NO.	PART NO.	DESCRIPTION	USA	CAN	GENE	JPN	REMARKS
1	6D3-W0001-00	GASKET KIT FOR ENGINE UNIT	1	1	1	1	
2	60E-11193-01	.GASKET, HEAD COVER 1	1	1	1	1	
3	6D3-11181-00	.GASKET, CYLINDER HEAD 1	1	1	1	1	
4	4FM-12213-00	.GASKET, TENSIONER CASE	1	1	1	1	
5	6B6-13557-00	.GASKET	1	1	1	1	
6	93101-35004	.OIL SEAL	2	2	2	2	
7	6B6-13475-01	.GASKET	1	1	1	1	
8	6D3-14613-00	.GASKET, EXHAUST PIPE	1	1	1	1	
9	6D3-14739-00	.GASKET, MUFFLER DAMPER 1	1	1	1	1	
10	60E-14623-00	.GASKET, EXHAUST PIPE	2	2	2	2	
11	6D3-W0001-20	GASKET KIT FOR JET UNIT	1	1	1	1	
12	93101-25M55	.OIL SEAL	2	2	2	2	
13	93101-25M56	.OIL SEAL	1	1	1	1	
14	93210-464A3	.O-RING	1	1	1	1	
15	93101-21002	.OIL SEAL	1	1	1	1	
16	93101-21001	.OIL SEAL	1	1	1	1	
17	66V-42414-00	.O-RING	2	2	2	2	

NUMERICAL INDEX

PART NO.	GRID NO.	PART NO.	GRID NO.	PART NO.	GRID NO.	PART NO.	GRID NO.	PART NO.	GRID NO.	PART NO.	GRID NO.
6D3-11102-00-94	B - 2	4SV-12119-00	B - 8	6D3-1244G-00	C - 4	6D3-14413-00	B - 11	67X-44517-10-94	B - 5	GA7-65772-00	D - 13
4KG-1111G-00	B - 2	4TV-12119-00	B - 8	60E-12474-00	B - 3	6D3-14414-00	B - 11	6D3-44574-00	B - 5	EU0-65901-01	E - 5
6D3-11125-00	B - 13	5LV-12121-00	B - 8	6D3-12482-00	B - 3	6D3-14419-00	B - 10	66V-45214-00-94	C - 6	F1B-65986-00	E - 5
6D3-11126-00	B - 12	3GM-12126-00	B - 8	60E-12483-10	B - 3	6D3-14421-01	B - 10	6D3-45235-00	C - 8	F0D-67250-03	E - 2
3TJ-11133-10	B - 2	3FV-12153-10	B - 9	60E-12494-00	B - 3	6D3-14437-00	B - 10	6D3-45332-00-94	C - 8	F0D-67255-01	E - 2
1WG-11133-11	B - 2	3LN-12153-10	B - 9	6D3-12494-00	C - 5	63P-14446-00	B - 11	6D3-45511-00	C - 6	EW2-67256-00	E - 2
6D3-11164-00	B - 12	1HX-12168-00	B - 8	60E-12495-00	B - 3	60E-14449-00	B - 11	6D3-45514-00	C - 6	F0D-67257-00	E - 2
6D3-11165-00	B - 14	1HX-12168-20	B - 8	6B6-12499-00	C - 5	6D3-14451-00	B - 10	65V-45538-00	C - 6	EW2-67258-01	E - 2
6D3-11166-00	B - 13	1HX-12168-40	B - 8	60E-12537-00	B - 3	4XV-14452-00	B - 10	6D3-45593-00-94	C - 8	EW2-67259-01	E - 2
6D3-11167-00	B - 15	1HX-12168-60	B - 8	6D3-12577-00	C - 4	6D3-14457-00	B - 11	6D3-45813-00-94	B - 6	F1K-6753B-00	D - 13
6D3-11181-00	B - 2	1HX-12168-80	B - 8	63M-12580-00	C - 4	68V-14475-00	B - 11	6D3-4581J-00	C - 8	F1B-67564-00	D - 13
	E - 10	1HX-12168-A0	B - 8	60E-12581-00	C - 4	6D3-14495-00	B - 10	66V-46882-00	C - 6	F1K-67743-00	D - 12
6D3-1118A-00	B - 2	1HX-12168-F0	B - 8	60E-12584-00	C - 4	6D3-14613-00	C - 2	61X-51162-00	D - 6	F1B-67747-00	D - 11
6D3-11191-01-94	B - 2	1HX-12168-H1	B - 8	6D3-12584-00	C - 4		E - 10	66V-51312-01-94	C - 6	EU0-67767-31	D - 11
60E-11193-01	B - 2	1HX-12168-K1	B - 8	6D3-12880-00	B - 11	6D3-14615-00	C - 2	6B6-51315-01-94	C - 6	EW2-67821-00	D - 13
	E - 10	1HX-12168-M1	B - 9	6B6-1310A-00-94	B - 4	60E-14623-00	C - 2	6B6-51326-10	C - 6	F1K-6820A-01	D - 2
69J-11301-00	B - 4	1HX-12168-R1	B - 9	6B6-13151-00-94	B - 14		E - 10	60E-51341-00-94	B - 15	GU2-6822E-01	D - 2
69J-11301-10	B - 4	1HX-12168-U1	B - 9	60E-13161-00	B - 4	6D3-14625-00	C - 2	6D3-52358-00	C - 9	60E-682E0-00	D - 2
6E5-11325-00	B - 14	1HX-12168-W1	B - 9	6D3-13300-01	B - 12	6D3-1469W-00	C - 2	F1B-61438-00	D - 14	F1B-68303-10	E - 2
67F-11325-01	B - 4	1HX-12168-Y1	B - 9	6B6-13317-00	B - 14	6D3-14711-00-94	C - 2	F1B-61460-00	D - 14	FK7-68310-07	E - 2
68V-11325-02	B - 4	1HX-12169-11	B - 9	6B6-13327-01-94	B - 12	6D3-14712-00-94	C - 2	F1B-61461-02	D - 14	FK7-68312-02	E - 2
67F-11328-00	B - 4	1HX-12169-31	B - 9	6B6-13360-00	B - 12	6D3-14721-00-94	C - 2	F1K-61481-01	D - 14	FK7-68313-02	E - 2
60E-11372-10	C - 2	1HX-12169-50	B - 9	6B6-13411-00	B - 12	6D3-14739-00	C - 2	F1K-6149C-00	D - 14	F1S-68341-00	E - 3
60E-11411-11	B - 6	1HX-12169-70	B - 9	60E-13421-00	B - 14		E - 10	F1B-6151S-00	D - 14	EW2-68348-00	E - 2
6D3-11416-00	B - 6	1HX-12169-90	B - 9	5GH-13440-00	B - 5	6D3-14752-00-94	C - 3	F1K-61624-00	D - 6	6D3-81147-00	B - 11
6D3-11416-10	B - 6	1HX-12169-E0	B - 9	6D3-13443-00-94	B - 14	6B6-1475E-00	C - 3	F1K-61628-00	D - 6	60E-81315-00	C - 14
6D3-11416-20	B - 6	1HX-12169-G0	B - 9	60E-13446-00	B - 14	6D3-1475F-00	C - 3		D - 10	60E-81328-00	C - 10
6D3-11416-30	B - 6	1HX-12169-J0	B - 9	6D3-13462-00-94	B - 14	60E-14784-00-94	C - 2	F0X-61637-00	D - 6	66V-8132W-00	C - 12
6D3-11416-A0	B - 6	1HX-12169-L0	B - 9	6D3-13463-00-94	B - 14	6D3-15100-00-94	B - 4	EU0-61652-00	C - 4	6D3-81337-00-94	C - 10
6B6-11478-00	B - 6	1HX-12169-N0	B - 9	60E-13473-00	B - 14	60E-15362-00	B - 14		D - 6	6D3-81410-01	C - 10
6D3-11603-00	B - 6	1HX-12169-T0	B - 9	60E-13475-00	B - 14	6D3-15515-00	C - 10	F0X-61652-00	D - 6	6D3-81450-00	C - 10
6D3-11631-00-B0	B - 6	6D3-12171-00	B - 8	6B6-13475-01	B - 12	60E-15517-00	C - 10	EW2-62140-00	D - 11	6D3-81800-00	C - 11
4XV-11633-00	B - 6	6D3-12171-10	B - 8		E - 10	60E-15521-00	C - 10	EW2-62142-00	D - 11	3AJ-81809-00	C - 11
6D3-11650-00	B - 6	6D3-12176-00	B - 8	60E-13476-10	B - 14	4WM-15590-00	C - 10	F1G-62149-00	D - 11	6M6-81826-00	C - 11
5JW-11654-00	B - 6	6D3-12181-00	B - 8	6D3-13477-00	B - 14	6D3-17572-00	B - 6	GP7-62159-02	D - 11	6M6-81830-00	C - 11
60E-11656-00	B - 6	6D3-12210-00	B - 9	6B6-13557-00	E - 10	6B6-17585-00	B - 6	GJ3-6215F-00	D - 2	6M6-81840-10	C - 11
60E-11656-10	B - 6	4FM-12213-00	B - 9	6B6-13557-01	B - 4	6B6-17586-00	B - 6	EU0-62241-30	D - 2	11H-81844-00	C - 11
60E-11656-20	B - 6		E - 10	6D3-13563-00	B - 12	EU0-23814-30	E - 3	FN8-6269B-00	D - 6	66V-81844-00	C - 12
60E-11656-30	B - 6	5BE-12241-00	B - 9	68V-13573-00	B - 11	60E-24300-01	B - 11	F0X-62733-00	D - 13	6D3-81845-00	C - 10
4XV-12111-00	B - 8	6D3-12251-00	B - 9	6D3-13641-00	B - 11	6D3-24387-00	D - 2	GU2-62875-01	D - 4	1FK-81847-00	C - 11
4XV-12112-00	B - 8	4XV-12252-00	B - 9	6D3-13750-00	B - 11	60E-24474-00	D - 2	GJ3-63850-03	D - 10	6M6-81850-00	C - 11
4XV-12113-00	B - 8	6D3-12411-00	C - 5	6D3-13761-10	B - 11	6D3-24481-00	D - 2	F1S-6415B-20	E - 9	6D3-81921-00	C - 12
4XV-12114-00	B - 8	60E-12413-10-94	C - 5	6D3-13795-01	B - 11	70R-24489-00	D - 11	F1K-641B1-21	E - 9	6B6-81940-00	C - 12
1HX-12116-01	B - 8	60E-12417-10-94	C - 5	60E-13907-01	D - 2	70R-24543-00	D - 11	F0V-641D5-40	E - 9	60E-81950-00	C - 12
1HX-12117-00	B - 8	60E-12435-00	C - 5	60E-14147-00	B - 11	6D3-26311-01	D - 14	F0V-641DB-20	E - 9	68V-81950-00	C - 12
1WG-12117-00	B - 8	6D3-1243A-10	C - 4	6D3-14294-00	B - 11	67F-2812A-00	C - 12	F1S-641E2-20	E - 9	6D3-81960-00	C - 12
1HX-12118-00	B - 8	6D3-1243E-10	C - 4	6D3-14305-20	C - 14	66V-42414-00	C - 6	F1K-6517C-00	D - 5	EU0-82110-09	D - 2
1WG-12118-00	B - 8	6D3-12446-00	C - 5	6D3-14411-00	B - 10		E - 10	F0X-6517R-01	D - 4	6D3-82115-00	C - 12

NUMERICAL INDEX

PART NO.	GRID NO.	PART NO.	GRID NO.	PART NO.	GRID NO.	PART NO.	GRID NO.	PART NO.	GRID NO.	PART NO.	GRID NO.
6D3-82116-00	C - 13	F1K-U135C-00	D - 5	F1K-U351H-11	D - 8	F1K-U417K-70	E - 5	F1K-U516N-41-P0	D - 4	F1K-U8169-00	D - 7
6D3-82117-00	C - 12	F1K-U142D-00	E - 4	F1K-U351J-11	D - 8	F1K-U417L-60	E - 5	F1K-U517B-10-P0	D - 5	F1K-U8211-01	D - 2
67F-82151-00	C - 12	F1K-U143C-00	E - 2	F1K-U351K-11	D - 8	F1K-U417L-70	E - 5	F1K-U517B-40-P0	D - 5	F1K-U821D-00	D - 2
67F-82151-10	C - 12	F1K-U143D-01	E - 4	F1K-U351M-11	D - 8	F1K-U417M-60	E - 5	F1K-U517D-05	D - 5	F1K-U8221-00	D - 2
67F-82151-30	C - 12	F1K-U143E-00	E - 4	F1K-U3581-11	D - 8	F1K-U417M-70	E - 5	F1K-U517F-01	D - 5	F1K-U8221-00	D - 12
67F-82151-40	C - 12	EU0-U1461-02	C - 9	F1K-U371A-11	D - 10	F1K-U417N-60	E - 5	F1K-U517H-01	D - 4		D - 13
6D3-82157-00	C - 12	F1K-U1467-00	E - 3	F1K-U371A-41	D - 10	F1K-U417N-70	E - 5	F1K-U517R-00	D - 5	F1S-U826C-00	C - 14
6D3-82170-00	C - 12	F1K-U1467-11	D - 14	F1K-U371B-10	D - 10	F1G-U418F-00	E - 6	F1K-U518E-04	D - 5	F1K-U826C-02	D - 14
6D3-82310-00	C - 14	F1K-U1468-03	E - 3	F1K-U371B-40	D - 10		E - 7	F1K-U519D-00	D - 4	F1K-U828K-00	D - 5
6A0-82317-00	B - 12	GH3-U146E-00	E - 2	F1K-U3774-00	D - 10		E - 8	F1K-U5633-02	D - 4	F1G-U8572-00	C - 7
	C - 12	GK5-U146F-00	D - 14	F1K-U378C-00	D - 10		E - 9	F1B-U5646-00	D - 4	F1K-U8572-02	B - 10
68V-82504-00	C - 14	F1K-U146G-01	D - 15	GA9-U411B-00	E - 9	F1S-U419E-01	E - 7	F1K-U5772-02	D - 2	F1K-U8577-00	C - 7
60E-82532-00	C - 14	F1K-U146H-01	E - 2	F1S-U411C-00	E - 6	GJ1-U419F-21	E - 7		D - 12	F1K-U883B-00	C - 8
60E-82556-00	D - 2	F1K-U151B-02	E - 2		E - 7		E - 8		D - 13	F1K-U883E-00	C - 8
6D3-82560-01	C - 14	F1K-U151N-02	D - 14		E - 8	F1K-U41B1-01	E - 6	F1S-U596B-10	D - 4	F1S-U883N-01	D - 6
60E-82560-A1	C - 14	F1K-U152M-00	E - 2		E - 9	F1K-U41B1-11	E - 7	F1S-U596C-10	D - 4	F1S-U883P-01	D - 6
60E-8259E-00	C - 12	F1K-U152N-00	D - 14	F1S-U411C-10	E - 5		E - 8	F1X-U5983-01	D - 5	F1X-U883T-00	D - 7
6D3-8259L-A2	C - 13	F1K-U1541-02	E - 2	F1X-U411C-10	E - 5	F1B-U41B1-21	E - 7	EU0-U7354-00-01	B - 5	F1S-U8K31-02	D - 2
6D3-8273J-01	C - 14	F1K-U154A-04	E - 2	F1X-U411C-20	E - 6		E - 8	EU0-U7354-00-03	B - 5	6D3-W0001-00	E - 10
6B6-83623-00	B - 14	F1K-U1552-00	E - 2		E - 7	F1B-U41B1-31	E - 7	EU0-U7354-00-05	B - 5	6D3-W0001-20	E - 10
60E-83627-00	B - 14	GP7-U155D-00	E - 2		E - 8		E - 8	EU0-U7354-00-10	B - 5	6D3-W009A-00-94	B - 2
68F-83688-00	B - 11	GP7-U155F-00	E - 2		E - 9	F1B-U41B2-01	E - 7	EU0-U7354-00-20	B - 5	6D3-W009A-10-94	B - 2
682-84385-01	C - 4	F1K-U156E-01	E - 4	F1K-U411H-00	E - 6		E - 8	F1B-U751G-00	D - 13	6D3-W009B-10-94	B - 4
6D3-85132-00	B - 2	F1B-U1653-01	D - 6		E - 7	F0V-U41D5-21	E - 6	F1K-U7550-01	D - 13	90101-069U0	C - 7
61A-85790-00	C - 14	F1K-U1794-02	D - 14		E - 8	F0V-U41D5-31	E - 7	F1K-U7555-00	D - 13	90105-06026	B - 2
6D3-85896-00	C - 14	F1K-U1949-00	E - 3		E - 9		E - 8	F1K-U7557-00	C - 7	90105-06033	B - 4
6D3-8591A-A0	C - 12	F1K-U2103-00	D - 5	F1K-U413N-20	E - 6	F0V-U41DB-02	E - 6	F1S-U757B-00	D - 13	90105-06035	C - 5
6D3-8591A-B0	C - 12	F1K-U2127-00	D - 9	F1X-U413P-01	E - 8		E - 9	F1K-U757E-01	C - 7	90105-06036	B - 14
6D3-85991-01	C - 12	F1K-U213G-00	D - 9	F1K-U413R-00	E - 8	F0V-U41DB-12	E - 7	F1K-U757F-01	C - 7	90105-06054	C - 5
6B6-86261-00	C - 14	F1K-U2155-00	C - 8	F1S-U415B-01	E - 6		E - 8	F1K-U758D-00	D - 13	90105-06790	C - 2
6B6-86261-10	C - 14	F1K-U2187-00	D - 9	F1S-U415B-11	E - 7	F1S-U41E1-01	E - 6	F1K-U759B-00	D - 12	90105-06826	D - 5
6B6-86265-00	C - 14	F1K-U2188-00	D - 9		E - 8	F1S-U41E1-11	E - 7	F1B-U759C-00	D - 12	90105-06M07	B - 4
6B6-86265-10	C - 15	F1S-U2280-00	D - 7	GP8-U416H-01	E - 8		E - 8	F1K-U759C-00	D - 5		B - 14
67X-E2590-00	C - 5	F1S-U2285-00	D - 7	F1K-U417B-60	E - 5	F0V-U41F5-01	E - 6	F1B-U761D-02	D - 6	90105-06M17	B - 4
67X-E2590-10	C - 5	F1K-U2501-01	D - 8	F1K-U417B-70	E - 5	F1B-U41F5-21	E - 7	F1K-U7711-02	D - 11	90105-07004	B - 8
6D3-G5831-00	C - 6	F1K-U2512-03	D - 8	F1K-U417C-60	E - 5		E - 8	F1B-U7773-00	D - 11	90105-08860	D - 7
6D3-R1313-00	C - 7	F1K-U2519-20	D - 8	F1K-U417C-70	E - 5	F1S-U41G1-01	E - 6	GP7-U7831-11	D - 11	90105-093A5	B - 4
6D3-R1314-00	C - 9	F1K-U251D-01	D - 8	F1K-U417D-60	E - 5		E - 9	GP7-U7832-01	D - 11	90105-105A6	C - 10
6D3-R1318-00	C - 6	F1K-U251E-01	D - 8	F1K-U417D-70	E - 5		D - 13	GP7-U7833-10	D - 11	90109-06051	B - 4
6D3-R1319-00	C - 6	F1K-U2521-02	D - 8	F1K-U417F-60	E - 5	F1K-U4261-00	D - 4	GP7-U7834-00	D - 11	90109-066F0	B - 2
6D3-R1321-02	C - 6	F1K-U2663-00	D - 5	F1K-U417F-70	E - 5	F0V-U471E-00	D - 4	GP7-U7835-00	D - 11	90109-06832	C - 8
6D3-R1333-00-94	C - 6	F1K-U2664-01	D - 10	F1K-U417G-60	E - 5	F1K-U471E-03	D - 5	GP7-U783F-00	D - 11	90109-06M92	B - 5
6D3-R1341-00	C - 7	F1K-U266B-00	D - 5	F1K-U417G-70	E - 5	F0V-U471F-00	D - 4	F1K-U7844-01	D - 11	90109-08041	C - 7
60E-R1381-01	C - 8	F1K-U266C-00	D - 4	F1K-U417H-60	E - 5	F1K-U475F-01	D - 5	F0D-U7856-10	D - 12	90110-05908	E - 2
F1K-U1316-02	D - 15	F1K-U2714-02	D - 14	F1K-U417H-70	E - 5	F1K-U491K-00	D - 8	F1K-U785G-00	D - 12	90110-06040	D - 6
F1K-U1336-00	D - 14	F1K-U271B-04	D - 10	F1K-U417J-60	E - 5	GP7-U4953-10	D - 6	F0D-U785G-10	D - 2	90110-06822	C - 6
F1K-U134A-00	D - 14	F1K-U273B-03	C - 7	F1K-U417J-70	E - 5		D - 5	GP7-U785H-00	D - 11	90110-08041	B - 12
F1K-U1355-00	D - 14	F1K-U283B-02	D - 5	F1K-U417K-60	E - 5	F1K-U515A-00	D - 5	F1K-U815D-00	C - 12	90110-08212	C - 10

NUMERICAL INDEX

PART NO.	GRID NO.	PART NO.	GRID NO.	PART NO.	GRID NO.	PART NO.	GRID NO.	PART NO.	GRID NO.	PART NO.	GRID NO.
90111-05008	D - 2	90119-10837	C - 7	90340-27001	B - 2	90464-32801	D - 2	90601-162U5	C - 8	93210-464A3	E - 10
90111-06803	D - 8	90119-10M02	B - 15	90387-06080	C - 7		D - 6	90601-175UR	B - 10	93210-60ME8	C - 14
90116-10016	B - 15	90119-10M19	C - 10	90387-06083	C - 5		D - 9		D - 13	93212-04001	C - 10
90116-10619	B - 4	90149-05903	E - 4	90387-06119	B - 12		D - 11	90601-200U1	D - 6	93306-07801	B - 6
90119-06048	C - 14	90150-05807	D - 2		C - 12		D - 13		E - 3	93306-205A3	C - 8
90119-06800	C - 6	90151-05802	D - 14	90387-06M05	B - 14		D - 15	90601-200U2	D - 3	93306-205U0	C - 6
90119-06820	D - 10	90154-06017	E - 4	90387-06M30	C - 9	90464-35132	C - 5	90601-200U7	D - 9	93306-27211	C - 6
90119-06827	C - 7	90159-05013	B - 10	90387-06M60	C - 8		C - 13	90605-502U1	D - 4	93306-30441	B - 12
90119-06835	C - 6	90159-05014	B - 10	90387-08M06	C - 7	90464-38800	B - 10	91317-05010	C - 10	93306-30610	B - 6
90119-06878	D - 4	90159-059U2	D - 5	90387-08M30	C - 9	90464-40825	B - 10	91317-05014	B - 14	93430-47M04	C - 8
		90167-04003	E - 4	90387-08M37	C - 13		D - 15	91317-05016	B - 14	93440-07149	B - 2
90119-069UD	C - 8	90169-049U1	D - 11	90387-11002	C - 2	90464-99804	D - 9	91317-06014	B - 14	93440-10153	B - 2
90119-069UH	D - 5	90169-059U1	D - 8	90401-20145	B - 5	90465-11829	C - 7		C - 10	93440-28062	B - 7
		90176-10001	B - 2	90430-06014	B - 2		D - 2	91317-06016	B - 3	93603-14M15	B - 4
90119-069UK	C - 7		B - 15	90430-06M03	B - 4		D - 12		B - 12	93606-12019	C - 2
90119-069UP	D - 10	90179-08327	B - 6	90430-09002	B - 11	90465-12M53	B - 14	91317-06035	C - 10		C - 6
90119-069UX	C - 9	90179-10006	B - 2	90430-12002	C - 7	90465-13M18	C - 14	91380-06016	C - 14	93606-25M00	B - 12
90119-06M35	C - 12	90179-10414	B - 2	90445-14008	C - 7	90467-089U1	D - 2	91380-06020	B - 15	93607-54002	B - 9
90119-06M65	B - 12	90183-06902	D - 4	90445-16005	C - 2	90467-110A1	B - 13	91380-06025	B - 9	93608-16M16	B - 12
90119-08031	C - 2	90201-06801	C - 9	90445-16006	C - 6	90467-120A0	C - 5	91808-16023	B - 2		C - 2
90119-08034	B - 12	90201-06906	D - 14	90445-18007	C - 4	90467-150A0	C - 4	92990-06100	C - 11		C - 10
90119-08036	C - 2	90201-096J9	B - 4	90445-18M03	C - 4	90467-160A0	C - 2	92990-10600	C - 14	94591-49130	B - 9
90119-08043	B - 12	90201-099U3	B - 5	90445-20805	D - 6		C - 4	92990-12200	C - 7	94702-00409	C - 14
90119-08045	B - 12		C - 12	90445-21004	C - 5	90467-170A0	B - 12		D - 6	94709-00409	C - 14
90119-08050	B - 11		D - 10	90445-21805	C - 4		B - 15	92995-06600	B - 15	95023-06012	B - 2
90119-08074	B - 11	90201-10013	B - 2	90445-22003	C - 5	90467-18804	D - 6	92999-05200	D - 7	95027-06010	B - 4
90119-08075	C - 2	90201-10019	B - 2	90445-25004	C - 5	90467-200A0	C - 4	9299R-06200	D - 4	95380-06700	C - 11
90119-08085	B - 12	90201-103U7	C - 10	90445-26004	C - 5		D - 6		D - 5	9538R-06600	C - 9
90119-08823	B - 5	90201-248M5	C - 8	90446-14M23	C - 14	90467-210A0	C - 5		D - 8	9538R-06700	D - 14
		90209-25008	B - 6	90446-20MF5	C - 7		D - 6		D - 10	9572R-05300	D - 7
90119-08826	E - 2	90267-329UR	D - 11	90446-24M79	C - 4	90467-21800	D - 6		D - 13	9572R-06300	C - 7
90119-08836	E - 3	90267-47801	D - 8	90446-27M55	D - 6	90467-240A0	C - 5	9299R-08200	D - 4		D - 4
90119-08840	C - 7	90267-48806	D - 9	90447-06800	D - 14	90468-12069	B - 6	9299R-10200	D - 10		D - 5
			E - 3	90447-06802	D - 14	90480-06M46	B - 15	93101-21001	C - 6		D - 8
90119-089U7	C - 7	90267-48809	D - 5	90447-22001	C - 4	90480-21M63	C - 2		E - 10		D - 10
90119-089UR	B - 5	90267-489U1	D - 2	90447-22004	C - 4	90480-22M15	B - 10	93101-21002	C - 6		D - 11
90119-089UU	C - 8		D - 12	90447-22005	C - 5		C - 13		E - 10		D - 13
			D - 13	90450-17M17	B - 11	90600-900U6	E - 3	93101-25M55	C - 8	9572R-08300	B - 10
90119-08M22	B - 10	90267-489U2	D - 11	90450-57006	B - 11	90600-917U4	D - 2		E - 10		C - 12
		90267-489U6	D - 2	90450-88M15	C - 2		D - 6	93101-25M56	C - 8		D - 4
			D - 9	90450-94001	C - 3		D - 9		E - 10		D - 6
90119-10011	C - 2		D - 11	90450-99004	C - 3		D - 11	93101-35004	B - 6		D - 10
90119-10013	C - 2		D - 13	90450-99005	C - 2		D - 13		E - 10		D - 14
90119-10016	C - 10		D - 14	90464-12089	B - 10		D - 15	93210-06667	B - 4	95780-08300	C - 14
90119-10017	C - 2	90267-489U8	D - 6	90464-18006	B - 13	90601-118UF	C - 6	93210-08001	B - 4	95880-06016	C - 14
90119-10020	B - 14	90267-489U9	C - 14	90464-21001	B - 12		D - 6	93210-18322	B - 14	97513-05514	C - 10
90119-10804	D - 10	90269-08801	D - 5	90464-31001	B - 2		D - 13	93210-18417	B - 3	97513-06520	B - 4
90119-10805	C - 7	90280-03047	C - 10		C - 5	90601-155U4	D - 11	93210-464A3	C - 6	97513-06525	B - 12
90119-10836	C - 6										

NUMERICAL INDEX

PART NO.	GRID NO.	PART NO.	GRID NO.	PART NO.	GRID NO.	PART NO.	GRID NO.	PART NO.	GRID NO.
97513-06535	B - 12								
97513-06555	B - 2								
	B - 12								
97513-08520	B - 2								
97513-08530	C - 11								
97595-06416	C - 14								
97595-06520	B - 14								
97595-08540	B - 4								
97880-03008	E - 2								
97880-05025	E - 2								
9788R-05025	D - 7								
98580-05025	E - 2								
98780-04015	B - 14								
99009-52500	B - 12								
99009-72500	B - 6								
99530-08012	B - 4								
99530-10014	B - 4								
99590-14016	C - 6								
99780-12600	D - 6								