

PARTS CATALOGUE

WaveRunner VX

VX1100C-L (F2NS,F2NT,F2NU/6BUR,6BUS/6BU2)



1LF2N-100EA

()

VX1100C-L
PARTS CATALOGUE
©2011 by Yamaha Motor Co., Ltd.
1st edition, September 2011
All rights reserved.
Any reprinting or unauthorized use
without the written permission of
Yamaha Motor Co., Ltd.
is expressly prohibited.
Printed in Japan.

FOREWORD

This Parts Catalogue is related to the parts for the model(s) on the cover page. When you are ordering replacement parts, please refer to this Parts Catalogue and quote both part numbers and part names correctly.

1. Modifications or additions which have been made after the issue of the Parts Catalogue will be announced in the Parts News.

It is advisable that you make the necessary corrections to the Parts Catalogue according to the Parts News.

2. Abbreviations

The following abbreviations are used in this Parts Catalogue.

“UR” Use specified parts number.

“UN” Use as many as needed.

“AP” Alternate Parts

“LM” Locally Made (Parts need to be ordered locally)

“F#” Frame No. (Applicable machine No.)

“O/S” Over Size

3. The number of components for assembly

- Parts, which are to be supplied in an assembly, are listed with a dot (.) in front of the part name as shown below.
- The numeral appearing to the right of each component part indicates the quantity of parts for each assembly unit.

PART NO.	DESCRIPTION	Q'TY	REMARKS
2F5-83310-60	FRONT FLASHER LIGHT ASSY	2	
115-83311-60	.BULB (6V-18W)	1	

4. Applicable colours of graphics are represented in the “REMARKS” as shown below.

PART NO.	DESCRIPTION	Q'TY	REMARKS
2N4-24110-00-X5	FUEL TANK COMP.	2	MXR
3J1-24240-10	.GRAPHIC, FUEL TANK	1	FOR MXR

5. Note that the illustrations for reference in finding parts numbers are not to be used for assembling. When assembling, please use the applicable service manual.

6. The asterisk (*) before a reference number indicates modified items after the first edition.

FOREWORD

7. Applicable Serial No.

Engine Serial No.

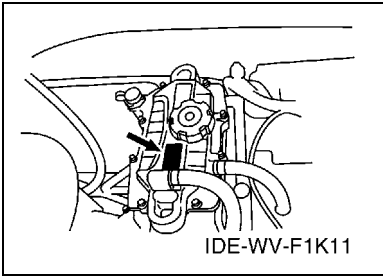

Primary Identification No.

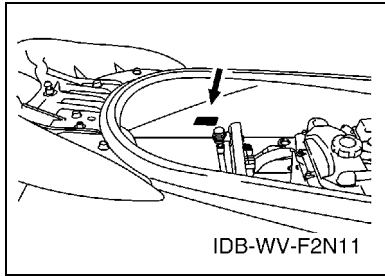

8. Applicable Colour Code (The (*) mark shows Model colour.)

Abbreviation	Colour Name	Colour Code
PURW(*)	PURE WHITE	0240
SSA	BLACK SOLID A	1000
DPBM11	DARK PURPLISH BLUE METALLIC 11	1187

9. Quantity Column Information

Column No.	Name Of Q'ty Column	Destination
1	CAN	CANADA
2	EUR	EUROPE
3	GENE	EXCEPT CANADA, EUROPE

10. Applicable Starting Serial No.

Engine Serial No.

Serial No.	Name Of Q'ty Column	Model Code
6BU-1021201	CAN	6BUR
6BU-1021201	EUR	6BUS
6BU-1021201	GENE	6BUR

Primary Identification No.

Serial No.	Name Of Q'ty Column	Model Code
F2N-819901	CAN	F2NS
F2N-819901	EUR	F2NU
F2N-819901	GENE	F2NT

CONTENTS

CYLINDER	1
CRANKCASE	3
CRANKSHAFT & PISTON	4
VALVE	6
INTAKE	8
INTAKE 2	9
OIL PUMP	10
OIL COOLER	12
EXHAUST 1	14
EXHAUST 2	16
EXHAUST 3	18
JET UNIT 1	20
JET UNIT 2	22
GENERATOR	23
STARTING MOTOR	24
ELECTRICAL 1	25
ELECTRICAL 2	27
ELECTRICAL 3	29
ENGINE MOUNT	31
ENGINE HATCH 1	32
ENGINE HATCH 2	33
HULL & DECK	35
GUNWALE & MAT	37
VENTILATION	38
SEAT & UNDER LOCKER	39
FUEL TANK	40
EXHAUST 4	42
CONTROL CABLE	43
STEERING 1	44
STEERING 2	46
GRAPHICS	47
IMPORTANT LABELS	48
IMPORTANT LABELS 2	49
REPAIR KIT 1	50

INDEX

NUMERICAL INDEX	51
-----------------------	----

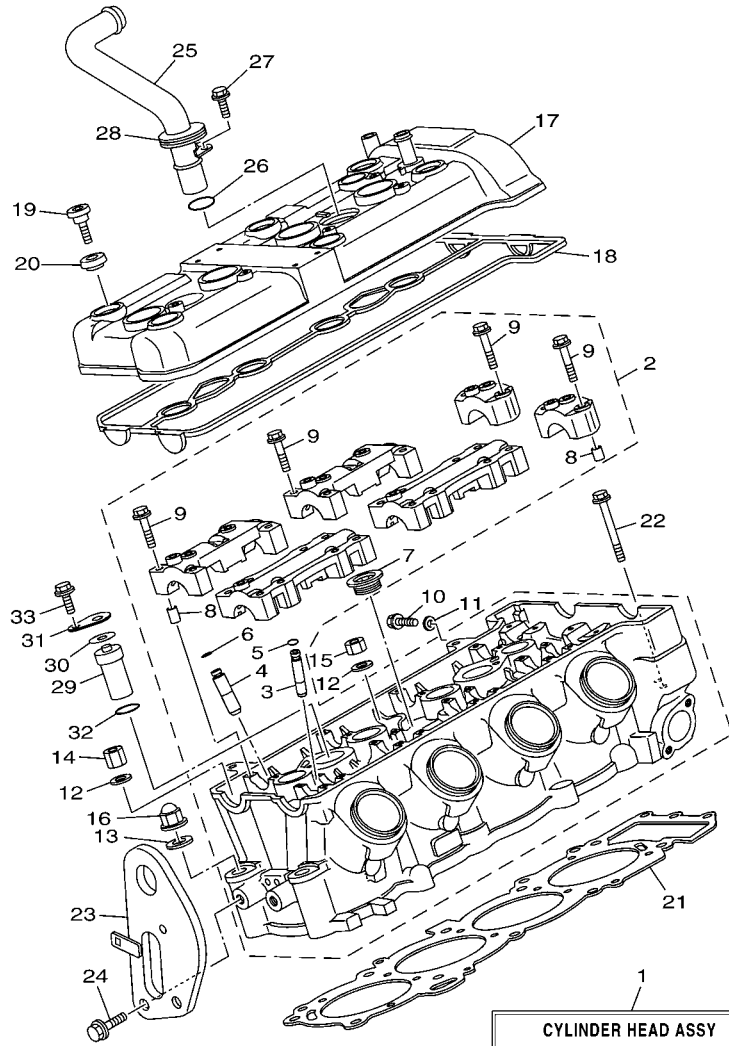

CYLINDER HEAD ASSY
 Fig. 1 CYLINDER
 Ref. No. 2 to 11
 17 to 21 and 29 to 33
 Fig. 4 VALVE
 Ref. No. 1 to 20 and 22
 Fig.17 ELECTRICAL 2
 Ref. No. 8



F2NS100-L010

FIG. 1 CYLINDER

REF. NO.	PART NO.	DESCRIPTION	CAN	EUR	GENE	REMARKS
1	6D3-W009A-11-94	CYLINDER HEAD ASSY	1	1	1	
2	6D3-11102-00-94	CYLINDER HEAD ASSY	1	1	1	
3	3TJ-11133-10	.GUIDE, VALVE	12	12	12	
4	1WG-11133-11	.GUIDE, VALVE	8	8	8	
5	93440-07149	.CIRCLIP	12	12	12	
6	93440-10153	.CIRCLIP	8	8	8	
7	90340-27001	.PLUG, STRAIGHT SCREW	1	1	1	
8	91808-16023	.PIN, DOWEL	12	12	12	
9	90105-06026	.BOLT, FLANGE	28	28	28	
10	95023-06012	BOLT	1	1	1	
11	90430-06014	GASKET	1	1	1	
12	90201-10013	WASHER, PLATE	8	8	8	
13	90201-10019	WASHER, PLATE	2	2	2	
14	90179-10006	NUT	3	3	3	
15	90179-10414	NUT	5	5	5	
16	90176-10001	NUT, CROWN	2	2	2	
17	6D3-11191-10	COVER, CYLINDER HEAD 1	1	1	1	
18	60E-11193-01	GASKET, HEAD COVER 1	1	1	1	
19	90109-066F0	BOLT	6	6	6	
20	4KG-1111G-00	RUBBER, MOUNT 1	6	6	6	
21	6D3-11181-00	GASKET, CYLINDER HEAD 1	1	1	1	
22	97513-06555	BOLT, WITH WASHER	3	3	3	
23	6D3-85132-00	BRACKET, REFLECTOR 1	1	1	1	
24	97513-08520	BOLT, WITH WASHER	2	2	2	
25	6D3-12482-00	PIPE 2	1	1	1	
26	93210-18417	O-RING	1	1	1	
27	91317-06016	BOLT	1	1	1	

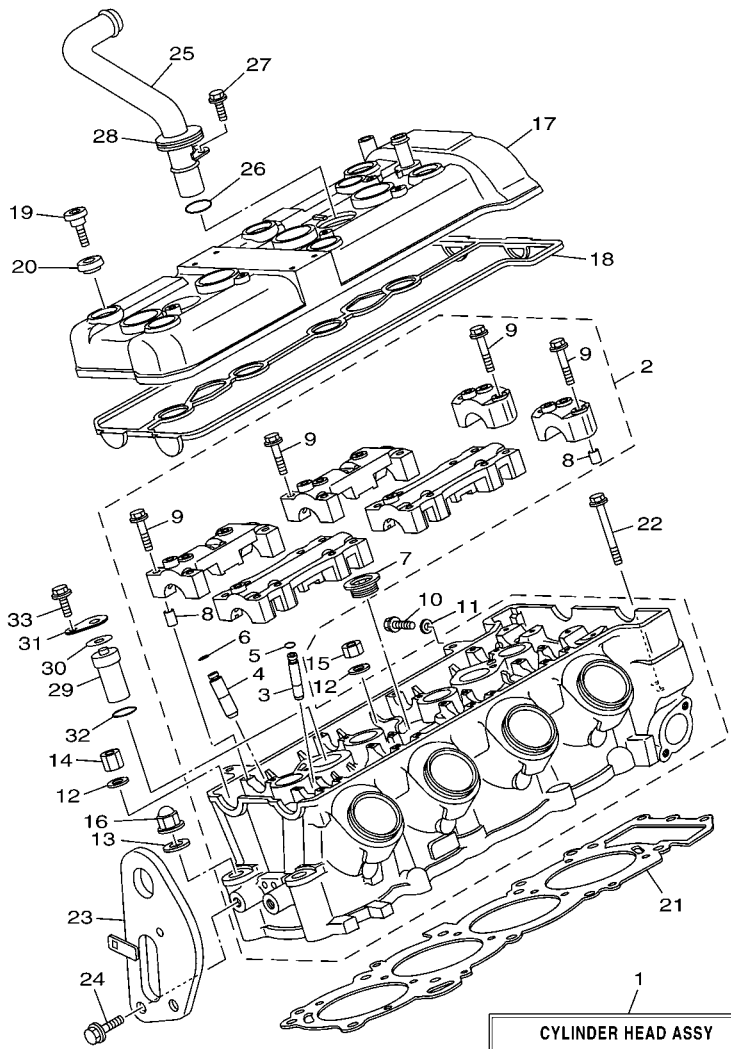

CYLINDER HEAD ASSY
 Fig. 1 CYLINDER
 Ref. No. 2 to 11
 17 to 21 and 29 to 33
 Fig. 4 VALVE
 Ref. No. 1 to 20 and 22
 Fig.17 ELECTRICAL 2
 Ref. No. 8



F2NS100-L010

FIG. 1 CYLINDER

REF. NO.	PART NO.	DESCRIPTION	CAN	EUR	GENE	REMARKS
28	60E-12494-00	SEAL, PIPE 1	1	1	1	
29	60E-12483-10	PIPE 3	1	1	1	
30	60E-12474-00	GASKET 1	1	1	1	
31	60E-12537-00	PLATE 2	1	1	1	
32	93210-18417	O-RING	1	1	1	
33	91317-06016	BOLT	1	1	1	
<hr/>						
<hr/>						
<hr/>						
<hr/>						
<hr/>						
<hr/>						
<hr/>						
<hr/>						
<hr/>						
<hr/>						

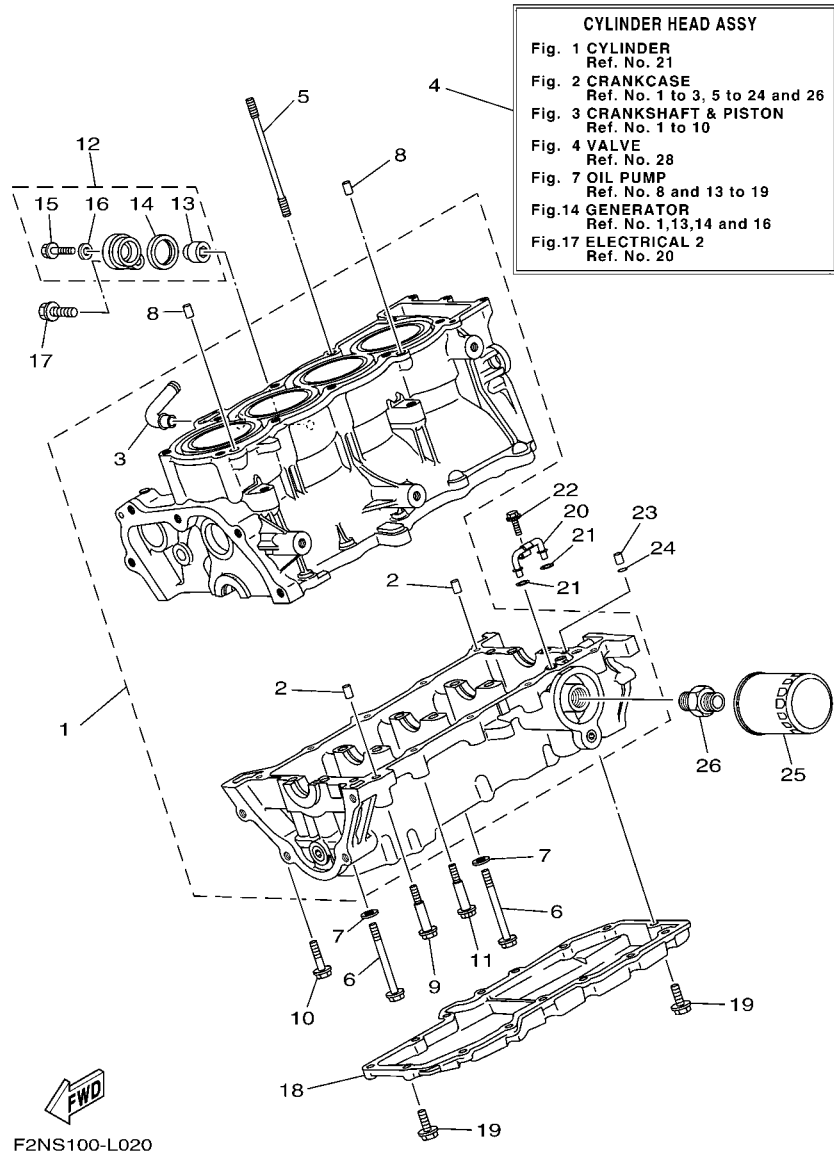

FIG. 2 CRANKCASE

REF. NO.	PART NO.	DESCRIPTION	CAN	EUR	GENE	REMARKS
1	6BU-15100-00	CRANKCASE ASSY	1	1	1	
2	99530-10014	.PIN, DOWEL	2	2	2	
3	6D3-51129-00	.NIPPLE	1	1	1	
4	6BU-W009B-00-94	CYLINDER BLOCK ASSY	1	1	1	
5	90116-10058	BOLT, STUD	10	10	10	
6	90105-093A5	BOLT, FLANGE	10	10	10	
7	90201-096J9	WASHER, PLATE	10	10	10	
8	99530-10014	PIN, DOWEL	2	2	2	
9	90109-06051	BOLT	2	2	2	
10	90105-06033	BOLT, FLANGE	1	1	1	
11	90105-06M17	BOLT, FLANGE	7	7	7	
12	69J-11301-10	ANODE COVER ASSY	1	1	1	
13	68V-11325-02	.ANODE	1	1	1	
14	67F-11328-00	.GROMMET, ANODE	1	1	1	
15	90105-06M07	.BOLT, FLANGE	1	1	1	
16	90430-06M03	.GASKET	1	1	1	
17	97595-08540	BOLT, WITH WASHER	1	1	1	
18	6B6-1310A-01-94	PAN, OIL	1	1	1	
19	97513-06520	BOLT, WITH WASHER	15	15	15	
20	60E-13161-00	PIPE, DELIVERY 1	1	1	1	
21	93210-06667	O-RING	2	2	2	
22	95027-06010	BOLT, FLANGE	1	1	1	
23	99530-08012	PIN, DOWEL	1	1	1	
24	93210-08001	O-RING	1	1	1	
25	5GH-13440-20	ELEMENT ASSY, OIL CLEANER	1	1	1	
26	90401-20007	BOLT, UNION	1	1	1	

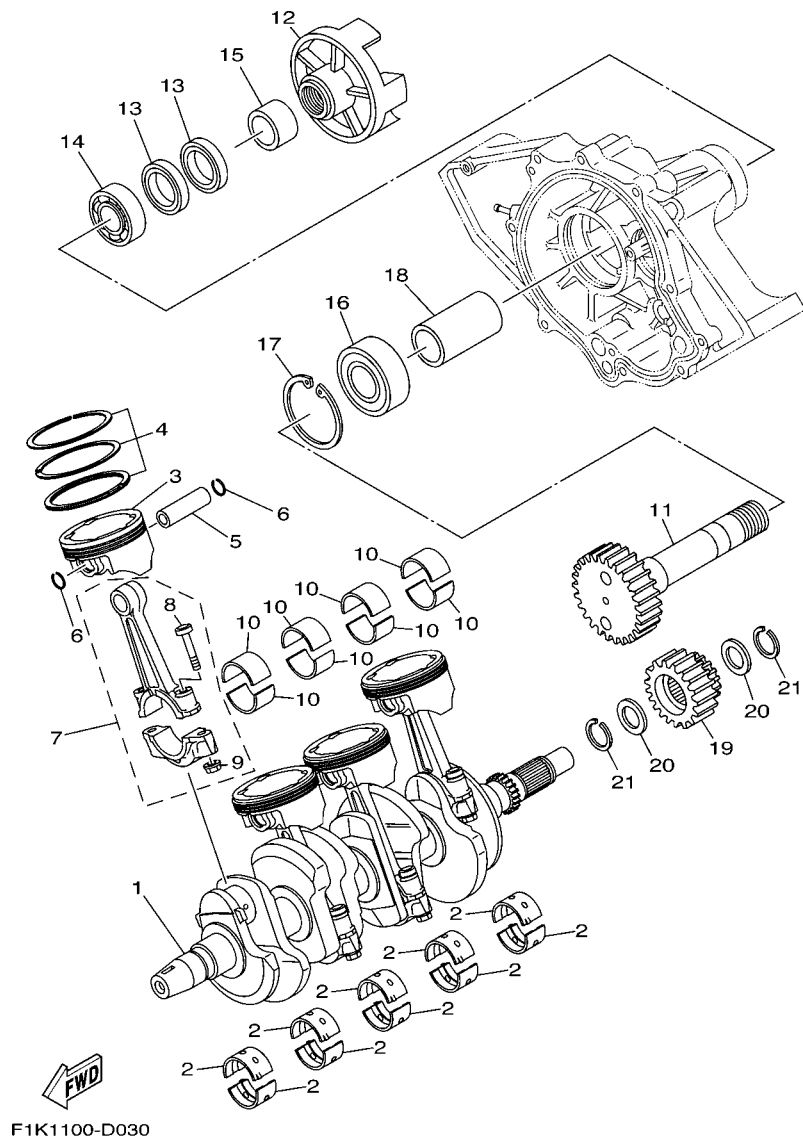
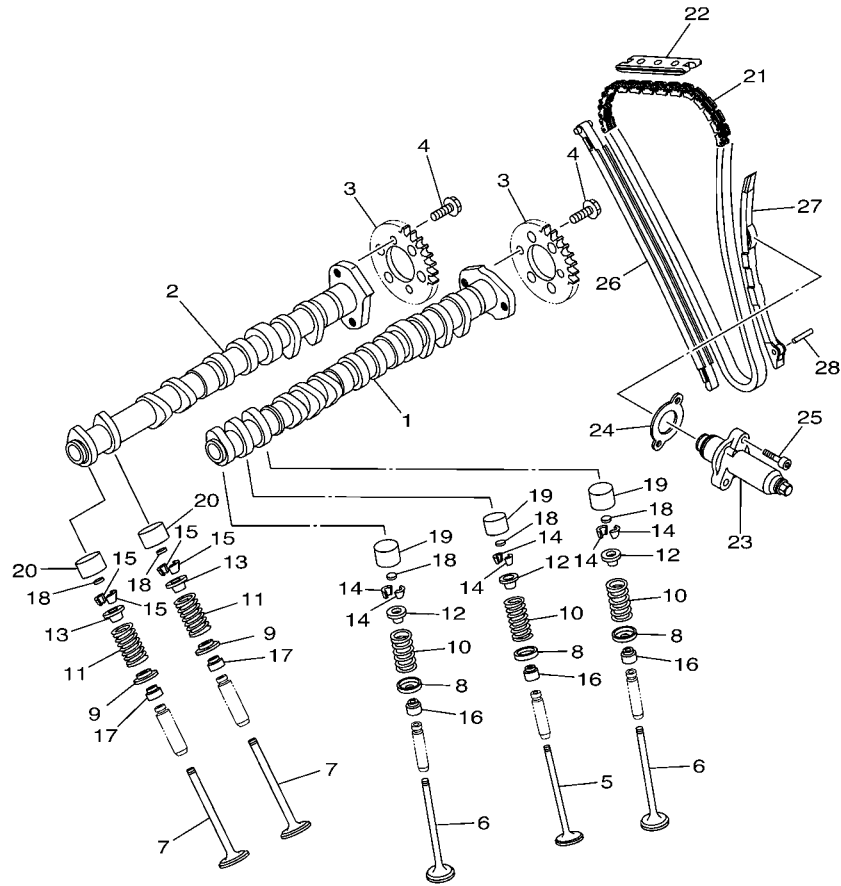

FIG. 3 CRANKSHAFT & PISTON

REF. NO.	PART NO.	DESCRIPTION	CAN	EUR	GENE	REMARKS
1	60E-11411-11	CRANKSHAFT	1	1	1	
2	6D3-11416-A0	PLANE BEARING, CRANKSHAFT 1	10	10	10	UR RED/RED
	6D3-11416-00	PLANE BEARING, CRANKSHAFT 1	10	10	10	UR RED/BROWN
	6D3-11416-10	PLANE BEARING, CRANKSHAFT 1	10	10	10	UR RED/BLACK
	6D3-11416-20	PLANE BEARING, CRANKSHAFT 1	10	10	10	UR RED/BLUE
	6D3-11416-30	PLANE BEARING, CRANKSHAFT 1	10	10	10	UR RED/GREEN
3	6D3-11631-01-B0	PISTON (STD)	4	4	4	
4	6D3-11603-00	PISTON RING SET (STD)	4	4	4	
5	6D3-11633-00	PIN, PISTON	4	4	4	
6	90468-12069	CLIP	8	8	8	
7	6D3-11650-00	CONNECTING ROD ASSY	4	4	4	
8	5JW-11654-00	.BOLT, CONNECTING ROD	2	2	2	
9	90179-08327	.NUT	2	2	2	
10	60E-11656-00	PLANE BEARING, CONNECTING ROD	8	8	8	UR BROWN
	60E-11656-10	PLANE BEARING, CONNECTING ROD	8	8	8	UR BLACK
	60E-11656-20	PLANE BEARING, CONNECTING ROD	8	8	8	UR BLUE
	60E-11656-30	PLANE BEARING, CONNECTING ROD	8	8	8	UR GREEN
11	6D3-17572-00	SHAFT, TRANSFER	1	1	1	
12	6D3-45813-00-94	FLANGE, COUPLING	1	1	1	
13	93101-35004	OIL SEAL	2	2	2	
14	93306-07801	BEARING	1	1	1	
15	6B6-11478-00	COLLAR	1	1	1	
16	93306-30610	BEARING	1	1	1	
17	99009-72500	CIRCLIP	1	1	1	
18	6B6-17585-00	COLLAR, GEAR	1	1	1	
19	6B6-17586-00	GEAR, TRANSFER DRIVE	1	1	1	
20	90209-25008	WASHER	2	2	2	



FWD
F1K1100-D040

FIG. 4 VALVE

REF. NO.	PART NO.	DESCRIPTION	CAN	EUR	GENE	REMARKS
1	6D3-12171-11	CAMSHAFT 1	1	1	1	
2	6D3-12181-00	CAMSHAFT 2	1	1	1	
3	6D3-12176-00	SPROCKET, CAM CHAIN	2	2	2	
4	90105-07004	BOLT, FLANGE	4	4	4	
5	4XV-12111-00	VALVE, INTAKE	4	4	4	
6	4XV-12112-00	VALVE, INTAKE 2	8	8	8	
7	5LV-12121-00	VALVE, EXHAUST	8	8	8	
8	1HX-12116-01	SEAT, VALVE SPRING	12	12	12	
9	3GM-12126-00	SEAT, VALVE SPRING 2	8	8	8	
10	4XV-12113-00	SPRING, VALVE INNER	12	12	12	
11	4XV-12114-00	SPRING, VALVE OUTER	8	8	8	
12	1HX-12117-00	RETAINER, VALVE SPRING	12	12	12	
13	1WG-12117-00	RETAINER, VALVE SPRING	8	8	8	
14	1HX-12118-00	COTTER, VALVE	24	24	24	
15	1WG-12118-00	COTTER, VALVE	16	16	16	
16	4TV-12119-00	SEAL, VALVE STEM	12	12	12	
17	4SV-12119-00	SEAL, VALVE STEM	8	8	8	
18	1HX-12168-00	PAD, ADJUSTING 2 (1.20)	20	20	20	UR
	1HX-12168-20	PAD, ADJUSTING 2 (1.25)	20	20	20	UR
	1HX-12168-40	PAD, ADJUSTING 2 (1.30)	20	20	20	UR
	1HX-12168-60	PAD, ADJUSTING 2 (1.35)	20	20	20	UR
	1HX-12168-80	PAD, ADJUSTING 2 (1.40)	20	20	20	UR
	1HX-12168-A0	PAD, ADJUSTING 2 (1.45)	20	20	20	UR
	1HX-12168-F0	PAD, ADJUSTING 2 (1.50)	20	20	20	UR
	1HX-12168-H1	PAD, ADJUSTING 2 (1.55)	20	20	20	UR
	1HX-12168-K1	PAD, ADJUSTING 2 (1.60)	20	20	20	UR
	1HX-12168-M1	PAD, ADJUSTING 2 (1.65)	20	20	20	UR

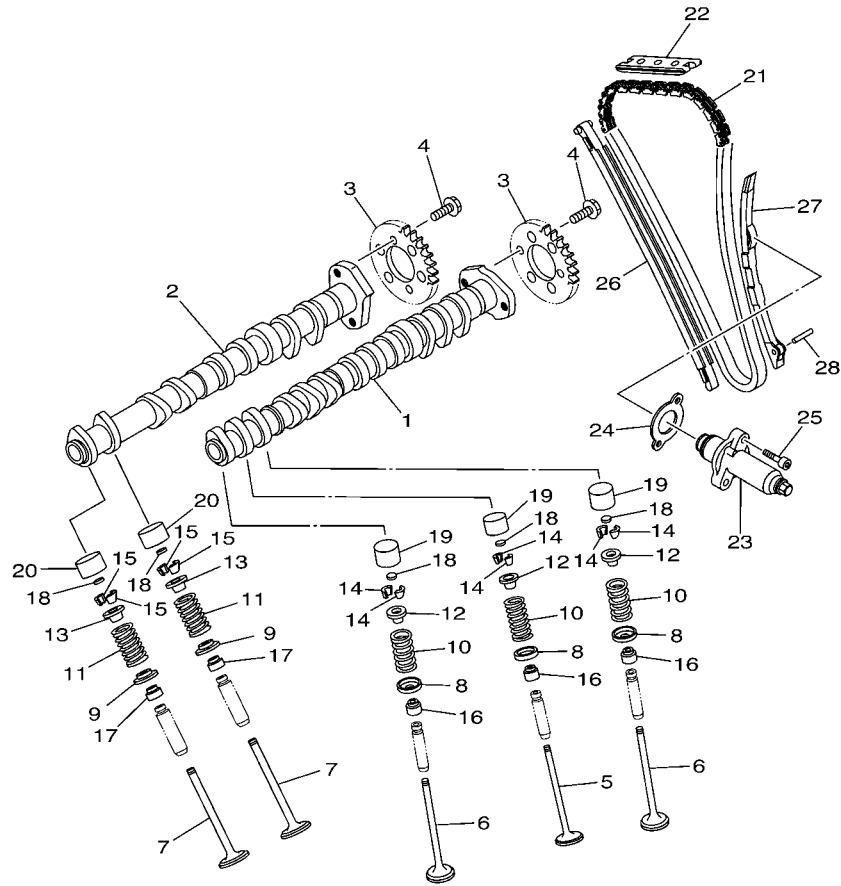

FWD
F1K1100-D040

FIG. 4 VALVE

REF. NO.	PART NO.	DESCRIPTION	CAN	EUR	GENE	REMARKS
18	1HX-12168-R1	PAD, ADJUSTING 2 (1.70)	20	20	20	UR
	1HX-12168-U1	PAD, ADJUSTING 2 (1.75)	20	20	20	UR
	1HX-12168-W1	PAD, ADJUSTING 2 (1.80)	20	20	20	UR
	1HX-12168-Y1	PAD, ADJUSTING 2 (1.85)	20	20	20	UR
	1HX-12169-11	PAD, ADJUSTING 2 (1.90)	20	20	20	UR
	1HX-12169-31	PAD, ADJUSTING 2 (1.95)	20	20	20	UR
	1HX-12169-50	PAD, ADJUSTING 2 (2.00)	20	20	20	UR
	1HX-12169-70	PAD, ADJUSTING 2 (2.05)	20	20	20	UR
	1HX-12169-90	PAD, ADJUSTING 2 (2.10)	20	20	20	UR
	1HX-12169-E0	PAD, ADJUSTING 2 (2.15)	20	20	20	UR
	1HX-12169-G0	PAD, ADJUSTING 2 (2.20)	20	20	20	UR
	1HX-12169-J0	PAD, ADJUSTING 2 (2.25)	20	20	20	UR
	1HX-12169-L0	PAD, ADJUSTING 2 (2.30)	20	20	20	UR
	1HX-12169-N0	PAD, ADJUSTING 2 (2.35)	20	20	20	UR
	1HX-12169-T0	PAD, ADJUSTING 2 (2.40)	20	20	20	UR
19	3LN-12153-10	LIFTER, VALVE	12	12	12	YELLOW
20	3FV-12153-10	LIFTER, VALVE	8	8	8	YELLOW
21	94591-49130	CHAIN	1	1	1	
22	5BE-12241-00	GUIDE, STOPPER 2	1	1	1	
23	6D3-12210-00	TENSIONER ASSY, CAM CHAIN	1	1	1	
24	4FM-12213-00	GASKET, TENSIONER CASE	1	1	1	
25	91380-06025	BOLT	2	2	2	
26	6D3-12251-00	DAMPER, CHAIN 1	1	1	1	
27	4XV-12252-00	DAMPER, CHAIN 2	1	1	1	
28	93607-44002	PIN, DOWEL	1	1	1	

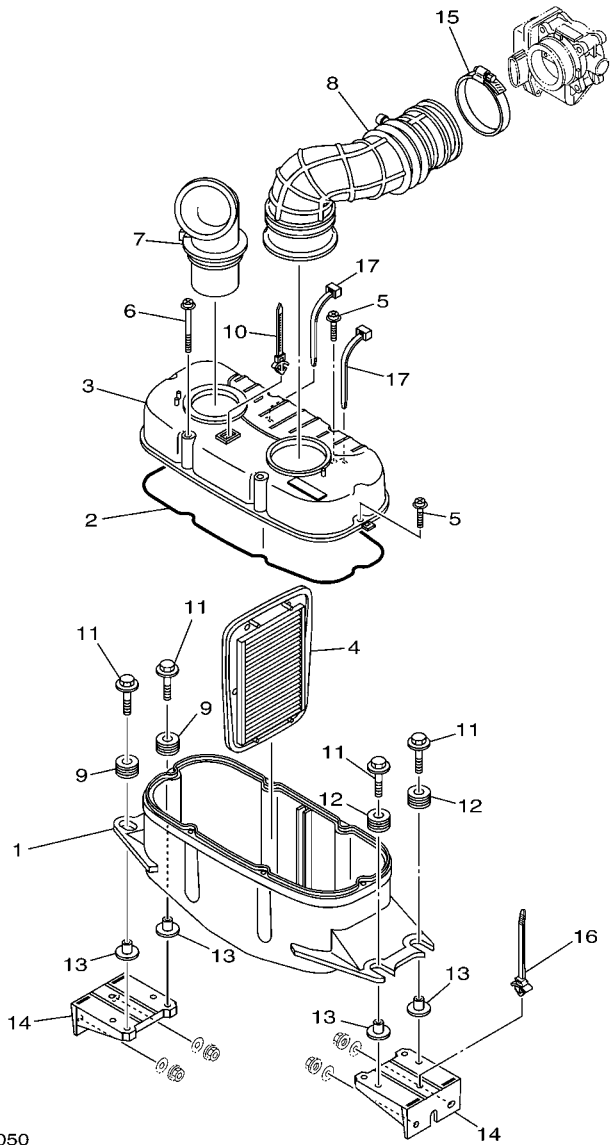

F2NG100-K050

FIG. 5 INTAKE

REF. NO.	PART NO.	DESCRIPTION	CAN	EUR	GENE	REMARKS
1	6D3-14411-00	CASE, AIR CLEANER 1	1	1	1	
2	4XV-14452-00	SEAL	1	1	1	
3	6D3-14421-02	CASE, AIR CLEANER 2	1	1	1	
4	6D3-14451-00	ELEMENT, AIR CLEANER	1	1	1	
5	90159-05013	SCREW, WITH WASHER	4	4	4	
6	90159-05014	SCREW, WITH WASHER	2	2	2	
7	6D3-14437-00	DUCT	1	1	1	
8	6D3-14419-01	PIPE	1	1	1	
9	90480-22M15	GROMMET	2	2	2	
10	90464-12089	CLAMP	1	1	1	
11	90119-08M22	BOLT, WITH WASHER	4	4	4	
12	90480-22M15	GROMMET	2	2	2	
13	6D3-14495-00	COLLAR	4	4	4	
14	F2N-U8572-00	BRACKET 2	2	2	2	
15	90601-175UR	BAND, HOSE 75	1	1	1	
16	90464-38800	CLAMP	1	1	1	
17	90464-40825	CLAMP	2	2	2	

FIG. 6 INTAKE 2

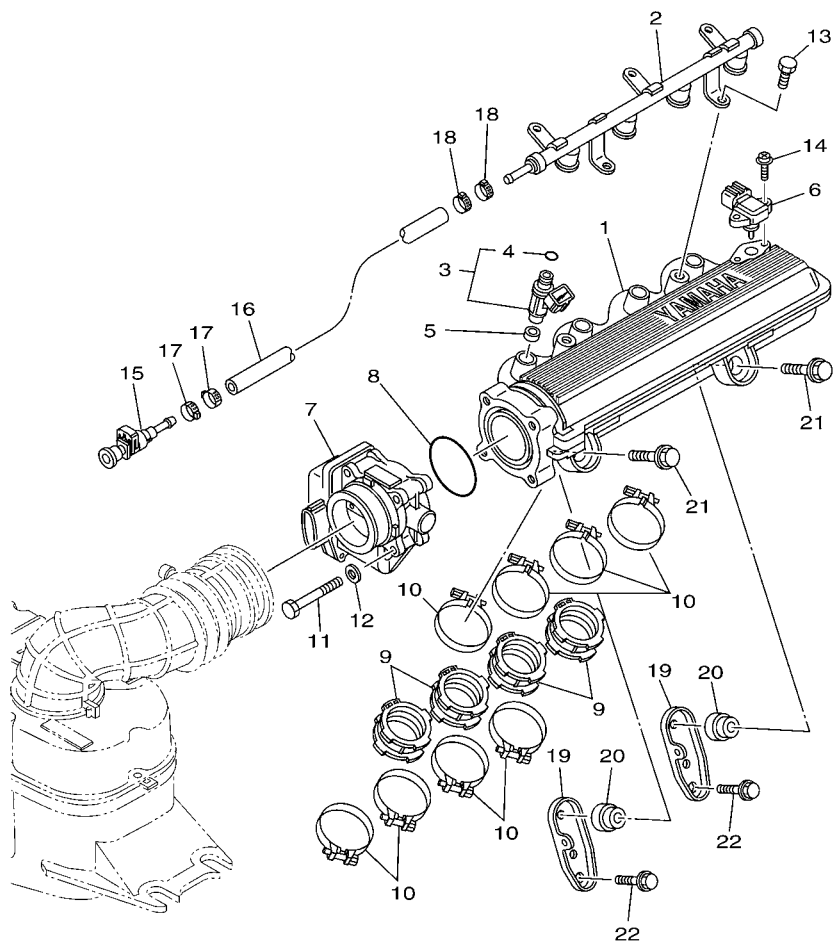

F2NK100-L060

REF. NO.	PART NO.	DESCRIPTION	CAN	EUR	GENE	REMARKS
1	6D3-13641-00	MANIFOLD, INTAKE 1	1	1	1	
2	6BU-12880-10	DELIVERY PIPE	1	1	1	
3	60E-13761-20	INJECTOR	4	4	4	
4	68V-1416A-00	.O-RING	1	1	1	
5	8FP-13556-10	GASKET, MANIFOLD	4	4	4	
6	68F-83688-10	SENSOR ASSY	1	1	1	
7	6BU-13750-00	THROTTLE BODY ASSY	1	1	1	
8	6D3-14457-00	SEAL	1	1	1	
9	6D3-13795-01	JOINT, THROTTLE BODY 1	4	4	4	
10	90450-57006	HOSE CLAMP ASSY	8	8	8	
11	68V-13573-00	BOLT 1	4	4	4	
12	68V-14475-00	WASHER	4	4	4	
13	63P-14446-00	BOLT	2	2	2	
14	6D3-81147-00	SCREW 3	2	2	2	
15	6S5-24300-01	FUEL PIPE JOINT	1	1	1	
16	6D3-14294-10	HOSE	1	1	1	
17	90450-17M17	HOSE CLAMP ASSY	2	2	2	
18	90450-17M17	HOSE CLAMP ASSY	2	2	2	
19	6D3-14414-10	STAY 2	2	2	2	
20	60E-14449-00-94	COLLAR	2	2	2	
21	90119-08050	BOLT, WITH WASHER	2	2	2	
22	90119-08074	BOLT, WITH WASHER	2	2	2	

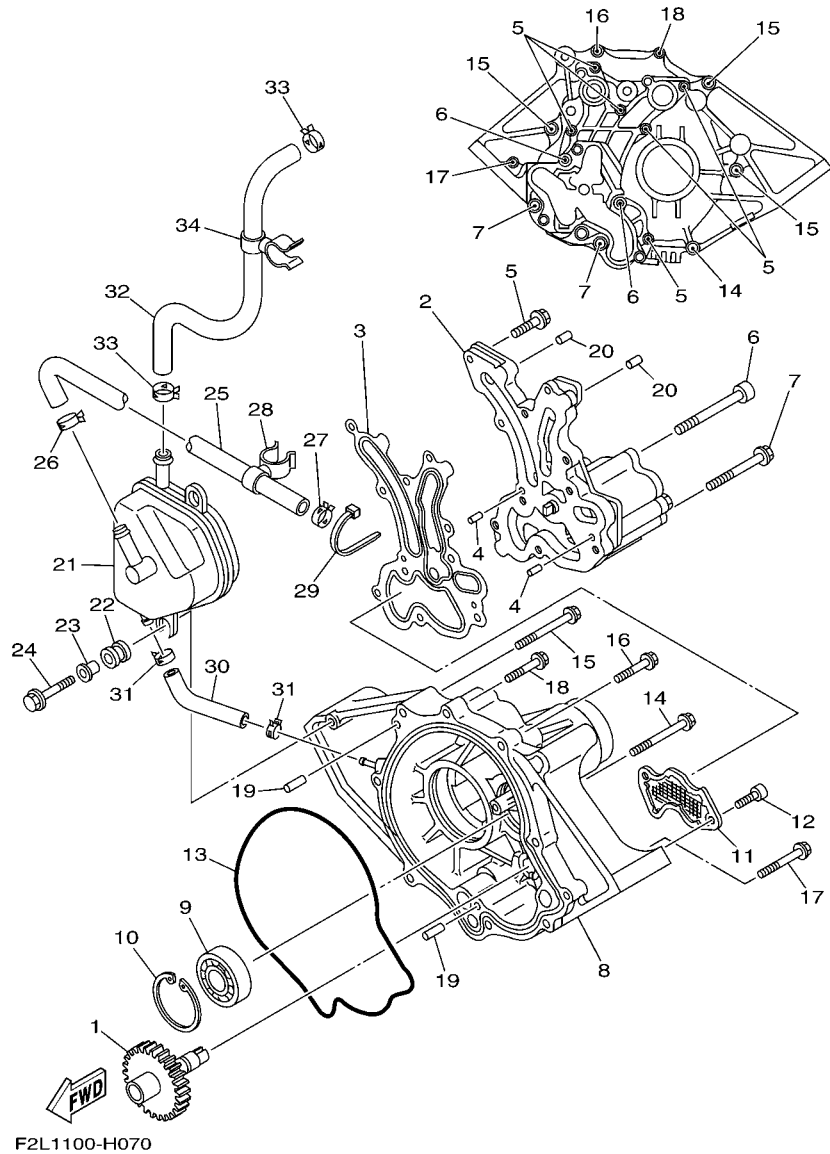
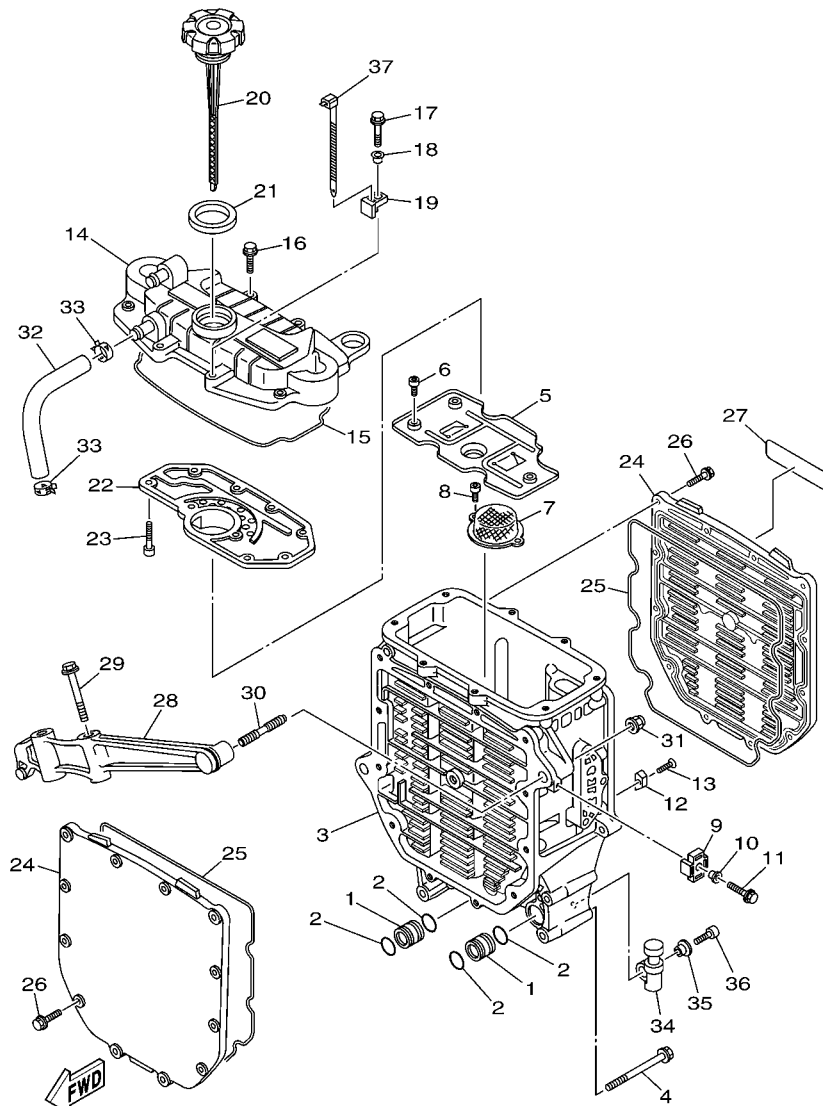

FIG. 7 OIL PUMP

REF. NO.	PART NO.	DESCRIPTION	CAN	EUR	GENE	REMARKS
1	6B6-13360-00	DRIVEN GEAR ASSY	1	1	1	
2	6D3-13300-10	OIL PUMP ASSY	1	1	1	
3	6B6-13563-01	GASKET	1	1	1	
4	93603-12221	PIN, DOWEL	2	2	2	
5	97513-06525	BOLT, WITH WASHER	6	6	6	
6	90110-08041	BOLT, HEXAGON SOCKET HEAD	2	2	2	
7	90119-08085	BOLT, WITH WASHER	2	2	2	
8	6B6-13327-02-94	COVER, PUMP GEAR	1	1	1	
9	93306-30441	BEARING	1	1	1	
10	99009-52500	CIRCLIP	1	1	1	
11	6B6-13411-00	STRAINER, OIL	1	1	1	
12	91317-06016	BOLT	2	2	2	
13	6B6-13475-01	GASKET	1	1	1	
14	90119-08045	BOLT, WITH WASHER	1	1	1	
15	90119-08034	BOLT, WITH WASHER	3	3	3	
16	90119-08043	BOLT, WITH WASHER	1	1	1	
17	97513-06555	BOLT, WITH WASHER	1	1	1	
18	97513-06535	BOLT, WITH WASHER	1	1	1	
19	93608-16M16	PIN, DOWEL	2	2	2	
20	93606-25M00	PIN, DOWEL	2	2	2	
21	6D3-11164-00	SEPERATOR, OIL	1	1	1	
22	6A0-82317-00	DAMPER, IGNITION COIL	2	2	2	
23	90387-06119	COLLAR	2	2	2	
24	90119-06M65	BOLT, WITH WASHER	2	2	2	
25	6D3-11126-00	PIPE, BREATHER 3	1	1	1	
26	90467-170A4	CLIP	1	1	1	
27	90467-170A4	CLIP	1	1	1	



F2NK100-L080

FIG. 8 OIL COOLER

REF. NO.	PART NO.	DESCRIPTION	CAN	EUR	GENE	REMARKS
1	60E-13446-00	CONNECTOR	2	2	2	
2	93210-18322	O-RING	4	4	4	
3	6D3-13462-00-94	CASE, OIL COOLER	1	1	1	
4	90119-10020	BOLT, WITH WASHER	5	5	5	
5	6B6-13317-00	PLATE, BAFFLE	1	1	1	
6	91317-05014	BOLT	3	3	3	
7	60E-13421-00	STRAINER 2	1	1	1	
8	91317-06014	BOLT	2	2	2	
9	6BU-85542-00	BRACKET	1	1	1	
10	90387-06M05	COLLAR	1	1	1	
11	97595-06520	BOLT, WITH WASHER	1	1	1	
12	6E5-11325-00	ANODE	1	1	1	
13	98780-04015	SCREW, FLAT HEAD	1	1	1	
14	6D3-13463-00-94	COVER, OIL COOLER	1	1	1	
15	60E-13475-00	GASKET	1	1	1	
16	90105-06036	BOLT, FLANGE	7	7	7	
17	90105-06035	BOLT, FLANGE	1	1	1	
18	90387-06M05	COLLAR	1	1	1	
19	6AA-85542-00	BRACKET	1	1	1	
20	60E-15362-00	PLUG, OIL LEVEL	1	1	1	
21	60E-13473-00	O-RING	1	1	1	
22	6D3-11165-00	PLATE, BREATHER	1	1	1	
23	91317-05016	BOLT	9	9	9	
24	6D3-13443-00-94	COVER, OIL COOLER	2	2	2	
25	60E-13476-10	GASKET	2	2	2	
26	90105-06M07	BOLT, FLANGE	24	24	24	
27	60E-83627-00	LABEL, CAUTION 7	1	1	1	

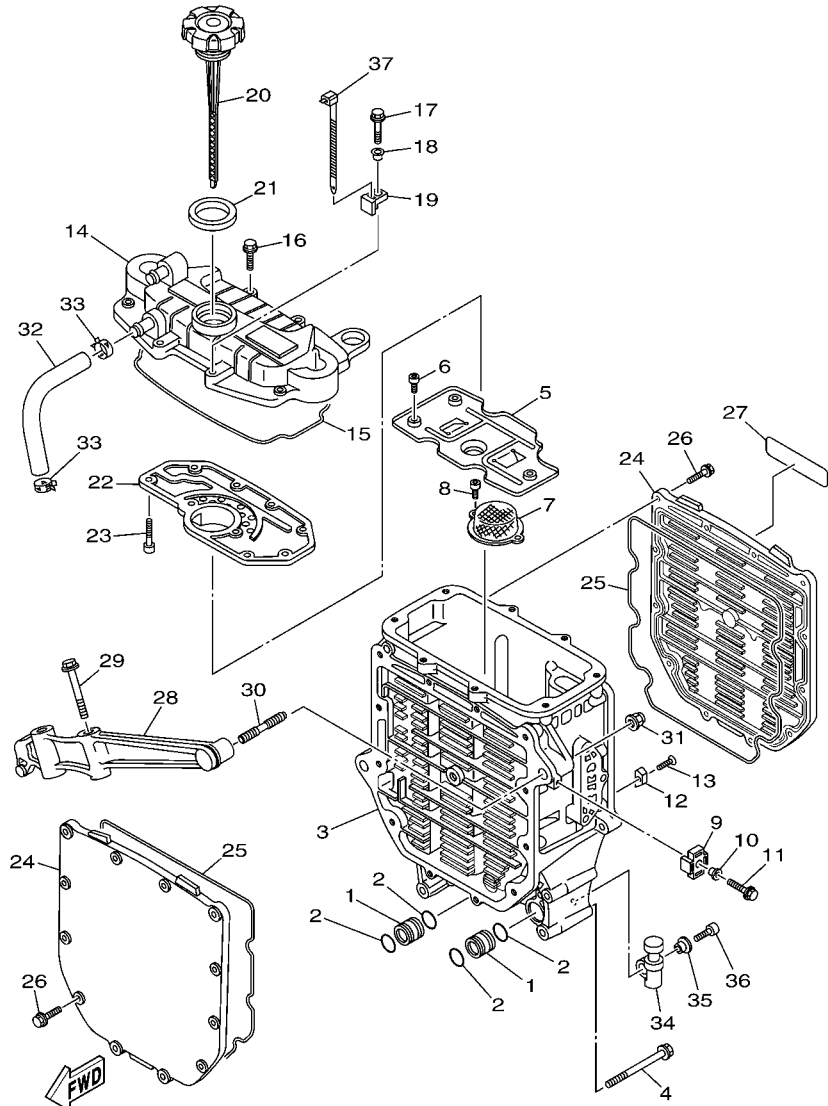

F2NK100-L080

FIG. 8 OIL COOLER

REF. NO.	PART NO.	DESCRIPTION	CAN	EUR	GENE	REMARKS
28	6B6-13151-00-94	STAY	1	1	1	
29	90119-10M02	BOLT, WITH WASHER	2	2	2	
30	90116-10016	BOLT, STUD	2	2	2	
31	90176-10001	NUT, CROWN	2	2	2	
32	6D3-11167-00	PIPE, BREATHER 2	1	1	1	
33	90467-170A4	CLIP	2	2	2	
34	6S5-81364-10	GROMMET	2	2	2	
35	90387-06M05	COLLAR	2	2	2	
36	91380-06020	BOLT	2	2	2	
37	90465-13M39	CLAMP	1	1	1	

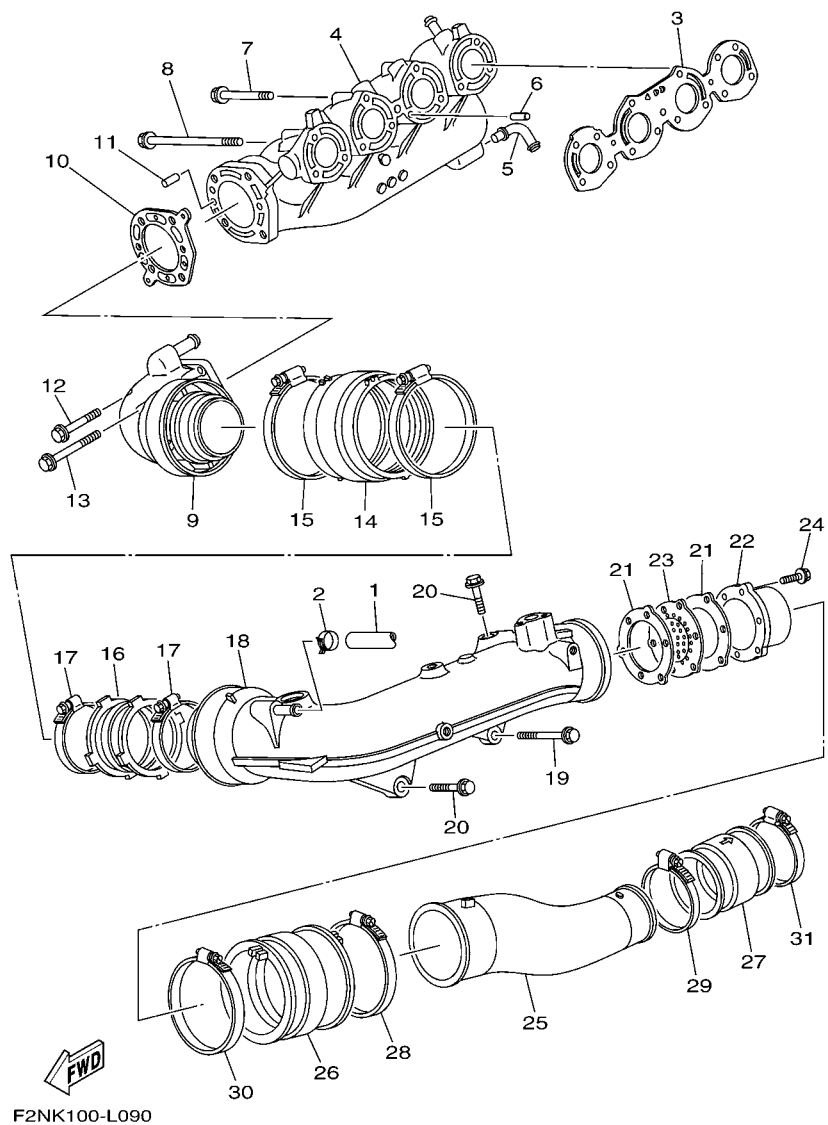

FIG. 9 EXHAUST 1

REF. NO.	PART NO.	DESCRIPTION	CAN	EUR	GENE	REMARKS
1	6BU-1244G-10	HOSE, 4	1	1	1	
2	90467-160A0	CLIP	1	1	1	
3	6D3-14613-10	GASKET, EXHAUST PIPE	1	1	1	
4	6D3-14711-10	MUFFLER 1	1	1	1	
5	60E-11372-10	NIPPLE, HOSE	1	1	1	
6	93608-16M16	PIN, DOWEL	2	2	2	
7	90119-08036	BOLT, WITH WASHER	5	5	5	
8	90119-08075	BOLT, WITH WASHER	6	6	6	
9	6D3-14712-00-94	RING, JOINT	1	1	1	
10	6D3-14739-10	GASKET, MUFFLER DAMPER 1	1	1	1	
11	93606-12019	PIN, DOWEL	2	2	2	
12	90119-08036	BOLT, WITH WASHER	2	2	2	
13	90119-08031	BOLT, WITH WASHER	2	2	2	
14	6D3-14615-00	JOINT, EXHAUST 1	1	1	1	
15	90450-99005	HOSE CLAMP ASSY	2	2	2	
16	6D3-14625-00	JOINT, EXHAUST 2	1	1	1	
17	90450-90001	HOSE CLAMP ASSY	2	2	2	
18	6D3-14721-10	MUFFLER 2	1	1	1	
19	90119-10017	BOLT, WITH WASHER	1	1	1	
20	90119-10013	BOLT, WITH WASHER	3	3	3	
21	60E-14623-00	GASKET, EXHAUST PIPE	2	2	2	
22	60E-14784-00-94	PIPE, TAIL	1	1	1	
23	6D3-1469W-10	PLATE, SILENCER 6	1	1	1	
24	90105-06790	BOLT, FLANGE	3	3	3	
25	6BU-14752-00-94	PIPE, OUTLET	1	1	1	
26	6BU-1475E-00	PIPE 2	1	1	1	
27	6BU-1475F-00	PIPE 3	1	1	1	

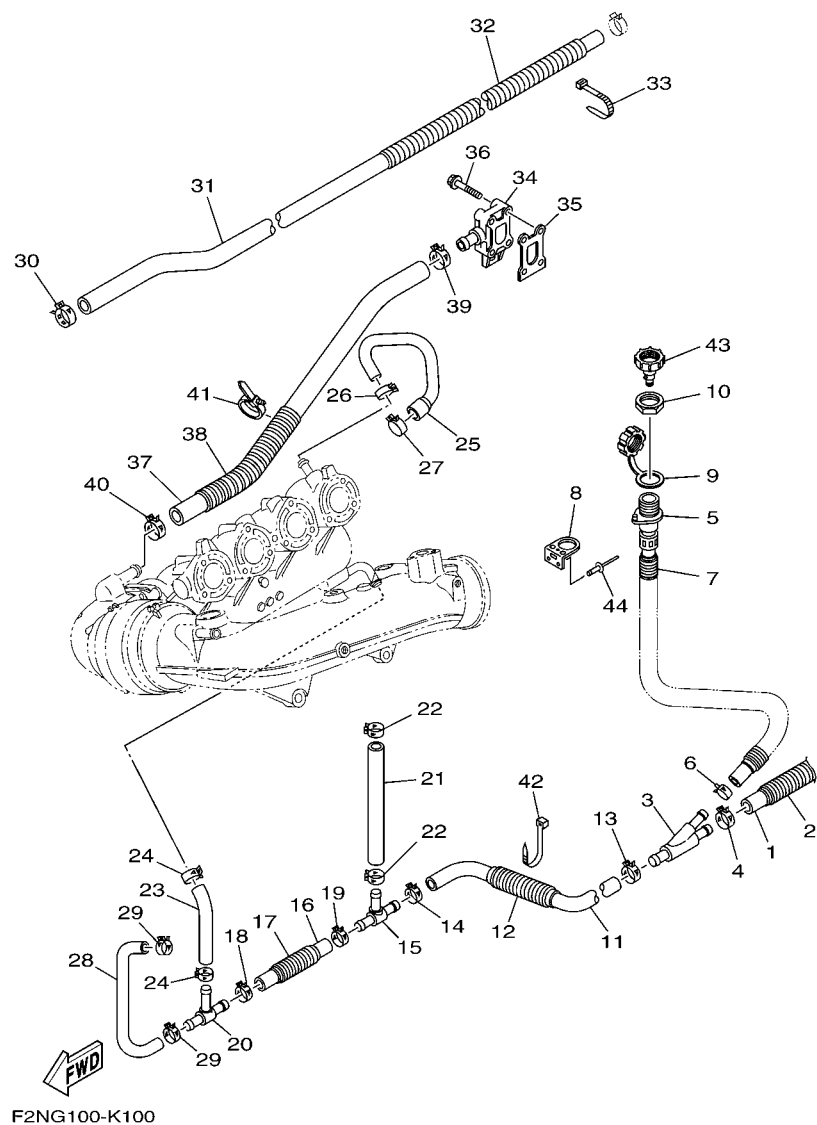

FIG. 10 EXHAUST 2

REF. NO.	PART NO.	DESCRIPTION	CAN	EUR	GENE	REMARKS
1	90445-21805	HOSE (L300)	1		1	
2	90447-22004	HOSE, WITH SPRING (L200)	1		1	
3	60E-12581-00	JOINT, HOSE 1	1		1	
4	90467-200A3	CLIP	1		1	
5	63M-12580-00	JOINT ASSY	1		1	
6	90467-150A5	CLIP	1		1	
7	90447-19801	TUBE (L485)	1		1	
8	60E-12443-00	STAY	1		1	
9	682-84385-01	CAP,1	1		1	
10	EU0-61652-00	NUT	1		1	
11	6BU-1243A-00	HOSE 1	1		1	
12	90447-22003	HOSE, WITH SPRING (L300)	1		1	
13	90467-200A3	CLIP	1		1	
14	90467-200A3	CLIP	1		1	
15	60E-12584-00	JOINT, HOSE 3	1		1	
16	6D3-1243E-10	HOSE 2	1		1	
17	90447-22001	HOSE, WITH SPRING (L100)	1		1	
18	90467-200A3	CLIP	1		1	
19	90467-200A3	CLIP	1		1	
20	6D3-12584-00	JOINT, HOSE 3	1		1	
21	6D3-1244H-10	HOSE 5	1		1	
22	90467-160A0	CLIP	2		2	
23	90445-18M03	HOSE (L108)	1		1	
24	90467-160A0	CLIP	2		2	
25	6D3-12577-10	HOSE 2	1		1	
26	90467-170A4	CLIP	1		1	
27	90467-200A3	CLIP	1		1	

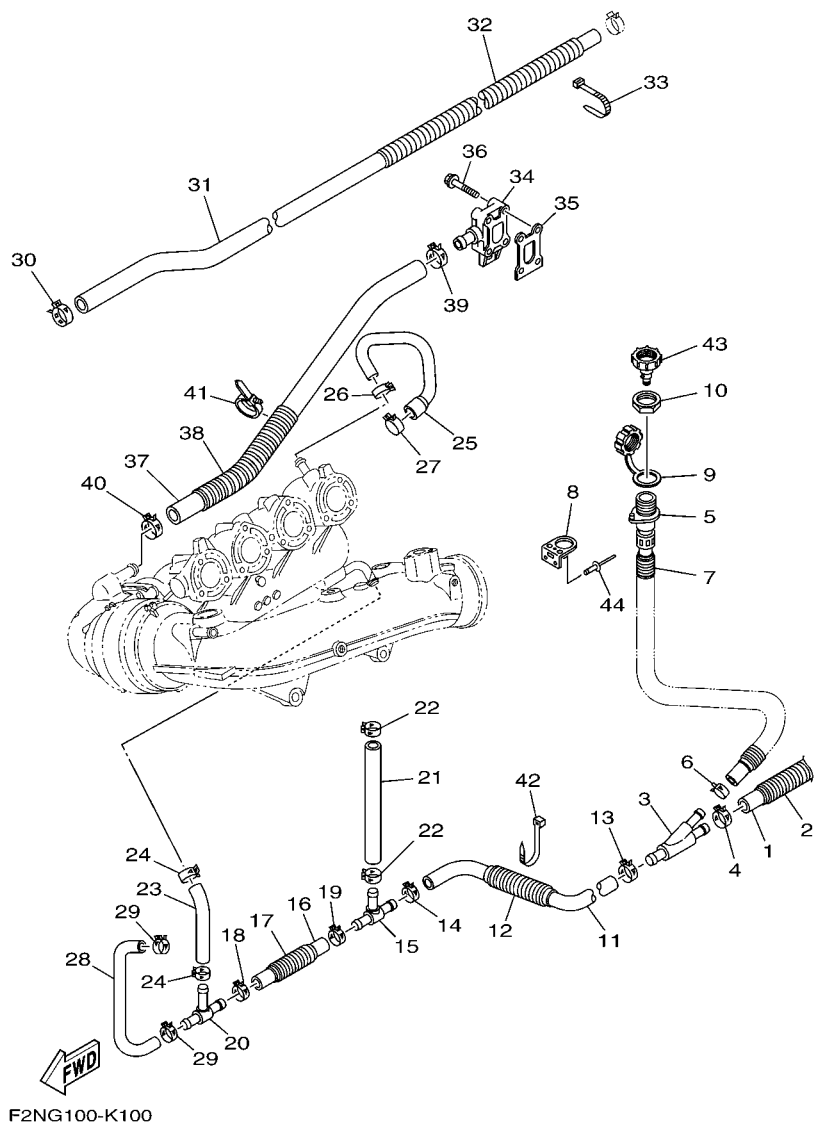

FIG. 10 EXHAUST 2

REF. NO.	PART NO.	DESCRIPTION	CAN	EUR	GENE	REMARKS
28	6D3-1244G-10	HOSE, 4	1		1	
29	90467-160A0	CLIP	2		2	
30	90467-210A0	CLIP	1		1	
31	90445-22007	HOSE (L1165)	1		1	
32	90447-25002	TUBE (L800)	1		1	
33	90464-35132	CLAMP	1		1	
34	6D3-12446-00	JOINT	1		1	
35	60E-12435-00	GASKET	1		1	
36	90105-06035	BOLT, FLANGE	4		4	
37	6BU-1243F-10	HOSE,3	1		1	
38	90447-22005	HOSE, WITH SPRING (L200)	1		1	
39	90467-200A3	CLIP	1		1	
40	90467-200A3	CLIP	1		1	
41	90464-31001	CLAMP	1		1	
42	90464-35132	CLAMP	1		1	
43	67X-E2590-10	CONDUCTION ASSY	1		1	
44	90267-489U1	RIVET,BLIND	2		2	

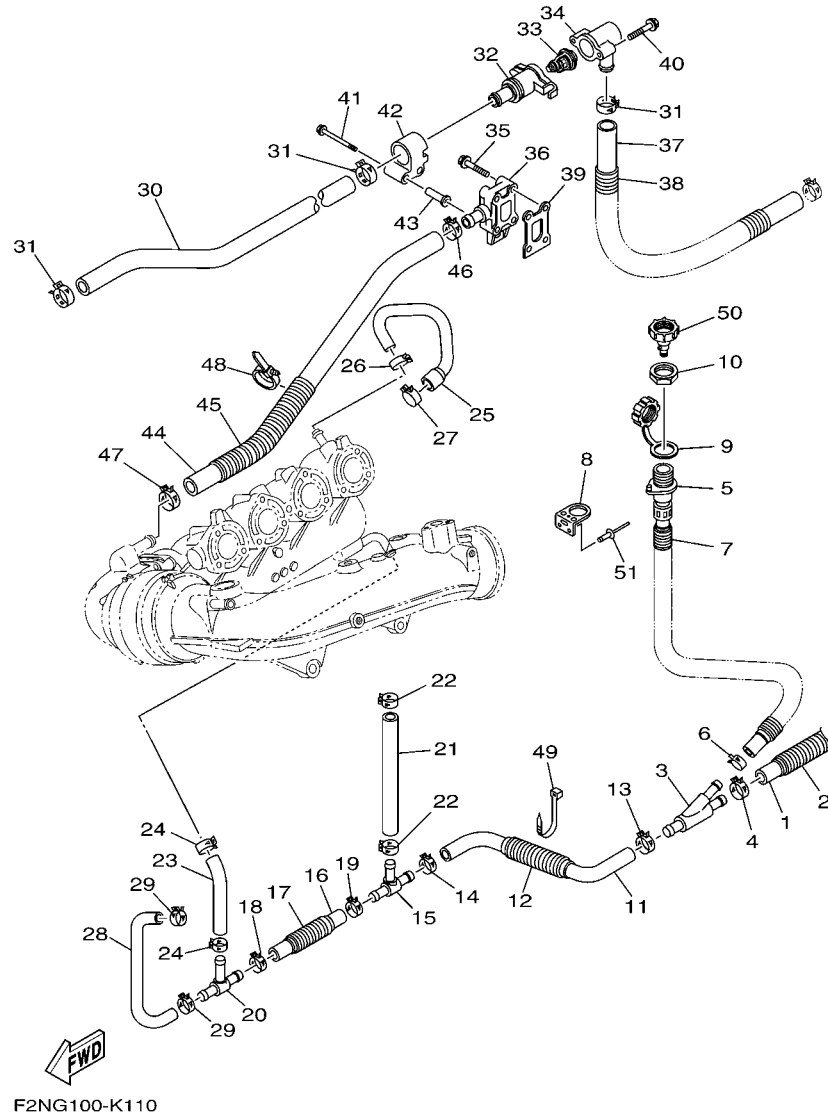

FIG. 11 EXHAUST 3

REF. NO.	PART NO.	DESCRIPTION	CAN	EUR	GENE	REMARKS
1	90445-21805	HOSE (L300)		1		
2	90447-22004	HOSE, WITH SPRING (L200)		1		
3	60E-12581-00	JOINT, HOSE 1		1		
4	90467-200A3	CLIP		1		
5	63M-12580-00	JOINT ASSY		1		
6	90467-150A5	CLIP		1		
7	90447-19801	TUBE (L485)		1		
8	60E-12443-00	STAY		1		
9	682-84385-01	CAP,1		1		
10	EU0-61652-00	NUT		1		
11	6BU-1243A-00	HOSE 1		1		
12	90447-22003	HOSE, WITH SPRING (L300)		1		
13	90467-200A3	CLIP		1		
14	90467-200A3	CLIP		1		
15	60E-12584-00	JOINT, HOSE 3		1		
16	6D3-1243E-10	HOSE 2		1		
17	90447-22001	HOSE, WITH SPRING (L100)		1		
18	90467-200A3	CLIP		1		
19	90467-200A3	CLIP		1		
20	6D3-12584-00	JOINT, HOSE 3		1		
21	6D3-1244H-10	HOSE 5		1		
22	90467-160A0	CLIP		2		
23	90445-18M03	HOSE (L108)		1		
24	90467-160A0	CLIP		2		
25	6D3-12577-10	HOSE 2		1		
26	90467-170A4	CLIP		1		
27	90467-200A3	CLIP		1		

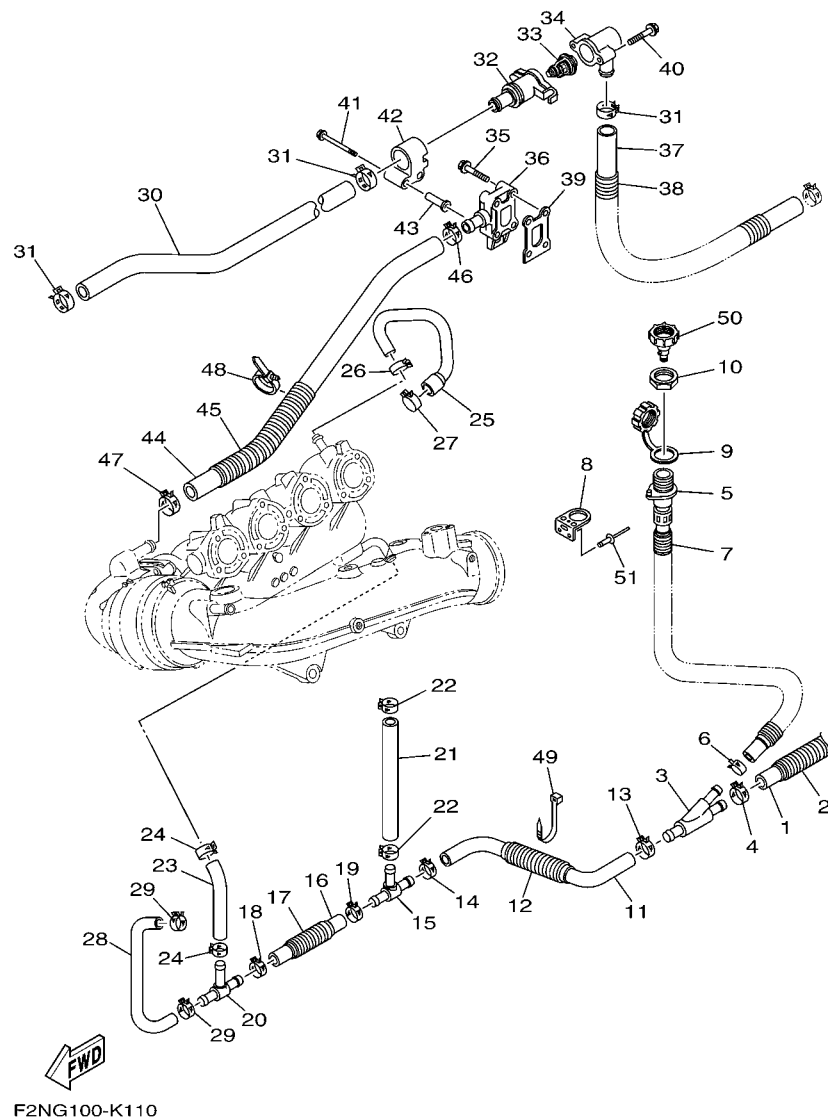

FIG. 11 EXHAUST 3

REF. NO.	PART NO.	DESCRIPTION	CAN	EUR	GENE	REMARKS
28	6D3-1244G-10	HOSE, 4		1		
29	90467-160A0	CLIP		2		
30	90445-26004	HOSE (L375)		1		
31	90467-240A0	CLIP		3		
32	60E-12417-10	HOUSING, THERMOSTAT		1		
33	6D3-12411-00	THERMOSTAT		1		
34	6BH-12413-00	COVER, THERMOSTAT		1		
35	90105-06035	BOLT, FLANGE		2		
36	6D3-12446-00	JOINT		1		
37	90445-25006	HOSE (L760)		1		
38	90447-28010	TUBE (L650)		1		
39	60E-12435-00	GASKET		1		
40	90105-06035	BOLT, FLANGE		2		
41	90105-06054	BOLT, FLANGE		2		
42	6B6-12499-00	JOINT		1		
43	90387-06083	COLLAR		2		
44	6BU-1243F-10	HOSE,3		1		
45	90447-22005	HOSE, WITH SPRING (L200)		1		
46	90467-200A3	CLIP		1		
47	90467-200A3	CLIP		1		
48	90464-31001	CLAMP		1		
49	90464-35132	CLAMP		1		
50	67X-E2590-10	CONDUCTION ASSY		1		
51	90267-489U1	RIVET,BLIND		2		

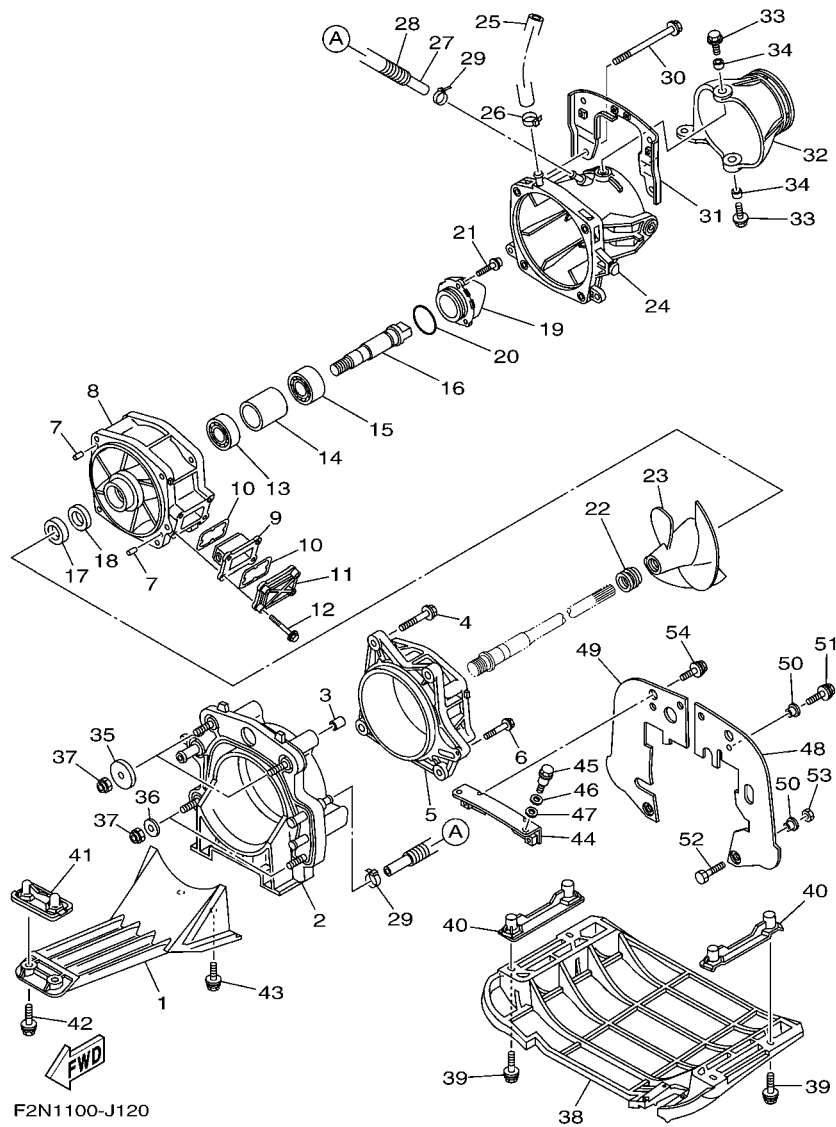

FIG. 12 JET UNIT 1

REF. NO.	PART NO.	DESCRIPTION	CAN	EUR	GENE	REMARKS
1	6D3-R1333-01-94	SCREEN, INTAKE	1	1	1	
2	6D3-G5831-00	PLATE, TRANSOM	1	1	1	
3	99590-14016	PIN, DOWEL	2	2	2	
4	90119-10810	BOLT, WITH WASHER	4	4	4	
5	66V-51312-01-94	HOUSING, IMPELLER	1	1	1	
6	90119-06893	BOLT, WITH WASHER	1	1	1	
7	93606-12019	PIN, DOWEL	2	2	2	
8	6B6-51315-01-94	DUCT, IMPELLER	1	1	1	
9	6AN-G6882-00	FILTER	1	1	1	
10	66V-42414-00	O-RING	2	2	2	
11	6AN-G5214-00-94	COVER, WATER INLET 1	1	1	1	
12	90119-06897	BOLT, WITH WASHER	4	4	4	
13	93306-27211	BEARING	1	1	1	
14	65V-45538-00	SPACER 1	1	1	1	
15	93306-205U0	BEARING	1	1	1	
16	6D3-45514-00	SHAFT, DRIVE 4	1	1	1	
17	93101-21001	OIL SEAL	1	1	1	
18	93101-21002	OIL SEAL	1	1	1	
19	6B6-51326-10-94	CAP	1	1	1	
20	93210-464A3	O-RING	1	1	1	
21	90110-06822	BOLT, HEXAGON SOCKET HEAD	3	3	3	
22	6D3-R1319-00	CAP, IMPELLER	1	1	1	
23	6D3-R1321-02	IMPELLER	1	1	1	
24	6BU-R1318-00	NOZZLE	1	1	1	
25	90445-16006	HOSE (L260)	1	1	1	
26	90601-118UF	BAND, HOSE 18	1	1	1	
27	90445-14807	HOSE (L355)	1	1	1	

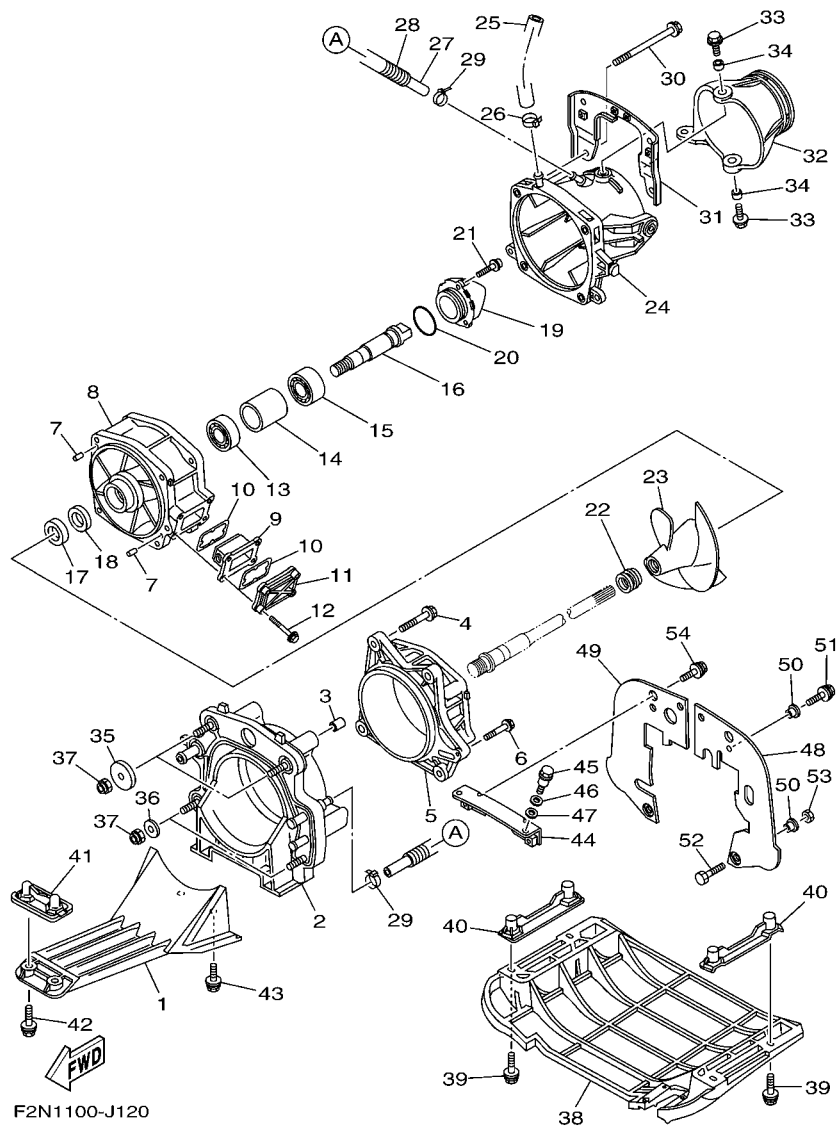

FIG. 12 JET UNIT 1

REF. NO.	PART NO.	DESCRIPTION	CAN	EUR	GENE	REMARKS
28	90446-20MF5	HOSE (L320)	1	1	1	
29	90465-11829	CLAMP	2	2	2	
30	90119-10806	BOLT, WITH WASHER	4	4	4	
31	6D3-R1341-00	BRACKET 1	1	1	1	
32	6BU-R1313-00-94	NOZZLE, DEFLECTOR	1	1	1	
33	90119-08840	BOLT, WITH WASHER	2	2	2	
34	90387-08M06	COLLAR	2	2	2	
35	F1S-U725E-01	WASHER	2	2	2	
36	90201-10801	WASHER, PLATE	2	2	2	
37	9572R-10300	NUT, NYLON	4	4	4	
38	F2N-U273B-00	PLATE 2	1	1	1	
39	90119-08829	BOLT, WITH WASHER	4	4	4	
40	F1G-U8572-02	BRACKET 2	2	2	2	
41	F1K-U8577-01	BRACKET, 3	1	1	1	
42	90119-06895	BOLT, WITH WASHER	2	2	2	
43	90119-10809	BOLT, WITH WASHER	2	2	2	
44	F1K-U7557-01	BRACKET	1	1	1	
45	90109-08041	BOLT	2	2	2	
46	92990-12200	WASHER, PLAIN	2	2	2	
47	90430-12002	GASKET	2	2	2	
48	F1K-U757E-01	PLATE, RUBBER 1	1	1	1	
49	F1K-U757F-01	PLATE, RUBBER 2	1	1	1	
50	90387-06080	COLLAR	6	6	6	
51	90119-06880	BOLT, WITH WASHER	4	4	4	
52	90101-069U0	BOLT	2	2	2	
53	9572R-06300	NUT, NYLON	2	2	2	
54	90119-08800	BOLT, WITH WASHER	2	2	2	

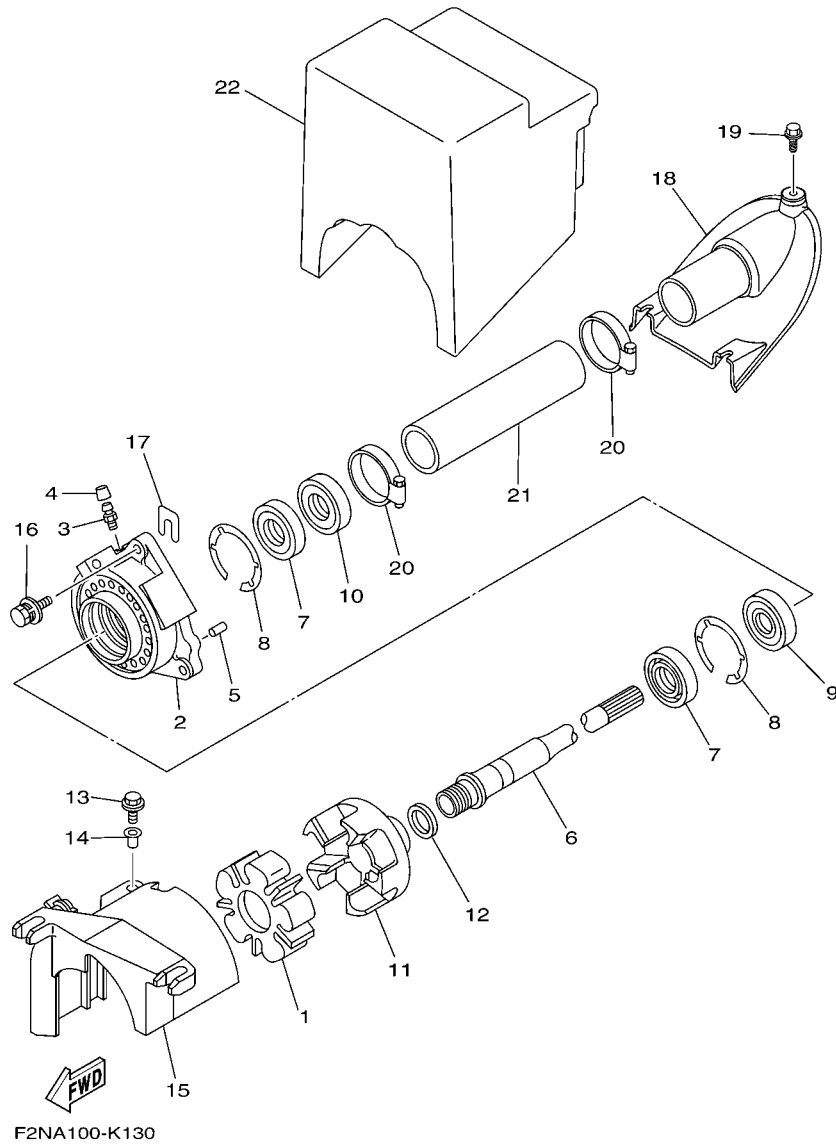

FIG. 13 JET UNIT 2

REF. NO.	PART NO.	DESCRIPTION	CAN	EUR	GENE	REMARKS
1	6D3-4581J-00	RUBBER SHAFT COUPLING	1	1	1	
2	61X-45332-03-94	HOUSING, BEARING	1	1	1	
3	93700-06M03	NIPPLE, GREASE	1	1	1	
4	663-45119-00	CAP, GREASE NIPPLE	1	1	1	
5	93606-12019	PIN, DOWEL	2	2	2	
6	6BU-45511-00	SHAFT, DRIVE	1	1	1	
7	93101-25M55	OIL SEAL	2	2	2	
8	93430-47M04	CIRCLIP	2	2	2	
9	93306-205A3	BEARING	1	1	1	
10	93102-25009	OIL SEAL	1	1	1	
11	6D3-45593-00-94	FLANGE, COUPLING 1	1	1	1	
12	90201-24800	WASHER, PLATE	1	1	1	
13	90119-06891	BOLT, WITH WASHER	1	1	1	
14	90387-06M60	COLLAR	1	1	1	
15	60E-R1381-01	COVER	1	1	1	
16	90119-089UL	BOLT, WITH WASHER	3	3	3	
17	GD0-U7249-00-05	SHIM (T=0.5)	2	2	2	UN
18	F2N-U883E-00	JOINT, PIPE	1	1	1	
19	90109-06832	BOLT	3	3	3	
20	90601-155U4	BAND, HOSE 55	2	2	2	
21	F2N-U883B-00	PIPE, 1	1	1	1	
22	F1K-U892D-00	FLOTATION, STERN	1	1	1	

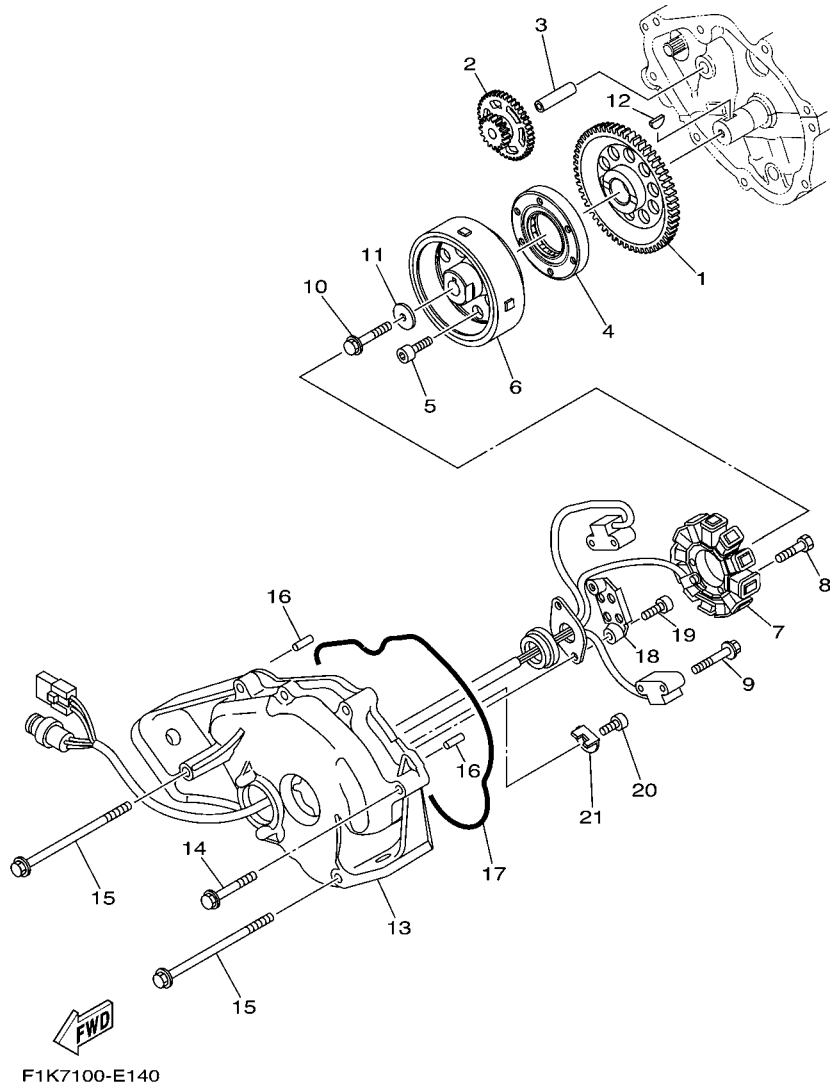
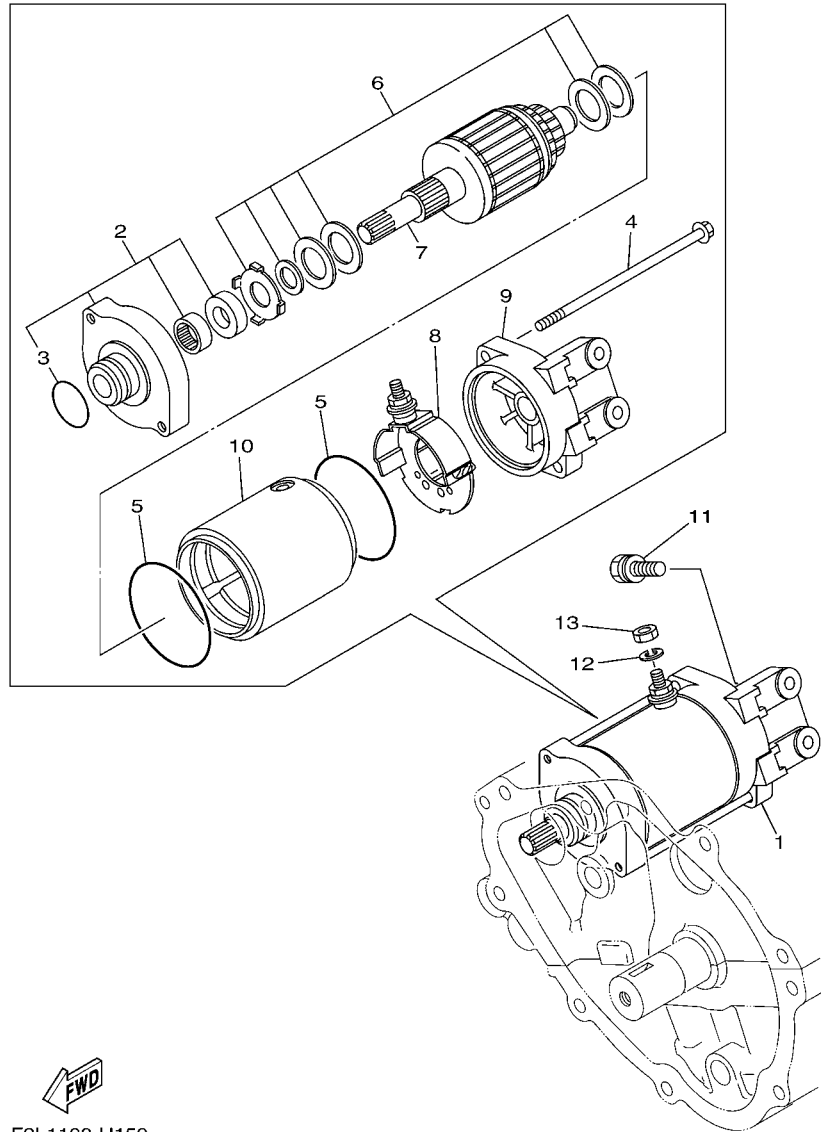

FIG. 14 GENERATOR

REF. NO.	PART NO.	DESCRIPTION	CAN	EUR	GENE	REMARKS
1	6D3-15515-00	GEAR 3	1	1	1	
2	60E-15517-00	GEAR, IDLER 2	1	1	1	
3	60E-15521-00	SHAFT 1	1	1	1	
4	4WM-15590-00	STARTER ONE-WAY ASSY	1	1	1	
5	90110-08212	BOLT, HEXAGON SOCKET HEAD	6	6	6	
6	6D3-81450-00	ROTOR ASSY	1	1	1	
7	6D3-81410-01	STATOR ASSY	1	1	1	
8	91317-06035	BOLT	3	3	3	
9	97513-05514	BOLT, WITH WASHER	2	2	2	
10	90105-105A6	BOLT, FLANGE	1	1	1	
11	90201-103U7	WASHER, PLATE	1	1	1	
12	90280-03047	KEY, WOODRUFF	1	1	1	
13	6D3-81337-00-94	COVER, FLYWHEEL	1	1	1	
14	90119-10016	BOLT, WITH WASHER	6	6	6	
15	90119-10M19	BOLT, WITH WASHER	2	2	2	
16	93608-16M16	PIN, DOWEL	2	2	2	
17	93212-04001	O-RING	1	1	1	
18	60E-81328-00	CLAMP	1	1	1	
19	91317-06014	BOLT	2	2	2	
20	91317-05010	BOLT	1	1	1	
21	6D3-81845-00	PLATE	1	1	1	



 F2L1100-H150

FIG. 15 STARTING MOTOR

REF. NO.	PART NO.	DESCRIPTION	CAN	EUR	GENE	REMARKS
1	6D3-81800-00	STARTING MOTOR ASSY	1	1	1	
2	6M6-81830-00	.FRONT BRACKET ASSY	1	1	1	
3	1FK-81847-00	..O-RING	1	1	1	
4	6M6-81826-00	.BOLT	2	2	2	
5	11H-81844-00	.GASKET	2	2	2	
6	3AJ-81809-00	.WASHER KIT	1	1	1	
7	6M6-81850-00	.ARMATURE ASSY	1	1	1	
8	6M6-81840-10	.BRUSH HOLDER ASSY	1	1	1	
9	6D3-81820-00	.REAR BRACKET ASSY	1	1	1	
10	60E-81810-00	.STATOR ASSY	1	1	1	
11	97513-08530	BOLT, WITH WASHER	2	2	2	
12	92990-06100	WASHER, SPRING	1	1	1	
13	95380-06700	NUT	1	1	1	

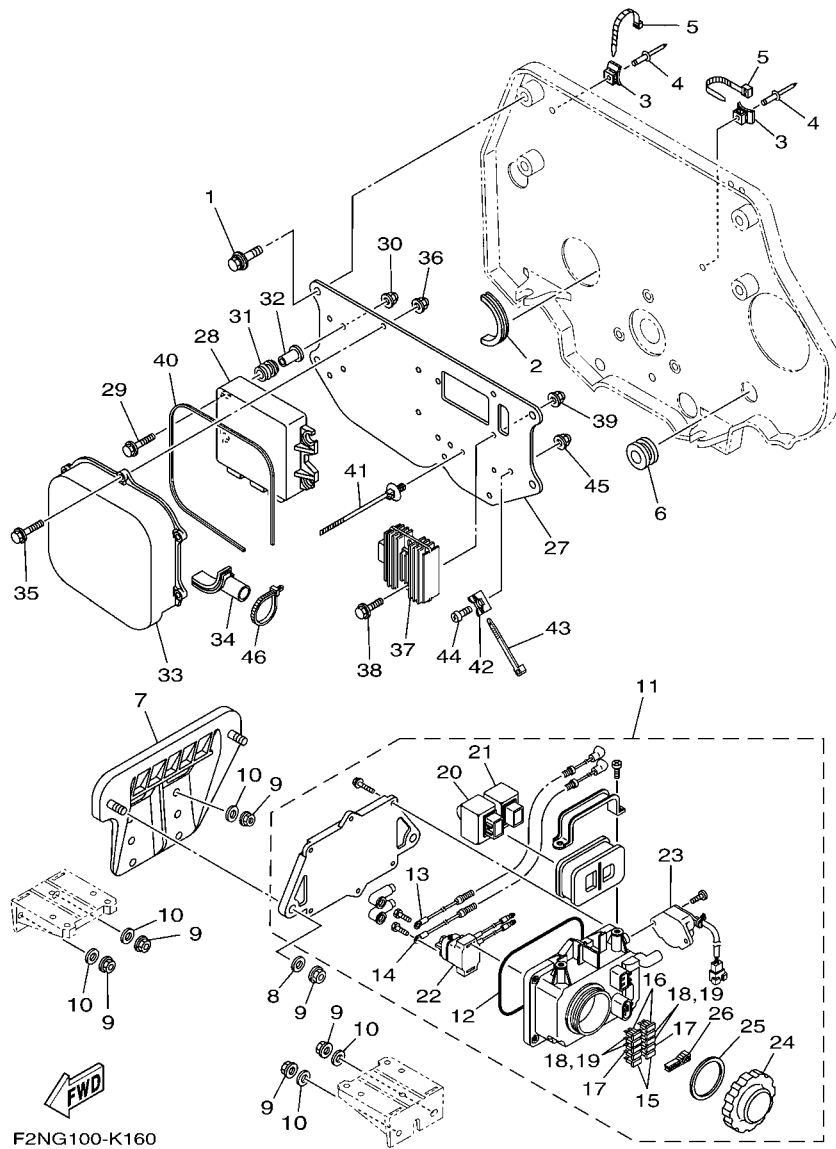

FIG. 16 ELECTRICAL 1

REF. NO.	PART NO.	DESCRIPTION	CAN	EUR	GENE	REMARKS
1	90119-089U7	BOLT, WITH WASHER	4	4	4	
2	F1S-U828H-01	TRIM, 1	1	1	1	
3	F1W-U828M-00	BASE, CLAMP	2	2	2	
4	90267-48802	RIVET, BLIND	2	2	2	
5	90464-32801	CLAMP	2	2	2	
6	90480-279U1	GROMMET	1	1	1	
7	F2N-U815D-01	BRACKET, ELECTRIC BOX	1	1	1	
8	90201-099U3	WASHER, PLATE	2	2	2	
9	9572R-08300	NUT, FLANGE	10	10	10	
10	9299R-08200	WASHER	8	8	8	
11	6BU-82170-00	FUSE BOX ASSY	1	1	1	
12	6D3-81921-00	.GASKET, TERMINAL	1	1	1	
13	6BU-82115-00	.WIRE, PLUS LEAD	1	1	1	
14	6D3-82117-00	.WIRE, LEAD	1	1	1	
15	67F-82151-00	.FUSE (20A)	2	2	2	
16	67F-82151-10	.FUSE (30A)	2	2	2	
17	67F-82151-30	.FUSE (3A)	2	2	2	
18	67F-82151-40	.FUSE (10A)	2	2	2	
19	67F-82151-40	.FUSE (10A)	2	2	2	
20	60E-81950-00	.RELAY ASSY	1	1	1	
21	68V-81950-00	.RELAY ASSY	1	1	1	
22	6B6-81940-00	.STARTER RELAY ASSY	1	1	1	
23	60E-8259E-00	.SWITCH ASSY	1	1	1	
24	66V-8132W-00	.CAP	1	1	1	
25	66V-81844-00	.GASKET	1	1	1	
26	67F-2812A-00	.PULLER, FUSE	1	1	1	
27	6BU-81845-00	PLATE	1	1	1	

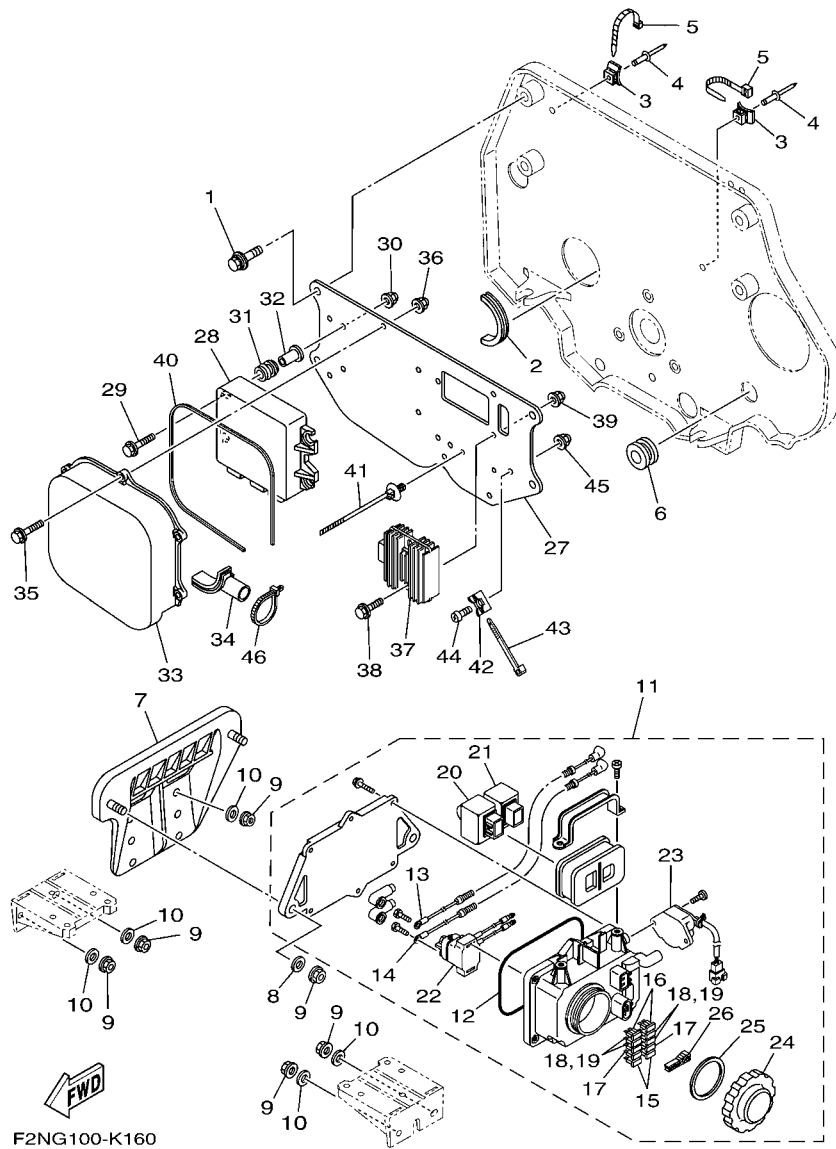

FIG. 16 ELECTRICAL 1

REF. NO.	PART NO.	DESCRIPTION	CAN	EUR	GENE	REMARKS
28	6BU-8591A-20	ENGINE CONTROL UNIT ASSY	1		1	FOR CAN, GENE
	6BU-8591A-10	ENGINE CONTROL UNIT ASSY		1		FOR EUR
29	95814-06025	BOLT, FLANGE	4	4	4	
30	90176-06047	NUT,CAP	4	4	4	
31	6A0-82317-00	DAMPER, IGNITION COIL	4	4	4	
32	90387-06119	COLLAR	4	4	4	
33	6BU-81639-00	COVER	1	1	1	
34	6BU-81336-00	GROMMET	1	1	1	
35	95814-06020	BOLT, FLANGE	5	5	5	
36	90176-06047	NUT,CAP	5	5	5	
37	6S8-81960-00	RECTIFIER & REGULATOR ASSY	1	1	1	
38	95814-06020	BOLT, FLANGE	2	2	2	
39	90176-06047	NUT,CAP	2	2	2	
40	6BU-81861-00	GASKET	1	1	1	
41	90464-31001	CLAMP	1	1	1	
42	60E-1244E-00	BRACKET 1	1	1	1	
43	90465-13M24	CLAMP	1	1	1	
44	92014-06012	BOLT, BUTTON HEAD	1	1	1	
45	90176-06047	NUT,CAP	1	1	1	
46	90465-13M18	CLAMP	1	1	1	

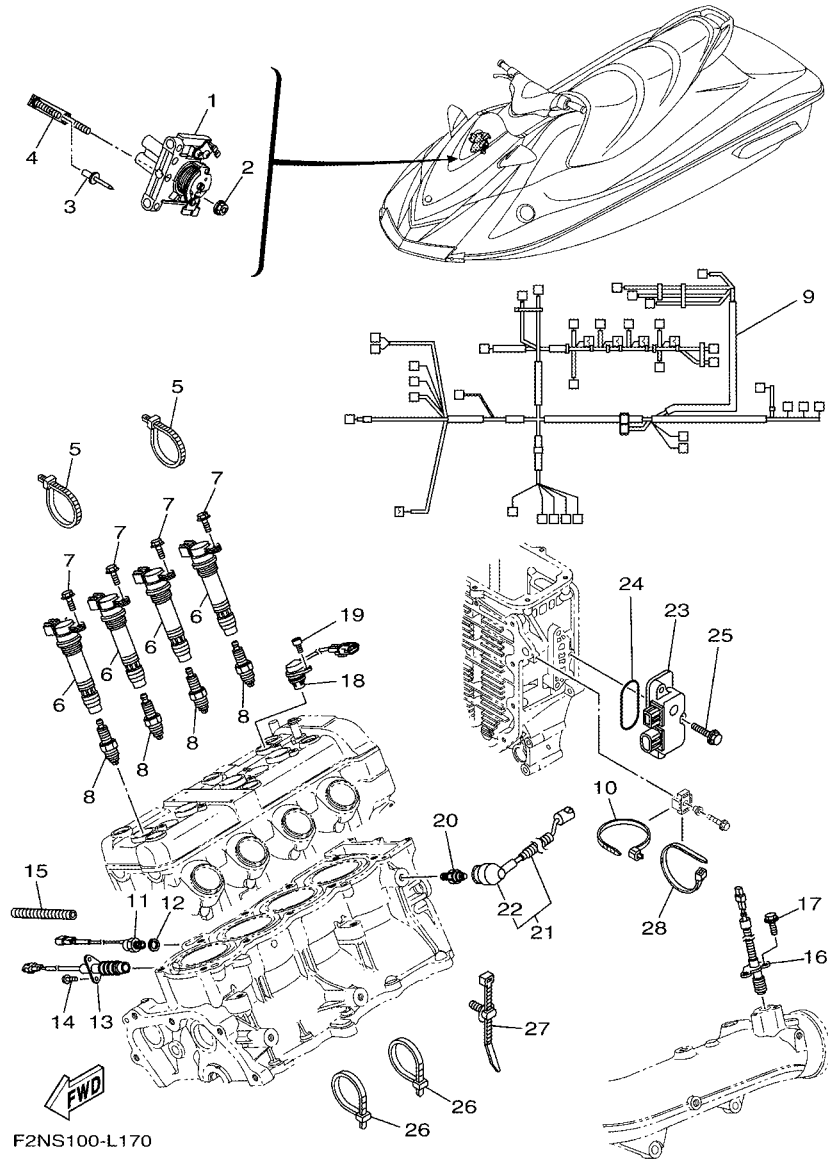

FIG. 17 ELECTRICAL 2

REF. NO.	PART NO.	DESCRIPTION	CAN	EUR	GENE	REMARKS
1	6D3-14305-21	ACCEL. POSITON SENSOR ASSY	1	1	1	
2	95780-08300	NUT, FLANGE	2	2	2	
3	90267-489U1	RIVET,BLIND	1	1	1	
4	F1W-U7254-00	BRACKET, THROTTLE	1	1	1	
5	90464-35132	CLAMP	2	2	2	
6	6D3-82310-01	IGNITION COIL ASSY	4	4	4	
7	95880-06016	BOLT, FLANGE	4	4	4	
8	94702-00409	PLUG, SPARK (NGK CR9EB)	4	4	4	
9	6BU-8259L-20	WIRE HARNESS ASSY 1	1	1	1	
10	90465-13M24	CLAMP	1	1	1	
11	61A-85790-00	THERMOSENSOR ASSY	1	1	1	
12	92990-10600	WASHER, PLATE	1	1	1	
13	60E-82560-A1	THERMO SWITCH ASSY	1	1	1	
14	97595-06416	BOLT, WITH WASHER	2	2	2	
15	90446-14M23	HOSE (L180)	1	1	1	
16	6D3-82560-01	THERMO SWITCH ASSY	1	1	1	
17	97595-06416	BOLT, WITH WASHER	2	2	2	
18	6D3-85896-00	SENSOR, CAM POSITION	1	1	1	
19	91380-06016	BOLT	1	1	1	
20	68V-82504-00	OIL PRESSURE SWITCH ASSY	1	1	1	
21	60E-81315-00	LEAD WIRE ASSY	1	1	1	
22	60E-82532-00	.CAP	1	1	1	
23	6D3-8273J-01	EARTH PLATE COMP.	1	1	1	
24	93210-60ME8	O-RING	1	1	1	
25	90119-06048	BOLT, WITH WASHER	3	3	3	
26	90465-13M18	CLAMP	2	2	2	
27	90464-45002	CLAMP	1	1	1	

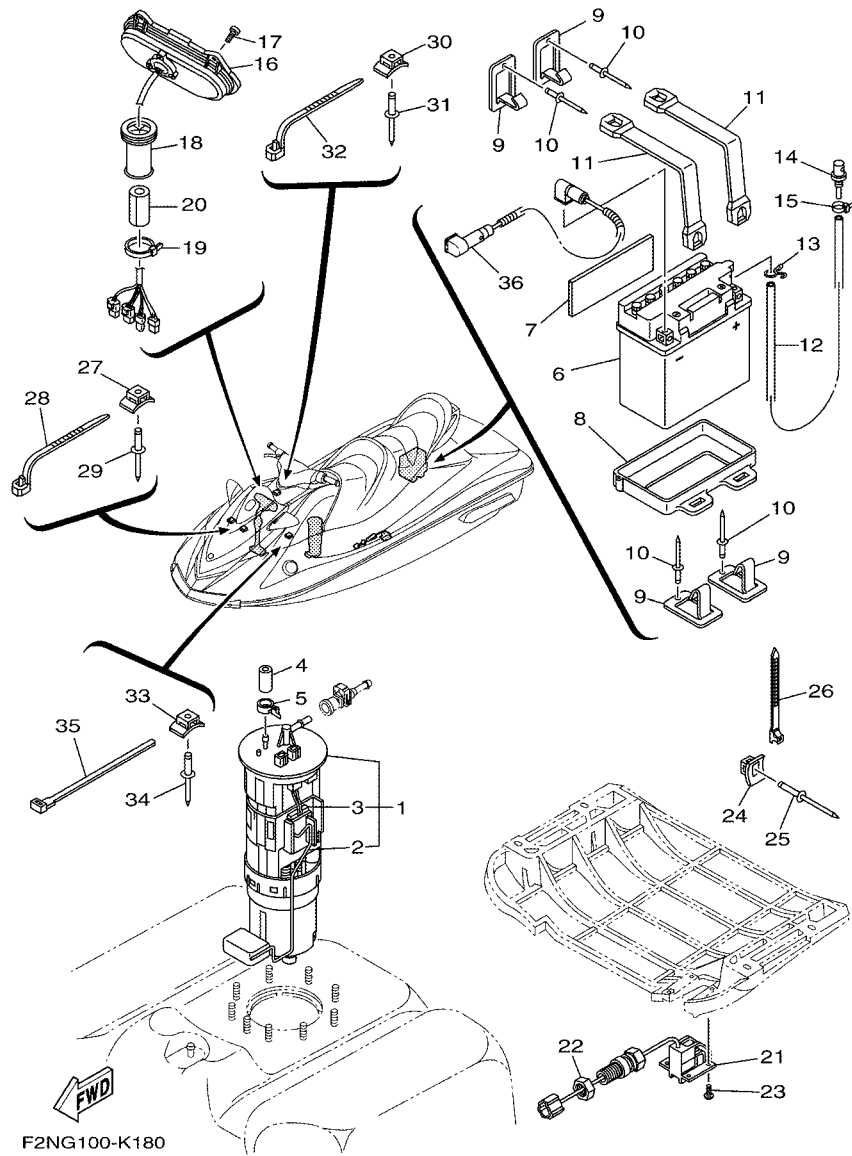
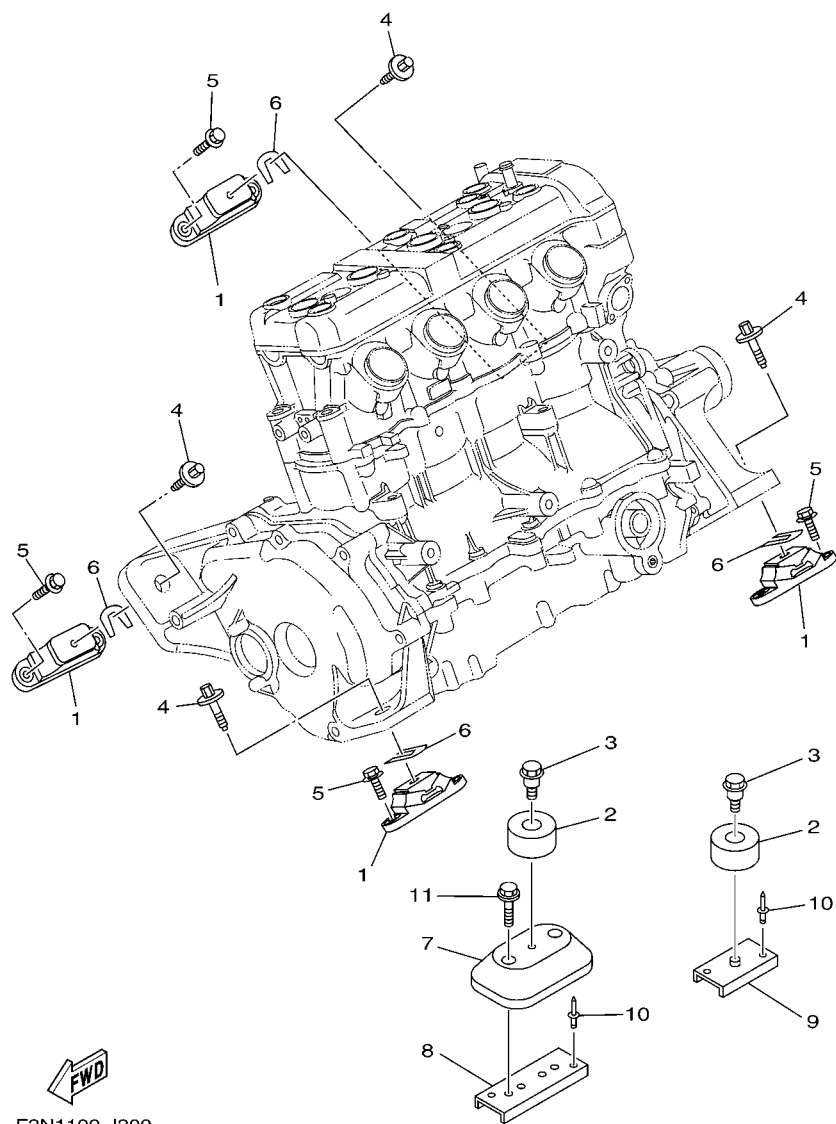

FIG. 18 ELECTRICAL 3

REF. NO.	PART NO.	DESCRIPTION	CAN	EUR	GENE	REMARKS
1	60E-13907-02	FUEL PUMP COMP.	1	1	1	
2	60E-682E0-00	.FUEL SENDER ASSY	1	1	1	
3	60E-82556-00	.DAMPER, STOPPER	1	1	1	
4	6D3-24481-00	PLUG	1	1	1	
5	6D3-24387-00	CLIP	1	1	1	
6	EU0-82110-09	BATTERY ASSY (YB16CL-B)	1	1	1	YUASA
7	F1K-U8221-00	PAD, BATTERY	1	1	1	
8	F1K-U8211-01	CASE, BATTERY	1	1	1	
9	F1K-U5772-04	HOOK A	4	4	4	
10	90267-489U1	RIVET,BLIND	4	4	4	
11	F1K-U821D-01	BAND, BATTERY 1	2	2	2	
12	F0D-U785G-10	HOSE, AIR VENT	1	1	1	
13	90467-089U1	CLIP	1	1	1	
14	GJ3-6215F-00	NIPPLE	1	1	1	
15	90465-11829	CLAMP	1	1	1	
16	F2N-6820A-10	METER ASSY	1	1	1	
17	90111-05008	BOLT,HEX. SOCKET BUTTON	4	4	4	
18	GU2-6822E-01	GROMMET	1	1	1	
19	90464-32801	CLAMP	1	1	1	
20	GJ1-U7578-21	PACKING, HOSE 2	1	1	1	
21	F1S-U8K31-02	SENSOR SPEED	1	1	1	
22	F2C-U151S-00	NUT	1	1	1	
23	90150-05807	SCREW, ROUND HEAD	4	4	4	
24	F1W-U828M-00	BASE, CLAMP	6	6	6	
25	90267-489U6	RIVET, BLIND	6	6	6	
26	90464-32801	CLAMP	6	6	6	
27	F1W-U828M-00	BASE, CLAMP	2	2	2	

FIG. 19 ENGINE MOUNT



F2N1100-J200

REF. NO.	PART NO.	DESCRIPTION	CAN	EUR	GENE	REMARKS
1	67X-44517-10-94	MOUNT RUBBER	4	4	4	
2	6D3-44574-00	STOPPER, LOWER MOUNT RUBBER	2	2	2	
3	90109-06M92	BOLT	2	2	2	
4	90119-08859	BOLT, WITH WASHER	4	4	4	
5	90119-08823	BOLT, WITH WASHER	8	8	8	
6	EU0-U7354-00-01	SHIM (T=0.1)	4	4	4	UN
	EU0-U7354-00-03	SHIM (T=0.3)	4	4	4	UN
	EU0-U7354-00-05	SHIM (T=0.5)	4	4	4	UN
	EU0-U7354-00-10	SHIM (T=1.0)	4	4	4	UN
	EU0-U7354-00-20	SHIM (T=2.0)	4	4	4	UN
7	F2N-U721B-00	SPACER,ENGINE MOUNT	1	1	1	
8	F2N-U732B-10	PLATE	1	1	1	
9	F2N-U732B-01	PLATE	1	1	1	
10	90267-489U2	RIVET, BLIND	4	4	4	
11	90119-06891	BOLT, WITH WASHER	2	2	2	

FIG. 20 ENGINE HATCH 1

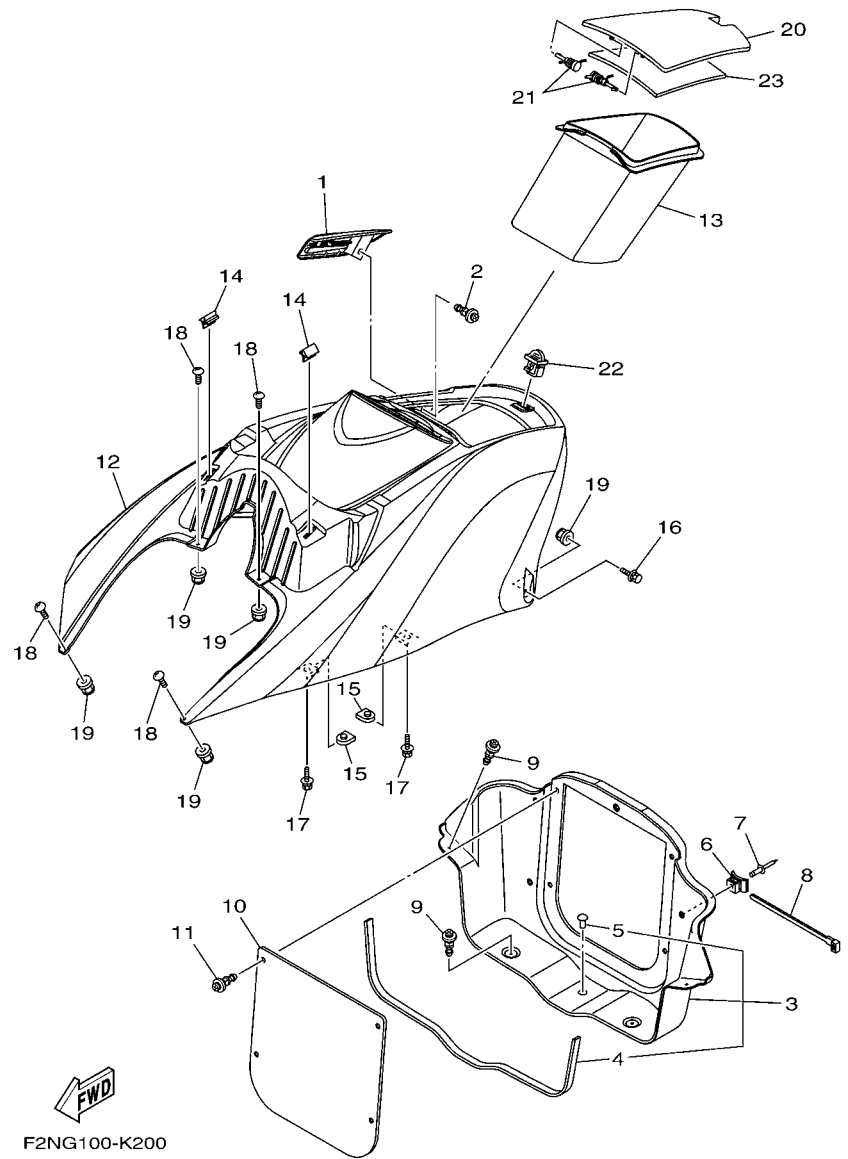

REF. NO.	PART NO.	DESCRIPTION	CAN	EUR	GENE	REMARKS
1	F2N-U2723-00	SEAL	1	1	1	
2	90269-08801	RIVET	1	1	1	
3	F2N-U475B-03	LOCKER,BOW	1	1	1	
4	F2N-U266C-01	.PACKING 4	1	1	1	
5	90605-502U1	.PLUG, BLIND	1	1	1	
6	F1W-U828M-00	BASE, CLAMP	1	1	1	
7	90267-48803	RIVET, BLIND	1	1	1	
8	90464-32801	CLAMP	1	1	1	
9	90269-08801	RIVET	4	4	4	
10	F1W-U475F-01	PLATE, LOKER BOW	1	1	1	
11	90269-08801	RIVET	5	5	5	
12	F2N-U516N-00-P7	COVER, ENGINE HATCH (DPBM11)	1	1	1	
13	F2N-U516P-00	BOX GLOVE	1	1	1	
14	F1K-U266C-00	PACKING 4	2	2	2	
15	90183-06902	NUT, SPRING	4	4	4	
16	90119-06880	BOLT, WITH WASHER	2	2	2	
17	90119-06882	BOLT, WITH WASHER	4	4	4	
18	F2N-67823-10	SCREW	4	4	4	
19	F2N-U142L-00	NUT, LOCK	6	6	6	
20	F2N-U517H-01	LID HATCH	1	1	1	
21	F0X-6517R-01	PIN, HINGE	2	2	2	
22	GU2-62875-01	LOCK	1	1	1	
23	F2N-U519D-00	PACKING CASE	1	1	1	

FIG. 21 ENGINE HATCH 2

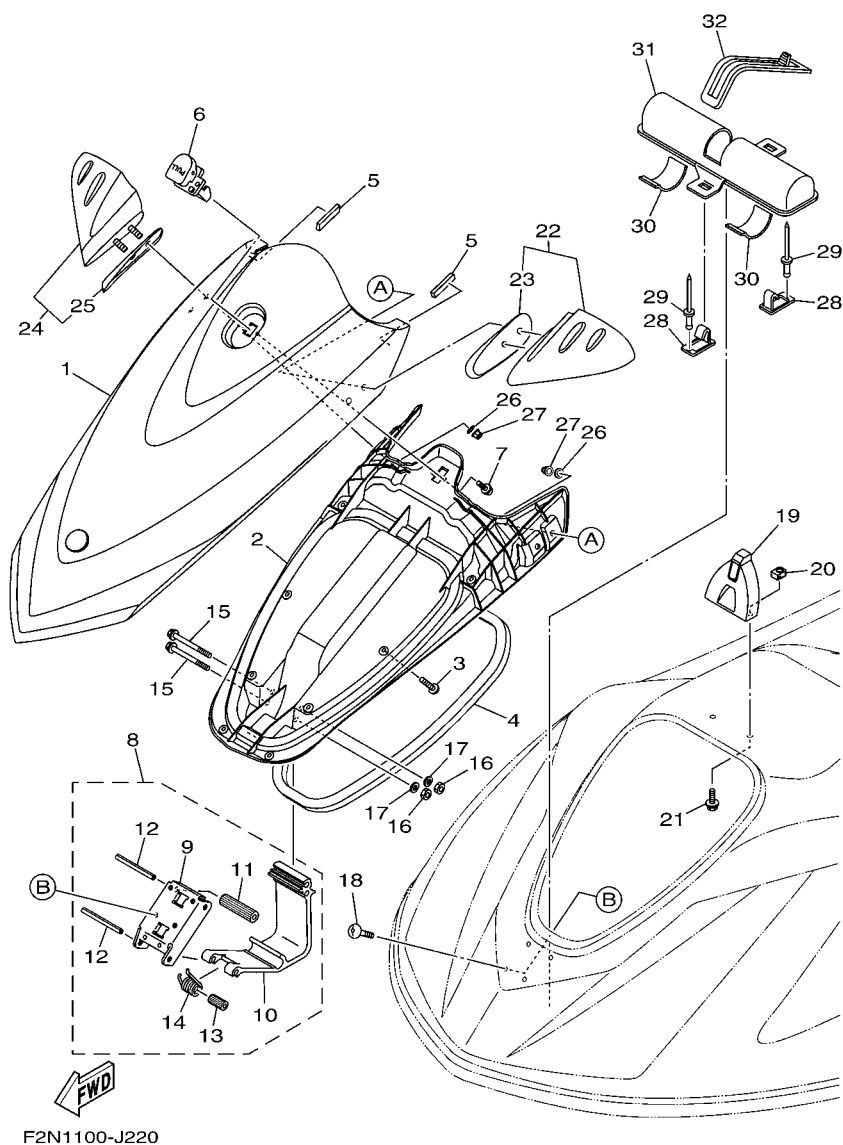

REF. NO.	PART NO.	DESCRIPTION	CAN	EUR	GENE	REMARKS
1	F2N-U517B-10-P4	LID, ENGINE ROOM (DPBM11)	1	1	1	
2	F2N-U213B-00	COVER, VENTILATOR 1	1	1	1	
3	90149-05903	SCREW	8	8	8	
4	F2N-U2663-01	PACKING 1	1	1	1	
5	F1K-U266B-00	PACKING 3	2	2	2	
6	F1K-6517C-00	LOCK, LID	1	1	1	
7	90119-059U4	BOLT, WITH WASHER	2	2	2	
8	F1K-U515A-00	HINGE ASSY.	1	1	1	
9	F1K-U518E-04	.PLATE, HINGE LID	1	1	1	
10	F1K-U517D-05	.HINGE, LID	1	1	1	
11	F1K-U135C-01	.ROLLER, DETENT	1	1	1	
12	F1K-U517R-00	.PIN, HINGE	2	2	2	
13	F1K-U471E-03	.SPACER 1	1	1	1	
14	F1K-U283B-02	.SPRING, TORSION	1	1	1	
15	90105-06826	BOLT, FLANGE	2	2	2	
16	9572R-06300	NUT, NYLON	2	2	2	
17	9299R-06200	WASHER	2	2	2	
18	F2N-67823-00	SCREW	4	4	4	
19	F2N-U517F-00	HOOK, LID LOCK	1	1	1	
20	F1X-U517E-01	NUT	2	2	2	
21	90119-06880	BOLT, WITH WASHER	2	2	2	
22	F2N-U596B-00	MIRROR LH	1	1	1	
23	F2N-U471E-00	.SPACER 1	1	1	1	
24	F2N-U596C-00	MIRROR RH	1	1	1	
25	F2N-U471F-00	.SPACER 2	1	1	1	
26	9299R-08200	WASHER	4	4	4	
27	9572R-08300	NUT, FLANGE	4	4	4	

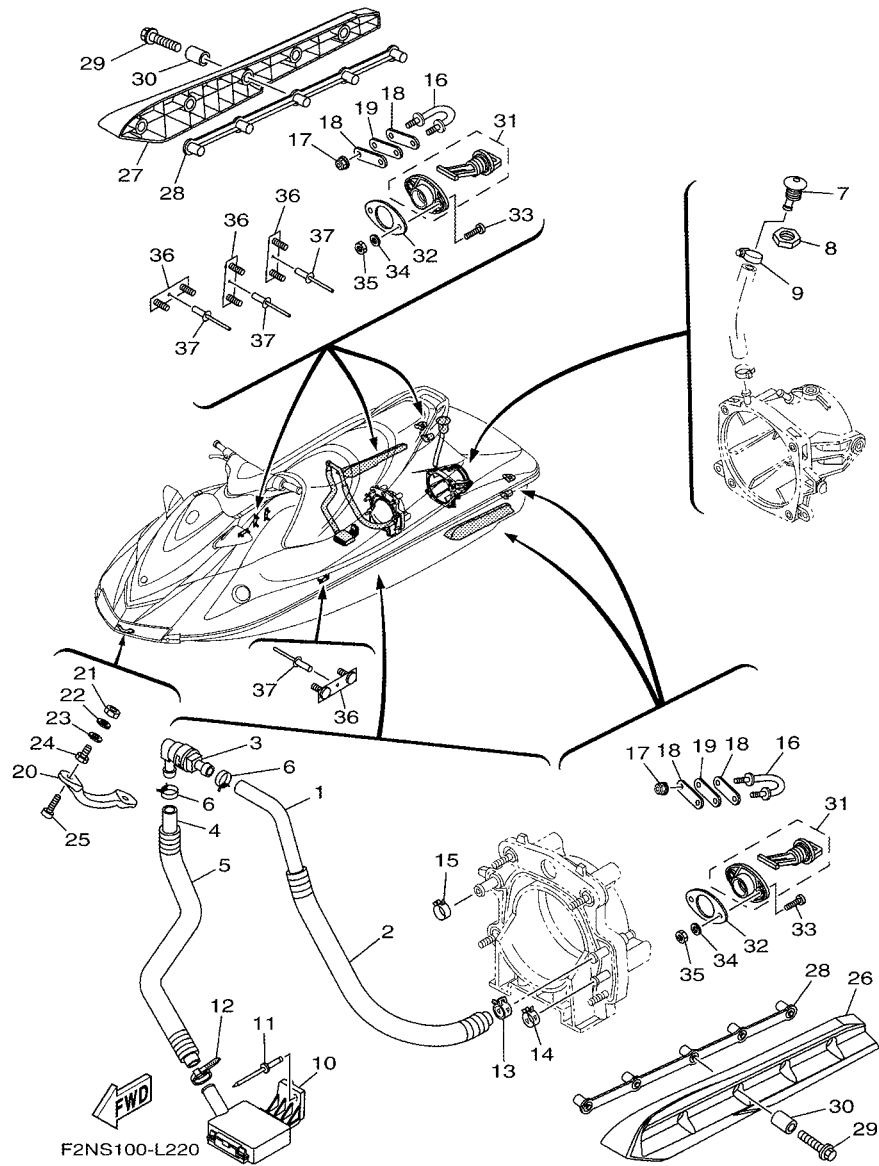
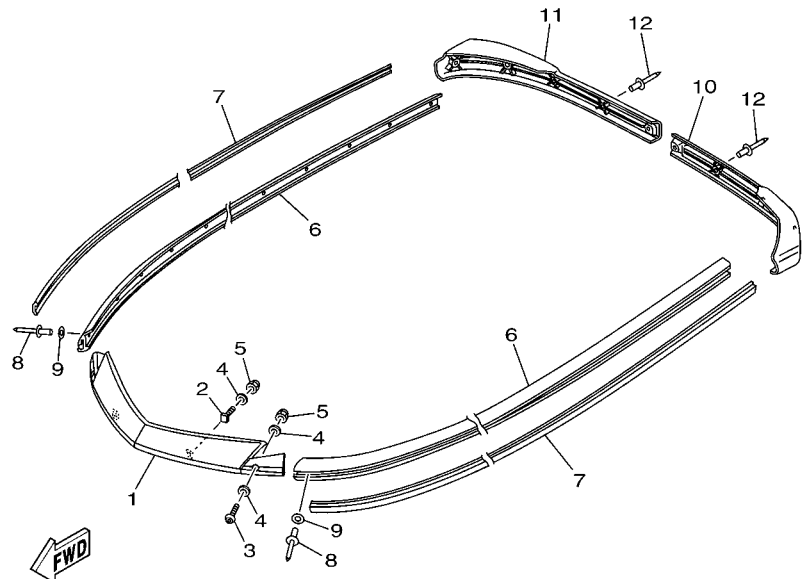
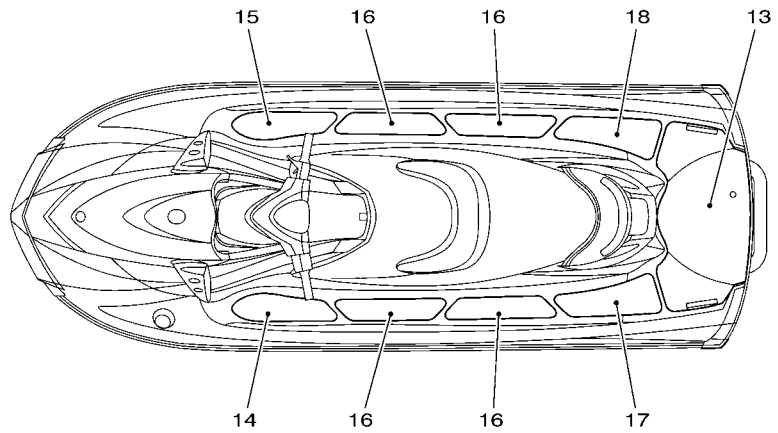

FIG. 22 HULL & DECK

REF. NO.	PART NO.	DESCRIPTION	CAN	EUR	GENE	REMARKS
1	90445-20804	HOSE (L860)	1	1	1	
2	90446-27M73	HOSE (L700)	1	1	1	
3	68N-5112T-00	JOINT, HOSE	1	1	1	
4	90445-20800	HOSE (L500)	1	1	1	
5	90446-27M55	TUBE (L400)	1	1	1	
6	90467-18804	CLIP	2	2	2	
7	F1W-U269B-00	SPOUT	1	1	1	
8	EU0-61652-00	NUT	1	1	1	
9	90601-118UF	BAND, HOSE 18	1	1	1	
10	F1B-U761D-02	STRAINER, BILGE	1	1	1	
11	90267-489U8	RIVET, BLIND	1	1	1	
12	90465-11829	CLAMP	1	1	1	
13	90467-21800	CLIP	1	1	1	
14	90467-200A0	CLIP	1	1	1	
15	90467-210A0	CLIP	1	1		FOR CAN, GENE
	90467-250A0	CLIP		1		FOR EUR
16	F2N-U1628-02	STERN EYE	2	2	2	
17	9572R-08300	NUT, FLANGE	4	4	4	
18	GP7-U4953-10	PLATE A	4	4	4	
19	F1B-U1653-02	PACKING	2	2	2	
20	F1K-61624-00	BOWEYE 1	1	1	1	
21	99780-12600	NUT.HEX.(COARS)	2	2	2	
22	92990-12200	WASHER, PLAIN	2	2	2	
23	F0X-61637-00	WASHER	2	2	2	
24	F0X-61652-00	NUT (BOLT/NUT)	2	2	2	
25	90110-06040	BOLT, HEXAGON SOCKET HEAD	2	2	2	
26	F2N-U883N-00	STABILIZER LH	1	1	1	



F2V1100-K170

FIG. 23 GUNWALE & MAT

REF. NO.	PART NO.	DESCRIPTION	CAN	EUR	GENE	REMARKS
1	F2N-U2511-02	GUNWALE, BOW	1	1	1	
2	F1W-U491K-00	BOLT, SPECIAL	2	2	2	
3	90111-06803	BOLT,HEX. SOCKET BUTTON	2	2	2	
4	9299R-06200	WASHER	6	6	6	
5	9572R-06300	NUT, NYLON	4	4	4	
6	F1K-U2512-03	GUNWALE, SIDE	2	2	2	GRAY
7	F1K-U2519-20	INNER,GUNWALE	2	2	2	YAMAHA BLACK
8	90267-489U8	RIVET, BLIND	30	30	30	
9	9299R-05200	WASHER	30	30	30	
10	F1K-U251D-01	GUNWALE, STERN 1	1	1	1	GRAY
11	F1K-U251E-01	GUNWALE, STERN 2	1	1	1	GRAY
12	90267-48963	RIVET, BLIND	9	9	9	
13	F2N-U3581-00	MAT, UPPER	1	1	1	DARK GREY
14	F2N-U351H-00	MAT, STEP 1	1	1	1	DARK GREY
15	F2N-U351J-00	MAT, STEP 2	1	1	1	DARK GREY
16	F2N-U351K-00	MAT, STEP 3	4	4	4	DARK GREY
17	F2N-U351M-00	MAT, STEP 4	1	1	1	DARK GREY
18	F2N-U351N-00	MAT, STEP 5	1	1	1	DARK GREY

FIG. 25 SEAT & UNDER LOCKER

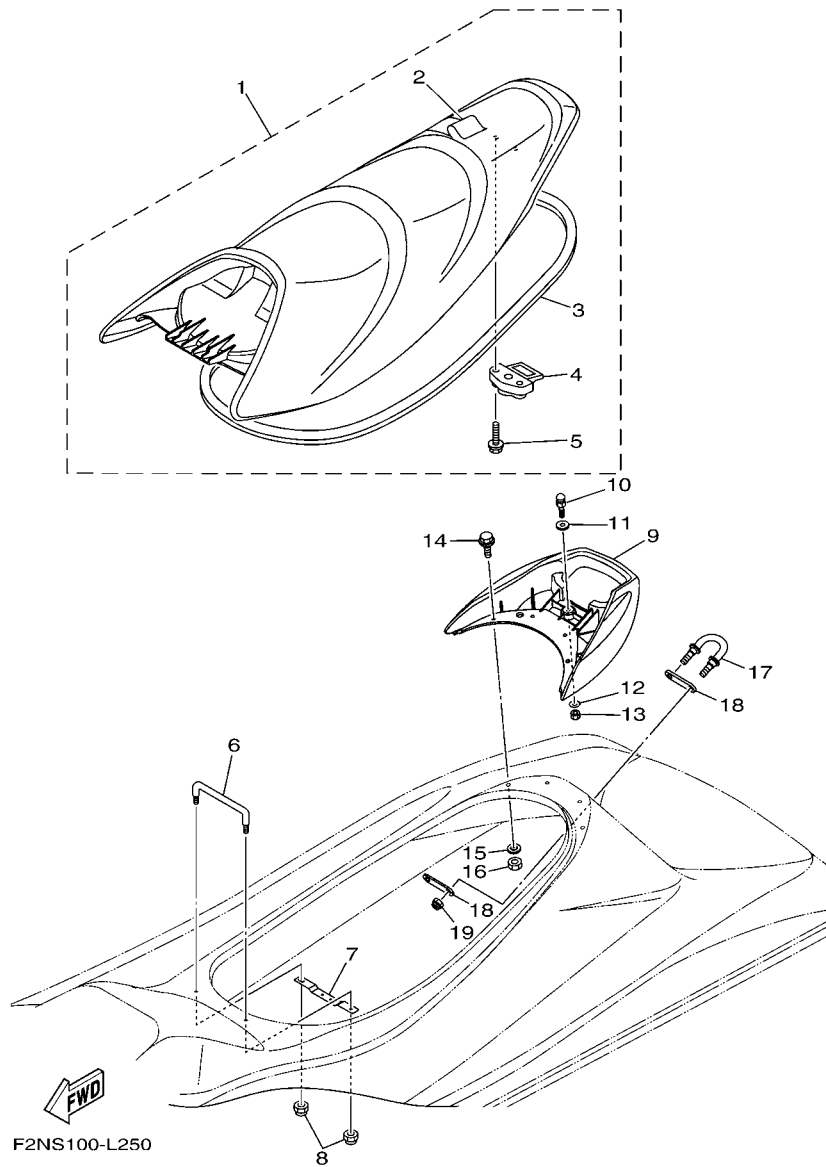

REF. NO.	PART NO.	DESCRIPTION	CAN	EUR	GENE	REMARKS
1	F2N-U371A-04	DOUBLE SEAT ASSY	1	1	1	
2	F2N-U371B-00	.COVER, SEAT 1	1	1	1	
3	F2N-U2664-00	.PACKING	1	1	1	
4	F2C-U3850-00	.SEAT LOCK ASSY	1	1	1	
5	90119-069UP	.BOLT, WITH WASHER	2	2	2	
6	F0X-6378C-00	STAY, SEAT 1	1	1	1	
7	F2N-U781E-00	BRACKET, FILTER	1	1	1	
8	9572R-08300	NUT, FLANGE	2	2	2	
9	F2N-U271B-01	GRIP, HAND	1	1	1	
10	GH1-U3774-00	PIN	1	1	1	
11	90201-109U6	WASHER, PLATE	1	1	1	
12	9299R-10200	WASHER	1	1	1	
13	9572R-10300	NUT, NYLON	1	1	1	
14	90119-089U2	BOLT, WITH WASHER	4	4	4	
15	9299R-08200	WASHER	4	4	4	
16	9572R-08300	NUT, FLANGE	4	4	4	
17	F2N-U1628-02	STERN EYE	1	1	1	
18	GP7-U4953-10	PLATE A	2	2	2	
19	9572R-08300	NUT, FLANGE	2	2	2	

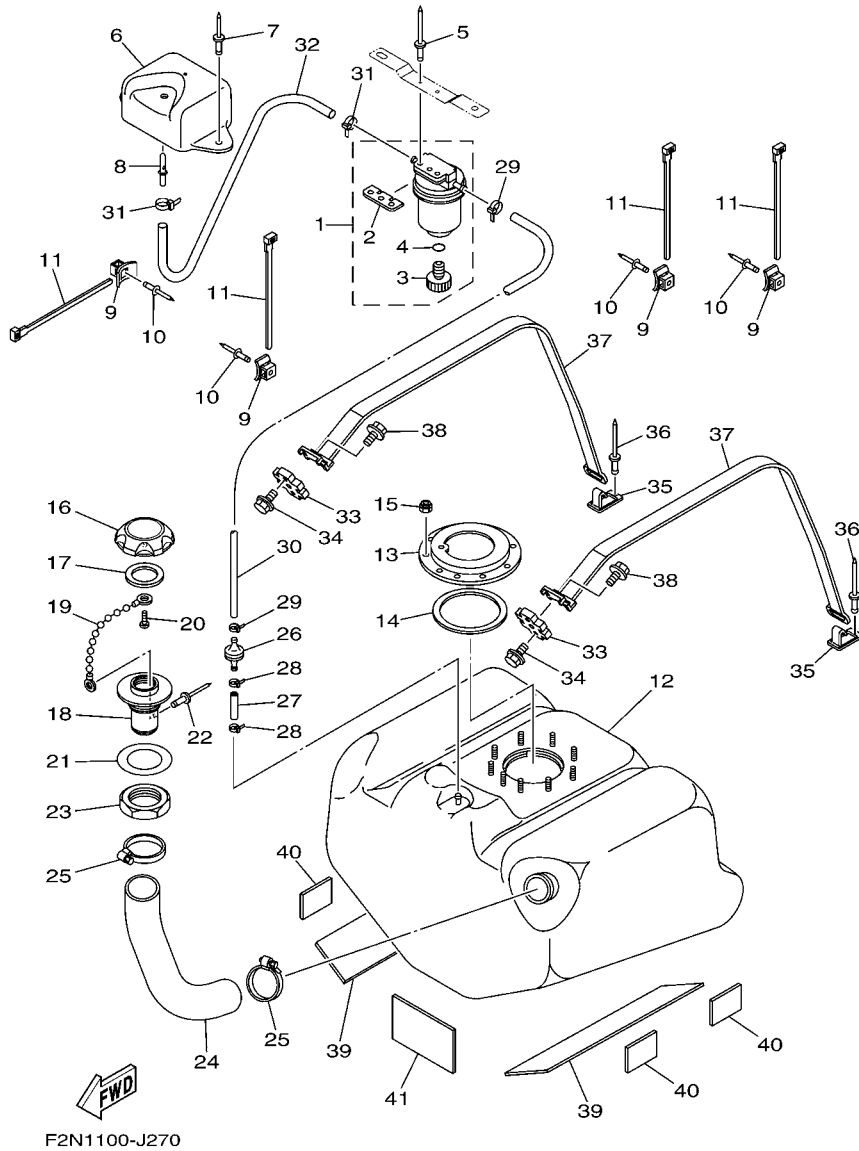
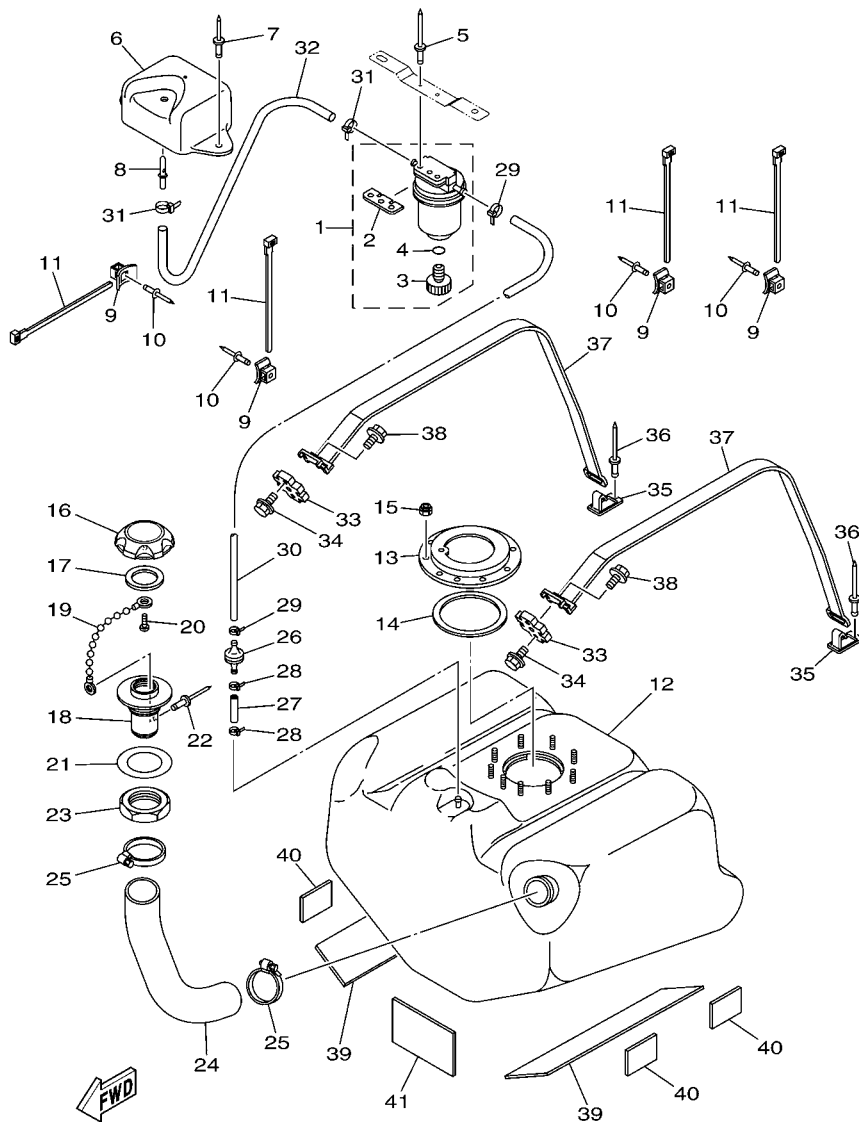

FIG. 26 FUEL TANK

REF. NO.	PART NO.	DESCRIPTION	CAN	EUR	GENE	REMARKS
1	F2F-6214A-00	FILTER, VENT ASSY	1	1	1	
2	EW2-62142-00	.PLATE, FILTER	1	1	1	
3	70R-24543-00	.PLUG, DRAIN	1	1	1	
4	70R-24489-00	.O-RING	1	1	1	
5	90267-489U1	RIVET,BLIND	2	2	2	
6	F1W-U2159-00	SOCKET, VENTILATION	1	1	1	
7	90267-489U6	RIVET, BLIND	2	2	2	
8	F1G-62149-00	PIPE, VENTILATION	1	1	1	
9	F1W-U828M-00	BASE, CLAMP	4	4	4	
10	90267-489U6	RIVET, BLIND	4	4	4	
11	90464-32801	CLAMP	4	4	4	
12	F1K-U7711-10	TANK, FUEL	1			FOR CAN
	F1K-U7711-02	TANK, FUEL		1	1	FOR EUR, GENE
13	F1B-U7773-00	RING	1	1	1	
14	F1B-67747-00	PACKING, SEAL	1	1	1	
15	9572R-06300	NUT, NYLON	9	9	9	
16	F2N-U7831-10	CAP, FUEL FILLER	1	1	1	BLACK
17	GP7-U7832-01	PACKING	1	1	1	
18	GP7-U7833-11	SOCKET	1	1	1	BLACK
19	GP7-U7835-00	CHAIN BALL	1	1	1	
20	90169-049U1	TAPPING SCREW	1	1	1	
21	GP7-U7834-00	PACKING FUEL FILLER	1	1	1	
22	90267-329UR	RIVET, BLIND	1	1	1	
23	GP7-U783F-00	NUT, FUEL FILLER	1	1	1	
24	F2N-U7844-00	HOSE	1	1	1	
25	90601-155U4	BAND, HOSE 55	2	2	2	
26	EU0-67767-31	CHECK VALVE	1	1	1	



F2N1100-J270

FIG. 26 FUEL TANK

REF. NO.	PART NO.	DESCRIPTION	CAN	EUR	GENE	REMARKS
27	GP7-U785H-00	HOSE, AIR VENT 3	1	1	1	
28	90465-11829	CLAMP	2	2	2	
29	90465-11829	CLAMP	2	2	2	
30	F1K-U785G-00	HOSE, AIR VENT	1	1	1	
31	90465-11829	CLAMP	2	2	2	
32	F0D-U7856-10	HOSE, AIR VENT 3	1	1	1	
33	F1X-U2873-00	NUT, SPECIAL	2	2	2	
34	90119-069UH	BOLT, WITH WASHER	4	4	4	
35	F1K-U5772-04	HOOK A	2	2	2	
36	90267-489U1	RIVET,BLIND	2	2	2	
37	F2N-67743-00	BELT, TANK 1	2	2	2	
38	90119-089U7	BOLT, WITH WASHER	2	2	2	
39	F1K-U759B-00	MAT 1	2	2	2	
40	F1W-U759C-01	MAT 2	4	4	4	
41	F1S-U8221-00	PAD, BATTERY	1	1	1	

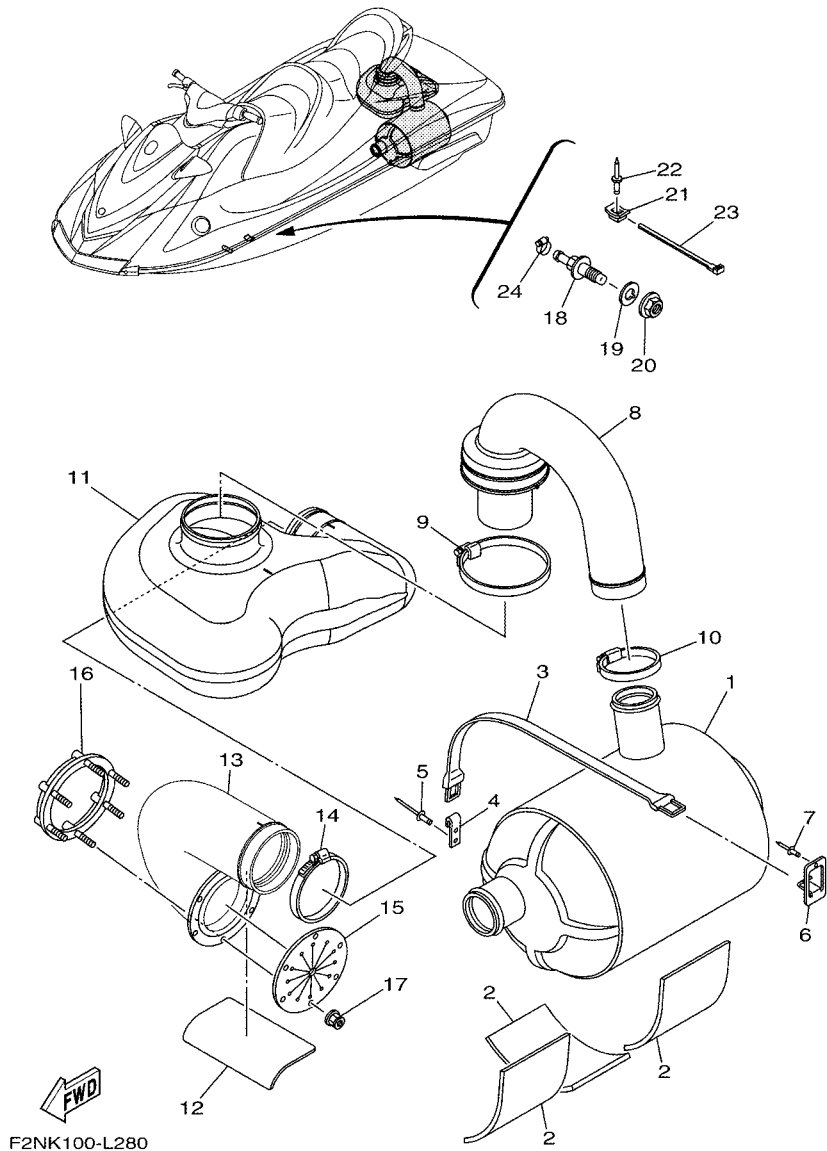
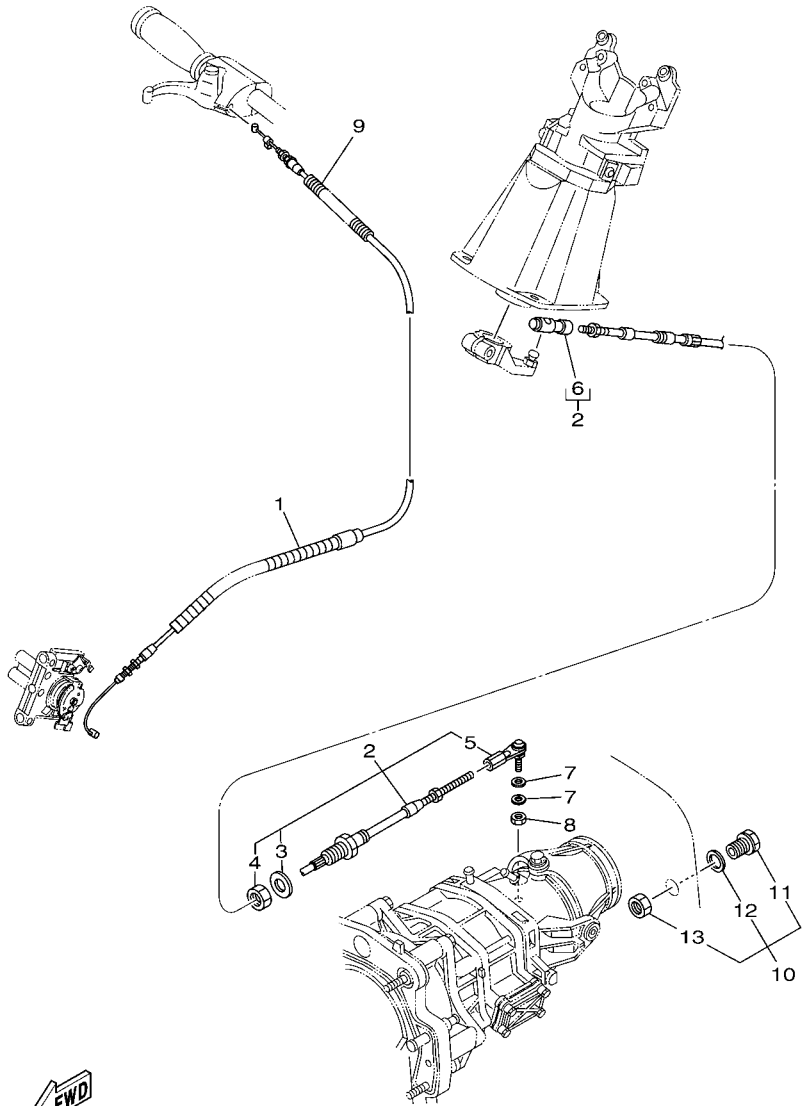

FIG. 27 EXHAUST 4

REF. NO.	PART NO.	DESCRIPTION	CAN	EUR	GENE	REMARKS
1	F1K-U7550-02	WATER LOCK COMP.	1	1	1	
2	F1S-U8221-00	PAD, BATTERY	3	3	3	
3	EW2-67821-00	BAND, FUEL TANK	1	1	1	
4	GA7-65772-00	HOOK A	1	1	1	
5	90267-489U1	RIVET,BLIND	2	2	2	
6	F1K-U5772-04	HOOK A	1	1	1	
7	90267-489U1	RIVET,BLIND	1	1	1	
8	F2N-U7555-00	HOSE, EXHAUST	1	1	1	
9	90601-179U8	BAND, HOSE 79	1	1	1	
10	90450-99804	HOSE CLAMP ASSY	1	1	1	
11	F2N-U4261-00	TANK, WATER	1	1	1	
12	F1S-U8221-00	PAD, BATTERY	1	1	1	
13	F2N-U758D-00	HOSE,EXHAUST 3	1	1	1	
14	90450-99801	HOSE CLAMP ASSY	1	1	1	
15	F1B-U751G-00	VALVE, EXHAUST	1	1	1	
16	F1S-U757B-01	PLATE	1	1	1	
17	F2N-U142L-00	NUT, LOCK	6	6	6	
18	F1K-6753B-00	PILOT, WATER	1	1	1	
19	F1B-67564-00	GASKET	1	1	1	
20	F0X-62733-00	NUT	1	1	1	
21	F1W-U828M-00	BASE, CLAMP	1	1	1	
22	90267-489U6	RIVET, BLIND	1	1	1	
23	90464-32801	CLAMP	1	1	1	
24	90467-17802	CLIP	1	1	1	



F2N7100-J280

FIG. 28 CONTROL CABLE

REF. NO.	PART NO.	DESCRIPTION	CAN	EUR	GENE	REMARKS
1	6BU-26311-00	CABLE, THROTTLE 1	1	1	1	
2	F2N-61481-00	CABLE, STEERING	1	1	1	
3	F1B-61438-00	.PACKING C	1	1	1	
4	F1B-6151S-00	.NUT	1	1	1	
5	F1B-61461-02	.STUD, JOINT BALL	1	1	1	
6	F2N-61460-00	.BALL JOINT ASSY	1	1	1	
7	90201-06906	WASHER, PLATE	2	2	2	
8	9538R-06700	NUT	1	1	1	
9	90447-06803	TUBE	1	1	1	
10	F1K-67267-00	CONNECTOR, CABLE	1	1	1	
11	F1K-61436-00	.BODY	1	1	1	
12	F1B-61438-00	.PACKING C	1	1	1	
13	F1B-6151S-00	.NUT	1	1	1	

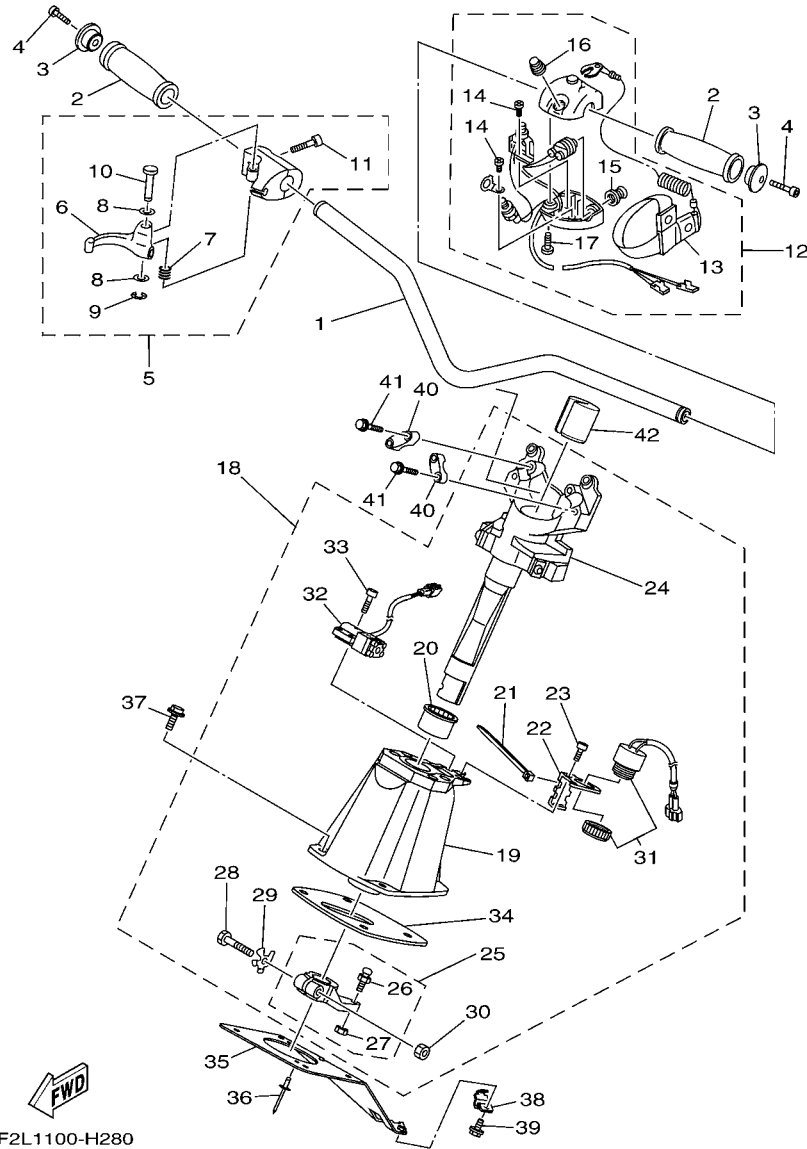

F2L1100-H280

FIG. 29 STEERING 1

REF. NO.	PART NO.	DESCRIPTION	CAN	EUR	GENE	REMARKS
1	F2N-U1552-00	HANDLE	1	1	1	
2	GP7-U155D-01	GRIP, HANDLE	2	2	2	
3	GP7-U155F-00	GRIP, END	2	2	2	
4	90110-05908	BOLT, HEXAGON SOCKET HEAD	2	2	2	
5	F0D-67250-10	THROTTLE LEVER ASSY	1	1	1	
6	F0D-67255-02	.LEVER, THROTTLE	1	1	1	
7	EW2-67256-00	.SPRING	1	1	1	
8	EW2-67258-01	.WASHER	2	2	2	
9	EW2-67259-01	.E-RING	1	1	1	
10	F0D-67257-00	.SHAFT	1	1	1	
11	F1X-6725F-01	.BOLT, THROTTLE	2	2	2	
12	FK7-68310-07	SWITCH BOX ASSY	1	1	1	
13	EW2-68348-00	.LANYARD, STOP SWITCH	1	1	1	
14	97880-03008	.SCREW, PAN HEAD	2	2	2	
15	FK7-68312-02	.STOP BUTTON COMP	1	1	1	
16	FK7-68313-02	.START BUTTON COMP.	1	1	1	
17	97880-05025	.SCREW, PAN HEAD	2	2	2	
18	F1K-61400-01	STEERING MASTER ASSY	1	1	1	
19	F1K-6152M-00	.HOUSING ASSY	1	1	1	
20	F1K-6134M-00	.BUSH	1	1	1	
21	703-82591-00	.BAND	2	2	2	
22	F1K-6146H-10	.SPACER, BRKT.	1	1	1	
23	F1B-613C1-00	.SCREW	2	2	2	
24	F1K-67410-00	.SHAFT ASSY	1	1	1	
25	F1K-6153R-00	.ARM ASSY.	1	1	1	
26	EU0-61461-02	..STUD, JOINT BALL	1	1	1	
27	95720-06300	..NUT, SELF-LOCKING	1	1	1	

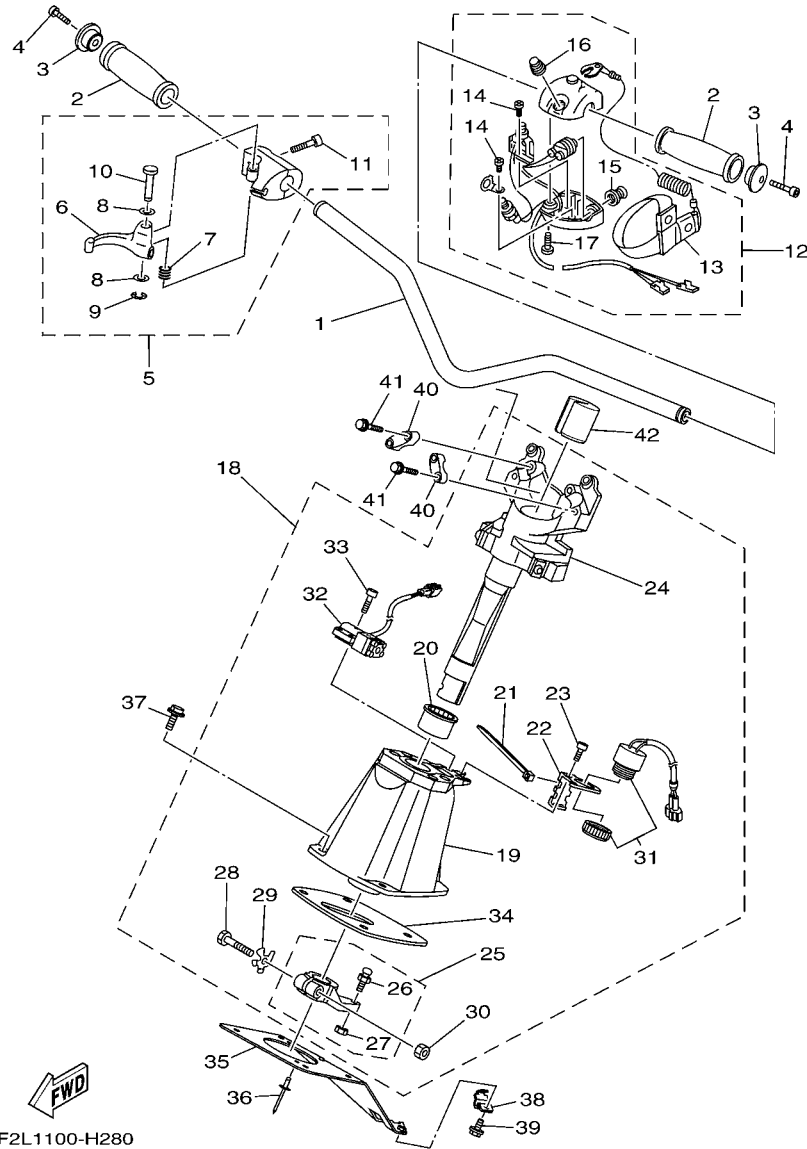

F2L1100-H280

FIG. 29 STEERING 1

REF. NO.	PART NO.	DESCRIPTION	CAN	EUR	GENE	REMARKS
28	F1K-61355-00	.BOLT	1	1	1	
29	F1K-6142B-00	.PLATE, RETAINING	1	1	1	
30	95720-08300	.NUT, SELF-LOCKING	1	1	1	
31	F1S-68341-00	.BUZZER	1	1	1	
32	F1W-68303-00	.SENSOR ASSY	1	1	1	
33	F1W-61516-00	.BOLT	4	4	4	
34	F1K-6143C-00	.SEAL, RUBBER	1	1	1	
35	F1K-U1467-01	BRACKET, STOPPER CABLE	1	1	1	
36	90267-489U2	RIVET, BLIND	2	2	2	
37	90119-08836	BOLT, WITH WASHER	4	4	4	
38	F1K-U1468-03	STOPPER, CABLE	1	1	1	
39	90119-069UH	BOLT, WITH WASHER	1	1	1	
40	EU0-23814-31	HOLDER, HANDLE UPPER	2	2	2	
41	90119-08827	BOLT, WITH WASHER	4	4	4	
42	F1K-U1949-00	PLUG	1	1	1	

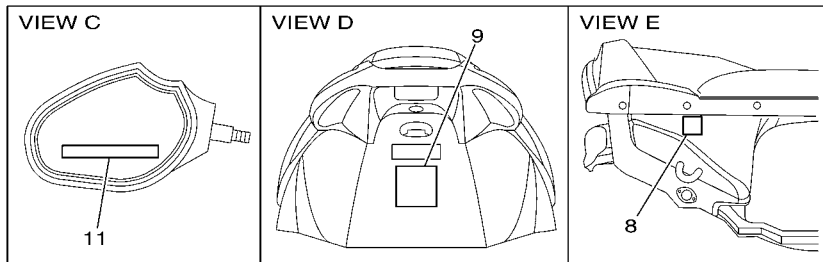
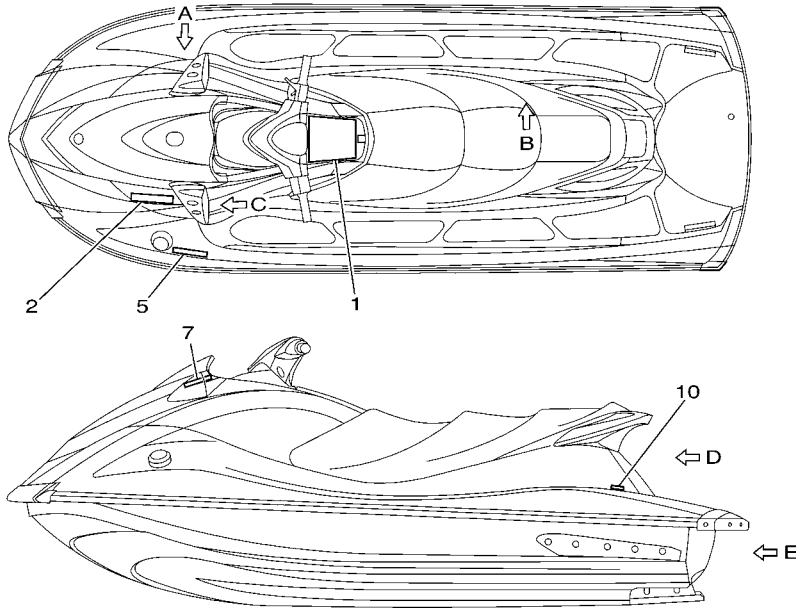
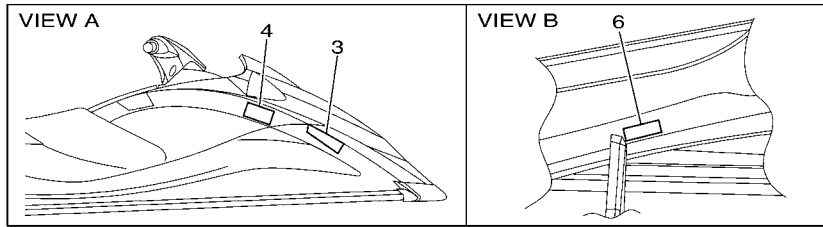

F2N7100-J320

FIG. 32 IMPORTANT LABELS

REF. NO.	PART NO.	DESCRIPTION	CAN	EUR	GENE	REMARKS
1	F2N-U41B1-10	LABEL, WARNING UNIFORM 1	1			
2	F1B-U41B1-21	LABEL, WARNING UNIFORM 1	1			
3	F0V-U41B1-31	LABEL, WARNING UNIFORM 1	1			
4	F1B-U41B2-01	LABEL, WARNING UNIFORM 2	1			
5	F1B-U415B-11	LABEL, WARNING(FUEL)	1			
6	F0V-U41DB-12	LABEL, WARNING BATTERY	1			
7	F1B-U41F5-21	LABEL, FIRE EXTINGUISHER 1	1			
8	F1G-U418F-00	LABEL, RIGHTING	1			
9	F0V-U41E1-41	LABEL, SET 1	1			
10	GJ3-U419E-00	LABEL 4	1			
11	GJ1-U419F-21	LABEL,5	2			

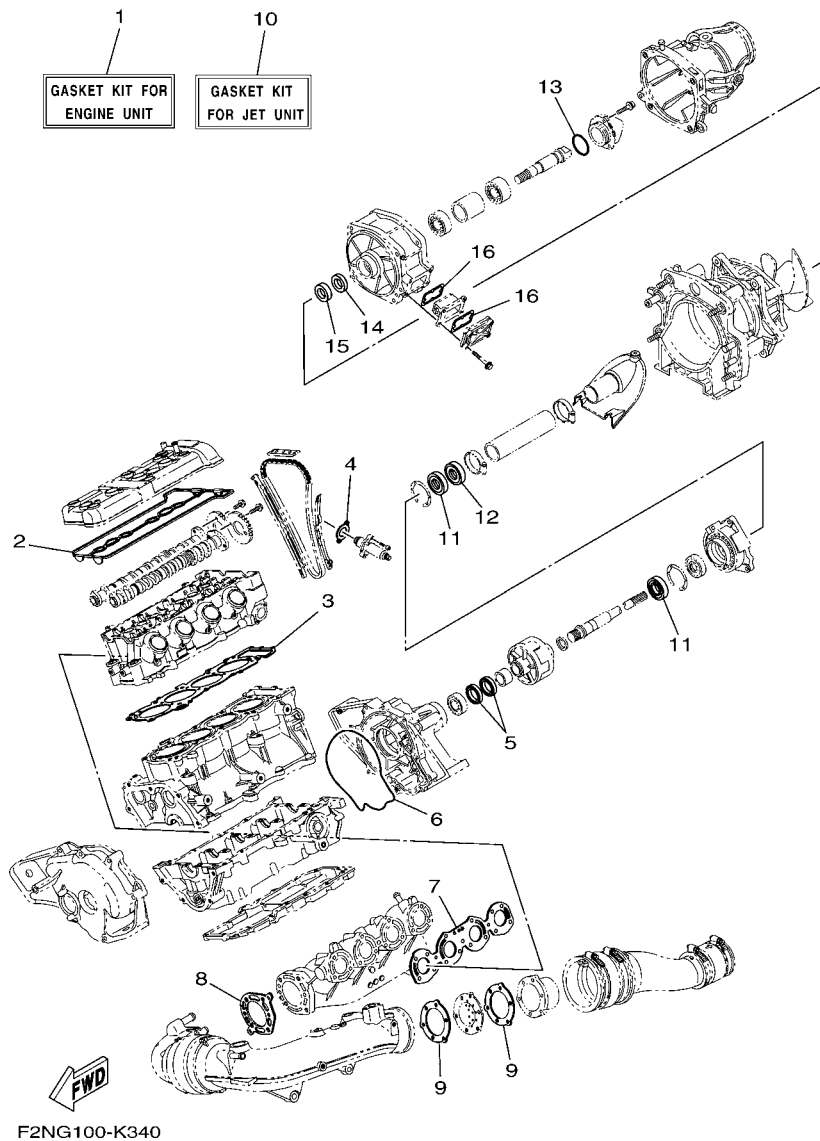

FIG. 34 REPAIR KIT 1

REF. NO.	PART NO.	DESCRIPTION	CAN	EUR	GENE	REMARKS
1	6D3-W0001-01	GASKET KIT FOR ENGINE UNIT	1	1	1	
2	60E-11193-01	.GASKET, HEAD COVER 1	1	1	1	
3	6D3-11181-00	.GASKET, CYLINDER HEAD 1	1	1	1	
4	4FM-12213-00	.GASKET, TENSIONER CASE	1	1	1	
5	93101-35004	.OIL SEAL	2	2	2	
6	6B6-13475-01	.GASKET	1	1	1	
7	6D3-14613-10	.GASKET, EXHAUST PIPE	1	1	1	
8	6D3-14739-10	.GASKET, MUFFLER DAMPER 1	1	1	1	
9	60E-14623-00	.GASKET, EXHAUST PIPE	2	2	2	
10	6BU-W0001-20	GASKET KIT FOR JET UNIT	1	1	1	
11	93101-25M55	.OIL SEAL	2	2	2	
12	93102-25009	.OIL SEAL	1	1	1	
13	93210-464A3	.O-RING	1	1	1	
14	93101-21002	.OIL SEAL	1	1	1	
15	93101-21001	.OIL SEAL	1	1	1	
16	66V-42414-00	.O-RING	2	2	2	

NUMERICAL INDEX

PART NO.	REF. NO.	PART NO.	REF. NO.	PART NO.	REF. NO.	PART NO.	REF. NO.	PART NO.	REF. NO.	PART NO.	REF. NO.
6D3-11102-00-94	1 - 2	3GM-12126-00	4 - 9	60E-12443-00	10 - 8	68V-13573-00	6 - 11	6D3-24387-00	18 - 5	EW2-62142-00	26 - 2
4KG-1111G-00	1 - 20	3FV-12153-10	4 - 20		11 - 8	6D3-13641-00	6 - 1	6D3-24481-00	18 - 4	F1G-62149-00	26 - 8
6D3-11125-00	7 - 30	3LN-12153-10	4 - 19	6D3-12446-00	10 - 34	6BU-13750-00	6 - 7	70R-24489-00	26 - 4	F2F-6214A-00	26 - 1
6D3-11126-00	7 - 25	1HX-12168-00	4 - 18		11 - 36	60E-13761-20	6 - 3	70R-24543-00	26 - 3	GJ3-6215F-00	18 - 14
3TJ-11133-10	1 - 3	1HX-12168-20	4 - 18	60E-1244E-00	16 - 42	6D3-13795-01	6 - 9	6BU-26311-00	28 - 1	F0X-62733-00	27 - 20
1WG-11133-11	1 - 4	1HX-12168-40	4 - 18	6BU-1244G-10	9 - 1	60E-13907-02	18 - 1	67F-2812A-00	16 - 26	GU2-62875-01	20 - 22
6D3-11164-00	7 - 21	1HX-12168-60	4 - 18	6D3-1244G-10	10 - 28	68V-1416A-00	6 - 4	66V-42414-00	12 - 10	F0X-6378C-00	25 - 6
6D3-11165-00	8 - 22	1HX-12168-80	4 - 18		11 - 28	6D3-14294-10	6 - 16		34 - 16	F1K-6517C-00	21 - 6
6D3-11166-00	7 - 32	1HX-12168-A0	4 - 18	6D3-1244H-10	10 - 21	6D3-14305-21	17 - 1	67X-44517-10-94	19 - 1	F0X-6517R-01	20 - 21
6D3-11167-00	8 - 32	1HX-12168-F0	4 - 18		11 - 21	6D3-14411-00	5 - 1	6D3-44574-00	19 - 2	GA7-65772-00	27 - 4
6D3-11181-00	1 - 21	1HX-12168-H1	4 - 18	60E-12474-00	1 - 30	6D3-14414-10	6 - 19	663-45119-00	13 - 4	EU0-65901-01	31 - 11
	34 - 3	1HX-12168-K1	4 - 18	6D3-12482-00	1 - 25	6D3-14419-01	5 - 8	61X-45332-03-94	13 - 2	F1B-65986-10	31 - 10
6D3-11191-10	1 - 17	1HX-12168-M1	4 - 18	60E-12483-10	1 - 29	6D3-14421-02	5 - 3	6BU-45511-00	13 - 6	F0D-67250-10	29 - 5
60E-11193-01	1 - 18	1HX-12168-R1	4 - 18	60E-12494-00	1 - 28	6D3-14437-00	5 - 7	6D3-45514-00	12 - 16	F0D-67255-02	29 - 6
	34 - 2	1HX-12168-U1	4 - 18	6B6-12499-00	11 - 42	63P-14446-00	6 - 13	65V-45538-00	12 - 14	EW2-67256-00	29 - 7
69J-11301-10	2 - 12	1HX-12168-W1	4 - 18	60E-12537-00	1 - 31	60E-14449-00-94	6 - 20	6D3-45593-00-94	13 - 11	F0D-67257-00	29 - 10
6E5-11325-00	8 - 12	1HX-12168-Y1	4 - 18	6D3-12577-10	10 - 25	6D3-14451-00	5 - 4	6D3-45813-00-94	3 - 12	EW2-67258-01	29 - 8
68V-11325-02	2 - 13	1HX-12169-11	4 - 18		11 - 25	4XV-14452-00	5 - 2	6D3-4581J-00	13 - 1	EW2-67259-01	29 - 9
67F-11328-00	2 - 14	1HX-12169-31	4 - 18	63M-12580-00	10 - 5	6D3-14457-00	6 - 8	6D3-51129-00	2 - 3	F1X-6725F-01	29 - 11
60E-11372-10	9 - 5	1HX-12169-50	4 - 18		11 - 5	68V-14475-00	6 - 12	68N-5112T-00	22 - 3	F1K-67267-00	28 - 10
60E-11411-11	3 - 1	1HX-12169-70	4 - 18	60E-12581-00	10 - 3	6D3-14495-00	5 - 13	66V-51312-01-94	12 - 5	F1K-67410-00	29 - 24
6D3-11416-00	3 - 2	1HX-12169-90	4 - 18		11 - 3	6D3-14613-10	9 - 3	6B6-51315-01-94	12 - 8	F1K-6753B-00	27 - 18
6D3-11416-10	3 - 2	1HX-12169-E0	4 - 18	60E-12584-00	10 - 15		34 - 7	6B6-51326-10-94	12 - 19	F1B-67564-00	27 - 19
6D3-11416-20	3 - 2	1HX-12169-G0	4 - 18		11 - 15	6D3-14615-00	9 - 14	F1K-6134M-00	29 - 20	F2N-67743-00	26 - 37
6D3-11416-30	3 - 2	1HX-12169-J0	4 - 18	6D3-12584-00	10 - 20	60E-14623-00	9 - 21	F1K-61355-00	29 - 28	F1B-67747-00	26 - 14
6D3-11416-A0	3 - 2	1HX-12169-L0	4 - 18		11 - 20		34 - 9	F1B-613C1-00	29 - 23	EU0-67767-31	26 - 26
6B6-11478-00	3 - 15	1HX-12169-N0	4 - 18	6BU-12880-10	6 - 2	6D3-14625-00	9 - 16	F1K-61400-01	29 - 18	EW2-67821-00	27 - 3
6D3-11603-00	3 - 4	1HX-12169-T0	4 - 18	6B6-1310A-01-94	2 - 18	6D3-1469W-10	9 - 23	F1K-6142B-00	29 - 29	F2N-67823-00	21 - 18
6D3-11631-01-B0	3 - 3	6D3-12171-11	4 - 1	6B6-13151-00-94	8 - 28	6D3-14711-10	9 - 4	F1K-61436-00	28 - 11	F2N-67823-10	20 - 18
6D3-11633-00	3 - 5	6D3-12176-00	4 - 3	60E-13161-00	2 - 20	6D3-14712-00-94	9 - 9	F1B-61438-00	28 - 3	F2N-6820A-10	18 - 16
6D3-11650-00	3 - 7	6D3-12181-00	4 - 2	6D3-13300-10	7 - 2	6D3-14721-10	9 - 18		28 - 12	GU2-6822E-01	18 - 18
5JW-11654-00	3 - 8	6D3-12210-00	4 - 23	6B6-13317-00	8 - 5	6D3-14739-10	9 - 10	F1K-6143C-00	29 - 34	60E-682E0-00	18 - 2
60E-11656-00	3 - 10	4FM-12213-00	4 - 24	6B6-13327-02-94	7 - 8		34 - 8	F2N-61460-00	28 - 6	F1W-68303-00	29 - 32
60E-11656-10	3 - 10		34 - 4	6B6-13360-00	7 - 1	6BU-14752-00-94	9 - 25	EU0-61461-02	29 - 26	FK7-68310-07	29 - 12
60E-11656-20	3 - 10	5BE-12241-00	4 - 22	6B6-13411-00	7 - 11	6BU-1475E-00	9 - 26	F1B-61461-02	28 - 5	FK7-68312-02	29 - 15
60E-11656-30	3 - 10	6D3-12251-00	4 - 26	60E-13421-00	8 - 7	6BU-1475F-00	9 - 27	F1K-6146H-10	29 - 22	FK7-68313-02	29 - 16
4XV-12111-00	4 - 5	4XV-12252-00	4 - 27	5GH-13440-20	2 - 25	60E-14784-00-94	9 - 22	F2N-61481-00	28 - 2	F1S-68341-00	29 - 31
4XV-12112-00	4 - 6	6D3-12411-00	11 - 33	6D3-13443-00-94	8 - 24	6BU-15100-00	2 - 1	F1W-61516-00	29 - 33	EW2-68348-00	29 - 13
4XV-12113-00	4 - 10	6BH-12413-00	11 - 34	60E-13446-00	8 - 1	60E-15362-00	8 - 20	F1B-6151S-00	28 - 4	6D3-81147-00	6 - 14
4XV-12114-00	4 - 11	60E-12417-10	11 - 32	6D3-13462-00-94	8 - 3	6D3-15515-00	14 - 1		28 - 13	60E-81315-00	17 - 21
1HX-12116-01	4 - 8	60E-12435-00	10 - 35	6D3-13463-00-94	8 - 14	60E-15517-00	14 - 2	F1K-6152M-00	29 - 19	60E-81328-00	14 - 18
1HX-12117-00	4 - 12		11 - 39	60E-13473-00	8 - 21	60E-15521-00	14 - 3	F1K-6153R-00	29 - 25	66V-8132W-00	16 - 24
1WG-12117-00	4 - 13	6BU-1243A-00	10 - 11	60E-13475-00	8 - 15	4WM-15590-00	14 - 4	F1K-61624-00	22 - 20	6BU-81336-00	16 - 34
1HX-12118-00	4 - 14		11 - 11	6B6-13475-01	7 - 13	6D3-17572-00	3 - 11	FOX-61637-00	22 - 23	6D3-81337-00-94	14 - 13
1WG-12118-00	4 - 15	6D3-1243E-10	10 - 16		34 - 6	6B6-17585-00	3 - 18	EU0-61652-00	10 - 10	6S5-81364-10	8 - 34
4SV-12119-00	4 - 17		11 - 16	60E-13476-10	8 - 25	6B6-17586-00	3 - 19		11 - 10	6D3-81410-01	14 - 7
4TV-12119-00	4 - 16	6BU-1243F-10	10 - 37	8FP-13556-10	6 - 5	EU0-23814-31	29 - 40		22 - 8	6D3-81450-00	14 - 6
5LV-12121-00	4 - 7		11 - 44	6B6-13563-01	7 - 3	6S5-24300-01	6 - 15	FOX-61652-00	22 - 24	6BU-81639-00	16 - 33

NUMERICAL INDEX

PART NO.	REF. NO.	PART NO.	REF. NO.	PART NO.	REF. NO.	PART NO.	REF. NO.	PART NO.	REF. NO.	PART NO.	REF. NO.
6D3-81800-00	15 - 1	61A-85790-00	17 - 11	F1K-U266B-00	21 - 5	F0V-U41E1-41	33 - 9	F1K-U757F-01	12 - 49	F1X-U883T-01	22 - 28
3AJ-81809-00	15 - 6	6D3-85896-00	17 - 18	F1K-U266C-00	20 - 14	F1B-U41F5-21	32 - 7	F2N-U758D-00	27 - 13	F1K-U892D-00	13 - 22
60E-81810-00	15 - 10	6BU-8591A-10	16 - 28	F2N-U266C-01	20 - 4		33 - 7	F1K-U759B-00	26 - 39	F1S-U8K31-02	18 - 21
6D3-81820-00	15 - 9	6BU-8591A-20	16 - 28	F1W-U269B-00	22 - 7	F2N-U4261-00	27 - 11	F1K-U759C-00	21 - 30	6D3-W0001-01	34 - 1
6M6-81826-00	15 - 4	67X-E2590-10	10 - 43	F2N-U271B-01	25 - 9	F2N-U471E-00	21 - 23	F1W-U759C-01	26 - 40	6BU-W0001-20	34 - 10
6M6-81830-00	15 - 2		11 - 50	F2N-U2723-00	20 - 1	F1K-U471E-03	21 - 13	F1B-U761D-02	22 - 10	6D3-W009A-11-94	1 - 1
6M6-81840-10	15 - 8	6AN-G5214-00-94	12 - 11	F2N-U273B-00	12 - 38	F2N-U471F-00	21 - 25	F1K-U7711-02	26 - 12	6BU-W009B-00-94	2 - 4
11H-81844-00	15 - 5	6D3-G5831-00	12 - 2	F1K-U283B-02	21 - 14	F2N-U475B-03	20 - 3	F1K-U7711-10	26 - 12	90101-069U0	12 - 52
66V-81844-00	16 - 25	6AN-G6882-00	12 - 9	F1X-U2873-00	26 - 33	F1W-U475F-01	20 - 10	F1B-U7773-00	26 - 13	90105-06026	1 - 9
6BU-81845-00	16 - 27	6BU-R1313-00-94	12 - 32	F2N-U351H-00	23 - 14	F1W-U491K-00	23 - 2	F2N-U781E-00	25 - 7	90105-06033	2 - 10
6D3-81845-00	14 - 21	6BU-R1318-00	12 - 24	F2N-U351J-00	23 - 15	GP7-U4953-10	22 - 18	F2N-U7831-10	26 - 16	90105-06035	8 - 17
1FK-81847-00	15 - 3	6D3-R1319-00	12 - 22	F2N-U351K-00	23 - 16		25 - 18	GP7-U7832-01	26 - 17		10 - 36
6M6-81850-00	15 - 7	6D3-R1321-02	12 - 23	F2N-U351M-00	23 - 17	F1K-U515A-00	21 - 8	GP7-U7833-11	26 - 18		11 - 35
6BU-81861-00	16 - 40	6D3-R1333-01-94	12 - 1	F2N-U351N-00	23 - 18	F2N-U516N-00-P7	20 - 12	GP7-U7834-00	26 - 21		11 - 40
6D3-81921-00	16 - 12	6D3-R1341-00	12 - 31	F2N-U3581-00	23 - 13	F2N-U516P-00	20 - 13	GP7-U7835-00	26 - 19	90105-06036	8 - 16
6B6-81940-00	16 - 22	60E-R1381-01	13 - 15	F2N-U371A-04	25 - 1	F2N-U517B-10-P4	21 - 1	GP7-U783F-00	26 - 23	90105-06054	11 - 41
60E-81950-00	16 - 20	F1K-U135C-01	21 - 11	F2N-U371B-00	25 - 2	F1K-U517D-05	21 - 10	F2N-U7844-00	26 - 24	90105-06790	9 - 24
68V-81950-00	16 - 21	F1K-U142D-00	30 - 4	GH1-U3774-00	25 - 10	F1X-U517E-01	21 - 20	F0D-U7856-10	26 - 32	90105-06826	21 - 15
6S8-81960-00	16 - 37	F2N-U142L-00	20 - 19	F2C-U3850-00	25 - 4	F2N-U517F-00	21 - 19	F1K-U785G-00	26 - 30	90105-06M07	2 - 15
EU0-82110-09	18 - 6		27 - 17	F2N-U411C-00	31 - 7	F2N-U517H-01	20 - 20	F0D-U785G-10	18 - 12		8 - 26
6BU-82115-00	16 - 13	F1K-U143D-01	30 - 2	F1B-U411C-02	31 - 8	F1K-U517R-00	21 - 12	GP7-U785H-00	26 - 27	90105-06M17	2 - 11
6BU-82116-00	18 - 36	F1K-U143E-01	30 - 3	F1K-U411H-00	31 - 9	F1K-U518E-04	21 - 9	F2N-U815D-01	16 - 7	90105-07004	4 - 4
6D3-82117-00	16 - 14	F1K-U1467-01	29 - 35	F1X-U413P-02	33 - 12	F2N-U519D-00	20 - 23	F2N-U8169-00	22 - 30	90105-08860	22 - 29
67F-82151-00	16 - 15	F1K-U1468-03	29 - 38	F1B-U415B-11	32 - 5	F1K-U5772-04	18 - 9	F1K-U8211-01	18 - 8	90105-093A5	2 - 6
67F-82151-10	16 - 16	F2C-U151S-00	18 - 22		33 - 5		21 - 28	F1K-U821D-01	18 - 11	90105-105A6	14 - 10
67F-82151-30	16 - 17	F2N-U1552-00	29 - 1	GJ3-U416H-01	33 - 11		26 - 35	F1K-U8221-00	18 - 7	90109-06051	2 - 9
67F-82151-40	16 - 18	GP7-U155D-01	29 - 2	F2N-U417D-D0	31 - 1		27 - 6	F1S-U8221-00	26 - 41	90109-066F0	1 - 19
	16 - 19	GP7-U155F-00	29 - 3	F2N-U417E-D0	31 - 2	F2N-U596B-00	21 - 22		27 - 2	90109-06832	13 - 19
6BU-82170-00	16 - 11	F1K-U156E-01	30 - 1	F2N-U417F-D0	31 - 3	F2N-U596C-00	21 - 24		27 - 12	90109-06M92	19 - 3
6D3-82310-01	17 - 6	F2N-U1628-02	22 - 16	F2N-U417G-D0	31 - 4	F1K-U5983-01	21 - 31	F1K-U826C-03	22 - 36	90109-08041	12 - 45
6A0-82317-00	7 - 22		25 - 17	F2N-U417H-D0	31 - 5	F2N-U721B-00	19 - 7	F1S-U828H-01	16 - 2	90110-05908	29 - 4
	16 - 31	F1B-U1653-02	22 - 19	F2N-U417J-D0	31 - 6	GD0-U7249-00-05	13 - 17	F1K-U828K-00	21 - 32	90110-06040	22 - 25
68V-82504-00	17 - 20	F1K-U1949-00	29 - 42	F1G-U418F-00	32 - 8	F1W-U7254-00	17 - 4	F1W-U828M-00	16 - 3	90110-06822	12 - 21
60E-82532-00	17 - 22	F2N-U2127-00	24 - 1		33 - 8	F1S-U725E-01	12 - 35		18 - 24	90110-08041	7 - 6
60E-82556-00	18 - 3	F2N-U213B-00	21 - 2	GJ3-U419E-00	32 - 10	F2N-U732B-01	19 - 9		18 - 27	90110-08212	14 - 5
6D3-82560-01	17 - 16	F2N-U213G-01	24 - 2	GJ1-U419F-21	32 - 11	F2N-U732B-10	19 - 8		18 - 30	90111-05008	18 - 17
60E-82560-A1	17 - 13	F1W-U2159-00	26 - 6		33 - 10	EU0-U7354-00-01	19 - 6		18 - 33	90111-06803	23 - 3
703-82591-00	29 - 21	F2N-U2187-00	24 - 6	F2N-U41B1-10	32 - 1	EU0-U7354-00-03	19 - 6		20 - 6	90116-10016	8 - 30
60E-8259E-00	16 - 23	F2N-U2188-00	24 - 7		33 - 1	EU0-U7354-00-05	19 - 6		24 - 3	90116-10058	2 - 5
6BU-8259L-20	17 - 9	F1S-U2280-01	22 - 31	F1B-U41B1-21	32 - 2	EU0-U7354-00-10	19 - 6		26 - 9	90119-059U4	21 - 7
6D3-8273J-01	17 - 23	F1S-U2285-00	22 - 32		33 - 2	EU0-U7354-00-20	19 - 6		27 - 21	90119-06048	17 - 25
60E-83627-00	8 - 27	F2N-U2511-02	23 - 1	F0V-U41B1-31	32 - 3	F1B-U751G-00	27 - 15	F2N-U8572-00	5 - 14	90119-06880	12 - 51
68F-83688-10	6 - 6	F1K-U2512-03	23 - 6		33 - 3	F1K-U7550-02	27 - 1	F1G-U8572-02	12 - 40		20 - 16
682-84385-01	10 - 9	F1K-U2519-20	23 - 7	F1B-U41B2-01	32 - 4	F2N-U7555-00	27 - 8	F1K-U8577-01	12 - 41		21 - 21
	11 - 9	F1K-U251D-01	23 - 10		33 - 4	F1K-U7557-01	12 - 4	F2N-U883B-00	13 - 21	90119-06882	20 - 17
6D3-85132-00	1 - 23	F1K-U251E-01	23 - 11	F0V-U41DB-12	32 - 6	GJ1-U7578-21	18 - 20	F2N-U883E-00	13 - 18	90119-06891	13 - 13
6AA-85542-00	8 - 19	F2N-U2663-01	21 - 4		33 - 6	F1S-U757B-01	27 - 16	F2N-U883N-00	22 - 26		19 - 11
6BU-85542-00	8 - 9	F2N-U2664-00	25 - 3	F0V-U41E1-41	32 - 9	F1K-U757E-01	12 - 48	F2N-U883P-00	22 - 27	90119-06893	12 - 6

NUMERICAL INDEX

PART NO.	REF. NO.	PART NO.	REF. NO.	PART NO.	REF. NO.	PART NO.	REF. NO.	PART NO.	REF. NO.	PART NO.	REF. NO.
90119-06895	12 - 42	90176-06047	16 - 45	90340-27001	1 - 7	90450-99004	9 - 28	90467-160A0	11 - 22	91317-06014	8 - 8
90119-06897	12 - 12	90176-10001	1 - 16	90387-06080	12 - 50		9 - 30		11 - 24		14 - 19
90119-069UH	26 - 34		8 - 31	90387-06083	11 - 43	90450-99005	9 - 15		11 - 29	91317-06016	1 - 27
	29 - 39	90179-08327	3 - 9	90387-06119	7 - 23	90450-99801	27 - 14	90467-170A4	7 - 26		1 - 33
90119-069UP	25 - 5	90179-10006	1 - 14		16 - 32	90450-99804	27 - 10		7 - 27		7 - 12
90119-06M65	7 - 24	90179-10414	1 - 15	90387-06M05	8 - 10	90464-12089	5 - 10		7 - 33	91317-06035	14 - 8
90119-08031	9 - 13	90183-06902	20 - 15		8 - 18	90464-18006	7 - 29		8 - 33	91380-06016	17 - 19
90119-08034	7 - 15	90201-06906	28 - 7		8 - 35	90464-21001	7 - 28		10 - 26	91380-06020	8 - 36
90119-08036	9 - 7	90201-096J9	2 - 7	90387-06M60	13 - 14		7 - 34		11 - 26	91380-06025	4 - 25
	9 - 12	90201-099U3	16 - 8	90387-08M06	12 - 34	90464-31001	10 - 41	90467-17802	27 - 24	91808-16023	1 - 8
90119-08043	7 - 16	90201-10013	1 - 12	90401-20007	2 - 26		11 - 48	90467-18804	22 - 6	92014-06012	16 - 44
90119-08045	7 - 14	90201-10019	1 - 13	90430-06014	1 - 11		16 - 41	90467-200A0	22 - 14	92990-06100	15 - 12
90119-08050	6 - 21	90201-103U7	14 - 11	90430-06M03	2 - 16	90464-32801	16 - 5	90467-200A3	10 - 4	92990-10600	17 - 12
90119-08074	6 - 22	90201-10801	12 - 36	90430-12002	12 - 47		18 - 19		10 - 13	92990-12200	12 - 46
90119-08075	9 - 8	90201-109U6	25 - 11	90445-14807	12 - 27		18 - 26		10 - 14		22 - 22
90119-08085	7 - 7	90201-24800	13 - 12	90445-16006	12 - 25		18 - 28		10 - 18	9299R-05200	22 - 34
90119-08800	12 - 54	90209-25008	3 - 20	90445-18M03	10 - 23		18 - 32		10 - 19		23 - 9
90119-08823	19 - 5	90267-329UR	26 - 22		11 - 23		20 - 8		10 - 27	9299R-06200	21 - 17
90119-08827	29 - 41	90267-48802	16 - 4	90445-20800	22 - 4		26 - 11		10 - 39		23 - 4
90119-08829	12 - 39	90267-48803	20 - 7	90445-20804	22 - 1		27 - 23		10 - 40	9299R-08200	16 - 10
90119-08836	29 - 37	90267-48806	24 - 8	90445-21805	10 - 1	90464-35132	10 - 33		11 - 4		21 - 26
90119-08840	12 - 33	90267-48963	23 - 12		11 - 1		10 - 42		11 - 13		25 - 15
90119-08859	19 - 4	90267-489U1	10 - 44	90445-22007	10 - 31		11 - 49		11 - 14	9299R-10200	25 - 12
90119-089U2	25 - 14		11 - 51	90445-25006	11 - 37		17 - 5		11 - 18	93101-21001	12 - 17
90119-089U7	16 - 1		17 - 3	90445-26004	11 - 30	90464-38800	5 - 16		11 - 19		34 - 15
	26 - 38		18 - 10	90446-14M23	17 - 15	90464-40825	5 - 17		11 - 27	93101-21002	12 - 18
90119-089UL	13 - 16		21 - 29	90446-20MF5	12 - 28	90464-45002	17 - 27		11 - 46		34 - 14
90119-08M22	5 - 11		22 - 37	90446-27M55	22 - 5	90464-99804	24 - 5		11 - 47	93101-25M55	13 - 7
90119-10013	9 - 20		26 - 5	90446-27M73	22 - 2	90465-11829	12 - 29	90467-210A0	10 - 30		34 - 11
90119-10016	14 - 14		26 - 36	90447-06803	28 - 9		18 - 15		22 - 15	93101-35004	3 - 13
90119-10017	9 - 19		27 - 5	90447-19801	10 - 7		22 - 12	90467-21800	22 - 13		34 - 5
90119-10020	8 - 4		27 - 7		11 - 7		26 - 28	90467-240A0	11 - 31	93102-25009	13 - 10
90119-10806	12 - 30	90267-489U2	19 - 10	90447-22001	10 - 17		26 - 29	90467-250A0	22 - 15		34 - 12
90119-10809	12 - 43		29 - 36		11 - 17		26 - 31	90468-12069	3 - 6	93210-06667	2 - 21
90119-10810	12 - 4	90267-489U6	18 - 25	90447-22003	10 - 12	90465-13152	17 - 28	90480-22M15	5 - 9	93210-08001	2 - 24
90119-10M02	8 - 29		18 - 29		11 - 12	90465-13M18	16 - 46		5 - 12	93210-18322	8 - 2
90119-10M19	14 - 15		18 - 31	90447-22004	10 - 2		17 - 26	90480-279U1	16 - 6	93210-18417	1 - 26
90149-05903	21 - 3		18 - 34		11 - 2	90465-13M24	16 - 43	90601-118UF	12 - 26		1 - 32
	30 - 6		24 - 4	90447-22005	10 - 38		17 - 10		22 - 9	93210-464A3	12 - 20
90150-05807	18 - 23		26 - 7		11 - 45	90465-13M39	8 - 37	90601-155U4	13 - 20		34 - 13
90154-06017	30 - 5		26 - 10	90447-25002	10 - 32	90467-089U1	18 - 13		26 - 25	93210-60ME8	17 - 24
90159-05013	5 - 5		27 - 22	90447-28010	11 - 38	90467-110A1	7 - 31	90601-175UR	5 - 15	93212-04001	14 - 17
90159-05014	5 - 6	90267-489U8	22 - 11	90450-17M17	6 - 17	90467-150A5	10 - 6	90601-179U8	27 - 9	93306-07801	3 - 14
90167-04003	30 - 7		23 - 8		6 - 18		11 - 6	90601-200U2	18 - 35	93306-205A3	13 - 9
90169-049U1	26 - 20	90269-08801	20 - 2	90450-57006	6 - 10	90467-160A0	9 - 2	90605-502U1	20 - 5	93306-205U0	12 - 15
90176-06047	16 - 30		20 - 9	90450-90001	9 - 17		10 - 22	91317-05010	14 - 20	93306-27211	12 - 13
	16 - 36		20 - 11	90450-94001	9 - 29		10 - 24	91317-05014	8 - 6	93306-30441	7 - 9
	16 - 39	90280-03047	14 - 12		9 - 31		10 - 29	91317-05016	8 - 23	93306-30610	3 - 16

NUMERICAL INDEX

PART NO.	REF. NO.	PART NO.	REF. NO.	PART NO.	REF. NO.	PART NO.	REF. NO.	PART NO.	REF. NO.	PART NO.	REF. NO.
93430-47M04	13 - 8	97595-06416	17 - 14								
93440-07149	1 - 5		17 - 17								
93440-10153	1 - 6	97595-06520	8 - 11								
93440-28062	3 - 21	97595-08540	2 - 17								
93603-12221	7 - 4	97880-03008	29 - 14								
93606-12019	9 - 11	97880-05025	29 - 17								
	12 - 7	9788R-05025	22 - 33								
	13 - 5	98780-04015	8 - 13								
93606-25M00	7 - 20	99009-52500	7 - 10								
93607-44002	4 - 28	99009-72500	3 - 17								
93608-16M16	7 - 19	99530-08012	2 - 23								
	9 - 6	99530-10014	2 - 2								
	14 - 16		2 - 8								
93700-06M03	13 - 3	99590-14016	12 - 3								
94591-49130	4 - 21	99780-12600	22 - 21								
94702-00409	17 - 8										
95023-06012	1 - 10										
95027-06010	2 - 22										
95380-06700	15 - 13										
9538R-06700	28 - 8										
95720-06300	29 - 27										
95720-08300	29 - 30										
9572R-05300	22 - 35										
9572R-06300	12 - 53										
	21 - 16										
	23 - 5										
	26 - 15										
9572R-08300	16 - 9										
	21 - 27										
	22 - 17										
	25 - 8										
	25 - 16										
	25 - 19										
9572R-10300	12 - 37										
	25 - 13										
95780-08300	17 - 2										
95814-06020	16 - 35										
	16 - 38										
95814-06025	16 - 29										
95880-06016	17 - 7										
97513-05514	14 - 9										
97513-06520	2 - 19										
97513-06525	7 - 5										
97513-06535	7 - 18										
97513-06555	1 - 22										
	7 - 17										
97513-08520	1 - 24										
97513-08530	15 - 11										