

# PARTS CATALOGUE

## *WaveRunner VX700* **VX700-K** (F2V1/6CPA/6CP1)

---



1KF2V-100E1

( )

VX700-K  
PARTS CATALOGUE  
©2010 by Yamaha Motor Co., Ltd.  
1st edition, August 2010  
All rights reserved.  
Any reprinting or unauthorized use  
without the written permission of  
Yamaha Motor Co., Ltd.  
is expressly prohibited.  
Printed in Japan.

# FOREWORD

This Parts Catalogue is related to the parts for the model(s) on the cover page. When you are ordering replacement parts, please refer to this Parts Catalogue and quote both part numbers and part names correctly.

1. Modifications or additions which have been made after the issue of the Parts Catalogue will be announced in the Parts News.

It is advisable that you make the necessary corrections to the Parts Catalogue according to the Parts News.

2. Abbreviations

The following abbreviations are used in this Parts Catalogue.

“UR” Use specified parts number.

“UN” Use as many as needed.

“AP” Alternate Parts

“LM” Locally Made (Parts need to be ordered locally)

“F#” Frame No. (Applicable machine No.)

“O/S” Over Size

3. The number of components for assembly

- Parts, which are to be supplied in an assembly, are listed with a dot (.) in front of the part name as shown below.
- The numeral appearing to the right of each component part indicates the quantity of parts for each assembly unit.

PART NO.	DESCRIPTION	Q'TY	REMARKS
2F5-83310-60	FRONT FLASHER LIGHT ASSY	2	
115-83311-60	.BULB (6V-18W)	1	

4. Applicable colours of graphics are represented in the “REMARKS” as shown below.

PART NO.	DESCRIPTION	Q'TY	REMARKS
2N4-24110-00-X5	FUEL TANK COMP.	2	MXR
3J1-24240-10	.GRAPHIC, FUEL TANK	1	FOR MXR

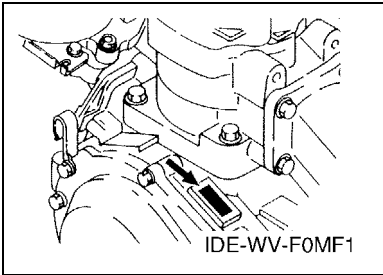
5. Note that the illustrations for reference in finding parts numbers are not to be used for assembling. When assembling, please use the applicable service manual.

6. The asterisk (\*) before a reference number indicates modified items after the first edition.

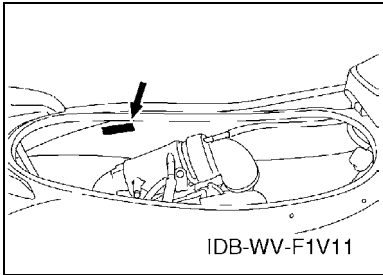
# FOREWORD

7. Applicable Serial No.

Engine Serial No.



Primary Identification No.



8. Applicable Colour Code (The (\*) mark shows Model colour.)

Abbreviation	Colour Name	Colour Code
NMC(*)	GRAY METALLIC C	008S
PURW(*)	PURE WHITE	0240
SS4(*)	BLACK SOLID 4	008P
RYM4	REDDISH YELLOW METALLIC 4	1190

9. Quantity Column Information

Column No.	Name Of Q'ty Column	Destination
1	OTH	OTHERS

10. Applicable Starting Serial No.

Engine Serial No.

Serial No.	Name Of Q'ty Column	Model Code
6CP-1000001	OTH	6CPA

Primary Identification No.

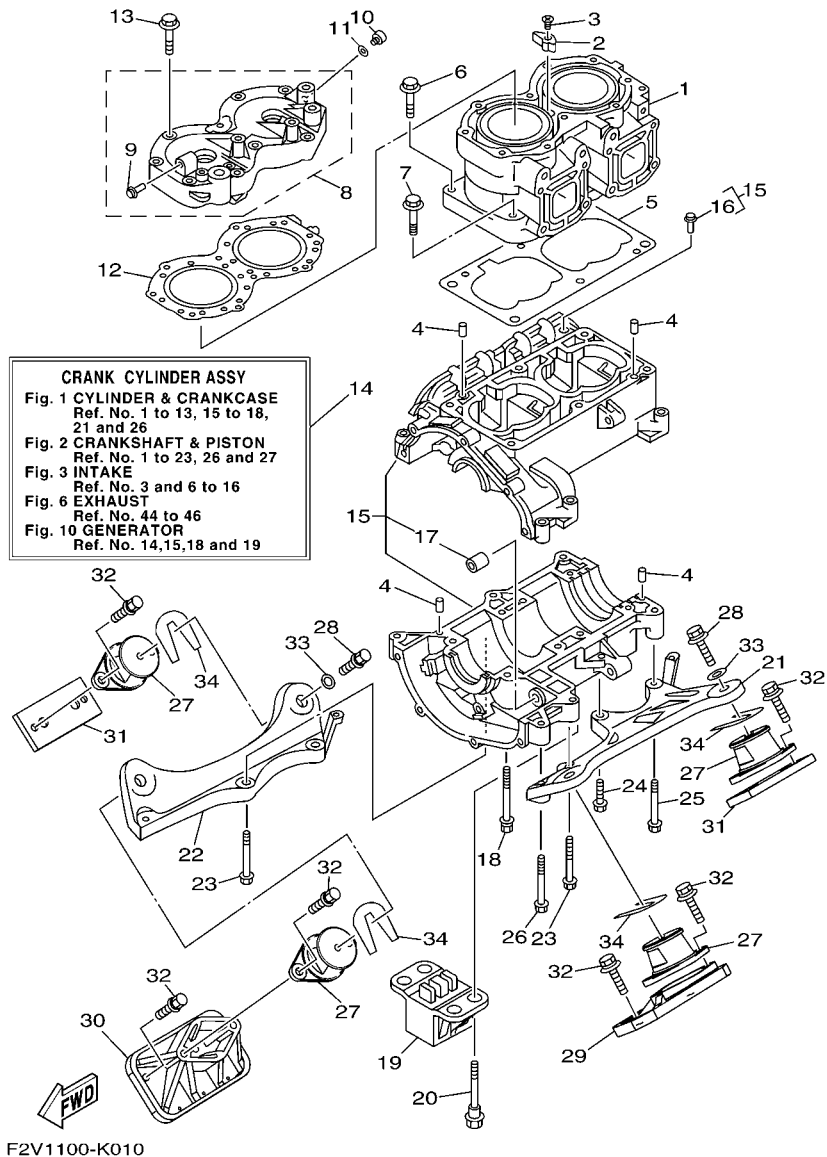
Serial No.	Name Of Q'ty Column	Model Code
F2V-800101	OTH	F2V1

# CONTENTS

CYLINDER & CRANKCASE .....	1
CRANKSHAFT & PISTON .....	3
INTAKE .....	5
CARBURETOR .....	7
OIL PUMP .....	9
EXHAUST 1 .....	10
FUEL .....	13
JET UNIT 1 .....	14
JET UNIT 2 .....	17
GENERATOR .....	18
STARTING MOTOR .....	19
ELECTRICAL 1 .....	20
ELECTRICAL 2 .....	22
ENGINE HATCH 1 .....	24
ENGINE HATCH 2 .....	25
HULL & DECK .....	27
GUNWALE & MAT .....	29
VENTILATION .....	30
SEAT & UNDER LOCKER .....	31
OIL TANK .....	32
FUEL TANK .....	33
EXHAUST 2 .....	35
CONTROL CABLE .....	36
STEERING 1 .....	37
STEERING 2 .....	39
GRAPHICS .....	40
IMPORTANT LABELS .....	41
REPAIR KIT 1 .....	42
REPAIR KIT 2 .....	43

## INDEX

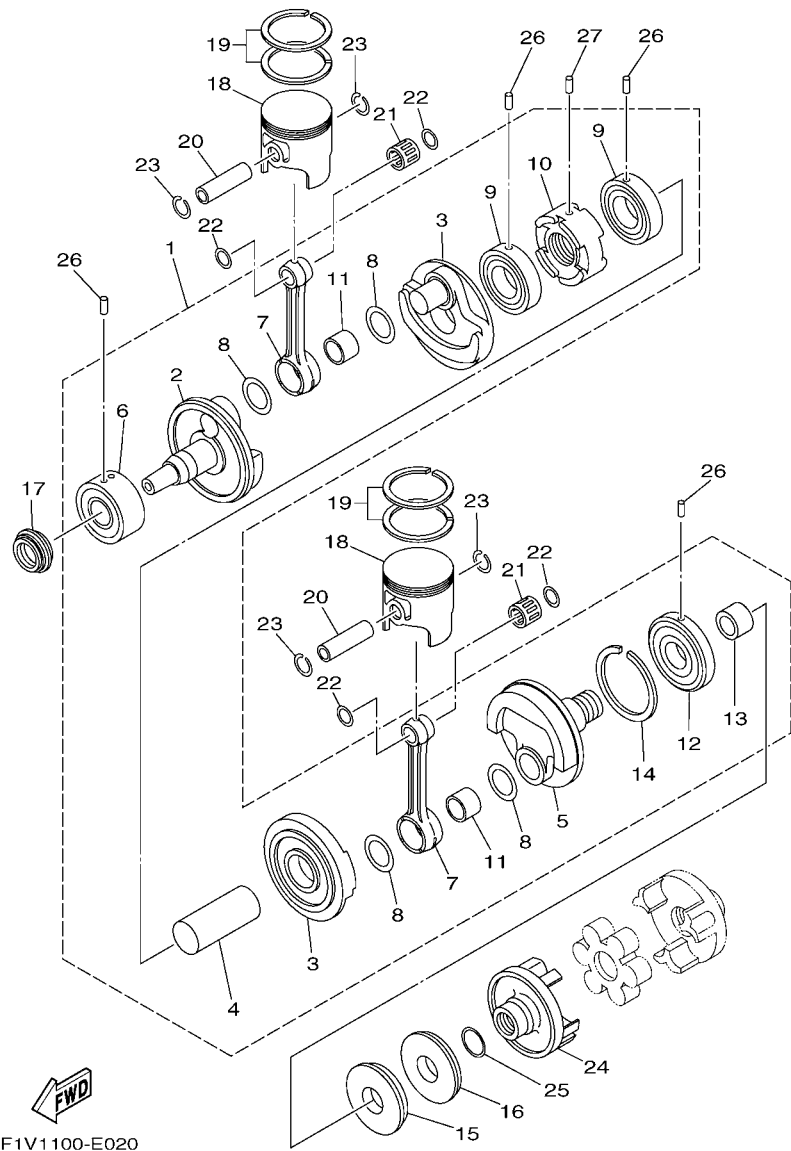
NUMERICAL INDEX .....	44
-----------------------	----



**FIG. 1 CYLINDER & CRANKCASE**

REF. NO.	PART NO.	DESCRIPTION	QTY				REMARKS
1	62T-11311-00-8S	CYLINDER 1	1				
2	6E5-11325-00	ANODE	1				
3	98780-04015	SCREW, FLAT HEAD	1				
4	93606-12019	PIN, DOWEL	4				
5	6M6-11351-A2	GASKET, CYLINDER	1				
6	90119-10M56	BOLT, WITH WASHER	4				
7	90119-10M07	BOLT, WITH WASHER	2				
8	62T-11111-00-8S	HEAD, CYLINDER 1	1				
9	6K8-51129-00	.NIPPLE	1				
10	90340-08M04	PLUG, STRAIGHT SCREW	1				
11	90430-08020	GASKET	1				
12	62T-11181-01	GASKET, CYLINDER HEAD 1	1				
13	90119-08M96	BOLT, WITH WASHER	10				
14	62T-W0090-03-8S	CRANK CYLINDER ASSY	1				
15	62T-15100-00-8S	CRANKCASE ASSY	1				
16	62T-14251-10	.NIPPLE	1				
17	90380-12M29	.BUSH, SOLID	1				
18	90119-08M55	BOLT, WITH WASHER	4				
19	6CP-44532-00	STOPPER, UPPER MOUNT	1				
20	90109-08M56	BOLT	4				
21	6R7-21415-01-94	BRACKET, FRONT UPPER 1	1				
22	6R7-21425-01-94	BRACKET, REAR UPPER 1	1				
23	90119-10M02	BOLT, WITH WASHER	4				
24	90119-10M00	BOLT, WITH WASHER	1				
25	90119-10M03	BOLT, WITH WASHER	1				
26	90119-10M01	BOLT, WITH WASHER	1				
27	62E-44517-A1-8P	MOUNT RUBBER	4				





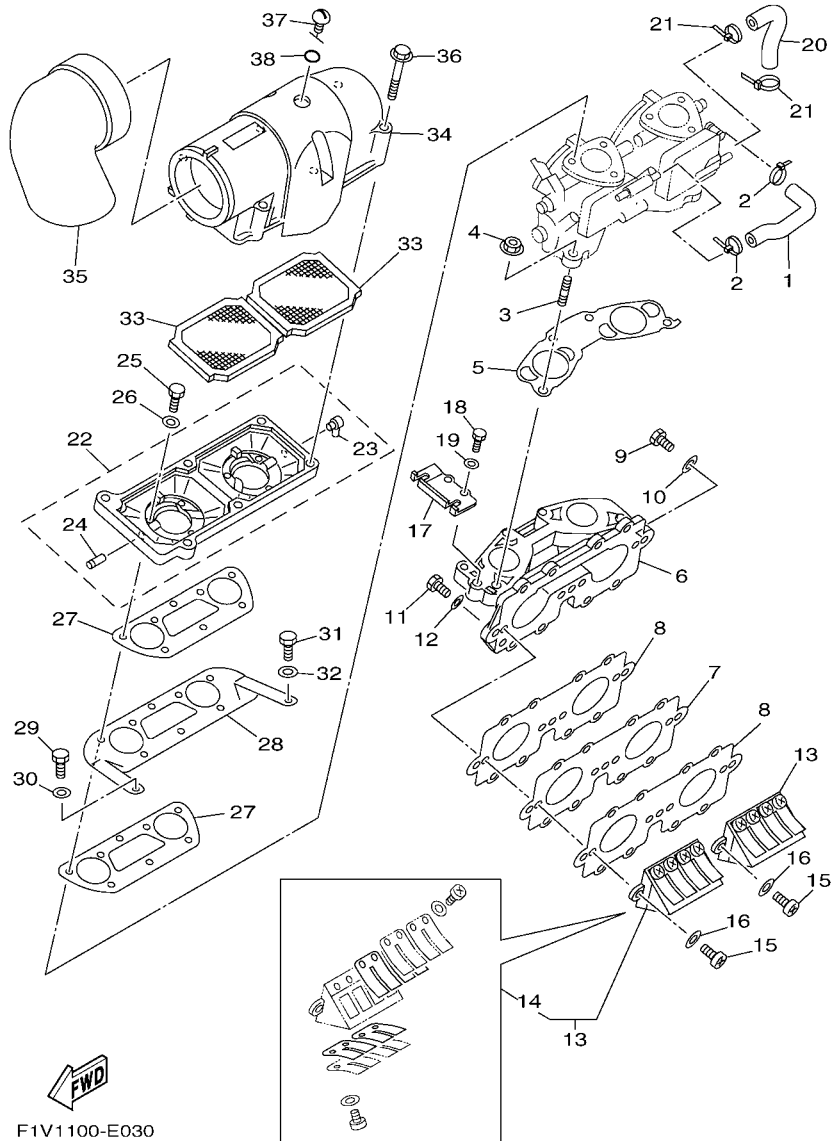
F1V1100-E020

FIG. 2 CRANKSHAFT & PISTON

REF. NO.	PART NO.	DESCRIPTION	QTY				REMARKS
1	62T-11400-02	CRANKSHAFT ASSY	1				
2	6M6-11412-00	.CRANK 1	1				
3	6M6-11422-00	.CRANK 2	2				
4	6M6-11431-10	.CRANK 3	1				
5	6M6-11442-01	.CRANK 4	1				
6	93305-30601	.BEARING	1				
7	64X-11651-01	.ROD, CONNECTING	2				
8	82M-11685-00	.WASHER, CRANK PIN	4				
9	93306-207U2	.BEARING	2				
10	65U-11515-00	.SEAL, LABYRINTH 1	1				
11	93310-525U3	.BEARING	2				
12	93306-307U3	.BEARING	1				
13	62T-45526-00	.COLLAR, DRIVE SHAFT	1				
14	93440-80023	.CIRCLIP	1				
15	93102-36M33	OIL SEAL	1				
16	93101-36M46	OIL SEAL	1				
17	93103-32M01	OIL SEAL	1				
18	62T-11631-02-92	PISTON (STD)	2				
	62T-11635-02	PISTON (0.25MM O/S)	2				AP
	62T-11636-02	PISTON (0.50MM O/S)	2				AP
19	61X-11603-01	PISTON RING SET (STD)	2				
	61X-11604-01	PISTON RING SET (0.25MM O/S)	2				AP
	61X-11605-01	PISTON RING SET (0.50MM O/S)	2				AP
20	62T-11633-00	PIN, PISTON	2				
21	93310-320U2	BEARING	2				
22	90201-20M04	WASHER, PLATE	4				
23	93450-21053	CIRCLIP	4				





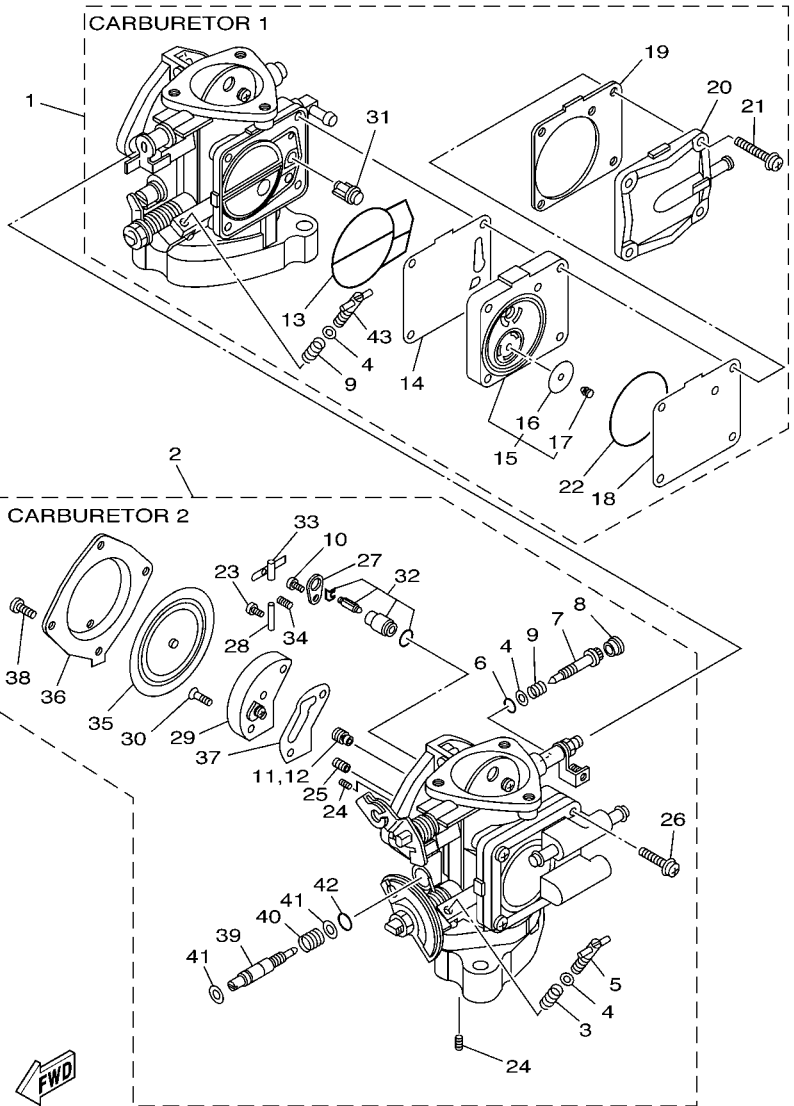


F1V1100-E030

FIG. 3 INTAKE

REF. NO.	PART NO.	DESCRIPTION	QTY				REMARKS
1	62T-24313-01	PIPE 3	1				
2	90465-11M10	CLAMP	2				
3	90116-08M60	BOLT, STUD	4				
4	90179-08M15	NUT	4				
5	62T-13556-00	GASKET, MANIFOLD	1				
6	62T-13555-00-94	MANIFOLD, INTAKE	1				
7	62T-13624-00	PLATE, REED VALVE	1				
8	62T-13566-00	GASKET	2				
9	97013-06035	BOLT	3				
10	92903-06600	WASHER, PLATE	3				
11	97013-06025	BOLT	8				
12	92903-06600	WASHER, PLATE	8				
13	62T-13610-00	REED VALVE ASSY	2				
14	62T-W0004-00	.REED SET	1				
15	97880-05016	SCREW, PAN HEAD	4				
16	92990-05600	WASHER, PLATE	4				
17	62T-14527-02	PLATE	1				
18	97013-06016	BOLT	2				
19	92903-06600	WASHER, PLATE	2				
20	62T-24314-01	PIPE 4	1				
21	90465-11M10	CLAMP	2				
22	62T-14284-01-8S	COVER, CARBURETOR 2	1				
23	6E5-11372-01	.NIPPLE, HOSE	1				
24	6H1-14485-00	.PIPE, JOINT	1				
25	97013-06020	BOLT	6				
26	92903-06600	WASHER, PLATE	6				
27	62T-13674-00	GASKET, AIR COOLER COVER 1	2				

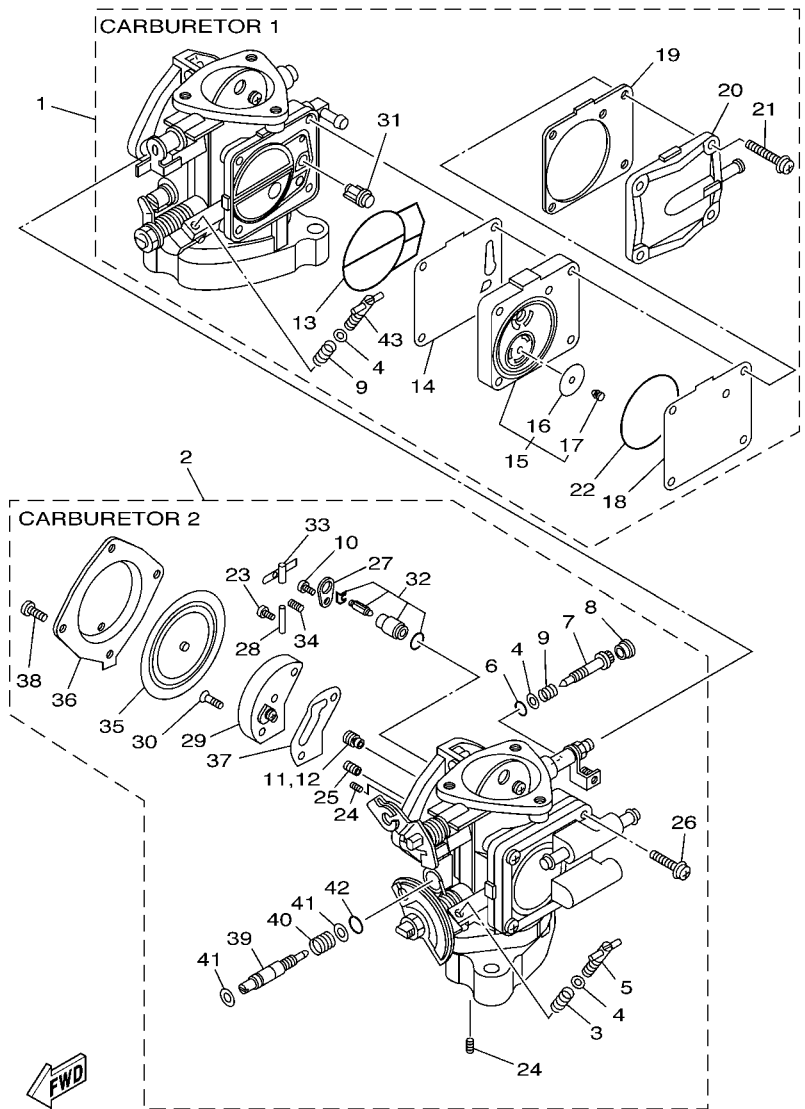




FOM5100-0040

FIG. 4 CARBURETOR

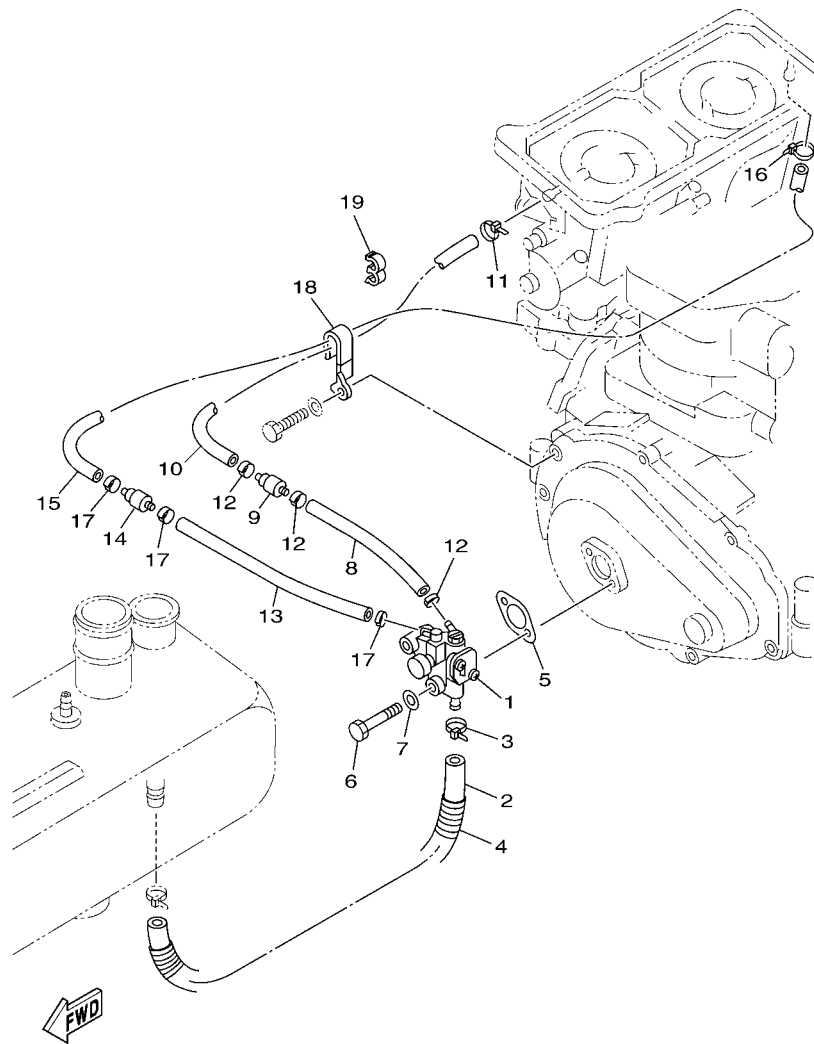
REF. NO.	PART NO.	DESCRIPTION	QTY			REMARKS
1	62T-14301-03	CARBURETOR ASSY 1	1			
2	62T-14302-03	CARBURETOR ASSY 2	1			
3	47X-14133-00	.SPRING, THROTTLE STOP	1			CARBURETOR 2
4	812-14235-00	.WASHER, NEEDLE	4			
5	6M6-14521-00	.SCREW, ADJUST	1			CARBURETOR 2
6	812-14147-00	.O-RING	2			
7	6K8-14946-10	.METERING NEEDLE	2			
8	6K8-14471-10	.CAP, CARBURETOR	2			
9	3KW-14932-00	.SPRING, THROTTLE 2	3			
10	6M6-14503-00	.SCREW	2			
11	3G2-14231-26	.JET, MAIN (#130)	1			CARBURETOR 1
12	3G2-14231-24	.JET, MAIN (#120)	1			CARBURETOR 2
13	6K8-14564-00	.O-RING	2			
14	6K8-24411-20	.DIAPHRAGM	1			CARBURETOR 1
15	6M6-24413-01	.BODY 2	1			CARBURETOR 1
16	65U-24421-00	..VALVE, CHECK	2			CARBURETOR 1
17	65U-24492-00	..BUSH, FUEL PUMP	2			CARBURETOR 1
18	6K8-24421-10	.VALVE, CHECK	1			CARBURETOR 1
19	6K8-24431-20	.GASKET, FUEL PUMP 1	1			CARBURETOR 1
20	6K8-24452-10	.COVER	1			UR CARBURETOR 1
	62T-14293-00	.COVER 1	1			UR CARBURETOR 2
21	97980-05330	.SCREW, WITH WASHER	4			CARBURETOR 1
22	6K8-14563-00	.O-RING	1			CARBURETOR 1
23	6K8-14503-02	.SCREW	2			
24	6K8-14521-10	.SCREW	4			
25	830-1423A-64	.JET, MAIN (# 67.5)	2			
26	98580-05018	.SCREW, PAN HEAD	4			CARBURETOR 2



FOM5100-0040

FIG. 4 CARBURETOR

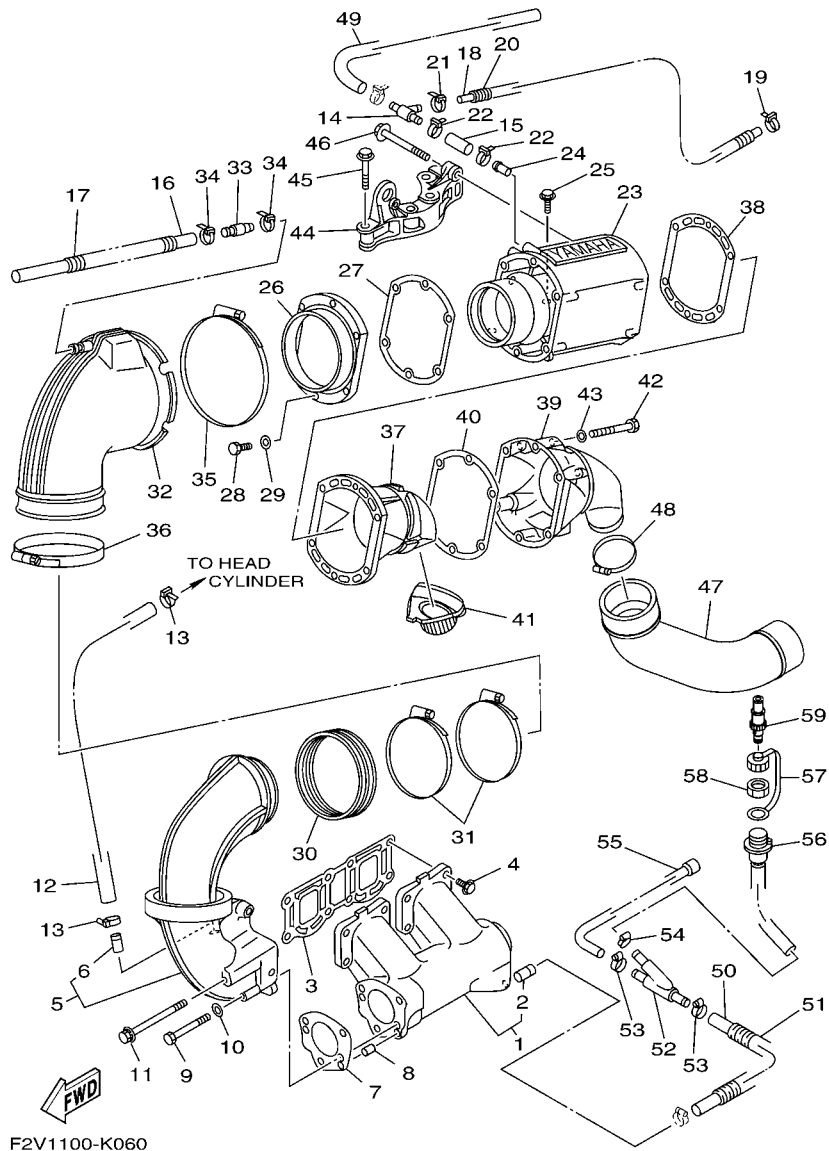
REF. NO.	PART NO.	DESCRIPTION	QTY				REMARKS
27	6K8-14527-11	.PLATE	2				
28	439-14186-00	.PIN, FLOAT	2				
29	6R7-24412-01	.BODY 1	2				
30	6K8-14523-11	.SCREW, STOP	4				
31	6R7-14569-00	.STRAINER	2				
32	61X-14916-16	.JET NEEDLE COMP.	2				
33	6K8-14547-01	.ARM, FLOAT	2				
34	6R7-14253-00	.SPRING	2				
35	6R7-14541-00	.DIAPHRAGM, PUMP	2				
36	6R7-14542-00	.BODY, PUMP 1	2				
37	6K8-14536-11	.GASKET	2				
38	97880-05012	.SCREW, PAN HEAD	8				
39	65U-14923-10	.SCREW, PILOT	2				
40	6K8-14589-00	.SPRING	2				
41	822-14235-00	.WASHER, NEEDLE	4				
42	583-14561-00	.O-RING	2				
43	6K8-14521-00	.SCREW, ADJUST	1				CARBURETOR 1



F2V1100-K050

FIG. 5 OIL PUMP

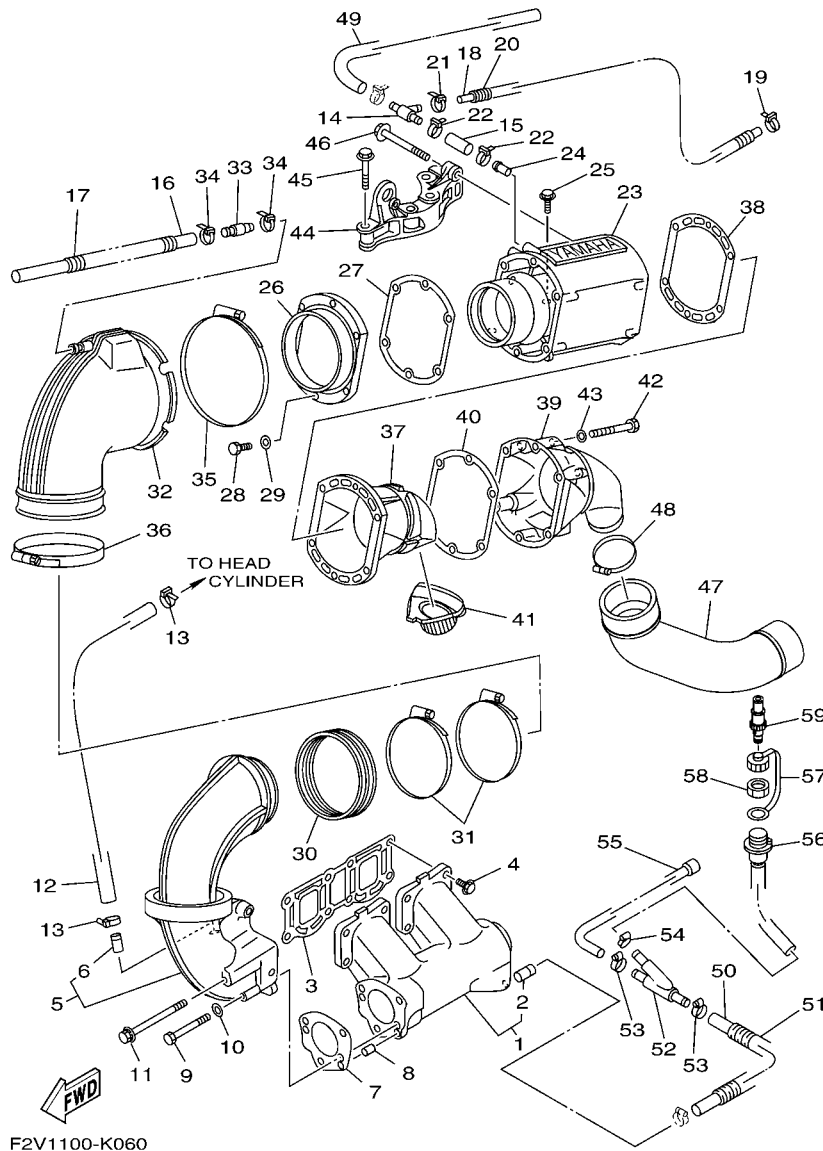
REF. NO.	PART NO.	DESCRIPTION	QTY				REMARKS
1	61X-13200-12	OIL INJECTION PUMP ASSY	1				
2	90445-11083	HOSE (L800)	1				
3	90465-11M10	CLAMP	1				
4	90447-13013	TUBE (L650)	1				
5	6R8-13116-A0	GASKET, PUMP CASE	1				
6	97095-06035	BOLT	2				
7	92995-06600	WASHER	2				
8	90445-07009	HOSE (L85)	1				
9	67X-13183-00	VALVE, CHECK	1				
10	90446-07M18	HOSE (L210)	1				
11	90465-11M10	CLAMP	1				
12	90468-02001	CLIP	3				
13	90445-07008	HOSE (L70)	1				
14	67X-13183-00	VALVE, CHECK	1				
15	90446-07M48	HOSE (L450)	1				
16	90465-11M10	CLAMP	1				
17	90468-02001	CLIP	3				
18	90465-08M69	CLAMP	1				
19	90464-10M38	CLAMP	2				



F2V1100-K060

FIG. 6 EXHAUST 1

REF. NO.	PART NO.	DESCRIPTION	QTY			REMARKS
1	62T-14711-10-94	MUFFLER 1	1			
2	6K8-51129-00	.NIPPLE	1			
3	62T-14613-01	GASKET, EXHAUST PIPE	1			
4	90105-10M60	BOLT, FLANGE	8			
5	62T-14712-00-94	RING, JOINT	1			
6	6K8-51129-00	.NIPPLE	1			
7	62T-14749-02	GASKET, MUFFLER DAMPER 2	1			
8	93605-12M21	PIN, DOWEL	2			
9	97013-08075	BOLT	2			
10	92903-08600	WASHER, PLATE	2			
11	90119-08M11	BOLT, WITH WASHER	2			
12	90445-14M24	HOSE (L260)	1			
13	90465-11M10	CLAMP	2			
14	63N-24378-00	PIPE, JOINT 3	1			
15	90445-21010	HOSE (L70)	1			
16	90445-14M07	HOSE (L1070)	1			
17	90447-15004	TUBE	1			
18	90445-14M25	HOSE (L380)	1			
19	90465-11M10	CLAMP	1			
20	90446-20M31	HOSE (L340)	1			
21	90465-11M10	CLAMP	1			
22	90465-11M59	CLAMP	2			
23	62T-14721-00-8S	MUFFLER 2	1			
24	62T-14485-10	PIPE, JOINT	1			
25	90105-10M60	BOLT, FLANGE	2			
26	62T-41113-00-8S	OUTER COVER, EXHAUST	1			
27	62T-41114-01	GASKET, EXHAUST OUTER COVER	1			



F2V1100-K060

FIG. 6 EXHAUST 1

REF. NO.	PART NO.	DESCRIPTION	QTY				REMARKS
28	97013-06025	BOLT	6				
29	92903-06600	WASHER, PLATE	6				
30	62T-14625-00	JOINT, EXHAUST 2	1				
31	90450-99M06	HOSE CLAMP ASSY	2				
32	62T-14615-01	JOINT, EXHAUST 1	1				
33	6R3-24377-00	PIPE, JOINT 2	1				
34	90465-11M10	CLAMP	2				
35	90450-99M01	HOSE CLAMP ASSY	1				
36	90450-99M02	HOSE CLAMP ASSY	1				
37	62T-41121-00-8S	INNER COVER, EXHAUST	1				
38	62T-41122-00	GASKET, EXHAUST INNER COVER	1				
39	62T-41123-01-8S	OUTER COVER, EXHAUST	1				
40	62T-41124-00	GASKET, EXHAUST OUTER COVER	1				
41	63N-15761-00	SEAL, RUBBER 1	1				
42	97013-06070	BOLT	6				
43	92903-06600	WASHER, PLATE	6				
44	62T-14771-00-94	STAY, MUFFLER 1	1				
45	90119-10M17	BOLT, WITH WASHER	4				
46	90105-10M88	BOLT, FLANGE	2				
47	6AE-14752-00	PIPE, OUTLET	1				
48	90450-70M03	HOSE CLAMP ASSY	1				
49	90445-21009	HOSE (L1030)	1				
50	90445-14M14	HOSE (L330)	1				
51	90446-20M13	HOSE (L260)	1				
52	64X-12581-00	JOINT, HOSE 1	1				
53	90450-14M05	HOSE CLAMP ASSY	2				
54	90450-18M09	HOSE CLAMP ASSY	1				





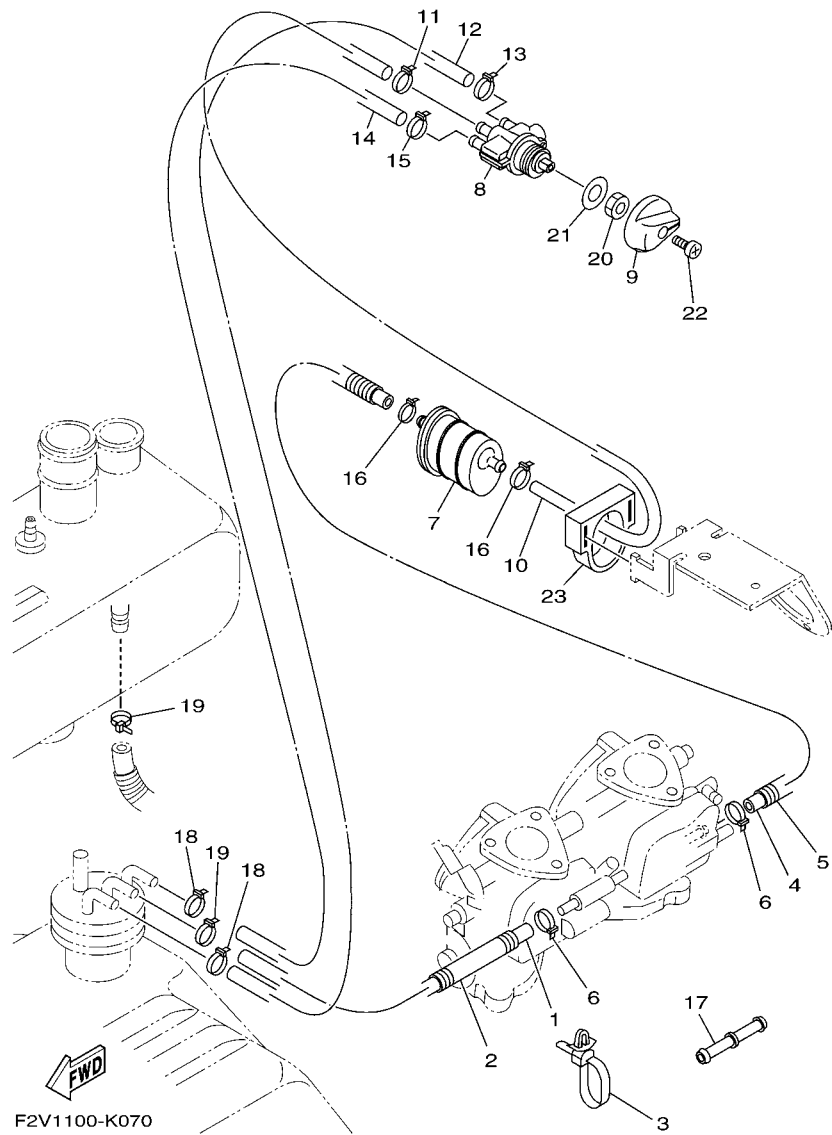
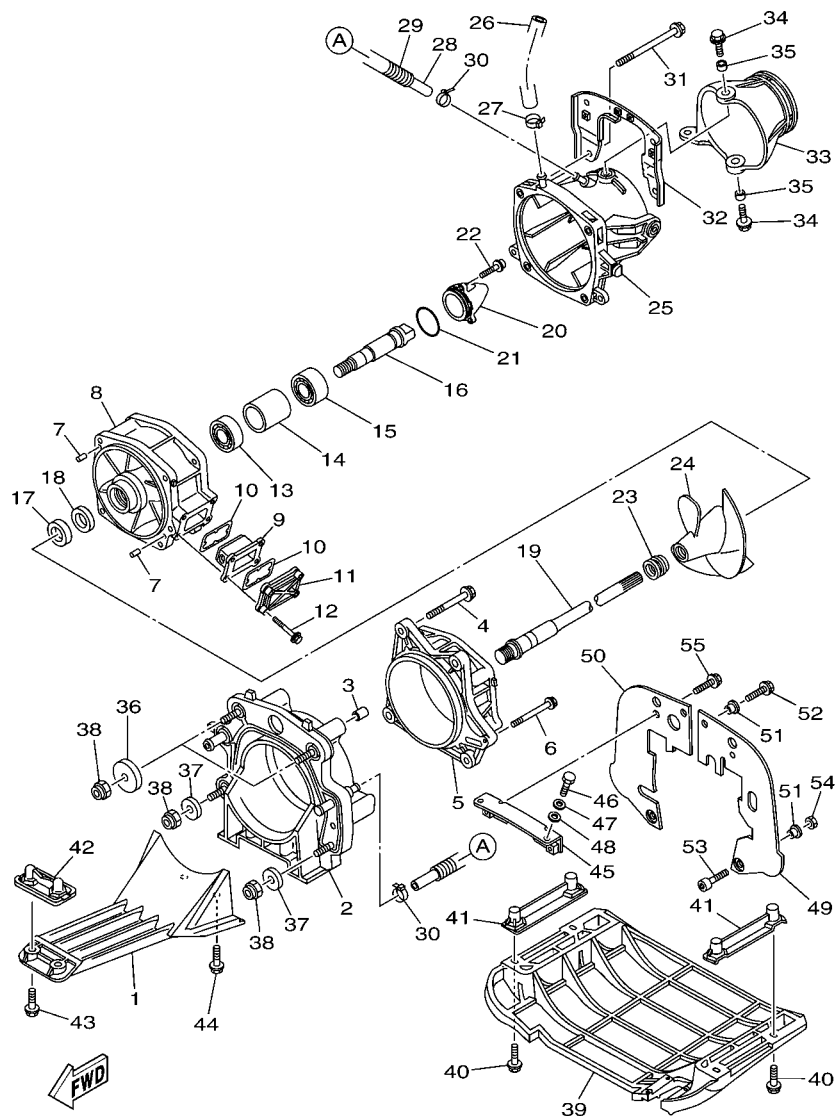


FIG. 7 FUEL

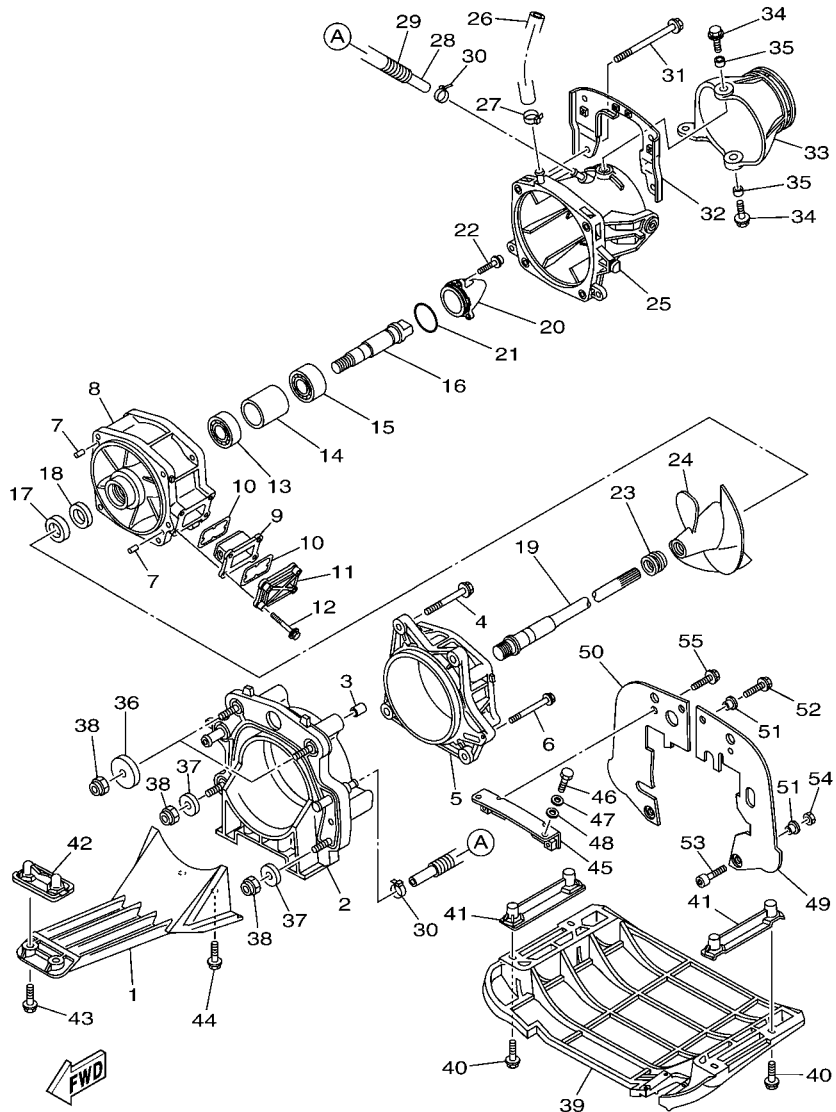
REF. NO.	PART NO.	DESCRIPTION	QTY				REMARKS
1	6CP-24313-00	PIPE 3	1				
2	90447-13006	TUBE (L1250)	1				
3	90465-12M56	CLAMP	1				
4	6CP-24312-00	PIPE 2	1				
5	90447-13006	TUBE (L1250)	1				
6	90465-11M10	CLAMP	2				
7	66V-24560-01	FILTER ASSY	1				
8	66V-24500-02	FUEL COCK ASSY 1	1				
9	6K8-24524-10	LEVER, COCK	1				
10	90445-11089	HOSE (L590)	1				
11	90465-11M10	CLAMP	1				
12	90445-11085	HOSE (L370)	1				
13	90465-11M10	CLAMP	1				
14	90445-11086	HOSE (L370)	1				
15	90465-11M10	CLAMP	1				
16	90465-11829	CLAMP	2				
17	6G8-24376-00	PIPE, JOINT 1	1				
18	90465-11829	CLAMP	2				
19	90465-11829	CLAMP	2				
20	90170-22187	NUT	1				
21	90202-229U1	WASHER, PLATE	1				
22	90159-04800	SCREW, WITH WASHER	1				
23	EU0-U7817-00	HOLDER, FILTER	1				



F2V1100-K080

FIG. 8 JET UNIT 1

REF. NO.	PART NO.	DESCRIPTION	QTY				REMARKS
1	6D3-R1333-01-94	SCREEN, INTAKE	1				
2	6AE-G5831-00	PLATE, TRANSOM	1				
3	99590-14016	PIN, DOWEL	2				
4	90119-10810	BOLT, WITH WASHER	4				
5	66V-51312-01-94	HOUSING, IMPELLER	1				
6	90119-06893	BOLT, WITH WASHER	1				
7	93606-12019	PIN, DOWEL	2				
8	66V-51315-01	DUCT, IMPELLER	1				
9	66V-46882-00	FILTER	1				
10	66V-42414-00	O-RING	2				
11	66V-45214-00-94	COVER, WATER INLET 1	1				
12	90119-06897	BOLT, WITH WASHER	4				
13	93306-27211	BEARING	1				
14	65V-45538-00	SPACER 1	1				
15	93306-205U0	BEARING	1				
16	6D3-45514-00	SHAFT, DRIVE 4	1				
17	93101-21001	OIL SEAL	1				
18	93101-21002	OIL SEAL	1				
19	6D3-45511-00	SHAFT, DRIVE	1				
20	65A-R1326-10	CAP	1				
21	93210-464A3	O-RING	1				
22	90119-06889	BOLT, WITH WASHER	3				
23	6D3-R1319-00	CAP, IMPELLER	1				
24	6AE-R1321-00	IMPELLER	1				
25	6BU-R1318-00	NOZZLE	1				
26	90445-16006	HOSE (L260)	1				
27	90601-118UF	BAND, HOSE 18	1				

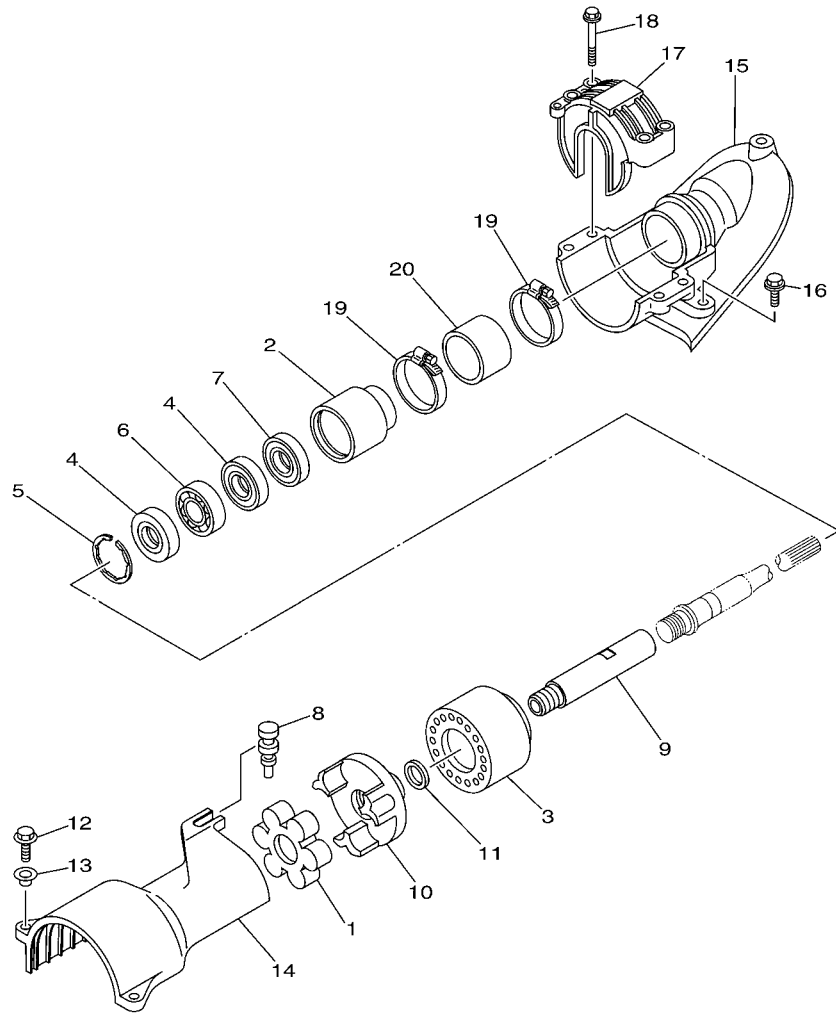


F2V1100-K080

FIG. 8 JET UNIT 1

REF. NO.	PART NO.	DESCRIPTION	QTY				REMARKS
28	90445-14008	HOSE (L355)	1				
29	90446-20MF5	HOSE (L320)	1				
30	90465-11829	CLAMP	2				
31	90119-10806	BOLT, WITH WASHER	4				
32	6D3-R1341-00	BRACKET 1	1				
33	6BU-R1313-00-94	NOZZLE, DEFLECTOR	1				
34	90119-08840	BOLT, WITH WASHER	2				
35	90387-08M06	COLLAR	2				
36	F1S-U725E-01	WASHER	2				
37	90201-10801	WASHER, PLATE	2				
38	9572R-10300	NUT, NYLON	4				
39	F2N-U273B-00	PLATE 2	1				
40	90119-08829	BOLT, WITH WASHER	4				
41	F1G-U8572-02	BRACKET 2	2				
42	F1K-U8577-01	BRACKET, 3	1				
43	90119-06896	BOLT, WITH WASHER	2				
44	90119-10809	BOLT, WITH WASHER	2				
45	F1K-U7557-01	BRACKET	1				
46	90109-08041	BOLT	2				
47	92990-12200	WASHER, PLAIN	2				
48	90430-12002	GASKET	2				
49	F1K-U757E-01	PLATE, RUBBER 1	1				
50	F1K-U757F-01	PLATE, RUBBER 2	1				
51	90387-06080	COLLAR	6				
52	90119-06827	BOLT, WITH WASHER	4				
53	90101-069U0	BOLT	2				
54	9572R-06300	NUT, NYLON	2				

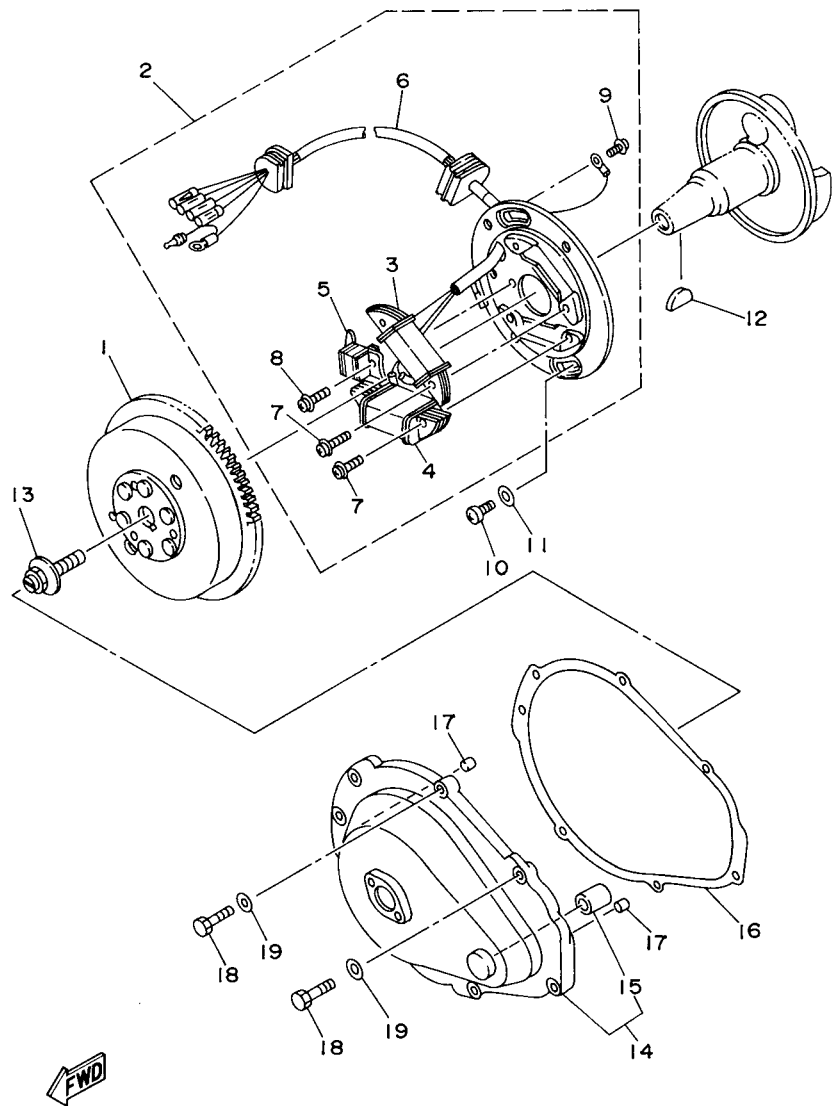




F1V3100-G090

FIG. 9 JET UNIT 2

REF. NO.	PART NO.	DESCRIPTION	QTY				REMARKS
1	61X-4581J-00	RUBBER SHAFT COUPLING	1				
2	6D3-45332-00-94	HOUSING, BEARING	1				
3	6D3-45235-00	DAMPER	1				
4	93101-25M55	OIL SEAL	2				
5	93430-47M04	CIRCLIP	1				
6	93306-205A3	BEARING	1				
7	93101-25M56	OIL SEAL	1				
8	90480-06M46	GROMMET	1				
9	6AE-51323-00	SHAFT, COUPLER	1				
10	6M6-45813-22-8P	FLANGE, COUPLING	1				
11	90201-24800	WASHER, PLATE	1				
12	90119-06891	BOLT, WITH WASHER	2				
13	90387-06M60	COLLAR	2				
14	63N-51381-00	COVER	1				
15	F1K-U883E-01	JOINT, PIPE	1				
16	90109-06832	BOLT	3				
17	F1V-U2155-01	CAP	1				
18	90119-089U1	BOLT, WITH WASHER	4				
19	90601-162U5	BAND, HOSE 62	2				
20	F1K-U883B-00	PIPE, 1	1				



GHI4010-4100

FIG. 10 GENERATOR

REF. NO.	PART NO.	DESCRIPTION	QTY				REMARKS
1	62T-85550-00	ROTOR ASSY	1				
2	62T-85560-00	BASE ASSY	1				
3	62T-85520-01	.COIL, CHARGE	1				
4	62T-85533-00	.COIL, LIGHTING	1				
5	6M6-85580-00	.COIL, PULSER	1				
6	62T-85515-00	.LEAD WIRE ASSY	1				
7	97902-05125	.SCREW, WITH WASHER	4				
8	97902-04122	.SCREW, WITH WASHER	2				
9	97802-04008	.SCREW, PAN HEAD	1				
10	97880-06016	SCREW, PAN HEAD	2				
11	92990-06600	WASHER, PLATE	2				
12	90280-05013	KEY, WOODRUFF	1				
13	90109-10M47	BOLT	1				
14	6R8-81337-00-8S	COVER, FLYWHEEL	1				
15	90380-12M29	.BUSH, SOLID	1				
16	6M6-81365-A0	GASKET, HOLE COVER	1				
17	93606-12019	PIN, DOWEL	2				
18	97095-06025	BOLT	7				
19	92995-06600	WASHER	7				

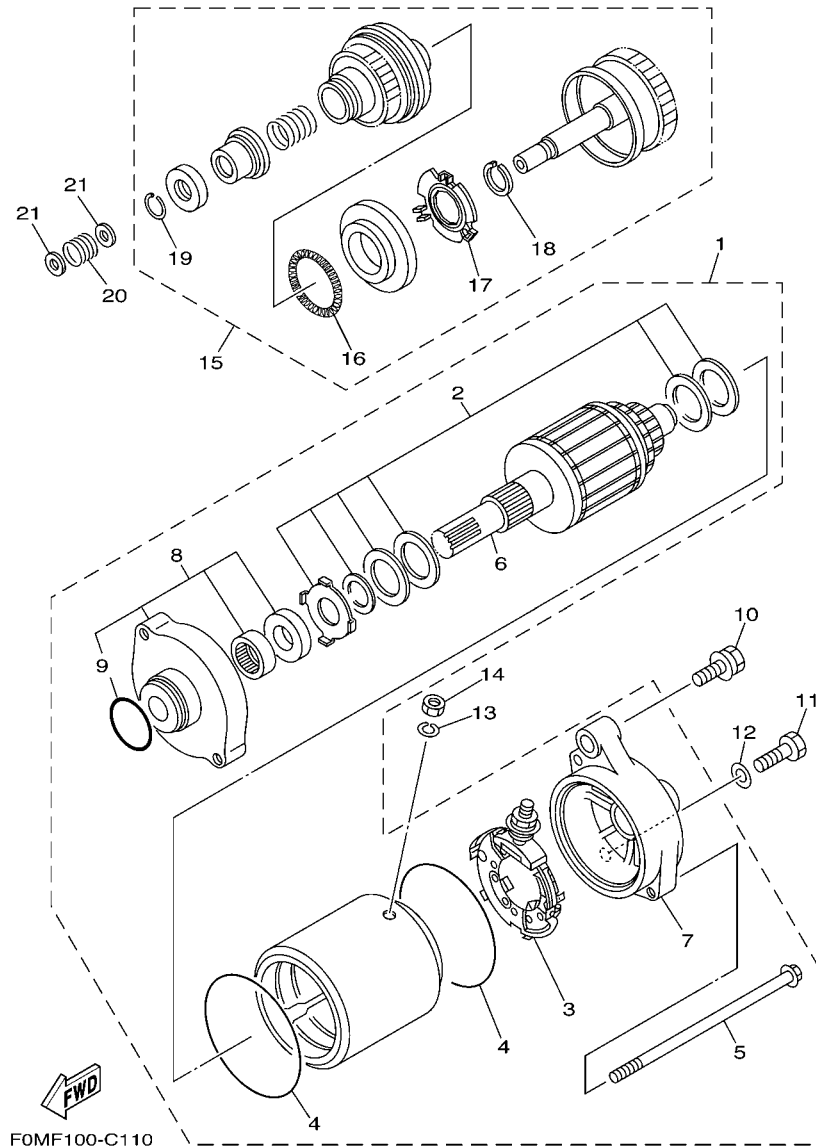


FIG. 11 STARTING MOTOR

REF. NO.	PART NO.	DESCRIPTION	QTY				REMARKS
1	6M6-81800-10	STARTING MOTOR ASSY	1				
2	3AJ-81809-00	.WASHER KIT	1				
3	6M6-81840-10	.BRUSH HOLDER ASSY	1				
4	11H-81844-00	.GASKET	2				
5	6M6-81826-00	.BOLT	2				
6	6M6-81850-00	.ARMATURE ASSY	1				
7	6M6-81820-00	.REAR BRACKET ASSY	1				
8	6M6-81830-00	.FRONT BRACKET ASSY	1				
9	26H-81847-00	..O-RING	1				
10	97513-08540	BOLT, WITH WASHER	1				
11	97013-08035	BOLT	1				
12	92903-08600	WASHER, PLATE	1				
13	92990-06100	WASHER, SPRING	1				
14	95380-06700	NUT	1				
15	6M6-8183E-01	IDLE GEAR COMP.	1				
16	6M6-81866-00	.WEIGHT SPRING	1				
17	6M6-81865-00	.WEIGHT HOLDER	1				
18	93440-25M08	.CIRCLIP	1				
19	93450-18M06	.CIRCLIP	1				
20	90501-14M73	SPRING, COMPRESSION	1				
21	92903-06600	WASHER, PLATE	2				



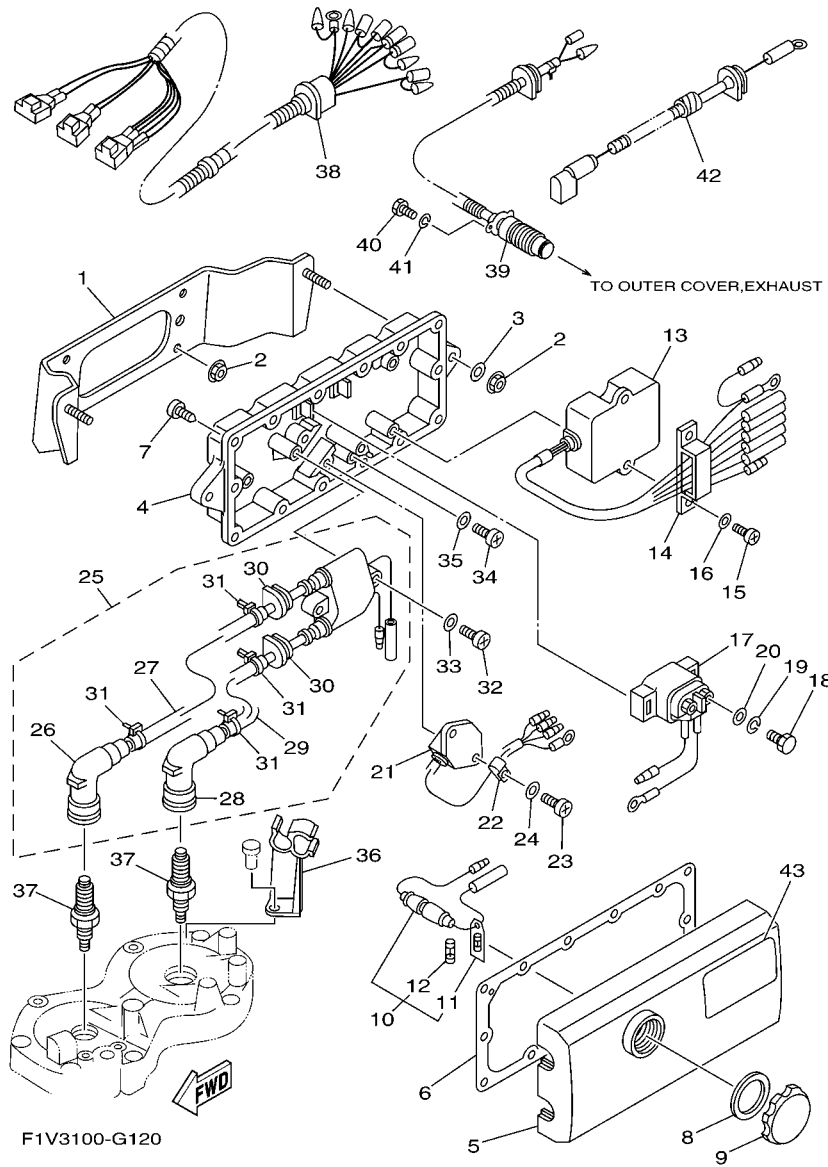


FIG. 12 ELECTRICAL 1

REF. NO.	PART NO.	DESCRIPTION	QTY				REMARKS
1	F1V-U815D-00	BRACKET, ELECTRIC BOX	1				
2	9572R-08300	NUT, FLANGE	6				
3	9299R-08200	WASHER	2				
4	62L-8552A-00-8P	HOUSING	1				
5	6M6-8552E-01	COVER, CASE	1				
6	6M6-81921-00	GASKET, TERMINAL	1				
7	97780-60525	SCREW, TAPPING	14				
8	6M6-81844-00	GASKET	1				
9	6M6-8132W-00	CAP	1				
10	6K8-82150-01	FUSE HOLDER ASSY	1				
11	6G1-82151-00	.FUSE (10A)	1				
12	6K8-82159-00	.FUSE SPEAR (10A)	1				
13	62T-85540-01	C.D.I. UNIT ASSY	1				
14	90464-06M29	CLAMP	1				
15	97880-06016	SCREW, PAN HEAD	2				
16	92990-06600	WASHER, PLATE	2				
17	68N-81940-00	STARTER RELAY ASSY	1				
18	97095-06010	BOLT	2				
19	92995-06100	WASHER, SPRING	2				
20	92995-06600	WASHER	2				
21	6M6-81960-A0	RECTIFIER & REGULATOR ASSY	1				
22	90465-06M86	CLAMP	1				
23	97880-06016	SCREW, PAN HEAD	2				
24	92990-06600	WASHER, PLATE	2				
25	62E-85570-11	IGNITION COIL ASSY	1				
26	62E-82371-11	.CAP, PLUG	1				
27	62E-82351-01	.TUBE, CORD	1				

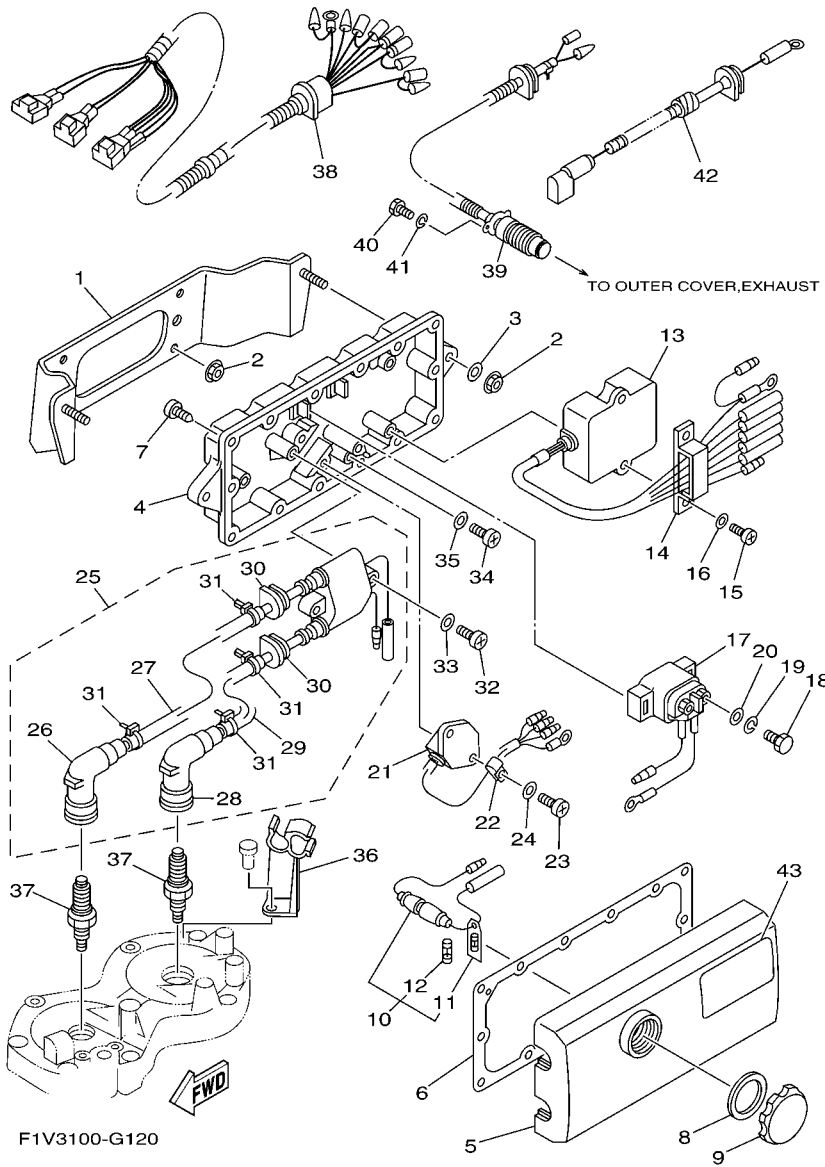


FIG. 12 ELECTRICAL 1

REF. NO.	PART NO.	DESCRIPTION	QTY				REMARKS
28	62E-82371-11	.CAP, PLUG	1				
29	62E-82352-01	.TUBE, CORD 2	1				
30	90480-06M43	.GROMMET	2				
31	90465-11M10	.CLAMP	4				
32	97880-06030	SCREW, PAN HEAD	2				
33	92990-06600	WASHER, PLATE	2				
34	97880-06016	SCREW, PAN HEAD	2				
35	92990-06600	WASHER, PLATE	2				
36	62T-82361-00	CLAMP, CORD	1				
37	94702-00195	PLUG, SPARK (NGK BR8HS)	2				
38	6AE-82553-00	EXTENSION, WIRE LEAD	1				
39	62T-82560-11	THERMO SWITCH ASSY	1				
40	97095-06016	BOLT	2				
41	92995-06100	WASHER, SPRING	2				
42	6AE-82117-20	WIRE, LEAD	1				
43	6B6-83623-00	MARK 3	1				

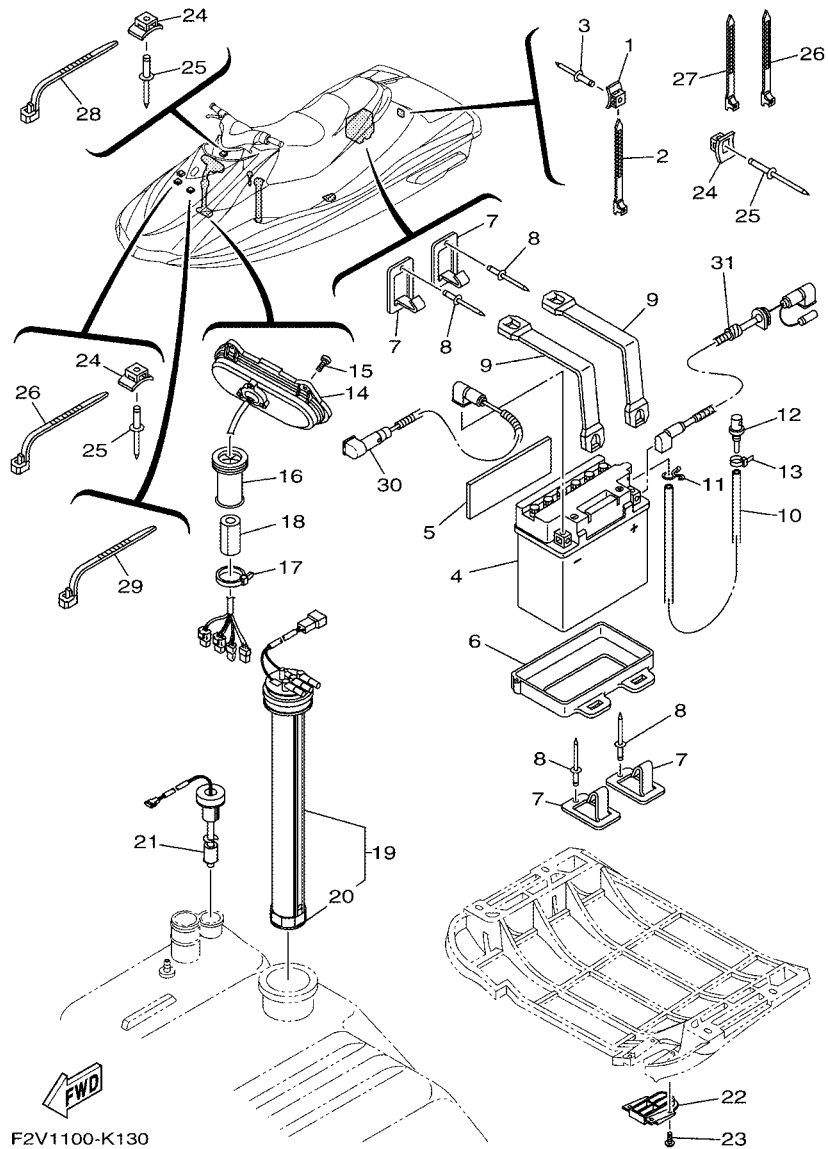


FIG. 13 ELECTRICAL 2

REF. NO.	PART NO.	DESCRIPTION	QTY				REMARKS
1	F1W-U828M-00	BASE, CLAMP	1				
2	90464-32801	CLAMP	1				
3	90267-489U6	RIVET, BLIND	1				
4	EU0-82110-09	BATTERY ASSY (YB16CL-B)	1				YUASA
5	F1K-U8221-00	PAD, BATTERY	1				
6	F1K-U8211-01	CASE, BATTERY	1				
7	F1K-U5772-04	HOOK A	4				
8	90267-489U1	RIVET, BLIND	4				
9	F1K-U821D-01	BAND, BATTERY 1	2				
10	F0D-U785G-10	HOSE, AIR VENT	1				
11	90467-089U1	CLIP	1				
12	GJ3-6215F-00	NIPPLE	1				
13	90465-11829	CLAMP	1				
14	F1V-6820A-01	METER ASSY	1				
15	90111-05009	BOLT, HEX. SOCKET BUTTON	4				
16	GU2-6822E-01	GROMMET	1				
17	90464-32801	CLAMP	1				
18	GJ1-U7578-21	PACKING, HOSE 2	1				
19	F0V-U824B-04	SENDER, FUEL	1				
20	F0V-H369N-00	.FLOAT	1				
21	GJ8-U824C-02	SENDER, OIL	1				
22	F1V-U273C-01	COVER, PLATE	1				
23	90150-05807	SCREW, ROUND HEAD	4				
24	F1W-U828M-00	BASE, CLAMP	6				
25	90267-489U6	RIVET, BLIND	6				
26	90464-32801	CLAMP	4				
27	90601-200U2	BAND	1				

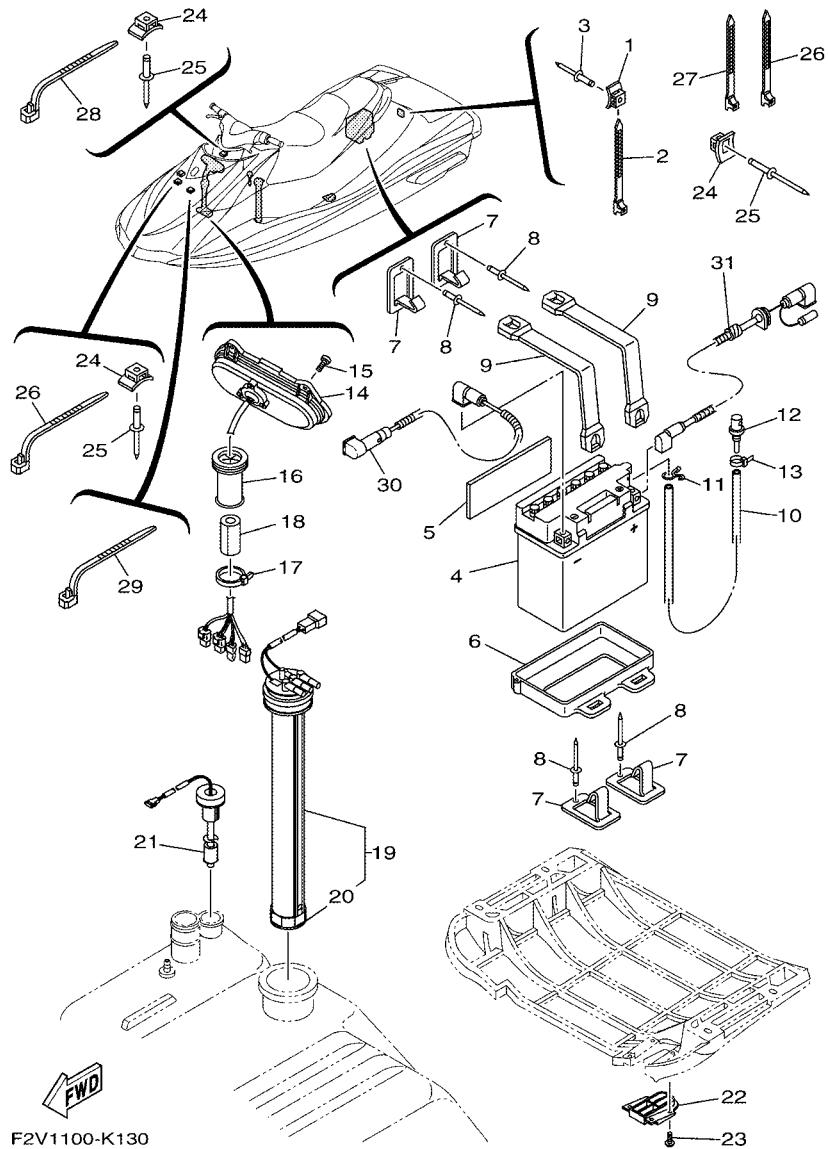
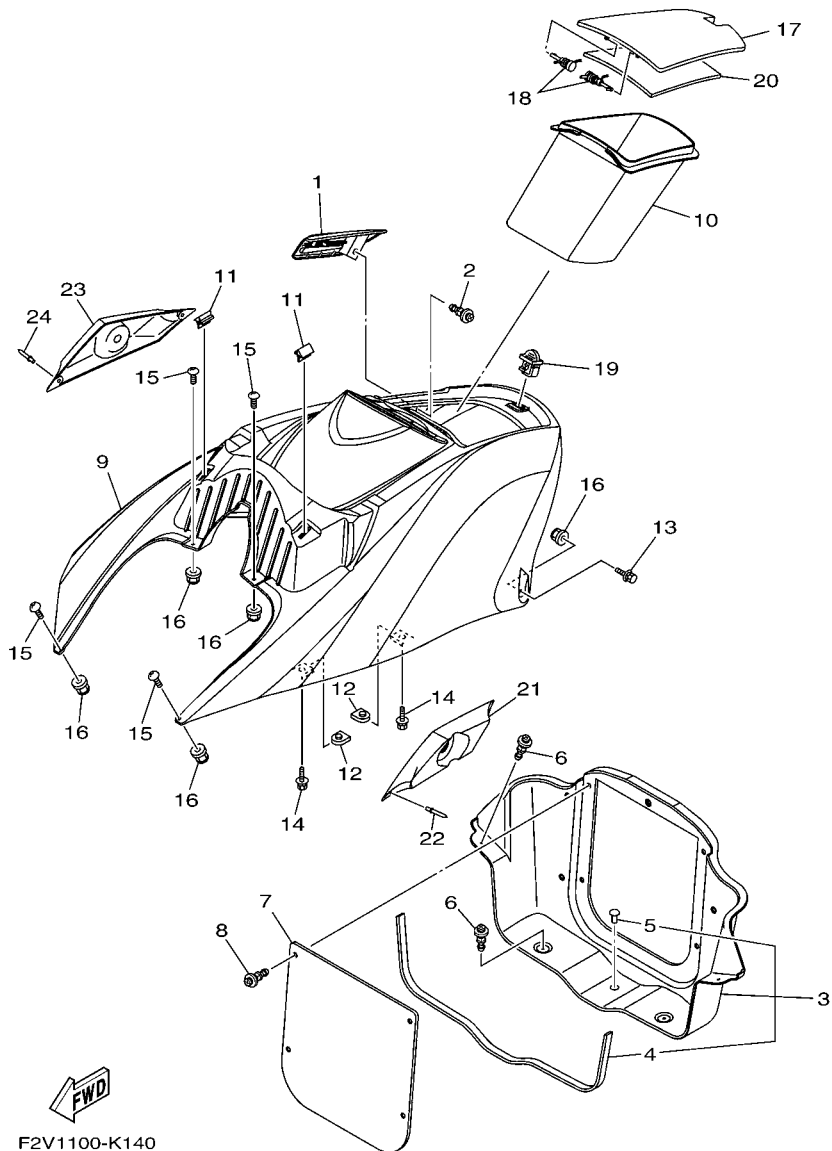


FIG. 13 ELECTRICAL 2

REF. NO.	PART NO.	DESCRIPTION	QTY				REMARKS
28	90601-200U2	BAND	1				
29	90601-200U2	BAND	2				
30	6AE-82117-00	WIRE, LEAD	1				
31	63N-82117-11	WIRE, LEAD	1				
-----							
-----							
-----							
-----							
-----							
-----							
-----							
-----							
-----							
-----							

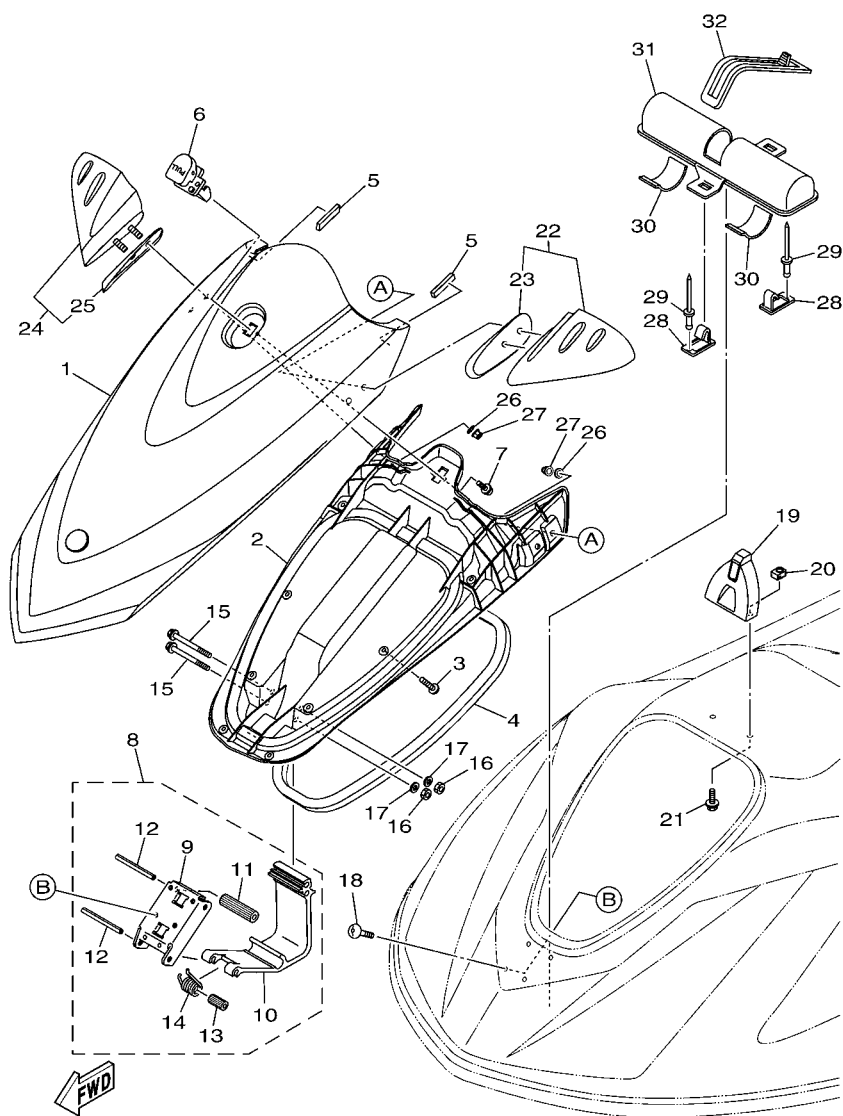


F2V1100-K140

FIG. 14 ENGINE HATCH 1

REF. NO.	PART NO.	DESCRIPTION	QTY			REMARKS
1	F2N-U2723-00	SEAL	1			
2	90269-08801	RIVET	1			
3	F2N-U475B-02	LOCKER,BOW	1			
4	F2N-U266C-00	.PACKING 4	1			
5	90605-502U1	.PLUG, BLIND	1			
6	90269-08801	RIVET	4			
7	F1W-U475F-01	PLATE, LOKER BOW	1			
8	90269-08801	RIVET	5			
9	F2N-U516N-00-P8	COVER, ENGINE HATCH	1			RYM4
10	F2N-U516P-00	BOX GLOVE	1			
11	F1K-U266C-00	PACKING 4	2			
12	90183-06902	NUT, SPRING	4			
13	90119-06880	BOLT, WITH WASHER	2			
14	90119-06882	BOLT, WITH WASHER	4			
15	F2N-67823-10	SCREW	4			
16	F2N-U142L-00	NUT, LOCK	6			
17	F2N-U517H-01	LID HATCH	1			
18	F0X-6517R-01	PIN, HINGE	2			
19	GU2-62875-01	LOCK	1			
20	F2N-U519D-00	PACKING CASE	1			
21	F2V-U7437-00	COVER	1			
22	90267-48824	RIVET, BLIND	2			
23	F2V-U7437-10	COVER	1			
24	90267-48824	RIVET, BLIND	2			

FIG. 15 ENGINE HATCH 2



F2N1100-J220

REF. NO.	PART NO.	DESCRIPTION	QTY			REMARKS
1	F2N-U517B-10-P6	LID, ENGINE ROOM	1			RYM4
2	F2N-U213B-00	COVER, VENTILATOR 1	1			
3	90149-05903	SCREW	8			
4	F2N-U2663-01	PACKING 1	1			
5	F1K-U266B-00	PACKING 3	2			
6	F1K-6517C-00	LOCK, LID	1			
7	90119-059U4	BOLT, WITH WASHER	2			
8	F1K-U515A-00	HINGE ASSY.	1			
9	F1K-U518E-04	.PLATE, HINGE LID	1			
10	F1K-U517D-05	.HINGE, LID	1			
11	F1K-U135C-01	.ROLLER, DETENT	1			
12	F1K-U517R-00	.PIN, HINGE	2			
13	F1K-U471E-03	.SPACER 1	1			
14	F1K-U283B-02	.SPRING, TORSION	1			
15	90105-06826	BOLT, FLANGE	2			
16	9572R-06300	NUT, NYLON	2			
17	9299R-06200	WASHER	2			
18	F2N-67823-00	SCREW	4			
19	F2N-U517F-00	HOOK, LID LOCK	1			
20	F1X-U517E-01	NUT	2			
21	90119-06880	BOLT, WITH WASHER	2			
22	F2N-U596B-00	MIRROR LH	1			
23	F2N-U471E-00	.SPACER 1	1			
24	F2N-U596C-00	MIRROR RH	1			
25	F2N-U471F-00	.SPACER 2	1			
26	9299R-08200	WASHER	4			
27	9572R-08300	NUT, FLANGE	4			



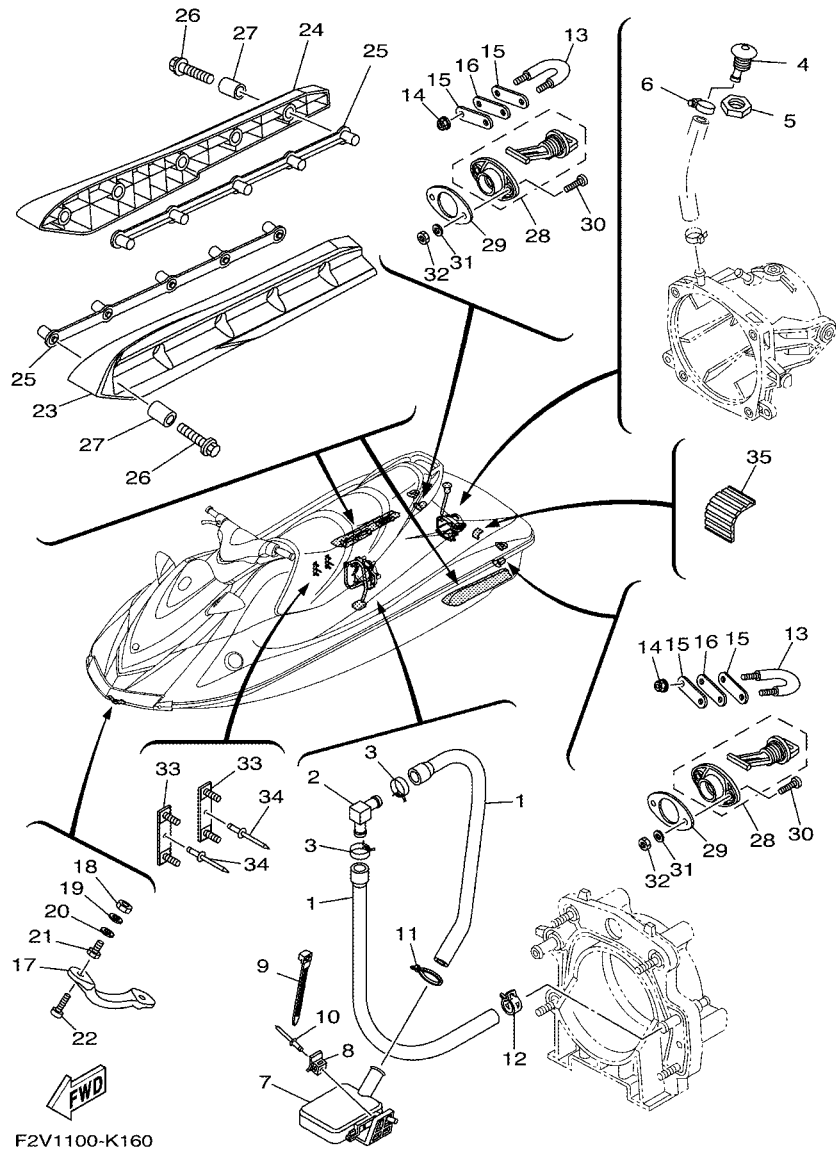
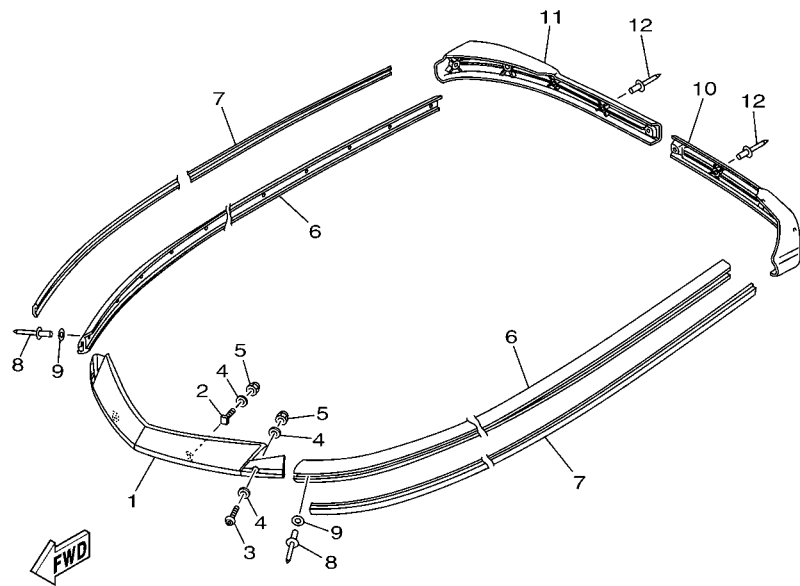
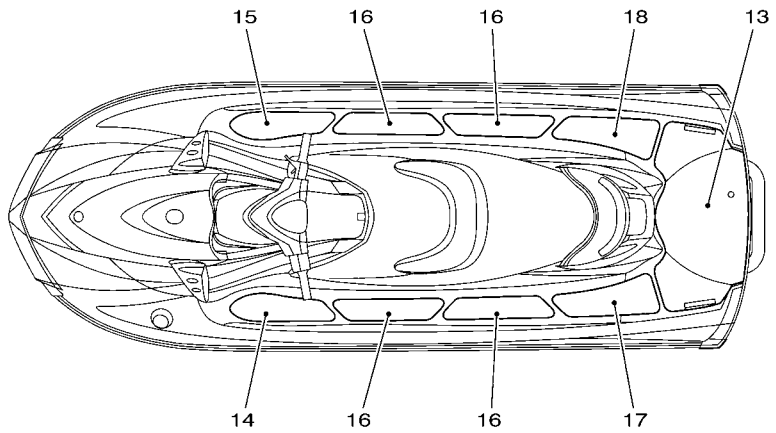


FIG. 16 HULL & DECK

REF. NO.	PART NO.	DESCRIPTION	QTY				REMARKS
1	90445-20805	HOSE (L710)	2				
2	61X-51162-00	JOINT, HOSE	1				
3	90467-18804	CLIP	2				
4	F1W-U269B-00	SPOUT	1				
5	EU0-61652-00	NUT	1				
6	90601-118UF	BAND, HOSE 18	1				
7	F1B-U761D-02	STRAINER, BILGE	1				
8	F1W-U828M-00	BASE, CLAMP	1				
9	90464-32801	CLAMP	1				
10	90267-489U8	RIVET, BLIND	1				
11	90601-200U1	BAND	1				
12	90467-21800	CLIP	1				
13	F2N-U1628-00	STERN EYE	2				
14	9572R-08300	NUT, FLANGE	4				
15	GP7-U4953-10	PLATE A	4				
16	F1B-U1653-01	PACKING	2				
17	F1K-61624-00	BOWEYE 1	1				
18	99780-12600	NUT,HEX.(COARS)	2				
19	92990-12200	WASHER, PLAIN	2				
20	F0X-61637-00	WASHER	2				
21	F0X-61652-00	NUT (BOLT/NUT)	2				
22	90110-06040	BOLT, HEXAGON SOCKET HEAD	2				
23	F2N-U883N-00	STABILIZER LH	1				
24	F2N-U883P-00	STABILIZER RH	1				
25	F1X-U883T-01	BRACKET,STABILIZER	2				
26	90105-08860	BOLT, FLANGE	10				
27	F2N-U8169-00	SPACER	10				







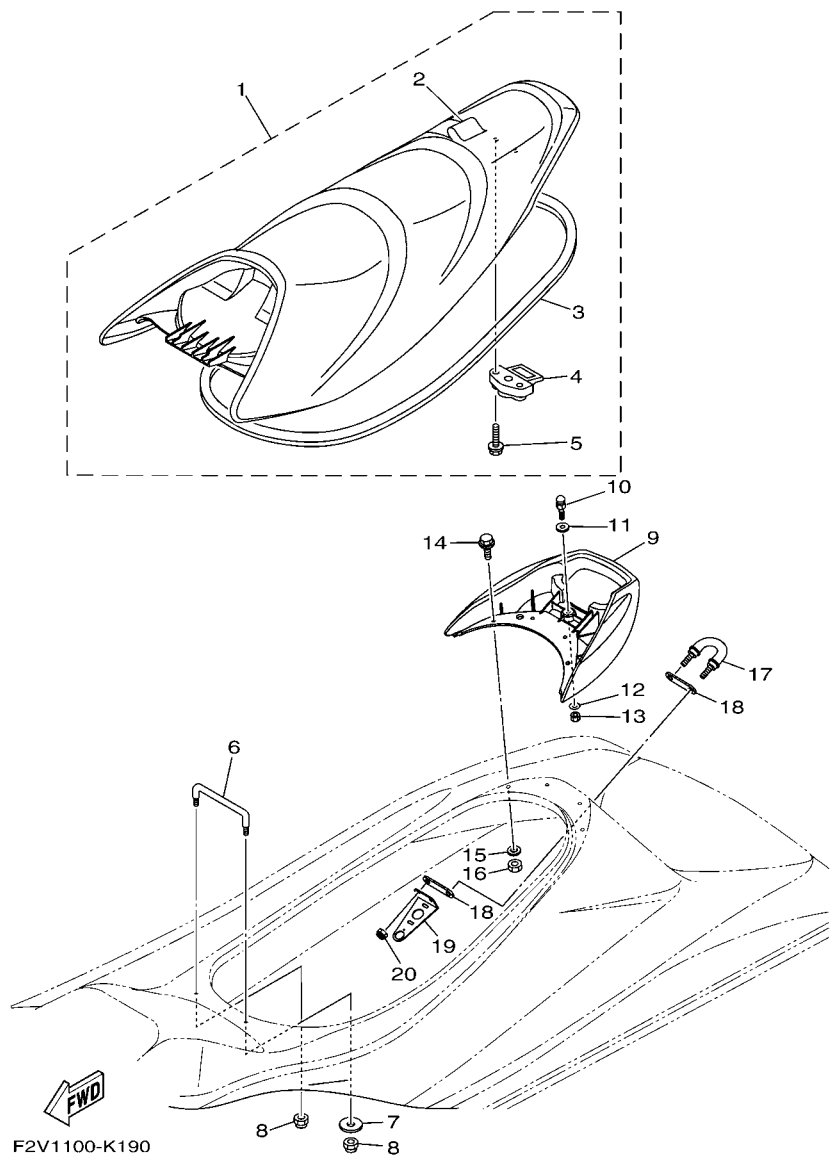
F2V1100-K170

FIG. 17 GUNWALE & MAT

REF. NO.	PART NO.	DESCRIPTION	QTY			REMARKS
1	F2N-U2511-01	GUNWALE, BOW	1			
2	F1W-U491K-00	BOLT, SPECIAL	2			
3	90111-06803	BOLT, HEX. SOCKET BUTTON	2			
4	9299R-06200	WASHER	6			
5	9572R-06300	NUT, NYLON	4			
6	F1K-U2512-03	GUNWALE, SIDE	2			GRAY
7	F1K-U2519-02	INNER, GUNWALE	2			GRAY
8	90267-489U8	RIVET, BLIND	30			
9	9299R-05200	WASHER	30			
10	F1K-U251D-01	GUNWALE, STERN 1	1			GRAY
11	F1K-U251E-01	GUNWALE, STERN 2	1			GRAY
12	90267-48963	RIVET, BLIND	9			
13	F2N-U3581-00	MAT, UPPER	1			DARK GREY
14	F2N-U351H-00	MAT, STEP 1	1			DARK GREY
15	F2N-U351J-00	MAT, STEP 2	1			DARK GREY
16	F2N-U351K-00	MAT, STEP 3	4			DARK GREY
17	F2N-U351M-00	MAT, STEP 4	1			DARK GREY
18	F2N-U351N-00	MAT, STEP 5	1			DARK GREY

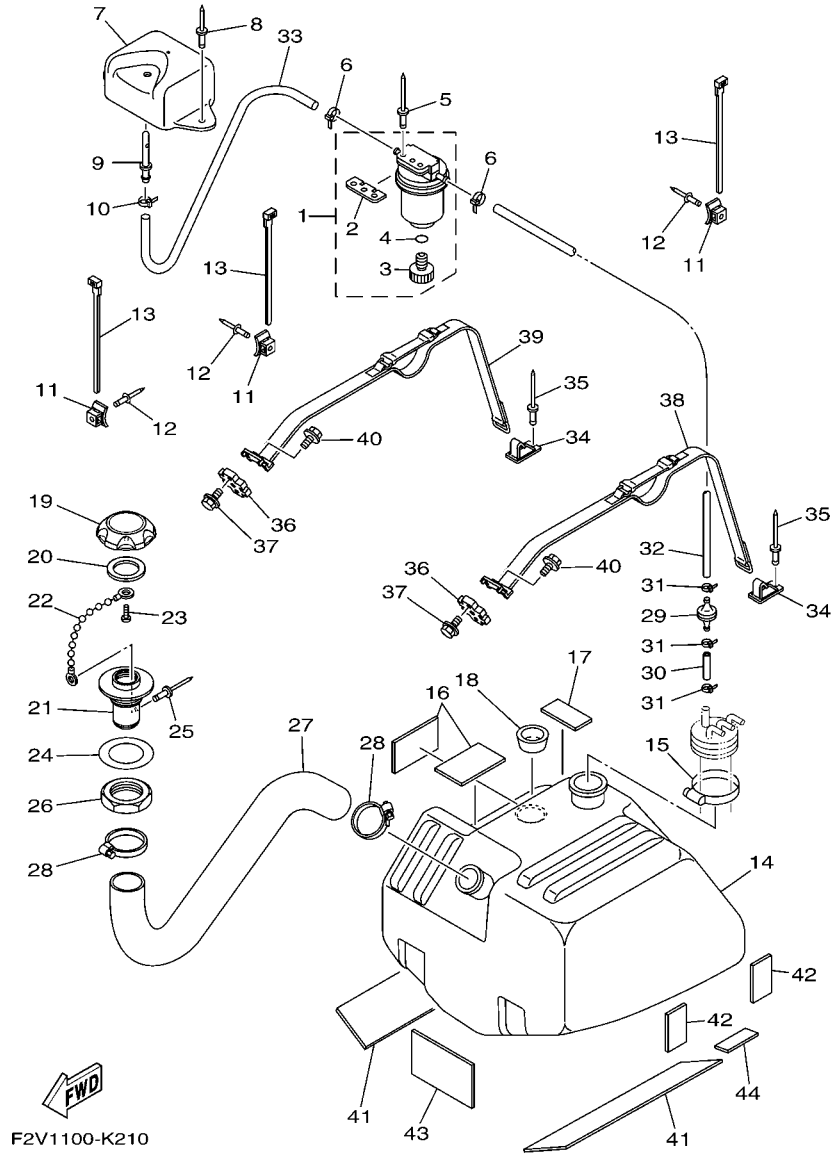


**FIG. 19 SEAT & UNDER LOCKER**



REF. NO.	PART NO.	DESCRIPTION	QTY				REMARKS
1	F2N-U371A-03	DOUBLE SEAT ASSY	1				
2	F2N-U371B-00	.COVER, SEAT 1	1				
3	F2N-U2664-00	.PACKING	1				
4	F2C-U3850-00	.SEAT LOCK ASSY	1				
5	90119-069UP	.BOLT, WITH WASHER	2				
6	F0X-6378C-00	STAY, SEAT 1	1				
7	90201-099U3	WASHER, PLATE	1				
8	9572R-08300	NUT, FLANGE	2				
9	F2N-U271B-01	GRIP, HAND	1				
10	GH1-U3774-00	PIN	1				
11	90201-109U6	WASHER, PLATE	1				
12	9299R-10200	WASHER	1				
13	9572R-10300	NUT, NYLON	1				
14	90119-089U2	BOLT, WITH WASHER	4				
15	9299R-08200	WASHER	4				
16	9572R-08300	NUT, FLANGE	4				
17	F2N-U1628-00	STERN EYE	1				
18	GP7-U4953-10	PLATE A	2				
19	F1V-U826C-01	BRACKET	1				
20	9572R-08300	NUT, FLANGE	2				





F2V1100-K210

FIG. 21 FUEL TANK

REF. NO.	PART NO.	DESCRIPTION	QTY				REMARKS
1	F2F-6214A-00	FILTER, VENT ASSY	1				
2	EW2-62142-00	.PLATE, FILTER	1				
3	70R-24543-00	.PLUG, DRAIN	1				
4	70R-24489-00	.O-RING	1				
5	90267-489U2	RIVET, BLIND	2				
6	90465-11829	CLAMP	2				
7	F1W-U2159-00	SOCKET, VENTILATION	1				
8	90267-489U6	RIVET, BLIND	2				
9	F1G-62149-00	PIPE, VENTILATION	1				
10	90465-11829	CLAMP	1				
11	F1W-U828M-00	BASE, CLAMP	3				
12	90267-489U6	RIVET, BLIND	3				
13	90464-32801	CLAMP	3				
14	GU2-U7711-01	TANK, FUEL	1				
15	90601-162U5	BAND, HOSE 62	1				
16	GJ1-U759B-00	MAT 1	2				
17	GJ1-U759C-00	MAT 2	1				
18	GH1-U759D-00	MAT 3	1				
19	F2N-U7831-10	CAP, FUEL FILLER	1				BLACK
20	GP7-U7832-01	PACKING	1				
21	GP7-U7833-11	SOCKET	1				BLACK
22	GP7-U7835-00	CHAIN BALL	1				
23	90169-049U1	TAPPING SCREW	1				
24	GP7-U7834-00	PACKING FUEL FILLER	1				
25	90267-329UR	RIVET, BLIND	1				
26	GP7-U783F-00	NUT, FUEL FILLER	1				
27	F2V-U7844-00	HOSE	1				

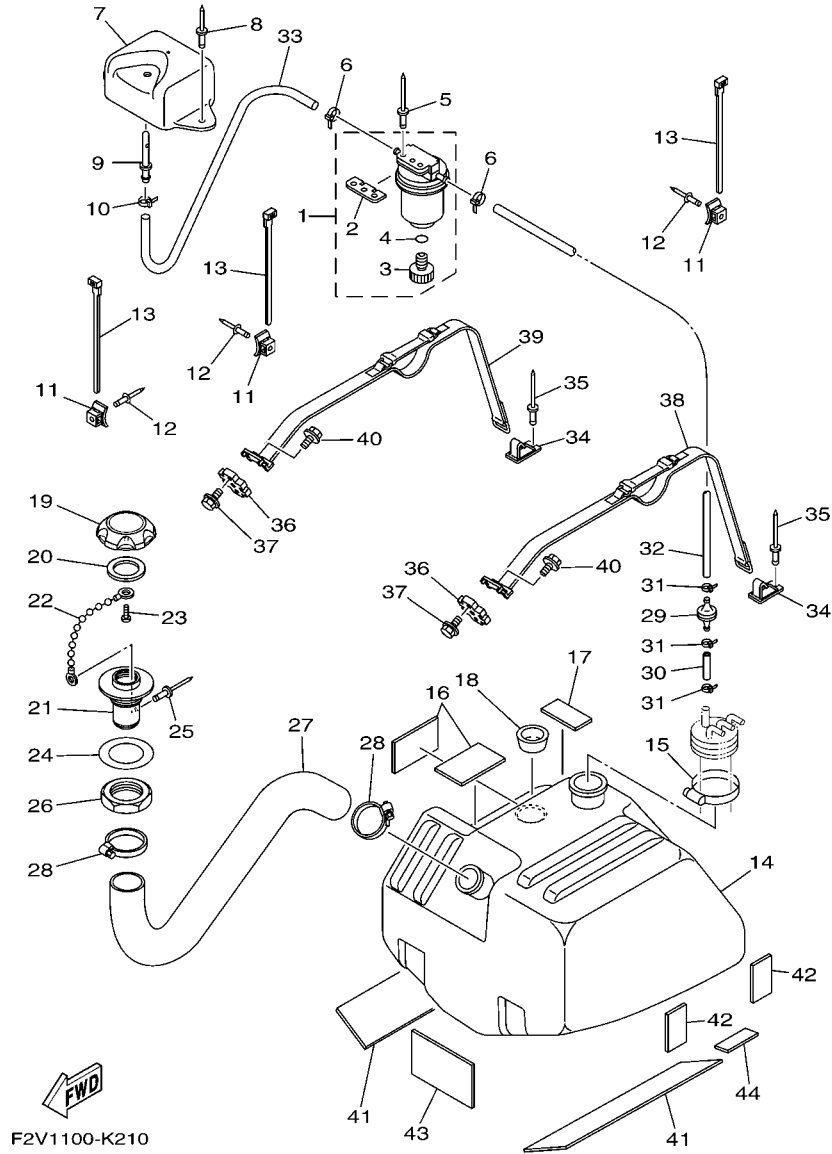


FIG. 21 FUEL TANK

REF. NO.	PART NO.	DESCRIPTION	QTY				REMARKS
28	90601-155U4	BAND, HOSE 55	2				
29	EU0-67767-31	CHECK VALVE	1				
30	GP7-U785H-00	HOSE, AIR VENT 3	1				
31	90465-11829	CLAMP	3				
32	GJ3-U7856-10	HOSE, AIR VENT 3	1				
33	F0D-U7856-10	HOSE, AIR VENT 3	1				
34	F1K-U5772-04	HOOK A	2				
35	90267-489U1	RIVET,BLIND	2				
36	F1X-U2873-00	NUT, SPECIAL	2				
37	90119-06830	BOLT, WITH WASHER	4				
38	F2N-67743-00	BELT, TANK 1	1				
39	F2C-67743-00	BELT, TANK 1	1				
40	90119-089U7	BOLT, WITH WASHER	2				
41	F1K-U759B-00	MAT 1	2				
42	F1W-U759C-01	MAT 2	2				
43	F1W-U8831-01	BED,TANK 1	1				
44	F1K-U759C-00	MAT 2	2				

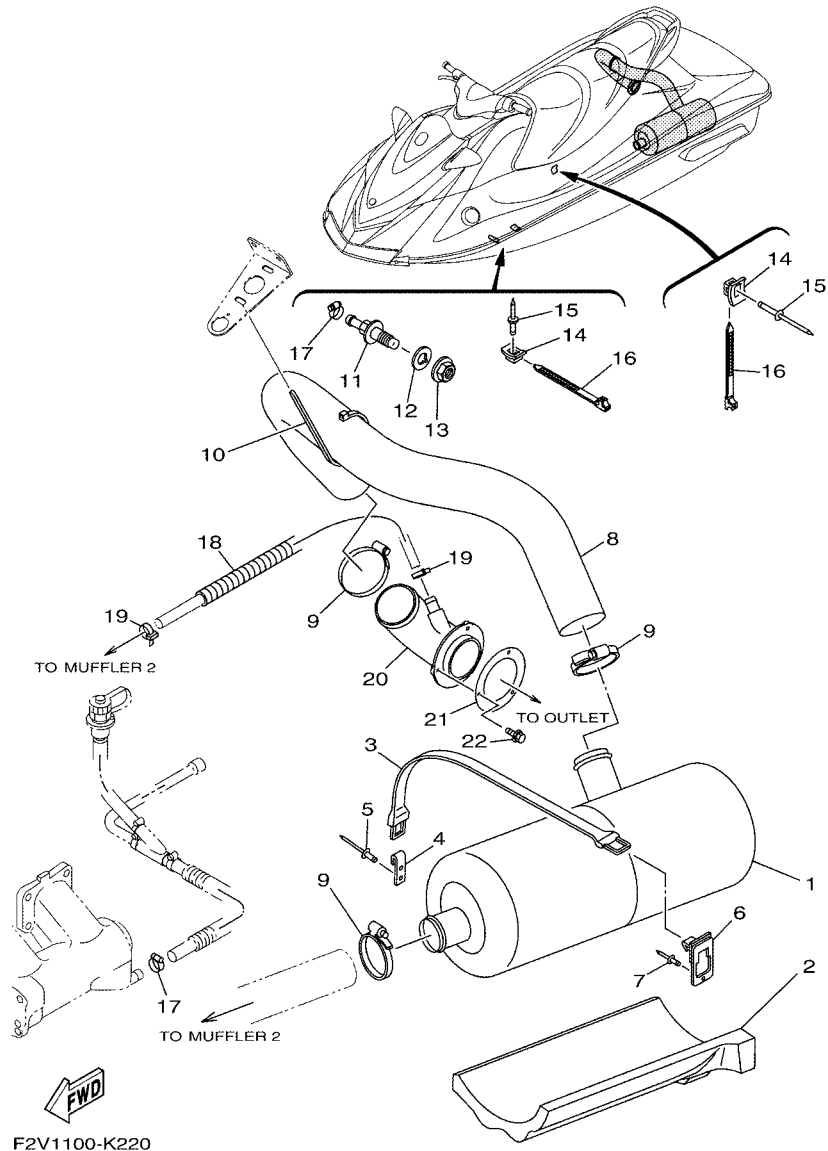
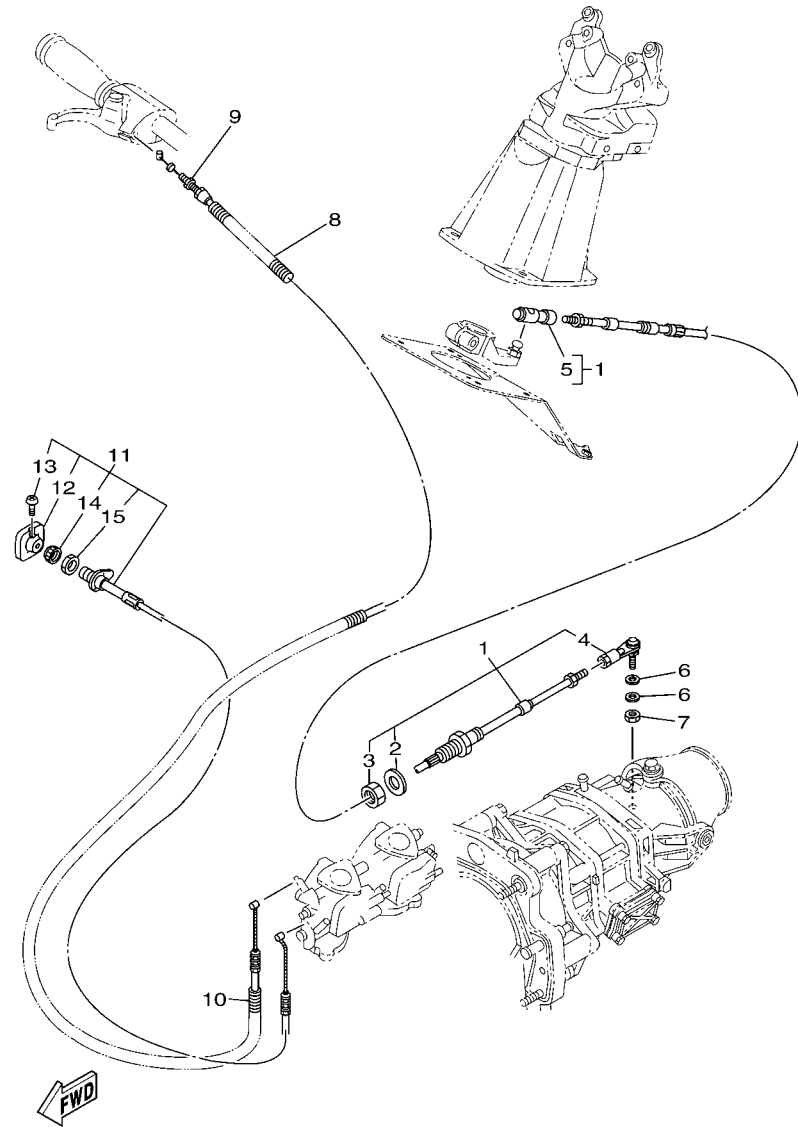


FIG. 22 EXHAUST 2

REF. NO.	PART NO.	DESCRIPTION	QTY				REMARKS
1	F2V-U7550-00	WATER LOCK COMP.	1				
2	F2V-U892F-00	FLOATATION, BASE 1	1				
3	EU0-U821D-00	BAND,BATTERY 1	1				
4	GA7-65772-00	HOOK A	1				
5	90267-489U1	RIVET,BLIND	2				
6	F1K-U5772-04	HOOK A	1				
7	90267-489U1	RIVET,BLIND	1				
8	F1V-U7555-00	HOSE, EXHAUST	1				
9	90601-170UG	BAND, HOSE 70	3				
10	90601-200U7	BAND	1				
11	F1G-6753B-00	PILOT, WATER	1				
12	F1B-67564-00	GASKET	1				
13	FOX-62733-00	NUT	1				
14	F1W-U828M-00	BASE, CLAMP	2				
15	90267-489U6	RIVET, BLIND	2				
16	90464-32801	CLAMP	2				
17	90601-118UF	BAND, HOSE 18	3				
18	90447-22800	TUBE	1				
19	90601-200U1	BAND	2				
20	GJ3-U7560-01	EXHAUST, THRU-HALL COMP.	1				
21	GA9-U7525-00	PACKING	1				
22	90119-059U4	BOLT, WITH WASHER	3				

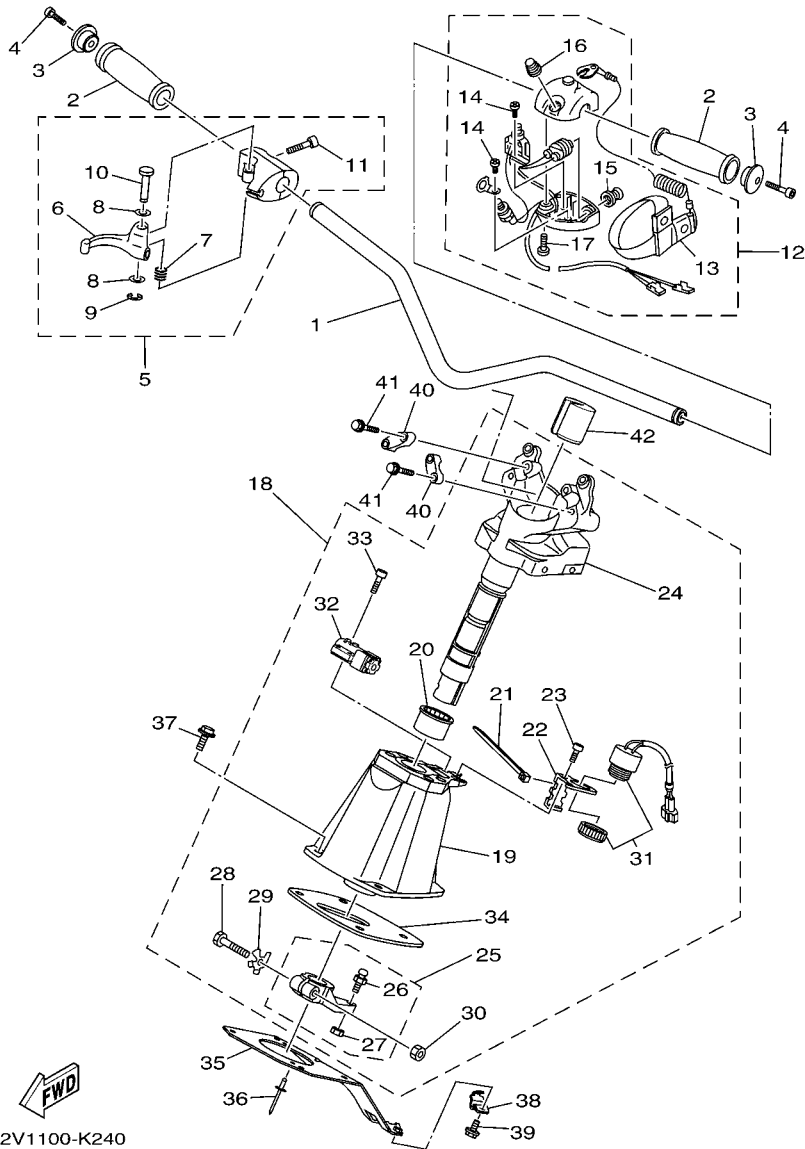




F2V1100-K230

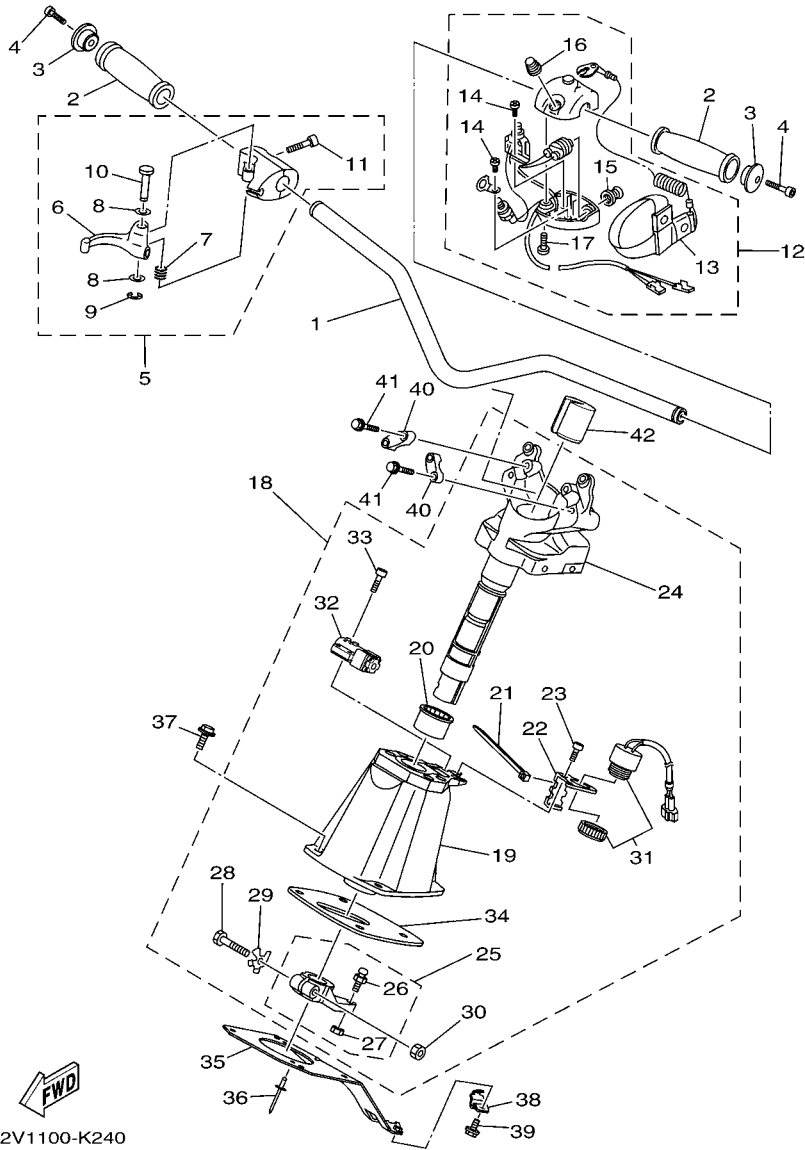
FIG. 23 CONTROL CABLE

REF. NO.	PART NO.	DESCRIPTION	QTY				REMARKS
1	F2N-61481-00	CABLE, STEERING	1				
2	F1B-61438-00	.PACKING	1				
3	F1B-6151S-00	.NUT	1				
4	F1B-61461-02	.STUD, JOINT BALL	1				
5	F2N-61460-00	.BALL JOINT ASSY	1				
6	90201-06906	WASHER, PLATE	2				
7	9538R-06700	NUT	1				
8	90447-06803	TUBE	1				
9	F0M-U7252-00	CABLE, THROTTLE	1				
10	90447-09800	TUBE	1				
11	F1V-67242-01	CABLE, CHOKE	1				
12	EW2-67243-00	.KNOB	1				
13	90149-03930	.SCREW	1				
14	F0N-6724E-00	.NUT, COMPRESSION	1				
15	F0P-6724F-00	.NUT	1				



**FIG. 24 STEERING 1**

REF. NO.	PART NO.	DESCRIPTION	QTY				REMARKS
1	F2N-U1552-00	HANDLE	1				
2	GP7-U155D-01	GRIP, HANDLE	2				
3	GP7-U155F-00	GRIP, END	2				
4	90110-05908	BOLT, HEXAGON SOCKET HEAD	2				
5	F0D-67250-10	THROTTLE LEVER ASSY	1				
6	F0D-67255-02	.LEVER, THROTTLE	1				
7	EW2-67256-00	.SPRING	1				
8	EW2-67258-01	.WASHER	2				
9	EW2-67259-01	.E-RING	1				
10	F0D-67257-00	.SHAFT	1				
11	F1X-6725F-01	.BOLT, THROTTLE	2				
12	FK7-68310-07	SWITCH BOX ASSY	1				
13	EW2-68348-00	.LANYARD, STOP SWITCH	1				
14	97880-03008	.SCREW, PAN HEAD	2				
15	FK7-68312-02	.STOP BUTTON COMP	1				
16	FK7-68313-02	.START BUTTON COMP.	1				
17	97880-05025	.SCREW, PAN HEAD	2				
18	F1V-61400-00	STEERING MASTER ASSY	1				
19	F1K-6152M-00	.HOUSING ASSY	1				
20	F1K-6134M-00	.BUSH	1				
21	703-82591-00	.BAND	2				
22	F1K-6146H-10	.SPACER, BRKT.	1				
23	F1B-613C1-00	.SCREW	2				
24	F1K-6152D-00	.SHAFT	1				
25	F1K-6153R-00	.ARM ASSY.	1				
26	EU0-61461-02	..STUD, JOINT BALL	1				
27	95720-06300	..NUT, SELF-LOCKING	1				



F2V1100-K240

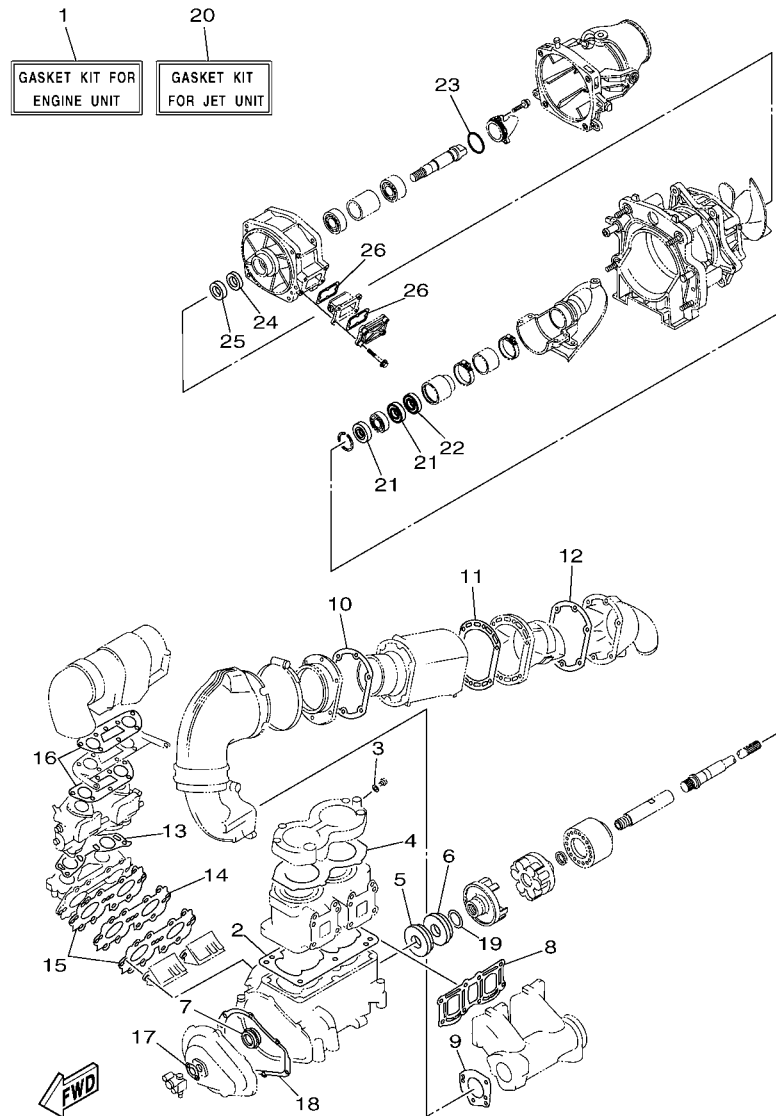
FIG. 24 STEERING 1

REF. NO.	PART NO.	DESCRIPTION	QTY				REMARKS
28	F1K-61355-00	.BOLT	1				
29	F1K-6142B-00	.PLATE, RETAINING	1				
30	95720-08300	.NUT, SELF-LOCKING	1				
31	F1S-68341-00	.BUZZER	1				
32	F1V-82144-00	.CASE ASSY.	1				
33	F1W-61516-00	.BOLT	4				
34	F1K-6143C-00	.SEAL, RUBBER	1				
35	F1K-U1467-01	BRACKET, STOPPER CABLE	1				
36	90267-489U2	RIVET, BLIND	2				
37	90119-08836	BOLT, WITH WASHER	4				
38	F1K-U1468-03	STOPPER, CABLE	1				
39	90119-069UH	BOLT, WITH WASHER	1				
40	EU0-23814-31	HOLDER, HANDLE UPPER	2				
41	90119-08827	BOLT, WITH WASHER	4				
42	F1K-U1949-00	PLUG	1				





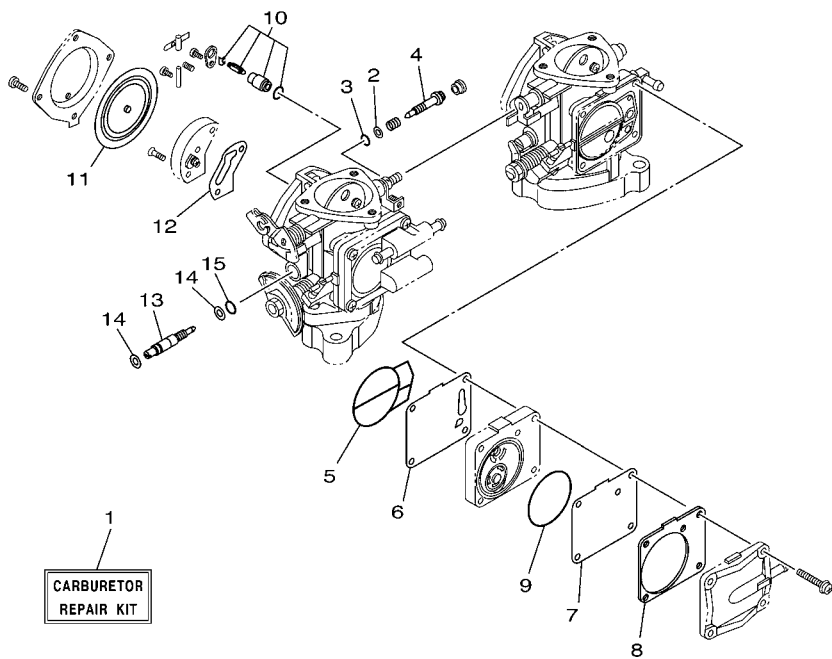




FOV1100-E280

FIG. 28 REPAIR KIT 1

REF. NO.	PART NO.	DESCRIPTION	QTY				REMARKS
1	62T-W0001-02	GASKET KIT FOR ENGINE UNIT	1				
2	6M6-11351-A2	.GASKET, CYLINDER	1				
3	90430-08020	.GASKET	1				
4	62T-11181-01	.GASKET, CYLINDER HEAD 1	1				
5	93102-36M33	.OIL SEAL	1				
6	93101-36M46	.OIL SEAL	1				
7	93103-32M01	.OIL SEAL	1				
8	62T-14613-01	.GASKET, EXHAUST PIPE	1				
9	62T-14749-02	.GASKET, MUFFLER DAMPER 2	1				
10	62T-41114-01	.GASKET, EXHAUST OUTER COVER	1				
11	62T-41122-00	.GASKET, EXHAUST INNER COVER	1				
12	62T-41124-00	.GASKET, EXHAUST OUTER COVER	1				
13	62T-13556-00	.GASKET, MANIFOLD	1				
14	62T-13624-00	.PLATE, REED VALVE	1				
15	62T-13566-00	.GASKET	2				
16	62T-13674-00	.GASKET, AIR COOLER COVER 1	2				
17	6R8-13116-A0	.GASKET, PUMP CASE	1				
18	6M6-81365-A0	.GASKET, HOLE COVER	1				
19	62T-45127-00	.SEAL	1				
20	6D3-W0001-20	GASKET KIT FOR JET UNIT	1				
21	93101-25M55	.OIL SEAL	2				
22	93101-25M56	.OIL SEAL	1				
23	93210-464A3	.O-RING	1				
24	93101-21002	.OIL SEAL	1				
25	93101-21001	.OIL SEAL	1				
26	66V-42414-00	.O-RING	2				



1  
CARBURETOR  
REPAIR KIT



GM6D100-9250

FIG. 29 REPAIR KIT 2

REF. NO.	PART NO.	DESCRIPTION	QTY				REMARKS
1	67E-W0093-00	CARBURETOR REPAIR KIT	1				
2	812-14235-00	.WASHER, NEEDLE	4				
3	812-14147-00	.O-RING	2				
4	6K8-14946-10	.METERING NEEDLE	2				
5	6K8-14564-00	.O-RING	2				
6	6K8-24411-20	.DIAPHRAGM	1				
7	6K8-24421-10	.VALVE, CHECK	1				
8	6K8-24431-20	.GASKET, FUEL PUMP 1	1				
9	6K8-14563-00	.O-RING	1				
10	61X-14916-16	.JET NEEDLE COMP.	2				
11	6R7-14541-00	.DIAPHRAGM, PUMP	2				
12	6K8-14536-11	.GASKET	2				
13	65U-14923-10	.SCREW, PILOT	2				
14	822-14235-00	.WASHER, NEEDLE	4				
15	583-14561-00	.O-RING	2				



NUMERICAL INDEX

PART NO.	REF. NO.	PART NO.	REF. NO.	PART NO.	REF. NO.	PART NO.	REF. NO.	PART NO.	REF. NO.	PART NO.	REF. NO.
62T-11111-00-8S	1 - 8	3G2-14231-26	4 - 11	62T-14721-00-8S	6 - 23	62T-41124-00	28 - 12	EW2-62142-00	21 - 2	6M6-81840-10	11 - 3
62T-11181-01	1 - 12	812-14235-00	4 - 4	62T-14749-02	6 - 7	66V-42414-00	8 - 10	F1G-62149-00	21 - 9	11H-81844-00	11 - 4
	28 - 4		29 - 2		28 - 9		28 - 26	F2F-6214A-00	21 - 1	6M6-81844-00	12 - 8
62T-11311-00-8S	1 - 1	822-14235-00	4 - 41	6AE-14752-00	6 - 47	62E-44517-A1-8P	1 - 27	GJ3-6215F-00	13 - 12	26H-81847-00	11 - 9
6E5-11325-00	1 - 2		29 - 14	62T-14771-00-94	6 - 44	6CP-44532-00	1 - 19	FOX-62733-00	22 - 13	6M6-81850-00	11 - 6
6M6-11351-A2	1 - 5	830-1423A-64	4 - 25	61X-14916-16	4 - 32	62T-45127-00	2 - 25	GU2-62875-01	14 - 19	6M6-81865-00	11 - 17
	28 - 2	62T-14251-10	1 - 16		29 - 10		28 - 19	FOX-6378C-00	19 - 6	6M6-81866-00	11 - 16
6E5-11372-01	3 - 23	6R7-14253-00	4 - 34	65U-14923-10	4 - 39	66V-45214-00-94	8 - 11	F1K-6517C-00	15 - 6	6M6-81921-00	12 - 6
62T-11400-02	2 - 1	62T-14255-00	3 - 28		29 - 13	6D3-45235-00	9 - 3	FOX-6517R-01	14 - 18	68N-81940-00	12 - 17
6M6-11412-00	2 - 2	62T-14283-01	3 - 34	3KW-14932-00	4 - 9	6D3-45332-00-94	9 - 2	GA7-65772-00	22 - 4	6M6-81960-A0	12 - 21
6M6-11422-00	2 - 3	62T-14284-01-8S	3 - 22	6K8-14946-10	4 - 7	6D3-45511-00	8 - 19	EU0-65901-01	26 - 11	EU0-82110-09	13 - 4
6M6-11431-10	2 - 4	62T-14293-00	4 - 20		29 - 4	6D3-45514-00	8 - 16	EU0-65986-00	26 - 10	6AE-82117-00	13 - 30
6M6-11442-01	2 - 5	62T-14301-03	4 - 1	62T-15100-00-8S	1 - 15	62T-45526-00	2 - 13	F1V-67242-01	23 - 11	63N-82117-11	13 - 31
65U-11515-00	2 - 10	62T-14302-03	4 - 2	63N-15761-00	6 - 41	65V-45538-00	8 - 14	EW2-67243-00	23 - 12	6AE-82117-20	12 - 42
61X-11603-01	2 - 19	62T-14419-00	3 - 35	6R7-21415-01-94	1 - 21	6M6-45813-22-8P	9 - 10	F0N-6724E-00	23 - 14	F1V-82144-00	24 - 32
61X-11604-01	2 - 19	62T-14435-00	3 - 37	6R7-21425-01-94	1 - 22	6M6-45813-32-8P	2 - 24	F0P-6724F-00	23 - 15	6K8-82150-01	12 - 10
61X-11605-01	2 - 19	62T-14451-00	3 - 33	EU0-23814-31	24 - 40	61X-4581J-00	9 - 1	F0D-67250-10	24 - 5	6G1-82151-00	12 - 11
62T-11631-02-92	2 - 18	6K8-14471-10	4 - 8	6CP-24312-00	7 - 4	66V-46882-00	8 - 9	F0D-67255-02	24 - 6	6K8-82159-00	12 - 12
62T-11633-00	2 - 20	6H1-14485-00	3 - 24	6CP-24313-00	7 - 1	6K8-51129-00	1 - 9	EW2-67256-00	24 - 7	62E-82351-01	12 - 27
62T-11635-02	2 - 18	62T-14485-10	6 - 24	62T-24313-01	3 - 1		6 - 2	F0D-67257-00	24 - 10	62E-82352-01	12 - 29
62T-11636-02	2 - 18	6M6-14503-00	4 - 10	62T-24314-01	3 - 20		6 - 6	EW2-67258-01	24 - 8	62T-82361-00	12 - 36
64X-11651-01	2 - 7	6K8-14503-02	4 - 23	6G8-24376-00	7 - 17	61X-51162-00	16 - 2	EW2-67259-01	24 - 9	62E-82371-11	12 - 26
82M-11685-00	2 - 8	6K8-14521-00	4 - 43	6R3-24377-00	6 - 33	66V-51312-01-94	8 - 5	F1X-6725F-01	24 - 11		12 - 28
6AE-12564-00	6 - 55	6M6-14521-00	4 - 5	63N-24378-00	6 - 14	66V-51315-01	8 - 8	F1G-6753B-00	22 - 11	6AE-82553-00	12 - 38
64T-12580-00	6 - 56	6K8-14521-10	4 - 24	6K8-24411-20	4 - 14	6AE-51323-00	9 - 9	F1B-67564-00	22 - 12	62T-82560-11	12 - 39
64X-12581-00	6 - 52	6K8-14523-11	4 - 30		29 - 6	63N-51381-00	9 - 14	F2C-67743-00	21 - 39	703-82591-00	24 - 21
6R8-13116-A0	5 - 5	62T-14527-02	3 - 17	6R7-24412-01	4 - 29	F1K-6134M-00	24 - 20	F2N-67743-00	21 - 38	6B6-83623-00	12 - 43
	28 - 17	6K8-14527-11	4 - 27	6M6-24413-01	4 - 15	F1K-61355-00	24 - 28	FJ0-67766-00	20 - 16	682-84385-01	6 - 57
67X-13183-00	5 - 9	6K8-14536-11	4 - 37	65U-24421-00	4 - 16	F1B-613C1-00	24 - 23	EU0-67767-31	21 - 29	62T-85515-00	10 - 6
	5 - 14		29 - 12	6K8-24421-10	4 - 18	F1V-61400-00	24 - 18	F2N-67823-00	15 - 18	62T-85520-01	10 - 3
61X-13200-12	5 - 1	6R7-14541-00	4 - 35		29 - 7	F1K-6142B-00	24 - 29	F2N-67823-10	14 - 15	62L-8552A-00-8P	12 - 4
6J8-13411-00	20 - 2		29 - 11	6K8-24431-20	4 - 19	F1B-61438-00	23 - 2	F1V-6820A-01	13 - 14	6M6-8552E-01	12 - 5
6J8-13414-00	20 - 3	6R7-14542-00	4 - 36		29 - 8	F1K-6143C-00	24 - 34	GU2-6822E-01	13 - 16	62T-85533-00	10 - 4
62T-13555-00-94	3 - 6	6K8-14547-01	4 - 33	6K8-24452-10	4 - 20	F2N-61460-00	23 - 5	FK7-68310-07	24 - 12	62T-85540-01	12 - 13
62T-13556-00	3 - 5	583-14561-00	4 - 42	70R-24489-00	21 - 4	EU0-61461-02	24 - 26	FK7-68312-02	24 - 15	62T-85550-00	10 - 1
	28 - 13		29 - 15	65U-24492-00	4 - 17	F1B-61461-02	23 - 4	FK7-68313-02	24 - 16	62T-85560-00	10 - 2
62T-13566-00	3 - 8	6K8-14563-00	4 - 22	66V-24500-02	7 - 8	F1K-6146H-10	24 - 22	F1S-68341-00	24 - 31	62E-85570-11	12 - 25
	28 - 15		29 - 9	6K8-24524-10	7 - 9	F2N-61481-00	23 - 1	EW2-68348-00	24 - 13	6M6-85580-00	10 - 5
62T-13610-00	3 - 13	6K8-14564-00	4 - 13	70R-24543-00	21 - 3	F1W-61516-00	24 - 33	6M6-8132W-00	12 - 9	67X-E2590-10	6 - 59
62T-13624-00	3 - 7		29 - 5	66V-24560-01	7 - 7	F1B-6151S-00	23 - 3	6R8-81337-00-8S	10 - 14	6AE-G5831-00	8 - 2
	28 - 14	6R7-14569-00	4 - 31	62T-41113-00-8S	6 - 26	F1K-6152D-00	24 - 24	6M6-81365-A0	10 - 16	F0V-H369N-00	13 - 20
62T-13674-00	3 - 27	6K8-14589-00	4 - 40	62T-41114-01	6 - 27	F1K-6152M-00	24 - 19		28 - 18	6BU-R1313-00-94	8 - 33
	28 - 16	62T-14613-01	6 - 3		28 - 10	F1K-6153R-00	24 - 25	6M6-81800-10	11 - 1	6BU-R1318-00	8 - 25
	4 - 3		28 - 8	62T-41121-00-8S	6 - 37	F1K-61624-00	16 - 17	3AJ-81809-00	11 - 2	6D3-R1319-00	8 - 23
47X-14133-00	4 - 6	62T-14615-01	6 - 32	62T-41122-00	6 - 38	FOX-61637-00	16 - 20	6M6-81820-00	11 - 7	6AE-R1321-00	8 - 24
812-14147-00	29 - 3	62T-14625-00	6 - 30		28 - 11	EU0-61652-00	6 - 58	6M6-81826-00	11 - 5	65A-R1326-10	8 - 20
	4 - 28	62T-14711-10-94	6 - 1	62T-41123-01-8S	6 - 39		16 - 5	6M6-81830-00	11 - 8	6D3-R1333-01-94	8 - 1
3G2-14231-24	4 - 12	62T-14712-00-94	6 - 5	62T-41124-00	6 - 40	FOX-61652-00	16 - 21	6M6-8183E-01	11 - 15	6D3-R1341-00	8 - 32

NUMERICAL INDEX

PART NO.	REF. NO.	PART NO.	REF. NO.	PART NO.	REF. NO.	PART NO.	REF. NO.	PART NO.	REF. NO.	PART NO.	REF. NO.
F1K-U135C-01	15 - 11	F2N-U371B-00	19 - 2	F1K-U5983-01	15 - 31	F0D-U7856-10	21 - 33	90109-10M47	10 - 13	90154-06017	25 - 5
F1K-U142D-00	25 - 4	GH1-U3774-00	19 - 10	F2V-U721B-00	1 - 29	GJ3-U7856-10	21 - 32	90110-05908	24 - 4	90159-04800	7 - 22
F2N-U142L-00	14 - 16	F2C-U3850-00	19 - 4	F2V-U721B-10	1 - 30	F0D-U785G-10	13 - 10	90110-06040	16 - 22	90167-04003	25 - 7
F1K-U143D-01	25 - 2	F1B-U411C-02	26 - 8	F2V-U721B-20	1 - 31	GP7-U785H-00	21 - 30	90111-05009	13 - 15	90169-049U1	21 - 23
F1K-U143E-01	25 - 3	F0V-U411C-10	26 - 7	F0M-U7252-00	23 - 9	GU2-U785H-00	20 - 20	90111-06803	17 - 3	90170-22187	7 - 20
F1K-U1467-01	24 - 35	F1K-U411H-00	26 - 9	F1S-U725E-01	8 - 36	F1V-U815D-00	12 - 1	90116-08M60	3 - 3	90179-08M15	3 - 4
F1K-U1468-03	24 - 38	F1B-U415B-11	27 - 5	EU0-U7354-00-01	1 - 34	F2N-U8169-00	16 - 27	90119-059U4	15 - 7	90183-06902	14 - 12
F2N-U1552-00	24 - 1	GJ3-U416H-01	27 - 8	EU0-U7354-00-03	1 - 34	F1K-U8211-01	13 - 6		22 - 22	90201-06906	23 - 6
GP7-U155D-01	24 - 2	F2V-U417D-00	26 - 1	EU0-U7354-00-05	1 - 34	EU0-U821D-00	22 - 3	90119-05M02	3 - 36	90201-06M31	3 - 32
GP7-U155F-00	24 - 3	F2V-U417E-00	26 - 2	EU0-U7354-00-10	1 - 34	F1K-U821D-01	13 - 9	90119-06827	8 - 52	90201-099U3	1 - 33
F1K-U156E-01	25 - 1	F2V-U417F-00	26 - 3	EU0-U7354-00-20	1 - 34	F1K-U8221-00	13 - 5	90119-06830	21 - 37		19 - 7
F2N-U1628-00	16 - 13	F2V-U417G-00	26 - 4	F2V-U7437-00	14 - 21	F0V-U824B-04	13 - 19	90119-06880	14 - 13	90201-10801	8 - 37
	19 - 17	F2V-U417H-00	26 - 5	F2V-U7437-10	14 - 23	GJ8-U824C-02	13 - 21		15 - 21	90201-109U6	19 - 11
F1B-U1653-01	16 - 16	F2V-U417J-00	26 - 6	GA9-U7525-00	22 - 21	F1V-U826C-01	19 - 19	90119-06882	14 - 14	90201-20M04	2 - 22
F1K-U1949-00	24 - 42	F1G-U418F-00	27 - 9	F2V-U7550-00	22 - 1	F1K-U826C-03	16 - 33	90119-06889	8 - 22	90201-24800	9 - 11
F1K-U2127-00	18 - 1	GJ1-U419F-21	27 - 11	F1V-U7555-00	22 - 8	F1K-U828K-00	15 - 32	90119-06891	9 - 12	90202-229U1	7 - 21
F2N-U213B-00	15 - 2	F2N-U41B1-10	27 - 1	F1K-U7557-01	8 - 45	F1W-U828M-00	13 - 1	90119-06893	8 - 6	90267-329UR	21 - 25
F2V-U213G-00	18 - 2	F1B-U41B1-21	27 - 2	GJ3-U7560-01	22 - 20		13 - 24	90119-06896	8 - 43	90267-40935	20 - 10
F1V-U2155-01	9 - 17	F0V-U41B1-31	27 - 3	GJ1-U7578-21	13 - 18		16 - 8	90119-06897	8 - 12	90267-48806	18 - 8
F1W-U2159-00	21 - 7	F1B-U41B2-01	27 - 4	F1K-U757E-01	8 - 49		18 - 3	90119-069UH	24 - 39	90267-48824	14 - 22
F2N-U2187-00	18 - 6	F0V-U41DB-12	27 - 6	F1K-U757F-01	8 - 50		18 - 9	90119-069UP	19 - 5		14 - 24
F2N-U2188-00	18 - 7	F0V-U41E1-41	27 - 10	F1K-U759B-00	21 - 41		20 - 17	90119-08800	8 - 55	90267-48963	17 - 12
F1S-U2280-00	16 - 28	F1B-U41F5-21	27 - 7	GJ1-U759B-00	21 - 16		21 - 11	90119-08827	24 - 41	90267-489U1	13 - 8
F1S-U2285-00	16 - 29	F2N-U471E-00	15 - 23	F1K-U759C-00	15 - 30		22 - 14	90119-08829	1 - 32		15 - 29
F2N-U2511-01	17 - 1	F1K-U471E-03	15 - 13		16 - 35	F1G-U8572-02	8 - 41		8 - 40		16 - 34
F1K-U2512-03	17 - 6	F2N-U471F-00	15 - 25		21 - 44	F1K-U8577-01	8 - 42	90119-08836	24 - 37		20 - 15
F1K-U2519-02	17 - 7	F2N-U475B-02	14 - 3	GJ1-U759C-00	21 - 17	F1W-U8831-01	21 - 43	90119-08840	8 - 34		21 - 35
F1K-U251D-01	17 - 10	F1W-U475F-01	14 - 7	F1W-U759C-01	21 - 42	F1K-U883B-00	9 - 20	90119-08856	1 - 28		22 - 5
F1K-U251E-01	17 - 11	F1W-U491K-00	17 - 2	GH1-U759D-00	21 - 18	F1K-U883E-01	9 - 15	90119-089U1	9 - 18		22 - 7
F2N-U2663-01	15 - 4	GP7-U4953-10	16 - 15	F1B-U761D-02	16 - 7	F2N-U883N-00	16 - 23	90119-089U2	19 - 14	90267-489U2	21 - 5
F2N-U2664-00	19 - 3		19 - 18	GU2-U7711-01	21 - 14	F2N-U883P-00	16 - 24	90119-089U7	21 - 40		24 - 36
F1K-U266B-00	15 - 5	F1K-U515A-00	15 - 8	F1V-U775B-00	20 - 1	F1X-U883T-01	16 - 25	90119-08M11	6 - 11	90267-489U6	13 - 3
F1K-U266C-00	14 - 11	F2N-U516N-00-P8	14 - 9	F2V-U776C-00	20 - 12	F2V-U892F-00	22 - 2	90119-08M55	1 - 18		13 - 25
F2N-U266C-00	14 - 4	F2N-U516P-00	14 - 10	F0X-U778B-00	20 - 6	62T-W0001-02	28 - 1	90119-08M96	1 - 13		18 - 4
F1W-U269B-00	16 - 4	F2N-U517B-10-P6	15 - 1	GJ3-U778C-00	20 - 4	6D3-W0001-20	28 - 20	90119-10806	8 - 31		18 - 10
F2N-U271B-01	19 - 9	F1K-U517D-05	15 - 10	F0X-U778D-00	20 - 7	62T-W0004-00	3 - 14	90119-10809	8 - 44		20 - 19
F2N-U2723-00	14 - 1	F1X-U517E-01	15 - 20	F0X-U778E-01	20 - 5	62T-W0090-03-8S	1 - 14	90119-10810	8 - 4		21 - 8
F2N-U273B-00	8 - 39	F2N-U517F-00	15 - 19	F0X-U778H-01	20 - 11	67E-W0093-00	29 - 1	90119-10M00	1 - 24		21 - 12
F1V-U273C-01	13 - 22	F2N-U517H-01	14 - 17	EU0-U7817-00	7 - 23	90101-069U0	8 - 53	90119-10M01	1 - 26		22 - 15
F1K-U283B-02	15 - 14	F1K-U517R-00	15 - 12	F1V-U781E-01	20 - 14	90105-06826	15 - 15	90119-10M02	1 - 23	90267-489U8	16 - 10
F1X-U2873-00	21 - 36	F1K-U518E-04	15 - 9	F2N-U7831-10	21 - 19	90105-08860	16 - 26	90119-10M03	1 - 25		17 - 8
F2N-U351H-00	17 - 14	F2N-U519D-00	14 - 20	GP7-U7832-01	21 - 20	GP7-U7833-11	6 - 4	90119-10M07	1 - 7	90269-08801	14 - 2
F2N-U351J-00	17 - 15	F1K-U5772-04	13 - 7	GP7-U7833-11	21 - 21	GP7-U7834-00	6 - 25	90119-10M17	6 - 45		14 - 6
F2N-U351K-00	17 - 16		15 - 28	GP7-U7834-00	21 - 24	90105-10M88	6 - 46	90119-10M56	1 - 6		14 - 8
F2N-U351M-00	17 - 17		21 - 34	EU0-U7835-00	20 - 8	90109-06832	9 - 16	90149-03930	23 - 13	90280-05013	10 - 12
F2N-U351N-00	17 - 18		22 - 6	GP7-U7835-00	21 - 22	90109-06M66	3 - 31	90149-05903	15 - 3	90340-08M04	1 - 10
F2N-U3581-00	17 - 13	F2N-U596B-00	15 - 22	GP7-U783F-00	21 - 26	90109-08041	8 - 46		25 - 6	90380-12M29	1 - 17
F2N-U371A-03	19 - 1	F2N-U596C-00	15 - 24	F2V-U7844-00	21 - 27	90109-08M56	1 - 20	90150-05807	13 - 23		10 - 15

NUMERICAL INDEX

PART NO.	REF. NO.	PART NO.	REF. NO.	PART NO.	REF. NO.	PART NO.	REF. NO.	PART NO.	REF. NO.	PART NO.	REF. NO.
90387-06080	8 - 51	90464-32801	22 - 16	90601-200U2	13 - 28	93103-32M01	2 - 17	97013-08035	11 - 11		
90387-06M60	9 - 13	90464-99804	18 - 5		13 - 29		28 - 7	97013-08075	6 - 9		
90387-08M06	8 - 35	90465-06M86	12 - 22	90601-200U7	22 - 10	93210-13M63	3 - 38	97095-06010	12 - 18		
90430-08020	1 - 11	90465-08M69	5 - 18	90605-502U1	14 - 5	93210-464A3	8 - 21	97095-06016	12 - 40		
	28 - 3	90465-11829	7 - 16	92903-06600	3 - 10		28 - 23	97095-06025	10 - 18		
90430-12002	8 - 48		7 - 18		3 - 12	93305-30601	2 - 6	97095-06035	5 - 6		
90445-07008	5 - 13		7 - 19		3 - 19	93306-205A3	9 - 6	97513-08540	11 - 10		
90445-07009	5 - 8		8 - 30		3 - 26	93306-205U0	8 - 15	97780-04110	20 - 9		
90445-11083	5 - 2		13 - 13		3 - 30	93306-207U2	2 - 9	97780-60525	12 - 7		
90445-11085	7 - 12		20 - 21		6 - 29	93306-27211	8 - 13	97802-04008	10 - 9		
90445-11086	7 - 14		21 - 6		6 - 43	93306-307U3	2 - 12	97880-03008	24 - 14		
90445-11089	7 - 10		21 - 10		11 - 21	93310-320U2	2 - 21	97880-05012	4 - 38		
90445-14008	8 - 28		21 - 31	92903-08600	6 - 10	93310-525U3	2 - 11	97880-05016	3 - 15		
90445-14M07	6 - 16	90465-11M10	3 - 2		11 - 12	93430-47M04	9 - 5	97880-05025	24 - 17		
90445-14M14	6 - 50		3 - 21	92990-05600	3 - 16	93440-25M08	11 - 18	97880-06016	10 - 10		
90445-14M24	6 - 12		5 - 3	92990-06100	11 - 13	93440-80023	2 - 14		12 - 15		
90445-14M25	6 - 18		5 - 11	92990-06600	10 - 11	93450-18M06	11 - 19		12 - 23		
90445-16006	8 - 26		5 - 16		12 - 16	93450-21053	2 - 23		12 - 34		
90445-20805	16 - 1		6 - 13		12 - 24	93603-10049	2 - 26	97880-06030	12 - 32		
90445-21009	6 - 49		6 - 19		12 - 33	93604-07141	2 - 27	9788R-05025	16 - 30		
90445-21010	6 - 15		6 - 21		12 - 35	93605-12M21	6 - 8	97902-04122	10 - 8		
90446-07M18	5 - 10		6 - 34	92990-12200	8 - 47	93606-12019	1 - 4	97902-05125	10 - 7		
90446-07M48	5 - 15		7 - 6		16 - 19		8 - 7	97980-05330	4 - 21		
90446-20M13	6 - 51		7 - 11	92995-06100	12 - 19		10 - 17	98580-05018	4 - 26		
90446-20M31	6 - 20		7 - 13		12 - 41	94702-00195	12 - 37	98780-04015	1 - 3		
90446-20MF5	8 - 29		7 - 15	92995-06600	5 - 7	95380-06700	11 - 14	99590-14016	8 - 3		
90447-06803	23 - 8		12 - 31		10 - 19	9538R-06700	23 - 7	99780-12600	16 - 18		
90447-09800	23 - 10	90465-11M59	6 - 22		12 - 20	95720-06300	24 - 27				
90447-13006	7 - 2	90465-12M56	7 - 3	9299R-05200	16 - 31	95720-08300	24 - 30				
	7 - 5	90467-089U1	13 - 11		17 - 9	9572R-05300	16 - 32				
90447-13013	5 - 4	90467-18804	16 - 3	9299R-06200	15 - 17	9572R-06300	8 - 54				
90447-15004	6 - 17	90467-21800	16 - 12		17 - 4		15 - 16				
90447-22800	22 - 18	90468-02001	5 - 12	9299R-08200	12 - 3		17 - 5				
90450-14M05	6 - 53		5 - 17		15 - 26	9572R-08300	12 - 2				
90450-18M09	6 - 54	90480-06M43	12 - 30		19 - 15		15 - 27				
90450-70M03	6 - 48	90480-06M46	9 - 8	9299R-10200	19 - 12		16 - 14				
90450-99M01	6 - 35	90501-14M73	11 - 20	93101-21001	8 - 17		19 - 8				
90450-99M02	6 - 36	90601-118UF	8 - 27		28 - 25		19 - 16				
90450-99M06	6 - 31		16 - 6	93101-21002	8 - 18		19 - 20				
90464-06M29	12 - 14		22 - 17		28 - 24	9572R-10300	8 - 38				
90464-10M38	5 - 19	90601-142U6	20 - 13	93101-25M55	9 - 4		19 - 13				
90464-32801	13 - 2	90601-155U4	21 - 28		28 - 21	97013-06012	3 - 29				
	13 - 17	90601-162U5	9 - 19	93101-25M56	9 - 7	97013-06016	3 - 18				
	13 - 26		21 - 15		28 - 22	97013-06020	3 - 25				
	16 - 9	90601-170UG	22 - 9	93101-36M46	2 - 16	97013-06025	3 - 11				
	18 - 11	90601-200U1	16 - 11		28 - 6		6 - 28				
	20 - 18		22 - 19	93102-36M33	2 - 15	97013-06035	3 - 9				
	21 - 13	90601-200U2	13 - 27		28 - 5	97013-06070	6 - 42				