



PARTS CATALOGUE

WaveRunner VXR/VX-18R

VX1800A-K (F2M1/6CNA/6CN1)

VX1800A-K (F2M2/6CNB/6CN1)

VX1800A-K (F2M3/6CNB/6CN1)

VX1800A-K
PARTS CATALOGUE
©2010 by Yamaha Motor Co., Ltd.
1st edition, September 2010
All rights reserved.
Any reprinting or unauthorized use
without the written permission of
Yamaha Motor Co., Ltd.
is expressly prohibited.
Printed in Japan.

FOREWORD

This Parts Catalogue is related to the parts for the model(s) on the cover page. When you are ordering replacement parts, please refer to this Parts Catalogue and quote both part numbers and part names correctly.

1. Modifications or additions which have been made after the issue of the Parts Catalogue will be announced in the Parts News.

It is advisable that you make the necessary corrections to the Parts Catalogue according to the Parts News.

2. Abbreviations

The following abbreviations are used in this Parts Catalogue.

“UR” Use specified parts number.

“UN” Use as many as needed.

“AP” Alternate Parts

“LM” Locally Made (Parts need to be ordered locally)

“F#” Frame No. (Applicable machine No.)

“O/S” Over Size

3. The number of components for assembly

- Parts, which are to be supplied in an assembly, are listed with a dot (.) in front of the part name as shown below.
- The numeral appearing to the right of each component part indicates the quantity of parts for each assembly unit.

PART NO.	DESCRIPTION	Q'TY	REMARKS
2F5-83310-60	FRONT FLASHER LIGHT ASSY	2	
115-83311-60	.BULB (6V-18W)	1	

4. Applicable colours of graphics are represented in the “REMARKS” as shown below.

PART NO.	DESCRIPTION	Q'TY	REMARKS
2N4-24110-00-X5	FUEL TANK COMP.	2	MXR
3J1-24240-10	.GRAPHIC, FUEL TANK	1	FOR MXR

5. Note that the illustrations for reference in finding parts numbers are not to be used for assembling. When assembling, please use the applicable service manual.

6. The asterisk (*) before a reference number indicates modified items after the first edition.

FOREWORD

7. Applicable Serial No.

Engine Serial No.

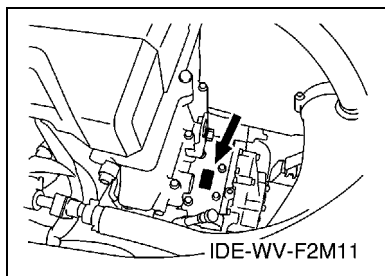

Primary Identification No.

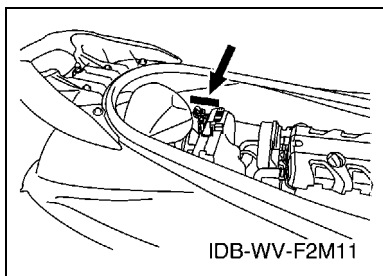

8. Applicable Colour Code (The (*) mark shows Model colour.)

Abbreviation	Colour Name	Colour Code
DPBMT(*)	DEEP PURPLISH BLUE METALLIC T	0978
LGM3(*)	LIGHT GRAY METALLIC 3	0137
LNMP	LIGHT GRAY METALLIC P	0925
SSA	BLACK SOLID A	1000

9. Quantity Column Information

Column No.	Name Of Q'ty Column	Destination
1	CAN	CANADA
2	EUR	EUROPE
3	GENE	EXCEPT CANADA, EUROPE

10. Applicable Starting Serial No.

Engine Serial No.

Serial No.	Name Of Q'ty Column	Model Code
6CN-1000001	CAN	6CNA
6CN-1000001	EUR	6CNB
6CN-1000001	GENE	6CNB

Primary Identification No.

Serial No.	Name Of Q'ty Column	Model Code
F2M-800529	CAN	F2M1
F2M-800101	EUR	F2M3
F2M-800301	GENE	F2M2

CONTENTS

CYLINDER 1	1
CYLINDER 2	2
CRANKCASE	3
CRANKSHAFT & PISTON	5
VALVE	6
INTAKE 1	8
INTAKE 2	10
OIL PUMP	11
OIL PAN	12
OIL COOLER	13
BREATHER OIL	14
EXHAUST 1	15
EXHAUST 2	16
JET UNIT 1	18
JET UNIT 2	20
JET UNIT 3	21
JET UNIT 4	22
GENERATOR	23
STARTING MOTOR	24
ELECTRICAL 1	25
ELECTRICAL 2	27
ELECTRICAL 3	29
ENGINE MOUNT	31
ENGINE HATCH 1	32
ENGINE HATCH 2	33
HULL & DECK	35
GUNWALE & MAT	37
VENTILATION	38
SEAT & UNDER LOCKER	39
FUEL TANK	40
EXHAUST 3	42
CONTROL CABLE	44
STEERING 1	45
STEERING 2	47
GRAPHICS	48
IMPORTANT LABELS	50
IMPORTANT LABELS 2	51
REPAIR KIT 1	52

INDEX

NUMERICAL INDEX	54
-----------------------	----

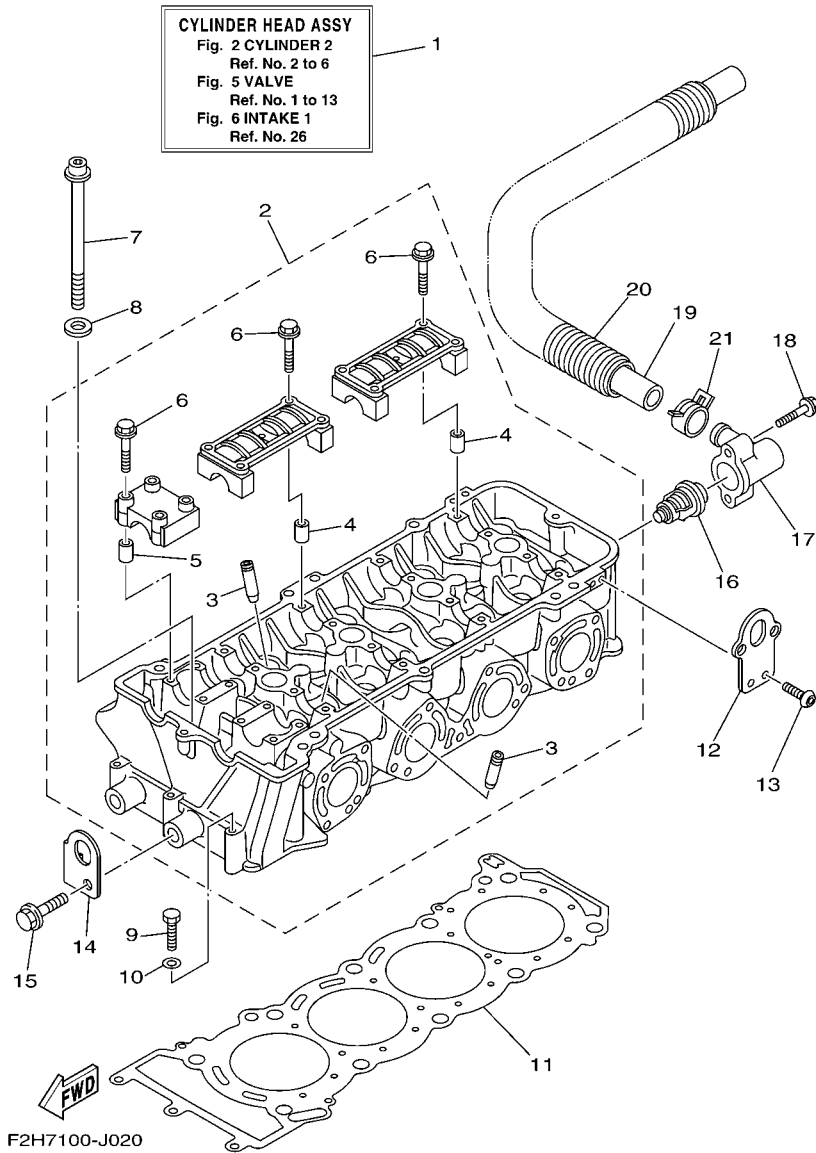

FIG. 2 CYLINDER 2

REF. NO.	PART NO.	DESCRIPTION	CAN	EUR	GENE	REMARKS
1	6BH-W009A-00-94	CYLINDER HEAD ASSY	1	1	1	
2	6BH-11102-00-94	CYLINDER HEAD ASSY	1	1	1	
3	6S5-11133-10	.GUIDE, VALVE 1	16	16	16	
4	91809-16001	.PIN, DOWEL	8	8	8	
5	91809-16001	.PIN, DOWEL	4	4	4	
6	90105-07009	.BOLT, FLANGE	24	24	24	
7	6S5-12228-01	BOLT	10	10	10	
8	90201-12039	WASHER, PLATE	10	10	10	
9	97013-06055	BOLT	3	3	3	
10	92903-06600	WASHER, PLATE	3	3	3	
11	6BH-11181-00	GASKET, CYLINDER HEAD 1	1	1	1	
12	6BH-1111E-00	HANGER, ENGINE 2	2	2	2	
13	92014-06012	BOLT, BUTTON HEAD	4	4	4	
14	6BH-11119-00	HANGER, ENGINE	1	1	1	
15	97513-10525	BOLT, WITH WASHER	1	1	1	
16	6D3-12411-00	THERMOSTAT	1	1	1	
17	6BH-12413-00	COVER, THERMOSTAT	1	1	1	
18	90105-06035	BOLT, FLANGE	2	2	2	
19	6S5-12578-00	HOSE 3	1	1	1	
20	90447-28008	TUBE	1	1	1	
21	90467-240A0	CLIP	1	1	1	

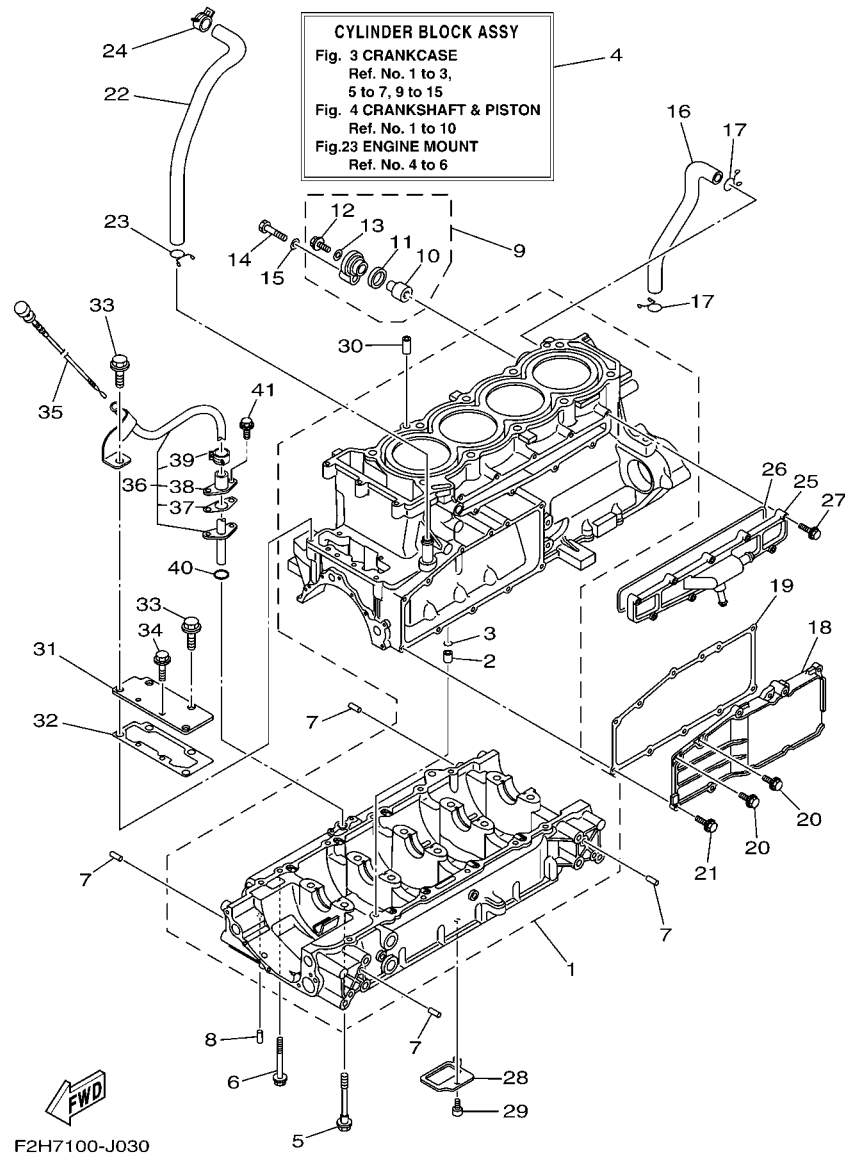
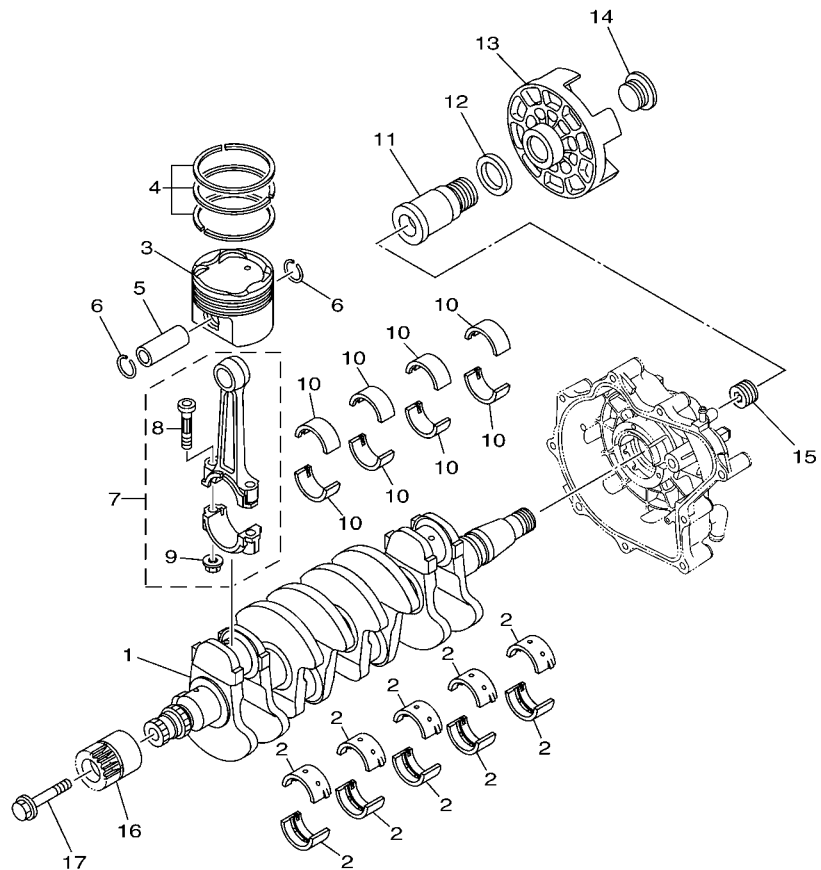

FIG. 3 CRANKCASE

REF. NO.	PART NO.	DESCRIPTION	CAN	EUR	GENE	REMARKS
1	6BH-15100-10	CRANKCASE ASSY	1	1	1	
2	99530-10114	.PIN, DOWEL	1	1	1	
3	93210-11453	.O-RING	1	1	1	
4	6BH-W009B-10-94	CYLINDER BLOCK ASSY	1	1	1	
5	90105-10071	BOLT, FLANGE	10	10	10	
6	95814-06070	BOLT, FLANGE	12	12	12	
7	93606-12019	PIN, DOWEL	8	8	8	
8	93604-10M03	PIN, DOWEL	2	2	2	
9	69J-11301-10	ANODE COVER ASSY	1	1	1	
10	68V-11325-02	.ANODE	1	1	1	
11	67F-11328-00	.GROMMET, ANODE	1	1	1	
12	90105-06M07	.BOLT, FLANGE	1	1	1	
13	90430-06M03	.GASKET	1	1	1	
14	97095-08040	BOLT	1	1	1	
15	92995-08600	WASHER	1	1	1	
16	6S5-11377-00	HOSE	1	1	1	
17	90467-190A0	CLIP	2	2	2	
18	6S5-1131M-00-94	COVER	1	1	1	
19	6BH-13557-00	GASKET	1	1	1	
20	95024-06014	BOLT, FLG.(SMALL HEAD)	2	2	2	
21	95024-06020	BOLT, FLG.(SMALL HEAD)	9	9	9	
22	6S5-11126-00	PIPE, BREATHER 3	1	1	1	
23	90467-190A0	CLIP	1	1	1	
24	90467-200A0	CLIP	1	1	1	
25	6S5-12469-01-94	JOINT 1	1	1	1	
26	6S5-12517-01	GASKET, WATER INLET	1	1	1	
27	95023-06025	BOLT	9	9	9	



F2H1100-H040

FIG. 4 CRANKSHAFT & PISTON

REF. NO.	PART NO.	DESCRIPTION	CAN	EUR	GENE	REMARKS
1	6S5-11411-00	CRANKSHAFT	1	1	1	
2	6S5-11416-00	PLANE BEARING, CRANKSHAFT 1	10	10	10	UR BROWN
	6S5-11416-10	PLANE BEARING, CRANKSHAFT 1	10	10	10	UR BLACK
	6S5-11416-20	PLANE BEARING, CRANKSHAFT 1	10	10	10	UR BLUE
	6S5-11416-30	PLANE BEARING, CRANKSHAFT 1	10	10	10	UR GREEN
	6S5-11416-40	PLANE BEARING, CRANKSHAFT 1	10	10	10	UR YELLOW
3	6BH-11631-00-B0	PISTON (STD)	4	4	4	
4	6S5-11603-00	PISTON RING SET (STD)	4	4	4	
5	6S5-11633-00	PIN, PISTON	4	4	4	
6	93450-24028	CIRCLIP	8	8	8	
7	6BH-11650-00	CONNECTING ROD ASSY	4	4	4	
8	6S5-11654-00	.BOLT, CONNECTING ROD	2	2	2	
9	90179-09379	.NUT	2	2	2	
10	6S5-11656-00	PLANE BEARING, CONNECTING ROD	8	8	8	UR BROWN
	6S5-11656-10	PLANE BEARING, CONNECTING ROD	8	8	8	UR BLACK
	6S5-11656-20	PLANE BEARING, CONNECTING ROD	8	8	8	UR BLUE
	6S5-11656-30	PLANE BEARING, CONNECTING ROD	8	8	8	UR GREEN
11	6S5-17572-01	SHAFT, TRANSFER	1	1	1	
12	6S5-12289-00	WASHER	1	1	1	
13	6S5-45813-01-94	FLANGE, COUPLING	1	1	1	
14	6S5-17525-01	HOLDER 2	1	1	1	
15	6S5-11459-01	NUT, SPECIAL	1	1	1	
16	6BH-17586-00	GEAR, TRANSFER DRIVE	1	1	1	
17	6S5-17031-00	BOLT	1	1	1	

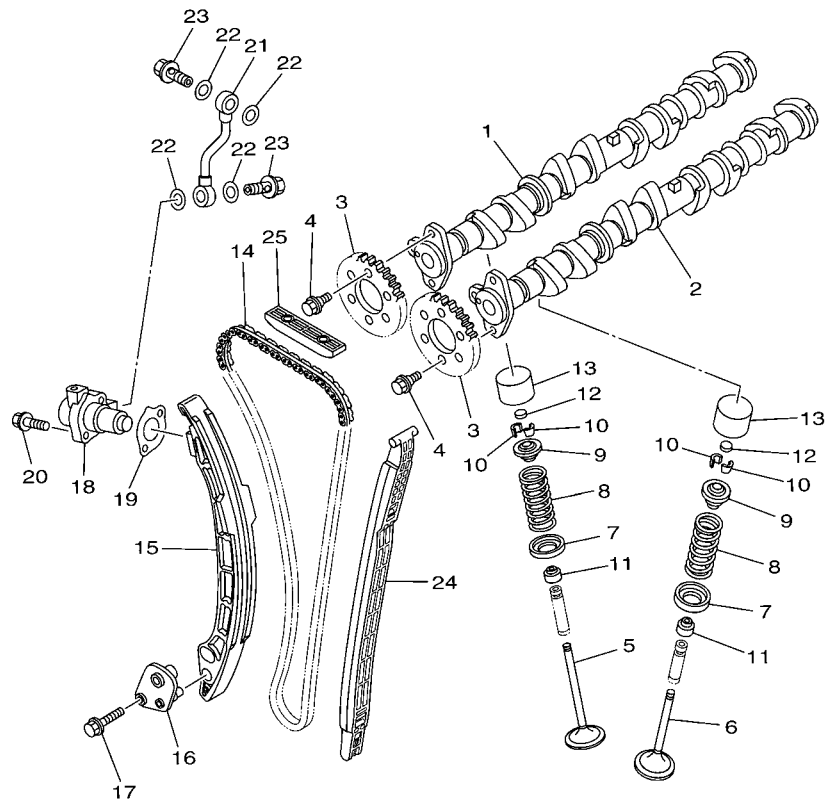

F2H1100-H050

FIG. 5 VALVE

REF. NO.	PART NO.	DESCRIPTION	CAN	EUR	GENE	REMARKS
1	6BH-12171-00	CAMSHAFT 1	1	1	1	
2	6BH-12181-00	CAMSHAFT 2	1	1	1	
3	6D3-12176-00	SPROCKET, CAM CHAIN	2	2	2	
4	90105-07004	BOLT, FLANGE	4	4	4	
5	6S5-12111-00	VALVE, INTAKE	8	8	8	
6	6S5-12121-00	VALVE, EXHAUST	8	8	8	
7	6S5-12116-00	SEAT, VALVE SPRING	16	16	16	
8	6S5-12113-00	SPRING, VALVE INNER	16	16	16	
9	6S5-12117-00	RETAINER, VALVE SPRING	16	16	16	
10	3LD-12118-00	COTTER, VALVE	32	32	32	
11	51Y-12119-00	SEAL, VALVE STEM	16	16	16	
12	3LD-12168-00	PAD, ADJUSTING (1.20)	16	16	16	UR
	3LD-12168-20	PAD, ADJUSTING (1.25)	16	16	16	UR
	3LD-12168-40	PAD, ADJUSTING (1.30)	16	16	16	UR
	3LD-12168-60	PAD, ADJUSTING (1.35)	16	16	16	UR
	3LD-12168-80	PAD, ADJUSTING (1.40)	16	16	16	UR
	3LD-12168-A0	PAD, ADJUSTING (1.45)	16	16	16	UR
	3LD-12168-F0	PAD, ADJUSTING (1.50)	16	16	16	UR
	3LD-12168-H1	PAD, ADJUSTING (1.55)	16	16	16	UR
	3LD-12168-K1	PAD, ADJUSTING (1.60)	16	16	16	UR
	3LD-12168-M1	PAD, ADJUSTING (1.65)	16	16	16	UR
	3LD-12168-R1	PAD, ADJUSTING (1.70)	16	16	16	UR
	3LD-12168-U1	PAD, ADJUSTING (1.75)	16	16	16	UR
	3LD-12168-W1	PAD, ADJUSTING (1.80)	16	16	16	UR
	3LD-12168-Y1	PAD, ADJUSTING (1.85)	16	16	16	UR
	3LD-12169-11	PAD, ADJUSTING (1.90)	16	16	16	UR
	3LD-12169-31	PAD, ADJUSTING (1.95)	16	16	16	UR

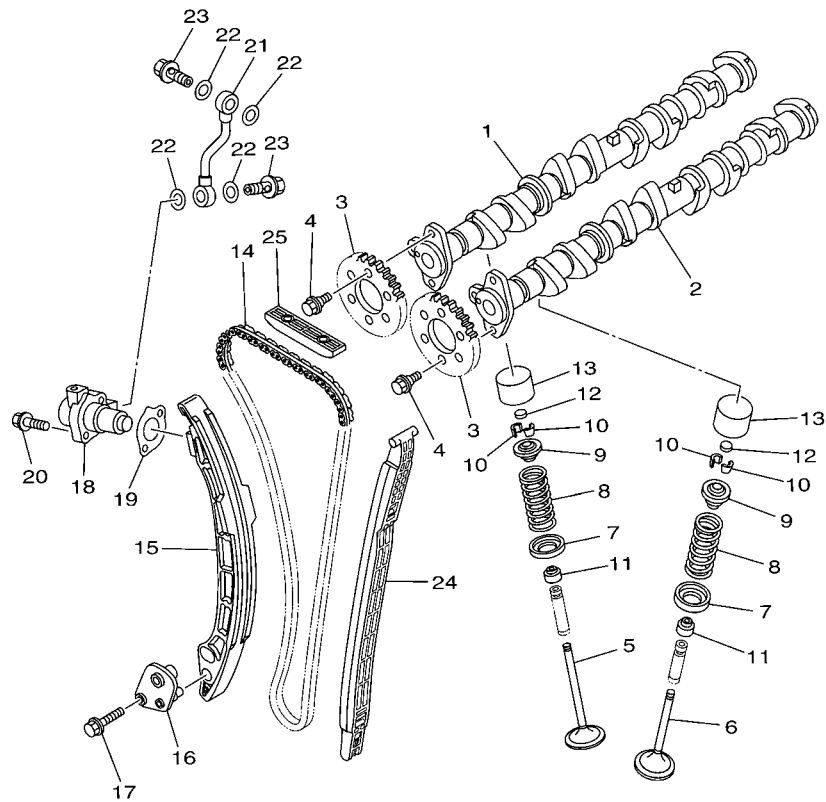

F2H1100-H050

FIG. 5 VALVE

REF. NO.	PART NO.	DESCRIPTION	CAN	EUR	GENE	REMARKS
12	3LD-12169-50	PAD, ADJUSTING (2.00)	16	16	16	UR
	3LD-12169-70	PAD, ADJUSTING (2.05)	16	16	16	UR
	3LD-12169-90	PAD, ADJUSTING (2.10)	16	16	16	UR
	3LD-12169-E0	PAD, ADJUSTING (2.15)	16	16	16	UR
	3LD-12169-G0	PAD, ADJUSTING (2.20)	16	16	16	UR
	3LD-12169-J0	PAD, ADJUSTING (2.25)	16	16	16	UR
	3LD-12169-L0	PAD, ADJUSTING (2.30)	16	16	16	UR
13	6S5-12153-00	LIFTER, VALVE	16	16	16	
14	94591-66152	CHAIN	1	1	1	
15	6BH-12252-00	DAMPER, CHAIN 2	1	1	1	
16	6BH-12279-00	PLATE	1	1	1	
17	95814-06030	BOLT, FLANGE	2	2	2	
18	6S5-12210-00	TENSIONER ASSY, CAM CHAIN	1	1	1	
19	6S5-121E2-00	GASKET	1	1	1	
20	91380-06025	BOLT	2	2	2	
21	6S5-13418-00	PIPE, OIL 2	1	1	1	
22	90430-10007	GASKET	4	4	4	
23	90401-10040	BOLT, UNION	2	2	2	
24	6BH-12251-00	DAMPER, CHAIN 1	1	1	1	
25	6BH-12241-00	GUIDE, STOPPER 2	1	1	1	

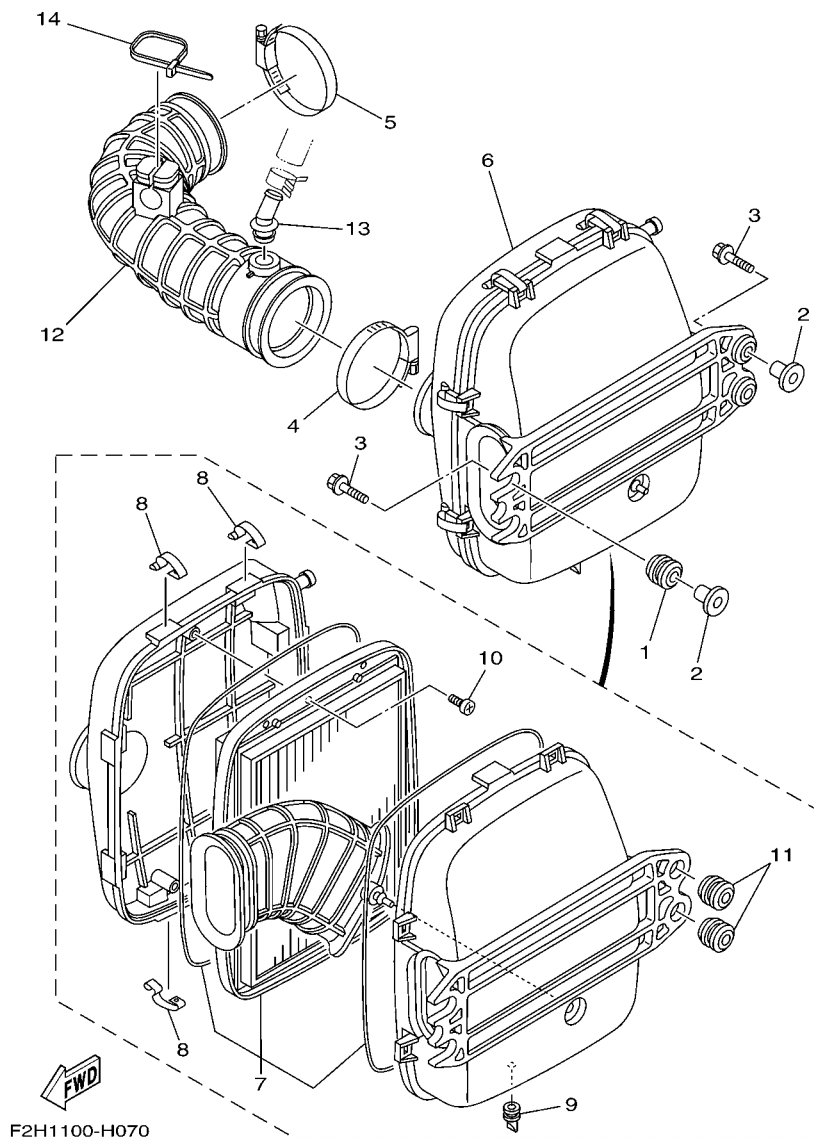

F2H1100-H070

FIG. 7 INTAKE 2

REF. NO.	PART NO.	DESCRIPTION	CAN	EUR	GENE	REMARKS
1	90480-22M15	GROMMET	2	2	2	
2	6D3-14495-00	COLLAR	4	4	4	
3	90119-08M22	BOLT, WITH WASHER	4	4	4	
4	90450-90001	HOSE CLAMP ASSY	1	1	1	
5	90450-90001	HOSE CLAMP ASSY	1	1	1	
6	6S5-E4410-01	AIR CLEANER ASSY.	1	1	1	
7	6S5-E4451-00	.ELEMENT, AIR CLEANER	1	1	1	
8	6S5-E4436-00	.HOOK	8	8	8	
9	6S5-G2717-00	.RUBBER, SEAL 2	1	1	1	
10	97780-60516	.SCREW, TAPPING	3	3	3	
11	90480-22801	.GROMMET	2	2	2	
12	6BH-E4419-00	PIPE	1	1	1	
13	6BH-R1142-00	CONNECTION	1	1	1	
14	90464-40825	CLAMP	1	1	1	

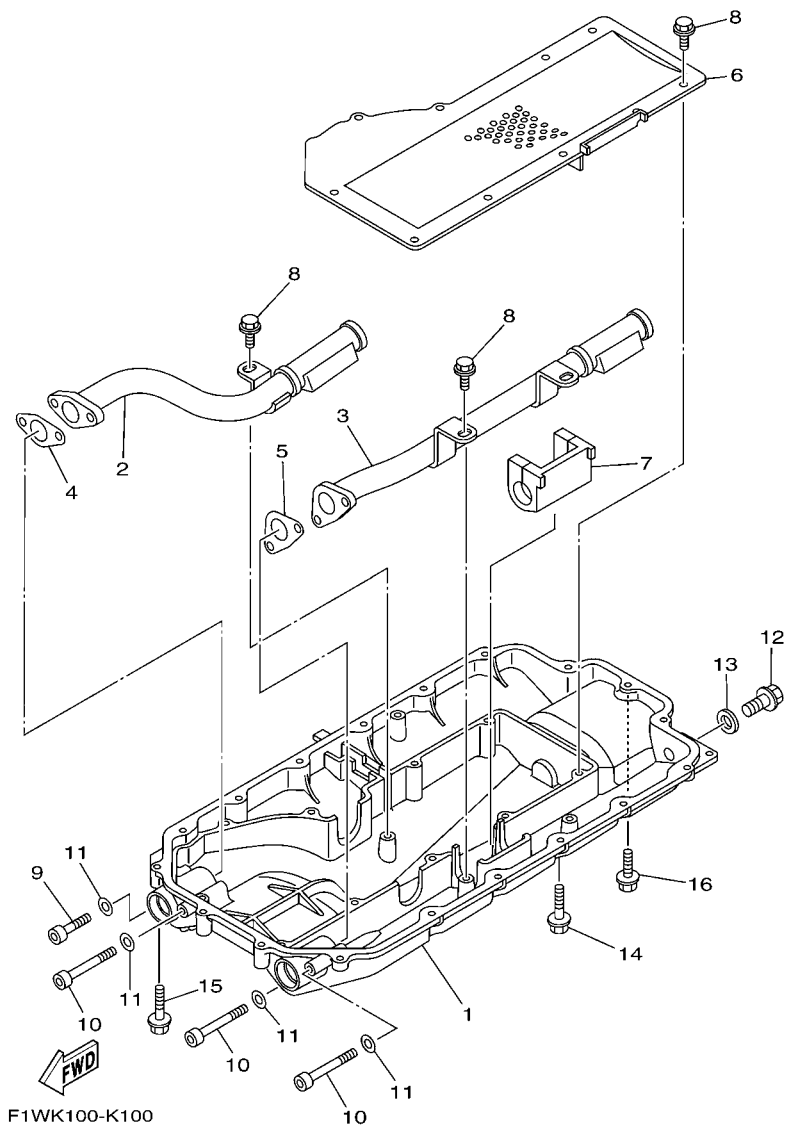
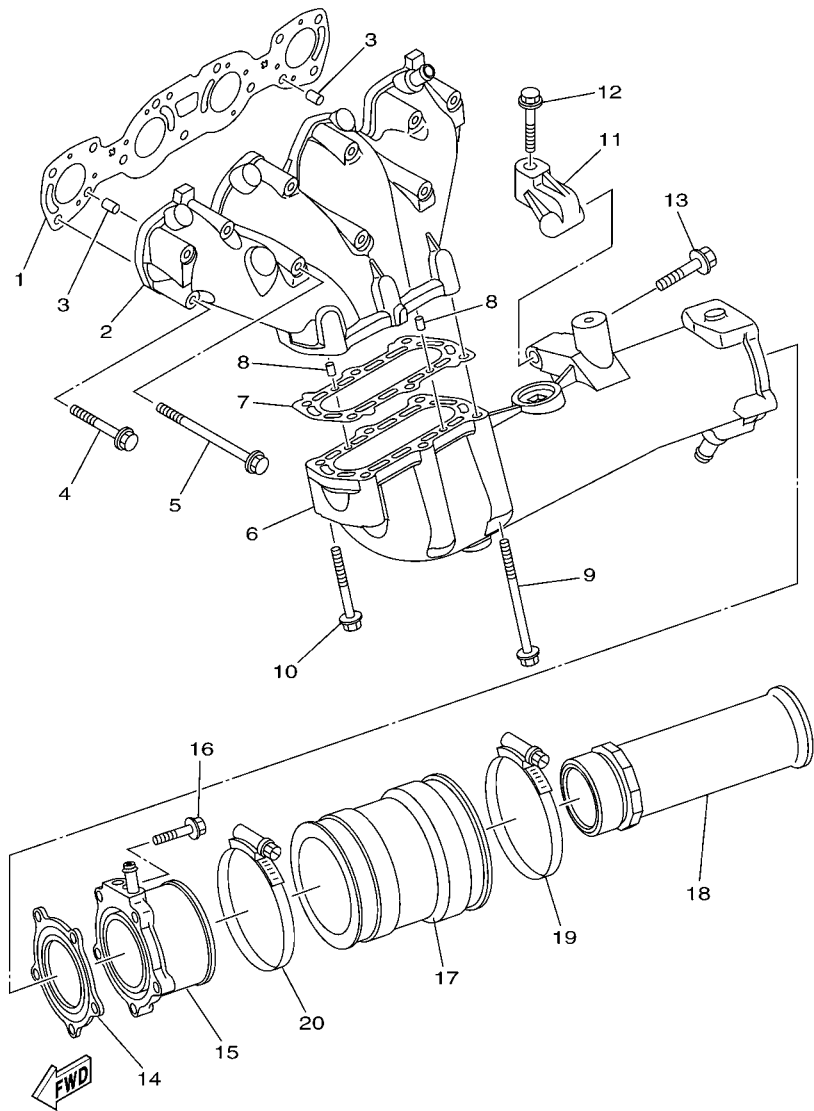

FIG. 9 OIL PAN

REF. NO.	PART NO.	DESCRIPTION	CAN	EUR	GENE	REMARKS
1	6S5-1310A-10-94	PAN, OIL	1	1	1	
2	6S5-13405-00	OIL PIPE COMP. 1	1	1	1	
3	6S5-13406-00	OIL PIPE COMP. 2	1	1	1	
4	6S5-13476-00	GASKET	1	1	1	
5	6S5-13477-00	GASKET	1	1	1	
6	6S5-13317-00	PLATE, BAFFLE	1	1	1	
7	6S5-15486-00	GROMMET	1	1	1	
8	95817-06014	BOLT, FLANGE	13	13	13	
9	91314-06035	BOLT, HEXAGON SOCKET HEAD	1	1	1	
10	91314-06060	BOLT, HEXAGON SOCKET HEAD	3	3	3	
11	90201-06028	WASHER, PLATE	4	4	4	
12	95814-08016	BOLT, FLANGE	1	1	1	
13	90430-08209	GASKET	1	1	1	
14	95024-06035	BOLT, FLG.(SMALL HEAD)	16	16	16	
15	95024-06030	BOLT, FLG.(SMALL HEAD)	1	1	1	
16	95024-06020	BOLT, FLG.(SMALL HEAD)	1	1	1	



F2H1100-H120

FIG. 12 EXHAUST 1

REF. NO.	PART NO.	DESCRIPTION	CAN	EUR	GENE	REMARKS
1	6BH-14613-00	GASKET, EXHAUST PIPE	1	1	1	
2	6BH-14711-00-94	MUFFLER 1	1	1	1	
3	93608-16M16	PIN, DOWEL	2	2	2	
4	90119-08034	BOLT, WITH WASHER	8	8	8	
5	90119-08097	BOLT, WITH WASHER	3	3	3	
6	6BH-14721-00-94	MUFFLER 2	1	1	1	
7	6S5-14739-00	GASKET, MUFFLER DAMPER 1	1	1	1	
8	93606-12019	PIN, DOWEL	2	2	2	
9	90119-08097	BOLT, WITH WASHER	4	4	4	
10	90119-08034	BOLT, WITH WASHER	2	2	2	
11	6S5-14771-00-94	STAY, MUFFLER 1	1	1	1	
12	90119-08096	BOLT, WITH WASHER	1	1	1	
13	90119-10029	BOLT, WITH WASHER	1	1	1	
14	6BH-14749-00	GASKET, MUFFLER DAMPER 2	1	1	1	
15	6BH-14784-01-94	PIPE, TAIL	1	1	1	
16	95024-08035	BOLT, FLG.(SMALL HEAD)	5	5	5	
17	6S5-14752-00	PIPE, OUTLET	1	1	1	
18	6S5-1475A-00	PIPE 1	1	1	1	
19	90450-99M06	HOSE CLAMP ASSY	1	1	1	
20	90450-90M10	HOSE CLAMP ASSY	1	1	1	

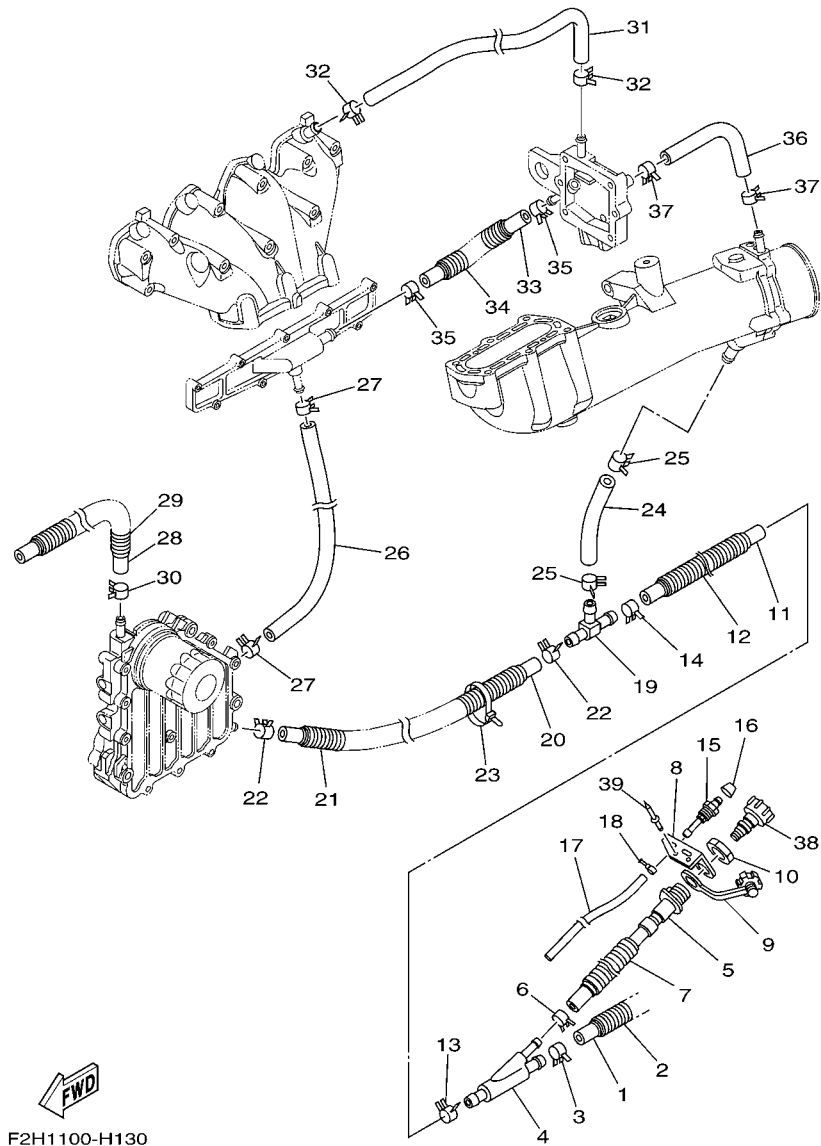

F2H1100-H130

FIG. 13 EXHAUST 2

REF. NO.	PART NO.	DESCRIPTION	CAN	EUR	GENE	REMARKS
1	90445-21806	HOSE (L250)	1	1	1	
2	90447-22801	TUBE (L200)	1	1	1	
3	90467-200A0	CLIP	1	1	1	
4	60E-12581-00	JOINT, HOSE 1	1	1	1	
5	63M-12580-00	JOINT ASSY	1	1	1	
6	90467-150A0	CLIP	1	1	1	
7	90447-19801	TUBE(L485)	1	1	1	
8	6S5-12443-00	STAY	1	1	1	
9	682-84385-01	CAP,1	1	1	1	
10	EU0-61652-00	NUT	1	1	1	
11	6S5-1243E-00	HOSE 2	1	1	1	
12	90447-22011	TUBE (L170)	1	1	1	
13	90467-200A0	CLIP	1	1	1	
14	90467-200A0	CLIP	1	1	1	
15	61L-5169A-00	NIPPLE, GREASE	1	1	1	
16	663-45119-00	CAP, GREASE NIPPLE	1	1	1	
17	90445-09M21	HOSE (L445)	1	1	1	
18	90465-11829	CLAMP	1	1	1	
19	6BH-12584-00	JOINT, HOSE 3	1	1	1	
20	90445-18012	HOSE (L400)	1	1	1	
21	90447-19005	TUBE (L260)	1	1	1	
22	90467-160A0	CLIP	2	2	2	
23	90464-35132	CLAMP	1	1	1	
24	6S5-12589-00	HOSE 6	1	1	1	
25	90467-200A0	CLIP	2	2	2	
26	6BH-1244H-00	HOSE 5	1	1	1	
27	90467-150A1	CLIP	2	2	2	

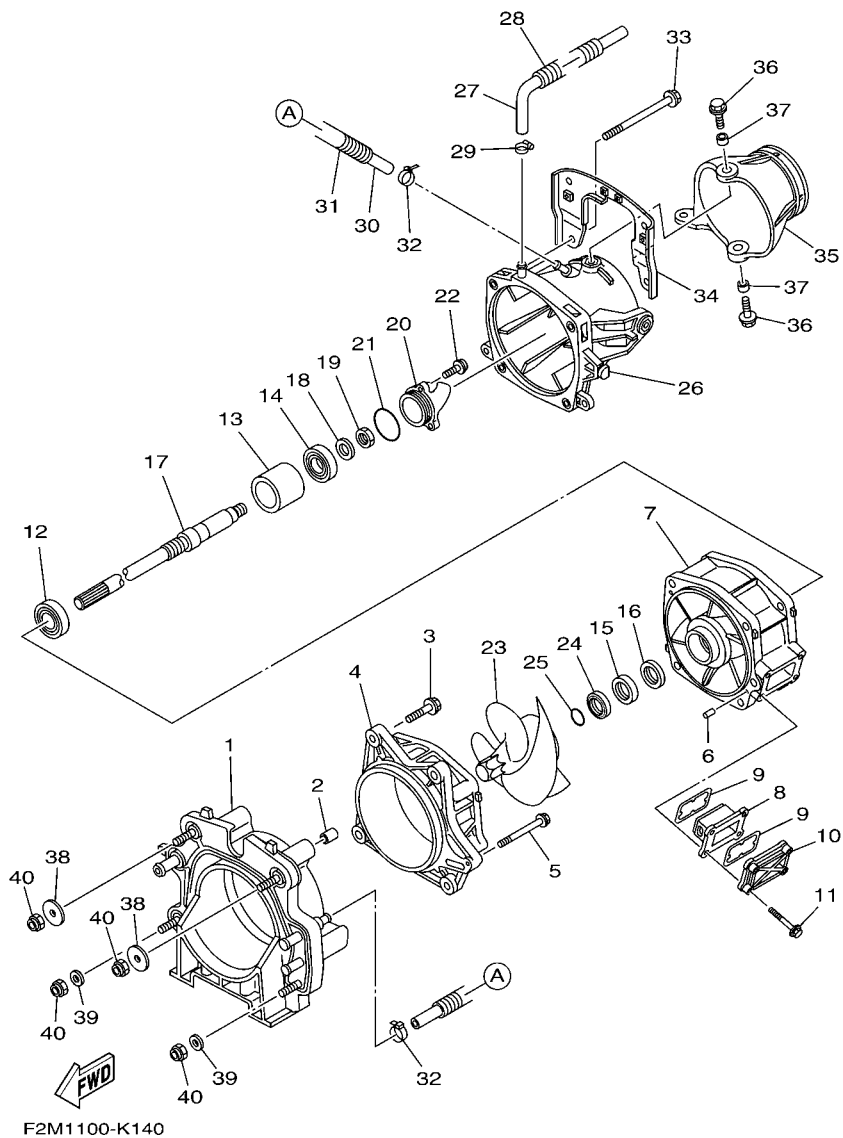

F2M1100-K140

FIG. 14 JET UNIT 1

REF. NO.	PART NO.	DESCRIPTION	CAN	EUR	GENE	REMARKS
1	6AN-G5831-00	PLATE, TRANSOM	1	1	1	
2	99590-14016	PIN, DOWEL	2	2	2	
3	90119-10810	BOLT, WITH WASHER	4	4	4	
4	66V-51312-01-94	HOUSING, IMPELLER	1	1	1	
5	90119-06893	BOLT, WITH WASHER	1	1	1	
6	93606-12019	PIN, DOWEL	2	2	2	
7	6S5-51315-00-94	DUCT, IMPELLER	1	1	1	
8	66V-46882-00	FILTER	1	1	1	
9	66V-42414-00	O-RING	2	2	2	
10	66V-45214-00-94	COVER, WATER INLET 1	1	1	1	
11	90119-06897	BOLT, WITH WASHER	4	4	4	
12	93306-20654	BEARING	1	1	1	
13	6S5-45538-00	SPACER 1	1	1	1	
14	93306-30582	BEARING	1	1	1	
15	93102-31009	OIL SEAL	1	1	1	
16	93101-31001	OIL SEAL	1	1	1	
17	6S5-45511-00	SHAFT, DRIVE	1	1	1	
18	9290P-20600	WASHER	1	1	1	
19	90170-20802	NUT	1	1	1	
20	6S5-51326-00-94	CAP	1	1	1	
21	6S5-5111K-00	O-RING 1	1	1	1	
22	90110-06822	BOLT, HEXAGON SOCKET HEAD	3	3	3	
23	6AP-R1321-01	IMPELLER	1	1	1	
24	6BH-51348-01	SPACER	1	1	1	
25	93210-30611	O-RING	1	1	1	
26	6BU-R1318-00	NOZZLE	1	1	1	
27	6CN-U72M2-00	HOSE 1	1	1	1	

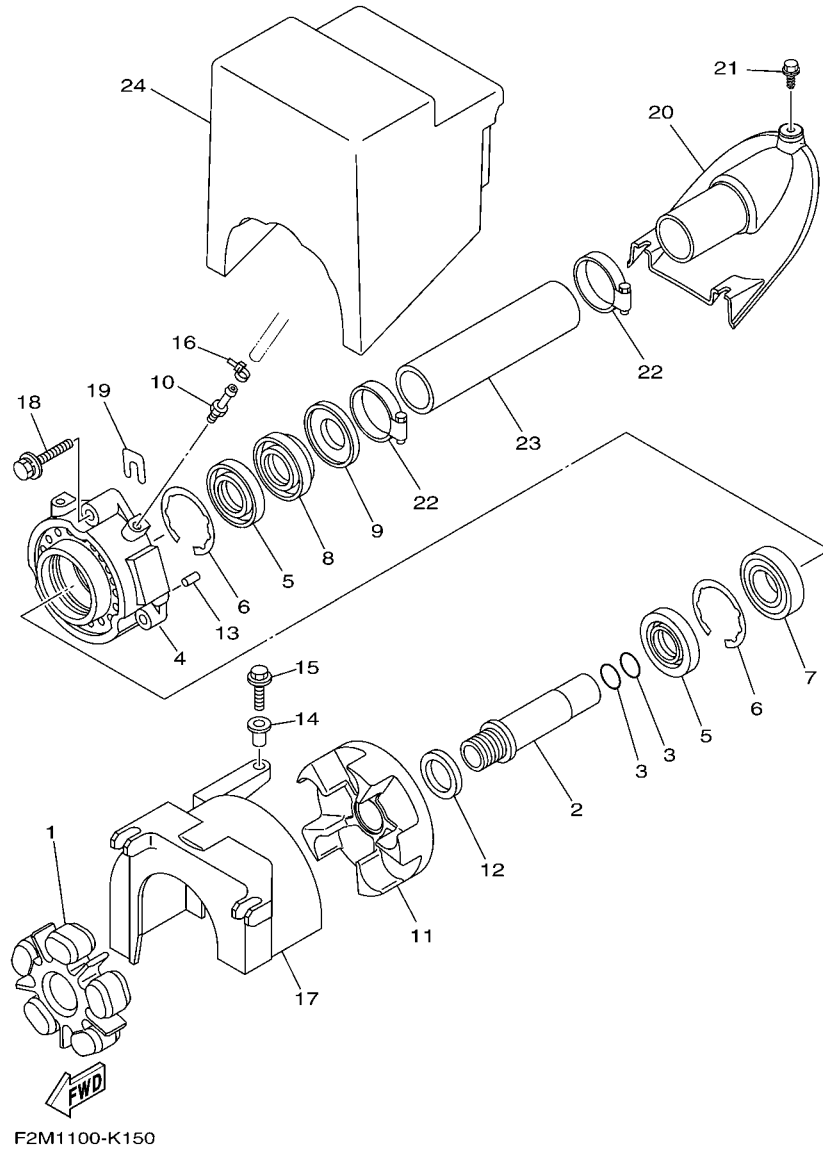
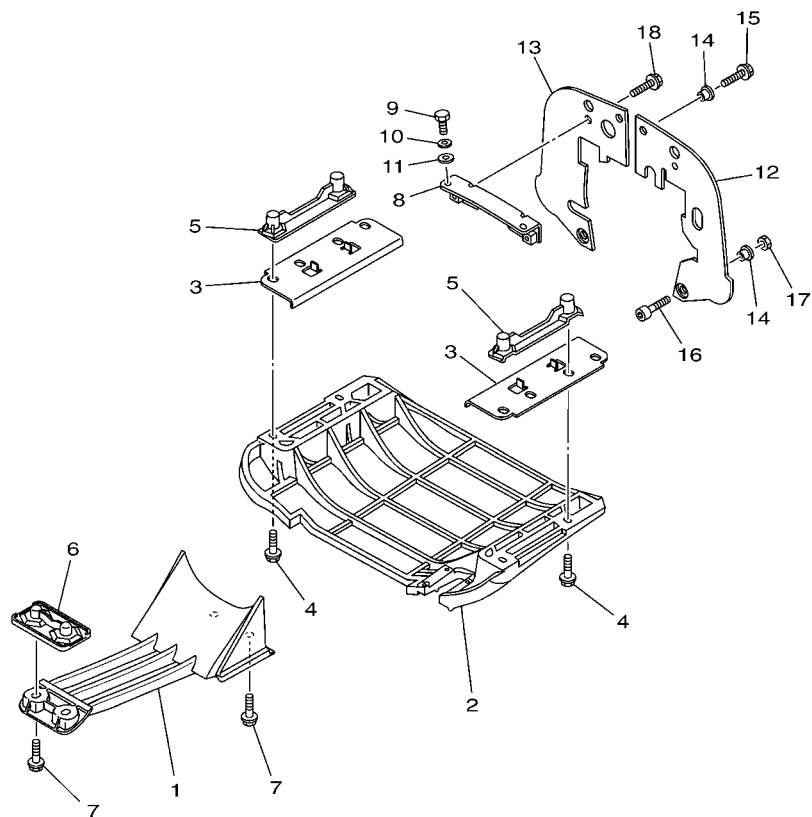

FIG. 15 JET UNIT 2

REF. NO.	PART NO.	DESCRIPTION	CAN	EUR	GENE	REMARKS
1	6BH-4581J-00	RUBBER SHAFT COUPLING	1	1	1	
2	6S5-51323-00	SHAFT, COUPLER	1	1	1	
3	93210-22MF1	O-RING	2	2	2	
4	6S5-45332-00-94	HOUSING, BEARING	1	1	1	
5	93102-29008	OIL SEAL	2	2	2	
6	93450-66156	CIRCLIP	2	2	2	
7	93306-20655	BEARING	1	1	1	
8	93102-29009	OIL SEAL	1	1	1	
9	6S5-45613-10	WASHER, THRUST	1	1	1	
10	61L-45378-00	NIPPLE, HOSE	1	1	1	
11	6S5-45593-00-94	FLANGE, COUPLING 1	1	1	1	
12	6S5-12289-00	WASHER	1	1	1	
13	93606-12019	PIN, DOWEL	2	2	2	
14	90387-06M60	COLLAR	1	1	1	
15	90119-06891	BOLT, WITH WASHER	1	1	1	
16	90465-11829	CLAMP	1	1	1	
17	6S5-R1381-01	COVER	1	1	1	
18	90119-089UU	BOLT, WITH WASHER	3	3	3	
19	GD0-U7249-00-05	SHIM (T=0.5)	2	2	2	UN
20	F2N-U883E-00	JOINT, PIPE	1	1	1	
21	90109-06832	BOLT	3	3	3	
22	90601-155U4	BAND, HOSE 55	2	2	2	
23	F2C-U883B-00	PIPE, 1	1	1	1	
24	F1K-U892D-00	FLOTATION, STERN	1	1	1	

FIG. 17 JET UNIT 4



F2M1100-K170

REF. NO.	PART NO.	DESCRIPTION	CAN	EUR	GENE	REMARKS
1	6CN-R1333-00-94	SCREEN, INTAKE	1	1	1	
2	F1K-U273B-06	PLATE 2	1	1	1	
3	F2M-U143G-00	SPACER	2	2	2	
4	90119-08829	BOLT, WITH WASHER	4	4	4	
5	F1G-U8572-02	BRACKET 2	2	2	2	
6	F2C-U8577-03	BRACKET, 3	1	1	1	
7	90119-10809	BOLT, WITH WASHER	4	4	4	
8	F1K-U7557-01	BRACKET	1	1	1	
9	90109-08041	BOLT	2	2	2	
10	92990-12200	WASHER, PLAIN	2	2	2	
11	90430-12002	GASKET	2	2	2	
12	F1K-U757E-01	PLATE, RUBBER 1	1	1	1	
13	F1K-U757F-01	PLATE, RUBBER 2	1	1	1	
14	90387-06080	COLLAR	6	6	6	
15	90119-06880	BOLT, WITH WASHER	4	4	4	
16	90101-069U0	BOLT	2	2	2	
17	9572R-06300	NUT, NYLON	2	2	2	
18	90119-08800	BOLT, WITH WASHER	2	2	2	

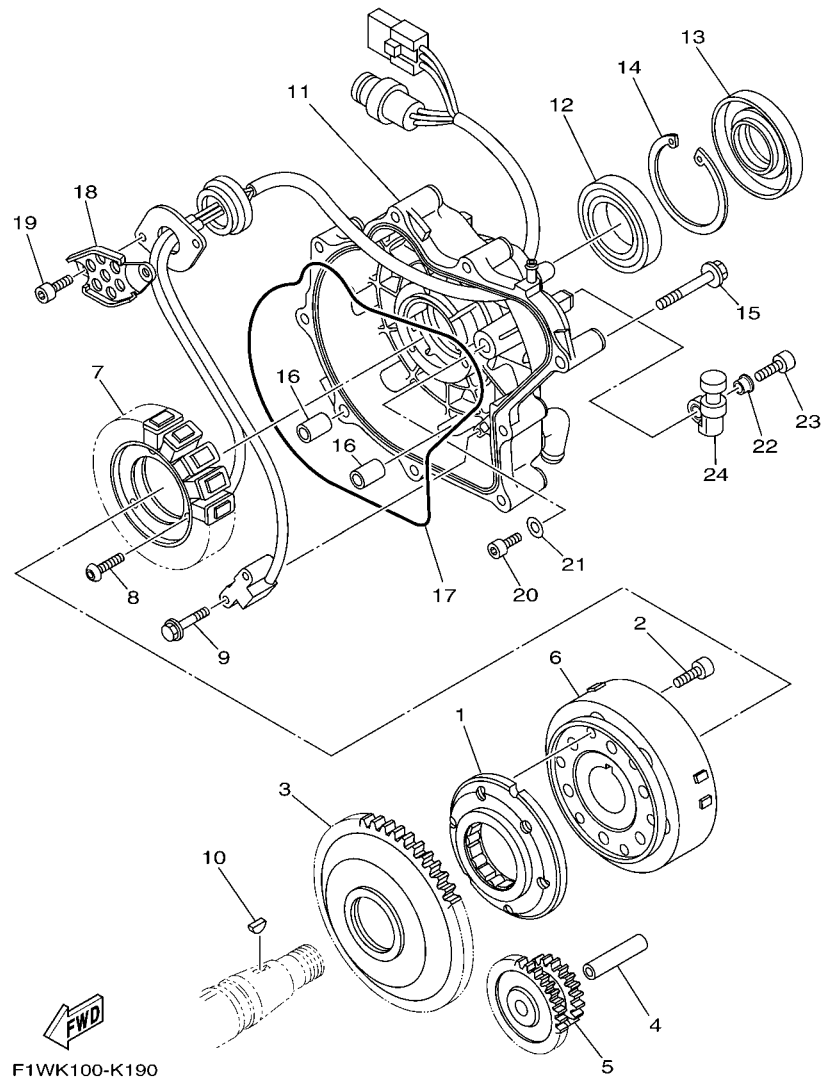
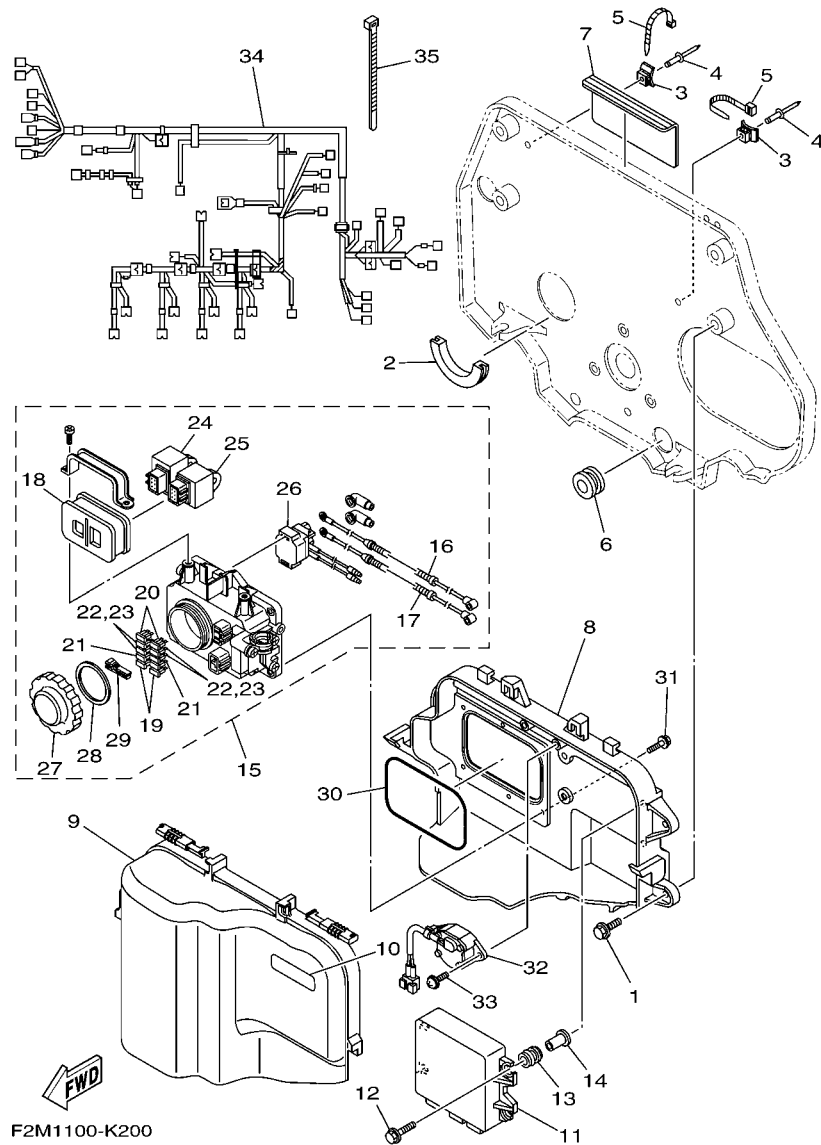

FIG. 18 GENERATOR

REF. NO.	PART NO.	DESCRIPTION	CAN	EUR	GENE	REMARKS
1	6S5-15590-00	STARTER ONE-WAY ASSY	1	1	1	
2	90110-08212	BOLT, HEXAGON SOCKET HEAD	6	6	6	
3	6S5-15515-00	GEAR 3	1	1	1	
4	6S5-15521-00	SHAFT 1	1	1	1	
5	6S5-15517-00	GEAR, IDLER 2	1	1	1	
6	6S5-81450-01	ROTOR ASSY	1	1	1	
7	6S5-81410-00	STATOR ASSY	1	1	1	
8	90149-06229	SCREW	3	3	3	
9	97513-05514	BOLT, WITH WASHER	2	2	2	
10	90280-03047	KEY, WOODRUFF	1	1	1	
11	6S5-81337-10-94	COVER, FLYWHEEL	1	1	1	
12	93306-00805	BEARING	1	1	1	
13	6S5-81167-10	OIL SEAL	1	1	1	
14	99009-72500	CIRCLIP	1	1	1	
15	95024-08050	BOLT, FLG.(SMALL HEAD)	9	9	9	
16	99530-10114	PIN, DOWEL	2	2	2	
17	6S5-81168-00	O-RING	1	1	1	
18	6S5-81328-00	CLAMP	1	1	1	
19	91317-06014	BOLT	2	2	2	
20	91317-05010	BOLT	1	1	1	
21	90201-052E8	WASHER, PLATE	1	1	1	
22	90387-06M05	COLLAR	2	2	2	
23	91380-06020	BOLT	2	2	2	
24	6S5-81364-00	GROMMET	2	2	2	



F2M1100-K200

FIG. 20 ELECTRICAL 1

REF. NO.	PART NO.	DESCRIPTION	CAN	EUR	GENE	REMARKS
1	90119-089UT	BOLT, WITH WASHER	4	4	4	
2	F1S-U828H-01	TRIM, 1	1	1	1	
3	F1W-U828M-00	BASE, CLAMP	2	2	2	
4	90267-48802	RIVET, BLIND	2	2	2	
5	90464-32801	CLAMP	2	2	2	
6	90480-38800	GROMMET	1	1	1	
7	F1S-U8221-00	PAD, BATTERY	1	1	1	
8	6BH-81845-00	PLATE	1	1	1	
9	6S5-81942-10	COVER	1	1	1	
10	60E-83627-00	LABEL, CAUTION 7	1	1	1	
11	6CN-8591A-00	ENGINE CONTROL UNIT ASSY	1	1	1	
12	90119-06M35	BOLT, WITH WASHER	4	4	4	
13	6A0-82317-00	DAMPER, IGNITION COIL	4	4	4	
14	90387-06119	COLLAR	4	4	4	
15	6BH-82170-00	FUSE BOX ASSY	1	1	1	
16	6S5-82115-00	.WIRE, PLUS LEAD	1	1	1	
17	6S5-82117-00	.WIRE, LEAD	1	1	1	
18	6D3-82157-00	.DAMPER	1	1	1	
19	67F-82151-00	.FUSE (20A)	2	2	2	
20	67F-82151-10	.FUSE (30A)	2	2	2	
21	67F-82151-30	.FUSE (3A)	2	2	2	
22	67F-82151-40	.FUSE (10A)	2	2	2	
23	67F-82151-40	.FUSE (10A)	2	2	2	
24	60E-81950-00	.RELAY ASSY	1	1	1	
25	68V-81950-00	.RELAY ASSY	1	1	1	
26	6B6-81940-00	.STARTER RELAY ASSY	1	1	1	
27	66V-8132W-00	.CAP	1	1	1	

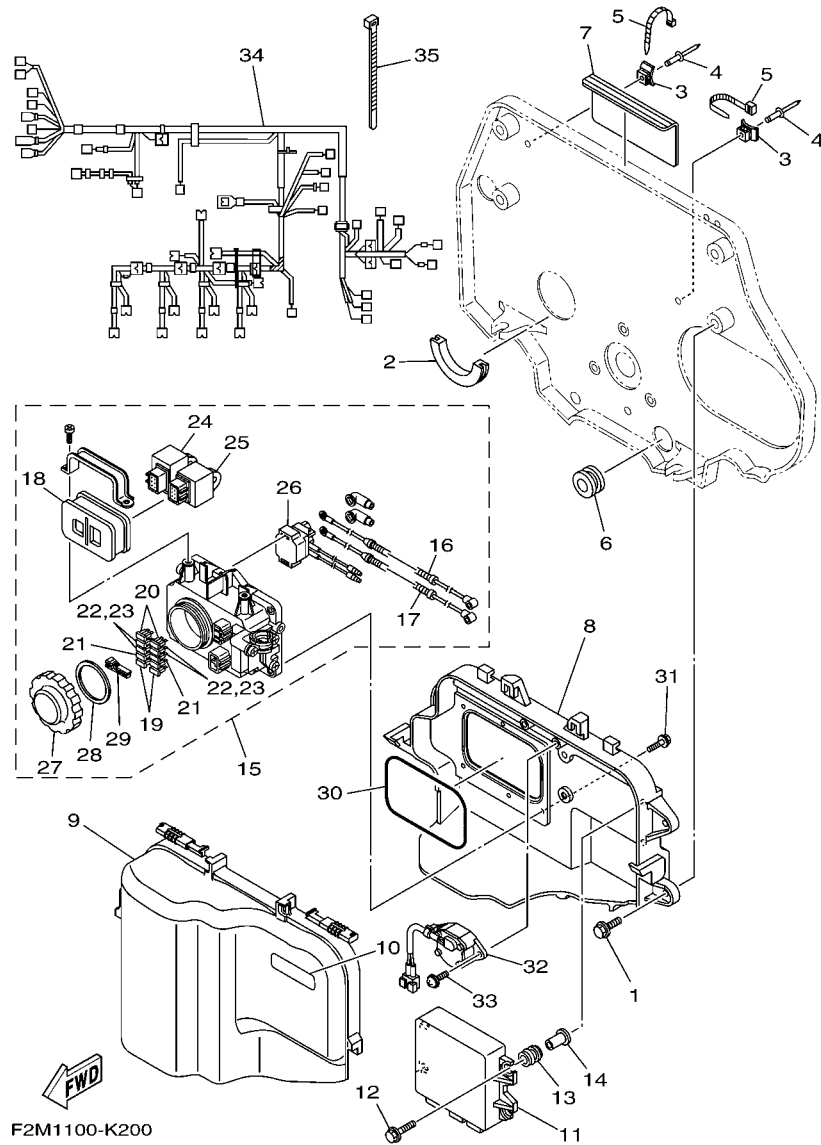

FIG. 20 ELECTRICAL 1

REF. NO.	PART NO.	DESCRIPTION	CAN	EUR	GENE	REMARKS
28	66V-81844-00	.GASKET	1	1	1	
29	67F-2812A-00	.PULLER, FUSE	1	1	1	
30	6BH-81847-00	O-RING	1	1	1	
31	90119-06091	BOLT, WITH WASHER	6	6	6	
32	6S5-8259E-00	SWITCH ASSY	1	1	1	
33	97780-60520	SCREW, TAPPING	2	2	2	
34	6CN-8259L-00	WIRE HARNESS ASSY 1	1	1	1	
35	90465-14M66	CLAMP	1	1	1	

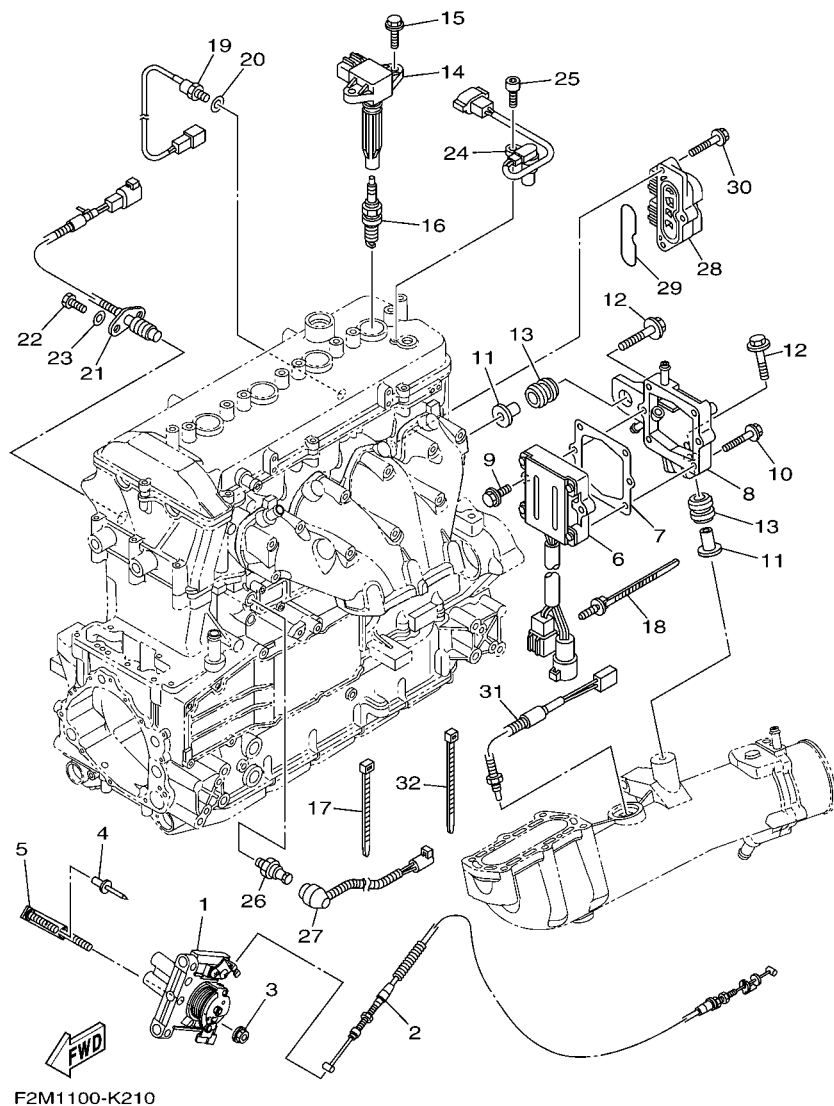

FIG. 21 ELECTRICAL 2

REF. NO.	PART NO.	DESCRIPTION	CAN	EUR	GENE	REMARKS
1	6D3-14305-21	ACCEL. POSITON SENSOR ASSY	1	1	1	
2	6BU-26311-00	CABLE, THROTTLE 1	1	1	1	
3	95780-08300	NUT, FLANGE	2	2	2	
4	90267-489U1	RIVET,BLIND	1	1	1	
5	F1W-U7254-00	BRACKET, THROTTLE	1	1	1	
6	6S5-81960-00	RECTIFIER & REGULATOR ASSY	1	1	1	
7	6S5-81975-00	PLATE, RECTIFIER FITTING	1	1	1	
8	6S5-81972-01-94	COVER, RECTIFIER	1	1	1	
9	90119-06MA3	BOLT, WITH WASHER	2	2	2	
10	90119-06048	BOLT, WITH WASHER	4	4	4	
11	6D3-14495-00	COLLAR	2	2	2	
12	90119-08M22	BOLT, WITH WASHER	2	2	2	
13	90480-22M15	GROMMET	2	2	2	
14	6S5-82310-00	IGNITION COIL ASSY	4	4	4	
15	90105-06903	BOLT, FLANGE	8	8	8	
16	94702-00427	PLUG, SPARK (NGK LFR6A)	4	4	4	
17	90465-13M18	CLAMP	8	8	8	
18	90464-31001	CLAMP	1	1	1	
19	61A-85790-00	THERMOSENSOR ASSY	1	1	1	
20	92990-10600	WASHER, PLATE	1	1	1	
21	60E-82560-01	THERMO SWITCH ASSY	1	1	1	
22	97095-06016	BOLT	2	2	2	
23	92995-06600	WASHER	2	2	2	
24	6D3-85896-00	SENSOR, CAM POSITION	1	1	1	
25	91380-06016	BOLT	1	1	1	
26	68V-82504-00	OIL PRESSURE SWITCH ASSY	1	1	1	
27	6S5-81315-00	LEAD WIRE ASSY	1	1	1	

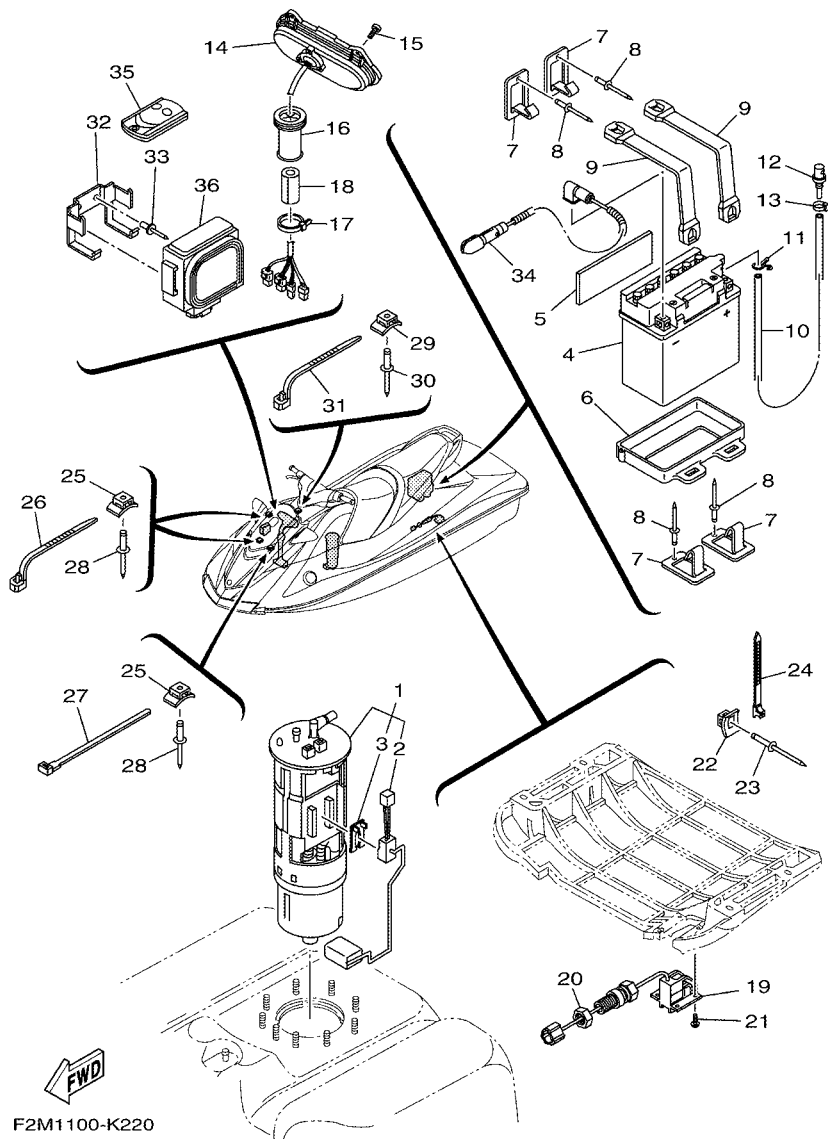
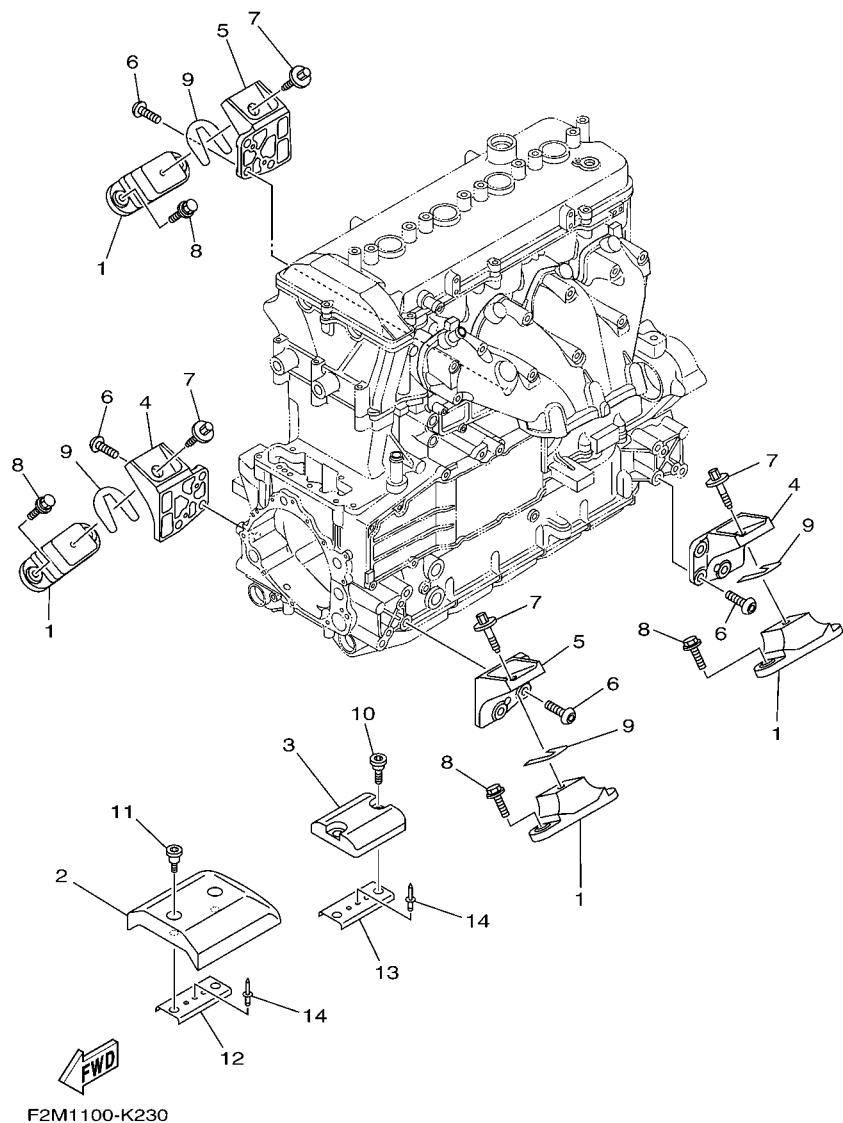

FIG. 22 ELECTRICAL 3

REF. NO.	PART NO.	DESCRIPTION	CAN	EUR	GENE	REMARKS
1	6S5-13907-00	FUEL PUMP COMP.	1	1	1	
2	6S5-682E0-00	.FUEL SENDER ASSY	1	1	1	
3	60E-82556-00	.DAMPER, STOPPER	1	1	1	
4	EU0-82110-09	BATTERY ASSY (YB16CL-B)	1	1	1	YUASA
5	F1K-U8221-00	PAD, BATTERY	1	1	1	
6	F1K-U8211-01	CASE, BATTERY	1	1	1	
7	F1K-U5772-04	HOOK A	4	4	4	
8	90267-489U1	RIVET,BLIND	4	4	4	
9	F1K-U821D-01	BAND, BATTERY 1	2	2	2	
10	F0D-U785G-10	HOSE, AIR VENT	1	1	1	
11	90467-089U1	CLIP	1	1	1	
12	GJ3-6215F-00	NIPPLE	1	1	1	
13	90465-11829	CLAMP	1	1	1	
14	F1K-6820A-20	METER ASSY	1	1	1	
15	90111-05008	BOLT,HEX. SOCKET BUTTON	4	4	4	
16	GU2-6822E-01	GROMMET	1	1	1	
17	90464-32801	CLAMP	1	1	1	
18	GJ1-U7578-21	PACKING, HOSE 2	1	1	1	
19	F1S-U8K31-02	SENSOR SPEED	1	1	1	
20	F2C-U151S-00	NUT	1	1	1	
21	90150-05807	SCREW, ROUND HEAD	4	4	4	
22	F1W-U828M-00	BASE, CLAMP	7	7	7	
23	90267-489U6	RIVET, BLIND	7	7	7	
24	90464-32801	CLAMP	7	7	7	
25	F1W-U828M-00	BASE, CLAMP	3	3	3	
26	90464-32801	CLAMP	2	2	2	
27	90601-200U2	BAND	2	2	2	

FIG. 23 ENGINE MOUNT



REF. NO.	PART NO.	DESCRIPTION	CAN	EUR	GENE	REMARKS
1	67X-44517-10-94	MOUNT RUBBER	4	4	4	
2	6CN-G4532-00	STOPPER, UPPER MOUNT	1	1	1	
3	6CN-G4574-00	STOPPER, LOWER MOUNT RUBBER	1	1	1	
4	6BH-41661-00-94	BRACKET 1	2	2	2	
5	6BH-41662-00-94	BRACKET 2	2	2	2	

6	90149-10052	SCREW	12	12	12	
7	90119-08860	BOLT, WITH WASHER	4	4	4	
8	90119-08829	BOLT, WITH WASHER	8	8	8	
9	EU0-U7354-00-01	SHIM (T=0.1)	4	4	4	UR
	EU0-U7354-00-03	SHIM (T=0.3)	4	4	4	UR

	EU0-U7354-00-05	SHIM (T=0.5)	4	4	4	UR
	EU0-U7354-00-10	SHIM (T=1.0)	4	4	4	UR
	EU0-U7354-00-20	SHIM (T=2.0)	4	4	4	UR
10	90109-06864	BOLT	2	2	2	
11	90109-06857	BOLT	2	2	2	

12	F2M-U732B-00	PLATE	1	1	1	
13	F2M-U732B-00	PLATE	1	1	1	
14	90267-489U2	RIVET, BLIND	2	2	2	

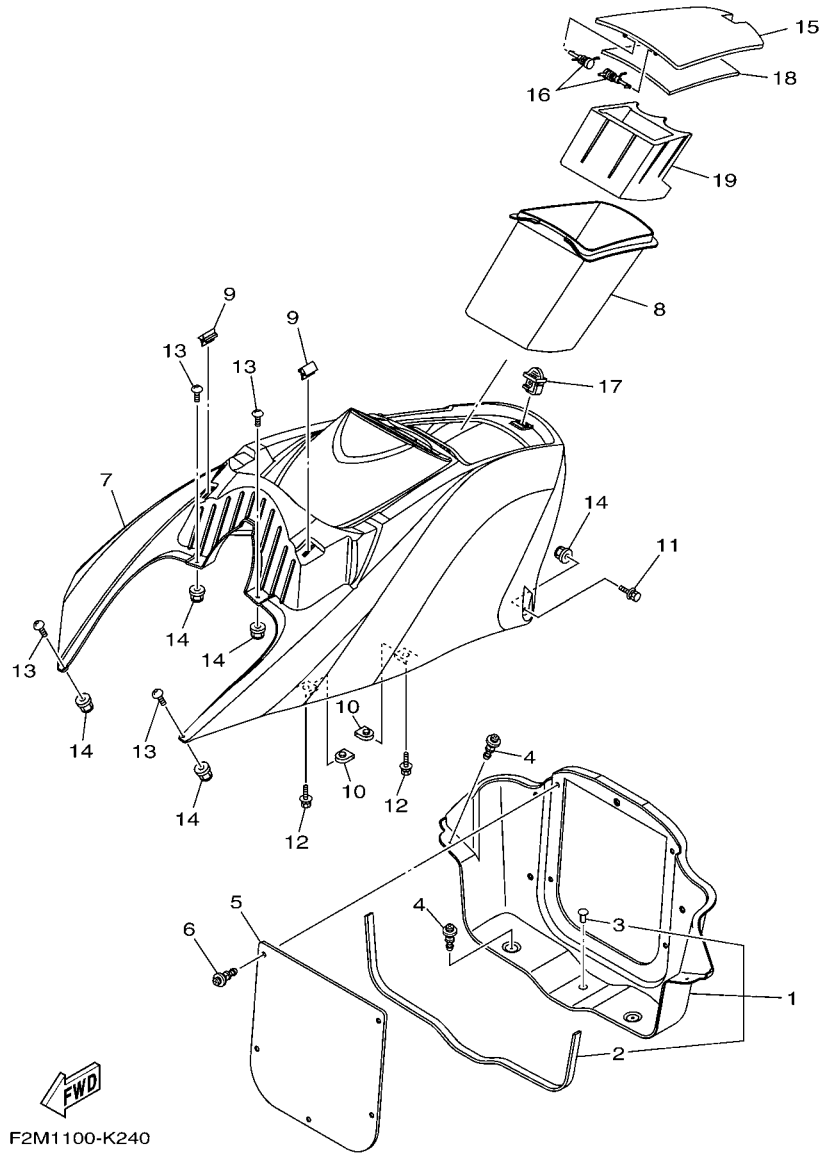

FIG. 24 ENGINE HATCH 1

REF. NO.	PART NO.	DESCRIPTION	CAN	EUR	GENE	REMARKS
1	F2N-U475B-02	LOCKER, BOW	1	1	1	
2	F2N-U266C-00	.PACKING 4	1	1	1	
3	90605-502U1	.PLUG, BLIND	1	1	1	
4	90269-08801	RIVET	4	4	4	
5	F1W-U475F-01	PLATE, LOKER BOW	1	1	1	
6	90269-08801	RIVET	5	5	5	
7	F2N-U516N-00-P2	COVER, ENGINE HATCH (DPBMT)	1	1	1	FOR DPBMT
	F2N-U516N-00-P4	COVER, ENGINE HATCH (LNMP)	1	1	1	FOR LGM3
8	F2N-U516P-00	BOX GLOVE	1	1	1	
9	F1K-U266C-00	PACKING 4	2	2	2	
10	90183-06902	NUT, SPRING	4	4	4	
11	90119-06880	BOLT, WITH WASHER	2	2	2	
12	90119-06882	BOLT, WITH WASHER	4	4	4	
13	F2N-67823-10	SCREW	4	4	4	
14	F2N-U142L-00	NUT, LOCK	6	6	6	
15	F2N-U517H-01	LID HATCH	1	1	1	
16	F0X-6517R-01	PIN, HINGE	2	2	2	
17	GU2-62875-01	LOCK	1	1	1	
18	F2N-U519D-00	PACKING CASE	1	1	1	
19	F2N-U5633-00	HOLDER, DRINK	1	1	1	

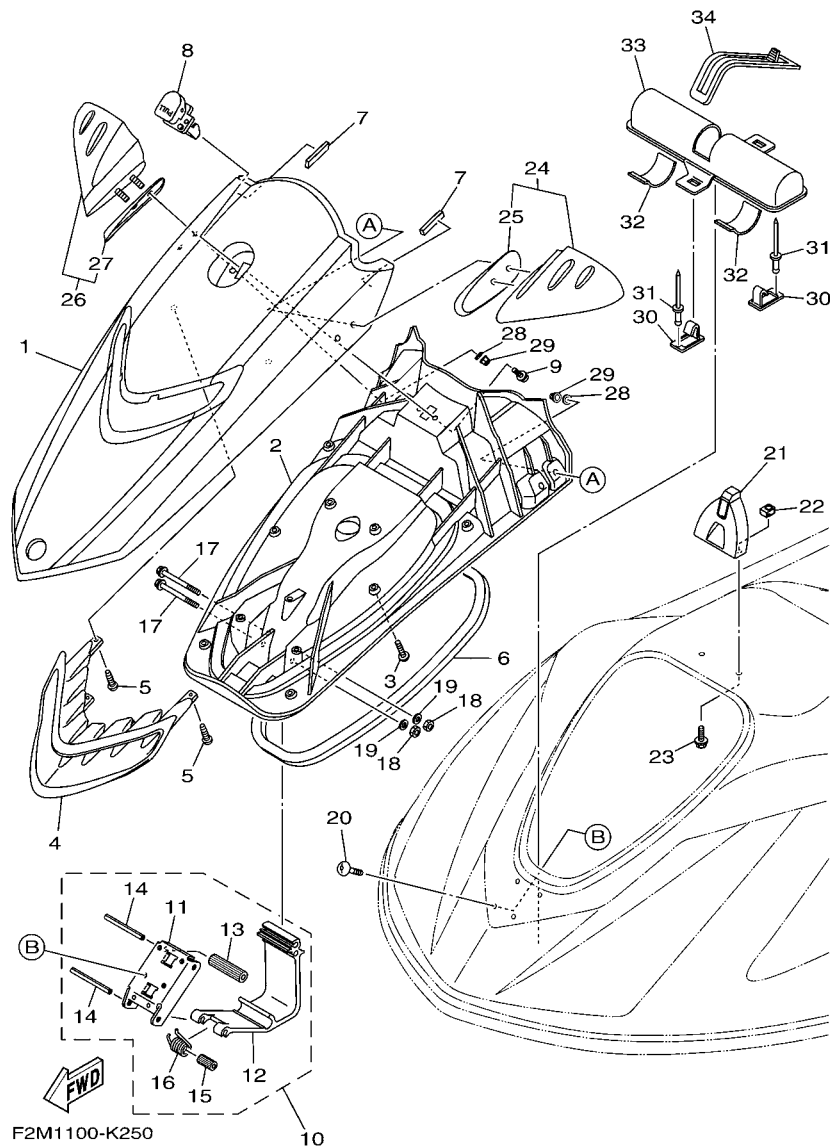

FIG. 25 ENGINE HATCH 2

REF. NO.	PART NO.	DESCRIPTION	CAN	EUR	GENE	REMARKS
1	F2M-U517B-00-P0	LID, ENGINE HATCH (DPBMT)	1	1	1	FOR DPBMT
	F2M-U517B-00-P1	LID, ENGINE HATCH (LNMP)	1	1	1	FOR LGM3
2	F2M-U213B-00	COVER, VENTILATOR 1	1	1	1	
3	90149-05903	SCREW	9	9	9	
4	F2M-U517V-00	ORNAMENT, CENTER	1	1	1	
5	90149-05903	SCREW	4	4	4	
6	F2N-U2663-01	PACKING 1	1	1	1	
7	F2C-U1743-00	PACKING	2	2	2	
8	F2M-6517C-00	LOCK, LID	1	1	1	
9	90119-059U4	BOLT, WITH WASHER	2	2	2	
10	F1K-U515A-00	HINGE ASSY.	1	1	1	
11	F1K-U518E-04	.PLATE, HINGE LID	1	1	1	
12	F1K-U517D-05	.HINGE, LID	1	1	1	
13	F1K-U135C-01	.ROLLER, DETENT	1	1	1	
14	F1K-U517R-00	.PIN, HINGE	2	2	2	
15	F1K-U471E-03	.SPACER 1	1	1	1	
16	F1K-U283B-02	.SPRING, TORSION	1	1	1	
17	90105-06826	BOLT, FLANGE	2	2	2	
18	9572R-06300	NUT, NYLON	2	2	2	
19	9299R-06200	WASHER	2	2	2	
20	F2N-67823-00	SCREW	4	4	4	
21	F2N-U517F-00	HOOK, LID LOCK	1	1	1	
22	F1X-U517E-01	NUT	2	2	2	
23	90119-06880	BOLT, WITH WASHER	2	2	2	
24	F2N-U596B-00	MIRROR LH	1	1	1	
25	F2N-U471E-00	.SPACER 1	1	1	1	
26	F2N-U596C-00	MIRROR RH	1	1	1	

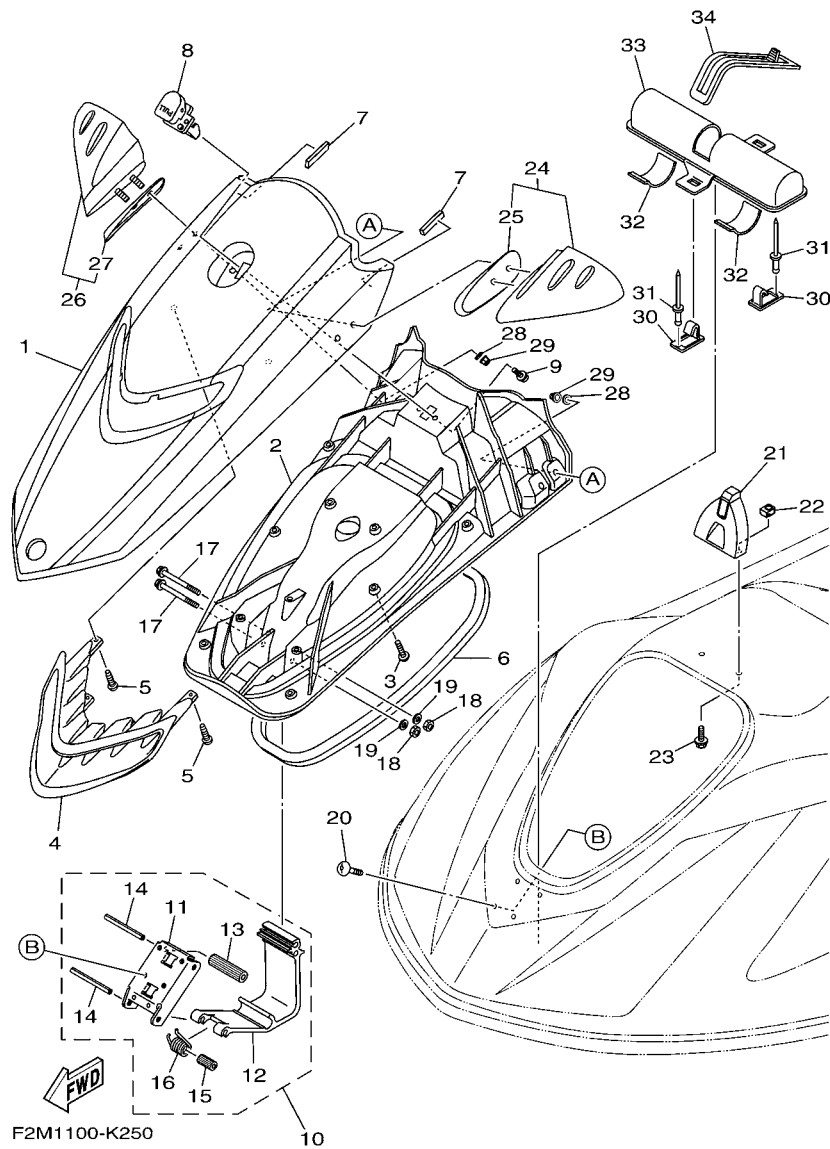
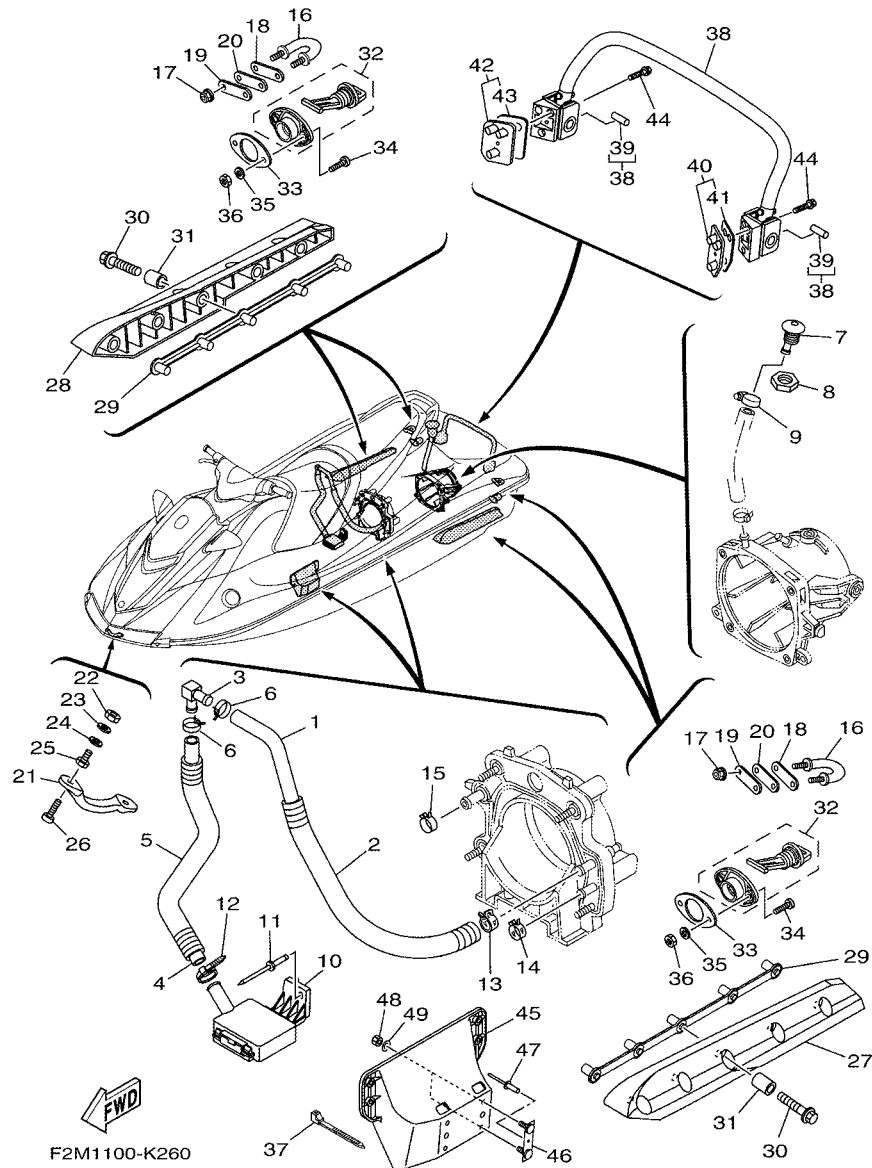

FIG. 25 ENGINE HATCH 2

REF. NO.	PART NO.	DESCRIPTION	CAN	EUR	GENE	REMARKS
27	F2N-U471F-00	.SPACER 2	1	1	1	
28	9299R-08200	WASHER	4	4	4	
29	9572R-08300	NUT, FLANGE	4	4	4	
30	F1K-U5772-04	HOOK A	2	2	2	
31	90267-489U1	RIVET,BLIND	2	2	2	
32	F1K-U759C-00	MAT 2	2	2	2	
33	F1K-U5983-01	BOX, FIRE EXTINGUISHER	1	1	1	
34	F1K-U828K-00	BAND, 1	1	1	1	

FIG. 26 HULL & DECK



REF. NO.	PART NO.	DESCRIPTION	CAN	EUR	GENE	REMARKS
1	90445-20804	HOSE (L860)	1	1	1	
2	90446-27M73	HOSE (L700)	1	1	1	
3	61X-51162-00	JOINT, HOSE	1	1	1	
4	90445-20800	HOSE (L500)	1	1	1	
5	90446-27M55	TUBE (L400)	1	1	1	
6	90467-18804	CLIP	2	2	2	
7	F1W-U269B-00	SPOUT	1	1	1	
8	EU0-61652-00	NUT	1	1	1	
9	90601-118UF	BAND, HOSE 18	1	1	1	
10	F1B-U761D-02	STRAINER, BILGE	1	1	1	
11	90267-489U8	RIVET, BLIND	1	1	1	
12	90465-11829	CLAMP	1	1	1	
13	90467-21800	CLIP	1	1	1	
14	90467-200A0	CLIP	1	1	1	
15	90467-250A0	CLIP	1	1	1	
16	F2N-U1628-00	STERN EYE	2	2	2	
17	9572R-08300	NUT, FLANGE	4	4	4	
18	GP7-U4953-10	PLATE A	2	2	2	
19	F2C-U4953-10	PLATE A	2	2	2	
20	F1B-U1653-01	PACKING	2	2	2	
21	F1K-61624-00	BOWEYE 1	1	1	1	
22	99780-12600	NUT.HEX.(COARS)	2	2	2	
23	92990-12200	WASHER, PLAIN	2	2	2	
24	F0X-61637-00	WASHER	2	2	2	
25	F0X-61652-00	NUT (BOLT/NUT)	2	2	2	
26	90110-06040	BOLT, HEXAGON SOCKET HEAD	2	2	2	
27	F1S-U883N-01	STABILIZER LH	1	1	1	BLACK

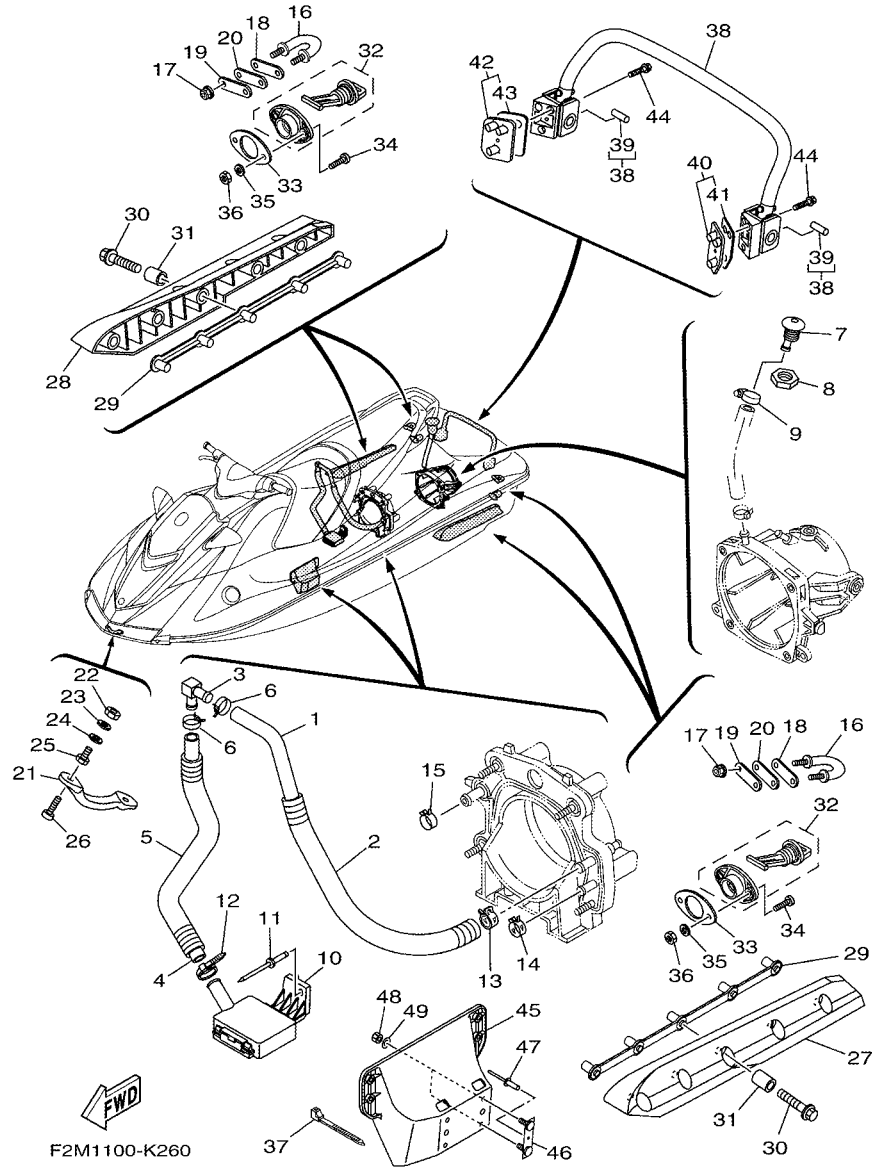
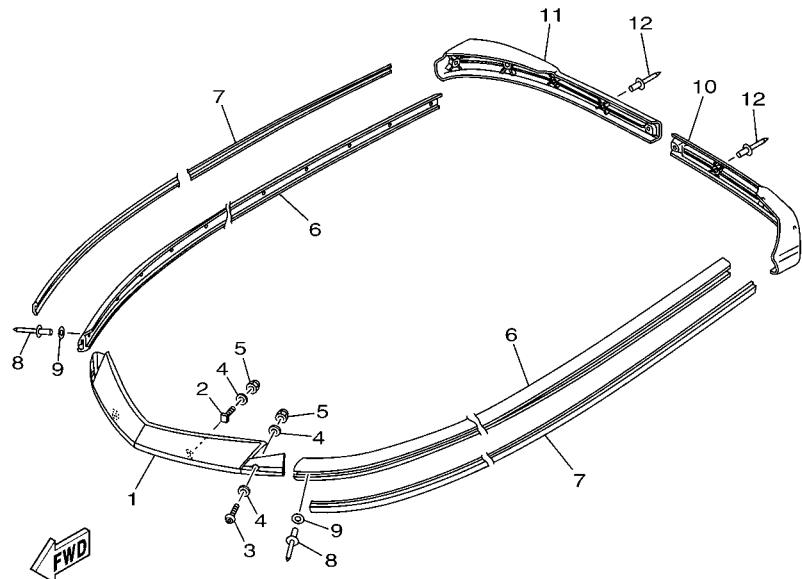
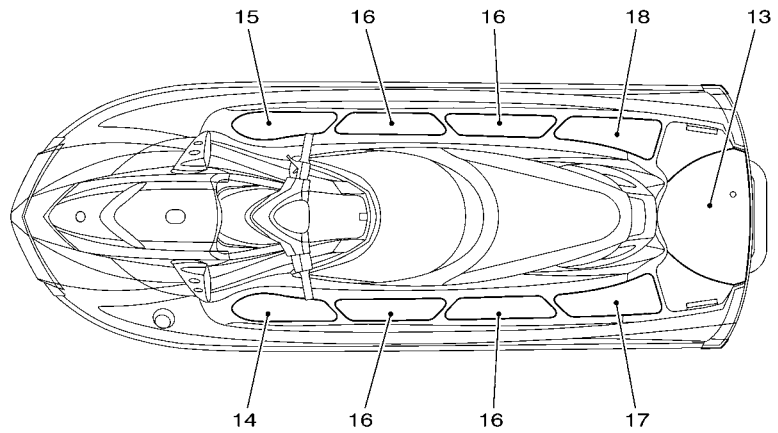

FIG. 26 HULL & DECK

REF. NO.	PART NO.	DESCRIPTION	CAN	EUR	GENE	REMARKS
28	F1S-U883P-01	STABILIZER RH	1	1	1	BLACK
29	F1X-U883T-01	BRACKET,STABILIZER	2	2	2	
30	90105-08860	BOLT, FLANGE	10	10	10	
31	F2N-U8169-00	SPACER	10	10	10	
32	F1S-U2280-00	DRAIN PLUG ASSY.	2	2	2	
33	F1S-U2285-00	PACKING, DRAIN	2	2	2	
34	9788R-05025	SCREW, PAN HEAD	4	4	4	
35	9299R-05200	WASHER	4	4	4	
36	9572R-05300	NUT, FLANGE	4	4	4	
37	90464-32801	CLAMP	1	1	1	
38	F2N-U278A-00	LADDER, STEP ASSY	1	1	1	
39	F1W-U771H-00	.SLEEVE 1	2	2	2	
40	F2L-U278F-01	BRACKET, LADDER LH	1	1	1	
41	F2L-U278H-00	.PACKING, BRKT. 1	1	1	1	
42	F2L-U278G-01	BRACKET, LADDER RH	1	1	1	
43	F2L-U278H-00	.PACKING, BRKT. 1	1	1	1	
44	90119-08844	BOLT, WITH WASHER	6	6	6	
45	F1W-U8572-01	BRACKET 2	1	1	1	
46	F1K-U826C-03	BRACKET	2	2	2	
47	90267-489U1	RIVET,BLIND	2	2	2	
48	9572R-08300	NUT, FLANGE	4	4	4	
49	9299R-08200	WASHER	4	4	4	



F2M1100-K270

FIG. 27 GUNWALE & MAT

REF. NO.	PART NO.	DESCRIPTION	CAN	EUR	GENE	REMARKS
1	F2N-U2511-01	GUNWALE, BOW	1	1	1	
2	F1W-U491K-00	BOLT, SPECIAL	2	2	2	
3	90111-06803	BOLT,HEX. SOCKET BUTTON	2	2	2	
4	9299R-06200	WASHER	6	6	6	
5	9572R-06300	NUT, NYLON	4	4	4	
6	F1K-U2512-03	GUNWALE, SIDE	2	2	2	GRAY
7	F1K-U2519-20	INNER,GUNWALE	2	2	2	YAMAHA BLACK
8	90267-489U8	RIVET, BLIND	30	30	30	
9	9299R-05200	WASHER	30	30	30	
10	F1K-U251D-01	GUNWALE, STERN 1	1	1	1	GRAY
11	F1K-U251E-01	GUNWALE, STERN 2	1	1	1	GRAY
12	90267-48963	RIVET, BLIND	9	9	9	
13	F2N-U3581-00	MAT, UPPER	1	1	1	DARK GREY
14	F2N-U351H-00	MAT, STEP 1	1	1	1	DARK GREY
15	F2N-U351J-00	MAT, STEP 2	1	1	1	DARK GREY
16	F2N-U351K-00	MAT, STEP 3	4	4	4	DARK GREY
17	F2N-U351M-00	MAT, STEP 4	1	1	1	DARK GREY
18	F2N-U351N-00	MAT, STEP 5	1	1	1	DARK GREY

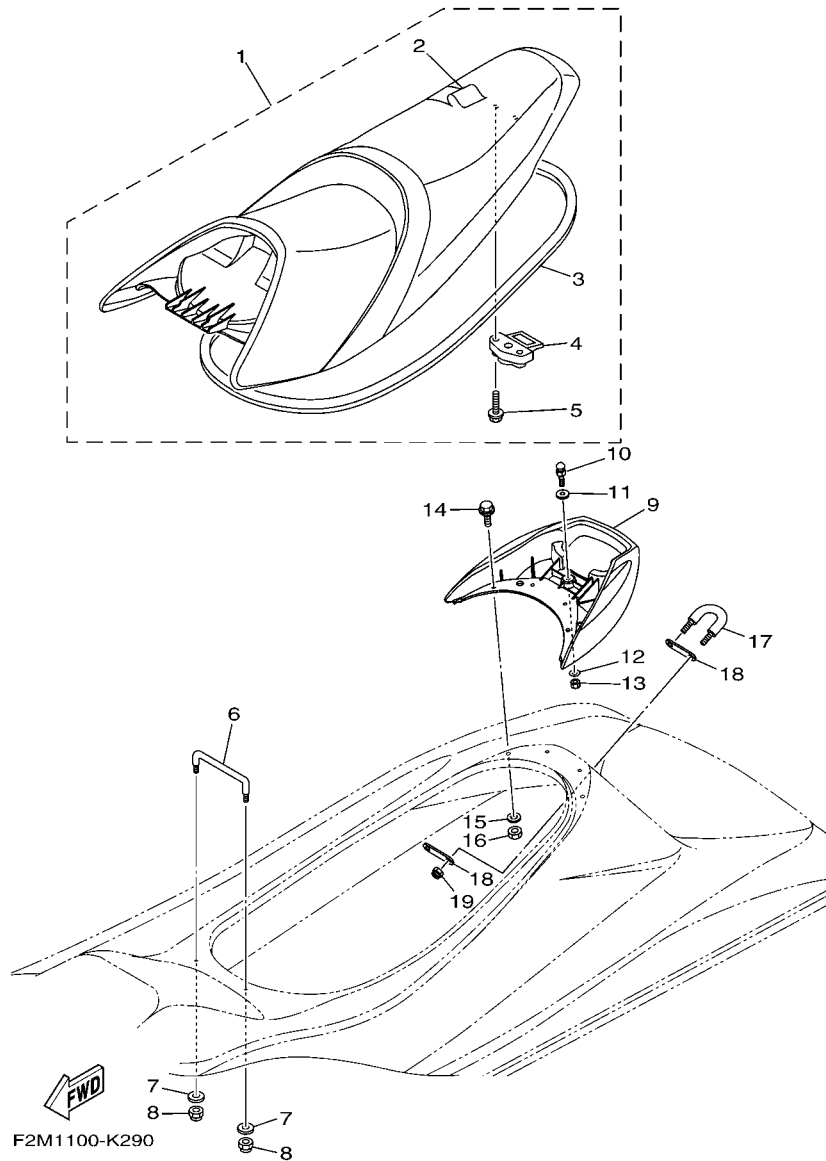

FIG. 29 SEAT & UNDER LOCKER

REF. NO.	PART NO.	DESCRIPTION	CAN	EUR	GENE	REMARKS
1	F2M-U371A-00	DOUBLE SEAT ASSY	1	1	1	
2	F2M-U371B-00	.COVER, SEAT 1	1	1	1	
3	F2N-U2664-00	.PACKING	1	1	1	
4	F2C-U3850-00	.SEAT LOCK ASSY	1	1	1	
5	90119-069UP	.BOLT, WITH WASHER	2	2	2	
6	F0X-6378C-00	STAY, SEAT 1	1	1	1	
7	90201-099U3	WASHER, PLATE	2	2	2	
8	9572R-08300	NUT, FLANGE	2	2	2	
9	F2N-U271B-01	GRIP, HAND	1	1	1	
10	GH1-U3774-00	PIN	1	1	1	
11	90201-109U6	WASHER, PLATE	1	1	1	
12	9299R-10200	WASHER	1	1	1	
13	9572R-10300	NUT, NYLON	1	1	1	
14	90119-089U2	BOLT, WITH WASHER	4	4	4	
15	9299R-08200	WASHER	4	4	4	
16	9572R-08300	NUT, FLANGE	4	4	4	
17	F2N-U1628-00	STERN EYE	1	1	1	
18	GP7-U4953-10	PLATE A	2	2	2	
19	9572R-08300	NUT, FLANGE	2	2	2	

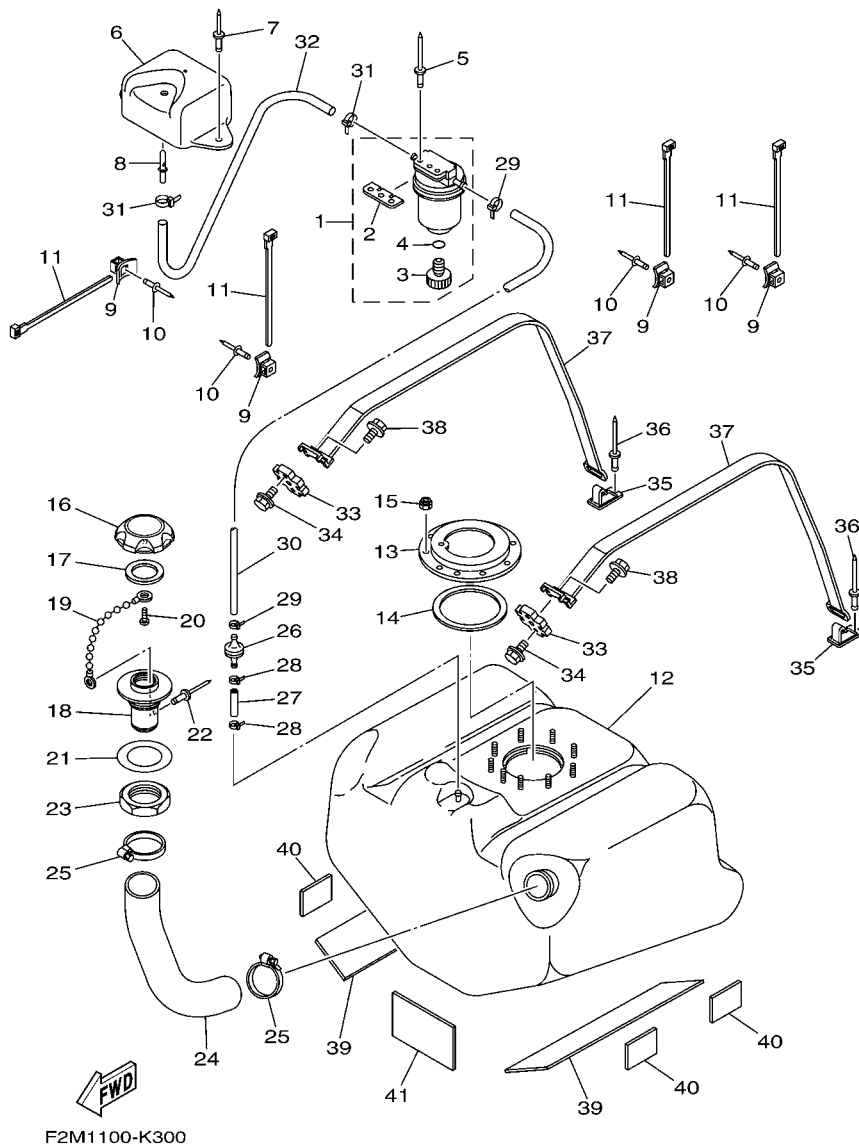

FIG. 30 FUEL TANK

REF. NO.	PART NO.	DESCRIPTION	CAN	EUR	GENE	REMARKS
1	F2F-6214A-00	FILTER, VENT ASSY	1	1	1	
2	EW2-62142-00	.PLATE, FILTER	1	1	1	
3	70R-24543-00	.PLUG, DRAIN	1	1	1	
4	70R-24489-00	.O-RING	1	1	1	
5	90267-489U2	RIVET, BLIND	2	2	2	
6	F1W-U2159-00	SOCKET, VENTILATION	1	1	1	
7	90267-489U6	RIVET, BLIND	2	2	2	
8	F1G-62149-00	PIPE, VENTILATION	1	1	1	
9	F1W-U828M-00	BASE, CLAMP	4	4	4	
10	90267-489U6	RIVET, BLIND	4	4	4	
11	90464-32801	CLAMP	4	4	4	
12	F1K-U7711-10	TANK, FUEL	1			FOR CAN
	F1K-U7711-02	TANK, FUEL		1	1	FOR EUR, GENE
13	F1B-U7773-00	RING	1	1	1	
14	F1B-67747-00	PACKING, SEAL	1	1	1	
15	9572R-06300	NUT, NYLON	9	9	9	
16	F2N-U7831-10	CAP, FUEL FILLER	1	1	1	BLACK
17	GP7-U7832-01	PACKING	1	1	1	
18	GP7-U7833-11	SOCKET	1	1	1	BLACK
19	GP7-U7835-00	CHAIN BALL	1	1	1	
20	90169-049U1	TAPPING SCREW	1	1	1	
21	GP7-U7834-00	PACKING FUEL FILLER	1	1	1	
22	90267-329UR	RIVET, BLIND	1	1	1	
23	GP7-U783F-00	NUT, FUEL FILLER	1	1	1	
24	F2N-U7844-00	HOSE	1	1	1	
25	90601-155U4	BAND, HOSE 55	2	2	2	
26	EU0-67767-31	CHECK VALVE	1	1	1	

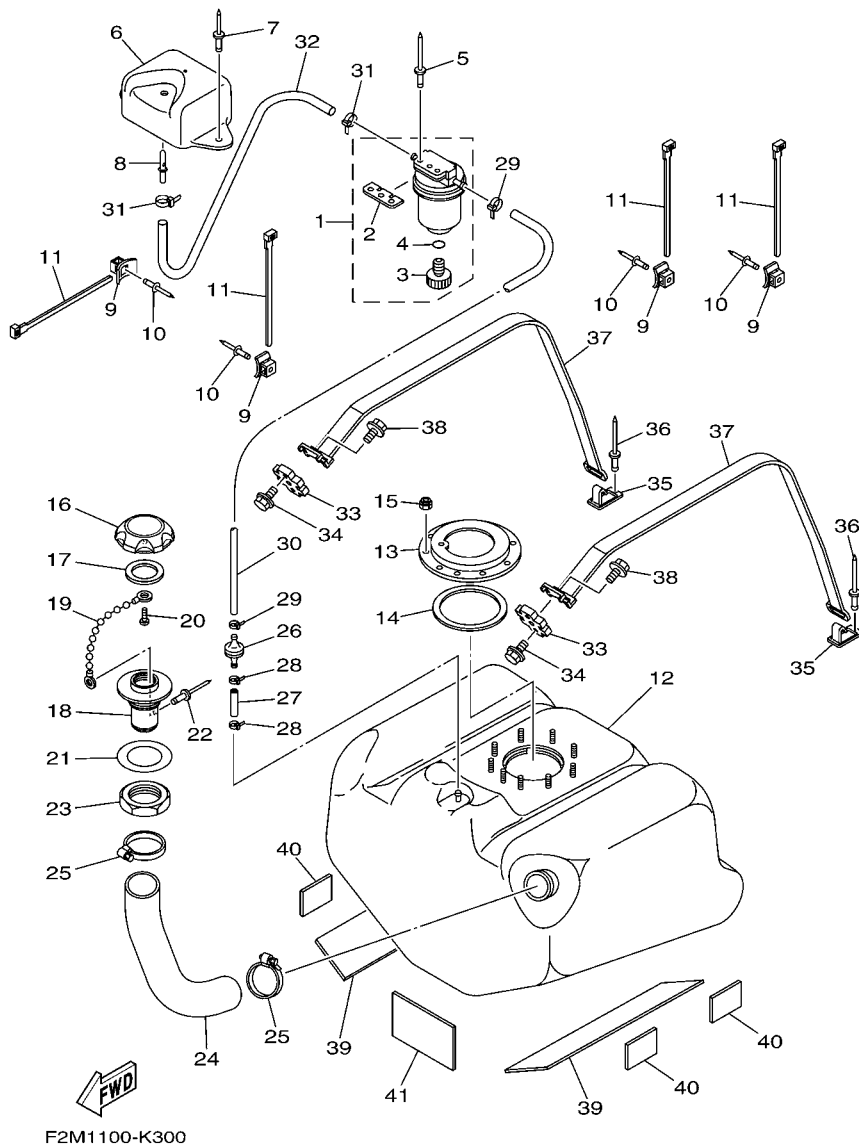

FIG. 30 FUEL TANK

REF. NO.	PART NO.	DESCRIPTION	CAN	EUR	GENE	REMARKS
27	GP7-U785H-00	HOSE, AIR VENT 3	1	1	1	
28	90465-11829	CLAMP	2	2	2	
29	90465-11829	CLAMP	2	2	2	
30	F1K-U785G-00	HOSE, AIR VENT	1	1	1	
31	90465-11829	CLAMP	2	2	2	
32	F0D-U7856-10	HOSE, AIR VENT 3	1	1	1	
33	F1X-U2873-00	NUT, SPECIAL	2	2	2	
34	90119-069UH	BOLT, WITH WASHER	4	4	4	
35	F1K-U5772-04	HOOK A	2	2	2	
36	90267-489U1	RIVET,BLIND	2	2	2	
37	F2N-67743-00	BELT, TANK 1	2	2	2	
38	90119-089U7	BOLT, WITH WASHER	2	2	2	
39	F1K-U759B-00	MAT 1	2	2	2	
40	F1W-U759C-01	MAT 2	4	4	4	
41	F1S-U8221-00	PAD, BATTERY	1	1	1	

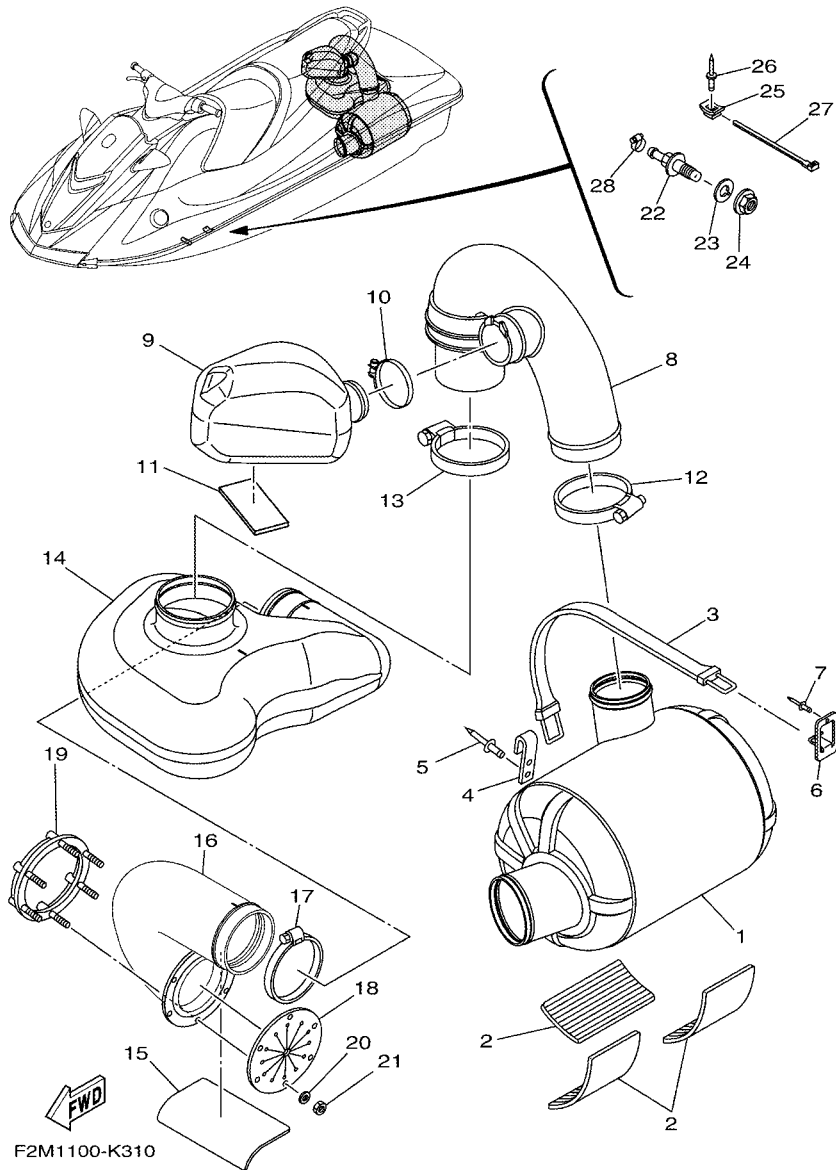
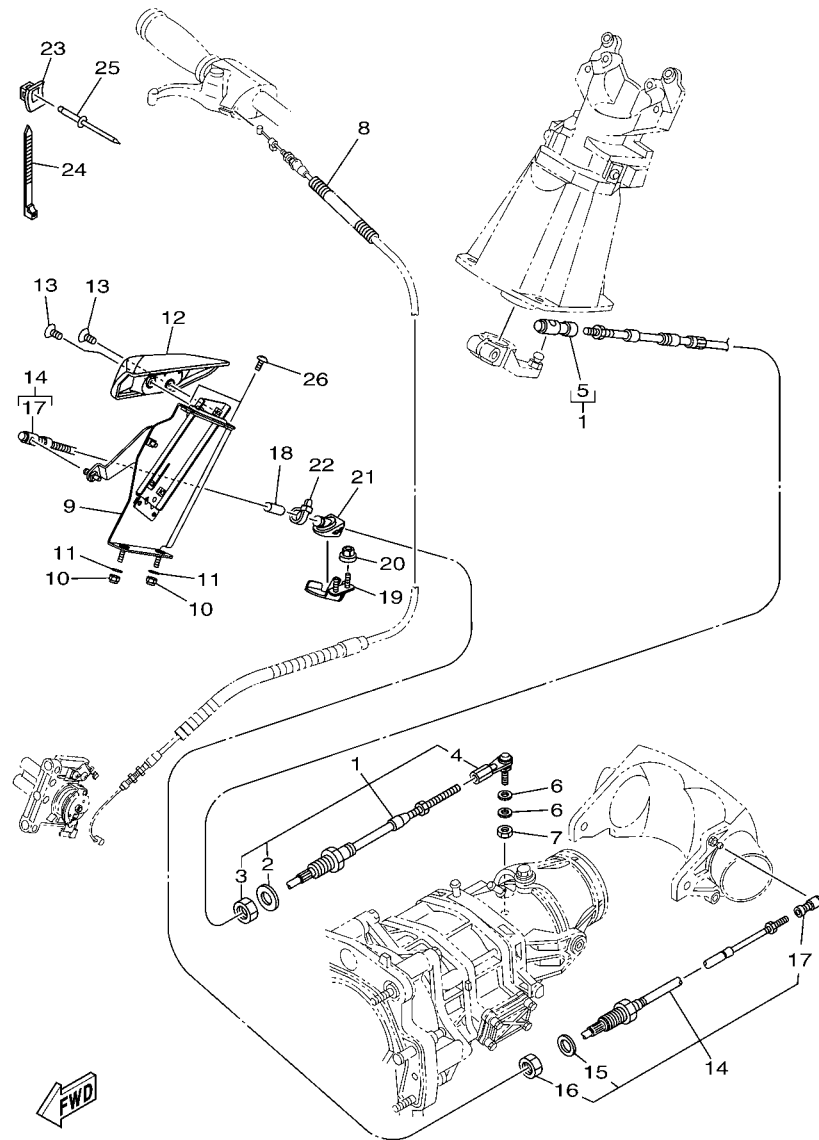

FIG. 31 EXHAUST 3

REF. NO.	PART NO.	DESCRIPTION	CAN	EUR	GENE	REMARKS
1	F1W-U7550-01	WATER LOCK COMP.	1	1	1	
2	F1S-U8221-00	PAD, BATTERY	3	3	3	
3	EW2-67821-00	BAND, FUEL TANK	1	1	1	
4	GA7-65772-00	HOOK A	1	1	1	
5	90267-489U1	RIVET,BLIND	2	2	2	
6	F1K-U5772-04	HÖÖK A	1	1	1	
7	90267-489U1	RIVET,BLIND	1	1	1	
8	F1W-U7555-00	HOSE, EXHAUST	1	1	1	
9	F1W-U753C-01	RESONATOR 1	1	1	1	
10	90601-170UG	BAND, HOSE 70	1	1	1	
11	F1K-U759C-00	MAT 2	1	1	1	
12	90450-99801	HOSE CLAMP ASSY	1	1	1	
13	90450-99804	HOSE CLAMP ASSY	1	1	1	
14	F2N-U4261-00	TANK, WATER	1	1	1	
15	F1S-U8221-00	PAD, BATTERY	1	1	1	
16	F2N-U758D-00	HÖÖSE,EXHAUST 3	1	1	1	
17	90450-99801	HOSE CLAMP ASSY	1	1	1	
18	F1B-U751G-00	VALVE, EXHAUST	1	1	1	
19	F1S-U757B-01	PLATE	1	1	1	
20	9299R-06200	WASHER	6	6	6	
21	9572R-06300	NUT, NYLON	6	6	6	
22	F1K-6753B-00	PILOT, WATER	1	1	1	
23	F1B-67564-00	GASKET	1	1	1	
24	F0X-62733-00	NUT	1	1	1	
25	F1W-U828M-00	BASE, CLAMP	1	1	1	
26	90267-489U6	RIVET, BLIND	1	1	1	
27	90464-32801	CLAMP	1	1	1	



F2M1100-K320

FIG. 32 CONTROL CABLE

REF. NO.	PART NO.	DESCRIPTION	CAN	EUR	GENE	REMARKS
1	F2N-61481-00	CABLE, STEERING	1	1	1	
2	F1B-61438-00	.PACKING	1	1	1	
3	F1B-6151S-00	.NUT	1	1	1	
4	F1B-61461-02	.STUD, JOINT BALL	1	1	1	
5	F2N-61460-00	.BALL JOINT ASSY	1	1	1	
6	90201-06906	WASHER, PLATE	2	2	2	
7	9538R-06700	NUT	1	1	1	
8	90447-06803	TUBE	1	1	1	
9	F2N-U134A-00	REMOCON. LEVER ASSY.	1	1	1	
10	9572R-06300	NUT, NYLON	2	2	2	
11	9299R-06200	WASHER	2	2	2	
12	F2N-U2714-01	GRIP	1	1	1	
13	90151-06815	SCREW, COUNTERSUNK	2	2	2	
14	F2N-6149C-00	CABLE, REVERSE	1	1	1	
15	F1B-61438-00	.PACKING	1	1	1	
16	F1B-6151S-00	.NUT	1	1	1	
17	F1B-61460-00	.BALL JOINT ASSY	2	2	2	
18	F1W-U146G-00	PACKING, CABLE	1	1	1	
19	F2N-U1467-00	BRACKET, STOPPER CABLE	1	1	1	
20	F2N-U142L-00	NUT, LOCK	2	2	2	
21	F2N-U146G-00	PACKING, CABLE	1	1	1	
22	90465-11829	CLAMP	1	1	1	
23	F1W-U828M-00	BASE, CLAMP	3	3	3	
24	90464-32801	CLAMP	3	3	3	
25	90267-489U6	RIVET, BLIND	3	3	3	
26	F2N-67823-00	SCREW	2	2	2	

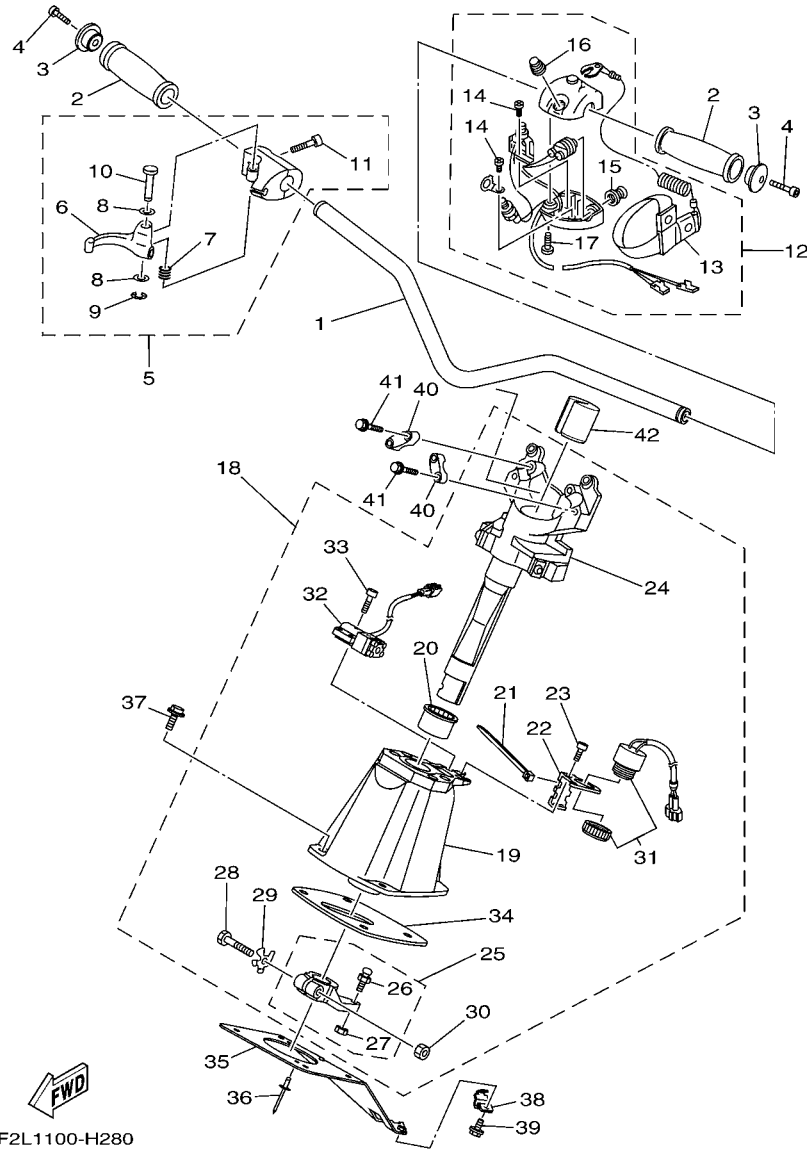

F2L1100-H280

FIG. 33 STEERING 1

REF. NO.	PART NO.	DESCRIPTION	CAN	EUR	GENE	REMARKS
1	F2N-U1552-00	HANDLE	1	1	1	
2	GP7-U155D-01	GRIP, HANDLE	2	2	2	
3	GP7-U155F-00	GRIP, END	2	2	2	
4	90110-05908	BOLT, HEXAGON SOCKET HEAD	2	2	2	
5	F0D-67250-10	THROTTLE LEVER ASSY	1	1	1	
6	F0D-67255-02	.LEVER, THROTTLE	1	1	1	
7	EW2-67256-00	.SPRING	1	1	1	
8	EW2-67258-01	.WASHER	2	2	2	
9	EW2-67259-01	.E-RING	1	1	1	
10	F0D-67257-00	.SHAFT	1	1	1	
11	F1X-6725F-01	.BOLT, THROTTLE	2	2	2	
12	FK7-68310-07	SWITCH BOX ASSY	1	1	1	
13	EW2-68348-00	.LANYARD, STOP SWITCH	1	1	1	
14	97880-03008	.SCREW, PAN HEAD	2	2	2	
15	FK7-68312-02	.STOP BUTTON COMP	1	1	1	
16	FK7-68313-02	.START BUTTON COMP.	1	1	1	
17	97880-05025	.SCREW, PAN HEAD	2	2	2	
18	F1K-61400-01	STEERING MASTER ASSY	1	1	1	
19	F1K-6152M-00	.HOUSING ASSY	1	1	1	
20	F1K-6134M-00	.BUSH	1	1	1	
21	703-82591-00	.BAND	2	2	2	
22	F1K-6146H-10	.SPACER, BRKT.	1	1	1	
23	F1B-613C1-00	.SCREW	2	2	2	
24	F1K-67410-00	.SHAFT ASSY	1	1	1	
25	F1K-6153R-00	.ARM ASSY.	1	1	1	
26	EU0-61461-02	..STUD, JOINT BALL	1	1	1	
27	95720-06300	..NUT, SELF-LOCKING	1	1	1	

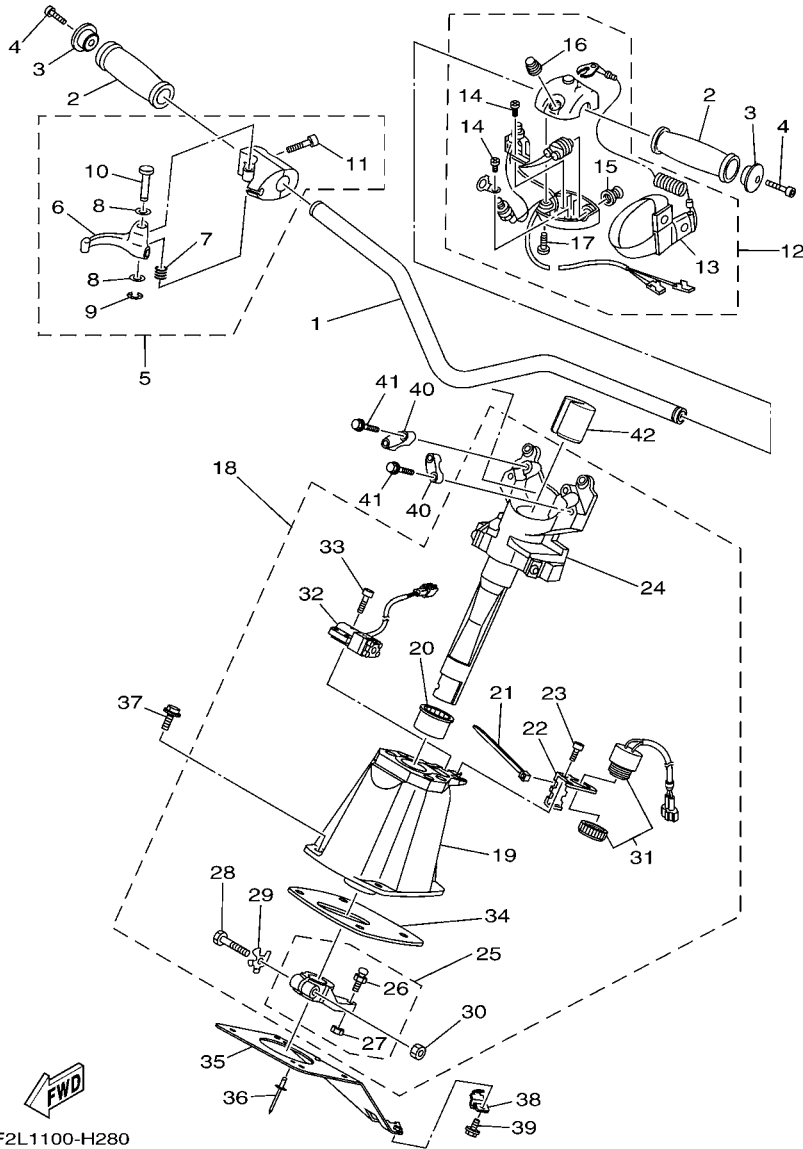

F2L1100-H280

FIG. 33 STEERING 1

REF. NO.	PART NO.	DESCRIPTION	CAN	EUR	GENE	REMARKS
28	F1K-61355-00	.BOLT	1	1	1	
29	F1K-6142B-00	.PLATE, RETAINING	1	1	1	
30	95720-08300	.NUT, SELF-LOCKING	1	1	1	
31	F1S-68341-00	.BUZZER	1	1	1	
32	F1W-68303-00	.SENSOR ASSY	1	1	1	
33	F1W-61516-00	.BOLT	4	4	4	
34	F1K-6143C-00	.SEAL, RUBBER	1	1	1	
35	F1K-U1467-01	BRACKET, STOPPER CABLE	1	1	1	
36	90267-489U2	RIVET, BLIND	2	2	2	
37	90119-08836	BOLT, WITH WASHER	4	4	4	
38	F1K-U1468-03	STOPPER, CABLE	1	1	1	
39	90119-069UH	BOLT, WITH WASHER	1	1	1	
40	EU0-23814-31	HOLDER, HANDLE UPPER	2	2	2	
41	90119-08827	BOLT, WITH WASHER	4	4	4	
42	F1K-U1949-00	PLUG	1	1	1	

FIG. 34 STEERING 2

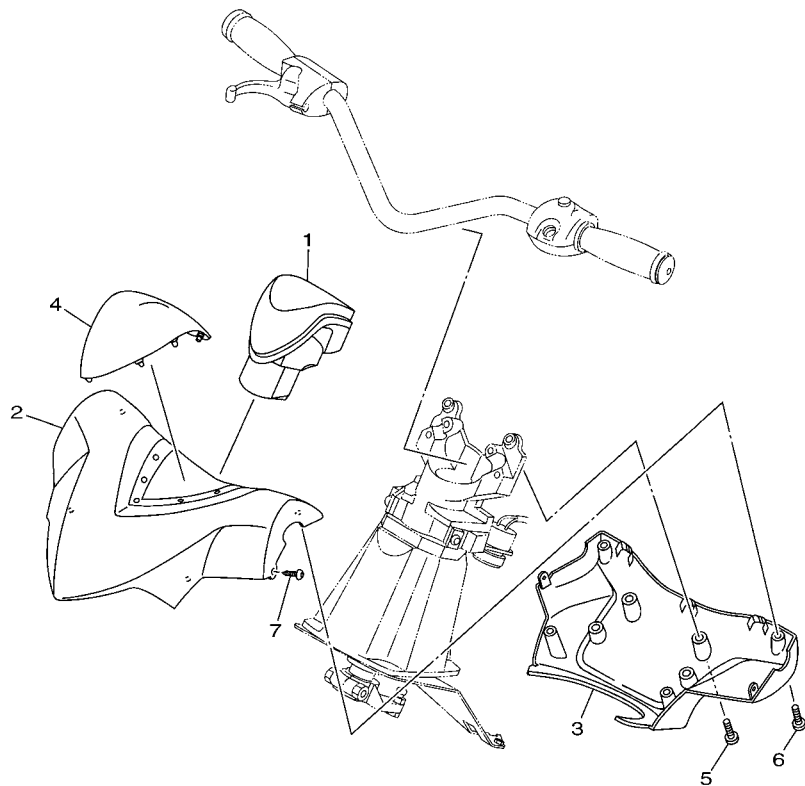

REF. NO.	PART NO.	DESCRIPTION	CAN	EUR	GENE	REMARKS
1	F1K-U156E-01	PAD 1	1	1	1	
2	F1K-U143D-01	PAD, STEERING 1	1	1	1	
3	F1K-U143E-01	PAD, STEERING 2	1	1	1	
4	F1K-U142D-00	COVER, PAD	1	1	1	
5	90154-06017	SCREW, BINDING	4	4	4	
6	90149-05903	SCREW	4	4	4	
7	90167-04003	SCREW, TAPPING	2	2	2	

 F2L1100-H290

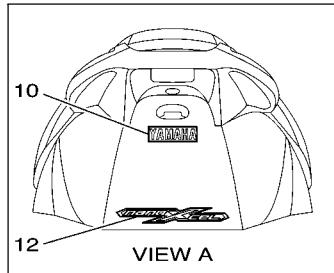
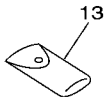
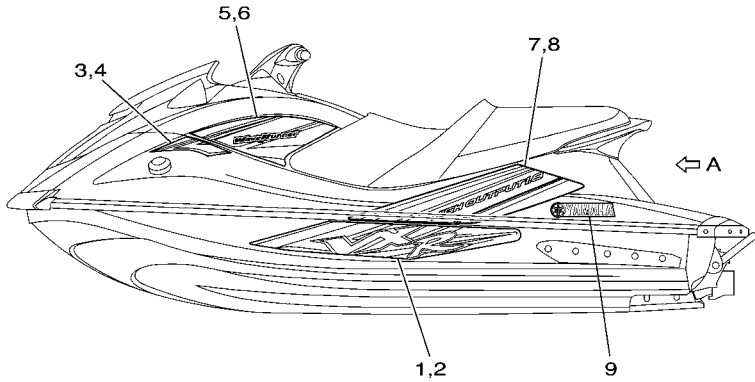
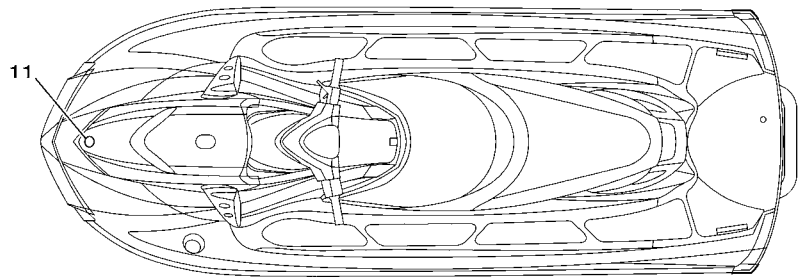

F2M1100-K350

FIG. 35 GRAPHICS

REF. NO.	PART NO.	DESCRIPTION	CAN	EUR	GENE	REMARKS
1	F2M-U417B-00	GRAPHIC 1 (LH)	1	1		FOR DPBMT VXR
	F2M-U417B-20	GRAPHIC 1 (LH)			1	FOR DPBMT VX-18R
	F2M-U417B-10	GRAPHIC 1 (LH)	1	1		FOR LGM3 VXR
	F2M-U417B-30	GRAPHIC 1 (LH)			1	FOR LGM3 VX-18R
2	F2M-U417C-00	GRAPHIC 2 (RH)	1	1		FOR DPBMT VXR
	F2M-U417C-20	GRAPHIC 2 (RH)			1	FOR DPBMT VX-18R
	F2M-U417C-10	GRAPHIC 2 (RH)	1	1		FOR LGM3 VXR
3	F2M-U417D-00	GRAPHIC 3 (LH)	1	1	1	FOR DPBMT
	F2M-U417D-10	GRAPHIC 3 (LH)	1	1	1	FOR LGM3
4	F2M-U417E-00	GRAPHIC 4 (RH)	1	1	1	FOR DPBMT
	F2M-U417E-10	GRAPHIC 4 (RH)	1	1	1	FOR LGM3
5	F2M-U417F-00	GRAPHIC 5 (LH)	1	1	1	FOR DPBMT
	F2M-U417F-10	GRAPHIC 5 (LH)	1	1	1	FOR LGM3
6	F2M-U417G-00	GRAPHIC 6 (RH)	1	1	1	FOR DPBMT
	F2M-U417G-10	GRAPHIC 6 (RH)	1	1	1	FOR LGM3
7	F2M-U417H-00	GRAPHIC 7 (LH)	1	1		FOR DPBMT VXR
	F2M-U417H-20	GRAPHIC 7 (LH)			1	FOR DPBMT VX-18R
	F2M-U417H-10	GRAPHIC 7 (LH)	1	1		FOR LGM3 VXR
	F2M-U417H-30	GRAPHIC 7 (LH)			1	FOR LGM3 VX-18R
8	F2M-U417J-00	GRAPHIC 8 (RH)	1	1		FOR DPBMT VXR
	F2M-U417J-20	GRAPHIC 8 (RH)			1	FOR DPBMT VX-18R
	F2M-U417J-10	GRAPHIC 8 (RH)	1	1		FOR LGM3 VXR
	F2M-U417J-30	GRAPHIC 8 (RH)			1	FOR LGM3 VX-18R
9	F1X-U411C-50	EMBLEM, YAMAHA	2	2	2	FOR DPBMT
	F1X-U411C-60	EMBLEM, YAMAHA	2	2	2	FOR LGM3
10	F1X-U4114-50	MARK, YAMAHA A	1	1	1	FOR DPBMT

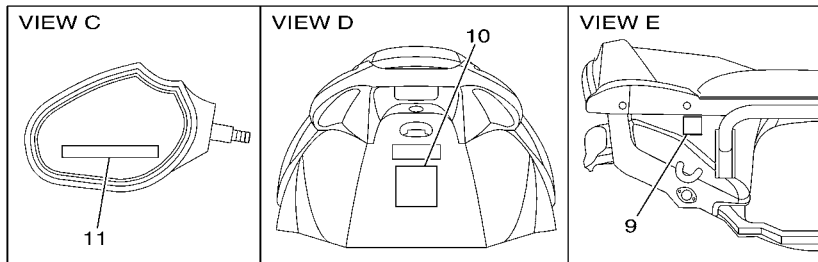
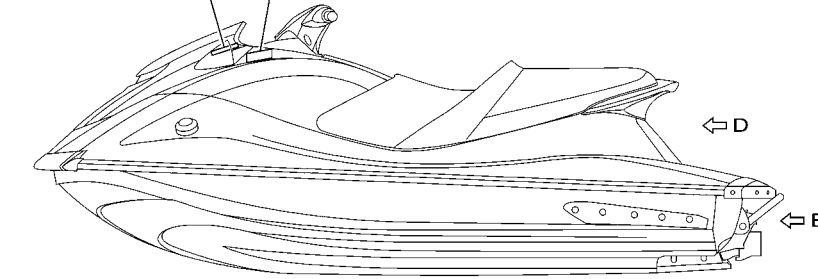
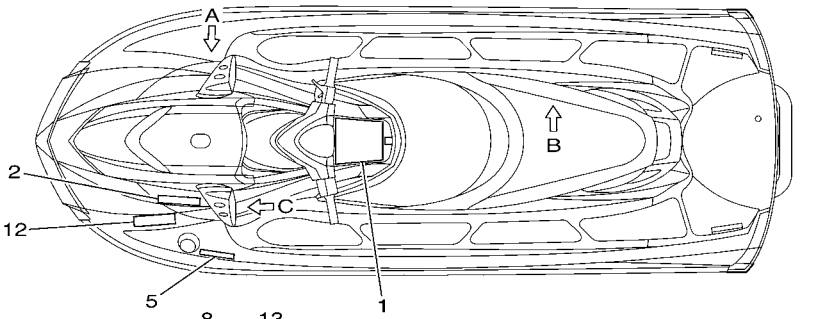
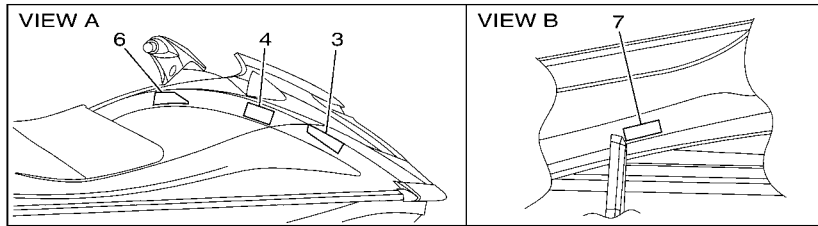

F2M1100-K370

FIG. 37 IMPORTANT LABELS 2

REF. NO.	PART NO.	DESCRIPTION	CAN	EUR	GENE	REMARKS
1	F2N-U41B1-10	LABEL, WARNING UNIFORM 1		1	1	
2	F1B-U41B1-21	LABEL, WARNING UNIFORM 1		1	1	
3	F1B-U41B1-31	LABEL, WARNING UNIFORM 1		1	1	
4	F1B-U41B2-01	LABEL, WARNING UNIFORM 2		1	1	
5	F1S-U415B-11	LABEL, WARNING(FUEL)		1	1	
6	F0V-U41D5-31	LABEL, WARNING SHIFT LEVER		1	1	
7	F0V-U41DB-12	LABEL, WARNING BATTERY		1	1	
8	F1B-U41F5-21	LABEL, FIRE EXTINGUISHER 1		1	1	
9	F1G-U418F-00	LABEL, RIGHTING		1	1	
10	F1S-U41E1-11	LABEL, SET 1		1	1	
11	GJ1-U419F-21	LABEL,5		2	2	
12	GP8-U416H-01	LABEL,WARNING(FRANCE)		1		FOR EUR
13	F1X-U413P-02	LABEL, BUILDERS PLATE		1		FOR EUR

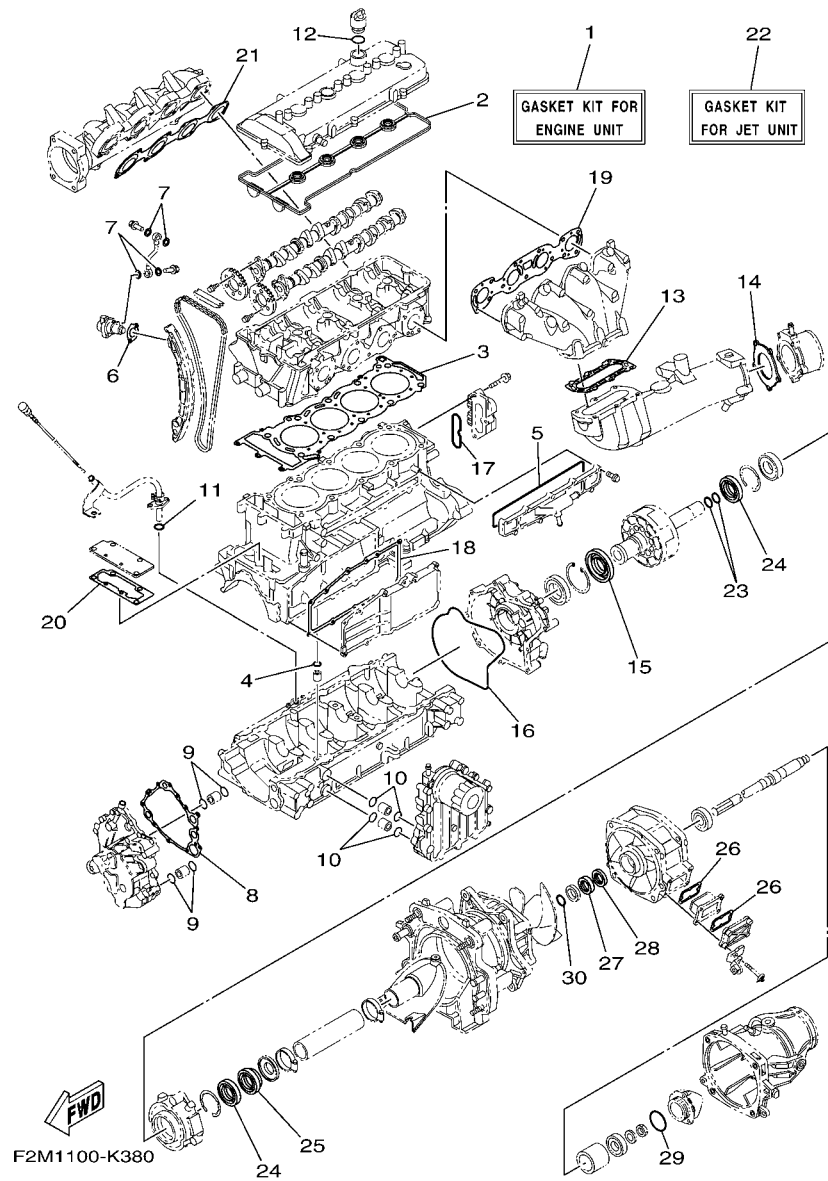

FIG. 38 REPAIR KIT 1

REF. NO.	PART NO.	DESCRIPTION	CAN	EUR	GENE	REMARKS
1	6BH-W0001-00	GASKET KIT FOR ENGINE UNIT	1	1	1	
2	6BH-11193-00	.GASKET, HEAD COVER 1	1	1	1	
3	6BH-11181-00	.GASKET, CYLINDER HEAD 1	1	1	1	
4	93210-11453	.O-RING	1	1	1	
5	6S5-12517-01	.GASKET, WATER INLET	1	1	1	
6	6S5-121E2-00	.GASKET	1	1	1	
7	90430-10007	.GASKET	4	4	4	
8	6S5-13563-00	.GASKET	1	1	1	
9	93210-21631	.O-RING	4	4	4	
10	93210-18322	.O-RING	4	4	4	
11	93210-12790	.O-RING	1	1	1	
12	93210-24M79	.O-RING	1	1	1	
13	6S5-14739-00	.GASKET, MUFFLER DAMPER 1	1	1	1	
14	6BH-14749-00	.GASKET, MUFFLER DAMPER 2	1	1	1	
15	6S5-81167-10	.OIL SEAL	1	1	1	
16	6S5-81168-00	.O-RING	1	1	1	
17	93210-60ME8	.O-RING	1	1	1	
18	6BH-13557-00	.GASKET	1	1	1	
19	6BH-14613-00	.GASKET, EXHAUST PIPE	1	1	1	
20	6BH-1131B-00	.GASKET, COVER	1	1	1	
21	6BH-13645-00	.GASKET, MANIFOLD 1	1	1	1	
22	6S5-W0001-22	GASKET KIT FOR JET UNIT	1	1	1	
23	93210-22MF1	.O-RING	2	2	2	
24	93102-29008	.OIL SEAL	2	2	2	
25	93102-29009	.OIL SEAL	1	1	1	
26	66V-42414-00	.O-RING	2	2	2	
27	93102-31009	.OIL SEAL	1	1	1	

NUMERICAL INDEX

PART NO.	REF. NO.	PART NO.	REF. NO.	PART NO.	REF. NO.	PART NO.	REF. NO.	PART NO.	REF. NO.	PART NO.	REF. NO.
6BH-11102-00-94	2 - 2	3LD-12168-40	5 - 12	6CN-12588-00	13 - 28	6BH-14711-00-94	12 - 2	66V-51312-01-94	14 - 4	EW2-67258-01	33 - 8
6BH-11119-00	2 - 14	3LD-12168-60	5 - 12	6S5-12589-00	13 - 24	6BH-14721-00-94	12 - 6	6S5-51315-00-94	14 - 7	EW2-67259-01	33 - 9
6BH-1111E-00	2 - 12	3LD-12168-80	5 - 12	6S5-12858-00	10 - 2	6S5-14739-00	12 - 7	6S5-51323-00	15 - 2	F1X-6725F-01	33 - 11
6S5-11125-00	11 - 9	3LD-12168-A0	5 - 12	6S5-12880-00	6 - 4		38 - 13	6S5-51326-00-94	14 - 20	F1K-67410-00	33 - 24
6S5-11126-00	3 - 22	3LD-12168-F0	5 - 12	6S5-1310A-10-94	9 - 1	6BH-14749-00	12 - 14	6BH-51348-01	14 - 24	F1K-6753B-00	31 - 22
6S5-11133-10	2 - 3	3LD-12168-H1	5 - 12	6BH-1319K-00	3 - 37		38 - 14	61L-5169A-00	13 - 15	F1B-67564-00	31 - 23
6BH-11160-00	11 - 5	3LD-12168-K1	5 - 12	6BH-13300-00	8 - 1	6S5-14752-00	12 - 17	6D3-52358-00	16 - 8	F2N-67743-00	30 - 37
6S5-11166-00	11 - 1	3LD-12168-M1	5 - 12	6S5-13317-00	9 - 6	6S5-1475A-00	12 - 18	F1K-6134M-00	33 - 20	F1B-67747-00	30 - 14
6S5-11167-00	11 - 11	3LD-12168-R1	5 - 12	6S5-13337-00	3 - 28	6S5-14771-00-94	12 - 11	F1K-61355-00	33 - 28	EU0-67767-31	30 - 26
6BH-11181-00	2 - 11	3LD-12168-U1	5 - 12	6S5-13405-00	9 - 2	6BH-14784-01-94	12 - 15	F1B-613C1-00	33 - 23	EW2-67821-00	31 - 3
	38 - 3	3LD-12168-W1	5 - 12	6S5-13406-00	9 - 3	6BH-15100-10	3 - 1	F1K-61400-01	33 - 18	F2N-67823-00	25 - 20
6BH-11191-00-94	1 - 1	3LD-12168-Y1	5 - 12	6S5-13418-00	5 - 21	6BH-15362-00	3 - 35	F1K-6142B-00	33 - 29		32 - 26
6BH-11193-00	1 - 3	3LD-12169-11	5 - 12	69J-13440-01	10 - 1	6S5-15363-00	1 - 11	F1B-61438-00	32 - 2	F2N-67823-10	24 - 13
	38 - 2	3LD-12169-31	5 - 12	60E-13446-00	8 - 6	6S5-15486-00	9 - 7		32 - 15	F1K-6820A-20	22 - 14
69J-11301-10	3 - 9	3LD-12169-50	5 - 12	6S5-13446-00	10 - 3	5EL-15511-00	19 - 6	F1K-6143C-00	33 - 34	GU2-6822E-01	22 - 16
6BH-1131B-00	3 - 32	3LD-12169-70	5 - 12	6BH-13470-00	10 - 4	6S5-15515-00	18 - 3	F1B-61460-00	32 - 17	6S5-682E0-00	22 - 2
	38 - 20	3LD-12169-90	5 - 12	6S5-13476-00	9 - 4	6S5-15517-00	18 - 5	F2N-61460-00	32 - 5	F1W-68303-00	33 - 32
6BH-1131C-00	3 - 31	3LD-12169-E0	5 - 12	6S5-13477-00	9 - 5	6S5-15521-00	18 - 4	EU0-61461-02	33 - 26	FK7-68310-07	33 - 12
6S5-1131M-00-94	3 - 18	3LD-12169-G0	5 - 12	6BH-13532-00	6 - 19	6S5-15590-00	18 - 1	F1B-61461-02	32 - 4	FK7-68312-02	33 - 15
68V-11325-02	3 - 10	3LD-12169-J0	5 - 12	6BH-13556-00	10 - 5	6S5-17031-00	4 - 17	F1K-6146H-10	33 - 22	FK7-68313-02	33 - 16
67F-11328-00	3 - 11	3LD-12169-L0	5 - 12	8FP-13556-00	6 - 13	6S5-17525-01	4 - 14	F2N-61481-00	32 - 1	F1S-68341-00	33 - 31
6S5-11377-00	3 - 16	6BH-12171-00	5 - 1	6BH-13557-00	3 - 19	6S5-17572-01	4 - 11	F2N-6149C-00	32 - 14	EW2-68348-00	33 - 13
6S5-11411-00	4 - 1	6D3-12176-00	5 - 3		38 - 18	6BH-17586-00	4 - 16	F1W-61516-00	33 - 33	6S5-81167-10	18 - 13
6S5-11416-00	4 - 2	6BH-12181-00	5 - 2	6S5-13563-00	8 - 2	EU0-23814-31	33 - 40	F1B-6151S-00	32 - 3		38 - 15
6S5-11416-10	4 - 2	6S5-121E2-00	5 - 19		38 - 8	6S5-24300-01	6 - 21		32 - 16	6S5-81168-00	18 - 17
6S5-11416-20	4 - 2		38 - 6	6P2-13578-00	6 - 6	70R-24489-00	30 - 4	F1K-6152M-00	33 - 19		38 - 16
6S5-11416-30	4 - 2	6S5-12210-00	5 - 18	6P2-13588-00	6 - 5	70R-24543-00	30 - 3	F1K-6153R-00	33 - 25	6S5-81315-00	21 - 27
6S5-11416-40	4 - 2	6S5-12228-01	2 - 7	6BH-13641-01	6 - 2	6BU-26311-00	21 - 2	F1K-61624-00	26 - 21	6S5-81328-00	18 - 18
6S5-11459-01	4 - 15	6BH-12241-00	5 - 25	6BH-13645-00	6 - 24	67F-2812A-00	20 - 29	FOX-61637-00	26 - 24	66V-8132W-00	20 - 27
6S5-11603-00	4 - 4	6BH-12251-00	5 - 24		38 - 21	6BH-41661-00-94	23 - 4	EU0-61652-00	13 - 10	6S5-81337-10-94	18 - 11
6BH-11631-00-B0	4 - 3	6BH-12252-00	5 - 15	6BH-13750-00	6 - 1	6BH-41662-00-94	23 - 5		26 - 8	6S5-81364-00	18 - 24
6S5-11633-00	4 - 5	6BH-12279-00	5 - 16	6S5-13761-00	6 - 11	66V-42414-00	14 - 9	FOX-61652-00	26 - 25	6S5-81410-00	18 - 7
6BH-11650-00	4 - 7	6S5-12289-00	4 - 12	6S5-13907-00	22 - 1		38 - 26	EW2-62142-00	30 - 2	6S5-81450-01	18 - 6
6S5-11654-00	4 - 8		15 - 12	60E-14147-00	6 - 12	67X-44517-10-94	23 - 1	F1G-62149-00	30 - 8	6S5-81800-00	19 - 1
6S5-11656-00	4 - 10	6D3-12411-00	2 - 16	6S5-14285-00	6 - 16	663-45119-00	13 - 16	F2F-6214A-00	30 - 1	6S5-81810-00	19 - 13
6S5-11656-10	4 - 10	6BH-12413-00	2 - 17	6CN-14294-00	6 - 20	66V-45214-00-94	14 - 10	GJ3-6215F-00	22 - 12	6S5-81820-00	19 - 12
6S5-11656-20	4 - 10	6S5-1243E-00	13 - 11	6D3-14305-21	21 - 1	6S5-45332-00-94	15 - 4	FOX-62733-00	31 - 24	6S5-81826-00	19 - 10
6S5-11656-30	4 - 10	6S5-12443-00	13 - 8	6BH-14360-00	6 - 10	61L-45378-00	15 - 10	GU2-62875-01	24 - 17	6S5-81830-00	19 - 3
6S5-12111-00	5 - 5	6BH-1244H-00	13 - 26	6S5-14413-00-94	6 - 28	6S5-45511-00	14 - 17	FOX-6378C-00	29 - 6	6S5-81840-00	19 - 8
6S5-12113-00	5 - 8	6S5-12469-01-94	3 - 25	6BH-14445-00	6 - 18	6S5-45538-00	14 - 13	F2M-6517C-00	25 - 8	11H-81844-00	19 - 2
6S5-12116-00	5 - 7	6S5-12517-01	3 - 26	63P-14446-00	6 - 7	6S5-45593-00-94	15 - 11	FOX-6517R-01	24 - 16	4G0-81844-00	19 - 4
6S5-12117-00	5 - 9		38 - 5	6BH-1444B-00	6 - 14	6S5-45613-10	15 - 9	GA7-65772-00	31 - 4	66V-81844-00	20 - 28
3LD-12118-00	5 - 10	6BH-12577-00	13 - 31	6BH-14457-00	6 - 17	6S5-45813-01-94	4 - 13	EU0-65901-01	35 - 14	5EL-81845-00	19 - 11
51Y-12119-00	5 - 11	6S5-12578-00	2 - 19	6D3-14495-00	7 - 2	6BH-4581J-00	15 - 1	F1B-65986-10	35 - 13	6BH-81845-00	20 - 8
6S5-12121-00	5 - 6	6S5-12579-00	13 - 33		21 - 11	66V-46882-00	14 - 8	FOD-67250-10	33 - 5	3TB-81847-00	19 - 9
6S5-12153-00	5 - 13	63M-12580-00	13 - 5	6S5-14496-00	6 - 9	6S5-5111K-00	14 - 21	FOD-67255-02	33 - 6	6BH-81847-00	20 - 30
3LD-12168-00	5 - 12	60E-12581-00	13 - 4	6BH-14613-00	12 - 1		38 - 29	EW2-67256-00	33 - 7	1J7-81847-60	19 - 5
3LD-12168-20	5 - 12	6BH-12584-00	13 - 19		38 - 19	61X-51162-00	26 - 3	FOD-67257-00	33 - 10	5A8-81850-10	19 - 14

NUMERICAL INDEX

PART NO.	REF. NO.	PART NO.	REF. NO.	PART NO.	REF. NO.	PART NO.	REF. NO.	PART NO.	REF. NO.	PART NO.	REF. NO.
6B6-81940-00	20 - 26	6BH-E4419-00	7 - 12	F1K-U2512-03	27 - 6	F2M-U417D-10	35 - 3	F2N-U516N-00-P4	24 - 7	F1W-U771H-00	26 - 39
6S5-81942-10	20 - 9	6S5-E4436-00	7 - 8	F1K-U2519-20	27 - 7	F2M-U417E-00	35 - 4	F2N-U516P-00	24 - 8	F1B-U7773-00	30 - 13
60E-81950-00	20 - 24	6S5-E4451-00	7 - 7	F1K-U251D-01	27 - 10	F2M-U417E-10	35 - 4	F2M-U517B-00-P0	25 - 1	F2N-U7831-10	30 - 16
68V-81950-00	20 - 25	6S5-G2717-00	7 - 9	F1K-U251E-01	27 - 11	F2M-U417F-00	35 - 5	F2M-U517B-00-P1	25 - 1	GP7-U7832-01	30 - 17
6S5-81960-00	21 - 6	6CN-G4532-00	23 - 2	F2N-U2663-01	25 - 6	F2M-U417G-10	35 - 5	F1K-U517D-05	25 - 12	GP7-U7833-11	30 - 18
6S5-81972-01-94	21 - 8	6CN-G4574-00	23 - 3	F2N-U2664-00	29 - 3	F2M-U417G-00	35 - 6	F1X-U517E-01	25 - 22	GP7-U7834-00	30 - 21
6S5-81975-00	21 - 7	6AN-G5831-00	14 - 1	F1K-U266C-00	24 - 9	F2M-U417G-10	35 - 6	F2N-U517F-00	25 - 21	GP7-U7835-00	30 - 19
EU0-82110-09	22 - 4	6BH-R1142-00	7 - 13	F2N-U266C-00	24 - 2	F2M-U417H-00	35 - 7	F2N-U517H-01	24 - 15	GP7-U783F-00	30 - 23
6S5-82115-00	20 - 16	6BU-R1313-00-94	14 - 35	F1W-U269B-00	26 - 7	F2M-U417H-10	35 - 7	F1K-U517R-00	25 - 14	F2N-U7844-00	30 - 24
6S5-82116-00	22 - 34	6D3-R1314-00	16 - 1	F2N-U2714-01	32 - 12	F2M-U417H-20	35 - 7	F2M-U517V-00	25 - 4	F0D-U7856-10	30 - 32
6S5-82117-00	20 - 17	6BU-R1318-00	14 - 26	F2N-U271B-01	29 - 9	F2M-U417H-30	35 - 7	F1K-U518E-04	25 - 11	F1K-U785G-00	30 - 30
67F-82151-00	20 - 19	6AP-R1321-01	14 - 23	F1K-U273B-06	17 - 2	F2M-U417J-00	35 - 8	F2N-U519D-00	24 - 18	F0D-U785G-10	22 - 10
67F-82151-10	20 - 20	6CN-R1333-00-94	17 - 1	F2N-U278A-00	26 - 38	F2M-U417J-10	35 - 8	F2N-U5633-00	24 - 19	GP7-U785H-00	30 - 27
67F-82151-30	20 - 21	6D3-R1341-00	14 - 34	F2L-U278F-01	26 - 40	F2M-U417J-20	35 - 8	F1K-U5772-04	22 - 7	F2N-U8169-00	26 - 31
67F-82151-40	20 - 22	6S5-R1381-01	15 - 17	F2L-U278G-01	26 - 42	F2M-U417J-30	35 - 8		25 - 30	F1K-U8211-01	22 - 6
	20 - 23	F2N-U134A-00	32 - 9	F2L-U278H-00	26 - 41	F1G-U418F-00	36 - 9		30 - 35	F1K-U821D-01	22 - 9
6D3-82157-00	20 - 18	F1K-U135C-01	25 - 13		26 - 43		37 - 9		31 - 6	F1K-U8221-00	22 - 5
6BH-82170-00	20 - 15	F1K-U142D-00	34 - 4	F1K-U283B-02	25 - 16	F1S-U419E-01	36 - 11	F2N-U596B-00	25 - 24	F1S-U8221-00	20 - 7
6S5-82310-00	21 - 14	F2N-U142L-00	24 - 14	F1X-U2873-00	30 - 33	GJ1-U419F-21	36 - 12	F2N-U596C-00	25 - 26		30 - 41
61N-82317-00	1 - 8		32 - 20	F2N-U351H-00	27 - 14		37 - 11	F1K-U5983-01	25 - 33		31 - 2
	11 - 6	F1K-U143D-01	34 - 2	F2N-U351J-00	27 - 15	F2N-U41B1-10	36 - 1	GDO-U7249-00-05	15 - 19		31 - 15
6A0-82317-00	20 - 13	F1K-U143E-01	34 - 3	F2N-U351K-00	27 - 16		37 - 1	F1W-U7254-00	21 - 5	F1W-U826C-00	22 - 32
6BH-82380-00	6 - 8	F2M-U143G-00	17 - 3	F2N-U351M-00	27 - 17	F1B-U41B1-21	36 - 2	F1S-U725E-01	14 - 38	F1K-U826C-03	26 - 46
68V-82504-00	21 - 26	EU0-U1461-02	16 - 11	F2N-U351N-00	27 - 18		37 - 2	6CN-U72M2-00	14 - 27	F1S-U828H-01	20 - 2
60E-82556-00	22 - 3	F2N-U1467-00	32 - 19	F2N-U3581-00	27 - 13	F1B-U41B1-31	36 - 3	F2M-U732B-00	23 - 12	F1K-U828K-00	25 - 34
60E-82560-01	21 - 21	F1K-U1467-01	33 - 35	F2M-U371A-00	29 - 1		37 - 3		23 - 13	F1W-U828M-00	20 - 3
703-82591-00	33 - 21	F1K-U1468-03	33 - 38	F2M-U371B-00	29 - 2	F1B-U41B2-01	36 - 4	EU0-U7354-00-01	23 - 9		22 - 22
6S5-8259E-00	20 - 32	F1W-U146G-00	32 - 18	GH1-U3774-00	29 - 10		37 - 4	EU0-U7354-00-03	23 - 9		22 - 25
6CN-8259L-00	20 - 34	F2N-U146G-00	32 - 21	F2C-U3850-00	29 - 4	F0V-U41D5-31	36 - 6	EU0-U7354-00-05	23 - 9		22 - 29
6D3-8273J-01	21 - 28	F2C-U151S-00	22 - 20	F1X-U4114-50	35 - 10		37 - 6	EU0-U7354-00-10	23 - 9		28 - 3
60E-83627-00	20 - 10	F2N-U1552-00	33 - 1	F1X-U4114-60	35 - 10	F0V-U41DB-12	36 - 7	EU0-U7354-00-20	23 - 9		30 - 9
682-84385-01	13 - 9	GP7-U155D-01	33 - 2	F1X-U411C-50	35 - 9		37 - 7	F1B-U751G-00	31 - 18		31 - 25
6BH-85516-00	3 - 38	GP7-U155F-00	33 - 3	F1X-U411C-60	35 - 9	F1S-U41E1-11	36 - 10	F1W-U753C-01	31 - 9		32 - 23
6BH-8572F-00	3 - 36	F1K-U156E-01	34 - 1	F1K-U411H-00	35 - 11		37 - 10	F1W-U7550-01	31 - 1	F1W-U8572-01	26 - 45
61A-85790-00	21 - 19	F2N-U1628-00	26 - 16	F1W-U4121-00	35 - 12	F1B-U41F5-21	36 - 8	F1W-U7555-00	31 - 8	F1G-U8572-02	17 - 5
6AA-85790-00	21 - 31		29 - 17	F1X-U413P-02	37 - 13		37 - 8	F1K-U7557-01	17 - 8	F2C-U8577-03	17 - 6
65L-85886-00	6 - 15	F1B-U1653-01	26 - 20	F1S-U415B-11	36 - 5	F2N-U4261-00	31 - 14	GJ1-U7578-21	22 - 18	F2C-U883B-00	15 - 23
6D3-85896-00	21 - 24	F2C-U1743-00	25 - 7		37 - 5	F2N-U471E-00	25 - 25	F1S-U757B-01	31 - 19	F2N-U883E-00	15 - 20
6CN-8591A-00	20 - 11	F1K-U1949-00	33 - 42	GP8-U416H-01	37 - 12	F1K-U471E-03	25 - 15	F1K-U757E-01	17 - 12	F1S-U883N-01	26 - 27
6B6-86261-00	22 - 35	F2N-U2127-00	28 - 1	F2M-U417B-00	35 - 1	F2N-U471F-00	25 - 27	F1K-U757F-01	17 - 13	F1S-U883P-01	26 - 28
6B6-86261-10	22 - 35	F2M-U213B-00	25 - 2	F2M-U417B-10	35 - 1	F2N-U475B-02	24 - 1	F2N-U758D-00	31 - 16	F1X-U883T-01	26 - 29
6B6-86265-00	22 - 36	F2N-U213G-00	28 - 2	F2M-U417B-20	35 - 1	F1W-U475F-01	24 - 5	F1K-U759B-00	30 - 39	F1K-U892D-00	15 - 24
6B6-86265-10	22 - 36	F1W-U2159-00	30 - 6	F2M-U417B-30	35 - 1	F1W-U491K-00	27 - 2	F1K-U759C-00	25 - 32	F1S-U8K31-02	22 - 19
6BH-E110M-00	1 - 4	F2N-U2187-00	28 - 6	F2M-U417C-00	35 - 2	F2C-U4953-10	26 - 19		31 - 11	6BH-W0001-00	38 - 1
6S5-E118E-00	1 - 7	F2N-U2188-00	28 - 7	F2M-U417C-10	35 - 2	GP7-U4953-10	26 - 18	F1W-U759C-01	30 - 40	6S5-W0001-22	38 - 22
6S5-E1328-00	1 - 5	F1S-U2280-00	26 - 32	F2M-U417C-20	35 - 2		29 - 18	F1B-U761D-02	26 - 10	6BH-W009A-00-94	2 - 1
67X-E2590-10	13 - 38	F1S-U2285-00	26 - 33	F2M-U417C-30	35 - 2	F1K-U515A-00	25 - 10	F1K-U7711-02	30 - 12	6BH-W009B-10-94	3 - 4
6S5-E4410-01	7 - 6	F2N-U2511-01	27 - 1	F2M-U417D-00	35 - 3	F2N-U516N-00-P2	24 - 7	F1K-U7711-10	30 - 12	90101-069U0	17 - 16

NUMERICAL INDEX

PART NO.	REF. NO.	PART NO.	REF. NO.	PART NO.	REF. NO.	PART NO.	REF. NO.	PART NO.	REF. NO.	PART NO.	REF. NO.
90105-06028	1 - 2	90119-08097	12 - 5	90267-48963	27 - 12	90445-21806	13 - 1	90465-14M66	20 - 35	91809-16001	2 - 5
90105-06035	2 - 18		12 - 9	90267-489U1	13 - 39	90446-20MF5	14 - 31	90467-089U1	22 - 11	92014-06012	2 - 13
90105-06184	10 - 7	90119-08099	6 - 30		21 - 4	90446-27M55	26 - 5	90467-11019	11 - 10	92903-06600	2 - 10
90105-06185	10 - 8	90119-08800	17 - 18		22 - 8	90446-27M73	26 - 2	90467-150A0	13 - 6	92903-08600	19 - 16
90105-06826	25 - 17	90119-08827	33 - 41		25 - 31	90446-30MF1	11 - 2	90467-150A1	3 - 39	9290P-20600	14 - 18
90105-06903	21 - 15	90119-08829	17 - 4		26 - 47	90447-06803	32 - 8		13 - 27	92990-06100	19 - 17
90105-06M07	3 - 12		23 - 8		30 - 36	90447-19005	13 - 21	90467-160A0	13 - 22	92990-10600	21 - 20
90105-07004	5 - 4	90119-08836	33 - 37		31 - 5	90447-19011	13 - 34		13 - 30	92990-12200	17 - 10
90105-07009	2 - 6	90119-08840	14 - 36		31 - 7	90447-19020	6 - 22		13 - 32		26 - 23
90105-08169	10 - 10		16 - 2	90267-489U2	23 - 14	90447-19021	13 - 29		13 - 35	92995-06600	21 - 23
90105-08170	10 - 11	90119-08844	26 - 44		30 - 5	90447-19022	14 - 28		13 - 37	92995-08600	3 - 15
90105-08860	26 - 30	90119-08860	23 - 7		33 - 36	90447-19801	13 - 7	90467-17802	31 - 28	9299R-05200	26 - 35
90105-10071	3 - 5	90119-089U2	29 - 14	90267-489U6	22 - 23	90447-22011	13 - 12	90467-18804	26 - 6		27 - 9
90109-06268	3 - 41	90119-089U7	30 - 38		22 - 28	90447-22801	13 - 2	90467-190A0	3 - 17	9299R-06200	25 - 19
90109-06832	15 - 21	90119-089UT	20 - 1		22 - 30	90447-28008	2 - 20		3 - 23		27 - 4
90109-06857	23 - 11	90119-089UU	15 - 18		28 - 4	90450-17M17	6 - 23	90467-200A0	3 - 24		31 - 20
90109-06864	23 - 10	90119-08M22	7 - 3		30 - 7	90450-90001	7 - 4		13 - 3		32 - 11
90109-08041	17 - 9		21 - 12		30 - 10		7 - 5		13 - 13	9299R-08200	25 - 28
90110-05908	33 - 4	90119-10029	12 - 13		31 - 26	90450-90M10	12 - 20		13 - 14		26 - 49
90110-06040	26 - 26	90119-10806	14 - 33		32 - 25	90450-99801	31 - 12		13 - 25		29 - 15
90110-06182	3 - 29	90119-10809	17 - 7	90267-489U8	26 - 11		31 - 17		26 - 14	9299R-10200	29 - 12
90110-06822	14 - 22	90119-10810	14 - 3		27 - 8	90450-99804	31 - 13	90467-21800	26 - 13	93101-31001	14 - 16
90110-08212	18 - 2	90149-05903	25 - 3	90267-489U9	22 - 33	90450-99M06	12 - 19	90467-240A0	2 - 21		38 - 28
90111-05008	22 - 15		25 - 5	90269-08801	24 - 4	90464-31001	21 - 18		11 - 13	93102-29008	15 - 5
90111-06803	27 - 3		34 - 6		24 - 6		21 - 32	90467-240A2	11 - 3		38 - 24
90116-08032	6 - 26	90149-06229	18 - 8	90280-03047	18 - 10	90464-32801	20 - 5		11 - 4	93102-29009	15 - 8
90119-059U4	25 - 9	90149-10052	23 - 6	90387-06080	17 - 14		22 - 17		11 - 12		38 - 25
90119-06048	21 - 10	90150-05807	22 - 21	90387-06119	1 - 9		22 - 24	90467-250A0	26 - 15	93102-31009	14 - 15
	21 - 30	90151-06815	32 - 13		11 - 7		22 - 26	90480-22801	7 - 11		38 - 27
90119-06091	20 - 31	90154-06017	34 - 5		20 - 14		22 - 31	90480-22M15	7 - 1	93210-11453	3 - 3
90119-06880	17 - 15	90167-04003	34 - 7	90387-06M05	18 - 22		26 - 37		21 - 13		38 - 4
	24 - 11	90169-049U1	30 - 20	90387-06M30	16 - 5		30 - 11	90480-38800	20 - 6	93210-12790	3 - 40
	25 - 23	90170-20802	14 - 19	90387-06M60	15 - 14		31 - 27	90601-118UF	14 - 29		38 - 11
90119-06882	24 - 12	90176-08080	6 - 27	90387-08M06	14 - 37		32 - 24		26 - 9	93210-18322	10 - 12
90119-06891	15 - 15	90179-09379	4 - 9	90387-08M30	16 - 3	90464-35132	13 - 23	90601-155U4	15 - 22		38 - 10
90119-06893	14 - 5	90183-06902	24 - 10	90401-10040	5 - 23	90464-40825	1 - 6		30 - 25	93210-21631	8 - 5
90119-06897	14 - 11	90201-052E8	18 - 21	90430-06232	10 - 9		7 - 14	90601-170UG	31 - 10		38 - 9
90119-069UH	30 - 34	90201-06028	9 - 11	90430-06M03	3 - 13	90464-99804	28 - 5	90601-200U2	22 - 27	93210-22MF1	15 - 3
	33 - 39	90201-06801	16 - 6	90430-08209	9 - 13	90465-11829	13 - 18	90605-502U1	24 - 3		38 - 23
90119-069UP	29 - 5		16 - 9	90430-10007	5 - 22		14 - 32	91314-06020	8 - 4	93210-24M79	1 - 12
90119-069UX	16 - 4	90201-06906	32 - 6		38 - 7		15 - 16	91314-06035	9 - 9		38 - 12
90119-06M35	20 - 12	90201-099U3	29 - 7	90430-12002	17 - 11		22 - 13	91314-06060	9 - 10	93210-30611	14 - 25
90119-06MA3	21 - 9	90201-10801	14 - 39	90445-09M21	13 - 17		26 - 12	91317-05010	18 - 20		38 - 30
90119-08022	6 - 25	90201-109U6	29 - 11	90445-14008	14 - 30		30 - 28	91317-06014	18 - 19	93210-60ME8	21 - 29
90119-08034	12 - 4	90201-12039	2 - 8	90445-16013	13 - 36		30 - 29	91380-06016	21 - 25		38 - 17
	12 - 10	90267-329UR	30 - 22	90445-18012	13 - 20		30 - 31	91380-06020	18 - 23	93306-00805	18 - 12
90119-08043	6 - 29	90267-48802	20 - 4	90445-20800	26 - 4		32 - 22	91380-06025	5 - 20	93306-20654	14 - 12
90119-08096	12 - 12	90267-48806	28 - 8	90445-20804	26 - 1	90465-13M18	21 - 17	91809-16001	2 - 4	93306-20655	15 - 7

NUMERICAL INDEX

PART NO.	REF. NO.	PART NO.	REF. NO.	PART NO.	REF. NO.	PART NO.	REF. NO.	PART NO.	REF. NO.	PART NO.	REF. NO.
93306-30582	14 - 14	95814-08016	9 - 12								
93410-12003	19 - 7	95814-08020	3 - 33								
93450-24028	4 - 6	95817-06014	9 - 8								
93450-66156	15 - 6	95824-06025	1 - 10								
93604-10011	6 - 3	95824-06030	11 - 8								
93604-10M03	3 - 8	97013-06055	2 - 9								
	10 - 6	97013-08030	19 - 15								
93606-12019	3 - 7	97095-06016	21 - 22								
	8 - 3	97095-08040	3 - 14								
	12 - 8	97513-05514	18 - 9								
	14 - 6	97513-10525	2 - 15								
	15 - 13	97780-60516	7 - 10								
93608-16M16	12 - 3	97780-60520	20 - 33								
94591-66152	5 - 14	97880-03008	33 - 14								
94702-00427	21 - 16	97880-05025	33 - 17								
95023-06025	3 - 27	9788R-05025	26 - 34								
95024-06014	3 - 20	99009-72500	18 - 14								
95024-06020	3 - 21	99530-10114	3 - 2								
	9 - 16		3 - 30								
95024-06030	9 - 15		18 - 16								
95024-06035	9 - 14	99590-14016	14 - 2								
95024-08035	12 - 16	99780-12600	26 - 22								
95024-08050	18 - 15										
95380-06700	19 - 18										
9538R-06600	16 - 7										
	16 - 10										
9538R-06700	32 - 7										
95720-06300	33 - 27										
95720-08300	33 - 30										
9572R-05300	26 - 36										
9572R-06300	17 - 17										
	25 - 18										
	27 - 5										
	30 - 15										
	31 - 21										
	32 - 10										
9572R-08300	25 - 29										
	26 - 17										
	26 - 48										
	29 - 8										
	29 - 16										
	29 - 19										
9572R-10300	14 - 40										
	29 - 13										
95780-08300	21 - 3										
95814-06016	3 - 34										
95814-06030	5 - 17										
95814-06070	3 - 6										