

PARTS CATALOGUE

MJ-800TZ'99 (F0N1)
WB800X (F0N2)

FOREWORD

This Parts Catalogue is related to the parts for the model(s) in the below frame. When you are ordering replacement parts, please refer to this Parts Catalogue and quote both part numbers and part names correctly.

MJ-800TZ'99(F0N1), WB800X(F0N2)

1. Modifications or additions which have been made after issue of the Parts Catalogue will be announced in the Yamaha Parts News.
It is advisable that you make necessary corrections to the Parts Catalogue according to the Yamaha Parts News.

2. Abbreviations
The following abbreviations are used in this Parts Catalogue.

"UR" Use specified parts number.

"UN" Use as many as needed.

"AP" Alternate Parts

"LM" Local Made (Parts need to be ordered locally)

"F#" Frame No. (Applicable machine No.)

3. Parts, which are to be supplied in an assembly, are listed with a dot(.) in front of the part name as shown below.

The numeral appearing to the right of each component part indicates the quantity of parts for each assembly unit.

EXAMPLE

PART NO.	DESCRIPTION	Q'TY	REMARKS
EU0-62280-00	DRAIN PLUG ASSY	2	
EU0-62282-00	.PLUG,DRAIN	1	

4. Applicable Serial No. and Color Code

Hull Serial No.	(F0N1) (F0N2)	F0N-0300101- F0N-910101-
Engine Serial No.		67U-000101-

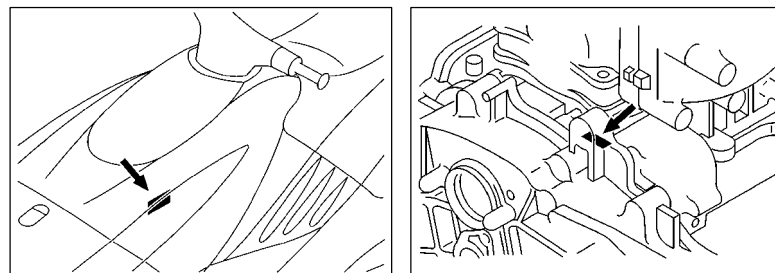

Color Code	Color Name	Abbreviation
GA3C	WHITE COAT 2	WC2

5. Note that the illustration for reference in funding parts numbers, not to be used for assembling. When assembling, please use the applicable service manual.

6. A part with "YMUS" in the remarks column can be obtained from YMUS (USA) and not from YAMAHA MOTOR CO.,LTD (JAPAN).

EXAMPLE

PART NO.	DESCRIPTION	Q'TY	REMARKS
EW2-U5160-00	ENGINE HATCH COMP.	2	.. YMUS
90601-168U7	BAND, HOSE	1	.. YMUS

ADDRESS:

YAMAHA MOTOR CORPORATION U.S.A.
PARTS & ACCESSORY DIV.
6555 KATELLA AVENUE
CYPRESS, CALIFORNIA 90630 U.S.A.

CRANK CYLINDER ASSY
 (Fig. 1, Ref. No. 2 to 17, 21, 22 and 26 to 29
 Fig. 2, Ref. No. 1 to 5, 9 to 11 and 13 to 17
 Fig. 3, Ref. No. 1 to 21
 Fig. 4, Ref. No. 4 to 9
 Fig. 7, Ref. No. 58 and 59
 Fig. 11, Ref. No. 10, 11 and 14)

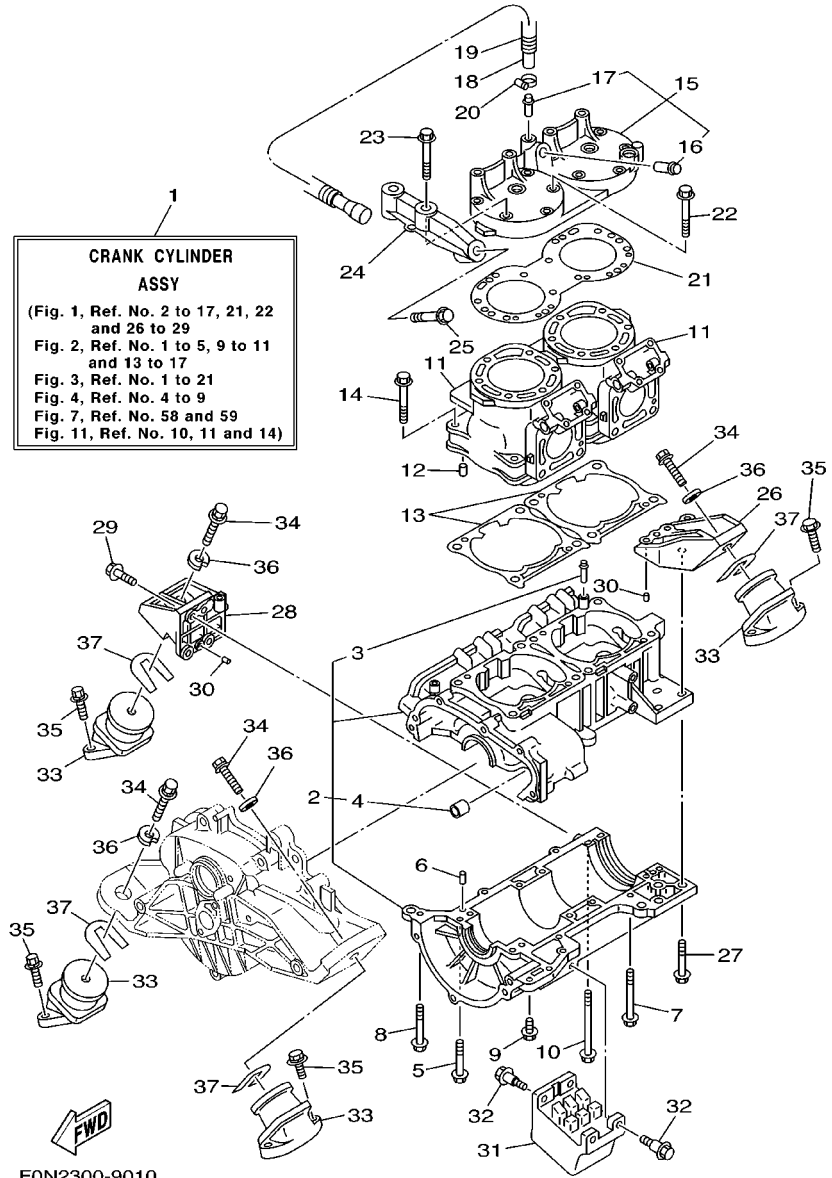

FON2300-9010

FIG. 1 CYLINDER, CRANKCASE 1

REF. NO.	PART NO.	DESCRIPTION	FON1	FON2	REMARKS
1	66E-W0090-10-8P	CRANK CYLINDER ASSY	1	1	
2	66E-15100-10-8P	CRANKCASE ASSY	1	1	
3	62T-14251-10	.NIPPLE	2	2	
4	90380-12M29	.BUSH, SOLID	1	1	
5	90119-08M55	BOLT, WITH WASHER	10	10	
6	93606-12019	PIN, DOWEL	2	2	
7	90119-06M78	BOLT, WITH WASHER	3	3	
8	90119-08M61	BOLT, WITH WASHER	1	1	
9	90119-06M13	BOLT, WITH WASHER	4	4	
10	90119-08M56	BOLT, WITH WASHER	2	2	
11	66E-11311-00-94	CYLINDER 1	2	2	
12	93606-12019	PIN, DOWEL	4	4	
13	66E-11351-01	GASKET, CYLINDER	2	2	
14	90119-10M07	BOLT, WITH WASHER	8	8	
15	66E-11111-00-94	HEAD, CYLINDER 1	1	1	
16	66E-51129-00	.NIPPLE	1	1	
17	6K8-51129-00	.NIPPLE	1	1	
18	67U-12588-00	HOSE 5	1	1	
19	90446-24ME7	HOSE	1	1	
20	90450-14M05	HOSE CLAMP ASSY	1	1	
21	66E-11181-00	GASKET, CYLINDER HEAD 1	1	1	
22	90119-08M62	BOLT, WITH WASHER	10	10	
23	90119-08M55	BOLT, WITH WASHER	2	2	
24	66E-14781-10-94	STAY, MUFFLER 2	1	1	
25	90119-10M00	BOLT, WITH WASHER	1	1	
26	66E-21425-10-8P	BRACKET, REAR UPPER 1	1	1	
27	97513-08545	BOLT, WITH WASHER	3	3	

**CRANK CYLINDER
ASSY**
(Fig. 1, Ref. No. 2 to 17, 21, 22
and 26 to 29
Fig. 2, Ref. No. 1 to 5, 9 to 11
and 13 to 17
Fig. 3, Ref. No. 1 to 21
Fig. 4, Ref. No. 4 to 9
Fig. 7, Ref. No. 58 and 59
Fig. 11, Ref. No. 10, 11 and 14)

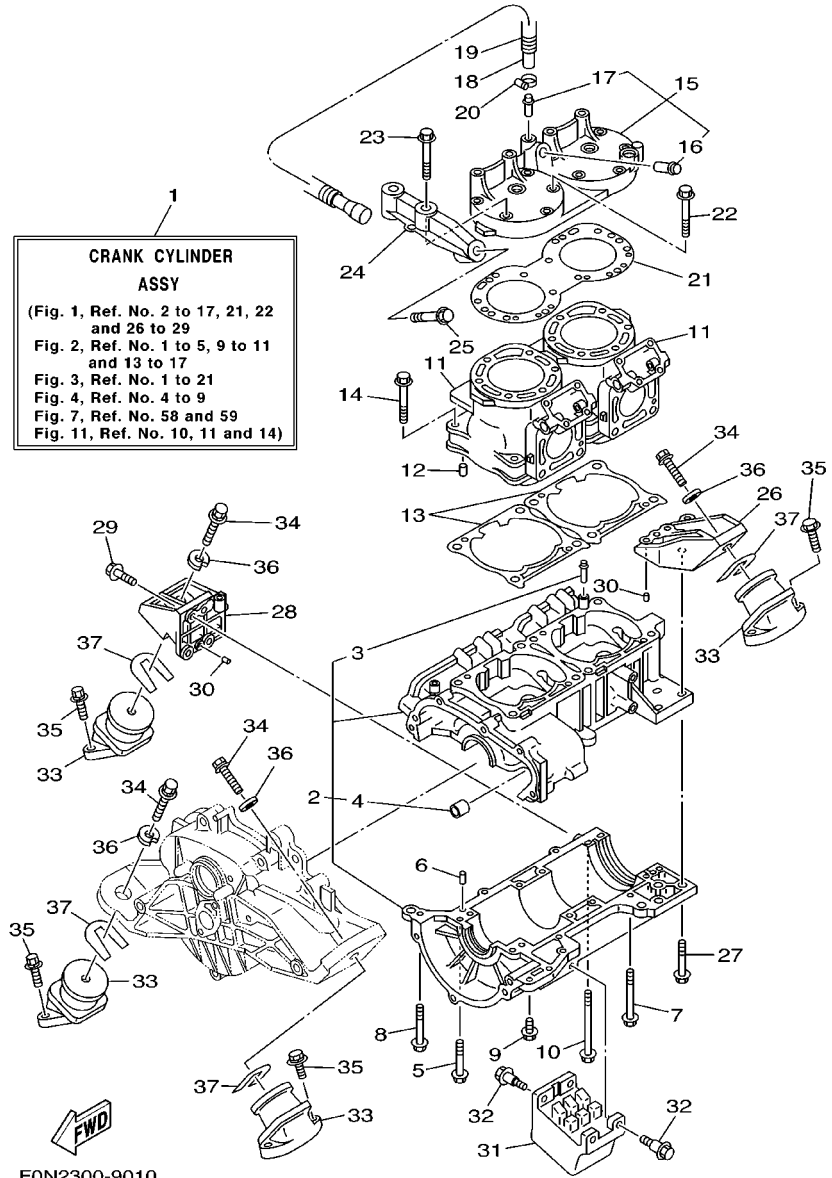

FON2300-9010

FIG. 1 CYLINDER. CRANKCASE 1

REF. NO.	PART NO.	DESCRIPTION	FON1	FON2	REMARKS
28	66E-21426-10-8P	BRACKET, REAR UPPER 2	1	1	
29	97513-08530	BOLT, WITH WASHER	3	3	
30	93606-12019	PIN, DOWEL	4	4	
31	66E-44532-00	STOPPER, UPPER MOUNT	1	1	
32	90109-06M92	BOLT	4	4	
33	6M6-44517-A1-5B	MOUNT RUBBER	4	4	
34	90119-08904	BOLT, WITH WASHER	4	4	
35	90119-08960	BOLT, WITH WASHER	8	8	
36	EU0-67324-00	PLATE	4	4	
37	EU0-67354-00-01	SHIM (T=0.1)	10	10	UN
	EU0-67354-00-02	SHIM (T=0.2)	10	10	UN
	EU0-67354-00-03	SHIM (T=0.3)	10	10	UN
	EU0-67354-00-05	SHIM (T=0.5)	10	10	UN
	EU0-67354-00-10	SHIM (T=1.0)	10	10	UN
	EU0-67354-00-20	SHIM (T=2.0)	10	10	UN

FIG. 2 CYLINDER. CRANKCASE 2

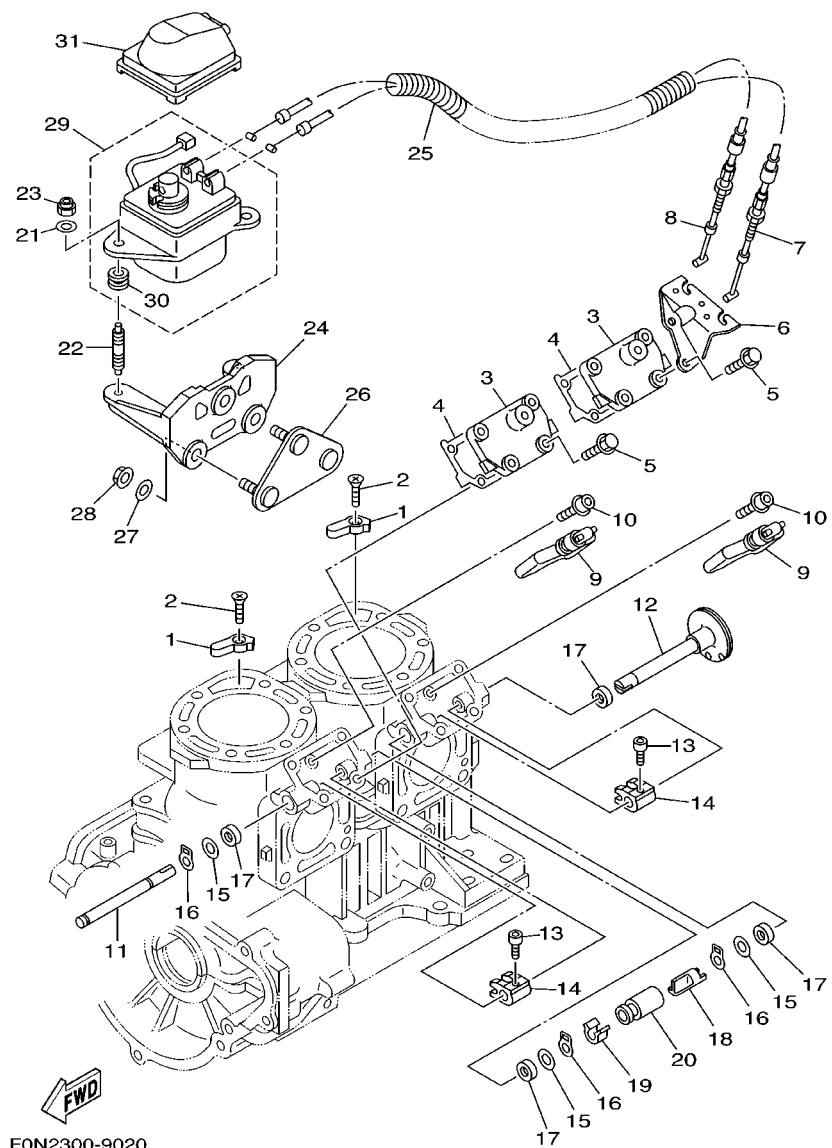

F0N2300-9020

REF. NO.	PART NO.	DESCRIPTION	F0N1	F0N2				REMARKS
1	66E-11325-00	ANODE	2	2				
2	98780-05020	SCREW, FLAT HEAD	2	2				
3	66E-1131M-01-8P	COVER	2	2				
4	66E-1131B-00	GASKET, COVER	2	2				
5	97513-06525	BOLT, WITH WASHER	8	8				
6	66E-11998-10	BRACKET 1	1	1				
7	66E-1133E-10	CABLE, PULLEY 1	1	1				
8	66E-1133F-10	CABLE, PULLEY 2	1	1				
9	66E-1131S-02	VALVE ASSY.	2	2				
10	90109-05M95	BOLT	2	2				
11	66E-1131V-00	SHAFT 1	1	1				
12	66E-1132C-00	PULLEY, SHAFT	1	1				
13	90110-04M03	BOLT, HEXAGON SOCKET HEAD	2	2				
14	66E-11832-00	LEVER, LINK	2	2				
15	90201-08M09	WASHER, PLATE	3	3				
16	93410-08M12	CIRCLIP	3	3				
17	93109-08M07	OIL SEAL	4	4				
18	66E-1131H-00	JOINT 1	1	1				
19	66E-1131J-10	JOINT 2	1	1				
20	66E-1131C-10	COVER, JOINT	1	1				
21	90201-065F3	WASHER, PLATE	2	2				
22	90116-06M67	BOLT, STUD	2	2				
23	95780-06300	NUT, FLANGE	2	2				
24	66E-85112-00-94	BRACKET, REFLECTOR 1	1	1				
25	90446-24M79	HOSE	1	1				
26	GÜÖ-6824E-00	BRÄCKĚT, ŸPVŠ	1	1				
27	92990-08200	WASHER, PLAIN	3	3				

FIG. 2 CYLINDER. CRANKCASE 2

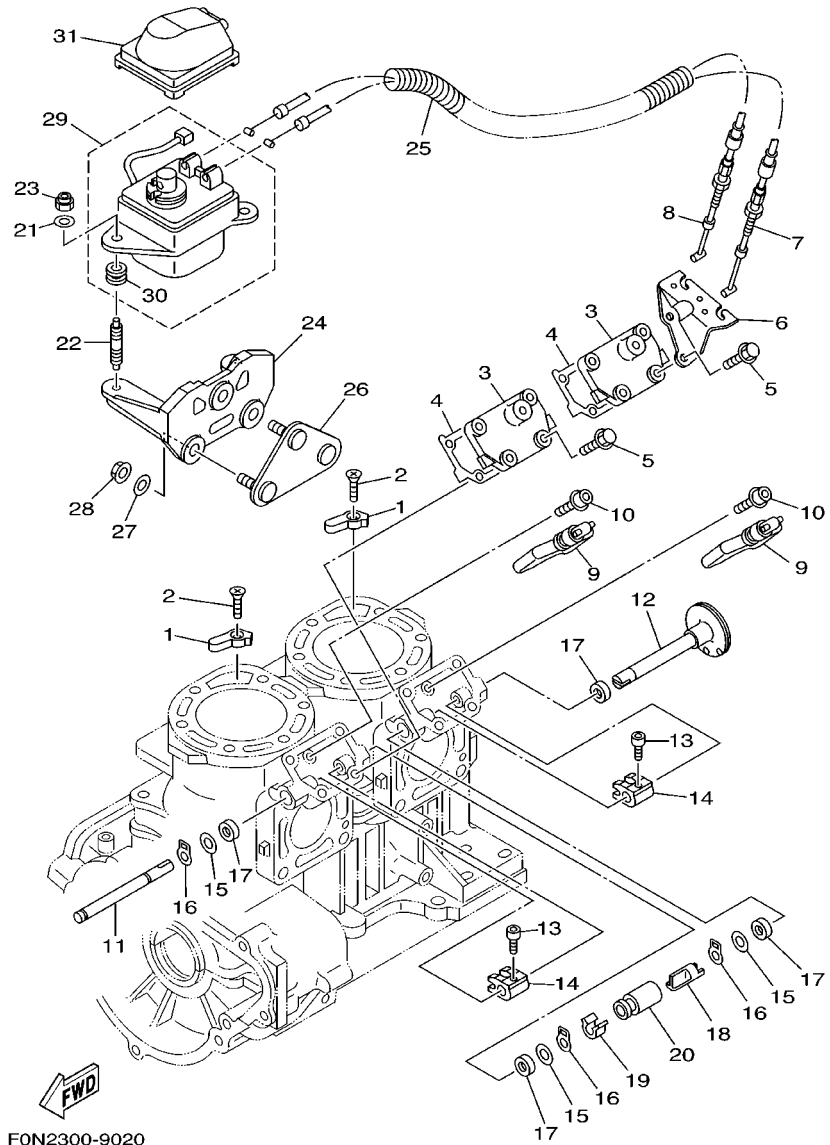

F0N2300-9020

REF. NO.	PART NO.	DESCRIPTION	F0N1	F0N2				REMARKS
28	95720-08300	NUT, SELF-LOCKING	3	3				
29	66E-85820-10	SERVO MOTOR ASSY	1	1				
30	90480-14023	.GROMMET	2	2				
31	66E-85825-00	COVER, WIRE	1	1				

FIG. 3 CRANKSHAFT. PISTON

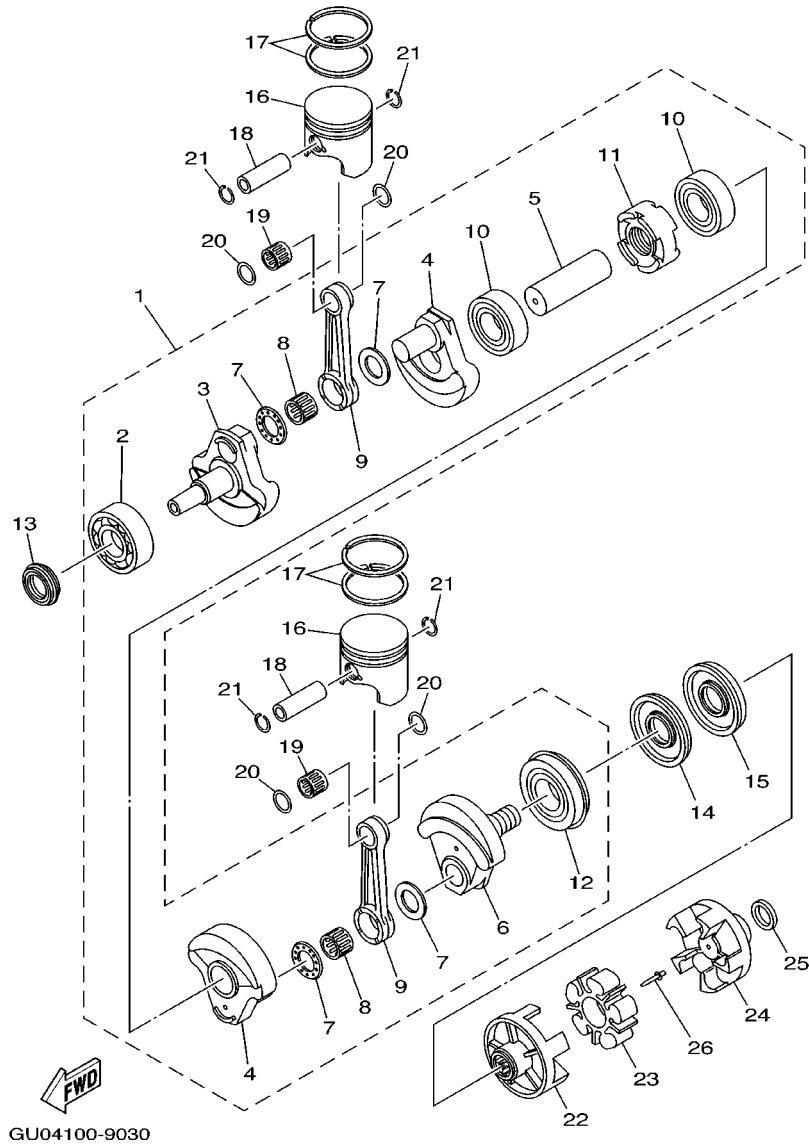

REF. NO.	PART NO.	DESCRIPTION	F0N1	F0N2				REMARKS
1	66E-11400-00	CRANKSHAFT ASSY	1	1				
2	93305-307U0	.BEARING	1	1				
3	66E-11412-00	.CRANK 1	1	1				
4	66E-11422-00	.CRANK 2	2	2				
5	66E-11431-00	.CRANK 3	1	1				
6	66E-11442-00	.CRANK 4	1	1				
7	66E-11685-00	.WASHER, CRANK PIN	4	4				
8	93310-627U6	.BEARING	2	2				
9	66E-11651-00	.ROD, CONNECTING	2	2				
10	93306-208U1	.BEARING	2	2				
11	66E-11515-00	.SEAL, LABYRINTH 1	1	1				
12	93306-308U1	.BEARING	1	1				
13	93103-35M03	OIL SEAL	1	1				
14	93101-36M62	OIL SEAL	1	1				
15	93101-36M61	OIL SEAL	1	1				
16	66E-11631-00-A0	PISTON (STD)	2	2				UR
	66E-11631-00-B0	PISTON (STD)	2	2				UR
	66E-11631-00-C0	PISTON (STD)	2	2				UR
	66E-11631-00-D0	PISTON (STD)	2	2				UR
17	66E-11603-01	PISTON RING SET (STD)	2	2				
18	66E-11633-00	PIN, PISTON	2	2				
19	93310-422U2	BEARING	2	2				
20	90201-22M04	WASHER, PLATE	4	4				
21	66E-11634-00	CLIP, PISTON PIN	4	4				
22	66E-45813-10-94	FLANGE, COUPLING	1	1				
23	66E-4581J-00	RUBBER SHAFT COUPLING	1	1				
24	66E-45593-10-94	FLANGE, COUPLING 1	1	1				

FIG. 3 CRANKSHAFT. PISTON

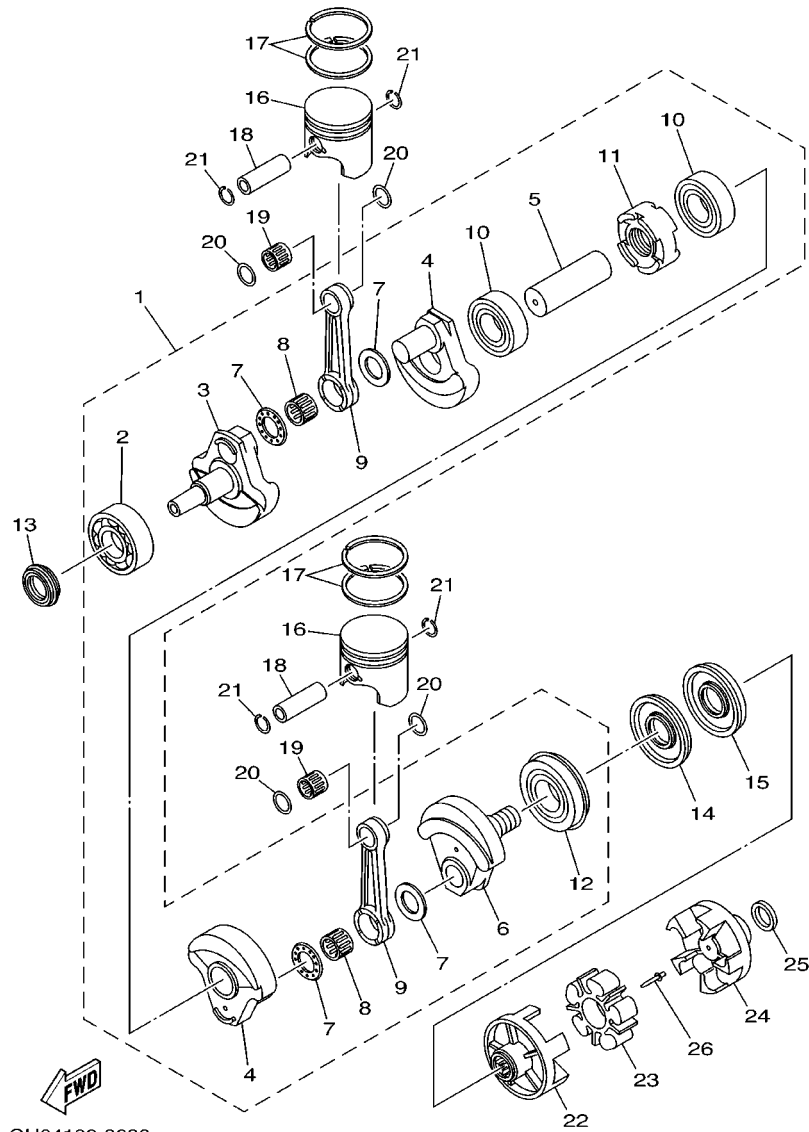

REF. NO.	PART NO.	DESCRIPTION	F0N1	F0N2				REMARKS
25	90201-24M02	WASHER, PLATE	1	1				
26	90267-48957	RIVET, BLIND	1	1				

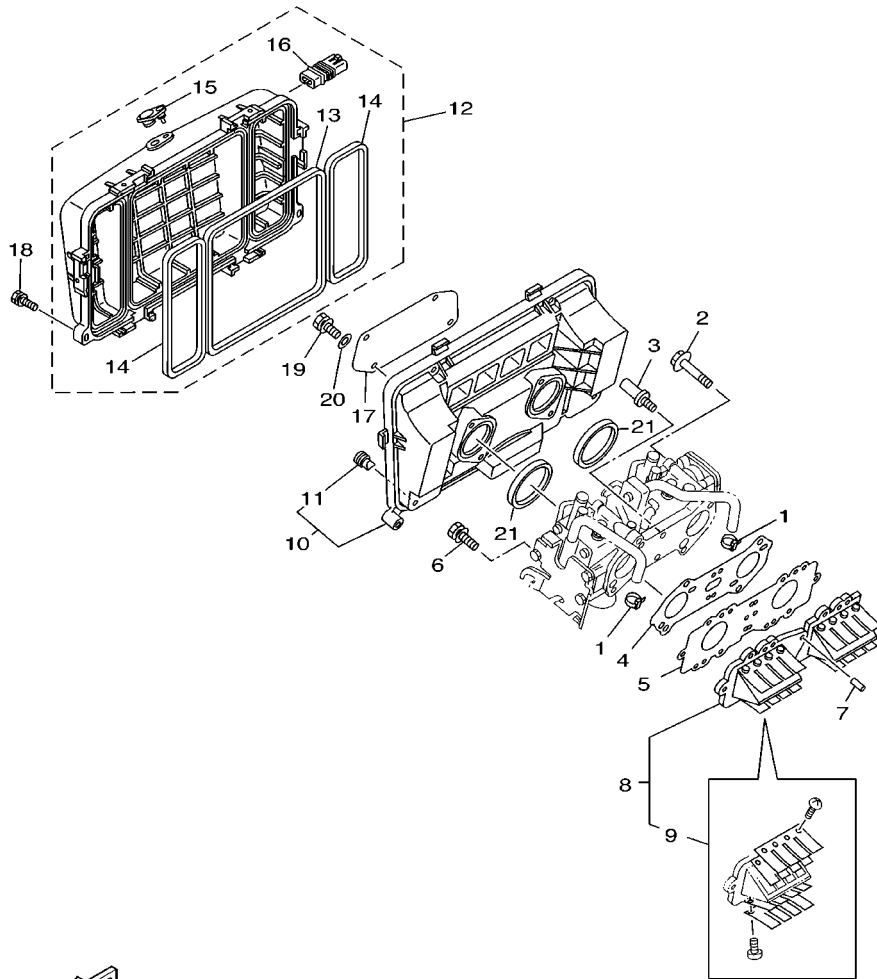
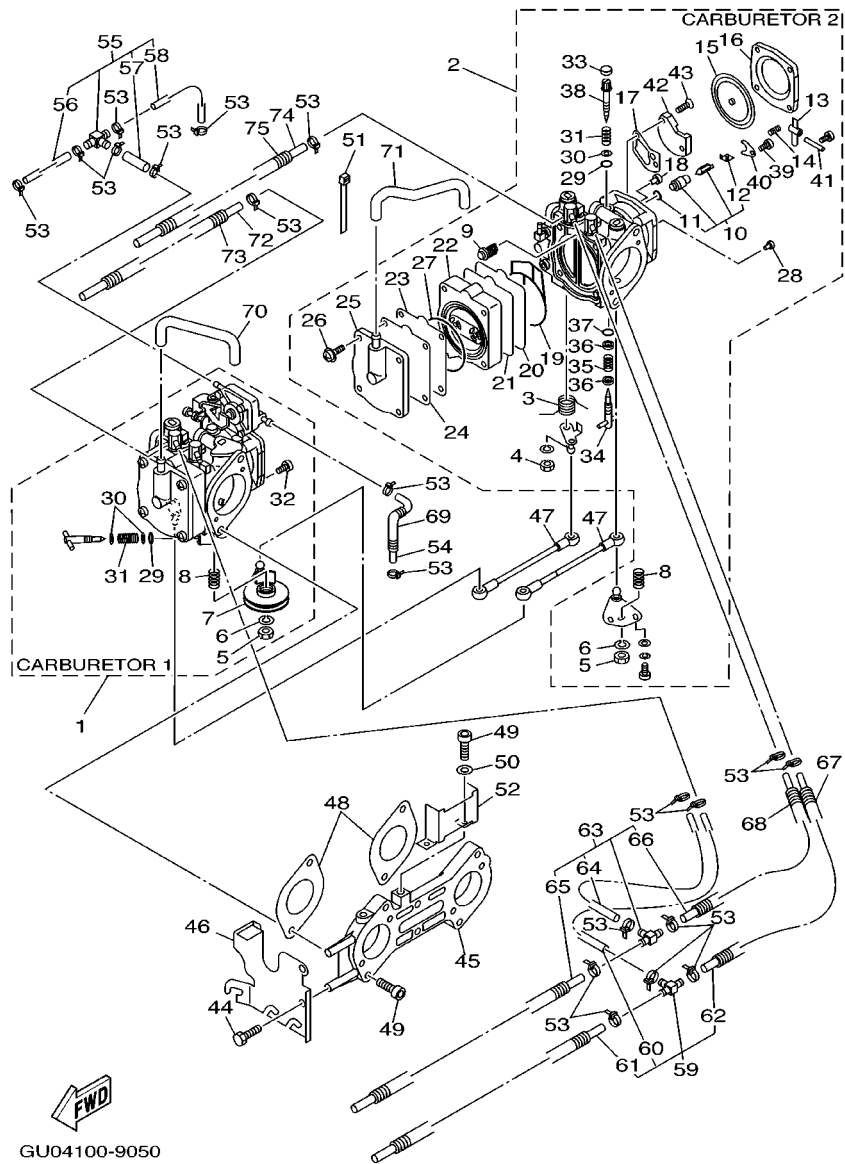

FIG. 4 INTAKE

REF. NO.	PART NO.	DESCRIPTION	F0N1	F0N2				REMARKS
1	90465-11M10	CLAMP	2	2				
2	90105-08M86	BOLT, WASHER BASED	4	4				
3	90109-06M00	BOLT	2	2				
4	66E-13556-00	GASKET, MANIFOLD	1	1				
5	66E-13624-10	PLATE, REED VALVE	1	1				
6	97513-06525	BOLT, WITH WASHER	12	12				
7	93606-19M23	PIN, DOWEL	2	2				
8	66E-13610-00	REED VALVE ASSY	1	1				
9	66E-W0004-00	.REED SET	1	1				
10	66E-1441E-00	COVER, CLEANER CASE 2	1	1				
11	66E-42717-00	.RUBBER, SEAL 2	2	2				
12	66E-14480-10	COVER SUB ASSY	1	1				
13	66E-14457-10	.SEAL	1	1				
14	66E-14452-00	.SEAL	2	2				
15	66E-14435-00	.GROMMET	1	1				
16	66E-13898-10	.HOLDER	6	6				
17	66E-14451-00	ELEMENT, AIR CLEANER	1	1				
18	97595-06535	BOLT, WITH WASHER	3	3				
19	97513-06545	BOLT, WITH WASHER	4	4				
20	92903-06600	WASHER, PLATE	4	4				
21	66E-13473-00	O-RING	2	2				

F0N2300-9040

FIG. 5 CARBURETOR



GU04100-9050

REF. NO.	PART NO.	DESCRIPTION	F0N1	F0N2	REMARKS
1	67U-14301-00	CARBURETOR ASSY 1	1	1	
2	67U-14302-00	CARBURETOR ASSY 2	1	1	
3	66E-14218-00	.SPRING, CHOKE LEVER	2	2	
4	95382-06700	.NUT	2	2	
5	3CF-14594-00	.NUT	2	2	
6	92991-08100	.WASHER	2	2	
7	66E-14930-00	.THROTTLE SHAFT ASSY	1	1	CARBURETOR 1
8	66E-14275-00	.SPRING	2	2	
9	6R7-14569-00	.STRAINER	2	2	
10	64T-14916-00	.NEEDLE	2	2	
11	8F2-14147-00	.O-RING	1	1	
12	7EG-14159-00	.CLIP	1	1	
13	6K8-14547-01	.ARM, FLOAT	2	2	
14	6R7-14253-00	.SPRING	2	2	
15	6R7-14541-00	.DIAPHRAGM, PUMP	2	2	
16	6R7-14542-00	.BODY, PUMP 1	1	1	CARBURETOR 2
17	6K8-14536-11	.GASKET	2	2	
18	3G2-14231-30	.JET, MAIN (#150)	1	1	UR CARBURETOR 1
	3G2-14231-30	.JET, MAIN (#150)	1	1	UR CARBURETOR 2
19	66E-14563-00	.O-RING	2	2	
20	66E-24471-00	.DIAPHRAGM	2	2	
21	66E-24411-00	.DIAPHRAGM	2	2	
22	66E-24413-00	.BODY 2	2	2	
23	66E-24421-00	.VALVE, CHECK	2	2	
24	66E-24431-00	.GASKET, FUEL PUMP 1	2	2	
25	66E-24452-00	.COVER	2	2	
26	90157-05M17	.SCREW, PAN HEAD	8	8	

FIG. 5 CARBURETOR

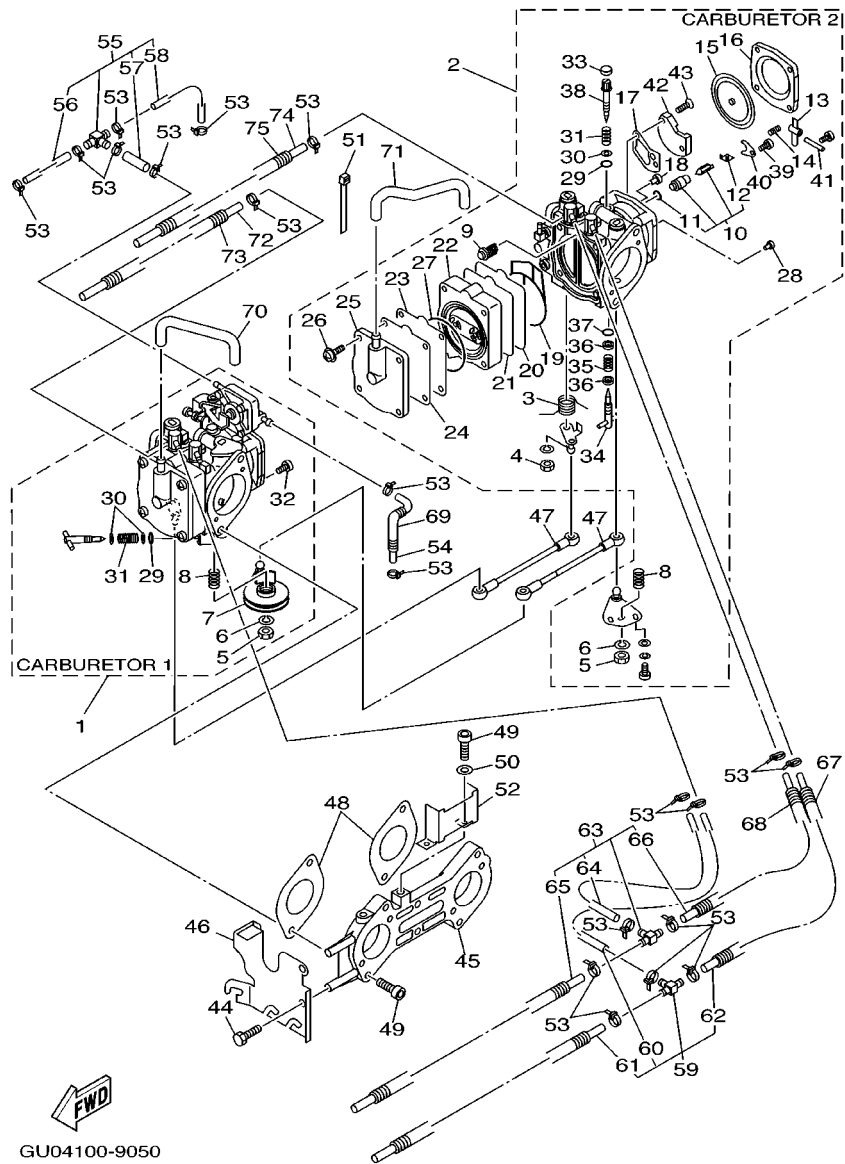

GU04100-9050

REF. NO.	PART NO.	DESCRIPTION	F0N1	F0N2	REMARKS
27	66E-14564-00	.O-RING	2	2	
28	830-14231-18	.JET, MAIN (# 90)	2	2	
29	812-14147-00	.O-RING	3	3	
30	812-14235-00	.WASHER, NEEDLE	4	4	
31	3KW-14932-00	.SPRING, THROTTLE 2	3	3	
32	97890-05014	.SCREW, PAN HEAD	4	4	CARBURETOR 1
33	6K8-14471-10	.CAP, CARBURETOR	2	2	
34	66E-14211-00	.SCREW, PILOT ADJUSTING	2	2	
35	6K8-14589-00	.SPRING	2	2	
36	822-14235-00	.WASHER, NEEDLE	4	4	
37	583-14561-00	.O-RING	2	2	
38	6K8-14946-10	.METERING NEEDLE	2	2	
39	6M6-14503-00	.SCREW	2	2	
40	6K8-14527-11	.PLATE	2	2	
41	439-14186-00	.PIN, FLOAT	2	2	
42	66E-24412-00	.BODY 1	2	2	
43	6K8-14523-11	.SCREW, STOP	4	4	
44	90101-06M25	BOLT	3	3	
45	66E-14243-00	PLATE	1	1	
46	66E-14291-00	BRACKET 1	1	1	
47	66E-41217-00	ROD, ACCEL. LEVER	2	2	
48	66E-14398-00	GASKET	2	2	
49	66E-14162-00	BOLT, HOLDING	6	6	
50	90204-06M01	WASHER, SPRING	2	2	
51	4KM-14137-00	CLIP	1	1	
52	66E-14146-00	PLATE	1	1	
53	35H-14139-00	CLIP, PIPE	20	20	

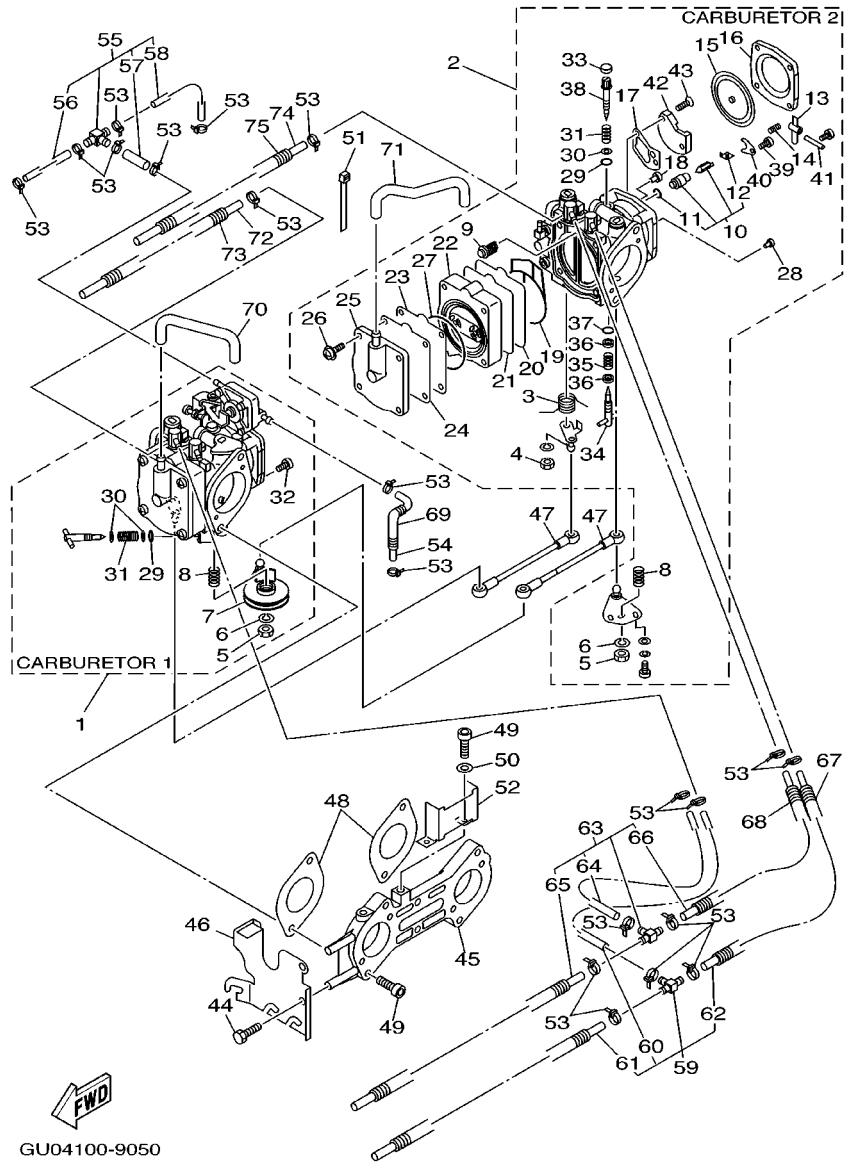
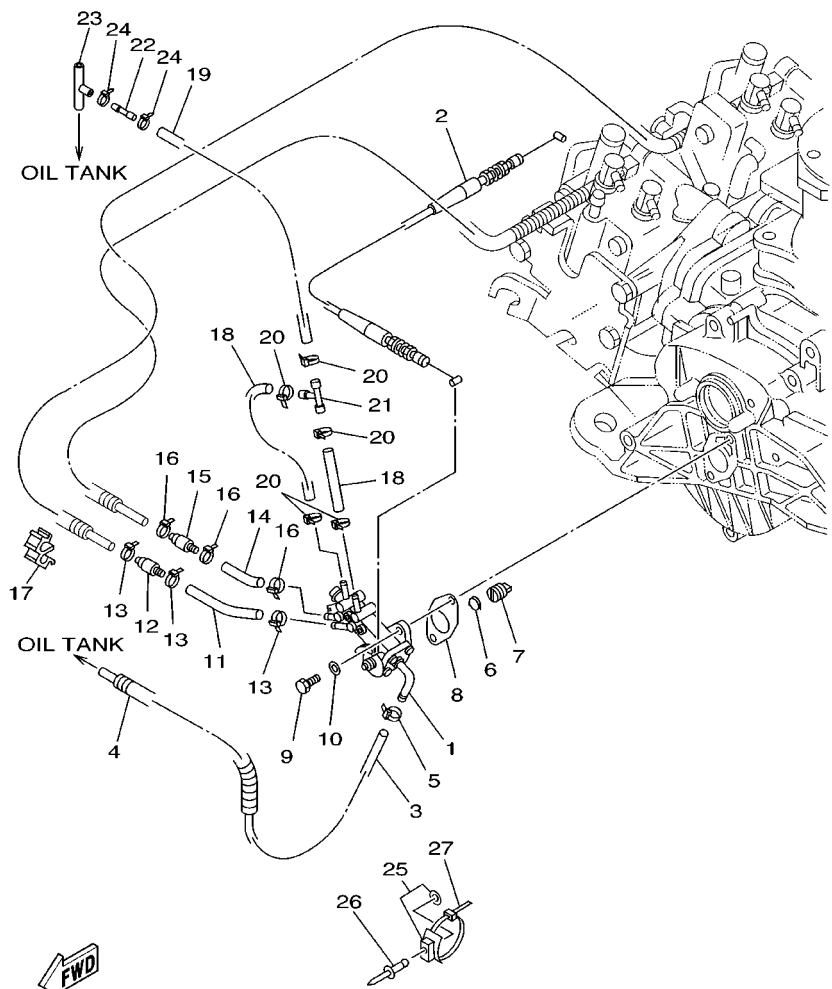

FIG. 5 CARBURETOR

REF. NO.	PART NO.	DESCRIPTION	F0N1	F0N2	REMARKS
54	3XP-14294-00	HOSE	1	1	
55	66E-24376-00	PIPE, JOINT 1	1	1	
56	90445-07M78	.HOSE	1	1	
57	90445-07M42	.HOSE	1	1	
58	90445-07M79	.HOSE	1	1	
59	66E-24377-00	PIPE, JOINT 3	1	1	
60	90445-10MH0	.HOSE	1	1	
61	90445-10MH1	.HOSE	1	1	
62	90445-10MH2	.HOSE	1	1	
63	66E-24378-00	PIPE, JOINT 4	1	1	
64	90445-10MH3	.HOSE	1	1	
65	90445-10MH4	.HOSE	1	1	
66	90445-10MH5	.HOSE	1	1	
67	90446-14M98	HOSE	1	1	
68	90446-14M99	HOSE	1	1	
69	90446-10MA2	HOSE	1	1	
70	66E-24314-00	PIPE 4	1	1	
71	66E-24315-00	PIPE 5	1	1	
72	90446-07M96	HOSE	1	1	
73	90446-10MA0	HOSE	1	1	
74	90446-07M97	HOSE	1	1	
75	90446-10MA1	HOSE	1	1	

FIG. 6 OIL PUMP



F0N2300-9060

REF. NO.	PART NO.	DESCRIPTION	F0N1	F0N2	REMARKS
1	66E-13200-01	OIL INJECTION PUMP ASSY	1	1	
2	66E-26320-00	PUMP CABLE ASSY	1	1	
3	90445-11M72	HOSE	1	1	
4	90446-17ME5	HOSE	1	1	
5	90465-11M10	CLAMP	1	1	
6	66E-13469-00	SPRING	1	1	
7	65U-13132-00	JOINT	1	1	
8	63M-13116-00	GASKET, PUMP CASE	1	1	
9	97095-06020	BOLT	2	2	
10	92995-06600	WASHER	2	2	
11	90446-07M14	HOSE	1	1	
12	6R3-13183-00	VALVE, CHECK	1	1	
13	90465-11M10	CLAMP	3	3	
14	90446-07M14	HOSE	1	1	
15	6R3-13183-00	VALVE, CHECK	1	1	
16	90465-11M10	CLAMP	3	3	
17	90464-07M20	CLAMP	1	1	
18	90445-07M25	HOSE	2	2	
19	90445-07M82	HOSE	1	1	
20	90465-11M10	CLAMP	5	5	
21	6E0-24378-00	PIPE, JOINT 4	1	1	
22	63M-13132-00	JOINT	1	1	
23	63M-24378-00	PIPE, JOINT 4	1	1	
24	90465-11M10	CLAMP	2	2	
25	90600-91736	CLAMP COMP.	1	1	
26	90267-48007	RIVET, BLIND	1	1	
27	90601-20006	BAND	1	1	

FIG. 7 EXHAUST 1

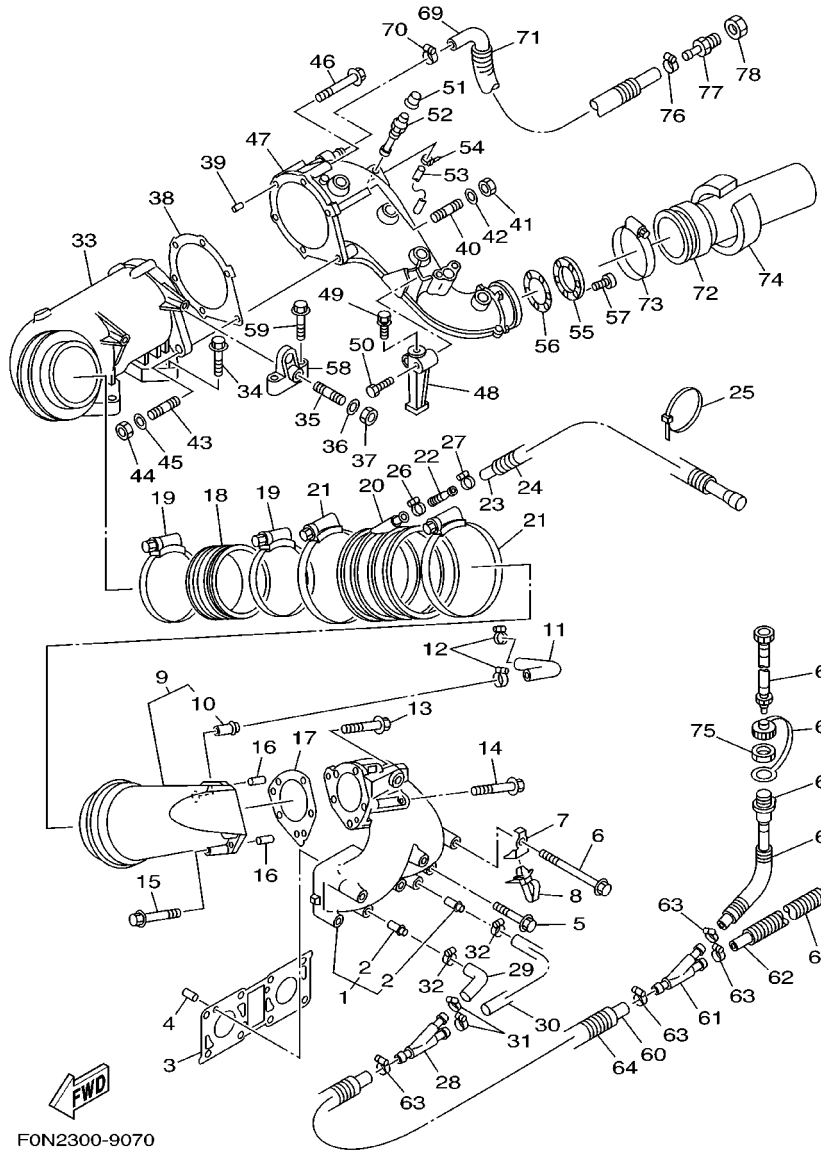

FON2300-9070

REF. NO.	PART NO.	DESCRIPTION	FON1	FON2	REMARKS
1	66E-14711-10-8P	MUFFLER 1	1	1	
2	6K8-51129-00	.NIPPLE	2	2	
3	66E-14613-00	GASKET, EXHAUST PIPE	1	1	
4	93606-12019	PIN, DOWEL	2	2	
5	90105-10M85	BOLT, WASHER BASED	4	4	
6	90105-10M86	BOLT, WASHER BASED	4	4	
7	90465-20M78	CLAMP	2	2	
8	90465-12M56	CLAMP	2	2	
9	66E-14712-10-8P	RING, JOINT	1	1	
10	66E-51129-00	.NIPPLE	1	1	
11	66E-12576-00	HOSE 1	1	1	
12	90450-22M14	HOSE CLAMP ASSY	2	2	
13	90105-08M83	BOLT, WASHER BASED	2	2	
14	90105-08M84	BOLT, WASHER BASED	2	2	
15	90105-08M66	BOLT, WASHER BASED	1	1	
16	93606-12019	PIN, DOWEL	2	2	
17	66E-14749-00	GASKET, MUFFLER DAMPER 2	1	1	
18	66E-14625-00	JOINT, EXHAUST 2	1	1	
19	90450-99M02	HOSE CLAMP ASSY	2	2	
20	66E-14615-00	JOINT, EXHAUST 1	1	1	
21	90450-99M18	HOSE CLAMP ASSY	2	2	
22	66E-51142-00	CONNECTION	1	1	
23	67U-12589-00	HOSE 6	1	1	
24	90446-20M65	HOSE	1	1	
25	90465-13M36	CLAMP	1	1	
26	90450-18M09	HOSE CLAMP ASSY	1	1	
27	90450-14M05	HOSE CLAMP ASSY	1	1	

FIG. 7 EXHAUST 1

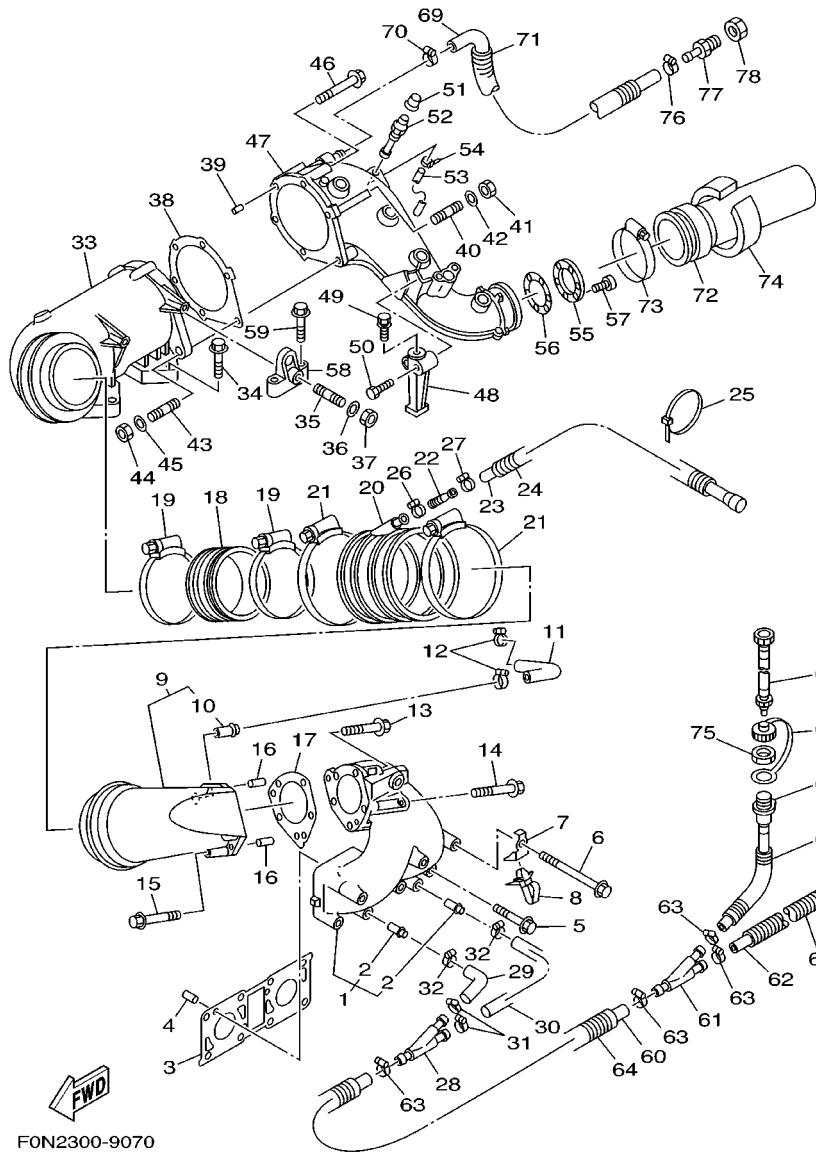

FON2300-9070

REF. NO.	PART NO.	DESCRIPTION	FON1	FON2				REMARKS
28	63M-12581-00	JOINT, HOSE 1	1	1				
29	66E-12577-00	HOSE 2	1	1				
30	66E-12579-00	HOSE 4	1	1				
31	90450-18M09	HOSE CLAMP ASSY	2	2				
32	90450-14M05	HOSE CLAMP ASSY	2	2				
<hr/>								
33	66E-14721-10-94	MUFFLER 2	1	1				
34	90105-10M82	BOLT, WASHER BASED	2	2				
35	90116-10M66	BOLT, STUD	2	2				
36	92990-10600	WASHER, PLATE	2	2				
37	95380-10600	NUT	2	2				
<hr/>								
38	66E-41124-10	GASKET, EXHAUST OUTER COVER	1	1				
39	93606-12019	PIN, DOWEL	2	2				
40	90116-08M64	BOLT, STUD	2	2				
41	95333-08600	NUT	2	2				
42	92990-08600	WASHER, PLATE	2	2				
<hr/>								
43	90116-10M65	BOLT, STUD	1	1				
44	95380-10600	NUT	1	1				
45	92990-10600	WASHER, PLATE	1	1				
46	90105-08M83	BOLT, WASHER BASED	3	3				
47	66E-41123-10-94	OUTER COVER, EXHAUST	1	1				
<hr/>								
48	66E-14791-00-94	STAY, MUFFLER	1	1				
49	90119-10M10	BOLT, WITH WASHER	1	1				
50	90119-10M00	BOLT, WITH WASHER	1	1				
51	663-45119-00	CAP, GREASE NIPPLE	1	1				
52	61L-5169A-00	NIPPLE, GREASE	1	1				
<hr/>								
53	90445-09M17	HOSE	1	1				
<hr/>								
54	90465-11M10	CLAMP	1	1				

FIG. 7 EXHAUST 1

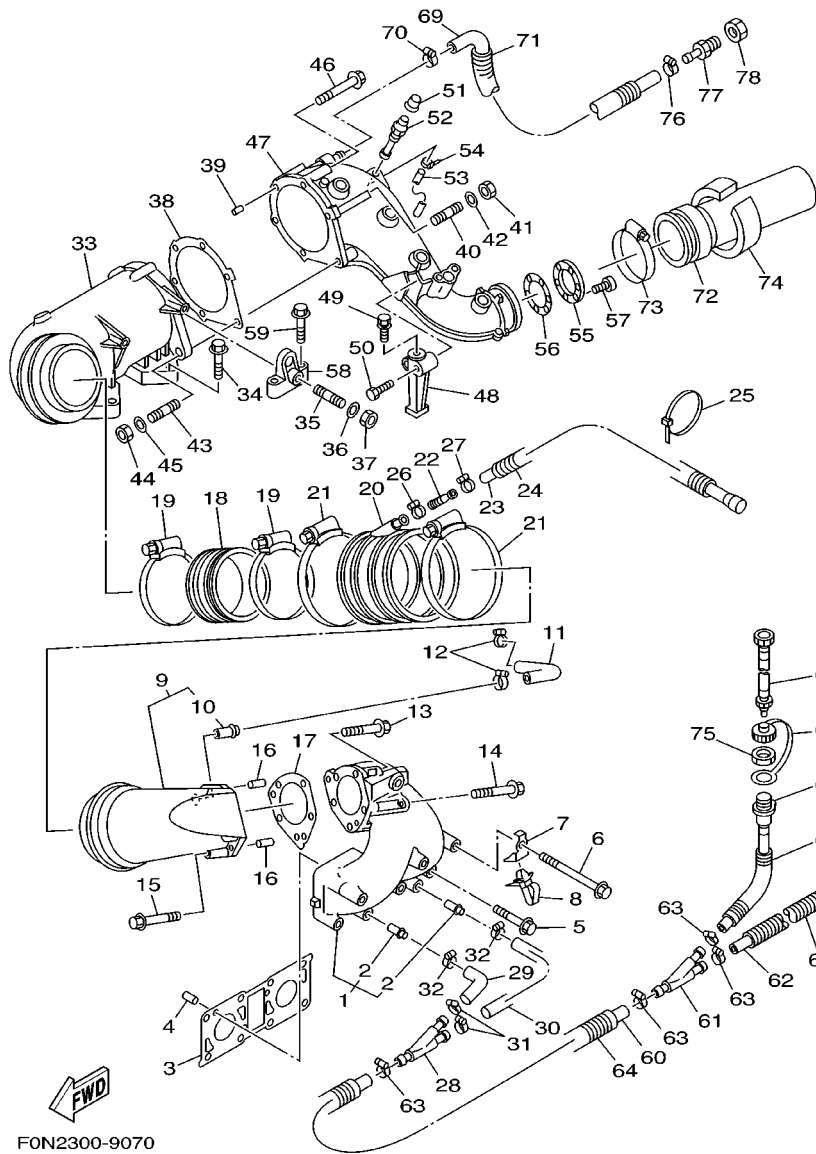

FON2300-9070

REF. NO.	PART NO.	DESCRIPTION	FON1	FON2				REMARKS
55	66E-14763-10-94	SPACER	1	1				
56	66E-14623-00	GASKET, EXHAUST PIPE	1	1				
57	97985-06216	SCREW, WITH WASHER	3	3				
58	66E-14771-01-94	STAY, MUFFLER 1	2	2				
59	97513-10550	BOLT, WITH WASHER	4	4				
<hr/>								
60	90445-18M02	HOSE	1	1				
61	63M-12581-00	JOINT, HOSE 1	1	1				
62	90445-18M02	HOSE	1	1				
63	90450-18M09	HOSE CLAMP ASSY	4	4				
64	90446-24M52	HOSE	2	2				
<hr/>								
65	63M-12580-00	JOINT ASSY	1	1				
66	90446-24M89	HOSE	1	1				
67	682-84385-01	CAP,1	1	1				
68	63M-12590-10	CONDUCTION ASSY	1					
	63M-12590-20	CONDUCTION ASSY		1				
<hr/>								
69	66E-12578-00	HOSE 3	1	1				
70	90450-22M14	HOSE CLAMP ASSY	1	1				
71	90446-27M95	HOSE	1	1				
72	66E-14752-10	PIPE, OUTLET	1	1				
73	90460-90M11	CLAMP, HOSE	1	1				
<hr/>								
74	GK5-67577-00	PACKING, HOSE 1	1	1				
75	EU0-61652-00	NUT	1	1				
76	90450-22M14	HOSE CLAMP ASSY	1	1				
77	90604-80798	THROUGH HULL	1	1				
78	EU0-62241-30	NUT, DRAIN 1	1	1				
<hr/>								

FIG. 8 FUEL

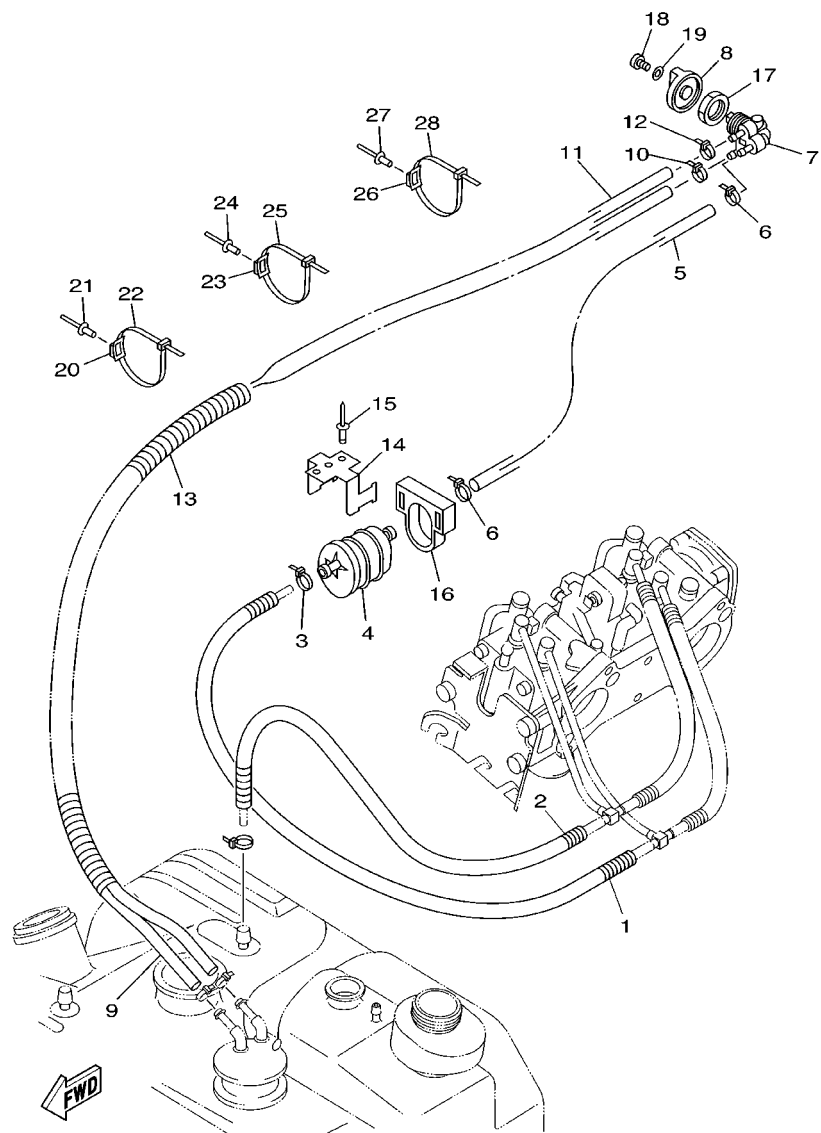

REF. NO.	PART NO.	DESCRIPTION	F0N1	F0N2	REMARKS
1	90446-17MF9	HOSE	1	1	
2	90446-17ME5	HOSE	1	1	
3	90465-11M10	CLAMP	1	1	
4	6K8-24560-10	FILTER ASSY	1	1	
5	90445-10MH6	HOSE	1	1	
6	90465-11M10	CLAMP	2	2	
7	65U-24500-00	FUEL COCK ASSY 1	1	1	
8	6K8-24524-10	LEVER, COCK	1	1	
9	90445-10MG8	HOSE	1	1	
10	90465-11M10	CLAMP	1	1	
11	90445-10MG9	HOSE	1	1	
12	90465-11M10	CLAMP	1	1	
13	90446-27MF2	HOSE	1	1	
14	FN8-67816-00	BRACKET, FUEL FILTER	1	1	
15	90267-48940	RIVET, BLIND	2	2	
16	EU0-67817-00	HOLDER	1	1	
17	90170-22M11	NUT	1	1	
18	97880-04010	SCREW, PAN HEAD	1	1	
19	92990-04600	WASHER, PLATE	1	1	
20	90600-91736	CLAMP COMP.	2	2	
21	90267-48932	RIVET, BLIND	2	2	
22	90601-20006	BAND	2	2	
23	90600-91736	CLAMP COMP.	2	2	
24	90267-48007	RIVET, BLIND	2	2	
25	90601-20009	BAND	2	2	
26	90600-91736	CLAMP COMP.	2	2	
27	90267-48007	RIVET, BLIND	2	2	

FIG. 8 FUEL

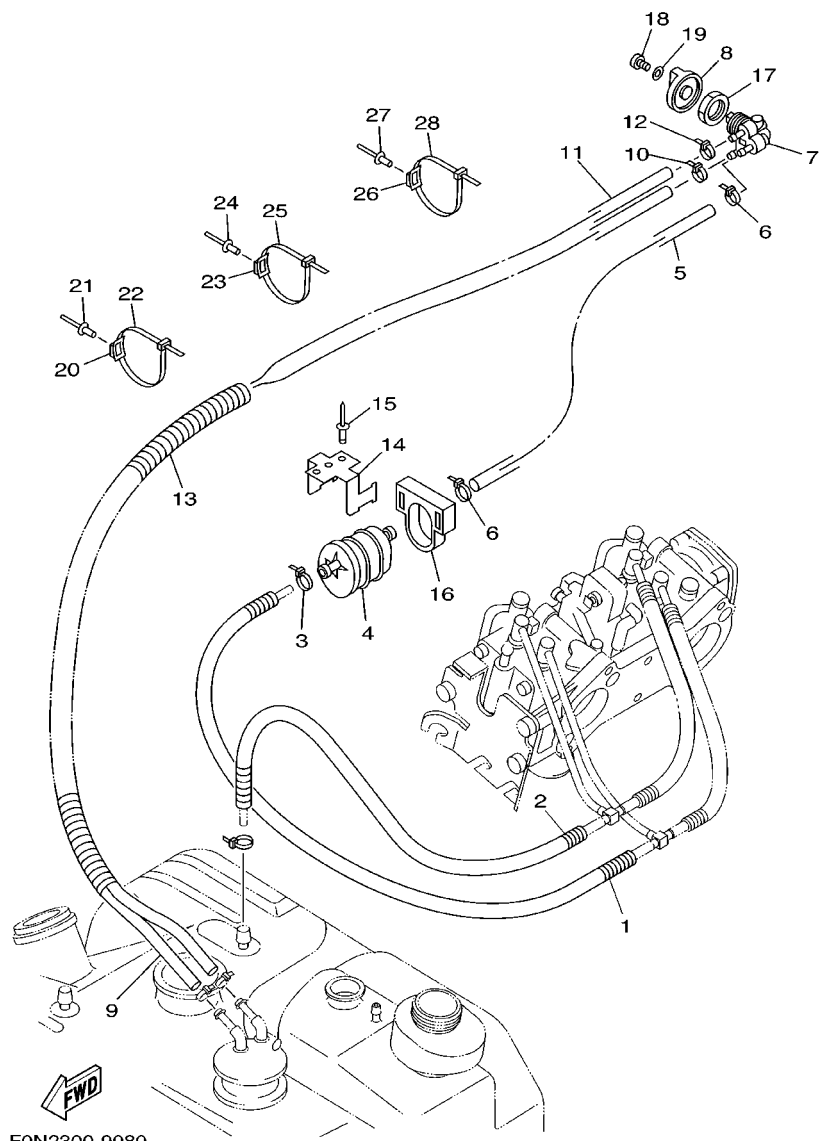

F0N2300-9080

REF. NO.	PART NO.	DESCRIPTION	F0N1	F0N2			REMARKS
28	90601-20006	BAND	2	2			

FIG. 9 JET UNIT 1

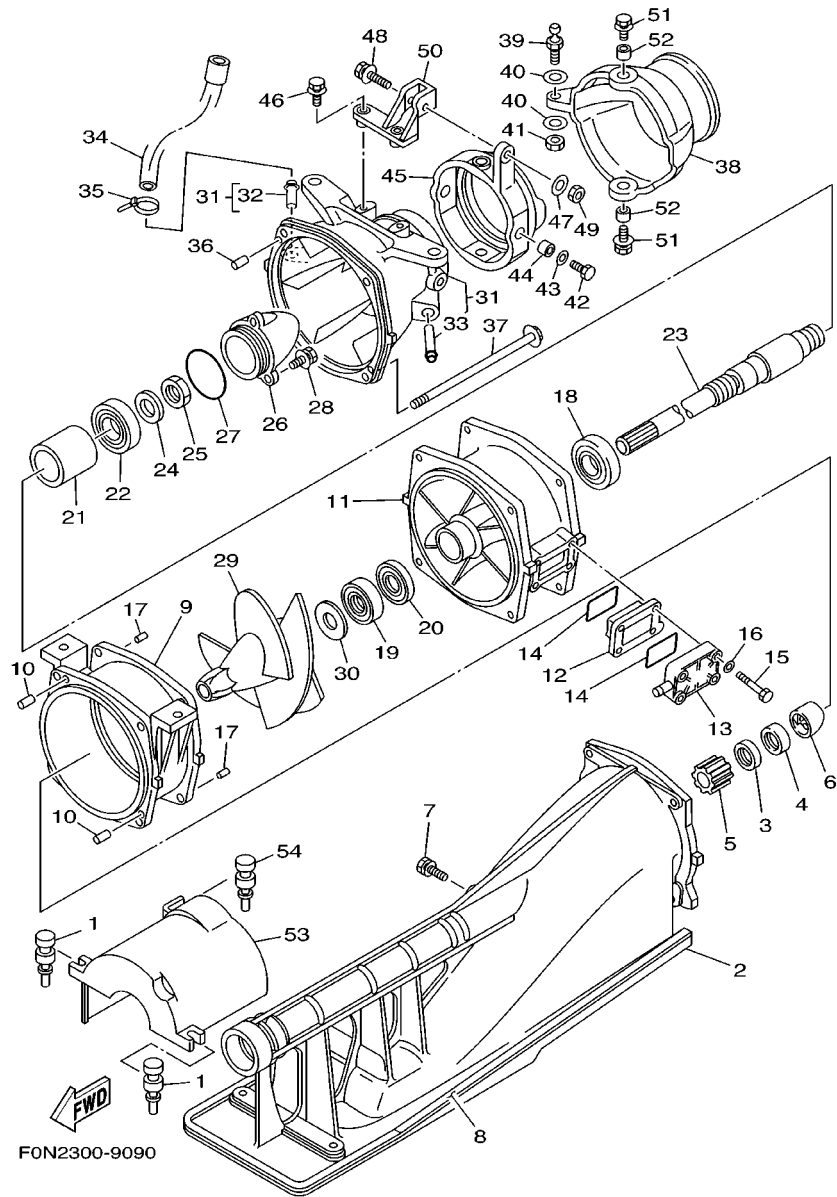

REF. NO.	PART NO.	DESCRIPTION	F0N1	F0N2	REMARKS
1	90480-06M46	GROMMET	2	2	
2	65V-51311-01-94	DUCT, INTAKE	1	1	
3	93102-17M49	OIL SEAL	1	1	
4	93102-17M50	OIL SEAL	1	1	
5	65V-45318-00	BUSHING, DRIVE SHAFT	1	1	
6	65V-51348-01-94	SPACER	1	1	
7	97595-06525	BOLT, WITH WASHER	1	1	
8	6R8-51367-01	FELT, PACKING	2	2	
9	6R8-51312-03-94	HOUSING, IMPELLER	1	1	
10	93606-12019	PIN, DOWEL	2	2	
11	66E-51315-00-94	DUCT, IMPELLER	1	1	
12	66E-46882-00	FILTER	1	1	
13	66E-45214-00-94	COVER, WATER INLET	1	1	
14	66E-42414-00	O-RING	2	2	
15	97095-06045	BOLT	4	4	
16	92995-06600	WASHER	4	4	
17	93606-12019	PIN, DOWEL	2	2	
18	93306-205U0	BEARING	1	1	
19	93102-25M34	OIL SEAL	1	1	
20	93101-25M50	OIL SEAL	1	1	
21	65V-45538-00	SPACER 1	1	1	
22	93306-304U1	BEARING	1	1	
23	66E-45511-10	SHAFT, DRIVE	1	1	
24	92990-16600	WASHER	1	1	
25	95317-16700	NUT	1	1	
26	62T-51326-00	CAP	1	1	
27	93210-46M16	O-RING	1	1	

FIG. 9 JET UNIT 1

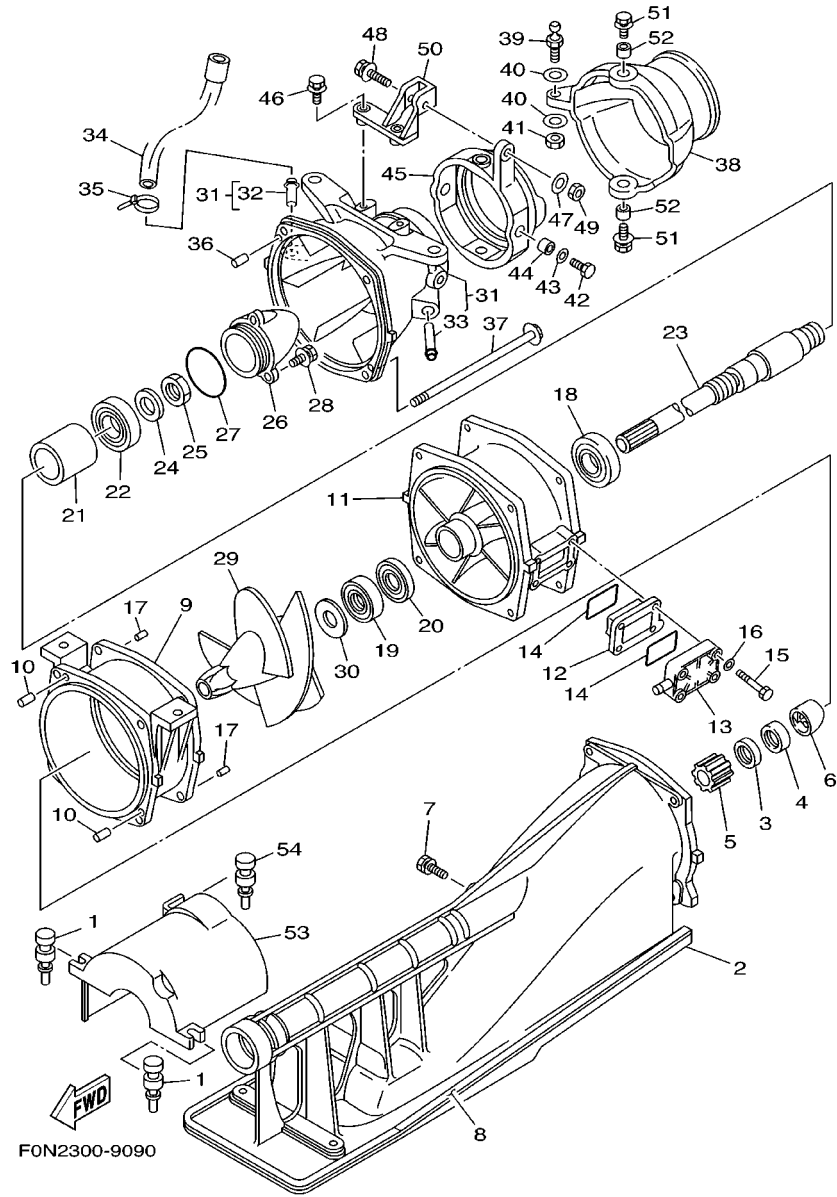

REF. NO.	PART NO.	DESCRIPTION	F0N1	F0N2	REMARKS
28	97595-06520	BOLT, WITH WASHER	3	3	
29	66E-51321-B0	IMPELLER	1	1	
30	62T-51348-00-5B	SPACER	1	1	
31	67U-51318-00-94	NOZZLE	1	1	
32	6K8-51129-00	.NIPPLE	1	1	
33	62T-51129-00	.NIPPLE	1	1	
34	62E-51673-00	PIPE 1	1	1	
35	90450-14M05	HOSE CLAMP ASSY	1	1	
36	93606-12019	PIN, DOWEL	2	2	
37	90101-06M04	BOLT	4	4	
38	65V-51313-00	NOZZLE,DEFLECTOR	1	1	
39	6R7-42316-00	BOLT, JOINT	1	1	
40	90201-06M31	WASHER, PLATE	2	2	
41	95380-06700	NUT	1	1	
42	97095-08018	BOLT	2	2	
43	92995-08600	WASHER	2	2	
44	90387-08M08	COLLAR	2	2	
45	64Y-51190-00-94	RING,TRIM	1	1	
46	97595-06520	BOLT, WITH WASHER	2	2	
47	90201-06M31	WASHER, PLATE	1	1	
48	97595-06535	BOLT, WITH WASHER	1	1	
49	95380-06700	NUT	1	1	
50	67U-51387-00-94	STAY	1	1	
51	97595-08520	BOLT, WITH WASHER	2	2	
52	90387-08M06	COLLAR	2	2	
53	66E-51381-01	COVER	1	1	
54	90480-06M46	GROMMET	1	1	

FIG. 10 JET UNIT 2

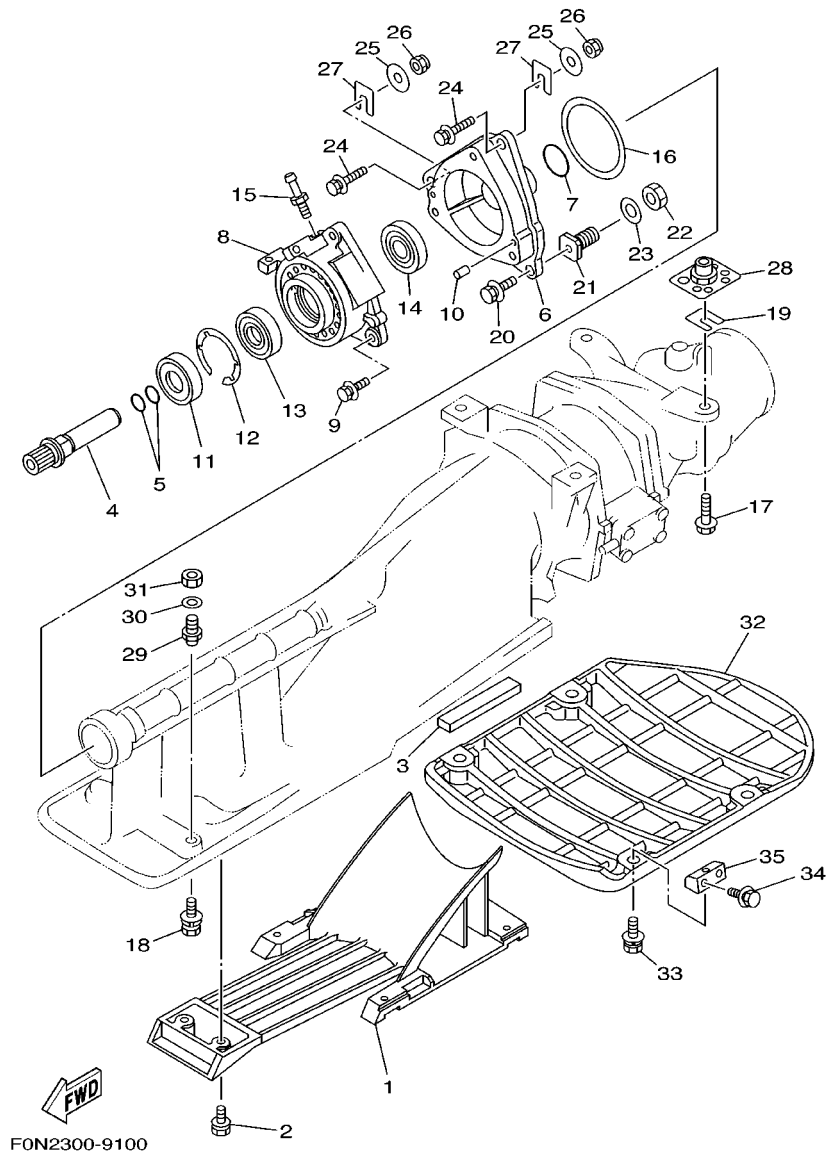

F0N2300-9100

REF. NO.	PART NO.	DESCRIPTION	F0N1	F0N2	REMARKS
1	63N-51333-02-94	SCREEN, INTAKE	1	1	
2	97595-06518	BOLT, WITH WASHER	6	6	
3	63N-51368-00	FELT, PACKING	2	2	
4	66E-51323-00	SHAFT, COUPLOR	1	1	
5	93210-17MA4	O-RING	2	2	
6	62G-45331-01-94	HOUSING, BEARING	1	1	
7	93210-35M72	O-RING	1	1	
8	65U-45332-02-94	HOUSING, BEARING	1	1	
9	97595-08525	BOLT, WITH WASHER	3	3	
10	93606-12019	PIN, DOWEL	2	2	
11	93101-25M55	OIL SEAL	1	1	
12	93430-47M04	CIRCLIP	1	1	
13	93306-205U6	BEARING	1	1	
14	93101-25M56	OIL SEAL	1	1	
15	61L-45378-00	NIPPLE, HOSE	1	1	
16	6K8-45127-00	SEAL	1	1	
17	90119-10958	BOLT, WITH WASHER	4	4	
18	90119-06947	BOLT, WITH WASHER	2	2	
19	EW2-67354-00-01	SHIM (T=0.1)	8	8	UN
	EW2-67354-00-03	SHIM (T=0.3)	8	8	UN
	EW2-67354-00-05	SHIM (T=0.5)	8	8	UN
	EW2-67354-00-10	SHIM (T=1.0)	8	8	UN
20	90119-08955	BOLT, WITH WASHER	1	1	
21	90180-08912	NUT, T	1	1	
22	95380-14600	NUT		1	
	95380-14700	NUT	1		
23	92990-14600	WASHER	1	1	

FIG. 10 JET UNIT 2

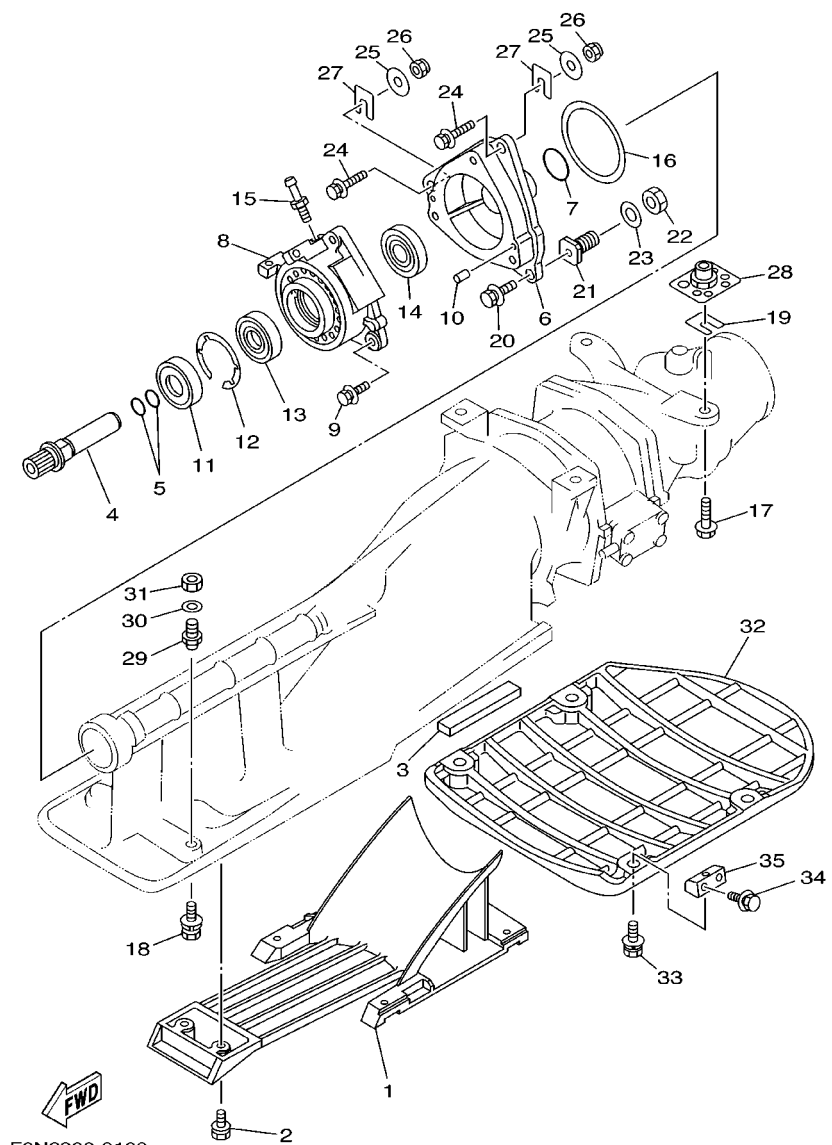

REF. NO.	PART NO.	DESCRIPTION	F0N1	F0N2	REMARKS
24	90119-08904	BOLT, WITH WASHER	2	2	
25	90201-08929	WASHER, PLATE	2	2	
26	95720-08300	NUT, SELF-LOCKING	2	2	
27	GD0-67249-00-05	SHIM (T=0.5)	2	2	UN
	GD0-67249-00-10	SHIM (T=1.0)	2	2	UN
28	90179-10972	NUT	4	4	
29	90180-06900	NUT, T	2	2	
30	92990-10600	WASHER, PLATE	2	2	
31	95380-10600	NUT	2	2	
32	GH1-6273B-01	PLATE 2	1	1	
33	90119-08953	BOLT, WITH WASHER	4	4	
34	90119-08957	BOLT, WITH WASHER	8	8	
35	FX1-62733-00	PACKING	4	4	

FIG. 11 GENERATOR

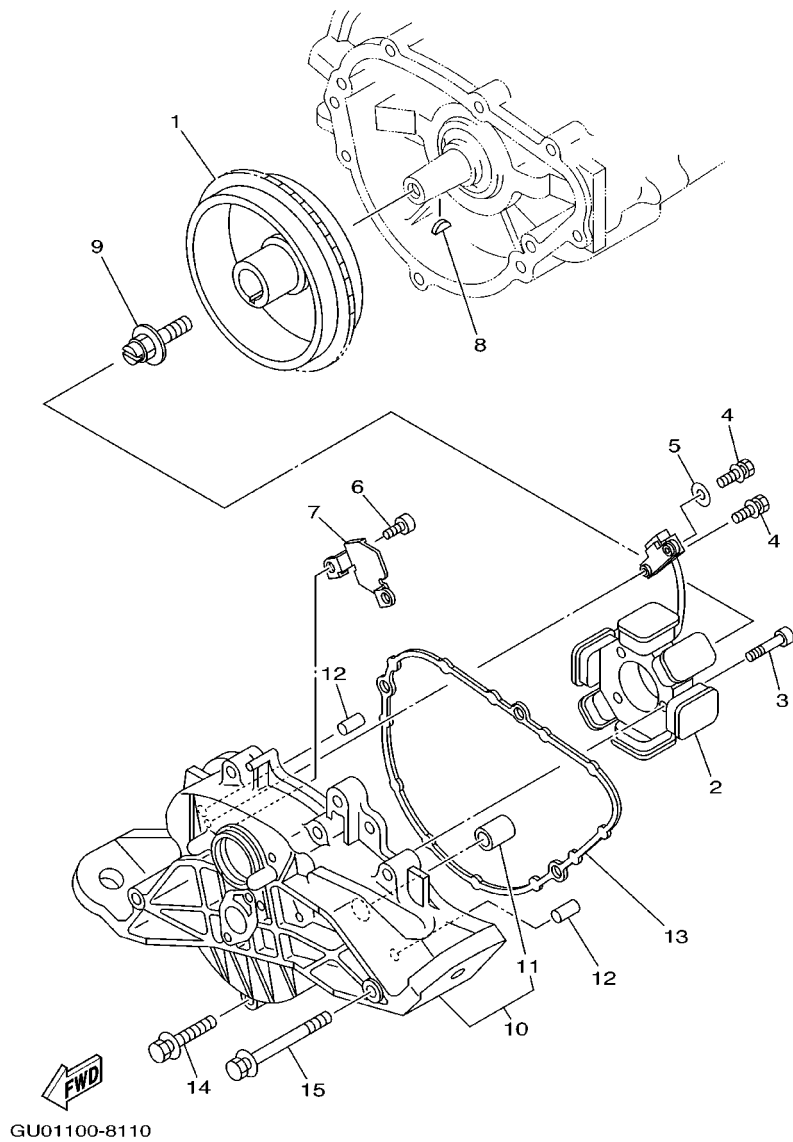

REF. NO.	PART NO.	DESCRIPTION	F0N1	F0N2	REMARKS
1	66E-85550-00	ROTOR ASSY	1	1	
2	66E-85510-00	STATOR ASSY	1	1	
3	91318-06030	BOLT	3	3	
4	97513-05514	BOLT, WITH WASHER	2	2	
5	90201-05M09	WASHER, PLATE	1	1	
6	91318-06014	BOLT	2	2	
7	66E-81328-00	CLAMP	1	1	
8	90280-05013	KEY, WOODRUFF	1	1	
9	90109-10M72	BOLT	1	1	
10	66E-81337-10-8P	COVER, FLYWHEEL	1	1	
11	90380-12M29	.BUSH, SOLID	1	1	
12	93608-16M16	PIN, DOWEL	2	2	
13	66E-81168-00	O-RING	1	1	
14	90119-08M18	BOLT, WITH WASHER	6	6	
15	90119-08M55	BOLT, WITH WASHER	2	2	

FIG. 12 STARTING MOTOR

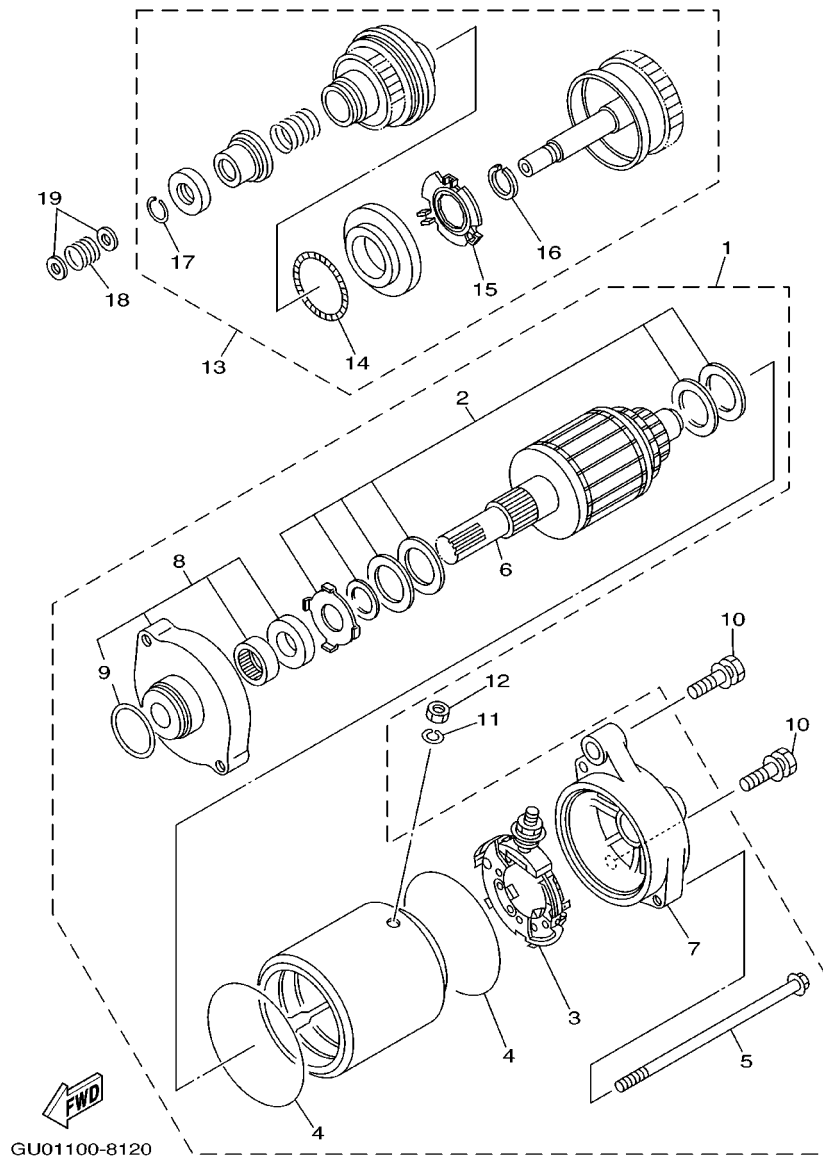

REF. NO.	PART NO.	DESCRIPTION	F0N1	F0N2				REMARKS
1	63M-81800-00	STARTING MOTOR ASSY	1	1				
2	3AJ-81809-00	.WASHER KIT	1	1				
3	6M6-81840-10	.BRUSH HOLDER ASSY	1	1				
4	11H-81844-00	.GASKET	2	2				
5	6M6-81826-00	.BOLT	2	2				
6	6M6-81850-00	.ARMATURE ASSY	1	1				
7	63M-81830-00	.REAR BRACKET ASSY	1	1				
8	6M6-81830-00	.FRONT BRACKET ASSY	1	1				
9	1FK-81847-00	.O-RING	1	1				
10	97513-08525	BOLT, WITH WASHER	2	2				
11	92990-06100	WASHER, SPRING	1	1				
12	95380-06700	NUT	1	1				
13	6M6-8183E-00	IDLE GEAR COMP	1	1				
14	6M6-81866-00	.WEIGHT SPRING	1	1				
15	6M6-81865-00	.WEIGHT HOLDER	1	1				
16	93440-25M08	.CIRCLIP	1	1				
17	93450-18M06	.CIRCLIP	1	1				
18	90501-14M73	SPRING, COMPRESSION	1	1				
19	92903-06600	WASHER, PLATE	2	2				

FIG. 13 ELECTRICAL 1

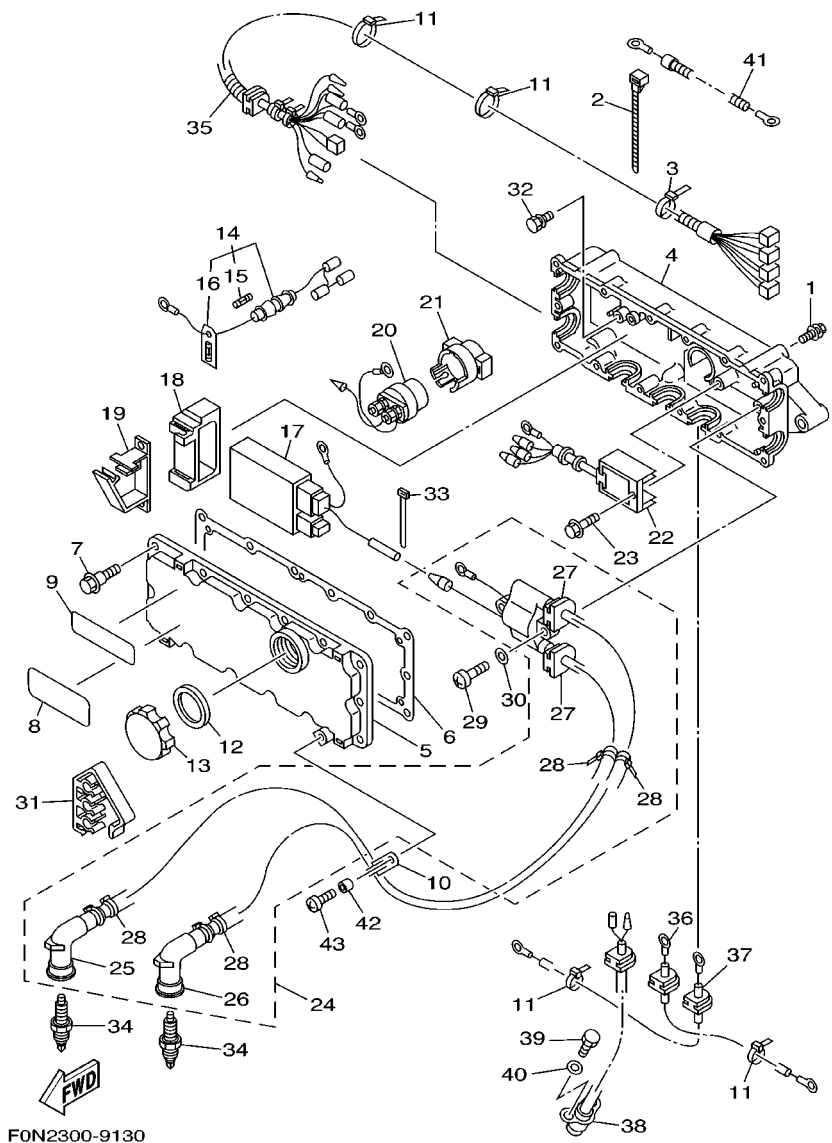

F0N2300-9130

REF. NO.	PART NO.	DESCRIPTION	F0N1	F0N2	REMARKS
1	90119-08957	BOLT, WITH WASHER	3	3	
2	90601-20006	BAND	1	1	
3	90465-12M56	CLAMP	1	1	
4	66E-8552A-00-94	HOUSING	1	1	
5	66E-8552E-00	COVER, CASE	1	1	
6	66E-81921-00	GASKET, TERMINAL	1	1	
7	90109-05MA0	BOLT	14	14	
8	6R7-83623-50	MARK 3	1		
9	63N-83623-00	MARK 3	1		
	6R7-83623-40	MARK 3	1		
10	90465-12M53	CLAMP	1	1	
11	90465-13M36	CLAMP	4	4	
12	6M6-81844-00	GASKET	1	1	
13	6M6-8132W-00	CAP	1	1	
14	66E-82150-00	FUSE HOLDER ASSY	1	1	
15	6G1-82151-00	.FUSE	1	1	
16	6K8-82159-00	.FUSE SPEAR	1	1	
17	66E-85540-00	C.D.I. UNIT ASSY	1	1	
18	64X-85546-00	BAND	1	1	
19	90464-06M29	CLAMP	1	1	
20	6G1-81941-10	STARTER RELAY ASSY	1	1	
21	6M6-81952-01	HOLDER, RELAY	1	1	
22	63M-81960-00	RECTIFIER & REGULATOR ASSY	1	1	
23	97595-06512	BOLT, WITH WASHER	1	1	
24	64X-85570-01	IGNITION COIL ASSY	1	1	
25	62E-82371-11	.CAP, PLUG	1	1	
26	62E-82371-11	.CAP, PLUG	1	1	

FIG. 13 ELECTRICAL 1

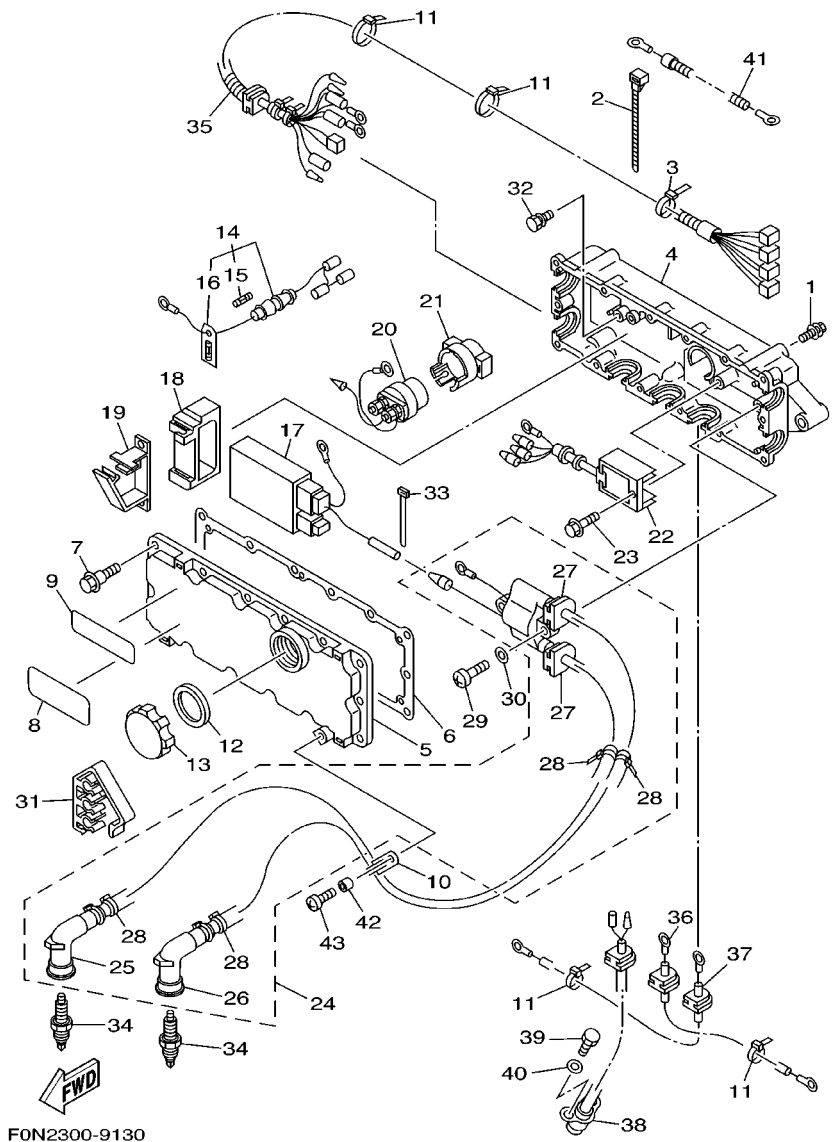

F0N2300-9130

REF. NO.	PART NO.	DESCRIPTION	F0N1	F0N2	REMARKS
27	90480-06M43	.GROMMET	2	2	
28	90465-11M10	.CLAMP	4	4	
29	97880-06030	SCREW, PAN HEAD	2	2	
30	92990-06600	WASHER, PLATE	2	2	
31	65U-81317-10	CLAMP, CORD	1	1	
32	97980-06216	SCREW, WITH WASHER	2	2	
33	90465-11M10	CLAMP	1	1	
34	94702-00204	PLUG, SPARK (NGK BR8ES)		2	
	94709-00204	PULG, SPARK (NGK BR8ES)		2	
35	66E-82553-00	EXTENSION, WIRE LEAD	1	1	
36	6M6-82117-21	WIRE, LEAD	1	1	
37	66E-82117-10	WIRE, LEAD	1	1	
38	67U-82560-00	THERMO SWITCH ASSY	1	1	
39	97095-06016	BOLT	2	2	
40	92995-06100	WASHER, SPRING	2	2	
41	61L-82117-00	WIRE, LEAD	1	1	
42	90387-06M05	COLLAR	1	1	
43	97780-60425	SCREW, TAPPING	1	1	

FIG. 14 ELECTRICAL 2

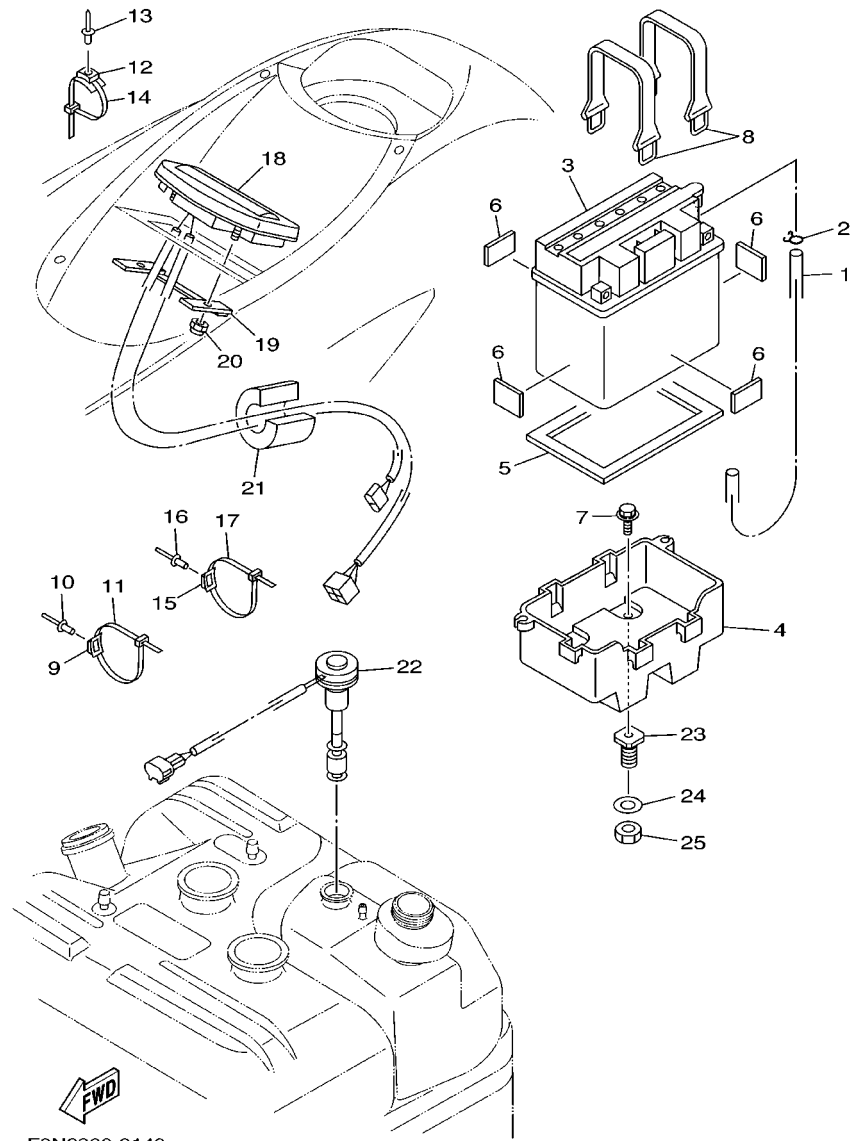

F0N2300-9140

REF. NO.	PART NO.	DESCRIPTION	F0N1	F0N2				REMARKS
1	90699-50090	HOSE	1	1				
2	90467-08M10	CLIP	1	1				
3	EU0-82110-09	BATTERY ASSY	1	1				
4	EW2-68211-00	CASE, BATTERY	1	1				
5	EU0-68221-00	PAD, BATTERY 1	1	1				
6	EU0-68221-30	PAD, BATTERY 2	4	4				
7	90119-06920	BOLT, WITH WASHER	4	4				
8	EU0-68218-04	BAND, BATTERY	2	2				
9	90600-91736	CLAMP COMP.	1	1				
10	90267-48932	RIVET, BLIND	1	1				
11	90601-20006	BAND	1	1				
12	90600-91736	CLAMP COMP.	3	3				
13	90267-48007	RIVET, BLIND	3	3				
14	90601-20006	BAND	3	3				
15	90600-91736	CLAMP COMP.	1	1				
16	90267-48007	RIVET, BLIND	1	1				
17	90601-20009	BAND	1	1				
18	F0M-6820A-10	METER ASSY	1	1				
19	F0M-68238-00	BRACKET, METER	1	1				
20	95720-05300	NUT, FLANGE	2	2				
21	GK5-68244-00	PACKING	1	1				
22	GH1-6824C-00	SENDER,OIL	1	1				
23	90180-06900	NUT, T	4	4				
24	92990-10600	WASHER, PLATE	4	4				
25	95380-10600	NUT	4	4				

FIG. 15 ENGINE HATCH 1

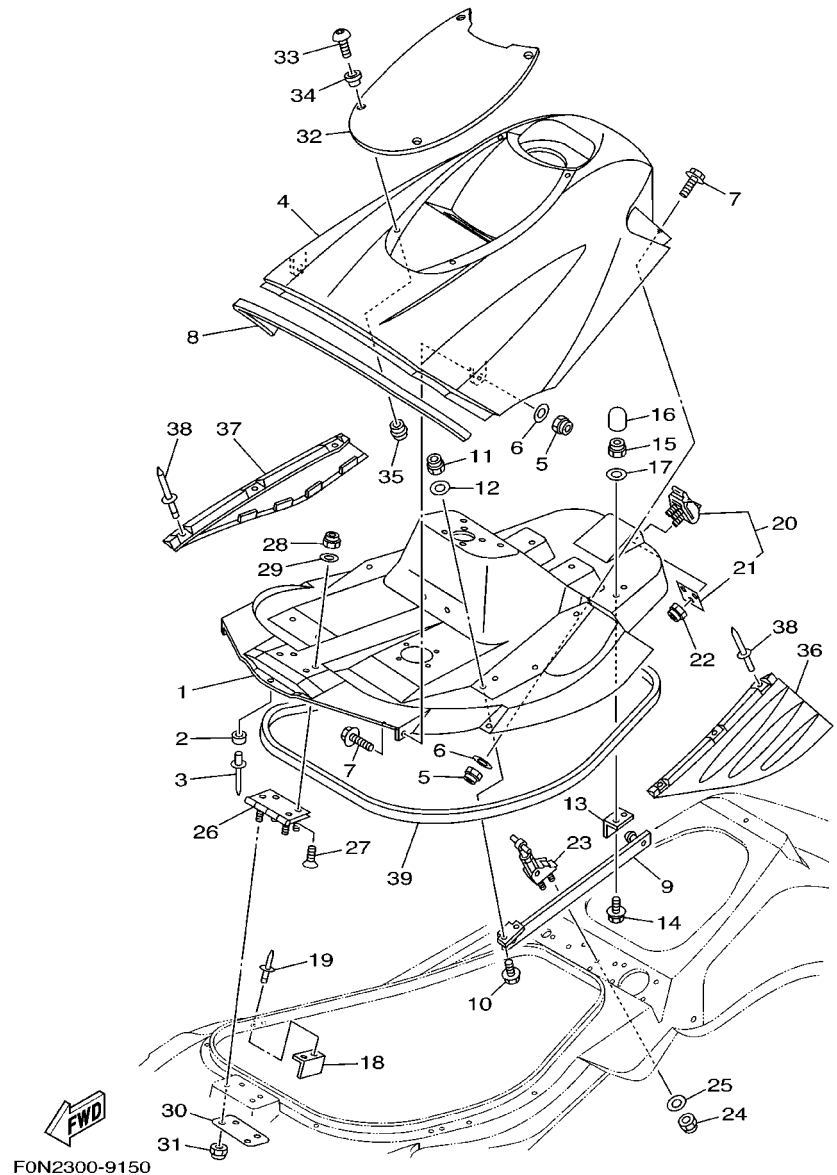

F0N2300-9150

REF. NO.	PART NO.	DESCRIPTION	F0N1	F0N2	REMARKS
1	F0N-6516B-00	HATCH, ENGINE	1	1	
2	GA7-63768-00	CUSHION,RUBBER	1	1	
3	90267-48931	RIVET, BLIND	1	1	
4	F0N-6516N-00-5D	COVER, ENGINE HATCH	1	1	
5	95720-06300	NUT, SELF-LOCKING	4	4	
6	92990-06200	WASHER, PLAIN	4	4	
7	90119-06900	BOLT, WITH WASHER	4	4	
8	F0N-6516C-00	TRIM 1	1	1	
9	GH1-62891-01	SUPPORT, HATCH	1	1	
10	90119-06900	BOLT, WITH WASHER	2	2	
11	95720-06300	NUT, SELF-LOCKING	2	2	
12	92990-06200	WASHER, PLAIN	2	2	
13	GK5-62892-00	FIX, PLATE	1	1	
14	90119-06901	BOLT, WITH WASHER	2	2	
15	95720-06300	NUT, SELF-LOCKING	2	2	
16	90190-06006	CLING	2	2	
17	92990-06200	WASHER, PLAIN	2	2	
18	FN8-62884-00	BRACKET, HATCH SUPPORT	1	1	
19	90267-48940	RIVET, BLIND	2	2	
20	FJ0-62840-02	HATCH LOCK ASSY	1	1	
21	FJ0-6284F-00	.PLATE,HATCH LOCK	1	1	
22	95720-05300	NUT, FLANGE	3	3	
23	F0N-62843-00	HOOK, HATCH LOCK	1	1	
24	95720-06300	NUT, SELF-LOCKING	2	2	
25	92990-06200	WASHER, PLAIN	2	2	
26	GK5-6517G-01	HINGE, HATCH	1	1	
27	98780-06025	SCREW, FLAT HEAD	4	4	

FIG. 15 ENGINE HATCH 1

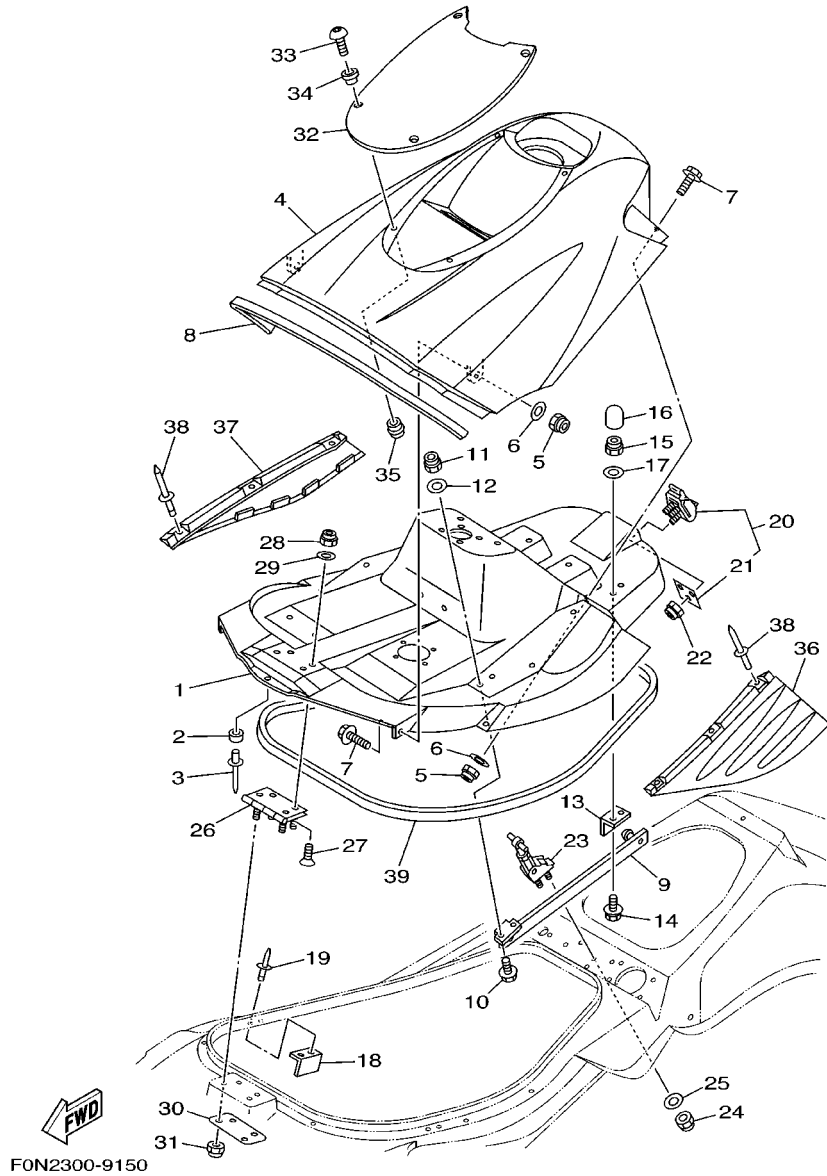

REF. NO.	PART NO.	DESCRIPTION	F0N1	F0N2				REMARKS
28	95720-06300	NUT, SELF-LOCKING	4	4				
29	92990-06200	WASHER, PLAIN	4	4				
30	GK5-65193-00	PLATE	1	1				
31	95720-06300	NUT, SELF-LOCKING	4	4				
32	F0N-6515N-00	VISOR	1	1				
33	90149-05919	SCREW	4	4				
34	E31-61749-00	BUSH 3	4	4				
35	90179-05633	NUT	4	4				
36	F0N-6377B-00	COVER, SIDE 1	1	1				
37	F0N-6377C-00	COVER, SIDE 2	1	1				
38	90267-48931	RIVET, BLIND	4	4				
39	F0N-62664-00	PACKING	1	1				

FIG. 16 ENGINE HATCH 2

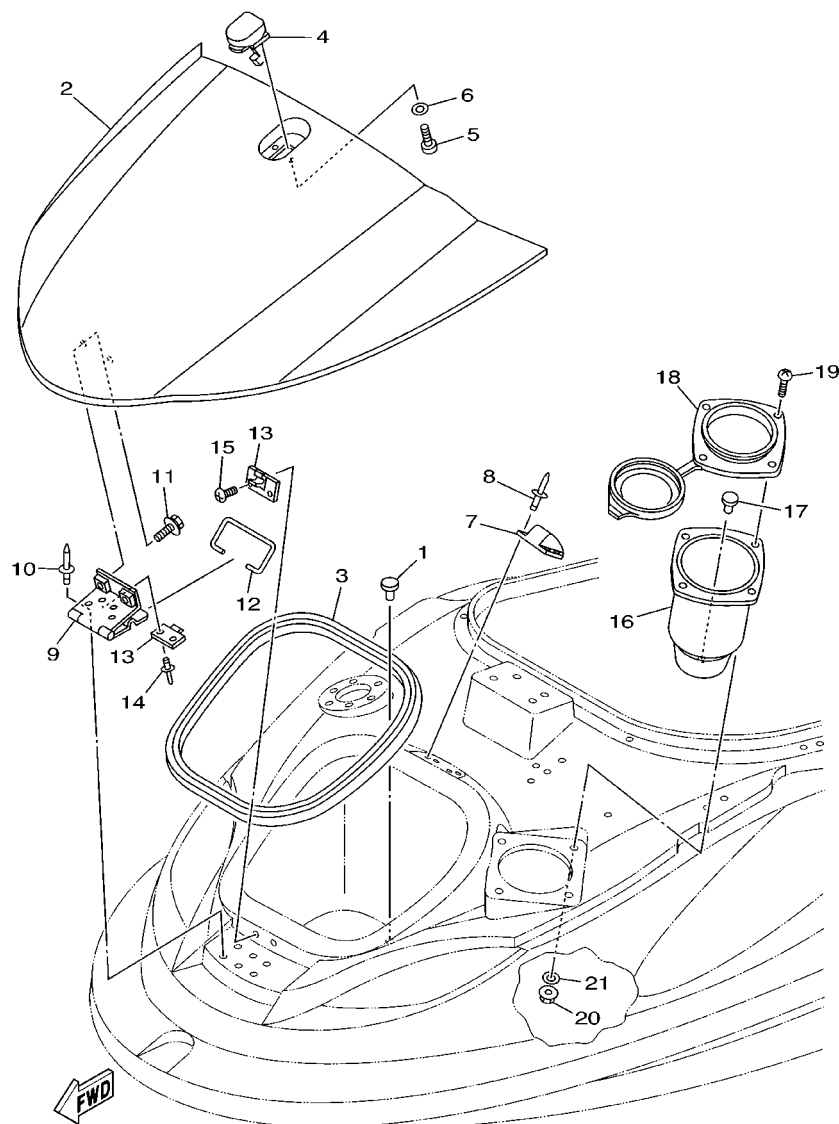

F0N2300-9160

REF. NO.	PART NO.	DESCRIPTION	F0N1	F0N2				REMARKS
1	90605-50201	PLUG	1	1				
2	F0N-6476A-00-5D	LID,LOCKER BOW	1	1				
3	F0N-6266D-00	PACKING 5	1	1				
4	GP7-6517C-00	LOCK, LID	1	1				
5	90149-05918	SCREW	2	2				
6	92990-05200	WASHER, PLAIN	2	2				
7	GP7-6517F-10	HOOK,LID LOCK	1	1				
8	90267-48932	RIVET, BLIND	4	4				
9	F0N-6517D-00	HINGE, LID	1	1				
10	90267-48940	RIVET, BLIND	6	6				
11	90119-06908	BOLT, WITH WASHER	2	2				
12	F0N-6517P-00	SUPPORT, LID	1	1				
13	F0N-6517U-00	HOLDER, LID SUPPORT	2	2				
14	90267-48934	RIVET, BLIND	2	2				
15	97780-50114	SCREW, PAN HEAD TAPPING	2	2				
16	FJ0-65911-01	CASE 1	1	1				
17	90605-50201	PLUG	1	1				
18	F0N-6591C-00	CAP,CASE	1	1				
19	90149-05960	SCREW	4	4				
20	95720-05300	NUT, FLANGE	4	4				
21	92990-05200	WASHER, PLAIN	4	4				

FIG. 17 HULL DECK

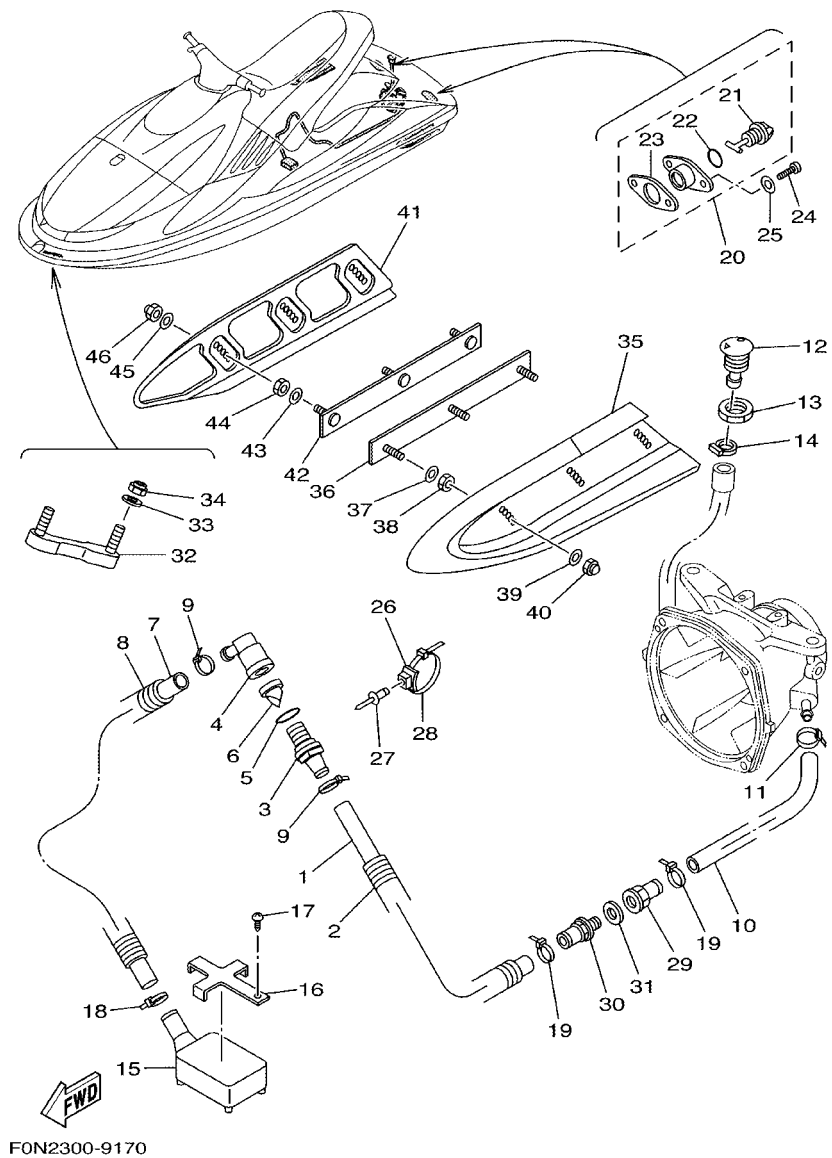

REF. NO.	PART NO.	DESCRIPTION	F0N1	F0N2	REMARKS
1	90445-19M10	HOSE	1	1	
2	90446-27M73	HOSE	1	1	
3	63M-51162-00	JOINT, HOSE	1	1	
4	63M-51165-00	JOINT HOSE 2	1	1	
5	93210-22ME5	O-RING	1	1	
6	63M-5316M-00	VALVE 1	1	1	
7	90445-19M09	HOSE	1	1	
8	90446-27M55	HOSE	1	1	
9	90465-13M11	CLAMP	2	2	
10	90445-14M40	HOSE	1	1	
11	90465-11M10	CLAMP	1	1	
12	FN8-6269B-00	SPOUT	1	1	
13	EU0-61652-00	NUT	1	1	
14	90600-91755	CLIP	1	1	
15	GD0-6761D-00	STRAINER, BILGE	1	1	
16	FJ0-67618-00	BASE	1	1	
17	97780-50114	SCREW, PAN HEAD TAPPING	1	1	
18	90601-20005	BAND	1	1	
19	90601-20005	BAND	2	2	
20	EU0-62280-00	DRAIN PLUG ASSY	2	2	
21	EU0-62282-00	.PLUG, DRAIN	1	1	
22	EU0-62283-00	.O-RING	1	1	
23	EU0-62285-01	.PACKING DRAIN (EU0)	1	1	
24	97780-50520	SCREW, TAPPING	4	4	
25	92990-05200	WASHER, PLAIN	4	4	
26	90600-91736	CLAMP COMP.	1	1	
27	90267-48925	RIVET, BLIND	1	1	

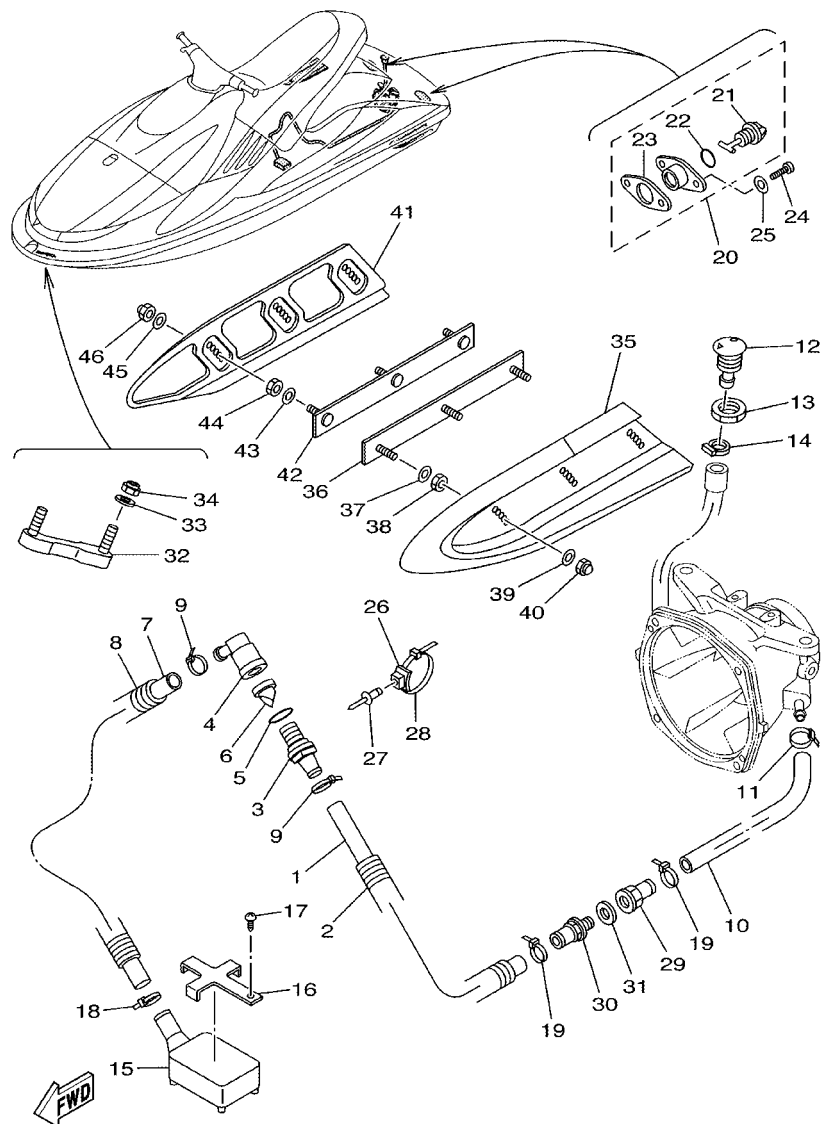

FON2300-9170

FIG. 17 HULL DECK

REF. NO.	PART NO.	DESCRIPTION	F0N1	F0N2				REMARKS
28	90601-20006	BAND	1	1				
29	90604-80759	CONNECTION, THRU-HULL 1/4	1	1				
30	90604-80775	THROUGH, HULL CONNECTION	1	1				
31	90430-13909	GASKET	1	1				
32	F0D-61624-01	BOWEYE 1 (S)	1	1				
33	92990-08200	WASHER, PLAIN	2	2				
34	95720-08300	NUT, SELF-LOCKING	2	2				
35	F0N-6883N-00	STABILIZER LH	1	1				
36	F0N-6883T-00	BRACKET,STABILIZER	1	1				
37	92990-06200	WASHER, PLAIN	3	3				
38	95380-06700	NUT	3	3				
39	90201-065F3	WASHER, PLATE	3	3				
40	90179-06959	NUT	3	3				
41	F0N-6883P-00	STABILIZER RH	1	1				
42	F0N-6883T-00	BRACKET,STABILIZER	1	1				
43	92990-06200	WASHER, PLAIN	3	3				
44	95380-06700	NUT	3	3				
45	90201-065F3	WASHER, PLATE	3	3				
46	90179-06959	NUT	3	3				

FIG. 18 GUNWALE. MAT

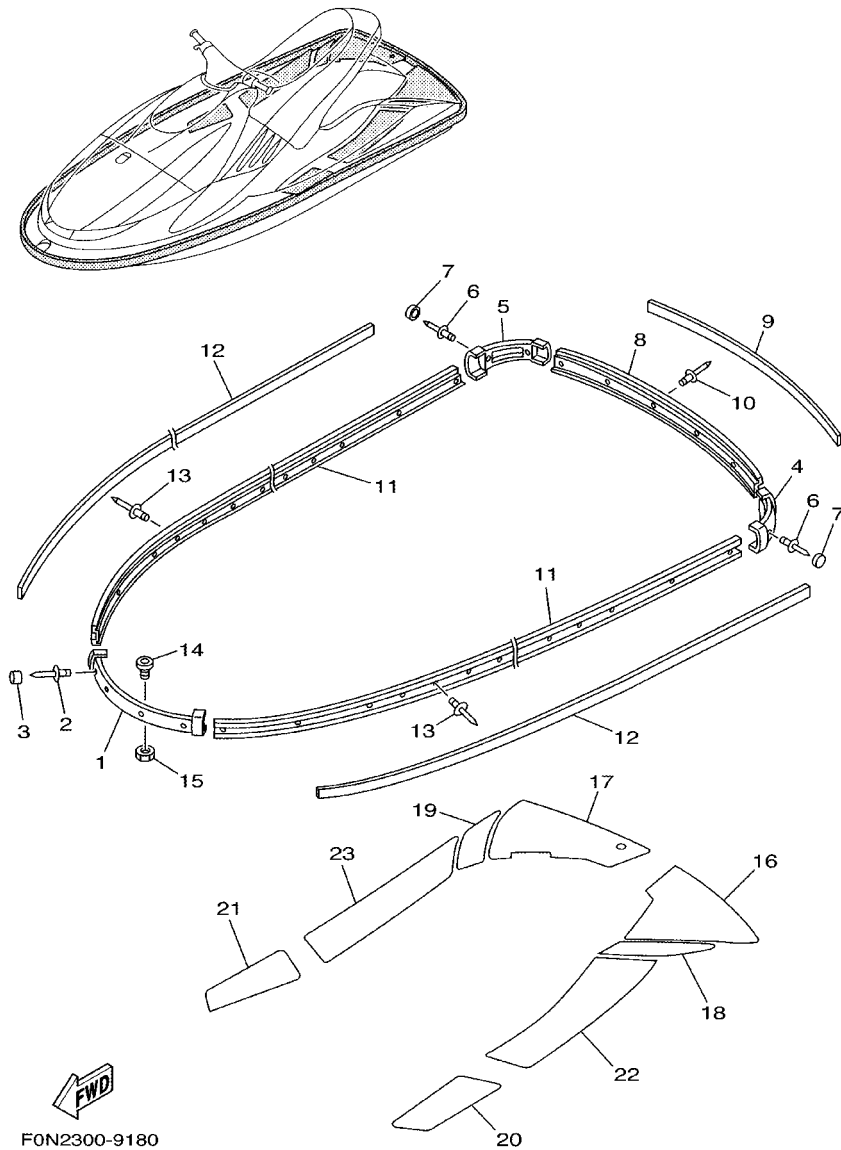

REF. NO.	PART NO.	DESCRIPTION	F0N1	F0N2				REMARKS
1	GK5-62501-20	BOW GUNWALE COMP.	1	1				
2	90267-48932	RIVET, BLIND	4	4				
3	GK5-62576-20	CAP, GUNWALE BOW	4	4				
4	GK5-6251D-20	GUNWALE, STERN 1	1	1				
5	GK5-6251E-20	GUNWALE, STERN 2	1	1				
6	90267-48932	RIVET, BLIND	4	4				
7	GH1-6354D-60	CAP, HEAD	4	4				
8	F0N-6252C-00	COVER, GUNWALE 1	1	1				
9	F0N-6252D-00	COVER, GUNWALE 2	1	1				
10	90267-48932	RIVET, BLIND	6	6				
11	F0N-62552-00	GUNWALE, SIDE 1	2	2				
12	F0N-62553-00	GUNWALE, SIDE 2	2	2				
13	90267-48932	RIVET, BLIND	34	34				
14	FN8-61651-00	ROPE HOLE	2	2				
15	EU0-61652-00	NUT	2	2				
16	F0N-6358F-00	MAT, UPPER LH	1	1				
17	F0N-6358G-00	MAT, UPPER RH	1	1				
18	F0N-6358H-00	MAT, UPPER 1	1	1				
19	F0N-6358J-00	MAT, UPPER 2	1	1				
20	F0N-6351H-00	MAT, STEP 1	1	1				
21	F0N-6351J-00	MAT, STEP 2	1	1				
22	F0N-6351K-00	MAT, STEP 3	1	1				
23	F0N-6351M-00	MAT, STEP 4	1	1				

FIG. 19 VENTILATION

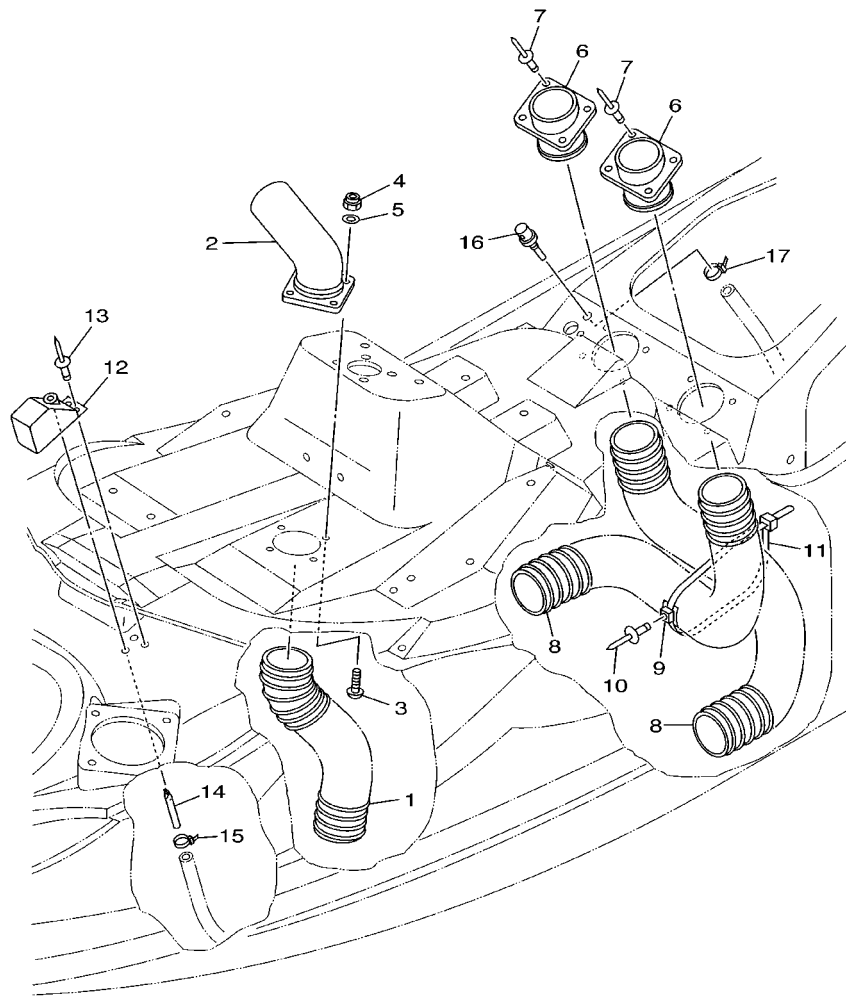

F0N2300-9190

REF. NO.	PART NO.	DESCRIPTION	F0N1	F0N2				REMARKS
1	F0N-6213F-10	HOSE, VENTILATOR 1	1	1				
2	F0N-6213K-00	HOSE, VENTILATOR3	1	1				
3	90149-05946	SCREW	4	4				
4	95720-05300	NUT, FLANGE	4	4				
5	92990-05200	WASHER, PLAIN	4	4				
6	GH1-62127-00	BASE, AIR INTAKE	2	2				
7	90267-48007	RIVET, BLIND	8	8				
8	F0N-6213G-00	HOSE, VENTILATOR 2	2	2				
9	90600-91736	CLAMP COMP.	1	1				
10	90267-48925	RIVET, BLIND	1	1				
11	90601-20027	BAND	1	1				
12	GP7-62159-01	SOCKET, VENTILATION	1	1				
13	90267-48007	RIVET, BLIND	2	2				
14	GK5-62149-00	PIPE, VENTILATION	1	1				
15	90465-11M10	CLAMP	1	1				
16	GJ3-6215F-00	NIPPLE	1	1				
17	90465-11M10	CLAMP	1	1				

FIG. 20 SEAT, UNDER LOCKER

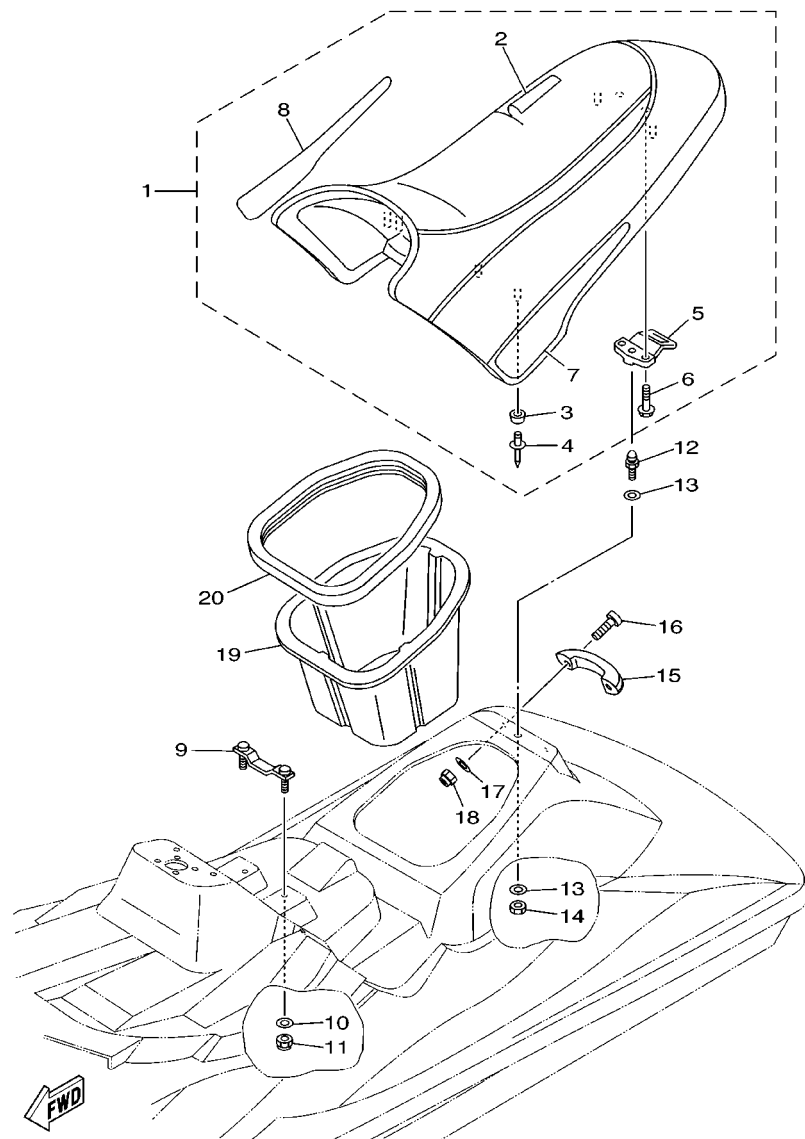

F0N2300-9200

REF. NO.	PART NO.	DESCRIPTION	F0N1	F0N2	REMARKS
1	F0N-6371A-00	DOUBLE SEAT ASSY	1	1	
2	F0N-6371B-00	.COVER, SEAT 1	1	1	
3	GK5-63729-00	.STOPPER,SEAT	6	6	
4	90267-48953	.RIVET, BLIND	6	6	
5	GH1-63850-03	.SEAT LOCK ASSY	1	1	
6	90119-06914	.BOLT, WITH WASHER	2	2	
7	F0N-64195-00	.GRAPHIC C	1	1	
8	F0N-64194-00	.GRAPHIC B	1	1	
9	F0N-6378C-00	STAY, SEAT 1	1	1	
10	95720-06300	NUT, SELF-LOCKING	2	2	
11	92990-06200	WASHER, PLAIN	2	2	
12	GU3-63774-00	PIN	1	1	
13	92990-10200	WASHER, PLAIN	2	2	
14	95720-10300	NUT	1	1	
15	GA7-6271B-10	GRIP, HAND	1	1	
16	90149-06973	SCREW	2	2	
17	90201-065F3	WASHER, PLATE	2	2	
18	95720-06300	NUT, SELF-LOCKING	2	2	
19	F0N-64742-00	LOCKER, UNDER 2	1	1	
20	F0N-6266B-00	PACKING 3	1	1	

FIG. 21 OIL TANK

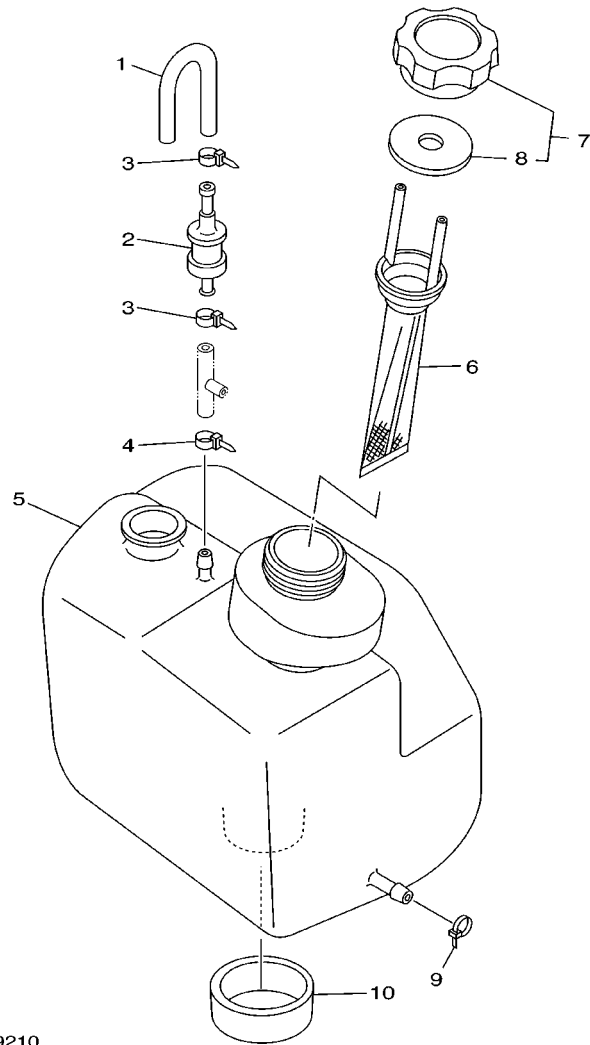

F0N2300-9210

REF. NO.	PART NO.	DESCRIPTION	F0N1	F0N2	REMARKS
1	GK5-6215E-00	HOSE	1	1	
2	FJ0-67766-00	ROLL OVER VALVE	1	1	
3	90465-11M10	CLAMP	2	2	
4	90465-11M10	CLAMP	1	1	
5	GH1-6775B-00	TANK,OIL	1	1	
6	GH1-6775C-00	FILTER	1	1	
7	GE2-6784A-00	OIL TANK CAP ASSY.	1	1	
8	FJ0-67841-01	.PACKING, OIL CAP	1	1	
9	90465-11M10	CLAMP	1	1	
10	GH1-6759D-00	MAT,3	1	1	

FIG. 22 FUEL TANK

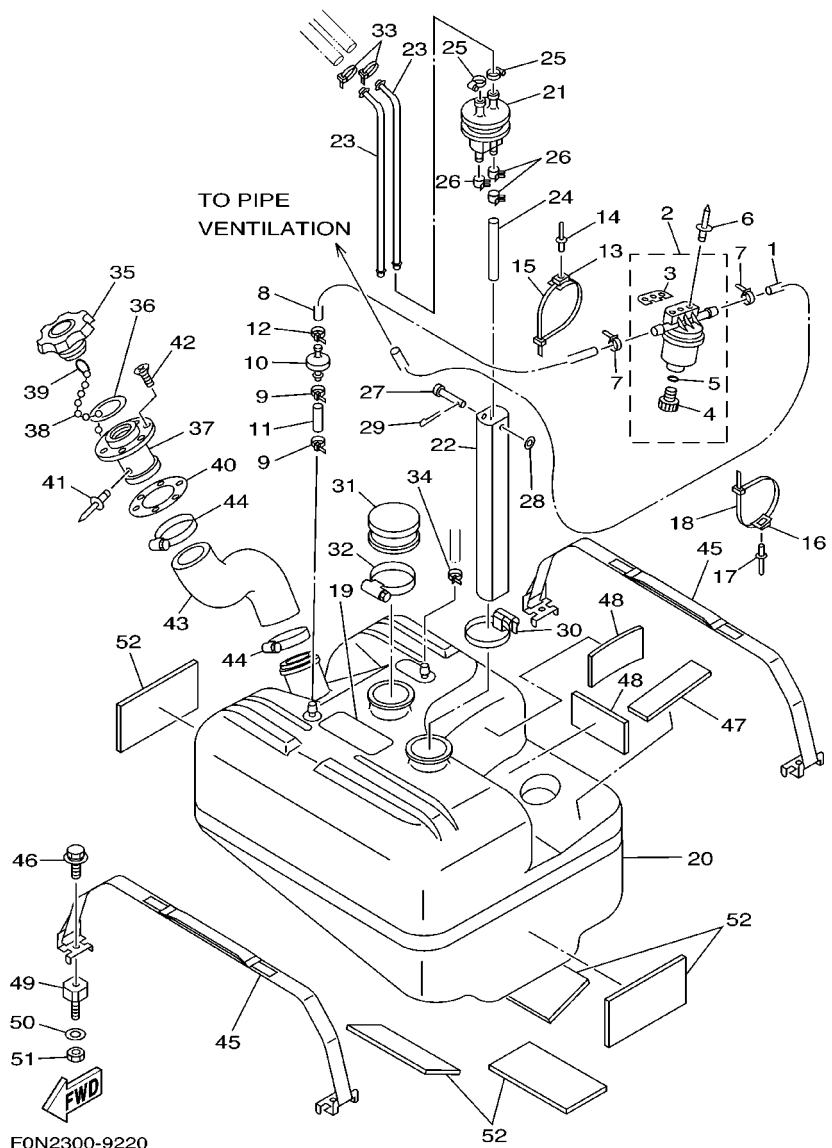

FON2300-9220

REF. NO.	PART NO.	DESCRIPTION	F0N1	F0N2				REMARKS
1	90699-50100	HOSE	1	1				
2	EW2-62140-00	FILTER, VENT ASSY	1	1				
3	EW2-62142-00	.PLATE, FILTER	1	1				
4	70R-24543-00	.PLUG, DRAIN	1	1				
5	70R-24489-00	.O-RING	1	1				
6	90267-48940	RIVET, BLIND	2	2				
7	90465-11M10	CLAMP	2	2				
8	90699-50050	HOSE	1	1				
9	90465-11M10	CLAMP	2	2				
10	EU0-67767-31	CHECK VALVE	1	1				
11	90699-50004	HOSE	1	1				
12	90465-11M10	CLAMP	1	1				
13	90600-91736	CLAMP COMP.	1	1				
14	90267-48932	RIVET, BLIND	1	1				
15	90601-20006	BAND	1	1				
16	90600-91736	CLAMP COMP.	1	1				
17	90267-48007	RIVET, BLIND	1	1				
18	90601-20006	BAND	1	1				
19	GH1-6418D-01	LABEL, FUEL TANK		1				
20	GH1-67711-01	TANK, FUEL	1	1				
21	FJ0-67713-00	PIPE, JOINT	1	1				
22	F0E-677H0-00	SLEEVE ASSY.	1	1				
23	FN8-67714-02	PIPE, SUCTION 3	2	2				
24	90445-11900	HOSE	1	1				
25	90601-11062	BAND, HOSE 11	2	2				
26	90467-11032	CLIP	3	3				
27	91790-05040	PIN, CLEVIS	1	1				

FIG. 22 FUEL TANK

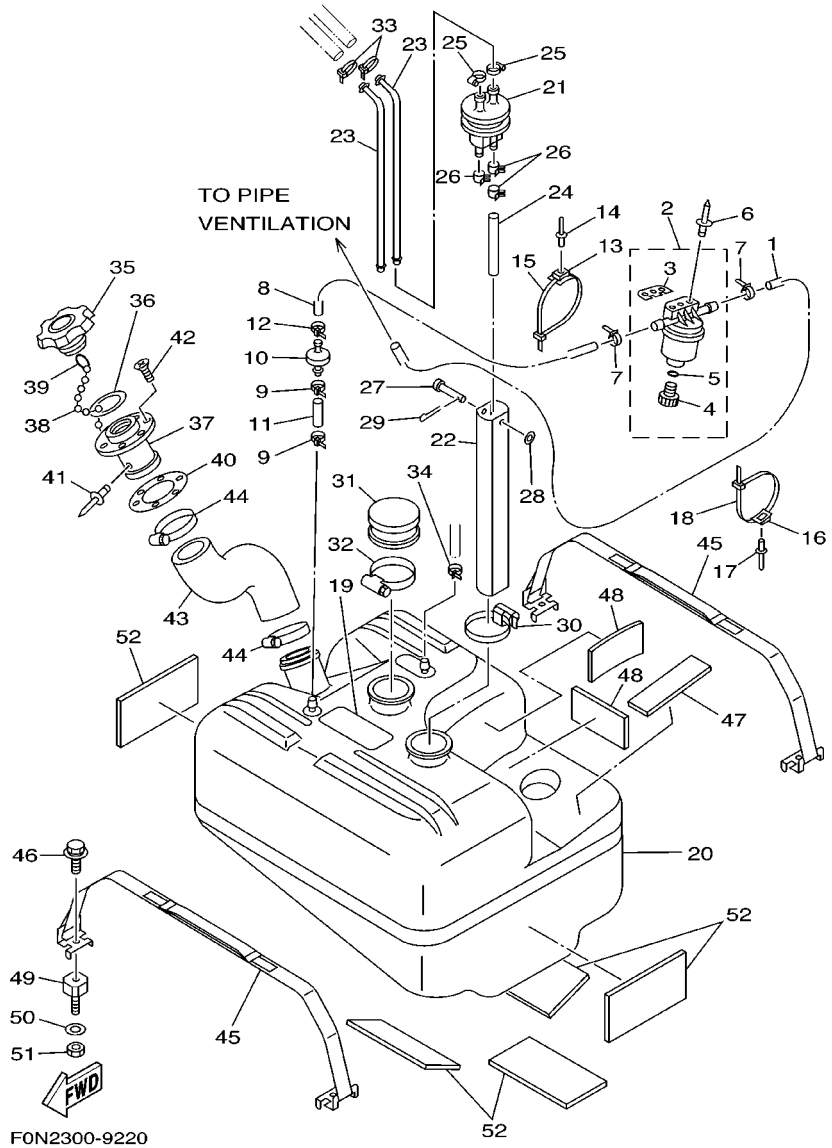

FON2300-9220

REF. NO.	PART NO.	DESCRIPTION	F0N1	F0N2				REMARKS
28	92990-05600	WASHER, PLATE	1	1				
29	91490-16010	PIN, COTTER	1	1				
30	90601-16274	BAND, HOSE 62	1	1				
31	FN8-6771K-00	COVER	1	1				
32	90601-16274	BAND, HOSE 62	1	1				
33	90465-11M10	CLAMP	2	2				
34	90465-11M10	CLAMP	1	1				
35	FN8-67831-01	CAP, FUEL FILLER	1	1				
36	EU0-67832-00	PACKING 1	1	1				
37	FN8-67833-00	SOCKET	1	1				
38	EU0-67835-00	CHAIN BALL	1	1				
39	EU0-67839-00	COUPLING	1	1				
40	EU0-67834-00	PACKING, FUEL FILLER	1	1				
41	90267-40935	RIVET, BLIND	1	1				
42	EU0-67869-00	SCREW, FLAT HEAD	6	6				
43	F0N-67844-00	HOSE	1	1				
44	90601-15573	BAND, HOSE 55	2	2				
45	F0N-67743-00	BELT, TANK 1	2	2				
46	90119-08954	BOLT, WITH WASHER	4	4				
47	GH1-6759B-00	MAT 1	1	1				
48	GH1-6759C-00	MAT 2	2	2				
49	90180-08907	NUT, T	4	4				
50	92990-14600	WASHER	4	4				
51	95380-14700	NUT	4	4				
52	F0N-6759B-00	MAT 1	5	5				

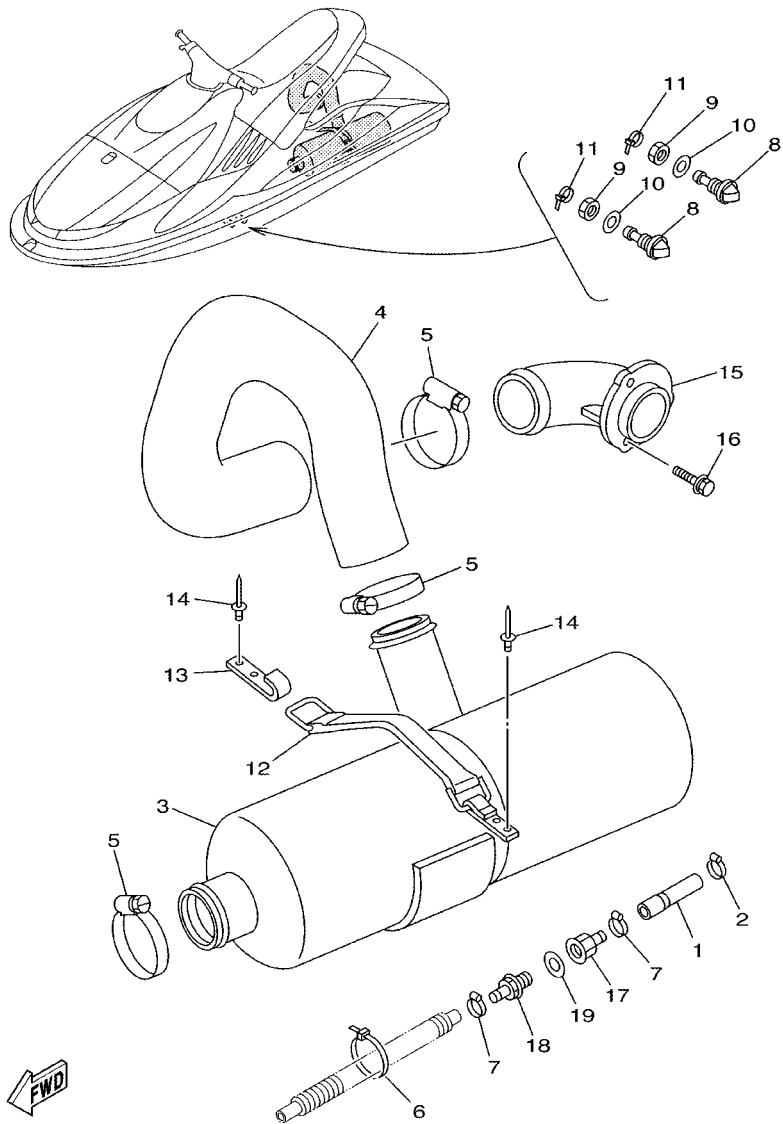

F0N2300-9230

FIG. 23 EXHAUST 2

REF. NO.	PART NO.	DESCRIPTION	F0N1	F0N2				REMARKS
1	67U-4383A-00	HOSE	1	1				
2	90450-18M09	HOSE CLAMP ASSY	1	1				
3	F0N-67550-00	WATER LOCK COMP.	1	1				
4	F0N-67555-00	HOSE, EXHAUST	1	1				
5	90601-17586	BAND, HOSE 75	3	3				
6	90601-20009	BAND	1	1				
7	90450-18M09	HOSE CLAMP ASSY	2	2				
8	GU0-6753B-00	PILOT, WATER	2	2				
9	GU0-61652-00	NUT	2	2				
10	92990-16200	WASHER, PLAIN	2	2				
11	90450-18M09	HOSE CLAMP ASSY	2	2				
12	F0E-67570-00	C HOOK COMP.	1	1				
13	GA7-65772-00	HOOK A	1	1				
14	90267-48938	RIVET, BLIND	4	4				
15	FJ0-67565-01	THRU-HULL, EXHAUST	1	1				
16	90119-05912	BOLT, WITH WASHER	3	3				
17	90604-80793	THROGUH-HULL CONNECTION 3/8	1	1				
18	90604-80794	THROGUH-HULL CONNECTION 3/8	1	1				
19	90430-16910	GASKET	1	1				

FIG. 24 CONTROL CABLE

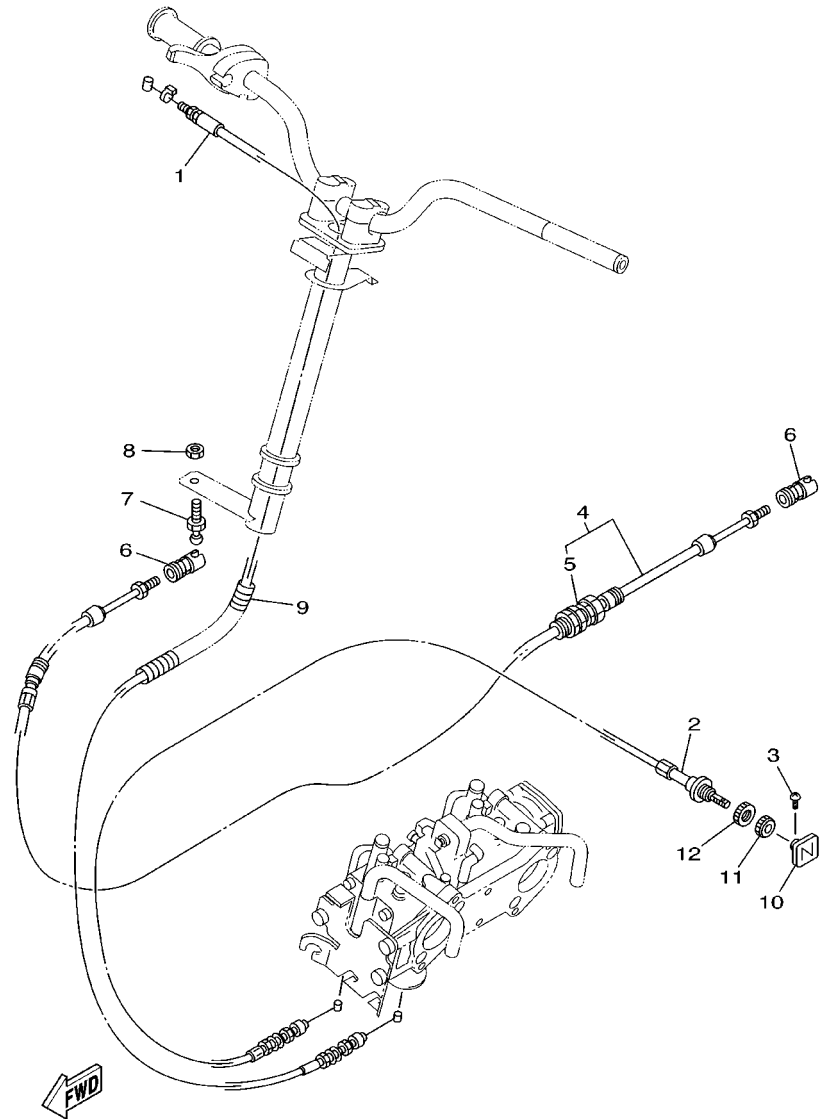

F0N2300-9240

REF. NO.	PART NO.	DESCRIPTION	F0N1	F0N2				REMARKS
1	67U-67252-00	CABLE, THROTTLE	1	1				
2	67U-67242-00	CABLE, CHOKE	1	1				
3	90149-03M15	SCREW	1	1				
4	F0N-61480-00	STEERING CABLE ASSY	1	1				
5	GK5-67267-00	.CONNECTOR, CABLE	1	1				
6	GK5-6146F-00	SHAFT, JOINT BALL	2	2				
7	EU0-61461-01	STOOD, JOINT BALL	1	1				
8	95720-06300	NUT, SELF-LOCKING	1	1				
9	90699-36085	SPIRAP 11	1	1				
10	EW2-67243-00	KNOB	1	1				
11	F0N-6724E-00	NUT, COMPRESSION	1	1				
12	F0N-6724F-00	NUT	1	1				

FIG. 25 STEERING 1

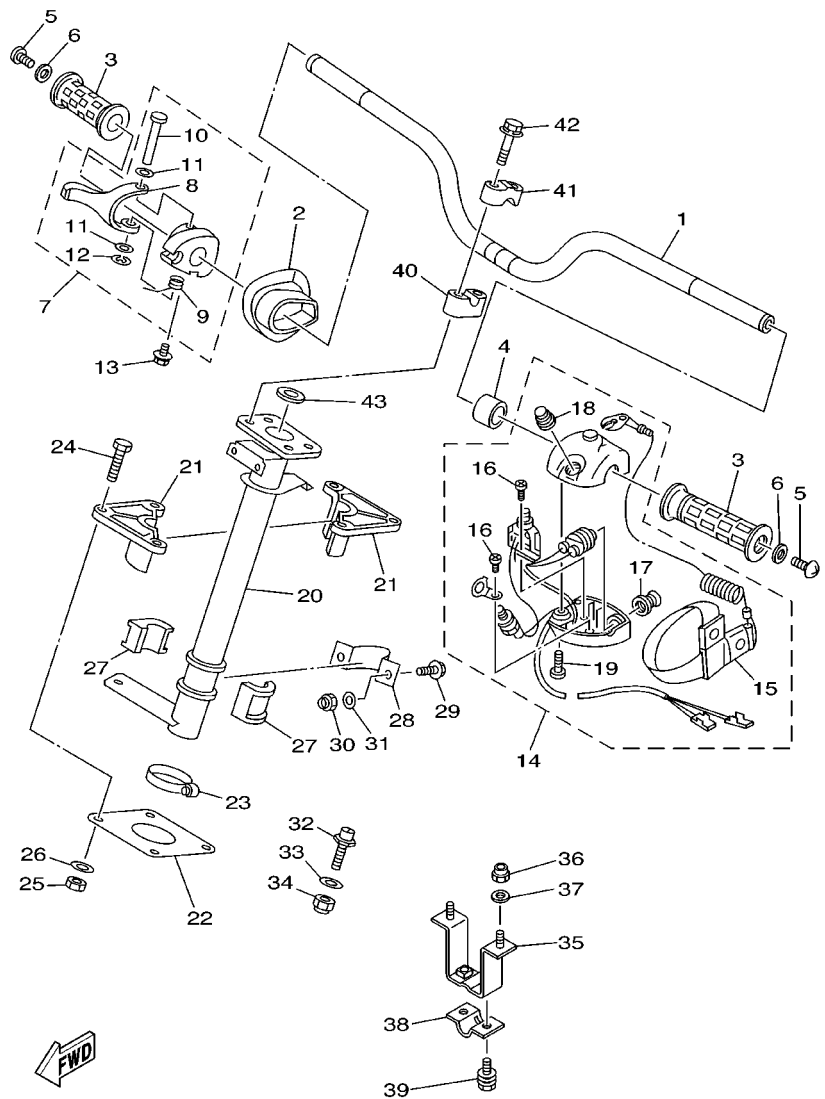

FON2300-9250

REF. NO.	PART NO.	DESCRIPTION	FON1	FON2				REMARKS
1	GK5-61552-02	HANDLE	1	1				
2	F0N-6143G-00	SPACER	1	1				
3	EW2-61553-00	GRIP, HANDLE 1	2	2				
4	90560-22281	SPACER	1	1				
5	90149-05959	SCREW	2	2				
6	90201-05928	WASHER, PLATE	2	2				
7	GJ1-67250-01	THROTTLE LEVER ASSY	1	1				
8	GJ1-67255-00	.LEVER, THROTTLE	1	1				
9	EW2-67256-00	.SPRING	1	1				
10	EW2-67257-01	.SHAFT	1	1				
11	EW2-67258-01	.WASHER	2	2				
12	EW2-67259-01	.E RING	1	1				
13	90159-05900	SCREW, WITH WASHER	1	1				
14	F0N-68310-00	SWITCH BOX ASSY	1	1				
15	GA7-6834C-00	.LANYARD, STOP SWITCH	1	1				
16	97880-03008	.SCREW, PAN HEAD	2	2				
17	FK7-68312-02	.STOP BUTTON COMP	1	1				
18	FK7-68313-01	.START BUTTON COMP	1	1				
19	97880-05025	.SCREW, PAN HEAD	2	2				
20	GK5-61541-01	COLUMN, STEERING	1	1				
21	GH1-6141B-00	BEARING, COLUMN	2	2				
22	GH1-6143C-30	SEAL, RUBBER	1	1				
23	90601-14271	BAND, HOSE	1	1				
24	97080-06030	BOLT	4	4				
25	95720-06300	NUT, SELF-LOCKING	4	4				
26	92990-06200	WASHER, PLAIN	4	4				
27	GH1-6141D-01	BEARING, STEERING	2	2				

FIG. 25 STEERING 1

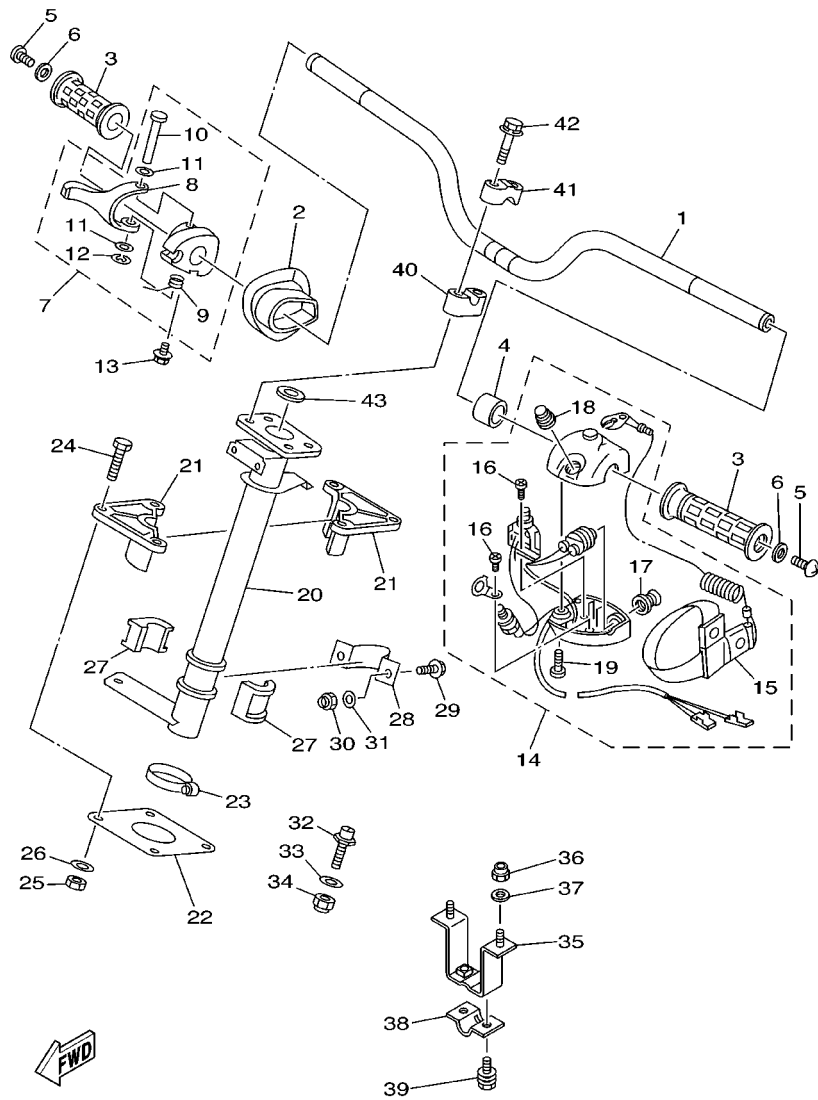

FON2300-9250

REF. NO.	PART NO.	DESCRIPTION	F0N1	F0N2				REMARKS
28	EU0-61588-00	JOINT, BEARING	1	1				
29	90119-08038	BOLT, WITH WASHER	2	2				
30	95720-08300	NUT, SELF-LOCKING	2	2				
31	92990-08200	WASHER, PLAIN	2	2				
32	FN8-6131B-00	PIN, STOPPER	2	2				
33	92990-10200	WASHER, PLAIN	2	2				
34	95720-10300	NUT	2	2				
35	F0N-61467-00	BRACKET, STOPPER CABLE	1	1				
36	95720-06300	NUT, SELF-LOCKING	2	2				
37	92990-06200	WASHER, PLAIN	2	2				
38	GK5-61468-00	STOPPER, CABLE	1	1				
39	90119-06950	BOLT, WITH WASHER	2	2				
40	EU0-23814-01	HOLDER, HANDLE LOWER	2	2				
41	EU0-23814-30	HOLDER, HANDLE UPPER	2	2				
42	90119-08925	BOLT, WITH WASHER	4	4				
43	GH1-61469-00	PACKING, STEERING COLUMN	1	1				

FIG. 26 STEERING 2

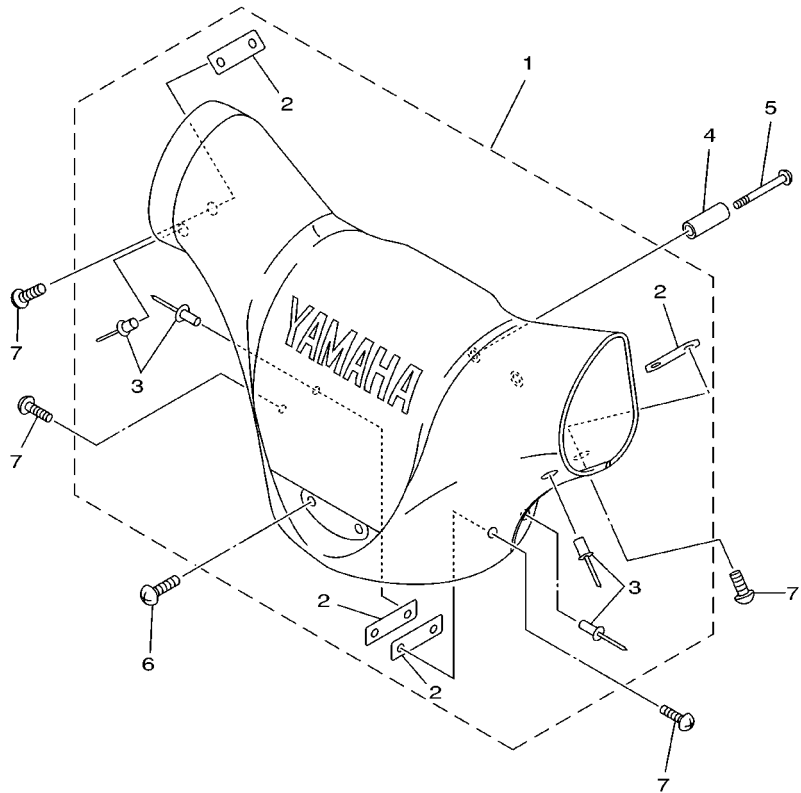

REF. NO.	PART NO.	DESCRIPTION	F0N1	F0N2	REMARKS
1	GK5-6142A-10	STEERING PAD COMP	1	1	
2	GA7-6144D-00	.PLATE	4	4	
3	90267-48934	.RIVET, BLIND	4	4	
4	90387-06921	COLLAR	2	2	
5	90149-05938	SCREW	2	2	
6	90149-05981	SCREW	2	2	
7	90149-04904	SCREW	4	4	



GK59100-8250

FIG. 27 GRAPHIC 1. TOOL

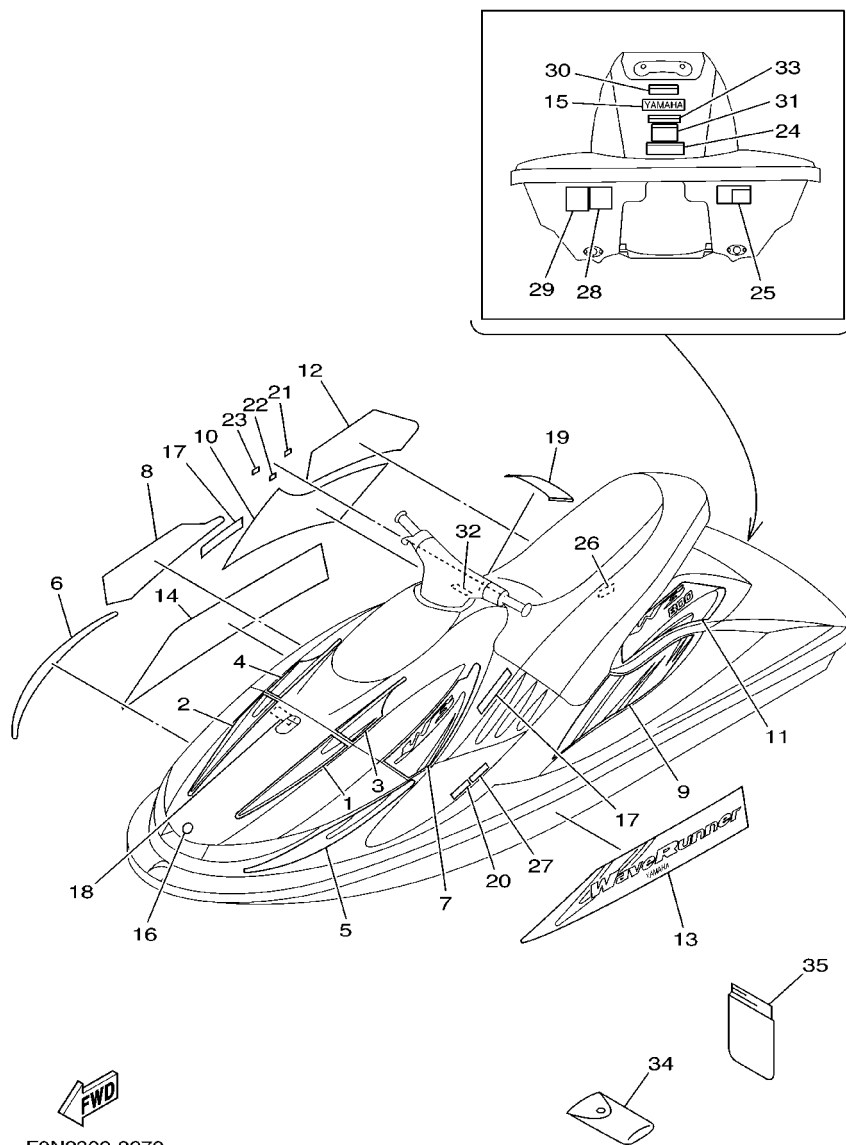

F0N2300-9270

REF. NO.	PART NO.	DESCRIPTION	F0N1	F0N2	REMARKS
1	F0N-6417B-00	GRAPHIC 1	1		
2	F0N-6417C-00	GRAPHIC 2	1		
3	F0N-6417D-00	GRAPHIC 3	1		
4	F0N-6417E-00	GRAPHIC 4	1		
5	F0N-6417F-00	GRAPHIC 5	1		
6	F0N-6417G-00	GRAPHIC 6	1		
7	F0N-6417H-00	GRAPHIC 7	1		
8	F0N-6417J-00	GRAPHIC 8	1		
9	F0N-6417K-00	GRAPHIC 9	1		
10	F0N-6417L-00	GRAPHIC B	1		
11	F0N-6417M-00	GRAPHIC C	1		
12	F0N-6417N-00	GRAPHIC D	1		
13	F0N-6417P-00	GRAPHIC E	1		
14	F0N-6417R-00	GRAPHIC F	1		
15	F0N-6417S-00	GRAPHIC G	1		
16	GM6-6411H-00	EMBLEM, TUNING FORK	1		
17	F0N-64123-00	EMBLEM,3	2		
18	GP7-6415B-00	LABEL, WARNING(FUEL)	1		
19	F0N-6416C-00	LABEL, WARNING 1	1		
20	GJ1-6416F-00	LABEL, WARNING 4	1		
21	F0N-6419C-00	LABEL 2	1		
22	F0N-6419C-10	LABEL 2	1		
23	F0N-6419C-20	LABEL 2	1		
24	GK5-6419D-10	LABEL,3	1		
25	GL3-6418G-00	LABEL, CAUTION	1		
26	GL3-6418B-00	LABEL, CAUTION	1		
27	GK5-6418J-10	LABEL,CAUTION	1		

FIG. 27 GRAPHIC 1. TOOL

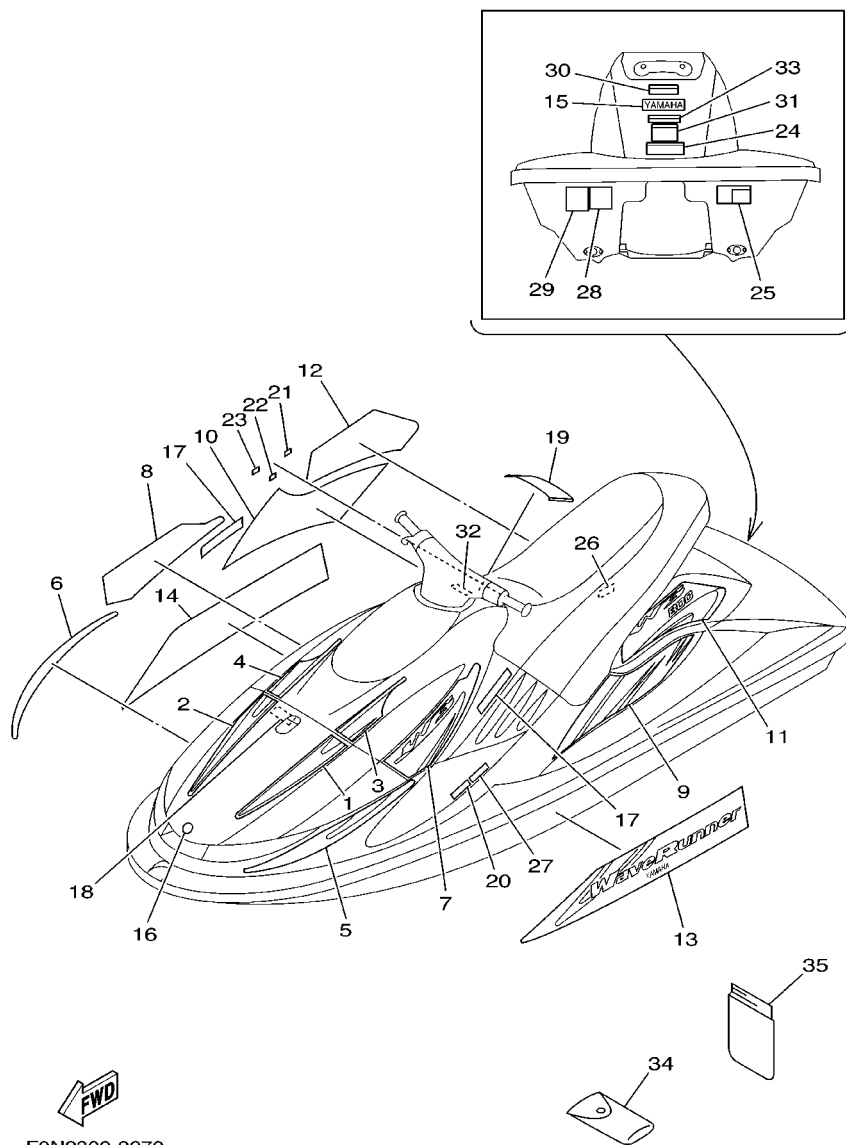

F0N2300-9270

REF. NO.	PART NO.	DESCRIPTION	F0N1	F0N2				REMARKS
28	GK5-6418F-00	LABEL,RIGHTING	1					
29	GL3-6415G-01	LABEL,WARNING 5	1					
30	GL3-6418C-00	LABEL, CAUTION	1					
31	EU0-64197-00	PLATE CAPACITY	1					
32	GK5-6415E-20	LABEL, WARNING	1					
33	GK5-6415F-20	LABEL, WARNING	1					
34	EU0-65986-00	TOOL SET	1					
35	EU0-65901-01	TOOL BAG	1					

FIG. 28 GRAPHIC 2. TOOL

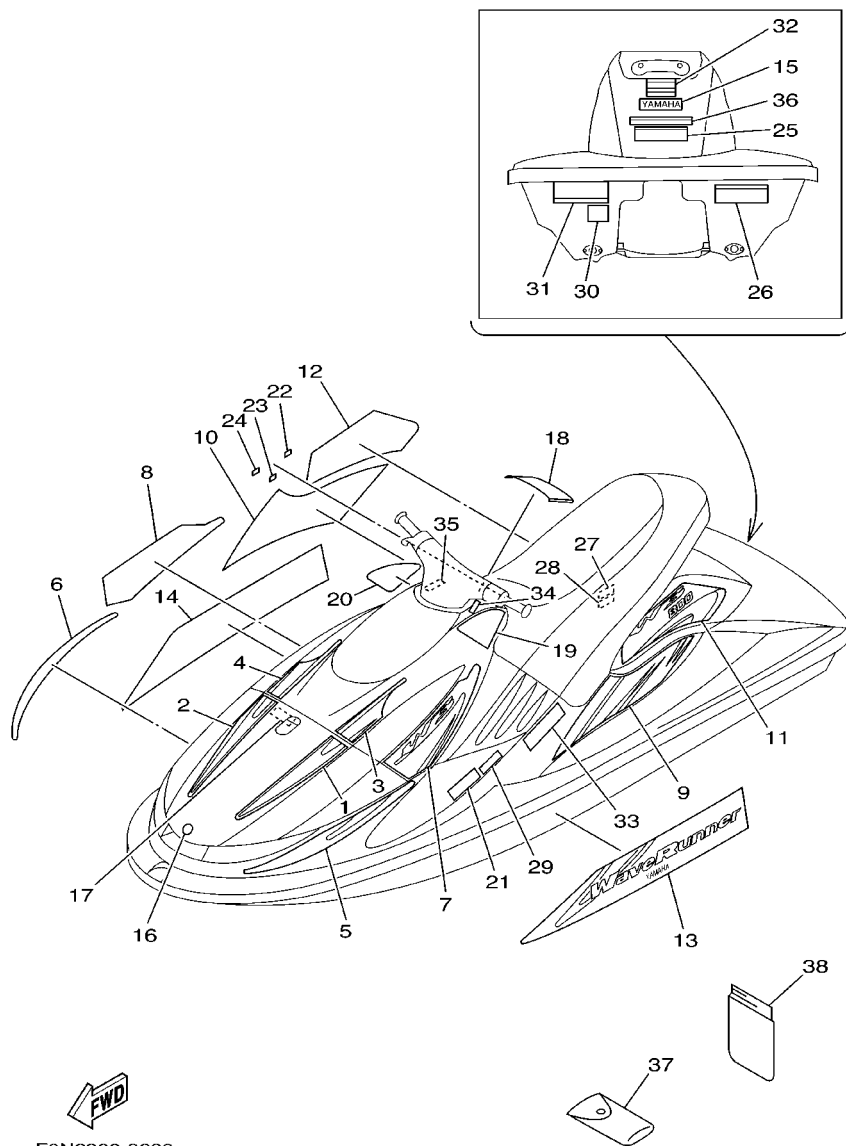

F0N2300-9280

REF. NO.	PART NO.	DESCRIPTION	F0N1	F0N2	REMARKS
1	F0N-6417B-00	GRAPHIC 1		1	
2	F0N-6417C-00	GRAPHIC 2		1	
3	F0N-6417D-00	GRAPHIC 3		1	
4	F0N-6417E-00	GRAPHIC 4		1	
5	F0N-6417F-00	GRAPHIC 5		1	
6	F0N-6417G-00	GRAPHIC 6		1	
7	F0N-6417H-00	GRAPHIC 7		1	
8	F0N-6417J-00	GRAPHIC 8		1	
9	F0N-6417K-00	GRAPHIC 9		1	
10	F0N-6417L-00	GRAPHIC B		1	
11	F0N-6417M-00	GRAPHIC C		1	
12	F0N-6417N-00	GRAPHIC D		1	
13	F0N-6417P-00	GRAPHIC E		1	
14	F0N-6417R-00	GRAPHIC F		1	
15	F0N-6417S-00	GRAPHIC G		1	
16	GM6-6411H-00	EMBLEM, TUNING FORK		1	
17	GK5-6416B-21	LABEL, WARNING		1	
18	F0N-6416C-10	LABEL, WARNING 1		1	
19	F0N-6416C-20	LABEL, WARNING 1		1	
20	F0N-6416C-30	LABEL, WARNING 1		1	
21	GK5-6416F-20	LABEL, WARNING 4		1	
22	F0N-6419C-00	LABEL 2		1	
23	F0N-6419C-10	LABEL 2		1	
24	F0N-6419C-20	LABEL 2		1	
25	GK5-6419D-20	LABEL,3		1	
26	GK5-6418G-20	LABEL, CAUTION		1	
27	GA7-6418B-00	LABEL,CAUTION		1	

FIG. 28 GRAPHIC 2. TOOL

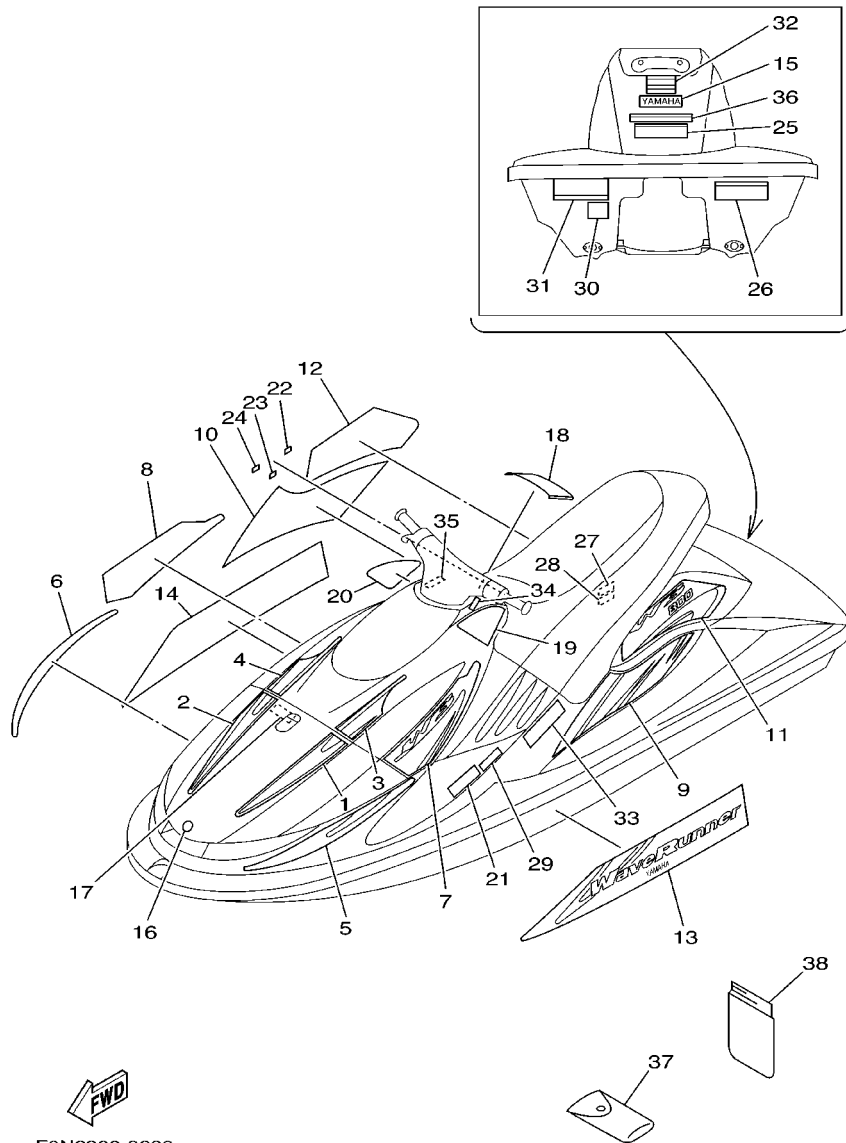

REF. NO.	PART NO.	DESCRIPTION	F0N1	F0N2	REMARKS
28	GA7-6418B-20	LABEL,CAUTION		1	
29	FJ0-6418J-A1	LABEL,CAUTION		1	
30	GK5-6418F-00	LABEL,RIGHTING		1	
31	GK5-6416G-20	LABEL,WARNING		1	
32	GK5-6418C-20	LABEL, CAUTION		1	
33	GK5-6416H-20	LABEL,WARNING(FRANCE)		1	
34	GK5-6415E-10	LABEL, WARNING		1	
35	GK5-6415E-30	LABEL, WARNING		1	
36	GK5-6415F-30	LABEL, WARNING		1	
37	EU0-65986-00	TOOL SET		1	
38	EU0-65901-01	TOOL BAG		1	

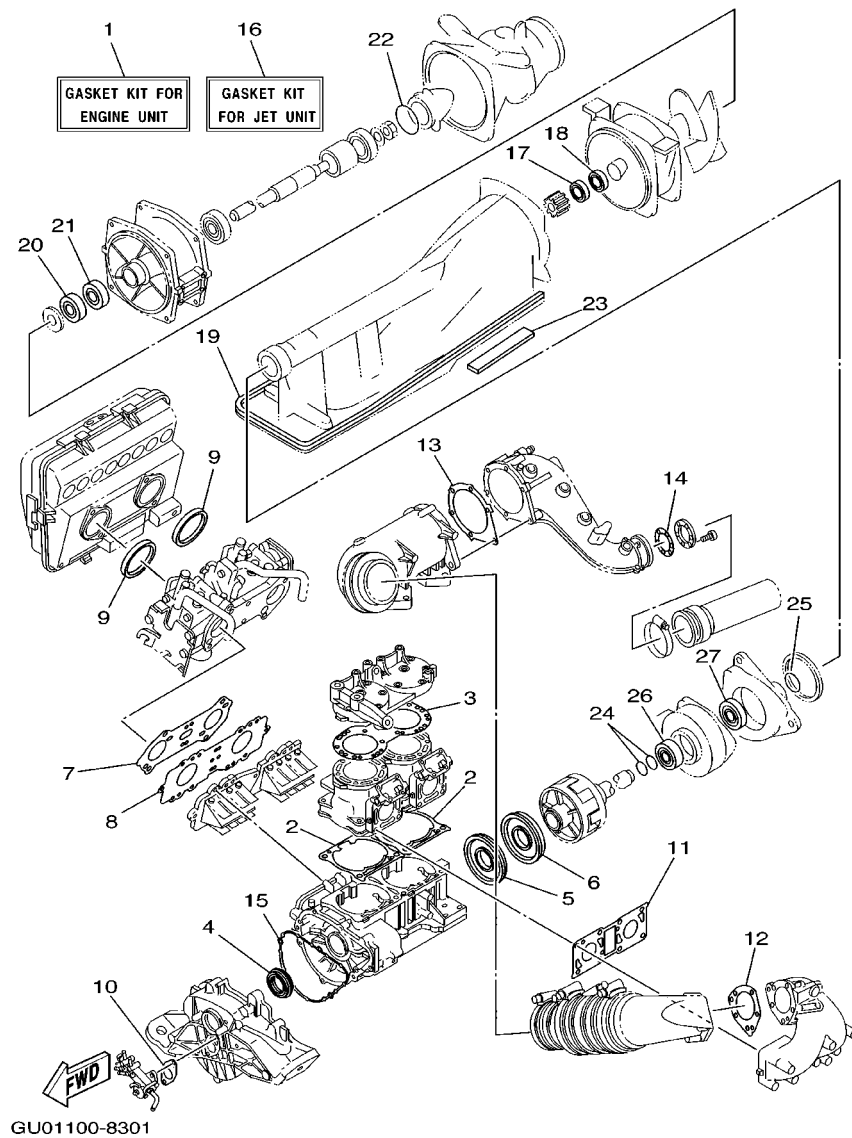
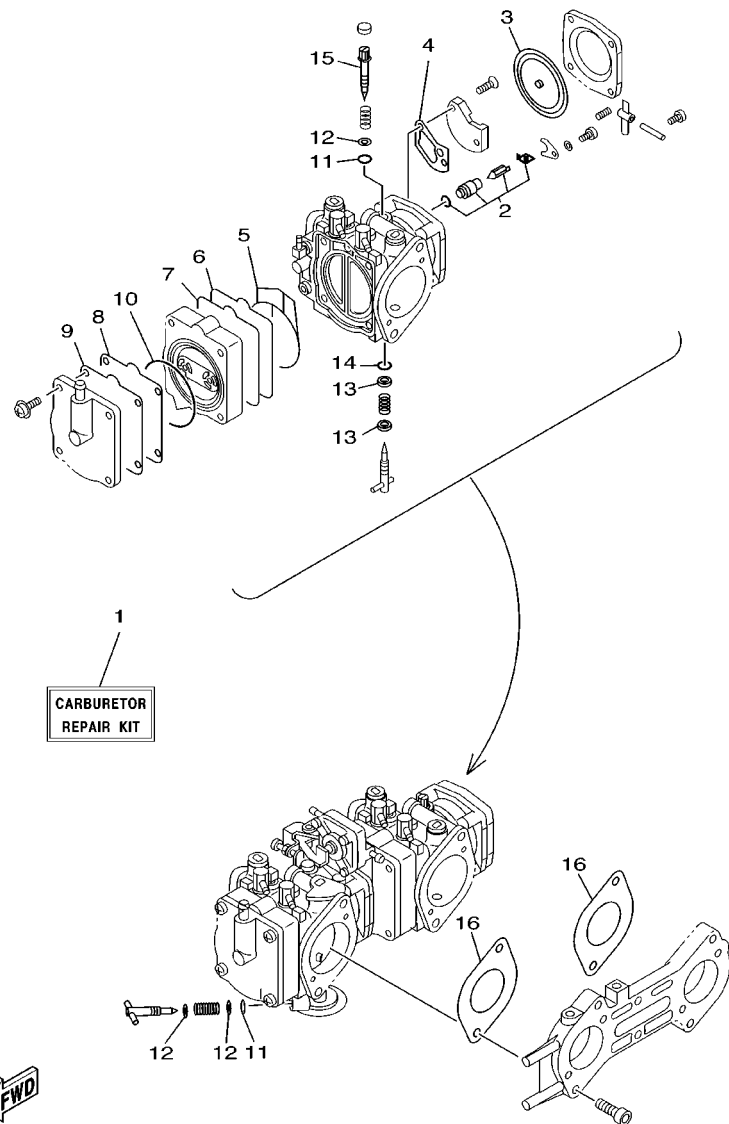

FIG. 29 REPAIR KIT 1

REF. NO.	PART NO.	DESCRIPTION	F0N1	F0N2	REMARKS
1	66E-W0001-00	GASKET KIT FOR ENGINE UNIT	1	1	
2	66E-11351-00	.GASKET, CYLINDER	2	2	
3	66E-11181-00	.GASKET, CYLINDER HEAD 1	1	1	
4	93103-35M03	.OIL SEAL	1	1	
5	93101-36M62	.OIL SEAL	1	1	
6	93101-36M61	.OIL SEAL	1	1	
7	66E-13556-00	.GASKET, MANIFOLD	1	1	
8	66E-13624-00	.PLATE, REED VALVE	1	1	
9	66E-13473-00	.O-RING	2	2	
10	63M-13116-00	.GASKET, PUMP CASE	1	1	
11	66E-14613-00	.GASKET, EXHAUST PIPE	1	1	
12	66E-14749-00	.GASKET, MUFFLER DAMPER 2	1	1	
13	66E-41124-10	.GASKET, EXHAUST OUTER COVER	1	1	
14	66E-14623-00	.GASKET, EXHAUST PIPE	1	1	
15	66E-81168-00	.O-RING	1	1	
16	66E-W0001-20	GASKET KIT FOR JET UNIT	1	1	
17	93102-17M49	.OIL SEAL	1	1	
18	93102-17M50	.OIL SEAL	1	1	
19	6R8-51367-01	.FELT, PACKING	2	2	
20	93102-25M34	.OIL SEAL	1	1	
21	93101-25M50	.OIL SEAL	1	1	
22	93210-46M16	.O-RING	1	1	
23	63N-51368-00	.FELT, PACKING	2	2	
24	93210-17MA4	.O-RING	2	2	
25	93210-35M72	.O-RING	1	1	
26	93101-25M55	.OIL SEAL	1	1	
27	93101-25M56	.OIL SEAL	1	1	

FIG. 30 REPAIR KIT 2



GU04100-9300

REF. NO.	PART NO.	DESCRIPTION	F0N1	F0N2	REMARKS
1	66E-W0093-00	CARBURETOR REPAIR KIT	1	1	
2	64T-14916-00	.NEEDLE	2	2	
3	6R7-14541-00	.DIAPHRAGM, PUMP	2	2	
4	6K8-14536-11	.GASKET	2	2	
5	66E-14563-00	.O-RING	2	2	
6	66E-24471-00	.DIAPHRAGM	2	2	
7	66E-24411-00	.DIAPHRAGM	2	2	
8	66E-24421-00	.VALVE, CHECK	2	2	
9	66E-24431-00	.GASKET, FUEL PUMP 1	2	2	
10	66E-14564-00	.O-RING	2	2	
11	812-14147-00	.O-RING	3	3	
12	812-14235-00	.WASHER, NEEDLE	4	4	
13	822-14235-00	.WASHER, NEEDLE	4	4	
14	583-14561-00	.O-RING	2	2	
15	6K8-14946-10	.METERING NEEDLE	2	2	
16	66E-14398-00	.GASKET	2	2	

NUMERICAL INDEX

PART NO.	GRID NO.	PART NO.	GRID NO.	PART NO.	GRID NO.	PART NO.	GRID NO.	PART NO.	GRID NO.	PART NO.	GRID NO.
66E-W0001-00	E - 5	63M-12590-10	B - 15	66E-14457-10	B - 8	66E-24314-00	B - 11	6K8-51129-00	B - 2	EU0-61652-00	B - 15
66E-W0001-20	E - 5	63M-12590-20	B - 15	6K8-14471-10	B - 10	66E-24315-00	B - 11		C - 5		B - 2
66E-W0004-00	B - 8	63M-13116-00	B - 12	66E-14480-10	B - 8	66E-24376-00	B - 11	62T-51129-00	C - 5		D - 4
66E-W0090-10-8P	B - 2		E - 5	6M6-14503-00	B - 10	66E-24377-00	B - 11	66E-51129-00	B - 13	GU0-61652-00	D - 10
66E-W0093-00	E - 6	63M-13132-00	B - 12	6K8-14523-11	B - 10	6E0-24378-00	B - 12		B - 2	E31-61749-00	C - 14
66E-11111-00-94	B - 2	65U-13132-00	B - 12	6K8-14527-11	B - 10	63M-24378-00	B - 12	66E-51142-00	B - 13	GH1-62127-00	D - 5
66E-11181-00	B - 2	6R3-13183-00	B - 12	6K8-14536-11	B - 9	66E-24378-00	B - 11	63M-51162-00	D - 2	F0N-6213F-10	D - 5
	E - 5	66E-13200-01	B - 12		E - 6	66E-24411-00	B - 9	63M-51165-00	D - 2	F0N-6213G-00	D - 5
66E-1131B-00	B - 4	66E-13469-00	B - 12	6R7-14541-00	B - 9		E - 6	64Y-51190-00-94	C - 5	F0N-6213K-00	D - 5
66E-1131C-10	B - 4	66E-13473-00	B - 8		E - 6	66E-24412-00	B - 10	65V-51311-01-94	C - 4	EW2-62140-00	D - 8
66E-1131H-00	B - 4		E - 5	6R7-14542-00	B - 9	66E-24413-00	B - 9	6R8-51312-03-94	C - 4	EW2-62142-00	D - 8
66E-1131J-10	B - 4	66E-13556-00	B - 8	6K8-14547-01	B - 9	66E-24421-00	B - 9	65V-51313-00	C - 5	GK5-62149-00	D - 5
66E-1131M-01-8P	B - 4		E - 5	583-14561-00	B - 10		E - 6	66E-51315-00-94	C - 4	GK5-6215E-00	D - 7
66E-1131S-02	B - 4	66E-13610-00	B - 8		E - 6	66E-24431-00	B - 9	67U-51318-00-94	C - 5	GJ3-6215F-00	D - 5
66E-1131V-00	B - 4	66E-13624-00	E - 5	66E-14563-00	B - 9		E - 6	66E-51321-B0	C - 5	GP7-62159-01	D - 5
66E-11311-00-94	B - 2	66E-13624-10	B - 8		E - 6	66E-24452-00	B - 9	66E-51323-00	C - 6	EU0-62241-30	B - 15
66E-1132C-00	B - 4	66E-13898-10	B - 8	66E-14564-00	B - 10	66E-24471-00	B - 9	62T-51326-00	C - 4	EU0-62280-00	D - 2
66E-11325-00	B - 4	4KM-14137-00	B - 10		E - 6		E - 6	63N-51333-02-94	C - 6	EU0-62282-00	D - 2
66E-1133E-10	B - 4	35H-14139-00	B - 10	6R7-14569-00	B - 9	70R-24489-00	D - 8	62T-51348-00-5B	C - 5	EU0-62283-00	D - 2
66E-1133F-10	B - 4	66E-14146-00	B - 10	6K8-14589-00	B - 10	65U-24500-00	C - 2	65V-51348-01-94	C - 4	EU0-62285-01	D - 2
66E-11351-00	E - 5	8F2-14147-00	B - 9	3CF-14594-00	B - 9	6K8-24524-10	C - 2	6R8-51367-01	C - 4	GK5-62501-20	D - 4
66E-11351-01	B - 2	812-14147-00	B - 10	66E-14613-00	B - 13	70R-24543-00	D - 8		E - 5	GK5-6251D-20	D - 4
66E-11400-00	B - 6		E - 6		E - 5	6K8-24560-10	C - 2	63N-51368-00	C - 6	GK5-6251E-20	D - 4
66E-11412-00	B - 6	7EG-14159-00	B - 9	66E-14615-00	B - 13	66E-26320-00	B - 12		E - 5	F0N-6252C-00	D - 4
66E-11422-00	B - 6	66E-14162-00	B - 10	66E-14623-00	B - 15	66E-41123-10-94	B - 14	66E-51381-01	C - 5	F0N-6252D-00	D - 4
66E-11431-00	B - 6	439-14186-00	B - 10		E - 5	66E-41124-10	B - 14	67U-51387-00-94	C - 5	F0N-62552-00	D - 4
66E-11442-00	B - 6	66E-14211-00	B - 10	66E-14625-00	B - 13		E - 5	62E-51673-00	C - 5	F0N-62553-00	D - 4
66E-11515-00	B - 6	66E-14218-00	B - 9	66E-14711-10-8P	B - 13	66E-41217-00	B - 10	61L-5169A-00	B - 14	GK5-62576-20	D - 4
66E-11603-01	B - 6	3G2-14231-30	B - 9	66E-14712-10-8P	B - 13	6R7-42316-00	C - 5	63M-5316M-00	D - 2	F0N-6266B-00	D - 6
66E-11631-00-A0	B - 6	830-14231-18	B - 10	66E-14721-10-94	B - 14	66E-42414-00	C - 4	FN8-6131B-00	D - 13	F0N-6266D-00	C - 15
66E-11631-00-B0	B - 6	812-14235-00	B - 10	66E-14749-00	B - 13	66E-42717-00	B - 8	GH1-6141B-00	D - 12	F0N-62664-00	C - 14
66E-11631-00-C0	B - 6		E - 6		E - 5	67U-4383A-00	D - 10	GH1-6141D-01	D - 12	FN8-6269B-00	D - 2
66E-11631-00-D0	B - 6	822-14235-00	B - 10	66E-14752-10	B - 15	6M6-44517-A1-5B	B - 3	GK5-6142A-10	D - 14	GA7-6271B-10	D - 6
66E-11633-00	B - 6		E - 6	66E-14763-10-94	B - 15	66E-44532-00	B - 3	GH1-6143C-30	D - 12	GH1-6273B-01	C - 7
66E-11634-00	B - 6	66E-14243-00	B - 10	66E-14771-01-94	B - 15	663-45119-00	B - 14	F0N-6143G-00	D - 12	FX1-62733-00	C - 7
66E-11651-00	B - 6	62T-14251-10	B - 2	66E-14781-10-94	B - 2	6K8-45127-00	C - 6	GA7-6144D-00	D - 14	FJ0-6284F-00	C - 13
66E-11685-00	B - 6	6R7-14253-00	B - 9	66E-14791-00-94	B - 14	66E-45214-00-94	C - 4	GK5-6146F-00	D - 11	FJ0-62840-02	C - 13
66E-11832-00	B - 4	66E-14275-00	B - 9	64T-14916-00	B - 9	65V-45318-00	C - 4	EU0-61461-01	D - 11	F0N-62843-00	C - 13
66E-11998-10	B - 4	66E-14291-00	B - 10		E - 6	62G-45331-01-94	C - 6	F0N-61467-00	D - 13	FN8-62884-00	C - 13
66E-12576-00	B - 13	3XP-14294-00	B - 11	66E-14930-00	B - 9	65U-45332-02-94	C - 6	GK5-61468-00	D - 13	GH1-62891-01	C - 13
66E-12577-00	B - 14	67U-14301-00	B - 9	3KW-14932-00	B - 10	61L-45378-00	C - 6	GH1-61469-00	D - 13	GK5-62892-00	C - 13
66E-12578-00	B - 15	67U-14302-00	B - 9	6K8-14946-10	B - 10	66E-45511-10	C - 4	F0N-61480-00	D - 11	F0N-6351H-00	D - 4
66E-12579-00	B - 14	66E-14398-00	B - 10		E - 6	65V-45538-00	C - 4	GK5-61541-01	D - 12	F0N-6351J-00	D - 4
63M-12580-00	B - 15		E - 6	66E-15100-10-8P	B - 2	66E-45593-10-94	B - 6	GK5-61552-02	D - 12	F0N-6351K-00	D - 4
63M-12581-00	B - 14	66E-1441E-00	B - 8	66E-21425-10-8P	B - 2	66E-4581J-00	B - 6	EW2-61553-00	D - 12	F0N-6351M-00	D - 4
	B - 15	66E-14435-00	B - 8	66E-21426-10-8P	B - 3	66E-45813-10-94	B - 6	EU0-61588-00	D - 13	GH1-6354D-60	D - 4
67U-12588-00	B - 2	66E-14451-00	B - 8	EU0-23814-01	D - 13	66E-46882-00	C - 4	F0D-61624-01	D - 3	F0N-6358F-00	D - 4
67U-12589-00	B - 13	66E-14452-00	B - 8	EU0-23814-30	D - 13	6K8-51129-00	B - 13	FN8-61651-00	D - 4	F0N-6358G-00	D - 4

NUMERICAL INDEX

PART NO.	GRID NO.	PART NO.	GRID NO.	PART NO.	GRID NO.	PART NO.	GRID NO.	PART NO.	GRID NO.	PART NO.	GRID NO.
F0N-6358H-00	D - 4	F0N-6417L-00	D - 15	GA7-65772-00	D - 10	FN8-67714-02	D - 8	6M6-81844-00	C - 10	90110-04M03	B - 4
F0N-6358J-00	D - 4		E - 3	EU0-65901-01	E - 2	F0N-67743-00	D - 9	1FK-81847-00	C - 9	90116-06M67	B - 4
F0N-6371A-00	D - 6	F0N-6417M-00	D - 15		E - 4	GH1-6775B-00	D - 7	6M6-81850-00	C - 9	90116-08M64	B - 14
F0N-6371B-00	D - 6		E - 3	F0N-6591C-00	C - 15	GH1-6775C-00	D - 7	6M6-81865-00	C - 9	90116-10M65	B - 14
GK5-63729-00	D - 6	F0N-6417N-00	D - 15	FJ0-65911-01	C - 15	FJ0-67766-00	D - 7	6M6-81866-00	C - 9	90116-10M66	B - 14
GA7-63768-00	C - 13		E - 3	EU0-65986-00	E - 2	EU0-67767-31	D - 8	66E-81921-00	C - 10	90119-05912	D - 10
F0N-6377B-00	C - 14	F0N-6417P-00	D - 15		E - 4	FN8-67816-00	C - 2	6G1-81941-10	C - 10	90119-06M13	B - 2
F0N-6377C-00	C - 14		E - 3	F0N-6724E-00	D - 11	EU0-67817-00	C - 2	6M6-81952-01	C - 10	90119-06M78	B - 2
GU3-63774-00	D - 6	F0N-6417R-00	D - 15	F0N-6724F-00	D - 11	FN8-67831-01	D - 9	63M-81960-00	C - 10	90119-06900	C - 13
F0N-6378C-00	D - 6		E - 3	67U-67242-00	D - 11	EU0-67832-00	D - 9	EU0-82110-09	C - 12	90119-06901	C - 13
GH1-63850-03	D - 6	F0N-6417S-00	D - 15	EW2-67243-00	D - 11	FN8-67833-00	D - 9	6M6-82117-21	C - 11	90119-06908	C - 15
GM6-6411H-00	D - 15		E - 3	GD0-67249-00-05	C - 7	EU0-67834-00	D - 9	61L-82117-00	C - 11	90119-06914	D - 6
	E - 3	GA7-6418B-00	E - 3	GD0-67249-00-10	C - 7	EU0-67835-00	D - 9	66E-82117-10	C - 11	90119-06920	C - 12
F0N-64123-00	D - 15	GA7-6418B-20	E - 4	GJ1-67250-01	D - 12	EU0-67839-00	D - 9	66E-82150-00	C - 10	90119-06947	C - 6
GP7-6415B-00	D - 15	GL3-6418B-00	D - 15	67U-67252-00	D - 11	GE2-6784A-00	D - 7	6G1-82151-00	C - 10	90119-06950	D - 13
GK5-6415E-10	E - 4	GK5-6418C-20	E - 4	GJ1-67255-00	D - 12	FJ0-67841-01	D - 7	6K8-82159-00	C - 10	90119-08M18	C - 8
GK5-6415E-20	E - 2	GL3-6418C-00	E - 2	EW2-67256-00	D - 12	F0N-67844-00	D - 9	62E-82371-11	C - 10	90119-08M55	B - 2
GK5-6415E-30	E - 4	GH1-6418D-01	D - 8	EW2-67257-01	D - 12	EU0-67869-00	D - 9	66E-82553-00	C - 11		C - 8
GK5-6415F-20	E - 2	GK5-6418F-00	E - 2	EW2-67258-01	D - 12	F0M-6820A-10	C - 12	67U-82560-00	C - 11	90119-08M56	B - 2
GK5-6415F-30	E - 4		E - 4	EW2-67259-01	D - 12	EW2-68211-00	C - 12	6R7-83623-40	C - 10	90119-08M61	B - 2
GL3-6415G-01	E - 2	GK5-6418G-20	E - 3	GK5-67267-00	D - 11	EU0-68218-04	C - 12	6R7-83623-50	C - 10	90119-08M62	B - 2
GK5-6416B-21	E - 3	GL3-6418G-00	D - 15	EU0-67324-00	B - 3	EU0-68221-00	C - 12	63N-83623-00	C - 10	90119-08038	D - 13
F0N-6416C-00	D - 15	FJ0-6418J-A1	E - 4	EU0-67354-00-01	B - 3	EU0-68221-30	C - 12	682-84385-01	B - 15	90119-08904	B - 3
F0N-6416C-10	E - 3	GK5-6418J-10	D - 15	EU0-67354-00-02	B - 3	F0M-68238-00	C - 12	66E-85112-00-94	B - 4		C - 7
F0N-6416C-20	E - 3	F0N-6419C-00	D - 15	EU0-67354-00-03	B - 3	GH1-6824C-00	C - 12	66E-85510-00	C - 8	90119-08925	D - 13
F0N-6416C-30	E - 3		E - 3	EU0-67354-00-05	B - 3	GU0-6824E-00	B - 4	66E-8552A-00-94	C - 10	90119-08953	C - 7
GJ1-6416F-00	D - 15	F0N-6419C-10	D - 15	EU0-67354-00-10	B - 3	GK5-68244-00	C - 12	66E-8552E-00	C - 10	90119-08954	D - 9
GK5-6416F-20	E - 3		E - 3	EU0-67354-00-20	B - 3	F0N-68310-00	D - 12	66E-85540-00	C - 10	90119-08955	C - 6
GK5-6416G-20	E - 4	F0N-6419C-20	D - 15	EW2-67354-00-01	C - 6	FK7-68312-02	D - 12	64X-85546-00	C - 10	90119-08957	C - 10
GK5-6416H-20	E - 4		E - 3	EW2-67354-00-03	C - 6	FK7-68313-01	D - 12	66E-85550-00	C - 8		C - 7
F0N-6417B-00	D - 15	GK5-6419D-10	D - 15	EW2-67354-00-05	C - 6	GA7-6834C-00	D - 12	64X-85570-01	C - 10	90119-08960	B - 3
	E - 3	GK5-6419D-20	E - 3	EW2-67354-00-10	C - 6	F0N-6883N-00	D - 3	66E-85820-10	B - 5	90119-10M00	B - 14
F0N-6417C-00	D - 15	F0N-64194-00	D - 6	GU0-6753B-00	D - 10	F0N-6883P-00	D - 3	66E-85825-00	B - 5		B - 2
	E - 3	F0N-64195-00	D - 6	F0N-67550-00	D - 10	F0N-6883T-00	D - 3	90101-06M04	C - 5	90119-10M07	B - 2
F0N-6417D-00	D - 15	EU0-64197-00	E - 2	F0N-67555-00	D - 10	66E-81168-00	C - 8	90101-06M25	B - 10	90119-10M10	B - 14
	E - 3	F0N-64742-00	D - 6	FJ0-67565-01	D - 10		E - 5	90105-08M66	B - 13	90119-10958	C - 6
F0N-6417E-00	D - 15	F0N-6476A-00-5D	C - 15	F0E-67570-00	D - 10	65U-81317-10	C - 11	90105-08M83	B - 13	90149-03M15	D - 11
	E - 3	F0N-6515N-00	C - 14	GK5-67577-00	B - 15	6M6-8132W-00	C - 10		B - 14	90149-04904	D - 14
F0N-6417F-00	D - 15	F0N-6516B-00	C - 13	F0N-6759B-00	D - 9	66E-81328-00	C - 8	90105-08M84	B - 13	90149-05918	C - 15
	E - 3	F0N-6516C-00	C - 13	GH1-6759B-00	D - 9	66E-81337-10-8P	C - 8	90105-08M86	B - 8	90149-05919	C - 14
F0N-6417G-00	D - 15	F0N-6516N-00-5D	C - 13	GH1-6759C-00	D - 9	63M-81800-00	C - 9	90105-10M82	B - 14	90149-05938	D - 14
	E - 3	GP7-6517C-00	C - 15	GH1-6759D-00	D - 7	3AJ-81809-00	C - 9	90105-10M85	B - 13	90149-05946	D - 5
F0N-6417H-00	D - 15	F0N-6517D-00	C - 15	GD0-6761D-00	D - 2	6M6-81826-00	C - 9	90105-10M86	B - 13	90149-05959	D - 12
	E - 3	GP7-6517F-10	C - 15	FJ0-67618-00	D - 2	6M6-8183E-00	C - 9	90109-05MA0	C - 10	90149-05960	C - 15
F0N-6417J-00	D - 15	GK5-6517G-01	C - 13	F0E-677H0-00	D - 8	6M6-81830-00	C - 9	90109-05M95	B - 4	90149-05981	D - 14
	E - 3	F0N-6517P-00	C - 15	FN8-6771K-00	D - 9	63M-81830-00	C - 9	90109-06M00	B - 8	90149-06973	D - 6
F0N-6417K-00	D - 15	F0N-6517U-00	C - 15	GH1-67711-01	D - 8	6M6-81840-10	C - 9	90109-06M92	B - 3	90157-05M17	B - 9
	E - 3	GK5-65193-00	C - 14	FJ0-67713-00	D - 8	11H-81844-00	C - 9	90109-10M72	C - 8	90159-05900	D - 12

NUMERICAL INDEX

PART NO.	GRID NO.	PART NO.	GRID NO.	PART NO.	GRID NO.	PART NO.	GRID NO.	PART NO.	GRID NO.	PART NO.	GRID NO.
90170-22M11	C - 2	90387-06921	D - 14	90450-14M05	B - 2	90601-16274	D - 9	92990-10200	D - 13	93410-08M12	B - 4
90179-05633	C - 14	90387-08M06	C - 5		C - 5	90601-17586	D - 10		D - 6	93430-47M04	C - 6
90179-06959	D - 3	90387-08M08	C - 5	90450-18M09	B - 13	90601-20005	D - 2	92990-10600	B - 14	93440-25M08	C - 9
90179-10972	C - 7	90430-13909	D - 3		B - 14	90601-20006	B - 12		C - 12	93450-18M06	C - 9
90180-06900	C - 12	90430-16910	D - 10		B - 15		C - 10		C - 7	93606-12019	B - 13
	C - 7	90445-07M25	B - 12		D - 10		C - 12	92990-14600	C - 6		B - 14
90180-08907	D - 9	90445-07M42	B - 11	90450-22M14	B - 13		C - 2		D - 9		B - 2
90180-08912	C - 6	90445-07M78	B - 11		B - 15		C - 3	92990-16200	D - 10		B - 3
90190-06006	C - 13	90445-07M79	B - 11	90450-99M02	B - 13		D - 3	92990-16600	C - 4		C - 4
90201-05M09	C - 8	90445-07M82	B - 12	90450-99M18	B - 13		D - 8	92991-08100	B - 9		C - 5
90201-05928	D - 12	90445-09M17	B - 14	90460-90M11	B - 15	90601-20009	C - 12	92995-06100	C - 11		C - 6
90201-06M31	C - 5	90445-10MG8	C - 2	90464-06M29	C - 10		C - 2	92995-06600	B - 12	93606-19M23	B - 8
90201-065F3	B - 4	90445-10MG9	C - 2	90464-07M20	B - 12		D - 10		C - 4	93608-16M16	C - 8
	D - 3	90445-10MHO	B - 11	90465-11M10	B - 12	90601-20027	D - 5	92995-08600	C - 5	94702-00204	C - 11
	D - 6	90445-10MH1	B - 11		B - 14	90604-80759	D - 3	93101-25M50	C - 4	94709-00204	C - 11
90201-08M09	B - 4	90445-10MH2	B - 11		B - 8	90604-80775	D - 3		E - 5	95317-16700	C - 4
90201-08929	C - 7	90445-10MH3	B - 11		C - 11	90604-80793	D - 10	93101-25M55	C - 6	95333-08600	B - 14
90201-22M04	B - 6	90445-10MH4	B - 11		C - 2	90604-80794	D - 10		E - 5	95380-06700	C - 5
90201-24M02	B - 7	90445-10MH5	B - 11		D - 2	90604-80798	B - 15	93101-25M56	C - 6		C - 9
90204-06M01	B - 10	90445-10MH6	C - 2		D - 5	90605-50201	C - 15		E - 5		D - 3
90267-40935	D - 9	90445-11M72	B - 12		D - 7	90699-36085	D - 11	93101-36M61	B - 6	95380-10600	B - 14
90267-48007	B - 12	90445-11900	D - 8		D - 8	90699-50004	D - 8		E - 5		C - 12
	C - 12	90445-14M40	D - 2		D - 9	90699-50050	D - 8	93101-36M62	B - 6		C - 7
	C - 2	90445-18M02	B - 15	90465-12M53	C - 10	90699-50090	C - 12		E - 5	95380-14600	C - 6
	D - 5	90445-19M09	D - 2	90465-12M56	B - 13	90699-50100	D - 8	93102-17M49	C - 4	95380-14700	C - 6
	D - 8	90445-19M10	D - 2		C - 10	91318-06014	C - 8		E - 5		D - 9
90267-48925	D - 2	90446-07M14	B - 12	90465-13M11	D - 2	91318-06030	C - 8	93102-17M50	C - 4	95382-06700	B - 9
	D - 5	90446-07M96	B - 11	90465-13M36	B - 13	91490-16010	D - 9		E - 5	95720-05300	C - 12
90267-48931	C - 13	90446-07M97	B - 11		C - 10	91790-05040	D - 8	93102-25M34	C - 4		C - 13
	C - 14	90446-10MA0	B - 11	90465-20M78	B - 13	92903-06600	B - 8		E - 5		C - 15
90267-48932	C - 12	90446-10MA1	B - 11	90467-08M10	C - 12		C - 9	93103-35M03	B - 6		D - 5
	C - 15	90446-10MA2	B - 11	90467-11032	D - 8	92990-04600	C - 2		E - 5	95720-06300	C - 13
	C - 2	90446-14M98	B - 11	90480-06M43	C - 11	92990-05200	C - 15	93109-08M07	B - 4		C - 14
	D - 4	90446-14M99	B - 11	90480-06M46	C - 4		D - 2	93210-17MA4	C - 6		D - 11
	D - 8	90446-17ME5	B - 12		C - 5		D - 5		E - 5		D - 12
90267-48934	C - 15		C - 2	90480-14023	B - 5	92990-05600	D - 9	93210-22ME5	D - 2		D - 13
	D - 14	90446-17MF9	C - 2	90501-14M73	C - 9	92990-06100	C - 9	93210-35M72	C - 6		D - 6
90267-48938	D - 10	90446-20M65	B - 13	90560-22281	D - 12	92990-06200	C - 13		E - 5	95720-08300	B - 5
90267-48940	C - 13	90446-24ME7	B - 2	90600-91736	B - 12		C - 14	93210-46M16	C - 4		C - 7
	C - 15	90446-24M52	B - 15		C - 12		D - 12		E - 5		D - 13
	C - 2	90446-24M79	B - 4		C - 2		D - 13	93305-307U0	B - 6		D - 3
	D - 8	90446-24M89	B - 15		D - 2		D - 3	93306-205U0	C - 4	95720-10300	D - 13
90267-48953	D - 6	90446-27MF2	C - 2		D - 5		D - 6	93306-205U6	C - 6		D - 6
90267-48957	B - 7	90446-27M55	D - 2		D - 8	92990-06600	C - 11	93306-208U1	B - 6	95780-06300	B - 4
90280-05013	C - 8	90446-27M73	D - 2	90600-91755	D - 2	92990-08200	B - 4	93306-304U1	C - 4	97080-06030	D - 12
90380-12M29	B - 2	90446-27M95	B - 15	90601-11062	D - 8		D - 13	93306-308U1	B - 6	97095-06016	C - 11
	C - 8	90450-14M05	B - 13	90601-14271	D - 12		D - 3	93310-422U2	B - 6	97095-06020	B - 12
90387-06M05	C - 11		B - 14	90601-15573	D - 9	92990-08600	B - 14	93310-627U6	B - 6	97095-06045	C - 4

NUMERICAL INDEX

PART NO.	GRID NO.	PART NO.	GRID NO.	PART NO.	GRID NO.	PART NO.	GRID NO.	PART NO.	GRID NO.	PART NO.	GRID NO.
97095-08018	C - 5										
97513-05514	C - 8										
97513-06525	B - 4										
	B - 8										
97513-06545	B - 8										
97513-08525	C - 9										
97513-08530	B - 3										
97513-08545	B - 2										
97513-10550	B - 15										
97595-06512	C - 10										
97595-06518	C - 6										
97595-06520	C - 5										
97595-06525	C - 4										
97595-06535	B - 8										
	C - 5										
97595-08520	C - 5										
97595-08525	C - 6										
97780-50114	C - 15										
	D - 2										
97780-50520	D - 2										
97780-60425	C - 11										
97880-03008	D - 12										
97880-04010	C - 2										
97880-05025	D - 12										
97880-06030	C - 11										
97890-05014	B - 10										
97980-06216	C - 11										
97985-06216	B - 15										
98780-05020	B - 4										
98780-06025	C - 13										

CONTENTS

CYLINDER. CRANKCASE 1	B2
CYLINDER. CRANKCASE 2	B4
CRANKSHAFT. PISTON	B6
INTAKE	B8
CARBURETOR	B9
OIL PUMP	B12
EXHAUST 1	B13
FUEL	C2
JET UNIT 1	C4
JET UNIT 2	C6
GENERATOR	C8
STARTING MOTOR	C9
ELECTRICAL 1	C10
ELECTRICAL 2	C12
ENGINE HATCH 1	C13
ENGINE HATCH 2	C15
HULL. DECK	D2
GUNWALE. MAT	D4
VENTILATION	D5
SEAT. UNDER LOCKER	D6

OIL TANK	D7
FUEL TANK	D8
EXHAUST 2	D10
CONTROL CABLE	D11
STEERING 1	D12
STEERING 2	D14
GRAPHIC 1. TOOL	D15
GRAPHIC 2. TOOL	E3
REPAIR KIT 1	E5
REPAIR KIT 2	E6

INDEX

NUMERICAL INDEX	M1
-----------------------	----