



PARTS CATALOGUE

WaveRunner XLT800

XA800A-C (F1F7/60GG/60G1)

XA800A-C (F1F8/60GH/60G1)

XA800A-C
PARTS CATALOGUE
©2003 by Yamaha Motor Co., Ltd.
1st edition, July 2003
All rights reserved.
Any reprinting or unauthorized use
without the written permission of
Yamaha Motor Co., Ltd.
is expressly prohibited.
Printed in Japan.

A3



A4

FOREWORD

This Parts Catalogue is related to the parts for the model(s) on the cover page. When you are ordering replacement parts, please refer to this Parts Catalogue and quote both part numbers and part names correctly.

1. Modifications or additions which have been made after the issue of the Parts Catalogue will be announced in the Parts News.

It is advisable that you make the necessary corrections to the Parts Catalogue according to the Parts News.

2. Abbreviations

The following abbreviations are used in this Parts Catalogue.

“UR” Use specified parts number.

“UN” Use as many as needed.

“AP” Alternate Parts

“LM” Locally Made (Parts need to be ordered locally)

“F#” Frame No. (Applicable machine No.)

“O/S” Over Size

3. The number of components for assembly

- Parts, which are to be supplied in an assembly, are listed with a dot (.) in front of the part name as shown below.
- The numeral appearing to the right of each component part indicates the quantity of parts for each assembly unit.

PART NO.	DESCRIPTION	Q'TY	REMARKS
2F5-83310-60	FRONT FLASHER LIGHT ASSY	2	
115-83311-60	.BULB (6V-18W)	1	

4. Applicable colours of graphics are represented in the “REMARKS” as shown below.

PART NO.	DESCRIPTION	Q'TY	REMARKS
2N4-24110-00-X5	FUEL TANK COMP.	2	MXR
3J1-24240-10	.GRAPHIC, FUEL TANK	1	FOR MXR

5. Note that the illustrations for reference in finding parts numbers are not to be used for assembling. When assembling, please use the applicable service manual.

6. The asterisk (*) before a reference number indicates modified items after the first edition.
7. A part with “YMUS” in the remarks column can be obtained from YMUS (USA) and not from YAMAHA MOTOR CO.,LTD (JAPAN).

PART NO.	DESCRIPTION	Q'TY	REMARKS
EW2-U5160-00	ENGINE HATCH COMP	2	YMUS
90601-168U7	BAND,HOSE	1	YMUS

ADDRESS:

YAMAHA MOTOR CORPORATION U.S.A.
PARTS & ACCESSORY DIV.
6555 KATELLA AVENUE
CYPRESS, CALIFORNIA 90630 U.S.A.

FOREWORD

8. Applicable Serial No.

Engine Serial No.

Hull Serial No.

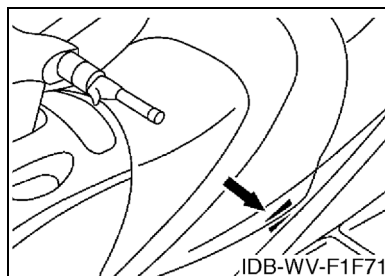
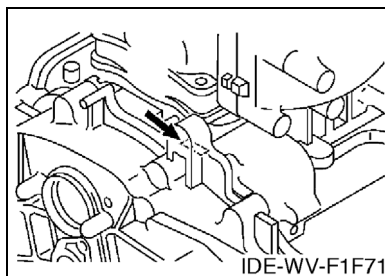

9. Applicable Colour Code (The (*) mark shows Model colour.)

Abbreviation	Colour Name	Colour Code
BMD	BLUE METALLIC D	0881
NMC	GRAY METALLIC C	008S
PURW(*)	PURE WHITE	0240
YB	YAMAHA BLACK	0033

10. Quantity Column Information

Column No.	Name Of Q'ty Column	Destination
1	USA	U.S.A.
2	GENE	EXCEPT U.S.A.

11. Applicable Starting Serial No.

Engine Serial No.

Serial No.	Name Of Q'ty Column	Model Code
60G-1003801	USA	60GG
60G-1003801	GENE	60GH

Hull Serial No.

Serial No.	Name Of Q'ty Column	Model Code
F1F-807801	USA	F1F7
F1F-808001	GENE	F1F8

CONTENTS

CYLINDER & CRANKCASE 1	B2
CYLINDER & CRANKCASE 2	B4
CRANKSHAFT & PISTON	B5
INTAKE	B7
CARBURETOR	B8
OIL PUMP	B11
EXHAUST 1	B13
FUEL	C2
JET UNIT 1	C3
JET UNIT 2	C6
JET UNIT 3	C7
GENERATOR	C8
STARTING MOTOR	C9
ELECTRICAL 1	C10
ELECTRICAL 2	C12
ENGINE HATCH 1	C13
ENGINE HATCH 2	C14
HULL & DECK	D2
GUNWALE & MAT	D4
VENTILATION	D5
SEAT & UNDER LOCKER	D6
OIL TANK	D8
FUEL TANK	D9
EXHAUST 2	D11
CONTROL CABLE	D12
STEERING 1	D15
STEERING 2	E3
GRAPHICS	E4
IMPORTANT LABELS	E5
IMPORTANT LABELS 2	E6
REPAIR KIT 1	E7
REPAIR KIT 2	E8

INDEX

NUMERICAL INDEX	M1
-----------------------	----

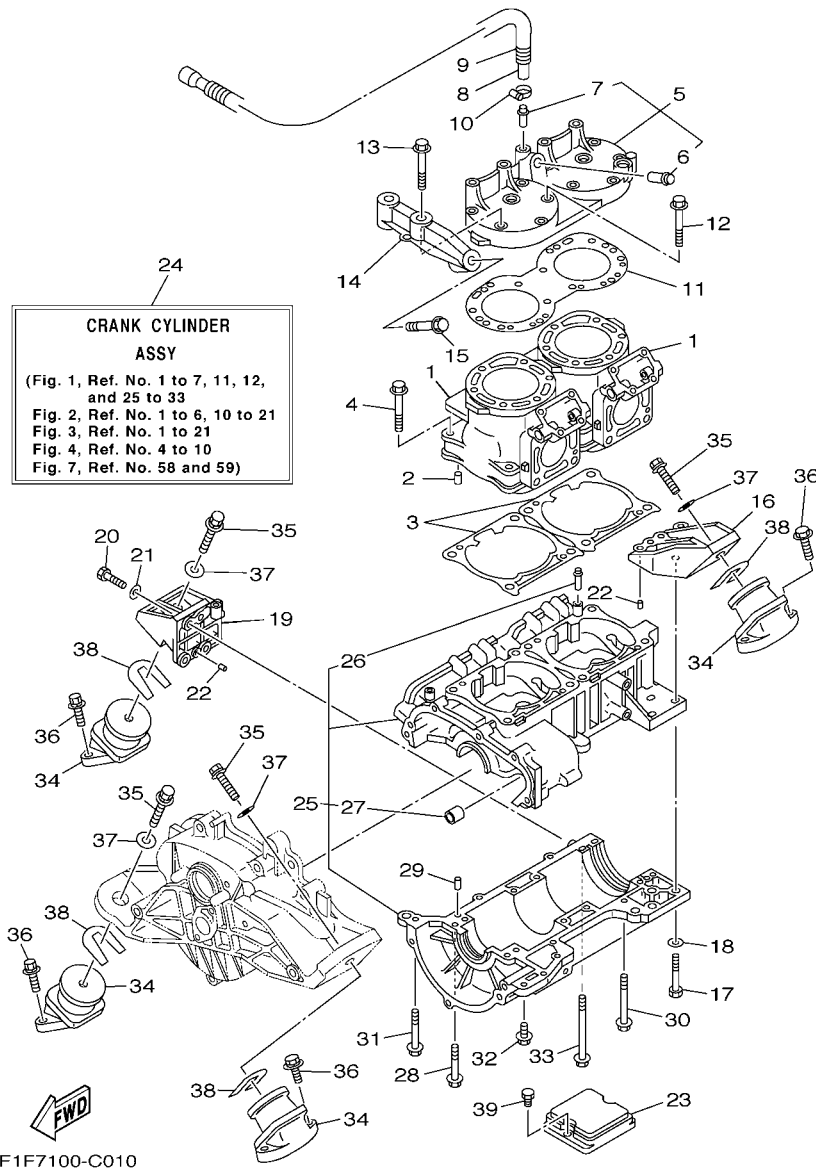
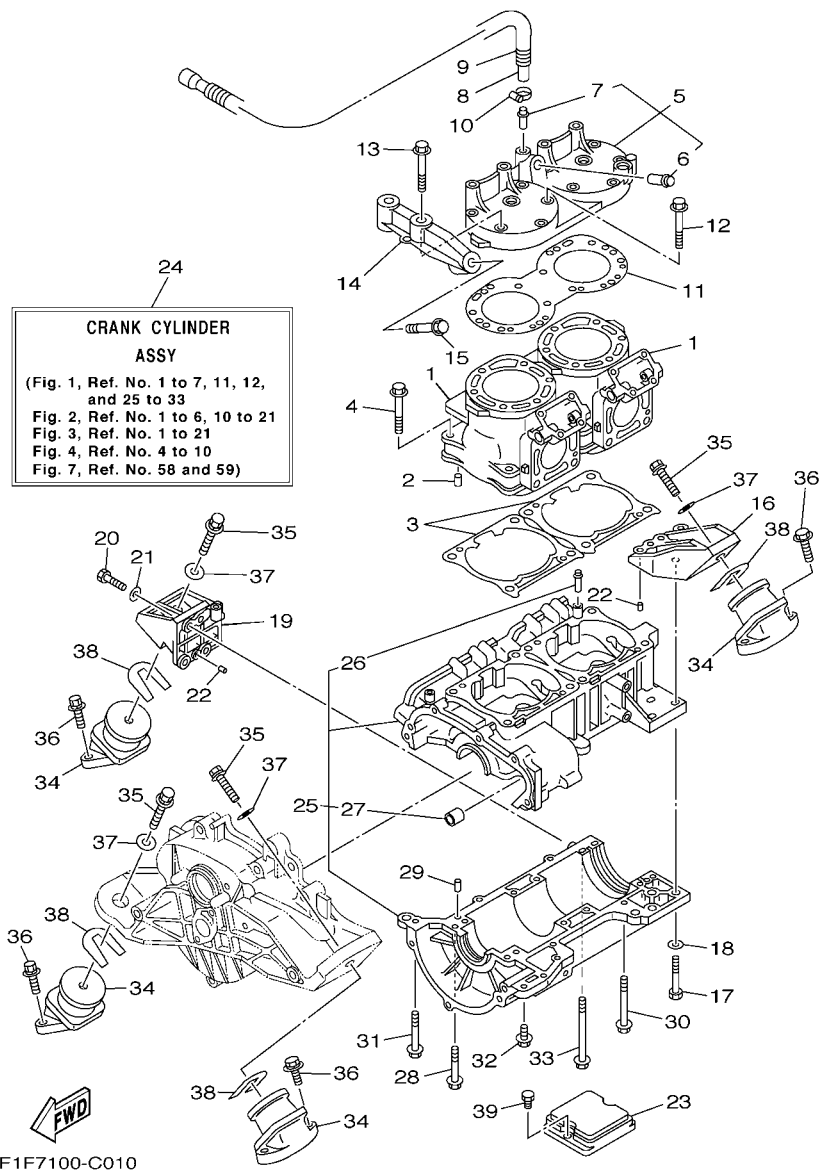

FIG. 1 CYLINDER & CRANKCASE 1

REF. NO.	PART NO.	DESCRIPTION	USA	GENE	REMARKS
1	66E-11311-00-94	CYLINDER 1	2	2	
2	93606-12019	PIN, DOWEL	4	4	
3	66E-11351-01	GASKET, CYLINDER	2	2	
4	90119-10M07	BOLT, WITH WASHER	8	8	
5	66E-11111-00-8S	HEAD, CYLINDER 1	1	1	
6	66E-51129-00	.NIPPLE	1	1	
7	6K8-51129-00	.NIPPLE	1	1	
8	90445-14003	HOSE (L1650)	1	1	
9	90447-19003	HOSE, WITH SPRING	1	1	
10	90450-14M05	HOSE CLAMP ASSY	1	1	
11	66E-11181-00	GASKET, CYLINDER HEAD 1	1	1	
12	90119-08MA1	BOLT, WITH WASHER	10	10	
13	90119-08MA2	BOLT, WITH WASHER	2	2	
14	66E-14781-10-94	STAY, MUFFLER 2	1	1	
15	90119-10M00	BOLT, WITH WASHER	1	1	
16	66E-21425-10-8S	BRACKET, REAR UPPER 1	1	1	
17	97013-08045	BOLT	3	3	
18	92903-08600	WASHER, PLATE	3	3	
19	66E-21426-10-8S	BRACKET, REAR UPPER 2	1	1	
20	97013-08030	BOLT	3	3	
21	92903-08600	WASHER, PLATE	3	3	
22	93606-12019	PIN, DOWEL	4	4	
23	67A-44532-00-94	STOPPER, UPPER MOUNT	1	1	
24	66E-W0090-13-8S	CRANK CYLINDER ASSY	1	1	
25	66E-15100-10-8S	CRANKCASE ASSY	1	1	
26	62T-14251-10	.NIPPLE	2	2	
27	90380-12M29	.BUSH, SOLID	1	1	

FIG. 1 CYLINDER & CRANKCASE 1



F1F7100-C010

REF. NO.	PART NO.	DESCRIPTION	USA	GENE	REMARKS
28	90119-08M55	BOLT, WITH WASHER	10	10	
29	93606-12019	PIN, DOWEL	2	2	
30	90119-06M78	BOLT, WITH WASHER	3	3	
31	90119-08M61	BOLT, WITH WASHER	1	1	
32	90119-06M13	BOLT, WITH WASHER	4	4	
33	90119-08M56	BOLT, WITH WASHER	2	2	
34	6M6-44517-A1-8P	MOUNT RUBBER	4	4	
35	90119-089UR	BOLT, WITH WASHER	4	4	YMUS
36	90119-08823	BOLT, WITH WASHER	8	8	YMUS
37	90201-099U3	WASHER, PLATE	4	4	YMUS
38	EU0-U7354-00-01	SHIM (T=0.1)	10	10	UR, YMUS
	EU0-U7354-00-03	SHIM (T=0.3)	10	10	UR, YMUS
	EU0-U7354-00-05	SHIM (T=0.5)	10	10	UR, YMUS
	EU0-U7354-00-10	SHIM (T=1.0)	10	10	UR, YMUS
	EU0-U7354-00-20	SHIM (T=2.0)	10	10	UR, YMUS
39	90101-06917	BOLT	2	2	

FIG. 2 CYLINDER & CRANKCASE 2

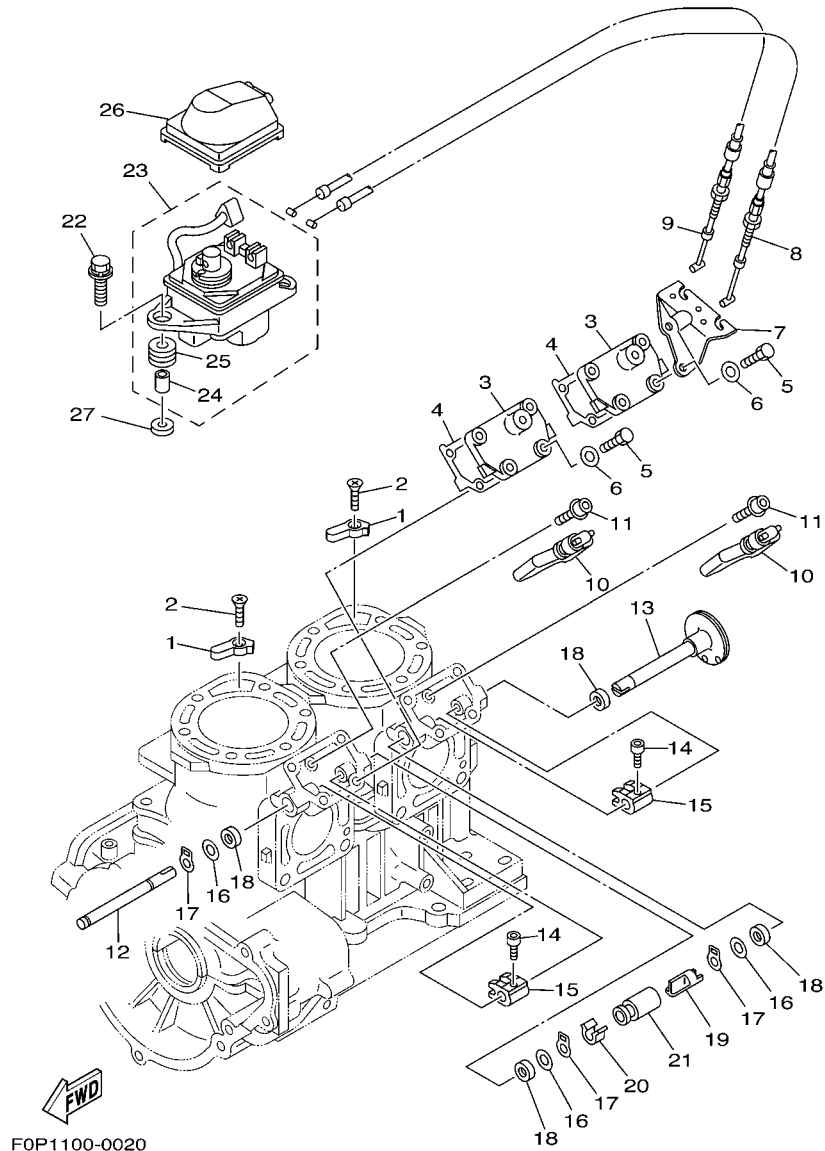

F0P1100-0020

REF. NO.	PART NO.	DESCRIPTION	USA	GENE	REMARKS
1	66E-11325-00	ANODE	2	2	
2	98780-05020	SCREW, FLAT HEAD	2	2	
3	66E-1131M-01-94	COVER	2	2	
4	66E-1131B-01	GASKET, COVER	2	2	
5	97013-06025	BOLT	8	8	
6	92903-06600	WASHER, PLATE	8	8	
7	66E-11998-00	BRACKET 1	1	1	
8	66V-1133E-00	CABLE, PULLEY 1	1	1	
9	66V-1133F-00	CABLE, PULLEY 2	1	1	
10	66E-1131S-10	VALVE ASSY.	2	2	
11	90110-05008	BOLT, HEXAGON SOCKET HEAD	2	2	
12	66E-1131V-00	SHAFT 1	1	1	
13	66E-1132C-00	PULLEY, SHAFT	1	1	
14	90110-04M03	BOLT, HEXAGON SOCKET HEAD	2	2	
15	60T-11832-00	LEVER, LINK	2	2	
16	90201-08M09	WASHER, PLATE	3	3	
17	93410-08M12	CIRCLIP	3	3	
18	93109-08M07	OIL SEAL	4	4	
19	66E-1131H-00	JOINT 1	1	1	
20	66E-1131J-10	JOINT 2	1	1	
21	66E-1131C-10	COVER, JOINT	1	1	
22	90119-069UX	BOLT, WITH WASHER	2	2	YMUS
23	60G-85820-00	SERVO MOTOR ASSY	1	1	
24	90387-07598	.COLLAR	2	2	
25	90480-14023	.GROMMET	2	2	
26	66E-85825-00	COVER, WIRE	1	1	
27	90201-06M04	WASHER, PLATE	2	2	

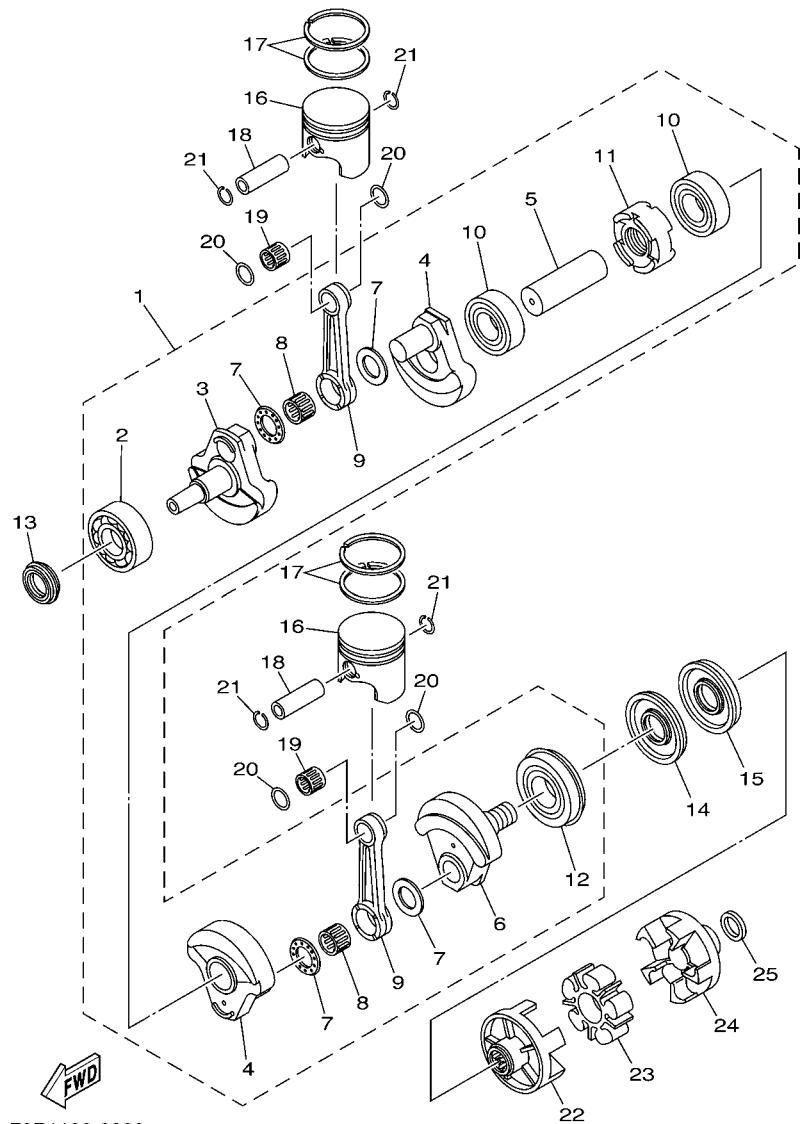

FOP1100-0030

FIG. 3 CRANKSHAFT & PISTON

REF. NO.	PART NO.	DESCRIPTION	USA	GENE	REMARKS
1	66E-11400-00	CRANKSHAFT ASSY	1	1	
2	93305-307U0	.BEARING	1	1	
3	66E-11412-00	.CRANK 1	1	1	
4	66E-11422-00	.CRANK 2	2	2	
5	66E-11431-00	.CRANK 3	1	1	
6	66E-11442-00	.CRANK 4	1	1	
7	66E-11685-00	.WASHER, CRANK PIN	4	4	
8	93310-627U6	.BEARING	2	2	
9	66E-11651-00	.ROD, CONNECTING	2	2	
10	93306-208U1	.BEARING	2	2	
11	66E-11515-00	.SEAL, LABYRINTH 1	1	1	
12	93306-308U1	.BEARING	1	1	
13	93103-35M03	OIL SEAL	1	1	
14	93101-34001	OIL SEAL	1	1	
15	93101-34002	OIL SEAL	1	1	
16	66E-11631-00-A0	PISTON (STD)	2	2	UR, RED
	66E-11631-00-B0	PISTON (STD)	2	2	UR, ORANGE
	66E-11631-00-C0	PISTON (STD)	2	2	UR, GREEN
	66E-11631-00-D0	PISTON (STD)	2	2	UR, PURPLE
17	66E-11603-01	PISTON RING SET (STD)	4	4	
18	60T-11633-00	PIN, PISTON	2	2	
19	93310-422U2	BEARING	2	2	
20	90201-22M04	WASHER, PLATE	4	4	
21	66E-11634-00	CLIP, PISTON PIN	4	4	
22	66E-45813-10-94	FLANGE, COUPLING	1	1	
23	66E-4581J-00	RUBBER SHAFT COUPLING	1	1	
24	68N-45593-00-94	FLANGE, COUPLING 1	1	1	

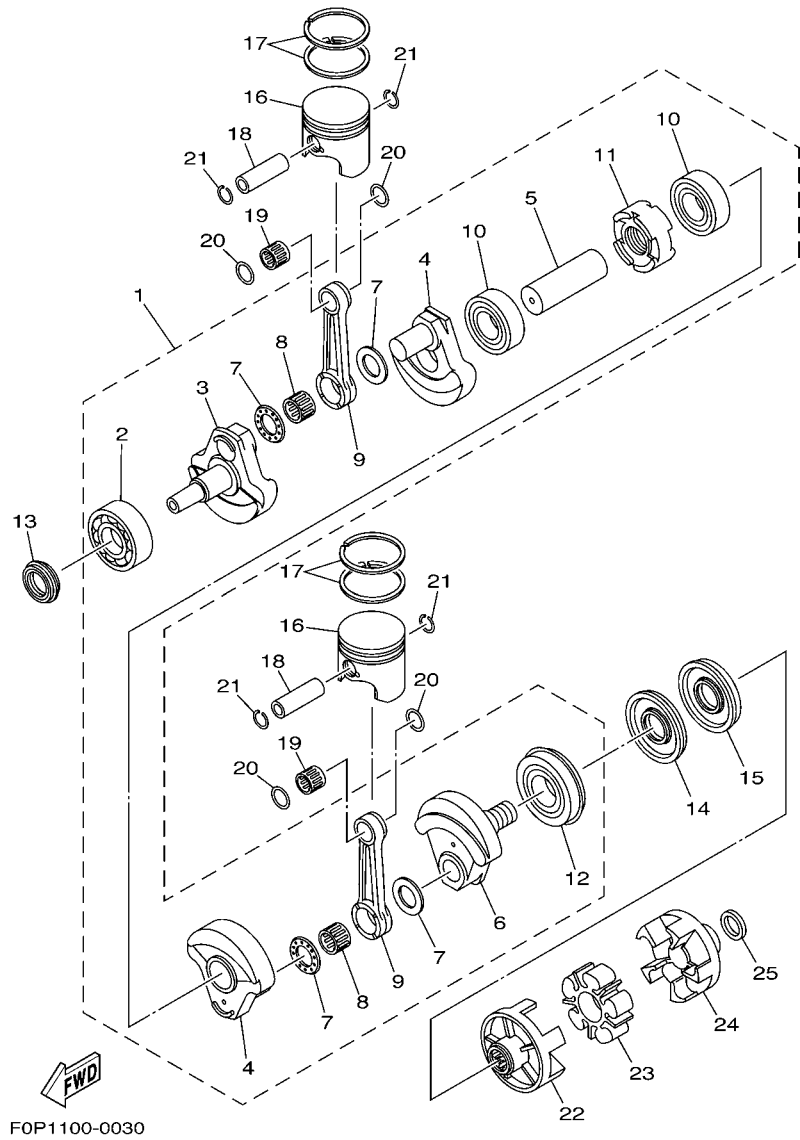
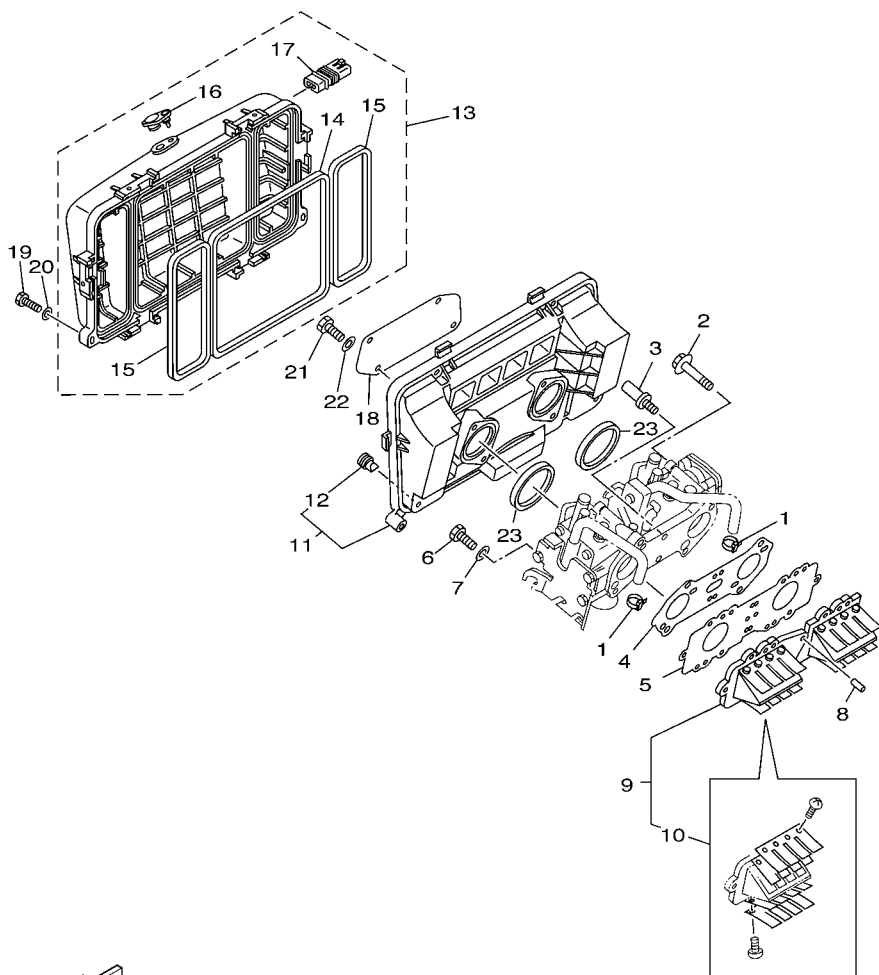

FIG. 3 CRANKSHAFT & PISTON

REF. NO.	PART NO.	DESCRIPTION	USA	GENE	REMARKS
25	90201-248M5	WASHER, PLATE	1	1	YMUS

FIG. 4 INTAKE

REF. NO.	PART NO.	DESCRIPTION	USA	GENE	REMARKS
1	90465-11M10	CLAMP	2	2	
2	90105-08M86	BOLT, FLANGE	4	4	
3	90109-06M00	BOLT	2	2	
4	66E-13556-00	GASKET, MANIFOLD	1	1	
5	66E-13624-10	PLATE, REED VALVE	1	1	
6	97013-06025	BOLT	12	12	
7	92903-06600	WASHER, PLATE	12	12	
8	93606-19M23	PIN, DOWEL	2	2	
9	66E-13610-00	REED VALVE ASSY	2	2	
10	66E-W0004-00	.REED SET	1	1	
11	66E-1441E-00	COVER, CLEANER CASE 2	1	1	
12	66E-42717-00	.RUBBER, SEAL 2	2	2	
13	66E-14480-11	COVER SUB ASSY	1	1	
14	66E-14457-10	.SEAL	1	1	
15	66E-14452-00	.SEAL	2	2	
16	66E-14435-00	.GROMMET	1	1	
17	66E-13898-11	.HOLDER	6	6	
18	66E-14451-00	ELEMENT, AIR CLEANER	1	1	
19	97095-06035	BOLT	3	3	
20	92995-06600	WASHER	3	3	
21	97013-06045	BOLT	4	4	
22	92903-06600	WASHER, PLATE	4	4	
23	66E-13473-00	O-RING	2	2	



F0N3300-0041

FIG. 5 CARBURETOR

REF. NO.	PART NO.	DESCRIPTION	USA	GENE	REMARKS
1	67A-14301-03	CARBURETOR ASSY 1	1	1	
2	67A-14302-03	CARBURETOR ASSY 2	1	1	
3	6R7-14569-00	.STRAINER	2	2	
4	64T-14916-01	.NEEDLE	2	2	
5	8F2-14147-00	..O-RING	1	1	
6	7EG-14159-00	..CLIP	1	1	
7	6K8-14547-01	.ARM, FLOAT	2	2	
8	6R7-14253-00	.SPRING	2	2	
9	6R7-14541-00	.DIAPHRAGM, PUMP	2	2	
10	6R7-14542-00	.BODY, PUMP 1	1	1	CARBURETOR 1
11	6K8-14536-11	.GASKET	2	2	
12	6K8-14503-02	.SCREW	2	2	
13	3G2-14231-30	.JET, MAIN (#150)	1	1	UR CARBURETOR 1
	3G2-14231-30	.JET, MAIN (#150)	1	1	UR CARBURETOR 2
14	66E-14563-01	.O-RING	2	2	
15	66E-24471-00	.DIAPHRAGM	2	2	
16	66E-24411-00	.DIAPHRAGM	2	2	
17	66E-24413-01	.BODY 2	2	2	
18	66E-24362-00	..VALVE, CHECK 1	1	1	
19	65U-24492-00	..BUSH, FULEL PUMP	1	1	
20	66E-24421-00	.VALVE, CHECK	2	2	
21	66E-24431-00	.GASKET, FUEL PUMP 1	2	2	
22	66E-24452-00	.COVER	2	2	
23	90157-05M17	.SCREW, PAN HEAD	8	8	
24	66E-14564-01	.O-RING	2	2	
25	830-14231-18	.JET, MAIN (# 90)	2	2	
26	812-14147-00	.O-RING	3	3	

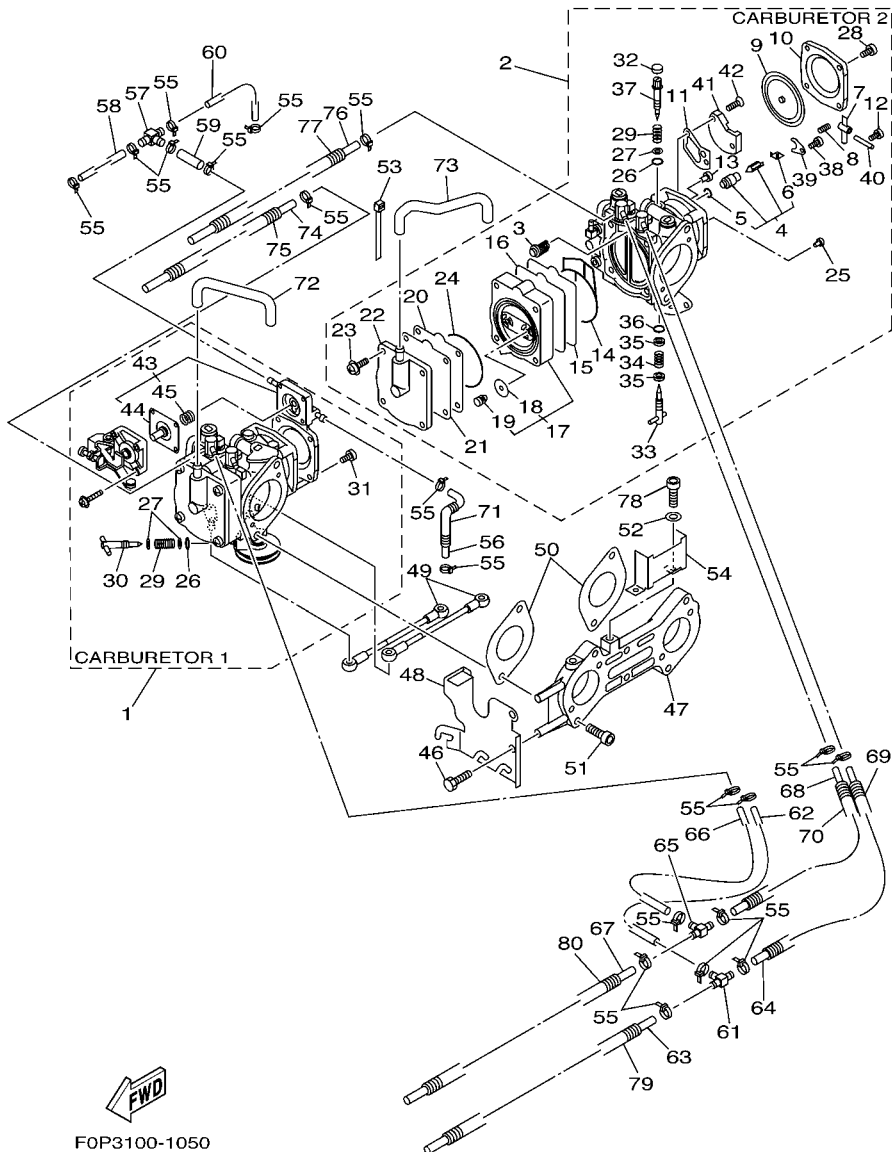

FOP3100-1050

FIG. 5 CARBURETOR

REF. NO.	PART NO.	DESCRIPTION	USA	GENE	REMARKS
27	812-14235-00	.WASHER, NEEDLE	4	4	
28	97880-05010	.SCREW, PAN HEAD	4	4	CARBURETOR 2
29	3KW-14932-00	.SPRING, THROTTLE 2	3	3	
30	66E-14521-00	.SCREW, ADJUST	1	1	CARBURETOR 1
31	97890-05014	.SCREW, PAN HEAD	4	4	CARBURETOR 1
32	6K8-14471-10	.CAP, CARBURETOR	2	2	
33	66E-14211-00	.SCREW, PILOT ADJUSTING	2	2	
34	6K8-14589-00	.SPRING	2	2	
35	822-14235-00	.WASHER, NEEDLE	4	4	
36	583-14561-00	.O-RING	2	2	
37	6K8-14946-10	.METERING NEEDLE	2	2	
38	6M6-14503-00	.SCREW	2	2	
39	6K8-14527-11	.PLATE	2	2	
40	439-14186-00	.PIN, FLOAT	2	2	
41	66E-24412-00	.BODY 1	2	2	
42	6K8-14523-11	.SCREW, STOP	4	4	
43	66E-14280-00	.COVER, CARBURETOR	1	1	CARBURETOR 1
44	66E-14170-00	..DIAPHRAGM ASS'Y	1	1	CARBURETOR 1
45	66E-14286-00	..SPRING	1	1	CARBURETOR 1
46	90101-06M25	BOLT	3	3	
47	66E-14243-00	PLATE	1	1	
48	66E-14291-00	BRACKET 1	1	1	
49	66E-41217-00	ROD, ACCEL. LEVER	2	2	
50	66E-14398-00	GASKET	2	2	
51	66E-14162-01	BOLT, HOLDING	4	4	
52	90204-06M01	WASHER, SPRING	2	2	
53	4KM-14137-00	CLIP	1	1	

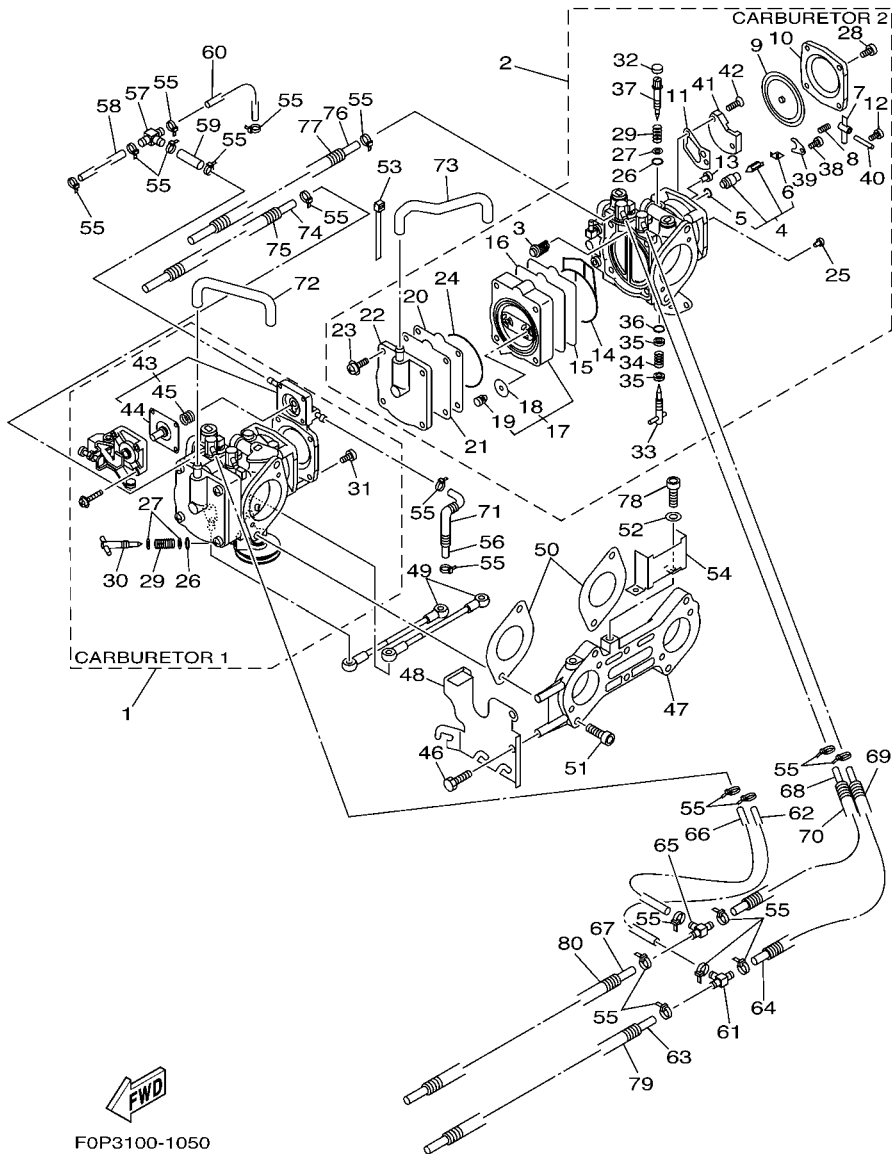

FOP3100-1050

FIG. 5 CARBURETOR

REF. NO.	PART NO.	DESCRIPTION	USA	GENE	REMARKS
54	66E-14146-00	PLATE	1	1	
55	35H-14139-00	CLIP, PIPE	20	20	
56	3XP-14294-00	HOSE	1	1	
57	4N0-14251-00	NIPPLE	1	1	
58	90445-07M78	HOSE	1	1	
59	90445-07M42	HOSE	1	1	
60	90445-07M79	HOSE	1	1	
61	66E-14251-00	NIPPLE	1	1	
62	90445-10MH0	HOSE	1	1	
63	67A-14294-00	HOSE	1	1	
64	90445-10MH2	HOSE	1	1	
65	66E-14251-00	NIPPLE	1	1	
66	90445-10MH3	HOSE	1	1	
67	67A-14298-00	PIPE	1	1	
68	90445-10MH5	HOSE	1	1	
69	90446-14M98	HOSE	1	1	
70	90446-14M99	HOSE	1	1	
71	90446-10MA2	HOSE	1	1	
72	66E-24314-00	PIPE 4	1	1	
73	66E-24315-00	PIPE 5	1	1	
74	90446-07M96	HOSE	1	1	
75	90446-10MA0	HOSE	1	1	
76	90446-07M97	HOSE	1	1	
77	90446-10MA1	HOSE	1	1	
78	66E-14162-00	BOLT, HOLDING	2	2	
79	90446-17ME5	HOSE	1	1	
80	90446-17MA7	HOSE (L800)	1	1	

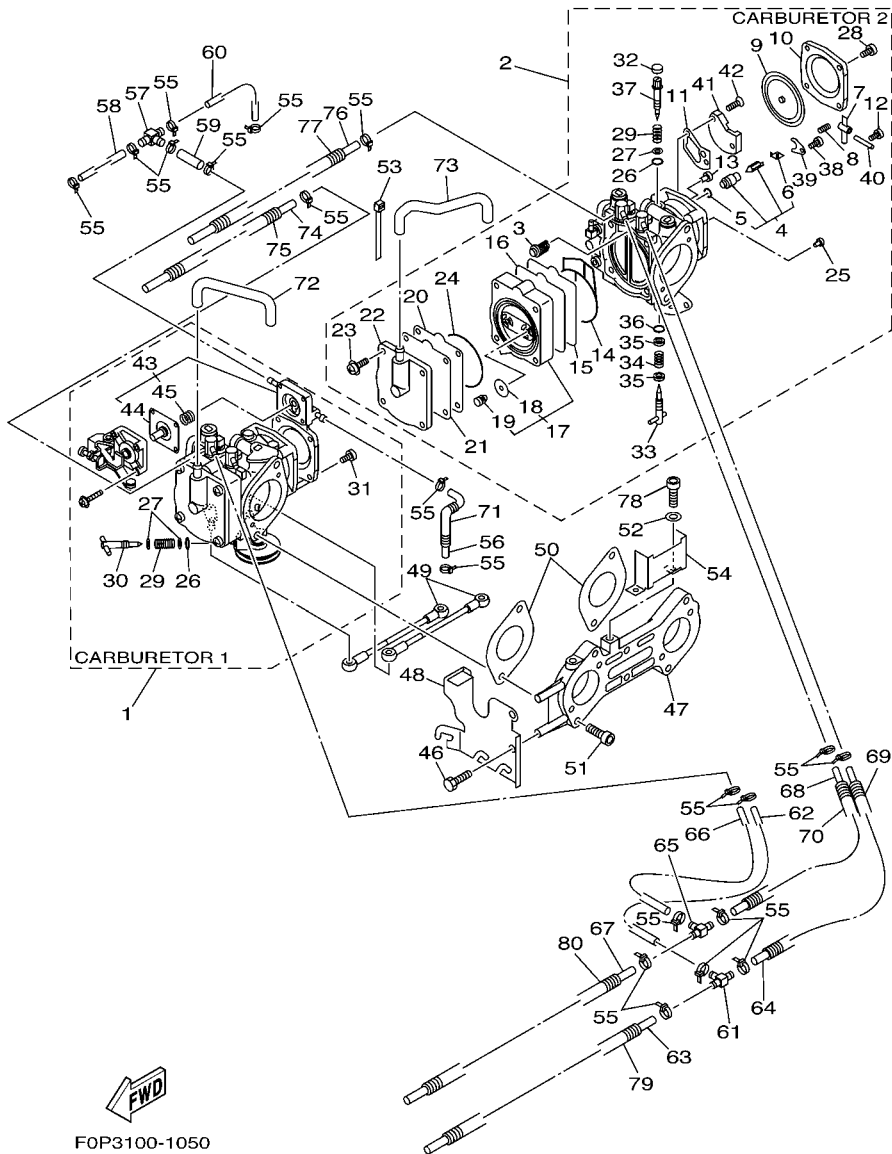

FOP3100-1050

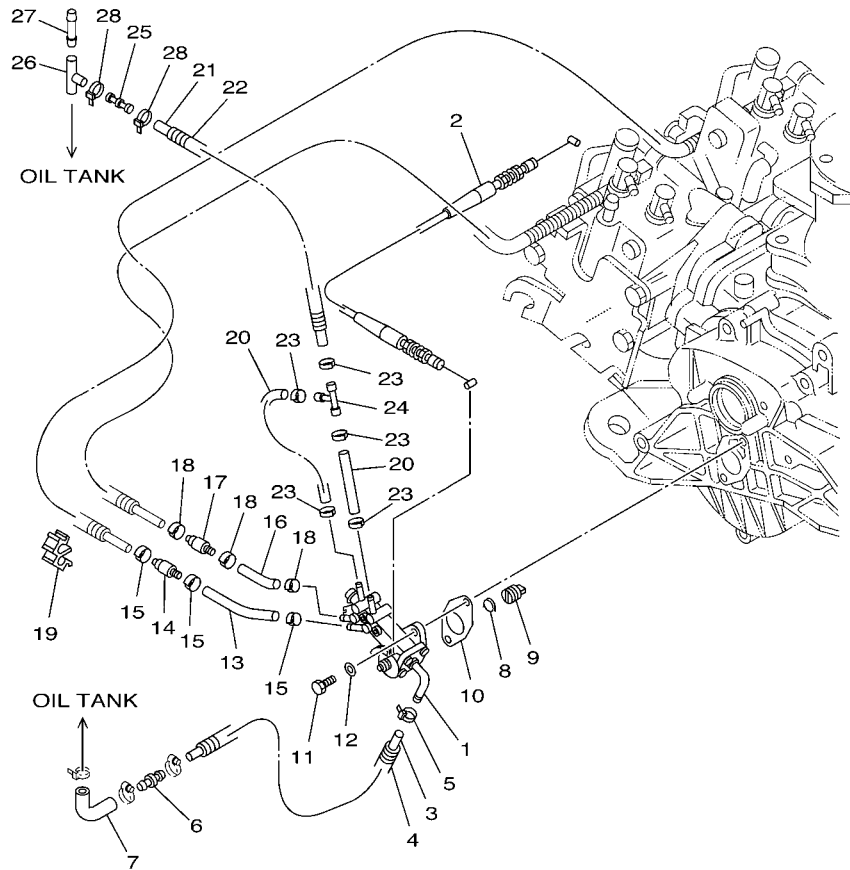

F0W3100-2060

FIG. 6 OIL PUMP

REF. NO.	PART NO.	DESCRIPTION	USA	GENE	REMARKS
1	66E-13200-02	OIL INJECTION PUMP ASSY	1	1	
2	66E-26320-00	PUMP CABLE ASSY	1	1	
3	90445-11012	HOSE (L600)	1	1	
4	90447-13002	TUBE (L530)	1	1	
5	90465-11M10	CLAMP	1	1	
6	66V-51142-00	CONNECTION	1	1	
7	66V-13416-01	PIPE, OIL 1	1	1	
8	66E-13469-00	SPRING	1	1	
9	65U-13132-00	JOINT	1	1	
10	63M-13116-00	GASKET, PUMP CASE	1	1	
11	97095-06020	BOLT	2	2	
12	92995-06600	WASHER	2	2	
13	90445-07009	HOSE (L85)	1	1	
14	67X-13183-00	VALVE, CHECK	1	1	
15	90468-02001	CLIP	3	3	
16	90445-07009	HOSE (L85)	1	1	
17	67X-13183-00	VALVE, CHECK	1	1	
18	90468-02001	CLIP	3	3	
19	90464-07M20	CLAMP	1	1	
20	90445-07M25	HOSE (L53)	2	2	
21	90445-07002	HOSE (L720)	1	1	
22	90447-07002	TUBE (L650)	1	1	
23	90468-02001	CLIP	5	5	
24	6E0-24378-00	PIPE, JOINT 4	1	1	
25	63M-13132-00	JOINT	1	1	
26	63M-24378-00	PIPE, JOINT 4	1	1	
27	6G8-24376-00	PIPE, JOINT 1	1	1	

FIG. 6 OIL PUMP

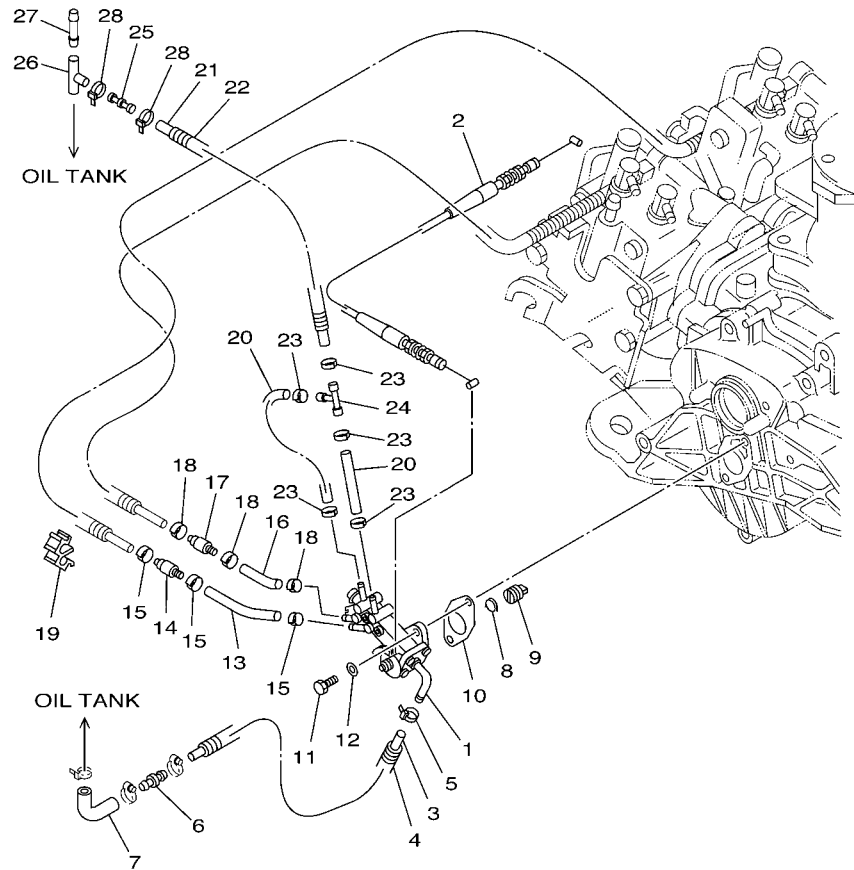

F0W3100-2060

REF. NO.	PART NO.	DESCRIPTION	USA	GENE	REMARKS
28	90465-11829	CLAMP	2	2	YMUS

FIG. 7 EXHAUST 1

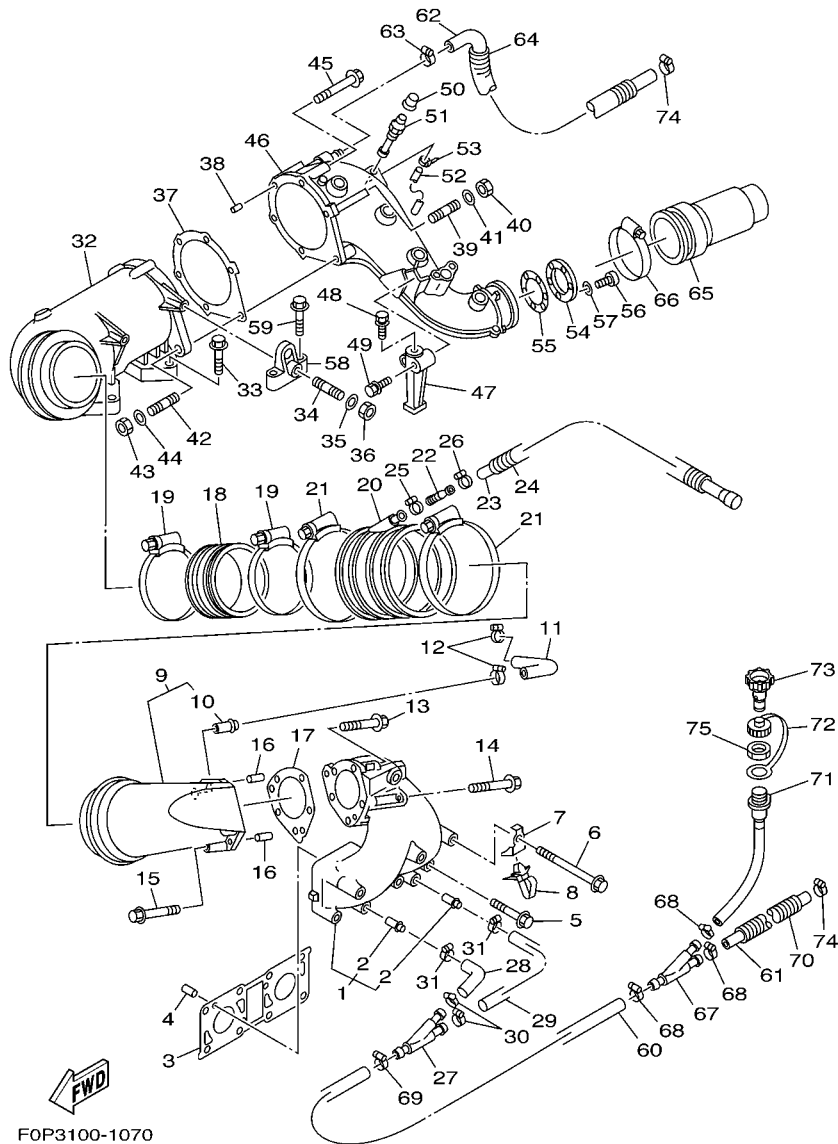

FOP3100-1070

REF. NO.	PART NO.	DESCRIPTION	USA	GENE	REMARKS
1	66E-14711-10-94	MUFFLER 1	1	1	
2	6K8-51129-00	.NIPPLE	2	2	
3	66E-14613-00	GASKET, EXHAUST PIPE	1	1	
4	93606-12019	PIN, DOWEL	2	2	
5	90105-10M85	BOLT, FLANGE	4	4	
6	90105-10M86	BOLT, FLANGE	4	4	
7	90465-20M78	CLAMP	2	2	
8	90465-12M56	CLAMP	2	2	
9	66E-14712-10-94	RING, JOINT	1	1	
10	66E-51129-00	.NIPPLE	1	1	
11	66E-12576-00	HOSE 1	1	1	
12	90450-22M14	HOSE CLAMP ASSY	2	2	
13	90105-08M83	BOLT, FLANGE	2	2	
14	90105-08M84	BOLT, FLANGE	2	2	
15	90105-08M66	BOLT, FLANGE	1	1	
16	93606-12019	PIN, DOWEL	2	2	
17	66E-14749-00	GASKET, MUFFLER DAMPER 2	1	1	
18	66E-14625-00	JOINT, EXHAUST 2	1	1	
19	90450-99M02	HOSE CLAMP ASSY	2	2	
20	66E-14615-00	JOINT, EXHAUST 1	1	1	
21	90450-99M18	HOSE CLAMP ASSY	2	2	
22	60E-12594-00	JOINT, HOSE 4	1	1	
23	90445-14M33	HOSE (L1150)	1	1	
24	90446-24M94	TUBE (L1040)	1	1	
25	90450-18M09	HOSE CLAMP ASSY	1	1	
26	90450-14M05	HOSE CLAMP ASSY	1	1	
27	63M-12581-00	JOINT, HOSE 1	1	1	

FIG. 7 EXHAUST 1

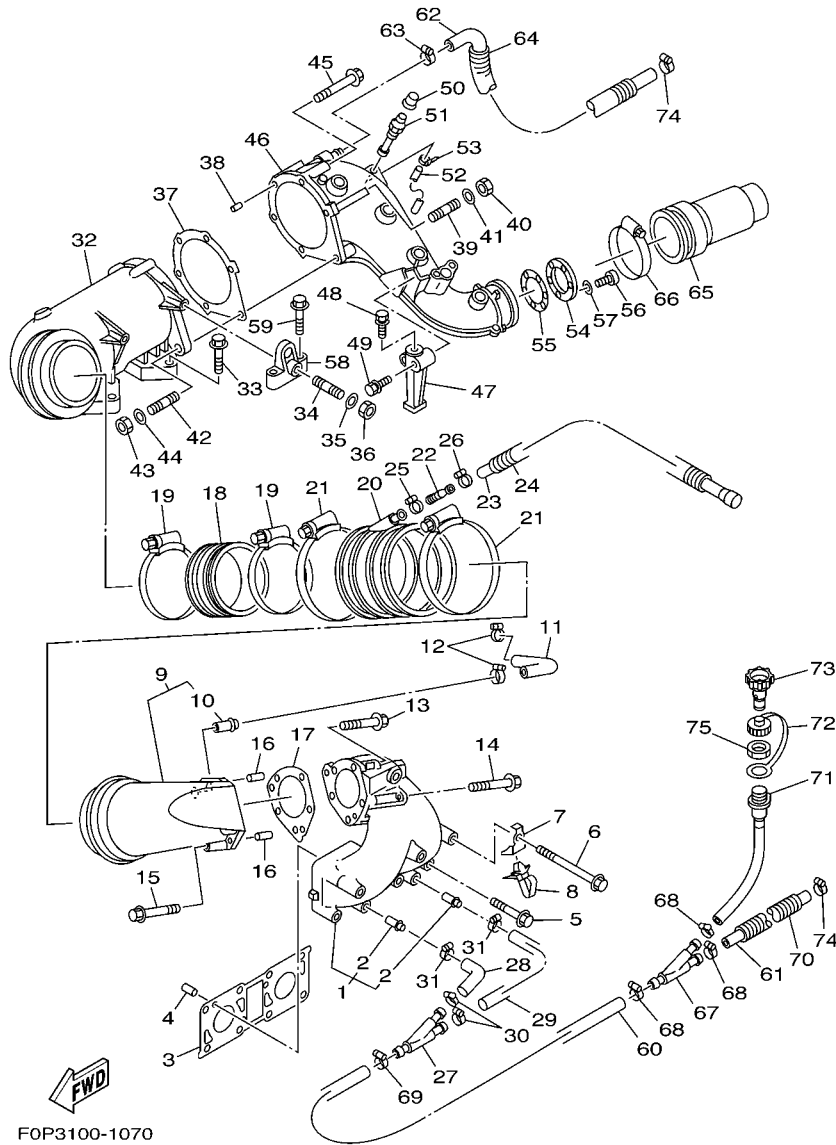

FOP3100-1070

REF. NO.	PART NO.	DESCRIPTION	USA	GENE	REMARKS
28	66E-12577-00	HOSE 2	1	1	
29	66E-12579-00	HOSE 4	1	1	
30	90450-18M09	HOSE CLAMP ASSY	2	2	
31	90450-14M05	HOSE CLAMP ASSY	2	2	
32	66E-14721-10-8S	MUFFLER 2	1	1	
33	90105-10M82	BOLT, FLANGE	2	2	
34	90116-10M66	BOLT, STUD	2	2	
35	92990-10600	WASHER, PLATE	2	2	
36	95380-10600	NUT	2	2	
37	66E-41124-10	GASKET, EXHAUST OUTER COVER	1	1	
38	93606-12019	PIN, DOWEL	2	2	
39	90116-08M64	BOLT, STUD	2	2	
40	95333-08600	NUT	2	2	
41	92990-08600	WASHER, PLATE	2	2	
42	90116-10M65	BOLT, STUD	1	1	
43	95380-10600	NUT	1	1	
44	92990-10600	WASHER, PLATE	1	1	
45	90105-08M83	BOLT, FLANGE	3	3	
46	67A-41123-00-94	OUTER COVER, EXHAUST	1	1	
47	66E-14791-00-8S	STAY, MUFFLER	1	1	
48	90119-10M10	BOLT, WITH WASHER	1	1	
49	90119-10M00	BOLT, WITH WASHER	1	1	
50	663-45119-00	CAP, GREASE NIPPLE	1	1	
51	61L-5169A-00	NIPPLE, GREASE	1	1	
52	90445-09M21	HOSE (L445)	1	1	
53	90465-11M10	CLAMP	1	1	
54	66E-14763-10-94	SPACER	1	1	

FIG. 7 EXHAUST 1

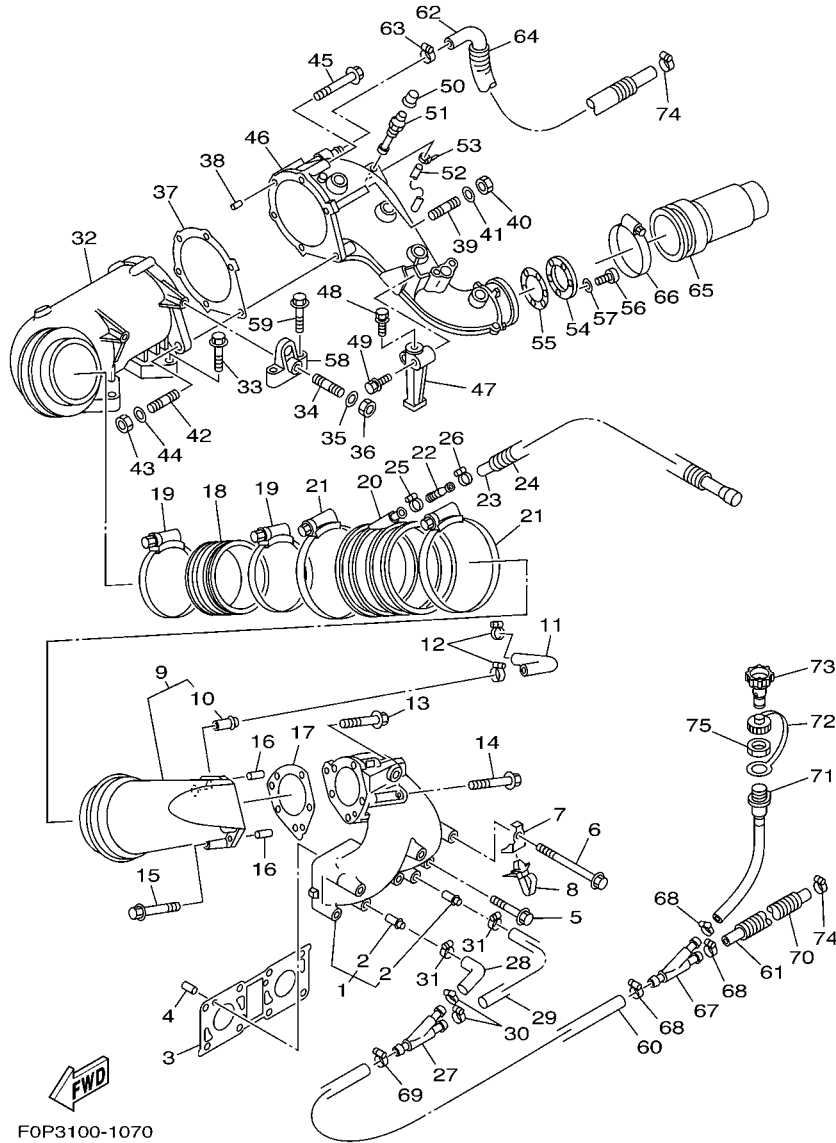

REF. NO.	PART NO.	DESCRIPTION	USA	GENE	REMARKS
55	66E-14623-00	GASKET, EXHAUST PIPE	1	1	
56	97885-06016	SCREW, PAN HEAD	3	3	
57	92995-06600	WASHER	3	3	
58	66E-14771-01-8S	STAY, MUFFLER 1	2	2	
59	90119-10M18	BOLT, WITH WASHER	4	4	
60	90445-18M17	HOSE (L60)	1	1	
61	90445-18M02	HOSE (L700)	1	1	
62	66E-12578-00	HOSE 3	1	1	
63	90450-22M14	HOSE CLAMP ASSY	1	1	
64	90446-27M95	HOSE (L800)	1	1	
65	67A-14752-00	PIPE, OUTLET	1	1	
66	90460-90M11	CLAMP, HOSE	1	1	
67	63M-12581-00	JOINT, HOSE 1	1	1	
68	90450-18M09	HOSE CLAMP ASSY	3	3	
69	90450-18M09	HOSE CLAMP ASSY	1	1	
70	90446-24M52	HOSE (L540)	1	1	
71	64T-12580-00	JOINT ASSY	1	1	
72	682-84385-01	CAP,1	1	1	
73	67X-12590-00	CONDUCTION ASSY	1		FOR USA
	67X-12590-20	CONDUCTION ASSY		1	FOR GENE
74	90601-118UF	BAND, HOSE 18	2	2	YMUS
75	EU0-61652-00	NUT	1	1	

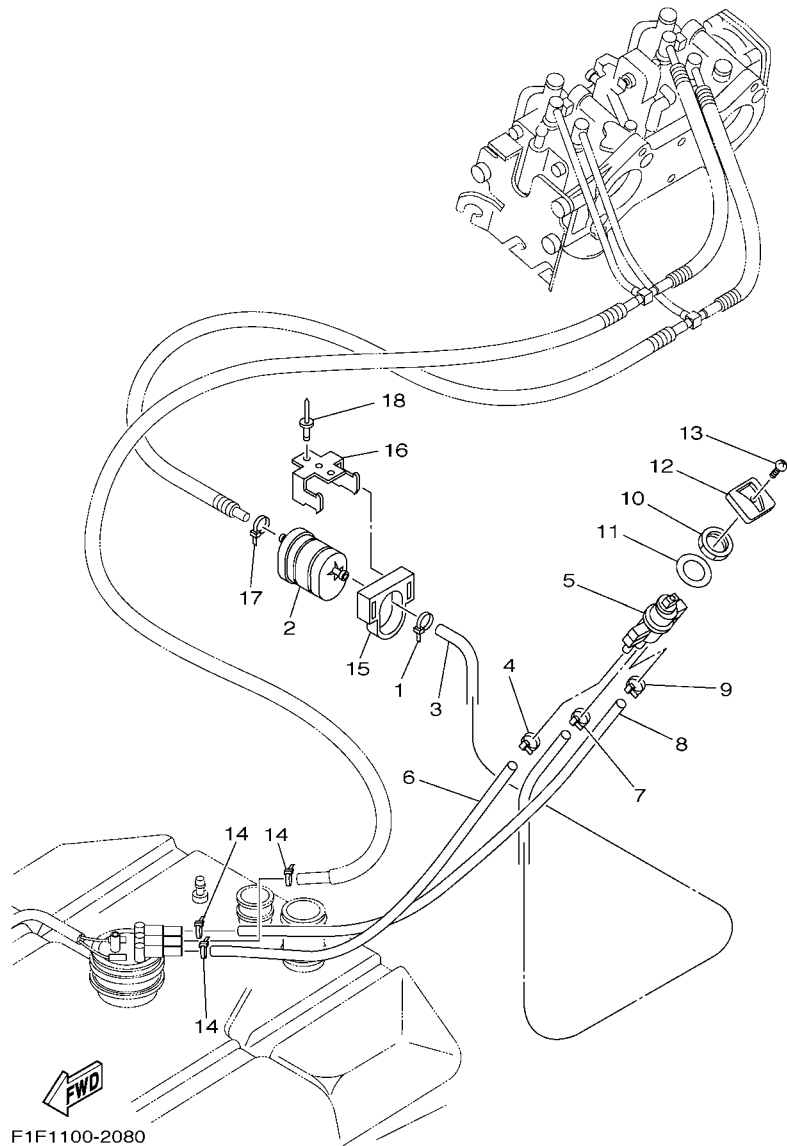
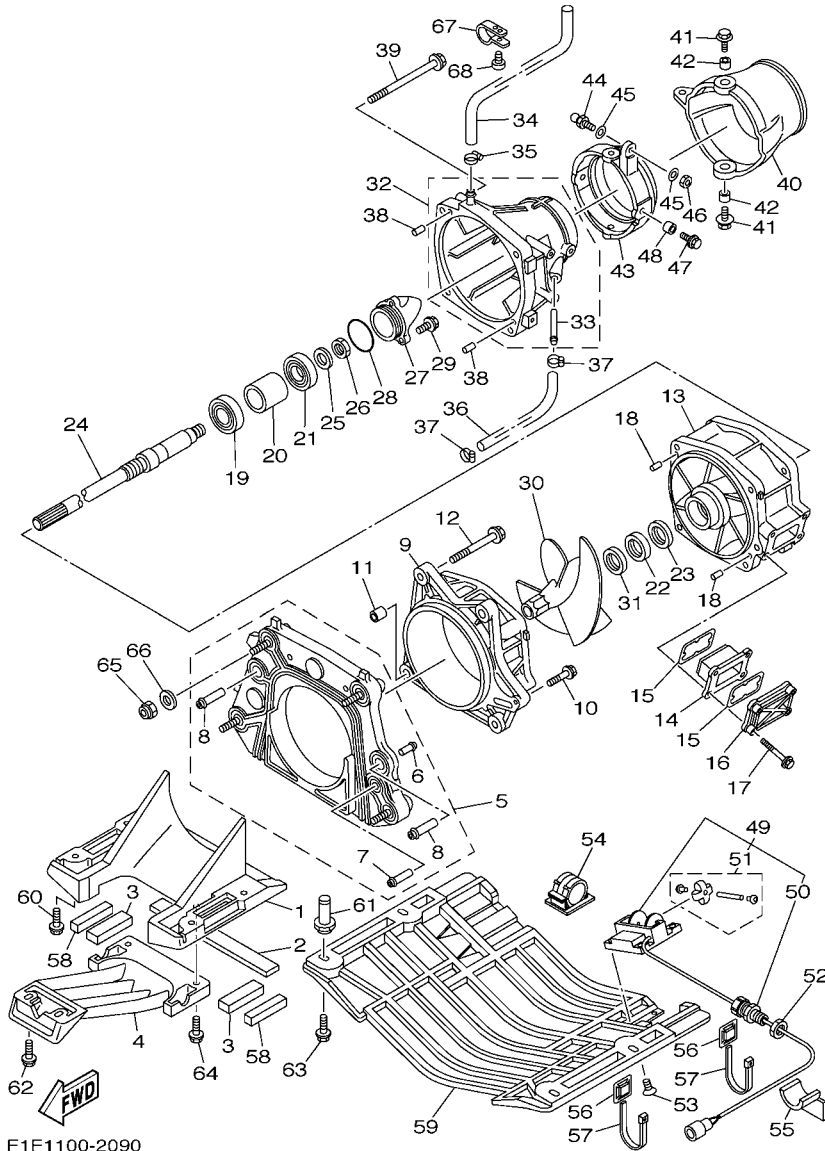

FIG. 8 FUEL

REF. NO.	PART NO.	DESCRIPTION	USA	GENE	REMARKS
1	90465-11829	CLAMP	1	1	YMUS
2	66V-24560-00	FILTER ASSY	1	1	
3	90445-11M68	HOSE (L450)	1	1	
4	90465-11M10	CLAMP	2	2	
5	66V-24500-02	FUEL COCK ASSY 1	1	1	
6	90445-11M67	HOSE (L450)	1	1	
7	90465-11M10	CLAMP	1	1	
8	90445-11M69	HOSE (L450)	1	1	
9	90465-11829	CLAMP	1	1	YMUS
10	90170-22187	NUT	1	1	
11	90202-229U1	WASHER, PLATE	1	1	YMUS
12	F0D-6777C-00	LEVER, COCK	1	1	
13	98980-04008	SCREW, BIND	1	1	
14	90465-11829	CLAMP	3	3	YMUS
15	EU0-U7817-00	HOLDER, FILTER	1	1	YMUS
16	FN8-67816-00	BRACKET, FUEL FILTER	1	1	
17	90465-11829	CLAMP	1	1	YMUS
18	90267-489U1	RIVET,BLIND	2	2	YMUS



F1F1100-2090

FIG. 9 JET UNIT 1

REF. NO.	PART NO.	DESCRIPTION	USA	GENE	REMARKS
1	66V-51311-00-94	DUCT, INTAKE	1	1	
2	66V-51367-00	FELT, PACKING	1	1	
3	66V-51368-00	FELT, PACKING	1	1	
4	66V-51333-00-94	SCREEN, INTAKE	1	1	
5	66V-G5831-02	PLATE, TRANSOM	1	1	YMUS
6	65A-R1129-00	.NIPPLE	1	1	YMUS
7	66V-51129-01	.NIPPLE	1	1	
8	66V-51129-10	.NIPPLE	2	2	
9	66V-51312-01-94	HOUSING, IMPELLER	1	1	
10	90119-06835	BOLT, WITH WASHER	1	1	YMUS
11	99590-14016	PIN, DOWEL	2	2	
12	90119-10836	BOLT, WITH WASHER	4	4	YMUS
13	66V-51315-00-94	DUCT, IMPELLER	1	1	
14	66V-46882-00	FILTER	1	1	
15	66V-42414-00	O-RING	2	2	
16	66V-45214-00-94	COVER, WATER INLET	1	1	
17	90119-06800	BOLT, WITH WASHER	4	4	YMUS
18	93606-12019	PIN, DOWEL	2	2	
19	93306-205U0	BEARING	1	1	
20	65V-45538-00	SPACER 1	1	1	
21	93306-304U1	BEARING	1	1	
22	93101-28M66	OIL SEAL	1	1	
23	93101-28M65	OIL SEAL	1	1	
24	68Y-45511-00	SHAFT, DRIVE	1	1	
25	9299R-16600	WASHER	1	1	YMUS
26	9531P-16700	NUT	1	1	YMUS
27	65A-R1326-00	CAP	1	1	YMUS

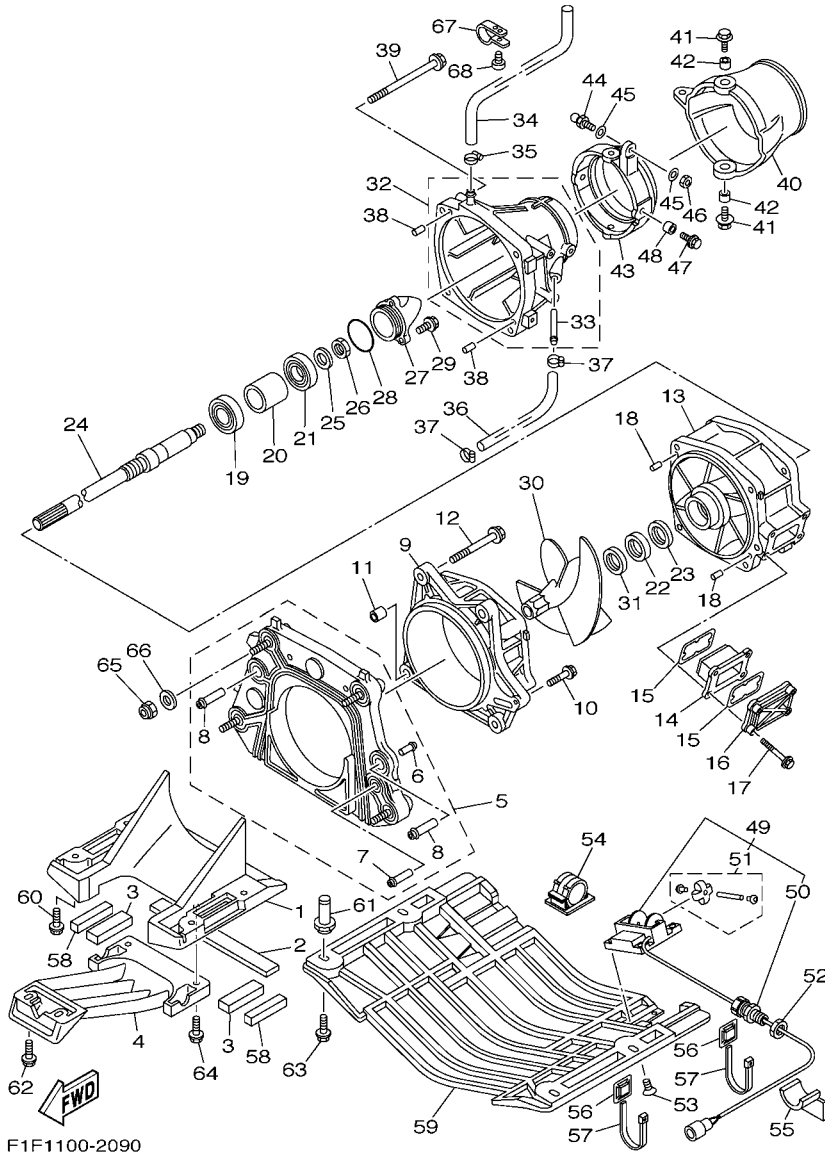
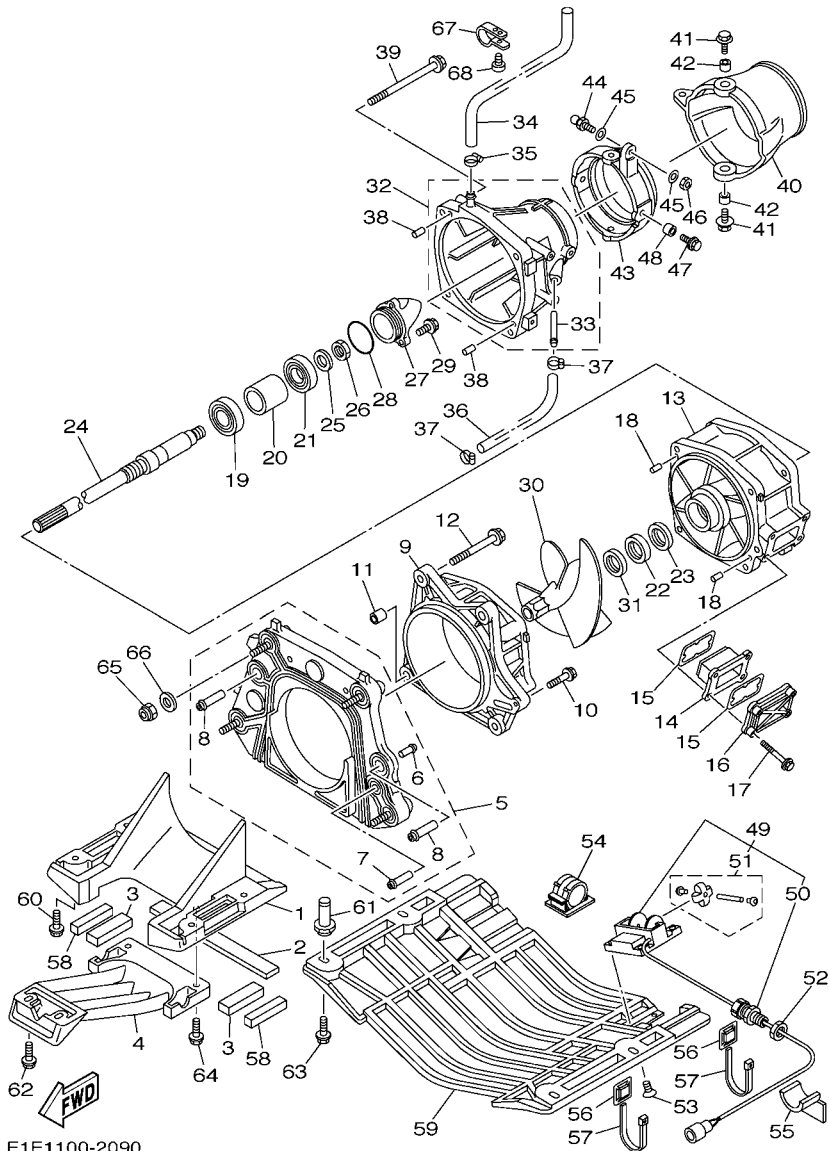

FIG. 9 JET UNIT 1

REF. NO.	PART NO.	DESCRIPTION	USA	GENE	REMARKS
28	93210-46M16	O-RING	1	1	
29	90119-069UB	BOLT, WITH WASHER	3	3	YMUS
30	67A-R1321-00	IMPELLER	1	1	YMUS
31	66V-R1348-10	SPACER	1	1	YMUS
32	66V-51318-00-94	NOZZLE	1	1	
33	63M-51334-00	.NIPPLE,HOSE	1	1	
34	90445-16M09	HOSE (L310)	1	1	
35	90601-118UF	BAND, HOSE 18	1	1	YMUS
36	90445-14898	HOSE (L270)	1	1	YMUS
37	90465-11829	CLAMP	2	2	YMUS
38	93606-12019	PIN, DOWEL	2	2	
39	90119-10837	BOLT, WITH WASHER	4	4	YMUS
40	66V-R1313-01	NOZZLE,DEFLECTOR	1	1	YMUS
41	90119-089UE	BOLT, WITH WASHER	2	2	YMUS
42	90387-08M06	COLLAR	2	2	
43	66G-51190-00-94	RING,TRIM	1	1	
44	GH3-U146E-00	STUD, JOINT BALL	1	1	YMUS
45	90201-068M4	WASHER, PLATE	2	2	YMUS
46	9538R-06700	NUT	1	1	YMUS
47	90119-089UE	BOLT, WITH WASHER	2	2	YMUS
48	90387-08M06	COLLAR	2	2	
49	F0V-U8K31-00	SENSOR SPEED	1	1	YMUS
50	EU0-67267-20	.CONNECTOR, CABLE	1	1	
51	GJ1-U835D-00	.SERVIS KIT (SPEED SENSOR)	1	1	YMUS
52	EU0-62241-30	NUT, DRAIN 1	1	1	
53	9878R-05512	SCREW, FLAT HEAD	4	4	YMUS
54	90600-925U9	CLAMP	2	2	YMUS



F1F1100-2090

FIG. 9 JET UNIT 1

REF. NO.	PART NO.	DESCRIPTION	USA	GENE	REMARKS
55	GJ1-U7578-11	PACKING, HOSE 2	1	1	YMUS
56	90600-900U6	BASE, CLAMP	5	5	YMUS
57	90464-40825	CLAMP	5	5	YMUS
58	F0V-U7525-01	PACKING	1	1	YMUS
59	F0V-U273B-00	PLATE 2	1	1	YMUS
60	90119-08823	BOLT, WITH WASHER	4	4	YMUS
61	90179-08815	NUT	4	4	YMUS
62	90119-069UK	BOLT, WITH WASHER	2	2	YMUS
63	90119-08823	BOLT, WITH WASHER	4	4	YMUS
64	90119-069UB	BOLT, WITH WASHER	2	2	YMUS
65	9572R-10300	NUT, FLANGE	4	4	YMUS
66	90201-10801	WASHER, PLATE	4	4	YMUS
67	90600-921U1	CLIP, NYLON 21	1	1	YMUS
68	97780-50514	SCREW, TAPPING	1	1	

FIG. 10 JET UNIT 2

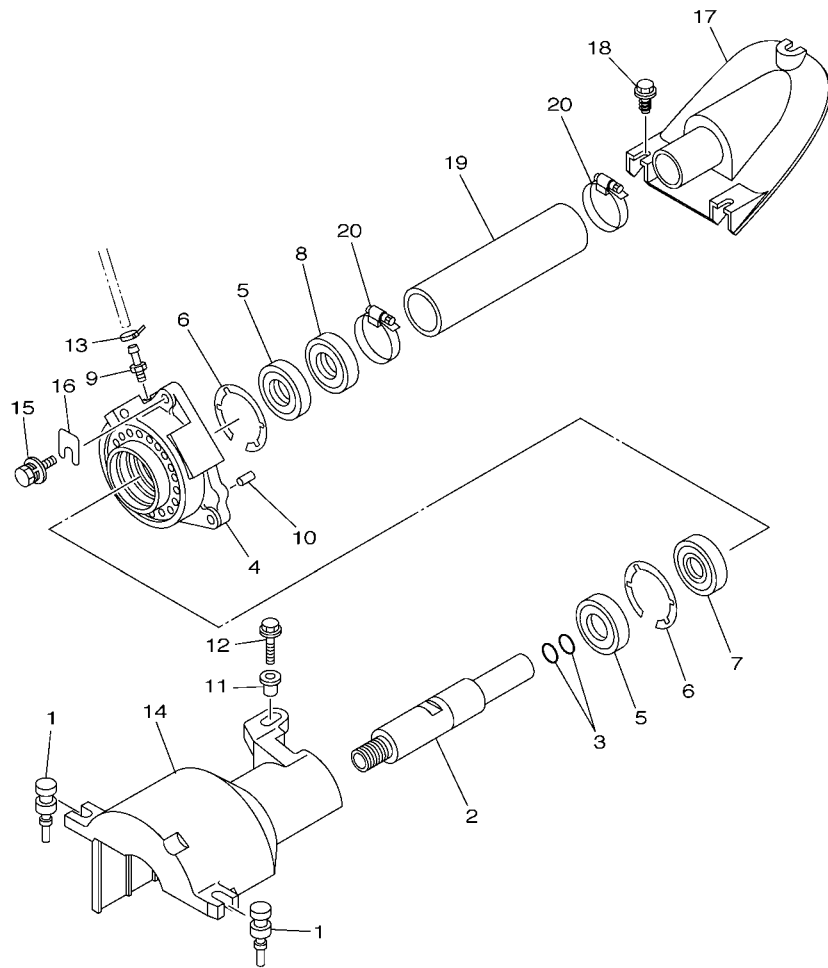

F1F1100-2100

REF. NO.	PART NO.	DESCRIPTION	USA	GENE	REMARKS
1	90480-06M46	GROMMET	2	2	
2	68N-51323-00	SHAFT, COUPLOR	1	1	
3	93210-19MJ4	O-RING	2	2	
4	61X-45332-03-94	HOUSING, BEARING	1	1	
5	93101-25M55	OIL SEAL	2	2	
6	93430-47M04	CIRCLIP	2	2	
7	93306-205U6	BEARING	1	1	
8	93101-25M56	OIL SEAL	1	1	
9	61L-45378-00	NIPPLE, HOSE	1	1	
10	93606-12019	PIN, DOWEL	2	2	
11	90387-06M60	COLLAR	1	1	
12	90119-069UD	BOLT, WITH WASHER	1	1	YMUS
13	90465-11829	CLAMP	1	1	YMUS
14	67A-R1381-00	COVER	1	1	YMUS
15	90119-089UL	BOLT, WITH WASHER	3	3	YMUS
16	GD0-U7249-00-05	SHIM (T=0.5)	1	1	UR, YMUS
	GD0-U7249-00-10	SHIM (T=1.0)	1	1	UR, YMUS
17	F0D-U883E-00	JOINT, PIPE	1	1	YMUS
18	90149-069UA	SCREW	3	3	YMUS
19	F0D-U883B-01	PIPE, 1	1	1	YMUS
20	90601-152U3	BAND, HOSE 52	2	2	YMUS

FIG. 11 JET UNIT 3

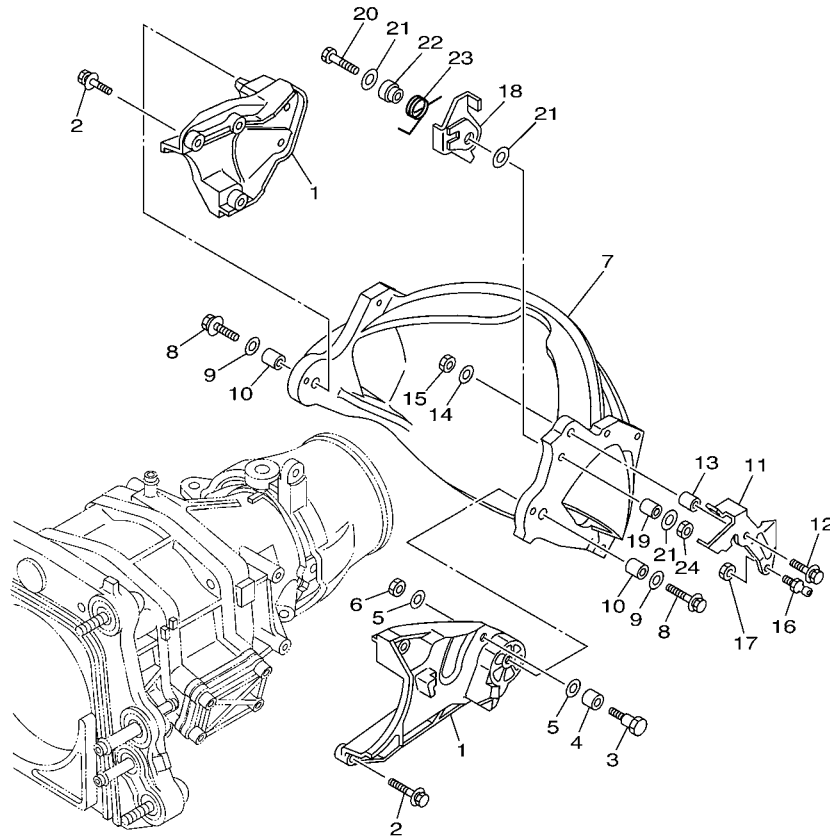

F1F4100-B110

REF. NO.	PART NO.	DESCRIPTION	USA	GENE	REMARKS
1	66V-51341-00-94	BRACKET 1	2	2	
2	90119-069UD	BOLT, WITH WASHER	6	6	YMUS
3	90109-08879	BOLT	1	1	YMUS
4	90387-10M09	COLLAR	1	1	
5	9299R-08600	WASHER	2	2	YMUS
6	9538R-08600	NUT	1	1	YMUS
7	66V-51314-11	GATE, REVERSE	1	1	
8	90119-089UF	BOLT, WITH WASHER	2	2	YMUS
9	90201-088T2	WASHER, PLATE	2	2	YMUS
10	90387-08M30	COLLAR	2	2	
11	66V-44121-00	LEVER, SHIFT ROD	1	1	
12	90119-069UB	BOLT, WITH WASHER	1	1	YMUS
13	90387-06M74	COLLAR	1	1	
14	90201-068T1	WASHER, PLATE	1	1	YMUS
15	9538R-06600	NUT	1	1	YMUS
16	66V-U146E-00	STUD, JOINT BALL	1	1	YMUS
17	9538R-06600	NUT	1	1	YMUS
18	66V-44125-00	LEVER, SHIFT ROD	1	1	
19	90387-06M74	COLLAR	1	1	
20	90101-06806	BOLT	1	1	YMUS
21	90201-068T1	WASHER, PLATE	3	3	YMUS
22	90387-06M84	COLLAR	1	1	
23	90508-14M43	SPRING, TORSION	1	1	
24	9538R-06600	NUT	1	1	YMUS

FIG. 12 GENERATOR

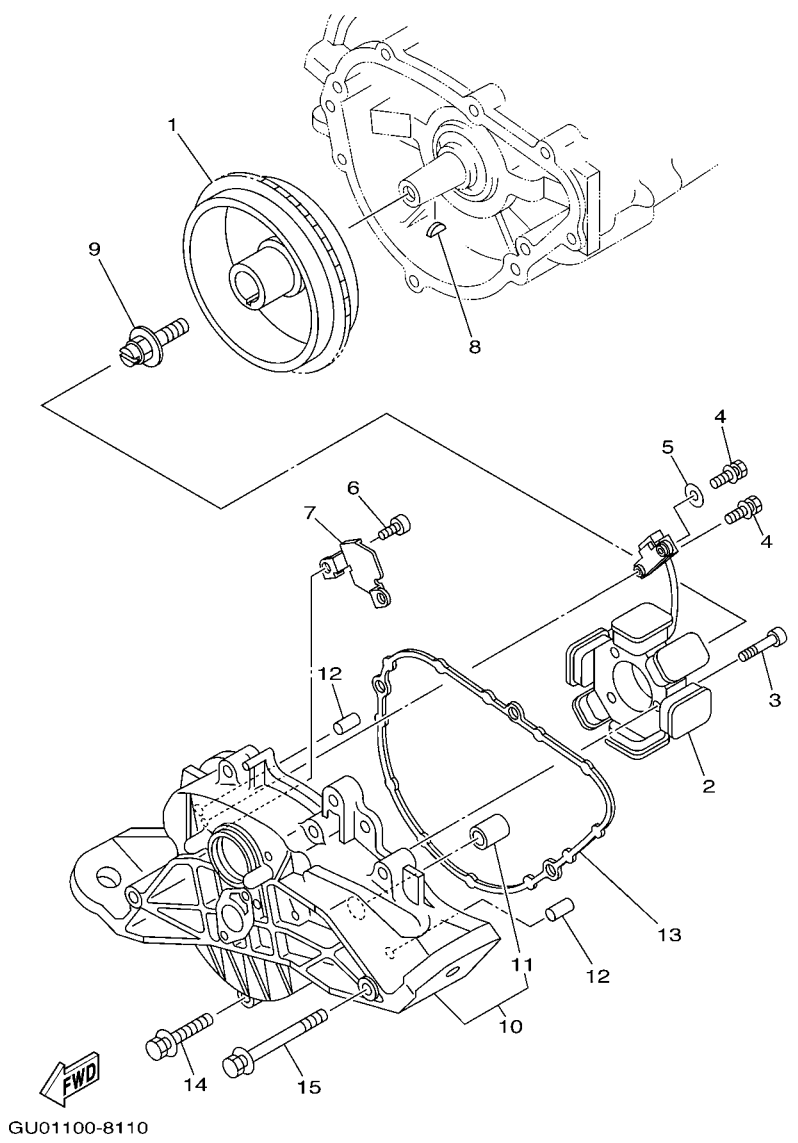

REF. NO.	PART NO.	DESCRIPTION	USA	GENE	REMARKS
1	66E-85550-00	ROTOR ASSY	1	1	
2	66E-85510-00	STATOR ASSY	1	1	
3	91318-06030	BOLT	3	3	
4	97513-05514	BOLT, WITH WASHER	2	2	
5	90201-05M09	WASHER, PLATE	1	1	
6	91318-06014	BOLT	2	2	
7	66E-81328-00	CLAMP	1	1	
8	90280-05013	KEY, WOODRUFF	1	1	
9	90109-10M72	BOLT	1	1	
10	66E-81337-11-8S	COVER, FLYWHEEL	1	1	
11	90380-12M29	.BUSH, SOLID	1	1	
12	93608-16M16	PIN, DOWEL	2	2	
13	66E-81168-10	O-RING	1	1	
14	90119-08M18	BOLT, WITH WASHER	6	6	
15	90119-08M55	BOLT, WITH WASHER	2	2	

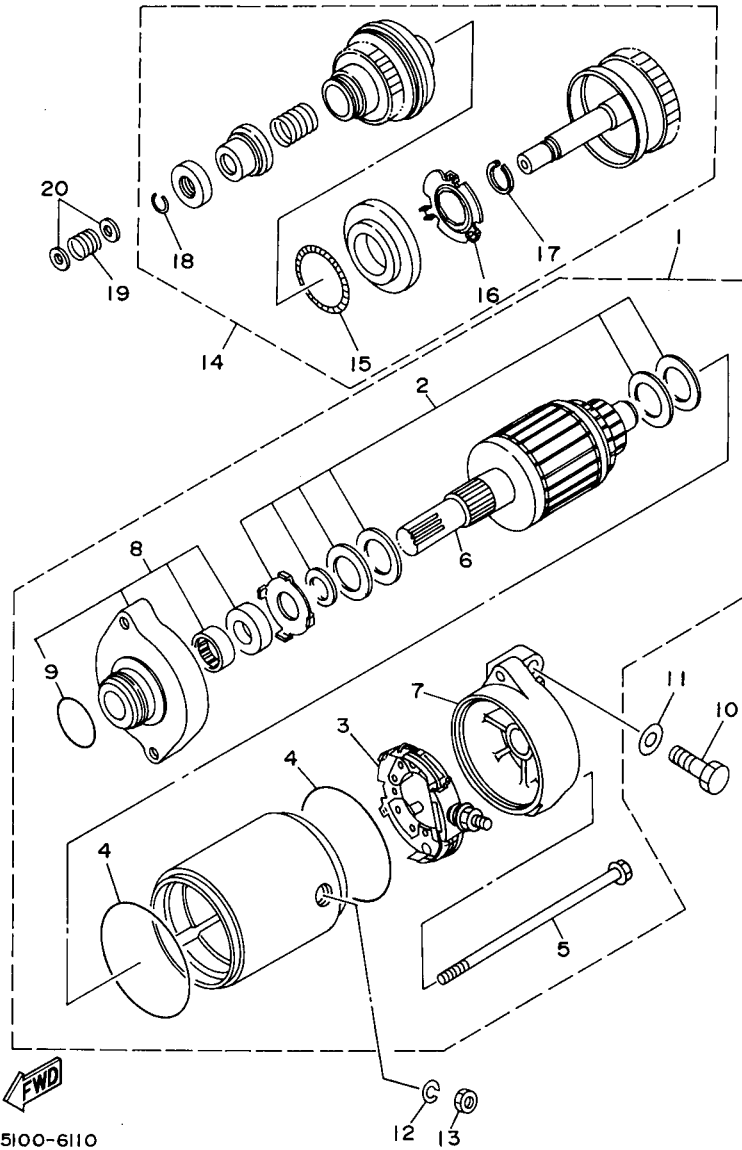

FIG. 13 STARTING MOTOR

REF. NO.	PART NO.	DESCRIPTION	USA	GENE	REMARKS
1	63M-81800-00	STARTING MOTOR ASSY	1	1	
2	3AJ-81809-00	.WASHER KIT	1	1	
3	6M6-81840-10	.BRUSH HOLDER ASSY	1	1	
4	11H-81844-00	.GASKET	2	2	
5	6M6-81826-00	.BOLT	2	2	
6	6M6-81850-00	.ARMATURE ASSY	1	1	
7	63M-81830-00	.REAR BRACKET ASSY	1	1	
8	6M6-81830-00	.FRONT BRACKET ASSY	1	1	
9	1FK-81847-00	..O-RING	1	1	
10	97013-08025	BOLT	2	2	
11	92903-08600	WASHER, PLATE	2	2	
12	92990-06100	WASHER, SPRING	1	1	
13	95380-06700	NUT	1	1	
14	6M6-8183E-01	IDLE GEAR COMP.	1	1	
15	6M6-81866-00	.WEIGHT SPRING	1	1	
16	6M6-81865-00	.WEIGHT HOLDER	1	1	
17	93440-25M08	.CIRCLIP	1	1	
18	93450-18M06	.CIRCLIP	1	1	
19	90501-14M73	SPRING, COMPRESSION	1	1	
20	92903-06600	WASHER, PLATE	2	2	

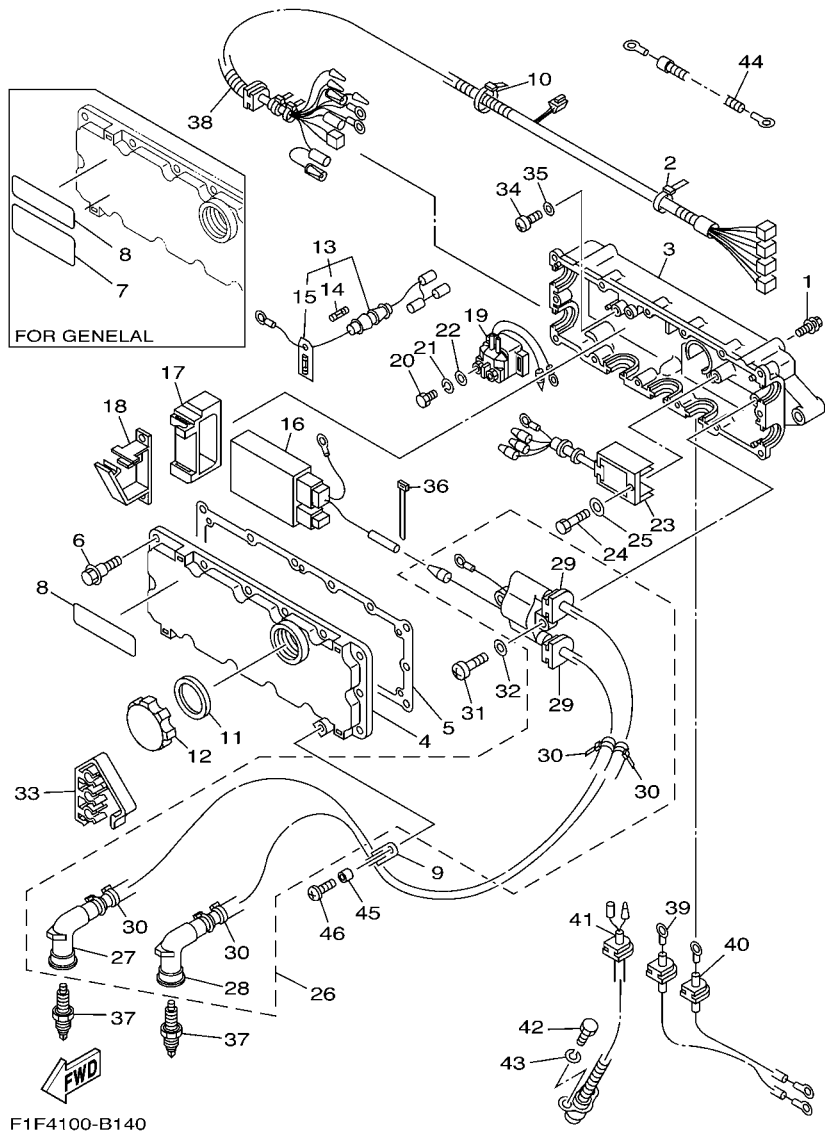

FIG. 14 ELECTRICAL 1

REF. NO.	PART NO.	DESCRIPTION	USA	GENE	REMARKS
1	90119-08827	BOLT, WITH WASHER	2	2	YMUS
2	90465-12M56	CLAMP	1	1	
3	66E-8552A-00-94	HOUSING	1	1	
4	66E-8552E-00	COVER, CASE	1	1	
5	66E-81921-00	GASKET, TERMINAL	1	1	
6	90109-05MA0	BOLT	14	14	
7	6R7-83623-50	MARK 3	1		
8	6R7-83623-40	MARK 3	1	1	
9	90465-12M53	CLAMP	1	1	
10	90465-13M36	CLAMP	4	4	
11	6M6-81844-00	GASKET	1	1	
12	6M6-8132W-00	CAP	1	1	
13	66E-82150-00	FUSE HOLDER ASSY	1	1	
14	6G1-82151-00	.FUSE (10A)	1	1	
15	6K8-82159-00	.FUSE SPEAR (10A)	1	1	
16	66E-85540-00	C.D.I. UNIT ASSY	1	1	
17	64X-85546-00	BAND	1	1	
18	90464-06M29	CLAMP	1	1	
19	68N-81940-00	STARTER RELAY ASSY	1	1	
20	97095-06010	BOLT	2	2	
21	92995-06100	WASHER, SPRING	2	2	
22	92995-06600	WASHER	2	2	
23	63M-81960-00	RECTIFIER & REGULATOR ASSY	1	1	
24	97095-06012	BOLT	1	1	
25	92995-06600	WASHER	1	1	
26	64X-85570-01	IGNITION COIL ASSY	1	1	
27	62E-82371-11	.CAP, PLUG	1	1	

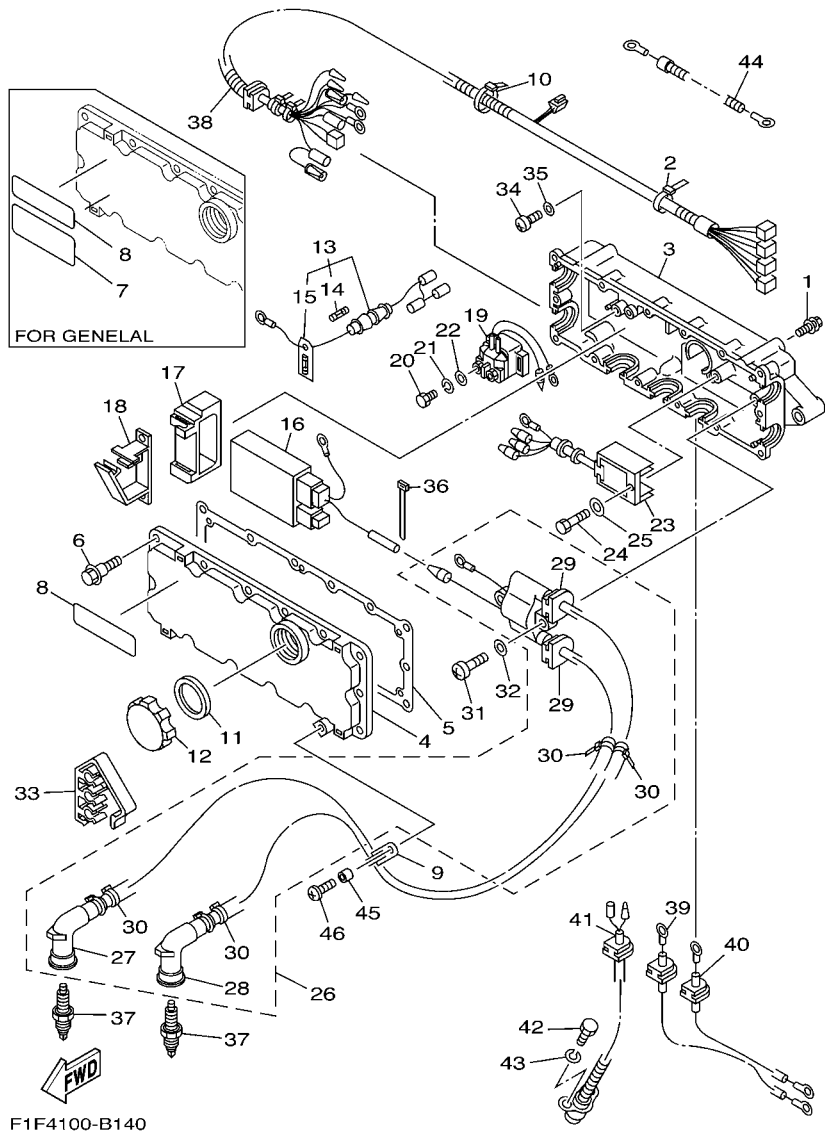
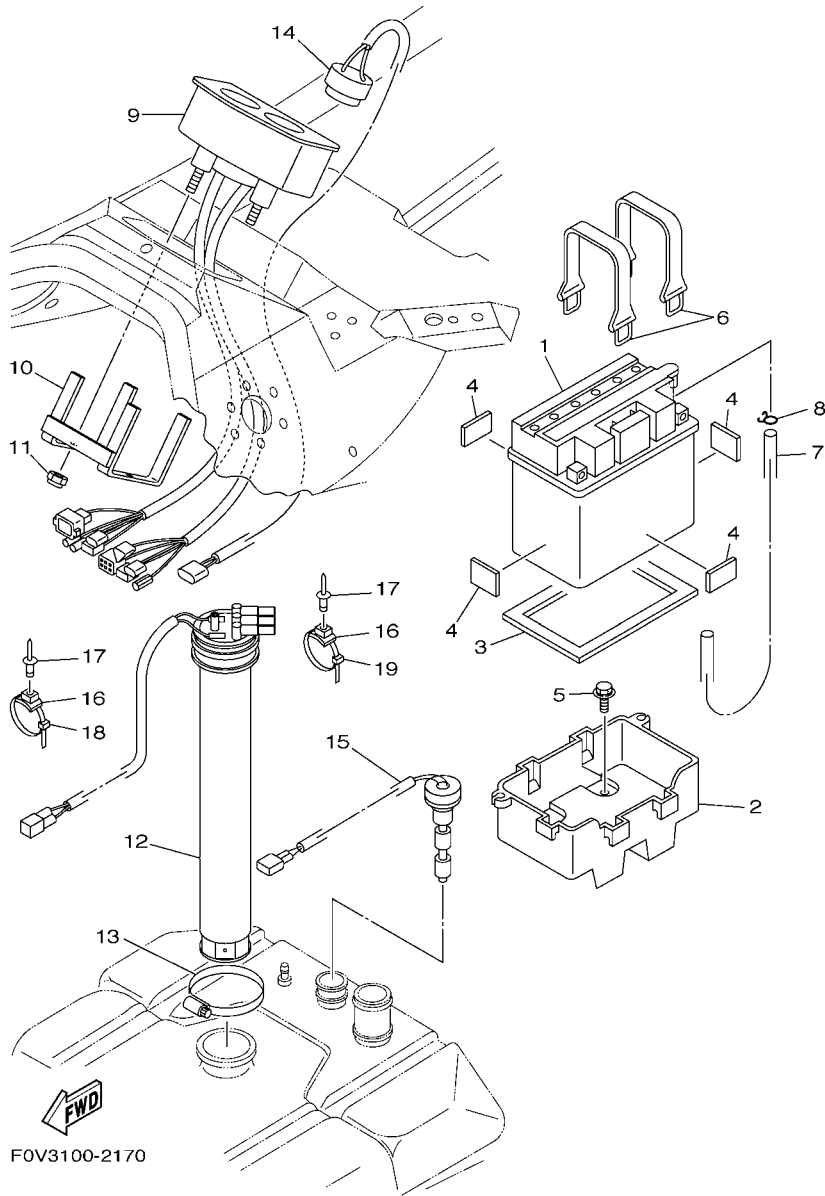

FIG. 14 ELECTRICAL 1

REF. NO.	PART NO.	DESCRIPTION	USA	GENE	REMARKS
28	62E-82371-11	.CAP, PLUG	1	1	
29	90480-06M43	.GROMMET	2	2	
30	90465-11M10	.CLAMP	4	4	
31	97880-06030	SCREW, PAN HEAD	2	2	
32	92990-06600	WASHER, PLATE	2	2	
33	65U-81317-10	CLAMP, CORD	1	1	
34	97880-06016	SCREW, PAN HEAD	2	2	
35	92990-06600	WASHER, PLATE	2	2	
36	90465-11M10	CLAMP	1	1	
37	94702-00204	PLUG, SPARK (NGK BR8ES)	2	2	
38	60G-82553-00	EXTENSION, WIRE LEAD	1	1	
39	6M6-82117-21	WIRE, LEAD	1	1	
40	66E-82117-10	WIRE, LEAD	1	1	
41	68A-82560-00	THERMO SWITCH ASSY	1	1	
42	97095-06016	BOLT	2	2	
43	92995-06100	WASHER, SPRING	2	2	
44	61L-82117-00	WIRE, LEAD	1	1	
45	90387-06M05	COLLAR	1	1	
46	97780-60425	SCREW, TAPPING	1	1	



F0V3100-2170

FIG. 15 ELECTRICAL 2

REF. NO.	PART NO.	DESCRIPTION	USA	GENE	REMARKS
1	EU0-82110-09	BATTERY ASSY (YB16CL-B)	1	1	YUASA
2	GP7-U8211-00	CASE, BATTERY	1	1	YMUS
3	F0X-U8221-00	PAD, BATTERY	1	1	YMUS
4	EU0-U8221-30	PAD, BATTERY 2	4	4	YMUS
5	90119-069US	BOLT, WITH WASHER	4	4	YMUS
6	EU0-U821D-00	BAND, BATTERY 2	2	2	YMUS
7	F0D-U785G-10	HOSE, AIR VENT	1	1	YMUS
8	90467-089U1	CLIP	1	1	YMUS
9	F0P-6820A-01	METER ASSY	1		FOR USA
	F0P-6820A-11	METER ASSY		1	FOR GENE
10	F0D-68238-10	BRACKET, METER	1	1	
11	9572R-05300	NUT, FLANGE	2	2	YMUS
12	F0V-U824B-03	SENDER, FUEL	1	1	YMUS
13	90601-162U5	BAND, HOSE 62	1	1	YMUS
14	F0D-U8341-00	BUZZER	1	1	YMUS
15	F0D-U824C-20	SENDER, OIL	1	1	YMUS
16	90600-917U4	CLAMP COMP.	8	8	YMUS
17	90267-48802	RIVET, BLIND	7	7	YMUS
18	90464-32801	CLAMP	2	2	YMUS
19	90601-20009	BAND	5	5	

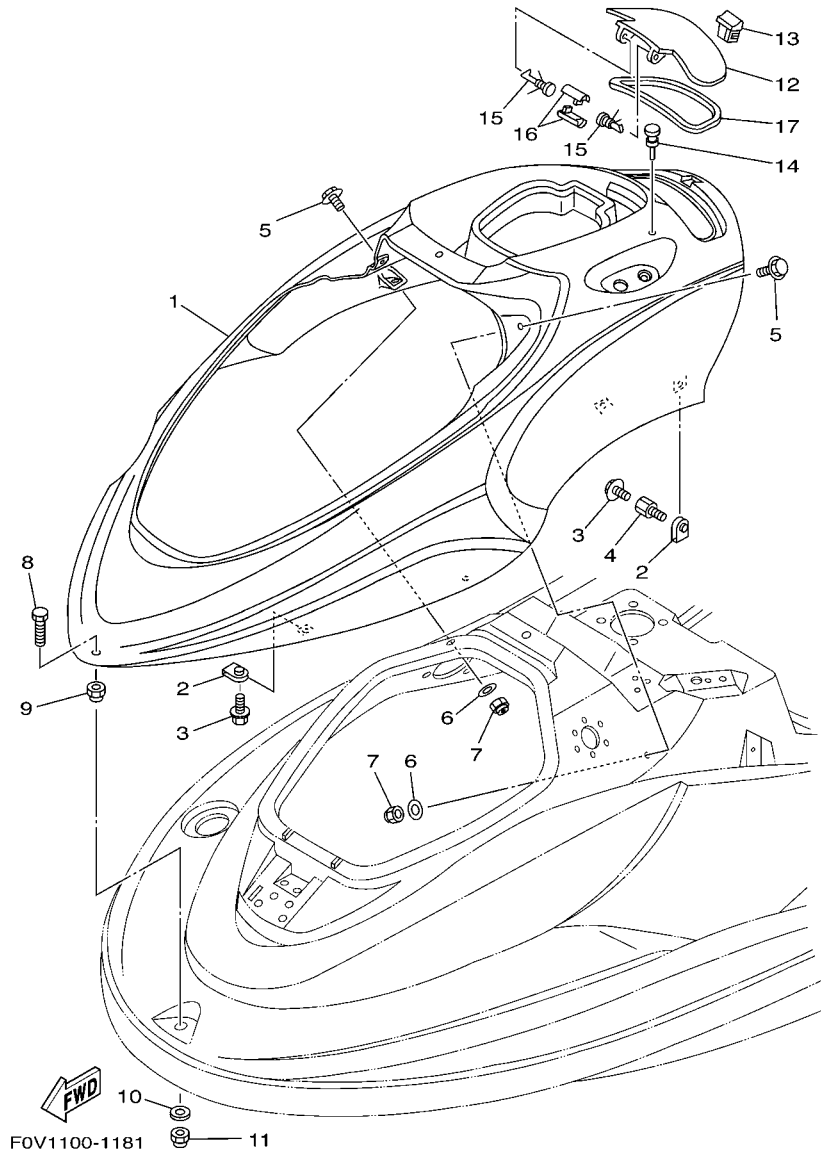
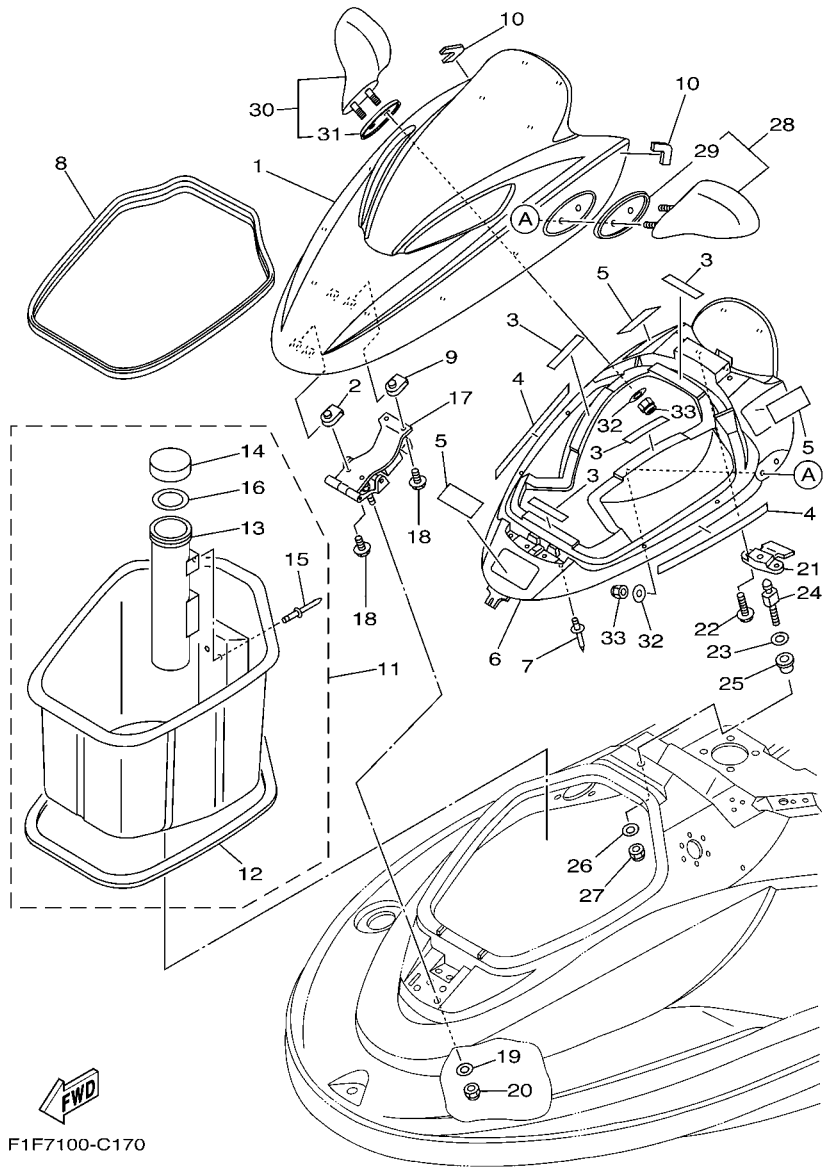

FIG. 16 ENGINE HATCH 1

REF. NO.	PART NO.	DESCRIPTION	USA	GENE	REMARKS
1	F0V-U516N-A0-P1	COVER, ENGINE HATCH	1	1	BMD, YMUS
2	90183-06902	NUT, SPRING	8	8	
3	90119-06858	BOLT, WITH WASHER	8	8	YMUS
4	F0V-U7772-00	NUT, JOINT	2	2	YMUS
5	90119-06803	BOLT, WITH WASHER	2	2	YMUS
6	9299R-06200	WASHER	2	2	YMUS
7	9572R-06300	NUT, NYLON	2	2	YMUS
8	9708R-06030	BOLT	1	1	YMUS
9	9538R-06700	NUT	1	1	YMUS
10	9299R-06200	WASHER	1	1	YMUS
11	9572R-06300	NUT, NYLON	1	1	YMUS
12	F0V-U517H-20	LID HATCH	1	1	YB, YMUS
13	F0D-62875-00	LOCK	1	1	
14	90605-502U2	PLUG	1	1	YMUS
15	F0D-6517R-00	PIN, HINGE	2	2	
16	F0D-6517T-00	JOINT, HINGE	2	2	
17	F0D-U519D-00	PACKING CASE	1	1	YMUS

FIG. 17 ENGINE HATCH 2



F1F7100-C170

REF. NO.	PART NO.	DESCRIPTION	USA	GENE	REMARKS
1	F0V-U517B-A0-P1	LID, ENGINE ROOM	1	1	BMD, YMUS
2	90183-06902	NUT, SPRING	2	2	
3	F0V-U3635-00	TAPE, FITTING	4	4	YMUS
4	F0V-U3635-10	TAPE, FITTING	2	2	YMUS
5	F0V-U3635-20	TAPE, FITTING	3	3	YMUS
6	F0V-U2103-10	VENTILATOR COVER COMP., 2	1	1	YMUS
7	90267-48809	RIVET, BLIND	10	10	YMUS
8	F0V-U266B-00	PACKING 3	1	1	YMUS
9	90183-06902	NUT, SPRING	2	2	
10	F0V-U517M-00	PAD, HATCH 1	2	2	YMUS
11	F0D-U475A-00	BOWLOCKER ASSY	1	1	YMUS
12	GJ3-U266C-31	.PACKING 4	1	1	YMUS
13	GP7-U5983-00	.BOX, FIRE EXTINGUISHER	1	1	YMUS
14	EW2-U5912-01	.CAP, CASE	1	1	YMUS
15	90267-489UP	.RIVET, BLIND	3	3	YMUS
16	EW2-U5913-01	.PACKING, CASE	1	1	YMUS
17	F0V-6515A-01	HINGE ASSY.	1	1	
18	90119-069UB	BOLT, WITH WASHER	4	4	YMUS
19	90201-06802	WASHER, PLATE	4	4	YMUS
20	9572R-06300	NUT, NYLON	4	4	YMUS
21	F0D-6517C-04	LOCK, LID	1	1	
22	90119-069UH	BOLT, WITH WASHER	2	2	YMUS
23	F0V-U515E-00	DAMPER 2	1	1	YMUS
24	F0D-63774-01	PIN	1	1	
25	90387-08802	COLLAR	1	1	YMUS
26	9299R-08200	WASHER	1	1	YMUS
27	9572R-08300	NUT, FLANGE	1	1	YMUS

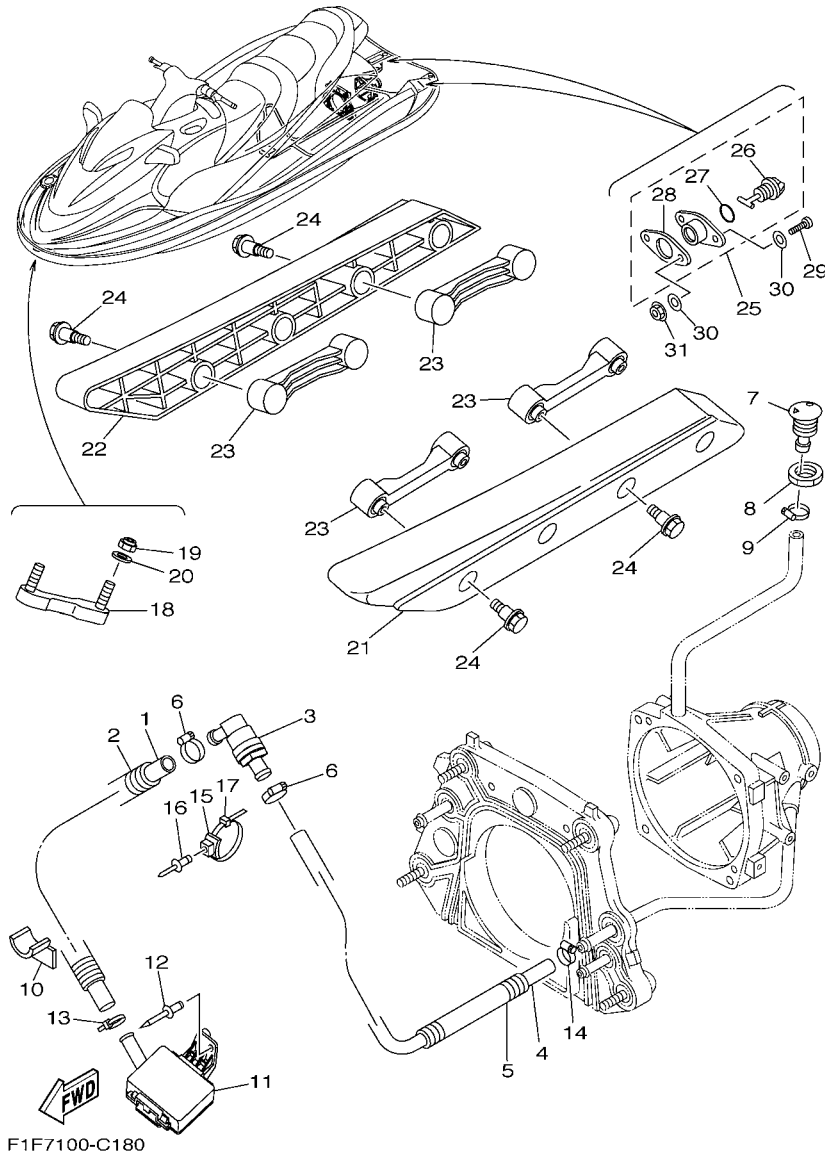

FIG. 18 HULL & DECK

REF. NO.	PART NO.	DESCRIPTION	USA	GENE	REMARKS
1	90445-198C0	HOSE (L1000)	1	1	YMUS
2	90446-27M73	HOSE (L700)	1	1	
3	68N-5112T-00	JOINT, HOSE	1	1	
4	90445-198B9	HOSE (L650)	1	1	YMUS
5	90446-27M55	TUBE (L400)	1	1	
6	90601-118UF	BAND, HOSE 18	2	2	YMUS
7	FN8-6269B-00	SPOUT	1	1	
8	EU0-61652-00	NUT	1	1	
9	90601-118UF	BAND, HOSE 18	1	1	YMUS
10	GJ1-U7578-21	PACKING, HOSE 2	1	1	YMUS
11	F1B-U761D-01	STRAINER, BILGE	1	1	YMUS
12	90267-489U8	RIVET, BLIND	1	1	YMUS
13	90465-11829	CLAMP	1	1	YMUS
14	90601-118UF	BAND, HOSE 18	1	1	YMUS
15	90600-917U4	CLAMP COMP.	2	2	YMUS
16	90267-48802	RIVET, BLIND	2	2	YMUS
17	90464-32801	CLAMP	2	2	YMUS
18	F0D-61624-01	BOWEYE 1 (S)	1	1	
19	9572R-08300	NUT, FLANGE	2	2	YMUS
20	9299R-08200	WASHER	2	2	YMUS
21	F0D-U883N-20	STABILIZER LH	1	1	YB, YMUS
22	F0D-U883P-20	STABILIZER RH	1	1	YB, YMUS
23	F1F-U883T-01	BRACKET,STABILIZER	4	4	YMUS
24	F0V-U2624-00	BOLT	8	8	YMUS
25	EU0-62280-00	DRAIN PLUG ASSY	2	2	
26	EU0-62282-00	.PLUG, DRAIN	1	1	
27	EU0-62283-00	.O-RING	1	1	

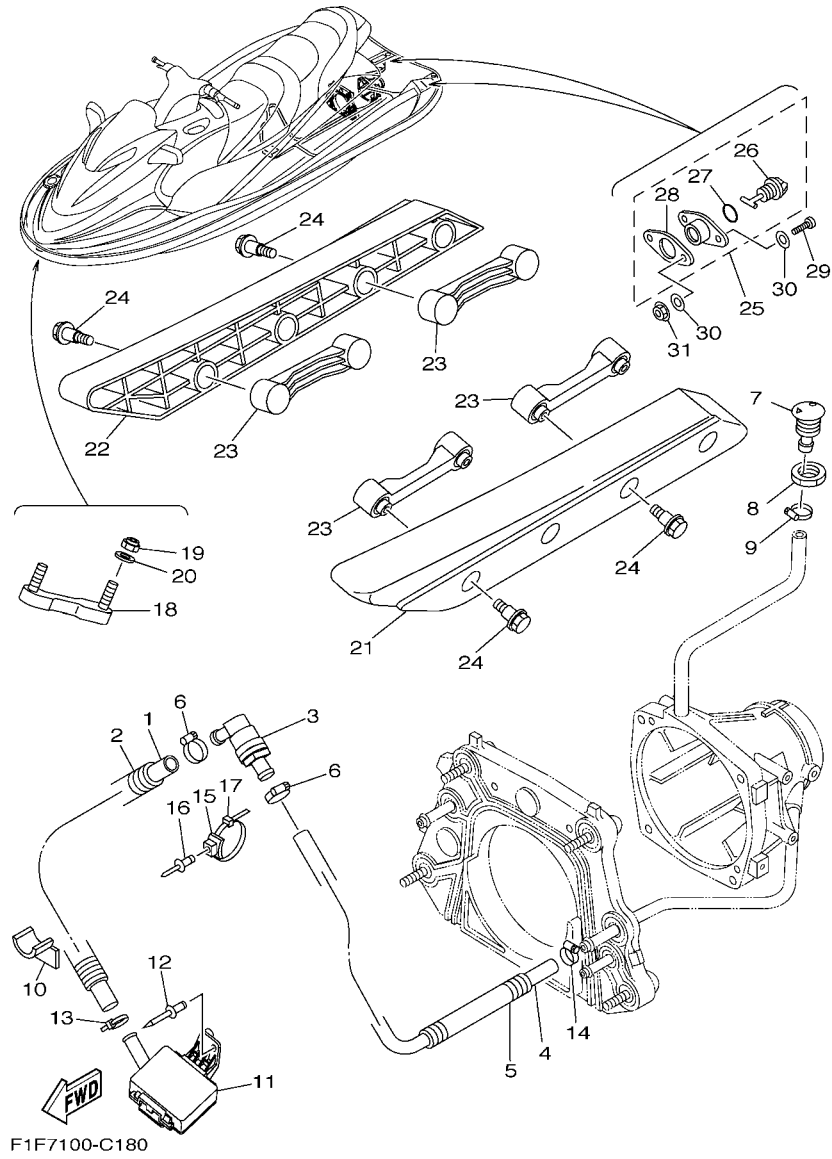
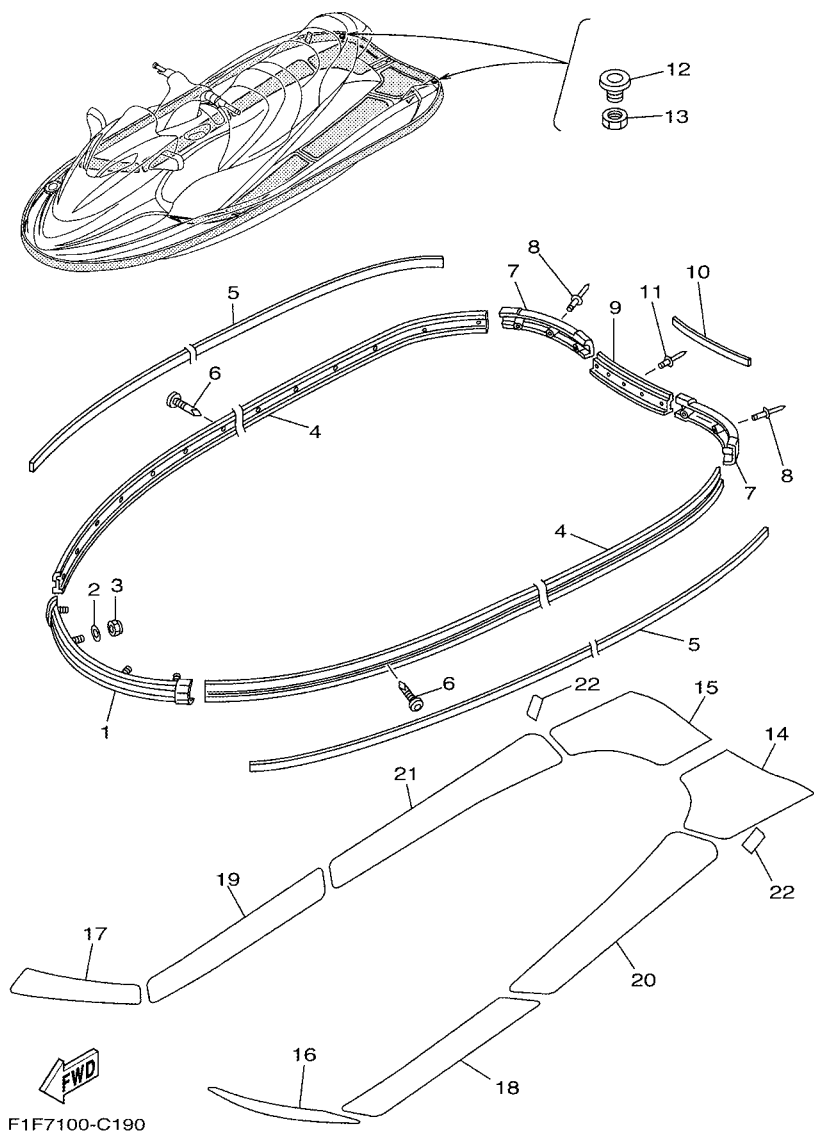

FIG. 18 HULL & DECK

REF. NO.	PART NO.	DESCRIPTION	USA	GENE	REMARKS
28	EU0-62285-01	.PACKING DRAIN (EU0)	1	1	
29	9788R-05025	SCREW, PAN HEAD	4	4	YMUS
30	9299R-05200	WASHER	8	8	YMUS
31	9572R-05300	NUT, FLANGE	4	4	YMUS

FIG. 19 GUNWALE & MAT



REF. NO.	PART NO.	DESCRIPTION	USA	GENE	REMARKS
1	GP7-U2501-20	BOW GUNWALE COMP.	1	1	YB, YMUS
2	9299R-06200	WASHER	4	4	YMUS
3	9572R-06300	NUT, NYLON	4	4	YMUS
4	F0D-U2512-00	GUNWALE, SIDE	2	2	YB, YMUS
5	F1F-U2519-01	INNER, GUNWALE	2	2	BL, YMUS
6	90169-059U1	SCREW, TAPPING	32	32	YMUS
7	F0D-U251D-00	GUNWALE, STERN 1	2	2	YB, YMUS
8	90267-47801	RIVET, BLIND	6	6	YMUS
9	F0D-U252C-00	COVER, GUNWALE 1	1	1	YB, YMUS
10	F0V-U252D-00	COVER, GUNWALE 2	1	1	YB, YMUS
11	90267-489US	RIVET, BLIND	4	4	YMUS
12	GH1-61651-01	ROPE HOLE	2	2	
13	EU0-61652-00	NUT	2	2	
14	F0V-U358F-03	MAT, UPPER LH	1	1	BL, YMUS
15	F0V-U358G-03	MAT, UPPER RH	1	1	BL, YMUS
16	F0P-U351H-00	MAT, STEP 1	1	1	BL, YMUS
17	F0P-U351J-00	MAT, STEP 2	1	1	BL, YMUS
18	F0V-U351K-00	MAT, STEP 3	1	1	BL, YMUS
19	F0V-U351M-00	MAT, STEP 4	1	1	BL, YMUS
20	F0V-U351N-00	MAT, STEP 5	1	1	BL, YMUS
21	F0V-U351P-00	MAT, STEP 6	1	1	BL, YMUS
22	F0D-U351R-00	MAT, STEP 7	2	2	BL, YMUS

FIG. 20 VENTILATION

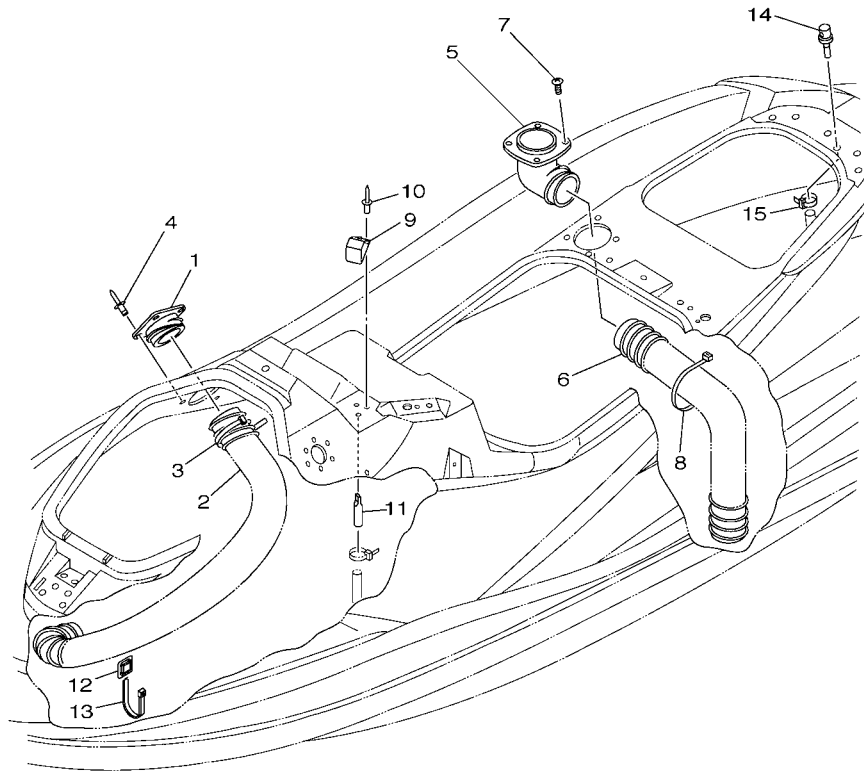

REF. NO.	PART NO.	DESCRIPTION	USA	GENE				REMARKS
1	F0D-62127-00	BASE, AIR INTAKE	1	1				
2	F0D-U213F-05	HOSE, VENTILATOR 1	1	1				YMUS
3	90464-99804	CLAMP	1	1				YMUS
4	90267-489UE	RIVET, BLIND	4	4				YMUS
5	F0D-62139-00	VENTILATOR, OUTLET	1	1				
6	F0D-U213G-04	HOSE, VENTILATOR 2	1	1				YMUS
7	90149-05962	SCREW	4	4				
8	90601-200U7	BAND	2	2				YMUS
9	GP7-62159-01	SOCKET, VENTILATION	1	1				
10	90267-48802	RIVET, BLIND	2	2				YMUS
11	EW2-62149-00	PIPE, VENTILATION 1	1	1				
12	90600-900U6	BASE, CLAMP	1	1				YMUS
13	90465-11829	CLAMP	1	1				YMUS
14	GJ3-6215F-00	NIPPLE	1	1				
15	90464-99801	CLAMP	1	1				YMUS

F1F1100-2200

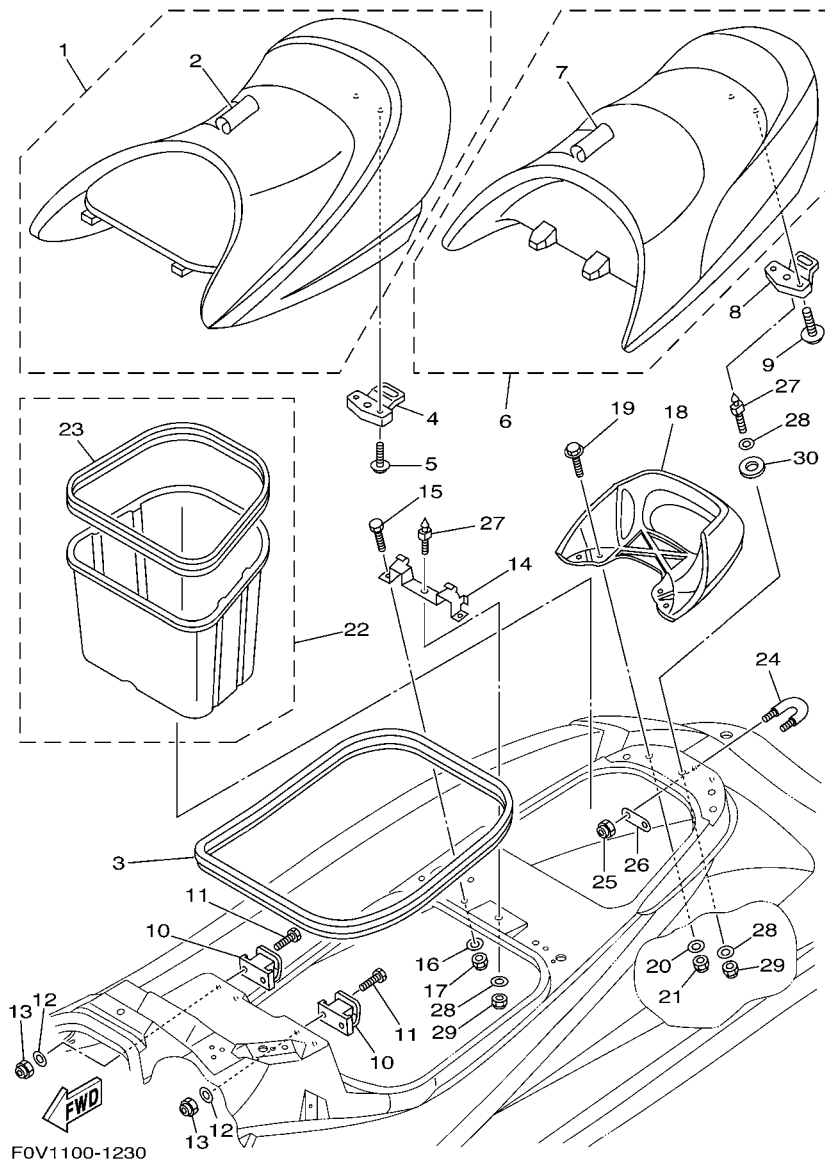

FIG. 21 SEAT & UNDER LOCKER

REF. NO.	PART NO.	DESCRIPTION	USA	GENE	REMARKS
1	F0V-U371A-50	DOUBLE SEAT ASSY	1	1	YMUS
2	F0V-U371B-50	.COVER, SEAT 1	1	1	YMUS
3	F0D-U266C-00	PACKING 4	1	1	YMUS
4	F0D-63850-01	SEAT LOCK ASSY	1	1	
5	90119-069UP	BOLT, WITH WASHER	2	2	YMUS
6	F0V-U372A-50	SINGLE SEAT ASSY	1	1	YMUS
7	F0V-U372B-50	.COVER, SEAT	1	1	YMUS
8	F0D-63850-01	SEAT LOCK ASSY	1	1	
9	90119-069UP	BOLT, WITH WASHER	2	2	YMUS
10	F0V-U378C-00	STAY, SEAT 1	2	2	YMUS
11	90101-069U0	BOLT	4	4	YMUS
12	9299R-06200	WASHER	4	4	YMUS
13	9572R-06300	NUT, NYLON	4	4	YMUS
14	F0D-6378D-01	STAY, SEAT 2	1	1	
15	97080-10025	BOLT	2	2	
16	9299R-10200	WASHER	2	2	YMUS
17	9572R-10300	NUT, FLANGE	2	2	YMUS
18	F0D-U271B-00	GRIP, HAND	1	1	YB, YMUS
19	90119-06820	BOLT, WITH WASHER	4	4	YMUS
20	9299R-06200	WASHER	4	4	YMUS
21	9572R-06300	NUT, NYLON	4	4	YMUS
22	F0D-U474A-00	UNDER LOCKER ASSY	1	1	YMUS
23	F0D-U266D-00	.PACKING 5	1	1	YMUS
24	GP7-61628-00	STERN EYE	1	1	
25	9572R-08300	NUT, FLANGE	2	2	YMUS
26	GP7-U4953-00	PLATE A	1	1	YMUS
27	GH1-U3774-00	PIN	2	2	YMUS

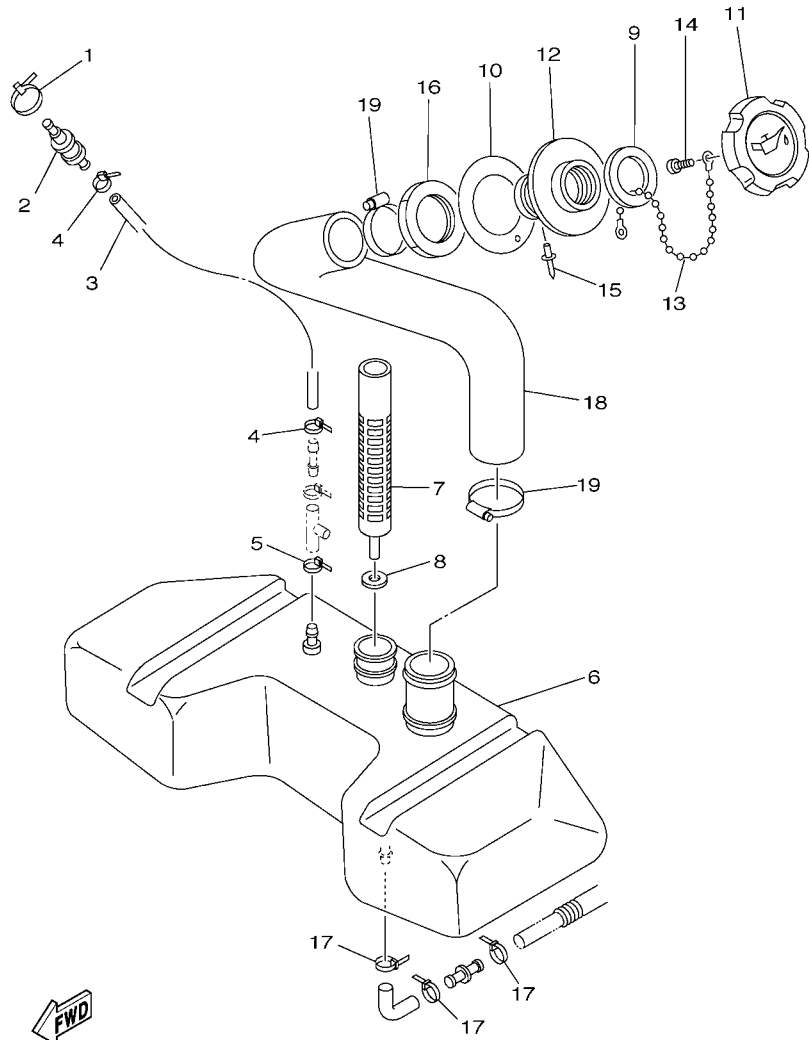
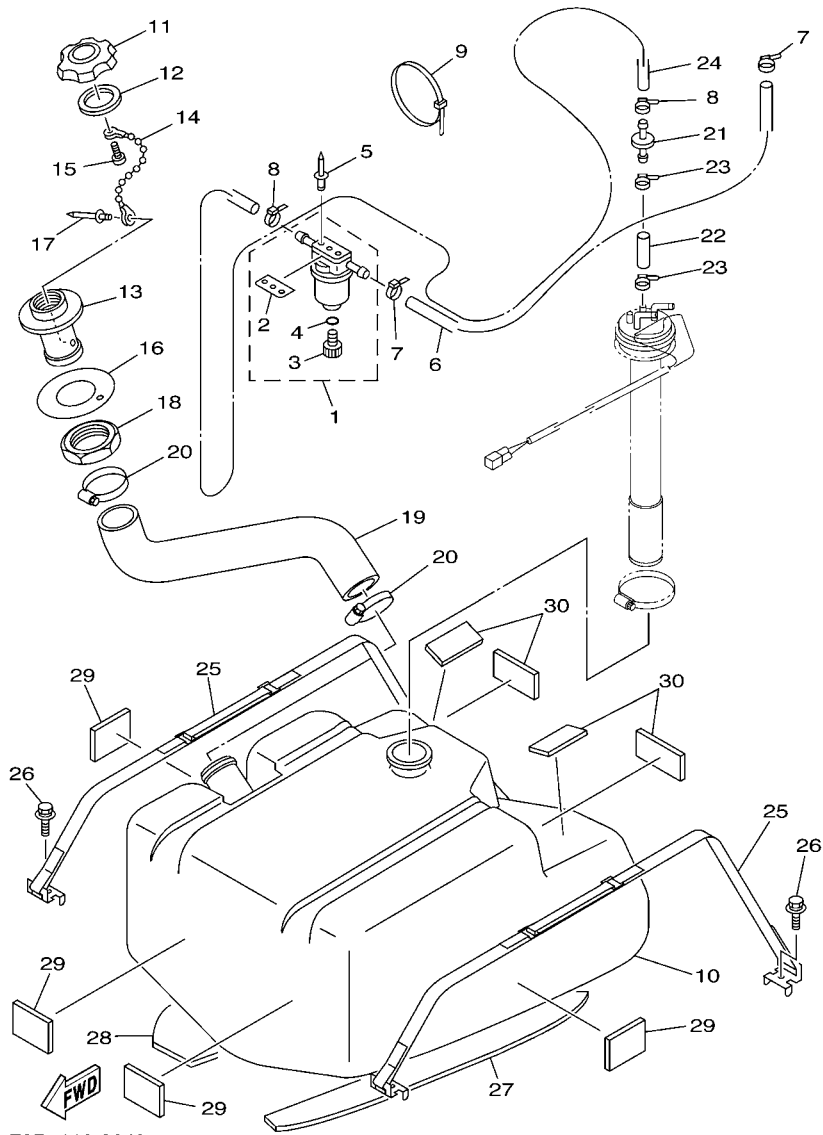

FIG. 22 OIL TANK

REF. NO.	PART NO.	DESCRIPTION	USA	GENE	REMARKS
1	90464-32801	CLAMP	2	2	YMUS
2	FJ0-67766-00	ROLL OVER VALVE	1	1	
3	GJ3-U7856-20	HOSE, AIR VENT 3	1	1	YMUS
4	90465-11829	CLAMP	2	2	YMUS
5	90465-11829	CLAMP	1	1	YMUS
6	F0D-U775B-02	TANK, OIL	1	1	YMUS
7	F0D-6775C-01	FILTER	1	1	
8	F0D-6775E-01	PACKING	1	1	
9	GJ3-U778C-00	PACKING,OIL CAP	1	1	YMUS
10	F0X-U778E-00	PACKING,OIL FILLER	1	1	YMUS
11	GJ3-U778B-00	CAP,OIL FILLER	1	1	YMUS
12	F0X-U778D-00	SOCKET,OIL FILLER	1	1	YMUS
13	EU0-U7835-00	CHAIN BALL	1	1	YMUS
14	97780-04110	SCREW, TAPPING	1	1	
15	90267-40935	RIVET, BLIND	1	1	
16	F0X-U778H-00	NUT, OIL FILLER	1	1	YMUS
17	90465-11829	CLAMP	3	3	YMUS
18	F0D-U776C-10	HOSE,OIL FILLER	1	1	YMUS
19	90601-142U6	BAND, HOSE 42	2	2	YMUS

FWD
F1F1100-2220



FOD5110-0240

FIG. 23 FUEL TANK

REF. NO.	PART NO.	DESCRIPTION	USA	GENE	REMARKS
28	F0D-U759B-10	MAT 1	1	1	YMUS
29	F0D-U759C-00	MAT 2	4	4	YMUS
30	GJ1-U759C-00	MAT 2	4	4	YMUS

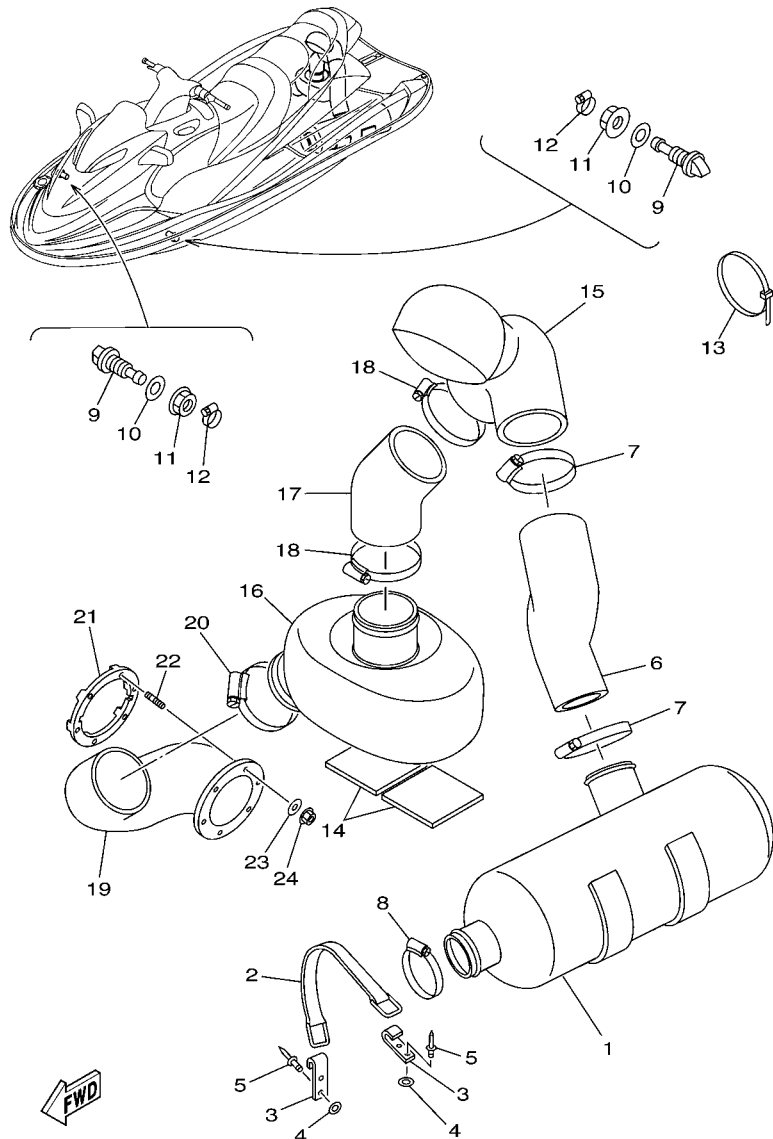

F1F4100-B240

FIG. 24 EXHAUST 2

REF. NO.	PART NO.	DESCRIPTION	USA	GENE	REMARKS
1	F0P-67550-01	WATER LOCK COMP.	1	1	
2	GA7-6756E-00	BAND,WATER LOCK	1	1	
3	GA7-65772-00	HOOK A	2	2	
4	9299R-05200	WASHER	4	4	YMUS
5	90267-489U7	RIVET, BLIND	4	4	YMUS
6	F0P-U758B-00	HOSE,EXHAUST 1	1	1	YMUS
7	90601-175UR	BAND, HOSE 75	2	2	YMUS
8	90601-195UD	BAND, HOSE 95	1	1	YMUS
9	F0P-6753B-00	PILOT, WATER	2	2	
10	90430-16910	GASKET	2	2	
11	F0X-62733-00	NUT	2	2	
12	90601-118UF	BAND, HOSE 18	2	2	YMUS
13	90464-32801	CLAMP	1	1	YMUS
14	F0D-U7578-00	PACKING, HOSE 2	2	2	YMUS
15	F0D-6753D-01	RESONATOR, 2	1	1	
16	F0D-64261-02	TANK, WATER	1	1	
17	F0D-6758C-01	HOSE,EXHAUST2	1	1	
18	90601-195UD	BAND, HOSE 95	2	2	YMUS
19	F0V-U758D-00	HOSE,EXHAUST 3	1	1	YMUS
20	90601-195UD	BAND, HOSE 95	1	1	YMUS
21	F0V-U757B-00	PLATE	1	1	YMUS
22	90116-06802	BOLT, STUD	6	6	YMUS
23	9299R-06200	WASHER	6	6	YMUS
24	9572R-06300	NUT, NYLON	6	6	YMUS

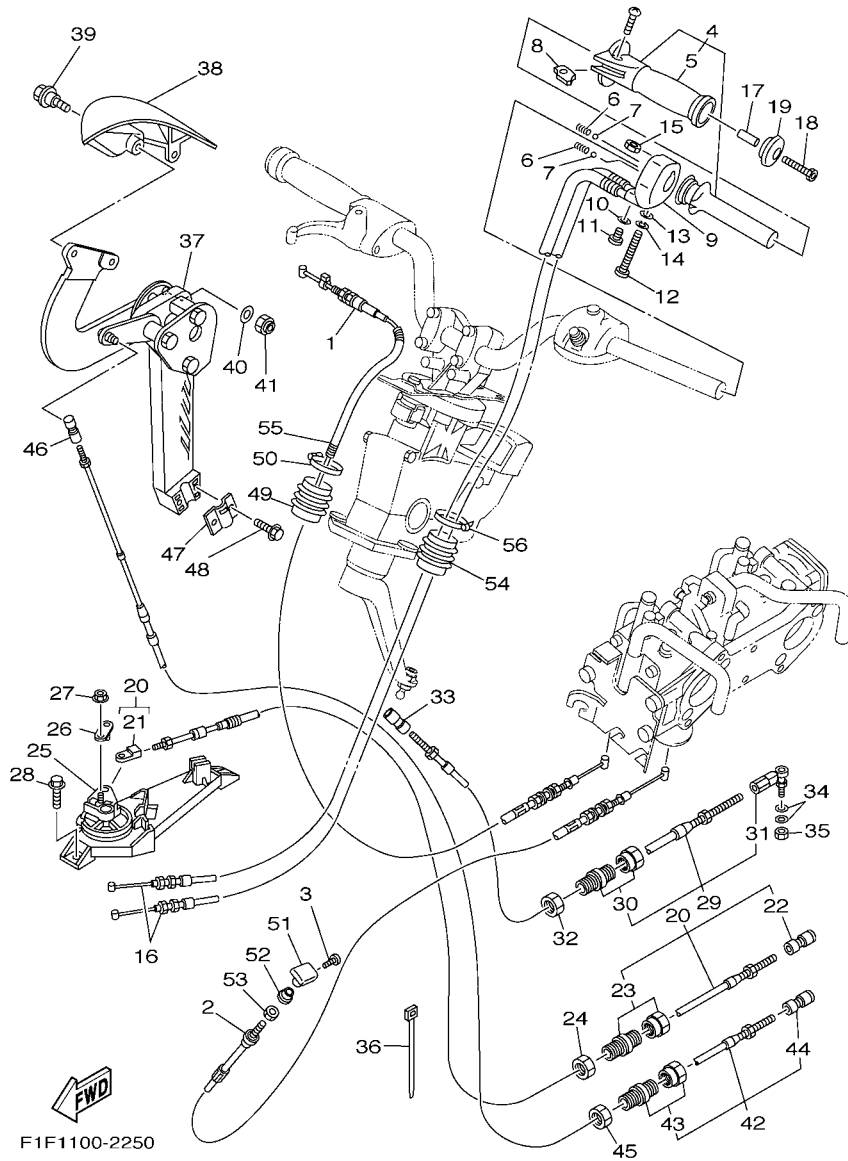

F1F1100-2250

FIG. 25 CONTROL CABLE

REF. NO.	PART NO.	DESCRIPTION	USA	GENE	REMARKS
1	66E-67252-00	CABLE, THROTTLE	1	1	
2	67A-67242-01	CABLE, CHOKE	1	1	
3	90149-03M15	SCREW	1	1	
4	GP7-U157A-00	GRIP HANDLE ASSY.	1	1	YMUS
5	GP7-U155C-00	.GRIP,HANDLE	1	1	YMUS
6	GP7-U152P-00	SPRING	2	2	YMUS
7	GP7-U152R-00	BALL	2	2	YMUS
8	GP7-U151M-00	LEVER ASSY	1	1	YMUS
9	GP7-U152M-00	HOUSING ASSY	1	1	YMUS
10	92990-04600	WASHER, PLATE	1	1	
11	98980-04010	SCREW, BIND	1	1	
12	97880-06065	SCREW, PAN HEAD	1	1	
13	92990-06600	WASHER, PLATE	1	1	
14	9299R-06100	WASHER	1	1	YMUS
15	GH1-U143B-00	NUT,SPECIAL	1	1	YMUS
16	F0D-U153D-01	CABLE,NOZZLE CONTROL 2	2	2	YMUS
17	90387-05800	COLLAR	1	1	YMUS
18	90110-05908	BOLT, HEXAGON SOCKET HEAD	1	1	
19	GP7-U155F-00	GRIP, END	1	1	YMUS
20	F0D-U153E-10	CABLE,NOZZLE CONTROL 3	1	1	YMUS
21	GH1-U046C-00	.END,CABLE	1	1	YMUS
22	EU0-U1461-30	.SHAFT, JOINT BALL	1	1	YMUS
23	EU0-67267-10	.CONNECTOR, CABLE	1	1	
24	EU0-62241-30	NUT, DRAIN 1	1	1	
25	F0D-U153J-10	REMOCON,NOZZLE 2	1	1	YMUS
26	F0D-U152C-10	PIN	1	1	YMUS
27	9572R-06300	NUT, NYLON	1	1	YMUS

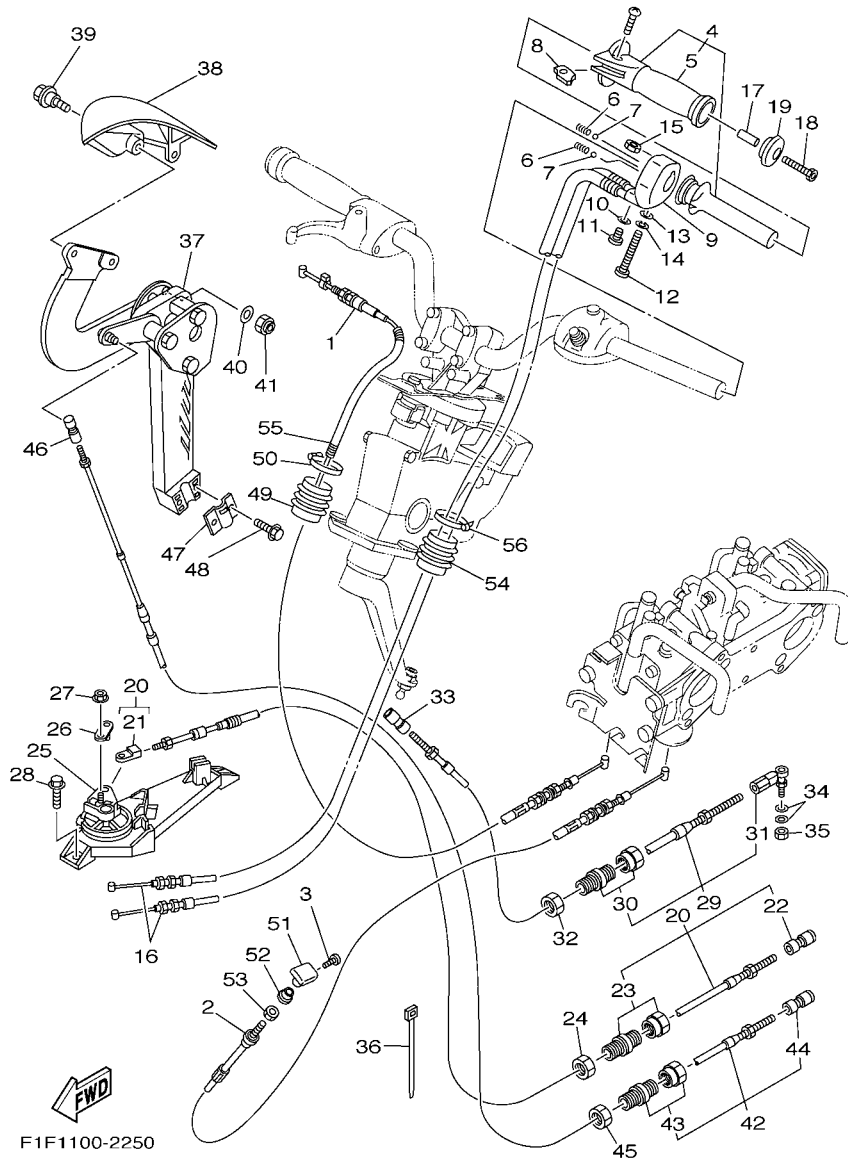

FIG. 25 CONTROL CABLE

REF. NO.	PART NO.	DESCRIPTION	USA	GENE	REMARKS
28	90119-069UJ	BOLT, WITH WASHER	2	2	YMUS
29	F0D-U1481-10	CABLE, STEERING	1	1	YMUS
30	GK5-67267-10	.CONNECTOR, CABLE	1	1	
31	GP8-U1461-T0	.STUD, JOINT BALL	1	1	YMUS
32	EU0-62241-30	NUT, DRAIN 1	1	1	
33	GK5-U146F-00	SHAFT, JOINT BALL	1	1	YMUS
34	90201-06906	WASHER, PLATE	2	2	
35	9538R-06700	NUT	1	1	YMUS
36	90601-200U1	BAND	1	1	YMUS
37	F0V-6134A-00	REMOCON. LEVER ASSY.	1	1	
38	F0V-U2714-00	GRIP	1	1	YMUS
39	90109-06803	BOLT	2	2	YMUS
40	9299R-06200	WASHER	3	3	YMUS
41	9572R-06300	NUT, NYLON	3	3	YMUS
42	F0V-U149C-00	CABLE, REVERSE	1	1	YMUS
43	F0V-U7267-00	.CONNECTOR, CABLE	1	1	YMUS
44	F0V-U1461-00	.STUD, JOINT BALL	1	1	YMUS
45	EU0-62241-30	NUT, DRAIN 1	1	1	
46	EU0-U1461-30	SHAFT, JOINT BALL	1	1	YMUS
47	GH1-61468-01	STOPPER, CABLE	1	1	
48	90119-069UJ	BOLT, WITH WASHER	2	2	YMUS
49	F0D-6822E-00	GROMMET	1	1	
50	90601-200U1	BAND	1	1	YMUS
51	EW2-67243-00	KNOB	1	1	
52	F0N-6724E-00	NUT, COMPRESSION	1	1	
53	F0P-6724F-00	NUT	1	1	
54	F0D-6822E-00	GROMMET	1	1	

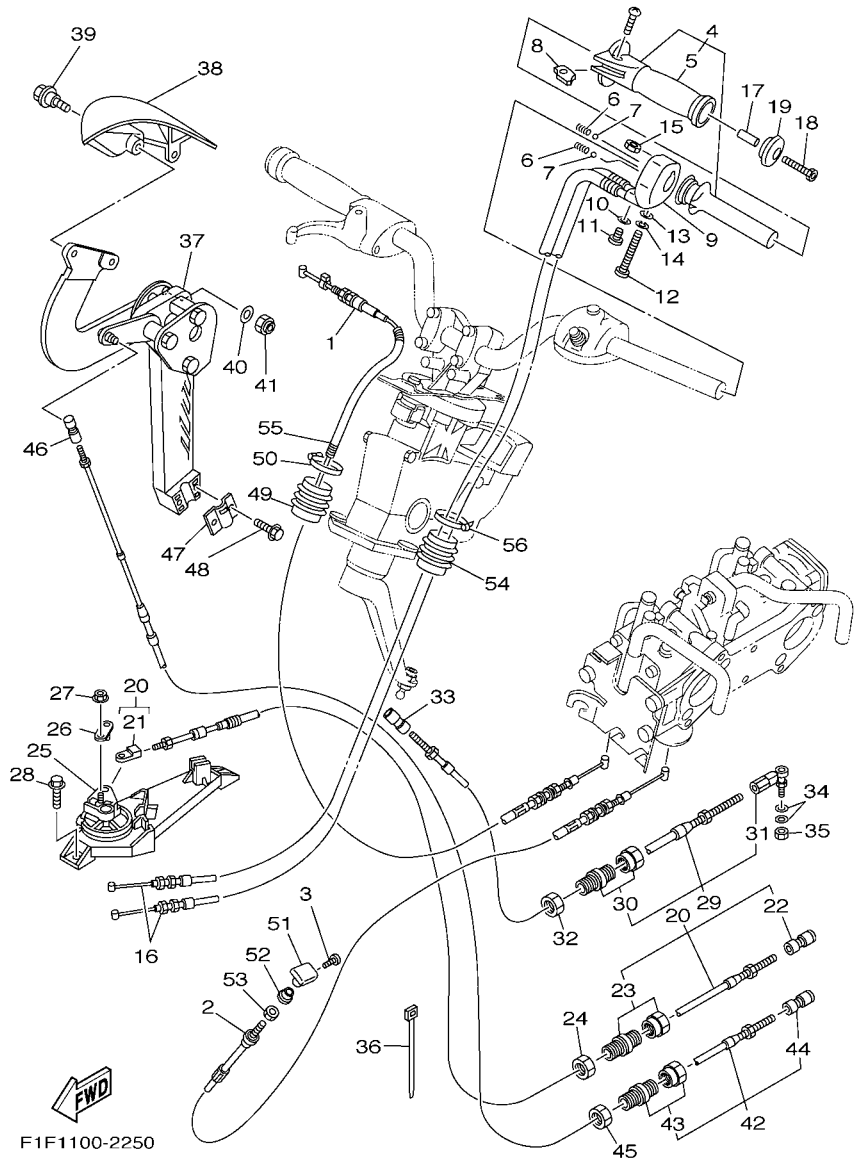
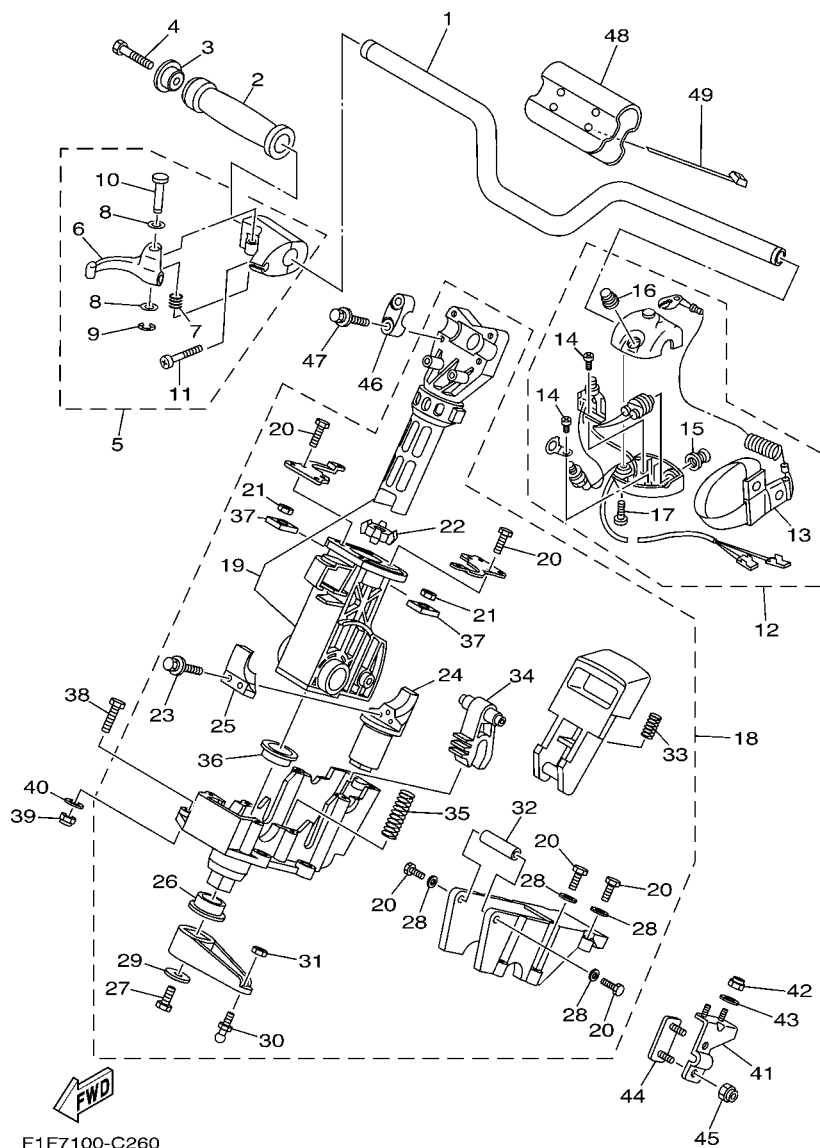

FIG. 25 CONTROL CABLE

REF. NO.	PART NO.	DESCRIPTION	USA	GENE	REMARKS
55	F0D-6773E-00	TUBE,2	1	1	
56	90601-200U1	BAND	1	1	YMUS



F1F7100-C260

FIG. 26 STEERING 1

REF. NO.	PART NO.	DESCRIPTION	USA	GENE	REMARKS
1	F0D-U1552-00	HANDLE	1	1	YMUS
2	GP7-U155D-00	GRIP, HANDLE	1	1	YMUS
3	GP7-U155F-00	GRIP, END	1	1	YMUS
4	90110-05908	BOLT, HEXAGON SOCKET HEAD	1	1	
5	F0D-67250-03	THROTTLE LEVER ASSY	1	1	
6	F0D-67255-01	.LEVER, THROTTLE	1	1	
7	EW2-67256-00	.SPRING	1	1	
8	EW2-67258-01	.WASHER	2	2	
9	EW2-67259-01	.E-RING	1	1	
10	F0D-67257-00	.SHAFT	1	1	
11	98580-05025	.SCREW, PAN HEAD	2	2	
12	GP7-68310-01	SWITCH BOX ASSY	1	1	
13	EW2-68348-00	.LANYARD, STOP SWITCH	1	1	
14	97880-03008	.SCREW, PAN HEAD	2	2	
15	FK7-68312-02	.STOP BUTTON COMP	1	1	
16	FK7-68313-02	.START BUTTON COMP.	1	1	
17	97880-05025	.SCREW, PAN HEAD	2	2	
18	F0D-61400-05	STEERING MASTER ASSY	1	1	
19	F0D-67410-00	.SHAFT ASSY. (D=45)	1	1	
20	F0D-61355-00	.BOLT	12	12	
21	F0D-6151S-00	.NUT	4	4	
22	F0D-6152R-00	.BALL	1	1	
23	F0D-62624-00	.BOLT	2	2	
24	F0D-6152D-00	.SHAFT	1	1	
25	F0D-52543-00	.JOINT, UNIVERSAL	1	1	
26	F0D-6134M-00	.BUSH	1	1	
27	F0D-6491K-00	.BOLT, SPECIAL	1	1	

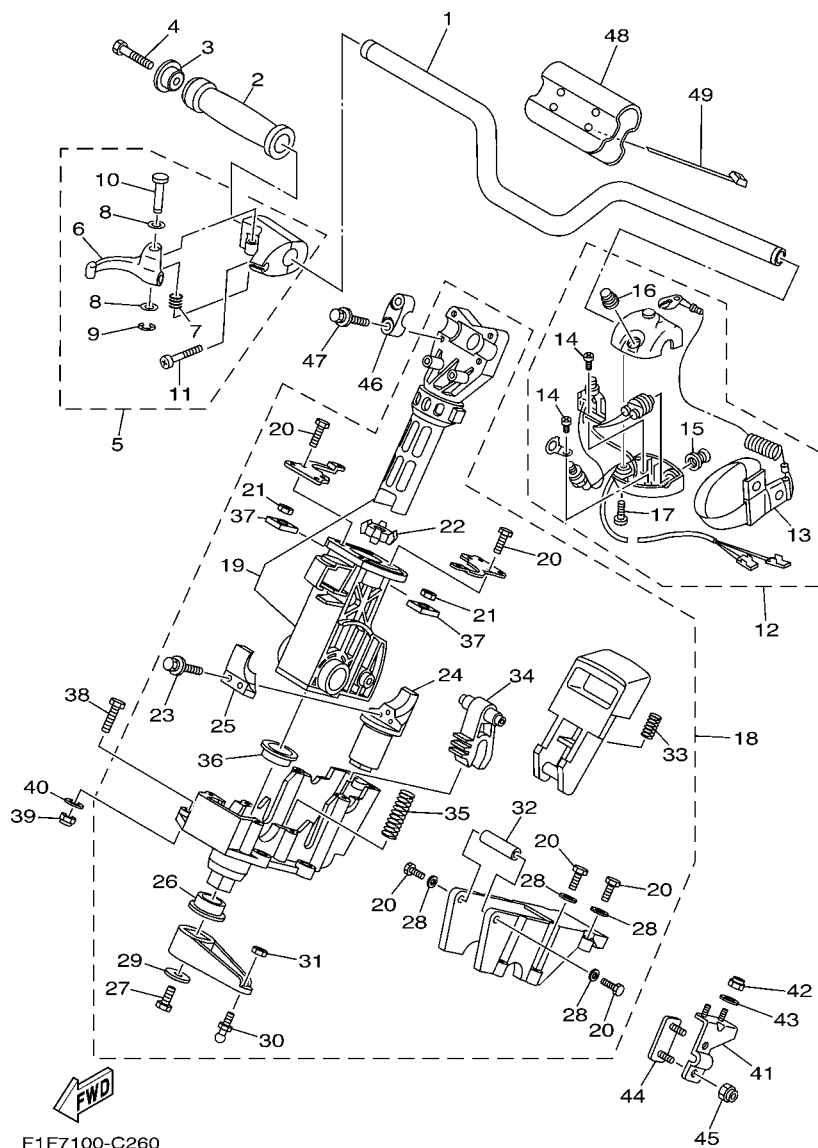

F1F7100-C260

FIG. 26 STEERING 1

REF. NO.	PART NO.	DESCRIPTION	USA	GENE	REMARKS
28	F0D-6134E-00	.WASHER	8	8	
29	F0D-6135D-00	.WASHER	1	1	
30	EU0-61461-02	.STUD, JOINT BALL	1	1	
31	95720-06300	.NUT, SELF-LOCKING	1	1	
32	F0D-61574-00	.CONNECTOR	1	1	
33	F0D-61349-00	.SPRING	1	1	
34	F0D-61782-00	.LOCK 1	1	1	
35	F0D-6134K-00	.SPRING	1	1	
36	F0D-62814-00	.BUSH	1	1	
37	F0D-6724H-00	.HOLDER	4	4	
38	97080-08030	BOLT	4	4	
39	9572R-08300	NUT, FLANGE	4	4	YMUS
40	90201-099U3	WASHER, PLATE	4	4	YMUS
41	F0D-61467-00	BRACKET, STOPPER CABLE	1	1	
42	9572R-06300	NUT, NYLON	3	3	YMUS
43	9299R-06200	WASHER	3	3	YMUS
44	GH3-61468-00	STOPPER, CABLE	1	1	
45	9572R-06300	NUT, NYLON	2	2	YMUS
46	EU0-23814-30	HOLDER, HANDLE UPPER	2	2	
47	90119-089UU	BOLT, WITH WASHER	4	4	YMUS
48	F0D-U156E-00	PAD 1	1	1	YMUS
49	90601-200U2	BAND	2	2	YMUS

FIG. 27 STEERING 2

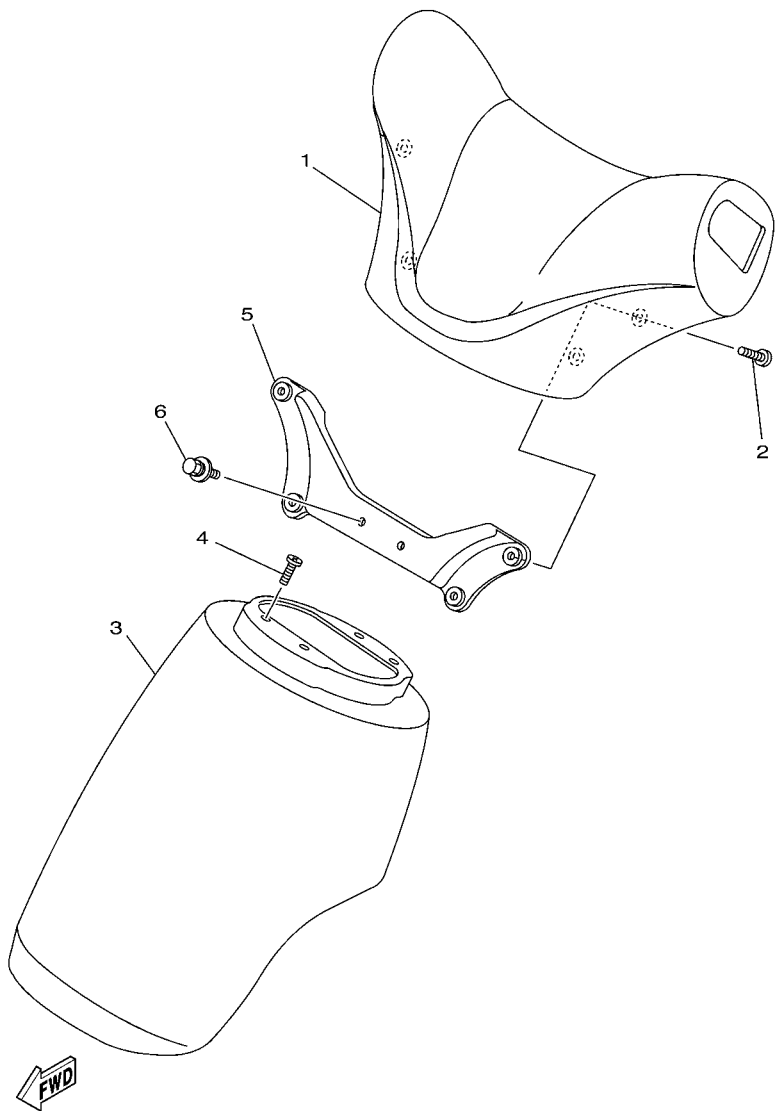

F0D1110-9280

REF. NO.	PART NO.	DESCRIPTION	USA	GENE			REMARKS
1	F0D-U143D-00	PAD, STEERING 1	1	1			BL, YMUS
2	90149-06910	SCREW	4	4			
3	F0D-U143E-00	PAD, STEERING 2	1	1			BL, YMUS
4	90149-06906	SCREW	4	4			
5	F0D-U142K-00	FIX, STEERING PAD	1	1			YMUS
6	90119-069US	BOLT, WITH WASHER	2	2			YMUS

FIG. 28 GRAPHICS

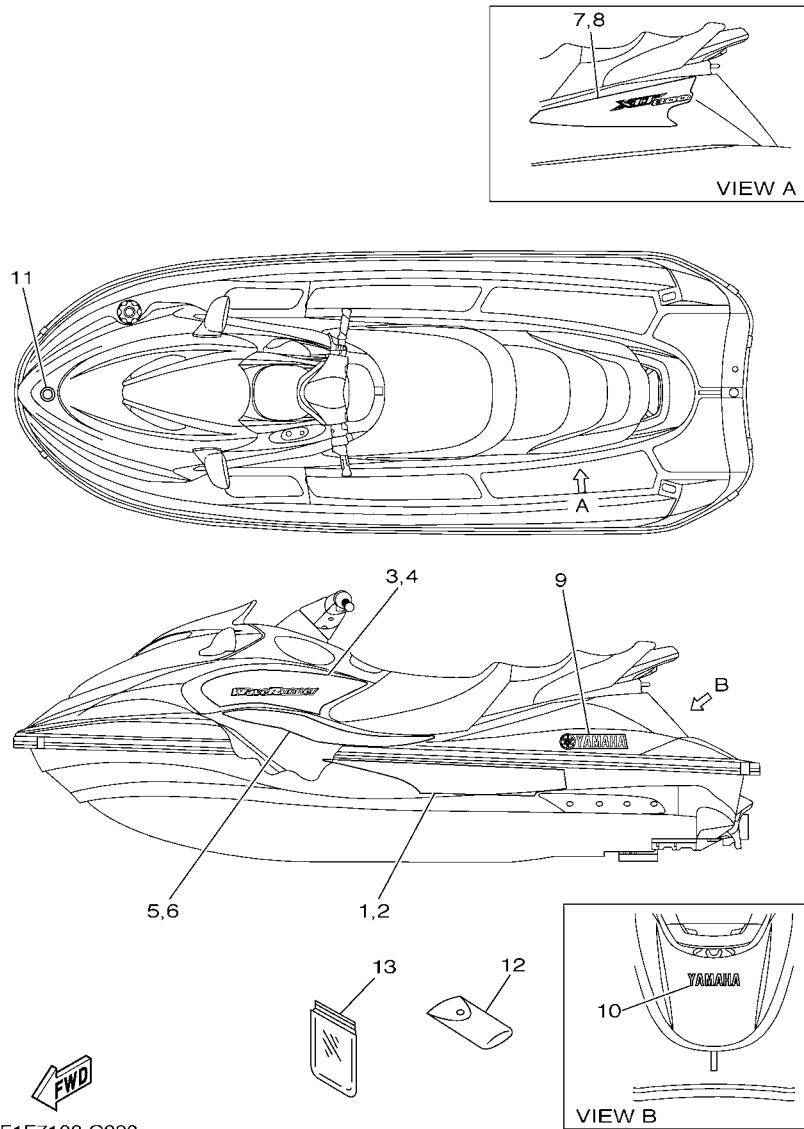

REF. NO.	PART NO.	DESCRIPTION	USA	GENE	REMARKS
1	F1F-U417B-40	GRAPHIC 1	1	1	LH, YMUS
2	F1F-U417C-40	GRAPHIC 2	1	1	RH, YMUS
3	F1F-U417D-40	GRAPHIC 3	1	1	LH, YMUS
4	F1F-U417E-40	GRAPHIC 4	1	1	RH, YMUS
5	F1F-U417F-40	GRAPHIC 5	1	1	LH, YMUS
6	F1F-U417G-40	GRAPHIC 6	1	1	RH, YMUS
7	F1F-U417H-40	GRAPHIC 7	1	1	LH, YMUS
8	F1F-U417J-40	GRAPHIC 8	1	1	RH, YMUS
9	F0V-U411C-10	EMBLEM, YAMAHA	2	2	YMUS
10	GJ3-U4114-52	MARK, YAMAHA A	1	1	YMUS
11	F1B-U411H-00	EMBLEM, TUNING FORK	1	1	YMUS
12	EU0-65986-00	TOOL SET	1	1	
13	EU0-65901-01	TOOL BAG	1	1	

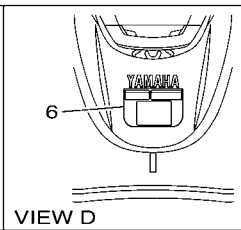
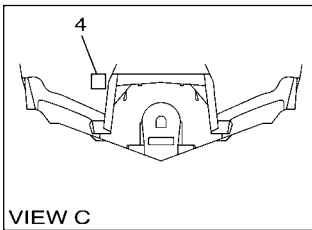
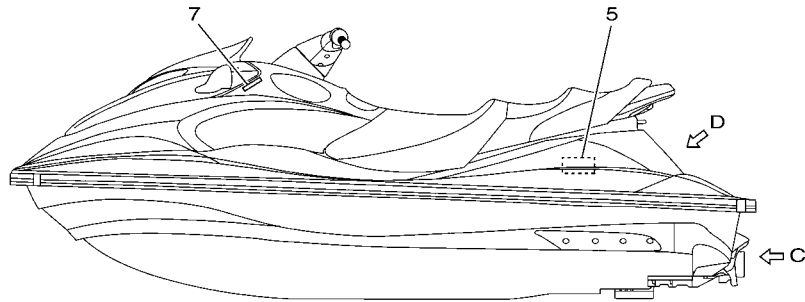
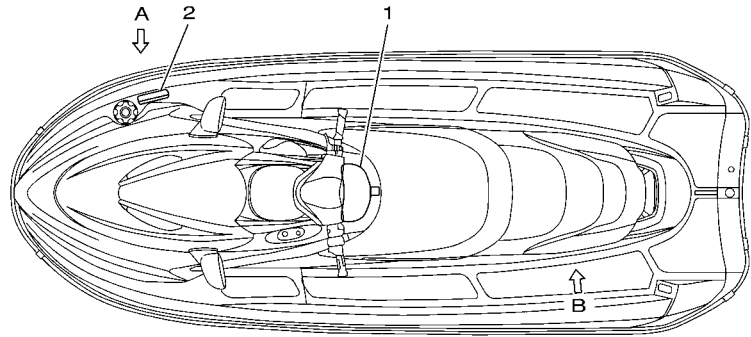
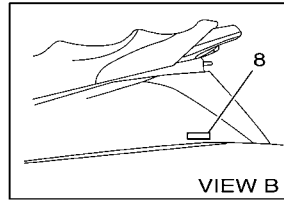
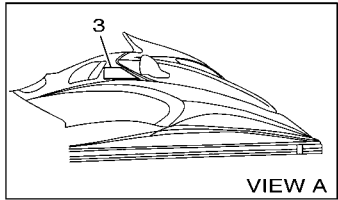

F1F4100-B290

FIG. 29 IMPORTANT LABELS

REF. NO.	PART NO.	DESCRIPTION	USA	GENE		REMARKS
1	F0V-U41B1-41	LABEL, WARNING JDC 1	1			YMUS
2	F0V-U415B-10	LABEL, WARNING(FUEL)	1			YMUS
3	F0V-U41D5-20	LABEL, WARNING SHIFT LEVER	1			YMUS
4	GA9-U418F-00	LABEL, RIGHTING	1			YMUS
5	F0V-U41DB-01	LABEL, WARNING BATTERY	1			YMUS
6	F0V-U41E1-30	LABEL, SET 1	1			YMUS
7	F0V-U41F5-00	LABEL, FIRE EXTINGUISHER 1	1			YMUS
8	F0P-U41G1-00	LABEL, CAPACITY	1			YMUS
<hr/>						
<hr/>						
<hr/>						
<hr/>						
<hr/>						
<hr/>						
<hr/>						
<hr/>						
<hr/>						
<hr/>						

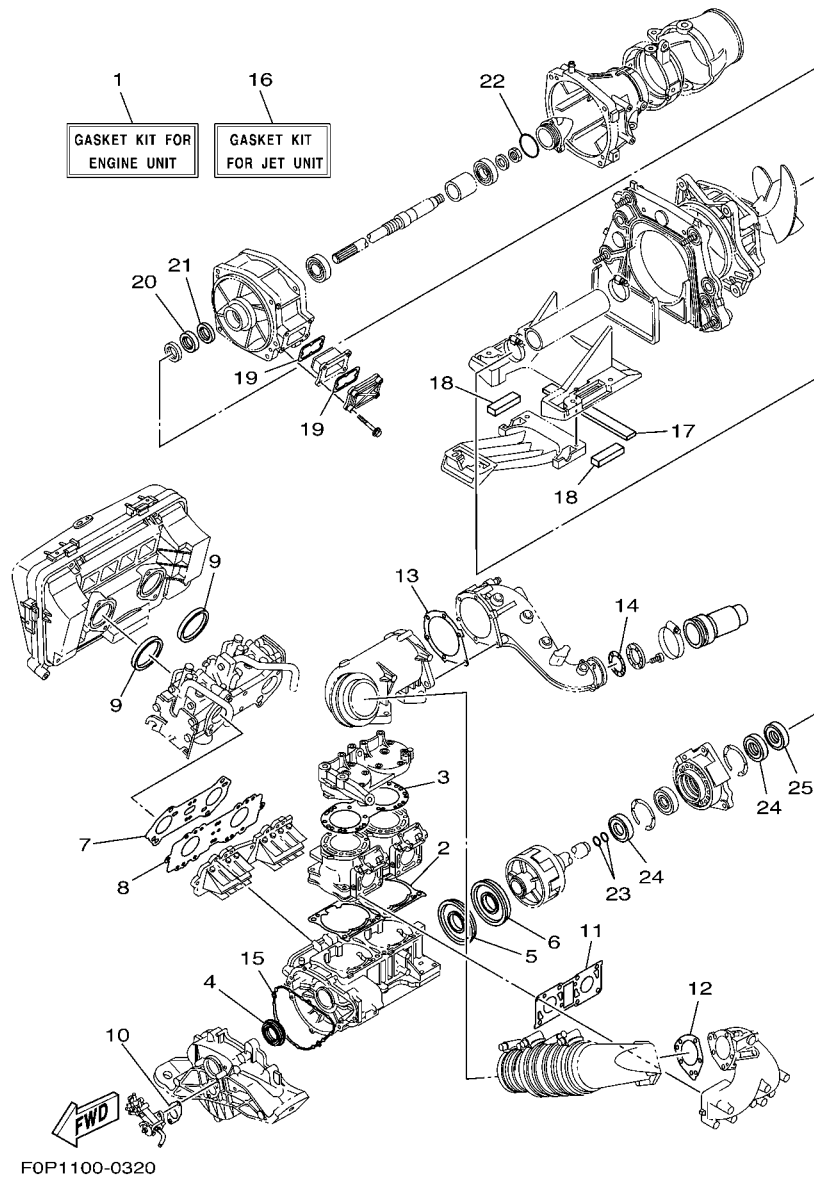

FOP1100-0320

FIG. 31 REPAIR KIT 1

REF. NO.	PART NO.	DESCRIPTION	USA	GENE	REMARKS
1	66E-W0001-02	GASKET KIT FOR ENGINE UNIT	1	1	
2	66E-11351-01	.GASKET, CYLINDER	2	2	
3	66E-11181-00	.GASKET, CYLINDER HEAD 1	1	1	
4	93103-35M03	.OIL SEAL	1	1	
5	93101-36M62	.OIL SEAL	1	1	
6	93101-36M61	.OIL SEAL	1	1	
7	66E-13556-00	.GASKET, MANIFOLD	1	1	
8	66E-13624-10	.PLATE, REED VALVE	1	1	
9	66E-13473-00	.O-RING	2	2	
10	63M-13116-00	.GASKET, PUMP CASE	1	1	
11	66E-14613-00	.GASKET, EXHAUST PIPE	1	1	
12	66E-14749-00	.GASKET, MUFFLER DAMPER 2	1	1	
13	66E-41124-10	.GASKET, EXHAUST OUTER COVER	1	1	
14	66E-14623-00	.GASKET, EXHAUST PIPE	1	1	
15	66E-81168-10	.O-RING	1	1	
16	66V-W0001-20	GASKET KIT FOR JET UNIT	1	1	
17	66V-51367-00	.FELT, PACKING	1	1	
18	66V-51368-00	.FELT, PACKING	1	1	
19	66V-42414-00	.O-RING	2	2	
20	93101-28M66	.OIL SEAL	1	1	
21	93101-28M65	.OIL SEAL	1	1	
22	93210-46M16	.O-RING	1	1	
23	93210-19MJ4	.O-RING	2	2	
24	93101-25M55	.OIL SEAL	2	2	
25	93101-25M56	.OIL SEAL	1	1	

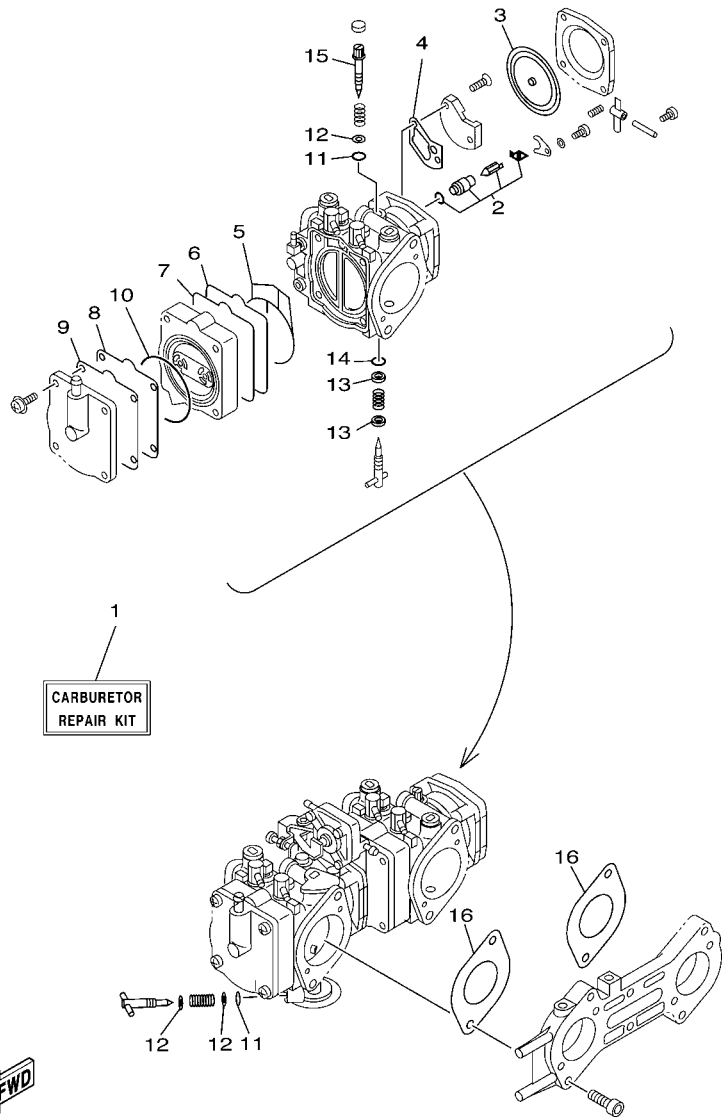

GU04100-9300

FIG. 32 REPAIR KIT 2

REF. NO.	PART NO.	DESCRIPTION	USA	GENE	REMARKS
1	66E-W0093-01	CARBURETOR REPAIR KIT	1	1	
2	64T-14916-00	.NEEDLE	2	2	
3	6R7-14541-00	.DIAPHRAGM, PUMP	2	2	
4	6K8-14536-11	.GASKET	2	2	
5	66E-14563-01	.O-RING	2	2	
6	66E-24471-00	.DIAPHRAGM	2	2	
7	66E-24411-00	.DIAPHRAGM	2	2	
8	66E-24421-00	.VALVE, CHECK	2	2	
9	66E-24431-00	.GASKET, FUEL PUMP 1	2	2	
10	66E-14564-01	.O-RING	2	2	
11	812-14147-00	.O-RING	3	3	
12	812-14235-00	.WASHER, NEEDLE	4	4	
13	822-14235-00	.WASHER, NEEDLE	4	4	
14	583-14561-00	.O-RING	2	2	
15	6K8-14946-10	.METERING NEEDLE	2	2	
16	66E-14398-00	.GASKET	2	2	

NUMERICAL INDEX

PART NO.	GRID NO.	PART NO.	GRID NO.	PART NO.	GRID NO.	PART NO.	GRID NO.	PART NO.	GRID NO.	PART NO.	GRID NO.
66E-11111-00-8S	B - 2	66E-13200-02	B - 11	66E-14457-10	B - 7	66E-24315-00	B - 10	66V-51129-10	C - 3	GJ3-6215F-00	D - 5
66E-11181-00	B - 2	66V-13416-01	B - 11	6K8-14471-10	B - 9	66E-24362-00	B - 8	68N-5112T-00	D - 2	EU0-62241-30	C - 4
	E - 7	66E-13469-00	B - 11	66E-14480-11	B - 7	6G8-24376-00	B - 11	66V-51142-00	B - 11		D - 12
66E-11311-00-94	B - 2	66E-13473-00	B - 7	6M6-14503-00	B - 9	63M-24378-00	B - 11	66G-51190-00-94	C - 4	EU0-62280-00	D - 2
66E-1131B-01	B - 4		E - 7	6K8-14503-02	B - 8	6E0-24378-00	B - 11	66V-51311-00-94	C - 3	EU0-62282-00	D - 2
66E-1131C-10	B - 4	66E-13556-00	B - 7	66E-14521-00	B - 9	66E-24411-00	B - 8	66V-51312-01-94	C - 3	EU0-62283-00	D - 2
66E-1131H-00	B - 4		E - 7	6K8-14523-11	B - 9		E - 8	66V-51314-11	C - 7	EU0-62285-01	D - 3
66E-1131J-10	B - 4	66E-13610-00	B - 7	6K8-14527-11	B - 9	66E-24412-00	B - 9	66V-51315-00-94	C - 3	F0D-62624-00	D - 15
66E-1131M-01-94	B - 4	66E-13624-10	B - 7	6K8-14536-11	B - 8	66E-24413-01	B - 8	66V-51318-00-94	C - 4	FN8-6269B-00	D - 2
66E-1131S-10	B - 4		E - 7		E - 8	66E-24421-00	B - 8	68N-51323-00	C - 6	F0X-62733-00	D - 11
66E-1131V-00	B - 4	66E-13898-11	B - 7	6R7-14541-00	B - 8		E - 8	66V-51333-00-94	C - 3	F0D-62814-00	E - 2
66E-11325-00	B - 4	4KM-14137-00	B - 9		E - 8	66E-24431-00	B - 8	63M-51334-00	C - 4	F0D-62875-00	C - 13
66E-1132C-00	B - 4	35H-14139-00	B - 10	6R7-14542-00	B - 8		E - 8	66V-51341-00-94	C - 7	F0D-6376D-00	D - 7
66V-1133E-00	B - 4	66E-14146-00	B - 10	6K8-14547-01	B - 8	66E-24452-00	B - 8	66V-51367-00	C - 3	F0D-63774-01	C - 14
66V-1133F-00	B - 4	812-14147-00	B - 8	583-14561-00	B - 9	66E-24471-00	B - 8		E - 7	F0D-6378D-01	D - 6
66E-11351-01	B - 2		E - 8		E - 8		E - 8	66V-51368-00	C - 3	F0D-63850-01	D - 6
	E - 7	8F2-14147-00	B - 8	66E-14563-01	B - 8	70R-24489-00	D - 9		E - 7	F0D-64261-02	D - 11
66E-11400-00	B - 5	7EG-14159-00	B - 8		E - 8	65U-24492-00	B - 8	61L-5169A-00	B - 14	F0D-6491K-00	D - 15
66E-11412-00	B - 5	66E-14162-00	B - 10	66E-14564-01	B - 8	66V-24500-02	C - 2	F0D-52543-00	D - 15	F0V-6515A-01	C - 14
66E-11422-00	B - 5	66E-14162-01	B - 9		E - 8	70R-24543-00	D - 9	F0D-61349-00	E - 2	F0D-6517C-04	C - 14
66E-11431-00	B - 5	66E-14170-00	B - 9	6R7-14569-00	B - 8	66V-24560-00	C - 2	F0V-6134A-00	D - 13	F0D-6517R-00	C - 13
66E-11442-00	B - 5	439-14186-00	B - 9	6K8-14589-00	B - 9	66E-26320-00	B - 11	F0D-6134E-00	E - 2	F0D-6517T-00	C - 13
66E-11515-00	B - 5	66E-14211-00	B - 9	66E-14613-00	B - 13	67A-41123-00-94	B - 14	F0D-6134K-00	E - 2	GA7-65772-00	D - 11
66E-11603-01	B - 5	830-14231-18	B - 8		E - 7	66E-41124-10	B - 14	F0D-6134M-00	D - 15	EU0-65901-01	E - 4
66E-11631-00-A0	B - 5	3G2-14231-30	B - 8	66E-14615-00	B - 13		E - 7	F0D-61355-00	D - 15	EU0-65986-00	E - 4
66E-11631-00-B0	B - 5	812-14235-00	B - 9	66E-14623-00	B - 15	66E-41217-00	B - 9	F0D-6135D-00	E - 2	67A-67242-01	D - 12
66E-11631-00-C0	B - 5		E - 8		E - 7	66V-42414-00	C - 3	F0D-61400-05	D - 15	EW2-67243-00	D - 13
66E-11631-00-D0	B - 5	822-14235-00	B - 9	66E-14625-00	B - 13		E - 7	EU0-61461-02	E - 2	F0N-6724E-00	D - 13
60T-11633-00	B - 5		E - 8	66E-14711-10-94	B - 13	66E-42717-00	B - 7	F0D-61467-00	E - 2	F0P-6724F-00	D - 13
66E-11634-00	B - 5	66E-14243-00	B - 9	66E-14712-10-94	B - 13	66V-44121-00	C - 7	GH3-61468-00	E - 2	F0D-6724H-00	E - 2
66E-11651-00	B - 5	4N0-14251-00	B - 10	66E-14721-10-8S	B - 14	66V-44125-00	C - 7	GH1-61468-01	D - 13	F0D-67250-03	D - 15
66E-11685-00	B - 5	66E-14251-00	B - 10	66E-14749-00	B - 13	6M6-44517-A1-8P	B - 3	F0D-6151S-00	D - 15	66E-67252-00	D - 12
60T-11832-00	B - 4	62T-14251-10	B - 2		E - 7	67A-44532-00-94	B - 2	F0D-6152D-00	D - 15	F0D-67255-01	D - 15
66E-11998-00	B - 4	6R7-14253-00	B - 8	67A-14752-00	B - 15	663-45119-00	B - 14	F0D-6152R-00	D - 15	EW2-67256-00	D - 15
66E-12576-00	B - 13	66E-14280-00	B - 9	66E-14763-10-94	B - 14	66V-45214-00-94	C - 3	F0D-61574-00	E - 2	F0D-67257-00	D - 15
66E-12577-00	B - 14	66E-14286-00	B - 9	66E-14771-01-8S	B - 15	61X-45332-03-94	C - 6	F0D-61624-01	D - 2	EW2-67258-01	D - 15
66E-12578-00	B - 15	66E-14291-00	B - 9	66E-14781-10-94	B - 2	61L-45378-00	C - 6	GP7-61628-00	D - 6	EW2-67259-01	D - 15
66E-12579-00	B - 14	3XP-14294-00	B - 10	66E-14791-00-8S	B - 14	68Y-45511-00	C - 3	GH1-61651-01	D - 4	EU0-67267-10	D - 12
64T-12580-00	B - 15	67A-14294-00	B - 10	64T-14916-00	E - 8	65V-45538-00	C - 3	EU0-61652-00	B - 15	GK5-67267-10	D - 13
63M-12581-00	B - 13	67A-14298-00	B - 10	64T-14916-01	B - 8	68N-45593-00-94	B - 5		D - 2	EU0-67267-20	C - 4
67X-12590-00	B - 15	67A-14301-03	B - 8	3KW-14932-00	B - 9	66E-45813-10-94	B - 5		E - 4	F0D-67410-00	D - 15
67X-12590-20	B - 15	67A-14302-03	B - 8	6K8-14946-10	B - 9	66E-4581J-00	B - 5	F0D-61782-00	D - 2	F0P-6753B-00	D - 11
60E-12594-00	B - 13	66E-14398-00	B - 9		E - 8	66V-46882-00	C - 3	F0D-62127-00	D - 5	F0D-6753D-01	D - 11
63M-13116-00	B - 11		E - 8	66E-15100-10-8S	B - 2	66E-51129-00	B - 2	F0D-62139-00	D - 5	F0P-67550-01	D - 11
	E - 7	66E-1441E-00	B - 7	66E-21425-10-8S	B - 2		B - 13	EW2-62140-00	D - 9	GA7-6756E-00	D - 11
63M-13132-00	B - 11	66E-14435-00	B - 7	66E-21426-10-8S	B - 2	6K8-51129-00	B - 2	EW2-62142-00	D - 9	F0D-6758C-01	D - 11
65U-13132-00	B - 11	66E-14451-00	B - 7	EU0-23814-30	E - 2		B - 13	EW2-62149-00	D - 5	F0D-6773E-00	D - 14
67X-13183-00	B - 11	66E-14452-00	B - 7	66E-24314-00	B - 10	66V-51129-01	C - 3	GP7-62159-01	D - 5	GH3-67743-01	D - 9

NUMERICAL INDEX

PART NO.	GRID NO.	PART NO.	GRID NO.	PART NO.	GRID NO.	PART NO.	GRID NO.	PART NO.	GRID NO.	PART NO.	GRID NO.
F0D-6775C-01	D - 8	682-84385-01	B - 15	GP7-U2501-20	D - 4	GJ1-U419F-21	E - 6	GJ1-U759C-00	D - 10	90105-08M66	B - 13
F0D-6775E-01	D - 8	66E-85510-00	C - 8	F0D-U2512-00	D - 4	F0V-U41B1-41	E - 5	F1B-U761D-01	D - 2	90105-08M83	B - 13
FJ0-67766-00	D - 8	66E-8552A-00-94	C - 10	F1F-U2519-01	D - 4	F0V-U41B1-51	E - 6	F0D-U7711-00	D - 9	90105-08M84	B - 13
EU0-67767-31	D - 9	66E-8552E-00	C - 10	F0D-U251D-00	D - 4	F0V-U41B1-60	E - 6	F0D-U775B-02	D - 8	90105-08M86	B - 7
F0D-6777C-00	C - 2	66E-85540-00	C - 10	F0D-U252C-00	D - 4	F0M-U41B2-10	E - 6	F0D-U776C-10	D - 8	90105-10M82	B - 14
FN8-67816-00	C - 2	64X-85546-00	C - 10	F0V-U252D-00	D - 4	F0V-U41D5-20	E - 5	F0V-U7772-00	C - 13	90105-10M85	B - 13
F0P-6820A-01	C - 12	66E-85550-00	C - 8	F0V-U2624-00	D - 2	F0V-U41D5-30	E - 6	GJ3-U778B-00	D - 8	90105-10M86	B - 13
F0P-6820A-11	C - 12	64X-85570-01	C - 10	F0V-U266B-00	C - 14	F0V-U41DB-01	E - 5	GJ3-U778C-00	D - 8	90109-05MA0	C - 10
F0D-6822E-00	D - 13	60G-85820-00	B - 4	F0D-U266C-00	D - 6	F0V-U41DB-11	E - 6	F0X-U778D-00	D - 8	90109-06803	D - 13
F0D-68238-10	C - 12	66E-85825-00	B - 4	GJ3-U266C-31	C - 14	F0V-U41E1-30	E - 5	F0X-U778E-00	D - 8	90109-06M00	B - 7
GP7-68310-01	D - 15	66V-G5831-02	C - 3	F0D-U266D-00	D - 6	F0V-U41E1-40	E - 6	F0X-U778H-00	D - 8	90109-08879	C - 7
FK7-68312-02	D - 15	65A-R1129-00	C - 3	F0V-U2714-00	D - 13	F0V-U41F5-00	E - 5	EU0-U7817-00	C - 2	90109-10M72	C - 8
FK7-68313-02	D - 15	66V-R1313-01	C - 4	F0D-U271B-00	D - 6	F0V-U41F5-10	E - 6	GP7-U7831-01	D - 9	90110-04M03	B - 4
EW2-68348-00	D - 15	67A-R1321-00	C - 4	F0V-U273B-00	C - 5	F0P-U41G1-00	E - 5	GP7-U7832-01	D - 9	90110-05008	B - 4
66E-81168-10	C - 8	65A-R1326-00	C - 3	F0P-U351H-00	D - 4	F0V-U471E-00	C - 15	GP7-U7833-00	D - 9	90110-05908	D - 12
	E - 7	66V-R1348-10	C - 4	F0P-U351J-00	D - 4	F0V-U471F-00	C - 15	GP7-U7834-00	D - 9		D - 15
65U-81317-10	C - 11	67A-R1381-00	C - 6	F0V-U351K-00	D - 4	F0D-U474A-00	D - 6	EU0-U7835-00	D - 8	90116-06802	D - 11
66E-81328-00	C - 8	GH1-U046C-00	D - 12	F0V-U351M-00	D - 4	F0D-U475A-00	C - 14	GP7-U7835-00	D - 9	90116-08M64	B - 14
6M6-8132W-00	C - 10	F0D-U142K-00	E - 3	F0V-U351N-00	D - 4	GP7-U4953-00	D - 6	GP7-U783F-00	D - 9	90116-10M65	B - 14
66E-81337-11-8S	C - 8	GH1-U143B-00	D - 12	F0V-U351P-00	D - 4	F0V-U515E-00	C - 14	F0D-U7844-10	D - 9	90116-10M66	B - 14
63M-81800-00	C - 9	F0D-U143D-00	E - 3	F0D-U351R-00	D - 4	F0V-U516N-A0-P1	C - 13	F0D-U7856-10	D - 9	90119-06800	C - 3
3AJ-81809-00	C - 9	F0D-U143E-00	E - 3	F0V-U358F-03	D - 4	F0V-U517B-A0-P1	C - 14	GJ3-U7856-20	D - 8	90119-06803	C - 13
6M6-81826-00	C - 9	F0V-U1461-00	D - 13	F0V-U358G-03	D - 4	F0V-U517H-20	C - 13	F0D-U785G-10	C - 12	90119-06820	D - 6
63M-81830-00	C - 9	EU0-U1461-30	D - 12	F0V-U3635-00	C - 14	F0V-U517M-00	C - 14		D - 9	90119-06835	C - 3
6M6-81830-00	C - 9	GP8-U1461-T0	D - 13	F0V-U3635-10	C - 14	F0D-U519D-00	C - 13	GP7-U785H-00	D - 9	90119-06858	C - 13
6M6-8183E-01	C - 9	66V-U146E-00	C - 7	F0V-U3635-20	C - 14	EW2-U5912-01	C - 14	GP7-U8211-00	C - 12	90119-069UB	C - 4
6M6-81840-10	C - 9	GH3-U146E-00	C - 4	F0V-U371A-50	D - 6	EW2-U5913-01	C - 14	EU0-U821D-00	C - 12		C - 7
11H-81844-00	C - 9	GK5-U146F-00	D - 13	F0V-U371B-50	D - 6	F0V-U596B-04	C - 15	F0X-U8221-00	C - 12		C - 14
6M6-81844-00	C - 10	F0D-U1481-10	D - 13	F0V-U372A-50	D - 6	F0V-U596C-04	C - 15	EU0-U8221-30	C - 12	90119-069UD	C - 6
1FK-81847-00	C - 9	F0V-U149C-00	D - 13	F0V-U372B-50	D - 6	GP7-U5983-00	C - 14	F0V-U824B-03	C - 12		C - 7
6M6-81850-00	C - 9	GP7-U151M-00	D - 12	GH1-U3774-00	D - 6	GD0-U7249-00-05	C - 6	F0D-U824C-20	C - 12	90119-069UH	C - 14
6M6-81865-00	C - 9	F0D-U152C-10	D - 12	F0V-U378C-00	D - 6	GD0-U7249-00-10	C - 6	F0D-U8341-00	C - 12	90119-069UJ	D - 13
6M6-81866-00	C - 9	GP7-U152M-00	D - 12	GJ3-U4114-52	E - 4	F0V-U7267-00	D - 13	GJ1-U835D-00	C - 4	90119-069UK	C - 5
66E-81921-00	C - 10	GP7-U152P-00	D - 12	F0V-U411C-10	E - 4	EU0-U7354-00-01	B - 3	F0D-U883B-01	C - 6	90119-069UP	D - 6
68N-81940-00	C - 10	GP7-U152R-00	D - 12	F1B-U411H-00	E - 4	EU0-U7354-00-03	B - 3	F0D-U883E-00	C - 6	90119-069US	C - 12
63M-81960-00	C - 10	F0D-U153D-01	D - 12	F0V-U415B-00	E - 6	EU0-U7354-00-05	B - 3	F0D-U883N-20	D - 2		E - 3
EU0-82110-09	C - 12	F0D-U153E-10	D - 12	F0V-U415B-10	E - 5	EU0-U7354-00-10	B - 3	F0D-U883P-20	D - 2	90119-069UX	B - 4
61L-82117-00	C - 11	F0D-U153J-10	D - 12	GJ3-U416H-00	E - 6	EU0-U7354-00-20	B - 3	F1F-U883T-01	D - 2	90119-06M13	B - 3
66E-82117-10	C - 11	F0D-U1552-00	D - 15	F1F-U417B-40	E - 4	F0V-U7525-01	C - 5	F0V-U8K31-00	C - 4	90119-06M78	B - 3
6M6-82117-21	C - 11	GP7-U155C-00	D - 12	F1F-U417C-40	E - 4	F0D-U7578-00	D - 11	66E-W0001-02	E - 7	90119-08823	B - 3
66E-82150-00	C - 10	GP7-U155D-00	D - 15	F1F-U417D-40	E - 4	GJ1-U7578-11	C - 5	66V-W0001-20	E - 7		C - 5
6G1-82151-00	C - 10	GP7-U155F-00	D - 12	F1F-U417E-40	E - 4	F0V-U7578-21	D - 2	66E-W0004-00	B - 7	90119-08827	C - 10
6K8-82159-00	C - 10		D - 15	F1F-U417F-40	E - 4	F0V-U757B-00	D - 11	66E-W0090-13-8S	B - 2	90119-089U7	D - 9
62E-82371-11	C - 10	F0D-U156E-00	E - 2	F1F-U417G-40	E - 4	F0P-U758B-00	D - 11	66E-W0093-01	E - 8	90119-089UE	C - 4
60G-82553-00	C - 11	GP7-U157A-00	D - 12	F1F-U417H-40	E - 4	F0V-U758D-00	D - 11	90101-06806	C - 7	90119-089UF	C - 7
68A-82560-00	C - 11	F0V-U2103-10	C - 14	F1F-U417J-40	E - 4	F0D-U759B-00	D - 9	90101-06917	B - 3	90119-089UL	C - 6
6R7-83623-40	C - 10	F0D-U213F-05	D - 5	GA9-U418F-00	E - 5	F0D-U759B-10	D - 10	90101-069U0	D - 6	90119-089UR	B - 3
6R7-83623-50	C - 10	F0D-U213G-04	D - 5		E - 6	F0D-U759C-00	D - 10	90101-06M25	B - 9	90119-089UU	E - 2

NUMERICAL INDEX

PART NO.	GRID NO.	PART NO.	GRID NO.	PART NO.	GRID NO.	PART NO.	GRID NO.	PART NO.	GRID NO.	PART NO.	GRID NO.
90119-08M18	C - 8	90267-489U1	C - 2	90446-10MA2	B - 10	90467-089U1	C - 12	9299R-06100	D - 12	93608-16M16	C - 8
90119-08M55	B - 3	90267-489U2	D - 9	90446-14M98	B - 10	90468-02001	B - 11	9299R-06200	C - 13	94702-00204	C - 11
	C - 8	90267-489U7	D - 11	90446-14M99	B - 10	90480-06M43	C - 11		D - 4	9531P-16700	C - 3
90119-08M56	B - 3	90267-489U8	D - 2	90446-17MA7	B - 10	90480-06M46	C - 6		D - 6	95333-08600	B - 14
90119-08M61	B - 3	90267-489UE	D - 5	90446-17ME5	B - 10	90480-14023	B - 4		D - 11	95380-06700	C - 9
90119-08MA1	B - 2	90267-489UP	C - 14	90446-24M52	B - 15	90501-14M73	C - 9		D - 13	95380-10600	B - 14
90119-08MA2	B - 2	90267-489US	D - 4	90446-24M94	B - 13	90508-14M43	C - 7		E - 2	9538R-06600	C - 7
90119-10836	C - 3	90280-05013	C - 8	90446-27M55	D - 2	90600-900U6	C - 5	9299R-08200	C - 14	9538R-06700	C - 4
90119-10837	C - 4	90380-12M29	B - 2	90446-27M73	D - 2		D - 5		D - 2		C - 13
90119-10M00	B - 2		C - 8	90446-27M95	B - 15	90600-917U4	C - 12		C - 7		D - 13
	B - 14	90387-05800	D - 12	90447-07002	B - 11		D - 2	9299R-08600	D - 6	9538R-08600	C - 7
90119-10M07	B - 2	90387-06M05	C - 11	90447-13002	B - 11	90600-921U1	C - 5	9299R-10200	C - 3	95720-06300	E - 2
90119-10M10	B - 14	90387-06M60	C - 6	90447-19003	B - 2	90600-925U9	C - 4	9299R-16600	C - 6	9572R-05300	C - 12
90119-10M18	B - 15	90387-06M74	C - 7	90450-14M05	B - 2	90601-118UF	B - 15	93101-25M55	C - 6		D - 3
90149-03M15	D - 12	90387-06M84	C - 7		B - 13		C - 4	93101-25M56	C - 6	9572R-06300	C - 13
90149-05962	D - 5	90387-07598	B - 4	90450-18M09	B - 13		D - 2		E - 7		C - 14
90149-06906	E - 3	90387-08802	C - 14	90450-22M14	B - 13		D - 11	93101-28M65	C - 3		D - 4
90149-06910	E - 3	90387-08M06	C - 4	90450-99M02	B - 13	90601-142U6	D - 8		E - 7		D - 6
90149-069UA	C - 6	90387-08M30	C - 7	90450-99M18	B - 13	90601-152U3	C - 6	93101-28M66	C - 3		D - 11
90157-05M17	B - 8	90387-10M09	C - 7	90460-90M11	B - 15	90601-155U4	D - 9		E - 7		D - 12
90169-049U1	D - 9	90430-16910	D - 11	90464-06M29	C - 10	90601-162U5	C - 12	93101-34001	B - 5		E - 2
90169-059U1	D - 4	90445-07002	B - 11	90464-07M20	B - 11	90601-175UR	D - 11	93101-34002	B - 5	9572R-08300	C - 14
90170-22187	C - 2	90445-07009	B - 11	90464-32801	C - 12	90601-195UD	D - 11	93101-36M61	E - 7		D - 2
90179-08815	C - 5	90445-07M25	B - 11		D - 2	90601-20009	C - 12	93101-36M62	E - 7		D - 6
90183-06902	C - 13	90445-07M42	B - 10		D - 8	90601-200U1	D - 13	93103-35M03	B - 5		E - 2
	C - 14	90445-07M78	B - 10		D - 11	90601-200U2	E - 2		E - 7	9572R-10300	C - 5
90201-05M09	C - 8	90445-07M79	B - 10	90464-40825	C - 5	90601-200U7	D - 5	93109-08M07	B - 4		D - 6
90201-06802	C - 14	90445-09M21	B - 14	90464-99801	D - 5	90605-502U2	C - 13	93210-19MJ4	C - 6	97013-06025	B - 4
90201-068M4	C - 4	90445-10MH0	B - 10		D - 9	91318-06014	C - 8		E - 7		B - 7
90201-068T1	C - 7	90445-10MH2	B - 10	90464-99804	D - 5	91318-06030	C - 8	93210-46M16	C - 4	97013-06045	B - 7
90201-06906	D - 13	90445-10MH3	B - 10	90465-11829	B - 12	92903-06600	B - 4		E - 7	97013-08025	C - 9
90201-06M04	B - 4	90445-10MH5	B - 10		C - 2		B - 7	93305-307U0	B - 5	97013-08030	B - 2
90201-088T2	C - 7	90445-11012	B - 11		C - 4		C - 9	93306-205U0	C - 3	97013-08045	B - 2
90201-08M09	B - 4	90445-11M67	C - 2		C - 6	92903-08600	B - 2	93306-205U6	C - 6	97080-08030	E - 2
90201-099U3	B - 3	90445-11M68	C - 2		D - 2		C - 9	93306-208U1	B - 5	97080-10025	D - 6
	E - 2	90445-11M69	C - 2		D - 5	92990-04600	D - 12	93306-304U1	C - 3	9708R-06030	C - 13
90201-10801	C - 5	90445-14003	B - 2		D - 8	92990-06100	C - 9	93306-308U1	B - 5	97095-06010	C - 10
90201-22M04	B - 5	90445-14898	C - 4		D - 9	92990-06600	C - 11	93310-422U2	B - 5	97095-06012	C - 10
90201-248M5	B - 6	90445-14M33	B - 13	90465-11M10	B - 7		D - 12	93310-627U6	B - 5	97095-06016	C - 11
90202-229U1	C - 2	90445-16M09	C - 4		B - 11	92990-08600	B - 14	93410-08M12	B - 4	97095-06020	B - 11
90204-06M01	B - 9	90445-18M02	B - 15		B - 14	92990-10600	B - 14	93430-47M04	C - 6	97095-06035	B - 7
90267-329UR	D - 9	90445-18M17	B - 15		C - 2	92995-06100	C - 10	93440-25M08	C - 9	97513-05514	C - 8
90267-40935	D - 8	90445-198B9	D - 2		C - 11	92995-06600	B - 7	93450-18M06	C - 9	97780-04110	D - 8
90267-47801	D - 4	90445-198C0	D - 2	90465-12M53	C - 10		B - 11	93606-12019	B - 2	97780-50514	C - 5
90267-48802	C - 12	90446-07M96	B - 10	90465-12M56	B - 13		B - 15		B - 13	97780-60425	C - 11
	D - 2	90446-07M97	B - 10		C - 10		C - 10		C - 3	97880-03008	D - 15
	D - 5	90446-10MA0	B - 10	90465-13M36	C - 10	9299R-05200	D - 3		C - 6	97880-05010	B - 9
90267-48809	C - 14	90446-10MA1	B - 10	90465-20M78	B - 13		D - 11	93606-19M23	B - 7	97880-05025	D - 15

NUMERICAL INDEX

PART NO.	GRID NO.	PART NO.	GRID NO.	PART NO.	GRID NO.	PART NO.	GRID NO.	PART NO.	GRID NO.
97880-06016	C - 11								
97880-06030	C - 11								
97880-06065	D - 12								
97885-06016	B - 15								
9788R-05025	D - 3								
97890-05014	B - 9								
98580-05025	D - 15								
98780-05020	B - 4								
9878R-05512	C - 4								
98980-04008	C - 2								
98980-04010	D - 12								
99590-14016	C - 3								