

PARTS CATALOGUE

WaveRunner XLT800

XA800A-B (F1F4/60GD/60G1)

XA800A-B (F1F5/60GE/60G1)

MJ-XA800A'03 (F1F6/60GF/60G1)

XA800A-B/MJ-XA800A
PARTS CATALOGUE
©2002 by Yamaha Motor Co., Ltd.
1st Edition, Sep. 2002
All rights reserved.
Any reprinting or unauthorized use
without the written permission of
Yamaha Motor Co., Ltd.
is expressly prohibited.
Printed in Japan

A3



A4

FOREWORD

This Parts Catalogue is related to the parts for the model(s) in the below frame. When you are ordering replacement parts, please refer to this Parts Catalogue and quote both part numbers and part names correctly.

XA800A-B(F1F4/60GD/60G1), XA800A-B(F1F5/60GE/60G1),
MJ-XA800A'03(F1F6/60GF/60G1)

1. Modifications or additions which have been made after issue of the Parts Catalogue will be announced in the Yamaha Parts News.

It is advisable that you make necessary corrections to the Parts Catalogue according to the Yamaha Parts News.

2. Abbreviations

The following abbreviations are used in this Parts Catalogue.

“UR” Use specified parts number.

“UN” Use as many as needed.

“AP” Alternate Parts

“LM” Local Made (Parts need to be ordered locally)

“F#” Frame No. (Applicable machine No.)

3. Parts, which are to be supplied in an assembly, are listed with a dot(.) in front of the part name as shown below.

The numeral appearing to the right of each component part indicates the quantity of parts for each assembly unit.

EXAMPLE

PART NO.	DESCRIPTION	Q'TY	REMARKS
EU0-62280-00	DRAIN PLUG ASSY	2	
EU0-62282-00	.PLUG,DRAIN	1	

4. Quantity Column Information

NAME for Q'TY COLUMN	COUNTRY (destination)
USA	USA
GENE	EXCEPT USA,JAPAN
JPN	JAPAN

5. Note that the illustration for reference in finding parts numbers, not to be used for assembling. When assembling, please use the applicable service manual.

6. A part with “YMUS” in the remarks column can be obtained from YMUS (USA) and not from YAMAHA MOTOR CO.,LTD (JAPAN).

EXAMPLE

PART NO.	DESCRIPTION	Q'TY	REMARKS
EW2-U5160-00	ENGINE HATCH COMP.	2	.. YMUS
90601-168U7	BAND, HOSE	1	.. YMUS

ADDRESS:

YAMAHA MOTOR CORPORATION U.S.A.
PARTS & ACCESSORY DIV.
6555 KATELLA AVENUE
CYPRESS, CALIFORNIA 90630 U.S.A.

FOREWORD

7. Applicable Starting Serial No. and Color Code

Starting Serial No.

Hull Serial No. ... F1F4(FOR USA)	F1F-804001
..... F1F5(FOR GENE)	F1F-804201
Engine Serial No.	60G-1000501

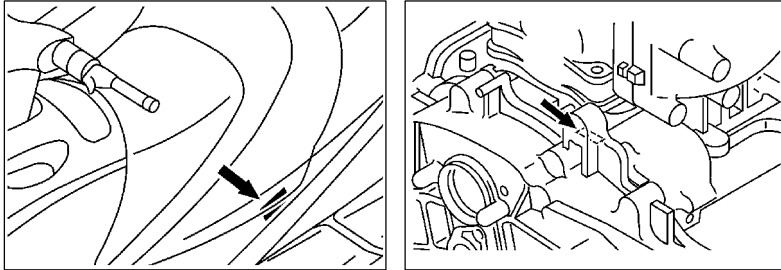

Color Code

Coloring Type code	Parts No./Part Name	Color Code	Color Name	Abbreviation
A	F0V-U516N-50-P0 COVER, ENGINE HATCH	0810	GRAYISH CYAN METALLIC 3	NCM3
	F0V-U517B-40-P0 LID, ENGINE ROOM	0810	GRAYISH CYAN METALLIC 3	NCM3
	F0D-U517H-80-P0 LID, HATCH	0810	GRAYISH CYAN METALLIC 3	NCM3
B	F0V-U516N-60-P0 COVER, ENGINE HATCH	0880	YELLOW METALLIC 2	YM2
	F0V-U517B-50-P0 LID, ENGINE ROOM	0880	YELLOW METALLIC 2	YM2
	F0D-U517H-90-P0 LID, HATCH	0880	YELLOW METALLIC 2	YM2

CONTENTS

CYLINDER. CRANKCASE 1	B2	SEAT. UNDER LOCKER	D6
CYLINDER. CRANKCASE 2	B4	OIL TANK	D8
CRANKSHAFT. PISTON	B5	FUEL TANK	D9
INTAKE	B7	EXHAUST 2	D11
CARBURETOR	B8	CONTROL CABLE	D12
OIL PUMP	B11	STEERING 1	D15
EXHAUST 1	B13	STEERING 2	E3
FUEL	C2	GRAPHICS	E4
JET UNIT 1	C3	IMPORTANT LABELS	E5
JET UNIT 2	C6	IMPORTANT LABELS 2	E6
JET UNIT 3	C7	IMPORTANT LABELS 3	E7
GENERATOR	C8	REPAIR KIT 1	E8
STARTING MOTOR	C9	REPAIR KIT 2	E9
ELECTRICAL 1	C10		
ELECTRICAL 2	C12		
ENGINE HATCH 1	C13		
ENGINE HATCH 2	C14		
HULL. DECK	D2		
GUNWALE. MAT	D4		
VENTILATION	D5		

INDEX

NUMERICAL INDEX	M1
-----------------------	----

FIG. 1 CYLINDER. CRANKCASE 1

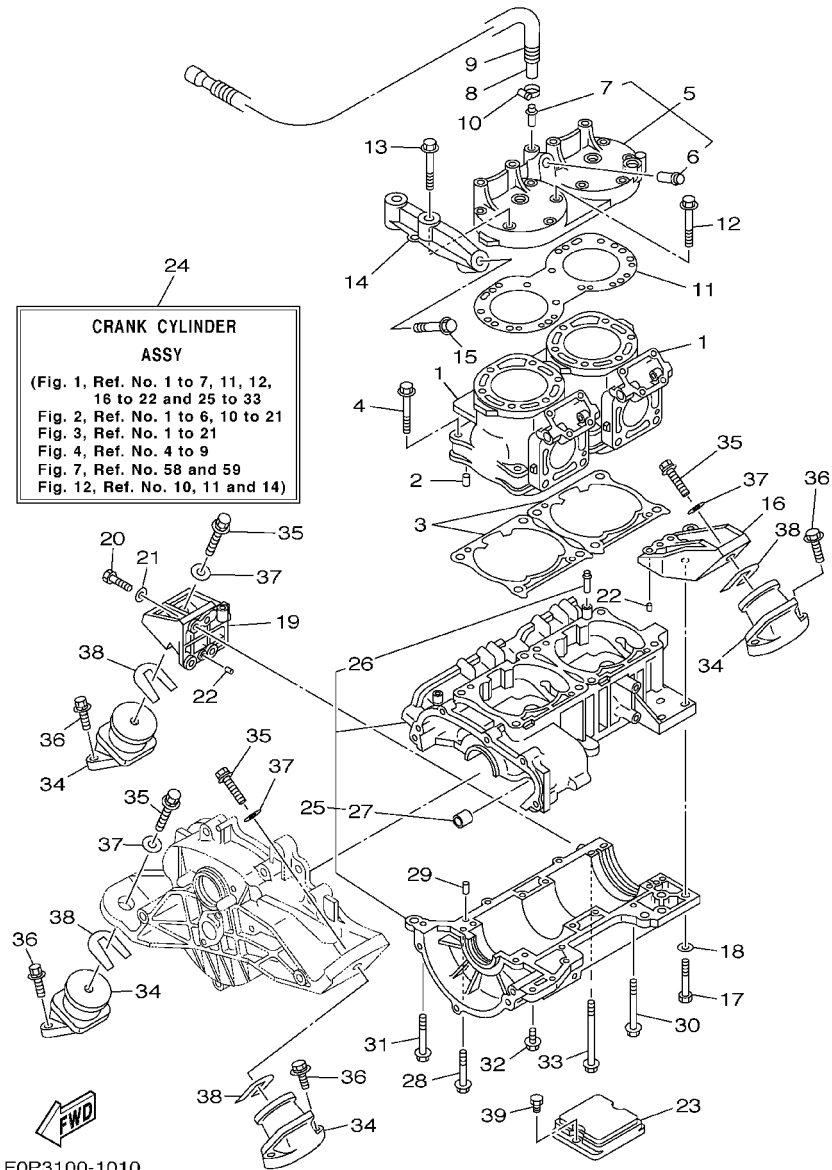

FOP3100-1010

REF. NO.	PART NO.	DESCRIPTION	USA	GENE	JPN	REMARKS
1	66E-11311-00-94	CYLINDER 1	2	2	2	
2	93606-12019	PIN, DOWEL	4	4	4	
3	66E-11351-01	GASKET, CYLINDER	2	2	2	
4	90119-10M07	BOLT, WITH WASHER	8	8	8	
5	66E-11111-00-94	HEAD, CYLINDER 1	1	1	1	
6	66E-51129-00	.NIPPLE	1	1	1	
7	6K8-51129-00	.NIPPLE	1	1	1	
8	90445-14003	HOSE	1	1	1	
9	90447-19003	HOSE, WITH SPRING	1	1	1	
10	90450-14M05	HOSE CLAMP ASSY	1	1	1	
11	66E-11181-00	GASKET, CYLINDER HEAD 1	1	1	1	
12	90119-08MA1	BOLT, WITH WASHER	10	10	10	
13	90119-08MA2	BOLT, WITH WASHER	2	2	2	
14	66E-14781-10-94	STAY, MUFFLER 2	1	1	1	
15	90119-10M00	BOLT, WITH WASHER	1	1	1	
16	66E-21425-10-8P	BRACKET, REAR UPPER 1	1	1	1	
17	97013-08045	BOLT	3	3	3	
18	92903-08600	WASHER, PLATE	3	3	3	
19	66E-21426-10-8P	BRACKET, REAR UPPER 2	1	1	1	
20	97013-08030	BOLT	3	3	3	
21	92903-08600	WASHER, PLATE	3	3	3	
22	93606-12019	PIN, DOWEL	4	4	4	
23	67A-44532-00-94	STOPPER, UPPER MOUNT	1	1	1	
24	66E-W0090-12-8P	CRANK CYLINDER ASSY	1	1	1	
25	66E-15100-10-8P	CRANKCASE ASSY	1	1	1	
26	62T-14251-10	.NIPPLE	2	2	2	
27	90380-12M29	.BUSH, SOLID	1	1	1	

FIG. 1 CYLINDER. CRANKCASE 1

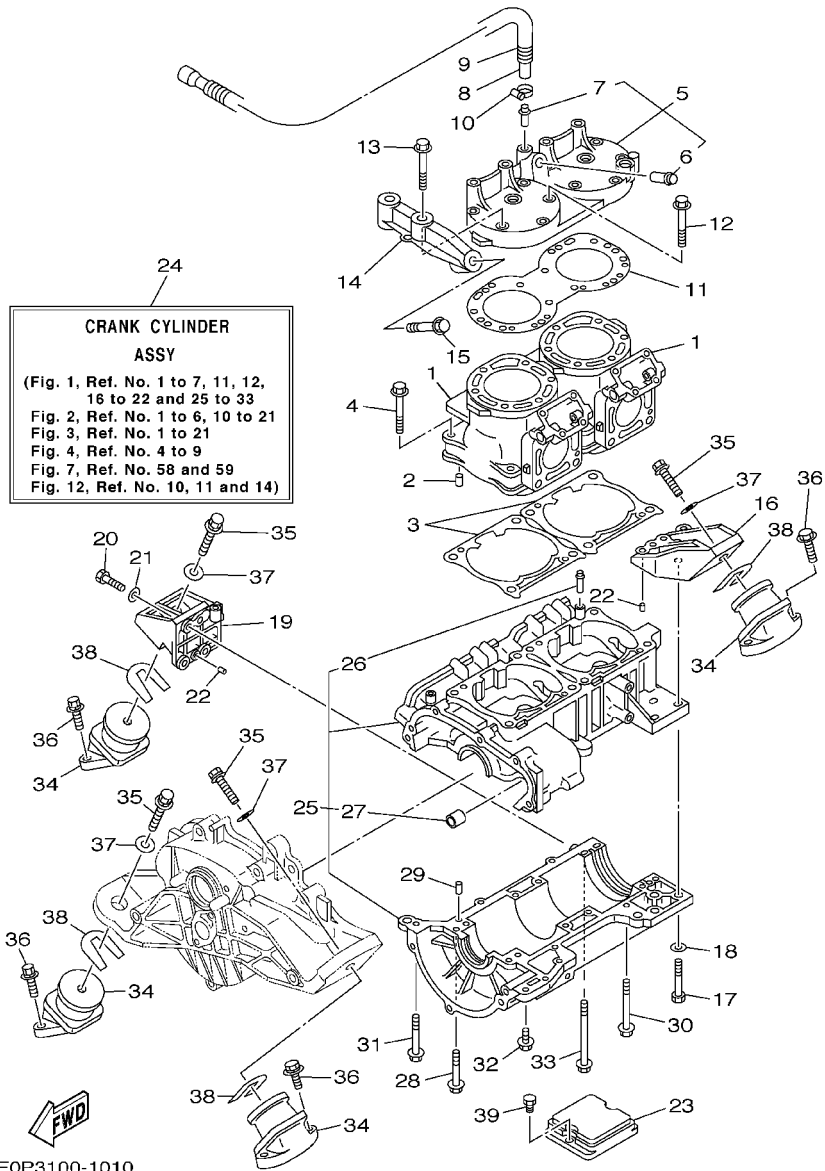

FOP3100-1010

REF. NO.	PART NO.	DESCRIPTION	USA	GENE	JPN	REMARKS
28	90119-08M55	BOLT, WITH WASHER	10	10	10	
29	93606-12019	PIN, DOWEL	2	2	2	
30	90119-06M78	BOLT, WITH WASHER	3	3	3	
31	90119-08M61	BOLT, WITH WASHER	1	1	1	
32	90119-06M13	BOLT, WITH WASHER	4	4	4	
33	90119-08M56	BOLT, WITH WASHER	2	2	2	
34	6M6-44517-A1-5B	MOUNT RUBBER	4	4	4	
35	90119-089UR	BOLT, WITH WASHER	4	4	4	YMUS
36	90119-089U6	BOLT, WITH WASHER	8	8	8	YMUS
37	90201-099U3	WASHER, PLATE	4	4	4	YMUS
38	EU0-U7354-00-01	SHIM (T=0.1)	10	10	10	UR, YMUS
	EU0-U7354-00-03	SHIM (T=0.3)	10	10	10	UR, YMUS
	EU0-U7354-00-05	SHIM (T=0.5)	10	10	10	UR, YMUS
	EU0-U7354-00-10	SHIM (T=1.0)	10	10	10	UR, YMUS
	EU0-U7354-00-20	SHIM (T=2.0)	10	10	10	UR, YMUS
39	90101-06917	BOLT	2	2	2	

FIG. 2 CYLINDER. CRANKCASE 2

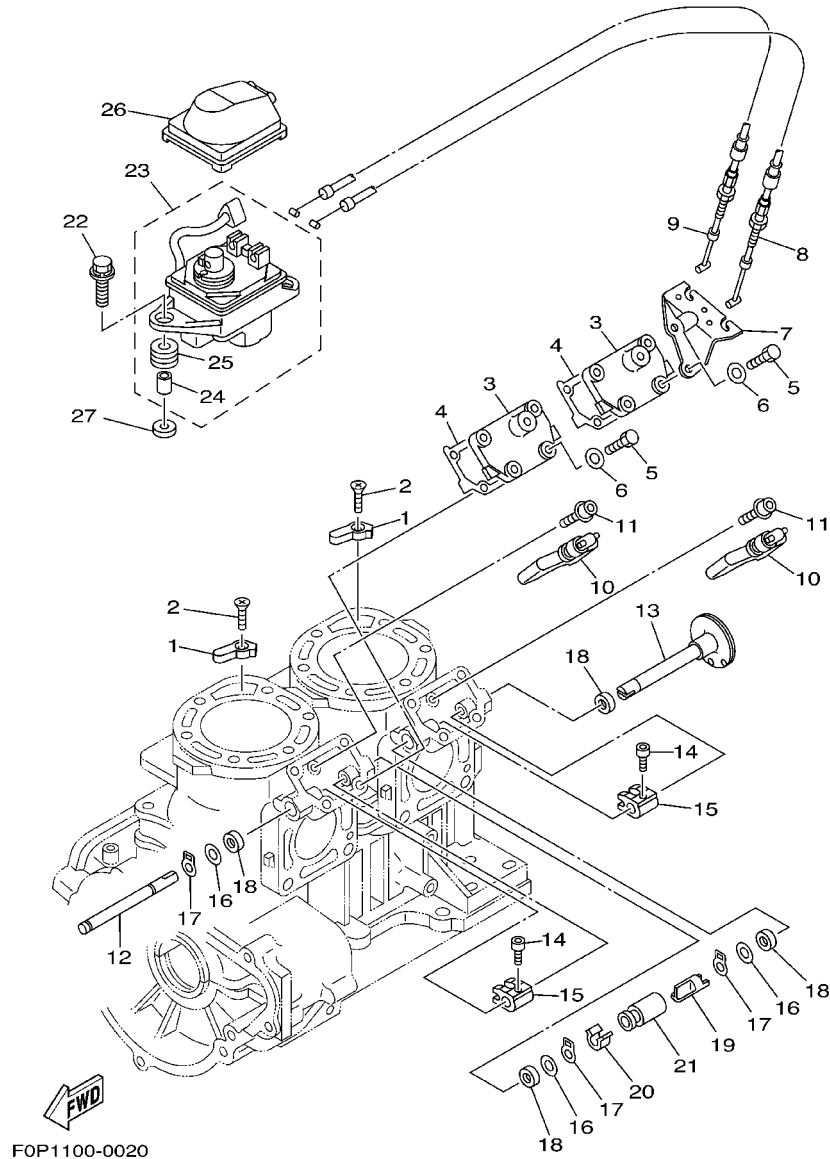

REF. NO.	PART NO.	DESCRIPTION	USA	GENE	JPN	REMARKS
1	66E-11325-00	ANODE	2	2	2	
2	98780-05020	SCREW, FLAT HEAD	2	2	2	
3	66E-1131M-01-8P	COVER	2	2	2	
4	66E-1131B-01	GASKET, COVER	2	2	2	
5	97013-06025	BOLT	8	8	8	
6	92903-06600	WASHER, PLATE	8	8	8	
7	66E-11998-00	BRACKET 1	1	1	1	
8	66V-1133E-00	CABLE, PULLEY 1	1	1	1	
9	66V-1133F-00	CABLE, PULLEY 2	1	1	1	
10	66E-1131S-10	VALVE ASSY.	2	2	2	
11	90110-05008	BOLT, HEXAGON SOCKET HEAD	2	2	2	
12	66E-1131V-00	SHAFT 1	1	1	1	
13	66E-1132C-00	PULLEY, SHAFT	1	1	1	
14	90110-04M03	BOLT, HEXAGON SOCKET HEAD	2	2	2	
15	66E-11832-01	LEVER, LINK	2	2	2	
16	90201-08M09	WASHER, PLATE	3	3	3	
17	93410-08M12	CIRCLIP	3	3	3	
18	93109-08M07	OIL SEAL	4	4	4	
19	66E-1131H-00	JOINT 1	1	1	1	
20	66E-1131J-10	JOINT 2	1	1	1	
21	66E-1131C-10	COVER, JOINT	1	1	1	
22	90119-069UX	BOLT, WITH WASHER	2	2	2	YMUS
23	60G-85820-00	SERVO MOTOR ASSY	1	1	1	
24	90387-07598	.COLLAR	2	2	2	
25	90480-14023	.GROMMET	2	2	2	
26	66E-85825-00	COVER, WIRE	1	1	1	
27	90201-06M04	WASHER, PLATE	2	2	2	

FIG. 3 CRANKSHAFT. PISTON

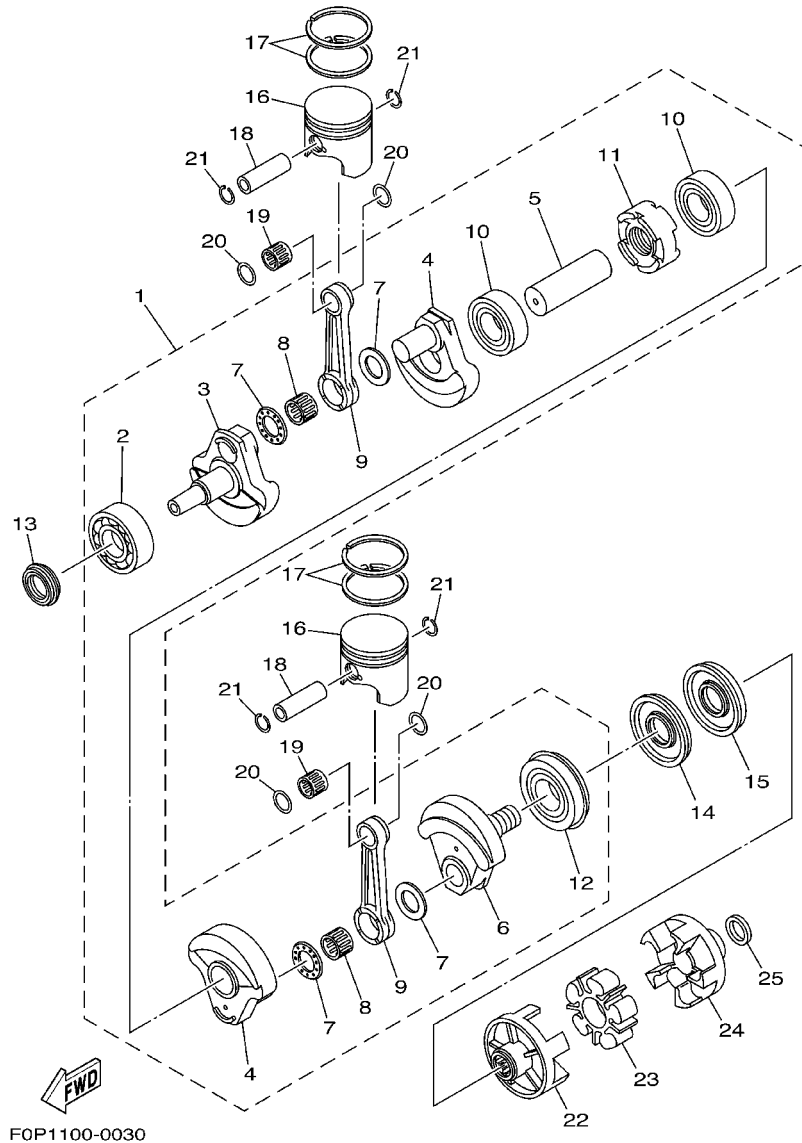

FOP1100-0030

REF. NO.	PART NO.	DESCRIPTION	USA	GENE	JPN	REMARKS
1	66E-11400-00	CRANKSHAFT ASSY	1	1	1	
2	93305-307U0	.BEARING	1	1	1	
3	66E-11412-00	.CRANK 1	1	1	1	
4	66E-11422-00	.CRANK 2	2	2	2	
5	66E-11431-00	.CRANK 3	1	1	1	
6	66E-11442-00	.CRANK 4	1	1	1	
7	66E-11685-00	.WASHER, CRANK PIN	4	4	4	
8	93310-627U6	.BEARING	2	2	2	
9	66E-11651-00	.ROD, CONNECTING	2	2	2	
10	93306-208U1	.BEARING	2	2	2	
11	66E-11515-00	.SEAL, LABYRINTH 1	1	1	1	
12	93306-308U1	.BEARING	1	1	1	
13	93103-35M03	OIL SEAL	1	1	1	
14	93101-36M62	OIL SEAL	1	1	1	
15	93101-36M61	OIL SEAL	1	1	1	
16	66E-11631-00-A0	PISTON (STD)	2	2	2	UR RED
	66E-11631-00-B0	PISTON (STD)	2	2	2	UR ORANGE
	66E-11631-00-C0	PISTON (STD)	2	2	2	UR GREEN
	66E-11631-00-D0	PISTON (STD)	2	2	2	UR PURPLE
17	66E-11603-01	PISTON RING SET (STD)	4	4	4	
18	66E-11633-00	PIN, PISTON	2	2	2	
19	93310-422U2	BEARING	2	2	2	
20	90201-22M04	WASHER, PLATE	4	4	4	
21	66E-11634-00	CLIP, PISTON PIN	4	4	4	
22	66E-45813-10-94	FLANGE, COUPLING	1	1	1	
23	66E-4581J-00	RUBBER SHAFT COUPLING	1	1	1	
24	68N-45593-00-94	FLANGE, COUPLING 1	1	1	1	

FIG. 3 CRANKSHAFT. PISTON

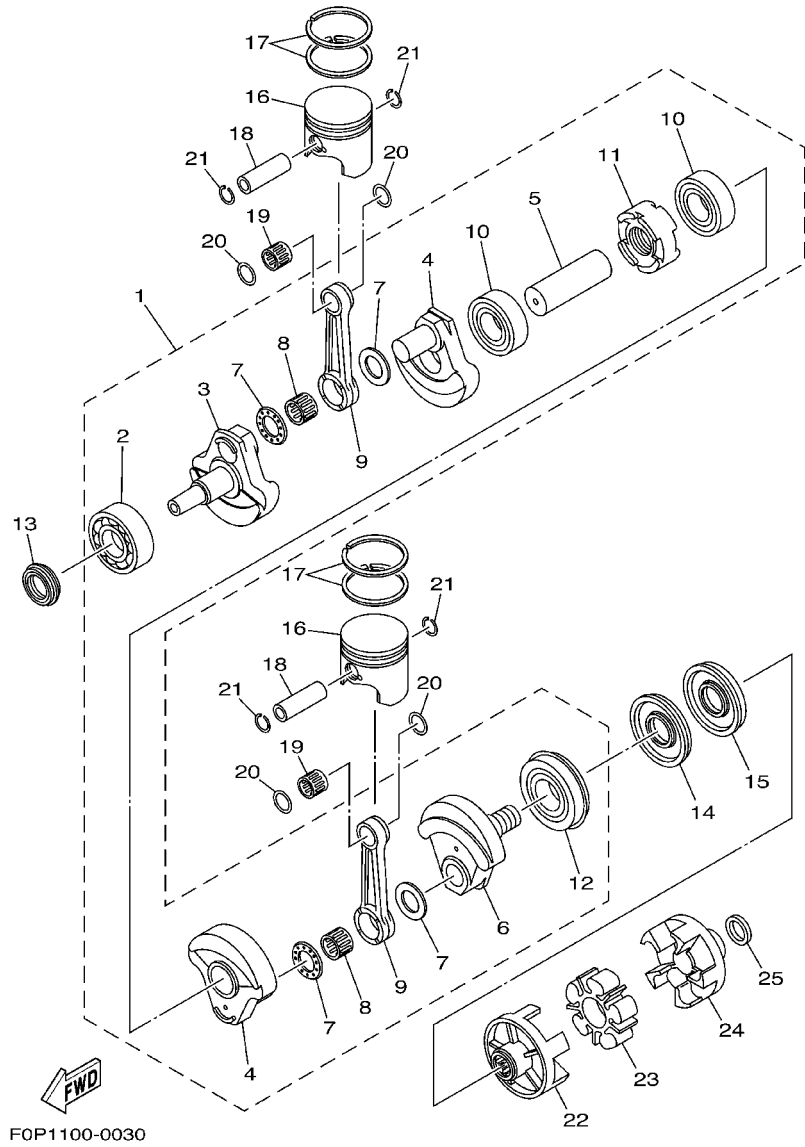

FOP1100-0030

REF. NO.	PART NO.	DESCRIPTION	USA	GENE	JPN	REMARKS
25	90201-248M5	WASHER, PLATE	1	1	1	

FIG. 4 INTAKE

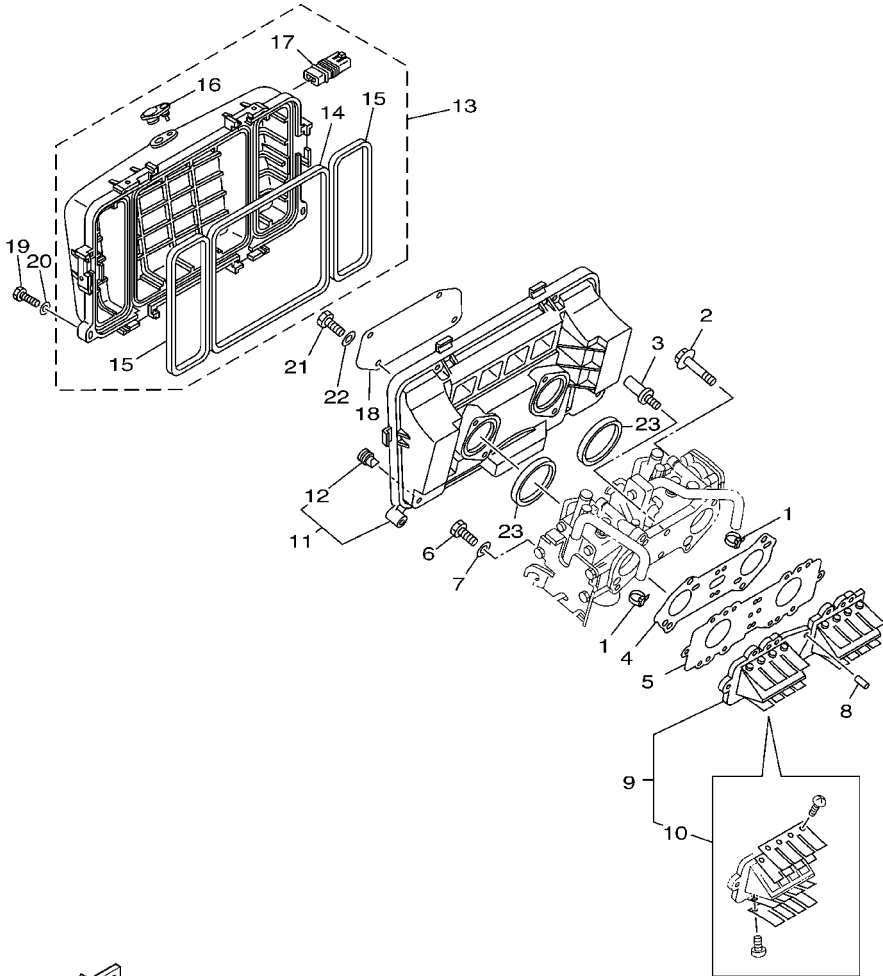

REF. NO.	PART NO.	DESCRIPTION	USA	GENE	JPN	REMARKS
1	90465-11M10	CLAMP	2	2	2	
2	90105-08M86	BOLT, FLANGE	4	4	4	
3	90109-06M00	BOLT	2	2	2	
4	66E-13556-00	GASKET, MANIFOLD	1	1	1	
5	66E-13624-10	PLATE, REED VALVE	1	1	1	
6	97013-06025	BOLT	12	12	12	
7	92903-06600	WASHER, PLATE	12	12	12	
8	93606-19M23	PIN, DOWEL	2	2	2	
9	66E-13610-00	REED VALVE ASSY	2	2	2	
10	66E-W0004-00	.REED SET	1	1	1	
11	66E-1441E-00	COVER, CLEANER CASE 2	1	1	1	
12	66E-42717-00	.RUBBER, SEAL 2	2	2	2	
13	66E-14480-11	COVER SUB ASSY	1	1	1	
14	66E-14457-10	.SEAL	1	1	1	
15	66E-14452-00	.SEAL	2	2	2	
16	66E-14435-00	.GROMMET	1	1	1	
17	66E-13898-11	.HOLDER	6	6	6	
18	66E-14451-00	ELEMENT, AIR CLEANER	1	1	1	
19	97095-06035	BOLT	3	3	3	
20	92995-06600	WASHER	3	3	3	
21	97013-06045	BOLT	4	4	4	
22	92903-06600	WASHER, PLATE	4	4	4	
23	66E-13473-00	O-RING	2	2	2	



F0N3300-0041

FIG. 5 CARBURETOR

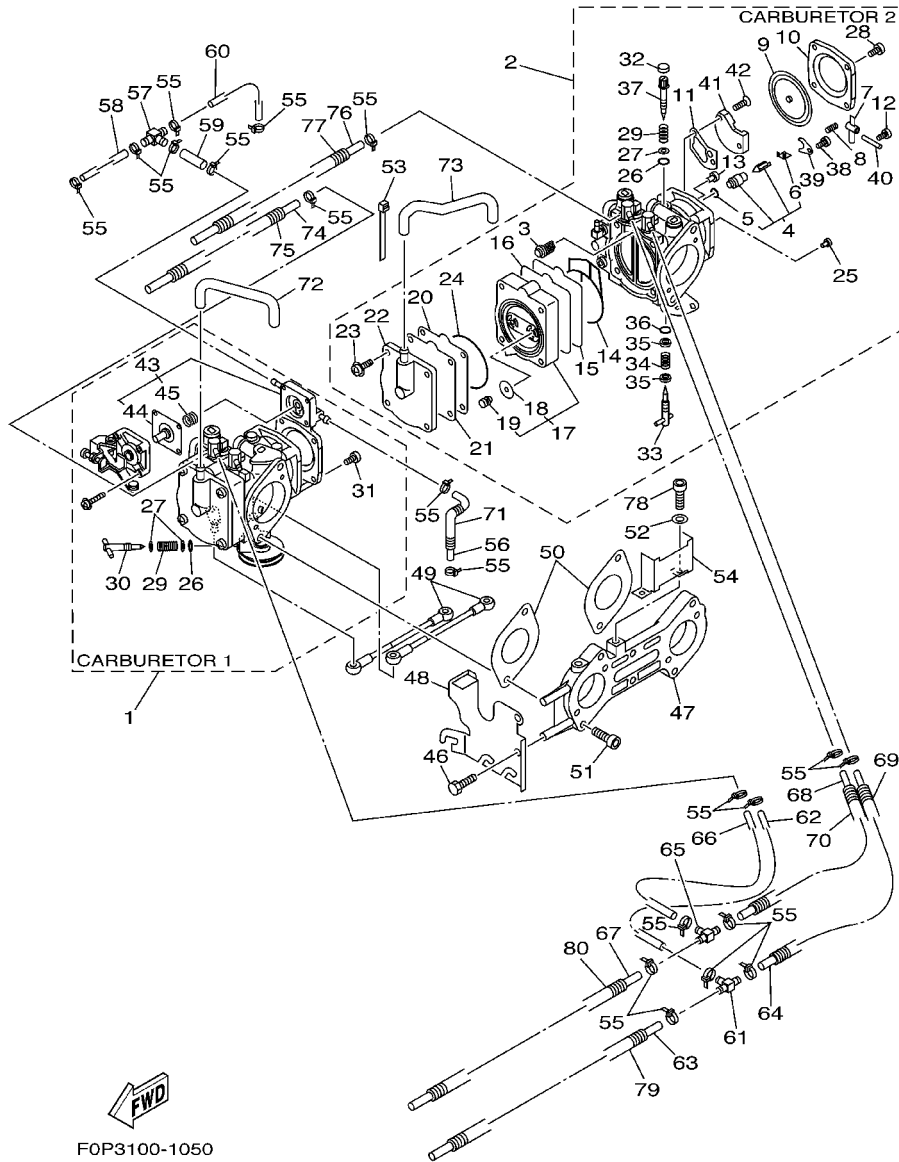

FOP3100-1050

REF. NO.	PART NO.	DESCRIPTION	USA	GENE	JPN	REMARKS
1	67A-14301-03	CARBURETOR ASSY 1	1	1	1	
2	67A-14302-03	CARBURETOR ASSY 2	1	1	1	
3	6R7-14569-00	.STRAINER	2	2	2	
4	64T-14916-01	.NEEDLE	2	2	2	
5	8F2-14147-00	..O-RING	1	1	1	
6	7EG-14159-00	..CLIP	1	1	1	
7	6K8-14547-01	.ARM, FLOAT	2	2	2	
8	6R7-14253-00	.SPRING	2	2	2	
9	6R7-14541-00	.DIAPHRAGM, PUMP	2	2	2	
10	6R7-14542-00	.BODY, PUMP 1	1	1	1	CARBURETOR 2
11	6K8-14536-11	.GASKET	2	2	2	
12	6K8-14503-02	.SCREW	2	2	2	
13	3G2-14231-30	.JET, MAIN (#150)	1	1	1	UR CARBURETOR 1
	3G2-14231-30	.JET, MAIN (#150)	1	1	1	UR CARBURETOR 2
14	66E-14563-01	.O-RING	2	2	2	
15	66E-24471-00	.DIAPHRAGM	2	2	2	
16	66E-24411-00	.DIAPHRAGM	2	2	2	
17	66E-24413-01	.BODY 2	2	2	2	
18	66E-24362-00	..VALVE, CHECK 1	1	1	1	
19	65U-24492-00	..BUSH, FULEL PUMP	1	1	1	
20	66E-24421-00	.VALVE, CHECK	2	2	2	
21	66E-24431-00	.GASKET, FUEL PUMP 1	2	2	2	
22	66E-24452-00	.COVER	2	2	2	
23	90157-05M17	.SCREW, PAN HEAD	8	8	8	
24	66E-14564-01	.O-RING	2	2	2	
25	830-14231-18	.JET, MAIN (# 90)	2	2	2	
26	812-14147-00	.O-RING	3	3	3	

FIG. 5 CARBURETOR

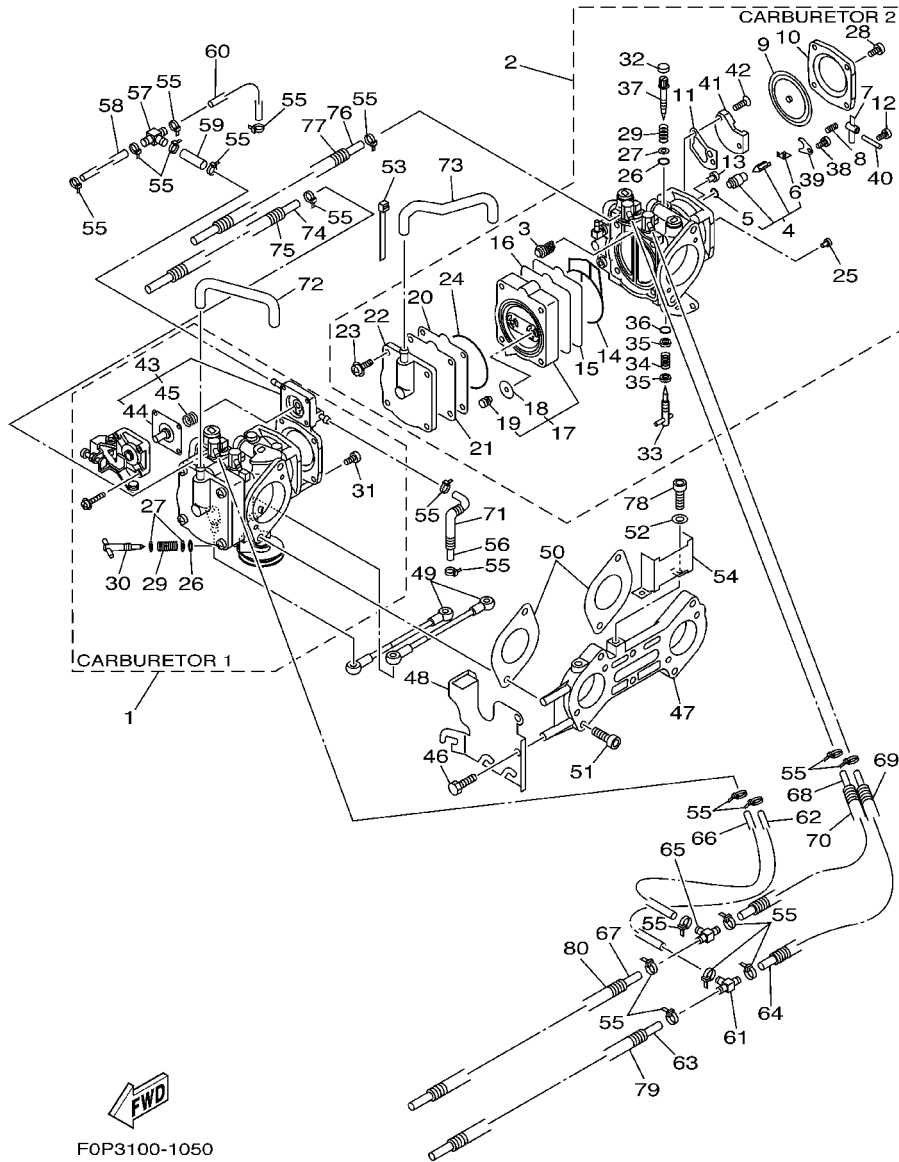

FOP3100-1050

REF. NO.	PART NO.	DESCRIPTION	USA	GENE	JPN	REMARKS
27	812-14235-00	.WASHER, NEEDLE	4	4	4	
28	97880-05010	.SCREW, PAN HEAD	4	4	4	CARBURETOR 2
29	3KW-14932-00	.SPRING, THROTTLE 2	3	3	3	
30	66E-14521-00	.SCREW, ADJUST	1	1	1	CARBURETOR 1
31	97890-05014	.SCREW, PAN HEAD	4	4	4	CARBURETOR 1
32	6K8-14471-10	.CAP, CARBURETOR	2	2	2	
33	66E-14211-00	.SCREW, PILOT ADJUSTING	2	2	2	
34	6K8-14589-00	.SPRING	2	2	2	
35	822-14235-00	.WASHER, NEEDLE	4	4	4	
36	583-14561-00	.O-RING	2	2	2	
37	6K8-14946-10	.METERING NEEDLE	2	2	2	
38	6M6-14503-00	.SCREW	2	2	2	
39	6K8-14527-11	.PLATE	2	2	2	
40	439-14186-00	.PIN, FLOAT	2	2	2	
41	66E-24412-00	.BODY 1	2	2	2	
42	6K8-14523-11	.SCREW, STOP	4	4	4	
43	66E-14280-00	.COVER, CARBURETOR	1	1	1	CARBURETOR 1
44	66E-14170-00	..DIAPHRAGM ASS'Y	1	1	1	CARBURETOR 1
45	66E-14286-00	..SPRING	1	1	1	CARBURETOR 1
46	90101-06M25	BOLT	3	3	3	
47	66E-14243-00	PLATE	1	1	1	
48	66E-14291-00	BRACKET 1	1	1	1	
49	66E-41217-00	ROD, ACCEL. LEVER	2	2	2	
50	66E-14398-00	GASKET	2	2	2	
51	66E-14162-01	BOLT, HOLDING	4	4	4	
52	90204-06M01	WASHER, SPRING	2	2	2	
53	4KM-14137-00	CLIP	1	1	1	

FIG. 5 CARBURETOR

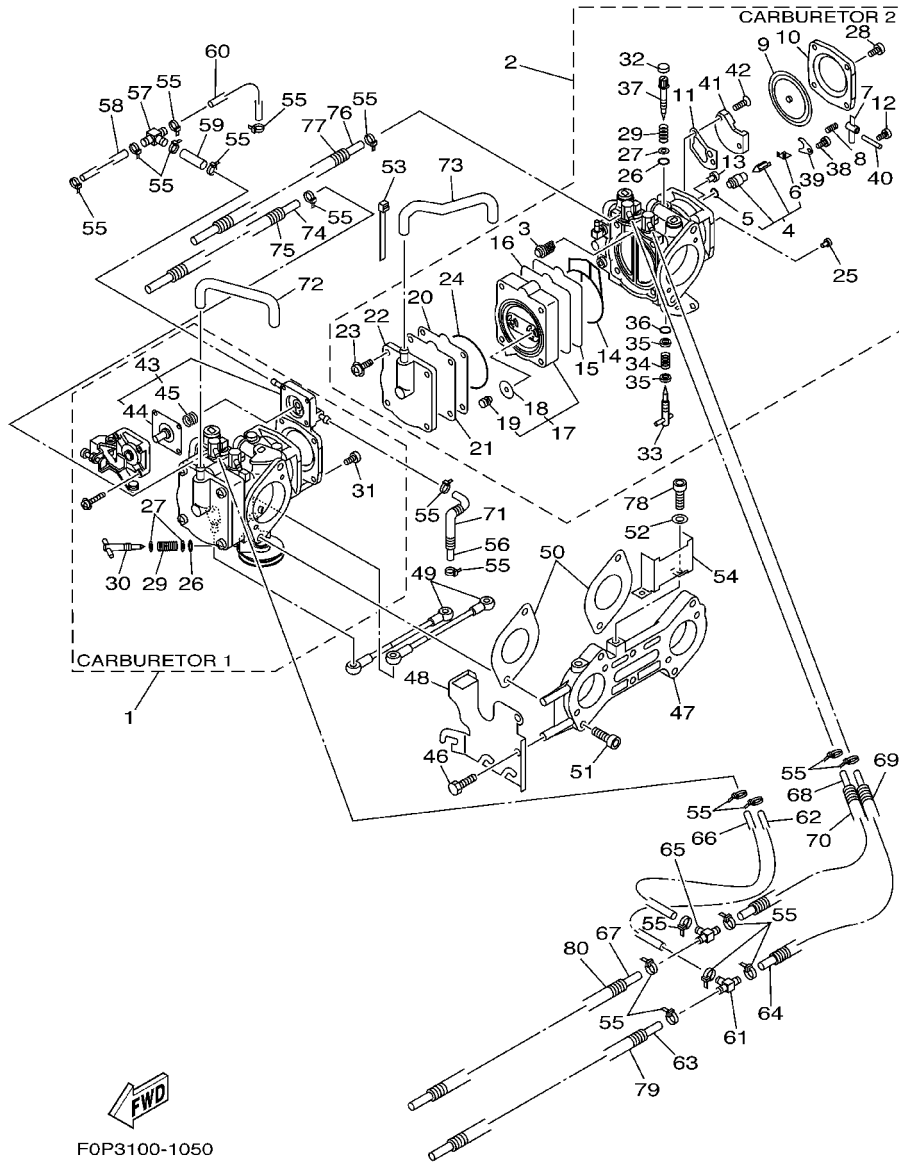

FOP3100-1050

REF. NO.	PART NO.	DESCRIPTION	USA	GENE	JPN	REMARKS
54	66E-14146-00	PLATE	1	1	1	
55	35H-14139-00	CLIP, PIPE	20	20	20	
56	3XP-14294-00	HOSE	1	1	1	
57	4N0-14251-00	NIPPLE	1	1	1	
58	90445-07M78	HOSE	1	1	1	
59	90445-07M42	HOSE	1	1	1	
60	90445-07M79	HOSE	1	1	1	
61	66E-14251-00	NIPPLE	1	1	1	
62	90445-10MH0	HOSE	1	1	1	
63	67A-14294-00	HOSE	1	1	1	
64	90445-10MH2	HOSE	1	1	1	
65	66E-14251-00	NIPPLE	1	1	1	
66	90445-10MH3	HOSE	1	1	1	
67	67A-14298-00	PIPE	1	1	1	
68	90445-10MH5	HOSE	1	1	1	
69	90446-14M98	HOSE	1	1	1	
70	90446-14M99	HOSE	1	1	1	
71	90446-10MA2	HOSE	1	1	1	
72	66E-24314-00	PIPE 4	1	1	1	
73	66E-24315-00	PIPE 5	1	1	1	
74	90446-07M96	HOSE	1	1	1	
75	90446-10MA0	HOSE	1	1	1	
76	90446-07M97	HOSE	1	1	1	
77	90446-10MA1	HOSE	1	1	1	
78	66E-14162-00	BOLT, HOLDING	2	2	2	
79	90446-17ME5	HOSE	1	1	1	
80	90446-17MA7	HOSE	1	1	1	

FIG. 6 OIL PUMP

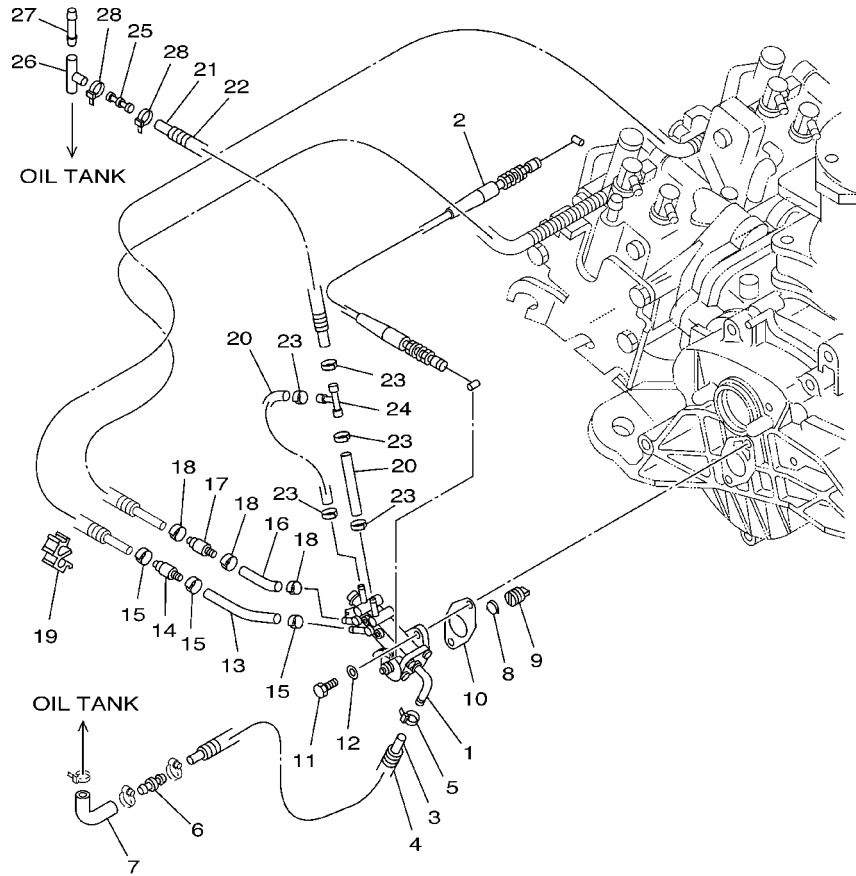

FOW3100-2060

REF. NO.	PART NO.	DESCRIPTION	USA	GENE	JPN	REMARKS
1	66E-13200-02	OIL INJECTION PUMP ASSY	1	1	1	
2	66E-26320-00	PUMP CABLE ASSY	1	1	1	
3	90445-11012	HOSE (L600)	1	1	1	
4	90447-13002	HOSE, WITH SPRING	1	1	1	
5	90465-11M10	CLAMP	1	1	1	
6	66V-51142-00	CONNECTION	1	1	1	
7	66V-13416-01	PIPE, OIL 1	1	1	1	
8	66E-13469-00	SPRING	1	1	1	
9	65U-13132-00	JOINT	1	1	1	
10	63M-13116-00	GASKET, PUMP CASE	1	1	1	
11	97095-06020	BOLT	2	2	2	
12	92995-06600	WASHER	2	2	2	
13	90445-07009	HOSE	1	1	1	
14	67X-13183-00	VALVE, CHECK	1	1	1	
15	90468-02001	CLIP	3	3	3	
16	90445-07009	HOSE	1	1	1	
17	67X-13183-00	VALVE, CHECK	1	1	1	
18	90468-02001	CLIP	3	3	3	
19	90464-07M20	CLAMP	1	1	1	
20	90445-07M25	HOSE (L53)	2	2	2	
21	90445-07002	HOSE (L720)	1	1	1	
22	90447-07002	HOSE, WITH SPRING	1	1	1	
23	90468-02001	CLIP	5	5	5	
24	6E0-24378-00	PIPE, JOINT 4	1	1	1	
25	63M-13132-00	JOINT	1	1	1	
26	63M-24378-00	PIPE, JOINT 4	1	1	1	
27	6G8-24376-00	PIPE, JOINT 1	1	1	1	

FIG. 7 EXHAUST 1

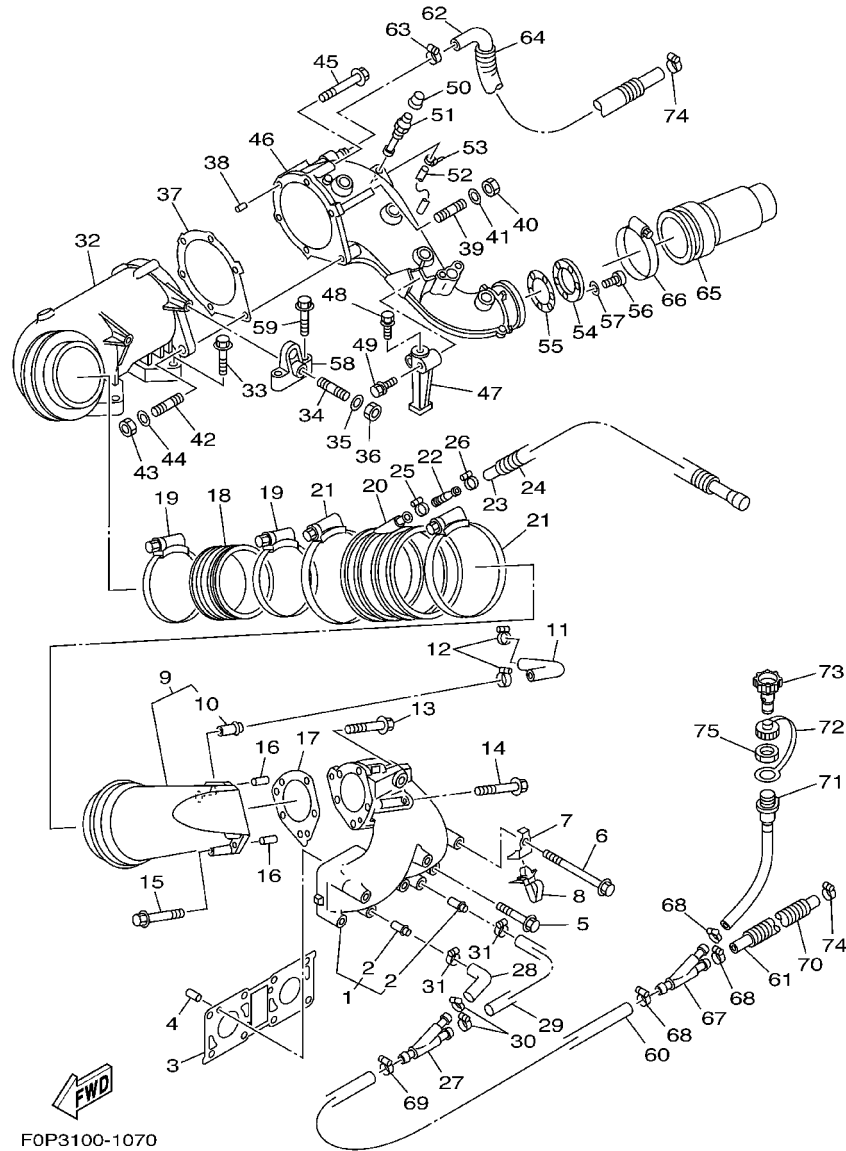

FOP3100-1070

REF. NO.	PART NO.	DESCRIPTION	USA	GENE	JPN	REMARKS
1	66E-14711-10-8P	MUFFLER 1	1	1	1	
2	6K8-51129-00	.NIPPLE	2	2	2	
3	66E-14613-00	GASKET, EXHAUST PIPE	1	1	1	
4	93606-12019	PIN, DOWEL	2	2	2	
5	90105-10M85	BOLT, FLANGE	4	4	4	
6	90105-10M86	BOLT, FLANGE	4	4	4	
7	90465-20M78	CLAMP	2	2	2	
8	90465-12M56	CLAMP	2	2	2	
9	66E-14712-10-8P	RING, JOINT	1	1	1	
10	66E-51129-00	.NIPPLE	1	1	1	
11	66E-12576-00	HOSE 1	1	1	1	
12	90450-22M14	HOSE CLAMP ASSY	2	2	2	
13	90105-08M83	BOLT, FLANGE	2	2	2	
14	90105-08M84	BOLT, FLANGE	2	2	2	
15	90105-08M66	BOLT, FLANGE	1	1	1	
16	93606-12019	PIN, DOWEL	2	2	2	
17	66E-14749-00	GASKET, MUFFLER DAMPER 2	1	1	1	
18	66E-14625-00	JOINT, EXHAUST 2	1	1	1	
19	90450-99M02	HOSE CLAMP ASSY	2	2	2	
20	66E-14615-00	JOINT, EXHAUST 1	1	1	1	
21	90450-99M18	HOSE CLAMP ASSY	2	2	2	
22	60E-12594-00	JOINT, HOSE 4	1	1	1	
23	90445-14M33	HOSE (L1150)	1	1	1	
24	90446-24M94	HOSE	1	1	1	
25	90450-18M09	HOSE CLAMP ASSY	1	1	1	
26	90450-14M05	HOSE CLAMP ASSY	1	1	1	
27	63M-12581-00	JOINT, HOSE 1	1	1	1	

FIG. 7 EXHAUST 1

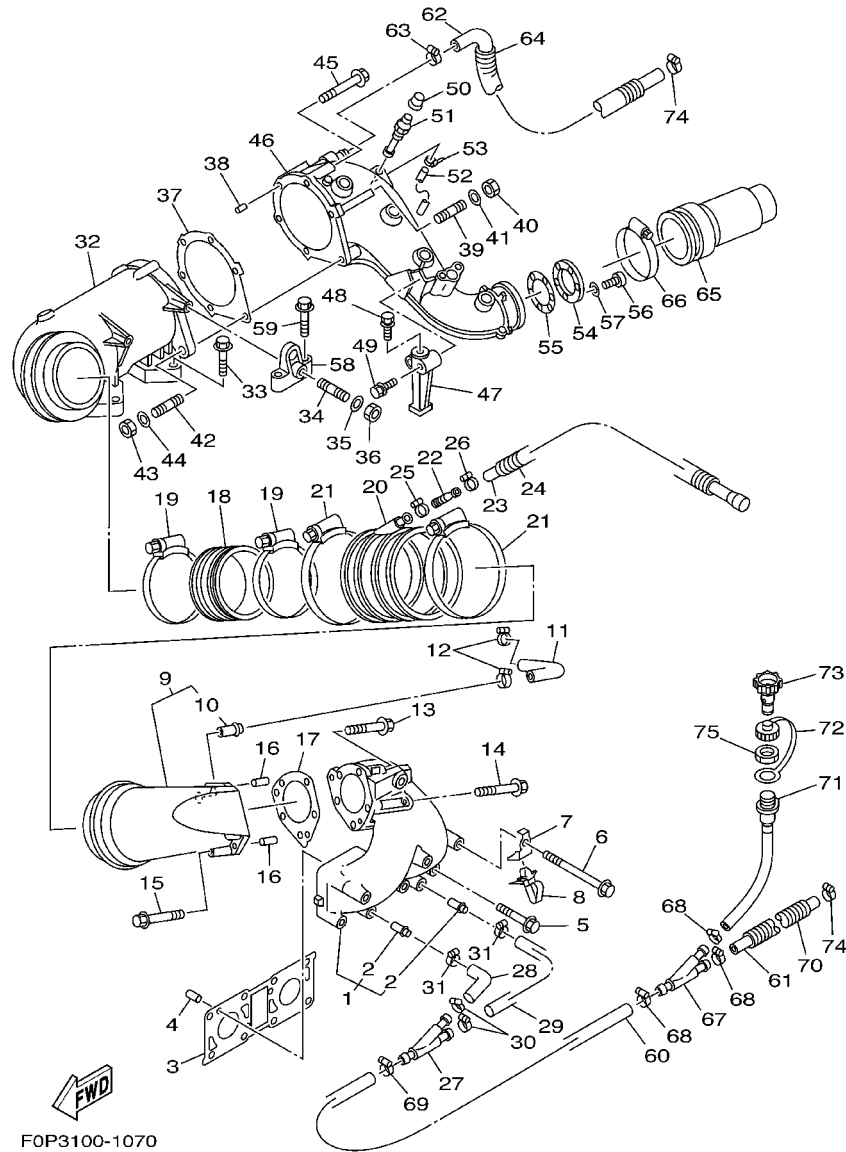

FOP3100-1070

REF. NO.	PART NO.	DESCRIPTION	USA	GENE	JPN	REMARKS
28	66E-12577-00	HOSE 2	1	1	1	
29	66E-12579-00	HOSE 4	1	1	1	
30	90450-18M09	HOSE CLAMP ASSY	2	2	2	
31	90450-14M05	HOSE CLAMP ASSY	2	2	2	
32	66E-14721-10-94	MUFFLER 2	1	1	1	
33	90105-10M82	BOLT, FLANGE	2	2	2	
34	90116-10M66	BOLT, STUD	2	2	2	
35	92990-10600	WASHER, PLATE	2	2	2	
36	95380-10600	NUT	2	2	2	
37	66E-41124-10	GASKET, EXHAUST OUTER COVER	1	1	1	
38	93606-12019	PIN, DOWEL	2	2	2	
39	90116-08M64	BOLT, STUD	2	2	2	
40	95333-08600	NUT	2	2	2	
41	92990-08600	WASHER, PLATE	2	2	2	
42	90116-10M65	BOLT, STUD	1	1	1	
43	95380-10600	NUT	1	1	1	
44	92990-10600	WASHER, PLATE	1	1	1	
45	90105-08M83	BOLT, FLANGE	3	3	3	
46	67A-41123-00-94	OUTER COVER, EXHAUST	1	1	1	
47	66E-14791-00-94	STAY, MUFFLER	1	1	1	
48	90119-10M10	BOLT, WITH WASHER	1	1	1	
49	90119-10M00	BOLT, WITH WASHER	1	1	1	
50	663-45119-00	CAP, GREASE NIPPLE	1	1	1	
51	61L-5169A-00	NIPPLE, GREASE	1	1	1	
52	90445-09M21	HOSE (L445)	1	1	1	
53	90465-11M10	CLAMP	1	1	1	
54	66E-14763-10-94	SPACER	1	1	1	

FIG. 7 EXHAUST 1

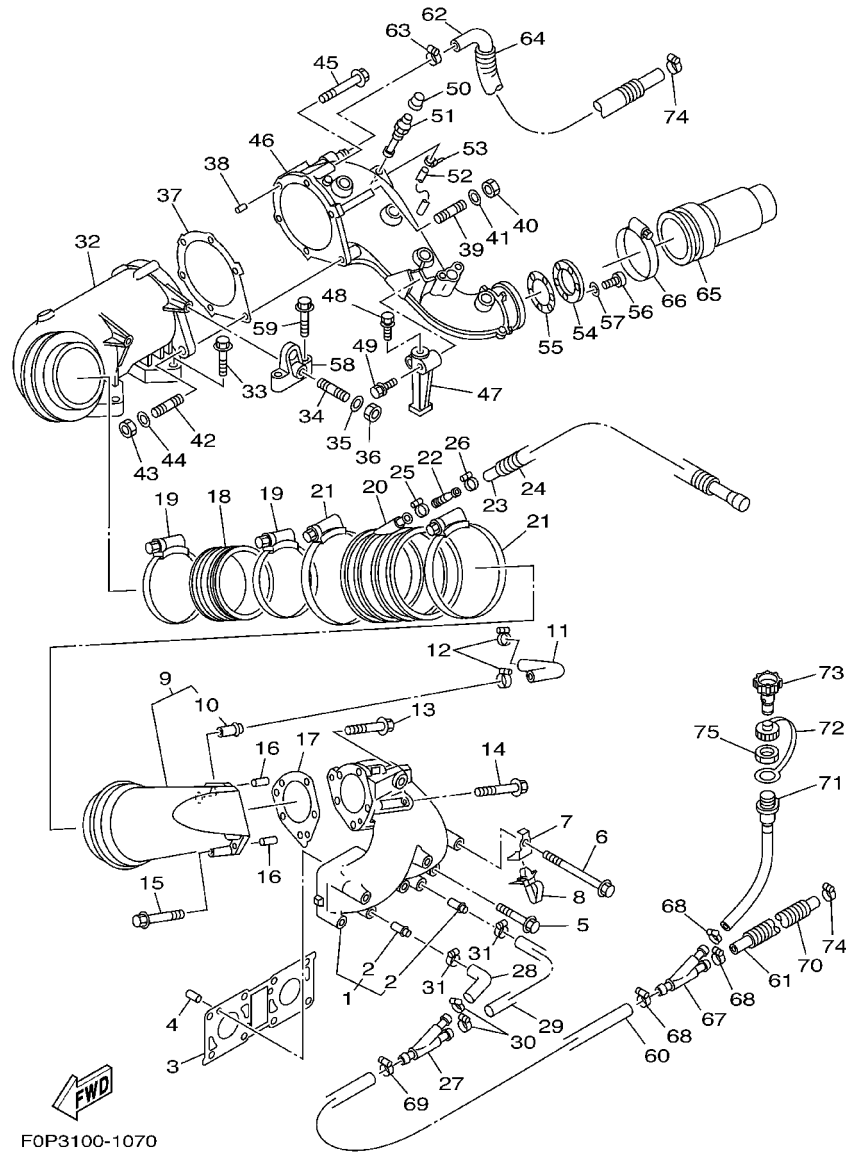

FOP3100-1070

REF. NO.	PART NO.	DESCRIPTION	USA	GENE	JPN	REMARKS
55	66E-14623-00	GASKET, EXHAUST PIPE	1	1	1	
56	97885-06016	SCREW, PAN HEAD	3	3	3	
57	92995-06600	WASHER	3	3	3	
58	66E-14771-01-94	STAY, MUFFLER 1	2	2	2	
59	90119-10M18	BOLT, WITH WASHER	4	4	4	
60	90445-18M17	HOSE (L60)	1	1	1	
61	90445-18M02	HOSE (L700)	1	1	1	
62	66E-12578-00	HOSE 3	1	1	1	
63	90450-22M14	HOSE CLAMP ASSY	1	1	1	
64	90446-27M95	HOSE	1	1	1	
65	67A-14752-00	PIPE, OUTLET	1	1	1	
66	90460-90M11	CLAMP, HOSE	1	1	1	
67	63M-12581-00	JOINT, HOSE 1	1	1	1	
68	90450-18M09	HOSE CLAMP ASSY	3	3	3	
69	90450-18M09	HOSE CLAMP ASSY	1	1	1	
70	90446-24M52	HOSE	1	1	1	
71	64T-12580-00	JOINT ASSY	1	1	1	
72	682-84385-01	CAP,1	1	1	1	
73	67X-12590-00	CONDUCTION ASSY	1			FOR USA
	67X-12590-20	CONDUCTION ASSY		1		FOR GENE
	67X-12590-10	CONDUCTION ASSY			1	FOR JPN
74	90601-118UF	BAND, HOSE 18	2	2	2	YMUS
75	EU0-61652-00	NUT	1	1	1	

FIG. 8 FUEL

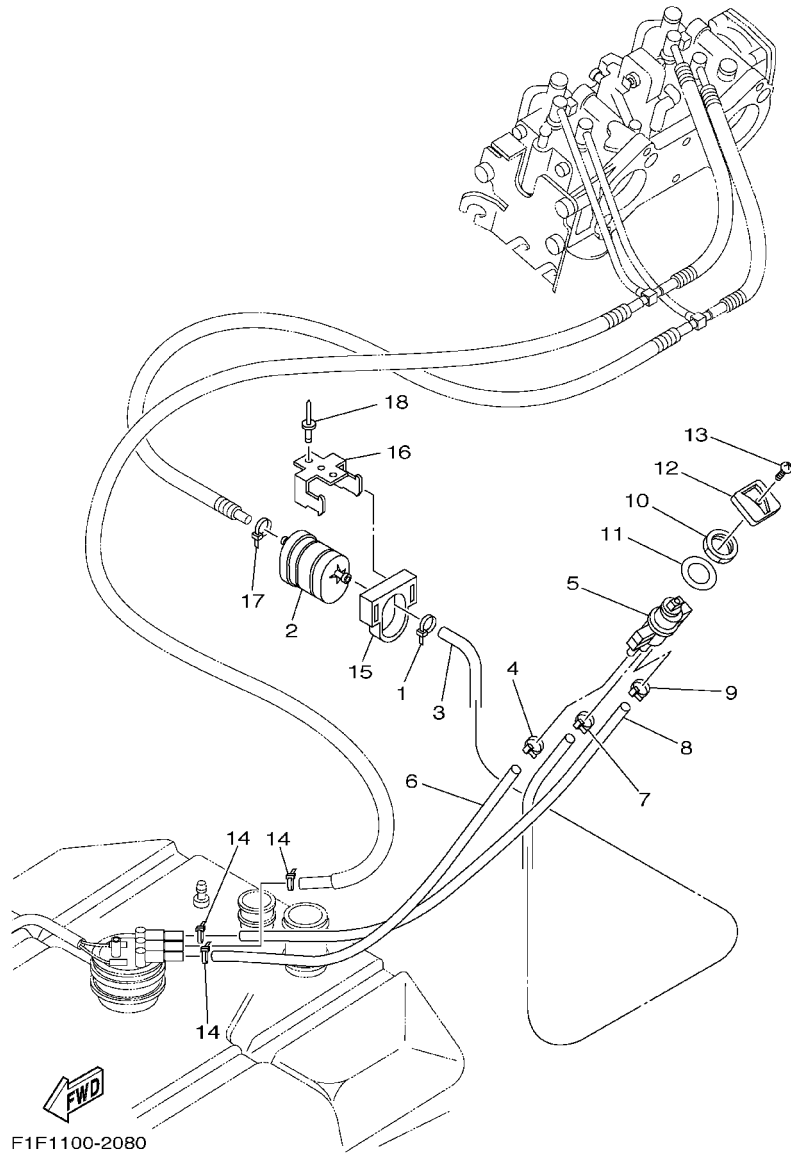

REF. NO.	PART NO.	DESCRIPTION	USA	GENE	JPN	REMARKS
1	90465-11829	CLAMP	1	1	1	YMUS
2	66V-24560-00	FILTER ASSY	1	1	1	
3	90445-11M68	HOSE (L450)	1	1	1	
4	90465-11M10	CLAMP	2	2	2	
5	66V-24500-02	FUEL COCK ASSY 1	1	1	1	
6	90445-11M67	HOSE (L450)	1	1	1	
7	90465-11M10	CLAMP	1	1	1	
8	90445-11M69	HOSE (L450)	1	1	1	
9	90465-11829	CLAMP	1	1	1	YMUS
10	90170-22187	NUT	1	1	1	
11	90202-229U1	WASHER, PLATE	1	1	1	YMUS
12	F0D-6777C-00	LEVER, COCK	1	1	1	
13	98980-04008	SCREW, BIND	1	1	1	
14	90465-11829	CLAMP	3	3	3	YMUS
15	EU0-U7817-00	HOLDER, FILTER	1	1	1	YMUS
16	FN8-67816-00	BRACKET, FUEL FILTER	1	1	1	
17	90465-11829	CLAMP	1	1	1	YMUS
18	90267-489U1	RIVET,BLIND	2	2	2	YMUS

FIG. 9 JET UNIT 1

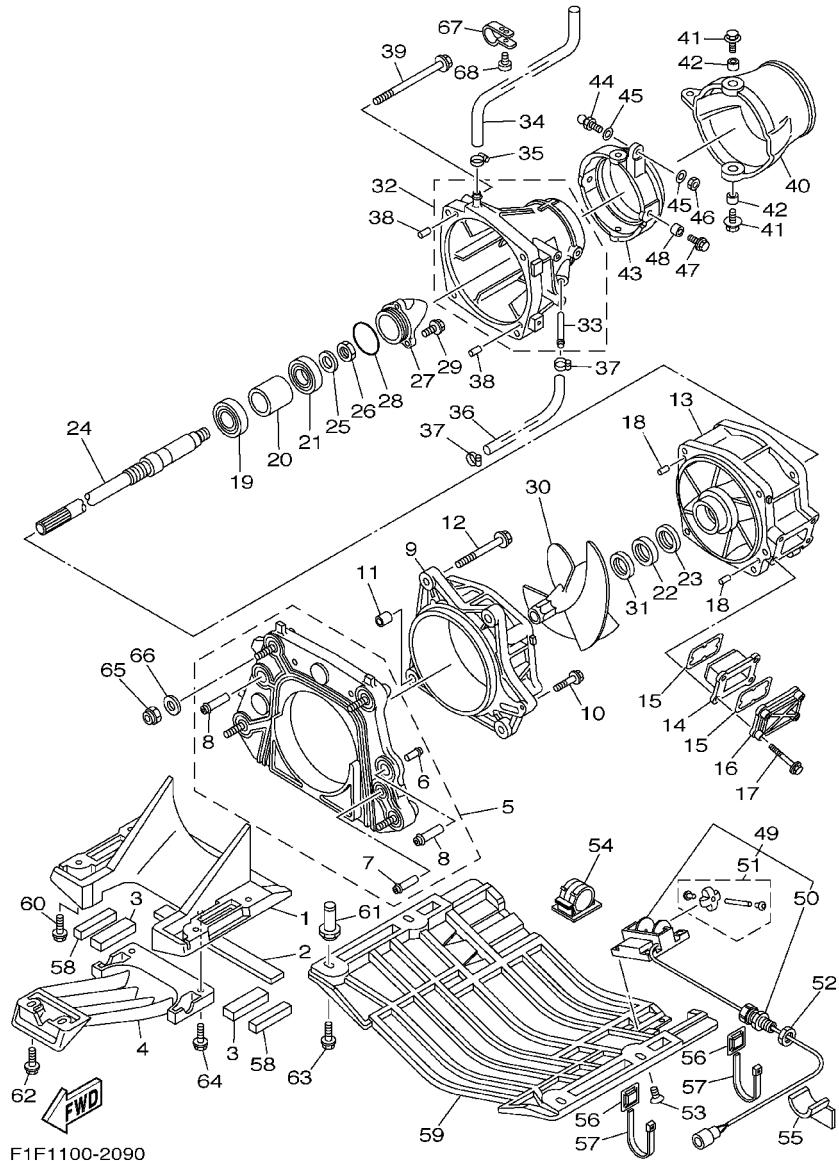

F1F1100-2090

REF. NO.	PART NO.	DESCRIPTION	USA	GENE	JPN	REMARKS
1	66V-51311-00-94	DUCT, INTAKE	1	1	1	
2	66V-51367-00	FELT, PACKING	1	1	1	
3	66V-51368-00	FELT, PACKING	1	1	1	
4	66V-51333-00-94	SCREEN, INTAKE	1	1	1	
5	66V-G5831-02	PLATE, TRANSOM	1	1	1	YMUS
6	65A-R1129-00	.NIPPLE	1	1	1	YMUS
7	66V-51129-01	.NIPPLE	1	1	1	
8	66V-51129-10	.NIPPLE	2	2	2	
9	66V-51312-01-94	HOUSING, IMPELLER	1	1	1	
10	90119-06835	BOLT, WITH WASHER	1	1	1	YMUS
11	99590-14016	PIN, DOWEL	2	2	2	
12	90119-10836	BOLT, WITH WASHER	4	4	4	YMUS
13	66V-51315-00-94	DUCT, IMPELLER	1	1	1	
14	66V-46882-00	FILTER	1	1	1	
15	66V-42414-00	O-RING	2	2	2	
16	66V-45214-00-94	COVER, WATER INLET	1	1	1	
17	90119-06800	BOLT, WITH WASHER	4	4	4	YMUS
18	93606-12019	PIN, DOWEL	2	2	2	
19	93306-205U0	BEARING	1	1	1	
20	65V-45538-00	SPACER 1	1	1	1	
21	93306-304U1	BEARING	1	1	1	
22	93101-28M66	OIL SEAL	1	1	1	
23	93101-28M65	OIL SEAL	1	1	1	
24	68Y-45511-00	SHAFT, DRIVE	1	1	1	
25	9299R-16600	WASHER	1	1	1	YMUS
26	9531P-16700	NUT	1	1	1	YMUS
27	65A-R1326-00	CAP	1	1	1	YMUS

FIG. 9 JET UNIT 1

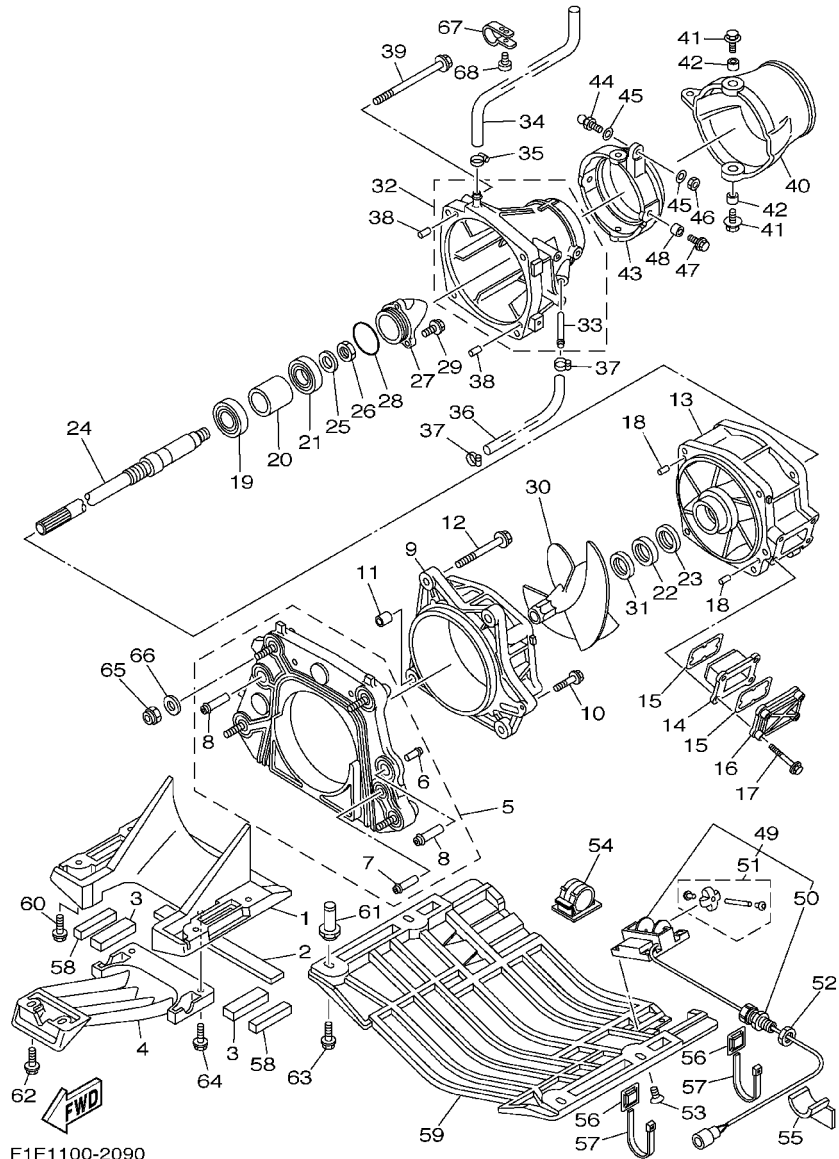

F1F1100-2090

REF. NO.	PART NO.	DESCRIPTION	USA	GENE	JPN	REMARKS
28	93210-46M16	O-RING	1	1	1	
29	90119-069UB	BOLT, WITH WASHER	3	3	3	YMUS
30	67A-R1321-00	IMPELLER	1	1	1	YMUS
31	66V-R1348-10	SPACER	1	1	1	YMUS
32	66V-51318-00-94	NOZZLE	1	1	1	
33	63M-51334-00	.NIPPLE,HOSE	1	1	1	
34	90445-16M09	HOSE (L310)	1	1	1	
35	90601-118UF	BAND, HOSE 18	1	1	1	YMUS
36	90445-14898	HOSE (L270)	1	1	1	YMUS
37	90465-11829	CLAMP	2	2	2	YMUS
38	93606-12019	PIN, DOWEL	2	2	2	
39	90119-10837	BOLT, WITH WASHER	4	4	4	YMUS
40	66V-R1313-01	NOZZLE,DEFLECTOR	1	1	1	YMUS
41	90119-089UE	BOLT, WITH WASHER	2	2	2	YMUS
42	90387-08M06	COLLAR	2	2	2	
43	66G-51190-00-94	RING,TRIM	1	1	1	
44	GH3-U146E-00	STUD, JOINT BALL	1	1	1	YMUS
45	90201-068M4	WASHER, PLATE	2	2	2	YMUS
46	9538R-06700	NUT	1	1	1	YMUS
47	90119-089UE	BOLT, WITH WASHER	2	2	2	YMUS
48	90387-08M06	COLLAR	2	2	2	
49	F0V-U8K31-00	SENSOR SPEED	1	1	1	YMUS
50	EU0-67267-20	.CONNECTOR, CABLE	1	1	1	
51	GJ1-U835D-00	.SERVIS KIT (SPEED SENSOR)	1	1	1	YMUS
52	EU0-62241-30	NUT, DRAIN 1	1	1	1	
53	9878R-05512	SCREW, FLAT HEAD	4	4	4	YMUS
54	90600-925U9	CLAMP	2	2	2	YMUS

FIG. 9 JET UNIT 1

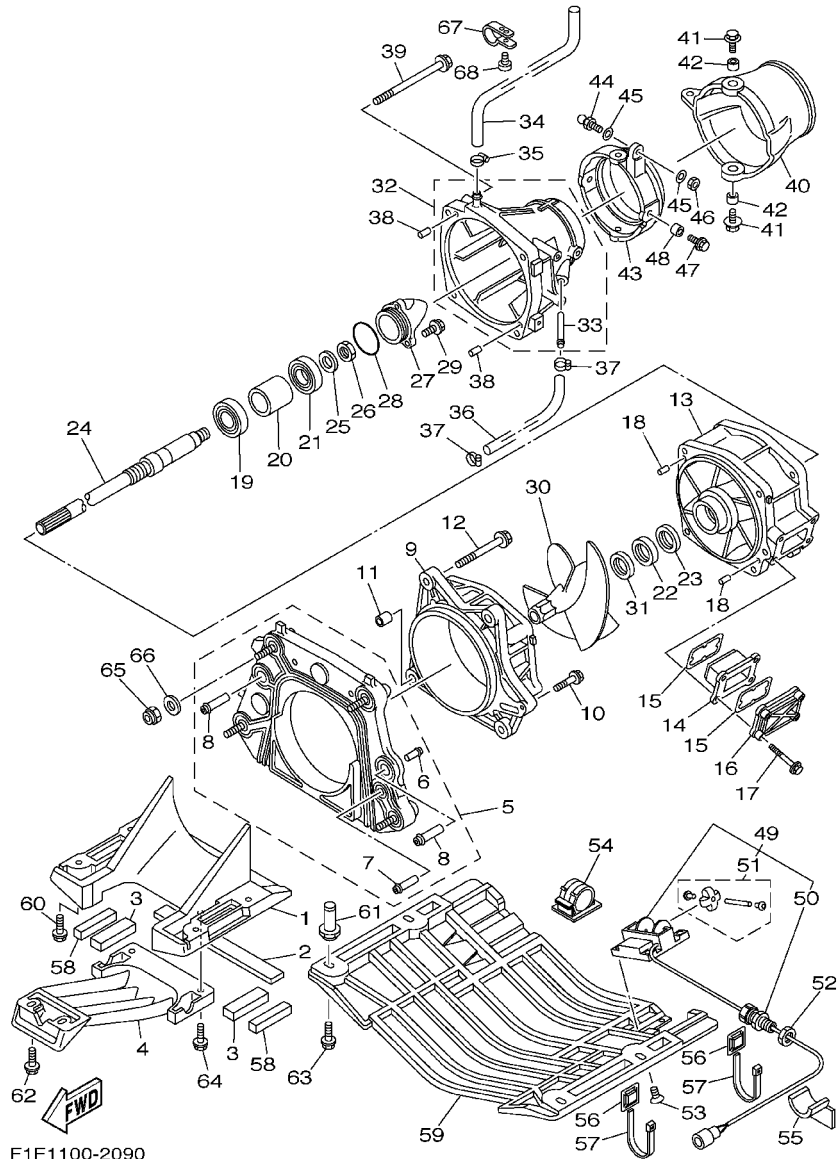

F1F1100-2090

REF. NO.	PART NO.	DESCRIPTION	USA	GENE	JPN	REMARKS
55	GJ1-U7578-11	PACKING, HOSE 2	1	1	1	YMUS
56	90600-900U6	BASE, CLAMP	5	5	5	YMUS
57	90464-40825	CLAMP	5	5	5	YMUS
58	F0V-U7525-01	PACKING	1	1	1	YMUS
59	F0V-U273B-00	PLATE 2	1	1	1	YMUS
60	90119-089U6	BOLT, WITH WASHER	4	4	4	YMUS
61	90179-08812	NUT	4	4	4	YMUS
62	90119-069UK	BOLT, WITH WASHER	2	2	2	YMUS
63	90119-089U6	BOLT, WITH WASHER	4	4	4	YMUS
64	90119-069UB	BOLT, WITH WASHER	2	2	2	YMUS
65	9572R-10300	NUT, FLANGE	4	4	4	YMUS
66	90201-10801	WASHER, PLATE	4	4	4	YMUS
67	90600-921U1	CLIP, NYLON 21	1	1	1	YMUS
68	97780-50514	SCREW, TAPPING	1	1	1	

FIG. 10 JET UNIT 2

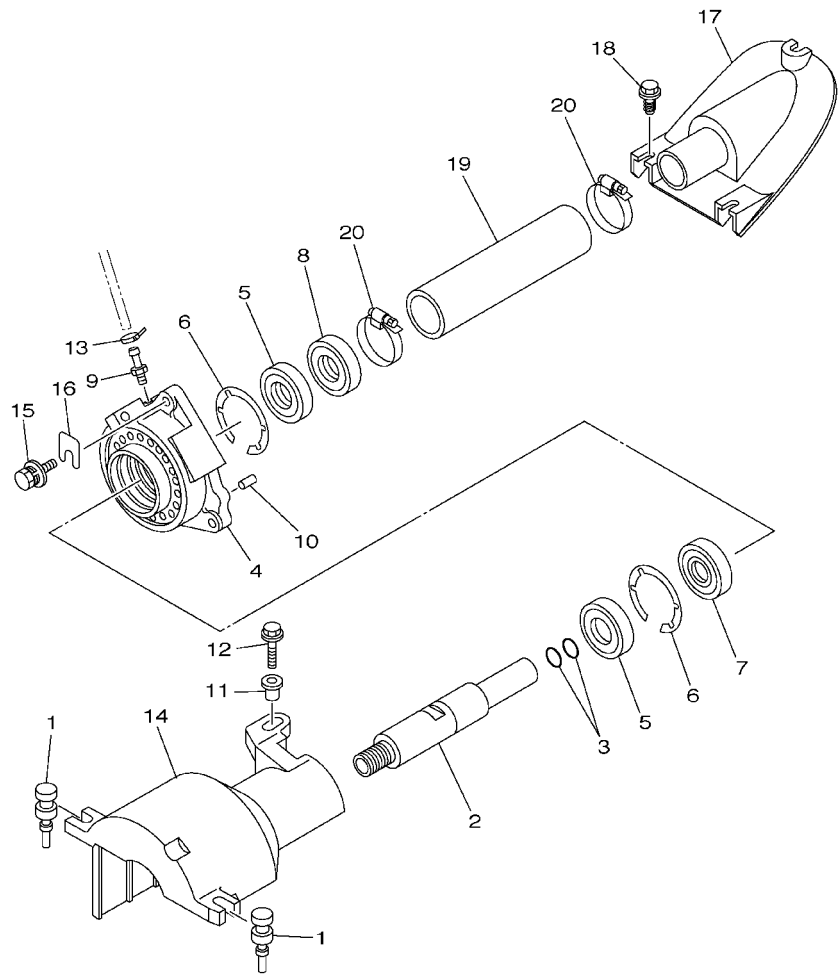

F1F1100-2100

REF. NO.	PART NO.	DESCRIPTION	USA	GENE	JPN	REMARKS
1	90480-06M46	GROMMET	2	2	2	
2	68N-51323-00	SHAFT, COUPLOR	1	1	1	
3	93210-19MJ4	O-RING	2	2	2	
4	61X-45332-03-94	HOUSING, BEARING	1	1	1	
5	93101-25M55	OIL SEAL	2	2	2	
6	93430-47M04	CIRCLIP	2	2	2	
7	93306-205U6	BEARING	1	1	1	
8	93101-25M56	OIL SEAL	1	1	1	
9	61L-45378-00	NIPPLE, HOSE	1	1	1	
10	93606-12019	PIN, DOWEL	2	2	2	
11	90387-06M60	COLLAR	1	1	1	
12	90119-069UD	BOLT, WITH WASHER	1	1	1	YMUS
13	90465-11829	CLAMP	1	1	1	YMUS
14	67A-R1381-00	COVER	1	1	1	YMUS
15	90119-089UL	BOLT, WITH WASHER	3	3	3	YMUS
16	GD0-U7249-00-05	SHIM (T=0.5)	1	1	1	UR, YMUS
	GD0-U7249-00-10	SHIM (T=1.0)	1	1	1	UR, YMUS
17	F0D-U883E-00	JOINT, PIPE	1	1	1	YMUS
18	90149-069UA	SCREW	3	3	3	YMUS
19	F0D-U883B-01	PIPE, 1	1	1	1	YMUS
20	90601-152U3	BAND, HOSE 52	2	2	2	YMUS

FIG. 11 JET UNIT 3

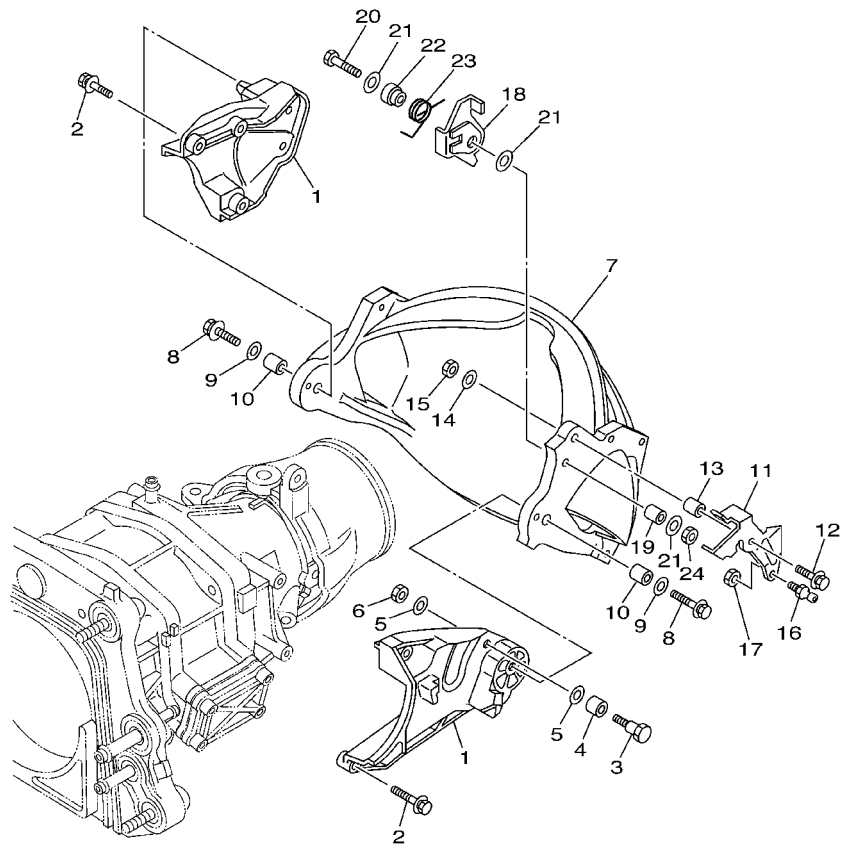

REF. NO.	PART NO.	DESCRIPTION	USA	GENE	JPN	REMARKS
1	66V-51341-00-94	BRACKET 1	2	2	2	
2	90119-069UD	BOLT, WITH WASHER	6	6	6	YMUS
3	90109-08879	BOLT	1	1	1	YMUS
4	90387-10M09	COLLAR	1	1	1	
5	9299R-08600	WASHER	2	2	2	YMUS
6	9538R-08600	NUT	1	1	1	YMUS
7	66V-51314-11	GATE, REVERSE	1	1	1	
8	90119-089UF	BOLT, WITH WASHER	2	2	2	YMUS
9	90201-088T2	WASHER, PLATE	2	2	2	YMUS
10	90387-08M30	COLLAR	2	2	2	
11	66V-44121-00	LEVER, SHIFT ROD	1	1	1	
12	90119-069UB	BOLT, WITH WASHER	1	1	1	YMUS
13	90387-06M74	COLLAR	1	1	1	
14	90201-068T1	WASHER, PLATE	1	1	1	YMUS
15	9538R-06600	NUT	1	1	1	YMUS
16	66V-U146E-00	STUD, JOINT BALL	1	1	1	YMUS
17	9538R-06600	NUT	1	1	1	YMUS
18	66V-44125-00	LEVER, SHIFT ROD	1	1	1	
19	90387-06M74	COLLAR	1	1	1	
20	90101-06806	BOLT	1	1	1	YMUS
21	90201-068T1	WASHER, PLATE	3	3	3	YMUS
22	90387-06M84	COLLAR	1	1	1	
23	90508-14M43	SPRING, TORSION	1	1	1	
24	9538R-06600	NUT	1	1	1	YMUS



F1F4100-B110

FIG. 12 GENERATOR

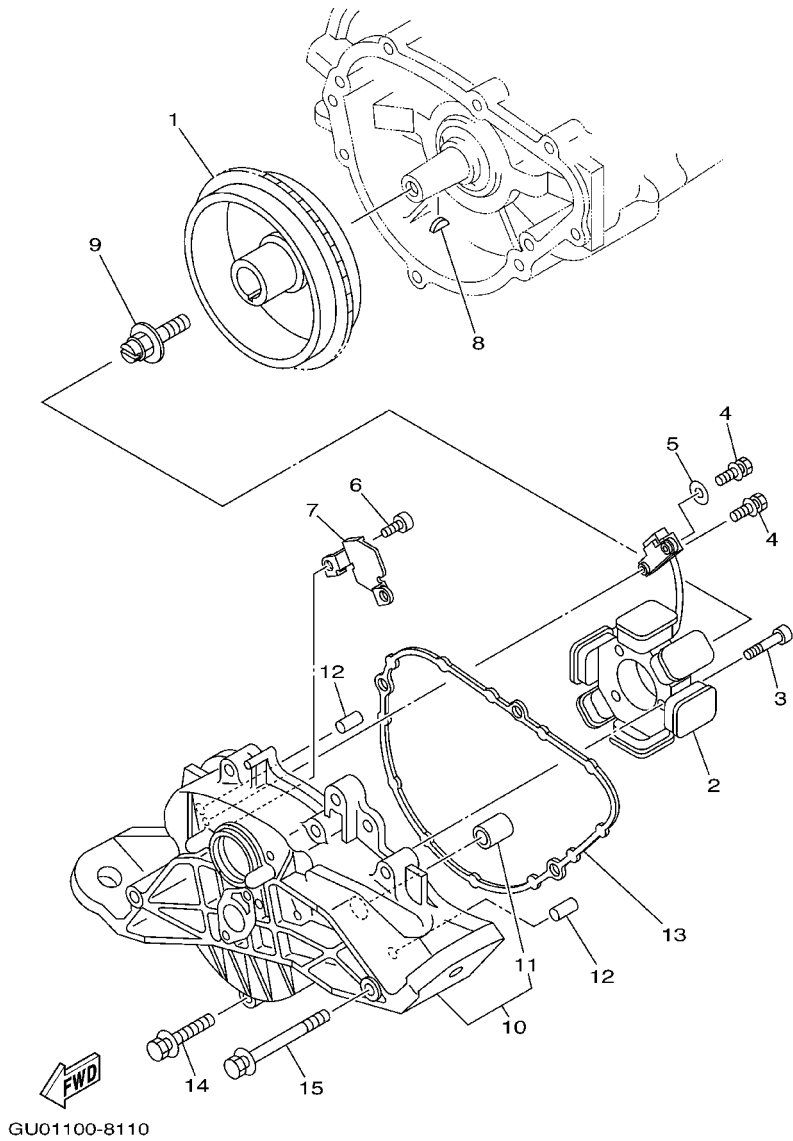

REF. NO.	PART NO.	DESCRIPTION	USA	GENE	JPN	REMARKS
1	66E-85550-00	ROTOR ASSY	1	1	1	
2	66E-85510-00	STATOR ASSY	1	1	1	
3	91318-06030	BOLT	3	3	3	
4	97513-05514	BOLT, WITH WASHER	2	2	2	
5	90201-05M09	WASHER, PLATE	1	1	1	
6	91318-06014	BOLT	2	2	2	
7	66E-81328-00	CLAMP	1	1	1	
8	90280-05013	KEY, WOODRUFF	1	1	1	
9	90109-10M72	BOLT	1	1	1	
10	66E-81337-11-8P	COVER, FLYWHEEL	1	1	1	
11	90380-12M29	.BUSH, SOLID	1	1	1	
12	93608-16M16	PIN, DOWEL	2	2	2	
13	66E-81168-10	O-RING	1	1	1	
14	90119-08M18	BOLT, WITH WASHER	6	6	6	
15	90119-08M55	BOLT, WITH WASHER	2	2	2	

FIG. 13 STARTING MOTOR

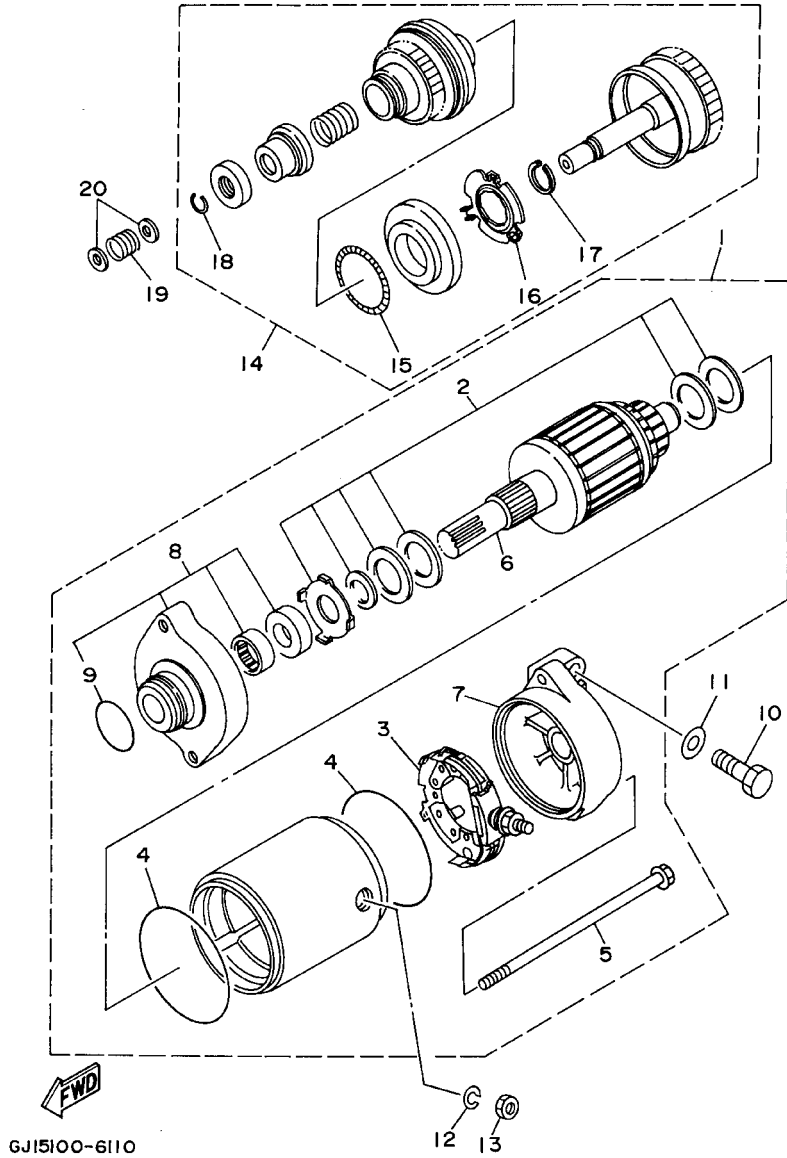

REF. NO.	PART NO.	DESCRIPTION	USA	GENE	JPN	REMARKS
1	63M-81800-00	STARTING MOTOR ASSY	1	1	1	
2	3AJ-81809-00	.WASHER KIT	1	1	1	
3	6M6-81840-10	.BRUSH HOLDER ASSY	1	1	1	
4	11H-81844-00	.GASKET	2	2	2	
5	6M6-81826-00	.BOLT	2	2	2	
6	6M6-81850-00	.ARMATURE ASSY	1	1	1	
7	63M-81830-00	.REAR BRACKET ASSY	1	1	1	
8	6M6-81830-00	.FRONT BRACKET ASSY	1	1	1	
9	1FK-81847-00	.O-RING	1	1	1	
10	97013-08025	BOLT	2	2	2	
11	92903-08600	WASHER, PLATE	2	2	2	
12	92990-06100	WASHER, SPRING	1	1	1	
13	95380-06700	NUT	1	1	1	
14	6M6-8183E-01	IDLE GEAR COMP.	1	1	1	
15	6M6-81866-00	.WEIGHT SPRING	1	1	1	
16	6M6-81865-00	.WEIGHT HOLDER	1	1	1	
17	93440-25M08	.CIRCLIP	1	1	1	
18	93450-18M06	.CIRCLIP	1	1	1	
19	90501-14M73	SPRING, COMPRESSION	1	1	1	
20	92903-06600	WASHER, PLATE	2	2	2	

FIG. 14 ELECTRICAL 1

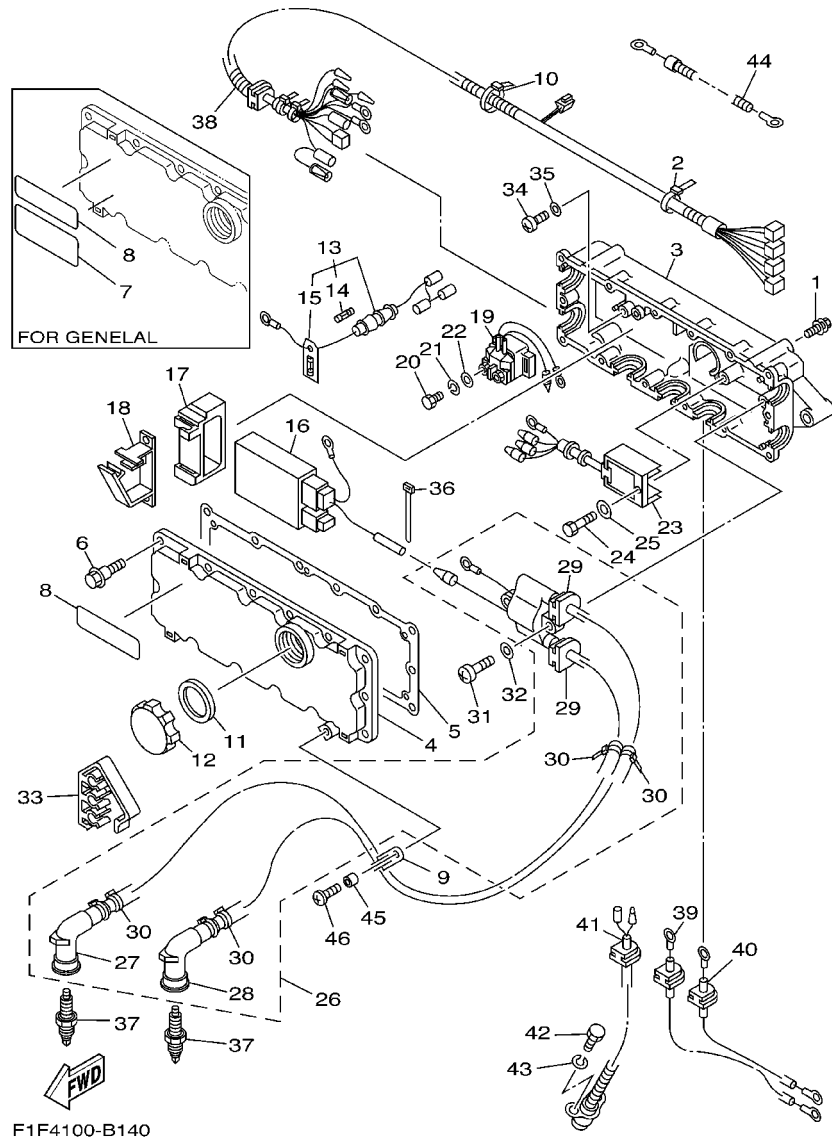

REF. NO.	PART NO.	DESCRIPTION	USA	GENE	JPN	REMARKS
1	90119-08809	BOLT, WITH WASHER	2	2	2	YMUS
2	90465-12M56	CLAMP	1	1	1	
3	66E-8552A-00-94	HOUSING	1	1	1	
4	66E-8552E-00	COVER, CASE	1	1	1	
5	66E-81921-00	GASKET, TERMINAL	1	1	1	
6	90109-05MA0	BOLT	14	14	14	
7	6R7-83623-50	MARK 3		1		FOR GENE
8	6R7-83623-40	MARK 3	1	1		FOR USA, GENE
	63N-83623-00	MARK 3			1	FOR JPN
9	90465-12M53	CLAMP	1	1	1	
10	90465-13M36	CLAMP	4	4	4	
11	6M6-81844-00	GASKET	1	1	1	
12	6M6-8132W-00	CAP	1	1	1	
13	66E-82150-00	FUSE HOLDER ASSY	1	1	1	
14	6G1-82151-00	.FUSE (10A)	1	1	1	
15	6K8-82159-00	.FUSE SPEAR (10A)	1	1	1	
16	66E-85540-00	C.D.I. UNIT ASSY	1	1	1	
17	64X-85546-00	BAND	1	1	1	
18	90464-06M29	CLAMP	1	1	1	
19	68N-81940-00	STARTER RELAY ASSY	1	1	1	
20	97095-06010	BOLT	2	2	2	
21	92995-06100	WASHER, SPRING	2	2	2	
22	92995-06600	WASHER	2	2	2	
23	63M-81960-00	RECTIFIER & REGULATOR ASSY	1	1	1	
24	97095-06012	BOLT	1	1	1	
25	92995-06600	WASHER	1	1	1	
26	64X-85570-01	IGNITION COIL ASSY	1	1	1	

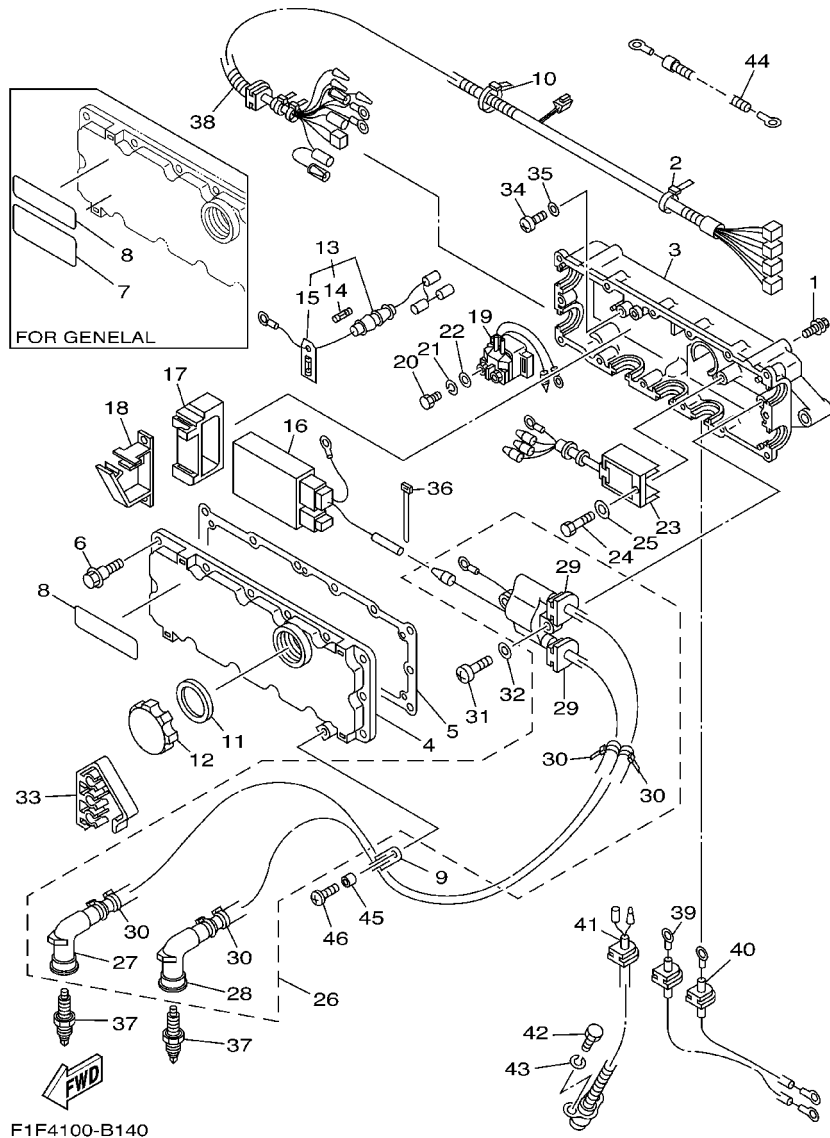
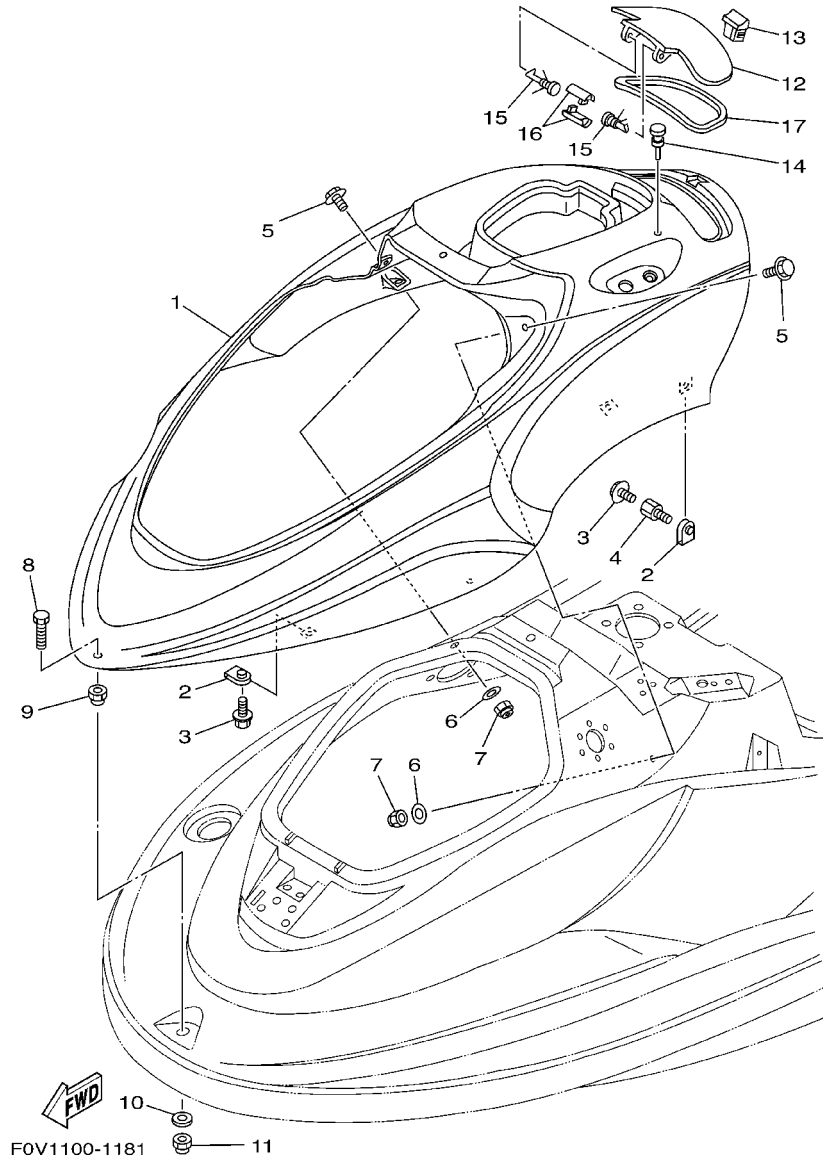

FIG. 14 ELECTRICAL 1

REF. NO.	PART NO.	DESCRIPTION	USA	GENE	JPN	REMARKS
27	62E-82371-11	.CAP, PLUG	1	1	1	
28	62E-82371-11	.CAP, PLUG	1	1	1	
29	90480-06M43	.GROMMET	2	2	2	
30	90465-11M10	.CLAMP	4	4	4	
31	97880-06030	SCREW, PAN HEAD	2	2	2	
32	92990-06600	WASHER, PLATE	2	2	2	
33	65U-81317-10	CLAMP, CORD	1	1	1	
34	97880-06016	SCREW, PAN HEAD	2	2	2	
35	92990-06600	WASHER, PLATE	2	2	2	
36	90465-11M10	CLAMP	1	1	1	
37	94702-00204	PULG, SPARK (NGK BR8ES)	2	2		FOR USA, GENE
	94709-00204	PULG, SPARK (NGK BR8ES)			2	FOR JPN
38	60G-82553-00	EXTENSION, WIRE LEAD	1	1	1	
39	6M6-82117-21	WIRE, LEAD	1	1	1	
40	66E-82117-10	WIRE, LEAD	1	1	1	
41	68A-82560-00	THERMO SWITCH ASSY	1	1	1	
42	97095-06016	BOLT	2	2	2	
43	92995-06100	WASHER, SPRING	2	2	2	
44	61L-82117-00	WIRE, LEAD	1	1	1	
45	90387-06M05	COLLAR	1	1	1	
46	97780-60425	SCREW, TAPPING	1	1	1	

FIG. 16 ENGINE HATCH 1



REF. NO.	PART NO.	DESCRIPTION	USA	GENE	JPN	REMARKS
1	FOV-U516N-50-P0	COVER, ENGINE HATCH	1	1	1	UR NCM3, YMUS
	FOV-U516N-60-P0	COVER, ENGINE HATCH	1	1	1	UR YM2, YMUS
2	90183-06902	NUT, SPRING	8	8	8	
3	90119-06858	BOLT, WITH WASHER	8	8	8	YMUS
4	FOV-U7772-00	NUT, JOINT	2	2	2	YMUS
5	90119-06803	BOLT, WITH WASHER	2	2	2	YMUS
6	9299R-06200	WASHER	2	2	2	YMUS
7	9572R-06300	NUT, FLANGE	2	2	2	YMUS
8	9708R-06030	BOLT	1	1	1	YMUS
9	9538R-06700	NUT	1	1	1	YMUS
10	9299R-06200	WASHER	1	1	1	YMUS
11	9572R-06300	NUT, FLANGE	1	1	1	YMUS
12	F0D-U517H-80-P0	LID HATCH	1	1	1	UR NCM3, YMUS
	F0D-U517H-90-P0	LID HATCH	1	1	1	UR YM2, YMUS
13	F0D-62875-00	LOCK	1	1	1	
14	90605-502U2	PLUG	1	1	1	YMUS
15	F0D-6517R-00	PIN, HINGE	2	2	2	
16	F0D-6517T-00	JOINT, HINGE	2	2	2	
17	F0D-U519D-00	PACKING CASE	1	1	1	YMUS

FIG. 17 ENGINE HATCH 2

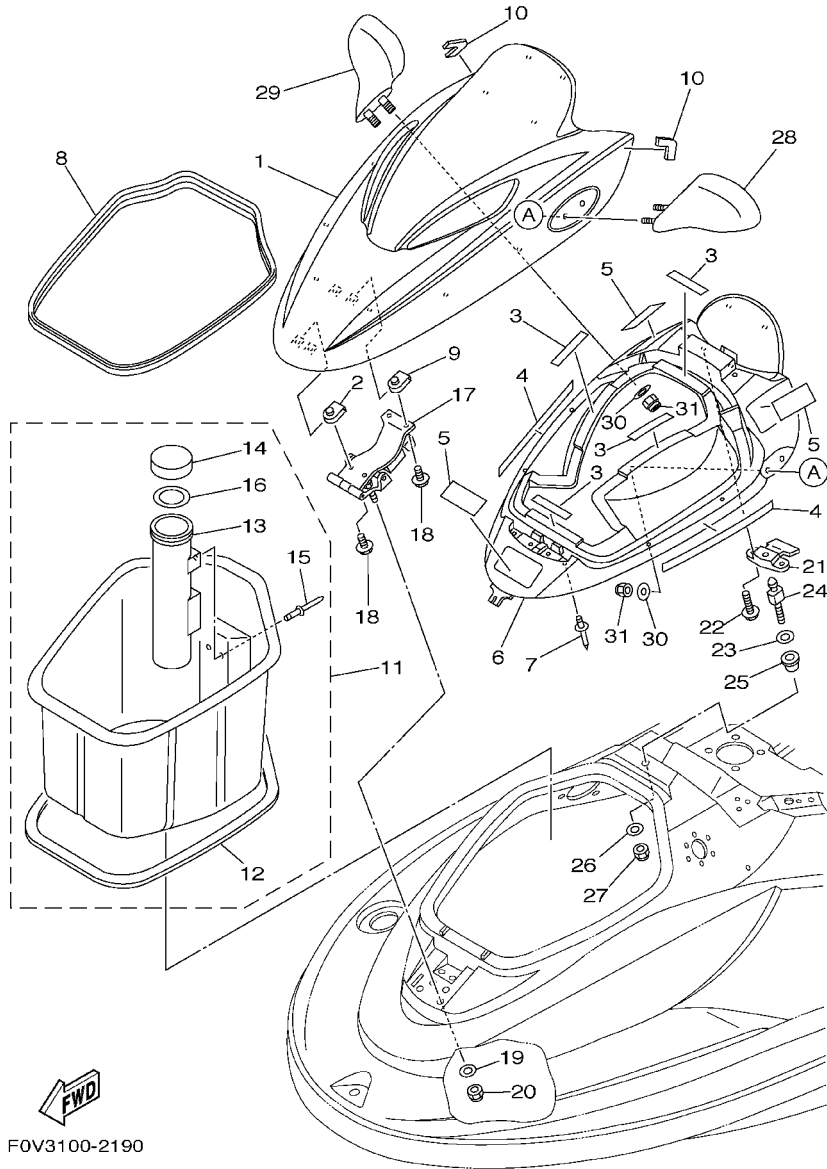

F0V3100-2190

REF. NO.	PART NO.	DESCRIPTION	USA	GENE	JPN	REMARKS
1	F0V-U517B-40-P0	LID, ENGINE ROOM	1	1	1	UR NCM3, YMUS
	F0V-U517B-50-P0	LID, ENGINE ROOM	1	1	1	UR YM2, YMUS
2	90183-06902	NUT, SPRING	2	2	2	
3	F0V-U3635-00	TAPE, FITTING	4	4	4	YMUS
4	F0V-U3635-10	TAPE, FITTING	2	2	2	YMUS
5	F0V-U3635-20	TAPE, FITTING	3	3	3	YMUS
6	F0V-U2103-10	VENTILATOR COVER COMP., 2	1	1	1	YMUS
7	90267-48809	RIVET, BLIND	10	10	10	YMUS
8	F0V-U266B-00	PACKING 3	1	1	1	YMUS
9	90183-06902	NUT, SPRING	2	2	2	
10	F0V-U517M-00	PAD, HATCH 1	2	2	2	YMUS
11	F0D-U475A-00	BOWLOCKER ASSY	1	1	1	YMUS
12	GJ3-U266C-31	.PACKING 4	1	1	1	YMUS
13	GP7-U5983-00	.BOX, FIRE EXTINGUISHER	1	1	1	YMUS
14	EW2-U5912-01	.CAP, CASE	1	1	1	YMUS
15	90267-489UP	.RIVET, BLIND	3	3	3	YMUS
16	EW2-U5913-01	.PACKING, CASE	1	1	1	YMUS
17	F0V-6515A-01	HINGE ASSY.	1	1	1	
18	90119-069UB	BOLT, WITH WASHER	4	4	4	YMUS
19	90201-06802	WASHER, PLATE	4	4	4	YMUS
20	9572R-06300	NUT, FLANGE	4	4	4	YMUS
21	F0D-6517C-04	LOCK, LID	1	1	1	
22	90119-069UH	BOLT, WITH WASHER	2	2	2	YMUS
23	F0V-U515E-00	DAMPER 2	1	1	1	YMUS
24	F0D-63774-01	PIN	1	1	1	
25	90387-08802	COLLAR	1	1	1	YMUS
26	9299R-08200	WASHER	1	1	1	YMUS

FIG. 17 ENGINE HATCH 2

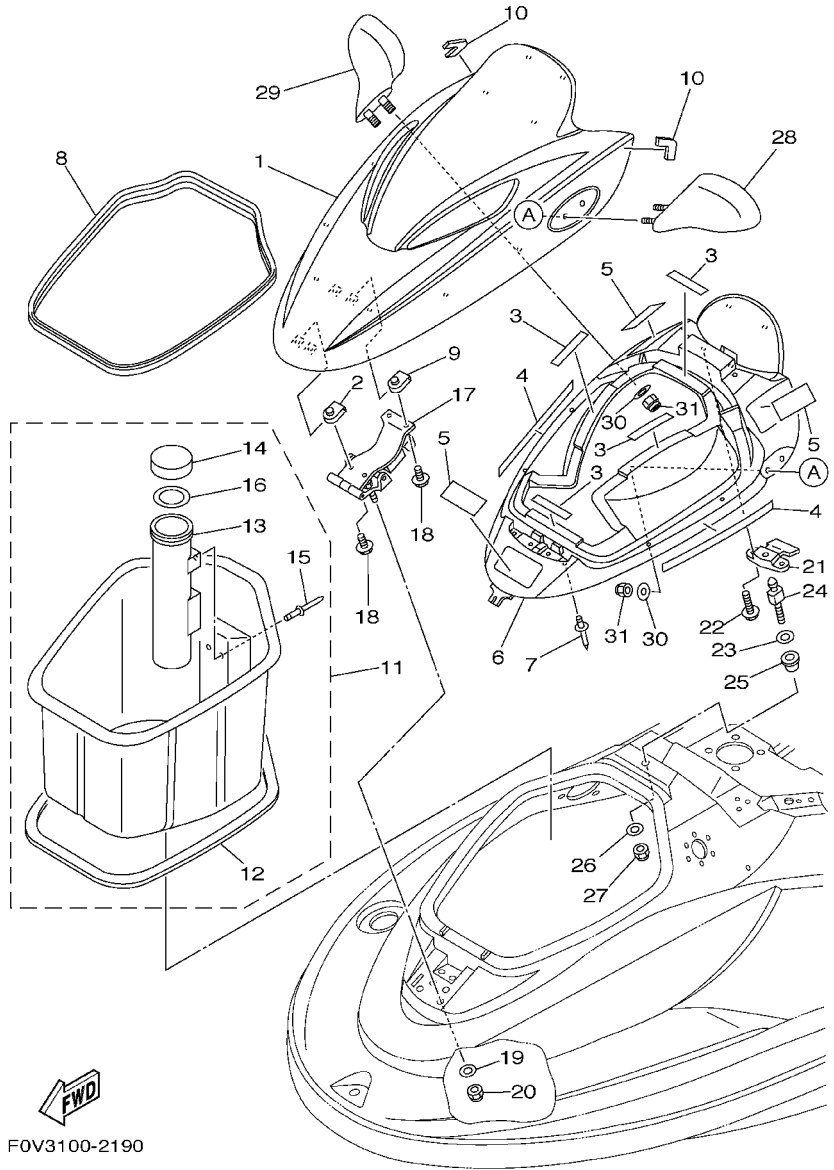

F0V3100-2190

REF. NO.	PART NO.	DESCRIPTION	USA	GENE	JPN	REMARKS
27	9572R-08300	NUT, FLANGE	1	1	1	YMUS
28	F0V-U596B-03	MIRROR LH	1	1	1	YB, YMUS
29	F0V-U596C-03	MIRROR RH	1	1	1	YB, YMUS
30	9299R-08200	WASHER	4	4	4	YMUS
31	9572R-08300	NUT, FLANGE	4	4	4	YMUS

FIG. 18 HULL. DECK

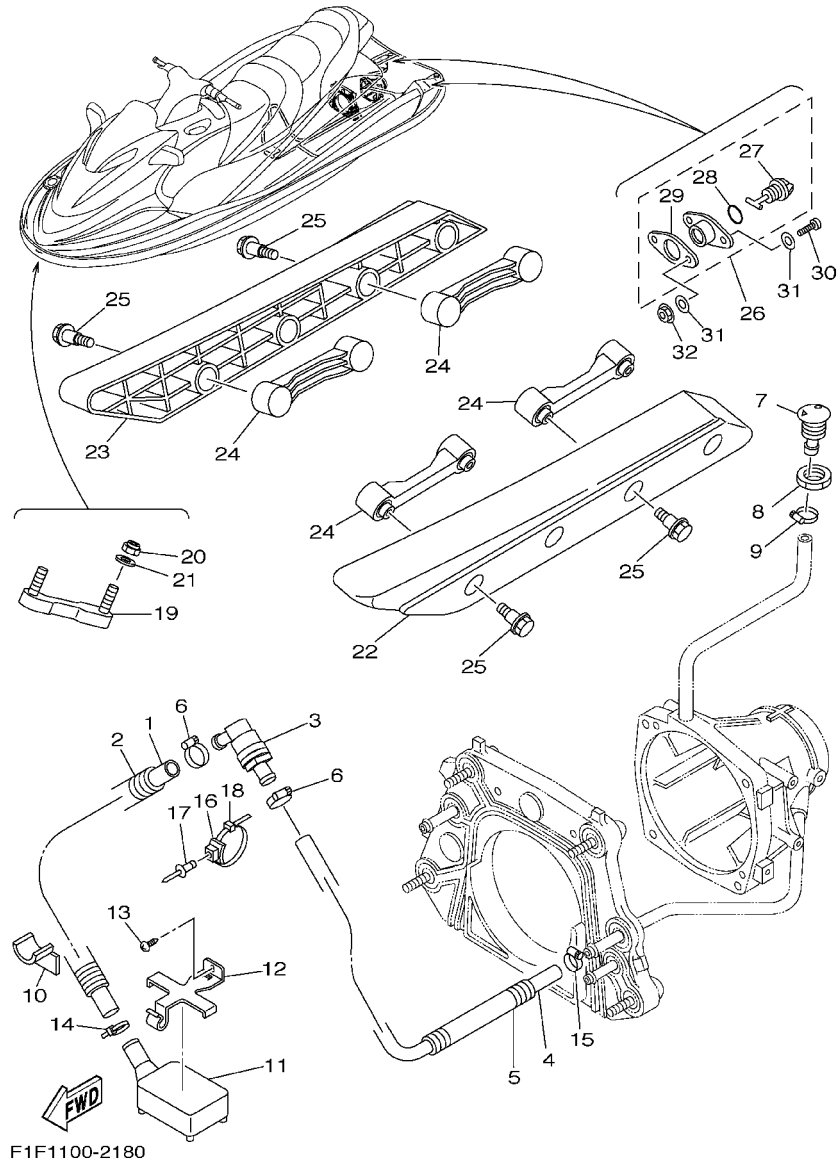

REF. NO.	PART NO.	DESCRIPTION	USA	GENE	JPN	REMARKS
1	90445-198C0	HOSE (L1000)	1	1	1	YMUS
2	90446-27M73	HOSE	1	1	1	
3	68N-5112T-00	JOINT, HOSE	1	1	1	
4	90445-198B9	HOSE (L650)	1	1	1	YMUS
5	90446-27M55	HOSE	1	1	1	
6	90601-118UF	BAND, HOSE 18	2	2	2	YMUS
7	FN8-6269B-00	SPOUT	1	1	1	
8	EU0-61652-00	NUT	1	1	1	
9	90601-118UF	BAND, HOSE 18	1	1	1	YMUS
10	GJ1-U7578-21	PACKING, HOSE 2	1	1	1	YMUS
11	GD0-U761D-00	STRAINER, BILGE	1	1	1	YMUS
12	EW2-67618-00	BASE, STRAINER BLIGE	1	1	1	
13	9778R-50112	SCREW, TAPPING	1	1	1	YMUS
14	90465-11829	CLAMP	1	1	1	YMUS
15	90601-118UF	BAND, HOSE 18	1	1	1	YMUS
16	90600-917U4	CLAMP COMP.	2	2	2	YMUS
17	90267-48802	RIVET, BLIND	2	2	2	YMUS
18	90464-32801	CLAMP	2	2	2	YMUS
19	F0D-61624-01	BOWEYE 1 (S)	1	1	1	
20	9572R-08300	NUT, FLANGE	2	2	2	YMUS
21	9299R-08200	WASHER	2	2	2	YMUS
22	F0D-U883N-20	STABILIZER LH	1	1	1	YB, YMUS
23	F0D-U883P-20	STABILIZER RH	1	1	1	YB, YMUS
24	F1F-U883T-00	BRACKET,STABILIZER	4	4	4	YMUS
25	F0V-U2624-00	BOLT	8	8	8	YMUS
26	EU0-62280-00	DRAIN PLUG ASSY	2	2	2	
27	EU0-62282-00	.PLUG, DRAIN	1	1	1	

FIG. 18 HULL. DECK

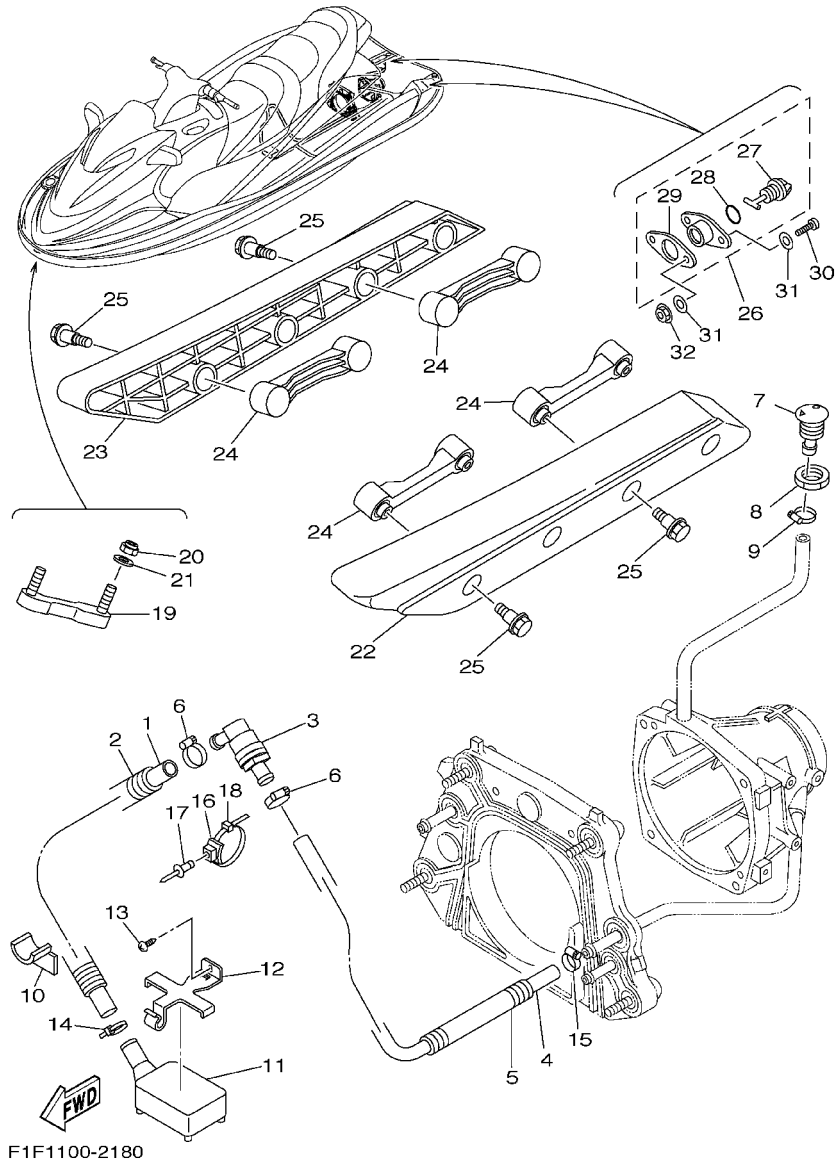

REF. NO.	PART NO.	DESCRIPTION	USA	GENE	JPN	REMARKS
28	EU0-62283-00	.O-RING	1	1	1	
29	EU0-62285-01	.PACKING DRAIN (EU0)	1	1	1	
30	9788R-05025	SCREW, PAN HEAD	4	4	4	YMUS
31	9299R-05200	WASHER	8	8	8	YMUS
32	9572R-05300	NUT, FLANGE	4	4	4	YMUS
<hr/>						
<hr/>						
<hr/>						
<hr/>						
<hr/>						
<hr/>						
<hr/>						
<hr/>						
<hr/>						

FIG. 19 GUNWALE. MAT

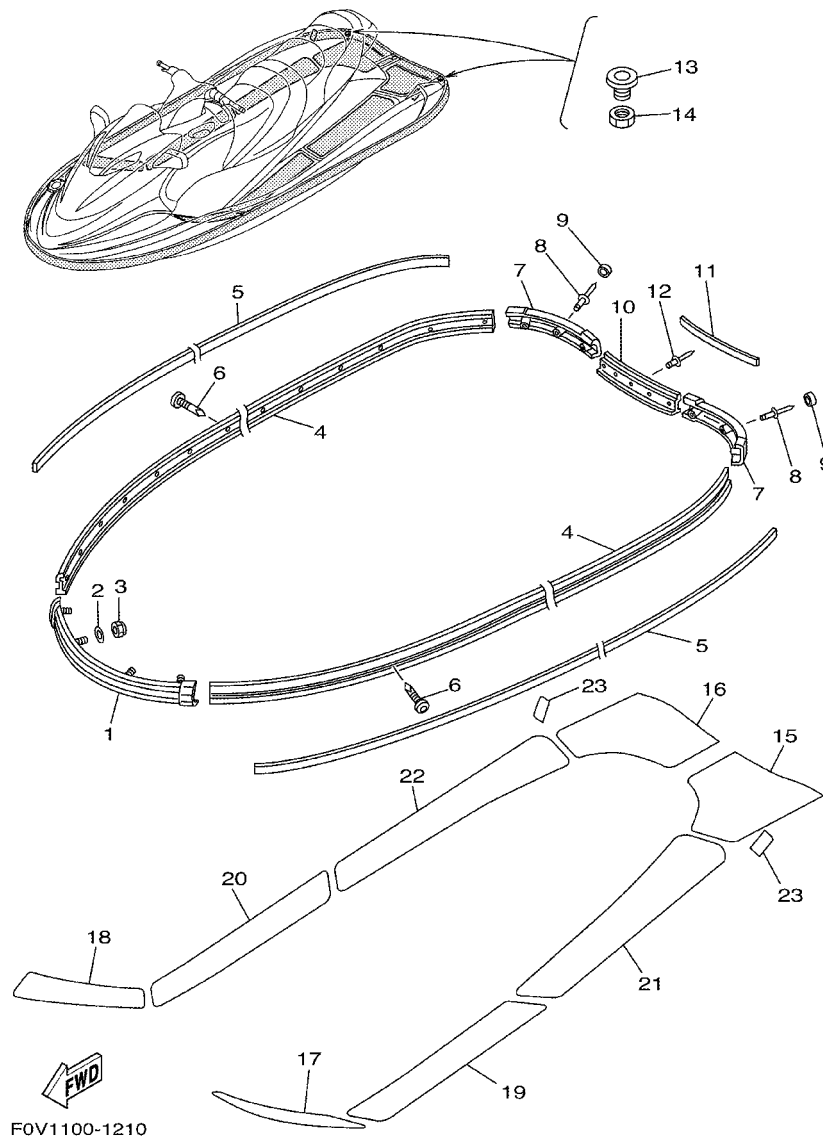

REF. NO.	PART NO.	DESCRIPTION	USA	GENE	JPN	REMARKS
1	GP7-U2501-20	BOW GUNWALE COMP.	1	1	1	YB, YMUS
2	9299R-06200	WASHER	4	4	4	YMUS
3	9572R-06300	NUT, FLANGE	4	4	4	YMUS
4	F0D-U2512-00	GUNWALE, SIDE	2	2	2	YB, YMUS
5	F1F-U2519-01	INNER,GUNWALE	2	2	2	BL, YMUS
6	90169-059U1	SCREW,TAPPING	32	32	32	YMUS
7	F0D-U251D-00	GUNWALE, STERN 1	2	2	2	YMUS
8	90267-489UT	RIVET, BLIND	6	6	6	YMUS
9	F0D-U352E-00	MAT, BOW	6	6	6	DGY, YMUS
10	F0D-U252C-00	COVER, GUNWALE 1	1	1	1	YB, YMUS
11	F0V-U252D-00	COVER, GUNWALE 2	1	1	1	YB, YMUS
12	90267-489US	RIVET, BLIND	4	4	4	YMUS
13	GH1-61651-01	ROPE HOLE	2	2	2	
14	EU0-61652-00	NUT	2	2	2	
15	F0V-U358F-01	MAT, UPPER LH	1	1	1	BL, YMUS
16	F0V-U358G-01	MAT, UPPER RH	1	1	1	BL, YMUS
17	F0P-U351H-00	MAT, STEP 1	1	1	1	BL, YMUS
18	F0P-U351J-00	MAT, STEP 2	1	1	1	BL, YMUS
19	F0D-U351K-01	MAT, STEP 3	1	1	1	BL, YMUS
20	F0D-U351M-01	MAT, STEP 4	1	1	1	BL, YMUS
21	F0D-U351N-01	MAT, STEP 5	1	1	1	BL, YMUS
22	F0D-U351P-01	MAT, STEP 6	1	1	1	BL, YMUS
23	F0D-U351R-00	MAT, STEP 7	2	2	2	BL, YMUS

FIG. 20 VENTILATION

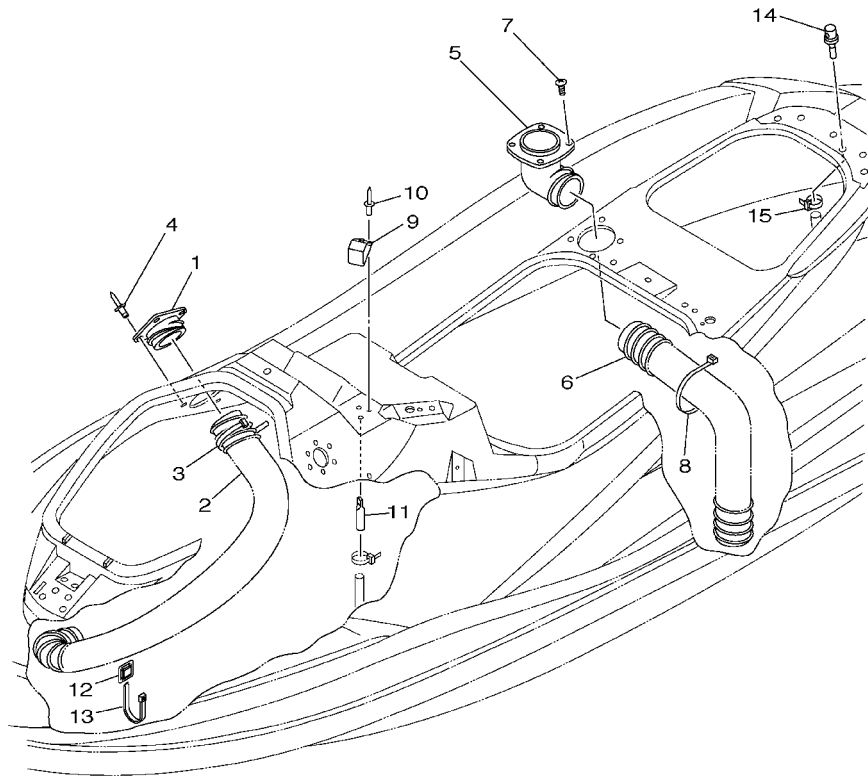

F1F1100-2200

REF. NO.	PART NO.	DESCRIPTION	USA	GENE	JPN	REMARKS
1	F0D-62127-00	BASE, AIR INTAKE	1	1	1	
2	F0D-U213F-05	HOSE, VENTILATOR 1	1	1	1	YMUS
3	90464-99804	CLAMP	1	1	1	YMUS
4	90267-489UE	RIVET, BLIND	4	4	4	YMUS
5	F0D-62139-00	VENTILATOR, OUTLET	1	1	1	
6	F0D-U213G-04	HOSE, VENTILATOR 2	1	1	1	YMUS
7	90149-05962	SCREW	4	4	4	
8	90601-200U7	BAND	2	2	2	YMUS
9	GP7-62159-01	SOCKET, VENTILATION	1	1	1	
10	90267-48802	RIVET, BLIND	2	2	2	YMUS
11	EW2-62149-00	PIPE, VENTILATION 1	1	1	1	
12	90600-900U6	BASE, CLAMP	1	1	1	YMUS
13	90464-99801	CLAMP	1	1	1	YMUS
14	GJ3-6215F-00	NIPPLE	1	1	1	
15	90465-11829	CLAMP	1	1	1	YMUS

FIG. 21 SEAT. UNDER LOCKER

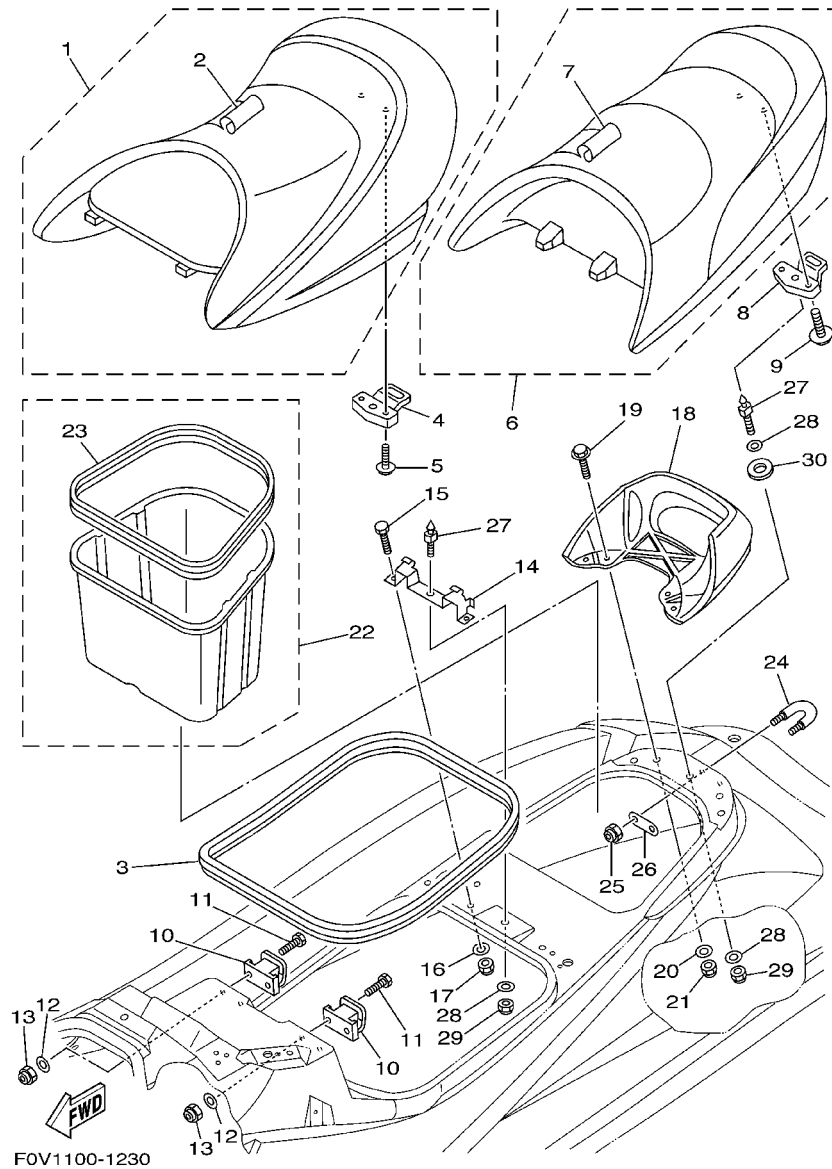

REF. NO.	PART NO.	DESCRIPTION	USA	GENE	JPN	REMARKS
1	F1F-U371A-10	DOUBLE SEAT ASSY	1	1	1	UR FOR NCM3, YMUS
	F1F-U371A-20	DOUBLE SEAT ASSY	1	1	1	UR FOR YM2, YMUS
2	F1F-U371B-10	.COVER, SEAT 1	1	1	1	UR FOR NCM3, YMUS
	F1F-U371B-20	.COVER, SEAT 1	1	1	1	UR FOR YM2, YMUS
3	F0D-U266C-00	PACKING 4	1	1	1	YMUS
4	F0D-63850-01	SEAT LOCK ASSY	1	1	1	
5	90119-06853	BOLT, WITH WASHER	2	2	2	YMUS
6	F1F-U372A-10	SINGLE SEAT ASSY	1	1	1	UR FOR NCM3, YMUS
	F1F-U372A-20	SINGLE SEAT ASSY	1	1	1	UR FOR YM2, YMUS
7	F1F-U372B-10	.COVER, SEAT	1	1	1	UR FOR NCM3, YMUS
	F1F-U372B-20	.COVER, SEAT	1	1	1	UR FOR YM2, YMUS
8	F0D-63850-01	SEAT LOCK ASSY	1	1	1	
9	90119-06853	BOLT, WITH WASHER	2	2	2	YMUS
10	F0V-U378C-00	STAY, SEAT 1	2	2	2	YMUS
11	90101-069U0	BOLT	4	4	4	YMUS
12	9299R-06200	WASHER	4	4	4	YMUS
13	9572R-06300	NUT, FLANGE	4	4	4	YMUS
14	F0D-6378D-01	STAY,SEAT 2	1	1	1	
15	97080-10025	BOLT	2	2	2	
16	9299R-10200	WASHER	2	2	2	YMUS
17	9572R-10300	NUT, FLANGE	2	2	2	YMUS
18	F0D-U271B-00	GRIP, HAND	1	1	1	YB, YMUS
19	90119-06820	BOLT, WITH WASHER	4	4	4	YMUS
20	9299R-06200	WASHER	4	4	4	YMUS
21	9572R-06300	NUT, FLANGE	4	4	4	YMUS
22	F0D-U474A-00	UNDER LOCKER ASSY	1	1	1	YMUS
23	F0D-U266D-00	.PACKING 5	1	1	1	YMUS

FIG. 22 OIL TANK

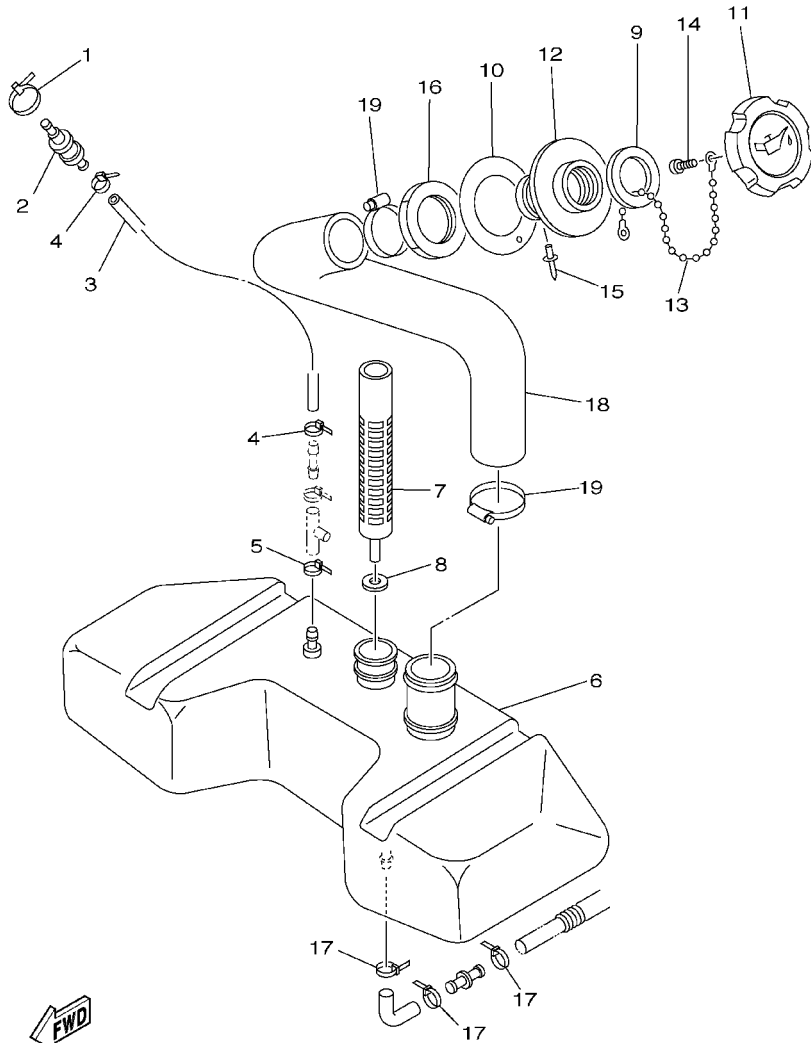

F1F1100-2220

REF. NO.	PART NO.	DESCRIPTION	USA	GENE	JPN	REMARKS
1	90464-32801	CLAMP	2	2	2	YMUS
2	FJ0-67766-00	ROLL OVER VALVE	1	1	1	
3	GJ3-U7856-20	HOSE, AIR VENT 3	1	1	1	YMUS
4	90465-11829	CLAMP	2	2	2	YMUS
5	90465-11829	CLAMP	1	1	1	YMUS
6	F0D-U775B-02	TANK, OIL	1	1	1	YMUS
7	F0D-6775C-01	FILTER	1	1	1	
8	F0D-6775E-01	PACKING	1	1	1	
9	GJ3-U778C-00	PACKING,OIL CAP	1	1	1	YMUS
10	F0X-U778E-00	PACKING,OIL FILLER	1	1	1	YMUS
11	GJ3-U778B-00	CAP,OIL FILLER	1	1	1	YMUS
12	F0X-U778D-00	SOCKET,OIL FILLER	1	1	1	YMUS
13	EU0-U7835-00	CHAIN BALL	1	1	1	YMUS
14	97780-04110	SCREW, TAPPING	1	1	1	
15	90267-40935	RIVET, BLIND	1	1	1	
16	F0X-U778H-00	NUT, OIL FILLER	1	1	1	YMUS
17	90465-11829	CLAMP	3	3	3	YMUS
18	F0D-U776C-10	HOSE,OIL FILLER	1	1	1	YMUS
19	90601-142U6	BAND, HOSE 42	2	2	2	YMUS

FIG. 23 FUEL TANK

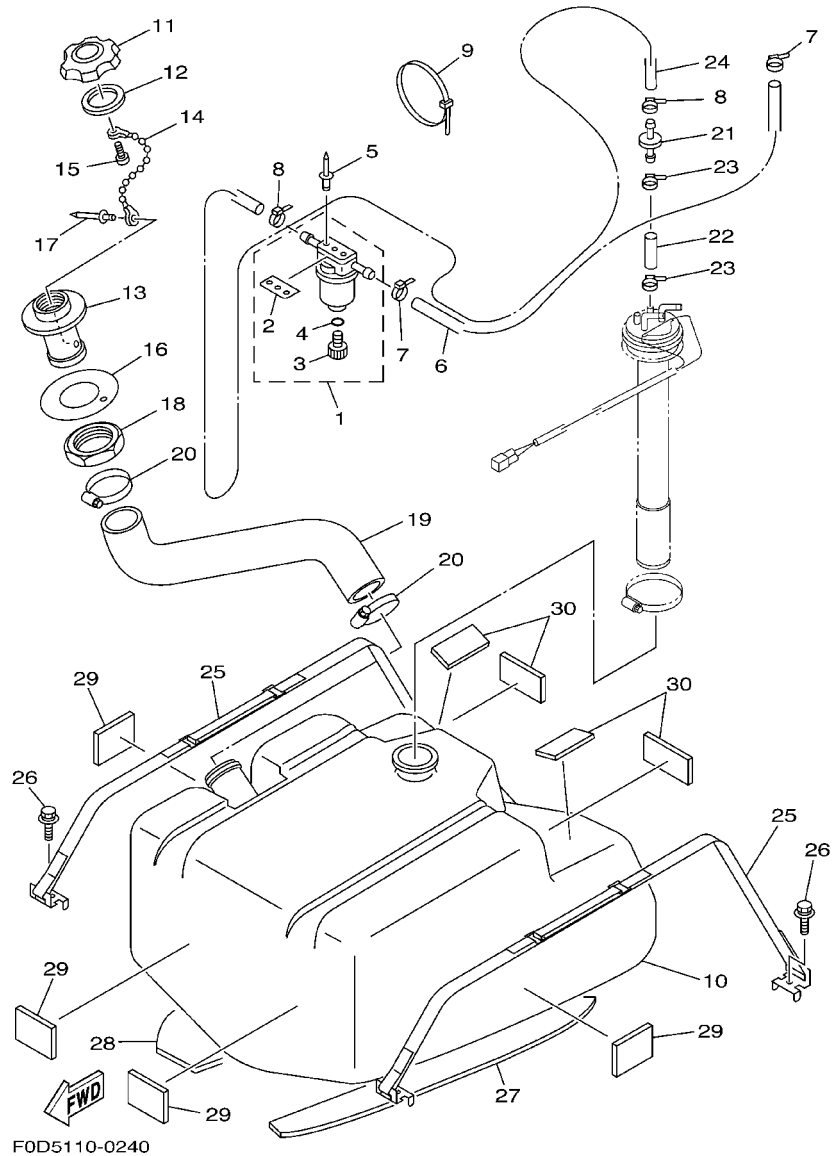

F0D5110-0240

REF. NO.	PART NO.	DESCRIPTION	USA	GENE	JPN	REMARKS
1	EW2-62140-00	FILTER, VENT ASSY	1	1	1	
2	EW2-62142-00	.PLATE, FILTER	1	1	1	
3	70R-24543-00	.PLUG, DRAIN	1	1	1	
4	70R-24489-00	.O-RING	1	1	1	
5	90267-489U2	RIVET, BLIND	2	2	2	YMUS
6	F0D-U785G-10	HOSE, AIR VENT	1	1	1	YMUS
7	90465-11829	CLAMP	2	2	2	YMUS
8	90465-11829	CLAMP	2	2	2	YMUS
9	90464-99801	CLAMP	1	1	1	YMUS
10	F0D-U7711-00	TANK, FUEL	1	1	1	YMUS
11	GP7-U7831-01	CAP, FUEL FILLER	1	1	1	PURW, YMUS
12	GP7-U7832-01	PACKING	1	1	1	YMUS
13	GP7-U7833-00	SOCKET	1	1	1	YMUS
14	GP7-U7835-00	CHAIN BALL	1	1	1	YMUS
15	90169-049U1	TAPPING SCREW	1	1	1	YMUS
16	GP7-U7834-00	PACKING FUEL FILLER	1	1	1	YMUS
17	90267-329UR	RIVET, BLIND	1	1	1	YMUS
18	GP7-U783F-00	NUT, FUEL FILLER	1	1	1	YMUS
19	F0D-U7844-10	HOSE	1	1	1	YMUS
20	90601-155U4	BAND, HOSE 55	2	2	2	YMUS
21	EU0-67767-31	CHECK VALVE	1	1	1	
22	GP7-U785H-00	HOSE, AIR VENT 3	1	1	1	YMUS
23	90465-11829	CLAMP	2	2	2	YMUS
24	F0D-U7856-10	HOSE, AIR VENT 3	1	1	1	YMUS
25	GH3-67743-01	BELT, TANK 1	2	2	2	
26	90119-089U7	BOLT, WITH WASHER	4	4	4	YMUS
27	F0D-U759B-00	MAT 1	1	1	1	YMUS

FIG. 23 FUEL TANK

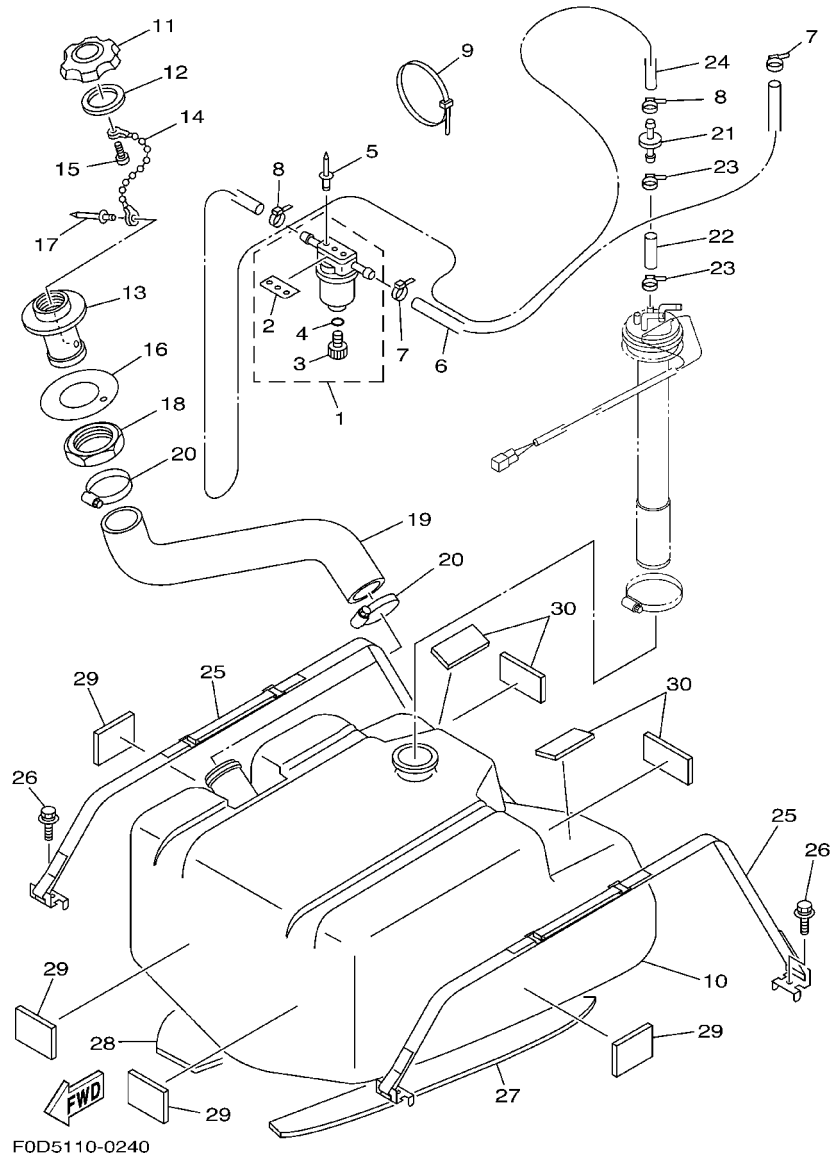

REF. NO.	PART NO.	DESCRIPTION	USA	GENE	JPN	REMARKS
28	F0D-U759B-10	MAT 1	1	1	1	YMUS
29	F0D-U759C-00	MAT 2	4	4	4	YMUS
30	GJ1-U759C-00	MAT 2	4	4	4	YMUS

FIG. 24 EXHAUST 2

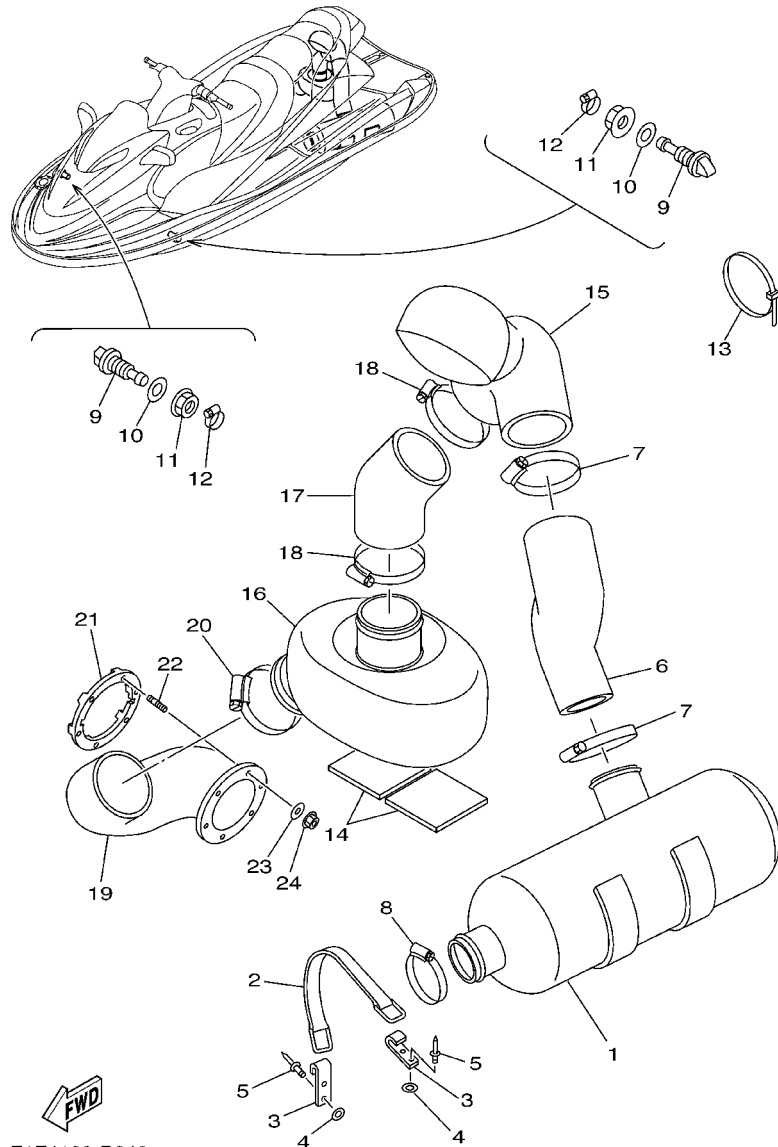

F1F4100-B240

REF. NO.	PART NO.	DESCRIPTION	USA	GENE	JPN	REMARKS
1	F0P-67550-01	WATER LOCK COMP.	1	1	1	
2	GA7-6756E-00	BAND, WATER LOCK	1	1	1	
3	GA7-65772-00	HOOK A	2	2	2	
4	9299R-05200	WASHER	4	4	4	YMUS
5	90267-489U7	RIVET, BLIND	4	4	4	YMUS
6	F0P-U758B-00	HOSE, EXHAUST 1	1	1	1	YMUS
7	90601-175UR	BAND, HOSE 75	2	2	2	YMUS
8	90601-195UD	BAND, HOSE 95	1	1	1	YMUS
9	F0P-6753B-00	PILOT, WATER	2	2	2	
10	90430-16910	GASKET	2	2	2	
11	FOX-62733-00	NUT	2	2	2	
12	90601-118UF	BAND, HOSE 18	2	2	2	YMUS
13	90464-32801	CLAMP	1	1	1	YMUS
14	F0D-U7578-00	PACKING, HOSE 2	2	2	2	YMUS
15	F0D-6753D-01	RESONATOR, 2	1	1	1	
16	F0D-64261-02	TANK, WATER	1	1	1	
17	F0D-6758C-01	HOSE, EXHAUST 2	1	1	1	
18	90601-195UD	BAND, HOSE 95	2	2	2	YMUS
19	F0V-U758D-00	HOSE, EXHAUST 3	1	1	1	YMUS
20	90601-195UD	BAND, HOSE 95	1	1	1	YMUS
21	F0V-U757B-00	PLATE	1	1	1	YMUS
22	90116-06802	BOLT, STUD	6	6	6	YMUS
23	9299R-06200	WASHER	6	6	6	YMUS
24	9572R-06300	NUT, FLANGE	6	6	6	YMUS

FIG. 25 CONTROL CABLE

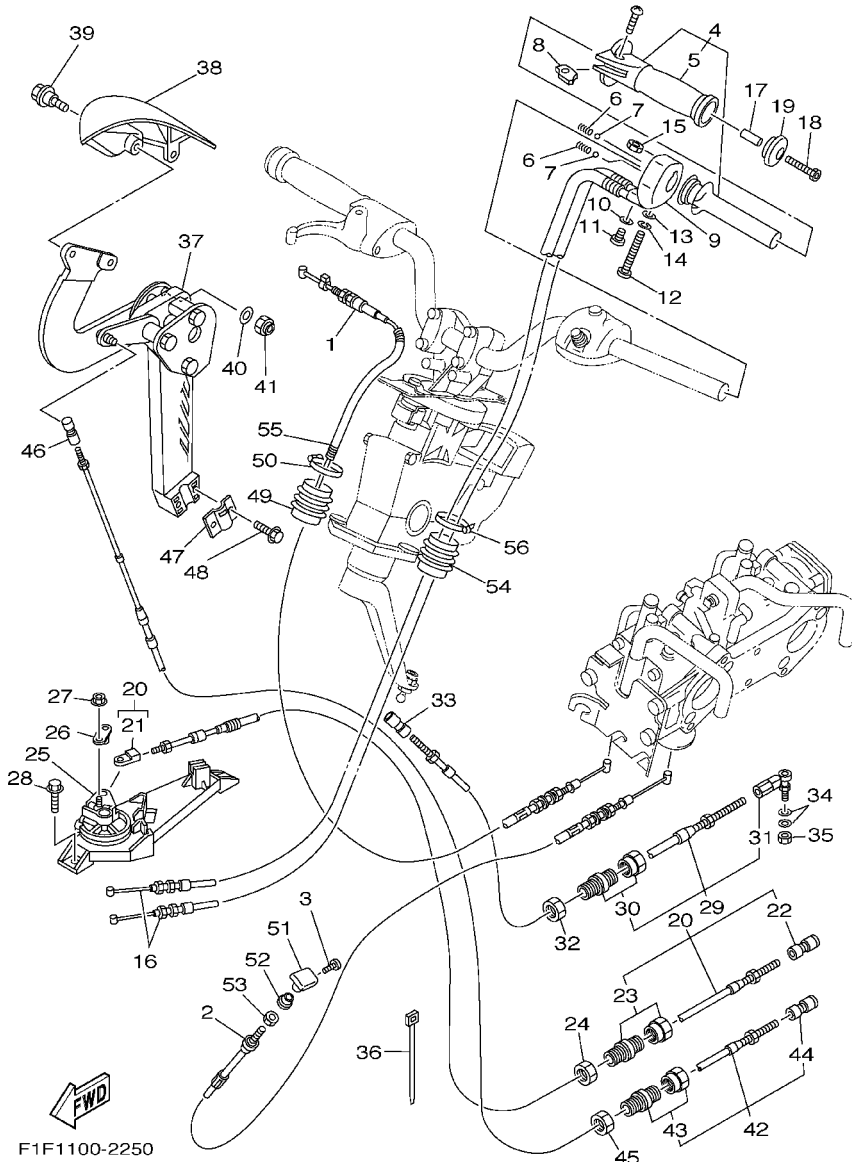

F1F1100-2250

REF. NO.	PART NO.	DESCRIPTION	USA	GENE	JPN	REMARKS
1	66E-67252-00	CABLE, THROTTLE	1	1	1	
2	67A-67242-01	CABLE, CHOKE	1	1	1	
3	90149-03M15	SCREW	1	1	1	
4	GP7-U157A-00	GRIP HANDLE ASSY.	1	1	1	YMUS
5	GP7-U155C-00	.GRIP,HANDLE	1	1	1	YMUS
6	GP7-U152P-00	SPRING	2	2	2	YMUS
7	GP7-U152R-00	BALL	2	2	2	YMUS
8	GP7-U151M-00	LEVER ASSY	1	1	1	YMUS
9	GP7-U152M-00	HOUSING ASSY	1	1	1	YMUS
10	92990-04600	WASHER, PLATE	1	1	1	
11	98980-04010	SCREW, BIND	1	1	1	
12	97880-06065	SCREW, PAN HEAD	1	1	1	
13	92990-06600	WASHER, PLATE	1	1	1	
14	9299R-06100	WASHER	1	1	1	YMUS
15	GH1-U143B-00	NUT,SPECIAL	1	1	1	YMUS
16	F0D-U153D-01	CABLE,NOZZLE CONTROL 2	2	2	2	YMUS
17	90387-05800	COLLAR	1	1	1	YMUS
18	90110-05908	BOLT, HEXAGON SOCKET HEAD	1	1	1	
19	GP7-U155F-00	GRIP, END	1	1	1	YMUS
20	F0D-U153E-10	CABLE,NOZZLE CONTROL 3	1	1	1	YMUS
21	GH1-U046C-00	.END,CABLE	1	1	1	YMUS
22	EU0-U1461-30	.SHAFT, JOINT BALL	1	1	1	YMUS
23	EU0-67267-10	.CONNECTOR, CABLE	1	1	1	
24	EU0-62241-30	NUT, DRAIN 1	1	1	1	
25	F0D-U153J-10	REMOCON,NOZZLE 2	1	1	1	YMUS
26	F0D-U152C-10	PIN	1	1	1	YMUS
27	9572R-06300	NUT, FLANGE	1	1	1	YMUS

FIG. 25 CONTROL CABLE

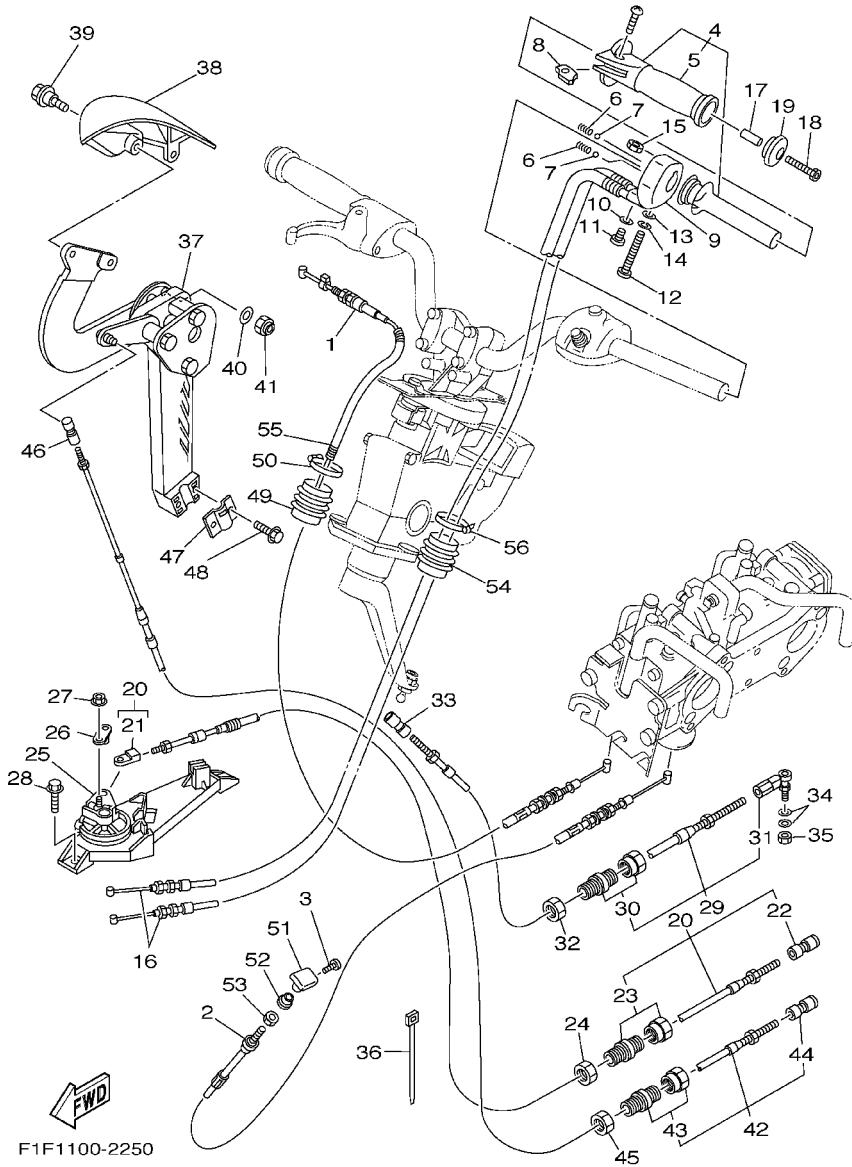

F1F1100-2250

REF. NO.	PART NO.	DESCRIPTION	USA	GENE	JPN	REMARKS
28	90119-069UJ	BOLT, WITH WASHER	2	2	2	YMUS
29	F0D-U1481-10	CABLE, STEERING	1	1	1	YMUS
30	GK5-67267-10	.CONNECTOR, CABLE	1	1	1	
31	GP8-U1461-T0	.STUD, JOINT BALL	1	1	1	YMUS
32	EU0-62241-30	NUT, DRAIN 1	1	1	1	
33	GK5-U146F-00	SHAFT,JOINT BALL	1	1	1	YMUS
34	90201-06906	WASHER, PLATE	2	2	2	
35	9538R-06700	NUT	1	1	1	YMUS
36	90601-200U1	BAND	1	1	1	YMUS
37	F0V-6134A-00	REMOCON. LEVER ASSY.	1	1	1	
38	F0V-U2714-00	GRIP	1	1	1	YMUS
39	90109-06803	BOLT	2	2	2	YMUS
40	9299R-06200	WASHER	3	3	3	YMUS
41	9572R-06300	NUT, FLANGE	3	3	3	YMUS
42	F0V-U149C-00	CABLE,REVERSE	1	1	1	YMUS
43	F0V-U7267-00	.CONNECTOR, CABLE	1	1	1	YMUS
44	F0V-U1461-00	.STUD, JOINT BALL	1	1	1	YMUS
45	EU0-62241-30	NUT, DRAIN 1	1	1	1	
46	EU0-U1461-30	SHAFT, JOINT BALL	1	1	1	YMUS
47	GH1-61468-01	STOPPER, CABLE	1	1	1	
48	90119-069UJ	BOLT, WITH WASHER	2	2	2	YMUS
49	F0D-6822E-00	GROMMET	1	1	1	
50	90601-200U1	BAND	1	1	1	YMUS
51	EW2-67243-00	KNOB	1	1	1	
52	F0N-6724E-00	NUT, COMPRESSION	1	1	1	
53	F0P-6724F-00	NUT	1	1	1	
54	F0D-6822E-00	GROMMET	1	1	1	

FIG. 25 CONTROL CABLE

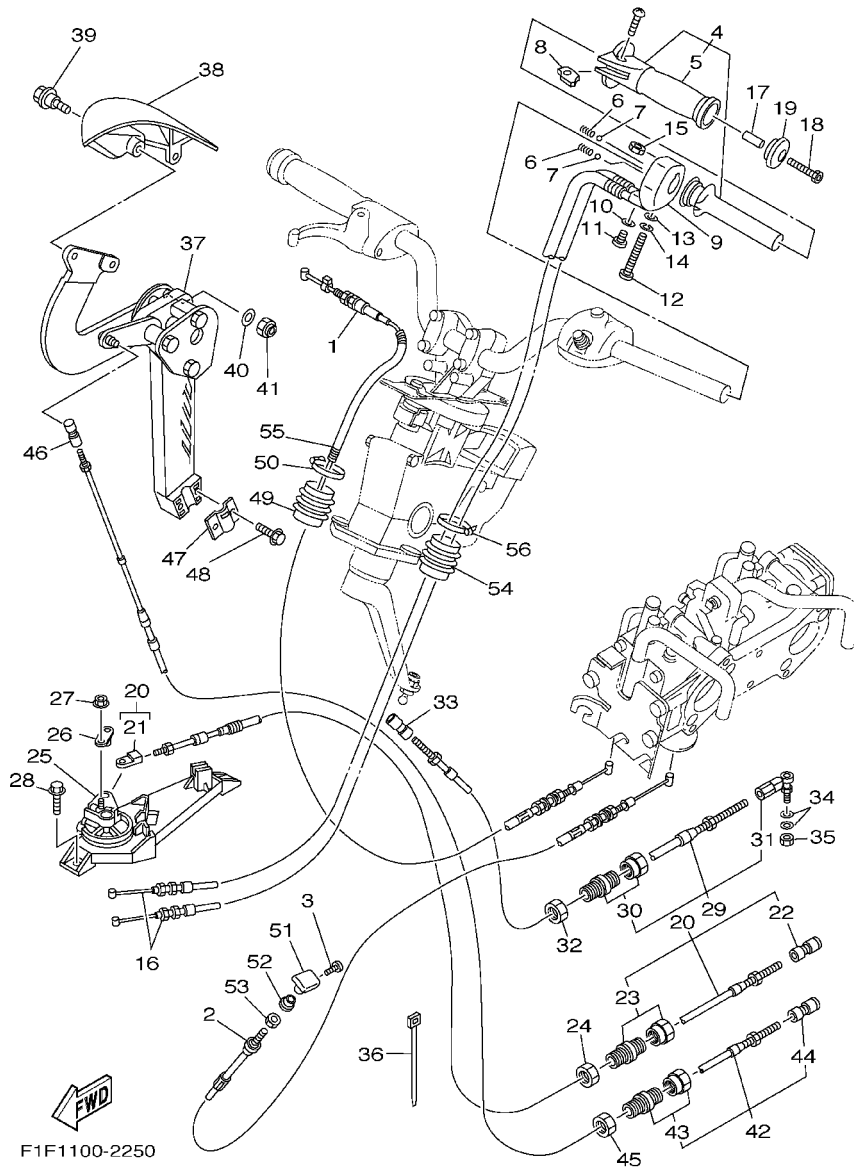

REF. NO.	PART NO.	DESCRIPTION	USA	GENE	JPN	REMARKS
55	F0D-6773E-00	TUBE,2	1	1	1	
56	90601-200U1	BAND	1	1	1	YMUS

FIG. 26 STEERING 1

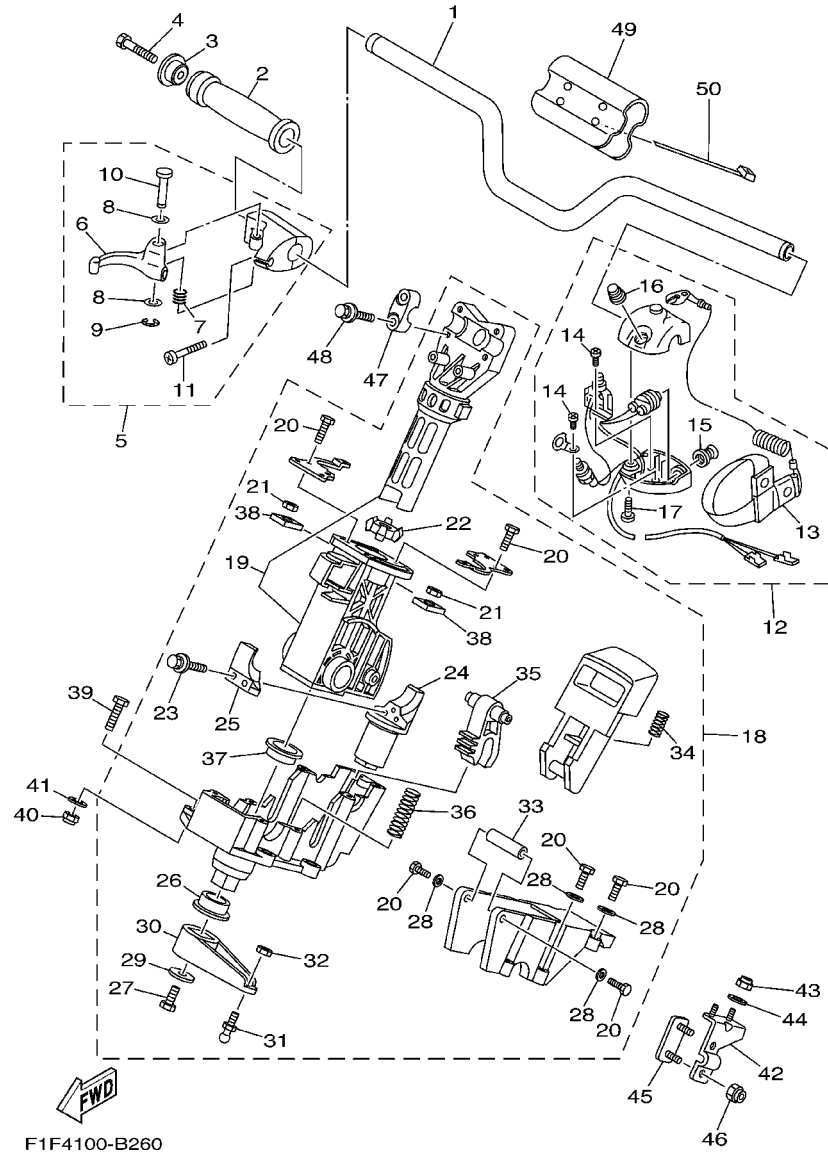

REF. NO.	PART NO.	DESCRIPTION	USA	GENE	JPN	REMARKS
1	F0D-U1552-00	HANDLE	1	1	1	YMUS
2	GP7-U155D-00	GRIP, HANDLE	1	1	1	YMUS
3	GP7-U155F-00	GRIP, END	1	1	1	YMUS
4	90110-05908	BOLT, HEXAGON SOCKET HEAD	1	1	1	
5	F0D-67250-03	THROTTLE LEVER ASSY	1	1	1	
6	F0D-67255-01	.LEVER, THROTTLE	1	1	1	
7	EW2-67256-00	.SPRING	1	1	1	
8	EW2-67258-01	.WASHER	2	2	2	
9	EW2-67259-01	.E-RING	1	1	1	
10	F0D-67257-00	.SHAFT	1	1	1	
11	98580-05025	.SCREW, PAN HEAD	2	2	2	
12	GP7-68310-01	SWITCH BOX ASSY	1	1	1	
13	EW2-68348-00	.LANYARD, STOP SWITCH	1	1	1	
14	97880-03008	.SCREW, PAN HEAD	2	2	2	
15	FK7-68312-02	.STOP BUTTON COMP	1	1	1	
16	FK7-68313-02	.START BUTTON COMP.	1	1	1	
17	97880-05025	.SCREW, PAN HEAD	2	2	2	
18	F0D-61400-04	STEERING MASTER ASSY	1	1	1	
19	F0D-67410-00	.SHAFT ASSY.	1	1	1	
20	F0D-61355-00	.BOLT	12	12	12	
21	F0D-6151S-00	.NUT	4	4	4	
22	F0D-6152R-00	.BALL	1	1	1	
23	F0D-62624-00	.BOLT	2	2	2	
24	F0D-6152D-00	.SHAFT	1	1	1	
25	F0D-52543-00	.JOINT, UNIVERSAL	1	1	1	
26	F0D-6134M-00	.BUSH	1	1	1	
27	F0D-6491K-00	.BOLT, SPECIAL	1	1	1	

FIG. 26 STEERING 1

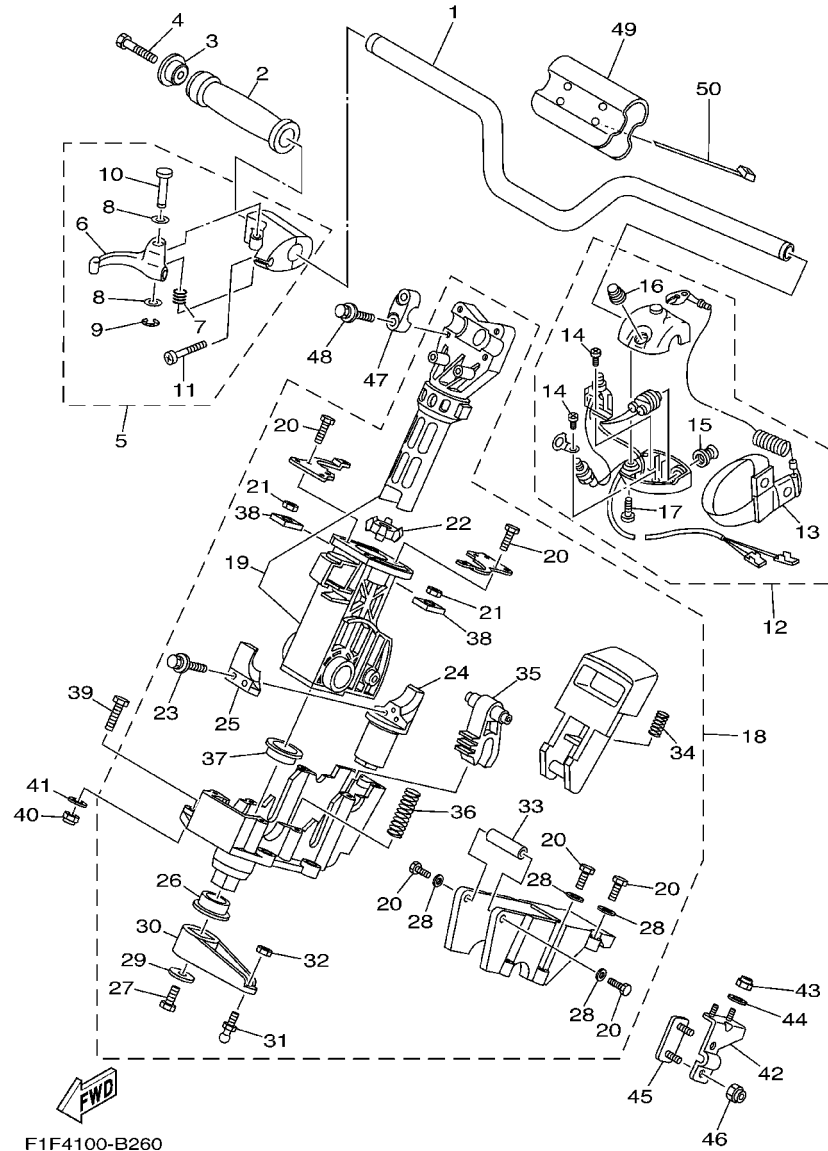

F1F4100-B260

REF. NO.	PART NO.	DESCRIPTION	USA	GENE	JPN	REMARKS
28	F0D-6134E-00	.WASHER	8	8	8	
29	F0D-6135D-00	.WASHER	1	1	1	
30	F1B-6151B-00	.ARM, STEERING	1	1	1	
31	EU0-61461-02	.STUD, JOINT BALL	1	1	1	
32	95720-06300	.NUT, SELF-LOCKING	1	1	1	
33	F0D-61574-00	.CONNECTOR	1	1	1	
34	F0D-61349-00	.SPRING	1	1	1	
35	F0D-61782-00	.LOCK 1	1	1	1	
36	F0D-6134K-00	.SPRING	1	1	1	
37	F0D-62814-00	.BUSH	1	1	1	
38	F0D-6724H-00	.HOLDER	4	4	4	
39	97080-08030	BOLT	4	4	4	
40	9572R-08300	NUT, FLANGE	4	4	4	YMUS
41	90201-099U3	WASHER, PLATE	4	4	4	YMUS
42	F0D-61467-00	BRACKET, STOPPER CABLE	1	1	1	
43	9572R-06300	NUT, FLANGE	3	3	3	YMUS
44	9299R-06200	WASHER	3	3	3	YMUS
45	GH3-61468-00	STOPPER, CABLE	1	1	1	
46	9572R-06300	NUT, FLANGE	2	2	2	YMUS
47	EU0-23814-30	HOLDER, HANDLE UPPER	2	2	2	
48	90119-089UU	BOLT, WITH WASHER	4	4	4	YMUS
49	F0D-U156E-00	PAD 1	1	1	1	YMUS
50	90601-200U2	BAND	2	2	2	YMUS

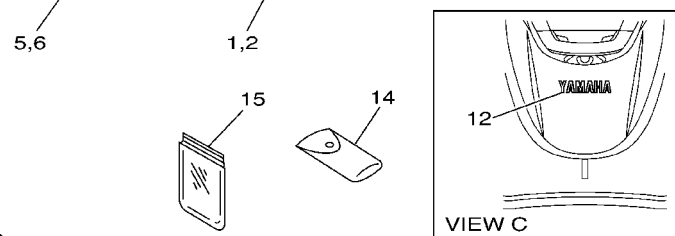
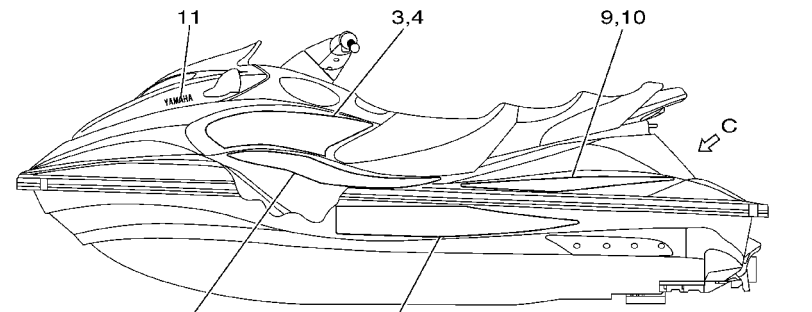
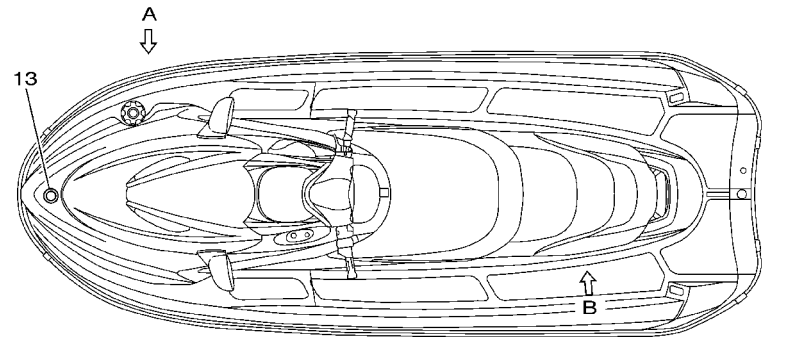
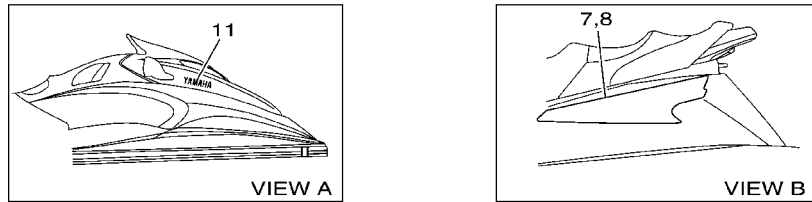

FWD
F1F4100-B280

FIG. 28 GRAPHICS

REF. NO.	PART NO.	DESCRIPTION	USA	GENE	JPN	REMARKS
1	F1F-U417B-10	GRAPHIC 1	1	1	1	UR FOR NCM3 LH, YMUS
	F1F-U417B-20	GRAPHIC 1	1	1	1	UR FOR YM2 LH, YMUS
2	F1F-U417C-10	GRAPHIC 2	1	1	1	UR FOR NCM3 RH, YMUS
	F1F-U417C-20	GRAPHIC 2	1	1	1	UR FOR YM2 RH, YMUS
3	F1F-U417D-10	GRAPHIC 3	1	1	1	UR FOR NCM3 LH, YMUS
	F1F-U417D-20	GRAPHIC 3	1	1	1	UR FOR YM2 LH, YMUS
4	F1F-U417E-10	GRAPHIC 4	1	1	1	UR FOR NCM3 RH, YMUS
	F1F-U417E-20	GRAPHIC 4	1	1	1	UR FOR YM2 RH, YMUS
5	F1F-U417F-10	GRAPHIC 5	1	1	1	UR FOR NCM3 LH, YMUS
	F1F-U417F-20	GRAPHIC 5	1	1	1	UR FOR YM2 LH, YMUS
6	F1F-U417G-10	GRAPHIC 6	1	1	1	UR FOR NCM3 RH, YMUS
	F1F-U417G-20	GRAPHIC 6	1	1	1	UR FOR YM2 RH, YMUS
7	F1F-U417H-10	GRAPHIC 7	1	1	1	UR FOR NCM3 LH, YMUS
	F1F-U417H-20	GRAPHIC 7	1	1	1	UR FOR YM2 LH, YMUS
8	F1F-U417J-10	GRAPHIC 8	1	1	1	UR FOR NCM3 RH, YMUS
	F1F-U417J-20	GRAPHIC 8	1	1	1	UR FOR YM2 RH, YMUS
9	F1F-U417K-10	GRAPHIC 9	1	1	1	UR FOR NCM3 LH, YMUS
	F1F-U417K-20	GRAPHIC 9	1	1	1	UR FOR YM2 LH, YMUS
10	F1F-U417L-10	GRAPHIC B	1	1	1	UR FOR NCM3 RH, YMUS
	F1F-U417L-20	GRAPHIC B	1	1	1	UR FOR YM2 RH, YMUS
11	F1F-U4122-00	EMBLEM 2	2	2	2	YMUS
12	GJ3-U4114-52	MARK, YAMAHA A	1	1	1	YMUS
13	GU2-U411H-00	EMBLEM, TUNING FORK	1	1	1	YMUS
14	EU0-65986-00	TOOL SET	1	1	1	
15	EU0-65901-01	TOOL BAG	1	1	1	

FIG. 29 IMPORTANT LABELS

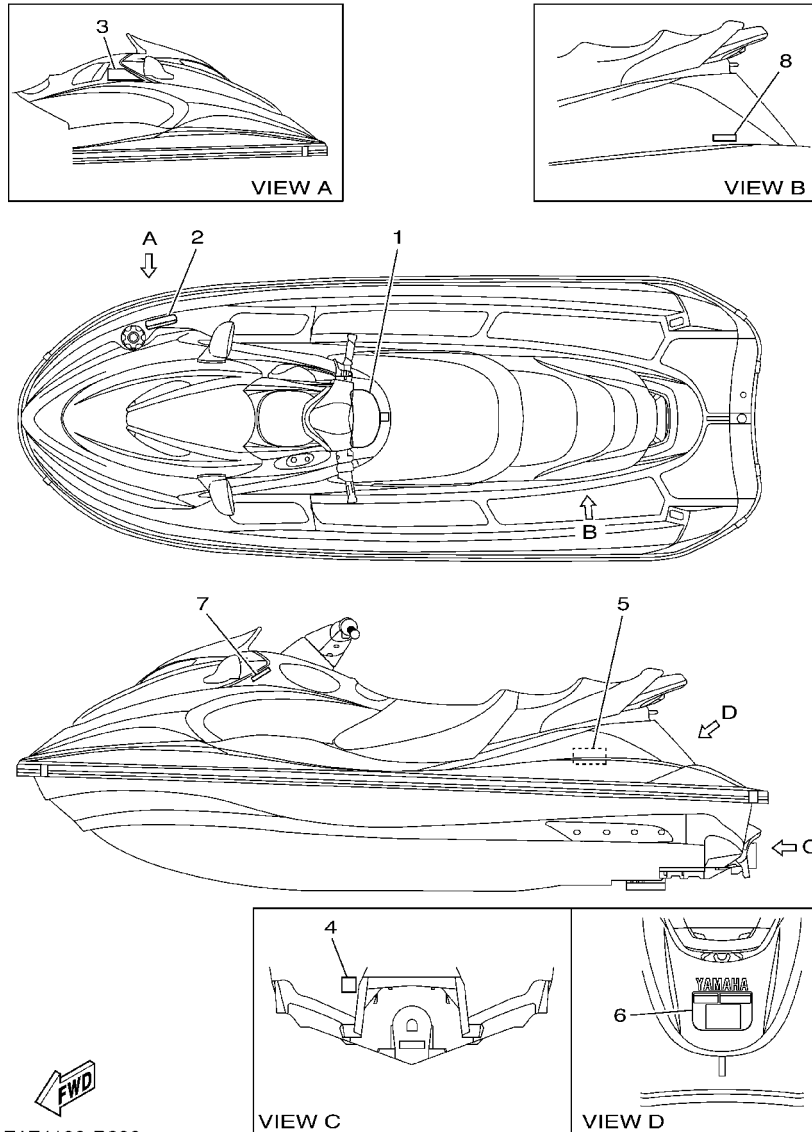

F1F4100-B290

REF. NO.	PART NO.	DESCRIPTION	USA	GENE	JPN	REMARKS
1	F0V-U41B1-41	LABEL, WARNING JDC 1	1			YMUS
2	F0V-U415B-10	LABEL, WARNING(FUEL)	1			YMUS
3	F0V-U41D5-20	LABEL, WARNING SHIFT LEVER	1			YMUS
4	GA9-U418F-00	LABEL, RIGHTING	1			YMUS
5	F0V-U41DB-00	LABEL, WARNING BATTERY	1			YMUS
6	F0V-U41E1-30	LABEL, SET 1	1			YMUS
7	F0V-U41F5-00	LABEL, FIRE EXTINGUISHER 1	1			YMUS
8	F0P-U41G1-00	LABEL, CAPACITY	1			YMUS
<hr/>						
<hr/>						
<hr/>						
<hr/>						
<hr/>						
<hr/>						
<hr/>						
<hr/>						
<hr/>						
<hr/>						

FIG. 32 REPAIR KIT 1

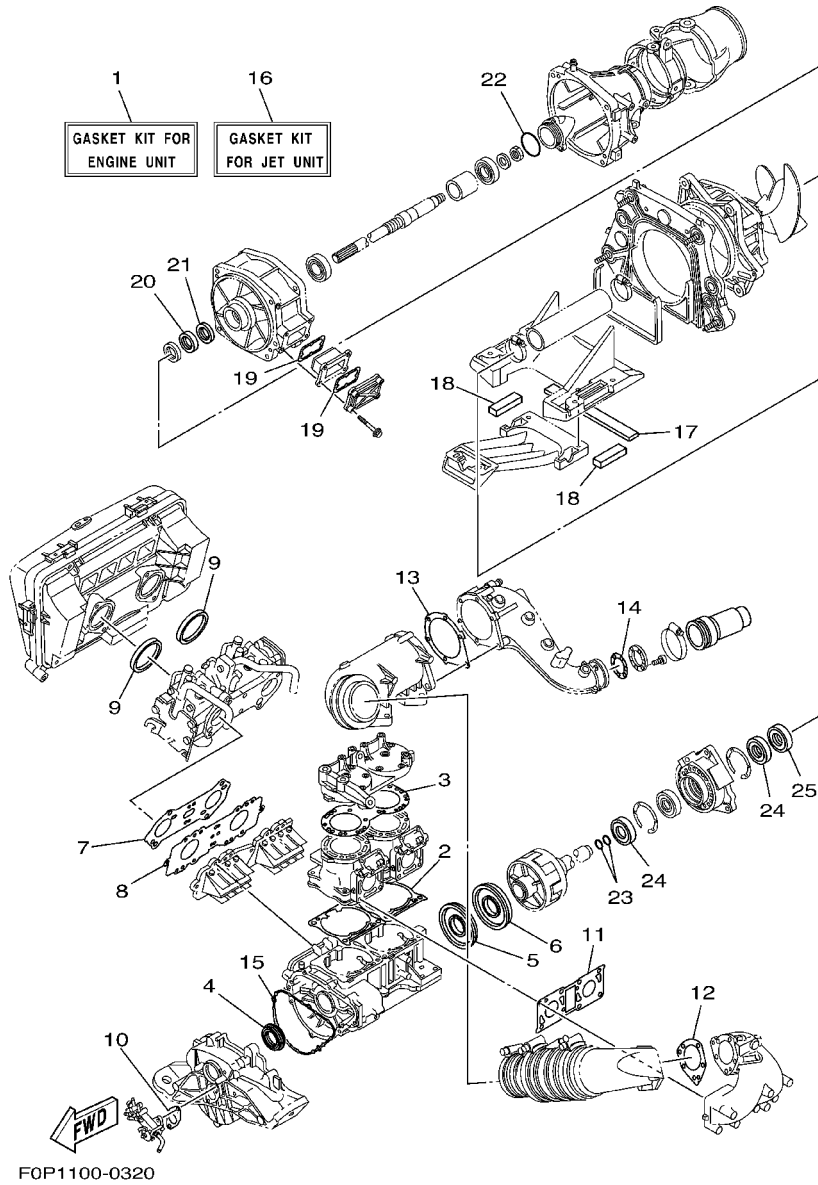

REF. NO.	PART NO.	DESCRIPTION	USA	GENE	JPN	REMARKS
1	66E-W0001-02	GASKET KIT FOR ENGINE UNIT	1	1	1	
2	66E-11351-01	.GASKET, CYLINDER	2	2	2	
3	66E-11181-00	.GASKET, CYLINDER HEAD 1	1	1	1	
4	93103-35M03	.OIL SEAL	1	1	1	
5	93101-36M62	.OIL SEAL	1	1	1	
6	93101-36M61	.OIL SEAL	1	1	1	
7	66E-13556-00	.GASKET, MANIFOLD	1	1	1	
8	66E-13624-10	.PLATE, REED VALVE	1	1	1	
9	66E-13473-00	.O-RING	2	2	2	
10	63M-13116-00	.GASKET, PUMP CASE	1	1	1	
11	66E-14613-00	.GASKET, EXHAUST PIPE	1	1	1	
12	66E-14749-00	.GASKET, MUFFLER DAMPER 2	1	1	1	
13	66E-41124-10	.GASKET, EXHAUST OUTER COVER	1	1	1	
14	66E-14623-00	.GASKET, EXHAUST PIPE	1	1	1	
15	66E-81168-10	.O-RING	1	1	1	
16	66V-W0001-20	GASKET KIT FOR JET UNIT	1	1	1	
17	66V-51367-00	.FELT, PACKING	1	1	1	
18	66V-51368-00	.FELT, PACKING	1	1	1	
19	66V-42414-00	.O-RING	2	2	2	
20	93101-28M66	.OIL SEAL	1	1	1	
21	93101-28M65	.OIL SEAL	1	1	1	
22	93210-46M16	.O-RING	1	1	1	
23	93210-19MJ4	.O-RING	2	2	2	
24	93101-25M55	.OIL SEAL	2	2	2	
25	93101-25M56	.OIL SEAL	1	1	1	

FIG. 33 REPAIR KIT 2

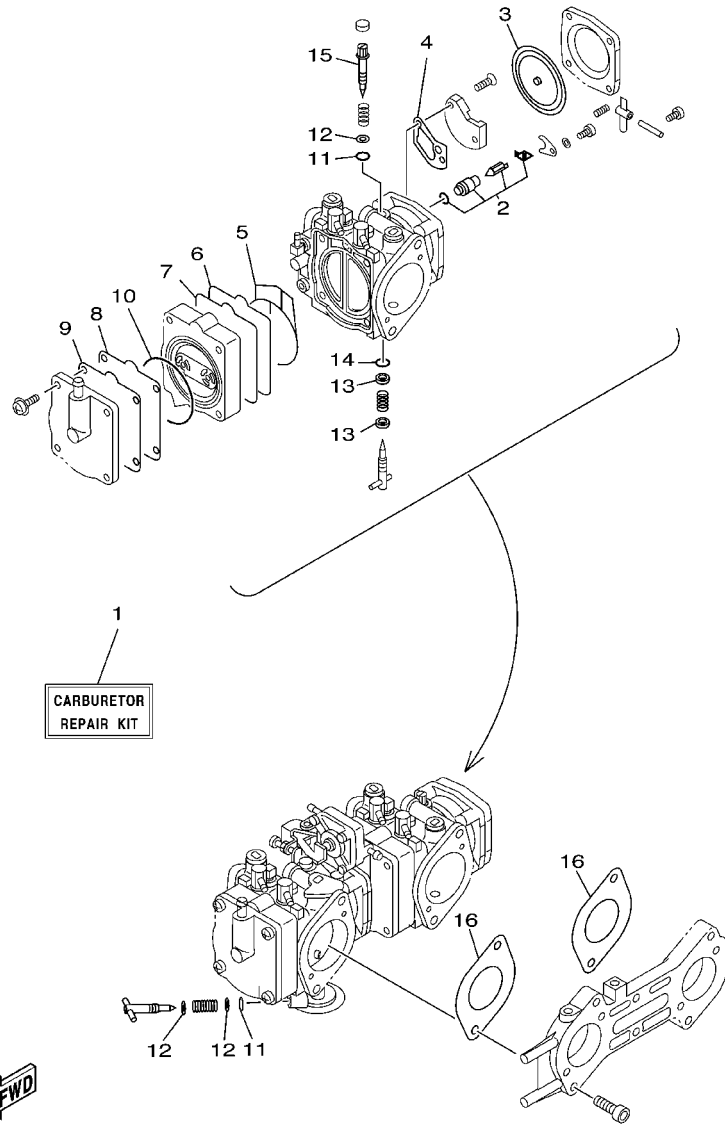

GU04100-9300

REF. NO.	PART NO.	DESCRIPTION	USA	GENE	JPN	REMARKS
1	66E-W0093-01	CARBURETOR REPAIR KIT	1	1	1	
2	64T-14916-00	.NEEDLE	2	2	2	
3	6R7-14541-00	.DIAPHRAGM, PUMP	2	2	2	
4	6K8-14536-11	.GASKET	2	2	2	
5	66E-14563-01	.O-RING	2	2	2	
6	66E-24471-00	.DIAPHRAGM	2	2	2	
7	66E-24411-00	.DIAPHRAGM	2	2	2	
8	66E-24421-00	.VALVE, CHECK	2	2	2	
9	66E-24431-00	.GASKET, FUEL PUMP 1	2	2	2	
10	66E-14564-01	.O-RING	2	2	2	
11	812-14147-00	.O-RING	3	3	3	
12	812-14235-00	.WASHER, NEEDLE	4	4	4	
13	822-14235-00	.WASHER, NEEDLE	4	4	4	
14	583-14561-00	.O-RING	2	2	2	
15	6K8-14946-10	.METERING NEEDLE	2	2	2	
16	66E-14398-00	.GASKET	2	2	2	

NUMERICAL INDEX

PART NO.	GRID NO.	PART NO.	GRID NO.	PART NO.	GRID NO.	PART NO.	GRID NO.	PART NO.	GRID NO.	PART NO.	GRID NO.
66V-G5831-02	C-3	GJ3-U266C-31	C-14	F1F-U417B-10	E-4	EU0-U7354-00-20	B-3	F0D-U883P-20	D-2	67X-12590-00	B-15
65A-R1129-00	C-3	F0D-U266D-00	D-6	F1F-U417B-20	E-4	F0V-U7525-01	C-5	F1F-U883T-00	D-2	67X-12590-10	B-15
66V-R1313-01	C-4	F0D-U271B-00	D-6	F1F-U417C-10	E-4	F0V-U757B-00	D-11	66E-W0001-02	E-8	67X-12590-20	B-15
67A-R1321-00	C-4	F0V-U2714-00	D-13	F1F-U417C-20	E-4	F0D-U7578-00	D-11	66V-W0001-20	E-8	60E-12594-00	B-13
65A-R1326-00	C-3	F0V-U273B-00	C-5	F1F-U417D-10	E-4	GJ1-U7578-11	C-5	66E-W0004-00	B-7	63M-13116-00	B-11
66V-R1348-10	C-4	F0P-U351H-00	D-4	F1F-U417D-20	E-4	GJ1-U7578-21	D-2	66E-W0090-12-8P	B-2		E-8
67A-R1381-00	C-6	F0P-U351J-00	D-4	F1F-U417E-10	E-4	F0P-U758B-00	D-11	66E-W0093-01	E-9	63M-13132-00	B-11
GH1-U046C-00	D-12	F0D-U351K-01	D-4	F1F-U417E-20	E-4	F0V-U758D-00	D-11	66E-11111-00-94	B-2	65U-13132-00	B-11
F0D-U142K-00	E-3	F0D-U351M-01	D-4	F1F-U417F-10	E-4	F0D-U759B-00	D-9	66E-11181-00	B-2	67X-13183-00	B-11
GH1-U143B-00	D-12	F0D-U351N-01	D-4	F1F-U417F-20	E-4	F0D-U759B-10	D-10		E-8	66E-13200-02	B-11
F0D-U143D-00	E-3	F0D-U351P-01	D-4	F1F-U417G-10	E-4	F0D-U759C-00	D-10	66E-1131B-01	B-4	66V-13416-01	B-11
F0D-U143E-00	E-3	F0D-U351R-00	D-4	F1F-U417G-20	E-4	GJ1-U759C-00	D-10	66E-1131C-10	B-4	66E-13469-00	B-11
GH3-U146E-00	C-4	F0D-U352E-00	D-4	F1F-U417H-10	E-4	GD0-U761D-00	D-2	66E-1131H-00	B-4	66E-13473-00	B-7
66V-U146E-00	C-7	F0V-U358F-01	D-4	F1F-U417H-20	E-4	F0D-U7711-00	D-9	66E-1131J-10	B-4		E-8
GK5-U146F-00	D-13	F0V-U358G-01	D-4	F1F-U417J-10	E-4	F0D-U775B-02	D-8	66E-1131M-01-8P	B-4	66E-13556-00	B-7
EU0-U1461-30	D-12	F0V-U3635-00	C-14	F1F-U417J-20	E-4	F0D-U776C-10	D-8	66E-1131S-10	B-4		E-8
	D-13	F0V-U3635-10	C-14	F1F-U417K-10	E-4	F0V-U7772-00	C-13	66E-1131V-00	B-4	66E-13610-00	B-7
F0V-U1461-00	D-13	F0V-U3635-20	C-14	F1F-U417K-20	E-4	GJ3-U778B-00	D-8	66E-11311-00-94	B-2	66E-13624-10	B-7
GP8-U1461-70	D-13	F1F-U371A-10	D-6	F1F-U417L-10	E-4	GJ3-U778C-00	D-8	66E-1132C-00	B-4		E-8
F0D-U1481-10	D-13	F1F-U371A-20	D-6	F1F-U417L-20	E-4	F0X-U778D-00	D-8	66E-11325-00	B-4	66E-13898-11	B-7
F0V-U149C-00	D-13	F1F-U371B-10	D-6	F1F-U417L-20	E-4	F0X-U778E-00	D-8	66V-1133E-00	B-4	4KM-14137-00	B-9
GP7-U151M-00	D-12	F1F-U371B-20	D-6	GA9-U418F-00	E-5	F0X-U778H-00	D-8	66V-1133F-00	B-4	35H-14139-00	B-10
F0D-U152C-10	D-12	F1F-U372A-10	D-6		E-6	EU0-U7817-00	C-2	66E-11351-01	B-2	66E-14146-00	B-10
GP7-U152M-00	D-12	F1F-U372A-20	D-6		E-7	GP7-U783F-00	D-9		E-8	8F2-14147-00	B-8
GP7-U152P-00	D-12	F1F-U372B-10	D-6	GJ1-U419F-21	E-6	GP7-U7831-01	D-9	66E-11400-00	B-5	812-14147-00	B-8
GP7-U152R-00	D-12	F1F-U372B-20	D-6	F0D-U474A-00	D-6	GP7-U7832-01	D-9	66E-11412-00	B-5		E-9
F0D-U153D-01	D-12	GH1-U3774-00	D-7	F0D-U475A-00	C-14	GP7-U7833-00	D-9	66E-11422-00	B-5	7EG-14159-00	B-8
F0D-U153E-10	D-12	F0V-U378C-00	D-6	GP7-U4953-00	D-7	GP7-U7834-00	D-9	66E-11431-00	B-5	66E-14162-00	B-10
F0D-U153J-10	D-12	F0V-U41B1-41	E-5	F0V-U515E-00	C-14	EU0-U7835-00	D-8	66E-11442-00	B-5	66E-14162-01	B-9
GP7-U155C-00	D-12	F0V-U41B1-51	E-6	F0V-U516N-50-P0	C-13	GP7-U7835-00	D-9	66E-11515-00	B-5	66E-14170-00	B-9
GP7-U155D-00	D-15	F0V-U41B1-60	E-6	F0V-U517B-40-P0	C-14	F0D-U7844-10	D-9	66E-11603-01	B-5	439-14186-00	B-9
GP7-U155F-00	D-12	F0M-U41B2-10	E-6	F0V-U517B-50-P0	C-14	F0D-U785G-10	C-12	66E-11631-00-A0	B-5	66E-14211-00	B-9
	D-15	F0V-U41DB-00	E-5	F0D-U517H-80-P0	C-13		D-9	66E-11631-00-B0	B-5	3G2-14231-30	B-8
F0D-U1552-00	D-15	F0V-U41DB-10	E-6	F0D-U517H-90-P0	C-13	GP7-U785H-00	D-9	66E-11631-00-C0	B-5	830-14231-18	B-8
F0D-U156E-00	E-2	F0V-U41D5-20	E-5	F0V-U517M-00	C-14	F0D-U7856-10	D-9	66E-11631-00-D0	B-5	812-14235-00	B-9
GP7-U157A-00	D-12	F0V-U41D5-30	E-6	F0D-U519D-00	C-13	GJ3-U7856-20	D-8	66E-11633-00	B-5		E-9
F0V-U2103-10	C-14	F0V-U41E1-30	E-5	EW2-U5912-01	C-14	F0V-U8K31-00	C-4	66E-11634-00	B-5	822-14235-00	B-9
F0D-U213F-05	D-5	F0V-U41E1-40	E-6	EW2-U5913-01	C-14	EU0-U821D-00	C-12	66E-11651-00	B-5		E-9
F0D-U213G-04	D-5	F0V-U41F5-00	E-5	F0V-U596B-03	C-15	GP7-U8211-00	C-12	66E-11685-00	B-5	66E-14243-00	B-9
GP7-U2501-20	D-4	F0V-U41F5-10	E-6	F0V-U596C-03	C-15	EU0-U8221-30	C-12	66E-11832-01	B-4	4N0-14251-00	B-10
F0D-U251D-00	D-4	F0P-U41G1-00	E-5	GP7-U5983-00	C-14	F0X-U8221-00	C-12	66E-11998-00	B-4	62T-14251-10	B-2
F0D-U2512-00	D-4	GA9-U411B-00	E-7	GD0-U7249-00-05	C-6	F0V-U824B-01	C-12	66E-12576-00	B-13	66E-14251-00	B-10
F1F-U2519-01	D-4	GU2-U411H-00	E-4	GD0-U7249-00-10	C-6	F0D-U824C-20	C-12	66E-12577-00	B-14	6R7-14253-00	B-8
F0D-U252C-00	D-4	GJ3-U4114-52	E-4	F0V-U7267-00	D-13	F0D-U8341-00	C-12	66E-12578-00	B-15	66E-14280-00	B-9
F0V-U252D-00	D-4	F1F-U4122-00	E-4	EU0-U7354-00-01	B-3	GJ1-U835D-00	C-4	66E-12579-00	B-14	66E-14286-00	B-9
F0V-U2624-00	D-2	F0V-U415B-00	E-6	EU0-U7354-00-03	B-3	F0D-U883B-01	C-6	64T-12580-00	B-15	66E-14291-00	B-9
F0V-U266B-00	C-14	F0V-U415B-10	E-5	EU0-U7354-00-05	B-3	F0D-U883E-00	C-6	63M-12581-00	B-13	3XP-14294-00	B-10
F0D-U266C-00	D-6	GJ3-U416H-00	E-6	EU0-U7354-00-10	B-3	F0D-U883N-20	D-2		B-15	67A-14294-00	B-10

NUMERICAL INDEX

PART NO.	GRID NO.	PART NO.	GRID NO.	PART NO.	GRID NO.	PART NO.	GRID NO.	PART NO.	GRID NO.	PART NO.	GRID NO.
67A-14298-00	B-10	64T-14916-01	B-8	68N-45593-00-94	B-5	EU0-61652-00	B-15	F0D-67255-01	D-15	6M6-81865-00	C-9
67A-14301-03	B-8	3KW-14932-00	B-9	66E-4581J-00	B-5		D-2	EW2-67256-00	D-15	6M6-81866-00	C-9
67A-14302-03	B-8	6K8-14946-10	B-9	66E-45813-10-94	B-5		D-4	F0D-67257-00	D-15	66E-81921-00	C-10
66E-14398-00	B-9		E-9	66V-46882-00	C-3	F0D-61782-00	E-2	EW2-67258-01	D-15	68N-81940-00	C-10
	E-9	66E-15100-10-8P	B-2	68N-5112T-00	D-2	F0D-62127-00	D-5	EW2-67259-01	D-15	63M-81960-00	C-10
66E-1441E-00	B-7	66E-21425-10-8P	B-2	6K8-51129-00	B-13	F0D-62139-00	D-5	EU0-67267-10	D-12	EU0-82110-09	C-12
66E-14435-00	B-7	66E-21426-10-8P	B-2		B-2	EW2-62140-00	D-9	EU0-67267-20	C-4	6M6-82117-21	C-11
66E-14451-00	B-7	EU0-23814-30	E-2	66E-51129-00	B-13	EW2-62142-00	D-9	GK5-67267-10	D-13	61L-82117-00	C-11
66E-14452-00	B-7	66E-24314-00	B-10		B-2	EW2-62149-00	D-5	F0D-67410-00	D-15	66E-82117-10	C-11
66E-14457-10	B-7	66E-24315-00	B-10	66V-51129-01	C-3	GJ3-6215F-00	D-5	F0P-6753B-00	D-11	66E-82150-00	C-10
6K8-14471-10	B-9	66E-24362-00	B-8	66V-51129-10	C-3	GP7-62159-01	D-5	F0D-6753D-01	D-11	6G1-82151-00	C-10
66E-14480-11	B-7	6G8-24376-00	B-11	66V-51142-00	B-11	EU0-62241-30	C-4	F0P-67550-01	D-11	6K8-82159-00	C-10
6K8-14503-02	B-8	6E0-24378-00	B-11	66G-51190-00-94	C-4		D-12	GA7-6756E-00	D-11	62E-82371-11	C-11
6M6-14503-00	B-9	63M-24378-00	B-11	66V-51311-00-94	C-3		D-13	F0D-6758C-01	D-11	60G-82553-00	C-11
66E-14521-00	B-9	66E-24411-00	B-8	66V-51312-01-94	C-3	EU0-62280-00	D-2	EW2-67618-00	D-2	68A-82560-00	C-11
6K8-14523-11	B-9		E-9	66V-51314-11	C-7	EU0-62282-00	D-2	F0D-6773E-00	D-14	6R7-83623-40	C-10
6K8-14527-11	B-9	66E-24412-00	B-9	66V-51315-00-94	C-3	EU0-62283-00	D-3	GH3-67743-01	D-9	6R7-83623-50	C-10
6K8-14536-11	B-8	66E-24413-01	B-8	EU0-51318-00-94	C-4	EU0-62285-01	D-3	F0D-6775C-01	D-8	63N-83623-00	C-10
	E-9	66E-24421-00	B-8	68N-51323-00	C-6	F0D-62624-00	D-15	F0D-6775E-01	D-8	682-84385-01	B-15
6R7-14541-00	B-8		E-9	66V-51333-00-94	C-3	FN8-6269B-00	D-2	FJ0-67766-00	D-8	66E-85510-00	C-8
	E-9	66E-24431-00	B-8	63M-51334-00	C-4	F0X-62733-00	D-11	EU0-67767-31	D-9	66E-8552A-00-94	C-10
6R7-14542-00	B-8		E-9	66V-51341-00-94	C-7	F0D-62814-00	E-2	F0D-6777C-00	C-2	66E-8552E-00	C-10
6K8-14547-01	B-8	66E-24452-00	B-8	66V-51367-00	C-3	F0D-62875-00	C-13	FN8-67816-00	C-2	66E-85540-00	C-10
583-14561-00	B-9	66E-24471-00	B-8		E-8	F0D-6376D-00	D-7	F0P-6820A-01	C-12	64X-85546-00	C-10
	E-9		E-9	66V-51368-00	C-3	F0D-63774-01	C-14	F0P-6820A-11	C-12	66E-85550-00	C-8
66E-14563-01	B-8	70R-24489-00	D-9		E-8	F0D-6378D-01	D-6	F0D-6822E-00	D-13	64X-85570-01	C-10
	E-9	65U-24492-00	B-8	61L-5169A-00	B-14	F0D-63850-01	D-6	F0D-68238-10	C-12	60G-85820-00	B-4
66E-14564-01	B-8	66V-24500-02	C-2	F0D-52543-00	D-15	F0V-641B1-70	E-7	GP7-68310-01	D-15	66E-85825-00	B-4
	E-9	70R-24543-00	D-9	F0V-6134A-00	D-13	F0V-641DB-20	E-7	FK7-68312-02	D-15	90101-06M25	B-9
6R7-14569-00	B-8	66V-24560-00	C-2	F0D-6134E-00	E-2	F0V-641D5-40	E-7	FK7-68313-02	D-15	90101-06806	C-7
6K8-14589-00	B-9	66E-26320-00	B-11	F0D-6134K-00	E-2	F1F-641E2-20	E-7	EW2-68348-00	D-15	90101-069U0	D-6
66E-14613-00	B-13	67A-41123-00-94	B-14	F0D-6134M-00	D-15	F0V-6415B-20	E-7	66E-81168-10	C-8	90101-06917	B-3
	E-8	66E-41124-10	B-14	F0D-61349-00	E-2	F0D-64261-02	D-11		E-8	90105-08M66	B-13
66E-14615-00	B-13		E-8	F0D-6135D-00	E-2	F0D-6491K-00	D-15	65U-81317-10	C-11	90105-08M83	B-13
66E-14623-00	B-15	66E-41217-00	B-9	F0D-61355-00	D-15	F0V-6515A-01	C-14	6M6-8132W-00	C-10		B-14
	E-8	66V-42414-00	C-3	F0D-61400-04	D-15	F0D-6517C-04	C-14	66E-81328-00	C-8	90105-08M84	B-13
66E-14625-00	B-13		E-8	EU0-61461-02	E-2	F0D-6517R-00	C-13	66E-81337-11-8P	C-8	90105-08M86	B-7
66E-14711-10-8P	B-13	66E-42717-00	B-7	F0D-61467-00	E-2	F0D-6517T-00	C-13	63M-81800-00	C-9	90105-10M82	B-14
66E-14712-10-8P	B-13	66V-44121-00	C-7	GH1-61468-01	D-13	GA7-65772-00	D-11	3AJ-81809-00	C-9	90105-10M85	B-13
66E-14721-10-94	B-14	66V-44125-00	C-7	GH3-61468-00	E-2	EU0-65901-01	E-4	6M6-81826-00	C-9	90105-10M86	B-13
66E-14749-00	B-13	6M6-44517-A1-5B	B-3	F1B-6151B-00	E-2	EU0-65986-00	E-4	6M6-8183E-01	C-9	90109-05MA0	C-10
	E-8	67A-44532-00-94	B-2	F0D-6151S-00	D-15	F0N-6724E-00	D-13	6M6-81830-00	C-9	90109-06M00	B-7
67A-14752-00	B-15	663-45119-00	B-14	F0D-6152D-00	D-15	F0P-6724F-00	D-13	63M-81830-00	C-9	90109-06803	D-13
66E-14763-10-94	B-14	66V-45214-00-94	C-3	F0D-6152R-00	D-15	F0D-6724H-00	E-2	6M6-81840-10	C-9	90109-08879	C-7
66E-14771-01-94	B-15	61X-45332-03-94	C-6	F0D-61574-00	E-2	67A-67242-01	D-12	11H-81844-00	C-9	90109-10M72	C-8
66E-14781-10-94	B-2	61L-45378-00	C-6	F0D-61624-01	D-2	EW2-67243-00	D-13	6M6-81844-00	C-10	90110-04M03	B-4
66E-14791-00-94	B-14	68Y-45511-00	C-3	GP7-61628-00	D-7	F0D-67250-03	D-15	1FK-81847-00	C-9	90110-05008	B-4
64T-14916-00	E-9	65V-45538-00	C-3	GH1-61651-01	D-4	66E-67252-00	D-12	6M6-81850-00	C-9	90110-05908	D-12

NUMERICAL INDEX

PART NO.	GRID NO.	PART NO.	GRID NO.	PART NO.	GRID NO.	PART NO.	GRID NO.	PART NO.	GRID NO.	PART NO.	GRID NO.
90110-05908	D - 15	90149-03M15	D - 12	90387-07598	B - 4	90450-14M05	B - 2	90600-921U1	C - 5	92995-06100	C - 11
90116-06802	D - 11	90149-05962	D - 5	90387-08M06	C - 4	90450-18M09	B - 13	90600-925U9	C - 4	92995-06600	B - 11
90116-08M64	B - 14	90149-069UA	C - 6	90387-08M30	C - 7		B - 14	90601-118UF	B - 15		B - 15
90116-10M65	B - 14	90149-06906	E - 3	90387-08802	C - 14		B - 15		C - 4		B - 7
90116-10M66	B - 14	90149-06910	E - 3	90387-10M09	C - 7	90450-22M14	B - 13		D - 11		C - 10
90119-06M13	B - 3	90157-05M17	B - 8	90430-16910	D - 11		B - 15		D - 2	93101-25M55	C - 6
90119-06M78	B - 3	90169-049U1	D - 9	90445-07M25	B - 11	90450-99M02	B - 13	90601-142U6	D - 8		E - 8
90119-06800	C - 3	90169-059U1	D - 4	90445-07M42	B - 10	90450-99M18	B - 13	90601-152U3	C - 6	93101-25M56	C - 6
90119-06803	C - 13	90170-22187	C - 2	90445-07M78	B - 10	90460-90M11	B - 15	90601-155U4	D - 9		E - 8
90119-06820	D - 6	90179-08812	C - 5	90445-07M79	B - 10	90464-06M29	C - 10	90601-162U5	C - 12	93101-28M65	C - 3
90119-06835	C - 3	90183-06902	C - 13	90445-07002	B - 11	90464-07M20	B - 11	90601-175UR	D - 11		E - 8
90119-06853	D - 6		C - 14	90445-07009	B - 11	90464-32801	C - 12	90601-195UD	D - 11	93101-28M66	C - 3
90119-06854	C - 12	90201-05M09	C - 8	90445-09M21	B - 14		D - 11	90601-200U1	D - 13		E - 8
	E - 3	90201-06M04	B - 4	90445-10MH0	B - 10		D - 2		D - 14	93101-36M61	B - 5
90119-06858	C - 13	90201-068M4	C - 4	90445-10MH2	B - 10		D - 8	90601-200U2	E - 2		E - 8
90119-069UB	C - 14	90201-068T1	C - 7	90445-10MH3	B - 10	90464-40825	C - 5	90601-200U7	D - 5	93101-36M62	B - 5
	C - 4	90201-06802	C - 14	90445-10MH5	B - 10	90464-99801	D - 5	90601-20009	C - 12		E - 8
	C - 5	90201-06906	D - 13	90445-11M67	C - 2		D - 9	90605-502U2	C - 13	93103-35M03	B - 5
	C - 7	90201-08M09	B - 4	90445-11M68	C - 2	90464-99804	D - 5	91318-06014	C - 8		E - 8
90119-069UD	C - 6	90201-088T2	C - 7	90445-11M69	C - 2	90465-11M10	B - 11	91318-06030	C - 8	93109-08M07	B - 4
	C - 7	90201-099U3	B - 3	90445-11012	B - 11		B - 14	92903-06600	B - 4	93210-19MJ4	C - 6
	C - 14		E - 2	90445-14M33	B - 13		B - 7		B - 7		E - 8
90119-069UH	C - 14	90201-10801	C - 5	90445-14003	B - 2		C - 11		C - 9	93210-46M16	C - 4
90119-069UJ	D - 13	90201-22M04	B - 5	90445-14898	C - 4		C - 2	92903-08600	B - 2		E - 8
90119-069UK	C - 5	90201-248M5	B - 6	90445-16M09	C - 4	90465-11829	B - 12		C - 9	93305-307U0	B - 5
90119-069UX	B - 4	90202-229U1	C - 2	90445-18M02	B - 15		C - 2	9299R-05200	D - 11	93306-205U0	C - 3
90119-08MA1	B - 2	90204-06M01	B - 9	90445-18M17	B - 15		C - 4		D - 3	93306-205U6	C - 6
90119-08MA2	B - 2	90267-329UR	D - 9	90445-198B9	D - 2		C - 6	9299R-06100	D - 12	93306-208U1	B - 5
90119-08M18	C - 8	90267-40935	D - 8	90445-198C0	D - 2		D - 2	9299R-06200	C - 13	93306-304U1	C - 3
90119-08M55	B - 3	90267-48802	C - 12	90446-07M96	B - 10		D - 5		D - 11	93306-308U1	B - 5
	C - 8		D - 2	90446-07M97	B - 10		D - 8		D - 13	93310-422U2	B - 5
90119-08M56	B - 3		D - 5	90446-10MA0	B - 10		D - 9		D - 4	93310-627U6	B - 5
90119-08M61	B - 3	90267-48809	C - 14	90446-10MA1	B - 10	90465-12M53	C - 10		D - 6	93410-08M12	B - 4
90119-08809	C - 10	90267-489UE	D - 5	90446-10MA2	B - 10	90465-12M56	B - 13		E - 2	93430-47M04	C - 6
90119-089UE	C - 4	90267-489UP	C - 14	90446-14M98	B - 10		C - 10	9299R-08200	C - 14	93440-25M08	C - 9
90119-089UF	C - 7	90267-489US	D - 4	90446-14M99	B - 10	90465-13M36	C - 10		C - 15	93450-18M06	C - 9
90119-089UL	C - 6	90267-489UT	D - 4	90446-17MA7	B - 10	90465-20M78	B - 13		D - 2	93606-12019	B - 13
90119-089UR	B - 3	90267-489U1	C - 2	90446-17ME5	B - 10	90467-089U1	C - 12	9299R-08600	C - 7		B - 14
90119-089UU	E - 2	90267-489U2	D - 9	90446-24M52	B - 15	90468-02001	B - 11	9299R-10200	D - 6		B - 2
90119-089UU6	B - 3	90267-489U7	D - 11	90446-24M94	B - 13	90480-06M43	C - 11		D - 7		B - 3
	C - 5	90280-05013	C - 8	90446-27M55	D - 2	90480-06M46	C - 6	9299R-16600	C - 3		C - 3
90119-089U7	D - 9	90380-12M29	B - 2	90446-27M73	D - 2	90480-14023	B - 4	92990-04600	D - 12		C - 4
90119-10M00	B - 14		C - 8	90446-27M95	B - 15	90501-14M73	C - 9	92990-06100	C - 9		C - 6
	B - 2	90387-05800	D - 12	90447-07002	B - 11	90508-14M43	C - 7	92990-06600	C - 11	93606-19M23	B - 7
90119-10M07	B - 2	90387-06M05	C - 11	90447-13002	B - 11	90600-900U6	C - 5		D - 12	93608-16M16	C - 8
90119-10M10	B - 14	90387-06M60	C - 6	90447-19003	B - 2		D - 5	92990-08600	B - 14	94702-00204	C - 11
90119-10M18	B - 15	90387-06M74	C - 7	90450-14M05	B - 13		C - 12	92990-10600	B - 14	94709-00204	C - 11
90119-10836	C - 3	90387-06M84	C - 7		B - 14	90600-917U4	C - 12	92995-06100	C - 10	9531P-16700	C - 3
90119-10837	C - 4		C - 7				D - 2				

NUMERICAL INDEX

PART NO.	GRID NO.	PART NO.	GRID NO.	PART NO.	GRID NO.	PART NO.	GRID NO.	PART NO.	GRID NO.
95333-08600	B - 14	97880-05025	D - 15						
9538R-06600	C - 7	97880-06016	C - 11						
9538R-06700	C - 13	97880-06030	C - 11						
	C - 4	97880-06065	D - 12						
	D - 13	97885-06016	B - 15						
9538R-08600	C - 7	97890-05014	B - 9						
95380-06700	C - 9	98580-05025	D - 15						
95380-10600	B - 14	9878R-05512	C - 4						
9572R-05300	C - 12	98780-05020	B - 4						
	D - 3	98980-04008	C - 2						
9572R-06300	C - 13	98980-04010	D - 12						
	C - 14	99590-14016	C - 3						
	D - 11								
	D - 12								
	D - 13								
	D - 4								
	D - 6								
	E - 2								
9572R-08300	C - 15								
	D - 2								
	D - 7								
	E - 2								
9572R-10300	C - 5								
	D - 6								
	D - 7								
95720-06300	E - 2								
97013-06025	B - 4								
	B - 7								
97013-06045	B - 7								
97013-08025	C - 9								
97013-08030	B - 2								
97013-08045	B - 2								
9708R-06030	C - 13								
97080-08030	E - 2								
97080-10025	D - 6								
97095-06010	C - 10								
97095-06012	C - 10								
97095-06016	C - 11								
97095-06020	B - 11								
97095-06035	B - 7								
97513-05514	C - 8								
9778R-50112	D - 2								
97780-04110	D - 8								
97780-50514	C - 5								
97780-60425	C - 11								
9788R-05025	D - 3								
97880-03008	D - 15								
97880-05010	B - 9								