

PARTS CATALOGUE

WaveRunner XL700

XL700-B (F0MC/67EH/67E5)

XL700-B (F0MD/67EJ/67E5)

MJ-XL700Ltd'03 (F0ME/67EK/67E5)

XL700-B/MJ-XL700Ltd
PARTS CATALOGUE
©2002 by Yamaha Motor Co., Ltd.
1st Edition, Oct. 2002
All rights reserved.
Any reprinting or unauthorized use
without the written permission of
Yamaha Motor Co., Ltd.
is expressly prohibited.
Printed in Japan

A3



A4

FOREWORD

This Parts Catalogue is related to the parts for the model(s) in the below frame. When you are ordering replacement parts, please refer to this Parts Catalogue and quote both part numbers and part names correctly.

XL700-B(F0MC/67EH/67E5), XL700-B(F0MD/67EJ/67E5),
MJ-XL700Ltd'03(F0ME/67EK/67E5)

1. Modifications or additions which have been made after issue of the Parts Catalogue will be announced in the Yamaha Parts News.

It is advisable that you make necessary corrections to the Parts Catalogue according to the Yamaha Parts News.

2. Abbreviations

The following abbreviations are used in this Parts Catalogue.

“UR” Use specified parts number.

“UN” Use as many as needed.

“AP” Alternate Parts

“LM” Local Made (Parts need to be ordered locally)

“F#” Frame No. (Applicable machine No.)

3. Parts, which are to be supplied in an assembly, are listed with a dot(.) in front of the part name as shown below.

The numeral appearing to the right of each component part indicates the quantity of parts for each assembly unit.

EXAMPLE

PART NO.	DESCRIPTION	Q'TY	REMARKS
EU0-62280-00	DRAIN PLUG ASSY	2	
EU0-62282-00	.PLUG,DRAIN	1	

4. Quantity Column Information

NAME for Q'TY COLUMN	COUNTRY (destination)
USA	USA
GENE	EXCEPT USA, JAPAN
JPN	JAPAN

5. Note that the illustration for reference in finding parts numbers, not to be used for assembling. When assembling, please use the applicable service manual.

6. A part with “YMUS” in the remarks column can be obtained from YMUS (USA) and not from YAMAHA MOTOR CO.,LTD (JAPAN).

EXAMPLE

PART NO.	DESCRIPTION	Q'TY	REMARKS
EW2-U5160-00	ENGINE HATCH COMP.	2	.. YMUS
90601-168U7	BAND, HOSE	1	.. YMUS

ADDRESS:

YAMAHA MOTOR CORPORATION U.S.A.
PARTS & ACCESSORY DIV.
6555 KATELLA AVENUE
CYPRESS, CALIFORNIA 90630 U.S.A.

FOREWORD

7. Applicable Starting Serial No. and Color Code

Starting Serial No.

Hull Serial No.	F0M-820181
Engine Serial No.	63N-1000081

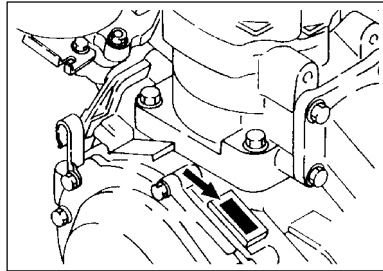
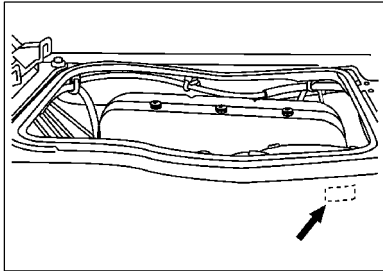

Color Code

Parts No./Part Name	Color Code	Color Name	Abbreviation
F0M-U516N-20-P0 COVER, SIDE 1	0881	BLUE METALLIC D	BMD
GU2-U377B-30-P0 COVER, SIDE 1	0881	BLUE METALLIC D	BMD
GU2-U377C-30-P0 COVER, SIDE 2	0881	BLUE METALLIC D	BMD
GU2-U513M-30-P0 COVER, FRONT	0881	BLUE METALLIC D	BMD
GU2-U517B-30-P0 LID, ENGINE ROOM	0881	BLUE METALLIC D	BMD
GU2-U517H-30-P0 LID HATCH	0881	BLUE METALLIC D	BMD
ENGINE	008P	BLACK SOLID 4	SS4

CONTENTS

CYLINDER. CRANKCASE	B2
CRANKSHAFT. PISTON	B4
INTAKE	B6
CARBURETOR	B8
OIL PUMP	B10
EXHAUST 1	B11
FUEL	B14
JET UNIT 1	C2
JET UNIT 2	C4
GENERATOR	C6
STARTING MOTOR	C7
ELECTRICAL 1	C8
ELECTRICAL 2	C10
ENGINE HATCH 1	C11
ENGINE HATCH 2	C12
HULL. DECK	C14
GUNWALE. MAT	D2
VENTILATION	D4
SEAT. UNDER LOCKER	D5
OIL TANK	D7

FUEL TANK	D8
EXHAUST 2	D10
CONTROL CABLE	D11
STEERING 1	D12
STEERING 2	D14
GRAPHICS	D15
IMPORTANT LABELS	E2
IMPORTANT LABELS 2	E3
IMPORTANT LABELS 3	E4
REPAIR KIT 1	E5
REPAIR KIT 2	E7

INDEX

NUMERICAL INDEX	M1
-----------------------	----

FIG. 1 CYLINDER. CRANKCASE

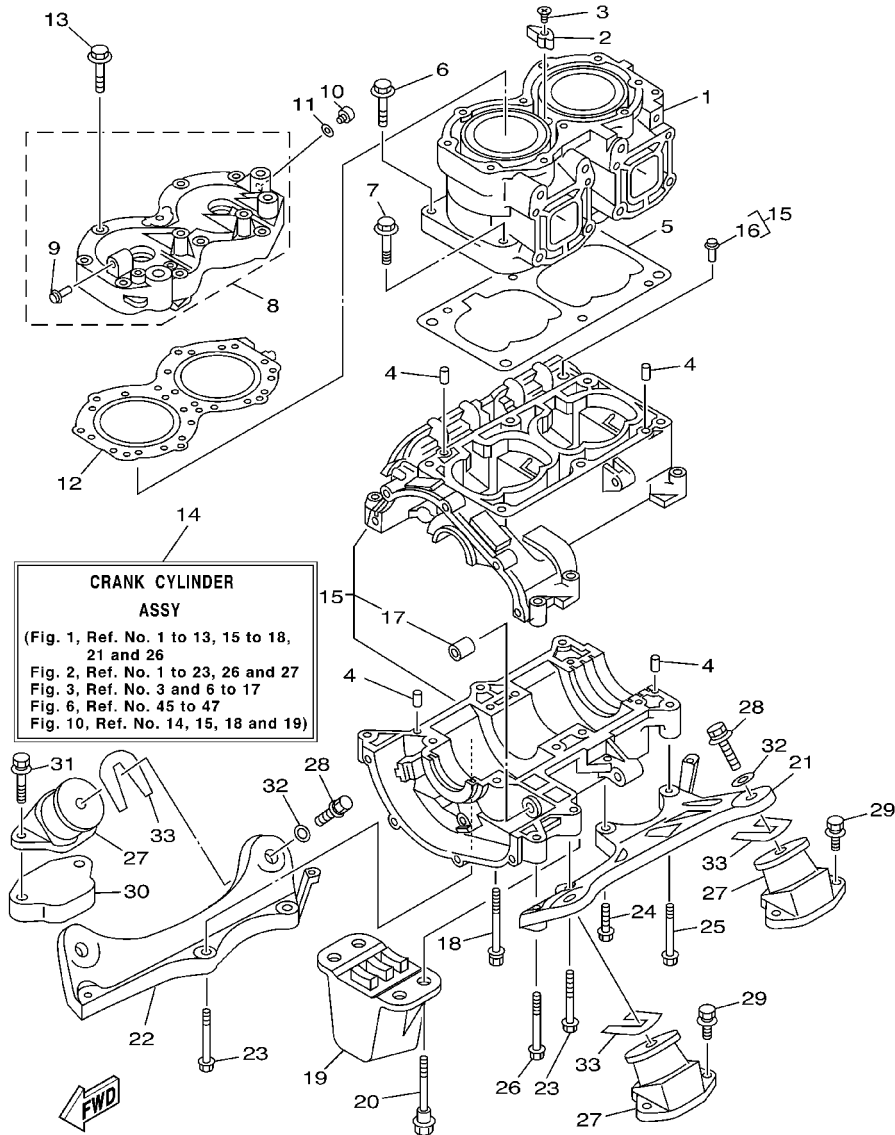

F0M7100-1011

REF. NO.	PART NO.	DESCRIPTION	USA	GENE	JPN	REMARKS
1	62T-11311-00-94	CYLINDER 1	1	1	1	
2	6E5-11325-00	ANODE	1	1	1	
3	98780-04015	SCREW, FLAT HEAD	1	1	1	
4	93606-12019	PIN, DOWEL	4	4	4	
5	6M6-11351-A2	GASKET, CYLINDER	1	1	1	
6	90119-10M56	BOLT, WITH WASHER	4	4	4	
7	90119-10M07	BOLT, WITH WASHER	2	2	2	
8	62T-11111-00-94	HEAD, CYLINDER 1	1	1	1	
9	6K8-51129-00	.NIPPLE	1	1	1	
10	90340-08M04	PLUG, STRAIGHT SCREW	1	1	1	
11	90430-08020	GASKET	1	1	1	
12	62T-11181-00	GASKET, CYLINDER HEAD 1	1	1	1	
13	90119-08M96	BOLT, WITH WASHER	10	10	10	
14	62T-W0090-03-8P	CRANK CYLINDER ASSY	1	1	1	
15	62T-15100-00-8P	CRANKCASE ASSY	1	1	1	
16	62T-14251-10	.NIPPLE	1	1	1	
17	90380-12M29	.BUSH, SOLID	1	1	1	
18	90119-08M55	BOLT, WITH WASHER	4	4	4	
19	63N-44532-01	STOPPER, UPPER MOUNT	1	1	1	
20	90109-08M56	BOLT	4	4	4	
21	6R7-21415-01-94	BRACKET, FRONT UPPER 1	1	1	1	
22	6R7-21425-01-94	BRACKET, REAR UPPER 1	1	1	1	
23	90119-10M02	BOLT, WITH WASHER	4	4	4	
24	90119-10M00	BOLT, WITH WASHER	1	1	1	
25	90119-10M03	BOLT, WITH WASHER	1	1	1	
26	90119-10M01	BOLT, WITH WASHER	1	1	1	
27	6M6-44517-A1-5B	MOUNT RUBBER	4	4	4	

FIG. 1 CYLINDER. CRANKCASE

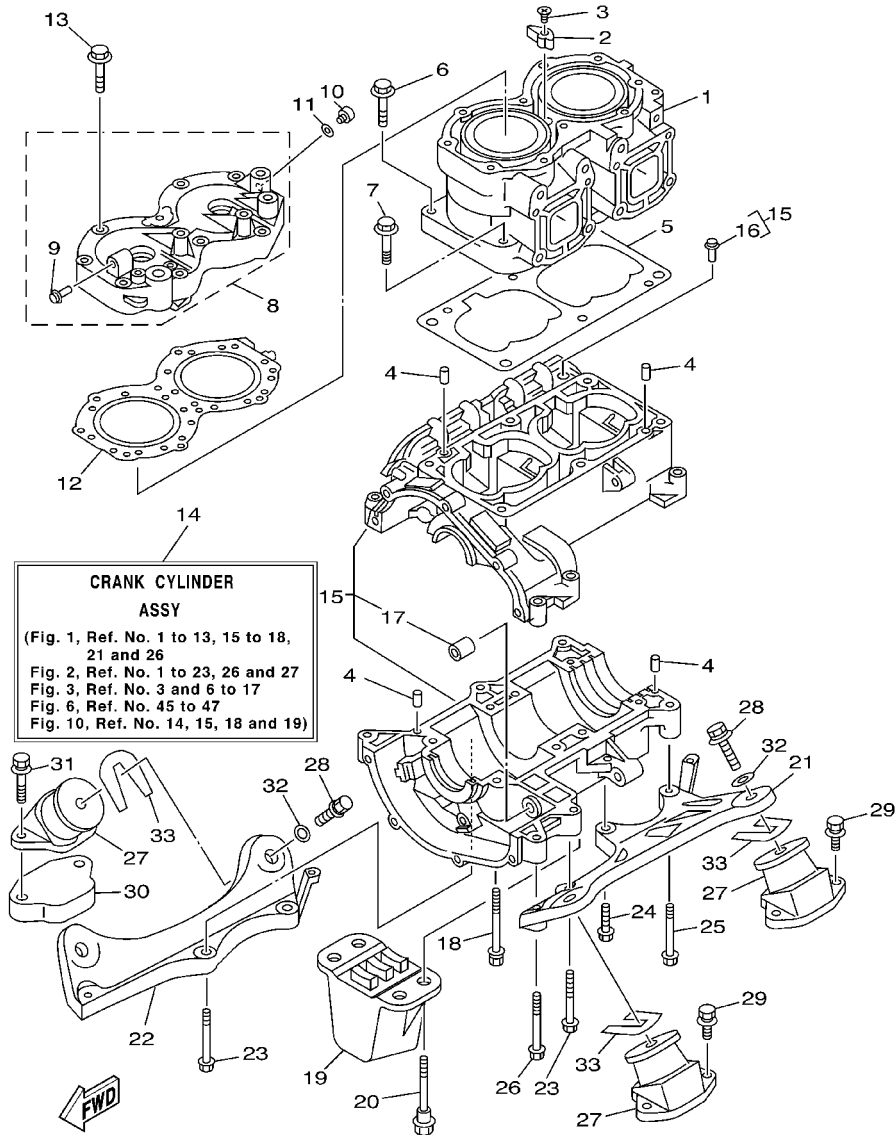

FOM7100-1011

REF. NO.	PART NO.	DESCRIPTION	USA	GENE	JPN	REMARKS
28	90119-08817	BOLT, WITH WASHER	4	4	4	YMUS
29	90119-089UU	BOLT, WITH WASHER	4	4	4	YMUS
30	GJ1-6721B-00	SPACER, ENGINE MOUNT	2	2	2	
31	90119-089UR	BOLT, WITH WASHER	4	4	4	YMUS
32	90201-099U3	WASHER, PLATE	4	4	4	YMUS
33	EU0-U7354-00-01	SHIM (T=0.1)	10	10	10	UR, YMUS
	EU0-U7354-00-03	SHIM (T=0.3)	10	10	10	UR, YMUS
	EU0-U7354-00-05	SHIM (T=0.5)	10	10	10	UR, YMUS
	EU0-U7354-00-10	SHIM (T=1.0)	10	10	10	UR, YMUS
	EU0-U7354-00-20	SHIM (T=2.0)	10	10	10	UR, YMUS

FIG. 2 CRANKSHAFT. PISTON

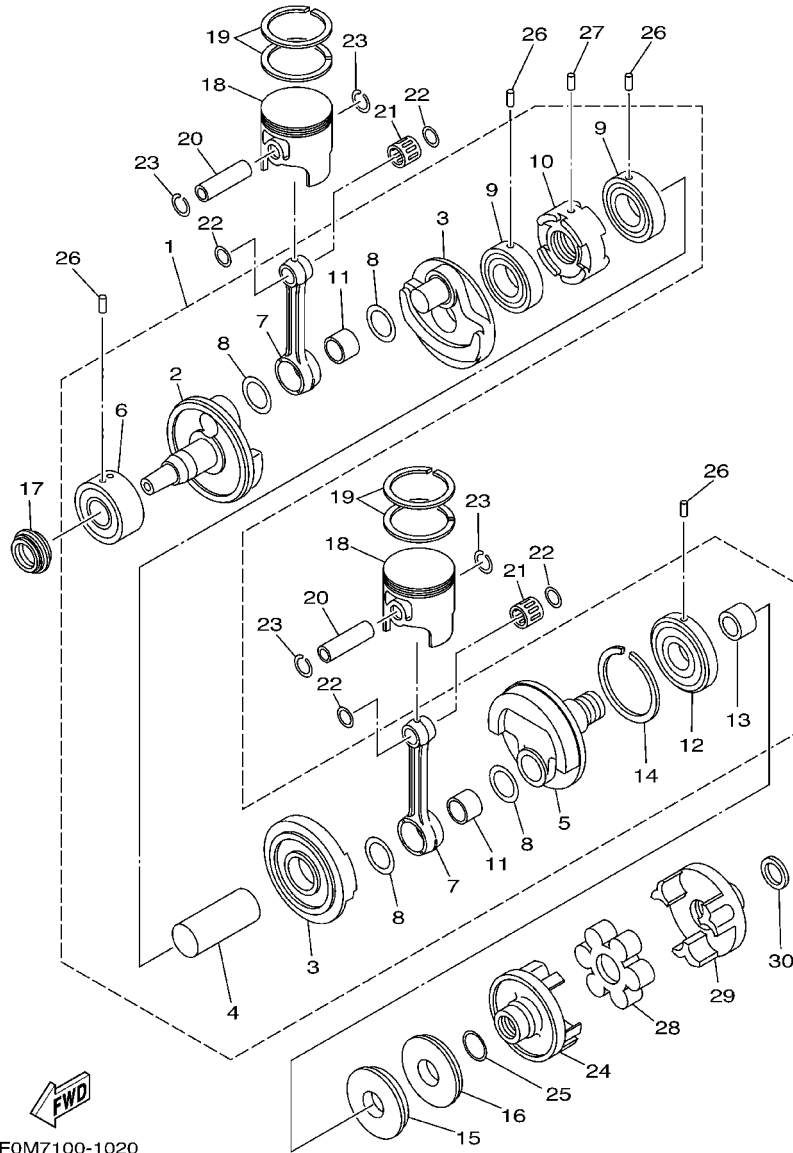

REF. NO.	PART NO.	DESCRIPTION	USA	GENE	JPN	REMARKS
1	62T-11400-02	CRANKSHAFT ASSY	1	1	1	
2	6M6-11412-00	.CRANK 1	1	1	1	
3	6M6-11422-00	.CRANK 2	2	2	2	
4	6M6-11431-00	.CRANK 3	1	1	1	
5	6M6-11442-01	.CRANK 4	1	1	1	
6	93305-30601	.BEARING	1	1	1	
7	62T-11651-00	.ROD, CONNECTING	2	2	2	
8	82M-11685-00	.WASHER, CRANK PIN	4	4	4	
9	93306-207U2	.BEARING	2	2	2	
10	82M-11515-00	.SEAL, LABYRINTH 1	1	1	1	
11	93310-525U3	.BEARING	2	2	2	
12	93306-307U3	.BEARING	1	1	1	
13	62T-45526-00	.COLLAR, DRIVE SHAFT	1	1	1	
14	93440-80023	.CIRCLIP	1	1	1	
15	93102-36M33	OIL SEAL	1	1	1	
16	93101-36M46	OIL SEAL	1	1	1	
17	93103-32M01	OIL SEAL	1	1	1	
18	62T-11631-02-92	PISTON (STD)	2	2	2	
	62T-11635-02	PISTON (0.25MM O/S)	2	2	2	AP
	62T-11636-02	PISTON (0.50MM O/S)	2	2	2	AP
19	61X-11603-01	PISTON RING SET (STD)	2	2	2	
	61X-11604-01	PISTON RING SET (0.25MM O/S)	2	2	2	AP
	61X-11605-01	PISTON RING SET (0.50MM O/S)	2	2	2	AP
20	62T-11633-00	PIN, PISTON	2	2	2	
21	93310-320U2	BEARING	2	2	2	
22	90201-20M04	WASHER, PLATE	4	4	4	
23	93450-21053	CIRCLIP	4	4	4	

FIG. 2 CRANKSHAFT. PISTON

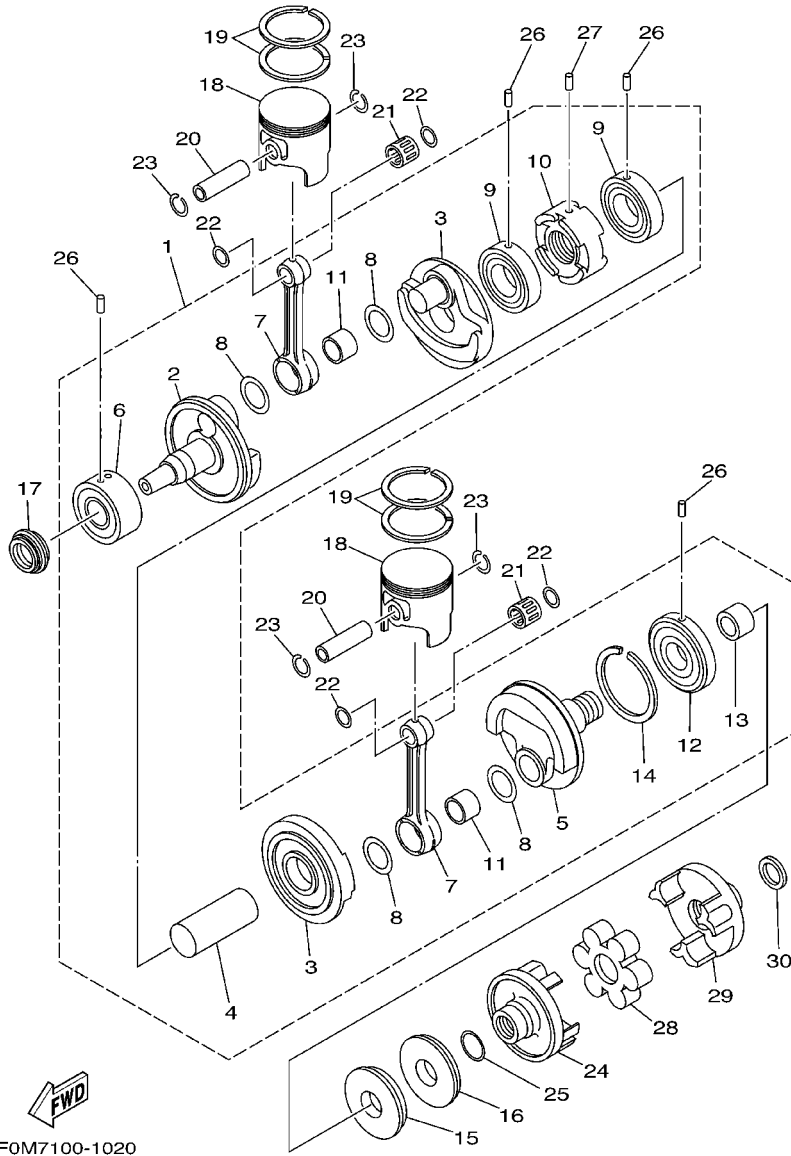

REF. NO.	PART NO.	DESCRIPTION	USA	GENE	JPN	REMARKS
24	6M6-45813-32-8P	FLANGE, COUPLING	1	1	1	
25	62T-45127-00	SEAL	1	1	1	
26	93603-10049	PIN, DOWEL	4	4	4	
27	93604-07141	PIN, DOWEL	1	1	1	
28	61X-4581J-00	RUBBER SHAFT COUPLING	1	1	1	
29	6M6-45813-22-8P	FLANGE, COUPLING	1	1	1	
30	90201-248M5	WASHER, PLATE	1	1	1	YMUS

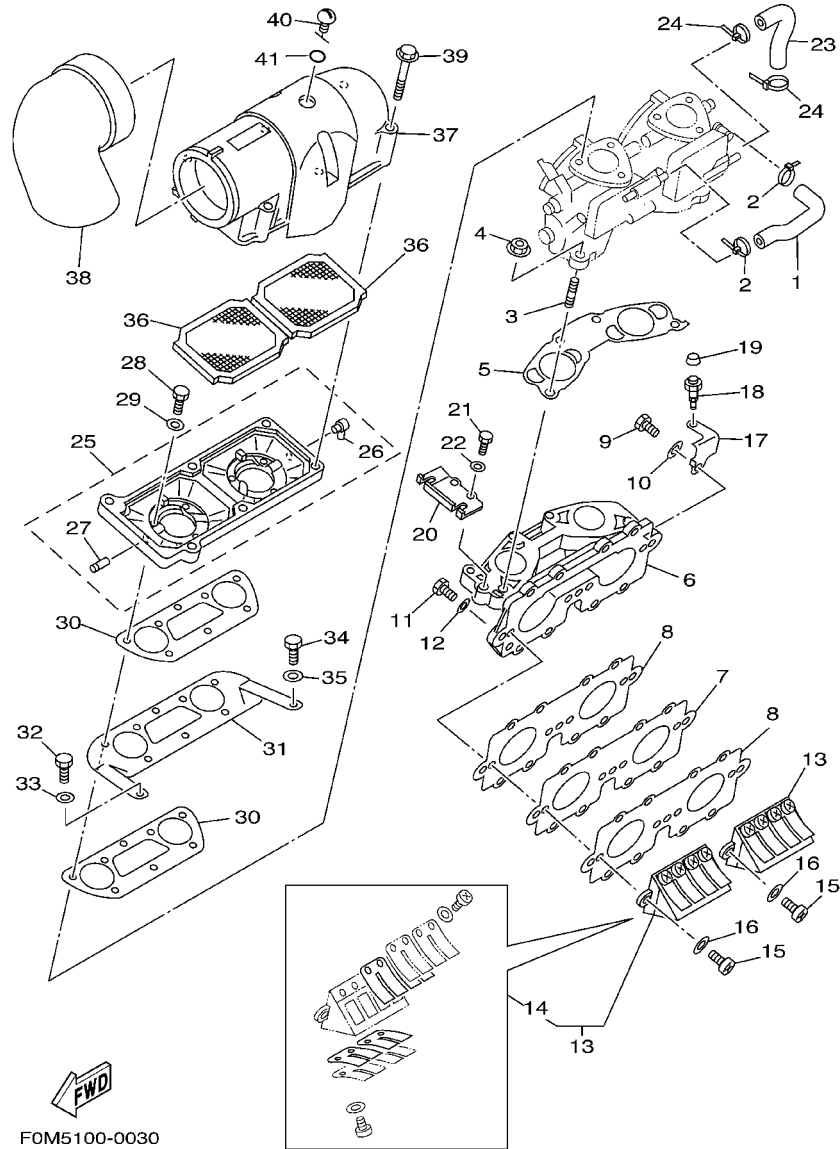
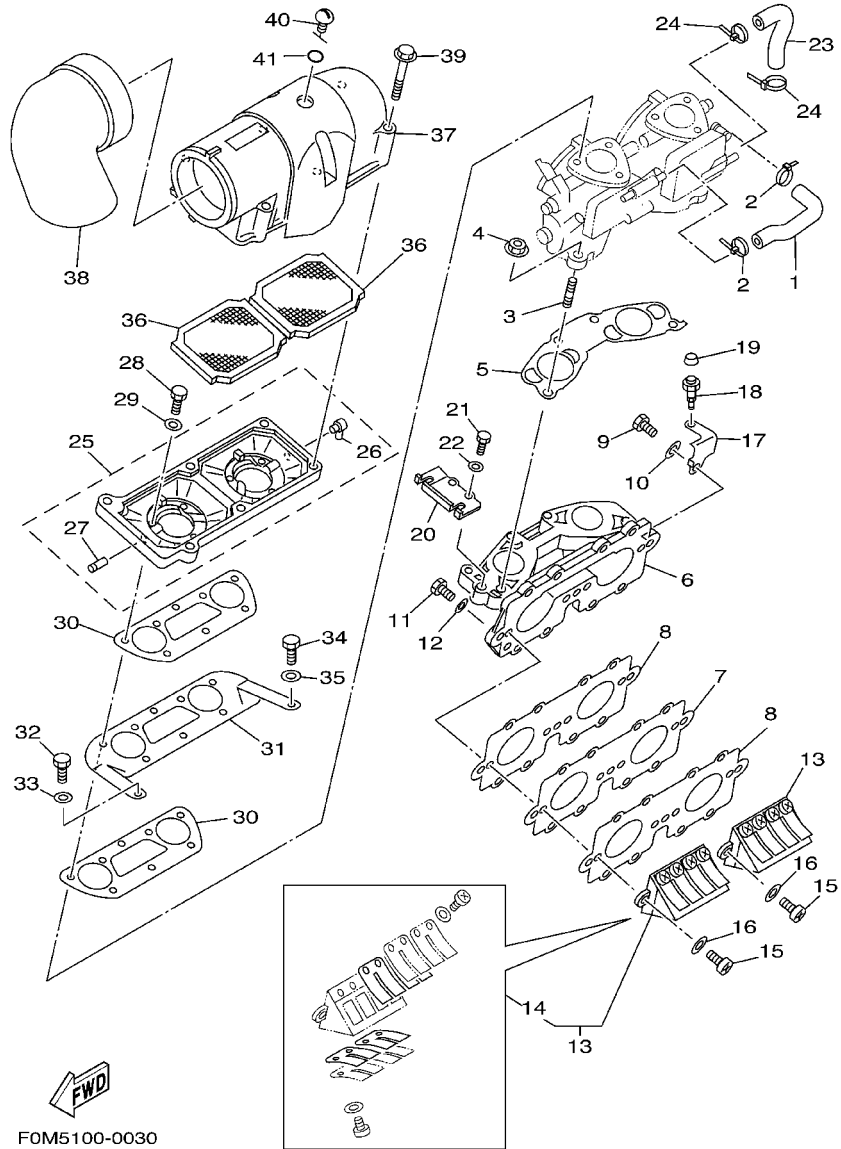

FIG. 3 INTAKE

REF. NO.	PART NO.	DESCRIPTION	USA	GENE	JPN	REMARKS
1	62T-24313-01	PIPE 3	1	1	1	
2	90465-11M10	CLAMP	2	2	2	
3	90116-08M60	BOLT, STUD	4	4	4	
4	90179-08M15	NUT	4	4	4	
5	62T-13556-00	GASKET, MANIFOLD	1	1	1	
6	62T-13555-00-8P	MANIFOLD, INTAKE	1	1	1	
7	62T-13624-00	PLATE, REED VALVE	1	1	1	
8	62T-13566-00	GASKET	2	2	2	
9	97013-06035	BOLT	3	3	3	
10	92903-06600	WASHER, PLATE	3	3	3	
11	97013-06025	BOLT	8	8	8	
12	92903-06600	WASHER, PLATE	8	8	8	
13	62T-13610-00	REED VALVE ASSY	2	2	2	
14	62T-W0004-00	.REED SET	1	1	1	
15	97880-05016	SCREW, PAN HEAD	4	4	4	
16	92990-05600	WASHER, PLATE	4	4	4	
17	62T-14243-01	PLATE	1	1	1	
18	61L-5169A-00	NIPPLE, GREASE	1	1	1	
19	663-45119-00	CAP, GREASE NIPPLE	1	1	1	
20	62T-14527-02	PLATE	1	1	1	
21	97013-06016	BOLT	2	2	2	
22	92903-06600	WASHER, PLATE	2	2	2	
23	62T-24314-01	PIPE 4	1	1	1	
24	90465-11M10	CLAMP	2	2	2	
25	62T-14284-01-8P	COVER, CARBURETOR 2	1	1	1	
26	6E5-11372-00	.NIPPLE, HOSE	1	1	1	
27	6H1-14485-00	.PIPE, JOINT	1	1	1	

FIG. 3 INTAKE



REF. NO.	PART NO.	DESCRIPTION	USA	GENE	JPN	REMARKS
28	97013-06020	BOLT	6	6	6	
29	92903-06600	WASHER, PLATE	6	6	6	
30	62T-13674-00	GASKET, AIR COOLER COVER 1	2	2	2	
31	62T-14255-00	PLATE	1	1	1	
32	97013-06012	BOLT	1	1	1	
33	92903-06600	WASHER, PLATE	1	1	1	
34	90109-06M66	BOLT	1	1	1	
35	90201-06M31	WASHER, PLATE	1	1	1	
36	62T-14451-00	ELEMENT, AIR CLEANER	2	2	2	
37	62T-14283-00	COVER, CARBURETOR 1	1	1	1	
38	62T-14419-00	PIPE	1	1	1	
39	90119-05M02	BOLT, WITH WASHER	6	6	6	
40	62T-14435-00	GROMMET	1	1	1	
41	93210-13M63	O-RING	1	1	1	

FIG. 4 CARBURETOR

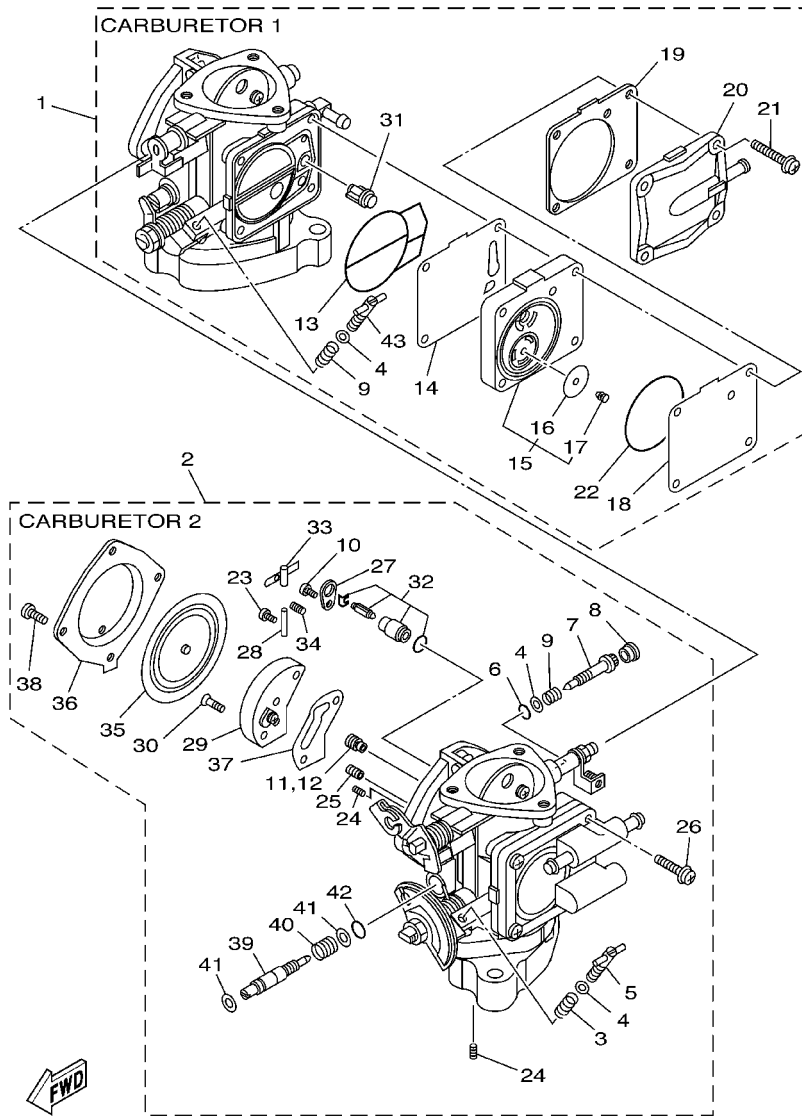

F0M5100-0040

REF. NO.	PART NO.	DESCRIPTION	USA	GENE	JPN	REMARKS
1	62T-14301-03	CARBURETOR ASSY 1	1	1	1	
2	62T-14302-03	CARBURETOR ASSY 2	1	1	1	
3	47X-14133-00	.SPRING, THROTTLE STOP	1	1	1	CARBURETOR 2
4	812-14235-00	.WASHER, NEEDLE	4	4	4	
5	6M6-14521-00	.SCREW, ADJUST	1	1	1	CARBURETOR 2
6	812-14147-00	.O-RING	2	2	2	
7	6K8-14946-10	.METERING NEEDLE	2	2	2	
8	6K8-14471-10	.CAP, CARBURETOR	2	2	2	
9	3KW-14932-00	.SPRING, THROTTLE 2	3	3	3	
10	6M6-14503-00	.SCREW	2	2	2	
11	3G2-14231-26	.JET, MAIN (#130)	1	1	1	CARBURETOR 1
12	3G2-14231-24	.JET, MAIN (#120)	1	1	1	CARBURETOR 2
13	6K8-14564-00	.O-RING	2	2	2	
14	6K8-24411-20	.DIAPHRAGM	1	1	1	CARBURETOR 1
15	6M6-24413-01	.BODY 2	1	1	1	CARBURETOR 1
16	65U-24421-00	..VALVE, CHECK	2	2	2	CARBURETOR 1
17	65U-24492-00	..BUSH, FULEL PUMP	2	2	2	CARBURETOR 1
18	6K8-24421-10	.VALVE, CHECK	1	1	1	CARBURETOR 1
19	6K8-24431-20	.GASKET, FUEL PUMP 1	1	1	1	CARBURETOR 1
20	6K8-24452-10	.COVER	1	1	1	UR CARBURETOR 1
	62T-14293-00	.COVER 1	1	1	1	UR CARBURETOR 2
21	97980-05330	.SCREW, WITH WASHER	4	4	4	CARBURETOR 1
22	6K8-14563-00	.O-RING	1	1	1	CARBURETOR 1
23	6K8-14503-02	.SCREW	2	2	2	
24	6K8-14521-10	.SCREW	4	4	4	
25	830-1423A-64	.JET, MAIN (# 67.5)	2	2	2	
26	98580-05018	.SCREW, PAN HEAD	4	4	4	CARBURETOR 2

FIG. 4 CARBURETOR

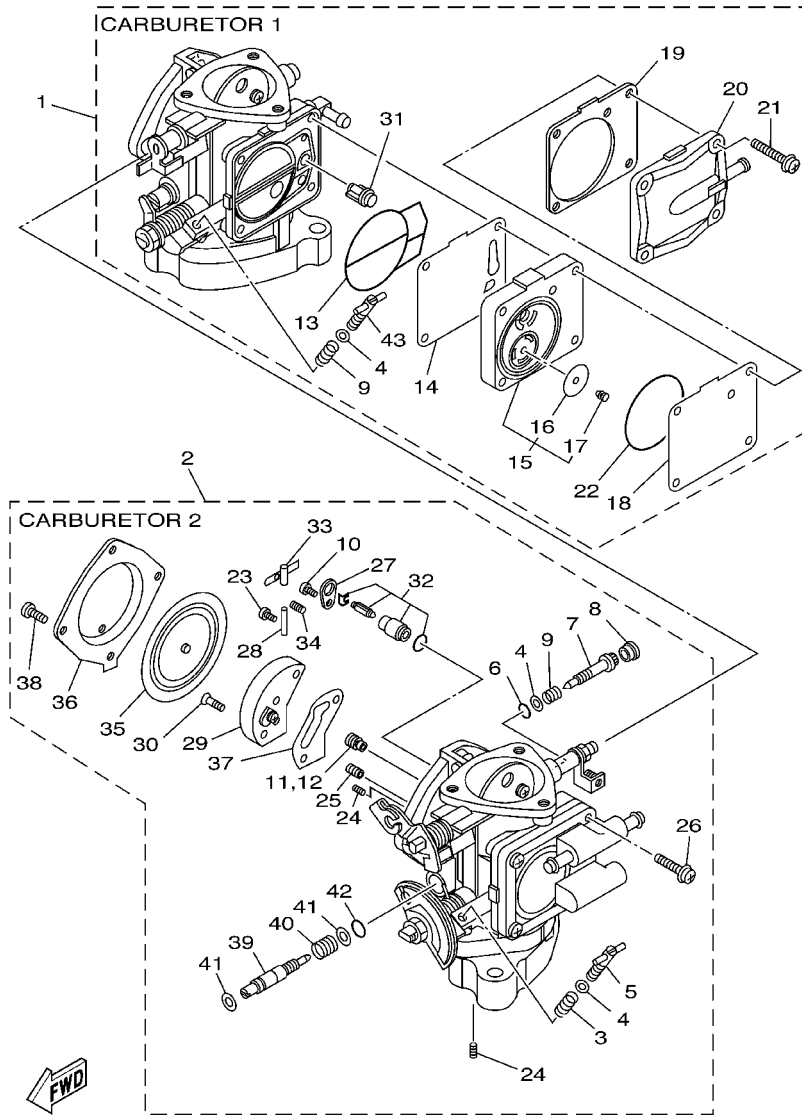

F0M5100-0040

REF. NO.	PART NO.	DESCRIPTION	USA	GENE	JPN	REMARKS
27	6K8-14527-11	.PLATE	2	2	2	
28	439-14186-00	.PIN, FLOAT	2	2	2	
29	6R7-24412-01	.BODY 1	2	2	2	
30	6K8-14523-11	.SCREW, STOP	4	4	4	
31	6R7-14569-00	.STRAINER	2	2	2	
32	61X-14916-16	.NEEDLE	2	2	2	
33	6K8-14547-01	.ARM, FLOAT	2	2	2	
34	6R7-14253-00	.SPRING	2	2	2	
35	6R7-14541-00	.DIAPHRAGM, PUMP	2	2	2	
36	6R7-14542-00	.BODY, PUMP 1	2	2	2	
37	6K8-14536-11	.GASKET	2	2	2	
38	97880-05012	.SCREW, PAN HEAD	8	8	8	
39	65U-14923-10	.SCREW, PILOT	2	2	2	
40	6K8-14589-00	.SPRING	2	2	2	
41	822-14235-00	.WASHER, NEEDLE	4	4	4	
42	583-14561-00	.O-RING	2	2	2	
43	6K8-14521-00	.SCREW, ADJUST	1	1	1	CARBURETOR 1

FIG. 5 OIL PUMP

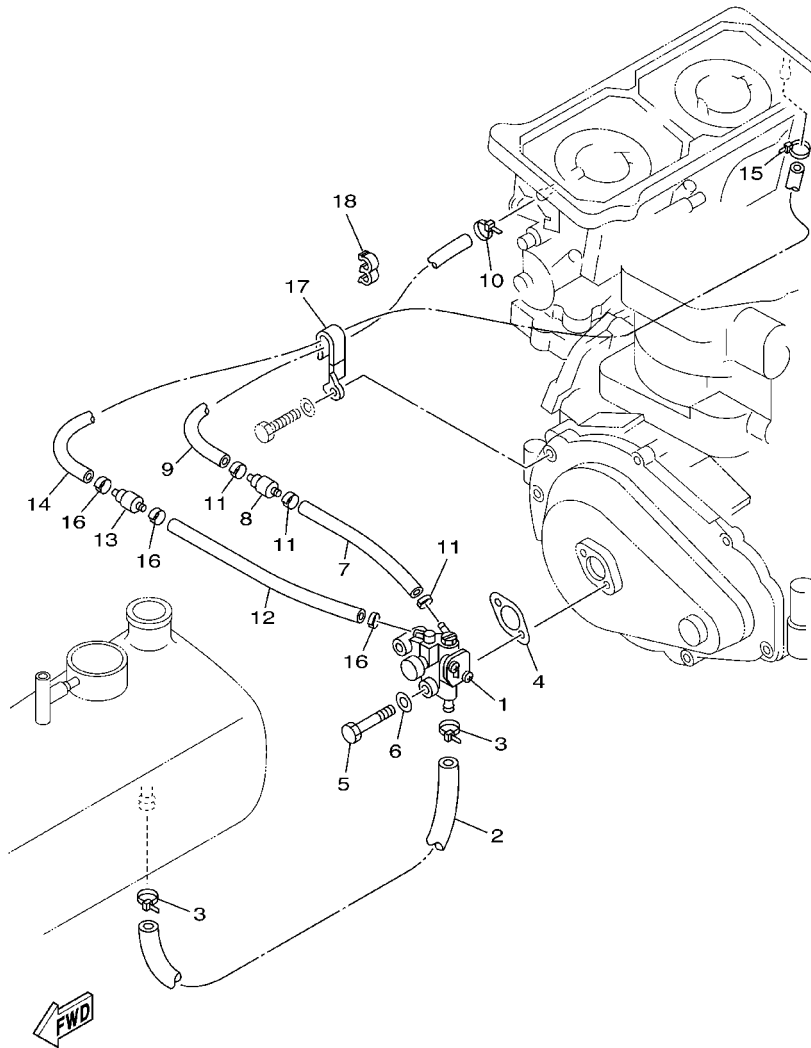

F0M9100-2051

REF. NO.	PART NO.	DESCRIPTION	USA	GENE	JPN	REMARKS
1	61X-13200-12	OIL INJECTION PUMP ASSY	1	1	1	
2	90445-11M34	HOSE (L480)	1	1	1	
3	90465-11M10	CLAMP	2	2	2	
4	6R8-13116-A0	GASKET, PUMP CASE	1	1	1	
5	97095-06035	BOLT	2	2	2	
6	92995-06600	WASHER	2	2	2	
7	90445-07009	HOSE	1	1	1	
8	67X-13183-00	VALVE, CHECK	1	1	1	
9	90446-07M18	HOSE	1	1	1	
10	90465-11M10	CLAMP	1	1	1	
11	90468-02001	CLIP	3	3	3	
12	90445-07008	HOSE	1	1	1	
13	67X-13183-00	VALVE, CHECK	1	1	1	
14	90446-07M48	HOSE	1	1	1	
15	90465-11M10	CLAMP	1	1	1	
16	90468-02001	CLIP	3	3	3	
17	90465-08M69	CLAMP	1	1	1	
18	90464-10M38	CLAMP	2	2	2	

FIG. 6 EXHAUST 1

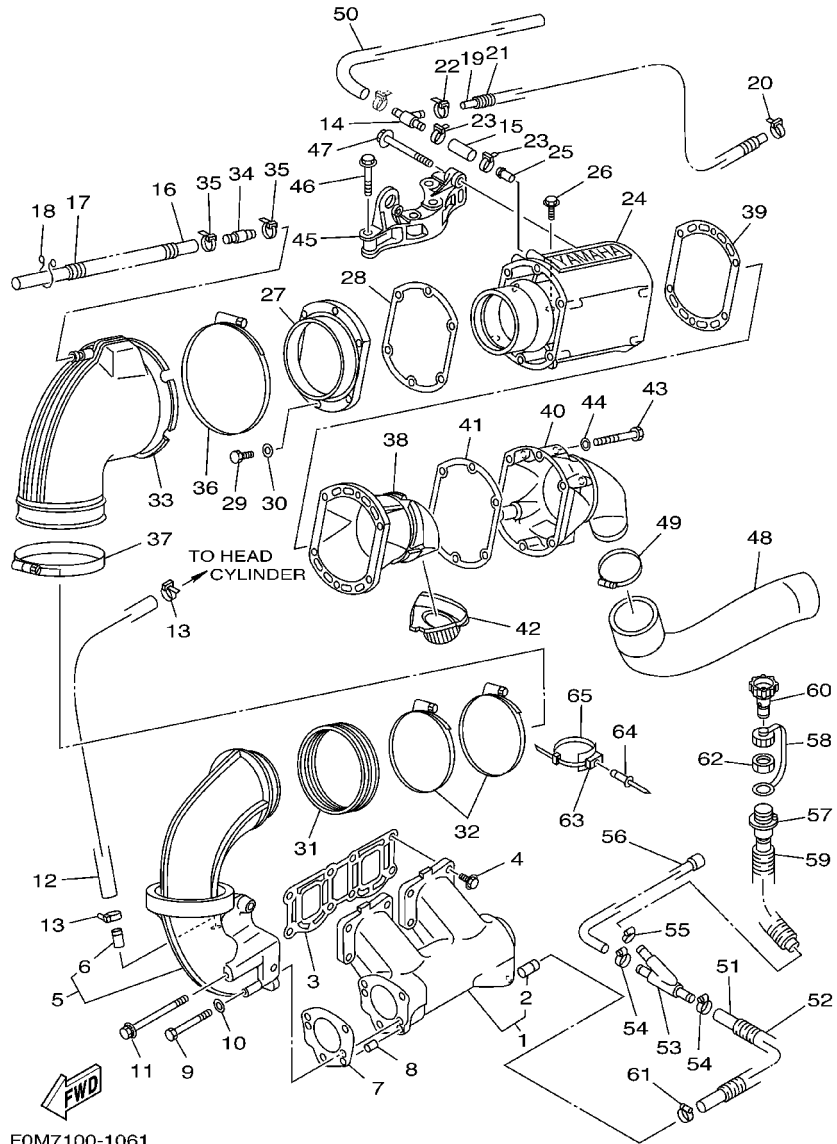

FOM7100-1061

REF. NO.	PART NO.	DESCRIPTION	USA	GENE	JPN	REMARKS
1	62T-14711-10-9P	MUFFLER 1	1	1	1	
2	6K8-51129-00	.NIPPLE	1	1	1	
3	62T-14613-00	GASKET, EXHAUST PIPE	1	1	1	
4	90105-10M60	BOLT, FLANGE	8	8	8	
5	62T-14712-00-9P	RING, JOINT	1	1	1	
6	6K8-51129-00	.NIPPLE	1	1	1	
7	62T-14749-00	GASKET, MUFFLER DAMPER 2	1	1	1	
8	93605-12M21	PIN, DOWEL	2	2	2	
9	97013-08075	BOLT	2	2	2	
10	92903-08600	WASHER, PLATE	2	2	2	
11	90119-08M11	BOLT, WITH WASHER	2	2	2	
12	90445-14M24	HOSE (L260)	1	1	1	
13	90465-11M10	CLAMP	2	2	2	
14	63N-24378-00	PIPE, JOINT 4	1	1	1	
15	90445-21M02	HOSE (L50)	1	1	1	
16	90445-14M21	HOSE (L890)	1	1	1	
17	90446-20M31	HOSE	1	1	1	
18	90464-15M11	CLAMP	1	1	1	
19	90445-14M25	HOSE (L380)	1	1	1	
20	90465-11M10	CLAMP	1	1	1	
21	90446-20M31	HOSE	1	1	1	
22	90465-11M10	CLAMP	1	1	1	
23	90465-11M59	CLAMP	2	2	2	
24	62T-14721-00-94	MUFFLER 2	1	1	1	
25	62T-14485-10	PIPE, JOINT	1	1	1	
26	90105-10M60	BOLT, FLANGE	2	2	2	
27	62T-41113-00-9M	OUTER COVER, EXHAUST	1	1	1	

FIG. 6 EXHAUST 1

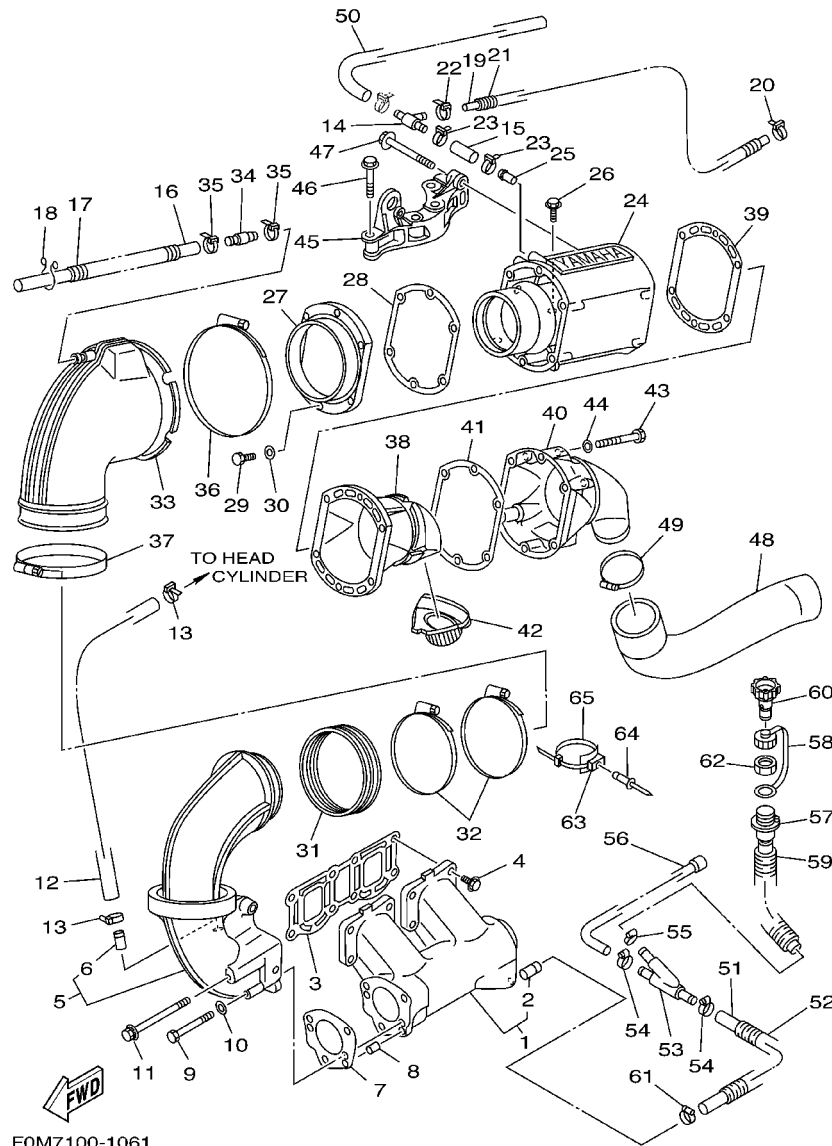

FOM7100-1061

REF. NO.	PART NO.	DESCRIPTION	USA	GENE	JPN	REMARKS
28	62T-41114-01	GASKET, EXHAUST OUTER COVER	1	1	1	
29	97013-06025	BOLT	6	6	6	
30	92903-06600	WASHER, PLATE	6	6	6	
31	62T-14625-00	JOINT, EXHAUST 2	1	1	1	
32	90450-99M06	HOSE CLAMP ASSY	2	2	2	
33	62T-14615-01	JOINT, EXHAUST 1	1	1	1	
34	6R3-24377-00	PIPE, JOINT 3	1	1	1	
35	90465-11M10	CLAMP	2	2	2	
36	90450-99M01	HOSE CLAMP ASSY	1	1	1	
37	90450-99M02	HOSE CLAMP ASSY	1	1	1	
38	62T-41121-00-9M	INNER COVER, EXHAUST	1	1	1	
39	62T-41122-00	GASKET, EXHAUST INNER COVER	1	1	1	
40	62T-41123-01-9M	OUTER COVER, EXHAUST	1	1	1	
41	62T-41124-00	GASKET, EXHAUST OUTER COVER	1	1	1	
42	63N-15761-00	SEAL, RUBBER 1	1	1	1	
43	97013-06070	BOLT	6	6	6	
44	92903-06600	WASHER, PLATE	6	6	6	
45	62T-14771-00-94	STAY, MUFFLER 1	1	1	1	
46	90119-10M17	BOLT, WITH WASHER	4	4	4	
47	90105-10M88	BOLT, FLANGE	2	2	2	
48	63N-14752-30	PIPE, OUTLET	1	1	1	
49	90450-70M03	HOSE CLAMP ASSY	1	1	1	
50	90445-21M00	HOSE (L1390)	1	1	1	
51	90445-14M10	HOSE (L500)	1	1	1	
52	90446-20M65	HOSE	1	1	1	
53	64X-12581-00	JOINT, HOSE 1	1	1	1	
54	90450-14M05	HOSE CLAMP ASSY	2	2	2	

FIG. 7 FUEL

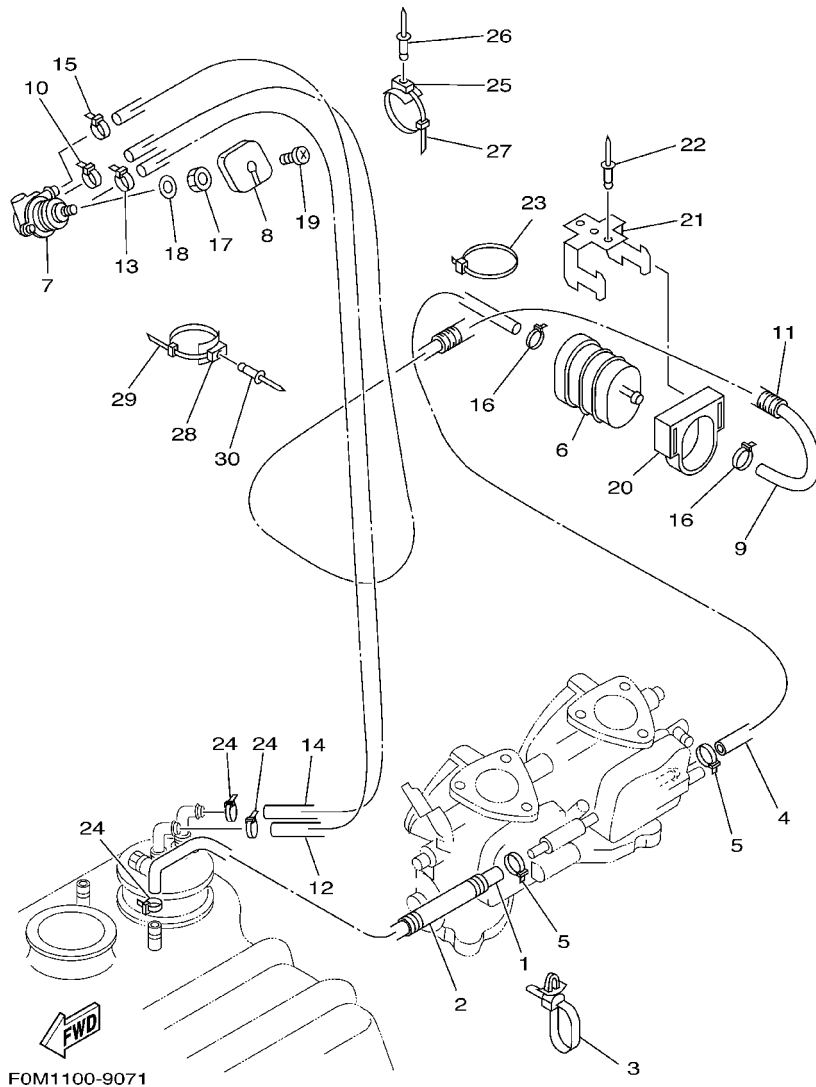

REF. NO.	PART NO.	DESCRIPTION	USA	GENE	JPN	REMARKS
1	90445-10MA1	HOSE (L910)	1	1	1	
2	90446-14M61	HOSE	1	1	1	
3	90465-12M56	CLAMP	1	1	1	
4	90445-10MG0	HOSE (L505)	1	1	1	
5	90465-11M10	CLAMP	2	2	2	
6	6K8-24560-10	FILTER ASSY	1	1	1	
7	65U-24500-01	FUEL COCK ASSY 1	1	1	1	
8	6R7-24524-00	LEVER, COCK	1	1	1	
9	90445-10MG2	HOSE (L1400)	1	1	1	
10	90465-11M10	CLAMP	1	1	1	
11	90446-14M62	HOSE	1	1	1	
12	90445-10MG1	HOSE (L600)	1	1	1	
13	90465-11M10	CLAMP	1	1	1	
14	90445-10MG3	HOSE (L600)	1	1	1	
15	90465-11M10	CLAMP	1	1	1	
16	90465-11829	CLAMP	2	2	2	YMUS
17	90170-22187	NUT	1	1	1	
18	90202-229U1	WASHER, PLATE	1	1	1	YMUS
19	98980-04008	SCREW, BIND	1	1	1	
20	EU0-67817-00	HOLDER	1	1	1	
21	EU0-67816-30	BRACKET, FUEL FILTER	1	1	1	
22	90267-489U1	RIVET,BLIND	2	2	2	YMUS
23	90464-32801	CLAMP	1	1	1	YMUS
24	90465-11829	CLAMP	3	3	3	YMUS
25	90600-91736	CLAMP COMP.	6	6	6	
26	90267-48802	RIVET, BLIND	6	6	6	YMUS
27	90464-32801	CLAMP	6	6	6	YMUS

FIG. 7 FUEL

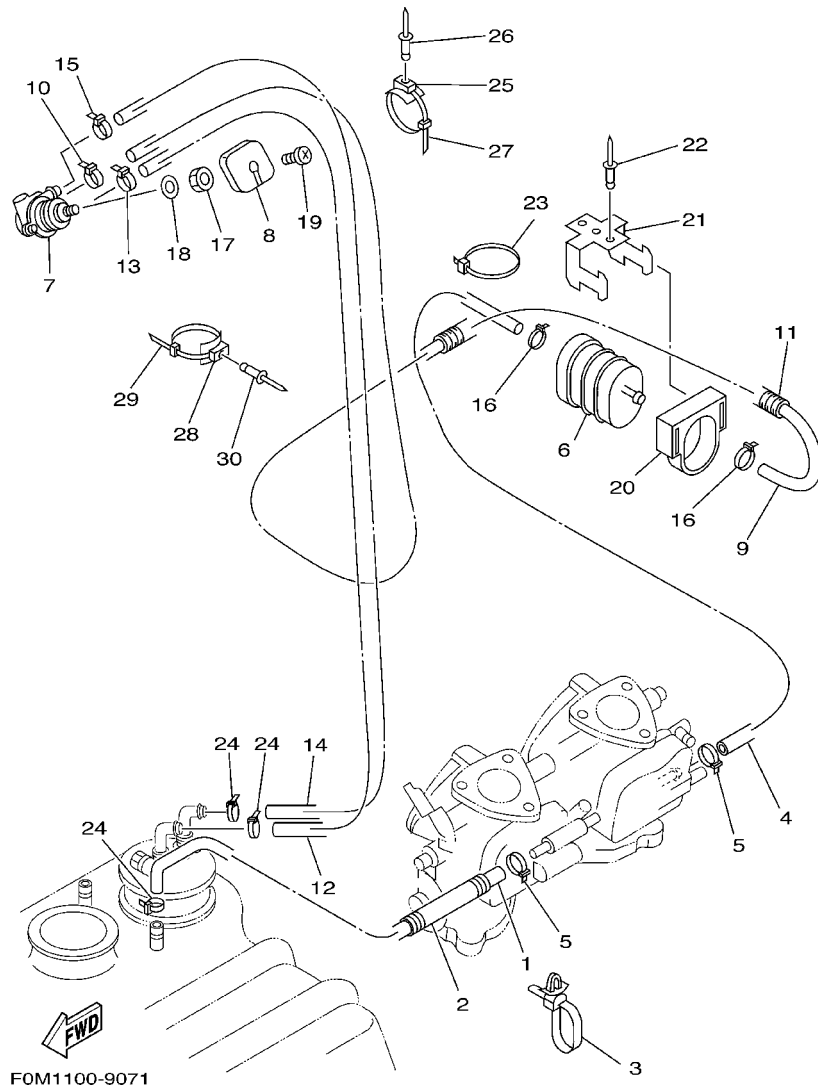

REF. NO.	PART NO.	DESCRIPTION	USA	GENE	JPN	REMARKS
28	90600-91736	CLAMP COMP.	1	1	1	
29	90464-32801	CLAMP	1	1	1	YMUS
30	90267-48802	RIVET, BLIND	1	1	1	YMUS

FIG. 8 JET UNIT 1

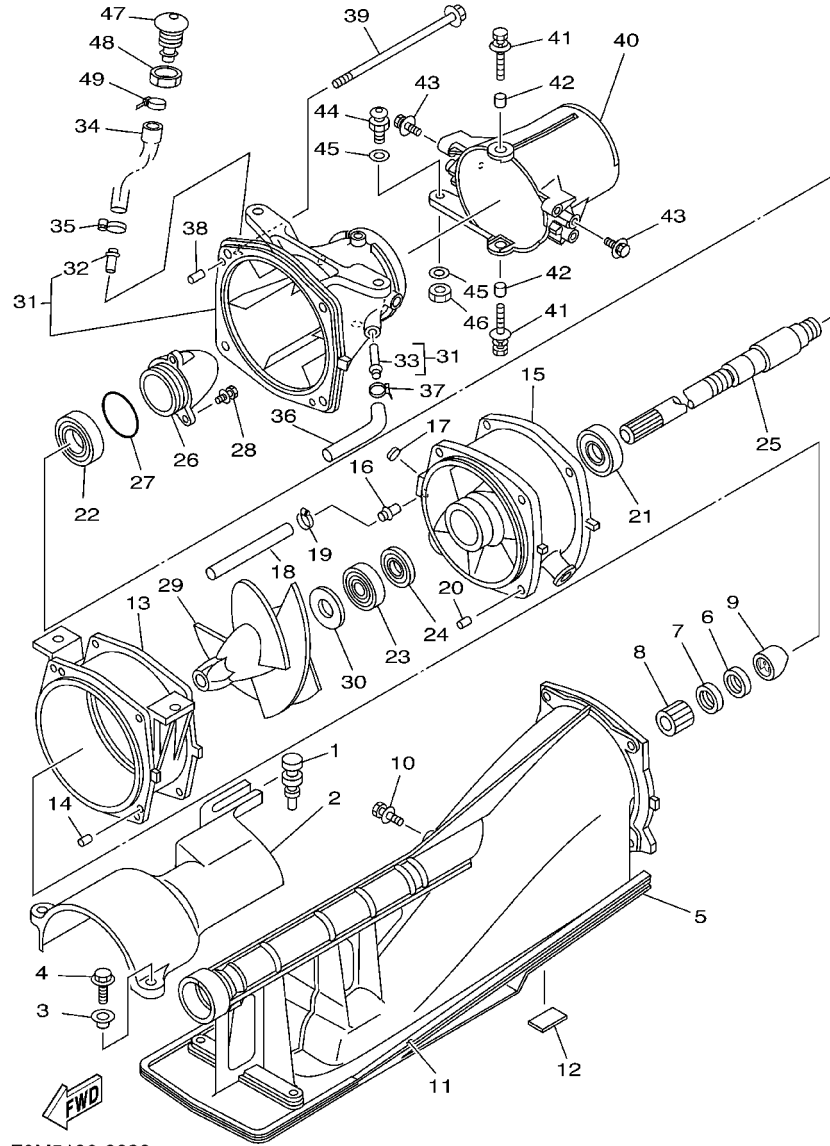

FOM5100-0080

REF. NO.	PART NO.	DESCRIPTION	USA	GENE	JPN	REMARKS
1	90480-06M46	GROMMET	1	1	1	
2	65R-R1381-00	COVER	1	1	1	YMUS
3	90387-06M60	COLLAR	2	2	2	
4	90119-069UD	BOLT, WITH WASHER	2	2	2	YMUS
5	65U-R1311-00	DUCT, INTAKE	1	1	1	YMUS
6	93102-17M49	OIL SEAL	1	1	1	
7	93102-17M50	OIL SEAL	1	1	1	
8	65V-45318-00	BUSHING, DRIVE SHAFT	1	1	1	
9	65U-R1348-01	SPACER	1	1	1	YMUS
10	90119-069UD	BOLT, WITH WASHER	1	1	1	YMUS
11	6R8-51367-01	FELT, PACKING	2	2	2	
12	63M-51368-00	FELT, PACKING	2	2	2	
13	63M-51312-02-94	HOUSING, IMPELLER	1	1	1	
14	93606-12019	PIN, DOWEL	2	2	2	
15	63M-51315-02-94	DUCT, IMPELLER	1	1	1	
16	65A-R1129-10	NIPPLE	1	1	1	YMUS
17	90331-12M05	PLUG	1	1	1	
18	90445-18M03	HOSE (L108)	1	1	1	
19	90601-118UF	BAND, HOSE 18	1	1	1	YMUS
20	93606-12019	PIN, DOWEL	2	2	2	
21	93305-205U1	BEARING	1	1	1	
22	93306-205U0	BEARING	1	1	1	
23	93102-25M34	OIL SEAL	1	1	1	
24	93101-25M50	OIL SEAL	1	1	1	
25	65R-45511-00	SHAFT, DRIVE	1	1	1	
26	65A-R1326-00	CAP	1	1	1	YMUS
27	93210-46M16	O-RING	1	1	1	

FIG. 8 JET UNIT 1

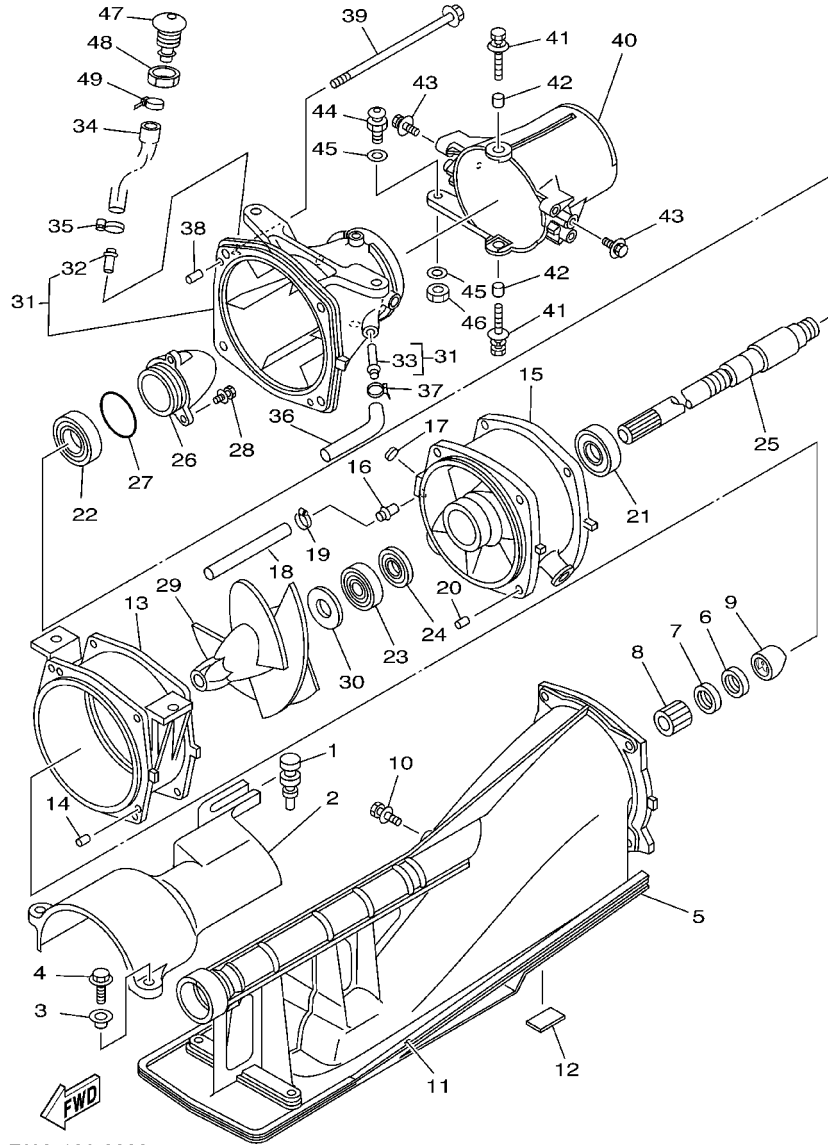

FOM5100-0080

REF. NO.	PART NO.	DESCRIPTION	USA	GENE	JPN	REMARKS
28	90119-069UB	BOLT, WITH WASHER	3	3	3	YMUS
29	65R-R1321-10	IMPELLER	1	1	1	YMUS
30	62T-51348-00	SPACER	1	1	1	
31	65R-R1318-00	NOZZLE	1	1	1	YMUS
32	65A-R1129-00	.NIPPLE	1	1	1	YMUS
33	65A-R1334-01	.NIPPLE,HOSE	1	1	1	YMUS
34	62E-51673-00	PIPE 1	1	1	1	
35	90601-118UF	BAND, HOSE 18	1	1	1	YMUS
36	90445-14898	HOSE (L270)	1	1	1	YMUS
37	90465-11829	CLAMP	1	1	1	YMUS
38	93606-12019	PIN, DOWEL	2	2	2	
39	90105-089U1	BOLT, FLANGE	4	4	4	YMUS
40	65R-R1313-01	NOZZLE,DEFLECTOR	1	1	1	YMUS
41	90119-089UE	BOLT, WITH WASHER	2	2	2	YMUS
42	90387-08M08	COLLAR	2	2	2	
43	90119-089UE	BOLT, WITH WASHER	2	2	2	YMUS
44	GH3-U146E-00	STUD, JOINT BALL	1	1	1	YMUS
45	90201-068M4	WASHER, PLATE	2	2	2	YMUS
46	9538R-06700	NUT	1	1	1	YMUS
47	FN8-6269B-00	SPOUT	1	1	1	
48	EU0-61652-00	NUT	1	1	1	
49	90600-91755	CLIP	1	1	1	

FIG. 9 JET UNIT 2

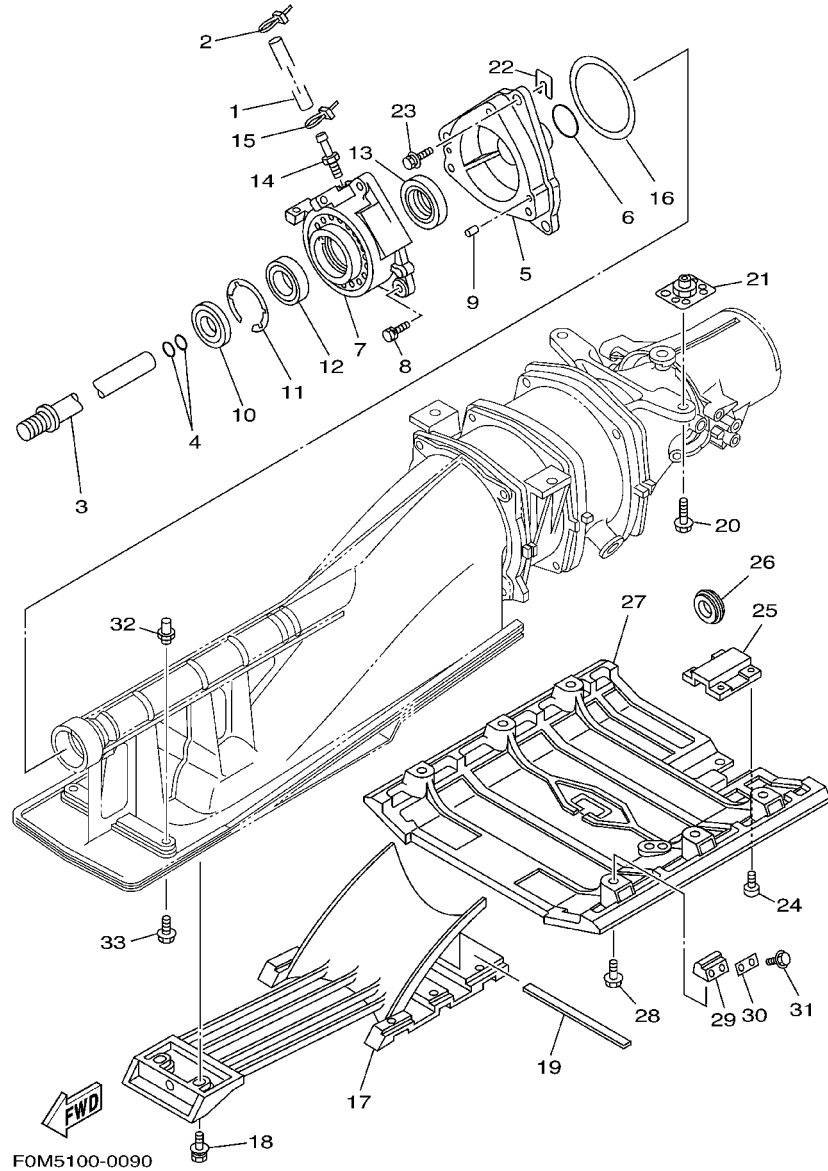

REF. NO.	PART NO.	DESCRIPTION	USA	GENE	JPN	REMARKS
1	90445-09M21	HOSE (L445)	1	1	1	
2	90465-11M10	CLAMP	1	1	1	
3	63N-51323-10	SHAFT, COUPLOR	1	1	1	
4	93210-17MA4	O-RING	2	2	2	
5	65A-G5331-00	HOUSING, BEARING	1	1	1	YMUS
6	93210-35M72	O-RING	1	1	1	
7	65U-45332-02-94	HOUSING, BEARING	1	1	1	
8	90119-089UF	BOLT, WITH WASHER	3	3	3	YMUS
9	93606-12019	PIN, DOWEL	2	2	2	
10	93101-25M55	OIL SEAL	1	1	1	
11	93430-47M04	CIRCLIP	1	1	1	
12	93306-205U6	BEARING	1	1	1	
13	93101-25M56	OIL SEAL	1	1	1	
14	61L-45378-00	NIPPLE, HOSE	1	1	1	
15	90465-11829	CLAMP	1	1	1	YMUS
16	6K8-45127-00	SEAL	1	1	1	
17	65R-R1333-00	SCREEN, INTAKE	1	1	1	YMUS
18	90119-069UC	BOLT, WITH WASHER	8	8	8	YMUS
19	63M-51367-00	FELT, PACKING	1	1	1	
20	90119-109U8	BOLT, WITH WASHER	4	4	4	YMUS
21	90179-10800	NUT	4	4	4	YMUS
22	GD0-U7249-00-05	SHIM (T=0.5)	2	2	2	UR, YMUS
	GD0-U7249-00-10	SHIM (T=1.0)	2	2	2	UR, YMUS
23	90119-089UL	BOLT, WITH WASHER	3	3	3	YMUS
24	90149-05904	SCREW	4	4	4	
25	GT3-6273C-00	COVER, PLATE	1	1	1	
26	GJ8-60469-01	CAP	1	1	1	

FIG. 9 JET UNIT 2

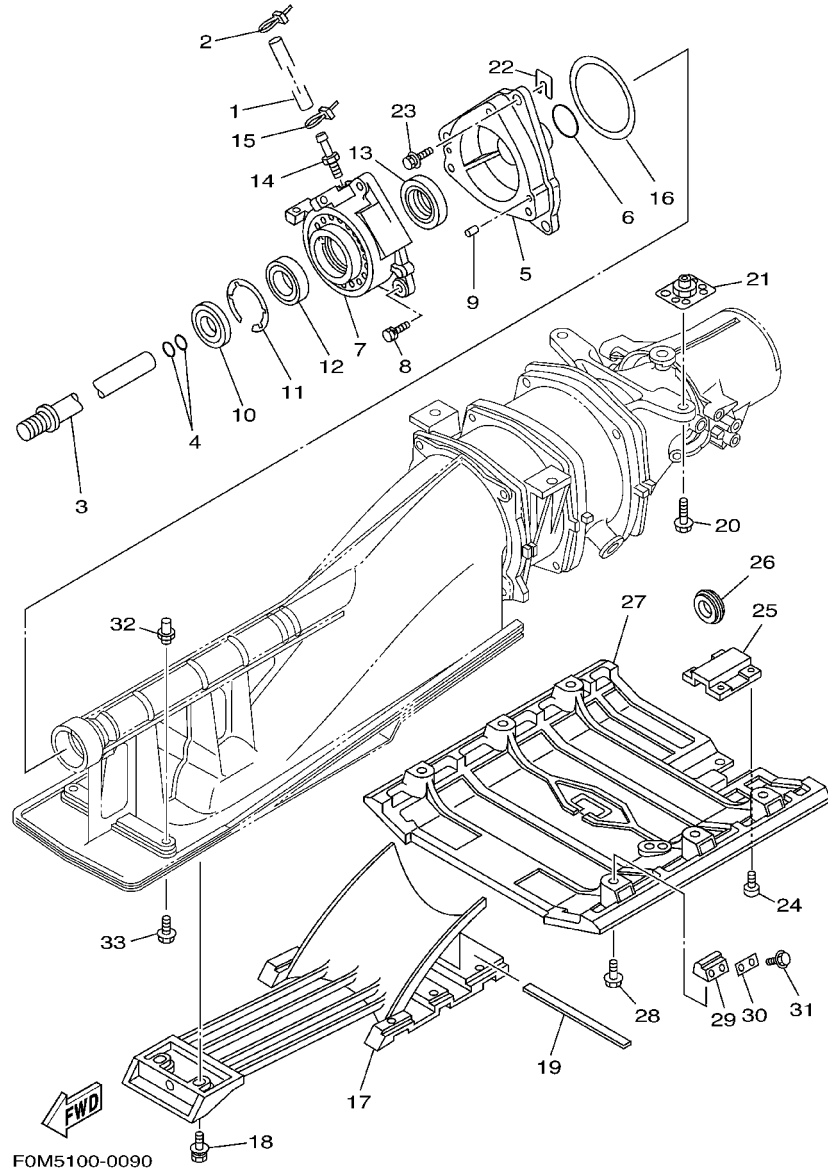

REF. NO.	PART NO.	DESCRIPTION	USA	GENE	JPN	REMARKS
27	GJ3-U273B-00	PLATE 2	1	1	1	YMUS
28	90119-089U6	BOLT, WITH WASHER	6	6	6	YMUS
29	GJ1-62733-00	PACKING	6	6	6	
30	GJ1-62663-00	PACKING 1	6	6	6	
31	90119-089U5	BOLT, WITH WASHER	12	12	12	YMUS
32	90179-06811	NUT	2	2	2	YMUS
33	90119-069UK	BOLT, WITH WASHER	2	2	2	YMUS

FIG. 10 GENERATOR

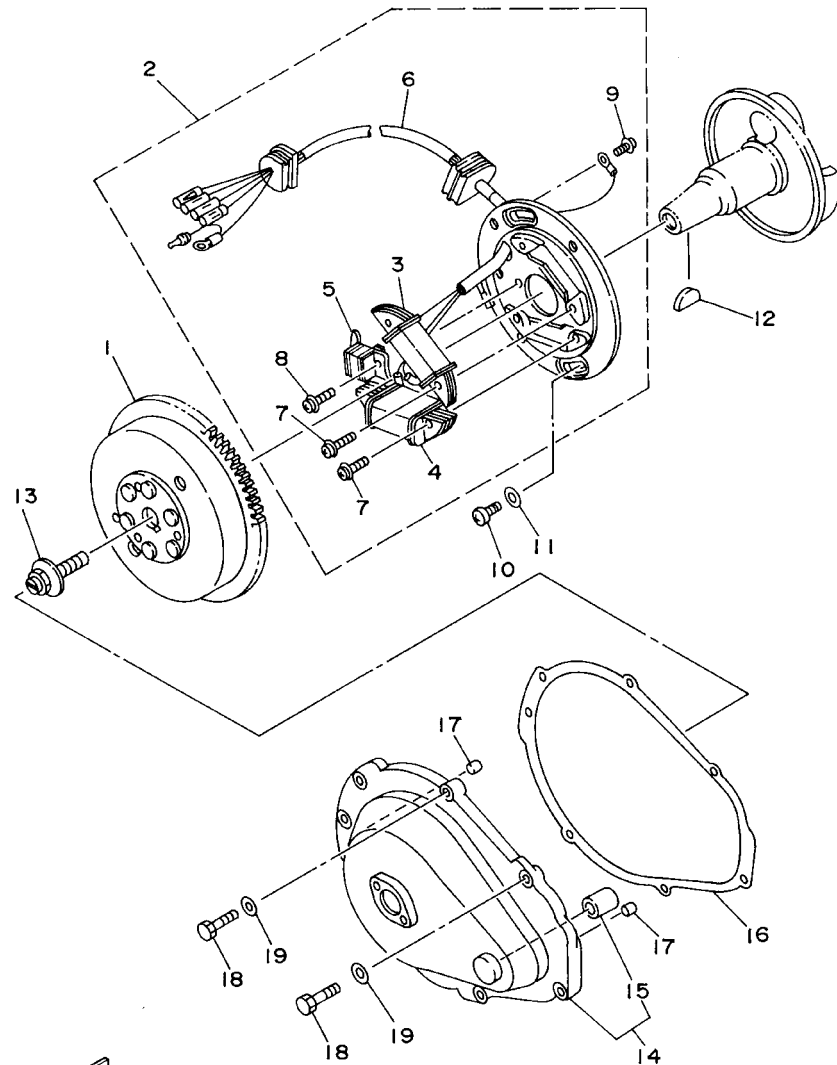

GHI4010-4100

REF. NO.	PART NO.	DESCRIPTION	USA	GENE	JPN	REMARKS
1	62T-85550-00	ROTOR ASSY	1	1	1	
2	62T-85560-00	BASE ASSY	1	1	1	
3	62T-85520-00	.COIL, CHARGE	1	1	1	
4	62T-85533-00	.COIL, LIGHTING	1	1	1	
5	6M6-85580-00	.COIL, PULSER	1	1	1	
6	62T-85515-00	.LEAD WIRE ASSY	1	1	1	
7	97902-05125	.SCREW, WITH WASHER	4	4	4	
8	97902-04122	.SCREW, WITH WASHER	2	2	2	
9	97802-04008	.SCREW, PAN HEAD	1	1	1	
10	97880-06016	SCREW, PAN HEAD	2	2	2	
11	92990-06600	WASHER, PLATE	2	2	2	
12	90280-05013	KEY, WOODRUFF	1	1	1	
13	90109-10M47	BOLT	1	1	1	
14	6R8-81337-00-8P	COVER, FLYWHEEL	1	1	1	
15	90380-12M29	.BUSH, SOLID	1	1	1	
16	6M6-81365-A0	GASKET, HOLE COVER	1	1	1	
17	93606-12019	PIN, DOWEL	2	2	2	
18	97095-06025	BOLT	7	7	7	
19	92995-06600	WASHER	7	7	7	

FIG. 11 STARTING MOTOR

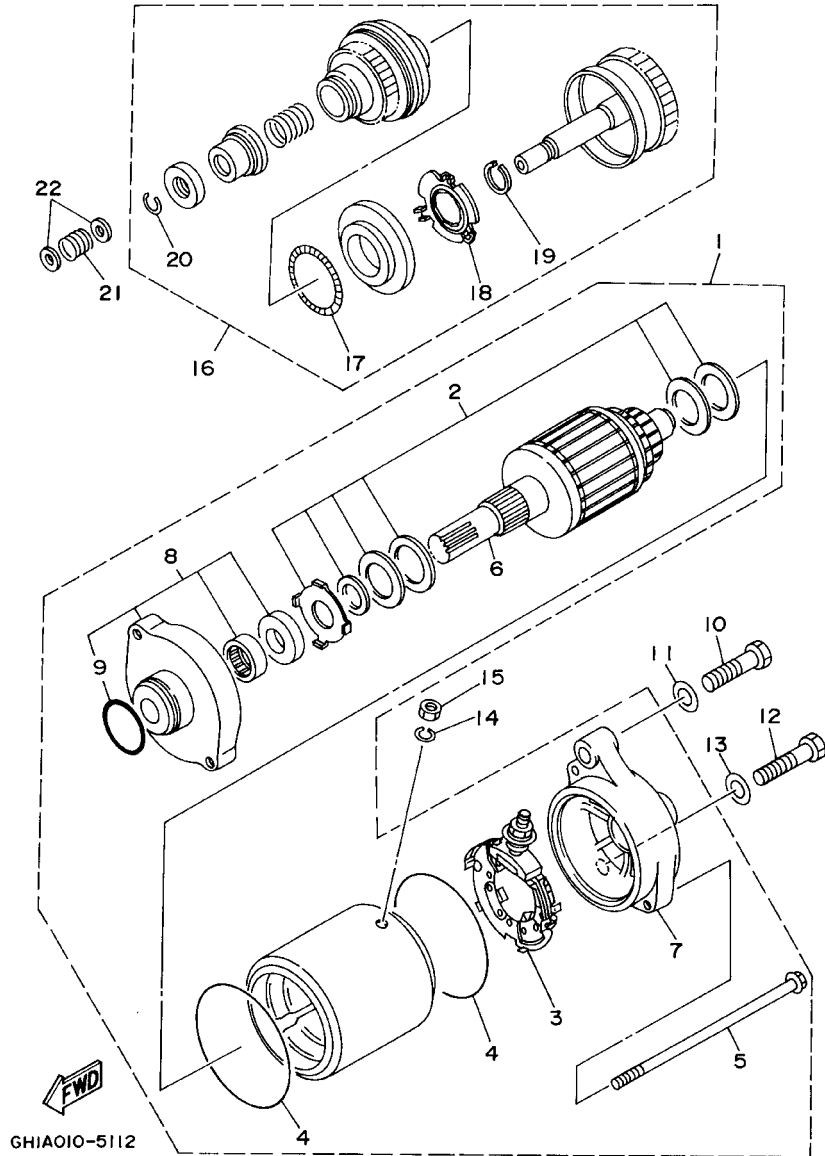

REF. NO.	PART NO.	DESCRIPTION	USA	GENE	JPN	REMARKS
1	6M6-81800-10	STARTING MOTOR ASSY	1	1	1	
2	3AJ-81809-00	.WASHER KIT	1	1	1	
3	6M6-81840-10	.BRUSH HOLDER ASSY	1	1	1	
4	11H-81844-00	.GASKET	2	2	2	
5	6M6-81826-00	.BOLT	2	2	2	
6	6M6-81850-00	.ARMATURE ASSY	1	1	1	
7	6M6-81820-00	.REAR BRACKET ASSY	1	1	1	
8	6M6-81830-00	.FRONT BRACKET ASSY	1	1	1	
9	26H-81847-00	.O-RING	1	1	1	
10	97013-08040	BOLT	1	1	1	
11	92903-08600	WASHER, PLATE	1	1	1	
12	97013-08035	BOLT	1	1	1	
13	92903-08600	WASHER, PLATE	1	1	1	
14	92990-06100	WASHER, SPRING	1	1	1	
15	95380-06700	NUT	1	1	1	
16	6M6-8183E-01	IDLE GEAR COMP.	1	1	1	
17	6M6-81866-00	.WEIGHT SPRING	1	1	1	
18	6M6-81865-00	.WEIGHT HOLDER	1	1	1	
19	93440-25M08	.CIRCLIP	1	1	1	
20	93450-18M06	.CIRCLIP	1	1	1	
21	90501-14M73	SPRING, COMPRESSION	1	1	1	
22	92903-06600	WASHER, PLATE	2	2	2	

FIG. 12 ELECTRICAL 1

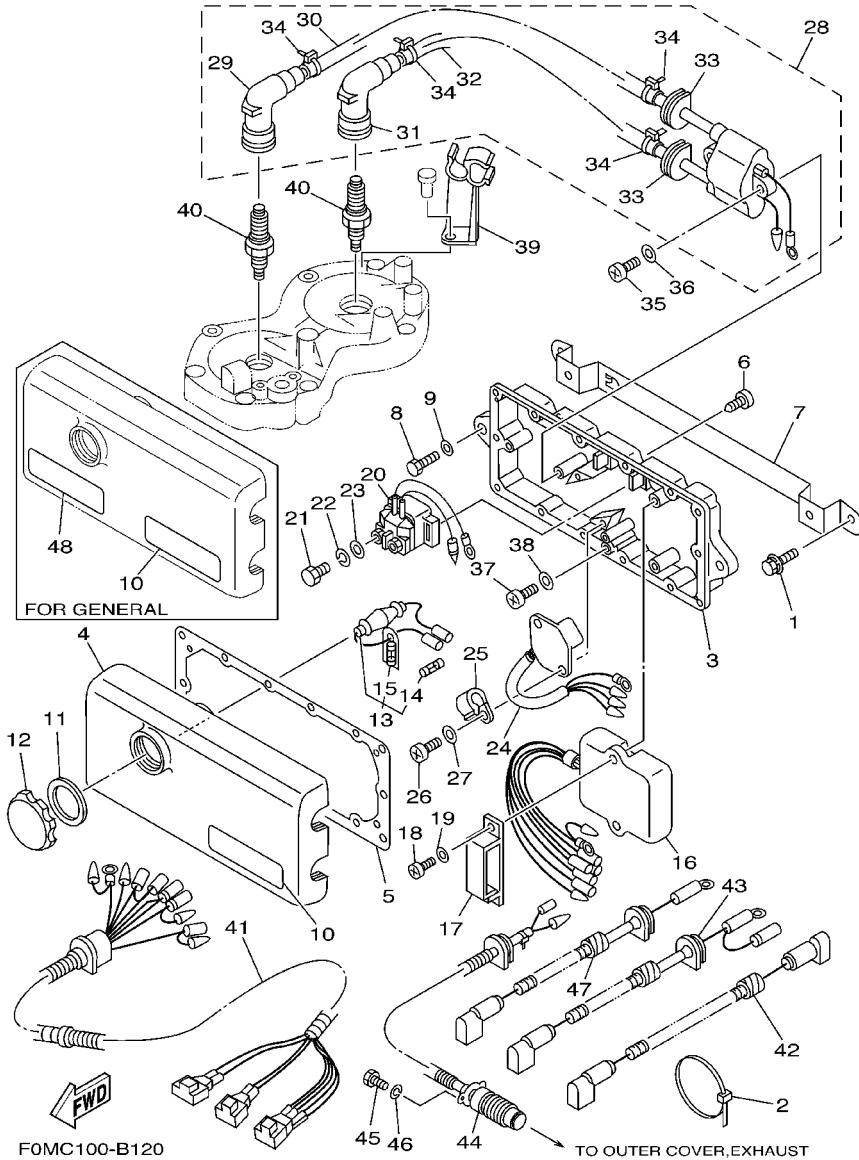

REF. NO.	PART NO.	DESCRIPTION	USA	GENE	JPN	REMARKS
1	90119-089U7	BOLT, WITH WASHER	2	2	2	YMUS
2	90601-20009	BAND	2	2	2	
3	62L-8552A-00-8P	HOUSING	1	1	1	
4	6M6-8552E-01	COVER, CASE	1	1	1	
5	6M6-81921-00	GASKET, TERMINAL	1	1	1	
6	97780-60525	SCREW, TAPPING	14	14	14	
7	66D-85542-00	BRACKET	1	1	1	
8	97095-08025	BOLT	2	2	2	
9	92995-08600	WASHER	2	2	2	
10	6R7-83623-40	MARK 3	1	1		FOR USA,GENE
	63N-83623-00	MARK 3			1	FOR JPN
11	6M6-81844-00	GASKET	1	1	1	
12	6M6-8132W-00	CAP	1	1	1	
13	6K8-82150-01	FUSE HOLDER ASSY	1	1	1	
14	6G1-82151-00	.FUSE (10A)	1	1	1	
15	6K8-82159-00	.FUSE SPEAR (10A)	1	1	1	
16	62T-85540-01	C.D.I. UNIT ASSY	1	1	1	
17	90464-06M29	CLAMP	1	1	1	
18	97880-06016	SCREW, PAN HEAD	2	2	2	
19	92990-06600	WASHER, PLATE	2	2	2	
20	68N-81940-00	STARTER RELAY ASSY	1	1	1	
21	97095-06010	BOLT	2	2	2	
22	92995-06100	WASHER, SPRING	2	2	2	
23	92995-06600	WASHER	2	2	2	
24	6M6-81960-A0	RECTIFIER & REGULATOR ASSY	1	1	1	
25	90465-06M86	CLAMP	1	1	1	
26	97880-06016	SCREW, PAN HEAD	2	2	2	

FIG. 12 ELECTRICAL 1

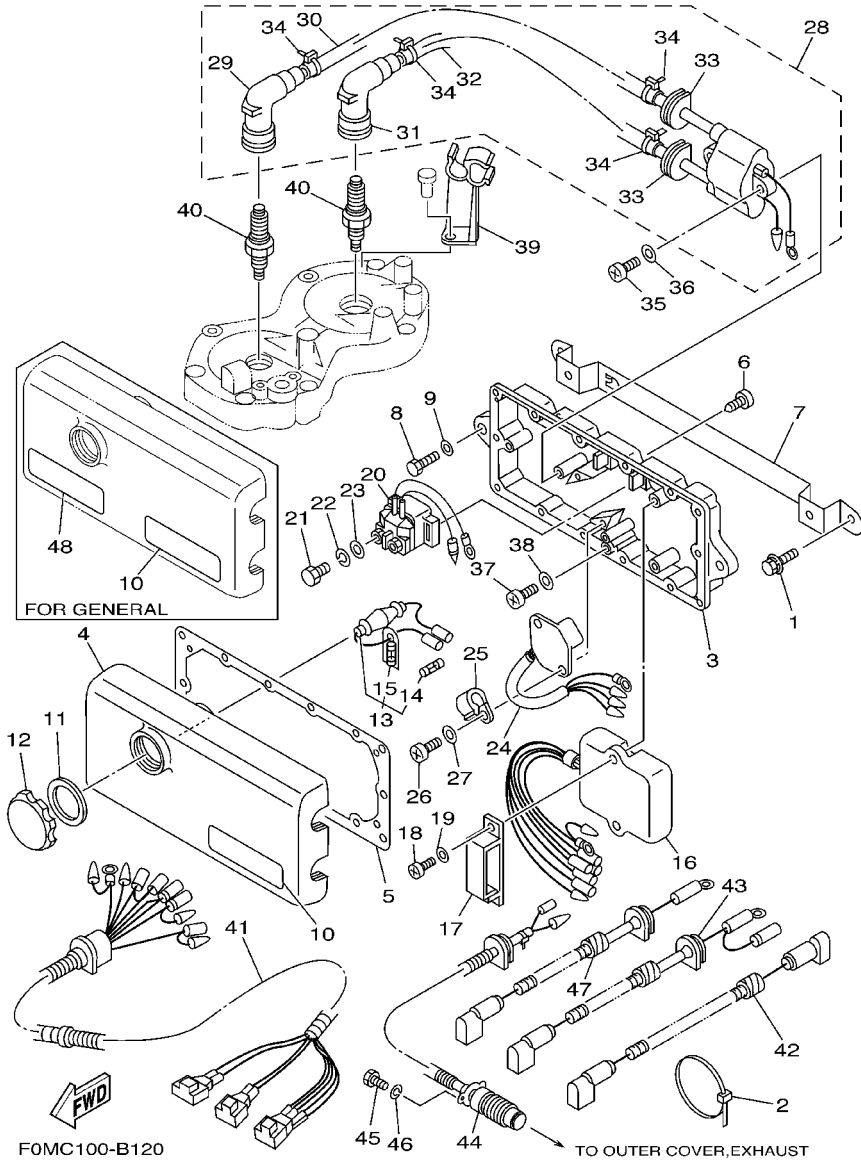

REF. NO.	PART NO.	DESCRIPTION	USA	GENE	JPN	REMARKS
27	92990-06600	WASHER, PLATE	2	2	2	
28	62E-85570-11	IGNITION COIL ASSY	1	1	1	
29	62E-82371-11	.CAP, PLUG	1	1	1	
30	62E-82351-01	.TUBE, CORD	1	1	1	
31	62E-82371-11	.CAP, PLUG	1	1	1	
32	62E-82352-01	.TUBE, CORD 2	1	1	1	
33	90480-06M43	.GROMMET	2	2	2	
34	90465-11M10	.CLAMP	4	4	4	
35	97880-06030	SCREW, PAN HEAD	2	2	2	
36	92990-06600	WASHER, PLATE	2	2	2	
37	97880-06016	SCREW, PAN HEAD	2	2	2	
38	92990-06600	WASHER, PLATE	2	2	2	
39	62T-82361-00	CLAMP, CORD	1	1	1	
40	94702-00195	PLUG, SPARK (NGK BR8HS)	2	2		FOR USA, GENE
	94709-00195	PLUG, SPARK(51X) NGK BR8HS			2	FOR JPN
41	63N-82553-00	EXTENSION, WIRE LEAD	1	1	1	
42	63N-82117-00	WIRE, LEAD	1	1	1	
43	63N-82117-10	WIRE, LEAD	1	1	1	
44	62T-82560-10	THERMO SWITCH ASSY	1	1	1	
45	97095-06016	BOLT	2	2	2	
46	92995-06100	WASHER, SPRING	2	2	2	
47	62L-82117-20	WIRE, LEAD	1	1	1	
48	6R7-83623-50	MARK 3		1		FOR GENE

FIG. 13 ELECTRICAL 2

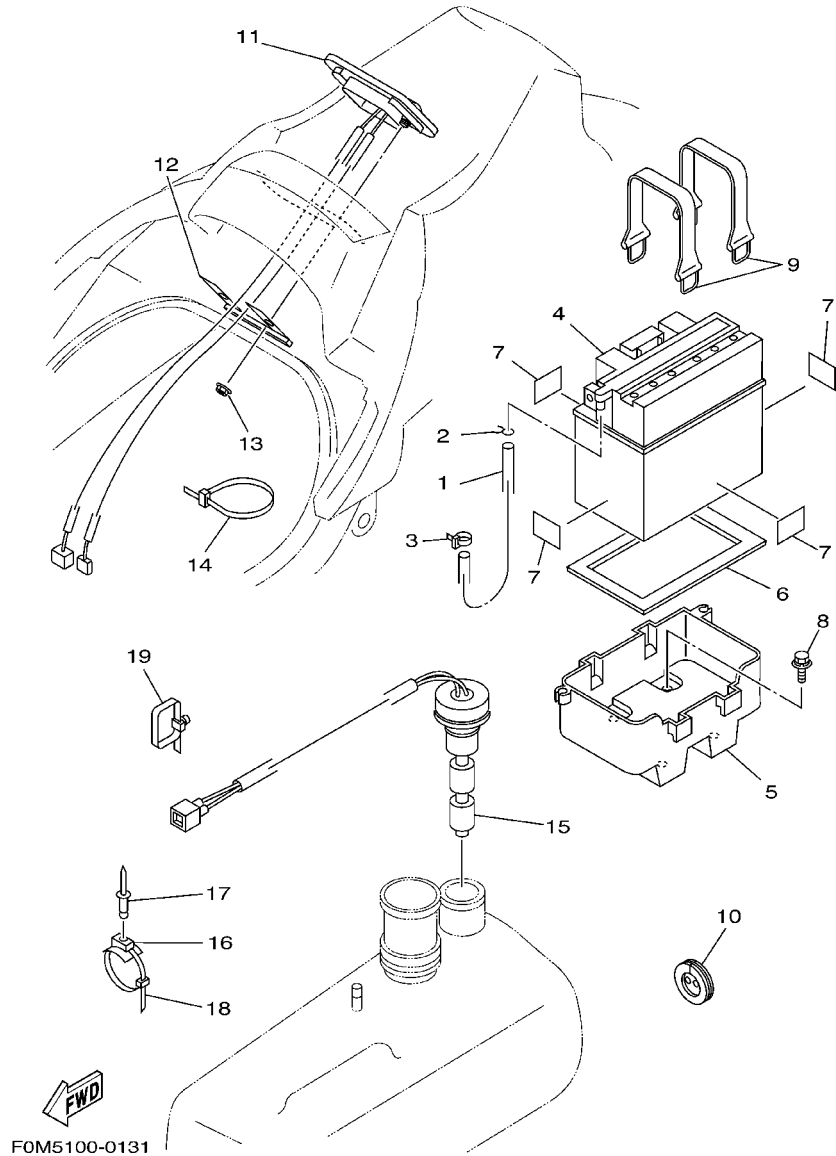

REF. NO.	PART NO.	DESCRIPTION	USA	GENE	JPN	REMARKS
1	EU0-U7856-50	HOSE, AIR VENT 3	1	1	1	YMUS
2	90467-089U1	CLIP	1	1	1	YMUS
3	90600-91060	CLAMP	1	1	1	
4	EU0-82110-09	BATTERY ASSY (YB16CL-B)	1	1	1	YUASA
5	GP7-U8211-00	CASE, BATTERY	1	1	1	YMUS
6	F0X-U8221-00	PAD, BATTERY	1	1	1	YMUS
7	EU0-U8221-30	PAD, BATTERY 2	4	4	4	YMUS
8	90119-06854	BOLT, WITH WASHER	4	4	4	YMUS
9	EU0-U821D-00	BAND, BATTERY 2	2	2	2	YMUS
10	FJ0-68222-01	GROMMET	1	1	1	
11	F0M-6820A-00	METER ASSY	1	1	1	
12	F0M-68238-00	BRACKET, METER	1	1	1	
13	9572R-05300	NUT, FLANGE	2	2	2	YMUS
14	90464-32801	CLAMP	1	1	1	YMUS
15	GJ8-U824C-00	SENDER, OIL	1	1	1	YMUS
16	90600-91736	CLAMP COMP.	4	4	4	
17	90267-48802	RIVET, BLIND	4	4	4	YMUS
18	90464-32801	CLAMP	4	4	4	YMUS
19	90600-944U8	CLAMP	1	1	1	YMUS

FIG. 14 ENGINE HATCH 1

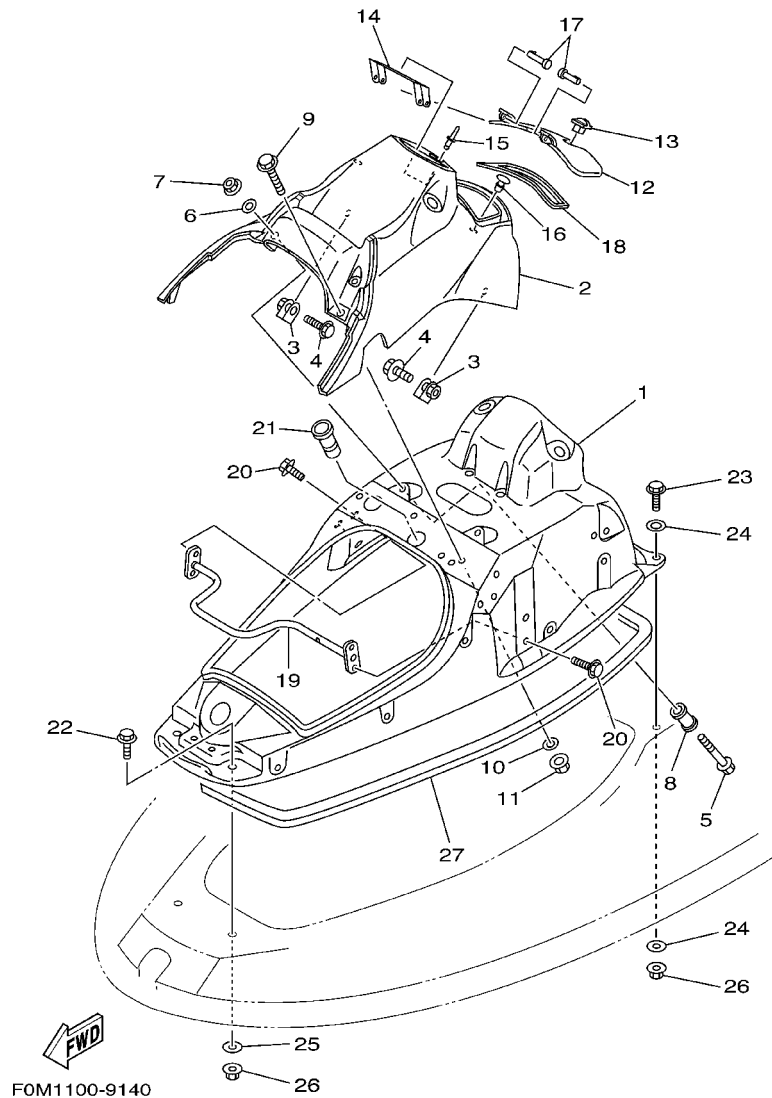

REF. NO.	PART NO.	DESCRIPTION	USA	GENE	JPN	REMARKS
1	F0M-U516A-00	ENGINE HATCH COMP.	1	1	1	YMUS
2	F0M-U516N-20-P0	COVER, ENGINE HATCH	1	1	1	BMD, YMUS
3	90183-06902	NUT, SPRING	2	2	2	
4	90119-069UH	BOLT, WITH WASHER	2	2	2	YMUS
5	90119-06808	BOLT, WITH WASHER	1	1	1	YMUS
6	9299R-06200	WASHER	1	1	1	YMUS
7	9572R-06300	NUT, FLANGE	1	1	1	YMUS
8	90387-06922	COLLAR	1	1	1	
9	90119-06803	BOLT, WITH WASHER	1	1	1	YMUS
10	9299R-06200	WASHER	1	1	1	YMUS
11	9572R-06300	NUT, FLANGE	1	1	1	YMUS
12	GU2-U517H-30-P0	LID HATCH	1	1	1	BMD, YMUS
13	GU2-62875-01	LOCK	1	1	1	
14	GU2-U517G-00	HINGE, HATCH	1	1	1	YMUS
15	90267-40937	RIVET, BLIND	3	3	3	
16	90605-502U2	PLUG	1	1	1	YMUS
17	GU2-6517R-00	PIN, HINGE	2	2	2	
18	GU2-U519D-00	PACKING CASE	1	1	1	YMUS
19	GU2-6516L-00	BEAM, ENGINE HATCH	1	1	1	
20	90119-069UH	BOLT, WITH WASHER	4	4	4	YMUS
21	GU2-6822E-01	GROMMET	1	1	1	
22	90119-089U9	BOLT, WITH WASHER	2	2	2	YMUS
23	90119-089U6	BOLT, WITH WASHER	2	2	2	YMUS
24	90201-099U1	WASHER, PLATE	4	4	4	YMUS
25	90201-08929	WASHER, PLATE	2	2	2	
26	9572R-08300	NUT, FLANGE	4	4	4	YMUS
27	GJ3-U2663-01	PACKING 1	1	1	1	YMUS

FIG. 15 ENGINE HATCH 2

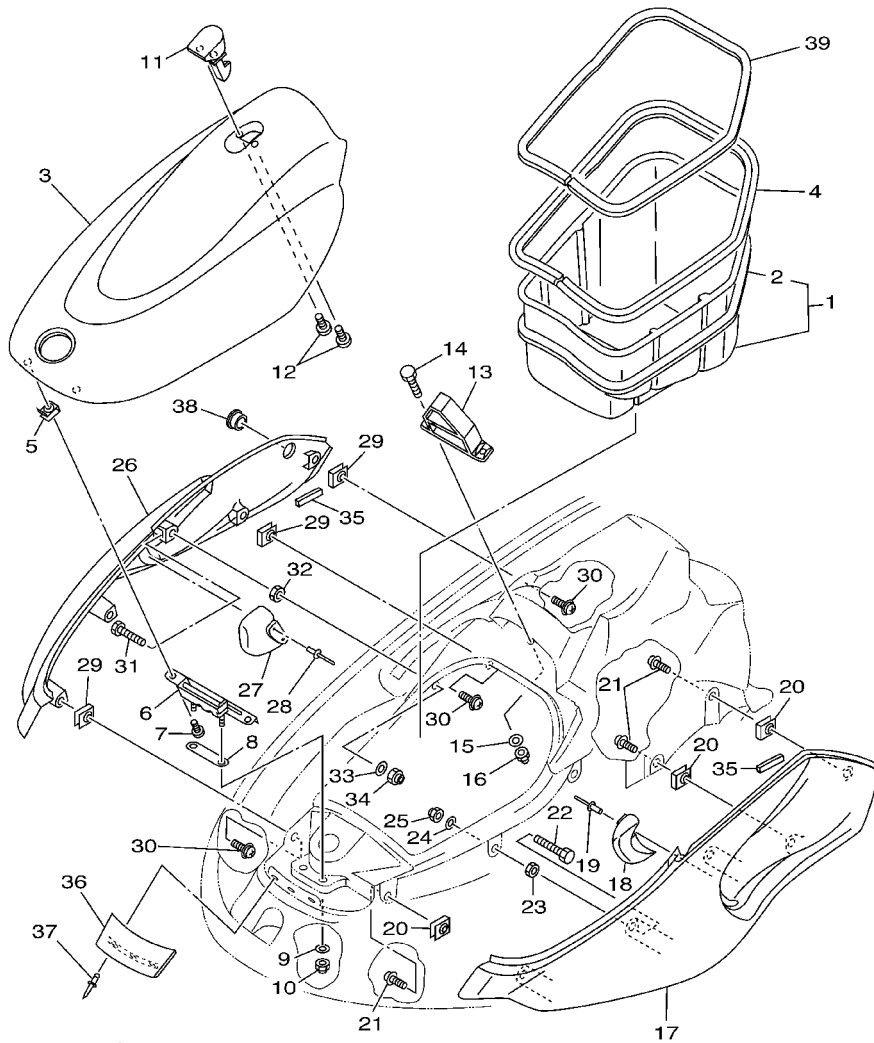

FOM7100-1151

REF. NO.	PART NO.	DESCRIPTION	USA	GENE	JPN	REMARKS
1	GU2-U475A-00	BOWLOCKER ASSY	1	1	1	YMUS
2	GJ3-U266C-31	.PACKING 4	1	1	1	YMUS
3	GU2-U517B-30-P0	LID, ENGINE ROOM	1	1	1	BMD, YMUS
4	GU2-U266B-30	PACKING 3	1	1	1	YMUS
5	90183-06902	NUT, SPRING	2	2	2	
6	GU2-6517D-00	HINGE, LID	1	1	1	
7	90119-069UJ	BOLT, WITH WASHER	2	2	2	YMUS
8	GU2-U518E-01	PRATE, HINGE LID	1	1	1	YMUS
9	9299R-06200	WASHER	2	2	2	YMUS
10	9572R-06300	NUT, FLANGE	2	2	2	YMUS
11	GP7-6517C-00	LOCK, LID	1	1	1	
12	90159-059U2	SCREW, WITH WASHER	2	2	2	YMUS
13	GU2-6517F-01	HOOK, LID LOCK	1	1	1	
14	9708R-06020	BOLT	2	2	2	YMUS
15	9299R-06200	WASHER	2	2	2	YMUS
16	9572R-06300	NUT, FLANGE	2	2	2	YMUS
17	GU2-U377B-30-P0	COVER, SIDE 1	1	1	1	BMD, YMUS
18	GU2-U377H-01	INNER, COVER SIDE 1	1	1	1	YMUS
19	90267-48802	RIVET, BLIND	2	2	2	YMUS
20	90183-06902	NUT, SPRING	3	3	3	
21	90119-069UH	BOLT, WITH WASHER	3	3	3	YMUS
22	90101-069U0	BOLT	2	2	2	YMUS
23	9538R-06700	NUT	2	2	2	YMUS
24	9299R-06200	WASHER	2	2	2	YMUS
25	9572R-06300	NUT, FLANGE	2	2	2	YMUS
26	GU2-U377C-30-P0	COVER, SIDE 2	1	1	1	BMD, YMUS
27	GU2-U377J-01	INNER, COVER SIDE 2	1	1	1	YMUS

FIG. 16 HULL. DECK

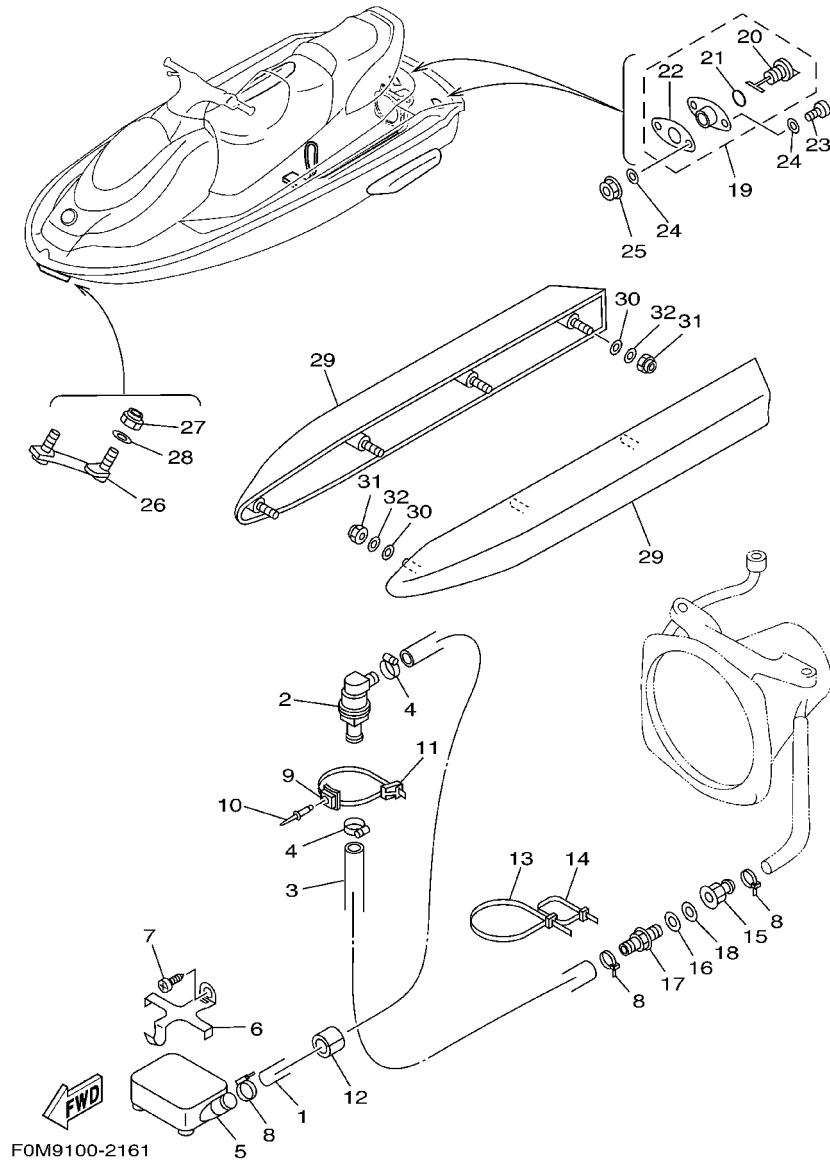

REF. NO.	PART NO.	DESCRIPTION	USA	GENE	JPN	REMARKS
1	90445-19895	HOSE (L720)	1	1	1	YMUS
2	68N-5112T-00	JOINT, HOSE	1	1	1	
3	90445-19896	HOSE (L500)	1	1	1	YMUS
4	90601-118UF	BAND, HOSE 18	2	2	2	YMUS
5	GD0-U761D-00	STRAINER, BILGE	1	1	1	YMUS
6	EW2-67618-00	BASE, STRAINER BLIGE	1	1	1	
7	9778R-50112	SCREW, TAPPING	1	1	1	YMUS
8	90601-200U1	BAND	3	3	3	YMUS
9	90600-91736	CLAMP COMP.	1	1	1	
10	90267-489U7	RIVET, BLIND	1	1	1	YMUS
11	90464-32801	CLAMP	1	1	1	YMUS
12	GJ1-U7578-11	PACKING, HOSE 2	1	1	1	YMUS
13	90601-20016	BAND	1	1	1	
14	90601-200U4	BAND	1	1	1	YMUS
15	90604-80759	CONNECTION, THRU-HULL 1/4	1	1	1	
16	90430-13909	GASKET	1	1	1	
17	90604-80775	THROUGH, HULL CONNECTION	1	1	1	
18	90430-13909	GASKET	1	1	1	
19	EU0-62280-00	DRAIN PLUG ASSY	2	2	2	
20	EU0-62282-00	.PLUG, DRAIN	1	1	1	
21	EU0-62283-00	.O-RING	1	1	1	
22	EU0-62285-01	.PACKING DRAIN (EU0)	1	1	1	
23	9788R-05025	SCREW, PAN HEAD	4	4	4	YMUS
24	9299R-05200	WASHER	8	8	8	YMUS
25	9572R-05300	NUT, FLANGE	4	4	4	YMUS
26	FN8-U1624-00	BOWEYE 1 (S)	1	1	1	YMUS
27	9572R-08300	NUT, FLANGE	2	2	2	YMUS

FIG. 16 HULL. DECK

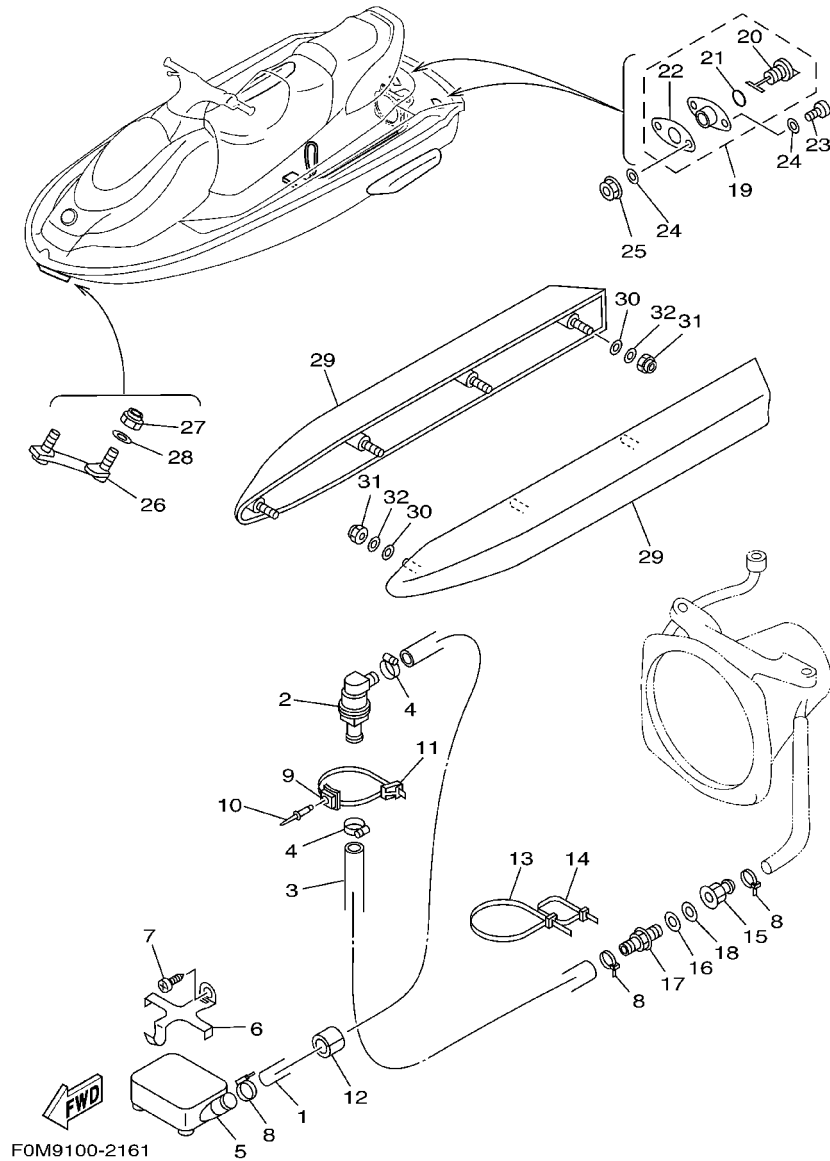

REF. NO.	PART NO.	DESCRIPTION	USA	GENE	JPN	REMARKS
28	9299R-08200	WASHER	2	2	2	YMUS
29	GH3-U883M-30	STABILIZER	2	2	2	YB, YMUS
30	GT3-U883U-00	PACKING,STABILIZER	8	8	8	YMUS
31	9572R-06300	NUT, FLANGE	8	8	8	YMUS
32	9299R-06200	WASHER	8	8	8	YMUS

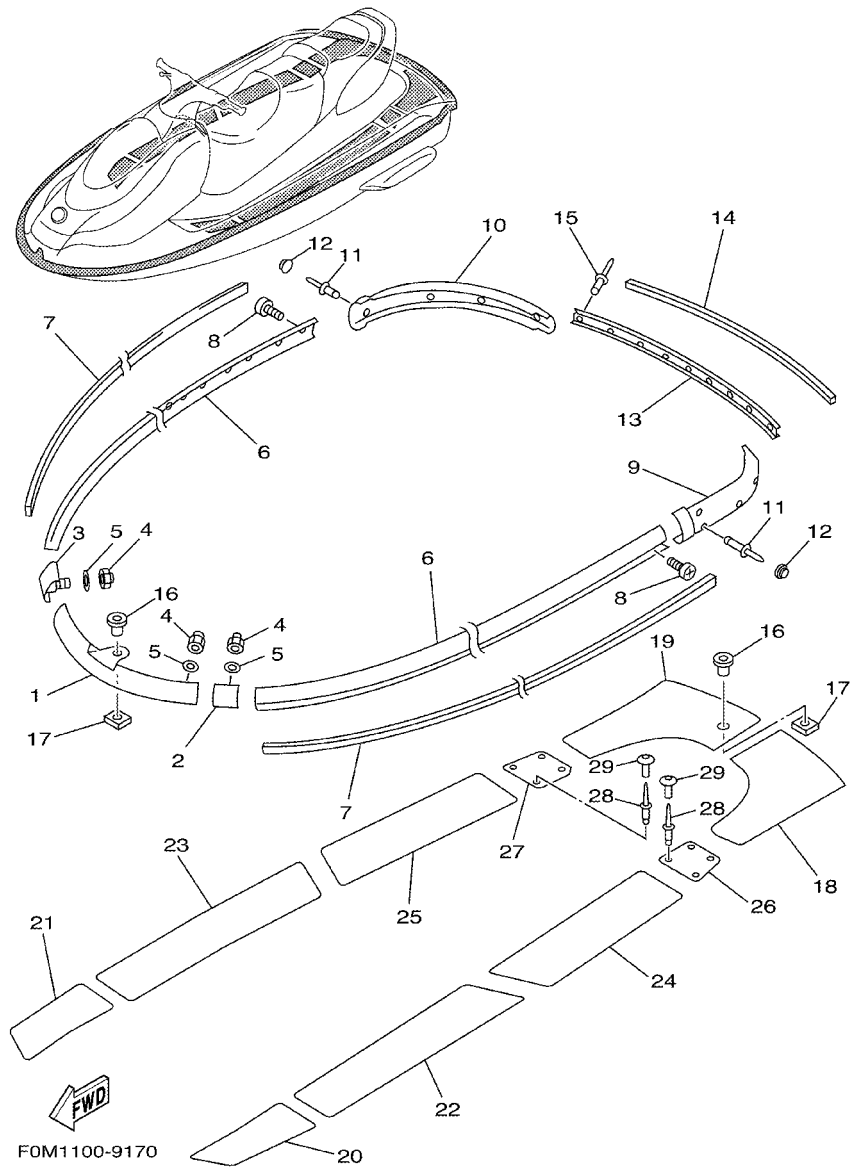
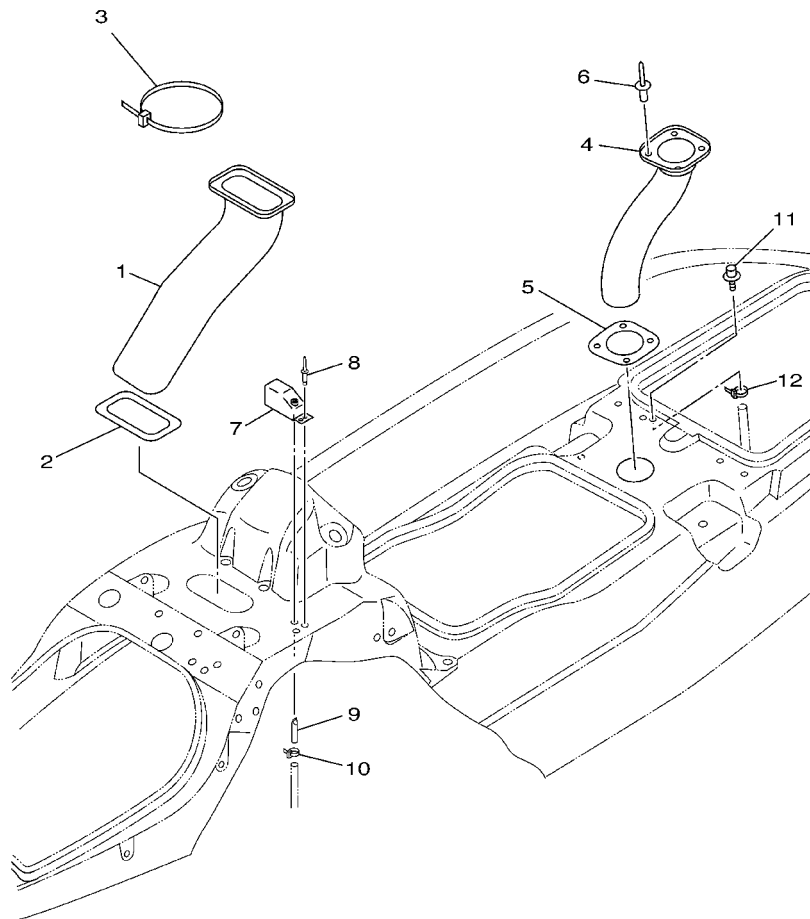

FIG. 17 GUNWALE. MAT

REF. NO.	PART NO.	DESCRIPTION	USA	GENE	JPN	REMARKS
1	GJ3-U2501-20	BOW GUNWALE COMP.	1	1	1	YB, YMUS
2	GU2-6252E-10	JOINT, GUNWALE LH	1	1	1	YB
3	GU2-6252F-10	JOINT, GUNWALE RH	1	1	1	YB
4	9572R-06300	NUT, FLANGE	6	6	6	YMUS
5	9299R-06200	WASHER	6	6	6	YMUS
6	GH3-U2512-20	GUNWALE, SIDE	2	2	2	YB, YMUS
7	GJ3-U2519-60	INNER, GUNWALE	2	2	2	YB, YMUS
8	90169-059U1	SCREW, TAPPING	28	28	28	YMUS
9	GJ3-U251D-21	GUNWALE, STERN 1	1	1	1	YB, YMUS
10	GJ3-U251E-21	GUNWALE, STERN 2	1	1	1	YB, YMUS
11	90267-489U8	RIVET, BLIND	10	10	10	YMUS
12	GJ3-U354D-30	CAP, HEAD	10	10	10	YB, YMUS
13	GJ3-U252C-20	COVER, GUNWALE 1	1	1	1	YB, YMUS
14	GJ3-U252D-60	COVER, GUNWALE 2	1	1	1	YB, YMUS
15	90267-489U8	RIVET, BLIND	5	5	5	YMUS
16	FN8-61651-01	ROPE HOLE	2	2	2	
17	EU0-61652-00	NUT	2	2	2	
18	GU2-U358F-04	MAT, UPPER LH	1	1	1	BL, YMUS
19	GU2-U358G-04	MAT, UPPER RH	1	1	1	BL, YMUS
20	GU2-U351H-10	MAT, STEP 1	1	1	1	BL, YMUS
21	GU2-U351J-10	MAT, STEP 2	1	1	1	BL, YMUS
22	GU2-U351N-10	MAT, STEP 5	1	1	1	BL, YMUS
23	GU2-U351P-10	MAT, STEP 6	1	1	1	BL, YMUS
24	GU2-U351R-10	MAT, STEP 7	1	1	1	BL, YMUS
25	GU2-U351S-10	MAT, STEP 8	1	1	1	BL, YMUS
26	GH3-U351M-50	MAT, STEP 4	1	1	1	YB, YMUS
27	GH3-U351M-60	MAT, STEP 4	1	1	1	YB, YMUS

FIG. 18 VENTILATION



REF. NO.	PART NO.	DESCRIPTION	USA	GENE	JPN	REMARKS
1	GU2-U213F-01	HOSE, VENTILATOR 1	1	1	1	YMUS
2	GU2-U2117-00	SEAL, AIRINTAKE 1	1	1	1	YMUS
3	90601-200U7	BAND	1	1	1	YMUS
4	GU2-U213G-00	HOSE, VENTILATOR 2	1	1	1	YMUS
5	GU2-U2118-00	SEAL, AIRINTAKE 2	1	1	1	YMUS
6	90269-07923	RIVET	2	2	2	
7	GP7-62159-01	SOCKET, VENTILATION	1	1	1	
8	90267-48802	RIVET, BLIND	2	2	2	YMUS
9	EW2-62149-00	PIPE, VENTILATION 1	1	1	1	
10	90465-11829	CLAMP	1	1	1	YMUS
11	GJ3-6215F-00	NIPPLE	1	1	1	
12	90465-11829	CLAMP	1	1	1	YMUS

 GU21100-8190

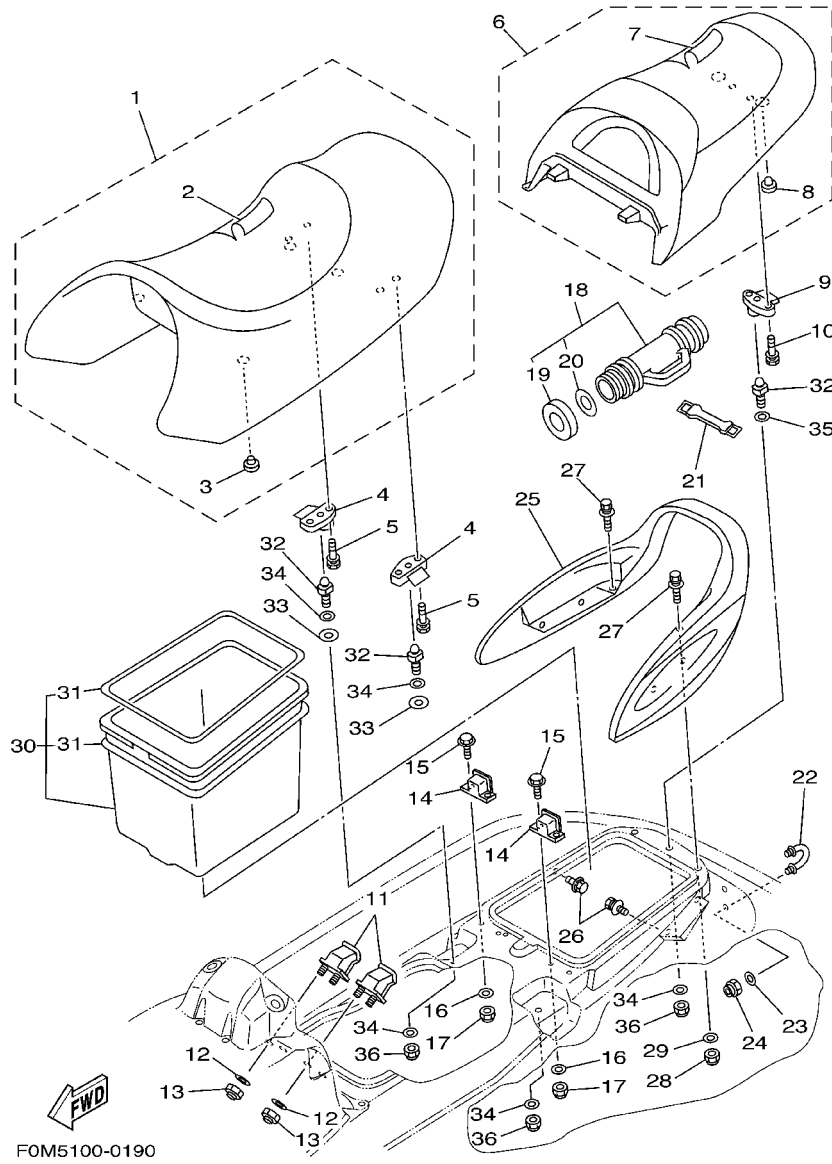

FIG. 19 SEAT. UNDER LOCKER

REF. NO.	PART NO.	DESCRIPTION	USA	GENE	JPN	REMARKS
1	GU2-U371A-50	DOUBLE SEAT ASSY	1	1	1	
2	GU2-U371B-50	.COVER, SEAT 1	1	1	1	
3	278-27114-00	.STOPPER, MAIN STAND	4	4	4	
4	GJ3-63850-03	SEAT LOCK ASSY	2	2	2	
5	90119-06853	BOLT, WITH WASHER	4	4	4	YMUS
6	GU2-U372A-50	SINGLE SEAT ASSY	1	1	1	
7	GU2-U372B-50	.COVER, SEAT	1	1	1	
8	278-27114-00	.STOPPER, MAIN STAND	2	2	2	
9	GJ3-63850-03	SEAT LOCK ASSY	1	1	1	
10	90119-06853	BOLT, WITH WASHER	2	2	2	YMUS
11	GU2-6378C-00	STAY, SEAT 1	2	2	2	
12	9299R-06200	WASHER	4	4	4	YMUS
13	9572R-06300	NUT, FLANGE	4	4	4	YMUS
14	GU2-6378D-01	STAY, SEAT 2	2	2	2	
15	90101-069U0	BOLT	4	4	4	YMUS
16	9299R-06200	WASHER	4	4	4	YMUS
17	9572R-06300	NUT, FLANGE	4	4	4	YMUS
18	EW2-U5920-00	CASE 2 ASSY.	1	1	1	YMUS
19	EW2-U5912-01	.CAP, CASE	1	1	1	YMUS
20	EW2-U5913-01	.PACKING, CASE	1	1	1	YMUS
21	EU0-U756E-00	BAND, WATER LOCK	2	2	2	YMUS
22	A00-61624-60	BOWEYE 1 (S)	1	1	1	
23	9299R-08200	WASHER	2	2	2	YMUS
24	9572R-08300	NUT, FLANGE	2	2	2	YMUS
25	GU2-U271B-00	GRIP, HAND	1	1	1	YMUS
26	90119-06819	BOLT, WITH WASHER	4	4	4	YMUS
27	90119-06820	BOLT, WITH WASHER	2	2	2	YMUS

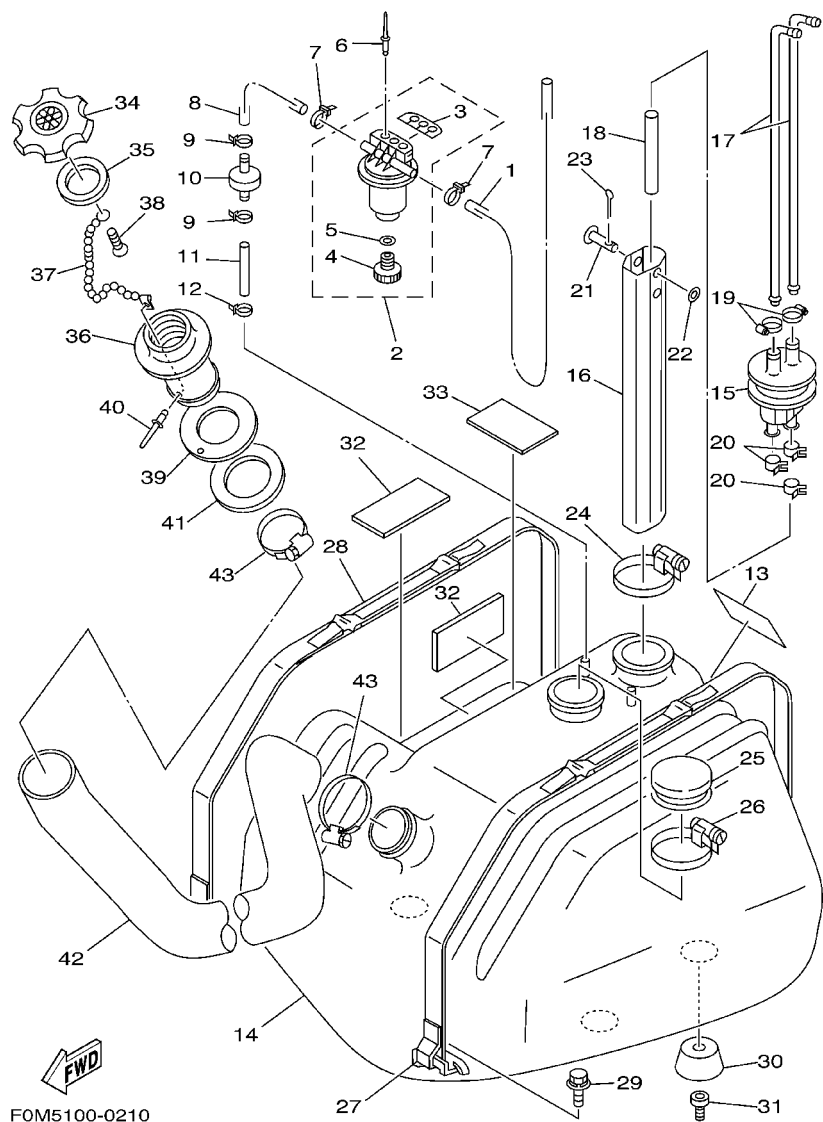
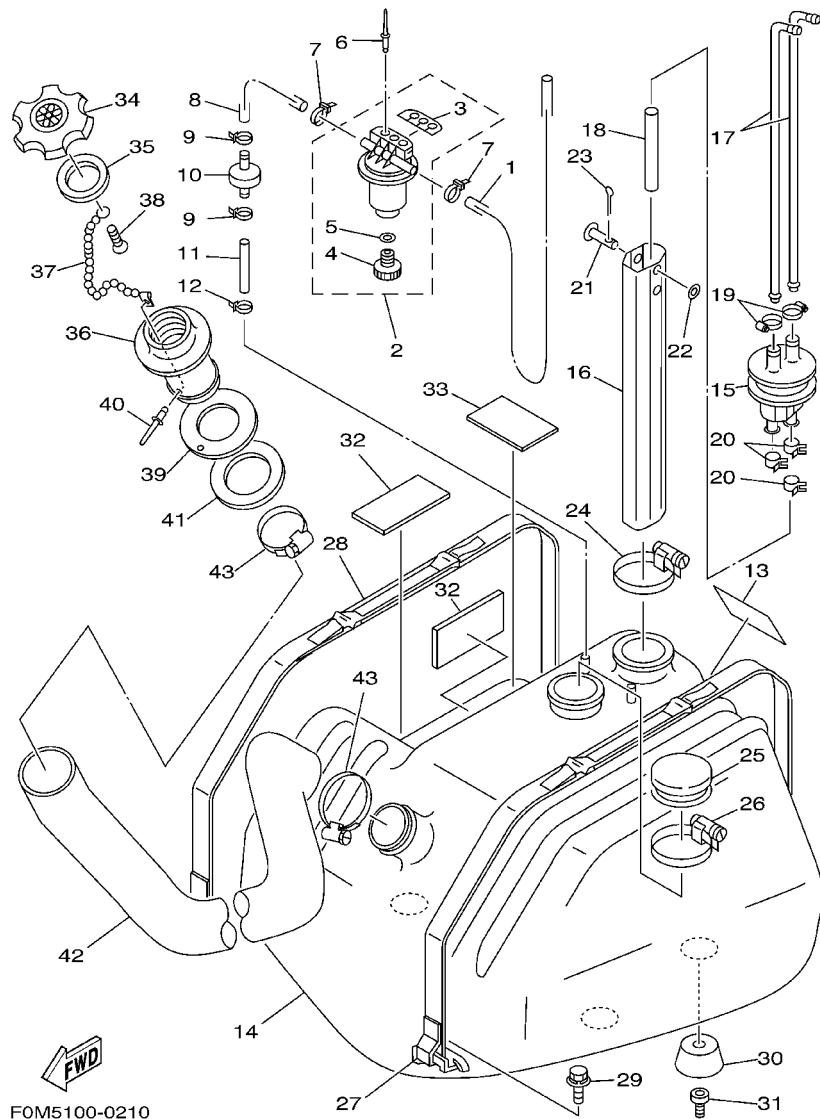

FIG. 21 FUEL TANK

REF. NO.	PART NO.	DESCRIPTION	USA	GENE	JPN	REMARKS
1	GP7-U785J-00	HOSE AIR VENT	1	1	1	YMUS
2	EW2-62140-00	FILTER, VENT ASSY	1	1	1	
3	EW2-62142-00	.PLATE, FILTER	1	1	1	
4	70R-24543-00	.PLUG, DRAIN	1	1	1	
5	70R-24489-00	.O-RING	1	1	1	
6	90267-489U2	RIVET, BLIND	2	2	2	YMUS
7	90465-11829	CLAMP	2	2	2	YMUS
8	GU2-U785H-00	HOSE, AIR VENT 3	1	1	1	YMUS
9	90465-11829	CLAMP	2	2	2	YMUS
10	EU0-67767-31	CHECK VALVE	1	1	1	
11	GA7-U785G-00	HOSE, AIR VENT	1	1	1	YMUS
12	90465-11829	CLAMP	1	1	1	YMUS
13	GH3-6418D-00	LABEL,FUEL TANK	1	1		FOR USA,GENE
14	GH3-U7711-00	TANK, FUEL	1	1	1	YMUS
15	FJ0-67713-00	PIPE, JOINT	1	1	1	
16	FJ0-67716-01	PIPE, FILLER	1	1	1	
17	FJ0-67714-02	PIPE, SUCTION 3	2	2	2	
18	90445-11903	HOSE (L105)	1	1	1	
19	90601-11062	BAND, HOSE 11	2	2	2	
20	90467-11032	CLIP	3	3	3	
21	91790-05040	PIN, CLEVIS	1	1	1	
22	92990-05600	WASHER, PLATE	1	1	1	
23	91490-16010	PIN, COTTER	1	1	1	
24	90601-162U5	BAND, HOSE 62	1	1	1	YMUS
25	FN8-6771K-00	COVER	1	1	1	
26	90601-162U5	BAND, HOSE 62	1	1	1	YMUS
27	GJ1-67743-01	BELT, TANK 1	1	1	1	

FIG. 21 FUEL TANK



F0M5100-0210

REF. NO.	PART NO.	DESCRIPTION	USA	GENE	JPN	REMARKS
28	GH3-67743-01	BELT, TANK 1	1	1	1	
29	90119-089U7	BOLT, WITH WASHER	4	4	4	YMUS
30	GH1-U782B-00	DAMPER, FUEL TANK	4	4	4	YMUS
31	90110-089U1	BOLT, HEXAGON SOCKET HEAD	4	4	4	YMUS
32	GJ1-U759B-00	MAT 1	2	2	2	YMUS
33	GJ1-U759C-00	MAT 2	1	1	1	YMUS
34	GP7-U7831-11	CAP, FUEL FILLER	1	1	1	BL, YMUS
35	GP7-U7832-01	PACKING	1	1	1	YMUS
36	GP7-U7833-10	SOCKET	1	1	1	YMUS
37	GP7-U7835-00	CHAIN BALL	1	1	1	YMUS
38	90169-049U1	TAPPING SCREW	1	1	1	YMUS
39	GP7-U7834-10	PACKING FUEL FILLER	1	1	1	YMUS
40	90267-329UR	RIVET, BLIND	1	1	1	YMUS
41	GP7-U783F-00	NUT, FUEL FILLER	1	1	1	YMUS
42	GP3-U7844-00	HOSE	1	1	1	YMUS
43	90601-155U4	BAND, HOSE 55	2	2	2	YMUS

FIG. 22 EXHAUST 2

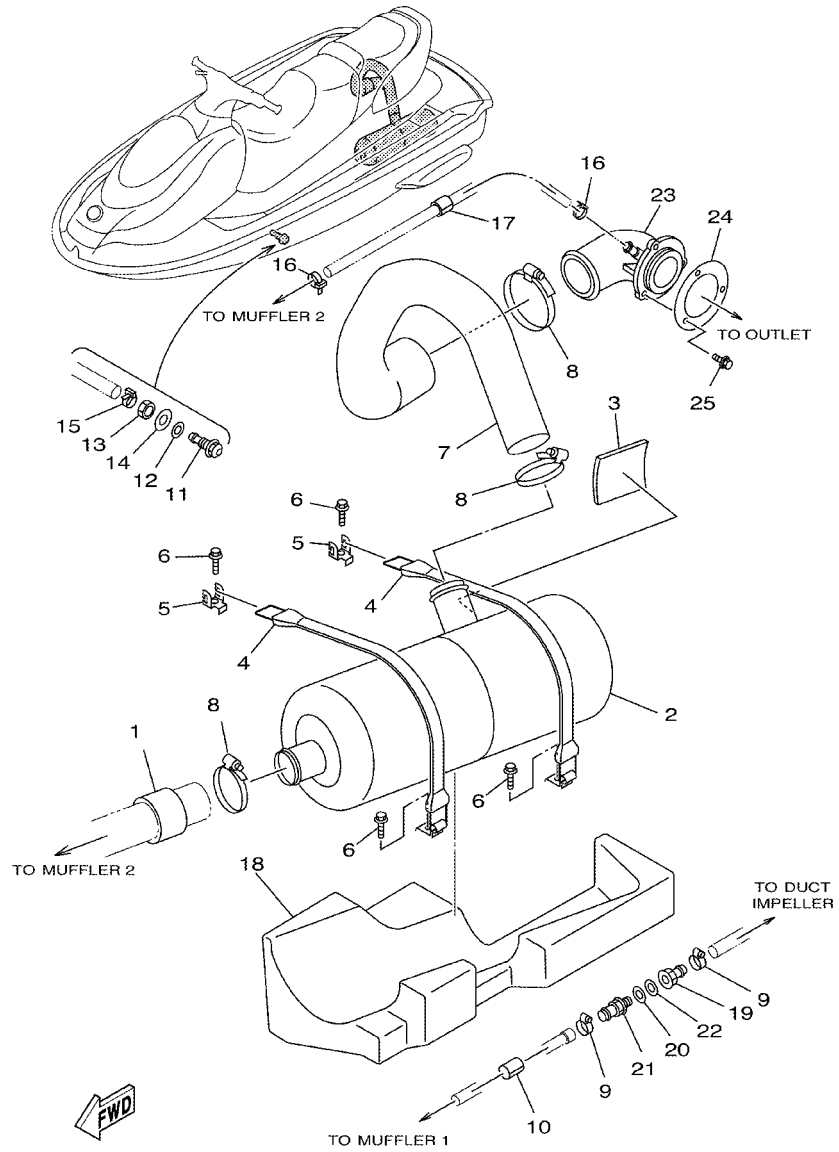

FOM5100-0220

REF. NO.	PART NO.	DESCRIPTION	USA	GENE	JPN	REMARKS
1	GH6-67577-01	PACKING, HOSE 1	1	1	1	
2	GJ3-U7550-00	WATER LOCK COMP.	1	1	1	YMUS
3	GJ3-U755J-00	MAT,WATER LOCK	1	1	1	YMUS
4	GJ3-U7570-00	C HOOK COMP.	2	2	2	YMUS
5	EW2-65772-00	HOOK A	2	2	2	
6	90119-069UJ	BOLT, WITH WASHER	4	4	4	YMUS
7	GJ3-U7555-00	HOSE, EXHAUST	1	1	1	YMUS
8	90601-170UG	BAND, HOSE 70	3	3	3	YMUS
9	90601-118UF	BAND, HOSE 18	2	2	2	YMUS
10	GJ1-U7578-11	PACKING, HOSE 2	1	1	1	YMUS
11	GJ1-6753B-02	PILOT,WATER	1	1	1	
12	GP3-U1438-00	PACKING	1	1	1	YMUS
13	GP7-61652-00	NUT	1	1	1	
14	9299R-14200	WASHER	1	1	1	YMUS
15	90465-11829	CLAMP	1	1	1	YMUS
16	90601-200U1	BAND	2	2	2	YMUS
17	GJ1-U7578-11	PACKING, HOSE 2	1	1	1	YMUS
18	GJ3-U892F-01	FLOATATION, BASE 1	1	1	1	YMUS
19	90604-80793	THROGUH-HULL CONNECTION 3/8	1	1	1	
20	90430-16910	GASKET	1	1	1	
21	90604-80794	THROGUH-HULL CONNECTION 3/8	1	1	1	
22	90430-16910	GASKET	1	1	1	
23	GJ3-U7560-01	EXHAUST, THRU-HALL COMP.	1	1	1	YMUS
24	GA9-U7525-00	PACKING	1	1	1	YMUS
25	90119-059U4	BOLT, WITH WASHER	3	3	3	YMUS

FIG. 23 CONTROL CABLE

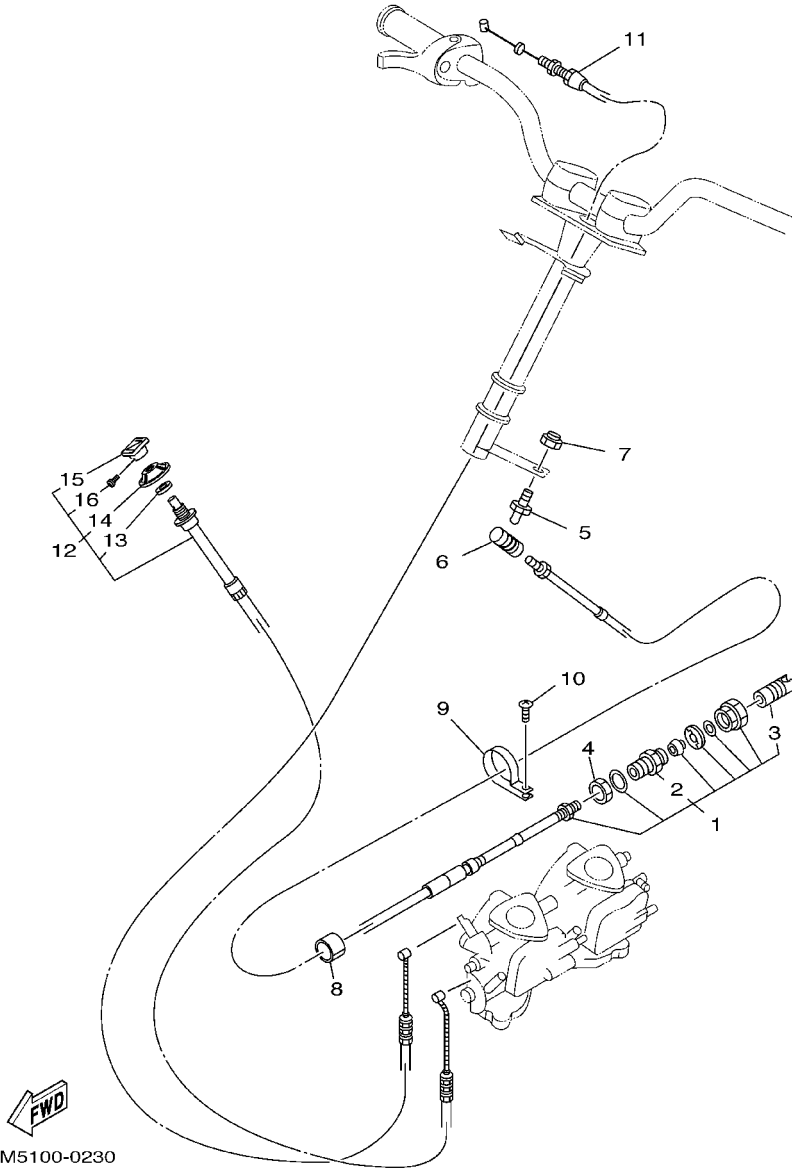

F0M5100-0230

REF. NO.	PART NO.	DESCRIPTION	USA	GENE	JPN	REMARKS
1	GU2-U1481-10	CABLE, STEERING	1	1	1	YMUS
2	GK5-67267-10	.CONNECTOR, CABLE	1	1	1	
3	GK5-U146F-00	.SHAFT,JOINT BALL	1	1	1	YMUS
4	EU0-62241-30	NUT, DRAIN 1	1	1	1	
5	EU0-U1461-02	STUD, JOINT BALL	1	1	1	YMUS
6	GK5-U146F-00	SHAFT,JOINT BALL	1	1	1	YMUS
7	9572R-06300	NUT, FLANGE	1	1	1	YMUS
8	GJ1-U7578-01	PACKING, HOSE 2	1	1	1	YMUS
9	90600-918U3	CLIP, NYLON 18	1	1	1	YMUS
10	9778R-60116	SCREW, TAPPING	1	1	1	YMUS
11	F0M-U7252-00	CABLE, THROTTLE	1	1	1	YMUS
12	F0M-U7242-00	CABLE, CHOKE	1	1	1	YMUS
13	GA9-U724F-01	.NUT	1	1	1	YMUS
14	GP7-U724E-00	.NUT, COMPRESSION	1	1	1	YMUS
15	GA9-U724C-00	.KNOB	1	1	1	YMUS
16	GP7-U724D-00	.SCREW, KNOB	1	1	1	YMUS

FIG. 24 STEERING 1

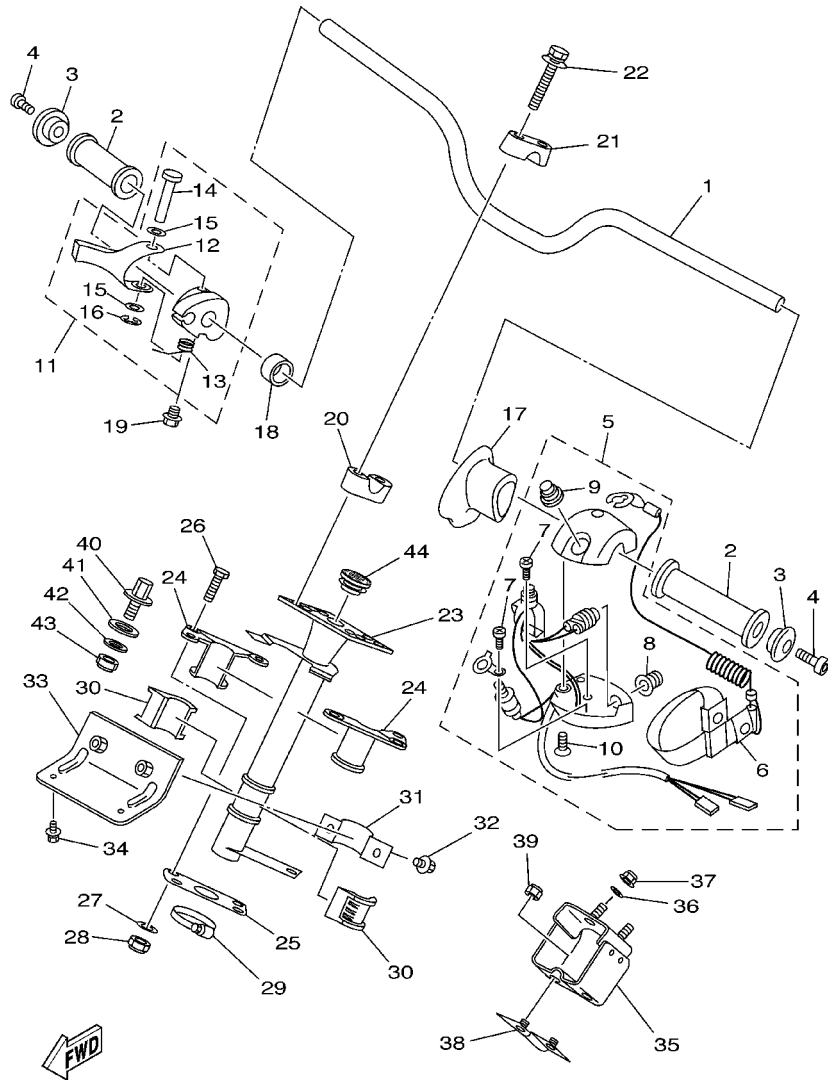

F0MC100-B240

REF. NO.	PART NO.	DESCRIPTION	USA	GENE	JPN	REMARKS
1	GU2-U1552-00	HANDLE	1	1	1	YMUS
2	GP7-U155D-00	GRIP, HANDLE	2	2	2	YMUS
3	GP7-U155F-00	GRIP, END	2	2	2	YMUS
4	90110-05908	BOLT, HEXAGON SOCKET HEAD	2	2	2	
5	FK7-68310-07	SWITCH BOX ASSY	1	1	1	
6	EW2-68348-00	.LANYARD, STOP SWITCH	1	1	1	
7	97880-03008	.SCREW, PAN HEAD	2	2	2	
8	FK7-68312-02	.STOP BUTTON COMP	1	1	1	
9	FK7-68313-02	.START BUTTON COMP.	1	1	1	
10	97880-05025	.SCREW, PAN HEAD	2	2	2	
11	GJ1-67250-01	THROTTLE LEVER ASSY	1	1	1	
12	GJ1-67255-00	.LEVER, THROTTLE	1	1	1	
13	EW2-67256-00	.SPRING	1	1	1	
14	EW2-67257-01	.SHAFT	1	1	1	
15	EW2-67258-01	.WASHER	2	2	2	
16	EW2-67259-01	.E-RING	1	1	1	
17	GU2-6143G-00	SPACER	1	1	1	
18	90560-22281	SPACER	1	1	1	
19	90159-059U2	SCREW, WITH WASHER	1	1	1	YMUS
20	EU0-23814-01	HOLDER, HANDLE LOWER	2	2	2	
21	EU0-23814-30	HOLDER, HANDLE UPPER	2	2	2	
22	90119-08806	BOLT, WITH WASHER	4	4	4	YMUS
23	GU2-61541-00	COLUMN, STEERING	1	1	1	
24	GH1-6141B-00	BEARING,COLUMN	2	2	2	
25	GH1-U143C-30	SEAL, RUBBER	1	1	1	YMUS
26	9708R-06030	BOLT	4	4	4	YMUS
27	9299R-06200	WASHER	4	4	4	YMUS

FIG. 24 STEERING 1

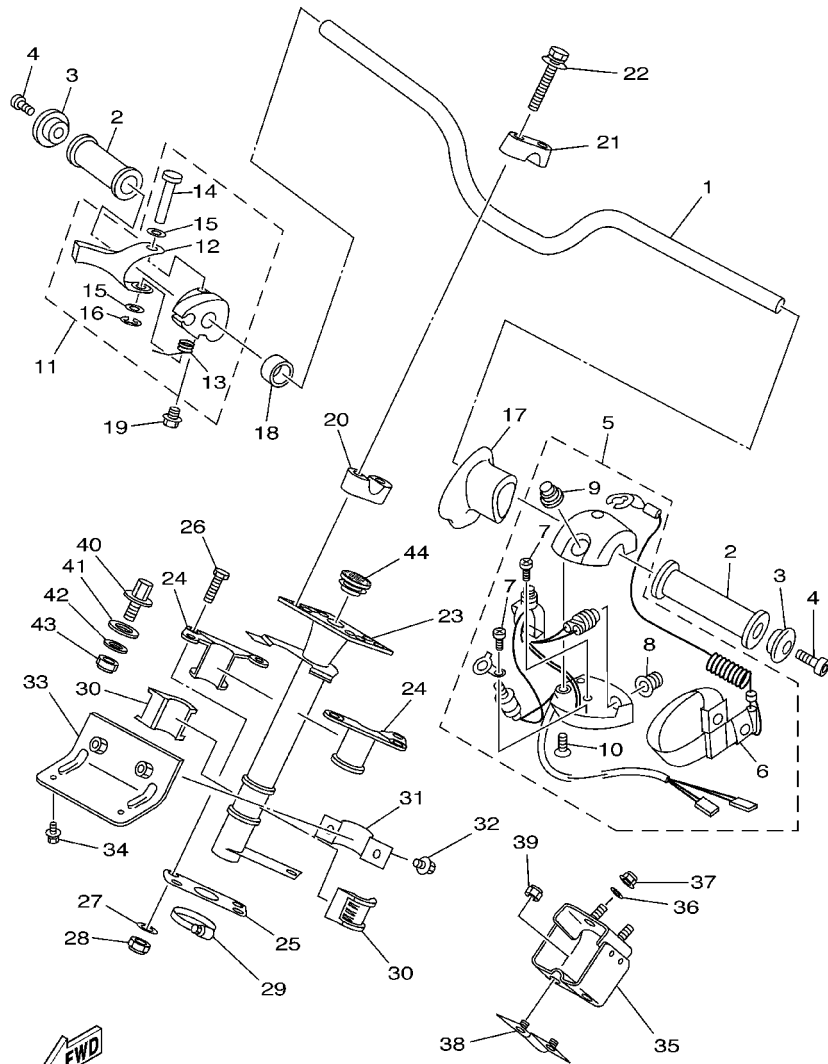

F0MC100-B240

REF. NO.	PART NO.	DESCRIPTION	USA	GENE	JPN	REMARKS
28	9572R-06300	NUT, FLANGE	4	4	4	YMUS
29	90601-142U6	BAND, HOSE 42	1	1	1	YMUS
30	GH1-6141D-01	BEARING,STEERING	2	2	2	
31	EU0-61588-00	JOINT, BEARING	1	1	1	
32	90119-089U7	BOLT, WITH WASHER	2	2	2	YMUS
33	GU2-61433-00	BRACKET, BEARING	1	1	1	
34	90119-089U7	BOLT, WITH WASHER	2	2	2	YMUS
35	GU2-61467-00	BRACKET,STOPPER CABLE	1	1	1	
36	9299R-06200	WASHER	3	3	3	YMUS
37	9572R-06300	NUT, FLANGE	3	3	3	YMUS
38	GH3-61468-00	STOPPER, CABLE	1	1	1	
39	9572R-06300	NUT, FLANGE	2	2	2	YMUS
40	FN8-6131B-00	PIN,STOPPER	1	1	1	
41	90201-10940	WASHER, PLATE	1	1	1	
42	9299R-10200	WASHER	1	1	1	YMUS
43	9572R-10300	NUT, FLANGE	1	1	1	YMUS
44	F0M-61469-00	PACKING, STEERING COLUMN	1	1	1	

FIG. 25 STEERING 2

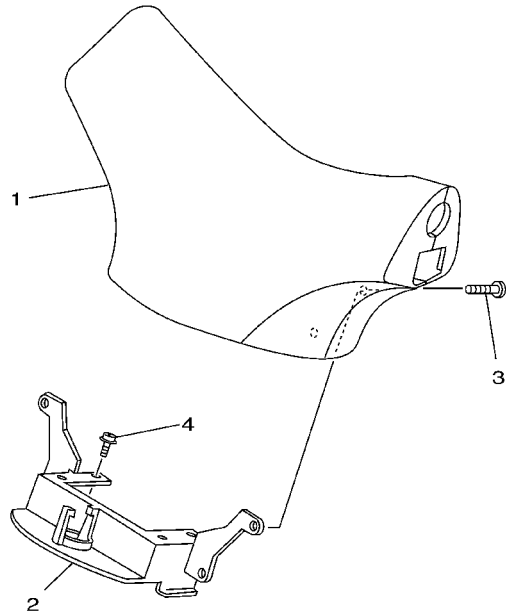

GU21100-8260

REF. NO.	PART NO.	DESCRIPTION	USA	GENE	JPN	REMARKS
1	GP7-U142A-11	STEERING PAD COMP	1	1	1	YB, YMUS
2	GP7-U142K-00	FIX, STEERING PAD	1	1	1	YMUS
3	90149-069U9	SCREW	4	4	4	YMUS
4	90159-069U1	SCREW, WITH WASHER	4	4	4	YMUS

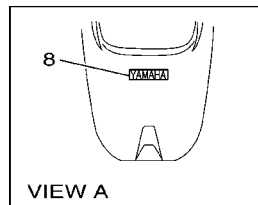
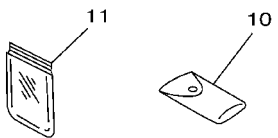
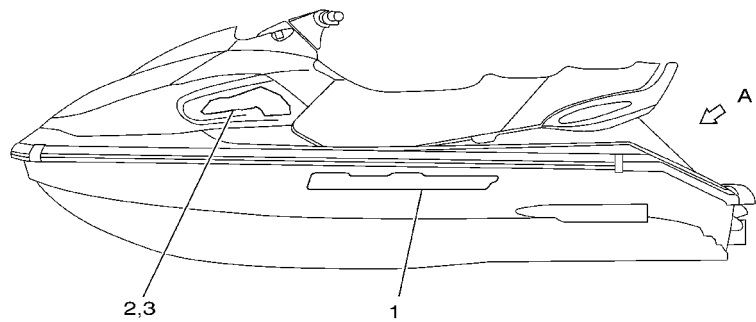
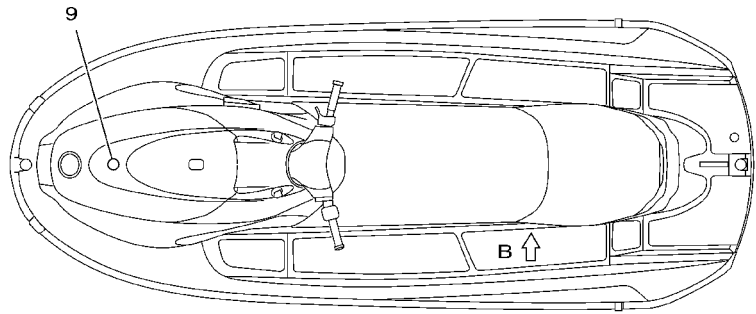
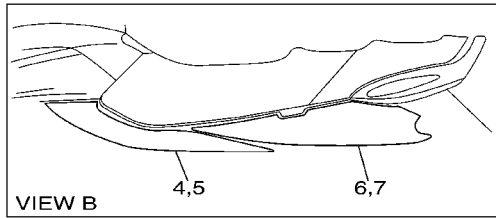

F0MC100-B260

FIG. 26 GRAPHICS

REF. NO.	PART NO.	DESCRIPTION	USA	GENE	JPN	REMARKS
1	F0M-U417B-31	GRAPHIC 1	2	2	2	YMUS
2	F0M-U417D-31	GRAPHIC 3	1	1	1	LH, YMUS
3	F0M-U417E-31	GRAPHIC 4	1	1	1	RH, YMUS
4	F0M-U417F-30	GRAPHIC 5	1	1	1	LH, YMUS
5	F0M-U417G-30	GRAPHIC 6	1	1	1	RH, YMUS
6	F0M-U417H-30	GRAPHIC 7	1	1	1	LH, YMUS
7	F0M-U417J-30	GRAPHIC 8	1	1	1	RH, YMUS
8	GJ3-U4114-52	MARK, YAMAHA A	1	1	1	YMUS
9	GU2-U411H-00	EMBLEM, TUNING FORK	1	1	1	YMUS
10	EU0-65986-00	TOOL SET	1	1	1	
11	EU0-65901-01	TOOL BAG	1	1	1	

FIG. 27 IMPORTANT LABELS

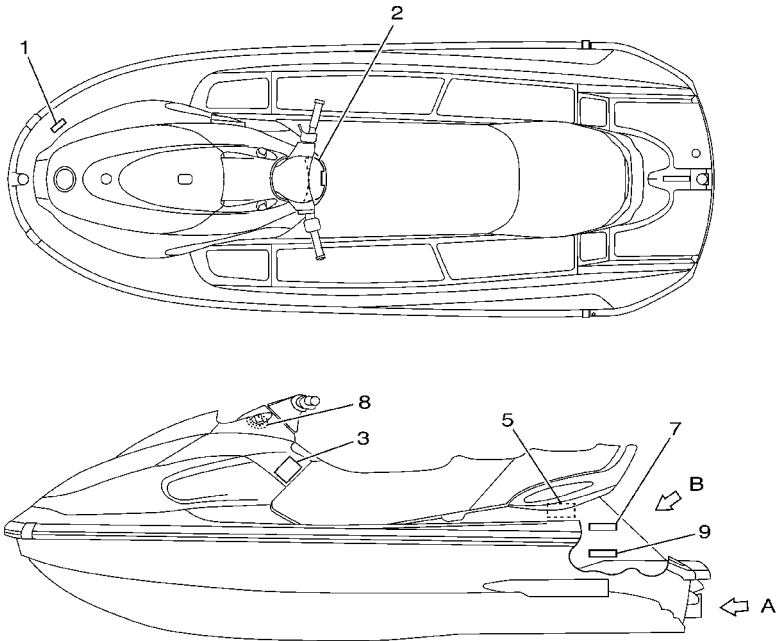
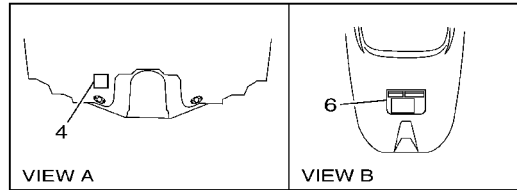

REF. NO.	PART NO.	DESCRIPTION	USA	GENE	JPN	REMARKS
1	F0V-U415B-10	LABEL, WARNING(FUEL)	1			YMUS
2	F0M-U41B1-03	LABEL, WARNING JDC 1	1			YMUS
3	F0P-U41B2-00	LABEL, WARNING JDC 2	1			YMUS
4	GA9-U418F-00	LABEL, RIGHTING	1			YMUS
5	F0V-U41DB-00	LABEL, WARNING BATTERY	1			YMUS
6	F0V-U41E1-30	LABEL, SET 1	1			YMUS
7	F0M-U41F6-00	LABEL, FIRE EXTINGUISHER 2	1			YMUS
8	GU2-U419C-01	LABEL 2	1			YMUS
9	F0P-U41G1-00	LABEL, CAPACITY	1			YMUS



F0MC100-B270

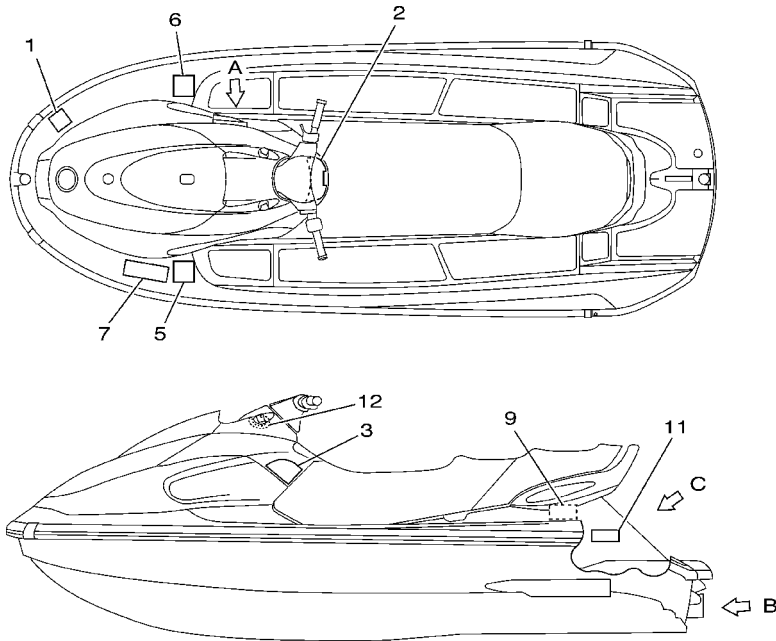
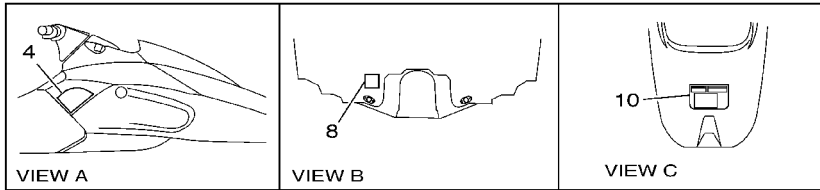

F0MC100-B280

FIG. 28 IMPORTANT LABELS 2

REF. NO.	PART NO.	DESCRIPTION	USA	GENE	JPN	REMARKS
1	F0V-U415B-00	LABEL, WARNING(FUEL)		1		YMUS
2	F0M-U41B1-12	LABEL, WARNING JDC 1		1		YMUS
3	F0M-U41B1-21	LABEL, WARNING JDC 1		1		YMUS
4	F0M-U41B1-30	LABEL, WARNING JDC 1		1		YMUS
5	F0M-U41B2-00	LABEL, WARNING JDC 2		1		YMUS
6	F0M-U41B2-10	LABEL, WARNING JDC 2		1		YMUS
7	GJ3-U416H-00	LABEL,WARNING(FRANCE)		1		YMUS
8	GA9-U418F-00	LABEL, RIGHTING		1		YMUS
9	F0V-U41DB-10	LABEL, WARNING BATTERY		1		YMUS
10	F0V-U41E1-40	LABEL, SET 1		1		YMUS
11	F0M-U41F6-11	LABEL, FIRE EXTINGUISHER 2		1		YMUS
12	GU2-U419C-01	LABEL 2		1		YMUS

FIG. 29 IMPORTANT LABELS 3

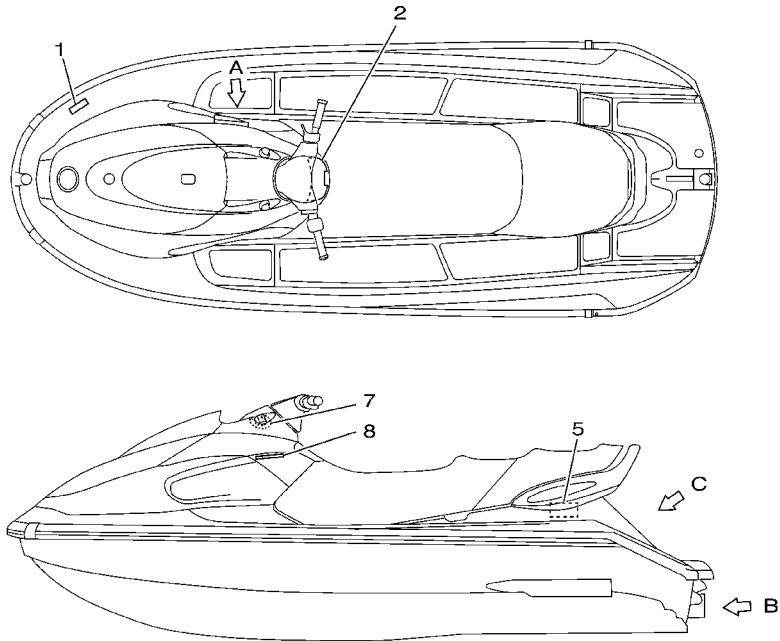
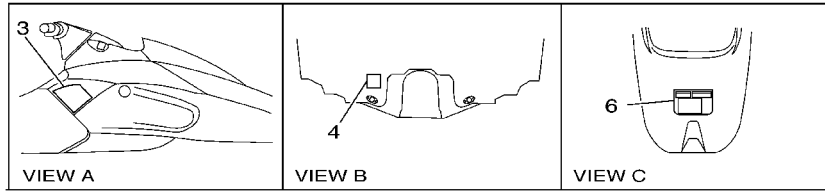

F0MC100-B290

REF. NO.	PART NO.	DESCRIPTION	USA	GENE	JPN	REMARKS
1	F0V-6415B-20	LABEL, WARNING(FUEL)			1	
2	F0M-641B1-20	LABEL, WARNING JDC 1			1	
3	F0M-641B2-20	LABEL, WARNING JDC 2			1	
4	GA9-U418F-00	LABEL, RIGHTING			1	YMUS
5	F0V-641DB-20	LABEL, WARNING BATTERY			1	
6	F1F-641E2-20	LABEL, SET 2			1	
7	GU2-U419C-01	LABEL 2			1	YMUS
8	GA9-U411B-00	PLATE,ASSY			1	YMUS

FIG. 30 REPAIR KIT 1

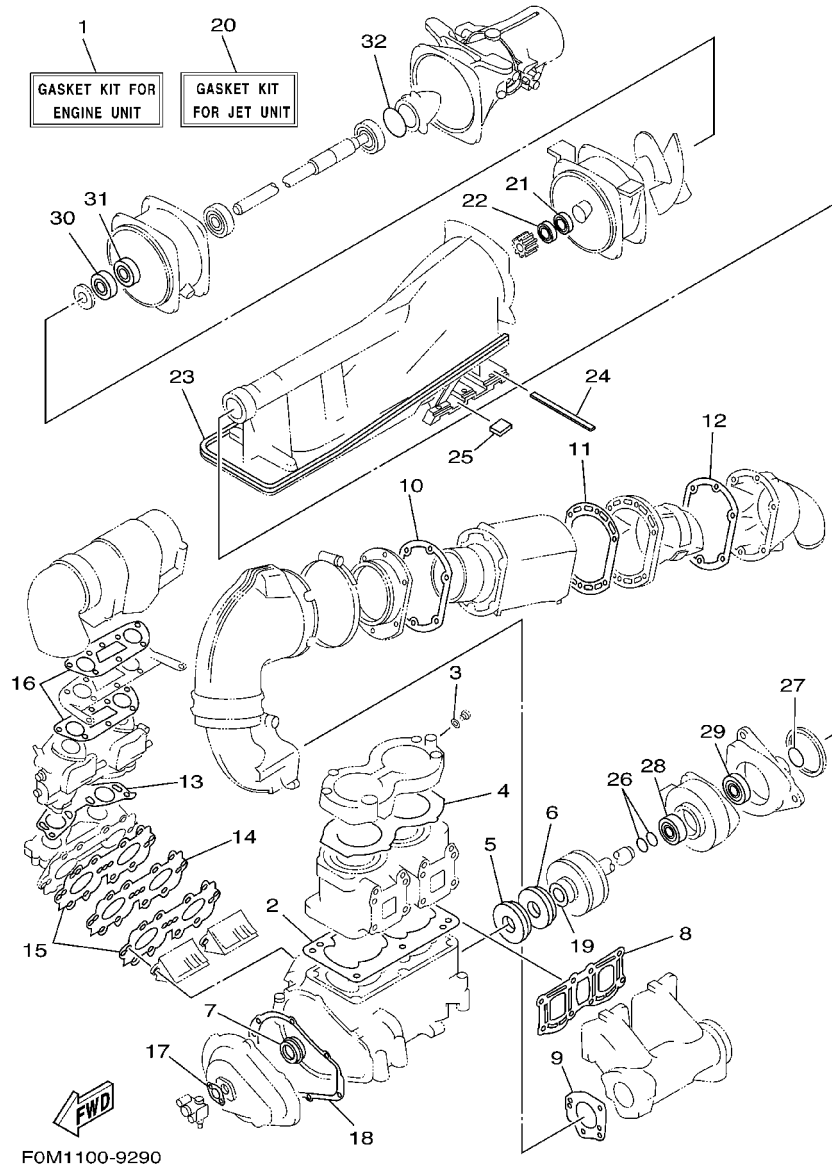

F0M1100-9290

REF. NO.	PART NO.	DESCRIPTION	USA	GENE	JPN	REMARKS
1	62T-W0001-02	GASKET KIT FOR ENGINE UNIT	1	1	1	
2	6M6-11351-A2	.GASKET, CYLINDER	1	1	1	
3	90430-08020	.GASKET	1	1	1	
4	62T-11181-00	.GASKET, CYLINDER HEAD 1	1	1	1	
5	93102-36M33	.OIL SEAL	1	1	1	
6	93101-36M46	.OIL SEAL	1	1	1	
7	93103-32M01	.OIL SEAL	1	1	1	
8	62T-14613-00	.GASKET, EXHAUST PIPE	1	1	1	
9	62T-14749-00	.GASKET, MUFFLER DAMPER 2	1	1	1	
10	62T-41114-01	.GASKET, EXHAUST OUTER COVER	1	1	1	
11	62T-41122-00	.GASKET, EXHAUST INNER COVER	1	1	1	
12	62T-41124-00	.GASKET, EXHAUST OUTER COVER	1	1	1	
13	62T-13556-00	.GASKET, MANIFOLD	1	1	1	
14	62T-13624-00	.PLATE, REED VALVE	1	1	1	
15	62T-13566-00	.GASKET	2	2	2	
16	62T-13674-00	.GASKET, AIR COOLER COVER 1	2	2	2	
17	6R8-13116-A0	.GASKET, PUMP CASE	1	1	1	
18	6M6-81365-A0	.GASKET, HOLE COVER	1	1	1	
19	62T-45127-00	.SEAL	1	1	1	
20	65U-W0001-20	GASKET KIT FOR JET UNIT	1	1	1	
21	93102-17M49	.OIL SEAL	1	1	1	
22	93102-17M50	.OIL SEAL	1	1	1	
23	6R8-51367-01	.FELT, PACKING	2	2	2	
24	63M-51367-00	.FELT, PACKING	1	1	1	
25	63M-51368-00	.FELT, PACKING	2	2	2	
26	93210-17MA4	.O-RING	2	2	2	
27	93210-35M72	.O-RING	1	1	1	

FIG. 30 REPAIR KIT 1

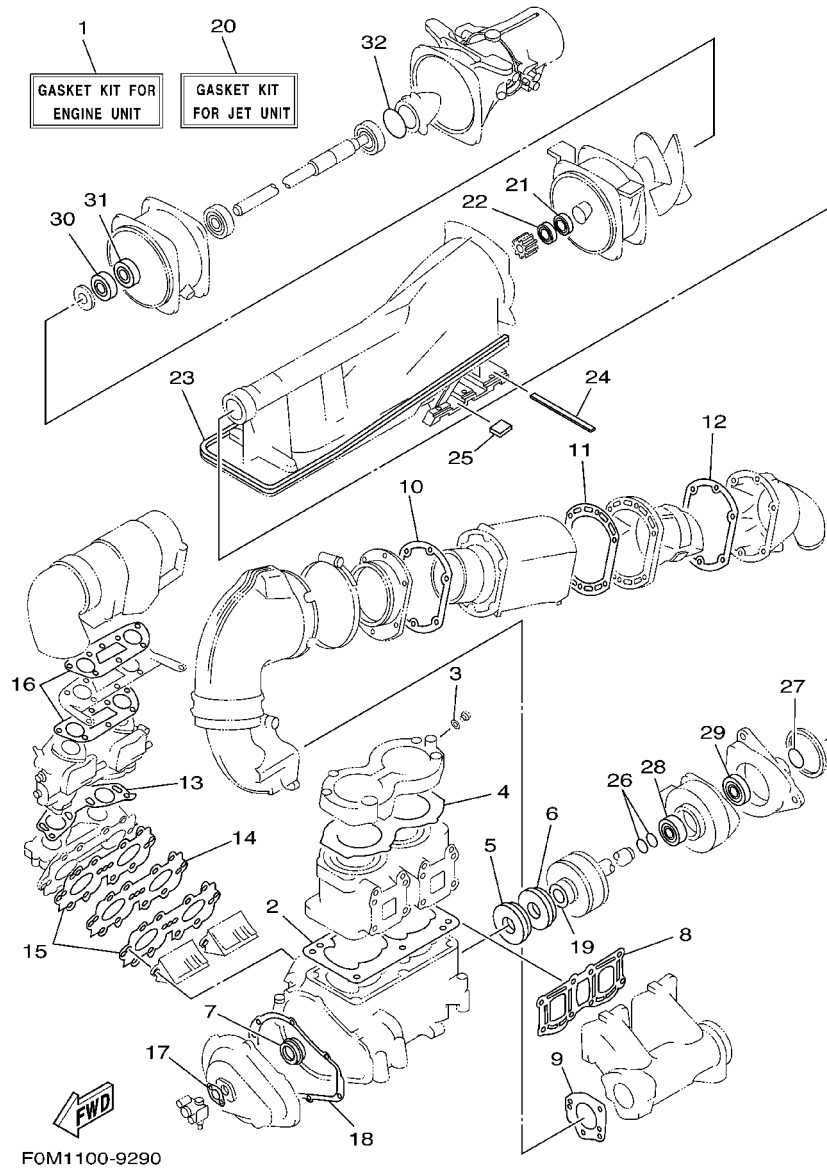

REF. NO.	PART NO.	DESCRIPTION	USA	GENE	JPN	REMARKS
28	93101-25M55	.OIL SEAL	1	1	1	
29	93101-25M56	.OIL SEAL	1	1	1	
30	93102-25M34	.OIL SEAL	1	1	1	
31	93101-25M50	.OIL SEAL	1	1	1	
32	93210-46M16	.O-RING	1	1	1	

FIG. 31 REPAIR KIT 2

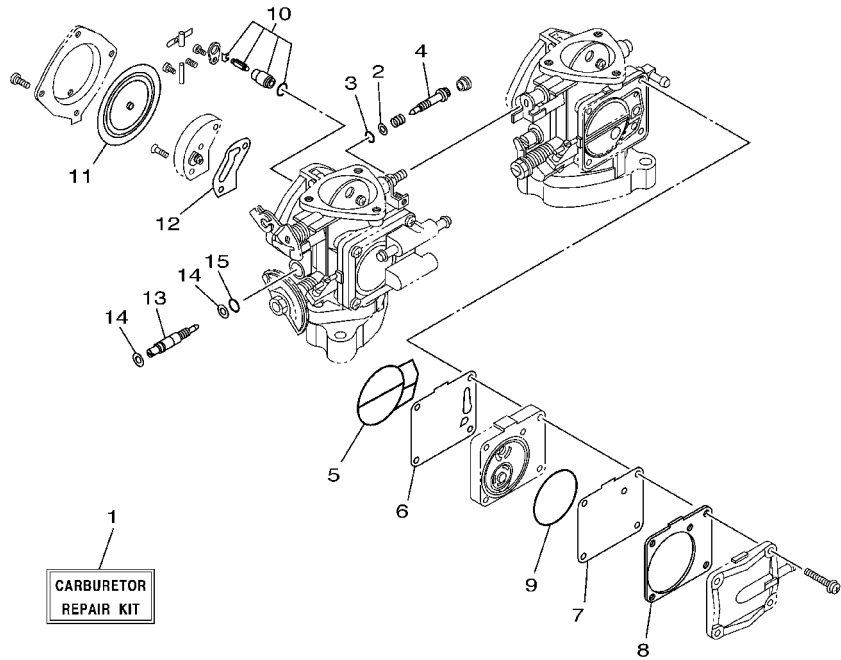

CARBURETOR
REPAIR KIT



GM6D100-9250

REF. NO.	PART NO.	DESCRIPTION	USA	GENE	JPN	REMARKS
1	67E-W0093-00	CARBURETOR REPAIR KIT	1	1	1	
2	812-14235-00	.WASHER, NEEDLE	4	4	4	
3	812-14147-00	.O-RING	2	2	2	
4	6K8-14946-10	.METERING NEEDLE	2	2	2	
5	6K8-14564-00	.O-RING	2	2	2	
6	6K8-24411-20	.DIAPHRAGM	1	1	1	
7	6K8-24421-10	.VALVE, CHECK	1	1	1	
8	6K8-24431-20	.GASKET, FUEL PUMP 1	1	1	1	
9	6K8-14563-00	.O-RING	1	1	1	
10	61X-14916-16	.NEEDLE	2	2	2	
11	6R7-14541-00	.DIAPHRAGM, PUMP	2	2	2	
12	6K8-14536-11	.GASKET	2	2	2	
13	65U-14923-10	.SCREW, PILOT	2	2	2	
14	822-14235-00	.WASHER, NEEDLE	4	4	4	
15	583-14561-00	.O-RING	2	2	2	

NUMERICAL INDEX

PART NO.	GRID NO.	PART NO.	GRID NO.	PART NO.	GRID NO.	PART NO.	GRID NO.	PART NO.	GRID NO.	PART NO.	GRID NO.
65A-G5331-00	C-4	GU2-U351R-10	D-2	GU2-U475A-00	C-12	GJ3-U778E-00	D-7	62T-11636-02	B-4	6K8-14471-10	B-8
65A-R1129-00	C-3	GU2-U351S-10	D-2	GU2-U513M-30-P0	C-13	GH1-U782B-00	D-9	62T-11651-00	B-4	6H1-14485-00	B-6
65A-R1129-10	C-2	GJ3-U352E-50	D-3	F0M-U516A-00	C-11	GP7-U783F-00	D-9	82M-11685-00	B-4	62T-14485-10	B-11
65U-R1311-00	C-2	GJ3-U354D-30	D-2	F0M-U516N-20-P0	C-11	GP7-U7831-11	D-9	65R-12564-00	B-13	6K8-14503-02	B-8
65R-R1313-01	C-3	GU2-U358F-04	D-2	F0M-U516X-00	C-13	GP7-U7832-01	D-9	64T-12580-00	B-13	6M6-14503-00	B-8
65R-R1318-00	C-3	GU2-U358G-04	D-2	GU2-U5162-00	C-13	GP7-U7833-10	D-9	64X-12581-00	B-12	6K8-14521-00	B-9
65R-R1321-10	C-3	GU2-U371A-50	D-5	GU2-U517B-30-P0	C-12	GP7-U7834-10	D-9	67X-12590-00	B-13	6K8-14521-10	B-8
65A-R1326-00	C-2	GU2-U371B-50	D-5	GU2-U517G-00	C-11	EU0-U7835-00	D-7	67X-12590-10	B-13	6M6-14521-00	B-8
65R-R1333-00	C-4	GU2-U372A-50	D-5	GU2-U517H-30-P0	C-11	GP7-U7835-00	D-9	67X-12590-20	B-13	6K8-14523-11	B-9
65A-R1334-01	C-3	GU2-U372B-50	D-5	GU2-U518E-01	C-12	GP3-U7844-00	D-9	6R8-13116-A0	B-10	6K8-14527-11	B-9
65U-R1348-01	C-2	GU2-U377B-30-P0	C-12	GU2-U519D-00	C-11	GA7-U785G-00	D-8		E-5	62T-14527-02	B-6
65R-R1381-00	C-2	GU2-U377C-30-P0	C-12	GJ3-U5578-00	D-6	GU2-U785H-00	D-8	67X-13183-00	B-10	62T-14527-11	B-9
GP7-U142A-11	D-14	GU2-U377H-01	C-12	EW2-U5912-01	D-5	GP7-U785J-00	D-8	61X-13200-12	B-10	6K8-14536-11	B-9
GP7-U142K-00	D-14	GU2-U377J-01	C-12	EW2-U5913-01	D-5	EU0-U7856-50	C-10	6J8-13411-00	D-7	6R7-14541-00	B-9
GH1-U143C-30	D-12	F0M-U41B1-03	E-2	EW2-U5920-00	D-5	GJ3-U7856-20	D-7	6J8-13414-00	D-7		E-7
GP3-U1438-00	D-10	F0M-U41B1-12	E-3	GA9-U724C-00	D-11	EU0-U821D-00	C-10	62T-13555-00-8P	B-6	6R7-14542-00	B-9
GH3-U146E-00	C-3	F0M-U41B1-21	E-3	GP7-U724D-00	D-11	GP7-U8211-00	C-10	62T-13556-00	B-6	6K8-14547-01	B-9
GK5-U146F-00	D-11	F0M-U41B1-30	E-3	GP7-U724E-00	D-11	EU0-U8221-30	C-10		E-5	583-14561-00	B-9
EU0-U1461-02	D-11	F0M-U41B2-00	E-3	GA9-U724F-01	D-11	F0X-U8221-00	C-10	62T-13566-00	B-6		E-7
GU2-U1481-10	D-11	F0M-U41B2-10	E-3	F0M-U7242-00	D-11	GJ8-U824C-00	C-10		E-5	6K8-14563-00	B-8
GP7-U155D-00	D-12	F0P-U41B2-00	E-2	GD0-U7249-00-05	C-4	GH3-U883M-30	C-15	62T-13610-00	B-6		E-7
GP7-U155F-00	D-12	F0V-U41DB-00	E-2	GD0-U7249-00-10	C-4	GT3-U883J-00	C-15	62T-13624-00	B-6	6K8-14564-00	B-8
GU2-U1552-00	D-12	F0V-U41DB-10	E-3	F0M-U7252-00	D-11	GJ3-U892F-01	D-10		E-5		E-7
FN8-U1624-00	C-14	F0V-U41E1-30	E-2	EU0-U7354-00-01	B-3	62T-W0001-02	E-5	62T-13674-00	B-7	6R7-14569-00	B-9
GU2-U2117-00	D-4	F0V-U41E1-40	E-3	EU0-U7354-00-03	B-3	65U-W0001-20	E-5		E-5	6K8-14589-00	B-9
GU2-U2118-00	D-4	F0M-U41F6-00	E-2	EU0-U7354-00-05	B-3	62T-W0004-00	B-6	47X-14133-00	B-8	62T-14613-00	B-11
GU2-U213F-01	D-4	F0M-U41F6-11	E-3	EU0-U7354-00-10	B-3	62T-W0090-03-8P	B-2	812-14147-00	B-8		E-5
GU2-U213G-00	D-4	F0P-U41G1-00	E-2	EU0-U7354-00-20	B-3	67E-W0093-00	E-7		E-7	62T-14615-01	B-12
GJ3-U2501-20	D-2	GA9-U411B-00	E-4	GA9-U7525-00	D-10	62T-11111-00-94	B-2	439-14186-00	B-9	62T-14625-00	B-12
GJ3-U251D-21	D-2	GU2-U411H-00	D-15	GJ3-U755J-00	D-10	62T-11181-00	B-2	830-1423A-64	B-8	62T-14711-10-9P	B-11
GJ3-U251E-21	D-2	GJ3-U4114-52	D-15	GJ3-U7550-00	D-10		E-5	3G2-14231-24	B-8	62T-14712-00-9P	B-11
GH3-U2512-20	D-2	F0V-U415B-00	E-3	GJ3-U7555-00	D-10	62T-11311-00-94	B-2	3G2-14231-26	B-8	62T-14721-00-94	B-11
GJ3-U2519-60	D-2	F0V-U415B-10	E-2	EU0-U756E-00	D-5	6E5-11325-00	B-2	812-14235-00	B-8	62T-14749-00	B-11
GJ3-U252C-20	D-2	GJ3-U416H-00	E-3	GJ3-U7560-01	D-10	6M6-11351-A2	B-2		E-7		E-5
GJ3-U252D-60	D-2	F0M-U417B-31	D-15	GJ3-U7570-00	D-10		E-5	822-14235-00	B-9	63N-14752-30	B-12
GU2-U266B-30	C-12	F0M-U417D-31	D-15	GJ1-U7578-01	D-11	6E5-11372-00	B-6		E-7	62T-14771-00-94	B-12
GJ3-U266C-02	D-6	F0M-U417E-31	D-15	GJ1-U7578-11	C-14	62T-11400-02	B-4	62T-14243-01	B-6	61X-14916-15	E-7
GJ3-U266C-31	C-12	F0M-U417F-30	D-15		D-10	6M6-11412-00	B-4	62T-14251-10	B-2	61X-14916-16	B-9
GJ3-U2663-01	C-11	F0M-U417G-30	D-15	GJ1-U759B-00	D-9	6M6-11422-00	B-4	6R7-14253-00	B-9	65U-14923-10	B-9
GJ3-U2664-02	C-13	F0M-U417H-30	D-15	GJ1-U759C-00	D-9	6M6-11431-00	B-4	62T-14255-00	B-7		E-7
GU2-U271B-00	D-5	F0M-U417J-30	D-15	GH1-U759D-00	D-7	6M6-11442-01	B-4	62T-14283-00	B-7	3KW-14932-00	B-8
GJ3-U273B-00	C-5	GA9-U418F-00	E-2	GD0-U761D-00	C-14	82M-11515-00	B-4	62T-14284-01-8P	B-6	6K8-14946-10	B-8
GU2-U351H-10	D-2		E-3	GH3-U7711-00	D-8	61X-11603-01	B-4	62T-14293-00	B-8		E-7
GU2-U351J-10	D-2		E-4	GJ3-U775B-01	D-7	61X-11604-01	B-4	62T-14301-03	B-8	62T-15100-00-8P	B-2
GH3-U351M-50	D-2	GU2-U419C-01	E-2	GU2-U776C-00	D-7	61X-11605-01	B-4	62T-14302-03	B-8	63N-15761-00	B-12
GH3-U351M-60	D-2		E-3	GJ3-U778B-00	D-7	62T-11631-02-92	B-4	62T-14419-00	B-7	6R7-21415-01-94	B-2
GU2-U351N-10	D-2		E-4	GJ3-U778C-00	D-7	62T-11633-00	B-4	62T-14435-00	B-7	6R7-21425-01-94	B-2
GU2-U351P-10	D-2	GJ3-U474A-01	D-6	GJ3-U778D-00	D-7	62T-11635-02	B-4	62T-14451-00	B-7	EU0-23814-01	D-12

NUMERICAL INDEX

PART NO.	GRID NO.	PART NO.	GRID NO.	PART NO.	GRID NO.	PART NO.	GRID NO.	PART NO.	GRID NO.	PART NO.	GRID NO.
EU0-23814-30	D - 12	63M-51312-02-94	C - 2	GU2-6378D-01	D - 5	6M6-81365-A0	C - 6	90101-069U0	D - 5	90119-10M07	B - 2
62T-24313-01	B - 6	63M-51315-02-94	C - 2	GJ3-63850-03	D - 5		E - 5	90105-089U1	C - 3	90119-10M17	B - 12
62T-24314-01	B - 6	63N-51323-10	C - 4	F0M-641B1-20	E - 4	6M6-81800-10	C - 7	90105-10M60	B - 11	90119-10M56	B - 2
6R3-24377-00	B - 12	62T-51348-00	C - 3	F0M-641B2-20	E - 4	3AJ-81809-00	C - 7	90105-10M88	B - 12	90119-109U8	C - 4
63N-24378-00	B - 11	6R8-51367-01	C - 2	F0V-641DB-20	E - 4	6M6-81820-00	C - 7	90109-06M66	B - 7	90149-05904	C - 4
6K8-24411-20	B - 8		E - 5	F1F-641E2-20	E - 4	6M6-81826-00	C - 7	90109-08M56	B - 2	90149-069U9	D - 14
	E - 7	63M-51367-00	C - 4	F0V-6415B-20	E - 4	6M6-8183E-01	C - 7	90109-10M47	C - 6	90159-059U2	C - 12
6R7-24412-01	B - 9		E - 5	GH3-6418D-00	D - 8	6M6-81830-00	C - 7	90110-05908	D - 12		D - 12
6M6-24413-01	B - 8	63M-51368-00	C - 2	GU2-6516L-00	C - 11	6M6-81840-10	C - 7	90110-089U1	D - 9	90159-069U1	D - 14
6K8-24421-10	B - 8		E - 5	GP7-6517C-00	C - 12	11H-81844-00	C - 7	90116-08M60	B - 6	90169-049U1	D - 9
	E - 7	62E-51673-00	C - 3	GU2-6517D-00	C - 12	6M6-81844-00	C - 8	90119-05M02	B - 7	90169-059U1	D - 2
65U-24421-00	B - 8	61L-5169A-00	B - 6	GU2-6517F-01	C - 12	26H-81847-00	C - 7	90119-059U4	D - 10	90170-22187	B - 14
6K8-24431-20	B - 8	GJ8-60469-01	C - 4	GU2-6517R-00	C - 11	6M6-81850-00	C - 7	90119-06803	C - 11	90179-06811	C - 5
	E - 7	FN8-6131B-00	D - 13	EW2-65772-00	D - 10	6M6-81865-00	C - 7	90119-06808	C - 11	90179-08M15	B - 6
6K8-24452-10	B - 8	GH1-6141B-00	D - 12	EU0-65901-01	D - 15	6M6-81866-00	C - 7	90119-06819	D - 5	90179-10800	C - 4
70R-24489-00	D - 8	GH1-6141D-01	D - 13	EU0-65986-00	D - 15	6M6-81921-00	C - 8	90119-06820	D - 5	90183-06902	C - 11
65U-24492-00	B - 8	GU2-6143G-00	D - 12	GJ1-6721B-00	B - 3	68N-81940-00	C - 8	90119-06853	D - 5		C - 12
65U-24500-01	B - 14	GU2-61433-00	D - 13	GU2-67250-01	D - 12	6M6-81960-A0	C - 8	90119-06854	C - 10		C - 13
6R7-24524-00	B - 14	GU2-61467-00	D - 13	GJ1-67255-00	D - 12	EU0-82110-09	C - 10	90119-069UB	C - 3	90201-06M31	B - 7
70R-24543-00	D - 8	GH3-61468-00	D - 13	EW2-67256-00	D - 12	62L-82117-20	C - 9	90119-069UC	C - 4	90201-068M4	C - 3
6K8-24560-10	B - 14	F0M-61469-00	D - 13	EW2-67257-01	D - 12	63N-82217-00	C - 9	90119-069UD	C - 2	90201-08929	C - 11
278-27114-00	D - 5	GU2-61541-00	D - 12	EW2-67258-01	D - 12	63N-82217-10	C - 9	90119-069UH	C - 11	90201-099U1	C - 11
62T-41113-00-9M	B - 11	EU0-61588-00	D - 13	EW2-67259-01	D - 12	6K8-82150-01	C - 8		C - 12	90201-099U3	B - 3
62T-41114-01	B - 12	A00-61624-60	D - 5	GK5-67267-10	D - 11	6G1-82151-00	C - 8		C - 13	90201-109U6	D - 6
	E - 5	FN8-61651-01	D - 2	GJ1-6753B-02	D - 10	6K8-82159-00	C - 8	90119-069UJ	C - 12	90201-10940	D - 13
62T-41121-00-9M	B - 12	EU0-61652-00	B - 13	GH6-67577-01	D - 10	62E-82351-01	C - 9		D - 10	90201-20M04	B - 4
62T-41122-00	B - 12		C - 3	EW2-67618-00	C - 14	62E-82352-01	C - 9	90119-069UK	C - 5	90201-248M5	B - 5
	E - 5		D - 2	FN8-6771K-00	D - 8	62T-82361-00	C - 9	90119-08M11	B - 11	90202-229U1	B - 14
62T-41123-01-9M	B - 12	GP7-61652-00	D - 10	FJ0-67713-00	D - 8	62E-82371-11	C - 9	90119-08M55	B - 2	90267-329UR	D - 9
62T-41124-00	B - 12	EW2-62140-00	D - 8	FJ0-67714-02	D - 8	63N-82553-00	C - 9	90119-08M96	B - 2	90267-40935	D - 7
	E - 5	EW2-62142-00	D - 8	FJ0-67716-01	D - 8	62T-82560-10	C - 9	90119-08806	D - 12	90267-40937	C - 11
6M6-44517-A1-5B	B - 2	EW2-62149-00	D - 4	GH3-67743-01	D - 9	6R7-83623-40	C - 8	90119-08817	B - 3	90267-48802	B - 14
63N-44532-01	B - 2	GJ3-6215F-00	D - 4	GJ1-67743-01	D - 8	6R7-83623-50	C - 9	90119-089UE	C - 3		B - 15
663-45119-00	B - 6	GP7-62159-01	D - 4	FJ0-67766-00	D - 7	63N-83623-00	C - 8	90119-089UF	C - 4		C - 10
6K8-45127-00	C - 4	EU0-62241-30	D - 11	EU0-67767-31	D - 8	682-84385-01	B - 13	90119-089UL	C - 4		C - 12
62T-45127-00	B - 5	EU0-62280-00	C - 14	EU0-67816-30	B - 14	62T-85515-00	C - 6	90119-089UR	B - 3		C - 13
	E - 5	EU0-62282-00	C - 14	EU0-67817-00	B - 14	62L-8552A-00-8P	C - 8	90119-089UU	B - 3		D - 3
65V-45318-00	C - 2	EU0-62283-00	C - 14	FX1-67869-00	D - 7	6M6-8552E-01	C - 8	90119-089U5	C - 5		D - 4
65U-45332-02-94	C - 4	EU0-62285-01	C - 14	F0M-6820A-00	C - 10	62T-85520-00	C - 6	90119-089U6	C - 11		D - 7
61L-45378-00	C - 4	GU2-6252E-10	D - 2	GU2-6822E-01	C - 11	62T-85533-00	C - 6		C - 5	90267-489U1	B - 14
65R-45511-00	C - 2	GU2-6252F-10	D - 2	FJ0-68222-01	C - 10	62T-85540-01	C - 8	90119-089U7	C - 8	90267-489U2	D - 8
62T-45526-00	B - 4	GJ1-62663-00	C - 5	F0M-68238-00	C - 10	66D-85542-00	C - 8		D - 13	90267-489U7	B - 13
61X-4581J-00	B - 5	FN8-6269B-00	C - 3	FK7-68310-07	D - 12	62T-85550-00	C - 6		D - 9		C - 14
6M6-45813-22-8P	B - 5	GT3-6273C-00	C - 4	FK7-68312-02	D - 12	62T-85560-00	C - 6	90119-089U9	C - 11	90267-489U8	D - 2
6M6-45813-32-8P	B - 5	GJ1-62733-00	C - 5	FK7-68313-02	D - 12	62E-85570-11	C - 9	90119-10M00	B - 2	90269-07923	D - 4
68N-5112T-00	C - 14	GU2-62875-01	C - 11	EW2-68348-00	D - 12	6M6-85580-00	C - 6	90119-10M01	B - 2	90280-05013	C - 6
6K8-51129-00	B - 11	GH1-63774-01	D - 6	6M6-8132W-00	C - 8	90101-069U0	C - 12	90119-10M02	B - 2	90331-12M05	C - 2
	B - 2	GU2-6378C-00	D - 5	6R8-81337-00-8P	C - 6		C - 13	90119-10M03	B - 2	90340-08M04	B - 2

NUMERICAL INDEX

PART NO.	GRID NO.	PART NO.	GRID NO.	PART NO.	GRID NO.	PART NO.	GRID NO.	PART NO.	GRID NO.	PART NO.	GRID NO.
90380-12M29	B - 2	90464-32801	C - 10	90601-170UG	D - 10	93101-25M50	E - 6	9538R-06700	C - 13	97880-06016	C - 9
	C - 6		C - 14	90601-200U1	C - 14	93101-25M55	C - 4		C - 3	97880-06030	C - 9
90387-06M60	C - 2		D - 7		D - 10		E - 6	95380-06700	C - 7	97902-04122	C - 6
90387-06922	C - 11	90465-06M86	C - 8	90601-200U4	C - 14	93101-25M56	C - 4	9572R-05300	C - 10	97902-05125	C - 6
90387-08M08	C - 3	90465-08M69	B - 10	90601-200U7	D - 4		E - 6		C - 14	97980-05330	B - 8
90430-08020	B - 2	90465-11M10	B - 10	90601-20009	C - 8	93101-36M46	B - 4	9572R-06300	C - 11	98580-05018	B - 8
	E - 5		B - 11	90601-20016	C - 14		E - 5		C - 12	98780-04015	B - 2
90430-13909	C - 14		B - 12	90604-80759	C - 14	93102-17M49	C - 2		C - 13	98980-04008	B - 14
90430-16910	D - 10		B - 14	90604-80775	C - 14		E - 5		C - 15		
90445-07008	B - 10		B - 6	90604-80793	D - 10	93102-17M50	C - 2		D - 11		
90445-07009	B - 10		C - 4	90604-80794	D - 10		E - 5		D - 13		
90445-09M21	C - 4		C - 9	90605-502U2	C - 11	93102-25M34	C - 2		D - 2		
90445-10MA1	B - 14	90465-11M59	B - 11	91490-16010	D - 8		E - 6		D - 5		
90445-10MG0	B - 14	90465-11829	B - 14	91790-05040	D - 8	93102-36M33	B - 4		D - 6		
90445-10MG1	B - 14		C - 3	92903-06600	B - 12		E - 5	9572R-08300	C - 11		
90445-10MG2	B - 14		C - 4		B - 6	93103-32M01	B - 4		C - 14		
90445-10MG3	B - 14		D - 10		B - 7		E - 5		D - 5		
90445-11M34	B - 10		D - 4		C - 7	93210-13M63	B - 7	9572R-10300	D - 13		
90445-11903	D - 8		D - 7	92903-08600	B - 11	93210-17MA4	C - 4		D - 6		
90445-14M10	B - 12		D - 8		C - 7		E - 5	97013-06012	B - 7		
90445-14M21	B - 11	90465-12M56	B - 14	9299R-05200	C - 14	93210-35M72	C - 4	97013-06016	B - 6		
90445-14M24	B - 11	90467-089U1	C - 10	9299R-06200	C - 11		E - 5	97013-06020	B - 7		
90445-14M25	B - 11	90467-11032	D - 8		C - 12	93210-46M16	C - 2	97013-06025	B - 12		
90445-14898	C - 3	90468-02001	B - 10		C - 13		E - 6		B - 6		
90445-18M03	C - 2	90480-06M43	C - 9		C - 15	93305-205U1	C - 2	97013-06035	B - 6		
90445-19895	C - 14	90480-06M46	C - 2		D - 12	93305-30601	B - 4	97013-06070	B - 12		
90445-19896	C - 14	90501-14M73	C - 7		D - 13	93306-205U0	C - 2	97013-08035	C - 7		
90445-21M00	B - 12	90560-22281	D - 12		D - 2	93306-205U6	C - 4	97013-08040	C - 7		
90445-21M02	B - 11	90600-91060	C - 10		D - 5	93306-207U2	B - 4	97013-08075	B - 11		
90446-07M18	B - 10	90600-91736	B - 13		D - 6	93306-307U3	B - 4	9708R-06020	C - 12		
90446-07M48	B - 10		B - 14	9299R-08200	C - 15	93310-320U2	B - 4	9708R-06030	D - 12		
90446-14M61	B - 14		B - 15		D - 5	93310-525U3	B - 4	97095-06010	C - 8		
90446-14M62	B - 14		C - 10	9299R-10200	D - 13	93430-47M04	C - 4	97095-06016	C - 9		
90446-20M31	B - 11		C - 14		D - 6	93440-25M08	C - 7	97095-06025	C - 6		
90446-20M65	B - 12		D - 7	9299R-14200	D - 10	93440-80023	B - 4	97095-06035	B - 10		
90446-24M89	B - 13	90600-91755	C - 3	92990-05600	B - 6	93450-18M06	C - 7	97095-08025	C - 8		
90450-14M05	B - 12	90600-918U3	D - 11		D - 8	93450-21053	B - 4	9778R-50112	C - 14		
90450-18M09	B - 13	90600-944U8	C - 10	92990-06100	C - 7	93603-10049	B - 5	9778R-60116	D - 11		
90450-70M03	B - 12	90601-11062	D - 8	92990-06600	C - 6	93604-07141	B - 5	97780-04110	D - 7		
90450-99M01	B - 12	90601-118UF	B - 13		C - 8	93605-12M21	B - 11	97780-60525	C - 8		
90450-99M02	B - 12		C - 14		C - 9	93606-12019	B - 2	97802-04008	C - 6		
90450-99M06	B - 12		C - 2	92995-06100	C - 8		C - 2	9788R-05025	C - 14		
90464-06M29	C - 8		C - 3		C - 9		C - 3	97880-03008	D - 12		
90464-10M38	B - 10		D - 10	92995-06600	B - 10		C - 4	97880-05012	B - 9		
90464-15M11	B - 11	90601-142U6	D - 13		C - 6		C - 6	97880-05016	B - 6		
90464-32801	B - 13	90601-152U3	D - 7		C - 8	94702-00195	C - 9	97880-05025	D - 12		
	B - 14	90601-155U4	D - 9	92995-08600	C - 8	94709-00195	C - 9	97880-06016	C - 6		
	B - 15	90601-162U5	D - 8	93101-25M50	C - 2	9538R-06700	C - 12		C - 8		