

PARTS CATALOGUE

VMX12P	(5GK9)	U49
VMX12PC	(5GKA)	CALIFORNIA
VMX12P	(5GKB)	CANADA

VMX12P/VMX12PC
PARTS CATALOGUE
©2001 by Yamaha Motor Co., Ltd.
1st Edition, May 2001
All rights reserved.
Any reprinting or unauthorized use
without the written permission of
Yamaha Motor Co., Ltd.
is expressly prohibited.

A3



A4

FOREWORD

This Parts Catalogue is related to the parts for the model(s) in the below frame. When you are ordering replacement parts, please refer to this Parts Catalogue and quote both part numbers and part names correctly.

VMX12P/VMX12PC(5GK9,5GKB/5GKA)

1. Modifications or additions which have been made after issue of the Parts Catalogue will be announced in the Yamaha Parts News.
It is advisable that you make necessary corrections to the Parts Catalogue according to the Yamaha Parts News.

2. Abbreviations

The Following abbreviations are used in this Parts Catalogue.

- "UR" Use specified parts number.
- "UN" Use as many as needed.
- "AP" Alternate Parts
- "LM" Local Made (Parts need to be ordered locally)
- "F#" Frame No. (Applicable machine No.)

3. Parts, which are to be supplied in an assembly, are listed with a dot(.) in front of the part name as shown below.

EXAMPLE

CARBURETOR ASSY
.JET, PILOT
.NOZZLE, MAIN

4. Number of component for assembly

The numeral appearing to the right of each component part indicates the quantity of parts for each assembly unit.

EXAMPLE

PART NO.	DESCRIPTION	Q'TY	REMARKS
2F5-83310-60	FRONT FLASHER LIGHT ASSY	2	
115-83311-60	.BULB (6V-18W)	1	
1M1-83309-60	.REFLECTOR	1	

5. Applicable colors of graphics are represented in the "REMARKS" as shown below.

PART NO.	DESCRIPTION	Q'TY	REMARKS
2N4-24110-00-X5	.FUEL TANK COMP.	2	MXR
3J1-24240-10	.GRAPHIC, FUEL TANK	1	for MXR

6. Applicable Serial No.

Engine Serial No.

Frame Serial No.

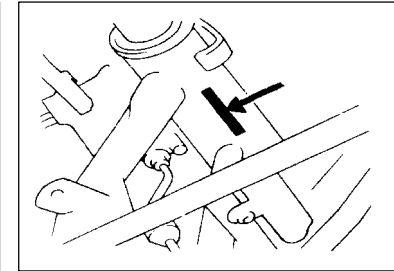
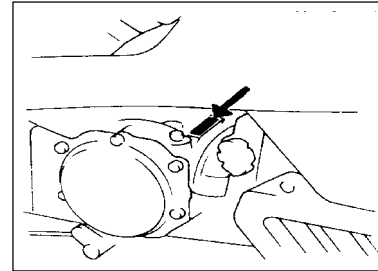

7. Note that the illustrations for reference in finding parts numbers, not to be used for assembling. When assembling, please use the applicable service manual.

8. The asterisk (*) before a reference number indicates modification items after the first edition.

MODEL LABEL

(1) A label called "Model Label" is affixed in the location as indicated in (3) below.
When using this parts catalogue, please be sure to cross-refer the "model code – production code No." in the catalogue to the "model code – production code No." indicated on the Model Label affixed onto the product concerned.

(2) "Model Label" Indication

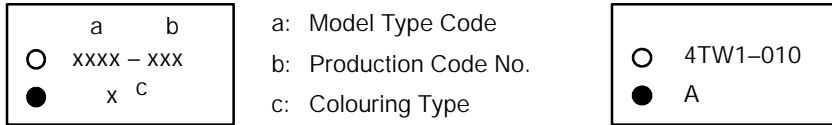

(3) Model Label Affixing Location

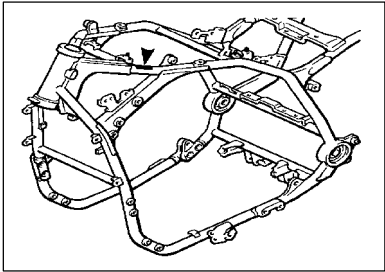

(4) Model Code – Production Code Number of Model Listed in This Parts Catalog

Model Code	Production Code No.	Country (destination)	Model Code	Production Code No.	Country (destination)
5GK9	010	U49			
5GKA	010	CALIFORNIA			
5GKB	010	CANADA			

(5) Colouring Information

Colouring type code	Colour code	Colour Name	Abbreviation
A	003H	NEW SILVER DUST	NSD

FIG. 1 CYLINDER HEAD

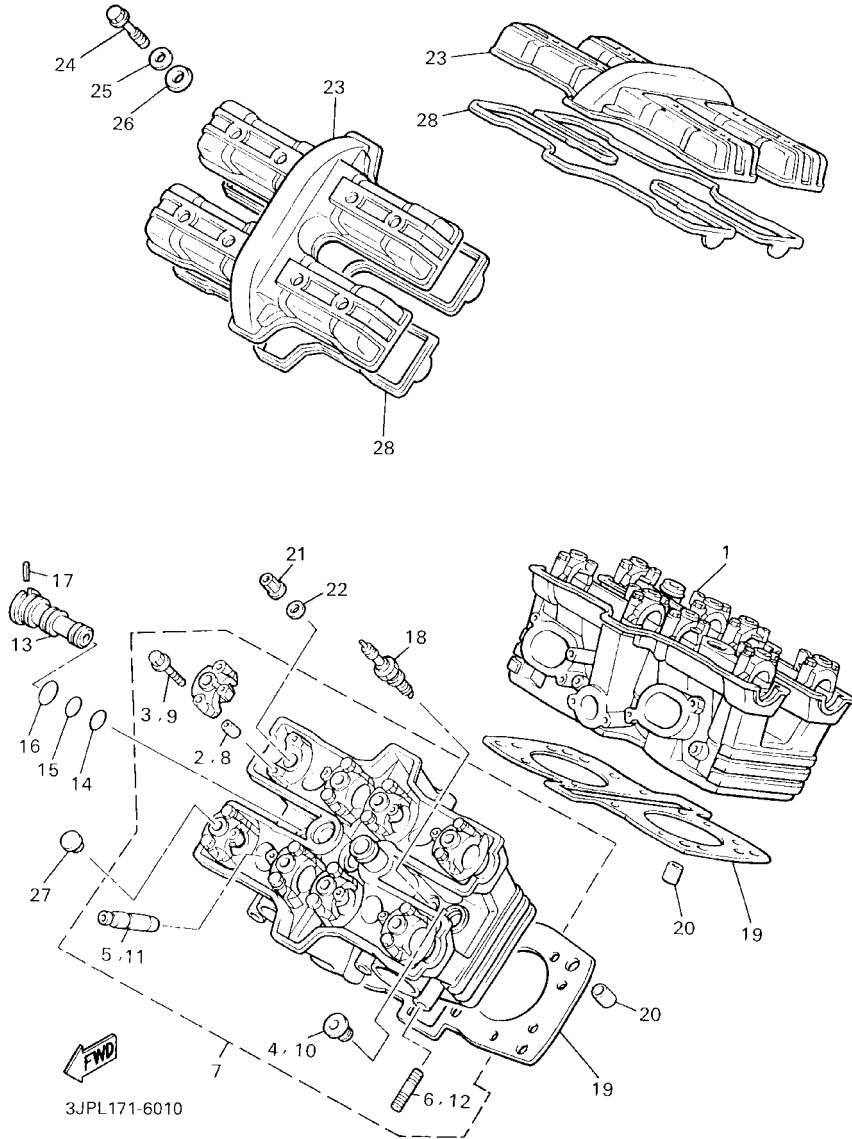

REF. NO.	PART NO.	DESCRIPTION	5GK9	5GKA	5GKB	REMARKS
1	1FK-11101-02	CYLINDER HEAD ASSY	1	1	1	
2	91808-16023	.PIN, DOWEL	16	16	16	
3	90105-06153	.BOLT, FLANGE	16	16	16	
4	90340-20090	.PLUG, STRAIGHT SCREW	3	3	3	
5	30X-11133-10	.GUIDE, INTAKE VALVE	8	8	8	
6	95617-08620	.BOLT, STUD	4	4	4	
7	1FK-W1112-02	CYLINDER HEAD ASSY 2	1	1	1	
8	91808-16023	.PIN, DOWEL	16	16	16	
9	90105-06153	.BOLT, FLANGE	16	16	16	
10	90340-20090	.PLUG, STRAIGHT SCREW	3	3	3	
11	30X-11133-10	.GUIDE, INTAKE VALVE	8	8	8	
12	95617-08635	.BOLT, STUD	4	4	4	
13	26H-12469-01	JOINT 1	2	2	2	
14	93210-16629	O-RING	2	2	2	
15	93210-18322	O-RING	2	2	2	
16	93210-21631	O-RING	2	2	2	
17	90254-03008	PIN, SPRING	2	2	2	
18	94701-00241	PLUG, SPARK (NGK DPR8EA-9)	4	4	4	UR
	94701-00242	PLUG, SPARK (ND X24EPR-U9)	4	4	4	UR
19	26H-11181-00	GASKET, CYLINDER HEAD 1	2	2	2	
20	99530-14016	PIN, DOWEL	4	4	4	
21	90179-10414	NUT	16	16	16	
22	90201-102G9	WASHER, PLATE	16	16	16	
23	1FK-11191-00	COVER, CYLINDER HEAD 1	2	2	2	
24	90119-06218	BOLT, WITH WASHER	16	16	16	
25	90209-11262	WASHER	16	16	16	
26	2GH-1111G-00	RUBBER, MOUNT 1	16	16	16	

FIG. 1 CYLINDER HEAD

REF. NO.	PART NO.	DESCRIPTION	5GK9	5GKA	5GKB	REMARKS
27	90338-10150	PLUG	16	16	16	
28	26H-11193-00	GASKET, HEAD COVER 1	2	2	2	

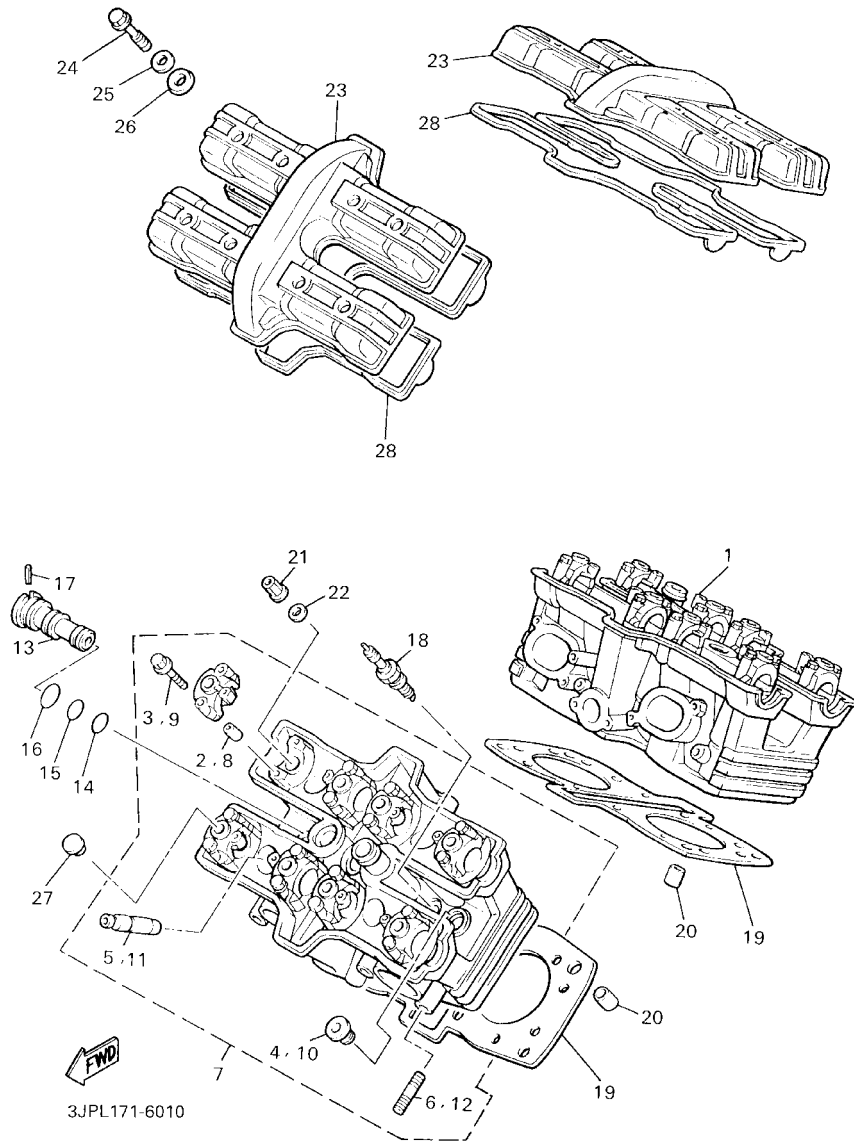
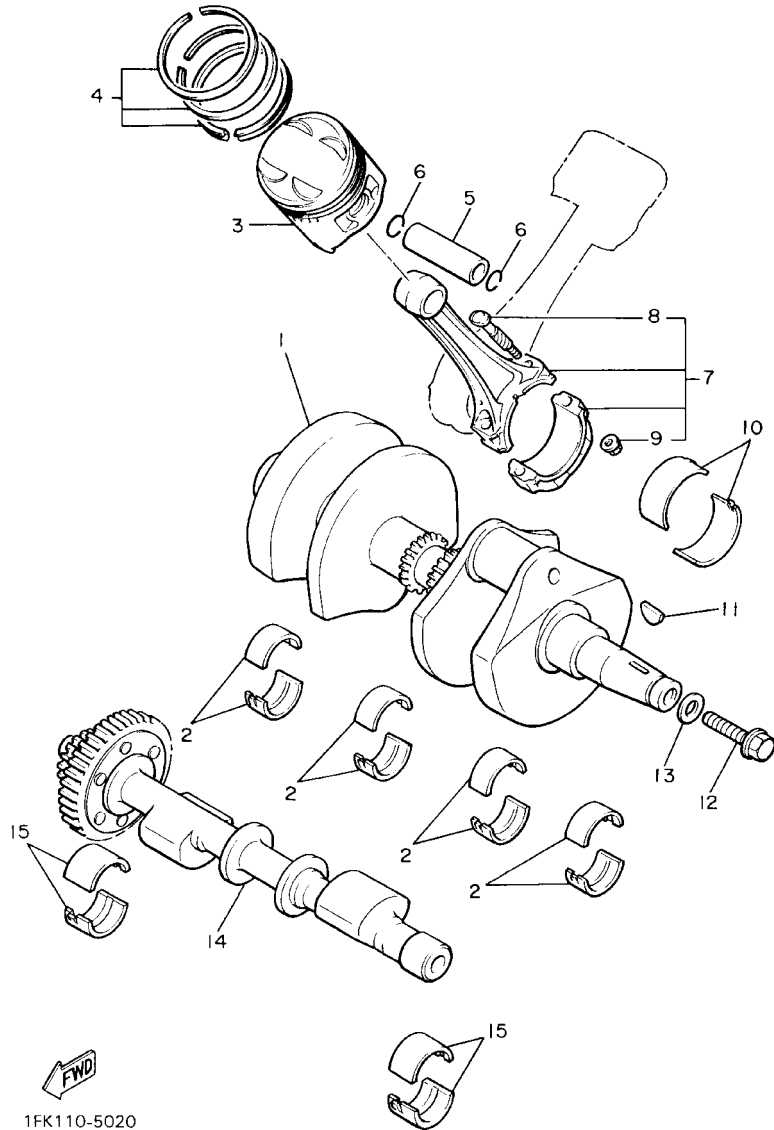
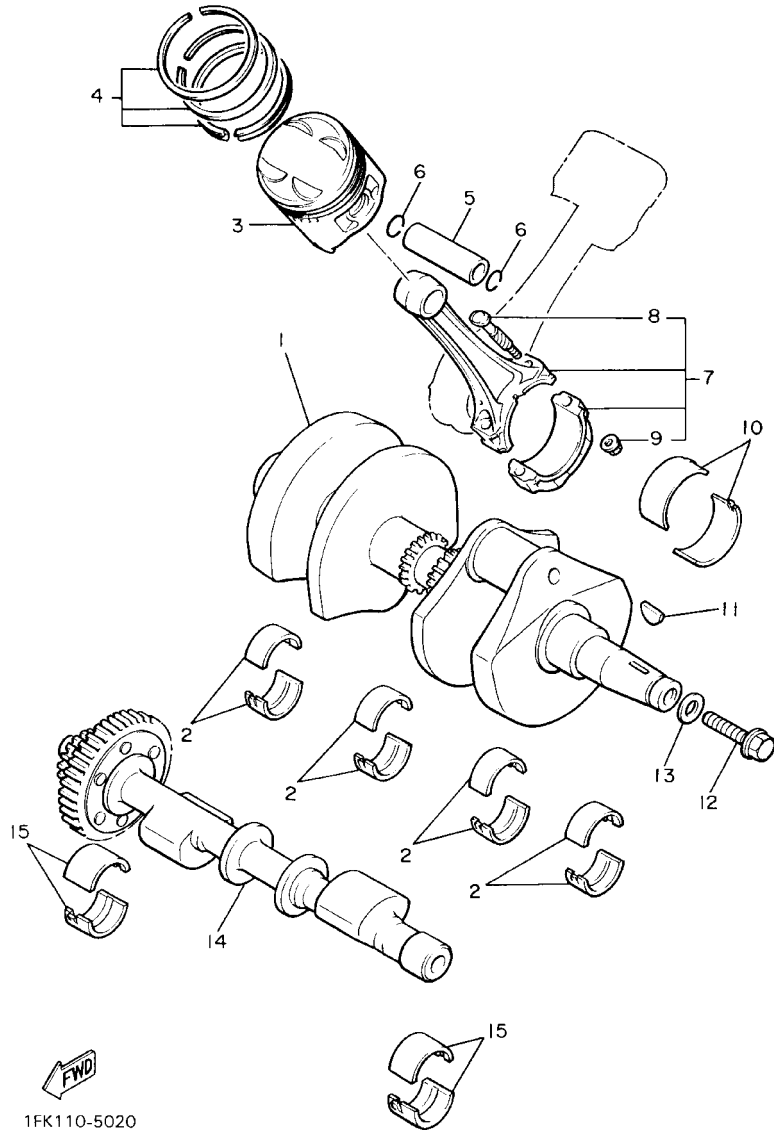

FIG. 2 CRANKSHAFT. PISTON



REF. NO.	PART NO.	DESCRIPTION	5GK9	5GKA	5GKB	REMARKS
1	1FK-11400-00	CRANKSHAFT ASSY	1	1	1	
2	1FK-11416-01	PLANE BEARING, CRANKSHAFT 1	8	8	8	UR BLUE
	1FK-11416-11	PLANE BEARING, CRANKSHAFT 1	8	8	8	UR BLACK
	1FK-11416-21	PLANE BEARING, CRANKSHAFT 1	8	8	8	UR BROWN
	1FK-11416-31	PLANE BEARING, CRANKSHAFT 1	8	8	8	UR GREEN
	1FK-11416-41	PLANE BEARING, CRANKSHAFT 1	8	8	8	UR YELLOW
	1FK-11416-51	PLANE BEARING, CRANKSHAFT 1	8	8	8	UR PINK
	1FK-11416-61	PLANE BEARING, CRANKSHAFT 1	8	8	8	UR RED
3	1FK-11631-00-A0	PISTON (STD)	4	4	4	
	1FK-11635-00	PISTON (0.25MM O/S)	4	4	4	AP
	1FK-11636-00	PISTON (0.50MM O/S)	4	4	4	AP
4	1FK-11610-00	PISTON RING SET (STD)	4	4	4	
	1FK-11610-10	PISTON RING SET (0.25MM O/S)	4	4	4	AP
	1FK-11610-20	PISTON RING SET (0.50MM O/S)	4	4	4	AP
5	3JP-11633-00	PIN, PISTON	4	4	4	
6	93450-19095	CIRCLIP	8	8	8	
7	1FK-11650-01	CONNECTING ROD ASSY	4	4	4	
8	26H-11654-00	.BOLT, CONNECTING ROD	2	2	2	
9	90179-08327	.NUT	2	2	2	
10	1FK-11656-00	PLANE BEARING, CONNECTING ROD	8	8	8	UR BLUE
	1FK-11656-10	PLANE BEARING, CONNECTING ROD	8	8	8	UR BLACK
	1FK-11656-20	PLANE BEARING, CONNECTING ROD	8	8	8	UR BROWN
	1FK-11656-30	PLANE BEARING, CONNECTING ROD	8	8	8	UR GREEN
	1FK-11656-40	PLANE BEARING, CONNECTING ROD	8	8	8	UR YELLOW
	1FK-11656-50	PLANE BEARING, CONNECTING ROD	8	8	8	UR PINK
11	90280-05029	KEY, WOODRUFF	1	1	1	
12	90105-12374	BOLT, FLANGE	1	1	1	

FIG. 2 CRANKSHAFT. PISTON



REF. NO.	PART NO.	DESCRIPTION	5GK9	5GKA	5GKB	REMARKS
13	90201-121H0	WASHER, PLATE	1	1	1	
14	1FK-11500-10	BALANCER ASSY	1	1	1	
15	26H-11413-01	PLANE BEARING, BALANCE WEIGHT	4	4	4	UR BLUE
	26H-11413-11	PLANE BEARING, BALANCE WEIGHT	4	4	4	UR BLACK
	26H-11413-21	PLANE BEARING, BALANCE WEIGHT	4	4	4	UR BROWN
	26H-11413-31	PLANE BEARING, BALANCE WEIGHT	4	4	4	UR GREEN
	26H-11413-41	PLANE BEARING, BALANCE WEIGHT	4	4	4	UR YELLOW
	26H-11413-51	PLANE BEARING, BALANCE WEIGHT	4	4	4	UR PINK
	26H-11413-61	PLANE BEARING, BALANCE WEIGHT	4	4	4	UR RED

FIG. 3 VALVE

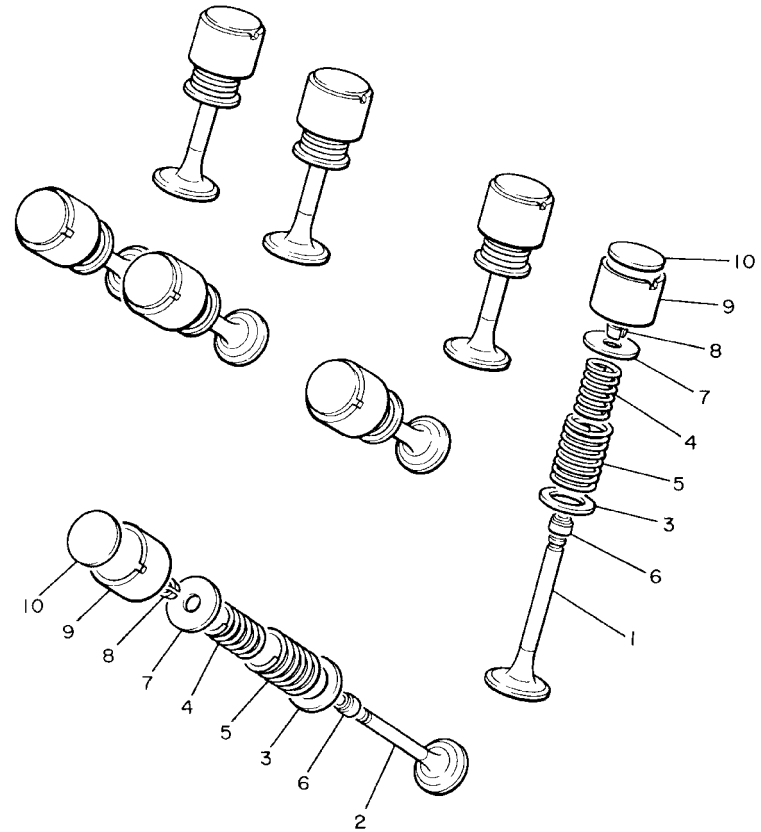

REF. NO.	PART NO.	DESCRIPTION	5GK9	5GKA	5GKB	REMARKS
1	1FK-12111-01	VALVE, INTAKE	8	8	8	
2	1FK-12121-01	VALVE, EXHAUST	8	8	8	
3	26H-12116-00	SEAT, VALVE SPRING	16	16	16	
4	36Y-12113-00	SPRING, VALVE INNER	16	16	16	
5	36Y-12114-00	SPRING, VALVE OUTER	16	16	16	
6	51Y-12119-00	SEAL, VALVE STEM	16	16	16	
7	30X-12117-00	RETAINER, VALVE SPRING	16	16	16	
8	30X-12118-00	COTTER, VALVE	32	32	32	
9	26H-12153-00-Y0	LIFTER, VALVE	16	16	16	
	26H-12153-00-J0	LIFTER, VALVE(O/S)	16	16	16	
10	26H-12168-00	PAD, ADJUSTING (2.00)	16	16	16	UR
	26H-12168-20	PAD, ADJUSTING (2.05)	16	16	16	UR
	26H-12168-40	PAD, ADJUSTING (2.10)	16	16	16	UR
	26H-12168-60	PAD, ADJUSTING (2.15)	16	16	16	UR
	26H-12168-80	PAD, ADJUSTING (2.20)	16	16	16	UR
	26H-12168-A0	PAD, ADJUSTING (2.25)	16	16	16	UR
	26H-12168-F0	PAD, ADJUSTING (2.30)	16	16	16	UR
	26H-12168-H0	PAD, ADJUSTING (2.35)	16	16	16	UR
	26H-12168-K0	PAD, ADJUSTING (2.40)	16	16	16	UR
	26H-12168-M0	PAD, ADJUSTING (2.45)	16	16	16	UR
	26H-12168-R0	PAD, ADJUSTING (2.50)	16	16	16	UR
	26H-12168-U0	PAD, ADJUSTING (2.55)	16	16	16	UR
	26H-12168-W0	PAD, ADJUSTING (2.60)	16	16	16	UR
	26H-12168-Y0	PAD, ADJUSTING (2.65)	16	16	16	UR
	26H-12169-10	PAD, ADJUSTING (2.70)	16	16	16	UR
	26H-12169-30	PAD, ADJUSTING (2.75)	16	16	16	UR
	26H-12169-50	PAD, ADJUSTING (2.80)	16	16	16	UR



1FK110-5030

B6

FIG. 3 VALVE

REF. NO.	PART NO.	DESCRIPTION	5GK9	5GKA	5GKB	REMARKS
10	26H-12169-70	PAD, ADJUSTING (2.85)	16	16	16	UR
	26H-12169-90	PAD, ADJUSTING (2.90)	16	16	16	UR
	26H-12169-E0	PAD, ADJUSTING (2.95)	16	16	16	UR
	26H-12169-G0	PAD, ADJUSTING (3.00)	16	16	16	UR
	26H-12169-J0	PAD, ADJUSTING (3.05)	16	16	16	UR
	26H-12169-L0	PAD, ADJUSTING (3.10)	16	16	16	UR
	26H-12169-N0	PAD, ADJUSTING (3.15)	16	16	16	UR
	26H-12169-T0	PAD, ADJUSTING (3.20)	16	16	16	UR

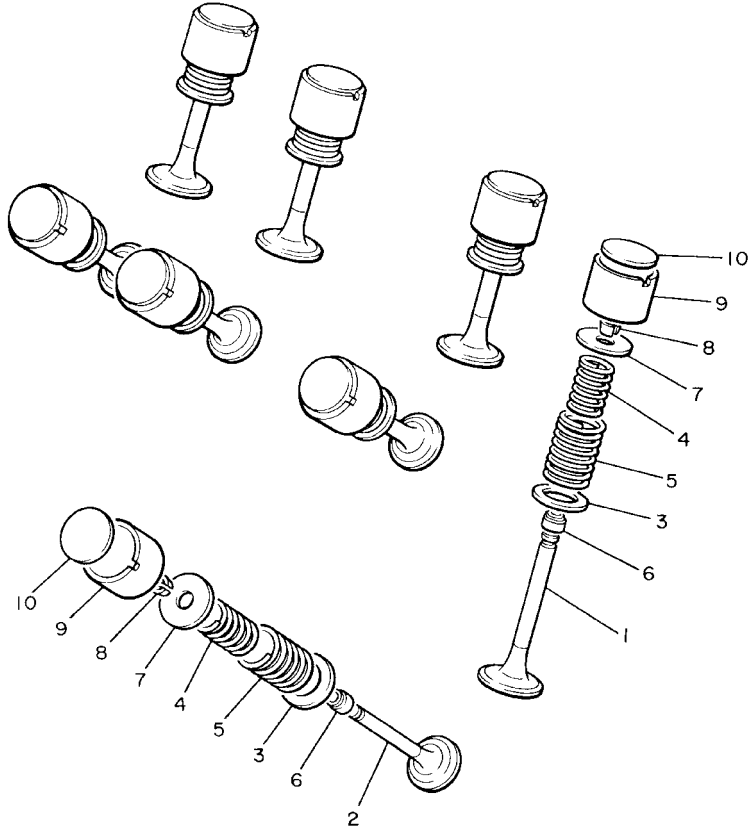



1FK110-5030

FIG. 4 CAMSHAFT. CHAIN



REF. NO.	PART NO.	DESCRIPTION	5GK9	5GKA	5GKB	REMARKS
1	1FK-12171-00	CAMSHAFT 1	2		2	
	2WF-12171-01	CAMSHAFT 1		1		
2	3JP-12171-01	CAMSHAFT 1		1		
3	1FK-12181-00	CAMSHAFT 2	2		2	
	2WF-12181-00	CAMSHAFT 2		2		
4	26H-12176-02	SPROCKET, CAM CHAIN	2	2	2	
5	26H-12177-01	SPROCKET, CAM CHAIN	2	2	2	
6	90105-07342	BOLT, FLANGE	8	8	8	
7	94580-81118	CHAIN (D.I.D 219FTS118LL)	2	2	2	
8	4SV-11498-00	PIN, JOINT	1	1	1	
9	26H-12241-00	GUIDE, STOPPER 2	2	2	2	
10	26H-12251-00	DAMPER, CHAIN 1	2	2	2	
11	26H-12252-00	DAMPER, CHAIN 2	2	2	2	
12	26H-12233-00	PLATE, GUIDE STOPPER 1	1	1	1	
13	95817-08025	BOLT, FLANGE	1	1	1	
14	26H-12210-03	TENSIONER ASSY, CAM CHAIN	2	2	2	
15	3JP-12213-01	GASKET, TENSIONER CASE	2	2	2	
16	91317-06020	BOLT	4	4	4	

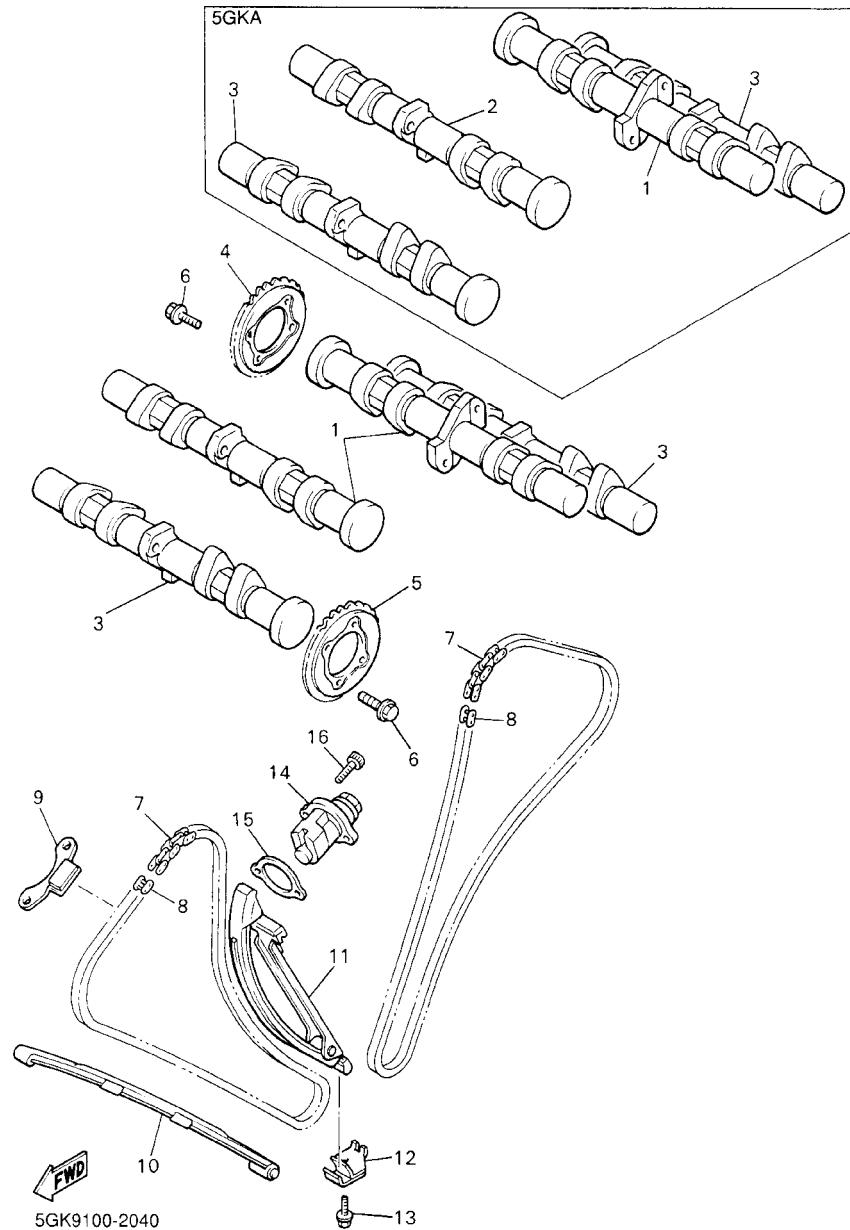
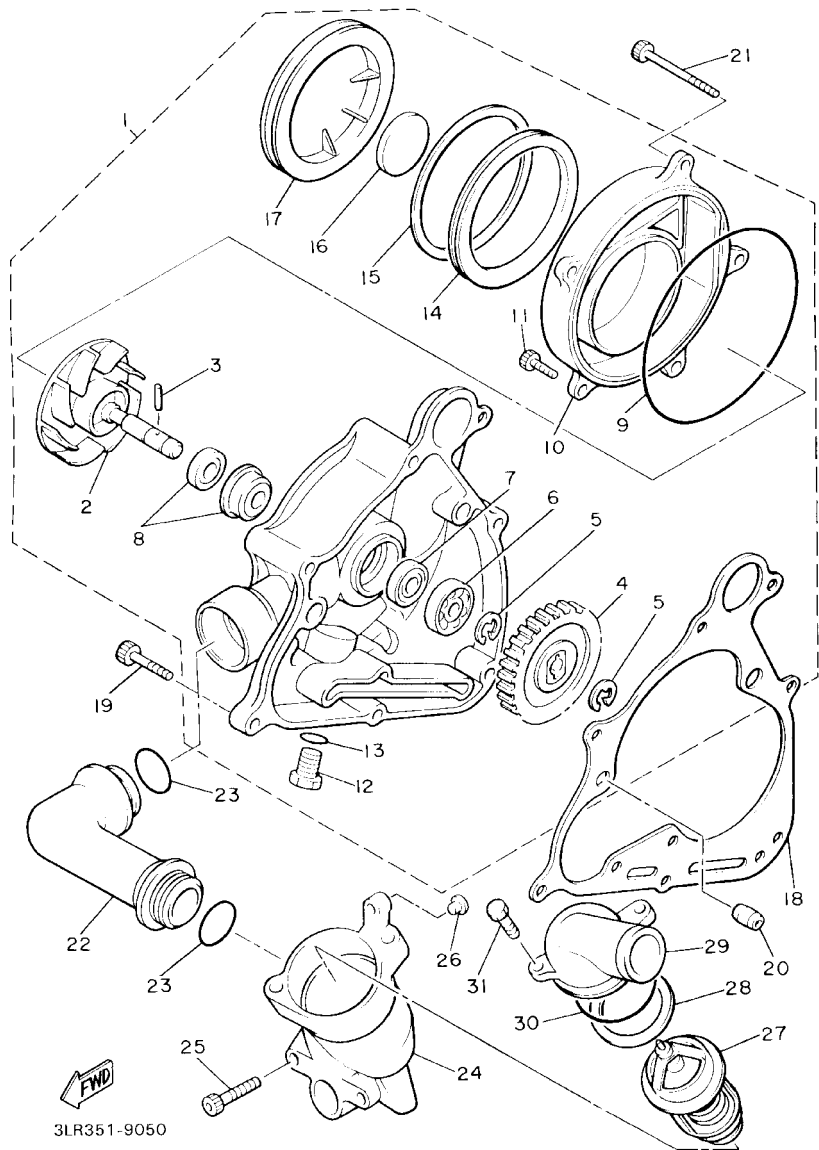

FIG. 5 WATER PUMP

REF. NO.	PART NO.	DESCRIPTION	5GK9	5GKA	5GKB	REMARKS
1	1FK-12420-10	WATER PUMP ASSY	1	1	1	
2	1FK-12450-00	.IMPELLER SHAFT ASSY	1	1	1	
3	93603-14026	.PIN, DOWEL	1	1	1	
4	26H-12459-00	.GEAR, IMPELLER SHAFT (31T)	1	1	1	
5	99009-10400	.CIRCLIP	2	2	2	
6	93306-00006	.BEARING (B6000)	1	1	1	
7	93101-10090	.OIL SEAL	1	1	1	
8	11H-12438-10	.SEAL, MECHANICAL	1	1	1	
9	93211-16591	.O-RING	1	1	1	
10	1FK-12422-00	.COVER, HOUSING	1	1	1	
11	91316-06016	.BOLT	2	2	2	
12	90340-14132	.PLUG, STRAIGHT SCREW	1	1	1	
13	214-11198-01	.GASKET	1	1	1	
14	26H-15337-01	.DAMPER 4	1	1	1	
15	90468-98132	.CLIP	1	1	1	
16	26H-15338-00	.DAMPER, ENGINE MOUNT 5	1	1	1	
17	1FK-15428-00	.COVER, CHAIN CASE 2	1	1	1	
18	3JP-12449-02	GASKET, WATER PUMP	1	1	1	
19	90110-06240	BOLT, HEXAGON SOCKET HEAD	4	4	4	
20	99530-10114	PIN, DOWEL	2	2	2	
21	90110-06241	BOLT, HEXAGON SOCKET HEAD	3	3	3	
22	1FK-12446-00	JOINT	1	1	1	
23	93210-27194	O-RING	2	2	2	
24	1FK-12417-00	HOUSING, THERMOSTAT	1	1	1	
25	91317-06020	BOLT	2	2	2	
26	90338-06134	PLUG	1	1	1	
27	11H-12410-01	THERMOSTAT ASSY	1	1	1	

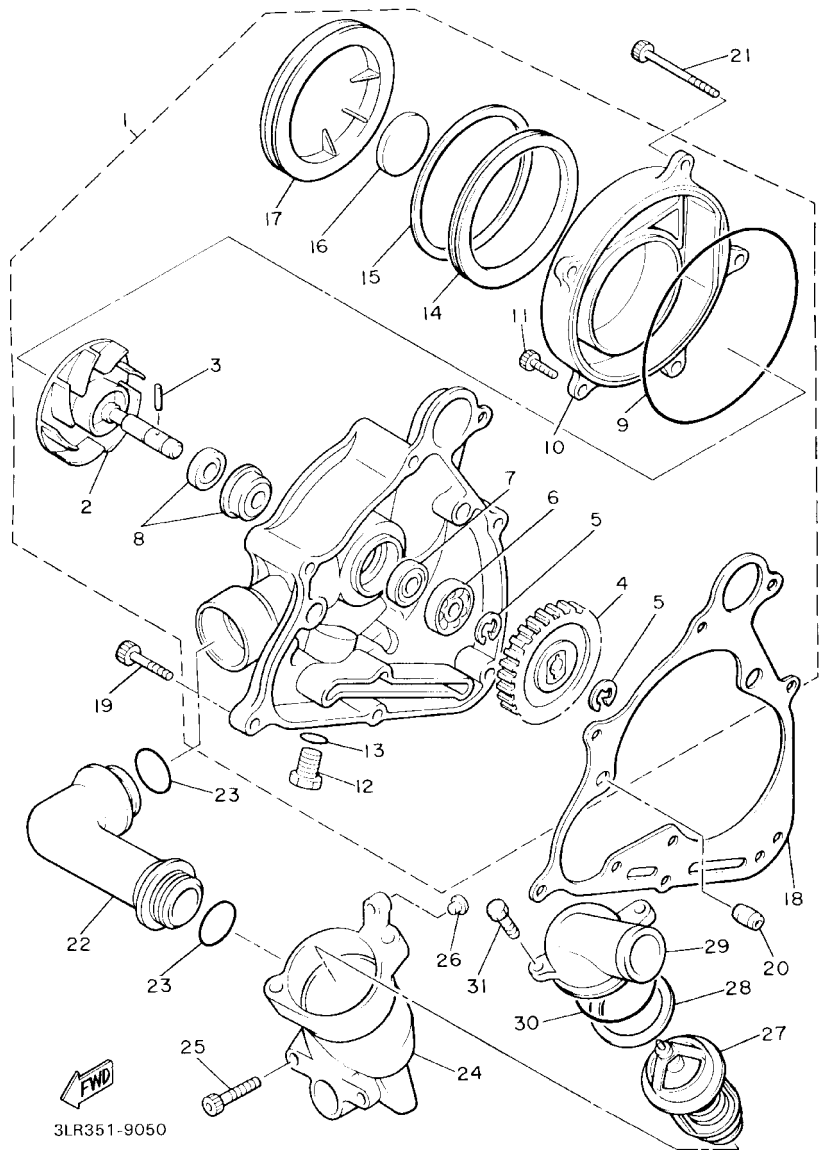
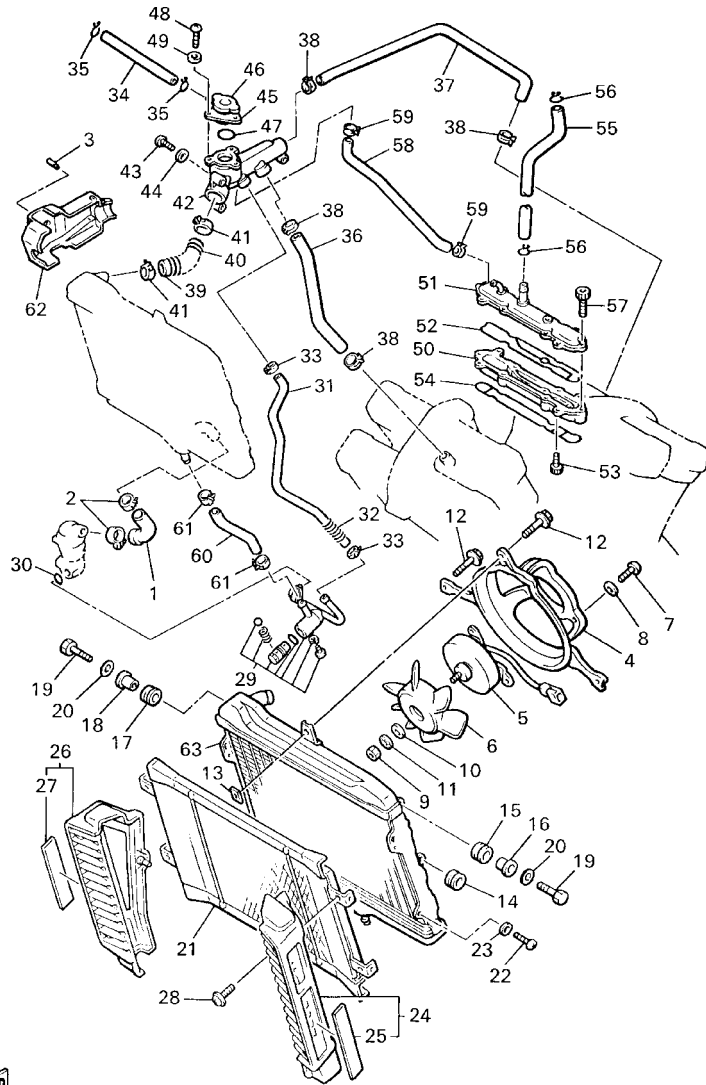

FIG. 5 WATER PUMP

REF. NO.	PART NO.	DESCRIPTION	5GK9	5GKA	5GKB	REMARKS
28	11H-12412-01	SEAL, THERMOSTAT	1	1	1	
29	26H-12413-00	COVER, THERMOSTAT	1	1	1	
30	93210-45511	O-RING	1	1	1	
31	90110-06084	BOLT, HEXAGON SOCKET HEAD	2	2	2	

FIG. 6 RADIATOR. HOSE



FWD

3JPU171-8060

REF. NO.	PART NO.	DESCRIPTION	5GK9	5GKA	5GKB	REMARKS
1	1FK-12578-00	HOSE 3	1	1	1	
2	90460-38241	CLAMP, HOSE	2	2	2	
3	90338-05151	PLUG	1	1	1	
4	1FK-12620-00	AIR SHROUD ASSY	1	1	1	
5	26H-12630-00	MOTOR ASSY	1	1	1	
6	26H-12611-00	FAN	1	1	1	
7	98507-05008	SCREW, PAN HEAD	3	3	3	
8	92907-05600	WASHER, PLATE	3	3	3	
9	95307-05600	NUT	1	1	1	
10	11H-12673-00	WASHER	1	1	1	
11	92907-05300	WASHER	1	1	1	
12	11H-12675-00	BOLT, BLOWER HOLDING	3	3	3	
13	1AA-12535-00	PLATE	3	3	3	
14	90480-14052	GROMMET	2	2	2	
15	90480-18276	GROMMET	2	2	2	
16	90387-07037	COLLAR	2	2	2	
17	90480-19283	GROMMET	2	2	2	
18	90387-06033	COLLAR	2	2	2	
19	97007-06020	BOLT	4	4	4	
20	92907-06600	WASHER, PLATE	4	4	4	
21	1FK-12467-00	COVER, RADIATOR	1	1	1	
22	98507-05012	SCREW, PAN HEAD	4	4	4	
23	92907-05600	WASHER, PLATE	4	4	4	
24	1FK-1240J-00	RADIATOR COVER ASS'Y	1	1	1	
25	1FK-12535-00	.PLATE	1	1	1	
26	1FK-1240K-00	RADIATOR COVER ASS'Y 2	1	1	1	
27	1FK-12537-00	.PLATE 2	1	1	1	

FIG. 6 RADIATOR. HOSE

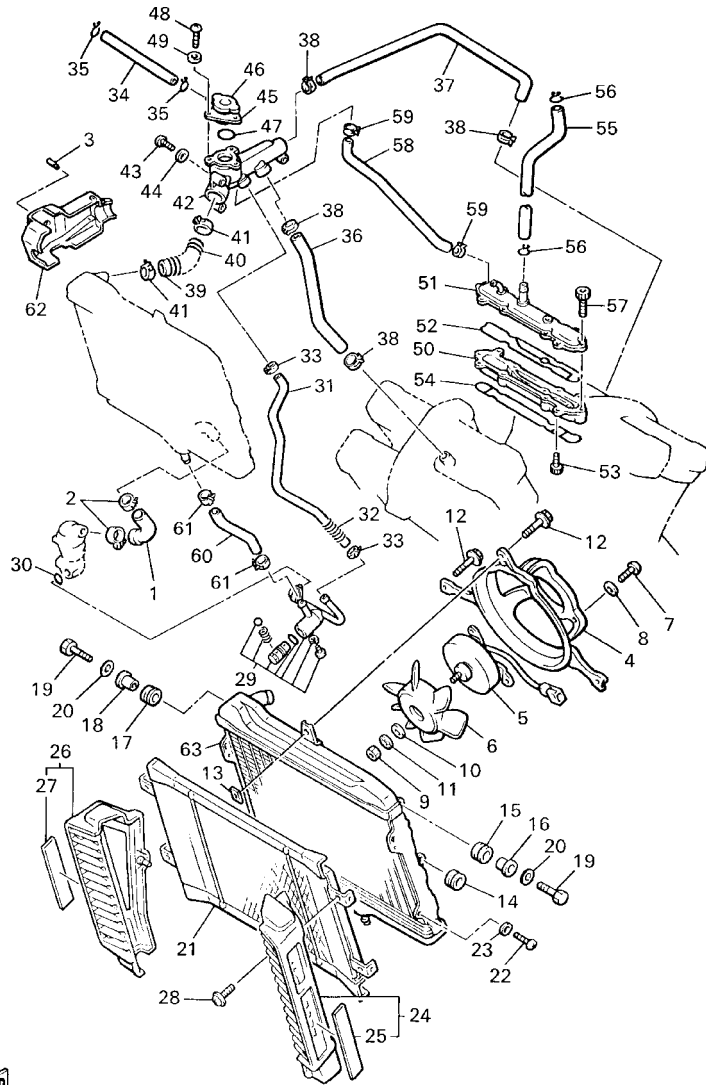

FWD

3JPU171-8060

REF. NO.	PART NO.	DESCRIPTION	5GK9	5GKA	5GKB	REMARKS
28	90159-05073	SCREW, WITH WASHER	4	4	4	
29	1FK-12560-01	DRAIN COCK ASSY.	1	1	1	
30	93210-14104	O-RING	1	1	1	
31	1FK-12566-00	PIPE, BYPASS	1	1	1	
32	90501-106A4	SPRING, COMPRESSION	1	1	1	
33	90460-15227	CLAMP, HOSE	2	2	2	
34	90445-09112	HOSE (L470)	1	1	1	
35	90467-08003	CLIP	2	2	2	
36	1FK-12576-00	HOSE 1	1	1	1	
37	1FK-12577-00	HOSE 2	1	1	1	
38	90467-23067	CLIP	4	4	4	
39	1FK-12579-00	HOSE 4	1	1	1	
40	90501-106A5	SPRING, COMPRESSION	1	1	1	
41	90460-38241	CLAMP, HOSE	2	2	2	
42	1FK-12479-01	JOINT	1	1	1	
43	98507-06030	SCREW, PAN HEAD	3	3	3	
44	92907-06600	WASHER, PLATE	3	3	3	
45	1FK-12591-00	SUPT, FILLER NECK	1	1	1	
46	22W-12462-00	CAP, RADIATOR	1	1	1	
47	93210-27194	O-RING	1	1	1	
48	98507-06016	SCREW, PAN HEAD	3	3	3	
49	92907-06600	WASHER, PLATE	3	3	3	
50	1FK-1246A-01	COVER 1	1	1	1	
51	1FK-1246E-01	COVER 2	1	1	1	
52	26H-12428-00	GASKET, HOUSING COVER 2	1	1	1	
53	90110-06239	BOLT, HEXAGON SOCKET HEAD	4	4	4	
54	26H-12427-00	GASKET, HOUSING COVER 1	1	1	1	

FIG. 6 RADIATOR. HOSE

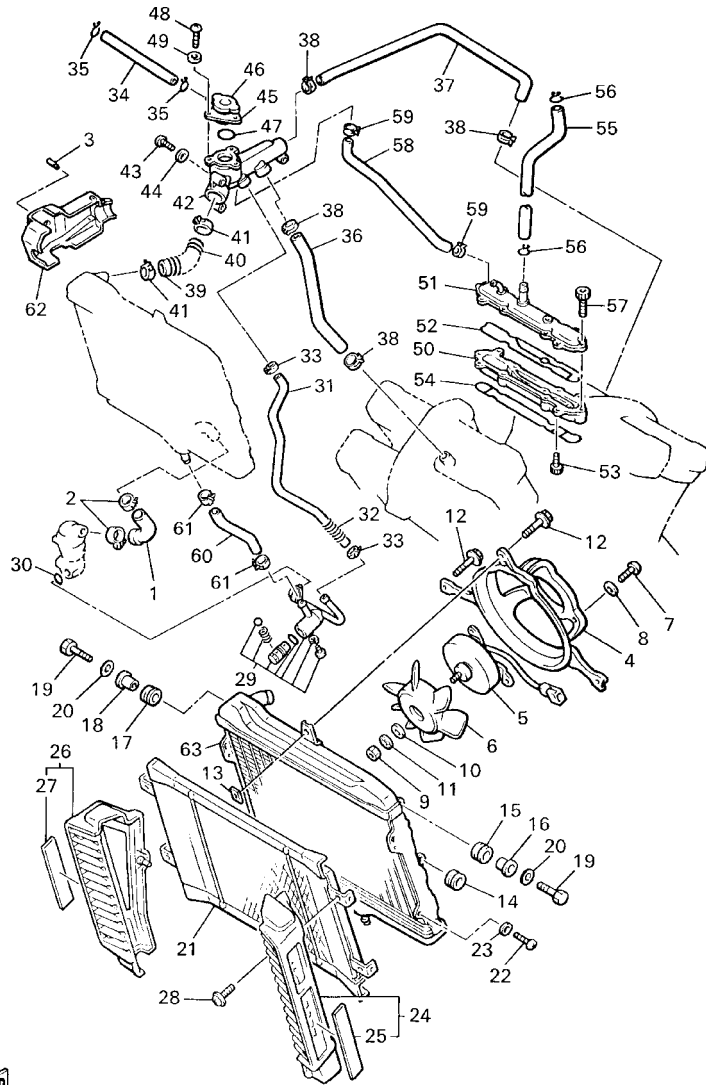

3JPU171-8060

REF. NO.	PART NO.	DESCRIPTION	5GK9	5GKA	5GKB	REMARKS
55	1FK-11166-00	PIPE, BREATHER 1	1	1	1	
56	90467-14015	CLIP	2	2	2	
57	1FK-12615-00	BOLT	6	6	6	
58	1FK-12589-00	HOSE 6	1	1	1	
59	90467-11090	CLIP	2	2	2	
60	26H-12588-01	HOSE 5	1	1	1	
61	90460-15227	CLAMP, HOSE	2	2	2	
62	1FK-1246K-00	COVER 7	1	1	1	
63	1FK-12461-00	RADIATOR ASSY	1	1	1	

FIG. 7 OIL PUMP

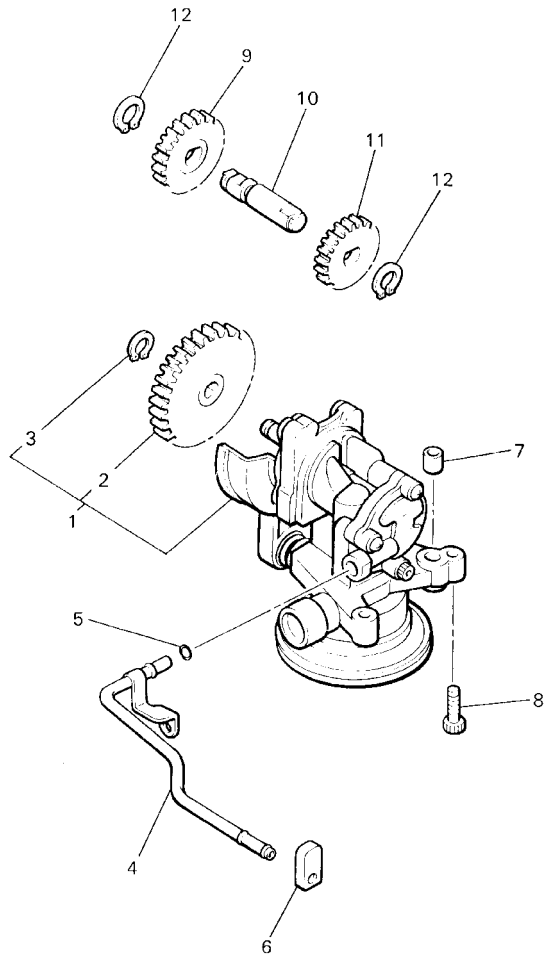

REF. NO.	PART NO.	DESCRIPTION	5GK9	5GKA	5GKB	REMARKS
1	1FK-13300-00	OIL PUMP ASSY	1	1	1	
2	26H-13325-00	.GEAR, PUMP DRIVEN (28T)	1	1	1	
3	93410-11002	.CIRCLIP	1	1	1	
4	1FK-13161-00	PIPE, DELIVERY 1	1	1	1	
5	93210-06667	O-RING	1	1	1	
6	1FK-15365-00	GROMMET	1	1	1	
7	99530-10114	PIN, DOWEL	2	2	2	
8	91317-06025	BOLT	3	3	3	
9	26H-13351-01	GEAR, PUMP IDLE 1 (16T)	1	1	1	
10	26H-13342-00	SHAFT, IDLE GEAR	1	1	1	
11	26H-13361-00	GEAR, PUMP IDLE 2 (15T)	1	1	1	
12	99009-12400	CIRCLIP	2	2	2	



3LRB351-7070

FIG. 8 OIL CLEANER

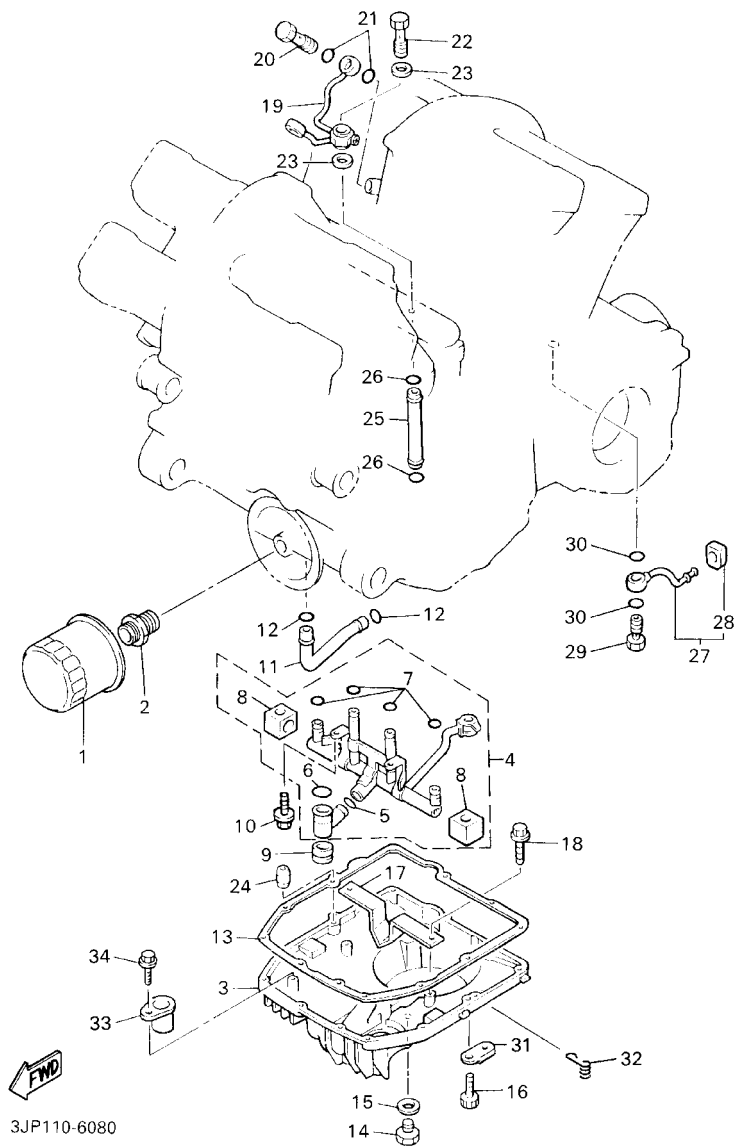

REF. NO.	PART NO.	DESCRIPTION	5GK9	5GKA	5GKB	REMARKS
1	5GH-13440-00	ELEMENT ASSY, OIL CLEANER	1	1	1	
2	90401-20145	BOLT, UNION	1	1	1	
3	26H-13417-01	COVER, STRAINER	1	1	1	
4	26H-Y1319-10	DELIVERY PIPE ASS'Y	1	1	1	
5	93210-13361	.O-RING	1	1	1	
6	93210-14637	.O-RING	1	1	1	
7	93210-06667	.O-RING	4	4	4	
8	26H-15365-00	.GROMMET	2	2	2	
9	26H-15366-01	GROMMET	1	1	1	
10	95817-06012	BOLT, FLANGE	2	2	2	
11	26H-13161-00	PIPE, DELIVERY 1	1	1	1	
12	93210-14579	O-RING	2	2	2	
13	3JP-13414-01	GASKET, STRAINER COVER	1	1	1	
14	90340-14132	PLUG, STRAIGHT SCREW	1	1	1	
15	214-11198-01	GASKET	1	1	1	
16	91317-06030	BOLT	12	12	12	
17	26H-13337-01	PLATE, BAFFLE LOWER	1	1	1	
18	95817-06012	BOLT, FLANGE	2	2	2	
19	26H-13181-03	PIPE, DELIVERY 3	1	1	1	
20	90401-08038	BOLT, UNION	2	2	2	
21	90430-08119	GASKET	4	4	4	
22	90401-10108	BOLT, UNION	1	1	1	
23	90201-10128	WASHER, PLATE	2	2	2	
24	99530-08016	PIN, DOWEL	2	2	2	
25	26H-13171-00	PIPE, DELIVERY 2	1	1	1	
26	93210-06667	O-RING	2	2	2	
27	26H-13416-01	PIPE, OIL 1	1	1	1	

FIG. 8 OIL CLEANER

REF. NO.	PART NO.	DESCRIPTION	5GK9	5GKA	5GKB	REMARKS
28	26H-13476-00	.GASKET	1	1	1	
29	90401-08093	BOLT, UNION	1	1	1	
30	90430-08119	GASKET	2	2	2	
31	90465-08193	CLAMP	1	1	1	
32	90465-23286	CLAMP	1	1	1	
33	1FK-13151-00	STAY	1	1	1	
34	95817-06012	BOLT, FLANGE	1	1	1	
<hr/>						
<hr/>						
<hr/>						
<hr/>						
<hr/>						
<hr/>						
<hr/>						
<hr/>						
<hr/>						

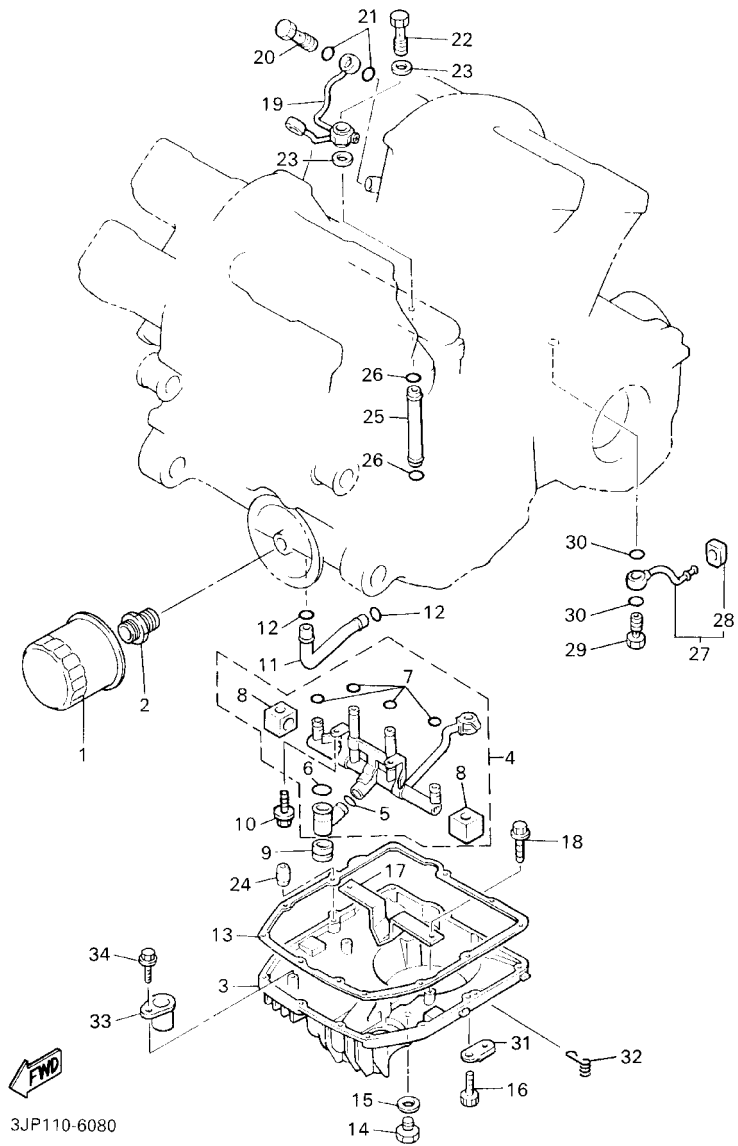

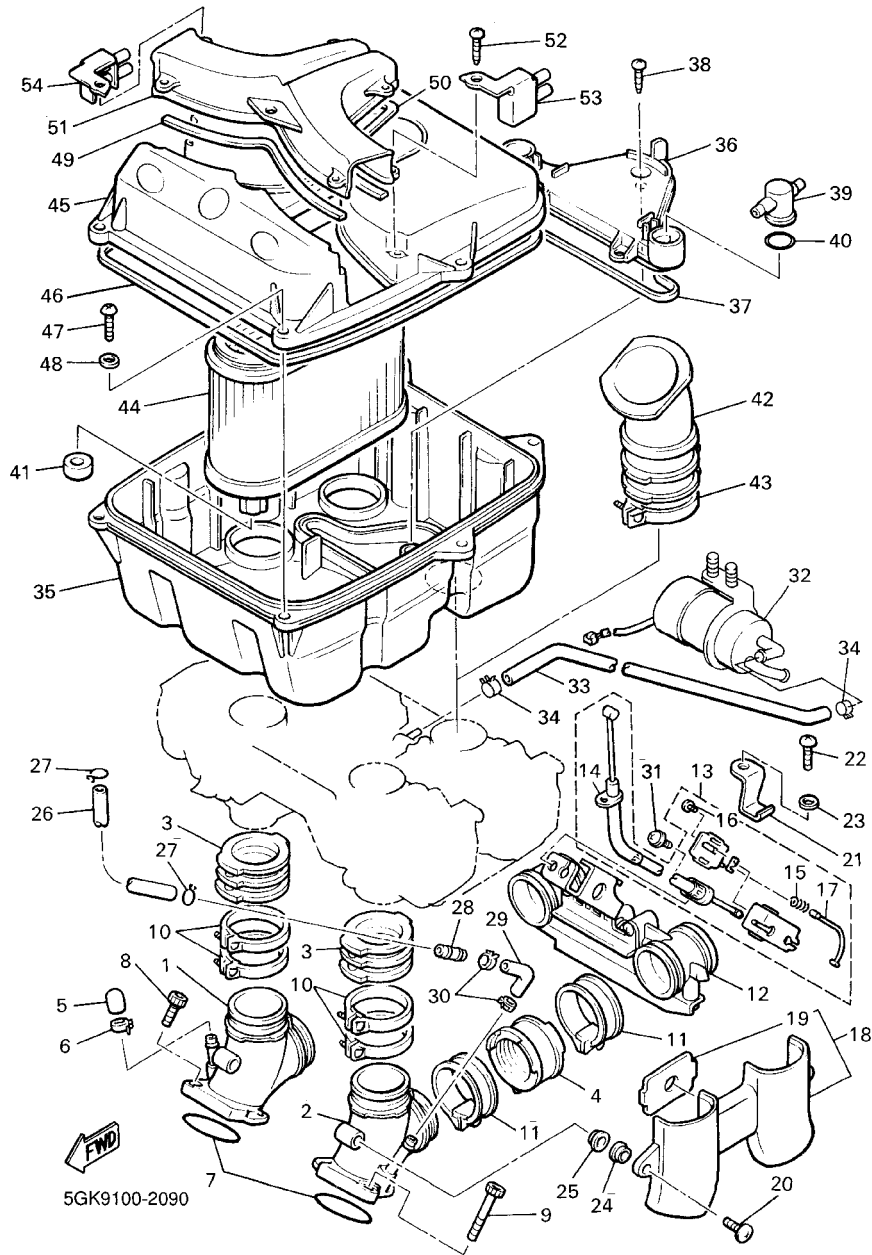

FIG. 9 INTAKE

REF. NO.	PART NO.	DESCRIPTION	5GK9	5GKA	5GKB	REMARKS
1	1FK-13586-00	JOINT, CARBURETOR 1	2	2	2	
2	1FK-13596-00	JOINT, CARBURETOR 2	2	2	2	
3	1FK-13597-00	JOINT, CARBURETOR 3	4	4	4	
4	1FK-13595-01	JOINT	4	4	4	
5	16G-13569-00	PLUG, BLIND	3	3	3	
6	90467-10039	CLIP	3	3	3	
7	93210-45578	O-RING	4	4	4	
8	91317-06020	BOLT	6	6	6	
9	91314-06016	BOLT	2	2	2	
10	1AE-13575-01	BAND	8	8	8	
11	90460-49274	CLAMP, HOSE	4	4	4	
12	1UT-13510-00	VALVE ASSY.	1	1	1	
13	1FK-1130E-00	CABLE PULLEY ASSY	1	1	1	
14	1FK-1133E-00	.CABLE, PULLEY 1	1	1	1	
15	90501-06585	.SPRING, COMPRESSION			1	
16	92017-05010	.BOLT, BUTTON HEAD	1	1	1	
17	1FK-1133F-00	.CABLE, PULLEY 2	1	1	1	
18	1FK-13550-00	VALVE COVER ASS'Y	2	2	2	
19	1FK-13593-00	.DAMPER	1	1	1	
20	90154-06033	SCREW, BINDING	4	4	4	
21	90462-20149	CLAMP	1	1	1	
22	98507-05010	SCREW, PAN HEAD	1	1	1	
23	92907-05600	WASHER, PLATE	1	1	1	
24	90480-13018	GROMMET	4	4	4	
25	90387-06500	COLLAR	4	4	4	
26	90445-08715	HOSE (L150)	1	1	1	
27	90467-08021	CLIP	2	2	2	

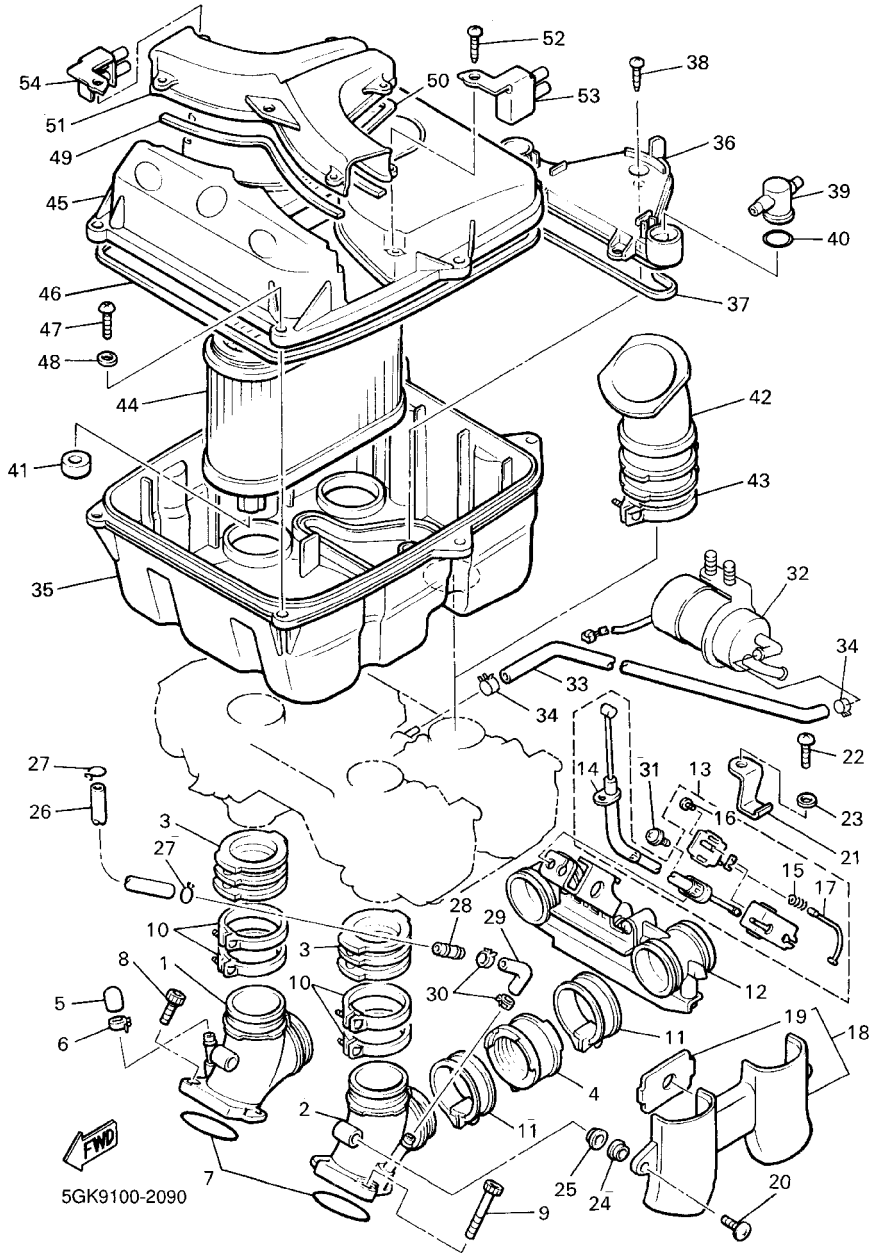
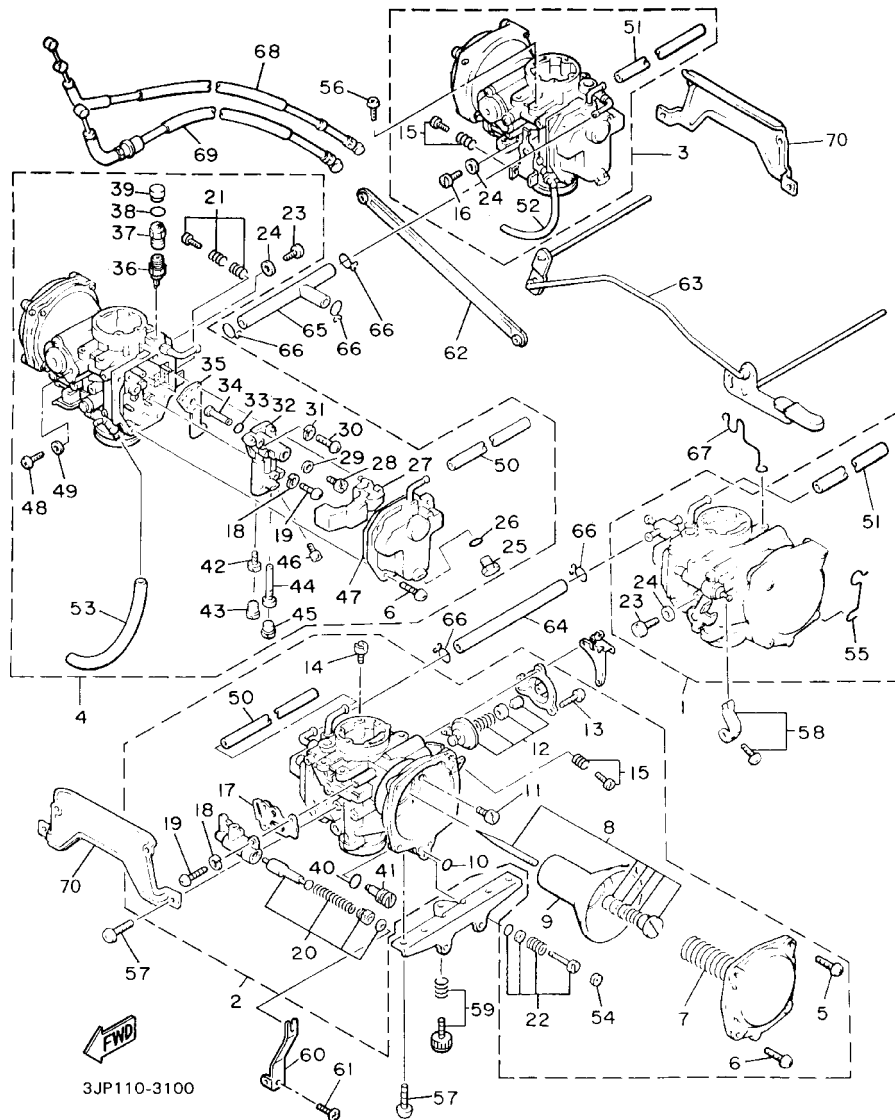

FIG. 9 INTAKE

REF. NO.	PART NO.	DESCRIPTION	5GK9	5GKA	5GKB	REMARKS
28	41R-14489-00	NOZZLE	1	1	1	
29	90445-090A9	HOSE (L90)	1	1	1	
30	90467-08092	CLIP	2	2	2	
31	90159-05119	SCREW, WITH WASHER	1	1	1	
32	1FK-13907-00	FUEL PUMP COMP.	1	1	1	
33	90445-120E7	HOSE (L220)	1	1	1	
34	90467-10135	CLIP	2	2	2	
35	1FK-14411-01	CASE, AIR CLEANER 1	1	1	1	
36	1FK-14417-00	COVER 1	1	1	1	
37	1AE-14452-00	SEAL	1	1	1	
38	97707-50114	SCREW, TAPPING	3	3	3	
39	1FK-14454-00	JOINT	2	2	2	
40	93210-22382	O-RING	2	2	2	
41	1FK-1445E-00	FILTER 1	1	1	1	
42	1FK-14453-00	JOINT, AIR CLEANER 1	4	4	4	
43	90460-59211	CLAMP, HOSE	4	4	4	
44	1FK-14451-00	ELEMENT, AIR CLEANER	1	1	1	
45	1FK-14412-00	CAP, CLEANER CASE 1	1	1	1	
46	1FK-14452-00	SEAL	1	1	1	
47	98507-05020	SCREW, PAN HEAD	6	6	6	
48	92907-05600	WASHER, PLATE	6	6	6	
49	1FK-14457-00	SEAL	1	1	1	
50	1FK-14467-00	SEAL	1	1	1	
51	1FK-14437-00	DUCT	1	1	1	
52	97707-50114	SCREW, TAPPING	7	7	7	
53	1FK-14413-00	STAY	1	1	1	
54	1FK-14414-00	STAY 2	1	1	1	

FIG. 10 CARBURETOR



REF. NO.	PART NO.	DESCRIPTION	5GK9	5GKA	5GKB	REMARKS
1	1FK-14901-02	CARBURETOR ASSY 1	1			
	2WF-14901-02	CARBURETOR ASSY 1		1		
2	1FK-14902-02	CARBURETOR ASSY 2	1			
	2WF-14902-02	CARBURETOR ASSY 2		1		
3	1FK-14903-02	CARBURETOR ASSY 3	1			
	2WF-14903-02	CARBURETOR ASSY 3		1		
4	1FK-14904-02	CARBURETOR ASSY 4	1			
	2WF-14904-02	CARBURETOR ASSY 4		1		
5	90157-05050	.SCREW, PAN HEAD	1	1		
6	97801-05012	.SCREW, PAN HEAD	7	7		
7	1FK-14933-00	.SPRING, DIAPHRAGM	1	1		
8	1FK-1490J-00	.NEEDLE SET	1			
	2WF-1490J-00	.NEEDLE SET		1		
9	1FK-14940-00	.DIAPHRAGM ASSY	1	1		
10	93210-03119	.O-RING	1	1		
11	3G2-14231-34	.JET, PILOT AIR (#170)	1	1		
12	26H-1490H-00	.DIAPHRAGM SET 5	1	1		
13	97801-04010	.SCREW, PAN HEAD	3	3		
14	3G2-14231-18	.JET, MAIN (# 90)	1			
	3G2-14231-20	.JET, MAIN (#100)		1		
15	31H-1490K-00	.STOP SCREW SET	1	1		
16	2F1-14991-00	.SCREW	1	1		
17	3JB-14536-00	.GASKET	1	1		
18	92901-04100	.WASHER, SPRING	4	4		
19	98511-04012	.SCREW, PAN HEAD	4	4		
20	1GR-1410A-00	.STARTER SET	1	1		
21	26H-1490K-00	.STOP SCREW SET	1	1		

FIG. 10 CARBURETOR

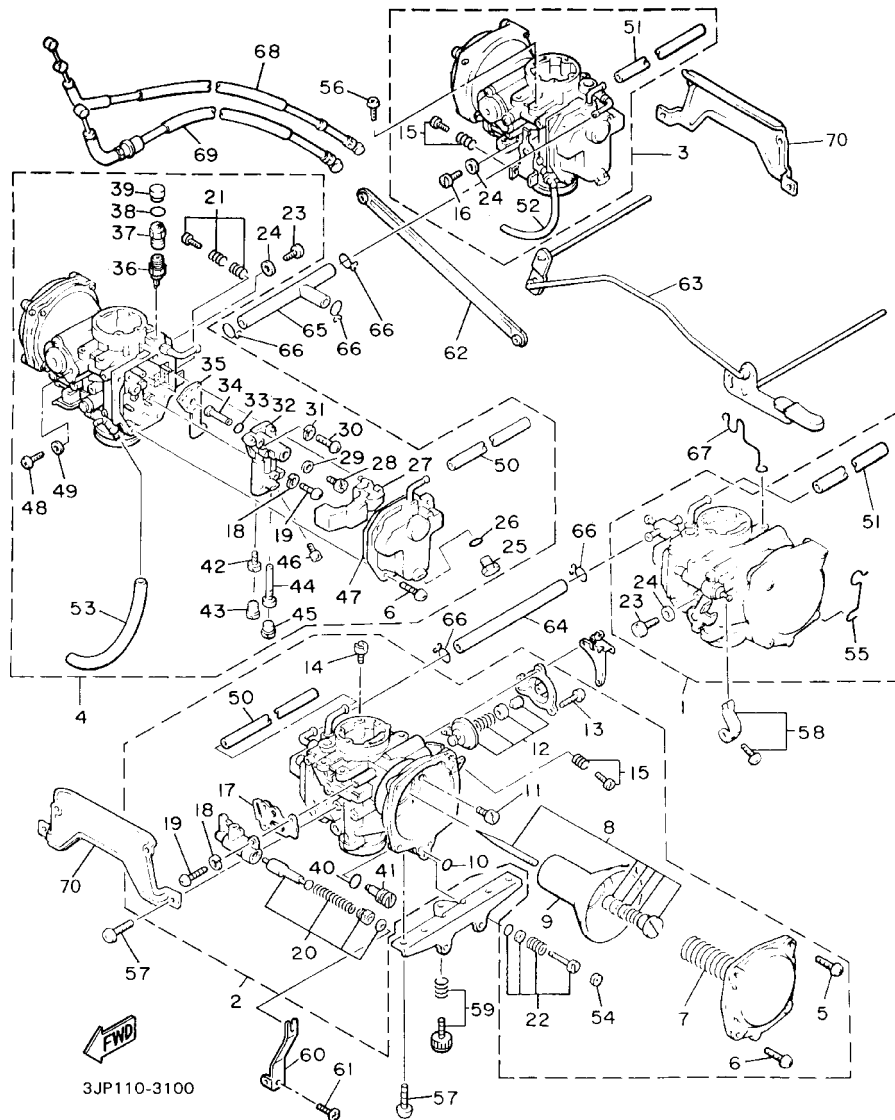

REF. NO.	PART NO.	DESCRIPTION	5GK9	5GKA	5GKB	REMARKS
22	12R-14105-00	.PILOT SCREW SET	1	1		
23	341-14991-00	.SCREW	1	1		
24	26H-14952-22	.WASHER	1	1		
25	22U-14115-00	.PLUG, SCREW	1	1		
26	22U-14561-00	.O-RING	1	1		
27	1FK-14985-00	.FLOAT	1	1		
28	22U-14565-00	.SCREW	1	1		
29	137-14153-00	.WASHER, MAIN JET	1	1		
30	98511-04008	.SCREW, PAN HEAD	1	1		
31	92901-04100	.WASHER, SPRING	1	1		
32	26H-1411A-00	.BLOCK JET ASSY	1	1		
33	22U-14147-00	.O-RING	1	1		
34	26H-14941-90	.NOZZLE, MAIN	1	1		
35	3JB-14199-00	.GASKET	1	1		
36	1FK-14190-15	.NEEDLE VALVE ASSY	1	1		
37	1J7-14994-00	.NET, FILTER	1	1		
38	1FK-14147-00	.O-RING	1	1		
39	41R-14118-01	.CAP	1	1		
40	214-14147-00	.O-RING	1	1		
41	2L1-14191-00	.PLUG, DRAIN	1	1		
42	4G0-14142-37	.JET, PILOT (#37.5)	1	1		
43	22V-14968-00	.CAP	1	1		
44	26H-1414G-00	.PIPE, MAIN BREED	1	1		
45	22U-14968-00	.CAP	1	1		
46	3G2-14231-81	.JET, MAIN (#152.5)	1	1		
47	22V-14147-00	.O-RING	1	1		
48	98511-04012	.SCREW, PAN HEAD	3	3		

FIG. 10 CARBURETOR

REF. NO.	PART NO.	DESCRIPTION	5GK9	5GKA	5GKB	REMARKS
49	92901-04100	.WASHER, SPRING	3	3		
50	1GR-14197-01	.PIPE	1	1		
51	1FK-14197-01	.PIPE	1	1		
52	41R-14193-00	.PIPE	1	1		
53	41U-14193-00	.PIPE	1	1		
54	3F9-14118-00	.CAP	1	1		
55	1JH-14139-00	.CLIP, PIPE	1	1		
56	97801-05008	SCREW, PAN HEAD	9	9		
57	97801-06010	SCREW, PAN HEAD	16	16		
58	22U-1490M-00	STARTER LEVER SET, 2	3	3		
59	26H-14103-00	THROTTLE SCREW SET	1	1		
60	1FK-14905-00	LEVER, STARTER	1	1		
61	11H-14991-00	SCREW	1	1		
62	26H-14504-00	ROD SET	1	1		
63	1FK-1490L-00	STARTER LEVER SET, 1	1	1		
64	31H-14987-00	HOSE	1	1		
65	26H-14987-00	HOSE	1	1		
66	90467-10008	CLIP	5	5		
67	26H-14139-00	CLIP, PIPE	1	1		
68	1FK-2631J-00	CABLE, THROTTLE 4	1	1		
69	1FK-26313-01	CABLE, THROTTLE 3	1	1		
70	26H-14291-00	BRACKET 1	2	2		

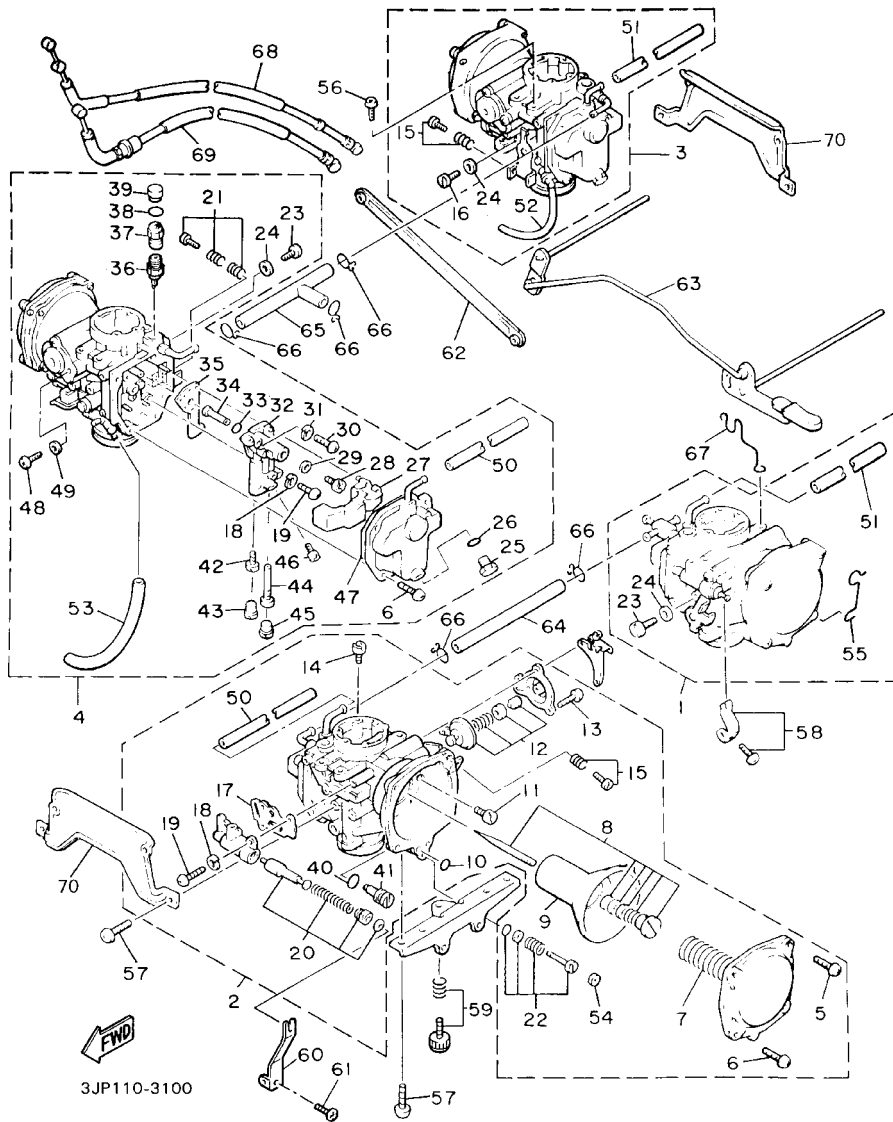

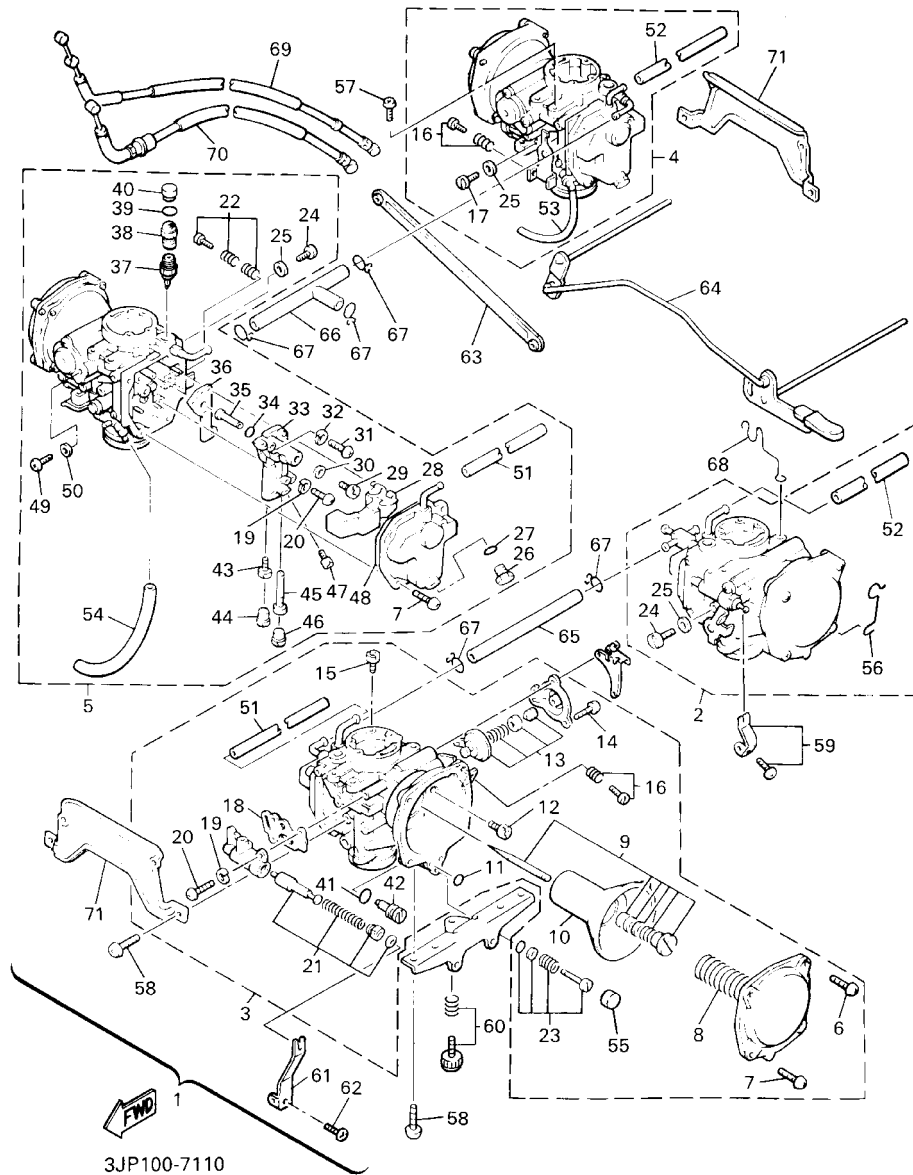

FIG. 11 CARBURETOR 2

REF. NO.	PART NO.	DESCRIPTION	5GK9	5GKA	5GKB	REMARKS
1	1FK-14900-02	CARBURETOR ASSY			1	
2	1FK-14901-02	..CARBURETOR ASSY 1			1	
3	1FK-14902-02	..CARBURETOR ASSY 2			1	
4	1FK-14903-02	..CARBURETOR ASSY 3			1	
5	1FK-14904-02	..CARBURETOR ASSY 4			1	
6	90157-05050	..SCREW, PAN HEAD			1	
7	97801-05012	..SCREW, PAN HEAD			7	
8	1FK-14933-00	..SPRING, DIAPHRAGM			1	
9	1FK-1490J-00	..NEEDLE SET			1	
10	1FK-14940-00	..DIAPHRAGM ASSY			1	
11	93210-03119	..O-RING			1	
12	3G2-14231-34	..JET, PILOT AIR (#170)			1	
13	26H-1490H-00	..DIAPHRAGM SET 5			1	
14	97801-04010	..SCREW, PAN HEAD			3	
15	3G2-14231-18	..JET, MAIN (# 90)			1	
16	31H-1490K-00	..STOP SCREW SET			1	
17	2F1-14991-00	..SCREW			1	
18	3JB-14536-00	..GASKET			1	
19	92901-04100	..WASHER, SPRING			4	
20	98511-04012	..SCREW, PAN HEAD			4	
21	1GR-1410A-00	..STARTER SET			1	
22	26H-1490K-00	..STOP SCREW SET			1	
23	12R-14105-00	..PILOT SCREW SET			1	
24	341-14991-00	..SCREW			1	
25	26H-14952-22	..WASHER			1	
26	22U-14115-00	..PLUG, SCREW			1	
27	22U-14561-00	..O-RING			1	

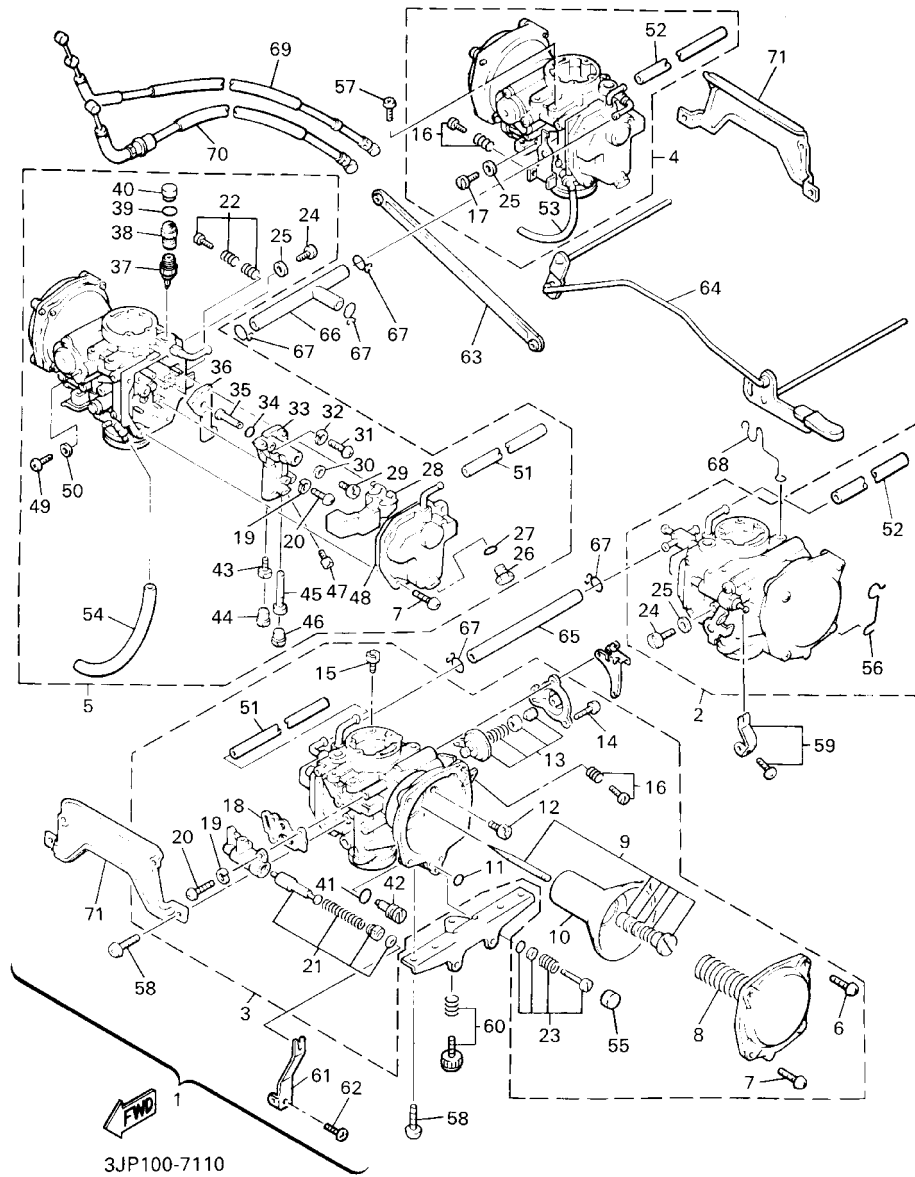

FIG. 11 CARBURETOR 2

REF. NO.	PART NO.	DESCRIPTION	5GK9	5GKA	5GKB	REMARKS
28	1FK-14985-00	..FLOAT			1	
29	22U-14565-00	..SCREW			1	
30	137-14153-00	..WASHER, MAIN JET			1	
31	98511-04008	..SCREW, PAN HEAD			1	
32	92901-04100	..WASHER, SPRING			1	
33	26H-1411A-00	..BLOCK JET ASSY			1	
34	22U-14147-00	..O-RING			1	
35	26H-14941-90	..NOZZLE, MAIN			1	
36	3JB-14199-00	..GASKET			1	
37	1FK-14190-15	..NEEDLE VALVE ASSY			1	
38	1J7-14994-00	..NET, FILTER			1	
39	1FK-14147-00	..O-RING			1	
40	41R-14118-01	..CAP			1	
41	214-14147-00	..O-RING			1	
42	2L1-14191-00	..PLUG, DRAIN			1	
43	4G0-14142-37	..JET, PILOT (#37.5)			1	
44	22V-14968-00	..CAP			1	
45	26H-1414G-00	..PIPE, MAIN BREED			1	
46	22U-14968-00	..CAP			1	
47	3G2-14231-81	..JET, MAIN (#152.5)			1	
48	22V-14147-00	..O-RING			1	
49	98511-04012	..SCREW, PAN HEAD			3	
50	92901-04100	..WASHER, SPRING			3	
51	1GR-14197-01	..PIPE			1	
52	1FK-14197-01	..PIPE			1	
53	41R-14193-00	..PIPE			1	
54	41U-14193-00	..PIPE			1	

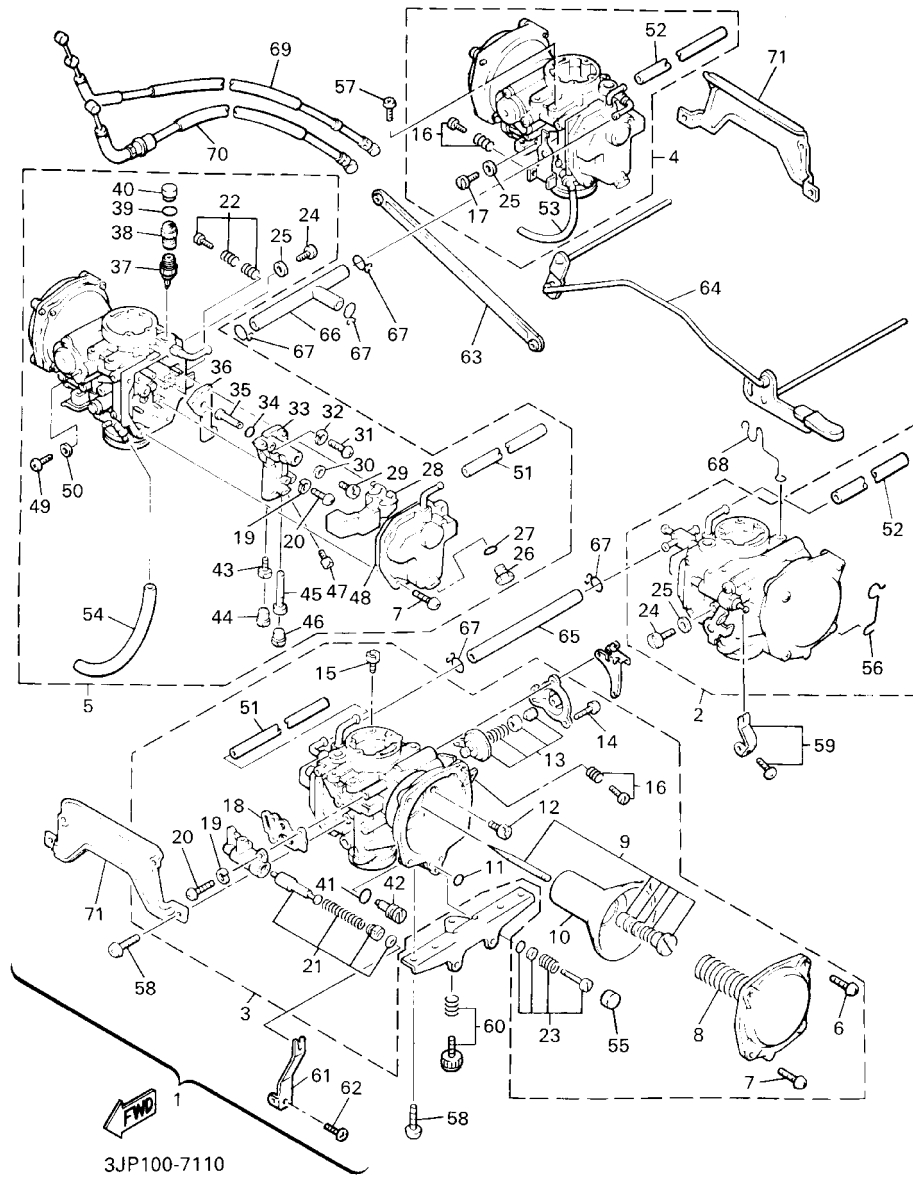
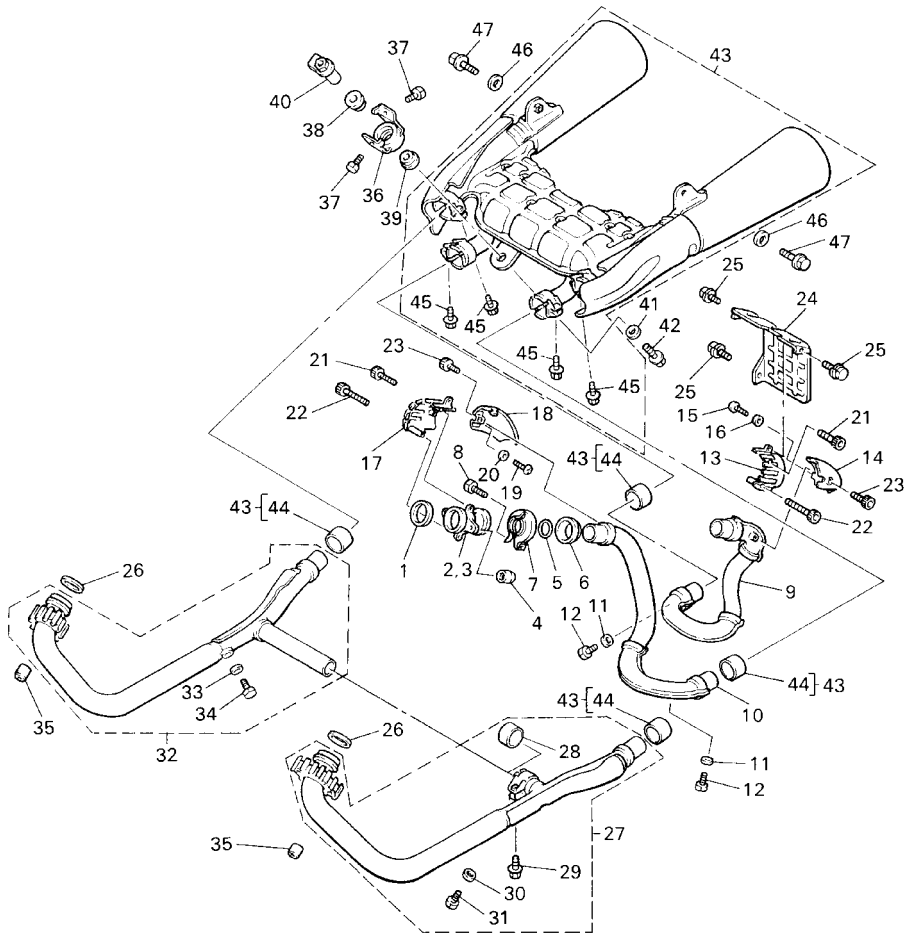

FIG. 11 CARBURETOR 2

REF. NO.	PART NO.	DESCRIPTION	5GK9	5GKA	5GKB	REMARKS
55	3F9-14118-00	..CAP			1	
56	1JH-14139-00	..CLIP, PIPE			1	
57	97801-05008	..SCREW, PAN HEAD			9	
58	97801-06010	..SCREW, PAN HEAD			16	
59	22U-1490M-00	..STARTER LEVER SET, 2			3	
60	26H-14103-00	..THROTTLE SCREW SET			1	
61	1FK-14905-00	..LEVER, STARTER			1	
62	11H-14991-00	..SCREW			1	
63	26H-14504-00	..ROD SET			1	
64	1FK-1490L-00	..STARTER LEVER SET, 1			1	
65	31H-14987-00	..HOSE			1	
66	26H-14987-00	..HOSE			1	
67	90467-10008	..CLIP			5	
68	26H-14139-00	..CLIP, PIPE			1	
69	1FK-2631J-00	..CABLE, THROTTLE 4			1	
70	1FK-26313-01	..CABLE, THROTTLE 3			1	
71	26H-14291-00	..BRACKET 1			2	

FIG. 12 EXHAUST

REF. NO.	PART NO.	DESCRIPTION	5GK9	5GKA	5GKB	REMARKS
1	3GD-14613-00	GASKET, EXHAUST PIPE	2	2	2	
2	1FK-14615-00	JOINT, EXHAUST 1	1	1	1	
3	1FK-14625-00	JOINT, EXHAUST 2	1	1	1	
4	90179-08673	NUT	4	4	4	
5	1FK-14613-00	GASKET, EXHAUST PIPE	2	2	2	
6	1FK-14618-00	RING, STOPPER	2	2	2	
7	26H-14715-01	BAND, MUFFLER	2	2	2	
8	90110-06054	BOLT, HEXAGON SOCKET HEAD	2	2	2	
9	1FK-14611-00	PIPE, EXHAUST 1	1	1	1	
10	1FK-14631-00	PIPE, EXHAUST 3	1	1	1	
11	92990-06600	WASHER, PLATE	2	2	2	
12	97080-06008	BOLT	2	2	2	
13	1FK-14603-00	COVER 1	1	1	1	
14	1FK-1465R-00	PLATE, PROTECTOR	1	1	1	
15	98507-05010	SCREW, PAN HEAD	2	2	2	
16	92907-05600	WASHER, PLATE	2	2	2	
17	1FK-14624-00	COVER, EXHAUST	1	1	1	
18	1FK-1465T-00	PLATE, PROTECTOR	1	1	1	
19	98507-05010	SCREW, PAN HEAD	2	2	2	
20	92907-05600	WASHER, PLATE	2	2	2	
21	91380-05025	BOLT	2	2	2	
22	91380-05045	BOLT	2	2	2	
23	91380-05008	BOLT	2	2	2	
24	1FK-14604-00	COVER, AIR 1	1	1	1	
25	90119-06115	BOLT, WITH WASHER	3	3	3	
26	3GD-14613-00	GASKET, EXHAUST PIPE	2	2	2	
27	1FK-14610-11	EXHAUST PIPE ASSY 1	1	1	1	



3JP110-6110

FIG. 12 EXHAUST

REF. NO.	PART NO.	DESCRIPTION	5GK9	5GKA	5GKB	REMARKS
28	3XW-14755-00	.GASKET, SILENCER	1	1	1	
29	95027-08025	.BOLT, FLANGE	1	1	1	
30	92990-06600	.WASHER, PLATE	1	1	1	
31	97080-06008	.BOLT	1	1	1	
32	1FK-14620-01	EXHAUST PIPE ASSY 2	1	1	1	
33	92990-06600	.WASHER, PLATE	1	1	1	
34	97080-06008	.BOLT	1	1	1	
35	90179-08673	NUT	4	4	4	
36	1FK-14771-00	STAY, MUFFLER 1	1	1	1	
37	97017-06010	BOLT	2	2	2	
38	4K0-14747-00	DAMPER, MUFFLER	1	1	1	
39	1FK-14747-00	DAMPER, MUFFLER	1	1	1	
40	1FK-14638-00	COLLAR	1	1	1	
41	90201-106E0	WASHER, PLATE	1	1	1	
42	97017-10045	BOLT	1	1	1	
43	1UT-14710-12	MUFFLER ASSY 1	1	1	1	
44	3XW-14755-00	.GASKET, SILENCER	4	4	4	
45	95027-08025	.BOLT, FLANGE	4	4	4	
46	90201-10742	WASHER, PLATE	2	2	2	
47	90105-10271	BOLT, FLANGE	2	2	2	

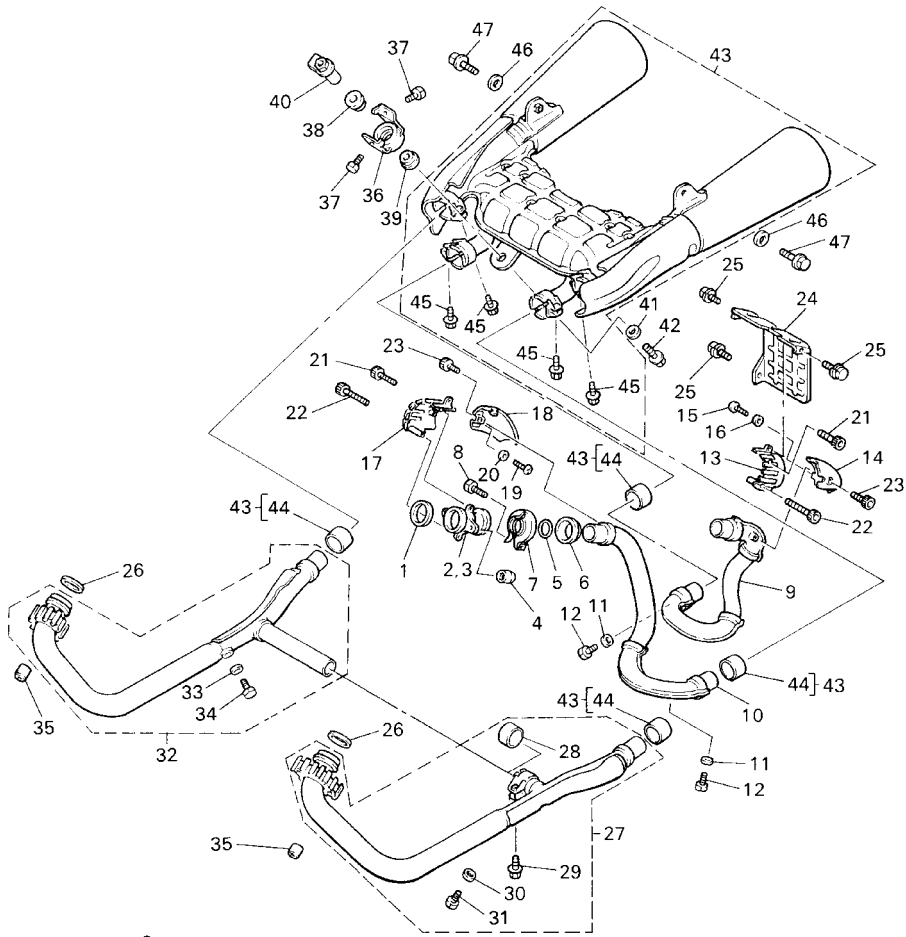

3JP110-6110

FIG. 13 CRANKCASE

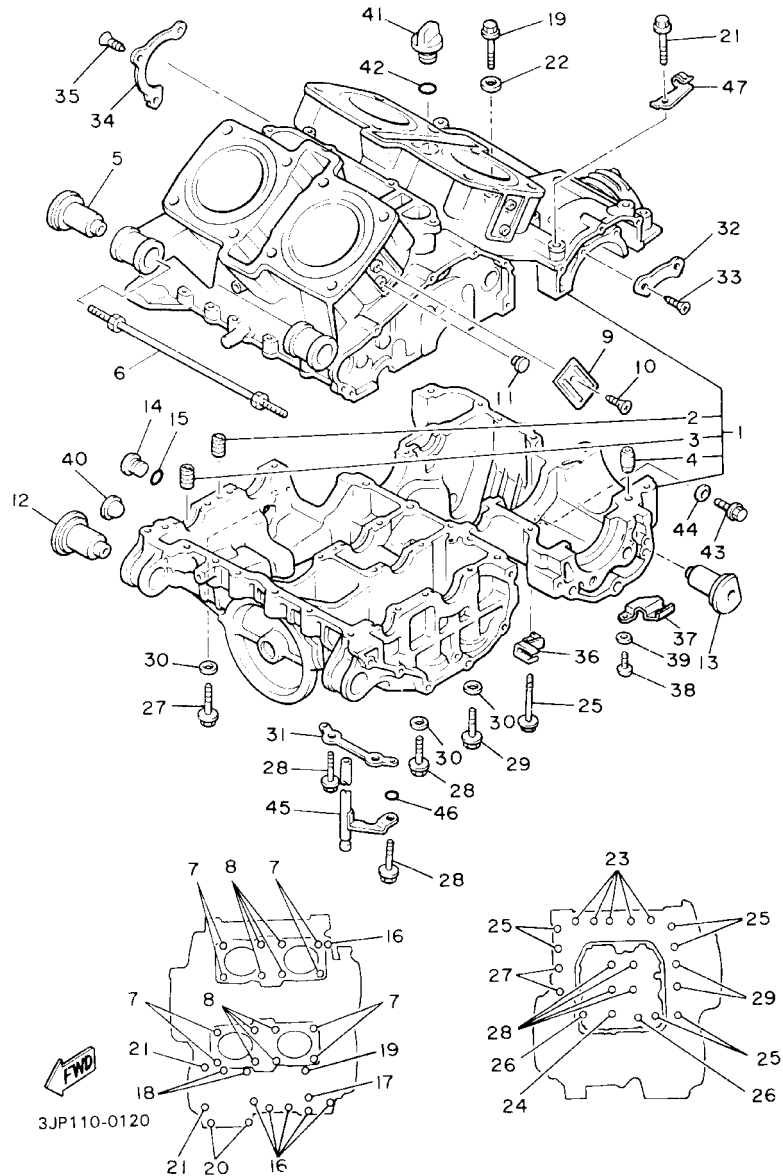

REF. NO.	PART NO.	DESCRIPTION	5GK9	5GKA	5GKB	REMARKS
1	1FK-15100-03	CRANKCASE ASSY	1	1	1	
2	26H-15138-00	.NOZZLE 1	1	1	1	
3	4G0-15138-00	.NOZZLE 1	1	1	1	
4	99530-10114	.PIN, DOWEL	1	1	1	
5	1AA-15336-00	DAMPER, ENGINE MOUNT 3	2	2	2	
6	90109-106A1	BOLT	1	1	1	
7	90116-10411	BOLT, STUD	8	8	8	
8	90116-10429	BOLT, STUD	8	8	8	
9	1FK-15417-00	COVER, CAP	4	4	4	
10	90151-06061	SCREW, COUNTERSUNK	4	4	4	
11	90338-11152	PLUG	4	4	4	
12	1AA-15336-00	DAMPER, ENGINE MOUNT 3	2	2	2	
13	1AA-15326-00	DAMPER, ENGINE MOUNT 2	2	2	2	
14	4H7-15189-00	PLUG	1	1	1	
15	93210-22382	O-RING	1	1	1	
16	95814-06045	BOLT, FLANGE	6	6	6	
17	95814-06070	BOLT, FLANGE	1	1	1	
18	95814-06090	BOLT, FLANGE	2	2	2	
19	95817-06095	BOLT, FLANGE	1	1	1	
20	95814-08045	BOLT, FLANGE	2	2	2	
21	95814-08080	BOLT, FLANGE	2	2	2	
22	90430-06166	GASKET	2	2	2	
23	95817-08050	BOLT, FLANGE	5	5	5	
24	95817-08065	BOLT, FLANGE	1	1	1	
25	95814-08080	BOLT, FLANGE	6	6	6	
26	95817-08095	BOLT, FLANGE	2	2	2	
27	90109-103G0	BOLT	2	2	2	

FIG. 13 CRANKCASE

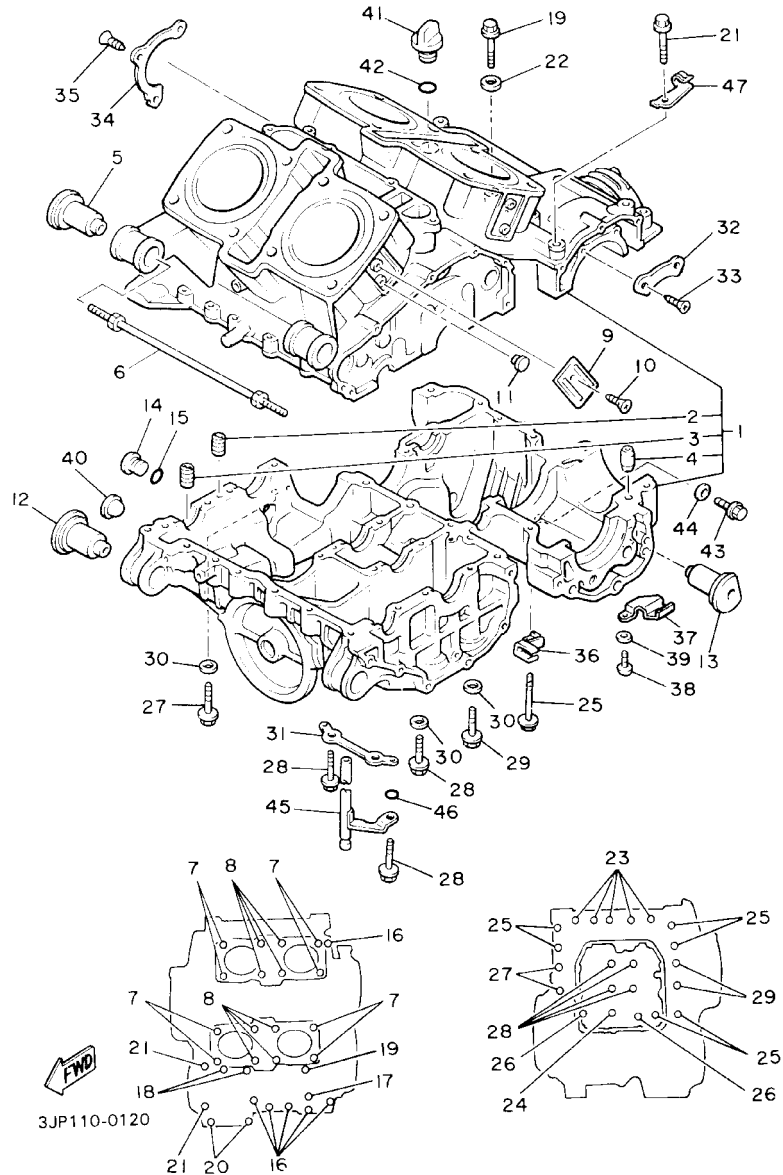

REF. NO.	PART NO.	DESCRIPTION	5GK9	5GKA	5GKB	REMARKS
28	90105-10248	BOLT, FLANGE	4	4	4	
29	90105-10249	BOLT, FLANGE	2	2	2	
30	90201-11597	WASHER, PLATE	6	6	6	
31	26H-15113-00	PLATE	1	1	1	
32	26H-15381-00	PLATE, BEARING COVER	2	2	2	
33	90149-08152	SCREW	4	4	4	
34	26H-15383-00	PLATE, BEARING COVER	1	1	1	
35	90151-06041	SCREW, COUNTERSUNK	3	3	3	
36	90465-08233	CLAMP	1	1	1	
37	90465-08287	CLAMP	1	1	1	
38	98507-06012	SCREW, PAN HEAD	1	1	1	
39	92907-06600	WASHER, PLATE	1	1	1	
40	2H7-15361-00	GAUGE, LEVEL	1	1	1	
41	2H9-15363-00	PLUG, OIL	1	1	1	
42	93210-27370	O-RING	1	1	1	
43	95807-12016	BOLT, FLANGE	1	1	1	
44	90201-12790	WASHER, PLATE	1	1	1	
45	26H-15373-00	PIPE, BREATHER	1	1	1	
46	93210-06667	O-RING	1	1	1	
47	1FK-15441-00	HOLDER, CLUTCH CABLE	1	1	1	

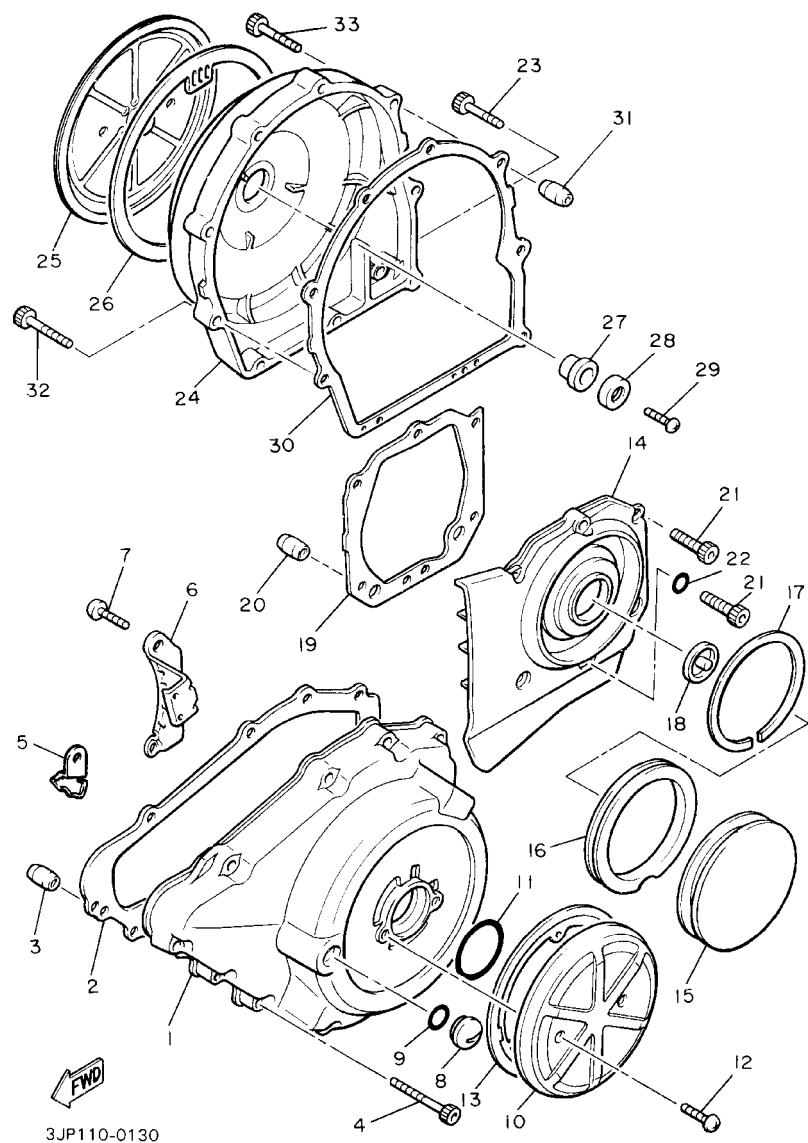
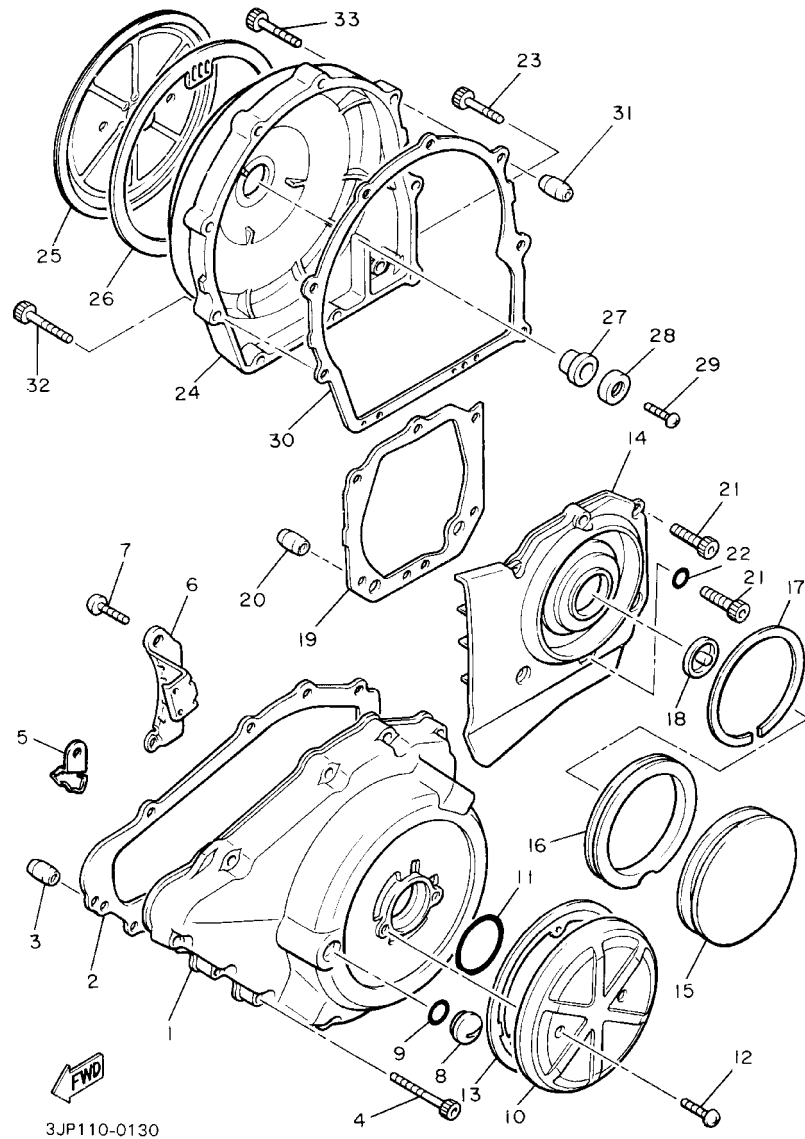

FIG. 14 CRANKCASE COVER 1

REF. NO.	PART NO.	DESCRIPTION	5GK9	5GKA	5GKB	REMARKS
1	1FK-15411-00	COVER, CRANKCASE 1	1	1	1	
2	3JP-15451-01	GASKET, CRANKCASE COVER 1	1	1	1	
3	99530-10114	PIN, DOWEL	2	2	2	
4	90110-06238	BOLT, HEXAGON SOCKET HEAD	11	11	11	
5	90462-06192	CLAMP	1	1	1	
6	90465-08220	CLAMP	1	1	1	
7	98507-06016	SCREW, PAN HEAD	1	1	1	
8	90340-14068	PLUG, STRAIGHT SCREW	1	1	1	
9	93210-14369	O-RING	1	1	1	
10	3JP-15427-00	COVER, CAP 2	1	1	1	
11	93210-45150	O-RING	1	1	1	
12	90151-06061	SCREW, COUNTERSUNK	2	2	2	
13	1FK-15455-00	GASKET 1	1	1	1	
14	1FK-15421-02	COVER, CRANKCASE 2	1	1	1	
15	1FK-15428-00	COVER, CHAIN CASE 2	1	1	1	
16	26H-15337-01	DAMPER 4	1	1	1	
17	90468-98132	CLIP	1	1	1	
18	26H-15338-00	DAMPER, ENGINE MOUNT 5	1	1	1	
19	3JP-15461-01	GASKET, CRANKCASE COVER 2	1	1	1	
20	99530-10114	PIN, DOWEL	2	2	2	
21	90110-06240	BOLT, HEXAGON SOCKET HEAD	4	4	4	
22	90430-06014	GASKET	1	1	1	
23	90110-06242	BOLT, HEXAGON SOCKET HEAD	2	2	2	
24	1FK-15431-00	COVER, CRANKCASE 3	1	1	1	
25	3JP-15418-00	COVER, CHAIN CASE	1	1	1	
26	26H-15449-00	RING, RUBBER	1	1	1	
27	4H7-15486-00	GROMMET	1	1	1	

FIG. 14 CRANKCASE COVER 1



REF. NO.	PART NO.	DESCRIPTION	5GK9	5GKA	5GKB	REMARKS
28	90209-06096	WASHER	1	1	1	
29	98507-06008	SCREW, PAN HEAD	1	1	1	
30	3JP-15462-01	GASKET, CRANKCASE COVER 3	1	1	1	
31	99530-10114	PIN, DOWEL	2	2	2	
32	90110-06240	BOLT, HEXAGON SOCKET HEAD	7	7	7	
33	90110-06237	BOLT, HEXAGON SOCKET HEAD	2	2	2	

FIG. 15 STARTER CLUTCH

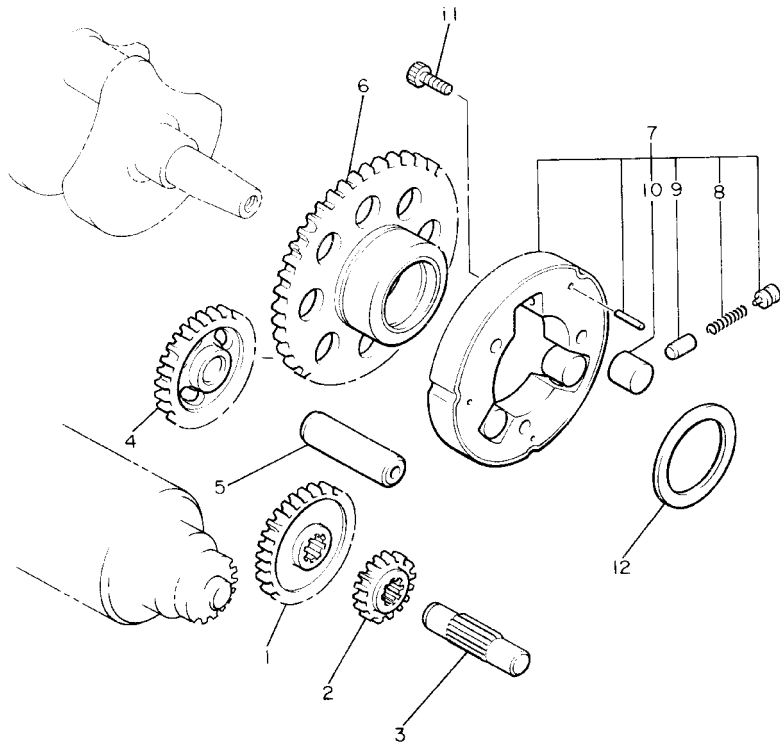

REF. NO.	PART NO.	DESCRIPTION	5GK9	5GKA	5GKB	REMARKS
1	26H-15514-00	GEAR 2 (42T)	1	1	1	
2	26H-15515-00	GEAR 3 (13T)	1	1	1	
3	26H-15522-00	SHAFT 2	1	1	1	
4	26H-15512-00	GEAR, IDLER 1 (27T)	1	1	1	
5	26H-15521-00	SHAFT 1	1	1	1	
6	26H-15517-00	GEAR, IDLER 2 (76T)	1	1	1	
7	11H-15580-00	STARTER CLUTCH OUTER ASSY	1	1	1	
8	90501-04623	.SPRING, COMPRESSION	3	3	3	
9	1J7-15583-01	.CAP, STARTER CLUTCH SPRING	3	3	3	
10	93615-12088	.PIN, DOWEL	3	3	3	
11	91317-08014	BOLT	3	3	3	
12	90201-350F3	WASHER, PLATE	1	1	1	

 26H110-3140

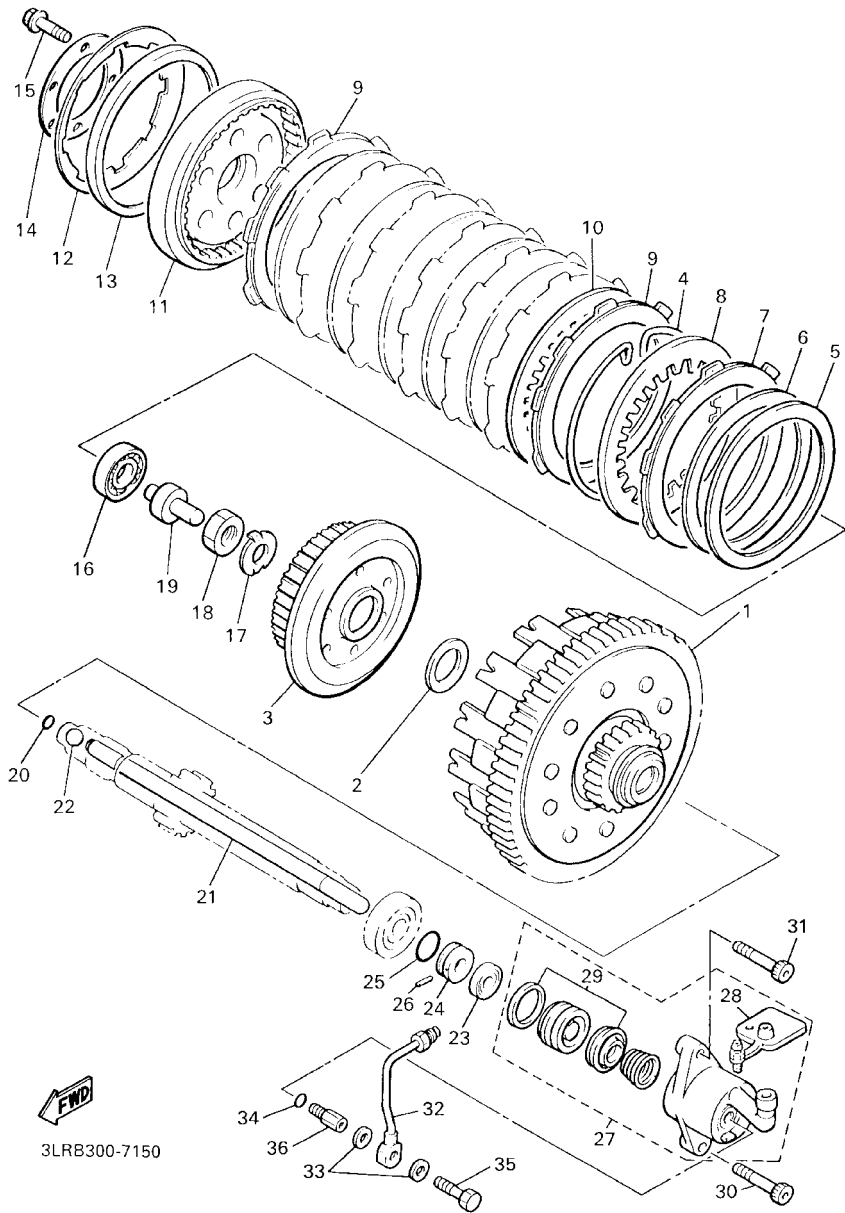
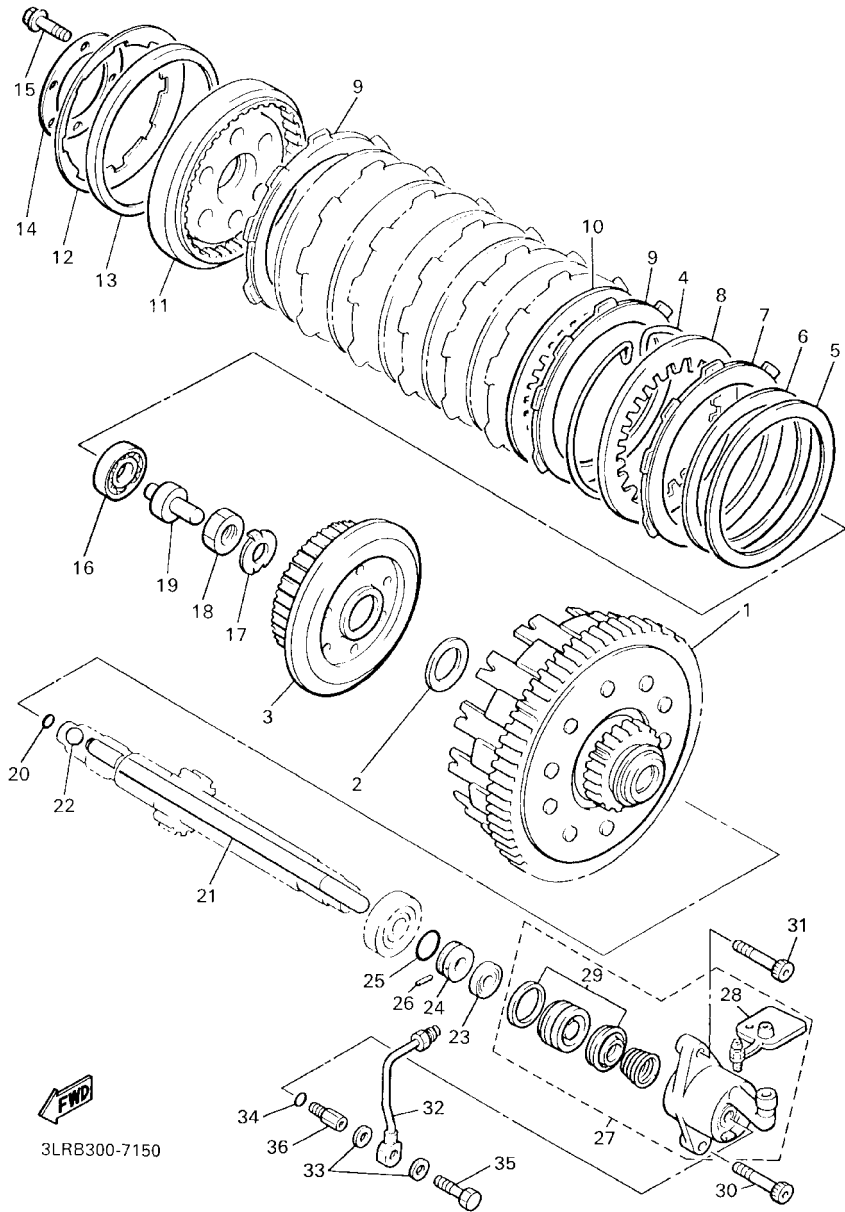

FIG. 16 CLUTCH

REF. NO.	PART NO.	DESCRIPTION	5GK9	5GKA	5GKB	REMARKS
1	26H-16150-10	PRIMARY DRIVEN GEAR COMP.	1	1	1	
2	26H-16154-00	PLATE, THRUST 1	1	1	1	
3	1FK-16371-00	BOSS, CLUTCH	1	1	1	
4	26H-16385-00	RING, CLUTCH BOSS	1	1	1	
5	26H-16384-00	PLATE, SEAT	1	1	1	
6	1FK-16383-00	SPRING, CLUTCH BOSS	1	1	1	
7	26H-16321-00	PLATE, FRICTION	1	1	1	
8	26H-16324-00	PLATE, CLUTCH 1	1	1	1	
9	26H-16307-00	PLATE, FRICTION 3	7	7	7	
10	26H-16324-00	PLATE, CLUTCH 1	6	6	6	
11	1FK-16351-00	PLATE, PRESSURE 1	1	1	1	
12	1FK-16334-00	SPRING, CLUTCH 2	1	1	1	
13	1FK-16335-00	HOUSING, SPRING	1	1	1	
14	1FK-16352-00	PLATE, PRESSURE 2	1	1	1	
15	97007-06025	BOLT	6	6	6	
16	93306-00304	BEARING (B6003C4)	1	1	1	
17	90215-25218	WASHER, LOCK	1	1	1	
18	90170-20323	NUT	1	1	1	
19	36Y-16356-00	ROD, PUSH 1	1	1	1	
20	93210-06632	O-RING	1	1	1	
21	4NK-16357-00	ROD, PUSH 2	1	1	1	
22	93511-32017	BALL	1	1	1	
23	93109-08061	OIL SEAL	1	1	1	
24	26H-16399-00	GUIDE, PUSH ROD	1	1	1	
25	93210-18322	O-RING	1	1	1	
26	93603-07073	PIN, DOWEL	1	1	1	
27	1FK-16381-11	PUSH LEVER COMP.	1	1	1	

FIG. 16 CLUTCH



REF. NO.	PART NO.	DESCRIPTION	5GK9	5GKA	5GKB	REMARKS
28	1NL-W0048-00	.BLEED SCREW KIT	1	1	1	
29	26H-W0098-00	.PUSH LEVER SEAL KIT	1	1	1	
30	90110-06035	BOLT, HEXAGON SOCKET HEAD	1	1	1	
31	90110-06243	BOLT, HEXAGON SOCKET HEAD	1	1	1	
32	1FK-1638A-00	PIPE, CLUTCH 1	1	1	1	
33	90201-10118	WASHER, PLATE	2	2	2	
34	90430-10148	GASKET	1	1	1	
35	90401-10084	BOLT, UNION	1	1	1	
36	1FK-16375-00	COLLAR	1	1	1	

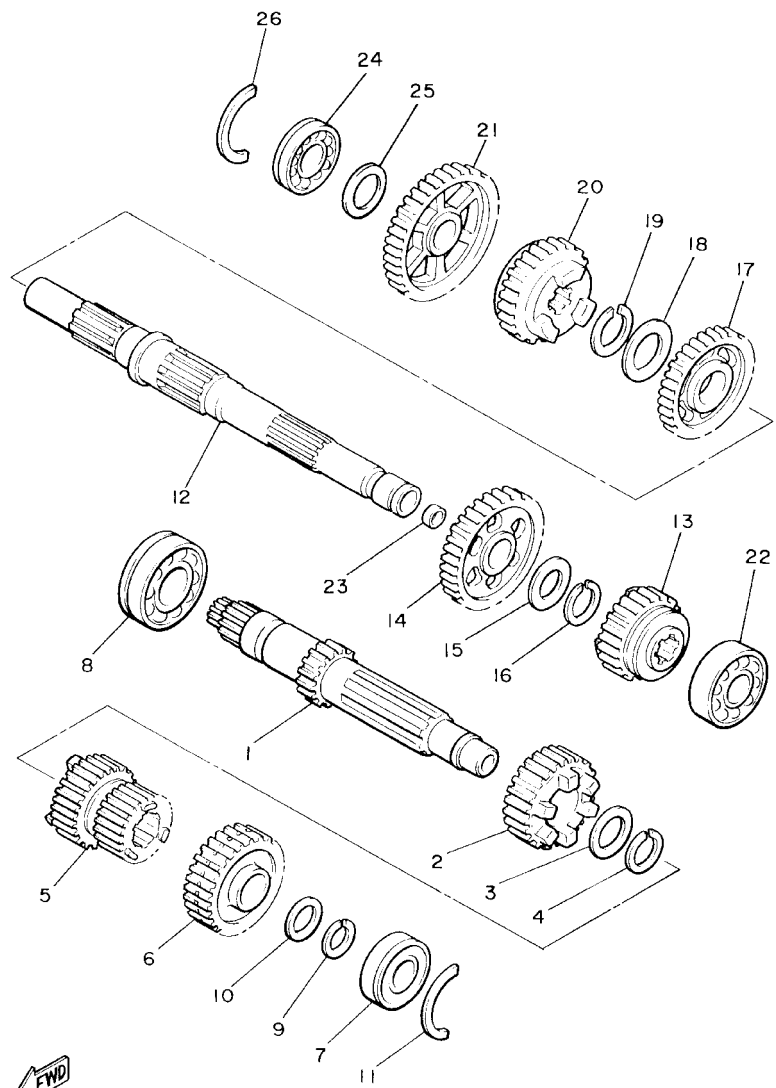

2LT171-7160

FIG. 17 TRANSMISSION

REF. NO.	PART NO.	DESCRIPTION	5GK9	5GKA	5GKB	REMARKS
1	1FK-17411-00	AXLE, MAIN	1	1	1	
2	1FK-17141-00	GEAR, 4TH PINION (26T)	1	1	1	
3	90209-25196	WASHER	1	1	1	
4	93440-28062	CIRCLIP	1	1	1	
5	1FK-17121-01	GEAR, 2ND/3RD PINION (22/23T)	1	1	1	
6	1FK-17151-01	GEAR, 5TH PINION (28T)	1	1	1	
7	93306-30430	BEARING	1	1	1	
8	93306-36401	BEARING	1	1	1	
9	93410-23056	CIRCLIP	1	1	1	
10	90201-232K5	WASHER, PLATE	1	1	1	
11	93440-52118	CIRCLIP	1	1	1	
12	4NK-17421-00	AXLE, DRIVE	1	1	1	
13	1FK-17251-01	GEAR, 5TH WHEEL (26T)	1	1	1	
14	1FK-17221-01	GEAR, 2ND WHEEL (39T)	1	1	1	
15	90209-32231	WASHER	1	1	1	
16	93440-34025	CIRCLIP	1	1	1	
17	26H-17231-01	GEAR, 3RD WHEEL (31T)	1	1	1	
18	90209-27192	WASHER	1	1	1	
19	93440-30077	CIRCLIP	1	1	1	
20	1FK-17241-00	GEAR, 4TH WHEEL (28T)	1	1	1	
21	1FK-17211-00	GEAR, 1ST WHEEL (43T)	1	1	1	
22	93306-20645	BEARING	1	1	1	
23	90331-15039	PLUG	1	1	1	
24	93306-20555	BEARING	1	1	1	
25	90201-256K5	WASHER, PLATE (0.5T)	1	1	1	UN
	90201-256K6	WASHER, PLATE (0.9T)	1	1	1	UN
	90201-256K7	WASHER, PLATE (1.3T)	1	1	1	UN

D6

FIG. 17 TRANSMISSION

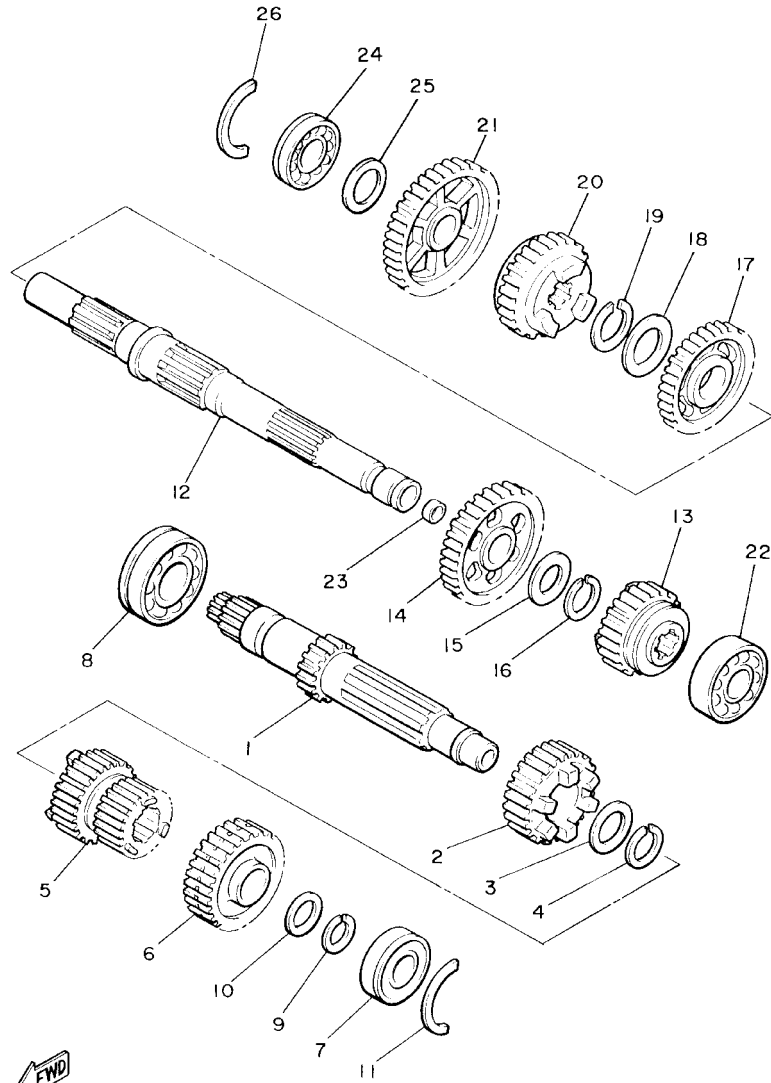

2LT171-7160

REF. NO.	PART NO.	DESCRIPTION	5GK9	5GKA	5GKB	REMARKS
26	93440-52118	CIRCLIP	1	1	1	

FIG. 18 MIDDLE DRIVE GEAR

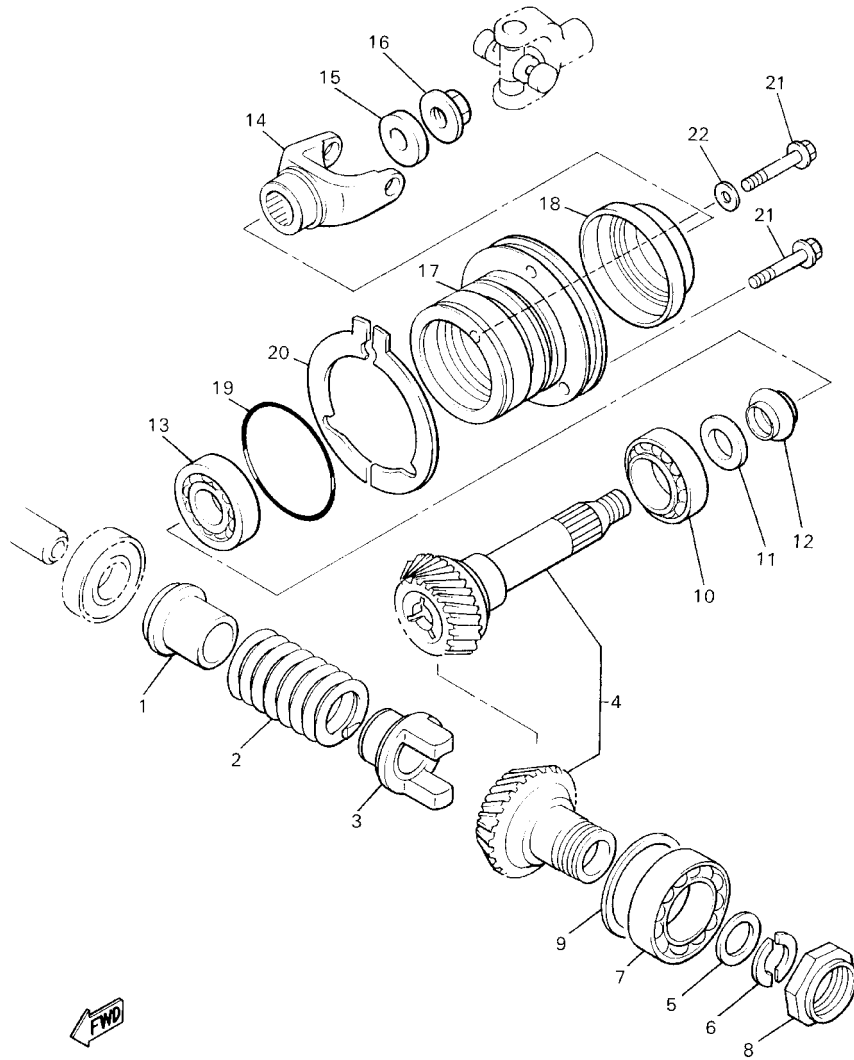

3JP110-6170

REF. NO.	PART NO.	DESCRIPTION	5GK9	5GKA	5GKB	REMARKS
1	2WE-17524-00	HOLDER	1	1	1	
2	90501-75638	SPRING, COMPRESSION	1	1	1	
3	2WE-17527-00	CAM, DRIVEN	1	1	1	
4	26H-W1751-01	MIDDLE GEAR COMP.	1	1	1	
5	90201-252K4	WASHER, PLATE	1	1	1	
6	90209-21281	WASHER	2	2	2	
7	93306-20901	BEARING (B6209RSH2-C2)	1	1	1	
8	90179-44328	NUT	1	1	1	
9	4X7-17531-00-15	SHIM, PINION (0.15T)	1	1	1	UR
	4X7-17531-00-30	SHIM, PINION (0.30T)	1	1	1	UR
	4X7-17531-00-50	SHIM, PINION (0.50T)	1	1	1	UR
10	93332-00028	BEARING	1	1	1	
11	90201-25634	WASHER, PLATE	1	1	1	
12	2H7-17571-01	SPACER, EXPANSION	1	1	1	
13	93332-00024	BEARING	1	1	1	
14	26H-17556-00	YOKE, JOINT	1	1	1	
15	90201-166R6	WASHER, PLATE	1	1	1	
16	90179-16662	NUT	1	1	1	
17	26H-17551-00	HOUSING, BEARING	1	1	1	
18	93101-35085	OIL SEAL	1	1	1	
19	93210-71360	O-RING	1	1	1	
20	3UF-17531-00	SHIM, PINION (0.10T)	2	2	2	UR
	3UF-17531-10	SHIM, PINION (0.15T)	2	2	2	UR
	3UF-17531-20	SHIM, PINION (0.20T)	2	2	2	UR
	3UF-17531-30	SHIM, PINION (0.30T)	2	2	2	UR
	3UF-17531-40	SHIM, PINION (0.40T)	2	2	2	UR
	3UF-17531-50	SHIM, PINION (0.50T)	2	2	2	UR

D8

FIG. 19 SHIFT CAM. FORK

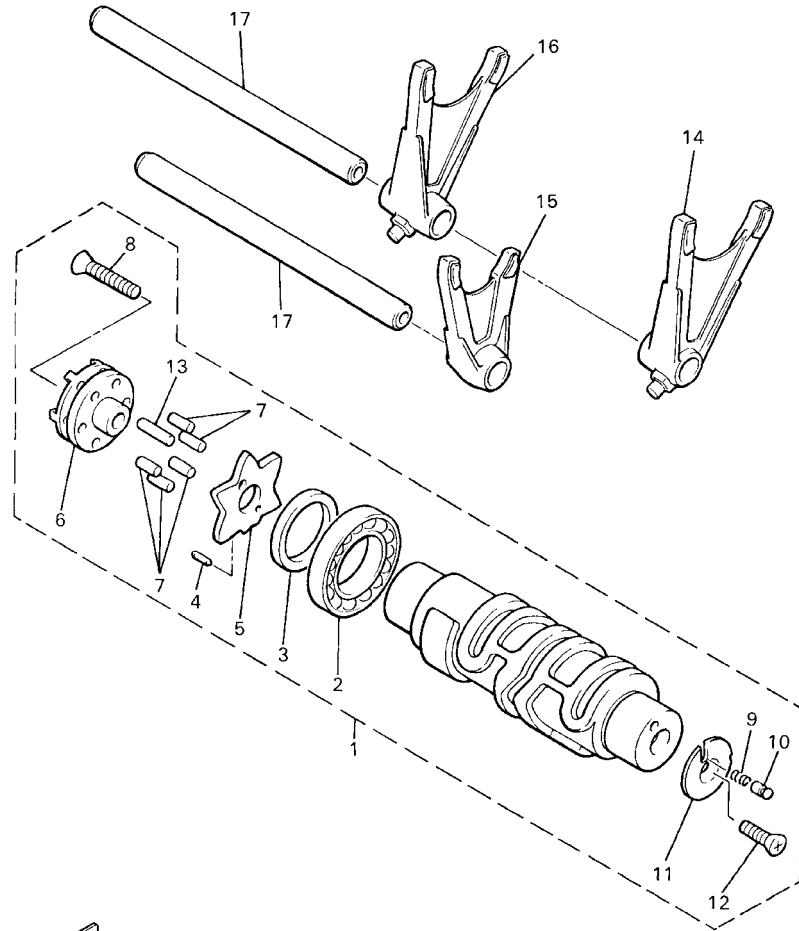

3JPX100-9190

REF. NO.	PART NO.	DESCRIPTION	5GK9	5GKA	5GKB	REMARKS
1	26H-18540-03	SHIFT CAM ASSY	1	1	1	
2	93306-90602	.BEARING	1	1	1	
3	90560-30234	.SPACER	1	1	1	
4	93603-10049	.PIN, DOWEL	1	1	1	
5	4NK-18141-00	.PLATE, STOPPER	1	1	1	
6	4NK-18185-00	.SEGMENT	1	1	1	
7	93604-12037	.PIN, DOWEL	5	5	5	
8	90151-06013	.SCREW, COUNTERSUNK	1	1	1	
9	90501-06022	.SPRING, COMPRESSION	1	1	1	
10	4UN-18542-00	.POINT, NEUTRAL	1	1	1	
11	4UN-18566-00	.PLATE, SIDE 2	1	1	1	
12	90149-05321	.SCREW	1	1	1	
13	93604-16092	.PIN, DOWEL	1	1	1	
14	26H-18511-01	FORK, SHIFT 1	1	1	1	
15	26H-18512-00	FORK, SHIFT 2	1	1	1	
16	26H-18513-00	FORK, SHIFT 3	1	1	1	
17	26H-18531-00	BAR, SHIFT FORK GUIDE 1	2	2	2	

FIG. 20 SHIFT SHAFT

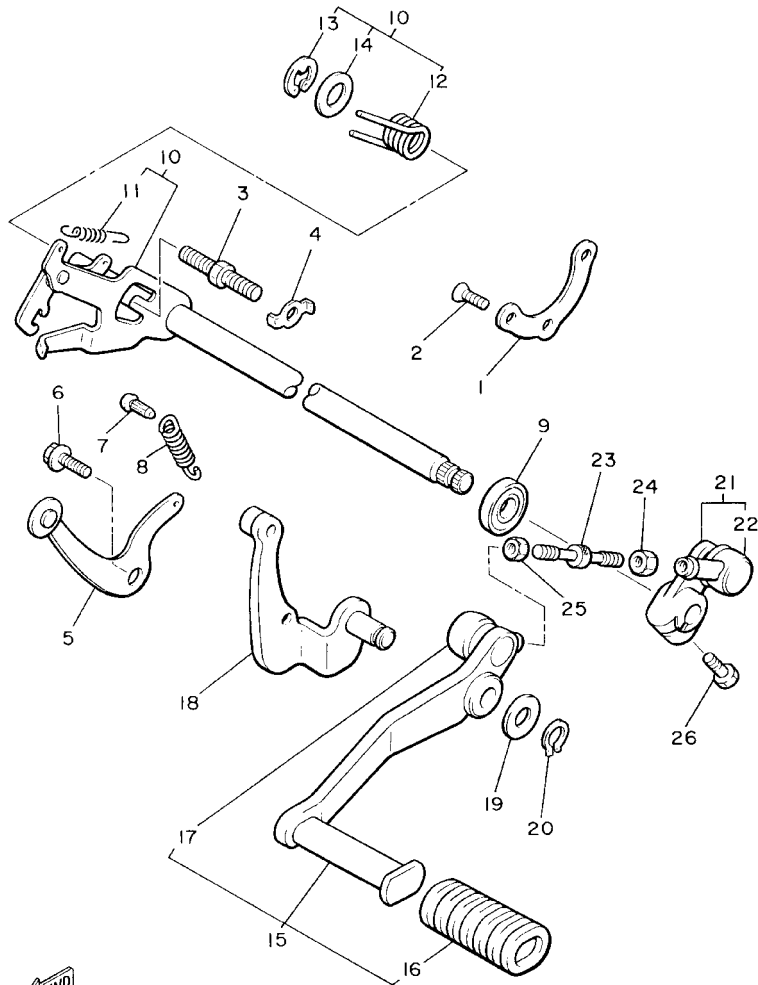

2LT171-7190

REF. NO.	PART NO.	DESCRIPTION	5GK9	5GKA	5GKB	REMARKS
1	26H-18536-00	STOPPER, SHIFT BAR	1	1	1	
2	90151-06041	SCREW, COUNTERSUNK	3	3	3	
3	90109-08441	BOLT	1	1	1	
4	90215-08115	WASHER, LOCK	1	1	1	
5	26H-18140-02	STOPPER LEVER ASSY	1	1	1	
6	90109-063F8	BOLT	1	1	1	
7	132-16346-00	HOOK, SPRING	1	1	1	
8	90506-13312	SPRING, TENSION	1	1	1	
9	93102-12106	OIL SEAL (SD 12-22-5 HS)	1	1	1	
10	1FK-18101-01	SHIFT SHAFT ASSY	1	1	1	
11	90506-08227	SPRING, TENSION	1	1	1	
12	90508-32588	SPRING, TORSION	1	1	1	
13	99001-10600	CIRCLIP	1	1	1	
14	90201-127E1	WASHER, PLATE	1	1	1	
15	1FK-18110-00	SHIFT PEDAL ASSY	1	1	1	
16	22N-18113-00	COVER, SHIFT PEDAL	1	1	1	
17	2H9-18154-00	COVER, DUST	1	1	1	
18	1FK-18128-00	BRACKET	1	1	1	
19	90201-12688	WASHER, PLATE	1	1	1	
20	99009-12400	CIRCLIP	1	1	1	
21	1FK-18152-00	LEVER, SHIFT 4	1	1	1	
22	2H9-18154-00	COVER, DUST	1	1	1	
23	42X-18115-00	ROD, SHIFT	1	1	1	
24	95304-06700	NUT	1	1	1	
25	90170-06228	NUT(COUNTER CLOCKWISE)	1	1	1	
26	97027-06020	BOLT	1	1	1	

FIG. 21 FRAME

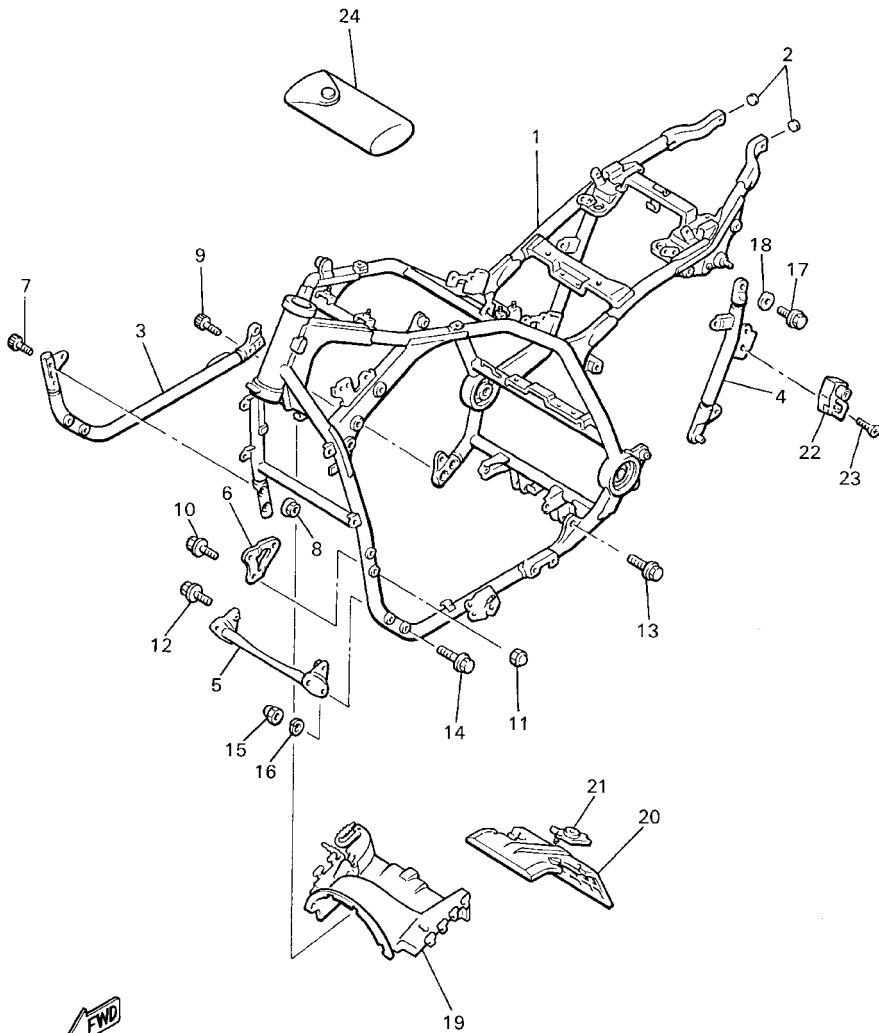

3JPX100-9210

REF. NO.	PART NO.	DESCRIPTION	5GK9	5GKA	5GKB	REMARKS
1	2EN-21110-01-33	FRAME COMP.	1	1	1	YB
2	1AA-2143A-00	CAP	2	2	2	
3	1FK-21140-00-33	DOWN TUBE COMP.	1	1	1	YB
4	3UF-21105-00-33	BACK STAY SUB COMP. 1	1	1	1	YB
5	1FK-2141V-10	CROSS BAR COMPLETE	1	1	1	
6	1FK-21315-00	STAY, ENGINE 2	1	1	1	
7	90110-10161	BOLT, HEXAGON SOCKET HEAD	2	2	2	
8	90179-10247	NUT	2	2	2	
9	90110-10092	BOLT, HEXAGON SOCKET HEAD	2	2	2	
10	90105-081A0	BOLT, FLANGE	2	2	2	
11	90176-10033	NUT, CROWN	2	2	2	
12	90105-10376	BOLT, FLANGE	2	2	2	
13	90105-12252	BOLT, FLANGE	2	2	2	
14	95827-08060	BOLT, FLANGE	4	4	4	
15	90176-08040	NUT, CROWN	4	4	4	
16	92907-08100	WASHER, SPRING	4	4	4	
17	90105-08066	BOLT, FLANGE	1	1	1	
18	90201-08326	WASHER, PLATE	1	1	1	
19	1FK-2117F-00	COVER	1	1	1	
20	1FK-2117M-00	COVER 2	1	1	1	
21	1FK-2117N-01	COVER 3	2	2	2	
22	4R8-21308-00	HELMET HANGER ASSY	1	1	1	
23	90149-06154	SCREW	1	1	1	
24	1FK-28100-01	TOOL KIT	1	1	1	

FIG. 22 FENDER

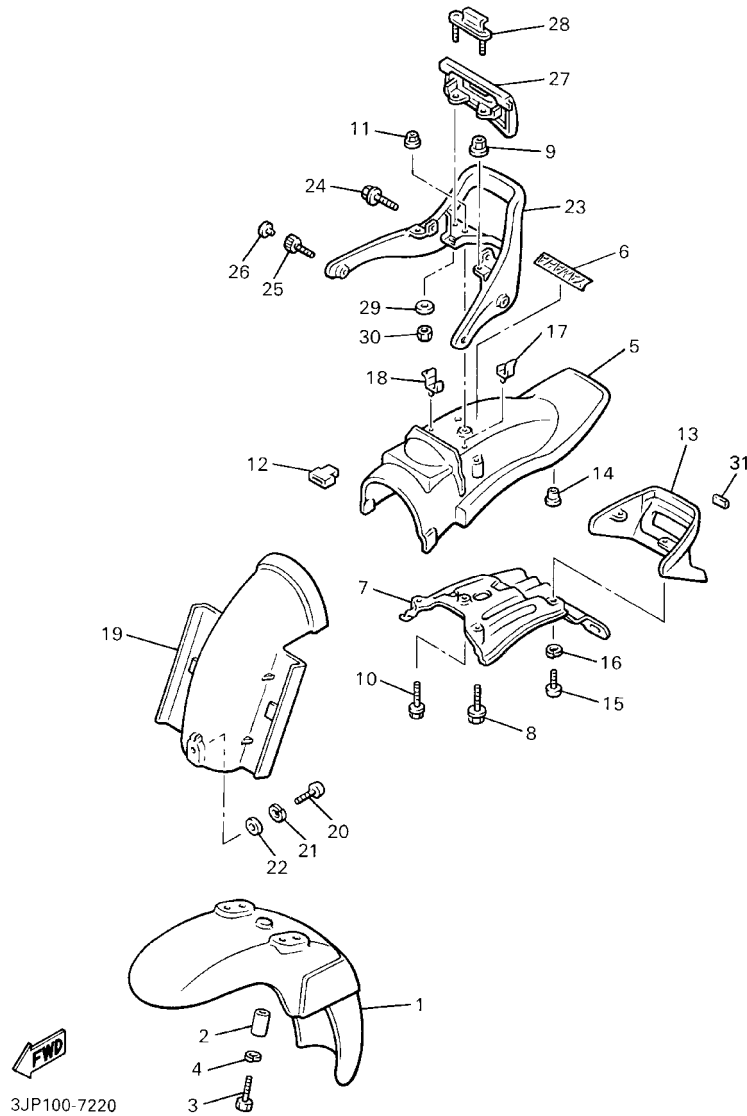

REF. NO.	PART NO.	DESCRIPTION	5GK9	5GKA	5GKB	REMARKS
1	3LR-21511-10	FENDER, FRONT	1	1	1	
2	90387-07789	COLLAR	4	4	4	
3	97027-06016	BOLT	4	4	4	
4	92907-06600	WASHER, PLATE	4	4	4	
5	3LR-21611-10	FENDER, REAR	1	1	1	
6	99246-00080	EMBLEM, YAMAHA	1	1	1	
7	1FK-21670-01	REINF. COMP.	1	1	1	
8	95827-08025	BOLT, FLANGE	2	2	2	
9	95707-08500	NUT, FLANGE	2	2	2	
10	95827-06020	BOLT, FLANGE	1	1	1	
11	95707-06500	NUT, FLANGE	1	1	1	
12	437-21717-10	DAMPER	2	2	2	
13	1FK-84516-01-98	COVER, TAILLIGHT	1	1	1	LGB
14	31A-14477-00	PLATE	2	2	2	
15	98507-06016	SCREW, PAN HEAD	2	2	2	
16	92907-06600	WASHER, PLATE	2	2	2	
17	90464-16021	CLAMP	1	1	1	
18	90464-16025	CLAMP	1	1	1	
19	1FK-21629-00	GUARD, MUD	1	1	1	
20	98507-06012	SCREW, PAN HEAD	1	1	1	
21	92907-06600	WASHER, PLATE	1	1	1	
22	90201-06055	WASHER, PLATE	1	1	1	
23	1FK-21645-00	STAY, REAR	1	1	1	
24	95827-08025	BOLT, FLANGE	2	2	2	
25	91317-08020	BOLT	2	2	2	
26	90338-08163	PLUG	2	2	2	
27	1FK-2163A-00	COVER, REAR FENDER 1	1	1	1	

FIG. 22 FENDER

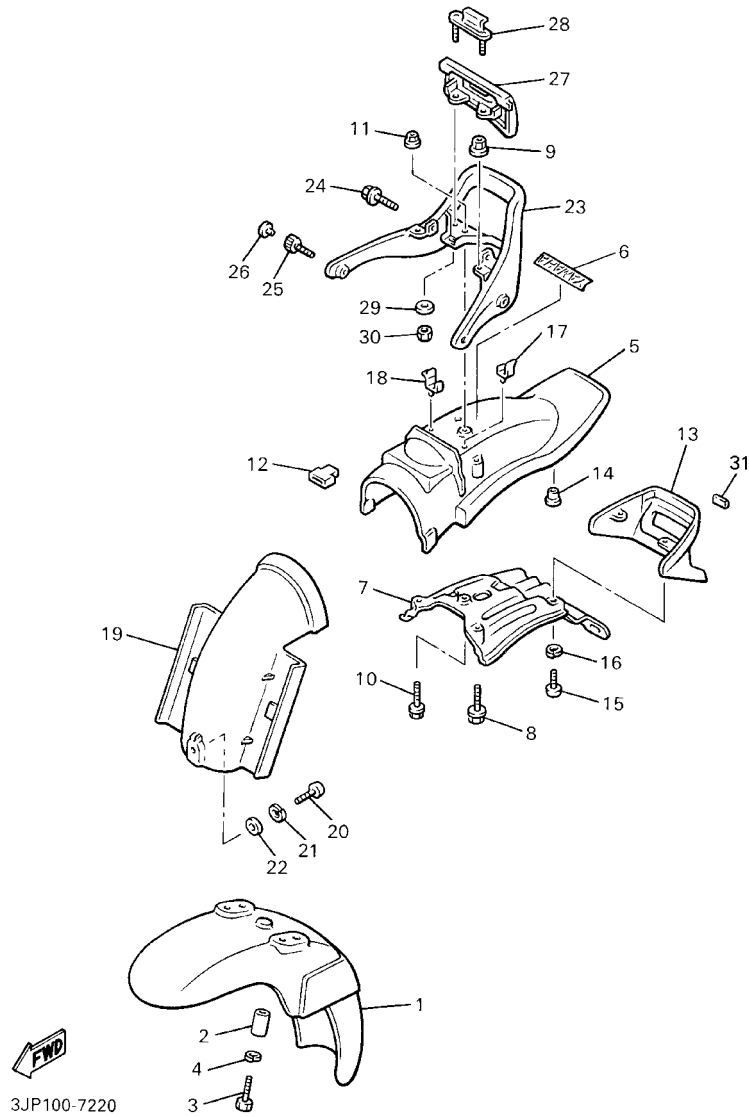

REF. NO.	PART NO.	DESCRIPTION	5GK9	5GKA	5GKB	REMARKS
28	1FK-2163E-00	COVER, REAR FENDER 2	1	1	1	
29	95307-06600	NUT	2	2	2	
30	90201-06057	WASHER, PLATE	2	2	2	
31	1FK-84527-00	DAMPER	2	2	2	

FIG. 23 SIDE COVER

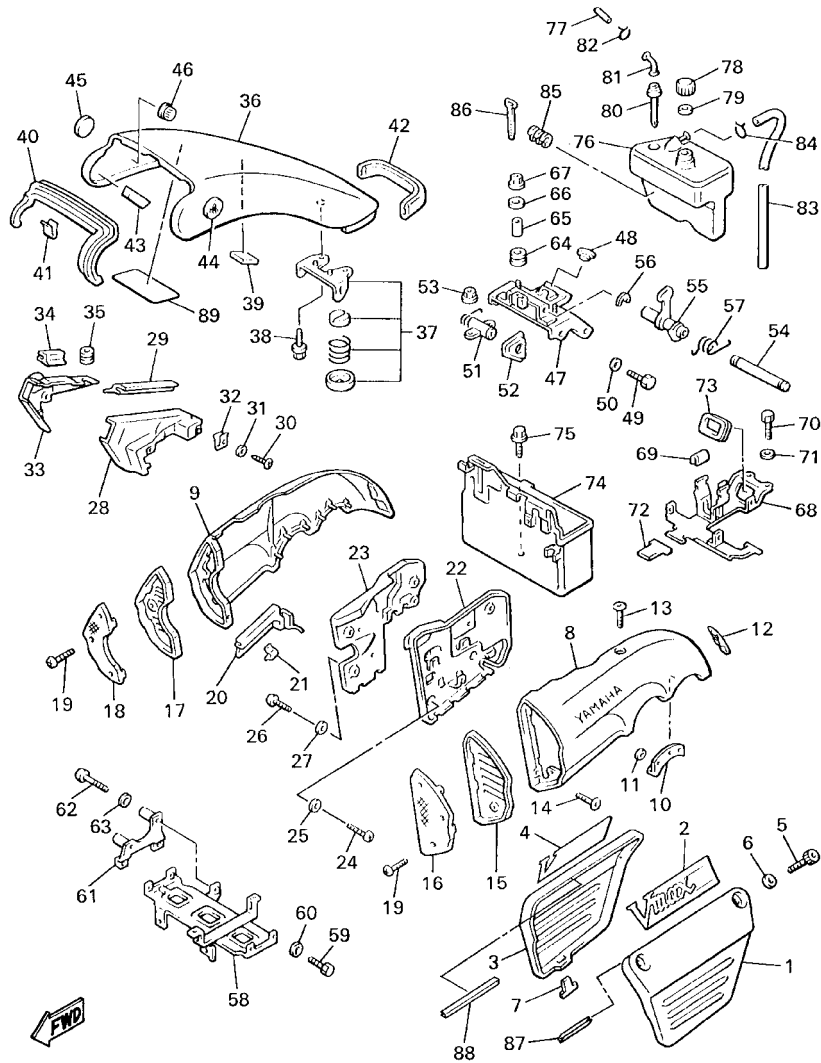

3JP100-7230

REF. NO.	PART NO.	DESCRIPTION	5GK9	5GKA	5GKB	REMARKS
1	3JP-21711-00	COVER, SIDE 1	1	1	1	
2	1UT-21783-00	EMBLEM 3	1	1	1	
3	3JP-21721-00	COVER, SIDE 2	1	1	1	
4	1UT-21784-00	EMBLEM 4	1	1	1	
5	90110-06102	BOLT, HEXAGON SOCKET HEAD	4	4	4	
6	92907-06200	WASHER	4	4	4	
7	2N4-21717-00	DAMPER	2	2	2	
8	3JP-21731-00	COVER, SIDE 3	1	1	1	
9	3JP-21741-00	COVER, SIDE 4	1	1	1	
10	1FK-21778-00	DAMPER, LOCATING 1	4	4	4	
11	90183-06008	NUT, SPRING	8	8	8	
12	1FK-21747-00	DAMPER	2	2	2	
13	92014-06012	BOLT, BUTTON HEAD	2	2	2	
14	92014-06025	BOLT, BUTTON HEAD	2	2	2	
15	1FK-2172G-00	PANEL 3	1	1	1	
16	1FK-2837N-00	GRILL, AIR INTAKE 1	1	1	1	
17	1FK-2172H-00	PANEL 4	1	1	1	
18	1FK-2837R-00	GRILL, AIR INTAKE 2	1	1	1	
19	90111-05012	BOLT	6	6	6	
20	1FK-2172W-00	COVER	1	1	1	
21	90468-03178	CLIP	3	3	3	
22	1FK-2172A-01	PANEL 1	1	1	1	
23	1FK-2172F-00	PANEL 2	1	1	1	
24	98507-06020	SCREW, PAN HEAD	3	3	3	
25	92907-06600	WASHER, PLATE	3	3	3	
26	98507-06016	SCREW, PAN HEAD	3	3	3	
27	92907-06600	WASHER, PLATE	3	3	3	

FIG. 23 SIDE COVER

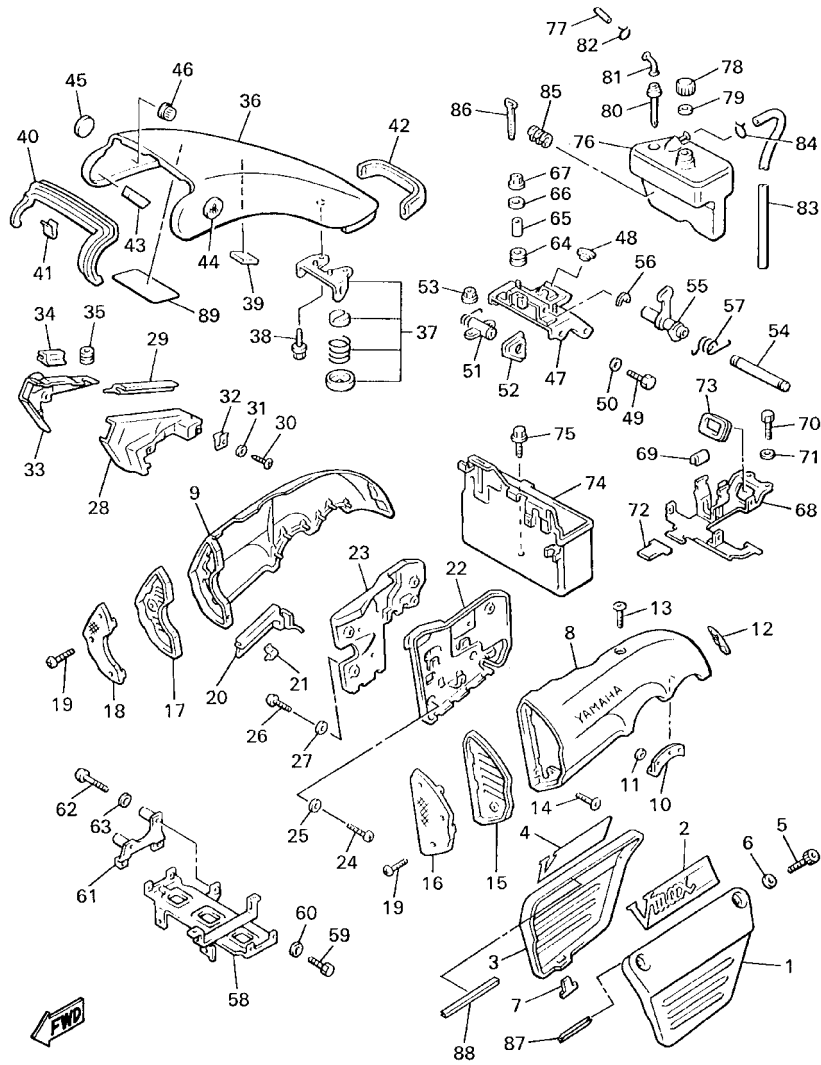

3JP100-7230

REF. NO.	PART NO.	DESCRIPTION	5GK9	5GKA	5GKB	REMARKS
28	1FK-2171E-00	COVER, SIDE 5	1	1	1	
29	1FK-2171T-00	MOLE, SIDE COVER 5	1	1	1	
30	97707-40512	SCREW, TAPPING	1	1	1	
31	92907-04200	WASHER	1	1	1	
32	90183-04027	NUT, SPRING	1	1	1	
33	1FK-2171X-00	COVER, SIDE 6	1	1	1	
34	1FK-2171U-00	MOLE, SIDE COVER 6	2	2	2	
35	90480-12296	GROMMET	1	1	1	
36	3LR-2171A-10	COVER, TOP	1	1	1	
37	1FK-2175J-00	LEVER LOCK COMP.	1	1	1	
38	95807-06010	BOLT, FLANGE	2	2	2	
39	1FK-21746-00	DAMPER	2	2	2	
40	1FK-28345-00	MOLE 1	1	1	1	
41	1FK-2171H-00	GUIDE	6	6	6	
42	1FK-2171L-00	MOLE, SIDE COVER 1	1	1	1	
43	1FK-21732-00	SEAL 1	2	2	2	
44	1FK-21781-00	EMBLEM 1	1	1	1	
45	1FK-21782-00	EMBLEM 2	1	1	1	
46	1FK-21779-00	DAMPER, LOCATING 2	2	2	2	
47	1FK-2172M-00	BRACKET 3	1	1	1	
48	18A-24724-00	DAMPEN, SEAT	1	1	1	
49	97007-06012	BOLT	4	4	4	
50	92907-06600	WASHER, PLATE	4	4	4	
51	1FK-21708-00	LOCK ASSY 2	1	1	1	
52	1FK-24796-00	COVER	1	1	1	
53	95707-06500	NUT, FLANGÉ	2	2	2	
54	1FK-2176U-00	SHAFT, LOCK	1	1	1	

FIG. 23 SIDE COVER

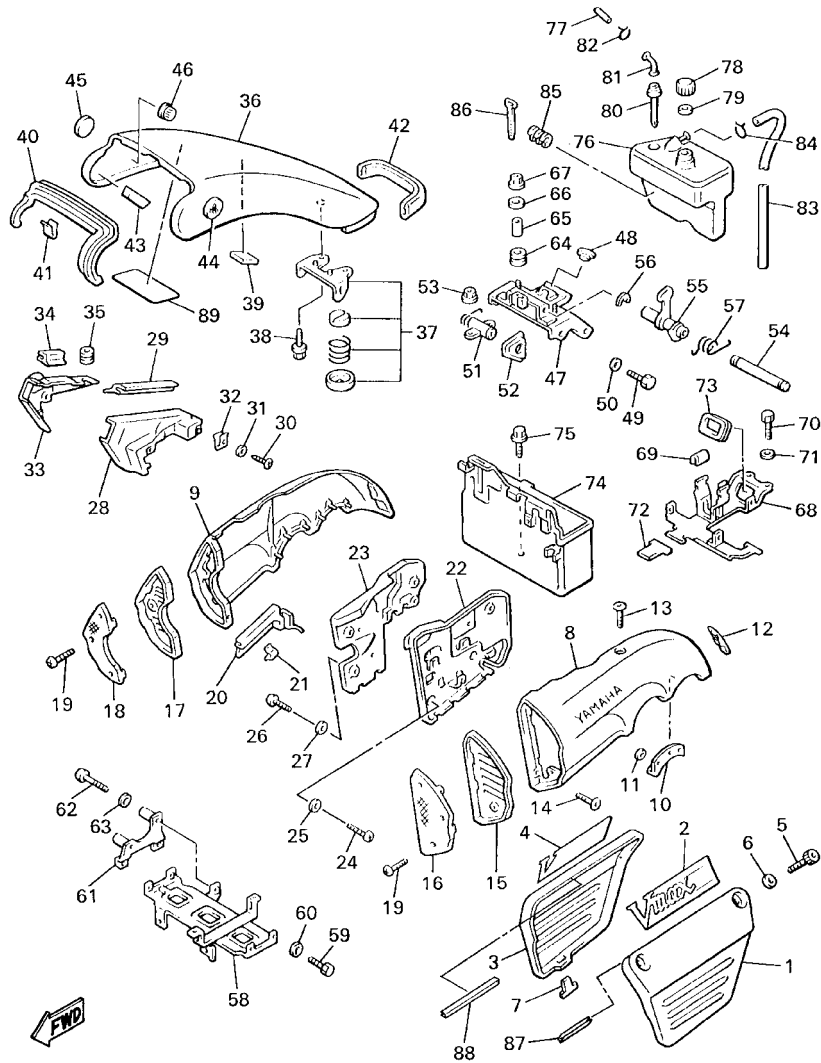

3JP100-7230

REF. NO.	PART NO.	DESCRIPTION	5GK9	5GKA	5GKB	REMARKS
55	1FK-2175K-00	LEVER, LOCK	1	1	1	
56	99001-05600	CIRCLIP	2	2	2	
57	1FK-2176V-00	SPRING, LOCK 2	1	1	1	
58	1FK-21243-01	PLATE, BRIDGE	1	1	1	
59	97007-06012	BOLT	4	4	4	
60	92907-06600	WASHER, PLATE	4	4	4	
61	1FK-2172K-01	BRACKET 1	1	1	1	
62	98507-06040	SCREW, PAN HEAD	2	2	2	
63	92907-06600	WASHER, PLATE	2	2	2	
64	90480-15235	GROMMET	2	2	2	
65	90387-060A7	COLLAR	2	2	2	
66	90201-06380	WASHER, PLATE	2	2	2	
67	95707-06500	NUT, FLANGE	2	2	2	
68	3UF-21359-00	BRACKET, COIL	1	1	1	
69	1FK-2171M-00	MOLE, SIDE COVER 2	2	2	2	
70	97007-06012	BOLT	2	2	2	
71	92907-06600	WASHER, PLATE	2	2	2	
72	2N4-21717-00	DAMPER	1	1	1	
73	214-84153-60	GROMMET, WIREHERNESS	1	1	1	
74	1FK-2177G-00	BOX, BATTERY	1	1	1	
75	90119-06056	BOLT, WITH WASHER	2	2	2	
76	1FK-21871-00	TANK, RECOVERY	1	1	1	
77	1FK-21816-00	PIPE 1	1	1	1	
78	26H-21875-00	CAP	1	1	1	
79	26H-21874-00	GASKET	1	1	1	
80	26H-21816-01	PIPE 1	1	1	1	
81	26H-21828-00	ELBOW	1	1	1	

FIG. 23 SIDE COVER

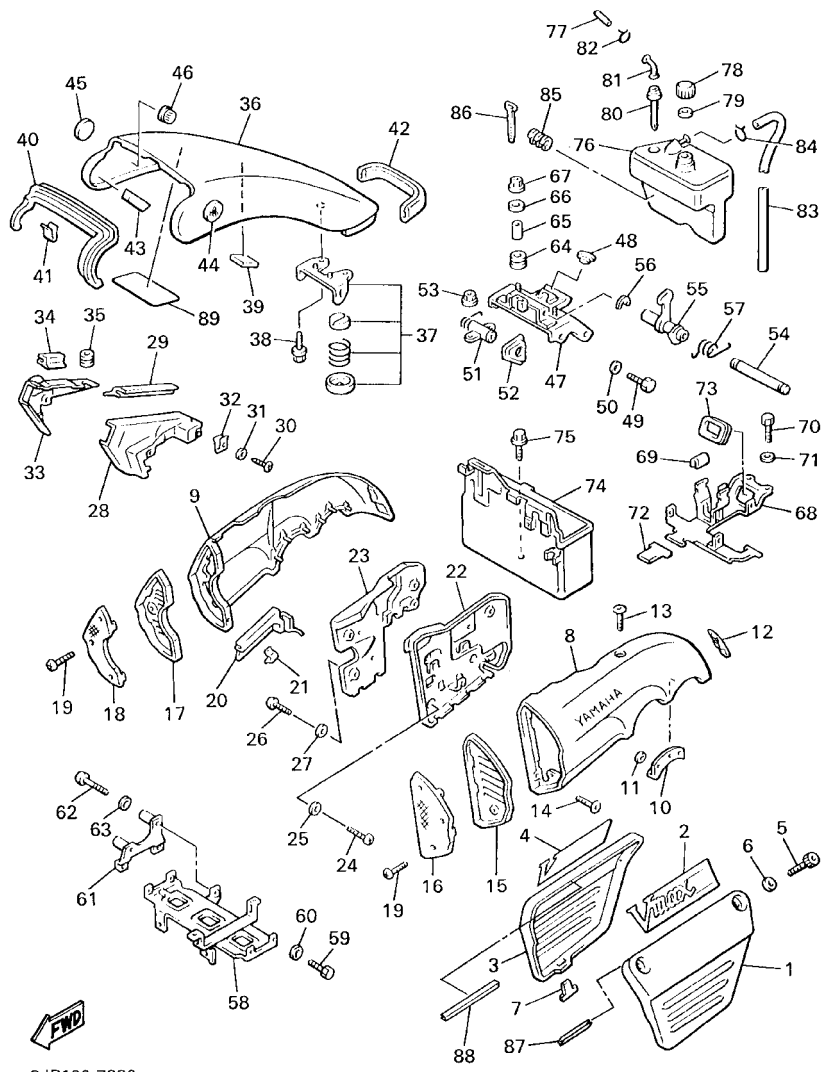

REF. NO.	PART NO.	DESCRIPTION	5GK9	5GKA	5GKB	REMARKS
82	90467-11019	CLIP	1	1	1	
83	1FK-21826-00	PIPE, BREATHER	1	1	1	
84	90467-09006	CLIP	1	1	1	
85	1FK-2177M-00	DAMPER, LOCATING 3	1	1	1	
86	5Y9-12491-00	CLAMP 1	1	1	1	
87	4KB-21268-00	SEAL	1	1	1	
88	3TU-28344-00	TAPE	1	1	1	
89	3JP-2179V-D0	PLATE, EPA 1(NON CALIFORNIA)	1			
	3JP-2179R-D0	PLATE, EPA 2(CALIFORNIA)		1		

FIG. 24 REAR ARM

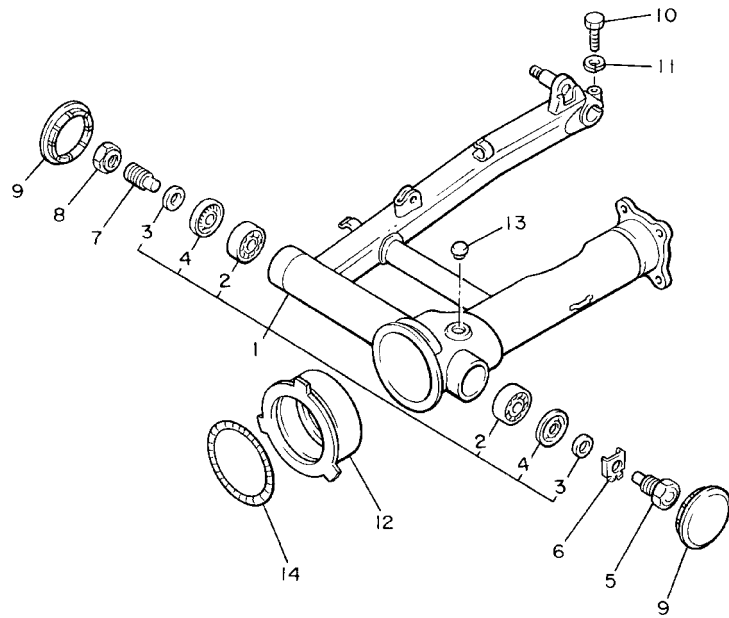

REF. NO.	PART NO.	DESCRIPTION	5GK9	5GKA	5GKB	REMARKS
1	2EN-W2211-00-35	REAR ARM COMP.	1	1	1	SL
2	93332-00010	.BEARING	2	2	2	
3	90387-17543	.COLLAR	2	2	2	
4	93102-25017	.OIL SEAL	2	2	2	
5	42X-22141-00	SHAFT, PIVOT	1	1	1	
6	90215-22238	WASHER, LOCK	1	1	1	
7	1J7-22141-00	SHAFT, PIVOT	1	1	1	
8	1J7-22143-00	NUT	1	1	1	
9	2H7-2219X-00	COVER	2	2	2	
10	97004-08035	BOLT	1	1	1	
11	92904-08600	WASHER	1	1	1	
12	26H-22189-00	BOOT, RUBBER	1	1	1	
13	90338-20113	PLUG	1	1	1	
14	90506-07136	SPRING, TENSION	1	1	1	



1FK110-5230

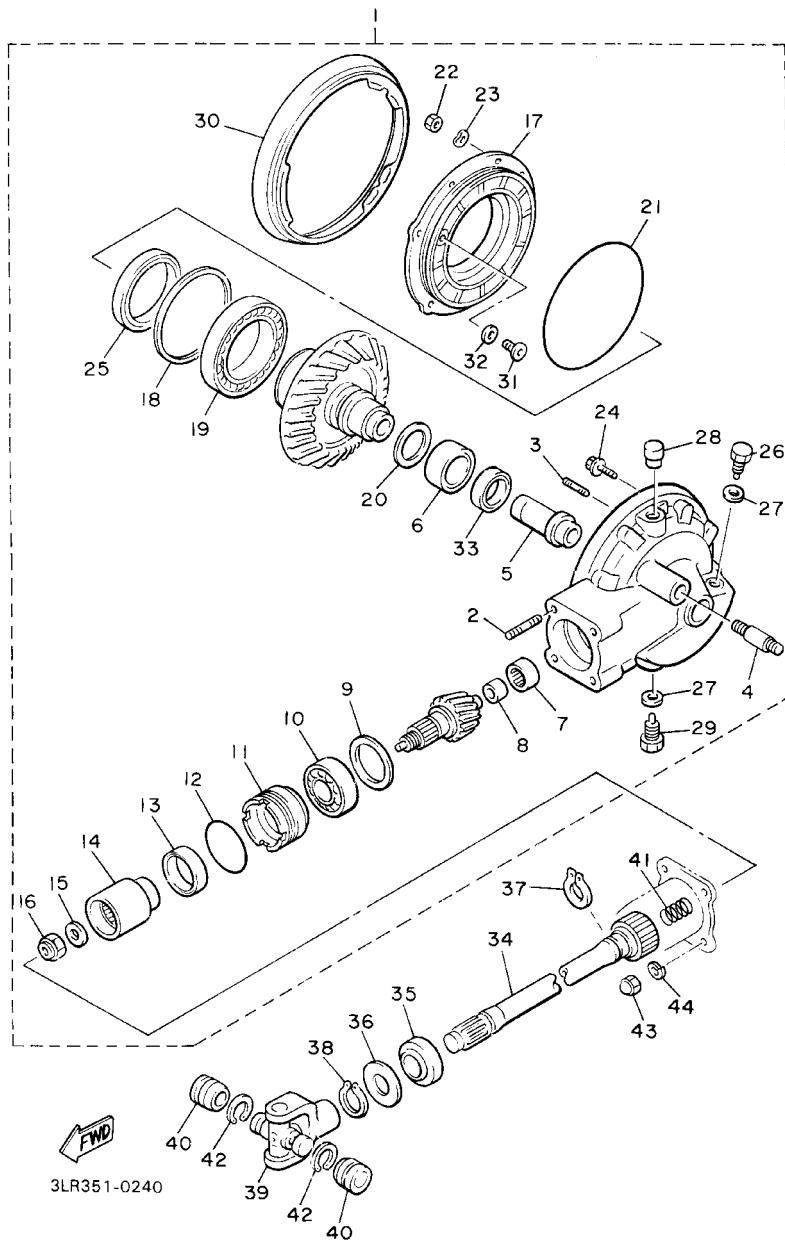

FIG. 25 DRIVE SHAFT

REF. NO.	PART NO.	DESCRIPTION	5GK9	5GKA	5GKB	REMARKS
1	1FK-46101-10	REAR AXLE GEAR CASE ASSY	1	1	1	
2	90116-10428	.BOLT, STUD	4	4	4	
3	90116-08427	.BOLT, STUD	6	6	6	
4	90116-10249	.BOLT, STUD	1	1	1	
5	4YE-46153-00	.COLLAR, GUIDE	1	1	1	
6	93311-43729	.BEARING	1	1	1	
7	93317-41510	.BEARING	1	1	1	
8	2H7-46122-00	.RACE, INNER	1	1	1	
9	1J7-17537-Y0-30	.SHIM, THRUST (0.30T)	1	1	1	UR
	1J7-17537-Y0-40	.SHIM, THRUST (0.40T)	1	1	1	UR
	1J7-17537-Y0-50	.SHIM, THRUST (0.50T)	1	1	1	UR
10	93306-30533	.BEARING (B6305RB1 SPECIAL)	1	1	1	
11	4H7-46125-00	.RETAINER, BEARING	1	1	1	
12	93210-60426	.O-RING	1	1	1	
13	93101-38098	.OIL SEAL	1	1	1	
14	4H7-46123-00	.COUPLING, GEAR	1	1	1	
15	90201-166R5	.WASHER, PLATE	1	1	1	
16	90179-16661	.NUT	1	1	1	
17	1FK-46152-01	.HOUSING, BEARING	1	1	1	
18	1J7-46117-Y0-25	.SHIM, RING GEAR (0.25T)	1	1	1	UR
	1J7-46117-Y0-30	.SHIM, RING GEAR (0.30T)	1	1	1	UR
	1J7-46117-Y0-40	.SHIM, RING GEAR (0.40T)	1	1	1	UR
	1J7-46117-Y0-50	.SHIM, RING GEAR (0.50T)	1	1	1	UR
19	93316-01403	.BEARING	1	1	1	
20	22U-46118-00-12	.SHIM, THRUST (1.2T)	1	1	1	UR
	22U-46118-00-14	.SHIM, THRUST (1.4T)	1	1	1	UR
	22U-46118-00-16	.SHIM, THRUST (1.6T)	1	1	1	UR

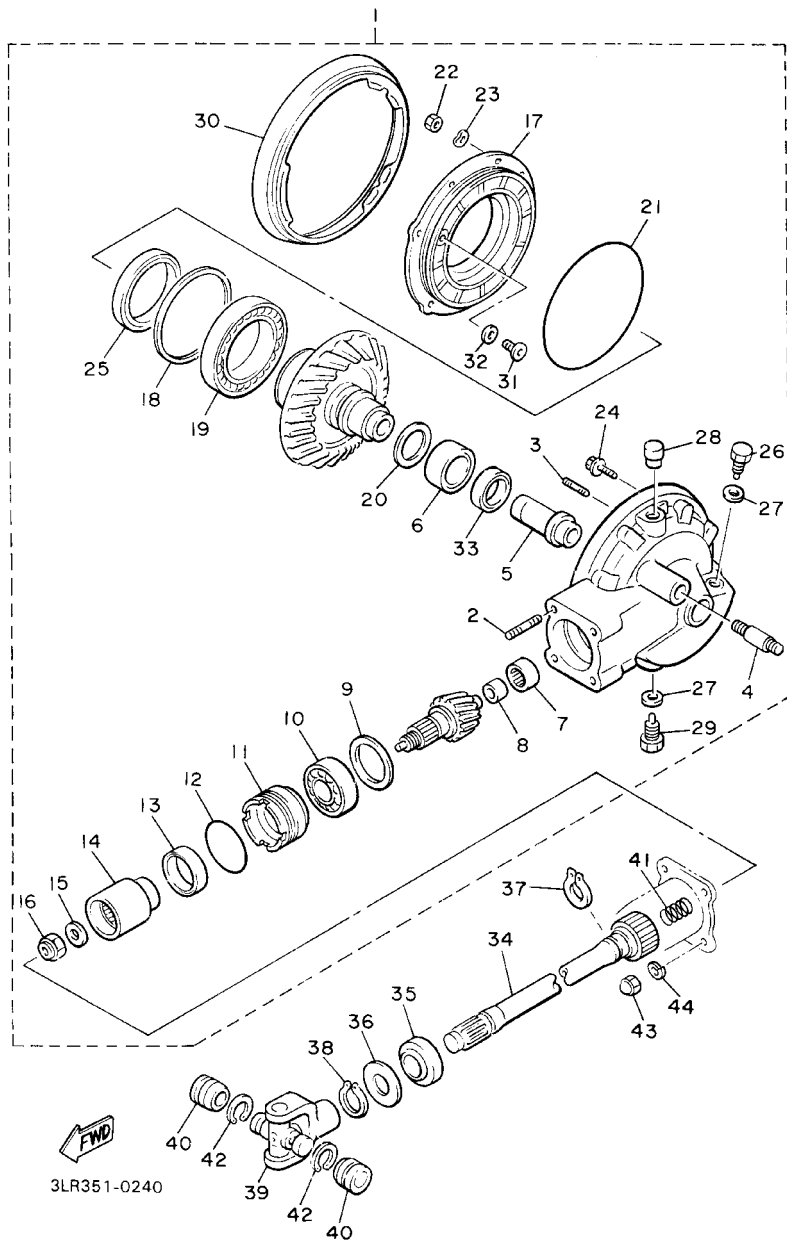
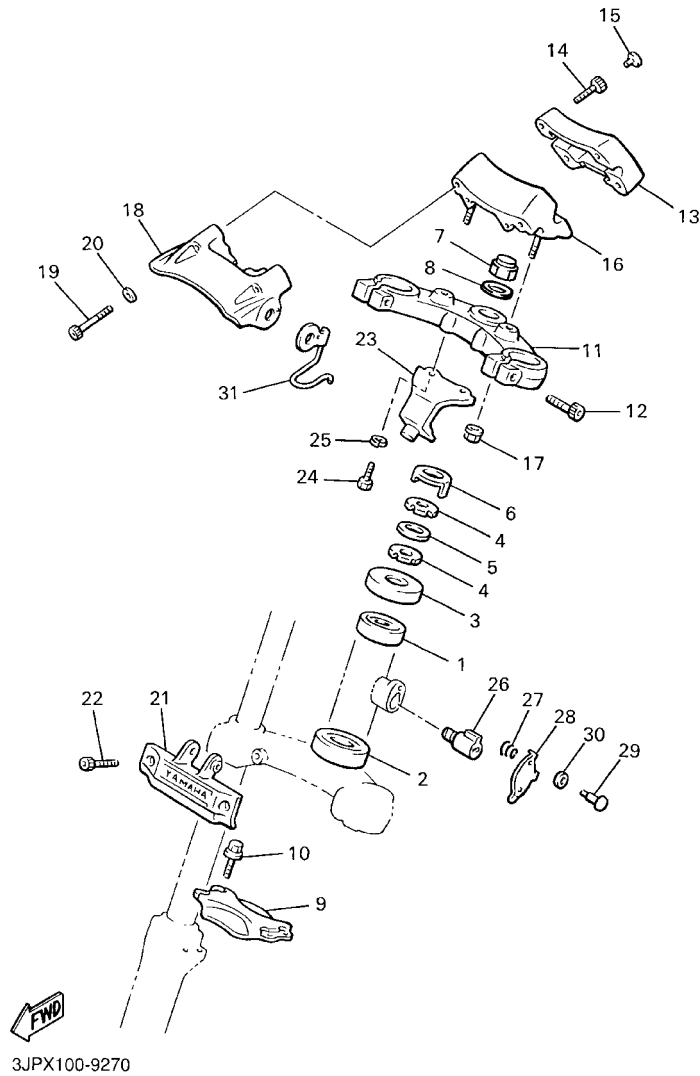

FIG. 25 DRIVE SHAFT

REF. NO.	PART NO.	DESCRIPTION	5GK9	5GKA	5GKB	REMARKS
20	22U-46118-00-18	.SHIM, THRUST (1.8T)	1	1	1	UR
	22U-46118-00-20	.SHIM, THRUST (2.0T)	1	1	1	UR
21	93211-54698	.O-RING	1	1	1	
22	95311-08600	.NUT	6	6	6	
23	92901-08700	.WASHER, WAVE	6	6	6	
24	95812-10050	.BOLT, FLANGE	2	2	2	
25	93102-70167	.OIL SEAL	1	1	1	
26	90340-14132	.PLUG, STRAIGHT SCREW	1	1	1	
27	214-11198-01	.GASKET	2	2	2	
28	2H7-17590-00	.BREATHER COMP.	1	1	1	
29	90340-14042	.PLUG, STRAIGHT SCREW	1	1	1	
30	1FK-46154-00	.COVER, HOUSING	1	1	1	
31	1FK-46156-00	.STOPPER, RING GEAR	1	1	1	
32	1FK-46157-00-15	.SHIM, STOPPER (T=0.15)	1	1	1	UR
	1FK-46157-00-20	.SHIM, STOPPER (T=0.20)	1	1	1	UR
33	93101-30084	.OIL SEAL	1	1	1	
34	1FK-46172-00	SHAFT, DRIVE	1	1	1	
35	93108-43013	OIL SEAL	1	1	1	
36	90201-231A2	WASHER, PLATE	1	1	1	
37	93410-23056	CIRCLIP	1	1	1	
38	93410-22039	CIRCLIP	1	1	1	
39	4X7-46180-00	CROSS JOINT COMP.	1	1	1	
40	93311-21044	BEARING	2	2	2	
41	90501-16491	SPRING, COMPRESSION	1	1	1	
42	93440-20088	CIRCLIP	2	2	2	
43	90176-10075	NUT, CROWN	4	4	4	
44	92903-10100	WASHER, SPRING	4	4	4	

FIG. 27 STEERING



REF. NO.	PART NO.	DESCRIPTION	5GK9	5GKA	5GKB	REMARKS
1	93332-00001	BEARING	1	1	1	
2	93332-00008	BEARING	1	1	1	
3	1J7-23415-00	COVER, BALL RACE 1	1	1	1	
4	90179-25033	NUT	2	2	2	
5	90202-26142	WASHER, PLATE	1	1	1	
6	26H-23418-01	WASHER, SPECIAL	1	1	1	
7	90176-22081	NUT, CROWN	1	1	1	
8	90201-220T0	WASHER, PLATE	1	1	1	
9	3LR-2313A-00	BRACE, FORK	1	1	1	
10	95024-08016	BOLT, FLANGE	4	4	4	
11	1FK-23435-10	CROWN, HANDLE	1	1	1	
12	91314-08040	BOLT	2	2	2	
13	1FK-23441-00-38	HOLDER, HANDLE UPPER	1	1	1	CLP
14	91317-08030	BOLT	4	4	4	
15	90338-08163	PLUG	4	4	4	
16	1FK-23442-00-38	HOLDER, HANDLE LOWER	1	1	1	CLP
17	95607-10200	NUT, SELF-LOCKING	2	2	2	
18	1FK-23437-00-38	COVER, CROWN	1	1	1	CLP
19	91314-06050	BOLT	2	2	2	
20	92903-06600	WASHER, PLATE	2	2	2	
21	1FK-23174-00	STAY, HEADLIGHT	1	1	1	
22	91314-06020	BOLT	2	2	2	
23	1FK-23486-00	STAY, PLATE	1	1	1	
24	97007-06012	BOLT	2	2	2	
25	92907-06600	WASHER, PLATE	2	2	2	
26	4R3-23408-00	STEERING LOCK ASSY	1	1	1	
27	90502-09024	SPRING, CONICAL	1	1	1	

FIG. 27 STEERING

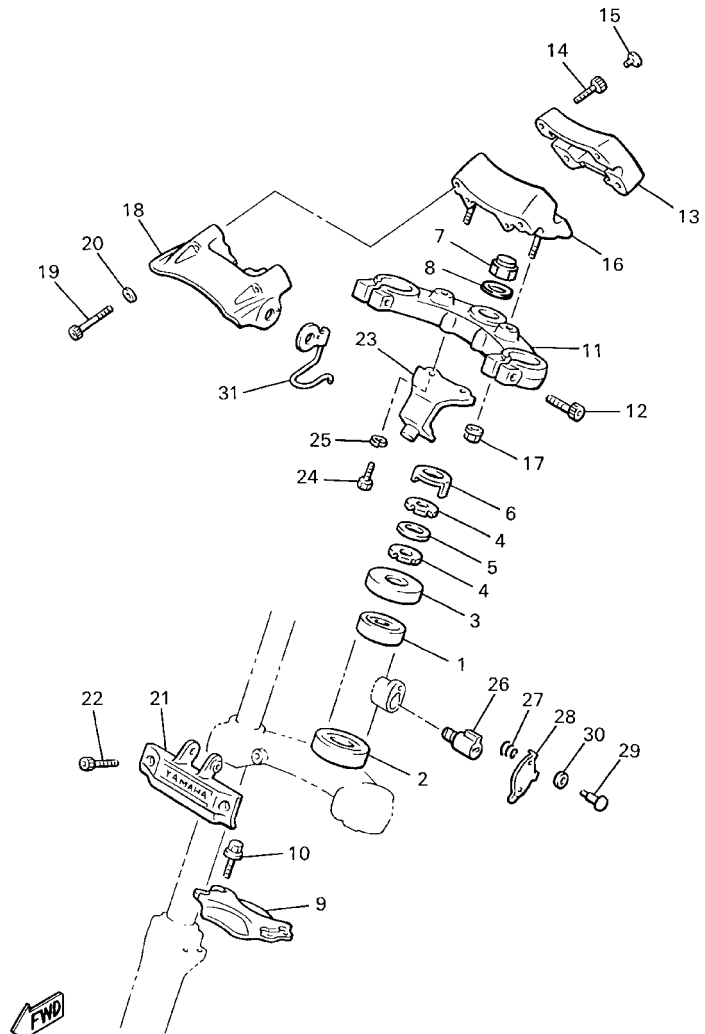

3JPX100-9270

REF. NO.	PART NO.	DESCRIPTION	5GK9	5GKA	5GKB	REMARKS
28	584-23484-01	CAP, HANDLE LOCK	1	1	1	
29	90269-04003	RIVET	1	1	1	
30	90208-04029	WASHER, CONICAL SPRING	1	1	1	
31	1FK-23317-00	HOLDER, CABLE	1	1	1	

FIG. 28 FRONT FORK

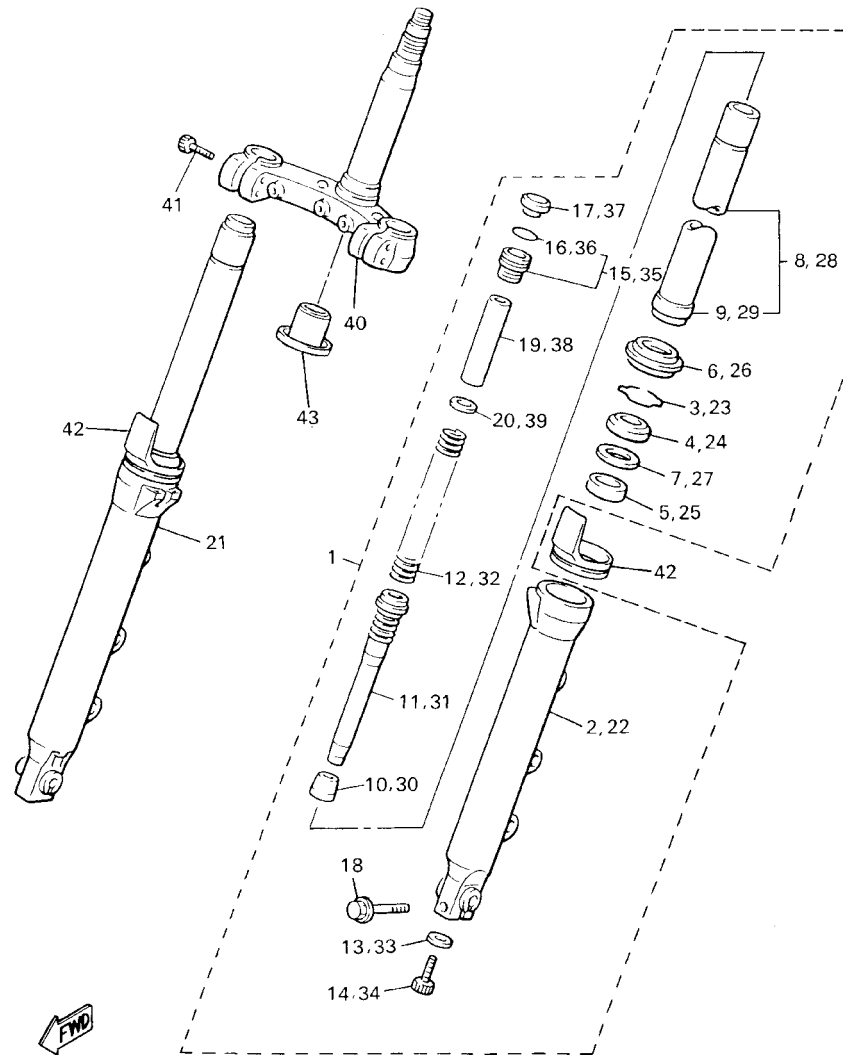

3LRD300-1270

REF. NO.	PART NO.	DESCRIPTION	5GK9	5GKA	5GKB	REMARKS
1	3LR-23102-21	FRONT FORK ASSY (L.H)	1	1	1	
2	3LR-23126-20	.TUBE, OUTER (LEFT)	1	1	1	
3	4V4-23153-L0	.RING, SNAP	1	1	1	
4	4PU-23145-01	.OIL SEAL	1	1	1	
5	3GM-23125-00	.METAL, SLIDE 1	1	1	1	
6	4PU-23144-00	.SEAL, DUST	1	1	1	
7	4V4-23146-L0	.WASHER, OIL SEAL	1	1	1	
8	3LR-23110-01	.INNER TUBE COMP.1	1	1	1	
9	3GM-23171-00	..PISTON, FRONT FORK	1	1	1	
10	3GM-23173-00	.SPINDLE, TAPER	1	1	1	
11	3LR-23170-20	.CYLINDER COMP., FRONT FORK	1	1	1	
12	3LR-23141-00	.SPRING, FRONT FORK	1	1	1	
13	509-23158-L0	.GASKET	1	1	1	
14	278-23181-50	.BOLT, HEXAGON SOCKET HEAD	1	1	1	
15	3LR-23111-00	.BOLT, CAP	1	1	1	
16	4V4-23188-L0	..O-RING	1	1	1	
17	3LR-23168-00	.CAP, FRONT FORK	1	1	1	
18	95824-08045	.BOLT, FLANGE	1	1	1	
19	3YF-23118-00	.SPACER	1	1	1	
20	3LR-23149-00	.WASHER, SPRING UPPER	1	1	1	
21	3LR-23103-21	FRONT FORK ASSY (R.H)	1	1	1	
22	3LR-23136-20	.TUBE, OUTER (RIGHT)	1	1	1	
23	4V4-23153-L0	.RING, SNAP	1	1	1	
24	4PU-23145-01	.OIL SEAL	1	1	1	
25	3GM-23125-00	.METAL, SLIDE 1	1	1	1	
26	4PU-23144-00	.SEAL, DUST	1	1	1	
27	4V4-23146-L0	.WASHER, OIL SEAL	1	1	1	

FIG. 28 FRONT FORK

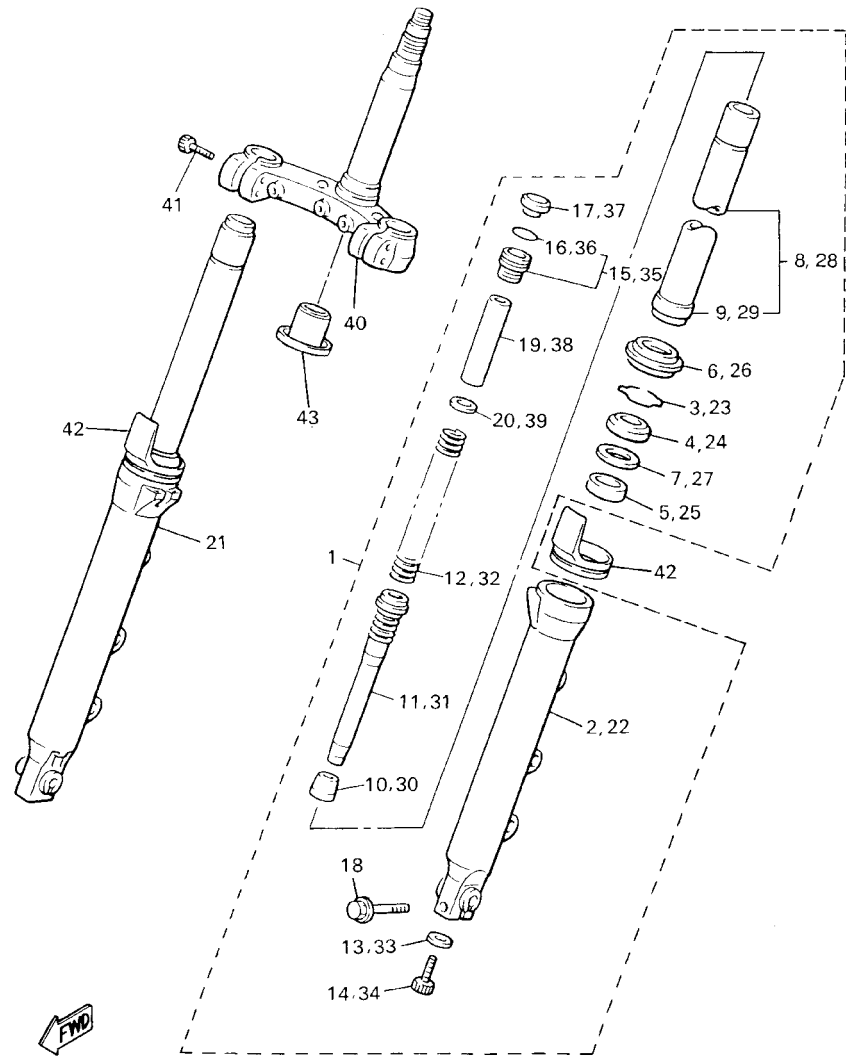

3LRD300-1270

REF. NO.	PART NO.	DESCRIPTION	5GK9	5GKA	5GKB	REMARKS
28	3LR-23110-01	.INNER TUBE COMP.1	1	1	1	
29	3GM-23171-00	..PISTON, FRONT FORK	1	1	1	
30	3GM-23173-00	.SPINDLE, TAPER	1	1	1	
31	3LR-23170-20	.CYLINDER COMP., FRONT FORK	1	1	1	
32	3LR-23141-00	.SPRING, FRONT FORK	1	1	1	
33	509-23158-L0	.GASKET	1	1	1	
34	278-23181-50	.BOLT, HEXAGON SOCKET HEAD	1	1	1	
35	3LR-23111-00	.BOLT, CAP	1	1	1	
36	4V4-23188-L0	..O-RING	1	1	1	
37	3LR-23168-00	.CAP, FRONT FORK	1	1	1	
38	3YF-23118-00	.SPACER	1	1	1	
39	3LR-23149-00	.WASHER, SPRING UPPER	1	1	1	
40	3LR-23340-10	UNDER BRACKET COMP.	1	1	1	
41	91314-08032	BOLT	4	4	4	
42	4PU-2331G-00	COVER	2	2	2	
43	4KM-23123-01	COVER, LOWER 1	1	1	1	

FIG. 29 FUEL TANK

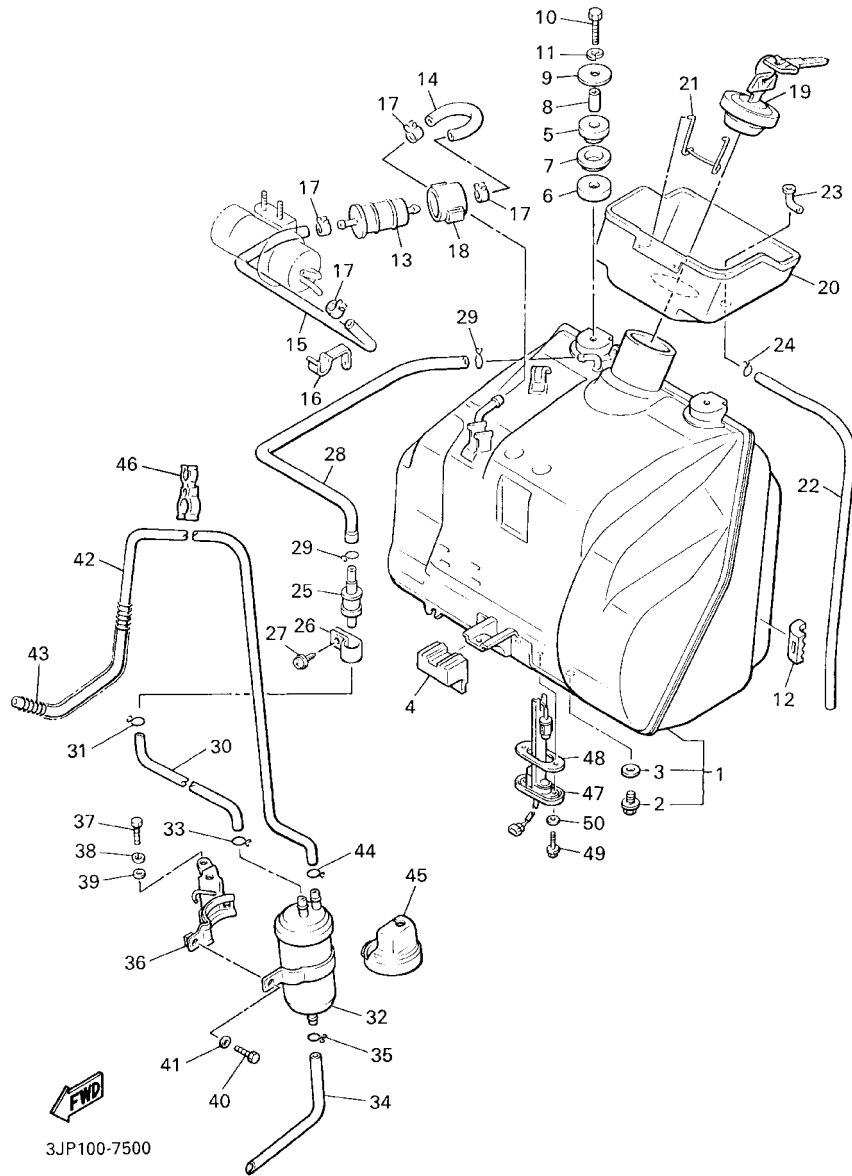

REF. NO.	PART NO.	DESCRIPTION	5GK9	5GKA	5GKB	REMARKS
1	1FK-24110-01-33	FUEL TANK COMP.	1	1	1	YB
2	95807-08012	.BOLT, FLANGE	1	1	1	
3	90201-08087	.WASHER, PLATE	1	1	1	
4	1FK-24181-00	DAMPER, LOCATING 1	1	1	1	
5	1FK-24182-00	DAMPER, LOCATING 2	2	2	2	
6	1FK-24183-00	DAMPER, LOCATING 3	2	2	2	
7	1FK-24186-00	WASHER, SPECIAL	2	2	2	
8	90387-062G5	COLLAR	2	2	2	
9	90201-065G8	WASHER, PLATE	2	2	2	
10	97027-06030	BOLT	2	2	2	
11	92907-06600	WASHER, PLATE	2	2	2	
12	1FK-24184-00	DAMPER, LOCATING 4	2	2	2	
13	1FK-24560-00	FILTER ASSY	1	1	1	
14	1FK-24314-00	PIPE 4	1	1	1	
15	1FK-24315-00	PIPE 5	1	1	1	
16	90464-30071	CLAMP	1	1	1	
17	90467-12124	CLIP	4	4	4	
18	1FK-24566-00	BRACKET, FILTER	1	1	1	
19	54K-24602-00	CAP ASSY	1	1	1	
20	1FK-2414A-00	COVER, FILLER	1	1	1	
21	1FK-24393-00	SPRING	1	1	1	
22	90445-086A8	HOSE (L500)	1	1	1	
23	1FK-24376-00	PIPE, JOINT 1	1	1	1	
24	90467-08075	CLIP	1	1	1	
25	25H-24180-00	ROLL OVER VALVE ASSY	1	1	1	
26	90461-15100	CLAMP	1	1	1	
27	97707-50612	SCREW, TAPPING	1	1	1	

FIG. 29 FUEL TANK

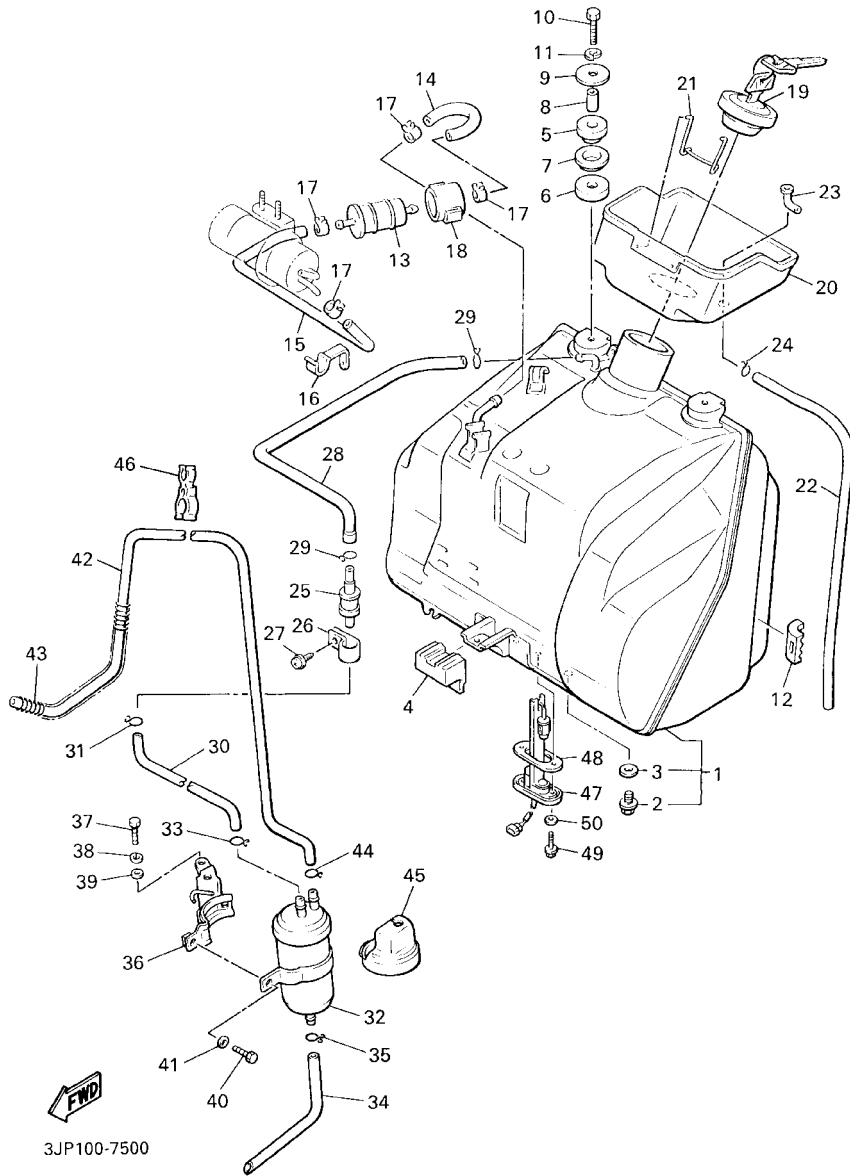

REF. NO.	PART NO.	DESCRIPTION	5GK9	5GKA	5GKB	REMARKS
28	1FK-24311-02	PIPE, FUEL 1	1	1	1	
29	90467-10041	CLIP	2	2	2	
30	90445-112K7	HOSE (L650)	1		1	
	1JH-24316-02	PIPE 6		1		
31	90467-10041	CLIP	1	1	1	
32	1JH-24170-00	CANISTER ASSY		1		
33	90467-10041	CLIP		1		
34	1JH-24335-00	PIPE, SUCTION 1		1		
35	90467-11106	CLIP		1		
36	1FK-2419A-00	HOLDER	1		1	
	1JH-24190-00	CANISTER HOLDER ASSY		1		
37	97007-06016	BOLT	1	1	1	
38	92907-06600	WASHER, PLATE	1	1	1	
39	92907-06200	WASHER		1		
40	97007-06014	BOLT		1		
41	92907-06600	WASHER, PLATE		1		
42	90445-11706	HOSE (L500)		1		
43	90501-08668	SPRING, COMPRESSION		1		
44	90467-10041	CLIP		1		
45	1JH-2419E-00	COVER, CANISTER		1		
46	90464-20070	CLAMP		1		
47	1FK-85752-01	SENDER UNIT ASSY, FUEL METER	1	1	1	
48	42X-85753-00	GASKET, SENDER UNIT	1	1	1	
49	90149-06011	SCREW	2	2	2	
50	90202-05193	WASHER, PLATE	2	2	2	

FIG. 30 SEAT

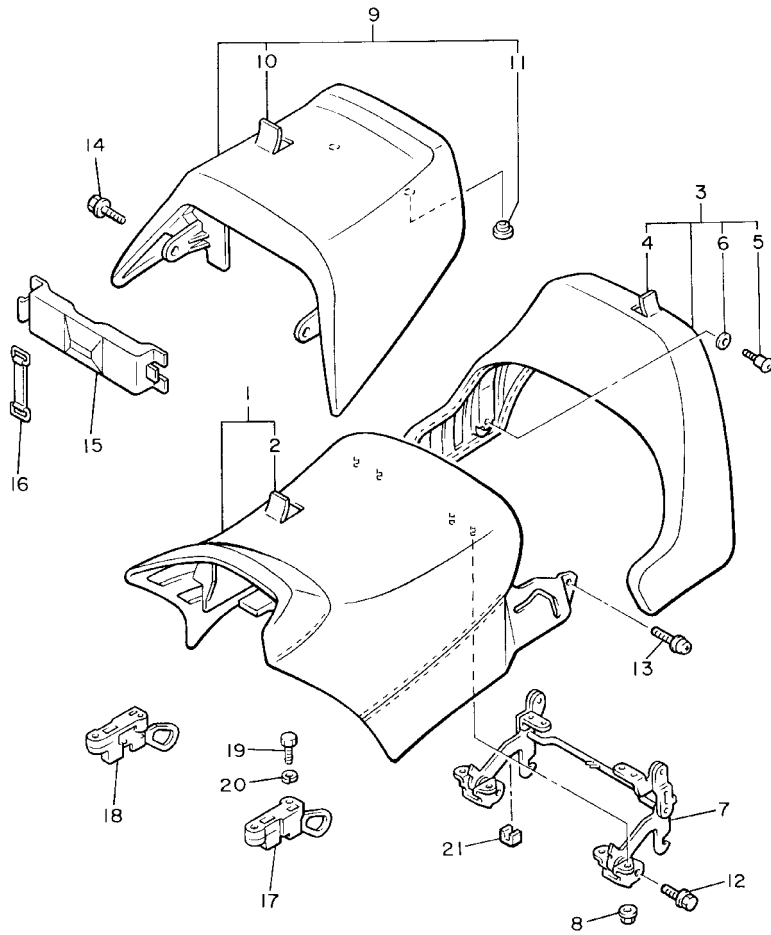

3LR351-0290

REF. NO.	PART NO.	DESCRIPTION	5GK9	5GKA	5GKB	REMARKS
1	1FK-24771-00	SEAT COMP.	1	1	1	
2	1FK-24711-00	.COVER, SINGLE SEAT	1	1	1	
3	1FK-24790-00	SEAT BACK ASSY	1	1	1	
4	1FK-24791-00	.COVER, SEAT BACK	1	1	1	
5	1FK-2476F-00	.PIN, GUIDE	2	2	2	
6	1FK-24736-00	.WASHER	2	2	2	
7	1FK-24772-00	HINGE ASS'Y	1	1	1	
8	95707-06500	NUT, FLANGE	8	8	8	
9	1FK-24750-00	TANDEM SEAT ASSY	1	1	1	
10	1FK-24751-00	.COVER, TANDEM SEAT	1	1	1	
11	22W-24741-00	.PAD, SEAT	2	2	2	
12	95807-06012	BOLT, FLANGE	2	2	2	
13	90159-06033	SCREW, WITH WASHER	2	2	2	
14	90119-06044	BOLT, WITH WASHER	2	2	2	
15	1FK-2473T-00	LID 1	1	1	1	
16	5H9-21376-00	BAND, TOOL	1	1	1	
17	1FK-24760-00	SEAT LEVER ASSY	1	1	1	
18	1FK-24780-00	SEAT LOCK ASSY	1	1	1	
19	97007-06012	BOLT	4	4	4	
20	92907-06600	WASHER, PLATE	4	4	4	
21	3UF-24737-00	DAMPÉR, SEAT	2	2	2	

FIG. 31 FRONT WHEEL

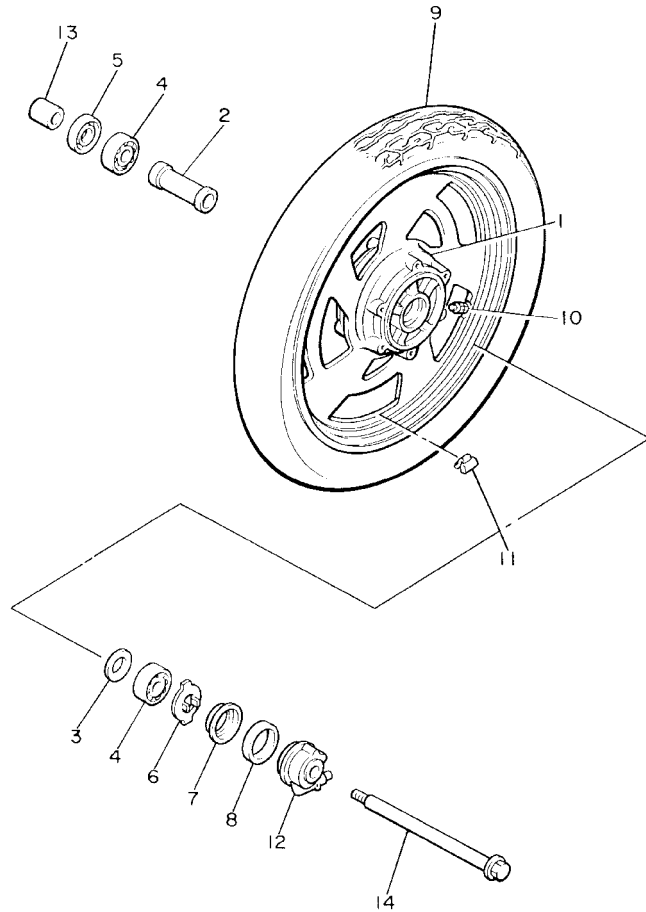

REF. NO.	PART NO.	DESCRIPTION	5GK9	5GKA	5GKB	REMARKS
1	2HY-25168-00-35	CAST WHEEL, FRONT	1	1	1	SL
2	90560-17322	SPACER	1	1	1	
3	148-25315-00	FLANGE, SPACER	1	1	1	
4	93306-30317	BEARING	2	2	2	
5	93102-28022	OIL SEAL	1	1	1	
6	341-25149-00	CLUTCH, METER	1	1	1	
7	341-25846-00	RETAINER, CLUTCH	1	1	1	
8	93105-45017	OIL SEAL	1	1	1	
9	94111-1805F	TIRE (110/90-V18 G525)	1	1	1	UR BRIDGESTONE
	94111-1805D	TIRE (110/90-V18 F20)	1	1	1	UR DUNLOP
10	93900-00025	VALVE, RIM	1	1	1	
11	29L-25398-00	BALANCER, WHEEL (10G)	1	1	1	UN
	29L-25398-10	BALANCER, WHEEL (20G)	1	1	1	UN
	29L-25398-20	BALANCER, WHEEL (30G)	1	1	1	UN
12	4TX-25190-10	GEAR UNIT ASSY	1	1	1	
13	90387-173R6	COLLAR	1	1	1	
14	1FK-25181-00	AXLE, WHEEL	1	1	1	



2WE110-8300

FIG. 32 FRONT BRAKE CALIPER

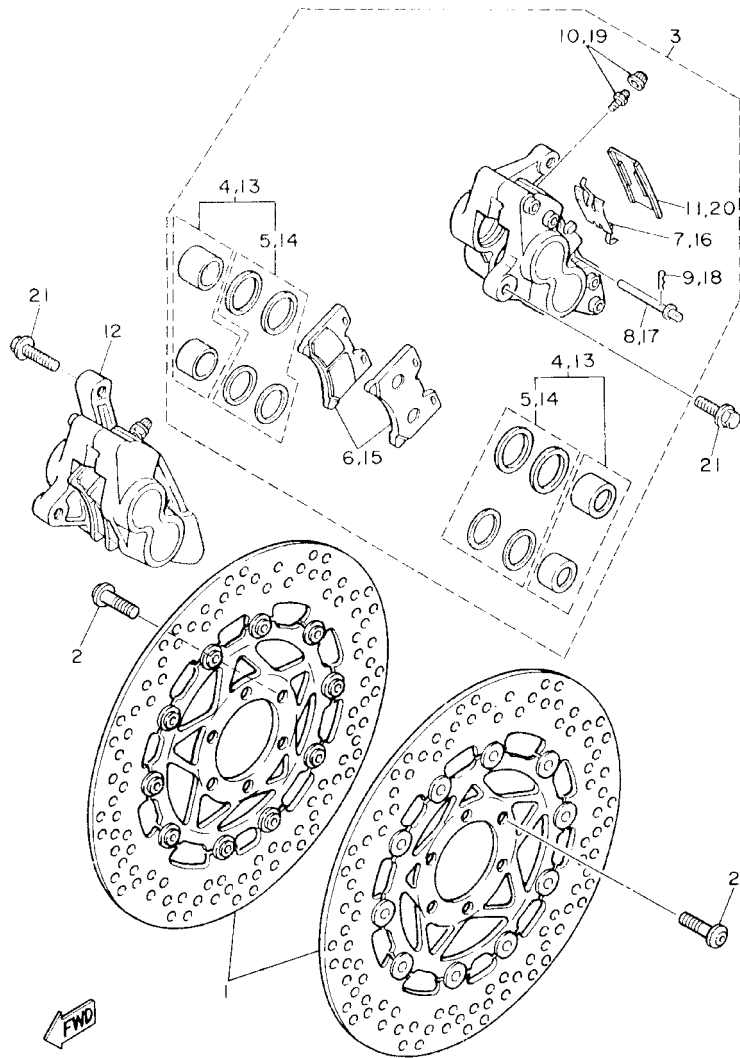

3HE351-1300

REF. NO.	PART NO.	DESCRIPTION	5GK9	5GKA	5GKB	REMARKS
1	3LR-2581T-00	DISC BRAKE ASSY	2	2	2	
2	90109-083G4	BOLT	12	12	12	
3	3JP-2580T-00	CALIPER ASSY (LEFT)	1	1	1	
4	3HE-W0057-50	.PISTON ASSY, CALIPER	2	2	2	
5	3HE-W0047-50	..CALIPER SEAL KIT	2	2	2	
6	3GM-W0045-02	.BRAKE PAD KIT	1	1	1	
7	3GM-25919-00	.SUPPORT, PAD	1	1	1	
8	3HE-25924-00	.PIN, PAD	2	2	2	
9	3GM-25925-00	.CLIP	2	2	2	
10	1J3-W0048-00	.BLEED SCREW KIT	1	1	1	
11	1KT-25836-00	.COVER, DUST	1	1	1	
12	3JP-2580U-00	CALIPER ASSY (RIGHT)	1	1	1	
13	3HE-W0057-50	.PISTON ASSY, CALIPER	2	2	2	
14	3HE-W0047-50	..CALIPER SEAL KIT	2	2	2	
15	3GM-W0045-02	.BRAKE PAD KIT	1	1	1	
16	3GM-25919-00	.SUPPORT, PAD	1	1	1	
17	3HE-25924-00	.PIN, PAD	2	2	2	
18	3GM-25925-00	.CLIP	2	2	2	
19	1J3-W0048-00	.BLEED SCREW KIT	1	1	1	
20	1KT-25836-00	.COVER, DUST	1	1	1	
21	90105-10638	BOLT, FLANGE	4	4	4	

FIG. 33 REAR WHEEL

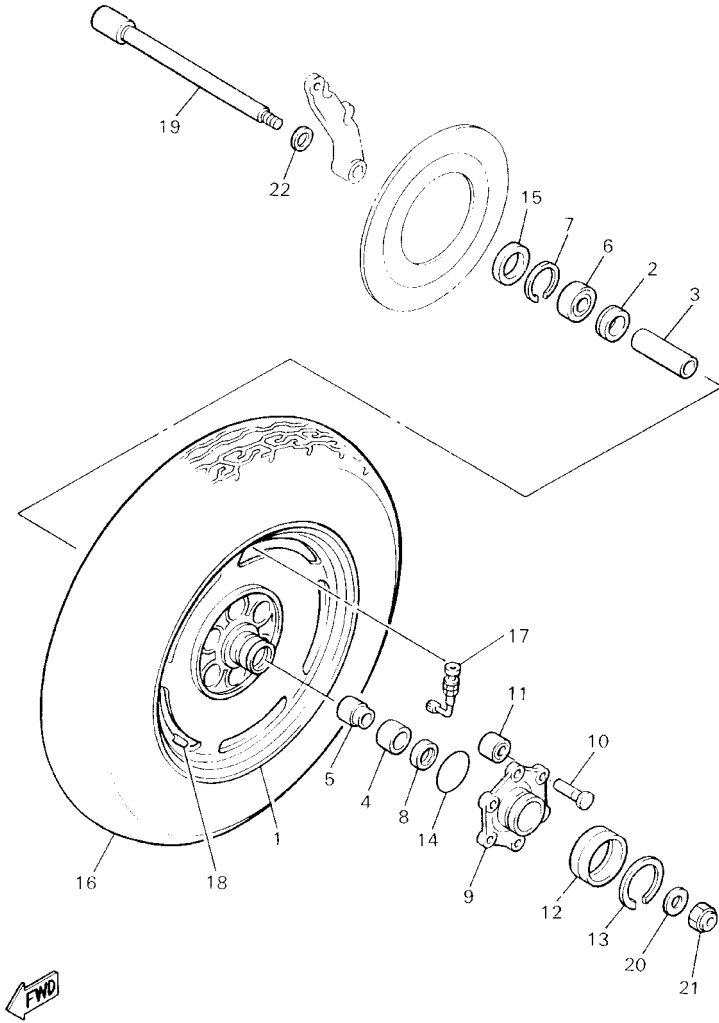

3JP110-6320

REF. NO.	PART NO.	DESCRIPTION	5GK9	5GKA	5GKB	REMARKS
1	1UT-25338-01-35	CAST WHEEL, REAR	1	1	1	SL
2	2H7-25315-00	FLANGE, SPACER	1	1	1	
3	90560-20295	SPACER	1	1	1	
4	93317-32677	BEARING	1	1	1	
5	90387-203H7	COLLAR	1	1	1	
6	93306-30437	BEARING	1	1	1	
7	99009-52500	CIRCLIP	1	1	1	
8	93102-25064	OIL SEAL	1	1	1	
9	26H-25366-01	CLUTCH, HUB	1	1	1	
10	90249-12167	PIN	6	6	6	
11	1FK-25364-00	DAMPER	6	6	6	
12	1J7-25319-02	SEAL, HUB DUST	1	1	1	
13	93440-45022	CIRCLIP	1	1	1	
14	93210-68347	O-RING	1	1	1	
15	93102-40367	OIL SEAL	1	1	1	
16	94115-1505G	TIRE (150/90-V15 G526)	1	1	1	UR BRIDGESTONE
	94115-1505E	TIRE (150/90-V15 K525)	1	1	1	UR DUNLOP
17	93900-00025	VALVE, RIM	1	1	1	
18	29L-25398-00	BALANCER, WHEEL (10G)	1	1	1	UN
	29L-25398-10	BALANCER, WHEEL (20G)	1	1	1	UN
	29L-25398-20	BALANCER, WHEEL (30G)	1	1	1	UN
19	4NK-25381-10	AXLE, WHEEL	1	1	1	
20	90201-181U5	WASHER, PLATE	1	1	1	
21	90185-18167	NUT, SELF-LOCKING	1	1	1	
22	92903-20600	WASHER	1	1	1	

FIG. 34 REAR BRAKE

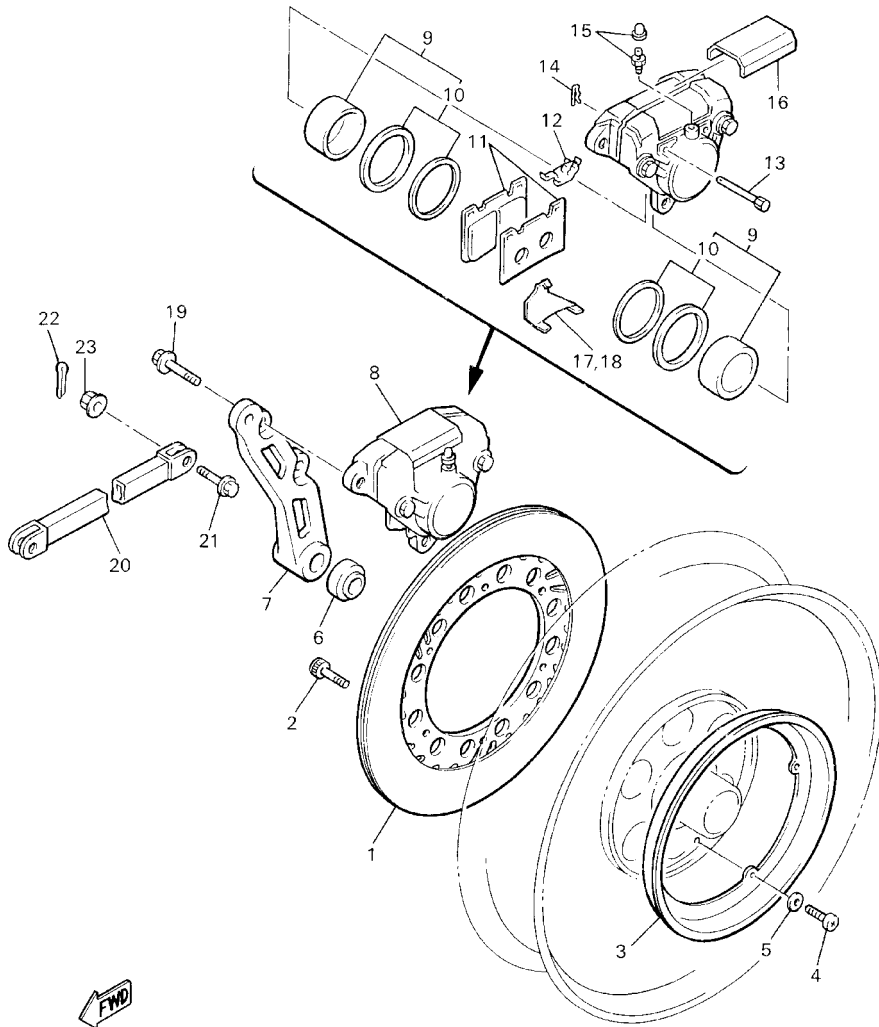

3JP100-7340

REF. NO.	PART NO.	DESCRIPTION	5GK9	5GKA	5GKB	REMARKS
1	3JP-2582U-00	DISC, BRAKE (RIGHT)	1	1	1	
2	90109-083G4	BOLT	6	6	6	
3	1FK-25327-00	COVER, PLATE	1	1	1	
4	98507-05020	SCREW, PAN HEAD	4	4	4	
5	92907-05600	WASHER, PLATE	4	4	4	
6	90387-200J2	COLLAR	1	1	1	
7	1FK-25819-00	BRACKET, CALIPER	1	1	1	
8	4BH-2580W-00	CALIPER ASSY, REAR 2	1	1	1	
9	31A-W0057-00	.PISTON ASSY, CALIPER	1	1	1	
10	31A-W0047-00	..CALIPER SEAL KIT	1	1	1	
11	1FK-W0046-01	.BRAKE PAD KIT 2	1	1	1	
12	26H-25919-00	.SUPPORT, PAD	1	1	1	
13	3HE-25924-00	.PIN, PAD	2	2	2	
14	3HE-25925-00	.CLIP	2	2	2	
15	1J3-W0048-00	.BLEED SCREW KIT	2	2	2	
16	41Y-25836-00	.COVER, DUST	1	1	1	
17	1FK-25827-00	.SHIM, CALIPER	1	1	1	
18	1FK-25828-00	.SHIM, CALIPER	1	1	1	
19	90105-10638	BOLT, FLANGE	2	2	2	
20	36Y-25371-00	BAR, TENSION	1	1	1	
21	90105-08777	BOLT, FLANGE	2	2	2	
22	91401-20020	PIN, COTTER	2	2	2	
23	95704-08500	NUT, FLANGE	2	2	2	

FIG. 35 STEERING HANDLE. CABLE

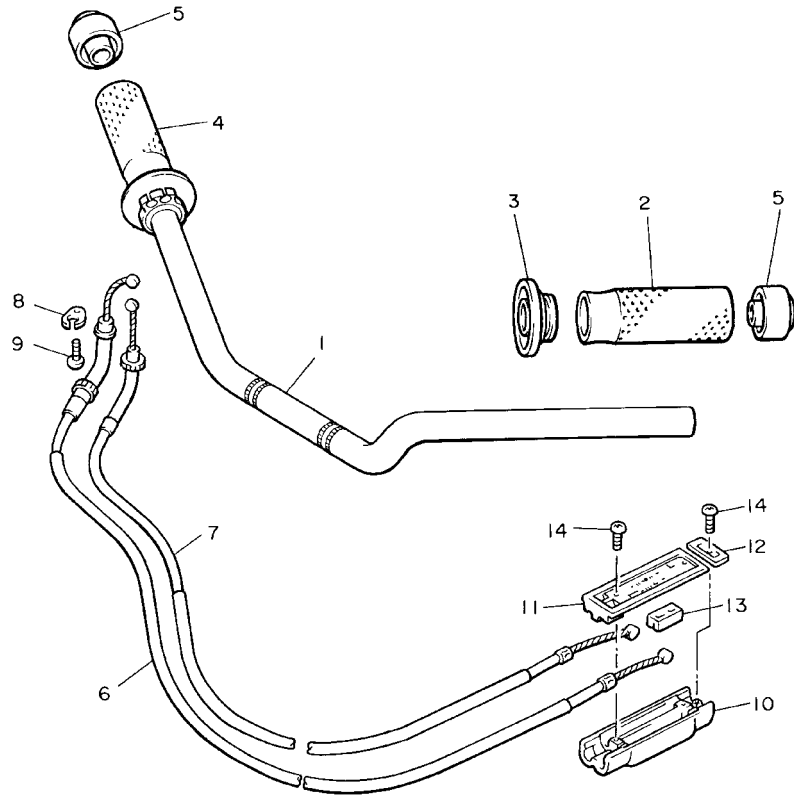

3JPX100-9350

REF. NO.	PART NO.	DESCRIPTION	5GK9	5GKA	5GKB	REMARKS
1	1FK-26111-10	HANDLEBAR	1	1	1	
2	3JB-26241-00	GRIP	1	1	1	
3	3JB-26273-00	ROTOR	1	1	1	
4	3JB-26240-00	GRIP ASSY	1	1	1	
5	3JB-2628J-00	CAP, GRIP	2	2	2	
6	1FK-26311-01	CABLE, THROTTLE 1	1	1	1	
7	1FK-26312-01	CABLE, THROTTLE 2	1	1	1	
8	5H0-26393-00	HOLDER	1	1	1	
9	98507-05008	SCREW, PAN HEAD	1	1	1	
10	26H-26261-01	CONNECTOR, CABLE	1	1	1	
11	26H-26262-01	CAP, CABLE CONNECTOR	1	1	1	
12	26H-26272-00	CAP	1	1	1	
13	26H-26244-01	SLIDER, THROTTLE	2	2	2	
14	97707-30112	SCREW, TAPPING	3	3	3	

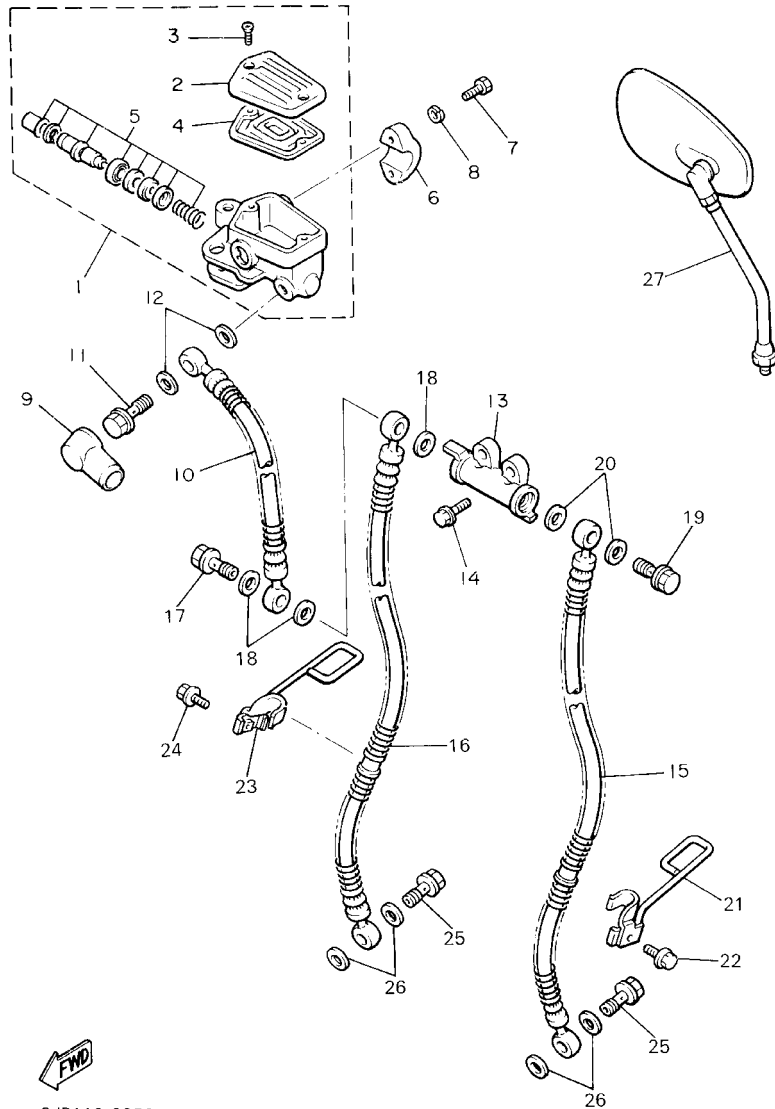

3JP110-3350

FIG. 36 FRONT MASTER CYLINDER

REF. NO.	PART NO.	DESCRIPTION	5GK9	5GKA	5GKB	REMARKS
1	3HE-2583T-01	MASTER CYLINDER ASSY	1	1	1	
2	3HE-25852-01	.CAP, RESERVOIR	1	1	1	
3	36Y-2589H-00	.SCREW	2	2	2	
4	36Y-25854-00	.DIAPHRAGM, RESERVOIR	1	1	1	
5	36Y-W0041-00	.CYLINDER KIT, MASTER	1	1	1	
6	36Y-25867-00	BRACKET, MASTER CYLINDER	1	1	1	
7	90110-06240	BOLT, HEXAGON SOCKET HEAD	2	2	2	
8	92907-06100	WASHER, SPRING	2	2	2	
9	4L0-25862-01	BOOT, MASTER CYLINDER	1	1	1	
10	1FK-25872-03	HOSE, BRAKE 1	1	1	1	
11	90401-10159	BOLT, UNION	1	1	1	
12	90201-10118	WASHER, PLATE	2	2	2	
13	42H-25885-01	JOINT	1	1	1	
14	91317-06020	BOLT	2	2	2	
15	3LR-25873-02	HOSE, BRAKE 2	1	1	1	
16	3LR-25874-02	HOSE, BRAKE	1	1	1	
17	90401-10160	BOLT, UNION	1	1	1	
18	90201-10118	WASHER, PLATE	3	3	3	
19	90401-10159	BOLT, UNION	1	1	1	
20	90201-10118	WASHER, PLATE	2	2	2	
21	55R-25875-00	HOLDER, BRAKE HOSE 1	1	1	1	
22	95024-06016	BOLT, FLANGE	1	1	1	
23	55R-25876-00	HOLDER, BRAKE HOSE 2	1	1	1	
24	95024-06016	BOLT, FLANGE	1	1	1	
25	90401-10159	BOLT, UNION	2	2	2	
26	90201-10118	WASHER, PLATE	4	4	4	
27	1AA-26290-02	REAR VIEW MIRROR ASSY(RIGHT)	1	1	1	

FIG. 37 FRONT MASTER CYLINDER 2

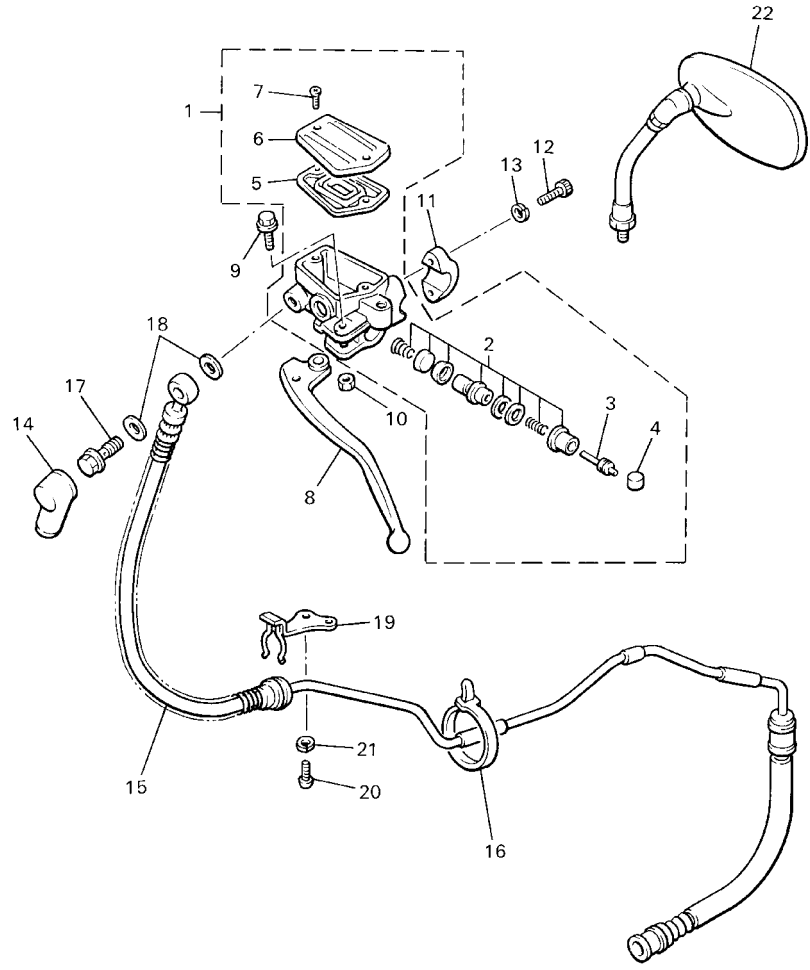

REF. NO.	PART NO.	DESCRIPTION	5GK9	5GKA	5GKB	REMARKS
1	2KW-W2645-00	MASTER CYLINDER SUB ASSY	1	1	1	
2	2KW-W0099-00	.CYLINDER KIT, MASTER (CLUTCH)	1	1	1	
3	26H-26464-00	.ROD, PUSH	1	1	1	
4	3GM-26455-00	.BUSH	1	1	1	
5	1AE-26454-00	.DIAPHRAGM, RESERVOIR	1	1	1	
6	1FK-26452-01	.CAP, RESERVOIR	1	1	1	
7	98706-04012	.SCREW, FLAT HEAD	2	2	2	
8	1FK-83912-01	LEVER 1	1	1	1	
9	1FK-2589F-00	BOLT, LEVER	1	1	1	
10	95606-06100	NUT, U	1	1	1	
11	1AE-26467-01	HOLDER	1	1	1	
12	90110-06240	BOLT, HEXAGON SOCKET HEAD	2	2	2	
13	92907-06100	WASHER, SPRING	2	2	2	
14	4L0-25862-01	BOOT, MASTER CYLINDER	1	1	1	
15	1FK-26470-01	HOSE, CLUTCH	1	1	1	
16	1UA-82591-00	BAND	1	1	1	
17	90401-10159	BOLT, UNION	1	1	1	
18	90201-10118	WASHER, PLATE	2	2	2	
19	1FK-26475-00	HOLDER	1	1	1	
20	98507-06012	SCREW, PAN HEAD	1	1	1	
21	92907-06600	WASHER, PLATE	1	1	1	
22	1AA-26280-02	REAR VIEW MIRROR ASSY(LEFT)	1	1	1	



3JPU171-8360

FIG. 38 STAND, FOOTREST

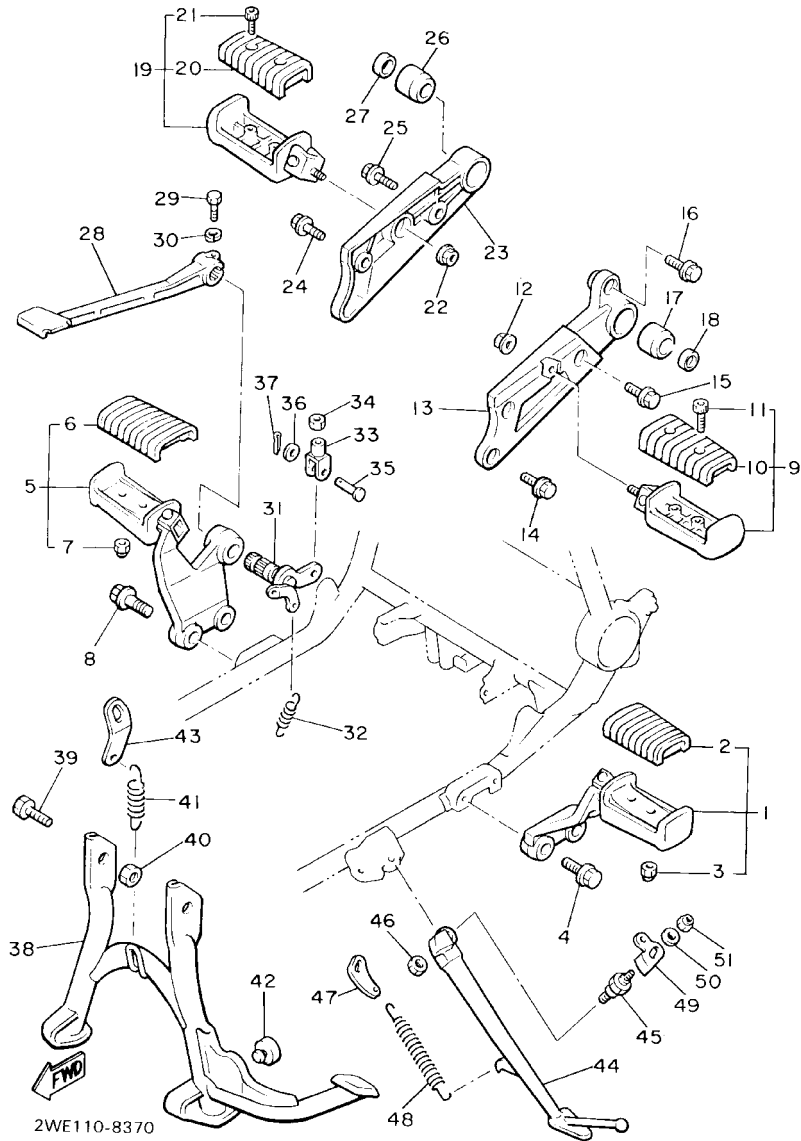

REF. NO.	PART NO.	DESCRIPTION	5GK9	5GKA	5GKB	REMARKS
1	1UT-27410-10	FRONT FOOTREST ASSY (LEFT)	1	1	1	
2	1NH-27413-00	.COVER, FOOTREST	1	1	1	
3	95607-06100	.NUT, U	2	2	2	
4	95024-10030	BOLT, FLANGE	2	2	2	
5	1UT-27420-10	FRONT FOOTREST ASSY (RIGHT)	1	1	1	
6	1NH-27413-00	.COVER, FOOTREST	1	1	1	
7	95607-06100	.NUT, U	2	2	2	
8	95024-10030	BOLT, FLANGE	2	2	2	
9	1UT-27430-01	REAR FOOTREST ASSY 1	1	1	1	
10	1NH-27433-00	.COVER, REAR FOOTREST	1	1	1	
11	98517-06012	.SCREW, PAN HEAD	2	2	2	
12	95707-10500	NUT, FLANGE	1	1	1	
13	1FK-27442-00	BRACKET 2	1	1	1	
14	95024-08016	BOLT, FLANGE	2	2	2	
15	95024-08020	BOLT, FLANGE	1	1	1	
16	90105-081A1	BOLT, FLANGE	1	1	1	
17	26H-27414-00	DAMPER, FOOTREST	1	1	1	
18	26H-2743E-00	STOPPER	1	1	1	
19	1UT-27440-01	REAR FOOTREST ASSY 2	1	1	1	
20	1NH-27433-00	.COVER, REAR FOOTREST	1	1	1	
21	98517-06012	.SCREW, PAN HEAD	2	2	2	
22	95707-10500	NUT, FLANGE	1	1	1	
23	1FK-27443-00	BRACKET 3	1	1	1	
24	95024-08020	BOLT, FLANGE	1	1	1	
25	95024-08030	BOLT, FLANGE	1	1	1	
26	26H-27414-00	DAMPÉR, FOOTREST	1	1	1	
27	26H-2743E-00	STOPPER	1	1	1	

FIG. 38 STAND, FOOTREST

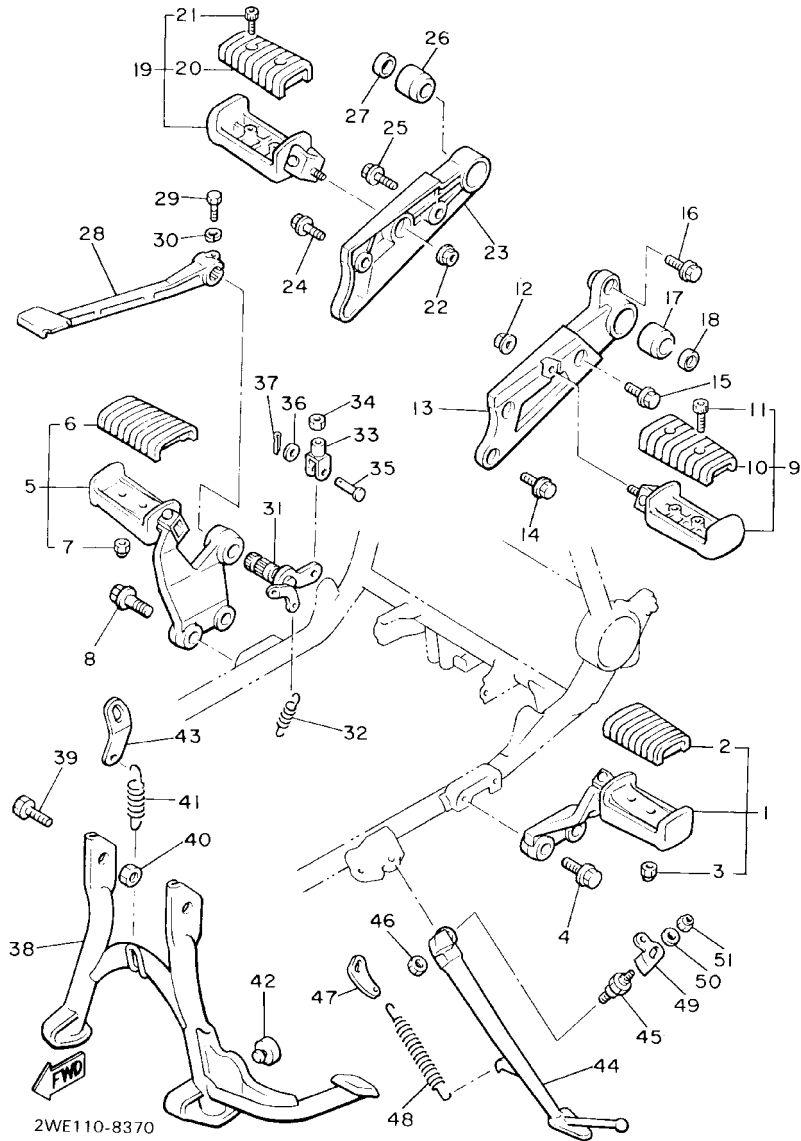

REF. NO.	PART NO.	DESCRIPTION	5GK9	5GKA	5GKB	REMARKS
28	1FK-27211-00-93	PEDAL, BRAKE	1	1	1	CM
29	90109-06468	BOLT	1	1	1	
30	92903-06100	WASHER, SPRING	1	1	1	
31	1FK-27212-00	SHAFT, BRAKE PEDAL	1	1	1	
32	90506-18305	SPRING, TENSION	1	1	1	
33	47X-27222-00	JOINT	1	1	1	
34	95307-08700	NUT	1	1	1	
35	90240-08013	PIN, CLEVIS	1	1	1	
36	90201-08083	WASHER, PLATE	1	1	1	
37	91401-16012	PIN, COTTER	1	1	1	
38	1UT-27111-01-R4	STAND, MAIN	1	1	1	HPB
39	90109-10658	BOLT	2	2	2	
40	90185-10091	NUT, SELF-LOCKING	2	2	2	
41	90506-45222	SPRING, TENSION	1	1	1	
42	371-27114-00	STOPPER, MAIN STAND	1	1	1	
43	1FK-27115-00	LINK, MAIN STAND	1	1	1	
44	1FK-27311-00-R4	STAND, SIDE	1	1	1	HPB
45	90109-107A2	BOLT	1	1	1	
46	90185-10037	NUT, SELF-LOCKING	1	1	1	
47	1FK-27315-00	LINK, SIDE STAND	1	1	1	
48	90507-29019	SPRING, TENSION	1	1	1	
49	1FK-27352-00	HOOK, SIDE STAND	1	1	1	
50	90201-06380	WASHER, PLATE	1	1	1	
51	95607-06100	NUT, U	1	1	1	

FIG. 39 REAR MASTER CYLINDER

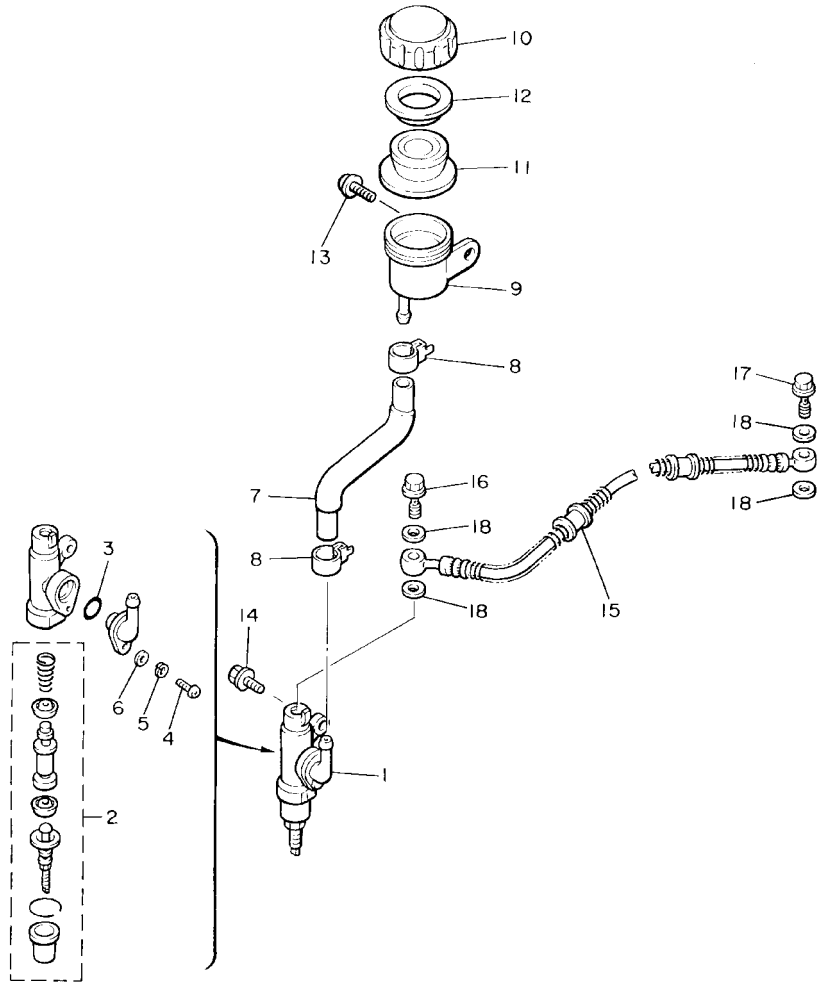

2LT171-8380

REF. NO.	PART NO.	DESCRIPTION	5GK9	5GKA	5GKB	REMARKS
1	1FK-25850-50	MASTER CYLINDER ASSY	1	1	1	
2	1FK-W0042-50	.CYLINDER KIT, MASTER	1	1	1	
3	93210-15620	.O-RING	1	1	1	
4	98501-04012	.SCREW, PAN HEAD	1	1	1	
5	92901-04100	.WASHER, SPRING	1	1	1	
6	92901-04600	.WASHER, PLATE	1	1	1	
7	1FK-25895-00	HOSE, RESERVOIR	1	1	1	
8	90467-14057	CLIP	2	2	2	
9	31A-25894-01	TANK, RESERVOIR	1	1	1	
10	2KF-25852-50	CAP, RESERVOIR	1	1	1	
11	360-25854-01	DIAPHRAGM, RESERVOIR	1	1	1	
12	2GU-25855-00	BUSH,DIAPHRAGM	1	1	1	
13	90159-06056	SCREW, WITH WASHER	1	1	1	
14	90105-081A1	BOLT, FLANGE	2	2	2	
15	1FK-25874-03	HOSE, BRAKE	1	1	1	
16	90401-10159	BOLT, UNION	1	1	1	
17	90401-10159	BOLT, UNION	1	1	1	
18	90201-10118	WASHER, PLATE	4	4	4	

FIG. 40 GENERATOR

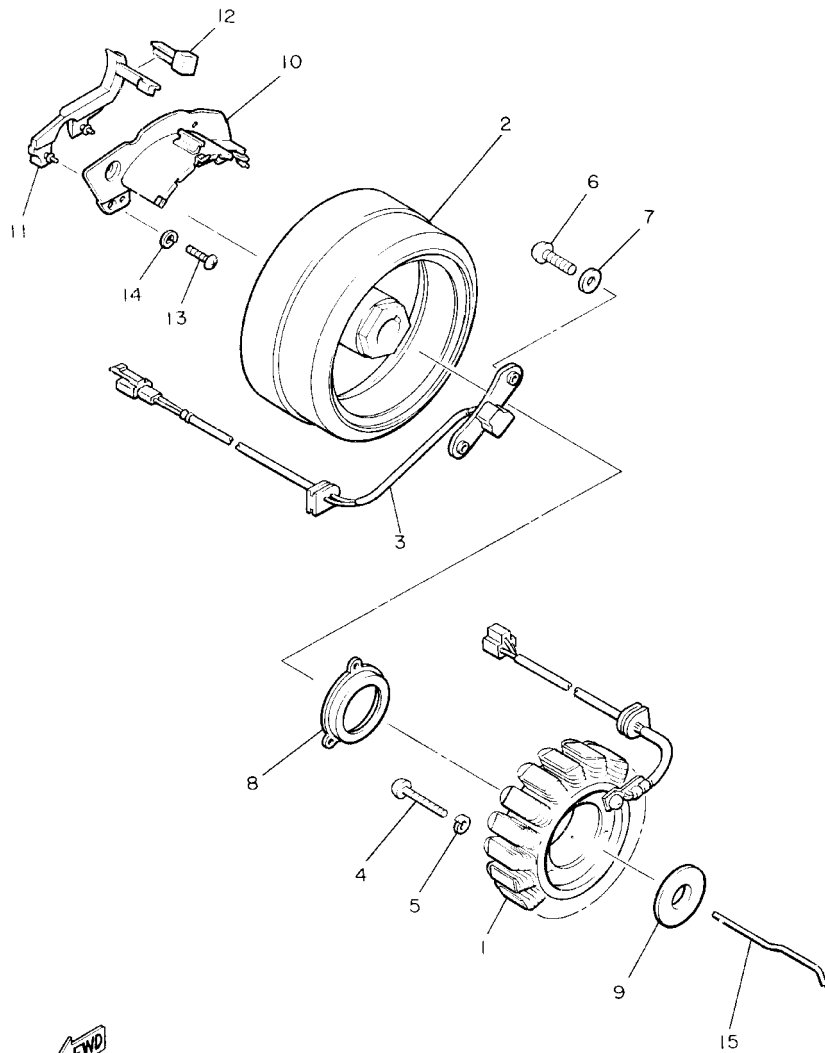

3JP110-0390

REF. NO.	PART NO.	DESCRIPTION	5GK9	5GKA	5GKB	REMARKS
1	3UF-81410-10	STATOR ASSY	1	1	1	
2	3UF-81450-10	ROTOR ASSY	1	1	1	
3	3UF-81670-00	PICK-UP ASSY	1	1	1	
4	98507-06040	SCREW, PAN HEAD	3	3	3	
5	92907-06600	WASHER, PLATE	3	3	3	
6	98507-06016	SCREW, PAN HEAD	2	2	2	
7	90201-06674	WASHER, PLATE	2	2	2	
8	59J-15113-00	PLATE	1	1	1	
9	59J-15191-00	PLATE	1	1	1	
10	1FK-15358-00	SEPARATOR, OIL	1	1	1	
11	1FK-15379-00	SEAL, CRANKCASE	1	1	1	
12	1FK-15494-00	SEAL, PROTECTOR	1	1	1	
13	98507-06012	SCREW, PAN HEAD	4	4	4	
14	92907-06600	WASHER, PLATE	4	4	4	
15	59J-11455-00	SHAFT 1	1	1	1	

FIG. 42 STARTING MOTOR

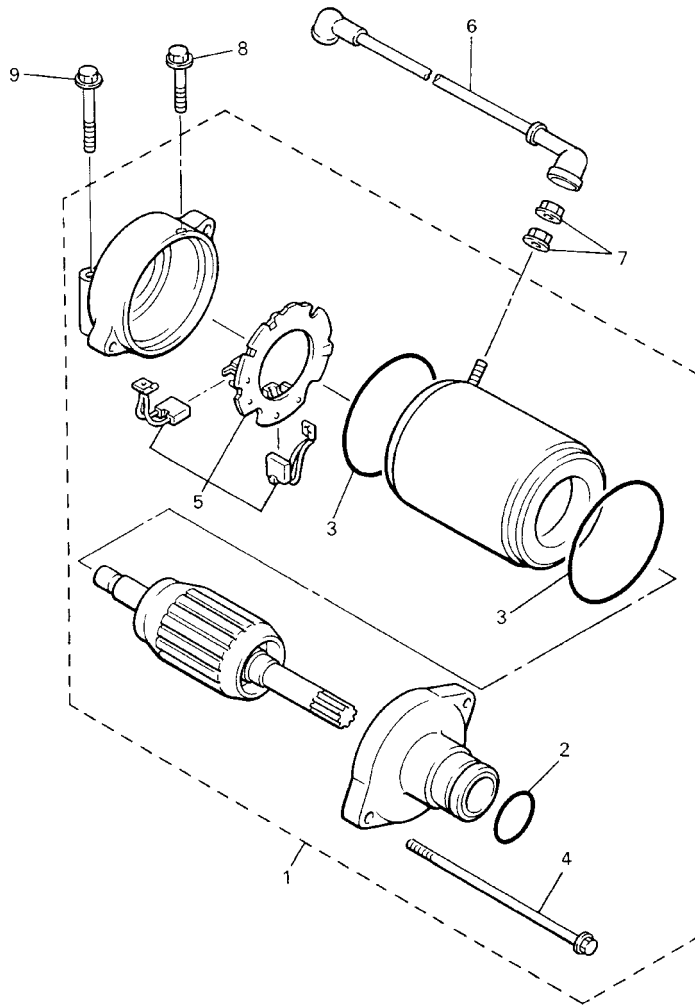

REF. NO.	PART NO.	DESCRIPTION	5GK9	5GKA	5GKB	REMARKS
1	1FK-81890-00	MOTOR ASSY	1	1	1	
2	1FK-81847-00	.O-RING	1	1	1	
3	11H-81844-00	.GASKET	2	2	2	
4	1FK-81826-10	.BOLT	2	2	2	
5	3AJ-81801-00	.BRUSH SET	1	1	1	
6	1FK-81815-00	CORD, STARTER MOTOR	1	1	1	
7	4XV-8182A-00	NUT	2	2	2	
8	95827-06025	BOLT, FLANGE	1	1	1	
9	95827-06055	BOLT, FLANGE	1	1	1	



3LR351-0401

FIG. 43 FLASHER LIGHT

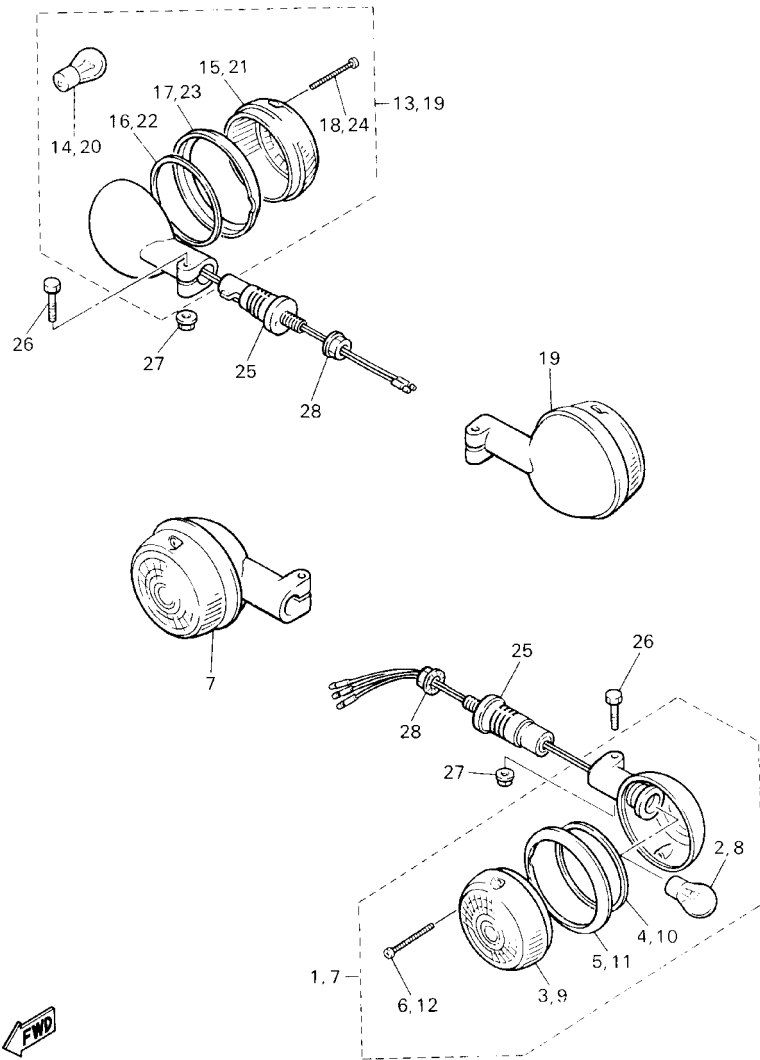

3JP100-7430

REF. NO.	PART NO.	DESCRIPTION	5GK9	5GKA	5GKB	REMARKS
1	42X-83310-K0	FRONT FLASHER LIGHT ASSY 1	1	1	1	
2	256-84714-61	.BULB (12V-27/8W)	1	1	1	
3	42X-83312-00	.LENS, FLASHER	1	1	1	
4	42X-83313-00	.GASKET, FLASHER LENS	1	1	1	
5	42X-83363-00	.LENS, RIM	1	1	1	
6	57M-83358-00	.SCREW, SPECIAL	2	2	2	
7	42X-83320-K0	FRONT FLASHER LIGHT ASSY 2	1	1	1	
8	256-84714-61	.BULB (12V-27/8W)	1	1	1	
9	42X-83312-00	.LENS, FLASHER	1	1	1	
10	42X-83313-00	.GASKET, FLASHER LENS	1	1	1	
11	42X-83363-00	.LENS, RIM	1	1	1	
12	57M-83358-00	.SCREW, SPECIAL	2	2	2	
13	42X-83330-K0	REAR FLASHER LIGHT ASSY 1	1	1	1	
14	256-83311-70	.BULB (12V-27W)	1	1	1	
15	42X-83312-00	.LENS, FLASHER	1	1	1	
16	42X-83313-00	.GASKET, FLASHER LENS	1	1	1	
17	42X-83363-00	.LENS, RIM	1	1	1	
18	57M-83358-00	.SCREW, SPECIAL	2	2	2	
19	42X-83340-K0	FLASHER LIGHT ASSY 2	1	1	1	
20	256-83311-70	.BULB (12V-27W)	1	1	1	
21	42X-83312-00	.LENS, FLASHER	1	1	1	
22	42X-83313-00	.GASKET, FLASHER LENS	1	1	1	
23	42X-83363-00	.LENS, RIM	1	1	1	
24	57M-83358-00	.SCREW, SPECIAL	2	2	2	
25	1AA-83318-00	STAY, FLASHER 1	4	4	4	
26	97004-06030	BOLT	4	4	4	
27	95704-06500	NUT, FLANGE	4	4	4	

FIG. 43 FLASHER LIGHT

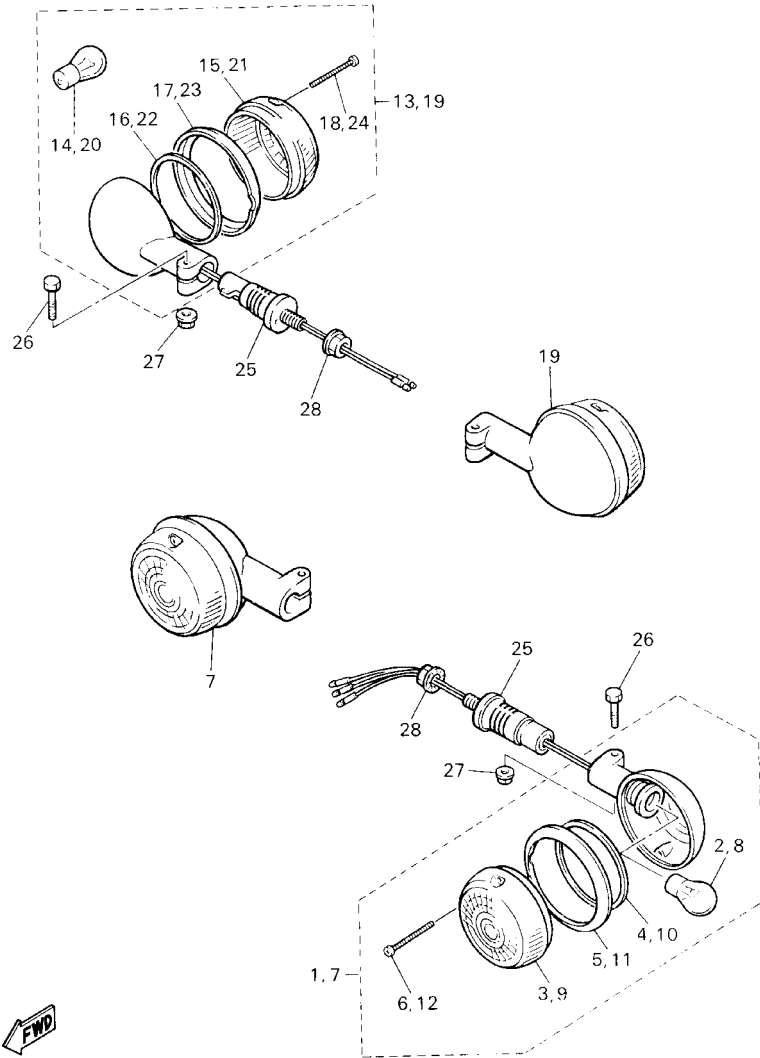

3JP100-7430

REF. NO.	PART NO.	DESCRIPTION	5GK9	5GKA	5GKB	REMARKS
28	95707-12500	NUT, FLANGE	4	4	4	

FIG. 44 METER

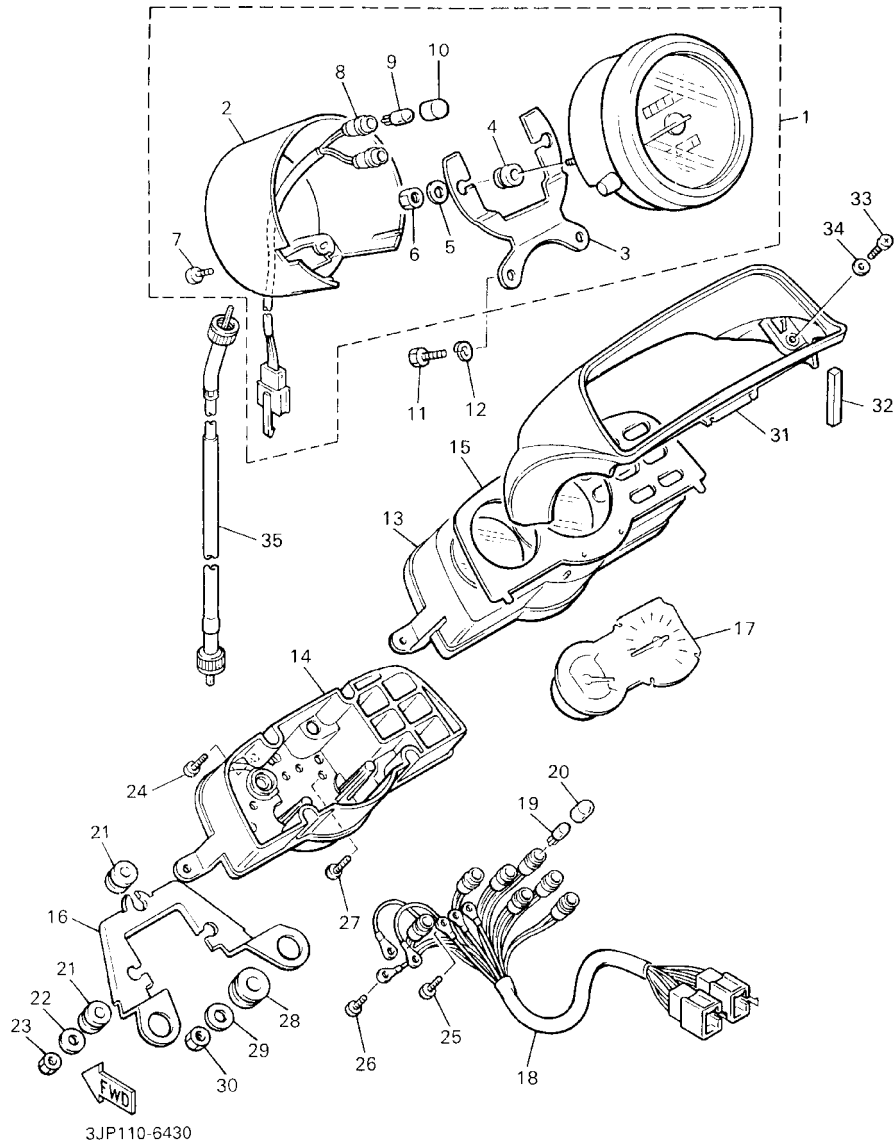

REF. NO.	PART NO.	DESCRIPTION	5GK9	5GKA	5GKB	REMARKS
1	1FK-83570-A2	SPEEDOMETER ASSY	1	1		KM/H
	1GR-83570-F2	SPEEDOMETER ASSY			1	
2	1GR-83507-01	.COVER, SPEEDOMETER	1	1	1	
3	1FK-83519-00	.BRACKET, METER	1	1	1	
4	12R-83523-00	.DAMPER	2	2	2	
5	92907-05600	.WASHER, PLATE	2	2	2	
6	95307-05600	.NUT	2	2	2	
7	90164-04009	.SCREW, TAPPING	1	1	1	
8	1FK-83509-00	.SOCKET CORD ASSY	1	1	1	
9	42X-83517-00	.BULB (12V-3W)	2	2	2	
10	1FK-83535-00	.TUBE	2	2	2	
11	97007-06016	BOLT	2	2	2	
12	92907-06600	WASHER, PLATE	2	2	2	
13	1FK-8353G-00	CASE, UPPER	1	1	1	
14	1FK-8353H-00	CASE, UNDER	1	1	1	
15	1FK-83611-00	PANEL, METER	1	1	1	
16	1FK-83545-00	BRACKET, TACHOMETER	1	1	1	
17	1FK-83540-00	TACHOMETER ASSY	1	1	1	
18	3UF-83520-00	SOCKET CORD ASSY	1	1	1	
19	42X-83517-00	BULB (12V-3W)	7	7	7	
20	1FK-83535-00	TUBE	2	2	2	
21	1FK-83523-00	DAMPER	3	3	3	
22	90201-052E2	WASHER, PLATE	2	2	2	
23	95301-05600	NUT	2	2	2	
24	90164-04005	SCREW, TAPPING	4	4	4	
25	90159-03102	SCREW, WITH WASHER	3	3	3	
26	90159-03044	SCREW, WITH WASHER	3	3	3	

FIG. 44 METER

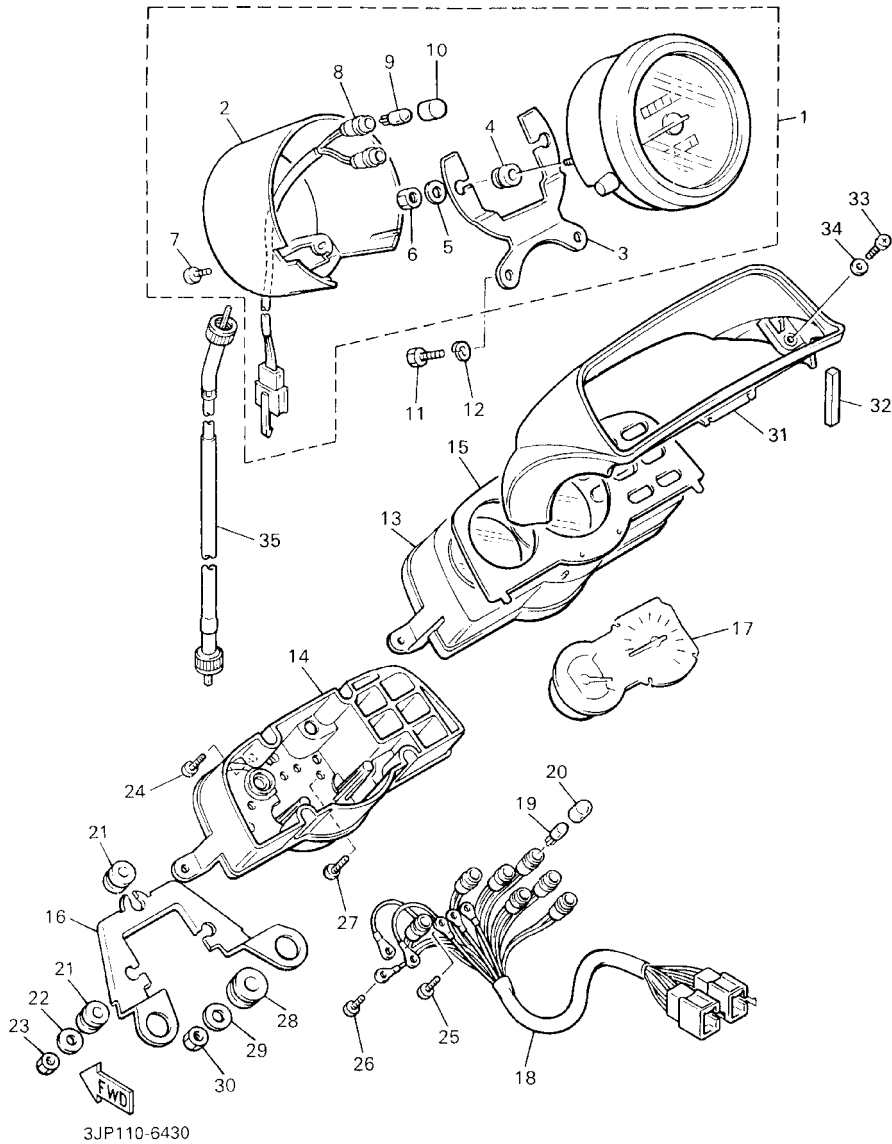

REF. NO.	PART NO.	DESCRIPTION	5GK9	5GKA	5GKB	REMARKS
27	90159-04043	SCREW, WITH WASHER	2	2	2	
28	90480-14229	GROMMET	2	2	2	
29	90201-06071	WASHER, PLATE	2	2	2	
30	95307-06600	NUT	2	2	2	
31	3JP-83559-00	COVER, METER	1	1	1	
32	1FK-83526-00	DAMPER 2	2	2	2	
33	98507-04016	SCREW, PAN HEAD	2	2	2	
34	92907-04600	WASHER	2	2	2	
35	1FK-83550-20	SPEEDOMETER CABLE ASSY	1	1	1	

FIG. 45 HEADLIGHT

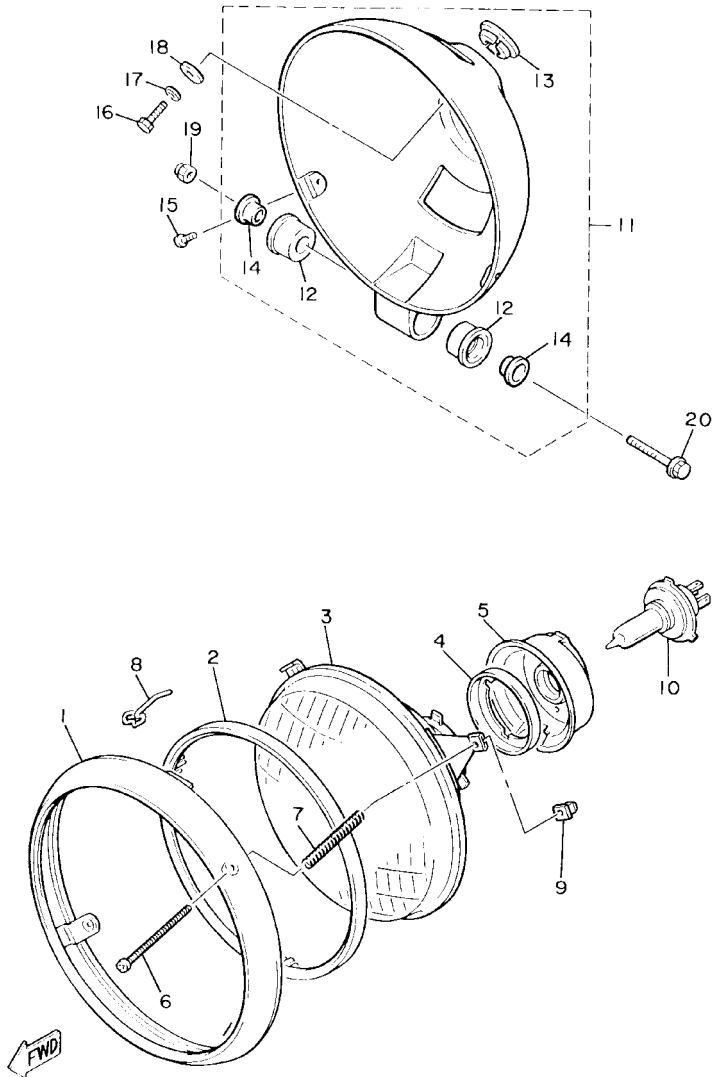

2LT171-7440

REF. NO.	PART NO.	DESCRIPTION	5GK9	5GKA	5GKB	REMARKS
1	42X-84315-01	RIM, HEADLIGHT	1	1	1	
2	5Y3-84395-00	RING, RETAINING	1	1	1	
3	42X-84321-A0	LENS ASSY	1	1	1	
4	2F9-84375-00	SETTING PLATE, BULB	1	1	1	
5	2F9-84397-01	COVER, SOCKET	1	1	1	
6	341-84331-60	SCREW, RIM ADJUSTING	2	2	2	
7	1A0-84332-60	SPRING, SCREW	2	2	2	
8	42X-84124-60	SPRING, SET	1	1	1	
9	198-84334-60	NUT, ADJUSTING	2	2	2	
10	2F9-84314-00	BULB (12V-60/55W)	1	1	1	(H4)HALOGEN
11	1FK-84330-00	BODY ASSY	1	1	1	
12	42X-84345-00	.DAMPER, HEADLIGHT	2	2	2	
13	42X-84366-00	.DAMPER, HEADLIGHT 1	1	1	1	
14	1FK-84338-00	.COLLAR, BODY FITTING	2	2	2	
15	90157-05084	SCREW, PAN HEAD	2	2	2	
16	97007-06016	BOLT	1	1	1	
17	92907-06600	WASHER, PLATE	1	1	1	
18	90201-060A3	WASHER, PLATE	1	1	1	
19	90176-06041	NUT, CROWN	1	1	1	
20	90105-06375	BOLT, FLANGE	1	1	1	

FIG. 46 TAILLIGHT

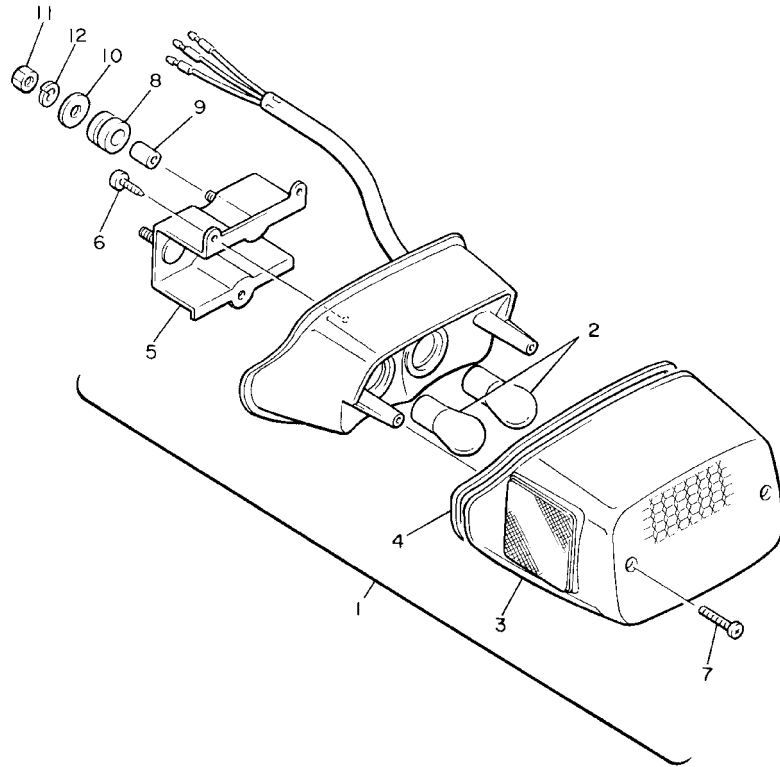

REF. NO.	PART NO.	DESCRIPTION	5GK9	5GKA	5GKB	REMARKS
1	1FK-84700-60	TAILLIGHT ASSY	1	1	1	
2	256-84714-61	.BULB (12V-27/8W)	2	2	2	
3	42X-84721-60	.LENS, TAILLIGHT	1	1	1	
4	42X-84723-01	.GASKET, TAIL LENS	1	1	1	
5	1FK-84702-00	.BRACKET, TAILLIGHT	1	1	1	
6	97707-40616	.SCREW, TAPPING	3	3	3	
7	97707-40625	.SCREW, TAPPING	2	2	2	
8	90480-15316	GROMMET	2	2	2	
9	90387-06026	COLLAR	2	2	2	
10	90201-06380	WASHER, PLATE	2	2	2	
11	95307-06600	NUT	2	2	2	
12	92907-06100	WASHER, SPRING	2	2	2	

← FWD
2LT171-7450

FIG. 47 HANDLE SWITCH. LEVER

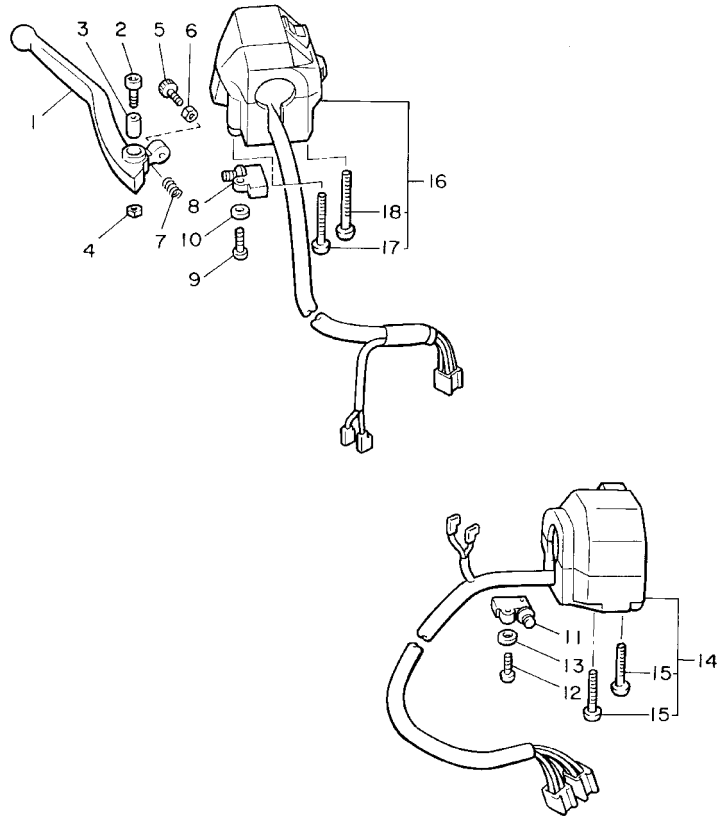

REF. NO.	PART NO.	DESCRIPTION	5GK9	5GKA	5GKB	REMARKS
1	1FK-83922-00	LEVER 2	1	1	1	
2	90110-06074	BOLT, HEXAGON SOCKET HEAD	1	1	1	
3	36Y-83913-01	COLLAR, LEVER 1	1	1	1	
4	95607-06100	NUT, U	1	1	1	
5	90149-06131	SCREW	1	1	1	
6	90170-06010	NUT	1	1	1	
7	90501-10312	SPRING, COMPRESSION	1	1	1	
8	36Y-83980-01	FRONT STOP SWITCH ASSY	1	1	1	
9	98507-04016	SCREW, PAN HEAD	1	1	1	
10	92907-04600	WASHER	1	1	1	
11	36Y-82917-00	SWITCH	1	1	1	
12	98507-04016	SCREW, PAN HEAD	1	1	1	
13	92907-04600	WASHER	1	1	1	
14	1FK-83973-00	SWITCH, HANDLE 3	1	1	1	
15	98506-05035	.SCREW, PAN HEAD	2	2	2	
16	1FK-83973-11	SWITCH, HANDLE 3	1	1	1	
17	98506-05040	.SCREW, PAN HEAD	1	1	1	
18	98506-05045	.SCREW, PAN HEAD	1	1	1	



2LT171-7460

FIG. 48 ELECTRICAL 1

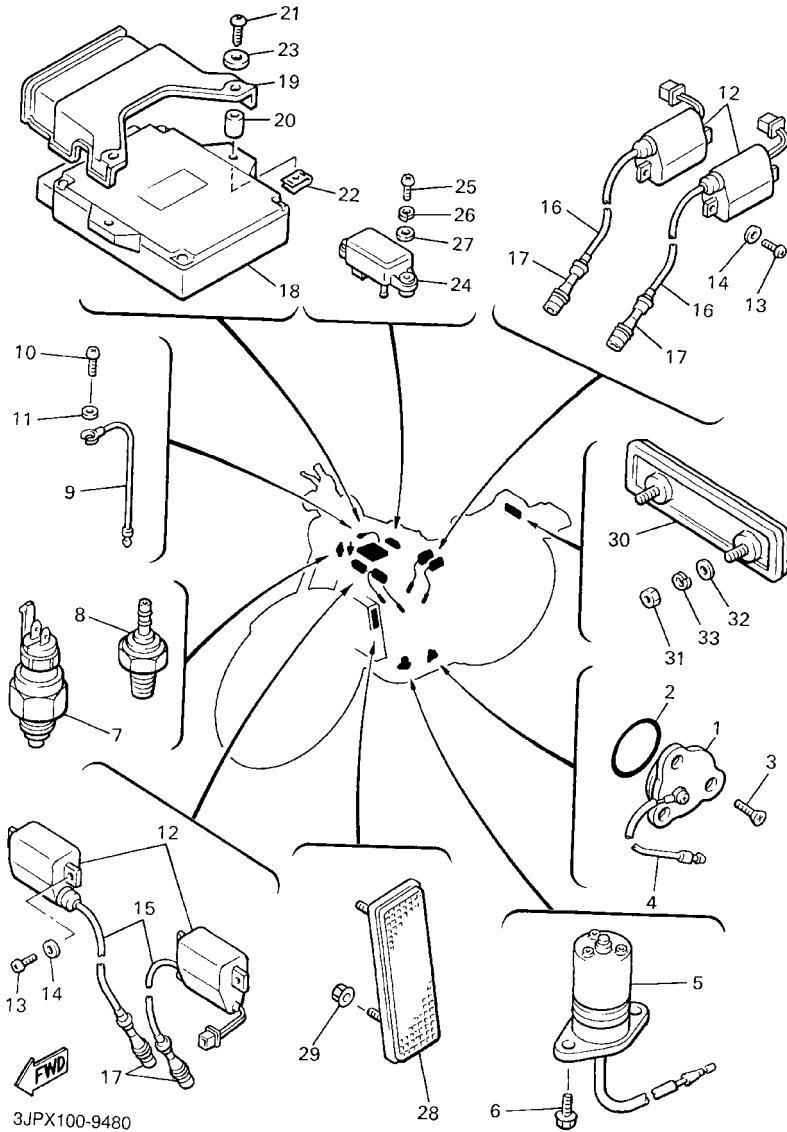

REF. NO.	PART NO.	DESCRIPTION	5GK9	5GKA	5GKB	REMARKS
1	1L9-82540-00	NEUTRAL SWITCH ASSY	1	1	1	
2	93210-29196	O-RING	1	1	1	
3	90149-05321	SCREW	3	3	3	
4	1FK-82541-00	WIRE, LEAD	1	1	1	
5	1FK-85720-00	OIL LEVEL GAUGE ASSY	1	1	1	
6	95027-06016	BOLT, FLANGE	2	2	2	
7	3LN-82560-01	THERMO SWITCH ASSY	1	1	1	
8	11H-83591-00	THERMO UNIT	1	1	1	
9	26H-83354-00	WIRE, EARTH LEAD 1	1	1	1	
10	98507-04008	SCREW, PAN HEAD	1	1	1	
11	92907-04600	WASHER	1	1	1	
12	25G-82310-10	IGNITION COIL ASSY	4	4	4	
13	98507-06020	SCREW, PAN HEAD	8	8	8	
14	92907-06600	WASHER, PLATE	8	8	8	
15	5H0-82341-00	CORD, HIGH TENSION 1	2	2	2	
16	4X7-82342-00	CORD, HIGH TENSION 2	2	2	2	
17	1FK-82370-00	PLUG CAP ASSY	4	4	4	
18	3JP-82305-12	IGNITOR UNIT ASSY	1	1	1	
19	2EN-82317-00	DAMPER, IGNITION COIL	1	1	1	
20	90387-045R4	COLLAR	2	2	2	
21	97707-40516	SCREW, TAPPING	2	2	2	
22	90183-04027	NUT, SPRING	2	2	2	
23	92907-04200	WASHER	2	2	2	
24	22N-82380-10	SENSOR, PRESSURE	1	1	1	FOR INTAKE PRESSURE
25	98507-06020	SCREW, PAN HEAD	2	2	2	
26	92907-06600	WASHER, PLATE	2	2	2	
27	90201-06557	WASHER, PLATE	2	2	2	

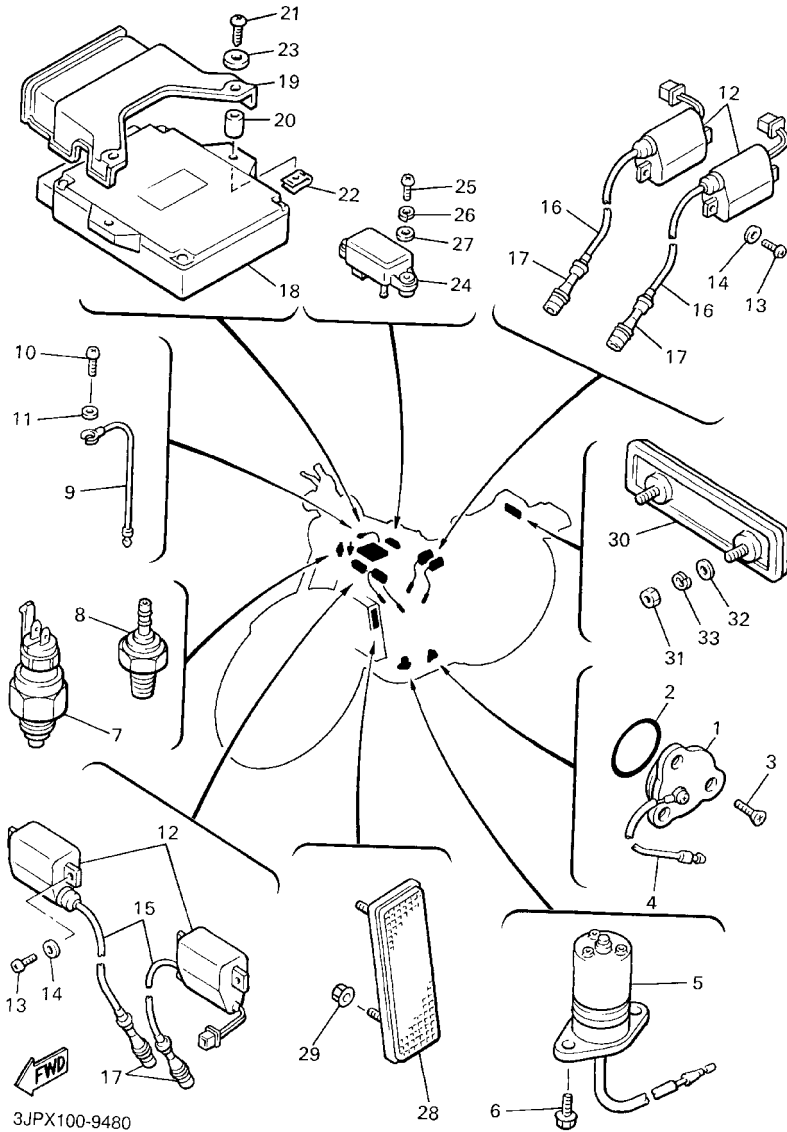
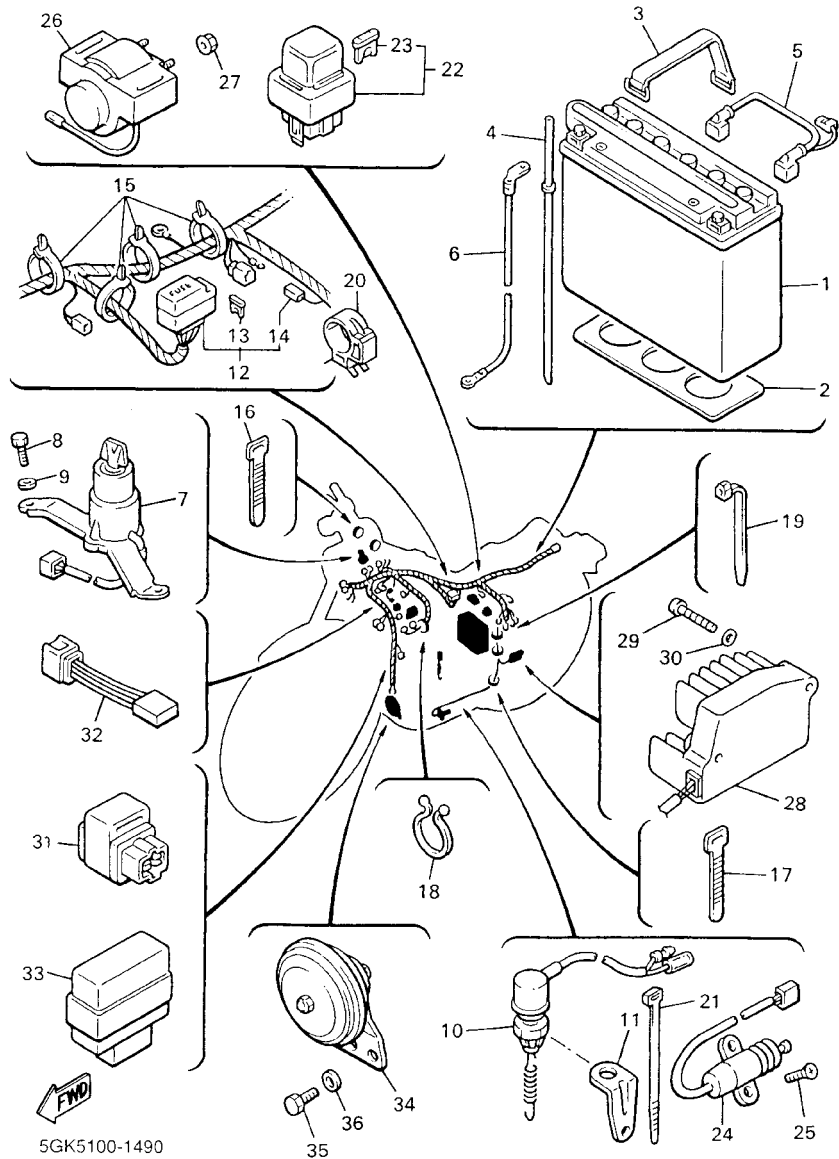

FIG. 48 ELECTRICAL 1

REF. NO.	PART NO.	DESCRIPTION	5GK9	5GKA	5GKB	REMARKS
28	11H-85110-01	REFLECTOR ASSY	2	2	2	
29	95707-05500	NUT, FLANGE	2	2	2	
30	1FK-85130-00	REAR REFLECTOR ASSY	1	1	1	
31	95307-05700	NUT	2	2	2	
32	92907-05200	WASHER	2	2	2	
33	92907-05100	WASHER, SPRING	2	2	2	

FIG. 49 ELECTRICAL 2



REF. NO.	PART NO.	DESCRIPTION	5GK9	5GKA	5GKB	REMARKS
1	5E3-82110-81	BATTERY ASSY (YUASA YB16AL-A2)	1	1	1	
2	1FK-82122-00	SEAT, BATTERY	1	1	1	
3	1E6-82131-00	BAND, BATTERY	1	1	1	
4	1FK-82112-00	PIPE, BREATHER	1	1	1	
5	1UT-82115-00	WIRE, PLUS LEAD	1	1	1	
6	1FK-82116-00	WIRE, MINUS LEAD	1	1	1	
7	1FK-82510-01	MAIN SWITCH ASSY	1	1	1	
8	97007-06016	BOLT	2	2	2	
9	92907-06600	WASHER, PLATE	2	2	2	
10	1FK-82530-02	STOP SWITCH ASSY	1	1	1	
11	1FK-82539-00	STAY, STOP SWITCH	1	1	1	
12	3JP-82590-00	WIRE HARNESS ASSY	1	1	1	
13	42X-82151-20	.FUSE (10A)	1	1	1	
14	3H5-81980-00	.DIODE ASSY	1	1	1	
15	1UA-82591-00	BAND	6	6	6	
16	437-83936-01	BAND, SWITCH CORD	2	2	2	
17	3TB-83936-00	BAND, SWITCH CORD	2	2	2	
18	90464-16039	CLAMP	1	1	1	
19	90464-13073	CLAMP	1	1	1	
20	1UA-82591-00	BAND	1	1	1	
21	90464-15192	CLAMP	1	1	1	
22	1AE-82150-00	FUSE HOLDER ASSY	1	1	1	
23	1AE-82151-00	.FUSE (30A-BL)	2	2	2	
24	3LD-82566-70	SWITCH, SIDE STAND	1	1	1	
25	90157-05079	SCREW, PAN HEAD	2	2	2	
26	3UF-81940-00	STARTER RELAY ASSY	1	1	1	
27	95707-06500	NUT, FLANGE	2	2	2	

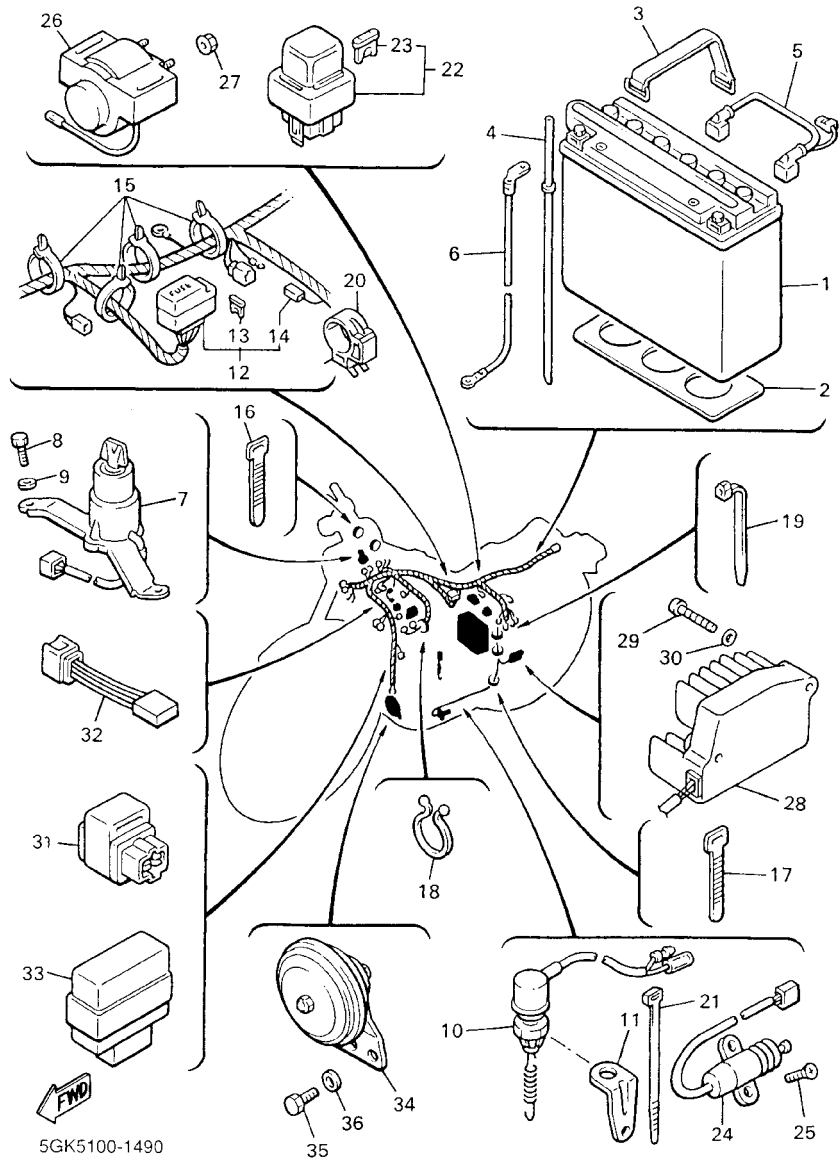

FIG. 49 ELECTRICAL 2

REF. NO.	PART NO.	DESCRIPTION	5GK9	5GKA	5GKB	REMARKS
28	3JP-81960-01	RECTIFIER & REGULATOR ASSY	1	1	1	
29	98507-06030	SCREW, PAN HEAD	2	2	2	
30	92907-06600	WASHER, PLATE	2	2	2	
31	1RL-81950-92	RELAY ASSY	1	1	1	
32	4U8-81980-M0	DIODE ASSY	1	1	1	FOR SIDE STAND SAFETY DEVISE
33	2UJ-83350-00	FLASHER RELAY ASSY	1	1	1	
34	1FK-83371-02	HORN	1	1	1	
35	97007-06016	BOLT	2	2	2	
36	92907-06600	WASHER, PLATE	2	2	2	

NUMERICAL INDEX

PART NO.	GRID NO.	PART NO.	GRID NO.	PART NO.	GRID NO.	PART NO.	GRID NO.	PART NO.	GRID NO.	PART NO.	GRID NO.
36Y-W0041-00	F - 7	1FK-11500-10	B - 5	26H-12169-10	B - 6	1FK-12577-00	B - 12	3F9-14118-00	C - 7	1FK-14414-00	C - 4
1FK-W0042-50	F - 11	1FK-11610-00	B - 4	26H-12169-30	B - 6	1FK-12578-00	B - 11			1FK-14417-00	C - 4
3GM-W0045-02	F - 3	1FK-11610-10	B - 4	26H-12169-50	B - 6	1FK-12579-00	B - 12	41R-14118-01	C - 6	1FK-14437-00	C - 4
1FK-W0046-01	F - 5	1FK-11610-20	B - 4	26H-12169-70	B - 7	26H-12588-01	B - 13			1FK-1445E-00	C - 4
3HE-W0047-50	F - 3	1FK-11631-00-A0	B - 4	26H-12169-90	B - 7	1FK-12589-00	B - 13	1JH-14139-00	C - 7	1FK-14451-00	C - 4
31A-W0047-00	F - 5	3JP-11633-00	B - 4	26H-12171-00	B - 8	1FK-12591-00	B - 12			1AE-14452-00	C - 4
1J3-W0048-00	F - 3	1FK-11635-00	B - 4	2WF-12171-01	B - 8	26H-12611-00	B - 11	26H-14139-00	C - 7	1FK-14452-00	C - 4
	F - 5		B - 5	3JP-12171-01	B - 8	1FK-12615-00	B - 13			1FK-14453-00	C - 4
1NL-W0048-00	D - 5	1FK-11636-00	B - 4	26H-12176-02	B - 8	1FK-12620-00	B - 11	26H-1414G-00	C - 6	1FK-14454-00	C - 4
3HE-W0057-50	F - 3		B - 5	26H-12177-01	B - 8	26H-12630-00	B - 11			1FK-14457-00	C - 4
31A-W0057-00	F - 5	1FK-11650-01	B - 4	1FK-12181-00	B - 8	11H-12673-00	B - 11	4G0-14142-37	C - 6	1FK-14467-00	C - 4
26H-W0098-00	D - 5	26H-11654-00	B - 4	2WF-12181-00	B - 8	11H-12675-00	B - 11			31A-14477-00	D - 13
2KW-W0099-00	F - 8	1FK-11656-00	B - 4	26H-12210-03	B - 8	1FK-13151-00	C - 2	1FK-14147-00	C - 6	41R-14489-00	C - 4
1FK-W1112-02	B - 2	1FK-11656-10	B - 4	3JP-12213-01	B - 8	1FK-13161-00	B - 14			26H-14504-00	C - 7
26H-W1751-01	D - 8	1FK-11656-20	B - 4	26H-12233-00	B - 8	26H-13161-00	B - 15	214-14147-00	C - 6		C - 10
2EN-W2211-00-35	E - 5	1FK-11656-30	B - 4	26H-12241-00	B - 8	26H-13171-00	B - 15			3JB-14536-00	C - 5
2KW-W2645-00	F - 8	1FK-11656-40	B - 4	26H-12251-00	B - 8	26H-13181-03	B - 15	22U-14147-00	C - 6		C - 8
26H-Y1319-10	B - 15	1FK-11656-50	B - 4	26H-12252-00	B - 8	1FK-13300-00	B - 14			22U-14561-00	C - 6
1FK-11101-02	B - 2	1FK-12111-01	B - 6	1FK-1240J-00	B - 11	26H-13325-00	B - 14	22V-14147-00	C - 6		C - 8
2GH-1111G-00	B - 2	36Y-12113-00	B - 6	1FK-1240K-00	B - 11	26H-13337-01	B - 15			22U-14565-00	C - 6
30X-11133-10	B - 2	36Y-12114-00	B - 6	11H-12410-01	B - 9	26H-13342-00	B - 14	137-14153-00	C - 6		C - 9
1FK-11166-00	B - 13	26H-12116-00	B - 6	11H-12412-01	B - 10	26H-13351-01	B - 14			1FK-14603-00	C - 11
26H-11181-00	B - 2	30X-12117-00	B - 6	26H-12413-00	B - 10	26H-13361-00	B - 14	1FK-14190-15	C - 6	1FK-14604-00	C - 11
1FK-11191-00	B - 2	30X-12118-00	B - 6	1FK-12417-00	B - 9	3JP-13414-01	B - 15			1FK-14610-11	C - 11
26H-11193-00	B - 3	51Y-12119-00	B - 6	1FK-12420-10	B - 9	26H-13416-01	B - 15	2L1-14191-00	C - 6	1FK-14611-00	C - 11
214-11198-01	B - 9	1FK-12121-01	B - 6	1FK-12422-00	B - 9	26H-13417-01	B - 15			1FK-14613-00	C - 11
	B - 15	26H-12153-00-J0	B - 6	26H-12427-00	B - 12	5GH-13440-00	B - 15	41R-14193-00	C - 7	3GD-14613-00	C - 11
	E - 7	26H-12153-00-Y0	B - 6	26H-12428-00	B - 12	26H-13476-00	C - 2			1FK-14615-00	C - 11
1FK-1130E-00	C - 3	26H-12168-A0	B - 6	11H-12438-10	B - 9	1UT-13510-00	C - 3	41U-14193-00	C - 7	1FK-14618-00	C - 11
1FK-1133E-00	C - 3	26H-12168-F0	B - 6	1FK-12446-00	B - 9	1FK-13550-00	C - 3			1FK-14620-01	C - 12
1FK-1133F-00	C - 3	26H-12168-H0	B - 6	3JP-12449-02	B - 9	16G-13569-00	C - 3	1FK-14197-01	C - 7	1FK-14624-00	C - 11
1FK-11400-00	B - 4	26H-12168-K0	B - 6	1FK-12450-00	B - 9	1AE-13575-01	C - 3			1FK-14625-00	C - 11
26H-11413-01	B - 5	26H-12168-M0	B - 6	26H-12459-00	B - 9	1FK-13586-00	C - 3	1GR-14197-01	C - 7	1FK-14631-00	C - 11
26H-11413-11	B - 5	26H-12168-R0	B - 6	1FK-1246A-01	B - 12	1FK-13593-00	C - 3			1FK-14638-00	C - 12
26H-11413-21	B - 5	26H-12168-U0	B - 6	1FK-1246E-01	B - 12	1FK-13595-01	C - 3	3JB-14199-00	C - 6	1FK-1465R-00	C - 11
26H-11413-31	B - 5	26H-12168-W0	B - 6	1FK-1246K-00	B - 13	1FK-13596-00	C - 3			1FK-1465T-00	C - 11
26H-11413-41	B - 5	26H-12168-Y0	B - 6	1FK-12461-00	B - 13	1FK-13597-00	C - 3	3G2-14231-18	C - 5	1UT-14710-12	C - 12
26H-11413-51	B - 5	26H-12168-00	B - 6	22W-12462-00	B - 12	1FK-13907-01	C - 4			26H-14715-01	C - 11
26H-11413-61	B - 5	26H-12168-20	B - 6	1FK-12467-00	B - 11	1GR-1410A-00	C - 5	3G2-14231-20	C - 5	1FK-14747-00	C - 12
1FK-11416-01	B - 4	26H-12168-40	B - 6	26H-12469-01	B - 2			3G2-14231-34	C - 5	4K0-14747-00	C - 12
1FK-11416-11	B - 4	26H-12168-60	B - 6	1FK-12479-01	B - 12	26H-14103-00	C - 7			3XW-14755-00	C - 12
1FK-11416-21	B - 4	26H-12168-80	B - 6	5Y9-12491-00	E - 4			3G2-14231-81	C - 6	1FK-14771-00	C - 12
1FK-11416-31	B - 4	26H-12169-E0	B - 7	1AA-12535-00	B - 11	12R-14105-00	C - 6			26H-1490H-00	C - 5
1FK-11416-41	B - 4	26H-12169-G0	B - 7	1FK-12535-00	B - 11			26H-14291-00	C - 7		C - 8
1FK-11416-51	B - 4	26H-12169-J0	B - 7	1FK-12537-00	B - 11	26H-1411A-00	C - 6			1FK-1490J-00	C - 5
1FK-11416-61	B - 4	26H-12169-L0	B - 7	1FK-12560-01	B - 12			1FK-14411-01	C - 4		C - 8
59J-11455-00	F - 12	26H-12169-N0	B - 7	1FK-12566-00	B - 12	22U-14115-00	C - 6	1FK-14412-00	C - 4	2WF-1490J-00	C - 5
4SV-11498-00	B - 8	26H-12169-T0	B - 7	1FK-12576-00	B - 12			1FK-14413-00	C - 4	26H-1490K-00	C - 5

NUMERICAL INDEX

PART NO.	GRID NO.	PART NO.	GRID NO.	PART NO.	GRID NO.	PART NO.	GRID NO.	PART NO.	GRID NO.	PART NO.	GRID NO.
26H-1490K-00	C - 8	1FK-15100-03	C - 13	26H-16154-00	D - 4	26H-17551-00	D - 8	1FK-2171M-00	E - 3	42X-22243-00	E - 8
31H-1490K-00	C - 5	26H-15113-00	C - 14	26H-16307-00	D - 4	26H-17556-00	D - 8	1FK-2171T-00	E - 2	3LR-23102-21	E - 11
	C - 8	59J-15113-00	F - 12	26H-16321-00	D - 4	2H7-17571-01	D - 8	1FK-2171U-00	E - 2	3LR-23103-21	E - 11
1FK-1490L-00	C - 7	26H-15138-00	C - 13	26H-16324-00	D - 4	2H7-17590-00	E - 7	1FK-2171X-00	E - 2	3LR-23110-01	E - 11
	C - 10	4G0-15138-00	C - 13	1FK-16334-00	D - 4	1FK-18101-01	D - 11	3JP-21711-00	D - 15		E - 12
22U-1490M-00	C - 7	4H7-15189-00	C - 13	1FK-16335-00	D - 4	1FK-18110-00	D - 11	2N4-21717-00	D - 15	3LR-23111-00	E - 11
	C - 10	59J-15191-00	F - 12	132-16346-00	D - 11	22N-18113-00	D - 11		E - 3		E - 12
1FK-14900-02	C - 8	1AA-15326-00	C - 13	1FK-16351-00	D - 4	42X-18115-00	D - 11	437-21717-10	D - 13	3YF-23118-00	E - 11
1FK-14901-02	C - 5	1AA-15336-00	C - 13	1FK-16352-00	D - 4	1FK-18128-00	D - 11	1FK-2172A-01	D - 15		E - 12
	C - 8	26H-15337-01	B - 9	36Y-16356-00	D - 4	26H-18140-02	D - 11	1FK-2172F-00	D - 15	4KM-23123-01	E - 12
2WF-14901-02	C - 5		C - 15	4NK-16357-00	D - 4	4NK-18141-00	D - 10	1FK-2172G-00	D - 15	3GM-23125-00	E - 11
1FK-14902-02	C - 5	26H-15338-00	B - 9	1FK-16371-00	D - 4	1FK-18152-00	D - 11	1FK-2172H-00	D - 15	3LR-23126-20	E - 11
	C - 8		C - 15	1FK-16375-00	D - 5	2H9-18154-00	D - 11	1FK-2172K-01	E - 3	3LR-2313A-00	E - 9
2WF-14902-02	C - 5	1FK-15358-00	F - 12	1FK-1638A-00	D - 5	4NK-18185-00	D - 10	1FK-2172M-00	E - 2	3LR-23136-20	E - 11
1FK-14903-02	C - 5	2H7-15361-00	C - 14	1FK-16381-11	D - 4	26H-18511-01	D - 10	1FK-2172W-00	D - 15	3LR-23141-00	E - 11
	C - 8	2H9-15363-00	C - 14	1FK-16383-00	D - 4	26H-18512-00	D - 10	3JP-21721-00	D - 15		E - 12
2WF-14903-02	C - 5	1FK-15365-00	B - 14	26H-16384-00	D - 4	26H-18513-00	D - 10	3JP-21731-00	D - 15	4PU-23144-00	E - 11
1FK-14904-02	C - 5	26H-15365-00	B - 15	26H-16385-00	D - 4	26H-18531-00	D - 10	1FK-21732-00	E - 2	4PU-23145-01	E - 11
	C - 8	26H-15366-01	B - 15	26H-16399-00	D - 4	26H-18536-00	D - 11	3JP-21741-00	D - 15	4V4-23146-L0	E - 11
2WF-14904-02	C - 5	26H-15373-00	C - 14	1FK-17121-01	D - 6	26H-18540-03	D - 10	1FK-21746-00	E - 2	3LR-23149-00	E - 11
1FK-14905-00	C - 7	1FK-15379-00	F - 12	1FK-17141-00	D - 6	4UN-18542-00	D - 10	1FK-21747-00	D - 15		E - 12
	C - 10	26H-15381-00	C - 14	1FK-17151-01	D - 6	4UN-18566-00	D - 10	1FK-2175J-00	E - 2	4V4-23153-L0	E - 11
1FK-14933-00	C - 5	26H-15383-00	C - 14	1FK-17211-00	D - 6	3UF-21105-00-33	D - 12	1FK-2175K-00	E - 3	509-23158-L0	E - 11
	C - 8	1FK-15411-00	C - 15	1FK-17221-01	D - 6	2EN-21110-01-33	D - 12	1FK-2176U-00	E - 2		E - 12
1FK-14940-00	C - 5	1FK-15417-00	C - 13	26H-17231-01	D - 6	1FK-21140-00-33	D - 12	1FK-2176V-00	E - 3	3LR-23168-00	E - 11
	C - 8	3JP-15418-00	C - 15	1FK-17241-00	D - 6	1FK-2117F-00	D - 12	1FK-2177G-00	E - 3		E - 12
26H-14941-90	C - 6	1FK-15421-02	C - 15	1FK-17251-01	D - 6	1FK-2117M-00	D - 12	1FK-2177M-00	E - 4	3LR-23170-20	E - 11
	C - 9	3JP-15427-00	C - 15	1FK-17411-00	D - 6	1FK-2117N-01	D - 12	1FK-21778-00	D - 15		E - 12
26H-14952-22	C - 6	1FK-15428-00	B - 9	4NK-17421-00	D - 6	1FK-21243-01	E - 3	1FK-21779-00	E - 2	3GM-23171-00	E - 11
	C - 8		C - 15	2WE-17524-00	D - 8	4KB-21268-00	E - 4	1FK-21781-00	E - 2		E - 12
22U-14968-00	C - 6	1FK-15431-00	C - 15	2WE-17527-00	D - 8	4R8-21308-00	D - 12	1FK-21782-00	E - 2	3GM-23173-00	E - 11
	C - 9	1FK-15441-00	C - 14	3UF-17531-00	D - 8	1FK-21315-00	D - 12	1UT-21783-00	D - 15		E - 12
22V-14968-00	C - 6	26H-15449-00	C - 15	3UF-17531-10	D - 8	3UF-21359-00	E - 3	1UT-21784-00	D - 15	1FK-23174-00	E - 9
	C - 9	3JP-15451-01	C - 15		D - 9	5H9-21376-00	E - 15	3JP-2179R-D0	E - 4	278-23181-50	E - 11
1FK-14985-00	C - 6	1FK-15455-00	C - 15	3UF-17531-20	D - 8	1FK-2141V-10	D - 12	3JP-2179V-D0	E - 4		E - 12
	C - 9	3JP-15461-01	C - 15		D - 9	1AA-2143A-00	D - 12	1FK-21816-00	E - 3	4V4-23188-L0	E - 11
26H-14987-00	C - 7	3JP-15462-01	D - 2	3UF-17531-30	D - 8	3LR-21511-10	D - 13	26H-21816-01	E - 3		E - 12
	C - 10	4H7-15486-00	C - 15		D - 9	3LR-21611-10	D - 13	1FK-21826-00	E - 4	4PU-2331G-00	E - 12
31H-14987-00	C - 7	1FK-15494-00	F - 12	3UF-17531-40	D - 8	1FK-21629-00	D - 13	26H-21828-00	E - 3	1FK-23317-00	E - 10
	C - 10	26H-15512-00	D - 3		D - 9	1FK-2163A-00	D - 13	1FK-21871-00	E - 3	3LR-23340-10	E - 12
11H-14991-00	C - 7	26H-15514-00	D - 3	3UF-17531-50	D - 8	1FK-2163E-00	D - 14	26H-21874-00	E - 3	4R3-23408-00	E - 9
	C - 10	26H-15515-00	D - 3		D - 9	1FK-21645-00	D - 13	26H-21875-00	E - 3	1J7-23415-00	E - 9
2F1-14991-00	C - 5	26H-15517-00	D - 3	4X7-17531-00-15	D - 8	1FK-21670-01	D - 13	1J7-22141-00	E - 5	26H-23418-01	E - 9
	C - 8	26H-15521-00	D - 3	4X7-17531-00-30	D - 8	1FK-21708-00	E - 2	42X-22141-00	E - 5	1FK-23435-10	E - 9
341-14991-00	C - 6	26H-15522-00	D - 3	4X7-17531-00-50	D - 8	3LR-2171A-10	E - 2	1J7-22143-00	E - 5	1FK-23437-00-38	E - 9
	C - 8	11H-15580-00	D - 3	1J7-17537-Y0-30	E - 6	1FK-2171E-00	E - 2	26H-22189-00	E - 5	1FK-23441-00-38	E - 9
1J7-14994-00	C - 6	1J7-15583-01	D - 3	1J7-17537-Y0-40	E - 6	1FK-2171H-00	E - 2	2H7-2219X-00	E - 5	1FK-23442-00-38	E - 9
	C - 9	26H-16150-10	D - 4	1J7-17537-Y0-50	E - 6	1FK-2171L-00	E - 2	3JP-22210-00	E - 8	584-23484-01	E - 10

NUMERICAL INDEX

PART NO.	GRID NO.	PART NO.	GRID NO.	PART NO.	GRID NO.	PART NO.	GRID NO.	PART NO.	GRID NO.	PART NO.	GRID NO.
1FK-23486-00	E - 9	1FK-25364-00	F - 4	1FK-26111-10	F - 6	1FK-2837R-00	D - 15	2EN-82317-00	G - 8	1FK-83912-01	F - 8
1FK-24110-01-33	E - 13	26H-25366-01	F - 4	3JB-26240-00	F - 6	1FK-46101-10	E - 6	5H0-82341-00	G - 8	36Y-83913-01	G - 7
1FK-2414A-00	E - 13	36Y-25371-00	F - 5	3JB-26241-00	F - 6	1J7-46117-Y0-25	E - 6	4X7-82342-00	G - 8	1FK-83922-00	G - 7
1JH-24170-00	E - 14	4NK-25381-10	F - 4	26H-26244-01	F - 6	1J7-46117-Y0-30	E - 6	1FK-82370-00	G - 8	3TB-83936-00	G - 10
25H-24180-00	E - 13	29L-25398-00	F - 2	26H-26261-01	F - 6	1J7-46117-Y0-40	E - 6	22N-82380-10	G - 8	437-83936-01	G - 10
1FK-24181-00	E - 13		F - 4	26H-26262-01	F - 6	1J7-46117-Y0-50	E - 6	1FK-82510-01	G - 10	1FK-83973-00	G - 7
1FK-24182-00	E - 13	29L-25398-10	F - 2	26H-26272-00	F - 6	22U-46118-00-12	E - 6	1FK-82530-02	G - 10	1FK-83973-11	G - 7
1FK-24183-00	E - 13		F - 4	3JB-26273-00	F - 6	22U-46118-00-14	E - 6	1FK-82539-00	G - 10	36Y-83980-01	G - 7
1FK-24184-00	E - 13	29L-25398-20	F - 2	3JB-2628J-00	F - 6	22U-46118-00-16	E - 6	1L9-82540-00	G - 8	42X-84124-60	G - 5
1FK-24186-00	E - 13		F - 4	1AA-26280-02	F - 8	22U-46118-00-18	E - 7	1FK-82541-00	G - 8	214-84153-60	E - 3
1FK-2419A-00	E - 14	3JP-2580T-00	F - 3	1AA-26290-02	F - 7	22U-46118-00-20	E - 7	3LN-82560-01	G - 8	2F9-84314-00	G - 5
1JH-2419E-00	E - 14	3JP-2580U-00	F - 3	1FK-2631J-00	C - 7	2H7-46122-00	E - 6	3LD-82566-70	G - 10	42X-84315-01	G - 5
1JH-24190-00	E - 14	4BH-2580W-00	F - 5		C - 10	4H7-46123-00	E - 6	3JP-82590-00	G - 10	42X-84321-A0	G - 5
1FK-24311-02	E - 14	3LR-2581T-00	F - 3	1FK-26311-01	F - 6	4H7-46125-00	E - 6	1UA-82591-00	F - 8	1FK-84330-00	G - 5
1FK-24314-00	E - 13	1FK-25819-00	F - 5	1FK-26312-01	F - 6	1FK-46152-01	E - 6		G - 10	341-84331-60	G - 5
1FK-24315-00	E - 13	3JP-2582U-00	F - 5	1FK-26313-01	C - 7	4YE-46153-00	E - 6	36Y-82917-00	G - 7	1A0-84332-60	G - 5
1JH-24316-02	E - 14	1FK-25827-00	F - 5		C - 10	1FK-46154-00	E - 7	42X-83310-K0	F - 15	198-84334-60	G - 5
1JH-24335-00	E - 14	1FK-25828-00	F - 5	5H0-26393-00	F - 6	1FK-46156-00	E - 7	256-83311-70	F - 15	1FK-84338-00	G - 5
1FK-24376-00	E - 13	3HE-2583T-01	F - 7	1FK-26452-01	F - 8	1FK-46157-00-15	E - 7	42X-83312-00	F - 15	42X-84345-00	G - 5
1FK-24393-00	E - 13	1KT-25836-00	F - 3	1AE-26454-00	F - 8	1FK-46157-00-20	E - 7	42X-83313-00	F - 15	42X-84366-00	G - 5
1FK-24560-00	E - 13	41Y-25836-00	F - 5	3GM-26455-00	F - 8	1FK-46172-00	E - 7	1AA-83318-00	F - 15	2F9-84375-00	G - 5
1FK-24566-00	E - 13	341-25846-00	F - 2	26H-26464-00	F - 8	4X7-46180-00	E - 7	42X-83320-K0	F - 15	5Y3-84395-00	G - 5
54K-24602-00	E - 13	1FK-25850-50	F - 11	1AE-26467-01	F - 8	3UF-81410-10	F - 12	42X-83330-K0	F - 15	2F9-84397-01	G - 5
1FK-24711-00	E - 15	2KF-25852-50	F - 11	1FK-26470-01	F - 8	3UF-81450-10	F - 12	42X-83340-K0	F - 15	1FK-84516-01-98	D - 13
18A-24724-00	E - 2	3HE-25852-01	F - 7	1FK-26475-00	F - 8	3UF-81670-00	F - 12	2UJ-83350-00	G - 11	1FK-84527-00	D - 14
1FK-2473T-00	E - 15	36Y-25854-00	F - 7	1UT-27111-01-R4	F - 10	3AJ-81801-00	F - 14	26H-83354-00	G - 8	1FK-84700-60	G - 6
1FK-24736-00	E - 15	360-25854-01	F - 11	371-27114-00	F - 10	1FK-81815-00	F - 14	57M-83358-00	F - 15	1FK-84702-00	G - 6
3UF-24737-00	E - 15	2GU-25855-00	F - 11	1FK-27115-00	F - 10	4XV-8182A-00	F - 14	42X-83363-00	F - 15	256-84714-61	F - 15
22W-24741-00	E - 15	4L0-25862-01	F - 7	1FK-27211-00-93	F - 10	1FK-81826-10	F - 14	1FK-83371-02	G - 11		G - 6
1FK-24750-00	E - 15		F - 8	1FK-27212-00	F - 10	11H-81844-00	F - 14	1GR-83507-01	G - 3	42X-84721-60	G - 6
1FK-24751-00	E - 15	36Y-25867-00	F - 7	47X-27222-00	F - 10	1FK-81847-00	F - 14	1FK-83509-00	G - 3	42X-84723-01	G - 6
1FK-2476F-00	E - 15	1FK-25872-03	F - 7	1FK-27311-00-R4	F - 10	1FK-81890-00	F - 14	42X-83517-00	G - 3	11H-85110-01	G - 9
1FK-24760-00	E - 15	3LR-25873-02	F - 7	1FK-27315-00	F - 10	3UF-81940-00	G - 10	1FK-83519-00	G - 3	1FK-85130-00	G - 9
1FK-24771-00	E - 15	1FK-25874-03	F - 11	1FK-27352-00	F - 10	1RL-81950-92	G - 11	3UF-83520-00	G - 3	1FK-85720-00	G - 8
1FK-24772-00	E - 15	3LR-25874-02	F - 7	1UT-27410-10	F - 9	3JP-81960-01	G - 11	1FK-83523-00	G - 3	42H-85740-00	F - 13
1FK-24780-00	E - 15	55R-25875-00	F - 7	1NH-27413-00	F - 9	3H5-81980-00	G - 10	12R-83523-00	G - 3	1FK-85752-01	E - 14
1FK-24790-00	E - 15	55R-25876-00	F - 7	26H-27414-00	F - 9	4U8-81980-M0	G - 11	1FK-83526-00	G - 4	42X-85753-00	E - 14
1FK-24791-00	E - 15	42H-25885-01	F - 7	1UT-27420-10	F - 9	5E3-82110-81	G - 10	1FK-8353G-00	G - 3	1FK-85821-00	F - 13
1FK-24796-00	E - 2	1FK-2589F-00	F - 8	26H-2743E-00	F - 9	1FK-82112-00	G - 10	1FK-8353H-00	G - 3	1FK-85826-00	F - 13
341-25149-00	F - 2	36Y-2589H-00	F - 7	1UT-27430-01	F - 9	1UT-82115-00	G - 10	1FK-83535-00	G - 3	1FK-85830-M2	F - 13
2HY-25168-00-35	F - 2	31A-2589A-01	F - 11	1NH-27433-00	F - 9	1FK-82116-00	G - 10	1FK-83540-00	G - 3	1FK-85850-00	F - 13
1FK-25181-00	F - 2	1FK-25895-00	F - 11	1UT-27440-01	F - 9	1FK-82122-00	G - 10	1FK-83545-00	G - 3	90105-06153	B - 2
4TX-25190-10	F - 2	26H-25919-00	F - 5	1FK-27442-00	F - 9	1E6-82131-00	G - 10	1FK-83550-20	G - 4	90105-06375	G - 5
148-25315-00	F - 2	3GM-25919-00	F - 3	1FK-27443-00	F - 9	1AE-82150-00	G - 10	3JP-83559-00	G - 4	90105-07342	B - 8
2H7-25315-00	F - 4	3HE-25924-00	F - 3	1FK-28100-01	D - 12	1AE-82151-00	G - 10	1FK-83570-A2	G - 4	90105-08066	D - 12
1J7-25319-02	F - 4		F - 5	3TU-28344-00	E - 4	42X-82151-20	G - 10	1GR-83570-F2	G - 3	90105-081A0	D - 12
1FK-25327-00	F - 5	3GM-25925-00	F - 3	1FK-28345-00	E - 2	3JP-82305-12	G - 8	11H-83591-00	G - 8	90105-081A1	F - 9
1UT-25338-01-35	F - 4	3HE-25925-00	F - 5	1FK-2837N-00	D - 15	25G-82310-10	G - 8	1FK-83611-00	G - 3		F - 11

NUMERICAL INDEX

PART NO.	GRID NO.	PART NO.	GRID NO.	PART NO.	GRID NO.	PART NO.	GRID NO.	PART NO.	GRID NO.	PART NO.	GRID NO.
90105-08777	F - 5	90149-06011	E - 14	90201-052E2	G - 3	90209-25196	D - 6	90430-06166	C - 13	90467-23067	B - 12
90105-10248	C - 14	90149-06131	G - 7	90201-060A3	G - 5	90209-27192	D - 6	90430-08119	B - 15	90468-03178	D - 15
90105-10249	C - 14	90149-06154	D - 12	90201-06055	D - 13	90209-32231	D - 6		C - 2	90468-12006	F - 13
90105-10271	C - 12	90149-08152	C - 14	90201-06057	D - 14	90215-08115	D - 11	90430-10148	D - 5	90468-98132	B - 9
90105-10376	D - 12	90151-05034	F - 13	90201-06071	G - 4	90215-22238	E - 5	90445-086A8	E - 13		C - 15
90105-10638	F - 3	90151-06013	D - 10	90201-06380	E - 3	90215-25218	D - 4	90445-08715	C - 3	90480-12296	E - 2
	F - 5	90151-06041	C - 14		F - 10	90240-08013	F - 10	90445-090A9	C - 4	90480-13018	C - 3
90105-12252	D - 12		D - 11		F - 13	90249-12167	F - 4	90445-09112	B - 12	90480-14023	F - 13
90105-12374	B - 4	90151-06061	C - 13		G - 6	90254-03008	B - 2	90445-112K7	E - 14	90480-14052	B - 11
90109-063F8	D - 11		C - 15	90201-065G8	E - 13	90269-04003	E - 10	90445-11706	E - 14	90480-14229	G - 4
90109-06468	F - 10	90154-06033	C - 3	90201-06557	G - 8	90280-05029	B - 4	90445-120E7	C - 4	90480-15235	E - 3
90109-083G4	F - 3	90157-05050	C - 5	90201-06674	F - 12	90331-15039	D - 6	90460-15227	B - 12	90480-15316	G - 6
	F - 5		C - 8	90201-08083	F - 10	90338-05151	B - 11		B - 13	90480-18276	B - 11
90109-08441	D - 11	90157-05079	G - 10	90201-08087	E - 13	90338-06134	B - 9	90460-38241	B - 11	90480-19283	B - 11
90109-103G0	C - 13	90157-05084	G - 5	90201-08326	D - 12	90338-08163	D - 13		B - 12	90501-04623	D - 3
90109-106A1	C - 13	90159-03044	G - 3	90201-08676	D - 9		E - 9	90460-49274	C - 3	90501-06022	D - 10
90109-10658	F - 10	90159-03102	G - 3	90201-100A1	E - 8	90338-10150	B - 3	90460-59211	C - 4	90501-06585	C - 3
90109-107A2	F - 10	90159-04043	G - 4	90201-10118	D - 5	90338-11152	C - 13	90460-15100	E - 13	90501-08668	E - 14
90110-06035	D - 5	90159-05073	B - 12		F - 7	90338-20113	E - 5	90462-06192	C - 15	90501-10312	G - 7
90110-06054	C - 11	90159-05119	C - 4		F - 8	90340-14042	E - 7	90462-20149	C - 3	90501-106A4	B - 12
90110-06074	G - 7	90159-06033	E - 15		F - 11	90340-14068	C - 15	90464-13073	G - 10	90501-106A5	B - 12
90110-06084	B - 10	90159-06056	F - 11	90201-10128	B - 15	90340-14132	B - 9	90464-15192	G - 10	90501-16491	E - 7
90110-06102	D - 15	90164-04005	G - 3	90201-102G9	B - 2		B - 15	90464-16021	D - 13	90501-75638	D - 8
90110-06237	D - 2	90164-04009	G - 3	90201-106E0	C - 12		E - 7	90464-16025	D - 13	90502-09024	E - 9
90110-06238	C - 15	90170-06010	G - 7	90201-10742	C - 12	90340-20090	B - 2	90464-16039	G - 10	90506-07136	E - 5
90110-06239	B - 12	90170-06228	D - 11	90201-11597	C - 14	90387-045R4	G - 8	90464-20070	E - 14	90506-08227	D - 11
90110-06240	B - 9	90170-20323	D - 4	90201-121H0	B - 5	90387-060A7	E - 3	90464-30071	E - 13	90506-13312	D - 11
	C - 15	90176-06041	G - 5	90201-12688	D - 11	90387-06026	G - 6	90465-08193	C - 2	90506-18305	F - 10
	D - 2	90176-08040	D - 12	90201-127E1	D - 11	90387-06033	B - 11	90465-08220	C - 15	90506-45222	F - 10
	F - 7	90176-10033	D - 12	90201-12790	C - 14	90387-062G5	E - 13	90465-08233	C - 14	90507-29019	F - 10
	F - 8	90176-10073	E - 8	90201-166R5	E - 6	90387-06299	F - 13	90465-08287	C - 14	90508-32588	D - 11
90110-06241	B - 9	90176-10075	E - 7	90201-166R6	D - 8	90387-06500	C - 3	90465-23286	C - 2	90560-17322	F - 2
90110-06242	C - 15	90176-22081	E - 9	90201-181U5	F - 4	90387-07037	B - 11	90467-08003	B - 12	90560-20295	F - 4
90110-06243	D - 5	90179-08327	B - 4	90201-220T0	E - 9	90387-07789	D - 13	90467-08021	C - 3	90560-30234	D - 10
90110-10092	D - 12	90179-08673	C - 11	90201-231A2	E - 7	90387-173R6	F - 2	90467-08075	E - 13	91314-06016	C - 3
90110-10161	D - 12		C - 12	90201-232K5	D - 6	90387-17543	E - 5	90467-08092	C - 4	91314-06020	E - 9
90111-05012	D - 15	90179-10247	D - 12	90201-252K4	D - 8	90387-200J2	F - 5	90467-09006	E - 4	91314-06050	E - 9
90116-08427	E - 6	90179-10414	B - 2	90201-256K5	D - 6	90387-203H7	F - 4	90467-10008	C - 7	91314-08032	E - 12
90116-10249	E - 6	90179-16661	E - 6	90201-256K6	D - 6	90401-08038	B - 15		C - 10	91314-08040	E - 9
90116-10411	C - 13	90179-16662	D - 8	90201-256K7	D - 6	90401-08093	C - 2	90467-10039	C - 3	91316-06016	B - 9
90116-10428	E - 6	90179-25033	E - 9	90201-25634	D - 8	90401-10084	D - 5	90467-10041	E - 14	91317-06020	B - 8
90116-10429	C - 13	90179-44328	D - 8	90201-350F3	D - 3	90401-10108	B - 15	90467-10135	C - 4		B - 9
90119-06044	E - 15	90183-04027	E - 2	90202-05193	E - 14	90401-10159	F - 7	90467-11019	E - 4		C - 3
90119-06056	E - 3		G - 8	90202-26142	E - 9		F - 8	90467-11090	B - 13		F - 7
90119-06115	C - 11	90183-06008	D - 15	90208-04029	E - 10		F - 11	90467-11106	E - 14	91317-06025	B - 14
90119-06218	B - 2	90185-10037	F - 10	90209-06096	D - 2	90401-10160	F - 7	90467-12124	E - 13	91317-06030	B - 15
90149-05321	D - 10	90185-10091	F - 10	90209-11262	B - 2	90401-20145	B - 15	90467-14015	B - 13	91317-08014	D - 3
	G - 8	90185-18167	F - 4	90209-21281	D - 8	90430-06014	C - 15	90467-14057	F - 11	91317-08020	D - 13

NUMERICAL INDEX

PART NO.	GRID NO.	PART NO.	GRID NO.	PART NO.	GRID NO.	PART NO.	GRID NO.	PART NO.	GRID NO.	PART NO.	GRID NO.
91317-08030	E - 9	92907-06600	E - 3	93210-27370	C - 14	93604-16092	D - 10	95807-06010	E - 2	97707-40616	G - 6
91380-05008	C - 11		E - 9	93210-29196	G - 8	93615-12088	D - 3	95807-06012	E - 15	97707-40625	G - 6
91380-05025	C - 11		E - 13	93210-45150	C - 15	93900-00025	F - 2	95807-08012	E - 13	97707-50114	C - 4
91380-05045	C - 11		E - 14	93210-45511	B - 10		F - 4	95807-12016	C - 14	97707-50612	E - 13
91401-16012	F - 10		E - 15	93210-45578	C - 3	94111-1805D	F - 2	95812-10050	E - 7	97707-60516	F - 13
91401-20020	F - 5		F - 8	93210-60426	E - 6	94111-1805F	F - 2	95814-06045	C - 13	97801-04010	C - 5
91808-16023	B - 2		F - 12	93210-68347	F - 4	94115-1505E	F - 4	95814-06070	C - 13		C - 8
92014-06012	D - 15		G - 3	93210-71360	D - 8	94115-1505G	F - 4	95814-06090	C - 13	97801-05008	C - 7
92014-06025	D - 15		G - 5	93211-16591	B - 9	94580-81118	B - 8	95814-08045	C - 13		C - 10
92017-05010	C - 3		G - 8	93211-54698	E - 7	94701-00241	B - 2	95814-08080	C - 13	97801-05012	C - 5
92901-04100	C - 5		G - 10	93306-00006	B - 9	94701-00242	B - 2	95817-06012	B - 15		C - 8
	C - 6		G - 11	93306-00304	D - 4	95024-06016	F - 7		C - 2	97801-06010	C - 7
	C - 7	92907-08100	D - 12	93306-20555	D - 6	95024-08016	E - 9	95817-06095	C - 13		C - 10
	C - 8	92990-06600	C - 11	93306-20645	D - 6		F - 9	95817-08025	B - 8	98501-04012	F - 11
	C - 9		C - 12	93306-20901	D - 8	95024-08020	E - 8	95817-08050	C - 13	98506-05035	G - 7
	F - 11	93101-10090	B - 9	93306-30317	F - 2		F - 9	95817-08065	C - 13	98506-05040	G - 7
92901-04600	F - 11	93101-30084	E - 7	93306-30430	D - 6	95024-08030	F - 9	95817-08095	C - 13	98506-05045	G - 7
92901-08700	E - 7	93101-35085	D - 8	93306-30437	F - 4	95024-10030	F - 9	95824-08045	E - 11	98507-04008	G - 8
92903-06100	F - 10	93101-38098	E - 6	93306-30533	E - 6	95027-06016	G - 8	95827-06020	D - 13	98507-04016	G - 4
92903-06600	E - 9	93102-12106	D - 11	93306-36401	D - 6	95027-08025	C - 12	95827-06025	F - 14		G - 7
92903-10100	E - 7	93102-25017	E - 5	93306-90602	D - 10	95301-05600	G - 3	95827-06055	F - 14	98507-05008	B - 11
92903-20600	F - 4	93102-25064	F - 4	93311-21044	E - 7	95304-06700	D - 11	95827-08025	D - 13		F - 6
92904-08600	E - 5	93102-28022	F - 2	93311-43729	E - 6	95307-05600	B - 11	95827-08030	D - 9	98507-05010	C - 3
92907-04200	E - 2	93102-40367	F - 4	93316-01403	E - 6		G - 3	95827-08060	D - 12		C - 11
	G - 8	93102-70167	E - 7	93317-32677	F - 4	95307-05700	G - 9	97004-06030	F - 15	98507-05012	B - 11
92907-04600	G - 4	93105-45017	F - 2	93317-41510	E - 6	95307-06600	D - 14	97004-08035	E - 5	98507-05020	C - 4
	G - 7	93108-43013	E - 7	93332-00001	E - 9		G - 4	97007-06012	E - 2		F - 5
	G - 8	93109-08061	D - 4	93332-00008	E - 9		G - 6		E - 3	98507-06008	D - 2
92907-05100	G - 9	93210-03119	C - 5	93332-00010	E - 5	95307-08700	F - 10		E - 9	98507-06012	C - 14
92907-05200	G - 9		C - 8	93332-00024	D - 8	95311-08600	E - 7		E - 15		D - 13
92907-05300	B - 11	93210-06632	D - 4	93332-00028	D - 8	95606-06100	F - 8	97007-06014	E - 14		F - 8
92907-05600	B - 11	93210-06667	B - 14	93410-11002	B - 14	95607-06100	F - 9	97007-06016	E - 14		F - 12
	C - 3		B - 15	93410-22039	E - 7		F - 10		G - 3	98507-06016	B - 12
	C - 4		C - 14	93410-23056	D - 6		G - 7		G - 5		C - 15
	C - 11	93210-13361	B - 15		E - 7	95607-10200	E - 9		G - 10		D - 13
	F - 5	93210-14104	B - 12	93440-20088	E - 7	95617-08620	B - 2		G - 11		D - 15
	G - 3	93210-14369	C - 15	93440-28062	D - 6	95617-08635	B - 2	97007-06020	B - 11		F - 12
92907-06100	F - 7	93210-14579	B - 15	93440-30077	D - 6	95704-06500	F - 15	97007-06025	D - 4	98507-06020	D - 15
	F - 8	93210-14637	B - 15	93440-34025	D - 6	95704-08500	F - 5	97017-06010	C - 12		G - 8
	G - 6	93210-15620	F - 11	93440-45022	F - 4	95707-05500	G - 9	97017-10045	C - 12	98507-06025	F - 13
92907-06200	D - 15	93210-16629	B - 2	93440-52118	D - 6	95707-06500	D - 13	97027-06016	D - 13	98507-06030	B - 12
	E - 14	93210-18322	B - 2		D - 7		E - 2	97027-06020	D - 11		G - 11
92907-06600	B - 11		D - 4	93450-19095	B - 4		E - 3	97027-06030	E - 13	98507-06040	E - 3
	B - 12	93210-21631	B - 2	93511-32017	D - 4		E - 15	97080-06008	C - 11		F - 12
	C - 14	93210-22382	C - 4	93603-07073	D - 4		G - 10		C - 12	98511-04008	C - 6
	D - 13		C - 13	93603-10049	D - 10	95707-08500	D - 13	97707-30112	F - 6		C - 9
	D - 15	93210-27194	B - 9	93603-14026	B - 9	95707-10500	F - 9	97707-40512	E - 2	98511-04012	C - 5
	E - 2		B - 12	93604-12037	D - 10	95707-12500	G - 2	97707-40516	G - 8		C - 6

NUMERICAL INDEX

PART NO.	GRID NO.	PART NO.	GRID NO.	PART NO.	GRID NO.	PART NO.	GRID NO.	PART NO.	GRID NO.
98511-04012	C - 8								
	C - 9								
98517-06012	F - 9								
98706-04012	F - 8								
99001-05600	E - 3								
99001-10600	D - 11								
99009-10400	B - 9								
99009-12400	B - 14								
	D - 11								
99009-52500	F - 4								
99246-00080	D - 13								
99530-08016	B - 15								
99530-10114	B - 9								
	B - 14								
	C - 13								
	C - 15								
	D - 2								
99530-14016	B - 2								

CONTENTS

ENGINE

CYLINDER HEAD	B2
CRANKSHAFT. PISTON	B4
VALVE	B6
CAMSHAFT. CHAIN	B8
WATER PUMP	B9
RADIATOR. HOSE	B11
OIL PUMP	B14
OIL CLEANER	B15
INTAKE	C3
CARBURETOR	C5
CARBURETOR 2	C8
EXHAUST	C11
CRANKCASE	C13
CRANKCASE COVER 1	C15
STARTER CLUTCH	D3
CLUTCH	D4
TRANSMISSION	D6
MIDDLE DRIVE GEAR	D8
SHIFT CAM. FORK	D10
SHIFT SHAFT	D11

CHASSIS

FRAME	D12
FENDER	D13
SIDE COVER	D15
REAR ARM	E5
DRIVE SHAFT	E6
REAR SUSPENSION	E8
STEERING	E9
FRONT FORK	E11
FUEL TANK	E13
SEAT	E15

FRONT WHEEL	F2
FRONT BRAKE CALIPER	F3
REAR WHEEL	F4
REAR BRAKE	F5
STEERING HANDLE. CABLE	F6
FRONT MASTER CYLINDER	F7
FRONT MASTER CYLINDER 2	F8
STAND. FOOTREST	F9
REAR MASTER CYLINDER	F11
GENERATOR	F12
PICK UP COIL. GOVERNOR	F13
STARTING MOTOR	F14
FLASHER LIGHT	F15
METER	G3
HEADLIGHT	G5
TAILLIGHT	G6
HANDLE SWITCH. LEVER	G7
ELECTRICAL 1	G8
ELECTRICAL 2	G10

INDEX

NUMERICAL INDEX	M1
-----------------------	----