



YAMAHA

PARTS CATALOGUE

CY50B(4CG1)

OCEANIA

/14CG-700E1

A2

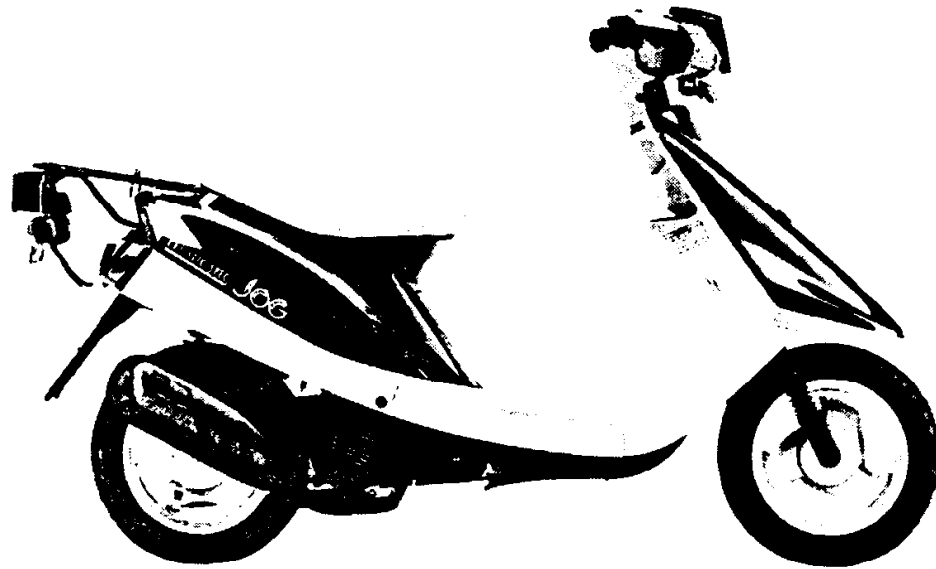

A3

FOREWORD

This Parts Catalogue is related to the parts in use for the Yamaha CY50B(4CG1).
When you are ordering replacement parts for the CY50B(4CG1), refer to this Parts Catalogue and quote both part numbers and part names correctly.

1. Modifications or additions which have been made after issue of the Parts Catalogue will be announced in the Yamaha Parts News.
It is advisable that according to the Yamaha Parts News you make necessary corrections to the Parts Catalogue on hand to keep it up-to-date.

2. Abbreviations

The following abbreviations are used in this Parts Catalogue.

- U.R. Use size (thickness) and/or number as required.
- U.N. Use as many as you need.
- A.P. Alternate Parts
- L.M. Local Made
- F# Frame No. (Applicable machine No.)

3. The parts marked with (+) in the parts number column of this Catalogue are not supplied with by Yamaha, those have to be found locally.
4. Parts, which are to be supplied in the form of assemblies, are listed with an indentation of one letter's space, and a dot (.) is put against the name of each part.

EXAMPLE CARBURETOR ASS'Y
 . JET, pilot
 . NOZZLE, main

5. Indication of No. of constituent parts for assembly

The numeral appearing to the right of each constituent part under the description indicates the quantity of such parts for each individual assembly unit.

EXAMPLE

Part No.	Description	Q'ty	Remarks
2F5-83310-60	FRONT FLASHER LIGHT ASS'Y	2	
115-83311-80	. BULB (6V-18W)	1	
1M1-83309-60	. REFLECTOR	1	

6. Initial Serial No. and Color Code

(A) Frame Serial No.	4CG-000101 and following
(B) Engine Serial No.	4CG-000101 and following

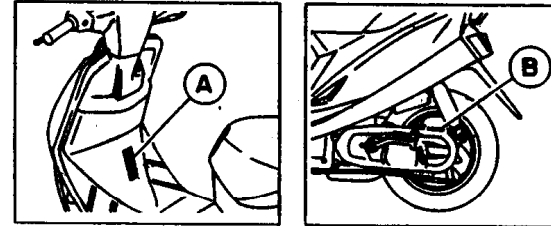

Color Code	Color Name	Abbreviate
0122	VERY DARK BLUE COCKTAIL 2	VDBC2
0121	VIVID RED COCKTAIL 1	VRC1

7. Applicable colors of graphics are represented in the "Remarks" column by the letter(s) appropriately picked out of the full word(s) showing such colors.

EXAMPLE

Part No.	Description	Q'ty	Remarks
2N4-24110-00-X5	FUEL TANK COMP.	1	MAXIM RED
3J1-24240-10	. GRAPHIC, fuel tank set	1	for MXR

CONTENTS

ENGINE

Cylinder	B2
Crankshaft. Piston	B3
Air Shroud. Fan	B4
Oil Pump	B5
Intake	B6
Carburetor	B7
Exhaust	B8
Crankcase	B9 ~ B10
Starter	B11
Clutch	B12 ~ B13
Transmission	B14

Meter	D4
Headlight	D5
Taillight	D6
Handle Switch. Lever	D7
Electrical 1	D8
Electrical 2	D9

INDEX

Numerical Index	M1 ~ M2
-----------------------	---------

CHASSIS

Frame	B15
Fender	C2
Side Cover	C3
Oil Tank	C4
Rear Suspension	C5
Front Fork	C6
Fuel Tank	C7
Seat. Carrier	C8
Front Wheel	C9 ~ C10
Rear Wheel	C11
Steering Handle. Cable	C12
Stand. Footrest	C13
Leg Shield	C14
Cowling 1	C15
Generator	D2
Flasher Light	D3

FIG. 1 CYLINDER

REF. NO.	PART NO.	DESCRIPTION	Q'TY	REMARKS
1	3KJ-11111-10	HEAD, cylinder 1	1	
2	3KJ-11181-00	GASKET, cylinder head 1	1	
3	94701-00227	PLUG, spark	1	UR
	94701-00327	PLUG, spark	1	UR
4	3KJ-11311-10	CYLINDER 1	1	
5	3KJ-11351-00	GASKET, cylinder	1	
6	90116-07353	BOLT, stud	4	
7	90179-07381	NUT	4	

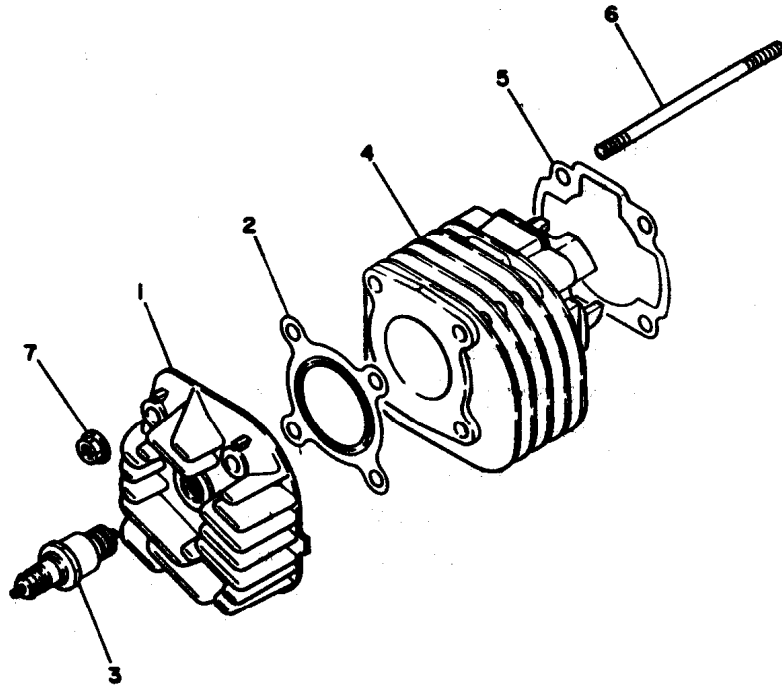

3KJ1010-9010

B2

FIG. 2 CRANKSHAFT. PISTON

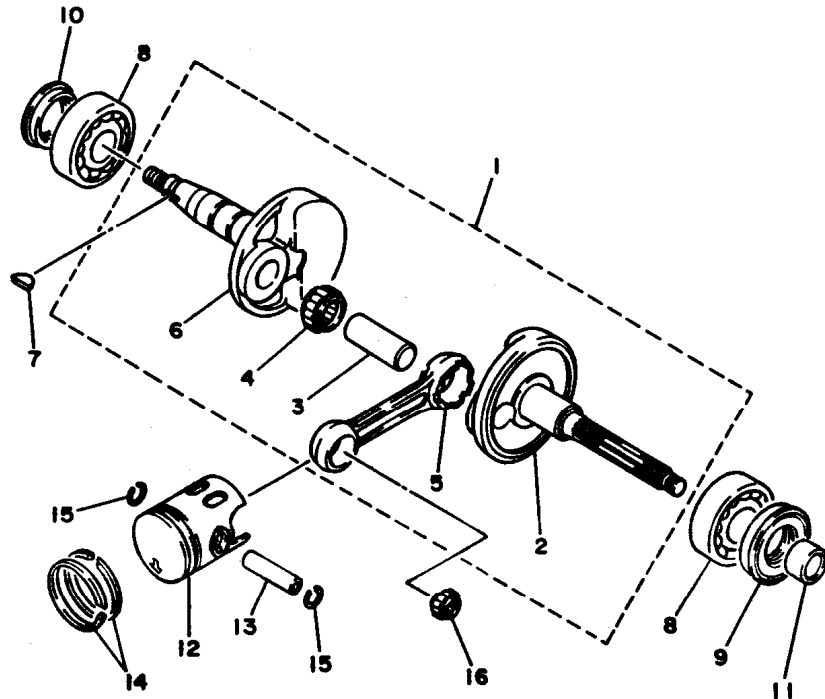

REF. NO.	PART NO.	DESCRIPTION	Q'TY	REMARKS
1	3KJ-11400-00	CRANKSHAFT ASSY	1	
2	3KJ-11412-00	.CRANK 1	1	
3	1YU-11681-00	.PIN, crank 1	1	
4	93310-416F7	.BEARING, cylindrical	1	
5	2E9-11651-00	.ROD, connecting	1	
6	3KJ-11422-00	.CRANK 2	1	
7	90280-03017	KEY, woodruff	1	
8	93306-20458	BEARING	2	
9	93102-20425	OIL SEAL	1	
10	93101-20138	OIL SEAL	1	
11	90387-15600	COLLAR	1	
12	3CP-11631-00-96	PISTON (STD)	1	
	3CP-11635-00	PISTON (0.25MM O/S)	1	AP
	3CP-11636-00	PISTON (0.50MM O/S)	1	AP
13	27V-11633-00	PIN, piston	1	
14	260-11601-02	PISTON RING SET (STD)	1	
	260-11601-12	PISTON RING SET (0.25MM O/S)	1	AP
	260-11601-22	PISTON RING SET (0.50MM O/S)	1	AP
15	93450-11120	CIRCLIP	2	
16	93310-210M0	BEARING, cylindrical	1	



3KJ1010-9020

B3

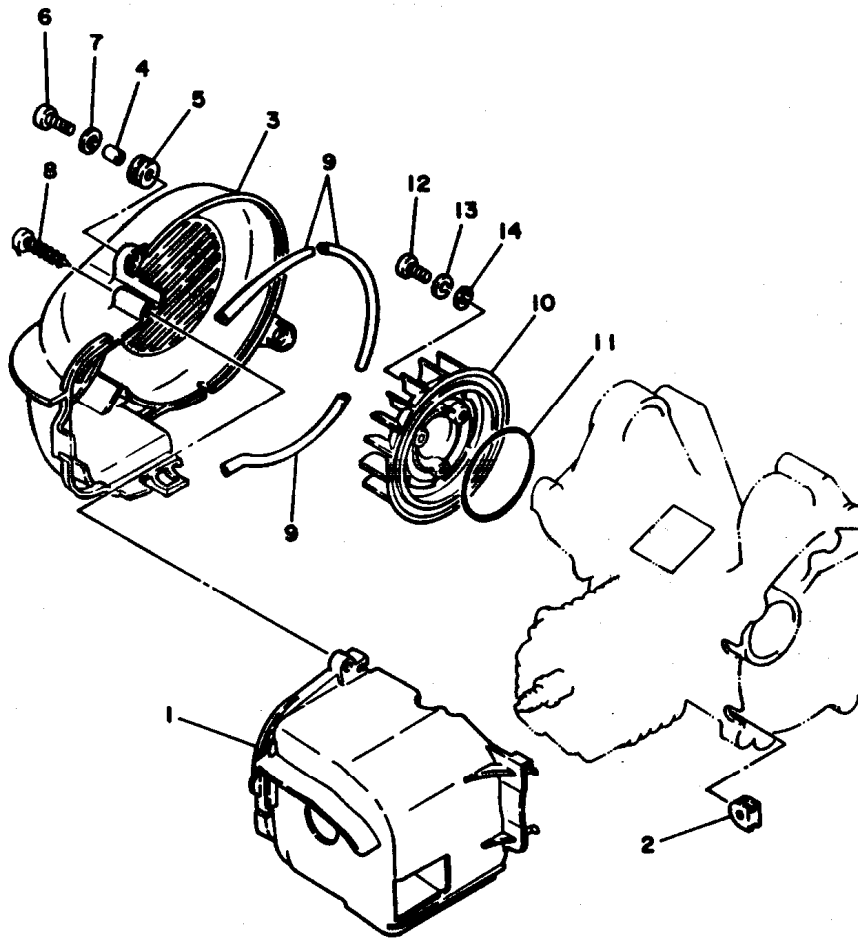

FIG. 3 AIR SHROUD. FAN

REF. NO.	PART NO.	DESCRIPTION	Q'TY	REMARKS
1	3KJ-12651-11	AIR SHROUD, cylinder 1	1	
2	90480-10468	GROMMET	2	
3	3KJ-12653-01	AIR SHROUD, cylinder 3	1	
4	90387-067V1	COLLAR	2	
5	90480-12497	GROMMET	2	
6	98516-06020	SCREW, pan head	2	
7	92906-06600	WASHER, plate	2	
8	97702-60540	SCREW, tapping	1	
9	3KJ-12658-01	DAMPER, air shroud 1	3	
10	3KJ-12611-00	FAN	1	
11	93210-64488	O-RING	1	
12	92501-06014	SCREW, pan head	3	
13	92990-06100	WASHER, spring	3	
14	92901-06600	WASHER, plate	3	



3KJ1010-9030

B4

FIG. 4 OIL PUMP

REF. NO.	PART NO.	DESCRIPTION	Q'TY	REMARKS
1	3KJ-13100-01	OIL PUMP ASSY	1	
2	1YU-13185-00	.BOLT, breather	1	
3	1YU-13187-00	.GASKET, breather bolt	1	
4	1YU-13473-00	.O-RING	1	
5	3AA-13124-00	.GEAR WORM WHEEL (40T)	1	
6	1YU-13516-00	.PIN, dowel	1	
7	1YU-13577-00	.CLIP	1	
8	90445-09304	.HOSE	1	
9	90467-08003	.CLIP	2	
10	90445-05431	.HOSE	1	
11	90468-02033	.CLIP	1	
12	90468-02033	CLIP	1	
13	98501-05016	SCREW, pan head	2	
14	2GM-13178-00	GEAR, pump drive	1	
15	93603-12007	PIN, dowel	1	
16	99009-19400	CIRCLIP	2	

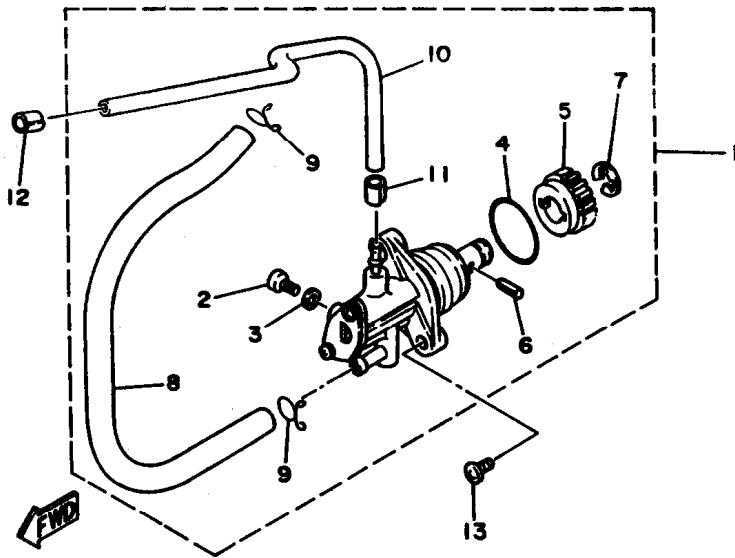
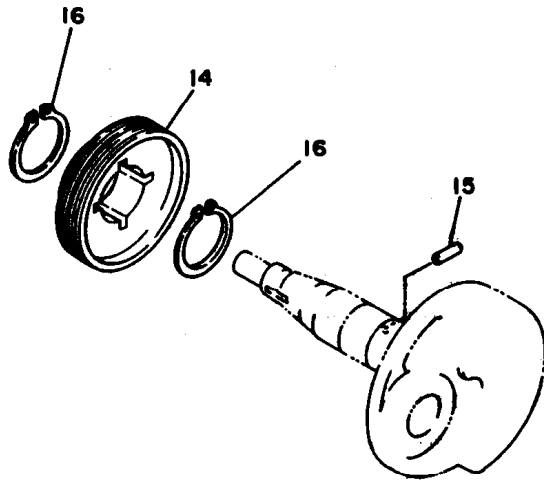

3KJ1010-9040

B5

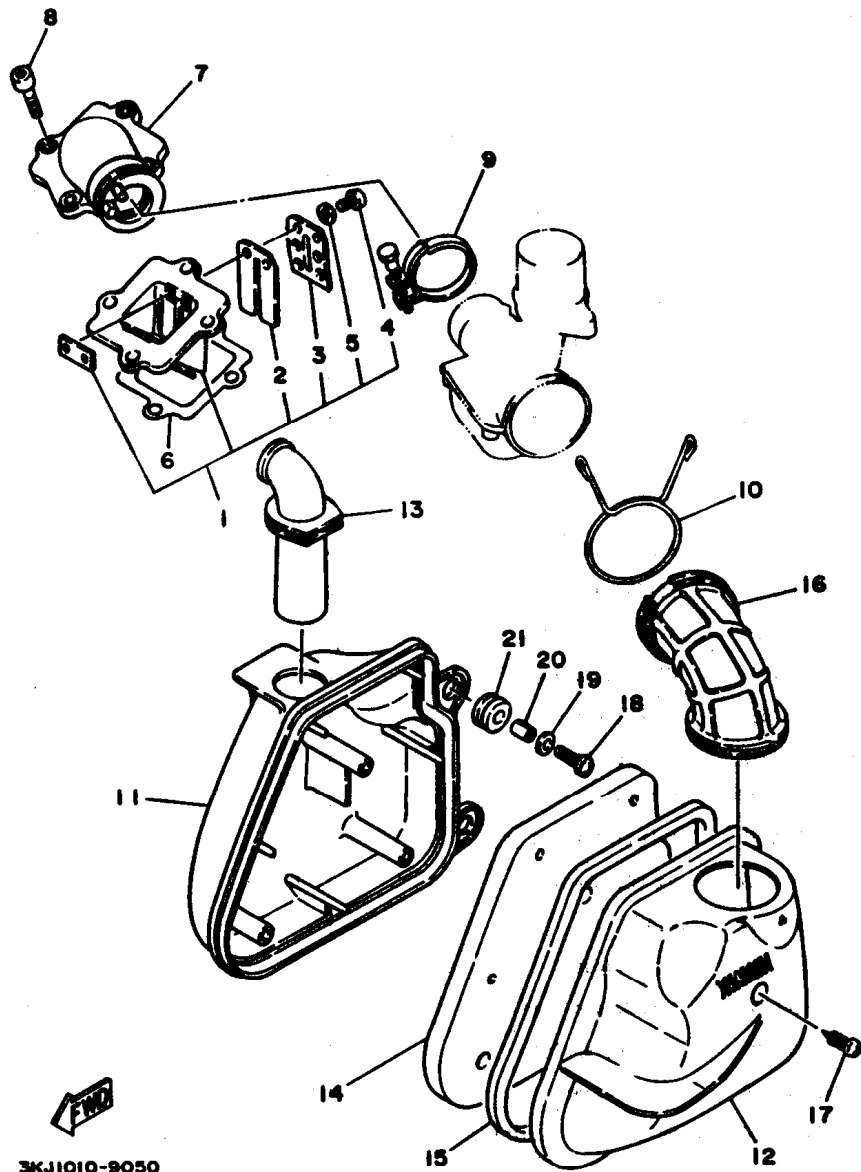

3KJ1010-9050

FIG. 5 INTAKE

REF. NO.	PART NO.	DESCRIPTION	Q'TY	REMARKS
1	3KJ-13610-00	REED VALVE ASSY.	1	
2	3KJ-13613-00	.REED, valve	2	
3	3KJ-13616-00	.STOPPER, reed valve	2	
4	98580-03008	.SCREW, pan head	4	
5	92902-03600	.WASHER, plate	4	
6	3KJ-13621-00	.GASKET, valve seat	1	
7	3KJ-13555-00	MANIFOLD, intake	1	
8	91316-06020	BOLT	4	
9	90460-32242	CLAMP, hose	1	
10	90468-20127	CLIP	1	
11	3KJ-14411-10	CASE, air cleaner 1	1	
12	3KJ-14412-00	CAP, cleaner case 1	1	
13	3KJ-14437-00	DUCT	1	
14	3KJ-14451-00	ELEMENT, air cleaner	1	
15	3KJ-14452-00	SEAL	1	
16	3KJ-14453-00	JOINT, air cleaner 1	1	
17	97780-50125	SCREW, tapping	3	
18	98516-06020	SCREW, pan head	2	
19	92906-06600	WASHER, plate	2	
20	90387-067V1	COLLAR	2	
21	90480-12497	GROMMET	2	

B6

FIG. 6 CARBURETOR

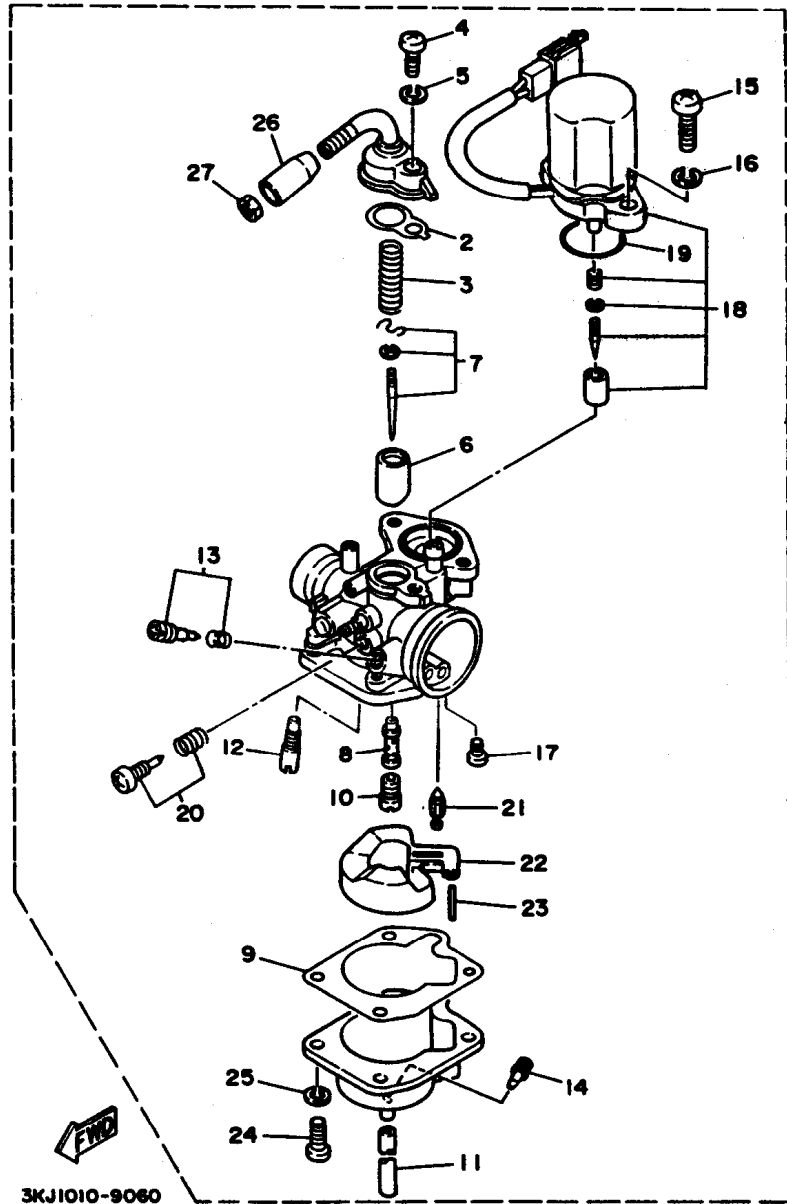

3KJ1010-9060

REF. NO.	PART NO.	DESCRIPTION	Q'TY	REMARKS
1	3KJ-14301-10	CARBURETOR ASSY 1	1	
2	2T4-14126-01	.GASKET	1	
3	1YU-14331-00	.SPRING, throttle valve	1	
4	98580-05016	.SCREW, pan head	1	
5	92901-05100	.WASHER, spring	1	
6	3KJ-14312-25	.VALVE, throttle 1	1	
7	3KJ-1490J-10	.NEEDLE SET	1	
8	14T-14341-01	.NOZZLE, main	1	
9	14T-14384-00	.GASKET, float chamber	1	
10	14T-14343-38	.JET, main (# 76)	1	
11	3KJ-14349-00	.PIPE	1	
12	3KJ-14353-21	.JET, pilot (# 42)	1	
13	14T-14104-00	.AIR SCREW SET	1	
14	14T-14323-00	.SCREW, air adjusting	1	
15	98580-06016	.SCREW, pan head	2	
16	92990-06100	.WASHER, spring	2	
17	98501-03006	.SCREW, pan head	1	
18	3KJ-1410A-10	.STARTER SET	1	
19	1HV-14147-00	.O-RING	1	
20	2JA-14103-00	.THROTTLE SCREW SET	1	
21	2JA-14392-00	.VALVE, needle	1	
22	1HV-14385-01	.FLOAT	1	
23	367-14386-00	.PIN, float	1	
24	98580-04016	.SCREW, pan head	4	
25	92901-04100	.WASHER, spring	4	
26	3KJ-26329-00	.CAP, rubber	1	
27	288-14161-00	.NUT, cable adjusting	1	

B7

FIG. 7 EXHAUST

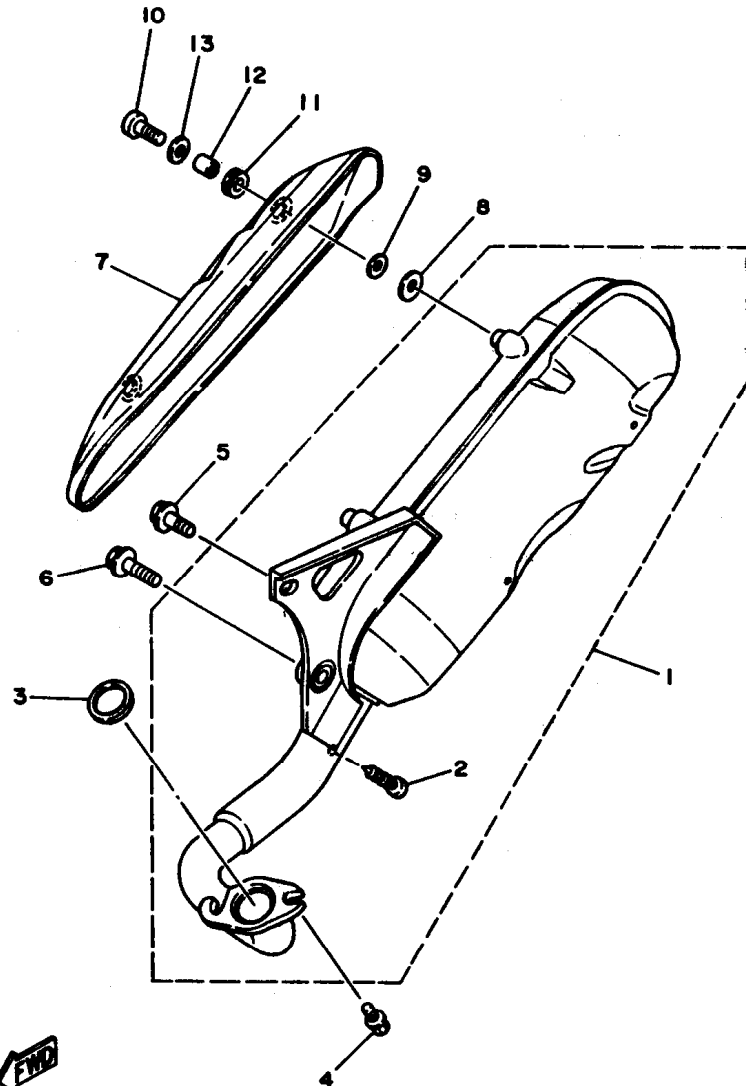

REF. NO.	PART NO.	DESCRIPTION	Q'TY	REMARKS
1	3KJ-14610-11	EXHAUST PIPE ASSY 1	1	
2	97706-30605	.SCREW, tapping	1	
3	24G-14613-00	GASKET, exhaust pipe	1	
4	90153-06061	SCREW, hexagon	2	
5	95816-08020	BOLT, flange	1	
6	95816-08030	BOLT, flange	1	
7	2JA-14718-00	PROTECTOR, muffler 1	1	
8	52W-14766-00	WASHER, protector	2	
9	92990-06200	WASHER, plain	2	
10	98906-06016	SCREW, blind	2	
11	90480-12237	GROMMET	2	
12	90387-06067	COLLAR	2	
13	2JA-14766-00	WASHER, protector	2	

3KJ1010-9070

B8

FIG. 8 CRANKCASE

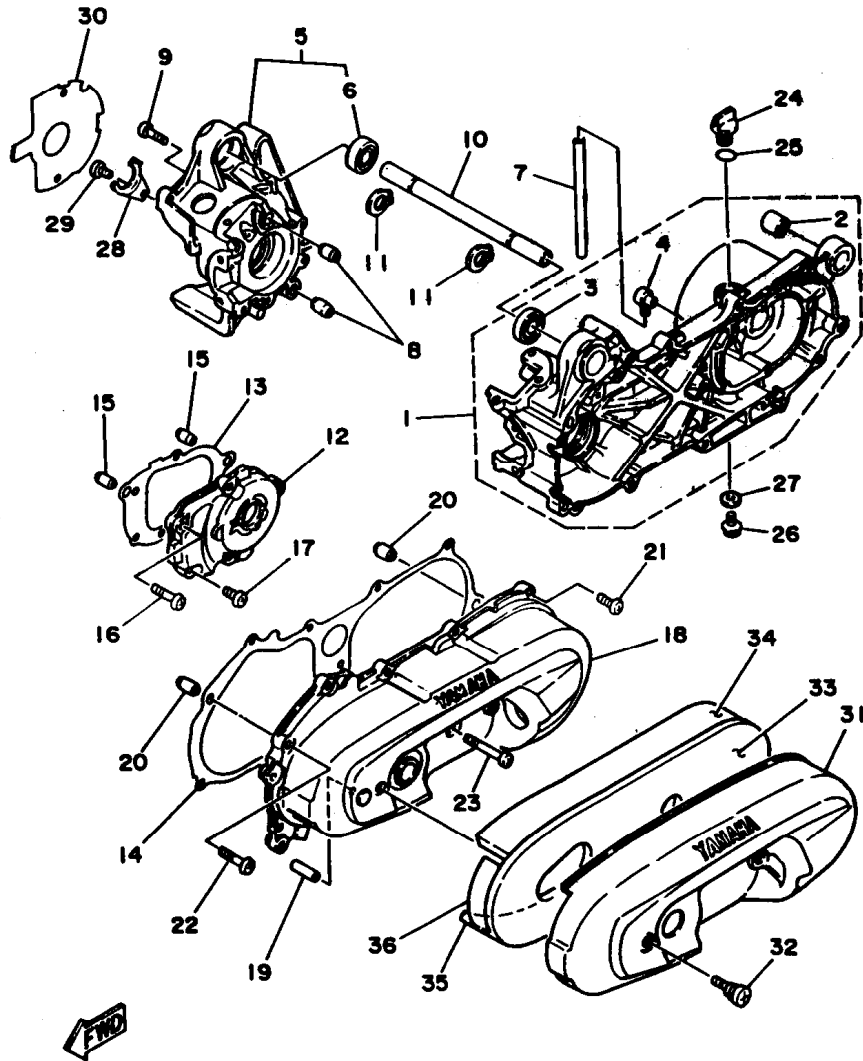

3KJ1010-9080

REF. NO.	PART NO.	DESCRIPTION	Q'TY	REMARKS
1	3KJ-15110-01	CRANKCASE ASSY 1	1	
2	164-22216-00	.BUSH, rear shock absorber	1	
3	93306-00314	.BEARING	1	
4	3YJ-15371-00	.BREATHER	1	
5	3KJ-15120-00	CRANKCASE ASSY 2	1	
6	93306-00314	.BEARING	1	
7	90446-11347	HOSE	1	
8	99510-12016	PIN, dowel	2	
9	98501-06035	SCREW, pan head	6	
10	3KJ-15317-00	SPACER, engine mount	1	
11	99009-17400	CIRCLIP	2	
12	3KJ-15421-00	COVER, crankcase 2	1	
13	3KJ-15461-00	GASKET, crankcase cover 2	1	
14	3KJ-15451-00	GASKET, crankcase cover 1	1	
15	99530-10014	PIN, dowel	2	
16	98501-06035	SCREW, pan head	2	
17	98501-06020	SCREW, pan head	3	
18	3KJ-15411-00	COVER, crankcase 1	1	
19	3KJ-15659-00	SHAFT	1	
20	99530-10014	PIN, dowel	2	
21	98501-06025	SCREW, pan head	8	
22	98501-06035	SCREW, pan head	2	
23	98501-06065	SCREW, pan head	1	
24	4J2-15363-00	PLUG, oil	1	
25	93210-14104	O-RING	1	
26	95801-08016	BOLT, flange	1	
27	90201-08087	WASHER, plate	1	
28	1HV-15128-00	HOLDER	1	

B9

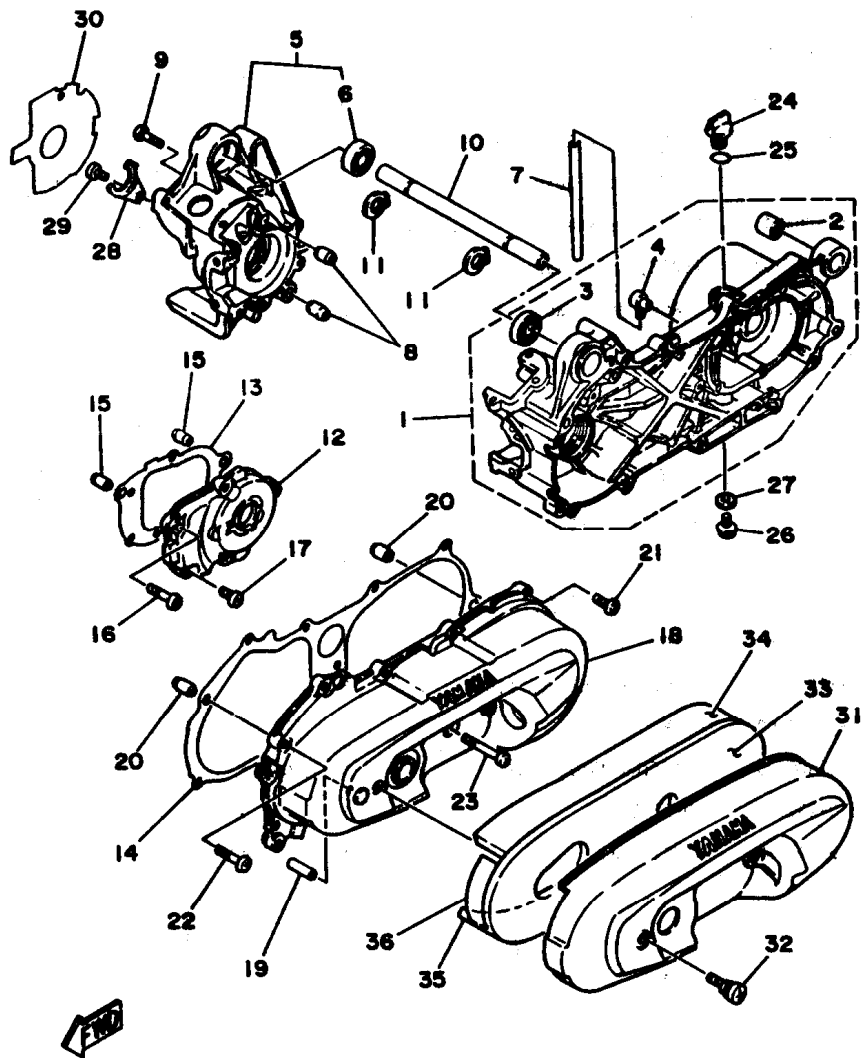

3KJ1010-9080

FIG. 8 CRANKCASE

REF. NO.	PART NO.	DESCRIPTION	Q'TY	REMARKS
29	98501-06012	SCREW, pan head	1	
30	3KJ-15462-00	GASKET, crankcase cover 3	1	
31	3KJ-15431-00	COVER, crankcase 3	1	
32	3KJ-15481-00	BOLT 1	2	
33	3KJ-15316-00	DAMPER, engine mount 1	1	
34	3KJ-15326-00	DAMPER, engine mount 2	1	
35	3KJ-15335-00	DAMPER 3	1	
36	3KJ-15337-00	DAMPER 4	1	

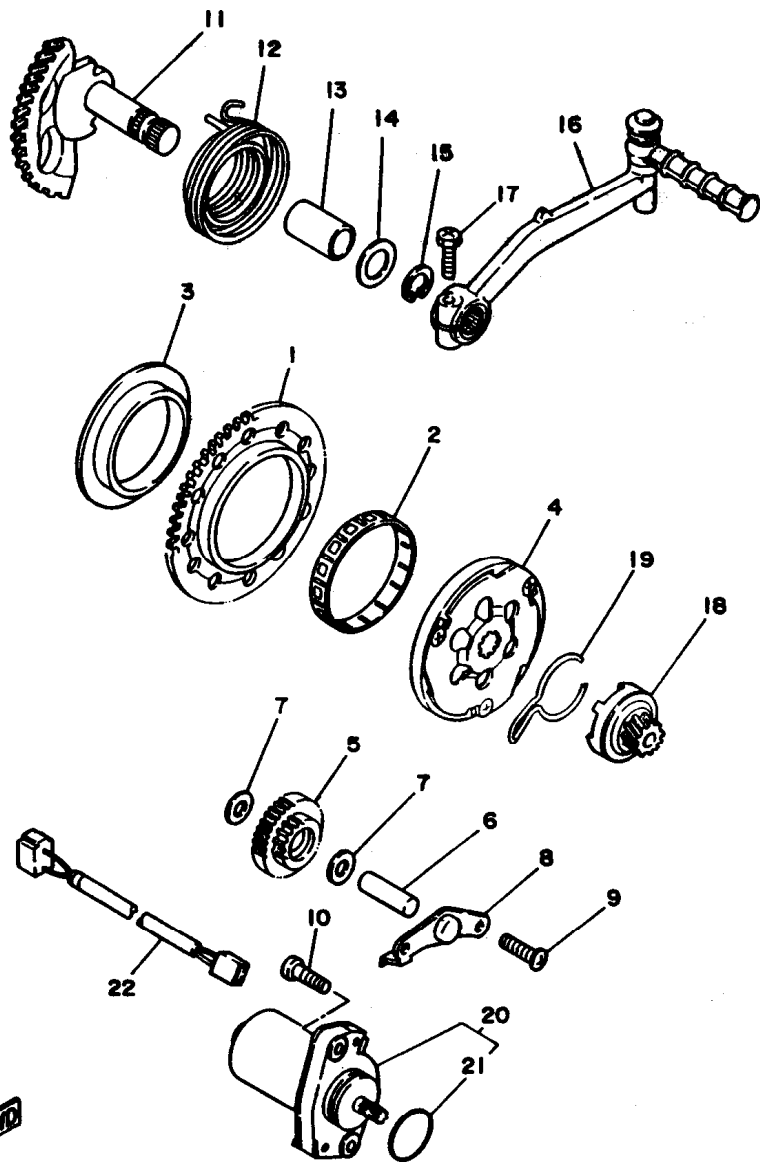

FIG. 9 STARTER

REF. NO.	PART NO.	DESCRIPTION	Q'TY	REMARKS
1	3AA-15513-00	GEAR 1 (71T)	1	
2	93310-257R1	BEARING, cylindrical	1	
3	3KJ-15528-00	BOSS, gear	1	
4	3KJ-15570-00	STARTER CLUTCH ASSY	1	
5	3AA-15650-00	IDLE GEAR ASSY (65T)	1	
6	50M-13342-00	SHAFT, idle gear	1	
7	90201-084M4	WASHER, plate	2	
8	3KJ-15532-00	PLATE, idle gear	1	
9	98501-06012	SCREW, pan head	2	
10	91316-06020	BOLT	2	
11	3KJ-15601-00	KICK SHAFT ASSY	1	
12	90508-32609	SPRING, torsion	1	
13	90380-15083	BUSH, solid	1	
14	90201-154E9	WASHER, plate	1	
15	99009-15400	CIRCLIP	1	
16	3KJ-15620-01	KICK CRANK ASSY	1	
17	90153-06038	SCREW, hexagon	1	
18	3AA-15631-00	GEAR, kick pinion (10T)	1	
19	32N-15673-00	CLIP	1	
20	3KJ-81800-00	STARTING MOTOR ASSY	1	YAMAHA
21	93210-23614	O-RING	1	
22	3KJ-82541-00	WIRE, lead	1	



4AG1351-1090

B11

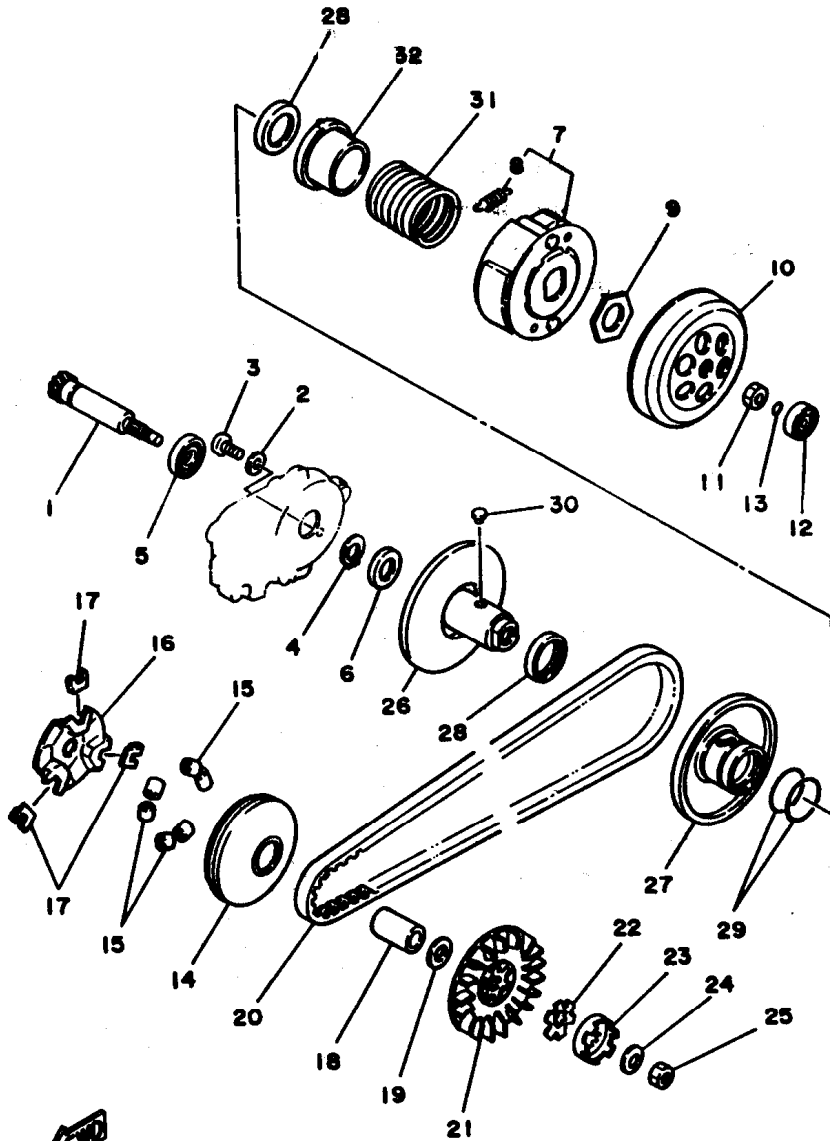

FWD
3KJ1010-9100

FIG. 10 CLUTCH

REF. NO.	PART NO.	DESCRIPTION	Q'TY	REMARKS
1	3KJ-16111-00	GEAR, primary drive (13T)	1	
2	90201-06412	WASHER, plate	1	
3	98501-06010	SCREW, pan head	1	
4	99009-17400	CIRCLIP	1	
5	93306-00315	BEARING (#0035H2C4)	1	
6	93102-17342	OIL SEAL	1	
7	2VK-16620-00	CLUTCH CARRIER ASSY	1	
8	246-16626-00	.SPRING; clutch weight 1	2	
9	90179-28415	NUT	1	
10	246-16611-03	CLUTCH HOUSING COMP.	1	
11	90170-10317	NUT	1	
12	93300-63808	BEARING	1	
13	93210-06550	O-RING	1	
14	2EX-17620-01	PRIMARY SLIDING SHEAVE COMP.	1	
15	52W-17632-00	WEIGHT	6	
16	3AA-17623-00	CAM	1	
17	1NT-17653-00	SLIDER	3	
18	90387-132W6	COLLAR	1	
19	90201-133M8	WASHER, plate	1	
20	3KJ-17641-00	V-BELT	1	
21	3KJ-17611-00	SHEAVE, primary fixed	1	
22	90214-13055	WASHER, claw	1	
23	3KJ-15657-00	CLUTCH, oneway	1	
24	90208-10012	WASHER, conical spring	1	
25	90170-10219	NUT	1	
26	3AA-17660-01	SECONDARY FIXED SHEAVE COMP.	1	
27	3WG-17608-00	SECONDARY SLIDING SHEAVE	1	
28	93109-33049	OIL SEAL	2	

B12

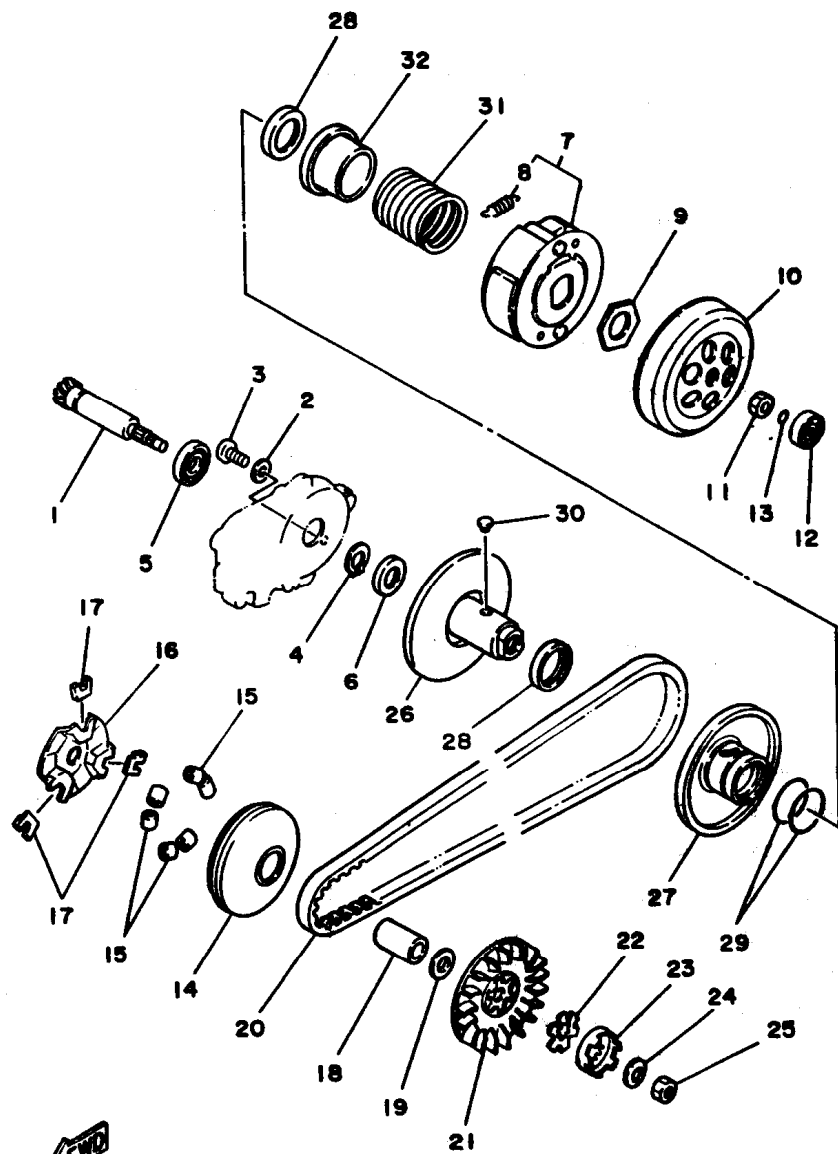

3KJ1010-9100

FIG. 10 CLUTCH

REF. NO.	PART NO.	DESCRIPTION	Q'TY	REMARKS
29	93210-38687	O-RING	2	
30	24G-17664-00	PIN, guide	2	
31	90501-357F3	SPRING, compression	1	
32	3KJ-17684-00	SEAT, secondary spring	1	

B13

FIG. 11 TRANSMISSION

REF. NO.	PART NO.	DESCRIPTION	Q'TY	REMARKS
1	3KJ-17410-00	MAIN AXLE COMP. (48/11T)	1	
2	93306-20006	BEARING (B6200)	1	UR NTN
	93306-20010	BEARING (6200)	1	UR NMB
3	90201-123K4	WASHER, plate	1	
4	90208-12049	WASHER, conical spring	1	
5	3KJ-17420-00	DRIVE AXLE ASSY (38T)	1	
6	93306-20310	BEARING (B6203DU)	1	
7	93102-22314	OIL SEAL	1	
8	93420-40064	CIRCLIP	1	

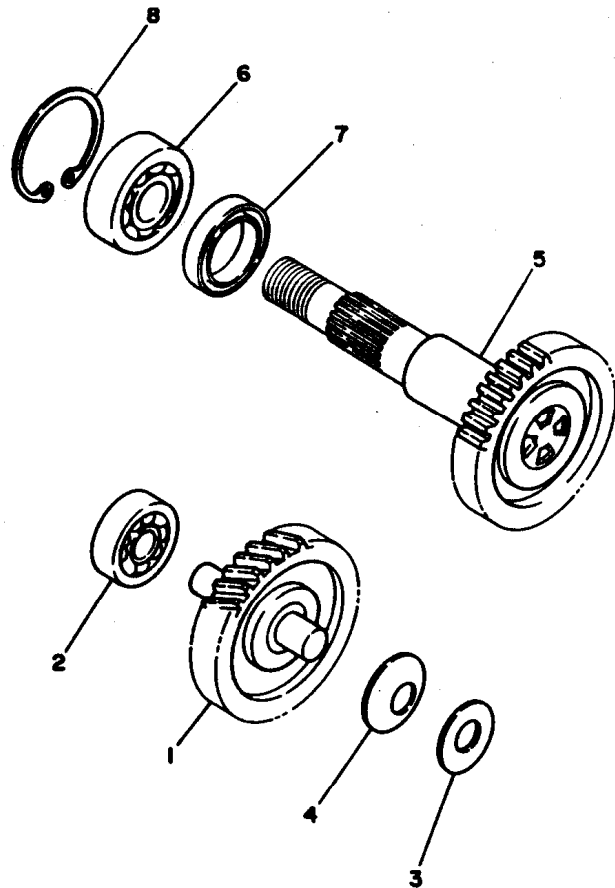

3KJ1010-9110

B14

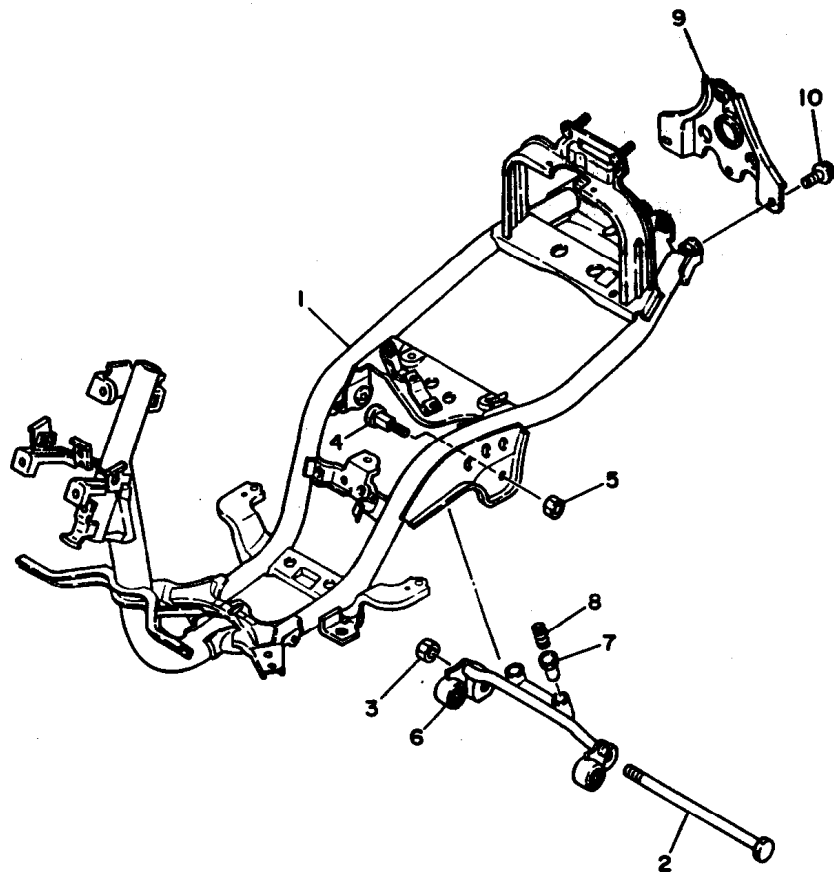

FIG. 12 FRAME

REF. NO.	PART NO.	DESCRIPTION	Q'TY	REMARKS
1	4CG-21110-00	FRAME COMP.	1	
2	3KJ-21481-00	BOLT, engine mounting 1	1	
3	95601-12200	NUT, self-locking	1	
4	2T4-21481-01	BOLT, engine mounting 1	2	
5	90185-10154	NUT, self-locking	2	
6	3KJ-21410-00	ENGINE BRACKET COMP.	1	
7	2T4-2139X-01	DAMPER	2	
8	90501-29517	SPRING, compression	2	
9	3KJ-21232-00	REINFORCEMENT, tail	1	
10	95816-06012	BOLT, flange	3	

3KJ1010-9121

B15

FIG. 13 FENDER

REF. NO.	PART NO.	DESCRIPTION	Q'TY	REMARKS
1	3KJ-21511-00-P0	FENDER, front	1	UR VERY DARK BLUE COCKTAIL 2
	3KJ-21511-00-P1	FENDER, front	1	UR VIVID RED COCKTAIL 1
2	3KJ-21781-11	EMBLEM 1	1	UR FOR BLUE
	3KJ-21781-21	EMBLEM 1	1	UR FOR RED
3	3KJ-21578-02	EMBLEM	1	
4	3KJ-21552-00	FENDER, inner	1	
5	27V-21553-03	FENDER, inner 2	1	
6	90159-06178	SCREW, with washer	3	
7	95816-06012	BOLT, flange	1	
8	95816-06012	BOLT, flange	2	
9	90119-06085	BOLT, with washer	2	
10	90167-05041	SCREW, tapping	2	

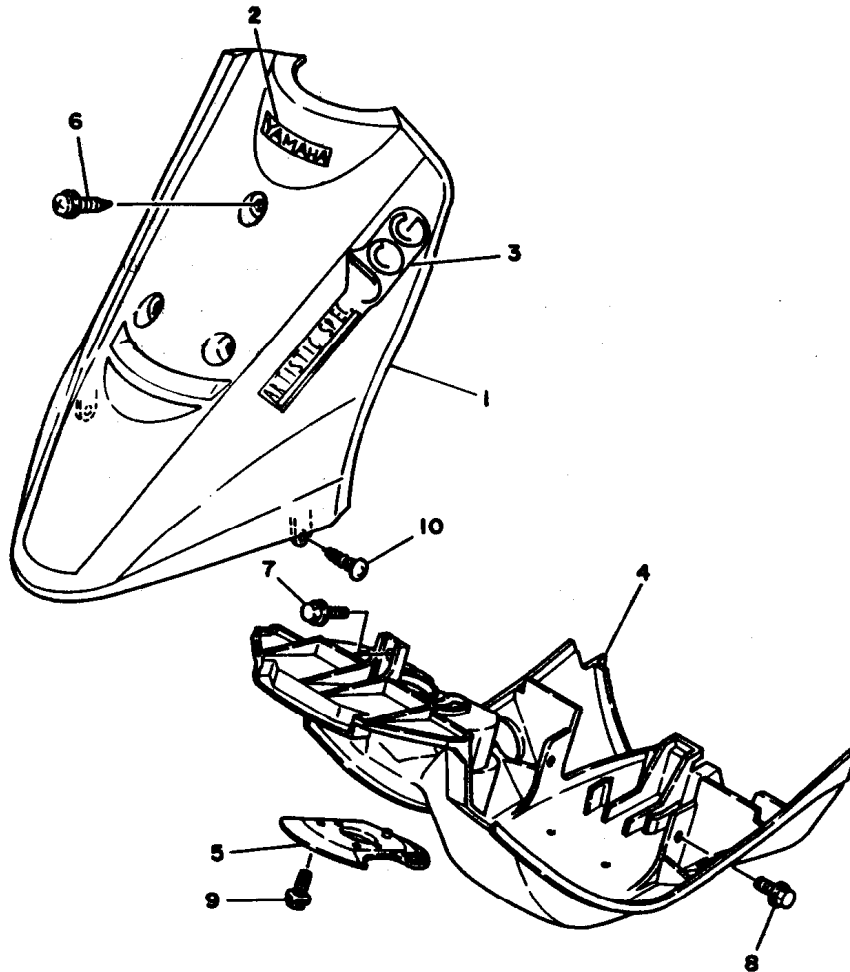

3KJ1010-9130

C2

FIG. 14 SIDE COVER

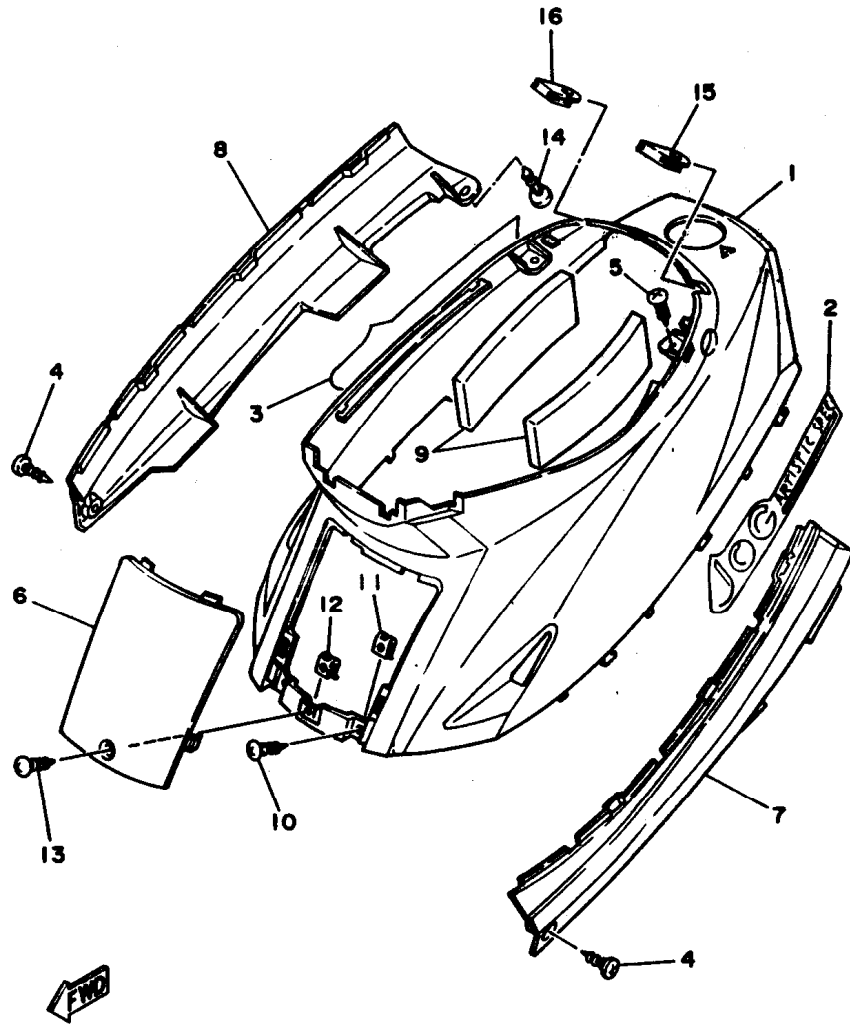

REF. NO.	PART NO.	DESCRIPTION	Q'TY	REMARKS
1	3KJ-21711-00-P0	COVER, side 1	1	UR VERY DARK BLUE COCKTAIL 2
	3KJ-21711-00-P1	COVER, side 1	1	UR VIVID RED COCKTAIL 1
2	3KJ-21782-02	EMBLEM 2	1	
3	3KJ-21783-02	EMBLEM 3	1	
4	90149-06184	SCREW	2	
5	90167-05041	SCREW, tapping	2	
6	3KJ-21721-00-P0	COVER, side 2	1	UR VERY DARK BLUE COCKTAIL 2
	3KJ-21721-00-P1	COVER, side 2	1	UR VIVID RED COCKTAIL 1
7	3KJ-2171L-00	MOLE, side cover 1	1	SOLID FINE SILVER
8	3KJ-2171M-00	MOLE, side cover 2	1	SOLID FINE SILVER
9	3KJ-21778-00	DAMPER, locating 1	2	
10	90167-05041	SCREW, tapping	2	
11	90183-05042	NUT, spring	2	
12	90183-05042	NUT, spring	1	
13	90167-05055	SCREW, tapping	1	
14	90167-05041	SCREW, tapping	2	
15	3KJ-24845-00	COVER 1	1	
16	3KJ-24846-00	COVER 2	1	

3KJ1010-9140

C3

FIG. 15 OIL TANK

REF. NO.	PART NO.	DESCRIPTION	Q'TY	REMARKS
1	3KJ-21751-00	TANK, oil	1	
2	2N3-21771-01	BODY, cap	1	
3	90119-06042	BOLT, with washer	2	

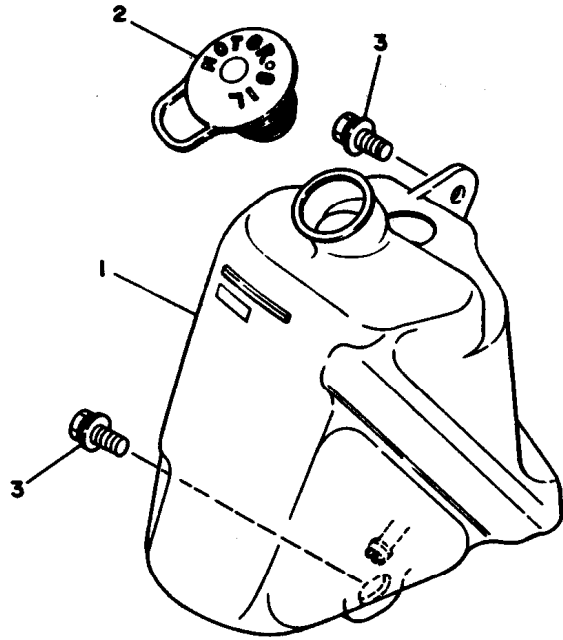

3KJ1010-9150

C4

FIG. 16 REAR SUSPENSION

REF. NO.	PART NO.	DESCRIPTION	Q'TY	REMARKS
1	3KJ-22210-00	SHOCK ABSORBER ASSY, rear	1	
2	90105-08121	BOLT, washer based	1	
3	90102-10059	BOLT, with hole	1	
4	95701-10500	NUT, flange	1	
5	90468-12182	CLIP	1	
6	3KJ-21381-00	BRACKET, rear shock absorber	1	
7	95811-08012	BOLT, flange	2	

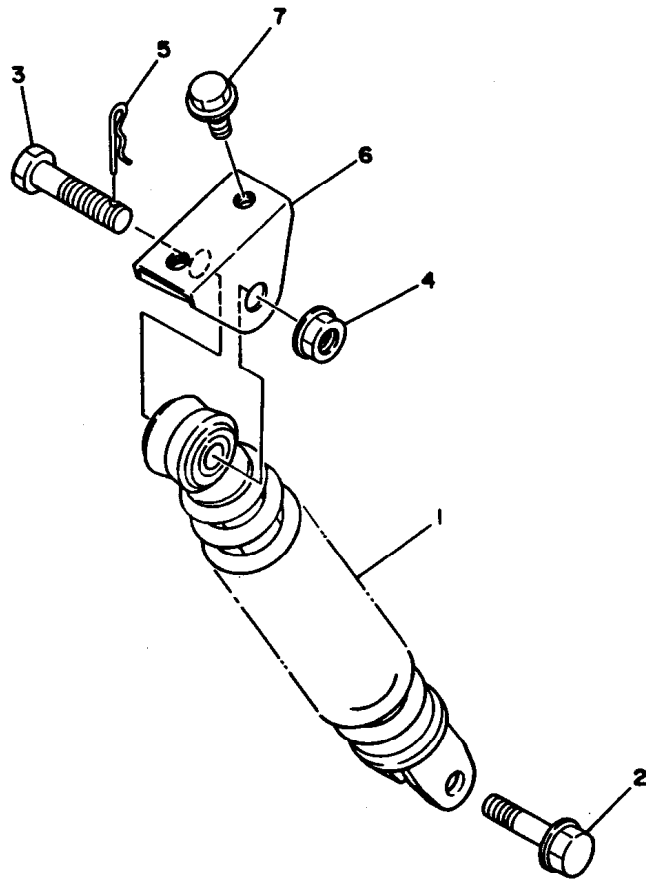

3KJ1010-9160

C5

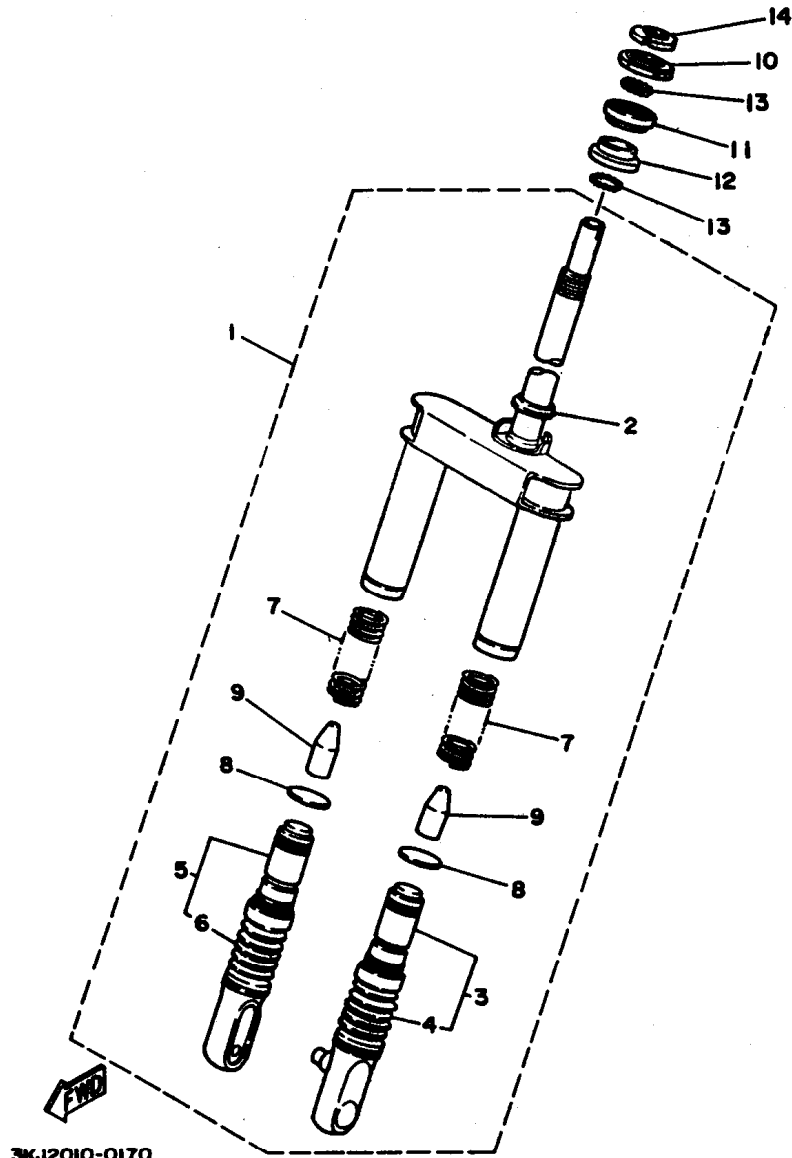

3KJ2010-0170

FIG. 17 FRONT FORK

REF. NO.	PART NO.	DESCRIPTION	Q'TY	REMARKS
1	3KJ-23100-01	FRONT FORK ASSY	1	
2	2E9-23414-01	.RACE, ball 4	1	
3	3YJ-23110-00	.INNER TUBE COMP.1	1	
4	3YJ-23191-00	..BOOT	1	
5	3YJ-23120-00	.INNER TUBE COMP.2	1	
6	3YJ-23191-00	..BOOT	1	
7	3KJ-23141-00	.SPRING, front fork	2	
8	2E9-23143-00	.SEAT, 'spring lower	2	
9	1RN-23195-00	.RUBBER	2	
10	3KJ-23411-01	RACE, ball 1	1	
11	2E9-23412-00	RACE, ball 2	1	
12	2E9-23413-01	RACE, ball 3	1	
13	93505-32002	BALL	52	
14	2E9-23454-00	NUT, fitting 2	1	

C6

FIG. 18 FUEL TANK

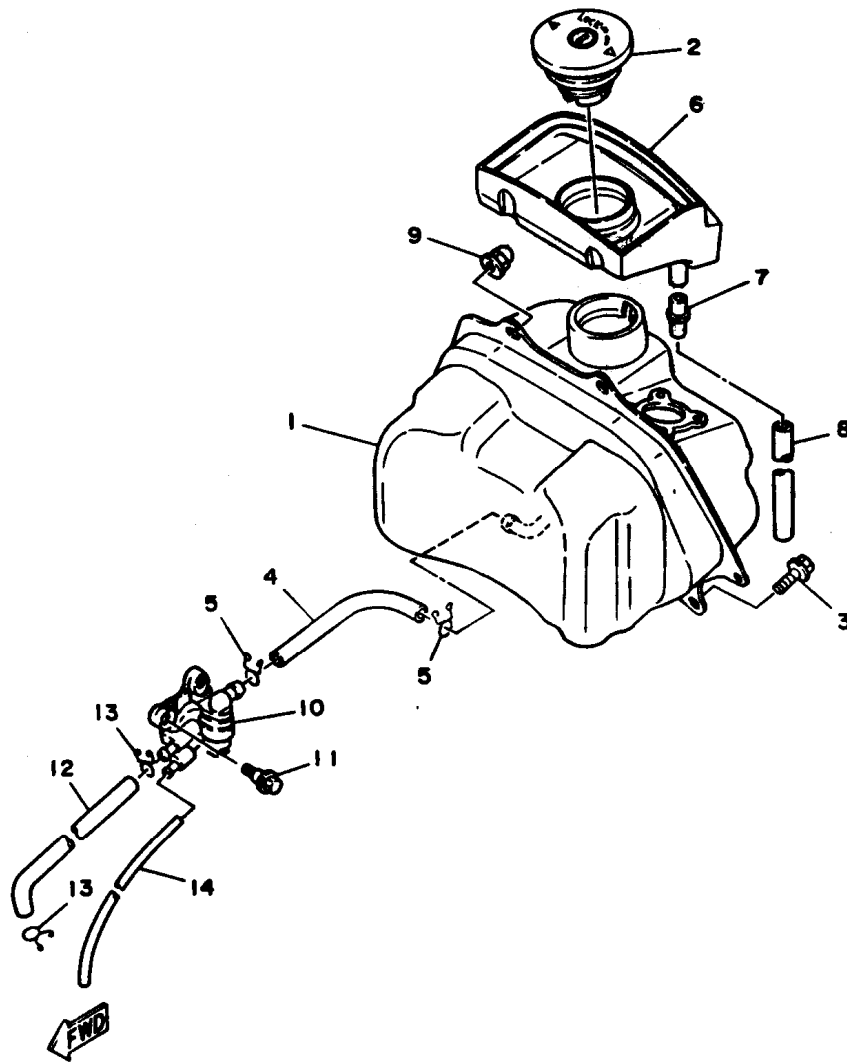

3KJ1010-9181

REF. NO.	PART NO.	DESCRIPTION	Q'TY	REMARKS
1	3KJ-24110-00	FUEL TANK COMP.	1	
2	3KJ-24602-00	CAP ASSY	1	
3	95816-06012	BOLT, flange	1	
4	90445-111G1	HOSE	1	
5	90467-10129	CLIP	2	
6	3KJ-2414A-01	COVER, filler	1	
7	90560-06366	SPACER	1	
8	90446-11345	HOSE	1	
9	90176-06065	NUT, crown	2	
10	3KJ-24500-01	FUEL COCK ASSY 1	1	
11	90109-063F5	BOLT	2	
12	3KJ-24311-00	PIPE, fuel 1	1	
13	90467-09006	CLIP	2	
14	90445-071G6	HOSE	1	

C7

FIG. 19 SEAT. CARRIER

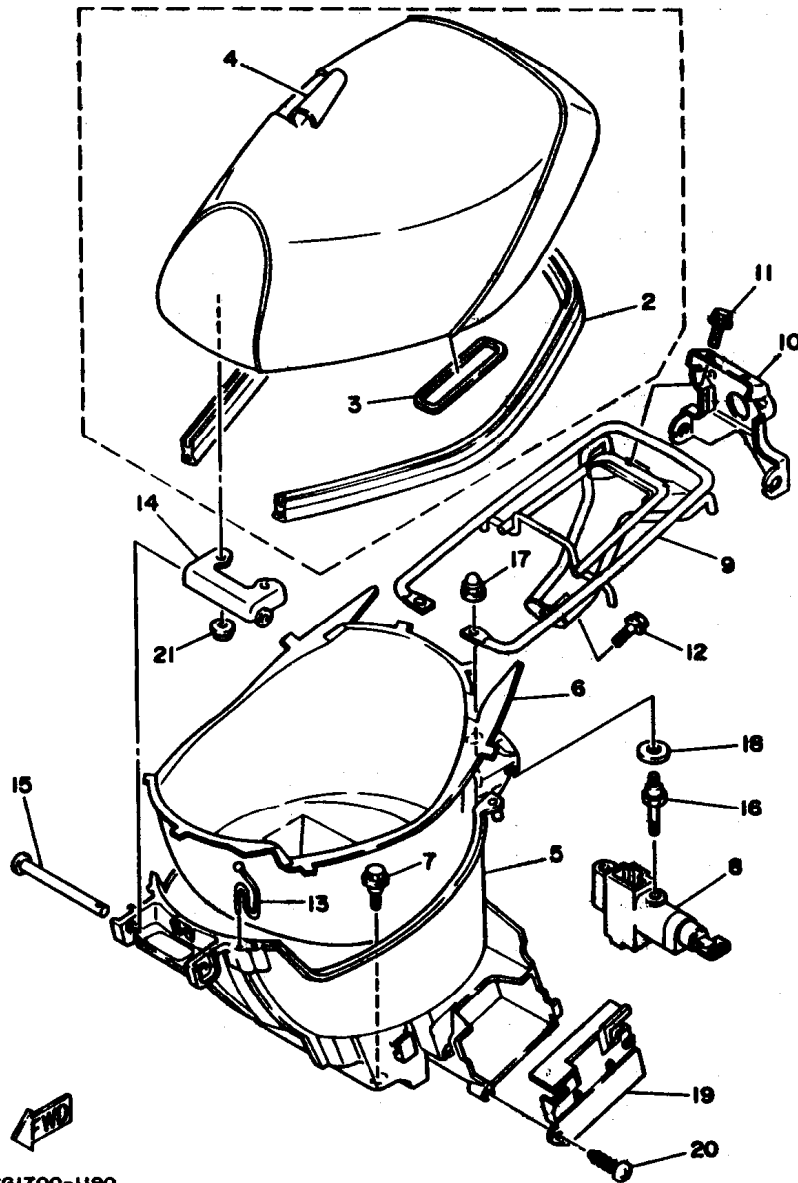

4CG1700-1190

REF. NO.	PART NO.	DESCRIPTION	Q'TY	REMARKS
1	3KJ-24710-01	SINGLE SEAT ASSY	1	SOLID FINE SILVER
2	3KJ-2475M-00	.SEAL	1	
3	3FC-2483H-00	.BAND	1	
4	3KJ-2470F-00	.COVER, seat	1	
5	3KJ-2473R-00	BOX 1	1	
6	3KJ-24747-00	DAMPER, seat	1	
7	90109-063F1	BOLT	2	
8	3FC-24705-03	SEAT LOCK ASSY	1	
9	3SA-24842-00	CARRIER, rear	1	
10	3SA-24718-00	BRACKET, seat	1	
11	90119-06066	BOLT, with washer	2	
12	95816-08012	BOLT, flange	1	
13	3KJ-21398-00	HANGER, helmet	1	
14	3KJ-24726-00	HINGE, seat	1	
15	90241-10015	PIN	1	
16	3KJ-24717-00	BOLT, seat fitting	2	
17	90176-06065	NUT, crown	2	
18	90201-12175	WASHER, plate	2	
19	3KJ-82129-00	COVER, battery	1	
20	3KJ-24453-00	SCREW	1	
21	95701-06500	NUT, flange	2	

C8

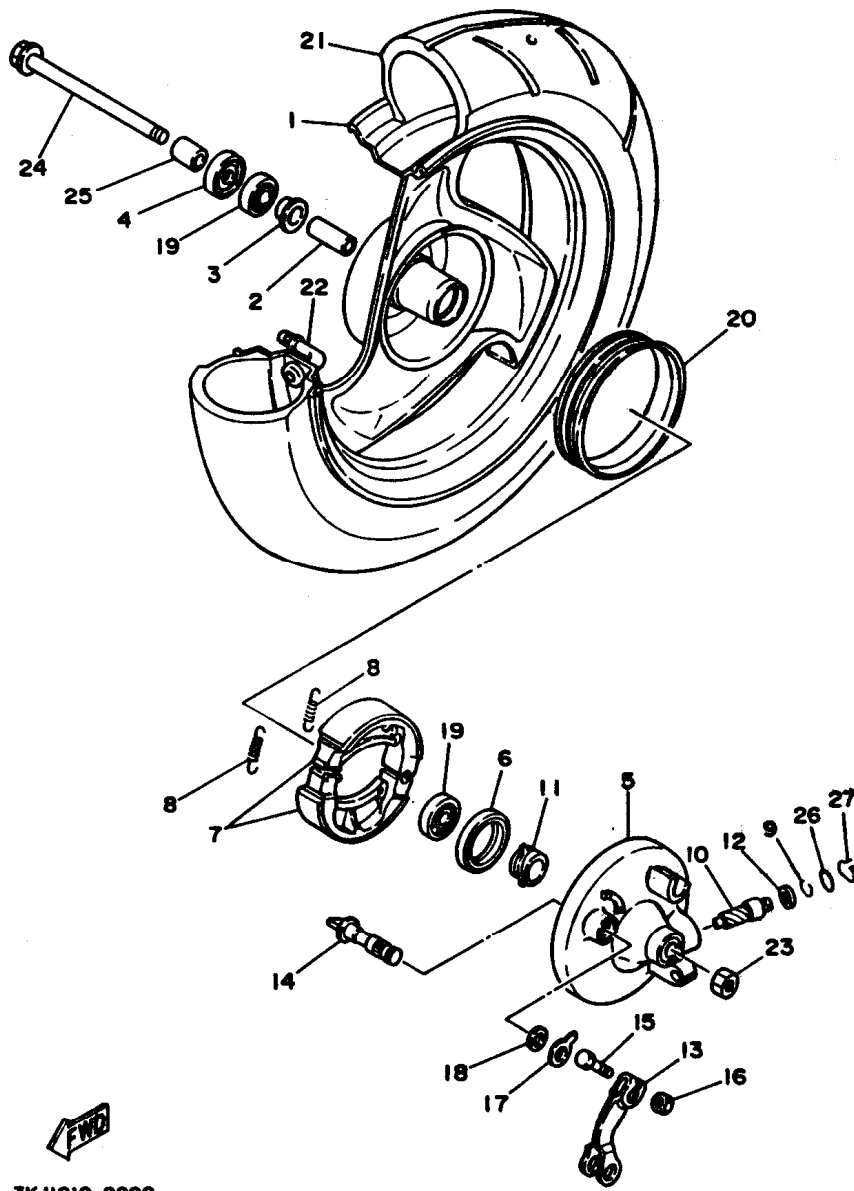

FWD
3KJ1010-9200

FIG. 20 FRONT WHEEL

REF. NO.	PART NO.	DESCRIPTION	Q'TY	REMARKS
1	3YJ-25180-00-UJ	FRONT WHEEL COMP.	1	UR RADICAL WHITE FOR RED
	3YJ-25180-00-35	FRONT WHEEL COMP.	1	UR SILVER FOR BLUE
2	90560-10289	SPACER	1	
3	25K-25116-00	FLANGE, spacer 2	1	
4	93106-17015	OIL SEAL	1	
5	2GM-25121-00-UJ	PLATE, brake shoe	1	UR RADICAL WHITE
	2GM-25121-00-35	PLATE, brake shoe	1	UR SILVER
6	93109-34057	OIL SEAL	1	
7	27V-W2536-00	BRAKE SHOE SET	1	
8	90506-14081	SPRING, tension	2	
9	2T4-25137-00	RING, stop	1	
10	2E9-25138-00	GEAR, meter	1	
11	2E9-25135-00	GEAR, drive (14T)	1	
12	90201-064L6	WASHER, plate	1	
13	2T4-25155-00	LEVER, camshaft 1	1	
14	3KJ-25151-00	CAMSHAFT	1	
15	97021-05020	BOLT	1	
16	95303-05600	NUT	1	
17	3L8-2513A-00	PLATE, indicator	1	
18	25K-25159-00	SEAL, camshaft	1	
19	93306-20005	BEARING (B6200)	2	UR KOYO
	93306-20006	BEARING (B6200)	2	UR NTN
20	3KJ-25185-00	RING 1	1	
21	94108-104W0	TIRE (80/90-10 34J MB38)	1	INOUE
22	93900-00027	VALVE, rim	1	INOUE
23	90185-10154	NUT, self-locking	1	
24	3YJ-25181-00	AXLE, wheel	1	
25	90560-10360	SPACER	1	

C9

FIG. 21 REAR WHEEL

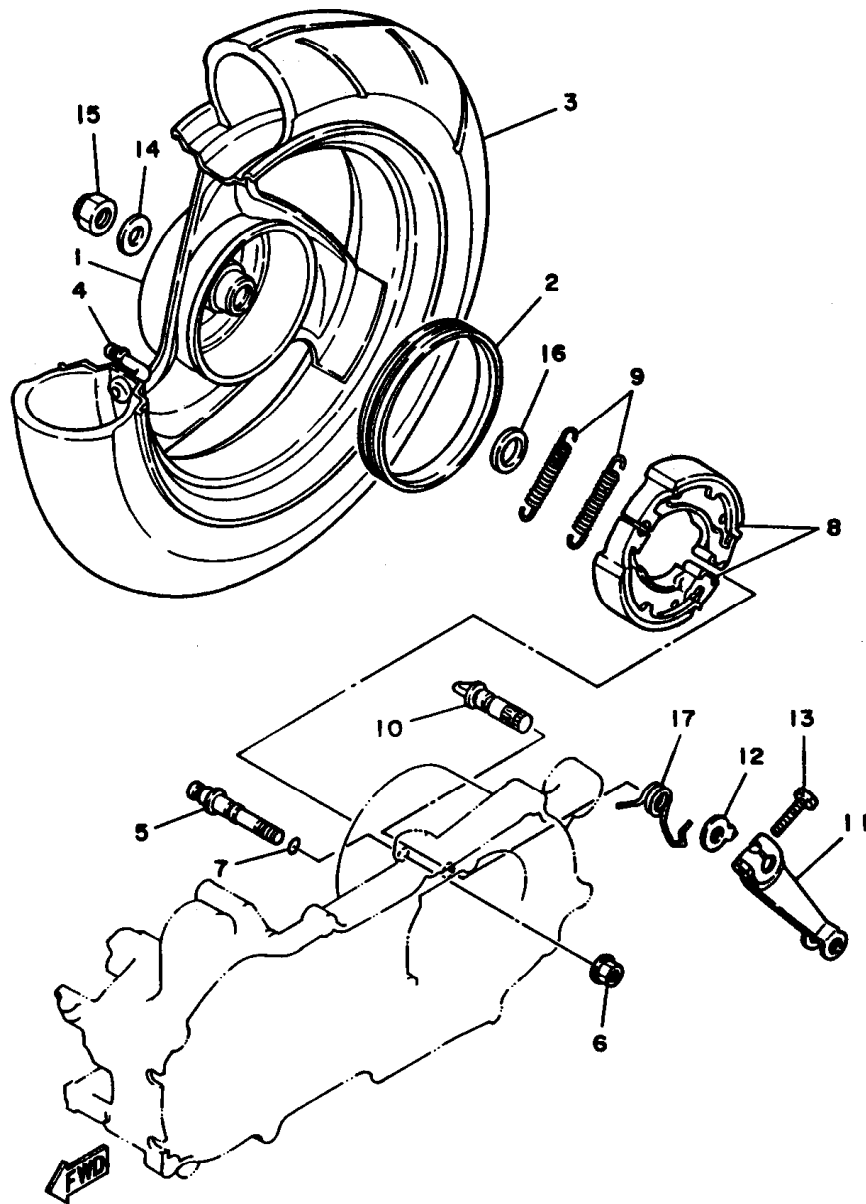

3KJ1010-9210

REF. NO.	PART NO.	DESCRIPTION	Q'TY	REMARKS
1	3YJ-25390-00-UJ	REAR WHEEL COMP.	1	UR RADICAL WHITE FOR RED
	3YJ-25390-00-35	REAR WHEEL COMP.	1	UR SILVER FOR BLUE
2	3KJ-25336-00	RING 2	1	
3	94108-104W0	TIRE (80/90-10 34J MB38)	1	INOUE
4	93900-00027	VALVE, rim	1	INOUE
5	3KJ-25326-00	PIN, pivot	1	
6	95701-08500	NUT, flange	1	
7	93210-07540	O-RING	1	
8	36R-W2536-00	BRAKE SHOE SET	1	
9	90506-18288	SPRING, tension	2	
10	3KJ-25351-00	CAMSHAFT	1	
11	3KJ-25355-00	LEVER, camshaft	1	
12	52H-2513A-00	PLATE, indicator	1	
13	90101-06278	BOLT	1	
14	90201-142M6	WASHER, plate	1	
15	90185-14150	NUT, self-locking	1	
16	90201-17255	WASHER, plate	1	
17	3KJ-25357-00	SPRING, lever return	1	

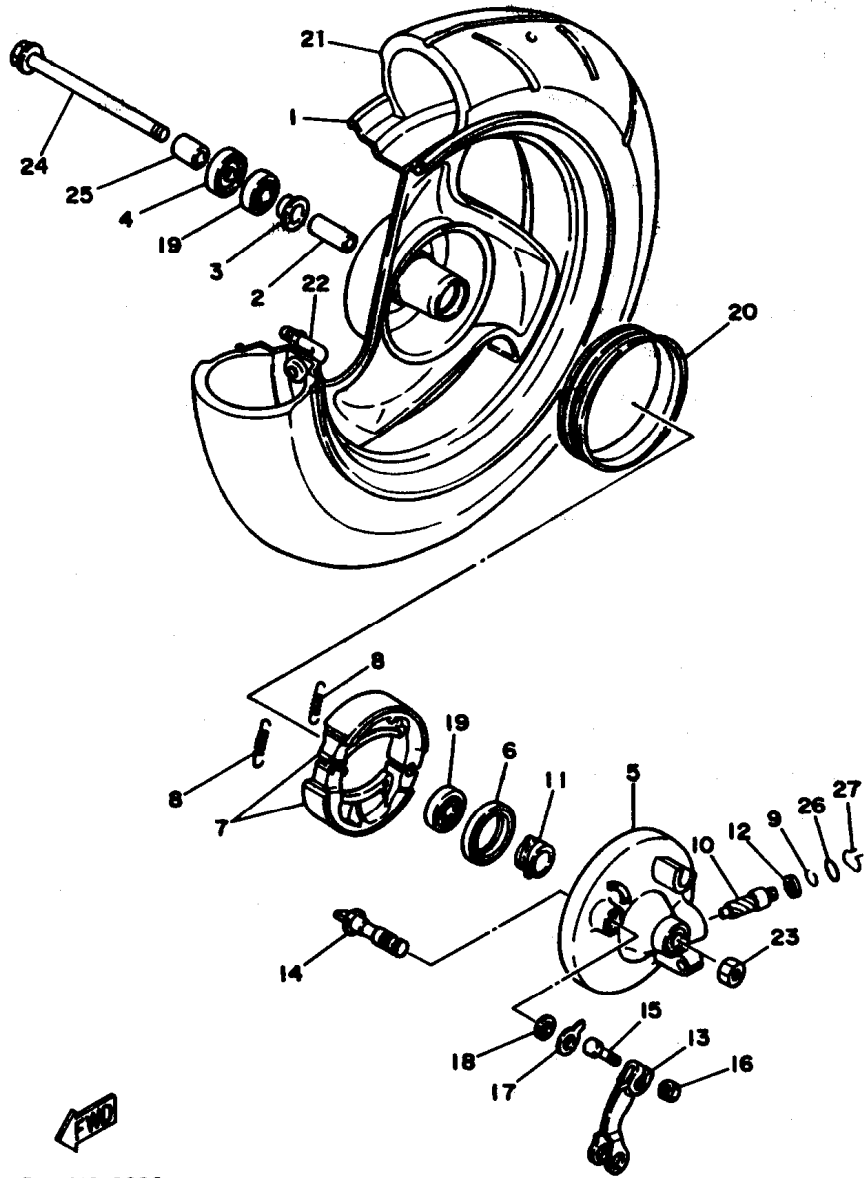

FIG. 20 FRONT WHEEL

REF. NO.	PART NO.	DESCRIPTION	Q'TY	REMARKS
26	93210-10096	O-RING	1	
7	2E9-25137-01	RING, stop	1	



3KJ1010-9200

C10

FIG. 22 STEERING HANDLE. CABLE

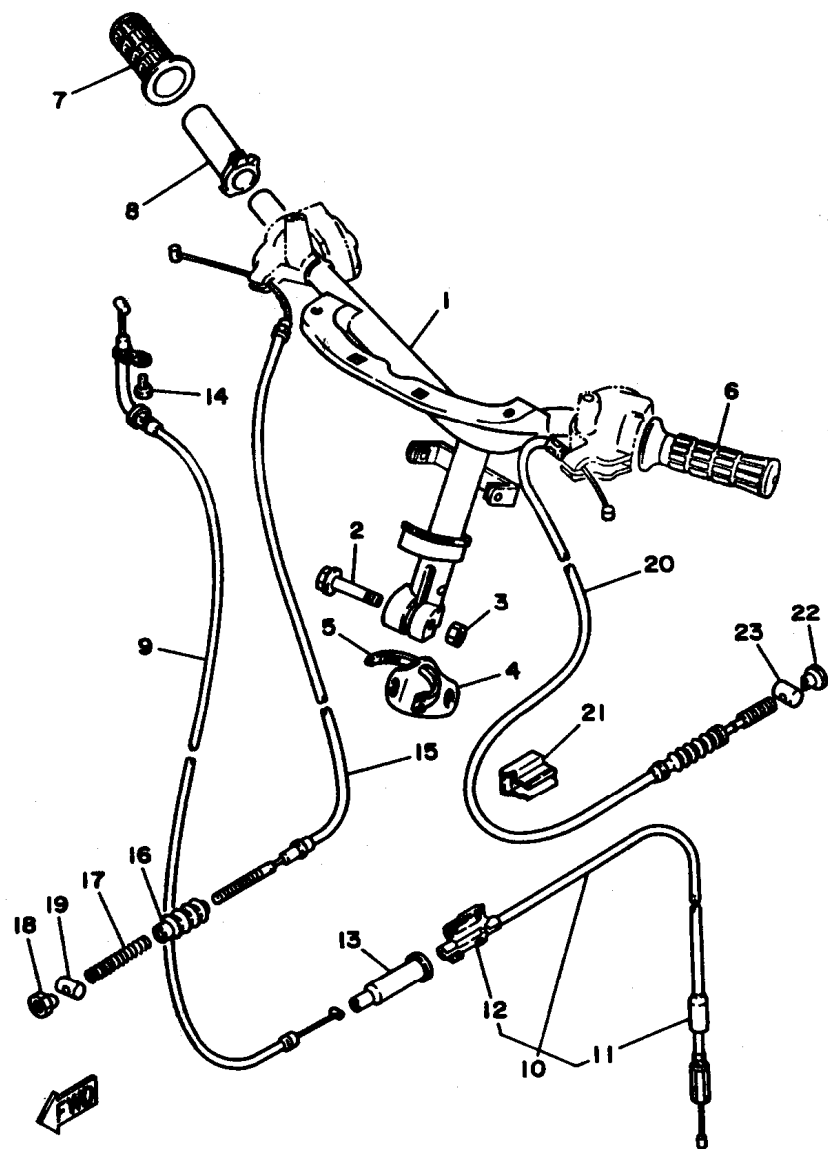

3YE1310-1220

REF. NO.	PART NO.	DESCRIPTION	Q'TY	REMARKS
1	2VK-26110-00	HANDLE COMP.	1	
2	90105-10036	BOLT, washer based	1	
3	95611-10200	NUT, self-locking	1	
4	2EK-26293-00	BAND	1	
5	12R-82591-00	BAND	1	
6	5G3-26241-00	GRIP (LEFT)	1	BLACK
7	5G3-26242-00	GRIP (RIGHT)	1	BLACK
8	2GN-26243-00	TUBE, throttle guide	1	
9	2EK-26311-01	CABLE, throttle 1	1	
10	3KJ-26312-00	CABLE, throttle 2	1	
11	304-26329-00	.CAP, rubber	1	
12	53L-26261-01	.CONNECTOR, cable	1	
13	1YU-26329-00	CAP, rubber	1	
14	98501-05012	SCREW, pan head	1	
15	3SA-26341-00	CABLE, brake	1	
16	3KJ-26342-00	BOOT, cable	1	
17	90501-10513	SPRING, compression	1	
18	90179-06176	NUT	1	
19	90249-12008	PIN	1	
20	3SA-26351-00	CABLE, brake	1	
21	3KJ-26393-00	HOLDER	1	
22	90179-06176	NUT	1	
23	90249-12008	PIN	1	

C12

FIG. 23 STAND. FOOTREST

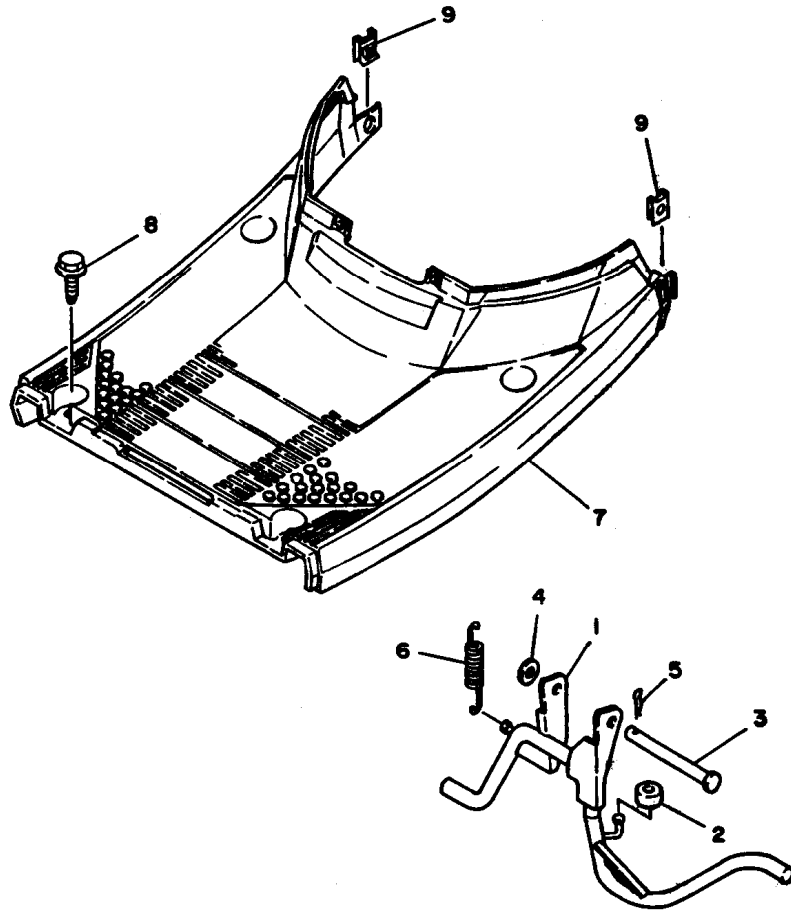

REF. NO.	PART NO.	DESCRIPTION	Q'TY	REMARKS
1	3YJ-27111-00	STAND, main	1	
2	90387-064A4	COLLAR	1	
3	90240-10132	PIN, clevis	1	
4	90202-10120	WASHER, plate	1	
5	90468-12006	CLIP	1	
6	90506-32464	SPRING, tension	1	
7	3KJ-27481-00	BOARD, footrest	1	SOLID FINE SILVER
8	90119-06060	BOLT, with washer	4	
9	25G-21535-00	NUT 1	2	



3KJ1010-9230

C13

FIG. 24 LEG SHIELD

REF. NO.	PART NO.	DESCRIPTION	Q'TY	REMARKS
1	3KJ-28300-00	LEG SHIELD ASSY	1	SOLID FINE SILVER
2	90159-06182	SCREW, with washer	1	
3	20H-28349-01	CAP	1	SOLID FINE SILVER
4	90167-05041	SCREW, tapping	2	
5	3FC-27475-20	CAP 1	2	SOLID FINE SILVER
6	90183-05042	NUT, spring	2	
7	3SA-28371-00	DAMPER	1	

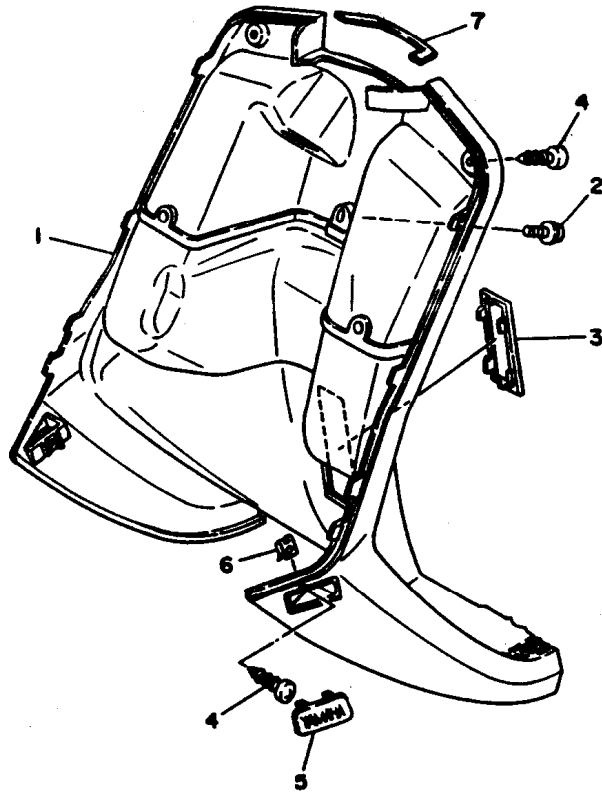

3YE1310-1240

C14

FIG. 25 COMING 1

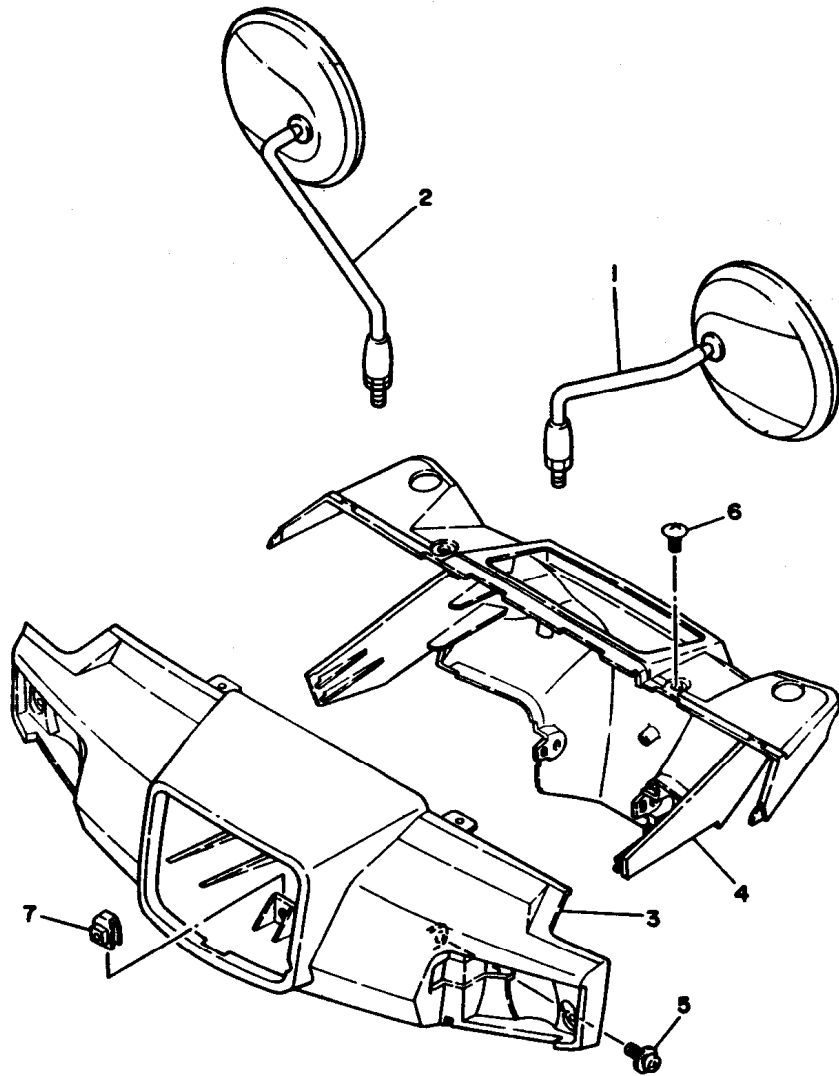

REF. NO.	PART NO.	DESCRIPTION	Q'TY	REMARKS
1	14T-26290-10	BACK MIRROR ASSY (LEFT)	1	
2	14T-26290-00	BACK MIRROR ASSY (RIGHT)	1	
3	4CG-26143-00-PO	COVER, handlebar upper 1	1	UR VERY DARK BLUE COCKTAIL 2
	4CG-26143-00-P1	COVER, handlebar upper 1	1	UR VIVID RED COCKTAIL 1
4	2EK-26145-30	COVER, handlebar upper 2	1	SOLID FINE SILVER
5	90159-05121	SCREW, with washer	2	
6	90154-05042	SCREW, binding	2	
7	35R-26294-00	NUT 1	3	



4AG1351-1250

C15

FIG. 26 GENERATOR

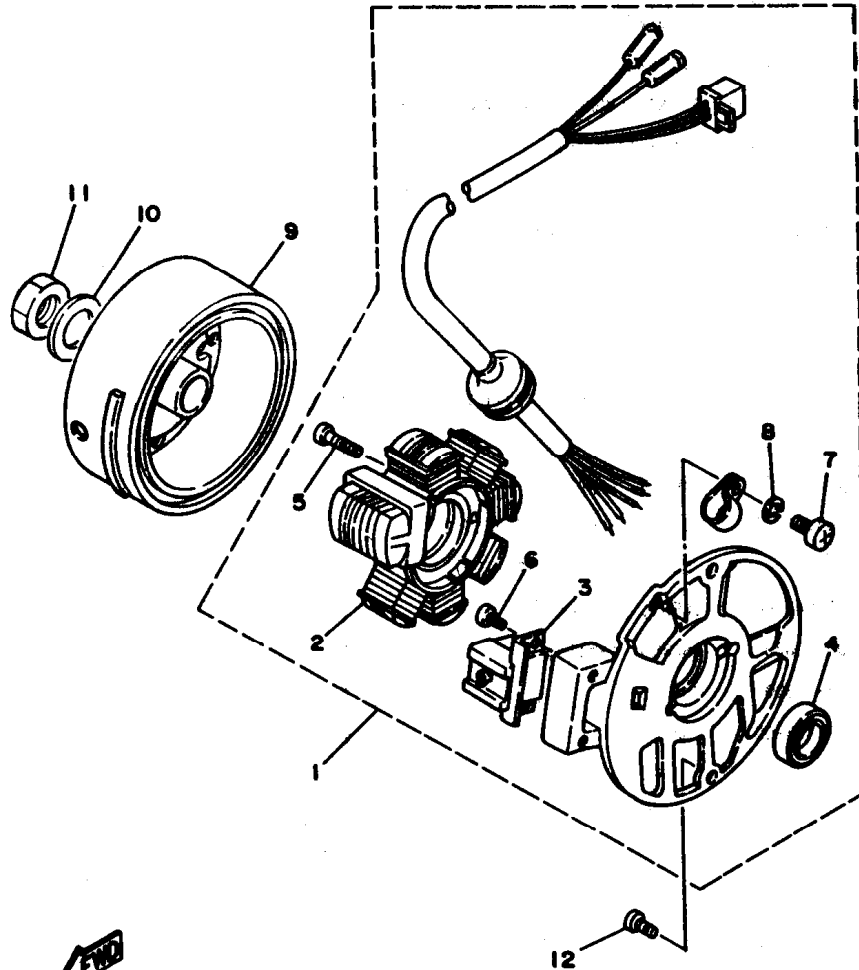

REF. NO.	PART NO.	DESCRIPTION	Q'TY	REMARKS
1	3KJ-85560-00	BASE ASSY	1	
2	2JA-81403-M0	.STATORCOMP.	1	
3	2JA-85580-M0	.COIL, pulser	1	
4	93104-19097	.OIL SEAL	1	
5	98501-05020	.SCREW, pan head	2	
6	98501-05010	.SCREW, pan head	2	
7	98501-04006	.SCREW, pan head	1	
8	92901-04100	.WASHER, spring	1	
9	2JA-85550-M0	ROTOR ASSY	1	
10	92990-10600	WASHER, plate	1	
11	90170-10219	NUT	1	
12	98501-06016	SCREW, pan head	2	

3KJ1010-9260

D2

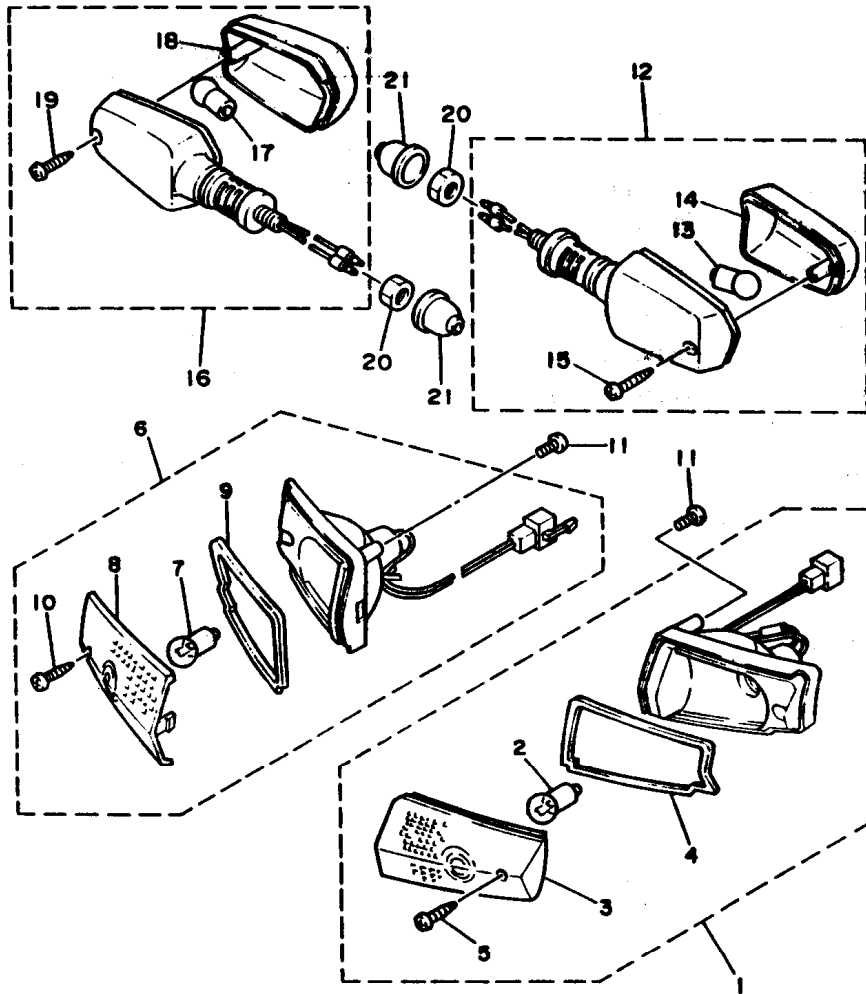

FIG. 27 FLASHER LIGHT

REF. NO.	PART NO.	DESCRIPTION	Q'TY	REMARKS
1	2YR-83310-00	FRONT FLASHER LIGHT ASSY 1	1	
2	851-84744-00	.BULB (12V-10W)	1	
3	2EK-83312-00	.LENS, flasher	1	
4	2EK-83313-00	.GASKET, flasher lens	1	
5	97780-40116	.SCREW, tapping	1	
6	2YR-83320-00	FRONT FLASHER LIGHT ASSY 2	1	
7	851-84744-00	.BULB (12V-10W)	1	
8	2EK-83322-00	.LENS, flasher 2	1	
9	2EK-83313-00	.GASKET, flasher lens	1	
10	97780-40116	.SCREW, tapping	1	
11	90167-05025	SCREW, tapping	4	
12	3YE-83330-01	REAR FLASHER LIGHT ASSY 1	1	
13	*	.BULB, flasher (12V-10W)	1	LM
14	2EK-83332-00	.LENS, flasher	1	
15	97706-40620	.SCREW, tapping	1	
16	3YE-83340-01	REAR FLASHER LIGHT ASSY 2	1	
17	*	.BULB, flasher (12V-10W)	1	LM
18	2EK-83342-00	.LENS, flasher 2	1	
19	97706-40620	.SCREW, tapping	1	
20	95303-12600	NUT	2	
21	10V-83365-00	CAP	2	



2YR310-8270

D3

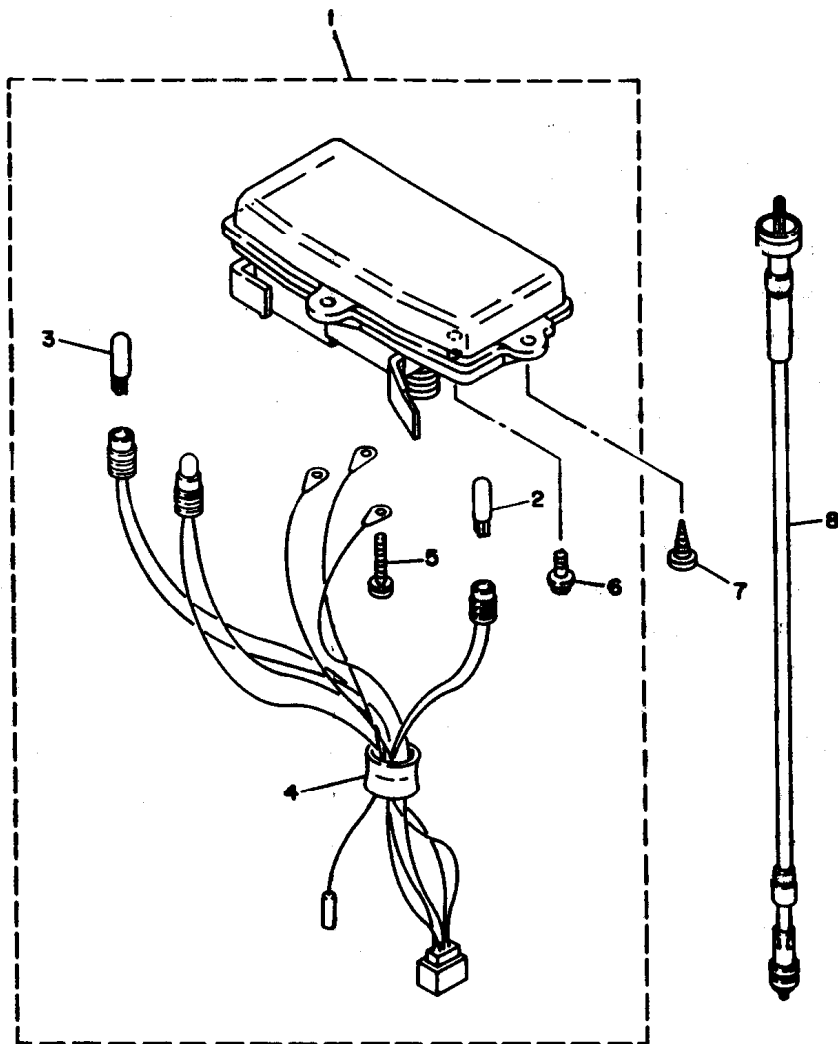

FIG. 28 METER

REF. NO.	PART NO.	DESCRIPTION	Q'TY	REMARKS
1	4AG-83510-00	SPEEDOMETER ASSY	1	
2	1YT-83517-00	.BULB (12V-1.7W, t10)	1	
3	4G1-84744-00	.BULB (12V-3.4W)	2	
4	4AG-83509-00	.SOCKET CORD ASSY	1	
5	90159-03102	.SCREW, with washer	3	
6	36F-83549-00	.SCREW, tapping	2	
7	90167-05030	SCREW, tapping	3	
8	3SA-83550-00	SPEEDOMETER CABLE ASSY	1	



4CG1700-1280

D4

FIG. 29 HEADLIGHT

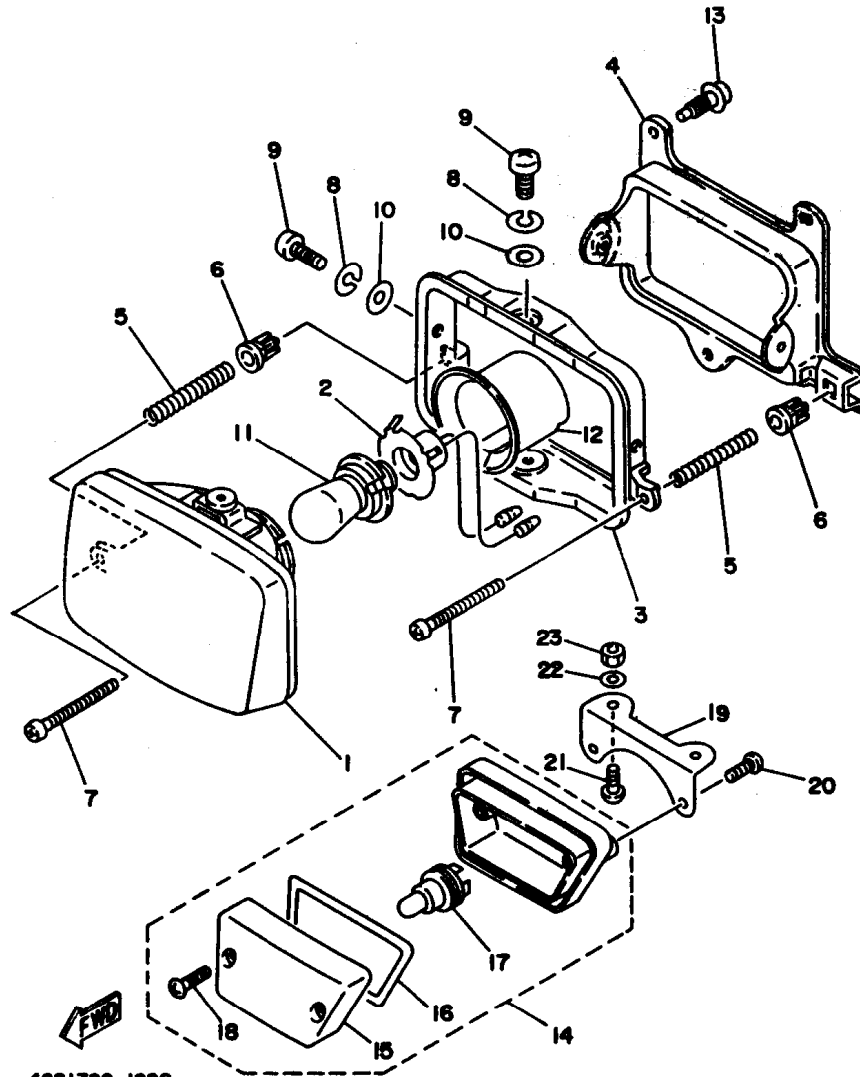

REF. NO.	PART NO.	DESCRIPTION	Q'TY	REMARKS
1	2KG-84320-00	LENS ASSY	1	
2	468-84112-40	SOCKET	1	
3	2EK-84395-00	RING, retaining	1	
4	2EK-84394-00	RING, mounting	1	
5	2EK-84132-00	SPRING, screw	2	
6	50W-84334-00	NUT, adjusting	2	
7	1M1-84524-60	SCREW, lens fitting	2	
8	92990-05100	WASHER, spring	4	
9	50W-84333-00	SCREW	4	
10	92901-05600	WASHER, plate	4	
11		BULB, headlight (12V-15W)	1	LM
12	30E-84197-45	COVER, socket	1	
13	90159-05089	SCREW, with washer	3	
14	3GM-84301-00	PILOT LIGHT ASSY 1	1	
15	3GM-84321-00	.LENS ASSY	1	
16	3GM-84322-00	.GASKET, lens	1	
17	2JE-84744-00	.BULB (12V-5W)	1	
18	3GM-84192-00	.SCREW (M4,1-12)	2	
19	4CG-23327-00	STAY, flasher	1	
20	97706-50010	SCREW, tapping	2	
21	98516-05012	SCREW, pan head	2	
22	92906-05200	WASHER, plain	2	
23	95606-05100	NUT, u	2	

4CG1700-1290

D5

FIG. 30 TAILLIGHT

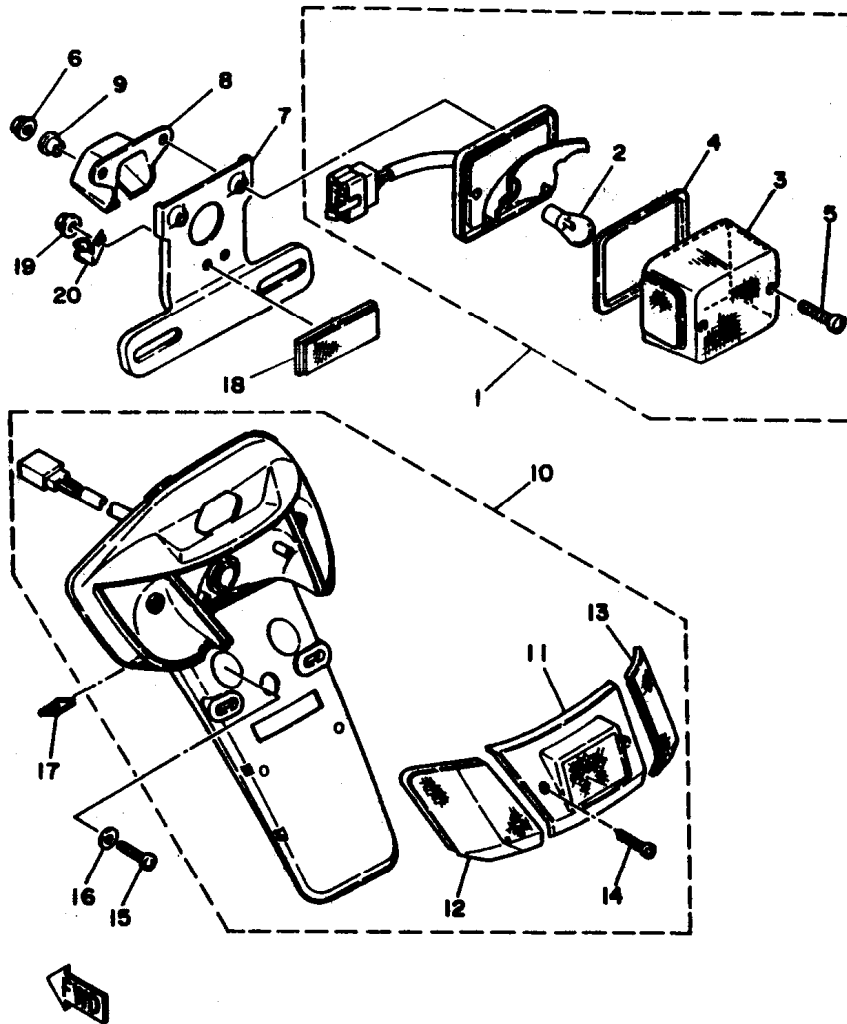

CG1700-1300

REF. NO.	PART NO.	DESCRIPTION	Q'TY	REMARKS
1	4CG-84710-00	TAILLIGHT UNIT ASSY	1	
2	31L-84714-00	.BULB, taillight (12V-21/5W)	1	
3	1MB-84521-40	.LENS, taillight	1	
4	1M1-84523-60	.GASKET, lens	1	
5	1M1-84524-60	.SCREW, lens fitting	2	
6	95701-06500	NUT, flange	2	
7	1UV-84751-00-98	BRACKET, license	1	LOW GLOSS BLACK
8	3L8-84544-00	COVER	1	
9	90387-06681	COLLAR	2	
10	3SA-21630-00	TAIL COVER ASSY	1	
11	3SA-2163A-00	.COVER, rear fender 1	1	
12	3SA-2163E-00	.COVER, rear fender 2	1	
13	3SA-2163F-00	.COVER, rear fender 3	1	
14	97701-40525	.SCREW, tapping	2	
15	92501-06014	SCREW, pan head	2	
16	92901-06600	WASHER, plate	2	
17	90183-05042	NUT, spring	2	
18	3Y6-85130-01	REAR REFLECTOR ASSY	1	
19	95701-05500	NUT, flange	1	
20	90462-06080	CLAMP	1	

FIG. 31 HANDLE SWITCH. LEVER

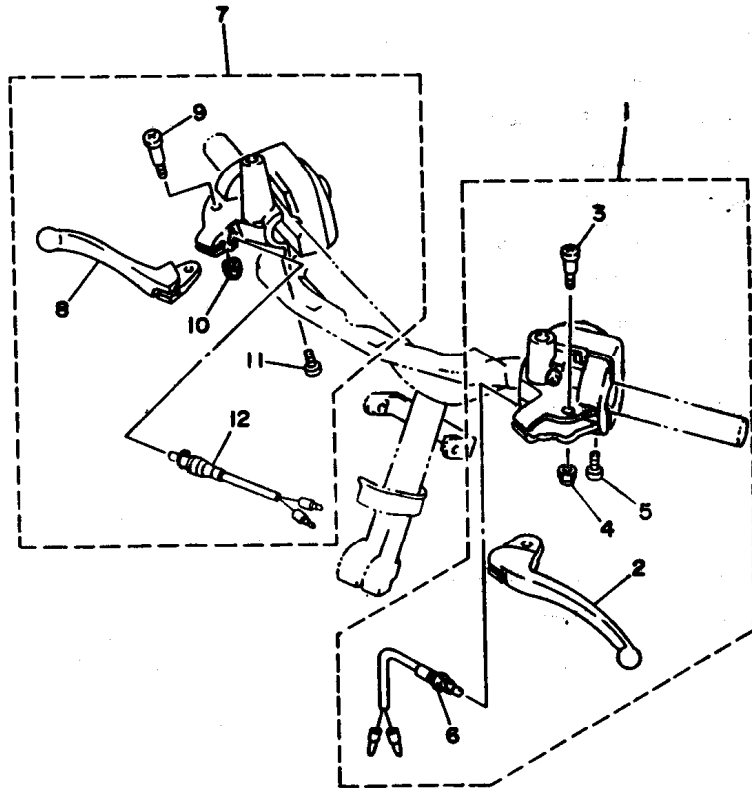

REF. NO.	PART NO.	DESCRIPTION	Q'TY	REMARKS
1	4CG-82910-01	LEVER HOLDER ASSY (LEFT)	1	
2	14T-83912-00	.LEVER 1	1	
3	90149-05119	.SCREW	1	
4	90185-05155	.NUT, self-locking	1	
5	98901-04010	.SCREW, bind	2	
6	3E1-83980-01	.FRONT STOP SWITCH ASSY	1	
7	4CG-82920-01	LEVER HOLDER ASSY (RIGHT)	1	
8	14T-83922-00	.LEVER 2	1	
9	90149-05119	.SCREW	1	
10	90185-05155	.NUT, self-locking	1	
11	98901-04010	.SCREW, bind	1	
12	3E1-83980-01	.FRONT STOP SWITCH ASSY	1	



4CG1700-1310

D7

FIG. 32 ELECTRICAL 1

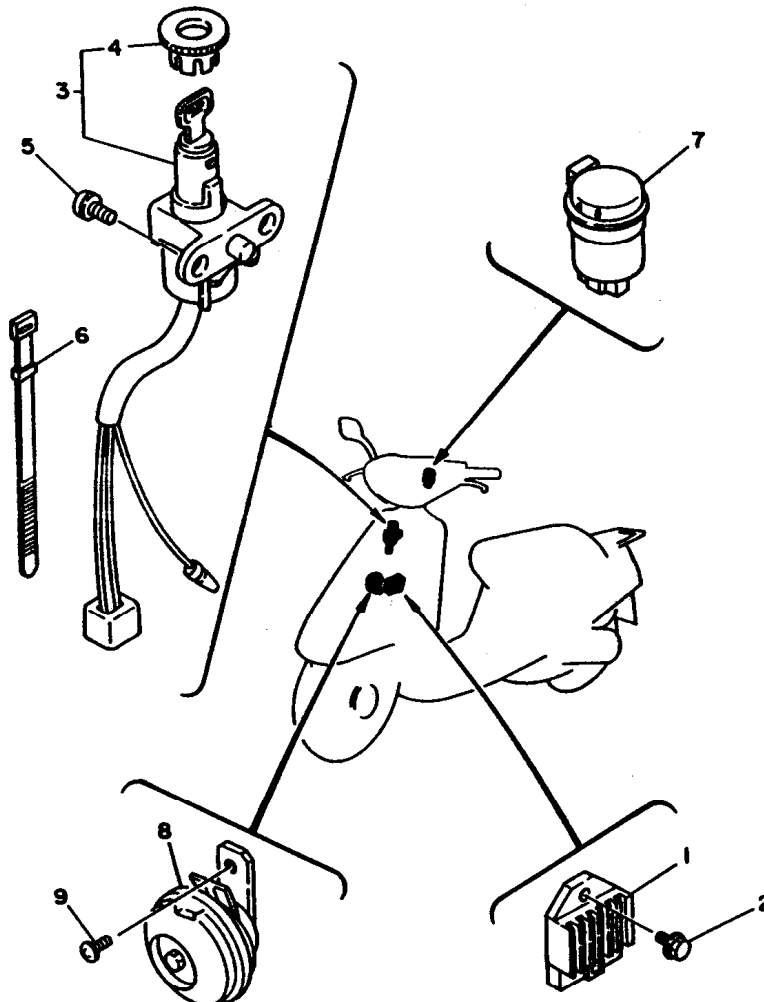

REF. NO.	PART NO.	DESCRIPTION	Q'TY	REMARKS
1	3AA-81960-00	RECTIFIER & REGULATOR ASSY	1	
2	95023-06016	BOLT	1	
3	3KJ-82501-00	MAIN SWITCH STEERING LOCK	1	
4	2EX-82552-20	.CAP, switch	1	
5	90149-06250	SCREW	2	
6	25G-83936-01	BAND, switch cord	1	
7	29G-83350-20	FLASHER RELAY ASSY	1	
8	27V-83371-20	HORN	1	
9	98501-06010	SCREW, pan head	1	



3KJ1010-9320

D8

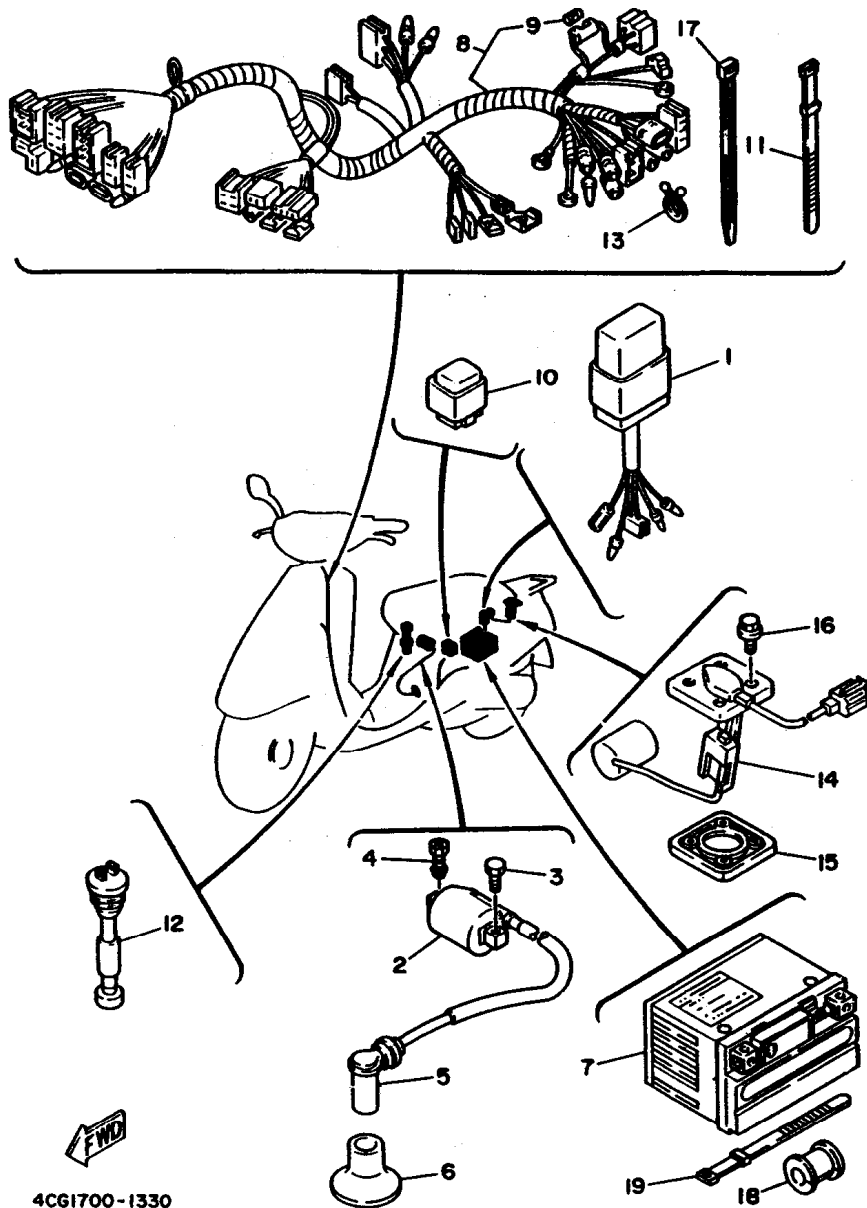

4CG1700-1330

FIG. 33 ELECTRICAL 2

REF. NO.	PART NO.	DESCRIPTION	Q'TY	REMARKS
1	3YE-85540-00	C.D.I. UNIT ASSY	1	
2	3KJ-82310-00	IGNITION COIL ASSY	1	
3	97313-06016	BOLT	1	
4	90153-06034	SCREW, hexagon	1	
5	56J-82370-00	PLUG CAP ASSY	1	
6	3KJ-82372-00	SEAL, plug cap	1	
7	3UC-82100-10	BATTERY ASSY (YT4L-BS 12V-3A)	1	
8	4CG-82590-00	WIRE HARNESS ASSY	1	
9	27V-82151-00	.FUSE (7A)	1	
10	27V-81940-02	STARTER RELAY ASSY	1	
11	437-83936-11	BAND, switch cord	2	
12	53L-85720-00	OIL LEVEL GAUGE ASSY	1	
13	90465-18147	CLAMP	1	
14	3KJ-85752-00	SENDER UNIT ASSY, fuel meter	1	
15	5G3-85753-00	GASKET, sender unit	1	
16	90119-05071	BOLT, with washer	4	
17	90465-13169	CLAMP	1	
18	90480-20543	GROMMET	1	
19	437-83936-01	BAND, switch cord	1	

D9

NUMERICAL INDEX

PART NO.	GRID NO.	PART NO.	GRID NO.	PART NO.	GRID NO.	PART NO.	GRID NO.	PART NO.	GRID NO.	PART NO.	GRID NO.
27V-W2536-00	C- 9	3KJ-14349-00	B- 7	2VK-16620-00	B-12	3YJ-23110-00	C- 6	3KJ-25326-00	C-11	12R-82591-00	C-12
36R-W2536-00	C-11	3KJ-14353-21	B- 7	24G-16626-00	B-12	3YJ-23120-00	C- 6	3KJ-25336-00	C-11	4CG-82910-01	D- 7
3KJ-11111-10	B- 2	14T-14384-00	B- 7	3KJ-17410-00	B-14	3KJ-23141-00	C- 6	3KJ-25351-00	C-11	4CG-82920-01	D- 7
3KJ-11181-00	B- 2	1HV-14385-01	B- 7	3KJ-17420-00	B-14	2E9-23143-00	C- 6	3KJ-25355-00	C-11	2YR-83310-00	D- 3
3KJ-11311-10	B- 2	367-14386-00	B- 7	3MG-17608-00	B-12	3YJ-23191-00	C- 6	3KJ-25357-00	C-11	2EK-83312-00	D- 3
3KJ-11351-00	B- 2	2JA-14392-00	B- 7	3KJ-17611-00	B-12		C- 6	3YJ-25390-00-UJ	C-11	2EK-83313-00	D- 3
3KJ-11400-00	B- 3	3KJ-14411-10	B- 6	2EX-17620-01	B-12	1RN-23195-00	C- 6	3YJ-25390-00-35	C-11		D- 3
3KJ-11412-00	B- 3	3KJ-14412-00	B- 6	3AA-17623-00	B-12	4CG-23327-00	D- 5	2VK-26110-00	C-12	2YR-83320-00	D- 3
3KJ-11422-00	B- 3	3KJ-14437-00	B- 6	52W-17632-00	B-12	3KJ-23411-01	C- 6	4CG-26143-00-PO	C-15	2EK-83322-00	D- 3
260-11601-02	B- 3	3KJ-14451-00	B- 6	3KJ-17641-00	B-12	2E9-23412-00	C- 6	4CG-26143-00-P1	C-15	3YE-83330-01	D- 3
260-11601-12	B- 3	3KJ-14452-00	B- 6	1NT-17653-00	B-12	2E9-23413-01	C- 6	2EK-26145-30	C-15	2EK-83332-00	D- 3
260-11601-22	B- 3	3KJ-14453-00	B- 6	3AA-17660-01	B-12	2E9-23414-01	C- 6	5G3-26241-00	C-12	3YE-83340-01	D- 3
3CP-11631-00-96	B- 3	3KJ-14610-11	B- 8	24G-17664-00	B-13	2E9-23454-00	C- 6	5G3-26242-00	C-12	2EK-83342-00	D- 3
27V-11633-00	B- 3	24G-14613-00	B- 8	3KJ-17684-00	B-13	3KJ-24110-00	C- 7	2GN-26243-00	C-12	29G-83350-20	D- 8
3CP-11635-00	B- 3	2JA-14718-00	B- 8	4CG-21110-00	B-15	3KJ-2414A-01	C- 7	53L-26261-01	C-12	10V-83365-00	D- 3
3CP-11636-00	B- 3	2JA-14766-00	B- 8	3KJ-21232-00	B-15	3KJ-24311-00	C- 7	14T-26290-00	C-15	27V-83371-20	D- 8
2E9-11651-00	B- 3	52W-14766-00	B- 8	3KJ-21381-00	C- 5	3KJ-24453-00	C- 8	14T-26290-10	C-15	4AG-83509-00	D- 4
1YU-11681-00	B- 3	3KJ-1490J-10	B- 7	2T4-2139X-01	B-15	3KJ-24500-01	C- 7	2EK-26293-00	C-12	4AG-83510-00	D- 4
3KJ-12611-00	B- 4	3KJ-15110-01	B- 9	3KJ-21398-00	C- 8	3KJ-24602-00	C- 7	35R-26294-00	C-15	1YT-83517-00	D- 4
3KJ-12651-11	B- 4	3KJ-15120-00	B- 9	3KJ-21410-00	B-15	3KJ-2470F-00	C- 8	2EK-26311-01	C-12	36F-83549-00	D- 4
3KJ-12653-01	B- 4	1HV-15128-00	B- 9	2T4-21481-01	B-15	3FC-24705-03	C- 8	3KJ-26312-00	C-12	3SA-83550-00	D- 4
3KJ-12658-01	B- 4	3KJ-15316-00	B-10	3KJ-21481-00	B-15	3KJ-24710-01	C- 8	1YU-26329-00	C-12	14T-83912-00	D- 7
3KJ-13100-01	B- 5	3KJ-15317-00	B- 9	3KJ-21511-00-PO	C- 2	3KJ-24717-00	C- 8	3KJ-26329-00	B- 7	14T-83922-00	D- 7
3AA-13124-00	B- 5	3KJ-15326-00	B-10	3KJ-21511-00-P1	C- 2	3SA-24718-00	C- 8	304-26329-00	C-12	25G-83936-01	D- 8
2GM-13178-00	B- 5	3KJ-15335-00	B-10	25G-21535-00	C-13	3KJ-24726-00	C- 8	3SA-26341-00	C-12	437-83936-01	D- 9
1YU-13185-00	B- 5	3KJ-15337-00	B-10	3KJ-21552-00	C- 2	3KJ-2473R-00	C- 8	3KJ-26342-00	C-12	437-83936-11	D- 9
1YU-13187-00	B- 5	4J2-15363-00	B- 9	27V-21553-03	C- 2	3KJ-24747-00	C- 8	3SA-26351-00	C-12	3E1-83980-01	D- 7
50M-13342-00	B-11	3YJ-15371-00	B- 9	3KJ-21578-02	C- 2	3KJ-2475M-00	C- 8	3KJ-26393-00	C-12		D- 7
1YU-13473-00	B- 5	3KJ-15411-00	B- 9	3SA-2163A-00	D- 6	3FC-2483H-00	C- 8	3YJ-27111-00	C-13	468-84112-40	D- 5
1YU-13516-00	B- 5	3KJ-15421-00	B- 9	3SA-2163E-00	D- 6	3SA-24842-00	C- 8	3FC-27475-20	C-14	2EK-84132-00	D- 5
3KJ-13555-00	B- 6	3KJ-15431-00	B-10	3SA-2163F-00	D- 6	3KJ-24845-00	C- 3	3KJ-27481-00	C-13	3GM-84192-00	D- 5
1YU-13577-00	B- 5	3KJ-15451-00	B- 9	3SA-21630-00	D- 6	3KJ-24846-00	C- 3	3KJ-28300-00	C-14	30E-84197-45	D- 5
3KJ-13610-00	B- 6	3KJ-15461-00	B- 9	3KJ-2171L-00	C- 3	25K-25116-00	C- 9	20H-28349-01	C-14	3GM-84301-00	D- 5
3KJ-13613-00	B- 6	3KJ-15462-00	B-10	3KJ-2171M-00	C- 3	2GM-25121-00-UJ	C- 9	3SA-28371-00	C-14	2KG-84320-00	D- 5
3KJ-13616-00	B- 6	3KJ-15481-00	B-10	3KJ-21711-00-PO	C- 3	2GM-25121-00-35	C- 9	2JA-81403-MO	D- 2	3GM-84321-00	D- 5
3KJ-13621-00	B- 6	3AA-15513-00	B-11	3KJ-21711-00-P1	C- 3	3L8-2513A-00	C- 9	3KJ-81800-00	B-11	3GM-84322-00	D- 5
3KJ-1410A-10	B- 7	3KJ-15528-00	B-11	3KJ-21721-00-PO	C- 3	52H-2513A-00	C-11	27V-81940-02	D- 9	50W-84333-00	D- 5
2JA-14103-00	B- 7	3KJ-15532-00	B-11	3KJ-21721-00-P1	C- 3	2E9-25135-00	C- 9	3AA-81960-00	D- 8	50W-84334-00	D- 5
14T-14104-00	B- 7	3KJ-15570-00	B-11	3KJ-21751-00	C- 4	2E9-25137-01	C-10	3UC-82100-10	D- 9	2EK-84394-00	D- 5
2T4-14126-01	B- 7	3KJ-15601-00	B-11	2N3-21771-01	C- 4	2T4-25137-00	C- 9	3KJ-82129-00	C- 8	2EK-84395-00	D- 5
1HV-14147-00	B- 7	3KJ-15620-01	B-11	3KJ-21778-00	C- 3	2E9-25138-00	C- 9	27V-82151-00	D- 9	1M8-84521-40	D- 6
288-14161-00	B- 7	3AA-15631-00	B-11	3KJ-21781-11	C- 2	3KJ-25151-00	C- 9	3KJ-82310-00	D- 9	1M1-84523-60	D- 6
3KJ-14301-10	B- 7	3AA-15650-00	B-11	3KJ-21781-21	C- 2	2T4-25155-00	C- 9	56J-82370-00	D- 9	1M1-84524-60	D- 5
3KJ-14312-25	B- 7	3KJ-15657-00	B-12	3KJ-21782-02	C- 3	25K-25159-00	C- 9	3KJ-82372-00	D- 9		D- 6
14T-14323-00	B- 7	3KJ-15659-00	B- 9	3KJ-21783-02	C- 3	3YJ-25180-00-UJ	C- 9	3KJ-82501-00	D- 8	3L8-84544-00	D- 6
1YU-14331-00	B- 7	32N-15673-00	B-11	3KJ-22210-00	C- 5	3YJ-25180-00-35	C- 9	3KJ-82541-00	B-11	4CG-84710-00	D- 6
14T-14341-01	B- 7	3KJ-16111-00	B-12	164-22216-00	B- 9	3YJ-25181-00	C- 9	2EX-82552-20	D- 8	31L-84714-00	D- 6
14T-14343-38	B- 7	24G-16611-03	B-12	3KJ-23100-01	C- 6	3KJ-25185-00	C- 9	4CG-82590-00	D- 9	2JE-84744-00	D- 5

NUMERICAL INDEX

PART NO.	GRID NO.	PART NO.	GRID NO.	PART NO.	GRID NO.	PART NO.	GRID NO.	PART NO.	GRID NO.	PART NO.	GRID NO.
4G1-84744-00	D- 4	90176-06065	C- 7	90460-32242	B- 6	93102-20425	B- 3	95811-08012	C- 5	99009-17400	B-12
851-84744-00	D- 3		C- 8	90462-06080	D- 6	93102-22314	B-14	95816-06012	B-15	99009-19400	B- 5
	D- 3	90179-06176	C-12	90465-13169	D- 9	93104-19097	D- 2		C- 2	99510-12016	B- 9
1UV-84751-00-98	D- 6		C-12	90465-18147	D- 9	93106-17015	C- 9		C- 2	99530-10014	B- 9
3Y6-85130-01	D- 6	90179-07381	B- 2	90467-08003	B- 5	93109-33049	B-12		C- 7		B- 9
3YE-85540-00	D- 9	90179-28415	B-12	90467-09006	C- 7	93109-34057	C- 9	95816-08012	C- 8		
2JA-85550-MO	D- 2	90183-05042	C- 3	90467-10129	C- 7	93210-06550	B-12	95816-08020	B- 8		
3KJ-85560-00	D- 2		C- 3	90468-02033	B- 5	93210-07540	C-11	95816-08030	B- 8		
2JA-85580-MO	D- 2		C-14		B- 5	93210-10096	C-10	97021-05020	C- 9		
53L-85720-00	D- 9		D- 6	90468-12006	C-13	93210-14104	B- 9	97313-06016	D- 9		
3KJ-85752-00	D- 9	90185-05155	D- 7	90468-12182	C- 5	93210-23614	B-11	97701-40525	D- 6		
5G3-85753-00	D- 9		D- 7	90468-20127	B- 6	93210-38687	B-13	97702-60540	B- 4		
90101-06278	C-11	90185-10154	B-15	90480-10468	B- 4	93210-64488	B- 4	97706-30605	B- 8		
90102-10059	C- 5		C- 9	90480-12237	B- 8	93300-63808	B-12	97706-40620	D- 3		
90105-08121	C- 5	90185-14150	C-11	90480-12497	B- 4	93306-00314	B- 9		D- 3		
90105-10036	C-12	90201-064L6	C- 9		B- 6		B- 9	97706-50010	D- 5		
90109-063F1	C- 8	90201-06412	B-12	90480-20543	D- 9	93306-00315	B-12	97780-40116	D- 3		
9Q109-063F5	C- 7	90201-08087	B- 9	90501-10513	C-12	93306-20005	C- 9		D- 3		
90116-07353	B- 2	90201-084M4	B-11	90501-29517	B-15	93306-20006	B-14	97780-50125	B- 6		
90119-05071	D- 9	90201-12175	C- 8	90501-357F3	B-13		C- 9	98501-03006	B- 7		
90119-06042	C- 4	90201-123K4	B-14	90506-14081	C- 9	93306-20010	B-14	98501-04006	D- 2		
90119-06060	C-13	90201-133M8	B-12	90506-18288	C-11	93306-20310	B-14	98501-05010	D- 2		
90119-06066	C- 8	90201-142M6	C-11	90506-32464	C-13	93306-20458	B- 3	98501-05012	C-12		
90119-06085	C- 2	90201-154E9	B-11	90508-32609	B-11	93310-210M0	B- 3	98501-05016	B- 5		
90149-05119	D- 7	90201-17255	C-11	90560-06366	C- 7	93310-257R1	B-11	98501-05020	D- 2		
	D- 7	90202-10120	C-13	90560-10289	C- 9	93310-416F7	B- 3	98501-06010	B-12		
90149-06184	C- 3	90208-10012	B-12	90560-10360	C- 9	93420-40064	B-14		D- 8		
90149-06250	D- 8	90208-12049	B-14	91316-06020	B- 6	93450-11120	B- 3	98501-06012	B-10		
90153-06034	D- 9	90214-13055	B-12		B-11	93505-32002	C- 6		B-11		
90153-06038	B-11	90240-10132	C-13	92501-06014	B- 4	93603-12007	B- 5	98501-06016	D- 2		
90153-06061	B- 8	90241-10015	C- 8		D- 6	93900-00027	C- 9	98501-06020	B- 9		
90154-05042	C-15	90249-12008	C-12	92901-04100	B- 7		C-11	98501-06025	B- 9		
90159-03102	D- 4		C-12		D- 2	94108-104W0	C- 9	98501-06035	B- 9		
90159-05089	D- 5	90280-03017	B- 3	92901-05100	B- 7		C-11		B- 9		
90159-05121	C-15	90380-15083	B-11	92901-05600	D- 5	94703-00227	B- 2		B- 9		
90159-06178	C- 2	90387-06067	B- 8	92901-06600	B- 4	94703-00327	B- 2	98501-06065	B- 9		
90159-06182	C-14	90387-064A4	C-13		D- 6	95023-06016	D- 8	98516-05012	D- 5		
90167-05025	D- 3	90387-06681	D- 6	92902-03600	B- 6	95303-05600	C- 9	98516-06020	B- 4		
90167-05030	D- 4	90387-067V1	B- 4	92906-05200	D- 5	95303-12600	D- 3		B- 6		
90167-05041	C- 2		B- 6	92906-06600	B- 4	95601-12200	B-15	98580-03008	B- 6		
	C- 3	90387-132M6	B-12		B- 6	95606-05100	D- 5	98580-04016	B- 7		
	C- 3	90387-156U0	B- 3	92990-05100	D- 5	95611-10200	C-12	98580-05016	B- 7		
	C- 3	90445-05431	B- 5	92990-06100	B- 4	95701-05500	D- 6	98580-06016	B- 7		
	C-14	90445-07166	C- 7		B- 7	95701-06500	C- 8	98901-04010	D- 7		
90167-05055	C- 3	90445-09304	B- 5	92990-06200	B- 8		D- 6		D- 7		
90170-10219	B-12	90445-11161	C- 7	92990-10600	D- 2	95701-08500	C-11	98906-06016	B- 8		
	D- 2	90446-11345	C- 7	93101-20138	B- 3	95701-10500	C- 5	99009-15400	B-11		
90170-10317	B-12	90446-11347	B- 9	93102-17342	B-12	95801-08016	B- 9	99009-17400	B- 9		